

# TA-F100/F200

## SERVICE MANUAL

*AEP Model*  
*UK Model*  
 TA-F100/F200  
*E Model*  
 TA-F100

TA-F100



TA-F200



### SPECIFICATIONS

#### Amplifier

Continuous RMS power output (both channels driven simultaneously)

#### West Germany model

		TA-F100	TA-F200
DIN, 1 kHz	4 ohms	42 W + 42 W	50 W + 50 W
	8 ohms	33 W + 33 W	38 W + 38 W
40 Hz - 20 kHz THD 0.05%	4 ohms	30 W + 30 W	42 W + 42 W
	8 ohms	28 W + 28 W	34 W + 34 W

#### Other models

		TA-F100	TA-F200
DIN, 1 kHz, 8 ohms		48 W + 48 W	65 W + 65 W
40 Hz - 20 kHz, THD 0.05%, 8 ohms		43 W + 43 W	55 W + 55 W

Music power output (TA-F100 except for AEP and UK models)  
 170 W

#### Input

Input jack			Jack type	Sensitivity	Impedance	S/N (weighting network, input level)	
						West Germany model	Other models
PHONO	MM	TA-F100	Phono	2.5 mV	50 kilohms	81 dB (A, 2.5 mV)	85 dB (A, 2.5 mV)
		TA-F200				82 dB (A, 2.5 mV)	88 dB (A, 2.5 mV)
	MC (TA-F200 only)		Phono	170 $\mu$ V	100 ohms	64 dB (A, 170 $\mu$ V)	68 dB (A, 170 $\mu$ V)
TUNER, CD, VIDEO/AUX, TAPE/DAT			Phono	150 mV	50 kilohms	100 dB (150 mV)	

#### Output

Output jack	Jack type	Voltage/impedance
REC OUT	Phono jacks	Voltage 150 mV Impedance 470 ohms
SPEAKERS	—	<b>West Germany model:</b> Accepts speakers of 4 - 16 ohms. <b>Other models:</b> Accepts speakers of 8 - 16 ohms.
HEAD-PHONES	Stereo phone jack	Accepts low and high impedance headphones.

#### Tone controls

	Response	Turnover frequency
BASS	$\pm 10$ dB (100 Hz)	500 Hz
TREBLE	$\pm 10$ dB (15 kHz)	3 kHz

- Continued on page 2 -

INTEGRATED STEREO AMPLIFIER  
**SONY**<sup>®</sup>



Loudness (Attenuation 30 dB)  
 + 6 dB (100 Hz)  
 + 3 dB (10 kHz)

Power bandwidth (IHF)  
 10 Hz - 40 kHz (8 ohms, 20 watts)

Dynamic headroom  
 1.5 dB (78 IHF)

Harmonic distortion  
 Less than 0.05% at rated output

Intermodulation (IM) distortion (60 Hz : 7 kHz = 4 : 1)  
 Less than 0.05% at rated output

Frequency response  
 PHONO: RIAA equalization curve  $\pm 0.5$  dB  
 TUNER, CD, VIDEO/AUX, TAPE1, TAPE2/DAT:  
 7 Hz - 100 kHz  $\pm 3$  dB

Residual noise  
 Less than 170  $\mu$ V (8 ohms, network A)

Damping factor  
 36 (8 ohms, 1 kHz)

**General**  
 System  
 Preamplifier: Low-noise, high-gain equalizer amplifier  
 Power amplifier: Pure-complementary SEPP OCL power amplifier with all stages directly coupled

Power requirements  
 AEP model: 220 V AC, 50 Hz  
 UK model: 240 V AC, 50 Hz  
 E model: 120 V, 220 V or 240 V AC adjustable, 50/60 Hz

Power consumption  
 West Germany model:  
 TA-F100: 90 W  
 TA-F200: 100 W  
 UK model:  
 TA-F100: 230 W  
 TA-F200: 270 W  
 AEP, E model:  
 TA-F100: 85 W  
 TA-F200: 110 W

Dimensions  
 Approx. 430 x 118 x 265 mm (w/h/d)  
 (17 x 4 $\frac{3}{4}$  x 10 $\frac{1}{2}$  inches)

Weight  
 TA-F100: Approx. 5.5 kg (12 lb 3 oz)  
 TA-F200: Approx. 6.4 kg (14 lb 2 oz)

## MODEL IDENTIFICATION

- Specification Label -

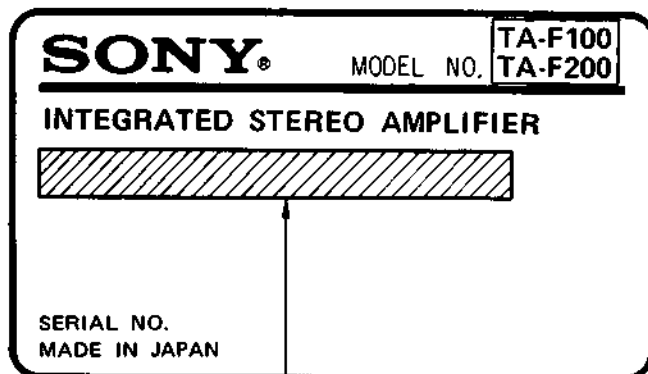

### TA-F100:

West Germany Model: AC: 220 V ~ 50/60 Hz 90 W  
 AEP Model: AC: 220 V ~ 50/60 Hz 85 W  
 UK Model: AC: 240 V ~ 50/60 Hz 230 W  
 E model: AC: 120, 220, 240 V ~ 50/60 Hz 85 W

### TA-F200:

West Germany Model: AC: 220 V ~ 50/60 Hz 100 W  
 AEP Model: AC: 220 V ~ 50/60 Hz 110 W  
 UK Model: AC: 240 V ~ 50/60 Hz 270 W  
 E Model: AC: 120, 220, 240 V ~ 50/60 Hz 110 W

### On operating voltage

Where purchased	Operating voltage
UK model	240 V AC
AEP model	220 V AC
E model	120 V, 220 V or 240 V AC adjustable The voltage selector is located on the rear panel.

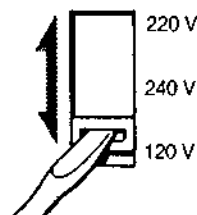

### SAFETY-RELATED COMPONENT WARNING!!

COMPONENTS IDENTIFIED BY SHADING AND MARK  ON THE SCHEMATIC DIAGRAMS AND IN THE PARTS LIST ARE CRITICAL TO SAFE OPERATION. REPLACE THESE COMPONENTS WITH SONY PARTS WHOSE PART NUMBERS APPEAR AS SHOWN IN THIS MANUAL OR IN SUPPLEMENTS PUBLISHED BY SONY.

## TABLE OF CONTENTS

<u>Section</u>	<u>Title</u>	<u>Page</u>	<u>Section</u>	<u>Title</u>	<u>Page</u>	
Specifications		1	<b>2. DIAGRAMS</b>	Circuit Boards Location	5	
Model Identification		2		2-1. Schematic Diagram	6	
On Operating Voltage		2		2-2. Printed Wiring Boards	9	
				Semiconductor Lead Layouts	12	
<b>1. GENERAL</b>			<b>3. EXPLODED VIEWS</b>		13	
Parts Identification		3	<b>4. ELECTRICAL PARTS LIST</b>			
Connection		4				
Troubleshooting Guide		4				

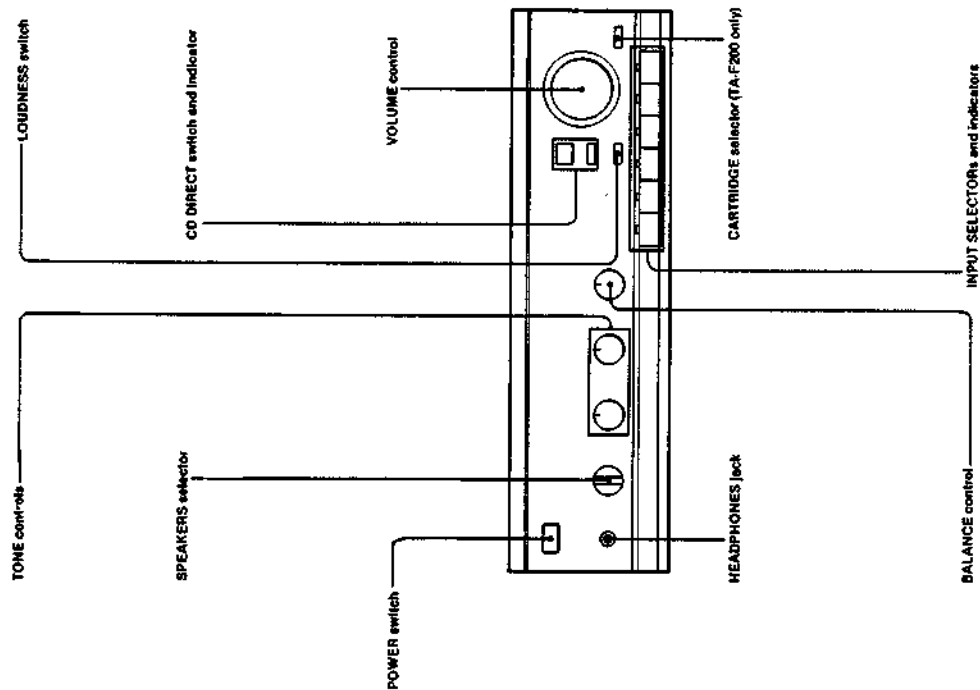
SECTION 1  
GENERAL

## Connection

### Notes on Connection

- Connect the AC power cord last. Make sure power is off.
- Cord plugs and jacks are color coded. Red plugs and jacks are for right channel (R) and white ones for left channel (L).
- Fully insert cable connectors into jacks. Loose connections may cause hum or noise.

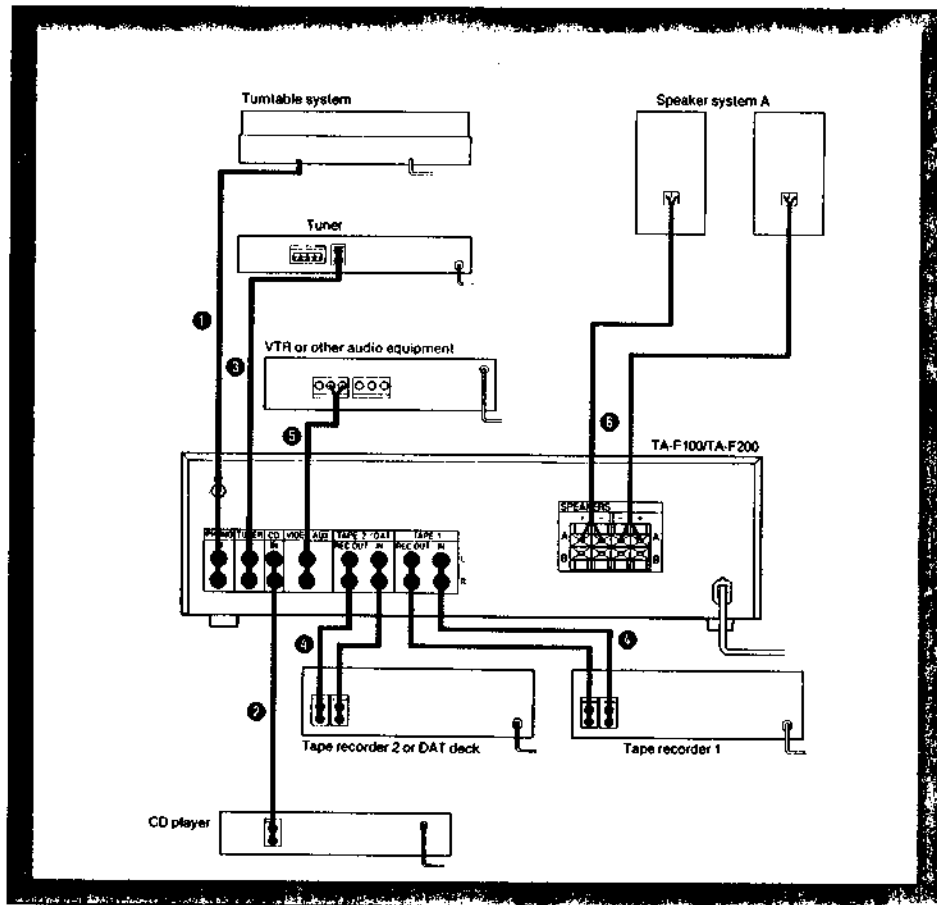

## Troubleshooting Guide

No audio	<ul style="list-style-type: none"> <li>• Check power cord connection.</li> <li>• Check speaker and program source connections.</li> <li>• Check SPEAKERS selector setting.</li> <li>• Check INPUT SELECTOR setting.</li> <li>• Check CD DIRECT switch setting.</li> <li>• Adjust VOLUME control.</li> </ul>
No audio from one channel or unbalanced left and right volume	<ul style="list-style-type: none"> <li>• Adjust BALANCE control.</li> <li>• Check speaker and input connections of inoperative channel.</li> </ul>
Abrupt sound loss from both speakers	<ul style="list-style-type: none"> <li>• Turn off amplifier. Check speaker terminals and connecting cords for short.</li> </ul>
Lack of bass sound or obscure instrument position	<ul style="list-style-type: none"> <li>• Check speaker +/- connections for proper phasing.</li> </ul>
TONE controls do not work.	<ul style="list-style-type: none"> <li>• Release CD DIRECT to OFF.</li> </ul>
Severe hum or noise	<ul style="list-style-type: none"> <li>• TV or VTR is too close to audio system.</li> <li>• Move connecting cords away from transformers, motors or fluorescent lights.</li> <li>• Fully insert connecting cord plugs.</li> <li>• Ground turntable system.</li> <li>• Disconnect turntable ground wire when using an MM cartridge with a ground piece.</li> <li>• Wipe plugs and jacks with a cloth lightly moistened with methanol.</li> </ul>

## SECTION 2 DIAGRAMS

### • CIRCUIT BOARDS LOCATION

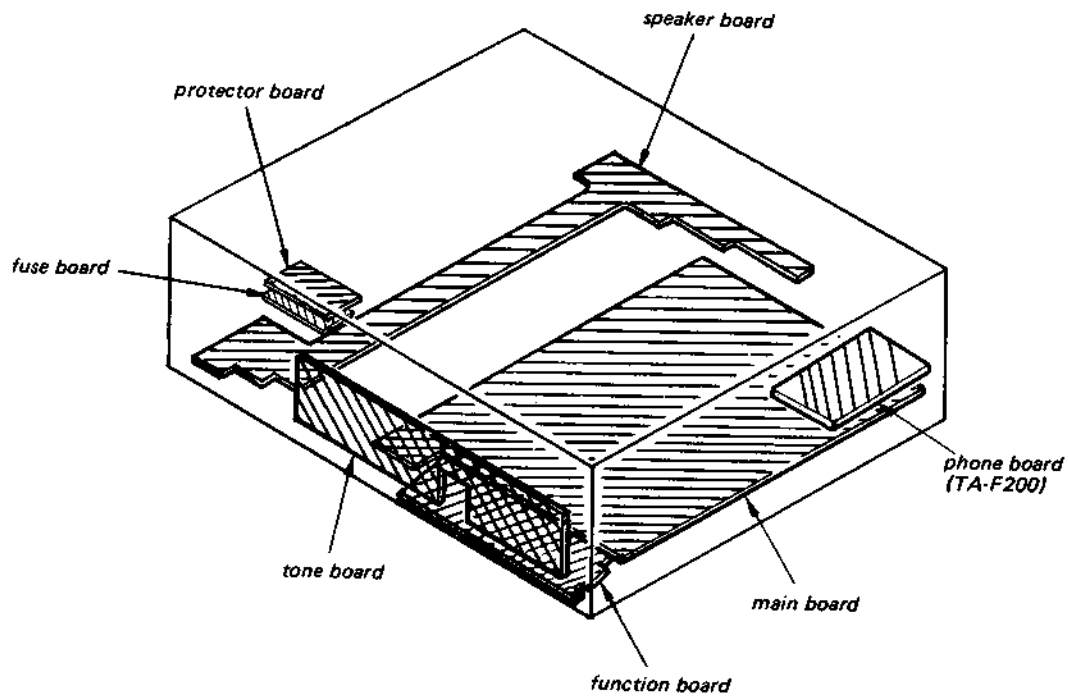

## 2-1. SCHEMATIC DIAGRAM

### Note:

- All capacitors are in  $\mu\text{F}$  unless otherwise noted. pF:  $\mu\text{F}$  50WV or less are not indicated except for electrolytics and tantalums.

- All resistors are in  $\Omega$  and  $1/4\text{W}$  or less unless otherwise specified.

- Signal path.

➡➡➡ PHONO

- ▬: nonflammable resistor.

- : B+ Line

- - - : B- Line

- Voltages are dc with respect to ground unless otherwise noted.

- Voltage variations may be noted due to normal production tolerances.

- Readings are taken under no-signal conditions with a VOM (50 k $\Omega$ /V).

no mark: TA-F100/F200

( ) : TA-F200

- Switch

Ref. No.	Switch	Position
S1	POWER	OFF
S100-1	PHONO	OFF
S100-2	TUNER	OFF
S100-3	CD	ON
S100-4	VIDEO/AUX	OFF
S100-5	TAPE 2/DAT	OFF
S100-6	TAPE 1	OFF
S103	CARTRIDGE (TA-F200)	OFF
S300	LOUDNESS	OFF
S301	CD DIRECT	OFF
S900	SPEAKERS	OFF
VS901	VOLTAGE SELECTOR (TA-F100: E)	120V

Note: The components identified by mark  $\Delta$  or dotted line with mark  $\Delta$  are critical for safety. Replace only with part number specified.

### IC700 ( $\mu\text{PC1237HA}$ ) BLOCK DIAGRAM

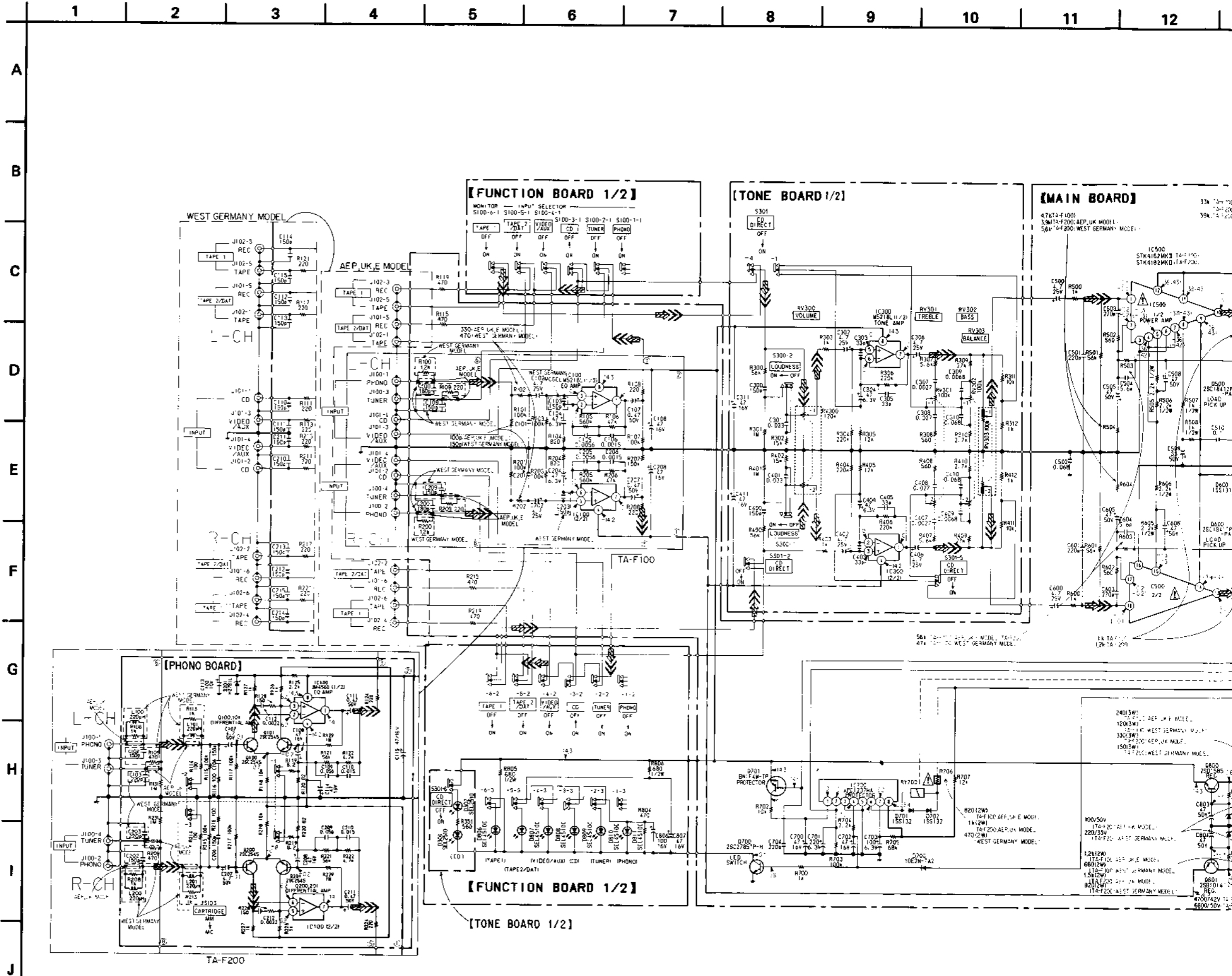
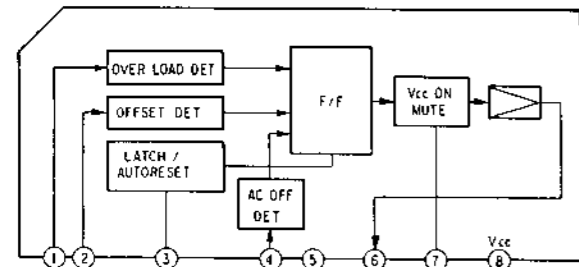

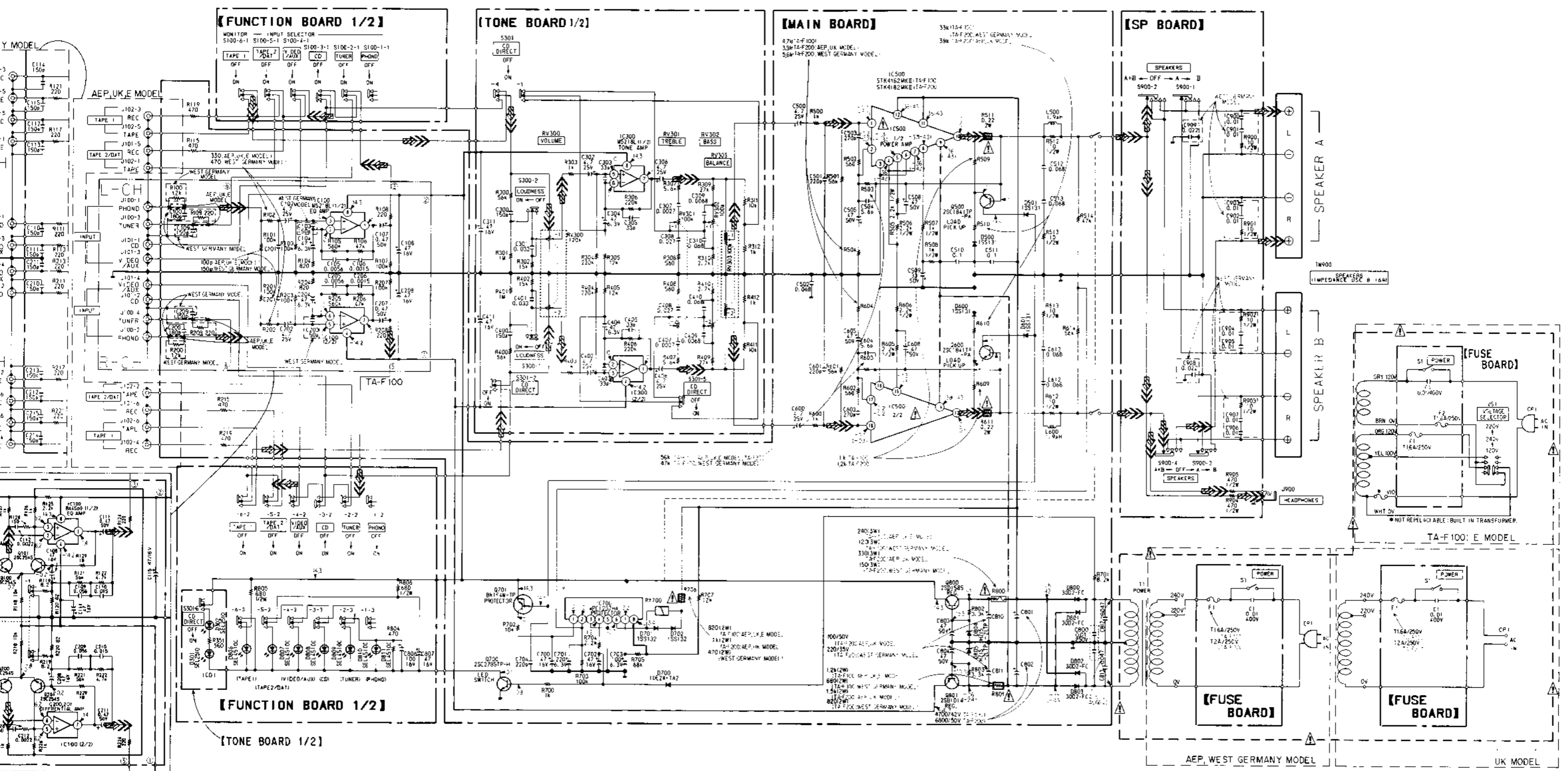

• Semiconductor Location

Ref. No.	Location
D201	F-12
D301	J-19
D302	J-19
D500	C-7
D501	G-8
D600	D-7
D601	D-7
D700	E-5
D701	E-6
D702	E-6
D800	D-5
D801	D-5
D802	D-5
D803	D-5
D804	F-5
D805	F-5
D806	J-7
D807	J-6
D808	J-5
D809	J-4
D810	J-3
D811	J-2
IC100	C-2
IC101	F-12
IC300	I-18
IC500	E-10
IC700	F-6
Q100	E-13
Q101	E-13
Q200	E-12
Q201	E-12
Q500	G-7
Q600	D-7
Q700	G-6
Q701	G-7
Q800	G-5
Q801	F-5

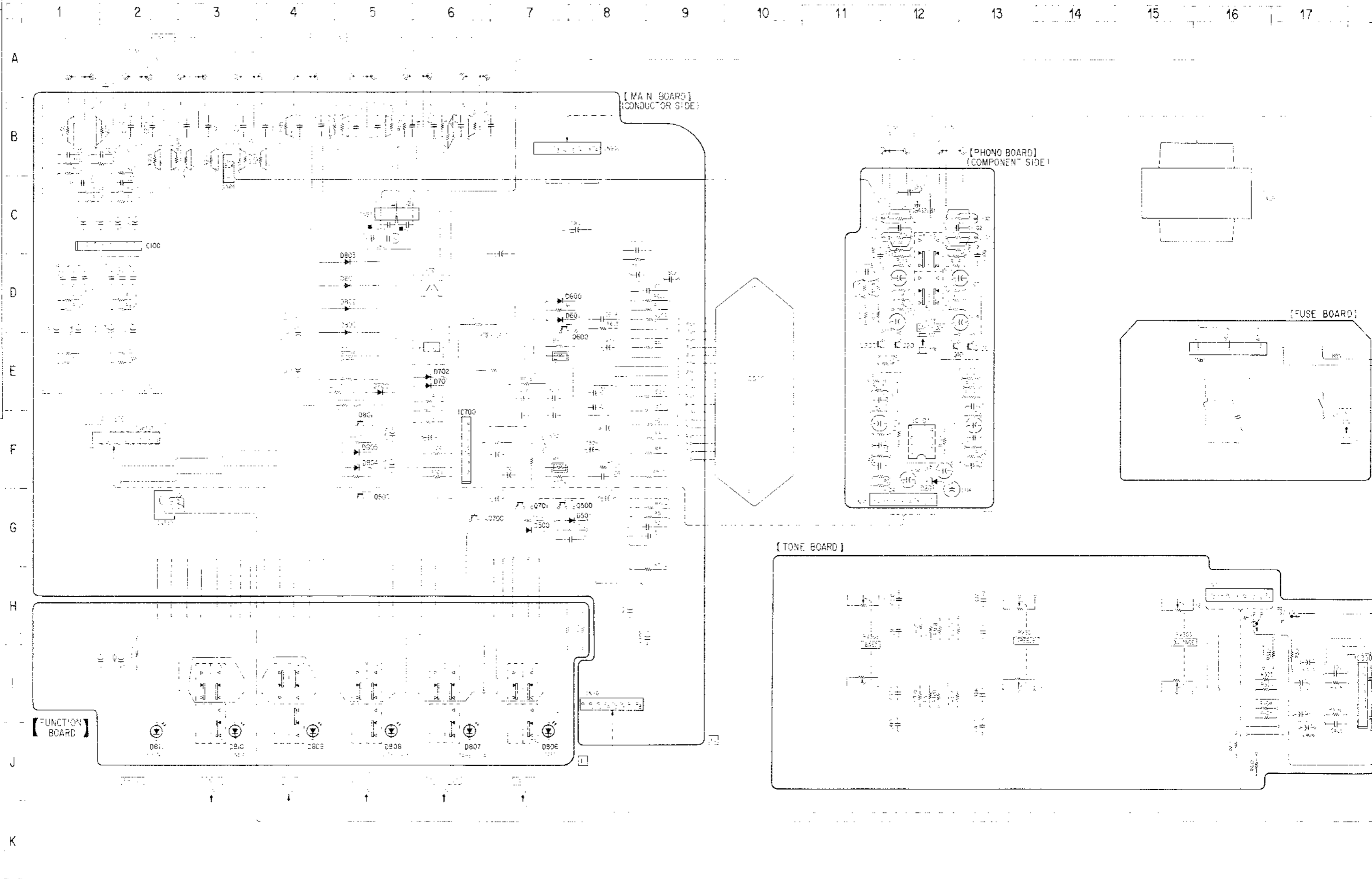



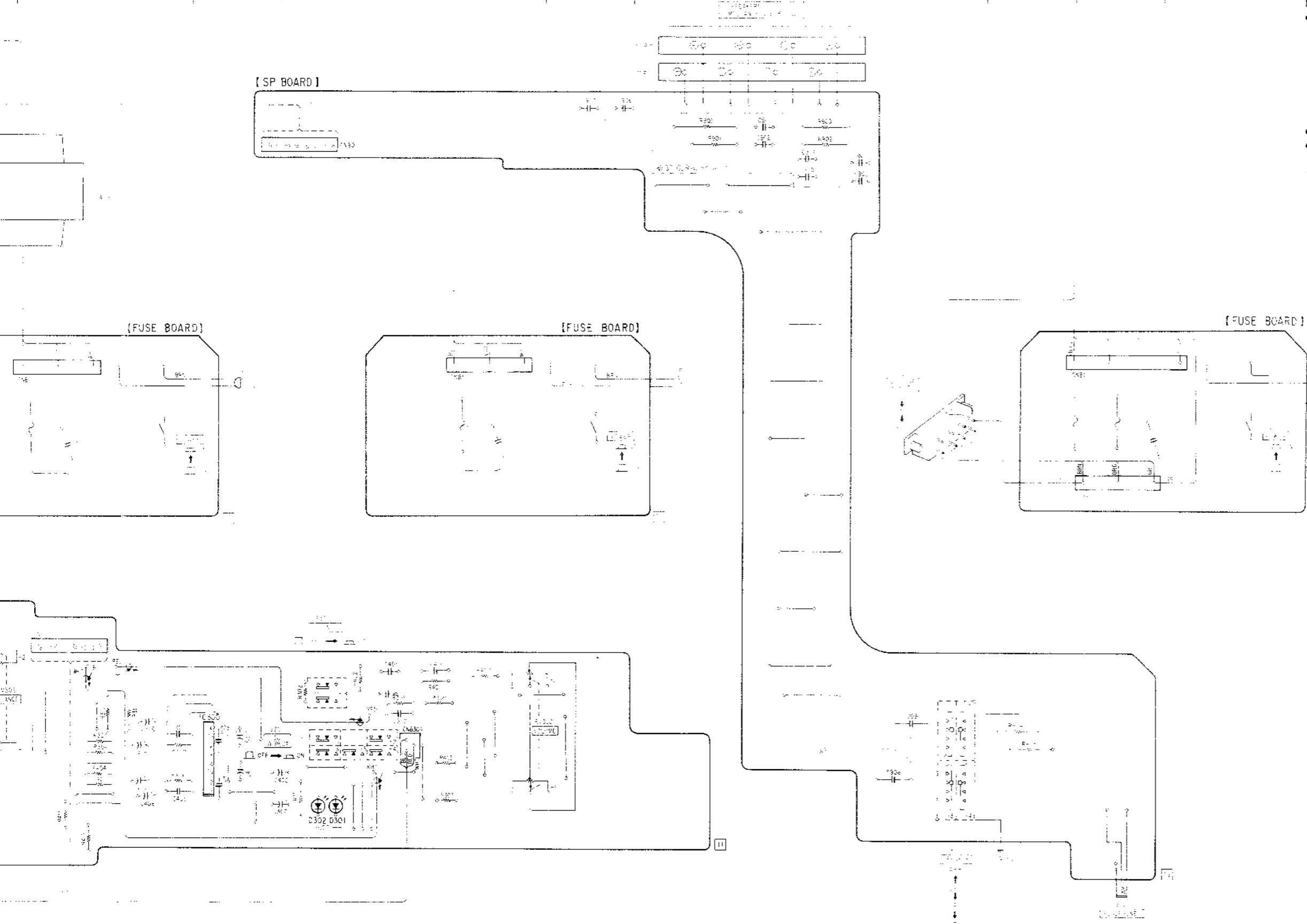





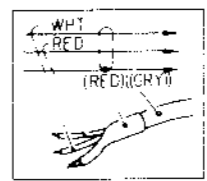

**Note:**

- Color code or sleeving over the end of the jacket

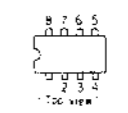
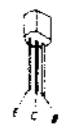
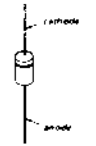
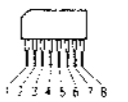

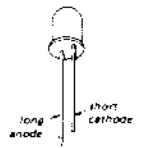
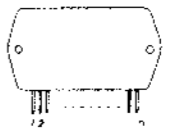
- ○ — parts extracted from the component side
- ● — parts extracted from the conductor side.

**Semiconductor Lead Layouts**

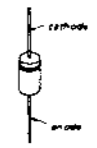
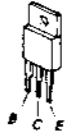
<b>BA4560</b> 	<b>2SC1841 2SC2545</b> 	<b>30D4</b> 
<b>M5218L μPC1237HA</b> 	<b>2SB1014</b> 	<b>SEL2510C</b> 
<b>STK4182MK2 STK4182MK2</b> 	<b>HZ7B2L</b> 	<b>SEL4510C</b> 
<b>DTA124ES 2SC634SP</b> 	<b>HZ15-2L US1060M 10E2N 1SS131</b> 	
<b>2SD1585</b> 		

# SECTION 3

## EXPLODED VIEWS

**NOTE:**

- The mechanical parts with no reference number in the exploded views are not supplied.
- The construction parts of an assembled part are indicated with a collation number in the remark column.
- Items marked "★" are not stocked since they are seldom required for routine service. Some delay should be anticipated when ordering these items.

- Due to standardization, parts with part number suffix -XX and -X may be different from the parts specified in the components used on the set.
- Color Indication of Appearance Parts  
Example:  
(RED) ... KNOB, BALANCE (WHITE)  
↑ Cabinet's Color                      ↑ Parts Color

The components identified by mark or dotted line with mark are critical for safety. Replace only with part number specified.

(1)

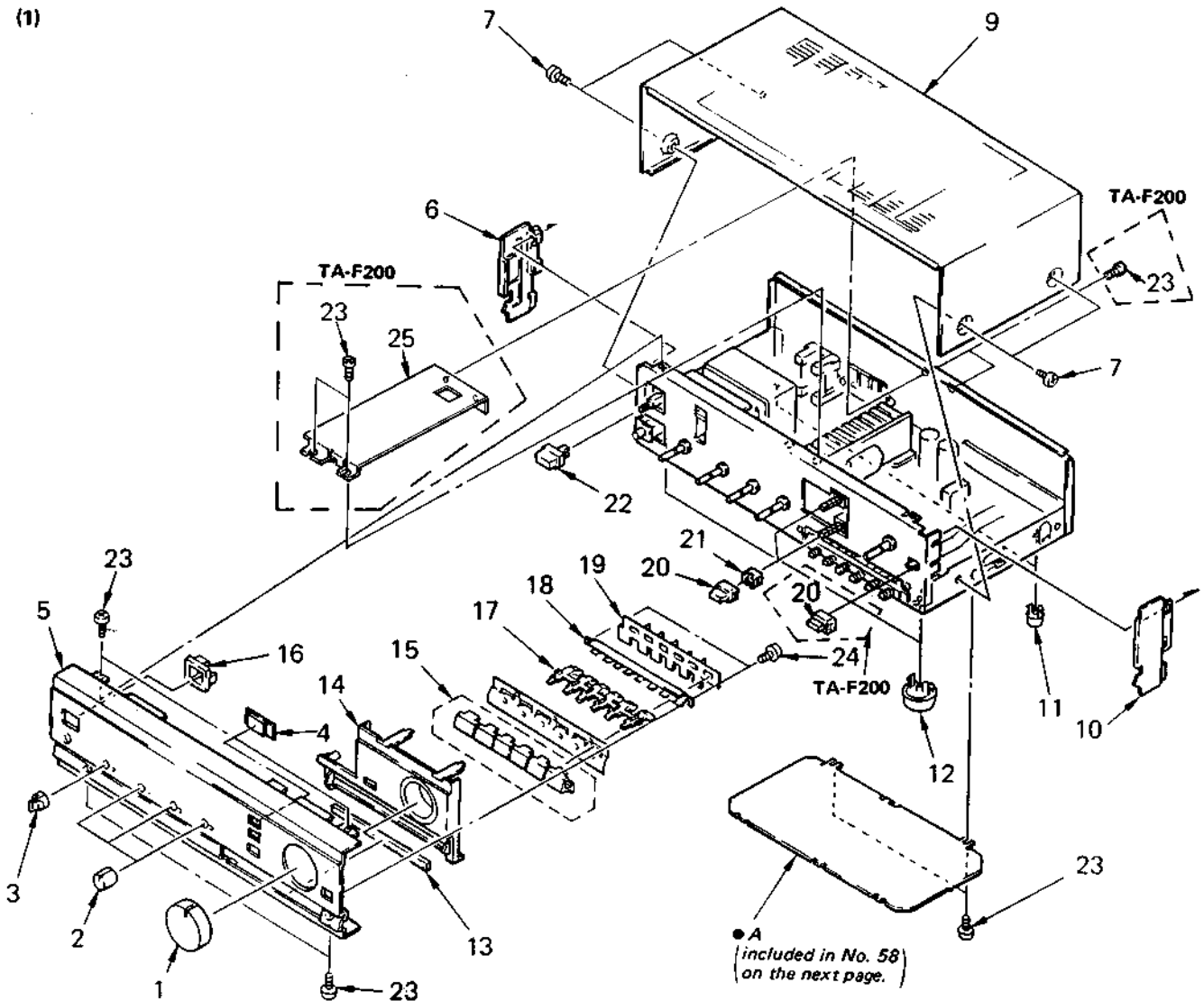

No.	Part No.	Description	Remarks	No.	Part No.	Description	Remarks
1	X-4919-703-1	KNOB (VOL) ASSY		15	X-4904-478-1	BUTTON ASSY	
2	4-916-746-01	KNOB (DIA.21)		16	4-908-044-11	ESCUTCHEON, POWER KNOB	
3	4-916-745-01	KNOB (DIA.21)		17	4-911-295-01	PLATE, LIGHT GUIDE	
4	4-921-387-01	PLATE (CD), INDICATION		18	*4-911-292-01	BRACKET	
5	4-921-319-11	PANEL, FRONT		19	*4-921-315-01	PLATE, LIGHT INTERCEPTION	
6	4-921-316-01	PANEL (LEFT), SIDE		20	3-315-105-21	KNOB (5X16), SQUARE	
7	3-704-366-01	(F200:West Germany,UK)..SCREW (CASE)(M3X8)		21	*4-864-307-00	RING	
	4-886-821-01	(F100:E)..... SCREW M3 CASE		22	4-917-460-01	KNOB, POWER	
9	3-327-853-11	CASE		23	7-682-548-04	SCREW +BVTT 3X8 (S)	
10	4-921-317-01	PANEL (RIGHT), SIDE		24	7-685-646-79	SCREW +BVTP 3X8 TYPE2 N-S	
11	X-4864-303-0	FOOT ASSY		25	*4-921-396-01	(F200)..BRACKET (HS)	
12	X-3337-104-1	FOOT ASSY, ORNAMENTAL					
13	*4-921-313-01	CUSHION					
14	4-921-318-01	ESCUTCHEON					

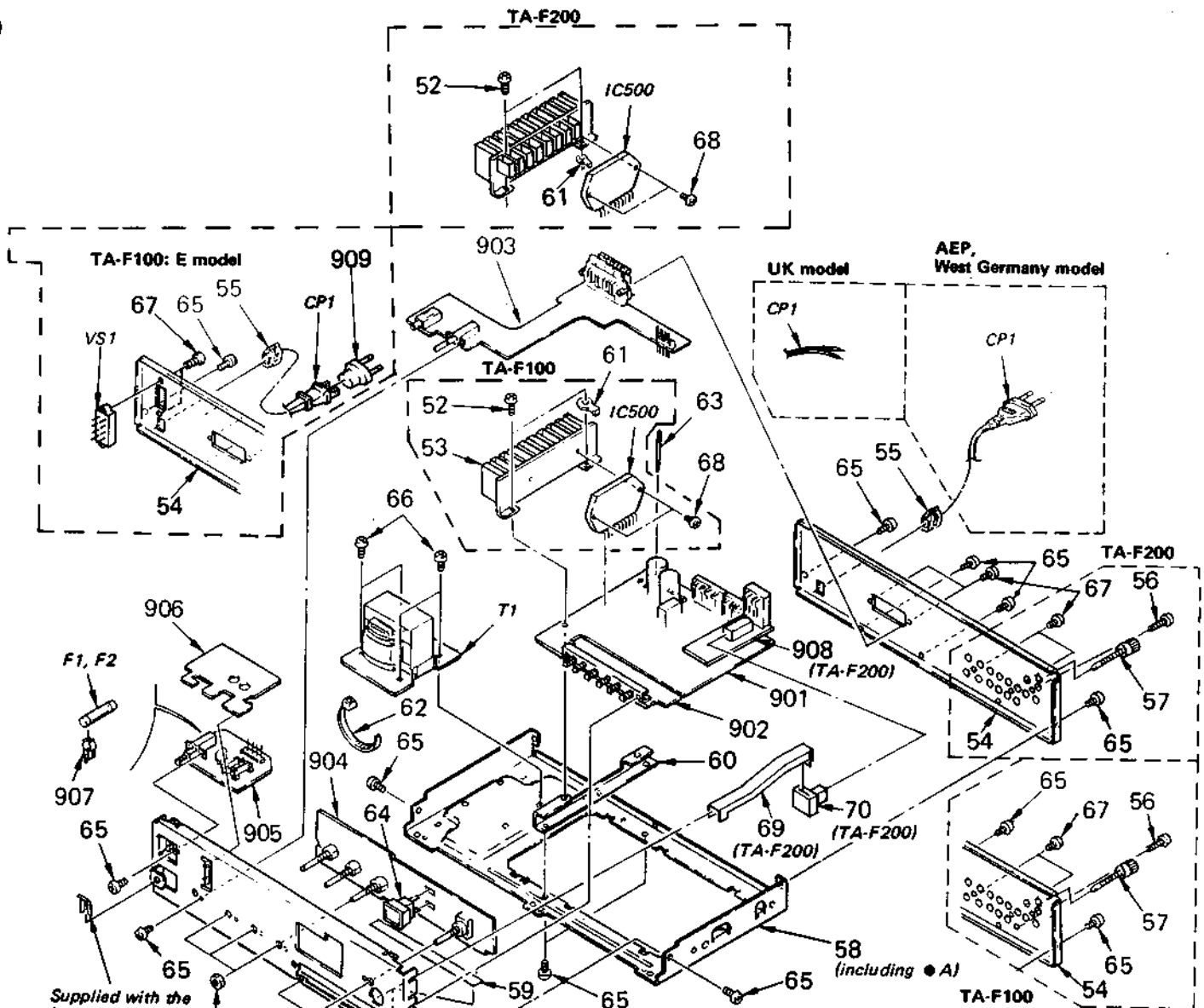

No.	Part No.	Description	Remarks	No.	Part No.	Description	Remarks
51	*4-921-320-01	CHASSIS, SUB		901	*A-4351-688-A	(F100:AEP,UK,E).....MOUNTED PCB, MAIN	
52	3-703-685-21	SCREW (+BV 3X8)			*A-4351-689-A	(F100:West Germany)...MOUNTED PCB, MAIN	
53	*4-914-027-01	(F100)...HEAT SINK (E)			*A-4351-690-A	(F200:AEP,UK).....MOUNTED PCB, MAIN	
					*A-4351-691-A	(F200:West Germany)...MOUNTED PCB, MAIN	
54	*4-921-378-11	(F200:AEP)....PANEL, BACK		902	*1-627-643-11	PC BOARD, FUNCTION	
	*4-921-378-21	(F200:West Germany)...PANEL, BACK		903	*1-627-646-11	PC BOARD, SP	
	*4-921-378-31	(F200:UK).....PANEL, BACK		904	*1-627-645-11	PC BOARD, TONE	
	*4-921-379-11	(F100:AEP)....PANEL, BACK		905	*1-627-644-11	PC BOARD, FUSE	
	*4-921-379-21	(F100:West Germany)...PANEL, BACK		906	*1-627-648-11	PC BOARD, PROTECTOR	
	*4-921-379-31	(F100:UK).....PANEL, BACK		907	1-533-183-11	HOLDER, FUSE	
	*4-921-379-41	(F100:E).....PANEL, BACK		908	*1-627-649-11	(F200)...PC BOARD, PHONO	
55	*3-703-244-00	(F200:West Germany,UK)		909	Δ 1-526-565-00	(F100:E)...AC PLUG ADAPTOR	
		.....BUSHING (2104), CORD		CP1	Δ 1-551-188-XX	(F100:E).....CORD, POWER	
	*3-703-571-00	(F100:E).....BUSHING (S)(4516), CORD		CP1	Δ 1-555-750-00	(AEP,West Germany)...CORD, POWER	
56	3-704-242-01	SCREW, TERMINAL, + BVTP CLAW		CP1	Δ 1-556-035-00	(UK).....CORD, POWER	
57	*3-706-165-00	SCREW		F1	Δ 1-532-203-00	(F200)...FUSE, TIME-LAG T2A	
58	*3-327-854-29	CHASSIS		F1	Δ 1-532-259-00	(F100)...FUSE, TIME-LAG T1.6A	
59	*4-921-312-01	SHEET, INSULATING		F2	Δ 1-532-259-00	(F100:E)...FUSE, TIME-LAG T1.6A	
60	*4-921-314-01	BRACKET (P)		T1	Δ 1-449-396-11	(F200:AEP,UK).....TRANSFORMER, POWER	
61	*4-881-629-00	PLATE (A), GROUND		T1	Δ 1-449-404-11	(F200:West Germany)...TRANSFORMER, POWER	
63	*3-683-631-01	(West Germany)...CLAMP		T1	Δ 1-449-397-11	(F100:E).....TRANSFORMER, POWER	
64	*4-921-389-01	HOUSE		T1	Δ 1-449-405-11	(F100:West Germany)...TRANSFORMER, POWER	
65	7-682-548-04	SCREW +BVTT 3X8 (S)		T1	Δ 1-449-997-11	(F100:AEP,UK).....TRANSFORMER, POWER	
66	7-682-560-04	SCREW +BVTT 4X6 (S)		VS1	Δ 1-570-307-11	(F100:E)...SWITCH (VOLTAGE SELECTOR)	
67	7-685-646-79	SCREW +BVTP 3X8 TYPE2 N-S					
68	7-685-650-79	SCREW +BVTP 3X16 TYPE2 IT-3					
69	*4-921-388-01	(F200)...JOINT (MC)					
70	4-866-342-00	(F200)...JOINT (B), KNOB					

# SECTION 4

## ELECTRICAL PARTS LIST

**NOTE:**

- Due to standardization, replacements in the parts list may be different from the parts specified in the diagrams or the components used on the set.
- Items marked "\*" are not stocked since they are seldom required for routine service. Some delay should be anticipated when ordering these items.
- If there are two or more same circuits in a set such as a stereophonic machine, only typical circuit parts may be indicated and capacitors and resistors in other same circuits may be omitted.

**CAPACITORS:**  
MF:  $\mu$ F, PF:  $\mu$ PF.

**RESISTORS**

- All resistors are in ohms.
- F: nonflammable

**COILS**

- MMH: mH, UH:  $\mu$ H

**SEMICONDUCTORS**

In each case, U:  $\mu$ , for example:  
UA...:  $\mu$ A..., UPA...:  $\mu$ PA...,  
UPC...:  $\mu$ PC, UPD...:  $\mu$ PD...

The components identified by mark  $\Delta$  or dotted line with mark  $\Delta$  are critical for safety. Replace only with part number specified.

Ref.No.	Part No.	Description
901	*A-4351-688-A	(F100:AEP,UK,E).....MOUNTED PCB, MAIN
	*A-4351-689-A	(F100:West Germany)...MOUNTED PCB, MAIN
	*A-4351-690-A	(F200:AEP,UK).....MOUNTED PCB, MAIN
	*A-4351-691-A	(F200:West Germany)...MOUNTED PCB, MAIN
902	*1-627-643-11	PC BOARD, FUNCTION
903	*1-627-646-11	PC BOARD, SP
904	*1-627-645-11	PC BOARD, TONE
905	*1-627-644-11	PC BOARD, FUSE
906	*1-627-648-11	PC BOARD, PROTECTOR
907	1-533-183-11	HOLDER, FUSE
908	*1-627-649-11	(F200)...PC BOARD, PHONO
909	$\Delta$ 1-526-565-00	(F100:E)...AC PLUG ADAPTOR
C1	$\Delta$ 1-161-744-00	CERAMIC 0.01MF 400V
C100	1-162-285-31	(F100:West Germany) ...CERAMIC 180PF 10% 50V
C101	1-162-282-31	(F100:AEP,UK,E) ...CERAMIC 100PF 10% 50V
C101	1-162-284-31	(F100:West Germany) ...CERAMIC 150PF 10% 50V
C102	1-126-094-11	(F100).....ELECT 4.7MF 20% 25V
C102	1-162-284-31	(F200:West Germany) ...CERAMIC 150PF 10% 50V
C103	1-101-361-00	(F100:West Germany) ...CERAMIC 150PF 5% 50V
C103	1-162-286-31	(F200:West Germany) ...CERAMIC 220PF 10% 50V
C104	1-126-154-11	(F100)...ELECT 47MF 20% 6.3V
C105	1-130-480-00	(F100)...MYLAR 0.0056MF 5% 50V
C106	1-130-473-00	(F100)...MYLAR 0.0015MF 5% 50V
C106	1-162-284-31	(F200)...CERAMIC 150PF 10% 50V
C107	1-124-465-00	(F100).....ELECT 0.47MF 20% 50V
C107	1-124-927-11	(F200:West Germany) ...ELECT 4.7MF 20% 50V
C108	1-124-477-11	ELECT 47MF 20% 16V
C109	1-136-162-00	(F200)....FILM 0.056MF 5% 50V
C109	1-162-284-31	(F100:West Germany) ...CERAMIC 150PF 10% 50V
C110	1-136-155-00	(F200:PHONO)...FILM 0.015MF 5% 50V
C110	1-162-284-31	(West Germany:MAIN) ...CERAMIC 150PF 10% 50V
C111	1-124-902-00	(F200:PHONO)...ELECT 0.47MF 20% 50V
C111	1-162-284-31	(West Germany:MAIN) ...CERAMIC 150PF 10% 50V
C112	1-130-475-00	(F200:PHONO)...MYLAR 0.0022MF 5% 50V
C112	1-162-284-31	(West Germany:MAIN) ...CERAMIC 150PF 10% 50V

Ref.No.	Part No.	Description
C113	1-124-443-00	(F200:PHONO)...ELECT 100MF 20% 10V
C113	1-162-284-31	(West Germany:MAIN) ...CERAMIC 150PF 10% 50V
C114	1-124-589-11	(F200:PHONO)...ELECT 47MF 20% 16V
C114	1-162-284-31	(West Germany:MAIN) ...CERAMIC 150PF 10% 50V
C115	1-124-589-11	(F200:PHONO)...ELECT 47MF 20% 16V
C115	1-162-284-31	(West Germany:MAIN) ...CERAMIC 150PF 10% 50V
C200	1-162-285-31	(F100:West Germany) ...CERAMIC 180PF 10% 50V
C201	1-162-282-31	(F100:AEP,UK,E) ...CERAMIC 100PF 10% 50V
C201	1-162-284-31	(F100:West Germany) ...CERAMIC 150PF 10% 50V
C202	1-126-094-11	(F100)...ELECT 4.7MF 20% 25V
C202	1-162-284-31	(F200:West Germany) ...CERAMIC 150PF 10% 50V
C203	1-101-361-00	(F100:West Germany) ...CERAMIC 150PF 5% 50V
C203	1-162-286-31	(F200:West Germany) ...CERAMIC 220PF 10% 50V
C204	1-126-154-11	(F100)...ELECT 47MF 20% 6.3V
C205	1-130-480-00	(F100)...MYLAR 0.0056MF 5% 50V
C206	1-130-473-00	(F100)...MYLAR 0.0015MF 5% 50V
C206	1-162-284-31	(F200)...CERAMIC 150PF 10% 50V
C207	1-124-465-00	(F100)...ELECT 0.47MF 20% 50V
C207	1-124-927-11	(F200)...ELECT 4.7MF 20% 50V
C208	1-124-477-11	ELECT 47MF 20% 16V
C209	1-136-162-00	(F200)...FILM 0.056MF 5% 50V
C209	1-162-284-31	(F100:West Germany) ...ELECT 150PF 10% 50V
C210	1-136-155-00	(F200:PHONO)...FILM 0.015MF 5% 50V
C210	1-162-284-31	(West Germany:MAIN) ...CERAMIC 150PF 10% 50V
C211	1-124-902-00	(F200:PHONO)...ELECT 0.47MF 20% 50V
C211	1-162-284-31	(West Germany:MAIN) ...CERAMIC 150PF 10% 50V
C212	1-130-475-00	(F200:PHONO)...MYLAR 0.0022MF 5% 50V
C212	1-162-284-31	(West Germany:MAIN) ...CERAMIC 150PF 10% 50V
C213	1-162-284-31	(West Germany:MAIN) ...CERAMIC 150PF 10% 50V
C214	1-162-284-31	(West Germany:MAIN) ...CERAMIC 150PF 10% 50V
C215	1-162-284-31	(West Germany:MAIN) ...CERAMIC 150PF 10% 50V

Ref.No.	Part No.	Description							
C300	1-162-284-31	CERAMIC	150PF	10%	50V				
C301	1-136-159-00	FILM	0.033MF	5%	50V				
C302	1-126-094-11	ELECT	4.7MF	20%	25V				
C303	1-162-211-31	CERAMIC	33PF	5%	50V				
C304	1-126-154-11	ELECT	47MF	20%	6.3V				
C305	1-162-211-31	CERAMIC	33PF	5%	50V				
C306	1-126-094-11	ELECT	4.7MF	20%	25V				
C307	1-130-476-00	MYLAR	0.0027MF	5%	50V				
C308	1-136-158-00	FILM	0.027MF	5%	50V				
C309	1-130-481-00	MYLAR	0.0068MF	5%	50V				
C310	1-136-163-00	FILM	0.068MF	5%	50V				
C311	1-124-589-11	ELECT	47MF	20%	16V				
C400	1-162-284-31	CERAMIC	150PF	10%	50V				
C401	1-136-159-00	FILM	0.033MF	5%	50V				
C402	1-126-094-11	ELECT	4.7MF	20%	25V				
C403	1-162-211-31	CERAMIC	33PF	5%	50V				
C404	1-126-154-11	ELECT	47MF	20%	6.3V				
C405	1-162-211-31	CERAMIC	33PF	5%	50V				
C406	1-126-094-11	ELECT	4.7MF	20%	25V				
C407	1-130-476-00	MYLAR	0.0027MF	5%	50V				
C408	1-136-158-00	FILM	0.027MF	5%	50V				
C409	1-130-481-00	MYLAR	0.0068MF	5%	50V				
C410	1-136-163-00	FILM	0.068MF	5%	50V				
C411	1-124-589-11	ELECT	47MF	20%	16V				
C500	1-126-094-11	ELECT	4.7MF	20%	25V				
C501	1-162-286-31	CERAMIC	220PF	10%	50V				
C502	1-136-163-00	FILM	0.068MF	5%	50V				
C503	1-162-287-31	CERAMIC	270PF	10%	50V				
C504	1-162-196-31	CERAMIC	5.6PF	10%	50V				
C505	1-124-910-11	ELECT	47MF	20%	50V				
C508	1-124-910-11	ELECT	47MF	20%	50V				
C509	1-124-917-11	ELECT	33MF	20%	50V				
C510	1-136-165-00	FILM	0.1MF	5%	50V				
C511	1-136-165-00	FILM	0.1MF	5%	50V				
C512	1-136-163-00	FILM	0.068MF	5%	50V				
C513	1-136-163-00	FILM	0.068MF	5%	50V				
C600	1-126-094-11	ELECT	4.7MF	20%	25V				
C601	1-162-286-31	CERAMIC	220PF	10%	50V				
C603	1-162-287-31	CERAMIC	270PF	10%	50V				
C604	1-162-196-31	CERAMIC	5.6PF	10%	50V				
C605	1-124-910-11	ELECT	47MF	20%	50V				
C608	1-124-910-11	ELECT	47MF	20%	50V				
C612	1-136-163-00	FILM	0.068MF	5%	50V				
C613	1-136-163-00	FILM	0.068MF	5%	50V				
C700	1-124-477-11	ELECT	47MF	20%	16V				
C701	1-126-176-11	ELECT	220MF	20%	6.3V				
C702	1-124-477-11	ELECT	47MF	20%	16V				
C703	1-124-443-00	ELECT	100MF	20%	6.3V				
C704	1-162-286-31	CERAMIC	220PF	10%	50V				
C800	1-102-355-00	CERAMIC	0.01MF		250V				
C801	1-126-224-11	(F100)...ELECT	4700MF	20%	42V				
C801	1-126-307-11	(F200)...ELECT	6800MF	20%	50V				
C802	1-126-224-11	(F100)...ELECT	4700MF	20%	42V				
C802	1-126-307-11	(F200)...ELECT	6800MF	20%	50V				
C803	1-124-910-11	ELECT	47MF	20%	50V				
C804	1-124-910-11	ELECT	47MF	20%	50V				
C806	1-126-101-11	ELECT	100MF	20%	16V				
C807	1-124-477-11	ELECT	47MF	20%	16V				
C810	1-124-484-11	(F200:West Germany) ...ELECT				220MF	20%	35V	
C810	1-124-122-11	(F200:AEP,UK)...ELECT				100MF	20%	50V	
C811	1-124-484-11	(F200:West Germany) ...ELECT				220MF	20%	35V	
C811	1-124-122-11	(F200:AEP,UK)...ELECT				100MF	20%	50V	
C812	1-136-161-00	FILM	0.047MF	5%	50V				
C813	1-136-161-00	FILM	0.047MF	5%	50V				
C900	1-136-153-00	(West Germany) ...FILM	0.01MF	5%	50V				
C901	1-136-153-00	(West Germany) ...FILM	0.01MF	5%	50V				
C902	1-136-153-00	(West Germany) ...FILM	0.01MF	5%	50V				
C903	1-136-153-00	(West Germany) ...FILM	0.01MF	5%	50V				
C904	1-136-153-00	(West Germany) ...FILM	0.01MF	5%	50V				
C905	1-136-153-00	(West Germany) ...FILM	0.01MF	5%	50V				
C906	1-136-153-00	(West Germany) ...FILM	0.01MF	5%	50V				
C907	1-136-153-00	(West Germany) ...FILM	0.01MF	5%	50V				
C908	1-161-494-00	(West Germany) ...CERAMIC	0.022MF	30%	25V				
C909	1-161-494-00	(West Germany) ...CERAMIC	0.022MF	30%	25V				
CN100	*1-566-878-11	(F200)...PIN, CONNECTOR (PC BOARD) 8P							
CN300	*1-566-879-11	PIN, CONNECTOR (PC BOARD) 8P							
CN301	*1-562-573-11	SOCKET, CONNECTOR 8P							
CN900	*1-566-878-11	PIN, CONNECTOR (PC BOARD) 8P							
CN901	*1-562-573-11	SOCKET, CONNECTOR 8P							
CNB1	*1-535-140-00	(EXCEPT FOR F100:E) ...BASE POST 22MM (10MM PITCH)3P							
CNB1	*1-535-141-00	(F100:E)..BASE POST 22MM (10MM PITCH)4P							
CNB2	*1-535-140-00	(F100:E)..BASE POST 22MM (10MM PITCH)3P							
CNB3	*1-535-116-00	TERMINAL							
CNB4	*1-535-115-00	(F200)...TERMINAL							
CNB302	*1-566-451-11	HOUSING, CONNECTOR 3P							
CNB303	*1-562-573-11	(F200)...SOCKET, CONNECTOR 8P							
CNB304	*1-566-839-11	HOLDER, CABLE (PC BOARD) 3P							
CNJ100	1-507-788-00	JACK, PIN 4P							
CNJ101	1-507-911-11	JACK, PIN 6P (CD, VIDEO/AUX, TAPE 2 REC OUT)							
CNJ102	1-507-911-11	JACK, PIN 6P (TAPE 2 IN, TAPE 1)							
CP1	$\Delta$ 1-551-188-XX	(F100:E).....CORD, POWER							
CP1	$\Delta$ 1-555-750-00	(AEP, West Germany)...CORD, POWER							
CP1	$\Delta$ 1-556-035-00	(UK).....CORD, POWER							
D201	8-719-910-75	(F200)...DIODE HZ7B2L							
D301	8-719-303-00	DIODE SEL2510C							
D302	8-719-303-00	DIODE SEL2510C							
D500	8-719-940-69	DIODE 1SS131							
D501	8-719-940-69	DIODE 1SS131							
D600	8-719-940-69	DIODE 1SS131							
D601	8-719-940-69	DIODE 1SS131							
D700	8-719-200-77	DIODE 10E2N							
D701	8-719-000-26	DIODE U51060M							

**Note:** The components identified by mark  $\Delta$  or dotted line with mark  $\Delta$  are critical for safety. Replace only with part number specified.



Ref.No.	Part No.	Description
D702	8-719-000-26	DIODE US1060M
D800	8-719-230-04	DIODE 3004
D801	8-719-230-04	DIODE 3004
D802	8-719-230-04	DIODE 3004
D803	8-719-230-04	DIODE 3004
D804	8-719-910-52	DIODE HZ15-2L
D805	8-719-910-52	DIODE HZ15-2L
D806	8-719-303-64	DIODE SEL4510C
D807	8-719-303-64	DIODE SEL4510C
D808	8-719-303-64	DIODE SEL4510C
D809	8-719-303-64	DIODE SEL4510C
D810	8-719-303-64	DIODE SEL4510C
D811	8-719-303-64	DIODE SEL4510C
F1	△.1-532-203-00	(F200)...FUSE, TIME-LAG T2A
F1	△.1-532-259-00	(F100)...FUSE, TIME-LAG T1.6A
F2	△.1-532-259-00	(F100:E)...FUSE, TIME-LAG T1.6A
IC100	8-759-600-02	(F100)...IC M5218L
IC100	8-759-923-90	(F200)...IC 8A4560
IC300	8-759-600-02	IC M5218L
IC500	△8-749-900-24	(F100)...IC STK4162MK2
IC500	△8-749-900-34	(F200)...IC STK4182MK2
IC700	8-759-111-68	IC UPC1237HA
J900	1-507-796-21	JACK (HEADPHONES)
L100	1-413-101-00	(F200:West Germany)...COIL, INPUT
L101	1-413-101-00	(F200:West Germany)...COIL, INPUT
L200	1-413-101-00	(F200:West Germany)...COIL, INPUT
L201	1-413-101-00	(F200:West Germany)...COIL, INPUT
L500	*1-420-872-00	COIL, AIR CORE
L600	*1-420-872-00	COIL, AIR CORE
Q100	8-729-354-52	(F200)...TRANSISTOR 2SC2545
Q101	8-729-354-52	(F200)...TRANSISTOR 2SC2545
Q200	8-729-354-52	(F200)...TRANSISTOR 2SC2545
Q201	8-729-354-52	(F200)...TRANSISTOR 2SC2545
Q500	8-729-108-06	TRANSISTOR 2SC1841
Q600	8-729-108-06	TRANSISTOR 2SC1841
Q700	8-729-600-27	TRANSISTOR 2SC6345P
Q701	8-729-900-63	TRANSISTOR DTA124ES
Q800	8-729-107-26	TRANSISTOR 2SD1585-K
Q801	8-729-802-22	TRANSISTOR 2SB1014
R100	1-249-418-11	(F100:West Germany) ...CARBON 1.2K 5% 1/4W
R101	1-249-441-11	(F100)...CARBON 100K 5% 1/4W
R102	1-249-411-11	(F100:AEP,UK,E) ...CARBON 330 5% 1/4W
R102	1-249-413-11	(F100:West Germany) ...CARBON 470 5% 1/4W
R103	1-249-441-11	(F100)...CARBON 100K 5% 1/4W
R104	1-249-416-11	(F100)...CARBON 820 5% 1/4W
R105	1-247-897-11	(F100)...CARBON 560K 5% 1/4W
R106	1-249-437-11	(F100)...CARBON 47K 5% 1/4W
R107	1-249-441-11	(F100)...CARBON 100K 5% 1/4W
R108	1-249-409-11	(F100)...CARBON 220 5% 1/4W
R108	1-249-417-11	(F200:West Germany) ...CARBON 1K 5% 1/4W
R109	1-249-409-11	(F100:West Germany) ...CARBON 220 5% 1/4W
R109	1-249-413-11	(F200:West Germany) ...CARBON 470 5% 1/4W
R111	1-249-409-11	(West Germany:MAIN) ...CARBON 220 5% 1/4W

Ref.No.	Part No.	Description
R113	1-249-409-11	(West Germany:MAIN) ...CARBON 220 5% 1/4W
R113	1-249-417-11	(F200:West Germany:PHONO) ...CARBON 1K 5% 1/4W
R114	1-249-405-11	(F200)...CARBON 100 5% 1/4W
R115	1-249-413-11	(MAIN)...CARBON 470 5% 1/4W
R115	1-249-441-11	(F200:PHONO)...CARBON 100K 5% 1/4W
R116	1-249-405-11	(F200)...CARBON 100 5% 1/4W
R117	1-249-409-11	(West Germany:MAIN) ...CARBON 220 5% 1/4W
R117	1-249-441-11	(F200:PHONO)...CARBON 100K 5% 1/4W
R118	1-249-429-11	(F200)...CARBON 10K 5% 1/4W
R119	1-249-392-11	(F200:PHONO)...CARBON 8.2 5% 1/4W
R119	1-249-413-11	(MAIN)...CARBON 470 5% 1/4W
R120	1-249-404-00	(F200)...CARBON 82 5% 1/4W
R121	1-249-409-11	(West Germany:MAIN) ...CARBON 220 5% 1/4W
R121	1-249-438-11	(F200:PHONO)...CARBON 56K 5% 1/4W
R122	1-249-425-11	(F200)...CARBON 4.7K 5% 1/4W
R124	1-249-409-11	(F200)...CARBON 220 5% 1/4W
R125	1-249-421-11	(F200)...CARBON 2.2K 5% 1/4W
R126	1-249-417-11	(F200)...CARBON 1K 5% 1/4W
R127	1-249-417-11	(F200)...CARBON 1K 5% 1/4W
R128	1-249-407-11	(F200)...CARBON 150 5% 1/4W
R129	1-247-903-00	(F200)...CARBON 1M 5% 1/4W
R131	1-247-903-00	(F200)...CARBON 1M 5% 1/4W
R200	1-249-418-11	(F100:West Germany) ...CARBON 1.2K 5% 1/4W
R201	1-249-441-11	(F100)...CARBON 100K 5% 1/4W
R202	1-249-411-11	(F100:AEP,UK,E) ...CARBON 330 5% 1/4W
R202	1-249-413-11	(F100:West Germany) ...CARBON 470 5% 1/4W
R203	1-249-441-11	(F100)...CARBON 100K 5% 1/4W
R204	1-249-416-11	(F100)...CARBON 820 5% 1/4W
R205	1-247-897-11	(F100)...CARBON 560K 5% 1/4W
R206	1-249-437-11	(F100)...CARBON 47K 5% 1/4W
R207	1-249-441-11	(F100)...CARBON 100K 5% 1/4W
R208	1-249-409-11	(F100)...CARBON 220 5% 1/4W
R208	1-249-417-11	(F200:West Germany) ...CARBON 1K 5% 1/4W
R209	1-249-409-11	(F100:West Germany) ...CARBON 220 5% 1/4W
R209	1-249-413-11	(F200:West Germany) ...CARBON 470 5% 1/4W
R211	1-249-409-11	(West Germany:MAIN) ...CARBON 220 5% 1/4W
R213	1-249-409-11	(West Germany:MAIN) ...CARBON 220 5% 1/4W
R213	1-249-417-11	(F200:West Germany,PHONO) ...CARBON 1K 5% 1/4W
R214	1-249-405-11	(F200)...CARBON 100 5% 1/4W
R215	1-249-413-11	(MAIN)...CARBON 470 5% 1/4W
R215	1-249-441-11	(F200:PHONO)...CARBON 100K 5% 1/4W
R216	1-249-405-11	(F200)...CARBON 100 5% 1/4W
R217	1-249-409-11	(West Germany:MAIN) ...CARBON 220 5% 1/4W
R217	1-249-441-11	(F200:PHONO)...CARBON 100K 5% 1/4W
R218	1-249-429-11	(F200)...CARBON 10K 5% 1/4W
R219	1-249-392-11	(F200:PHONO)...CARBON 8.2 5% 1/4W
R219	1-249-413-11	(MAIN)...CARBON 470 5% 1/4W

Note: The components identified by mark **△** or **dotted** line with mark **△** are critical for safety. Replace only with part number specified.

Ref.No.	Part No.	Description				
R220	1-249-404-00	(F200)...CARBON	82	5%	1/4W	
R221	1-249-409-11	(West Germany) ...CARBON	220	5%	1/4W	
R221	1-249-438-11	(F200:PHONO)...CARBON	56K	5%	1/4W	
R222	1-249-426-11	(F200)...CARBON	4.7K	5%	1/4W	
R224	1-249-409-11	(F200)...CARBON	220	5%	1/4W	
R226	1-249-417-11	(F200)...CARBON	1K	5%	1/4W	
R227	1-249-417-11	(F200)...CARBON	1K	5%	1/4W	
R228	1-249-407-11	(F200)...CARBON	150	5%	1/4W	
R229	1-247-903-00	(F200)...CARBON	1M	5%	1/4W	
R231	1-247-903-00	(F200)...CARBON	1M	5%	1/4W	
R300	1-249-438-11	CARBON	56K	5%	1/4W	
R301	1-247-903-00	CARBON	1M	5%	1/4W	
R302	1-249-431-11	CARBON	15K	5%	1/4W	
R303	1-249-417-11	CARBON	1K	5%	1/4W	
R304	1-247-887-00	CARBON	220K	5%	1/4W	
R305	1-249-430-11	CARBON	12K	5%	1/4W	
R306	1-247-887-00	CARBON	220K	5%	1/4W	
R307	1-249-426-11	CARBON	5.6K	5%	1/4W	
R308	1-249-414-11	CARBON	560	5%	1/4W	
R309	1-249-434-11	CARBON	27K	5%	1/4W	
R310	1-249-422-11	CARBON	2.7K	5%	1/4W	
R311	1-249-429-11	CARBON	10K	5%	1/4W	
R312	1-249-417-11	CARBON	1K	5%	1/4W	
R351	1-247-710-11	CARBON	560	5%	1/4W	
R400	1-249-438-11	CARBON	56K	5%	1/4W	
R401	1-247-903-00	CARBON	1M	5%	1/4W	
R402	1-249-431-11	CARBON	15K	5%	1/4W	
R403	1-249-417-11	CARBON	1K	5%	1/4W	
R404	1-247-887-00	CARBON	220K	5%	1/4W	
R405	1-249-430-11	CARBON	12K	5%	1/4W	
R406	1-247-887-00	CARBON	220K	5%	1/4W	
R407	1-249-426-11	CARBON	5.6K	5%	1/4W	
R408	1-249-414-11	CARBON	560	5%	1/4W	
R409	1-249-434-11	CARBON	27K	5%	1/4W	
R410	1-249-422-11	CARBON	2.7K	5%	1/4W	
R411	1-249-429-11	CARBON	10K	5%	1/4W	
R412	1-249-417-11	CARBON	1K	5%	1/4W	
R500	1-247-713-11	CARBON	1K	5%	1/4W	
R501	1-249-466-11	CARBON	56K	5%	1/4W	
R502	1-247-710-11	CARBON	560	5%	1/4W	
R503	1-249-465-11	(F100:West Germany) ...CARBON	47K	5%	1/4W	
R503	1-249-466-11	(EXCEPT F100:West Germany) ...CARBON	56K	5%	1/4W	

Ref.No.	Part No.	Description				
R504	1-247-721-11	(F100).....CARBON	4.7K	5%	1/4W	
R504	1-247-720-11	(F200:AEP,UK)...CARBON	3.9K	5%	1/4W	
R504	1-247-722-11	(F200:West Germany) ...CARBON	5.6K	5%	1/4W	
R505	1-247-756-11	CARBON	2.2K	5%	1/2W	
R506	1-247-756-11	CARBON	2.2K	5%	1/2W	
R507	1-247-752-11	CARBON	1K	5%	1/2W	
R508	1-247-752-11	CARBON	1K	5%	1/2W	
R509	1-247-713-11	(F100)...CARBON	1K	5%	1/4W	
R509	1-247-714-11	(F200)...CARBON	1.2K	5%	1/4W	
R510	1-247-726-11	(F200:West Germany,F100) ...CARBON	33K	5%	1/4W	
R510	1-249-464-11	(F200:AEP,UK)...CARBON	39K	5%	1/4W	
R511	△ 1-217-151-00	RES, METAL PLATE 0.22				
R512	△ 1-247-727-11	CARBON	10	5%	1/2W	
R513	1-247-727-11	CARBON	10	5%	1/2W	
R514	1-249-465-11	CARBON	47K	5%	1/4W	
R600	1-247-713-11	CARBON	1K	5%	1/4W	
R601	1-249-466-11	CARBON	56K	5%	1/4W	
R602	1-247-710-11	CARBON	560	5%	1/4W	
R603	1-249-465-11	(F100:West Germany) ...CARBON	47K	5%	1/4W	
R603	1-249-466-11	(EXCEPT F100:West Germany) ...CARBON	56K	5%	1/4W	
R604	1-247-721-11	(F100).....CARBON	4.7K	5%	1/4W	
R604	1-247-720-11	(F200:AEP,UK)...CARBON	3.9K	5%	1/4W	
R604	1-247-722-11	(F200:West Germany) ...CARBON	5.6K	5%	1/4W	
R605	1-247-756-11	CARBON	2.2K	5%	1/2W	
R606	1-247-756-11	CARBON	2.2K	5%	1/2W	
R609	1-247-714-11	(F200)...CARBON	1.2K	5%	1/4W	
R609	1-247-713-11	(F100)...CARBON	1K	5%	1/2W	
R610	1-247-726-11	(F200:West Germany,F100) ...CARBON	33K	5%	1/4W	
R610	1-249-464-11	(F200:AEP,UK)...CARBON	39K	5%	1/4W	
R611	△ 1-217-151-00	RES, METAL PLATE 0.22				
R612	1-247-727-11	CARBON	10	5%	1/2W	
R613	1-247-727-11	CARBON	10	5%	1/2W	
R614	1-249-466-11	CARBON	56K	5%	1/4W	
R700	1-247-713-11	CARBON	1K	5%	1/4W	
R701	1-247-724-11	CARBON	8.2K	5%	1/4W	
R702	1-247-725-11	CARBON	10K	5%	1/4W	
R703	1-249-469-11	CARBON	100K	5%	1/4W	
R704	1-247-717-11	CARBON	2.2K	5%	1/4W	
R705	1-249-467-11	CARBON	68K	5%	1/4W	

**Note:** The components identified by mark  or dotted line with mark  are critical for safety. Replace only with part number specified.

Ref.No.	Part No.	Description
R706	△.1-206-662-00	(F100:AEP,UK,E) ...METAL OXIDE 820 5% 2W F
R706	△.1-215-890-11	(West Germany) ...METAL OXIDE 470 5% 2W F
R706	△.1-215-892-11	(F200:AEP,UK) ...METAL OXIDE 1K 5% 2W F
R707	1-249-459-11	CARBON 12K 5% 1/4W
R800	△.1-207-637-00	(F200:West Germany) ...METAL OXIDE 150 5% 3W F
R800	△.1-206-713-00	(F200:AEP,UK) ...METAL OXIDE 330 5% 3W F
R800	△.1-206-710-00	(F100:AEP,UK,E) ...METAL OXIDE 240 5% 3W F
R800	△.1-216-475-11	(F100:West Germany) ...METAL OXIDE 120 5% 3W F
R801	△.1-206-660-00	(F100:West Germany) ...METAL OXIDE 680 5% 2W F
R801	△.1-206-666-00	(F100:AEP,UK,E) ...METAL OXIDE 1.2K 5% 2W F
R801	△.1-206-662-00	(F200:West Germany) ...METAL OXIDE 820 5% 2W F
R801	△.1-215-893-11	(F200:AEP,UK) ...METAL OXIDE 1.5K 5% 2W F
R802	1-247-719-11	CARBON 3.3K 5% 1/4W
R803	1-247-719-11	CARBON 3.3K 5% 1/4W
R804	1-247-708-11	CARBON 470 5% 1/4W
R805	1-247-750-11	CARBON 680 5% 1/2W
R806	1-247-750-11	CARBON 680 5% 1/2W
R900	1-247-727-11	(West Germany)...CARBON 10 5% 1/2W
R901	1-247-727-11	(West Germany)...CARBON 10 5% 1/2W
R902	1-247-727-11	(West Germany)...CARBON 10 5% 1/2W
R903	1-247-727-11	(West Germany)...CARBON 10 5% 1/2W
R904	1-247-747-11	CARBON 470 5% 1/2W
R905	1-247-747-11	CARBON 470 5% 1/2W
RV300	1-237-846-11	RES, VAR, CARBON 120K/120K (VOLUME)
RV301	1-237-740-11	RES, VAR, CARBON 100K/100K (TREBLE)
RV302	1-237-740-11	RES, VAR, CARBON 100K/100K (BASS)
RV303	1-237-739-11	RES, VAR, CARBON 100K/100K (BALANCE)
RY700	1-515-533-11	RELAY
S1	△.1-554-920-11	SWITCH, PUSH (AC POWER)(1 KEY)
S100	1-571-118-11	SWITCH, PUSH (6 KEY)(INPUT SELECTOR)
S103	1-571-111-11	(F200)..SWITCH, PUSH (1 KEY)(CARTRIDGE)
S300	1-571-112-11	SWITCH, PUSH (1 KEY)(LOUDNESS)
S301	1-571-637-11	SWITCH, PUSH (1 KEY)(CD DIRECT)
S900	1-571-109-11	SWITCH, ROTARY SLIDE (SPEAKERS)

Ref.No.	Part No.	Description
T1	△.1-449-396-11	(F200:AEP,UK).....TRANSFORMER, POWER
T1	△.1-449-397-11	(F100:E).....TRANSFORMER, POWER
T1	△.1-449-404-11	(F200:West Germany) ...TRANSFORMER, POWER
T1	△.1-449-405-11	(F100:West Germany) ...TRANSFORMER, POWER
T1	△.1-449-997-11	(F100:AEP,UK).....TRANSFORMER, POWER
TM900	1-536-706-00	TERMINAL BOARD (SPEAKERS)
VS1	△.1-570-307-11	(F100:E)...SWITCH (VOLTAGE SELECTOR)

#### ACCESSORY & PACKING MATERIAL

*3-346-378-41	(F100)....INDIVIDUAL CARTON
*3-346-378-51	(F200)....INDIVIDUAL CARTON
3-786-294-11	(AEP,UK,E)...MANUAL, INSTRUCTION (ENGLISH,FRENCH,SPANISH,PORTUGUESE)
3-786-294-41	(AEP,West Germany)...MANUAL, INSTRUCTION (GERMAN,DUTCH,SWEDISH,ITALIAN)
4-921-311-01	CUSHION

**Note:** The components identified by mark △ or dotted line with mark △ are critical for safety. Replace only with part number specified.