

TA-F45

US Model
Canadian Model
AEP Model
UK Model



INTEGRATED STEREO AMPLIFIER

SPECIFICATIONS

GENERAL

Power Requirements: 120 V ac, 60 Hz (US, Canadian model)
220 V ac, 50/60 Hz (AEP model)
240 V ac, 50/60 Hz (UK model)

Power Consumption: 90 W (US model)
140 W (Canadian model)
220 W (AEP model)
260 W (UK model)

AC Outlets: 1 switched, 100 W (at max.)
(US, Canadian model) 2 unswitched, total 100 W (at max.)

Dimensions: Approx. 430 (w) x 80 (h) x 335 (d) mm
17 (w) x 3 1/4 (h) x 13 1/4 (d) inches
including projecting parts and controls

Weight: Approx. 4.4 kg, 9 lb 12 oz (net)
Approx. 5.5 kg, 12 lb 3 oz (in shipping carton)

— Continued on page 2 —

SAFETY-RELATED COMPONENT WARNING!!

COMPONENTS IDENTIFIED BY SHADING AND MARK  ON THE SCHEMATIC DIAGRAMS, EXPLODED VIEWS AND IN THE PARTS LIST ARE CRITICAL TO SAFE OPERATION. REPLACE THESE COMPONENTS WITH SONY PARTS WHOSE PART NUMBERS APPEAR AS SHOWN IN THIS MANUAL OR IN SUPPLEMENTS PUBLISHED BY SONY.

ATTENTION AU COMPOSANT AYANT RAPPORT À LA SÉCURITÉ!

LES COMPOSANTS IDENTIFIÉS PAR UNE TRAME ET UNE MARQUE  SUR LES DIAGRAMMES SCHEMATIQUES, LES VUES EXPLOSEES ET LA LISTE DES PIÈCES SONT CRITIQUES POUR LA SÉCURITÉ DE FONCTIONNEMENT. NE REMPLACER CES COMPOSANTS QUE PAR DES PIÈCES SONY DONT LES NUMÉROS SONT DONNÉS DANS CE MANUEL OUDANS LES SUPPLÉMENTS PUBLIÉS PAR SONY.

WARNING!!

THIS SET USES THE SWITCHING-TYPE POWER-SUPPLY CIRCUIT, WHICH IS DIRECTLY CONNECTED TO THE AC POWER LINE. AN ISOLATION TRANSFORMER SHOULD BE USED BETWEEN THE AC OUTLET AND THE AC PLUG OF THE SET DURING ANY SERVICE TO AVOID POSSIBLE SHOCK HAZARD WHEN REPAIRING THE POWER SUPPLY CIRCUIT.

SONY

SERVICE MANUAL

TA-F45

AMPLIFIER SECTION

Power Output and Total Harmonic Distortion: (US, Canadian model)

With 8 Ω loads, both channels driven, from 20 – 20,000 Hz; rated 50W per channel minimum RMS power, with no more than 0.008 % total harmonic distortion from 250 mW to rated output.

Continuous RMS Power Output:

(Less than 0.008% THD, both channels driven simultaneously)
(AEP, UK model)

At 20 – 20,000 Hz
50 W + 50 W (8 Ω)
According to DIN 45500
50 W + 50 W (8 Ω)

Power Bandwidth: (IHF)

5 – 30,000 Hz (AEP, UK model)

Harmonic Distortion:

Less than 0.008 % at rated output
Less than 0.006 % at 25 W output

Intermodulation (IM)

Distortion:
(60Hz : 7kHz = 4 : 1)

Less than 0.008 % at rated output
Less than 0.006 % at 25 W output

Frequency Response:

PHONO RIAA equalization curve ± 0.2 dB

TUNER

AUX 5 – 70,000 Hz $\begin{matrix} +0 \\ -1 \end{matrix}$ dB

TAPE 1, 2

Residual Noise:

Less than 130 μV (8 Ω, Network A)

Damping Factor:

50 (8 Ω, 1 kHz)

Inputs:

	Setting of the CARTRIDGE LOAD selector	Sensitivity	Impedance	Maximum input capability (1 kHz)	S/N (weighting network, - input level)
PHONO	180 pF 330 pF	2.5 mV	50 kΩ	150 mV	90 dB 78 dB* (A, 2.5 mV)
	40 Ω 3 Ω	0.17 mV	100 Ω 33 Ω	11 mV	75 dB 74 dB* (A, 0.25 mV)
TUNER AUX TAPE 1, 2	—	150 mV	50 kΩ	—	104 dB 78 dB* (A, 150 mV)

* 78 IHF

Measured with rated output power into 8-ohm loads (both channels driven simultaneously) at 1 kHz

Outputs:

	Voltage	Impedance
REC OUT 1, 2	150 mV (-14.5 dB)	4.7 kΩ
SPEAKER A, B	Accepts speakers of 8 – 16 Ω	
HEAD- PHONES	Accepts low and high impedance headphones.	

Tone Controls: BASS = 10 dB at 100 Hz
(turnover frequency: 500 Hz)
TREBLE = 10 dB at 25 kHz
(turnover frequency: 5 kHz)

Loudness: +10 dB at 100 Hz, +3 dB at 10 kHz
(att. 30dB)

Low Filter: 6 dB/octave attenuation below 15 Hz

0 dB = 0.775 V

MODEL IDENTIFICATION

Specification Label

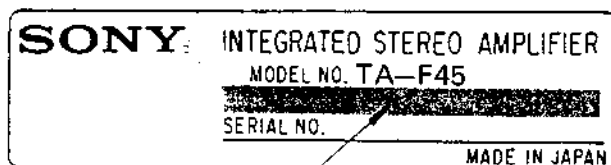

US model	: AC 120V	60Hz	90W
Canadian model	: AC 120V	60Hz	140W
AEP model	: AC 220V	~ 50/60Hz	220W
UK model	: AC 240V	~ 50/60Hz	260W

1. REPLACEMENT OF THE TRANSFORMERS IN THE INVERTER CIRCUIT

The lead wire arrangement for each of T901 and T902 in the inverter circuit are shown in Fig. 1.

As the repair parts, T901 and T902 are formed by only iron core. Thus, if the coils are defective, arrange a new transformers as shown below. Note that the lead lengths must be exact. Also wind the coil carefully.

2. INVERTER CIRCUIT TRANSISTOR REPLACEMENT

When any of the inverter transistors (Q903, Q904) is broken, replace their transistors together.

A pair of transistors with the same rank is provided for service field.

Ref. No.	Part No.	Description
Q903, 904	X-4863-506-1	Transistor Ass'y, service

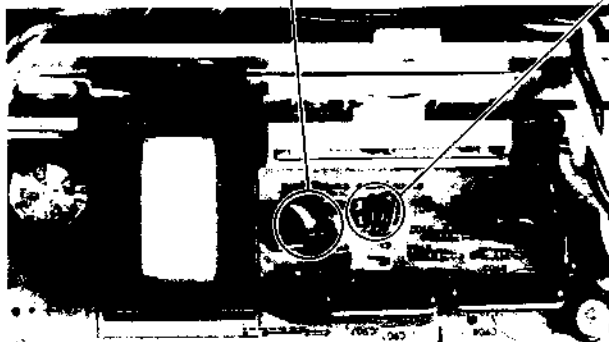
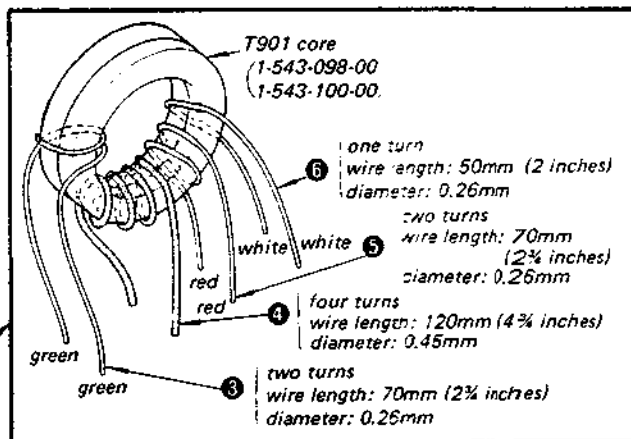
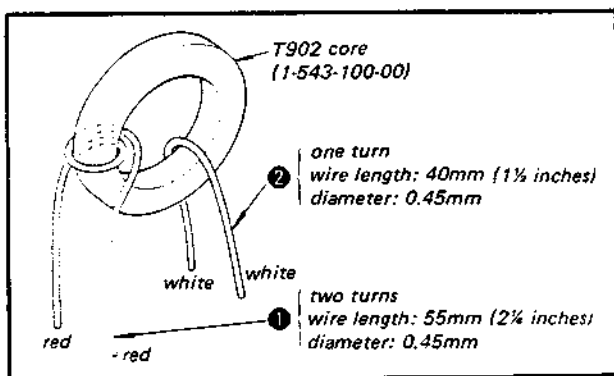

pulse power supply board

Fig. 1

SECTION 1
BLOCK DIAGRAM

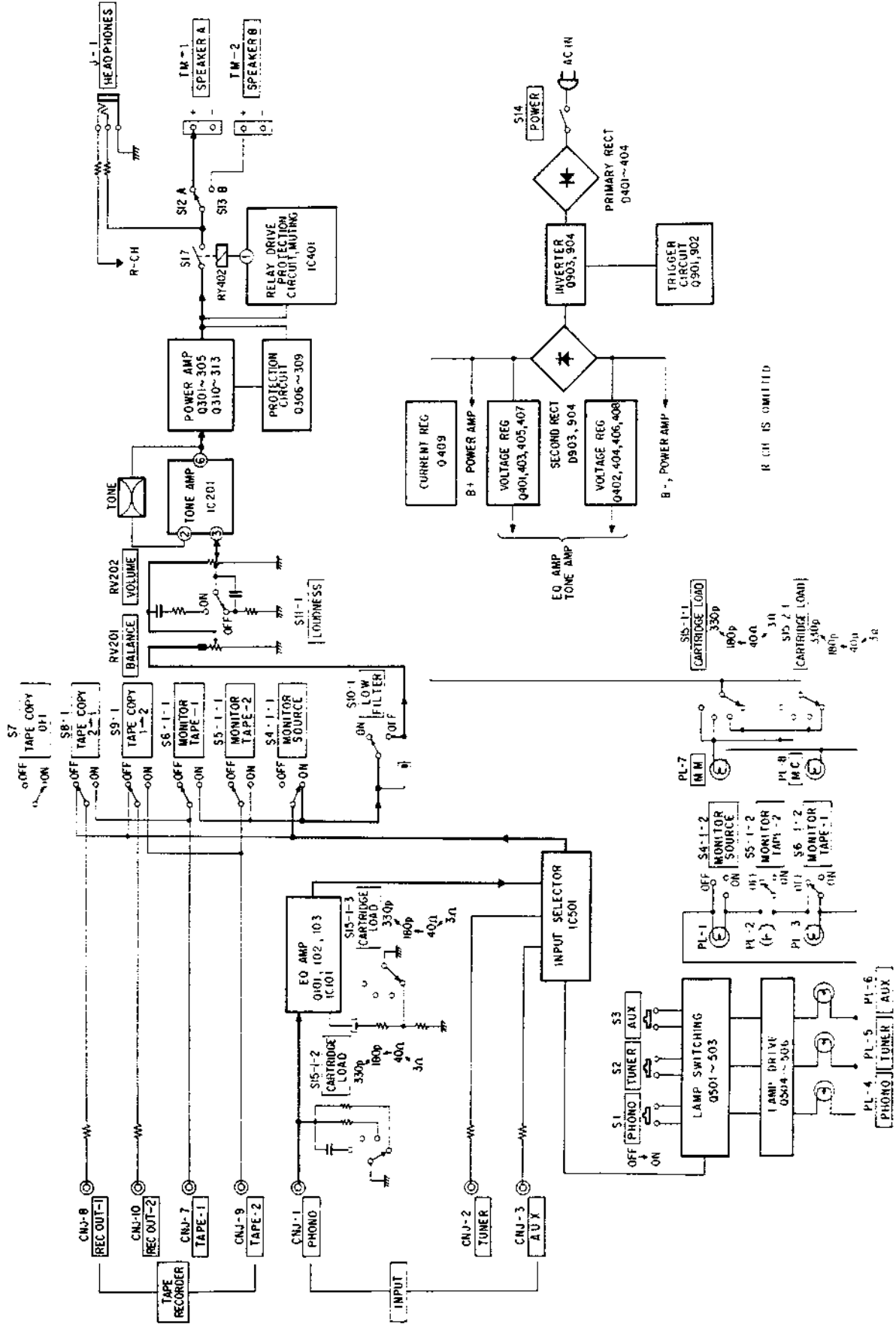

R CH IS OMITTED

SECTION 2 DISASSEMBLY

Note: Follow the disassembly procedure in the numerical order given.

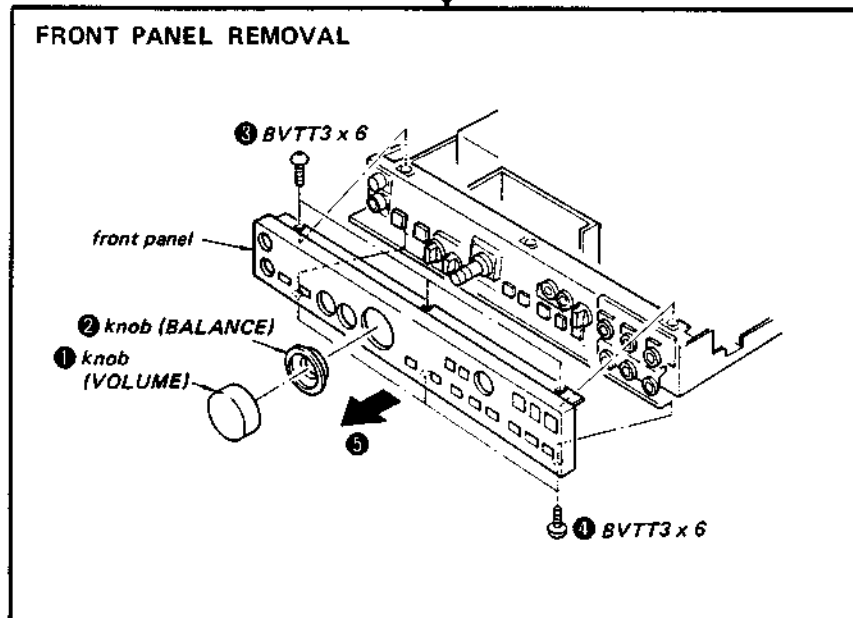
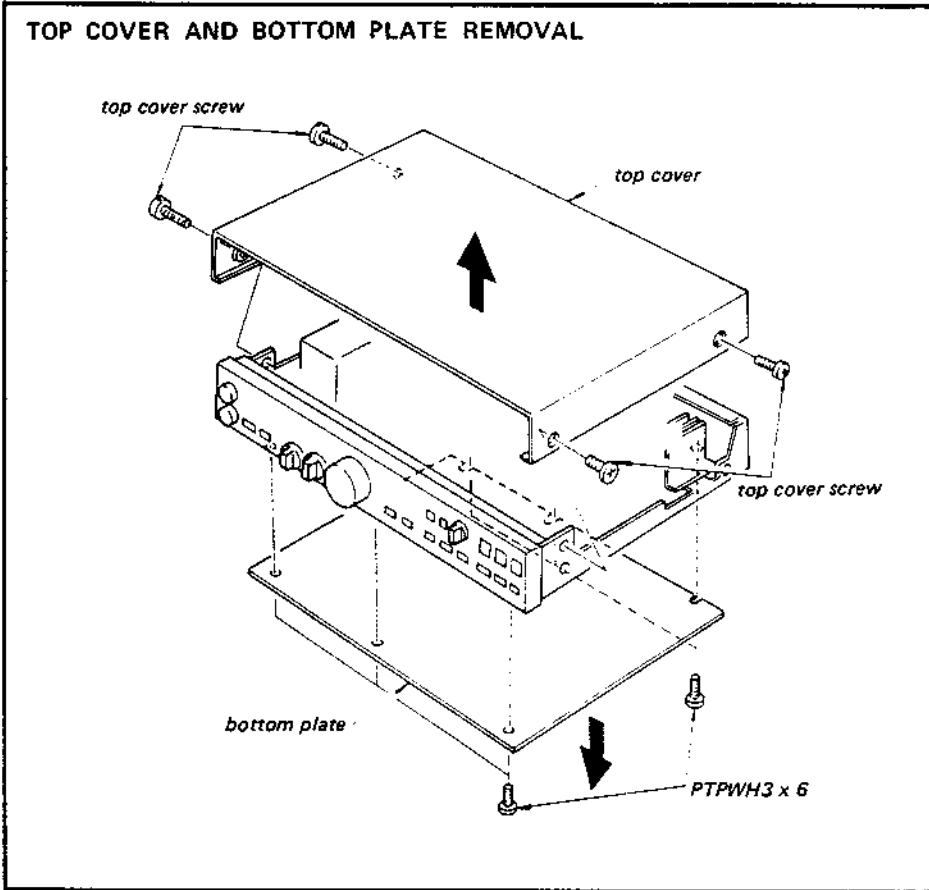

Under the condition shown below, the circuit boards can be checked except for the pulse power supply board.

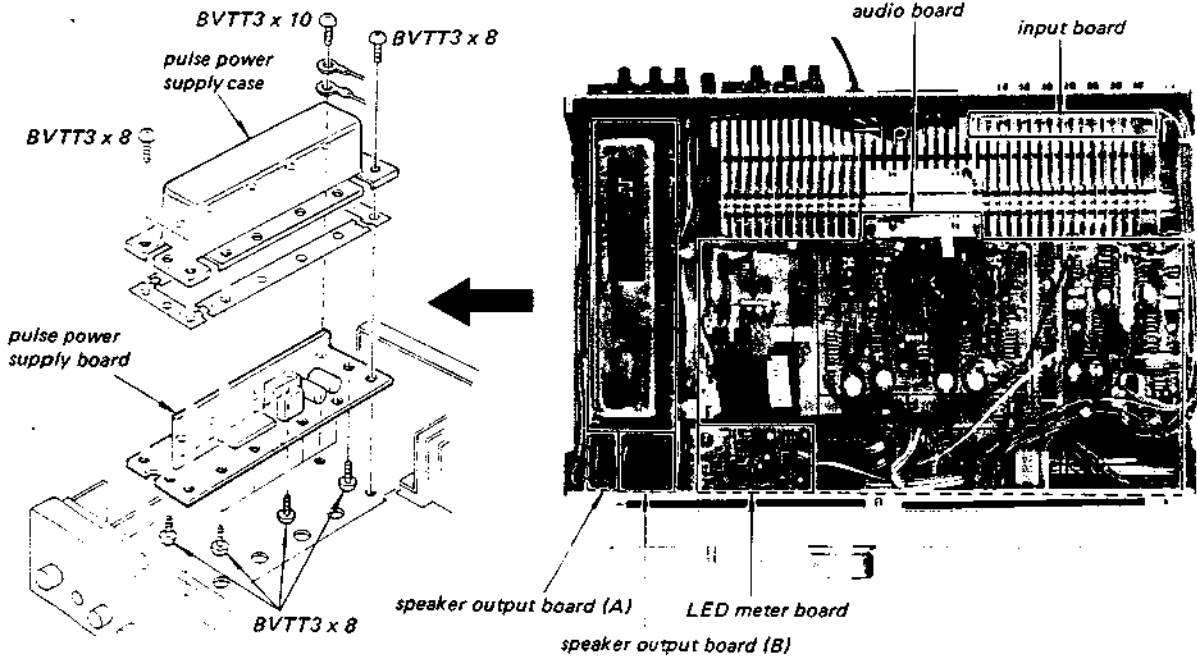
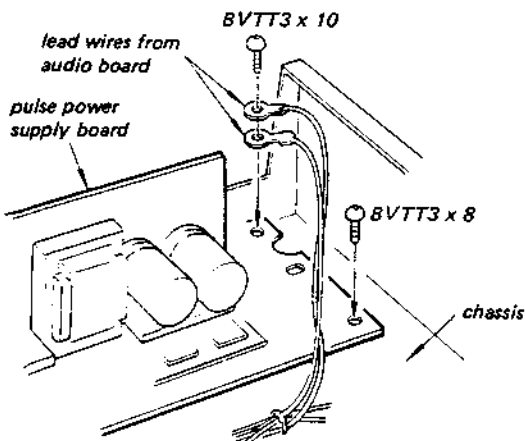

Photo : US, Canadian model

PULSE POWER SUPPLY BOARD REPAIRING

When checking the pulse power supply board out of the pulse power supply case, use the two lead wires to connect the ground pattern of circuit board with the chassis as shown below.



— With pulse power supply board grounded —

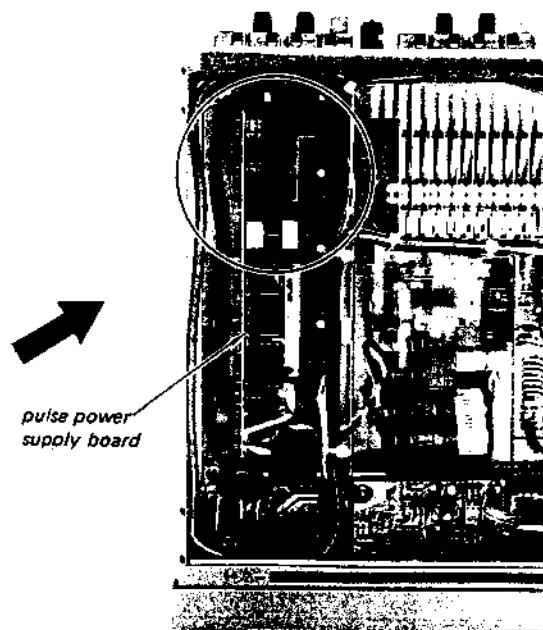

Photo : US, Canadian model

SECTION 3 ADJUSTMENTS

Note:

1. DC bias and DC balance adjustments should be made several minutes later after the POWER switch is turned on (POWER ON.).
2. Make DC bias adjustment first.
3. Repeat DC bias and DC balance adjustments two or three times.
4. After replacing the power transistors, DC bias and DC balance adjustments should be made.

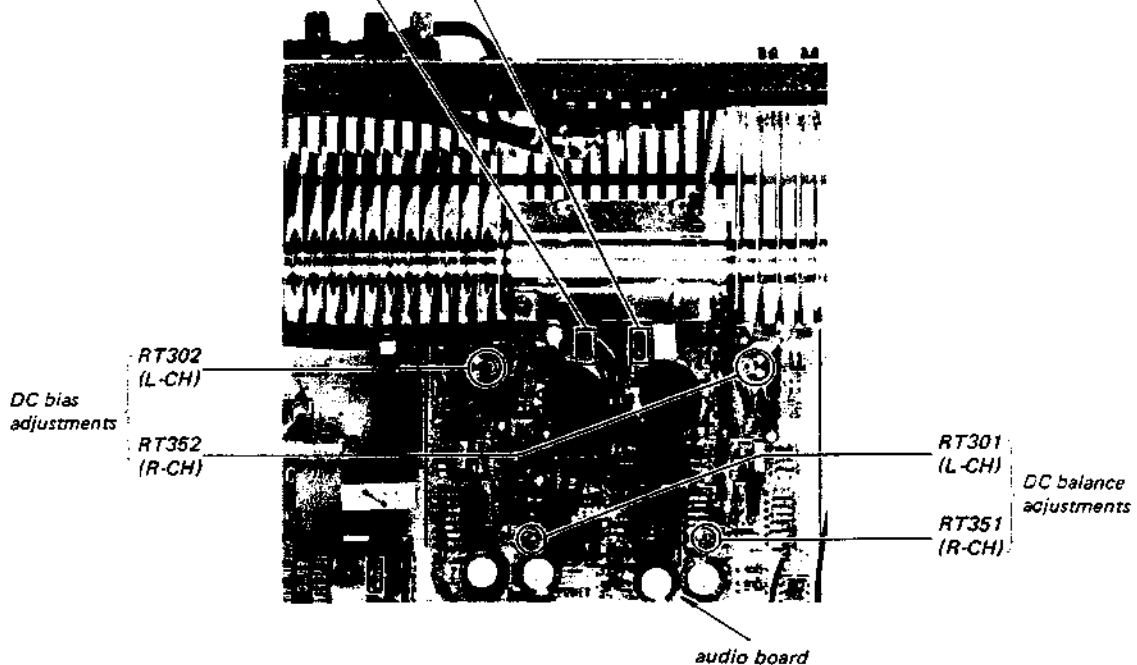
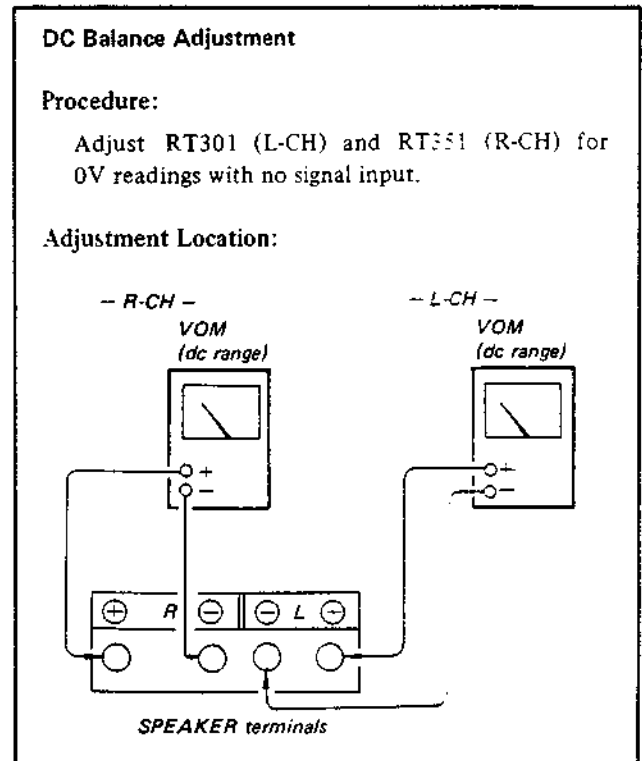
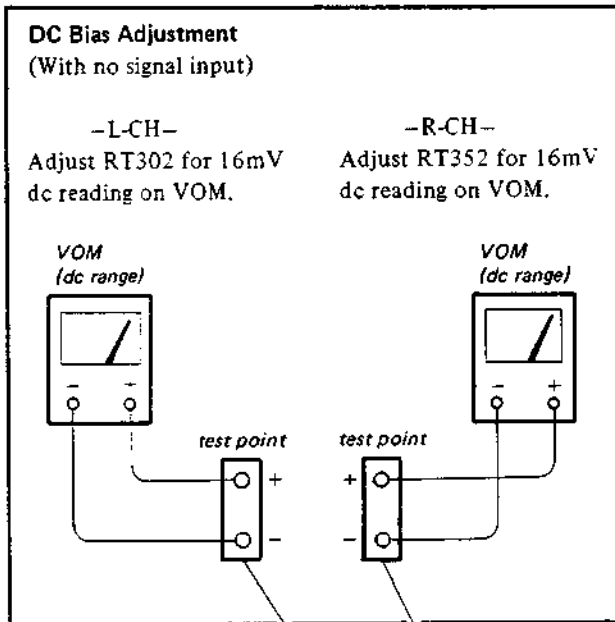
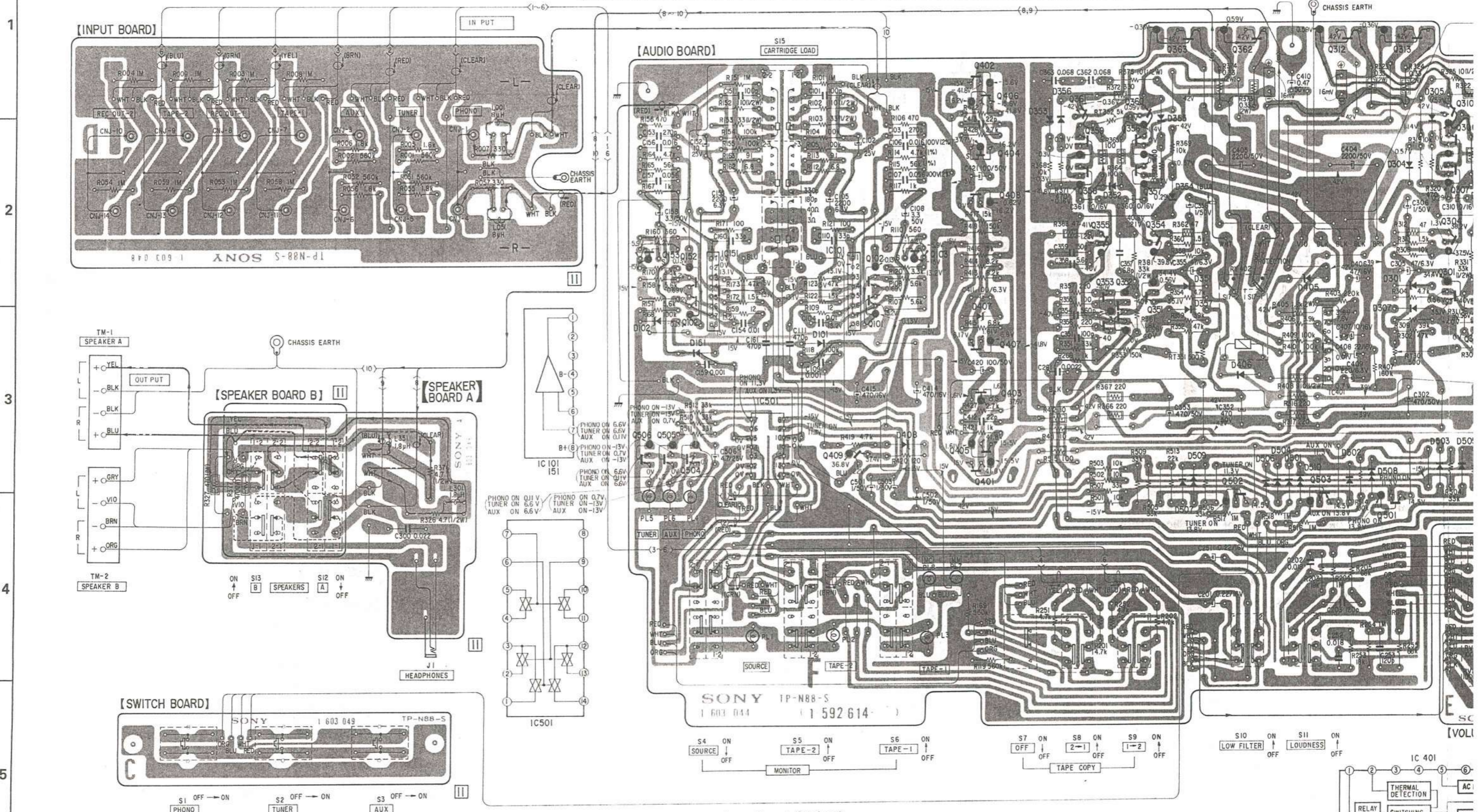

Photo : US, Canadian model

SECTION 4
DIAGRAMS

4-1. MOUNTING DIAGRAM
Replacement Semiconductors : See pages 14.

Q	153	152	IC151	IC501	IC101	102	103	402	406	361	360	356	363	362	312	313	311
IC	506	505	504		409	101		404	408	359	355	351	354	502	IC401	501	304
D	102	151		101		408		407		353	356	352	355	354	507	509	406
																	506
																	510
																	504
																	501
																	502
																	508
																	301
																	304
																	305
																	307
																	503
																	505



Note:

- : parts extracted from the component side.
- : B + pattern
- : B - pattern

- : signal path
- : L-CH signal path
- : R-CH signal path
- * : Connect VOM as illustrated in Fig. 1.

TA-F45 TA-F45

E										F										G										H										I										J										K										L									
151	IC501	IC101	102	103	402	406	361	360	356	363	362	312	313	310	311	903	904	902	901	404	408	359	355	351	354	358	353	352	351	354	502	502	503	IC401	501	501	304	305	310	306	305	309	308	301	302	303	IC251	IC201	402	404	403	401	904	903	902	901																							
101	408	407	353	356	352	355	354	351	406	506	510	405	504	501	502	508	301	304	305	307	503	505	302	306	303	402	404	403	401	904	903	902	901																																														

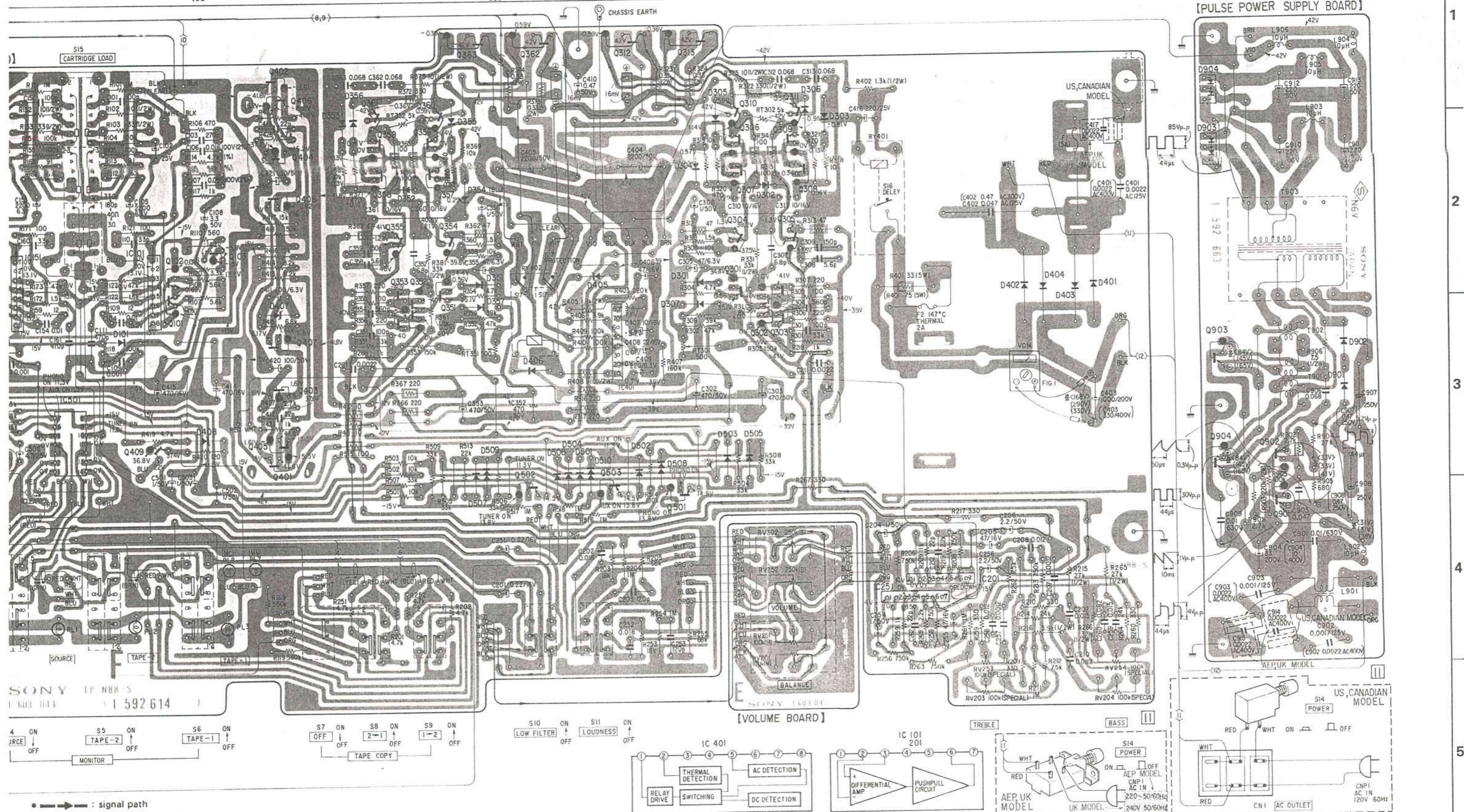

- : signal path
- : L-CH signal path
- : R-CH signal path
- : Connect VOM as illustrated in Fig. 1.

TA-F45 TA-F45

4-2. SCHEMATIC DIAGRAM

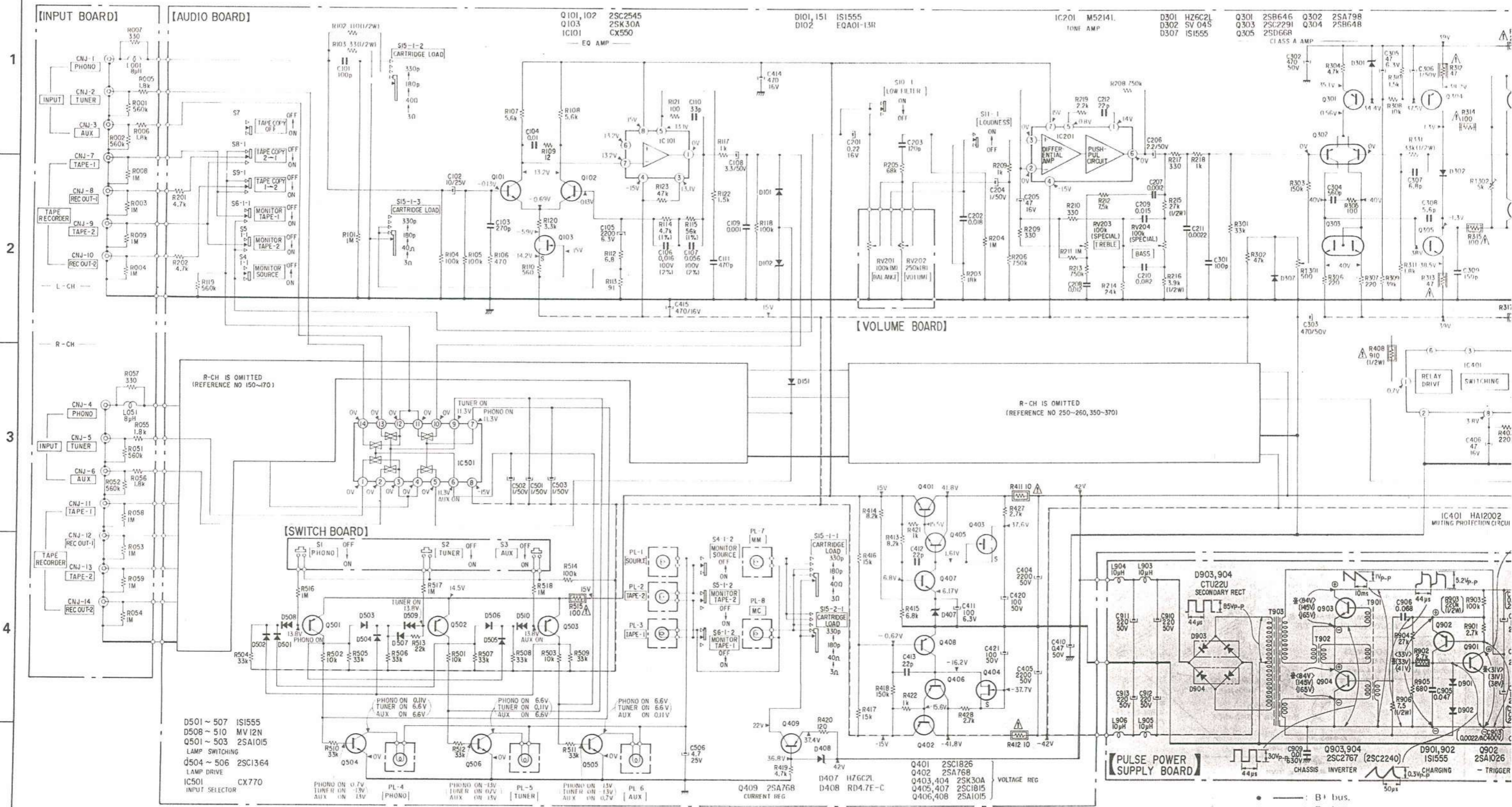

Note: Les composants identifiés par une trame et une marque sont critiques pour la sécurité. Ne les remplacer que par une pièce portant le numéro spécifié.

Note: The components identified by shading and mark are critical for safety. Replace only with part number specified.

Note:

- Components for right channel have same values as for left channel. Reference numbers are coded from 150-170, 250-260, 350-370.
- All capacitors are in μF unless otherwise noted. $\text{pF} : \mu\text{F} / 50\text{WV}$ or less are not indicated except for electrolytics and tantalums.

- All resistors are in ohms, $\frac{1}{2}\text{W}$ unless otherwise noted. $\text{k}\Omega : 1000\ \Omega$, $\text{M}\Omega : 1000\ \text{k}\Omega$
- [] : Resistance or capacitance value for AEP, UK model.
- : nonflammable resistor.

- : B+ bus.
- : B- bus.
- Voltages are dc with respect to ground unless otherwise noted.
- Readings are taken under no-signal condition a VOM (20k Ω /V).
- no mark : US, Canadian, AEP, UK model
- < > : US, Canadian model

E F G H I J K

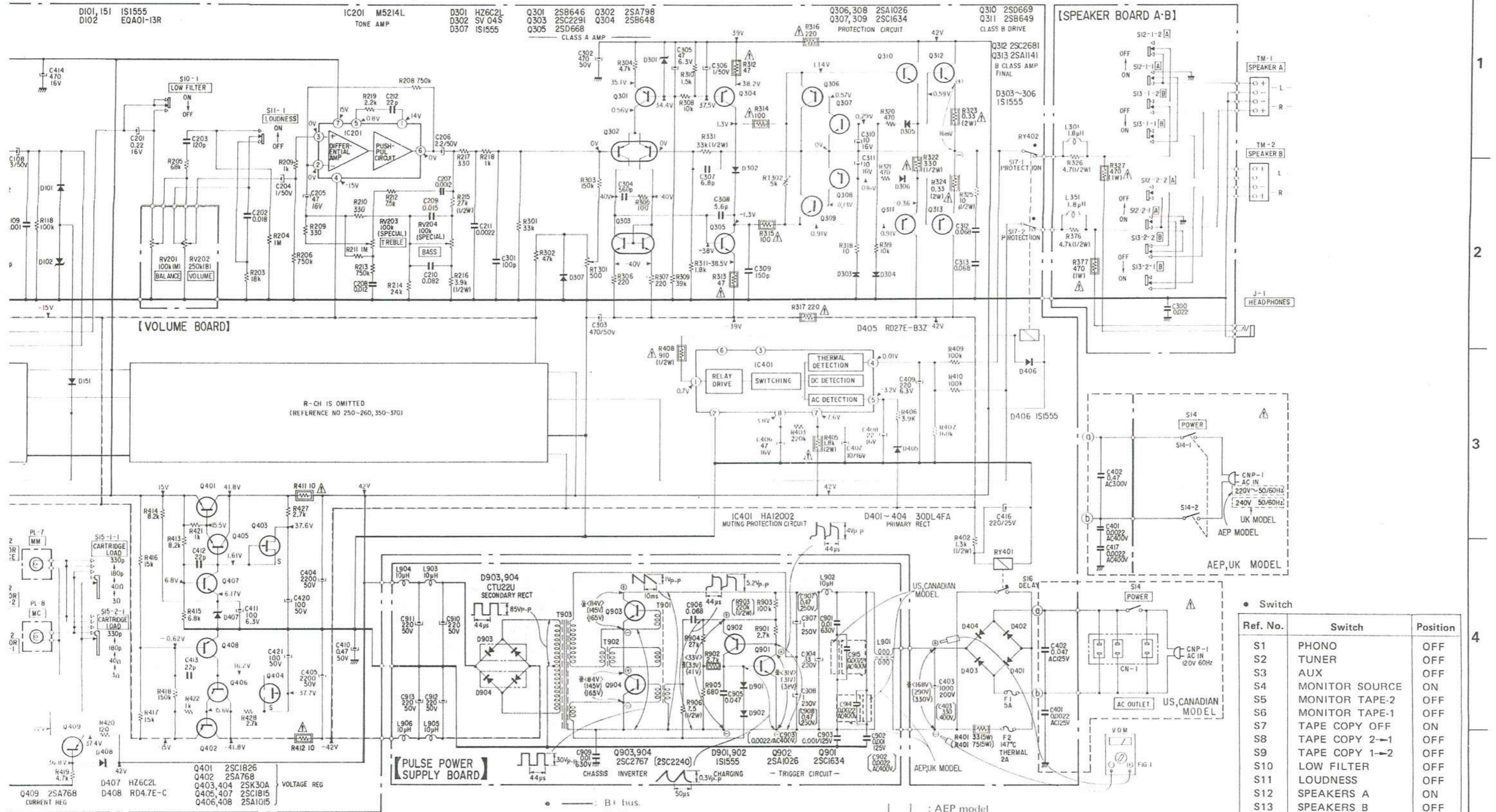

1
2
3
4
5

right channel have same values as for left
nce numbers are coded from 150-170,
370.
e in μF unless otherwise noted. pF : μpF
re not indicated except for electrolytics

- All resistors are in ohms, $\frac{1}{4}\text{W}$ unless otherwise noted. $\text{k}\Omega$: 1000 Ω , $\text{M}\Omega$: 1000 $\text{k}\Omega$
- [] : Resistance or capacitance value for AEP, UK model.
- : nonflammable resistor.

- : B+ bus.
- : B bus.
- Voltages are dc with respect to ground unless otherwise noted.
- Readings are taken under no-signal conditions with a VOM (20k Ω/V)
- no mark : US, Canadian, AEP, UK model
- : US, Canadian model

- : AEP model
- : UK model
- Voltage variations may be noted due to normal production tolerances.
- : Connect VOM as illustrated in Fig. 1.

• Switch

Ref. No.	Switch	Position
S1	PHONO	OFF
S2	TUNER	OFF
S3	AUX	OFF
S4	MONITOR SOURCE	ON
S5	MONITOR TAPE-2	OFF
S6	MONITOR TAPE-1	OFF
S7	TAPE COPY OFF	ON
S8	TAPE COPY 2-1	OFF
S9	TAPE COPY 1-2	OFF
S10	LOW FILTER	OFF
S11	LOUDNESS	OFF
S12	SPEAKERS A	ON
S13	SPEAKERS B	OFF
S14	POWER	OFF
S15	CARTRIDGE LOAD	3 Ω
S16	DELAY	OFF
S17	PROTECTION	ON

TA-F45 TA-F45

4.2. SCHEMATIC DIAGRAM

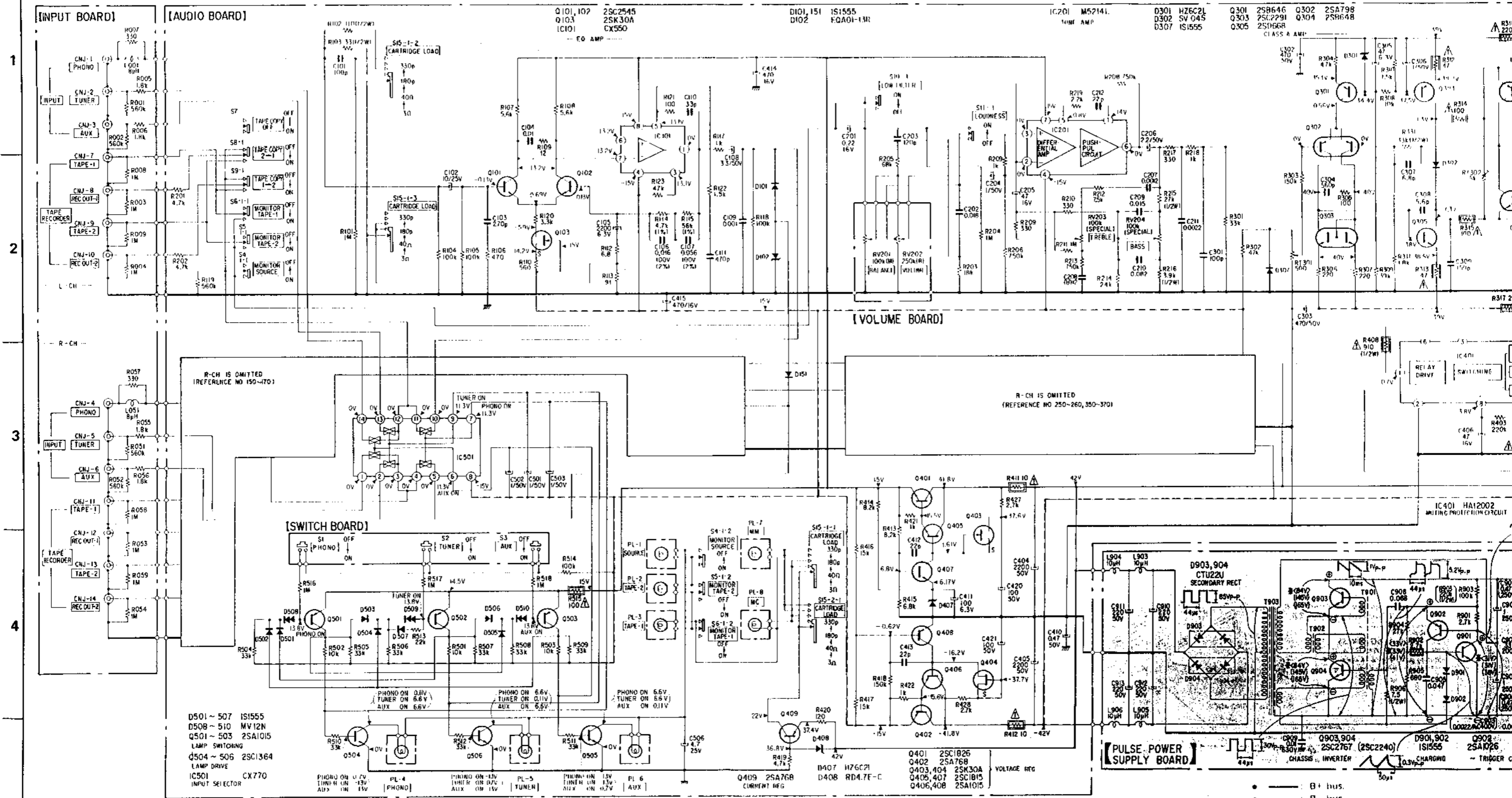

Note: Les composants identifiés par une trame et une marque sont critiques pour la sécurité. Ne les remplacer que par une pièce portant le numéro spécifié.

Note: The components identified by shading and mark are critical for safety. Replace only with part number specified.

Note:

- Components for right channel have same values as for left channel. Reference numbers are coded from 150-170, 250-260, 350-370.
- All capacitors are in μF unless otherwise noted. $\text{pF} = \mu\text{F} \times 10^{-6}$, 50WV or less are not indicated except for electrolytics and tantalums.

• All resistors are in ohms, $\frac{1}{2}\text{W}$ unless otherwise noted. $\text{k}\Omega : 1000\Omega$, $\text{M}\Omega : 1000\text{k}\Omega$

• [] : Resistance or capacitance value for AEP, UK model.

• : nonflammable resistor.

• — : B+ bus.

• - - - : B- bus.

• Voltages are dc with respect to ground unless otherwise noted.

• Readings are taken under no-signal conditions with a VOM (20k Ω /V).

no mark : US, Canadian, AEP, UK model

< > : US, Canadian model

E F G H I J K

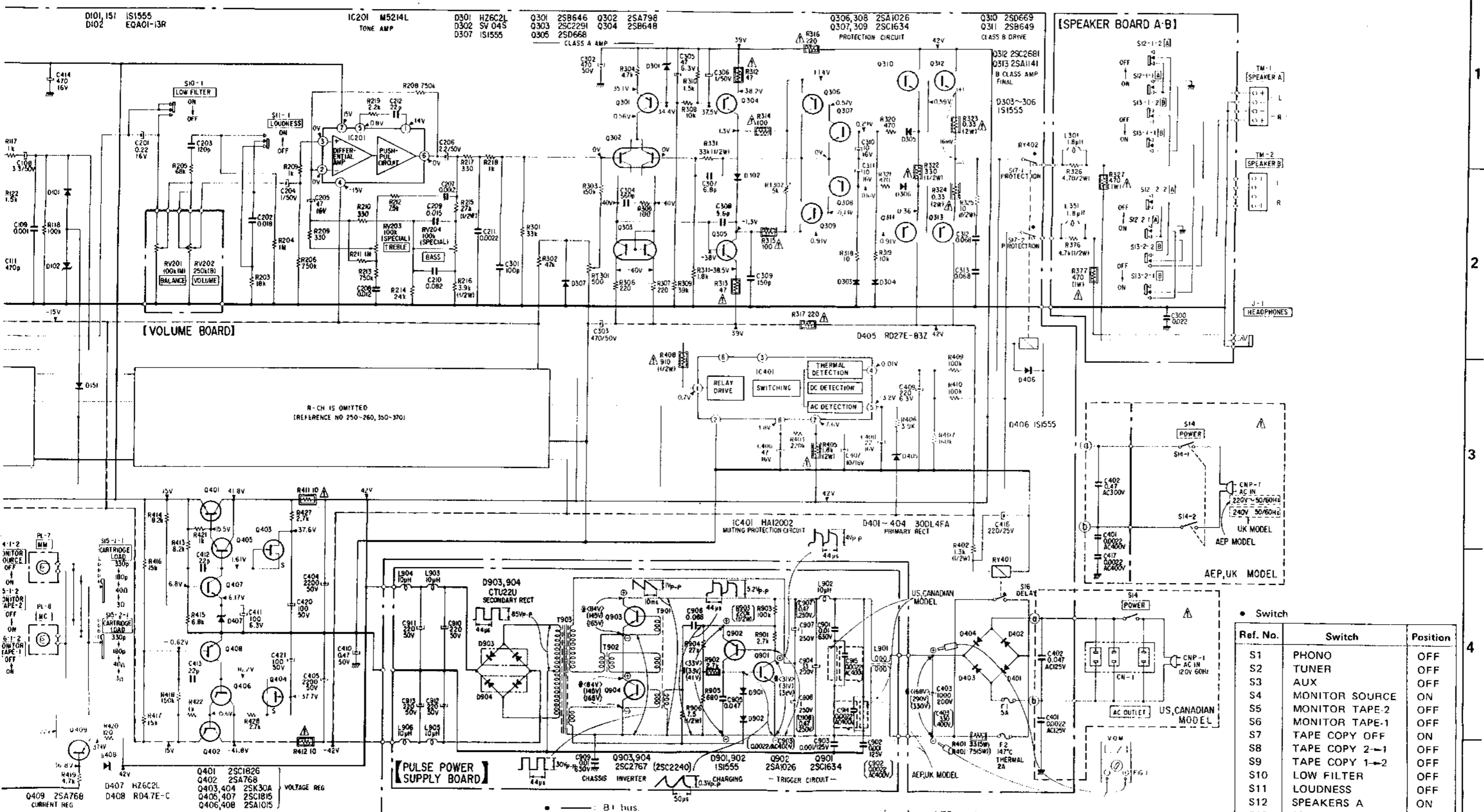

for right channel have same values as for left channel. Reference numbers are coded from 150-170, 171-370. Values in μF unless otherwise noted. μF : $\mu\mu F$ unless otherwise noted. Values are not indicated except for electrolytics.

- All resistors are in ohms, $\frac{1}{4}W$ unless otherwise noted. $k\Omega$: 1000 Ω , $M\Omega$: 1000 $k\Omega$.
- [] : Resistance or capacitance value for AEP, UK model.
- [] : nonflammable resistor.

- : B1 bus.
- - - : B bus.
- Voltages are dc with respect to ground unless otherwise noted.
- Readings are taken under no-signal conditions with a VOM (20k Ω).
- no mark : US, Canadian, AEP, UK model.
- : US, Canadian model.

- : AEP model.
- [] : UK model.
- Voltage variations may be noted due to normal production tolerances.
- : Connect VOM as illustrated in Fig. 1.

• Switch

Ref. No.	Switch	Position
S1	PHONO	OFF
S2	TUNER	OFF
S3	AUX	OFF
S4	MONITOR SOURCE	ON
S5	MONITOR TAPE-2	OFF
S6	MONITOR TAPE-1	OFF
S7	TAPE COPY OFF	ON
S8	TAPE COPY 2-1	OFF
S9	TAPE COPY 1-2	OFF
S10	LOW FILTER	OFF
S11	LOUDNESS	OFF
S12	SPEAKERS A	ON
S13	SPEAKERS B	OFF
S14	POWER	OFF
S15	CARTRIDGE LOAD	3 Ω
S16	DELAY	OFF
S17	PROTECTION	ON

Replacement Semiconductors

For replacement, use semiconductors except in ().

<p>2SA771 (2SA768)</p>	<p>2SC2291</p>	<p>M5214L</p>
<p>2SA798</p>	<p>2SC2545</p>	<p>1S1555 HZ6C2L RD4.7E (RD4.7E-C) RD27E-B2Z (RD27E-B3Z)</p>
<p>2SA1027R (2SA1026) (2SA1015)</p>	<p>2SC2681 2SD668 2SD669A (2SD669)</p>	<p>CTU22U</p>
<p>2SA1141</p>	<p>2SC2767</p>	<p>EQB01-13 (EQA01-13R)</p>
<p>2SB646A (2SB646)</p>	<p>2SK30A</p>	<p>MV12N</p>
<p>2SB648 2SB649A (2SB649)</p>	<p>CX550</p>	<p>SV04S</p>
<p>2SC1364 (2SC1634) (2SC1815)</p>	<p>CX770</p>	<p>U05G (30DL4FA)</p>
<p>2SC1986 (2SC1826)</p>	<p>HA12002</p>	

SECTION 5 EXPLODED VIEWS

TA-F45

A

B

C

D

5-1.

Note:

- Items marked "X" are not stocked since they are seldom required for routine service. Some delay should be anticipated when ordering these items.
- All screws are Phillips (cross recess) type unless otherwise noted.
(-) = slotted head

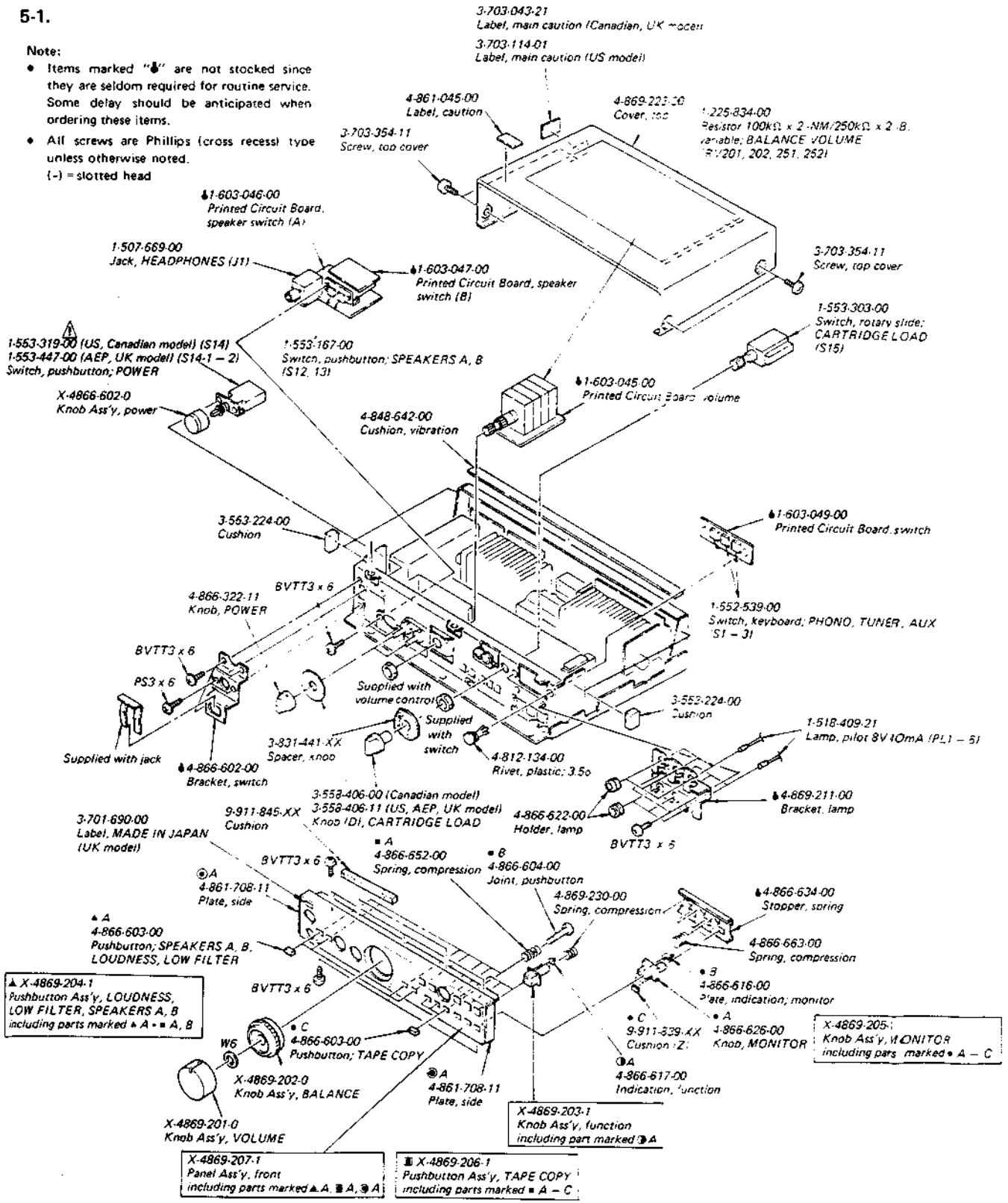

Note: The components identified by shading and mark **A** are critical for safety. Replace only with part number specified.

Note: Les composants identifiés par une trame et une marque **A** sont critiques pour la sécurité. Ne les remplacer que par une pièce portant le numéro spécifié.

TA-F45

A B C D

5-2.

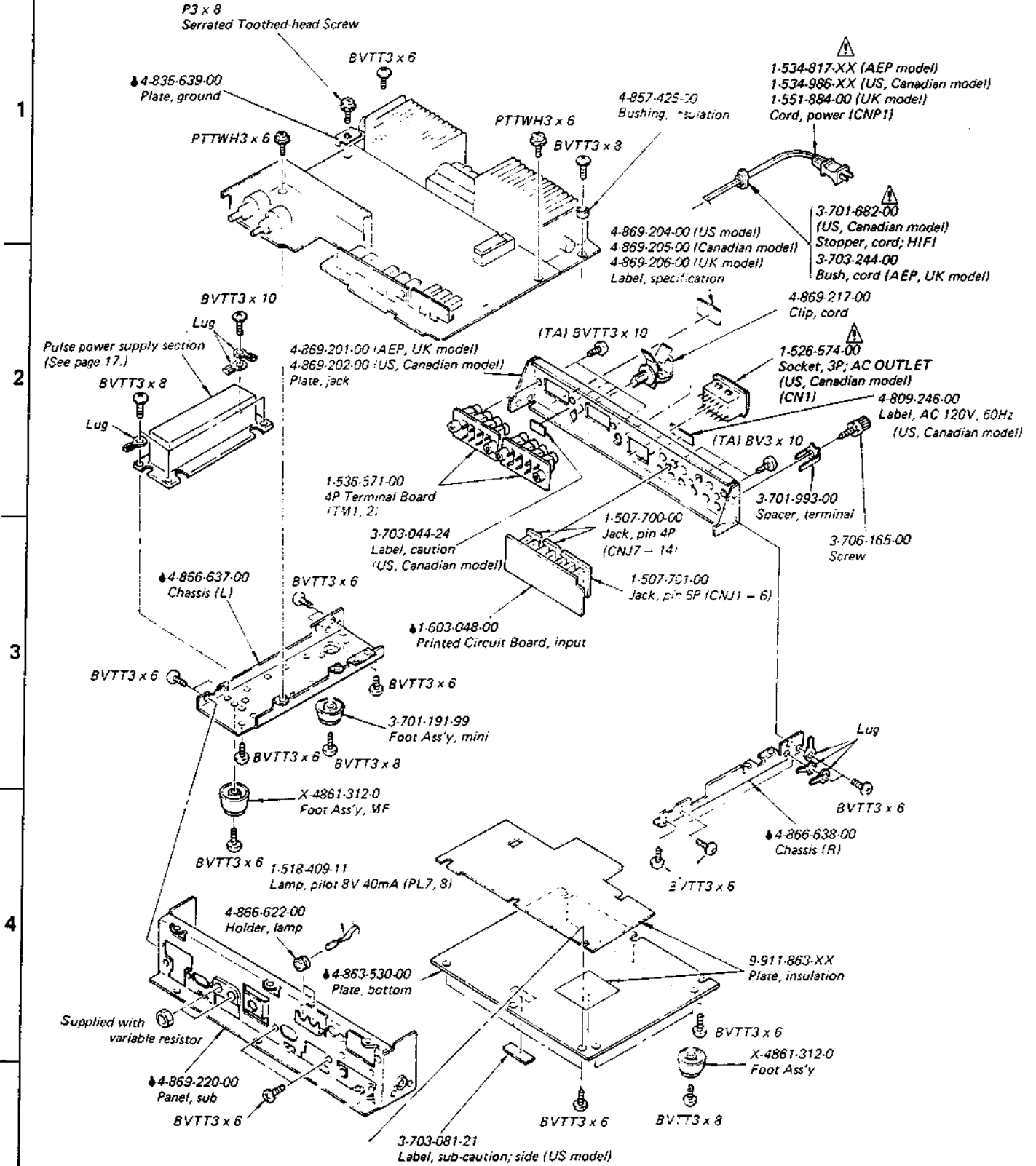

Note: The components identified by shading and mark  are critical for safety. Replace only with part number specified.

Note: Les composants identifiés par une trame et une marque  sont critiques pour la sécurité. Ne les remplacer que par une pièce portant le numéro spécifié.

5-3.

1
2
3
4
5

A B C D

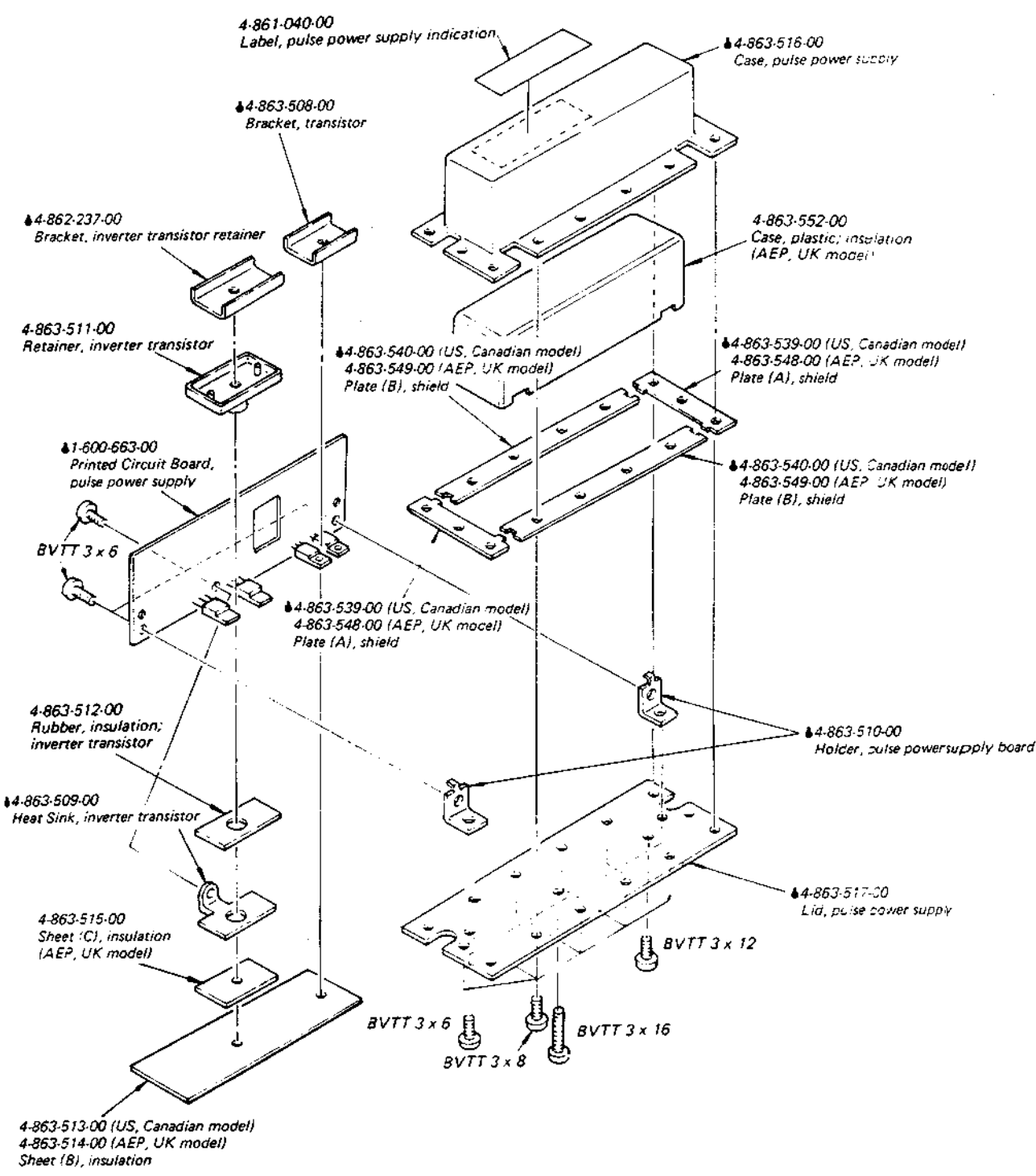

A

B

C

D

5-4.

1

2

3

4

5

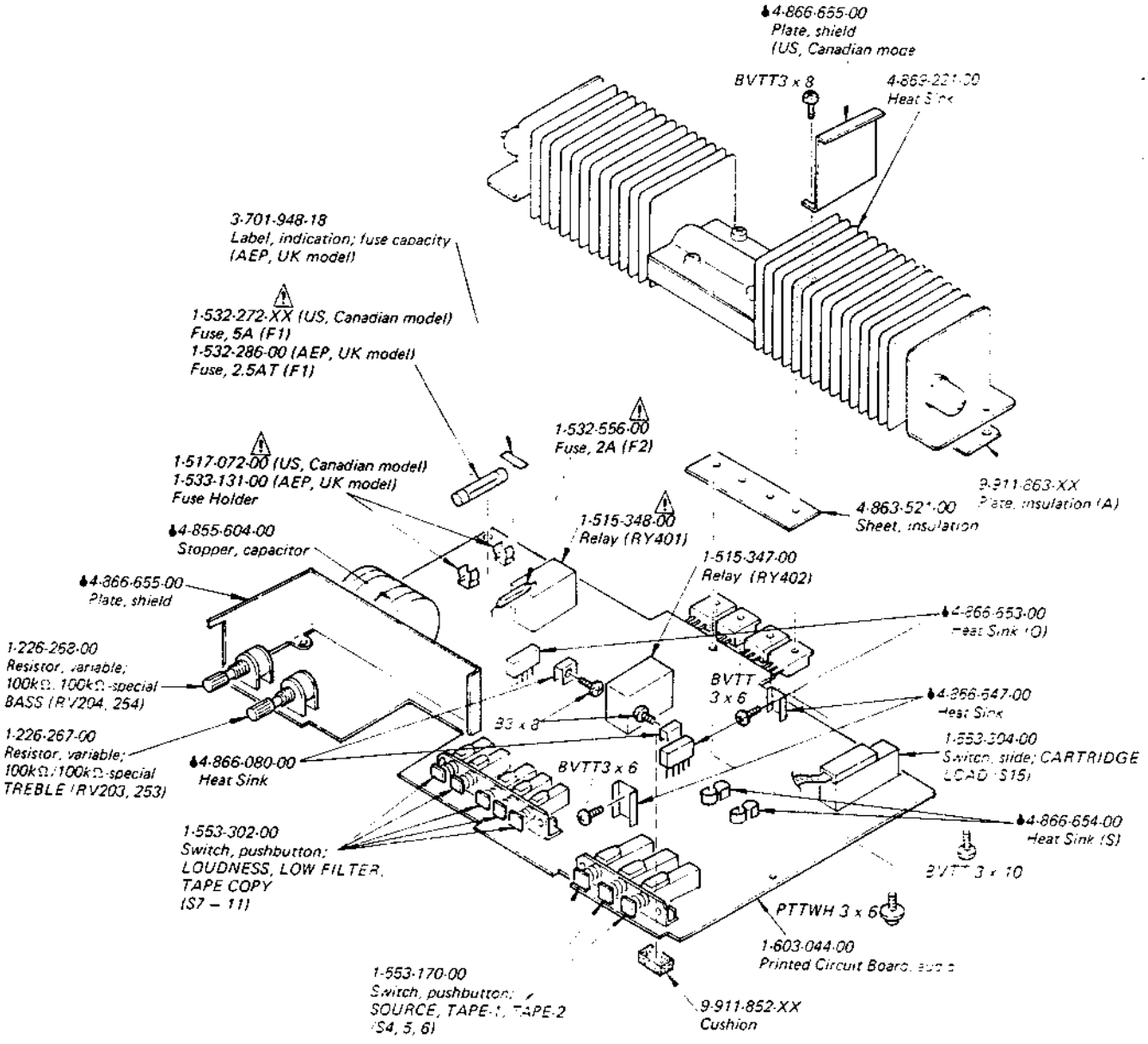

Note: The components identified by shading and mark  are critical for safety. Replace only with part number specified.

Note: Les composants identifiés par une trame et une marque  sont critiques pour la sécurité. Ne les remplacer que par une pièce portant le numéro spécifié.

SECTION 6
ELECTRICAL PARTS LIST

Ref. No. Part No. Description

SEMICONDUCTORS

Transistors

Q101, 151 Q102, 152	8-729-354-52	2SC2545
Q103, 153	8-729-203-04	2SK30A
Q301, 351	8-729-304-62	2SB646A
Q302, 352	8-729-679-82	2SA798
Q303, 353	8-729-629-12	2SC2291
Q304, 354	8-729-364-81	2SB648
Q305, 355	8-729-366-81	2SD668
Q306, 356	8-729-612-77	2SA1027R
Q307, 357	8-729-663-47	2SC1364
Q308, 358	8-729-612-77	2SA1027R
Q309, 359	8-729-663-47	2SC1364
Q310, 360	8-729-306-92	2SD669A
Q311, 361	8-729-304-92	2SB649A
Q312, 362	8-729-168-11	2SC2681
Q313, 363	8-729-114-11	2SA1141
Q401	8-729-308-62	2SC1986
Q402	8-729-377-12	2SA771
Q403, 404	8-729-203-04	2SK30A
Q405	8-729-663-47	2SC1364
Q406	8-729-612-77	2SA1027R
Q407	8-729-663-47	2SC1364
Q408	8-729-612-77	2SA1027R
Q409	8-729-377-12	2SA771
Q501-503	8-729-612-77	2SA1027R
Q504-506	8-729-663-47	2SC1364
Q901	▲8-729-663-47	2SC1364
Q902	▲8-729-612-77	2SA1027R
Q903, 904	▲X-4863-506-1	Transistor Ass'y, service 2SC2767 x 2

ICs

IC101, 151	8-759-305-50	CX550
IC201, 251	8-759-652-14	M5214L
IC401	8-759-320-02	HA12002
IC501	8-759-700-00	CX770

• Items marked "▲" are not stocked since they are seldom required for routine service. Some delay should be anticipated when ordering these items.

Note: The components identified by shading and mark ▲ are critical for safety. Replace only with part number specified.

Ref. No. Part No. Description

Diodes

D101, 151	8-719-815-55	1S1555
D102, 152	8-719-931-13	EQB01-13
D301, 351	8-719-910-68	HZ6C2L
D302, 352	8-719-300-11	SV04S
D303, 353	8-719-815-55	1S1555
D307, 357		
D401-404	▲8-719-911-55	U05G
D405	8-719-127-25	RD27E-B2Z
D406	8-719-815-55	1S1555
D407	8-719-910-68	HZ6C2L
D408	8-719-147-77	RD4.7E
D501-507	8-719-815-55	1S1555
D508-510	8-719-912-00	MV12N
D901, 902	▲8-719-815-55	1S1555
D903, 904	▲8-719-300-22	CTU22U

CAPACITORS

All capacitors are in μF unless otherwise noted. 50WV or less are not indicated except for electrolytics and tantalums. pF : $\mu\mu\text{F}$

C401	▲1-130-197-00	0.0022	125V	ceramic
				(US, Canadian model)
C401, 417	▲1-161-734-00	0.0022	400V	ceramic
				(AEP, UK model)
C402	▲1-130-234-00	0.047	125V	film
				(US, Canadian model)
C402	▲1-130-342-00	0.47	300V	film
				(AEP, UK model)
C403	▲1-125-222-00	330	400V	electrolytic
				(AEP, UK model)
C403	▲1-125-223-00	1000	200V	electrolytic
				(US, Canadian model)
C901, 909	▲1-130-141-00	0.01	630V	film
C902, 903	▲1-161-516-00	0.001	125V	ceramic
				(US, Canadian model)
C902, 903 C914, 915	▲1-161-734-00	0.0022	400V	ceramic
				(AEP, UK model)

Note: Les composants identifiés par une trame et une marque ▲ sont critiques pour la sécurité. Ne le remplacer que par une pièce portant le numéro spécifié.

Ref. No.	Part No.	Description
C904	△ A1-123-290-00	10 400V electrolytic (AEP, UK model)
C904	△ A1-123-565-00	33 200V electrolytic (US, Canadian model)
C905	△ A1-108-246-00	0.047 50V mylar
C907, 908	△ A1-130-356-00	0.47 250V film (AEP, UK model)
C907, 908	△ A1-130-357-00	1 250V film (US, Canadian model)
C910-913	△ A1-123-361-00	220 50V electrolytic

RESISTORS

All resistors are in ohms. Common 1/4W carbon resistors are omitted. Refer to the list on the last page for their part numbers.
 kΩ : 1000Ω, MΩ : 1000kΩ

R312, 362 R313, 363	△ A1-247-099-00	47 1/4W carbon (nonflammable)
R314, 364 R315, 365	△ A1-247-107-00	100 1/4W carbon (nonflammable)
R316, 366 R317, 367	△ A1-247-115-00	220 1/4W carbon (nonflammable)
R322, 372	△ A1-247-288-00	330 1/4W carbon (nonflammable)
R323, 373 R324, 374	△ A1-217-152-11	0.33 2W wirewound
R327, 377	△ A1-213-139-00	470 1W metal oxide (nonflammable)
R401	△ A1-205-598-00	33 5W wirewound (US, Canadian model)
R401	△ A1-205-599-00	75 5W wirewound (AEP, UK model)
R405	△ A1-206-670-00	1.8k 2W metal oxide (nonflammable)
R408	△ A1-247-239-00	910 1/4W carbon (nonflammable)
R411, 412	△ A1-247-083-00	10 1/4W carbon (nonflammable)
R515	△ A1-247-107-00	100 1/4W carbon (nonflammable)
R901	△ A1-246-483-15	2.7k 1/4W carbon

Note: The components identified by shading and mark **△** are critical for safety. Replace only with part number specified.

Ref. No.	Part No.	Description
R902	△ A1-247-141-00	2.7k 1/4W carbon (nonflammable)
R903	△ A1-244-521-15	100k 1/4W carbon (US, Canadian model)
R903	△ A1-244-929-00	220k 1/4W carbon (AEP, UK model)
R904	△ A1-246-507-15	27k 1/4W carbon
R905	△ A1-246-469-15	680 1/4W carbon
R906	△ A1-244-821-00	6.8 1/4W carbon (US, Canadian model)
R906	△ A1-244-822-00	7.5 1/4W carbon (AEP, UK model)

RT301,351	1-226-232-00	500-B, adjustable; dc balance
RT302,352	1-226-235-00	5k-B, adjustable; dc bias

RV201,251 RV202,252	1-226-834-00	100kx2-NM/250kx2-B. variable; BALANCE, VOLUME
RV203, 253	1-226-267-00	100k/100k-special. variable; TREBLE
RV204, 254	1-226-268-00	100k/100k-special. variable; BASS

MISCELLANEOUS

CN1	△ A1-526-574-00	AC-outlet, 3P (US, Canadian model)
CNJ1-6	1-507-701-00	Jack, pin 6P INPUT
CNJ7-14	1-507-700-00	Jack, pin 4P TAPE RECORDER
CNP1	△ A1-534-817-XX	Cord, power (AEP model)
CNP1	△ A1-534-986-XX	Cord, power (US, Canadian model)
CNP1	△ A1-551-884-00	Cord, power (UK model)
F1	△ A1-532-272-XX	Fuse, 5A (US, Canadian model)
F1	△ A1-532-286-00	Fuse, 2.5AT (AEP, UK model)
F2	△ A1-532-556-00	Fuse, 147°C 2A
J1	1-507-669-00	Jack, HEADPHONES
L001, 051	1-407-519-00	Microinductor, 8μH
• L301, 351	1-420-872-00	Coil, air-core 1.8μH
L901	△ A1-421-328-11	Coil, choke (Line Filter) (US, Canadian model)
L901	△ A1-421-340-00	Coil, choke (Line Filter) (AEP, UK model)
L902-906	△ A1-421-329-00	Coil, choke 10μH
PL1-6	1-518-409-21	Lamp, pilot 8V 40mA

Note: Les composants identifiés par une trame et une marque **△** sont critiques pour la sécurité. Ne les remplacer que par une pièce portant le numéro spécifié.

<u>Ref. No.</u>	<u>Part No.</u>	<u>Description</u>
PL7, 8	1-518-409-11	Lamp, pilot 8V 40mA
RY401	▲1-515-348-00	Relay
RY402	1-515-347-00	Relay
S1-3	1-552-539-00	Switch, keyboard; PHONO, TUNER, AUX
S4-6	1-553-170-00	Switch, pushbutton; SOURCE, TAPE-2, TAPE-1
S7-11	1-553-302-00	Switch, pushbutton; LOUDNESS, LOW FILTER, TAPE COPY
S12, 13	1-553-167-00	Switch, pushbutton; SPEAKERS A, B
S14	▲1-553-319-00	Switch, pushbutton; POWER (US, Canadian model)
S14-1-2	▲1-553-447-00	Switch, pushbutton; POWER (AEP, UK model)
S15	1-553-303-00	Switch, rotary slide; CARTRIDGE LOAD
S15	1-553-304-00	Switch, slide; CARTRIDGE LOAD
T901	▲1-543-098-00	Core
T901, 902	▲1-543-100-00	Core
T903	▲1-446-363-00	Transformer, converter (US, Canadian model)
T903	▲1-446-364-00	Transformer, converter (AEP, UK model)
TM1, 2	1-536-571-00	4P Terminal Board, SPEAKER A, B
	◆1-508-803-13	U Type Base Post
	▲1-517-072-00	Fuse Holder (US, Canadian model)
	▲1-533-131-00	Fuse Holder (AEP, UK model)

PRINTED CIRCUIT BOARDS

◆1-600-663-00	Pulse Power Supply
◆1-603-044-00	Audio
◆1-603-045-00	Volume
◆1-603-046-00	Speaker (A)
◆1-603-047-00	Speaker (B)
◆1-603-048-00	Input
◆1-603-049-00	Switch

Note: The components identified by shading and mark ▲ are critical for safety. Replace only with part number specified.

Ref. No. Part No. Description

ACCESSORIES AND PACKING MATERIALS

<u>Part No.</u>	<u>Description</u>
3-701-630-00	Bag, plastic (for instruction manual)
3-783-202-11	Manual, instruction (AEP, UK model)
3-783-202-21	Manual, instruction (US, Canadian model)
3-794-179-31	Leaflet in French (Canadian model)
4-863-543-00	Cushion
4-866-723-00	Bag, plastic (for amplifier)
4-869-227-00	Carton

Note: Les composants identifiés par une trame et une marque ▲ sont critiques pour la sécurité. Ne les remplacer que par une pièce portant le numéro spécifié.

ELECTROLYTIC CAPACITORS

CAP. (μF)	RATING → Use the high voltage rated one.					
	6.3 VOLT.	10 VOLT.	16 VOLT.	25 VOLT.	35 VOLT.	50 VOLT.
	PART No.	PART No.	PART No.	PART No.	PART No.	PART No.
0.47						1-121-326-00
1.0						1-121-391-00
2.2						1-121-450-00
3.3				1-121-392-00		1-121-393-00
4.7				1-121-395-00		1-121-396-00
10			1-121-651-00	1-121-398-00		1-121-438-00
22			1-121-479-00	1-121-480-00	1-121-662-00	1-121-452-00
33			1-121-403-00	1-121-404-00	1-121-652-00	1-121-405-00
47		1-121-392-00	1-121-409-00	1-121-410-00	1-121-653-00	1-121-411-00
100		1-121-414-00	1-121-415-00	1-121-416-00	1-121-654-00	1-121-417-00
220	1-121-419-00	1-121-420-00	1-121-421-00	1-121-422-00	1-121-655-00	1-121-423-00
330	1-121-751-00	1-121-803-00	1-121-521-00	1-121-654-00	1-121-655-00	1-121-656-00
470	1-121-424-00	1-121-425-00	1-121-426-00	1-121-733-00	1-121-394-00	1-121-410-00
1000		1-121-736-00	1-121-245-00	1-121-657-00	1-121-588-00	1-121-061-00
2200	1-121-658-00	1-121-659-00	1-121-660-00	1-121-067-00	1-121-354-00	
3300	1-121-661-00	1-121-375-00	1-121-071-00			

CAP. (μF)	100 VOLT.	160 VOLT.	250 VOLT.	350 VOLT.
	PART No.	PART No.	PART No.	PART No.
0.47				
1.0	1-123-249-00	1-123-250-00	1-123-003-00	1-121-168-00
2.2	1-123-250-00	1-123-026-00		1-123-028-00
3.3	1-121-995-00		1-123-004-00	1-123-006-00
4.7	1-123-255-00	1-121-246-00	1-121-759-00	1-123-007-00
10	1-121-126-00	1-121-399-00	1-123-254-00	1-123-008-00
22	1-121-996-00	1-123-253-00	1-123-005-00	1-123-022-00
33	1-121-997-00	1-121-757-00		
47	1-123-251-00	1-121-919-00		
100	1-123-084-00			

CERAMIC CAPACITORS

CAP. (pF)	RATING						
	50 VOLT.		50 VOLT.		50 VOLT.		
	PART No.	CAP. (pF)	PART No.	CAP. (pF)	PART No.	CAP. (pF)	
0.5	1-101-837-00	22	1-102-959-00	150	1-101-861-00	220	1-102-974-00
0.75	1-101-556-00	24	1-102-960-00	160	1-101-867-00	222	1-102-115-00
1.0	1-102-934-00	27	1-102-961-00	180	1-102-976-00	223	1-102-119-00
1.5	1-101-576-00	30	1-102-962-00	200	1-102-977-00	224	1-102-120-00
2.0	1-102-935-00	33	1-102-963-00	220	1-102-978-00	225	1-102-121-00
3	1-102-936-00	36	1-102-964-00	240	1-102-979-00	226	1-102-122-00
4	1-102-937-00	39	1-102-965-00	270	1-102-980-00	227	1-102-123-00
5	1-102-942-00	43	1-102-966-00	300	1-102-981-00	228	1-102-124-00
6	1-102-943-00	47	1-101-880-00	330	1-102-982-00	229	1-102-125-00
7	1-102-944-00	51	1-101-882-00	360	1-102-821-00	230	1-102-126-00
8	1-102-945-00	55	1-101-884-00	390	1-102-922-00	231	1-102-127-00
9	1-102-946-00	52	1-101-886-00	420	1-102-923-00	232	1-102-128-00
10	1-102-947-00	56	1-101-888-00	470	1-102-924-00	233	1-102-129-00
11	1-102-948-00	58	1-101-890-00	510	1-101-059-00	234	1-101-005-00
12	1-102-949-00	62	1-102-921-00	560	1-102-125-00	235	1-101-006-00
13	1-102-950-00	68	1-102-922-00	680	1-102-126-00		
15	1-102-951-00	75	1-102-923-00	820	1-102-127-00		
16	1-102-952-00	100	1-102-915-00				
18	1-102-953-00	120	1-102-816-00				
20	1-102-958-00	150	1-101-081-00				

0.001μF = 1,000pF

CERAMIC (SEMICONDUCTOR) CAPACITORS

CAP. (μF)	RATING → Use the high voltage rated one.				
	25 VOLT.	50 VOLT.	CAP. (μF)	25 VOLT.	50 VOLT.
	PART No.	PART No.		PART No.	PART No.
0.001		1-161-039-00	0.018	1-161-016-00	1-161-054-00
0.0012		1-161-040-00	0.022	1-161-017-00	1-161-055-00
0.0015		1-161-041-00	0.027	1-161-018-00	1-161-056-00
0.0018		1-161-042-00	0.033	1-161-019-00	1-161-057-00
0.0022		1-161-043-00	0.039	1-161-010-00	1-161-058-00
0.0027		1-161-044-00	0.047	1-161-021-00	1-161-059-00
0.0033		1-161-045-00	0.056		1-161-060-00
0.0039		1-161-046-00	0.068		1-161-061-00
0.0047		1-161-047-00	0.082	1-161-024-00	1-161-062-00
0.0056		1-161-048-00	0.1	1-161-025-00	1-161-063-00
0.0068		1-161-049-00			
0.0082	1-161-012-00	1-161-050-00			
0.01	1-161-013-00	1-161-051-00			
0.012		1-161-052-00			
0.015	1-161-015-00	1-161-053-00			

MYLAR CAPACITORS

RATING																			
CAP. (μF)	50 VOLT.			100 VOLT.			200 VOLT.			CAP. (μF)	50 VOLT.			100 VOLT.			200 VOLT.		
	PART No.	PART No.	PART No.	PART No.	PART No.	PART No.	PART No.	PART No.	PART No.		PART No.	PART No.	PART No.	PART No.	PART No.	PART No.	PART No.	PART No.	
0.001	1-108-227-00	1-108-365-00	1-108-409-00	0.01	1-108-229-00	1-108-377-00	1-108-421-00	0.1	1-108-231-00	1-108-389-00	1-108-423-00								
0.0012	1-108-351-00	1-108-366-00	1-108-410-00	0.012	1-108-357-00	1-108-378-00	1-108-422-00	0.12	1-108-363-00	1-108-390-00	1-108-424-00								
0.0015	1-108-228-00	1-108-367-00	1-108-411-00	0.015	1-108-240-00	1-108-379-00	1-108-423-00	0.15	1-108-252-00	1-108-391-00	1-108-425-00								
0.0018	1-108-352-00	1-108-368-00	1-108-412-00	0.018	1-108-358-00	1-108-380-00	1-108-424-00	0.18	1-108-364-00	1-108-392-00	1-108-426-00								
0.0022	1-108-230-00	1-108-369-00	1-108-413-00	0.022	1-108-242-00	1-108-381-00	1-108-425-00	0.22	1-108-254-00	1-108-393-00	1-108-427-00								
0.0027	1-108-353-00	1-108-370-00	1-108-414-00	0.027	1-108-359-00	1-108-382-00	1-108-426-00	0.27	1-108-354-00	-	-								
0.0033	1-108-232-00	1-108-371-00	1-108-415-00	0.033	1-108-244-00	1-108-383-00	1-108-427-00	0.33	1-108-355-00	-	-								
0.0039	1-108-354-00	1-108-372-00	1-108-416-00	0.039	1-108-360-00	1-108-384-00	1-108-428-00	0.39	1-108-356-00	-	-								
0.0047	1-108-234-00	1-108-373-00	1-108-417-00	0.047	1-108-246-00	1-108-385-00	1-108-429-00	0.47	1-108-357-00	-	-								
0.0056	1-108-355-00	1-108-374-00	1-108-418-00	0.056	1-108-361-00	1-108-386-00	1-108-430-00	-	-	-	-								
0.0068	1-108-237-00	1-108-375-00	1-108-419-00	0.068	1-108-249-00	1-108-387-00	1-108-431-00	-	-	-	-								
0.0082	1-108-356-00	1-108-376-00	1-108-420-00	0.082	1-108-362-00	1-108-388-00	1-108-432-00	-	-	-	-								



TANTALUM CAPACITORS

RATING														
CAP. (μF)	3.15 VOLT.		6.3 VOLT.		10 VOLT.		16 VOLT.		20 VOLT.		25 VOLT.		35 VOLT.	
	PART No.	PART No.	PART No.	PART No.	PART No.	PART No.	PART No.	PART No.	PART No.	PART No.	PART No.	PART No.	PART No.	PART No.
0.01	-	-	-	-	-	-	-	-	-	-	-	-	-	1-131-396-00
0.015	-	-	-	-	-	-	-	-	-	-	-	-	-	1-131-397-00
0.022	-	-	-	-	-	-	-	-	-	-	-	-	-	1-131-398-00
0.033	-	-	-	-	-	-	-	-	-	-	-	-	-	1-131-399-00
0.047	-	-	-	-	-	-	-	-	-	-	-	-	-	1-131-400-00
0.068	-	-	-	-	-	-	-	-	-	-	-	-	-	1-131-401-00
0.1	-	-	-	-	-	-	-	-	-	-	-	-	-	1-131-402-00
0.15	-	-	-	-	-	-	-	-	-	-	-	-	-	1-131-403-00
0.22	-	-	-	-	-	-	-	-	-	-	-	-	-	1-131-404-00
0.33	-	-	-	-	-	-	-	-	-	-	-	-	-	1-131-404-00
0.47	-	-	-	-	-	-	-	-	-	1-131-409-00	-	-	-	1-131-405-00
0.68	-	-	-	-	-	-	1-131-412-00	-	-	-	-	-	-	1-131-406-00
1.0	-	-	-	-	-	1-131-415-00	-	-	-	1-131-410-00	-	-	-	1-131-407-00
1.5	-	-	-	1-131-418-00	-	-	1-131-413-00	-	-	-	-	-	-	1-131-408-00
2.2	-	-	1-131-421-00	-	-	1-131-416-00	-	-	1-131-411-00	-	-	-	-	1-131-348-00
3.3	1-131-424-00	-	-	1-131-419-00	-	-	1-131-414-00	-	1-131-355-00	-	-	-	-	1-131-349-00
4.7	-	-	1-131-422-00	-	-	1-131-417-00	1-131-362-00	-	1-131-356-00	-	-	-	-	1-131-350-00
6.8	1-131-425-00	-	-	1-131-420-00	-	1-131-369-00	1-131-363-00	-	1-131-357-00	-	-	-	-	1-131-351-00
10	-	-	1-131-423-00	1-131-376-00	-	1-131-370-00	1-131-364-00	-	1-131-358-00	-	-	-	-	1-131-352-00
15	1-131-426-00	1-131-383-00	-	1-131-377-00	-	1-131-371-00	1-131-365-00	-	1-131-359-00	-	-	-	-	1-131-353-00
22	1-131-390-00	1-131-384-00	-	1-131-378-00	-	1-131-372-00	1-131-366-00	-	1-131-360-00	-	-	-	-	-
33	1-131-392-00	1-131-385-00	-	1-131-379-00	-	1-131-373-00	1-131-367-00	-	-	-	-	-	-	-
47	1-131-393-00	1-131-386-00	-	1-131-380-00	-	1-131-374-00	-	-	-	-	-	-	-	-
68	1-131-394-00	1-131-387-00	-	1-131-381-00	-	-	-	-	-	-	-	-	-	-
100	1-131-395-00	-	-	-	-	-	-	-	-	-	-	-	-	-



TANTALUM CAPACITORS

RATING												
CAP. (μF)	3 VOLT.		6.3 VOLT.		10 VOLT.		16 VOLT.		20 VOLT.		35 VOLT.	
	PART No.	PART No.	PART No.	PART No.	PART No.	PART No.	PART No.	PART No.	PART No.	PART No.	PART No.	PART No.
0.033	-	-	-	-	-	-	-	-	-	-	-	1-131-273-00
0.047	-	-	-	-	-	-	-	-	-	-	-	1-131-274-00
0.068	-	-	-	-	-	-	-	-	-	-	-	1-131-275-00
0.1	-	-	-	-	-	-	-	-	-	-	-	1-131-276-00
0.15	-	-	-	-	-	-	-	-	-	-	-	1-131-277-00
0.22	-	-	-	-	-	-	-	-	1-131-262-00	-	-	1-131-278-00
0.33	-	-	-	-	-	-	-	-	1-131-263-00	-	-	1-131-279-00
0.47	-	-	-	-	1-131-169-00	-	-	-	1-131-264-00	-	-	1-131-280-00
0.68	-	-	-	-	-	-	1-131-258-00	-	1-131-265-00	-	-	1-131-281-00
1.0	-	-	-	-	1-131-254-00	-	-	-	1-131-266-00	-	-	1-131-282-00
1.5	-	-	1-131-250-00	-	-	-	-	-	1-131-267-00	-	-	1-131-283-00
2.2	-	-	-	-	-	-	1-131-259-00	-	1-131-268-00	-	-	1-131-284-00
3.3	-	-	-	-	1-131-255-00	-	-	-	1-131-269-00	-	-	-
4.7	-	-	1-131-251-00	-	1-131-171-00	-	-	-	1-131-270-00	-	-	-
6.8	-	-	-	-	-	-	1-131-260-00	-	1-131-271-00	-	-	-
10	-	-	-	-	1-131-256-00	-	-	-	1-131-272-00	-	-	-
15	-	-	1-131-252-00	-	-	-	1-131-261-00	-	-	-	-	-
22	-	-	-	-	1-131-257-00	-	-	-	-	-	-	-
33	1-131-176-00	-	-	-	1-131-173-00	-	-	-	-	-	-	-
47	1-131-288-00	-	1-131-253-00	-	-	-	-	-	-	-	-	-
100	1-131-177-00	-	1-131-174-00	-	-	-	-	-	-	-	-	-

1/4 WATT CARBON RESISTORS

Ω	Part No.	Ω	Part No.	Ω	Part No.	Ω	Part No.	Ω	Part No.	Ω	Part No.		
1.0	1-246-401-00	10	1-246-425-00	100	1-246-449-00	1.0k	1-246-473-00	10k	1-246-497-00	100k	1-246-521-00	1.0M	1-246-545-00
1.1	1-246-402-00	11	1-246-426-00	110	1-246-450-00	1.1k	1-246-474-00	11k	1-246-498-00	110k	1-246-522-00	1.1M	1-210-814-00
1.2	1-246-403-00	12	1-246-427-00	120	1-246-451-00	1.2k	1-246-475-00	12k	1-246-499-00	120k	1-246-523-00	1.2M	1-210-815-00
1.3	1-246-404-00	13	1-246-428-00	130	1-246-452-00	1.3k	1-246-476-00	13k	1-246-500-00	130k	1-246-524-00	1.3M	1-210-816-00
1.5	1-246-405-00	15	1-246-429-00	150	1-246-453-00	1.5k	1-246-477-00	15k	1-246-501-00	150k	1-246-525-00	1.5M	1-210-817-00
1.6	1-246-406-00	16	1-246-430-00	160	1-246-454-00	1.6k	1-246-478-00	16k	1-246-502-00	160k	1-246-526-00	1.6M	1-210-818-00
1.8	1-246-407-00	18	1-246-431-00	180	1-246-455-00	1.8k	1-246-479-00	18k	1-246-503-00	180k	1-246-527-00	1.8M	1-210-819-00
2.0	1-246-408-00	20	1-246-432-00	200	1-246-456-00	2.0k	1-246-480-00	20k	1-246-504-00	200k	1-246-528-00	2.0M	1-210-820-00
2.2	1-246-409-00	22	1-246-433-00	220	1-246-457-00	2.2k	1-246-481-00	22k	1-246-505-00	220k	1-246-529-00	2.2M	1-210-821-00
2.4	1-246-410-00	24	1-246-434-00	240	1-246-458-00	2.4k	1-246-482-00	24k	1-246-506-00	240k	1-246-530-00	2.4M	1-244-754-00
2.7	1-246-411-00	27	1-246-435-00	270	1-246-459-00	2.7k	1-246-483-00	27k	1-246-507-00	270k	1-246-531-00	2.7M	1-244-755-00
3.0	1-246-412-00	30	1-246-436-00	300	1-246-460-00	3.0k	1-246-484-00	30k	1-246-508-00	300k	1-246-532-00	3.0M	1-244-756-00
3.3	1-246-413-00	33	1-246-437-00	330	1-246-461-00	3.3k	1-246-485-00	33k	1-246-509-00	330k	1-246-533-00	3.3M	1-244-757-00
3.6	1-246-414-00	36	1-246-438-00	360	1-246-462-00	3.6k	1-246-486-00	36k	1-246-510-00	360k	1-246-534-00	3.6M	1-244-758-00
3.9	1-246-415-00	39	1-246-439-00	390	1-246-463-00	3.9k	1-246-487-00	39k	1-246-511-00	390k	1-246-535-00	3.9M	1-244-759-00
4.3	1-246-416-00	43	1-246-440-00	430	1-246-464-00	4.3k	1-246-488-00	43k	1-246-512-00	430k	1-246-536-00	4.3M	1-244-760-00
4.7	1-246-417-00	47	1-246-441-00	470	1-246-465-00	4.7k	1-246-489-00	47k	1-246-513-00	470k	1-246-537-00	4.7M	1-244-761-00
5.1	1-246-418-00	51	1-246-442-00	510	1-246-466-00	5.1k	1-246-490-00	51k	1-246-514-00	510k	1-246-538-00	5.1M	1-244-762-00
5.6	1-246-419-00	56	1-246-443-00	560	1-246-467-00	5.6k	1-246-491-00	56k	1-246-515-00	560k	1-246-539-00		
6.2	1-246-420-00	62	1-246-444-00	620	1-246-468-00	6.2k	1-246-492-00	62k	1-246-516-00	620k	1-246-540-00		
6.8	1-246-421-00	68	1-246-445-00	680	1-246-469-00	6.8k	1-246-493-00	68k	1-246-517-00	680k	1-246-541-00		
7.5	1-246-422-00	75	1-246-446-00	750	1-246-470-00	7.5k	1-246-494-00	75k	1-246-518-00	750k	1-246-542-00		
8.2	1-246-423-00	82	1-246-447-00	820	1-246-471-00	8.2k	1-246-495-00	82k	1-246-519-00	820k	1-246-543-00		
9.1	1-246-424-00	91	1-246-448-00	910	1-246-472-00	9.1k	1-246-496-00	91k	1-246-520-00	910k	1-246-544-00		

HARDWARE NOMENCLATURE

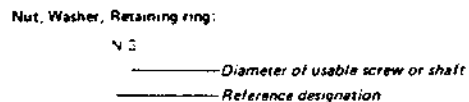
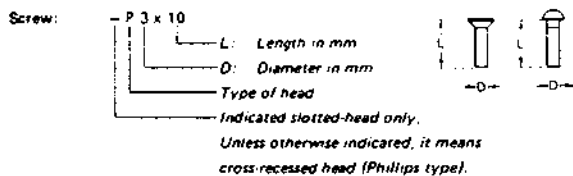

Reference Designation	Shape	Description	Remarks
SCREWS			
P		pan-head screw	binding-head (B) screw for replacement
PWH		pan-head screw with washer face	binding-head (B) screw and flat washer for replacement
PS PSP		pan-head screw with spring washer	binding-head (B) screw and spring washer for replacement
PSW PSPW		pan-head screw with spring and flat washers	binding-head (B) screw and spring and flat washers for replacement
R		round-head screw	binding-head (B) screw for replacement
K		flat-countersunk-head screw	
RK		oval-countersunk-head screw	
B		binding-head screw	
T		truss-head screw	binding-head (B) screw for replacement
F		flat-fillister-head screw	
RF		fillister-head screw	
BV		brazer-head screw	

Reference Designation	Shape	Description	Remarks
SELF-TAPPING SCREWS			
TA		self-tapping screw	ex: TA, P 3 x 10
PTP		pan-head self-tapping screw	binding-head self-tapping (TA, B) screw for replacement
PTPWH		pan-head self-tapping screw with washer face	binding-head self-tapping (TA, B) screw and flat washer for replacement
PTTWH		pan-head thread-rolling screw with washer face	binding-head (B) screw and flat washer for replacement
SET SCREWS			
SC		set screw	
SC		hexagon-socket set screw	ex: SC 2.6 x 4, hexagon socket
NUT			
N		nut	
WASHERS			
W		flat washer	
SW		spring washer	
LW		internal-tooth lock washer	ex: LW3, internal
LW		external-tooth lock washer	ex: LW3, external
RETAINING RINGS			
E		retaining ring	
G		grip-type retaining ring	

Sony Corporation