

# TA-F4A

AEP Model

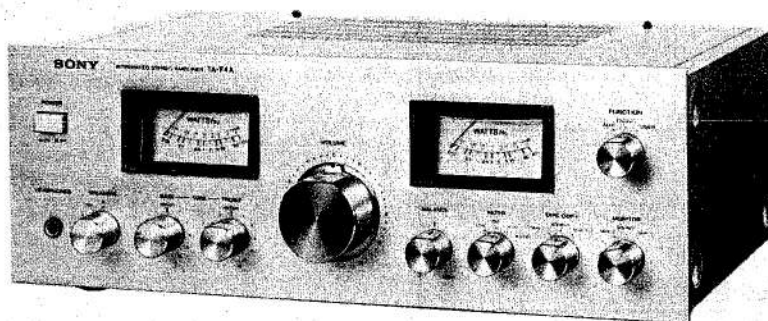

## INTEGRATED STEREO AMPLIFIER

### SPECIFICATIONS

#### GENERAL

<b>Power Requirements:</b>	220V ac (or 120V ac by internal rewiring), 50/60 Hz
<b>Power Consumption:</b>	170W
<b>Dimensions:</b>	Approx. 410 (w) x 145 (h) x 310 (d) mm 16 <sup>3</sup> / <sub>16</sub> (w) x 5 <sup>3</sup> / <sub>4</sub> (h) x 12 <sup>1</sup> / <sub>5</sub> (d) inches including projecting parts and controls
<b>Weight:</b>	Approx. 7.2 kg, 15 lb 14 oz (net) Approx. 9 kg, 19 lb 14 oz (with shipping carton)

<b>Power Bandwidth:</b>	5–35,000 Hz, IHF
<b>Damping Factor:</b>	35 (8Ω, 1 kHz)
<b>Harmonic Distortion:</b>	Less than 0.3% at rated output Less than 0.1% at 1W output
<b>IM Distortion:</b>	Less than 0.3% at rated output (60 Hz: 7 kHz = 4:1)
<b>Frequency Response:</b>	PHONO RIAA equalization curve ±0.3 dB TUNER AUX TAPE 1 TAPE 2 (REC/PB) } 5–100,000 Hz ±0.5 dB
<b>Residual Noise:</b>	Less than 300μV (8Ω, network A)

#### AMPLIFIER SECTION

<b>Continuous RMS Power Output:</b>	At 1 kHz 40 + 40W (8Ω)
(Less than 0.3% THD, both channels driven simultaneously)	At 20–20,000 Hz 40 + 40W (8Ω)
	According to DIN 45500 45 + 45W (8Ω)

– Continued on next page –

#### SAFETY-RELATED COMPONENT WARNING!!

COMPONENTS IDENTIFIED BY SHADING AND ⚠ MARK ON THE SCHEMATIC DIAGRAMS, EXPLODED VIEWS AND IN THE PARTS LIST ARE CRITICAL TO SAFE OPERATION. REPLACE THESE COMPONENTS WITH SONY PARTS WHOSE PART NUMBERS APPEAR AS SHOWN IN THIS MANUAL OR IN SUPPLEMENTS PUBLISHED BY SONY.

# SONY®

## SERVICE MANUAL

# TA-F4A

## Inputs:

	Sensitivity	Impedance	Maximum Input Capability (0.2% distortion)	S/N (weighting network, input level)
PHONO	2.5 mV (-50 dB)	50 k $\Omega$	150 mV (-14.5 dB)	80 dB (A, 2.5 mV)
TUNER AUX TAPE 1 TAPE 2 (REC/PB)	150 mV (-14.5 dB)	50 k $\Omega$	—	100 dB (A, 150 mV)

## Outputs:

	Output Level	Impedance
REC OUT 1	150 mV (-14.5 dB)	4.7 k $\Omega$
REC/PB	17 mV (-33 dB)	82 k $\Omega$
HEADPHONES	Accepts low and high impedance stereo headphones	
SPEAKER	Accepts speakers of 8–16 $\Omega$	

**Tone Controls:** BASS  $\pm 10$  dB at 60 Hz (turnover frequency 300 Hz)  
TREBLE  $\pm 10$  dB at 25 kHz (turnover frequency 5 kHz)

**Filters:** LOW 6 dB/oct. below 15 Hz  
HIGH 6 dB/oct. above 9 kHz

**0 dB = 0.775 V**

**SECTION 1  
OUTLINE**

**1-1. SERVICING NOTE**

When replacing a knob (SPEAKERS / TREBLE / BASS/BALANCE/FILTER/TAPE COPY/MONITOR/FUNCTION), prepare a knob cap (4-854-266-00) and a knob mold (4-854-267-00). Installation of the knob is as follows.

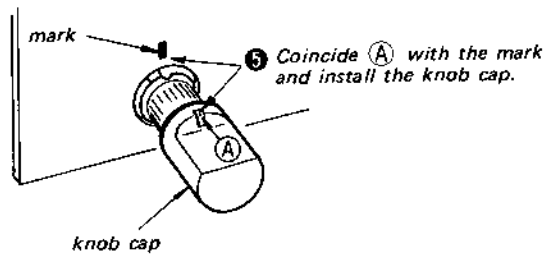
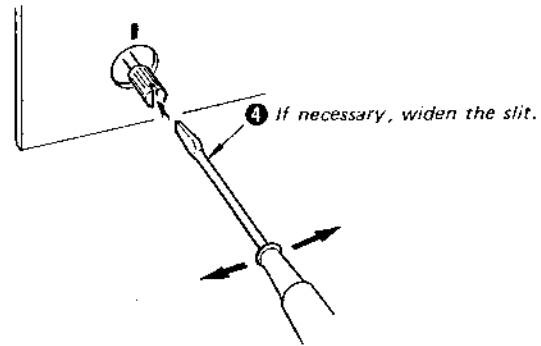
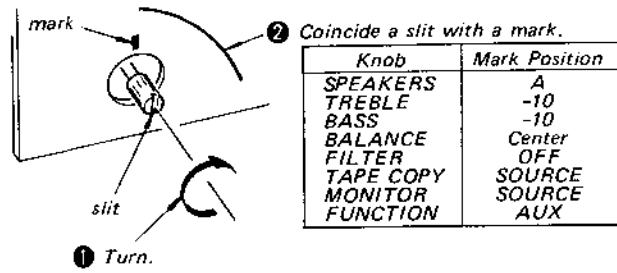

Part No.	Description
X-4854-213-1	Knob Ass'y
including;	
4-854-266-00	Cap, knob
4-854-267-00	Mold, knob

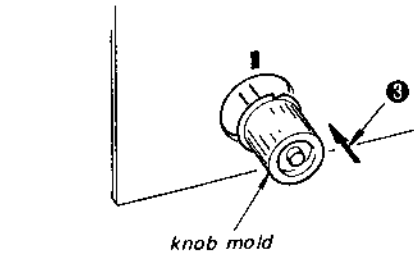

**1-2. BLOCK DIAGRAM**

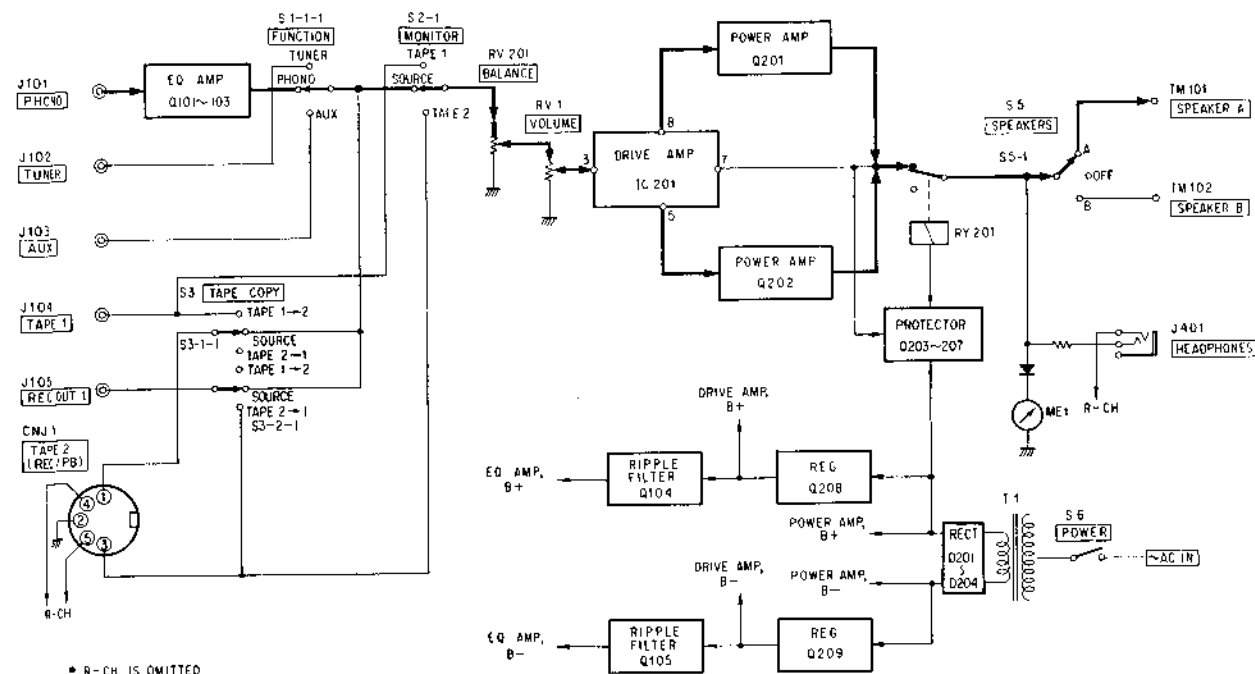

**SECTION 2  
DISASSEMBLY**

Note: Follow the disassembly procedure in the numerical order given.

**CASE AND BOTTOM COVER REMOVAL**

Case: ① to ④  
The component side of the speaker board and main amp board can be checked. Both side of the EQ amp board can be checked.

Bottom Cover: ⑤ to ⑦  
The conductor side of the main amp board can be checked.

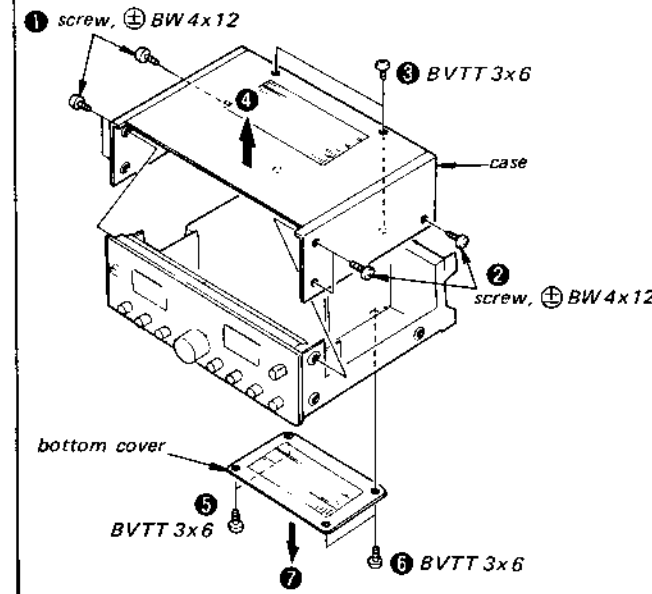

**FRONT PANEL REMOVAL**

The POWER switch, meters and variable resistors can be replaced, after removing the front panel.

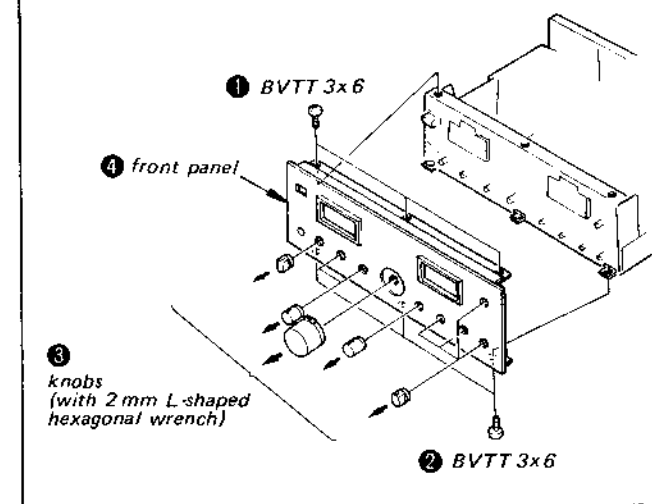

**METER LAMP REPLACEMENT**

Note: To obtain the same brightness of meter lamps, replace both lamps (L-CH and R-CH) together with new ones.

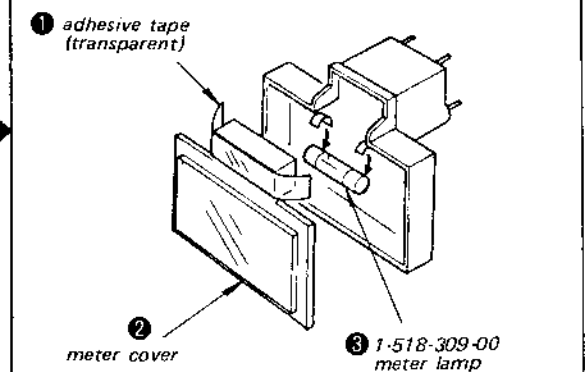

**SECTION 2  
DISASSEMBLY**

Note: Follow the disassembly procedure in the numerical order given.

**CASE AND BOTTOM COVER REMOVAL**

Case: ① to ④

The component side of the speaker board and main amp board can be checked.  
Both side of the EQ amp board can be checked.

Bottom Cover: ⑤ to ⑦

The conductor side of the main amp board can be checked.

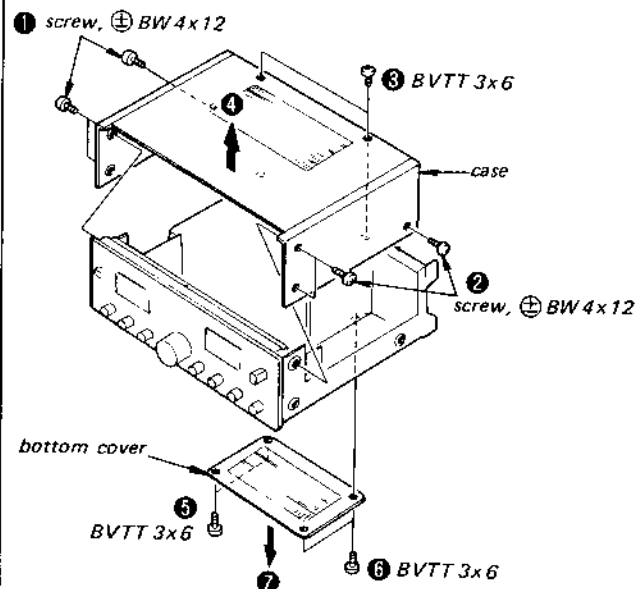

**FRONT PANEL REMOVAL**

The POWER switch, meters and variable resistors can be replaced, after removing the front panel.

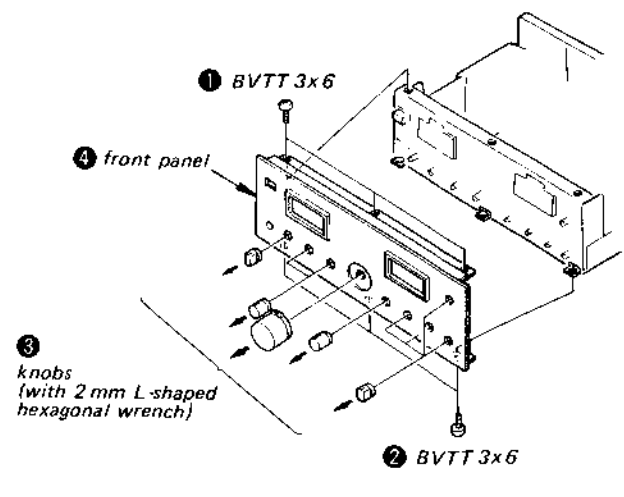

**METER LAMP REPLACEMENT**

Note: To obtain the same brightness of meter lamps, replace both lamps (L-CH and R-CH) together with new ones.

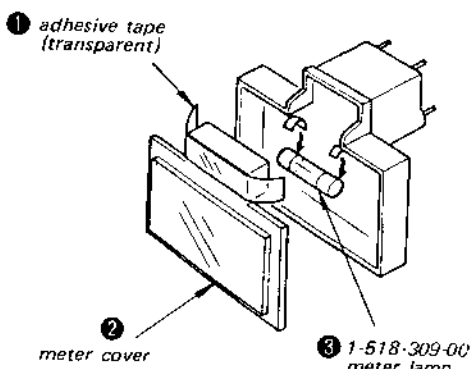

**SECTION 3  
ADJUSTMENT**

**DC Bias Adjustment**

Note: 1. Perform adjustments a few minutes passed after POWER switch turned ON.  
2. With no signal input.

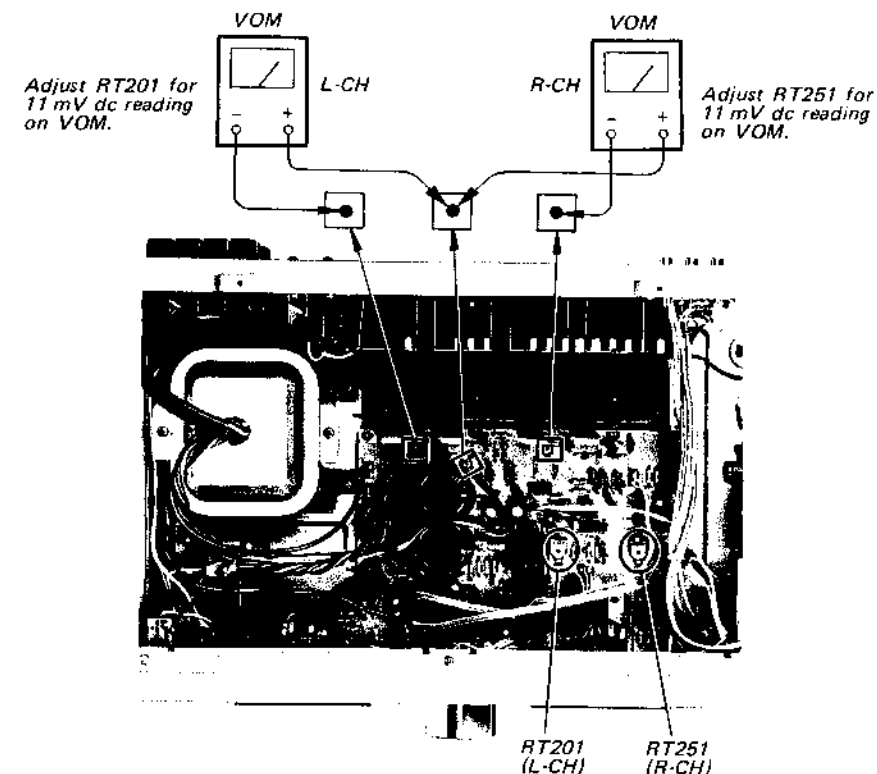

**Meter Level Adjustment**

Setting:

VOLUME control: maximum

Procedure:

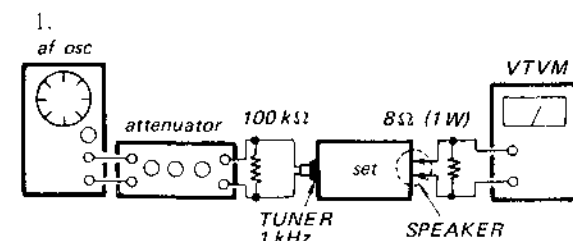

2. Adjust attenuator for 2.83 V (1W) reading on VTVM.  
3. Adjust RT401 (L-CH) and RT451 (R-CH) so that meters indicate 1W.

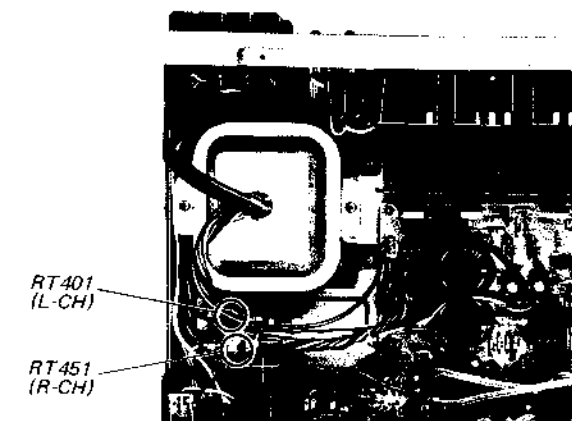





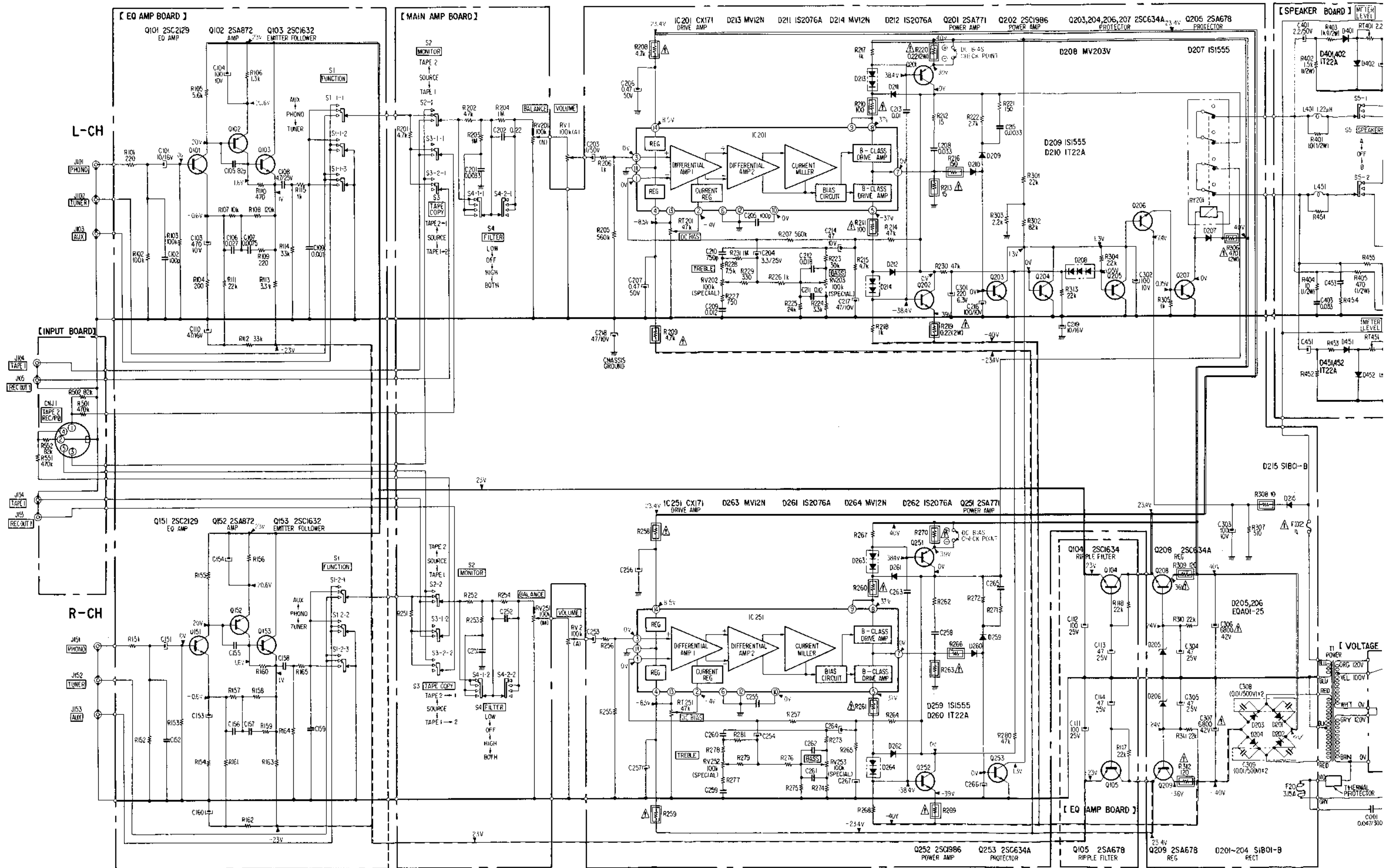

**Note: The components identified by shading and  $\Delta$  mark are critical for safety. Replace only with part number specified.**

- Note:**
- Components for right channel have same values as for left channel.
  - All capacitors are in  $\mu$ F unless otherwise noted. pF =  $\mu$ F/100.
  - All resistors are in ohms,  $\frac{1}{2}$ W unless otherwise noted. k $\Omega$  = 1000 $\Omega$ , M $\Omega$  = 1000 k $\Omega$ .
  - All adjustable resistors have characteristic curve B, unless otherwise noted.
  - $\Delta$  : nonflammable resistor.
  - B+ : B+ bus.
  - $\square$  : panel designation.
  - $\square$  : adjustment for repair.
  - $\square$  : B- bus.
  - Voltages are dc with respect to ground unless otherwise noted.
  - Readings are taken under no signal conditions with a VOM (20 k $\Omega$ /V).
  - Voltage variations may be noted due to normal production tolerances.
  - Switch

Ref. No.	Switch	Position
S1-1-1-3	FUNCTION	PHONO
S1-2-1-3		SOURCE
S2-1, 2		SOURCE
S3-1, 1, 2	TAPE COPY	SOURCE
S3-2-1, 2		OFF
S4-1-1, 2	FILTER	OFF
S4-2-1, 2		A
S5-1, 2	SPEAKERS	A
S6		POWER
S6	POWER	OFF

**Replacement Semiconductors**

For replacement, use semiconductors except in ( ).

Q101, 151: 2SC2129  
 Q103, 153: 2SC632A (2SC1632)  
 Q104: 2SC634A (2SC1634)  
 Q203, 204: 2SC634A  
 Q206, 207: 2SC634A

Q102, 152: 2SA705-8 (2SA872)

Q105, 205: 2SA678  
 Q209

Q201, 251: 2SA771

Q202, 252: 2SC1986C (2SC1986)

IC201, 251: CX171

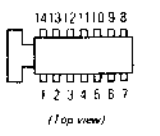

D201-204: U05G (S1B01-B)  
 D215

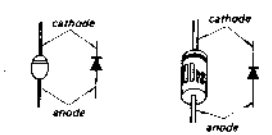

D205: EOB01-25 (EQA01-25)  
 D206

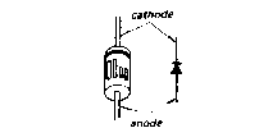

D207, 209: 1S1555  
 D210, 260: 1T22AM (1T22A)  
 D401, 451: 1T22AM (1T22A)  
 D402, 452: 1T22AM (1T22A)  
 D211, 261: 1S2076A  
 D212, 262: 1S2076A

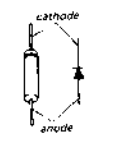

D208: MV203V

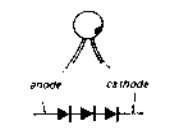

D213, 263: MV12N  
 D214, 264: MV12N

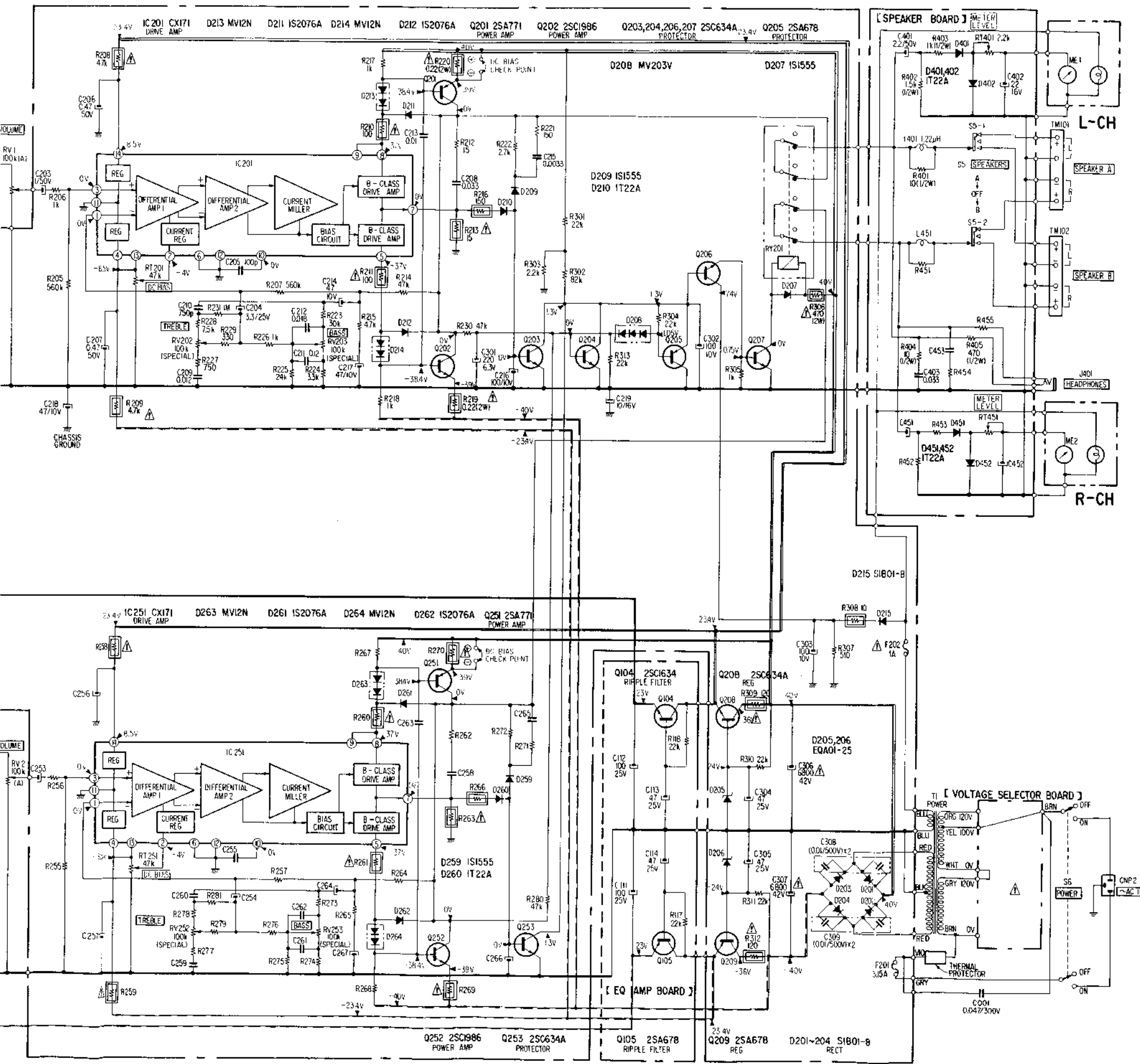
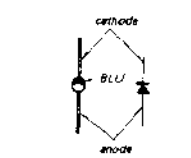



**4-3. MOUNTING DIAGRAM – Speaker Board –**

– Conductor Side –

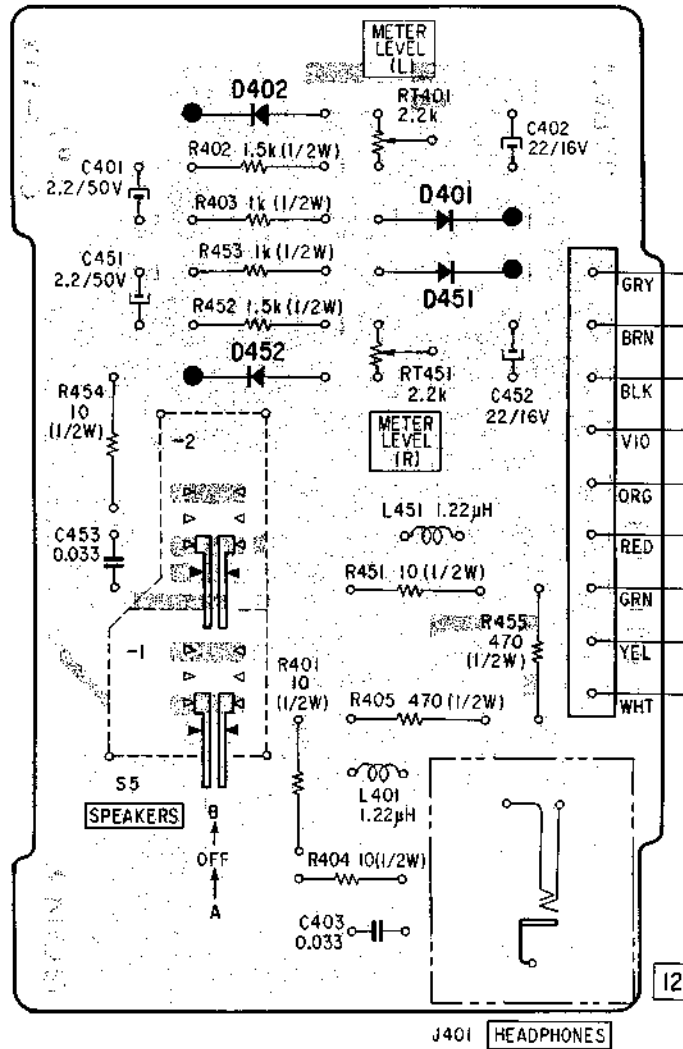









**SECTION 6  
ELECTRICAL PARTS LIST**

Note: Circled letters (A) to (Z) are applicable to European models only.

<u>Ref. No.</u>	<u>Part No.</u>	<u>Description</u>
<b>COMPLETE CIRCUIT BOARD</b>		
	▲A-4394-115-A	ⓕ Voltage Selector
<b>SEMICONDUCTORS</b>		
<b>Transistors</b>		
Q101,151	ⓑ	2SC2129
⇒ Q102,152	ⓒ	2SA705-8
⇒ Q103,153	ⓑ	2SC632A
⇒ Q104	ⓑ	2SC634A
Q105	ⓒ	2SA678
Q201,251	ⓔ	2SA771
⇒ Q202,252	ⓔ	2SC1986C
Q203,204	ⓑ	2SC634A
Q205	ⓒ	2SA678
Q206-208	ⓑ	2SC634A
Q209	ⓒ	2SA678
<b>ICs</b>		
IC201,251	ⓓ	CX171
<b>Diodes</b>		
⇒ D201-204	ⓑ	U05G
⇒ D205,206	ⓑ	EQB01-25
D207	ⓑ	1S1555
D208	ⓑ	MV203V
D209,259	ⓑ	1S1555
⇒ D210,260	ⓐ	1T22AM
D211,261	ⓑ	1S2076A
D212,262		
D213,263	ⓑ	MV12N
D214,264		
⇒ D215	ⓑ	U05G
⇒ D401,451	ⓐ	1T22AM
⇒ D402,452		

● ⇒: Due to standardization, interchangeable replacements may be substituted for parts specified in the diagrams.

<u>Ref. No.</u>	<u>Part No.</u>	<u>Description</u>
<b>CAPACITORS</b>		
All capacitors are in $\mu\text{F}$ and electrolytic unless otherwise noted.		
50WV or less are not indicated except for electrolytics. p = $\mu\text{F}$ .		
C001	▲1-108-749-12	ⓑ 0.047 300V mylar
C101,151	1-121-651-11	ⓐ 10 16V
C102,152	1-102-903-11	ⓐ 100p ceramic
C103,153	1-121-938-11	ⓑ 470 10V
C104,154	1-121-414-11	ⓑ 100 10V
C105,155	1-102-971-11	ⓐ 82p ceramic
C106,156	1-108-359-12	ⓐ 0.027 mylar
C107,157	1-108-576-12	ⓐ 0.0075 mylar
C108,158	1-123-232-11	ⓐ 4.7 25V (nonpolarized)
C109,159	1-108-227-12	ⓐ 0.001 mylar
C110,160	1-121-409-11	ⓐ 47 16V
C111,112	1-121-935-11	ⓑ 100 25V
C113,114	1-121-410-11	ⓑ 47 25V
C201,251	1-108-232-12	ⓐ 0.0033 mylar
C202,252	1-108-254-12	ⓑ 0.22 mylar
C203,253	1-121-391-11	ⓐ 1 50V
C204,254	1-121-392-11	ⓐ 3.3 25V
C205,255	1-102-971-11	ⓐ 100p ceramic
C206,256	1-121-726-11	ⓐ 0.47 50V
C207,257		
C208,258	1-108-244-12	ⓐ 0.033 mylar
C209,259	1-108-357-12	ⓐ 0.012 mylar
C210,260	1-104-074-11	ⓐ 750p polystyrol
C211,261	1-108-605-12	ⓑ 0.12 mylar
C212,262	1-108-358-12	ⓐ 0.018 mylar
C213,263	1-108-239-12	ⓐ 0.01 mylar
C214,264	1-121-409-11	ⓐ 47 10V
C215,265	1-108-232-12	ⓐ 0.0033 mylar
C216,266	1-121-414-11	ⓐ 100 10V
C217,267	1-121-409-11	ⓐ 47 10V
C218		
C219	1-121-651-11	ⓐ 10 16V
C301	1-121-981-11	ⓑ 220 6.3V
C302,303	1-121-414-11	ⓐ 100 10V

**Note: The components identified by shading and ▲ mark are critical for safety. Replace only with part number specified.**

Note: Circled letters (A) to (Z) are applicable to European models only.

Ref. No.	Part No.	Description
C304,305	1-121-410-11	(B) 47 25V
C306,307	(A) 1-125-157-11	(F) 6800 42V
C308,309	1-102-355-11	(B) 0.01+0.01 500V ceramic
C401,451	1-121-450-11	(A) 2.2 50V
C402,452	1-121-479-11	(A) 22 16V
C403,453	1-108-244-12	(A) 0.033 mylar

### RESISTORS

All resistors are in ohms. Common 1/4W carbon resistors are omitted.  
Refer to the list on page 19 for their parts numbers.  
Check schematic diagram for values.  
k = 1000

R208,258	(A) 1-211-559-11	(C) 4.7 k	1/4W carbon (nonflammable)
R209,259	(A) 1-211-522-11	(A) 100	1/4W carbon (nonflammable)
R210,260	(A) 1-211-502-11	(B) 15	1/4W carbon (nonflammable)
R211,261	(A) 1-211-502-11	(B) 15	1/4W carbon (nonflammable)
R213,263	(A) 1-211-502-11	(B) 15	1/4W carbon (nonflammable)
R216,266	(A) 1-211-526-11	(C) 150	1/4W carbon (nonflammable)
R219,269	(A) 1-217-151-11	(B) 0.22	2W wirewound (nonflammable)
R220,270	(A) 1-217-151-11	(B) 0.22	2W wirewound (nonflammable)
R306	(A) 1-206-656-11	(A) 470	2W metal oxide (nonflammable)
R308	(A) 1-211-498-11	(A) 10	1/4W carbon (nonflammable)
R309,312	(A) 1-211-524-11	(A) 120	1/4W carbon (nonflammable)
R401,451	1-212-372-11	(A) 10	1/2W carbon
R402,452	1-213-145-11	(B) 1.5 k	1/2W carbon
R403,453	1-213-143-11	(B) 1 k	1/2W carbon
R404,454	1-212-372-11	(A) 10	1/2W carbon
R405,455	1-213-139-11	(A) 470	1/2W carbon
RT201,251	1-224-186-31	(B) 47 k (B), adjustable; DC bias	
RT401,451	1-224-250-XX	(C) 2.2 k (B), adjustable; meter level	
RV1,2	1-226-201-00	(E) 100 k (A), variable; VOLUME	
RV201,251	1-226-215-00	(C) 100 k (N/M), variable; BALANCE	

Ref. No.	Part No.	Description
RV202,252	1-226-213-00	(D) 100 k (special), variable; TREBLE
RV203,253	1-226-214-00	(D) 100 k (special), variable; BASS

### SWITCHES

S1	1-552-375-00	(E) Rotary Slide, FUNCTION
S2,3	1-552-373-00	(E) Rotary Slide, MONITOR, TAPE COPY
S4	1-552-374-00	(E) Rotary Slide, FILTER
S5	1-552-372-00	(E) Rotary Slide, SPEAKERS
S6	(A) 1-552-206-11	(C) Pushbutton, POWER

### JACKS

J101-103	1-507-430-XX	(D) Phono, 6p; PHONO, TUNER, AUX
J151-153		
J104,154	1-507-433-21	(C) Phono, 4p; TAPE 1, REC OUT 1
J105,155		
J401	1-507-561-00	(B) Binaural, HEADPHONES

### MISCELLANEOUS

CNJ1	1-509-549-00	(B) Connector, REC/PB (TAPE 2)
CNP2	(A) 1-509-546-00	(C) Connector, 3p; ~ AC IN
F201	(A) 1-532-237-00	(B) Fuse, 3.15 A
F202	(A) 1-532-078-00	(A) Fuse, 1 A
ME1,2	1-520-320-00	(J) Meter, including lamp
RY201	1-515-302-00	(F) Relay
T1	(A) 1-446-051-11	(C) Transformer, power
TM101,102	1-536-524-00	(C) Terminal Strip, SPEAKER A, B
	1-518-309-00	(B) Lamp, included meter
	(A) 1-533-131-00	(A) Holder, fuse

Note: The components identified by shading and (A) mark are critical for safety. Replace only with part number specified.

Note: Circled letters (A to Z) are applicable to European models only.

**ACCESSORIES & PACKING MATERIALS**

<u>Part No.</u>	<u>Description</u>
3-701-020-00	(A) Bag, plastic; instruction manual
3-770-455-11	(E) Manual, instruction
4-853-916-00	(B) Cushion
4-854-329-00	(E) Carton
4-891-037-00	(B) Bag, plastic; unit











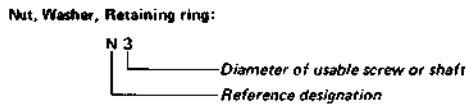
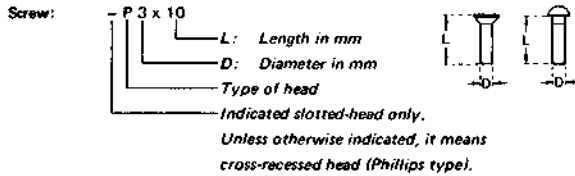



1/4 WATT CARBON RESISTORS (A)













Note: Circled letter (A) is applicable to European model only.

Ω	Part No.	Ω	Part No.	Ω	Part No.	Ω	Part No.	Ω	Part No.	Ω	Part No.	Ω	Part No.
1.0	1-244-601-11	10	1-244-625-11	100	1-244-649-11	1.0k	1-244-673-11	10k	1-244-697-11	100k	1-244-721-11	1.0M	1-244-745-11
1.1	1-244-602-11	11	1-244-626-11	110	1-244-650-11	1.1k	1-244-674-11	11k	1-244-698-11	110k	1-244-722-11	1.1M	1-244-746-11
1.2	1-244-603-11	12	1-244-627-11	120	1-244-651-11	1.2k	1-244-675-11	12k	1-244-699-11	120k	1-244-723-11	1.2M	1-244-747-11
1.3	1-244-604-11	13	1-244-628-11	130	1-244-652-11	1.3k	1-244-676-11	13k	1-244-700-11	130k	1-244-724-11	1.3M	1-244-748-11
1.5	1-244-605-11	15	1-244-629-11	150	1-244-653-11	1.5k	1-244-677-11	15k	1-244-701-11	150k	1-244-725-11	1.5M	1-244-749-11
1.6	1-244-606-11	16	1-244-630-11	160	1-244-654-11	1.6k	1-244-678-11	16k	1-244-702-11	160k	1-244-726-11	1.6M	1-244-750-11
1.8	1-244-607-11	18	1-244-631-11	180	1-244-655-11	1.8k	1-244-679-11	18k	1-244-703-11	180k	1-244-727-11	1.8M	1-244-751-11
2.0	1-244-608-11	20	1-244-632-11	200	1-244-656-11	2.0k	1-244-680-11	20k	1-244-704-11	200k	1-244-728-11	2.0M	1-244-752-11
2.2	1-244-609-11	22	1-244-633-11	220	1-244-657-11	2.2k	1-244-681-11	22k	1-244-705-11	220k	1-244-729-11	2.2M	1-244-753-11
2.4	1-244-610-11	24	1-244-634-11	240	1-244-658-11	2.4k	1-244-682-11	24k	1-244-706-11	240k	1-244-730-11	2.4M	1-244-754-11
2.7	1-244-611-11	27	1-244-635-11	270	1-244-659-11	2.7k	1-244-683-11	27k	1-244-707-11	270k	1-244-731-11	2.7M	1-244-755-11
3.0	1-244-612-11	30	1-244-636-11	300	1-244-660-11	3.0k	1-244-684-11	30k	1-244-708-11	300k	1-244-732-11	3.0M	1-244-756-11
3.3	1-244-613-11	33	1-244-637-11	330	1-244-661-11	3.3k	1-244-685-11	33k	1-244-709-11	330k	1-244-733-11	3.3M	1-244-757-11
3.6	1-244-614-11	36	1-244-638-11	360	1-244-662-11	3.6k	1-244-686-11	36k	1-244-710-11	360k	1-244-734-11	3.6M	1-244-758-11
3.9	1-244-615-11	39	1-244-639-11	390	1-244-663-11	3.9k	1-244-687-11	39k	1-244-711-11	390k	1-244-735-11	3.9M	1-244-759-11
4.3	1-244-616-11	43	1-244-640-11	430	1-244-664-11	4.3k	1-244-688-11	43k	1-244-712-11	430k	1-244-736-11	4.3M	1-244-760-11
4.7	1-244-617-11	47	1-244-641-11	470	1-244-665-11	4.7k	1-244-689-11	47k	1-244-713-11	470k	1-244-737-11	4.7M	1-244-761-11
5.1	1-244-618-11	51	1-244-642-11	510	1-244-666-11	5.1k	1-244-690-11	51k	1-244-714-11	510k	1-244-738-11	5.1M	1-244-762-11
5.6	1-244-619-11	56	1-244-643-11	560	1-244-667-11	5.6k	1-244-691-11	56k	1-244-715-11	560k	1-244-739-11		
6.2	1-244-620-11	62	1-244-644-11	620	1-244-668-11	6.2k	1-244-692-11	62k	1-244-716-11	620k	1-244-740-11		
6.8	1-244-621-11	68	1-244-645-11	680	1-244-669-11	6.8k	1-244-693-11	68k	1-244-717-11	680k	1-244-741-11		
7.5	1-244-622-11	75	1-244-646-11	750	1-244-670-11	7.5k	1-244-694-11	75k	1-244-718-11	750k	1-244-742-11		
8.2	1-244-623-11	82	1-244-647-11	820	1-244-671-11	8.2k	1-244-695-11	82k	1-244-719-11	820k	1-244-743-11		
9.1	1-244-624-11	91	1-244-648-11	910	1-244-672-11	9.1k	1-244-696-11	91k	1-244-720-11	910k	1-244-744-11		

HARDWARE NOMENCLATURE



Reference Designation	Shape	Description	Remarks
<b>SCREWS</b>			
P		pan-head screw	binding-head (B) screw for replacement
PWH		pan-head screw with washer face	binding-head (B) screw and flat washer for replacement
PS PSP		pan-head screw with spring washer	binding-head (B) screw and spring washer for replacement
PSW PSPW		pan-head screw with spring and flat washers	binding-head (B) screw and spring and flat washers for replacement
R		round-head screw	binding-head (B) screw for replacement
K		flat-countersunk-head screw	
RK		oval-countersunk-head screw	
B		binding-head screw	
T		truss-head screw	binding-head (B) screw for replacement
F		flat-fillister-head screw	
RF		fillister-head screw	
BV		braizer-head screw	

Reference Designation	Shape	Description	Remarks
<b>SELF-TAPPING SCREWS</b>			
TA		self-tapping screw	ex: TA, P 3 x 10
PTP		pan-head self-tapping screw	binding-head self-tapping (TA, B) screw for replacement
PTPWH		pan-head self-tapping screw with washer face	binding-head self-tapping (TA, B) screw and flat washer for replacement
PTTWH		pan-head thread-rolling screw with washer face	binding-head (B) screw and flat washer for replacement
<b>SET SCREWS</b>			
SC		set screw	
SC		hexagon-socket set screw	ex: SC 2.6 x 4, hexagon socket
<b>NUT</b>			
N		nut	
<b>WASHERS</b>			
W		flat washer	
SW		spring washer	
LW		internal-tooth lock washer	ex: LW3, internal
LW		external-tooth lock washer	ex: LW3, external
<b>RETAINING RINGS</b>			
E		retaining ring	
G		grip-type retaining ring	