

TA-EX66/EX77

SERVICE MANUAL

AEP Model
UK Model
E Model



TA-EX66/EX77 is the amplifier section
in MHC-EX66, DHC-EX77MD/MD77.

Photo: TA-EX77 (AEP, UK model)

SPECIFICATIONS

AEP, UK model:

DIN power output 45 + 45 watts (6 ohms at 1 kHz, DIN)

Continuous RMS power output 60 + 60 watts (6 ohms at 1kHz, 10% THD)

Music power output 105 + 105 watts

HK, SP model:

Continuous RMS power output 55 + 55 watts (6 ohms at 1 kHz, 5% THD)

Inputs

CD IN, MD IN (phono jacks): voltage 450 mV, impedance 47 kilohms
TUNER IN, TAPE IN, VIDEO1 IN, VIDEO2/AUX IN (TA-EX66/
EX77: AEP, UK model), VIDEO2 IN (TA-EX77: HK, SP model) (phono
jacks): voltage 250 mV, impedance 47 kilohms
MIX MIC (phone jack):
sensitivity 1 mV, impedance 10 kilohms or more

Outputs

MD OUT, TAPE OUT, VIDEO1 OUT (phono jacks):
voltage 250 mV, impedance 1 kilohm

PHONES (stereo phone jack):
accepts headphones of 6 ohms or more.

SPEAKER: accepts impedance of 6 to 16 ohms.

Dimensions (w/h/d) incl. projecting parts and controls:

Approx. 280 × 122.5 × 298 mm

Mass

Approx. 5.3 kg

General

Power requirements

AEP, UK model: 220 – 230 V AC, 50/60 Hz

HK, SP model: 220 – 240 V AC, 50/60 Hz

Power consumption 125 watts

Design and specifications are subject to change without notice.

• Abbreviation

HK : Hong Kong

SP : Singapore

INTEGRATED STEREO AMPLIFIER



SONY®

TABLE OF CONTENTS

1. GENERAL	3
2. DISASSEMBLY	6
3. DIAGRAMS	
3-1. IC Pin Function Description	9
3-2. Schematic Diagram	14
3-3. Printed Wiring Boards	19
4. EXPLODED VIEWS	22
5. ELECTRICAL PARTS LIST	24

MODEL IDENTIFICATION

– BACK PANEL –

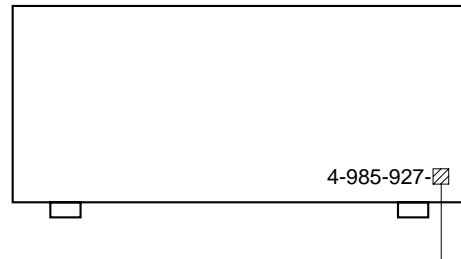

- TA-EX77 (AEP, UK model) : 1□ CED/CEK
- TA-EX77 (Singapore model) : 2□ SP
- TA-EX77 (Hong Kong model) : 3□ HK
- TA-EX66 (AEP, UK model) : 4□ CED/CEK
- TA-EX66 (Singapore model) : 5□ SP

SAFETY-RELATED COMPONENT WARNING!!

COMPONENTS IDENTIFIED BY MARK △ OR DOTTED LINE WITH MARK △ ON THE SCHEMATIC DIAGRAMS AND IN THE PARTS LIST ARE CRITICAL TO SAFE OPERATION. REPLACE THESE COMPONENTS WITH SONY PARTS WHOSE PART NUMBERS APPEAR AS SHOWN IN THIS MANUAL OR IN SUPPLEMENTS PUBLISHED BY SONY.

Connecting optional AV components

To enhance your system, you can connect optional components using audio cords (sold separately). Refer to the instructions of each component. Before making connections, take the cap off the jacks to be used, and keep it for future use.

Connecting a TV/VCR

Make sure to match the color of the plugs and the jacks.

For DHC-MD77/EX77MD

Connect a TV/VCR to VIDEO1, VIDEO2 (DHC-MD77) or VIDEO2/AUX (DHC-EX77MD) on the amplifier.

Set MODE SELECTOR to ANALOG REC when you connect a TV/VCR to VIDEO2 (DHC-MD77) or VIDEO2/AUX (DHC-EX77MD).

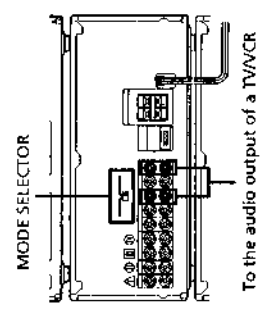

NOTE:

- DHC-MD77: TA-EX77; Hong Kong, Singapore model
- DHC-EX77MD: TA-EX77; AEP, UK model
- MHC-EX66: TA-EX66; AEP, UK, Singapore model

Connecting optional AV components (continued)

For MHC-EX66

Connect a TV/VCR to VIDEO1 or VIDEO2/AUX on the amplifier.

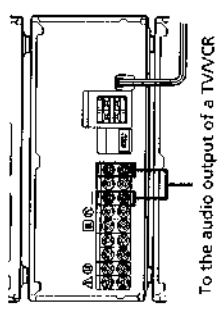

To listen to the sound of TV/VCR

Turn FUNCTION until the VIDEO 1, VIDEO2 (DHC-MD77) or VIDEO 2/AUX (other models) indicator lights up.

Connecting audio components

Connecting a tape deck

Connect a tape deck to TAPE on the amplifier. Make sure to match the color of the plugs and the jacks.

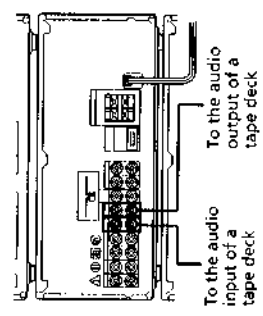

To listen to the sound of a tape deck

Turn FUNCTION until the TAPE indicator lights up.

Connecting other analog components

Connect an analog component to VIDEO1 on the amplifier. Make sure to match the color of the plugs and the jacks.

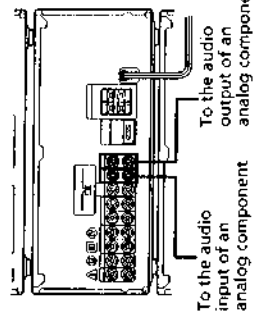

To listen to the sound of the connected component

Turn FUNCTION until the VIDEO 1 indicator lights up.

Connecting digital components

For DHC-MD77/EX77MD

You can make a digital recording onto the system's own MD deck from the connected digital component (e.g., a DAT deck, BS tuner or another MD deck).

- Connect a digital component to VIDEO2 DIGITAL IN on the MD deck using an optical cable.
- Connect a digital component to VIDEO2 (DHC-MD77) or VIDEO2/AUX (DHC-EX77MD) on the amplifier using audio cords.
- Set MODE SELECTOR to DIGITAL REC.

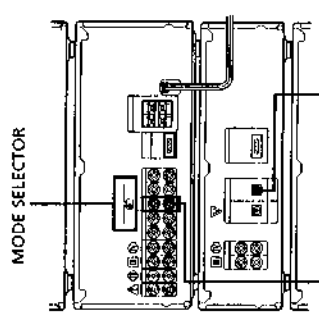

To listen to the sound of the connected component

Turn FUNCTION until the VIDEO 2 (DHC-MD77) or VIDEO 2/AUX (DHC-EX77MD) indicator lights up.

Tip

A built-in sampling rate converter automatically converts the sampling frequency of various digital sources to the 41.1 kHz sampling rate of the MD deck. This lets you record sources such as 32- and 48-KHz DAT or satellite broadcasts, as well as CDs and other MDs.

Notes

- If "Din Unlock" or "Cannot Copy" appears in the display, you cannot make a digital recording. In this case, record the sound source with MODE SELECTOR set to ANALOG REC.
- When you make a digital recording using an optical cable, you cannot adjust the recording level.
- When audio cords are not connected to VIDEO2 (DHC-MD77) or VIDEO2/AUX (DHC-EX77MD) on the amplifier, you cannot listen to the digital component.

Other Features

Adjusting the sound

You can adjust the bass/treble, mute the sound or listen to the source directly.

DBFB SOURCE DIRECT -20dB MUTING

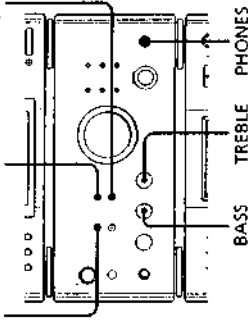

To	Do this
Adjust the bass sound	Turn BASS clockwise to increase and counterclockwise to decrease.
Adjust the treble sound	Turn TREBLE clockwise to increase and counterclockwise to decrease.
Reinforce the bass sound	Press DBFB* until the LOW or HIGH** indicator lights up. Press the button repeatedly until the indicator turns off to cancel.
Mute the sound	Press -20dB MUTING to turn on the indicator. Press the button again to return to the original volume.

* DBFB: Dynamic Bass Feedback.
**HIGH is more effective than LOW.

To listen to music without any audio effects

Press **SOURCE DIRECT** to turn on the indicator.

The system outputs the music signals directly without passing them through any circuit. Press the button again to cancel.

To listen through the headphones

Connect the headphones to **PHONES**.

For MHC-EX66

You can make a digital recording onto the connected MD deck from the system's own CD player. You can also make an analog recording if you connect the MD deck using audio cords.

- Connect an MD deck to **DIGITAL OUT** on the CD player using an optical cable.
- Connect an MD deck to MD on the amplifier using audio cords.

To the analog (line) input of an MD deck

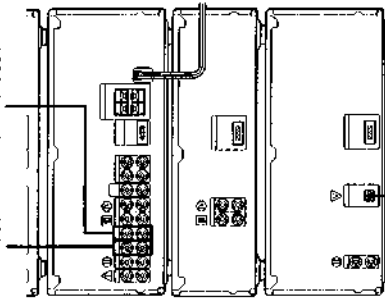

To the digital input of an MD deck

To listen to the sound of the MD deck

Turn **FUNCTION** until the MD indicator lights up.

Connecting a turntable with an MM cartridge

Connect a turntable to **VIDEO2** (DHC-MD77) or **VIDEO2/AUX** (other models) on the amplifier using the optional MM cartridge equalizer and the audio cords.

Set **MODE SELECTOR** to **ANALOG REC** (DHC-MD77/EX77MD only).

To listen to the sound of a turntable, turn **FUNCTION** until the **VIDEO 2** (DHC-MD77) or **VIDEO 2/AUX** (other models) indicator lights up.

15^{EN}

55^{EN} 56^{EN}

Singing along: Karaoke

You can sing along with any stereo CD, MD or tape by turning down the singer's voice. You need to connect an optional microphone.

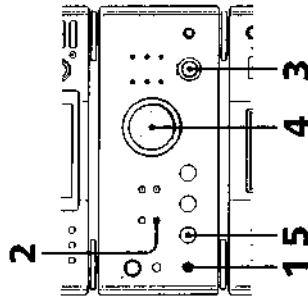

- 1 Connect an optional microphone to **MIX MIC**.
- 2 Press **KARAOKE PON**. The indicator lights up.
- 3 Select the source, then start playing.
- 4 Turn **VOLUME** to adjust the total volume of the system.
- 5 Turn **MIC LEVEL** to adjust the microphone volume.

When you are done

Disconnect the microphone from **MIX MIC** and press **KARAOKE PON** to turn off the indicator.

Notes

- The instrumental sound may be reduced as well as the singer's voice when the sound is recorded in monoaural.
- The singer's voice may not be reduced when:
 - only a few instruments are playing.
 - a duet is being played.
 - the source has strong echoes or chorus.
 - the singer's voice deviates from the center.

Tip

If acoustic feedback (howling) occurs, move the microphone away from the speakers or change the direction of the microphone.

Mixing and recording sounds

For DHC-MD77/EX77MD

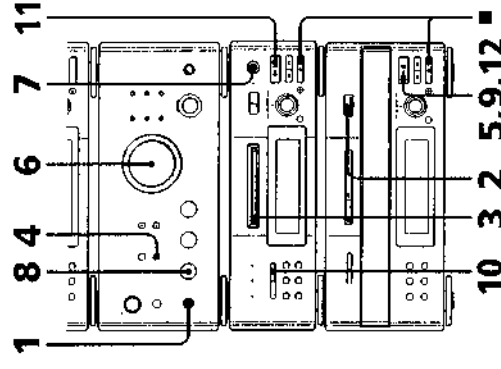

- 1 Connect an optional microphone to **MIX MIC**.
- 2 Place a CD on the disc tray.

**Singing along: Karaoke
(continued)**

- 8** Turn **REC LEVEL** to adjust the recording level.
See "Recording on a tape manually" on page 52.
- 9** Turn **MIC LEVEL** to adjust the microphone volume.
- 10** Select the track you want on the CD and set the **CD player** to pause.
- 11** Press **● REC** on the tape deck.
The tape deck stands by for recording.
- 12** Press **||** or **▷** on the tape deck.
Recording starts.
- 13** Press **▷** on the CD player.
CD playback starts. Start singing along with the music.

To stop recording
Press **■** on the tape deck and the CD player.

When you are done
Disconnect the microphone from **MIX MIC** and press **KARAOKE PON** to turn off the indicator.

Tips

- If you want to record your voice only through the microphone, you can do so by selecting the CD with the **FUNCTION** control and not playing a CD
- When you connect the microphone, the MD deck performs analog recording (for DHC-MD77/EX77MD)

For MHC-EX66

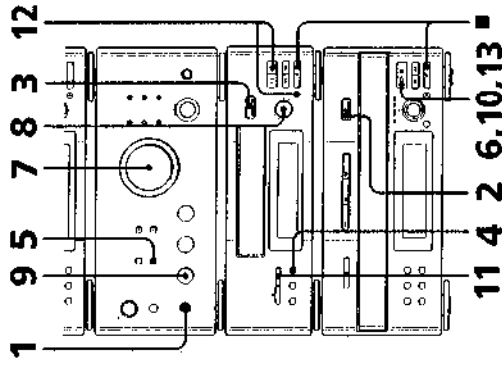

- 1** Connect an optional microphone to **MIX MIC**.
- 2** Place a CD on the disc tray.
- 3** Insert a blank tape.
- 4** Press **DIRECTION** repeatedly to select the side you want to record on.
- 5** Press **KARAOKE PON**.
The indicator lights up.
- 6** Start playing the CD.
- 7** Turn **VOLUME** to adjust the total volume of the system.

- 3** Insert a recordable MD.
- 4** Press **KARAOKE PON**.
The indicator lights up.
- 5** Start playing the CD.
- 6** Turn **VOLUME** to adjust the total volume of the system.
- 7** Turn **REC LEVEL** to adjust the recording level.
See "Adjusting the recording level" on page 37.
- 8** Turn **MIC LEVEL** to adjust the microphone volume.
- 9** Select the track you want on the CD and set the **CD player** to pause.
- 10** Press **● REC** on the MD deck.
The MD deck stands by for recording.
- 11** Press **▷** or **||** on the MD deck.
Recording starts.
- 12** Press **▷** on the CD player.
CD playback starts. Start singing along with the music.

To stop recording
Press **■** on the MD deck and the CD player.

SECTION 2 DISASSEMBLY

- This set can be disassembled in the order shown below.

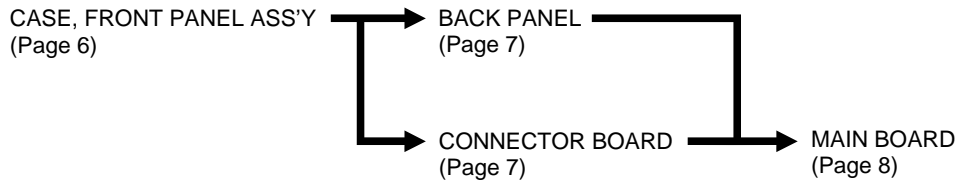

Note: Follow the disassembly procedure in the numerical order given.

CASE, FRONT PANEL ASS'Y

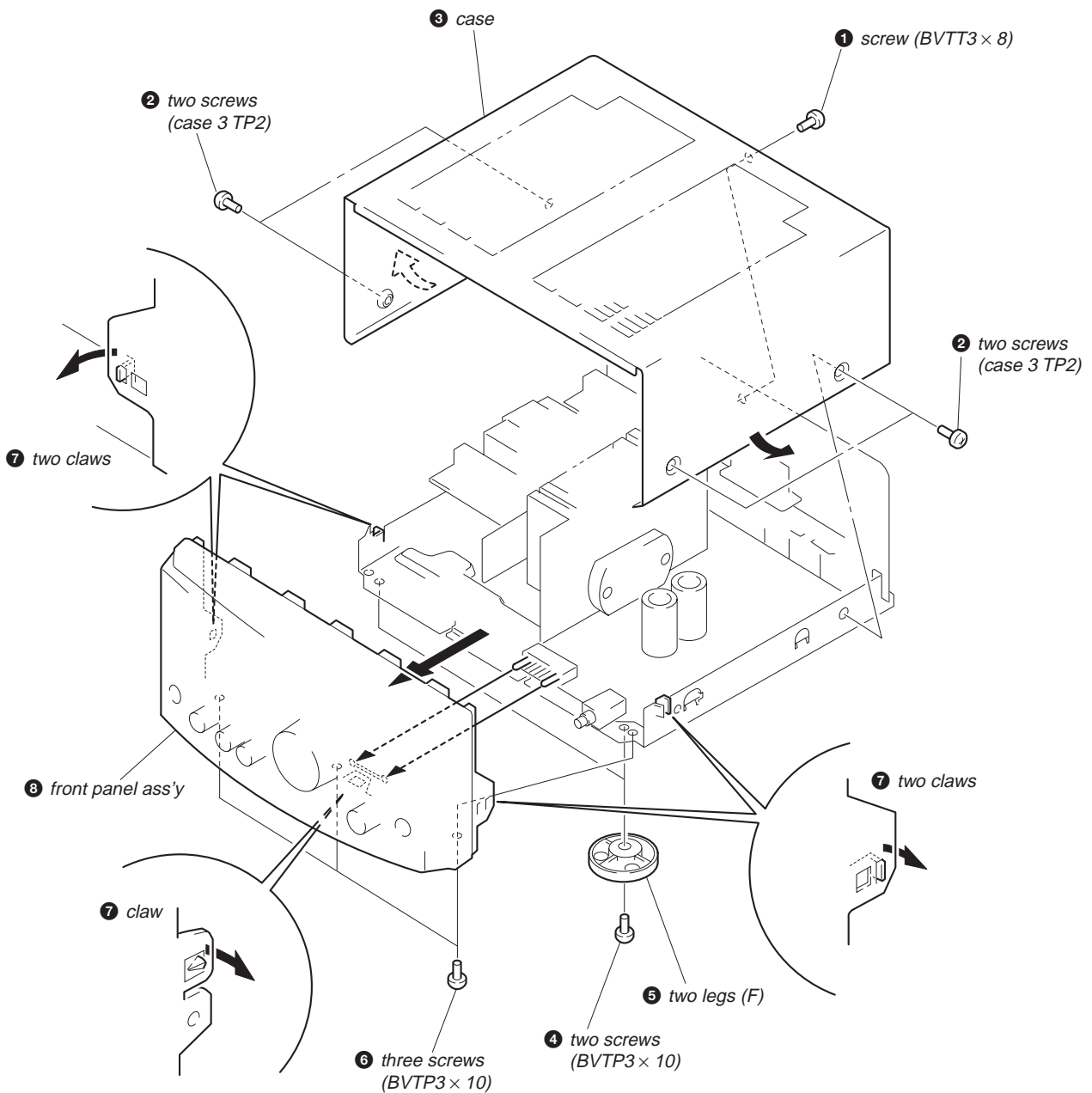

BACK PANEL

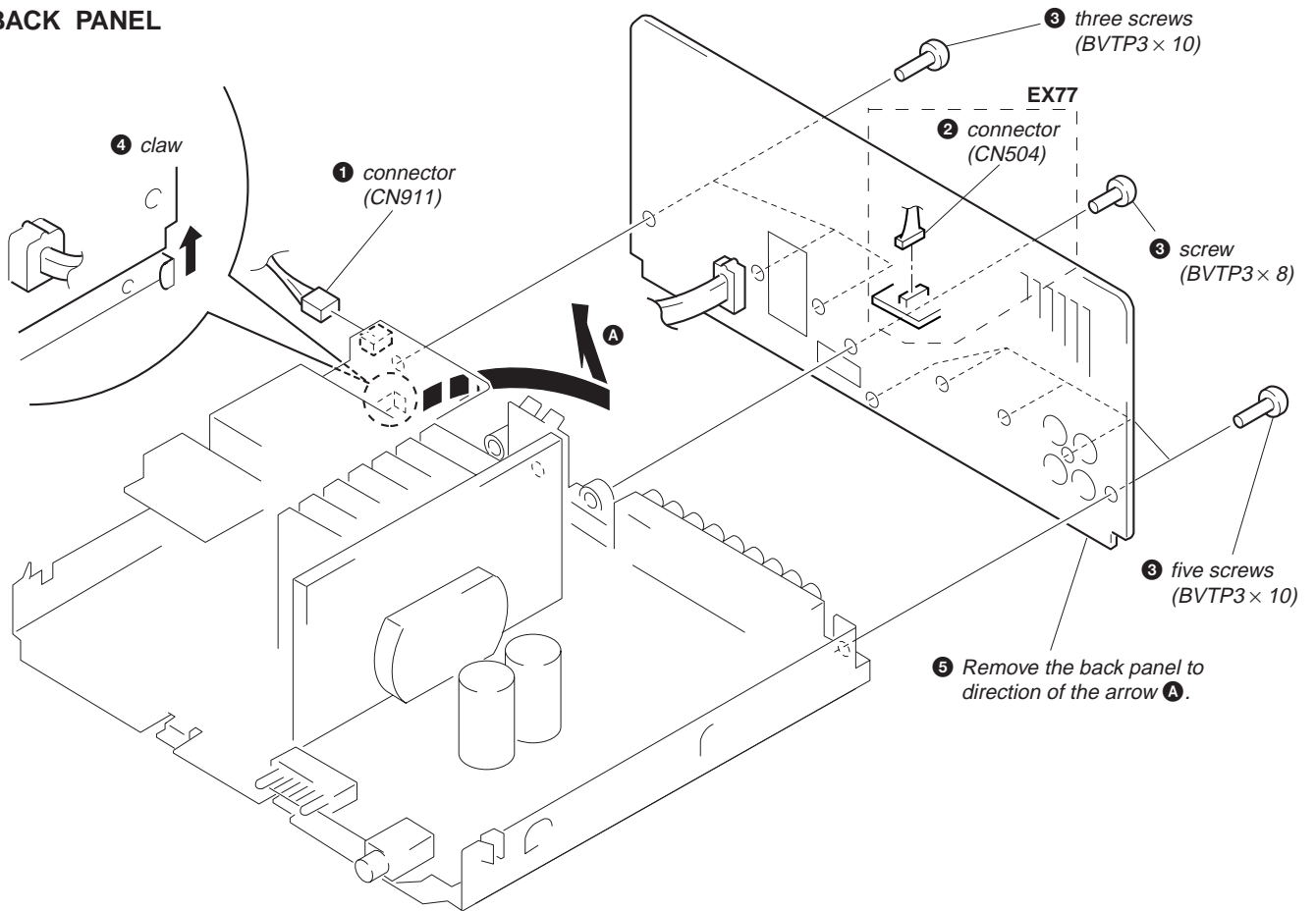

CONNECTOR BOARD

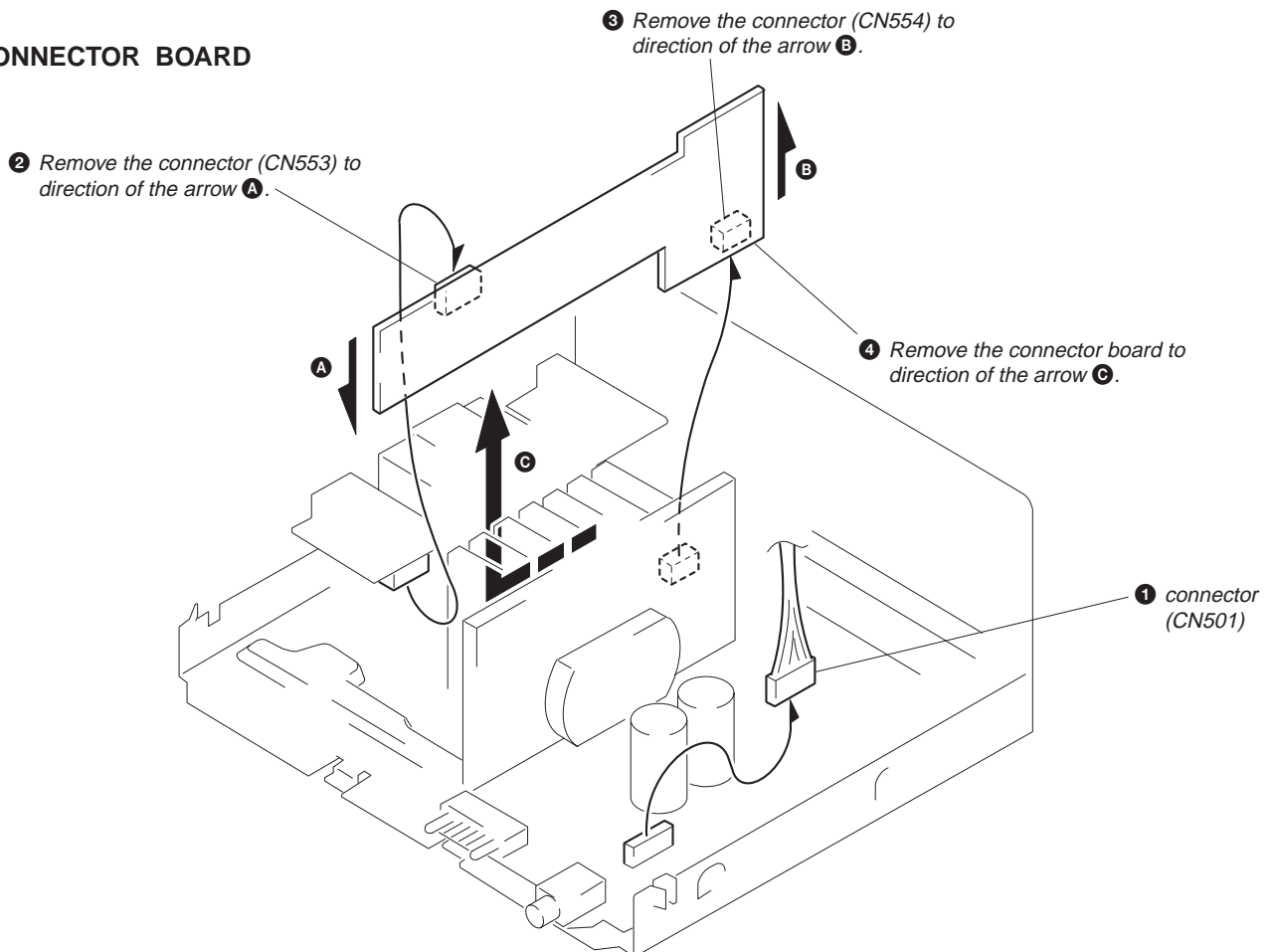

MAIN BOARD

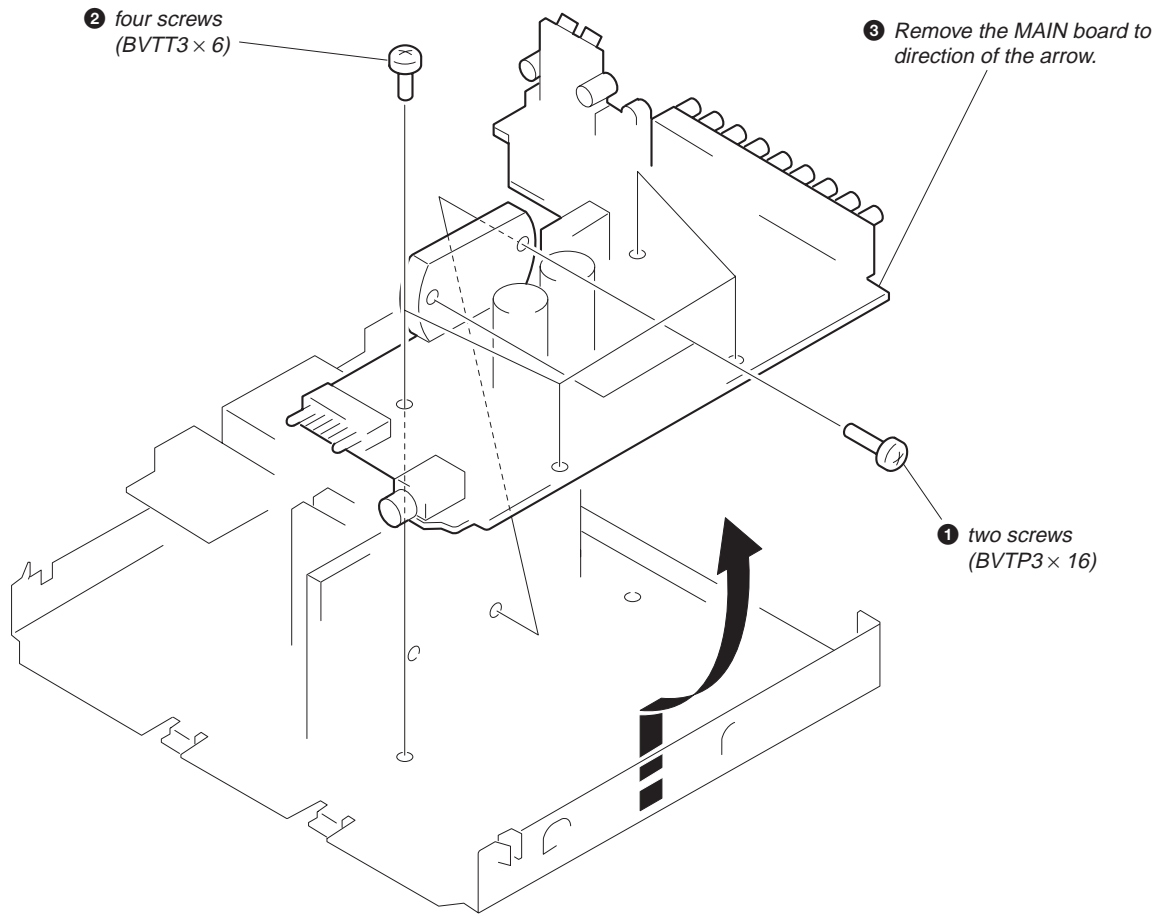

SECTION 3 DIAGRAMS

3-1. IC PIN FUNCTION DESCRIPTION

• PANEL BOARD IC101 MB89193A-157 (SYSTEM CONTROLLER)

Pin No.	Pin Name	I/O	Function
1	MIC-IN	I	Plug in detection signal input of the MIX MIC jack (J201) Insert the microphone plug with the jack when "H"
2	STANBY	O	Power on/off control signal output terminal "H": power on, "L": standby mode
3	K-PON	O	Control signal output to the KARAOKE PON circuit "H": KARAOKE PON on
4	KEY0	I	Key input terminal (A/D input) POWER key (S101) input
5	VSS	—	Ground terminal
6	$\overline{\text{RST}}$	I	Power on reset signal input from the reset signal generator (IC103) "L": reset For several hundreds msec. after the power supply rises, "L" is input, then it changes to "H"
7	XIN	I	System clock input terminal (4 MHz)
8	XOUT	O	System clock output terminal (4 MHz)
9	VSS	—	Ground terminal
10	AUB-OUT	O	Output terminal of the audio bus signal
11	AUB-IN	I	Input terminal of the audio bus signal
12	SIRCS-IN	I	Sircs signal input from the remote control receiver (IC102)
13	VOL-UP	O	Motor control signal output to the volume up/down motor driver IC (IC104) "H": volume up
14	VOL-DOWN	O	Motor control signal output to the volume up/down motor driver IC (IC104) "H": volume down
15	-20dB MUTE	O	Control signal output of the -20 dB mute "H": -20 dB mute on
16	DIRECT	O	Control signal output to the SOURCE DIRECT circuit "H": SOURCE DIRECT on
17	DBFB LEVEL	O	DBFB level select signal output terminal "H" : DBFB LOW, "L": DBFB HIGH
18	MUTE	O	Control signal output of the line mute "H": line mute on
19	KEY1	I	Key input terminal (A/D input) -20 dB MUTING, SOURCE DIRECT, KARAOKE PON, DBFB keys (S104 to S107) and rotary encoder (S110) for the FUNCTION
20	DBFB ON/OFF	O	Control signal output to the DBFB circuit "H": DBFB off, "L": DBFB on
21	OPEN	—	Not used (open)
22	VSS	—	Ground terminal
23	VCC	—	Power supply terminal (+5V)
24	ANALOG/ DIGITAL	I	Digital/analog recording mode select input (ANALOG/DIGITAL select switch (S901) input) of the AUX/VIDEO 2 IN terminal "H": analog recording mode, "L": digital recording mode (TA-EX77 only)
25	FUNCA	O	Function select signal output terminal *1
26	FUNCB	O	
27	FUNCC	O	
28	VCC	—	Power supply terminal (+5V)

*1

Function	Terminal	FUNCA (pin ⑳)	FUNCB (pin ㉑)	FUNCC (pin ㉒)
TAPE		"H"	"H"	"H"
VIDEO 2		"L"	"H"	"H"
VIDEO 1		"H"	"L"	"H"
MD		"L"	"L"	"H"
CD		"L"	"H"	"L"
TUNER		"H"	"L"	"L"

• IC Block Diagrams
IC104 BA6208

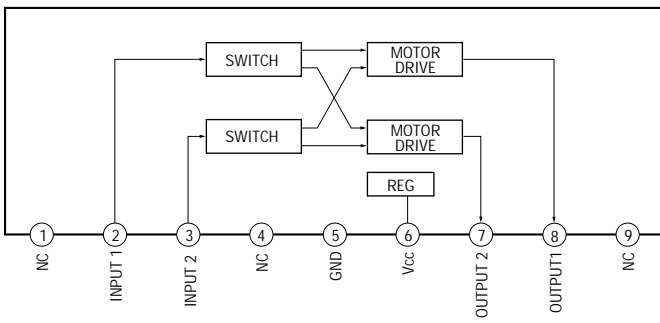

IC105 SN74HC138AN

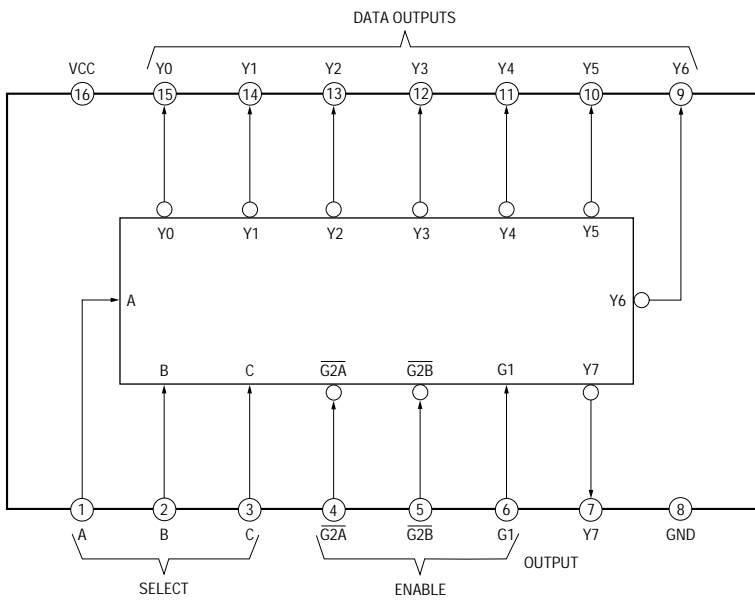

IC203, 503 MC14052BCP

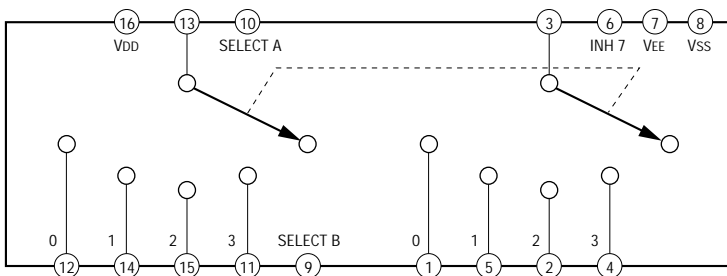

IC701 μ PC1237HA

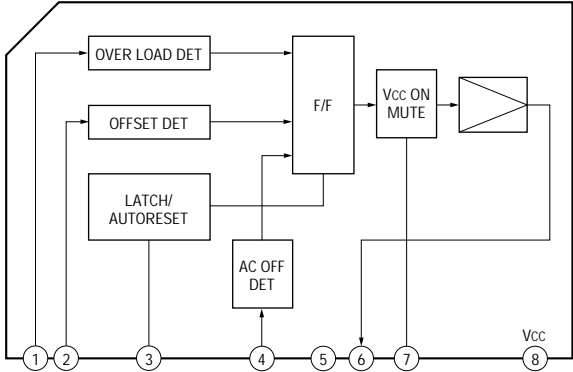

• Waveforms

① IC101 ⑦ (XIN)

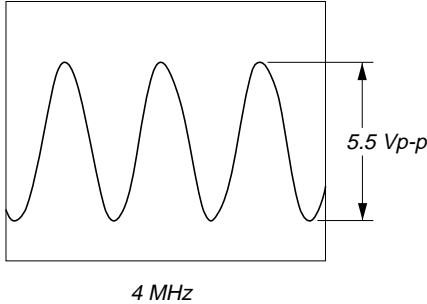

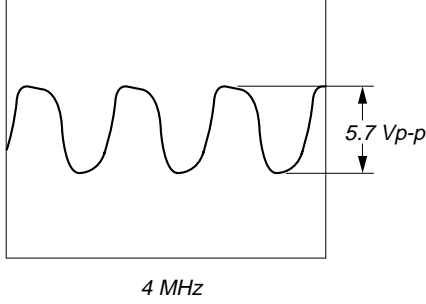

② IC101 ⑧ (XOUT)



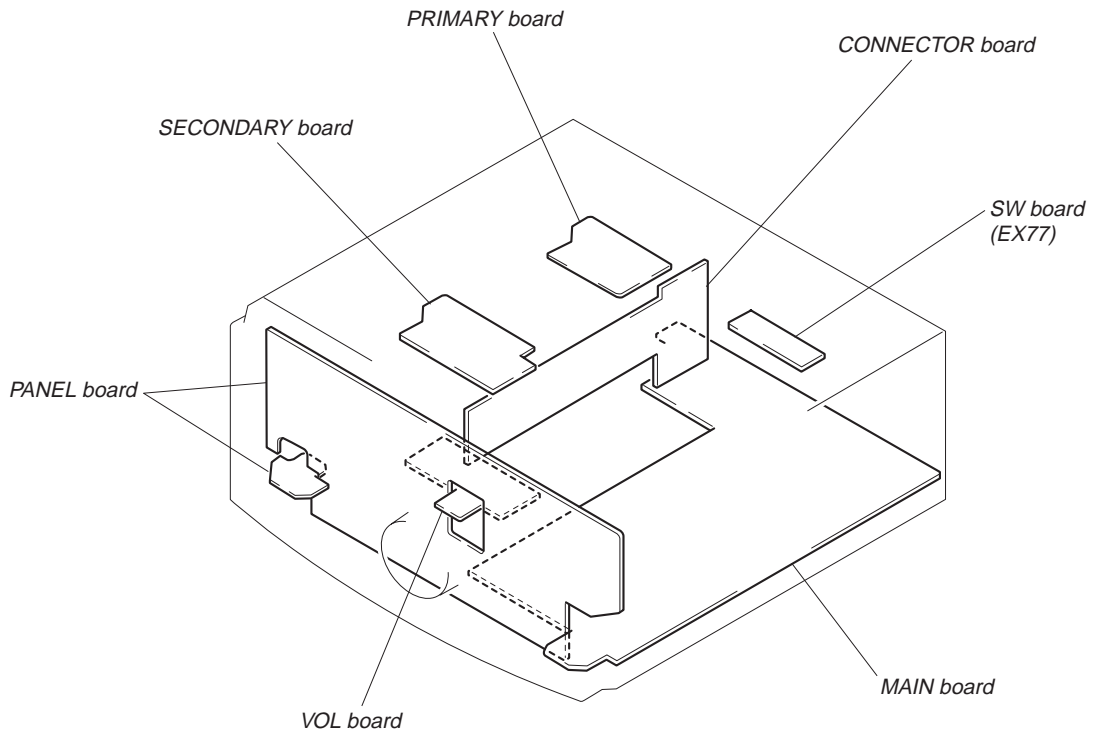



• **Circuit Boards Location**



Note on Schematic Diagram:

- All capacitors are in μF unless otherwise noted. pF: $\mu\mu\text{F}$
50 WV or less are not indicated except for electrolytics and tantalums.
- All resistors are in Ω and $1/4\text{W}$ or less unless otherwise specified.
- Δ : internal component.
-  : nonflammable resistor.
-  : fusible resistor.
-  : panel designation.

Note: The components identified by mark Δ or dotted line with mark Δ are critical for safety.
Replace only with part number specified.

-  : B+ Line.
-  : B- Line.
- Voltages and waveforms are dc with respect to ground under no-signal conditions.
no mark :FUNCTION switch TUNER position
- Voltages are taken with a VOM (Input impedance 10 M Ω).
Voltage variations may be noted due to normal production tolerances.
- Waveforms are taken with an oscilloscope.
Voltage variations may be noted due to normal production tolerances.
- Circled numbers refer to waveforms.
- Signal path.
 : TUNER input
 : MIC input
- Abbreviation
HK : Hong Kong
SP : Singapore

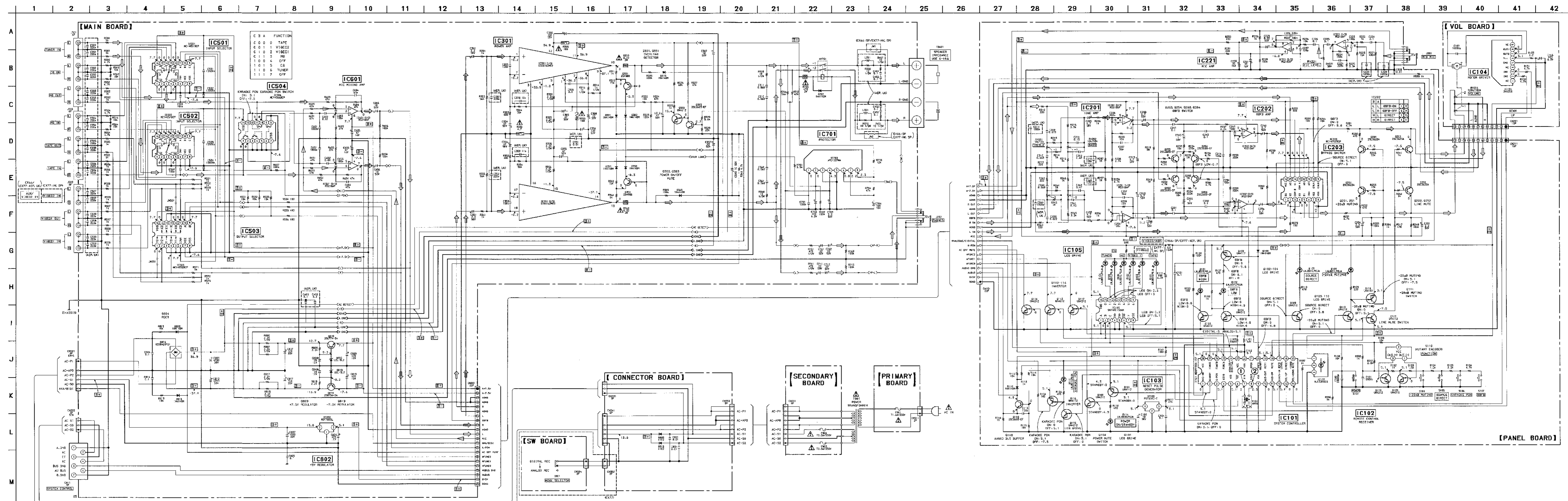

3-3. PRINTED WIRING BOARDS • See page 12 for Circuit Boards Location.

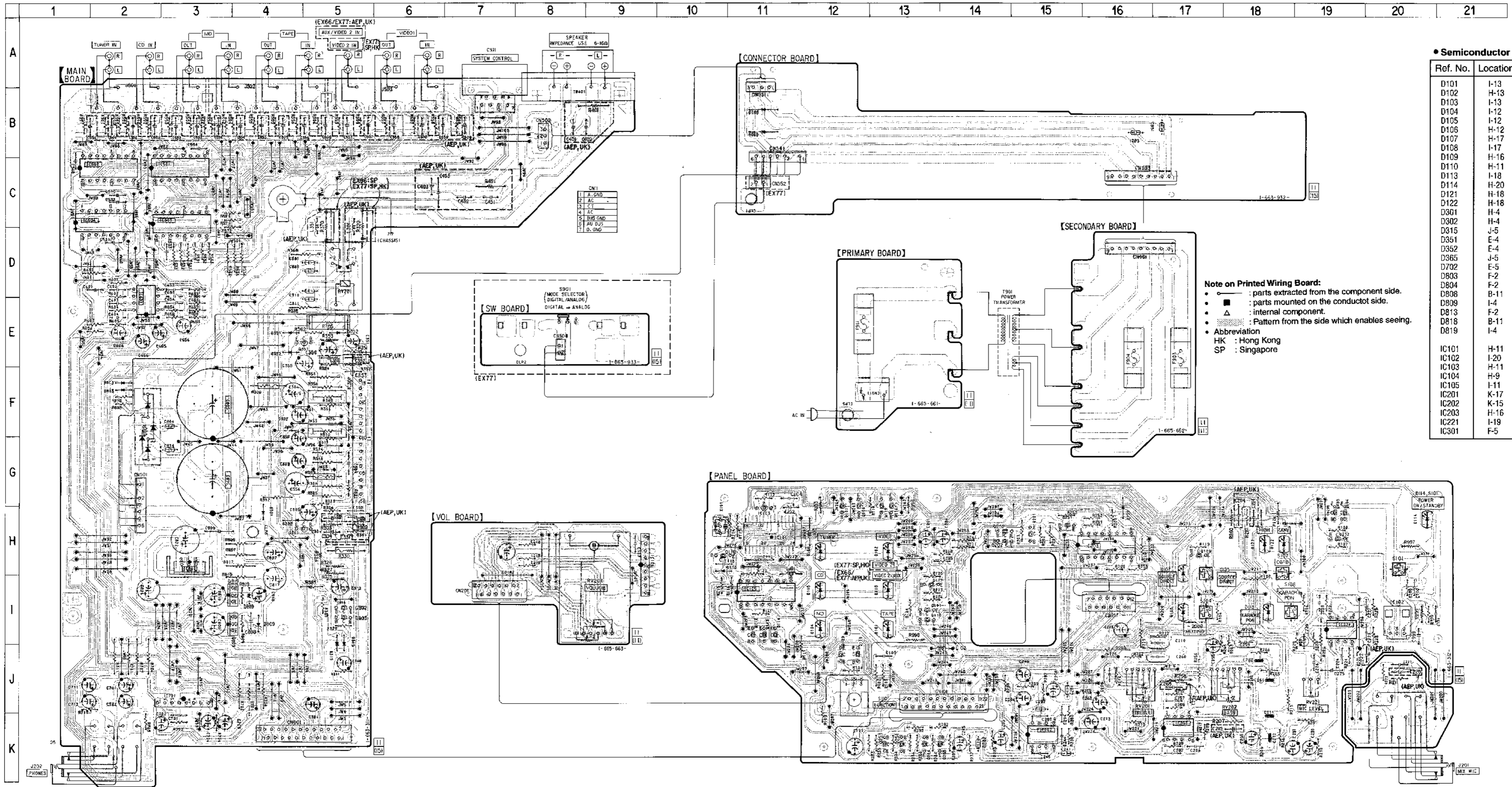

• Semiconductor Location

Ref. No.	Location	Ref. No.	Location
D101	I-13	IC501	C-3
D102	H-13	IC502	C-2
D103	I-13	IC503	C-3
D104	I-12	IC504	C-2
D105	I-12	IC601	E-2
D106	H-12	IC701	J-3
D107	H-17	IC802	H-3
D108	I-17		
D109	H-16	Q101	H-12
D110	H-11	Q102	H-19
D113	I-18	Q103	H-19
D114	H-20	Q104	H-19
D121	H-18	Q108	H-12
D122	H-18	Q109	H-17
D301	H-4	Q110	I-13
D302	H-4	Q111	I-13
D315	J-5	Q112	I-11
D351	E-4	Q113	I-11
D352	E-4	Q114	I-11
D365	J-5	Q115	H-13
D702	E-5	Q116	H-13
D803	F-2	Q117	I-13
D804	F-2	Q118	H-10
D808	B-11	Q119	J-12
D809	I-4	Q120	J-12
D813	F-2	Q201	H-15
D818	B-11	Q202	H-14
D819	I-4	Q251	H-15
		Q252	H-14
		Q253	K-13
IC101	H-11	Q254	K-13
IC102	I-20	Q283	K-14
IC103	H-11	Q284	K-13
IC104	H-9	Q301	H-4
IC105	I-11	Q302	I-5
IC201	K-17	Q303	I-5
IC202	K-15	Q351	E-5
IC203	H-16	Q809	I-4
IC221	I-19	Q819	I-4
IC301	F-5		

Note on Printed Wiring Board:

- : parts extracted from the component side.
- : parts mounted on the conductor side.
- ▲ : internal component.
- ▨ : Pattern from the side which enables seeing.
- Abbreviation
HK : Hong Kong
SP : Singapore

SECTION 4 EXPLODED VIEWS

NOTE:

- -XX and -X mean standardized parts, so they may have some difference from the original one.
- Color Indication of Appearance Parts
Example:
KNOB, BALANCE (WHITE) . . . (RED)
 ↑ ↑
 Parts Color Cabinet's Color
- Abbreviation
HK : Hong Kong
SP : Singapore
- Items marked “*” are not stocked since they are seldom required for routine service. Some delay should be anticipated when ordering these items.
- The mechanical parts with no reference number in the exploded views are not supplied.
- Hardware (# mark) list are given in the last of the electrical parts list.

The components identified by mark \triangle or dotted line with mark \triangle are critical for safety. Replace only with part number specified.

(1) CASE, FRONT PANEL SECTION

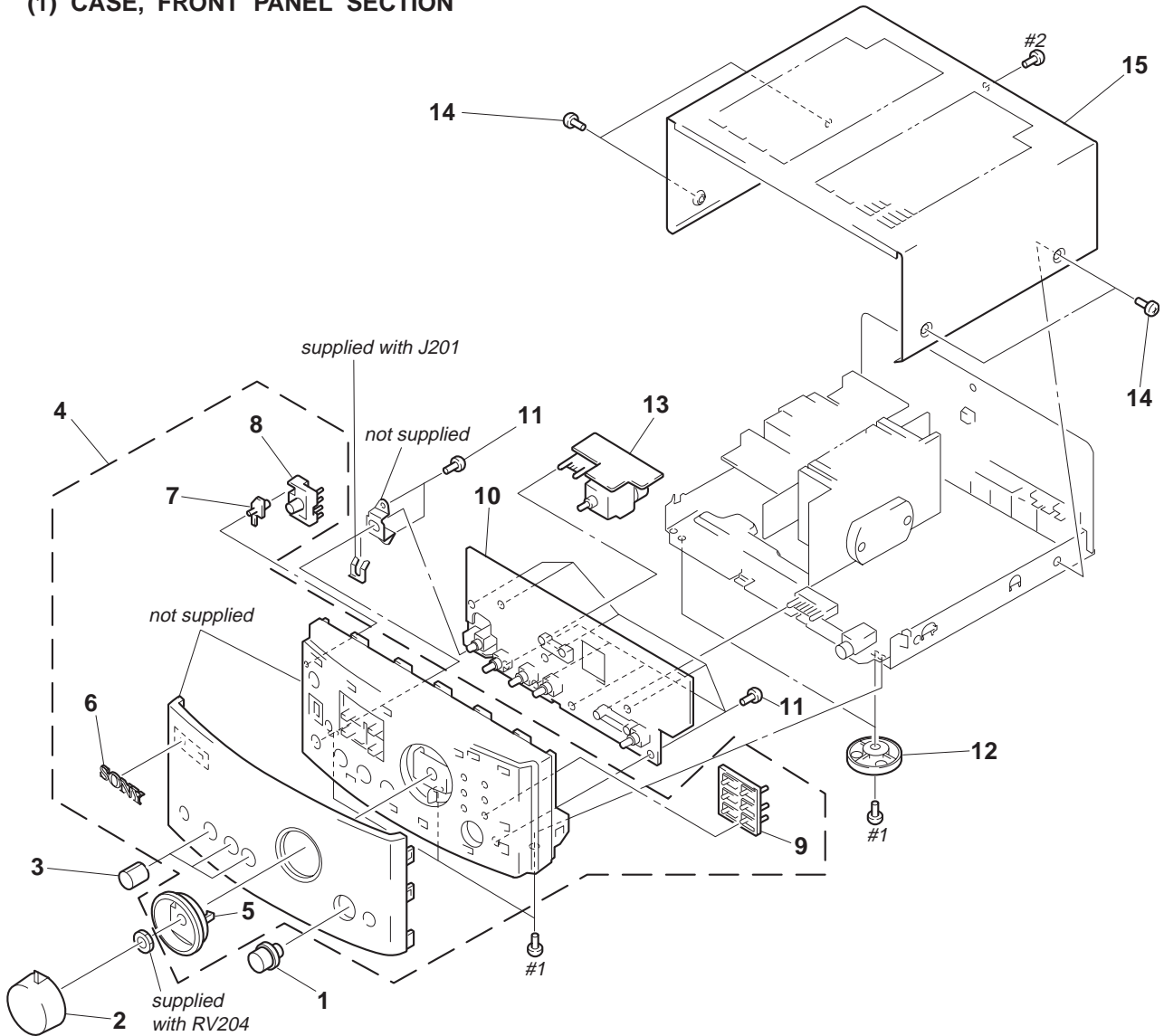

Ref. No.	Part No.	Description	Remark	Ref. No.	Part No.	Description	Remark
1	4-985-925-01	KNOB (JOG)		8	4-985-917-01	BUTTON (POWER)	
2	X-4947-837-1	KNOB (VOL) ASSY		9	4-985-920-01	INDICATOR (6)	
3	4-985-926-01	KNOB		* 10	A-4398-059-A	PANEL BOARD, COMPLETE (AEP, UK)	
4	X-4947-655-1	PANEL ASSY, FRONT (EX77: SP, HK)		* 10	A-4398-061-A	PANEL BOARD, COMPLETE (SP, HK)	
4	X-4948-359-1	PANEL ASSY, FRONT (EX66)		11	4-951-620-01	SCREW (2.6X8), +BVP	
4	X-4948-436-1	PANEL ASSY, FRONT (EX77: AEP, UK)		12	4-977-699-11	LEG (F)	
5	4-985-922-01	RING, ORNAMENTAL		* 13	1-665-663-11	VOL BOARD	
6	4-962-708-01	EMBLEM (4-A), SONY		14	3-363-099-01	SCREW (CASE 3 TP2)	
7	4-985-918-01	INDICATOR (POWER)		15	4-978-245-11	CASE	

(2) MAIN SECTION

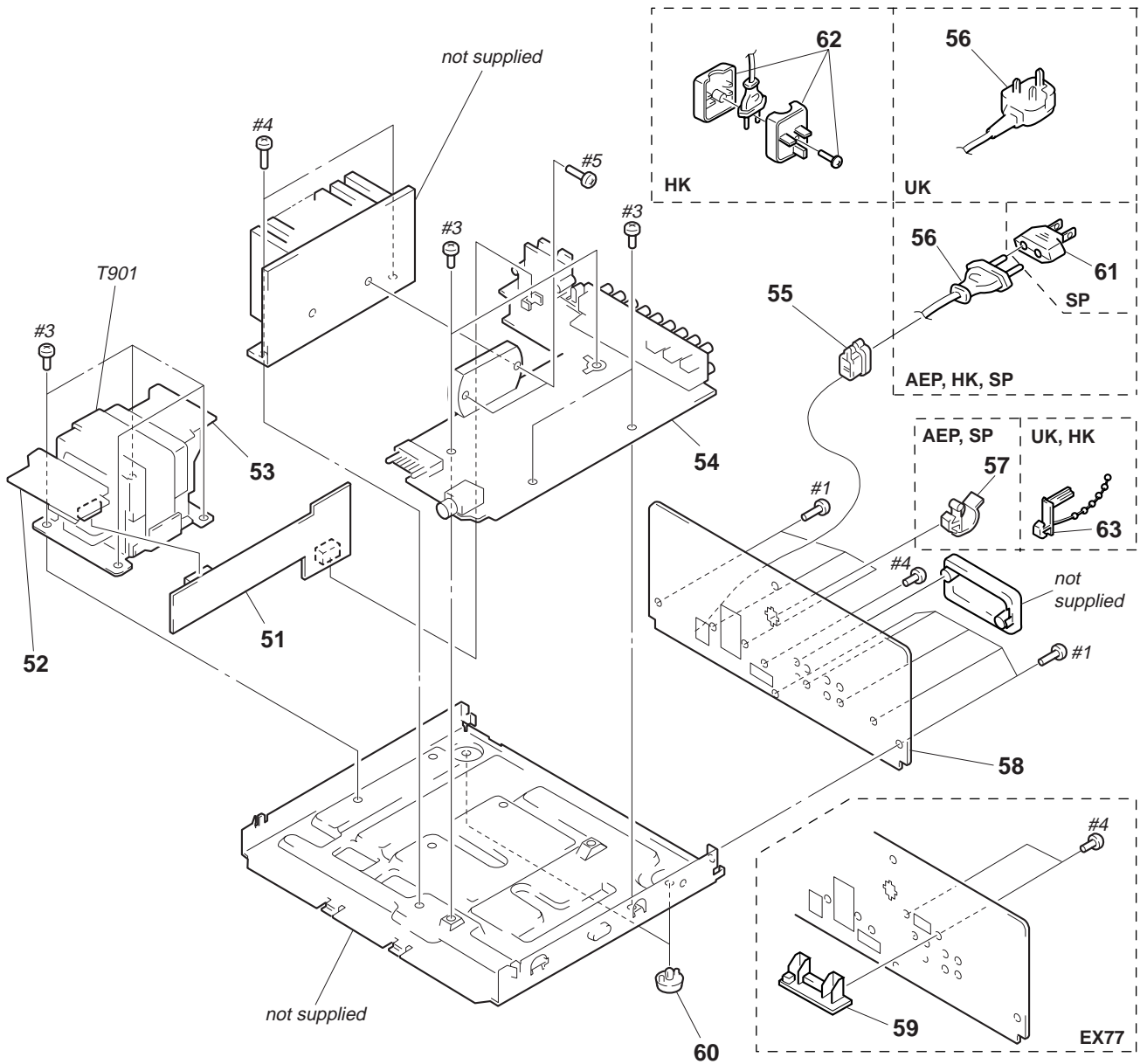

The components identified by mark \triangle or dotted line with mark \triangle are critical for safety. Replace only with part number specified.

Ref. No.	Part No.	Description	Remark	Ref. No.	Part No.	Description	Remark
* 51	1-663-932-11	CONNECTOR BOARD		* 58	4-985-927-11	PANEL, BACK (EX77: AEP, UK)	
* 52	1-665-662-11	SECONDARY BOARD		* 58	4-985-927-21	PANEL, BACK (EX77: SP)	
* 53	1-665-661-11	PRIMARY BOARD		* 58	4-985-927-31	PANEL, BACK (EX77: HK)	
* 54	A-4398-060-A	MAIN BOARD, COMPLETE (EX77: AEP, UK)		* 58	4-985-927-41	PANEL, BACK (EX66: AEP, UK)	
* 54	A-4398-062-A	MAIN BOARD, COMPLETE (EX77: HK, SP)		* 58	4-985-927-51	PANEL, BACK (EX66: SP)	
* 54	A-4403-012-A	MAIN BOARD, COMPLETE (EX66: SP)		* 59	1-663-933-11	SW BOARD (EX77)	
* 54	A-4403-013-A	MAIN BOARD, COMPLETE (EX66: AEP, UK)		60	4-965-822-01	FOOT	
* 55	3-703-244-00	BUSHING (2104), CORD		\triangle 61	1-569-008-11	ADAPTOR, CONVERSION 2P (SP)	
\triangle 56	1-575-651-11	CORD, POWER (AEP, HK, SP)		\triangle 62	1-770-019-11	ADAPTOR, CONVERSION PLUG 3P (HK)	
\triangle 56	1-696-570-21	CORD, POWER (UK)		63	4-956-370-02	BAND, PLUG FIXED (UK, HK)	
* 57	4-949-235-01	HOOK (AEP, SP)		\triangle T901	1-431-301-11	TRANSFORMER, POWER	

CONNECTOR

MAIN

**SECTION 5
ELECTRICAL PARTS LIST**

NOTE:

- Due to standardization, replacements in the parts list may be different from the parts specified in the diagrams or the components used on the set.
- -XX and -X mean standardized parts, so they may have some difference from the original one.
- RESISTORS
All resistors are in ohms.
METAL: Metal-film resistor.
METAL OXIDE: Metal oxide-film resistor.
F: nonflammable
- Abbreviation
HK : Hong Kong
SP : Singapore

- Items marked “*” are not stocked since they are seldom required for routine service. Some delay should be anticipated when ordering these items.
- SEMICONDUCTORS
In each case, u: μ , for example:
uA. . . : μ A. . . uPA. . . : μ PA. . .
uPB. . . : μ PB. . . uPC. . . : μ PC. . .
uPD. . . : μ PD. . .
- CAPACITORS
uF: μ F
- COILS
uH: μ H

The components identified by mark Δ or dotted line with mark Δ are critical for safety.
Replace only with part number specified.

When indicating parts by reference number, please include the board.

Ref. No.	Part No.	Description	Remark	Ref. No.	Part No.	Description	Remark
*	1-663-932-11	CONNECTOR BOARD *****		C351	1-126-045-11	ELECT	2.2uF 20% 50V
		< CAPACITOR >		C352	1-162-286-31	CERAMIC	220PF 10% 50V (AEP, UK)
C821	1-136-153-00	FILM	0.01uF 5% 50V	C353	1-162-282-31	CERAMIC	100PF 10% 50V
C831	1-136-153-00	FILM	0.01uF 5% 50V	C354	1-126-868-11	ELECT	47uF 20% 50V
		< CONNECTOR >		C355	1-126-868-11	ELECT	47uF 20% 50V
* CN531	1-569-499-11	PIN, CONNECTOR 3P		C356	1-124-122-11	ELECT	100uF 20% 50V
CN541	1-770-966-11	PIN, CONNECTOR (PCB) (V TYPE) 6P		C357	1-126-059-11	ELECT	10uF 20% 50V
CN552	1-764-325-11	PIN, CONNECTOR (PCB) (V TYPE) 2P (EX77)		C358	1-162-200-31	CERAMIC	11PF 5% 50V (AEP, UK)
* CN553	1-569-504-11	PIN, CONNECTOR 9P		C360	1-136-163-00	FILM	0.068uF 5% 50V
		< DIODE >		C361	1-136-163-00	FILM	0.068uF 5% 50V
D808	8-719-023-05	DIODE 11E2-TA2B		C401	1-164-159-11	CERAMIC	0.1uF 50V (AEP, UK)
D818	8-719-023-05	DIODE 11E2-TA2B		C402	1-164-159-11	CERAMIC	0.1uF 50V (AEP, UK)
*****				C403	1-164-159-11	CERAMIC	0.1uF 50V (AEP, UK)
* A-4403-012-A	MAIN BOARD, COMPLETE (EX66: SP)			C451	1-164-159-11	CERAMIC	0.1uF 50V (AEP, UK)
* A-4403-013-A	MAIN BOARD, COMPLETE (EX66: AEP, UK)			C452	1-164-159-11	CERAMIC	0.1uF 50V (AEP, UK)
* A-4398-060-A	MAIN BOARD, COMPLETE (EX77: AEP, UK)			C453	1-164-159-11	CERAMIC	0.1uF 50V (AEP, UK)
* A-4398-062-A	MAIN BOARD, COMPLETE (EX77: HK, SP)			C501	1-162-286-31	CERAMIC	220PF 10% 50V (AEP, UK)
*****				C502	1-162-286-31	CERAMIC	220PF 10% 50V (AEP, UK)
* 4-942-204-01	PLATE, GROUND			C503	1-162-286-31	CERAMIC	220PF 10% 50V (AEP, UK)
7-685-871-01	SCREW +BVTT 3X6 (S)			C504	1-162-286-31	CERAMIC	220PF 10% 50V (AEP, UK)
		< CAPACITOR >		C505	1-162-286-31	CERAMIC	220PF 10% 50V (AEP, UK)
C301	1-126-045-11	ELECT	2.2uF 20% 50V	C506	1-162-286-31	CERAMIC	220PF 10% 50V (AEP, UK)
C302	1-162-286-31	CERAMIC	220PF 10% 50V (AEP, UK)	C507	1-162-286-31	CERAMIC	220PF 10% 50V (AEP, UK)
C303	1-162-282-31	CERAMIC	100PF 10% 50V	C508	1-162-286-31	CERAMIC	220PF 10% 50V (AEP, UK)
C304	1-126-868-11	ELECT	47uF 20% 50V	C509	1-162-286-31	CERAMIC	220PF 10% 50V (AEP, UK)
C305	1-126-868-11	ELECT	47uF 20% 50V	C510	1-162-282-31	CERAMIC	100PF 10% 50V
C306	1-124-122-11	ELECT	100uF 20% 50V	C531	1-162-306-11	CERAMIC	0.01uF 20% 16V
C307	1-126-059-11	ELECT	10uF 20% 50V	C532	1-162-306-11	CERAMIC	0.01uF 20% 16V
C308	1-126-233-11	ELECT	22uF 20% 50V	C533	1-162-306-11	CERAMIC	0.01uF 20% 16V
C309	1-164-159-11	CERAMIC	0.1uF 50V	C534	1-162-306-11	CERAMIC	0.01uF 20% 16V
C310	1-136-163-00	FILM	0.068uF 5% 50V				
C311	1-136-163-00	FILM	0.068uF 5% 50V				
C312	1-126-868-11	ELECT	47uF 20% 50V				
C318	1-162-200-31	CERAMIC	11PF 5% 50V (AEP, UK)				
C331	1-162-306-11	CERAMIC	0.01uF 20% 16V (AEP, UK)				
C340	1-126-059-11	ELECT	10uF 20% 50V				

Ref. No.	Part No.	Description	Remark	Ref. No.	Part No.	Description	Remark
C551	1-162-286-31	CERAMIC	220PF 10%	50V (AEP, UK)	CN501	1-770-966-11	PIN, CONNECTOR (PCB) (V TYPE) 6P
C552	1-162-286-31	CERAMIC	220PF 10%	50V (AEP, UK)	CN502	1-569-490-11	SOCKET, CONNECTOR 3P
C553	1-162-286-31	CERAMIC	220PF 10%	50V (AEP, UK)	CN801	1-764-289-11	PIN, CONNECTOR (PC BOARD) 22P
C554	1-162-286-31	CERAMIC	220PF 10%	50V (AEP, UK)		< DIODE >	
C555	1-162-286-31	CERAMIC	220PF 10%	50V (AEP, UK)	D301	8-719-987-63	DIODE 1N4148M
C556	1-162-286-31	CERAMIC	220PF 10%	50V (AEP, UK)	D302	8-719-987-63	DIODE 1N4148M
C557	1-162-286-31	CERAMIC	220PF 10%	50V (AEP, UK)	D315	8-719-987-63	DIODE 1N4148M
C558	1-162-286-31	CERAMIC	220PF 10%	50V (AEP, UK)	D351	8-719-987-63	DIODE 1N4148M
C559	1-162-286-31	CERAMIC	220PF 10%	50V (AEP, UK)	D352	8-719-987-63	DIODE 1N4148M
C560	1-162-282-31	CERAMIC	100PF 10%	50V	D365	8-719-987-63	DIODE 1N4148M
C601	1-162-294-31	CERAMIC	0.001uF 10%	50V	D702	8-719-987-63	DIODE 1N4148M
C602	1-162-306-11	CERAMIC	0.01uF 20%	16V	D803	8-719-987-63	DIODE 1N4148M
C603	1-162-282-31	CERAMIC	100PF 10%	50V	D804	8-719-510-68	DIODE D5SBA20F01
C604	1-162-215-31	CERAMIC	47PF 5%	50V	D809	8-719-933-54	DIODE HZS9A2L
C605	1-126-022-11	ELECT	47uF 20%	16V	D813	8-719-987-63	DIODE 1N4148M
C606	1-126-059-11	ELECT	10uF 20%	50V	D819	8-719-933-54	DIODE HZS9A2L
C651	1-162-294-31	CERAMIC	0.001uF 10%	50V		< IC >	
C652	1-162-306-11	CERAMIC	0.01uF 20%	16V	IC301	8-749-900-24	IC STK-4162MK2
C653	1-162-282-31	CERAMIC	100PF 10%	50V	IC501	8-759-000-47	IC MC14051BCP
C654	1-162-215-31	CERAMIC	47PF 5%	50V	IC502	8-759-000-47	IC MC14051BCP
C655	1-126-022-11	ELECT	47uF 20%	16V	IC503	8-759-000-48	IC MC14052BCP
C656	1-126-059-11	ELECT	10uF 20%	50V	IC504	8-759-000-49	IC MC14066BCP
C701	1-162-294-31	CERAMIC	0.001uF 10%	50V	IC601	8-759-634-51	IC M5218AP
C702	1-104-666-11	ELECT	220uF 20%	6.3V	IC701	8-759-111-68	IC uPC1237HA
C703	1-126-045-11	ELECT	2.2uF 20%	50V	IC802	8-759-231-53	IC TA7805S
C704	1-126-052-11	ELECT	100uF 20%	10V		< JACK/PIN JACK >	
C711	1-126-233-11	ELECT	22uF 20%	50V	J202	1-764-256-21	JACK (LARGE TYPE) (PHONES)
C712	1-126-233-11	ELECT	22uF 20%	50V	J501	1-770-015-11	JACK, PIN 6P (TUNER IN, CD IN, MD OUT)
C761	1-126-233-11	ELECT	22uF 20%	50V	J502	1-770-015-11	JACK, PIN 6P (MD IN, TAPE OUT, TAPE IN)
C762	1-126-233-11	ELECT	22uF 20%	50V	J503	1-770-015-11	JACK, PIN 6P (AUX/VIDEO2 IN, VIDEO1 OUT, VIDEO1 IN) (EX66/EX77: AEP, UK)
C804	1-136-165-00	FILM	0.1uF 5%	50V	J503	1-770-015-11	JACK, PIN 6P (VIDEO2 IN, VIDEO1 OUT, VIDEO1 IN) (EX77: HK, SP)
C805	1-126-138-11	ELECT	4700uF 20%	50V		< COIL >	
C807	1-126-052-11	ELECT	100uF 20%	35V	L301	1-420-872-00	COIL, AIR-CORE (AEP, UK)
C808	1-126-052-11	ELECT	100uF 20%	10V	L351	1-420-872-00	COIL, AIR-CORE (AEP, UK)
C809	1-124-997-11	ELECT	470uF 20%	10V		< TRANSISTOR >	
C814	1-136-165-00	FILM	0.1uF 5%	50V	Q301	8-729-140-82	TRANSISTOR 2SA988-PAFAEA
C815	1-126-138-11	ELECT	4700uF 20%	50V	Q302	8-729-422-73	TRANSISTOR UN4212
C817	1-126-052-11	ELECT	100uF 20%	35V	Q303	8-729-620-05	TRANSISTOR 2SC2603-EF
C818	1-126-052-11	ELECT	100uF 20%	10V	Q351	8-729-140-82	TRANSISTOR 2SA988-PAFAEA
C819	1-124-997-11	ELECT	470uF 20%	10V	Q809	8-729-140-96	TRANSISTOR 2SD774-34
C822	1-126-942-61	ELECT	1000uF 20%	25V	Q819	8-729-140-97	TRANSISTOR 2SB734-34
C824	1-124-997-11	ELECT	470uF 20%	10V		< RESISTOR >	
C825	1-164-159-11	CERAMIC	0.1uF	50V	R301	1-249-417-11	CARBON 1K 5% 1/4W
		< CONNECTOR >			R302	1-249-438-11	CARBON 56K 5% 1/4W
CN11	1-770-158-21	HOUSING, CONNECTOR 7P (SYSTEM CONTROL)			R303	1-249-415-11	CARBON 680 5% 1/4W
					R304	1-249-438-11	CARBON 56K 5% 1/4W
					R305	1-260-103-11	CARBON 2.2K 5% 1/2W

MAIN

Ref. No.	Part No.	Description			Remark	Ref. No.	Part No.	Description			Remark
R306	1-260-103-11	CARBON	2.2K	5%	1/2W	R532	1-249-429-11	CARBON	10K	5%	1/4W
△R309	1-212-881-11	FUSIBLE	100	5%	1/4W F	R533	1-249-429-11	CARBON	10K	5%	1/4W
△R310	1-217-151-00	RES, METAL PLATE		0.22	2W	R534	1-247-807-31	CARBON	100	5%	1/4W
R311	1-249-417-11	CARBON	1K	5%	1/4W	R535	1-247-807-31	CARBON	100	5%	1/4W
R312	1-249-431-11	CARBON	15K	5%	1/4W	R536	1-247-807-31	CARBON	100	5%	1/4W
R314	1-260-099-11	CARBON	1K	5%	1/2W	R551	1-249-417-11	CARBON	1K	5%	1/4W
R316	1-260-099-11	CARBON	1K	5%	1/2W	R552	1-249-425-11	CARBON	4.7K	5%	1/4W
R318	1-260-076-11	CARBON	10	5%	1/2W	R553	1-249-417-11	CARBON	1K	5%	1/4W
R320	1-260-076-11	CARBON	10	5%	1/2W	R554	1-249-425-11	CARBON	4.7K	5%	1/4W
R322	1-249-429-11	CARBON	10K	5%	1/4W	R555	1-249-417-11	CARBON	1K	5%	1/4W
R323	1-247-881-00	CARBON	120K	5%	1/4W	R556	1-249-417-11	CARBON	1K	5%	1/4W
R324	1-249-437-11	CARBON	47K	5%	1/4W	R557	1-249-417-11	CARBON	1K	5%	1/4W
R325	1-249-417-11	CARBON	1K	5%	1/4W	R558	1-249-417-11	CARBON	1K	5%	1/4W
R326	1-249-439-11	CARBON	68K	5%	1/4W	R559	1-249-417-11	CARBON	1K	5%	1/4W
R327	1-249-437-11	CARBON	47K	5%	1/4W	R562	1-249-429-11	CARBON	10K	5%	1/4W
R328	1-249-426-11	CARBON	5.6K	5%	1/4W	R564	1-249-429-11	CARBON	10K	5%	1/4W
R329	1-249-433-11	CARBON	22K	5%	1/4W	R571	1-249-417-11	CARBON	1K	5%	1/4W
△R330	1-212-849-00	FUSIBLE	4.7	5%	1/4W F	R572	1-249-417-11	CARBON	1K	5%	1/4W
R335	1-249-441-11	CARBON	100K	5%	1/4W	R573	1-249-417-11	CARBON	1K	5%	1/4W
R341	1-249-425-11	CARBON	4.7K	5%	1/4W	R601	1-249-437-11	CARBON	47K	5%	1/4W
R351	1-249-417-11	CARBON	1K	5%	1/4W	R602	1-249-434-11	CARBON	27K	5%	1/4W
R352	1-249-438-11	CARBON	56K	5%	1/4W	R603	1-249-437-11	CARBON	47K	5%	1/4W
R353	1-249-415-11	CARBON	680	5%	1/4W	R604	1-249-437-11	CARBON	47K	5%	1/4W
R354	1-249-438-11	CARBON	56K	5%	1/4W	R605	1-249-437-11	CARBON	47K	5%	1/4W
R355	1-260-103-11	CARBON	2.2K	5%	1/2W	R606	1-249-441-11	CARBON	100K	5%	1/4W
R356	1-260-103-11	CARBON	2.2K	5%	1/2W	R607	1-249-441-11	CARBON	100K	5%	1/4W
△R359	1-212-881-11	FUSIBLE	100	5%	1/4W F	R651	1-249-437-11	CARBON	47K	5%	1/4W
△R360	1-217-151-00	RES, METAL PLATE		0.22	2W	R652	1-249-434-11	CARBON	27K	5%	1/4W
R361	1-249-417-11	CARBON	1K	5%	1/4W	R653	1-249-437-11	CARBON	47K	5%	1/4W
R362	1-249-431-11	CARBON	15K	5%	1/4W	R654	1-249-437-11	CARBON	47K	5%	1/4W
R368	1-260-076-11	CARBON	10	5%	1/2W	R655	1-249-437-11	CARBON	47K	5%	1/4W
R370	1-260-076-11	CARBON	10	5%	1/2W	R656	1-249-441-11	CARBON	100K	5%	1/4W
R385	1-249-441-11	CARBON	100K	5%	1/4W	R701	1-249-424-11	CARBON	3.9K	5%	1/4W
R401	1-260-076-11	CARBON	10	5%	1/2W	R702	1-249-441-11	CARBON	100K	5%	1/4W
R451	1-260-076-11	CARBON	10	5%	1/2W	R703	1-249-430-11	CARBON	12K	5%	1/4W
R501	1-249-417-11	CARBON	1K	5%	1/4W	R704	1-249-437-11	CARBON	47K	5%	1/4W
R502	1-249-425-11	CARBON	4.7K	5%	1/4W	△R705	1-215-890-11	METAL OXIDE	470	5%	2W F
R503	1-249-417-11	CARBON	1K	5%	1/4W	R706	1-249-438-11	CARBON	56K	5%	1/4W
R504	1-249-425-11	CARBON	4.7K	5%	1/4W	R707	1-249-437-11	CARBON	47K	5%	1/4W
R505	1-249-417-11	CARBON	1K	5%	1/4W	R711	1-260-095-11	CARBON	470	5%	1/2W
R506	1-249-417-11	CARBON	1K	5%	1/4W	R713	1-249-441-11	CARBON	100K	5%	1/4W
R507	1-249-417-11	CARBON	1K	5%	1/4W	R761	1-260-095-11	CARBON	470	5%	1/2W
R508	1-249-417-11	CARBON	1K	5%	1/4W	R763	1-249-441-11	CARBON	100K	5%	1/4W
R509	1-249-417-11	CARBON	1K	5%	1/4W	R803	1-249-429-11	CARBON	10K	5%	1/4W
R512	1-249-429-11	CARBON	10K	5%	1/4W	R805	1-260-103-11	CARBON	2.2K	5%	1/2W
R514	1-249-429-11	CARBON	10K	5%	1/4W	R807	1-260-103-11	CARBON	2.2K	5%	1/2W
R521	1-249-417-11	CARBON	1K	5%	1/4W	R809	1-249-421-11	CARBON	2.2K	5%	1/4W
R522	1-249-417-11	CARBON	1K	5%	1/4W	R813	1-249-429-11	CARBON	10K	5%	1/4W
R523	1-249-417-11	CARBON	1K	5%	1/4W	R815	1-260-103-11	CARBON	2.2K	5%	1/2W
R531	1-249-429-11	CARBON	10K	5%	1/4W	R817	1-260-103-11	CARBON	2.2K	5%	1/2W
						R819	1-249-421-11	CARBON	2.2K	5%	1/4W
								< RELAY >			
						RY701	1-755-126-11	RELAY			

The components identified by mark △ or dotted line with mark △ are critical for safety.
Replace only with part number specified.

Ref. No.	Part No.	Description	Remark
		< SPEAKER TERMINAL >	
TB401	1-537-240-11	TERMINAL BOARD (CHECKER PIN) (SPEAKER)	

*	A-4398-059-A	PANEL BOARD, COMPLETE (AEP, UK)	
*	A-4398-061-A	PANEL BOARD, COMPLETE (HK, SP)	

		< CAPACITOR >	
C100	1-162-306-11	CERAMIC	0.01uF 20% 16V
C101	1-162-306-11	CERAMIC	0.01uF 20% 16V
C102	1-124-907-11	ELECT	10uF 20% 50V
C104	1-164-159-11	CERAMIC	0.1uF 50V
C111	1-126-968-11	ELECT	100uF 20% 6.3V
C112	1-164-159-11	CERAMIC	0.1uF 50V
C113	1-162-282-31	CERAMIC	100PF 10% 50V
C121	1-164-159-11	CERAMIC	0.1uF 50V
C201	1-124-257-00	ELECT	2.2uF 20% 50V
C204	1-124-257-00	ELECT	2.2uF 20% 50V
C205	1-126-163-11	ELECT	4.7uF 20% 50V
C206	1-162-282-31	CERAMIC	100PF 10% 50V
C207	1-162-217-31	CERAMIC	56PF 5% 50V
C208	1-126-163-11	ELECT	4.7uF 20% 50V
C209	1-136-157-00	FILM	0.022uF 5% 50V
C210	1-136-163-00	FILM	0.068uF 5% 50V
C211	1-136-167-00	FILM	0.15uF 5% 50V
C212	1-136-173-00	FILM	0.47uF 5% 50V
C213	1-126-163-11	ELECT	4.7uF 20% 50V
C214	1-162-294-31	CERAMIC	0.001uF 10% 50V (AEP, UK)
C215	1-162-282-31	CERAMIC	100PF 10% 50V (AEP, UK)
C220	1-162-294-31	CERAMIC	0.001uF 10% 50V (AEP, UK)
C221	1-164-159-11	CERAMIC	0.1uF 50V
C222	1-162-294-31	CERAMIC	0.001uF 10% 50V (AEP, UK)
C223	1-162-282-31	CERAMIC	100PF 10% 50V
C224	1-162-286-31	CERAMIC	220PF 10% 50V
C225	1-164-159-11	CERAMIC	0.1uF 50V
C226	1-164-159-11	CERAMIC	0.1uF 50V
C227	1-162-282-31	CERAMIC	100PF 10% 50V
C228	1-162-286-31	CERAMIC	220PF 10% 50V
C229	1-126-957-11	ELECT	0.22uF 20% 50V
C230	1-104-663-11	ELECT	33uF 20% 16V
C231	1-104-663-11	ELECT	33uF 20% 16V
C241	1-136-165-00	FILM	0.1uF 5% 50V
C242	1-136-165-00	FILM	0.1uF 5% 50V
C243	1-162-282-31	CERAMIC	100PF 10% 50V
C244	1-162-282-31	CERAMIC	100PF 10% 50V
C245	1-126-301-11	ELECT	1uF 20% 50V
C246	1-126-163-11	ELECT	4.7uF 20% 50V
C255	1-126-163-11	ELECT	4.7uF 20% 50V
C256	1-162-282-31	CERAMIC	100PF 10% 50V
C257	1-162-217-31	CERAMIC	56PF 5% 50V
C258	1-126-163-11	ELECT	4.7uF 20% 50V
C259	1-136-157-00	FILM	0.022uF 5% 50V
C260	1-136-163-00	FILM	0.068uF 5% 50V
C261	1-136-167-00	FILM	0.15uF 5% 50V
C262	1-136-173-00	FILM	0.47uF 5% 50V

Ref. No.	Part No.	Description	Remark
C263	1-126-163-11	ELECT	4.7uF 20% 50V
C264	1-162-294-31	CERAMIC	0.001uF 10% 50V (AEP, UK)
C265	1-162-282-31	CERAMIC	100PF 10% 50V (AEP, UK)
C291	1-136-165-00	FILM	0.1uF 5% 50V
C292	1-136-165-00	FILM	0.1uF 5% 50V
C293	1-162-282-31	CERAMIC	100PF 10% 50V
C294	1-162-282-31	CERAMIC	100PF 10% 50V
C295	1-126-301-11	ELECT	1uF 20% 50V
C296	1-126-163-11	ELECT	4.7uF 20% 50V
C999	1-162-306-11	CERAMIC	0.01uF 20% 16V
		< CONNECTOR >	
CN101	1-764-301-11	HOUSING, CONNECTOR (PC BOARD)	22P
CN211	1-764-296-11	HOUSING, CONNECTOR (PC BOARD)	12P
		< DIODE >	
D101	8-719-057-09	LED	LNJ801LPDJA (TAPE)
D102	8-719-057-09	LED	LNJ801LPDJA (VIDEO1)
D103	8-719-057-09	LED	LNJ801LPDJA (VIDEO2/AUX) (EX66/EX77: AEP, UK)
D103	8-719-057-09	LED	LNJ801LPDJA (VIDEO2) (EX77: HK, SP)
D104	8-719-057-09	LED	LNJ801LPDJA (MD)
D105	8-719-057-09	LED	LNJ801LPDJA (CD)
D106	8-719-057-09	LED	LNJ801LPDJA (TUNER)
D107	8-719-057-09	LED	LNJ801LPDJA (SOURCE DIRECT)
D108	8-719-057-09	LED	LNJ801LPDJA (-20dB MUTING)
D109	8-719-987-63	DIODE	1N4148M
D110	8-719-987-63	DIODE	1N4148M
D113	8-719-057-09	LED	LNJ801LPDJA (KARAOKE PON)
D114	8-719-057-09	LED	LNJ801LPDJA (POWER ON/STANDBY)
D121	8-719-057-09	LED	LNJ801LPDJA (DBFB HIGH)
D122	8-719-057-09	LED	LNJ801LPDJA (DBFB LOW)
		< IC >	
IC101	8-759-439-41	IC	MB89193A-157
IC102	8-759-373-48	IC	NJL53H400
IC103	8-759-165-80	IC	PST600C-T
IC105	8-759-917-43	IC	SN74HC138AN
IC201	8-759-634-51	IC	M5218AP
IC202	8-759-634-51	IC	M5218AP
IC203	8-759-000-48	IC	MC14052BCP
IC221	8-759-634-51	IC	M5218AP
		< JACK >	
J201	1-770-226-11	JACK (LARGE TYPE)	(MIX MIC)
		< COIL >	
L101	1-414-142-11	INDUCTOR	1uH
L102	1-410-509-11	INDUCTOR	10uH
L103	1-410-509-11	INDUCTOR	10uH
		< TRANSISTOR >	
Q101	8-729-900-63	TRANSISTOR	DTA124ES
Q102	8-729-900-63	TRANSISTOR	DTA124ES
Q103	8-729-422-73	TRANSISTOR	UN4212
Q104	8-729-422-73	TRANSISTOR	UN4212
Q108	8-729-422-73	TRANSISTOR	UN4212

PANEL

Ref. No.	Part No.	Description	Remark	Ref. No.	Part No.	Description	Remark
Q109	8-729-422-73	TRANSISTOR UN4212		R213	1-247-903-00	CARBON 1M 5%	1/4W
Q110	8-729-422-73	TRANSISTOR UN4212		R214	1-247-903-00	CARBON 1M 5%	1/4W
Q111	8-729-900-63	TRANSISTOR DTA124ES					
Q112	8-729-422-73	TRANSISTOR UN4212		R215	1-247-843-11	CARBON 3.3K 5%	1/4W
Q113	8-729-422-73	TRANSISTOR UN4212		R216	1-249-417-11	CARBON 1K 5%	1/4W
				R217	1-249-413-11	CARBON 470 5%	1/4W
Q114	8-729-422-73	TRANSISTOR UN4212		R218	1-249-441-11	CARBON 100K 5%	1/4W
Q115	8-729-422-73	TRANSISTOR UN4212		R219	1-247-903-00	CARBON 1M 5%	1/4W
Q116	8-729-900-63	TRANSISTOR DTA124ES					
Q117	8-729-900-63	TRANSISTOR DTA124ES		R220	1-247-807-31	CARBON 100 5%	1/4W
Q118	8-729-620-05	TRANSISTOR 2SC2603-EF		R221	1-249-441-11	CARBON 100K 5%	1/4W
				R222	1-249-417-11	CARBON 1K 5%	1/4W
Q119	8-729-422-73	TRANSISTOR UN4212		R223	1-249-431-11	CARBON 15K 5%	1/4W
Q120	8-729-422-73	TRANSISTOR UN4212		R224	1-249-441-11	CARBON 100K 5%	1/4W
Q201	8-729-141-30	TRANSISTOR 2SC3623A-LK					
Q202	8-729-141-30	TRANSISTOR 2SC3623A-LK		R225	1-247-843-11	CARBON 3.3K 5%	1/4W
Q251	8-729-141-30	TRANSISTOR 2SC3623A-LK		R226	1-249-429-11	CARBON 10K 5%	1/4W
				R227	1-249-441-11	CARBON 100K 5%	1/4W
Q252	8-729-141-30	TRANSISTOR 2SC3623A-LK		R228	1-249-441-11	CARBON 100K 5%	1/4W
Q253	8-729-620-05	TRANSISTOR 2SC2603-EF		R229	1-249-417-11	CARBON 1K 5%	1/4W
Q254	8-729-620-05	TRANSISTOR 2SC2603-EF					
Q283	8-729-620-05	TRANSISTOR 2SC2603-EF		R230	1-249-409-11	CARBON 220 5%	1/4W
Q284	8-729-620-05	TRANSISTOR 2SC2603-EF		R231	1-249-409-11	CARBON 220 5%	1/4W
				R232	1-249-425-11	CARBON 4.7K 5%	1/4W
		< RESISTOR >		R233	1-249-432-11	CARBON 18K 5%	1/4W
R100	1-249-429-11	CARBON 10K 5%	1/4W	R234	1-247-887-00	CARBON 220K 5%	1/4W
R101	1-249-427-11	CARBON 6.8K 5%	1/4W				
R102	1-249-417-11	CARBON 1K 5%	1/4W	R235	1-247-903-00	CARBON 1M 5%	1/4W
R103	1-249-419-11	CARBON 1.5K 5%	1/4W	R236	1-249-425-11	CARBON 4.7K 5%	1/4W
R104	1-249-419-11	CARBON 1.5K 5%	1/4W	R237	1-249-421-11	CARBON 2.2K 5%	1/4W
				R238	1-247-891-00	CARBON 330K 5%	1/4W
R105	1-247-843-11	CARBON 3.3K 5%	1/4W	R239	1-247-903-00	CARBON 1M 5%	1/4W
R106	1-249-425-11	CARBON 4.7K 5%	1/4W				
R107	1-249-413-11	CARBON 470 5%	1/4W	R251	1-249-425-11	CARBON 4.7K 5%	1/4W
R108	1-249-417-11	CARBON 1K 5%	1/4W	R252	1-249-413-11	CARBON 470 5%	1/4W
R109	1-249-429-11	CARBON 10K 5%	1/4W	R253	1-249-429-11	CARBON 10K 5%	1/4W
				R255	1-249-429-11	CARBON 10K 5%	1/4W
R110	1-249-413-11	CARBON 470 5%	1/4W	R256	1-249-417-11	CARBON 1K 5%	1/4W
R111	1-249-415-11	CARBON 680 5%	1/4W				
R112	1-249-429-11	CARBON 10K 5%	1/4W	R257	1-247-903-00	CARBON 1M 5%	1/4W
R113	1-249-417-11	CARBON 1K 5%	1/4W	R258	1-249-422-11	CARBON 2.7K 5%	1/4W
R114	1-249-429-11	CARBON 10K 5%	1/4W	R259	1-249-429-11	CARBON 10K 5%	1/4W
				R260	1-249-411-11	CARBON 330 5%	1/4W
R115	1-249-429-11	CARBON 10K 5%	1/4W	R261	1-249-417-11	CARBON 1K 5%	1/4W
R116	1-249-393-11	CARBON 10 5%	1/4W				
R117	1-249-437-11	CARBON 47K 5%	1/4W	R262	1-249-409-11	CARBON 220 5%	1/4W
R119	1-249-413-11	CARBON 470 5%	1/4W	R263	1-247-903-00	CARBON 1M 5%	1/4W
R120	1-249-409-11	CARBON 220 5%	1/4W	R264	1-247-903-00	CARBON 1M 5%	1/4W
				R265	1-247-843-11	CARBON 3.3K 5%	1/4W
R126	1-249-413-11	CARBON 470 5%	1/4W	R266	1-249-417-11	CARBON 1K 5%	1/4W
R130	1-249-441-11	CARBON 100K 5%	1/4W				
R134	1-247-807-31	CARBON 100 5%	1/4W	R269	1-247-903-00	CARBON 1M 5%	1/4W
R141	1-249-441-11	CARBON 100K 5%	1/4W	R270	1-247-807-31	CARBON 100 5%	1/4W
R153	1-247-807-31	CARBON 100 5%	1/4W	R282	1-249-425-11	CARBON 4.7K 5%	1/4W
				R283	1-249-432-11	CARBON 18K 5%	1/4W
R200	1-249-429-11	CARBON 10K 5%	1/4W	R284	1-247-887-00	CARBON 220K 5%	1/4W
R201	1-249-425-11	CARBON 4.7K 5%	1/4W				
R202	1-249-413-11	CARBON 470 5%	1/4W	R285	1-247-903-00	CARBON 1M 5%	1/4W
R203	1-249-429-11	CARBON 10K 5%	1/4W	R286	1-249-425-11	CARBON 4.7K 5%	1/4W
R204	1-249-417-11	CARBON 1K 5%	1/4W	R287	1-249-421-11	CARBON 2.2K 5%	1/4W
				R288	1-247-891-00	CARBON 330K 5%	1/4W
R205	1-249-441-11	CARBON 100K 5%	1/4W	R289	1-247-903-00	CARBON 1M 5%	1/4W
R206	1-249-417-11	CARBON 1K 5%	1/4W				
R207	1-247-903-00	CARBON 1M 5%	1/4W	R996	1-249-417-11	CARBON 1K 5%	1/4W
R208	1-249-422-11	CARBON 2.7K 5%	1/4W	R997	1-249-417-11	CARBON 1K 5%	1/4W
R209	1-249-429-11	CARBON 10K 5%	1/4W	R998	1-249-417-11	CARBON 1K 5%	1/4W
				R999	1-249-417-11	CARBON 1K 5%	1/4W
R210	1-249-411-11	CARBON 330 5%	1/4W				
R211	1-249-417-11	CARBON 1K 5%	1/4W				
R212	1-249-409-11	CARBON 220 5%	1/4W				
						< VARIABLE RESISTOR >	
				RV201	1-223-973-11	RES, VAR, CARBON 10K/10K (TREBLE)	

PANEL

PRIMARY

SECONDARY

SW

VOL

Ref. No.	Part No.	Description	Remark	Ref. No.	Part No.	Description	Remark
RV202	1-223-973-11	RES, VAR, CARBON 10K/10K (BASS)				< SWITCH >	
RV221	1-223-974-11	RES, VAR, CARBON 50K (MIC LEVEL)					
		< SWITCH >		S901	1-762-884-11	SWITCH, SLIDE (MODE SELECTOR DIGITAL REC/ANALOG REC)	
S101	1-762-196-21	SWITCH, TACT (POWER)		*****			
S104	1-762-196-21	SWITCH, TACT (-20dB MUTING)		*	1-665-663-11	VOL BOARD	
S105	1-762-196-21	SWITCH, TACT (SOURCE DIRECT)		*****			
S106	1-762-196-21	SWITCH, TACT (KARAOKE PON)				< CAPACITOR >	
S107	1-762-196-21	SWITCH, TACT (DBFB)					
S110	1-762-848-11	SWITCH, ROTARY (FUNCTION)		C106	1-126-968-11	ELECT 100uF 20% 6.3V	
		< VIBRATOR >		C107	1-162-306-11	CERAMIC 0.01uF 20% 16V	
X101	1-577-358-21	VIBRATOR, CERAMIC (4MHz)				< CONNECTOR >	
*****				CN201	1-764-311-11	PIN, CONNECTOR (PC BOARD) 12P	
*	1-665-661-11	PRIMARY BOARD				< IC >	
*****				IC104	8-759-962-08	IC BA6208	
		< CONNECTOR >				< RESISTOR >	
* CN911	1-695-044-11	PIN, CONNECTOR 2P		R131	1-249-425-11	CARBON 4.7K 5% 1/4W	
		< FUSE >		R132	1-249-425-11	CARBON 4.7K 5% 1/4W	
△F911	1-532-259-00	FUSE, TIME-LAG (T1.6/250V)		R133	1-249-385-11	CARBON 2.2 5% 1/6W	
		< FUSE HOLDER >				< VARIABLE RESISTOR >	
FH901	1-533-293-11	FUSE HOLDER		RV204	1-223-811-11	RES, VAR, CARBON 100K/100K (VOLUME)	
FH911	1-533-293-11	FUSE HOLDER		*****			
*****						MISCELLANEOUS	
*	1-665-662-11	SECONDARY BOARD		*****			
		< CONNECTOR >		△56	1-575-651-11	CORD, POWER (AEP, HK, SP)	
* CN901	1-569-495-11	SOCKET, CONNECTOR 9P		△56	1-696-570-21	CORD, POWER (UK)	
		< FUSE >		△61	1-569-008-11	ADAPTOR, CONVERSION 2P (SP)	
△F903	1-532-286-00	FUSE, TIME-LAG (T2.5/250V)		△62	1-770-019-11	ADAPTOR, CONVERSION PLUG 3P (EX77: HK)	
△F904	1-532-286-00	FUSE, TIME-LAG (T2.5/250V)		△T901	1-431-301-11	TRANSFORMER, POWER	
		< FUSE HOLDER >		*****			
FH903	1-533-293-11	FUSE HOLDER		*****			
FH904	1-533-293-11	FUSE HOLDER		*****			
FH913	1-533-293-11	FUSE HOLDER		*****			
FH914	1-533-293-11	FUSE HOLDER		*****			
*****				*****			
*	1-663-933-11	SW BOARD (EX77)		*****			
		< CONNECTOR >		#1	7-685-647-79	SCREW +BVTP 3X10 TYPE2 N-S	
CN504	1-764-325-11	PIN, CONNECTOR (PCB) (V TYPE) 2P		#2	7-685-872-09	SCREW +BVTT 3X8 (S)	
				#3	7-685-871-01	SCREW +BVTT 3X6 (S)	
				#4	7-685-646-79	SCREW +BVTP 3X8 TYPE2 N-S	
				#5	7-685-650-79	SCREW +BVTP 3X16 TYPE2 IT-3	

The components identified by mark △ or dotted line with mark △ are critical for safety. Replace only with part number specified.

