

TA-E7/E7B

TA-E7 (Panel: Silver)
AEP Model
UK Model

TA-E7B (Panel: Black)
US Model
Canadian Model
AEP Model
UK Model



TA-E7 (AEP, UK Model)

STEREO PREAMPLIFIER

SPECIFICATIONS

GENERAL

- Power Requirements:** 110, 120, 220, or 240 V ac adjustable,
50/60 Hz (AEP, UK model)
120V ac
60 Hz (US, Canadian model)
- Power Consumption:** 22 W
- Dimensions:** (AEP, UK model)
Approx. 430 (w) x 170 (h) x 320 (d) mm
16⁷/₈ (w) x 6³/₄ (h) x 12⁵/₈ (d) inches
Including projecting parts and controls
(US, Canadian model)
Approx. 460 (w) x 170 (h) x 320 (d) mm
18¹/₈ (w) x 6³/₄ (h) x 12⁵/₈ (d) inches
Including projecting parts and controls
- Weight:** (AEP, UK model)
Approx. 11.2 kg, 24 lb 11 oz (net)
Approx. 13.4 kg, 29 lb 9 oz
(with shipping carton)
(US, Canadian model)
Approx. 12 kg, 26 lb 80 oz
Approx. 14.4 kg, 31 lb 130 oz
(with shipping carton)

Continued on page 2 -

SAFETY-RELATED COMPONENT WARNING!!

COMPONENTS IDENTIFIED BY SHADING AND \triangle MARK ON THE SCHEMATIC DIAGRAMS, EXPLODED VIEWS AND IN THE PARTS LIST ARE CRITICAL TO SAFE OPERATION. REPLACE THESE COMPONENTS WITH SONY PARTS WHOSE PART NUMBERS APPEAR AS SHOWN IN THIS MANUAL OR IN SUPPLEMENTS PUBLISHED BY SONY.

ATTENTION AU COMPOSANT AYANT RAPPORT À LA SÉCURITÉ !

LES COMPOSANTS IDENTIFIÉS PAR UN TRAMÉ ET UNE MARQUE \triangle SUR LES DIAGRAMMES SCHÉMATIQUES, LES VUES EXPLOSÉES ET LA LISTE DES PIÈCES SONT CRITIQUES POUR LA SÉCURITÉ DE FONCTIONNEMENT. NE REMPLACER CES COMPOSANTS QUE PAR DES PIÈCES SONY DONT LES NUMÉROS SONT DONNÉS DANS CE MANUEL OU DES SUPPLÉMENTS PUBLIÉS PAR SONY.

SONY[®]

SERVICE MANUAL

TA-E7/E7B

AMPLIFIER SECTION

Inputs:

	Sensitivity	Impedance	Maximum Input Capability (0.03% distortion, 1 kHz)	S/N (weighting network, input level)
PHONO 1	2.5 mV (-50dB)	50k Ω	250 mV (-10 dB)	85 dB (A, 2.5 mV)
PHONO 2		50k Ω /100k Ω		
HEAD AMP	0.125 mV (-76dB)	25 Ω (at "3 Ω ") 100 Ω (at "40 Ω ")	12.5 mV (-36 dB)	75 dB (A, 0.125 mV)
TUNER AUX 1, 2 TAPE 1, 2	150 mV (-15.5dB)	50k Ω	—	105 dB (A, 150 mV)

Outputs:

0 dB = 0.775 V

	Output Level	Impedance
REC OUT 1, 2	150 mV (max. 15 V) (-15.5dB)	1 k Ω
OUTPUT 1, 2	1.5 V (max. 10 V) (5.5dB)	1.5 k Ω
HEADPHONE	10 mW (8 Ω)	3.3 Ω

- Harmonic Distortion:** Less than 0.003% at 1.5 V output
- IM Distortion:** Less than 0.003% at 1.5 V output
(60 Hz: 7 kHz=4:1)
- Frequency Response:** PHONO 1, 2 RIAA equalization
curve ± 0.2 dB
TUNER
AUX 1, 2 } 1 Hz-150 kHz $^{+0}_{-1}$ dB
TAPE 1, 2 }
- Tone Controls:** BASS ± 10 dB at 30 Hz
(TURNOVER FREQ 150 Hz)
 ± 10 dB at 60 Hz
(TURNOVER FREQ 300 Hz)
TREBLE ± 10 dB at 20 kHz
(TURNOVER FREQ 4 kHz)
 ± 10 dB at 40 kHz
(TURNOVER FREQ 8 kHz)
- Filters:** LOW: 12 dB/oct. below 30 Hz
HIGH: 12 dB/oct. above 9 kHz
- Residual Noise:** Less than 6 μ V (A-Network, IHF)

LEVEL METER SECTION

- Frequency Response:** 20 Hz - 70 kHz $^{+0}_{-3}$ dB
- Response Time:** 300 msec. in AVERAGE mode
1 msec. in PEAK mode
- Response Range:** -40 dB to +10 dB (METER SENS
control at CAL position)
-60 dB to -10 dB (METER SENS
0 dB = 1 Vrms)
- Indication Error:** -10 dB to +10 dB ± 0.5 dB
-30 dB to -10 dB ± 1.5 dB

MODEL IDENTIFICATION

SPECIFICATION LABEL

TA-E7B (US, Canadian Model)

SONY	STEREO AMPLIFIER		
	MODEL NO. TA-E7B	60Hz	22W
	AC 120 V		
	SERIAL NO.		
MADE IN JAPAN			

TA-E7B (AEP, UK Model)

SONY	STEREO AMPLIFIER		
	MODEL NO. TA-E7B	50/60Hz	22W
	AC 110 120 220 240V		
	SERIAL NO.		
MADE IN JAPAN			

TA-E7 (AEP, UK Model)

SONY	STEREO AMPLIFIER		
	MODEL NO. TA-E7	50/60Hz	22W
	AC 110 120 220 240V		
	SERIAL NO.		
MADE IN JAPAN			

1-2. CIRCUIT DESCRIPTIONS

Meter Mode Switch (S13) Set to AVERAGE Position

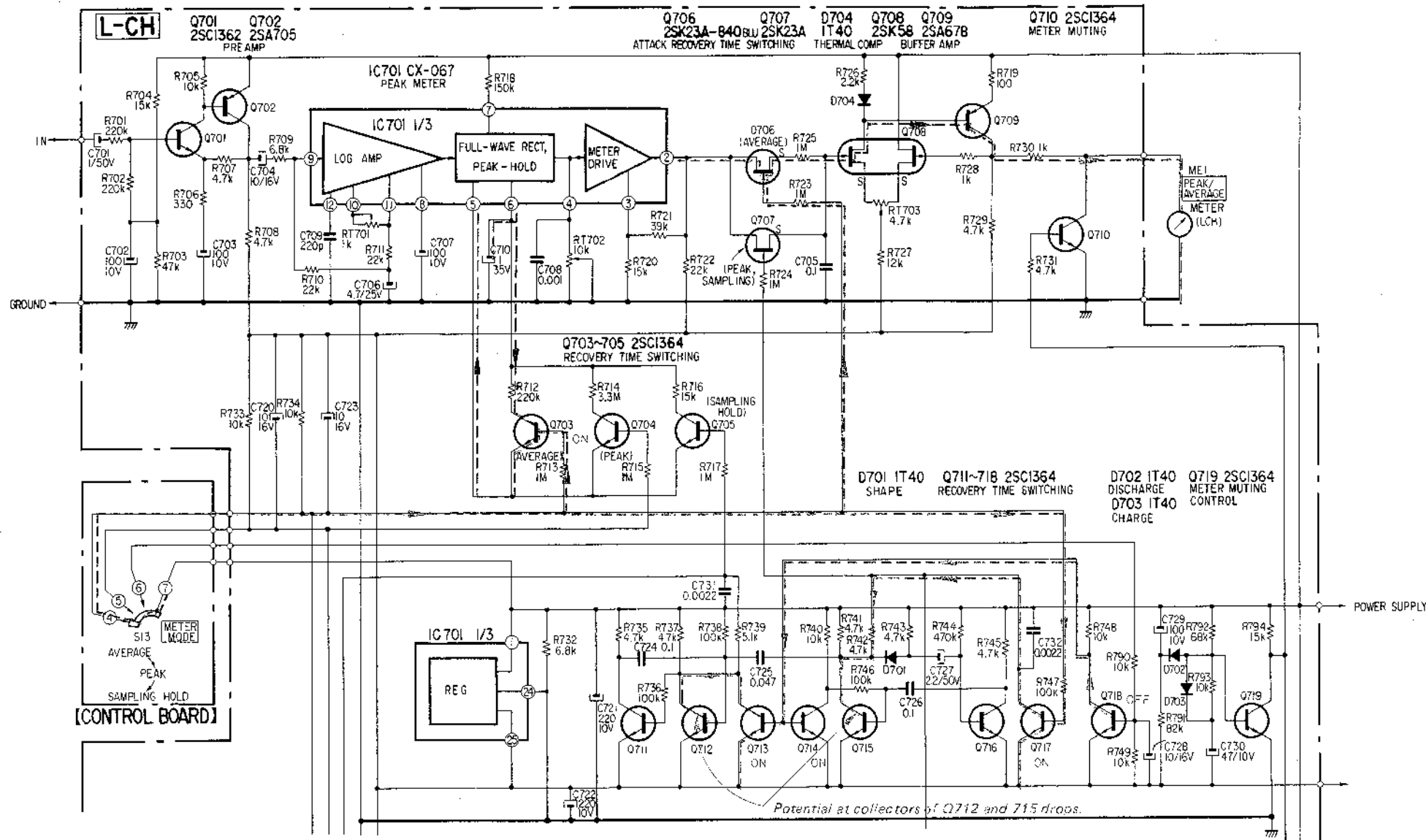

Fig. 1

PEAK METER CIRCUIT

The TA-E7/E7B features large-sized peak level meters which provide accurate checking of output levels. There are three different meter display modes, selected by the METER MODE switch (AVERAGE, PEAK, and SAMPLING HOLD).

1. Preamplifier Circuit (Fig. 1)

The tone amplifier output is passed via the RV404 METER SENS control and amplified by the preamplifier (Q701, Q702) of the meter circuit. The minimum value of this METER SENS control is 0dB—turning up to maximum value will increase meter sensitivity by approximately 20 dB. For example, when the meter reads 0 dB, the output level is approximately -20 dB.

In other words, the Q701, Q702 preamplifier provides a control margin of 20 dB.

Furthermore, this amplifier also includes a limiter 4 V in order to prevent excessive meter deflection.

The preamplifier output is applied to the terminal 9 of IC701, the major circuit component of the meter circuit.

2. IC701 (CX-067) and It's Surrounding Circuits (Fig. 1)

CX-067 is designed to perform Log conversion, full-wave rectification, peak holding, and other functions for two separate channels. It also incorporates a pair of power supply circuits in order to provide

voltages required for internal operation of the IC (powered by a single external power supply).

The following description refers to the left channel.

(1) Log Conversion Circuit

Input signals are converted to logarithmic form by means of the non-linearity of the diode inserted in the NFB circuit of the OP amplifier. The meter scale is thus compressed, permitting output levels to be checked over a wide range. The logarithmic function may be varied by changing the amount of NFB through the diode (i.e. changing the resistance of RT701 inserted across the terminals 10 and 11 of the IC.

(2) Full-Wave Rectifier Circuit

Full-wave rectification is necessary in order to detect both the \oplus and \ominus peaks of the input signal. In the CX-067, the \oplus side is half-wave-rectified, amplified two times in amplitude, and then mixed with the original (inverted) signal, thereby attaining full-wave rectification. The meter can thus be made to deflect in proportion to the peak levels in the input signal.

However, if this full-wave-rectified signal is applied directly, the meter needle can not respond to the pulse-like signal. For this reason, the CX-067 also includes a hold circuit where peak level signals charge up a capacitor, thereby permitting the meter to respond accurately to the peak levels.

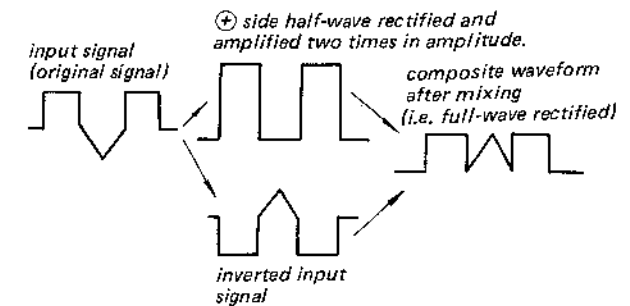

Fig. 2

(3) Hold Circuit and Attack Circuits

The three selectable meter modes are:

- a) Average ordinary response time, the same as ordinary VU meters.
- b) Peak extremely rapid response time, capable of responding to pulse-like signals. (minimum detectable pulse width 1 ms).
- c) Sampling hold... maximum peak level detected every 0.5 sec (approx.) and held for about 0.5 sec.

The hold and attack circuits are employed for easy reading the meter values.

1) Hold circuit

The capacitor C710 connected to terminal 6 of IC701 is charged up by the full-wave-rectified signal.

The charging amplifier is also used as the full-wave rectification circuit. Due to the voltage on C710, an NFB is applied to this full-wave rectification circuit, thereby determining meter hold time.

This hold time is determined by the discharge time of C710. For peak and average meter modes, the respective discharge resistors R712 and R714 are switched over by the transistor switches Q703 and Q704.

* During peak mode, Q704 is turned on (see Fig. 4), and C710 discharges through R714 (3.3 MΩ) taking approximately five times longer than during average mode (see Fig. 3).

* During average mode, Q703 is turned on (see Fig. 1), and C710 discharges relatively rapidly through R712 (220 kΩ) (see Fig. 3).

* During sampling hold mode, Q705 turns on every 0.5 seconds, and C710 discharges immediately through R716 (15 kΩ) (see Fig. 5).

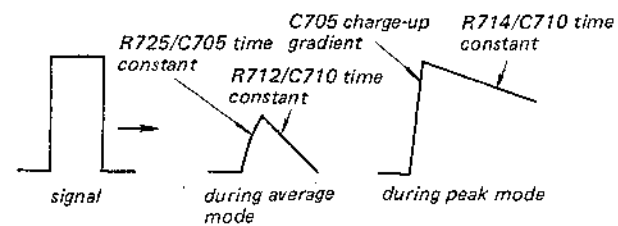

Fig. 3

Meter Mode Switch (S13) Set to PEAK Position

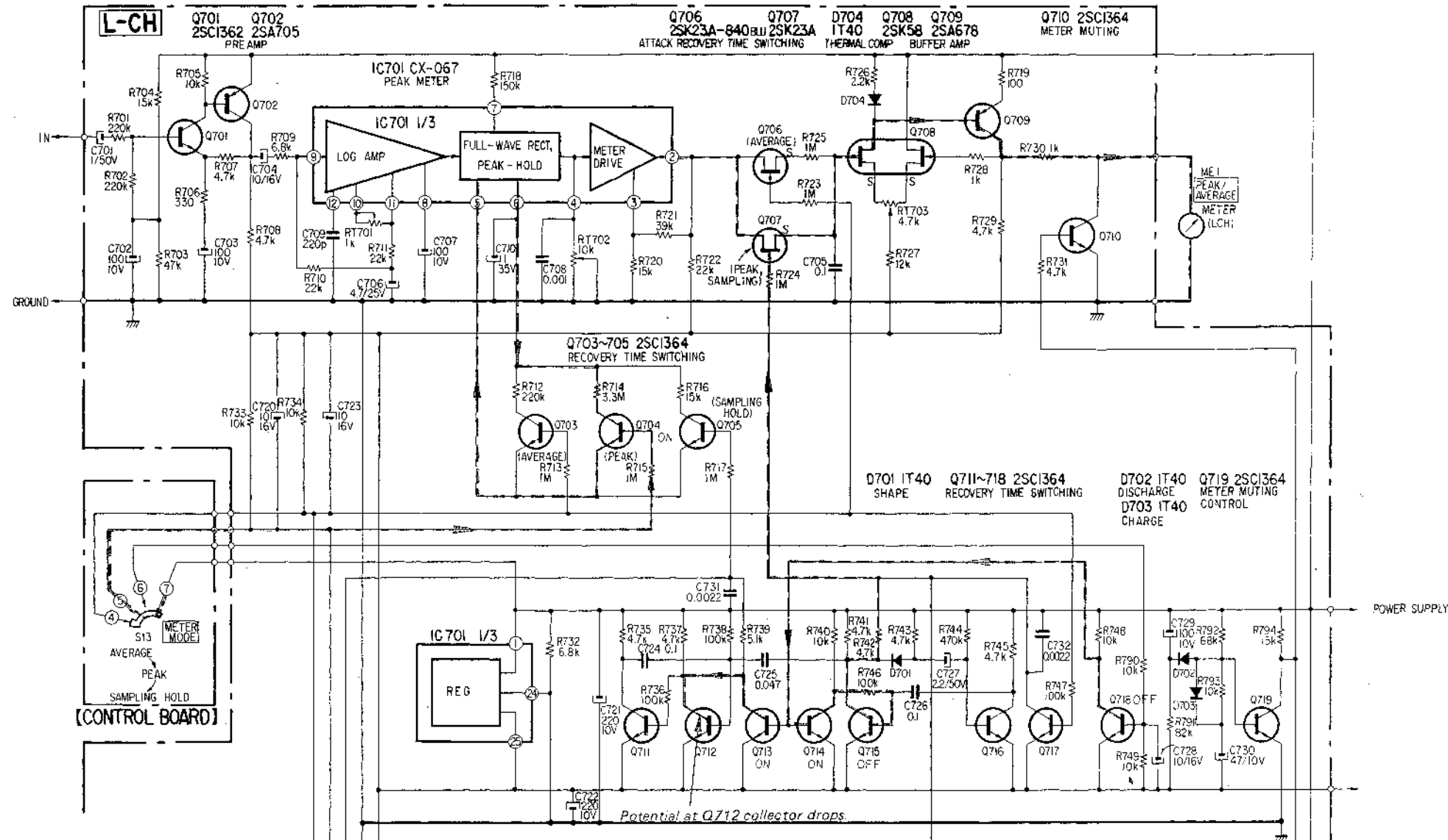

Fig. 4

2) Attack circuit

This circuit makes it possible to use ordinary level meters as peak level meters since the meter is overdriven (kicked) by the input signal and the differential value of the input signal.

The output signal from the hold circuit is gain-adjusted (RT702) by the drive amplifier, passed through FET switch Q706 or Q707, and applied to capacitor C705.

* During average mode, Q706 is turned on (Fig. 1) and current passed through R725, charges C705. Charge-up time is thus determined by the C705/R725 time constant. (Fig. 3).

* During peak mode, Q707 is turned on (Fig. 4), but since there is no resistor connected in series, C705 will charge up immediately (Fig. 3).

* During sampling hold mode, Q707 is turned on (Fig. 5) resulting in the same rapid charge-up time as during peak mode.

Meter Mode Switch (S13) Set to SAMPLING HOLD Position

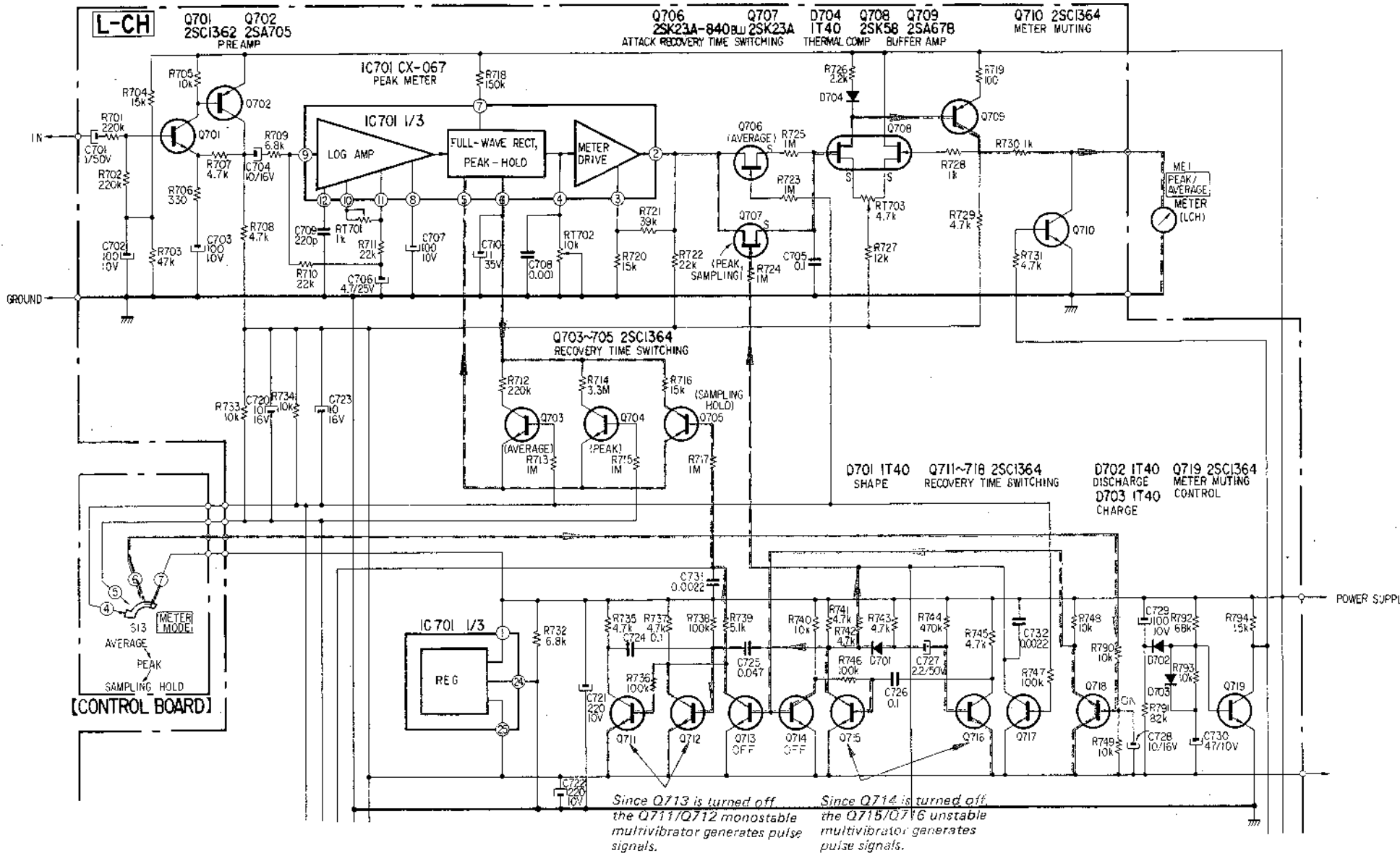

Fig. 5

3. Circuit Operation and Meter Display During Sampling Hold Mode (See Figs. 5 & 6)

Q705 is turned on at t_0 . C710 discharges rapidly through R716. Since Q705 turns off at t_1 , C710 starts to be charged up according to the input signal, and resulting in an increase of C710 terminal voltage. This terminal voltage is held at the value corresponding to the maximum peak level of the input signal between t_1 and t_3 (shown by mark *). Since the Q707 FET switch is turned on at t_2 , C705 is rapidly charged, and then Q707 turns off at t_3 , the C710 terminal voltage level is, therefore, maintained at the maximum peak voltage level (also shown by mark *), this being indicated by the meter until t_5 .

At the same time as Q707 is turned off (t_3), Q705 is turned on again, this cycle being repeated continuously. So actually, the maximum peak value in the 0.5 sec period from t_1 to t_3 (or more correctly to t_2) is indicated by the meter during the 0.5 sec period from t_2 to t_5 . If the maximum peak (shown by mark **) during the t_4 to t_6 period is even higher than the maximum peak during the previous 0.5 sec period (i.e. t_1 to t_3), C705 will be charged up further, resulting in an additional increase in the C705 terminal voltage. If, however, the following maximum peak is lower, C705 will discharge accordingly, resulting in a corresponding drop in terminal voltage, this being made possible by the bi-directional properties of the Q707 FET which permit reverse discharging.

In this sampling hold mode, the meters display the maximum peak level for every 0.5 sec, making it easier to follow the changes in peak level.

4. Meter Drive Circuit (Fig. 5)

Since the Q706 and Q707 FET switches are of high impedance, Q708 and Q709 are a buffer amplifier to drive the meter.

Q708 is a dual FET differential amplifier designed to stabilize the meter drive circuit.

5. Meter Muting Circuit (Fig. 5)

In order to prevent meter deflection caused by surge current when the power supply is turned on and off, a meter muting circuit, consisting of Q719 and Q710, is used. This surge current is used to activate Q719, which controls Q710, consequently Q710 turns on for duration of pulse caused by the surge current to mute the meter signal.

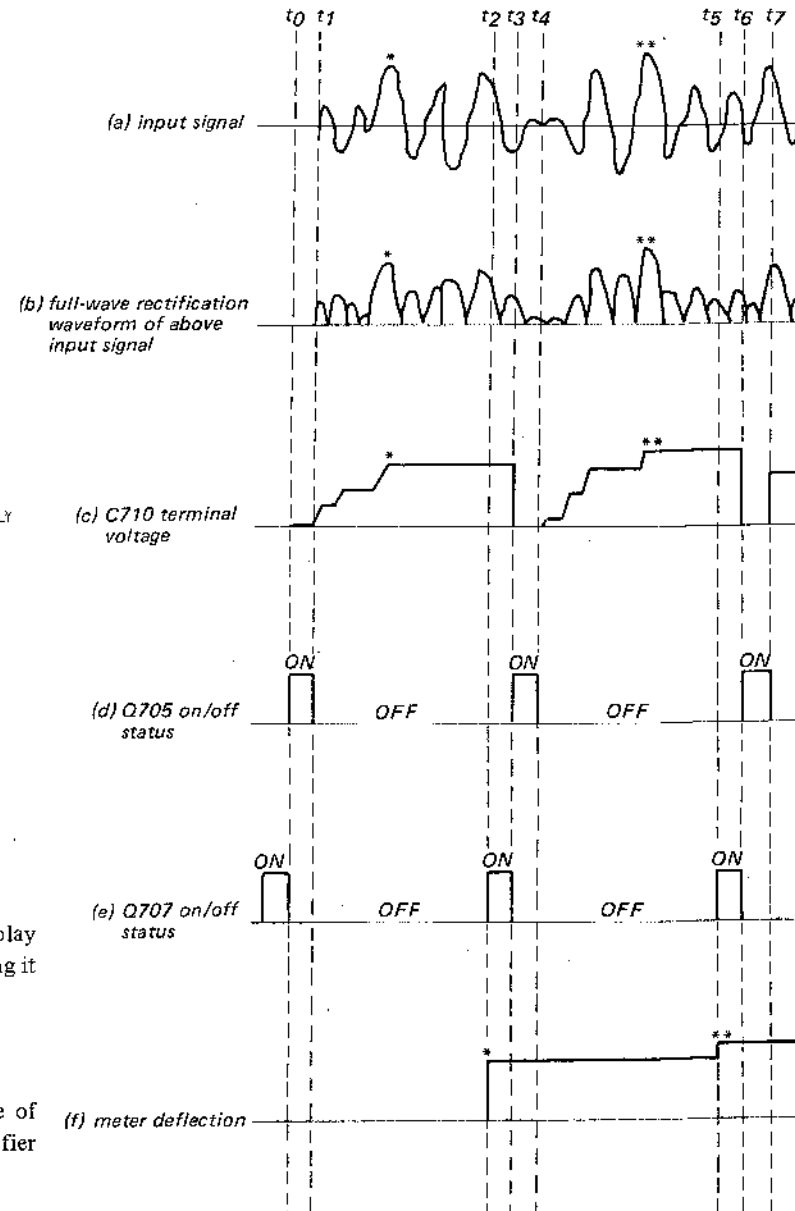
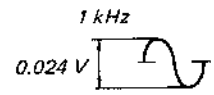

Fig. 6

Signal Waveforms at Important Points of the Circuit

(A) waveform at input terminals



with 1 V output signal at the output terminals

(B) waveform at pin 11 of IC701

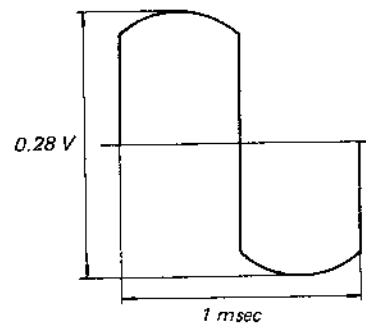

(C) waveform at pin 5 of IC701

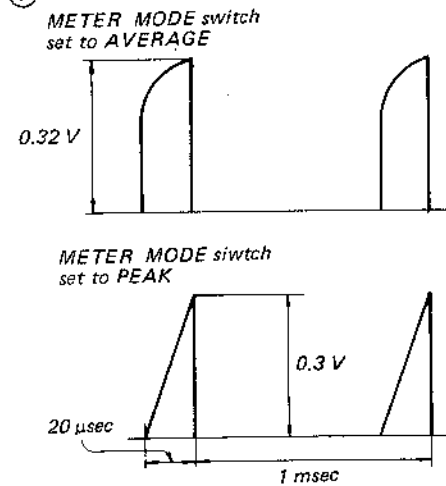

METER MODE switch set to SAMPLING HOLD

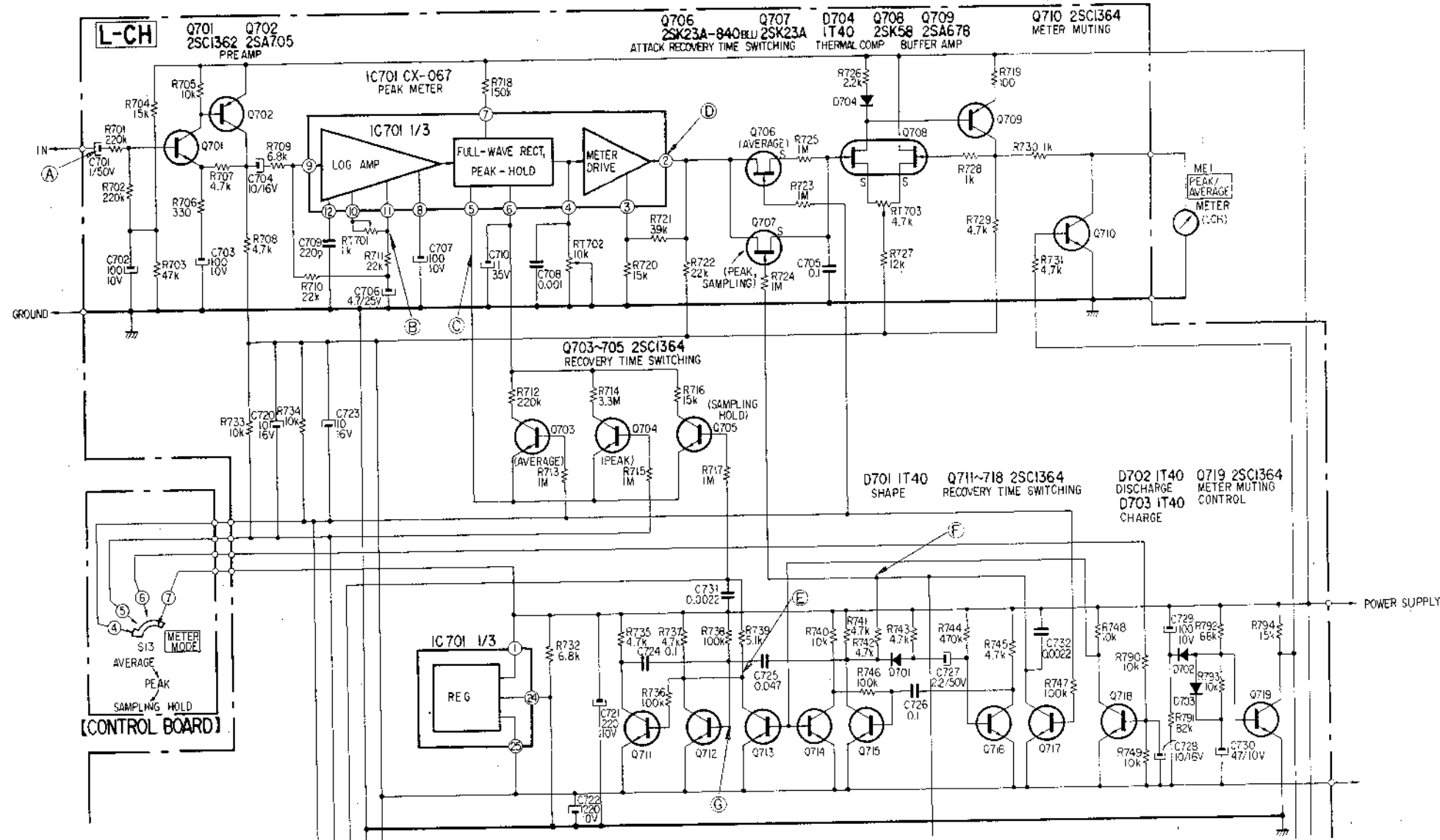
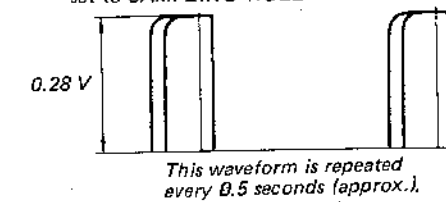
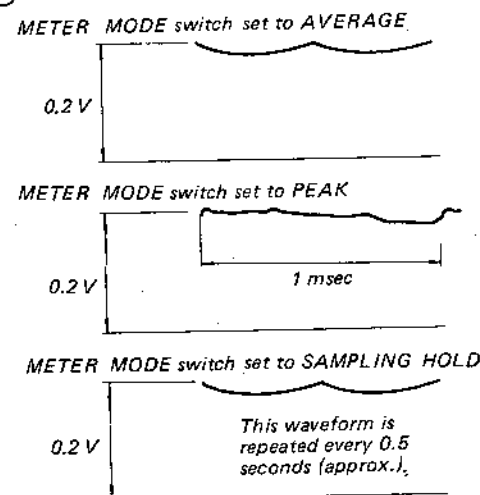
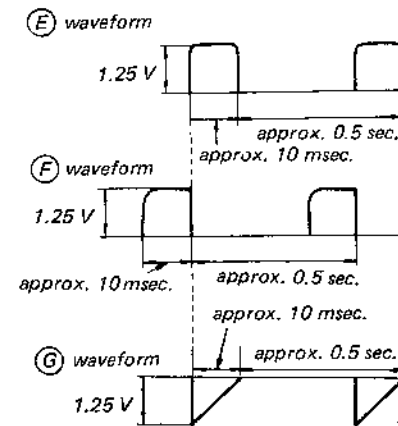

Fig. 7

(D) waveform at pin 2 of IC701



Waveforms for (E) and (F) refer to when the METER MODE switch is set to SAMPLING HOLD position.



HEAD AMPLIFIER CIRCUIT

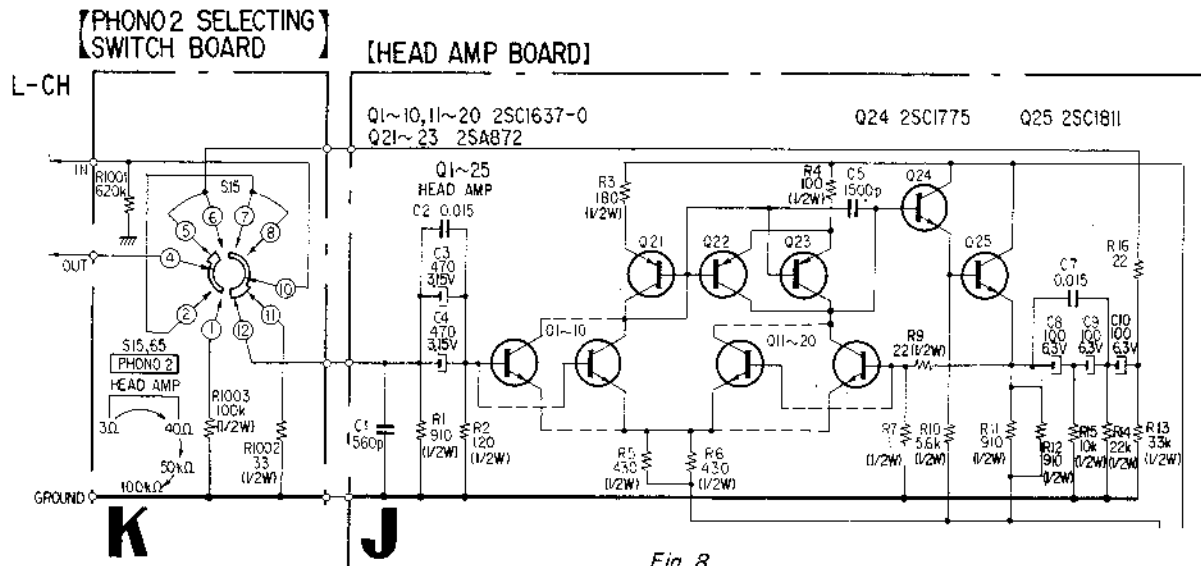

Fig. 8

The TA-E7 is equipped with a head amplifier in order to handle the low internal impedance and low output level of moving-coil type cartridges. A high S/N ratio has been achieved by adopting (in the first stage) a current mirror differential amplifier consisting of parallel-connected low-noise LEC (low emitter concentration) transistors which reduce the equivalent noise resistance.

Furthermore, a 3 Ω/40 Ω impedance selector is used in order to cope with the various different moving-coil type cartridges available on the market. High output moving-coil type cartridges and moving-magnet type cartridges can also be employed.

The left channel head amplifier circuit is shown in Fig. 8. The impedance selector switch is set to the value matching to the impedance of the cartridge being used. The input signal from the PHONO-2 terminals is applied to the parallel-connected differential amplifier formed by Q1 to Q10.

The head amplifier equivalent circuit is shown in Fig. 9. The input impedance is kept high by feedback circuit, and a choice of different values for terminating-resistance R_0 is available. Another important factor in designing a head amplifier of low equivalent input noise is the reduction of the number of amplifier stages. If most of the gain is obtained in the first stage, noise level will be determined by the first stage.

The open-loop gain of the first stage differential amplifier in the TA-E7 is 70 dB. The next stage is an impedance converter with approximately 0 dB gain and the output signal is fed back to the first stage.

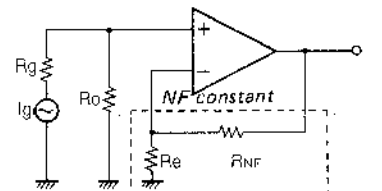

Fig. 9

The gain A of the actual amplifier shown in Fig. 9 is given as follows:

$$A = \frac{RNF + Re}{Re}$$

In the TA-E7, $A = \frac{R9 + R7}{R7} = 23$, or approximately 27 dB.

Since the output voltage produced by conventional cartridges includes both mechanical and electrical resonances, voltage amplification is required. Therefore, input impedance has to be at least greater than the cartridge impedance.

For this reason, the actual input impedance will be approximately 25 Ω when the impedance selector switch is set to the 3 Ω position, and approximately 100 Ω when set to the 40 Ω position.

Q21 to Q23 are a differential amplifier with current mirror circuit to increase the gain and form push-pull circuit for the load to improve distortion.

Low impedance is obtained at the head amplifier output stage (Q24, Q25) by means of a Darlington connection impedance conversion.

As was mentioned earlier, parallel-connected transistors are used to reduce the equivalent noise resistance. The reason for this reduction is briefly outlined below.

The effective noise level generated in a transistor is given by the following formula:

$$\sqrt{\bar{e}_n^2} = \sqrt{4KFT \left[r_{bb'} + \frac{r_e}{2} + \frac{(r_e + r_{bb'})^2}{2r_e h_{fe}} \right]} \dots (1)$$

where \bar{e}_n^2 = the effective noise level generated in the transistor,

K = Boltzmann's constant,

T = absolute temperature,

F = band width,

$r_{bb'}$ = base dispersion resistance,

r_e = effective emitter resistance $\frac{26}{I_e}$

h_{fe} = current amplification ratio, and

I_e = emitter current

But if h_{fe} is large, and r_e and $r_{bb'}$ both small,

$$\sqrt{\bar{e}_n^2} = \sqrt{4KFT (r_{bb'} + \frac{r_e}{2})} \dots (2)$$

In other words, it is necessary to select transistors of low $r_{bb'}$ and high h_{fe} .

Series connections are often used in order to reduce the $(r_{bb'} + \frac{r_e}{2})$ factor.

In Fig. 10, two transistors are shown as connected in series. The $r_{bb'} + r_e$ factor in the equivalent circuit will become $1/2$, so $(r_{bb'} + \frac{r_e}{2})$ will also become $1/2$. Consequently, according to formula (2), noise will become $1/\sqrt{2}$, that is, a reduction of 3 dB. If n transistors are connected in series, noise will be reduced by $1/\sqrt{n}$.

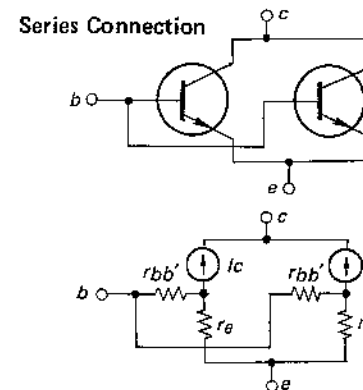

Fig. 10

Muting Circuit

In order to prevent the generation of switching noises when the power supply is turned on and off, and also to prevent the appearance of any signals at the output until the whole amplifier circuitry has been completely stabilized after switching on (approximately 3 seconds), the TA-E7 uses a muting circuit. This circuit mutes the input of the flat amplifier and output of the preamplifier by checking the surge of current at Q804.

**SECTION 2
DISASSEMBLY**

Remove the parts in the numerical order.

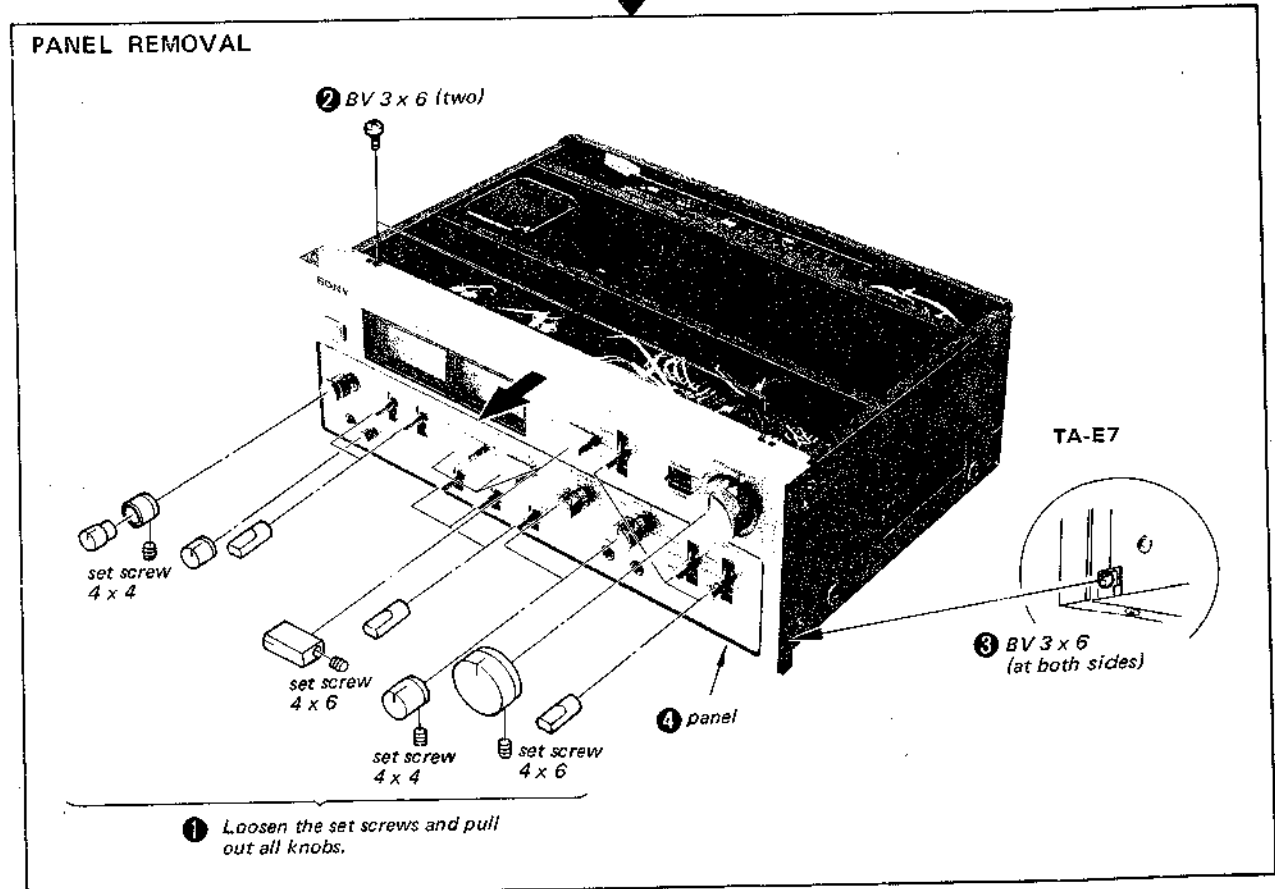
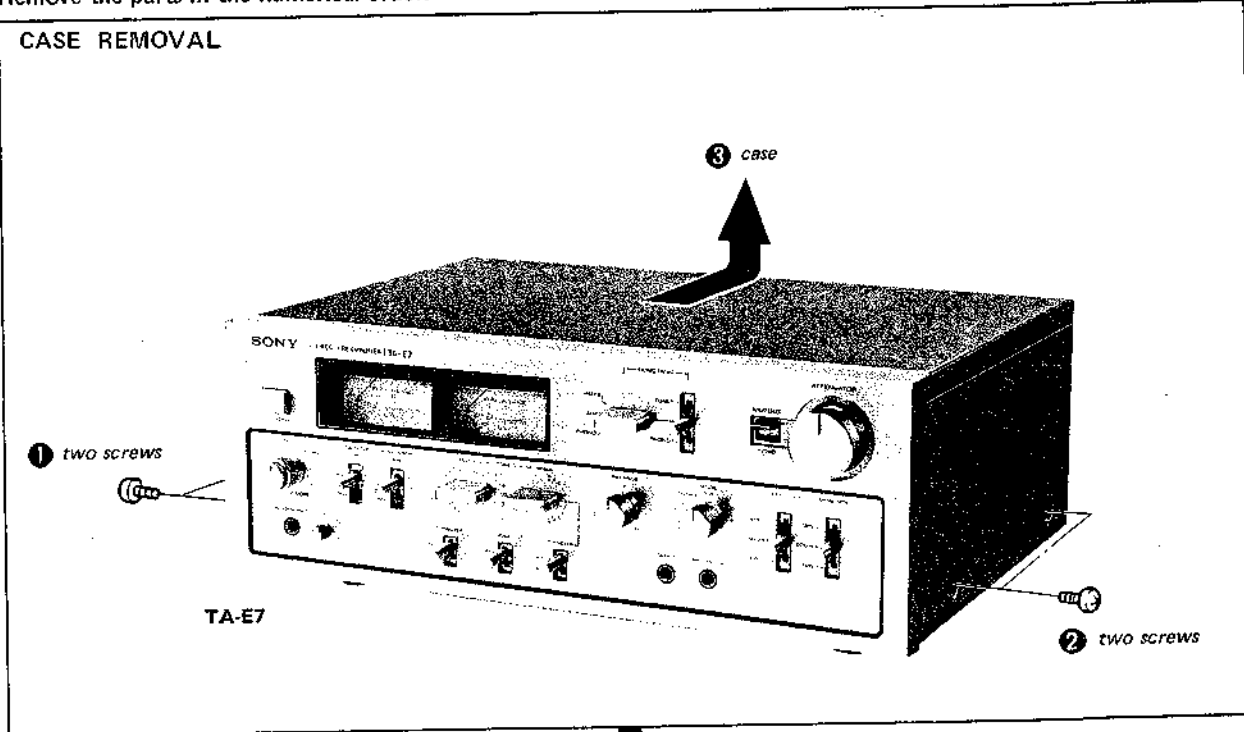

REMOVAL FOR CHECKING CIRCUIT BOARDS (1)

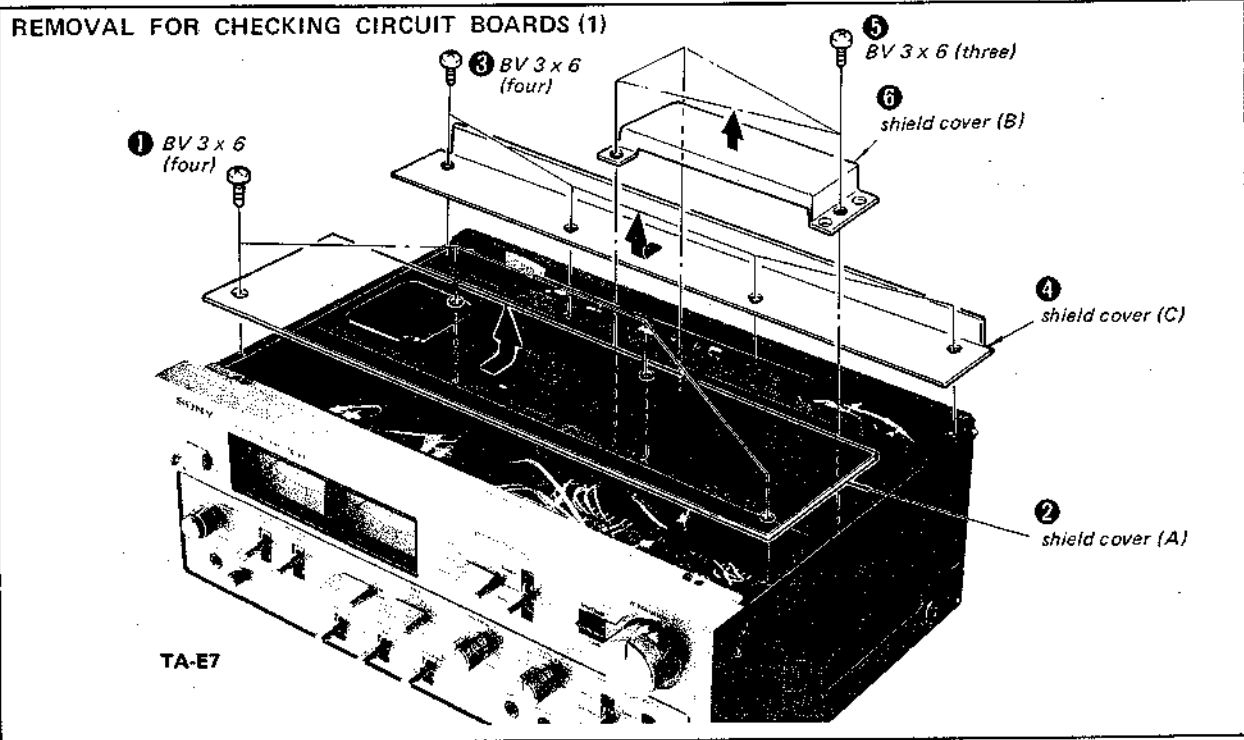

REMOVAL FOR CHECKING CIRCUIT BOARDS (2)

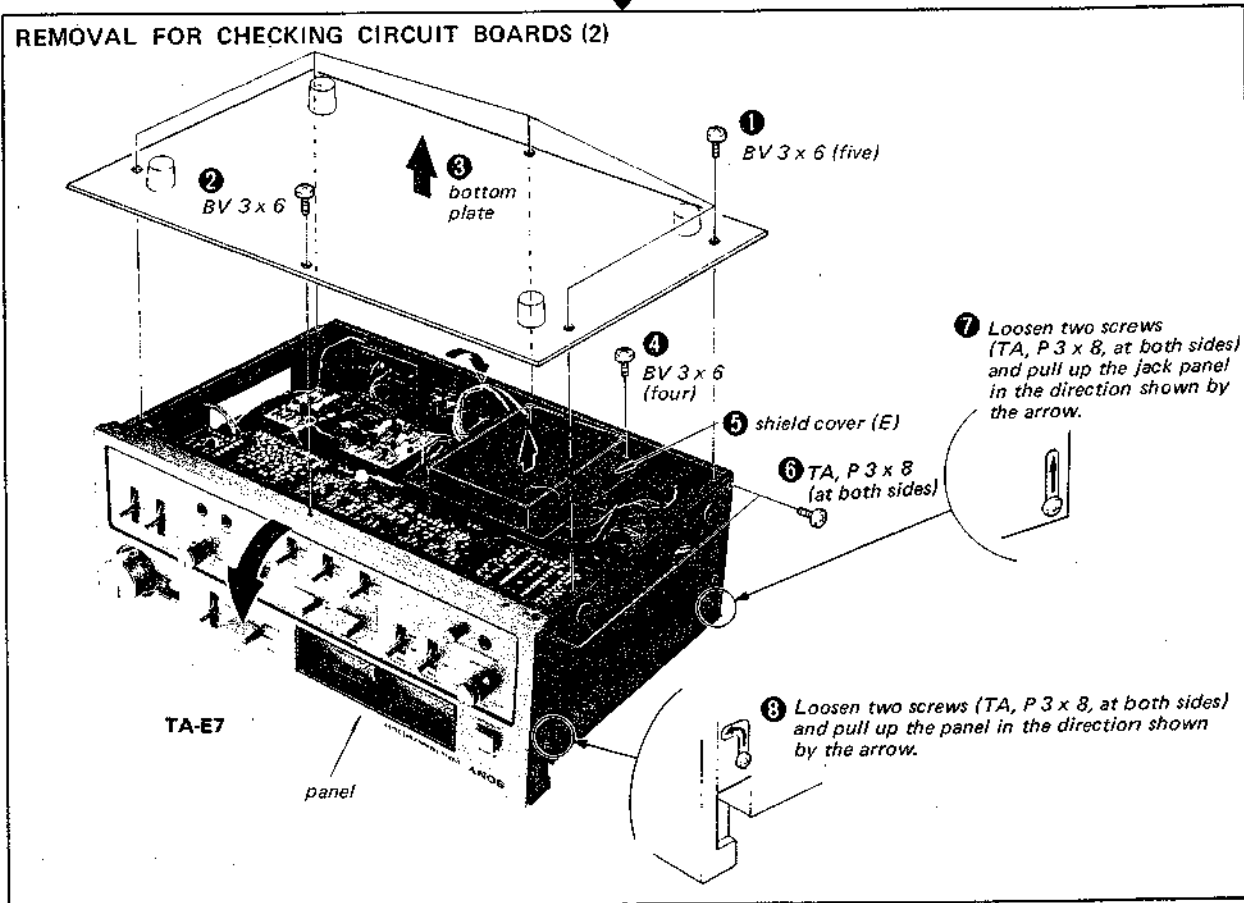

Meeter amp board can be checked.

meter amp board (H)

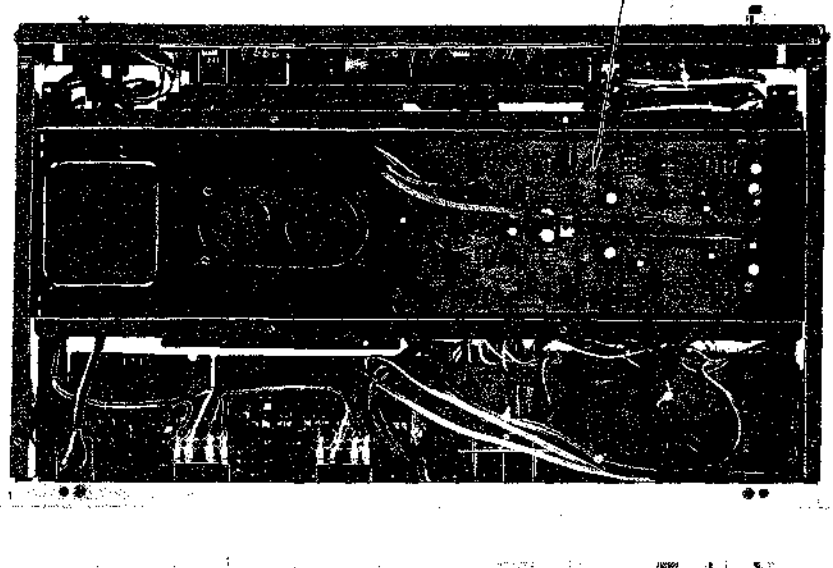

TA-E7

Circuit boards can be checked.

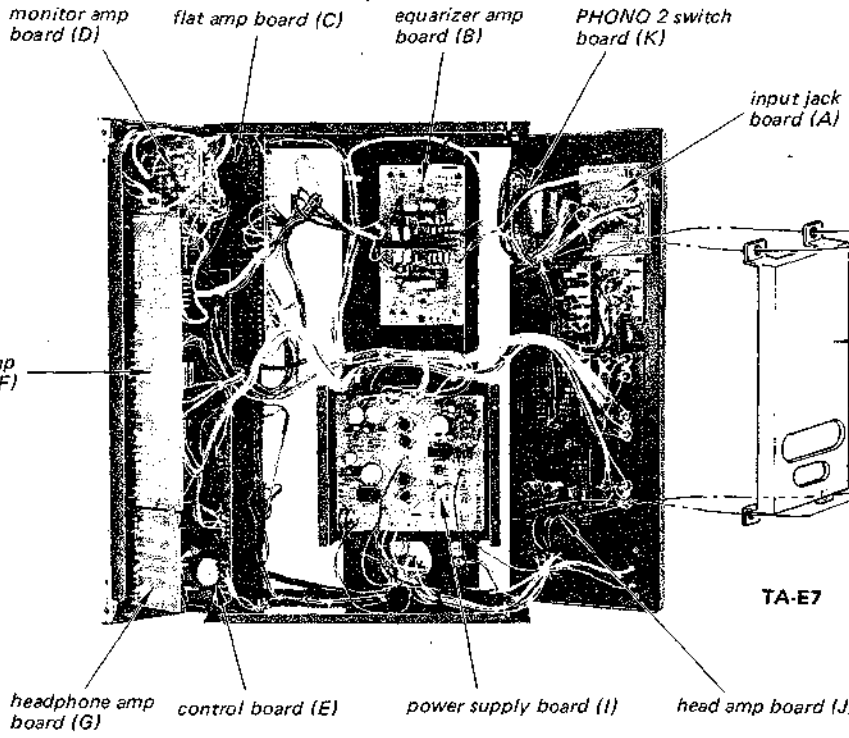

- 1 B 3 x 8 (two)
- 2 head amp board cover
- 3 B 3 x 8 (two)

TA-E7

SECTION 3 ADJUSTMENTS

Control and Switch Setting:

Unless otherwise specified, set the controls and switches as follows.

- FUNCTION switch: TUNER
- MODE switch: STEREO
- BALANCE control: mechanical mid
- TONE switch: OFF
- HIGH FILTER switch: OFF
- LOW FILTER switch: OFF
- METER MODE switch: PEAK
- METER SENS control: MIN

METER ZERO LEVEL ADJUSTMENT

Setting:

ATTENUATOR control: fully counterclockwise position (∞)

Procedure:

Adjust RT703 (L-CH) and RT753 (R-CH) for specified pointer position on the PEAK/AVERAGE meter as shown below.

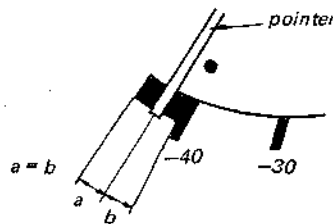

Adjustment Location:
- Meter Amp Board -

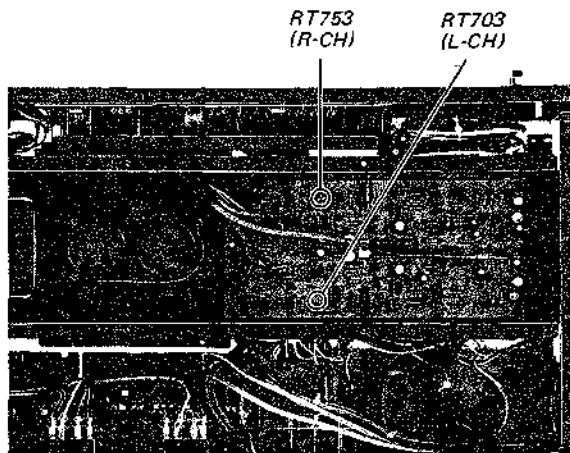

METER 0dB, -10 dB ADJUSTMENT

Setting:

ATTENUATOR control: fully clockwise position
(0)

Procedure:

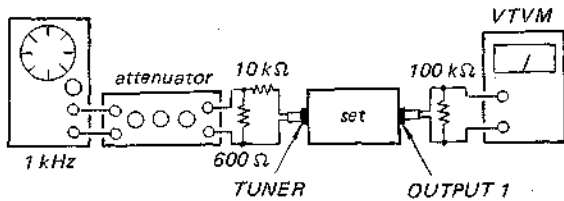

1. Adjust the attenuator for 1 V reading on VTVM.
2. Adjust RT701 (L-CH) and RT751 (R-CH) for 0 dB reading on the PEAK/AVERAGE meter.
3. Set the attenuator to 10 dB lowered position from the position obtained in step 1 above.
4. Adjust RT702 (L-CH) and RT752 (R-CH) for -10 dB reading on the PEAK/AVERAGE meter.
5. Repeat above steps several times.

Adjustment Location:

— Meter Amp Board —

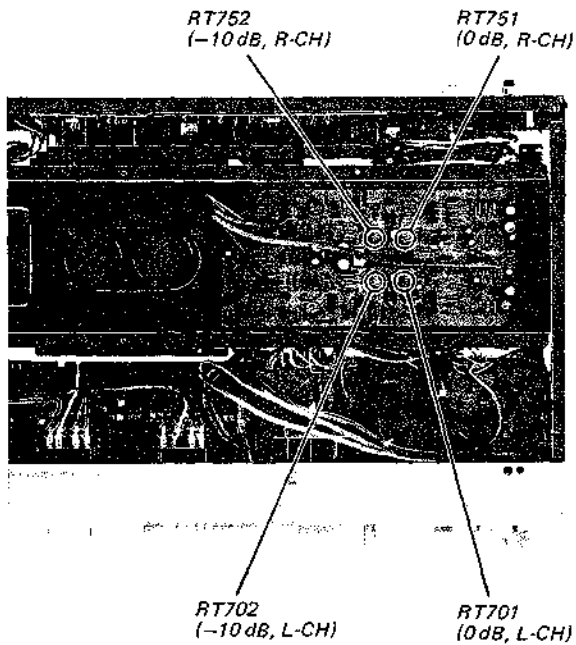

SECTION 4 DIAGRAMS

CIRCUIT BOARDS

A: INPUT JACK BOARD
 B: EQUALIZER AMP BOARD
 C: FLAT AMP BOARD
 D: MONITOR AMP BOARD
 E: CONTROL BOARD
 F: TONE AMP BOARD
 G: HEADPHONE AMP BOARD
 H: METER AMP BOARD
 I: POWER SUPPLY BOARD
 J: HEAD AMP BOARD
 K: PHONO 2 SWITCH BOARD
 MUTING SWITCH BOARD

4-1. SCHEMATIC DIAGRAM

J: HEAD AMP BOARD
 K: PHONO 2 SWITCH BOARD

Note:

- Components for right channel have same values as for left channel.
- All capacitors are in μF unless otherwise noted. $\text{pF} = \mu\mu\text{F}$ 50WV or less are not indicated except for electrolytics.
- All resistors are in ohms, $\frac{1}{2}\text{W}$.
 $\text{k}\Omega = 1000\Omega$, $\text{M}\Omega = 1000\text{k}\Omega$
- (N) : low-noise resistor.
- ——— : B+ bus.
- : panel designation.
- - - - : B- bus.
- Voltages are dc with respect to ground unless otherwise noted.
- Readings are taken under no signal conditions with a VOM (20 $\text{k}\Omega/\text{V}$).
- Switch

Ref. No.	Switch	Position
S15 S16	PHONO 2	HEAD AMP 3 Ω

Note: The components identified by shading and \triangle mark are critical for safety. Replace only with part number specified.

Note: Les composants identifiés par un tramé et une marque \triangle sont critiques pour la sécurité. Ne les remplacer que par une pièce portant le numéro spécifié.

J: HEAD AMP BOARD
K: PHONO 2 SWITCH BOARD

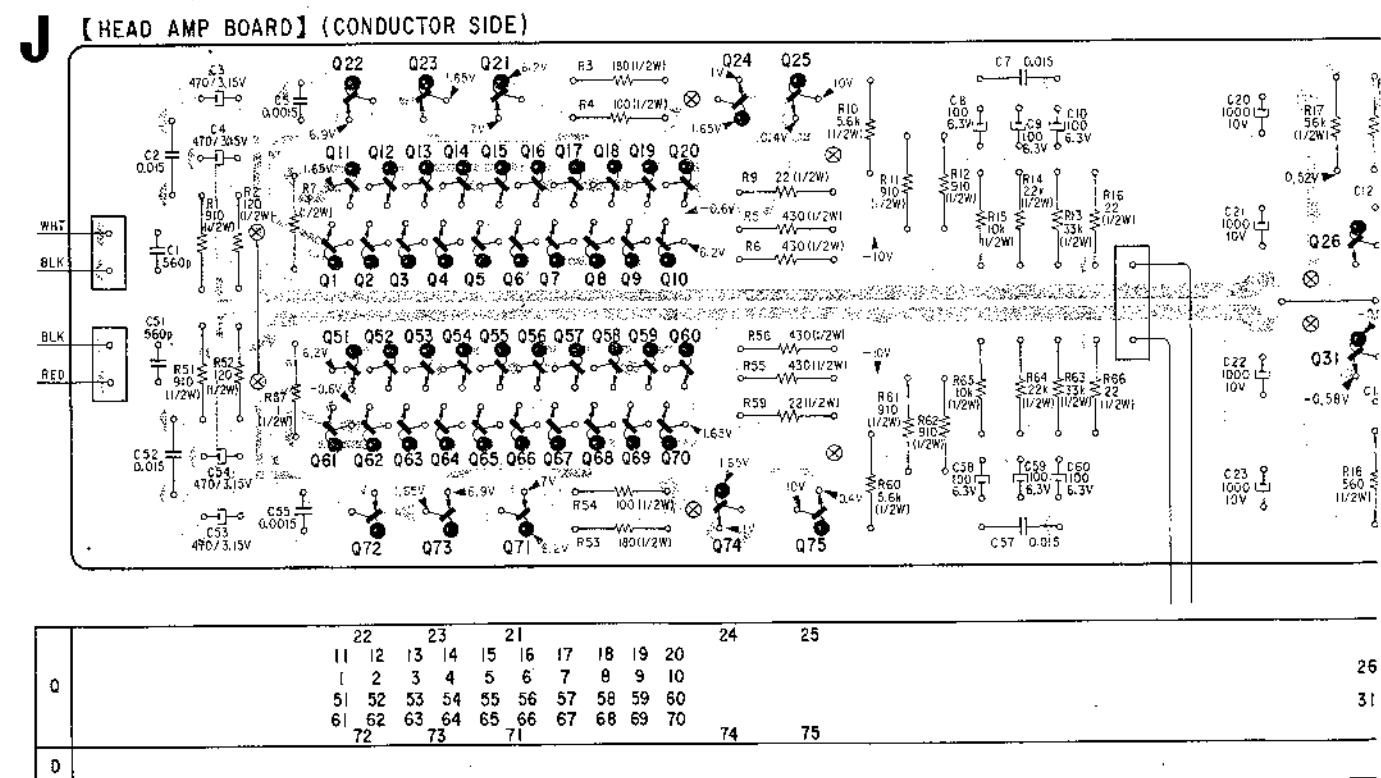
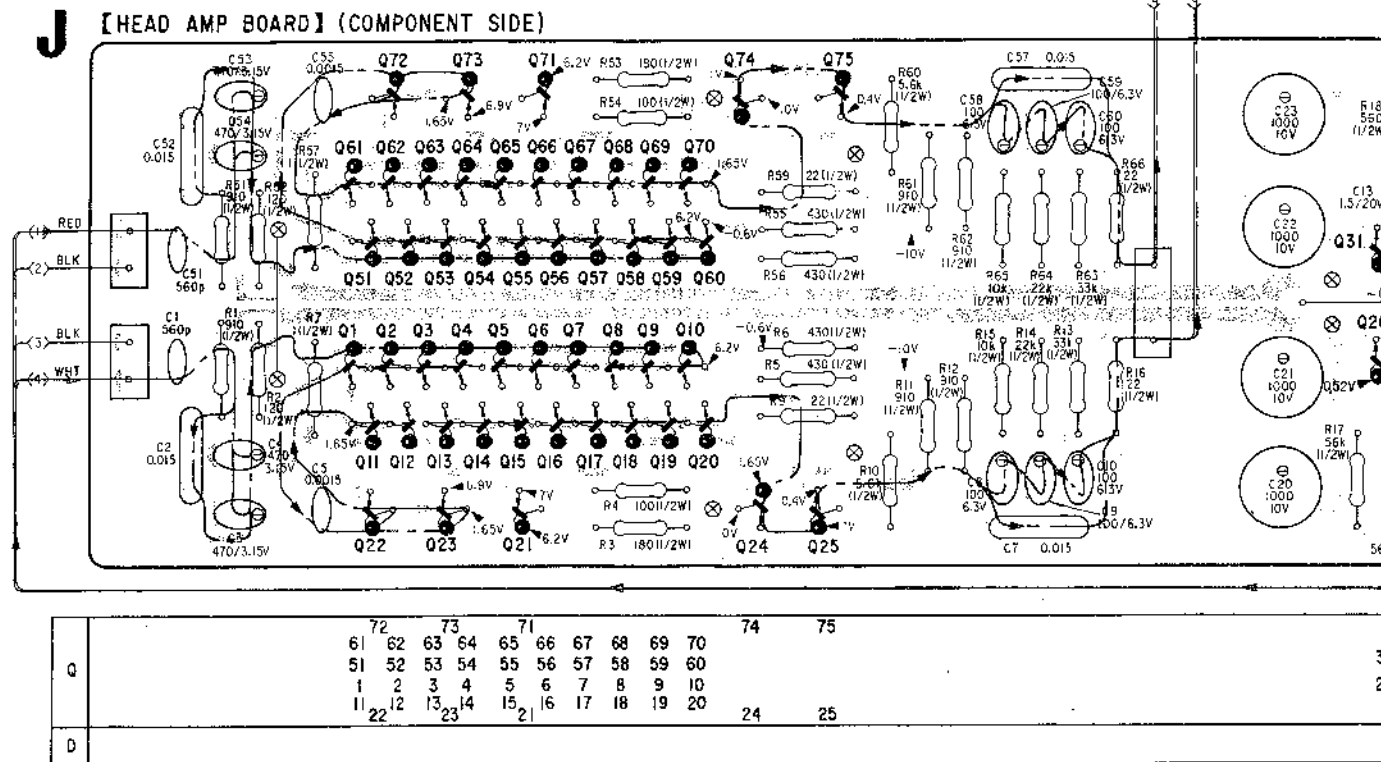
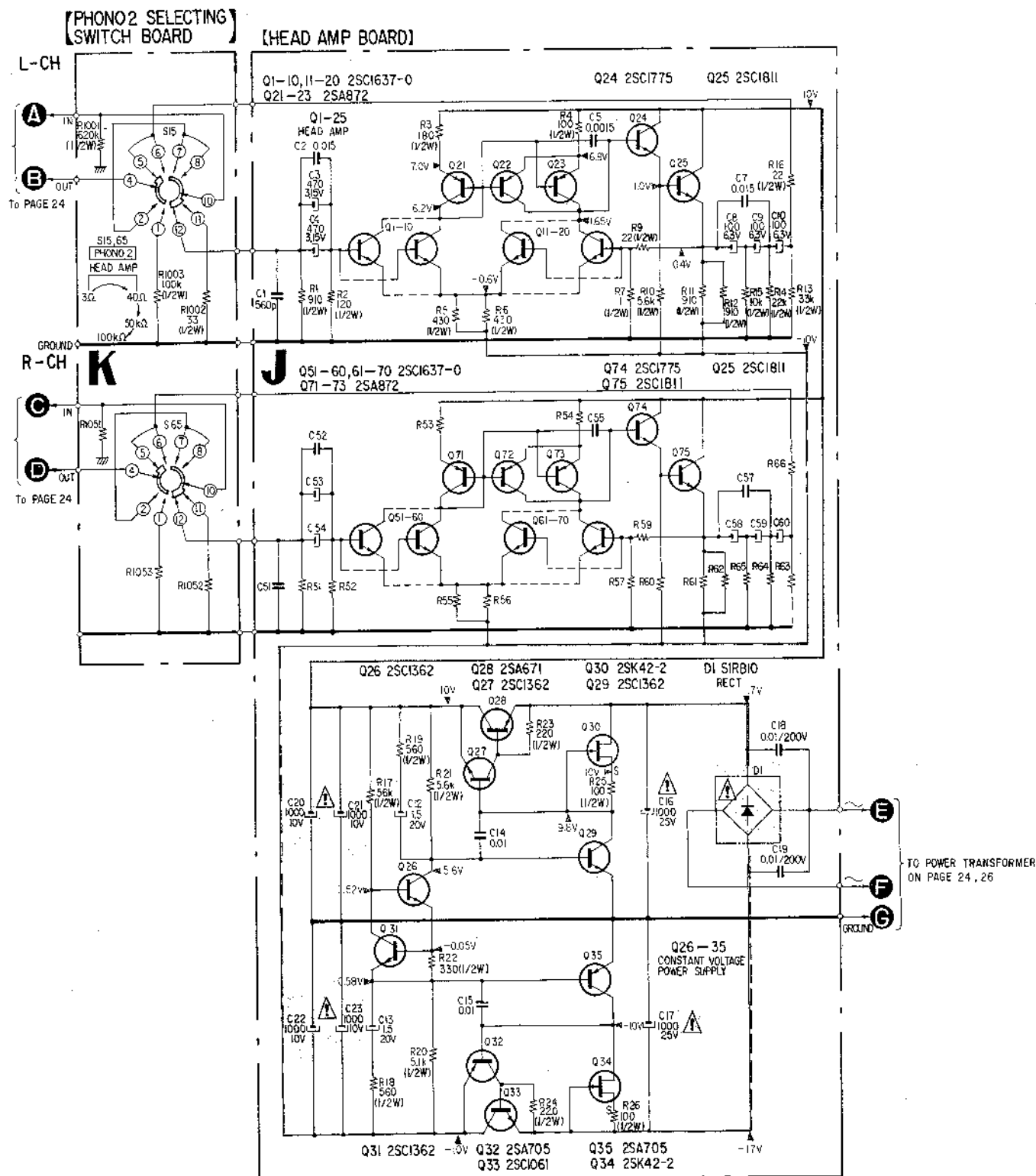

4-3. SCHEMATIC DIAGRAM

- A: INPUT JACK BOARD
- B: EQUALIZER AMP BOARD
- C: FLAT AMP BOARD
- D: MONITOR AMP BOARD
- E: CONTROL BOARD
- F: TONE AMP BOARD
- G: HEADPHONE AMP BOARD
- I: POWER SUPPLY BOARD

- Note:**
- Components for right channel have same values as for left channel.
 - All capacitors are in μF unless otherwise noted. $\text{pF} = \mu\mu\text{F}$
 - All resistors are in ohms, $\frac{1}{4}\text{W}$ unless otherwise noted. $\text{k}\Omega = 1000\Omega$, $\text{M}\Omega = 1000\text{k}\Omega$
 - : nonflammable resistor.
 - : fusible resistor.
 - (N) : low-noise resistor.
 - : panel designation.
 - : B+ bus.
 - : B- bus.
 - Voltages are dc with respect to ground unless otherwise noted.
 - Readings are taken under no signal conditions with a VOM (20 $\text{k}\Omega/\text{V}$).

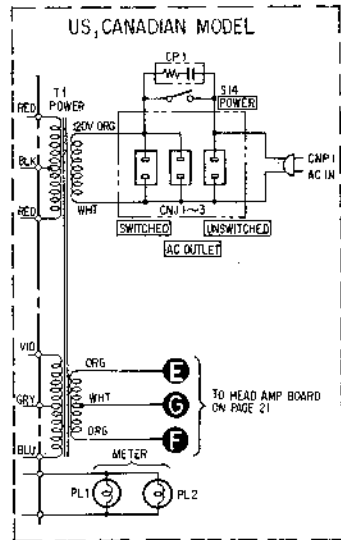
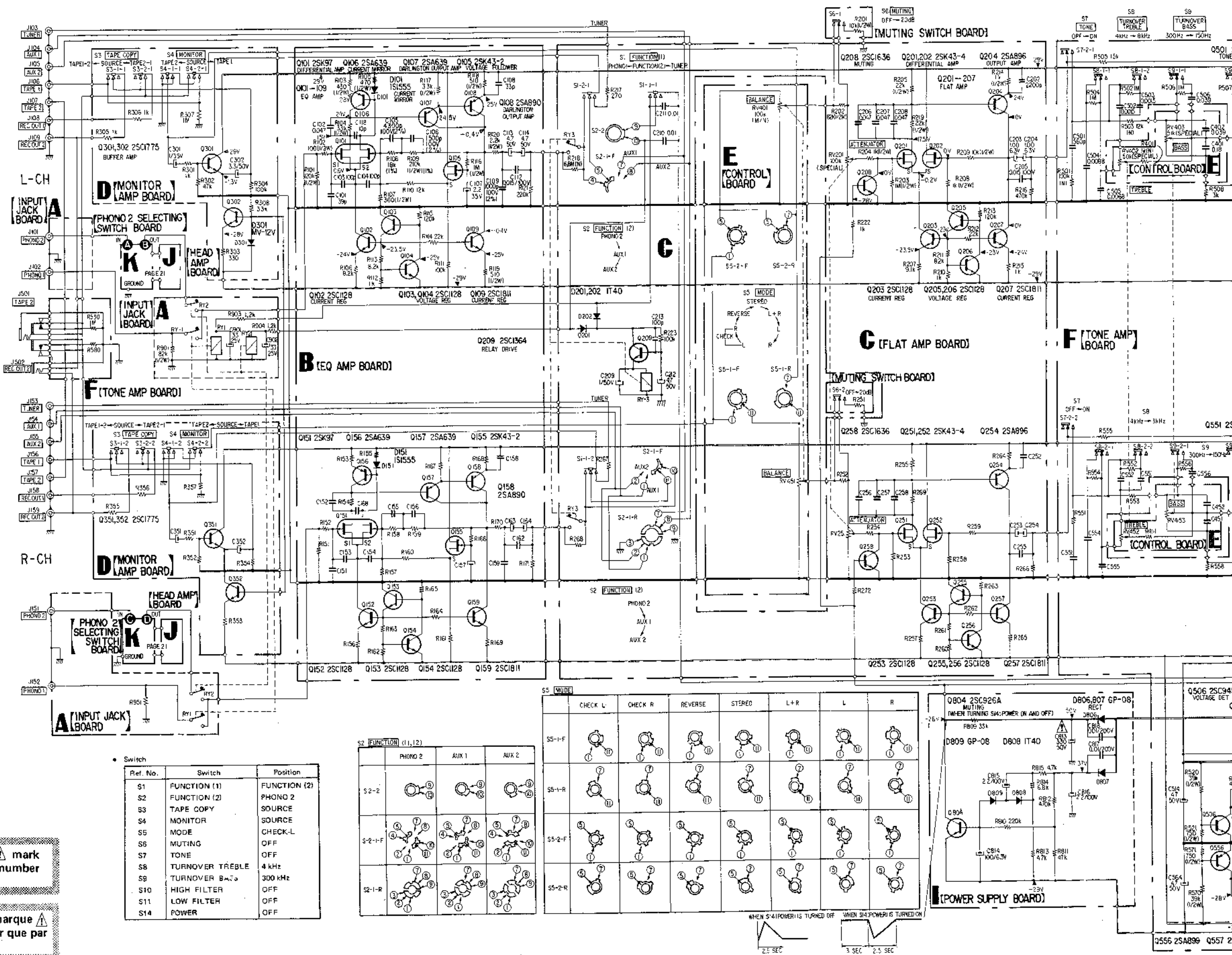

• Switch

Ref. No.	Switch	Position
S1	FUNCTION (1)	FUNCTION (2)
S2	FUNCTION (2)	PHONO 2
S3	TAPE COPY	SOURCE
S4	MONITOR	SOURCE
S5	MODE	CHECK-L
S6	MUTING	OFF
S7	STONE	OFF
S8	TURNOVER TREBLE	4 kHz
S9	TURNOVER BASS	300 kHz
S10	HIGH FILTER	OFF
S11	LOW FILTER	OFF
S14	POWER	OFF

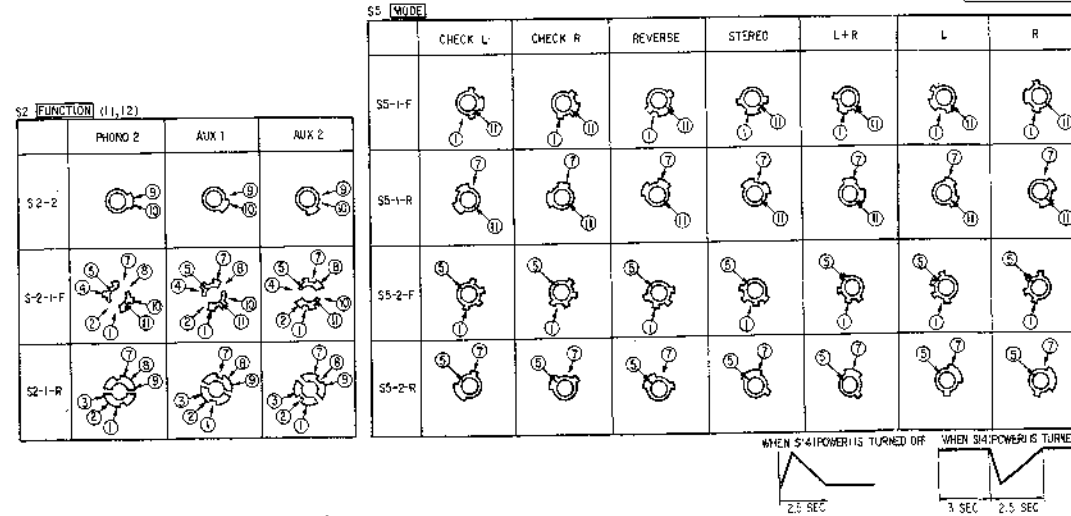

Note: The components identified by shading and Δ mark are critical for safety. Replace only with part number specified.

Note: Les composants identifiés par un trame et une marque Δ sont critiques pour la sécurité. Ne les remplacer que par une pièce portant le numéro spécifié.

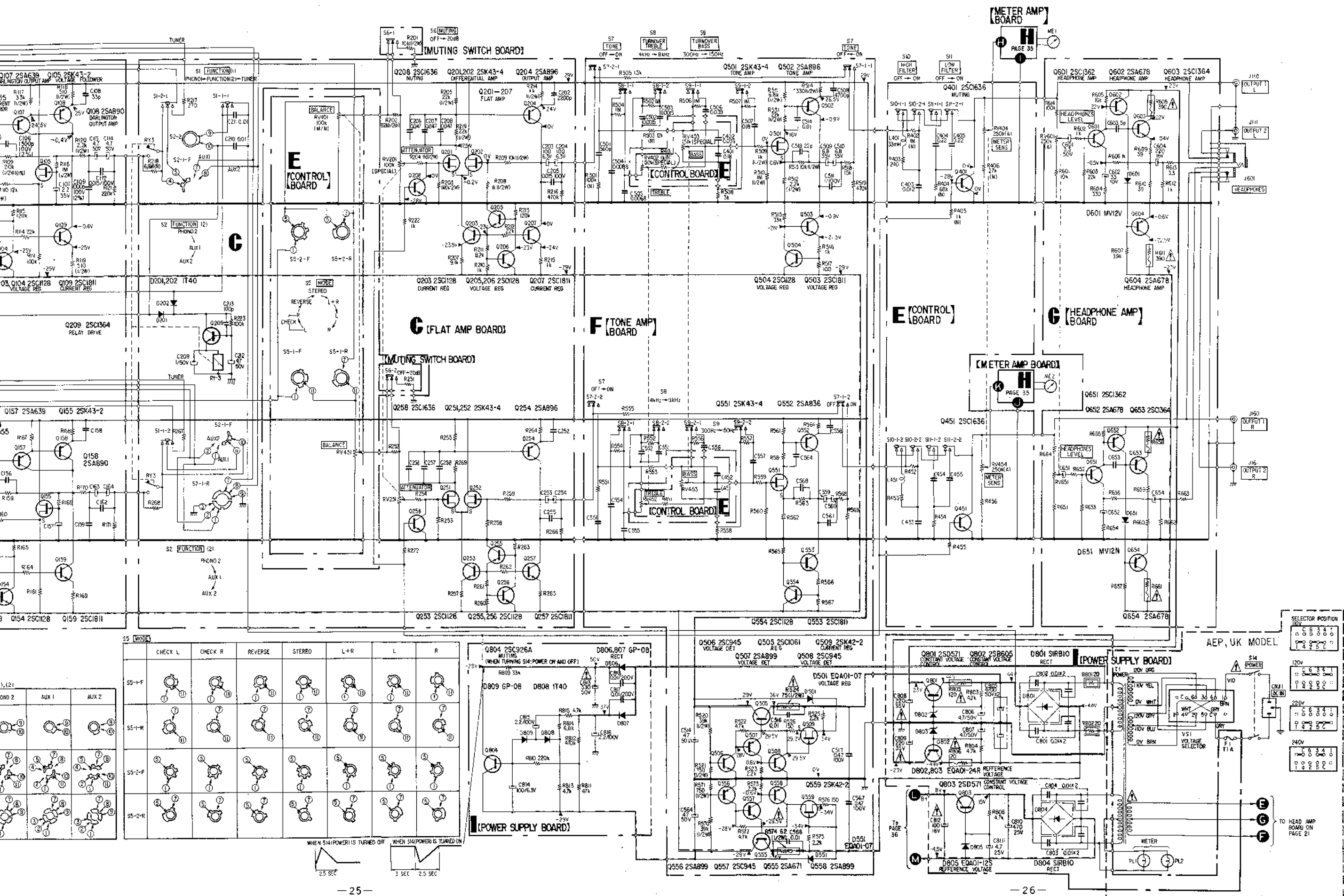

E: CONTROL BOARD G: HEADPHONE AMP BOARD
 F: TONE AMP BOARD I: POWER SUPPLY BOARD

TA-E7/E7B TA-E7/E7B

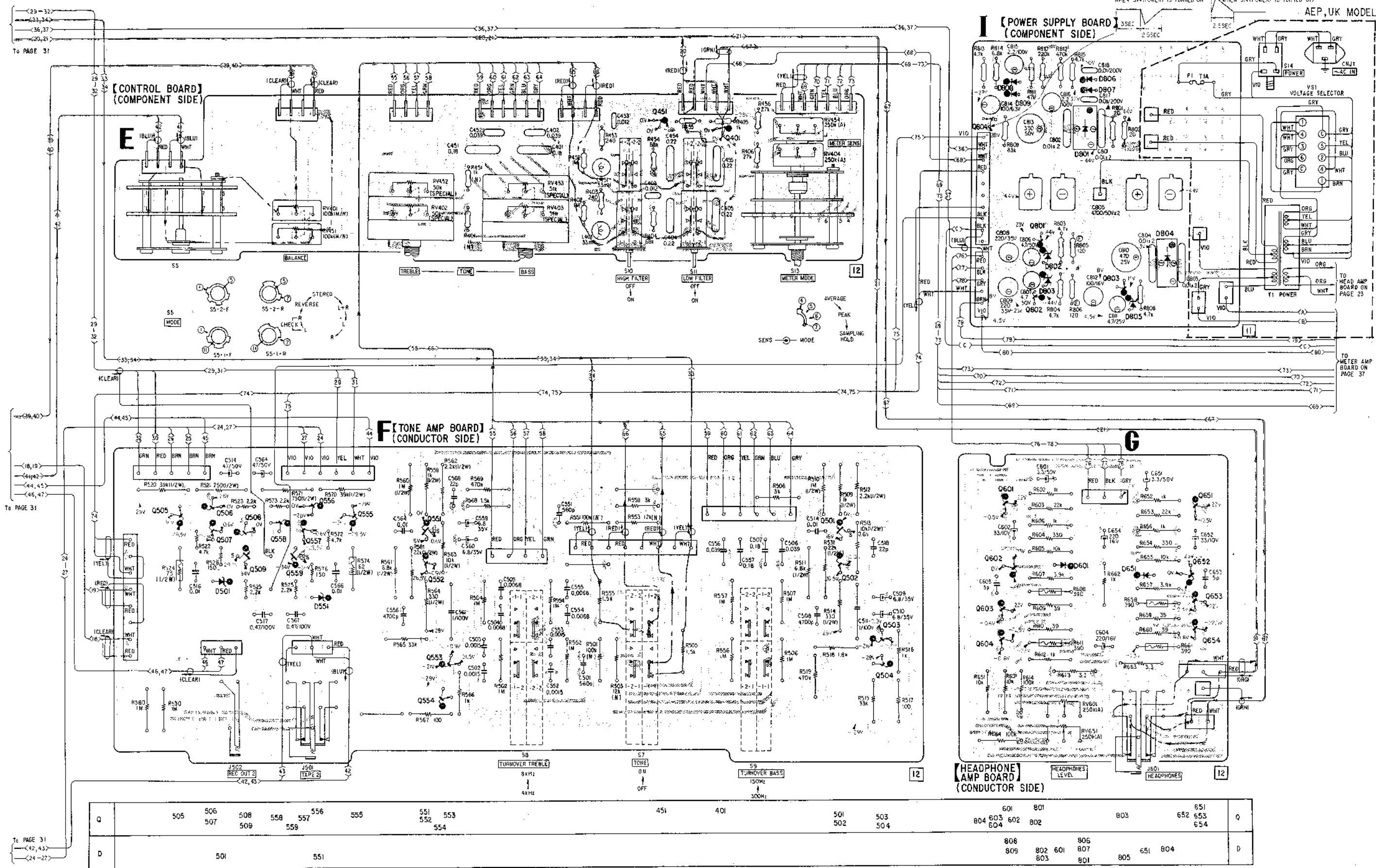

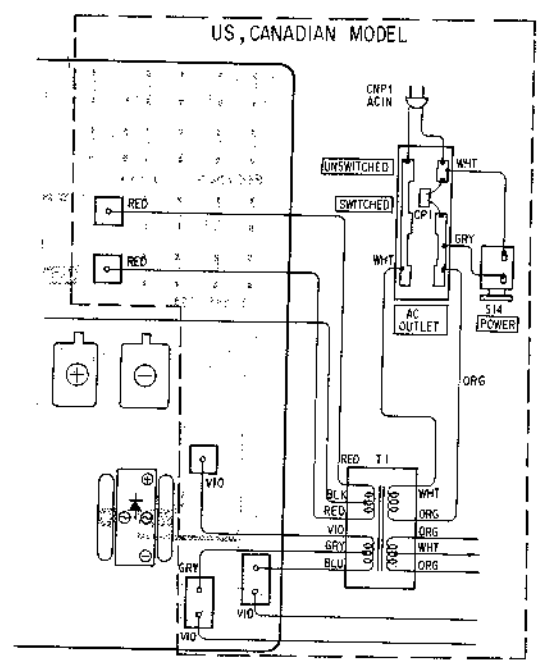
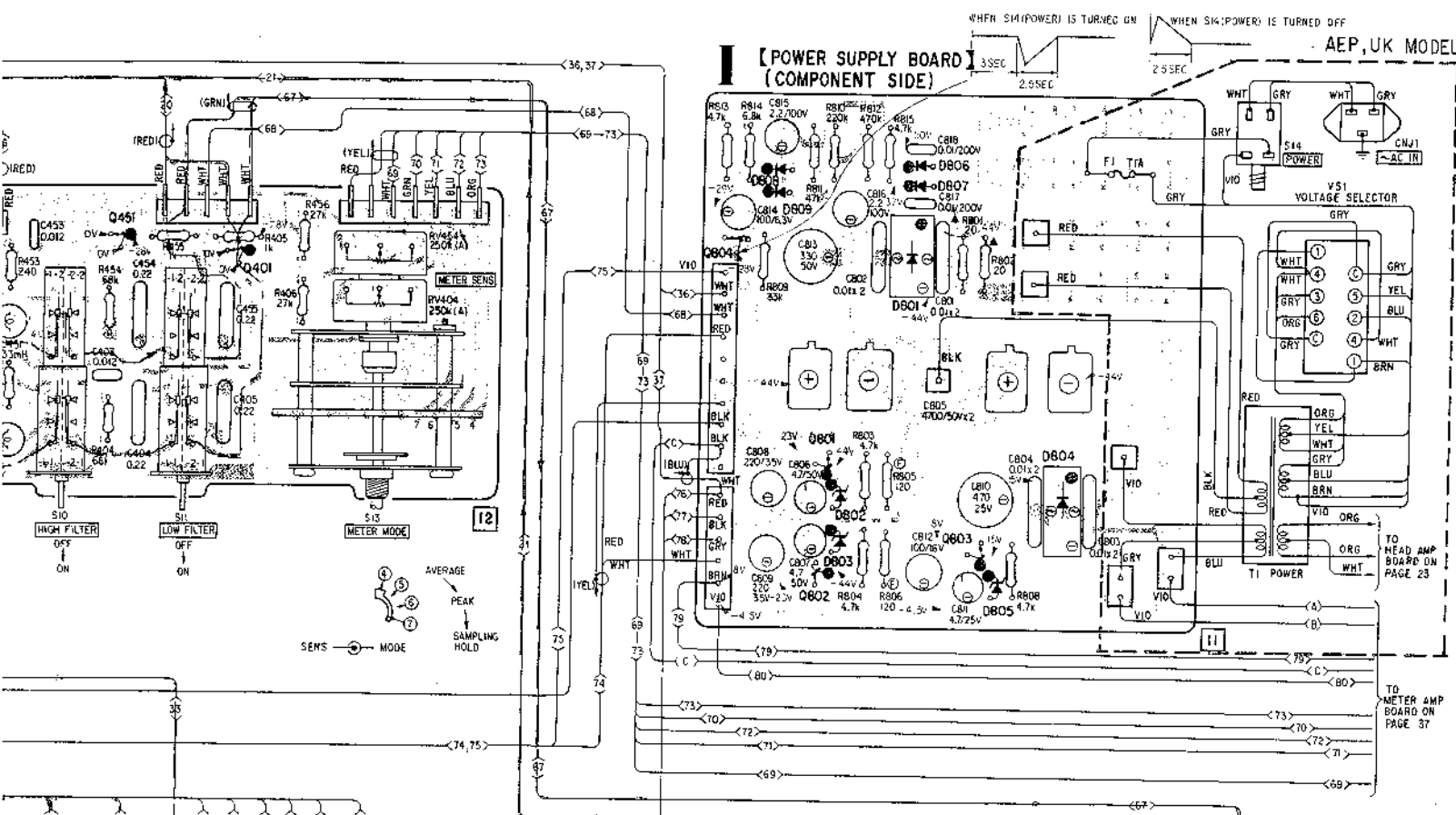

- : B+ pattern
- : B- pattern
- Signal Path
- : L-CH
- : R-CH
- ▲ : nonflammable resistor.
- ⊕ : fusible resistor.
- Voltages are dc with respect to ground unless otherwise noted.
- Readings are taken under no signal conditions with a VOM (20 kΩ/V).

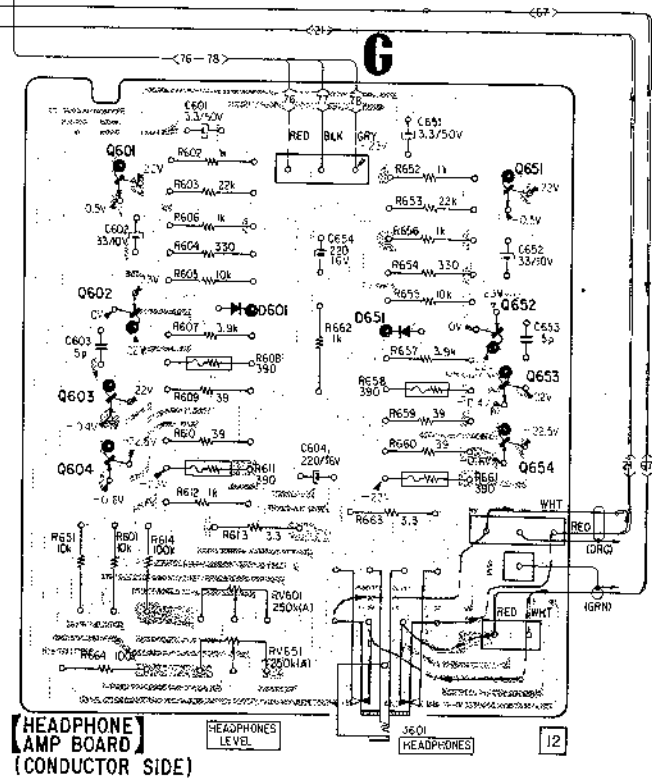
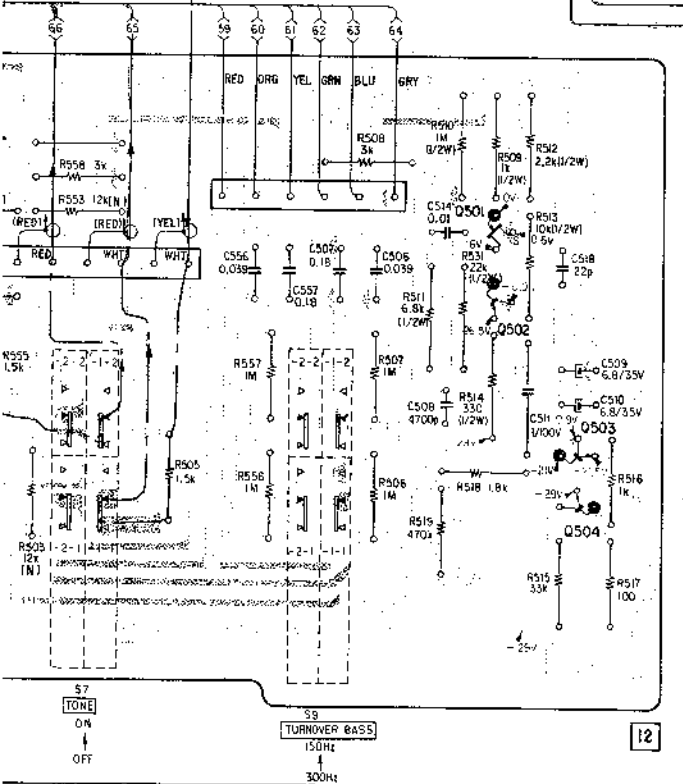

- Replacement Semiconductors**
For replacement, use semiconductors except in ().
- Q401, 451: 2SC1636
 - Q507, 556, 558: 2SA899
 - D601, 651: EQB01-07 (EQA01-07)
 - D802, 803: EQB01-24 (EQA01-24R)
 - D805: EQB01-12Z (EQA01-12S)
 - Q601, 651: 2SK43-4
 - Q509, 559: 2SK42-2
 - D601, 651: MV12N
 - Q502, 552: 2SA896
 - Q658: 2SA671
 - D801, 804: 1SRB10
 - Q603, 653: 2SC1811
 - Q601, 651: 2SC1362
 - Q603, 653: 2SC1364
 - Q504, 554: 2SC1128
 - Q602, 604: 2SA678
 - Q652, 654:
 - Q505: 2SC1061
 - Q601, 603: 2SC1475 (2SD571)
 - Q506, 508: 2SC845
 - Q597:
 - Q802: 2SA835 (2SB605)

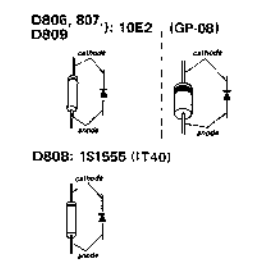

Note:
• Color code of sleeving over the end of the jacket.

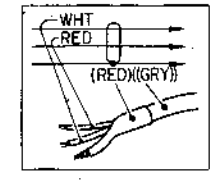

451	401	501	503	601	801	651	Q
		502	504	604	802	652	
				602	802	653	
				603	803	654	
				808	806		
				809	807		
				801	801		
				805	651	804	D

To PAGE 27

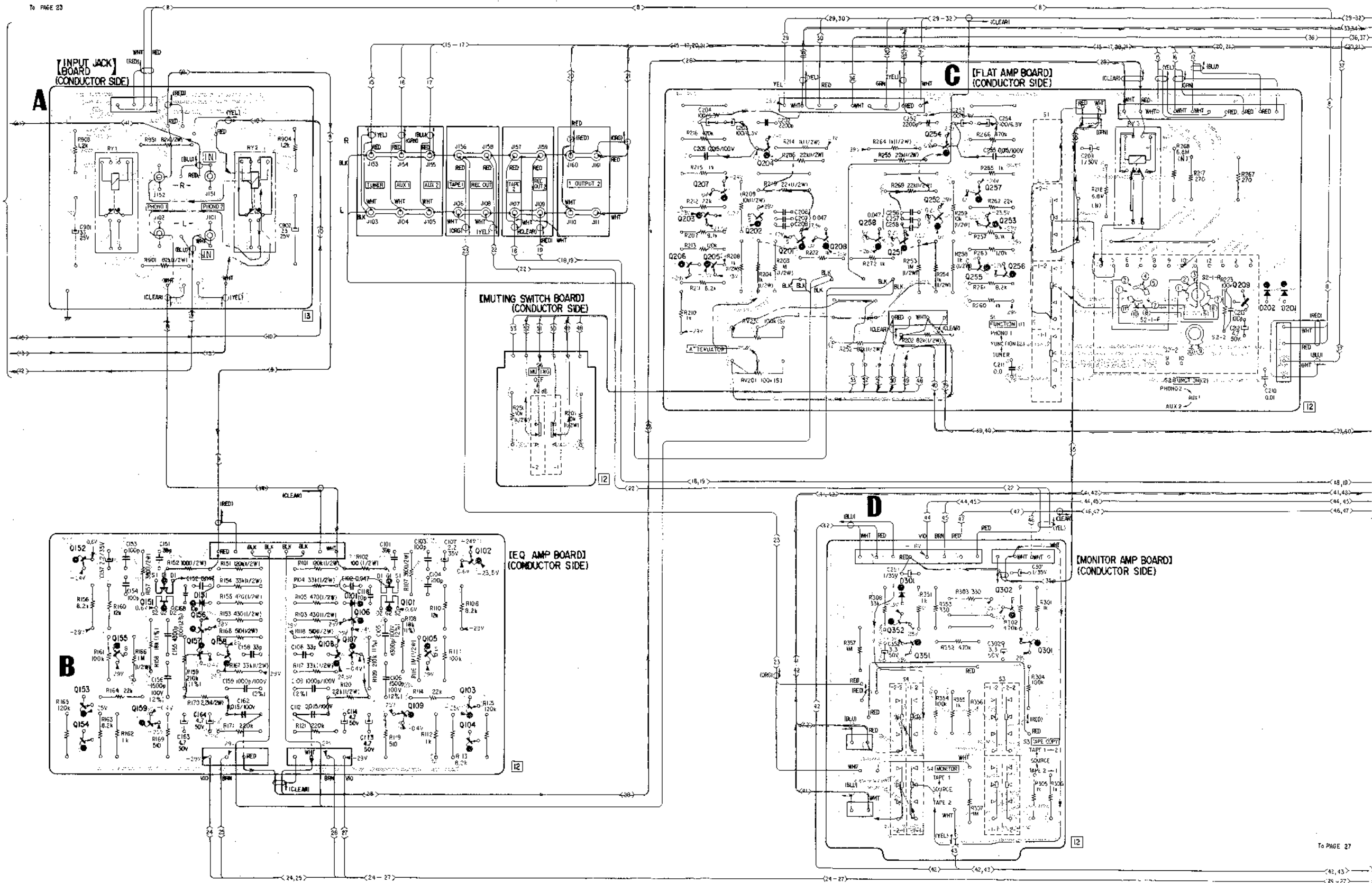

Note:
 • Color

• Signal
 • Voltmeter
 • Read VOM

Replacement
 For replacement ()

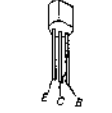
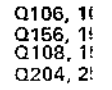
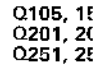
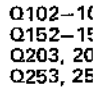
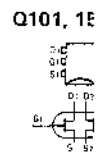

To PAGE 27

0	152	155	151	156	158	106	107	101	105	102	206	203	207	204	201	208	258	254	257	253	256	209	0	
D	154	159	151	151		101	109			104	205	202				301	352, 351	252	255	302	301	202	201	0

To PAGE 27

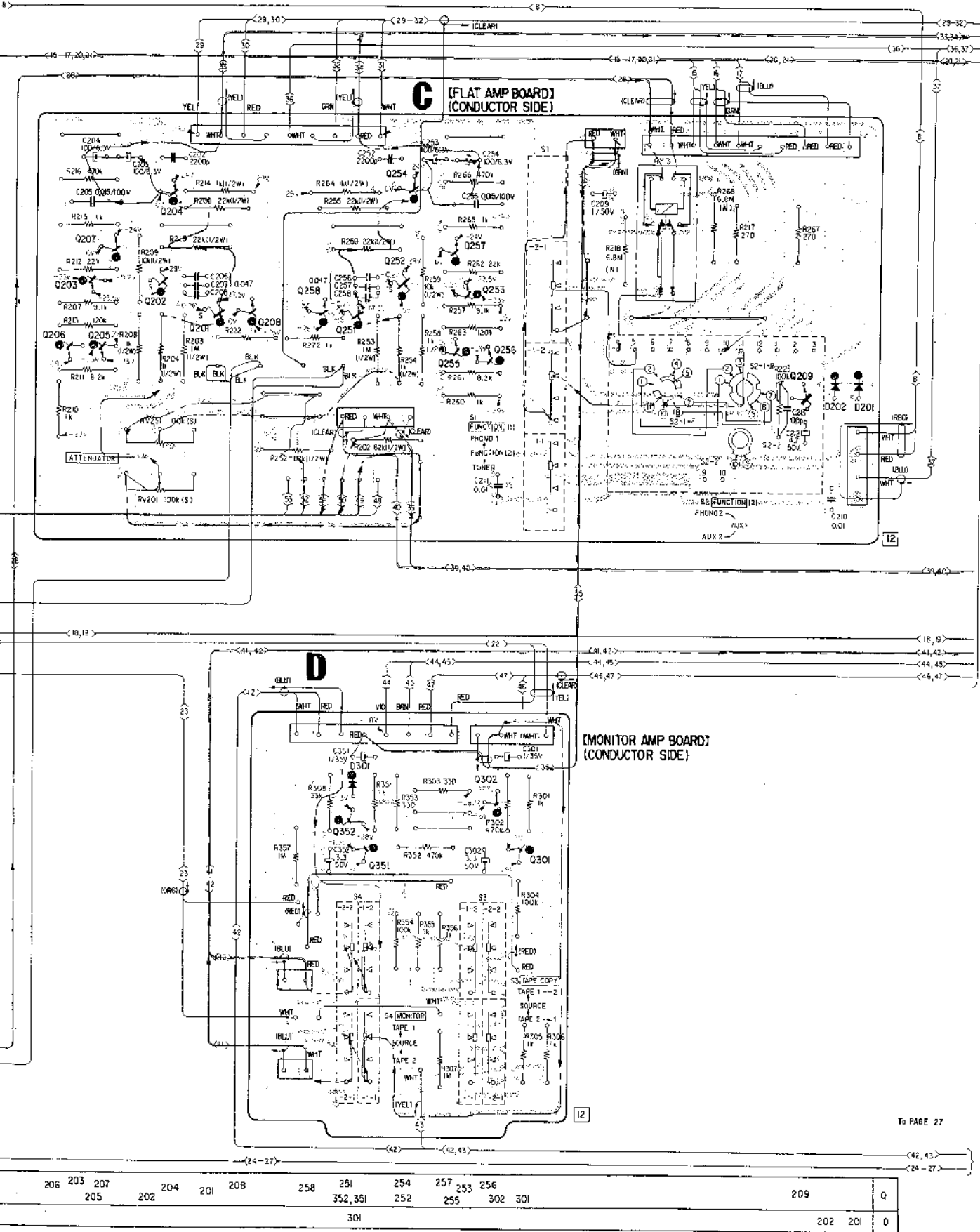

Note:

- Color code of sleeving over the end of the jacket.

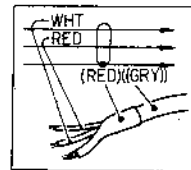

- : part mounted on the conductor side.
- : B+ pattern
- : B- pattern
- Signal Path
 - L-CH
 - R-CH
- Voltages are dc with respect to ground unless otherwise noted.
- Readings are taken under no signal conditions with a VOM (20 k Ω /V).

Replacement Semiconductors

For replacement, use semiconductors except in ().

Q101, 151: 2SK97

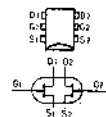

Q109, 159, Q207, 257, Q301, 302, Q351, 352): 2SC1811 (2SC1775) 2SC1775-E

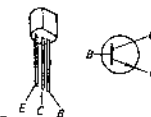

Q102-104, Q152-154, Q203, 205, 206, Q253, 255, 256) : (2SC1128) 2SC2009

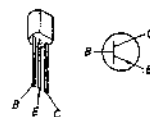

Q208, 209, 258, Q401, 451) : 2SC1636

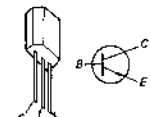

Q105, 155: 2SK43-2, Q201, 202, Q251, 252) : 2SK43-4

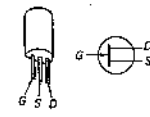

D101, 151: 1S1555 (MV12N), D201, 202, D808) : 1S1555 (1T40)

Q106, 107, Q156, 157) : 2SA639S (2SA639), Q108, 158, Q204, 254) : 2SA890 (2SA896), Q204, 254: 2SA896

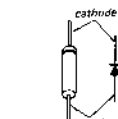
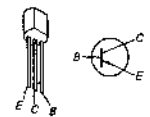

D301: MV-12N

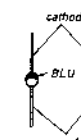

[CONTROL BOARD] (CONDUCTOR SIDE)

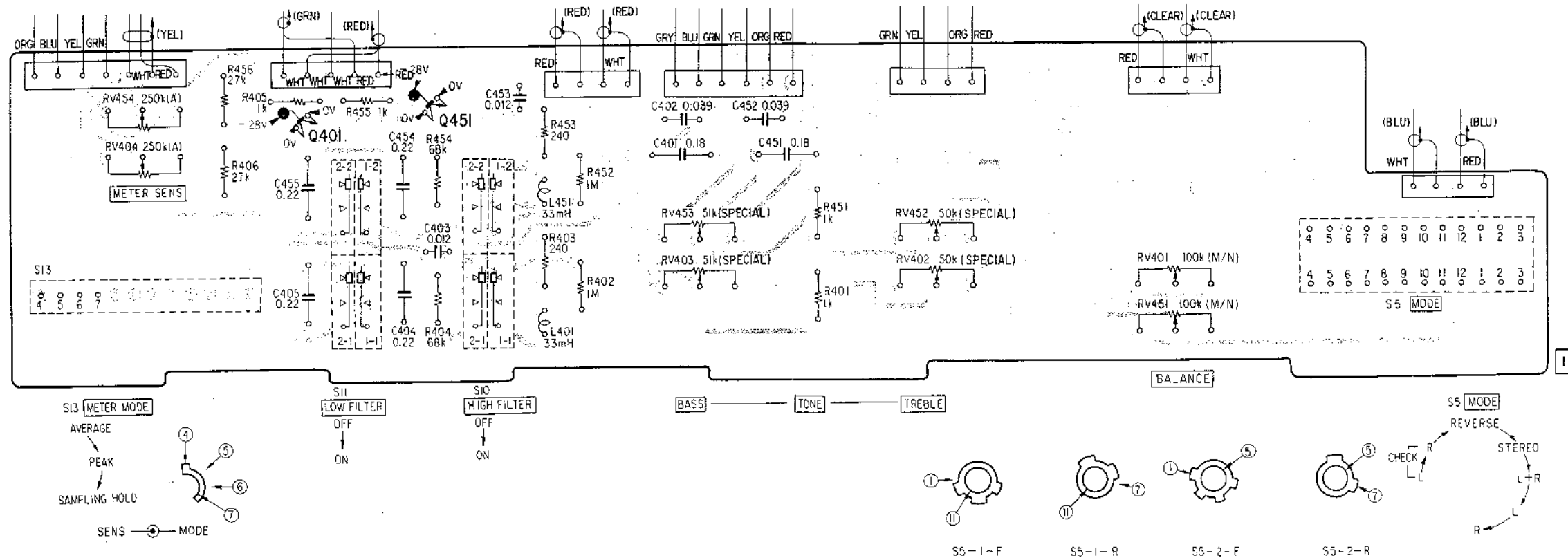

Note:

- Color code of sleeving over the end of the jacket.

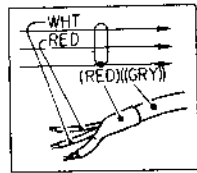

- ■ : part mounted on the conductor side.
- Voltages are dc with respect to ground unless otherwise noted.
- Readings are taken under no signal conditions with a VOM (20 k Ω /V).

4-6. SCHEMATIC DIAGRAM

H: METER AMP BOARD

Note:

- Components for right channel have same values as for left channel.
- All capacitors are in μF unless otherwise noted. $\text{pF} = \mu\mu\text{F}$ 50WV or less are not indicated except for electrolytics.
- All resistors are in ohms, $\frac{1}{4}\text{W}$ unless otherwise noted. $\text{k}\Omega = 1000 \Omega$, $\text{M}\Omega = 1000 \text{k}\Omega$
- (N) : low-noise resistor.
- — : B+ bus.
- □ : panel designation.
- □ : adjustment for repair.
- - - - : B- bus.
- Voltages are dc with respect to ground unless otherwise noted.
- Readings are taken under no signal conditions with a VOM (20 $\text{k}\Omega/\text{V}$).
- Switch

Ref. No.	Switch	Position
S13	METER MODE	AVERAGE

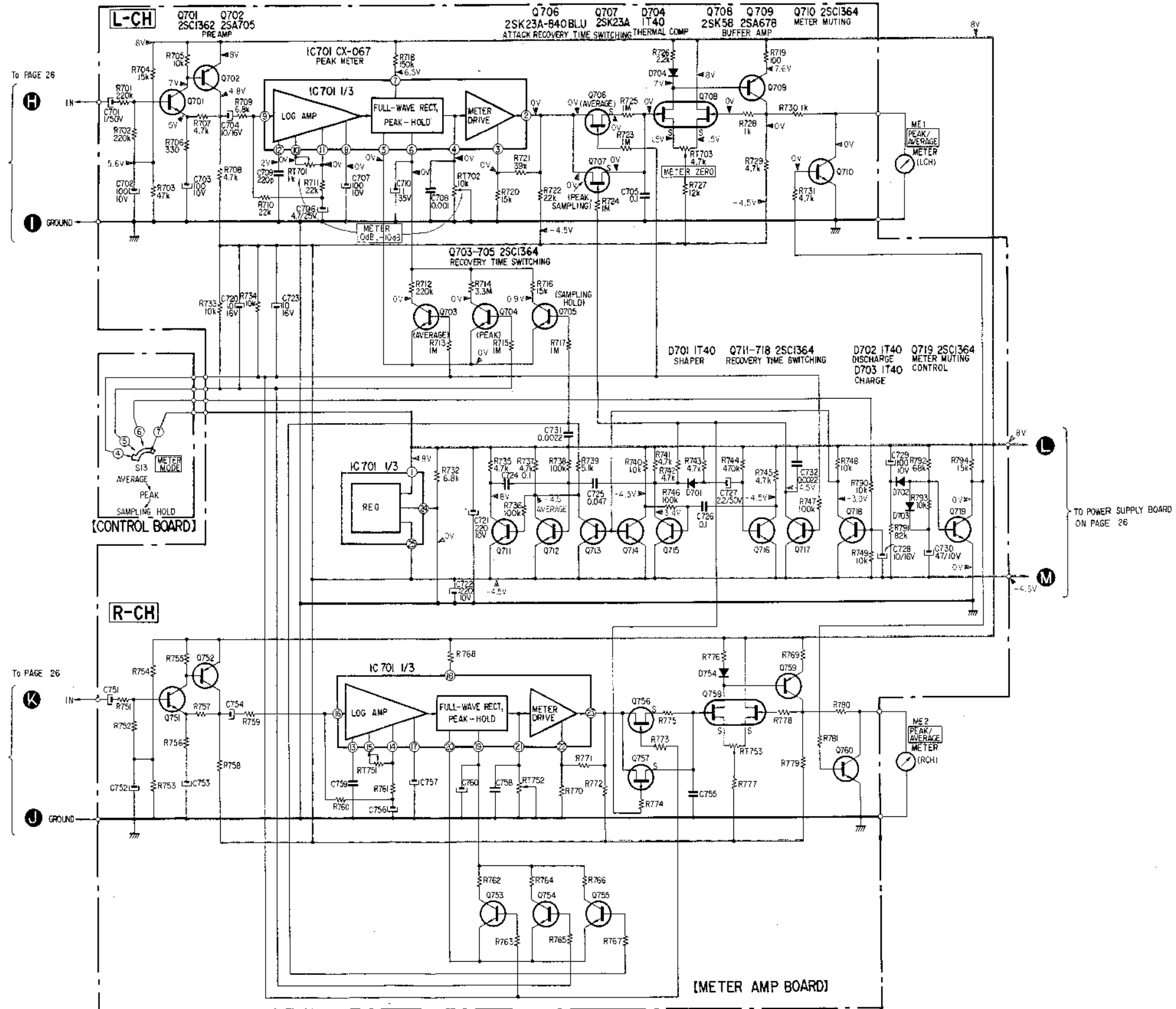

4.7. MOUNTING DIAGRAM H: METER AMP BOARD

- Component Side -

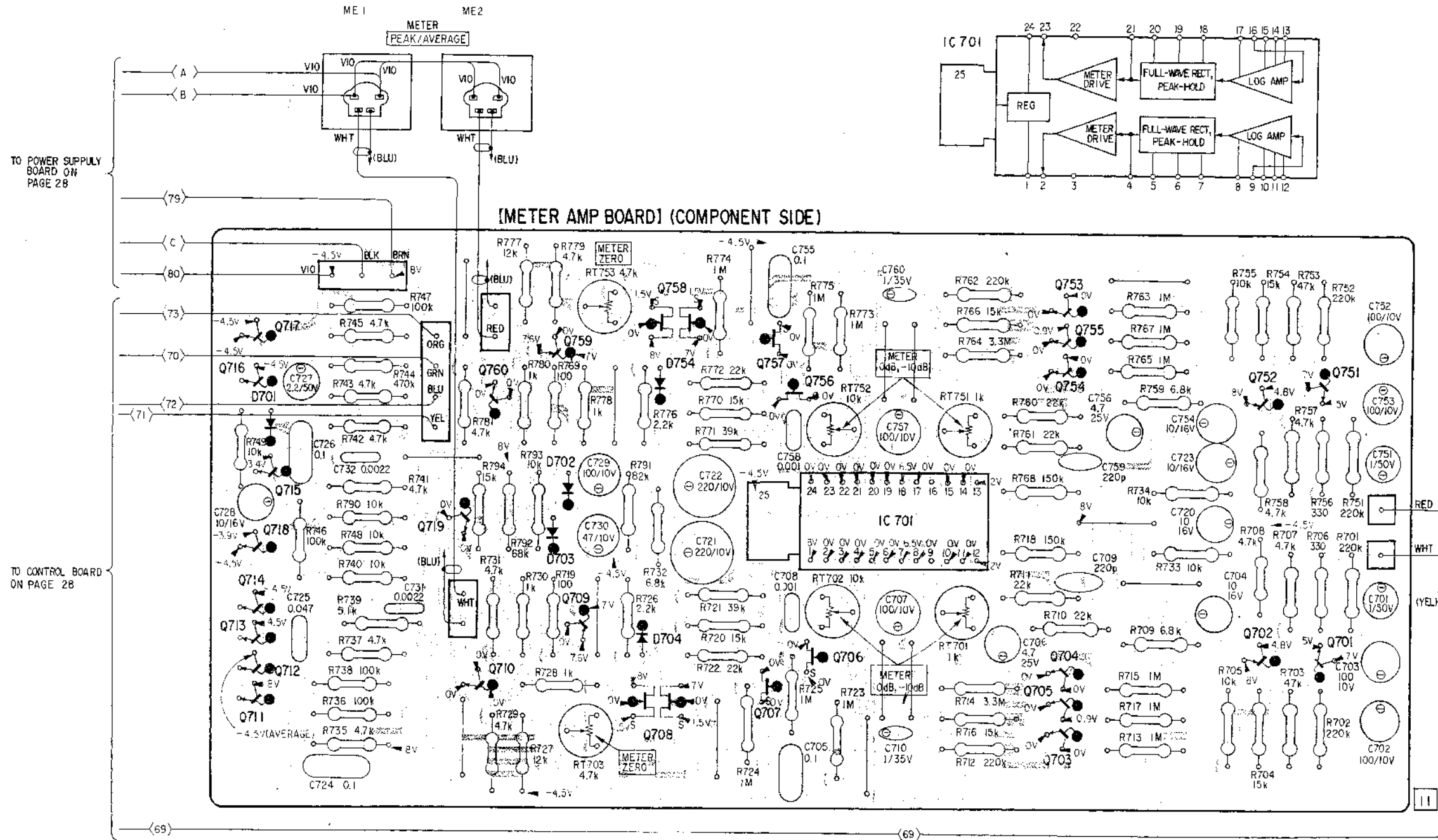

TO POWER SUPPLY BOARD ON PAGE 28

TO CONTROL BOARD ON PAGE 28

717	716	715	760	759	758	757	756	IC 701	753	752	751	Q
714	713	712	710	709	708	707	706		704	702	701	IC
701			703	702	754				705			D
711				704					703			

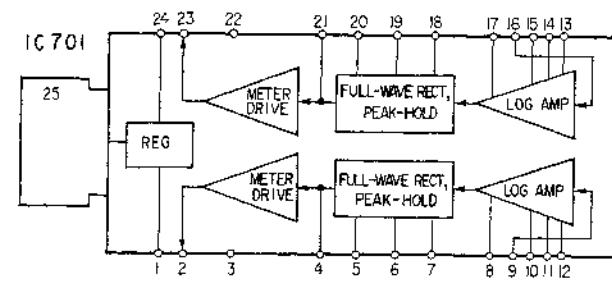

Replacement Semiconductor
For replacement, use semiconductors except in ().

- Q701, 751: 2SC1362
- Q703-705
- Q710-719
- Q753-755, 760 } : 2SC1364

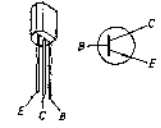

- Q702, 752: (2SA705), 2SA872D
- Q709, 759: 2SA678

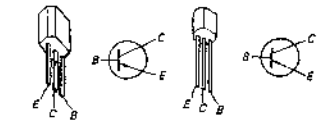

- Q706, 707, Q756, 757: 2SK23A-840 blue

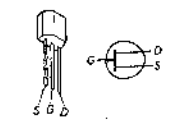

R-CH

- Q708, 758: 2SK58

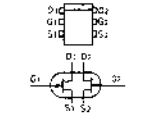

IC701: CX-067

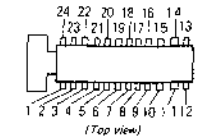

- D701-704, 754: 1S1555 (1T40)

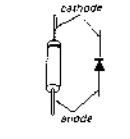

Note:
• Color code of sleeving over the end of the jacket.

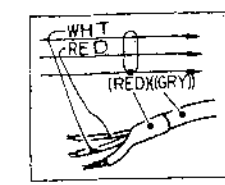

- : B+ pattern
- : B- pattern
- Voltages are dc with respect to ground unless otherwise noted.
- Readings are taken under no signal conditions with a VOM (20 kΩ/V).

4-8. MOUNTING DIAGRAM H: METER AMP BOARD

- Conductor Side -

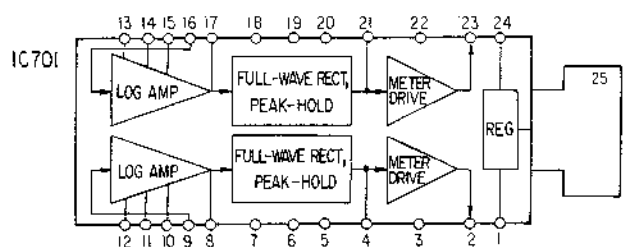

[METER AMP BOARD] (CONDUCTOR SIDE)

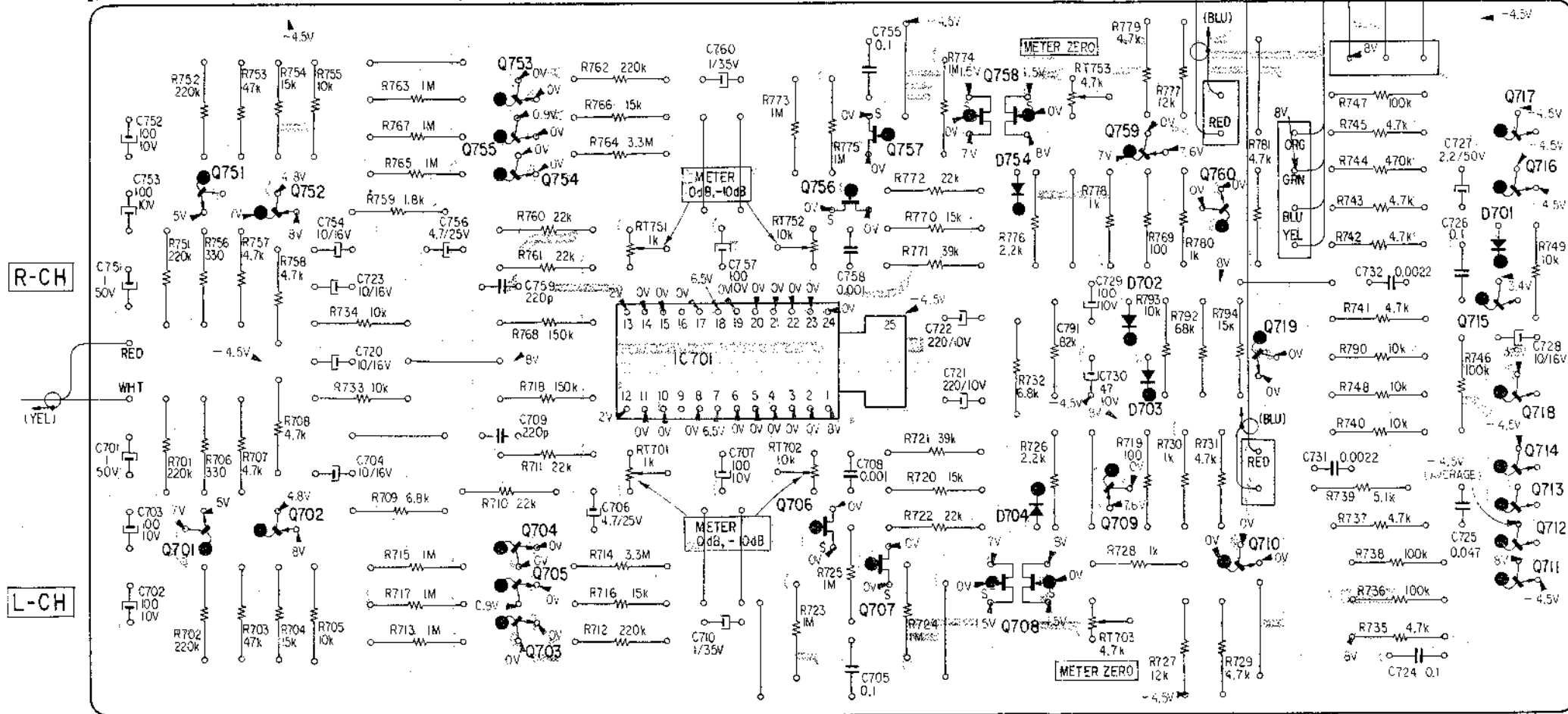

Replacement Semiconductor
For replacement, use semiconductors except in ().

Q701, 751: 2SC1362
Q703-705
Q710-719
Q753-755, 760 } 2SC1364

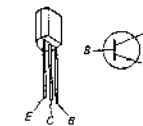

Q702, 752: (2SA705), 2SA872D
Q709, 759: 2SA678

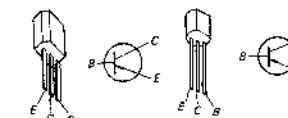

Q706, 707: 2SK23A-840 blue
Q756, 757

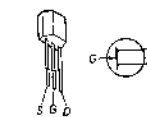

Q708, 758: 2SK58

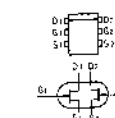

IC701: CX-067

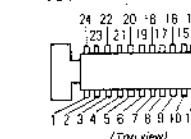

D701-704, 754: 1S1555 (1T40)

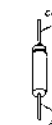

Note:

- Color code of sleeving over the end of the jacket.

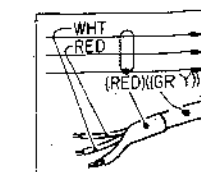

- : B+ pattern
- : B- pattern
- Voltages are dc with respect to ground unless otherwise noted.
- Readings are taken under no signal conditions with a VOM (20 kΩ/V).

Q	751	752	753	757	758	759	760	717
IC	701	702	704	706	707	708	709	710
D						754	702	701
						704	703	

SECTION 5
EXPLODED VIEWS

A B C D E
1 2 3 4

5-1

- Note:
- Items with no part number and/or no description are not stocked because they are seldom required for routine service.
 - All screws are Phillips (cross recess) type unless otherwise noted.
 - (□□□) shows the number of coils in spring.
 - Circled letters (A to Z) are applicable to European models only.

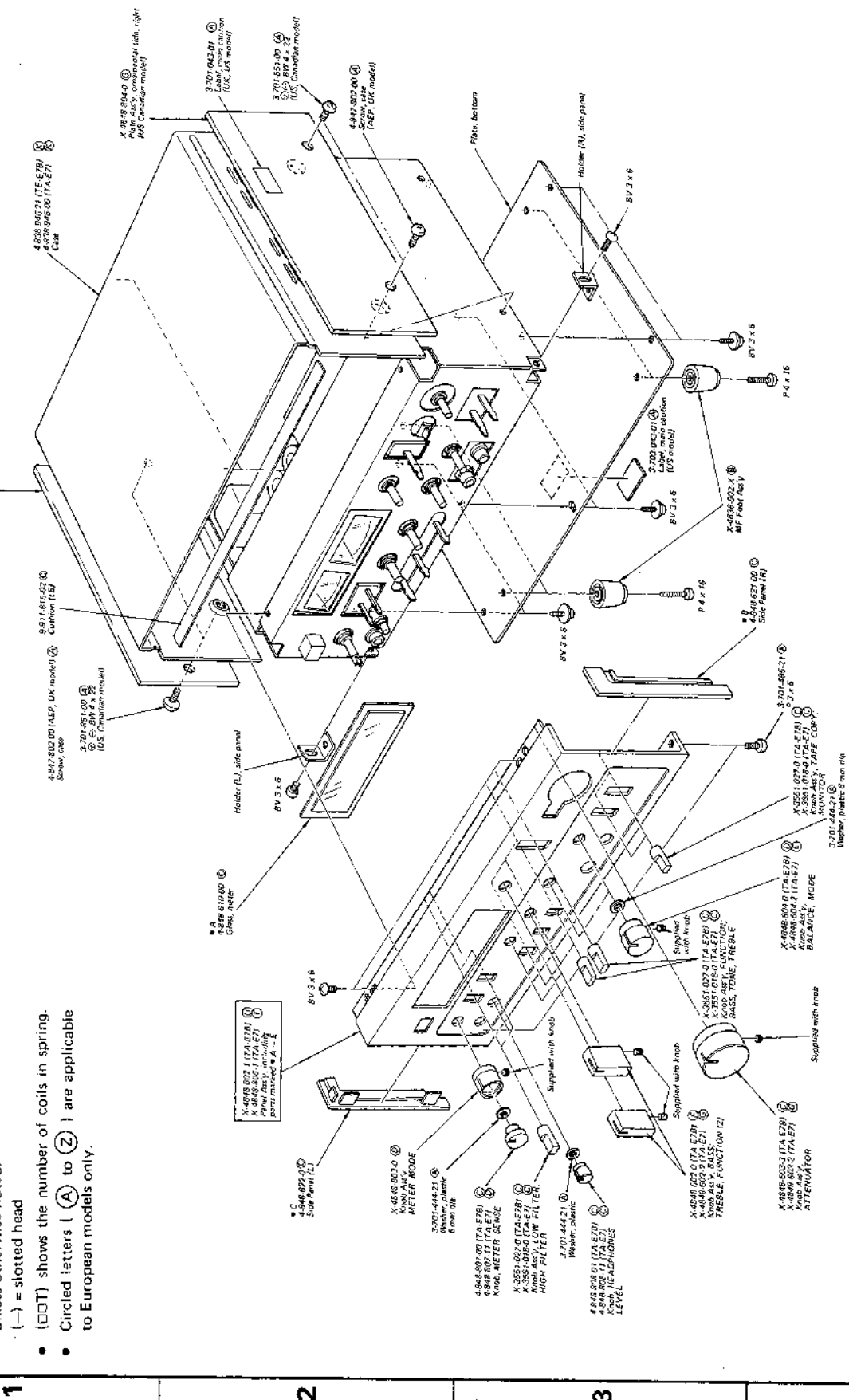

A B C D E
1 2 3 4

5-2

- Note:
- Items with no part number and/or no description are not stocked because they are seldom required for routine service.
 - All screws are Phillips (cross recess) type unless otherwise noted.
 - (□□□) shows the number of coils in spring.
 - Circled letters (A to Z) are applicable to European models only.

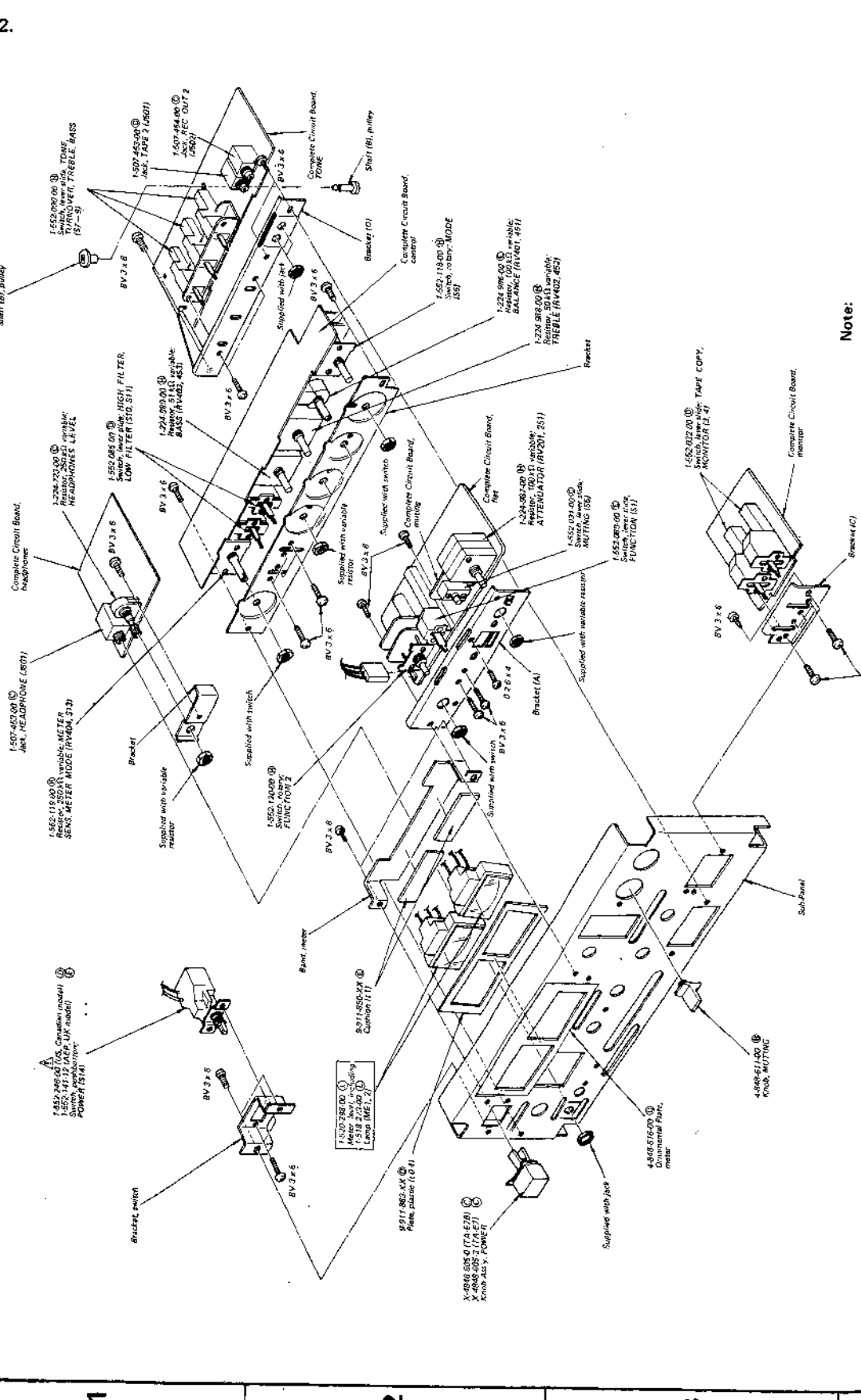

Note: The components identified by shading and A mark are critical for safety. Replace only with part number specified.

Note: Les composants identifiés par un trame et une marque A sont critiques pour la sécurité. Ne les remplacer que par une pièce portant le numéro spécifié.

- Note:
- Items with no part number and/or no description are not stocked because they are seldom required for routine service.
 - All screws are Phillips (cross recess) type unless otherwise noted.
 - (□□□) shows the number of coils in spring.
 - Circled letters (A to Z) are applicable to European models only.

TA-E7/E7B TA-E7/E7B

Note: The components identified by shading and ⚠ mark are critical for safety. Replace only with part number specified.

Note: Les composants identifiés par un trame et une marque ⚠ sont critiques pour la sécurité. Ne les remplacer que par une pièce portant le numéro spécifié.

5-3.

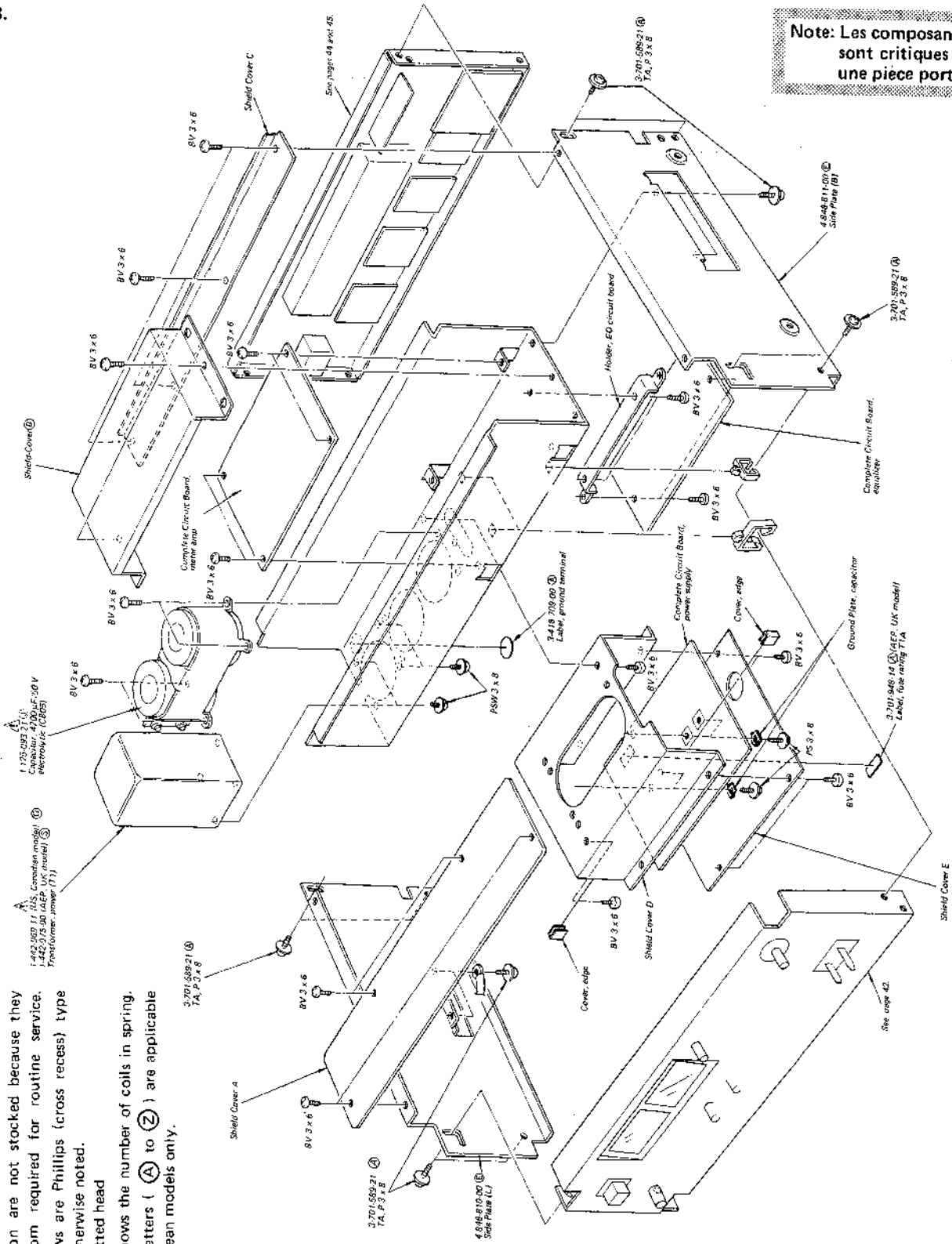

- Note:
- Items with no part number and/or no description are not stocked because they are seldom required for routine service.
 - All screws are Phillips (cross recess) type unless otherwise noted.
 - (—) = slotted head
 - (□□□) shows the number of coils in spring.
 - Circled letters (A) to (Z) are applicable to European models only.

5-4.

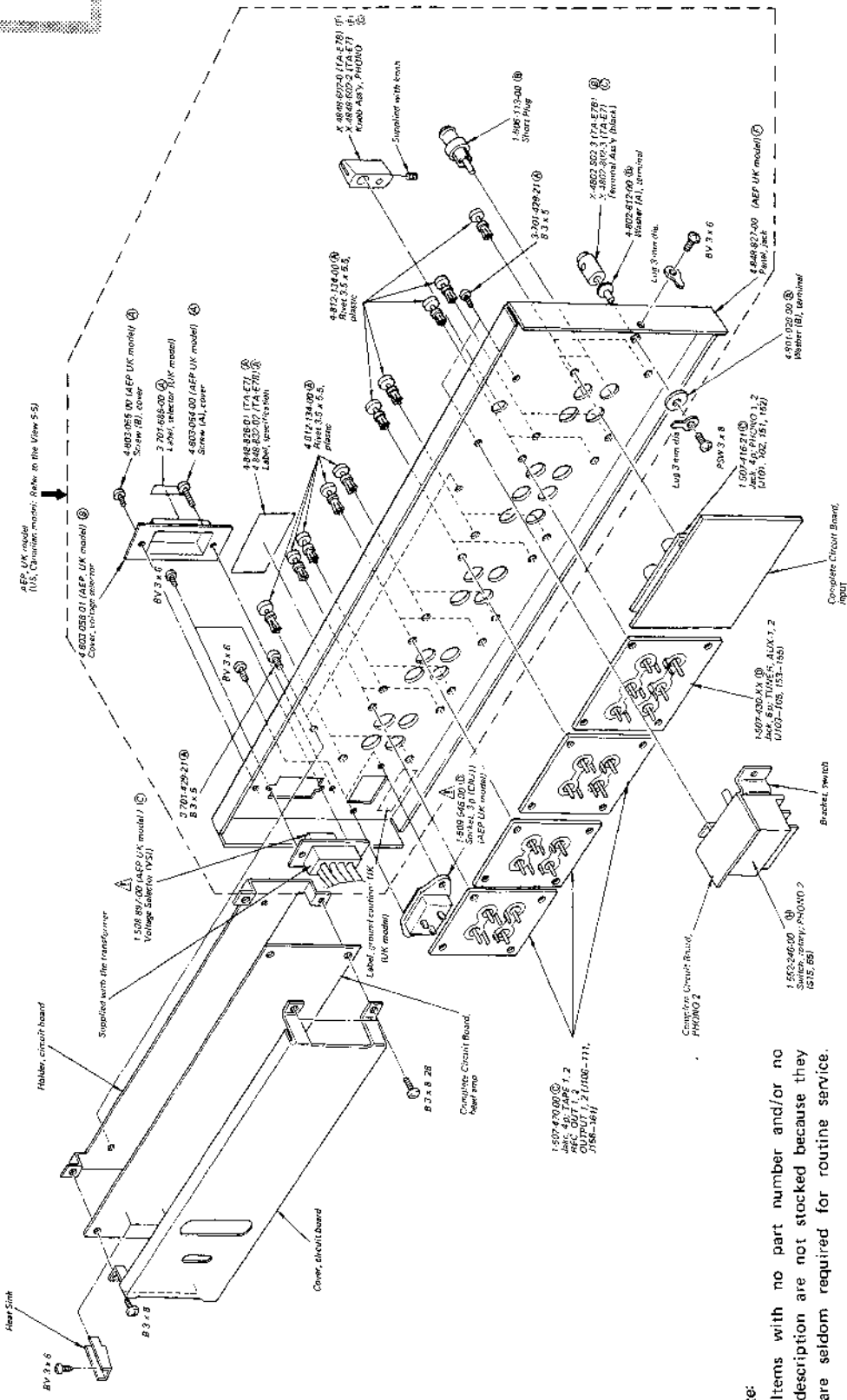

- Note:
- Items with no part number and/or no description are not stocked because they are seldom required for routine service.
 - All screws are Phillips (cross recess) type unless otherwise noted.
 - (□□□) shows the number of coils in spring.
 - Circled letters (A) to (Z) are applicable to European models only.

5-5.

US, Canadian model
 (Refer to the view 5-4 for part numbers except the mark •)

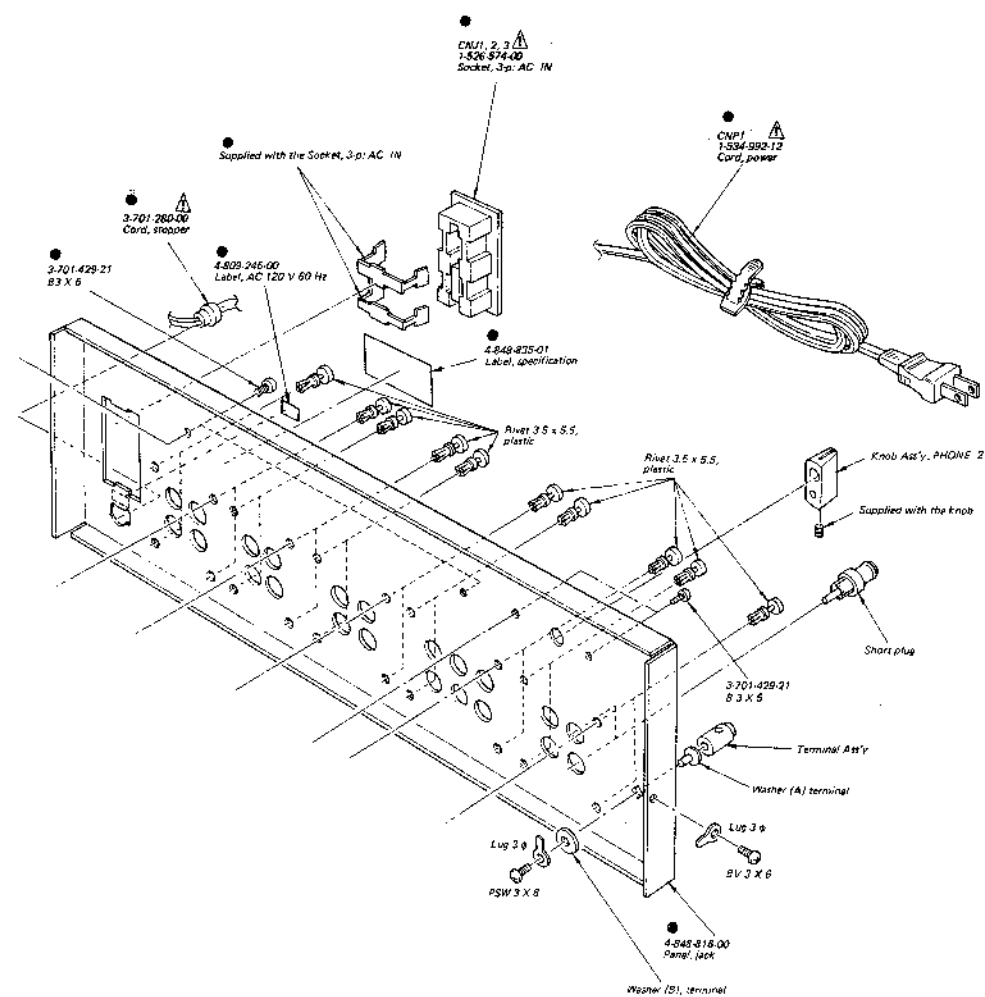

Note:

- Items with no part number and/or no description are not stocked because they are seldom required for routine service.
- All screws are Phillips (cross recess) type unless otherwise noted.
 (—) = slotted head
- (□□T) shows the number of coils in spring.

Note: The components identified by shading and  mark are critical for safety. Replace only with part number specified.

Note: Les composants identifiés par un trame et une marque  sont critiques pour la sécurité. Ne les remplacer que par une pièce portant le numéro spécifié.

SECTION 7
ELECTRICAL PARTS LIST

• Circled letters (A to Z) are applicable to European models only.

• Circled letters (A to Z) are applicable to European models only.

Ref. No.	Part No.	Description
SEMICONDUCTORS		
Transistors		
Q1-20	8-761-700-00	(B) 2SC1637-0
⇒ Q21-23	8-729-387-28	(B) 2SA872-E
⇒ Q24	8-729-377-58	(B) 2SC1775-E
Q25	8-765-012-20	(C) 2SC1811
Q26, 27	8-729-665-47	(B) 2SC1362
Q28	8-729-317-12	(E) 2SA671
Q29	8-729-665-47	(B) 2SC1362
Q30	8-727-312-00	(C) 2SK42-2
Q31	8-729-665-47	(B) 2SC1362
⇒ Q32	8-729-387-27	(B) 2SA872-D
Q33	8-729-316-12	(D) 2SC1061
Q34	8-727-312-00	(C) 2SK42-2
⇒ Q35	8-729-387-27	(B) 2SA872-D
Q51-70	8-761-700-00	(B) 2SC1637-0
⇒ Q71-73	8-729-387-28	(B) 2SA872-E
⇒ Q74	8-729-377-58	(B) 2SC1775-E
Q75	8-765-012-00	(C) 2SC1811
Q101	8-765-342-10	(F) 2SK97
⇒ Q102-104	8-765-300-00	(C) 2SC2009
Q105	8-723-302-00	(C) 2SK43-2
⇒ Q106, 107	8-729-163-93	(C) 2SA639S
⇒ Q108	8-765-082-20	(C) 2SA896
Q109	8-765-012-20	(C) 2SC1811
Q151	8-765-342-10	(F) 2SK97
⇒ Q152-154	8-765-300-00	(C) 2SC2009
Q155	8-723-302-00	(C) 2SK43-2
⇒ Q156, 157	8-729-163-93	(C) 2SA639S
⇒ Q158	8-765-082-20	(C) 2SA896
Q159	8-765-012-20	(C) 2SC1811
Q201, 202	8-723-304-00	(E) 2SK43-4
⇒ Q203	8-765-300-00	(C) 2SC2009
⇒ Q204	8-765-082-20	(C) 2SA896
⇒ Q205, 206	8-765-300-00	(C) 2SC2009
Q207	8-765-012-20	(C) 2SC1811

⇒: Due to standardization, interchangeable replacements may be substituted for parts specified in the diagrams.

Ref. No.	Part No.	Description
Q208	8-761-622-00	(B) 2SC1636
Q209	8-729-663-00	(B) 2SC1364
Q251, 252	8-723-304-00	(E) 2SK43-4
⇒ Q253	8-765-300-00	(C) 2SC2009
⇒ Q254	8-765-082-00	(C) 2SA896
⇒ Q255, 256	8-765-300-00	(C) 2SC2009
Q257	8-765-012-00	(C) 2SC1811
Q258	8-761-622-00	(B) 2SC1636
⇒ Q301, 302	8-729-377-58	(B) 2SC1775-E
⇒ Q351, 352	8-729-377-58	(B) 2SC1775-E
Q401	8-761-622-00	(B) 2SC1636
Q451	8-761-622-00	(B) 2SC1636
Q501	8-723-304-00	(E) 2SK43-4
Q502	8-765-082-20	(C) 2SA896
Q503	8-765-012-20	(C) 2SC1811
Q504	8-765-300-00	(C) 2SC2009
Q505	8-729-316-12	(D) 2SC1061
Q506	8-729-194-56	(B) 2SC945
Q507	8-729-989-93	(C) 2SA899
Q508	8-729-194-56	(B) 2SC945
Q509	8-727-312-00	(C) 2SK42-2
Q511	8-723-304-00	(E) 2SK43-4
Q552	8-765-082-20	(C) 2SA896
Q553	8-765-012-20	(C) 2SC1811
Q554	8-765-300-00	(C) 2SC2009
Q555	8-729-317-12	(E) 2SA671
Q556	8-729-989-93	(C) 2SA899
Q557	8-729-194-56	(B) 2SC945
Q558	8-729-989-93	(C) 2SA899
Q559	8-727-312-00	(C) 2SK42-2
Q601	8-729-665-47	(B) 2SC1362
Q602	8-727-788-00	(C) 2SA678
Q603	8-729-663-47	(B) 2SC1364
Q604	8-727-788-00	(C) 2SA678
Q651	8-729-665-47	(B) 2SC1362
Q652	8-727-788-00	(C) 2SA678
Q653	8-729-663-47	(B) 2SC1364
Q654	8-727-788-00	(C) 2SA678

Ref. No.	Part No.	Description
Q701	8-729-665-47	(B) 2SC1362
⇒ Q702	8-729-387-27	(B) 2SA872-D
⇒ Q703-705	8-729-663-47	(B) 2SC1364
Q706, 707	8-722-384-01	(C) 2SK23A-840 blue
Q708	8-761-510-06	(F) 2SK58
Q709	8-727-788-00	(C) 2SA678
⇒ Q710-719	8-729-663-47	(B) 2SC1364
Q751	8-729-665-47	(B) 2SC1362
⇒ Q752	8-729-387-27	(B) 2SA872-D
⇒ Q753-755	8-729-663-47	(B) 2SC1364
Q756, 757	8-722-384-01	(C) 2SK23A-840 blue
Q758	8-761-510-06	(F) 2SK58
Q759	8-727-788-00	(C) 2SA678
⇒ Q760	8-729-663-47	(B) 2SC1364
⇒ Q801	8-760-413-10	(C) 2SC1475
⇒ Q802	8-762-020-00	(E) 2SA835
⇒ Q803	8-760-413-10	(C) 2SC1475
Q804	8-720-950-03	(D) 2SC926A
IC		
IC701	8-750-670-00	(K) CX-067
Diodes		
D1	△ 8-719-510-10	(C) SIRB10
⇒ D101	8-719-815-55	(B) 1S1555
⇒ D151	8-719-815-55	(B) 1S1555
⇒ D201, 202	8-719-815-55	(B) 1S1555
D301	8-719-912-00	(B) MW-12N
⇒ D501	8-719-831-07	(B) EQB01-07
⇒ D551	8-719-931-07	(B) EQB01-07
D601	8-719-912-00	(B) MV12N
D651	8-719-912-00	(B) MV12N
⇒ D701-704	8-719-815-55	(B) 1S1555
⇒ D754	8-719-815-55	(B) 1S1555

⇒: Due to standardization, interchangeable replacements may be substituted for parts specified in the diagrams.

Ref. No.	Part No.	Description
D801	△ 8-719-510-10	(C) SIRB10
⇒ D802, 803	8-719-510-10	(B) EQB01-24
D804	△ 8-719-510-10	(C) SIRB10
⇒ D805	8-719-930-12	(B) EQB01-12Z
⇒ D806, 807	8-719-200-02	(B) 10E2
⇒ D808	8-719-815-55	(B) 1S1555
⇒ D809	8-719-200-02	(B) 10E2

CAPACITORS

All capacitors are in μF and ceramic unless otherwise noted. 50WV or less are not indicated except for electrolytics. pF = $\mu\mu\text{F}$, elect = electrolytic

C1, 51	1-102-115-11	(A) 560 p	
C2, 52	1-130-127-11	(B) 0.015	100 V polyethylene
C3, 53	1-131-429-11	(C) 470	3.15 V tantalum
C4, 54			
C5, 55	1-102-119-11	(A) 0.0015	
C7, 57	1-130-127-11	(B) 0.015	100 V polyethylene
C8-10	1-131-295-11	(C) 100	6.3 V tantalum
C58-60			
C12, 13	1-131-202-11	(B) 1.5	20 V tantalum
C14, 15	1-108-239-12	(A) 0.01	mylar
C16, 17	△ 1-123-066-11	(B) 1000	25 V elect
C18, 19	1-108-421-12	(B) 0.01	200 V mylar
C20-23	△ 1-121-943-11	(B) 1000	10 V elect
C101, 151	1-102-965-11	(A) 39 p	
C102, 152	1-101-006-11	(A) 0.047	
C103, 153	1-102-973-11	(A) 100 p	
C104, 154			
C105, 155	1-130-123-11	(B) 0.0043	100 V polyethylene
C106, 156	1-130-124-11	(B) 0.015	100 V polyethylene
C107, 157	1-131-217-11	(B) 2.2	35 V tantalum
C108, 158	1-102-963-11	(A) 33 p	
C109, 159	1-130-122-11	(B) 0.001	100 V polyethylene
C112, 162	1-130-127-11	(B) 0.015	100 V polyethylene
C113, 163	1-121-396-11	(A) 4.7	50 V elect
C114, 164			
C118, 168	1-102-947-11	(A) 10 p	

Note: The components identified by shading and △ mark are critical for safety. Replace only with part number specified.

Note: Les composants identifiés par un trame et une marque △ sont critiques pour la sécurité. Ne les remplacer que par une pièce portant le numéro spécifié.

• Circled letters (A to Z) are applicable to European models only.

Ref. No.	Part No.	Description
C202, 252	1-102-121-11 (A)0.0022	
C203, 253 C204, 254	1-131-295-11 (C)100	6.3 V tantalum
C205, 255	1-130-127-11 (B)0.015	100 V polyethylene
C206-208 C256-258	1-101-006-11 (A)0.047	
C209	1-121-391-11 (A)1	50 V elect
C210, 211	1-108-239-12 (A)0.01	mylar
C212	1-121-396-11 (A)4.7	elect
C213	1-102-973-11 (A)100 p	50 V
C301, 351	1-131-215-11 (B)1	35 V tantalum
C302, 352	1-121-393-11 (A)3.3	50 V elect
C401, 451	1-108-364-12 (B)0.18	mylar
C402, 452	1-108-360-12 (A)0.039	mylar
C403, 453	1-108-581-12 (B)0.012	mylar
C404, 454 C405, 455	1-108-611-12 (B)0.22	mylar
C501, 551	1-102-115-11 (A)560	
C502, 552 C503, 553	1-108-228-12 (A)0.0015	mylar
C504, 554 C505, 555	1-108-237-12 (A)0.0068	mylar
C506, 556	1-108-360-12 (A)0.039	mylar
C507, 557	1-108-364-12 (B)0.18	mylar
C508, 558	1-102-125-11 (A)0.0047	
C509, 559 C510, 560	1-131-239-11 (B)6.8	35 V tantalum
C511, 561	1-130-083-11 (C)1	100 V polyethylene
C514, 564	1-108-239-12 (A)0.01	mylar
C516, 566	1-108-239-12 (A)0.01	mylar
C517, 567	1-130-086-11 (B)0.47	100 V polyethylene
C518, 568	1-102-514-11 (A)22 p	
C601, 651	1-121-393-11 (A)3.3	50 V elect
C602, 652	1-121-402-11 (A)33	10 V elect
C603, 653	1-102-864-11 (A)5 p	
C604, 654	1-121-421-11 (B)220	16 V elect
C701, 751	1-121-391-11 (A)1	50 V elect
C702, 752 C703, 753	1-121-414-11 (A)100	10 V elect

Ref. No.	Part No.	Description
C704, 754	1-121-651-11 (A)10	16 V elect
C705, 755	1-108-849-11 (B)0.1	mylar
C706, 756	1-121-395-11 (A)4.7	25 V elect
C707, 757	1-121-414-11 (A)100	10 V elect
C708, 758	1-108-825-12 (A)0.001	mylar
C709, 759	1-102-978-11 (A)220 p	
C710, 760	1-131-448-11 (B)1	35 V tantalum
C720	1-121-651-11 (A)10	16 V elect
C721, 722	1-121-420-11 (B)220	10 V elect
C723	1-121-651-11 (A)10	16 V elect
C724	1-108-849-12 (B)0.1	mylar
C725	1-108-845-12 (A)0.47	mylar
C726	1-108-849-12 (B)0.1	mylar
C727	1-121-450-11 (A)2.2	50 V elect
C728	1-121-651-11 (A)10	16 V elect
C729	1-121-414-11 (A)100	10 V elect
C730	1-121-975-11 (A)47	10 V elect
C731, 732	1-108-829-12 (A)0.0022	mylar
C801-804	1-102-355-11 (B)0.01	500 V
C805	1-125-093-11 (J)4700+4700	50 V elect
C806, 807	1-121-396-11 (A)4.7	50 V
C808, 809	1-123-063-11 (B)220	35 V elect
C810	1-121-940-11 (B)470	25 V elect
C811	1-121-395-11 (A)4.7	25 V elect
C812	1-123-193-11 (B)100	16 V elect
C813	1-123-060-11 (B)330	50 V elect
C814	1-121-413-11 (A)100	6.3 V elect
C815, 816	1-123-250-11 (B)2.2	100 V elect
C817, 818	1-108-421-12 (B)0.01	mylar
C901, 902	1-119-216-11 (B)33	25 V elect

RESISTORS

All resistors are in ohms and of 1/2W carbon unless otherwise noted. Common 1/2W carbon resistors are omitted. Refer to the list on the last page for their part numbers.

R1, 51	1-244-872-11 (A)910
R2, 52	1-244-851-11 (A)120
R3, 53	1-244-855-11 (A)180
R4, 54	1-244-849-11 (A)100

Ref. No.	Part No.	Description
R5, 55 R6, 56	1-244-864-11 (A)430	
R7, 57	1-244-801-11 (A)1	
R9, 59	1-244-833-11 (A)22	
R10, 60	1-244-891-11 (A)5.6 k	
R11, 61 R12, 62	1-244-872-11 (A)910	
R13, 63	1-244-909-11 (A)33 k	
R14, 64	1-244-905-11 (A)22 k	
R15, 65	1-244-897-11 (A)10 k	
R16, 66	1-244-833-11 (A)22	
R17	1-244-915-11 (A)56 k	
R18, 19	1-244-867-11 (A)560	
R20	1-244-890-11 (A)5.1 k	
R21	1-244-891-11 (A)5.6 k	
R22	1-244-861-11 (A)330	
R23, 24	1-244-857-11 (A)220	
R25, 26	1-244-849-11 (A)100	
R101, 151	1-244-923-11 (A)120 k	
R102, 152	1-244-849-11 (A)100	
R103, 153	1-244-864-11 (A)430	
R104, 154	1-244-909-11 (A)33 k	
R105, 155	1-244-865-11 (A)470	
R107, 157	1-244-862-11 (A)360	
R108, 158	1-214-162-11 (B)18 k	1/2W metal oxide
R109, 159	1-214-472-11 (B)210 k	1/2W metal oxide
R116, 166	1-244-945-11 (A)1	
R117, 167	1-244-909-11 (A)33 k	
R118, 168	1-244-866-11 (A)510	
R120, 170	1-244-881-11 (A)2.2 k	
R201, 251	1-244-897-11 (A)10 k	
R202, 252	1-244-919-11 (A)82 k	
R203, 253	1-244-945-11 (A)1	
R204, 254	1-244-873-11 (A)1 k	
R205, 255	1-244-905-11 (A)22 k	
R208, 258	1-244-873-11 (A)1 k	
R209, 259	1-244-897-11 (A)10 k	
R214, 264	1-244-873-11 (A)1 k	

Ref. No.	Part No.	Description
R219, 269	1-244-905-11 (A)22 k	
R509, 559	1-244-873-11 (A)1 k	
R510, 560	1-244-945-11 (A)1	
R511, 561	1-244-893-11 (A)6.8 k	
R512, 562	1-244-881-11 (A)2.2 k	
R513, 563	1-244-897-11 (A)10 k	
R514, 564	1-244-861-11 (A)330	
R520, 570	1-244-911-11 (A)39 k	
R521, 571	1-244-870-11 (A)750	
R524	1-212-979-11 (A)75	1/2W fusible
R531, 581	1-244-905-11 (A)22 k	
R574	1-212-977-11 (A)62	1/2W fusible
R608, 658 R611, 661	1-212-895-11 (A)390	1/2W fusible
R801, 802	1-211-505-11 (A)20	1/2W nonflammable
R805, 806	1-212-883-11 (A)120	1/2W fusible
R901, 951	1-244-919-11 (A)82 k	
R1001, 1051	1-244-940-11 (A)620 k	
R1002, 1052	1-244-837-11 (A)33	
R1003, 1053	1-244-921-11 (A)100 k	
RT701, 751	1-222-804-00 (B)1 k	adjustable
RT702, 752	1-222-701-00 (B)10 k	adjustable
RT703, 753	1-222-978-00 (B)4.7 k	adjustable
RV201, 251	1-224-987-00 (H)100 k	variable; ATTENUATOR
RV401, 451	1-224-986-00 (E)100 k	variable; BALANCE
RV402, 452	1-224-988-00 (H)50 k	variable; TREBLE
RV403, 453	1-224-989-00 (H)51 k	variable; BASS
RV404	1-552-119-00 (K)250 k	variable; METER SENS/ MODE including S13
RV601, 651	1-224-723-00 (C)250 k	variable; HEADPHONES LEVEL

Note: The components identified by shading and A mark are critical for safety. Replace only with part number specified.

Note: Les composants identifiés par un tramé et une marque A sont critiques pour la sécurité. Ne les remplacer que par une pièce portant le numéro spécifié.

Note: The components identified by shading and A mark are critical for safety. Replace only with part number specified.

Note: Les composants identifiés par un tramé et une marque A sont critiques pour la sécurité. Ne les remplacer que par une pièce portant le numéro spécifié.

• Circled letters (A to Z) are applicable to European models only.

Ref. No.	Part No.	Description
SWITCHES		
S1	1-552-089-00	(E) Lever Slide, FUNCTION (1)
S2	1-552-120-00	(H) Rotary, FUNCTION (2)
S3, 4	1-552-032-00	(D) Lever Slide, TAPE COPY, MONITOR
S5	1-552-118-00	(H) Rotary, MODE
S6	1-552-031-00	(C) Lever Slide, MUTING
S7-9	1-552-090-00	(H) Lever Slide, TONE TURNOVER TREBLE, BASS
S10, 11	1-552-085-00	(D) Lever Slide, HIGH FILTER, LOW FILTER
S13	1-552-119-00	(K) Rotary, METER SENS/MODE; including in RV404
S14	(A) 1-552-141-12	(E) Pushbutton, POWER (AEP, UK model)
S14	(A) 1-552-246-00	Pushbutton, POWER (US Canadian model)
S15, 65	1-552-165-00	(H) Rotary, PHONO 2
JACKS		
J101, 151	1-507-416-XX	(C) 4 p, PHONO 1, 2
J102, 152		
J103-105	1-507-430-XX	(D) 6 p, TUNER, AUX-1, 2
J153-155		
J106-111	1-507-470-00	(C) 4 p, TAPE-1, 2, REC OUT-1, 2, OUTPUT-1, 2
J156-161		
J501	1-507-453-00	(C) TAPE 2
J502	1-507-454-00	(C) REC OUT 2
J601	1-507-453-00	(C) HEADPHONE
CNJ1	(A) 1-509-546-00	(D) Socket, 3 p (AEP, UK model)
CNJ 1-3	(A) 1-526-574-00	Socket, 3 p (US, Canadian model)
CNP1	(A) 1-534-992-XX	Cord, power (US, Canadian model)
CP1	(A) 1-231-326-11	Encapsulated Component, C-R (US, Canadian model)

MISCELLANEOUS		
F1	(A) 1-532-078-00	(B) Fuse, 1 A (AEP, UK model)
L401, 451	1-407-879-00	(B) Microinductor, 33 mH
ME1, 2	1-520-298-00	(L) Meter, level; including 1-518-273-00 Lamp (PL 1, 2)
RY1, 2	1-515-277-00	(F) Relay
RY3	1-515-267-00	(F) Reed Relay
T1	(A) 1-442-975-00	(S) Transformer, power (UK, AEP model)
	(A) 1-442-969-11	Transformer, power (US, Canadian model)
VSI	(A) 1-508-897-00	(C) Voltage selector (AEP, UK model)
	(A) 1-533-131-00	(A) Holder, fuse (AEP, UK model)

ACCESSORIES & PACKING MATERIALS	
Part No.	Description
1-506-113-00	(B) Short Plug
1-534-819-12	(G) Cord, power (UK model)
1-551-085-00	(F) Phono Cord
3-701-622-00	(A) Bag, plastic; power cord (UK model)
3-701-630-00	(A) Bag, plastic; printed matters
3-770-043-21	Manual, instruction (US, Canadian model)
3-770-432-11	(I) Manual, instruction (AEP, UK model)
3-794-246-31	Leaflet, french (Canadian model)
4-837-003-00	(C) Bag, protection
4-838-952-00	(C) Cushion
4-848-833-01	(H) Carton (AEP, UK model)
4-848-834-00	Carton (US, Canadian model)

Note: The components identified by shading and (A) mark are critical for safety. Replace only with part number specified.

Note: Les composants identifiés par un trame et une marque (A) sont critiques pour la sécurité. Ne les remplacer que par une pièce portant le numéro spécifié.

HARDWARE NOMENCLATURE

Screw:

Nut, Washer, Retaining ring:

Reference Designation	Shape	Description	Remarks
SELF-TAPPING SCREWS			
TA		self-tapping screw	ex: TA, P 3 x 10
PTP		pan-head self-tapping screw	binding-head self-tapping (TA, B) screw for replacement
PTPWH		pan-head self-tapping screw with washer face	binding-head self-tapping (TA, B) screw and flat washer for replacement
PTTWH		pan-head thread-rolling screw with washer face	binding-head (B) screw and flat washer for replacement
SET SCREWS			
SC		set screw	
SC		hexagon-socket set screw	ex: SC 2.6 x 4, hexagon socket
NUT			
N		nut	
WASHERS			
W		flat washer	
SW		spring washer	
LW		internal-tooth lock washer	ex: LW3, internal
LW		external-tooth lock washer	ex: LW3, external
RETAINING RINGS			
E		retaining ring	
G		grip-type retaining ring	

1/4 WATT CARBON RESISTORS

(A) : applicable to European models only

Ω	Part No.	Ω	Part No.	Ω	Part No.	Ω	Part No.	Ω	Part No.	Ω	Part No.	Ω	Part No.
1.0	1-244-601-11	10	1-244-625-11	100	1-244-649-11	1.0k	1-244-673-11	10k	1-244-697-11	100k	1-244-721-11	1.0M	1-244-745-11
1.1	1-244-602-11	11	1-244-626-11	110	1-244-650-11	1.1k	1-244-674-11	11k	1-244-698-11	110k	1-244-722-11	1.1M	1-244-746-11
1.2	1-244-603-11	12	1-244-627-11	120	1-244-651-11	1.2k	1-244-675-11	12k	1-244-699-11	120k	1-244-723-11	1.2M	1-244-747-11
1.3	1-244-604-11	13	1-244-628-11	130	1-244-652-11	1.3k	1-244-676-11	13k	1-244-700-11	130k	1-244-724-11	1.3M	1-244-748-11
1.5	1-244-605-11	15	1-244-629-11	150	1-244-653-11	1.5k	1-244-677-11	15k	1-244-701-11	150k	1-244-725-11	1.5M	1-244-749-11
1.6	1-244-606-11	16	1-244-630-11	160	1-244-654-11	1.6k	1-244-678-11	16k	1-244-702-11	160k	1-244-726-11	1.6M	1-244-750-11
1.8	1-244-607-11	18	1-244-631-11	180	1-244-655-11	1.8k	1-244-679-11	18k	1-244-703-11	180k	1-244-727-11	1.8M	1-244-751-11
2.0	1-244-608-11	20	1-244-632-11	200	1-244-656-11	2.0k	1-244-680-11	20k	1-244-704-11	200k	1-244-728-11	2.0M	1-244-752-11
2.2	1-244-609-11	22	1-244-633-11	220	1-244-657-11	2.2k	1-244-681-11	22k	1-244-705-11	220k	1-244-729-11	2.2M	1-244-753-11
2.4	1-244-610-11	24	1-244-634-11	240	1-244-658-11	2.4k	1-244-682-11	24k	1-244-706-11	240k	1-244-730-11	2.4M	1-244-754-11
2.7	1-244-611-11	27	1-244-635-11	270	1-244-659-11	2.7k	1-244-683-11	27k	1-244-707-11	270k	1-244-731-11	2.7M	1-244-755-11
3.0	1-244-612-11	30	1-244-636-11	300	1-244-660-11	3.0k	1-244-684-11	30k	1-244-708-11	300k	1-244-732-11	3.0M	1-244-756-11
3.3	1-244-613-11	33	1-244-637-11	330	1-244-661-11	3.3k	1-244-685-11	33k	1-244-709-11	330k	1-244-733-11	3.3M	1-244-757-11
3.6	1-244-614-11	36	1-244-638-11	360	1-244-662-11	3.6k	1-244-686-11	36k	1-244-710-11	360k	1-244-734-11	3.6M	1-244-758-11
3.9	1-244-615-11	39	1-244-639-11	390	1-244-663-11	3.9k	1-244-687-11	39k	1-244-711-11	390k	1-244-735-11	3.9M	1-244-759-11
4.3	1-244-616-11	43	1-244-640-11	430	1-244-664-11	4.3k	1-244-688-11	43k	1-244-712-11	430k	1-244-736-11	4.3M	1-244-760-11
4.7	1-244-617-11	47	1-244-641-11	470	1-244-665-11	4.7k	1-244-689-11	47k	1-244-713-11	470k	1-244-737-11	4.7M	1-244-761-11
5.1	1-244-618-11	51	1-244-642-11	510	1-244-666-11	5.1k	1-244-690-11	51k	1-244-714-11	510k	1-244-738-11	5.1M	1-244-762-11
5.6	1-244-619-11	56	1-244-643-11	560	1-244-667-11	5.6k	1-244-691-11	56k	1-244-715-11	560k	1-244-739-11		
6.2	1-244-620-11	62	1-244-644-11	620	1-244-668-11	6.2k	1-244-692-11	62k	1-244-716-11	620k	1-244-740-11		
6.8	1-244-621-11	68	1-244-645-11	680	1-244-669-11	6.8k	1-244-693-11	68k	1-244-717-11	680k	1-244-741-11		
7.5	1-244-622-11	75	1-244-646-11	750	1-244-670-11	7.5k	1-244-694-11	75k	1-244-718-11	750k	1-244-742-11		
8.2	1-244-623-11	82	1-244-647-11	820	1-244-671-11	8.2k	1-244-695-11	82k	1-244-719-11	820k	1-244-743-11		
9.1	1-244-624-11	91	1-244-648-11	910	1-244-672-11	9.1k	1-244-696-11	91k	1-244-720-11	910k	1-244-744-11		

Sony Corporation

9-958-390-12

© 1977

78D05100-1

Printed in Japan