

TA-AV670/AV670G

SERVICE MANUAL

US Model
Canadian Model
AEP Model
UK Model
TA-AV670
E Model
TA-AV670G

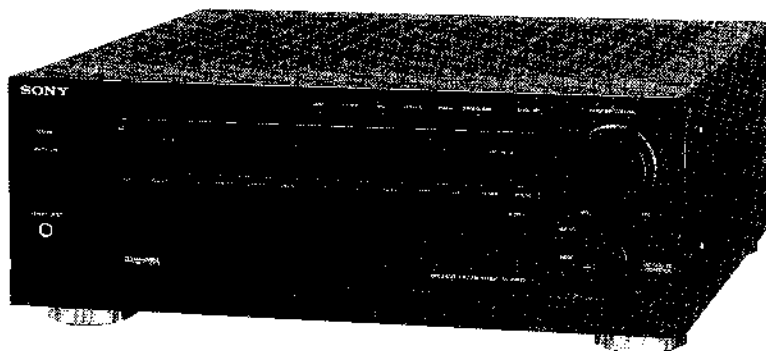

PHOTO : TA-AV670

SPECIFICATIONS

Amplifier Section US, Canadian Model

POWER OUTPUT AND TOTAL HARMONIC DISTORTION

With 8-ohm loads, both channels driven, from 20-20,000 Hz, rated 70 watts per channel minimum RMS power, with no more than 0.03% total harmonic distortion from 250 milliwatts to rated output.*

Continuous RMS power output (8 ohms)
Center: 70 W
Rear: 30 W + 30 W

Dynamic power output
Front: 120 W + 120 W (8 ohms, at 1 kHz IHF)

AEP, UK Model :

Power output
8 ohms, DIN
Front: 65 W + 65 W
Center: 65 W
Rear: 20 W + 20 W

6 ohms, DIN
(except for Scandinavian countries, Switzerland, Spain and Portugal)

Front: 80 W + 80 W
Center: 80 W
Rear: 22 W + 22 W

Continuous RMS power output*

8 ohms, 20 Hz - 20 kHz, THD 0.03%
60 W + 60 W

8 ohms, DIN 80 W + 80 W

6 ohms, 20 Hz - 20 kHz, THD 0.03%
(except for Scandinavian countries, Switzerland, Spain and Portugal)

65 W + 65 W

6 ohms, DIN (except for Scandinavian countries, Switzerland, Spain and Portugal)

95 W + 95 W

E Model :

Power output (6 ohms, at 1 kHz)
Front: 120 W + 120 W
Center: 120 W
Rear: 40 W + 40 W

Continuous RMS power output*
Front: 70 W + 70 W (6 ohms, 20 Hz—20 kHz, THD 0.03%)

Harmonic distortion at rated output*

Less than 0.03%

Intermodulation (IM) distortion at rated output*

Less than 0.03%

Frequency response

PHONO: RIAA equalization curve ± 0.5 dB
TUNER, CD TAPE 1, 2, VIDEO 1-5, LD, TV:
10 Hz — 100 kHz ± 0.5 dB

— Continued on page 2 —

INTEGRATED STEREO AV AMPLIFIER
SONY[®]

Residual noise* Less than 90 μ V (A)
 Damping factor 50 (8 ohms, at 1 kHz)
 S/N TUNER, TAPE 1, 2, VIDEO 1-5, LD, TV:
 92 dB(A)
 PHONO: 76 dB (A)

(*Source direct: ON)

Video section

Input

Input jack	Sensitivity	Impedance
VIDEO	VIDEO 1, 2, 3, 4, 5, LD, TV	1 Vp-p 75 ohms
S-VIDEO	VIDEO 1, 2, 4, 5, LD	Luminance (Y): 1 Vp-p/75 ohms Chroma (C): 0.285 Vp-p/75 ohms

Output

Output jack	Sensitivity	Impedance
VIDEO	VIDEO 1, 2, 3, MONITOR	1 Vp-p 75 ohms
S-VIDEO	VIDEO 1, 2, MONITOR	Luminance (Y): 1 Vp-p/75 ohms Chroma (C): 0.285 Vp-p/75 ohms

Surround

E.R. Time (HALL, STADIUM):
 0 to 90 ms at interval of 3 ms
 E.R. Time (THEATER, JAZZ CLUB):
 0 to 51 ms at interval of 3 ms
 Effect Level: 11 steps (0 to 100%)
 Delay Time: 15 to 30 ms
 at interval of 3 ms
 Rear Level: +10 to -60 dB, - ∞ ,
 at interval of 1 dB
 Center Level: +10 to -60 dB, - ∞ ,
 at interval of 1 dB
 Input balance: Automatically adjusted

General

Power requirements

US, Canadian Model : 120V AC, 60 Hz
 AEP Model : 220 - 230V AC, 50/60 Hz
 UK Model : 240V AC, 50/60 Hz
 E Model : 220V AC, 50/60 Hz

Power consumption

260 W

AC outlets

US, Canadian, E Model : 2 switched, total 300 W max
 1 unswitched, 300 W max

Dimensions

except for UK Model :

Approx. 470 x 165 x 430 mm (w/h/d)
 (18 1/2 x 6 1/2 x 17 inches)
 including projecting parts and controls

UK Model

Approx. 430 x 165 x 430 mm (w/h/d)
 (17 x 6 1/2 x 17 inches)
 including projecting parts and controls

Weight

US, Canadian Model : Approx. 17 kg (37 lb 7 oz)
 AEP, E Model : Approx. 16.4 kg (36 lb 2 oz)
 UK Model : Approx. 15.0 kg (33 lb 1 oz)

Supplied accessories

Remote commander RM-P651 (1)
 Sony Batteries SUM-3 (NS)(2)
 Screws (8)(except for UK Model)

E Model : AC plug adapter (1)

Design and specifications are subject to change without notice.

Audio section

Input



Input Jack	Sensitivity	Impedance
PHONO	2.5 mV	50 kilohms
TUNER, TAPE 1,2, VIDEO 1, 2, 3, 4, 5, LD, TV, CD.	200 mV	50 kilohms

Output

Output jack	Output level	Impedance
TAPE 1, 2, VIDEO 1, 2, 3	150 mV	470 ohms
MONO	100 mV	10 kilohms
CENTER	350 mV	2 kilohms
HEADPHONES	3 mW/ 8 ohms	Accepts low and high impedance headphones.

Equalizer FRONT: BASS (100 Hz) \pm 10 dB
 TREBLE (10 kHz) \pm 10 dB
 CENTER: BASS (100 Hz) \pm 10 dB
 MID (1 kHz) \pm 6 dB
 TREBLE (10 kHz) \pm 10 dB
 REAR: BASS (100 Hz) \pm 10 dB
 TREBLE (10kHz) \pm 10 dB

SAFETY-RELATED COMPONENT WARNING!

COMPONENTS IDENTIFIED BY MARK  OR DOTTED LINE WITH MARK  ON THE SCHEMATIC DIAGRAMS AND IN THE PARTS LIST ARE CRITICAL TO SAFE OPERATION. REPLACE THESE COMPONENTS WITH SONY PARTS WHOSE PART NUMBERS APPEAR AS SHOWN IN THIS MANUAL OR IN SUPPLEMENTS PUBLISHED BY SONY.

ATTENTION AU COMPOSANT AYANT RAPPORT À LA SÉCURITÉ!

LES COMPOSANTS IDENTIFIÉS PAR UNE MARQUE  SUR LES DIAGRAMMES SCHÉMATIQUES ET LA LISTE DES PIÈCES SONT CRITIQUES POUR LA SÉCURITÉ DE FONCTIONNEMENT. NE REMPLACER CES COMPOSANTS QUE PAR DES PIÈCES SONY DONT LES NUMÉROS SONT DONNÉS DANS CE MANUEL OU DANS LES SUPPLÉMENTS PUBLIÉS PAR SONY.

TABLE OF CONTENTS

Section	Title	Page
Specification	1
1. SERVICING NOTE	3
2. GENERAL		
2-1. Functions of Controls	4
2-2. Getting Ready to Enjoy Surround Sound	6
2-3. Listening to watching Program Sources	8
2-4. Recording Audio/Video Program Source	10
2-5. Enjoying the Surround Sound	11
2-6. Using the Remote Commander	13
2-7. Block Diagram	14
3. BLOCK DIAGRAM		
3-1. Block Diagram	15
3-2. Explanation of IC Terminals	19
4. ELECTRICAL ADJUSTMENTS	23
5. DIAGRAMS		
5-1. Circuit Boards Location	24
5-2. Printed Wiring Boards – AUDIO SECTION –	28
5-3. Schematic Diagram – AUDIO SECTION –	31
5-4. Printed Wiring Boards – AMP SECTION –	36
5-5. Schematic Diagram – AMP SECTION –	41
6. EXPLODED VIEWS		
6-1. Front Panel and Cabinet Section	49
6-2. Chassis Section-1	50
6-3. Chassis Section-2	51
7. ELECTRICAL PARTS LIST	52

**SECTION 1
SERVICING NOTE**

MODEL IDENTIFICATION

– Specification Table –

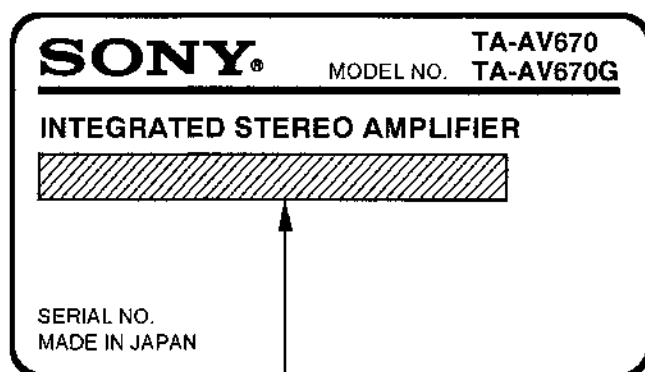

US, Canadian Model : AC : 120V ~ 60Hz
 AEP Model : AC : 220V – 230V ~ 50/60Hz
 UK Model : AC : 240V ~ 50/60Hz
 E Model : AC : 220V ~ 50/60Hz

SAFETY CHECK-OUT (US Model)

After correcting the original service problem, perform the following safety check before releasing the set to the customer:

Check the antenna terminals, metal trim, “metallized” knobs, screws, and all other exposed metal parts for AC leakage. Check leakage as described below.

LEAKAGE TEST

The AC leakage from any exposed metal part to earth ground and from all exposed metal parts to any exposed metal part having a return to chassis, must not exceed 0.5 mA (500 microamperes). Leakage current can be measured by any one of three methods.

1. A commercial leakage tester, such as the Simpson 229 or RCA WT-540A. Follow the manufacturers’ instructions to use these instruments.
2. A battery-operated AC milliammeter. The Data Precision 245 digital multimeter is suitable for this job.
3. Measuring the voltage drop across a resistor by means of a VOM or battery-operated AC voltmeter. The “limit” indication is 0.75 V, so analog meters must have an accurate low-voltage scale. The Simpson 250 and Sanwa SH-63Trd are examples of a passive VOM that is suitable. Nearly all battery operated digital multimeters that have a 2V AC range are suitable. (See Fig. A)

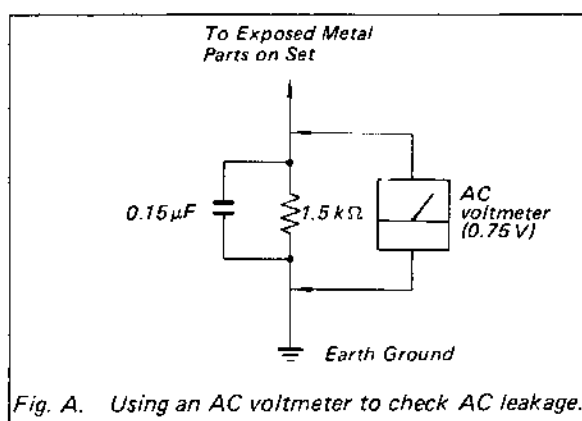

SECTION 2
GENERAL

This section is extracted from instruction manual.

2-1. FUNCTIONS OF CONTROLS

This section describes about such each name and function of this amplifier and remote commander. Please read carefully to operate these units correctly.

Front Panel

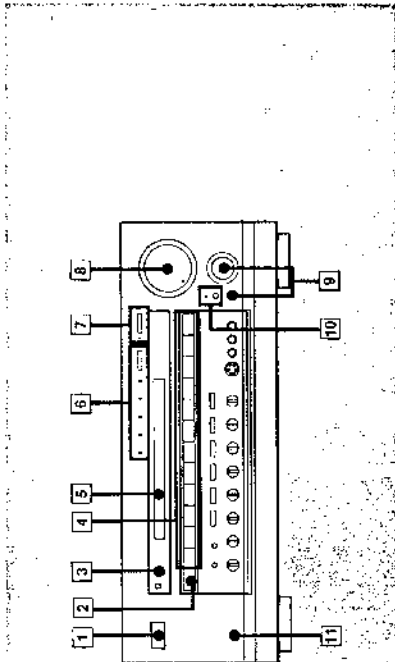

- 1 POWER switch
Press to turn on the unit. Press again to turn off.
- 2 MIX button
Press to combine a visual source and an audio source.
(Display changes as follows: VISUAL source → AUDIO source → off).
- 3 Remote control sensor
Select the program source.
- 4 Input selectors
Select the program source.
- 5 Display
- 6 SURROUND MODE selector and indicators
Selects the surround mode. To set the surround mode to off, press the selector so that no indicator lights up.
(Display and indicators changes as follows: DOLBY SURROUND → THEATER → HALL → JAZZ CLUB → STADIUM → off).
- 7 SOURCE DIRECT button and indicator
To enjoy more pure sound, press the button so that the indicator lights up. The sound signal of the program source are directly output to the power amplifier sections without passing through the surround processor, tone control, and balance control.
- 8 MASTER VOLUME control and indicator
Controls the sound volume. To increase the volume, turn the control clockwise. To decrease the volume, turn the control counterclockwise.
Note
Turn down the volume before switching on the unit. This prevents damage to speakers.
- 9 MODE button and ACOUSTIC control
Use these when adjusting volume of rear and center speakers, delay time, early reflection time, and effect level. Press the MODE button to select the parameter, and turn the ACOUSTIC control to adjust the parameter.
- 10 MUTING button and indicator
Press the button to mute the sound. Press again to resume the sound.
- 11 HEADPHONES jack
Accepts the stereo phone plug of headphones. The jack outputs the sound of front speakers only. To listen to the program source only with the headphones, set the FRONT/CENTER and REAR SPEAKERS buttons [12] to OFF [□].

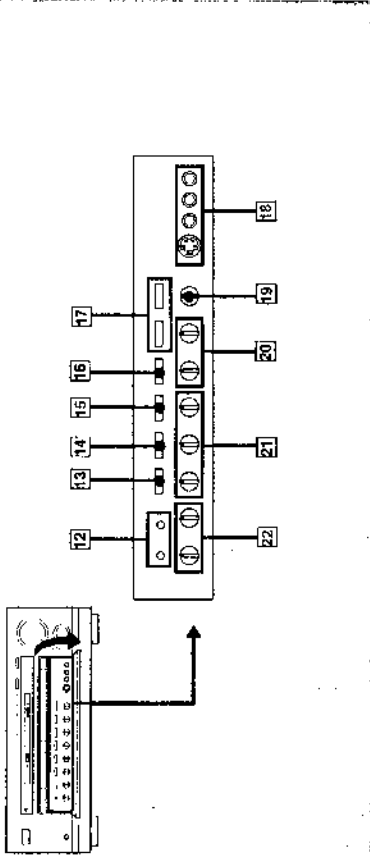

- 12 SPEAKERS buttons
Normally set these SPEAKERS buttons to ON (■).
FRONT/CENTER: Turns ON (■) and OFF (□) the front and center speakers.
REAR: Turns ON (■) and OFF (□) the rear speakers.
- 13 DISPLAY MODE button
Press the button to turn on and off the display information. When the display is turned off, if you press the other buttons or controls, all information appear on the display for about five seconds.
- 14 PRO LOGIC MODE button
Selects the speaker operation mode of Dolby Pro Logic function.
(Display changes as follows: PHANTOM → 3 CH LOGIC → CENTER OFF → NORMAL → WIDE)
- 15 TEST TONE button
Turns on and off the test tone to adjust the balance among front, rear, and center speakers.
- 16 CHARACTER button
Labels to input selectors.
- 17 REC OUT buttons
SET: Sets the desired program source for recording while you listen to watch another program source.
CHECK: Displays the program source set with the SET button.
- 18 VIDEO 5 INPUT jacks
Accept S-video, video, and audio signals.
- 19 BALANCE control
Adjusts the balance of the right and left front speakers.
- 20 FRONT tone controls
Control the tone quality of the front speakers.
BASS: Adjusts bass sound.
TREBLE: Adjusts treble sound.
- 21 CENTER tone controls
Control the tone quality of the center speaker(s).
BASS: Adjusts bass sound.
MID: Adjusts middle sound.
TREBLE: Adjusts treble sound.
- 22 REAR tone controls
Control the tone quality of the REAR speakers.
BASS: Adjusts bass sound.
TREBLE: Adjusts treble sound.

Programmable Remote Commander: RM-P651

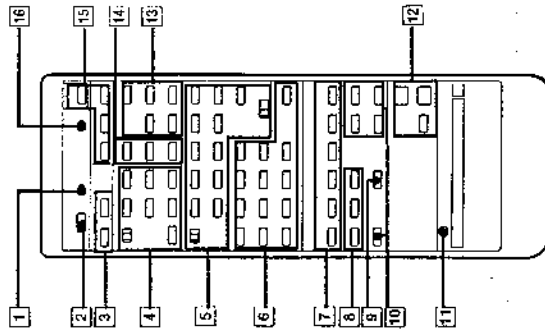

The RM-P651 can "learn" various functions of other remote commanders which use infrared rays (see page 30). When the mode selector is set to SONY STD (Sony standard), buttons on the RM-P651 can be used to perform the functions below:

- 1 LEARN indicator
Lights up when learning functions.
- 2 MODE selector
SONY STD (standard): To control Sony equipment.
USER STD (standard): To control equipment whose remote control functions are stored.
LEARN: To store functions of other remote commanders emitting infrared rays.
- 3 Display setting buttons
DISPLAY MODE button: Turns on and off the display information.
DIMMER button: Selects the brightness on the display.
- 4 CD player/LD player control section
CD/PLD selector: Selects CD player or LD (Laser disc) player to be played. The combined CD/LD player can be controlled with this selector set to LDP.
▶: Play
⏏: Stop
⏮/▶▶: AMS (Automatic Music Sensor)
◀◀/▶▶: Manual search (only for Laser disc player)
- 5 Tape deck/VTR control section
TAPE/VTR selector: Selects tape deck or VCR to be controlled.
▶: Play
⏏: Stop
⏮: Rewind
▶▶: Fast forward
● REC: Recording (Press both ● REC button and the right button for recording.)

Following buttons can be used when the TAPE/VTR selector is set to VTR.

DUAL button: Selects bilingual programs.
ANT (antenna) TV/VTR button: Selects the output signal from the antenna terminal on the VCR, either a TV signal or VCR programs.
CH (channel) +/- buttons: Select channel on the VTR.
VTR 1, 2, and 3 selector: Selects VCR type.
1: Betamax VCRs
2: 8 mm VCRs
3: VHS VCRs

6 Input selectors
VIDEO 1-5, LD, TV, TAPE 1-2, CD, TUNER, PHONO buttons: Selects program sources
MIX button: Combines a visual source and an audio source.

7 SURROUND MODE (ON/OFF, DOLBY, THEATER, HALL JAZZ CLUB, STADIUM) selectors:
Selects the surround mode.

8 MODE button and ACOUSTIC CONTROL buttons
MODE button: Selects the parameter.
ACOUSTIC CONTROL buttons: Adjust the parameter.

9 SOURCE DIRECT button
Bypasses the circuits of surround processor, tone control, and balance control.

10 Volume level controls of center and rear speakers
TEST TONE buttons: Turns on and off the test tone.
CENTER VOL +/- buttons: Adjust the volume level of the center speaker(s)
REAR VOL +/- buttons: Adjust the volume level of the rear speakers.

11 RESET button
Resets the commander to the initial state.

12 Master volume and muting buttons
MASTER VOL +/- buttons: Adjust the sound level from SPEAKERS and HEADPHONES.
MUTING button: Mutes the output signal.

13 TV control section
TV/VIDEO button: Selects the input signal of the TV.
CH +/- buttons: Select a preset channel.
VOL +/- buttons: Control the TV volume.

14 Tuner control section
BAND button: Selects the frequency band.
PRESET +/- buttons: Selects higher or lower preset number.

15 POWER buttons
POWER: Turns on/off this amplifier and the equipment connecting to the SWITCHED AC OUTLETS.
LDP POWER: Turns on and off the Laser disc player.
VTR POWER: Turns on and off the selected by the VTR 1,2,3 selector (usable only when the TAPE/VTR selector is set to VTR).
TV POWER: Turns on and off the TV.

16 PROGRAM CLEAR button
Clears the stored signals.

Inserting the Batteries into the Remote Commander

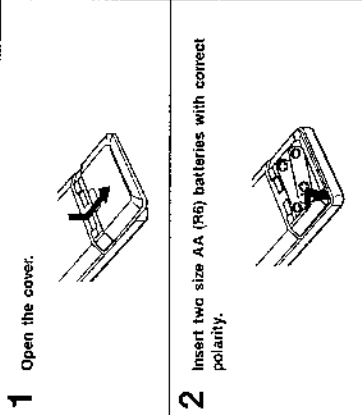

1 Open the cover.

2 Insert two size AA (R6) batteries with correct polarity.

Battery life
About half a year of normal operation can be expected when using the Sony SUM-3 (NS) batteries. When the batteries are exhausted, the commander can no longer operate the unit. Replace both batteries with new ones.

To avoid battery leakage
When the commander is not to be used for a long period of time, remove the batteries to avoid damage caused by battery leakage and corrosion.

2-2. GETTING READY TO ENJOY SURROUND SOUND

The quality of surround sound depends on where you place the speakers. This section describes the efficient placement of the speakers; then, explains how to adjust the speaker volume on each speaker and delay time of the rear speakers in Dolby surround mode.

Placement of the Speakers and Selecting the Dolby Pro Logic Mode

Where you place the speakers depends on the size and acoustics of the room where the system is to be installed. The examples shown in the following columns only represent typical cases. We recommend you experiment to find the speaker direction and arrangement that gives the most effective acoustics. Once you have arranged the speakers, in order to achieve the best sound distribution, you need to select the Dolby Pro Logic mode according to the type, size, and position of your speakers.

How to select the Dolby Pro Logic mode

After setting up the speakers for the best sound (see pages 16-17), select the Pro Logic mode for the best sound distribution. See the following pages for explanations of each setting.

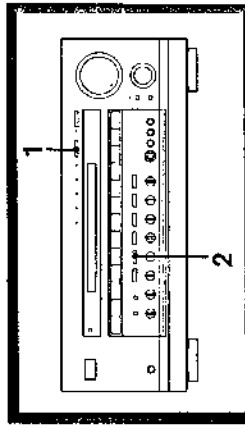

1 Press SURROUND MODE to select DOLBY or THEATER mode.

2 Press PRO LOGIC MODE to select the mode according to your types of speaker and arrangement. Each time you press PRO LOGIC MODE, the display changes as follows.

→ PHANTOM • 3CH LOGIC → CENTER OFF → WIDE → NORMAL

When you are using five or six speakers
Two front speakers, two rear speakers and one or two center speakers provide the best Dolby Pro Logic surround sound as well as make the most of this amplifier.

When you use two center speakers, place them beside the TV, so that the vocal image will be located at the center.

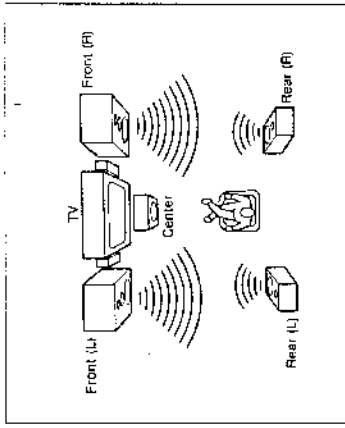

According to the size of the center speaker(s), set PRO LOGIC mode to NORMAL or WIDE.

NORMAL: Select this mode when you are using a small center speaker(s). With this setting, bass sound is distributed to the left and right front speakers equally because the small center speaker(s) cannot produce enough bass.

WIDE: Select this mode when you are using medium sized or large center speaker(s).

When you are using four speakers
Two front speakers and two rear speakers are used.

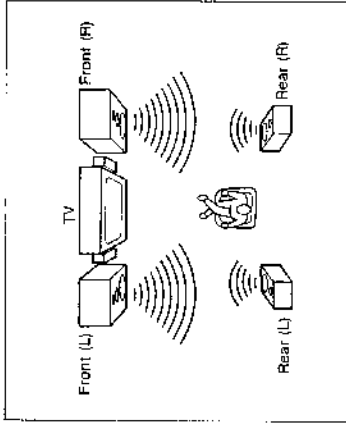

Set PRO LOGIC mode to PHANTOM.

PHANTOM: At this setting, the center channel sound is distributed to the left and right front speakers equally since a center speaker is not used.

Other cases

- When using only three speakers (two front speakers and one center speaker), set PRO LOGIC mode to 3CH LOGIC.
- 3CH LOGIC:** Rear channel sound will be heard from the two front speakers.
- A subwoofer speaker can be added to obtain a richer bass sound. Position the subwoofer speaker anywhere forward of your primary listening position. A deep bass sound is not as directional as the higher frequencies and therefore will not affect the stereo image.

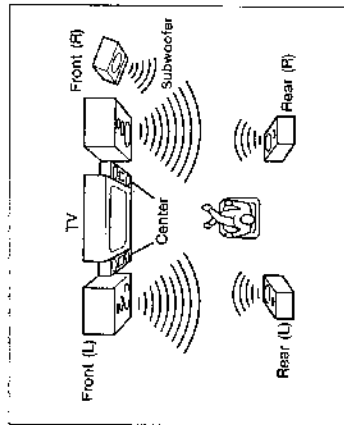

- CENTER OFF** mode is only used for checking the input balance in Dolby surround mode. Center channel sound, such as voice or vocal, is not heard from the speakers.

Automatic Input Balance (Only for DOLBY and THEATER modes)

When playing back a Dolby surround processed video tape or video disc, the input level and input balance must be adjusted to obtain the best surround effect. On this amplifier, the input balance is automatically adjusted.

Adjusting the Volume Level of the Speakers
—System with Center Speaker(s)

To enjoy the highest quality surround sound, adjust the front, center and rear speakers to the same volume level. The adjustment must be done with a test tone in Dolby Surround mode, but the level once adjusted can be used for all surround modes. You can adjust the volume level from your listening position when you use the remote commander. This following explains the adjustments according to how you have arranged your speakers.

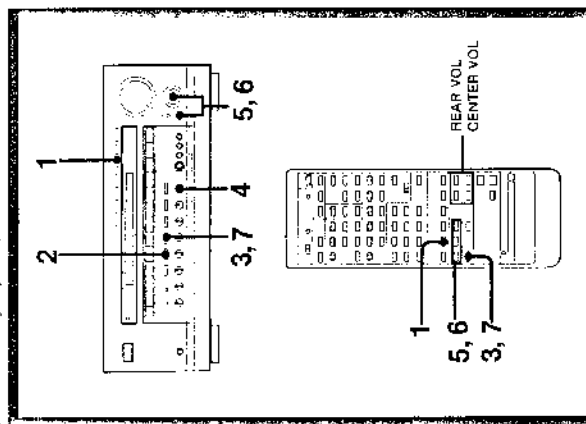



1 Press SURROUND MODE to select DOLBY mode.

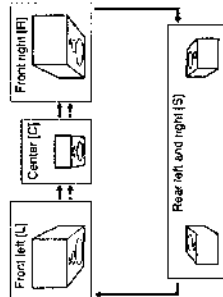

2 Make sure that the PRO LOGIC MODE is set to NORMAL or WIDE.

3 Press TEST TONE.

The test tone outputs from the left front (L), center (C), right front (R), and rear speakers (S) in succession.



4 Turn BALANCE to adjust the volume level of the left and right front speakers.



5 Press MODE to display [Center] dB.
 Turn **ACOUSTIC CONTROL** to adjust the volume level of the center speakers so that it will be the same as the front speakers. (It can be adjusted with the **CENTER VOL** buttons on the remote commander.)

6 Press MODE to display [Rear L] dB or [Rear R] dB.
 Turn **ACOUSTIC CONTROL** to adjust the volume level of the left and right rear speakers so that they will be the same as the front speakers respectively.
 (The volume levels of both channels can be simultaneously adjusted with the **REAR VOL** buttons on the remote commander.)

7 Press TEST TONE.
 The test tone goes off.

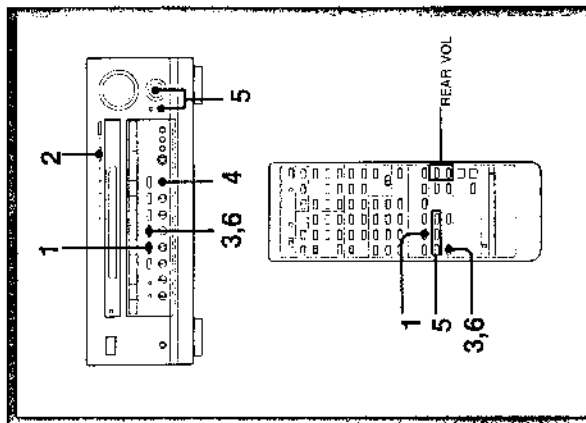
Adjusting the Volume Level of the Speakers
—System without Center Speaker(s)



1 Press SURROUND MODE to select DOLBY mode.



2 Make sure that PRO LOGIC MODE is set to PHANTOM.

3 Press TEST TONE.

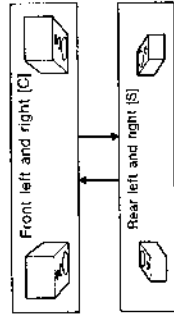
The test tone alternates between the front speakers (C) and rear speakers (S).



4 Turn BALANCE to adjust the volume level of the left and right front speakers.

5 Press MODE to display [Rear L] dB or [Rear R] dB.
 Turn **ACOUSTIC CONTROL** to adjust the volume level of the left and right rear speakers so that they will be the same as the front speakers respectively.
 (The volume levels of both channels can be simultaneously adjusted with the **REAR VOL** buttons on the remote commander.)

6 Press TEST TONE.
 The test tone goes off.

When not using rear speakers
 Set Pro Logic mode to 3CH LOGIC. Press TEST TONE to output test tone from the left front [L], center [C], and right front [R] speakers in succession.

2-3. LISTENING TO WATCHING PROGRAM SOURCES

This section describes the basic playback operation, combining the video image with the sound from another program source and then putting your own label on input selectors.

Basic Operation

- Before you begin, be sure to:
 - Turn on the connected audio/video equipment.
 - Set the SPEAKERS button to ON (→).

2 Press MODE to display the delay time mode.

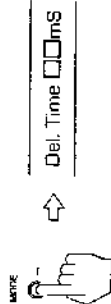

3 Turn ACOUSTIC CONTROL to adjust the delay time of the rear speakers.



Note
Adjusting the delay time of the rear speakers is available for the Dolby surround processed source.

Adjusting the Delay Time of the Rear Speakers (Only for DOLBY Surround Mode)

The delay time is a time difference between the sound from the front speakers (as direct sound) and that from rear speakers (as reflected sound). The delay time is adjustable from 15 ms to 30 ms. When setting the rear speakers in a large room or apart from your listening position, set the delay time shorter.

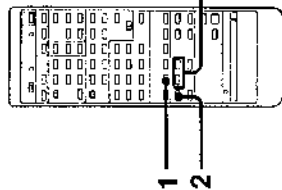
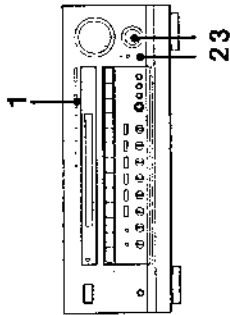

1 Press SURROUND MODE to select DOLBY mode.

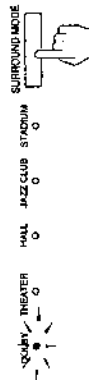

2 Select the program source.

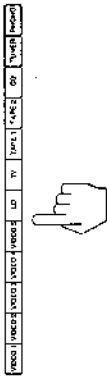

3 Play back the selected program sources.

4 Adjust the volume level.



When the MUTING indicator has been lit up Press MUTING to turn it off.

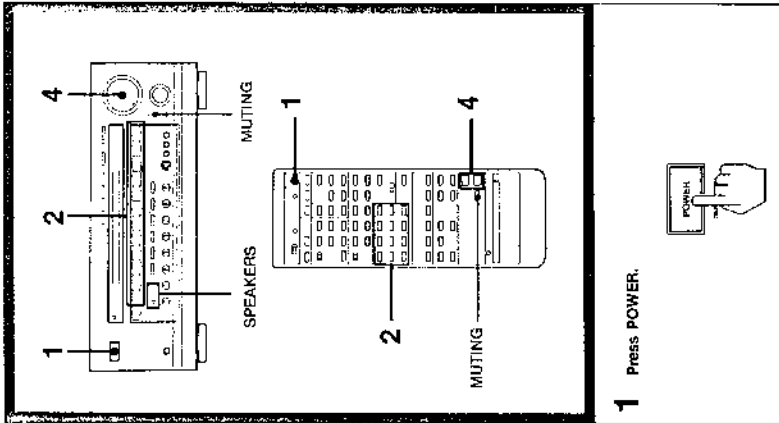

1 Press POWER.



Combining the Video Image with the Sound from Another Program Source

The MIX function allows you to combine a video image with sound from another program source as background music.

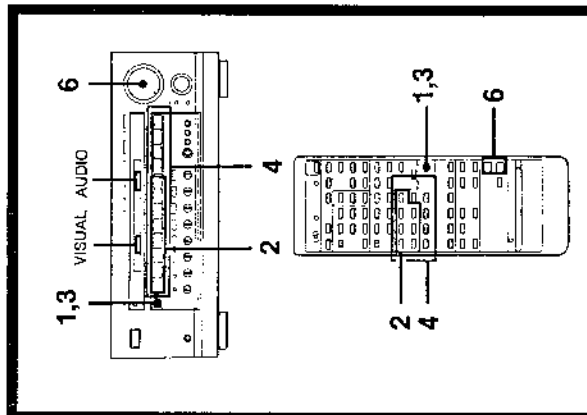

- 1 Press MIX.
- 2 Select the video source.

- 3 Press MIX.
- 4 Select the audio source. The audio signal of video source can be also selected.
- 5 Play back both the video and audio program sources.
- 6 Adjust the volume level.

How to cancel the MIX function
Press MIX after step 4.
The mix function is cancelled and the audio and video signals of the selected video program source is output.

Putting Your Own Label on Input Selectors

You can put a label of up to 8 characters on an input selector. The label will appear in the display window when a selector is pressed.

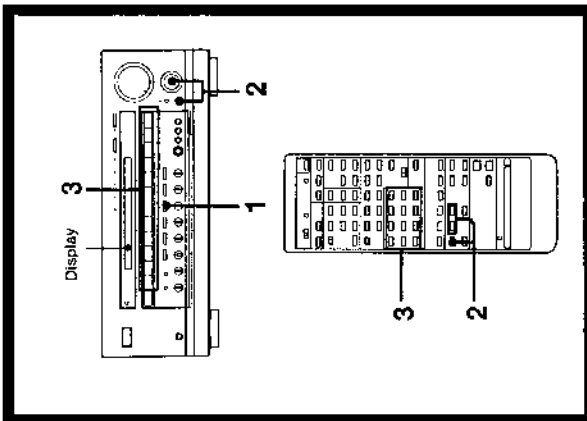

- 1 Press CHARACTER.

- 2 Create a name. Three of video selectors may be labeled as VHS, Beta, and 8mm, for example.
 - 1) Turn ACOUSTIC CONTROL to select a letter or number.
 - 2) Press MODE to move the cursor.

Now, to resume the last name press the CHARACTER button again.
- 3 Select an input selector to be labeled.

To resume the original name of the input selector Repeat steps 1 to 3 to input the original name.

If AC power card is unplugged The recorded labels are retained for approximately 2 weeks without AC power supply.

Usable letters and symbols

Space	←	→	#	%	&	.	()	*	+	-	/
0	1	2	3	4	5	6	7	8	9	:	<	>
!	A	B	C	D	E	F	G	H	I	J	K	L
P	Q	R	S	T	U	V	W	X	Y	Z	[]
↓	a	b	c	d	e	f	g	h	i	j	k	m
P	q	r	s	t	u	v	w	x	y	z		

To resume the present name of the input selectors

- 1 Press POWER switch to turn off the unit.
- 2 While pressing SET button, press the POWER switch to turn on the unit. All setting data in the unit is reset to the factory settings.

2-4. RECORDING AUDIO/VIDEO PROGRAM SOURCE

This section describes the basic recording and recording while listening to/watching another.

Basic Operation

You can operate two or more video or tape decks for recording at the same time as the audio (and video) signals of the program source is output simultaneously through all recording output jacks.

2 Set the video or tape deck in the recording mode.

3 Play back the selected program source.

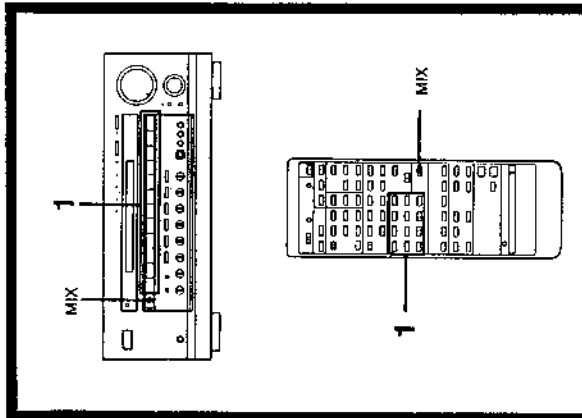

1 Select the video or audio program source. If you want to combine video image and the sound from another audio source, press the MIX button to select them independently. (See page 22).



Recording Program Sources while Listening to/Watching Another

This unit has separate circuits for line output and/or recording, so you can record a program source while listening to/watching another.

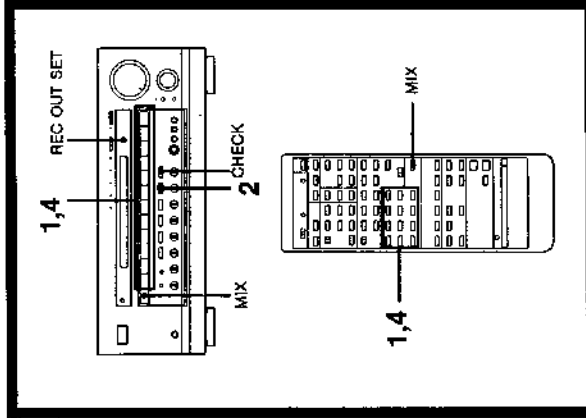

1 Select the program source to be recorded. If you want to combine a video image and the sound from another audio source, press the MIX button to select these sources independently. (See page 22).

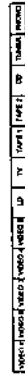

2 Press SET.

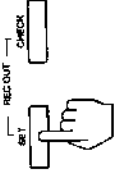

3 Play back the selected program source(s) to be recorded and set the video or tape deck into the recording mode.

4 After checking that the REC OUT SET is indicated in the display, select the program source to be listened to/watched.



5 Play back the selected program source(s).

To check the preset recording outputs
Press and hold the CHECK button to display them in the display window.

To record a listening program source
Press the SET button to go off the REC OUT SET indicator. The program source being listened to/watched is output from the REC OUT jacks.

Monitoring while recording
If a tape deck with 3-head system is connected, the recorded sound can be monitored. When the recording is done on the tape deck connected to the TAPE1 or TAPE2 jacks:

- 1 Press SET to set the rec out source.
- 2 Select TAPE 1 or TAPE2.

The recorded sound is immediately fed back to the amplifier and output to the speakers.

2-5. ENJOYING THE SURROUND SOUND

This section describes the digital surround system, functions of the surround sound mode and the selectable parameter and then how to adjust the tone quality of each speaker, the early reflection time and the effect level.

Understanding the Digital Surround System

The sound heard in a place such as a concert hall or a movie theater consists of direct sound, an early reflected sound (early reflections) and a reverberative sound (reverberation). The acoustics of the room affects the way these three sounds are heard. We can estimate the size or the type of a hall by listening to an differentiating these three kinds of sound. This amplifier reproduces the early reflections and the reverberation using its digital signal processor and allows you to design a variety of soundfields in your own room.

Types of the sound

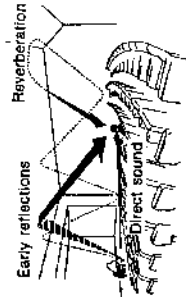

The sound transition of the direct sound, early reflections and reverberation can be illustrated as below:

Transition of the sound

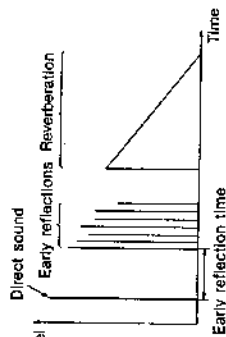

Note

Each surround mode has several internal (fixed) parameters in addition to the adjustable parameters explained in this section. Therefore, surround modes will not become the same even if you set all adjustable parameters in the same way.

Functions of the Surround Sound Modes

This amplifier incorporates Digital Signal Processor, and Dolby Pro Logic Decoder. The digital signal processor electronically reproduces the five kinds of surround soundfield programs which have been preset in the factory as shown below. In the DOLBY and THEATER modes, speaker operation modes can be changed with the Dolby Pro Logic Decoder. You can enjoy the digital surround sound effects easily by just selecting the surround mode according to the program source.

DOLBY mode (using Dolby Pro Logic function)

This mode is for reproducing the movie or sound program source processed with Dolby surround system on which the **CLUB** mark is labeled. You can hear dynamic sounds and natural voice just like listening to it in a movie theater or a concert hall.

THEATER mode (using Dolby Pro Logic function)

This mode is for reproducing the movie program source processed with the Dolby surround system. You can hear dynamic sound and natural voice just like listening to it in a movie theater. In this mode, reverberation effect is added to the signal processed through the Dolby Pro Logic Decoder.

HALL mode

You can hear the naturally acoustic sound having a reverberation effect that is produced in a medium sized concert hall.

JAZZ CLUB mode

You can hear the powerful and clear sound having an effect produced in a jazz club.

STADIUM mode

This mode is for adding the reverberation effect felt in an outdoor stadium to a program source recorded in studio.

Selecting the Surround Sound Mode

This amplifier has five surround modes, DOLBY, THEATER, HALL, JAZZ CLUB, and STADIUM, which have been preset in the factory. Since these are appropriate for the most types of music and listening situations, you can enjoy the digital surround sound effects by just selecting the surround modes according to the program source. You can also adjust several parameters to maximize the effect.

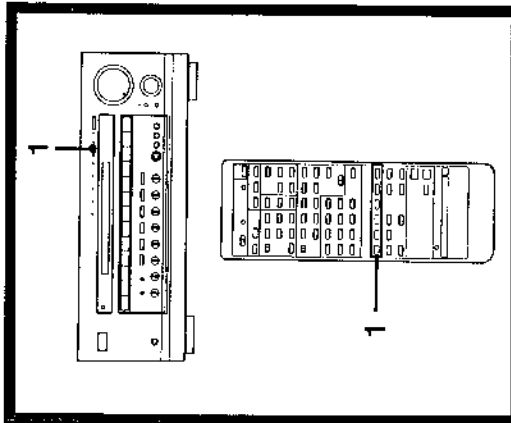

1 Press SURROUND MODE to select your favorite surround mode.

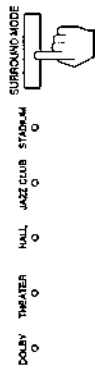

To resume the surround mode

Press the SURROUND MODE selector so that no indicator lights up. On using the remote commander, press the ON/OFF button in Surround Mode to turn off the Indicator.

Adjustable Parameters

This amplifier reproduces the early reflections and the reverberation using its digital processor and allows you to design a variety of soundfields in your own room. This amplifier incorporates 5 types of surround modes, and within each mode, you can adjust several parameters to maximize the effect in your listening room.

Before adjusting parameters, play back the program source, and press SURROUND MODE selector to turn on the surround function. You can adjust parameters while listening to the actual sound.

Surround Mode	DOLBY	THEATER	HALL	JAZZ CLUB	STADIUM
Parameter					
Rear Level	0*2	0*2	0	0	0
Center Level	0*1	0*1			
Early Reflection Time			0*2	0	0
Delay Time		0*2			
Effect Level			0	0	0

*1 except for PHANTOM mode
*2 except for 3CH LOGIC mode

- Adjusting the rear level and center level is shown on pages 18 and 19.
- Adjusting the delay time is shown on page 20.
- The data of the early reflection time and delay time can be programmed into each surround mode individually. The data of the center, rear, and effect level are the same on all modes.

Adjusting the Tone Quality of Each Speaker

To enjoy the surround sound sufficiently, adjust the tone of the front, center, and rear speakers respectively to your preference.

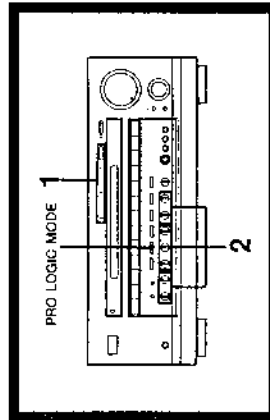

1 Press **SURROUND MODE** to select a surround mode.

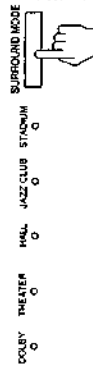

2 Adjust the tone quality of each speaker.



Adjusting the Early Reflection Time (Except for Dolby Surround Mode)

The early reflection time is the key parameter which determines the room size and listening position. Adjustment of this parameter will vary the time required for the sound to reach to the listening position. The longer the time, longer you will feel the distance to the origin of the sound.

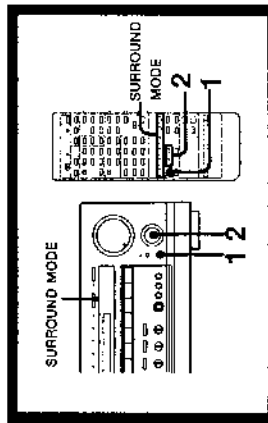
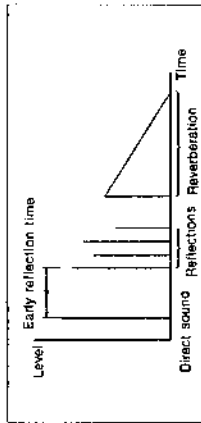

1 Press **MODE**.

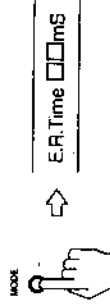

2 Turn **ACOUSTIC CONTROL** to adjust the early reflection time.

The early reflection time is adjustable from 0 ms to 51 ms on the **THEATER** or **JAZZ CLUB** mode, and from 0 ms to 90 ms on the **HALL** or **STADIUM** mode.



Note
When adjusting the parameter, noise may be output.

Adjusting the Effect Level (Except for Dolby Surround Mode)

This parameter adjusts the level of early reflections and reverberation. As the number gets larger, the room becomes more "live", and as it gets smaller, the room becomes "dead".

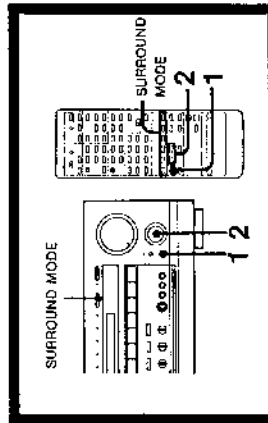
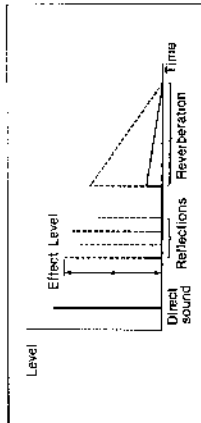

1 Press **MODE**.

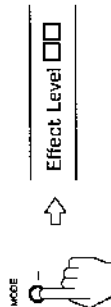

2 Turn **ACOUSTIC CONTROL** to adjust the effect level.

The effect level is adjustable from 0 to 10 (100%) on the **THEATER**, **HALL**, **JAZZ CLUB** and **STADIUM** modes.



2-6. USING THE REMOTE COMMANDER

The RM-P651 can learn various functions of other remote commanders emitting infrared rays and allows you to control most of the audio and video equipment from a distance.

Programming Signals of Other Audio/Video Equipment with RM-P651

Insert batteries before operation.

- The two remote commanders must:
- be placed straight and head to head.
 - be placed at a distance of approx. 5 cm (2 inches).
 - not be moved during the programming operation.

How to program

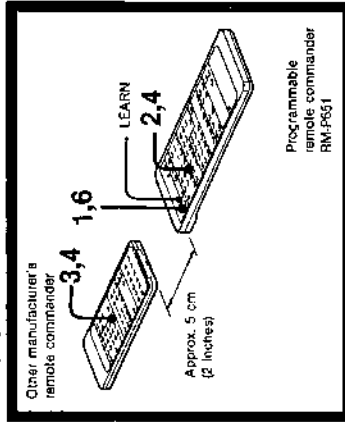

- 1 Set the mode selector to LEARN.



- 2 Press and hold the button which shall "learn" the remote-control signal until the LEARN indicator lights up.

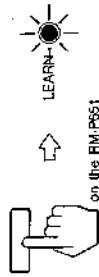

- 3 Press and hold the button of other manufacturer's remote commander whose signal is to be learned.



- 4 Remove your finger(s) from the button(s) after the LEARN indicator goes off.

- 5 Repeat operation for each button to be programmed.

- 6 Set the mode selector to USER STD or SONY STD.

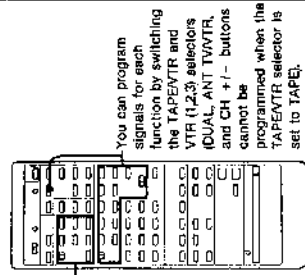

After programming
Be sure to test if the equipment really works with the programmed signals.

Number of signals that the commander can learn
It depends on the format of the signal. If you program signals of Sony equipment, approximately 90 signals can be programmed.

If the LEARN indicator flashes or does not go out in steps 2-4

The memory capacity has become full. This occurs when other signals stronger than the remote-control signals have been stored because the signals were programmed in a noisy environment or the remote commanders were placed too far apart from each other. In this case, clear all the signals following the procedure on the right and program from the beginning under the proper conditions again.

Notes on programming

- Remote-control signals of equipment of manufacturers other than Sony can be programmed only when they are compatible with the infrared wireless remote control system. Since the programmable commander can "learn" only the signals output from another remote commander, it cannot control equipment that does not use a remote commander. Also, note that there are some special remote-control signals that cannot be programmed.
- Do not attempt to use the programmable commander with an air conditioner or other household appliances.

To Program a New Signal onto a Previously Programmed Button

Follow the programming procedure.
The previously programmed signal is cleared and replaced by the new signal.

To clear all programmed signals

- 1 Set the mode selector to LEARN.
- 2 Press and hold any button until the LEARN indicator lights up.
- 3 Press PROGRAM CLEAR until the LEARN indicator flashes and goes off.

Note

It is not possible to clear the programmed content of just one button.

To program a signal onto the • REC button in the TAPE or VTR section

It is not possible to operate any equipment with only the REC button. To program a signal under the • REC button, press and hold the following buttons at the same time in step 2.



Controlling Equipment

By switching the mode selector as shown below, a single button alternately controls Sony equipment and another manufacturer equipment.

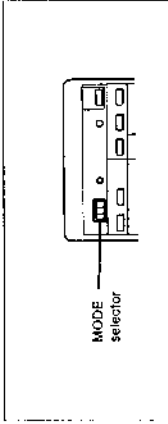

To control Sony equipment



To control equipment with programmed signals



When Sony equipment cannot be remote-controlled
Program the signal in the same way as for equipment from other manufacturers. In this case, even with Sony equipment, set the mode selector to USER STD.

Notes on using the remote commander

- When you manipulate buttons on the commander, be sure to point the head of the commander toward the remote control sensor of the equipment.
- If there is an obstacle between the equipment and the head of the commander, the remote commander may not function.

Notes on Battery

If the LEARN indicator does not light when a button is pressed, the batteries are almost exhausted. When the batteries are exhausted, the remote commander can no longer operate the unit or programming becomes impossible. If this happens, replace both batteries with new ones. We recommend the use of alkaline batteries for prolonged use.

If no signal has been programmed

The programmable commander can control Sony equipment even when the mode selector is set to USER STD.

If the equipment works incorrectly

Press RESET.
The programmed contents of the buttons are not cleared by pressing RESET.

2-7. BLOCK DIAGRAM

This section concisely illustrates the functions and connecting order in the circuit composition.

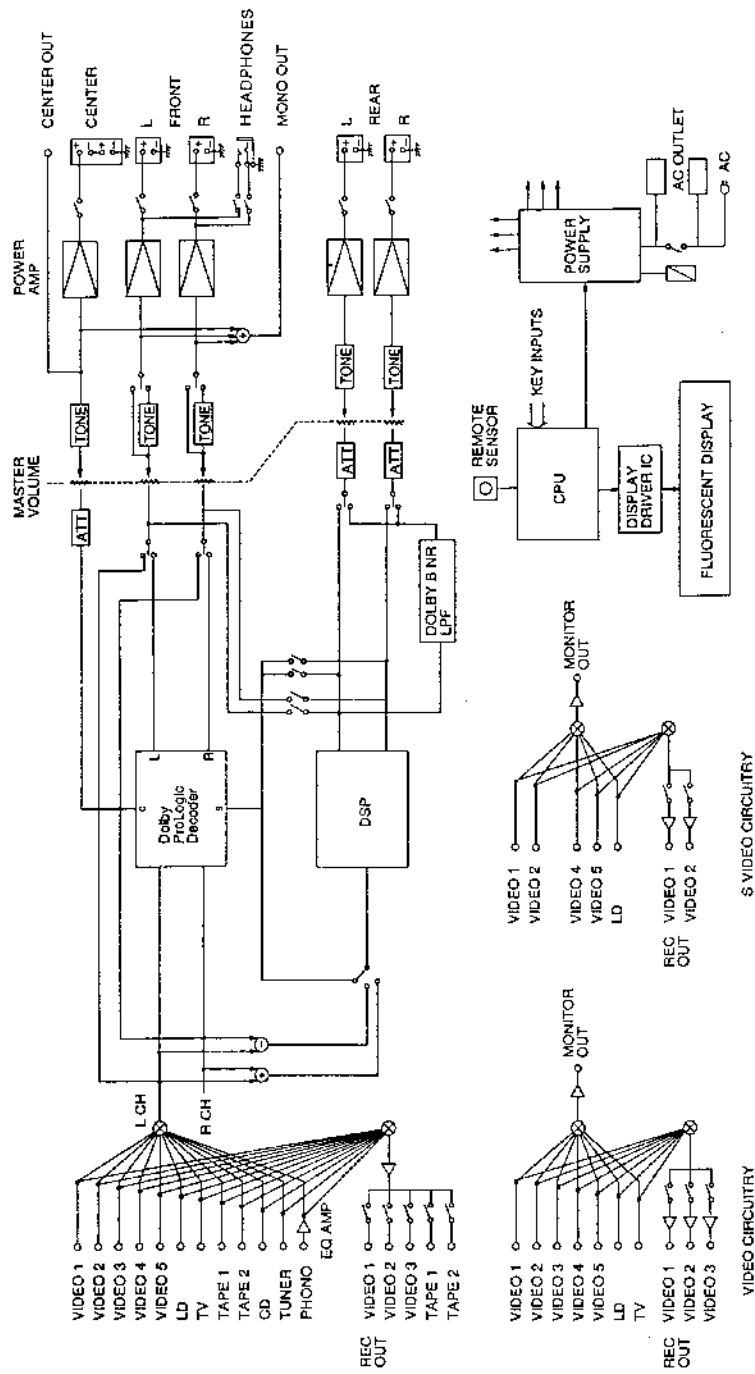

**SECTION 3
BLOCK DIAGRAM**

3-1. BLOCK DIAGRAM

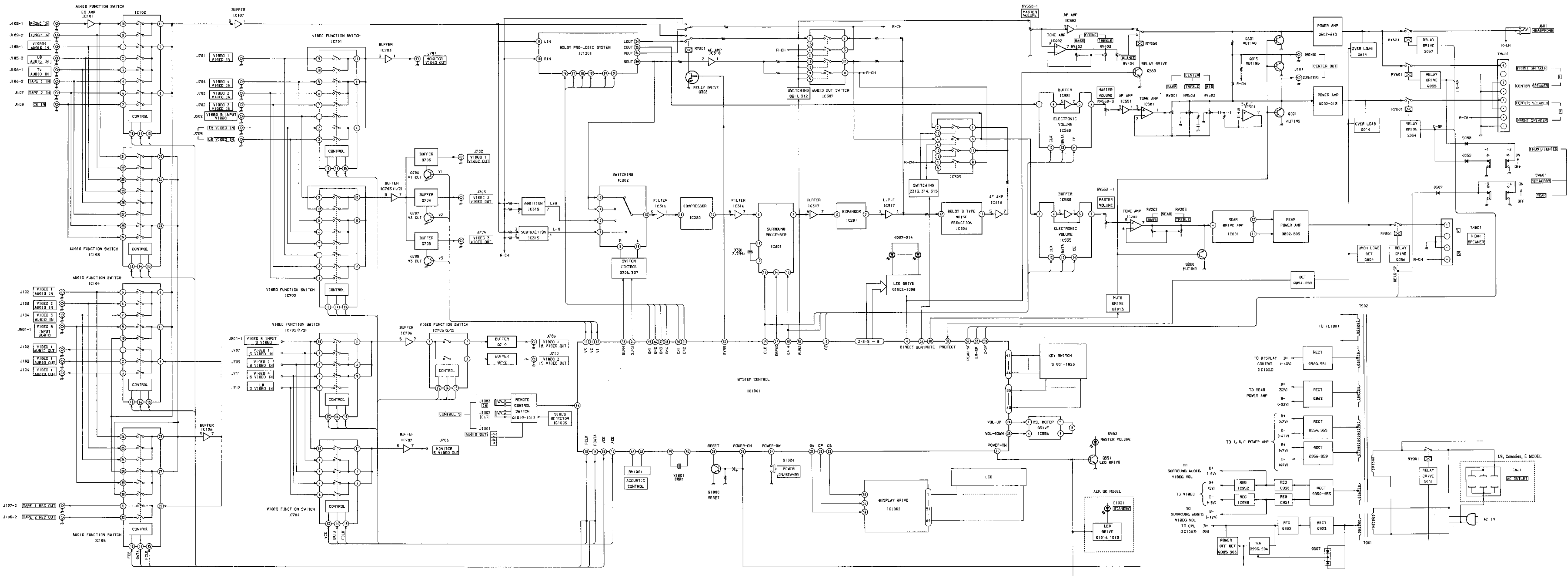

3-2. EXPLANATION OF IC TERMINALS

• IC301 Surround Processor (YM7128)

Pin. No.	Terminal name	I/O	Terminal explanation
1	VDD	-	Digital system +5 V power source
2	AVDD	-	Analog system +5 V power source
3	CH	O	External condenser terminal for sample hold
4	AIN	I	Analog signal input terminal
5	CV	O	Standard voltage output terminal for A/D converter
6	\overline{TI}	I	Test input terminal (always open)
7	LO	O	L-channel output (analog output) terminal
8	RO	O	R-channel output (analog output) terminal
9	AVSS	-	Analog system GND
10	VSS	-	Digital system GND
11	XO	O	Clock output
12	XI	I	Clock input (7.7 MHz)
13	SCI	I	Data shift clock input terminal
14	AC	I	Address/data identification signal input terminal "L" : Address term, "H" : Data term
15	DIN	I	Data input terminal
16	\overline{IC}	I	Initial clear terminal

• IC1002 Display Microcomputer (MSC7128)

Receives display data from the system controller and displays it on the fluorescent tube.

Pin. No.	Terminal name	I/O	Terminal explanation
1~51	COM2~6 SEG1~36	O	Fluorescent tube display drive output
52, 53	+5V	-	Power source terminal (+5 V)
54	\overline{RESET}	I	Reset input
55	CP	I	Data transmission clock input from system controller (IC1001)
56	DA	I	Serial data input from system controller (IC1001)
57	CS	I	Data latch input from system controller (IC1001)
58	OSC O	O	} CR external terminal for clock oscillator
59	OSC I	I	
60	TEST	-	Not use with this machine. (Always GND)
61	TEST	-	
62	Vss	-	GND
63	VEE	-	Power source terminal of driver circuit (-40 V)
64	COM1	O	Fluorescent tube display drive output

• IC1001 System Controller (M50747)

This controller controls the whole system, such as the control data transmission for DSP, switching the surround mode, data transmission for the display microcomputer (IC1002) to display it on the fluorescent lamp, switching the function switch, VOL control, ON/OFF of LED relay, and key input.

Pin. No.	Terminal name	I/O	Terminal explanation
1	VDD	—	Power source terminal (+5 V)
2	MUT	O	MUTE LED (D1014) output. "H" : light on
3	RECOUT	O	REC OUT LED (D1013) output. "H" : light on
4	DIRECT	O	SOURCE DIRECT LED (D1012), Relay (RY550) output. "H" : light on, Relay ON
5	STADIUM	O	STADIUM LED (D1011) output. "H" : light on
6	JAZZ	O	JAZZ CLUB LED (D1010) output. "H" : light on
7	HALL	O	HALL LED (D1009) output. "H" : light on
8	THEATER	O	THEATER LED (D1008) output. "H" : light on
9	DOLBY	O	DOLBY LED (D1007) output. "H" : light on
10	V3	O	Loop cut control terminal for Video 3 image output. Active : "L"
11	V2	O	Loop cut control terminal for Video 2 image output. Active : "L"
12	V1	O	Loop cut control terminal for Video 1 image output. Active : "L"
13	FCLK	O	Data transmission clock output for audio/video function switch
14	FDATA	O	Serial data output for audio/video function switch
15	FCE	O	Data latch output for audio function switch (IC102~105)
16	VCE	O	Data latch output for video function switch (IC701, 702, 704, and 705)
17	DSPA 0	O	Data latch output for surround processor (IC301)
18	C/R - CE	O	Data latch output for election VOL (IC550 and 555)
19	CLK	O	Data transmission clock output for election VOL (IC550 and 555) and surround processor.
20	DATA	O	Serial data output for election VOL (IC550 and 555) and surround processor.
21	DA	O	Serial data output for display microcomputer (IC1002)
22	\overline{CP}	O	Data transmission clock output for display microcomputer (IC1002)
23	\overline{CS}	O	Data latch output for display microcomputer (IC1002)
24	VOL - UP	O	Volume motor (RV550) UP output for IC556 (motor drive)
25	VOL - DOWN	O	Volume motor (RV550) DOWN output for IC556 (motor drive)
26	POWER - ON	I	Power source breakage detection input. Active : \overline{L}
27	Vss	—	Power source terminal (GND)
28	RES	I	Reset input
29	XIN	I	Clock input (8.0 MHz)
30	XOUT	O	Clock output
31	CLK	—	Not used with this machine.
32	Vss	—	Power source terminal (GND)
33	PROTECT	I	Protection detection input of speaker output
34	ON/OFF	I	POWER switch (S1024) input
35	KEY OUT	O	Key matrix output
36			
37			
38			
39			
40			

Pin. No.	Terminal name	I/O	Terminal explanation																																											
41 42 43 44	KEY IN	I	Key matrix input																																											
45				DM1	O	<table border="1"> <thead> <tr> <th>MODE</th> <th>DM1</th> <th>DM2</th> <th>DM3</th> <th>DM4</th> </tr> </thead> <tbody> <tr> <td>3CH LOGIC</td> <td>H</td> <td>L</td> <td>H</td> <td>H</td> </tr> <tr> <td>REAR SPEAKER NOISE</td> <td>L</td> <td>H</td> <td>H</td> <td>H</td> </tr> <tr> <td>RIGHT SPEAKER NOISE</td> <td>L</td> <td>H</td> <td>H</td> <td>L</td> </tr> <tr> <td>CENTER SPEAKER NOISE</td> <td>L</td> <td>H</td> <td>L</td> <td>H</td> </tr> <tr> <td>LEFT SPEAKER NOISE</td> <td>L</td> <td>H</td> <td>L</td> <td>L</td> </tr> <tr> <td>SYSTEM MUTE</td> <td>L</td> <td>L</td> <td>H</td> <td>H</td> </tr> <tr> <td>PRO LOGIC MODE</td> <td>H</td> <td>H</td> <td>H</td> <td>H</td> </tr> </tbody> </table>	MODE	DM1	DM2	DM3	DM4	3CH LOGIC	H	L	H	H	REAR SPEAKER NOISE	L	H	H	H	RIGHT SPEAKER NOISE	L	H	H	L	CENTER SPEAKER NOISE	L	H	L	H	LEFT SPEAKER NOISE	L	H	L	L	SYSTEM MUTE	L	L	H	H	PRO LOGIC MODE	H	H	H	H
MODE				DM1		DM2	DM3	DM4																																						
3CH LOGIC				H		L	H	H																																						
REAR SPEAKER NOISE	L	H	H	H																																										
RIGHT SPEAKER NOISE	L	H	H	L																																										
CENTER SPEAKER NOISE	L	H	L	H																																										
LEFT SPEAKER NOISE	L	H	L	L																																										
SYSTEM MUTE	L	L	H	H																																										
PRO LOGIC MODE	H	H	H	H																																										
46	DM2	O																																												
47	DM3	O																																												
48	DM4	O																																												
49	NC	-																																												
50 51	CM1 CM2	O O	<table border="1"> <thead> <tr> <th>CM1</th> <th>CM2</th> <th></th> </tr> </thead> <tbody> <tr> <td>L</td> <td>L</td> <td>CENTER OFF</td> </tr> <tr> <td>L</td> <td>H</td> <td>WIDE</td> </tr> <tr> <td>H</td> <td>L</td> <td>PHANTOM</td> </tr> <tr> <td>H</td> <td>H</td> <td>NORMAL</td> </tr> </tbody> </table>	CM1	CM2		L	L	CENTER OFF	L	H	WIDE	H	L	PHANTOM	H	H	NORMAL																												
CM1	CM2																																													
L	L	CENTER OFF																																												
L	H	WIDE																																												
H	L	PHANTOM																																												
H	H	NORMAL																																												
52	SUR5	O	Surround mode setting output. "L" : Dolby PRO LOGIC output.																																											
53 54	SUR4 SJR3	O O	} Surround mode setting output. <table border="1"> <thead> <tr> <th>SUR3</th> <th>SUR4</th> <th>Matrix</th> </tr> </thead> <tbody> <tr> <td>L</td> <td>L</td> <td>L + R</td> </tr> <tr> <td>L</td> <td>H</td> <td>Dolby S OUT</td> </tr> <tr> <td>H</td> <td>L</td> <td>Dolby S OUT</td> </tr> <tr> <td>H</td> <td>H</td> <td>L - R</td> </tr> </tbody> </table>	SUR3	SUR4	Matrix	L	L	L + R	L	H	Dolby S OUT	H	L	Dolby S OUT	H	H	L - R																												
SUR3	SUR4	Matrix																																												
L	L	L + R																																												
L	H	Dolby S OUT																																												
H	L	Dolby S OUT																																												
H	H	L - R																																												
55	SUR2	O	Surround mode setting output. "H" : DSP blend ON, "L" : DSP blend OFF																																											
56	SUR1	O	Surround mode setting output. "L" : Surround, "H" : Source direct																																											
57	REAR - SP	O	Rear speaker relay (RV801) control output. At source direct : "L". Normal : "H"																																											
58	LR - SP	O	Front speaker relay (RY601) and HP relay (RY681) control output. Normal : "H"																																											
59	C - SP	O	Center speaker relay (RY001) control output. At Dolby theater, WIDE • NORMAL : "H"																																											
			When power is on, the pins ⑤ to ⑧ are "L", and when PROTECT turns to "L", they turn to "L", too.																																											
60	MUT	O	Audio mute output. "L" : Mute																																											
61	RY	O	Power relay (RY901) control output. "H" : Relay ON (Power ON)																																											
62 63	ENC2 ENC1	I I	} Rotary encode (RV1001) input 																																											
64	SIRCS	I		SIRCS signal input																																										
			The phase of ENC1 and 2 has slipped 90°																																											

• SUR1~5 (pins ⑤ to ⑧) setting in surround mode

	DOLBY	THEATER	HALL	JAZZCLUB	STUDIUM	SURROUND OFF
SUR1	L	H	H	H	H	don't care
SUR2	L	H	L	L	L	L
SJR3	L	L	H	H	L	don't care
SUR4	H	L	H	H	L	don't care
SUR5	L	L	H	H	H	L

[INDICATOR TUBE, FLUORESCENT]

FL001

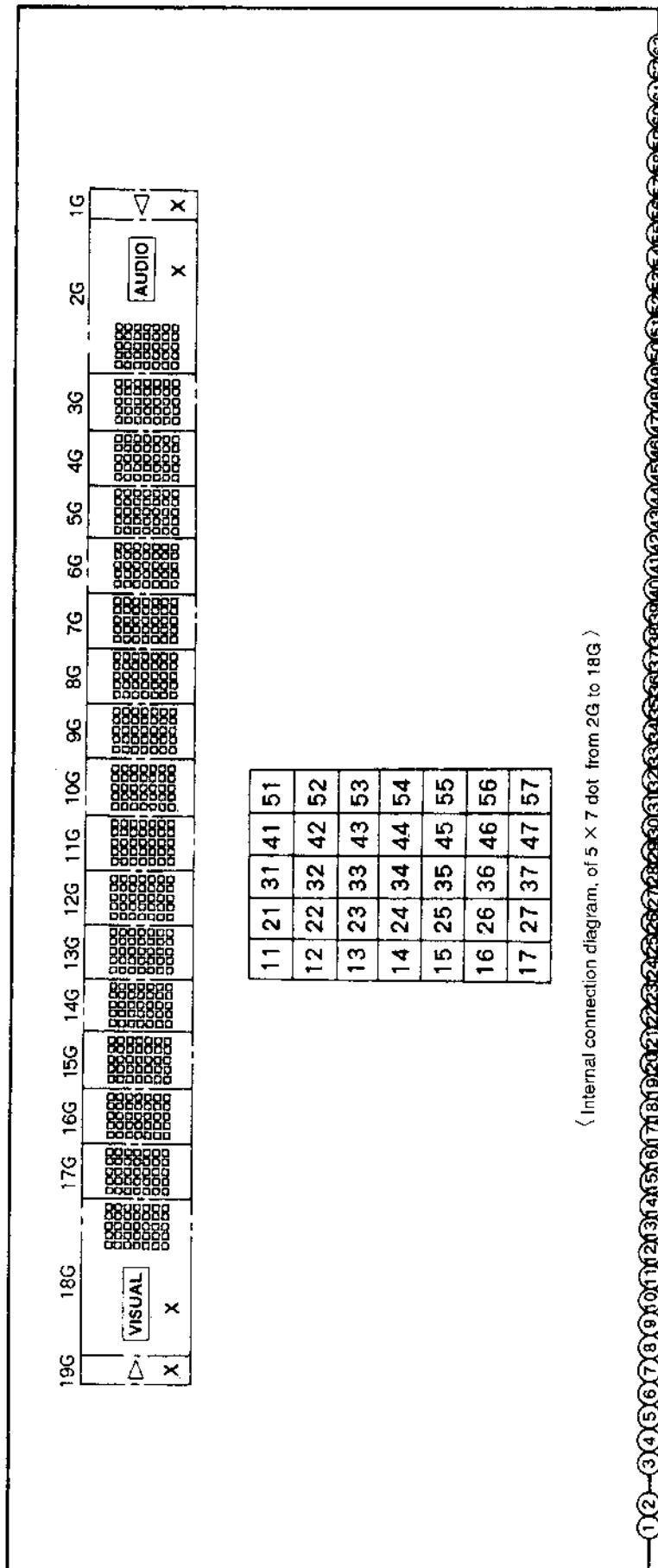

(Internal connection diagram, of 5 X 7 dot, from 2G to 18G)

* F : Filament
 G : Grid
 P : Anode
 NP : No Pin

SECTION 4 ELECTRICAL ADJUSTMENTS

● Service mode display with fluorescent lamp

When depressing the **DISPLAY MODE** button while pressing the **TEST TONE** button, the following three patterns are repeatedly displayed :

1. Diced pattern
2. Diced pattern(in reverse of pattern 1)
3. Everything lights

(However, since 10G in the center position is not used and connected, it does not light.)

[Idling adjustment]

Note:

Perform the adjustment procedures after the power switch has been turned ON and having waited for a few minutes.

<1> FRONT / CENTER SECTION

Adjusting method :

1. Set the master volume to MIN.
2. Connect a tester to the test points of TB001(Center), TB601(L-CH)and TB651(R-CH)and confirm that the reading of the tester become within the following values.
3. If the readings of the tester are bigger than the specified values, solder the taps of R201(CENTER), R621(L-CH)and R671(R-CH).
Specified value : 0.5 – 10.0mV

Adjusting point : AMP B circuit board

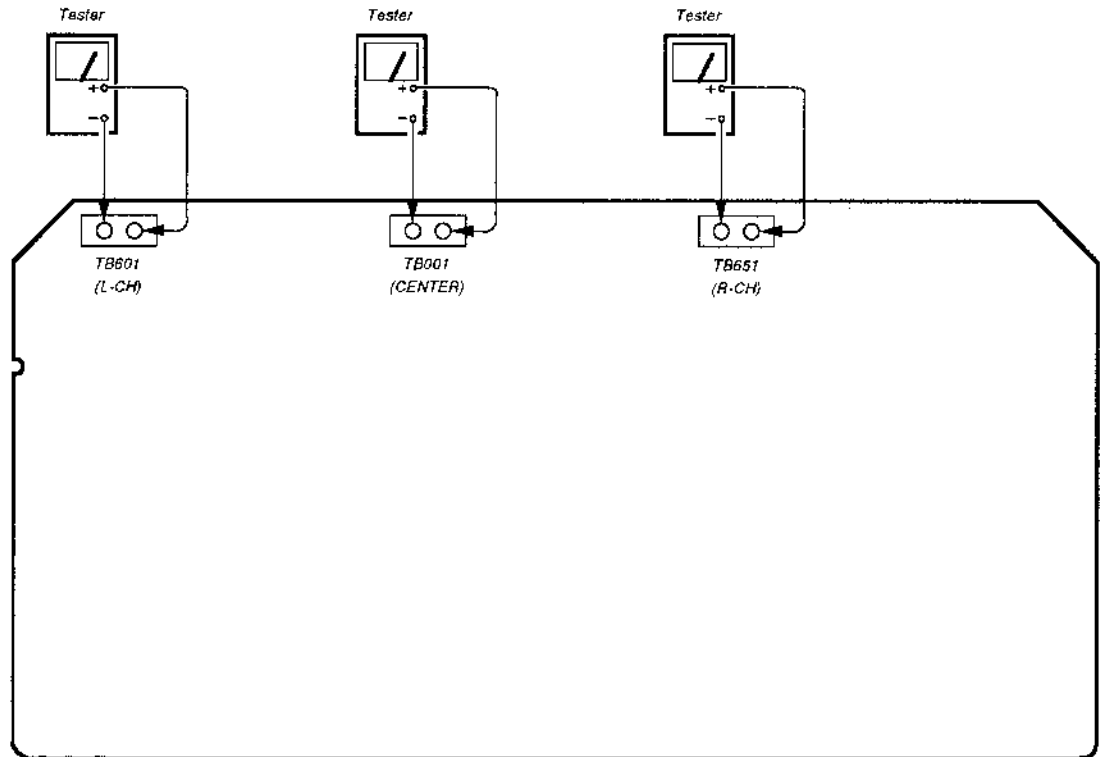

(Part surface side)

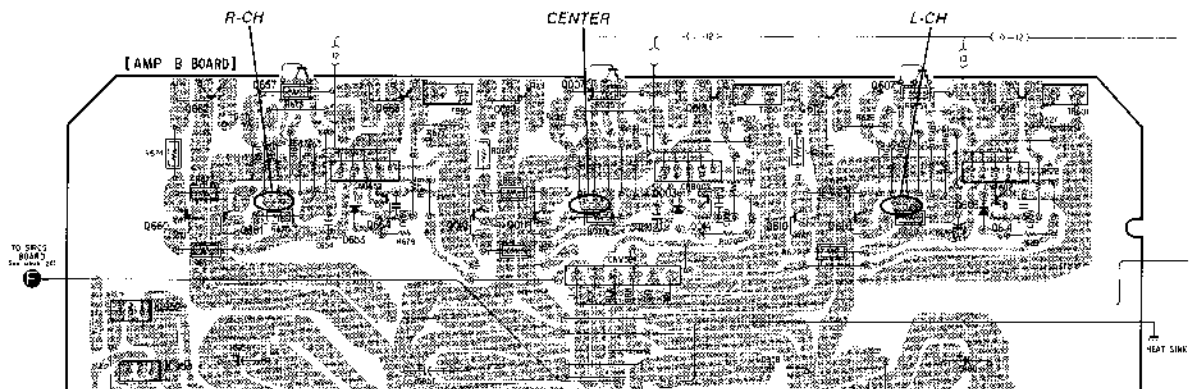

(Pattern surface side)

<2> REAR SECTION**Adjusting method :**

1. Set the master volume to MIN.
2. Connect a tester to the test points of TB801 (L-CH) and TB851(R-CH) and confirm that the reading of the tester become within the following values.
Specified value : 0.5 – 2.0mV

Adjusting point : REAR board

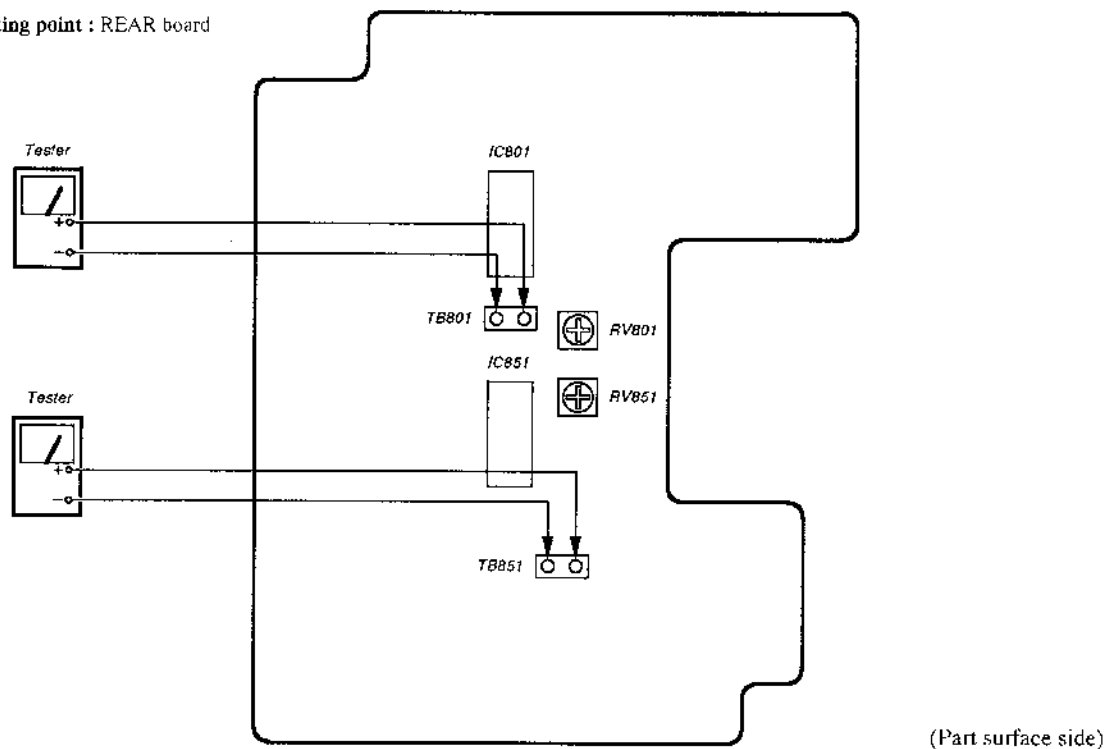
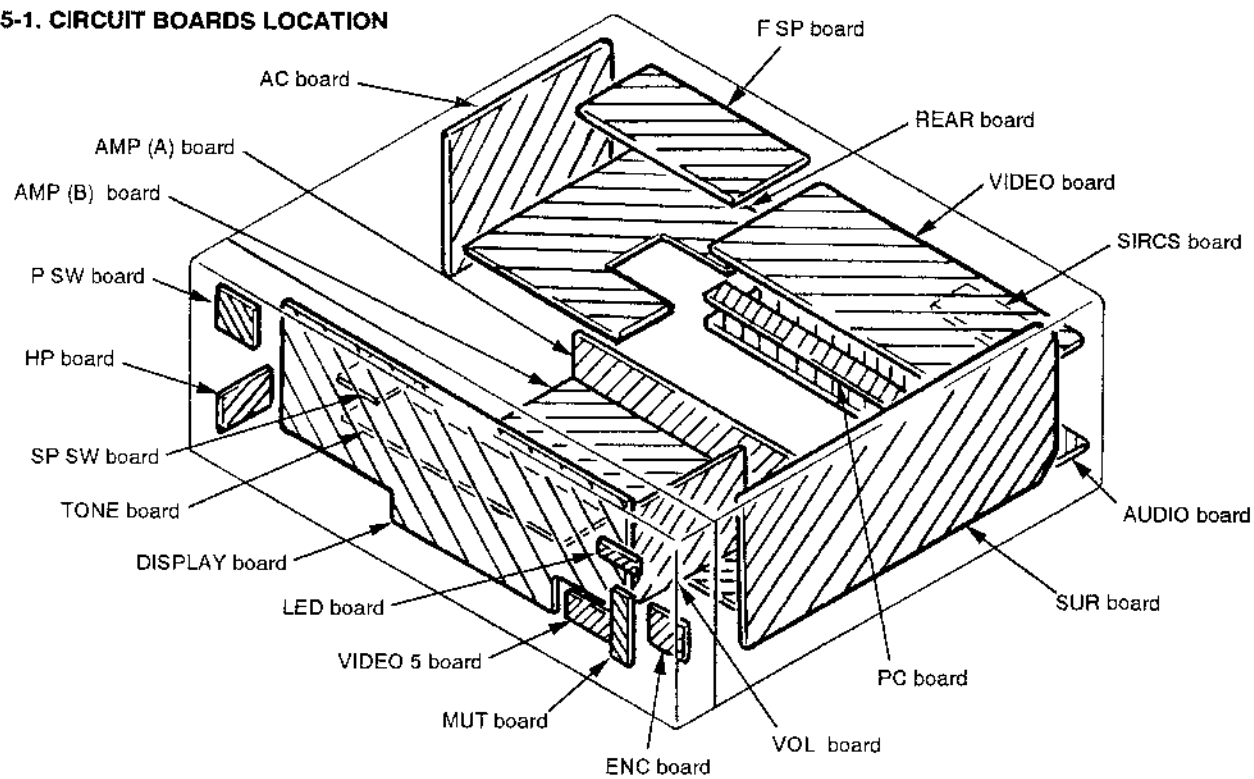
**SECTION 5
DIAGRAMS****5-1. CIRCUIT BOARDS LOCATION**

• SEMICONDUCTOR LEAD LAYOUTS

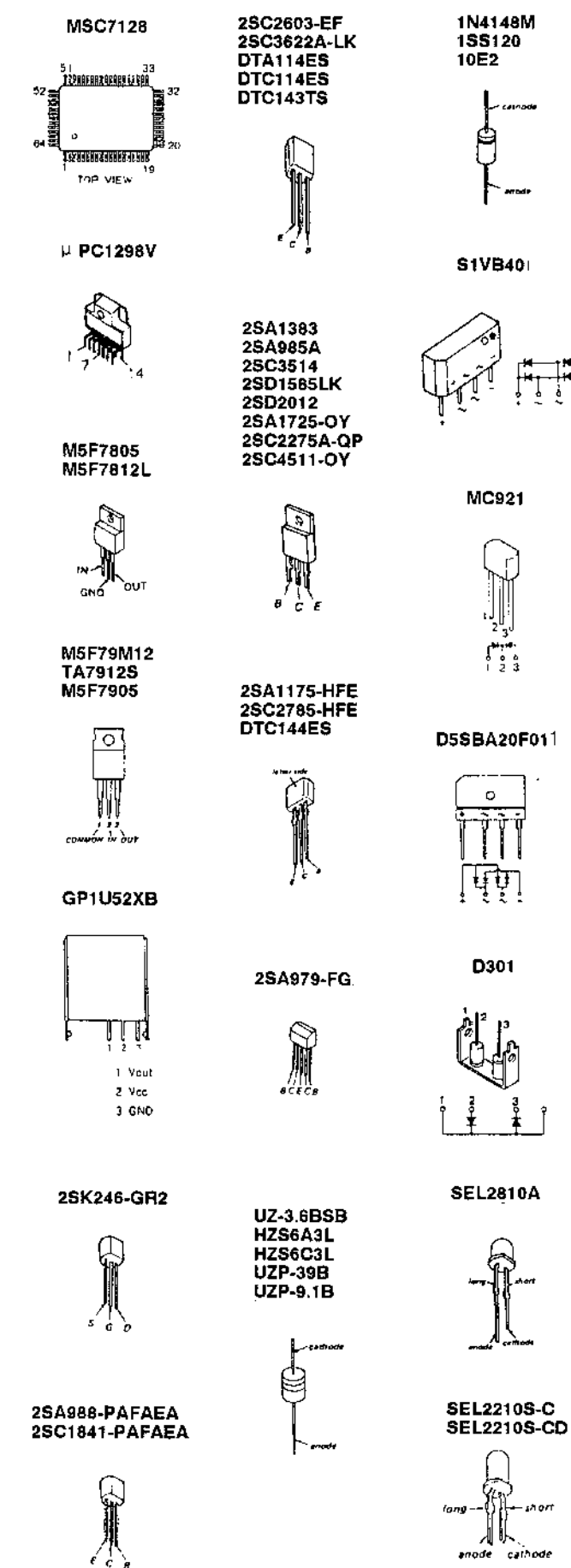

• SEMICONDUCTOR LOCATION

Ref. No.	Location	Ref. No.	Location
D301	H-6	IC703	C-21
D302	H-10	IC704	D-17
D701	C-20	IC705	D-14
D702	C-20	IC706	C-14
D703	C-19	IC707	C-16
D1001	H-3	IC1001	I-3
D1002	H-3	IC1201	J-10
D1003	H-3		
D1004	H-3		
D1006	J-2	Q306	J-7
		Q307	J-7
D1015	I-20	Q308	H-11
D1016	I-19	Q311	G-10
D1017	H-2	Q312	G-10
D1018	I-2		
D1019	J-2	Q313	G-11
D1020	H-4	Q314	G-11
		Q315	G-11
		Q703	C-21
		Q704	C-20
IC101	C-2		
IC102	C-4		
IC103	C-5	Q705	C-19
IC104	D-10	Q706	C-21
IC105	D-8	Q707	C-20
		Q708	C-19
		Q709	C-15
IC106	D-6	Q710	C-16
IC107	E-4		
IC280	J-6	Q711	C-13
IC281	G-4	Q712	C-14
IC301	H-6	Q713	C-17
		Q715	C-21
IC302	J-8		
IC306	G-8		
IC307	C-10	Q1000	J-2
IC309	G-11	Q1010	I-19
IC315	I-8	Q1011	I-20
		Q1012	I-20
		Q1013	H-5

Note on Schematic Diagram :

- All capacitors are in μF unless otherwise noted, pF : $\mu \mu F$ 50WV or less are not indicated except for electrolytics and tantalums.
- All resistors are in Ω and $1/4W$ or less unless otherwise specified.
- % : indicates tolerance.
- Δ : internal component.
- \square : nonflammable resistor.
- \square : fusible resistor.

Note :
The components identified by mark Δ or dotted line with mark Δ are critical for safety. Replace only with part number specified.

Les composants identifiés par une marque Δ sont critiques pour la sécurité. Ne les remplacer que par une pièce portant le numéro spécifié.

- \square : B+ Line
- \square : B- Line
- Voltage and waveforms are dc with respect to ground under no-signal conditions. no mark : PHONO
- Voltages are taken with a VOM (Input impedance $10M \Omega$). Voltage variations may be noted due to normal production tolerances.
- Signal path.
- \rightarrow : AUDIO
- \rightarrow : VIDEO 1

Note on Printed Wiring Boards :

- \square : parts extracted from the component side.
- \blacksquare : parts mounted on the conductor side.
- \dots : Pattern on the side which is seen.

5-2. PRINTED WIRING BOARDS - AUDIO SECTION -

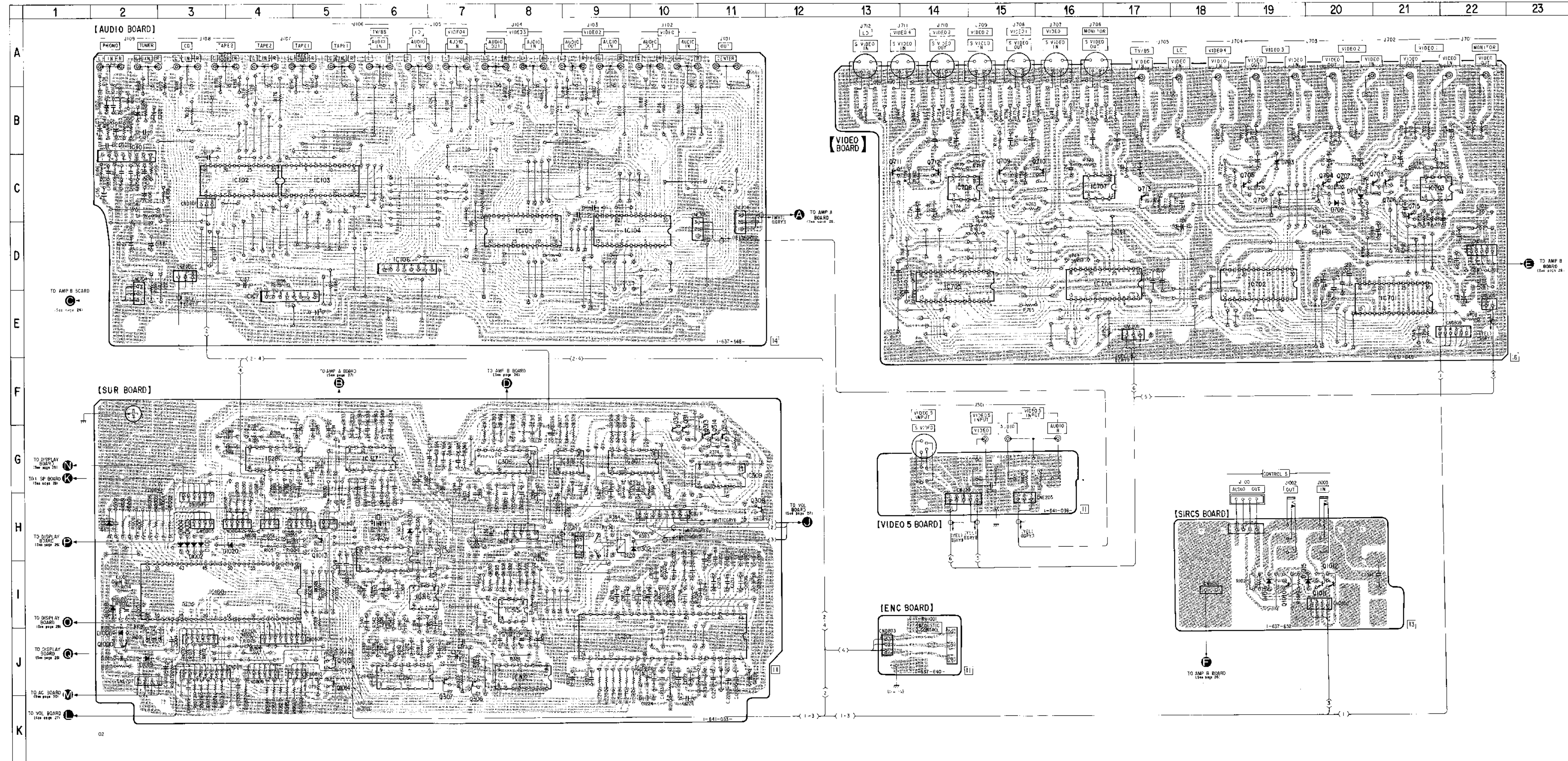

5-4. PRINTED WIRING BOARDS - AMP SECTION - Refer to page 26 for Semiconductor Lead Layouts.

• SEMICONDUCTOR LOCATION

Ref. No.	Location	Ref. No.	Location	Ref. No.	Location
D001	G-6	IC202	J-3	Q812	A-7
D002	G-6	IC280	E-12	Q813	A-9
D003	B-6	IC281	F-13	Q614	B-9
D006	C-15	IC402	J-9	Q651	H-5
D007	C-15	IC501	J-5	Q652	G-8
D050	C-16	IC550	H-14	Q653	G-8
D052	B-16	IC551	I-14	Q654	G-8
D054	B-16	IC552	J-14	Q655	G-9
D055	C-15	IC553	Q-12	Q656	G-9
D056	B-15	IC555	H-12	Q657	A-3
D550	I-12	IC556	F-12	Q658	G-10
D551	J-12	IC801	D-21	Q659	G-9
D552	E-16	IC950	D-4	Q660	B-2
D601	G-2	IC951	E-4	Q661	B-2
D602	G-2	IC952	C-2	Q662	A-2
D603	B-9	IC953	C-2	Q663	A-4
D651	G-8	IC1002	J-21	Q684	B-4
D652	G-8	IC1003	J-17	Q801	E-22
D653	B-4			Q851	E-22
D681	F-18			Q901	E-29
D682	F-19	Q001	G-4		
Q701	E-23	Q002	Q-6	Q902	F-29
D902	B-24	Q003	G-5	Q903	F-28
D951	F-22	Q004	G-5	Q904	E-29
D952	C-24	Q005	G-7	Q905	F-28
				Q906	G-28
D901	E-30	Q007	A-5	Q1001B	K-23
D902	E-30	Q008	G-7	Q1002	K-23
D903	G-30	Q009	G-7	Q1003	K-24
D907	F-30	Q010	B-5	Q1004	J-26
D908	F-29			Q1005	J-26
D909	E-30	Q011	B-5		
D910	E-28	Q012	A-5	Q1006	J-26
D950	E-5	Q013	A-6	Q1007	J-26
D951	D-5	Q014	B-6	Q1008	K-26
D952	E-5	Q015	H-4		
		Q051	C-16		
D953	E-5	Q052	C-16		
D954	E-8	Q053	C-16		
D955	D-8	Q054	B-15		
D956	D-7	Q055	B-15		
D957	E-7	Q056	B-15		
D959	E-7	Q057	D-14		
D959A	G-21	Q550	I-12		
D959B	D-7	Q551	F-13		
D960	G-21	Q601	H-4		
D961	G-21	Q602	G-2		
D962	E-23	Q603	G-1		
D1007	K-22	Q604	G-2		
D1008	K-23	Q605	G-3		
D1009	K-24	Q606	G-3		
D1010	K-25	Q607	A-8		
D1011	K-25	Q608	G-3		
D1012	K-27	Q609	G-3		
D1013	J-25	Q610	B-7		
D1014	J-31	Q611	B-6		

Note:

- : parts extracted from the component side.
- : parts mounted on the conductor side.
- ⊙ : Pattern on the side which is seen.

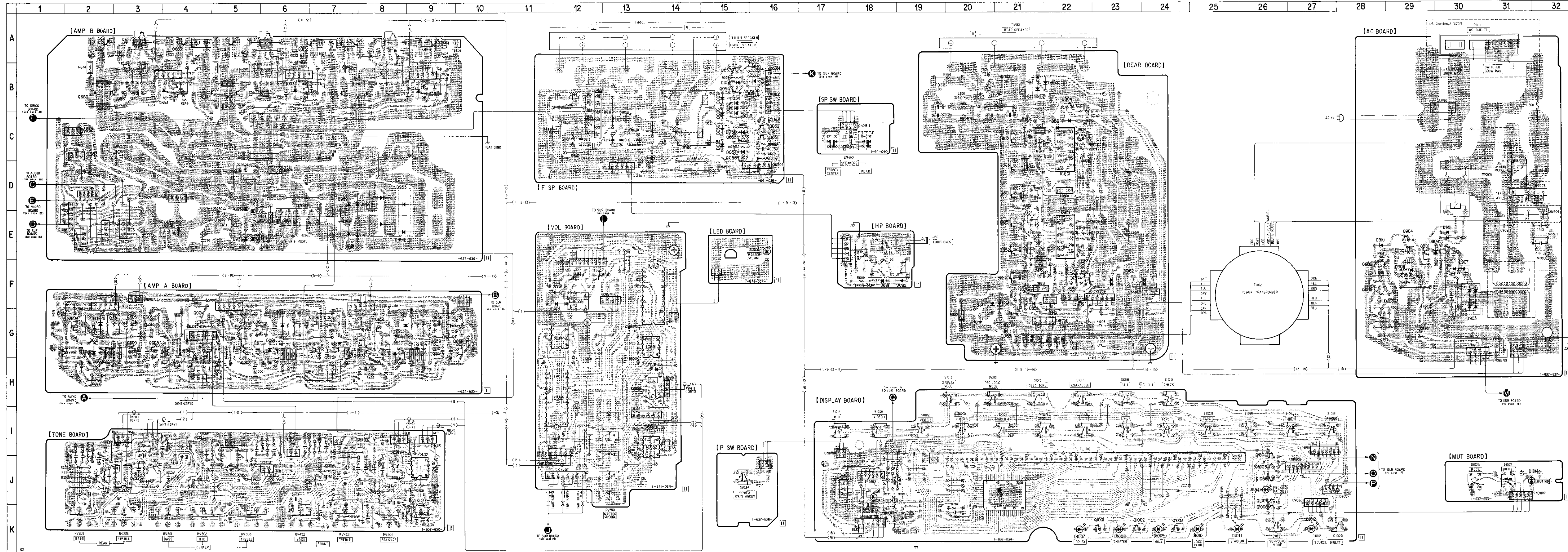

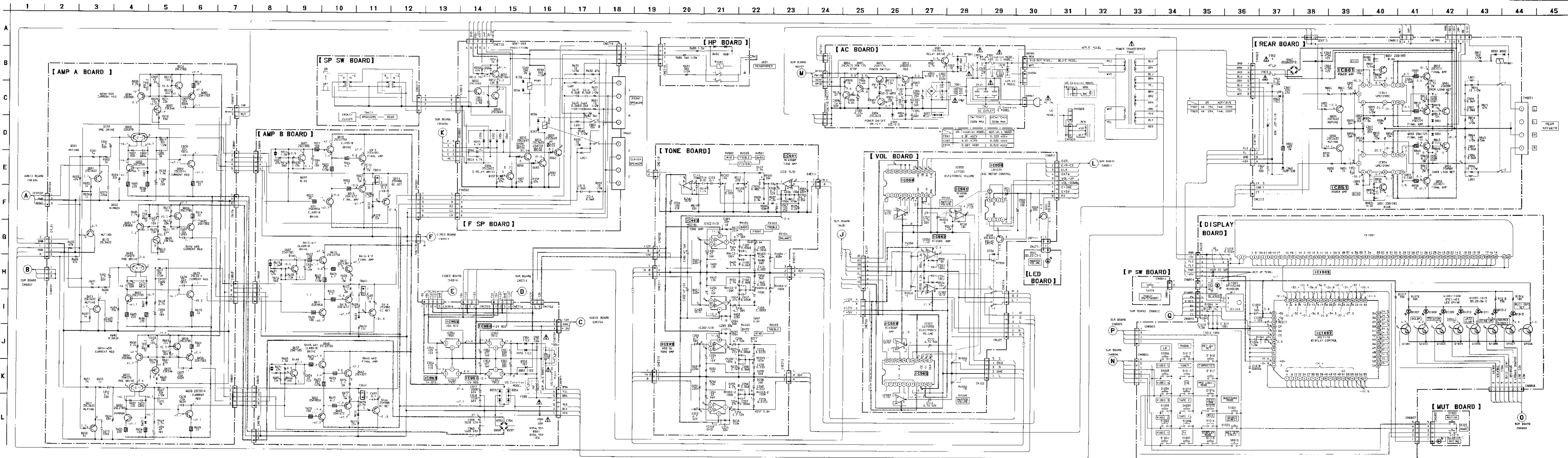

IC BLOCK DIAGRAMS

IC102, 103 LC7821

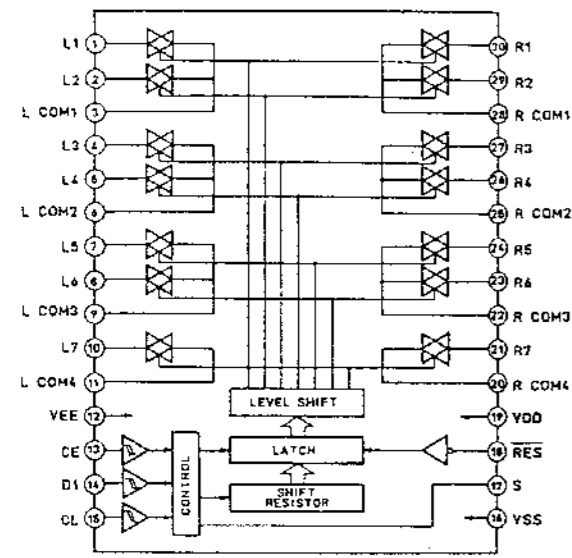

IC104, 105, 701, 702 LC7822

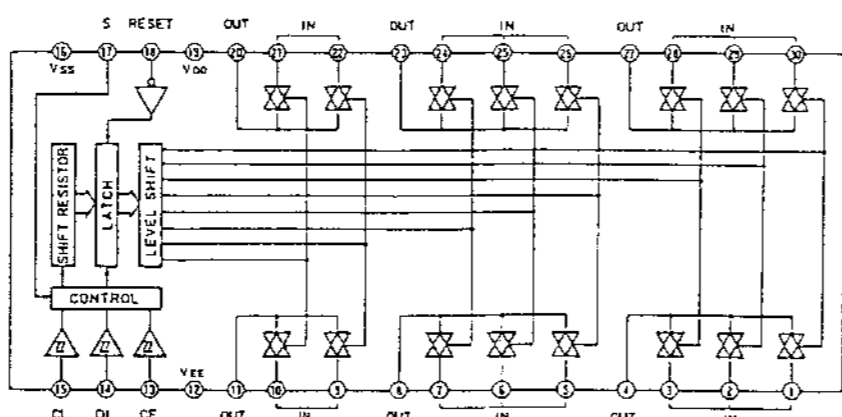

IC301 YM7128

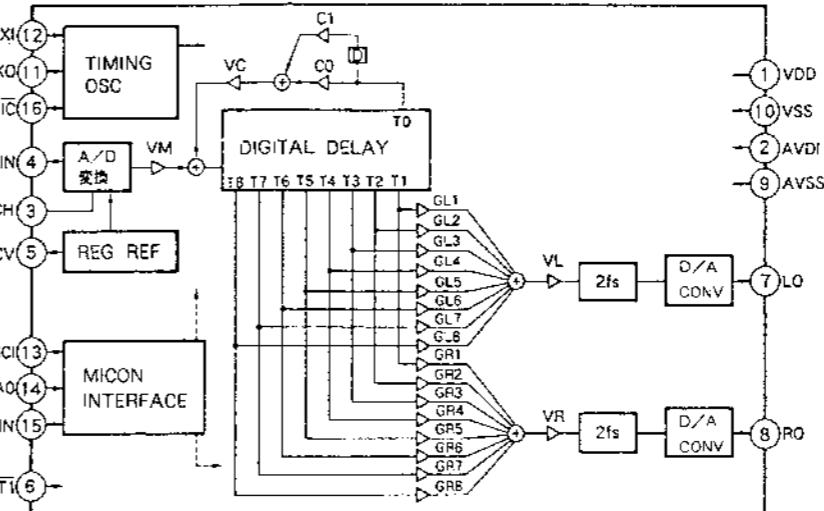

IC302 TC4052BPHB

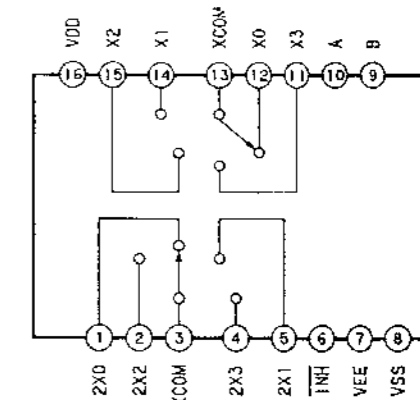

IC280, 281 NE571N-A

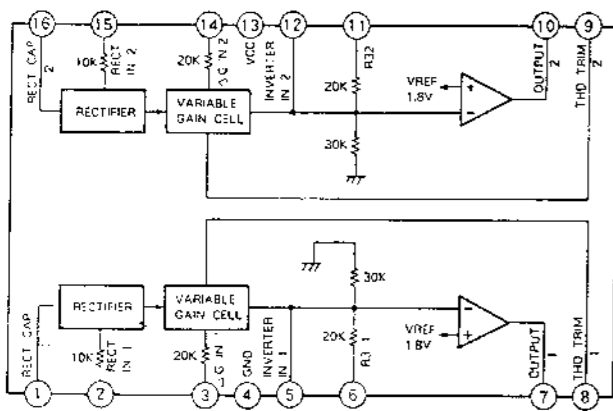

IC201 SSM2125

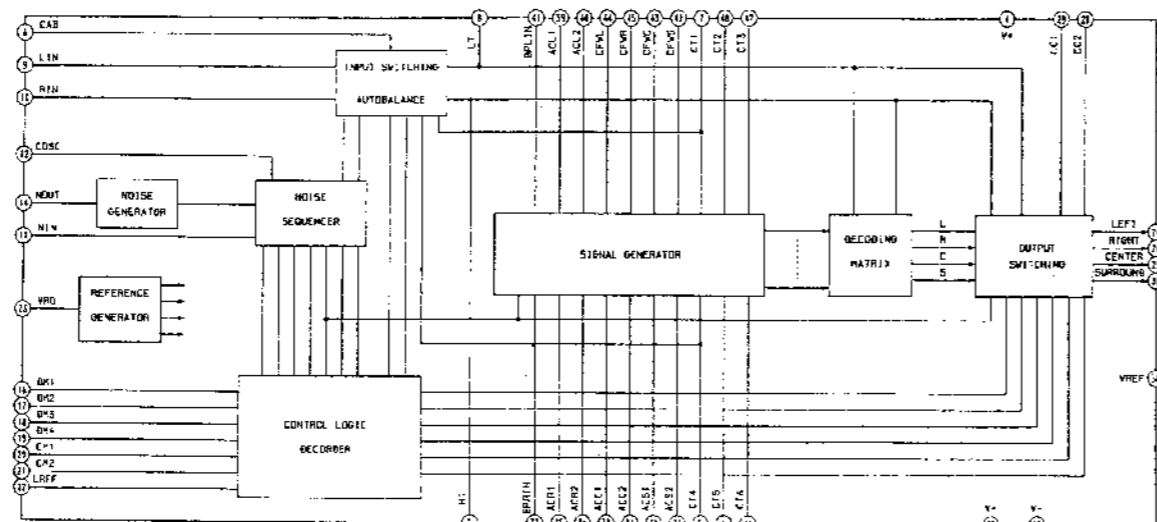

IC556 LB1639

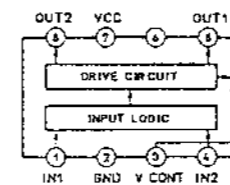

IC307, 308, 309 LC4966

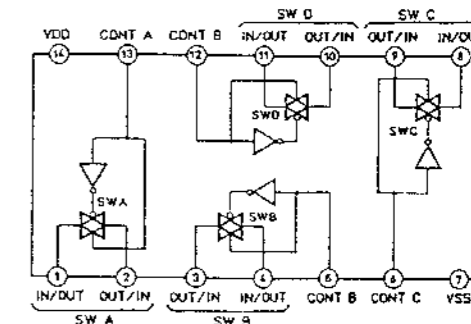

IC550, 555 LC7535

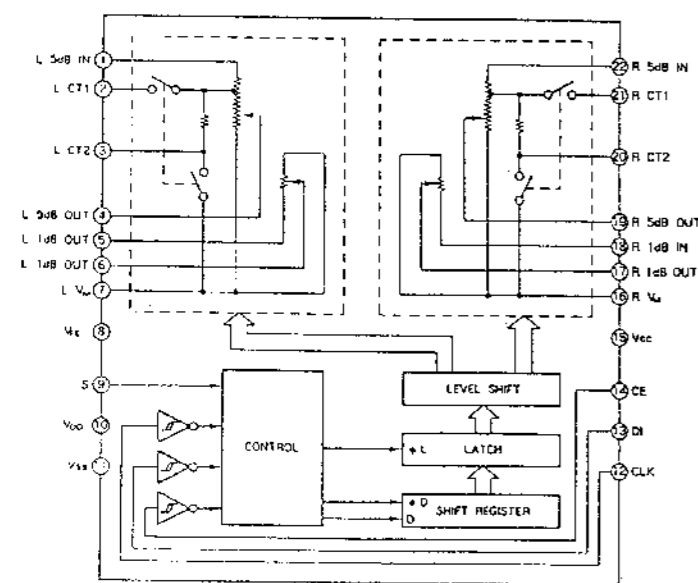

IC704, 705 LC7823

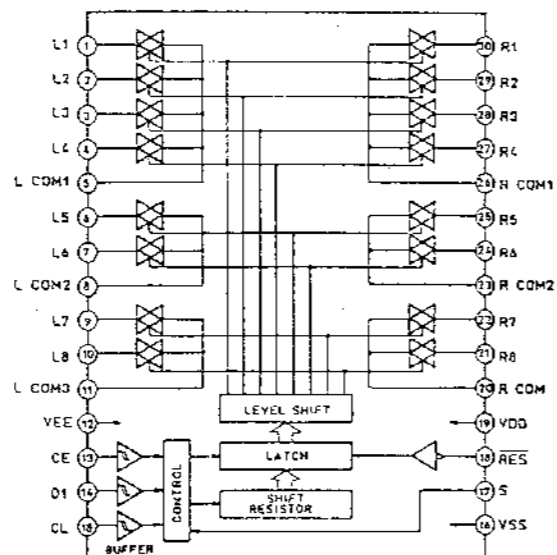

IC801, 851 μ PC1928V

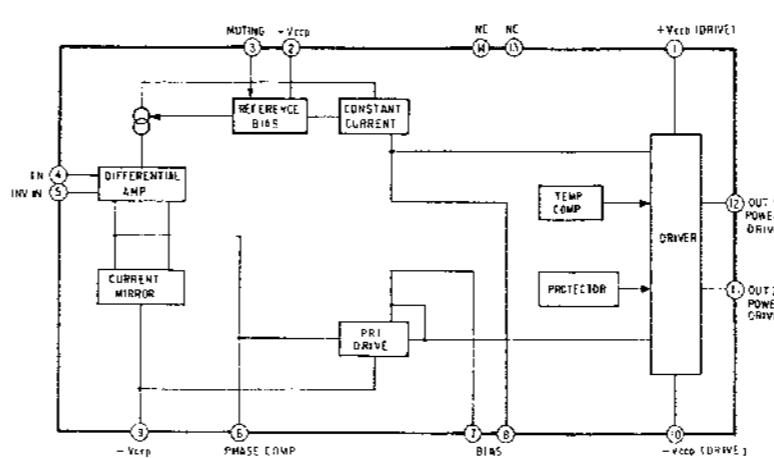

IC306 LA2730K

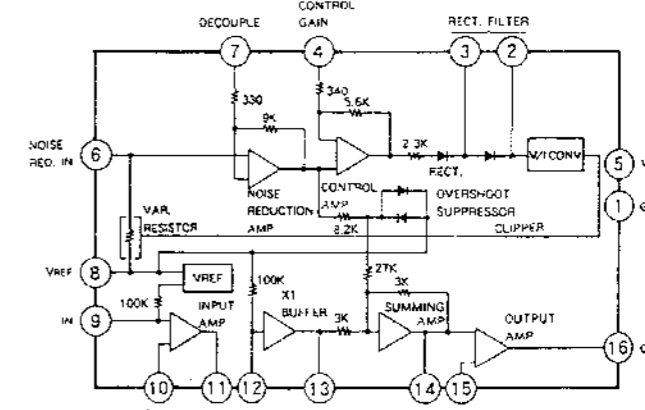

SECTION 6 EXPLODED VIEWS

TA-AV670/AV670G

NOTE :

- -XX, -X mean standardized parts, so they may have some difference from the original one.
- The construction parts of an assembled part are indicated with a collation number in the remark column.
- Color indication of Appearance Parts
Example :
KNOB, BALANCE (WHITE)...(RED)

↑ ↑
Parts color Cabinet's color

- US, Canadian, AEP, UK model : AV670 (BLACK)
E model : AV670G (GRAY)

- Items marked " * " are not stocked since they are seldom required for routine service. Some delay should be anticipated when ordering these items.
- The mechanical parts with no reference number in the exploded views are not supplied.
- Hardware (# mark) list is given in the last of this parts list.

The components identified by mark or dotted line with mark are critical for safety. Replace only with part number specified.

Les composants identifiés par une marque sont critiques pour la sécurité. Ne les remplacer que par une pièce portant le numéro spécifié.

When indicating parts by reference number, please include the board.

6-1. FRONT PANEL AND CABINET SECTION

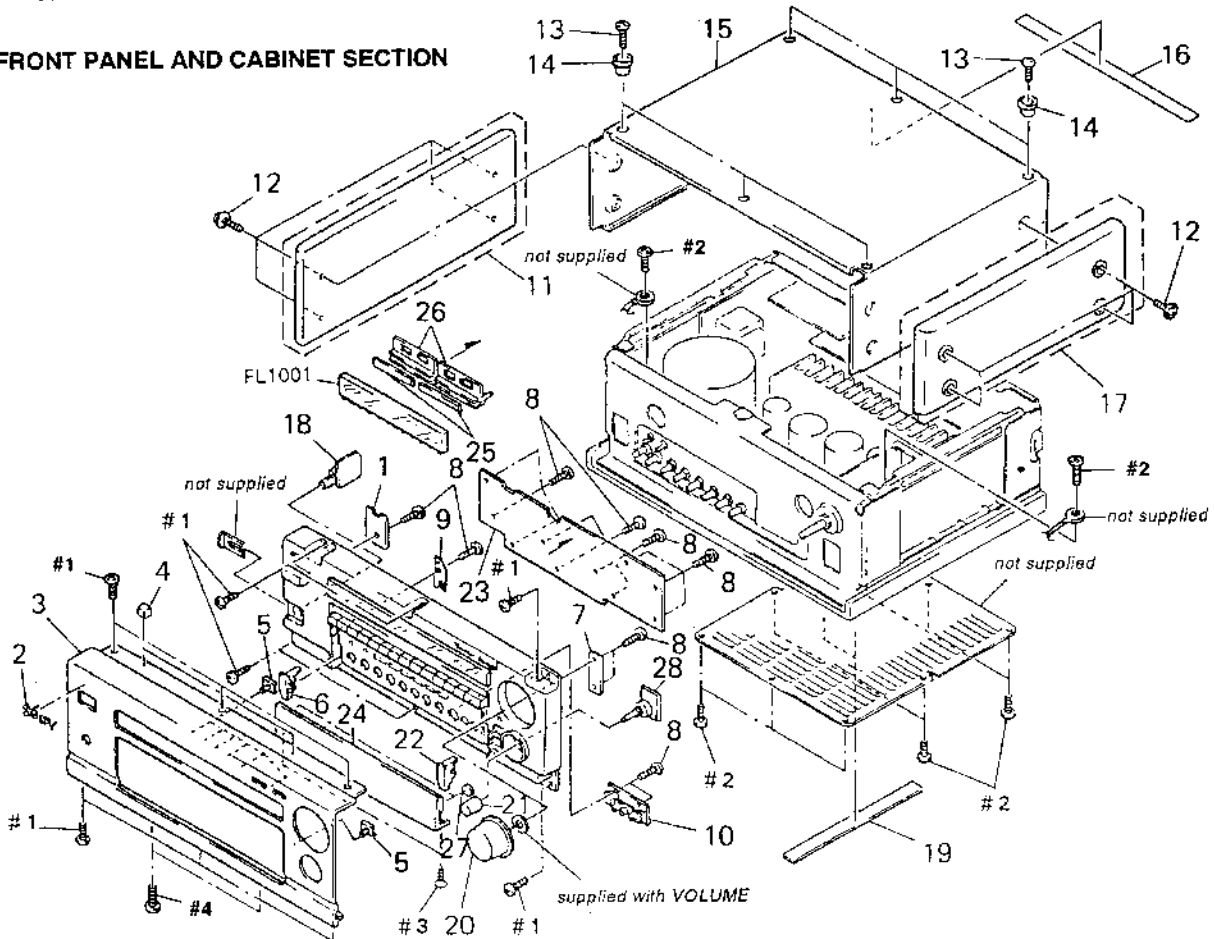

Ref. No.	Part No.	Description	Remark	Ref. No.	Part No.	Description	Remark
* 1	1-637-638-11	P SW BOARD		* 16	4-916-782-71	DAMPER	
2	4-908-848-01	EMBLEM, SONY		17	X-4885-958-1	PANEL (RIGHT) ASSY, SIDE (US, Canadian, AEP)	
3	4-941-905-21	PANEL, FRONT (US, Canadian, AEP, UK)		17	X-4941-127-1	PANEL (RIGHT) ASSY, SIDE (E)	
3	4-941-905-31	PANEL, FRONT (E)		* 18	1-641-038-11	HP BOARD	
4	9-911-840-XX	CUSHION, RUBBER		* 19	4-916-782-11	DAMPER	
5	4-884-612-11	INDICATOR, EJECT		20	X-4942-104-1	KNOB (DIA. 55) ASSY (US, Canadian, AEP, UK)	
6	4-941-911-01	ARM (L) (US, Canadian, AEP, UK)		20	X-4942-105-1	KNOB (DIA. 55) ASSY (E)	
6	4-941-911-11	ARM (L) (E)		21	4-941-909-01	KNOB (ROUND 21) (US, Canadian, AEP, UK)	
* 7	1-637-653-11	MUT BOARD		21	4-941-909-11	KNOB (ROUND 54) (E)	
8	4-951-620-01	SCREW (2.6X8), +BVTP		22	4-941-912-01	ARM (R) (US, Canadian, AEP, UK)	
9	4-941-907-C1	SPRING, LEAF		22	4-941-912-11	ARM (R) (E)	
* 10	1-641-039-11	VIDEO 5 BOARD		* 23	A-4341-307-A	DISPLAY BOARD, COMPLETE (US, Canadian, E)	
11	X-4885-957-1	PANEL (LEFT) ASSY, SIDE (US, Canadian, AEP)		* 23	A-4347-933-A	DISPLAY BOARD, COMPLETE (AEP, UK)	
11	X-4941-126-1	PANEL (LEFT) ASSY, SIDE (E)		24	X-4942-039-1	LID ASSY (E)	
12	4-847-862-00	SCREW (UK)		24	X-4942-584-1	LID ASSY (US, Canadian, AEP, UK)	
12	4-885-979-11	SCREW (4X25) (US, Canadian, AEP, E)		* 25	4-921-941-51	CUSHION (FL)	
13	3-704-366-01	SCREW (CASE) (M3X8)		26	4-933-419-01	HOLDER (FL)	
14	4-923-474-01	RING, ORNAMENTAL		27	9-911-838-XX	CUSHION	
* 15	4-931-944-21	CASE (US, Canadian, AEP, UK)		* 28	1-637-640-11	ENC BOARD	
* 15	4-931-944-41	CASE (E)		FL1001	1-519-628-11	INDICATOR TUBE, FLUORESCENT	

6-2. CHASSIS SECTION-1

▲ A : LED BOARD

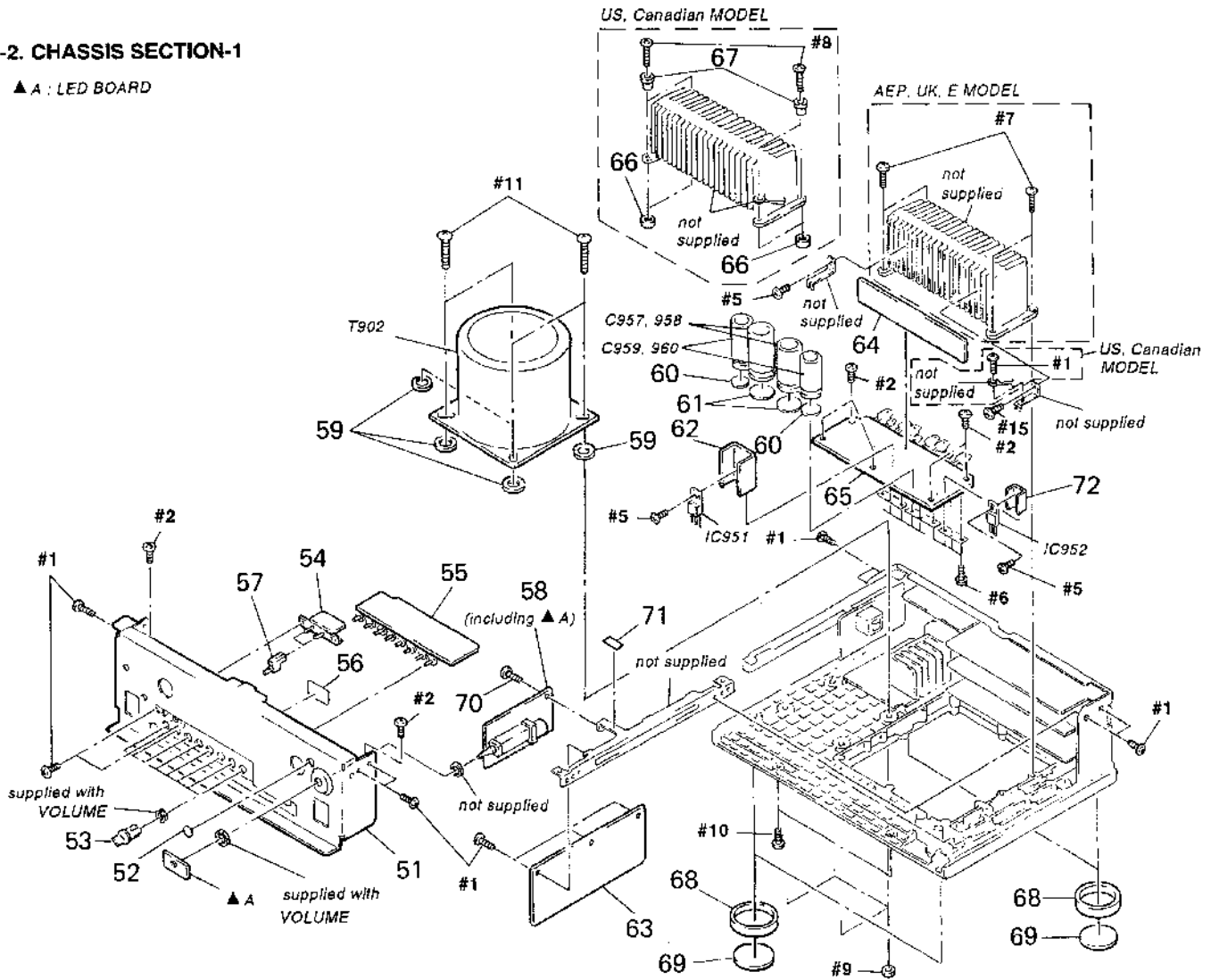

The components identified by mark ▲ or dotted line with mark ▲ are critical for safety. Replace only with part number specified.

Les composants identifiés par une marque ▲ sont critiques pour la sécurité. Ne les remplacer que par une pièce portant le numéro spécifié.

Ref. No.	Part No.	Description	Remark	Ref. No.	Part No.	Description	Remark
51	X-4941-116-1	PANEL (MOLD) ASSY (US, Canadian)		* 65	A-4347-530-A	AMP (B) BOARD, COMPLETE (US, Canadian)	
51	X-4942-042-1	PANEL (MOLD) ASSY (E)		* 66	4-945-985-01	SPACER (US, Canadian)	
51	X-4942-659-1	PANEL (MOLD) ASSY (AEP, UK)		* 67	4-945-934-01	COLLAR (US, Canadian)	
* 52	4-908-892-01	SPACER		68	4-931-967-02	RING, ORNAMENTAL (US, Canadian, AEP, UK)	
53	4-922-531-01	KNOB (A TYPE), LOV (US, Canadian, AEP, UK)		* 68	4-931-967-21	RING, ORNAMENTAL (E)	
53	4-922-531-51	KNOB (A TYPE), LOV (E)		* 69	4-923-850-01	FOOT (DIA. 46)	
* 54	1-641-040-11	SP SW BOARD		70	4-886-821-11	SCREW, S TIGHT, -PTTWH 3X6	
* 55	A-4341-297-A	TONE BOARD, COMPLETE		71	3-831-441-XX	CUSHION (25X15X0.3)	
* 56	3-703-044-26	LABEL, CAUTION (US, Canadian)		* 72	3-309-144-21	HEAT SINK	
57	4-923-879-01	BUTTON (DIA. 4) (US, Canadian, AEP, UK)		C957	1-125-460-11	CAP, ELECT 12000uF 63V	
57	4-923-879-11	BUTTON (DIA. 4) (E)		C958	1-125-460-11	CAP, ELECT 12000uF 63V	
* 58	A-4345-742-A	VOL BOARD, COMPLETE		C959	1-125-661-11	CAP, ELECT 5600uF 63V	
59	4-885-984-21	WASHER		C960	1-125-661-11	CAP, ELECT 5600uF 63V	
* 60	4-942-408-01	SPACER (DIA. 30)		IC951	8-759-604-45	IC MSF79M12 (US, Canadian)	
* 61	4-942-409-01	SPACER (DIA. 40)		IC951	8-759-245-86	IC TA7912S (AEP, UK, E)	
* 62	4-880-403-11	HEAT SINK		IC952	8-759-231-53	IC MSF7805	
* 63	A-4345-743-A	SUR BOARD, COMPLETE (US, Canadian, E)		▲T902	1-423-423-11	TRANSFORMER, POWER (Canadian)	
* 63	A-4347-937-A	SUR BOARD, COMPLETE (AEP, UK)		▲T902	1-450-509-11	TRANSFORMER, POWER (E)	
* 64	A-4341-308-A	AMP (A) BOARD, COMPLETE		▲T902	1-450-561-11	TRANSFORMER, POWER (US)	
* 65	A-4347-558-A	AMP (B) BOARD, COMPLETE (AEP, UK, E)		▲T902	1-450-909-11	TRANSFORMER, POWER (AEP, UK)	

6-3. CHASSIS SECTION-2

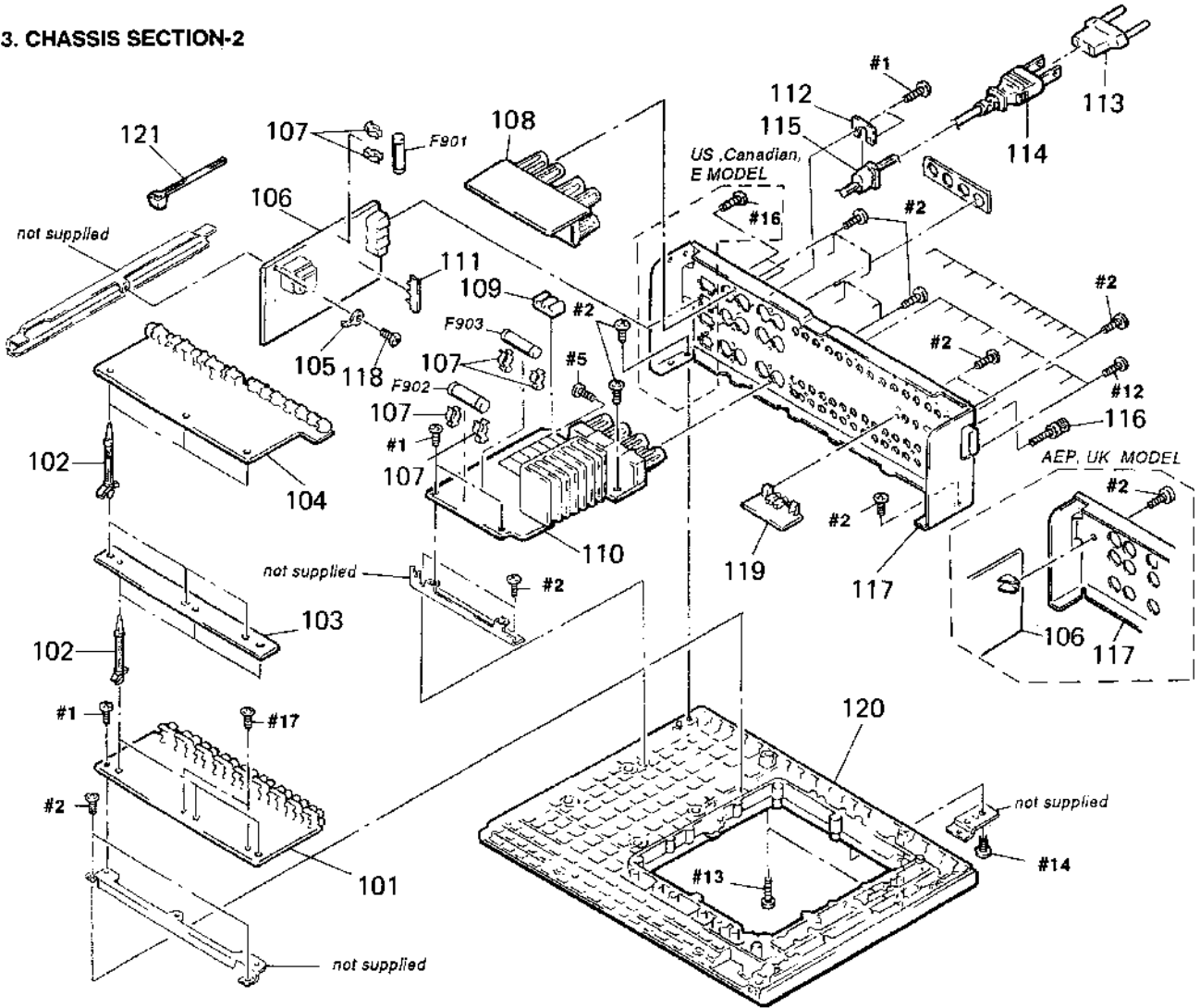

The components identified by mark ▲ or dotted line with mark ▲ are critical for safety. Replace only with part number specified.

Les composants identifiés par une marque ▲ sont critiques pour la sécurité. Ne les remplacer que par une pièce portant le numéro spécifié.

Ref. No.	Part No.	Description	Remark
* 101	A-4341-299-A	AUDIO BOARD, COMPLETE	
* 102	4-924-098-81	HOLDER, PC BOARD	
* 103	1-637-651-11	PC BOARD	
* 104	A-4345-957-A	VIDEO BOARD, COMPLETE	
105	4-870-539-00	PLATE, GROUND	
* 106	A-4345-484-A	AC BOARD, COMPLETE (US, Canadian)	
* 106	A-4347-555-A	AC BOARD, COMPLETE (AEP, UK)	
* 106	A-4347-816-A	AC BOARD, COMPLETE (E)	
107	1-533-225-11	HOLDER, FUSE	
* 108	A-4345-745-A	F SP BOARD, COMPLETE (US, Canadian, AEP, UK, E)	
* 108	A-4347-557-A	F SP BOARD, COMPLETE (AE2)	
* 109	3-674-805-00	HOLDER, PC BOARD (AEP, UK)	
* 110	A-4345-744-A	REAR BOARD, COMPLETE (US, Canadian, AEP, UK, E)	
* 110	A-4347-556-A	REAR BOARD, COMPLETE (AE2)	
* 111	1-560-242-11	BUS BAR 3P	
* 112	4-923-873-01	BRACKET, CORD STOPPER	
▲ 113	1-569-007-11	ADAPTER, CONVERSION 2P (E)	
▲ 114	1-559-272-21	CORD, POWER (UK)	
▲ 114	1-559-297-31	CORD, POWER (E)	
▲ 114	1-559-479-11	CORD, POWER (US, Canadian)	

Ref. No.	Part No.	Description	Remark
▲ 114	1-574-383-11	CORD, POWER (AE2)	
▲ 114	1-575-953-11	CORD, POWER (AE1)	
115	2-352-626-01	BUSHING, CORD (AE1, UK, E)	
* 115	3-703-244-00	BUSHING (2104), CORD (AE2)	
115	4-916-783-01	BUSHING, CORD (US, Canadian)	
* 116	4-941-033-01	SCREW, FIXED, FEEDER	
* 117	4-941-901-31	PANEL, BACK (US, Canadian)	
* 117	4-941-901-41	PANEL, BACK (AE2)	
* 117	4-941-901-51	PANEL, BACK (AE1, UK)	
* 117	4-941-901-61	PANEL, BACK (E)	
118	3-704-366-01	SCREW (CASE) (M3X8)	
* 119	1-637-652-11	SIRCS BOARD	
* 120	4-931-946-21	CHASSIS, MAIN	
121	3-655-653-21	BAND (TAITON), BINDING	
▲ F901	1-532-350-00	FUSE, TIME-LAG (AEP, UK, E)	
▲ F901	1-532-749-11	FUSE, GLASS TUBE (US, Canadian)	
▲ F902	1-532-350-00	FUSE, TIME-LAG (AEP, UK, E)	
▲ F902	1-532-746-11	FUSE, GLASS TUBE (US, Canadian)	
▲ F903	1-532-350-00	FUSE, TIME-LAG (AEP, UK, E)	
▲ F903	1-532-746-11	FUSE, GLASS TUBE (US, Canadian)	

SECTION 7
ELECTRICAL PARTS LIST

AC

NOTE :

- Due to standardization, replacements in the parts list may be different from the parts specified in the diagrams or the components used on the set.
- -XX, -X mean standardized parts, so they may have some difference from the original one.
- RESISTORS
All resistors are in ohms
METAL : Metal-film resistor
METAL OXIDE : Metal oxide-film resistor
F : nonflammable

- Items marked " * " are not stocked since they are seldom required for routine service. Some delay should be anticipated when ordering these items.
- SEMICONDUCTORS
In each case, u : μ , for example :
uA... : μ A..., uPA... : μ PA...
uPB... : μ PB..., uPC... : μ PC...
uPD... : μ PD...
- CAPACITORS
uF : μ F
- COILS
uH : μ H

- US, Canadian, AEP, UK model : AV670 (BLACK)
E model : AV670G (GRAY)

The components identified by mark Δ or dotted line with mark Δ are critical for safety. Replace only with part number specified.

Les composants identifiés par une marque Δ sont critiques pour la sécurité. Ne les remplacer que par une pièce portant le numéro spécifié.

When indicating parts by reference number, please include the board.

Ref. No.	Part No.	Description	Remark
*	A-4345-484-A	AC BOARD, COMPLETE (US, Canadian)	
*	A-4347-555-A	AC BOARD, COMPLETE (AEP, UK)	
*	A-4347-816-A	AC BOARD, COMPLETE (E)	
	1-533-225-11	HOLDER, FUSE	
*	1-560-242-11	BUS BAR 3P	
	4-870-539-00	PLATE, GROUND	
		< CAPACITOR >	
Δ C901	1-161-744-00	CERAMIC	0.01uF 400V (US, Canadian)
Δ C901	1-161-742-00	CERAMIC	0.0022uF 20% 400V (AEP, UK, E)
Δ C902	1-161-744-00	CERAMIC	0.01uF 400V (US, Canadian)
Δ C902	1-161-742-00	CERAMIC	0.0022uF 20% 400V (AEP, UK, E)
C903	1-102-394-11	CERAMIC	0.01uF 250V
C904	1-124-636-00	ELECT	3300uF 20% 25V
C905	1-124-907-11	ELECT	10uF 20% 50V
C906	1-124-903-11	ELECT	1uF 20% 50V
C907	1-124-907-11	ELECT	10uF 20% 50V
C908	1-124-464-11	ELECT	0.22uF 20% 50V
C909	1-124-903-11	ELECT	1uF 20% 50V
Δ C910	1-161-741-00	CERAMIC	0.001uF 10% 400V (US, Canadian)
Δ C910	1-161-742-00	CERAMIC	0.0022uF 20% 400V (AEP, UK, E)
Δ C911	1-161-742-00	CERAMIC	0.0022uF 20% 400V (AEP, UK, E)
		< CONNECTOR >	
*	CNE7C1	1-564-505-11	PLUG, CONNECTOR 2P
*	CNE7C7	1-564-507-11	PLUG, CONNECTOR 4P
*	CNE715	1-564-506-11	PLUG, CONNECTOR 3P

Ref. No.	Part No.	Description	Remark
		< JACK >	
Δ CNJ1	1-540-062-31	OUTLET, AC (POLAR) (AC OUTLET)	(US, Canadian)
Δ CNJ1	1-540-043-31	OUTLET, AC (NONPOAR) (3P) (AC OUTLET) (E)	
		< CONNECTOR >	
*	CNV901	1-564-321-00	PIN, CONNECTOR 2P
*	CNV903	1-564-687-11	PIN, CONNECTOR 3P (AEP, UK, E)
*	CNV904	1-564-687-11	PIN, CONNECTOR 3P (AEP, UK, E)
		< DIODE >	
D901	8-719-987-63	DIODE	1N4148M
D902	8-719-987-63	DIODE	1N4148M
D903	8-719-511-40	DIODE	S1VB40
D907	8-719-000-06	DIODE	MC921
D908	8-719-933-41	DIODE	HZS6C3L
D909	8-719-933-41	DIODE	HZS6C3L
D910	8-719-010-23	DIODE	UZ-3.6BSB
		< FUSE >	
Δ F901	1-532-350-00	FUSE, TIME-LAG (T4AL 250V)	(AEP, UK, E)
Δ F901	1-532-749-11	FUSE, GLASS TUBE (8A 125V)	(US, Canadian)
		< TRANSISTOR >	
Q901	8-729-620-05	TRANSISTOR	2SC2603-EF
Q902	8-729-209-15	TRANSISTOR	2SD2012
Q903	8-729-119-76	TRANSISTOR	2SA1175-HFE
Q904	8-729-620-05	TRANSISTOR	2SC2603-EF
Q905	8-729-119-76	TRANSISTOR	2SA1175-HFE
Q906	8-729-620-05	TRANSISTOR	2SC2603-EF
		< RESISTOR >	
R901	1-249-425-11	CARBON	4.7K 5% 1/4W
R902	1-249-396-11	CARBON	18 5% 1/6W
R903	1-249-417-11	CARBON	1K 5% 1/4W

AC **AMP (A)**

Ref. No.	Part No.	Description	Remark		
R904	1-249-439-11	CARBON	68K	5%	1/4W
R905	1-249-429-11	CARBON	10K	5%	1/4W
R906	1-249-426-11	CARBON	5.6K	5%	1/4W
R907	1-249-429-11	CARBON	10K	5%	1/4W
R908	1-249-426-11	CARBON	5.6K	5%	1/4W
R909	1-249-417-11	CARBON	1K	5%	1/4W
R913	1-249-429-11	CARBON	10K	5%	1/4W
R914	1-249-417-11	CARBON	1K	5%	1/4W
R915	1-249-401-11	CARBON	47	5%	1/4W
< RELAY >					
RY901	1-515-701-11	RELAY (US, Canadian)			
RY901	1-515-617-11	RELAY (AEP, UK, E)			
< TRANSFORMER >					
△T901	1-448-517-21	TRANSFORMER, POWER (US, Canadian)			
△T901	1-449-071-11	TRANSFORMER, POWER (AEP, UK, E)			
< TERMINAL >					
* TB901	1-560-595-00	TERMINAL (WITH BASE) (US, Canadian)			

*	A-4341-308-A	AMP (A) BOARD, COMPLETE			

< CAPACITOR >					
C001	1-126-163-11	ELECT	4.7uF	20%	50V
C002	1-130-469-00	MYLAR	680PF	5%	50V
C003	1-126-022-11	ELECT	47uF	20%	10V
C005	1-102-942-00	CERAMIC	5.0PF	+0.5PF	50V
C006	1-126-022-11	ELECT	47uF	20%	10V
C007	1-161-959-00	CERAMIC	22PF	10%	500V
C008	1-161-959-00	CERAMIC	22PF	10%	500V
C015	1-110-339-11	FILM	220PF	5%	50V
C601	1-126-163-11	ELECT	4.7uF	20%	50V
C602	1-130-469-00	MYLAR	680PF	5%	50V
C603	1-126-022-11	ELECT	47uF	20%	10V
C605	1-102-942-00	CERAMIC	5.0PF	+0.5PF	50V
C606	1-126-022-11	ELECT	47uF	20%	10V
C607	1-161-959-00	CERAMIC	22PF	10%	500V
C608	1-161-959-00	CERAMIC	22PF	10%	500V
C615	1-110-339-11	FILM	220PF	5%	50V
C651	1-126-163-11	ELECT	4.7uF	20%	50V
C652	1-130-469-00	MYLAR	680PF	5%	50V
C653	1-126-022-11	ELECT	47uF	20%	10V
C655	1-102-942-00	CERAMIC	5.0PF	+0.5PF	50V
C656	1-126-022-11	ELECT	47uF	20%	10V
C657	1-161-959-00	CERAMIC	22PF	10%	500V
C658	1-161-959-00	CERAMIC	22PF	10%	500V

Ref. No.	Part No.	Description	Remark		
C665	1-110-339-11	FILM	220PF	5%	50V
< CONNECTOR >					
* CNB001	1-565-481-11	CONNECTOR, BOARD TO BOARD 5P			
* CNB601	1-565-481-11	CONNECTOR, BOARD TO BOARD 5P			
* CNB651	1-565-481-11	CONNECTOR, BOARD TO BOARD 5P			
* CNE110	1-564-508-11	PLUG, CONNECTOR 5P			
* CNE204	1-564-506-11	PLUG, CONNECTOR 3P			
* CNE706	1-564-506-11	PLUG, CONNECTOR 3P			
< DIODE >					
D001	8-719-912-20	DIODE	1SS120		
D002	8-719-933-35	DIODE	HZS6A3L		
D601	8-719-912-20	DIODE	1SS120		
D602	8-719-933-35	DIODE	HZS6A3L		
D651	8-719-912-20	DIODE	1SS120		
D652	8-719-933-35	DIODE	HZS6A3L		
< TRANSISTOR >					
Q001	8-729-141-26	TRANSISTOR	2SC3622A-LK		
Q002	8-729-119-78	TRANSISTOR	2SC2785-HFE		
Q003	8-729-620-18	TRANSISTOR	2SA979-FG		
Q004	8-729-140-82	TRANSISTOR	2SA988-PAFAEA		
Q005	8-729-201-56	TRANSISTOR	2SK246-GR2		
Q006	8-729-119-78	TRANSISTOR	2SC2785-HFE		
Q008	8-729-104-91	TRANSISTOR	2SA1383		
Q009	8-729-104-18	TRANSISTOR	2SC3514		
Q015	8-729-141-26	TRANSISTOR	2SC3622A-LK		
Q601	8-729-141-26	TRANSISTOR	2SC3622A-LK		
Q602	8-729-119-78	TRANSISTOR	2SC2785-HFE		
Q603	8-729-620-18	TRANSISTOR	2SA979-FG		
Q604	8-729-140-82	TRANSISTOR	2SA988-PAFAEA		
Q605	8-729-201-56	TRANSISTOR	2SK246-GR2		
Q606	8-729-119-78	TRANSISTOR	2SC2785-HFE		
Q608	8-729-104-91	TRANSISTOR	2SA1383		
Q609	8-729-104-18	TRANSISTOR	2SC3514		
Q651	8-729-141-26	TRANSISTOR	2SC3622A-LK		
Q652	8-729-119-78	TRANSISTOR	2SC2785-HFE		
Q653	8-729-620-18	TRANSISTOR	2SA979-FG		
Q654	8-729-140-82	TRANSISTOR	2SA988-PAFAEA		
Q655	8-729-201-56	TRANSISTOR	2SK246-GR2		
Q656	8-729-119-78	TRANSISTOR	2SC2785-HFE		
Q658	8-729-104-91	TRANSISTOR	2SA1383		
Q659	8-729-104-18	TRANSISTOR	2SC3514		
< RESISTOR >					
R001	1-247-713-11	CARBON	1K	5%	1/4W
R002	1-247-721-11	CARBON	4.7K	5%	1/4W

<p>The components identified by mark △ or dotted line with mark △ are critical for safety. Replace only with part number specified.</p>	<p>Les composants identifiés par une marque △ sont critiques pour la sécurité. Ne les remplacer que par une pièce portant le numéro spécifié.</p>
---	--

AMP (A) AMP (B)

Ref. No.	Part No.	Description	Remark
R003	1-247-713-11	CARBON	1K 5% 1/4W
R004	1-249-497-11	CARBON	33K 5% 1/4W
△R005	1-247-704-11	CARBON	220 5% 1/4W F
△R006	1-247-704-11	CARBON	220 5% 1/4W F
R007	1-247-706-11	CARBON	330 5% 1/4W
R008	1-247-717-11	CARBON	2.2K 5% 1/4W
R009	1-249-460-11	CARBON	15K 5% 1/4W
R010	1-247-706-11	CARBON	330 5% 1/4W
R011	1-249-462-11	CARBON	22K 5% 1/4W
R012	1-249-497-11	CARBON	33K 5% 1/4W
R013	1-247-725-11	CARBON	10K 5% 1/4W
△R014	1-247-692-11	CARBON	22 5% 1/4W F
R017	1-249-709-11	CARBON	33K 5% 1/2W
R018	1-247-716-11	CARBON	1.8K 5% 1/4W
△R019	1-247-692-11	CARBON	22 5% 1/4W F
R033	1-249-465-11	CARBON	47K 5% 1/4W
R034	1-247-721-11	CARBON	4.7K 5% 1/4W
R601	1-247-713-11	CARBON	1K 5% 1/4W
R602	1-247-721-11	CARBON	4.7K 5% 1/4W
R603	1-247-713-11	CARBON	1K 5% 1/4W
R604	1-249-497-11	CARBON	33K 5% 1/4W
△R605	1-247-704-11	CARBON	220 5% 1/4W F
△R606	1-247-704-11	CARBON	220 5% 1/4W F
R607	1-247-706-11	CARBON	330 5% 1/4W
R608	1-247-717-11	CARBON	2.2K 5% 1/4W
R609	1-249-460-11	CARBON	15K 5% 1/4W
R610	1-247-706-11	CARBON	330 5% 1/4W
R611	1-249-462-11	CARBON	22K 5% 1/4W
R612	1-249-497-11	CARBON	33K 5% 1/4W
R613	1-247-725-11	CARBON	10K 5% 1/4W
△R614	1-247-692-11	CARBON	22 5% 1/4W F
R617	1-249-709-11	CARBON	33K 5% 1/2W
R618	1-247-718-11	CARBON	2.7K 5% 1/4W
△R619	1-247-692-11	CARBON	22 5% 1/4W F
R633	1-249-465-11	CARBON	47K 5% 1/4W
R651	1-247-713-11	CARBON	1K 5% 1/4W
R652	1-247-721-11	CARBON	4.7K 5% 1/4W
R653	1-247-713-11	CARBON	1K 5% 1/4W
R654	1-249-497-11	CARBON	33K 5% 1/4W
△R655	1-247-704-11	CARBON	220 5% 1/4W F
△R656	1-247-704-11	CARBON	220 5% 1/4W F
R657	1-247-706-11	CARBON	330 5% 1/4W
R658	1-247-717-11	CARBON	2.2K 5% 1/4W
R659	1-249-460-11	CARBON	15K 5% 1/4W
R660	1-247-706-11	CARBON	330 5% 1/4W
R661	1-249-462-11	CARBON	22K 5% 1/4W
R662	1-249-497-11	CARBON	33K 5% 1/4W
R663	1-247-725-11	CARBON	10K 5% 1/4W
△R664	1-247-692-11	CARBON	22 5% 1/4W F

Ref. No.	Part No.	Description	Remark
R667	1-249-709-11	CARBON	33K 5% 1/2W
R668	1-247-718-11	CARBON	2.7K 5% 1/4W
△R669	1-247-692-11	CARBON	22 5% 1/4W F
R683	1-249-465-11	CARBON	47K 5% 1/4W

*	A-4347-558-A	AMP (B) BOARD, COMPLETE (AEP, UK, E)	*****
*	A-4347-560-A	AMP (B) BOARD, COMPLETE (US, Canadian)	*****
*	3-309-144-21	HEAT SINK	
*	4-880-403-11	HEAT SINK	
	7-682-548-09	SCREW +BVTT 3X8 (S)	
		< CAPACITOR >	
C004	1-126-022-11	ELECT	47uF 20% 10V
C009	1-136-165-00	FILM	0.1uF 5% 50V
C604	1-126-022-11	ELECT	47uF 20% 10V
C609	1-136-165-00	FILM	0.1uF 5% 50V
C654	1-126-022-11	ELECT	47uF 20% 10V
C659	1-136-165-00	FILM	0.1uF 5% 50V
C950	1-126-042-11	ELECT	3300uF 20% 35V
C951	1-126-042-11	ELECT	3300uF 20% 35V
C952	1-126-012-11	ELECT	470uF 20% 16V
C953	1-126-012-11	ELECT	470uF 20% 16V
C955	1-124-997-11	ELECT	470uF 20% 10V
C956	1-124-997-11	ELECT	470uF 20% 10V
C957	1-125-460-11	CAP, ELECT	12000uF 63V
C958	1-125-460-11	CAP, ELECT	12000uF 63V
C959	1-125-661-11	CAP, ELECT	5600uF 63V
C960	1-125-661-11	CAP, ELECT	5600uF 63V
△C966	1-130-798-00	FILM	1uF 10% 250V
△C967	1-106-367-00	MYLAR	0.01uF 5% 200V
		< CONNECTOR >	
*	CNB002	1-560-552-00	PIN, CONNECTOR 5P
*	CNB602	1-560-552-00	PIN, CONNECTOR 5P
*	CNB652	1-560-552-00	PIN, CONNECTOR 5P
*	CND816	1-564-339-71	PIN, CONNECTOR 5P
*	CNE702	1-564-506-11	PLUG, CONNECTOR 3P
*	CNE703	1-564-507-11	PLUG, CONNECTOR 4P
*	CNE704	1-564-506-11	PLUG, CONNECTOR 3P
*	CNE714	1-564-508-11	PLUG, CONNECTOR 5P
	CNV010	1-564-320-00	PIN, CONNECTOR (B2P-VH) 2P
*	CNV501	1-564-243-00	PIN, CONNECTOR 6P
*	CNV921	1-564-915-11	PIN, CONNECTOR 7P

<p>The components identified by mark △ or dotted line with mark △ are critical for safety. Replace only with part number specified.</p>	<p>Les composants identifiés par une marque △ sont critiques pour la sécurité. Ne les remplacer que par une pièce portant le numéro spécifié.</p>
---	--

AMP (B)

Ref. No.	Part No.	Description	Remark
< DIODE >			
D003	8-719-987-63	DIODE 1N4148M	
D603	8-719-987-63	DIODE 1N4148M	
D653	8-719-987-63	DIODE 1N4148M	
D950	8-719-200-02	DIODE 10E2	
D951	8-719-200-02	DIODE 10E2	
D952	8-719-200-02	DIODE 10E2	
D953	8-719-200-02	DIODE 10E2	
D954	8-719-210-37	DIODE D301	
D955	8-719-210-37	DIODE D301	
D956	8-719-200-02	DIODE 10E2	
D957	8-719-200-02	DIODE 10E2	
D958	8-719-200-02	DIODE 10E2	
D959	8-719-200-02	DIODE 10E2	
< FUSE >			
△F904	1-532-783-21	FUSE, MICRO (SECONDARY) (5A) (US, Canadian)	
△F905	1-532-783-21	FUSE, MICRO (SECONDARY) (5A) (US, Canadian)	
< IC >			
IC950	8-759-604-39	IC AN6291 (US, Canadian)	
IC950	8-759-231-58	IC MSF7812L (AEP, UK, E)	
IC951	8-759-604-45	IC MSF79M12 (US, Canadian)	
IC951	8-759-245-86	IC TA7912S (AEP, UK, E)	
IC952	8-759-231-53	IC MSF7805	
IC953	8-759-245-79	IC MSF7905	
< IC LINK >			
△PS1	1-532-846-11	LINK, IC (AEP, UK, E)	
△PS2	1-532-846-11	LINK, IC (AEP, UK, E)	
< TRANSISTOR >			
Q007	8-729-141-89	TRANSISTOR 2SD1585-LK	
Q010	8-729-141-58	TRANSISTOR 2SC2275A-QP	
Q011	8-729-141-10	TRANSISTOR 2SA985A	
Q012	8-729-383-73	TRANSISTOR 2SC2837	
Q013	8-729-318-63	TRANSISTOR 2SA1186	
Q014	8-729-140-82	TRANSISTOR 2SA988-PAFABA	
Q607	8-729-141-89	TRANSISTOR 2SD1585-LK	
Q610	8-729-141-58	TRANSISTOR 2SC2275A-QP	
Q611	8-729-141-10	TRANSISTOR 2SA985A	
Q612	8-729-383-73	TRANSISTOR 2SC2837	
Q613	8-729-318-63	TRANSISTOR 2SA1186	
Q614	8-729-140-82	TRANSISTOR 2SA988-PAFABA	
Q657	8-729-141-89	TRANSISTOR 2SD1585-LK	
Q660	8-729-141-58	TRANSISTOR 2SC2275A-QP	
Q661	8-729-141-10	TRANSISTOR 2SA985A	

Ref. No.	Part No.	Description	Remark
Q662	8-729-383-73	TRANSISTOR 2SC2837	
Q663	8-729-318-63	TRANSISTOR 2SA1186	
Q664	8-729-140-82	TRANSISTOR 2SA988-PAFABA	
< RESISTOR >			
R015	1-249-556-11	CARBON 1.5K 5%	1/4W
R016	1-247-710-11	CARBON 560 5%	1/4W
△R020	1-247-700-11	CARBON 100 5%	1/4W F
R021	1-249-465-11	CARBON 47K 5%	1/4W
△R022	1-247-700-11	CARBON 100 5%	1/4W F
△R023	1-247-745-11	CARBON 330 5%	1/2W F
△R024	1-249-455-11	CARBON 4.7 5%	1/4W F
△R025	1-249-455-11	CARBON 4.7 5%	1/4W F
R026	1-217-611-00	RES, METAL PLATE	0.1
R027	1-217-611-00	RES, METAL PLATE	0.1
R028	1-249-556-11	CARBON 1.5K 5%	1/4W
R029	1-249-460-11	CARBON 15K 5%	1/4W
R035	1-249-460-11	CARBON 15K 5%	1/4W
R615	1-249-556-11	CARBON 1.5K 5%	1/4W
R616	1-247-710-11	CARBON 560 5%	1/4W
△R620	1-247-700-11	CARBON 100 5%	1/4W F
R621	1-249-465-11	CARBON 47K 5%	1/4W
△R622	1-247-700-11	CARBON 100 5%	1/4W F
△R623	1-247-745-11	CARBON 330 5%	1/2W F
△R624	1-249-455-11	CARBON 4.7 5%	1/4W F
△R625	1-249-455-11	CARBON 4.7 5%	1/4W F
R626	1-217-611-00	RES, METAL PLATE	0.1
R627	1-217-611-00	RES, METAL PLATE	0.1
R628	1-249-556-11	CARBON 1.5K 5%	1/4W
R629	1-249-460-11	CARBON 15K 5%	1/4W
R635	1-249-460-11	CARBON 15K 5%	1/4W
R665	1-249-556-11	CARBON 1.5K 5%	1/4W
R666	1-247-710-11	CARBON 560 5%	1/4W
△R670	1-247-700-11	CARBON 100 5%	1/4W F
R671	1-249-465-11	CARBON 47K 5%	1/4W
△R672	1-247-700-11	CARBON 100 5%	1/4W F
△R673	1-247-745-11	CARBON 330 5%	1/2W F
△R674	1-249-455-11	CARBON 4.7 5%	1/4W F
△R675	1-249-455-11	CARBON 4.7 5%	1/4W F
R676	1-217-611-00	RES, METAL PLATE	0.1
R677	1-217-611-00	RES, METAL PLATE	0.1
R678	1-249-556-11	CARBON 1.5K 5%	1/4W
R679	1-249-460-11	CARBON 15K 5%	1/4W
R685	1-249-460-11	CARBON 15K 5%	1/4W
< TERMINAL >			
* TB001	1-508-809-00	BASE POST (14MM) 2P	
* TB601	1-508-809-00	BASE POST (14MM) 2P	
* TB651	1-508-809-00	BASE POST (14MM) 2P	

<p>The components identified by mark △ or dotted line with mark △ are critical for safety. Replace only with part number specified.</p>	<p>Les composants identifiés par une marque △ sont critiques pour la sécurité. Ne les remplacer que par une pièce portant le numéro spécifié.</p>
---	---

AUDIO

Ref. No.	Part No.	Description	Remark
*	A-4341-299-A	AUDIO BOARD, COMPLETE *****	
	7-682-548-04	SCREW +BVT 3X8 (S)	
< CAPACITOR >			
C101	1-102-973-00	CERAMIC 100PF 5% 50V	
C102	1-124-925-11	ELECT 2.2uF 20% 100V	
C103	1-124-126-00	ELECT 47uF 20% 10V	
C104	1-130-480-00	MYLAR 0.0056uF 5% 50V	
C105	1-130-473-00	MYLAR 0.0015uF 5% 50V	
C106	1-124-252-00	ELECT 0.33uF 20% 50V	
C107	1-124-477-11	ELECT 47uF 20% 25V	
C110	1-164-159-11	CERAMIC 0.1uF 20% 50V	
C113	1-162-306-11	CERAMIC 0.01uF 20% 16V	
C115	1-162-306-11	CERAMIC 0.01uF 20% 16V	
C121	1-102-973-00	CERAMIC 100PF 5% 50V	
C149	1-161-294-31	CERAMIC 0.001uF 10% 50V	
C151	1-102-973-00	CERAMIC 100PF 5% 50V	
C152	1-124-925-11	ELECT 2.2uF 20% 100V	
C153	1-124-126-00	ELECT 47uF 20% 10V	
C154	1-130-480-00	MYLAR 0.0056uF 5% 50V	
C155	1-130-473-00	MYLAR 0.0015uF 5% 50V	
C156	1-124-252-00	ELECT 0.33uF 20% 50V	
C157	1-124-477-11	ELECT 47uF 20% 25V	
C167	1-126-163-11	ELECT 4.7uF 20% 50V	
C171	1-102-973-00	CERAMIC 100PF 5% 50V	
C177	1-126-163-11	ELECT 4.7uF 20% 50V	
< CONNECTOR >			
* CND810	1-564-337-71	PIN, CONNECTOR 3P	
* CND812	1-564-340-71	PIN, CONNECTOR 6P	
* CNE201	1-564-506-11	PLUG, CONNECTOR 3P	
* CNE204	1-564-506-11	PLUG, CONNECTOR 3P	
* CNE205	1-564-506-11	PLUG, CONNECTOR 3P	
* CNE704	1-564-506-11	PLUG, CONNECTOR 3P	
< IC >			
IC101	8-759-634-50	IC M5218AL	
IC102	8-759-805-13	IC LC7821	
IC103	8-759-805-13	IC LC7821	
IC104	8-759-805-14	IC LC7822	
IC105	8-759-805-14	IC LC7822	
IC106	8-759-634-50	IC M5218AL	
IC107	8-759-634-50	IC M5218AL	

Ref. No.	Part No.	Description	Remark
< JACK >			
J101	1-565-352-51	JACK, PIN 2P (MONO/CENTER OUT)	
J102	1-568-069-11	JACK, PIN 4P (VIDEO 1)	
J103	1-568-069-11	JACK, PIN 4P (VIDEO 2)	
J104	1-568-069-11	JACK, PIN 4P (VIDEO 3)	
J105	1-568-069-11	JACK, PIN 4P (VIDEO 4/LD)	
J106	1-568-069-11	JACK, PIN 4P (TV/BS, TAPE 1)	
J107	1-568-069-11	JACK, PIN 4P (TAPE 1/2)	
J108	1-568-069-11	JACK, PIN 4P (TAPE 2/CD)	
J109	1-568-069-11	JACK, PIN 4P (PHONO/TUNER)	
< RESISTOR >			
R101	1-249-411-11	CARBON 330 5% 1/4W	
R102	1-249-441-11	CARBON 100K 5% 1/4W	
R103	1-249-441-11	CARBON 100K 5% 1/4W	
R104	1-249-416-11	CARBON 820 5% 1/4W	
R105	1-247-897-11	CARBON 560K 5% 1/4W	
R106	1-249-437-11	CARBON 47K 5% 1/4W	
R107	1-249-441-11	CARBON 100K 5% 1/4W	
R108	1-249-409-11	CARBON 220 5% 1/4W	
R109	1-249-409-11	CARBON 220 5% 1/4W	
R110	1-249-417-11	CARBON 1K 5% 1/4W	
R112	1-249-417-11	CARBON 1K 5% 1/4W	
R116	1-249-417-11	CARBON 1K 5% 1/4W	
R118	1-249-417-11	CARBON 1K 5% 1/4W	
R120	1-249-417-11	CARBON 1K 5% 1/4W	
R122	1-249-417-11	CARBON 1K 5% 1/4W	
R124	1-249-417-11	CARBON 1K 5% 1/4W	
R126	1-249-417-11	CARBON 1K 5% 1/4W	
R128	1-249-417-11	CARBON 1K 5% 1/4W	
R130	1-249-417-11	CARBON 1K 5% 1/4W	
R132	1-249-417-11	CARBON 1K 5% 1/4W	
R134	1-249-417-11	CARBON 1K 5% 1/4W	
R136	1-249-417-11	CARBON 1K 5% 1/4W	
R138	1-249-417-11	CARBON 1K 5% 1/4W	
R140	1-249-417-11	CARBON 1K 5% 1/4W	
R146	1-249-441-11	CARBON 100K 5% 1/4W	
R148	1-249-441-11	CARBON 100K 5% 1/4W	
R151	1-249-411-11	CARBON 330 5% 1/4W	
R152	1-249-441-11	CARBON 100K 5% 1/4W	
R153	1-249-441-11	CARBON 100K 5% 1/4W	
R154	1-249-416-11	CARBON 820 5% 1/4W	
R155	1-247-897-11	CARBON 560K 5% 1/4W	
R156	1-249-437-11	CARBON 47K 5% 1/4W	
R157	1-249-441-11	CARBON 100K 5% 1/4W	
R158	1-249-409-11	CARBON 220 5% 1/4W	
R159	1-249-409-11	CARBON 220 5% 1/4W	
R160	1-249-417-11	CARBON 1K 5% 1/4W	

AUDIO	DISPLAY
-------	---------

Ref. No.	Part No.	Description	Remark	Ref. No.	Part No.	Description	Remark
R162	1-249-417-11	CARBON	1K 5% 1/4W	D1013	8-719-301-49	LED SEL2810A (REC OUT SE)	
R166	1-249-417-11	CARBON	1K 5% 1/4W	D1021	8-719-301-37	LED SEL2210S-CD (STANDBY) (AEP, UK)	
R168	1-249-417-11	CARBON	1K 5% 1/4W			< FILTER >	
R170	1-249-417-11	CARBON	1K 5% 1/4W				
R172	1-249-417-11	CARBON	1K 5% 1/4W	FL1001	1-519-628-11	INDICATOR TUBE, FLUORESCENT	
						< IC >	
R174	1-249-417-11	CARBON	1K 5% 1/4W	IC1002	8-759-505-99	IC MSC7128	
R176	1-249-417-11	CARBON	1K 5% 1/4W	IC1003	8-749-920-83	IC GPIU52XB	
R178	1-249-417-11	CARBON	1K 5% 1/4W			< TRANSISTOR >	
R180	1-249-417-11	CARBON	1K 5% 1/4W	Q1001	8-729-900-80	TRANSISTOR DTC114ES	
R182	1-249-417-11	CARBON	1K 5% 1/4W	Q1002	8-729-900-80	TRANSISTOR DTC114ES	
				Q1003	8-729-900-80	TRANSISTOR DTC114ES	
R184	1-249-417-11	CARBON	1K 5% 1/4W	Q1004	8-729-900-80	TRANSISTOR DTC114ES	
R186	1-249-417-11	CARBON	1K 5% 1/4W	Q1005	8-729-900-80	TRANSISTOR DTC114ES	
R188	1-249-417-11	CARBON	1K 5% 1/4W	Q1006	8-729-900-80	TRANSISTOR DTC114ES	
R190	1-249-417-11	CARBON	1K 5% 1/4W	Q1007	8-729-900-80	TRANSISTOR DTC114ES	
R195	1-249-429-11	CARBON	10K 5% 1/4W	Q1008	8-729-900-80	TRANSISTOR DTC114ES	
						< RESISTOR >	
R196	1-249-441-11	CARBON	100K 5% 1/4W	R1015	1-249-412-11	CARBON	390 5% 1/4W
R198	1-249-441-11	CARBON	100K 5% 1/4W	R1016	1-249-408-11	CARBON	180 5% 1/4W
*****				R1017	1-249-412-11	CARBON	390 5% 1/4W
*	A-4341-307-A	DISPLAY BOARD, COMPLETE (US, Canadian, E)	*****	R1018	1-249-412-11	CARBON	390 5% 1/4W
*	A-4347-933-A	DISPLAY BOARD, COMPLETE (AEP, UK)	*****	R1041	1-249-437-11	CARBON	47K 5% 1/4W
*	4-921-941-51	CUSHION (FL)		R1045	1-249-417-11	CARBON	1K 5% 1/4W (AEP, UK)
	4 933 419-01	HOLDER (FL)		R1046	1-249-417-11	CARBON	1K 5% 1/4W (AEP, UK)
		< CAPACITOR >		R1047	1-249-417-11	CARBON	1K 5% 1/4W (AEP, UK)
C1005	1-124-903-11	ELECT	1uF 20% 50V			< SWITCH >	
C1006	1-162-282-31	CERAMIC	100PF 10% 50V	S1001	1-554-303-21	SWITCH, TACTILE (VIDEO 1)	
C1007	1-124-907-11	ELECT	10uF 20% 50V	S1002	1-554-303-21	SWITCH, TACTILE (VIDEO 2)	
C1008	1-161-379-00	CERAMIC	0.01uF 20% 25V	S1003	1-554-303-21	SWITCH, TACTILE (VIDEO 3)	
C1009	1-126-233-11	ELECT	22uF 20% 50V	S1004	1-554-303-21	SWITCH, TACTILE (VIDEO 4)	
				S1005	1-554-303-21	SWITCH, TACTILE (VIDEO 5)	
C1010	1-162-282-31	CERAMIC	100PF 10% 50V	S1006	1-554-303-21	SWITCH, TACTILE (LD)	
C1011	1-162-282-31	CERAMIC	100PF 10% 50V	S1007	1-554-303-21	SWITCH, TACTILE (TV)	
C1012	1-162-282-31	CERAMIC	100PF 10% 50V	S1008	1-554-303-21	SWITCH, TACTILE (TAPE 1)	
C1013	1-161-494-00	CERAMIC	0.022uF 25V	S1009	1-554-303-21	SWITCH, TACTILE (TAPE 2)	
		< CONNECTOR >		S1010	1-554-303-21	SWITCH, TACTILE (CD)	
* CND807	1-564-339-61	PIN, CONNECTOR 5P		S1011	1-554-303-21	SWITCH, TACTILE (TUNER)	
* CND814	1-564-495-11	PIN, CONNECTOR 2P		S1012	1-554-303-21	SWITCH, TACTILE (PHONO)	
* CNE701	1-564-509-11	PLUG, CONNECTOR 6P		S1013	1-554-303-21	SWITCH, TACTILE (DISPLAY MODE)	
		< DIODE >		S1014	1-554-303-21	SWITCH, TACTILE (MIX)	
D1007	8-719-301-49	LED SEL2810A (DOLBY)		S1015	1-554-303-21	SWITCH, TACTILE (TEST TONE)	
D1008	8-719-301-49	LED SEL2810A (THEATER)		S1016	1-554-303-21	SWITCH, TACTILE (PRO LOGIC MODE)	
D1009	8-719-301-49	LED SEL2810A (HALL)		S1017	1-554-303-21	SWITCH, TACTILE (CHARACTER)	
D1010	8-719-301-49	LED SEL2810A (JAZZ CLUB)					
D1011	8-719-301-49	LED SEL2810A (STADIUM)					
D1012	8-719-301-49	LED SEL2810A (SOURCE DIRECT)					

DISPLAY **ENC** **F SP**

Ref.No.	Part No.	Description	Remark
S1018	1-554-303-21	SWITCH, TACTILE (REC OUT SET)	
S1019	1-554-303-21	SWITCH, TACTILE (REC OUT CHECK)	
S1020	1-554-303-21	SWITCH, TACTILE (SOURCE DIRECT)	
S1021	1-554-303-21	SWITCH, TACTILE (SORROUND MODE)	

*	1-637-640-11	ENC BOARD	

		< CONNECTOR >	
* CND8C3	1-564-337-61	PIN, CONNECTOR 3P	
		< VARIABLE RESISTOR >	
RV10C1	1-466-203-11	ENCODER, ROTARY (ACOUSTIC CONTROL)	

*	A-4345-745-A	F SP BOARD, COMPLETE	

		(US, Canadian, AB1, UK, E)	
*	A-4347-557-A	F SP BOARD, COMPLETE (AE2)	

		< CAPACITOR >	
C013	1-136-163-00	FILM 0.068uF 5% 50V	
C014	1-136-163-00	FILM 0.068uF 5% 50V	
C050	1-136-165-00	FILM 0.1uF 5% 50V	
C051	1-124-471-00	ELECT 1000uF 20% 6.3V	
C613	1-136-163-00	FILM 0.068uF 5% 50V	
C614	1-136-163-00	FILM 0.068uF 5% 50V	
C663	1-136-163-00	FILM 0.068uF 5% 50V	
C664	1-136-163-00	FILM 0.068uF 5% 50V	
		< CONNECTOR >	
* CND8C4	1-564-498-11	PIN, CONNECTOR 5P	
* CND813	1-564-338-71	PIN, CONNECTOR 4P	
* CNE7C9	1-564-521-11	PLUG, CONNECTOR 6P	
* CNE710	1-564-520-11	PLUG, CONNECTOR 5P	
* CNV5C2	1-564-243-00	PIN, CONNECTOR 6P	
		< DIODE >	
D006	8-719-987-63	DIODE 1N4148M	
D007	8-719-987-63	DIODE 1N4148M	
D050	8-719-987-63	DIODE 1N4148M	
D052	8-719-987-63	DIODE 1N4148M	
D054	8-719-987-63	DIODE 1N4148M	
D055	8-719-987-63	DIODE 1N4148M	
D056	8-719-987-63	DIODE 1N4148M	
D057	8-719-987-63	DIODE 1N4148M	
D058	8-719-987-63	DIODE 1N4148M	
D059	8-719-987-63	DIODE 1N4148M	

Ref.No.	Part No.	Description	Remark
D060	8-719-987-63	DIODE 1N4148M	
D061	8-719-987-63	DIODE 1N4148M	
		< COIL >	
L001	1-420-872-00	COIL, AIR CORE	
L601	1-420-872-00	COIL, AIR CORE	
L651	1-420-872-00	COIL, AIR CORE	
		< TRANSISTOR >	
Q051	8-729-140-84	TRANSISTOR 2SC1841-PAFAEA	
Q052	8-729-620-05	TRANSISTOR 2SC2603-EF	
Q053	8-729-620-05	TRANSISTOR 2SC2603-EF	
Q054	8-729-620-05	TRANSISTOR 2SC2603-EF	
Q055	8-729-620-05	TRANSISTOR 2SC2603-EF	
Q056	8-729-620-05	TRANSISTOR 2SC2603-EF	
Q057	8-729-620-05	TRANSISTOR 2SC2603-EF	
		< RESISTOR >	
R030	1-247-727-11	CARBON 10 5% 1/2W	
R031	1-247-727-11	CARBON 10 5% 1/2W	
R032	1-249-435-11	CARBON 33K 5% 1/4W	
R038	1-247-749-11	CARBON 560 5% 1/2W	
R050	1-249-429-11	CARBON 10K 5% 1/4W	
R051	1-249-417-11	CARBON 1K 5% 1/4W	
R052	1-249-436-11	CARBON 39K 5% 1/4W	
R054	1-249-425-11	CARBON 4.7K 5% 1/4W	
R055	1-249-425-11	CARBON 4.7K 5% 1/4W	
R056	1-249-437-11	CARBON 47K 5% 1/4W	
R057	1-249-437-11	CARBON 47K 5% 1/4W	
R058	1-249-437-11	CARBON 47K 5% 1/4W	
R059	1-249-437-11	CARBON 47K 5% 1/4W	
△R060	1-215-889-00	METAL OXIDE 330 5% 2W F	
R061	1-249-437-11	CARBON 47K 5% 1/4W	
R062	1-249-425-11	CARBON 4.7K 5% 1/4W	
R630	1-247-727-11	CARBON 10 5% 1/2W	
R631	1-247-727-11	CARBON 10 5% 1/2W	
R632	1-249-437-11	CARBON 47K 5% 1/4W	
R680	1-247-727-11	CARBON 10 5% 1/2W	
R681	1-247-727-11	CARBON 10 5% 1/2W	
R682	1-249-438-11	CARBON 56K 5% 1/4W	
		< RELAY >	
RY001	1-515-533-11	RELAY	
RY601	1-515-356-00	RELAY	
		< TERMINAL >	
TM601	1-537-235-11	TERMINAL BOARD (SP) (FRONT/CENTER SPEAKER) (US, Canadian, AB1, UK, E)	

<p>The components identified by mark △ or dotted line with mark △ are critical for safety. Replace only with part number specified.</p>	<p>Les composants identifiés par une marque △ sont critiques pour la sécurité. Ne les remplacer que par une pièce portant le numéro spécifié.</p>
---	--

F SP HP MUT P SWITCH REAR

Ref.No.	Part No.	Description	Remark
M601	1-537-227-11	TERMINAL BOARD (SP) (FRONT/CENTER SPEAKER)	(AE2)

*	1-641-C38-11	HP BOARD	*****
< CONNECTOR >			
* CNE710	1-564-520-11	PLUG, CONNECTOR 5P	
< DIODE >			
D681	8-719-987-63	DIODE	1N4148M
D682	8-719-987-63	DIODE	1N4148M
< JACK >			
J601	1 507-796-71	JACK (HEADPHONES)	
< RESISTOR >			
R634	1-247-749-11	CARBON	560 5% 1/2W
R684	1-247-749-11	CARBON	560 5% 1/2W
R689	1-249-556-11	CARBON	1.5K 5% 1/4W
< RELAY >			
RY681	1-515-727-11	RELAY	

*	1-637-653-11	MUT BOARD	*****
< CONNECTOR >			
* CND807	1-564-339-61	PIN, CONNECTOR 5P	
< DIODE >			
D1014	8-719-301-49	LED SEL2810A (MUTING)	
< SWITCH >			
S1022	1-554-303-21	SWITCH, TACTILE (MUTING)	
S1023	1-554-303-21	SWITCH, TACTILE (MODE)	

*	1-637-638-11	P SWITCH BOARD	*****
< SWITCH >			
S1024	1-554-303-21	SWITCH, TACTILE (POWER ON/STANDBY)	

*	1-637-651-11	PC BOARD	*****

Ref.No.	Part No.	Description	Remark
*	A-4345-744-A	REAR BOARD, COMPLETE	***** (US, Canadian, AE1, UK, E)
*	A-4347-556-A	REAR BOARD, COMPLETE (AE2)	*****
1-533-225-11 HOLDER, FUSE			
4-946-660-01 GUIDE (TR), LEAD			
7-682-548-09 SCREW +B 3X8			
< CAPACITOR >			
C801	1-126-045-11	ELECT	2.2uF 20% 50V
C802	1-126-023-11	ELECT	100uF 20% 25V
C803	1-164-019-11	CERAMIC	10PF 0.5PF 50V
C804	1-136-163-00	FILM	0.068uF 5% 50V
C806	1-136-163-00	FILM	0.068uF 5% 50V
C807	1-136-163-00	FILM	0.068uF 5% 50V
C851	1-126-045-11	ELECT	2.2uF 20% 50V
C852	1-126-023-11	ELECT	100uF 20% 25V
C853	1-164-019-11	CERAMIC	10PF 0.5PF 50V
C854	1-136-163-00	FILM	0.068uF 5% 50V
C856	1-136-163-00	FILM	0.068uF 5% 50V
C857	1-136-163-00	FILM	0.068uF 5% 50V
C961	1-124-919-11	ELECT	220uF 20% 63V
C962	1-124-910-11	ELECT	47uF 20% 50V
C963	1-126-975-11	ELECT	4700uF 20% 42V
C964	1-126-975-11	ELECT	4700uF 20% 42V
< CONNECTOR >			
* CND815	1-564-337-71	PIN, CONNECTOR 3P	
* CNE212	1-564-506-11	PLUG, CORNECTOR 3P	
* CNE708	1-564-507-11	PLUG, CONNECTOR 4P	
* CNE709	1-564-509-11	PLUG, CONNECTOR 6P	
* CNV922	1-564-674-11	PIN, CONNECTOR 8P	
< DIODE >			
D801	8-719-987-63	DIODE	1N4148M
D802	8-719-987-63	DIODE	1N4148M
D851	8-719-987-63	DIODE	1N4148M
D852	8-719-987-63	DIODE	1N4148M
D960	8-719-016-30	DIODE	UZP-39B
D961	8-719-015-06	DIODE	UZP-9.1B
D962	8-719-510-68	DIODE	D5SBA20F01
D963	8-719-200-02	DIODE	10E2
< FUSE >			
△F902	1-532-350-00	FUSE, TIME-LAG (AEP, UK, E)	
△F902	1-532-746-11	FUSE, GLASS TUBE (US, Canadian)	
△F903	1-532-350-00	FUSE, TIME-LAG (AEP, UK, E)	
△F903	1-532-746-11	FUSE, GLASS TUBE (US, Canadian)	

<p>The components identified by mark △ or dotted line with mark △ are critical for safety. Replace only with part number specified.</p>	<p>Les composants identifiés par une marque △ sont critiques pour la sécurité. Ne les remplacer que par une pièce portant le numéro spécifié.</p>
---	--

REAR SIRCS

Ref.No.	Part No.	Description	Remark
< IC >			
IC801	8-759-109-06	IC uPCI298V	
IC851	8-759-109-06	IC uPCI298V	
< COIL >			
L801	1-420-872-00	COIL, AIR CORE	
L851	1-420-872-00	COIL, AIR CORE	
< TRANSISTOR >			
Q800	8-729-141-26	TRANSISTOR 2SC3622A-LK	
Q801	8-729-141-89	TRANSISTOR 2SD1585-LK	
Q802	8-729-011-22	TRANSISTOR 2SC4511-OY	
Q803	8-729-011-19	TRANSISTOR 2SA1725-OY	
Q804	8-729-140-82	TRANSISTOR 2SA988-PAFAEA	
Q850	8-729-141-26	TRANSISTOR 2SC3622A-LK	
Q851	8-729-141-89	TRANSISTOR 2SD1585-LK	
Q852	8-729-011-22	TRANSISTOR 2SC4511-OY	
Q853	8-729-011-19	TRANSISTOR 2SA1725-OY	
Q854	8-729-140-82	TRANSISTOR 2SA988-PAFAEA	
< RESISTOR >			
R800	1-259-428-11	CARBON 1K 5%	1/6W
R801	1-259-428-11	CARBON 1K 5%	1/6W
R802	1-259-440-11	CARBON 3.3K 5%	1/6W
R803	1-259-470-11	CARBON 56K 5%	1/6W
R804	1-259-434-11	CARBON 1.8K 5%	1/6W
R805	1-249-466-11	CARBON 56K 5%	1/4W
R806	1-259-456-11	CARBON 15K 5%	1/6W
R807	1-259-434-11	CARBON 1.8K 5%	1/6W
R808	1-259-440-11	CARBON 3.3K 5%	1/6W
△R809	1-247-688-11	CARBON 10 5%	1/4W F
△R810	1-247-688-11	CARBON 10 5%	1/4W F
R811	1-217-151-00	RES, METAL PLATE	0.22
R812	1-217-151-00	RES, METAL PLATE	0.22
R813	1-259-456-11	CARBON 15K 5%	1/6W
R814	1-247-727-11	CARBON 10 5%	1/2W
R815	1-259-468-11	CARBON 47K 5%	1/6W
R816	1-247-727-11	CARBON 10 5%	1/2W
R817	1-247-749-11	CARBON 560 5%	1/2W
R819	1-259-428-11	CARBON 1K 5%	1/6W
R850	1-259-428-11	CARBON 1K 5%	1/6W
R851	1-259-428-11	CARBON 1K 5%	1/6W
R852	1-259-440-11	CARBON 3.3K 5%	1/6W
R853	1-259-470-11	CARBON 56K 5%	1/6W
R854	1-259-434-11	CARBON 1.8K 5%	1/6W
R855	1-249-466-11	CARBON 56K 5%	1/4W
R856	1-259-456-11	CARBON 15K 5%	1/6W
R857	1-259-434-11	CARBON 1.8K 5%	1/6W

Ref.No.	Part No.	Description	Remark
R858	1-259-440-11	CARBON 3.3K 5%	1/6W
△R859	1-247-688-11	CARBON 10 5%	1/4W F
△R860	1-247-688-11	CARBON 10 5%	1/4W F
R861	1-217-151-00	RES, METAL PLATE	0.22
R862	1-217-151-00	RES, METAL PLATE	0.22
R863	1-259-456-11	CARBON 15K 5%	1/6W
R864	1-247-727-11	CARBON 10 5%	1/2W
R865	1-259-470-11	CARBON 56K 5%	1/6W
R866	1-247-727-11	CARBON 10 5%	1/2W
R869	1-259-428-11	CARBON 1K 5%	1/6W
△R952	1-215-868-00	METAL OXIDE 680 5%	1W F
R953	1-247-756-11	CARBON 2.2K 5%	1/2W
< VARIABLE RESISTOR >			
RV801	1-237-456-11	RES, ADJ, CARBON 1K (BIAS L)	
RV851	1-237-456-11	RES, ADJ, CARBON 1K (BIAS R)	
< RELAY >			
RY801	1-515-533-11	RELAY	
< TERMINAL >			
* TB801	1-508-809-00	BASE POST (14MM) 2P	
* TB851	1-508-809-00	BASE POST (14MM) 2P	
< SP TERMINAL >			
TM801	1-537-314-11	TERMINAL BOARD (SP) (REAR SPEAKER) (US, Canadian, AE1, UK, E)	
TM801	1-537-314-31	TERMINAL BOARD (SP) (REAR SPEAKER) (AE2)	

* 1-637-652-11	SIRCS BOARD		

< CAPACITOR >			
C1014	1-161-379-00	CERAMIC 0.01uF 20% 25V	
< CONNECTOR >			
* CND802	1-564-338-00	PIN, CONNECTOR 4P	
CNV011	1-564-320-00	PIN, CONNECTOR (B2P-VH) 2P	
< DIODE >			
D1015	8-719-987-63	DIODE 1N4148M	
D1016	8-719-987-63	DIODE 1N4148M	
< JACK >			
J1001	1-564-980-11	PIN, CONNECTOR 4P (AUDIO OUT)	
J1002	1-566-740-11	JACK (CONTROL S OUT)	
J1003	1-566-740-11	JACK (CONTROL S IN)	

The components identified by mark △ or dotted line with mark △ are critical for safety. Replace only with part number specified.

Les composants identifiés par une marque △ sont critiques pour la sécurité. Ne les remplacer que par une pièce portant le numéro spécifié.

SIRCS

SP SW

SUR

Ref. No.	Part No.	Description	Remark
< TRANSISTOR >			
Q1010	8-729-900-80	TRANSISTOR DTC114ES	
Q1011	8-729-900-80	TRANSISTOR DTC114ES	
Q1012	8-729-900-61	TRANSISTOR DTA114ES	
< RESISTOR >			
R1019	1-249-421-11	CARBON 2.2K 5% 1/4W	
R1020	1-249-429-11	CARBON 10K 5% 1/4W	
R1021	1-249-393-11	CARBON 10 5% 1/4W	

*	1-641-040-11	SP SW BOARD	

< CONNECTOR >			
* CND813	1 564-497-11	PIN, CONNECTOR 4P	
< SWITCH >			
SW601	1-572-509-11	SWITCH, PUSH (2 KEY) (SPEAKERS)	

*	A-4345-743-A	SUR BOARD, COMPLETE (US, Canadian, E)	

*	A-4347-937-A	SUR BOARD, COMPLETE (AEP, UK)	

< CAPACITOR >			
C280	1-126-044-11	ELECT 1uF 20% 50V	
C281	1-126-045-11	ELECT 2.2uF 20% 50V	
C282	1-126-044-11	ELECT 1uF 20% 50V	
C283	1-126-044-11	ELECT 1uF 20% 50V	
C284	1-162-282-31	CERAMIC 100PF 10% 50V	
C285	1-126-044-11	ELECT 1uF 20% 50V	
C286	1-126-044-11	ELECT 1uF 20% 50V	
C287	1-126-045-11	ELECT 2.2uF 20% 50V	
C288	1-162-282-31	CERAMIC 100PF 10% 50V	
C289	1-162-282-31	CERAMIC 100PF 10% 50V	
C290	1-126-045-11	ELECT 2.2uF 20% 50V	
C291	1-126-044-11	ELECT 1uF 20% 50V	
C292	1-126-044-11	ELECT 1uF 20% 50V	
C301	1-126-163-11	ELECT 4.7uF 20% 50V	
C302	1-126-022-11	ELECT 47uF 20% 16V	
C303	1-164-159-11	CERAMIC 0.1uF 50V	
C304	1-130-478-00	MYLAR 0.0039uF 5% 50V	
C305	1-130-475-00	MYLAR 0.0022uF 5% 50V	
C307	1-126-163-11	ELECT 4.7uF 20% 50V	
C308	1-126-163-11	ELECT 4.7uF 20% 50V	
C309	1-126-163-11	ELECT 4.7uF 20% 50V	
C310	1-164-159-11	CERAMIC 0.1uF 50V	

Ref. No.	Part No.	Description	Remark
C312	1-126-059-11	ELECT 10uF 20% 50V	
C313	1-130-482-00	MYLAR 0.0082uF 5% 50V	
C315	1-130-476-00	MYLAR 0.0027uF 5% 50V	
C319	1-162-211-31	CERAMIC 33PF 5% 50V	
C320	1-162-211-31	CERAMIC 33PF 5% 50V	
C323	1-130-481-00	MYLAR 0.0068uF 5% 50V	
C324	1-110-342-11	MYLAR 390PF 5% 50V	
C326	1-126-044-11	ELECT 1uF 20% 50V	
C331	1-136-153-00	FILM 0.01uF 5% 50V	
C332	1-136-153-00	FILM 0.01uF 5% 50V	
C333	1-130-476-00	MYLAR 0.0027uF 5% 50V	
C334	1-110-341-11	MYLAR 330PF 5% 50V	
C335	1-110-341-11	MYLAR 330PF 5% 50V	
C336	1-130-481-00	MYLAR 0.0068uF 5% 50V	
C338	1-130-482-00	MYLAR 0.0082uF 5% 50V	
C339	1-130-482-00	MYLAR 0.0082uF 5% 50V	
C340	1-110-342-11	MYLAR 390PF 5% 50V	
C352	1-126-163-11	ELECT 4.7uF 20% 50V	
C367	1-136-169-00	FILM 0.22uF 5% 50V	
C371	1-136-169-00	FILM 0.22uF 5% 50V	
C372	1-126-059-11	ELECT 10uF 20% 50V	
C373	1-126-059-11	ELECT 10uF 20% 50V	
C374	1-126-059-11	ELECT 10uF 20% 50V	
C375	1-126-059-11	ELECT 10uF 20% 50V	
C379	1-126-044-11	ELECT 1uF 20% 50V	
C384	1-136-158-00	FILM 0.027uF 5% 50V	
C385	1-130-479-00	MYLAR 0.0047uF 5% 50V	
C388	1-136-159-00	FILM 0.033uF 5% 50V	
C390	1-136-171-00	FILM 0.33uF 5% 50V	
C391	1-126-023-11	ELECT 100uF 20% 25V	
C392	1-136-165-00	FILM 0.1uF 5% 50V	
C394	1-126-049-11	ELECT 22uF 20% 25V	
C396	1-126-023-11	ELECT 100uF 20% 25V	
C397	1-126-059-11	ELECT 10uF 20% 50V	
C398	1-126-044-11	ELECT 1uF 20% 50V	
C399	1-126-044-11	ELECT 1uF 20% 50V	
C1001	1-125-548-11	CAP, DOUBLE LAYERS 0.1F	
C1002	1-124-994-11	ELECT 100uF 20% 10V	
C1003	1-161-379-00	CERAMIC 0.01uF 20% 25V	
C1004	1-161-379-00	CERAMIC 0.01uF 20% 25V	
C1005	1-126-059-11	ELECT 10uF 20% 50V	
C1101	1-126-044-11	ELECT 1uF 20% 50V	
C1107	1-161-379-00	CERAMIC 0.01uF 20% 25V	
C1108	1-126-059-11	ELECT 10uF 20% 50V	
C1109	1-164-159-11	CERAMIC 0.1uF 50V	
C1110	1-161-379-00	CERAMIC 0.01uF 20% 25V	
C1201	1-136-165-00	FILM 0.1uF 5% 50V	
C1202	1-136-165-00	FILM 0.1uF 5% 50V	
C1203	1-130-469-00	MYLAR 680PF 5% 50V	

SUR

Ref. No.	Part No.	Description	Remark	Ref. No.	Part No.	Description	Remark
C1204	1-136-165-00	FILM	0.1uF 5% 50V			< JACK >	
C1205	1-136-165-00	FILM	0.1uF 5% 50V				
C1206	1-130-469-00	MYLAR	680PF 5% 50V				
C1207	1-126-163-11	ELECT	4.7uF 20% 50V	* CNJ31	1-564-511-11	PLUG, CONNECTOR 8P	
C1208	1-136-169-00	FILM	0.22uF 5% 50V			< DIODE >	
C1209	1-136-169-00	FILM	0.22uF 5% 50V	D301	8-719-987-63	DIODE 1N4148M	
C1210	1-136-171-00	FILM	0.33uF 5% 50V	D302	8-719-987-63	DIODE 1N4148M	
C1211	1-136-171-00	FILM	0.33uF 5% 50V	D1001	8-719-987-63	DIODE 1N4148M	
C1212	1-136-171-00	FILM	0.33uF 5% 50V	D1002	8-719-987-63	DIODE 1N4148M	
C1213	1-136-171-00	FILM	0.33uF 5% 50V	D1003	8-719-987-63	DIODE 1N4148M	
C1214	1-136-157-00	FILM	0.022uF 5% 50V	D1004	8-719-987-63	DIODE 1N4148M	
C1215	1-136-157-00	FILM	0.022uF 5% 50V	D1006	8-719-987-63	DIODE 1N4148M	
C1216	1-136-157-00	FILM	0.022uF 5% 50V	D1017	8-719-987-63	DIODE 1N4148M	
C1217	1-136-157-00	FILM	0.022uF 5% 50V	D1018	8-719-987-63	DIODE 1N4148M	
C1218	1-136-165-00	FILM	0.1uF 5% 50V	D1019	8-719-987-63	DIODE 1N4148M	
C1219	1-126-163-11	ELECT	4.7uF 20% 50V	D1020	8-719-987-63	DIODE 1N4148M	
C1220	1-136-169-00	FILM	0.22uF 5% 50V			< IC >	
C1221	1-136-169-00	FILM	0.22uF 5% 50V	IC280	8-759-514-77	IC NE571N-A	
C1222	1-126-059-11	ELECT	10uF 20% 50V	IC281	8-759-514-77	IC NE571N-A	
C1224	1-136-153-00	FILM	0.01uF 5% 50V	IC301	8-759-503-59	IC YM712	
C1225	1-136-153-00	FILM	0.01uF 5% 50V	IC302	8-759-900-48	IC uPD4052BC-A	
C1226	1-136-153-00	FILM	0.01uF 5% 50V	IC306	8-759-823-25	IC LA2730K	
C1228	1-164-159-11	CERAMIC	0.1uF 50V	IC307	8-759-801-01	IC LC4966	
C1229	1-126-052-11	ELECT	100uF 20% 35V	IC309	8-759-801-01	IC LC4966	
C1230	1-136-165-00	FILM	0.1uF 5% 50V	IC315	8-759-945-58	IC RC4558P	
C1232	1-164-159-11	CERAMIC	0.1uF 50V	IC316	8-759-945-58	IC RC4558P	
C1233	1-136-177-00	FILM	1uF 5% 50V	IC317	8-759-113-12	IC uPC4084C	
C1234	1-126-059-11	ELECT	10uF 20% 50V	IC318	8-759-945-58	IC RC4558P	
C1235	1-126-059-11	ELECT	10uF 20% 50V	IC1001	8-759-044-55	IC M50747-0F6SP	
C1236	1-126-059-11	ELECT	10uF 20% 50V	IC1201	8-759-512-93	IC SSM2125	
C1237	1-126-059-11	ELECT	10uF 20% 50V			< COIL >	
		< CONNECTOR >		L301	1-410-971-11	INDUCTOR 10uH	
* CND801	1-564-337-00	PIN, CONNECTOR 3P				< TRANSISTOR >	
* CND802	1-564-338-00	PIN, CONNECTOR 4P		Q306	8-729-900-89	TRANSISTOR DTC144ES	
* CND803	1-564-337-61	PIN, CONNECTOR 3P		Q307	8-729-900-89	TRANSISTOR DTC144ES	
* CND804	1-564-339-00	PIN, CONNECTOR 5P		Q308	8-729-900-80	TRANSISTOR DTC114ES	
* CND805	1-564-338-61	PIN, CONNECTOR 4P		Q311	8-729-900-89	TRANSISTOR DTC144ES	
* CND806	1-564-340-61	PIN, CONNECTOR 6P		Q312	8-729-900-65	TRANSISTOR DTA144ES	
* CND808	1-564-342-61	PIN, CONNECTOR 8P		Q313	8-729-900-89	TRANSISTOR DTC144ES	
* CND809	1-564-340-00	PIN, CONNECTOR 6P		Q314	8-729-900-65	TRANSISTOR DTA144ES	
* CND810	1-564-337-71	PIN, CONNECTOR 3P		Q315	8-729-900-89	TRANSISTOR DTC144ES	
* CND811	1-506-503-11	PIN, CONNECTOR 9P		Q1000	8-729-620-05	TRANSISTOR 2SC2603-EF	
* CND812	1-564-339-61	PIN, CONNECTOR 5P		Q1013	8-729-900-61	TRANSISTOR DTA114ES	
* CNE201	1-564-506-11	PLUG, CONNECTOR 3P		Q1014	8-729-900-89	TRANSISTOR DTC144ES (AEP, UK)	
* CNE707	1-564-507-11	PLUG, CONNECTOR 4P		Q1015	8-729-900-80	TRANSISTOR DTC114ES (AEP, UK)	
* CNE714	1-564-508-11	PLUG, CONNECTOR 5P					

SUR

Ref. No.	Part No.	Description	Remark			Ref. No.	Part No.	Description	Remark		
< RESISTOR >						R367	1-249-408-11	CARBON	180	5%	1/4W
R280	1-247-887-00	CARBON	220K	5%	1/4W	R368	1-249-423-11	CARBON	3.3K	5%	1/4W
R281	1-249-417-11	CARBON	1K	5%	1/4W	R369	1-249-437-11	CARBON	47K	5%	1/4W
R282	1-249-435-11	CARBON	33K	5%	1/4W	R370	1-247-889-00	CARBON	270K	5%	1/4W
R283	1-249-435-11	CARBON	33K	5%	1/4W	R371	1-247-850-11	CARBON	6.2K	5%	1/4W
R284	1-247-887-00	CARBON	220K	5%	1/4W	R373	1-247-889-00	CARBON	270K	5%	1/4W
R285	1-249-417-11	CARBON	1K	5%	1/4W	R374	1-249-409-11	CARBON	220	5%	1/4W
R286	1-249-429-11	CARBON	10K	5%	1/4W	R375	1-249-435-11	CARBON	33K	5%	1/4W
R287	1-249-417-11	CARBON	1K	5%	1/4W	R376	1-249-430-11	CARBON	12K	5%	1/4W
R288	1-247-887-00	CARBON	220K	5%	1/4W	R377	1-249-433-11	CARBON	22K	5%	1/4W
R289	1-249-429-11	CARBON	10K	5%	1/4W	R378	1-249-428-11	CARBON	8.2K	5%	1/4W
R301	1-249-426-11	CARBON	5.6K	5%	1/4W	R382	1-249-421-11	CARBON	2.2K	5%	1/4W
R302	1-249-429-11	CARBON	10K	5%	1/4W	R383	1-249-421-11	CARBON	2.2K	5%	1/4W
R303	1-249-429-11	CARBON	10K	5%	1/4W	R384	1-249-421-11	CARBON	2.2K	5%	1/4W
R304	1-249-429-11	CARBON	10K	5%	1/4W	R386	1-249-421-11	CARBON	2.2K	5%	1/4W
R305	1-249-429-11	CARBON	10K	5%	1/4W	R392	1-249-429-11	CARBON	10K	5%	1/4W
R308	1-249-429-11	CARBON	10K	5%	1/4W	R393	1-249-434-11	CARBON	27K	5%	1/4W
R309	1-249-433-11	CARBON	22K	5%	1/4W	R394	1-249-431-11	CARBON	15K	5%	1/4W
R310	1-249-437-11	CARBON	47K	5%	1/4W	R395	1-249-441-11	CARBON	100K	5%	1/4W
R312	1-249-429-11	CARBON	10K	5%	1/4W	R397	1-249-441-11	CARBON	100K	5%	1/4W
R315	1-249-429-11	CARBON	10K	5%	1/4W	R399	1-249-441-11	CARBON	100K	5%	1/4W
R322	1-247-903-00	CARBON	1M	5%	1/4W	R1003	1-249-429-11	CARBON	10K	5%	1/4W
R323	1-249-434-11	CARBON	27K	5%	1/4W	R1004	1-249-429-11	CARBON	10K	5%	1/4W
R324	1-249-431-11	CARBON	15K	5%	1/4W	R1005	1-249-429-11	CARBON	10K	5%	1/4W
R325	1-249-429-11	CARBON	10K	5%	1/4W	R1006	1-249-429-11	CARBON	10K	5%	1/4W
R330	1-249-429-11	CARBON	10K	5%	1/4W	R1007	1-249-429-11	CARBON	10K	5%	1/4W
R337	1-249-417-11	CARBON	1K	5%	1/4W	R1008	1-249-429-11	CARBON	10K	5%	1/4W
R338	1-249-417-11	CARBON	1K	5%	1/4W	R1009	1-249-429-11	CARBON	10K	5%	1/4W
R339	1-249-429-11	CARBON	10K	5%	1/4W	R1010	1-247-903-00	CARBON	1M	5%	1/4W
R340	1-249-428-11	CARBON	8.2K	5%	1/4W	R1011	1-247-895-00	CARBON	470K	5%	1/4W
R341	1-249-428-11	CARBON	8.2K	5%	1/4W	R1012	1-249-433-11	CARBON	22K	5%	1/4W
R342	1-249-429-11	CARBON	10K	5%	1/4W	R1013	1-249-429-11	CARBON	10K	5%	1/4W
R343	1-249-426-11	CARBON	5.6K	5%	1/4W	R1014	1-249-401-11	CARBON	47	5%	1/4W
R344	1-249-426-11	CARBON	5.6K	5%	1/4W	R1022	1-249-437-11	CARBON	47K	5%	1/4W
R345	1-249-429-11	CARBON	10K	5%	1/4W	R1023	1-249-437-11	CARBON	47K	5%	1/4W
R349	1-249-435-11	CARBON	33K	5%	1/4W	R1024	1-249-405-11	CARBON	100	5%	1/4W
R352	1-249-435-11	CARBON	33K	5%	1/4W	R1025	1-249-437-11	CARBON	47K	5%	1/4W
R356	1-249-433-11	CARBON	22K	5%	1/4W	R1026	1-249-437-11	CARBON	47K	5%	1/4W
R357	1-249-433-11	CARBON	22K	5%	1/4W	R1030	1-249-441-11	CARBON	100K	5%	1/4W
R358	1-249-429-11	CARBON	10K	5%	1/4W	R1031	1-249-425-11	CARBON	4.7K	5%	1/4W
R359	1-249-423-11	CARBON	3.3K	5%	1/4W	R1032	1-249-425-11	CARBON	4.7K	5%	1/4W
R360	1-249-423-11	CARBON	3.3K	5%	1/4W	R1033	1-249-429-11	CARBON	10K	5%	1/4W
R361	1-249-435-11	CARBON	33K	5%	1/4W	R1034	1-249-429-11	CARBON	10K	5%	1/4W
R362	1-249-421-11	CARBON	2.2K	5%	1/4W	R1035	1-249-417-11	CARBON	1K	5%	1/4W
R363	1-249-421-11	CARBON	2.2K	5%	1/4W	R1036	1-249-417-11	CARBON	1K	5%	1/4W
R364	1-249-421-11	CARBON	2.2K	5%	1/4W	R1037	1-249-433-11	CARBON	22K	5%	1/4W
R365	1-249-433-11	CARBON	22K	5%	1/4W	R1043	1-249-417-11	CARBON	1K	5%	1/4W
R366	1-249-429-11	CARBON	10K	5%	1/4W	R1053	1-249-405-11	CARBON	100	5%	1/4W
						R1055	1-249-433-11	CARBON	22K	5%	1/4W

SUR TONE

Ref. No.	Part No.	Description	Remark
R1056	1-249-433-11	CARBON	22K 5% 1/4W
R1057	1-249-433-11	CARBON	22K 5% 1/4W
R1058	1-249-433-11	CARBON	22K 5% 1/4W
R1059	1-249-433-11	CARBON	22K 5% 1/4W
R1060	1-249-433-11	CARBON	22K 5% 1/4W
R1061	1-249-433-11	CARBON	22K 5% 1/4W
R1062	1-249-433-11	CARBON	22K 5% 1/4W
R1063	1-249-433-11	CARBON	22K 5% 1/4W
R1064	1-249-433-11	CARBON	22K 5% 1/4W
R1065	1-249-433-11	CARBON	22K 5% 1/4W
R1066	1-249-433-11	CARBON	22K 5% 1/4W
R1067	1-249-433-11	CARBON	22K 5% 1/4W
R1068	1-249-433-11	CARBON	22K 5% 1/4W
R1069	1-249-433-11	CARBON	22K 5% 1/4W
R1070	1-249-433-11	CARBON	22K 5% 1/4W
R1071	1-249-433-11	CARBON	22K 5% 1/4W
R1072	1-249-433-11	CARBON	22K 5% 1/4W
R1073	1-249-433-11	CARBON	22K 5% 1/4W
R1074	1-249-433-11	CARBON	22K 5% 1/4W
R1075	1-249-433-11	CARBON	22K 5% 1/4W
R1076	1-249-433-11	CARBON	22K 5% 1/4W
R1077	1-249-433-11	CARBON	22K 5% 1/4W
R1078	1-249-412-11	CARBON	390 5% 1/4W(AEP, UK)
R1079	1-249-429-11	CARBON	10K 5% 1/4W(AEP, UK)
R1201	1-249-431-11	CARBON	15K 5% 1/4W
R1202	1-249-437-11	CARBON	47K 5% 1/4W
R1203	1-249-431-11	CARBON	15K 5% 1/4W
R1204	1-249-437-11	CARBON	47K 5% 1/4W
R1205	1-259-449-11	CARBON	7.5K 5% 1/6W
R1206	1-259-449-11	CARBON	7.5K 5% 1/6W
R1209	1-249-433-11	CARBON	22K 5% 1/4W
R1210	1-249-433-11	CARBON	22K 5% 1/4W
R1211	1-259-884-11	CARBON	4.7M 5% 1/4W
R1212	1-249-433-11	CARBON	22K 5% 1/4W
R1213	1-259-884-11	CARBON	4.7M 5% 1/4W
R1216	1-249-417-11	CARBON	1K 5% 1/4W
R1217	1-249-417-11	CARBON	1K 5% 1/4W
R1218	1-249-417-11	CARBON	1K 5% 1/4W
R1219	1-249-417-11	CARBON	1K 5% 1/4W
R1220	1-249-417-11	CARBON	1K 5% 1/4W
R1221	1-249-417-11	CARBON	1K 5% 1/4W
		< RELAY >	
RY301	1-515-614-11	RELAY	
		< VIBRATOR >	
X301	1-579-124-11	VIBRATOR, CERAMIC (7.7MHz)	
X1001	1-579-125-11	VIBRATOR, CERAMIC (8MHz)	

Ref. No.	Part No.	Description	Remark
*	A-4341-297-A	TONE BOARD, COMPLETE	

		< CAPACITOR >	
C203	1-126-163-11	ELECT	4.7uF 20% 50V
C204	1-126-022-11	ELECT	47uF 20% 16V
C205	1-162-211-31	CERAMIC	33PF 5% 50V
C206	1-126-163-11	ELECT	4.7uF 20% 50V
C207	1-130-481-00	MYLAR	0.0068uF 5% 50V
C208	1-136-163-00	FILM	0.068uF 5% 50V
C209	1-130-477-00	MYLAR	0.0033uF 5% 50V
C210	1-136-159-00	FILM	0.033uF 5% 50V
C253	1-126-163-11	ELECT	4.7uF 20% 50V
C254	1-126-022-11	ELECT	47uF 20% 16V
C255	1-162-211-31	CERAMIC	33PF 5% 50V
C256	1-126-163-11	ELECT	4.7uF 20% 50V
C257	1-130-481-00	MYLAR	0.0068uF 5% 50V
C258	1-136-163-00	FILM	0.068uF 5% 50V
C259	1-130-477-00	MYLAR	0.0033uF 5% 50V
C260	1-136-159-00	FILM	0.033uF 5% 50V
C402	1-126-022-11	ELECT	47uF 20% 16V
C404	1-126-022-11	ELECT	47uF 20% 16V
C405	1-162-211-31	CERAMIC	33PF 5% 50V
C406	1-126-163-11	ELECT	4.7uF 20% 50V
C407	1-130-481-00	MYLAR	0.0068uF 5% 50V
C408	1-136-163-00	FILM	0.068uF 5% 50V
C409	1-130-477-00	MYLAR	0.0033uF 5% 50V
C410	1-136-159-00	FILM	0.033uF 5% 50V
C452	1-126-022-11	ELECT	47uF 20% 16V
C454	1-126-022-11	ELECT	47uF 20% 16V
C455	1-162-211-31	CERAMIC	33PF 5% 50V
C456	1-126-163-11	ELECT	4.7uF 20% 50V
C457	1-130-481-00	MYLAR	0.0068uF 5% 50V
C458	1-136-163-00	FILM	0.068uF 5% 50V
C459	1-130-477-00	MYLAR	0.0033uF 5% 50V
C460	1-136-159-00	FILM	0.033uF 5% 50V
C504	1-126-023-11	ELECT	100uF 20% 25V
C505	1-126-022-11	ELECT	47uF 20% 25V
C506	1-110-335-11	MYLAR	100PF 5% 50V
C507	1-126-023-11	ELECT	100uF 20% 25V
C508	1-126-163-11	ELECT	4.7uF 20% 50V
C509	1-136-164-00	FILM	0.082uF 5% 50V
C511	1-136-159-00	FILM	0.033uF 5% 50V
C513	1-136-165-00	FILM	0.1uF 5% 50V
C514	1-136-153-00	FILM	0.01uF 5% 50V
C515	1-110-335-11	MYLAR	100PF 5% 50V

<p style="text-align: center;">TA-AV670/AV670G</p>	<p style="text-align: center;">TA-AV670/AV670G</p>	<p style="text-align: center;">TA-AV670/AV670G</p>
---	---	---

<p style="text-align: center;">TA-AV670/AV670G</p>	<p style="text-align: center;">TA-AV670/AV670G</p>	<p style="text-align: center;">TA-AV670/AV670G</p>
---	---	---

<p style="text-align: center;">TA-AV670/AV670G</p>	<p style="text-align: center;">TA-AV670/AV670G</p>	<p style="text-align: center;">TA-AV670/AV670G</p>
---	---	---

Ref. No.	Part No.	Description	Remark
< CONNECTOR >			
* CNE110	1-564-505-11	PLUG, CONNECTOR 2P	
* CNE111	1-564-505-11	PLUG, CONNECTOR 2P	
* CNE210	1-564-506-11	PLUG, CONNECTOR 3P	
* CNE211	1-564-506-11	PLUG, CONNECTOR 3P	
* CNE212	1-564-506-11	PLUG, CONNECTOR 3P	
* CNE213	1-564-506-11	PLUG, CONNECTOR 3P	
< IC >			
IC202	8-759-945-58	IC RC4558P	
IC402	8-759-945-58	IC RC4558P	
IC501	8-759-945-58	IC RC4558P	
< RESISTOR >			
R201	1-247-887-00	CARBON 220K 5% 1/4W	
R202	1-249-430-11	CARBON 12K 5% 1/4W	
R203	1-247-887-00	CARBON 220K 5% 1/4W	
R204	1-249-434-11	CARBON 27K 5% 1/4W	
R205	1-249-422-11	CARBON 2.7K 5% 1/4W	
R207	1-249-426-11	CARBON 5.6K 5% 1/4W	
R208	1-249-414-11	CARBON 560 5% 1/4W	
R251	1-247-887-00	CARBON 220K 5% 1/4W	
R252	1-249-430-11	CARBON 12K 5% 1/4W	
R253	1-247-887-00	CARBON 220K 5% 1/4W	
R254	1-249-434-11	CARBON 27K 5% 1/4W	
R255	1-249-422-11	CARBON 2.7K 5% 1/4W	
R257	1-249-426-11	CARBON 5.6K 5% 1/4W	
R258	1-249-414-11	CARBON 560 5% 1/4W	
R401	1-247-887-00	CARBON 220K 5% 1/4W	
R402	1-249-430-11	CARBON 12K 5% 1/4W	
R403	1-247-887-00	CARBON 220K 5% 1/4W	
R404	1-249-434-11	CARBON 27K 5% 1/4W	
R405	1-249-422-11	CARBON 2.7K 5% 1/4W	
R407	1-249-426-11	CARBON 5.6K 5% 1/4W	
R408	1-249-414-11	CARBON 560 5% 1/4W	
R451	1-247-887-00	CARBON 220K 5% 1/4W	
R452	1-249-430-11	CARBON 12K 5% 1/4W	
R453	1-247-887-00	CARBON 220K 5% 1/4W	
R454	1-249-434-11	CARBON 27K 5% 1/4W	
R455	1-249-422-11	CARBON 2.7K 5% 1/4W	
R457	1-249-426-11	CARBON 5.6K 5% 1/4W	
R458	1-249-414-11	CARBON 560 5% 1/4W	
R504	1-247-887-00	CARBON 220K 5% 1/4W	
R505	1-249-421-11	CARBON 2.2K 5% 1/4W	
R506	1-247-889-00	CARBON 270K 5% 1/4W	
R507	1-249-418-11	CARBON 1.2K 5% 1/4W	
R508	1-249-441-11	CARBON 100K 5% 1/4W	
R509	1-249-423-11	CARBON 3.3K 5% 1/4W	

Ref. No.	Part No.	Description	Remark
R510	1-249-422-11	CARBON 2.7K 5% 1/4W	
R512	1-249-410-11	CARBON 270 5% 1/4W	
R514	1-247-832-11	CARBON 1.1K 5% 1/4W	
R519	1-249-433-11	CARBON 22K 5% 1/4W	
< VARIABLE RESISTOR >			
RV202	1-237-885-11	RES, VAR, CARBON 100K/100K(REAR BASS)	
RV203	1-237-885-11	RES, VAR, CARBON 100K/100K(REAR TREBLE)	
RV402	1-237-885-11	RES, VAR, CARBON 100K/100K(FRONT BASS)	
RV403	1-237-885-11	RES, VAR, CARBON 100K/100K(FRONT TREBLE)	
RV404	1-237-886-11	RES, VAR, CARBON 100K/100K(BALANCE)	
RV501	1-241-252-11	RES, VAR, CARBON 20K/20K(BASS)	
RV502	1-241-253-11	RES, VAR, CARBON 20K/20K(MTD)	
RV503	1-241-253-11	RES, VAR, CARBON 20K/20K(CENTER)	

* 1-641-039-11	VIDEO 5 BOARD	*****	
< CAPACITOR >			
C749	1-164-159-11	CERAMIC 0.1uF 50V	
< CONNECTOR >			
* CNE205	1-564-518-11	PLUG, CONNECTOR 3P	
* CNJ20	1-564-520-11	PLUG, CONNECTOR 5P	
< JACK >			
J501	1-537-115-31	TERMINAL BOARD (VIDEO 5 INPUT)	
< RESISTOR >			
R147	1-249-417-11	CARBON 1K 5% 1/4W	
R197	1-249-417-11	CARBON 1K 5% 1/4W	

* A-4345-957-A	VIDEO BOARD, COMPLETE	*****	
< CAPACITOR >			
C701	1-124-471-00	ELECT 1000uF 20% 6.3V	
C702	1-124-471-00	ELECT 1000uF 20% 6.3V	
C703	1-124-471-00	ELECT 1000uF 20% 6.3V	
C704	1-124-471-00	ELECT 1000uF 20% 6.3V	
C709	1-124-907-11	ELECT 10uF 20% 50V	
C710	1-124-907-11	ELECT 10uF 20% 50V	
C711	1-161-379-00	CERAMIC 0.01uF 20% 25V	
C712	1-161-379-00	CERAMIC 0.01uF 20% 25V	
C713	1-161-379-00	CERAMIC 0.01uF 20% 25V	
C714	1-136-165-00	FILM 0.1uF 5% 50V	
C715	1-136-165-00	FILM 0.1uF 5% 50V	

VIDEO

Ref. No.	Part No.	Description	Remark	Ref. No.	Part No.	Description	Remark
C716	1-136-165-00	FILM	0.1uF 5% 50V	J706	1-566-847-21	CONNECTOR, (S) TERMINAL 4P (MONITOR)	
C717	1-124-471-00	ELECT	1000uF 20% 6.3V	J707	1-566-846-21	CONNECTOR, (S) TERMINAL 4P (VIDEO 1)	
C718	1-124-471-00	ELECT	1000uF 20% 6.3V	J708	1-566-846-21	CONNECTOR, (S) TERMINAL 4P (VIDEO 1)	
C719	1-124-471-00	ELECT	1000uF 20% 6.3V	J709	1-566-846-21	CONNECTOR, (S) TERMINAL 4P (VIDEO 2)	
C720	1-124-907-11	ELECT	10uF 20% 50V	J710	1-566-846-21	CONNECTOR, (S) TERMINAL 4P (VIDEO 2)	
C721	1-124-907-11	ELECT	10uF 20% 50V	J711	1-566-846-21	CONNECTOR, (S) TERMINAL 4P (VIDEO 4)	
C724	1-136-165-00	FILM	0.1uF 5% 50V	J712	1-566-846-21	CONNECTOR, (S) TERMINAL 4P (LD)	
C725	1-124-907-11	ELECT	10uF 20% 50V			< COIL >	
C726	1-124-907-11	ELECT	10uF 20% 50V	L701	1-410-977-11	INDUCTOR 100uH	
C727	1-161-379-00	CERAMIC	0.01uF 20% 25V	L702	1-410-977-11	INDUCTOR 100uH	
C728	1-161-379-00	CERAMIC	0.01uF 20% 25V	L703	1-410-977-11	INDUCTOR 100uH	
C730	1-126-101-11	ELECT	100uF 20% 16V	L704	1-410-977-11	INDUCTOR 100uH	
C731	1-126-101-11	ELECT	100uF 20% 16V			< TRANSISTOR >	
C732	1-126-101-11	ELECT	100uF 20% 16V	Q703	8-729-119-76	TRANSISTOR 2SA1175-HFE	
C733	1-126-101-11	ELECT	100uF 20% 16V	Q704	8-729-119-76	TRANSISTOR 2SA1175-HFE	
C734	1-124-907-11	ELECT	10uF 20% 50V	Q705	8-729-119-76	TRANSISTOR 2SA1175-HFE	
C736	1-126-101-11	ELECT	100uF 20% 16V	Q706	8-729-900-74	TRANSISTOR DTC143TS	
C740	1-126-101-11	ELECT	100uF 20% 16V	Q707	8-729-900-74	TRANSISTOR DTC143TS	
C745	1-162-294-31	CERAMIC	0.001uF 10% 50V	Q708	8-729-900-74	TRANSISTOR DTC143TS	
C746	1-161-379-00	CERAMIC	0.01uF 20% 25V	Q709	8-729-119-76	TRANSISTOR 2SA1175-HFE	
C747	1-161-379-00	CERAMIC	0.01uF 20% 25V	Q710	8-729-119-76	TRANSISTOR 2SA1175-HFE	
C795	1-124-925-11	ELECT	2.2uF 20% 100V	Q711	8-729-119-76	TRANSISTOR 2SA1175-HFE	
		< CONNECTOR >		Q712	8-729-119-76	TRANSISTOR 2SA1175-HFE	
* CND809	1-564-340-00	PIN, CONNECTOR 6P		Q713	8-729-620-05	TRANSISTOR 2SC2603-EF	
* CND816	1-564-339-71	PIN, CONNECTOR 5P		Q715	8-729-620-05	TRANSISTOR 2SC2603-EF	
* CNE105	1-564-505-11	PLUG, CONNECTOR 2P				< RESISTOR >	
* CNE206	1-564-506-11	PLUG, CONNECTOR 3P		R701	1-249-403-11	CARBON 68 5% 1/4W	
		< DIODE >		R702	1-247-804-11	CARBON 75 5% 1/4W	
D701	8-719-987-63	DIODE 1N4148M		R703	1-247-804-11	CARBON 75 5% 1/4W	
D702	8-719-987-63	DIODE 1N4148M		R704	1-247-804-11	CARBON 75 5% 1/4W	
D703	8-719-987-63	DIODE 1N4148M		R705	1-247-804-11	CARBON 75 5% 1/4W	
		< IC >		R706	1-247-804-11	CARBON 75 5% 1/4W	
IC701	8-759-805-14	IC LC7822		R707	1-247-804-11	CARBON 75 5% 1/4W	
IC702	8-759-805-14	IC LC7822		R708	1-247-804-11	CARBON 75 5% 1/4W	
IC703	8-759-037-42	IC MC14576AP		R709	1-249-403-11	CARBON 68 5% 1/4W	
IC704	8-759-805-15	IC LC7823		R710	1-249-403-11	CARBON 68 5% 1/4W	
IC705	8-759-805-15	IC LC7823		R711	1-249-403-11	CARBON 68 5% 1/4W	
IC706	8-759-037-42	IC MC14576AP		R713	1-249-429-11	CARBON 10K 5% 1/4W	
IC707	8-759-037-42	IC MC14576AP		R714	1-249-429-11	CARBON 10K 5% 1/4W	
		< JACK >		R715	1-249-429-11	CARBON 10K 5% 1/4W	
J701	1-565-319-91	JACK, PIN 2P (MONITOR/VIDEO1)		R717	1-249-429-11	CARBON 10K 5% 1/4W	
J702	1-565-319-91	JACK, PIN 2P (VIDEO 1/2)		R720	1-249-413-11	CARBON 470 5% 1/4W	
J703	1-565-319-91	JACK, PIN 2P (VIDEO 2/3)		R721	1-249-413-11	CARBON 470 5% 1/4W	
J704	1-565-319-91	JACK, PIN 2P (VIDEO 3/4)		R722	1-249-413-11	CARBON 470 5% 1/4W	
J705	1-565-319-91	JACK, PIN 2P (TV/BS, LD)		R727	1-249-421-11	CARBON 2.2K 5% 1/4W	
				R729	1-249-421-11	CARBON 2.2K 5% 1/4W	

VIDEO VOL

Ref.No.	Part No.	Description	Remark
R731	1-249-421-11	CARBON	2. 2K 5% 1/4W
R733	1-249-428-11	CARBON	8. 2K 5% 1/4W
R735	1-249-403-11	CARBON	68 5% 1/4W
R736	1-249-403-11	CARBON	68 5% 1/4W
R737	1-249-403-11	CARBON	68 5% 1/4W
R738	1-249-403-11	CARBON	68 5% 1/4W
R739	1-249-403-11	CARBON	68 5% 1/4W
R740	1-249-403-11	CARBON	68 5% 1/4W
R741	1-247-804-11	CARBON	75 5% 1/4W
R742	1-247-804-11	CARBON	75 5% 1/4W
R743	1-247-804-11	CARBON	75 5% 1/4W
R744	1-247-804-11	CARBON	75 5% 1/4W
R745	1-247-804-11	CARBON	75 5% 1/4W
R746	1-247-804-11	CARBON	75 5% 1/4W
R747	1-247-804-11	CARBON	75 5% 1/4W
R748	1-247-804-11	CARBON	75 5% 1/4W
R749	1-247-804-11	CARBON	75 5% 1/4W
R750	1-247-804-11	CARBON	75 5% 1/4W
R751	1-249-429-11	CARBON	10K 5% 1/4W
R752	1-249-429-11	CARBON	10K 5% 1/4W
R753	1-249-429-11	CARBON	10K 5% 1/4W
R754	1-249-429-11	CARBON	10K 5% 1/4W
R755	1-249-429-11	CARBON	10K 5% 1/4W
R756	1-249-429-11	CARBON	10K 5% 1/4W
R757	1-249-413-11	CARBON	470 5% 1/4W
R758	1-249-413-11	CARBON	470 5% 1/4W
R759	1-249-413-11	CARBON	470 5% 1/4W
R760	1-249-413-11	CARBON	470 5% 1/4W
R763	1-249-405-11	CARBON	100 5% 1/4W
R765	1-249-405-11	CARBON	100 5% 1/4W
R767	1-249-405-11	CARBON	100 5% 1/4W
R769	1-249-405-11	CARBON	100 5% 1/4W
R772	1-249-422-11	CARBON	2. 7K 5% 1/4W
R773	1-249-441-11	CARBON	100K 5% 1/4W
R774	1-249-441-11	CARBON	100K 5% 1/4W
R775	1-249-441-11	CARBON	100K 5% 1/4W
R776	1-249-428-11	CARBON	8. 2K 5% 1/4W
R777	1-249-425-11	CARBON	4. 7K 5% 1/4W
R778	1-249-422-11	CARBON	2. 7K 5% 1/4W
R780	1-249-439-11	CARBON	68K 5% 1/4W
R781	1-247-887-00	CARBON	220K 5% 1/4W
R782	1-247-887-00	CARBON	220K 5% 1/4W
R783	1-247-887-00	CARBON	220K 5% 1/4W
R784	1-247-895-00	CARBON	470K 5% 1/4W
R785	1-247-895-00	CARBON	470K 5% 1/4W
R786	1-247-700-11	CARBON	100 5% 1/4W
R787	1-249-429-11	CARBON	10K 5% 1/4W
R788	1-249-429-11	CARBON	10K 5% 1/4W
R789	1-249-413-11	CARBON	470 5% 1/4W

Ref.No.	Part No.	Description	Remark
R790	1-249-413-11	CARBON	470 5% 1/4W
R791	1-249-413-11	CARBON	470 5% 1/4W

*	A-4345-742-A	VOL BOARD, COMPLETE	*****
< CAPACITOR >			
C550	1-110-335-11	MYLAR	100PF 5% 50V
C551	1-110-335-11	MYLAR	100PF 5% 50V
C552	1-124-994-11	ELECT	100uF 20% 10V
C553	1-126-163-11	ELECT	4. 7uF 20% 50V
C554	1-126-163-11	ELECT	4. 7uF 20% 50V
C555	1-126-163-11	ELECT	4. 7uF 20% 50V
< CONNECTOR >			
* CND811	1-506-503-11	PIN, CONNECTOR	
* CNE214	1-564-506-11	PLUG, CONNECTOR 3P	
* CNE703	1-564-507-11	PLUG, CONNECTOR 4P	
* CNJ22	1-564-508-11	PLUG, CONNECTOR 5P	
* CNJ23	1-564-509-11	PLUG, CONNECTOR 6P	
* CNJ32	1-564-511-11	PLUG, CONNECTOR 8P	
* CNP711	1-564-704-11	PIN, CONNECTOR (SMALL TYPE) 2P	
< DIODE >			
D550	8-719-987-63	DIODE	1N4148M
D551	8-719-200-02	DIODE	10E2
D552	8-719-301-38	LED	SEL2210S-C (MASTER VOLUME)
< IC >			
IC550	8-759-820-11	IC	LC7535
IC551	8-759-945-58	IC	RC4558P
IC552	8-759-710-59	IC	NJM4580D-D
IC553	8-759-945-58	IC	RC4558P
IC555	8-759-820-11	IC	LC7535
IC556	8-759-820-62	IC	LB1639
< TRANSISTOR >			
Q550	8-729-900-80	TRANSISTOR	DTC114ES
Q551	8-729-900-80	TRANSISTOR	DTC114ES
< RESISTOR >			
R550	1-259-458-11	CARBON	18K 5% 1/6W
R551	1-259-430-11	CARBON	1. 2K 5% 1/6W
R552	1-259-430-11	CARBON	1. 2K 5% 1/6W
R553	1-259-452-11	CARBON	10K 5% 1/6W
R554	1-259-452-11	CARBON	10K 5% 1/6W
R555	1-259-430-11	CARBON	1. 2K 5% 1/6W

VOL

Ref.No.	Part No.	Description	Remark
R560	1-249-411-11	CARBON 330 5% 1/4W < VARIABLE RESISTOR >	
RV550	1-241-254-12	RES, VAR, CARBON 20KX5 (MASTER VOLUME) < RELAY >	
RY550	1-515-614-11	RELAY	

		MISCELLANEOUS *****	
△113	1-569-007-11	ADAPTER, CONVERSION 2P (E)	
△114	1-559-272-21	CORD, POWER (UK)	
△114	1-559-297-31	CODE, POWER (E)	
△114	1-559-479-11	CORD, POWER (US, Canadian)	
△114	1-574-383-11	CORD, POWER (AEP) (AE2)	
△114	1-575-953-11	CORD, POWER (AE1)	
△F902	1-532-350-00	FUSE, TIME-LAG (AEP, UK, E)	
△F902	1-532-746-11	FUSE, GLASS TUBE (US, Canadian)	
△F903	1-532-350-00	FUSE, TIME-LAG (AEP, UK, E)	
△F903	1-532-746-11	FUSE, GLASS TUBE (US, Canadian)	
△T902	1-423-423-11	TRANSFORMER, POWER (Canadian)	
△T902	1-450-509-11	TRANSFORMER, POWER (E)	
△T902	1-450-561-11	TRANSFORMER, POWER (US)	
△T902	1-450-909-11	TRANSFORMER, POWER (AEP, UK)	

		ACCESSORIES & PACKING MATERIALS *****	
	1-465-900-11	REMOTE COMMANDER (RM-P651)	
	3-752-315-11	MANUAL, INSTRUCTION (AEP, UK) (ENGLISH/FRENCH/SPANISH/PORTUGUESE)	
	3-752-315-21	MANUAL, INSTRUCTION (US, Canadian, E) (ENGLISH)	
	3-752-315-31	MANUAL, INSTRUCTION (Canadian) (FRENCH)	
	3-752-315-41	MANUAL, INSTRUCTION (AEP) (GERMAN/DUTCH/SWEDISH/ITALIAN)	
	3-752-315-51	MANUAL, INSTRUCTION (E) (CHINESE)	
	3-752-315-61	MANUAL, INSTRUCTION (AEP) (DANISH/FINNISH)	
	4-847-802-00	SCREW (US, Canadian, AEP, E)	
*	4-927-854-01	CUSHION (UK)	
*	4-933-001-01	CUSHION (US, Canadian, AEP, E)	
*	4-951-600-01	INDIVIDUAL CARTON (US, Canadian, AEP)	
*	4-951-601-01	INDIVIDUAL CARTON (UK)	
*	4-952-059-01	INDIVIDUAL CARTON (E)	
	9-910-999-33	INSTRUCTION (US)	

Ref.No.	Part No.	Description	Remark

HARDWARE LIST			

#1	7-682-547-09	SCREW +BV 3X6, S TIGHT	
#2	7-685-647-79	SCREW +BVTP 3X10 TYPE2 N-S	
#3	7-685-234-19	SCREW +KTP 2.6X8 TYPE2NON-SLIT	
#4	7-685-873-09	SCREW +BVTT 3X10 (S)	
#5	7-682-548-09	SCREW +B 3X8	
#6	7-685-648-79	SCREW +BVTP 3X12 TYPE2 IT-3	
#7	7-685-649-79	SCREW +BVTP 3X14 TYPE2 SLIT (AEP, UK, E)	
#8	7-685-152-19	SCREW +P 3X25 TYPE2 SLIT (US, Canadian)	
#9	7-684-024-04	N 4, TYPE 2	
#10	7-682-550-09	SCREW +BVTT 3X12 (S)	
#11	7-682-567-09	SCREW +B 4X25	
#12	7-621-849-00	SCREW (BV/RING)	
#13	7-682-551-09	SCREW +BVTT 3X14 (S)	
#14	7-682-554-09	SCREW +BVTT 3X25 (S)	
#15	7-685-646-79	SCREW +BVTP 3X8 TYPE2 IT-3	
#16	7-685-547-19	SCREW +BVTP 3X10 (US, E)	
#17	7-682-548-04	SCREW +BVTT 3X8 (S)	

The components identified by mark **△** or dotted line with mark **△** are critical for safety. Replace only with part number specified.

Les composants identifiés par une marque **△** sont critiques pour la sécurité. Ne les remplacer que par une pièce portant le numéro spécifié.