

# TA-3120

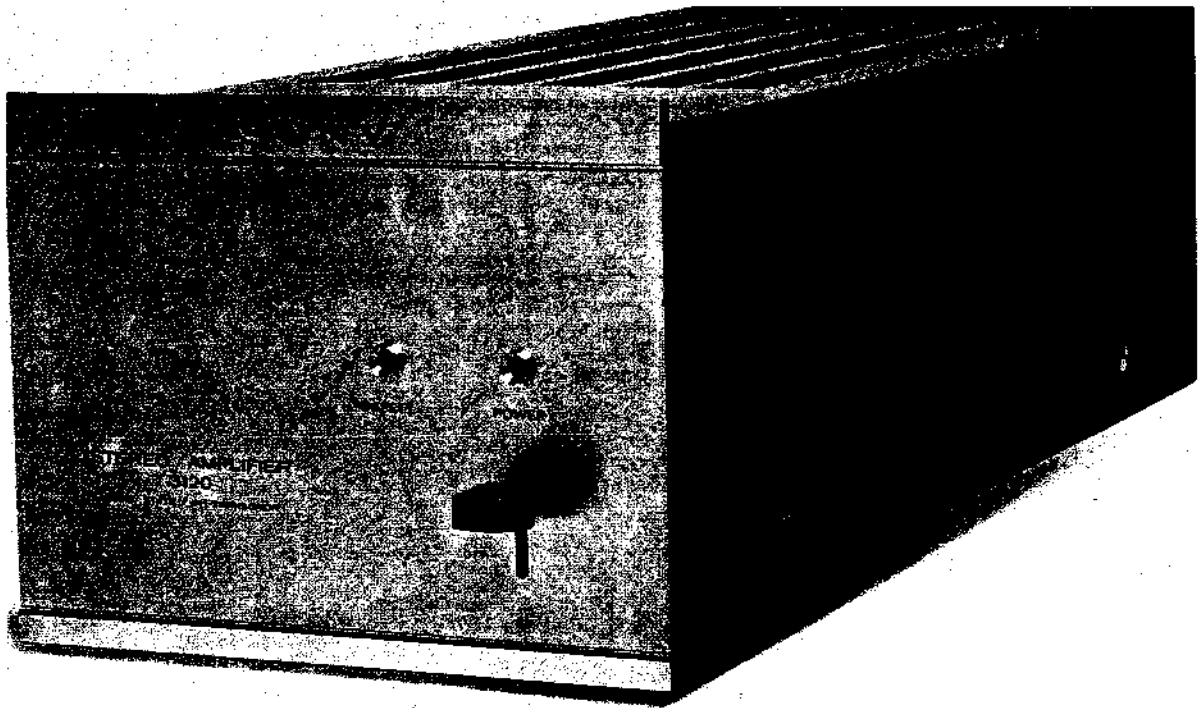

## Specifications (1)

**System:** All Silicon Transistor stereo amplifier

**Circuit:** Quasi-complementary symmetry circuit

**Transistor:** 2SC401 (4), 2SC293 (2), 2SC299 (5), 2SD45 (8), 2SA527 (2)

**Diode:** DS2M (4), S2C (2), 1T206 (10), SV6 (4), 2SF-103 (SCR) (1)

**Power requirement:** AC 100, 117, 220, 240V, 50/60 Hz

**Power consumption:** Approx. 30W at zero signal  
Approx. 250W at rated output

**Dimension:** 180 (W) × 145 (H) × 445mm (D) (7 $\frac{1}{8}$  × 5 $\frac{3}{4}$  × 17 $\frac{1}{2}$ " )

**Weight:** Approx. 8 kgs. (17 lbs, 10 ozs.)

**SONY®**  
**SERVICING GUIDE**

## Specifications (2)

- Power output:** Non-clip music power: 160W both channels (8 ohms)  
 Music power(IHFM) : 120W both channels (8 ohms)  $\pm 0.5$  db  
 Rated output : 50W per channel (8 ohms)  $\pm 0.5$  db  
 35W per channel (16 ohms)  $\pm 0.5$  db
- Harmonic distortion:** At 1 KHz: Less than 0.1% at rated output  
 Less than 0.07% at 25W output  
 Less than 0.05% at 500mW output  
 At 20 Hz - 80 KHz: Less than 0.5% at rated output.
- Intermodulation distortion:** Less than 0.3% at rated output, 70 Hz : 7 KHz 4 : 1 (SMPTE)
- Frequency response:** Normal: 30 Hz - 100 KHz  $+0$   $-1$  db at rated output  
 Test : 10 Hz - 100 KHz  $+0$   $-1$  db at rated output
- S/N:** Closed circuit 110 db (IHFM)  
 \*through weighted network as per ASAZ 24.3 - 1944 (40 db-A)
- Input impedance:** More than 100 k ohms
- Damping factor:** More than 70 at 1 KHz (8 ohms load)
- Sensitivity:** 1V for 50W output
- Rear panel facilities:** Input level adjusting screws (semi-fixed)  
 Low-cut filter switch  
 Input (2) : Phono type jacks. Accept outputs from Preamplifier  
 Output (4) : Speaker terminals. Match speakers having 8 - 16 ohm impedance  
 Grounding terminal  
 AC outlet: Switched (2)  
 Unswitched (1)

TA-3120

BLOCK DIAGRAM

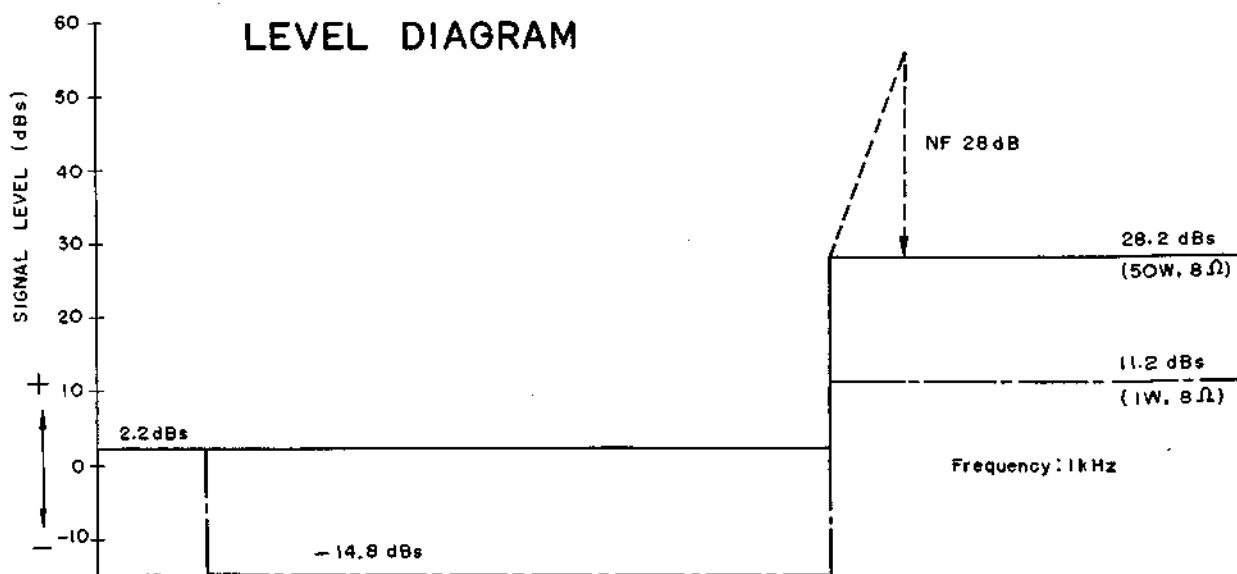
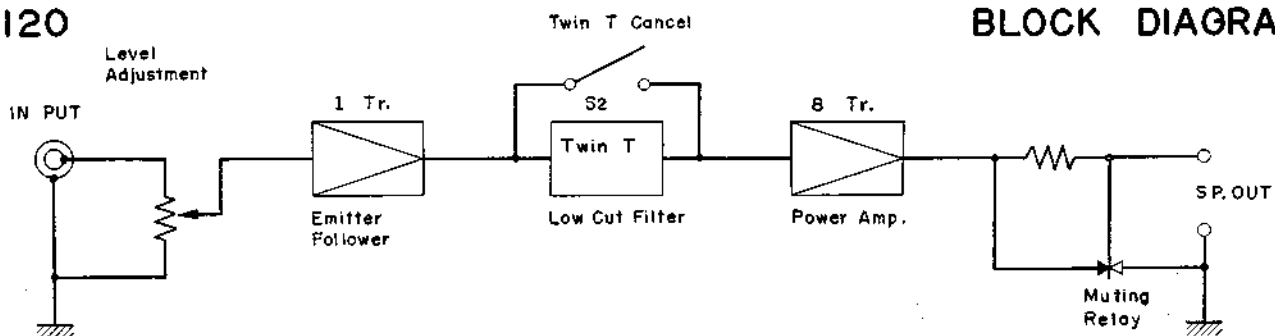

## **Warm-up Time for TA-3120**

Stereo integrated amplifier TA-3120 which have been in stock or not used for a long time, it takes several minutes to start operation after Power Switch is set on for the first time.

It is due to Electrolytic Capacitor in the Muting Relay Circuit which serves to give proper time-lag (usually 6-7 seconds) to the Amplifier.

When Electrolytic Capacitor is left unused, leakage current value increases and it takes much more time than usual for Electrolytic Capacitor to charge up to normal voltage.

It gives no affect to the natural performance of Amplifier itself.

Upon the reports so far received and the result of investigation, attention should be paid to the following points.

1. It dose not engender excessive time-lag to leave the unit unused for about one month.
2. It takes 2 or 3 minutes at longest to start operation, however only one set took 10 minutes in very rare case.

We hope you will take this phenomena in throughly, especially when you set Power Switch on in customer's presence for the first time.

### **Notes:**

To simplify the discussions, only Channel "1" be described. Channel "2" is identical.

## Method of Disassembling the Set

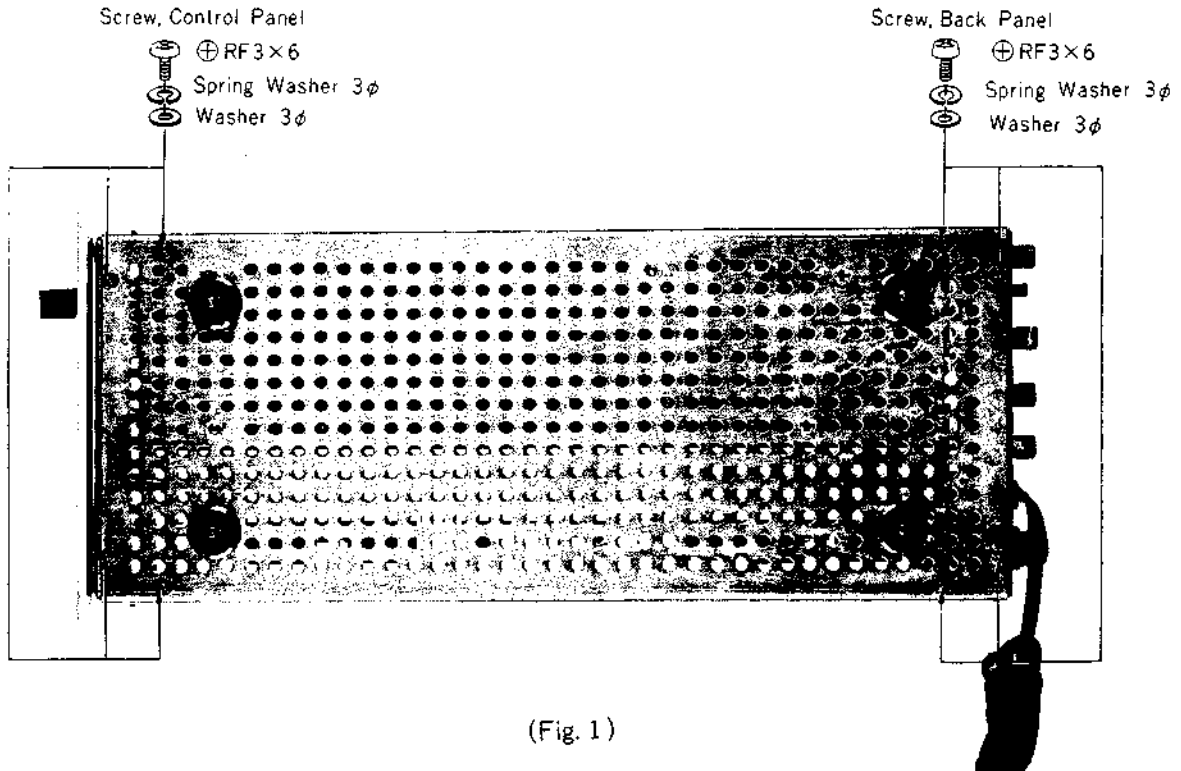

Removal of power amplifier and power supply block.

- (a) Remove the four machine screws from both side of the cabinet to take off the chassis cover, then remove the four screws from the bottom of the chassis to release the back panel section as shown in fig. 1.

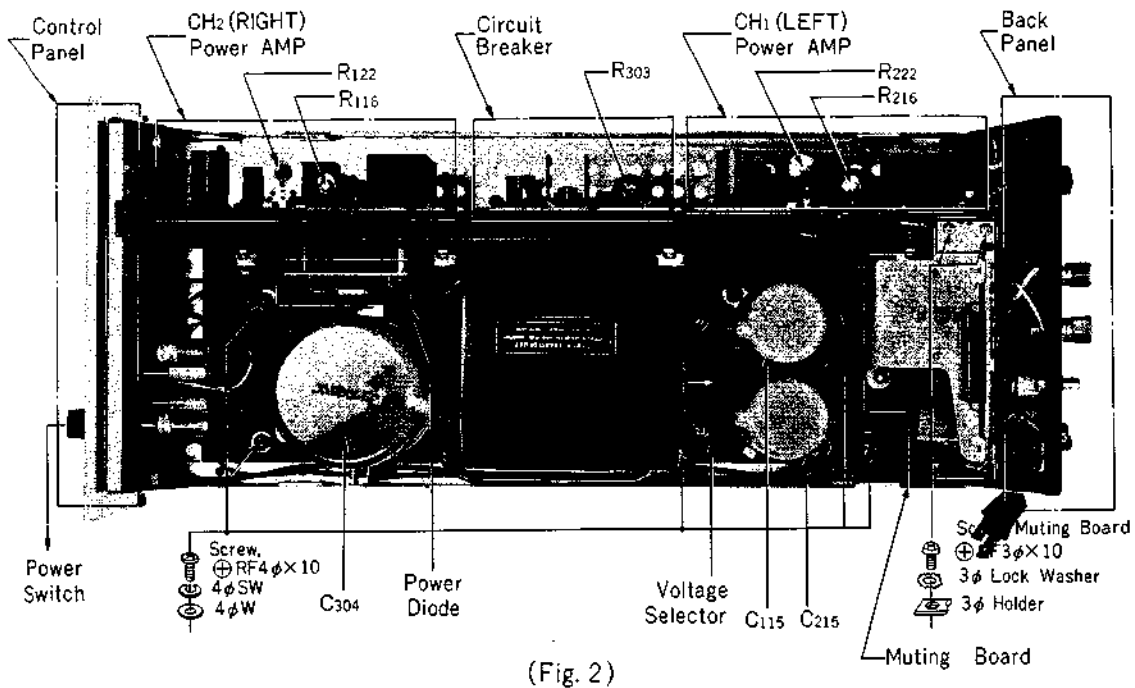

- (b) Remove the five screws, RF 4  $\phi$   $\times$  10 from chassis, fig.2, so you can turn that block to make the circuit board up as shown in fig. 3.

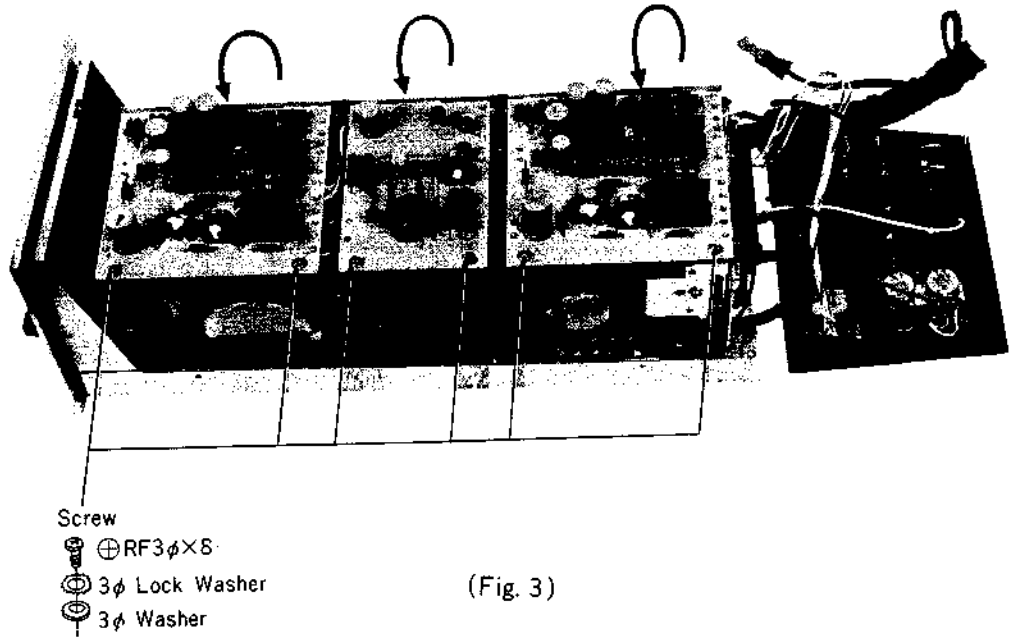

(Fig. 3)

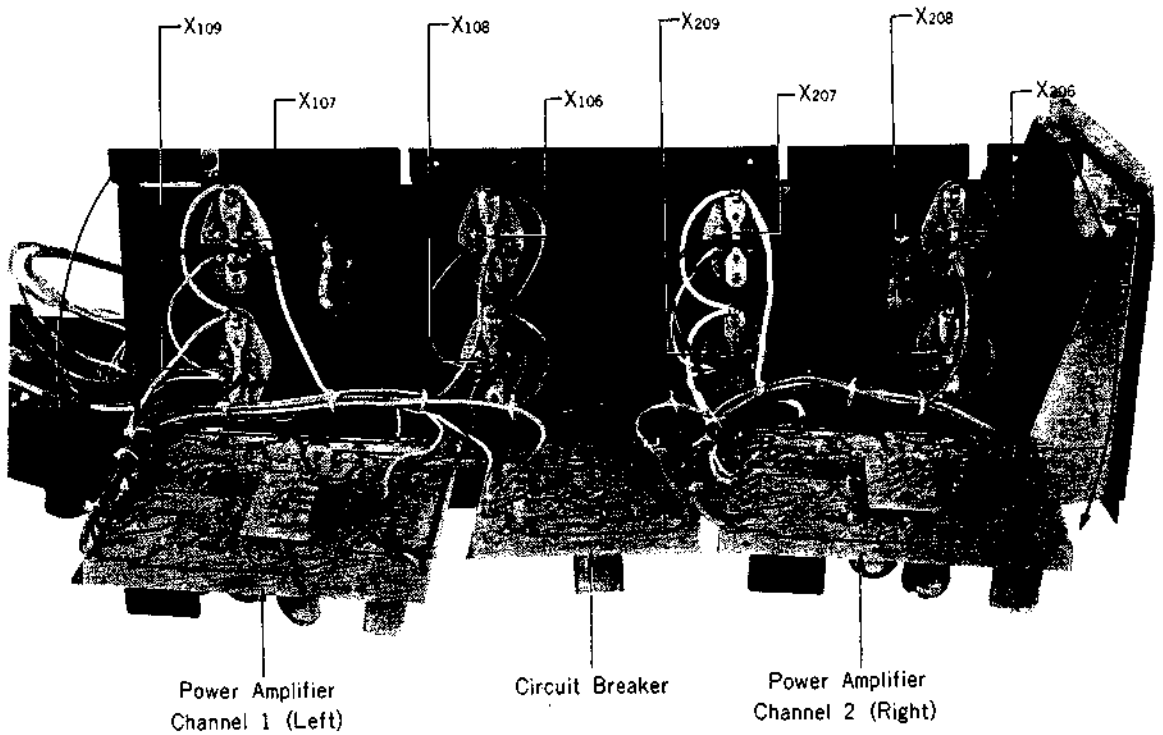

(Fig. 4)

(c) In checking the circuit board, removal of screws, RF 3 φ × 8, is recommended for your convenience, as shown in fig. 3, fig. 4.

# ADJUSTMENT

## Preparation for adjustment

- \*Voltage Selector Plug : Insert the Plug so that the top arrow mark of the plug points to the proper voltage figure.
- \*DC Balance Control (R122, 222) : Turn clockwise to the full.
- \*Compensation Diode : Check that the Diode is attached to heat sink.
- \*Load for output : Connect an 8 ohms/50w resistor instead of Speaker.
- \*Fuse : Set a 5A Fuse.

### (A) AC Balance Adjustment

1. Connect an oscilloscope and V.T.V.M. across the 8 ohms load resistor.
2. Feed an 1 kHz signal to the input terminal through the attenuator and increase the signal gradually as shown in Fig. 1.

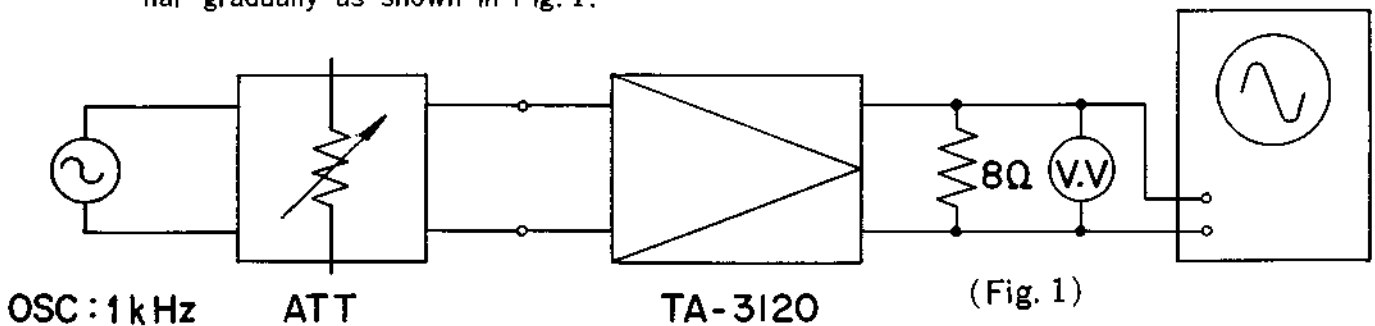

3. When the wave form on the oscilloscope is slightly clipped, adjust 50K ohms potentiometer (R116, 216) so that the both upper side and lower side of wave form are clipped at the same time as shown in Fig. 2.

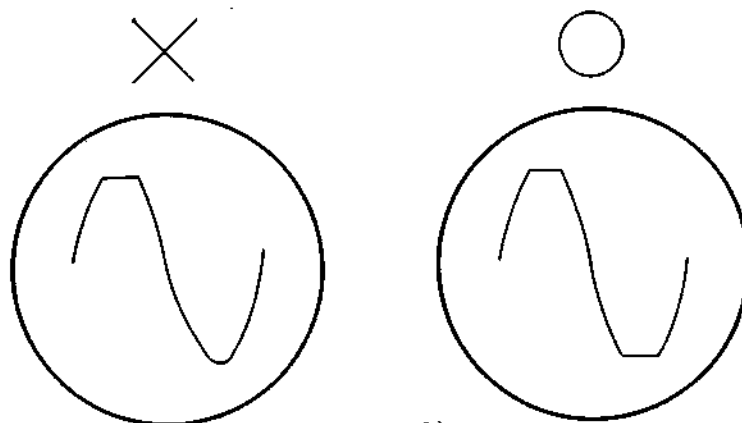

4. Make the above procedures on both channels.

(B) Current Adjustment at Zero Signal

1. Adjust the input signal to zero (less than  $-59$  dBs.)
2. Connect voltmeter (multitester) across the 0.5 ohms resistor (R135, 136, 235, 236).
3. Adjust the 200 ohms adjustable resistor (R122, 222) to obtain 25mV reading on the Voltmeter.
4. Repeat the above (A) adjustment.

(C) Circuit Breaker Adjustment

Make it a rule to adjust the circuit breaker block after repairing it, before connect it to amplifier.

1. Turn the 200 ohms adjustable resistor (R301) counterclockwise to the full.
2. Supply DC 2V  $\pm 0.02$ V through D15 and D16 respectively.
3. Supply 85V between B+ and E.
4. Connect the voltmeter across the B-out and E.
5. Turn the 200 ohms adjustable resistor (R301) clockwise, and fix it when the voltmeter indicates 0V on the dial.

**The Other Items for Confirmation :**

1. The operation time of relay will be less than 15 sec., at first, and the next time it will be less than 10~4 sec. after power switch is on, turned. The difference of time between channel "1" and channel "2" should be less than 10 sec.
2. Phase of both channels must be same.
3. The difference of output level between channel "1" and channel "2" must be less than 2 dB., when the input level control knob set to maximum level position.
4. Output level should be decreased to 0 with the input level control knob.
5. When short circuit of the speaker output, the circuit breaker must work perfectly.

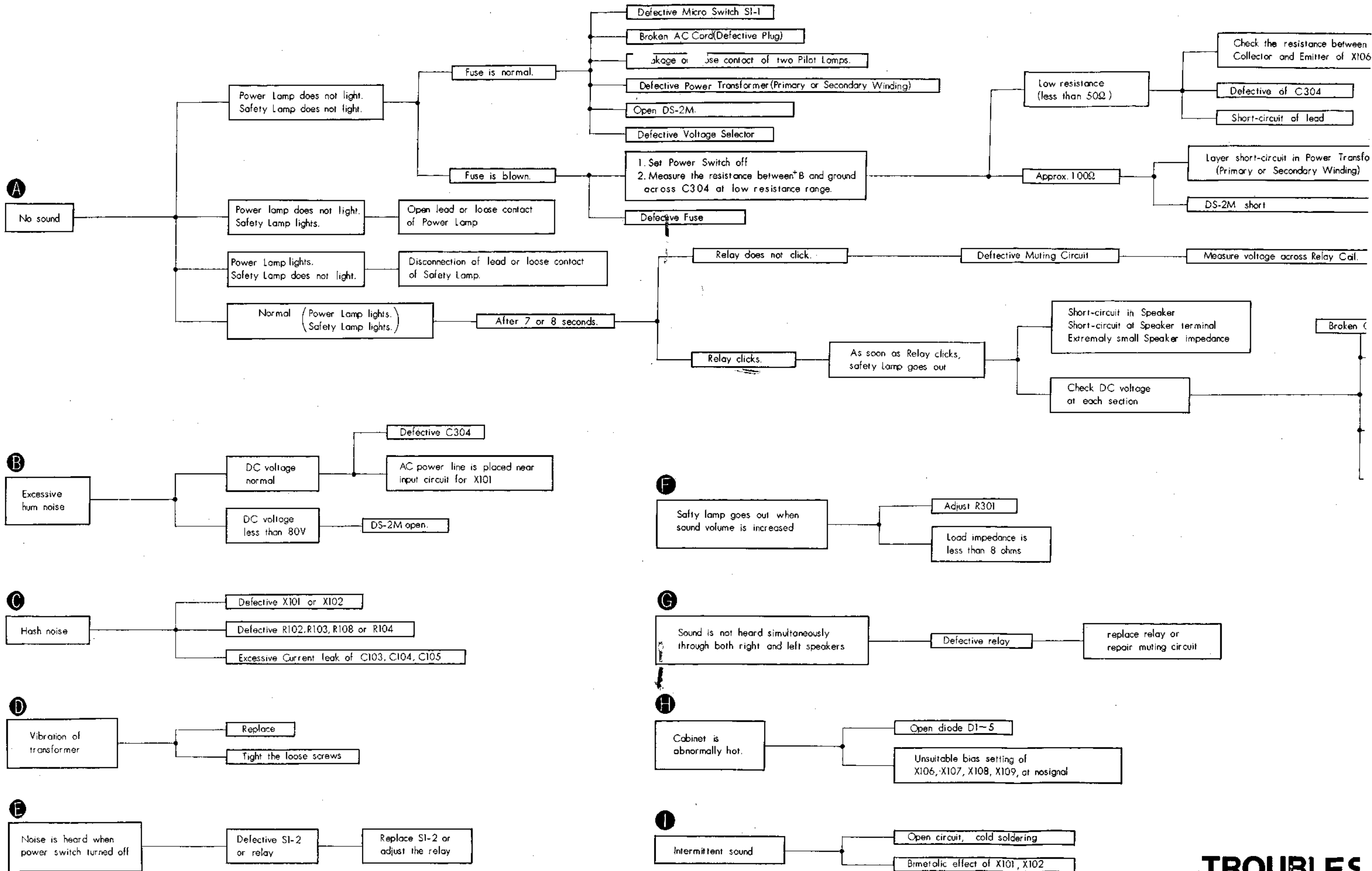



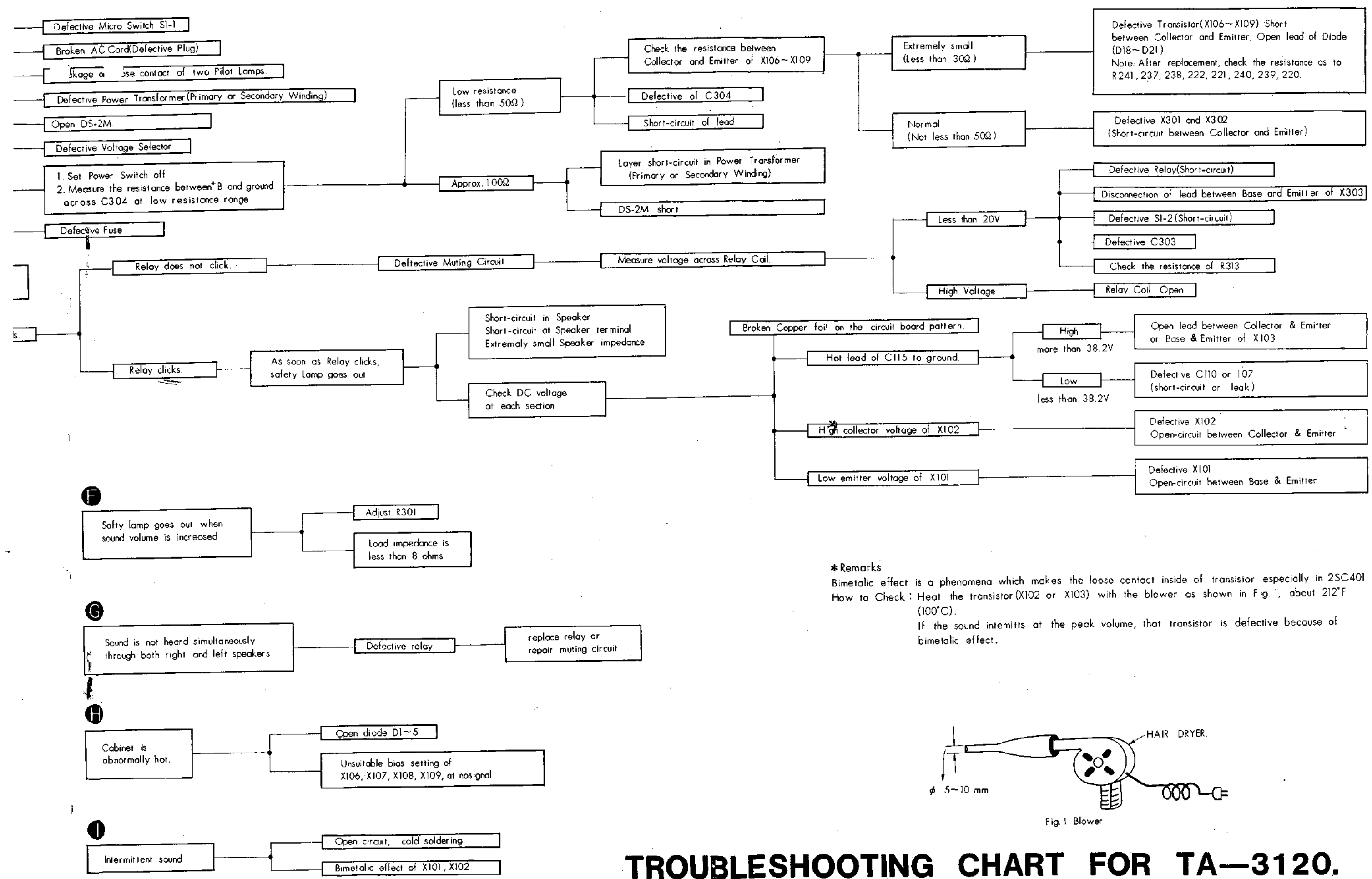

**\*Remarks**  
 Bimetalic effect is a phenomena which makes the loose contact inside of transistor especially in 2SC401  
 How to Check: Heat the transistor (X102 or X103) with the blower as shown in Fig. 1, about 212°F (100°C).  
 If the sound intermits at the peak volume, that transistor is defective because of bimetalic effect.

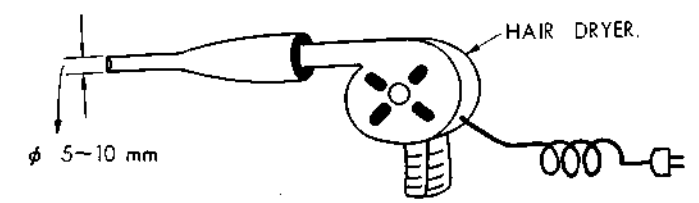
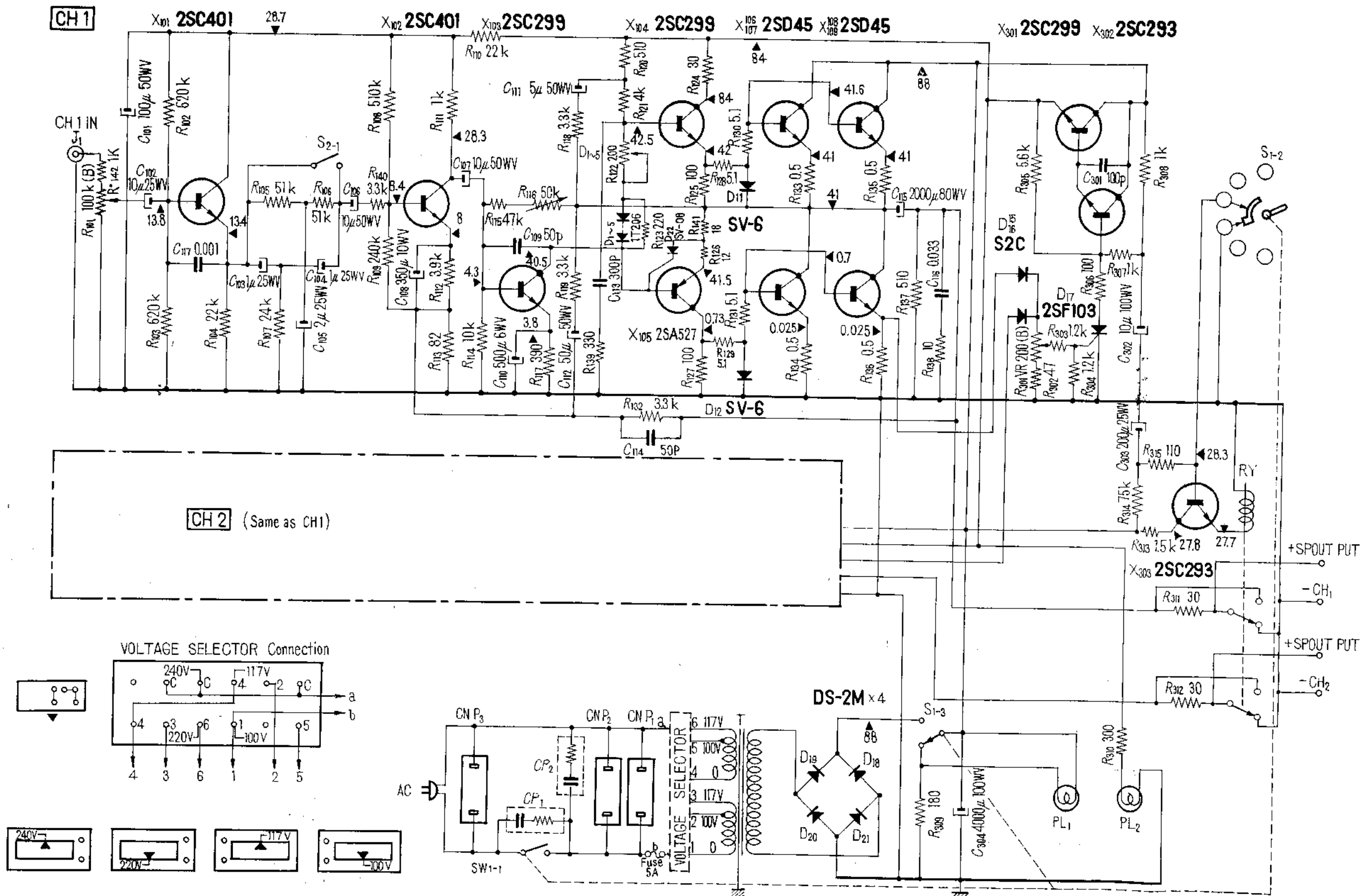

Fig. 1 Blower

# TROUBLESHOOTING CHART FOR TA-3120.

# Schematic Diagram of TA-3120



The voltages shown above are at zero signal

# Power Amplifier Section

— Conductor Side —

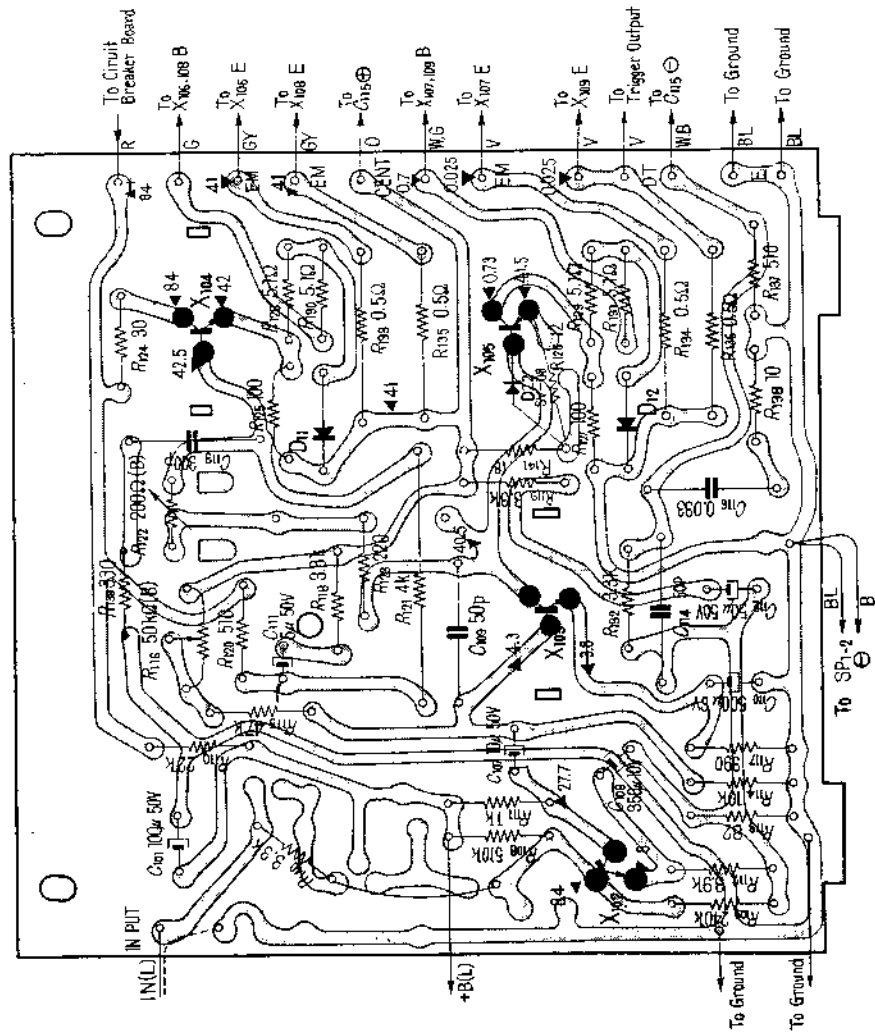

— Components Side —

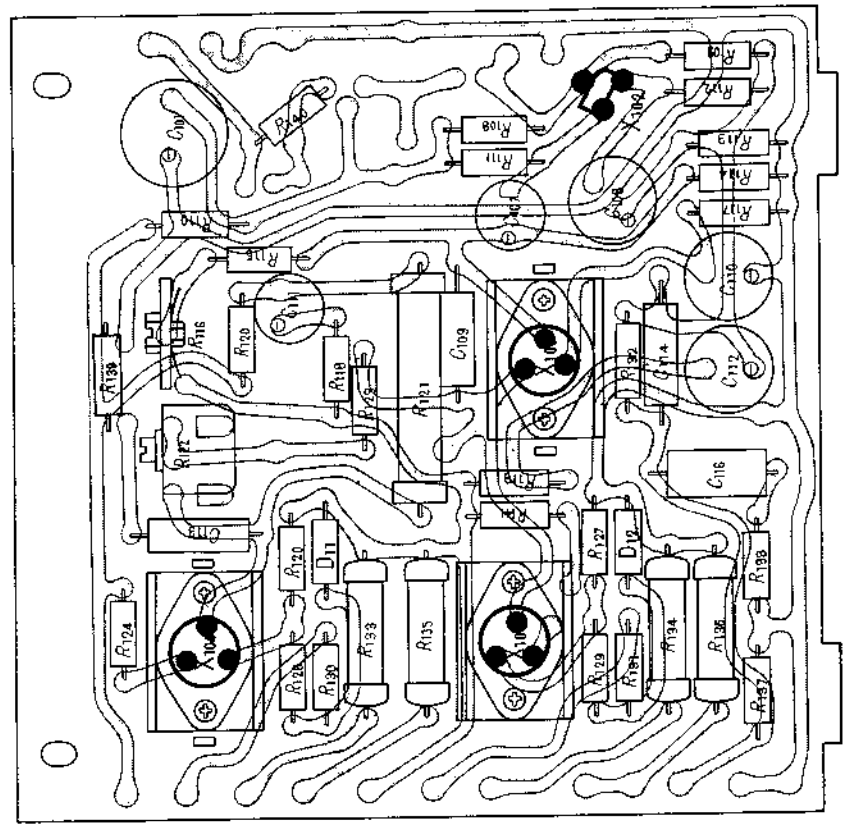

# Rectifier Section

— Conductor Side —

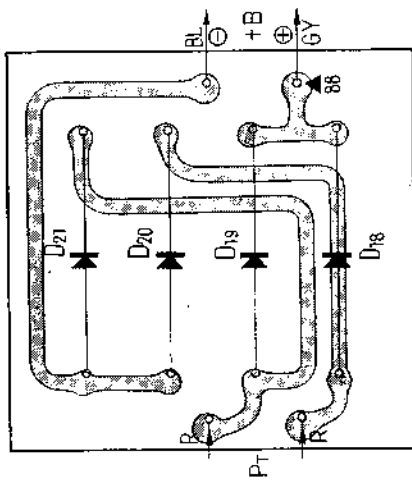

— Components Side —

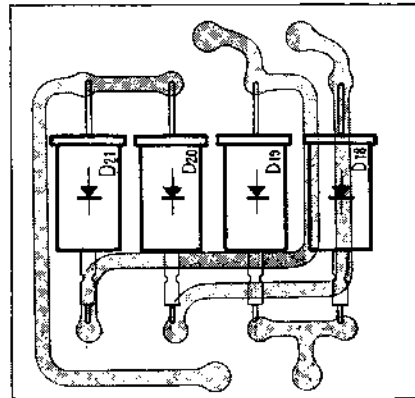

# Circuit Breaker Section

— Components Side —

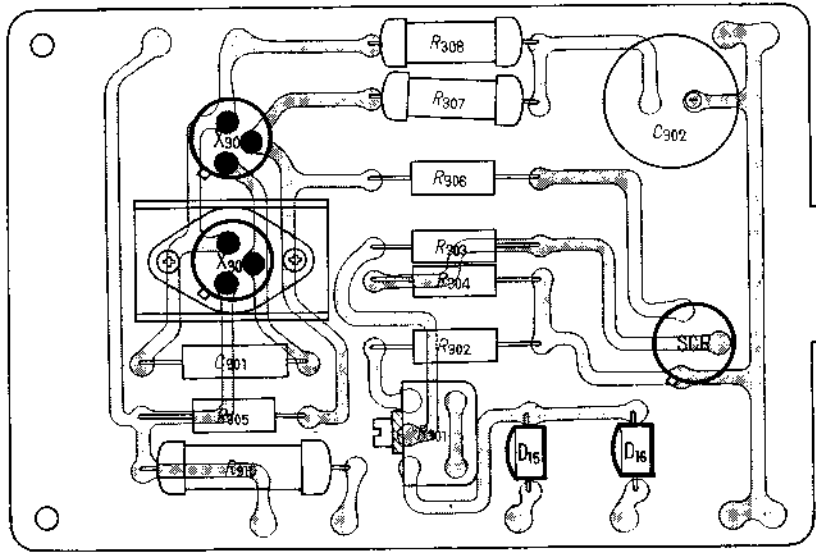

— Conductor Side —

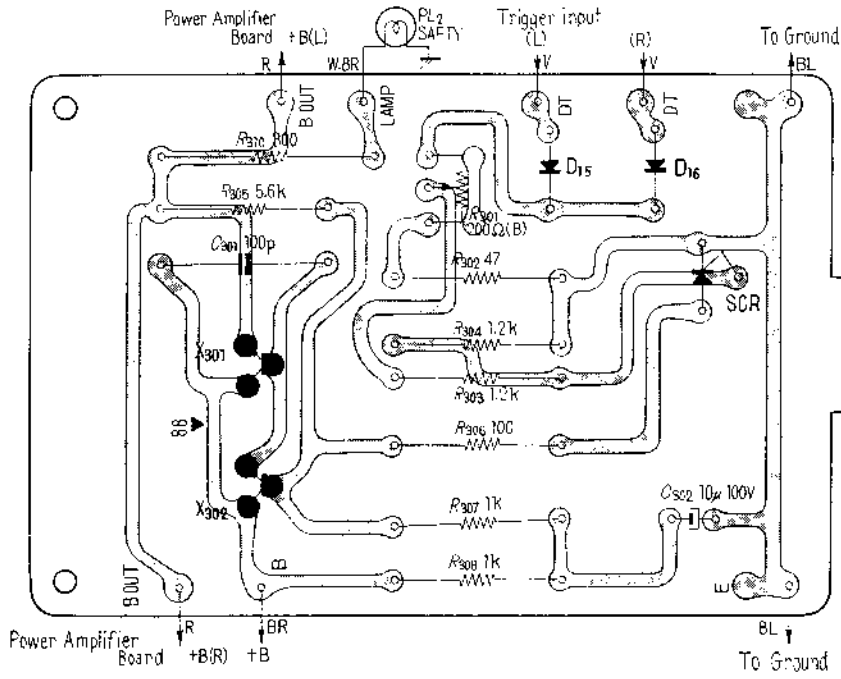

# Muting and Emitterfollower Section

## Thermo Compensator

### Diodes

— Conductor Side —

— Components Side —

— Conductor Side —

— Components Side —

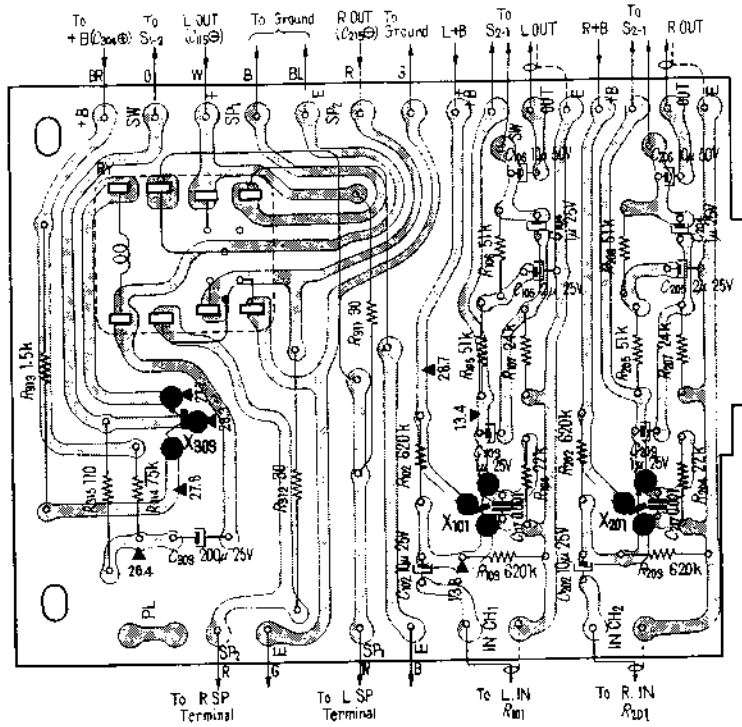
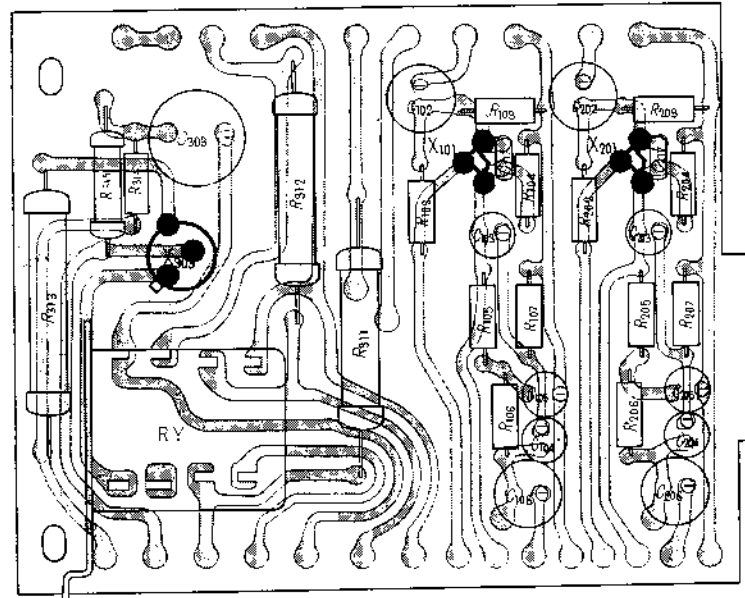
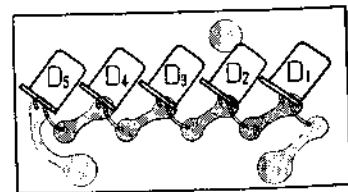
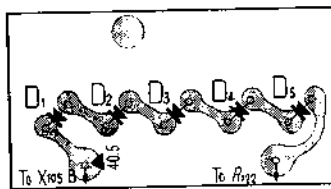

### Mechanical Ports

Part No.	Description	Q'ty	Part No.	Description	Q'ty
X-20321-01	Panel Ass'y, chassis; front	1	0-051-263-	Foot, rubber	4
X-20321-02	Plate Ass'y, chassis; bottom	1	3-701-030-	Label, serial number	1
			3-002-408-05	Spacer, 6 φ	2
X-20321-03	Panel Ass'y, front	1	-408-15	Spacer, 6 φ	2
2-032-103-	Panel, front	(1)	0-041-109-	Bag, polyethylene	1
2-031-956-	Escutcheon, pilot lamp	(2)	3-410-032-	Stopper, ac cord; black	1
-955-01	Lens, pilot lamp; red	(1)	3-790-707-11	Instruction Manual (E)	1
-955-02	Lens, pilot lamp; green	(1)	3-793-009-11	Tag, inspection	1
			1-506-105-01	Plug, RCA pin; red	1
X-20299-05	Terminal Ass'y, speaker output; middle type	4	-02	Plug, RCA pin; black	1
X-20299-06	Chassis Ass'y, power amplifier	1	X-44900-02-1	Cloth, polishing	1
			2-029-946-	Bag, accessory; polyethylene	1
			3-793-041-11	Sheet, check	1
X-20319-01	Terminal Ass'y, earth; small type	4	3-701-020-	Bag, polyethylene	1
2-032-111-	Cabinet cover; black	1	7-491-001-	Desiccant	1
-112-	Plate, jack	1			
-113-	Label, specification (E)	1	7-621-261-43	Screw, machine +RF 3 φ × 6	28
-114-	Cushion, styro-foam	2	-53	" " +RF 3 φ × 8	8
-116-02	Carton	1	-63	" " +RF 3 φ × 10	12
-117-	Plate, control panel protect; PVC	1	-73	" " +RF 3 φ × 12	18
			7-621-268-53	" " +RF 4 φ × 8	9
2-029-953-	Label, voltage	1	-83	" " +RF 4 φ × 14	4
			-770-50	" " +B 2.6 φ × 6	2
2-029-924-	Plate, relay	1	-39	" " +B 3 φ × 8	8
-925-	Plate, volume control	1	-561-53	" " +K 3 φ × 8	1
-928-	Heat Sink; aluminium	7	-999-01	" , hexagonal head 3 φ × 8	4
-930-	Screw, cabinet cover	4	7-623-108-12	Washer, plain 3 φ (middle)	33
-931-	Knob, power on/off; dark brown	1	-22	" " 3 φ (large)	4
-933-	Case Cover, relay; white	1	-110-12	" " 4 φ (middle)	4
-935-02	Spacer, speaker output; blue	2	-208-24	" , spring 3 φ	31
-935-12	Spacer, speaker output; red	2	-210-24	" , spring 4 φ	5
-936-	Spacer, speaker output; fiber	4	-408-04	" , lock 3 φ	50
-938-	Plate, printed circuit board	6	7-622-108-02	Nut 3 φ	41
-939-	Cover, electrolytic capacitor; large	1	-208-02	Nut, lock 3 φ	4
-940-	Cover, electrolytic capacitor; middle	2	7-623-508-01	Lug 3 φ	6
-943-	Cushion	1			
-950-	Spacer t=0.5	1			
-951-	Plate, nut	1			

### Electrical Parts

Part No.	Description	Q'ty	Part No.	Description	Q'ty
X-20321-53-	Circuit Board, power amplifier; mounted	2	1-538-345-11	Circuit Board, thermo compensation diode; printed	2
-55-	Circuit Board, muting; mounted	1			
-56-	Circuit Board, circuit breaker; mounted	1	-346-11	Circuit Board, power supply diode printed	1
-58-	Circuit Board, thermo compensation diode; mounted	2			
-57-	Circuit Board, power supply diode; mounted	1			
1-441-227-	Transformer, power	1		<b>Semi-Conductors</b>	
1-513-293-12	Switch, power on/off	1		Power Amplifier Section	
-091-	Switch, slide	1		Transistor 2SC401 X102,202	2
1-515-050-11	Relay	1		" 2SC299 X103,104,203,204	4
1-507-142-	Jack, input; RCA pin	1		" 2SA527 X105,205	2
1-536-151-	Terminal Strip 4P	1		" 2SD45 X106-109, X206-209	8
1-509-015-	Socket, ac	3		Varistor SV-6 D11-14	4
1-533-012-	Fuse Post	1		" SV-08 D22,23	2
1-532-017-	Fuse 5A	1		<b>Muting Section</b>	
1-517-021-11	Socket, pilot lamp	2		Transistor 2SC293 X303	1
1-518-050-12	Lamp, pilot	2		" 2SC401 X101,201	2
1-534-241-14	Cord, ac power	1		<b>Circuit Breaker Section</b>	
1-526-502-11	Socket, transistor 2SD45	8		Transistor 2SC299 (Red Mark) X301	1
-165-11	Socket, voltage selector	1		" 2SC293 (Red Mark) X302	1
1-538-348-12	Circuit Board, power amplifier; printed	2		Diode S2C(FR-1U) D15,16	2
-352-11	Circuit Board, muting; printed	1		" 2SF-103 D17	1
-344-11	Circuit Board, circuit breaker; printed	1		<b>Thermo Compensation Diode Section</b>	
				Diode 1T206 D1~10	10

Part No.	Description	Q'ty	Part No.	Description	Q'ty
	Power Supply Diode Section		1-201-087-	22K ohms RC1/2 ±10% R104,204	2
	Diode DS-2M D18-21	4	-282-	24K ohms RC1/2 ±10% R107,207	2
			-283-	51K ohms RC1/2 ±10% R105,106, 205,206	4
	<b>Resistors</b>			<b>Circuit Breaker Section</b>	
	<b>General Items</b>			Composition	
1-221-707-	Potentiometer 100K ohms (B) R101,201	2	1-201-079-	47 ohms RC1/2 ±10% R302	1
1-205-100-	Enameled 180 ohms 10W R309	1	-685-	1.2K " " " R303,304	2
1-201-021-	Composition 1K ohm RC1/2 R142,242	2	-086-	5.6K " " " R305	1
			-110-	100 " " " R306	1
	<b>Power Amplifier Section</b>		1-223-010-	Adjustable, wire wound 200 ohms(B) R301	1
	Composition		1-207-157-	Wire wound	
1-201-837-	510K ohms RC1/2 ±10% R108,208	2		1K ohm 1.5W ±10% R307,308	2
-087-	22K " " " R110,210	2	-156-	300 ohms 3W ±10% R310	1
-843-	240K " " " R109,209	2			
-683-	82 " " " R113,213	2		<b>Capacitors</b>	
-085-	3.9K " " " R112,212	2		<b>General</b>	
-021-	1K ohm " " R111,211	2	1-121-323-	Electrolytic 4000µF 100WV C304	1
-041-	10K ohms " " R114,214	2	-327-	" 2000µF 80WV C115,215	2
-472-	390 " " " R117,217	2	1-101-534-	Encapsulated Component	
-054-	47K " " " R115,215	2		120 ohms +0.1µF 500WV	2
-084-	3.3K " " " R118,140,218,240	4		<b>Power Amplifier Section</b>	
-845-	510 " " " R120,137,220,237	4	1-121-172-	Electrolytic 100µF 50WV C101,201	2
-100-	100 " " " R125,127,225,227	4	-143-	" 10µF 50WV C107,207	2
-838-	30 " " " R124,224	2	-140-	" 350µF 10WV C108,208	2
-094-	10 " " " R138,238	2	-161-	" 500µF 6WV C110,210	2
-081-	220 " " " R123,223	2	-163-	" 50µF 50WV C112,212	2
-794-	5.1 " " " R130,128,131 129,230,228, 231,229	8	-142-	" 5µF 50WV C111,211	2
-082-	330 " " " R139,239	2	1-109-001-	Mica 50pF 1KV ±10% C109,209, 114,214	4
1-203-058-	Carbon 3.3K ohms RD1/4L ±5% R119,132,229,232	4	-006-	" 300pF 1KV ±10% C113,213	2
1-221-334-	Adjustable 50K ohms(B) R116,216	2	1-105-679-	Mylar 0.033µF 50WV ±10% C116,216	2
1-223-010-	Adjustable, wire wound 200 ohms(B) R122,222	2		<b>Muting Section</b>	
1-209-576-	Carbon 4K ohms RD2L ±5% R121,221	2	1-121-190-	Electrolytic 200µF 25WV C303	1
1-207-151-	Wire wound 0.5 ohms 1.5W ±10% R133,134,135,136,233,234,235,236	8	-179-	" 10µF 25WV C102,202	2
1-203-459-	Carbon 18 ohms RD1/4L ±5% R141,241	2	-324-	" 1µF 25WV C103,104, 203,204	4
1-204-416-	Carbon 12 ohms RD1/4L ±5% R126,226	2		" 2µF 25WV C105,205	2
	<b>Muting Section</b>		-143-	" 10µF 50WV C106,206	2
1-207-104-	Wire wound		1-105-661-	Mylar 0.001µF 50WV ±10% C117,217	2
	30 ohms 4W ±10% R311,312	2		<b>Circuit Breaker Section</b>	
-153-	1.5K ohms 4W ±10% R313	1	1-121-126-	Electrolytic 10µF 100WV C302	1
-152-	110 ohms 1.5W ±10% R315	1	1-109-002-	Mica 100pF 1KV ±10% C301	1
1-201-844-	Composition				
	75K ohms RC1/2 ±10% R314	1			
-842-	620K " " " R102,103,202, 203	4			

Following parts are added to UL and CSA respectively

Part No.	Description	Q'ty	Part No.	Description	Q'ty
	<b>UL</b>		1-209-866-	Resistor, carbon 1 ohm 1W R133,233,134,234,135,235,136,236	16
2-032-130-	Label, specification	1		<b>CSA</b>	
3-422-204-	Label, caution	1	2-032-128-	Label, specification	1
2-029-955-	Plate, ac outlet	1	2-029-966-	Plate, ac outlet	1
3-790-707-22	Instruction Manual (UL)	1	3-407-956-	Label, caution	1
2-032-118-	Master Carton for 2 sets	1/2	3-790-707-22	Instruction Manual	1
1-534-330-31	Cord, ac power	1	1-534-330-31	Cord, ac power	1
1-513-293-22	Switch, power on/off	1			