

TA-2000

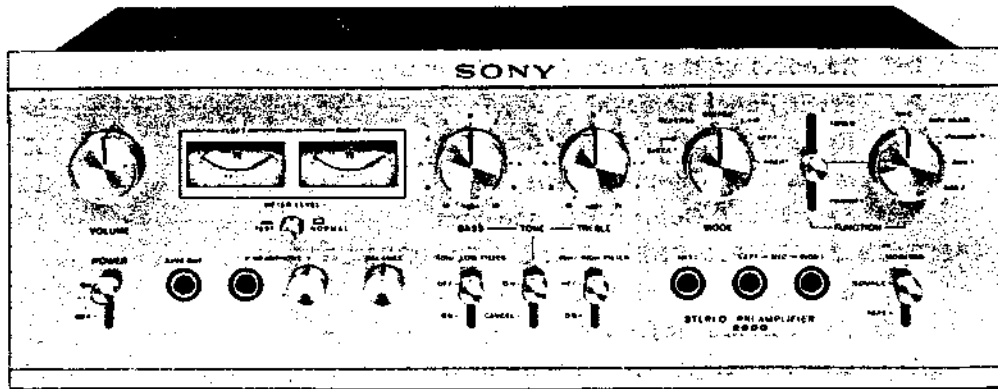

Specifications

- Circuit system:** All silicon transistor stereo preamplifier 31 Transistors, 9 diodes
- Frequency response:** TUNER, AUX-1, AUX-2, TAPE IN ; 20 Hz-100 kHz ± 0 dB
PHONO-1, PHONO-2 ; RIAA equalization curve tolerance ; within ± 0.5 dB
TAPE HEAD ; NAB equalization curve tolerance ; within ± 0.5 dB
(adjustable ± 6 dB at 10 kHz, by semi-fixed resistor)
MIC ; 20 Hz-30 kHz ± 0 dB
- S/N ratio:** TUNER, AUX-1, AUX-2, TAPE IN ; more than 90 dB (weighting network 'A')
(short-circuited) PHONO-1, PHONO-2 (NORMAL) ; more than 70 dB (weighting network 'A')
PHONO-2 (LOW) ; more than 50 dB (weighting network 'B')
TAPE HEAD ; more than 65 dB (weighting network 'B')
MIC ; more than 70 dB (weighting network 'A')
The test conditions are based on IHF standards.
- Tone controls:** BASS ; 100 Hz ± 10 dB (11 steps by 2 dB each)
TREBLE ; 10 kHz ± 10 dB (11 steps by 2 dB each)
- Filters:** HIGH FILTER ; 12 dB/oct above 9 kHz
LOW FILTER ; 12 dB/oct above 50 Hz
- Power requirements:** AC 100, 117, 220, 240 volts, 50/60 Hz
- Power consumption:** 10 watts (12 volt amperes)
- Dimensions:** 15 $\frac{3}{8}$ "(w) \times 5 $\frac{1}{2}$ "(h) \times 12 $\frac{3}{8}$ "(d) (400 \times 145 \times 315)mm
- Weight:** 19 lb 14 oz (9.0 kgs.)

SONY[®]
SERVICE MANUAL

TABLE OF CONTENTS

	Page
Specifications.....	1
SECTION 1 GENERAL DESCRIPTION.....	3~6
BLOCK DIAGRAM.....	7~8
LEVEL DIAGRAM.....	9~10
SECTION 2 DISASSEMBLY	
2-1 Removal of the Front Panel Assembly	11
2-2 Front Panel Removal	12
2-3 Removal of Back Panel Assembly	12
2-4 Meter Lamp Replacement	13
2-5 Switch and Control Replacement	13
SECTION 3 OVERALL CHECKS AND MEASUREMENTS	
3-1 Equipment Requirement	14
3-2 B+ Voltage Adjustment	15
3-3 Overall Sensitivity Measurement.....	15
3-4 Overall Rated Output Measurement	16
3-5 Overall Frequency Response Measurement	17
3-6 Overall Harmonic Distortion Measurement	17
3-7 Overall Noise Level Measurement	17
SCHEMATIC DIAGRAM	19~21
CHASSIS LAYOUT	22
MOUNTING DIAGRAM	
Output Level Switch S12 Section	23
Equalizer Section	24~25
Head Amplifier and Flat Amplifier (1) Section	26~27
Flat Amplifier (2) and Emitter Follower (2) Section	28~29
Meter, Center Amplifier and Emitter Follower (1) Section.....	30~31
Treble Control Section	32
Bass Control Section	33
Power Supply Section	34~35
EXPLODED VIEW.....	36~39

SECTION 1 GENERAL DESCRIPTION

General Information

The TA-2000 is a professional audio preamplifier that accepts and processes inputs from all sources and distributes output signals to power amplifiers, recorders, headphones, and professional (line) outputs. It provides very low distortion, superior signal-to-noise ratio, wide dynamic range, and extremely flat frequency response.

Technical Specifications

Circuit system

All silicon transistor stereo preamplifier
31 transistors, 9 diodes

* The test conditions are based on IHF standards.

Input Sensitivity and Impedance

Tape Head	(Adjustable)	1.2mV (max)	500k ohms
Phono-1	(")	1.2mV " 47k "	
Phono-2(Normal)	(")	1.2mV " 47k "	
	(Low)(")	0.06mV " 200 "	
Mic	(")	1.2mV " 500k "	
Tuner	(")	120mV " 100k "	
Aux-1	(")	120mV " 100k "	
Aux-2	(")	120mV " 100k "	
REC/PB		120mV " 100k "	
Tape In		120mV " 100k "	

Maximum Input Capability

Tape Head	100mV (at 1 kHz)
Phono-1	100mV "
Phono-2 (Normal)	100mV "
	(Low) 5mV "
Mic	100mV "

Output Voltage and Impedance (with rated input)

Preamp Out (Switchable)	1.0V	10k ohms
	max (1.5V)	
	0.3V	4k ohms
Center Out (Adjustable)	1.0V	7.5k ohms
	max (5.0V)	
Headphone Out (Adjustable)	3.0V	1.5k ohms
	max (10V)	
PEC/PB Out	12mV	80k ohms
	max (1.0V)	

Harmonic Distortion: (rated output at 1 kHz)

Tape Head	Less than 0.05%
Phono-1	" 0.05%
Phono-2 (normal)	" 0.05%
Mic	" 0.05%
Tuner	" 0.03%
Aux-1	" 0.03%

Aux-2 Less than 0.03%
(Measured with an input signal 38dB higher than maximum sensitivity)

IM Distortion: (60 Hz: 7 kHz=4:1)

Tape Head	Less than 0.05%
Phono-1	" 0.05%
Phono-2 (Normal)	" 0.05%
Mic	" 0.05%

Frequency Response:

Tape Head	NAB equalization curve ±0.5dB
Phono-1	RIAA equalization curve ±0.5dB
Phono-2	" "
Mic	20Hz - 30kHz $\begin{matrix} +0 \\ -2 \end{matrix}$ dB
Tuner	20Hz - 100kHz $\begin{matrix} +0 \\ -2 \end{matrix}$ dB
Aux-1	" "
Aux-2	" "

(Measured with an input signal 38dB higher than maximum sensitivity)

S/N Ratio: (short circuited)

Tape Head (weighting network 'A')	More than 70dB
Phono-1 (" ")	" 70dB
Phono-2(normal) (")	" 70dB
	(Low) (" network 'B') " 50dB
Mic (weighting network 'A')	" 70dB
Tuner (" ")	" 90dB
Aux-1 (" ")	" 90dB
Aux-2 (" ")	" 90dB
Tape in (" ")	" 90dB

Tone Controls:

Bass 100Hz±10dB (11 steps by 2 dB each)
Treble 10kHz±10dB (" ")

Filters:

High Filter 12dB/oct above 9kHz
Low Filter 12dB/oct above 50Hz

AC Outlets:

Switched 3
Unswitched 1
Total 500 watts maximum

Power Requirements:

AC 100, 117, 220, 240, volts
50/60 Hz

Power Consumption:

10 watts (12VA)

Dimensions:

15 $\frac{3}{8}$ "(W) × 5 $\frac{1}{2}$ "(h) × 12 $\frac{3}{8}$ "(d)
(400 × 145 × 315)mm

A-2000

Technical Specifications

Weight:

19 lbs 14 oz (9.0kgs.)

Accessories:

- Pin plug 4
- Connecting cord (RK-56) 2
- Coaxial cable with binaural plug (RK-81) 2
- Polishing Cloth 1

CAUTION:

The TA-2000 is a precision instrument. It should be serviced only by qualified service personnel trained in the service of high-quality instruments of this type.

Circuit Description

The following describes the functions of all stages and controls. The description follows the signal path and lists stages by the transistor symbol number at the left margin. Refer to the block diagram on page 7, 8 and the schematic diagram on page 19-21. Since the TA-2000 contains two identical amplifier chains, only the left channel will be described.

Stage/Control	Function
Equalizing Amplifier Q102, 103, 104	This section amplifies the small signal produced by the cartridge, microphone, and tape head. In addition RIAA, NAB, and MIC equalizing are achieved in conjunction with the settings of function switches S1 and S2. Q102 and Q103 form a two-stage direct-coupled amplifier which feeds Q104. About 40dB of negative feedback is applied from Q104 to the first stage Q102 to eliminate harmonic distortion which may result from the change in load-impedance of Q103 at high frequencies. As the frequency response of this stage is determined by the feedback loop frequency characteristic, three feedback loops, designed to satisfy each equalizing curve, are employed.
R126, 127, 128 C115, 116	RIAA equalization is achieved by the negative feedback loop containing these components.
R129, 130, 131 C117	NAB equalization is accomplished by the negative feedback loop containing these components.
R132	When the FUNCTION Switch is set to MIC, feedback is applied through R132 to provide a flat response in the equalizer amplifier.

Stage/Control	Function
Head Amplifier Q101	Amplifies extremely small input signals, as from a moving coil type cartridge. (Optimum load impedance of this type of cartridge is relatively low.) A common base configuration is employed in this circuit.
LEVEL Switch S11-1, S11-2	High level input signals are bypassed through the LEVEL Switch at the PHONO-2 inputs.
FUNCTION Switch S1, S2	Selects the input signal source to be amplified.
Level Adjust R143, 144, 145 146, 147, 148	These semi-fixed resistors control the input levels of the AUX-1, TUNER, TAPE IN, TAPE-HEAD, PHONO-2, PHONO-1 inputs, respectively, so that all input levels of the TA-2000 can be set to the same value.
Emitter Follower Q105	Acts as a buffer amplifier to provide line output for tape recorders and other facilities.
MONITOR Switch S3	Selects the signals from TAPE IN terminals (TAPE position) or equalizer output (SOURCE position).
MODE Selector S4	Selects the desired mode of operation. This switch may also be used for test purposes. Relation of outputs and Mode Selector positions are summarized in the table below.
TONE CANCEL Switch S5	In the OFF position, the equalized signals are routed to the tone control circuit. In the ON position, the signals are fed directly to flat amplifier 2.
Flat Amplifier (1) Q106, 107, 108	Provides a 20dB voltage gain which is consumed in tone control filters (filter insertion loss).

Stage/Control	Function
HIGH FILTER Switch S8	Negative feedback is applied to obtain optimum signal-to-noise ratio, distortion, and stability up to frequencies beyond the audible range. Eliminates unwanted high-frequency components from the input signal (12 dB/oct above 9kHz) in the ON position.
Emitter Follower Q109	Matches impedance to the following high-pass filter.
LOW FILTER C150, 151 R144	High-pass filter cuts out unwanted low frequency components from the input signal, such as rumble created by the turntable, record changer, or the record itself, 12 dB/oct below 50Hz, when the LOW FILTER Switch is set to ON.
TREBLE Control S6	Increases or decreases the prominence of high frequencies by switching the filter components in steps. Each switch step changes treble response approximately 2 dB at 10kHz.
Bass Control S7	Similar to treble control except for filter components and frequency characteristics. Each switch step of this control changes bass response approximately 2dB at 100Hz.
Flat Amplifier (2) Q110, 111, 112	This three-stage amplifier (including one emitter follower) provides a 29dB voltage gain, and increases the signal to the level required at the headphone output jack. The output of this amplifier is also fed to the OUTPUT LEVEL Switch S12 and METER LEVEL Switch S13. The output voltage can be changed by S12,
S12, 13	

Output \ Mode Selector Position	Check L	Check R	Reverse	Stereo	L+R	Left	Right
Preamp out: Left	L+R	...	R	L	L+R	L	R
Preamp out: Right	...	L+R	L	R	L+R	L	R
Center Out	L+R	L+R	L+R	L+R	L+R	L	R

A-2000

Stage/Control	Function	Stage/Control	Function
S12, 13	which has two calibrated positions, 0.3 V and 1 V, and should be set according to the requirements of the equipment to be connected. Level meter sensitivity can be varied by switching S13(METER LEVEL). In the TEST position, the reading of the meter shows the actual output value. A 0dB reading indicates that the channel supplies rated output (1 volt or 0.3 volt). In the NORMAL position, the sensitivity of the meter increases 14dB and the pointers are more responsive for stereo balancing.	Filter Circuit Q303	A change in output voltage, detected by Q304 results in a change in conduction of Q305 that offsets the original voltage shift. Provides effective filtering to eliminate ripple in the B+. The combination of Q303 and C168 can be considered, effectively, as a large capacitor.
HEADPHONE Level Control R224	The volume level for the headphone can be adjusted by turning the control knob located immediately to the right of the HEADPHONE jack.		
Meter Amplifier Q113 D6, D7	Output voltage is extracted through R210 and amplified to the level required to drive the level meter. The meter amplifier output is rectified and supplied to the meter through a modified bridge configuration.		
Sensitivity Adj. R210	Calibrates the VU meter.		
Center Channel Amplifier Q301, 302	Mixes the signal from L and R channels and delivers the L+R signal, which is used to drive a center-channel system.		
Center Channel Adj. R232	R232 adjusts the center channel output level.		
Power Supply AC Input	Line input is supplied to the Power Transformer through the power switch S10-1, and the voltage selector.		
Voltage Selector	The voltage selector provides the proper power transformer connections to suit local line-voltage conditions.		
DC Power Supply	A positive 73 volts is developed by full-wave rectifiers D3 and D4.		
Voltage Regulator Q304, 305	DC output from the rectifiers is filtered by C170 and applied to the series regulator Q305. Transistor Q304 compares a sample of the output voltage with a reference voltage supplied by Zener diode D5.		

TA-2000 TA-2000

BLOCK DIAGRAM TA-2000

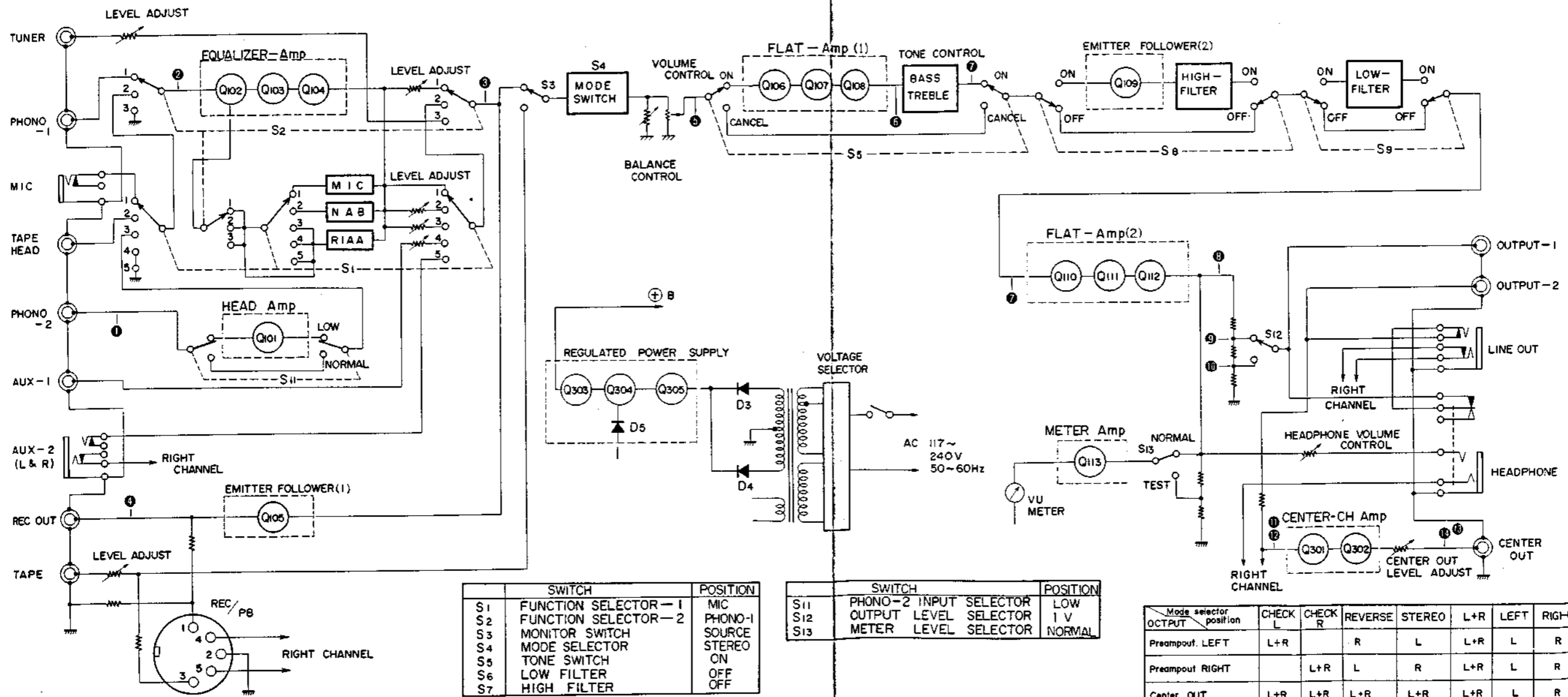

SWITCH	POSITION
S1	MIC
S2	PHONO-1
S3	SOURCE STEREO
S4	MODE SELECTOR
S5	ON
S6	OFF
S7	OFF

SWITCH	POSITION
S11	LOW
S12	1 V
S13	NORMAL

Mode selector position	CHECK L	CHECK R	REVERSE	STEREO	L+R	LEFT	RIGHT
Preamp. LEFT	L+R		R	L	L+R	L	R
Preamp. RIGHT		L+R	L	R	L+R	L	R
Center OUT	L+R	L+R	L+R	L+R	L+R	L	R

RELATION OF OUTPUTS AND SELECTOR

TA-2000

LEVEL DIAGRAM TA-2000

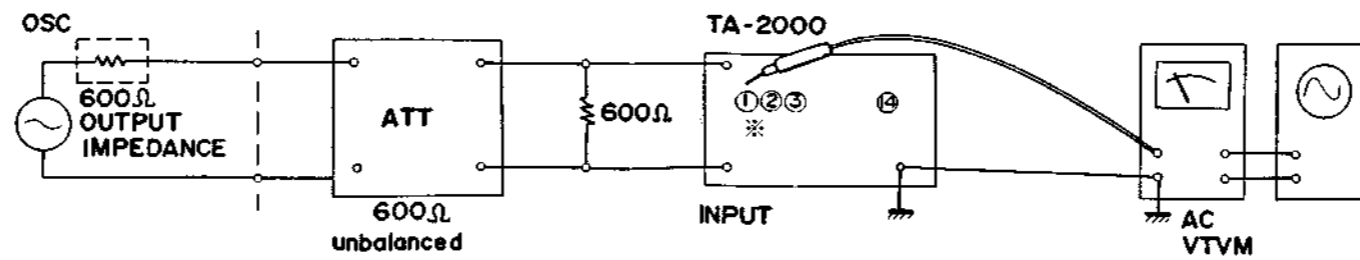
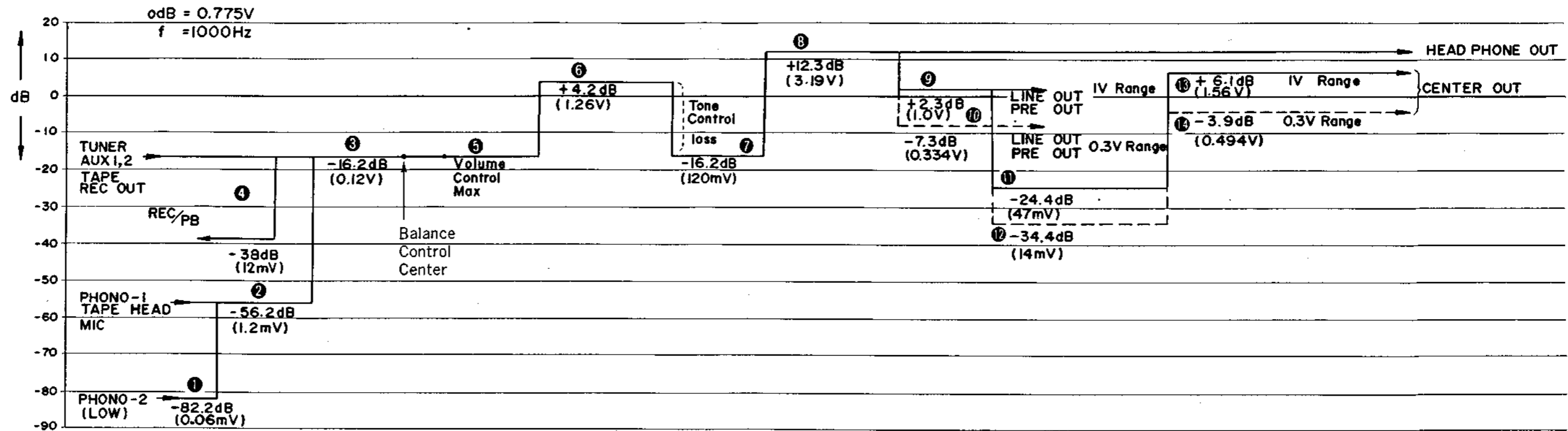

* See Block Diagram

SECTION 2 DISASSEMBLY

2-1 Removal of the Front-Panel Assembly

- a. Remove the two machine screws on each side of the set, and lift off the top cover.
- b. Remove the two self-tapping screws (+RF3 ϕ × 6) on each side of the chassis. See Fig. 2-2.
- c. Remove the four Phillips-Head screws (+RF3 ϕ × 6) that secure the shield plate. See Fig. 2-1.
- d. Turn the set over and remove the two self-tapping screws (+RF3 ϕ × 6) from the front-bottom edge of the chassis. See Fig. 2-3.
- e. The Front Panel Assembly is now free, and may be tilted forward and down as shown in Fig. 2-4. Place protective pads under the Front Panel to prevent it from being scratched.

Note: It is not necessary to remove the control knobs on the Front Panel.

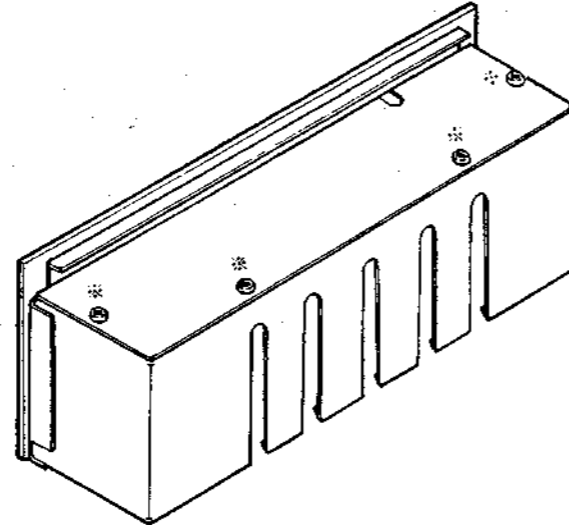

Fig. 2-1. Removal of Shield Plate

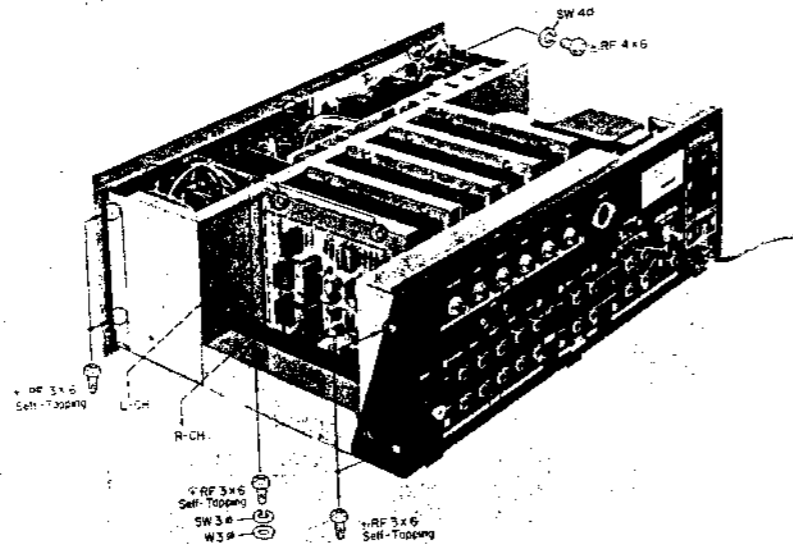

Fig. 2-2. Removal of Front-Panel Ass'y

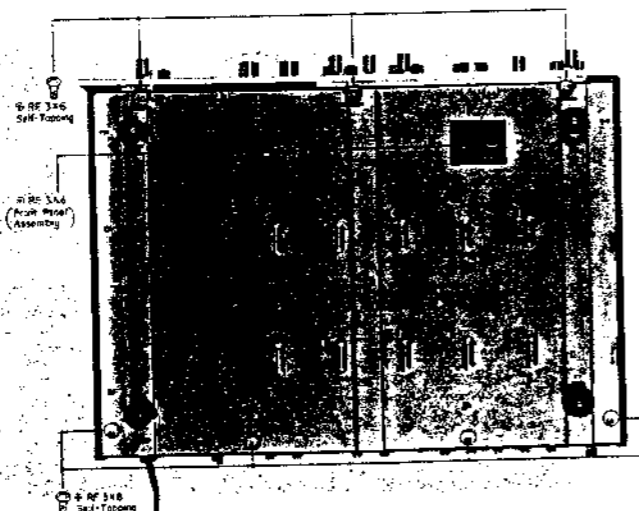

Fig. 2-3. Removal of Front-Panel Ass'y

2-2 Front Panel Removal

- a. Remove the top cover.
- b. Remove all control knobs by loosening the slotted set screws and pulling the knobs straight out. The switch knobs are simply pulled off.
- c. Remove the three Phillips-Head screws (+RF4φ × 6) behind the top edge of the Front Panel Assembly. See Fig. 2-2.
- d. Turn the set over and remove the three Phillips-Head screws (+RF3φ × 6) at the front-bottom edge of the chassis. See Fig. 2-3. This frees the Front Panel.

2-3 Removal of Back Panel Assembly

- a. Remove the top cover
- b. Remove the two self-tapping screws (+RF3φ × 6) on each side of the chassis. See Fig. 2-2.
- c. Turn the unit over and remove the four self-tapping screws (+RF3φ × 6) at the back bottom of the chassis. The Back Panel Assembly is now free, and may be tilted backward and down as shown in Fig. 2-5.

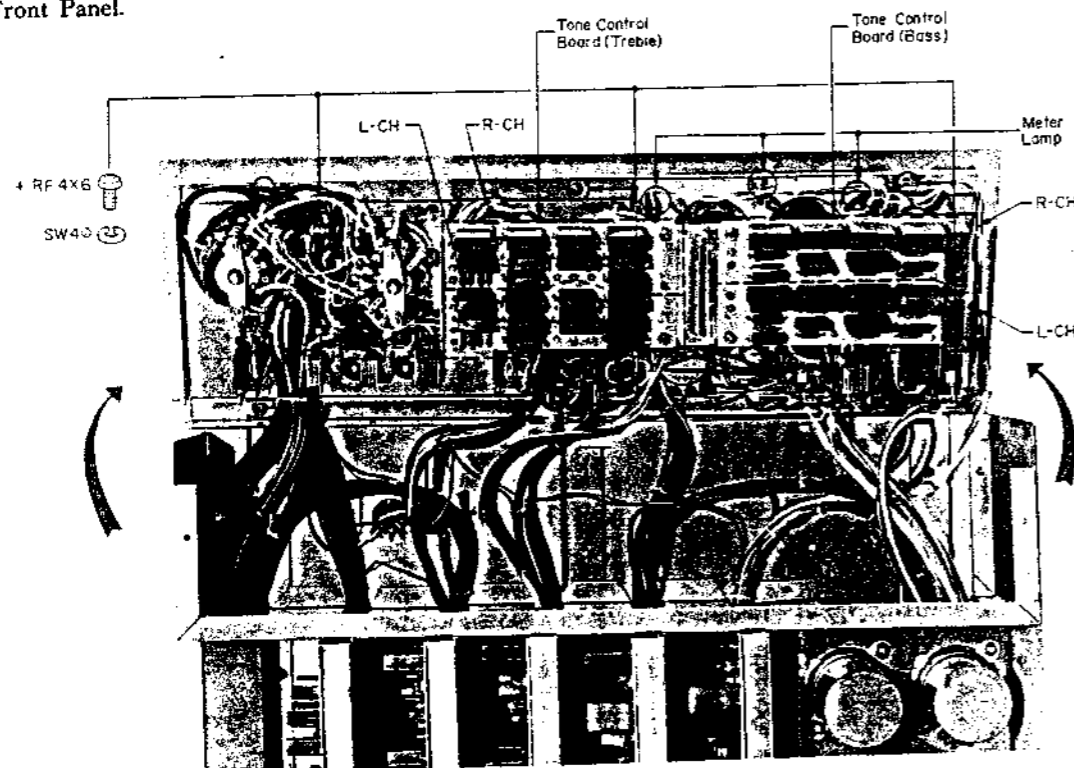

Fig. 2-4. Removal of Front-Panel Ass'y

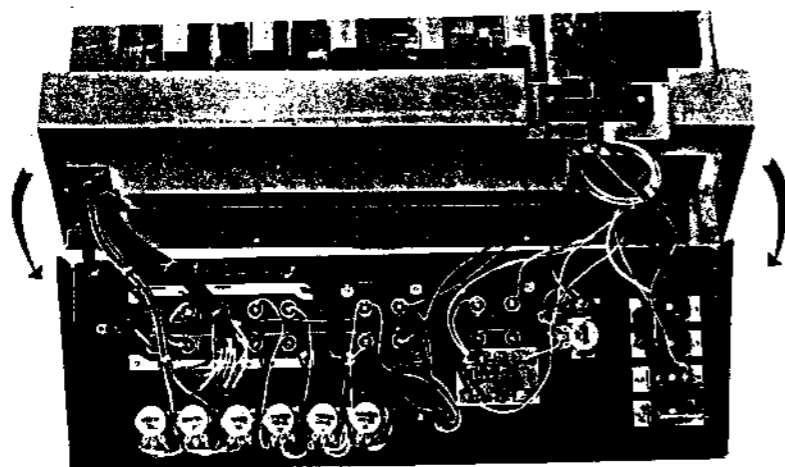

Fig. 2-5. Removal of Back-Panel Ass'y

2-4 Meter Lamp Replacement

- a. Unplug the AC power cord.
- b. Remove the top cover. See Section 2-1.
- c. Apply a drop of acetone-base cement solvent to the lamp socket and allow a few seconds for the paint to dissolve.
- d. Turn the black plastic lamp socket clockwise (as viewed from the back of the panel) and pull out the socket. See Fig. 2-6.

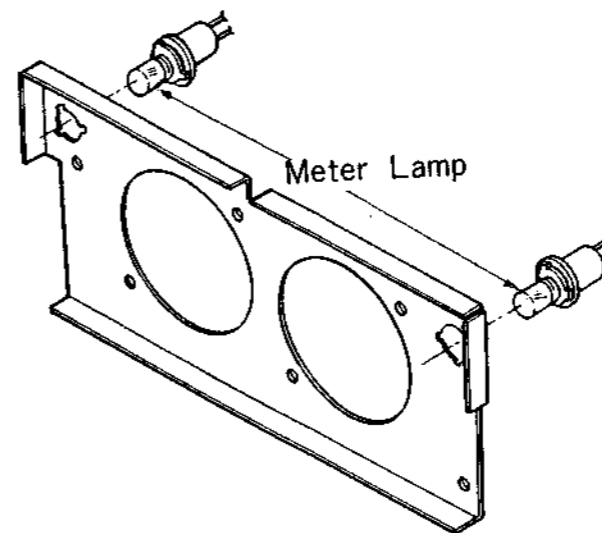

Fig. 2-6. Meter Lamp Replacement

- e. Unscrew the pilot lamp from the socket and install the replacement.
- f. Insert the socket into the slots in the Front Panel assembly and turn the socket counterclockwise until it is firmly seated. Put a drop of contact cement on the socket.

2-5 Switch and Control Replacement

- a. Remove the top cover and Front Panel. See Section. 2-2.
- b. Remove the rotary switches by loosening the hex nut that secures the control to the Front Panel Assembly.
- c. Remove the toggle switches by removing the two Phillips-Head screws from the Front Panel Assembly.

Note: The microswitch can be removed from the toggle bracket by loosening two Phillips-Head Screws. See Fig 2-7.

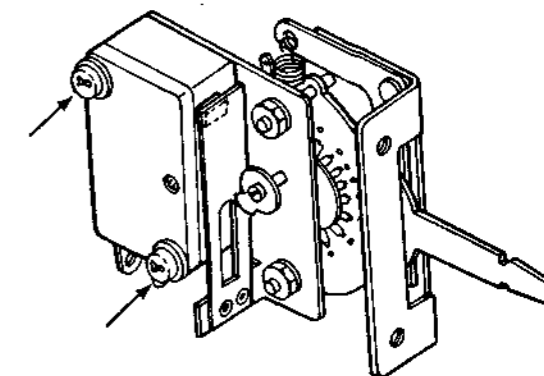

Fig. 2-7. Microswitch Replacement

SECTION 3 OVERALL CHECKS AND MEASUREMENTS

3-1 Equipment Requirement

1. Audio Oscillator
Frequency range: 10Hz to 100kHz
Distortion at rated output: 0.03% or less at 1kHz
2. Distortion Meter
Capable of measuring of 0.015% distortion, or less, at 1kHz
Frequency range: 20 Hz to 100 kHz, or more
Input impedance: 1 M ohm or more
3. AC VTVM
Capable of measuring rms voltage of 0.5 mV or less within a frequency range from 10 Hz to 100 kHz. Input impedance: 500 k ohms or more
4. Attenuator
Capable of attenuating signals 60 dB or more.
Characteristic impedance: 600 ohms, unbalanced
5. Oscilloscope
Bandwidth: 1 MHz or more

Note: a. When measuring the sensitivity of the PHONO-2 LOW input, insert a pad with a loss of 43 dB between the attenuator and input terminal. See Fig. 3-1.
The input sensitivity may be regarded as the reading on the attenuator plus the pad loss.

b. After it has been calibrated, use the VU meter for frequency response measurements from 30 Hz to 20 kHz.

c. Input sensitivity measurements can be accomplished without connecting a level meter to the output terminals. Use the VU meter for all applicable measurements that follow.

d. $0 \text{ dB} = 0.775 \text{ V (r.m.s)}$

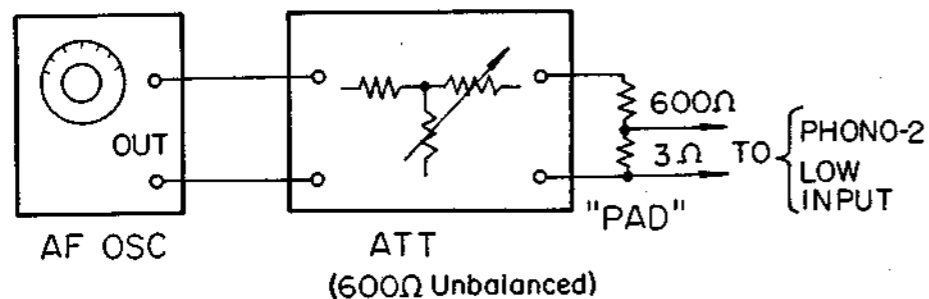

Fig. 3-1. PHONO-2 (LOW) Sensitivity Measurement Test Set-up

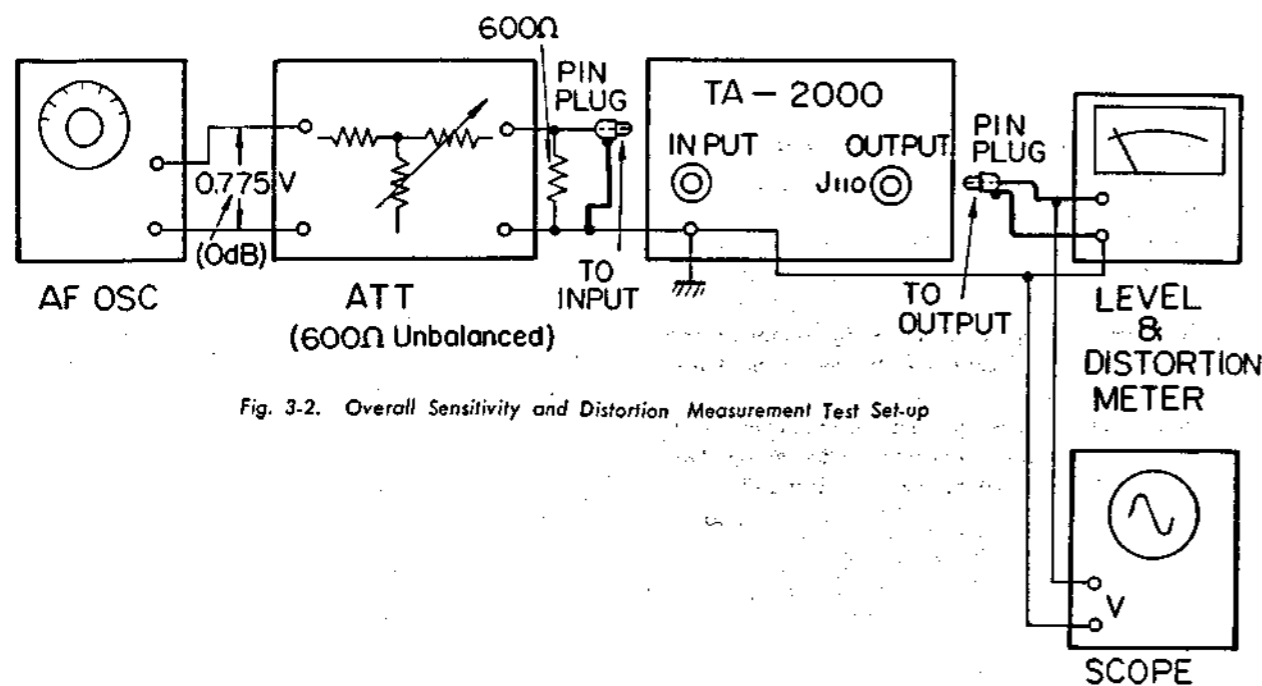

Fig. 3-2. Overall Sensitivity and Distortion Measurement Test Set-up

3-2 B+ Voltage Adjustment

- Step 1: Connect the DC voltmeter between B+ and ground. See Fig. 3-3.
- Step 2: If the voltage is higher than 55 volts, solder a jumper lead between resistors R236 and R237.
- Step 3: If the voltage is lower than 50 volts, solder a jumper lead between resistors R238 and R239.

3-3 Overall Sensitivity Measurement

Preparations: Set controls and switches as follows for all measurement procedures, unless otherwise noted.

MODE SelectorSTEREO
MONITOR SwitchSOURCE
TONE SwitchOFF
BASS Control0 (dB)
TREBLE Control0 (dB)
LOW FILTEROFF
HIGH FILTEROFF
BALANCE Controlcenter (mechanical)
OUTPUT LEVEL Switch	...1 V

All level adjustments are set to maximum.

(1) TUNER Input

- Step 1: Set the function switch to TUNER.
- Step 2: Confirm that no output is present at the terminal of the OUTPUT-1 (J110), and the reading of the VU meter is minimum at zero signal.
- Step 3: Feed a 1 kHz, -16 dB (0.15 V) signal to the TUNER input terminal. Adjust the attenuator and confirm that a 1 volt reading can be obtained at the output.

(2) VU meter Calibration

- Step 1: Feed a 1 kHz signal to the TUNER input terminal.
- Step 2: Adjust the attenuator to obtain a 1 V reading on VTVM.
- Step 3: Set the VU meter switch S13 to TEST, and adjust R210 (50 k ohms) on the Meter Amplifier board to obtain a precise reading of 0 dB on the VU meter. Confirm that the reading of the VU meter changes with variations in attenuator settings.
- Step 4: Decrease the input signal level 14 dB below the value of that in Step 3.

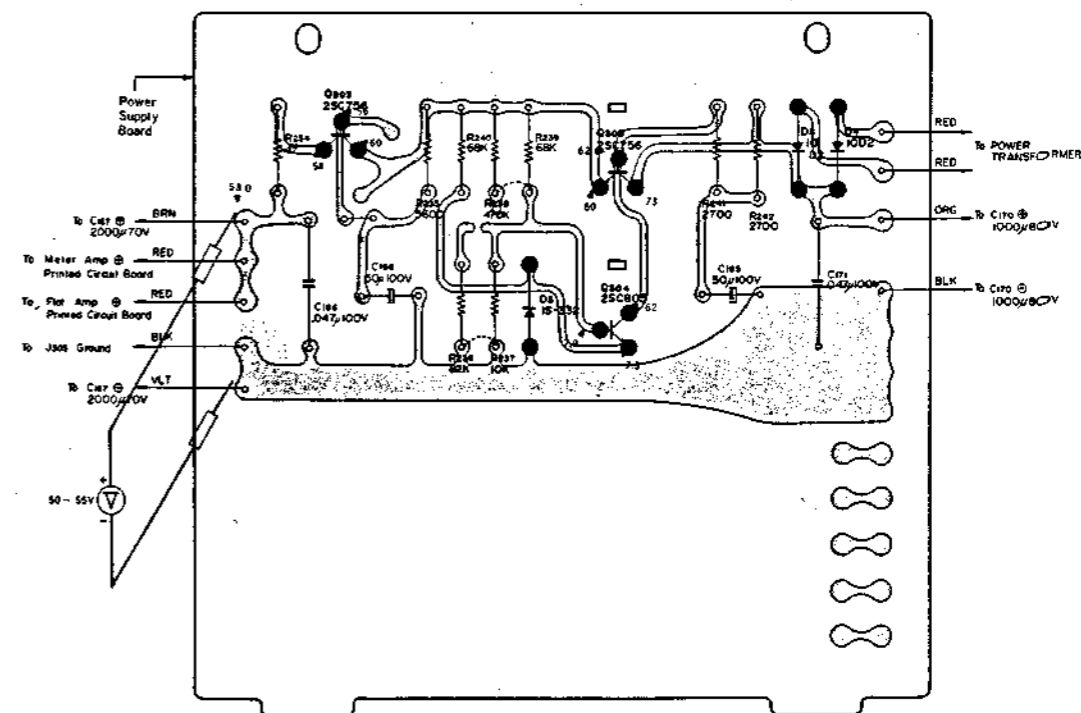

Fig. 3-3. B+ Voltage Adjustment Test Set-up

- Step 5: Set the VU METER LEVEL Switch S13 to NORMAL.
- Step 6: Confirm that the reading on the VU meter is 0 ± 0.5 dB. Reset the VU METER LEVEL Switch to the TEST position.
- Step 7: Confirm that the meter maintains a 0 dB reading when the frequency of the input signal is varied.

- (3) AUX-1 Input
- Step 1: Feed a 1 kHz, -16 dB signal to the AUX-1 input terminal and confirm that the VU meter (or VTVM) reading is nearly 1 dB.
- Step 2: Confirm that the level adjustment control operates correctly.
- (4) AUX-2 Input
- Same procedure as above.
- (5) TAPE Input
- Step 1: Set the MONITOR Switch to TAPE.
- Step 2: Feed a 1 kHz, -16 dB signal to the TAPE IN terminal and confirm that the VU meter (or VTVM) reading is nearly 1 dB.
- Step 3: Apply the foregoing procedures to the REC/PB connector.
- (3)-ground L-channel
(5)-ground R-channel
- Note: Maximum loss of the TAPE IN level adjust is 17 dB.
Reset the MONITOR Switch to SOURCE.

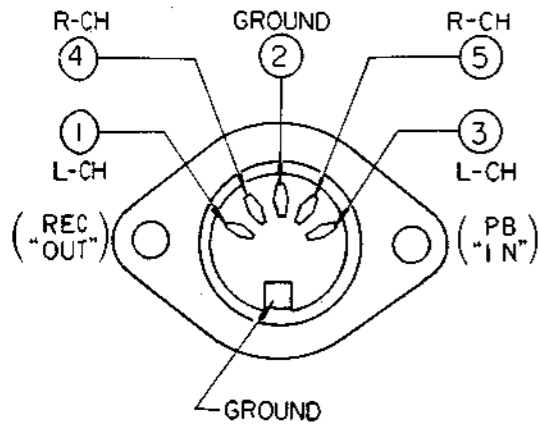

Fig. 3-4. REC/PB Connector

- (6) PHONO-1 Input
- Step 1: Set the FUNCTION lever to PHONO 1.
- Step 2: Feed a 1 kHz, -56 dB signal to the PHONO input terminal.
- Step 3: Adjust the attenuator to obtain a 1 volt reading on the VTVM. The attenuator reading shows the input sensitivity.
- Step 4: Confirm that the level adjustment control operates correctly.

- (7) PHONO-2 Input (NORMAL)
- Same as foregoing procedure.
- (8) PHONO-2 Input (LOW)
- Step 1: Set the FUNCTION Lever to the center position and the FUNCTION Switch to the PHONO-2 position.
- Step 2: Feed a 1 kHz, -82 dB signal to the PHONO-2 input terminal.
- Step 3: Adjust the attenuator to obtain a 1 volt reading on the VTVM. The input sensitivity is the attenuator reading plus the pad loss. See Fig. 3-1.
- (9) TAPE HEAD Input
- Step 1: Set the FUNCTION Switch to the TAPE HEAD position.
- Step 2: Feed a 1 kHz, -56 dB signal to the TAPE HEAD input terminal.
- Step 3: Adjust the attenuator to obtain a 1 volt reading on the VTVM.
- Step 4: The sensitivity is the reading on the attenuator.
- (10) MIC Input
- Step 1: Set the FUNCTION Switch to the MIC position.
- Step 2: Feed a 1 kHz, -56 dB signal to the MIC input terminal.
- Step 3: Adjust the attenuator to obtain a 1 volt reading on the VTVM.
- Step 4: The sensitivity is the reading on the attenuator.

3-4 Overall Rated Output Measurement

- (1) REC OUT, CENTER OUTPUT CHANNEL
REC/PB Connector, LINE OUT
- Step 1: Set the FUNCTION Switch to TUNER.
- Step 2: Feed a 1 kHz, signal to the tuner input terminal to obtain 1 volt at the output terminal.
- Step 3: Measure the level at REC OUT, LINE OUT, REC/PB(REC OUT), and CENTER OUT.
- Electrical Specifications:
- | | | |
|------------------|-------|----------------|
| REC OUT | | -17.3 ± 0.5 dB |
| LINE OUT | | + 2.2 ± 0.5 dB |
| CENTER OUT | | +11.7 ± 1 dB |
| REC/PB (REC OUT) | | -38.3 ± 1.5 dB |
- Step 4: Connect a dummy load (10 k ohms) to the HEADPHONE jack and measure the output level and control range.
Control range: 1 to 10 ± 2 dB
- (2) OUTPUT LEVEL Switch
- Step 1: Under the conditions described above, set the OUTPUT LEVEL Switch S12 to 0.3V.
- Step 2: Confirm that the output level decreases to -8.3 ± 0.5 dB. Reset the OUTPUT LEVEL Switch to 1 V.

3-5 Overall Frequency Response Measurement

- (1) TUNER
- Step 1: Under the same conditions as those in the TUNER Input Sensitivity measurement (see page 15), adjust the input level to obtain a 1 volt reading on the VTVM.
- Step 2: Check the frequency response by varying the input signal frequency while keeping the input level constant.
- Electrical Specifications:
- | | | | |
|-----------------------|-------|----|-------|
| OUTPUT-1, 20 Hz | | +0 | -2 dB |
| 100 kHz | | +0 | -2 dB |
| CENTER CHANNEL OUTPUT | | | |
| 20 Hz | | +0 | -2 dB |
| 20 kHz | | +0 | -2 dB |
- (2) PHONO-1, PHONO-2
- Step 1: Under the same conditions as those in the PHONO Input sensitivity measurement, (see page 16), adjust the input level to obtain a 1 volt reading on the VTVM.
- Step 2: Check the frequency response by varying the input signal frequency while keeping the input level constant.
- Electrical Specifications
- | | | |
|--------|-------|--------------|
| 100 Hz | | +13 ± 1 dB |
| 10 kHz | | -13.7 ± 1 dB |
- (3) TAPE HEAD
- Step 1: Under the same conditions as those in the TAPE HEAD sensitivity measurement (see page 16), adjust the input level to obtain a 1 volt reading on the VTVM.
- Step 2: Check the frequency response by varying the input signal frequency while keeping the input level constant.
- Electrical Specifications:
- | | | |
|--------|-------|--------------|
| 100 Hz | | +18.7 ± 1 dB |
| 10 kHz | | -10 dB |

Note: Tape Equalizing Adjust R131 (L-CH) and R331 (R-CH), varies the attenuation -6 dB to -12 dB at 10 kHz.

- (4) MIC
- Step 1: Under the same conditions as those in the MIC sensitivity measurement (see page 16) adjust the input level to obtain a 1 volt reading on the VTVM.
- Step 2: Check the frequency response by varying the input signal frequency while keeping the input level constant.
- Electrical Specifications:
- | | | | |
|--------|-------|----|---------|
| 20 Hz | | +0 | -2 dB |
| 30 kHz | | +0 | -5.5 dB |

3-6 Overall Harmonic Distortion Measurement

- Step 1: Under the same conditions as those in the PHONO-1 Input sensitivity measurement (see page 16) feed a 1 kHz, -20dB signal to the PHONO-1 Input terminal.
- Step 2: Adjust the volume control to obtain a 3 volt reading on the VTVM and measure the harmonic distortion.
- Electrical Specification:
- Harmonic Distortion.....0.05% or less

3-7 Overall Noise Level Measurement

- OVERALL NOISE LEVEL MEASUREMENT
- Measure the output noise level with a VTVM at each FUNCTION Switch position, with the corresponding input terminals shorted. See Fig. 3-5.
- | | | |
|-----------------------|--|----------------|
| TUNER | | |
| AUX-1, 2 | | -74 dB or less |
| TAPE IN | | |
| PHONO-1 | | -57 dB or less |
| PHONO-2 | | -57 dB or less |
| (NORMAL) | | |
| PHONO-2 | | -40 dB or less |
| (LOW) | | |
| MIC | | -56 dB or less |
| CENTER CHANNEL | | |
| OUTPUT | | -65 dB or less |
| (TUNER input shorted) | | |

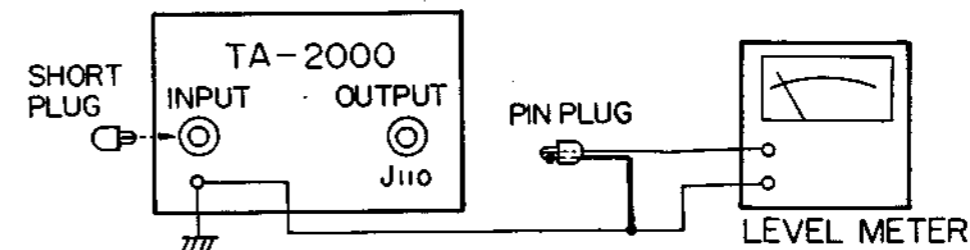
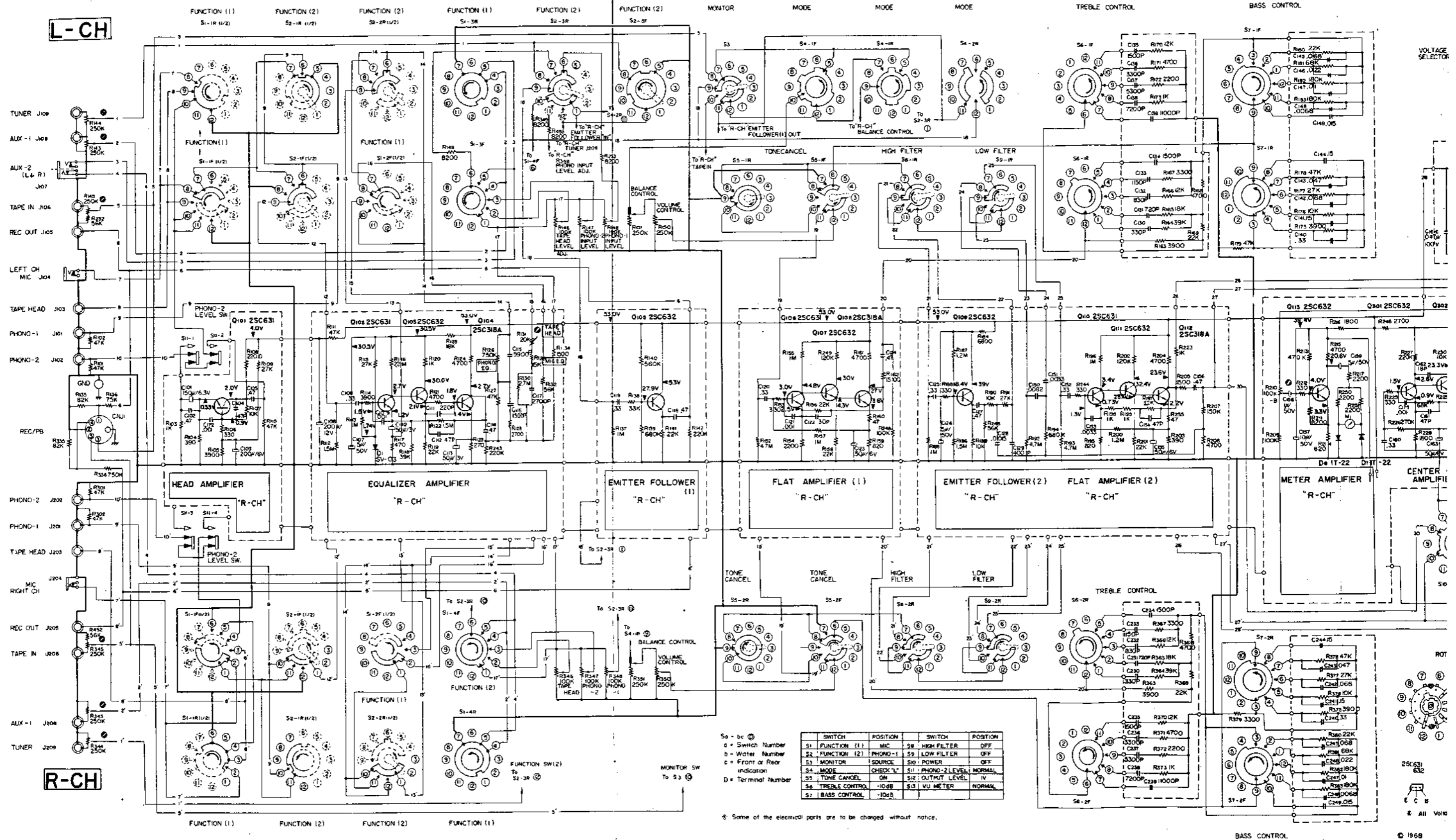
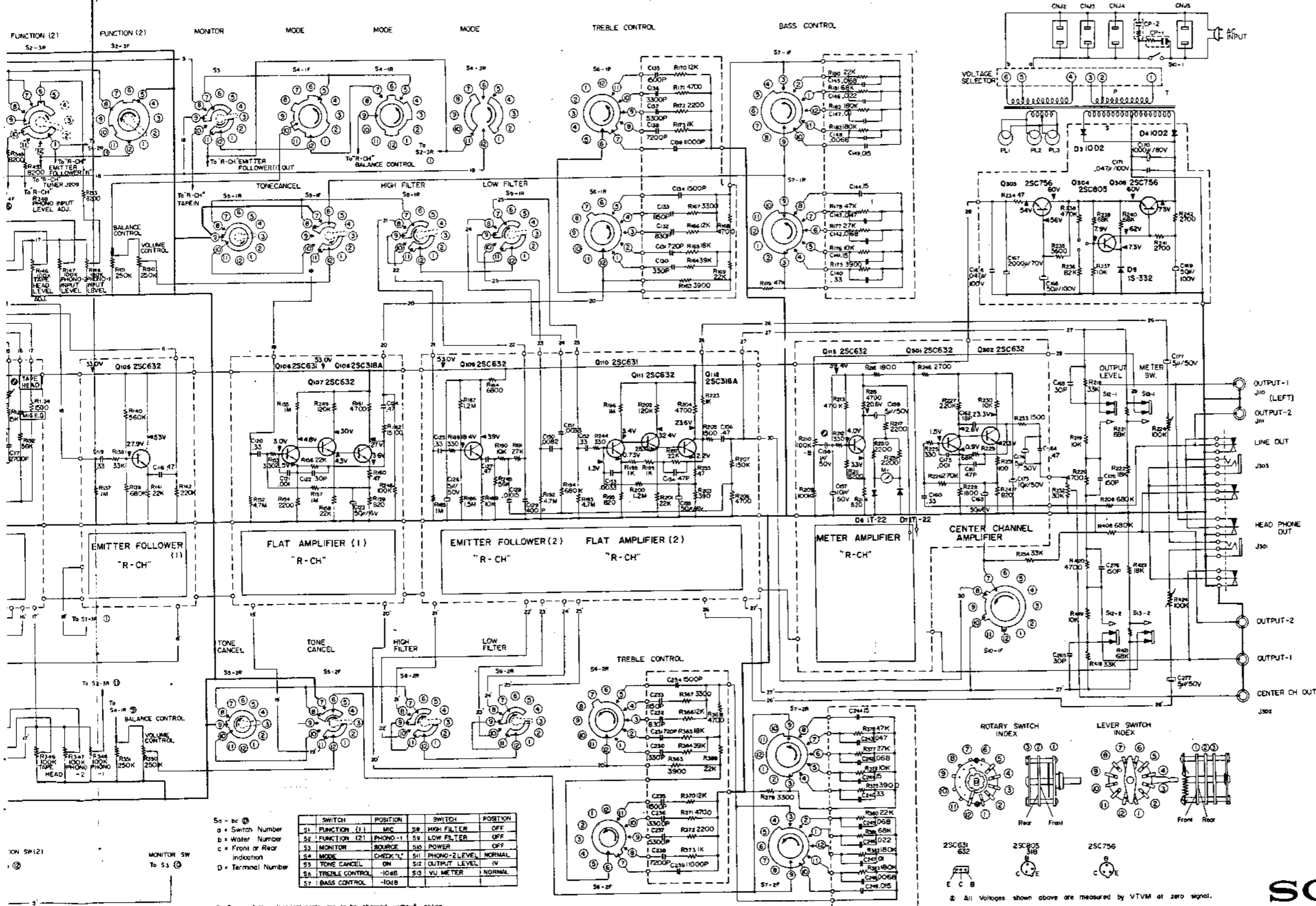

Fig. 3-5. Overall Noise Level Measurement Test Set-up

TA-2000 TA-2000

SCHEMATIC DIAGRAM





Sa - bc @
 a = Switch Number
 b = Water Number
 c = Front or Rear Indication
 d = Terminal Number

SWITCH	POSITION	SWITCH	POSITION
S1	FUNCTION (1)	S8	HIGH FILTER
S2	FUNCTION (2)	S9	LOW FILTER
S3	MONITOR	S10	POWER
S4	MODE	S11	PHONE-2 LEVEL
S5	TONE CANCEL	S12	OUTPUT LEVEL
S6	TREBLE CONTROL	S13	VU METER
S7	BASS CONTROL		NORMAL

* Some of the electrical parts are to be changed without notice.

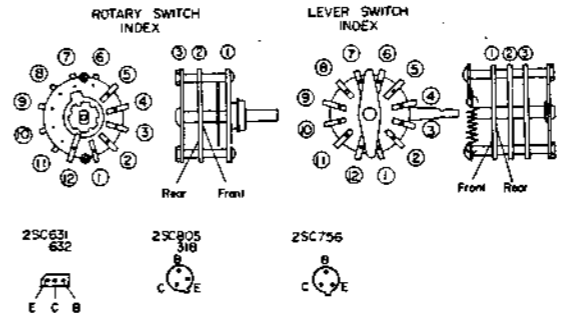

* All Voltages shown above are measured by VTVM at zero signal.

CHASSIS LAYOUT

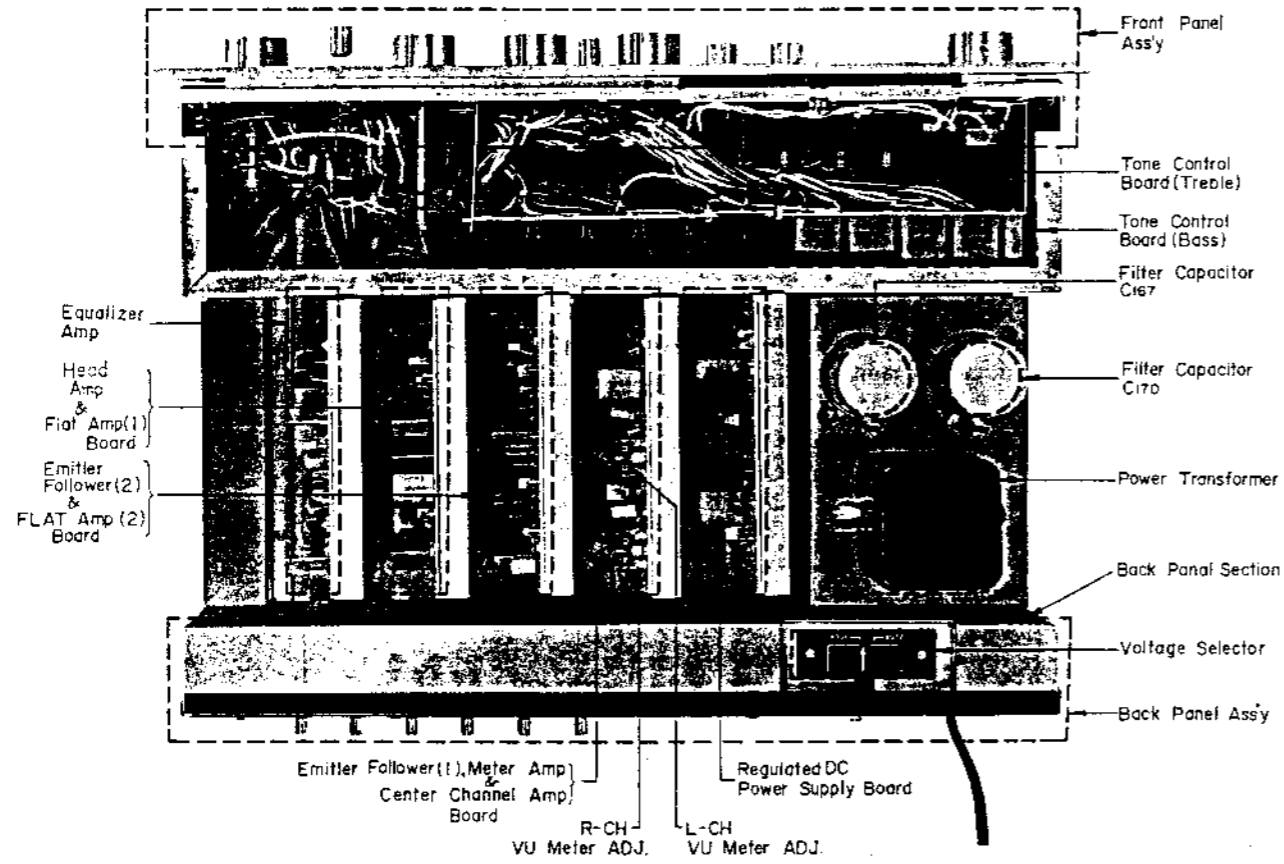

MOUNTING DIAGRAM

Output Level Switch S12 Section

— Conductor Side —

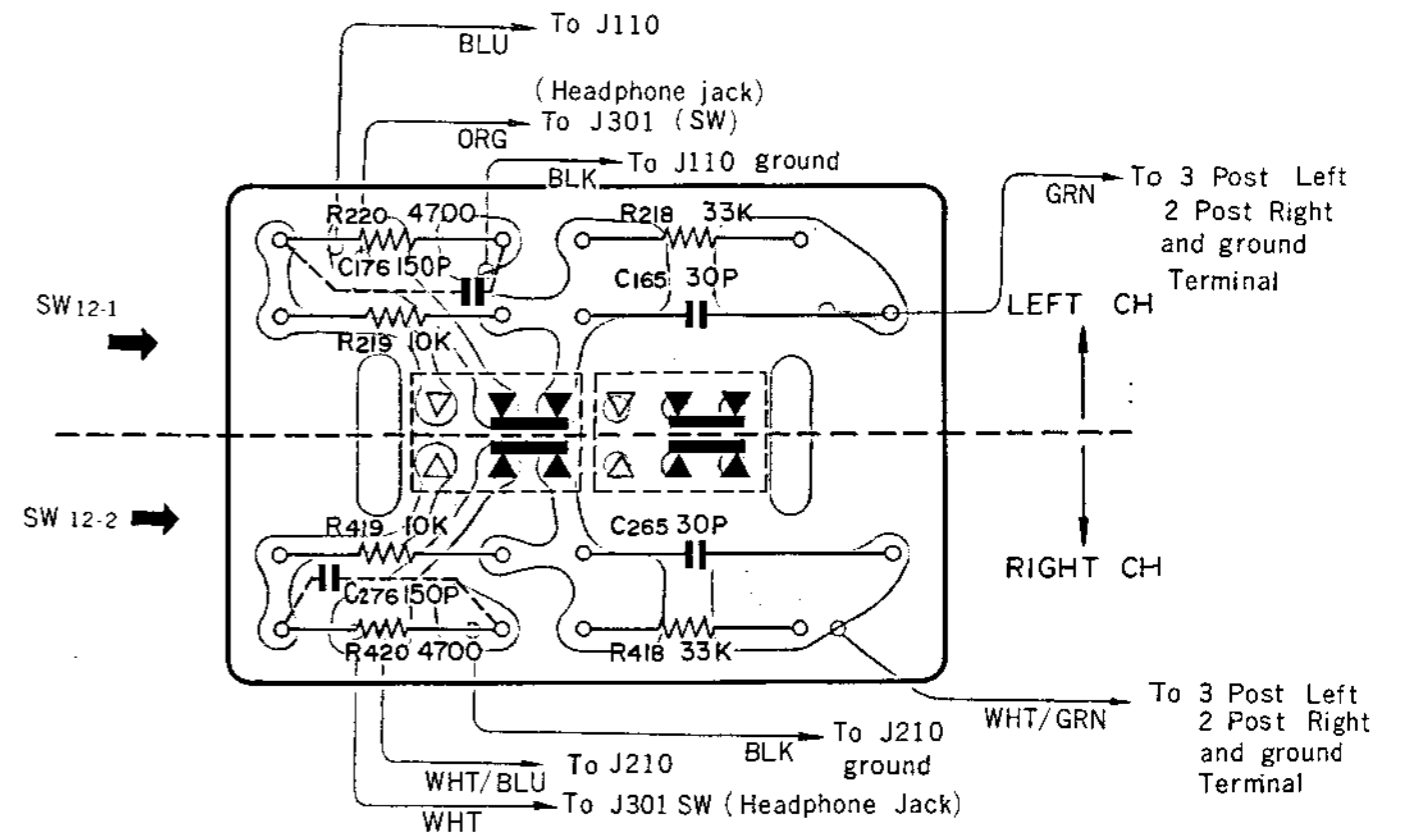

MOUNTING DIAGRAM

Equalizer Section

— Conductor Side —

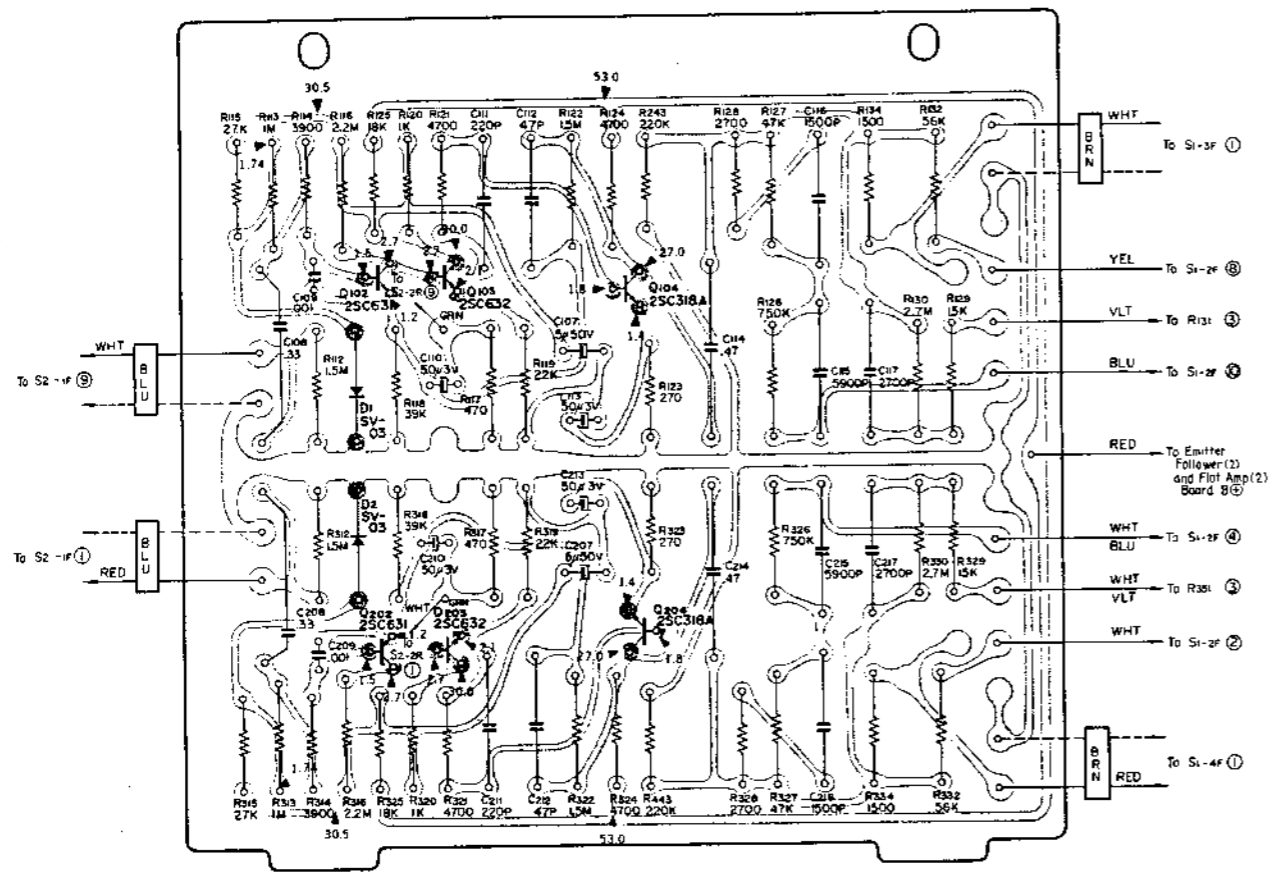

MOUNTING DIAGRAM

Equalizer Section

— Component Side —

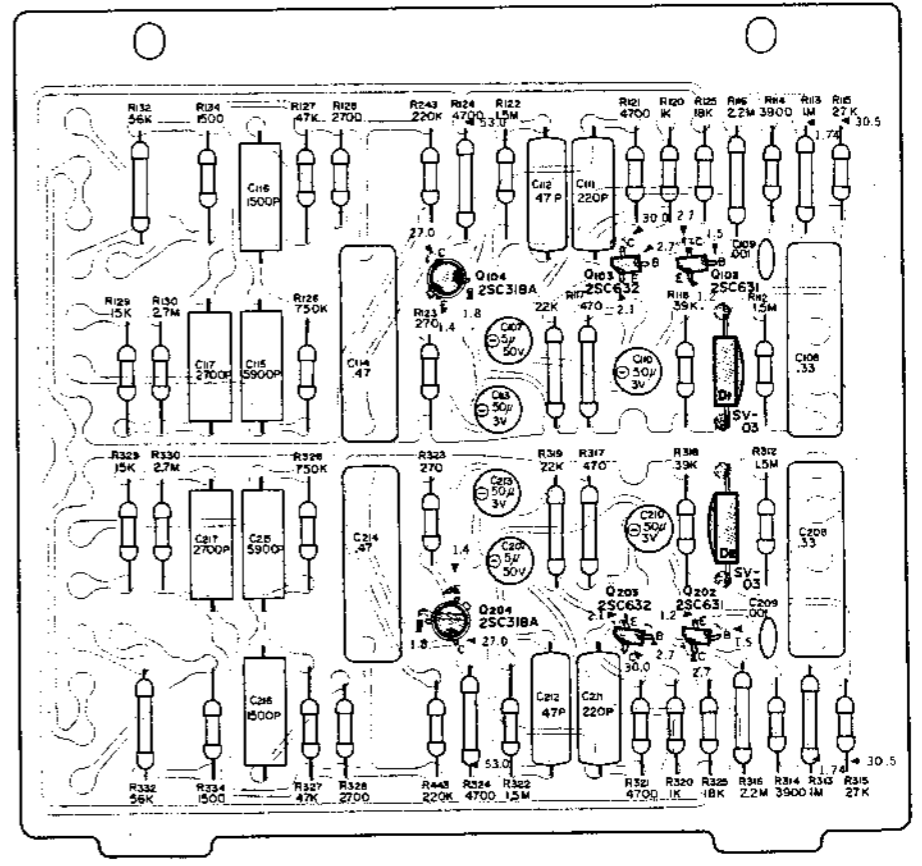

MOUNTING DIAGRAM

Head Amplifier and Flat Amplifier (1) Section

— Conductor Side —

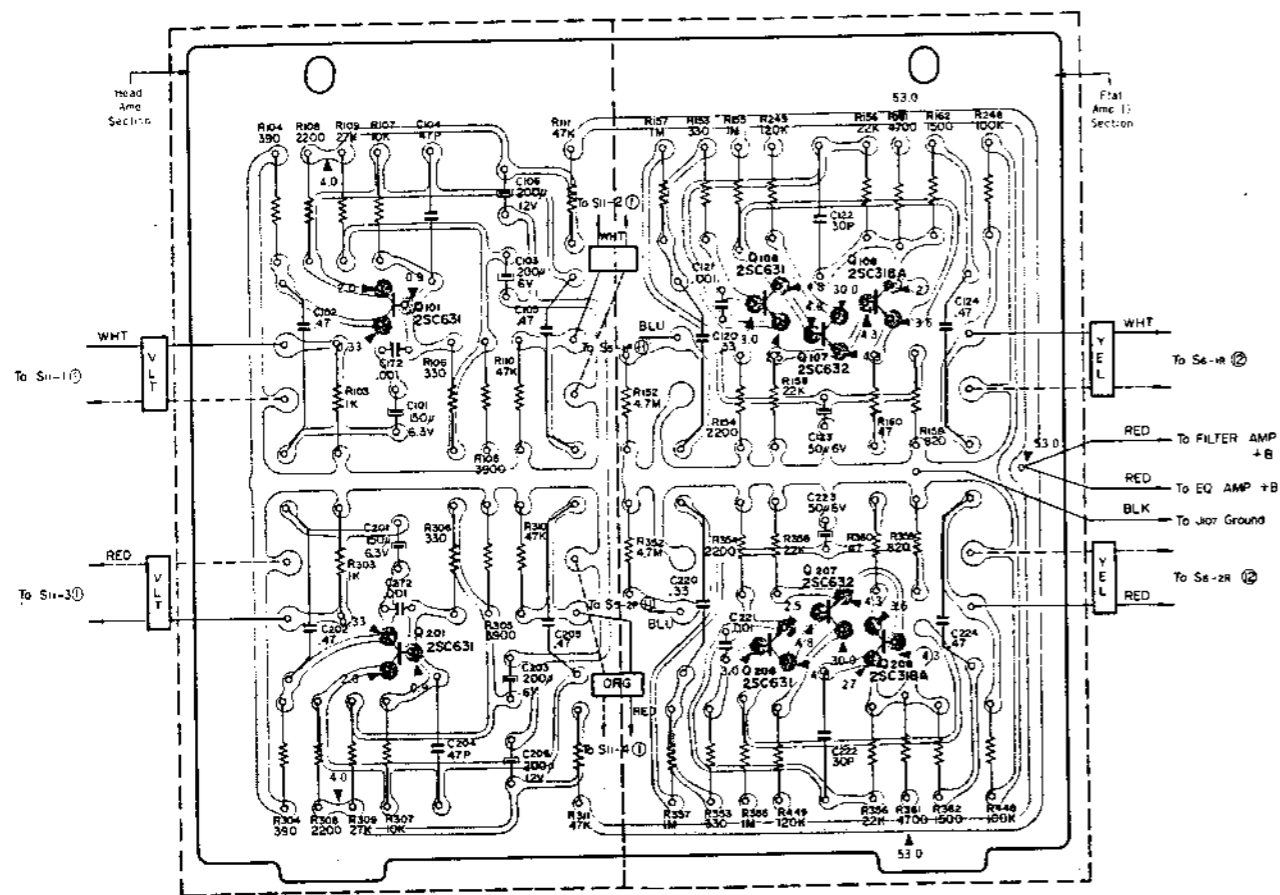

MOUNTING DIAGRAM

Head Amplifier and Flat Amplifier (1) Section

— Component Side —

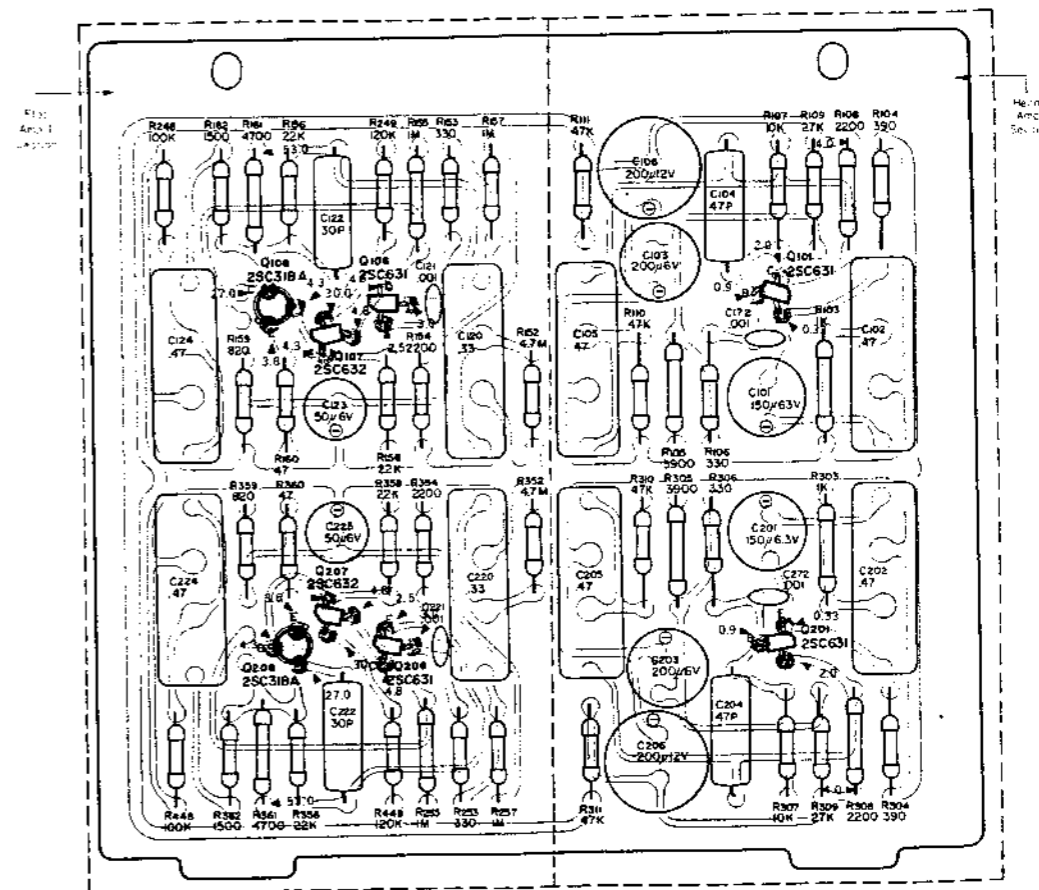

MOUNTING DIAGRAM

Flat Amplifier (2) and Emitter Follower (2) Section

— Conductor Side —

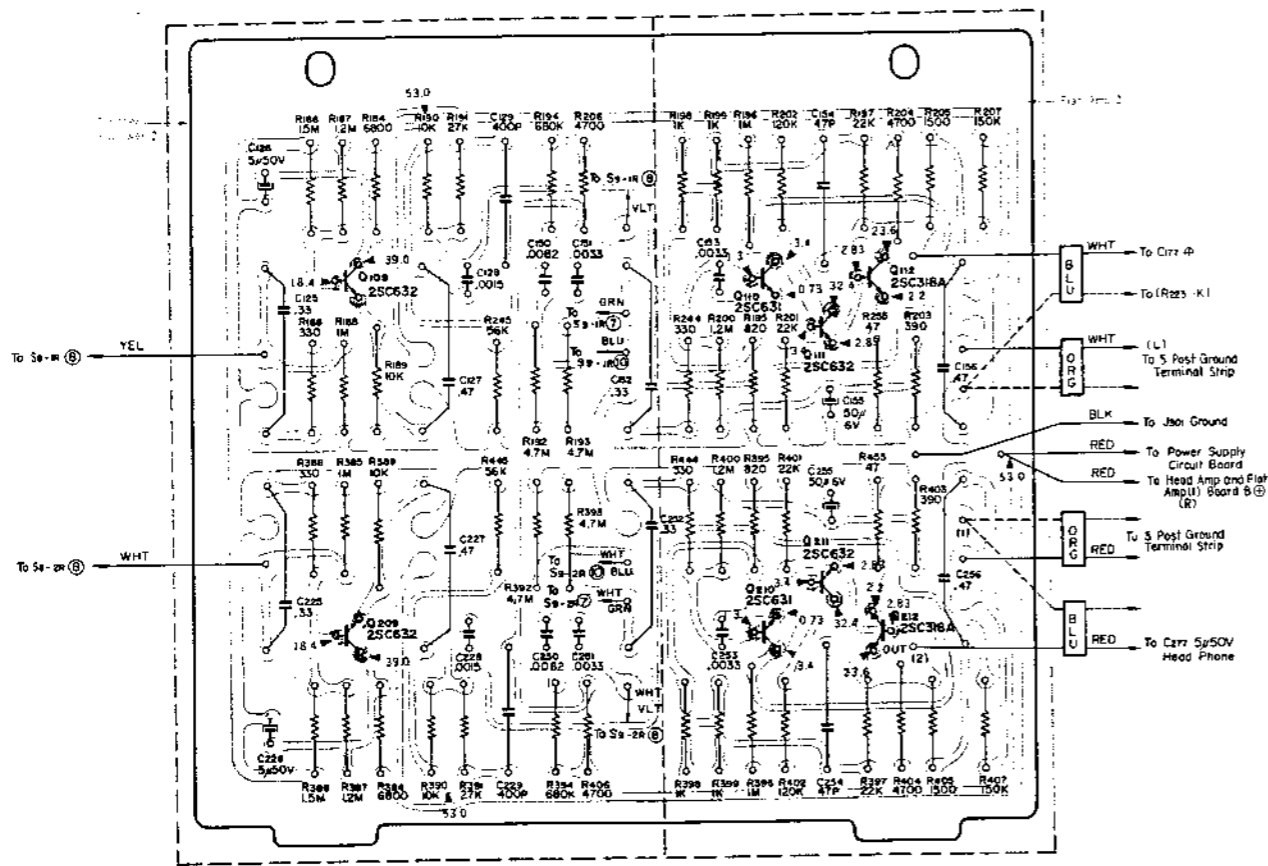

MOUNTING DIAGRAM

Flat Amplifier (2) and Emitter Follower (2) Section

— Component Side —

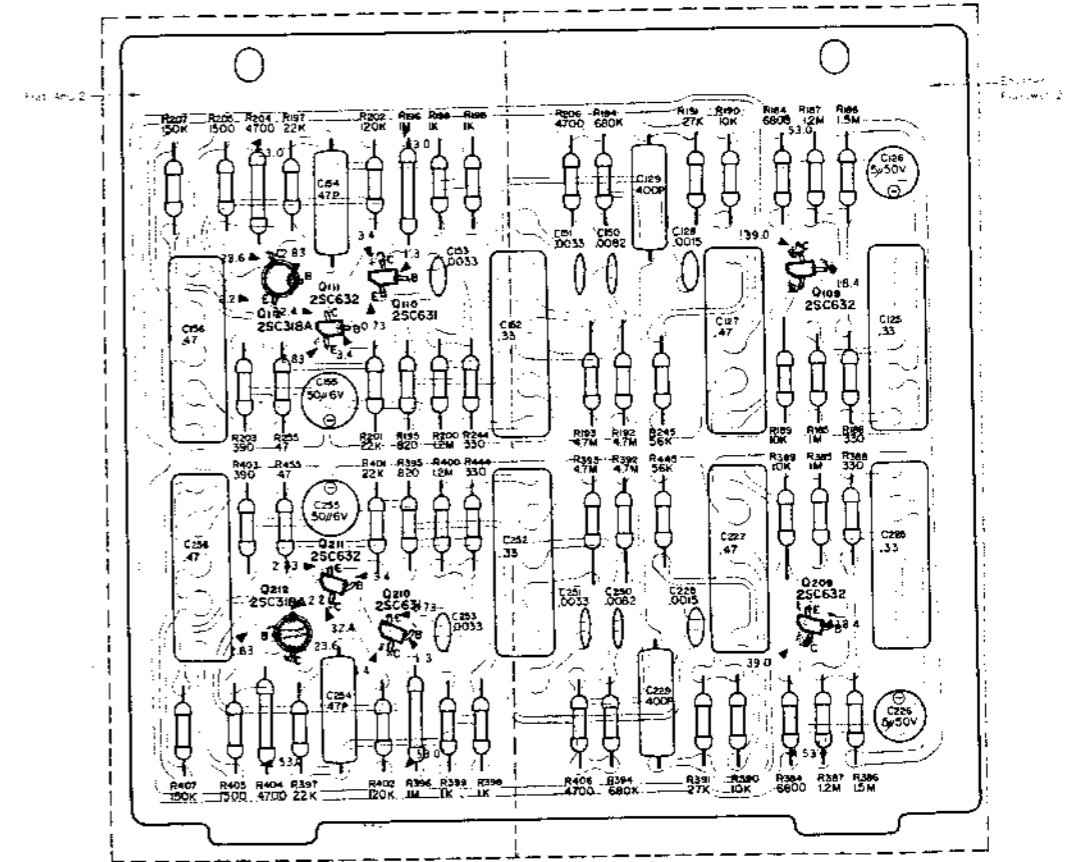

MOUNTING DIAGRAM

Meter, Center Amplifier and Emitter Follower (1) Section

— Conductor Side —

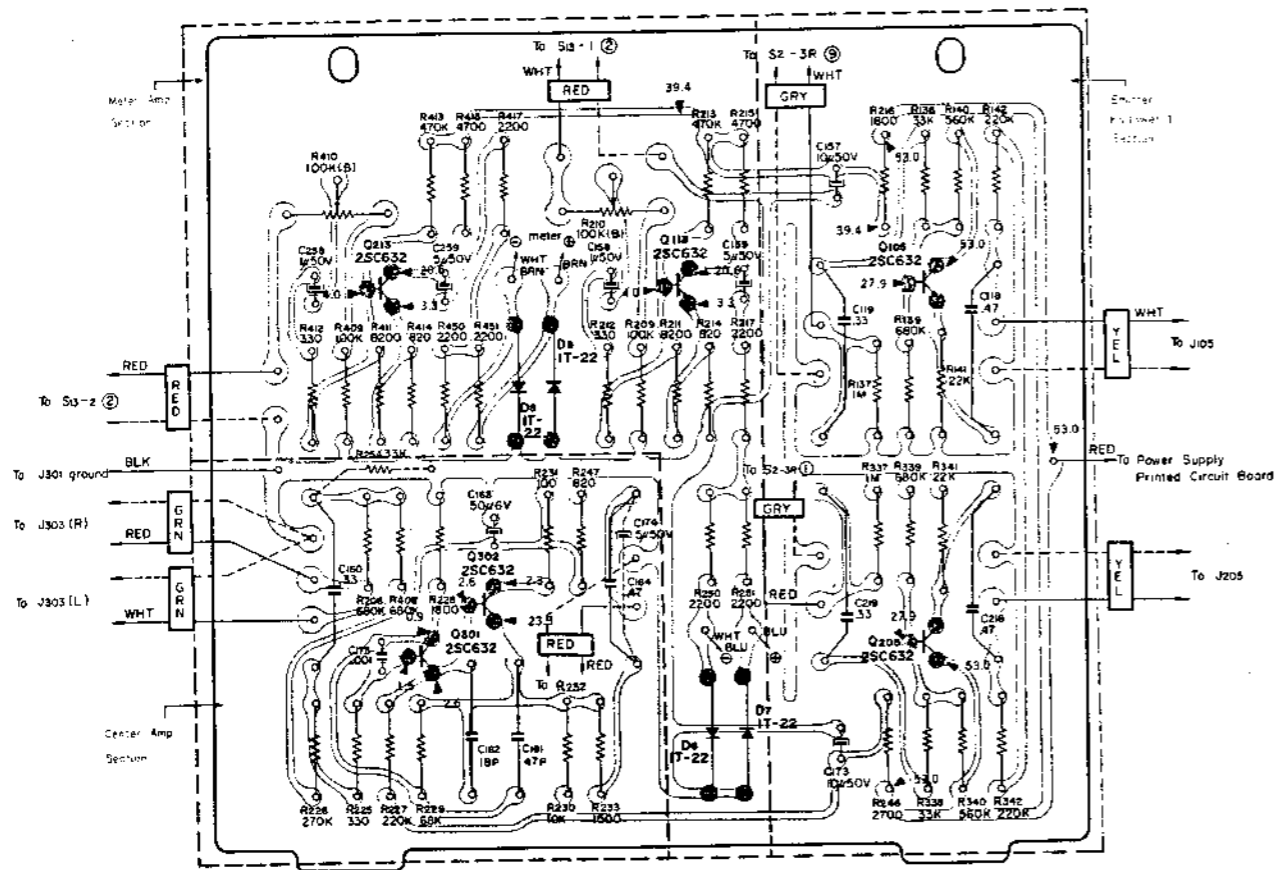

MOUNTING DIAGRAM

Meter, Center Amplifier and Emitter Follower (1) Section

— Component Side —

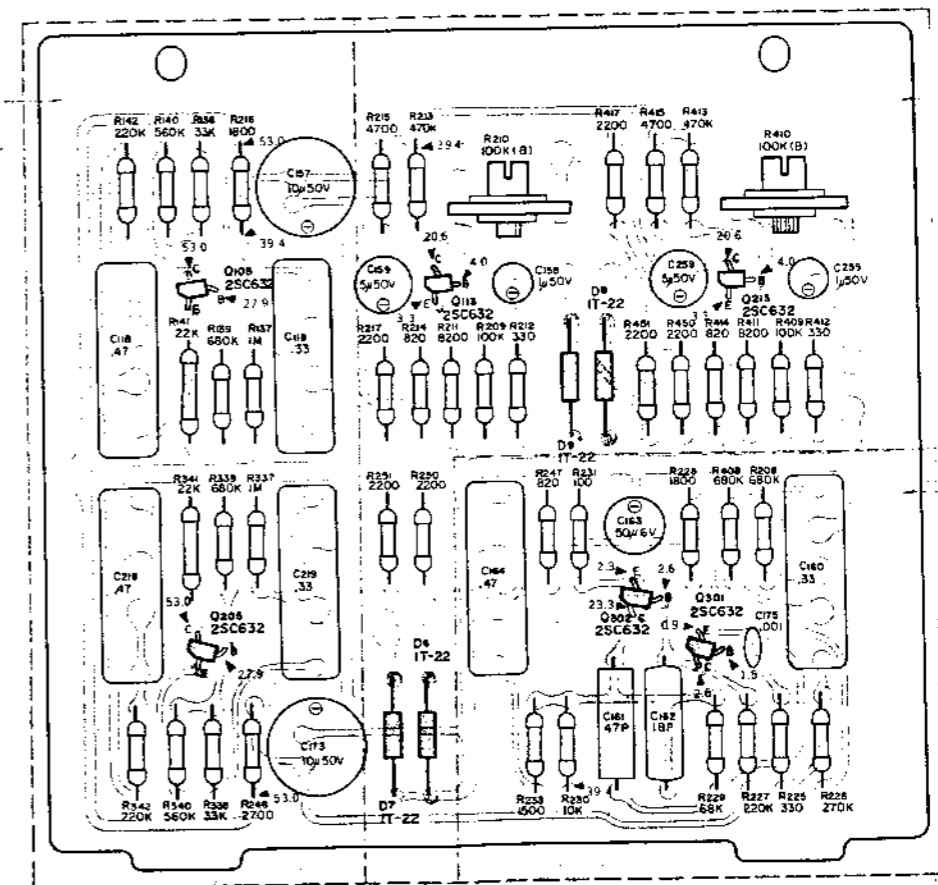

MOUNTING DIAGRAM

Treble Control Section

— Conductor Side —

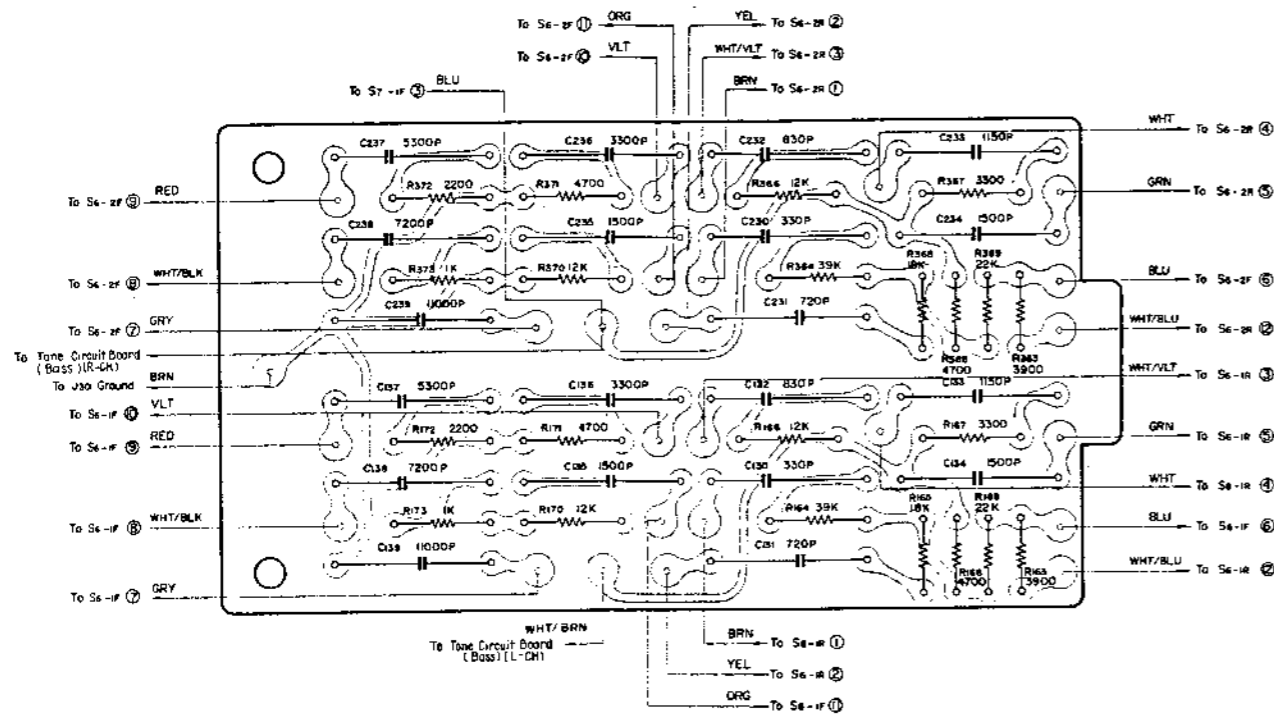

— Component Side —

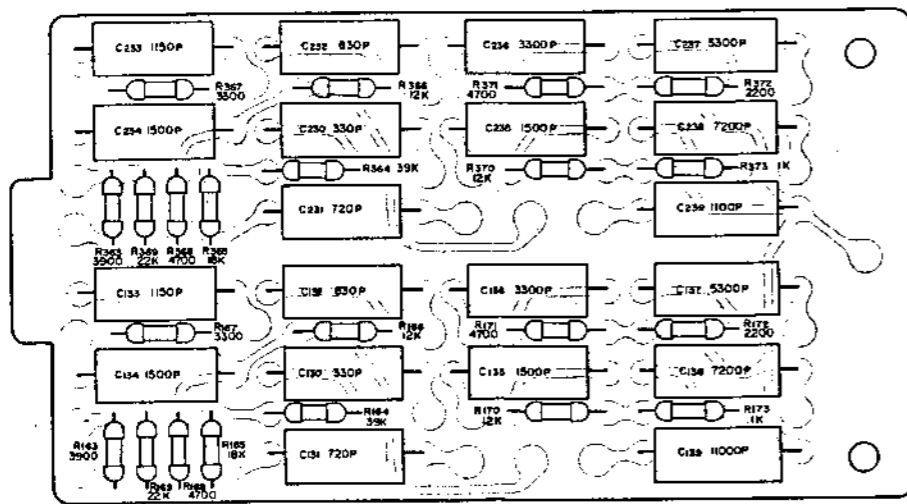

MOUNTING DIAGRAM

Bass Control Section

— Conductor Side —

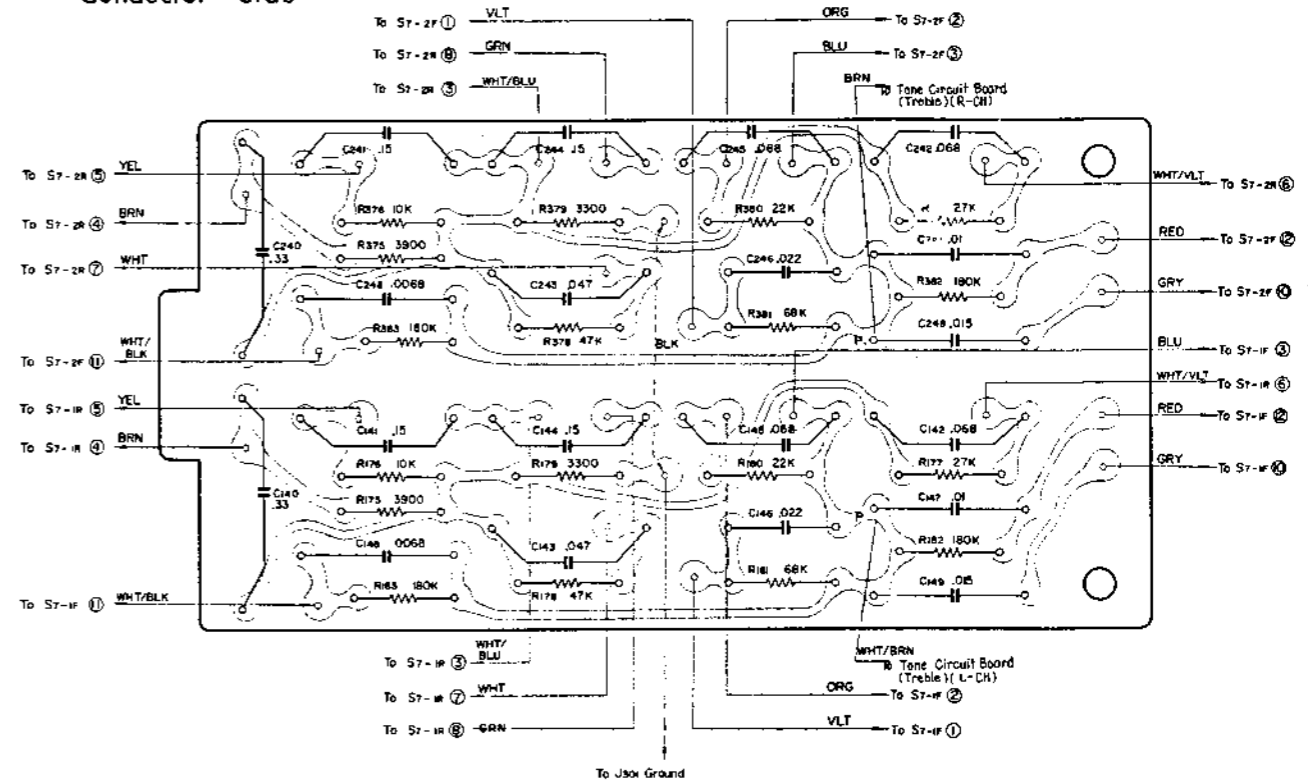

— Component Side —

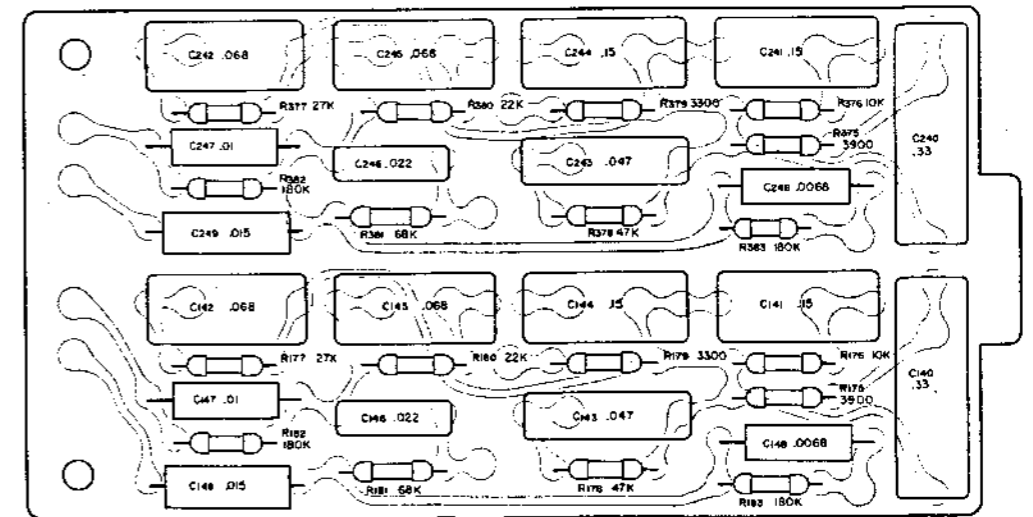

MOUNTING DIAGRAM

Power Supply Section

— Conductor Side —

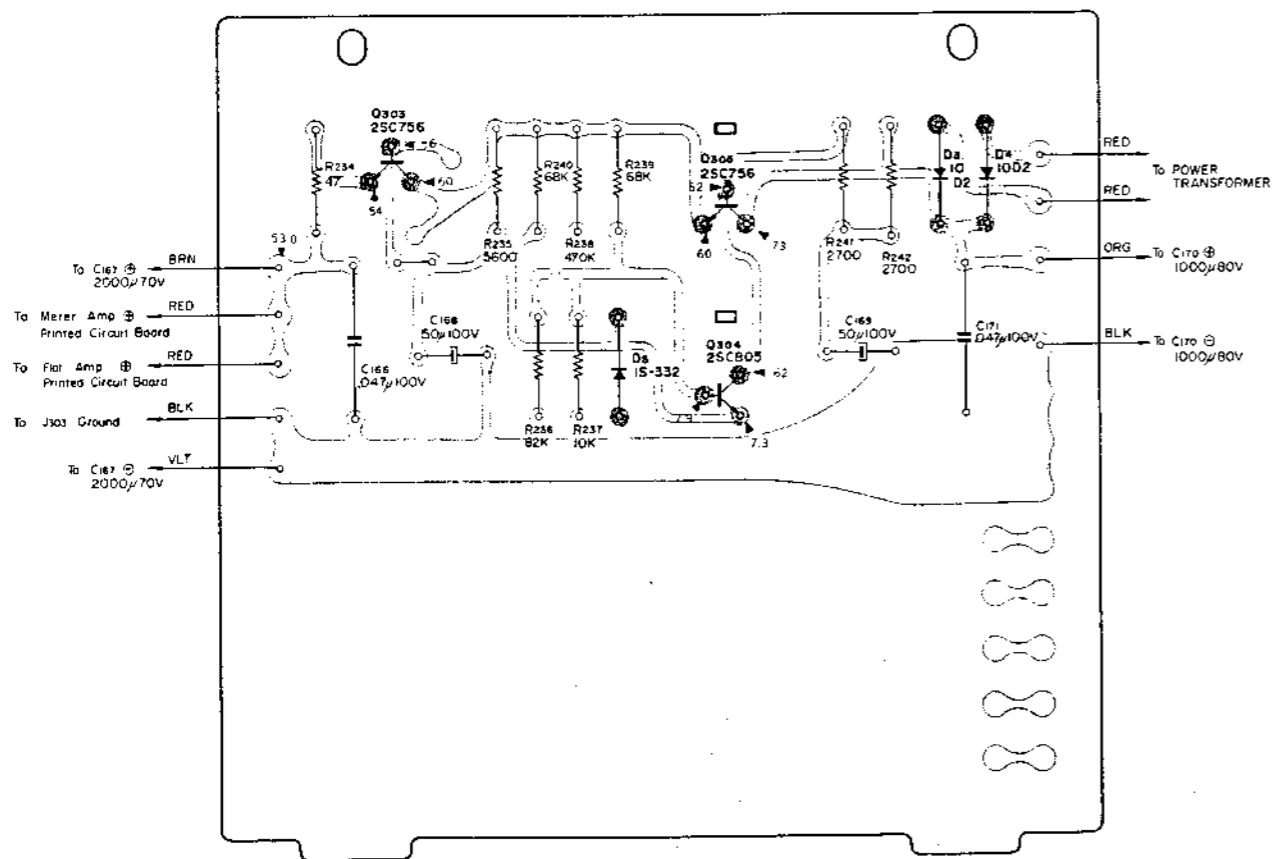

MOUNTING DIAGRAM

Power Supply Section

— Component Side —

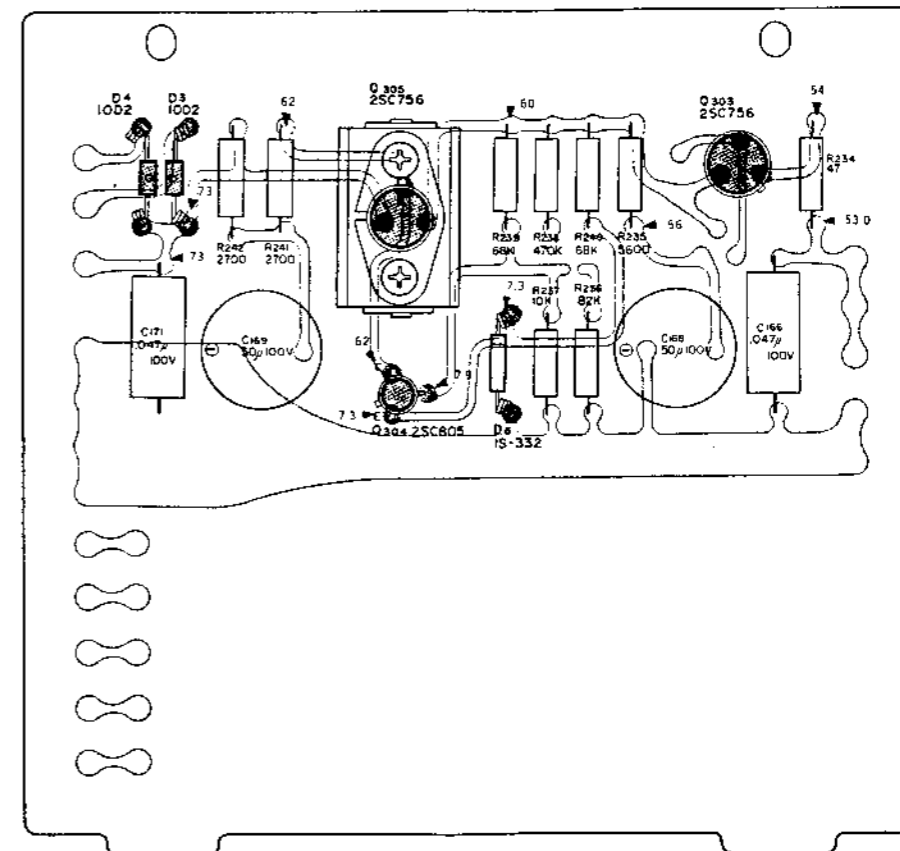

EXPLODED VIEW

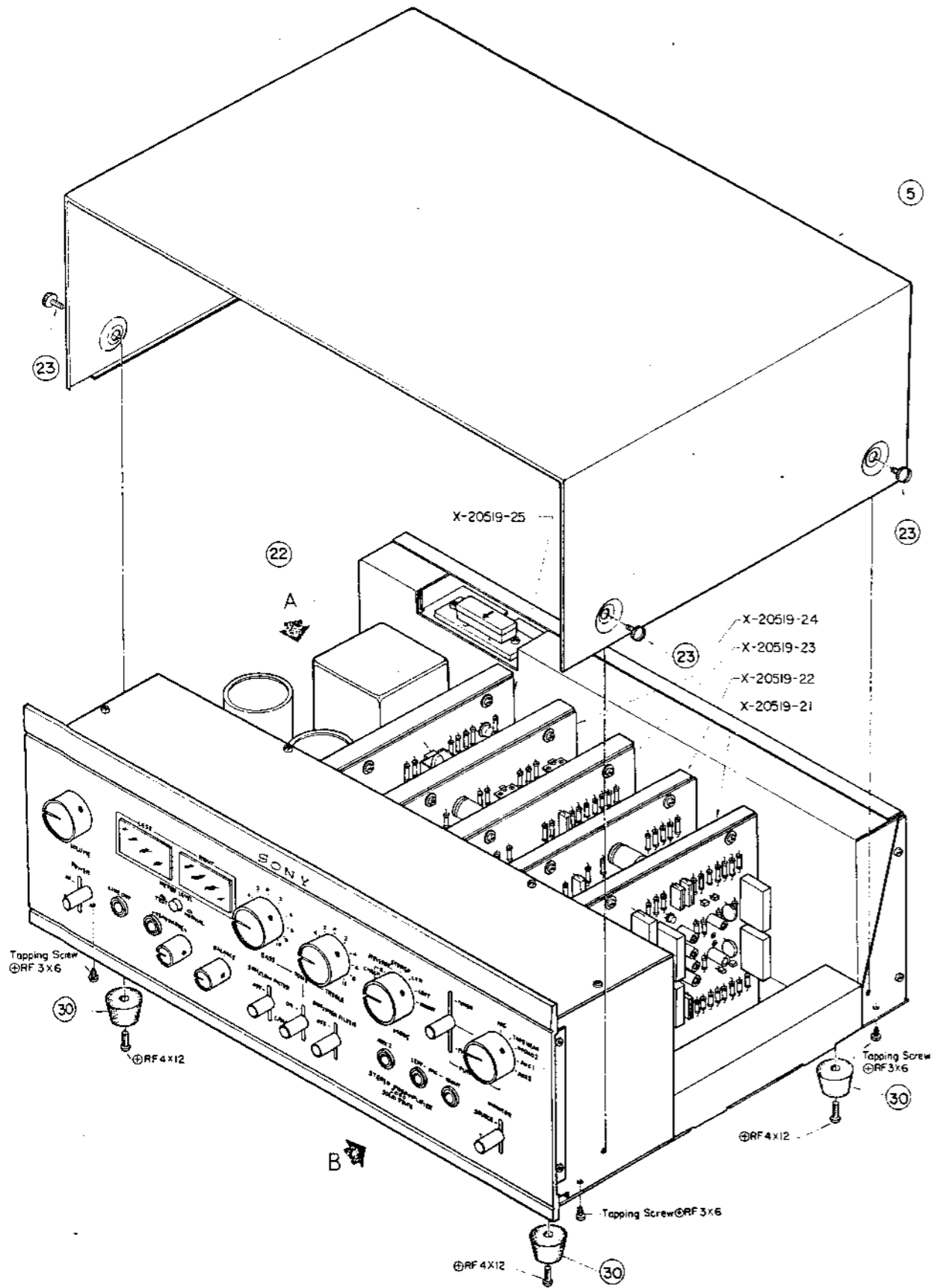

EXPLODED VIEW

Detail "A"

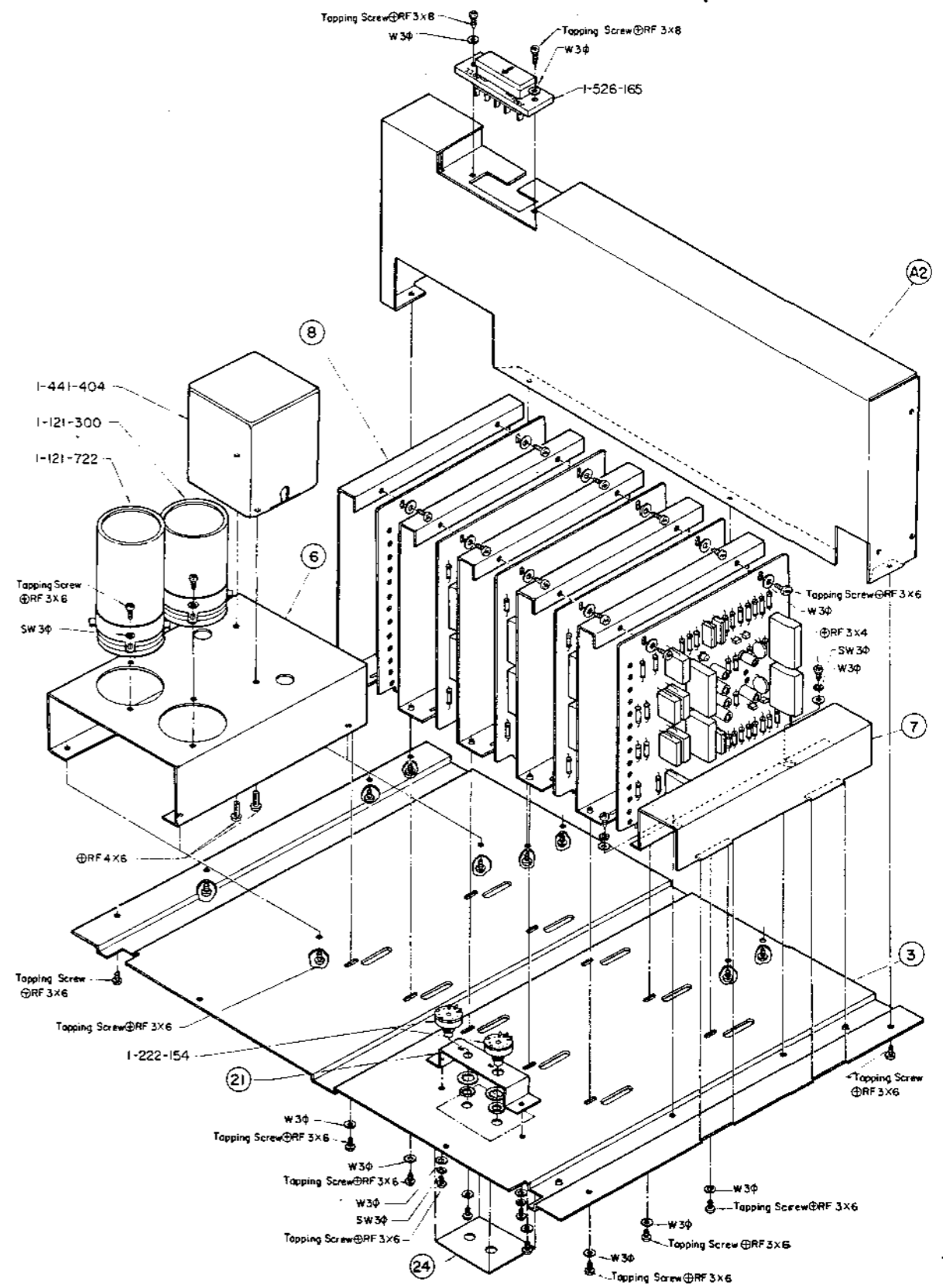

EXPLODED VIEW

Detail "B"

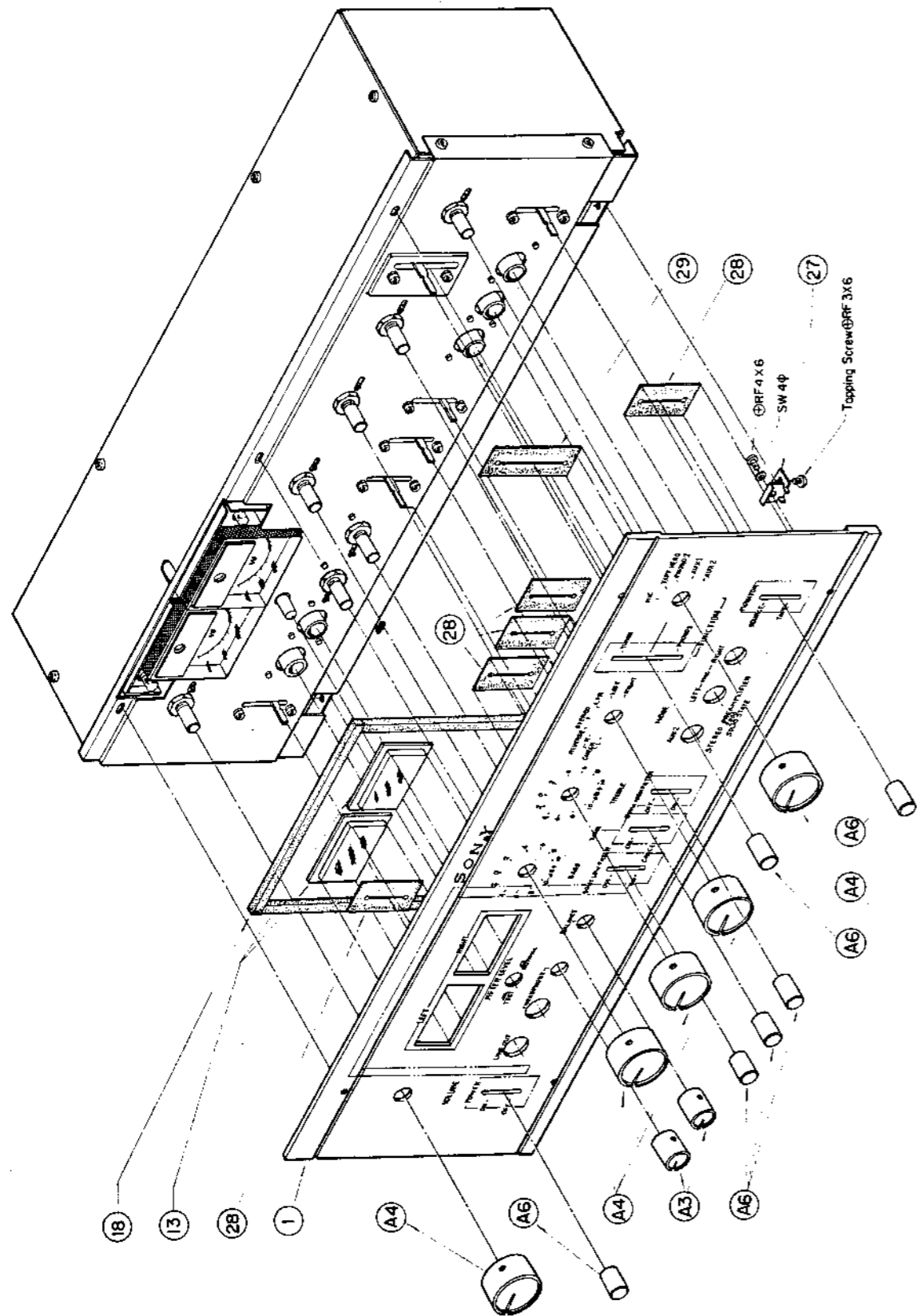

EXPLODED VIEW

Detail "B"

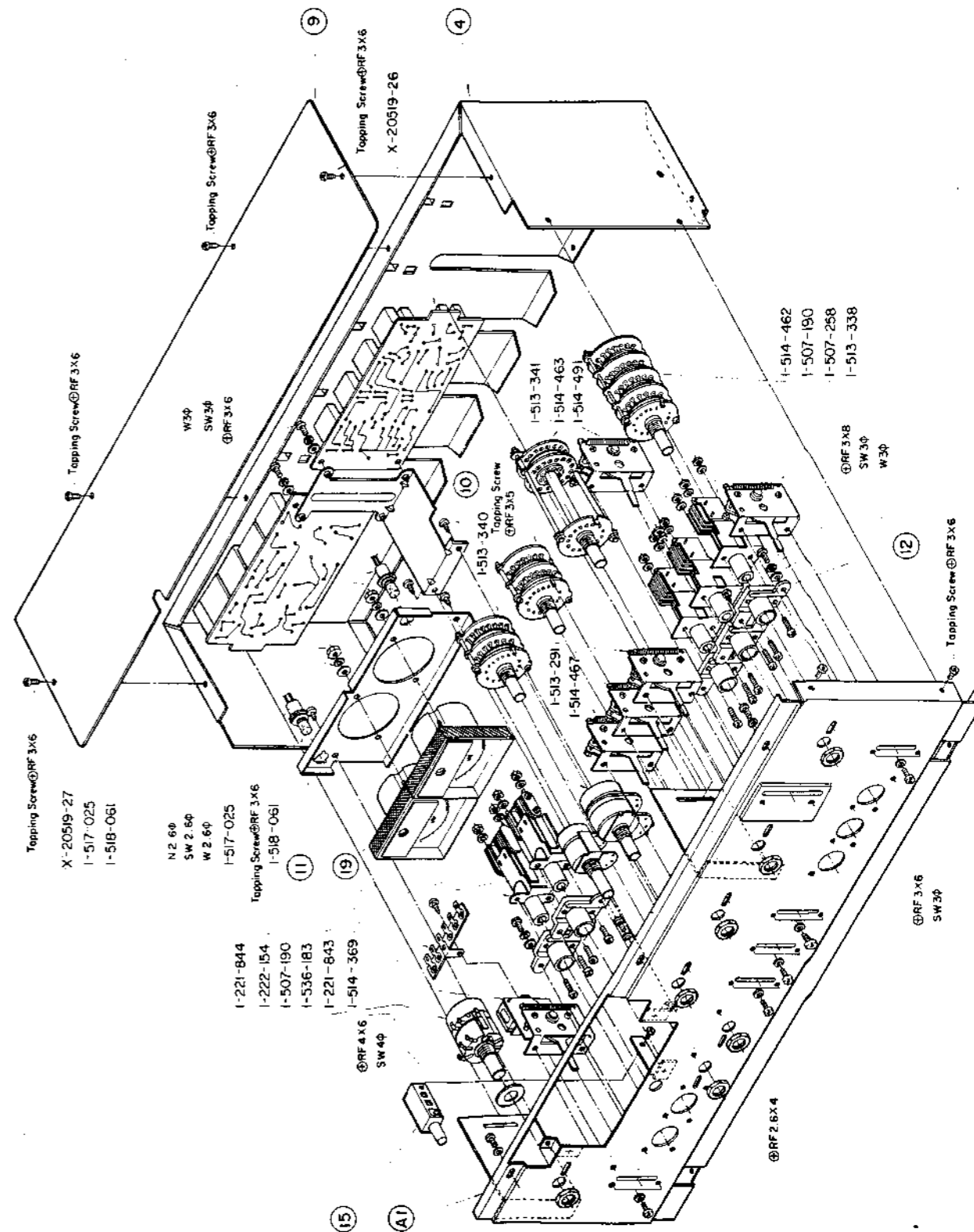

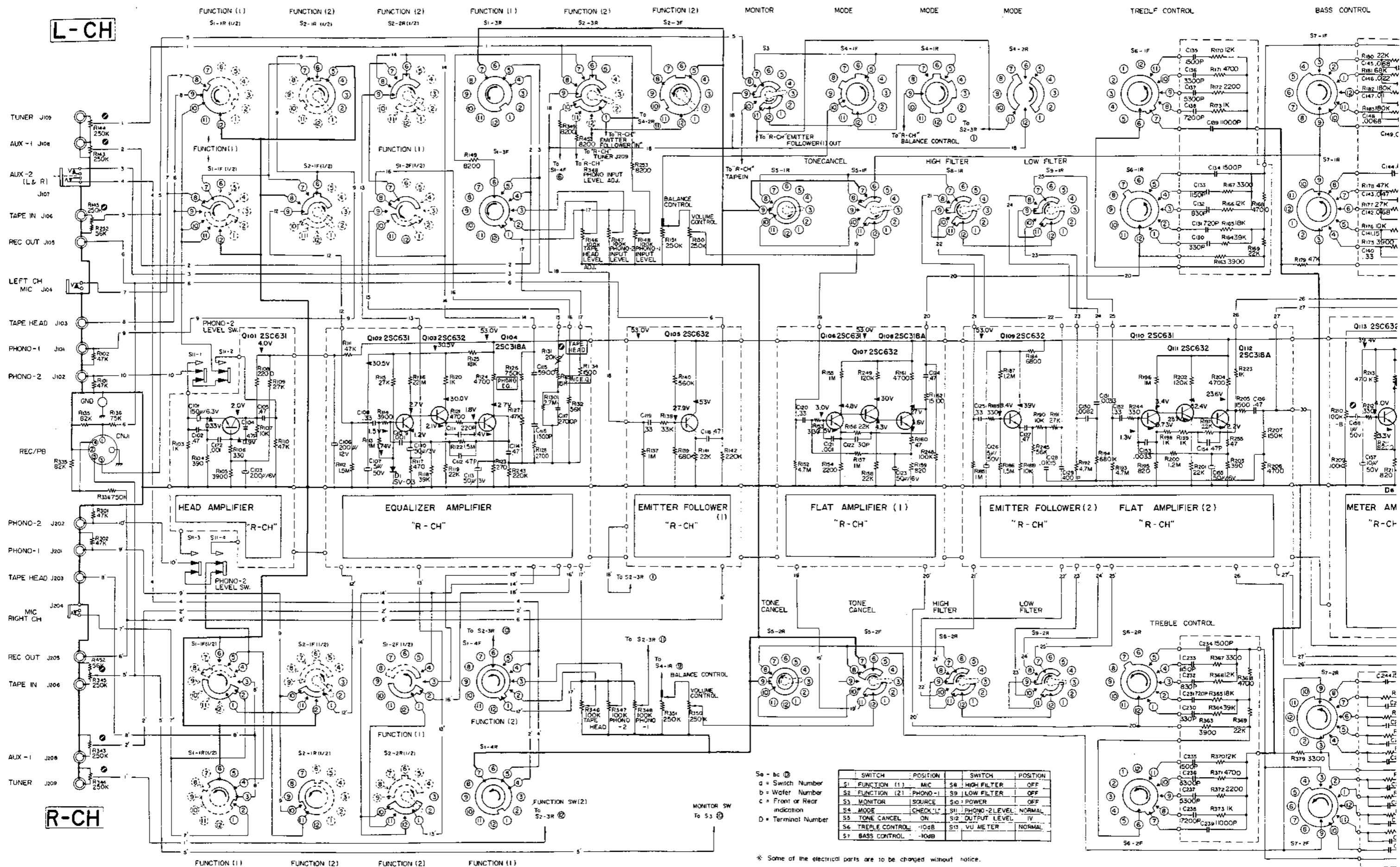

S1 - bc (D)

a = Switch Number
b = Wafer Number
c = Front or Rear indication
D = Terminal Number

SWITCH	POSITION	SWITCH	POSITION
S1	FUNCTION (1) - MIC	S8	HIGH FILTER - OFF
S2	FUNCTION (2) - PHONO-1	S9	LOW FILTER - OFF
S3	MONITOR - SOURCE	S10	POWER - OFF
S4	MODE - CHECK "L"	S11	PHONO-2 LEVEL - NORMAL
S5	TONE CANCEL - ON	S12	OUTPUT LEVEL - IV
S6	TREBLE CONTROL - -10dB	S13	VU METER - NORMAL
S7	BASS CONTROL - -10dB		

* Some of the electrical parts are to be changed without notice.

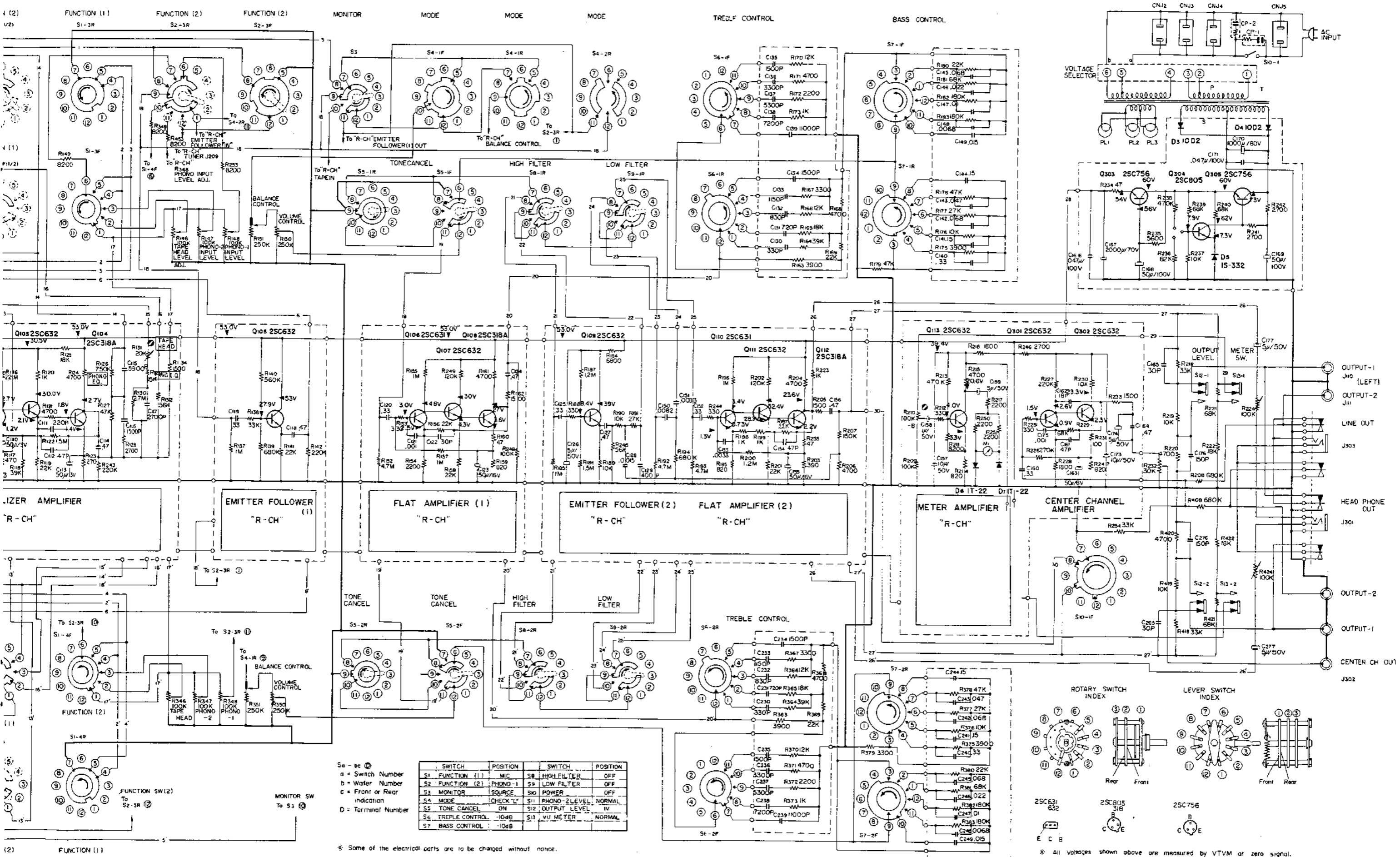

* Some of the electrical parts are to be changed without notice.
 * All voltages shown above are measured by VTVM at zero signal.