

TA-1150

USA Model
(Serial No. 804,001 and later)

Canada Model
(Serial No. 701,001 and later)

AEP Model

UK Model

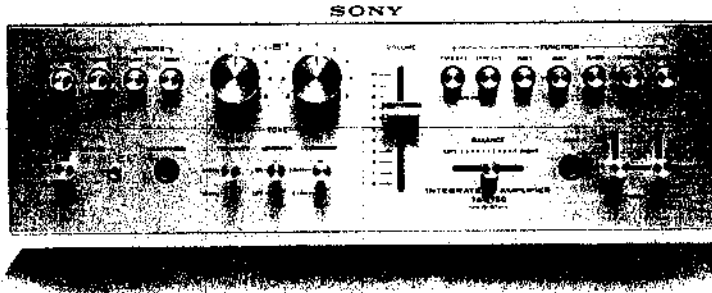

INTEGRATED STEREO AMPLIFIER

SPECIFICATIONS

POWER AMPLIFIER SECTION

Dynamic power output: 100 watts, both channels operating; 8 ohms
150 watts, both channels operating; 4 ohms

Continuous RMS power output (less than 0.2 % THD):
[Rated Output]
At 1 kHz
40 watts per channel, 8 ohms
55 watts per channel, 4 ohms
(One channel driven separately)
35 watts per channel, both channels operating, 8 ohms
40 watts per channel, both channels operating, 4 ohms
At 20 Hz ~ 20 kHz
30 watts per channel, both channels operating, 8 ohms

Power bandwidth: 8 Hz to 35 kHz, IHF

Harmonic distortion: Less than 0.2 % at 1 kHz rated output

IM distortion: Less than 0.2 % at rated output
(60 Hz : 7 kHz = 4 : 1)

PREAMPLIFIER SECTION

Frequency response: PHONO -1, -2 RIAA equalization curve ± 1 dB
TAPE -1, TAPE -2 }
TUNER } 15 Hz to 80 kHz ± 2 dB
AUX -1, -2 }
REC/PB (input)

Input sensitivity and impedance:

PHONO -1, -2 2 mV 47 k
TAPE -1, TAPE -2 }
TUNER } 140 mV 50 k
AUX -1, -2 }
REC/PB (input)

Signal output and output impedance:

REC OUT -1, -2 140 mV 10 k
PRE OUT 800 mV 2.7 k
REC/PB 24 mV 82 k
CENTER OUT 800 mV 680 Ω

GENERAL

Power consumption: 180 watts (USA and Canada Model)
250 watts (AEP and UK Model)

Power requirement: 120 volts ac (USA and Canada Model)
110, 127, 220, 240 volts ac (AEP and UK Model)

Dimensions: 400 (w) x 149 (h) x 316 (d) mm
15³/₄ (w) x 5¹³/₁₆ (h) x 12⁷/₁₆ (d) inches

Net weight: 8.3 kg (18 lb 5 oz)

Shipping weight: 11.5 kg (25 lb 6 oz)

SONY®

SERVICE MANUAL

TABLE OF CONTENTS

<u>Section</u>	<u>Title</u>	<u>Page</u>
SERVICING NOTES		
1.	Cautions on Handling ICs	1
1. TECHNICAL DESCRIPTION		
1-1.	Specifications	2
1-2.	Circuit Analysis	3
1-3.	Block Diagram	7
1-4.	Level Diagram	8
2. DISASSEMBLY AND REPLACEMENT		
2-1.	Top Cover and Front Panel Removal	9
2-2.	Front Subchassis Removal	9
2-3.	Control and Switch Replacement	9
2-4.	Neon Lamp Replacement	10
2-5.	Power Amplifier Board Removal	11
2-6.	Power Transistor Replacement	11
2-7.	Replacement of Components Secured to the Rear Panel by Nylon Rivets	12
2-8.	AC Outlet Replacement	12
2-9.	Chassis Layout	13
3. ADJUSTMENTS		
3-1.	DC Bias Adjustment	14
4. REPACKING		
5. DIAGRAMS		
5-1.	Mounting Diagram - Loudness Board -	17
5-2.	Mounting Diagram - Equalizer Amp Board -	18
5-3.	Mounting Diagram - Tone Amp/Power Supply Board -	19
5-4.	Mounting Diagram - Power Amplifier Board -	21
5-5.	Schematic Diagram	23
6. EXPLODED VIEWS		
7. ELECTRICAL PARTS LIST		
		28

SERVICING NOTES

1. Cautions on handling ICs
 - (a) Too much heat applied to the IC may cause its destruction. Therefore never reinstall the removed IC.
 - (b) Check the related components for defects before to replace the IC.
 - (c) Take care when installing new ICs not to apply too much heat. Solder quickly while holding a wet rag against the heat-sink tab shown in Fig. A.
 - (d) Take care not to short the adjacent IC leads when performing electrical checks. This might damage the IC.
 - (e) Never fail to solder the heat sink of the IC to the printed circuit board. Otherwise the IC might be damaged.

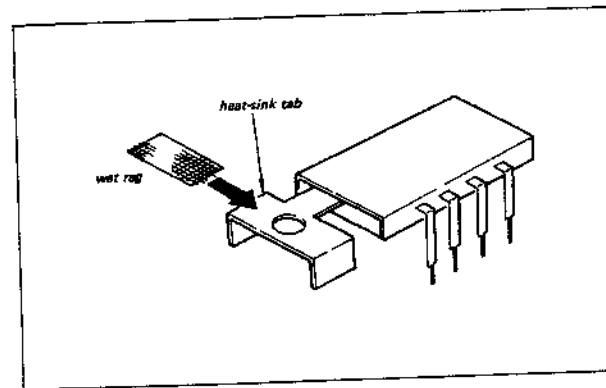

Fig. A. IC installation

SECTION 1
TECHNICAL DESCRIPTION

1-1. SPECIFICATIONS

Power Amplifier Section

Dynamic power output: 100 watts, both channels operating; 8 ohms
150 watts, both channels operating; 4 ohms

Continuous RMS power output (Rated output) [less than 0.2% THD]:

At 1 kHz
40 watts per channel, 8 ohms
55 watts per channel, 4 ohms
(One channel driven separately)
35 watts per channel, both channels operating, 8 ohms
40 watts per channel, both channels operating, 4 ohms
At 20 Hz ~ 20 kHz
30 watts per channel, both channels operating, 8 ohms

Power bandwidth: 8 Hz to 35 kHz, IHF

Harmonic distortion: Less than 0.2% at 1 kHz rated output

DM distortion: Less than 0.2% at rated output (60 Hz: 7 kHz = 4:1)

Input sensitivity: 0.8 V (50 k) for rated output

Signal-to-noise ratio: Greater than 110 dB (shorted input, A network)

Preamplifier Section

Frequency response: PHONO-1, -2 RIAA equalization curve ± 1 dB
TAPE-1
TAPE-2
TUNER } 15 Hz to 80 kHz ± 2 dB
AUX-1
AUX-2
REC/PB

Input sensitivity and impedance: PHONO-1, -2 2 mV 47 k
AUX-1, -2 }
TUNER } 140 mV 50 k
TAPE-1, }
TAPE-2, }
REC/PB }

Signal output and output impedance: REC OUT-1, } 140 mV 10 k
REC OUT-2 }
PRE OUT 800 mV 2.7 k
REC/PB 24 mV 82 k
CENTER OUT 800 mV 680 Ω

Signal-to-noise ratio: PHONO-1, -2 greater than 70 dB
(weighting network "B")
AUX-1, -2, } greater than
TUNER } 90 dB
TAPE-1, -2 }
REC/PB }
(weighting network "A")

Tone controls: BASS ± 10 dB at $\left\{ \begin{matrix} 50 \\ 100 \end{matrix} \right.$ Hz
TREBLE ± 10 dB at $\left\{ \begin{matrix} 10 \\ 20 \end{matrix} \right.$ kHz
TURNOVER (250 Hz, 500 Hz)
FREQUENCY 2.5 kHz, 5 kHz,

Filters: HIGH -6 dB/oct above 5 kHz
LOW -6 dB/oct below 100 Hz

Loudness control: +10 dB at 50 Hz, +3 dB at 10 kHz (at 30 dB attenuation)

General

Power consumption: 180 watts (USA and Canada Model)
250 watts (AEP and UK Model)

Power requirement: 120 volts ac (USA and Canada Model)
110, 127, 220, 240 volts ac (AEP and UK Model)

Dimensions: 400 (w) x 149 (h) x 316 (d) mm
15 $\frac{3}{4}$ (w) x 5 $\frac{13}{16}$ (h) x 12 $\frac{7}{16}$ (d) inches

Net weight: 8.3 kg (18 lb 5 oz)

Shipping weight: 11.5 kg (25 lb 6 oz)

1-2. CIRCUIT ANALYSIS

Stage/Control Function

Preamplifier Section

Equalizer amplifier IC101 (CX-0461) This amplifier amplifies the small signal provided by the phono cartridge to the level required at the input of the following transistor. Note that (CX-0461) contains two identical low noise amplifier chains and regulated power supply circuit. This requires two power supplies which are identical but oppositely polar. An IC block diagram is shown in Fig. 1-1.

Equalization circuit RIAA equalization is achieved by the negative-feedback loop containing R106, R107, R108, C106 and C107. R101 and C103 prevent rf interference. R109 in output circuit prevents interaction between left and right channel equalization when the MODE switch is set to MONO.

Stage/Control Function

FUNCTION switch All input signals are routed to the FUNCTION switches. Note that the TAPE PRINT operations are provided for tape duplication as noted in Table 1-1.

TABLE 1-1.

FUNCTION SW position	Tape Recorder-1	Tape Recorder-2
TAPE 1-2	Playback	Recording
TAPE 2-1	Recording	Playback

MONITOR In the TAPE-1 position, input signals connected to either the TAPE-1 terminal or REC/PB connector is selected. In the TAPE-2 position, the input program connected to the TAPE-2 terminal is selected. In the SOURCE position, all other program sources are selected.

MODE switch Select the desired mode of operation. S3 Note that in the 4 CH MASTER position, input signal applied to 4 CH IN terminal is routed to RV191 (one of the four ganged variable resistors), and then fed to the 4 CH OUT terminal. This makes the TA-1150's VOLUME control a master volume control when in a 4-CH system.

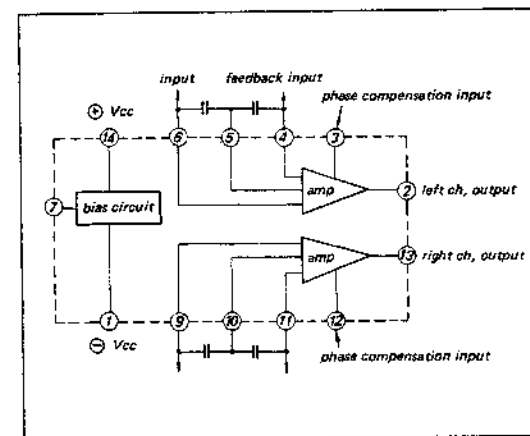

Fig. 1-1. CX-0461, CX-0462 diagram

Stage/Control Function

BALANCE control RV192 Input signal is routed to the BALANCE control through MODE switch S3. This is done to optimize stereo reproduction. To eliminate insertion loss at the mechanical center of movement, a special potentiometer having a conductive coating over half its element length is used.

VOLUME control RV193 The balanced input signals from BALANCE control RV192 is fed to VOLUME control RV193, which regulates the signal applied to the following tone-control circuit or output circuit. Note that this control is a four-gang resistor in order to operate as a master volume control in 4-CH operation.

LOUDNESS switch S4-1 This switch and R194, C194, R192 and C192 compensate for the characteristics of the human ear which vary according to the loudness of the sound being heard. When this switch is set to ON, and the VOLUME control is set for 30 dB attenuation, the overall frequency response is increased 10 dB at 50 Hz and 3 dB at 10 kHz with reference to the level at 1 kHz. The same type of loudness circuit is also provided in the volume control circuit for 4-CH operation.

Emitter follower Q101 Q101 acts as a buffer amplifier between the volume control and tone control circuits. This eliminates interaction between volume and tone controls since it provides high input impedance and low output impedance.

Tone-control circuit IC201 Fig. 1-2 shows the simplified circuit of the tone control incorporated with the treble and bass turnover switches. This circuit is a modified negative-feedback type tone-control. Note that the output of IC201 is fed back to the input circuit of IC201 through the treble and bass tone-control network.

Stage/Control Function

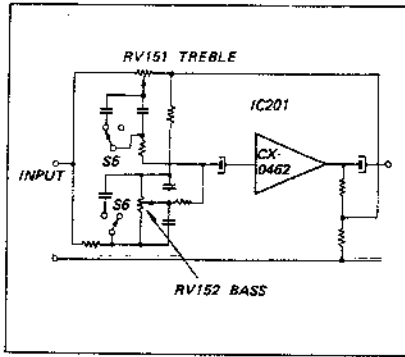

Fig. 1-2. Simplified tone control circuit

Note: CX-0462 (IC201) is basically identical with CX-0461 (IC101).

TREBLE control RV151 Decreases or increases the amount of negative feedback voltage by means of RV151.

TREBLE TURN-OVER FREQUENCY switch S5 S5 selects the specified turnover frequencies (2.5 kHz or 5 kHz). Refer to FREQUENCY Fig. 1-3.

BASS control RV152 Decreases or increases the amount of negative feedback voltage by means of RV152.

BASS TURN-OVER FREQUENCY switch S6 S6 selects the specified turnover frequencies (500 Hz or 250 Hz). Refer to Fig. 1-3.

HIGH FILTER switch S7 The high-cut filter (R167 and C165) cuts out unwanted high frequency components (5 kHz and higher) from the input signal when this switch is ON. Refer to Fig. 1-4.

LOW FILTER switch S8 The low-cut filter (C166, R169 and C167) eliminates unwanted low-frequency components (100 Hz and lower) from the input signal when this switch is ON. Refer to Fig. 1-4.

PREAMP/POWER AMP switch S9 In NORMAL, the output of the pre-amplifier section is fed to the power amplifier section through S9. In SEPARATE, the output of the preamplifier section is disconnected from the

Stage/Control Function

power amplifier's input terminal, allowing you to use the both sections separately.

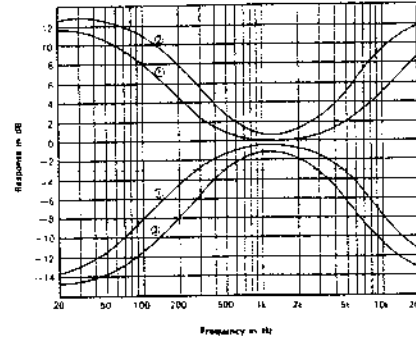

Fig. 1-3. Tone control frequency response

Note: TURN-OVER selector's setting

- ① TREBLE: 5 kHz. BASS: 250 Hz
- ② TREBLE: 2.5 kHz, BASS: 500 Hz

Muting circuit Q501, Q502, Q503 This muting circuit prevents the loud "pop" (due to initial current flow) or click noises produced by switch just after turning the power switch to ON. These transients might damage a delicate high-fidelity speaker system. The base of Q502 (Q503) is connected to the collector circuit of Q501, while the base of Q501 is connected to an RC network (R532, C534) with a long time constant. At the instant the power switch is

Stage/Control Function

turned on, Q501 is off due to the long time constant of the bias circuit, while Q502 (Q503) is forward biased by R535, forcing it into conduction. As a result, Q502 (Q503) is on, shorting the preamplifier's output to ground, and is effectively muted. As the Q501 is gradually turned on due to its base circuit, Q501 conducts and Q502, Q503 cuts off. The latter results in the cessation of muting.

Power Amplifier Section

Paraphase amplifier Q301, Q302 Q301 and Q302 form a paraphase amplifier but signal output is extracted from the collector circuit of Q301. This circuit has various advantages in direct-coupling systems. One is high stability despite temperature variations and another is high input impedance without reducing the amplifier's gain.

The ac output appears across load resistor R304 (2.7 k) in the collector circuit. An emitter decoupling circuit is formed by the emitter-base resistance of Q302, C302 and R305 in the base circuit of Q302.

Thermal compensation and noise suppressor D301 As all the stages are directly coupled, dc stability is required. The negative temperature coefficient of D301 provides thermal compensation for the following driver stage.

It also acts as a noise suppressor to reduce the popping noise due to unbalanced current flow in the following stages when the power switch is turned off.

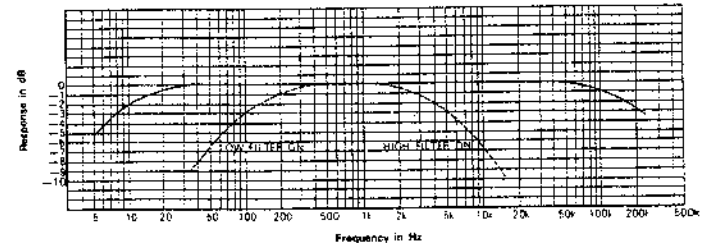
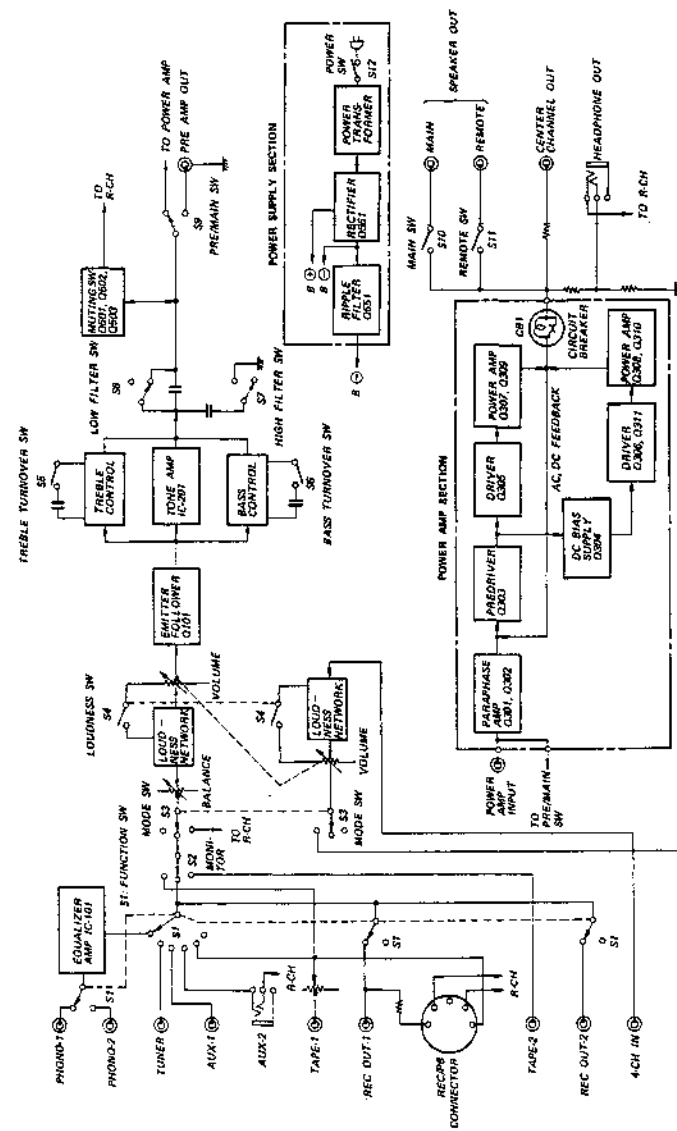

Fig. 1-4. Frequency and filter response

Stage/Control	Function
Driver Q303	Though this stage is a conventional flat amplifier, it determines the output voltage swings because the following stages are basically emitter-followers. The ac load resistor for this stage is R307.
Dc bias adj. (idling current)	Q304 is biased into heavy conduction and operates as a small resistance providing the necessary forward bias on the two cascaded emitter-followers.
RV301	RV301 controls the base bias of Q304, determining its emitter-collector impedance and thereby controls the dc bias voltage for the following complementary circuit. This circuit has the advantage of stable operation even at high power output levels.
Complementary (Driver) Q305, Q306	These transistors operate as emitter-followers to provide the current swings demanded of the output stages and also provide the necessary phase inversion to drive the power-output stages in push-pull. Phase inversion is performed by using PNP and NPN type transistors.
Power transistors Q307, Q309	The paralleled output transistors Q307, Q309 and Q308, Q310 are connected directly to a power supply of about ± 35 V. Q307, Q309 supply power to the load during positive half cycles and Q308, Q310 operate during negative half cycles. As all the stages are directly coupled and designed to obtain zero potential at the output ter-

Stage/Control	Function
Power transistor (CB-1)	To protect overloaded power transistors from destruction, a new circuit breaker which combines a bimetal switch and lamp is employed. In the event of a short circuit at the output terminals, the excessive current heats the contact points of the bimetal switch, causing the switch open. As the lamp is connected in parallel with the bimetal switch, the current now flows through the lamp. As a result, the breaker lamp lights, and its high resistance limits the excessive current flow to a low value, thereby protecting the power transistors. When the breaker lamp lights it will be noticed from the outside of the top cover. Note that the lamp lights only when a relatively large signal is applied with the speaker terminal shorted.
Power Supply Section	<p>Rectifier D551 A full-wave bridge rectifier and center-tapped transformer provides positive and negative dc power supplies for the power amplifier.</p> <p>Ripple filter Q551, R553, C552 These components reduce the ripple voltage in the negative dc power supply for preamplifier and driver stages of the power amplifier section to an extremely-low-value.</p>

1-3. BLOCK DIAGRAM



SECTION 2

DISASSEMBLY AND REPLACEMENT

1-4. LEVEL DIAGRAM

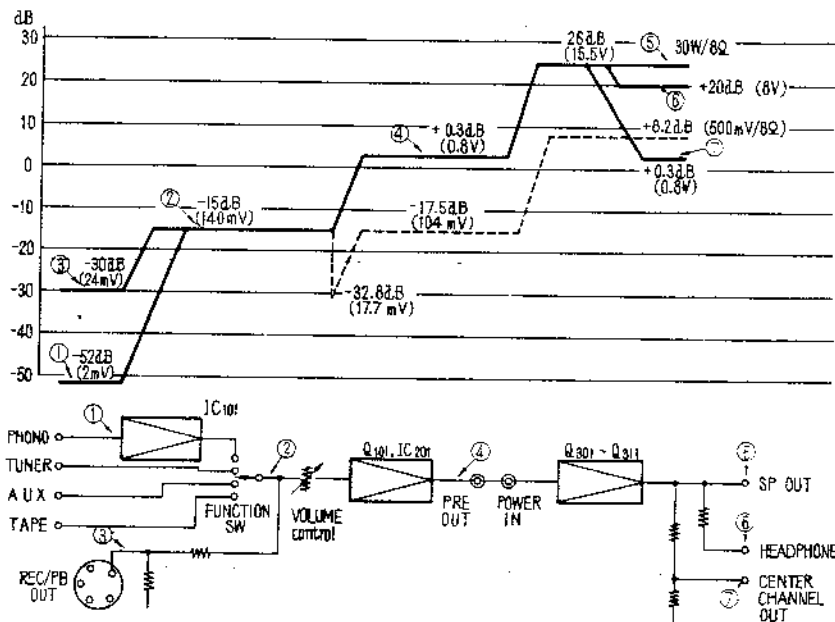

Note: Signal voltages are measured with an ac VTVM and expressed in dB referred to 0.775 V, 1 kHz.

WARNING

Unplug the ac power cord before starting any disassembly or replacement procedures.

2-1. TOP COVER AND FRONT PANEL REMOVAL

1. Remove the two machine screws at each side of the top cover, and lift off the top cover.
2. Pull off all the control knobs except push-buttons.
3. Remove the three self-tapping screws (⊕ B 3 x 8) at the front bottom of the chassis as shown in Fig. 2-1. This frees the front panel.
4. Remove the three self-tapping screws (⊕ PSW 4 x 6) behind the top edge of the front subchassis as shown in Fig. 2-2.



Fig. 2-3. Front subchassis removal

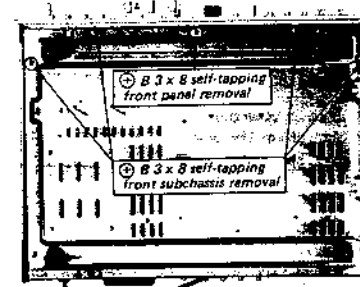

Fig. 2-1. Front panel and front subchassis removal

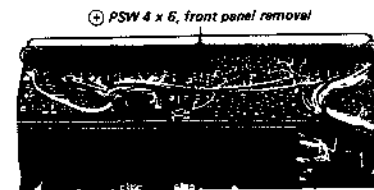

Fig. 2-2. Front panel removal

2-3. CONTROL AND SWITCH REPLACEMENT

Prepare for replacing any of the controls or switches by removing the front subchassis as described in procedure 2-2.

POWER, TURNOVER, LOUDNESS, MODE, MONITOR switches, HEADPHONE, AUX-2 jacks and BALANCE control

1. Remove the two screws securing switches, jacks and control to the front subchassis as shown in Fig. 2-4.
2. Unsolder the lead wires from the defective switches, jacks or control, and install a new one.

VOLUME control

1. Remove the two screws (⊕ B 3 x 4) securing the VOLUME control to the front subchassis.
2. Unsolder the lead wires on the LOUDNESS board.
3. With a soldering iron having a solder-sucking tip, clean the solder from each lug of the defective and the printed circuit board.
4. Install a new one.

2-2. FRONT SUBCHASSIS REMOVAL

The front subchassis is the vertical member on which all the controls and switches are attached.

1. Remove the top cover and front panel (if necessary) as described in Procedure 2-1.

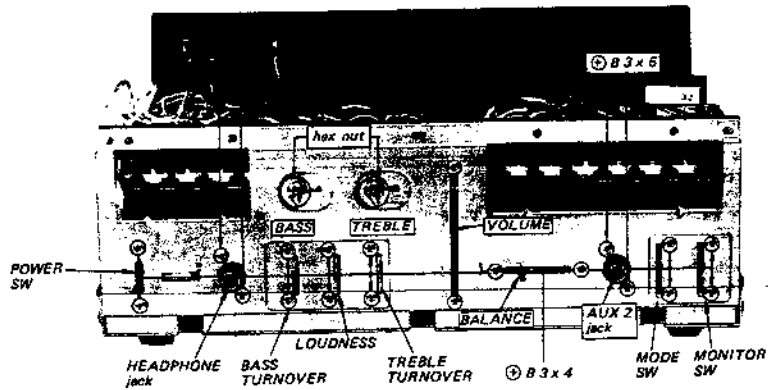

Fig. 2-4. Control and switch replacement

TONE controls

1. Remove the hex nuts securing BASS and TREBLE controls to the front subchassis as shown in Fig. 2-4.
2. Remove the three screws (⊕ B 2.6 x 4) securing the 4-key pushbutton switch to the front subchassis as shown in Fig. 2-6.
3. Remove the four screws (⊕ PSW 3 x 6) securing the tone amp/power supply board to the front subchassis as shown in Fig. 2-6. This frees tone amp/power supply board together with tone controls.
4. Cut each lug of the defective control on the board to remove the part.
5. With a soldering iron having a solder-sucking tip, clean the solder from each lug of the defective control and the printed circuit board.
6. Install a new one.

4-key or 7-key Pushbutton Switches

1. Remove the three screws (⊕ B 2.6 x 4) securing the pushbutton switch to the front subchassis as shown in Fig. 2-5.
2. Remove the screws (⊕ PSW 3 x 6) securing the equalizer amp or the tone amp/power supply amplifier board to its mounting bracket as shown in Fig. 2-6.

3. Cut each lug of the defective switch on the board to remove the part.
4. With a soldering-iron having a solder-sucking tip, clean the solder from each lug of the switches and the printed circuit board.
5. Install a new one.

PREAMP/POWER AMP switch

1. Remove the two screws (⊕ B 2.6 x 4) securing it to the rear panel.
2. Unsolder the lead wires from the defective switch and install a new one.

TAPE 1 LEVEL ADJ. control

1. Remove the two nuts securing the TAPE 1 LEVEL ADJ. control to the rear panel with a pliers.
2. Remove the power amplifier board as described in Procedure 2-5.
3. Unsolder the lead wires from the defective control and install a new one.

2-4. NEON LAMP REPLACEMENT

Prepare for replacing the lamp by removing the front subchassis as described in Procedure 2-4.

1. Remove the screw (⊕ B 3 x 4) securing the neon lamp to the chassis as shown in Fig. 2-5.
 2. Unsolder the lead wires from the defective lamp and install a new one.
- 2-5. POWER AMPLIFIER BOARD REMOVAL**
1. Remove the top cover as described in Procedure 2-1.
 2. Remove the four screws (⊕ B 3 x 6) securing the power amplifier board to its mounting bracket as shown in Fig. 2-7.
 3. Remove the power amplifier board along with the heat sink.

2-6. POWER TRANSISTOR REPLACEMENT

1. Remove the top cover as described in Procedure 2-1.
2. Remove the screw (⊕ P 3 x 10) securing the power transistor to the heat sink as shown in Fig. 2-8.
3. Remove the defective power transistor and install a new one.

Note: When replacing the power transistor, apply a coating of a heat-transferring grease to both sides of the mica insulator. Any excess grease squeezed out when the mounting screws are tightened should be wiped off with a clean cloth. This prevents it from accumulating conductive dust particles that might eventually cause a short.

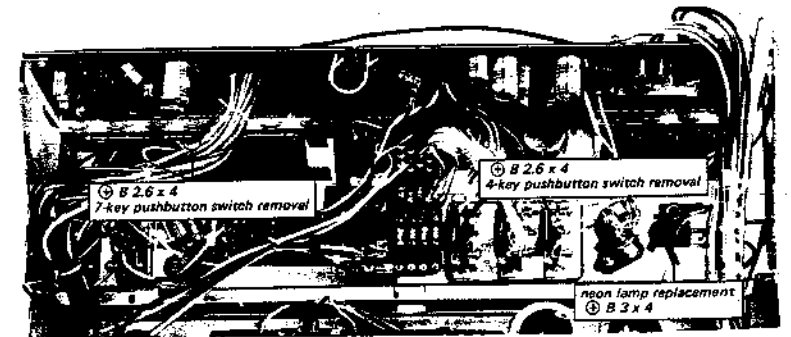

Fig. 2-5. Pushbutton switch and neon lamp replacement

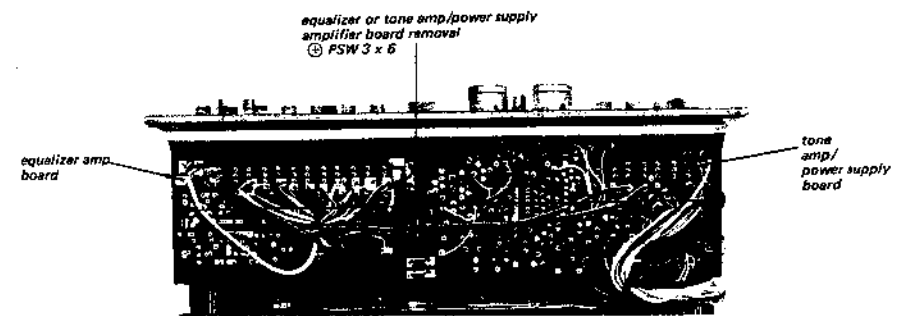

Fig. 2-6. Equalizer and tone amplifier/power supply board removal

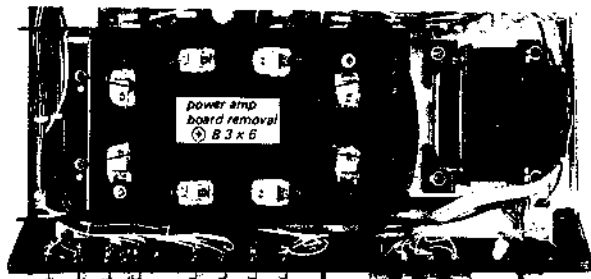

Fig. 2-7. Power amplifier board removal

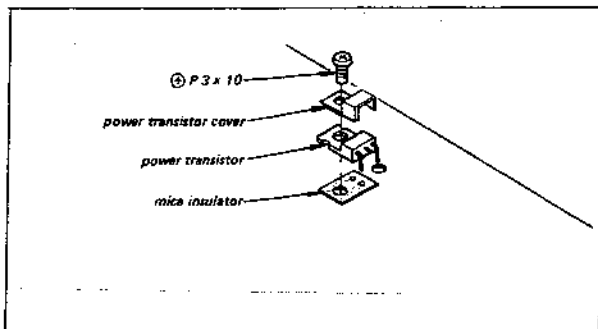

Fig. 2-8. Power transistor replacement

2-7. REPLACEMENT OF COMPONENTS SECURED TO THE REAR PANEL BY NYLON RIVETS

1. Remove the nylon rivets securing the defective component by pushing its end with a tweezers as shown in Fig. 2-9.
2. Remove the defective component and install a new one.
3. To reinstall the rivet, insert the flared part into the opening first, and push the head as far as it goes as shown in Fig. 2-10.

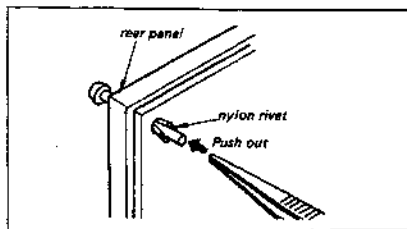

Fig. 2-9. Nylon rivet removal

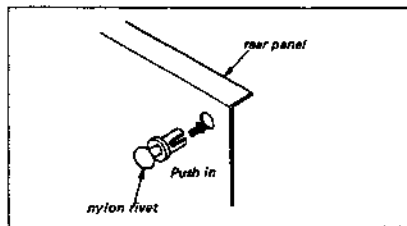

Fig. 2-10. Nylon rivet installation

2-8. AC OUTLET REPLACEMENT

1. Remove the top cover as described in Procedure 2-1.
2. Pry out the outlet retaining clip with a screwdriver. This frees the ac outlet.
3. Install a new one.

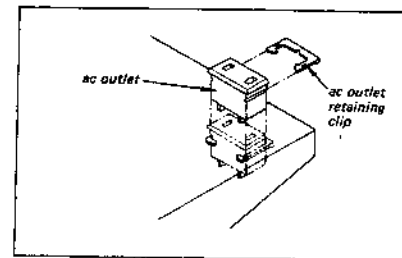
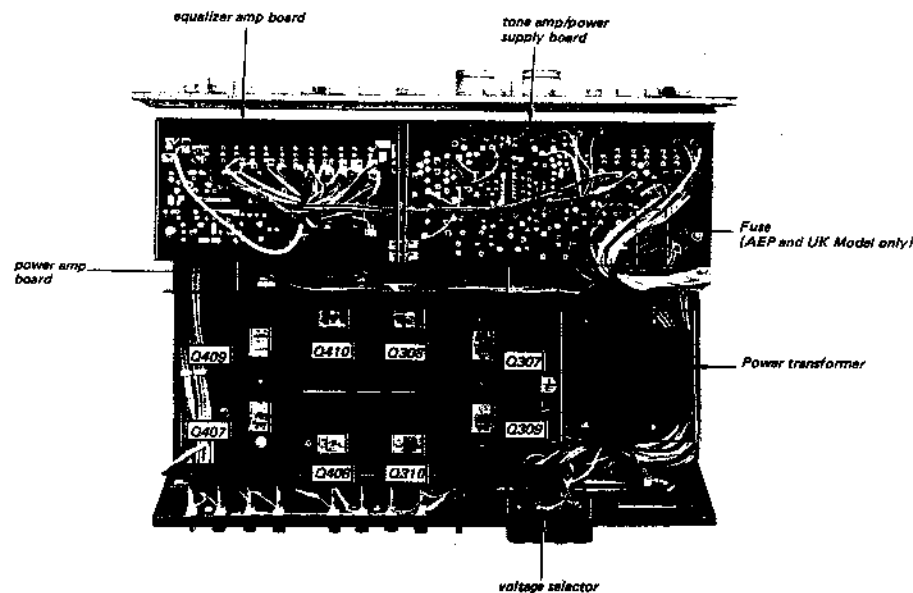

Fig. 2-11. Ac outlet installation

2-9. CHASSIS LAYOUT



SECTION 3 ADJUSTMENT

3-1. DC BIAS ADJUSTMENT

Note: There are usually two adjustments to be made in the power amplifier. One is dc-bias adjustment and the other is dc-balance adjustment or ac-balance adjustment. These adjustments should be alternately repeated two or three times after replacing any of the power transistors until best operation is obtained. In this case, only the dc-bias adjustment is described as the newly developed circuit made it possible to omit dc-balance adjustment.

CAUTION

To avoid accidental power transistor damage, increase the ac line voltage gradually, using a variable transformer, while measuring the voltage across test points as shown in Fig. 3-1. Check to see that the reading does not exceed 25 mV. If it does, turn off the power immediately, then check and repair the trouble in the power amplifier board.

Test Equipment Required

1. Dc millivoltmeter
Capable of measuring dc voltage of 100 mV or less.
2. Variable transformer

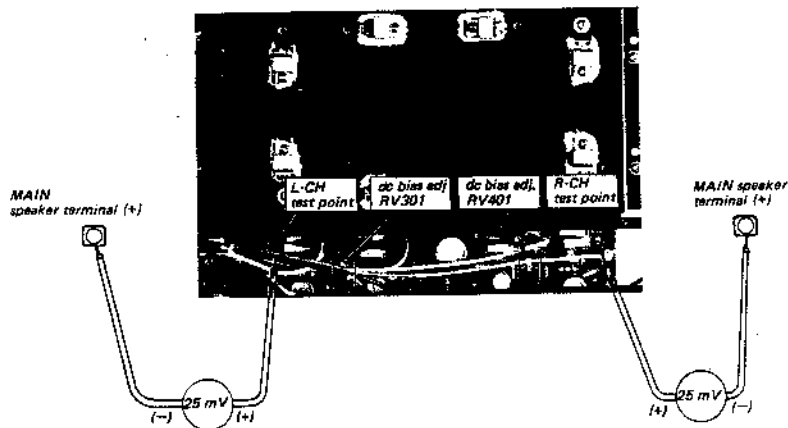

Fig. 3-1. Dc millivoltmeter connection and parts location

3. Screwdriver with 3 mm (1/8") blade.

Preparation

1. Remove the top cover as described in Procedure 2-1.
2. Connect the dc millivoltmeter across the test terminal post and MAIN speaker terminal as shown in Fig. 3-1.
3. Depress the MAIN speaker switch button.

Procedure

1. Apply a drop of cement solvent to the adjustable resistors RV301, RV401 (See Fig. 3-1) on the power amplifier board, and set them as follows:
RV301 (L-CH, dc-bias) . . . fully clockwise
RV401 (R-CH, dc-bias) . . . fully counterclockwise
2. Set the variable transformer for minimum output.
3. Turn the power switch to ON, and increase the line voltage up to the rated value.
4. Adjust RV301 and RV401 to obtain a 25 mV reading on the meter.

SECTION 4 REPACKING

The TA-1150's original shipping carton and packing materials are the ideal containers for shipping the unit. However to secure the maximum

protection, the TA-1150 must be repacked in these materials precisely as before. The proper repacking procedures are shown in Fig. 4-1.

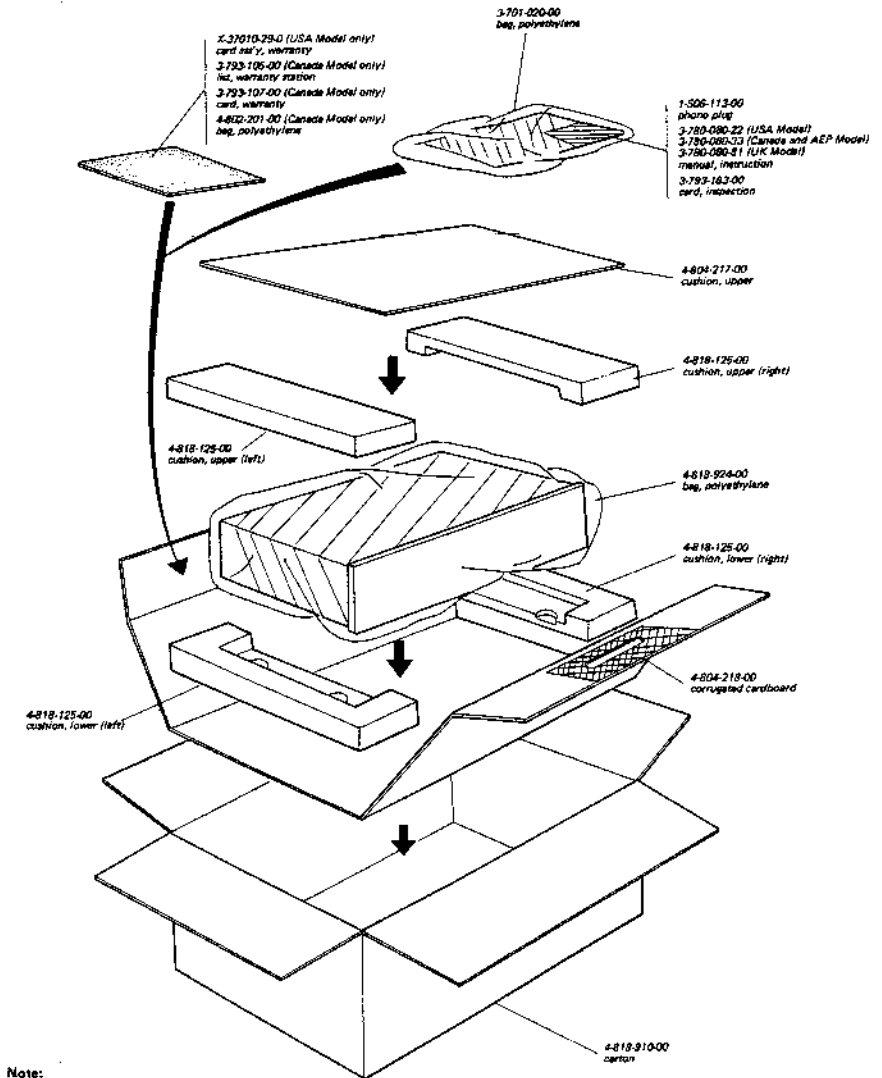

Note:
USA Model (Serial No. 804,001 and later)
Canada Model (Serial No. 701,001 and later)
AEP Model (Serial No. 900,001 and later)
UK Model (Serial No. 400,001 and later)

Fig. 4-1. Repacking

SECTION 5
DIAGRAMS

5-1. MOUNTING DIAGRAM -- Loudness Board --
-- Conductor Side --

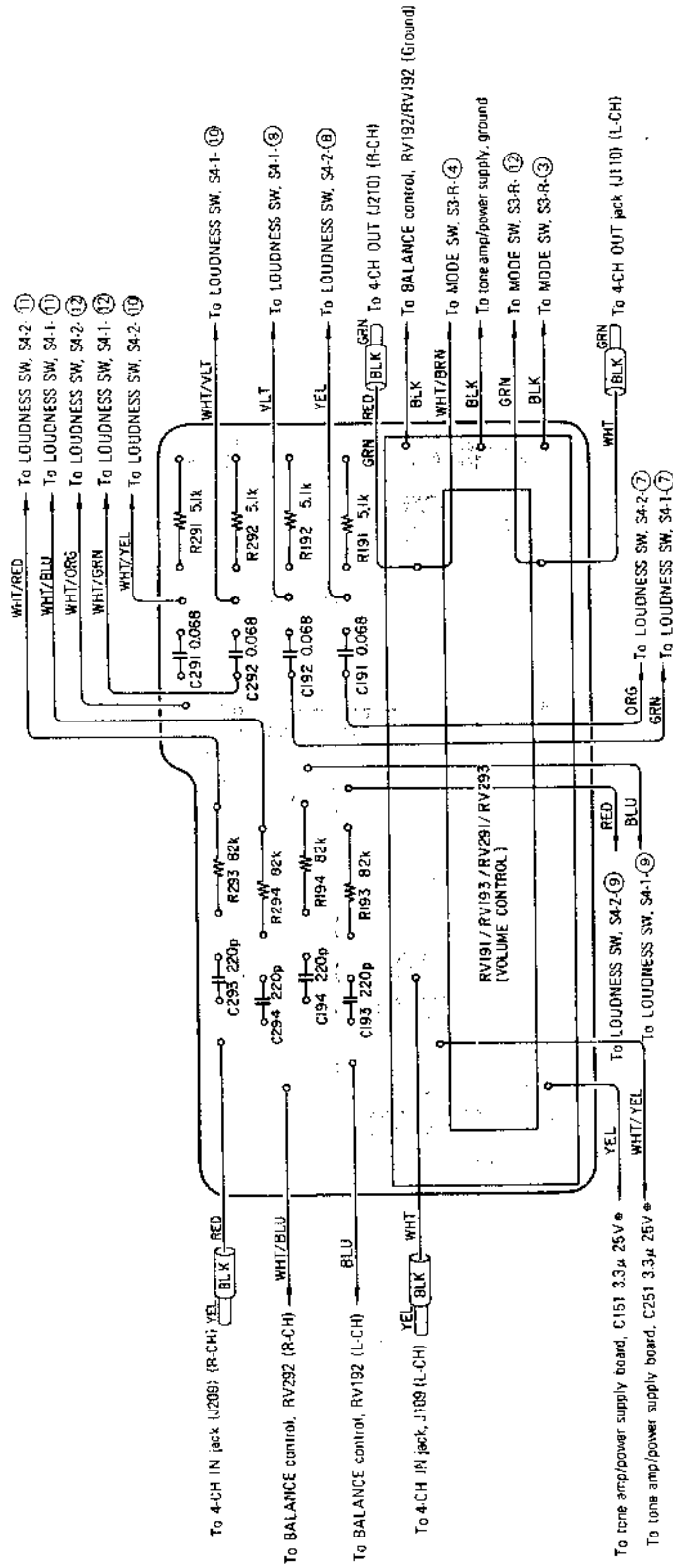

11

5-2. MOUNTING DIAGRAM – Equalizer Amp Board –
 – Conductor Side –

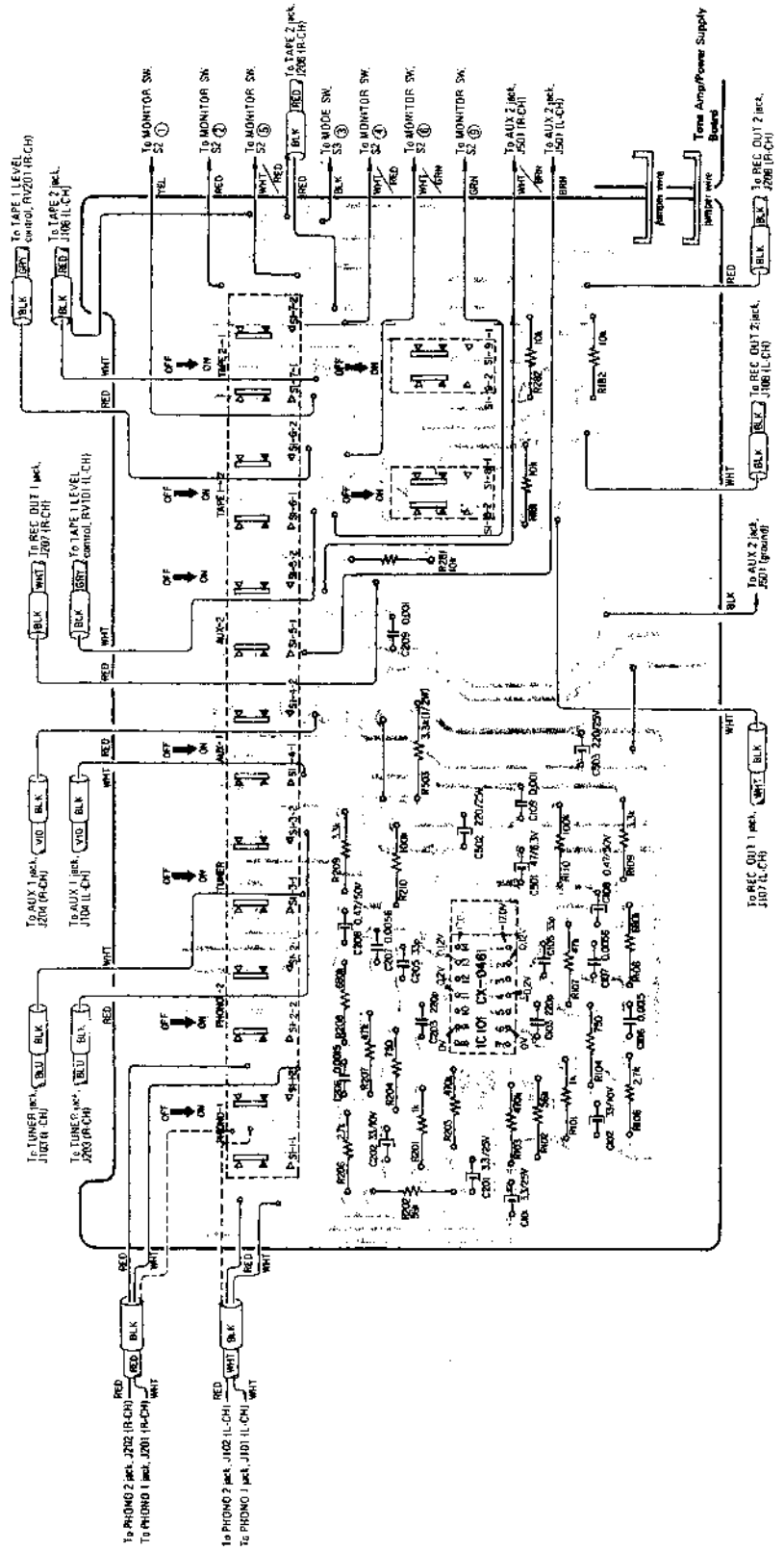

11

**5-3. MOUNTING DIAGRAM – Tone Amp/Power Supply Board –
– Conductor Side –**

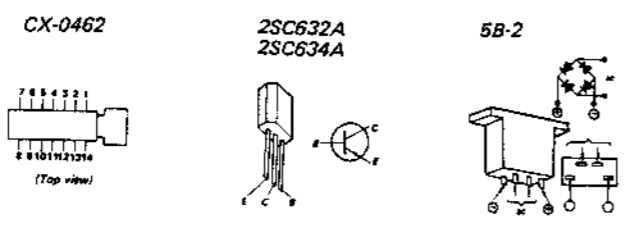
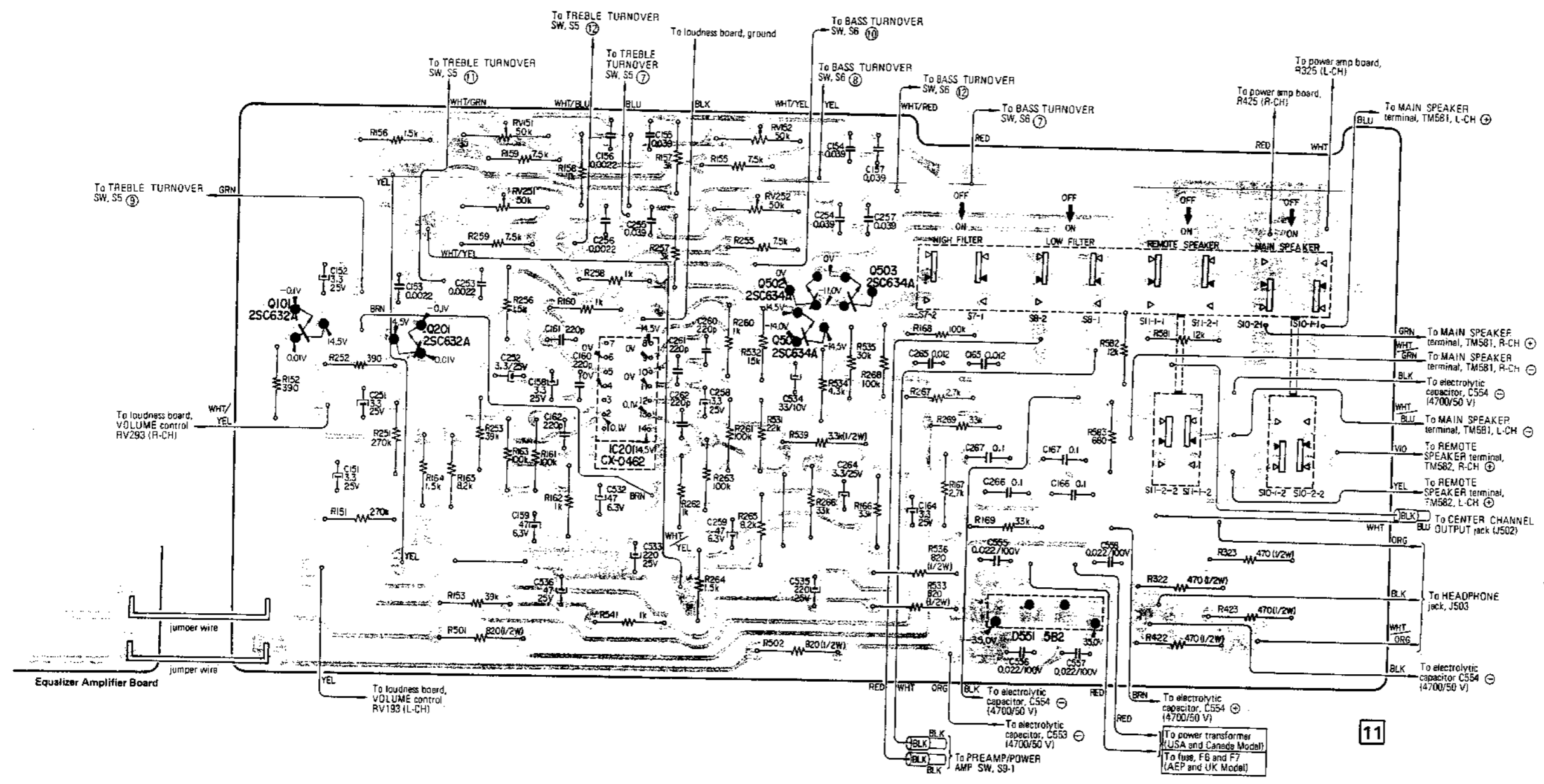

5-4. MOUNTING DIAGRAM — Power Amplifier Board —
— Conductor Side —

Parts Location		
Q	D	ADJ
408 310		
407 309		
409 307		
410 308		
404 304		
551	RV401	RV301
405 305		
406 306		
402 411 311 302		
403 303		
401 301		

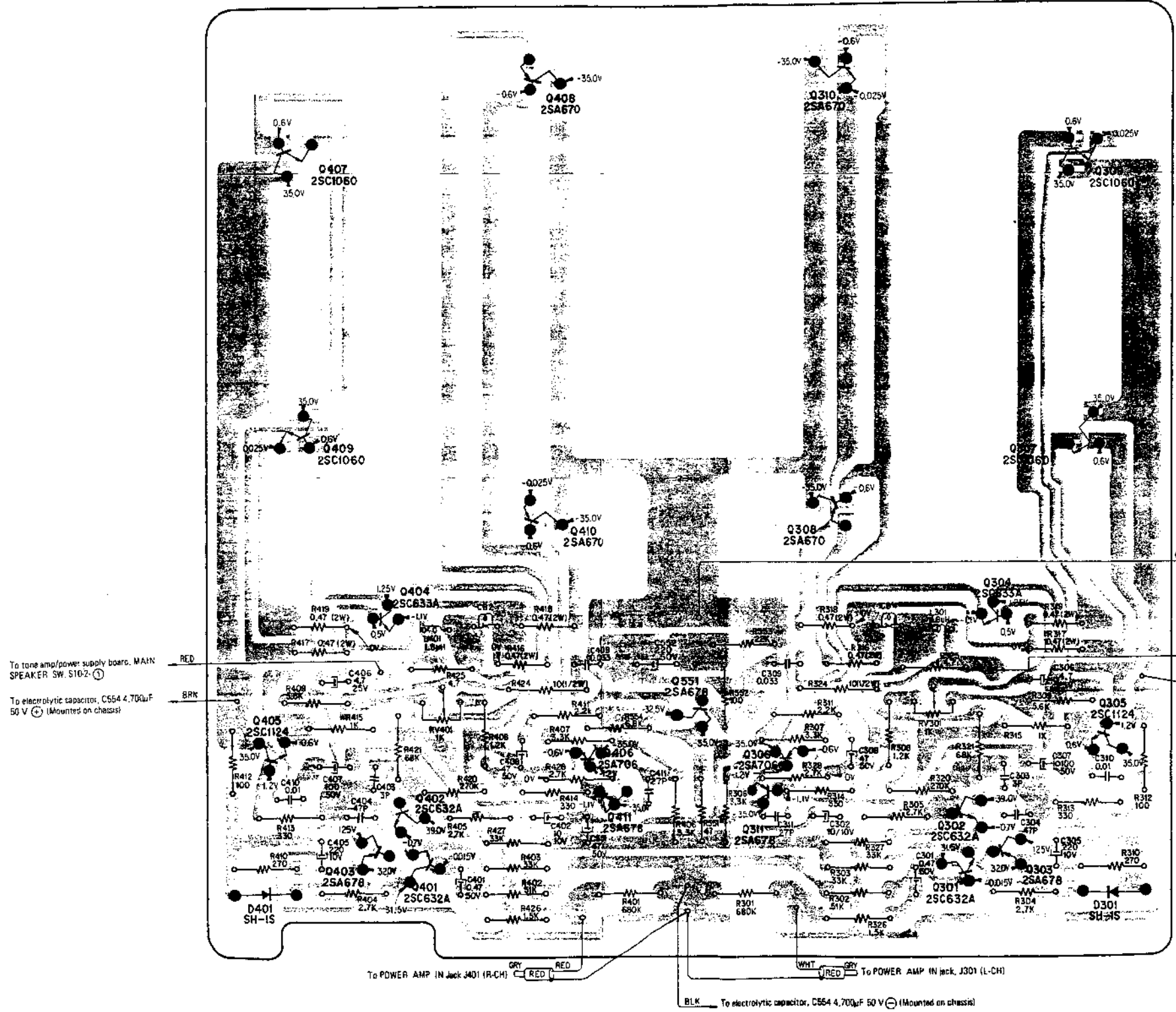

RED To tone amp/power supply board, MAIN SPEAKER SW, S10-2 (1)

BRN To electrolytic capacitor, C554 4,700µF 50 V (1) (Mounted on chassis)

ORG To electrolytic capacitor, C553 (4700/50 V)

WHT To tone amp/power supply board, MAIN SPEAKER SW, S10-1 (1)

BRN To electrolytic capacitor, C554 4,700µF 50 V (1) (Mounted on chassis)

GRY RED To POWER AMP IN Jack J401 (R-CH)

WHT GRY RED To POWER AMP IN Jack J301 (L-CH)

BLK To electrolytic capacitor, C554 4,700µF 50 V (1) (Mounted on chassis)

- 2SC632A
2SC633A
- 2SA678
- 2SA706
- 2SA670
- 2SC1124
- 2SC1060
- SH-1S

13

5-5. SCHEMATIC DIAGRAM

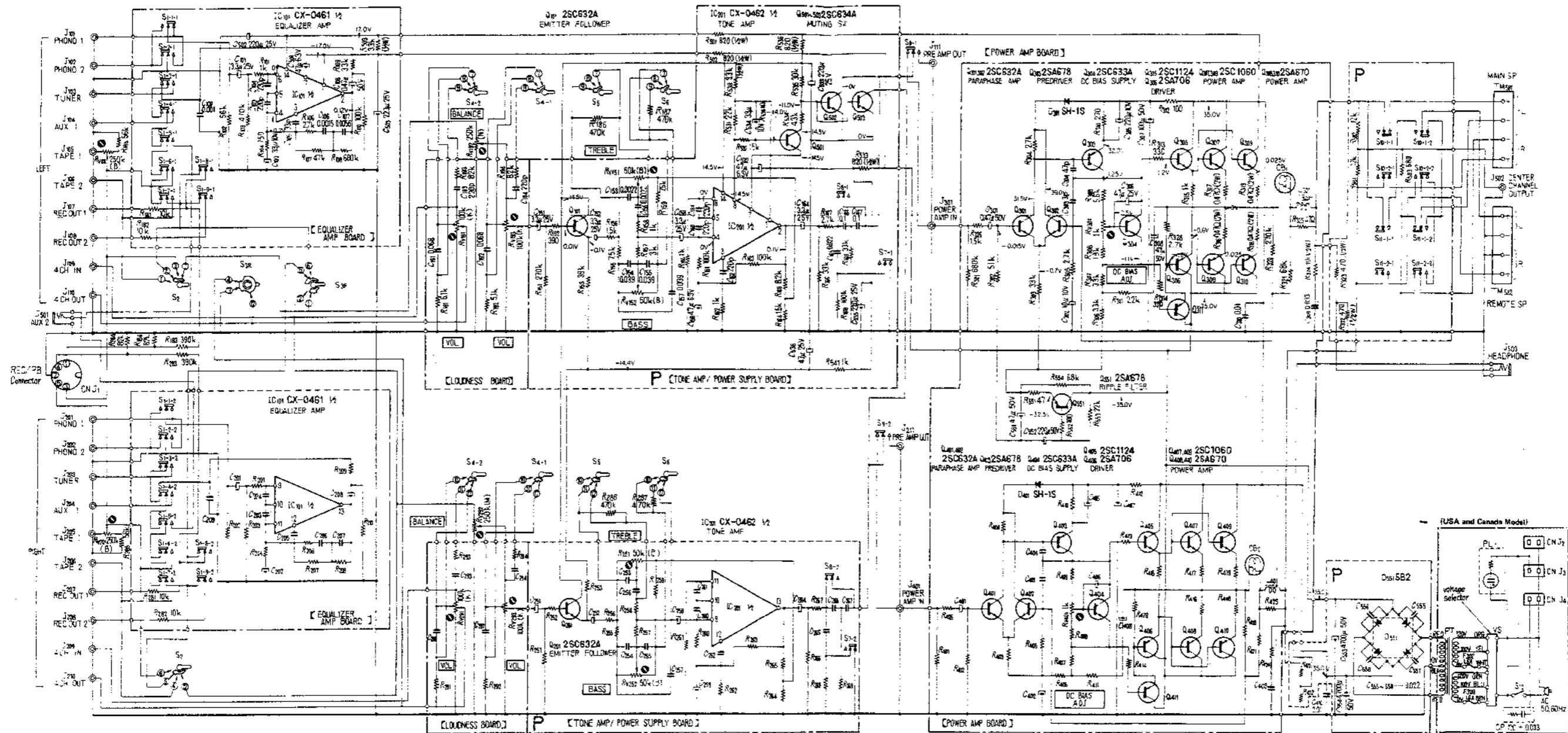

Ref. No.	Description	Position	Ref. No.	Description	Position
S1	FUNCTION SW	PHONO-1	S7	HIGH FILTER SW (OFF-ON)	OFF
S2	MONITOR SW (TAPE-1-SOURCE-TAPE-2)	SOURCE	S8	LOW FILTER SW (OFF-ON)	OFF
S3	MODE SW (MONO-2 CH-4 CH) (MASTER)	2 CH	S9	PRE/POWER AMP SW (NORMAL-SEPARATE)	NORMAL
S4	LOUDNESS SW (ON-OFF)	ON	S10	MAIN SPEAKER SW (ON-OFF)	ON
S5	TREBLE TURNOVER SW (2.5 kHz-5 kHz)	2.5 kHz	S11	REMOTE SPEAKER SW (ON-OFF)	OFF
S6	BASS TURNOVER SW (500 Hz-250 Hz)	500 Hz	S12	POWER SW	OFF

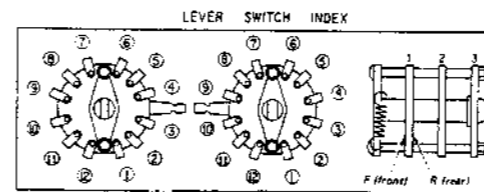

Note:
 All resistance values are in ohms, k = 1000, M = 1000 k
 All capacitance values are in μ F except as indicated with p, which means μ MF.
 All voltages are dc measured with a VOM which has an input impedance of 20 k ohms/volt. No signal in.
 Voltage variations may be noted due to normal production tolerances.

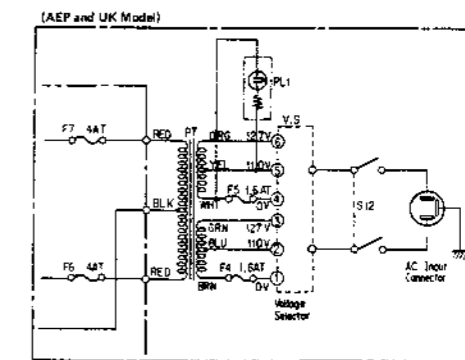

SECTION 6
EXPLODED VIEWS

(1)

Note: Applicable Serial Numbers:

- USA Model 804,001 and later
- Canada Model 701,001 and later
- AEP Model 900,001 and later
- UK Model 400,001 and later

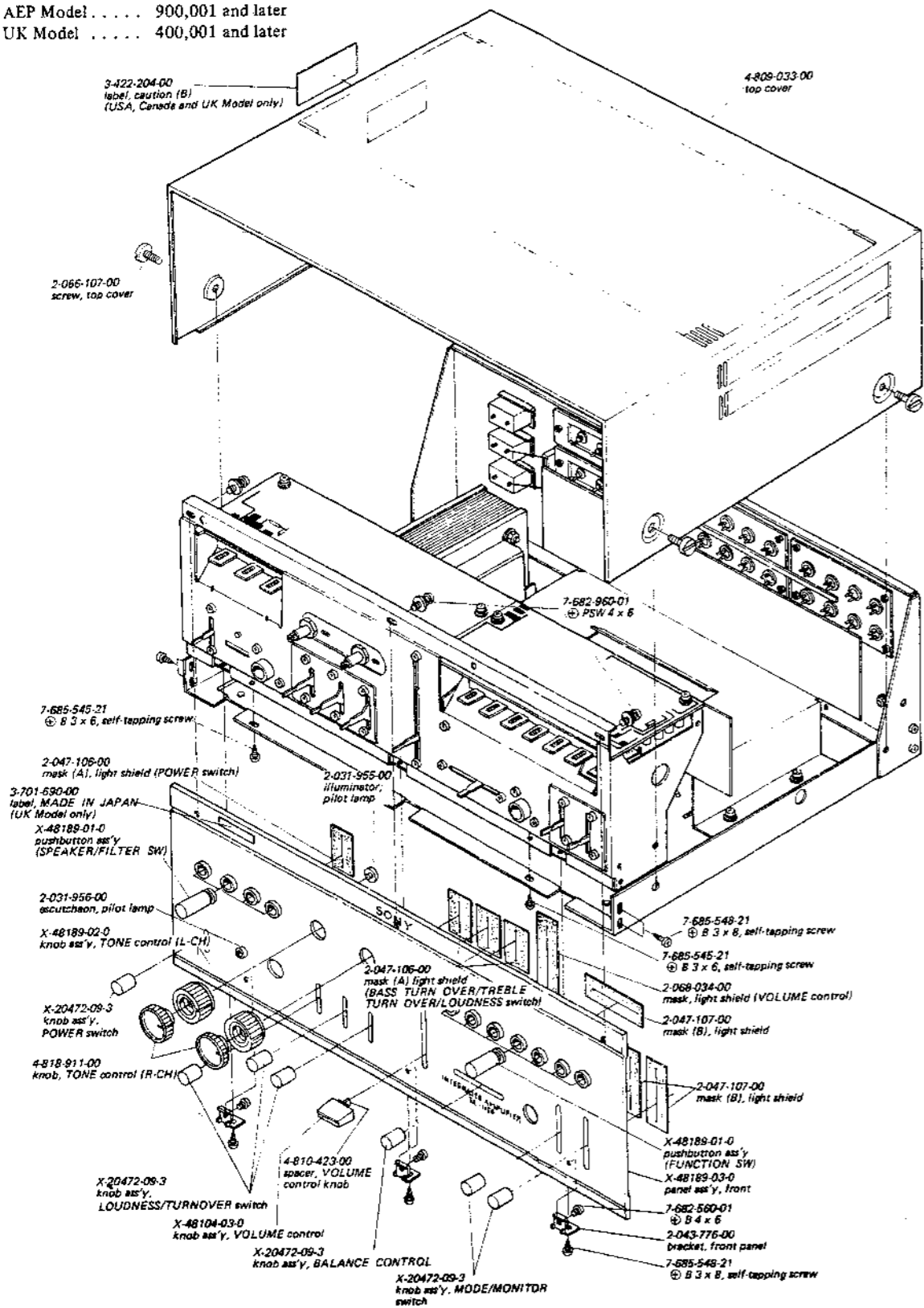

(2)

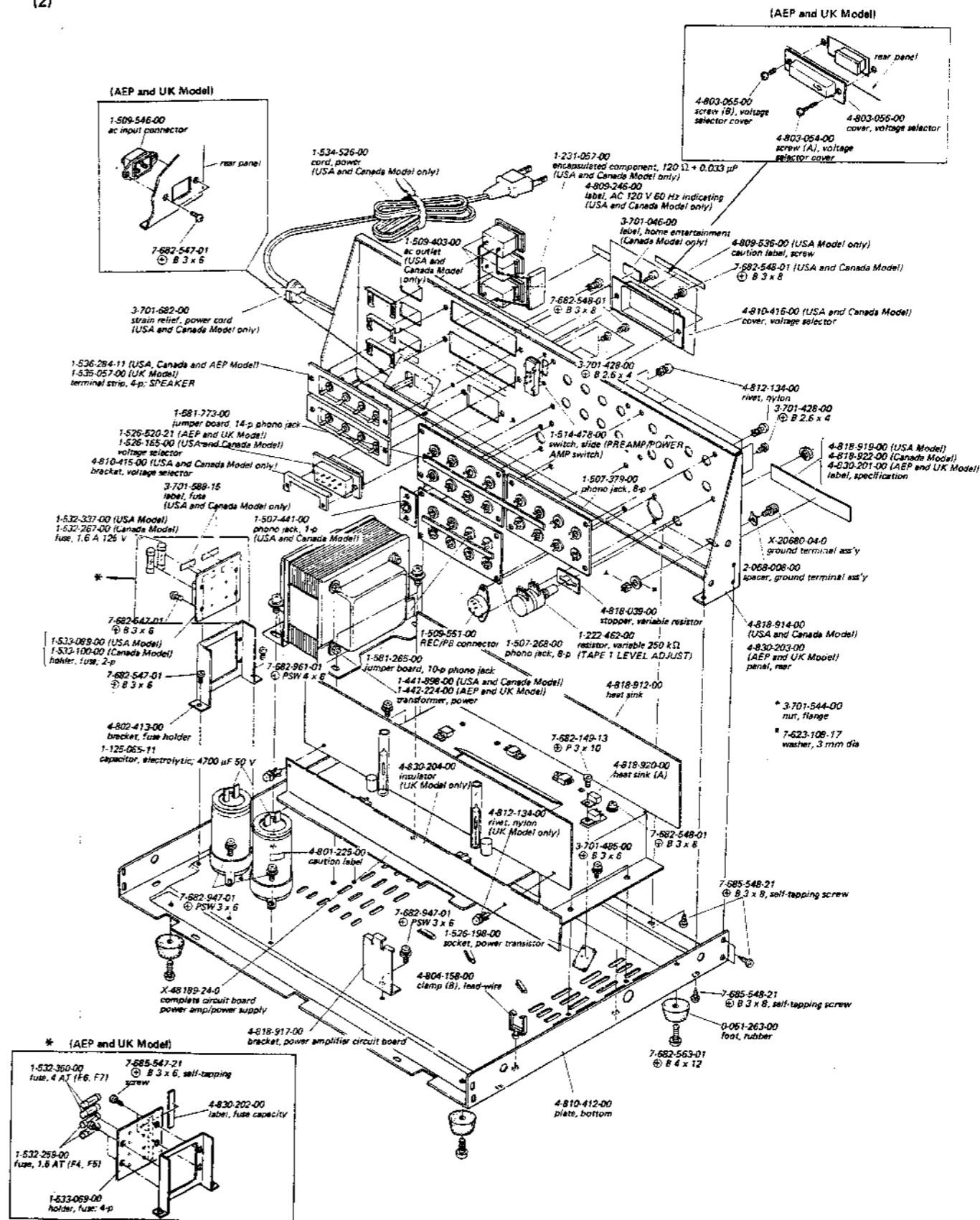

(3)

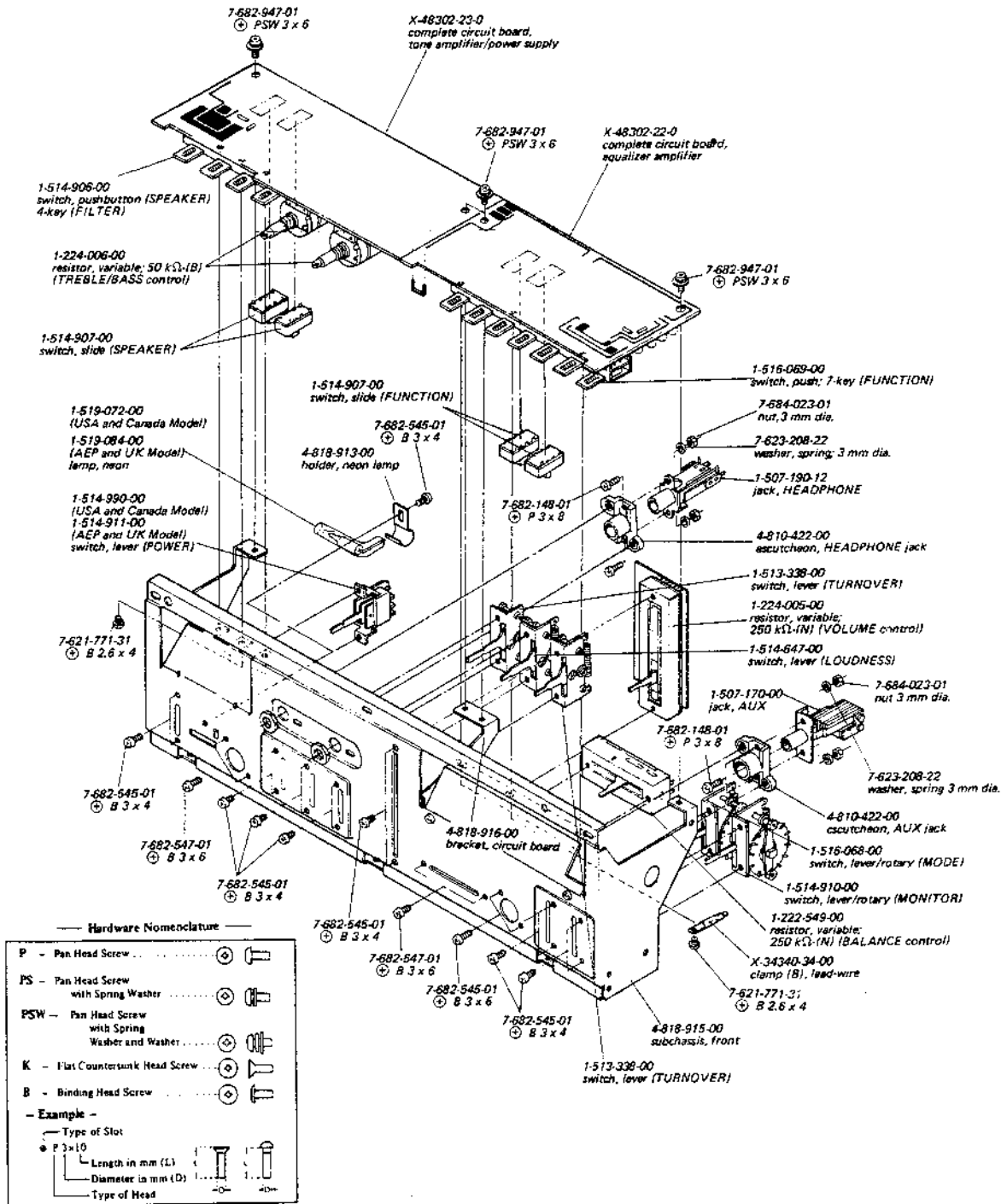

SECTION 7
ELECTRICAL PARTS LIST

Ref. No.	Part No.	Description
Note: Applicable Serial Numbers		
USA Model (804,001 and later)		
Canada Model (701,001 and later)		
AEP Model (900,001 and later)		
UK Model (400,001 and later)		
COMPLETE CIRCUIT BOARDS		
X-48189-24-0		power amplifier/power supply
X-48302-23-0		tone amp/power supply
X-48302-21-0		loudness
X-48302-22-0		equalizer amplifier
SEMICONDUCTORS		
Q101(Q201)		transistor 2SC632A
Q301(Q401)		transistor 2SC632A
Q302(Q402)		transistor 2SC632A
Q303(Q403)		transistor 2SA678
Q304(Q404)		transistor 2SC633A
Q305(Q405)		transistor 2SC1124
Q306(Q406)		transistor 2SA706
Q307(Q407)		transistor 2SC1060
Q308(Q408)		transistor 2SA670
Q309(Q409)		transistor 2SC1060
Q310(Q410)		transistor 2SA670
Q311(Q411)		transistor 2SA678
Q501		transistor 2SC634A
Q502		transistor 2SC634A
Q503		transistor 2SC634A
Q551		transistor 2SA678
IC101	IC	CX-0461
IC201	IC	CX-0462
D301(D401)	diode	SH-1S
D551	diode	5B-2
TRANSFORMER AND INDUCTOR		
L301(L401)	1-407-592-00	inductor, micro 1.8 μH
PT	1-441-898-00	transformer, power (USA and Canada Model)
	1-442-224-00	transformer, power (AEP and UK Model)
CAPACITORS		
All capacitors are in μF except as indicated with p, which means pF.		
C101(C201)	1-121-392-11	3.3 25 V electrolytic

Ref. No.	Part No.	Description
C102(C202)	1-121-402-11	33 10 V electrolytic
C103(C203)	1-102-978-11	220 p ± 5 % 50 V ceramic
C104(C204)		-----
C105(C205)	1-102-963-11	33 p ± 5 % 50 V ceramic
C106(C206)	1-105-503-12	0.0015 ± 5 % 50 V mylar
C107(C207)	1-105-510-12	0.0056 ± 5 % 50 V mylar
C108(C208)	1-121-726-11	0.47 50 V electrolytic
C109(C209)	1-105-661-12	0.001 ± 10 % 50 V mylar
C151(C251)	1-121-392-11	3.3 25 V electrolytic
C152(C252)	1-121-392-11	3.3 25 V electrolytic
C153(C253)	1-105-665-12	0.0022 ± 10 % 50 V mylar
C154(C254)	1-105-680-12	0.039 ± 10 % 50 V mylar
C155(C255)	1-105-680-12	0.039 ± 10 % 50 V mylar
C156(C256)	1-105-665-12	0.0022 ± 10 % 50 V mylar
C157(C257)	1-105-680-12	0.039 ± 10 % 50 V mylar
C158(C258)	1-121-392-11	3.3 25 V electrolytic
C159(C259)	1-121-407-11	47 6.3 V electrolytic
C160(C260)	1-102-978-11	220 p ± 5 % 50 V ceramic
C161(C261)	1-102-978-11	220 p ± 5 % 50 V ceramic
C162(C262)	1-102-978-11	220 p ± 5 % 50 V ceramic
C163(C263)		-----
C164(C264)	1-121-392-11	3.3 25 V electrolytic
C165(C265)	1-105-674-12	0.012 ± 10 % 50 V mylar
C166(C266)	1-105-685-12	0.1 ± 10 % 50 V mylar
C167(C267)	1-105-685-12	0.1 ± 10 % 50 V mylar
C191(C291)	1-105-683-12	0.068 ± 10 % 50 V mylar
C192(C292)	1-105-683-12	0.068 ± 10 % 50 V mylar
C193(C293)	1-102-978-11	220 p ± 5 % 50 V ceramic
C194(C294)	1-102-978-11	220 p ± 5 % 50 V ceramic
C301(C401)	1-121-726-11	0.47 50 V electrolytic
C302(C402)	1-121-469-11	10 10 V electrolytic
C303(C403)	1-101-940-11	3 p ± 0.5 pF 50 V ceramic
C304(C404)	1-101-880-11	47 p ± 5 % 50 V ceramic
C305(C405)	1-121-420-11	220 10 V electrolytic
C306(C406)	1-121-395-11	4.7 25 V electrolytic
C307(C407)	1-123-059-11	100 50 V electrolytic
C308(C408)	1-121-411-11	47 50 V electrolytic
C309(C409)	1-105-679-12	0.033 ± 10 % 50 V mylar
C310(C410)	1-105-673-12	0.01 ± 10 % 50 V mylar
C311(C411)	1-102-961-11	27 p ± 5 % 50 V ceramic
C501	1-121-407-11	47 6.3 V electrolytic
C502	1-121-936-11	220 25 V electrolytic
C503	1-121-936-11	220 25 V electrolytic
C532	1-121-407-11	47 6.3 V electrolytic
C533	1-121-936-11	220 25 V electrolytic
C534	1-121-402-11	33 10 V electrolytic
C535	1-121-936-11	220 25 V electrolytic
C536	1-121-410-11	47 25 V electrolytic
C551	1-121-411-11	47 50 V electrolytic
C552	1-121-937-11	220 50 V electrolytic
C553	1-125-085-11	4700 50 V electrolytic

Ref. No.	Part No.	Description
C554	1-125-085-11	4700 50 V electrolytic
C555	1-105-877-12	0.022 ± 20 % 100 V mylar
C556	1-105-877-12	0.022 ± 20 % 100 V mylar
C557	1-105-877-12	0.022 ± 20 % 100 V mylar
C558	1-105-877-12	0.022 ± 20 % 100 V mylar
RESISTORS		
All resistors are in Ω, ± 5 %, 1/4 W and carbon type unless otherwise indicated.		
R101(R201)	1-244-673-11	1 k
R102(R202)	1-244-715-11	56 k
R103(R203)	1-244-737-11	470 k
R104(R204)	1-244-670-11	750
R105(R205)		-----
R106(R206)	1-244-683-11	2.7 k
R107(R207)	1-244-713-11	47 k
R108(R208)	1-244-741-11	680 k
R109(R209)	1-244-685-11	3.3 k
R110(R210)	1-244-721-11	100 k
R151(R251)	1-244-731-11	270 k
R152(R252)	1-244-663-11	390
R153(R253)	1-244-711-11	39 k
R154		-----
R155(R255)	1-244-694-11	7.5 k
R156(R256)	1-244-677-11	1.5 k
R157(R257)	1-244-684-11	3 k
R158(R258)	1-244-673-11	1 k
R159(R259)	1-244-694-11	7.5 k
R160(R260)	1-244-673-11	1 k
R161(R261)	1-244-721-11	100 k
R162(R262)	1-244-673-11	1 k
R163(R263)	1-244-721-11	100 k
R164(R264)	1-244-677-11	1.5 k
R165(R265)	1-244-695-11	8.2 k
R166(R266)	1-244-709-11	33 k
R167(R267)	1-244-683-11	2.7 k
R168(R268)	1-244-721-11	100 k
R169(R269)	1-244-709-11	33 k
R181(R281)	1-244-697-11	10 k
R182(R282)	1-244-697-11	10 k
R183(R283)	1-244-735-11	390 k
R184(R284)	1-244-719-11	82 k
R185(R285)	1-244-715-11	56 k
R186(R286)	1-244-737-11	470 k
R187(R287)	1-244-737-11	470 k
R191(R291)	1-244-690-11	5.1 k
R192(R292)	1-244-690-11	5.1 k
R193(R293)	1-244-719-11	82 k
R194(R294)	1-244-719-11	82 k
R301(R401)	1-244-741-11	680 k

Ref. No.	Part No.	Description
R302(R402)	1-244-714-11	51 k
R303(R403)	1-244-709-11	33 k
R304(R404)	1-244-683-11	2.7 k
R305(R405)	1-244-683-11	2.7 k
R306(R406)	1-244-685-11	3.3 k
R307(R407)	1-244-685-11	3.3 k
R308(R408)	1-244-675-11	1.2 k
R309(R409)	1-244-691-11	5.6 k
R310(R410)	1-244-659-11	270
R311(R411)	1-244-681-11	2.2 k
R312(R412)	1-211-522-11	100
R313(R413)	1-244-661-11	330
R314(R414)	1-244-661-11	330
R315(R415)	1-244-673-11	1 k
R316(R416)	1-217-153-11	0.47 2 W metal-oxide
R317(R417)	1-217-153-11	0.47 2 W metal-oxide
R318(R418)	1-217-153-11	0.47 2 W metal-oxide
R319(R419)	1-217-153-11	0.47 2 W metal-oxide
R320(R420)	1-244-731-11	270 k
R321(R421)	1-244-717-11	68 k
R322(R422)	1-202-565-11	470 1/2 W composition
R323(R423)	1-202-565-11	470 1/2 W composition
R324(R424)	1-202-525-11	10 1/2 W composition
R325(R425)	1-244-617-11	4.7
R326(R426)	1-244-677-11	1.5 k
R327(R427)	1-244-709-11	33 k
R328(R428)	1-244-683-11	2.7 k
R501	1-244-871-11	820 1/2 W
R502	1-244-871-11	820 1/2 W
R503	1-202-585-11	3.3 k 1/2 W composition
R531	1-244-705-11	22 k
R532	1-244-701-11	15 k
R533	1-244-871-11	820 1/2 W
R534	1-244-688-11	4.3 k
R535	1-244-708-11	30 k
R536	1-244-871-11	820 1/2 W
R537		-----
R538		-----
R539	1-244-585-11	3.3 k
R540		-----
R541	1-244-673-11	1 k
R551	1-244-641-11	47
R552	1-244-649-11	100
R553	1-244-705-11	22 k
R554	1-244-693-11	6.8 k
R581	1-244-699-11	12 k
R582	1-244-699-11	12 k
R583	1-244-669-11	680
RV101 (RV201)	1-222-462-00	resistor, variable 250 kΩ(B) (TAPE LEVEL ADJUST)

<u>Ref. No.</u>	<u>Part No.</u>	<u>Description</u>
RV151 (RV251)	1-224-006-00	resistor, variable 50 k Ω -(B) [TONE (TREBLE control)]
RV152 (RV252)	1-224-006-00	resistor, variable 50 k Ω -(B) [TONE (BASS control)]
RV191 (RV291)	1-224-005-00	resistor, variable 100 k Ω (VOLUME control)
RV192 (RV292)	1-222-549-00	resistor, variable 250 k-(N/M) (BALANCE control)
RV193 (RV293)	1-224-005-00	resistor, variable 100 k Ω (VOLUME control)
RV301 (RV401)	1-222-945-00	resistor, adjustable 1 k-(B) (dc bias adj)
SWITCHES		
S1	1-516-069-00	7-key (FUNCTION)
S2	1-514-910-00	lever/rotary (MONITOR)
S3	1-516-068-00	lever/rotary (MODE)
S4	1-514-647-00	lever (LOUDNESS)
S5	1-513-338-00	lever (TREBLE TURNOVER)
S6	1-513-338-00	lever (BASS TURNOVER)
S7	1-514-906-00	4-key (HIGH FILTER)
S8	1-514-906-00	4-key (LOW FILTER)
S9	1-514-478-00	slide (PREAMP/POWER AMP)
S10	1-514-906-00	4-key (MAIN SPEAKER)
	1-514-907-00	slide (MAIN SPEAKER)
S11	1-415-906-00	4-key (REMOTE SPEAKER)
	1-514-907-00	slide (REMOTE SPEAKER)
	1-514-990-00	lever (POWER) (USA and Canada Model)
S12	1-514-911-00	lever (POWER) (AEP and UK Model)
MISCELLANEOUS		
CP1	1-231-057-00	encapsulated component, 120 Ω + 0.033 μ F (USA and Canada Model only)

<u>Ref. No.</u>	<u>Part No.</u>	<u>Description</u>
J501	1-507-170-00	jack, AUX-2 input
J502	1-507-441-00	phono jack, 1-p
J503	1-507-190-12	jack, HEADPHONE
J101 ~ 111 J201 ~ 211 J301, 401	1-507-379-00	phono jack, 8-p
CNJ1	1-509-551-00	REC/PB connector
CNJ2, 3, 4	1-509-403-00	ac outlet (USA and Canada Model only)
PL1	1-519-072-00	lamp, neon (USA and Canada Model)
	1-519-084-00	lamp, neon (AEP and UK Model)
VS	1-526-165-00	voltage selector (USA and Canada Model)
	1-526-520-00	voltage selector (AEP and UK Model)
	1-526-198-00	socket, power transistor
CB1, 2	1-532-320-00	circuit breaker
	1-533-100-00	holder, fuse; 2-p (Canada Model)
	1-533-089-00	holder, fuse; 2-p (USA Model)
F2, F3	1-532-337-00	fuse, 1.6 A 125 V (USA Model)
	1-532-267-00	fuse, 1.6 A 125 V (Canada Model)
	1-533-069-00	holder, fuse; 4-p (AEP and UK Model)
F4, F5	1-532-259-00	fuse, 1.6 AT (AEP and UK Model only)
F6, F7	1-532-350-00	fuse, 4 AT (AEP and UK Model only)
P1	1-534-526-00	cord, power (USA and Canada Model only)
TM581, 582	1-536-284-00	terminal strip, 4-p (SPEAKER) (USA, Canada and AEP Model)
	1-535-057-00	terminal strip, 4-p (SPEAKER) (UK Model)
	1-536-353-00	terminal post, connection
	1-536-354-00	terminal post, (test point)
	1-581-265-00	jumper board, 10-p phono jack
	1-581-773-00	jumper board, 14-p phono jack