

TA-1055

US Model
 Canadian Model
 AEP Model
 UK Model
 E Model

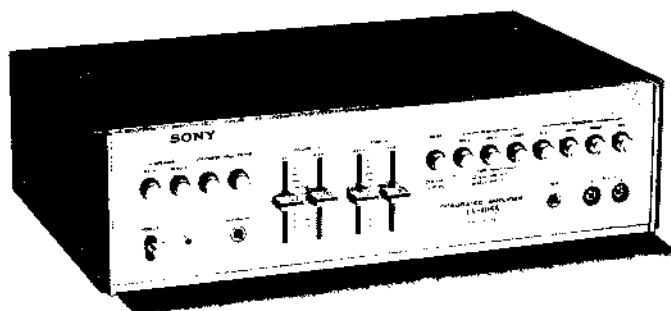

INTEGRATED STEREO AMPLIFIER

SPECIFICATIONS

POWER AMPLIFIER SECTION

Dynamic power: 70 watts, both channels operating; 8 ohms
 90 watts, both channels operating; 4 ohms

Continuous RMS power output

[Rated Output]: At 1 kHz
 28 watts per channel, 8 ohms
 35 watts per channel, 4 ohms
 23 watts per channel, both channels operating, 8 ohms
 27 watts per channel, both channels operating, 4 ohms

Power bandwidth: 10 Hz to 40 kHz, 1HF

Harmonic distortion: Less than 0.5% at 1 kHz rated output

IM distortion: Less than 0.5% at rated output

PREAMPLIFIER SECTION

Frequency response: MIC, 20 Hz to 20 kHz $\pm \frac{0}{3}$ dB
 PHONO, RIAA curve ± 1 dB
 TAPE -1, TAPE -2
 TUNER
 AUX
 REC/PB (input) } 10 Hz to 60 kHz ± 3 dB

Input sensitivity and impedance:

MIC } 2 mV 47 k
 PHONO }
 TAPE -1, TAPE -2 }
 TUNER } 250 mV 50 k
 AUX }
 REC/PB (input) }

Signal output and output impedance:

REC OUT 250 mV 10 k
 REC/PB 30 mV 82 k

GENERAL

Power consumption: Approx. 115 W (Canada Model)
 Approx. 70 W (USA Model)
 Approx. 165 W (AEP, UK and E Model)

Power requirement: 120 V ac (USA and Canada Model)
 110, 127, 220, 240 V ac (AEP, UK and E Model)

Dimensions: 410 (w) x 120 (h) x 280 (d) mm
 16 $\frac{1}{8}$ (w) x 4 $\frac{3}{4}$ (h) x 11 $\frac{1}{8}$ (d) inches

Net weight: 6.2 kg (13 lb 9 oz)

Shipping weight: 8.6 kg (18 lb 13 oz)

SONY®

SERVICE MANUAL



TABLE OF CONTENTS

<u>Section</u>	<u>Description</u>	<u>Page</u>
	SERVICING NOTES	1
1.	TECHNICAL DESCRIPTION	
1-1.	Specifications	2
1-2.	Circuit Description Digest	3
1-3.	Block Diagram	5
1-4.	Level Diagram	6
2.	DISASSEMBLY AND REPLACEMENT	
2-1.	Bottom Plate Removal	7
2-2.	Front Panel Removal	7
2-3.	Front Subchassis Removal	7
2-4.	Pushbutton Switch Replacement	7
2-5.	Chassis Layout	8
3.	REPACKING	9
4.	DIAGRAMS	
4-1.	Front Subchassis Wiring Diagram	10
4-2.	Mounting Diagram	11
4-3.	Schematic Diagram	13
5.	EXPLODED VIEWS	16
6.	ELECTRICAL PARTS LIST	18

Note: Applicable Serial No.
 USA Model 800,001 and later
 Canada Model 700,001 and later
 AEP Model 500,001 and later
 UK Model 600,001 and later
 E Model 400,001 and later

SERVICING NOTES

1. Cautions on handling IC's

- a. Excessive heat may destroy an IC. Never re-install a used IC.
- b. Check the related components for defects before replacing the IC.
- c. When installing new IC's, do not apply excessive heat. Solder quickly while holding a wet rag on the heat-sink tab as shown in Fig. A.
- d. Do not short adjacent IC leads when performing electrical checks as this might damage the IC.
- e. Always solder the IC heat sink to the printed circuit board to avoid damage.

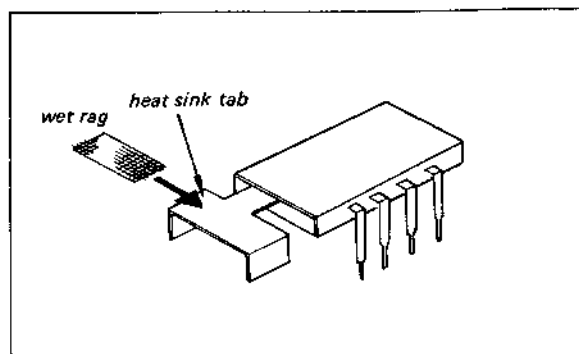

Fig. A. IC installation

2. Power amplifier adjustment

No adjustment is required.

3. Power transistor replacement

When replacing the power transistor, apply a coating of a heat-transferring grease to both sides of the mica insulator. Any excess grease squeezed out when the screw is tightened should be wiped off.

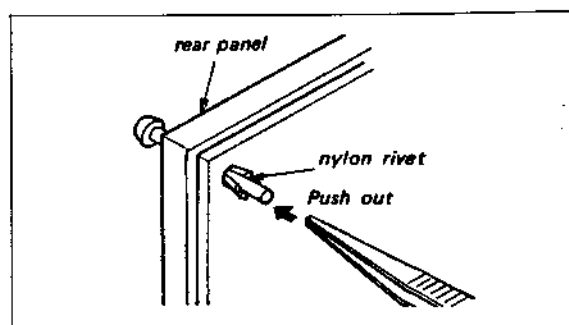

Fig. B. Nylon rivet removal

4. Nylon rivet removal

- a. To remove the nylon rivet, push its end with a tweezers as shown in Fig. B.
- b. To reinstall the rivet, insert the flared part into the opening first, then push its head as far as it will go.

5. This set uses bonded parallel lead wires shown in Fig. C. Refer to the lines stenciled on them when performing electrical checks.

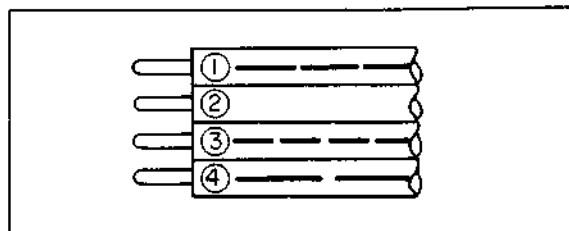

Fig. C. New lead wires

**SECTION 1
TECHNICAL DESCRIPTION**

1-1. SPECIFICATIONS

Power Amplifiers Section

Dynamic power: 70 watts, both channels operating; 8 ohms
90 watts, both channels operating; 4 ohms

Continuous RMS power output (Rated output): At 1 kHz
28 watts per channel, 8 ohms
35 watts per channel, 4 ohms
23 watts per channel both channels operating, 8 ohms
27 watts per channel, both channels operating, 4 ohms

Power bandwidth: 10 Hz to 40 kHz, IHF

Harmonic distortion: Less than 0.5 % at 1 kHz rated output

IM distortion: Less than 0.5 % at rated output

Preamplifier Section

Frequency response: MIC, 20 Hz to 20 kHz $\pm \frac{0}{3}$ dB
PHONO, RIAA curve ± 1 dB
TAPE - 1 }
TAPE - 2 } 10 Hz to 60 kHz
TUNER } ± 3 dB
AUX }
REC/PB }
(input) }

Input sensitivity and impedance: MIC }
PHONO } 2 mV 47 k
AUX }
TUNER }
TAPE - 1 } 250 mV 50 k
TAPE - 2 }
REC/PB }
(input) }

Signal output and output impedance: REC OUT 250 mV 10 k
REC/PB 30 mV 82 k (output)

Signal-to-noise ratio: MIC, greater than 65 dB (weighting network "B")
PHONO, greater than 70 dB (weighting network "B")
AUX }
TUNER } greater than 90 dB
TAPE - 1, - 2 } (weighting network "A")
REC/PB }
(input) }

Tone controls: BASS ± 10 dB at 100 Hz
TREBLE ± 10 dB at 10 kHz

Filters: HIGH, 6 dB/oct above 5 kHz

Loudness control: + 10 dB at 50 Hz, + 3.5 dB at 10 kHz (volume control attenuation: 30 dB)

General

Power consumption: Approx. 115 W (Canada Model)
Approx. 70 W (USA Model)
Approx. 165 W (AEP, UK and E Model)

Power requirement: 120 V ac (USA and Canada Model)
110, 127, 220, 240 V ac (AEP UK and E Model)

Dimensions: 410 (w) x 120 (h) x 280 (d) mm
16 $\frac{1}{8}$ (w) x 4 $\frac{3}{4}$ (h) x 11 $\frac{1}{8}$ (d) inches

Net weight: 6.2 kg (13 lb 9 oz)

Shipping weight: 8.6 kg (18 lb 13 oz)

1-2. CIRCUIT DESCRIPTION DIGEST

The following description might help your repair work. Since stages are listed by transistor or IC reference designation, refer to the block diagram on page 5 and schematic diagram on pages 13 and 14.

Preamplifier (IC101)

This amplifier increases the signal level provided by phono cartridge or other signals to the level required at the input of the following buffer amplifier, and also performs proper equalization. Fig. 1-1 shows that the preamplifier operates both as phono equalizer and flat amplifier corresponding to the selected feedback loop. Note that IC101 contains two identical low noise amplifier chains and bias circuit. This also requires two power supply which are same but oppositely poled. The IC101 block diagram is shown in Fig. 1-2.

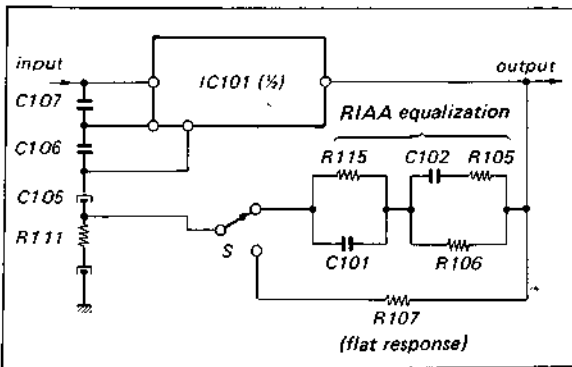

Fig. 1-1. Simplified preamplifier circuit

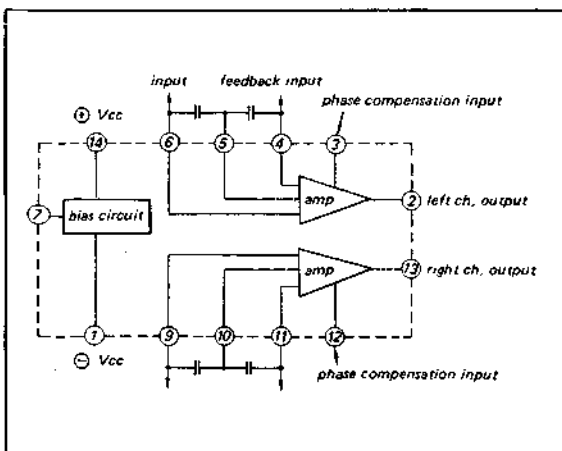

Fig. 1-2. IC diagram

LOUDNESS Circuit

R117, C113, C115 and R118 form a loudness circuit and compensate for the characteristics of the human ear which vary according to the loudness of the sound being heard. When LOUDNESS switch is ON and the VOLUME control is set for 30 dB attenuation, the frequency response is changed as shown in Fig. 1-3 regardless of the tone control function.

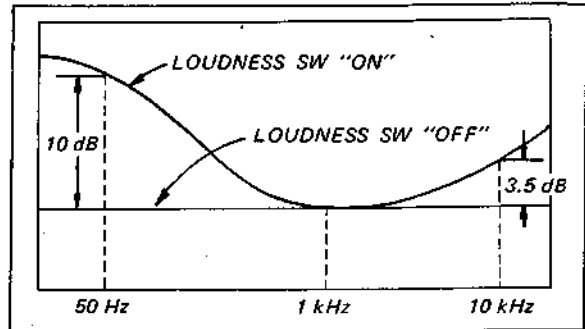

Fig. 1-3. Loudness circuit response

TONE CONTROL Circuit

Referring to Fig. 1-4, the tone control circuit consists of tone control network and power amplifier. This is basically same as the conventional negative feedback type tone control circuit as the power amplifier output is fed back to the input circuit through the tone control network.

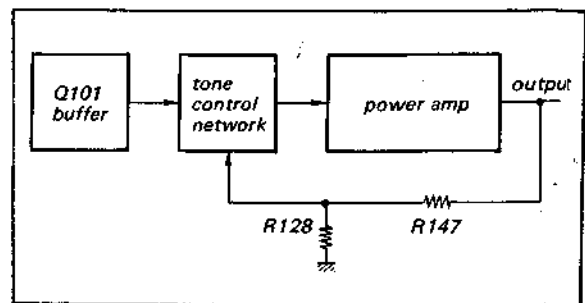

Fig. 1-4. Tone control circuit

Power Amplifier (Q102 ~ Q109)**[Pre-amplifier Q102, Q103]**

Q102 and Q103 form a paraphase amplifier but signal output is extracted from the collector circuit of Q102. This circuit has various advantages in direct-coupling systems. One is high stability despite temperature variations and another is high input impedance without reducing the amplifier gain. The ac output appears across load resistor R132 (2.2k) in the collector circuit. An emitter decoupling circuit is formed by the emitter-base resistance of Q103, R149 and C123 in the base circuit of Q103.

[Thermal compensation and noise suppressor (D101)]

As all the stages are directly coupled, dc stability is required. The negative temperature coefficient of D101 provides thermal compensation for the following driver stage. It also acts as a noise suppressor to reduce the popping noise due to unbalanced current flow in the following stages when the power switch is turned off.

[Driver (Q104)]

Though this stage is a conventional flat amplifier, it determines the output voltage swings because the following stages are basically emitter-followers. The ac load resistor for this stage is R135.

[Dc bias supply (Q105)]

Q105 is biased into heavy conduction and operates as a small resistance providing the necessary forward bias on the two cascaded emitter-followers. This circuit

has the advantage of stable operation even at high power output levels.

[Complementary (Driver) Q106, Q107]

These transistors operate as emitter-followers to provide the current swings demanded of the output stages and also provide the necessary phase inversion to drive the power-output stages in push-pull. Phase inversion is performed by using PNP and NPN type transistors.

[Power transistors (Q108, Q109)]

The output transistors Q108 and Q109 are connected directly to a power supply of about ± 30 V. Q108 supply power to the load during positive half cycles and Q109 operate during negative half cycles. As all the stages are directly coupled and designed to obtain zero potential at the output terminal, the large coupling capacitor at the output (which may cause power reduction and frequency distortion at low frequencies) is eliminated.

Power Supply**[Rectifier (D301 ~ D304)]**

A full-wave bridge rectifier and centertapped transformer provides positive and negative dc power supplies for the power amplifier.

[Ripple filter (Q301, R303, C308)]

These components reduce the ripple voltage in the negative dc power supply for buffer amplifier and driver stages of the power amplifier section to an extremely-low-value.

1-3. BLOCK DIAGRAM

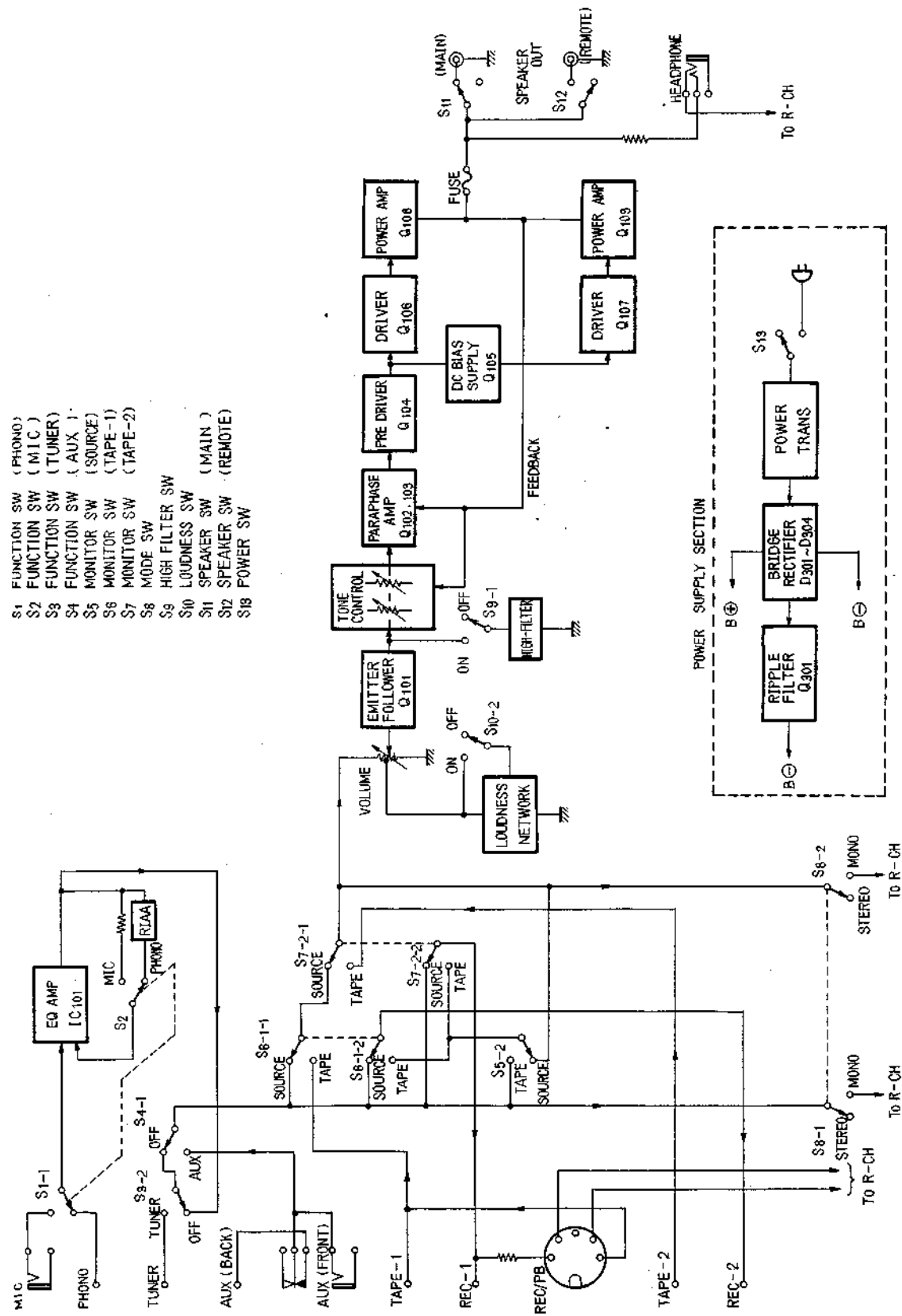

1-4. LEVEL DIAGRAM

Note: Signal voltages are measured with an ac VTVM and expressed in dB referred to 0.775 V, 1 kHz.

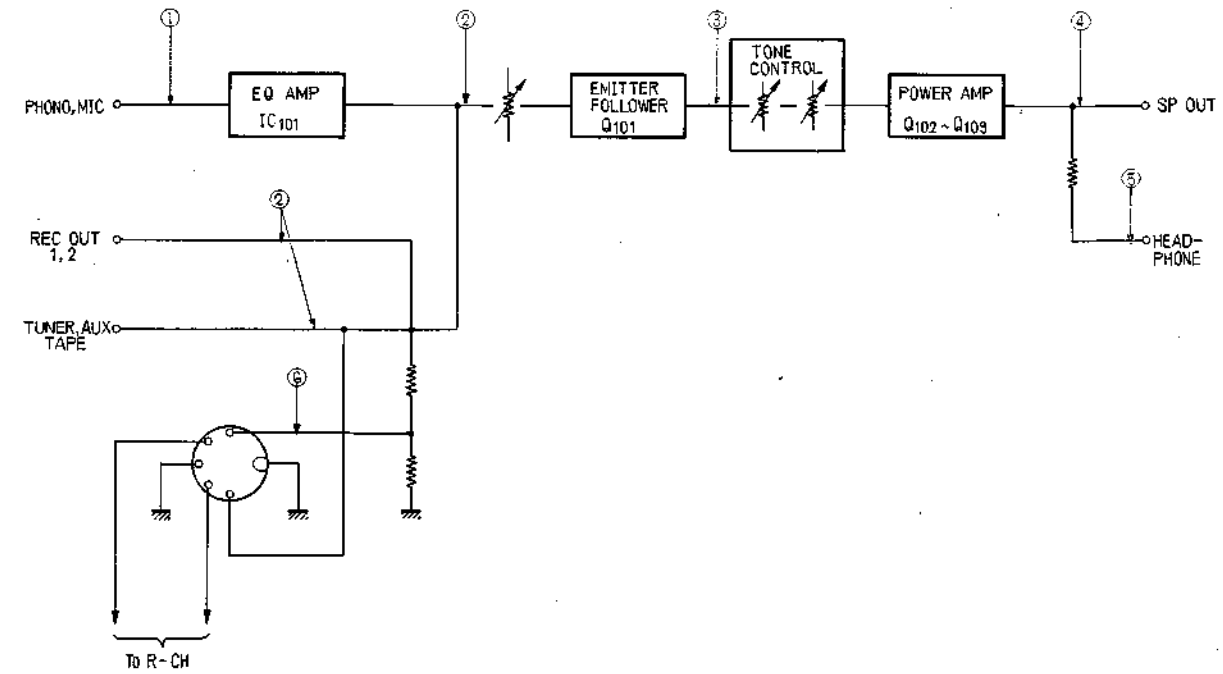
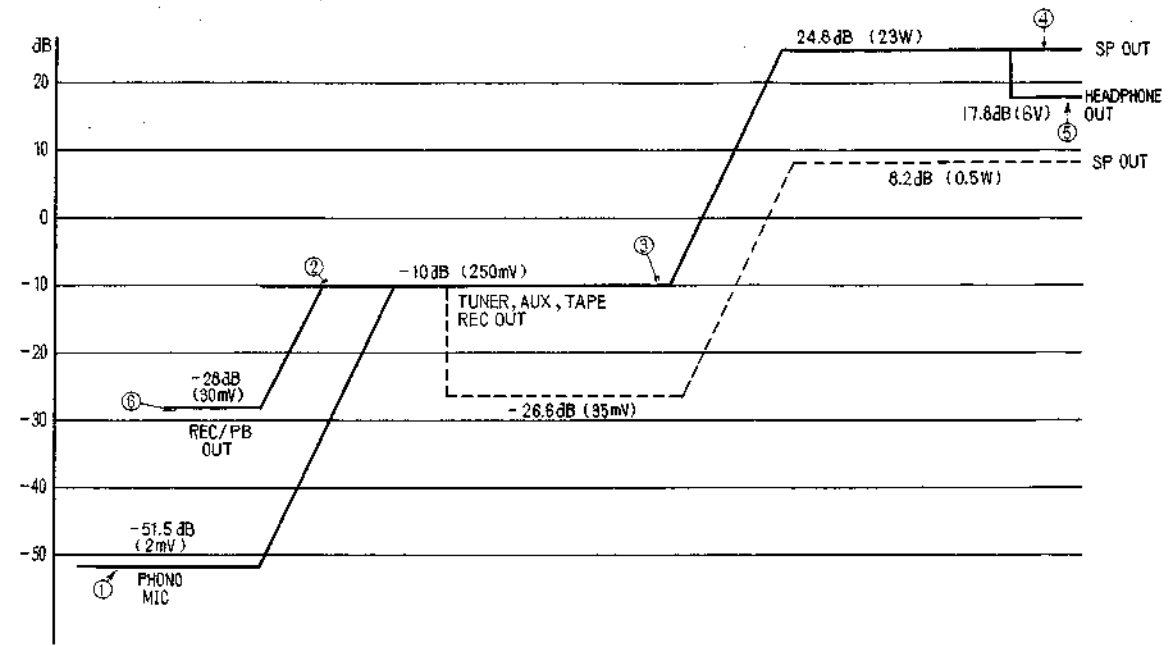

SECTION 2 DISASSEMBLY AND REPLACEMENT

Note: All screws in this service manual are Phillips type (cross recess type) unless otherwise indicated. (-): slotted head.

2-1. BOTTOM PLATE REMOVAL

1. Remove the seven screws shown in Fig. 2-1.

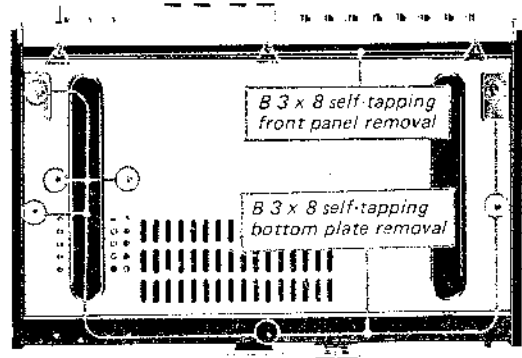

Fig. 2-1. Bottom view

2-2. FRONT PANEL REMOVAL

1. Remove the two screws at both sides of the wooden case.
2. Remove the bottom plate as described in Procedure 2-1.
3. Remove the three screws from front top and bottom of the front panel as shown in Fig. 2-1 and 2-2.
4. Pull off the TONE and VOLUME control knobs.
5. This frees the front panel with pushbutton.

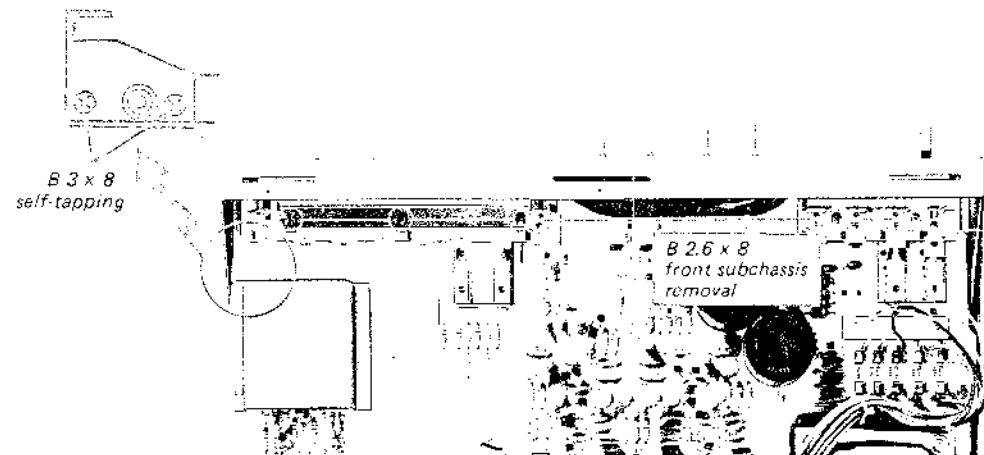

Fig. 2-3. Front subchassis removal

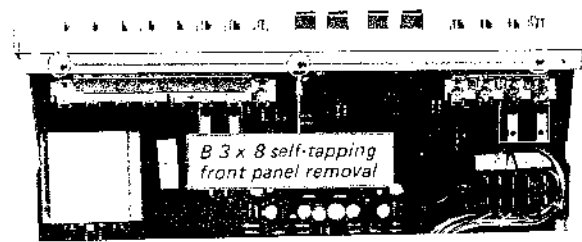

Fig. 2-2. Front panel removal

2-3. FRONT SUBCHASSIS REMOVAL

1. Remove the front panel as described in Procedure 2-2.
2. Remove the two screws at each side of the front subchassis as shown in Fig. 2-3.
3. Remove the five screws shown in Fig. 2-3.

2-4. PUSHBUTTON SWITCH REPLACEMENT

1. Remove the front subchassis as described in Procedure 2-3.
2. With a soldering iron having a soldersucking tip, clean the solder from each lug of the switches and printed circuit board.

2-5. CHASSIS LAYOUT

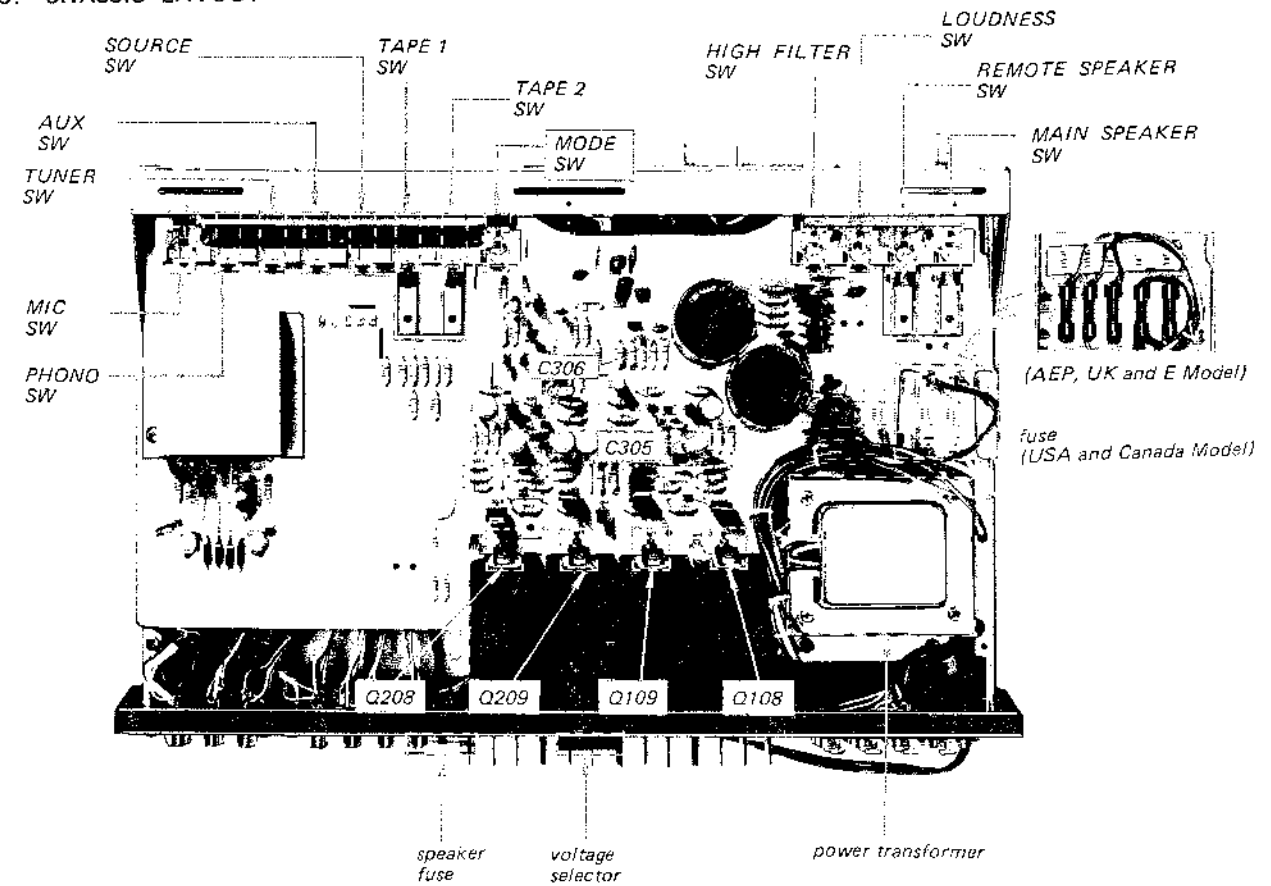

SECTION 3
REPACKING

The original shipping carton and packing materials are ideal containers for shipping the unit. However to secure the maximum protection, the am-

plifier must be repacked in these materials precisely as before as shown in Fig. 3-1.

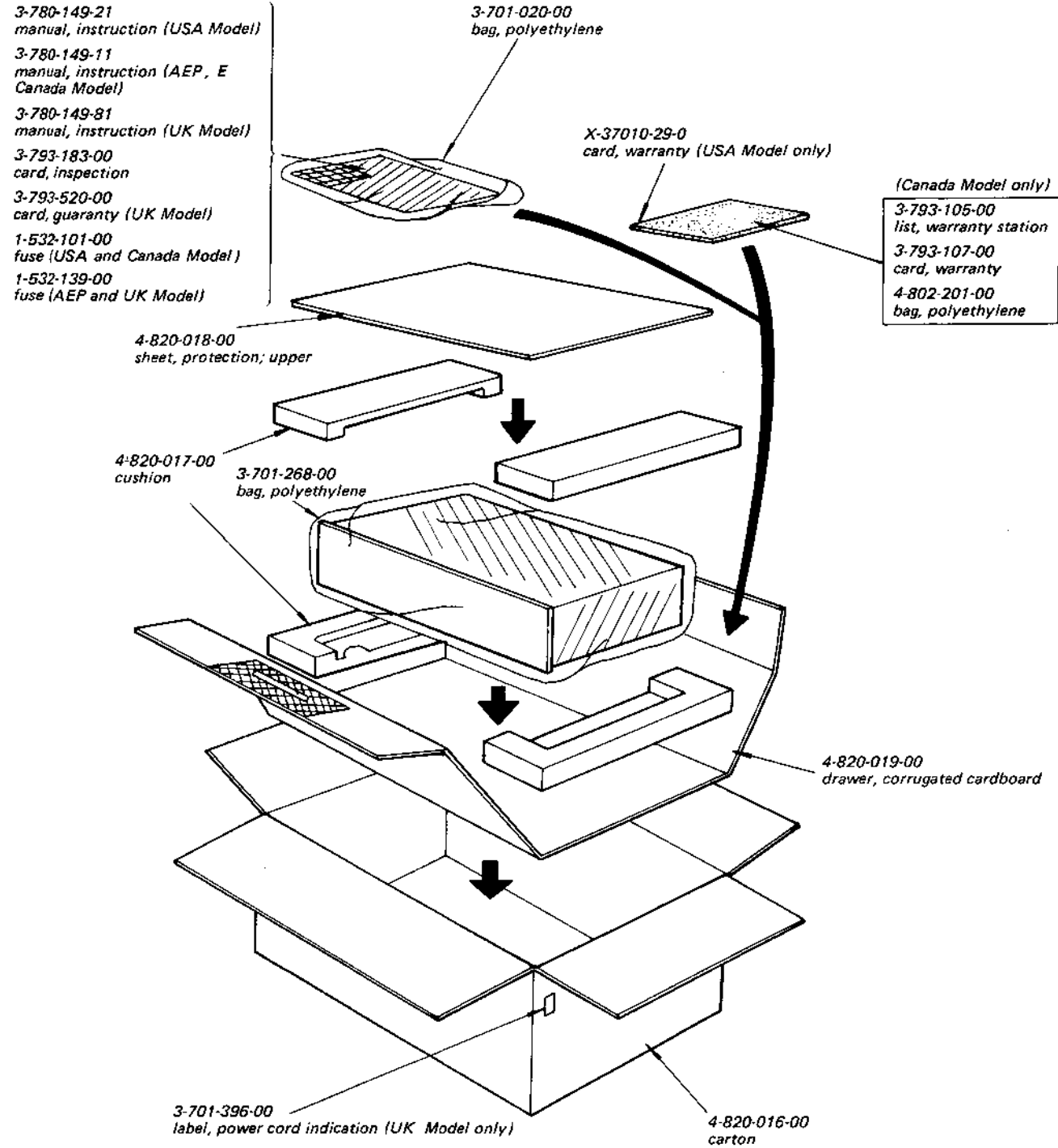

Fig. 3-1. Repacking

Applicable Serial No.

- USA Model 800,001 to 804,000
- Canada Model 700,001 to 701,300
- AEP Model 500,001 to 513,300
- UK Model 600,001 to 652,500

Note: See the supplement supplied with this manual for the sets not having the above serial numbers.

SECTION 4
DIAGRAMS

4-1. FRONT SUBCHASSIS WIRING DIAGRAM

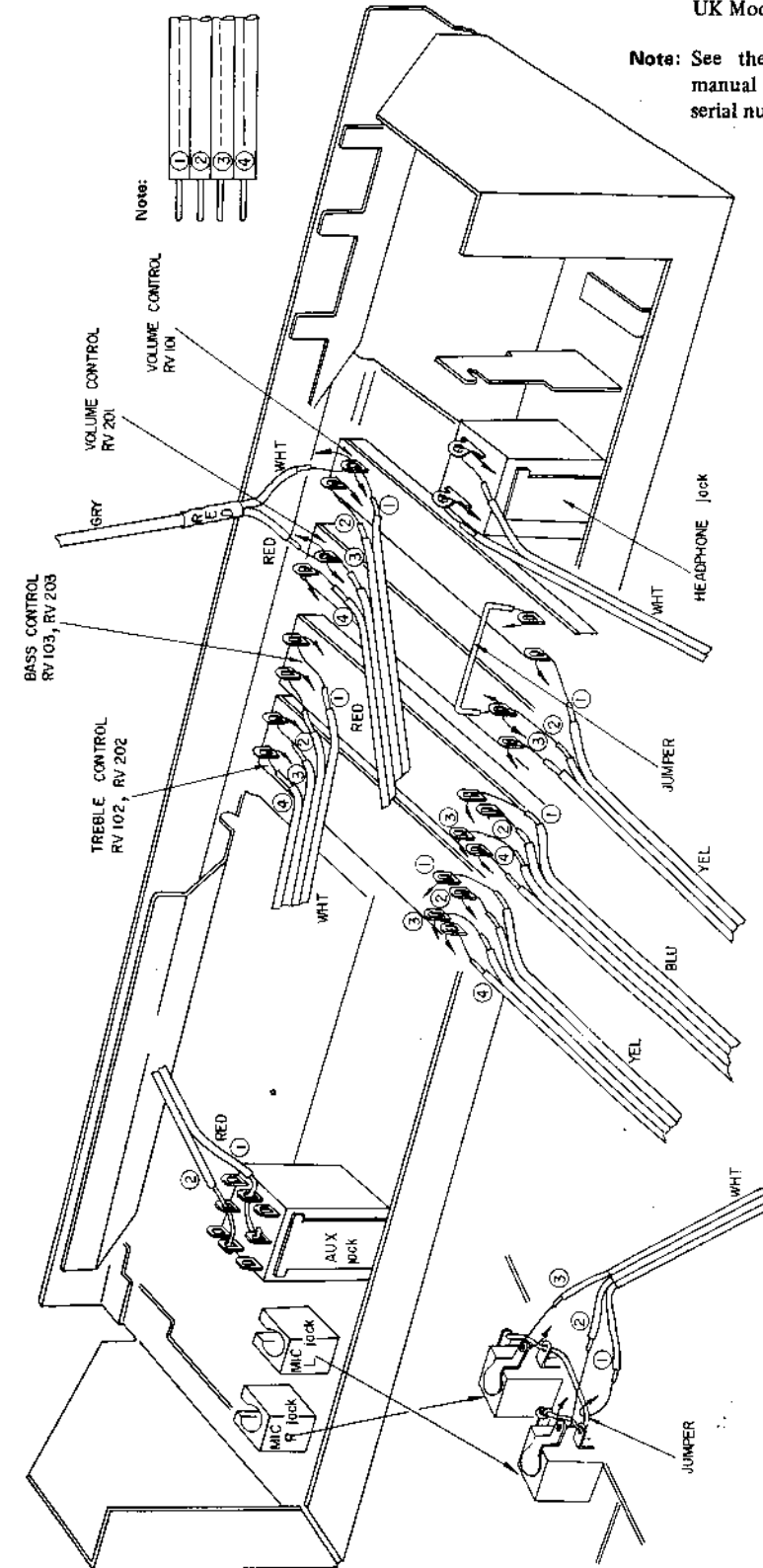

Applicable Serial No.

- USA Model 800,001 to 804,000
- Canada Model 700,001 to 701,300
- AEP Model 500,001 to 513,300
- UK Model 600,001 to 652,500

Note: See the supplement supplied with this manual for the sets not having the above serial numbers.

4-2. MOUNTING DIAGRAM
 ➔ Conductor Side —

Applicable Serial No.

- USA Model 800,001 to 804,000
- Canada Model 700,001 to 701,300
- AEP Model 500,001 to 513,300
- UK Model 600,001 to 652,500

Note: See the supplement supplied with this manual for the sets not having the above serial numbers.

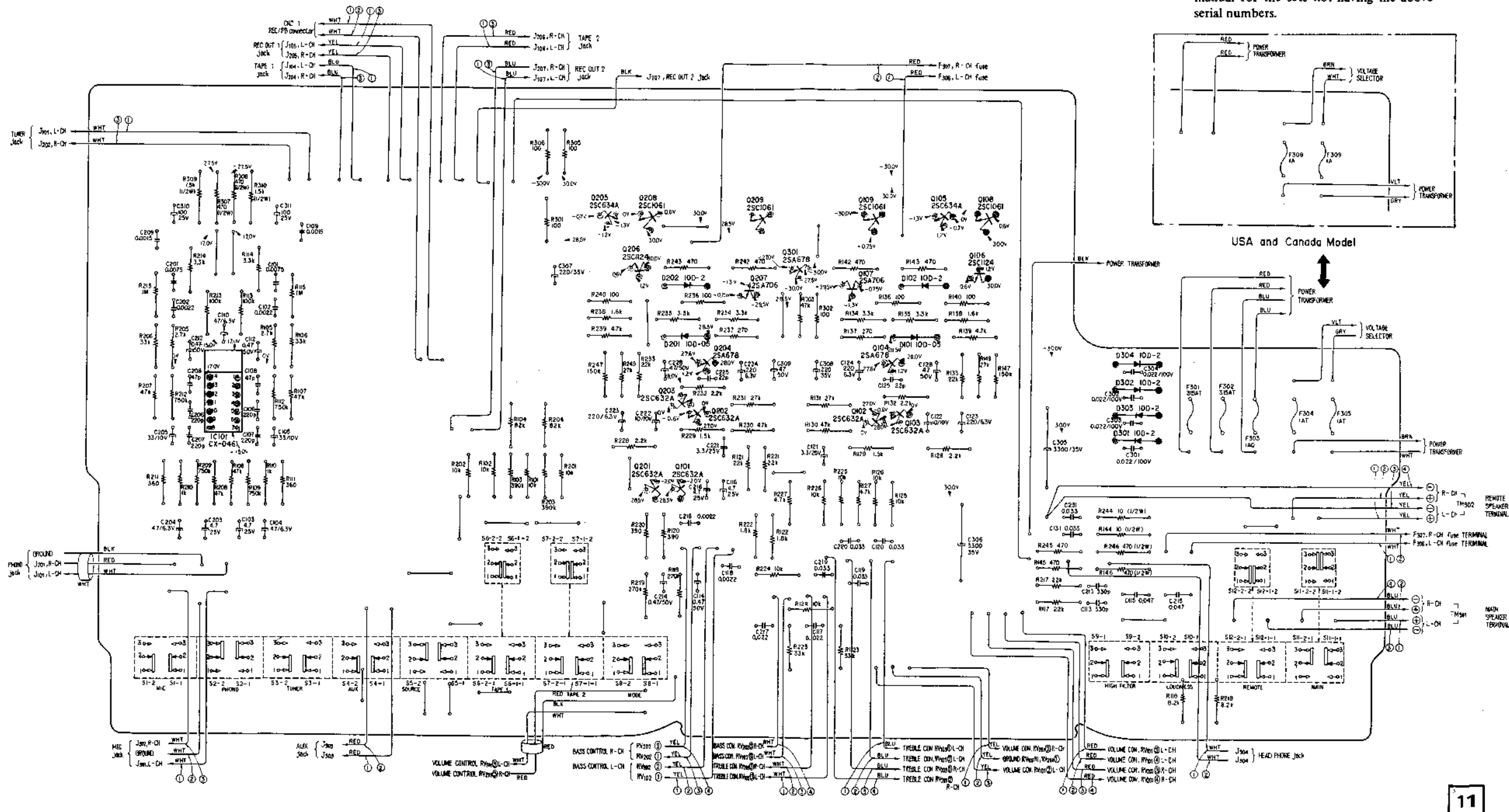

11

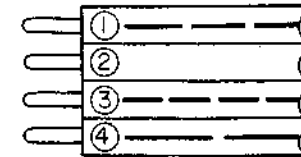
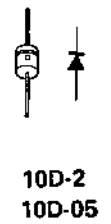
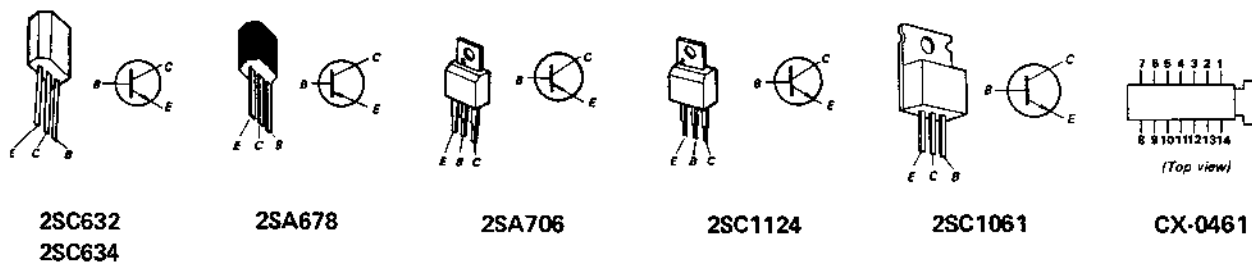

Note: Lead wires can be identified by the lines stenciled on them as shown.

4.3. SCHEMATIC DIAGRAM

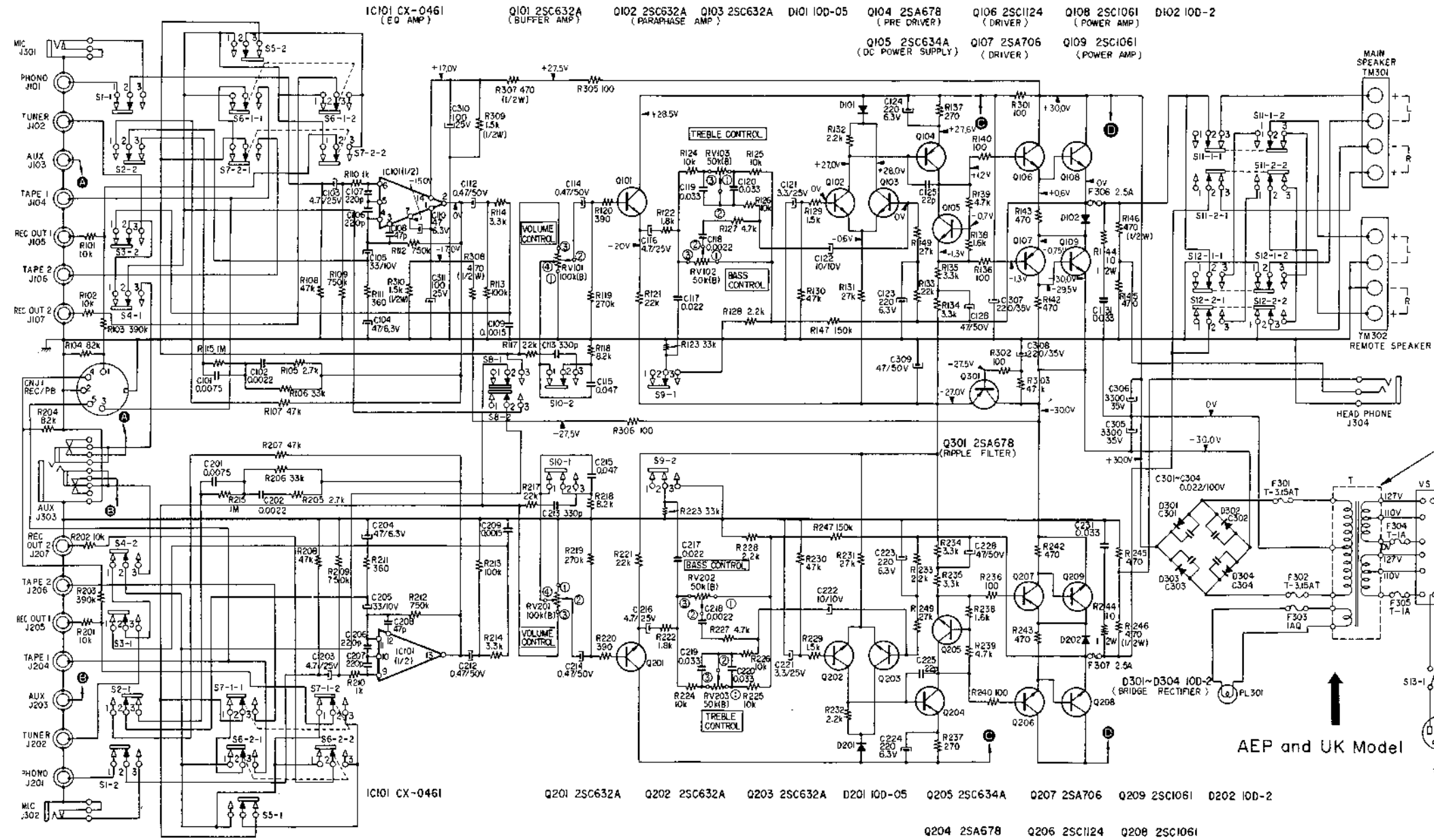

Volume Control's Wiring

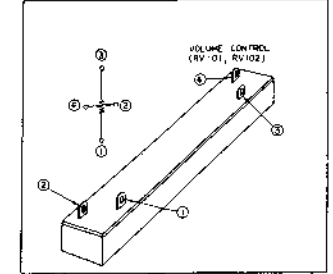

Tone Control's Wiring

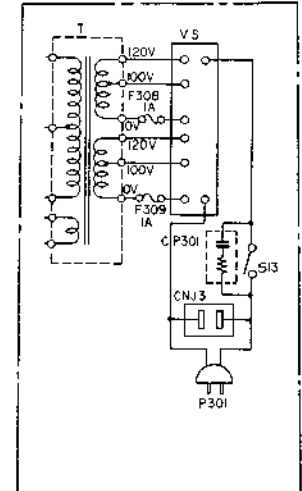
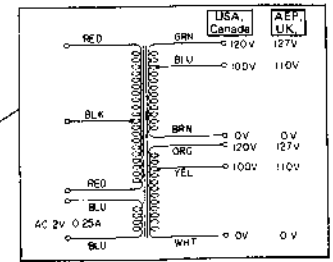
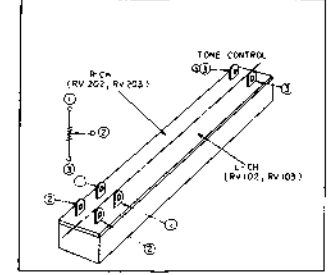

USA and Canada Model

Ref. No.	Description	Position	Ref. No.	Description	Position
S1, S2	FUNCTION SW (PHONO-MIC)	PHONO	S8	MODE SW (STEREO-MONO)	STEREO
S3	FUNCTION SW (TUNER-OFF)	OFF	S9	HIGH FILTER SW	OFF
S4	FUNCTION SW (AUX-OFF)	OFF	S10	LOUDNESS SW	OFF
S5	MONITOR SW (TAPE-SOURCE)	SOURCE	S11	MAIN SPEAKER SW	ON
S6	MONITOR SW (TAPE 1-SOURCE)	SOURCE	S12	REMOTE SPEAKER SW	OFF
S7	MONITOR SW (TAPE 2-SOURCE)	SOURCE	S13	POWER SW	OFF

Note: All resistance values are in ohms. k = 1,000 M = 1,000 k.
 All capacitance values are in μ F except as indicated with p, which means μ F.
 All voltages are dc measured with a VOM having 20 k ohms/volt input impedance. No signal in.
 Voltage variations may be noted due to normal production tolerances.

Applicable Serial No.
 USA Model 800,001 to 804,000
 Canada Model 700,001 to 701,300
 AEP Model 500,001 to 513,300
 UK Model 600,001 to 652,500

Note: See the supplement supplied with this manual for the sets not having the above serial numbers.

**SECTION 5
EXPLODED VIEWS**

Applicable Serial No.
 USA Model 800,001 to 804,000
 Canada Model 700,001 to 701,300
 AEP Model 500,001 to 513,300
 UK Model 600,001 to 652,500

Note: See the supplement supplied with this manual for the sets not having the above serial numbers.



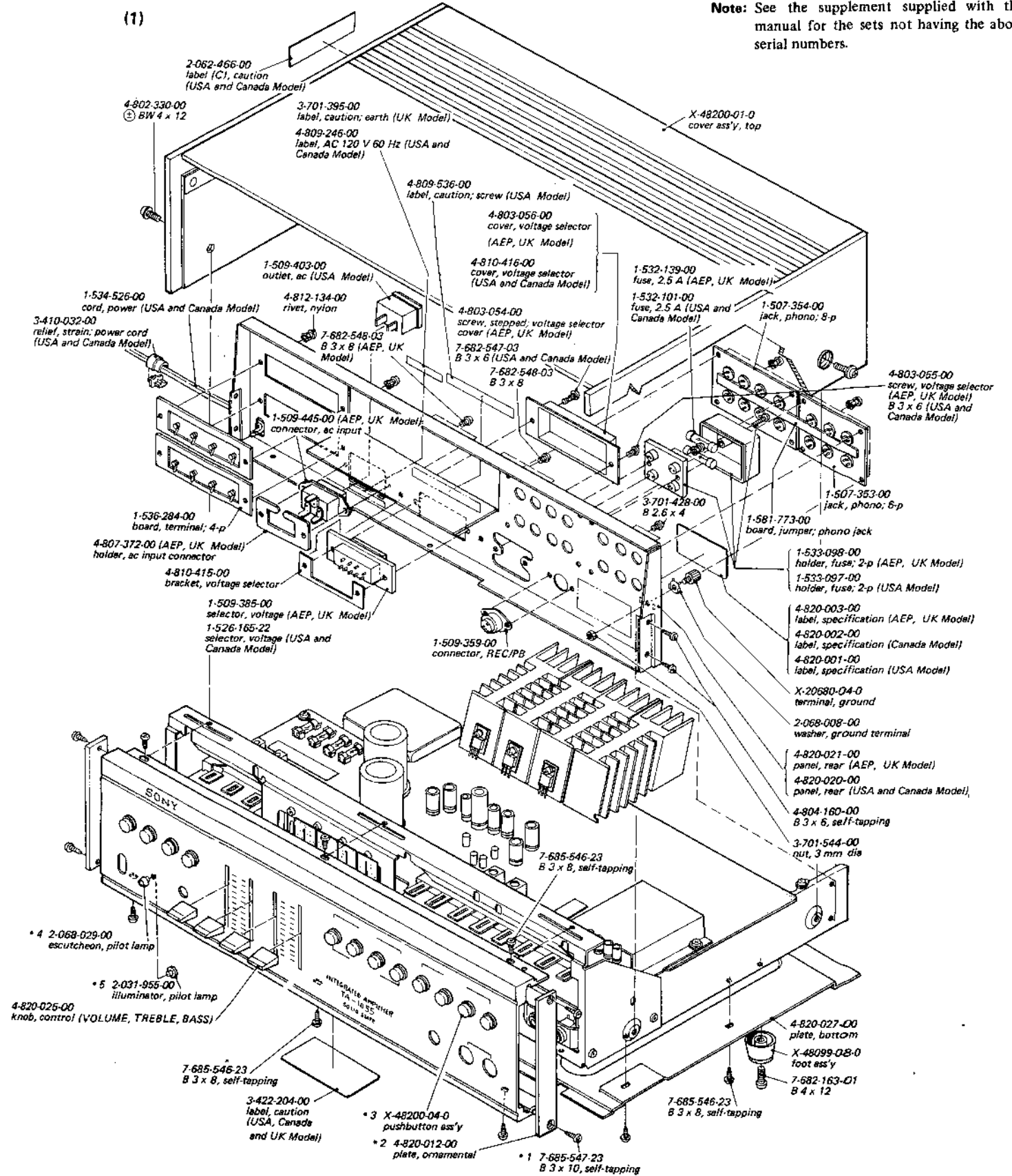

MEMO







Note: * 1 ~ front panel ass'y (X-48200-81-0) includes all the parts marked *.

(2)

Hardware Nomenclature

P	- Pan Head Screw	
PS	- Pan Head Screw with Spring Washer	
PSW	- Pan Head Screw with Spring Washer and Washer	
K	- Flat Countersunk Head Screw	
B	- Binding Head Screw	

- Example -

	Type of Slot
	Length in mm (L)
	Diameter in mm (D)
	Type of Head

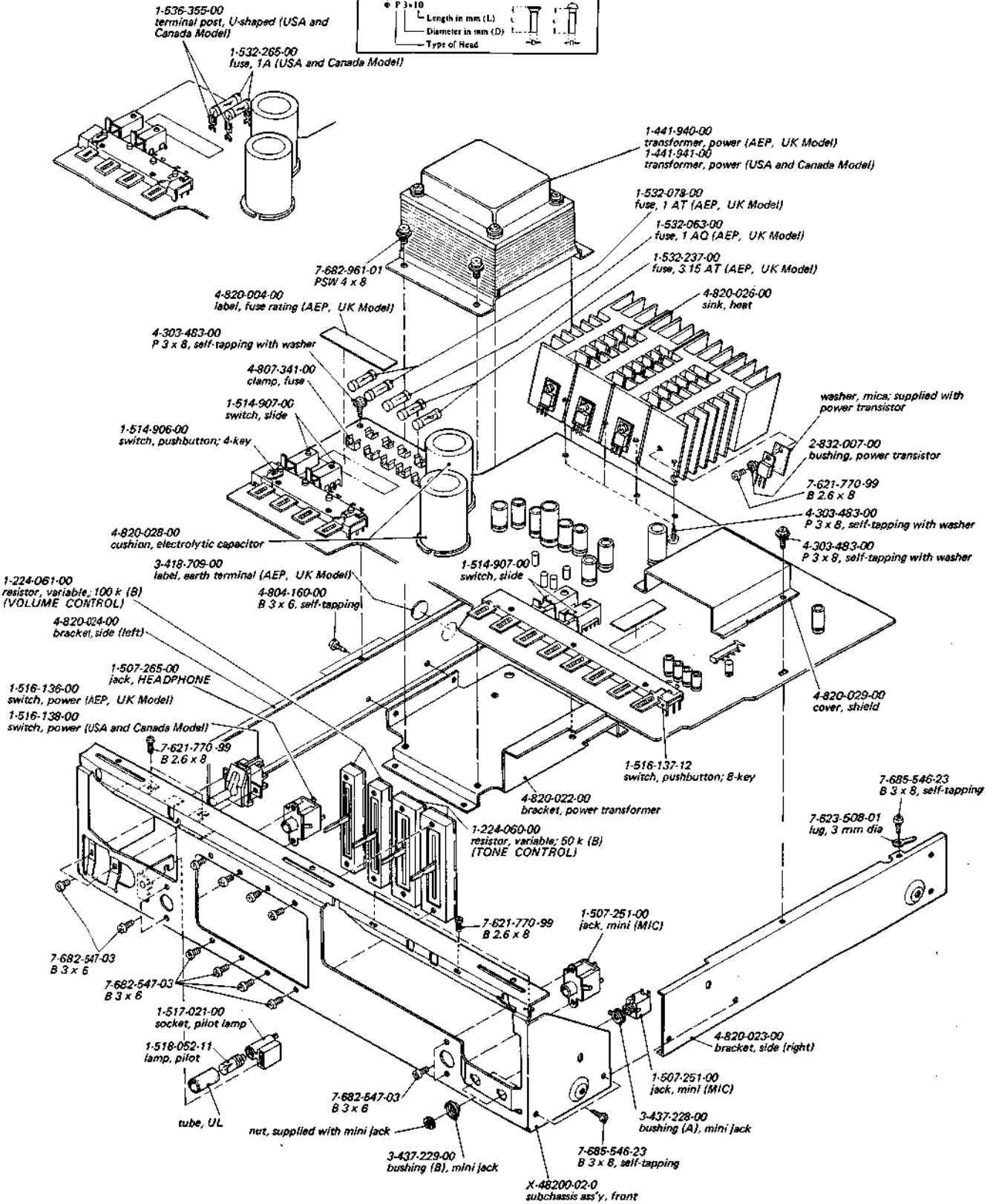

SECTION 6

ELECTRICAL PARTS LIST

Applicable Serial No.
 USA Model 800,001 and later
 Canada Model 700,001 and later
 AEP Model 500,001 and later
 UK Model 600,001 and later
 E Model 400,001 and later

Note: Refer to the supplement supplied with this manual.

Ref. No. Part No. Description

COMPLETE CIRCUIT BOARD

8-982-680-29 Preamp/Power amp/Power supply Board, complete

SEMICONDUCTORS

D101(D201)	diode	10D-05
D102(D202)	diode	10D-2
D301	diode	10D-2
D302	diode	10D-2
D303	diode	10D-2
D304	diode	10D-2
Q101(Q201)	transistor	2SC632A
Q102(Q202)	transistor	2SC632A
Q103(Q203)	transistor	2SC632A
Q104(Q204)	transistor	2SA678
Q105(Q205)	transistor	2SC634A
Q106(Q206)	transistor	2SC1124
Q107(Q207)	transistor	2SA706
Q108(Q208)	transistor	2SC1061
Q109(Q209)	transistor	2SC1061
Q301	transistor	2SA678
IC101	IC	CX-0461

TRANSFORMERS

T	1-441-940-00	transformer, power (AEP, UK and E Model)
	1-441-941-00	transformer, power (USA and Canada Model)

CAPACITORS

All capacitance values are in μF except as indicated with p, which means μmF .

C101(C201)	1-106-022-12	0.0075 $\pm 5\%$	50 V	mylar
C102(C202)	1-106-009-12	0.0022 $\pm 5\%$	50 V	mylar
C103(C203)	1-121-395-11	4.7	25 V	electrolytic
C104(C204)	1-121-407-11	47	6.3 V	electrolytic
C105(C205)	1-121-402-11	33	10 V	electrolytic
C106(C206)	1-102-110-11	220 p $\pm 10\%$	50 V	ceramic
C107(C207)	1-102-110-11	220 p $\pm 10\%$	50 V	ceramic
C108(C208)	1-101-880-11	47 p $\pm 5\%$	50 V	ceramic
C109(C209)	1-106-005-12	0.0015 $\pm 5\%$	50 V	mylar
C110	1-121-407-11	47	6.3 V	electrolytic
C111	-----	-----	-----	-----
C112(C212)	1-121-726-11	0.47	50 V	electrolytic
C113(C231)	1-102-820-11	330 p $\pm 5\%$	50 V	ceramic
C114(C214)	1-121-726-11	0.47	50 V	electrolytic

Ref. No. Part No. Description

C115(C215)	1-105-681-12	0.047	$\pm 10\%$	50 V	mylar
C116(C216)	1-121-395-11	4.7		25 V	electrolytic
C117(C217)	1-105-677-12	0.022	$\pm 10\%$	50 V	mylar
C118(C218)	1-105-665-12	0.0022	$\pm 10\%$	50 V	mylar
C119(C219)	1-105-679-12	0.033	$\pm 10\%$	50 V	mylar
C120(C220)	1-105-679-12	0.033	$\pm 10\%$	50 V	mylar
C121(C221)	1-121-392-11	3.3		25 V	electrolytic
C122(C222)	1-121-469-11	10		10 V	electrolytic
C123(C223)	1-121-419-11	220		6.3 V	electrolytic
C124(C224)	1-121-419-11	220		6.3 V	electrolytic
C125(C225)	1-102-959-11	22 p	$\pm 5\%$	50 V	ceramic
C126(C226)	-----	-----	-----	-----	-----
C127(C227)	-----	-----	-----	-----	-----
C128(C228)	1-121-411-11	47		50 V	electrolytic
C129	-----	-----	-----	-----	-----
C130	-----	-----	-----	-----	-----
C131(C231)	1-105-679-12	0.033	$\pm 10\%$	50 V	mylar
C301	1-105-717-12	0.022	$\pm 10\%$	100 V	mylar
C302	1-105-717-12	0.022	$\pm 10\%$	100 V	mylar
C303	1-105-717-12	0.022	$\pm 10\%$	100 V	mylar
C304	1-105-717-12	0.022	$\pm 10\%$	100 V	mylar
C305	1-123-048-11	3,300		35 V	electrolytic
C306	1-123-048-11	3,300		35 V	electrolytic
C307	1-121-261-11	220		35 V	electrolytic
C308	1-121-261-11	220		35 V	electrolytic
C309	1-121-411-11	47		50 V	electrolytic
C310	1-121-416-11	100		25 V	electrolytic
C311	1-121-416-11	100		25 V	electrolytic

RESISTORS

All resistance values are in Ω , $\pm 5\%$, $\frac{1}{4}W$ and carbon type unless otherwise indicated.

R101(R201)	1-244-697-11	10 k
R102(R202)	1-244-697-11	10 k
R103(R203)	1-244-735-11	390 k
R104(R204)	1-244-719-11	82 k
R105(R205)	1-244-683-11	2.7 k
R106(R206)	1-244-709-11	33 k
R107(R207)	1-244-713-11	47 k
R108(R208)	1-244-713-11	47 k
R109(R209)	1-244-742-11	750 k
R110(R210)	1-244-673-11	1 k
R111(R211)	1-244-662-11	360
R112(R212)	1-244-742-11	750 k
R113(R213)	1-244-721-11	100 k
R114(R214)	1-244-685-11	3.3 k
R115(R215)	1-244-745-11	1 M
R116(R216)	-----	-----
R117(R217)	1-244-705-11	22 k
R118(R218)	1-244-695-11	8.2 k

<u>Ref. No.</u>	<u>Part No.</u>	<u>Description</u>
R119(R219)	1-244-731-11	270 k
R120(R220)	1-244-663-11	390
R121(R221)	1-244-705-11	22 k
R122(R222)	1-244-679-11	1.8 k
R123(R223)	1-244-709-11	33 k
R124(R224)	1-244-697-11	10 k
R125(R225)	1-244-697-11	10 k
R126(R226)	1-244-697-11	10 k
R127(R227)	1-244-689-11	4.7 k
R128(R228)	1-244-681-11	2.2 k
R129(R229)	1-244-677-11	1.5 k
R130(R230)	1-244-713-11	47 k
R131(R231)	1-244-707-11	27 k
R132(R232)	1-244-681-11	2.2 k
R133(R233)	1-244-705-11	22 k
R134(R234)	1-244-685-11	3.3 k
R135(R235)	1-244-685-11	3.3 k
R136(R236)	1-244-649-11	100
R137(R237)	1-244-659-11	270
R138(R238)	1-244-678-11	1.6 k
R139(R239)	1-244-689-11	4.7 k
R140(R240)	1-244-649-11	100
R141(R241)	-----	-----
R142(R242)	1-244-665-11	470
R143(R243)	1-244-665-11	470
R144(R244)	1-202-525-11	10 ½ W composition
R145(R245)	1-244-665-11	470
R146(R246)	1-202-565-11	470 ½ W composition
R147(R247)	1-244-725-11	150 k
R148(R248)	-----	-----
R149(R249)	1-244-707-11	27 k
R301	1-244-649-11	100
R302	1-244-649-11	100
R303	1-244-713-11	47 k
R304	-----	-----
R305	1-244-649-11	100
R306	1-244-649-11	100
R307	1-202-565-11	470 ± 5 % ½ W composition
R308	1-202-565-11	470 ± 5 % ½ W composition
R309	1-202-577-11	1.5 k ± 5 % ½ W composition
R310	1-202-577-11	1.5 k ± 5 % ½ W composition
RV101 (RV201)	1-224-061-00	100 k (B), variable (VOLUME control)
RV102 (RV202)	1-224-060-00	50 k (B)/50 k (B) variable (BASS control)
RV103 (RV203)	1-224-060-00	50 k (B)/50 k (B) variable (TREBLE control)

<u>Ref. No.</u>	<u>Part No.</u>	<u>Description</u>
SWITCHES		
S1 ~ 4	1-516-137-12	switch, pushbutton; 8-key (FUNCTION)
S5 ~ 7		
S8		
S9		
S10		
S11	1-514-906-00	switch, pushbutton; 4-key (MAIN SPEAKER)
S12		
S13	1-516-136-00	switch, lever/seesaw (POWER) (AEP, UK and E Model)
	1-516-138-00	switch, lever/seesaw (POWER) (USA and Canada Model)
S6-1-2	1-514-907-00	switch, slide (MONITOR)
S6-2-2		
S7-1-2		
S7-2-2	1-514-907-00	switch, slide (MONITOR)
S11-1-2		
S11-2-2		
S12-1-2	1-514-907-00	switch, slide (MAIN SPEAKER)
S12-2-2		
MISCELLANEOUS		
CNJ1	1-509-359-00	connector, REC/PB
CNJ2	1-509-445-00	connector, ac input; 3-p (AEP, UK and E Model only)
CNJ3	1-509-403-00	outlet, ac (USA and Canada Model only)
CP301	1-231-057-00	encapsulated component (USA and Canada Model only)
F301,302	1-532-237-00	fuse, 3.15 AT (AEP, UK and E Model only)
F303	1-532-063-00	fuse, 1 AQ (AEP, UK and E Model only)
F304,305	1-532-078-00	fuse, 1 AT (AEP, UK and E Model only)
F306,307	1-532-101-00	fuse, 2.5 A (USA and Canada Model only)
	1-532-139-00	fuse, 2.5 A (AEP, UK and E Model only)
F308,309	1-532-265-00	fuse, 1 A (USA and Canada Model only)
J101 ~ 103 (J201 ~ 203)	1-507-353-00	jack, phono; 6-p
J104 ~ 107 (J204 ~ 207)	1-507-354-00	jack, phono; 8-p
J301,302	1-507-251-00	jack, mini (MIC)
J303	1-507-267-00	jack, AUX
J304	1-507-265-00	jack, HEADPHONE

<u>Ref. No.</u>	<u>Part No.</u>	<u>Description</u>	<u>Ref. No.</u>	<u>Part No.</u>	<u>Description</u>
PL301	1-518-052-00	lamp, pilot	1-533-098-00		holder, fuse; 2-p (AEP, UK and E Model)
TM301,302	1-536-284-00	board, terminal; 4-p	1-534-526-00		cord, power (USA and Canada Model)
VS	1-509-385-00	selector, voltage (AEP, UK and E Model)	1-534-819-00		cord, power (UK Model)
	1-526-165-22	selector, voltage (USA and Canada Model)	1-536-353-00		terminal post, U-shaped (single)
	1-517-021-00	socket, pilot lamp	1-536-355-00		terminal post, U-shaped (double) (USA and Canada Model only)
	1-533-097-00	holder, fuse; 2-p (USA and Canada Model)	1-581-773-00		board, jumper; 14-p phono jack

INTEGRATED STEREO AMPLIFIER

TA-1055

*US, Canadian, AEP, UK
and E Model*

SUPPLEMENT

No. 1
November, 1973

Subject: Modification of TA-1055

TA-1055 (USA, Canada, AEP, and UK Model) has been modified. This supplement contains revised diagrams and the changed and additional electrical parts list. File this supplement with TA-1055 Service Manual (USA, Canada, AEP, UK and E Model).

Note: E Model applies to this supplement from the sets with the serial number 400,001

The existing TA-1055 Service Manual (USA, Canada, AEP, UK and E Model) is valid except the followings:

<u>Page*</u>	<u>Section</u>	<u>Description</u>
9	3	REPACKING
10	4-1	Front Subchassis Wiring Diagram
11	4-2	Mounting Diagram
13	4-3	Schematic Diagram
16	5	EXPLODED VIEWS (1)
17	5	EXPLODED VIEWS (2)
18	6	ELECTRICAL PARTS LIST▲

* Pages in TA-1055 Service Manual (USA, Canada, AEP, UK and E Model)

▲ Parts which are listed in TA-1055 Service Manual but not mentioned in this supplement remain valid.

Applicable Serial Number:

USA Model No. 804,001 and later
Canada Model No. 701,301 and later
AEP Model No. 513,301 and later
UK Model No. 652,501 and later
E Model No. 400,001 and later

SONY®
SERVICE MANUAL

TABLE OF CONTENTS

<u>Section</u>	<u>Description</u>	<u>Page</u>
1.	REPACKING	1
2.	DIAGRAMS	
2-1.	Front Subchassis Wiring Diagram	2
2-2.	Mounting Diagram	3
2-3.	Schematic Diagram	5
3.	EXPLODED VIEWS	7
4.	ELECTRICAL PARTS LIST	
4-1.	Changed Electrical Parts	9
4-2.	Additional Electrical Parts	9

SECTION 1
REPACKING

The original shipping carton and packing materials are ideal containers for shipping the unit. For the maximum protection, the amplifier must

be repacked in these materials precisely as before as shown in the figure below.

Note: USA Model Serial No. 804,001 and later
 AEP Model Serial No. 513,301 and later
 UK Model Serial No. 652,501 and later
 Canada Model Serial No. 701,301 and later
 E Model Serial No. 400,001 and later

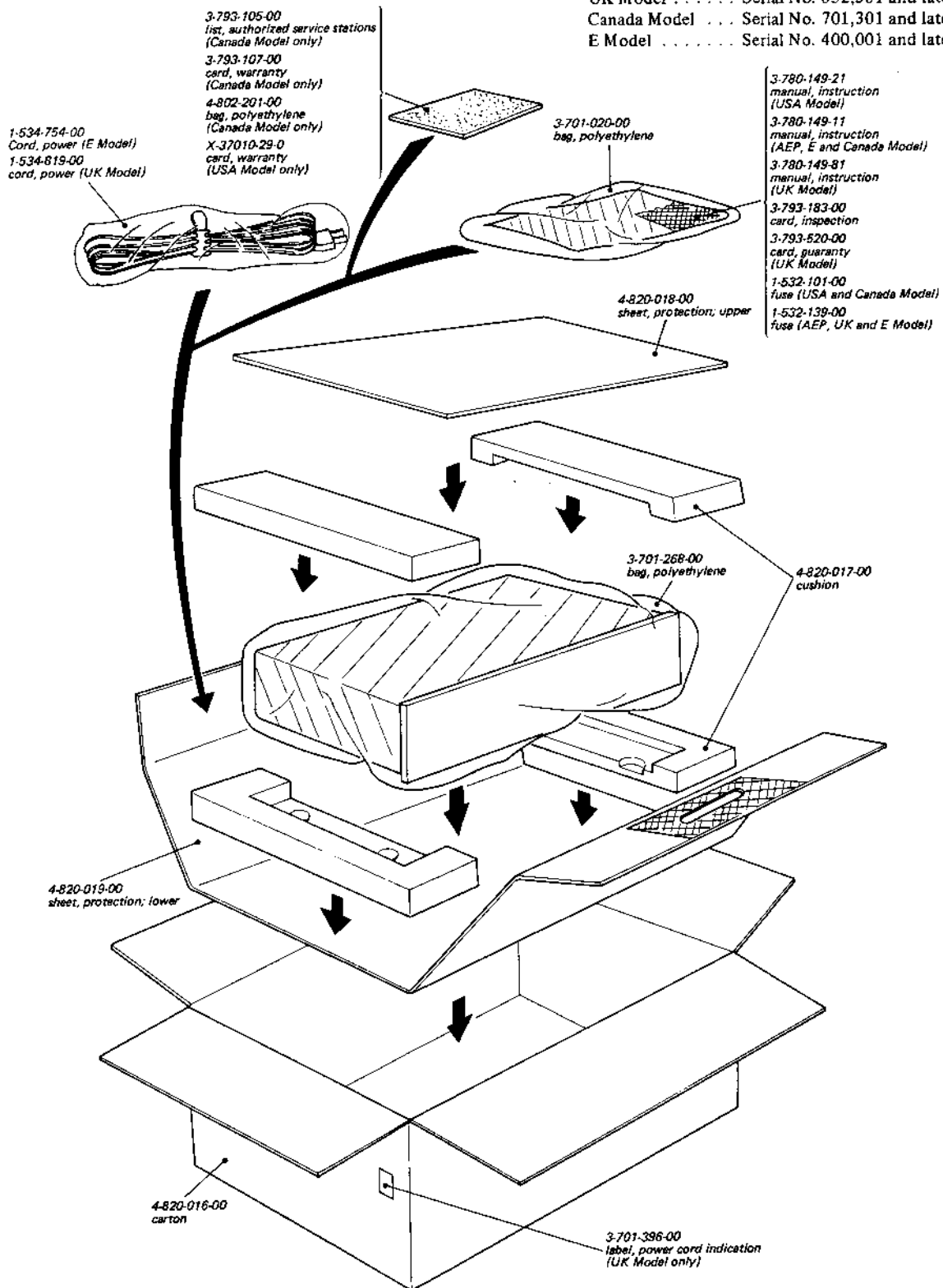

SECTION 2
DIAGRAMS

2-1. Front Subchassis Wiring Diagram

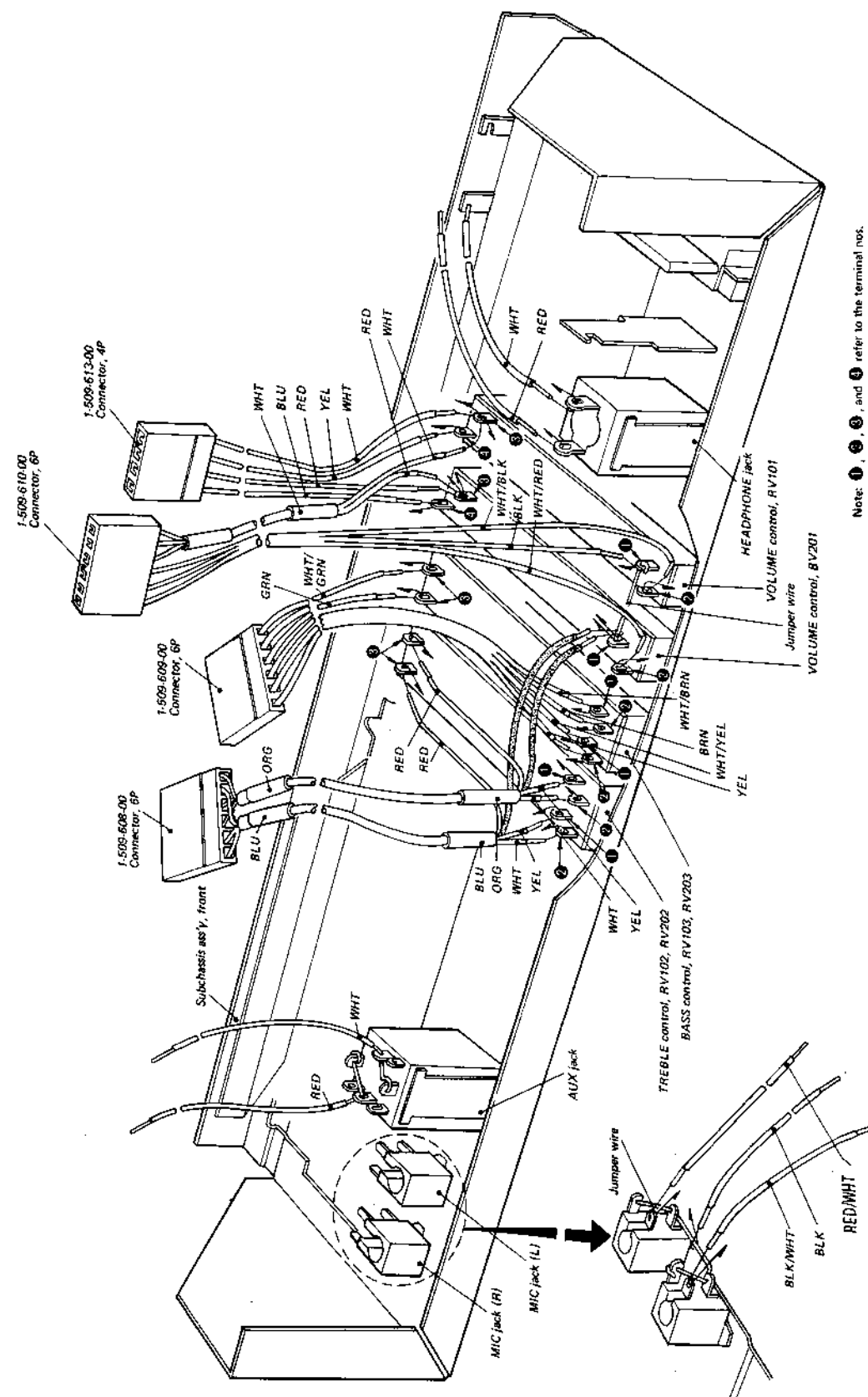

Note: 1, 2, 3, and 4 refer to the terminal nos. in the wiring diagrams [VOLUME and TONE controls] on page 6.

2-2. Mounting Diagram

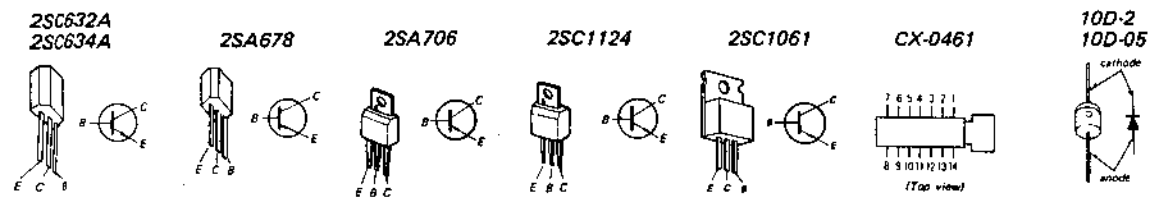
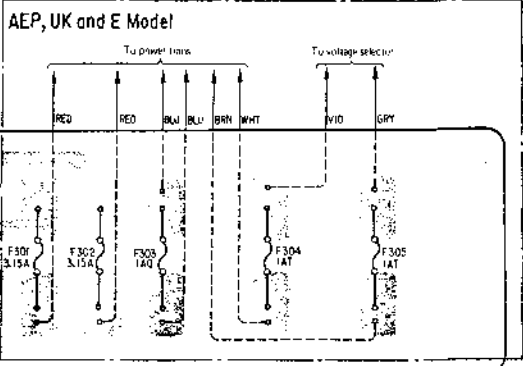
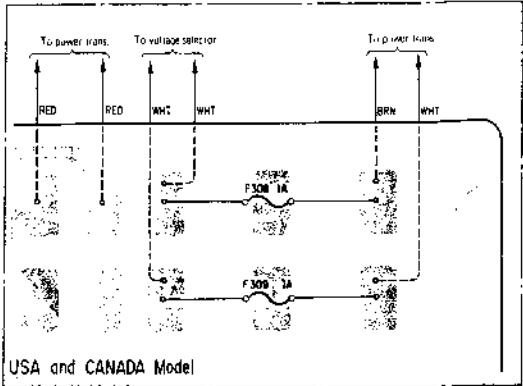
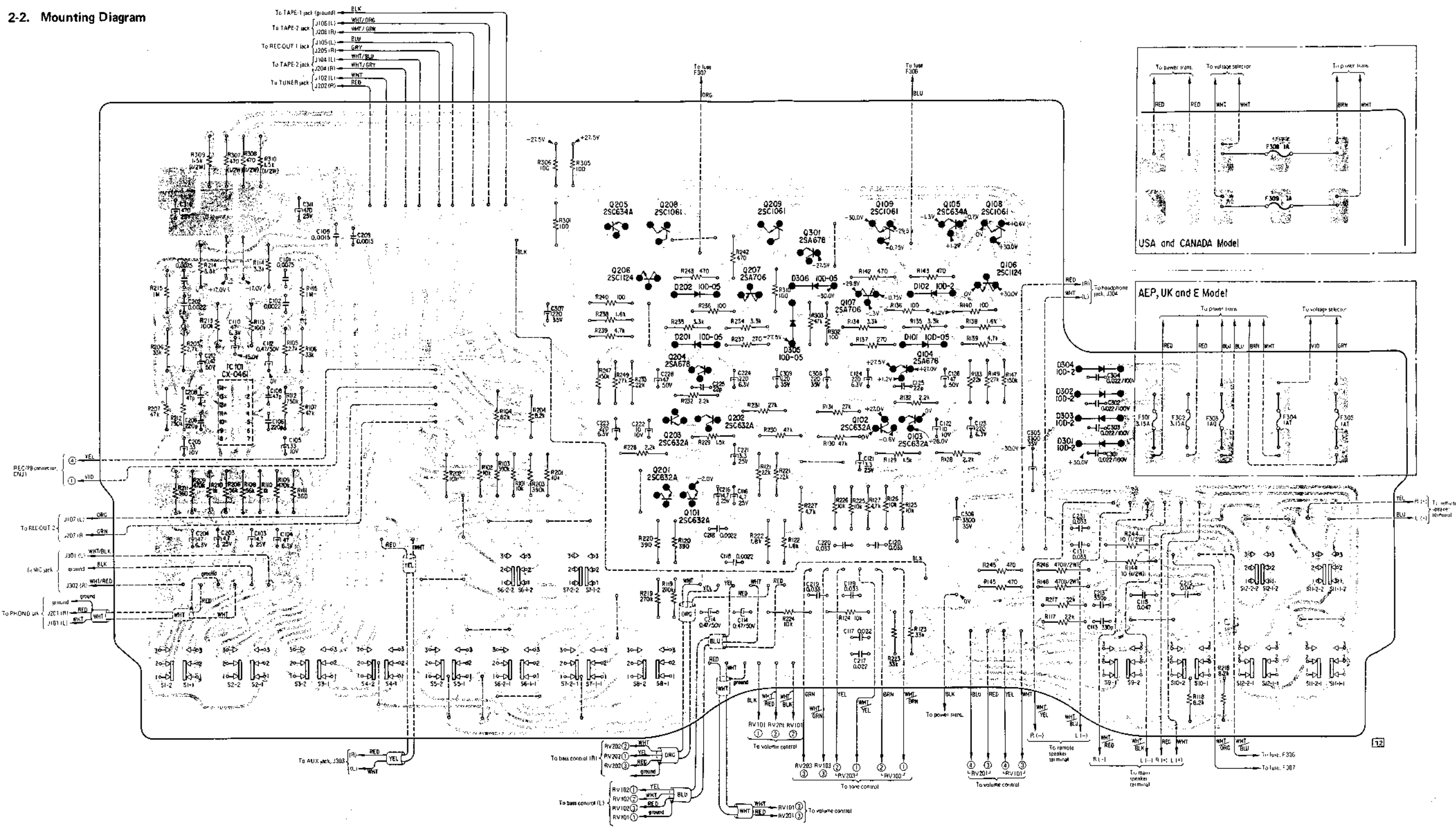

TA-1055 TA-1055

2.3. Schematic Diagram

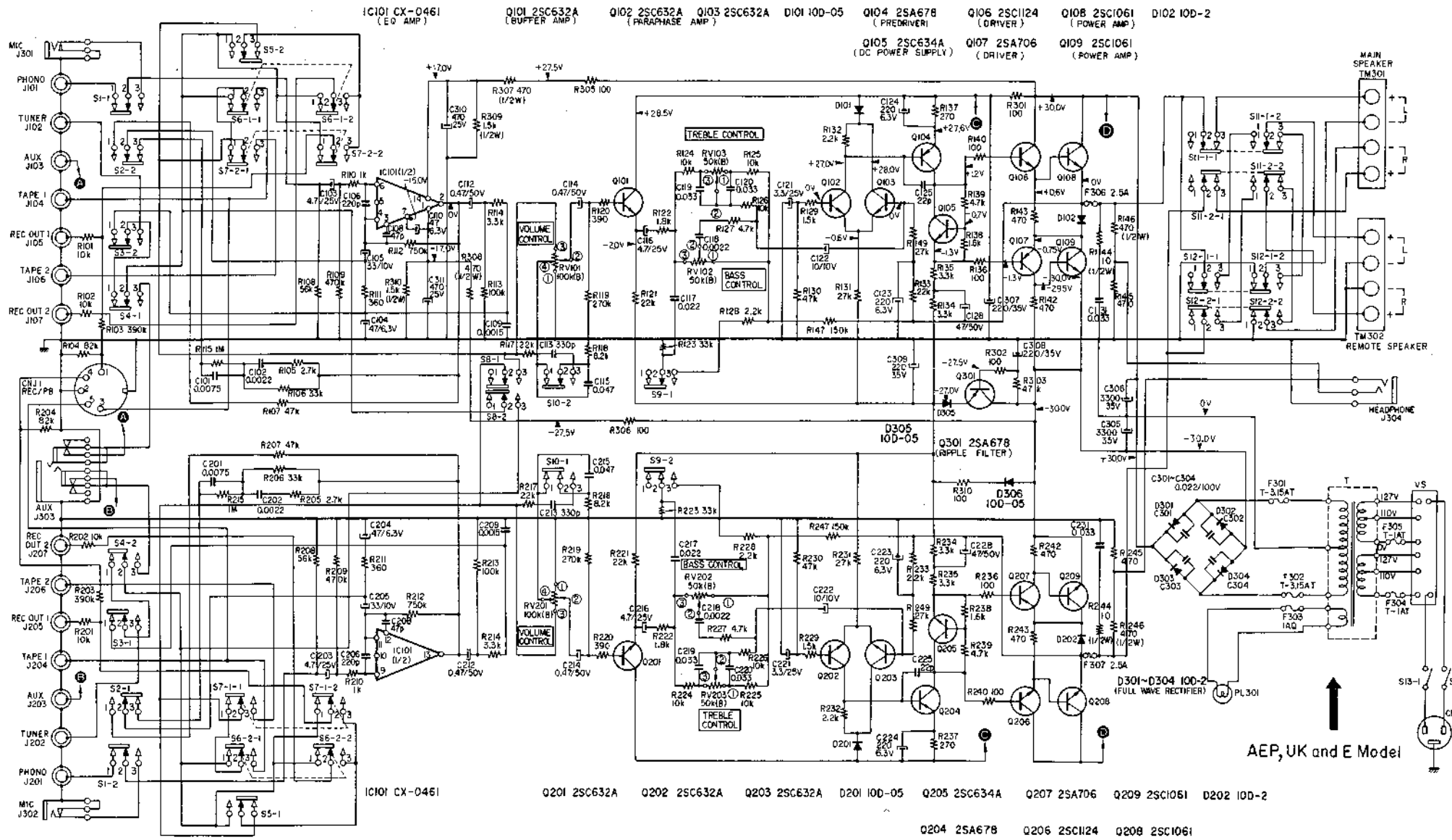
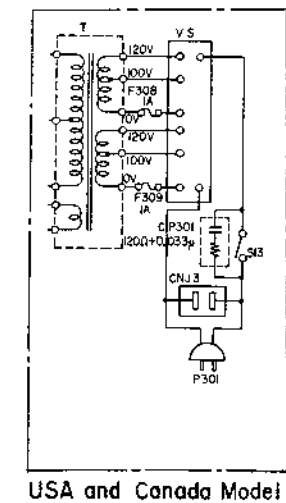
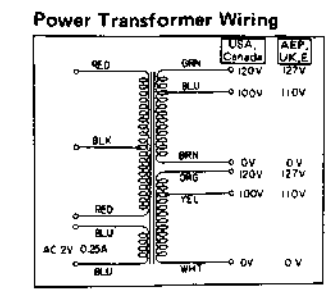
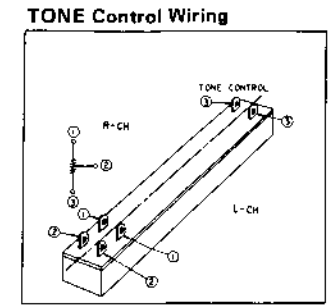
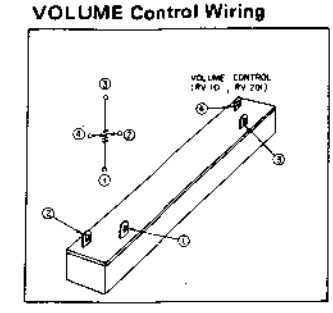

AEP, UK and E Model

USA and Canada Model

Ref. No.	Description	Position	Ref. No.	Description	Position
S1, S2	FUNCTION SW (PHONO-MIC)	PHONO	S8	MODE SW (STEREO-MONO)	STEREO
S3	FUNCTION SW (TUNER ON/OFF)	OFF	S9	HIGH FILTER SW	OFF
S4	FUNCTION SW (AUX ON/OFF)	OFF	S10	LOUDNESS SW	OFF
S5	MONITOR SW (TAPE-SOURCE)	SOURCE	S11	MAIN SPEAKER SW	ON
S6	MONITOR SW (TAPE 1-SOURCE)	SOURCE	S12	REMOTE SPEAKER SW	OFF
S7	MONITOR SW (TAPE 2-SOURCE)	SOURCE	S13	POWER SW	OFF

Notes: All resistance values are in ohms. k = 1000, M = 1000 k.
 All capacitance values are in μF except as indicated with p, which means $\mu\text{M}\text{F}$.
 All voltages are dc measured with a VOM having 20 k ohms/volt input impedance. No signal in.
 Voltage variations may be noted due to normal production tolerances.

Applicable Serial No.

USA Model	804,001 and later
Canada Model	701,301 and later
AEP Model	513,301 and later
UK Model	652,501 and later
E Model	400,001 and later

SECTION 3
EXPLODED VIEWS

(1)

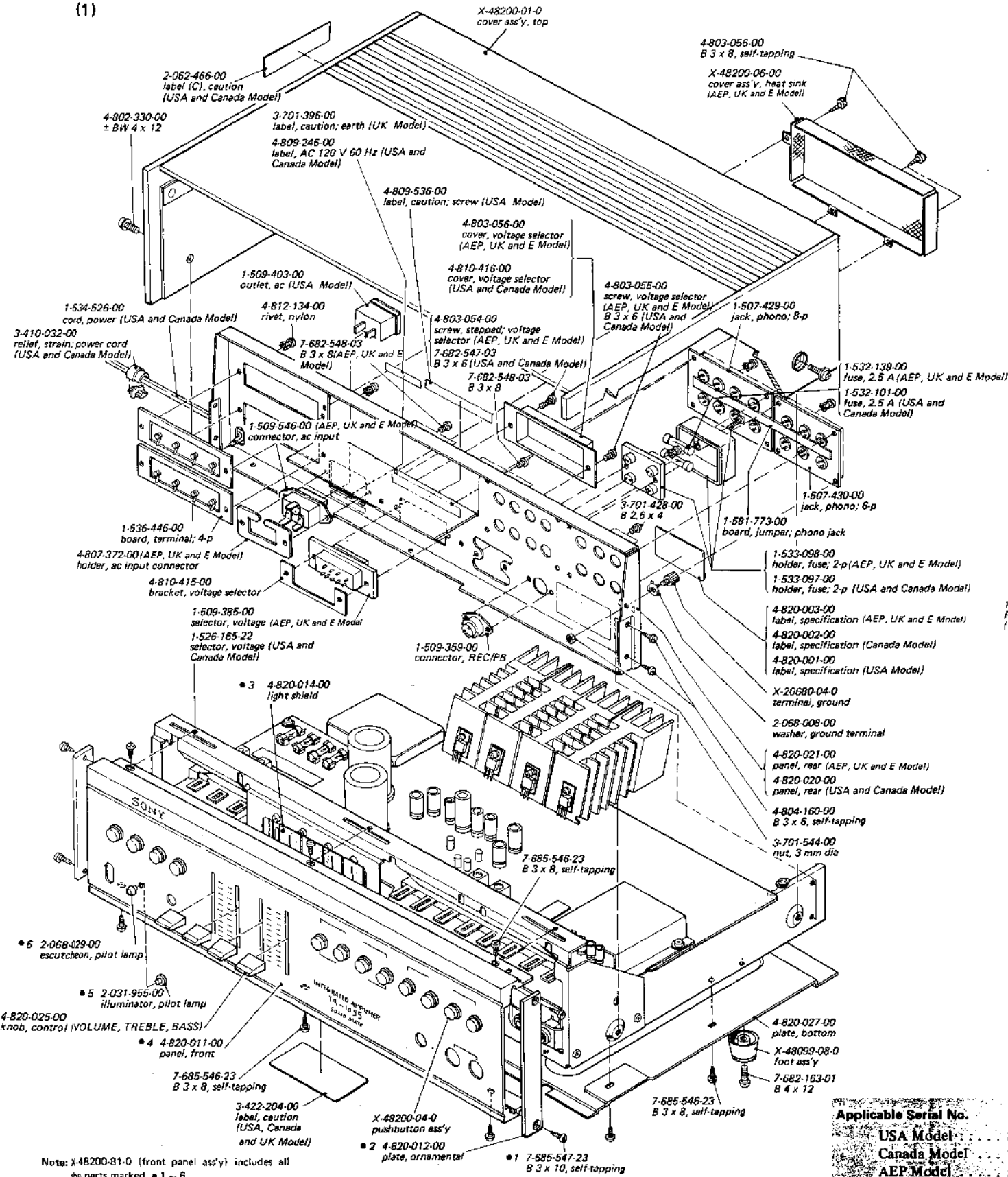

Note: X-48200-01-0 (front panel ass'y) includes all the parts marked 1 ~ 6.

(2)

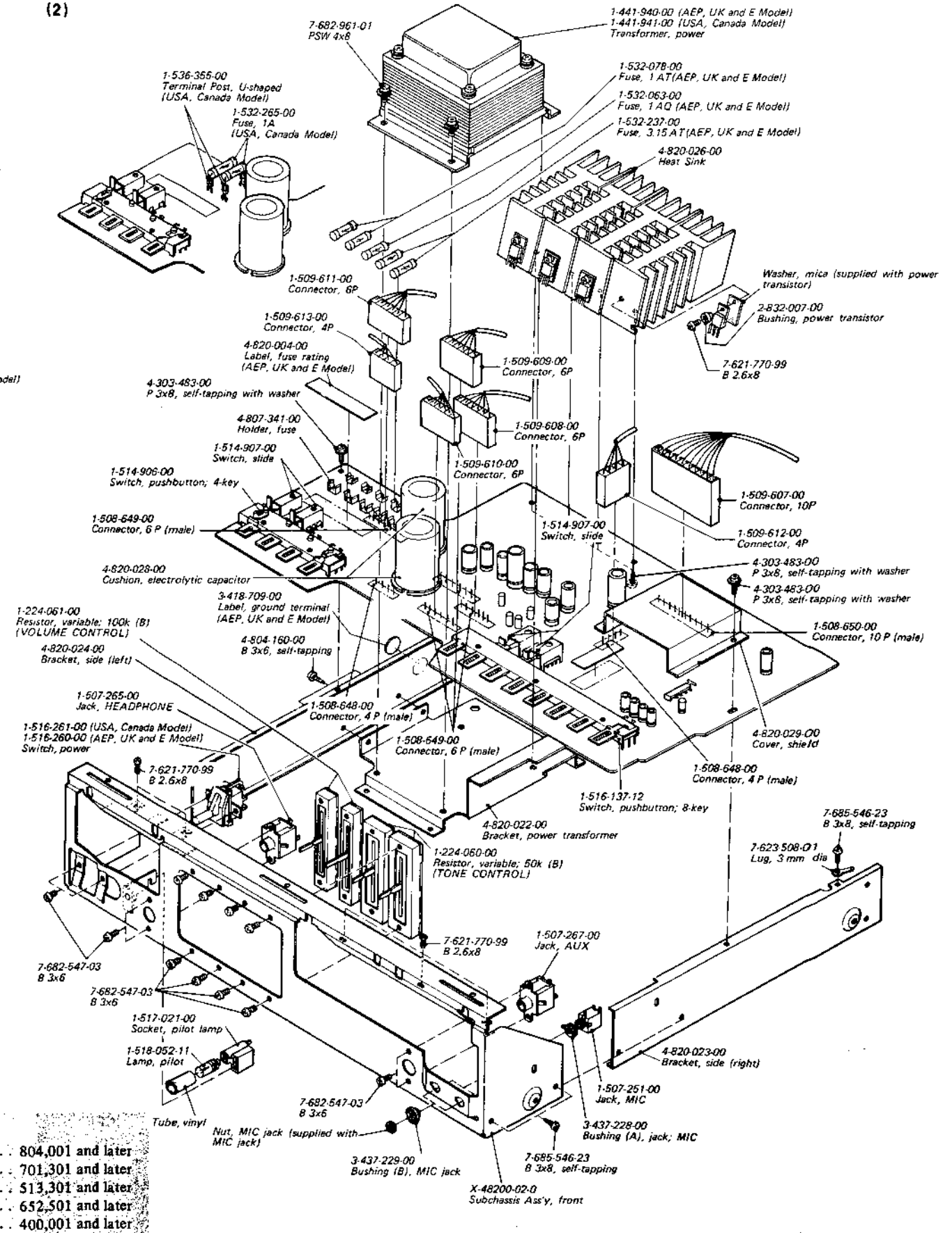

Applicable Serial No.	
USA Model	804,001 and later
Canada Model	701,301 and later
AEP Model	513,301 and later
UK Model	652,501 and later
E Model	400,001 and later

SECTION 4
ELECTRICAL PARTS LIST

4-1. Changed Electrical Parts

	<u>Ref. No.</u>	<u>Former Part No.</u>	<u>New Part No.</u>	<u>Description of New Parts</u>
COMPLETE CIRCUIT BOARD*		8-982-680-29	{ A-4404-001-A A-4404-002-A	Preamp/Power amp/Power supply Board (USA and Canada Model) Preamp/Power amp/Power supply Board (AEP, UK and E Model)
CAPACITORS	C107 (C207)	1-102-110-11	-----	- deleted -
	C305	1-123-048-11	1-123-118-11	3,300 μ F 35 V electrolytic
	C306	1-123-048-11	1-123-118-11	3,300 μ F 35 V electrolytic
	C307	1-121-261-11	1-121-063-11	220 μ F 35 V electrolytic
	C308	1-121-261-11	1-121-063-11	220 μ F 35 V electrolytic
	C309	1-121-411-11	1-121-063-11	220 μ F 35 V electrolytic
	C310	1-121-416-11	1-121-733-11	470 μ F 25 V electrolytic
	C311	1-121-416-11	1-121-733-11	470 μ F 25 V electrolytic
RESISTORS	R108 (R208)	1-244-713-11	1-244-715-11	56 k
	R109 (R209)	1-244-742-11	1-244-737-11	470 k
SWITCHES		{ 1-516-136-00	1-516-260-00	switch, lever/seesaw, POWER (AEP, UK and E Model)
	S13	{ 1-516-138-00	1-516-261-00	switch, lever/seesaw, POWER (USA and Canada Model)
MISCELLANEOUS	CNJ2	1-509-445-00	1-509-546-00	connector, ac input; 3 p (AEP, UK and E Model only)
	J101, J103 (J201, J203)	1-507-353-00	1-507-430-00	jack, phono; 6 p
	J104, J107 (J204, J207)	1-507-354-00	1-507-429-00	jack, phono; 8 p
	TM301 } TM302 }	1-536-284-00	1-536-446-00	board, terminal; 4 p

* The former and the new circuit boards are not interchangeable.

4-2. Additional Electrical Parts

<u>Part No.</u>	<u>Description</u>
1-508-648-00	connector, 4 P (male)
1-508-649-00	connector, 6 P (male)
1-508-650-00	connector, 10 P (male)
1-509-607-00	connector, 10 P; INPUT (female)
1-509-608-00	connector, 6 P; TREBLE (female)
1-509-609-00	connector, 6 P; BASS (female)
1-509-610-00	connector, 6 P; VOLUME (female)
1-509-611-00	connector, 6 P; SPEAKER (female)
1-509-612-00	connector, 4 P; REC OUT (female)
1-509-613-00	connector, 4 P; LOUDNESS (female)
1-534-819-00	cord, power (UK Model only)

