

SERVICE MANUAL

CD STEREO SYSTEM

BASIC TAPE MECHANISM : 6ZM-3 PR4NM
 BASIC CD MECHANISM : BZG-5 ZD5GNDM

SYSTEM	CD CASSEIVER	SPEAKER	REMOTE CONTROLLER
NSX-R80	CX-NR80	SX-NR80	RC-CAS01

If requiring information about the CD mechanism, see Service Manual of BZG-5 ZD5GNDM, (S/M Code No. 09-023-353-3NC).

TABLE OF CONTENTS -1/1

SPECIFICATIONS	3
PROTECTION OF EYES FROM LASER BEAM DURING SERVICING	4
NOTE ON BEFORE STARTING REPAIR	5, 6
ACCESSORIES PARTS LIST	7
ELECTRICAL PARTS LIST	8 ~ 22
TRANSISTOR ILLUSTRATION	23
SCHEMATIC DIAGRAM -1/5 (MAIN-1/2, AMP SECTION)	24
SCHEMATIC DIAGRAM -2/5 (MAIN-2/2, TUNER SECTION)	25
SCHEMATIC DIAGRAM -3/5 (HP SECTION)	26
WIRING -1/4 (MAIN C.B, HP C.B)	27
SCHEMATIC DIAGRAM -4/5 (FRONT/DECK/CD-LED SECTION)	28
WIRING -2/4 (FRONT C.B/CD-LED C.B)	29
WIRING -3/4 (DECK C.B/HEAD-1 C.B)	30
SCHEMATIC DIAGRAM -5/5 (POWER SECTION)	31
WIRING -4/4 (POWER C.B)	32
ELECTRICAL ADJUSTMENT	33 ~ 39
CD TEST MODE	40
LCD DISPLAY	41 ~ 42
IC BLOCK DIAGRAM	43
IC DESCRIPTION	44 ~ 45
MECHANICAL EXPLODED VIEW	46
MECHANICAL PARTS LIST	47
COLOR NAME TABLE	48
TAPE MECHANISM EXPLODED VIEW <6ZM-3 PR4NM>	49
TAPE MECHANISM PARTS LIST <6ZM-3 PR4NM>	50 ~ 51
GENERAL SPEAKER DISASSEMBLY INSTRUCTIONS (FOR REFERENCE)	52
SPEAKER PARTS LIST (SX-NR80)	53
OTHER PARTS LIST	54 ~ 55

SPECIFICATIONS -1/1

MAIN UNIT CX-NR80

TUNER

FM tuning range	FM1 (OIRT): 65 MHz to 74 MHz (10 kHz step) FM2 (CCIR): 87.5 MHz to 108 MHz (50 kHz step)
FM usable sensitivity (IHF)	FM1: 15.3 dBf FM2: 12.8 dBf
FM antenna terminal	75 ohms (unbalanced)
AM tuning range	531 kHz to 1602 kHz (9 kHz step) 530 kHz to 1710 kHz (10 kHz step)
AM usable sensitivity	350 μ V/m
AM antenna	Loop antenna

AMPLIFIER

Power output	Rated: 80 W + 80 W (6 ohms, T.H.D. 1%, 1 kHz/DIN 45500) Reference: 100 W + 100 W (6 ohms, T.H.D. 10 %, 1 kHz/DIN 45324)
Total harmonic distortion	0.08 % (40 W, 1 kHz, 6 ohms, DIN AUDIO)
Input	VIDEO/AUX: 700 mV
Outputs	SPEAKERS: 6 ohms or more PHONES: 32 ohms or more

CASSETTE DECK

Track format	4 tracks, 2 channels stereo
Frequency response	50 Hz - 15 kHz
Recording system	AC bias
Heads	DECK 1: playback x 1 DECK 2: recording/playback x 1, erase x 1

CD PLAYER

Laser	Semiconductor laser ($\lambda= 780$ nm)
D/A converter	1 bit dual
Signal-to-noise ratio	85 dB (1 kHz, 0 dB)
Harmonic distortion	0.05 % (1 kHz, 0 dB)

GENERAL

Power requirements	230 V AC, 50 Hz
Power consumption	110 W
Power consumption in standby mode	With ECO mode on: 0.6 W With ECO mode off: 20 W
Dimensions (W x H x D)	260 x 324 x 360 mm
Weight	7.8 kg

FRONT SPEAKERS SX-NR80

Speaker system	4 way, Built-in subwoofer (magnetic shielded)
Speaker units	Subwoofer: 160 mm cone Mid range: 80 mm cone Tweeter: 50 mm cone Super tweeter: 20 mm ceramic
Impedance	6 ohms
Dimensions (W x H x D)	266 x 324 x 259 mm
Weight	5.7 kg

Specifications and external appearance are subject to change without notice.

PROTECTION OF EYES FROM LASER BEAM DURING SERVICING -1/1

This set employs laser. Therefore, be sure to follow carefully the instructions below when servicing.

WARNING!!

WHEN SERVICING, DO NOT APPROACH THE LASER EXIT WITH THE EYE TOO CLOSELY. IN CASE IT IS NECESSARY TO CONFIRM LASER BEAM EMISSION. BE SURE TO OBSERVE FROM A DISTANCE OF MORE THAN 30cm FROM THE SURFACE OF THE OBJECTIVE LENS ON THE OPTICAL PICK-UP BLOCK.

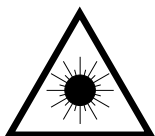

- Caution: Invisible laser radiation when open and interlocks defeated avoid exposure to beam.
- Advarsel: Usynlig laserstråling ved åbning, når sikkerhedsafbrydere er ude af funktion. Undgå udsættelse for stråling.

VAROITUS!

Laiteen Käyttäminen muulla kuin tässä käyttöohjeessa mainitulla tavalla saattaa altistaa käyttäjän turvallisuusluokan 1 ylittävälle näkymättömälle lasersäteilylle.

WARNING!

Om apparaten används på annat sätt än vad som specificeras i denna bruksanvisning, kan användaren utsättas för osynlig laserstråling, som överskrider gränsen för laserklass 1.

CAUTION

Use of controls or adjustments or performance of procedures other than those specified herein may result in hazardous radiation exposure.

ATTENTION

L'utilisation de commandes, réglages ou procédures autres que ceux spécifiés peut entraîner une dangereuse exposition aux radiations.

ADVARSEL

Usynlig laserstråling ved åbning, når sikkerhedsafbrydere er ude af funktion. Undgå udsættelse for stråling.

This Compact Disc player is classified as a CLASS 1 LASER product.

The CLASS 1 LASER PRODUCT label is located on the rear exterior.

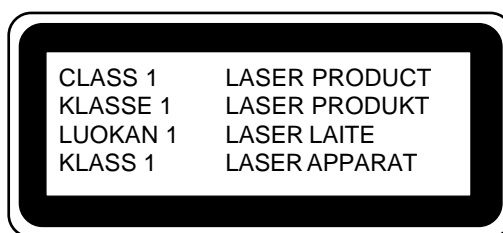

Precaution to replace Optical block

(KSM-213RSCM)

Body or clothes electrostatic potential could ruin laser diode in the optical block. Be sure ground body and workbench, and use care the clothes do not touch the diode.

- 1) After the connection, remove solder shown in right figure.

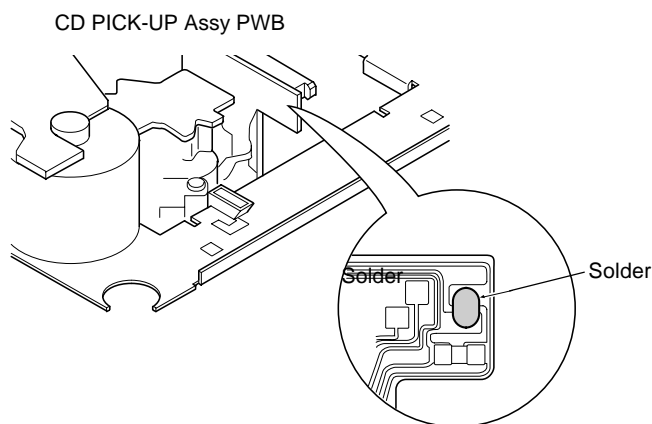

NOTE ON BEFORE STARTING REPAIR -1/2

1. Forced discharge of electrolytic capacitor of power supply block

When repair is going to be attempted in the set that uses relay circuit in the power supply block, electric potential is kept charged across the electrolytic capacitors (C101, 102) even though AC power cord is removed. If repair is attempted in this condition, secondary defect can occur. In order to prevent the secondary trouble, perform the following measures before starting repair work.

Discharge procedure

- ① Remove the AC power cord.
- ② Connect a discharging resistor at an end of lead wire that has clips at both ends. Connect the other end of the lead wire to metal chassis.
- ③ Contact the other end of the discharging resistor to the positive (+) side (+VH) of C101. (For two seconds)
- ④ Contact the same end of the discharging resistor as step ③ to the negative (-) side (-VH) of C102 in the same way. (For two seconds)
- ⑤ Check that voltage across C101 and C102 has decreased to 1 V or less using a multimeter or an oscilloscope.

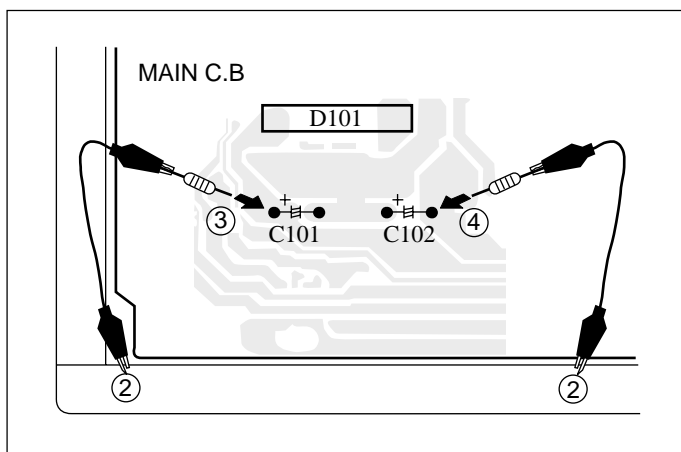

Fig-1

Select a discharging resistor referring to the following table.

Charging voltage (V) (C101, 102)	Discharging resistor (Ω)	Rated power (W)	Parts number
25-48	100	3	87-A00-247-090
49-140	220	5	87-A00-232-090

Note: The reference numbers (C101, C102) of the electrolytic capacitors can change depending on the models. Be sure to check the reference numbers of the charging capacitors on schematic diagram before starting the discharging work.

2. Check items before exchanging the MICROCOMPUTER

Be sure to check the following items before exchanging the MICROCOMPUTER. Exchange the MICROCOMPUTER after confirming that the MICROCOMPUTER is surely defective.

2-1. Regarding the HOLD terminal of the MICROCOMPUTER

When the HOLD terminal (INPUT) of the MICROCOMPUTER is "H", the MICROCOMPUTER is judged to be operating correctly.

When this terminal is "L", the main power cannot be turned on. Therefore, be sure to check the terminal voltage of the HOLD terminal before exchange.

When the MICROCOMPUTER is not defective, the HOLD terminal can also go "L" when the POWER AMPLIFIER has any abnormalities that triggers the abnormality detection circuit on the MAIN C. B. that sets the HOLD terminal to "L".

• Good or no good judgement of the MICROCOMPUTER

- ① Turn on the AC main power.
- ② Confirm that the main power is turned on and the HOLD terminal of the MICROCOMPUTER keeps the "H" level or not.
- ③ When the HOLD terminal is "L" level, the abnormality detection circuit is judged to be working correctly and the MICROCOMPUTER is judged to be good.

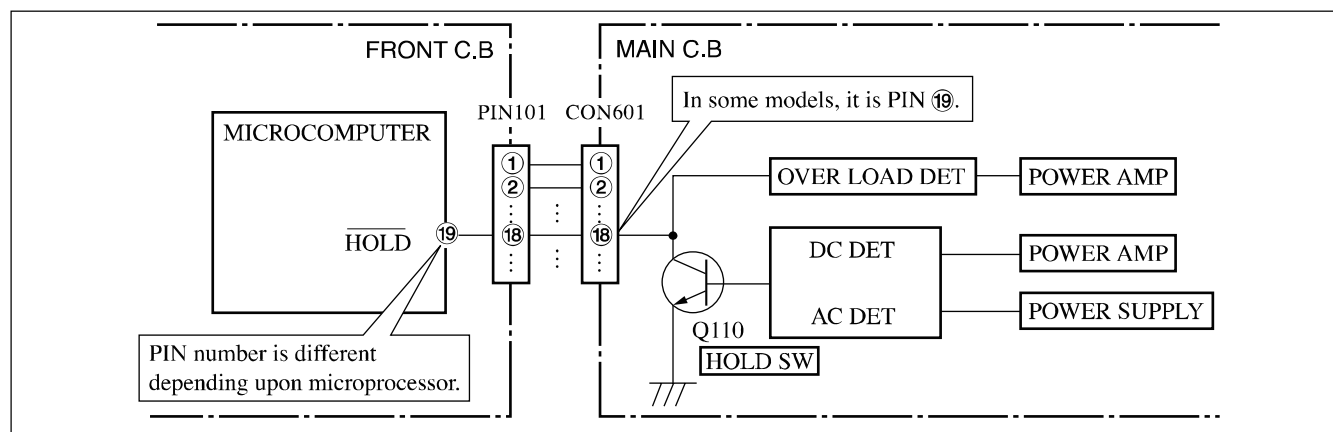

Fig-2-1

NOTE ON BEFORE STARTING REPAIR -2/2

In such a case, check also if the POWER AMPLIFIER circuit or power supply circuit has any abnormalities or not.

2-2. Regarding reset

There are cases that the machine does not work correctly because the MICROCOMPUTER is not reset even though the AC power cord is re-inserted, or the software reset (pressing the STOP key + POWER key) is performed.

When the above described phenomenon occurs, it can lead to wrong judgement as if the MICROCOMPUTER is defective and to exchange the MICROCOMPUTER. In such a case, perform the forced-reset by the following procedure and check good or no good of the MICROCOMPUTER.

- ① Remove the AC power cord.

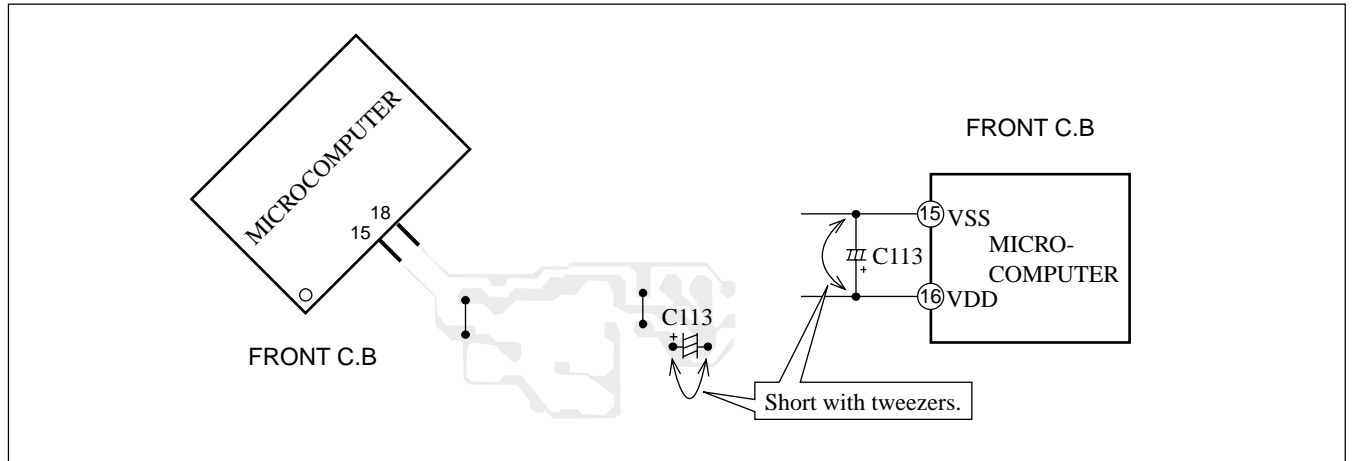

Fig-2-2

- ② Short both ends of the electrolytic capacitor C113 that is connected to VDD of the MICROCOMPUTER with tweezers.
- ③ Connect the AC power cord again. If the MICROCOMPUTER returns to the normal operation, the MICROCOMPUTER is good.

Note: The reference number or MICROCOMPUTER pin number of transistor (Q110) and electrolytic capacitor (C113) can change depending on the models. Be sure to check the reference numbers on schematic diagram before starting the discharging work.

2-3. Confirmation of soldering state of MICROCOMPUTER

Check the soldering state of the MICROCOMPUTER in addition to the above described procedures. Be sure to exchange the MICROCOMPUTER after surely confirming that the trouble is not caused by poor soldering but the MICROCOMPUTER itself.

ACCESSORIES PARTS LIST -1/1

! = SAFETY PARTS

C = Components marked

All components used on this model at the production line are shown in this service manual.

However, please note that not all components will be available as spare parts for after-sales service.

Components marked S and O are designated as spare parts for service and will be stocked at the spare parts centers.

Components marked X and R are not designated as spare parts for after sales service, and will not be stocked at the spare parts centers.

UNIT-NAME	! C	REF-NO	PARTS-NO	PARTS-NAME	SUFFIX&MODEL
					CX-SNR80
					VSM
	O	AS1001	8C-NF5-907-010	IB,V(ER)M NSX-R80	a
	X	AS1002	8B-NF1-701-110	RC UNIT,CAS01	a
	O	AS1003	87-006-225-010	ANT,LOOP ANT NC2	a
	O	AS1004	87-A92-345-010	ANT,WIRE FM(SEMI-ST)	a

ELECTRICAL PARTS LIST - 1/15

! = Δ SAFETY PARTS
 C = Components marked

All components used on this model at the production line are shown in this service manual.

However, please note that not all components will be available as spare parts for after-sales service.

Components marked S and O are designated as spare parts for service and will be stocked at the spare parts centers.

Components marked X and R are not designated as spare parts for after sales service, and will not be stocked at the spare parts centers.

UNIT-NAME	! C	REF-NO	PARTS-NO	PARTS-NAME	SUFFIX&MODEL
					CX-SNR80 VSM
CD-LED	O	CN 0201	87-099-211-010	CONN,4P V BLK 6216	a
CD-LED	O	LED0202	87-A41-120-040	LED,SEL6810ATP5 UMB	a
CD-LED	O	LED0203	87-A41-120-040	LED,SEL6810ATP5 UMB	a
CD-LED	O	LED0204	87-A41-120-040	LED,SEL6810ATP5 UMB	a
CD-LED	X R	0201	88-128-681-080	C-RES, 680-1/8W J	a
CD-LED	X R	0202	88-128-681-080	C-RES, 680-1/8W J	a
CD-LED	X R	0203	88-128-681-080	C-RES, 680-1/8W J	a
DECK	O	CN 0001	87-099-753-010	CONN,11P H 9604	a
DECK	X	CRD0001	82-ZM3-601-010	RBN-CORD,4P-75	a
DECK	S	IC 0001	87-A21-269-010	IC,EW732	a
DECK	S	IC 0002	87-A21-269-010	IC,EW732	a
DECK	O	M 0001	87-A92-321-010	MOT,SHU2L 60	a
DECK	X R	0001	88-121-392-080	RES,3.9K-1/8W J	a
DECK	O	SFR0001	87-024-581-010	SFR,3.3K H KVSF637A	a
DECK	O	SOL0001	82-ZM3-627-010	SOL ASSY,27 SO	a
DECK	O	SOL0002	82-ZM3-627-010	SOL ASSY,27 SO	a
DECK	O	SW 0001	87-A90-248-010	SW,MICRO ESE11SH2CXQ	a
DECK	O	SW 0002	87-A90-248-010	SW,MICRO ESE11SH2CXQ	a
DECK	O	SW 0003	87-A90-248-010	SW,MICRO ESE11SH2CXQ	a
DECK	O	SW 0004	87-A90-248-010	SW,MICRO ESE11SH2CXQ	a
					CX-SNR80 VSM
DECK	O	SW 0005	87-A90-248-010	SW,MICRO ESE11SH2CXQ	a
FRONT	O	C 0108	87-010-785-080	C-CAP,U 0.015-25 K B GRM	a
FRONT	O	C 0153	87-010-787-080	C-CAP,U 0.022-25 K B GRM	a
FRONT	O	C 0154	87-A12-078-040	CAP,E 47-35 SMG	a
FRONT	O	C 0155	87-A12-090-040	CAP,E 4.7-50 SMG	a
FRONT	O	C 0156	87-A12-090-040	CAP,E 4.7-50 SMG	a
FRONT	O	C 0201	87-010-759-080	C-CAP,U 0.1-25 Z F CM/CB	a
FRONT	O	C 0202	87-012-195-080	C-CAP,U 100P-50 J CH GRM	a
FRONT	O	C 0203	87-012-195-080	C-CAP,U 100P-50 J CH GRM	a
FRONT	O	C 0204	87-012-195-080	C-CAP,U 100P-50 J CH GRM	a
FRONT	O	C 0301	87-012-278-080	C-CAP,U 2200P-50 K B GRM	a
FRONT	O	C 0351	87-A10-353-080	C-CAP,U 0.22-10 K B	a
FRONT	O	C 0361	87-012-274-080	C-CAP,U 1000P-50 K B GRM	a
FRONT	O	C 0362	87-012-274-080	C-CAP,U 1000P-50 K B GRM	a
FRONT	O	C 0363	87-012-274-080	C-CAP,U 1000P-50 K B GRM	a
FRONT	O	C 0364	87-012-274-080	C-CAP,U 1000P-50 K B GRM	a
FRONT	O	C 0371	87-012-274-080	C-CAP,U 1000P-50 K B GRM	a
FRONT	O	C 0372	87-012-274-080	C-CAP,U 1000P-50 K B GRM	a
FRONT	O	C 0601	87-A12-069-040	CAP,E 22-25 SMG	a
FRONT	O	C 0801	87-A11-969-080	C-CAP,U 0.082U-16 K B	a
					CX-SNR80 VSM
FRONT	O	C 0803	87-012-280-080	C-CAP,U 3300P-50 K B GRM	a
FRONT	O	C 0804	87-A10-592-080	C-CAP,S 0.015-50 J B	a
FRONT	O	C 0806	87-012-286-080	C-CAP,U 0.01-25 K B GRM	a
FRONT	O	C 0808	87-A12-087-040	CAP,E 1-50 SMG	a
FRONT	O	C 0809	87-A12-092-040	CAP,E 22-50 SMG	a
FRONT	O	C 0810	87-A11-057-080	C-CAP,U 0.1-16 K B	a
FRONT	O	C 0811	87-012-280-080	C-CAP,U 3300P-50 K B GRM	a
FRONT	O	C 0812	87-012-281-080	C-CAP,U 3900P-50 K B GRM	a
FRONT	O	C 0901	87-012-195-080	C-CAP,U 100P-50 J CH GRM	a
FRONT	O	C 0902	87-012-195-080	C-CAP,U 100P-50 J CH GRM	a
FRONT	O	C 0903	87-012-195-080	C-CAP,U 100P-50 J CH GRM	a
FRONT	O	C 0904	87-012-195-080	C-CAP,U 100P-50 J CH GRM	a
FRONT	O	C 0905	87-012-195-080	C-CAP,U 100P-50 J CH GRM	a
FRONT	O	C 0906	87-012-195-080	C-CAP,U 100P-50 J CH GRM	a
FRONT	O	C 0907	87-012-195-080	C-CAP,U 100P-50 J CH GRM	a
FRONT	O	C 0908	87-012-195-080	C-CAP,U 100P-50 J CH GRM	a
FRONT	O	C 0909	87-012-195-080	C-CAP,U 100P-50 J CH GRM	a
FRONT	O	C 0910	87-012-195-080	C-CAP,U 100P-50 J CH GRM	a
FRONT	O	C 0911	87-012-274-080	C-CAP,U 1000P-50 K B GRM	a
FRONT	O	C 0912	87-010-759-080	C-CAP,U 0.1-25 Z F CM/CB	a
					CX-SNR80 VSM
FRONT	O	C 0913	87-A10-189-040	CAP,E 220-10 M 5L	a
FRONT	O	C 0915	87-010-759-080	C-CAP,U 0.1-25 Z F CM/CB	a
FRONT	O	C 0916	87-010-759-080	C-CAP,U 0.1-25 Z F CM/CB	a
FRONT	O	C 0917	87-010-759-080	C-CAP,U 0.1-25 Z F CM/CB	a
FRONT	O	C 0919	87-012-286-080	C-CAP,U 0.01-25 K B GRM	a
FRONT	O	C 0920	87-010-829-080	C-CAP,U 0.047-16 Z F CM/CB	a
FRONT	O	C 0921	87-012-282-080	C-CAP,U 4700P-50 K B GRM	a
FRONT	O	C 0922	87-012-195-080	C-CAP,U 100P-50 J CH GRM	a
FRONT	O	C 0951	87-012-172-080	C-CAP,U 10P-50 D CH GRM	a
FRONT	O	C 0952	87-010-854-080	C-CAP,S 560P-50 J CH CMC	a
FRONT	O	C 0953	87-012-349-080	C-CAP,S 1000P-50 J CH GRM	a
FRONT	O	C 0961	87-A12-075-040	CAP,E 10-35 SMG	a
FRONT	O	C 0962	87-012-336-080	C-CAP,U 330P-50 J SL GRM	a
FRONT	O	C 0963	87-010-759-080	C-CAP,U 0.1-25 Z F CM/CB	a
FRONT	O	CN 0104	87-A60-057-010	CONN,11P V 9604S-11C	a
FRONT	O	CN 0202	87-099-209-010	CONN,4P H BLK 6216	a
FRONT	O	CN 0701	87-099-720-010	CONN,30P BLK TYK-B(P)	a
FRONT	O	CN 0731	87-099-196-010	CONN,8P V BLK 6216	a
FRONT	S	D 0104	87-A40-291-080	DIODE,1N4148M (CPT)	a
FRONT	S	D 0301	87-A40-748-080	ZENER,UZ5.6BSA	a

ELECTRICAL PARTS LIST - 2/15

! = SAFETY PARTS

C = Components marked

All components used on this model at the production line are shown in this service manual.

However, please note that not all components will be available as spare parts for after-sales service.

Components marked S and O are designated as spare parts for service and will be stocked at the spare parts centers.

Components marked X and R are not designated as spare parts for after sales service, and will not be stocked at the spare parts centers.

UNIT-NAME	! C	REF-NO	PARTS-NO	PARTS-NAME	SUFFIX&MODEL
					CX-SNR80
					VSM
FRONT	S D	0302	87-A40-291-080	DIODE,1N4148M (CPT)	a
FRONT	S D	0601	87-A40-269-080	C-DIODE,MC2836	a
FRONT	S D	0658	87-A40-269-080	C-DIODE,MC2836	a
FRONT	X D	0702	88-100-000-010	PLATING-JW, 0.58 SN95	a
FRONT	X D	0703	88-100-000-010	PLATING-JW, 0.58 SN95	a
FRONT	S D	0801	87-A40-291-080	DIODE,1N4148M (CPT)	a
FRONT	S D	0981	87-A40-291-080	DIODE,1N4148M (CPT)	a
FRONT	S D	0985	87-A40-291-080	DIODE,1N4148M (CPT)	a
FRONT	O	FFC0104	88-911-101-110	FF-CABLE,11P 1.25 100MM	a
FRONT	O	FFC0202	88-904-201-110	FF-CABLE,4P 1.25	a
FRONT	O	FFC0731	88-908-301-110	FF-CABLE,8P 1.25 300MM	a
FRONT	O	FL 0901	8C-NF5-603-010	FL,HUA-11MM42T	a
FRONT	S IC	0601	87-070-289-040	C-IC,BU2092F	a
FRONT	S IC	0901	8C-NF5-601-130	C-IC,UPD780226GF-034-3BA	a
FRONT	S IC	0961	87-A21-831-010	IC,SPS-442-1-F1	a
FRONT	O	JR 0601	88-108-101-080	C-RES,U 100-1/16W J	a
FRONT	O	JR 0605	88-108-101-080	C-RES,U 100-1/16W J	a
FRONT	O	JR 0609	88-108-101-080	C-RES,U 100-1/16W J	a
FRONT	O	JR 0617	88-108-101-080	C-RES,U 100-1/16W J	a
FRONT	X	JW 0937	88-121-101-080	RES,100-1/8W J	a
					CX-SNR80
					VSM
FRONT	O	L 0951	87-A50-655-010	COIL,CLK 4.19MHZ (TOKO)7KLY	a
FRONT	O	LED0201	87-A41-062-040	LED,LTL-1CHEE-012A RED	a
FRONT	O	LED0205	87-A41-062-040	LED,LTL-1CHEE-012A RED	a
FRONT	O	LED0206	87-A41-062-040	LED,LTL-1CHEE-012A RED	a
FRONT	O	LED0207	87-A41-062-040	LED,LTL-1CHEE-012A RED	a
FRONT	O	LED0208	87-A41-062-040	LED,LTL-1CHEE-012A RED	a
FRONT	S Q	0102	87-A30-076-080	C-TR,2SC3052F	a
FRONT	S Q	0103	87-A30-538-040	C-TR,SRA2202S	a
FRONT	S Q	0104	87-A30-538-040	C-TR,SRA2202S	a
FRONT	S Q	0301	87-A30-494-080	TR,2SA1980G	a
FRONT	S Q	0302	87-A30-076-080	C-TR,2SC3052F	a
FRONT	S Q	0303	87-A30-076-080	C-TR,2SC3052F	a
FRONT	S Q	0601	87-A30-495-080	TR,2SA1981Y	a
FRONT	S Q	0602	87-A30-495-080	TR,2SA1981Y	a
FRONT	S Q	0603	89-112-965-080	TR,2SA1296GR	a
FRONT	S Q	0801	87-A30-076-080	C-TR,2SC3052F	a
FRONT	S Q	0803	87-A30-288-040	C-TR,DTC114YKA	a
FRONT	S Q	0804	87-A30-288-040	C-TR,DTC114YKA	a
FRONT	S Q	0805	87-A30-288-040	C-TR,DTC114YKA	a
FRONT	S Q	0806	87-A30-076-080	C-TR,2SC3052F	a
					CX-SNR80
					VSM
FRONT	S Q	0901	87-A30-538-040	C-TR,SRA2202S	a
FRONT	O	R 0109	88-108-224-080	C-RES,U 220K-1/16W J	a
FRONT	O	R 0110	88-108-153-080	C-RES,U 15K-1/16W J	a
FRONT	X R	0111	88-108-333-080	C-RES,U 33K-1/16W J	a
FRONT	O	R 0112	88-108-224-080	C-RES,U 220K-1/16W J	a
FRONT	O	R 0114	88-108-103-080	C-RES,U 10K-1/16W J	a
FRONT	O	R 0115	88-108-153-080	C-RES,U 15K-1/16W J	a
FRONT	X R	0116	88-108-104-080	C-RES,U 100K-1/16W J	a
FRONT	X R	0151	88-100-000-010	PLATING-JW, 0.58 SN95	a
FRONT	X R	0152	88-100-000-010	PLATING-JW, 0.58 SN95	a
FRONT	X R	0153	88-128-821-080	C-RES, 820-1/8W J	a
FRONT	X R	0154	88-128-821-080	C-RES, 820-1/8W J	a
FRONT	O	R 0155	88-108-332-080	C-RES,U 3.3K-1/16W J	a
FRONT	O	R 0156	88-108-332-080	C-RES,U 3.3K-1/16W J	a
FRONT	X R	0160	88-108-000-080	C-JUMPER,U	a
FRONT	X R	0161	88-108-000-080	C-JUMPER,U	a
FRONT	X R	0162	88-108-000-080	C-JUMPER,U	a
FRONT	X R	0163	88-108-000-080	C-JUMPER,U	a
FRONT	X R	0164	88-108-000-080	C-JUMPER,U	a
FRONT	X R	0165	88-108-000-080	C-JUMPER,U	a
					CX-SNR80
					VSM
FRONT	X R	0166	88-108-000-080	C-JUMPER,U	a
FRONT	X R	0206	88-128-102-080	C-RES, 1K-1/8W J	a
FRONT	X R	0207	88-128-102-080	C-RES, 1K-1/8W J	a
FRONT	X R	0208	88-128-102-080	C-RES, 1K-1/8W J	a
FRONT	X R	0211	88-121-102-080	RES,1K-1/8W J	a
FRONT	X R	0212	88-121-102-080	RES,1K-1/8W J	a
FRONT	X R	0213	88-121-103-080	RES,10K-1/8W J	a
FRONT	X R	0215	88-121-103-080	RES,10K-1/8W J	a
FRONT	X R	0216	88-121-103-080	RES,10K-1/8W J	a
FRONT	X R	0217	88-108-472-080	C-RES,U 4.7K-1/16W J	a
FRONT	X R	0218	88-121-101-080	RES,100-1/8W J	a
FRONT	X R	0301	88-108-104-080	C-RES,U 100K-1/16W J	a
FRONT	X R	0302	88-108-472-080	C-RES,U 4.7K-1/16W J	a
FRONT	O	R 0303	88-108-153-080	C-RES,U 15K-1/16W J	a
FRONT	O	R 0304	88-108-102-080	C-RES,U 1K-1/16W J	a
FRONT	X R	0306	88-108-471-080	C-RES,U 470-1/16W J	a
FRONT	O	R 0321	88-108-103-080	C-RES,U 10K-1/16W J	a
FRONT	O	R 0322	88-108-102-080	C-RES,U 1K-1/16W J	a
FRONT	X R	0323	88-108-821-080	C-RES,U 820-1/16W J	a
FRONT	X R	0324	88-121-122-080	RES,1.2K-1/8W J	a

ELECTRICAL PARTS LIST - 3/15

! = Δ SAFETY PARTS

C = Components marked

All components used on this model at the production line are shown in this service manual.

However, please note that not all components will be available as spare parts for after-sales service.

Components marked S and O are designated as spare parts for service and will be stocked at the spare parts centers.

Components marked X and R are not designated as spare parts for after sales service, and will not be stocked at the spare parts centers.

UNIT-NAME	! C	REF-NO	PARTS-NO	PARTS-NAME	SUFFIX&MODEL
					CX-SNR80 VSM
FRONT	X R	0325	88-108-122-080	C-RES,U 1.2K-1/16W J	a
FRONT	X R	0326	88-108-122-080	C-RES,U 1.2K-1/16W J	a
FRONT	X R	0327	88-108-182-080	C-RES,U 1.8K-1/16W J	a
FRONT	X R	0328	88-108-182-080	C-RES,U 1.8K-1/16W J	a
FRONT	X R	0329	88-121-272-080	RES,2.7K-1/8W J	a
FRONT	O R	0330	88-108-332-080	C-RES,U 3.3K-1/16W J	a
FRONT	X R	0331	88-108-472-080	C-RES,U 4.7K-1/16W J	a
FRONT	X R	0332	88-108-682-080	C-RES,U 6.8K-1/16W J	a
FRONT	O R	0333	88-108-103-080	C-RES,U 10K-1/16W J	a
FRONT	O R	0341	88-108-103-080	C-RES,U 10K-1/16W J	a
FRONT	O R	0342	88-108-102-080	C-RES,U 1K-1/16W J	a
FRONT	X R	0343	88-108-821-080	C-RES,U 820-1/16W J	a
FRONT	O R	0344	88-108-102-080	C-RES,U 1K-1/16W J	a
FRONT	X R	0345	88-108-122-080	C-RES,U 1.2K-1/16W J	a
FRONT	X R	0346	88-108-122-080	C-RES,U 1.2K-1/16W J	a
FRONT	X R	0347	88-108-182-080	C-RES,U 1.8K-1/16W J	a
FRONT	O R	0361	88-108-103-080	C-RES,U 10K-1/16W J	a
FRONT	O R	0362	88-108-103-080	C-RES,U 10K-1/16W J	a
FRONT	X R	0363	88-108-100-080	C-RES,U 10-1/16W J	a
FRONT	X R	0364	88-108-100-080	C-RES,U 10-1/16W J	a
					CX-SNR80 VSM
FRONT	O R	0365	88-108-103-080	C-RES,U 10K-1/16W J	a
FRONT	O R	0366	88-108-103-080	C-RES,U 10K-1/16W J	a
FRONT	X R	0367	88-108-100-080	C-RES,U 10-1/16W J	a
FRONT	X R	0368	88-108-100-080	C-RES,U 10-1/16W J	a
FRONT	O R	0371	88-108-103-080	C-RES,U 10K-1/16W J	a
FRONT	O R	0372	88-108-103-080	C-RES,U 10K-1/16W J	a
FRONT	X R	0373	88-108-100-080	C-RES,U 10-1/16W J	a
FRONT	X R	0374	88-108-100-080	C-RES,U 10-1/16W J	a
FRONT	O R	0601	88-108-103-080	C-RES,U 10K-1/16W J	a
FRONT	X R	0602	88-108-222-080	C-RES,U 2.2K-1/16W J	a
FRONT	O R	0603	88-108-103-080	C-RES,U 10K-1/16W J	a
FRONT	X R	0604	88-108-222-080	C-RES,U 2.2K-1/16W J	a
FRONT	O R	0605	88-108-103-080	C-RES,U 10K-1/16W J	a
FRONT	O R	0606	88-108-102-080	C-RES,U 1K-1/16W J	a
FRONT	X R	0607	88-108-000-080	C-JUMPER,U	a
FRONT	O R	0611	88-108-473-080	C-RES,U 47K-1/16W J	a
FRONT	O R	0613	88-108-473-080	C-RES,U 47K-1/16W J	a
FRONT	O R	0614	88-108-473-080	C-RES,U 47K-1/16W J	a
FRONT	O R	0615	88-108-473-080	C-RES,U 47K-1/16W J	a
FRONT	O R	0616	88-108-473-080	C-RES,U 47K-1/16W J	a
					CX-SNR80 VSM
FRONT	X R	0658	88-108-152-080	C-RES,U 1.5K-1/16W J	a
FRONT	O R	0704	88-108-102-080	C-RES,U 1K-1/16W J	a
FRONT	O R	0705	88-108-102-080	C-RES,U 1K-1/16W J	a
FRONT	O R	0706	88-108-102-080	C-RES,U 1K-1/16W J	a
FRONT	O R	0707	88-108-102-080	C-RES,U 1K-1/16W J	a
FRONT	O R	0708	88-108-102-080	C-RES,U 1K-1/16W J	a
FRONT	O R	0709	88-108-101-080	C-RES,U 100-1/16W J	a
FRONT	O R	0710	88-108-101-080	C-RES,U 100-1/16W J	a
FRONT	O R	0711	88-108-101-080	C-RES,U 100-1/16W J	a
FRONT	O R	0712	88-108-101-080	C-RES,U 100-1/16W J	a
FRONT	O R	0715	88-108-101-080	C-RES,U 100-1/16W J	a
FRONT	X R	0716	88-108-472-080	C-RES,U 4.7K-1/16W J	a
FRONT	X R	0719	88-108-100-080	C-RES,U 10-1/16W J	a
FRONT	X R	0721	88-128-101-080	C-RES, 100-1/8W J	a
FRONT	O R	0730	88-108-102-080	C-RES,U 1K-1/16W J	a
FRONT	O R	0732	88-108-101-080	C-RES,U 100-1/16W J	a
FRONT	O R	0733	88-108-101-080	C-RES,U 100-1/16W J	a
FRONT	O R	0734	88-108-102-080	C-RES,U 1K-1/16W J	a
FRONT	O R	0735	88-108-102-080	C-RES,U 1K-1/16W J	a
FRONT	O R	0740	88-108-102-080	C-RES,U 1K-1/16W J	a
					CX-SNR80 VSM
FRONT	O R	0741	88-108-101-080	C-RES,U 100-1/16W J	a
FRONT	O R	0742	88-108-102-080	C-RES,U 1K-1/16W J	a
FRONT	X R	0743	88-108-474-080	C-RES,U 470K-1/16W J	a
FRONT	O R	0744	88-108-823-080	C-RES,U 82K-1/16W J	a
FRONT	X R	0745	88-108-104-080	C-RES,U 100K-1/16W J	a
FRONT	X R	0749	88-108-474-080	C-RES,U 470K-1/16W J	a
FRONT	X R	0801	88-108-472-080	C-RES,U 4.7K-1/16W J	a
FRONT	X R	0802	88-108-222-080	C-RES,U 2.2K-1/16W J	a
FRONT	X R	0803	88-108-152-080	C-RES,U 1.5K-1/16W J	a
FRONT	O R	0804	88-108-224-080	C-RES,U 220K-1/16W J	a
FRONT	X R	0805	88-108-393-080	C-RES,U 39K-1/16W J	a
FRONT	X R	0807	88-108-000-080	C-JUMPER,U	a
FRONT	X R	0808	88-121-101-080	RES,100-1/8W J	a
FRONT	O R	0810	88-108-103-080	C-RES,U 10K-1/16W J	a
FRONT	X R	0811	88-108-334-080	C-RES,U 330K-1/16W J	a
FRONT	O R	0813	87-A11-057-080	C-CAP,U 0.1-16 K B	a
FRONT	X R	0815	88-108-472-080	C-RES,U 4.7K-1/16W J	a
FRONT	X R	0816	88-108-334-080	C-RES,U 330K-1/16W J	a
FRONT	O R	0818	87-A11-057-080	C-CAP,U 0.1-16 K B	a
FRONT	O R	0819	88-108-103-080	C-RES,U 10K-1/16W J	a

ELECTRICAL PARTS LIST - 4/15

! = SAFETY PARTS

C = Components marked

All components used on this model at the production line are shown in this service manual.

However, please note that not all components will be available as spare parts for after-sales service.

Components marked S and O are designated as spare parts for service and will be stocked at the spare parts centers.

Components marked X and R are not designated as spare parts for after sales service, and will not be stocked at the spare parts centers.

UNIT-NAME	! C	REF-NO	PARTS-NO	PARTS-NAME	SUFFIX&MODEL
					CX-SNR80
					VSM
FRONT	O R	0821	88-108-224-080	C-RES,U 220K-1/16W J	a
FRONT	O R	0822	87-A11-057-080	C-CAP,U 0.1-16 K B	a
FRONT	X R	0823	88-121-101-080	RES,100-1/8W J	a
FRONT	X R	0824	88-121-101-080	RES,100-1/8W J	a
FRONT	X R	0825	88-121-101-080	RES,100-1/8W J	a
FRONT	O R	0826	88-108-101-080	C-RES,U 100-1/16W J	a
FRONT	O R	0827	88-108-473-080	C-RES,U 47K-1/16W J	a
FRONT	O R	0828	88-108-224-080	C-RES,U 220K-1/16W J	a
FRONT	O R	0829	88-108-224-080	C-RES,U 220K-1/16W J	a
FRONT	X R	0830	88-108-104-080	C-RES,U 100K-1/16W J	a
FRONT	X R	0901	88-108-104-080	C-RES,U 100K-1/16W J	a
FRONT	X R	0902	88-108-104-080	C-RES,U 100K-1/16W J	a
FRONT	X R	0903	88-108-104-080	C-RES,U 100K-1/16W J	a
FRONT	X R	0904	88-108-104-080	C-RES,U 100K-1/16W J	a
FRONT	X R	0905	88-108-104-080	C-RES,U 100K-1/16W J	a
FRONT	X R	0906	88-108-104-080	C-RES,U 100K-1/16W J	a
FRONT	X R	0907	88-108-104-080	C-RES,U 100K-1/16W J	a
FRONT	X R	0908	88-108-104-080	C-RES,U 100K-1/16W J	a
FRONT	X R	0909	88-108-104-080	C-RES,U 100K-1/16W J	a
FRONT	X R	0910	88-108-104-080	C-RES,U 100K-1/16W J	a
					CX-SNR80
					VSM
FRONT	X R	0911	88-108-104-080	C-RES,U 100K-1/16W J	a
FRONT	X R	0912	88-108-104-080	C-RES,U 100K-1/16W J	a
FRONT	X R	0913	88-108-104-080	C-RES,U 100K-1/16W J	a
FRONT	X R	0914	88-108-104-080	C-RES,U 100K-1/16W J	a
FRONT	X R	0915	88-108-104-080	C-RES,U 100K-1/16W J	a
FRONT	X R	0916	88-108-104-080	C-RES,U 100K-1/16W J	a
FRONT	X R	0917	88-108-104-080	C-RES,U 100K-1/16W J	a
FRONT	X R	0918	88-108-104-080	C-RES,U 100K-1/16W J	a
FRONT	X R	0919	88-108-104-080	C-RES,U 100K-1/16W J	a
FRONT	X R	0920	88-108-104-080	C-RES,U 100K-1/16W J	a
FRONT	X R	0921	88-108-104-080	C-RES,U 100K-1/16W J	a
FRONT	X R	0922	88-108-104-080	C-RES,U 100K-1/16W J	a
FRONT	X R	0923	88-108-104-080	C-RES,U 100K-1/16W J	a
FRONT	X R	0924	88-108-104-080	C-RES,U 100K-1/16W J	a
FRONT	X R	0925	88-108-104-080	C-RES,U 100K-1/16W J	a
FRONT	X R	0926	88-108-104-080	C-RES,U 100K-1/16W J	a
FRONT	X R	0927	88-108-104-080	C-RES,U 100K-1/16W J	a
FRONT	X R	0928	88-108-104-080	C-RES,U 100K-1/16W J	a
FRONT	X R	0929	88-108-104-080	C-RES,U 100K-1/16W J	a
FRONT	X R	0930	88-108-104-080	C-RES,U 100K-1/16W J	a
					CX-SNR80
					VSM
FRONT	X R	0931	88-108-104-080	C-RES,U 100K-1/16W J	a
FRONT	X R	0932	88-108-104-080	C-RES,U 100K-1/16W J	a
FRONT	X R	0933	88-121-104-080	RES,100K-1/8W J	a
FRONT	X R	0934	88-108-683-080	C-RES,U 68K-1/16W J	a
FRONT	X R	0935	88-128-683-080	C-RES, 68K-1/8W J	a
FRONT	X R	0936	88-108-104-080	C-RES,U 100K-1/16W J	a
FRONT	X R	0937	88-128-472-080	C-RES, 4.7K-1/8W J	a
FRONT	X R	0938	88-108-472-080	C-RES,U 4.7K-1/16W J	a
FRONT	X R	0939	88-108-472-080	C-RES,U 4.7K-1/16W J	a
FRONT	X R	0940	88-108-104-080	C-RES,U 100K-1/16W J	a
FRONT	X R	0941	88-108-104-080	C-RES,U 100K-1/16W J	a
FRONT	O R	0942	88-108-103-080	C-RES,U 10K-1/16W J	a
FRONT	X R	0943	88-121-472-080	RES,4.7K-1/8W J	a
FRONT	X R	0946	88-108-000-080	C-JUMPER,U	a
FRONT	X R	0947	88-108-104-080	C-RES,U 100K-1/16W J	a
FRONT	X R	0948	88-121-104-080	RES,100K-1/8W J	a
FRONT	O R	0951	88-108-102-080	C-RES,U 1K-1/16W J	a
FRONT	X R	0955	88-108-104-080	C-RES,U 100K-1/16W J	a
FRONT	X R	0956	88-108-104-080	C-RES,U 100K-1/16W J	a
FRONT	X R	0957	88-108-104-080	C-RES,U 100K-1/16W J	a
					CX-SNR80
					VSM
FRONT	X R	0958	88-108-104-080	C-RES,U 100K-1/16W J	a
FRONT	O R	0960	88-108-103-080	C-RES,U 10K-1/16W J	a
FRONT	X R	0961	88-121-181-080	RES,180-1/8W J	a
FRONT	O R	0963	88-108-563-080	C-RES,U 56K-1/16W J	a
FRONT	X R	0969	88-121-103-080	RES,10K-1/8W J	a
FRONT	X R	0970	88-108-104-080	C-RES,U 100K-1/16W J	a
FRONT	X R	0971	88-108-104-080	C-RES,U 100K-1/16W J	a
FRONT	X R	0972	88-108-104-080	C-RES,U 100K-1/16W J	a
FRONT	X R	0973	88-108-104-080	C-RES,U 100K-1/16W J	a
FRONT	X R	0974	88-108-104-080	C-RES,U 100K-1/16W J	a
FRONT	O S	0321	87-A90-095-080	SW,TACT EVQ11G04M	a
FRONT	O S	0322	87-A90-095-080	SW,TACT EVQ11G04M	a
FRONT	O S	0323	87-A90-095-080	SW,TACT EVQ11G04M	a
FRONT	O S	0324	87-A90-095-080	SW,TACT EVQ11G04M	a
FRONT	O S	0325	87-A90-095-080	SW,TACT EVQ11G04M	a
FRONT	O S	0326	87-A90-095-080	SW,TACT EVQ11G04M	a
FRONT	O S	0327	87-A90-095-080	SW,TACT EVQ11G04M	a
FRONT	O S	0328	87-A90-095-080	SW,TACT EVQ11G04M	a
FRONT	O S	0329	87-A90-095-080	SW,TACT EVQ11G04M	a
FRONT	O S	0330	87-A90-095-080	SW,TACT EVQ11G04M	a

ELECTRICAL PARTS LIST - 5/15

! = SAFETY PARTS
 C = Components marked

All components used on this model at the production line are shown in this service manual.

However, please note that not all components will be available as spare parts for after-sales service.

Components marked S and O are designated as spare parts for service and will be stocked at the spare parts centers.

Components marked X and R are not designated as spare parts for after sales service, and will not be stocked at the spare parts centers.

UNIT-NAME	! C	REF-NO	PARTS-NO	PARTS-NAME	SUFFIX&MODEL
					CX-SNR80 VSM
FRONT	O S	0331	87-A90-095-080	SW,TACT EVQ11G04M	a
FRONT	O S	0332	87-A90-095-080	SW,TACT EVQ11G04M	a
FRONT	O S	0333	87-A90-095-080	SW,TACT EVQ11G04M	a
FRONT	O S	0341	87-A90-095-080	SW,TACT EVQ11G04M	a
FRONT	O S	0342	87-A90-095-080	SW,TACT EVQ11G04M	a
FRONT	O S	0343	87-A90-095-080	SW,TACT EVQ11G04M	a
FRONT	O S	0344	87-A90-095-080	SW,TACT EVQ11G04M	a
FRONT	O S	0345	87-A90-095-080	SW,TACT EVQ11G04M	a
FRONT	O S	0346	87-A90-095-080	SW,TACT EVQ11G04M	a
FRONT	O S	0347	87-A90-095-080	SW,TACT EVQ11G04M	a
FRONT	O S	0361	87-A92-359-010	SW,RTRY EC12E24604-30MM	a
FRONT	O S	0363	87-A92-273-110	SW,RTRY EC12E12204 30MM	a
FRONT	O S	0371	87-A92-273-110	SW,RTRY EC12E12204 30MM	a
HEAD-1	O CNA	0301	85-MA2-615-010	CONN ASSY,3P PH	a
HP	O J	0201	87-A60-420-010	JACK,3.5 ST (MSC)	a
HP	O R	0243	87-A01-001-050	RES,220-1/2W J BLT2J	a
HP	O R	0244	87-A01-001-050	RES,220-1/2W J BLT2J	a
HP	O R	0245	87-A01-001-050	RES,220-1/2W J BLT2J	a
HP	O R	0246	87-A01-001-050	RES,220-1/2W J BLT2J	a
HP	X R	0265	88-128-222-080	C-RES, 2.2K-1/8W J	a
					CX-SNR80 VSM
HP	X R	0266	88-128-222-080	C-RES, 2.2K-1/8W J	a
HP	O WH	0201	87-A90-459-010	HLDR,WIRE 2.5-5P	a
MAIN	O C	0003	87-A12-317-080	C-CAP,U 0.1-50 Z F	a
MAIN	O C	0004	87-A12-317-080	C-CAP,U 0.1-50 Z F	a
MAIN	O C	0005	87-A12-317-080	C-CAP,U 0.1-50 Z F	a
MAIN	O C	0006	87-A12-317-080	C-CAP,U 0.1-50 Z F	a
MAIN	O C	0009	87-010-759-080	C-CAP,U 0.1-25 Z F CM/CB	a
MAIN	O C	0010	87-010-759-080	C-CAP,U 0.1-25 Z F CM/CB	a
MAIN	O C	0011	87-010-759-080	C-CAP,U 0.1-25 Z F CM/CB	a
MAIN	O C	0012	87-010-759-080	C-CAP,U 0.1-25 Z F CM/CB	a
MAIN	O C	0013	87-012-282-080	C-CAP,U 4700P-50 K B GRM	a
MAIN	O C	0014	87-A12-071-080	CAP,E 47-25 SMG	a
MAIN	O C	0016	87-012-282-080	C-CAP,U 4700P-50 K B GRM	a
MAIN	O C	0019	87-A12-383-000	CAP,E 3300-65 M 85 IV LELON	a
MAIN	O C	0020	87-A12-383-000	CAP,E 3300-65 M 85 IV LELON	a
MAIN	O C	0021	87-A12-780-090	CAP,E 4700-35 M 85 SKR	a
MAIN	O C	0022	87-A12-780-090	CAP,E 4700-35 M 85 SKR	a
MAIN	O C	0031	87-A12-062-080	CAP,E 100-10 SMG	a
MAIN	O C	0034	87-A12-071-080	CAP,E 47-25 SMG	a
MAIN	O C	0035	87-A12-090-080	CAP,E 4.7-50 SMG	a
					CX-SNR80 VSM
MAIN	O C	0036	87-A12-071-080	CAP,E 47-25 SMG	a
MAIN	O C	0060	87-A12-089-080	CAP,E 3.3-50 SMG	a
MAIN	O C	0061	87-A12-071-080	CAP,E 47-25 SMG	a
MAIN	O C	0083	87-A12-068-080	CAP,E 470-16 SMG	a
MAIN	O C	0097	87-010-759-080	C-CAP,U 0.1-25 Z F CM/CB	a
MAIN	O C	0101	87-012-278-080	C-CAP,U 2200P-50 K B GRM	a
MAIN	O C	0102	87-012-278-080	C-CAP,U 2200P-50 K B GRM	a
MAIN	O C	0103	87-A12-084-080	CAP,E 0.22-50 SMG	a
MAIN	O C	0104	87-A12-084-080	CAP,E 0.22-50 SMG	a
MAIN	O C	0105	87-012-280-080	C-CAP,U 3300P-50 K B GRM	a
MAIN	O C	0106	87-012-280-080	C-CAP,U 3300P-50 K B GRM	a
MAIN	O C	0107	87-A12-091-080	CAP,E 10-50 SMG	a
MAIN	O C	0108	87-A12-091-080	CAP,E 10-50 SMG	a
MAIN	O C	0111	87-A12-077-080	CAP,E 33-35 SMG	a
MAIN	O C	0112	87-A12-077-080	CAP,E 33-35 SMG	a
MAIN	O C	0113	87-A10-596-080	C-CAP,S 100P-100 J CH	a
MAIN	O C	0114	87-A10-596-080	C-CAP,S 100P-100 J CH	a
MAIN	O C	0117	87-A12-317-080	C-CAP,U 0.1-50 Z F	a
MAIN	O C	0118	87-A12-317-080	C-CAP,U 0.1-50 Z F	a
MAIN	O C	0119	87-012-286-080	C-CAP,U 0.01-25 K B GRM	a
					CX-SNR80 VSM
MAIN	O C	0120	87-012-286-080	C-CAP,U 0.01-25 K B GRM	a
MAIN	O C	0121	87-A12-087-080	CAP,E 1-50 SMG	a
MAIN	O C	0122	87-A12-087-080	CAP,E 1-50 SMG	a
MAIN	O C	0123	87-010-177-080	C-CAP,S 820P-50 J SL C2012	a
MAIN	O C	0124	87-010-177-080	C-CAP,S 820P-50 J SL C2012	a
MAIN	O C	0125	87-A10-596-080	C-CAP,S 100P-100 J CH	a
MAIN	O C	0126	87-A10-596-080	C-CAP,S 100P-100 J CH	a
MAIN	O C	0133	87-012-282-080	C-CAP,U 4700P-50 K B GRM	a
MAIN	O C	0140	87-012-278-080	C-CAP,U 2200P-50 K B GRM	a
MAIN	O C	0186	87-010-759-080	C-CAP,U 0.1-25 Z F CM/CB	a
MAIN	O C	0187	87-A12-890-080	CAP,E 10-63 VR	a
MAIN	O C	0188	87-A12-890-080	CAP,E 10-63 VR	a
MAIN	O C	0193	87-012-273-080	C-CAP,U 820P-50 K B GRM	a
MAIN	O C	0194	87-012-273-080	C-CAP,U 820P-50 K B GRM	a
MAIN	O C	0225	87-A12-317-080	C-CAP,U 0.1-50 Z F	a
MAIN	O C	0226	87-A12-317-080	C-CAP,U 0.1-50 Z F	a
MAIN	O C	0227	87-A12-317-080	C-CAP,U 0.1-50 Z F	a
MAIN	O C	0228	87-A12-317-080	C-CAP,U 0.1-50 Z F	a
MAIN	O C	0229	87-010-191-080	C-CAP,S 0.015-50 Z F GRM	a
MAIN	O C	0230	87-010-191-080	C-CAP,S 0.015-50 Z F GRM	a

ELECTRICAL PARTS LIST - 6/15

! = Δ SAFETY PARTS
 C = Components marked

All components used on this model at the production line are shown in this service manual.

However, please note that not all components will be available as spare parts for after-sales service.

Components marked S and O are designated as spare parts for service and will be stocked at the spare parts centers.

Components marked X and R are not designated as spare parts for after sales service, and will not be stocked at the spare parts centers.

UNIT-NAME	! C	REF-NO	PARTS-NO	PARTS-NAME	SUFFIX&MODEL
					CX-SNR80 VSM
MAIN	O C	0301	87-012-275-080	C-CAP,U 1200P-50 K B GRM	a
MAIN	O C	0302	87-012-275-080	C-CAP,U 1200P-50 K B GRM	a
MAIN	O C	0303	87-012-275-080	C-CAP,U 1200P-50 K B GRM	a
MAIN	O C	0304	87-012-275-080	C-CAP,U 1200P-50 K B GRM	a
MAIN	O C	0305	87-012-270-080	C-CAP,U 470P-50 K B GRM	a
MAIN	O C	0306	87-012-274-080	C-CAP,U 1000P-50 K B GRM	a
MAIN	O C	0363	87-010-831-080	C-CAP,U 0.1-16 Z F GRM	a
MAIN	O C	0451	87-010-759-080	C-CAP,U 0.1-25 Z F CM/CB	a
MAIN	O C	0452	87-A12-092-080	CAP,E 22-50 SMG	a
MAIN	O C	0453	87-012-279-080	C-CAP,U 2700P-50 K B GRM	a
MAIN	O C	0454	87-012-279-080	C-CAP,U 2700P-50 K B GRM	a
MAIN	O C	0455	87-012-279-080	C-CAP,U 2700P-50 K B GRM	a
MAIN	O C	0456	87-012-286-080	C-CAP,U 0.01-25 K B GRM	a
MAIN	O C	0457	87-A12-361-080	CAP,M 5600P-100 J CP	a
MAIN	O C	0458	87-012-278-080	C-CAP,U 2200P-50 K B GRM	a
MAIN	O C	0459	87-012-271-080	C-CAP,U 560P-50 K B GRM	a
MAIN	O C	0460	87-010-759-080	C-CAP,U 0.1-25 Z F CM/CB	a
MAIN	O C	0461	87-012-158-080	C-CAP,S 390P-50 J CH GRM	a
MAIN	O C	0462	87-012-158-080	C-CAP,S 390P-50 J CH GRM	a
MAIN	O C	0463	87-010-831-080	C-CAP,U 0.1-16 Z F GRM	a
					CX-SNR80 VSM
MAIN	O C	0464	87-012-278-080	C-CAP,U 2200P-50 K B GRM	a
MAIN	O C	0601	87-012-188-080	C-CAP,U 47P-50 J CH GRM	a
MAIN	O C	0602	87-012-188-080	C-CAP,U 47P-50 J CH GRM	a
MAIN	O C	0603	87-A12-062-080	CAP,E 100-10 SMG	a
MAIN	O C	0604	87-A12-062-080	CAP,E 100-10 SMG	a
MAIN	X C	0605	88-700-740-810	CAP,M 6800P-50 J AMZV	a
MAIN	X C	0606	88-700-740-810	CAP,M 6800P-50 J AMZV	a
MAIN	O C	0607	87-012-270-080	C-CAP,U 470P-50 K B GRM	a
MAIN	O C	0608	87-012-270-080	C-CAP,U 470P-50 K B GRM	a
MAIN	O C	0609	87-A12-087-080	CAP,E 1-50 SMG	a
MAIN	O C	0610	87-A12-087-080	CAP,E 1-50 SMG	a
MAIN	O C	0611	87-012-273-080	C-CAP,U 820P-50 K B GRM	a
MAIN	O C	0612	87-012-273-080	C-CAP,U 820P-50 K B GRM	a
MAIN	X C	0613	88-700-610-810	CAP,M 1000P-50 J LDS	a
MAIN	X C	0614	88-700-610-810	CAP,M 1000P-50 J LDS	a
MAIN	X C	0615	88-700-610-810	CAP,M 1000P-50 J LDS	a
MAIN	X C	0616	88-700-610-810	CAP,M 1000P-50 J LDS	a
MAIN	O C	0617	87-A10-295-080	CAP,M 0.01-50 J	a
MAIN	O C	0618	87-A10-295-080	CAP,M 0.01-50 J	a
MAIN	O C	0619	87-A10-295-080	CAP,M 0.01-50 J	a
					CX-SNR80 VSM
MAIN	O C	0620	87-A10-295-080	CAP,M 0.01-50 J	a
MAIN	O C	0621	87-A12-085-080	CAP,E 0.33-50 SMG	a
MAIN	O C	0622	87-A12-085-080	CAP,E 0.33-50 SMG	a
MAIN	O C	0623	87-A12-085-080	CAP,E 0.33-50 SMG	a
MAIN	O C	0624	87-A12-085-080	CAP,E 0.33-50 SMG	a
MAIN	O C	0631	87-012-195-080	C-CAP,U 100P-50 J CH GRM	a
MAIN	O C	0632	87-012-195-080	C-CAP,U 100P-50 J CH GRM	a
MAIN	O C	0633	87-012-284-080	C-CAP,U 6800P-50 K B GRM	a
MAIN	O C	0634	87-012-284-080	C-CAP,U 6800P-50 K B GRM	a
MAIN	O C	0635	87-012-286-080	C-CAP,U 0.01-25 K B GRM	a
MAIN	O C	0636	87-012-286-080	C-CAP,U 0.01-25 K B GRM	a
MAIN	O C	0637	87-012-278-080	C-CAP,U 2200P-50 K B GRM	a
MAIN	O C	0638	87-012-278-080	C-CAP,U 2200P-50 K B GRM	a
MAIN	O C	0641	87-A12-087-080	CAP,E 1-50 SMG	a
MAIN	O C	0642	87-A12-087-080	CAP,E 1-50 SMG	a
MAIN	O C	0651	87-A12-063-080	CAP,E 220-10 SMG	a
MAIN	O C	0652	87-A12-071-080	CAP,E 47-25 SMG	a
MAIN	O C	0655	87-A12-090-080	CAP,E 4.7-50 SMG	a
MAIN	O C	0656	87-010-784-080	C-CAP,U 0.012-25 K B GRM	a
MAIN	O C	0663	87-010-831-080	C-CAP,U 0.1-16 Z F GRM	a
					CX-SNR80 VSM
MAIN	O C	0664	87-010-831-080	C-CAP,U 0.1-16 Z F GRM	a
MAIN	O C	0665	87-A10-504-080	C-CAP,U 0.047-16 K B	a
MAIN	O C	0666	87-A10-504-080	C-CAP,U 0.047-16 K B	a
MAIN	O C	0677	87-015-819-080	C-CAP, 0.01-50 K B C3216	a
MAIN	O C	0771	87-A12-062-080	CAP,E 100-10 SMG	a
MAIN	O C	0772	87-012-286-080	C-CAP,U 0.01-25 K B GRM	a
MAIN	X C	0781	88-108-000-080	C-JUMPER,U	a
MAIN	O C	0782	87-012-286-080	C-CAP,U 0.01-25 K B GRM	a
MAIN	O C	0783	87-012-286-080	C-CAP,U 0.01-25 K B GRM	a
MAIN	O C	0784	87-012-286-080	C-CAP,U 0.01-25 K B GRM	a
MAIN	O C	0785	87-012-286-080	C-CAP,U 0.01-25 K B GRM	a
MAIN	O C	0786	87-012-286-080	C-CAP,U 0.01-25 K B GRM	a
MAIN	O C	0788	87-012-167-080	C-CAP,U 5P-50 C CH GRM	a
MAIN	O C	0789	87-016-117-080	C-CAP,U 0.018-25 J B CB	a
MAIN	O C	0790	87-016-117-080	C-CAP,U 0.018-25 J B CB	a
MAIN	O C	0791	87-010-759-080	C-CAP,U 0.1-25 Z F CM/CB	a
MAIN	O C	0792	87-012-286-080	C-CAP,U 0.01-25 K B GRM	a
MAIN	O C	0793	87-A12-090-080	CAP,E 4.7-50 SMG	a
MAIN	O C	0795	87-012-286-080	C-CAP,U 0.01-25 K B GRM	a
MAIN	O C	0796	87-012-286-080	C-CAP,U 0.01-25 K B GRM	a

ELECTRICAL PARTS LIST - 7/15

! = Δ SAFETY PARTS
 C = Components marked

All components used on this model at the production line are shown in this service manual.

However, please note that not all components will be available as spare parts for after-sales service.

Components marked S and O are designated as spare parts for service and will be stocked at the spare parts centers.

Components marked X and R are not designated as spare parts for after sales service, and will not be stocked at the spare parts centers.

UNIT-NAME	! C	REF-NO	PARTS-NO	PARTS-NAME	SUFFIX&MODEL
					CX-SNR80 VSM
MAIN	O C	0797	87-A12-091-080	CAP,E 10-50 SMG	a
MAIN	O C	0798	87-012-286-080	C-CAP,U 0.01-25 K B GRM	a
MAIN	O C	0799	87-A12-065-080	CAP,E 33-16 SMG	a
MAIN	O C	0800	87-010-829-080	C-CAP,U 0.047-16 Z F CM/CB	a
MAIN	O C	0801	87-A12-089-080	CAP,E 3.3-50 SMG	a
MAIN	O C	0802	87-010-829-080	C-CAP,U 0.047-16 Z F CM/CB	a
MAIN	O C	0803	87-010-787-080	C-CAP,U 0.022-25 K B GRM	a
MAIN	O C	0804	87-A12-062-080	CAP,E 100-10 SMG	a
MAIN	O C	0807	87-A12-086-080	CAP,E 0.47-50 SMG	a
MAIN	O C	0808	87-A12-087-080	CAP,E 1-50 SMG	a
MAIN	O C	0809	87-A12-087-080	CAP,E 1-50 SMG	a
MAIN	O C	0810	87-010-759-080	C-CAP,U 0.1-25 Z F CM/CB	a
MAIN	O C	0814	87-012-286-080	C-CAP,U 0.01-25 K B GRM	a
MAIN	O C	0815	87-A12-086-080	CAP,E 0.47-50 SMG	a
MAIN	O C	0816	87-A12-086-080	CAP,E 0.47-50 SMG	a
MAIN	O C	0821	87-A12-091-080	CAP,E 10-50 SMG	a
MAIN	X C	0822	88-108-000-080	C-JUMPER,U	a
MAIN	O C	0823	87-010-177-080	C-CAP,S 820P-50 J SL C2012	a
MAIN	O C	0824	87-A12-090-080	CAP,E 4.7-50 SMG	a
MAIN	O C	0825	87-010-596-080	C-CAP,S 0.047-16 K R C2012	a
					CX-SNR80 VSM
MAIN	O C	0842	87-012-286-080	C-CAP,U 0.01-25 K B GRM	a
MAIN	X C	0843	88-108-000-080	C-JUMPER,U	a
MAIN	O C	0844	87-012-286-080	C-CAP,U 0.01-25 K B GRM	a
MAIN	X C	0845	88-108-000-080	C-JUMPER,U	a
MAIN	X C	0846	88-108-000-080	C-JUMPER,U	a
MAIN	X C	0847	88-108-000-080	C-JUMPER,U	a
MAIN	X C	0848	88-108-000-080	C-JUMPER,U	a
MAIN	X C	0849	88-108-000-080	C-JUMPER,U	a
MAIN	O C	0850	87-A12-071-080	CAP,E 47-25 SMG	a
MAIN	O C	0851	87-012-286-080	C-CAP,U 0.01-25 K B GRM	a
MAIN	O C	0852	87-012-286-080	C-CAP,U 0.01-25 K B GRM	a
MAIN	O C	0853	87-012-286-080	C-CAP,U 0.01-25 K B GRM	a
MAIN	O C	0860	87-012-286-080	C-CAP,U 0.01-25 K B GRM	a
MAIN	O C	0901	87-012-167-080	C-CAP,U 5P-50 C CH GRM	a
MAIN	O C	0904	87-A12-173-080	C-CAP,U 330P-50 CH	a
MAIN	O C	0906	87-012-168-080	C-CAP,U 6P-50 D CH GRM	a
MAIN	O C	0908	87-012-166-080	C-CAP,U 4P-50 C CH GRM	a
MAIN	O C	0909	87-A12-173-080	C-CAP,U 330P-50 CH	a
MAIN	O C	0911	87-012-166-080	C-CAP,U 4P-50 C CH GRM	a
MAIN	O C	0912	87-012-195-080	C-CAP,U 100P-50 J CH GRM	a
					CX-SNR80 VSM
MAIN	O C	0913	87-012-286-080	C-CAP,U 0.01-25 K B GRM	a
MAIN	O C	0914	87-012-286-080	C-CAP,U 0.01-25 K B GRM	a
MAIN	O C	0915	87-012-286-080	C-CAP,U 0.01-25 K B GRM	a
MAIN	O C	0917	87-012-168-080	C-CAP,U 6P-50 D CH GRM	a
MAIN	O C	0919	87-012-184-080	C-CAP,U 33P-50 J CH GRM	a
MAIN	O C	0920	87-012-184-080	C-CAP,U 33P-50 J CH GRM	a
MAIN	O C	0921	87-012-180-080	C-CAP,U 22P-50 J CH GRM	a
MAIN	O C	0922	87-012-174-080	C-CAP,U 12P-50 J CH GRM	a
MAIN	O C	0923	87-012-198-080	C-CAP,U 180P-50 J CH GRM	a
MAIN	O C	0925	87-012-164-080	C-CAP,U 2P-50 C CH GRM	a
MAIN	O C	0926	87-012-286-080	C-CAP,U 0.01-25 K B GRM	a
MAIN	O C	0931	87-A12-319-080	C-CAP,U 0.1-25 K B	a
MAIN	X C	0940	88-108-000-080	C-JUMPER,U	a
MAIN	O C	0959	87-010-759-080	C-CAP,U 0.1-25 Z F CM/CB	a
MAIN	O C	0960	87-010-759-080	C-CAP,U 0.1-25 Z F CM/CB	a
MAIN	O C	0961	87-012-169-080	C-CAP,U 7P-50 D CH GRM	a
MAIN	O C	0962	87-A12-087-080	CAP,E 1-50 SMG	a
MAIN	O C	0963	87-A12-319-080	C-CAP,U 0.1-25 K B	a
MAIN	O C	0971	87-A12-067-080	CAP,E 330-16 SMG	a
MAIN	O C	0972	87-A12-090-080	CAP,E 4.7-50 SMG	a
					CX-SNR80 VSM
MAIN	O C	0973	87-012-286-080	C-CAP,U 0.01-25 K B GRM	a
MAIN	O C	0974	87-012-286-080	C-CAP,U 0.01-25 K B GRM	a
MAIN	O C	0979	87-012-195-080	C-CAP,U 100P-50 J CH GRM	a
MAIN	O C	0981	87-A12-071-080	CAP,E 47-25 SMG	a
MAIN	O C	0982	87-010-759-080	C-CAP,U 0.1-25 Z F CM/CB	a
MAIN	O C	0983	87-012-286-080	C-CAP,U 0.01-25 K B GRM	a
MAIN	O C	0984	87-012-286-080	C-CAP,U 0.01-25 K B GRM	a
MAIN	O C	0987	87-012-286-080	C-CAP,U 0.01-25 K B GRM	a
MAIN	O C	0991	87-012-176-080	C-CAP,U 15P-50 J CH GRM	a
MAIN	O C	0992	87-012-176-080	C-CAP,U 15P-50 J CH GRM	a
MAIN	O C	0993	87-012-274-080	C-CAP,U 1000P-50 K B GRM	a
MAIN	O C	0995	87-012-274-080	C-CAP,U 1000P-50 K B GRM	a
MAIN	O C	0997	87-010-759-080	C-CAP,U 0.1-25 Z F CM/CB	a
MAIN	O C	0998	87-A12-071-080	CAP,E 47-25 SMG	a
MAIN	O C	0999	87-A11-155-080	CAP,TC U 0.01-16 Z F	a
MAIN	O CF	0831	87-008-261-010	FLTR,CF SFE10.7MA5	a
MAIN	O CF	0832	87-008-261-010	FLTR,CF SFE10.7MA5	a
MAIN	X CLP0301	87-A60-884-010	PIN,DIAL COATING-SHS	a	
MAIN	X CLP0601	87-A60-884-010	PIN,DIAL COATING-SHS	a	
MAIN	O CN	0301	87-A60-620-010	CONN,3P V 2MM JMT	a

ELECTRICAL PARTS LIST - 8/15

! = SAFETY PARTS
 C = Components marked

All components used on this model at the production line are shown in this service manual.

However, please note that not all components will be available as spare parts for after-sales service.

Components marked S and O are designated as spare parts for service and will be stocked at the spare parts centers.

Components marked X and R are not designated as spare parts for after sales service, and will not be stocked at the spare parts centers.

UNIT-NAME	! C	REF-NO	PARTS-NO	PARTS-NAME	SUFFIX&MODEL
					CX-SNR80 VSM
MAIN		O CN 0302	87-A60-625-010	CONN,8P V 2MM JMT	a
MAIN		O CN 0601	87-099-719-010	CONN,30P H BLK TYK-B(X)	a
MAIN		O CN 0602	87-A60-131-010	CONN,6P V FE	a
MAIN		O CNA0302	86-ZM3-605-110	CONN ASSY,8P -RPB	a
MAIN		S D 0001	87-070-178-090	DIODE,1N5402-BD54	a
MAIN		S D 0002	87-070-178-090	DIODE,1N5402-BD54	a
MAIN		S D 0003	87-070-178-090	DIODE,1N5402-BD54	a
MAIN		S D 0004	87-070-178-090	DIODE,1N5402-BD54	a
MAIN		S D 0009	87-A40-838-090	DIODE,G3SBA60L-6088	a
MAIN		S D 0011	87-A40-270-080	C-DIODE,MC2838	a
MAIN		S D 0012	87-A40-291-080	DIODE,1N4148M (CPT)	a
MAIN		S D 0013	87-A40-764-080	ZENER,UZ10BSC	a
MAIN		S D 0029	87-A40-776-080	ZENER,UZ27BSD	a
MAIN		S D 0033	87-A40-291-080	DIODE,1N4148M (CPT)	a
MAIN		S D 0041	87-A40-270-080	C-DIODE,MC2838	a
MAIN		S D 0042	87-A40-269-080	C-DIODE,MC2836	a
MAIN		S D 0060	87-A40-291-080	DIODE,1N4148M (CPT)	a
MAIN		S D 0063	87-A40-270-080	C-DIODE,MC2838	a
MAIN		S D 0064	87-A40-269-080	C-DIODE,MC2836	a
MAIN		S D 0076	87-A40-269-080	C-DIODE,MC2836	a
					CX-SNR80 VSM
MAIN		S D 0077	87-A40-270-080	C-DIODE,MC2838	a
MAIN		S D 0101	87-A40-269-080	C-DIODE,MC2836	a
MAIN		S D 0103	87-020-465-080	DIODE,1SS133	a
MAIN		S D 0104	87-020-465-080	DIODE,1SS133	a
MAIN		S D 0105	87-A40-269-080	C-DIODE,MC2836	a
MAIN		S D 0106	87-A40-269-080	C-DIODE,MC2836	a
MAIN		S D 0107	87-A40-270-080	C-DIODE,MC2838	a
MAIN		S D 0108	87-A40-270-080	C-DIODE,MC2838	a
MAIN		S D 0109	87-A40-488-080	DIODE,1SS244	a
MAIN		S D 0110	87-A40-488-080	DIODE,1SS244	a
MAIN		S D 0150	87-A40-270-080	C-DIODE,MC2838	a
MAIN		S D 0160	87-A40-270-080	C-DIODE,MC2838	a
MAIN		S D 0185	87-A40-370-090	DIODE,RK46-P20	a
MAIN		S D 0186	87-A40-370-090	DIODE,RK46-P20	a
MAIN		S D 0187	87-A40-747-080	ZENER,UZ5.1BSB	a
MAIN		S D 0188	87-A40-749-080	ZENER,UZ5.6BSB	a
MAIN		S D 0189	87-A40-270-080	C-DIODE,MC2838	a
MAIN		S D 0190	87-A40-269-080	C-DIODE,MC2836	a
MAIN		S D 0191	87-A40-764-080	ZENER,UZ10BSC	a
MAIN		S D 0192	87-A40-291-080	DIODE,1N4148M (CPT)	a
					CX-SNR80 VSM
MAIN		S D 0193	87-A40-291-080	DIODE,1N4148M (CPT)	a
MAIN		X D 0194	88-100-000-010	PLATING-JW, 0.58 SN95	a
MAIN		S D 0201	87-A40-291-080	DIODE,1N4148M (CPT)	a
MAIN		S D 0280	87-A40-269-080	C-DIODE,MC2836	a
MAIN		S D 0281	87-A40-270-080	C-DIODE,MC2838	a
MAIN		S D 0301	87-A40-269-080	C-DIODE,MC2836	a
MAIN		S D 0661	87-A40-745-080	ZENER,UZ4.7BSA	a
MAIN		S D 0662	87-A40-745-080	ZENER,UZ4.7BSA	a
MAIN		X D 0801	88-100-000-010	PLATING-JW, 0.58 SN95	a
MAIN		S D 0803	87-A40-291-080	DIODE,1N4148M (CPT)	a
MAIN		O D 0901	87-A40-969-040	C-VARI-CAP,HVC300A TRU	a
MAIN		O D 0902	87-A40-969-040	C-VARI-CAP,HVC300A TRU	a
MAIN		O D 0903	87-A40-969-040	C-VARI-CAP,HVC300A TRU	a
MAIN		X D 0944	88-100-000-010	PLATING-JW, 0.58 SN95	a
MAIN		O D 0951	87-A40-799-040	C-VARI-CAP,KV1610S	a
MAIN		S D 0991	87-017-149-080	ZENER,HZS6A2L	a
MAIN		S D 0994	87-A40-291-080	DIODE,1N4148M (CPT)	a
MAIN		X FB 0601	88-108-000-080	C-JUMPER,U	a
MAIN		X FB 0603	88-100-000-010	PLATING-JW, 0.58 SN95	a
MAIN		O FFC0602	88-906-251-110	FF-CABLE,6P 1.25	a
					CX-SNR80 VSM
MAIN		S IC 0001	87-A21-364-010	IC,NJM7806FA(A)	a
MAIN		S IC 0601	87-A22-235-040	C-IC,M61518FP	a
MAIN		S IC 0801	87-A22-060-010	IC,LA1845N-A	a
MAIN		S IC 0991	87-A21-928-010	IC,LC72131D-N	a
MAIN		O J 0203	87-A60-238-010	TERMINAL,SP 4P (MSC)	a
MAIN		X J 0602	87-A60-881-010	JACK,PIN 2P MSP 242V05 PBSN	a
MAIN		O J 0831	87-A60-202-010	TERMINAL,ANT 4P MSP-154V-02	a
MAIN		O L 0201	87-A50-610-010	COIL,1UH K(MDEC)	a
MAIN		O L 0202	87-A50-610-010	COIL,1UH K(MDEC)	a
MAIN		O L 0451	87-007-342-010	COIL,OSC 85KHZ BIAS	a
MAIN		O L 0801	87-A50-608-010	COIL,FM DET-N(TOK)	a
MAIN		O L 0802	87-A91-551-010	FLTR,PCFJZH-450 L(TOK)	a
MAIN		O L 0811	87-005-847-080	COIL,2.2UH K CECS	a
MAIN		O L 0832	87-005-847-080	COIL,2.2UH K CECS	a
MAIN		O L 0901	87-A50-774-010	COIL,FM ANT RF1-V	a
MAIN		O L 0903	86-ZA1-624-010	COIL,FM RF-1	a
MAIN		O L 0904	86-ZA1-625-010	COIL,FM ANT/RF-V	a
MAIN		O L 0906	87-005-847-080	COIL,2.2UH K CECS	a
MAIN		O L 0907	86-ZA1-629-010	COIL,FM OSC-V	a
MAIN		O L 0908	88-ZA1-624-010	COIL,FM IFT 7-6.2 (COILS)	a

ELECTRICAL PARTS LIST - 9/15

! = Δ SAFETY PARTS
 C = Components marked

All components used on this model at the production line are shown in this service manual.

However, please note that not all components will be available as spare parts for after-sales service.

Components marked S and O are designated as spare parts for service and will be stocked at the spare parts centers.

Components marked X and R are not designated as spare parts for after sales service, and will not be stocked at the spare parts centers.

UNIT-NAME	! C	REF-NO	PARTS-NO	PARTS-NAME	SUFFIX&MODEL
					CX-SNR80 VSM
MAIN		O L	0952 87-A50-752-010	COIL,MW ANT(2B)	a
MAIN		O L	0953 87-A50-753-010	COIL,MW OSC(2B)	a
MAIN		S Q	0001 87-A30-494-080	TR,2SA1980G	a
MAIN		S Q	0002 87-A30-494-080	TR,2SA1980G	a
MAIN		S Q	0003 87-A30-076-080	C-TR,2SC3052F	a
MAIN		S Q	0004 87-A30-494-080	TR,2SA1980G	a
MAIN		S Q	0009 87-A30-494-080	TR,2SA1980G	a
MAIN		S Q	0010 87-A30-076-080	C-TR,2SC3052F	a
MAIN		S Q	0011 87-A30-614-010	TR,2SB1548	a
MAIN		S Q	0012 87-A30-630-080	TR,2SC5343GL	a
MAIN		S Q	0013 87-A30-076-080	C-TR,2SC3052F	a
MAIN		S Q	0014 87-A30-075-080	C-TR,2SA1235F	a
MAIN		S Q	0060 87-A30-076-080	C-TR,2SC3052F	a
MAIN		S Q	0061 87-A30-075-080	C-TR,2SA1235F	a
MAIN		S Q	0062 87-A30-076-080	C-TR,2SC3052F	a
MAIN		S Q	0063 87-A30-075-080	C-TR,2SA1235F	a
MAIN		S Q	0064 87-A30-076-080	C-TR,2SC3052F	a
MAIN		S Q	0101 87-A30-257-080	C-TR,2SD1306E	a
MAIN		S Q	0102 87-A30-257-080	C-TR,2SD1306E	a
MAIN		S Q	0103 87-A30-669-040	C-TR,SBT5401	a
					CX-SNR80 VSM
MAIN		S Q	0104 87-A30-669-040	C-TR,SBT5401	a
MAIN		S Q	0105 87-A30-669-040	C-TR,SBT5401	a
MAIN		S Q	0106 87-A30-669-040	C-TR,SBT5401	a
MAIN		S Q	0107 87-A30-076-080	C-TR,2SC3052F	a
MAIN		S Q	0108 87-A30-076-080	C-TR,2SC3052F	a
MAIN		S Q	0109 87-A30-076-080	C-TR,2SC3052F	a
MAIN		S Q	0110 87-A30-076-080	C-TR,2SC3052F	a
MAIN		S Q	0111 87-A30-672-080	TR,2N5551C	a
MAIN		S Q	0112 87-A30-672-080	TR,2N5551C	a
MAIN		S Q	0113 87-A30-076-080	C-TR,2SC3052F	a
MAIN		S Q	0114 87-A30-076-080	C-TR,2SC3052F	a
MAIN		S Q	0115 87-A30-670-040	C-TR,SBT5551	a
MAIN		S Q	0116 87-A30-670-040	C-TR,SBT5551	a
MAIN		S Q	0121 87-A30-672-080	TR,2N5551C	a
MAIN		S Q	0122 87-A30-672-080	TR,2N5551C	a
MAIN		S Q	0123 87-A30-669-040	C-TR,SBT5401	a
MAIN		S Q	0124 87-A30-669-040	C-TR,SBT5401	a
MAIN		S Q	0126 87-A30-669-040	C-TR,SBT5401	a
MAIN		S Q	0127 87-A30-076-080	C-TR,2SC3052F	a
MAIN		S Q	0128 87-A30-076-080	C-TR,2SC3052F	a
					CX-SNR80 VSM
MAIN		S Q	0130 87-A30-670-040	C-TR,SBT5551	a
MAIN		S Q	0131 87-A30-098-010	TR,FP1016	a
MAIN		S Q	0132 87-A30-098-010	TR,FP1016	a
MAIN		S Q	0133 87-A30-097-010	TR,FN1016	a
MAIN		S Q	0134 87-A30-097-010	TR,FN1016	a
MAIN		S Q	0183 87-A30-186-010	FET,2SK3053	a
MAIN		S Q	0184 87-A30-186-010	FET,2SK3053	a
MAIN		S Q	0185 87-A30-076-080	C-TR,2SC3052F	a
MAIN		S Q	0186 87-A30-075-080	C-TR,2SA1235F	a
MAIN		S Q	0187 87-A30-075-080	C-TR,2SA1235F	a
MAIN		S Q	0235 87-A30-075-080	C-TR,2SA1235F	a
MAIN		S Q	0280 87-A30-538-040	C-TR,SRA2202S	a
MAIN		S Q	0281 87-A30-669-040	C-TR,SBT5401	a
MAIN		S Q	0301 87-A30-091-080	FET,2SJ460	a
MAIN		S Q	0302 87-A30-091-080	FET,2SJ460	a
MAIN		S Q	0303 87-A30-090-080	FET,2SK2541	a
MAIN		S Q	0304 87-A30-090-080	FET,2SK2541	a
MAIN		S Q	0305 87-A30-091-080	FET,2SJ460	a
MAIN		S Q	0306 87-A30-091-080	FET,2SJ460	a
MAIN		S Q	0307 87-A30-090-080	FET,2SK2541	a
					CX-SNR80 VSM
MAIN		S Q	0308 87-A30-090-080	FET,2SK2541	a
MAIN		S Q	0309 87-A30-090-080	FET,2SK2541	a
MAIN		S Q	0451 87-A30-630-080	TR,2SC5343GL	a
MAIN		S Q	0452 87-A30-076-080	C-TR,2SC3052F	a
MAIN		S Q	0453 89-333-317-880	TR,2SC3331(T/U)	a
MAIN		S Q	0454 89-333-317-880	TR,2SC3331(T/U)	a
MAIN		S Q	0601 87-A30-538-040	C-TR,SRA2202S	a
MAIN		S Q	0651 87-A30-087-080	C-FET,2SK2158	a
MAIN		S Q	0652 87-A30-087-080	C-FET,2SK2158	a
MAIN		S Q	0653 87-A30-076-080	C-TR,2SC3052F	a
MAIN		S Q	0835 87-A30-521-080	C-TR,2SC5345SF/S(O)	a
MAIN		S Q	0836 87-A30-677-040	C-TR,SRA2207S	a
MAIN		S Q	0901 89-503-602-080	C-FET,2SK360E	a
MAIN		S Q	0902 87-A30-664-080	C-TR,2SC2620B	a
MAIN		S Q	0904 87-A30-664-080	C-TR,2SC2620B	a
MAIN		S Q	0905 87-A30-664-080	C-TR,2SC2620B	a
MAIN		S Q	0981 87-A30-494-080	TR,2SA1980G	a
MAIN		S Q	0982 87-A30-076-080	C-TR,2SC3052F	a
MAIN		S Q	0983 87-A30-076-080	C-TR,2SC3052F	a
MAIN		X R	0003 88-128-229-080	C-RES, 2.2-1/8W J	a

ELECTRICAL PARTS LIST - 10/15

! = Δ SAFETY PARTS
 C = Components marked

All components used on this model at the production line are shown in this service manual.

However, please note that not all components will be available as spare parts for after-sales service.

Components marked S and O are designated as spare parts for service and will be stocked at the spare parts centers.

Components marked X and R are not designated as spare parts for after sales service, and will not be stocked at the spare parts centers.

UNIT-NAME	! C	REF-NO	PARTS-NO	PARTS-NAME	SUFFIX&MODEL
					CX-SNR80 VSM
MAIN	X R	0004	88-128-229-080	C-RES, 2.2-1/8W J	a
MAIN	X R	0007	88-128-229-080	C-RES, 2.2-1/8W J	a
MAIN	X R	0008	88-128-229-080	C-RES, 2.2-1/8W J	a
MAIN	X R	0009	88-108-273-080	C-RES,U 27K-1/16W J	a
MAIN	X R	0010	88-108-273-080	C-RES,U 27K-1/16W J	a
MAIN	X R	0011	88-118-472-080	C-RES,S 4.7K-1/10W J	a
MAIN	X R	0012	88-118-472-080	C-RES,S 4.7K-1/10W J	a
MAIN	X R	0013	88-108-472-080	C-RES,U 4.7K-1/16W J	a
MAIN	X R	0014	88-118-100-080	C-RES,S 10-1/10W J	a
MAIN	X R	0015	88-108-104-080	C-RES,U 100K-1/16W J	a
MAIN	O R	0024	88-108-103-080	C-RES,U 10K-1/16W J	a
MAIN	X R	0026	88-118-472-080	C-RES,S 4.7K-1/10W J	a
MAIN	X R	0027	88-118-472-080	C-RES,S 4.7K-1/10W J	a
MAIN	X R	0028	88-108-221-080	C-RES,U 220-1/16W J	a
MAIN	O R	0029	88-108-473-080	C-RES,U 47K-1/16W J	a
MAIN	X R	0030	88-129-000-080	C-JUMPER, 3216	a
MAIN	X R	0031	88-108-154-080	C-RES,U 150K-1/16W J	a
MAIN	X R	0032	88-118-472-080	C-RES,S 4.7K-1/10W J	a
MAIN	O R	0033	88-108-103-080	C-RES,U 10K-1/16W J	a
MAIN	O R	0035	88-108-123-080	C-RES,U 12K-1/16W J	a
					CX-SNR80 VSM
MAIN	X R	0037	88-118-102-080	C-RES,S 1K-1/10W J	a
MAIN	X R	0038	88-118-102-080	C-RES,S 1K-1/10W J	a
MAIN	X R	0041	88-100-000-010	PLATING-JW, 0.58 SN95	a
MAIN	X R	0042	88-129-000-080	C-JUMPER, 3216	a
MAIN	X R	0043	88-129-000-080	C-JUMPER, 3216	a
MAIN	X R	0044	88-128-271-080	C-RES, 270-1/8W J	a
MAIN	X R	0045	88-128-331-080	C-RES, 330-1/8W J	a
MAIN	X R	0046	88-121-271-080	RES,270-1/8W J	a
MAIN	X R	0047	88-128-331-080	C-RES, 330-1/8W J	a
MAIN	X R	0048	88-128-221-080	C-RES, 220-1/8W J	a
MAIN	X R	0049	88-121-221-080	RES,220-1/8W J	a
MAIN	O R	0050	88-108-223-080	C-RES,U 22K-1/16W J	a
MAIN	O R	0051	88-108-102-080	C-RES,U 1K-1/16W J	a
MAIN	O R	0052	88-108-102-080	C-RES,U 1K-1/16W J	a
MAIN	X R	0053	88-108-683-080	C-RES,U 68K-1/16W J	a
MAIN	X R	0054	88-118-562-080	C-RES,S 5.6K-1/10W J	a
MAIN	X R	0055	88-108-222-080	C-RES,U 2.2K-1/16W J	a
MAIN	X R	0056	88-118-680-080	C-RES,S 68-1/10W J	a
MAIN	X R	0057	88-108-472-080	C-RES,U 4.7K-1/16W J	a
MAIN	O R	0058	88-108-103-080	C-RES,U 10K-1/16W J	a
					CX-SNR80 VSM
MAIN	X R	0059	88-108-221-080	C-RES,U 220-1/16W J	a
MAIN	X R	0060	88-108-471-080	C-RES,U 470-1/16W J	a
MAIN	O R	0061	88-108-103-080	C-RES,U 10K-1/16W J	a
MAIN	O R	0062	88-108-223-080	C-RES,U 22K-1/16W J	a
MAIN	O R	0063	88-108-223-080	C-RES,U 22K-1/16W J	a
MAIN	O R	0064	88-108-103-080	C-RES,U 10K-1/16W J	a
MAIN	O R	0065	88-108-123-080	C-RES,U 12K-1/16W J	a
MAIN	X R	0066	88-108-104-080	C-RES,U 100K-1/16W J	a
MAIN	O R	0067	88-108-103-080	C-RES,U 10K-1/16W J	a
MAIN	O R	0068	88-108-103-080	C-RES,U 10K-1/16W J	a
MAIN	O R	0069	88-108-101-080	C-RES,U 100-1/16W J	a
MAIN	X R	0070	88-128-393-080	C-RES, 39K-1/8W J	a
MAIN	X R	0071	88-128-393-080	C-RES, 39K-1/8W J	a
MAIN	X R	0072	88-128-393-080	C-RES, 39K-1/8W J	a
MAIN	X R	0073	88-128-393-080	C-RES, 39K-1/8W J	a
MAIN	X R	0082	88-128-682-080	C-RES, 6.8K-1/8W J	a
MAIN	X R	0083	88-128-682-080	C-RES, 6.8K-1/8W J	a
MAIN	X R	0084	88-128-682-080	C-RES, 6.8K-1/8W J	a
MAIN	X R	0085	88-128-682-080	C-RES, 6.8K-1/8W J	a
MAIN	O R	0091	88-108-823-080	C-RES,U 82K-1/16W J	a
					CX-SNR80 VSM
MAIN	X R	0092	88-108-393-080	C-RES,U 39K-1/16W J	a
MAIN	O R	0093	88-108-153-080	C-RES,U 15K-1/16W J	a
MAIN	O R	0094	88-108-823-080	C-RES,U 82K-1/16W J	a
MAIN	X R	0095	88-108-393-080	C-RES,U 39K-1/16W J	a
MAIN	O R	0096	88-108-153-080	C-RES,U 15K-1/16W J	a
MAIN	O R	0103	88-108-153-080	C-RES,U 15K-1/16W J	a
MAIN	O R	0104	88-108-153-080	C-RES,U 15K-1/16W J	a
MAIN	X R	0105	88-108-273-080	C-RES,U 27K-1/16W J	a
MAIN	X R	0106	88-108-273-080	C-RES,U 27K-1/16W J	a
MAIN	O R	0107	88-108-101-080	C-RES,U 100-1/16W J	a
MAIN	O R	0108	88-108-101-080	C-RES,U 100-1/16W J	a
MAIN	X R	0109	88-118-332-080	C-RES,S 3.3K-1/10W J	a
MAIN	X R	0110	88-118-332-080	C-RES,S 3.3K-1/10W J	a
MAIN	X R	0111	88-118-102-080	C-RES,S 1K-1/10W J	a
MAIN	X R	0112	88-118-102-080	C-RES,S 1K-1/10W J	a
MAIN	X R	0113	88-118-273-080	C-RES,S 27K-1/10W J	a
MAIN	X R	0114	88-118-273-080	C-RES,S 27K-1/10W J	a
MAIN	X R	0115	88-128-222-080	C-RES, 2.2K-1/8W J	a
MAIN	X R	0116	88-128-222-080	C-RES, 2.2K-1/8W J	a
MAIN	O R	0117	88-108-103-080	C-RES,U 10K-1/16W J	a

ELECTRICAL PARTS LIST - 11/15

! = SAFETY PARTS
 C = Components marked

All components used on this model at the production line are shown in this service manual.
 However, please note that not all components will be available as spare parts for after-sales service.
 Components marked S and O are designated as spare parts for service and will be stocked at the spare parts centers.
 Components marked X and R are not designated as spare parts for after sales service, and will not be stocked at the spare parts centers.

UNIT-NAME	! C	REF-NO	PARTS-NO	PARTS-NAME	SUFFIX&MODEL
					CX-SNR80 VSM
MAIN		O R	0118 88-108-103-080	C-RES,U 10K-1/16W J	a
MAIN		X R	0119 88-118-101-080	C-RES,S 100-1/10W J	a
MAIN		X R	0120 88-118-101-080	C-RES,S 100-1/10W J	a
MAIN		X R	0121 88-118-101-080	C-RES,S 100-1/10W J	a
MAIN		X R	0122 88-118-101-080	C-RES,S 100-1/10W J	a
MAIN		X R	0123 88-128-222-080	C-RES, 2.2K-1/8W J	a
MAIN		X R	0124 88-128-222-080	C-RES, 2.2K-1/8W J	a
MAIN		X R	0125 88-128-102-080	C-RES, 1K-1/8W J	a
MAIN		X R	0126 88-128-102-080	C-RES, 1K-1/8W J	a
MAIN		X R	0127 88-118-390-080	C-RES,S 39-1/10W J	a
MAIN		X R	0128 88-118-390-080	C-RES,S 39-1/10W J	a
MAIN		O R	0129 87-A00-262-080	RES,M/F 0.15-2W J	a
MAIN		O R	0130 87-A00-262-080	RES,M/F 0.15-2W J	a
MAIN		O R	0131 87-A00-262-080	RES,M/F 0.15-2W J	a
MAIN		O R	0132 87-A00-262-080	RES,M/F 0.15-2W J	a
MAIN		X R	0133 88-108-182-080	C-RES,U 1.8K-1/16W J	a
MAIN		X R	0134 88-108-182-080	C-RES,U 1.8K-1/16W J	a
MAIN		X R	0135 88-108-182-080	C-RES,U 1.8K-1/16W J	a
MAIN		X R	0136 88-108-182-080	C-RES,U 1.8K-1/16W J	a
MAIN		O R	0137 88-108-101-080	C-RES,U 100-1/16W J	a
					CX-SNR80 VSM
MAIN		O R	0138 88-108-101-080	C-RES,U 100-1/16W J	a
MAIN		X R	0141 88-118-102-080	C-RES,S 1K-1/10W J	a
MAIN		X R	0142 88-118-102-080	C-RES,S 1K-1/10W J	a
MAIN		X R	0143 88-108-392-080	C-RES,U 3.9K-1/16W J	a
MAIN		X R	0144 88-108-392-080	C-RES,U 3.9K-1/16W J	a
MAIN		O R	0151 88-108-473-080	C-RES,U 47K-1/16W J	a
MAIN		O R	0152 88-108-473-080	C-RES,U 47K-1/16W J	a
MAIN		X R	0153 88-118-390-080	C-RES,S 39-1/10W J	a
MAIN		X R	0154 88-118-390-080	C-RES,S 39-1/10W J	a
MAIN		X R	0155 88-108-682-080	C-RES,U 6.8K-1/16W J	a
MAIN		X R	0156 88-108-682-080	C-RES,U 6.8K-1/16W J	a
MAIN		X R	0157 88-121-472-080	RES,4.7K-1/8W J	a
MAIN		X R	0158 88-108-472-080	C-RES,U 4.7K-1/16W J	a
MAIN		O R	0159 88-108-103-080	C-RES,U 10K-1/16W J	a
MAIN		X R	0160 88-118-103-080	C-RES,S 10K-1/10W J	a
MAIN		X R	0161 88-108-472-080	C-RES,U 4.7K-1/16W J	a
MAIN		X R	0162 88-108-472-080	C-RES,U 4.7K-1/16W J	a
MAIN		X R	0163 88-108-472-080	C-RES,U 4.7K-1/16W J	a
MAIN		X R	0164 88-108-472-080	C-RES,U 4.7K-1/16W J	a
MAIN		X R	0165 88-108-152-080	C-RES,U 1.5K-1/16W J	a
					CX-SNR80 VSM
MAIN		X R	0166 88-108-152-080	C-RES,U 1.5K-1/16W J	a
MAIN		O R	0167 88-108-103-080	C-RES,U 10K-1/16W J	a
MAIN		X R	0168 88-118-473-080	C-RES,S 47K-1/10W J	a
MAIN		X R	0171 88-118-222-080	C-RES,S 2.2K-1/10W J	a
MAIN		X R	0172 88-118-222-080	C-RES,S 2.2K-1/10W J	a
MAIN		X R	0173 88-118-182-080	C-RES,S 1.8K-1/10W J	a
MAIN		X R	0174 88-118-182-080	C-RES,S 1.8K-1/10W J	a
MAIN		X R	0175 88-118-331-080	C-RES,S 330-1/10W J	a
MAIN		X R	0176 88-118-331-080	C-RES,S 330-1/10W J	a
MAIN		X R	0178 88-118-103-080	C-RES,S 10K-1/10W J	a
MAIN		O R	0179 88-108-102-080	C-RES,U 1K-1/16W J	a
MAIN		O R	0180 88-108-102-080	C-RES,U 1K-1/16W J	a
MAIN		X R	0181 88-108-222-080	C-RES,U 2.2K-1/16W J	a
MAIN		X R	0182 88-108-222-080	C-RES,U 2.2K-1/16W J	a
MAIN		X R	0183 88-128-392-080	C-RES, 3.9K-1/8W J	a
MAIN		X R	0184 88-121-102-080	RES,1K-1/8W J	a
MAIN		O R	0185 88-108-332-080	C-RES,U 3.3K-1/16W J	a
MAIN		X R	0186 88-118-102-080	C-RES,S 1K-1/10W J	a
MAIN		X R	0187 88-118-103-080	C-RES,S 10K-1/10W J	a
MAIN		X R	0188 88-118-222-080	C-RES,S 2.2K-1/10W J	a
					CX-SNR80 VSM
MAIN		X R	0189 88-128-392-080	C-RES, 3.9K-1/8W J	a
MAIN		X R	0190 88-128-392-080	C-RES, 3.9K-1/8W J	a
MAIN		X R	0192 88-128-332-080	C-RES, 3.3K-1/8W J	a
MAIN		O R	0193 88-108-103-080	C-RES,U 10K-1/16W J	a
MAIN		O R	0194 88-108-103-080	C-RES,U 10K-1/16W J	a
MAIN		O R	0195 88-108-473-080	C-RES,U 47K-1/16W J	a
MAIN		O R	0196 88-108-473-080	C-RES,U 47K-1/16W J	a
MAIN		O R	0197 88-108-473-080	C-RES,U 47K-1/16W J	a
MAIN		O R	0198 88-108-473-080	C-RES,U 47K-1/16W J	a
MAIN		X R	0199 88-121-225-080	RES,2.2M-1/8W J	a
MAIN		X R	0204 88-128-332-080	C-RES, 3.3K-1/8W J	a
MAIN		X R	0205 88-128-332-080	C-RES, 3.3K-1/8W J	a
MAIN		X R	0206 88-128-392-080	C-RES, 3.9K-1/8W J	a
MAIN		X R	0207 88-128-392-080	C-RES, 3.9K-1/8W J	a
MAIN		X R	0208 88-128-392-080	C-RES, 3.9K-1/8W J	a
MAIN		X R	0217 88-108-683-080	C-RES,U 68K-1/16W J	a
MAIN		X R	0218 88-108-105-080	C-RES,U 1M-1/16W J	a
MAIN		O R	0219 88-108-153-080	C-RES,U 15K-1/16W J	a
MAIN		X R	0220 88-118-154-080	C-RES,S 150K-1/10W J	a
MAIN		X R	0221 88-128-180-080	C-RES, 18-1/8W J	a

ELECTRICAL PARTS LIST - 12/15

! = Δ SAFTY PARTS
 C = Components marked

All components used on this model at the production line are shown in this service manual.

However, please note that not all components will be available as spare parts for after-sales service.

Components marked S and O are designated as spare parts for service and will be stocked at the spare parts centers.

Components marked X and R are not designated as spare parts for after sales service, and will not be stocked at the spare parts centers.

UNIT-NAME	! C	REF-NO	PARTS-NO	PARTS-NAME	SUFFIX&MODEL
					CX-SNR80 VSM
MAIN	X R	0222	88-128-180-080	C-RES, 18-1/8W J	a
MAIN	X R	0223	88-128-180-080	C-RES, 18-1/8W J	a
MAIN	X R	0227	88-108-471-080	C-RES,U 470-1/16W J	a
MAIN	X R	0228	88-108-471-080	C-RES,U 470-1/16W J	a
MAIN	X R	0247	88-130-100-080	RES,10-1/4W J	a
MAIN	X R	0248	88-130-100-080	RES,10-1/4W J	a
MAIN	X R	0249	88-128-100-080	C-RES, 10-1/8W J	a
MAIN	X R	0250	88-128-100-080	C-RES, 10-1/8W J	a
MAIN	X R	0280	88-128-473-080	C-RES, 47K-1/8W J	a
MAIN	X R	0281	88-108-222-080	C-RES,U 2.2K-1/16W J	a
MAIN	O R	0282	88-108-103-080	C-RES,U 10K-1/16W J	a
MAIN	O R	0283	88-108-224-080	C-RES,U 220K-1/16W J	a
MAIN	O R	0284	88-108-224-080	C-RES,U 220K-1/16W J	a
MAIN	X R	0285	88-108-333-080	C-RES,U 33K-1/16W J	a
MAIN	O R	0286	88-108-473-080	C-RES,U 47K-1/16W J	a
MAIN	O R	0287	88-108-473-080	C-RES,U 47K-1/16W J	a
MAIN	X R	0301	88-108-393-080	C-RES,U 39K-1/16W J	a
MAIN	X R	0302	88-108-393-080	C-RES,U 39K-1/16W J	a
MAIN	O R	0303	88-108-823-080	C-RES,U 82K-1/16W J	a
MAIN	O R	0304	88-108-823-080	C-RES,U 82K-1/16W J	a
					CX-SNR80 VSM
MAIN	O R	0305	88-108-224-080	C-RES,U 220K-1/16W J	a
MAIN	X R	0451	88-121-222-080	RES,2.2K-1/8W J	a
MAIN	X R	0453	88-118-472-080	C-RES,S 4.7K-1/10W J	a
MAIN	X R	0454	88-121-829-080	RES,8.2-1/8W J	a
MAIN	X R	0455	88-108-183-080	C-RES,U 18K-1/16W J	a
MAIN	X R	0456	88-108-183-080	C-RES,U 18K-1/16W J	a
MAIN	X R	0457	88-108-104-080	C-RES,U 100K-1/16W J	a
MAIN	O R	0458	88-108-563-080	C-RES,U 56K-1/16W J	a
MAIN	X R	0459	88-118-472-080	C-RES,S 4.7K-1/10W J	a
MAIN	X R	0460	88-108-229-080	C-RES,U 2.2-1/16W J	a
MAIN	O R	0463	88-108-102-080	C-RES,U 1K-1/16W J	a
MAIN	O R	0464	88-108-102-080	C-RES,U 1K-1/16W J	a
MAIN	X R	0601	88-108-680-080	C-RES,U 68-1/16W J	a
MAIN	X R	0602	88-108-680-080	C-RES,U 68-1/16W J	a
MAIN	X R	0603	88-108-394-080	C-RES,U 390K-1/16W J	a
MAIN	X R	0604	88-108-394-080	C-RES,U 390K-1/16W J	a
MAIN	X R	0605	88-108-122-080	C-RES,U 1.2K-1/16W J	a
MAIN	X R	0606	88-108-122-080	C-RES,U 1.2K-1/16W J	a
MAIN	X R	0607	88-108-183-080	C-RES,U 18K-1/16W J	a
MAIN	X R	0608	88-108-183-080	C-RES,U 18K-1/16W J	a
					CX-SNR80 VSM
MAIN	X R	0609	88-108-472-080	C-RES,U 4.7K-1/16W J	a
MAIN	X R	0610	88-121-472-080	RES,4.7K-1/8W J	a
MAIN	X R	0611	88-108-682-080	C-RES,U 6.8K-1/16W J	a
MAIN	X R	0612	88-108-682-080	C-RES,U 6.8K-1/16W J	a
MAIN	X R	0613	88-108-682-080	C-RES,U 6.8K-1/16W J	a
MAIN	X R	0614	88-108-682-080	C-RES,U 6.8K-1/16W J	a
MAIN	X R	0615	88-108-273-080	C-RES,U 27K-1/16W J	a
MAIN	X R	0616	88-108-273-080	C-RES,U 27K-1/16W J	a
MAIN	X R	0617	88-121-822-080	RES,8.2K-1/8W J	a
MAIN	X R	0618	88-121-822-080	RES,8.2K-1/8W J	a
MAIN	O R	0619	88-108-153-080	C-RES,U 15K-1/16W J	a
MAIN	O R	0620	88-108-153-080	C-RES,U 15K-1/16W J	a
MAIN	O R	0621	88-108-332-080	C-RES,U 3.3K-1/16W J	a
MAIN	O R	0622	88-108-332-080	C-RES,U 3.3K-1/16W J	a
MAIN	X R	0623	88-108-682-080	C-RES,U 6.8K-1/16W J	a
MAIN	X R	0624	88-108-682-080	C-RES,U 6.8K-1/16W J	a
MAIN	O R	0625	88-108-332-080	C-RES,U 3.3K-1/16W J	a
MAIN	O R	0626	88-108-332-080	C-RES,U 3.3K-1/16W J	a
MAIN	X R	0627	88-108-222-080	C-RES,U 2.2K-1/16W J	a
MAIN	X R	0628	88-108-222-080	C-RES,U 2.2K-1/16W J	a
					CX-SNR80 VSM
MAIN	O R	0629	88-108-103-080	C-RES,U 10K-1/16W J	a
MAIN	O R	0630	88-108-103-080	C-RES,U 10K-1/16W J	a
MAIN	X R	0631	88-108-222-080	C-RES,U 2.2K-1/16W J	a
MAIN	X R	0632	88-108-222-080	C-RES,U 2.2K-1/16W J	a
MAIN	O R	0633	88-108-272-080	C-RES,U 2.7K-1/16W J	a
MAIN	O R	0634	88-108-272-080	C-RES,U 2.7K-1/16W J	a
MAIN	O R	0635	88-108-102-080	C-RES,U 1K-1/16W J	a
MAIN	O R	0636	88-108-102-080	C-RES,U 1K-1/16W J	a
MAIN	X R	0637	88-108-331-080	C-RES,U 330-1/16W J	a
MAIN	X R	0638	88-108-331-080	C-RES,U 330-1/16W J	a
MAIN	X R	0639	88-108-183-080	C-RES,U 18K-1/16W J	a
MAIN	X R	0640	88-108-183-080	C-RES,U 18K-1/16W J	a
MAIN	X R	0641	88-121-223-080	RES,22K-1/8W J	a
MAIN	X R	0642	88-108-222-080	C-RES,U 2.2K-1/16W J	a
MAIN	X R	0643	88-108-104-080	C-RES,U 100K-1/16W J	a
MAIN	X R	0644	88-108-104-080	C-RES,U 100K-1/16W J	a
MAIN	X R	0649	88-108-222-080	C-RES,U 2.2K-1/16W J	a
MAIN	X R	0650	88-108-222-080	C-RES,U 2.2K-1/16W J	a
MAIN	O R	0651	88-108-101-080	C-RES,U 100-1/16W J	a
MAIN	O R	0652	88-108-101-080	C-RES,U 100-1/16W J	a

ELECTRICAL PARTS LIST - 13/15

! = Δ SAFETY PARTS
 C = Components marked

All components used on this model at the production line are shown in this service manual.
 However, please note that not all components will be available as spare parts for after-sales service.
 Components marked S and O are designated as spare parts for service and will be stocked at the spare parts centers.
 Components marked X and R are not designated as spare parts for after sales service, and will not be stocked at the spare parts centers.

UNIT-NAME	! C	REF-NO	PARTS-NO	PARTS-NAME	SUFFIX&MODEL
					CX-SNR80 VSM
MAIN	X R	0656	88-108-474-080	C-RES,U 470K-1/16W J	a
MAIN	X R	0657	88-128-684-080	C-RES, 680K-1/8W J	a
MAIN	X R	0658	88-108-684-080	C-RES,U 680K-1/16W J	a
MAIN	X R	0659	88-108-394-080	C-RES,U 390K-1/16W J	a
MAIN	X R	0660	88-108-274-080	C-RES,U 270K-1/16W J	a
MAIN	X R	0661	88-108-392-080	C-RES,U 3.9K-1/16W J	a
MAIN	X R	0662	88-108-392-080	C-RES,U 3.9K-1/16W J	a
MAIN	X R	0669	88-108-273-080	C-RES,U 27K-1/16W J	a
MAIN	X R	0670	88-108-273-080	C-RES,U 27K-1/16W J	a
MAIN	O R	0672	88-108-103-080	C-RES,U 10K-1/16W J	a
MAIN	X R	0673	88-108-182-080	C-RES,U 1.8K-1/16W J	a
MAIN	O R	0674	88-108-123-080	C-RES,U 12K-1/16W J	a
MAIN	O R	0677	88-108-223-080	C-RES,U 22K-1/16W J	a
MAIN	X R	0678	88-128-223-080	C-RES, 22K-1/8W J	a
MAIN	O R	0789	88-108-473-080	C-RES,U 47K-1/16W J	a
MAIN	O R	0790	87-012-286-080	C-CAP,U 0.01-25 K B GRM	a
MAIN	O R	0791	88-108-102-080	C-RES,U 1K-1/16W J	a
MAIN	X R	0793	88-108-000-080	C-JUMPER,U	a
MAIN	X R	0795	88-108-000-080	C-JUMPER,U	a
MAIN	O R	0801	88-108-103-080	C-RES,U 10K-1/16W J	a
					CX-SNR80 VSM
MAIN	O R	0802	88-108-223-080	C-RES,U 22K-1/16W J	a
MAIN	X R	0803	88-128-183-080	C-RES, 18K-1/8W J	a
MAIN	X R	0804	88-108-000-080	C-JUMPER,U	a
MAIN	O R	0805	88-108-332-080	C-RES,U 3.3K-1/16W J	a
MAIN	X R	0806	88-108-682-080	C-RES,U 6.8K-1/16W J	a
MAIN	O R	0809	88-108-102-080	C-RES,U 1K-1/16W J	a
MAIN	O R	0810	88-108-102-080	C-RES,U 1K-1/16W J	a
MAIN	X R	0811	88-108-000-080	C-JUMPER,U	a
MAIN	X R	0812	88-108-000-080	C-JUMPER,U	a
MAIN	O R	0813	88-108-224-080	C-RES,U 220K-1/16W J	a
MAIN	X R	0814	88-108-105-080	C-RES,U 1M-1/16W J	a
MAIN	X R	0815	88-121-682-080	RES,6.8K-1/8W J	a
MAIN	O R	0818	88-108-103-080	C-RES,U 10K-1/16W J	a
MAIN	X R	0821	88-108-000-080	C-JUMPER,U	a
MAIN	X R	0823	88-108-333-080	C-RES,U 33K-1/16W J	a
MAIN	O R	0826	88-108-223-080	C-RES,U 22K-1/16W J	a
MAIN	X R	0832	88-108-391-080	C-RES,U 390-1/16W J	a
MAIN	X R	0840	88-108-221-080	C-RES,U 220-1/16W J	a
MAIN	O R	0850	88-108-103-080	C-RES,U 10K-1/16W J	a
MAIN	X R	0851	88-108-000-080	C-JUMPER,U	a
					CX-SNR80 VSM
MAIN	O R	0853	88-108-102-080	C-RES,U 1K-1/16W J	a
MAIN	X R	0854	88-108-331-080	C-RES,U 330-1/16W J	a
MAIN	X R	0855	88-108-183-080	C-RES,U 18K-1/16W J	a
MAIN	O R	0856	88-108-103-080	C-RES,U 10K-1/16W J	a
MAIN	X R	0857	88-108-181-080	C-RES,U 180-1/16W J	a
MAIN	O R	0858	88-108-101-080	C-RES,U 100-1/16W J	a
MAIN	O R	0860	88-108-101-080	C-RES,U 100-1/16W J	a
MAIN	O R	0901	88-108-473-080	C-RES,U 47K-1/16W J	a
MAIN	X R	0902	88-108-104-080	C-RES,U 100K-1/16W J	a
MAIN	O R	0903	88-108-101-080	C-RES,U 100-1/16W J	a
MAIN	O R	0904	88-108-473-080	C-RES,U 47K-1/16W J	a
MAIN	O R	0905	88-108-102-080	C-RES,U 1K-1/16W J	a
MAIN	X R	0906	88-108-564-080	C-RES,U 560K-1/16W J	a
MAIN	X R	0908	88-108-000-080	C-JUMPER,U	a
MAIN	X R	0909	88-108-331-080	C-RES,U 330-1/16W J	a
MAIN	X R	0911	88-108-181-080	C-RES,U 180-1/16W J	a
MAIN	X R	0912	88-108-104-080	C-RES,U 100K-1/16W J	a
MAIN	X R	0913	88-108-152-080	C-RES,U 1.5K-1/16W J	a
MAIN	X R	0914	88-108-472-080	C-RES,U 4.7K-1/16W J	a
MAIN	X R	0915	88-108-104-080	C-RES,U 100K-1/16W J	a
					CX-SNR80 VSM
MAIN	X R	0916	88-108-470-080	C-RES,U 47-1/16W J	a
MAIN	X R	0945	88-108-104-080	C-RES,U 100K-1/16W J	a
MAIN	X R	0962	88-121-102-080	RES,1K-1/8W J	a
MAIN	X R	0963	88-108-330-080	C-RES,U 33-1/16W J	a
MAIN	O R	0968	88-108-822-080	C-RES,U 8.2K-1/16W J	a
MAIN	O R	0975	88-108-562-080	C-RES,U 5.6K-1/16W J	a
MAIN	O R	0976	88-108-102-080	C-RES,U 1K-1/16W J	a
MAIN	O R	0977	88-108-102-080	C-RES,U 1K-1/16W J	a
MAIN	X R	0978	88-108-681-080	C-RES,U 680-1/16W J	a
MAIN	O R	0979	88-108-123-080	C-RES,U 12K-1/16W J	a
MAIN	X R	0980	88-108-684-080	C-RES,U 680K-1/16W J	a
MAIN	X R	0981	88-121-471-080	RES,470-1/8W J	a
MAIN	X R	0982	88-108-682-080	C-RES,U 6.8K-1/16W J	a
MAIN	X R	0983	88-108-392-080	C-RES,U 3.9K-1/16W J	a
MAIN	O R	0984	88-108-562-080	C-RES,U 5.6K-1/16W J	a
MAIN	X R	0985	88-121-471-080	RES,470-1/8W J	a
MAIN	X R	0986	88-121-221-080	RES,220-1/8W J	a
MAIN	X R	0987	88-121-472-080	RES,4.7K-1/8W J	a
MAIN	O R	0988	88-108-103-080	C-RES,U 10K-1/16W J	a
MAIN	X R	0989	88-121-102-080	RES,1K-1/8W J	a

ELECTRICAL PARTS LIST - 14/15

! = Δ SAFETY PARTS
 C = Components marked

All components used on this model at the production line are shown in this service manual.
 However, please note that not all components will be available as spare parts for after-sales service.
 Components marked S and O are designated as spare parts for service and will be stocked at the spare parts centers.
 Components marked X and R are not designated as spare parts for after sales service, and will not be stocked at the spare parts centers.

UNIT-NAME	! C	REF-NO	PARTS-NO	PARTS-NAME	SUFFIX&MODEL
					CX-SNR80 VSM
MAIN	O R	0990	88-108-563-080	C-RES,U 56K-1/16W J	a
MAIN	O R	0991	87-012-195-080	C-CAP,U 100P-50 J CH GRM	a
MAIN	O R	0992	88-108-103-080	C-RES,U 10K-1/16W J	a
MAIN	O R	0993	87-012-195-080	C-CAP,U 100P-50 J CH GRM	a
MAIN	O R	0994	88-108-103-080	C-RES,U 10K-1/16W J	a
MAIN	O R	0995	87-012-195-080	C-CAP,U 100P-50 J CH GRM	a
MAIN	O R	0996	88-108-103-080	C-RES,U 10K-1/16W J	a
MAIN	X R	0997	88-108-154-080	C-RES,U 150K-1/16W J	a
MAIN	O R	0998	88-108-102-080	C-RES,U 1K-1/16W J	a
MAIN	O R	0999	88-108-103-080	C-RES,U 10K-1/16W J	a
MAIN	O RY	0202	87-A91-686-010	RELAY, G5PA-28(OMRON)	a
MAIN	O	SFR0451	87-A90-432-080	SFR,30K H NVZ6TLTA	a
MAIN	O	SFR0452	87-A90-432-080	SFR,30K H NVZ6TLTA	a
MAIN	X SH	0301	8C-NF5-221-010	PLATE,SHLD DECK M	a
MAIN	X SH	0901	8B-ZA3-619-010	SHLD-CASE,BZA-3 EZ	a
MAIN	O TH	0101	87-A91-042-080	C-THMS,100K 55001	a
MAIN	O TH	0102	87-A91-042-080	C-THMS,100K 55001	a
MAIN	O W	0099	8B-NFJ-620-010	F-CABLE,9P 2.5 280MM	a
MAIN	O W	0101	8B-NF1-640-010	F-CABLE,5P 2.5 250MM	a
MAIN	O WH	0001	87-A90-510-010	HLDR,WIRE 2.5-9P	a
					CX-SNR80 VSM
MAIN	O WH	0101	87-A90-459-010	HLDR,WIRE 2.5-5P	a
MAIN	O X	0992	87-A70-306-010	VIB,XTAL 4.500MHZ CSA-309ST	a
POWER	O C	0085	87-010-831-080	C-CAP,U 0.1-16 Z F GRM	a
POWER	S D	0082	87-A40-270-080	C-DIODE,MC2838	a
POWER	S D	0083	87-A40-269-080	C-DIODE,MC2836	a
POWER	X F	0081	88-100-000-010	PLATING-JW, 0.58 SN95	a
POWER	X JW	0081	88-100-000-010	PLATING-JW, 0.58 SN95	a
POWER	X JW	0082	88-100-000-010	PLATING-JW, 0.58 SN95	a
POWER	X JW	0083	88-100-000-010	PLATING-JW, 0.58 SN95	a
POWER	X JW	0085	88-100-000-010	PLATING-JW, 0.58 SN95	a
POWER	X JW	0086	88-100-000-010	PLATING-JW, 0.58 SN95	a
POWER	X JW	0087	88-100-000-010	PLATING-JW, 0.58 SN95	a
POWER	X JW	0088	88-100-000-010	PLATING-JW, 0.58 SN95	a
POWER	X JW	0089	88-100-000-010	PLATING-JW, 0.58 SN95	a
POWER	X JW	0090	88-100-000-010	PLATING-JW, 0.58 SN95	a
POWER	! O PT	0001	8C-NF5-608-010	PT,CNF-5 EZ	a
POWER	! O PT	0081	8B-MA6-675-010	PT,SUB BMA E (VRK)	a
POWER	! O RY	0081	87-A91-418-010	RELAY,AC 12V G5PA-1-M	a
POWER	! O T	0081	87-A60-317-010	TERMINAL, 1P MSC	a
POWER	! O T	0082	87-A60-317-010	TERMINAL, 1P MSC	a
					CX-SNR80 VSM
POWER	O WH	0081	87-A90-510-010	HLDR,WIRE 2.5-9P	a

- Regarding connectors, they are not stocked as they are not the initial order items.

The connectors are available after they are supplied from connector manufacturers upon the order is received.

○チップ抵抗部品コード/CHIP RESISTOR PART CODE

チップ抵抗部品コードの成り立ち

Chip Resistor Part Coding

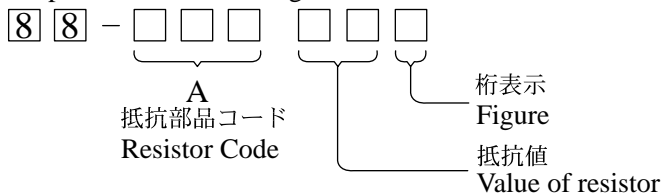

チップ抵抗
Chip resistor

容量 Wattage	種類 Type	許容誤差 Tolerance	記号 Symbol	寸法/Dimensions (mm)			抵抗コード : A	
				外形/Form	L	W	t	Resistor Code : A
1/16W	1005	± 5%	CJ		1.0	0.5	0.35	104
1/16W	1608	± 5%	CJ		1.6	0.8	0.45	108
1/10W	2125	± 5%	CJ		2	1.25	0.45	118
1/8W	3216	± 5%	CJ		3.2	1.6	0.55	128

TRANSISTOR ILLUSTRATION -1/1

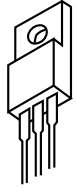

B C E

2SB1548
FN1016
FP1016



E C B

2SA1296GR



E C B

2SA1980G
2SA1981Y
2SC3331(T/U)



E C B

2SC5343GL



E C B

2N5551C



G D S

2SK3053

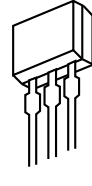

S D G

2SJ460
2SK2541

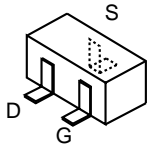

2SK360E

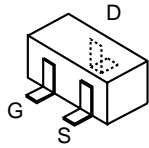

2SK2158

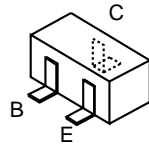

2SA1235F	DTC114YKA
2SC2620B	KRA102S
2SC3052F	SBT5401
2SC3906KR	SBT5551
2SC5345SF/S(O)	SRA2202S
2SD1306E	SRA2207S

SCHEMATIC DIAGRAM - 1/5 (MAIN -1/2, AMP SECTION)

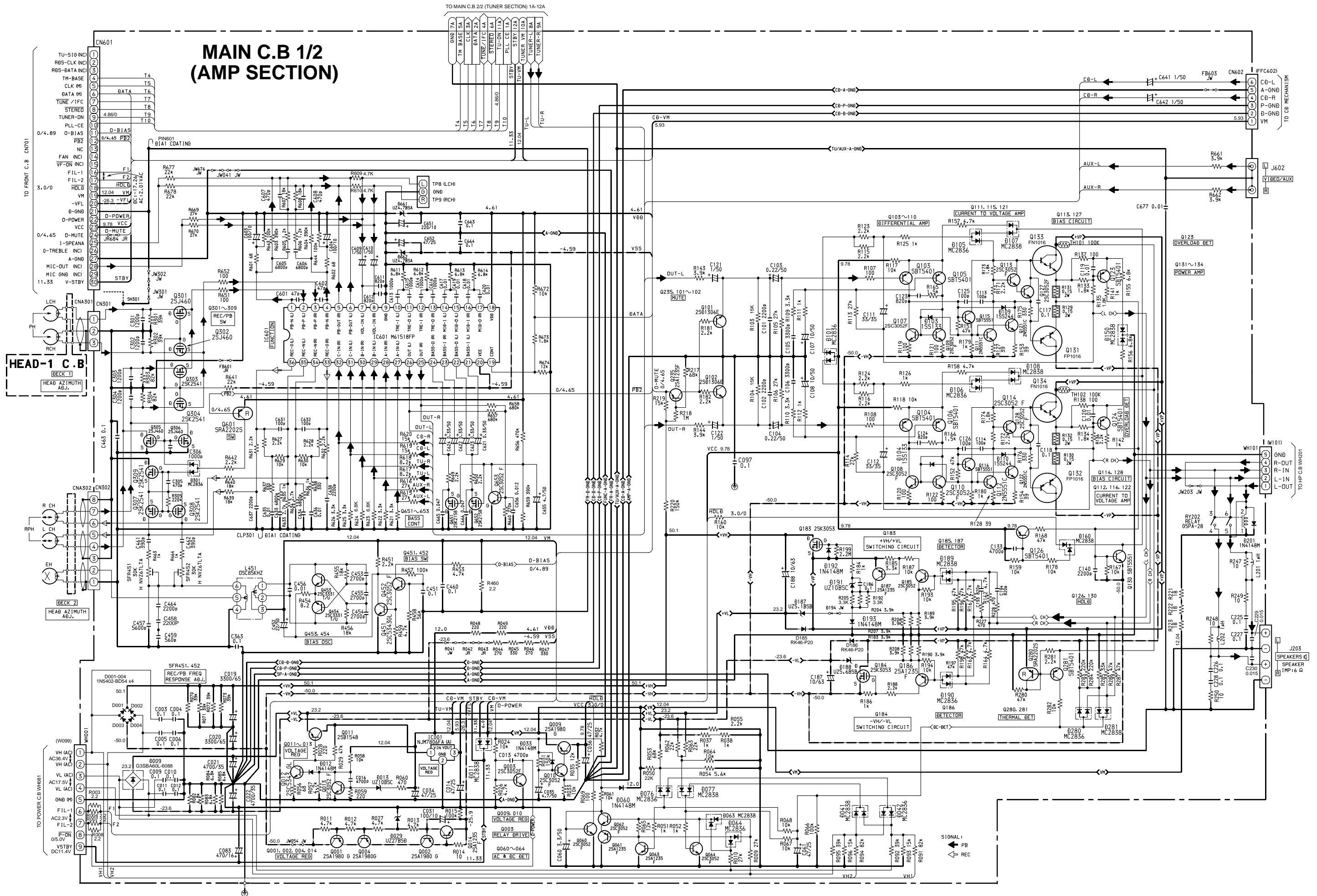

MAIN C.B 2/2 (TUNER SECTION)

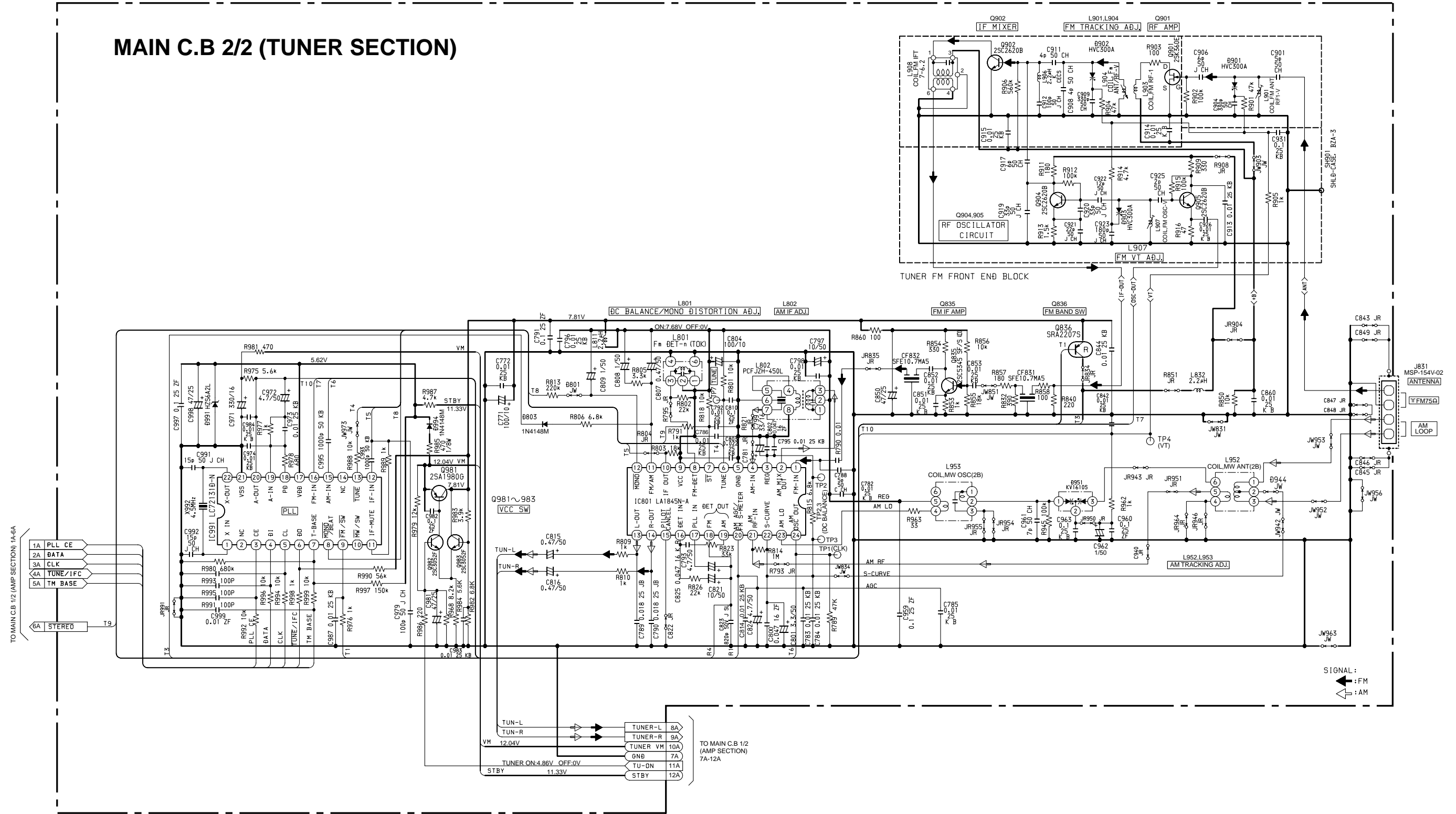

SCHEMATIC DIAGRAM -3/5 (HP SECTION)

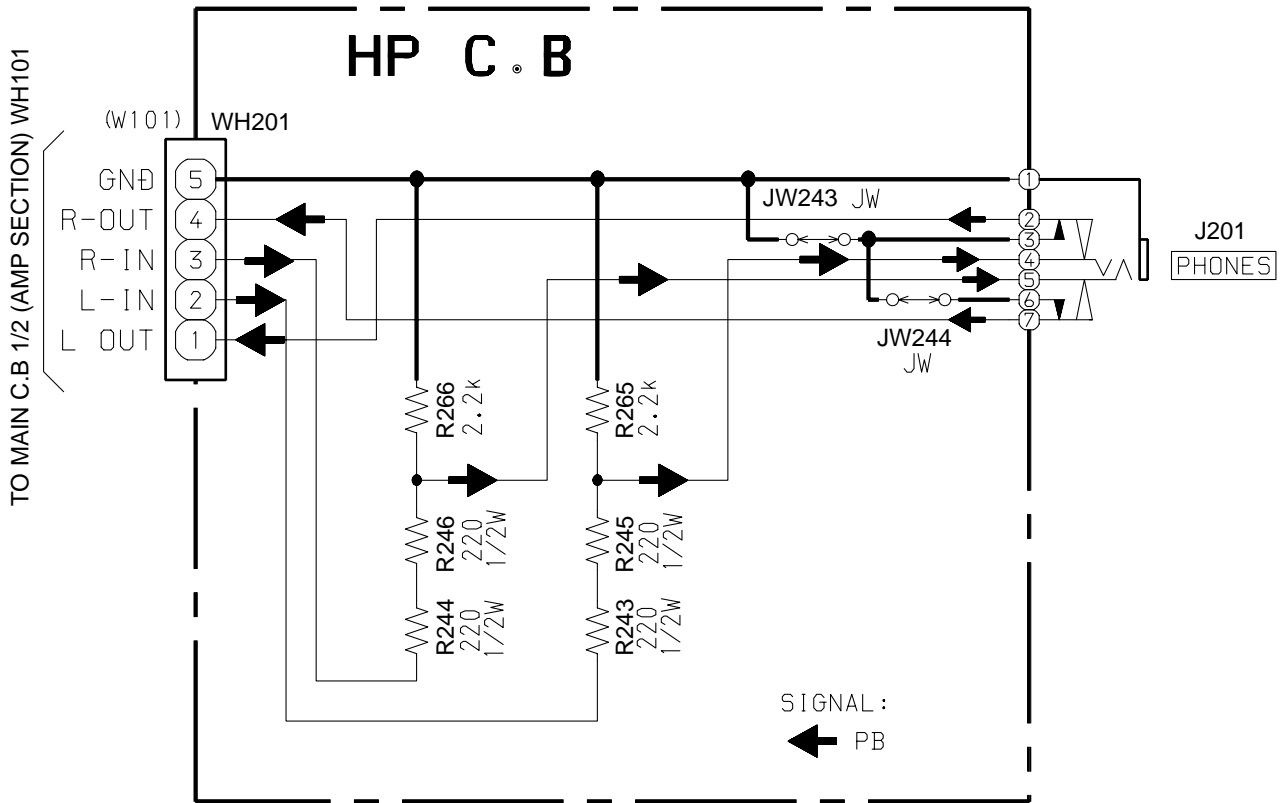

MAIN C.B

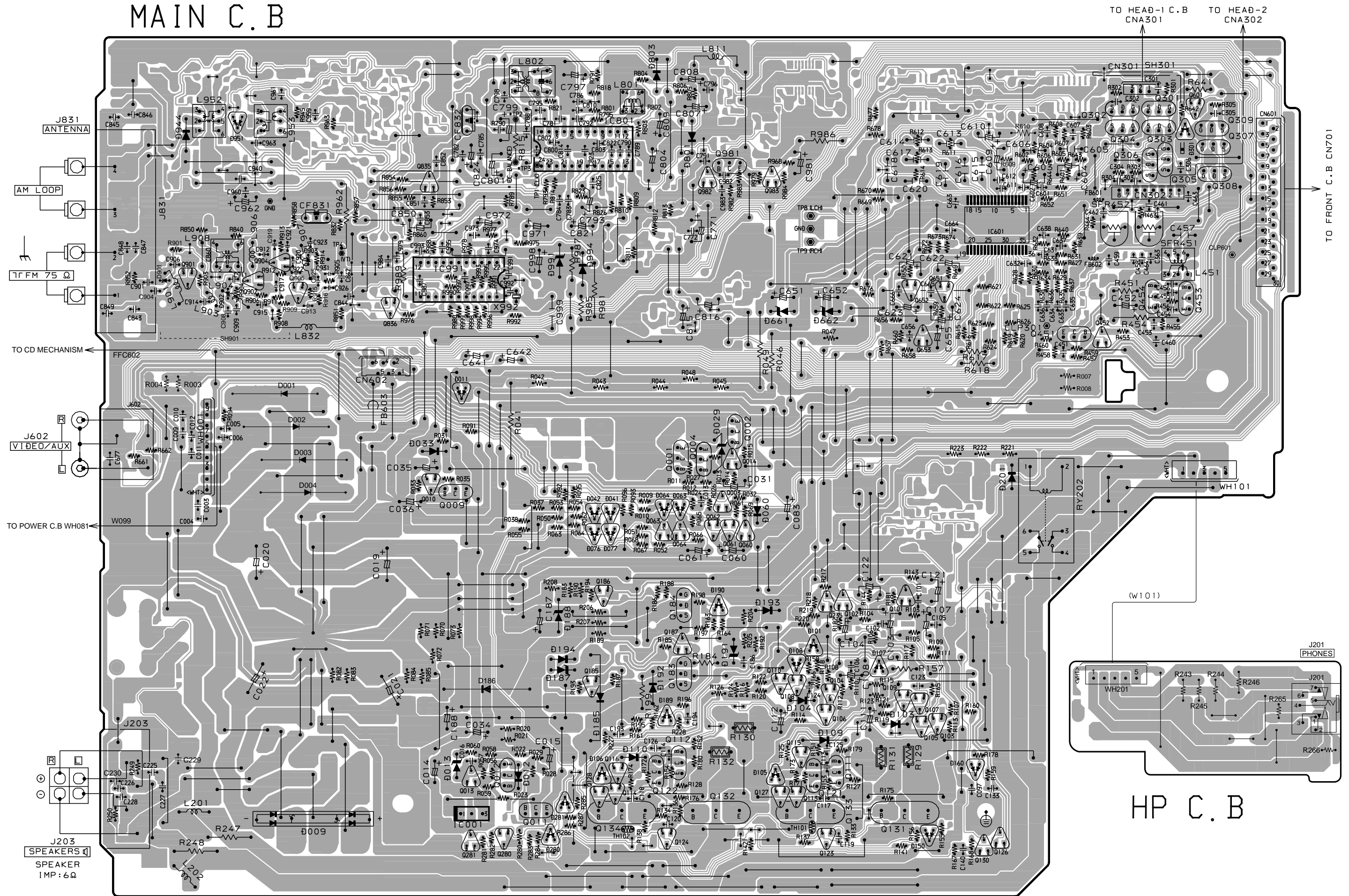

HP C.B

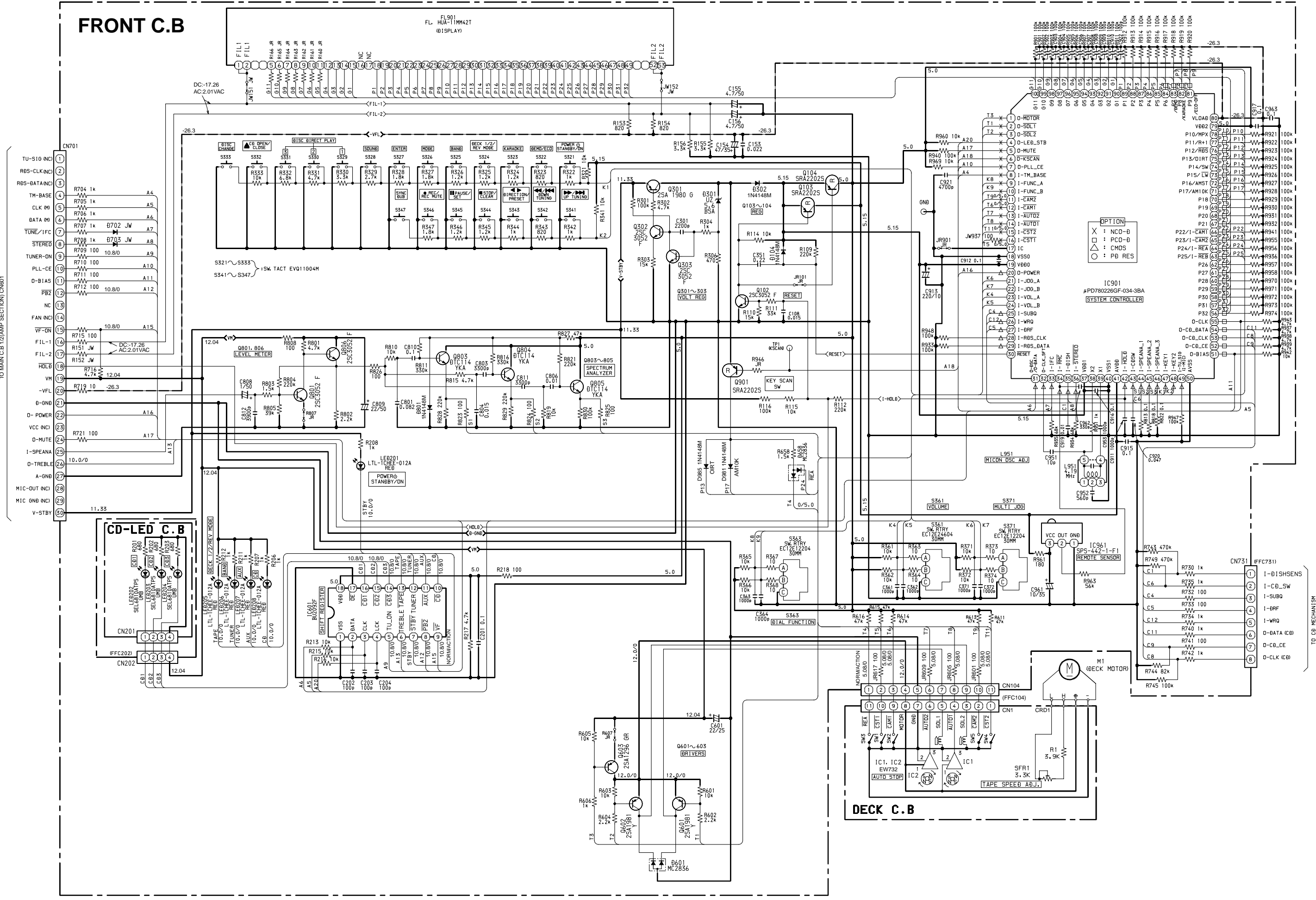

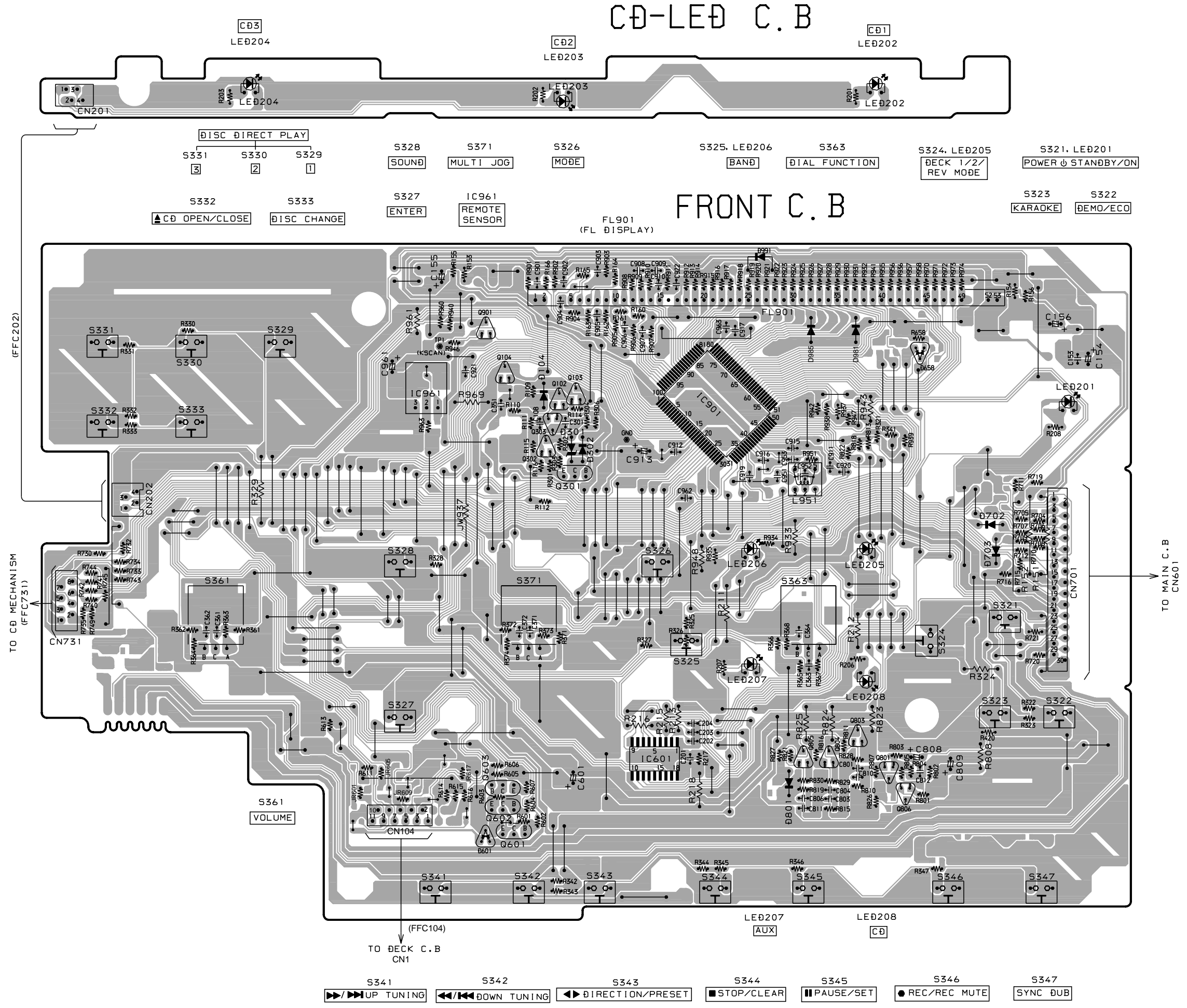

A
B
C
D
E
F
G
H
I
J
K
L
M
N
O
P
Q
R
S
T
U

32	31	30	29	28	27	26	25	24	23	22	21	20	19	18	17	16	15	14	13	12	11	10	9	8	7	6	5	4	3	2	1
----	----	----	----	----	----	----	----	----	----	----	----	----	----	----	----	----	----	----	----	----	----	----	---	---	---	---	---	---	---	---	---

DECK C.B

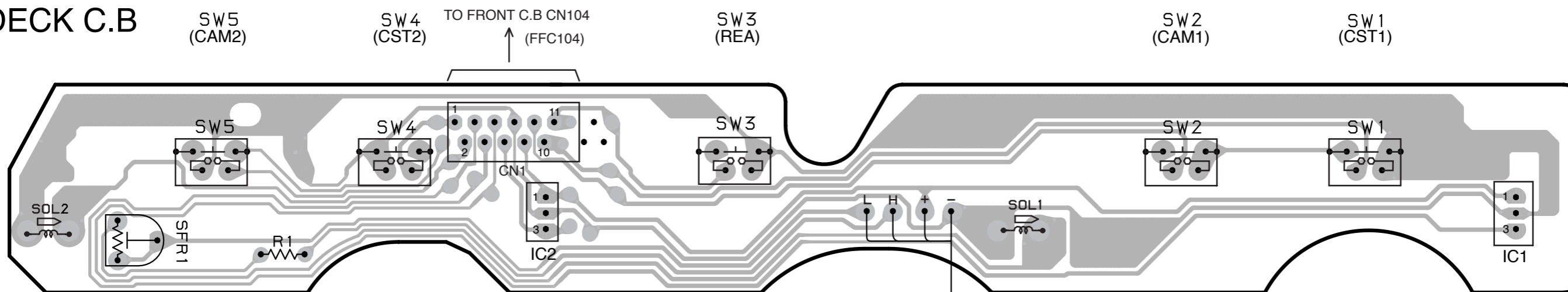

HEAD-1 C.B

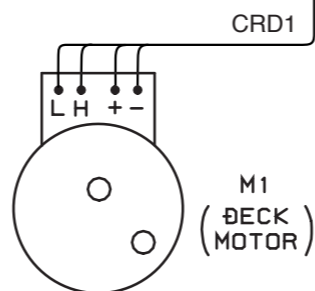
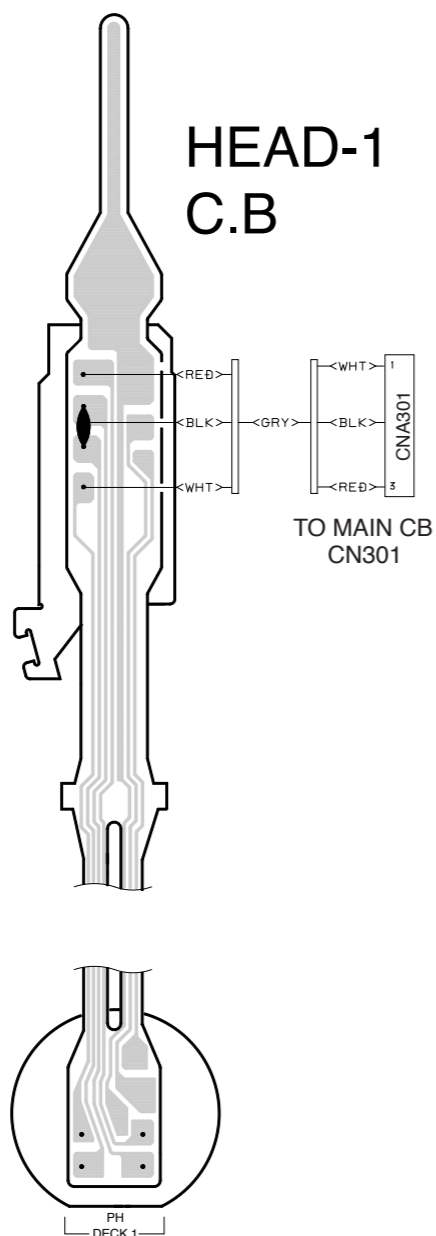

DECK-2

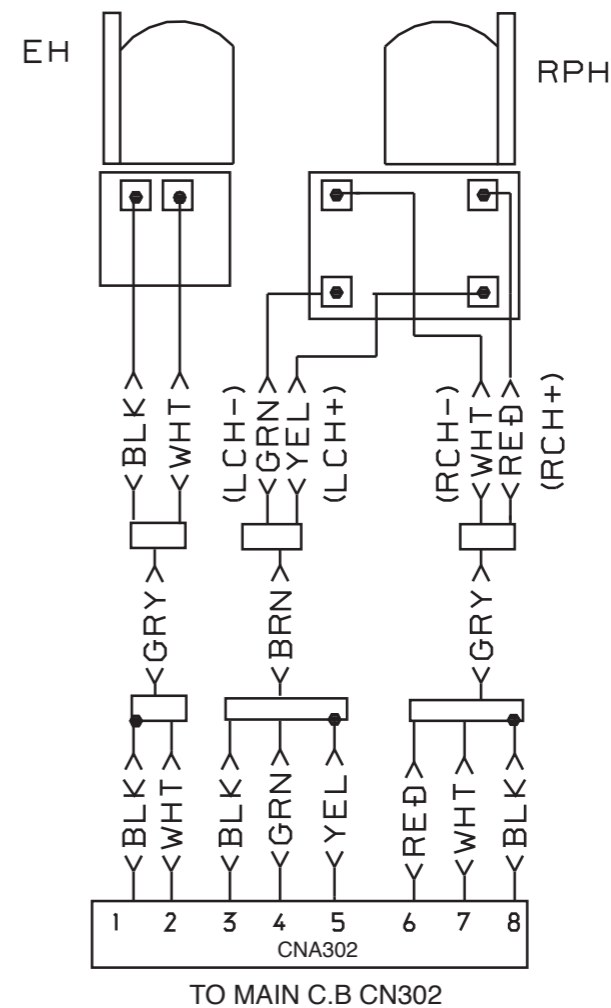

A
B
C
D
E
F
G
H
I
J
K
L
M
N
O
P
Q
R
S
T
U

SCHEMATIC DIAGRAM -5/5 (POWER SECTION)

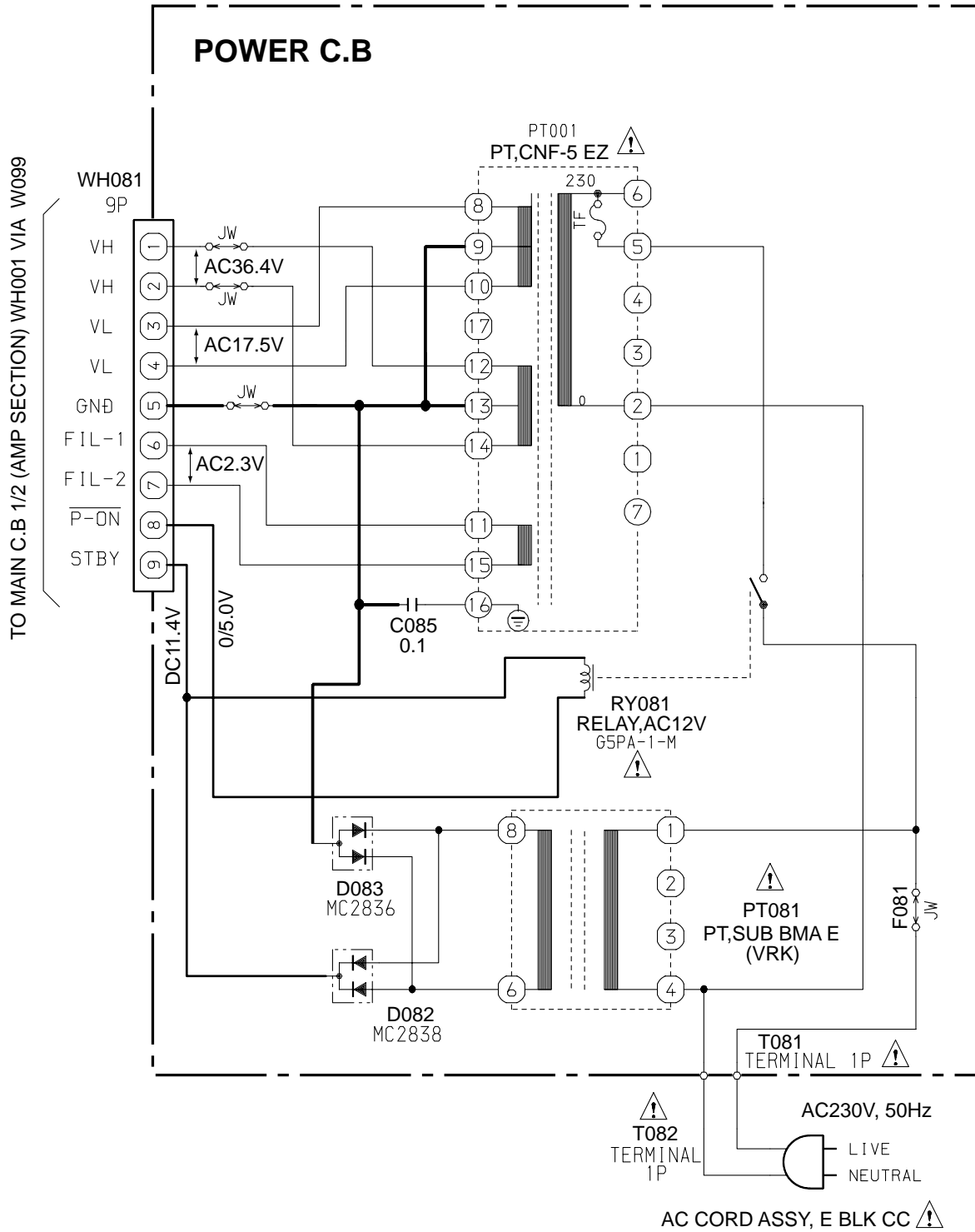

15	14	13	12	11	10	9	8	7	6	5	4	3	2	1
----	----	----	----	----	----	---	---	---	---	---	---	---	---	---

A
B
C
D
E
F
G
H
I
J
K
L
M
N
O
P
Q
R
S
T
U

POWER C.B

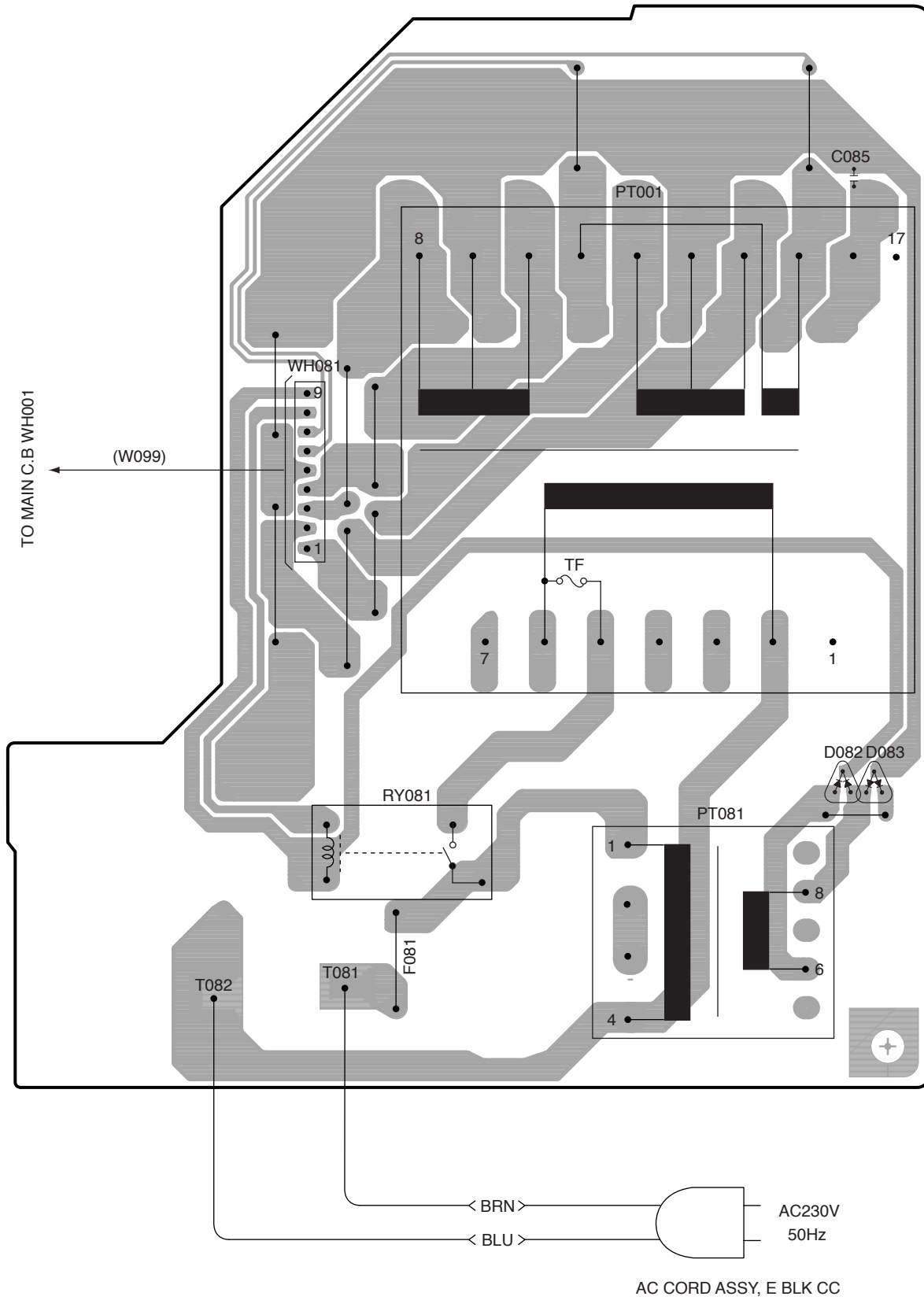

ELECTRICAL ADJUSTMENT -1/7

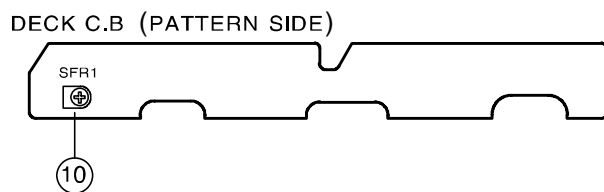
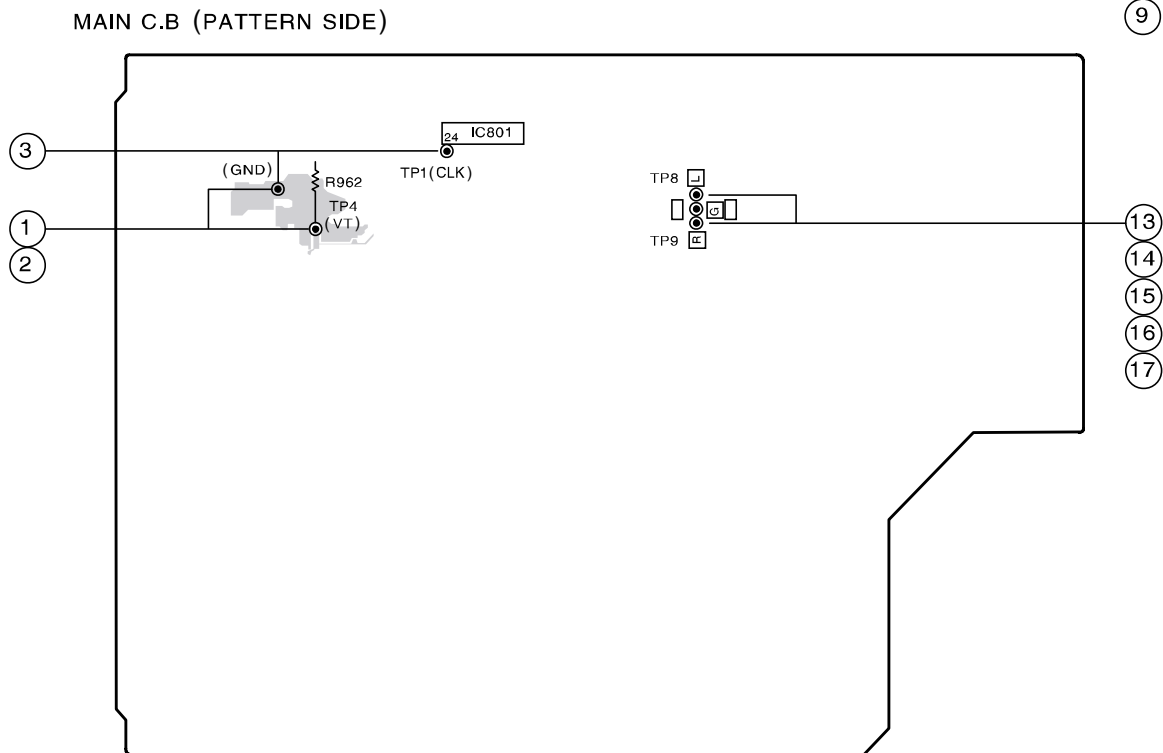
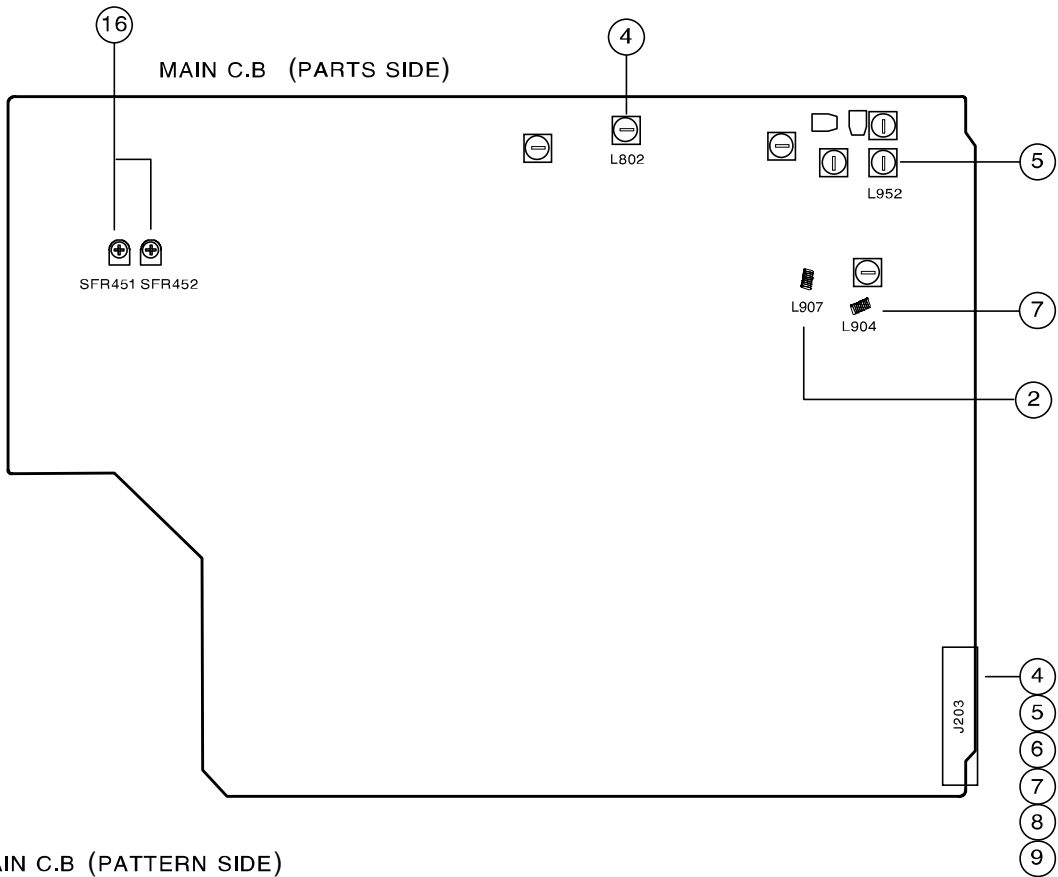

ELECTRICAL ADJUSTMENT -2/7

<TUNER SECTION>

1. VT Check (AM)

Requirements

- Measuring instrument: Digital multimeter

Test points: VT, GND

- 1) Connect the digital multimeter between VT and GND.
- 2) Set the function to AM, and tune the receiving frequency of the unit at 1,710 kHz.
- 3) Check that the digital multimeter ranges under 9 V.
- 4) Tune the receiving frequency of the unit at 530 kHz.
- 5) Check that the digital multimeter ranges above 0.5 V.

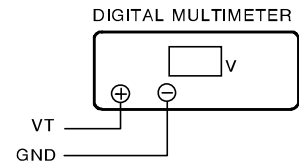

2. VT Adjustment and Check (FM)

Requirements: Same as the above.

- Adjustment point: L907

- 1) Connect the digital multimeter between VT and GND.
- 2) Set the function to FM, and tune the receiving frequency of the unit at 108.0MHz.
- 3) Adjust L907 so that the digital multimeter ranges at 9.0 ± 0.1 V.
- 4) Tune the receiving frequency of the unit at 65 MHz.
- 5) Check that the digital multimeter ranges under 0.5 V.

3. CLOCK Check (AM)

Requirements

- Measuring instrument: Frequency counter

Test point: CLK(IC801 24PIN), GND

- 1) Connect the frequency counter between CLK and GND.
- 2) Set the function to AM, and tune the receiving frequency of the unit at 1,710 kHz.
- 3) Check that the frequency counter ranges at $2,160 \text{ kHz} \pm 45 \text{ Hz}$.

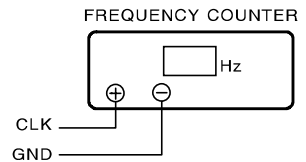

ELECTRICAL ADJUSTMENT -3/7

<AM Adjustment>

Make the following preparations for AM adjustment.

Preparations

- Standard Signal Generator (S.S.G.) / Loop antenna / Oscilloscope / Millivoltmeter / Dummy resistance (6 Ω)
 - 1) Connect the unit and measuring instruments as shown in the diagram below.
 - 2) Position the loop antenna connected to S.S.G. and the one connected to the unit 60 cm apart.

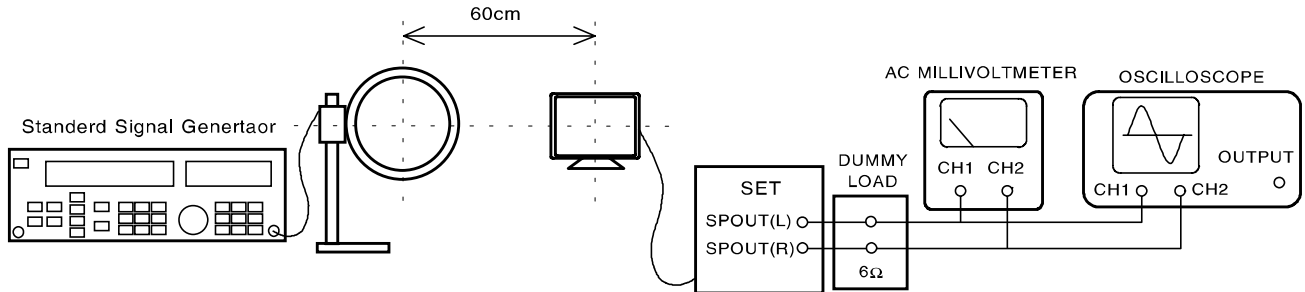

4. IF Adjustment (AM)

Requirements: As instructed in preparations.

- Adjustment point: L802
 - 1) Set S.S.G. to AM; carrier of 999 kHz with 30% modulation, and source at 1 kHz.
 - 2) Tune the receiving frequency of the unit at AM 999 kHz.
 - 3) While monitoring the waveform at 1 kHz through the oscilloscope, lower the output level of S.S.G. maximum (till a certain degree of noise is monitored).
 - 4) Adjust L802 so that the millivoltmeter points maximum.

5. Tracking Adjustment (AM)

Requirements: As instructed in preparations.

- Adjustment point: L952/L953
 - 1) Set S.S.G. to AM; carrier of 999 kHz with 30% modulation, and source at 1 kHz, position output at maximum.
 - 2) Tune the receiving frequency of the unit at AM 999 kHz.
 - 3) While monitoring the waveform at 1 kHz through the oscilloscope, lower the output level of S.S.G. maximum (till a certain degree of noise is monitored).
 - 4) Adjust L952 so that the millivoltmeter points maximum.
 - 5) Set S.S.G. to AM; carrier of 603 kHz with 30% modulation, and source at 1 kHz.
 - 6) Tune the receiving frequency of the unit at AM 603 kHz.
 - 7) Adjust L953 so that the millivoltmeter points maximum.
 - 8) Repeat above steps 1) to 7) 2 to 3 times.

6. Auto-Stop Check (AM)

Requirements: As instructed in preparations.

- 1) Set S.S.G. to AM; carrier of 999 kHz or 1,000 kHz with 30% modulation, source at 1 kHz, and output of 40 to 65 dBu.
- 2) Apply the tuning search function, and check that the unit automatically stops at AM 999 kHz or 1,000 kHz.

ELECTRICAL ADJUSTMENT -4/7

<FM Adjustment>

Make the following preparations for FM adjustment.

Preparations

- Standard Signal Generator (S.S.G.) / Loop antenna / Oscilloscope / Millivoltmeter / Dummy resistance (6 Ω)
 - 1) Connect the unit and measuring instruments as shown in the diagram below.
 - 2) Connect the output of S.S.G. to the antenna input of the unit.

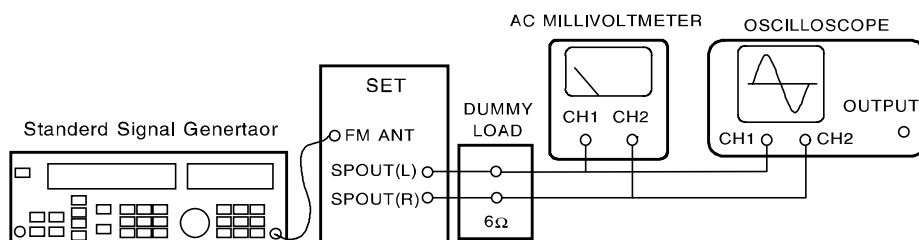

7. Tracking Adjustment (FM)

Requirements: As instructed in preparations.

- Adjustment point: L901/L904
 - 1) Set S.S.G. to FM; carrier of 65 MHz with 75 kHz modulation, and source at 1 kHz.
 - 2) Tune the receiving frequency of the unit at FM 65 MHz.
 - 3) While monitoring the waveform at 1 kHz through the oscilloscope, lower the output level of S.S.G. maximum (till a certain degree of noise is monitored).
 - 4) Adjust L901/L904 so that the millivoltmeter points maximum.

8. Separation Check (FM)

Requirements: As instructed in preparations.

- 1) Set S.S.G. to FM; carrier of 98 MHz or 83 MHz with 67.5 kHz modulation, source at 1 kHz, and output at 74 dBu.
- 2) Switch S.S.G. to PILOT ON, and set PILOT at 7.5 kHz.
- 3) Tune the receiving frequency of the unit at FM 98 MHz or 83 MHz.
- 4) Allow the output of S.S.G. only from Lch, and check that the difference between Lch and Rch is 25 dB or above.
- 5) Apply the above check to Rch.

9. Auto-Stop Check (FM)

Requirements: As instructed in preparations.

- 1) Set S.S.G. to FM; carrier of 98 MHz or 83 MHz with 75 kHz modulation, source at 1 kHz, and output at 10 to 35 dBu or less.
- 2) Apply the tuning search function, and check that the unit automatically stops at FM 98 MHz or 83 MHz.

ELECTRICAL ADJUSTMENT -5/7

<DECK SECTION>

10. Tape Speed Adjustment (DECK2)

Requirements

- Measuring instrument: Wow and flutter meter (frequency counter)

Test tape: TTA-100 (3 kHz)

Test point: HP OUT

Adjustment point: SFR1

- 1) Connect the wow and flutter meter to HP OUT of the unit.
- 2) Insert the test tape (TTA-100) to DECK 2. Play back the middle part of the tape, and adjust SFR1 so that the level 3,000 Hz \pm 5 Hz is monitored.

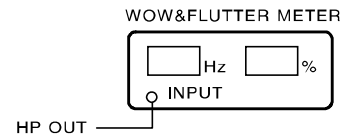

11. Tape Speed Check (DECK 1)

Requirements: Same as the above, 10.

- 1) Insert the test tape (TTA-100) to DECK 1. Play back the middle part of the tape, and check that the level is ranged within \pm 5 Hz as compared to the speed monitored for DECK 2.

12. Wow and Flutter Check (DECK1 and DECK2)

Requirements: Same as the above, 10.

- 1) Connect the wow and flutter meter to HP OUT of the unit.
- 2) Set the wow and flutter to JIS for INDICATOR and to W RMS (WTD) for mode.
- 3) Play back the middle part of the test tape (TTA-100), and check that the level ranges under 0.25%.

13. Head Azimuth Adjustment (DECK1 and DECK2)

Requirements

- Measuring instrument: Oscilloscope

Test tape: TTA-300 (10 kHz)

Test point: TP8 (Lch), TP9 (Rch)

Adjustment point: Head azimuth adjustment screw

- 1) Connect the probe CH1 of the oscilloscope to TP8 (Lch) and CH2 to TP9 (Rch).
- 2) Set V mode of the oscilloscope to ADD.
- 3) Insert the test tape (TTA-300) to DECK1. Forward and play back the middle part of the tape, and adjust the head azimuth adjustment screw so that the waveform achieves its maximum level when 10 kHz is played.
- 4) After adjustment, secure the screw with glue (1600 B).
- 5) Apply the above steps 3) and 4) to DECK2.

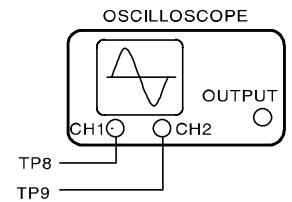

14. Playback Frequency Check (DECK1 and DECK2)

Requirements

- Measuring instrument: Millivoltmeter

Test tape: TTA-300 (315 Hz /10 kHz)

Test point: TP8 (Lch), TP9 (Rch)

- 1) Connect CH1 of the millivoltmeter to TP8 (Lch) and CH2 to TP9 (Rch).
- 2) Insert the test tape (TTA-300) to DECK1, and play back 315 Hz and 10 kHz.
- 3) Check that the level of 10kHz is ranged within 0 ± 3 dB compared to the output level of 315 Hz as a reference.
- 4) Apply the above steps 2) and 3) to DECK2.

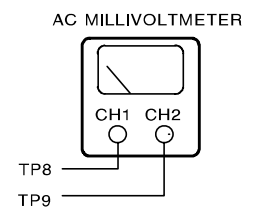

ELECTRICAL ADJUSTMENT -6/7

15. Playback Sensitivity Check (DECK1 and DECK2)

Requirements

- Measuring instrument: Millivoltmeter

Test tape: TTA-200(400Hz)

Test points: TP8(Lch), TP9(Rch)

- 1) Connect CH1 of the millivoltmeter to TP8 (Lch) and CH2 to TP9 (Rch).
- 2) Insert the test tape (TTA-200) to DECK1 and play back.
- 3) Check that the output level is ranged within $140\text{mV} \pm 3\text{dB}$.
- 4) Apply the above steps, 2) and 3) to DECK2.

16. Record/Playback Frequency Response Adjustment (DECK 2)

Requirements

- Measuring instrument: Millivoltmeter, Audio signal oscillator (low frequency oscillator), Attenuator

Test tape: TTA-602 (NORMAL)

Test points: TP8 (Lch), TP9 (Rch)

Input point: AUX (1 kHz / 10 kHz)

Adjustment points: SFR451(Lch), SFR452(Rch)

- 1) Connect CH1 of the millivoltmeter to TP8 (Lch) and CH2 to TP9 (Rch).
- 2) Connect the output of the oscillator to the attenuator, and then the attenuator to AUX of the unit.
- 3) Insert the test tape (TTA-602) to DECK2, and record 1 kHz signal from AUX.
- 4) Adjust the attenuator so that the output levels at TP8 and TP9 are ranged at 10 mV.
- 5) Record 1kHz and 10 kHz alternatively.
- 6) Play back the tape. Adjust SFR451 (Lch)/SFR452 (Rch) so that the playback output level of 10 kHz is ranged within $0 \pm 1\text{dB}$ compared to the playback output level of 1kHz as reference.

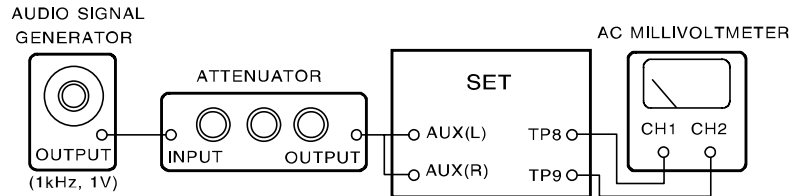

17. Record/Playback Sensitivity Check (DECK2)

Requirements

- Measuring instrument: Same as the above, 16

Test tape: TTA-602 (NORMAL)

Test point: TP8 (Lch), TP9 (Rch)

Input point: AUX (1 kHz)

- 1) Insert the test tape (TTA-602) to DECK2, and record 1 kHz signal from AUX.
- 2) Adjust the attenuator so that the output levels at TP8 and TP9 are 100 mV.
- 3) Play back 1 kHz, and check that the output level is ranged within $-2 \text{ dB} \pm 3.5 \text{ dB}$ compared to the recording output level.

ELECTRICAL ADJUSTMENT -7/7

FRONT C.B PATTERN SIDE

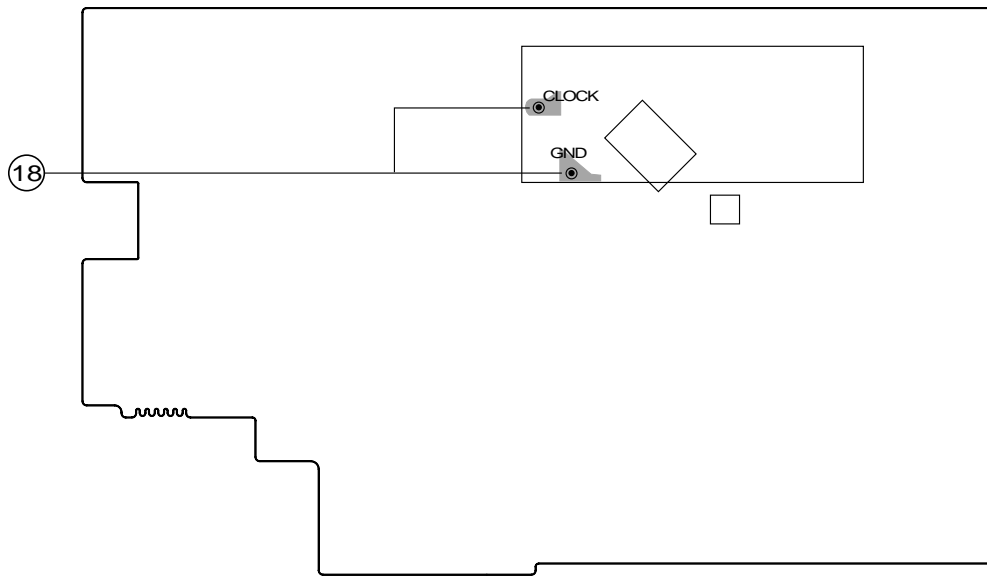

FRONT C.B PARTS SIDE

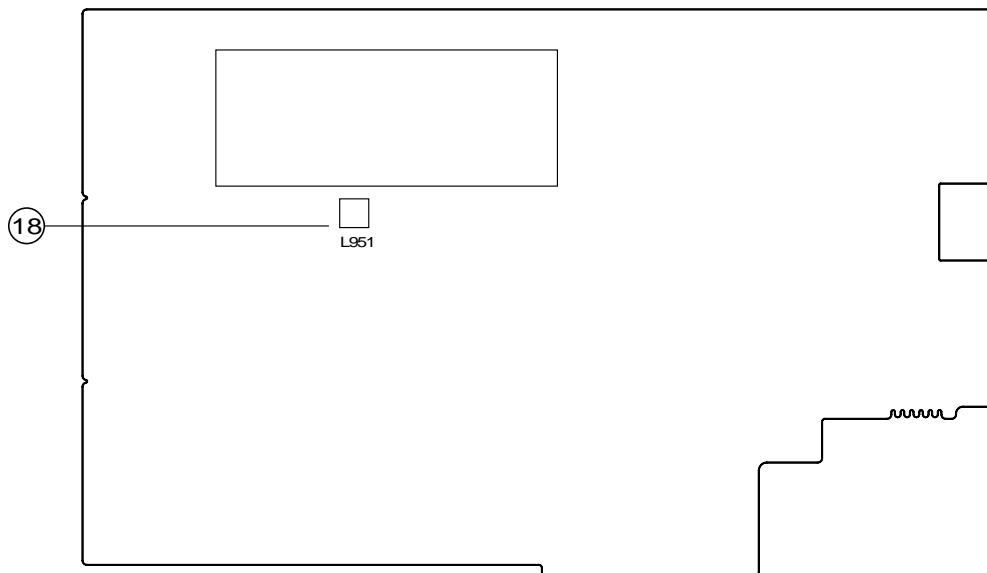

18. Clock Adjustment

Requirements

- Measuring instrument: Frequency counter

Test point: CLOCK, GND

Adjustment point: L951

- 1) While pressing the FF and POWER button, insert the AC plug to the outlet.
- 2) Adjust L951 so that the frequency counter indicates the frequency level within 84.804 ± 0.085 Hz.

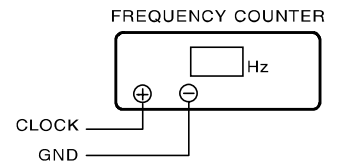

CD TEST MODE -1/1

CD TEST MODE Ver. 3.0

1. Starting CD Test Mode

While pressing and holding down the CD OPEN/CLOSE button, insert the AC plug to outlet.

When test mode starts, the message, TEST appears on the display .

2. Exiting CD Test Mode

Press the POWER button or remove the AC plug from outlet.

* When the other function keys are pressed during playback, test mode stops.

3. Function of CD Test Mode

No	Mode	Function Key	Display	Movement	Check
1	Start Mode		All lit.	FL all lit.	FL check Microcomputer check
2	Search Mode	STOP button	READING	LD constantly lit. Focus search continuous movement *1, 2 Spindle motor continuous kick	APC circuit check Laser current electricity measurement Focus search waveform check Focus error waveform check (DRF is ignored during search mode.)
3	Play Mode	PLAY button	Normal	Normal playback If TOC READ is unavailable, focus search is continued.	Each servo circuit check DRF check RF waveform check (1.55Vp-p Approx.)
4	Traverse Mode	PAUSE button	Normal	Tracking servo OFF/ON OFF and ON is repeated by every press of the PAUSE button.	Tracking balance check
5	Sled mode	FF button	TEST	PU moves to the innermost position. *3 At the same time, lens is kicked toward inner position.	Sled circuit check Tracking circuit check Mechanism movement check PU check
		RWD button	TEST	PU moves to the outermost position. *3 At the same time, lens is kicked toward outer position.	
6	Spindle mode	● REC/ REC MUTE button	All lit.	When the button is pressed at the first time, spindle motor rotates forward (at rough speed). At the second press, rotation is reversed. At the third press, rotation stops.	Spindle circuit check Spindle motor check

* 1 When Focus Search operates continuously more than 10 minutes, the protection circuit is activated due to heat generation of the driver IC. In this case, turn off the power, wait for approximately 10 minutes so that heat is released, and then restart.

* 2 When the Focus Search fails three times, the gain is switched for CD-RW at the fourth time.

* 3 Be careful not to damage the gear because the sled motor rotates while the FF or RWD button is being pressed even if the pickup is located in the innermost track or the outermost track.

GRID ASSIGNMENT

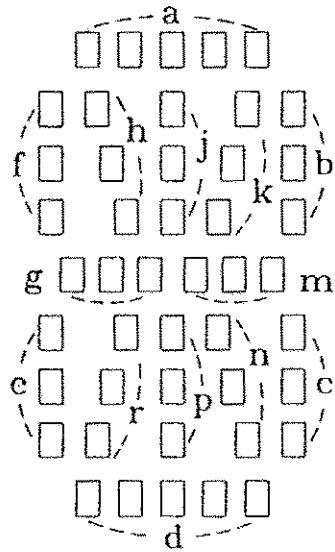
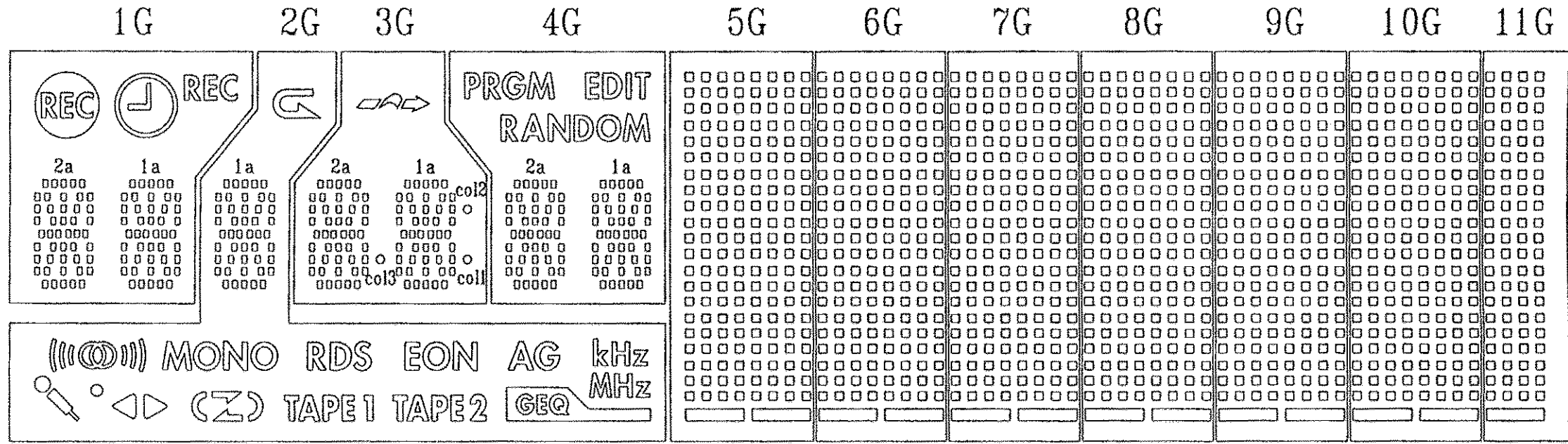

(1G - 4G)

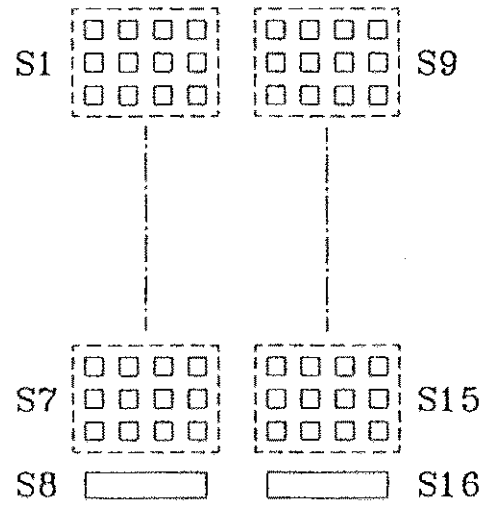

(5G, 7G, 9G)

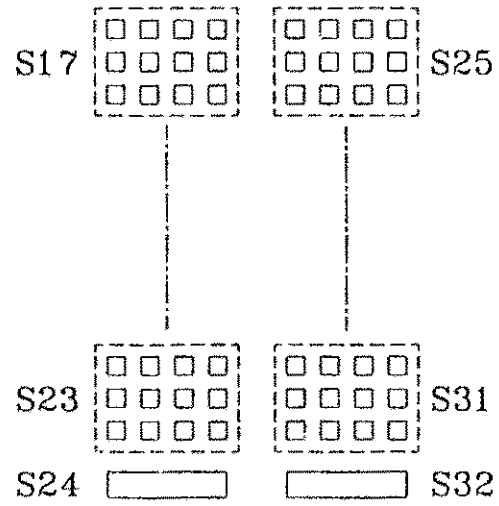

(6G, 8G, 10G)

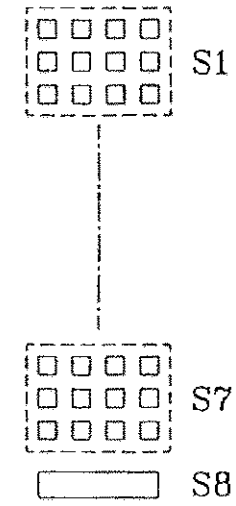

(11G)

ANODE CONNECTION

	1G	2G	3G	4G	5G	6G	7G	8G	9G	10G	11G
P1	REC			PRGM	S1	—	S1	—	S1	—	S1
P2			coll	EDIT	S9	—	S9	—	S9	—	—
P3			col2	RANDOM	—	S17	—	S17	—	S17	—
P4	—	o	col3	—	—	S25	—	S25	—	S25	—
P5	2a		2a	2a	S2	—	S2	—	S2	—	S2
P6	2h		2h	2h	S10	—	S10	—	S10	—	—
P7	2j	MONO	2j	2j	—	S18	—	S18	—	S18	—
P8	2k		2k	2k	—	S26	—	S26	—	S26	—
P9	2b		2b	2b	S3	—	S3	—	S3	—	S3
P10	2f		2f	2f	S11	—	S11	—	S11	—	—
P11	2m	TAPE1	2m	2m	—	S19	—	S19	—	S19	—
P12	2g	TAPE2	2g	2g	—	S27	—	S27	—	S27	—
P13	2c	RDS	2c	2c	S4	—	S4	—	S4	—	S4
P14	2e	EON	2e	2e	S12	—	S12	—	S12	—	—
P15	2r		2r	2r	—	S20	—	S20	—	S20	—
P16	2p	AG	2p	2p	—	S28	—	S28	—	S28	—
P17	2n	MHz	2n	2n	S5	—	S5	—	S5	—	S5
P18	2d	kHz	2d	2d	S13	—	S13	—	S13	—	—
P19	1a	1a	1a	1a	—	S21	—	S21	—	S21	—
P20	1h	1h	1h	1h	—	S29	—	S29	—	S29	—
P21	1j	1j	1j	1j	S6	—	S6	—	S6	—	S6
P22	1k	1k	1k	1k	S14	—	S14	—	S14	—	—
P23	1b	1b	1b	1b	—	S22	—	S22	—	S22	—
P24	1f	1f	1f	1f	—	S30	—	S30	—	S30	—
P25	1m	1m	1m	1m	S7	—	S7	—	S7	—	S7
P26	1g	1g	1g	1g	S15	—	S15	—	S15	—	—
P27	1c	1c	1c	1c	—	S23	—	S23	—	S23	—
P28	1e	1e	1e	1e	—	S31	—	S31	—	S31	—
P29	1r	1r	1r	1r	S8	—	S8	—	S8	—	S8
P30	1p	1p	1p	1p	S16	—	S16	—	S16	—	—
P31	1n	1n	1n	1n	—	S24	—	S24	—	S24	—
P32	1d	1d	1d	1d	—	S32	—	S32	—	S32	—

PIN CONNECTION

PIN NO.	53	52	51	50	49	48	47	46	45	44	43	42	41	40	39	38	37	36	35	34	33	32	31	30	29	28	27	26	25	24	23	22	21	20
CONNECTION	F2	F2	NP	NP	P32	P31	P30	P29	P28	P27	P26	P25	P24	P23	P22	P21	P20	P19	P18	P17	P16	P15	P14	P13	P12	P11	P10	P9	P8	P7	P6	P5	P4	P3

19	18	17	16	15	14	13	12	11	10	9	8	7	6	5	4	3	2	1
P2	P1	NC	NC	1G	2G	3G	4G	5G	6G	7G	8G	9G	10G	11G	NP	NP	F1	F1

IC BLOCK DIAGRAM -1/1

IC, LC72131D-N

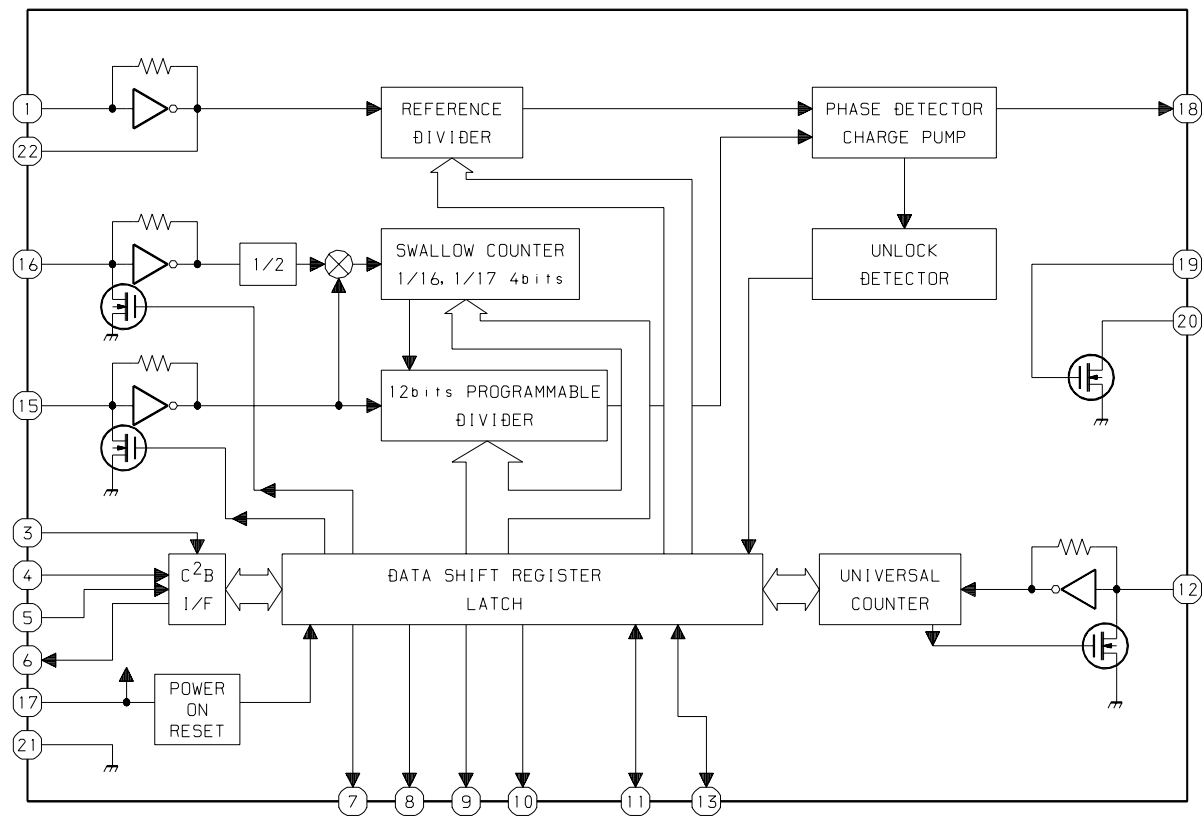

IC, BU2092F

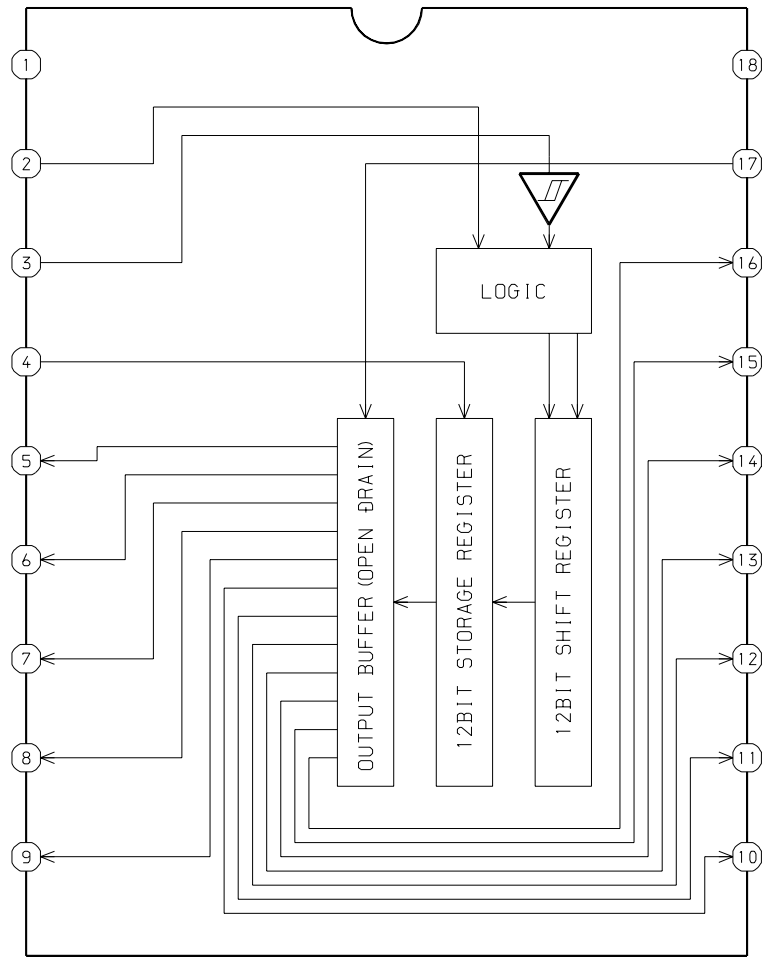

IC, M61518FP

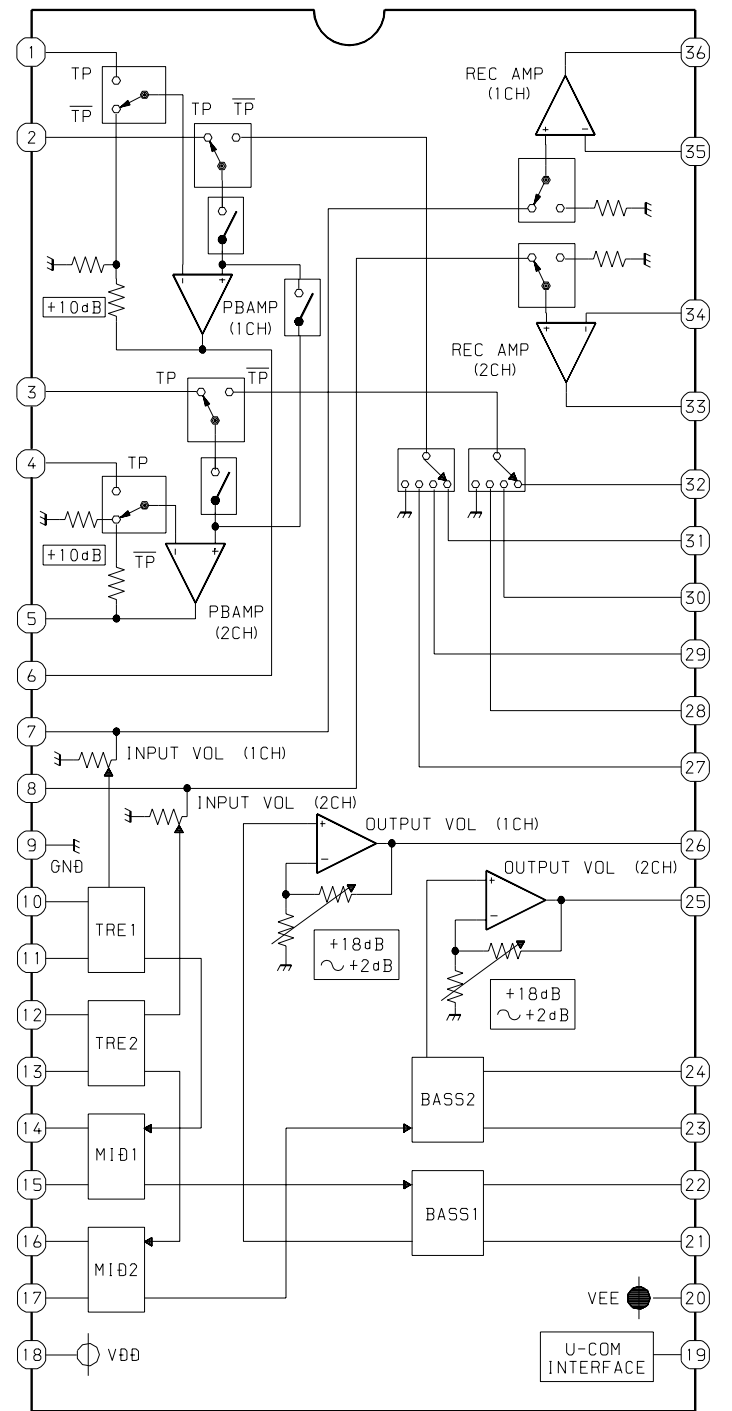

IC, LA1845N-A

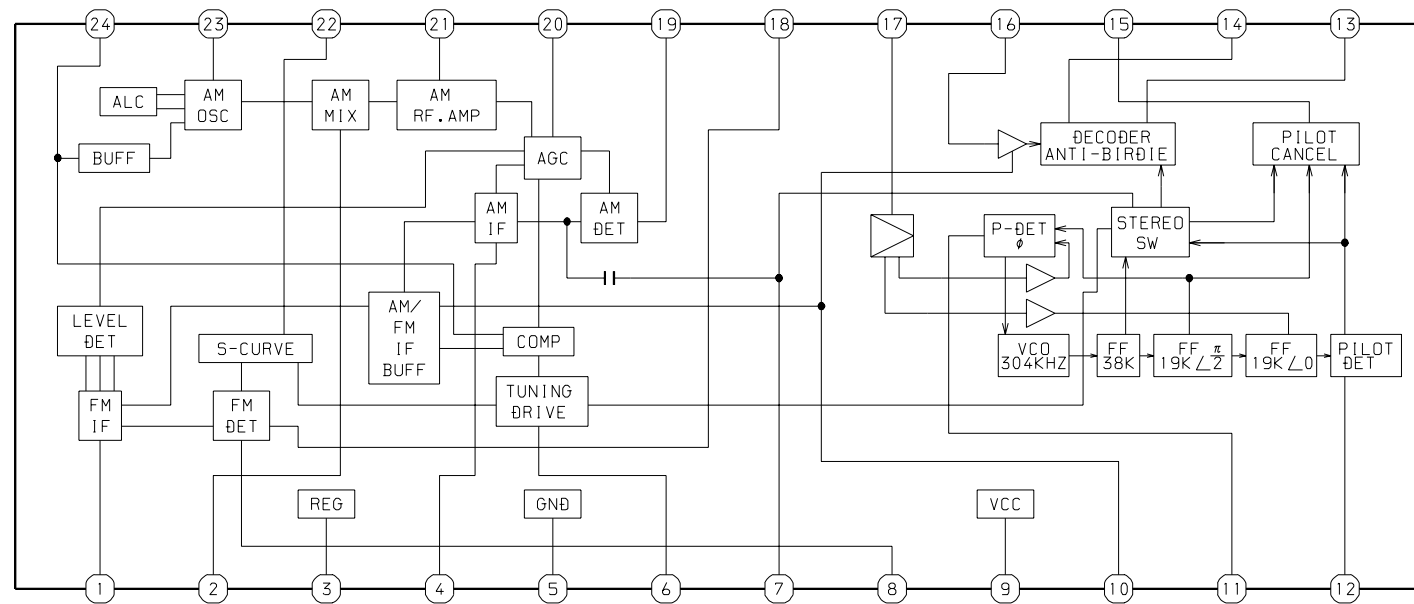

IC DESCRIPTION -1/1 (μPD780226GF-034-3BA) -1/2

Pin No.	Pin Name	I/O	Description
1	O-MOTOR	O	DECK MOTOR output.
2	O-SOL1	O	DECK SOL1 output.
3	O-SOL2	O	DECK SOL2 output.
4	O-LED_STB	O	STB output for shift registor.
5	O-MUTE	O	MUTE output.
6	O-KSCAN	O	Initial scan output.
7	O-PLL_CE	O	TUNER chip enable output.
8	I-TM_BASE	I	Reference clock input for clock. (8Hz)
9	I-FUNC_A	I	Rotary encoder input function A.
10	I-FUNC_B	I	Rotary encoder input function B.
11	I-CAM2	I	DECK CAM2 input.
12	I-CAM1	I	DECK CAM1 input.
13	I-AUTO2	I	DECK AUTO2 input.
14	I-AUTO1	I	DECK AUTO1 input.
15	I-CST2	I	DECK CST2 input.
16	I-CST1	I	DECK CST1 input.
17	IC	–	Connected to GND.
18	VSS0	–	GND for port part.
19	VDD0	–	Power supply for port part.
20	O-POWER	O	Power control output.
21	I-JOG_A	I	Rotary encoder input A.
22	I-JOG_B	I	Rotary encoder input B.
23	I-VOL_A	I	Rotary encoder input volume A.
24	I-VOL_B	I	Rotary encoder input volume B.
25	I-SUBQ	I	CD SUBQ input.
26	I-WRQ	I	CD WRQ input.
27	I-DRF	I	CD DRF input.
28	I-RDS_CLK	I	Clock input for RDS. (Connected to GND through a resistor)
29	I-RDS_DATA	I	Input TUNER RDS DATA. (Connected to GND through a resistor)
30	RESET	–	System RESET input
31	O-DSC/O-DATA	I/O	Function IC control / DATA output.
32	O-CLK_SFT	O	Clock shift output.
33	I-IFC	I	TUNER IF count serial data input.
34	I-RMC	I	System remote control signal input.
35	I-DISH	I	CD turntable photo sensor.
36	I-STEREO	I	Tuner stereo input.
37	VDD1	–	Power supply.
38	X2	O	Main system clock output 2. (4.19 MHz)
39	X1	I	Main system clock output 1. (4.19 MHz)
40	VSS1	–	GND.
41	AVDD	–	Voltage for A/D converter.
42	I-HOLD	I	Input for HOLD.

IC DESCRIPTION -1/1 (μPD780226GF-034-3BA) -2/2

Pin No.	Pin Name	I/O	Description
43	I-CDSW	I	CD mechanism SW input.
44	I-SPEANA_1	I	Input spectrum analyzer DATA (Low Frequency).
45	I-SPEANA_2	I	Input spectrum analyzer DATA (Middle Frequency).
46	I-SPEANA_3	I	Input spectrum analyzer DATA (High Frequency).
47	I-KEY1	I	Key input 1.
48	I-KEY2	I	Key input 2.
49	I-TU_SIG/(I-MIC)	I	Signal LEVEL A/D input for RDS / MIC Input for auto vocal fader. (Connected to GND through a resistor)
50	AVSS	–	GND for A/D converter.
51	O-BIAS	O	DECK BIAS output.
52	O-CD_CE	O	CD chip enable output.
53	O-CD_CLK	O	CD CLK output.
54	O-CD_DATA	O	CD DATA output.
55	O-CLK	O	CLOCK output.
56 ~ 62	P32 ~ P26	O	FL segment P32 ~ P26 output.
63	P25/I-REB	I/O	FL segment P25 output / DECK REB SW input.
64	P24/I-REA	I/O	FL segment P24 output / DECK REA SW input.
65	P23/I-CAM2	I/O	FL segment P23 output / DECK CAM2 input (Not used).
66	P22/I-CAM1	I/O	FL segment P22 output / DECK CAM1 input (Not used).
67 ~ 70	P21 ~ P18	O	FL segment P21 ~ P18 output.
71	P17/AM10K	I/O	FL segment P17 output / AM10K diode input (Not used).
72	P16/AMST	I/O	FL segment P16 output / AMST diode input (Not used).
73	P15/LW	I/O	FL segment P15 output / LW diode input (Not used).
74	P14/SW	I/O	FL segment P14 output / SW diode input (Not used).
75	P13/OIRT	I/O	FL segment P13 output / OIRT diode input (Not used).
76	P12/RDS	I/O	FL segment P12 output / DECK RDS diode input (Not used).
77	P11/R+1	I/O	FL segment P11 output / DECK R+1 diode input.
78	P10/MPX	I/O	FL segment P10 output / MPX initial diode input (Not used).
79	VDD2	–	Voltage supply for FIP controller.
80	VLOAD	–	Negative voltage supply for FIP controller.
81	P9/ECO-OFF	I/O	FL segment P9 output / ECO MODE initial OFF diode input (Not used).
82	P8/KARAOKE	I/O	FL segment P8 output / KARAOKE initial diode input.
83	P7/DEMO	I/O	FL segment P7 output / DEMO diode input (Not used).
84 ~ 89	P6 ~ P1	O	FL segment P6 ~ P1 output.
90 ~ 100	G1 ~ G11	O	FL grid G1 ~ G11 output.

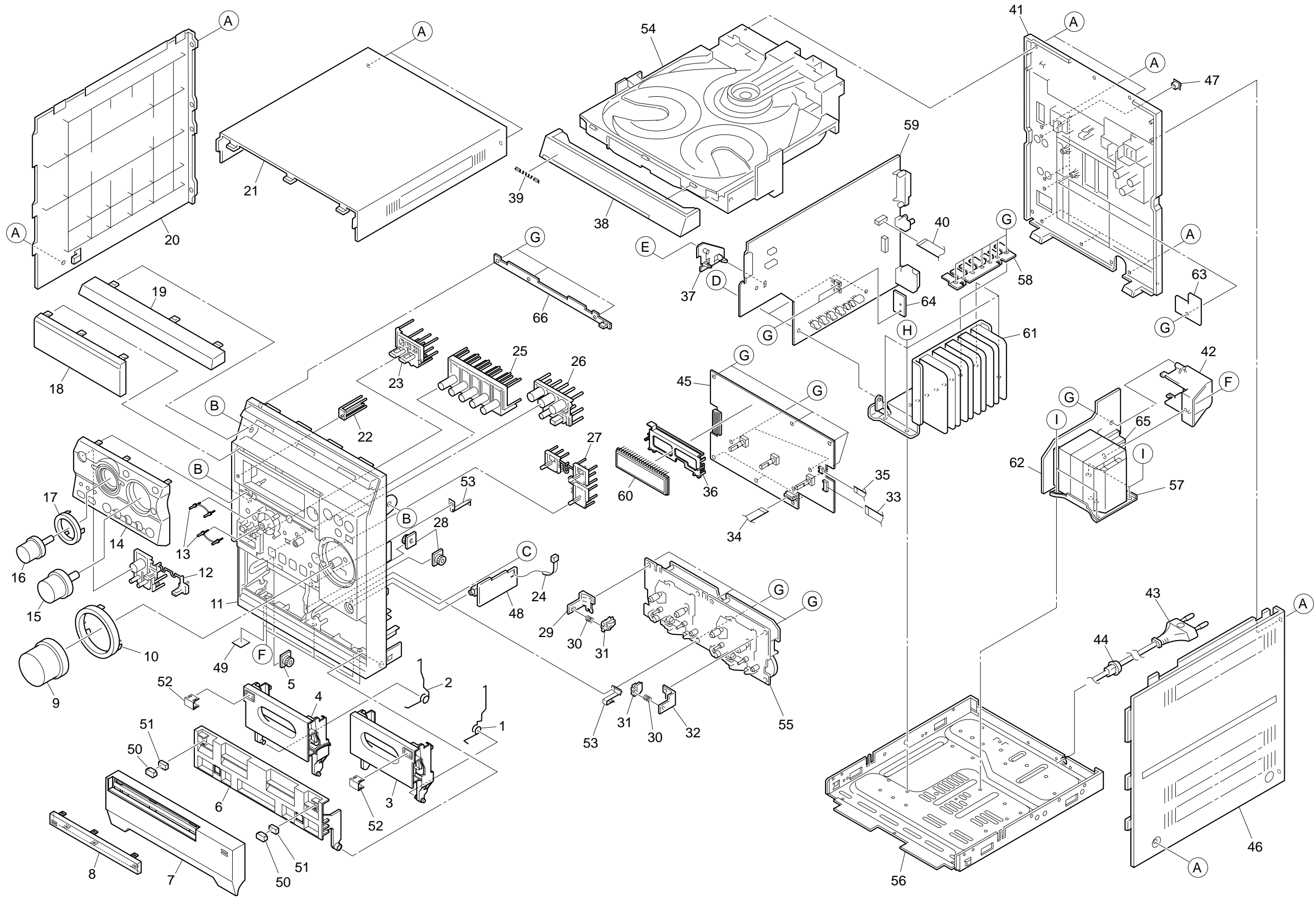

MECHANICAL MAIN PARTS LIST -1/1

! = SAFETY PARTS

C = Components marked

All components used on this model at the production line are shown in this service manual.

However, please note that not all components will be available as spare parts for after-sales service.

Components marked S and O are designated as spare parts for service and will be stocked at the spare parts centers.

Components marked X and R are not designated as spare parts for after sales service, and will not be stocked at the spare parts centers.

UNIT-NAME	! C	REF-NO	PARTS-NO	PARTS-NAME	SUFFIX&MODEL
					CX-SNR80
					VSM
	O	MC1001	8A-NF8-282-010	SPR-T, EJECT 2	a
	O	MC1002	8A-NF8-281-010	SPR-T, EJECT 1	a
	O	MC1003	8B-NF1-003-110	BOX, CASS 2	a
	O	MC1004	8B-NF1-002-110	BOX, CASS 1	a
	O	MC1005	8Z-NF6-210-010	DMPR, 150 N	a
	O	MC1006	8B-NF1-008-010	BOX, DOOR	a
	O	MC1007	8C-NF5-003-010	PANEL, DOOR R1	a
	O	MC1008	8B-NF1-010-010	WINDOW, CASS	a
	O	MC1009	8B-NF1-021-110	KNOB, RTRY VOL	a
	O	MC1010	8B-NF1-023-010	PANEL, VOL	a
	O	MC1011	8B-NF1-001-110	CABI, FR EZ	a
	O	MC1012	8B-NF1-015-110	KEY, POWER	a
	O	MC1013	8B-NF1-028-010	REFLECTOR, FUN	a
	O	MC1014	8C-NF5-009-010	PANEL, FR V	a
	O	MC1015	8B-NF1-022-110	KNOB, RTRY JOG	a
	O	MC1016	8B-NF1-024-010	KNOB, RTRY FUN	a
	O	MC1017	8B-NF1-025-010	WINDOW, FUN	a
	O	MC1018	8C-NF5-023-010	WINDOW, DISP H	a
	O	MC1019	8B-NF1-014-010	WINDOW, CD	a
	O	MC1020	8B-NF1-005-010	PANEL, LEFT	a
					CX-SNR80
					VSM
	O	MC1021	8B-NF1-007-010	PANEL, TOP	a
	O	MC1022	8B-NF1-027-010	REFLECTOR, ECO	a
	O	MC1023	8C-NF5-010-010	KEY, REC EZ	a
	O	MC1024	87-069-033-010	CABLE, TIE	a
	O	MC1025	8C-NF5-006-010	KEY, OPE LH	a
	O	MC1026	8B-NF1-016-010	KEY, CD	a
	O	MC1027	8B-NF1-017-110	KEY, ENTER	a
	O	MC1028	8A-NF8-209-010	OIL-DMPR, 120	a
	O	MC1029	87-NF4-216-010	HLDR, LOCK 1	a
	O	MC1030	86-NF9-224-010	SPR-C, LOCK	a
	O	MC1031	82-NF5-229-010	PLATE, LOCK(*)	a
	O	MC1032	87-NF4-217-110	HLDR, LOCK 2	a
	O	MC1033	88-908-301-110	FF-CABLE, 8P 1.25 300MM	a
	O	MC1034	88-911-101-110	FF-CABLE, 11P 1.25 100MM	a
	O	MC1035	88-904-201-110	FF-CABLE, 4P 1.25	a
	O	MC1036	8B-NF9-207-010	GUIDE, FL 90.2-20	a
	O	MC1037	8A-NF8-206-010	HLDR, PWB M	a
	O	MC1038	8B-NF1-013-010	PANEL, TRAY	a
	O	MC1039	87-CE3-023-010	BADGE, AIWA 30N SILV	a
	O	MC1040	88-906-251-110	FF-CABLE, 6P 1.25	a
					CX-SNR80
					VSM
	O	MC1041	8C-NF5-017-010	CABI, REAR VSM	a
	O	MC1042	8B-NF1-203-010	HLDR, PWB PT	a
	!	MC1043	87-A80-157-010	AC CORD ASSY, E BLK CC	a
	O	MC1044	87-085-185-010	BUSHING, AC CORD(E) CM-22B	a
	X	MC1045	8C-NF5-621-010	PWB, FRONT CNF-5	a
	O	MC1046	8B-NF1-006-010	PANEL, RIGHT	a
	O	MC1047	84-ZG1-245-210	CAP, OPTICAL	a
	X	MC1048	8C-NF5-633-210	PWB, HP1 U/LH/HR/V	a
	X	MC1049	8B-NF9-204-010	CUSH, 11-8.5-2	a
	O	MC1050	8B-NF1-209-010	COVER, MAGNET	a
	O	MC1051	8B-NF1-206-010	MAGNET, BOX 11-6-4	a
	O	MC1052	8B-NF1-207-010	PLATE, BOX	a
	X	MC1053	87-NF4-218-010	PLATE, EARTH MECHA	a
	X	MC1054	M8-BZG-581-130	BZG-5 ZD5GNDM	a
	X	MC1055	M8-6ZM-39C-130	6ZM-3 PR4NM	a
	X	MC1056	8C-NF5-207-010	CHAS, MAIN CM 76-60	a
	!	MC1057	8C-NF5-608-010	PT, CNF-5 EZ	a
	X	MC1058	8C-NF5-203-010	HLDR, TR 7	a
	X	MC1059	8C-NF5-631-210	PWB, MAIN U/LH/HR/V	a
	O	MC1060	8C-NF5-603-010	FL, HUA-11MM42T	a
					CX-SNR80
					VSM
	X	MC1061	8C-NF5-226-110	HT-SINK, ASSY140-3	a
	X	MC1061a	8C-NF5-212-110	HT-SINK, MAIN S	a
	X	MC1061b	8C-NF5-213-010	HT-SINK, FIN 140	a
	X	MC1062	8C-NF5-632-210	PWB, PT U/LH/HR/V	a
	X	MC1063	8C-NF5-636-210	PWB, HLDR WIRE1 U/LH/HR/V	a
	X	MC1064	8B-NF6-215-010	HT-SINK, FET	a
	!	MC1065	8B-MA6-675-010	PT, SUB BMA E (VRK)	a
	X	MC1066	8C-NF5-622-010	PWB, CD LED CNF-5	a
	O	MC1A	87-B10-091-010	UTT2+3-10 W/O SLOT BLK	a
	O	MC1B	87-721-096-410	QT2+3-10 W/O SLOT	a
	O	MC1C	88-AR1-217-010	S-SCREW, BFT2+3-8	a
	O	MC1D	87-NF4-224-010	S-SCREW, IT3B+3-8 CU	a
	O	MC1E	8C-NF5-222-010	W, 4-7-0.65 W/ADH	a
	O	MC1F	87-067-579-010	BVT2+3-8 W/O SLOT	a
	O	MC1G	87-067-703-010	BVT2+3-10 W/O SLOT	a
	O	MC1H	87-B10-315-010	BVIT3B+3-8 R W/O	a
	O	MC1I	87-078-200-010	S-SCREW, ITC+4-8 R	a

COLOR NAME TABLE -1/1

Basic color symbol	Color	Basic color symbol	Color	Basic color symbol	Color
B	Black	C	Cream	D	Orange
G	Green	H	Gray	L	Blue
LT	Transparent Blue	N	Gold	P	Pink
R	Red	S	Silver	ST	Titan Silver
T	Brown	V	Violet	W	White
WT	Transparent White	Y	Yellow	YT	Transparent Yellow
LM	Metallic Blue	LL	Light Blue	GT	Transparent Green
LD	Dark Blue	DT	Transparent Orange	GM	Metallic Green
YM	Metallic Yellow	DM	Metallic Orange	PT	Transparent Pink
LA	Aqua Blue	GL	Light Green	HT	Transparent Gray
HM	Metallic Gray	NH	Champagne Gold	M	Wood Pattern

TAPE MECHANISM EXPLODED VIEW -1/1 <6ZM-3 PR4NM>

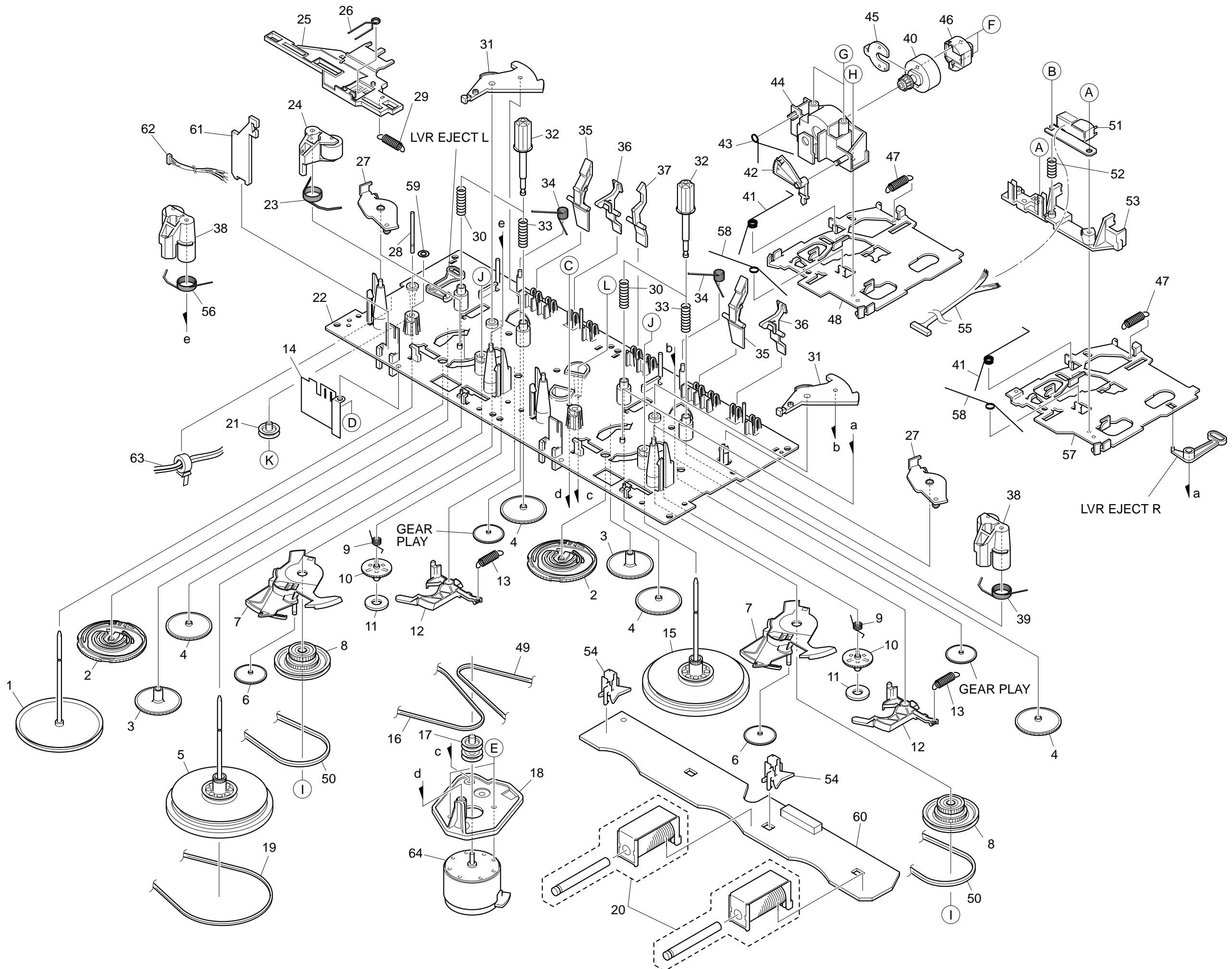

TAPE MECHANISM PARTS LIST -1/2 <6ZM-3 PR4NM>

! = SAFETY PARTS
 C = Components marked

All components used on this model at the production line are shown in this service manual.

However, please note that not all components will be available as spare parts for after-sales service.

Components marked S and O are designated as spare parts for service and will be stocked at the spare parts centers.

Components marked X and R are not designated as spare parts for after sales service, and will not be stocked at the spare parts centers.

UNIT-NAME	! C	REF-NO	PARTS-NO	PARTS-NAME	SUFFIX&MODEL
					6ZM-3 PR4NM
	O	ST1001	82-ZM1-234-310	FLY-WHL, L ASSY	a
	X	ST1001a	82-ZM1-348-110	FLY-WHL, L W	a
	X	ST1001b	82-ZM1-236-010	CAPSTAN, 2-41.5	a
	O	ST1002	82-ZM3-305-310	GEAR, CAM M2	a
	O	ST1003	82-ZM1-226-010	GEAR, REW	a
	O	ST1004	82-ZM1-216-510	GEAR, REEL	a
	X	ST1005	09-001-420-010	FLY-WHL, R ASSY	a
	X	ST1005a	82-ZM3-338-310	FLY-WHL, R3W	a
	X	ST1005b	82-ZM1-239-010	CAPSTAN, 2.2-41.7	a
	O	ST1006	82-ZM1-225-210	GEAR, FR	a
	O	ST1007	82-ZM3-306-110	LVR, FR M2	a
	O	ST1008	82-ZM3-333-310	SLIP DISK ASSY 2	a
	X	ST1008a	82-ZM3-332-310	PULLEY, FR 2	a
	X	ST1008b	82-ZM1-230-110	GEAR, TAKE UP	a
	X	ST1008c	82-ZM1-231-010	CLR, SLIP	a
	X	ST1008d	82-ZM1-232-010	FELT, DIA 8.4-13-1	a
	X	ST1008e	82-ZM1-233-110	SPR-C, SLIP	a
	O	ST1009	82-ZM1-322-010	SPR-T, FR 60	a
	O	ST1010	82-ZM1-220-210	GEAR, IDLER	a
	O	ST1011	82-ZM3-616-010	RING MAGNET 4	a
					6ZM-3 PR4NM
	O	ST1012	82-ZM1-227-310	LVR, TRIG	a
	O	ST1013	82-ZM1-265-310	SPR-E, TRIG	a
	X	ST1014	85-ZM3-201-210	PLATE, SHLD M3	a
	O	ST1015	82-ZM1-237-610	FLY-WHL ASSY, R	a
	X	ST1015a	82-ZM1-349-110	FLY-WHL, R W	a
	X	ST1015b	82-ZM1-239-010	CAPSTAN, 2.2-41.7	a
	O	ST1016	86-ZM3-210-010	BELT, PS	a
	O	ST1017	82-ZM3-221-210	PULLEY, MOT 2M	a
	O	ST1018	86-ZM3-203-010	HLDR, MOT S	a
	O	ST1019	86-ZM1-206-010	BELT, MAIN L	a
	O	ST1020	82-ZM3-627-010	SOL ASSY, 27 SO	a
	X	ST1020a	82-ZM3-629-010	HLDR, BOBBIN SOL SO	a
	X	ST1020b	82-ZM3-630-010	YOKE, SOL SO	a
	X	ST1020c	82-ZM3-631-010	SHAFT, CORE SOL SO	a
	X	ST1020d	82-ZM3-632-010	SHAFT, PLUNGER SOL SO	a
	X	ST1020e	82-ZM3-633-010	TERMINAL, SOL SO	a
	O	ST1021	82-ZM3-335-310	PULLEY, COUPLER M3	a
	O	ST1022	86-ZM3-215-110	CHAS ASSY, RS	a
	X	ST1022a	82-ZM1-317-210	OILLESS-BRG 2.2RN	a
	X	ST1022b	82-ZM1-318-210	OILLESS-BRG 2LN	a
					6ZM-3 PR4NM
	X	ST1022c	82-ZM3-302-610	OUT-SERT ASSY, M2	a
	X	ST1022d	82-ZM3-303-210	CHAS, M2	a
	O	ST1023	82-ZM1-258-210	SPR-T, PINCH L	a
	O	ST1024	82-ZM3-348-010	LEVER ASSY, PINCH YL	a
	X	ST1024a	82-ZM3-349-010	LEVER, PINCH YL	a
	X	ST1024b	82-ZM3-345-010	ROLLER ASSY, Y	a
	X	ST1024c	82-ZM3-346-010	CLR, ROLLER Y	a
	X	ST1024d	82-ZM3-347-010	ROLLER, RUBBER Y	a
	O	ST1025	82-ZM1-266-310	LVR, DIR	a
	O	ST1026	82-ZM1-214-010	SPR-T, DIR	a
	O	ST1027	82-ZM1-333-210	PLATE, LINK2	a
	O	ST1028	82-ZM3-339-110	SHAFT, COUPLER N3	a
	O	ST1029	82-ZM1-255-310	SPR-E, LVR DIR	a
	O	ST1030	82-ZM1-285-410	SPR-C, BT L	a
	O	ST1031	82-ZM1-222-310	LVR, PLAY	a
	O	ST1032	82-ZM1-217-410	REEL, TABLE	a
	O	ST1033	82-ZM1-244-510	SPR-C, BT	a
	O	ST1034	82-ZM1-257-010	SPR-T, CAS	a
	O	ST1035	82-ZM1-242-010	LVR, CAS	a
	O	ST1036	82-ZM1-243-010	LVR, STOP	a
					6ZM-3 PR4NM
	O	ST1037	82-ZM1-240-110	LVR, REC	a
	O	ST1038	82-ZM3-343-010	LEVER ASSY, PINCH YR	a
	X	ST1038a	82-ZM3-344-010	LEVER, PINCH YR	a
	X	ST1038b	82-ZM3-345-010	ROLLER ASSY, Y	a
	X	ST1038c	82-ZM3-346-010	CLR, ROLLER Y	a
	X	ST1038e	82-ZM3-347-010	ROLLER, RUBBER Y	a
	O	ST1039	86-ZM3-204-010	SPR-T, PINCH S	a
	O	ST1040	82-ZM1-208-310	HLDR, HEAD	a
	O	ST1041	82-ZM1-219-110	SPR-T, LINK	a
	O	ST1042	82-ZM1-210-110	GEAR, H T	a
	O	ST1043	82-ZM3-353-010	SPR-T, HEAD 2	a
	O	ST1044	82-ZM1-207-910	GUIDE, TAPE	a
	O	ST1045	82-ZM1-314-110	PLATE, HEAD	a
	O	ST1046	87-A92-196-010	HEAD, PH HADKH2604A FPC	a
	X	ST1046a	85-ZM3-602-010	PWB, FLEX A	a
	O	ST1047	82-ZM1-218-010	SPR-E, HB	a
	O	ST1048	82-ZM1-206-910	CHAS, HEAD	a
	O	ST1049	86-ZM3-214-110	BELT, SBU RR	a
	O	ST1050	82-ZM1-338-110	BELT, FR 4	a
	O	ST1051	87-A92-195-010	HEAD, RPH HASVH5507A	a

TAPE MECHANISM PARTS LIST -2/2 <6ZM-3 PR4NM>

! = Δ SAFETY PARTS
 C = Components marked

All components used on this model at the production line are shown in this service manual.
 However, please note that not all components will be available as spare parts for after-sales service.
 Components marked S and O are designated as spare parts for service and will be stocked at the spare parts centers.
 Components marked X and R are not designated as spare parts for after sales service, and will not be stocked at the spare parts centers.

UNIT-NAME	! C	REF-NO	PARTS-NO	PARTS-NAME	SUFFIX&MODEL
					6ZM-3 PR4NM
	O	ST1052	86-ZM3-222-010	SPR-C, RPH S2	a
	O	ST1053	86-ZM3-202-210	BASE, HEAD S	a
	O	ST1054	82-ZM3-351-010	HLDR, IC 2	a
	O	ST1055	86-ZM3-605-110	CONN ASSY, 8P -RPB	a
	O	ST1056	82-ZM1-259-310	SPR-T, PINCH R	a
	O	ST1057	86-ZM3-201-010	CHAS, HEAD S	a
	O	ST1058	82-ZM1-269-210	SPR-T, BRG	a
	O	ST1059	82-ZM1-288-010	SH, 1.63-3.2-0.5 SLT	a
	X	ST1060	86-ZM3-602-110	PWB, MAIN S	a
	X	ST1061	86-ZM3-603-110	PWB, HEAD S	a
	O	ST1062	85-MA2-615-010	CONN ASSY, 3P PH	a
	O	ST1063	87-069-033-010	CABLE, TIE	a
	O	ST1064	87-A92-321-010	MOT, SHU2L 60	a
	O	ST1A	86-ZM3-207-010	S-SCREW, RPH	a
	O	ST1B	86-ZM3-209-010	S-SCREW, AZIMUTH S	a
	O	ST1C	87-761-073-410	VFT2+2.6-6 W/O SLOT	a
	O	ST1D	82-ZM3-222-010	S-SCREW, SHILD PLATE	a
	O	ST1E	87-251-071-410	U+2.6-4	a
	O	ST1F	80-ZM6-207-010	V+1.6-7	a
	O	ST1G	86-ZM4-206-110	S-SCREW, AZIMUTH L	a
					6ZM-3 PR4NM
	O	ST1H	85-ZM3-202-010	S-SCREW, TG	a
	O	ST1I	82-ZM3-334-010	PW, 2.16-6-0.4	a
	O	ST1J	80-ZM6-243-010	SH 1.75-3.6-0.5 SLT	a
	O	ST1K	87-B10-043-010	W-P, 0.99-4-0.25 SLT	a
	O	ST1L	86-ZM3-213-010	S-SCREW, HLDR MOT S	a

GENERAL SPEAKER DISASSEMBLY INSTRUCTIONS (FOR REFERENCE) -1/1

Type.1

Insert a flat-bladed screwdriver into the position indicated by the arrows and remove the panel. Remove the screws of each speaker unit and then remove the speaker units.

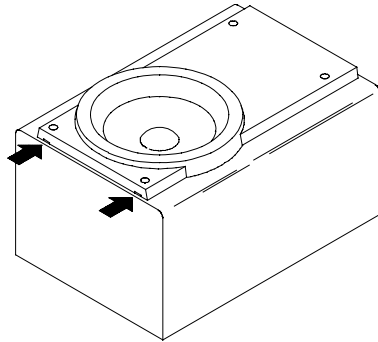

Type.2

Remove the grill frame and four pieces of rubber caps by pulling out with a flat-bladed screwdriver. Remove the screws from hole where installed rubber caps. Insert a flat-bladed screwdriver into the position indicated by the arrows and remove the panel. Remove the screws of each speaker unit and then remove the speaker units.

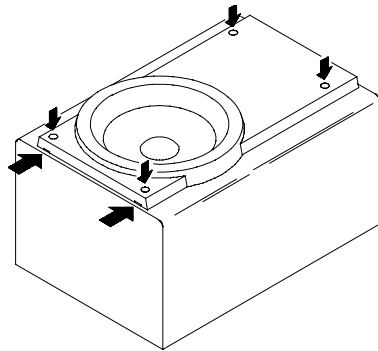

Type.3

Insert a flat-bladed screwdriver into the position indicated by the arrows and remove the panel. Turn the speaker unit to counter-clockwise direction while inserting a flat-bladed screwdriver into one of the hollows around speaker unit, and then remove the speaker unit. After replacing the speaker unit, install it turning to clockwise direction until "click" sound comes out.

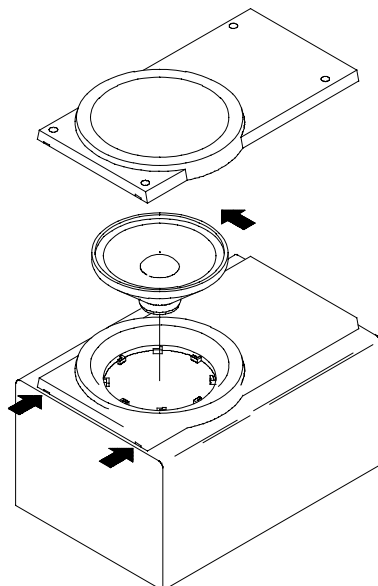

Type.4

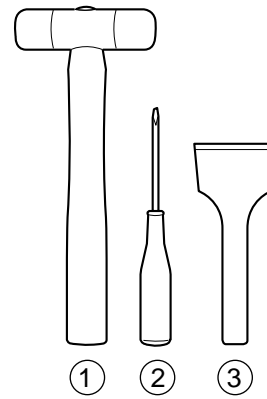

TOOLS

- ① Plastic head hammer
- ② (⊖) flat head screwdriver
- ③ Cut chisel

How to Remove the PANEL, FR

1. Insert the (⊖) flat head screwdriver tip into the gap between the PANEL, FR and the PANEL, SPKR. Tap the head of the (⊖) flat head screwdriver with the plastic hammer head, and create the clearance as shown in Fig-1.
2. Insert the cut chisel in the clearance, and tap the head of the cut chisel with plastic hammer as shown in Fig-2, to remove the PANEL, FR.
3. Place the speaker horizontally. Tap head of the cut chisel with plastic hammer as shown in Fig-3, and remove the PANEL, FR completely.

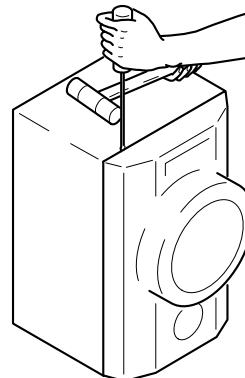

Fig-1

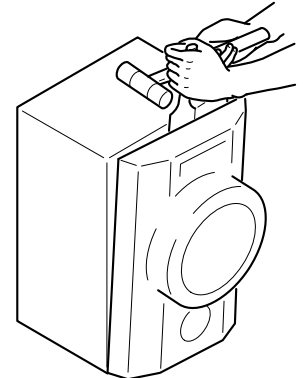

Fig-2

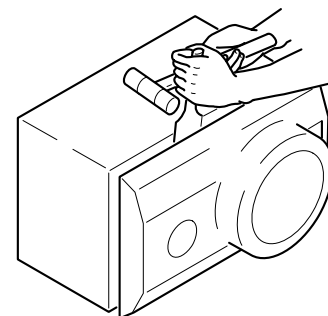

Fig-3

How to Attach the PANEL, FR

Attach the PANEL, FR to the PANEL, SPKR. Tap the four corners of the PANEL, FR with the plastic hammer to fit the PANEL, FR into the PANEL, SPKR completely.

SPEAKER PARTS LIST -1/1 <SX-NR80>

! = Δ SAFETY PARTS

C = Components marked

All components used on this model at the production line are shown in this service manual.

However, please note that not all components will be available as spare parts for after-sales service.

Components marked S and O are designated as spare parts for service and will be stocked at the spare parts centers.

Components marked X and R are not designated as spare parts for after sales service, and will not be stocked at the spare parts centers.

UNIT-NAME	! C	REF-NO	PARTS-NO	PARTS-NAME	SUFFIX&MODEL
					SX-SNR80
					YSN
	O	SP1001	88-NSK-610-010	SPKR, CERAMIC ASSY	a
	O	SP1002	8A-NSJ-006-010	BADGE, AIWA S35	a
	O	SP1003	8B-NSH-612-010	CORD, SPKR	a
	O	SP1004	8C-NS4-606-010	SPKR, T 50 14/2	a
	O	SP1005	8C-NS5-001-010	PANEL, FR A R	a
	O	SP1006	8C-NS5-002-010	PANEL, FR A L	a
	O	SP1007	8C-NS5-003-010	PANEL, BA A R	a
	O	SP1008	8C-NS5-004-010	PANEL, BA A L	a
	O	SP1009	8C-NS5-005-010	PANEL, FR B R	a
	O	SP1010	8C-NS5-006-010	PANEL, FR B L	a
	O	SP1011	8C-NS5-007-010	PANEL, BA B R	a
	O	SP1012	8C-NS5-008-010	PANEL, BA B L	a
	O	SP1013	8C-NS5-009-010	PLATE, W	a
	O	SP1014	8C-NS5-010-010	PROTECTOR, SQ	a
	X	SP1015	8C-NS5-011-010	LBL, SPEC YS R	a
	X	SP1016	8C-NS5-012-010	LBL, SPEC YS L	a
	O	SP1017	8C-NS5-013-010	PROTECTOR, TW L	a
	O	SP1018	8C-NS5-014-010	PROTECTOR, TW R	a
	O	SP1019	8C-NS5-602-010	SPKR, W 160 30/4	a
	O	SP1020	8C-NS5-604-010	SPKR, M 80 16/2	a
					SX-SNR80
					YSN
	O	SP1021	8Z-NS3-026-010	CORD, BUSH L	a
	X	SP1022	PC-NS5-943-070	SX-SNR80YSN	a

OTHER PARTS LIST -1/2

- ! = Δ SAFETY PARTS
- C = Components marked

All components used on this model at the production line are shown in this service manual.
 However, please note that not all components will be available as spare parts for after-sales service.
 Components marked S and O are designated as spare parts for service and will be stocked at the spare parts centers.
 Components marked X and R are not designated as spare parts for after sales service, and will not be stocked at the spare parts centers.

UNIT-NAME	! C	REF-NO	PARTS-NO	PARTS-NAME	SUFFIX&MODEL
					CX-SNR80
					VSM
	X		8B-NF1-031-110	SH,CD	a
	X		8B-NF1-213-010	SH, 12.5-17.5-0.07 W/ADH	a
	X		87-B40-281-010	LBL,BAR-CODE A 35X8	a
	X		87-057-995-010	LBL,CAUTION EFSD	a
	X		87-057-961-010	LBL,CAUTION TRIANGLE	a
	X		8B-NF1-029-010	SH,FL	a
	X		87-B40-447-010	SH, 28-10-0.35 W/ADH	a
	X		8B-NF1-214-010	SH,FFC	a
	X		8B-NF1-032-010	SH,LED	a
	X		87-B40-098-010	BAG,PV 0.025-650-750 PL	a
	X		93-704-337-010	SH,FOAMED-MAT 0.31-800-500	a
	X		87-B40-085-010	BAG,PV 0.04-200-350 PL	a
	X		87-B50-079-010	LIST,FACILITY(B)-0007	a
	X		8C-NF5-854-110	CUSHION,FRONT M	a
	X		8C-NF5-855-110	CUSHION,REAR M	a
	X		8C-NF5-917-010	SH,ADDITIONAL DIG(ER)	a
	X		8C-NF5-973-010	LBL,POP V	a

OTHER PARTS LIST -2/2 <TAPE MECHANISM 6ZM-3 PR4NM>

! = Δ SAFETY PARTS

C = Components marked

All components used on this model at the production line are shown in this service manual.

However, please note that not all components will be available as spare parts for after-sales service.

Components marked S and O are designated as spare parts for service and will be stocked at the spare parts centers.

Components marked X and R are not designated as spare parts for after sales service, and will not be stocked at the spare parts centers.

UNIT-NAME	! C	REF-NO	PARTS-NO	PARTS-NAME	SUFFIX&MODEL
					6ZM-3
					PR4NM
	X		82-ZM3-987-010	BAG, PV 0.04-300-210	a

アイワ株式会社 〒110-8710 東京都台東区池之端1-2-11 ☎03(3827)3111 (代表)
AIWA CO.,LTD. 2-11, IKENOHATA 1-CHOME, TAITO-KU, TOKYO 110-8710, JAPAN TEL:03 (3827) 3111

0251431