

STR-V45L

AEP Model
UK Model

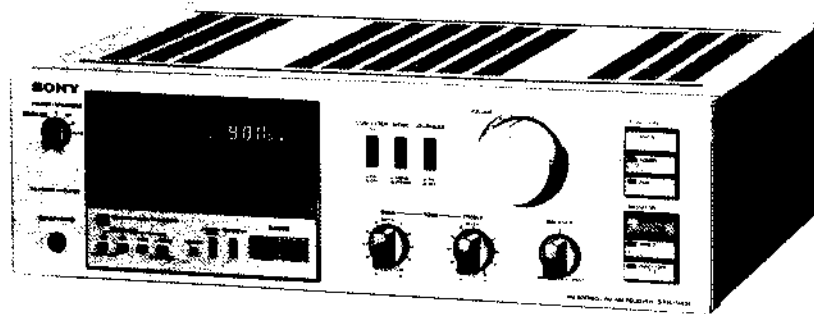

FM STEREO/FM-AM RECEIVER

SPECIFICATIONS

GENERAL

- Power Requirements:** 220 V ac, 50/60 Hz (AEP model)
240 V ac, 50/60 Hz (UK model)
- Power Consumption:** 180 W (AEP model)
210 W (UK model)
- Dimensions:** Approx. 430 (w) x 135 (h) x 380 (d) mm
17 (w) x 5 1/4 (h) x 14 7/8 (d) inches
including projecting parts and controls
- Weight:** Approx. 8.5 kg, 18 lb 12 oz (net)
9.7 kg, 21 lb 7 oz (in shipping carton)

Intermodulation (IM)

Distortion: Less than 0.04 % at rated output
(60Hz : 7kHz = 4 : 1)

Damping Factor: 50 at 1 kHz, 8 Ω

Dynamic Headroom: 1.4 dB

Residual Noise: Less than 0.23 mV at 8 Ω

AMPLIFIER SECTION

- Continuous RMS Power Output:** At 1 kHz
40 + 40 W (8 Ω)
At 20 Hz – 20 kHz
40 + 40 W (8 Ω)
According to DIN 45500
40 + 40 W (8 Ω)
- Power Bandwidth (IHF):** 5 Hz – 35 kHz
- Harmonic Distortion:** Less than 0.04 % at rated output

Inputs:

	Sensitivity	Impedance	S/N	Weighting network
PHONO	2.5 mV (-50 dB)	50 k Ω	80 dB 77 dB*	A
TAPE 1, 2	150 mV (-13.5 dB)	50 k Ω	97 dB 74 dB*	A
AUX	150 mV (-13.5 dB)	50 k Ω	97 dB 74 dB*	A

* '78 IHF, Measured with rated output power into 8 Ω loads
(both channels driven simultaneously) at 1 kHz.

— Continued on page 2 —

SAFETY RELATED COMPONENT WARNING!!
COMPONENTS IDENTIFIED BY SHADING AND MARK
ON THE SCHEMATIC DIAGRAMS, EXPLODED
VIEWS AND IN THE PARTS LIST ARE CRITICAL TO
SAFE OPERATION. REPLACE THESE COMPONENTS
WITH SONY PARTS WHOSE PART NUMBERS APPEAR
AS SHOWN IN THIS MANUAL OR IN SUPPLEMENTS
PUBLISHED BY SONY.

SONY

SERVICE MANUAL

STR-V45L

Outputs:

REC OUT 1, 2	Voltage 150 mV (-13.5 dB), Impedance 10 kΩ
HEADPHONES	Accepts low-impedance headphones
SPEAKERS	8 - 16 Ω speakers are suitable

Measured with rated input, FM 30 % modulation

Frequency Response: PHONO: RIAA equalization curve ± 0.5 dB
 AUX, TAPE 1, 2: 5 Hz - 50 kHz $\begin{matrix} +0 \\ -1 \end{matrix}$ dB

Tone Controls: BASS: ± 10 dB at 50 Hz
 TREBLE: ± 10 dB at 20 kHz

Loudness Control: +10 dB at 50 Hz, +3 dB at 10 kHz
 (att. 30dB)

Filter: LOW: 12 dB/octave attenuation below 15 Hz

FM TUNER SECTION

Tuning Range: 87.5 - 108.0 MHz
Antenna Terminals: 300 Ω balanced, 75 Ω unbalanced
Intermediate Frequency: 10.7 MHz

	(at 40 kHz deviation)
Sensitivity:	at 46 dB quieting 18.3 dBf, 4.5 μV (13 dB) (mono) 38.3 dBf, 45 μV (33 dB) (stereo)
Usable Sensitivity:	11.2 dBf, 2.0 μV (6 dB) (IHF) 9.8 dBf, 1.7 μV (4.5 dB) (S/N 26 dB)
Signal-to-noise Ratio:	72 dB (mono), 66 dB (stereo)
Harmonic Distortion:	at 100 Hz 0.1 % (mono), 0.25 % (stereo) at 1 kHz 0.1 % (mono), 0.2 % (stereo) at 6 kHz 0.15 % (mono), 0.2 % (stereo)

Separation: 40 dB at 100 Hz, 50 dB at 1 kHz,
 35 dB at 10 kHz

Frequency Response: 40 Hz - 12.5 kHz ± 0.3 dB
 30 Hz - 15 kHz $\begin{matrix} +0.5 \\ -1.5 \end{matrix}$ dB

Selectivity: 80 dB (300 kHz)

Capture Ratio: 1.5 dB
AM Suppression Ratio: 60 dB
Image Response Ratio: 85 dB
IF Response Ratio: 100 dB
Spurious Response Ratio: 95 dB
RF Intermodulation: 78 dB (IHF), 93 dB (2.4 MHz)
Sub-carrier Product Ratio: 55 dB
Muting Threshold: Approx. 25.2 dBf, 10 μV (20 dB)
Auto Tuning Level: LOW: 30 dBf, MID: 40 dBf, HIGH: 55 dBf

AM TUNER SECTION

	MW	LW
Tuning Range:	522 kHz - 1,602 kHz (9 kHz steps)	155 kHz - 344 kHz (1 kHz steps)
Antenna:		
built-in antenna	provided	provided
external antenna terminal	provided	provided
Intermediate Frequency:	450 kHz	450 kHz
Usable Sensitivity:		
built-in antenna	250 μV/m (48 dB/m) (1,000 kHz)	500 μV/m (54 dB/m) (254 kHz)
external antenna	100 μV (40 dB) (1,000 kHz)	150 μV (43.5 dB) (254 kHz)
Signal-to-noise Ratio: (at 50 mV/m (34 dB/m))	52 dB	52 dB
Harmonic Distortion: (at 50 mV/m (34 dB/m), 400 Hz)	0.5 %	0.5 %
Selectivity:	40 dB (9 kHz)	40 dB (9 kHz)

MODEL IDENTIFICATION

- Specification Label -

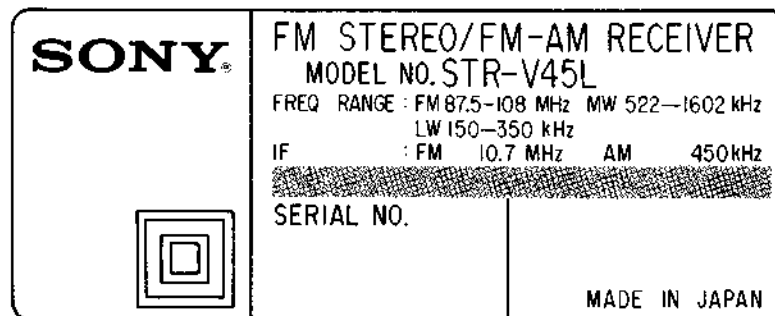

AEP MODEL AC 220V~ 50/60Hz 180W
 UK MODEL AC 240V~ 50/60Hz 210W

SERVICING NOTES

INSTALLATION PRECAUTION

The epoxy resin used in a luminous diode is a kind of thermosetting resin, but as a diode must let the light pass through, its heat resistance cannot be raised by mixing silica or glass fiber.

Thus, the resin used in the luminous diodes is usually weak against heat. As the tensile strength is not so strong while it is heated, note the following precautions during soldering.

- 1) Perform the soldering within 5 seconds with a soldering iron below 25W. The clearance between the tube and the board should be more than 3 mm (Fig. 1).
- 2) When changing the position of the luminous diode, do not move it right after soldering, but move it after it naturally cools off.
- 3) When bending the lead terminals, be sure to bend the point 2 mm farther from the tube. At this time, fix the foot of the terminal with a round nose plier and be sure that no force is applied to the tube. If not, a crack may occur (Fig. 2).

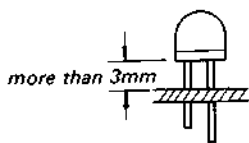

Fig. 1

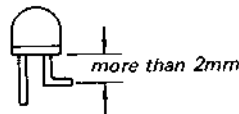

Fig. 2

THE CERAMIC CAPACITORS

This set uses tube-type ceramic capacitors whose shape is identical with the carbon resistors. Be careful not to use resistors instead of capacitors in repairing.

Disc-type ceramic capacitors can be used for replacing those originally used in the set.

Two kinds of drilled holes are provided in some patterns for mounting the tube-type and disc-type ceramic capacitors. Use appropriate holes where applicable.

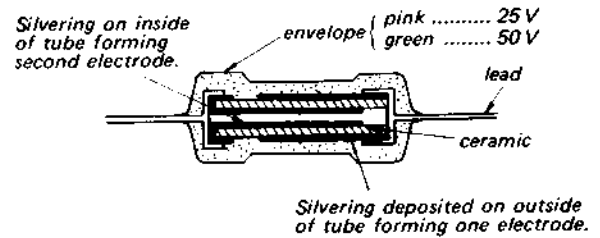

COLOR CODE (in pF)

Color	1st or 2nd Digit	Multiplier	Tolerance	Temperature characteristic
brown	1	10 ¹		Y
red	2	10 ²		D
orange	3	10 ³		
yellow	4	10 ⁴		RH
green	5			
blue	6			
violet	7			UJ
gray	8		± 30%	X
white	9			SL
black	0	10 ⁰	± 20%	CH
gold		10 ⁻¹	± 5%	V
silver		10 ⁻²	± 10%	B

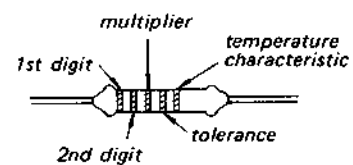

Example:

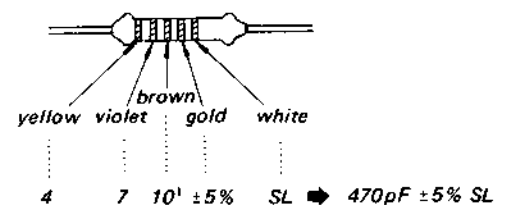

Handling Precautions for MOS ICs

Generally, the insulation resistance of the oxide layer in MOS IC structures is very high, and the oxide layer is very thin. Because of this, it is possible that the static voltages usually present on clothes and the human body will be enough to generate a potential difference across the insulator, high enough to cause a breakdown of the insulating layer.

The following precautions should be taken while handling these ICs.

(Particular care should be taken under conditions of low humidity.)

Precautions in Replacing MOS ICs

1. Store new ICs by inserting them into a urethane-polyester cushion (which is somewhat conductive), or wrapping it in aluminum foil, so that all the pins are at the same potential. (The ICs should be stored in that manner until mounted on the circuit board.)

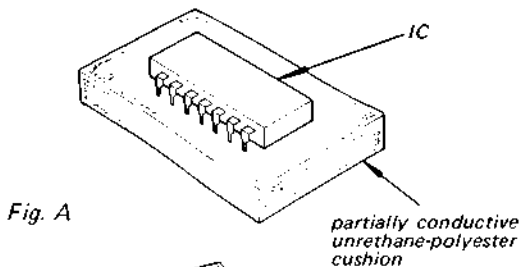

Fig. A

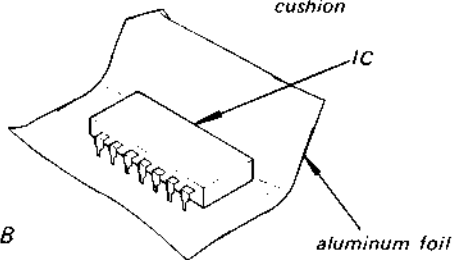

Fig. B

2. Check the soldering iron for possible power-line leakage current. Make sure that there is no leakage path by connecting an ohmmeter to the tip of the soldering iron and the plug as shown in Fig. C. If there is a leakage path, use some other soldering iron.

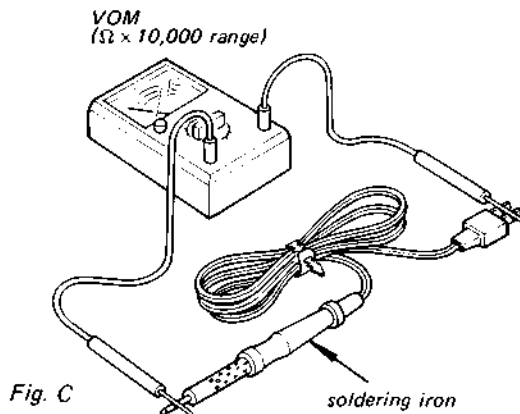

Fig. C

3. Equalize any potential difference between the clothes, the tools in use, the work bench, the set being worked on, and the packaged IC by touching them all in succession with the hands or a conductive wire or tool.
4. The following are effective methods for handling ICs that remove the potential difference across the oxide layer.
 - Use a paper clip modified by soldering in a wire braid insert.

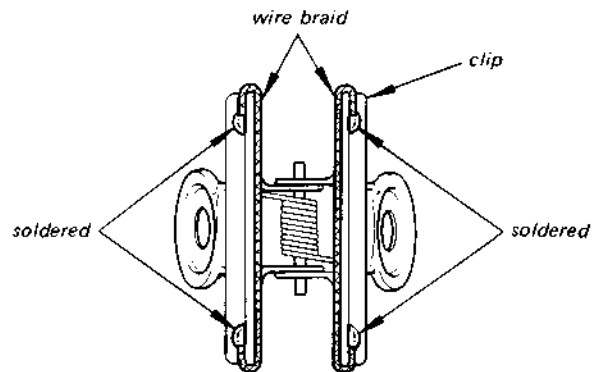

Fig. D

Make sure that there is no solder on the inside.

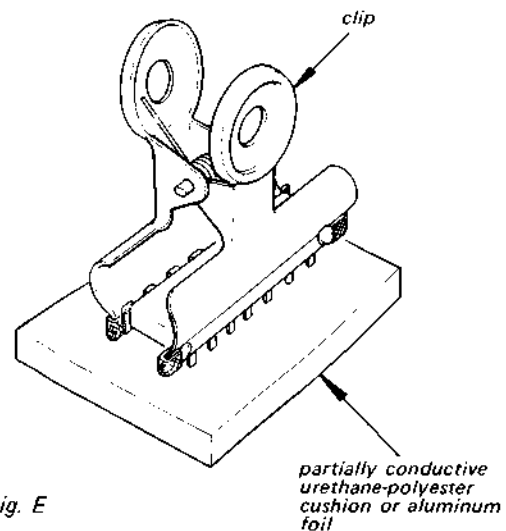

Fig. E

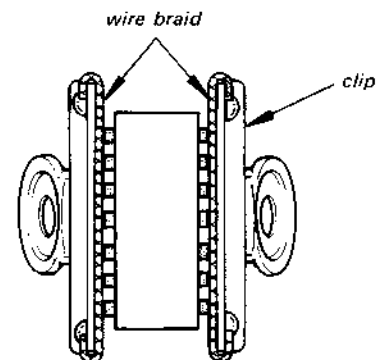

Fig. F

Make sure that all the pins are in contact with the wire braid (all the pins will then be at the same potential.).

SECTION 1
OUTLINE

1-1. BLOCK DIAGRAM

— Audio Amp and Power Supply Sections —

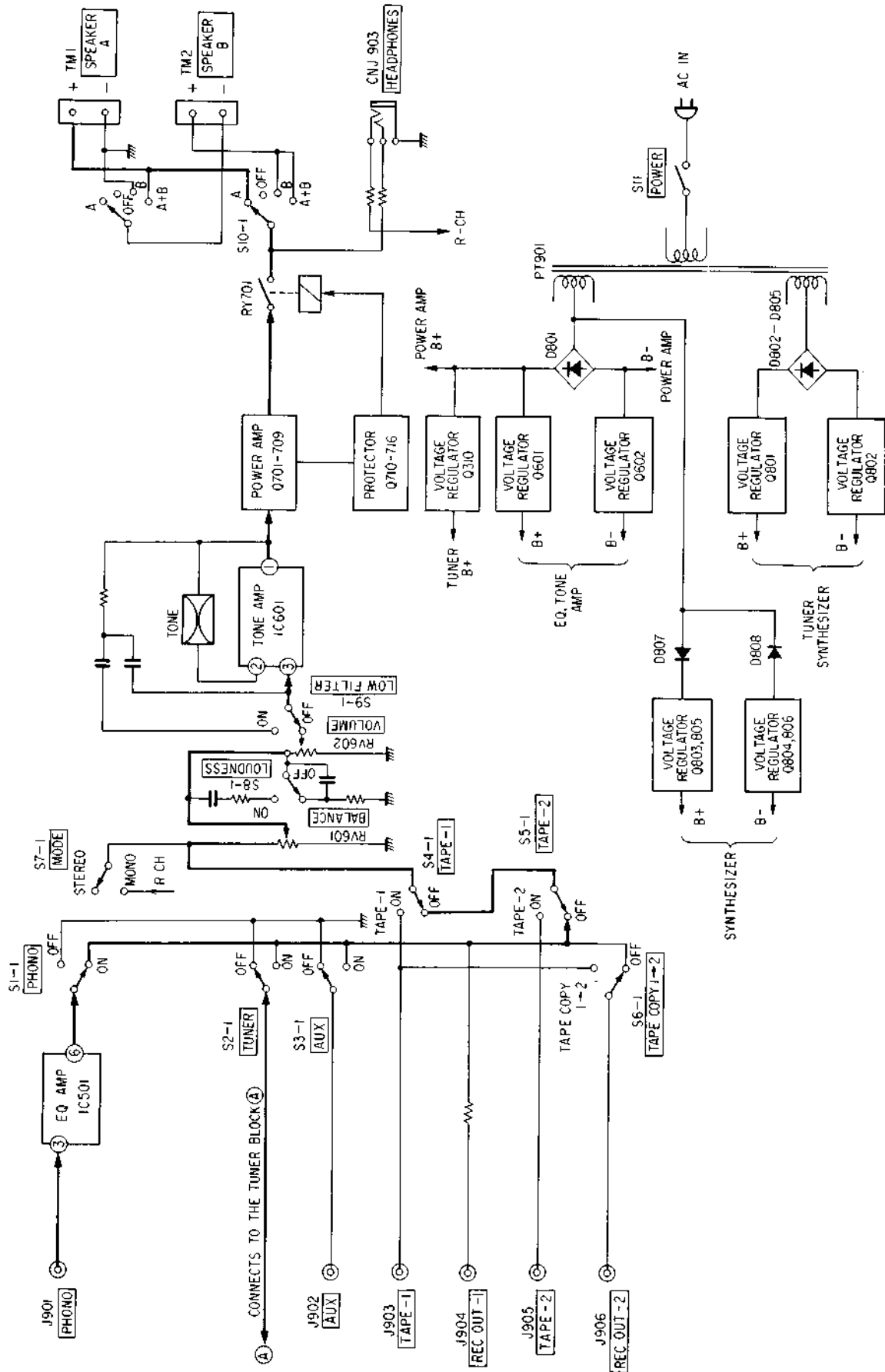

Outline of μ PD553C-065 (IC401):

This is a four-bit control microcomputer composed of ALU, ROM, RAM, I/O Ports and control circuit all of which are processed in four-bit parallel manner and are included on a small single chip.

P-channel MOS

ROM (1000 x 8-bits)

RAM (64 x 4-bits)

Input Ports

A and B

Input/output Ports

C and D

four-bits each except for Port I which is three bits

Output Ports

E, F, G, H and I

Clock Frequency: 360 kHz

Input signal is obtained from terminal 5 of the divider output in PLL CX778.

42-pin Plastic Dual-in-Line Package

I/O Ports:

Table 1

Port	Terminal	Function
PA ₀	33	AUTO/MANUAL
PA ₁	34	N/A
PA ₂	35	Input for AUTO TUNING stop signal
PA ₃	36	Input for memory IC's data
PB ₀₋₃	37 - 40	Refer to Fig. 1.
PC ₀₋₃	2 - 5	
PD ₀₋₃	8 - 11	
PF ₀₋₃	16 - 19	
PG ₀	22	
PG ₁	23	N/A
PG ₂	24	FM/ \overline{AM}
PG ₃	25	Output for muting pulse
PE ₀	12	Clock output for PLL memory IC
PE ₁	13	Output for muting pulse
PE ₂	14	Output for PLL
PE ₃	15	Output for PLL and memory IC
PH ₀	26	Outputs for memory IC address
PH ₁	27	
PH ₂	28	
PH ₃	29	
PI ₀	30	→ C1
PI ₁	31	→ C2
PI ₂	32	→ C3

Outputs for memory IC mode control

MEMORY IC CX761A (IC405)

Outline of CX761A:

- (a) This is a non-volatile memory IC. Has 228 (14 words x 16 bits + 4 bits) non-volatile memory transistors built in, and works for reading, erasure and writing the data word.
- (b) Because of being a non-volatile type memory, this IC maintains the memorized informations for a long time without a battery back-up after the power switch is turned off.
- (c) Word address is done by the BCD inputs.
- (d) Silicon-type P-channel enhancement MNOS IC construction.
- (e) 14-pin molded DIP casing.

Refer to the schematic diagram for the block diagram.

Table 2. Function of Terminals:

Terminal	IN or OUT	Function
1	IN	Word address D
2	IN	Word address C
3	IN	Word address B
4	IN	Word address A
5	IN	Power supply input
6	IN/OUT	Writing and erasure control inputs/memory-BUSY output
7	IN	Power supply input
8	IN/OUT	Inputs and outputs for test checkout
9	IN	Test signal
10	IN/OUT	Combined data inputs and data outputs
11	IN	Input for synchronous clock
12	IN	Input for mode control C3
13	IN	Input for mode control C2
14	IN	Input for mode control C1

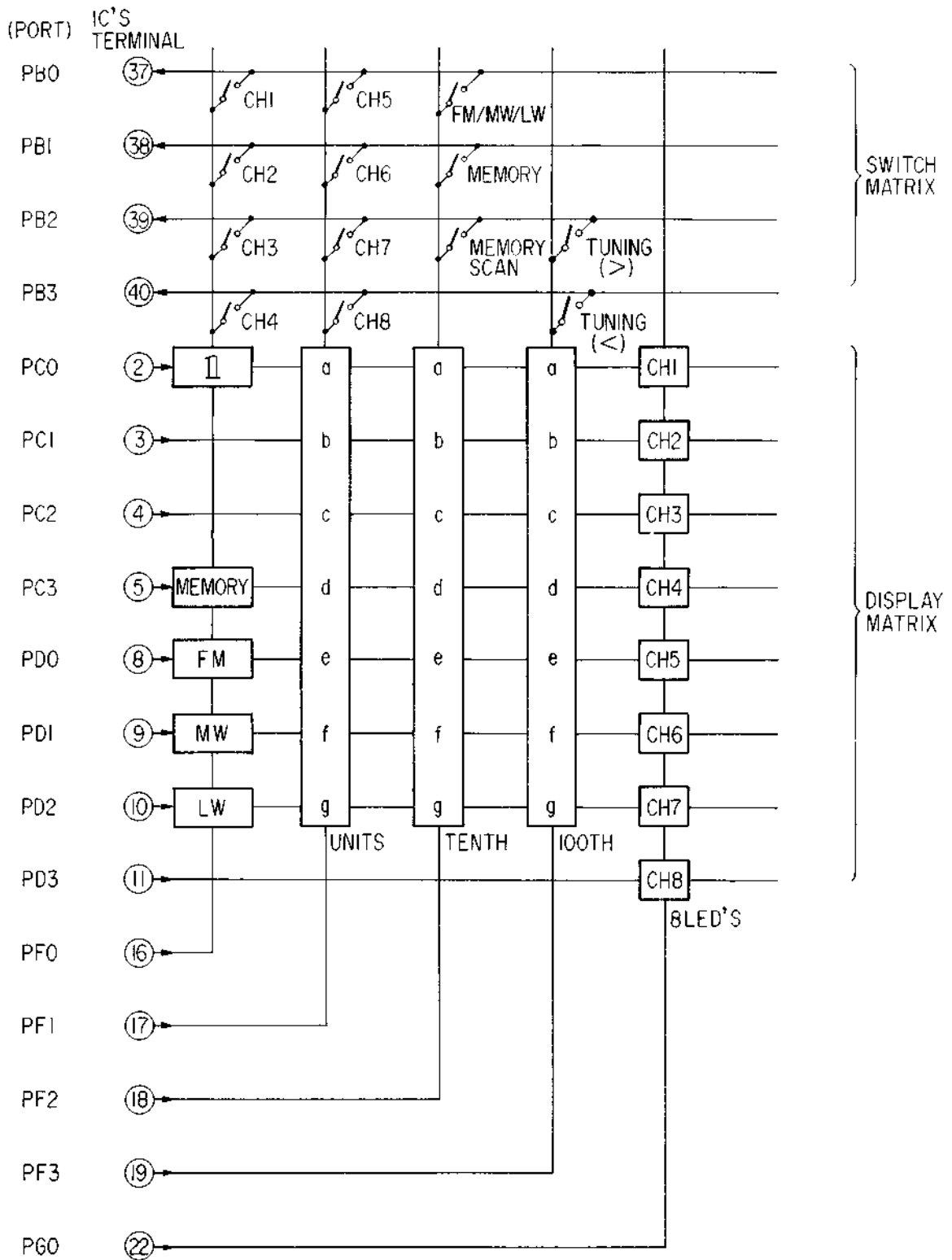

Fig. 1

SECTION 2 DISASSEMBLY

Note: Follow the disassembly procedure in the numerical order given.

TOP COVER AND BOTTOM PLATE REMOVAL

Note: Circuit-board checkouts and adjustments can be made after this removal.

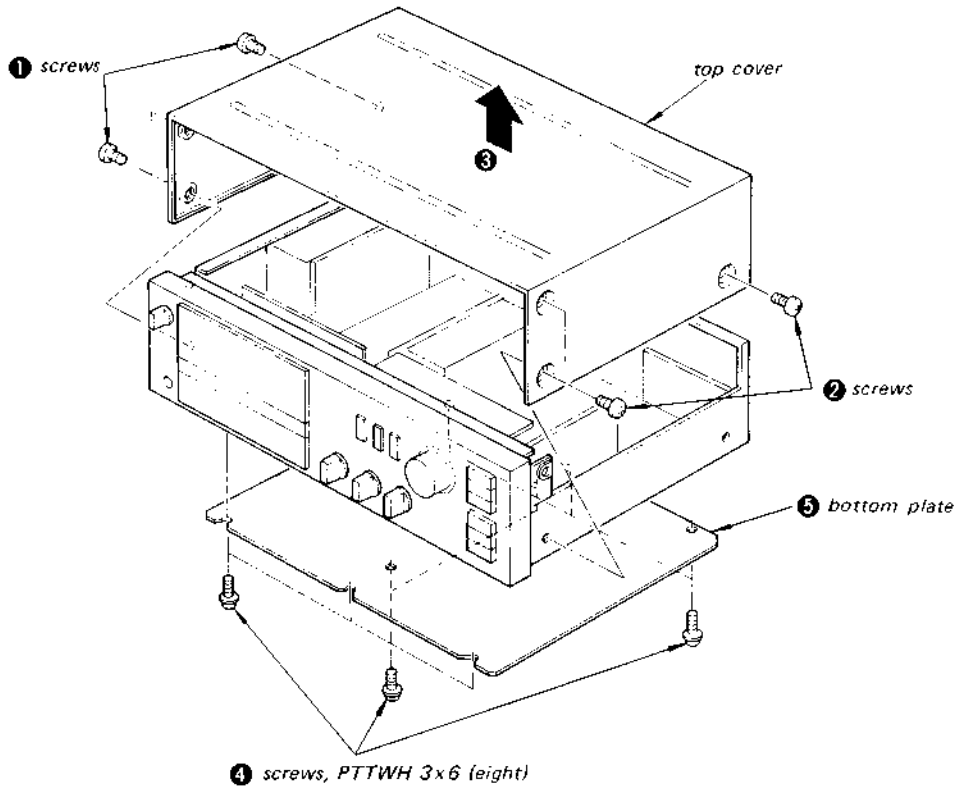

FRONT PANEL REMOVAL

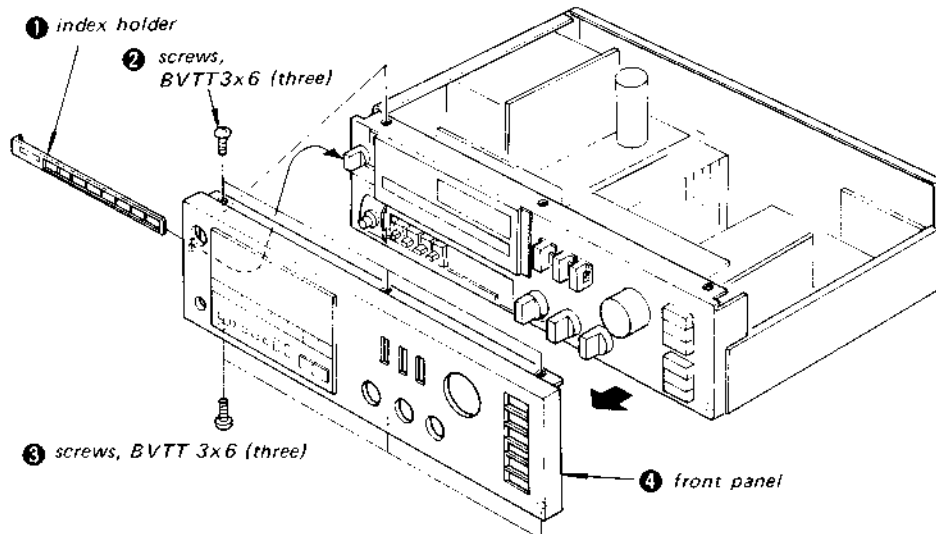

CIRCUIT BOARDS LAYOUT

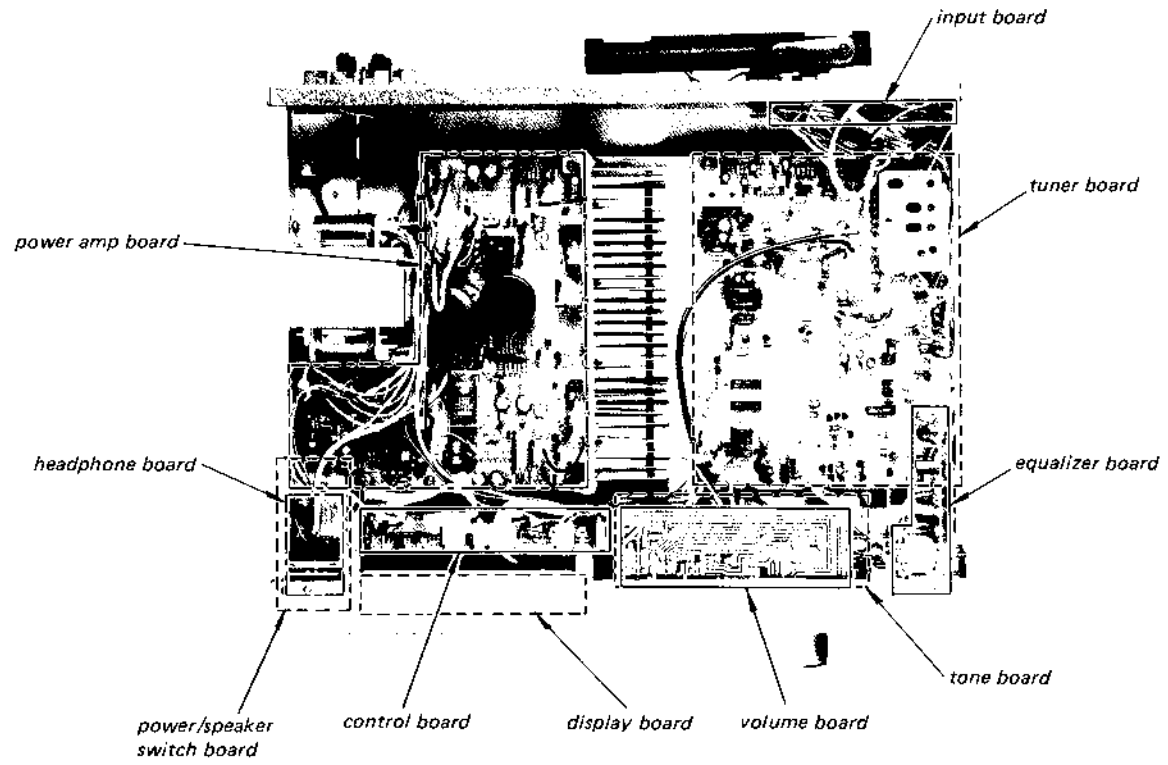

CONTROL BOARD REMOVAL

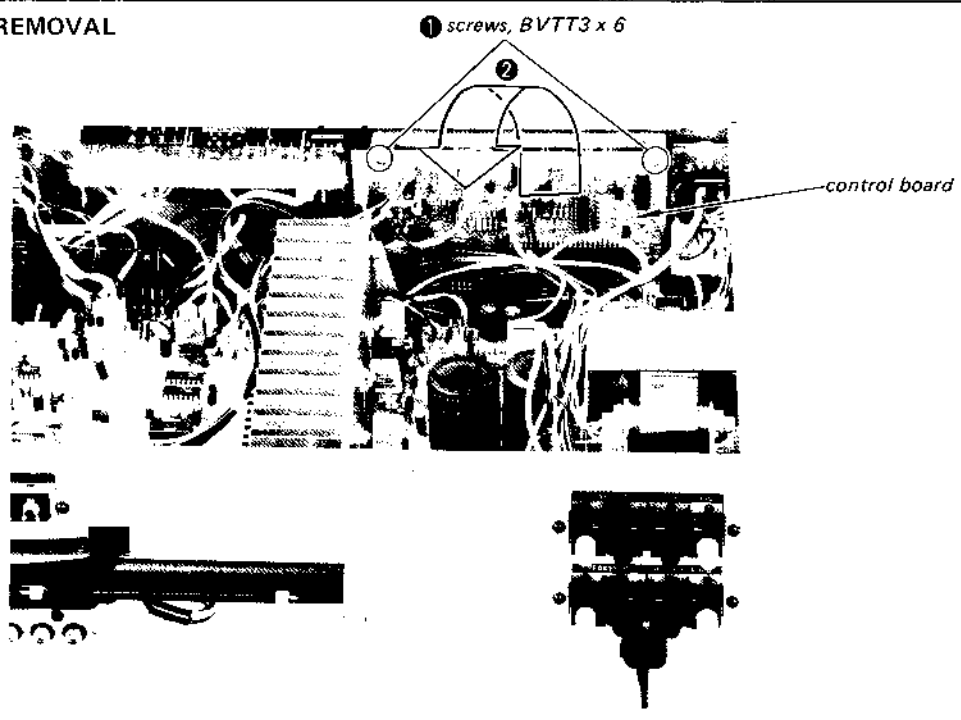

SECTION 3 ADJUSTMENTS

3-1. AMP SECTION

Note:

1. DC bias and DC balance adjustments should be made several minutes later after the POWER switch is turned on (POWER ON).
2. Make DC bias adjustment first.
3. Repeat DC bias and DC balance adjustments two or three times.
4. After replacing the power transistors, DC bias and DC balance adjustments should be made.

DC Bias Adjustment

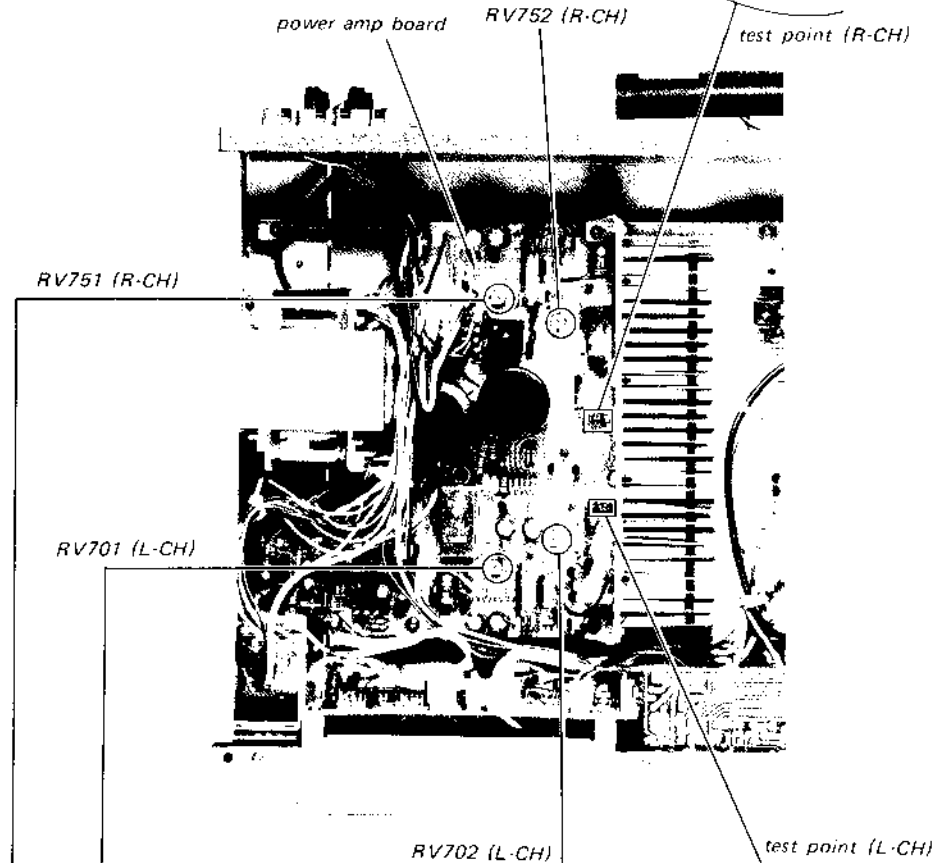
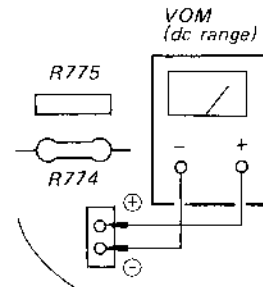

DC Balance Adjustment
(With no signal input)

-L-CH -R-CH
Adjust RV701 for 0V dc reading on VOM. Adjust RV751 for 0V dc reading on VOM.

DC Bias Adjustment
(With no signal input)

L-CH
Adjust RV702 for 10 mV dc reading on VOM.

-R-CH-
Adjust RV752 for 10 mV dc reading on VOM.

3-2. FM SECTION

FM stereo standard signal	FM monaural standard signal
Carrier frequency: 98 MHz	Carrier frequency: 98 MHz
Modulation: Audio 400Hz	Modulation: 400 Hz,
16.25kHz deviation	40kHz deviation (100%)
Sub channel 38kHz,	
16.25kHz deviation	
Pilot signal 19kHz,	
7.5kHz deviation	

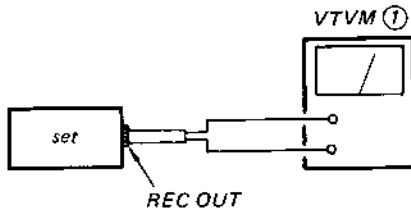
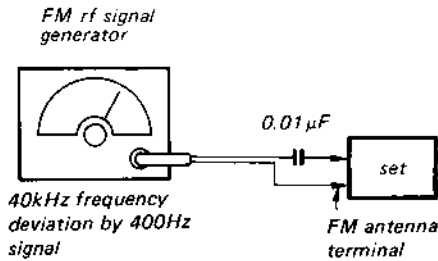

- Repeat the procedures in each adjustment several times, and the frequency coverage and tracking adjustments should be finally done by the trimmer capacitors.

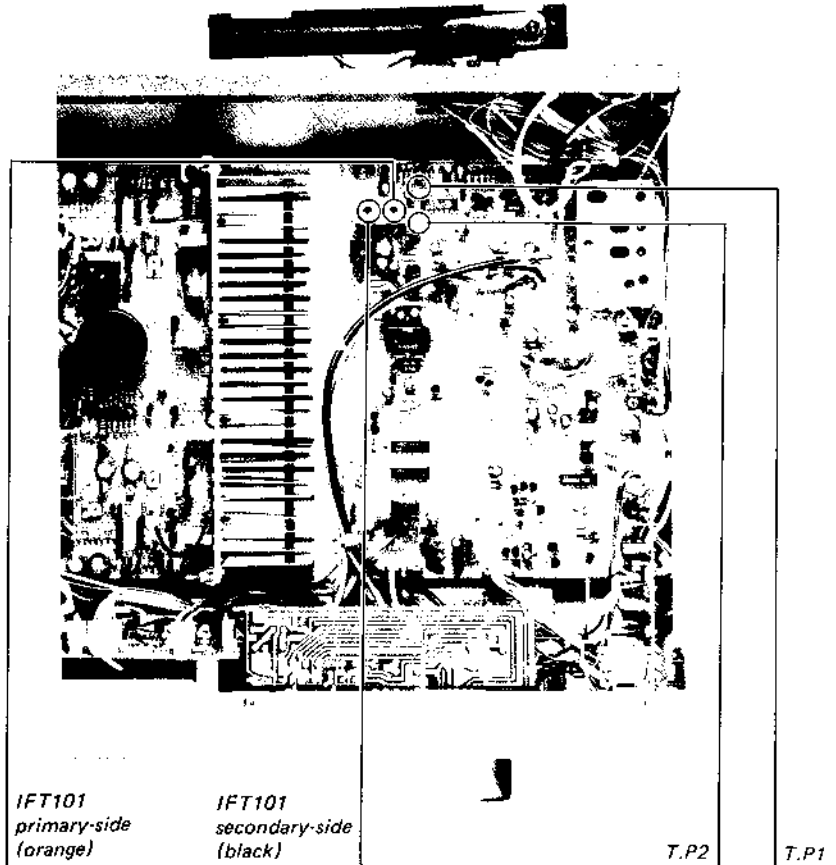

FM DISCRIMINATOR (IFT101) ALIGNMENT 1 (PRIMARY-SIDE)

Setting:

FUNCTION switch: TUNER
 FM/MW/LW switch: FM
 MODE switch: MONO
 TUNING switch: Detuned position

VOM
 (range: 5V dc)

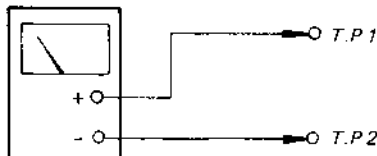

Procedure:

- Tune the set to 98MHz.
- Adjust the orange core (primary-side) of IFT101 for 0V reading on VOM.

Note: When replacing the ceramic filters (CF101-CF104), perform this alignment.

FM DISCRIMINATOR (IFT101) ALIGNMENT 2 (SECONDARY-SIDE)

Setting:

FUNCTION switch: TUNER
 FM/MW/LW switch: FM
 MODE switch: MONO

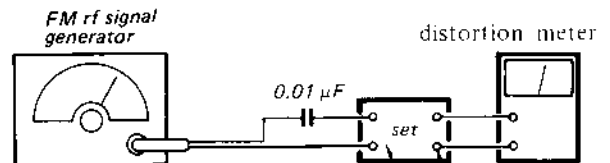

Procedure:

- Tune the set to 98MHz.
- Adjust the black core (secondary-side) of IFT101 for minimum distortion.

Note: Repeat the primary-side and secondary-side alignments several times.

FM MUTING LEVEL ADJUSTMENT

Setting:

TUNING LEVEL-LOW switch: ON

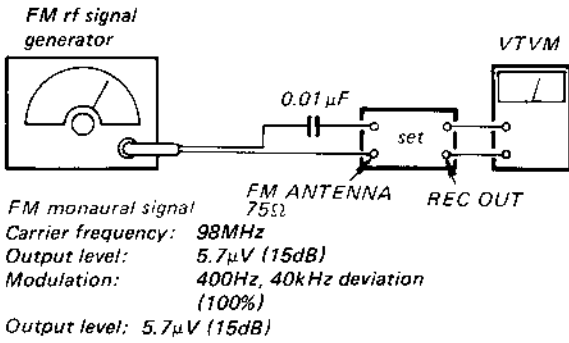

Procedure:

1. Push TUNING switches and tune the set to 98 MHz.
2. Turn RT103 and set it at the point just when the VTVM indication drops to 0 V.

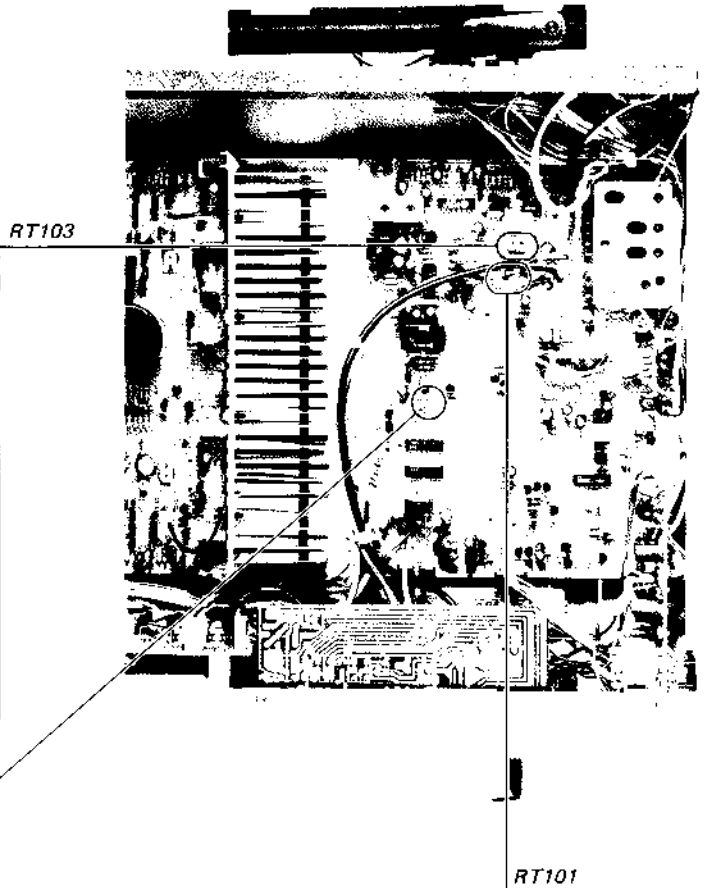

RT102

RT101

FM TUNING LEVEL ADJUSTMENT

Setting:

TUNING LEVEL-HIGH switch: ON

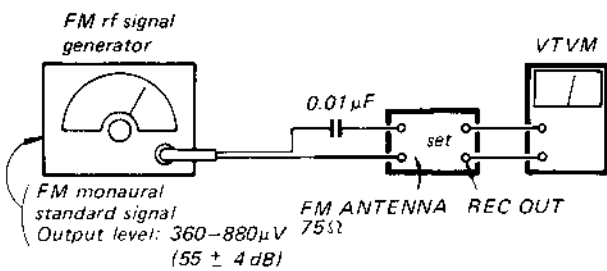

Procedure:

By varying the output level of the FM signal generator from 360 μ V (51 dB) to 880 μ V (59 dB), adjust RT102 so that the frequency scanning stops (observing the frequency counter of the set).

SIGNAL INDICATOR ADJUSTMENT

FM rf signal generator

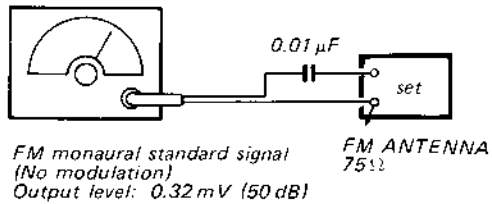

SIGNAL STRENGTH

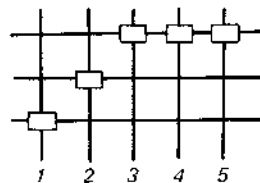

Procedure:

1. Tune the set to 98 MHz.
2. Adjust RT101 for all five LEDs of SIGNAL STRENGTH indicator lighting.

VCO ADJUSTMENT

Setting:

FUNCTION switch: TUNER
 FM/MW/LW switch: FM
 MODE switch: MONO

A) Regular Method

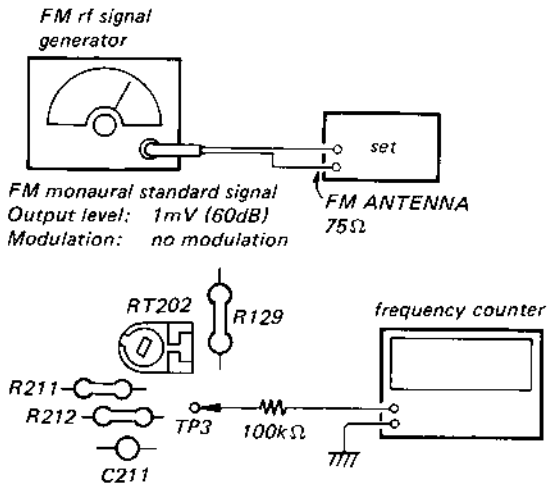

Procedure:

1. Tune the set to 98MHz.
2. Adjust RT202 for 76kHz \pm 100Hz reading on the frequency counter.

B) Simple Method

Procedure:

1. Tune the set to the FM stereo broadcasting signal.
2. Turn RT202 clockwise or counterclockwise and memorize the lighting-up ranges of STEREO lamp.

3. Secure RT202 at the center of the lighting-up range of both turns as shown below.

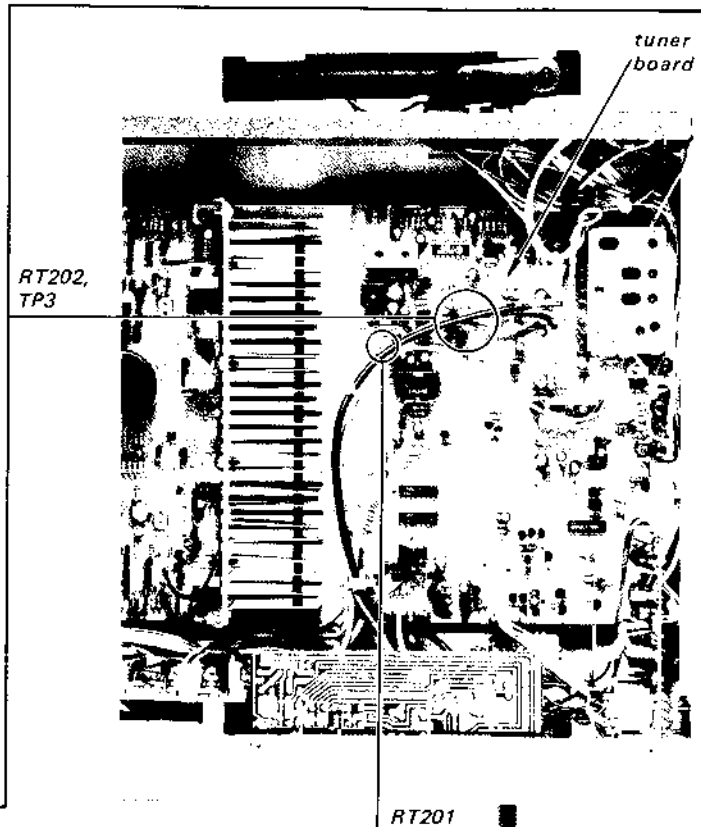
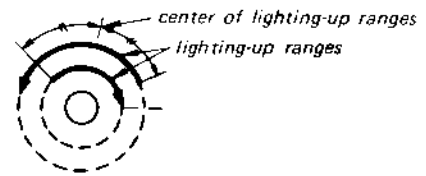

FM STEREO SEPARATION ADJUSTMENT

Setting:

FUNCTION switch: TUNER
 FM/MW/LW switch: FM
 MODE switch: STEREO/FM-AM MUTING

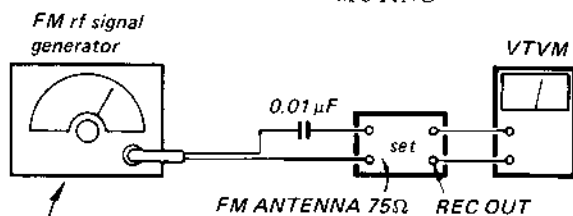

Carrier frequency: 98MHz
 Output level: 1mV (60dB)
 Modulation:
 Audio (400Hz): 16.25kHz deviation
 Pilot (19kHz): 7.5kHz deviation
 Sub channel (38kHz): 16.25kHz deviation

Procedure:

FM stereo signal generator output channel	VTVM connection	VTVM reading (dB)
L-CH	L-CH	(A)
R-CH	L-CH	(B) Adjust RT301 resistor for minimum reading.
R-CH	R-CH	(C)
L-CH	R-CH	(D) Adjust RT301 resistor for minimum reading.

L-CH Stereo Separation: (A) -- (B)
 R-CH Stereo Separation: (C) (D)

The separations of both channels should be equal.

PLL ADJUSTMENT

Setting:

FM/MW/LW switch: FM

Setting Up and Adjustment Location:

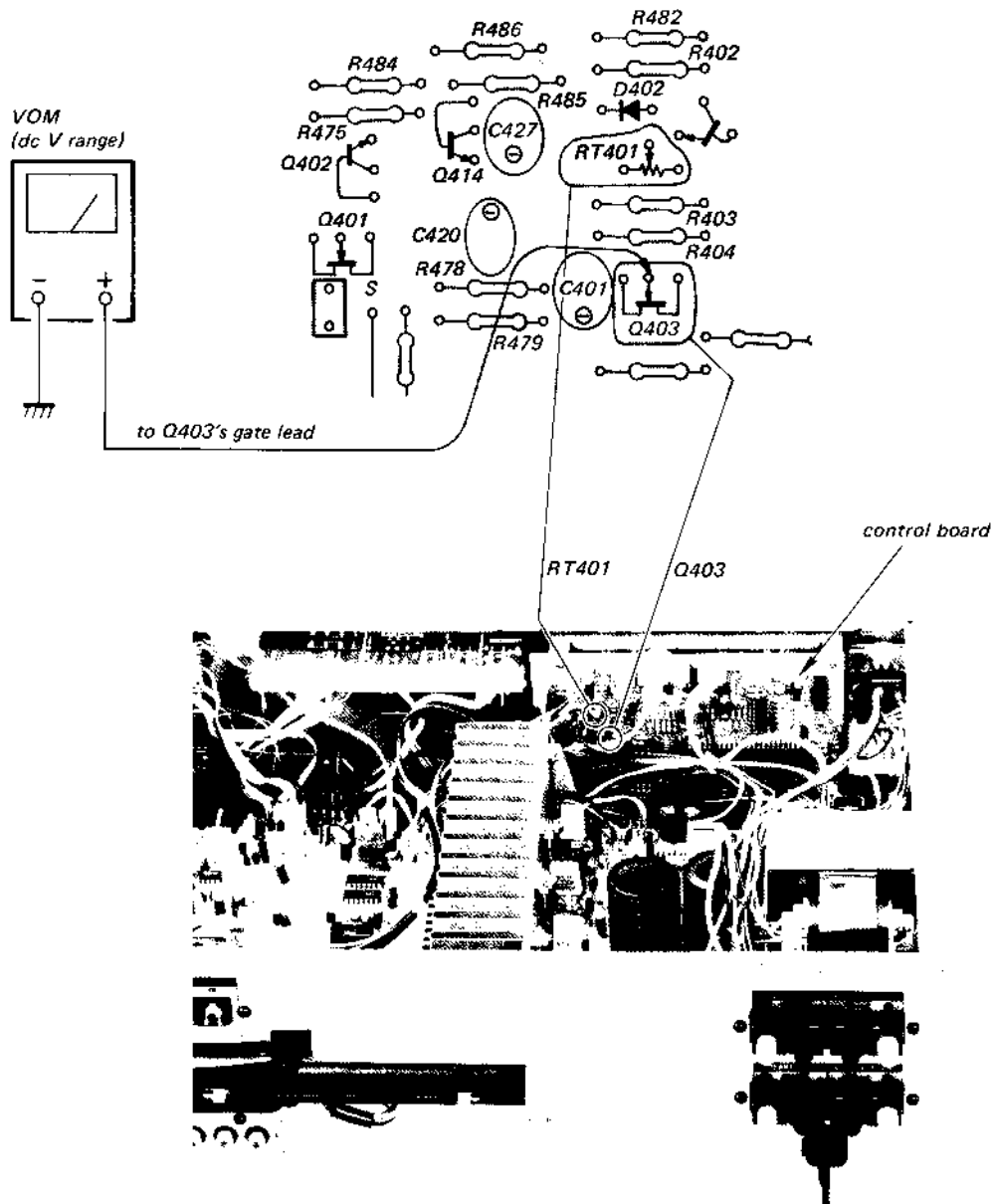

Procedure:

1. Tune the set to 98MHz.
2. Turn RT401 to its clockwise stop.
3. Turn RT401 counterclockwise to obtain 1.8V dc at the gate lead of Q403.

3-3. AM SECTION

MW Section

Setting:

FUNCTION switch TUNER

FM/MW/LW switch: MW

AM rf signal generator

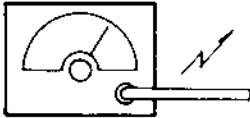

Put the lead-wire antenna close to the set.

Modulation: 400Hz, 30%

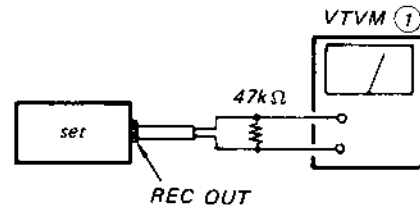

- Repeat the procedures in each adjustment several times, and the frequency coverage and tracking adjustments should be finally done by the trimmer capacitors.

AM I-F ALIGNMENT

When IFT301 through 303 are replaced, they do not need readjustment since they have been factory-adjusted.

MW FREQUENCY COVERAGE ADJUSTMENT

Frequency Dial Indication	1,602kHz	522kHz
VOM reading	22V	1.5V
Adjust	CT304	L303

CT304

L303

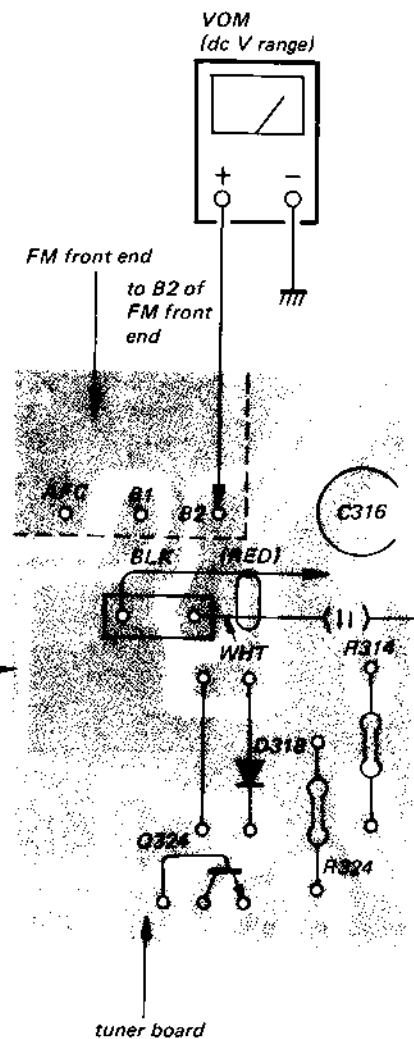
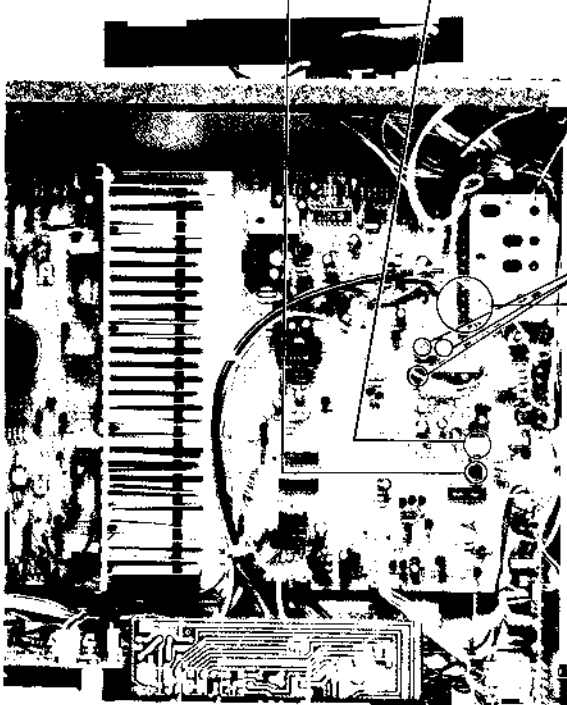

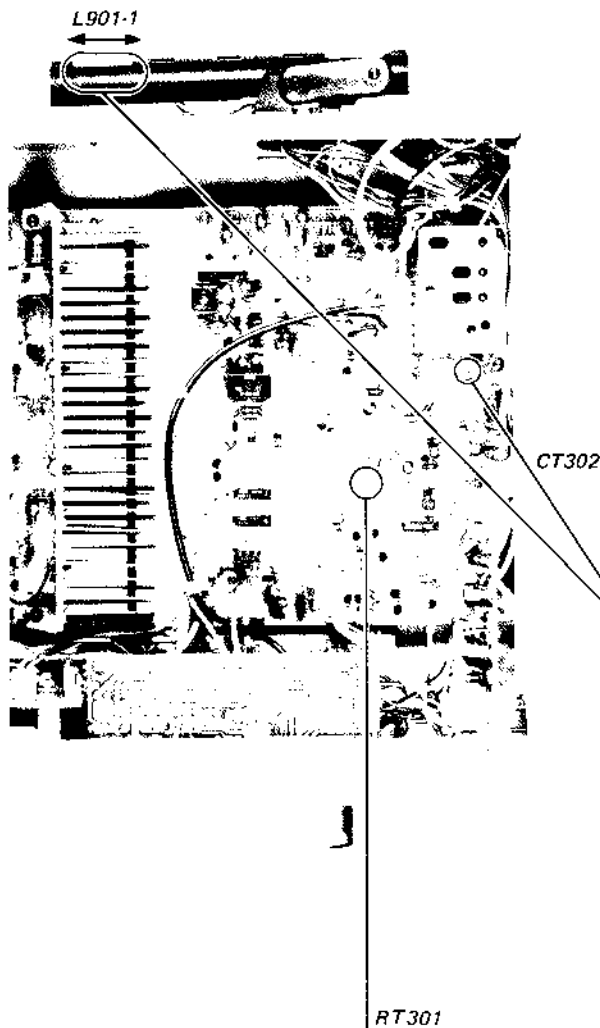

MW TRACKING ADJUSTMENT

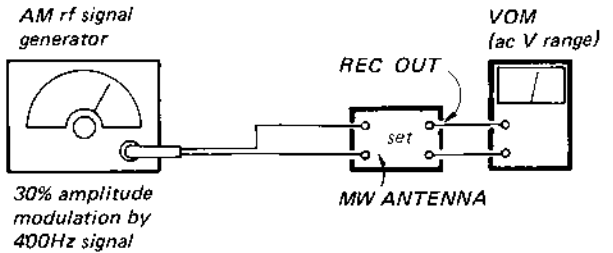

Output level: 30 – 100 μ V (30 – 40dB)
 Carrier frequency: 603kHz or 1,404kHz

Procedure:

Tune the set to the frequency of AM rf signal generator and adjust L901-1 and CT302 for maximum reading on the VOM.

	AM Rf Signal Generator Frequency	Adjust	VOM Reading
1	603kHz	L901-1	maximum
2	1,404kHz	CT302	

Note: Repeat the above adjustment several times ending with CT302.

TUNING LEVEL ADJUSTMENT

Setting:

TUNING LEVEL LOW switch: ON

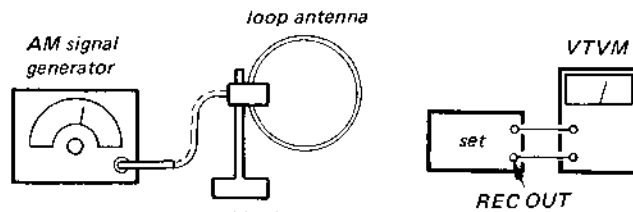

Carrier frequency: 1,000kHz
 Output level: 0.02V (86dB)
 Modulation: 400Hz, 30%

Procedure:

1. Place the loop antenna at a distance of 60cm (23 $\frac{3}{8}$ "') away from the ferrite-rod antenna in the set.
2. Turn RT301 until the VTVM indication drops to 0V with the output level of AM signal generator of 86 \pm 4dB.

STR-V45L

LW Section

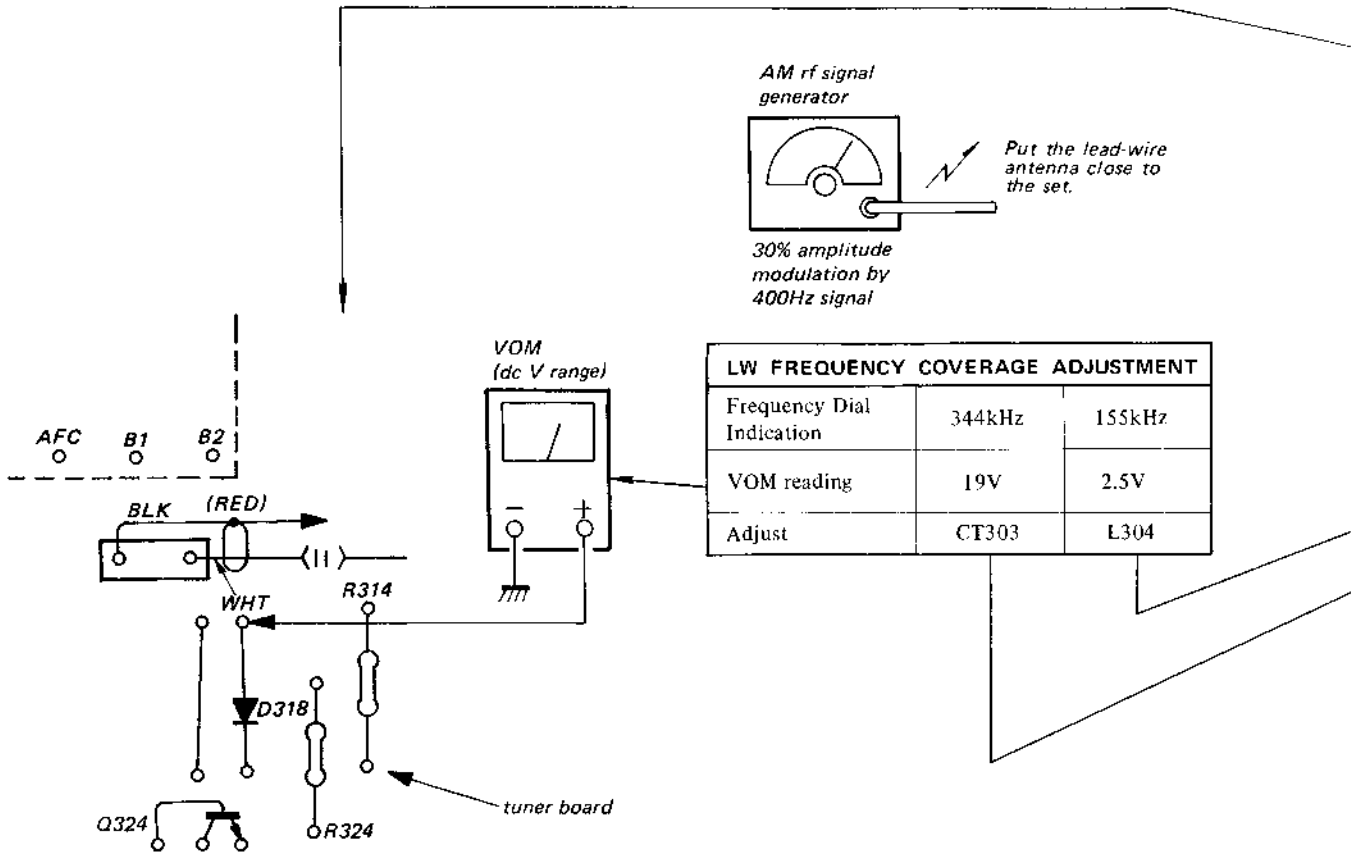

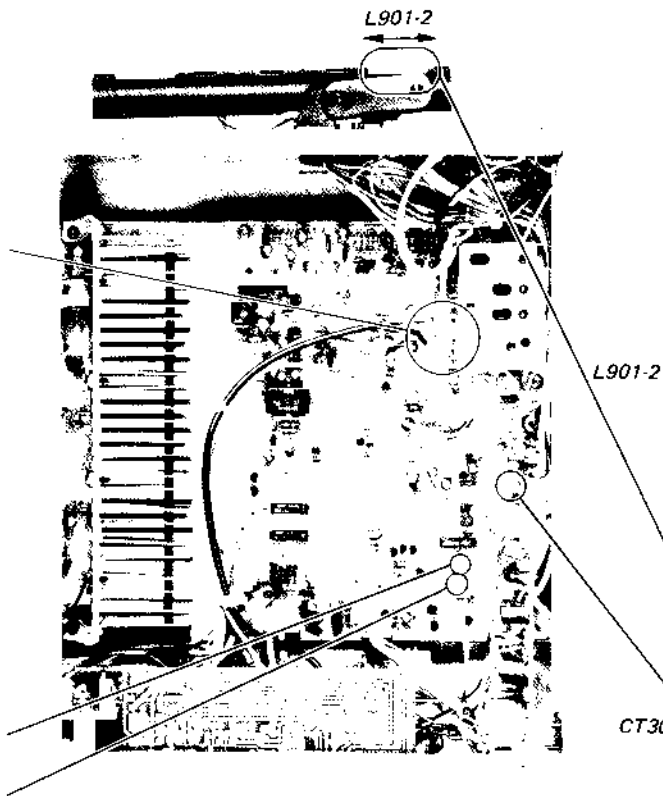

LW TRACKING ADJUSTMENT

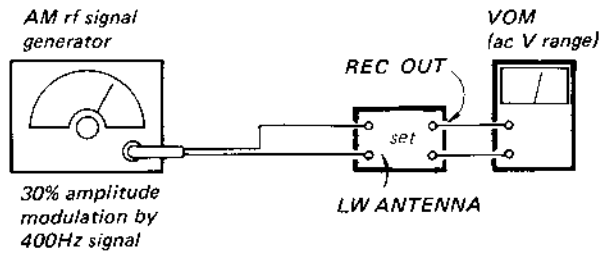

30% amplitude modulation by 400Hz signal

Output level: 30 – 100 μ V (30 – 40dB)
Carrier frequency: 173kHz or 308kHz

Procedure:

Tune the set to the frequency of AM rf signal generator and adjust L901-2 and CT301 for maximum reading on the VOM.

	AM Rf Signal Generator Frequency	Adjust	VOM Reading
1	173kHz	L901-2	maximum
2	308kHz	CT301	

Note: Repeat the above adjustment several times ending with CT301.

STR-V45L STR-V45L

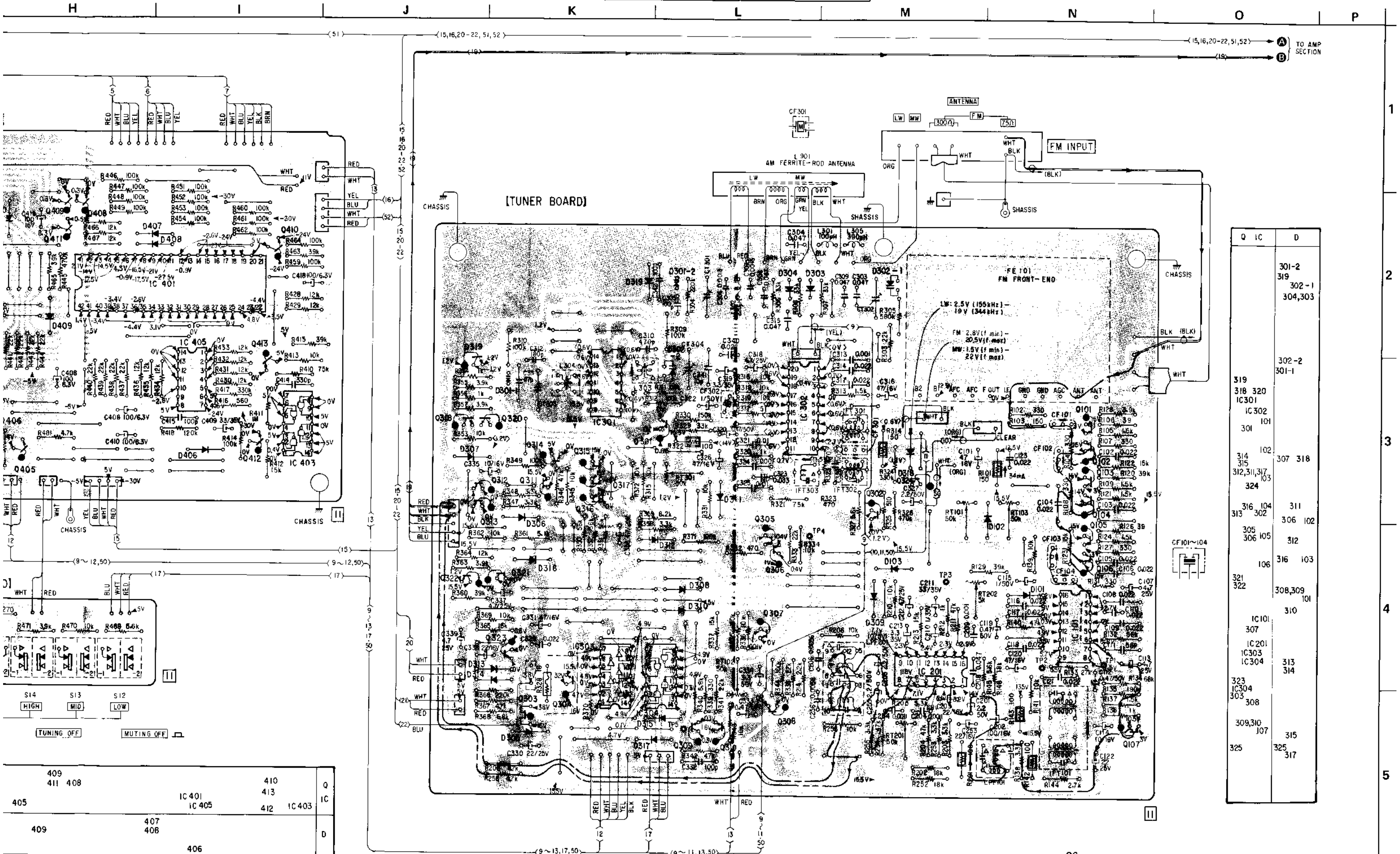

Q	IC	D
		301-2
		319
		302-1
		304,303
		302-2
		301-1
319		
318	320	
	IC 301	
	301	
	101	
	102	
314		307 318
315		
312,311,317		103
		324
		316 104
313	302	311
		306 102
		305 105
		306 105
		316 103
321		
322		308,309
		101
		310
	IC 101	
	307	
	IC 201	
	IC 303	
	IC 304	
		313
		314
323		
IC 304		
303		
		308
		309,310
		107
		315
325		
		325
		317

409		410	Q
411	408	413	IC
405	IC 401	412	IC 403
	IC 405		
409	407		
	406		D
	406		

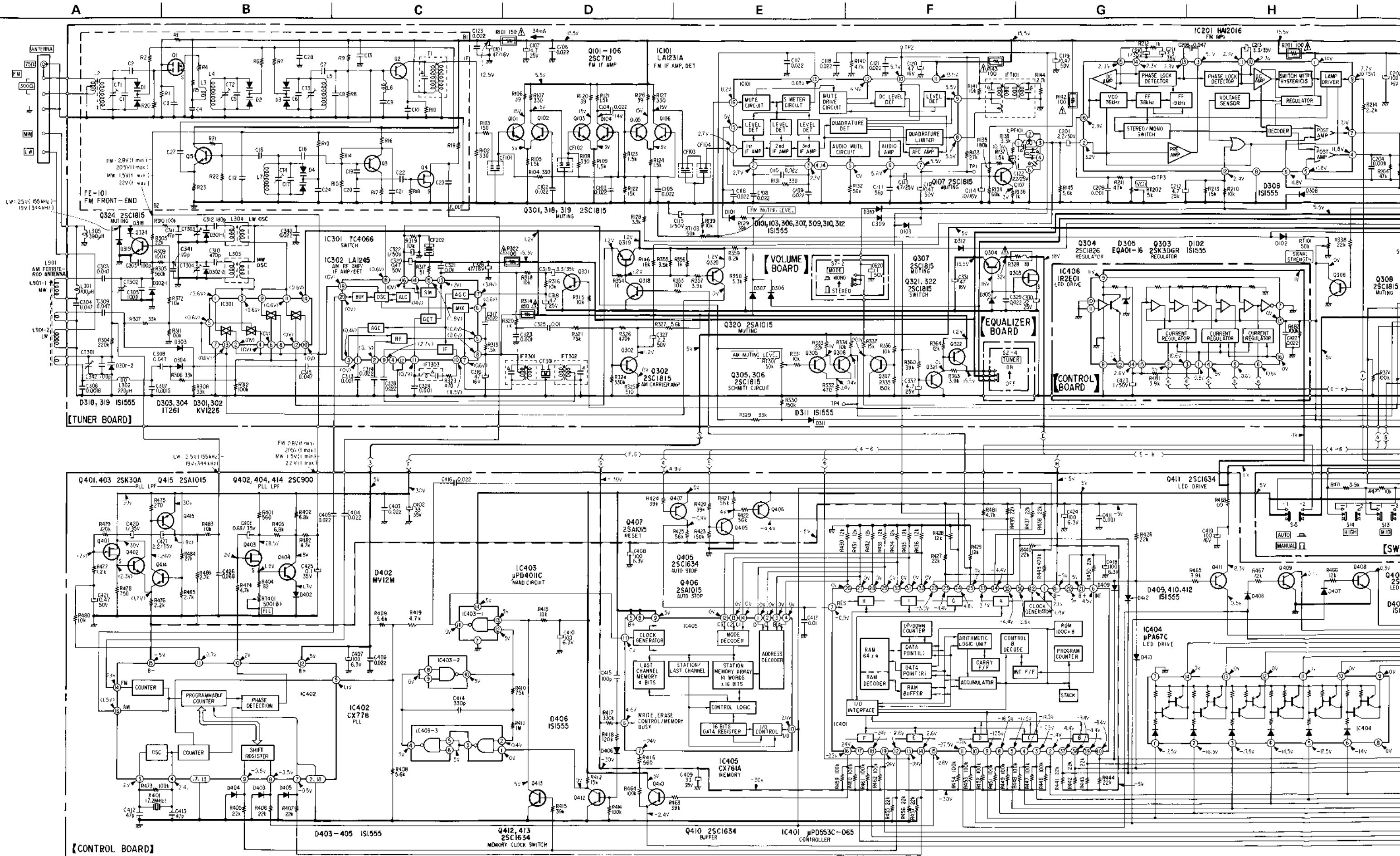

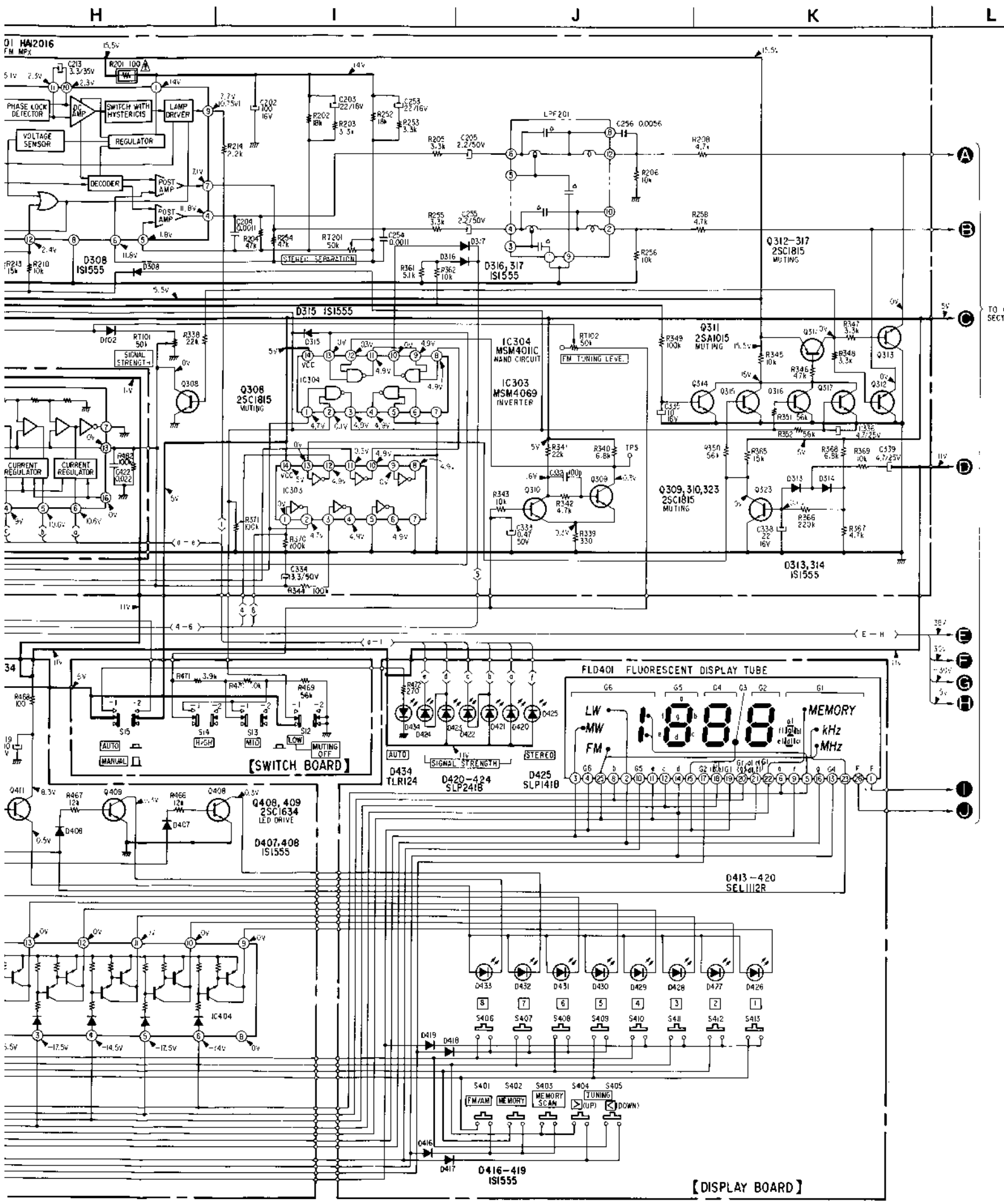

Note:

- All capacitors are in μF unless otherwise noted. $\text{pF} : \mu\text{F}$ 50WV or less are not indicated except for electrolytics.
- All resistors are in ohms, $\frac{1}{4}\text{W}$ unless otherwise noted. $\text{k}\Omega : 1000\Omega$, $\text{M}\Omega : 1000\text{k}\Omega$.
- Δ : internal component.
- \square : panel designation.
- \square : adjustment for repair.
- --- B+ bus.
- --- B- bus.
- Voltages are dc with respect to ground unless otherwise noted.
- Voltage variations may be noted due to normal production tolerances.
- Readings are taken under no-signal (detuned) conditions with a VOM (20 $\text{k}\Omega/\text{V}$).
- \square : FM STEREO
- \square : AM
- \square : signal path

Semiconductor Lead Layouts:

<p>2SA1015</p>	<p>2SK30-GR 2SK30A 2SK30A-GR3</p>	<p>MB84069B MSM4011C MSM4069 $\mu\text{PD4011C}$</p>	<p>MV12N</p>
<p>2SC710 2SC710-14</p>	<p>CX761A $\mu\text{PD553C065}$</p>	<p>TC4066 μPA67C $\mu\text{PD4066C}$</p>	<p>TLR124</p>
<p>2SC900 2SC1362 2SC1364 2SC1634 2SC1815</p>	<p>CX778</p>	<p>EQA01-16 EQB01-16</p>	<p>KV1226</p>
<p>2SC1826</p>	<p>HA12016</p>	<p>1S1555 1T26 1T261</p>	<p>SEL1112R</p>
<p>2SC1986</p>	<p>IR2E01 LA1231 LA1231A LA1245</p>	<p>SLP141B SLP241B</p>	

• Switch

Ref. No.	Switch	Position
S2	FUNCTION TUNER	OFF
S7	MODE	STEREO
S12-15	TUNING LEVEL	MANUAL
S401	FM/MW/LW	FM
S402	MEMORY	OFF
S403	MEMORY SCAN	OFF
S404	TUNING (UP)	OFF
S405	TUNING (DOWN)	OFF
S406-413	preset (1-8)	OFF

Note: The components identified by shading and mark Δ are critical for safety. Replace only with part number specified.

STR-V45L STR-V45L

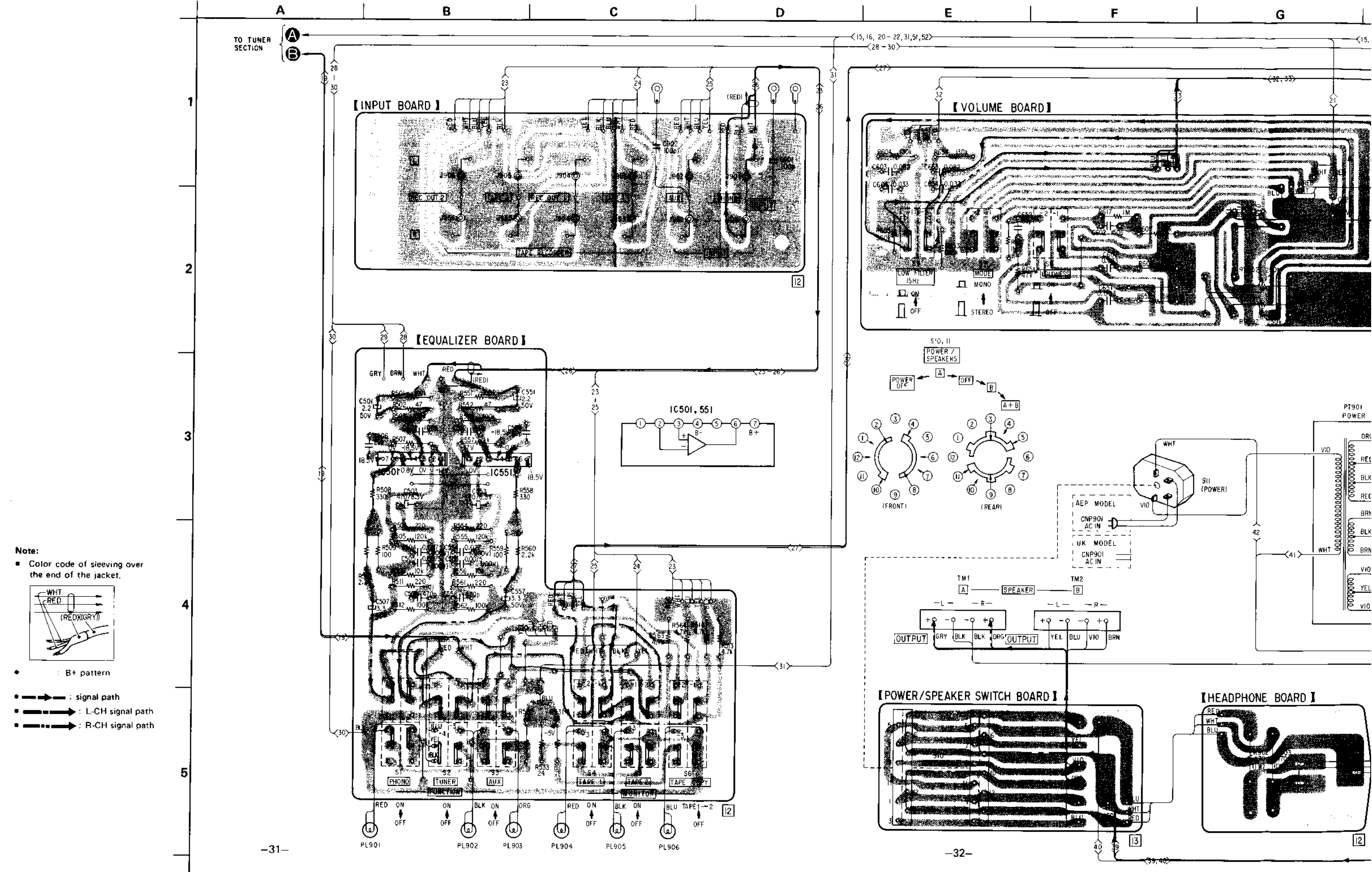

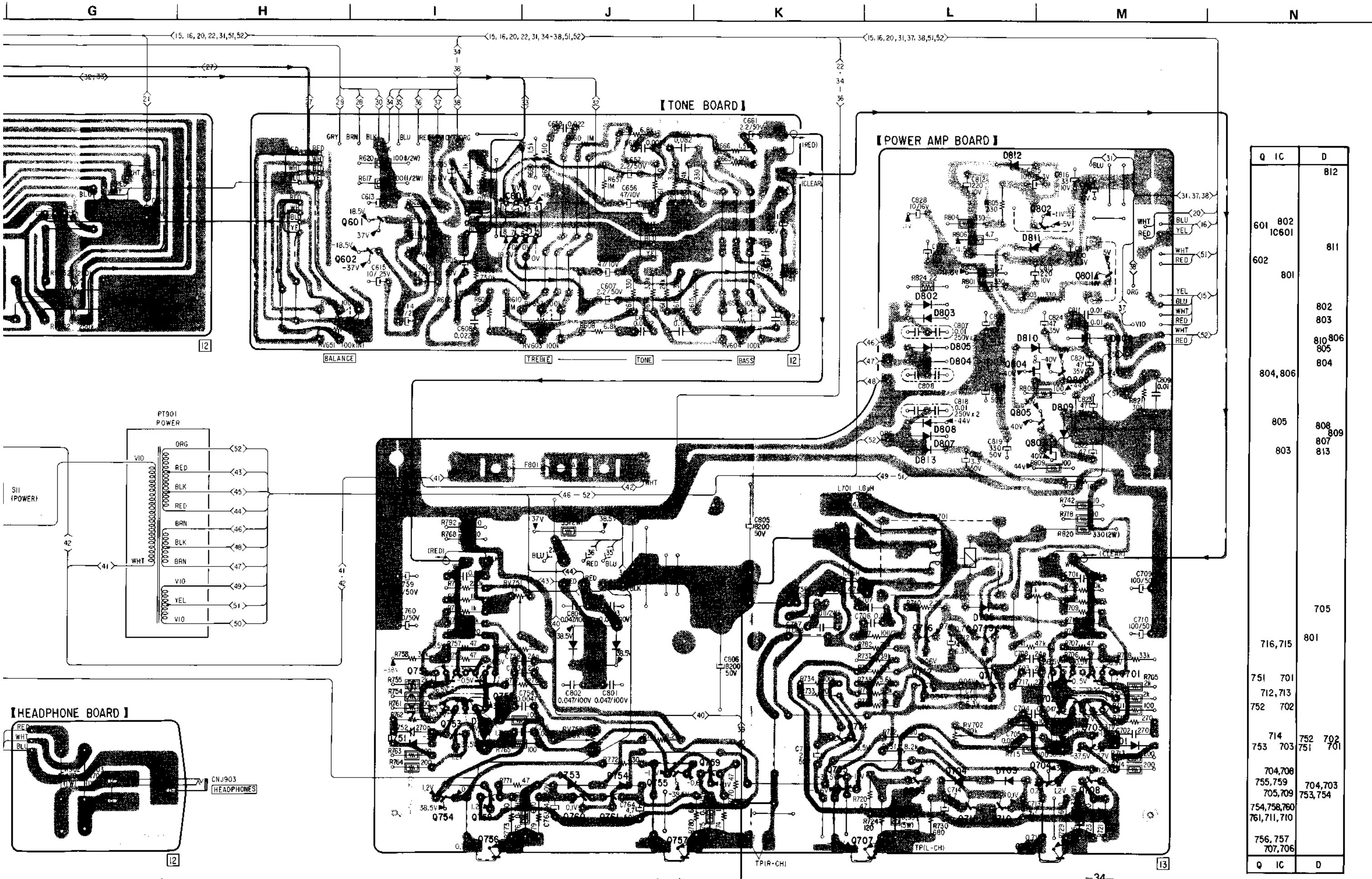

Q	IC	D
601	802	812
	IC601	
602		811
	801	
		802
		803
		810, 806
		805
		804
	804, 806	
		808
		809
		807
		813
		803
		705
	716, 715	801
	751	701
	712, 713	
	752	702
		714
	753	703
		752
		702
		751
		701
	704, 708	
	755, 759	704, 703
	705, 709	753, 754
	754, 758, 760	
	761, 711, 710	
	756, 757	
	707, 706	
Q	IC	D

STR-V45L STR-V45L

4-4. SCHEMATIC DIAGRAM — Amp Section —

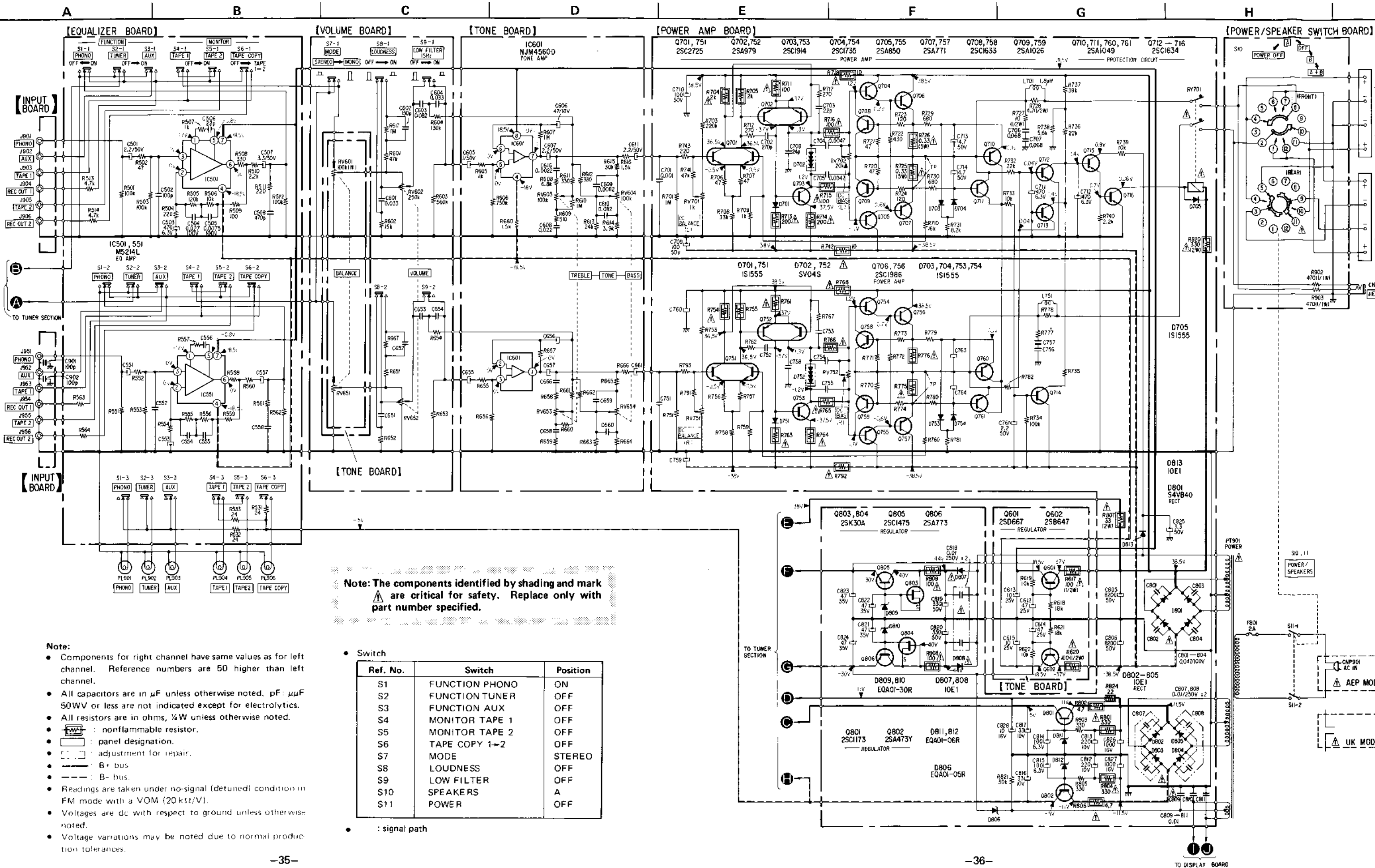

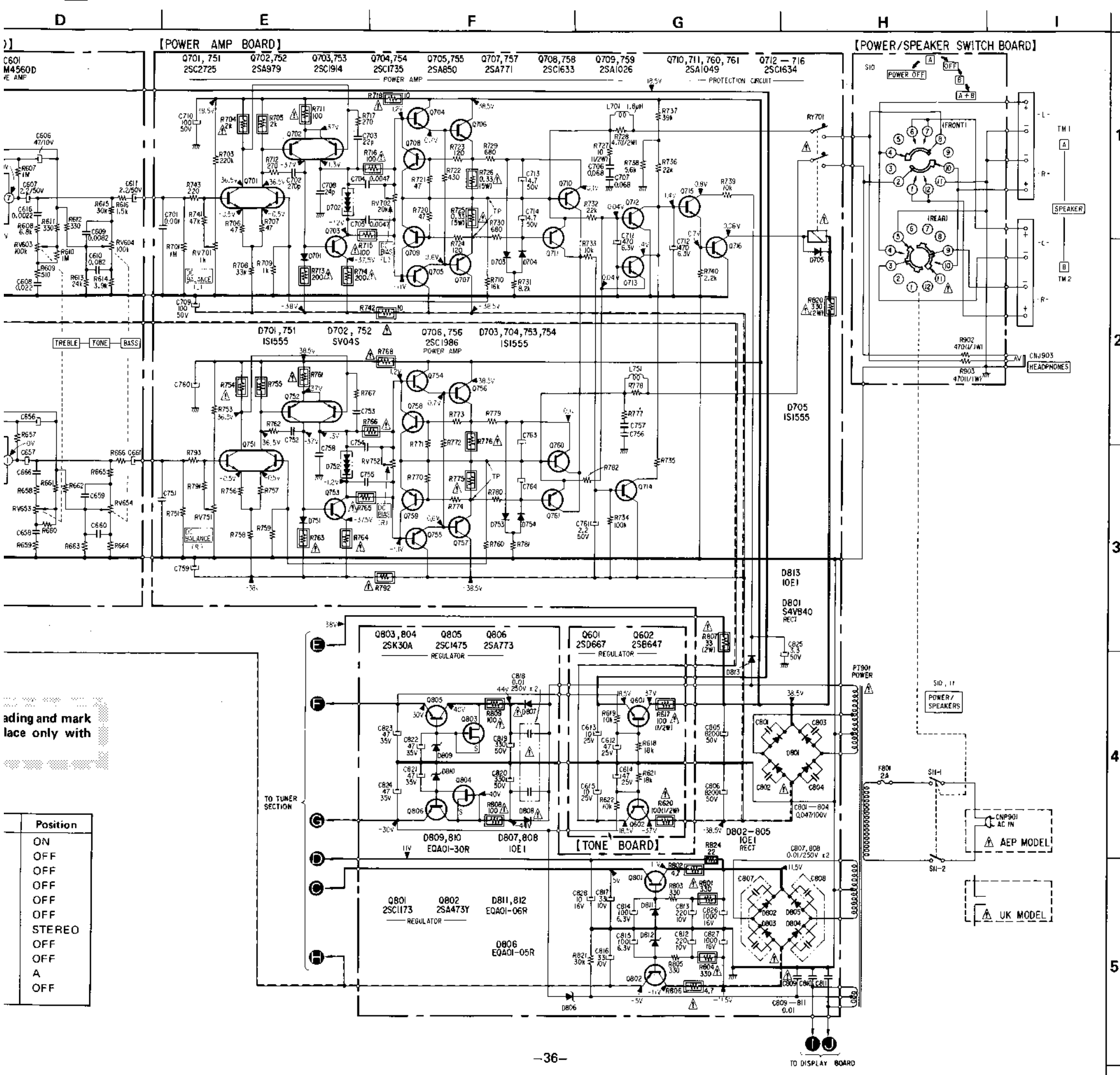

Semiconductor Lead Layouts:

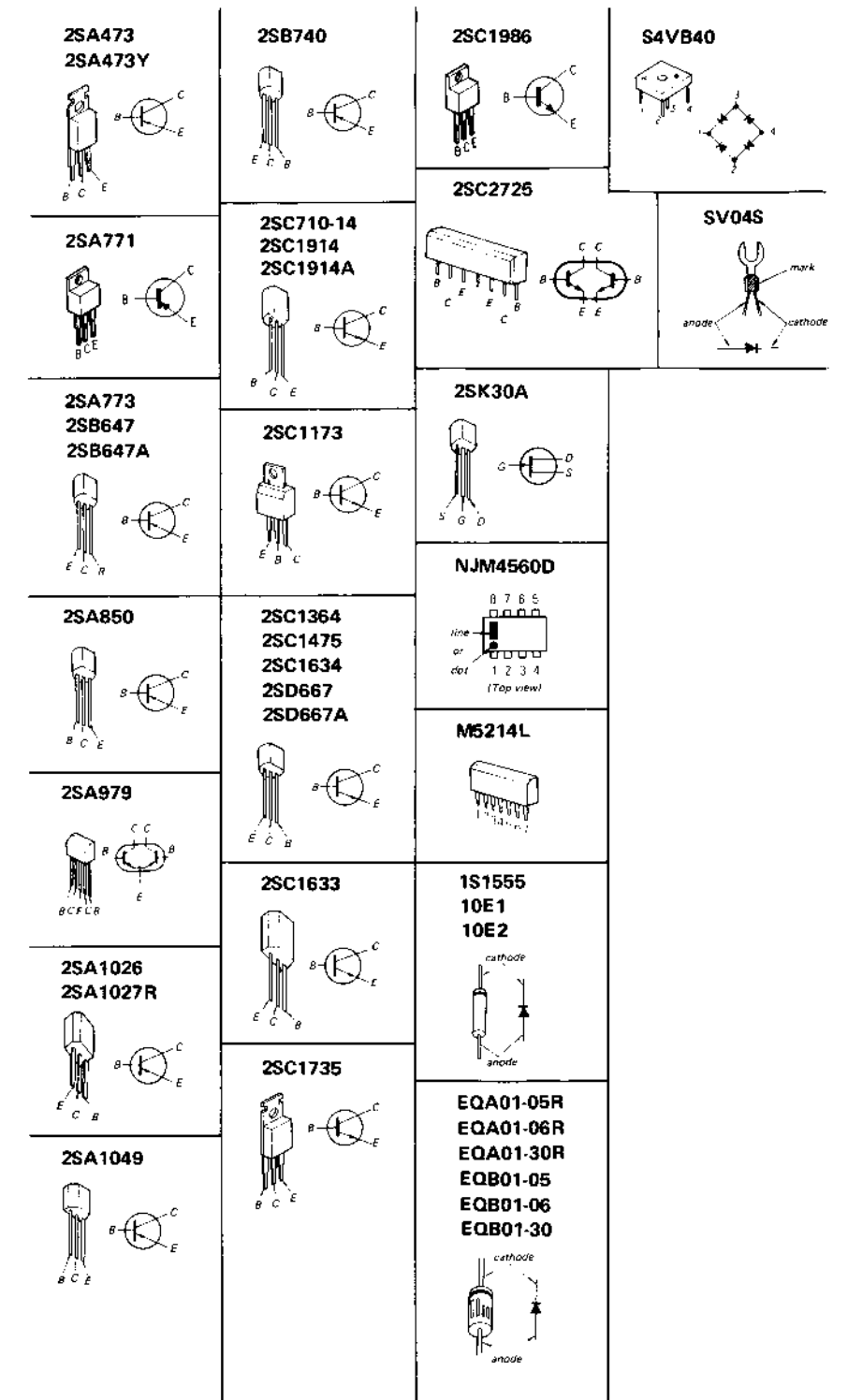

adding and mark
face only with

Position
ON
OFF
OFF
OFF
OFF
OFF
STEREO
OFF
OFF
A
OFF

SECTION 5
EXPLODED VIEWS

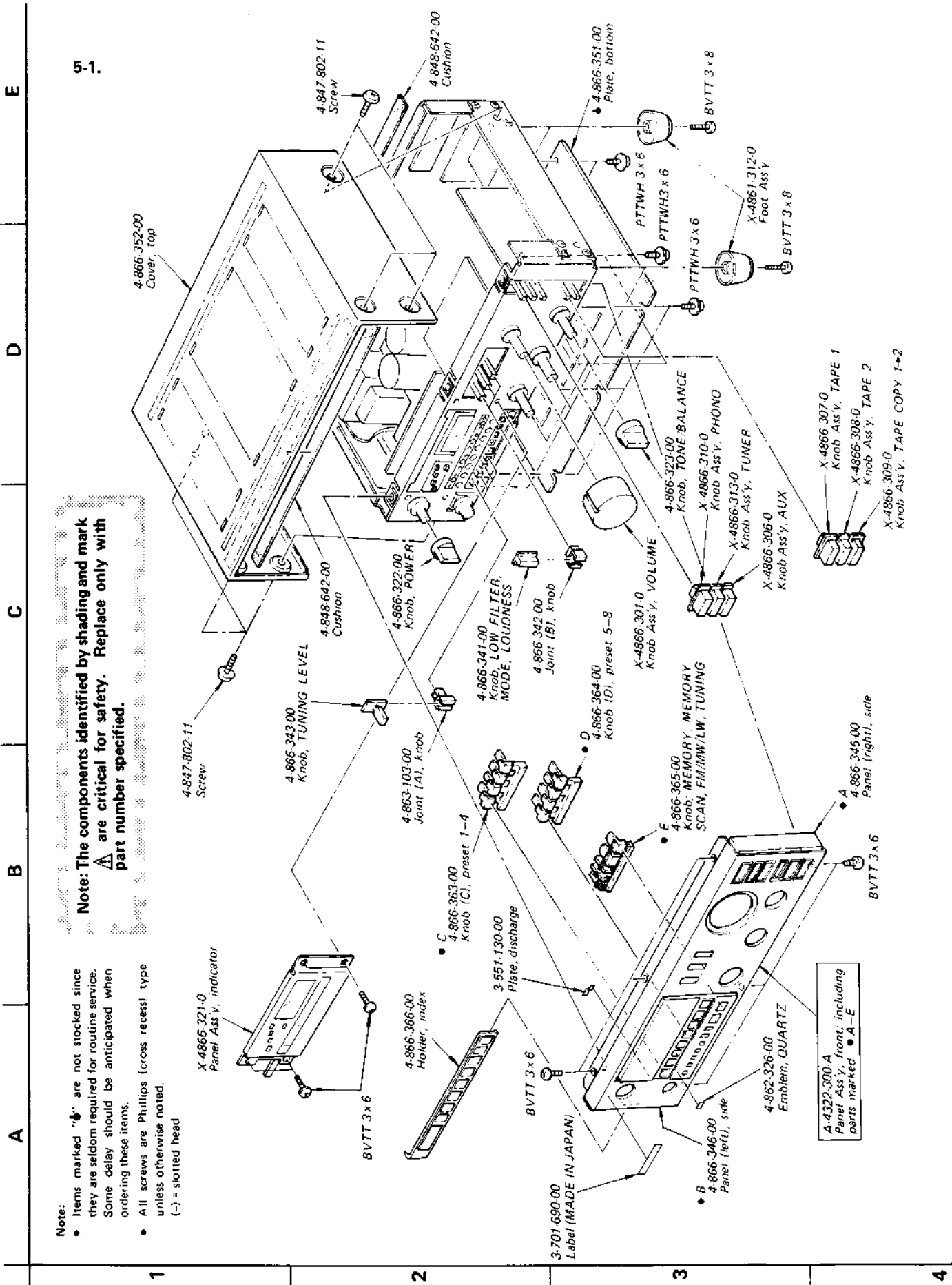

Note: The components identified by shading and mark **A** are critical for safety. Replace only with part number specified.

- Note:**
- Items marked "A" are not stocked since they are seldom required for routine service. Some delay should be anticipated when ordering these items.
 - All screws are Phillips (cross recess) type unless otherwise noted. (-) = slotted head

A.4322.300 A
Panel Ass'y, front; including parts marked • A-E

5-2.

A B C D E

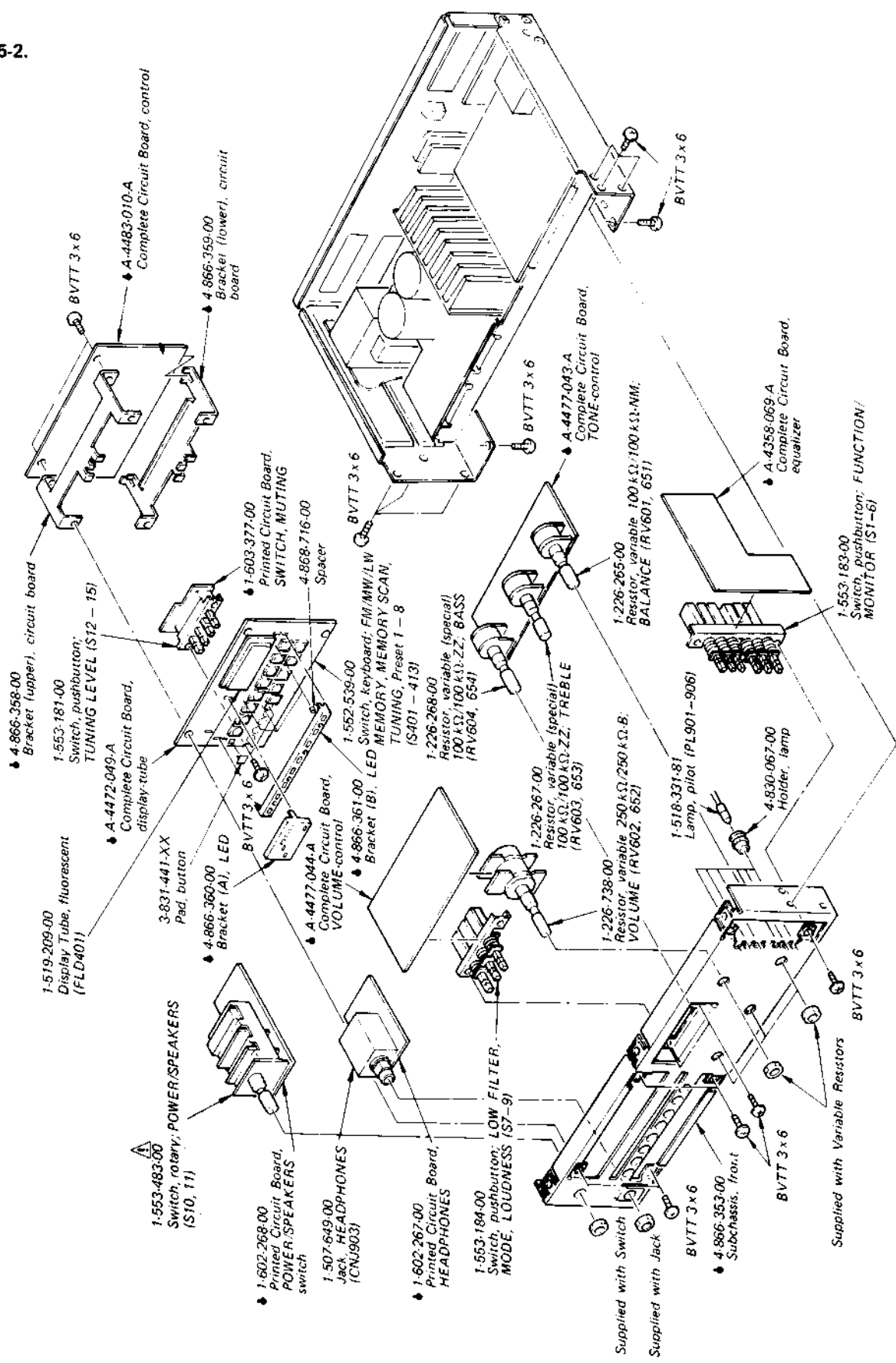

- 4-866-358-00 Bracket (upper), circuit board
- 1-519-209-00 Display Tube, fluorescent (FLD401)
- 1-553-181-00 Switch, pushbutton: TUNING LEVEL (S12 - 15)
- 4-4472-049-A Complete Circuit Board, display-tube
- 3-831-441-XX Pad, button
- 4-866-360-00 Bracket (A), LED
- 4-4477-044-A Complete Circuit Board, VOLUME control
- 4-866-361-00 Bracket (B), LED MEMORY SCAN, TUNING, Preset 1 - 8 (S401 - 413)
- 1-552-539-00 Switch, keyboard: FM/MW/LW TUNING, MEMORY SCAN, (S401 - 413)
- 1-602-268-00 Printed Circuit Board, POWER/SPEAKERS switch
- 1-507-649-00 Jack, HEADPHONES (CNJ903)
- 1-602-267-00 Printed Circuit Board, HEADPHONES
- 1-553-184-00 Switch, pushbutton: LOW FILTER, MODE, LOUDNESS (S7-9)
- 1-226-268-00 Resistor, variable (special) 100 kΩ, 100 kΩ-ZZ, BASS (RV604, 654)
- 1-226-267-00 Resistor, variable (special) 100 kΩ, 100 kΩ-ZZ, TREBLE (RV603, 653)
- 1-226-738-00 Resistor, variable 250 kΩ, 250 kΩ-B, VOLUME (RV602, 652)
- 1-518-331-81 Lamp, pilot (PL901-906)
- 4-830-067-00 Holder, lamp
- 1-226-265-00 Resistor, variable 100 kΩ, 100 kΩ-NM, BALANCE (RV601, 651)
- 4-4358-069-A Complete Circuit Board, equalizer
- 1-553-183-00 Switch, pushbutton: FUNCTION/MONITOR (S1-6)
- 4-866-359-00 Bracket (lower), circuit board
- 1-603-377-00 Printed Circuit Board, SWITCH, MUTING
- 4-868-716-00 Spacer
- 4-4477-043-A Complete Circuit Board, TONE control
- 4-4483-010-A Complete Circuit Board, control
- 4-866-353-00 Subchassis, front
- Supplied with Variable Resistors
- Supplied with Switch
- Supplied with Jack

1 2 3 4

53.

A B C D E

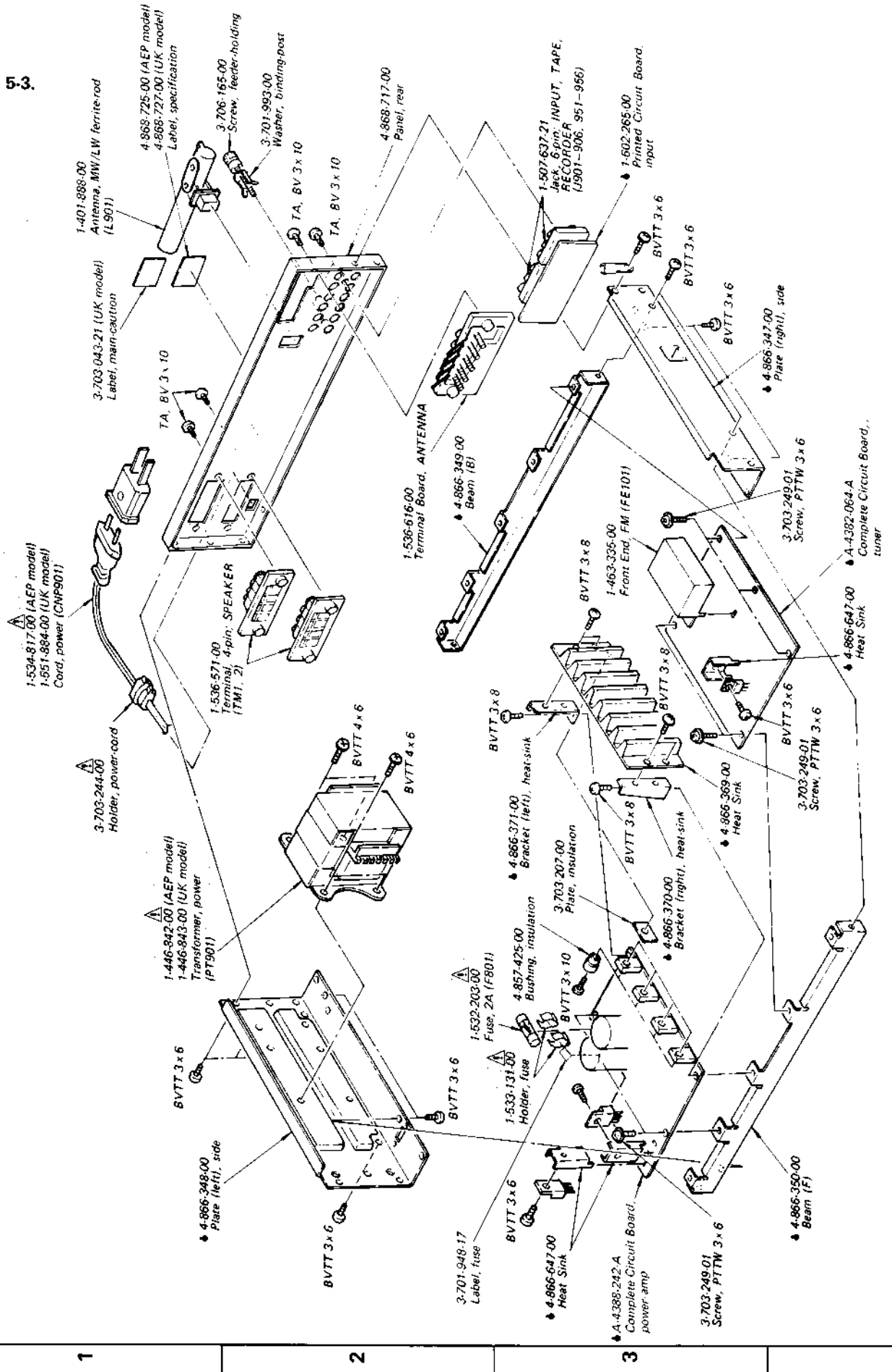

**SECTION 6
ELECTRICAL PARTS LIST**

<u>Ref. No.</u>	<u>Part No.</u>	<u>Description</u>	<u>Ref. No.</u>	<u>Part No.</u>	<u>Description</u>
SEMICONDUCTORS			ICs		
Transistors			IC101	8-759-812-31	LA1231
Q101-106	8-729-671-14	2SC710-14	IC201	8-759-320-16	HA12016
Q107	8-729-663-47	2SC1364	IC301	8-759-140-66	μPD4066C
Q301, 302	8-729-663-47	2SC1364	IC302	8-759-812-45	LA1245
Q303	8-729-203-04	2SK30A	IC303	8-759-984-69	MB84069B
Q304	8-729-398-62	2SC1986	IC304	8-759-140-11	μPD4011C
Q305-310	8-729-663-47	2SC1364	IC401	8-759-153-65	μPD553C065
Q311	8-729-201-52	2SA1015	IC402	8-759-607-78	CX778
Q312-319	8-729-634-47	2SC1364	IC403	8-759-140-11	μPD4011C
Q320	8-729-201-52	2SA1015	IC404	8-759-100-67	UPA67C
Q321-324	8-729-634-47	2SC1364	IC405	8-757-611-00	CX761A
Q401	8-729-203-05	2SK30A-GR3	IC406	8-759-920-10	IR2E01
Q402	8-729-665-47	2SC1362	IC501, 551	8-759-652-14	M5214L
Q403	8-729-203-05	2SK30A-GR3	IC601	8-759-745-60	NJM4560D
Q404	8-729-665-47	2SC1362	Diodes		
Q405	8-729-663-47	2SC1364	D101-103	8-719-815-55	1S1555
Q406, 407	8-729-201-52	2SA1015	D301, 302	8-719-912-27	KV1226
Q408-413	8-729-663-47	2SC1364	D303, 304	8-712-600-00	1T26
Q414	8-729-665-47	2SC1362	D305	8-719-931-16	EQB01-16
Q601	8-729-906-72	2SD667A	D306-319	8-719-815-55	1S1555
Q602	8-729-300-72	2SB647A	D402	8-719-912-00	MV-12N
Q701, 751	8-729-672-52	2SC2725	D403-412	8-719-815-55	1S1555
Q702, 752	8-729-697-92	2SA979	D416-419	8-719-815-55	1S1555
Q703, 753	8-729-601-42	2SC1914A	D420-424	8-719-922-41	SLP241B
Q704, 754	8-729-673-53	2SC1735	D425	8-719-900-41	SLP141B
Q705, 755	8-729-685-03	2SA850	D426-433	8-719-311-12	SEL1112R
Q706, 756	8-729-398-62	2SC1986	D434	8-719-812-41	TLR124
Q707, 757	8-729-377-12	2SA771	D701, 751	8-719-815-55	1S1555
Q708, 758	8-729-663-47	2SC1364	D703, 753		
Q709, 759	8-729-612-77	2SA1027R	D704, 754		
Q710, 760 Q711, 761	8-729-204-91	2SA1049	D705		
Q801	8-729-217-33	2SC1173	D702, 752	8-719-300-11	SV04S
Q802	8-729-247-33	2SA473	D801	▲8-719-504-40	S4VB40
Q803, 804	8-729-203-04	2SK30A	D802-805	▲8-719-200-02	10E2
Q805	8-760-413-10	2SC1475	D806	8-719-931-05	EQB01-05
Q806	8-729-374-02	2SB740	D807, 808	▲8-719-200-02	10E2

• Items marked "▲" are not stocked since they are seldom required for routine service. Some delay should be anticipated when ordering these items.

Note: The components identified by shading and mark ▲ are critical for safety. Replace only with part number specified.

STR-V45L

<u>Ref. No.</u>	<u>Part No.</u>	<u>Description</u>
D809, 810	8-719-931-30	EQB01-30
D811, 812	8-719-931-06	EQB01-06

CAPACITORS

All capacitors are in μ F. Common capacitors are omitted.
Refer to the lists on pages 44 and 45 for their part numbers.

C801-804	Δ 1-108-385-00	0.047	100V	mylar
C807, 808 C818	Δ 1-102-394-00	0.01	250V	ceramic
C809-811	Δ 1-161-330-51	0.01	25V	film
C819, 820	Δ 1-123-515-00	330	50V	electrolytic
CT301, 302	1-141-180-00			Trimmer
CT303, 304	1-141-171-00			Trimmer

RESISTORS

All resistors are in ohms. Common $\frac{1}{4}$ W carbon resistors are omitted. Refer to the list on page 46 for their part numbers.

R101	Δ 1-247-107-00	100	$\frac{1}{4}$ W	carbon (nonflammable)
R142, 143	Δ 1-247-107-00	100	$\frac{1}{4}$ W	carbon (nonflammable)
R201	Δ 1-247-107-00	100	$\frac{1}{4}$ W	carbon (nonflammable)
R314	Δ 1-247-111-00	150	$\frac{1}{4}$ W	carbon (nonflammable)
R322	Δ 1-247-107-00	100	$\frac{1}{4}$ W	carbon (nonflammable)
R328	Δ 1-212-863-00	18	$\frac{1}{4}$ W	fusible (nonflammable)
R617	Δ 1-247-216-00	100	$\frac{1}{4}$ W	carbon (nonflammable)
R620	Δ 1-247-216-00	100	$\frac{1}{4}$ W	carbon (nonflammable)
R704, 754 R705, 755	Δ 1-247-138-00	2k	$\frac{1}{4}$ W	carbon (nonflammable)

<u>Ref. No.</u>	<u>Part No.</u>	<u>Description</u>
R711, 761 R715, 765 R716, 766 R713, 763 R714, 764	Δ 1-247-107-00	100 $\frac{1}{4}$ W carbon (nonflammable)
	Δ 1-247-114-00	200 $\frac{1}{4}$ W carbon (nonflammable)
R718, 768	Δ 1-247-083-00	10 $\frac{1}{4}$ W carbon (nonflammable)
R725, 775 R726, 776	Δ 1-217-157-00	0.33 5W metal oxide
R727, 777	1-244-825-00	10 $\frac{1}{2}$ W carbon
R728, 778	1-244-817-00	4.7 $\frac{1}{2}$ W carbon
R742, 792	Δ 1-247-083-00	10 $\frac{1}{4}$ W carbon (nonflammable)
R801	Δ 1-247-119-00	330 $\frac{1}{4}$ W carbon (nonflammable)
R802	Δ 1-247-079-00	4.7 $\frac{1}{4}$ W carbon (nonflammable)
R804	Δ 1-247-119-00	330 $\frac{1}{4}$ W carbon (nonflammable)
R806	Δ 1-247-079-00	4.7 $\frac{1}{4}$ W carbon (nonflammable)
R807	Δ 1-206-475-00	33 2W metal oxide (nonflammable)
R808, 809	Δ 1-247-107-00	100 $\frac{1}{4}$ W carbon (nonflammable)
R820	Δ 1-206-652-00	330 2W metal oxide (nonflammable)
R824	Δ 1-247-091-00	22 $\frac{1}{4}$ W carbon (nonflammable)
R902, 903	1-213-139-00	470 1W metal oxide (nonflammable)
RT101-103 RT201, 301	1-226-238-00	50k-B, adjustable; signal meter, FM tuning level, FM muting level, stereo separation, A-M muting level
RT202	1-226-235-00	5k-B, adjustable; VCO
RT401, 402	1-226-427-00	500-B, adjustable; PLL
RV601, 651	1-226-265-00	100k/100k, variable; BALANCE
RV602, 652	1-226-738-00	250k/250k-B, variable; VOLUME
RV603, 653	1-226-267-00	100k/100k, variable; TREBLE
RV604, 654	1-226-268-00	100k/100k, variable; BASS

<u>Ref. No.</u>	<u>Part No.</u>	<u>Description</u>
RV701,751	1-226-233-00	1k-B, adjustable; dc balance
RV702,752	1-226-237-00	20k-B, adjustable; dc bias

MISCELLANEOUS

CF101-104	1-527-344-91	Filter, ceramic
CF301	1-527-403-00	Filter, mechanical
CF302	1-527-732-00	Filter, ceramic
CNJ903	1-507-649-00	Jack, HEADPHONES
CNP901	1-534-817-31	Cord, power (AEP model)
	1-551-884-00	Cord, power (UK model)
F801	1-532-203-00	Fuse, 2A
FE101	1-463-335-00	Front End
FLD401	1-519-209-00	Tube, fluorescent-display
IFT101	1-404-258-00	Transformer, discriminator
IFT301	1-409-323-00	Coil, mechanical-filter (PRI)
IFT302	1-409-324-00	Coil, mechanical-filter (SEC)
IFT303	1-404-266-00	Transformer, a-m IF
J901-906 J951-956	1-507-637-21	Jack, phono; 6-unit
L301	1-407-169-XX	100μH, microinductor
L302	1-407-173-XX	220μH, microinductor
L303	1-405-927-00	Coil, MW OSC
L304	1-405-914-00	Coil, LW OSC
L305	1-407-176-XX	390μH, microinductor
L701, 751	1-420-838-00	Coil, air-wound
L901	1-401-888-00	Antenna, LW/MW ferrite-rod
LPF101	1-231-729-00	Filter, lowpass
LPF201	1-231-574-00	Filter, lowpass
PL901-906	1-518-331-81	Lamp, pilot; 6V 35mA
RY701	1-553-227-00	Relay
S7-9	1-553-184-00	Switch, pushbutton; LOW FILTER, MODE, LOUDNESS
S10, 11	1-553-483-00	Switch, rotary; POWER/SPEAKERS
S12-15	1-553-181-00	Switch, pushbutton; TUNING LEVEL
S401-413	1-552-539-00	Switch, keyboard; FM/MW/LW, MEMORY, MEMORY SCAN, TUNING, preset 1-8
TP901	1-446-842-00	Transformer, power (AEP model)
	1-446-843-00	Transformer, power (UK model)

<u>Ref. No.</u>	<u>Part No.</u>	<u>Description</u>
X401	1-527-731-00	Crystal, quartz
	1-533-131-00	Holder, fuse

COMPLETE CIRCUIT BOARDS

A-4358-069-A	Equalizer
A-4382-064-A	Tuner
A-4388-242-A	Power Amp
A-4472-049-A	Display
A-4477-043-A	Tone-Control
A-4477-044-A	VOLUME-Control
A-4483-010-A	Control

PRINTED CIRCUIT BOARDS

1-602-265-00	Input
1-602-267-00	Headphone
1-602-268-00	POWER/SPEAKERS Switch
1-603-377-00	Switch, Muting

ACCESSORIES AND PACKING MATERIALS

<u>Part No.</u>	<u>Description</u>
1-501-161-00	Antenna, FM-feeder
3-701-630-00	Bag, plastic
3-783-168-11	Manual, instruction
3-795-036-11	Manual, instruction (Dutch and Swedish)
4-809-251-00	Bag, plastic
4-866-398-00	Cushion, top (front)
4-866-399-00	Cushion, bottom (left)
4-868-730-00	Carton
4-868-713-00	Cushion, top (back)
4-868-714-00	Cushion, bottom (right)

SONY-STANDARD CAPACITORS AND RESISTORS

ELECTROLYTIC CAPACITORS

CAP. (μF)	RATING → : Use the high voltage rated one.					
	6.3 VOLT.	10 VOLT.	16 VOLT.	25 VOLT.	35 VOLT.	50 VOLT.
	PART No.	PART No.	PART No.	PART No.	PART No.	PART No.
0.47						
1.0						1-121-726-00
2.2						1-121-391-00
3.3						1-121-450-00
4.7	→	→	→	1-121-392-00	→	1-121-393-00
	→	→	→	1-121-395-00	→	1-121-396-00
10	→	→	1-121-651-00	1-121-398-00	→	1-121-738-00
22	→	→	1-121-479-00	1-121-480-00	1-121-662-00	1-121-152-00
33	→	→	1-121-403-00	1-121-404-00	1-121-652-00	1-121-405-00
47	→	1-121-352-00	1-121-409-00	1-121-410-00	1-121-653-00	1-121-411-00
100	→	1-121-414-00	1-121-415-00	1-121-416-00	1-121-357-00	1-121-417-00
220	1-121-415-00	1-121-420-00	1-121-421-00	1-121-422-00	1-121-261-00	1-121-423-00
330	1-121-751-00	1-121-805-00	1-121-521-00	1-121-654-00	1-121-655-00	1-121-656-00
470	1-121-424-00	1-121-425-00	1-121-426-00	1-121-733-00	1-121-361-00	1-121-810-00
1000	-	1-121-736-00	1-121-245-00	1-121-657-00	1-121-388-00	1-123-061-00
2200	1-121-658-00	1-121-659-00	1-121-660-00	1-123-067-00	1-121-984-00	-
3300	1-121-661-00	1-123-075-00	1-123-071-00	-	-	-

CAP. (μF)	100 VOLT.	160 VOLT.	250 VOLT.	350 VOLT.
	PART No.	PART No.	PART No.	PART No.
0.47	-	-	-	-
1.0	1-123-249-00	1-123-252-00	1-123-003-00	1-121-168-00
2.2	1-123-250-00	1-123-026-00	-	1-123-028-00
3.3	1-121-995-00	-	1-123-004-00	1-123-006-00
4.7	1-123-255-00	1-121-246-00	1-121-759-00	1-123-007-00
10	1-121-126-00	1-121-999-00	1-123-254-00	1-123-008-00
22	1-121-996-00	1-123-253-00	1-123-005-00	1-123-022-00
33	1-121-997-00	1-121-757-00	-	-
47	1-123-251-00	1-121-919-00	-	-
100	1-123-084-00	-	-	-

CERAMIC CAPACITORS

CAP. (pF)	RATING							
	50 VOLT.	CAP. (pF)	50 VOLT.	CAP. (pF)	50 VOLT.	CAP. (μF)	50 VOLT.	
	PART No.		PART No.		PART No.		PART No.	
0.5	1-101-837-00	22	1-102-959-00	150	1-101-361-00	0.001	1-102-074-00	
0.75	1-101-586-00	24	1-102-960-00	160	1-101-367-00	0.0012	1-102-118-00	
1.0	1-102-934-00	27	1-102-961-00	180	1-102-976-00	0.0015	1-102-119-00	
1.5	1-101-576-00	30	1-102-962-00	200	1-102-977-00	0.0018	1-102-120-00	
2.0	1-102-935-00	33	1-102-963-00	220	1-102-978-00	0.0022	1-102-121-00	
3	1-102-936-00	36	1-102-964-00	240	1-102-979-00	0.0027	1-102-122-00	
4	1-102-937-00	39	1-102-965-00	270	1-102-980-00	0.0033	1-102-123-00	
5	1-102-942-00	43	1-102-966-00	300	1-102-981-00	0.0039	1-102-124-00	
6	1-102-943-00	47	1-101-880-00	330	1-102-820-00	0.0047	1-102-125-00	
7	1-102-944-00	51	1-101-882-00	360	1-102-821-00	0.0056	1-102-126-00	
8	1-102-945-00	56	1-101-884-00	390	1-102-822-00	0.0068	1-102-127-00	
9	1-102-946-00	62	1-101-886-00	430	1-102-823-00	0.0082	1-102-128-00	
10	1-102-947-00	68	1-101-888-00	470	1-102-824-00	0.01	1-102-129-00	
11	1-102-948-00	75	1-101-890-00	510	1-101-059-00	0.022	1-101-005-00	
12	1-102-949-00	82	1-102-971-00	560	1-102-115-00	0.047	1-101-006-00	
13	1-102-950-00	91	1-102-972-00	680	1-102-116-00			
15	1-102-951-00	100	1-102-973-00	820	1-102-117-00			
16	1-102-952-00	110	1-102-815-00					
18	1-102-953-00	120	1-102-816-00					
20	1-102-958-00	130	1-101-081-00					

0.001 μF = 1,000 pF

CERAMIC (SEMICONDUCTOR) CAPACITORS

CAP. (μF)	RATING → : Use the high voltage rated one.					
	25 VOLT.	50 VOLT.	CAP. (μF)	25 VOLT.	50 VOLT.	
	PART No.	PART No.		PART No.	PART No.	
0.001	→	1-161-039-00	0.018	1-161-016-00	1-161-054-00	
0.0012	→	1-161-040-00	0.022	1-161-017-00	1-161-055-00	
0.0015	→	1-161-041-00	0.027	1-161-018-00	1-161-056-00	
0.0018	→	1-161-042-00	0.033	1-161-019-00	1-161-057-00	
0.0022	→	1-161-043-00	0.039	1-161-010-00	1-161-058-00	
0.0027	→	1-161-044-00	0.047	1-161-021-00	1-161-059-00	
0.0033	→	1-161-045-00	0.056	→	1-161-060-00	
0.0039	→	1-161-046-00	0.068	→	1-161-061-00	
0.0047	→	1-161-047-00	0.082	1-161-024-00	1-161-062-00	
0.0056	→	1-161-048-00	0.1	1-161-025-00	1-161-063-00	
0.0068	→	1-161-049-00				
0.0082	1-161-012-00	1-161-050-00				
0.01	1-161-013-00	1-161-051-00				
0.012	→	1-161-052-00				
0.015	1-161-015-00	1-161-053-00				

MYLAR CAPACITORS

CAP. (μF)	RATING											
	50 VOLT.			CAP. (μF)	100 VOLT.			CAP. (μF)	200 VOLT.			
	PART No.	PART No.	PART No.		PART No.	PART No.	PART No.		PART No.	PART No.	PART No.	
0.001	1-108-227-00	1-108-365-00	1-108-409-00	0.01	1-108-239-00	1-108-377-00	1-108-421-00	0.1	1-108-251-00	1-108-389-00	1-108-433-00	
0.0012	1-108-351-00	1-108-366-00	1-108-410-00	0.012	1-108-357-00	1-108-378-00	1-108-422-00	0.12	1-108-363-00	1-108-390-00	1-108-434-00	
0.0015	1-108-228-00	1-108-367-00	1-108-411-00	0.015	1-108-240-00	1-108-379-00	1-108-423-00	0.15	1-108-252-00	1-108-391-00	1-108-435-00	
0.0018	1-108-352-00	1-108-368-00	1-108-412-00	0.018	1-108-358-00	1-108-380-00	1-108-424-00	0.18	1-108-364-00	1-108-392-00	1-108-436-00	
0.0022	1-108-230-00	1-108-369-00	1-108-413-00	0.022	1-108-242-00	1-108-381-00	1-108-425-00	0.22	1-108-254-00	1-108-393-00	1-108-437-00	
0.0027	1-108-353-00	1-108-370-00	1-108-414-00	0.027	1-108-359-00	1-108-382-00	1-108-426-00	0.27	1-108-354-00			
0.0033	1-108-232-00	1-108-371-00	1-108-415-00	0.033	1-108-244-00	1-108-383-00	1-108-427-00	0.33	1-108-355-00			
0.0039	1-108-354-00	1-108-372-00	1-108-416-00	0.039	1-108-360-00	1-108-384-00	1-108-428-00	0.39	1-108-356-00			
0.0047	1-108-234-00	1-108-373-00	1-108-417-00	0.047	1-108-246-00	1-108-385-00	1-108-429-00	0.47	1-108-357-00			
0.0056	1-108-355-00	1-108-374-00	1-108-418-00	0.056	1-108-361-00	1-108-386-00	1-108-430-00					
0.0068	1-108-237-00	1-108-375-00	1-108-419-00	0.068	1-108-249-00	1-108-387-00	1-108-431-00					
0.0082	1-108-356-00	1-108-376-00	1-108-420-00	0.082	1-108-362-00	1-108-388-00	1-108-432-00					



TANTALUM CAPACITORS

CAP. (μF)	RATING → Use the high voltage rated one.					
	3.15 VOLT.	6.3 VOLT.	10 VOLT.	16 VOLT.	20 VOLT.	35 VOLT.
	PART No.	PART No.	PART No.	PART No.	PART No.	PART No.
0.01					→	1-131-396-00
0.015					→	1-131-397-00
0.022					→	1-131-398-00
0.033					→	1-131-399-00
0.047					→	1-131-400-00
0.068					→	1-131-401-00
0.1					→	1-131-402-00
0.15					→	1-131-403-00
0.22					→	1-131-404-00
0.33					→	1-131-405-00
0.47					→	1-131-406-00
0.68				1-131-415-00	→	1-131-407-00
1.0			1-131-418-00		→	1-131-408-00
1.5		1-131-421-00		1-131-416-00	→	1-131-411-00
2.2	1-131-424-00		1-131-419-00		→	1-131-348-00
3.3					1-131-414-00	1-131-349-00
4.7	1-131-425-00	1-131-422-00		1-131-417-00	1-131-362-00	1-131-356-00
6.8			1-131-420-00	1-131-369-00	1-131-363-00	1-131-350-00
10	1-131-426-00	1-131-423-00	1-131-376-00	1-131-370-00	1-131-364-00	1-131-351-00
15	1-131-390-00	1-131-383-00	1-131-377-00	1-131-371-00	1-131-365-00	1-131-352-00
22	1-131-391-00	1-131-384-00	1-131-378-00	1-131-372-00	1-131-366-00	1-131-353-00
33	1-131-392-00	1-131-385-00	1-131-379-00	1-131-373-00	1-131-367-00	
47	1-131-393-00	1-131-386-00	1-131-380-00	1-131-374-00		
68	1-131-394-00	1-131-387-00	1-131-381-00			
100	1-131-395-00	1-131-388-00				

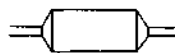

TANTALUM CAPACITORS

CAP. (μF)	RATING					
	3 VOLT.	6.3 VOLT.	10 VOLT.	16 VOLT.	20 VOLT.	35 VOLT.
	PART No.	PART No.	PART No.	PART No.	PART No.	PART No.
0.033						1-131-273-00
0.047						1-131-274-00
0.068						1-131-275-00
0.1						1-131-276-00
0.15						1-131-277-00
0.22					1-131-262-00	1-131-278-00
0.33					1-131-263-00	1-131-279-00
0.47			1-131-169-00		1-131-264-00	1-131-280-00
0.68				1-131-258-00	1-131-265-00	1-131-281-00
1.0			1-131-254-00		1-131-266-00	1-131-282-00
1.5		1-131-250-00			1-131-267-00	1-131-283-00
2.2				1-131-259-00	1-131-268-00	1-131-284-00
3.3			1-131-255-00		1-131-269-00	
4.7		1-131-251-00	1-131-171-00		1-131-270-00	
6.8				1-131-260-00	1-131-271-00	
10			1-131-256-00		1-131-272-00	
15		1-131-252-00		1-131-261-00		
22			1-131-257-00			
33	1-131-176-00	1-131-253-00	1-131-173-00			
47	1-131-288-00	1-131-174-00				
100	1-131-177-00					

1/16 WATT CARBON RESISTOR

Ω	Part No.	Ω	Part No.	Ω	Part No.	Ω	Part No.	Ω	Part No.	Ω	Part No.	Ω	Part No.
2.0	—	13	—	91	1-210-354-00	620	1-210-367-00	4.3k	1-209-772-00	30k	1-210-380-00	200k	1-210-839-00
2.2	—	15	—	100	1-210-355-00	680	1-210-106-00	4.7k	1-209-773-00	33k	1-210-381-00	220k	1-210-840-00
2.4	—	16	—	110	1-210-356-00	750	1-210-107-00	5.1k	1-209-774-00	36k	1-210-384-00	240k	—
2.7	—	18	1-211-688-00	120	1-210-357-00	820	1-210-108-00	5.6k	1-209-775-00	39k	1-210-382-00	270k	1-210-841-00
3.0	—	20	—	130	1-210-358-00	910	1-210-368-00	6.2k	1-209-776-00	43k	1-210-383-00	300k	—
3.3	—	22	—	150	1-210-102-00	1.0k	1-204-122-00	6.8k	1-209-777-00	47k	1-210-384-00	330k	1-210-842-00
3.6	—	24	—	160	1-210-359-00	1.1k	1-210-369-00	7.5k	1-209-778-00	51k	1-210-385-00	360k	—
3.9	—	27	—	180	1-210-360-00	1.2k	1-209-765-00	8.2k	1-209-779-00	56k	1-210-386-00	390k	1-210-843-00
4.3	—	30	1-210-845-00	200	1-210-361-00	1.3k	1-210-370-00	9.1k	1-209-780-00	62k	1-210-387-00	430k	—
4.7	—	33	1-210-846-00	220	1-210-362-00	1.5k	1-209-766-00	10k	1-209-781-00	68k	1-210-388-00	470k	1-210-844-00
5.1	—	36	1-210-847-00	240	1-209-762-00	1.6k	1-210-371-00	11k	1-210-374-00	75k	1-210-389-00	510k	—
5.6	—	39	1-210-848-00	270	1-210-363-00	1.8k	1-209-878-00	12k	1-210-111-00	82k	1-210-390-00	560k	1-211-695-00
6.2	—	43	1-210-849-00	300	1-210-364-00	2.0k	1-209-767-00	13k	1-210-375-00	91k	1-210-391-00	620k	—
6.8	—	47	1-210-395-00	330	1-209-763-00	2.2k	1-209-768-00	15k	1-210-112-00	100k	1-210-115-00	680k	1-211-696-00
7.5	—	51	1-210-101-00	360	1-210-103-00	2.4k	1-209-769-00	16k	1-210-376-00	110k	—	750k	—
8.2	—	56	1-210-351-00	390	1-210-365-00	2.7k	1-209-770-00	18k	1-210-113-00	120k	1-210-836-00	820k	1-211-698-00
9.1	—	62	1-210-352-00	430	1-210-366-00	3.0k	1-210-372-00	20k	1-210-377-00	130k	—	910k	—
10	—	68	1-210-353-00	470	1-209-764-00	3.3k	1-204-123-00	22k	1-210-114-00	150k	1-210-837-00	1 M	—
11	—	75	1-210-392-00	510	1-210-104-00	3.6k	1-210-373-00	24k	1-210-378-00	160k	—	—	—
12	—	82	1-210-393-00	560	1-210-105-00	3.9k	1-209-771-00	27k	1-210-379-00	180k	1-210-838-00	—	—

1/8 WATT CARBON RESISTOR

Ω	Part No.	Ω	Part No.	Ω	Part No.	Ω	Part No.	Ω	Part No.	Ω	Part No.	Ω	Part No.
2.0	—	13	1-246-821-00	91	1-246-831-00	620	1-246-841-00	4.3k	1-246-851-00	30k	1-246-861-00	200k	1-246-871-00
2.2	1-246-751-00	15	1-246-761-00	100	1-246-771-00	680	1-246-781-00	4.7k	1-246-791-00	33k	1-246-801-00	220k	1-246-811-00
2.4	—	16	1-246-822-00	110	1-246-832-00	750	1-246-842-00	5.1k	1-246-852-00	36k	1-246-862-00	240k	1-247-054-00
2.7	1-246-752-00	18	1-246-762-00	120	1-246-772-00	820	1-246-782-00	5.6k	1-246-792-00	39k	1-246-802-00	270k	1-247-046-00
3.0	—	20	1-246-823-00	130	1-246-833-33	910	1-246-843-00	6.2k	1-246-853-00	43k	1-246-863-00	300k	1-247-055-00
3.3	1-246-753-00	22	1-246-763-00	150	1-246-773-00	1.0k	1-246-783-00	6.8k	1-246-793-00	47k	1-246-803-00	330k	1-247-047-00
3.6	—	24	1-246-824-00	160	1-246-834-00	1.1k	1-246-844-00	7.5k	1-246-854-00	51k	1-246-864-00	360k	1-247-056-00
3.9	1-246-754-00	27	1-246-764-00	180	1-246-774-00	1.2k	1-246-784-00	8.2k	1-246-794-00	56k	1-246-804-00	390k	1-247-048-00
4.3	—	30	1-246-825-00	200	1-246-835-00	1.3k	1-246-845-00	9.1k	1-246-855-00	62k	1-246-865-00	430k	1-247-057-00
4.7	1-246-755-00	33	1-246-765-00	220	1-246-775-00	1.5k	1-246-785-00	10k	1-246-795-00	68k	1-246-805-00	470k	1-247-049-00
5.1	—	36	1-246-826-00	240	1-246-836-00	1.6k	1-246-846-00	11k	1-246-856-00	75k	1-246-866-00	510k	1-247-058-00
5.6	1-246-756-00	39	1-246-766-00	270	1-246-776-00	1.8k	1-246-786-00	12k	1-246-796-00	82k	1-246-806-00	560k	1-247-050-00
6.2	—	43	1-246-827-00	300	1-246-837-00	2.0k	1-246-847-00	13k	1-246-857-00	91k	1-246-867-00	620k	1-247-059-00
6.8	1-246-757-00	47	1-246-767-00	330	1-246-777-00	2.2k	1-246-787-00	15k	1-246-797-00	100k	1-246-807-00	680k	1-247-051-00
7.5	1-246-818-00	51	1-246-828-00	360	1-246-838-00	2.4k	1-246-848-00	16k	1-246-858-00	110k	1-246-868-00	750k	1-247-060-00
8.2	1-246-758-00	56	1-246-768-00	390	1-246-778-00	2.7k	1-246-788-00	18k	1-246-798-00	120k	1-246-808-00	820k	1-247-052-00
9.1	1-246-819-00	62	1-246-829-00	430	1-246-839-00	3.0k	1-246-849-00	20k	1-246-859-00	130k	1-246-869-00	910k	1-247-061-00
10	1-246-759-00	68	1-246-769-00	470	1-246-779-00	3.3k	1-246-789-00	22k	1-246-799-00	150k	1-246-809-00	1 M	1-247-053-00
11	1-246-820-00	75	1-246-830-00	510	1-246-840-00	3.6k	1-246-850-00	24k	1-246-860-00	160k	1-246-870-00	—	—
12	1-246-760-00	82	1-246-770-00	560	1-246-780-00	3.9k	1-246-790-00	27k	1-246-800-00	180k	1-246-810-00	—	—

1/4 WATT CARBON RESISTORS

Ω	Part No.	Ω	Part No.	Ω	Part No.	Ω	Part No.	Ω	Part No.	Ω	Part No.	Ω	Part No.
1.0	1-246-401-00	10	1-246-425-00	100	1-246-449-00	1.0k	1-246-473-00	10k	1-246-497-00	100k	1-246-521-00	1.0M	1-246-545-00
1.1	1-246-402-00	11	1-246-426-00	110	1-246-450-00	1.1k	1-246-474-00	11k	1-246-498-00	110k	1-246-522-00	1.1M	1-210-814-00
1.2	1-246-403-00	12	1-246-427-00	120	1-246-451-00	1.2k	1-246-475-00	12k	1-246-499-00	120k	1-246-523-00	1.2M	1-210-815-00
1.3	1-246-404-00	13	1-246-428-00	130	1-246-452-00	1.3k	1-246-476-00	13k	1-246-500-00	130k	1-246-524-00	1.3M	1-210-816-00
1.5	1-246-405-00	15	1-246-429-00	150	1-246-453-00	1.5k	1-246-477-00	15k	1-246-501-00	150k	1-246-525-00	1.5M	1-210-817-00
1.6	1-246-406-00	16	1-246-430-00	160	1-246-454-00	1.6k	1-246-478-00	16k	1-246-502-00	160k	1-246-526-00	1.6M	1-210-818-00
1.8	1-246-407-00	18	1-246-431-00	180	1-246-455-00	1.8k	1-246-479-00	18k	1-246-503-00	180k	1-246-527-00	1.8M	1-210-819-00
2.0	1-246-408-00	20	1-246-432-00	200	1-246-456-00	2.0k	1-246-480-00	20k	1-246-504-00	200k	1-246-528-00	2.0M	1-210-820-00
2.2	1-246-409-00	22	1-246-433-00	220	1-246-457-00	2.2k	1-246-481-00	22k	1-246-505-00	220k	1-246-529-00	2.2M	1-210-821-00
2.4	1-246-410-00	24	1-246-434-00	240	1-246-458-00	2.4k	1-246-482-00	24k	1-246-506-00	240k	1-246-530-00	2.4M	1-244-754-00
2.7	1-246-411-00	27	1-246-435-00	270	1-246-459-00	2.7k	1-246-483-00	27k	1-246-507-00	270k	1-246-531-00	2.7M	1-244-755-00
3.0	1-246-412-00	30	1-246-436-00	300	1-246-460-00	3.0k	1-246-484-00	30k	1-246-508-00	300k	1-246-532-00	3.0M	1-244-756-00
3.3	1-246-413-00	33	1-246-437-00	330	1-246-461-00	3.3k	1-246-485-00	33k	1-246-509-00	330k	1-246-533-00	3.3M	1-244-757-00
3.6	1-246-414-00	36	1-246-438-00	360	1-246-462-00	3.6k	1-246-486-00	36k	1-246-510-00	360k	1-246-534-00	3.6M	1-244-758-00
3.9	1-246-415-00	39	1-246-439-00	390	1-246-463-00	3.9k	1-246-487-00	39k	1-246-511-00	390k	1-246-535-00	3.9M	1-244-759-00
4.3	1-246-416-00	43	1-246-440-00	430	1-246-464-00	4.3k	1-246-488-00	43k	1-246-512-00	430k	1-246-536-00	4.3M	1-244-760-00
4.7	1-246-417-00	47	1-246-441-00	470	1-246-465-00	4.7k	1-246-489-00	47k	1-246-513-00	470k	1-246-537-00	4.7M	1-244-761-00
5.1	1-246-418-00	51	1-246-442-00	510	1-246-466-00	5.1k	1-246-490-00	51k	1-246-514-00	510k	1-246-538-00	5.1M	1-244-762-00
5.6	1-246-419-00	56	1-246-443-00	560	1-246-467-00	5.6k	1-246-491-00	56k	1-246-515-00	560k	1-246-539-00		
6.2	1-246-420-00	62	1-246-444-00	620	1-246-468-00	6.2k	1-246-492-00	62k	1-246-516-00	620k	1-246-540-00		
6.8	1-246-421-00	68	1-246-445-00	680	1-246-469-00	6.8k	1-246-493-00	68k	1-246-517-00	680k	1-246-541-00		
7.5	1-246-422-00	75	1-246-446-00	750	1-246-470-00	7.5k	1-246-494-00	75k	1-246-518-00	750k	1-246-542-00		
8.2	1-246-423-00	82	1-246-447-00	820	1-246-471-00	8.2k	1-246-495-00	82k	1-246-519-00	820k	1-246-543-00		
9.1	1-246-424-00	91	1-246-448-00	910	1-246-472-00	9.1k	1-246-496-00	91k	1-246-520-00	910k	1-246-544-00		

HARDWARE NOMENCLATURE

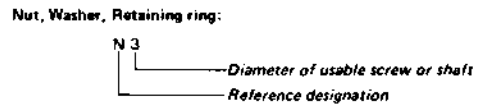
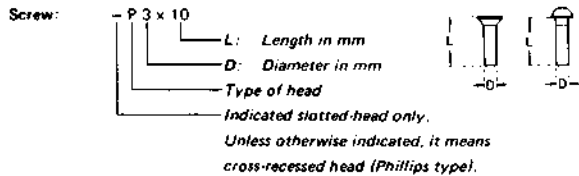

Reference Designation	Shape	Description	Remarks
SCREWS			
P		pan-head screw	binding-head (B) screw for replacement
PWH		pan-head screw with washer face	binding-head (B) screw and flat washer for replacement
PS PSP		pan-head screw with spring washer	binding-head (B) screw and spring washer for replacement
PSW PSPW		pan-head screw with spring and flat washers	binding-head (B) screw and spring and flat washers for replacement
R		round-head screw	binding-head (B) screw for replacement
K		flat-countersunk-head screw	
RK		oval-countersunk-head screw	
B		binding-head screw	
T		truss-head screw	binding-head (B) screw for replacement
F		flat-filister-head screw	
RF		filister-head screw	
BV		braizer-head screw	

Reference Designation	Shape	Description	Remarks
SELF-TAPPING SCREWS			
TA		self-tapping screw	ex. TA, P 3 x 10
PTP		pan-head self-tapping screw	binding-head self-tapping (TA, B) screw for replacement
PTPWH		pan-head self-tapping screw with washer face	binding-head self-tapping (TA, B) screw and flat washer for replacement
PTTWH		pan-head thread-rolling screw with washer face	binding-head (B) screw and flat washer for replacement
SET SCREWS			
SC		set screw	
SC		hexagon-socket set screw	ex. SC 2.6 x 4, hexagon socket
NUT			
N		nut	
WASHERS			
W		flat washer	
SW		spring washer	
LW		internal-tooth lock washer	ex. LW3, internal
LW		external-tooth lock washer	ex. LW3, external
RETAINING RINGS			
E		retaining ring	
G		grip-type retaining ring	