

STR-V6

PRELIMINARY

907

927

US Model
Canadian Model
AEP Model
UK Model
E Model



FM STEREO / FM-AM RECEIVER

GENERAL

- Power Requirements:** 120V ac, 60Hz (US, Canadian model)
110, 120, 220 or 240V ac adjustable,
50/60 Hz (AEP, UK, E model)
- Power Consumption:** 200W (US model)
450VA (Canadian model)
670W (AEP, E model)
620W (UK model)
- AC Outlets:** 1 switched, total 100W } (US, Canadian
1 unswitched, total 300W } model)
- Dimensions:** US, Canadian model
Approx. 522 (w) x 192 (h) x 450 (d) mm
20 1/2 (w) x 7 1/2 (h) x 17 3/4 (d) inches
including projecting parts and controls
AEP, UK, E model
Approx. 525 (w) x 195 (h) x 450 (d) mm
20 1/2 (w) x 7 1/2 (h) x 17 3/4 (d) inches
including projecting parts and controls

SPECIFICATIONS

- Weight:** US, Canadian model
Approx. 21.4 kg, 47 lb 12 oz (net)
Approx. 23.6 kg, 51 lb 15 oz (in shipping carton)
AEP, UK model
Approx. 21.9 kg, 48 lb 5 oz (net)
Approx. 25.4 kg, 55 lb 16 oz (in shipping carton)
E model
Approx. 23.2 kg, 51 lb 2 oz (net)
Approx. 26.6 kg, 58 lb 10 oz (in shipping carton)

FM SECTION

- Antenna:** 300Ω balanced
75Ω unbalanced
- Tuning Range:** 87.5 MHz–108 MHz
- Intermediate Frequency:** 10.7 MHz
- Sensitivity at 50 dB Quieting:** US, Canadian, E model
14.2 dBf, 2.8 μV (MONO)
37.3 dBf, 40 μV (STEREO)
- Sensitivity at 46 dB Quieting:** (40 kHz deviation)
AEP, UK model
3.8 μV, 16.8 dBf (MONO)
50 μV, 39.2 dBf (STEREO)
- Usable Sensitivity:** US, Canadian, E model
9.3 dBf, 1.6 μV
AEP, UK model
1.3 μV, S/N = 26 dB (40 kHz deviation)
1.7 μV, 9.8 dBf; IHF
- Limiting Threshold:** 1 μV (AEP, UK model)

SAFETY RELATED COMPONENT WARNING !!

COMPONENTS IDENTIFIED BY SHADING AND MARK  ON THE SCHEMATIC DIAGRAMS, EXPLODED VIEWS AND IN THE PARTS LIST ARE CRITICAL TO SAFE OPERATION. REPLACE THESE COMPONENTS WITH SONY PARTS WHOSE PART NUMBERS APPEAR AS SHOWN IN THIS MANUAL OR IN SUPPLEMENTS PUBLISHED BY SONY.

ATTENTION AU COMPOSANT AYANT RAPPORT À LA SÉCURITÉ !

LES COMPOSANTS IDENTIFIÉS PAR UN TRAMÉ ET UNE MARQUE  SUR LES DIAGRAMMES SCHEMATIQUES, LES VUES EXPLOSÉES ET LA LISTE DES PIÈCES SONT CRITIQUES POUR LA SÉCURITÉ DE FONCTIONNEMENT. NE REMPLACER CES COMPOSANTS QUE PAR DES PIÈCES SONY DONT LES NUMÉROS SONT DONNÉS DANS CE MANUEL OU DES SUPPLÉMENTS PUBLIÉS PAR SONY.

— Continued on page 2 —

SONY®

SERVICE MANUAL

S/N Ratio: US, Canadian, E model
75 dB (MONO)
70 dB (STEREO)
AEP, UK model
(40 kHz deviation)
70 dB (MONO)
65 dB (STEREO)

Harmonic Distortion: US, Canadian, E model
AEP, UK model (40 kHz deviation)

	MONO		STEREO	
	NORMAL	NARROW	NORMAL	NARROW
100 Hz	0.08%	0.2%	0.15%	0.4%
1 kHz	0.08%	0.2%	0.15%	0.4%
10 kHz	0.1%	0.2%	0.3%	0.6%

IM Distortion: US, Canadian, E model
AEP, UK model (40 kHz deviation)

	MONO		STEREO	
	NORMAL	NARROW	NORMAL	NARROW
	0.08%	0.2%	0.15%	0.4%

Separation:

	NORMAL	NARROW
100 Hz	40 dB	35 dB
1 kHz	48 dB	40 dB
10 kHz	43 dB	37 dB

Frequency Response: US, Canadian, E model
30 Hz–15 kHz $+0.2$ dB
 -1.5 dB
AEP, UK model
40 Hz–12.5 kHz $+0.2$ dB
 -1.0 dB
30 Hz–15 kHz $+0.2$ dB
 -1.5 dB

Selectivity: US, Canadian, E model
at 400 kHz
50 dB (NORMAL)
80 dB (NARROW)
AEP, UK model

	NORMAL	NARROW
300 kHz	30 dB	55 dB
400 kHz	55 dB	85 dB

Capture Ratio: 1.0 dB
AM Suppression Ratio: 60 dB
Image Response Ratio: 80 dB
IF Response Ratio: 100 dB
Spurious Response Ratio: 100 dB
RF Intermodulation: 70 dB
Sub-carrier Product Ratio: 60 dB
SCA Rejection Ratio: 60 dB (US, Canadian model)
Muting Threshold: Approx. 5 μ V

AM SECTION

Antenna: Built-in ferrite-rod antenna
External antenna terminal

Tuning Range: 530 kHz–1,605 kHz

Intermediate Frequency: 455 kHz (US, Canadian model)
468 kHz (AEP, UK, E model)

Usable Sensitivity: 200 μ V/m, built-in antenna
100 μ V, external antenna
at 1,000 kHz

S/N Ratio: 50 dB at 50 mV/m

Harmonic Distortion: 0.5W at 50 mV/m, 400 Hz

Selectivity: 40 dB at 10 kHz (US, Canadian model)
35 dB at 10 kHz (AEP, UK, E model)

Image Response Ratio: 40 dB at 1,000 kHz

IF Response Ratio: 40 dB at 1,000 kHz

AUDIO AMPLIFIER SECTION

Power Output and Total Harmonic Distortion:

With 8 Ω loads, both channels driven, from 20–20,000 Hz; rated 115W per channel minimum RMS power, with no more than 0.07% total harmonic distortion from 250 mW to rated output. (US, Canadian model)

Continuous RMS Power Output:

Less than 0.07% THD, both channels driven simultaneously
at 20 Hz–20 kHz
115+115W (8 Ω) (AEP, UK, E model)
110+110W (4 Ω) (AEP, E model)
at 1 kHz
120+120W (8 Ω) (AEP, UK, E model)
110+110W (4 Ω) (AEP, E model)
according to DIN 45500
115+115W (8 Ω) (AEP, UK, E model)

Dynamic Power Output: (IHF constant power supply method)

350W (8 Ω) (AEP, UK, E model)

Power Bandwidth: (IHF)

10 Hz–35 kHz (AEP, UK, E model)

Damping Factor:

40 at 1 kHz, 8 Ω

Harmonic Distortion:

Less than 0.07% at rated output (AEP, UK, E model)
Less than 0.05% at 1W output

IM Distortion: (60 Hz:7 kHz = 4:1)

Less than 0.07% at rated output
Less than 0.05% at 1W output

Residual Noise:

Less than 0.3 mV (A-network)

Frequency Response:

PHONO 1, 2
RIAA equalization curve ± 0.5 dB
AUX
TAPE 1, 2 } 5 Hz–50 kHz $+0$ dB
 -2 dB
REC/PB 5 Hz–50 kHz $+0$ dB
 -2 dB
(AEP, UK, E model)

Input Sensitivity, Impedance and S/N Ratio:

Measured with rated output power into 8 Ω loads (both channels driven simultaneously) at 1 kHz

	Sensitivity	Impedance	S/N	Weighting network
PHONO 1, 2	2.5 mV	50 k Ω	75 dB	A
AUX TAPE 1, 2 REC/PB (AEP, UK, E model)	150 mV	100 k Ω	100 dB	A

Output and Impedance: With rated input, FM 30% modulation, speaker rated output

	Voltage	Impedance
REC OUT 1, 2	150 mV	4.7 k Ω
REC/PB (AEP, UK, E model)	40 mV	82 k Ω

Headphones: Accepts 8 Ω to 10 k Ω headphones

Speaker: 4 Ω to 16 Ω speakers are suitable (AEP, E model)
8 Ω to 16 Ω speakers are suitable (US, Canadian, UK model)

Tone Controls:

BASS ± 10 dB at 100 Hz
TREBLE ± 10 dB at 10 kHz

Filters:

HIGH 6 dB/oct. above 9 kHz
LOW 6 dB/oct. below 50 Hz

Loudness Control: (att. 30 dB)

+10 dB at 50 Hz
+3 dB at 10 kHz

STR-V6 STR-V6

1. BLOCK DIAGRAM

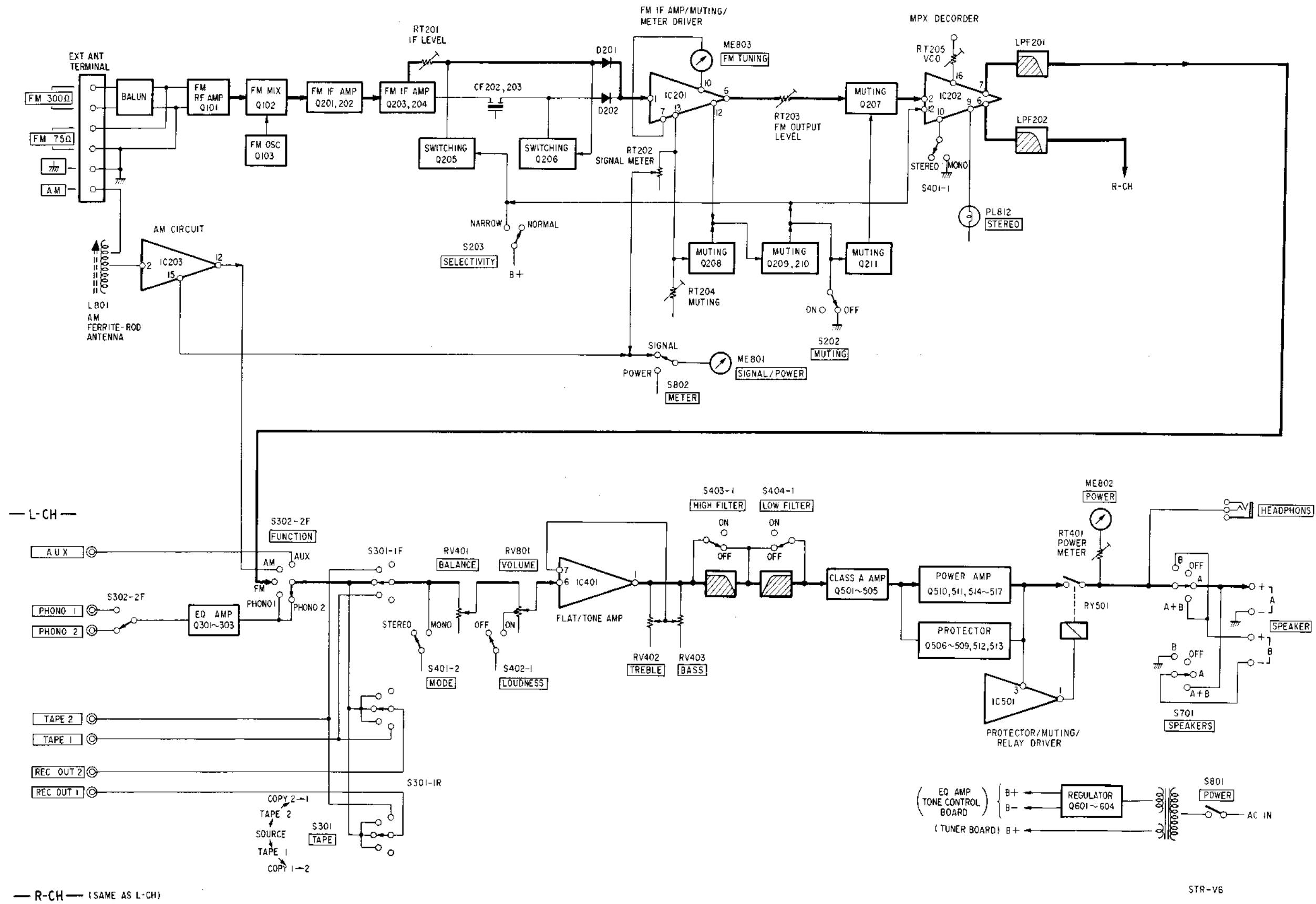

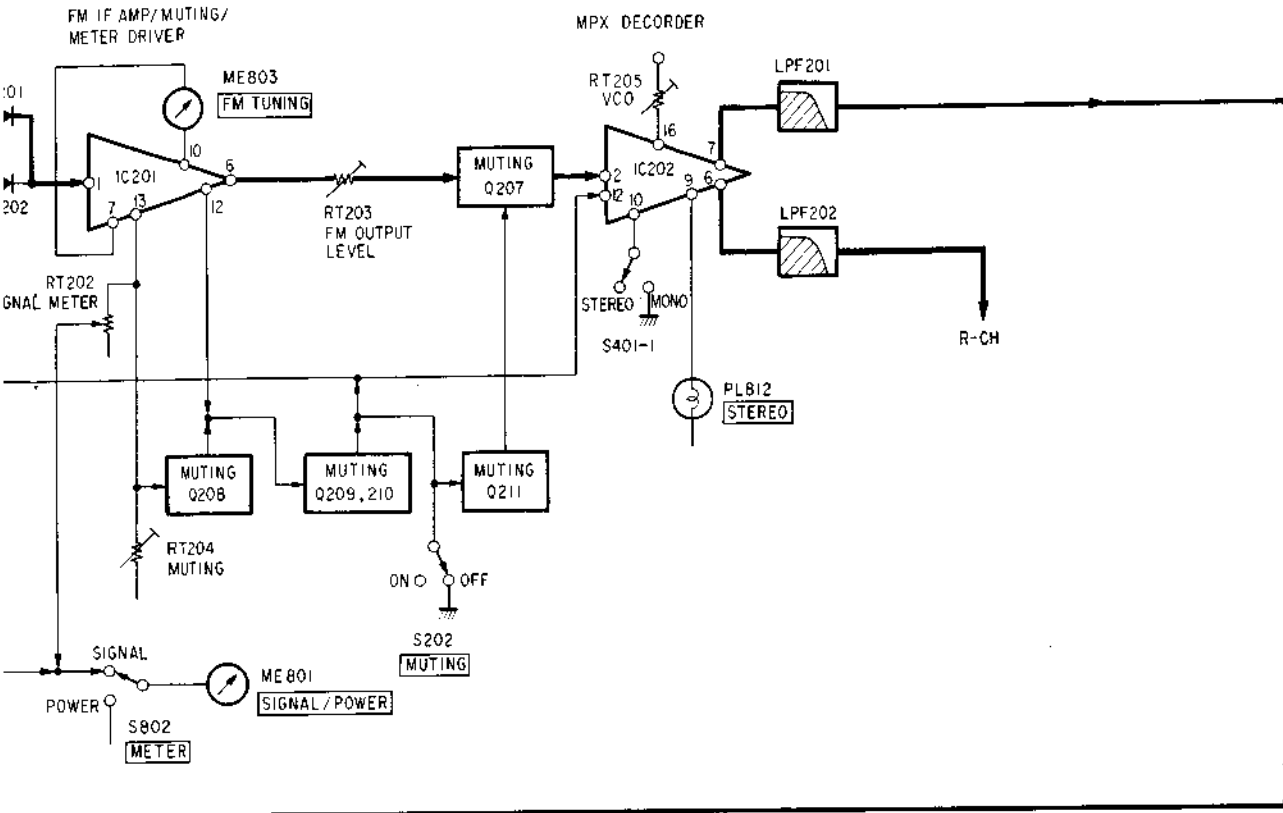

1/4 WATT CARBON RESISTORS (A) Note: Circled letter (A) is applicable to European models only.

Ω	Part No.	Ω	Part No.	Ω	Part No.	Ω	Part No.	Ω	Part No.	Ω	Part No.
1.0	1-244-601-11	10	1-244-625-11	100	1-244-649-11	1.0k	1-244-673-11	10k	1-244-697-11	100k	1-244-745-11
1.1	1-244-602-11	11	1-244-626-11	110	1-244-650-11	1.1k	1-244-674-11	11k	1-244-698-11	110k	1-244-746-11
1.2	1-244-603-11	12	1-244-627-11	120	1-244-651-11	1.2k	1-244-675-11	12k	1-244-699-11	120k	1-244-747-11
1.3	1-244-604-11	13	1-244-628-11	130	1-244-652-11	1.3k	1-244-676-11	13k	1-244-700-11	130k	1-244-748-11
1.5	1-244-605-11	15	1-244-629-11	150	1-244-653-11	1.5k	1-244-677-11	15k	1-244-701-11	150k	1-244-749-11
1.6	1-244-606-11	16	1-244-630-11	160	1-244-654-11	1.6k	1-244-678-11	16k	1-244-702-11	160k	1-244-750-11
1.8	1-244-607-11	18	1-244-631-11	180	1-244-655-11	1.8k	1-244-679-11	18k	1-244-703-11	180k	1-244-751-11
2.0	1-244-608-11	20	1-244-632-11	200	1-244-656-11	2.0k	1-244-680-11	20k	1-244-704-11	200k	1-244-752-11
2.2	1-244-609-11	22	1-244-633-11	220	1-244-657-11	2.2k	1-244-681-11	22k	1-244-705-11	220k	1-244-753-11
2.4	1-244-610-11	24	1-244-634-11	240	1-244-658-11	2.4k	1-244-682-11	24k	1-244-706-11	240k	1-244-754-11
2.7	1-244-611-11	27	1-244-635-11	270	1-244-659-11	2.7k	1-244-683-11	27k	1-244-707-11	270k	1-244-755-11
3.0	1-244-612-11	30	1-244-636-11	300	1-244-660-11	3.0k	1-244-684-11	30k	1-244-708-11	300k	1-244-756-11
3.3	1-244-613-11	33	1-244-637-11	330	1-244-661-11	3.3k	1-244-685-11	33k	1-244-709-11	330k	1-244-757-11
3.6	1-244-614-11	36	1-244-638-11	360	1-244-662-11	3.6k	1-244-686-11	36k	1-244-710-11	360k	1-244-758-11
3.9	1-244-615-11	39	1-244-639-11	390	1-244-663-11	3.9k	1-244-687-11	39k	1-244-711-11	390k	1-244-759-11
4.3	1-244-616-11	43	1-244-640-11	430	1-244-664-11	4.3k	1-244-688-11	43k	1-244-712-11	430k	1-244-760-11
4.7	1-244-617-11	47	1-244-641-11	470	1-244-665-11	4.7k	1-244-689-11	47k	1-244-713-11	470k	1-244-761-11
5.1	1-244-618-11	51	1-244-642-11	510	1-244-666-11	5.1k	1-244-690-11	51k	1-244-714-11	510k	1-244-762-11
5.6	1-244-619-11	56	1-244-643-11	560	1-244-667-11	5.6k	1-244-691-11	56k	1-244-715-11	560k	1-244-763-11
6.2	1-244-620-11	62	1-244-644-11	620	1-244-668-11	6.2k	1-244-692-11	62k	1-244-716-11	620k	1-244-764-11
6.8	1-244-621-11	68	1-244-645-11	680	1-244-669-11	6.8k	1-244-693-11	68k	1-244-717-11	680k	1-244-765-11
7.5	1-244-622-11	75	1-244-646-11	750	1-244-670-11	7.5k	1-244-694-11	75k	1-244-718-11	750k	1-244-766-11
8.2	1-244-623-11	82	1-244-647-11	820	1-244-671-11	8.2k	1-244-695-11	82k	1-244-719-11	820k	1-244-767-11
9.1	1-244-624-11	91	1-244-648-11	910	1-244-672-11	9.1k	1-244-696-11	91k	1-244-720-11	910k	1-244-768-11

HARDWARE NOMENCLATURE

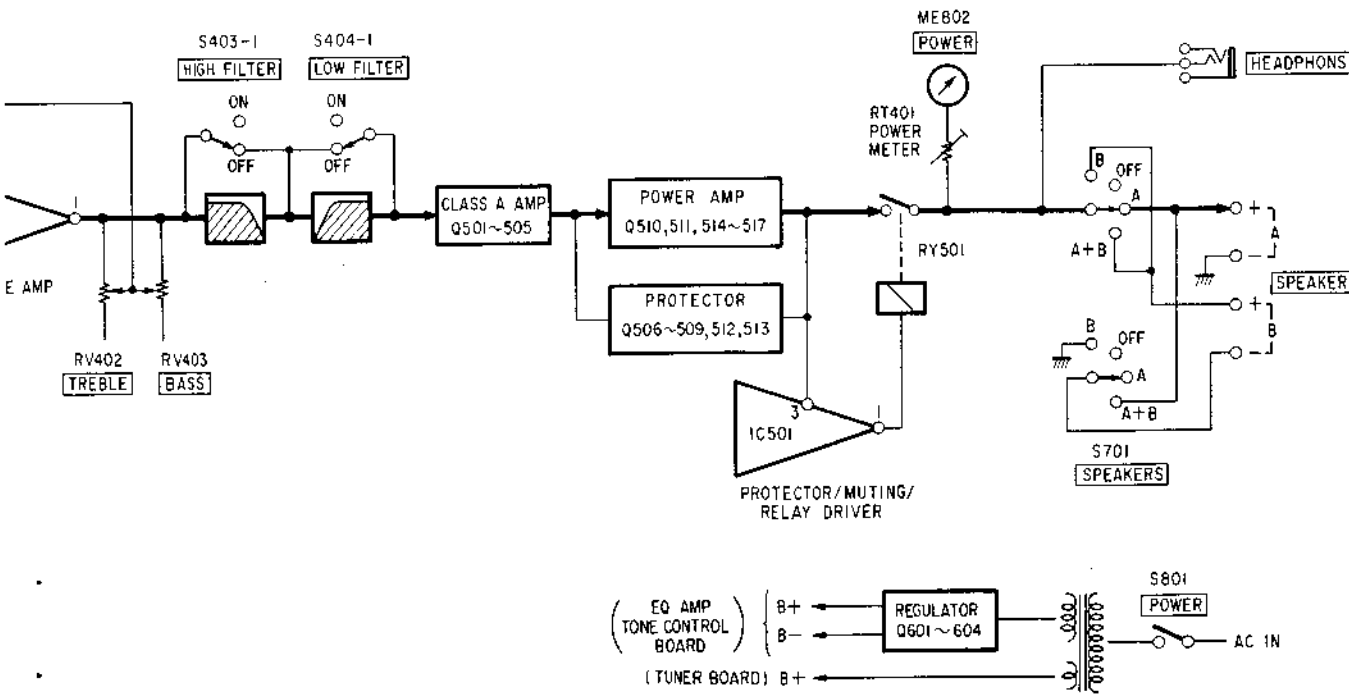
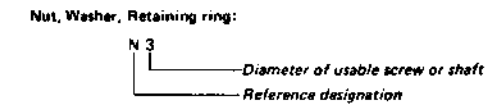
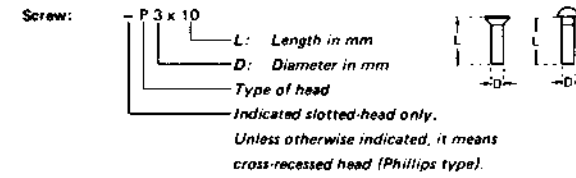

Reference Designation	Shape	Description	Remarks
SCREWS			
P		pan-head screw	binding-head (B) screw for replacement
PWH		pan-head screw with washer face	binding-head (B) screw and flat washer for replacement
PS		pan-head screw with spring washer	binding-head (B) screw and spring washer for replacement
PSP		pan-head screw with spring and flat washers	binding-head (B) screw and spring and flat washers for replacement
R		round-head screw	binding-head (B) screw for replacement
K		flat-countersunk-head screw	
RK		oval-countersunk-head screw	
B		binding-head screw	
T		truss-head screw	binding-head (B) screw for replacement
F		flat-fillister-head screw	
RF		fillister-head screw	
BV		braizer-head screw	

Reference Designation	Shape	Description	Remarks
SELF-TAPPING SCREWS			
TA		self-tapping screw	ex: TA, P 3 x 10
PTP		pan-head self-tapping screw	binding-head self-tapping (TA, B) screw for replacement
PTPWH		pan-head self-tapping screw with washer face	binding-head self-tapping (TA, B) screw and flat washer for replacement
PTTWH		pan-head thread-rolling screw with washer face	binding-head (B) screw and flat washer for replacement
SET SCREWS			
SC		set screw	
SC		hexagon-socket set screw	ex: SC 2.6 x 4, hexagon socket
NUT			
N		nut	
WASHERS			
W		flat washer	
SW		spring washer	
LW		internal-tooth lock washer	ex: LW3, internal
LW		external-tooth lock washer	ex: LW3, external
RETAINING RINGS			
E		retaining ring	
G		grip-type retaining ring	

STR-V6

2. SCHEMATIC DIAGRAM

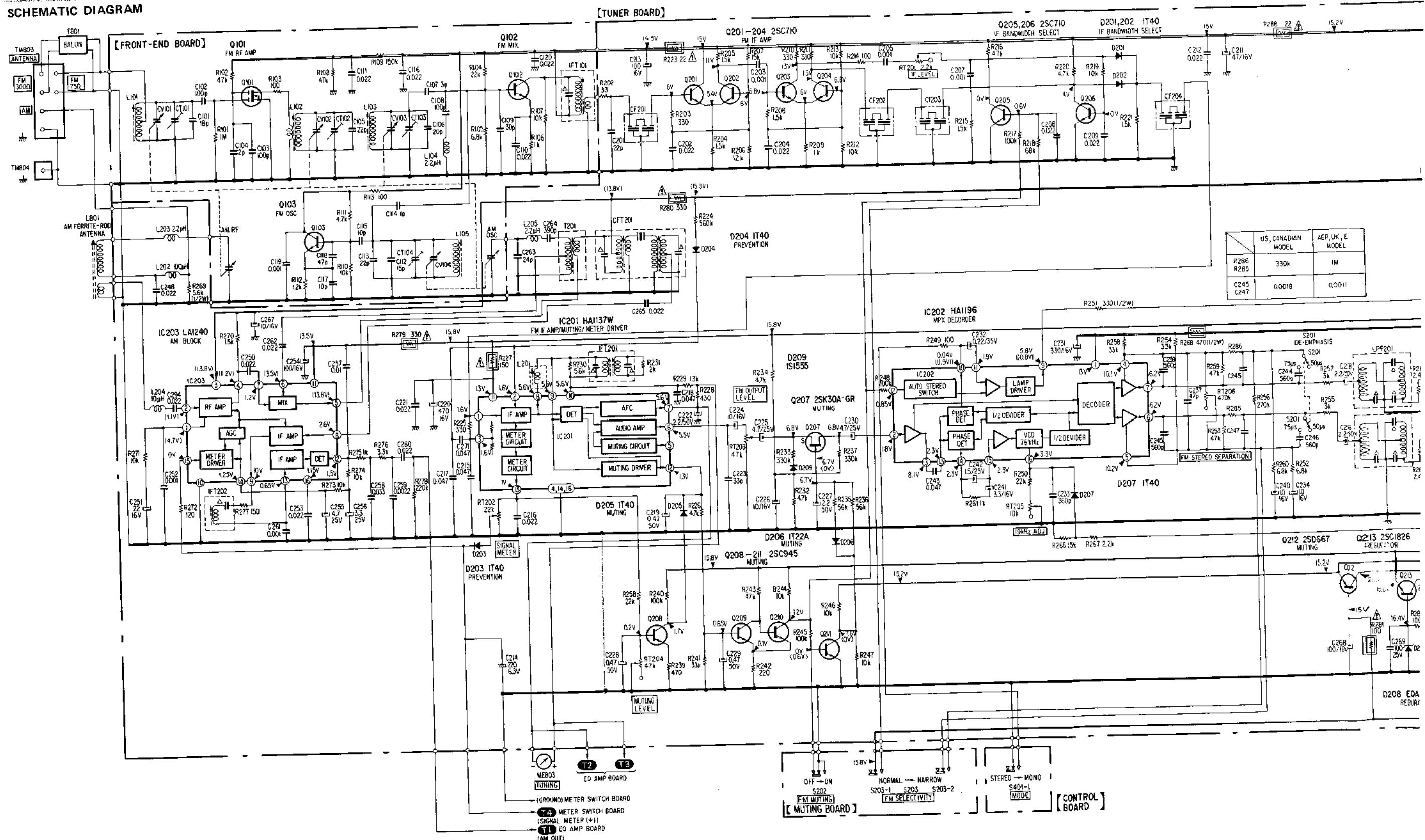

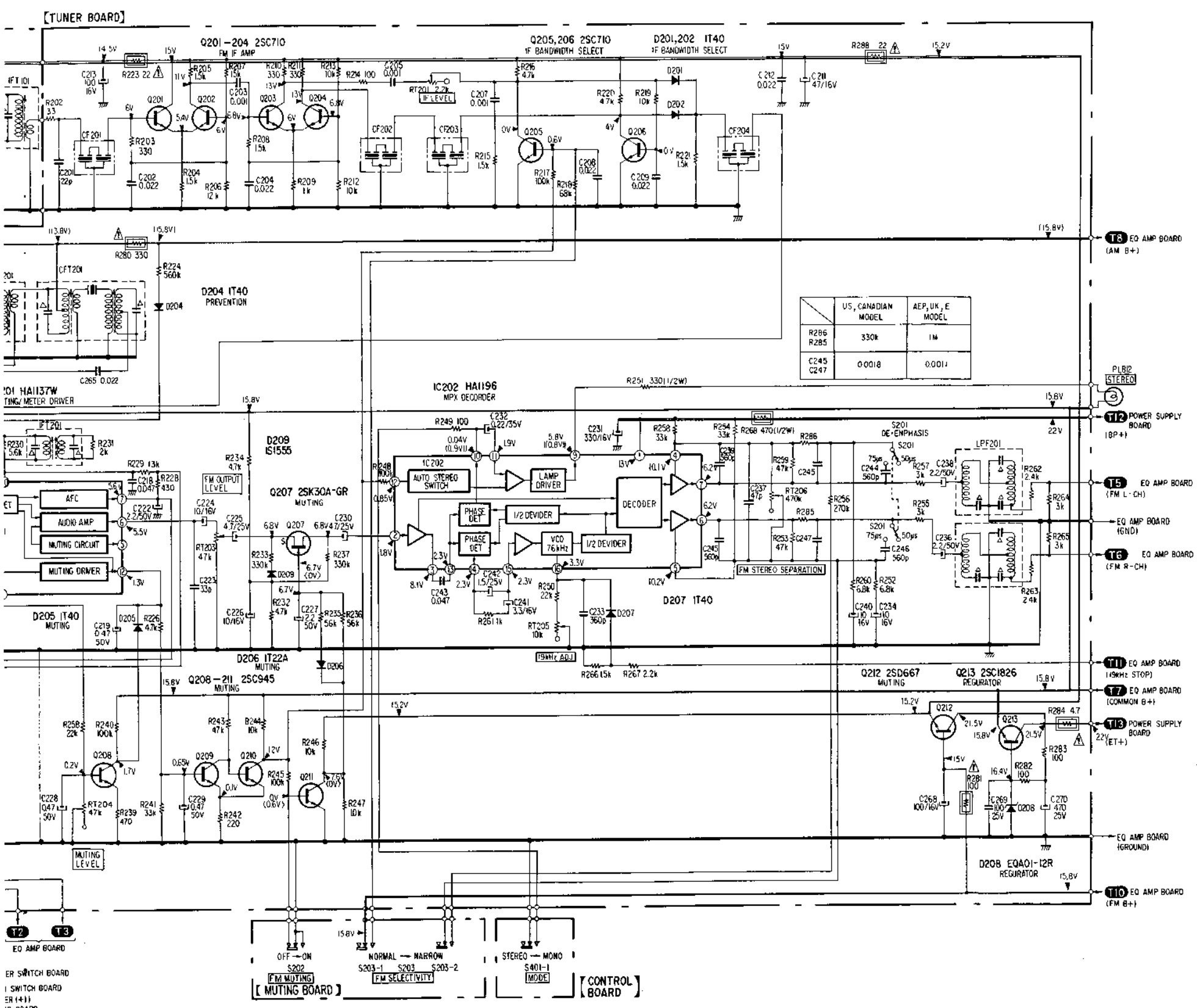

- Note:**
- All capacitors are in μF unless otherwise noted, $\text{pF} : \mu\text{F}$ 50WV or less are not indicated except for electrolytics.
 - All resistors are in ohms, $\frac{1}{2}\text{W}$ unless otherwise noted. $\text{k}\Omega : 1000\Omega$; $\text{M}\Omega : 1000\text{k}\Omega$
 - Voltage variations may be noted due to normal production tolerances.
 - \square : nonflammable resistor.
 - \triangle : internal component.
 - \square : panel designation.
 - \square : adjustment for repair.
 - Readings are taken under no-signal conditions with a VOM (20k Ω /V).
 - () : FUNCTION (S302) - AM
 - < > : FM MUTING (S202) ON (no signal input)
 - (()) : FM STEREO (Tuned in FM signal)
 - no mark : FUNCTION (S302) - FM
 - --- : B+ bus.
 - Switch

Ref. No.	Switch	Position
S201	DE. EMPHASIS	50 μs
S202	FM MUTING	OFF
S203-1, 2	FM SELECTIVITY	NORMAL
S401-1	MODE	STEREO

Note: The components identified by shading and mark \triangle are critical for safety. Replace only with part number specified.

Note: Les composants identifiés par un trame et une marque \triangle sont critiques pour la sécurité. Ne les remplacer que par une pièce portant le numéro spécifié.

3. MOUNTING DIAGRAM

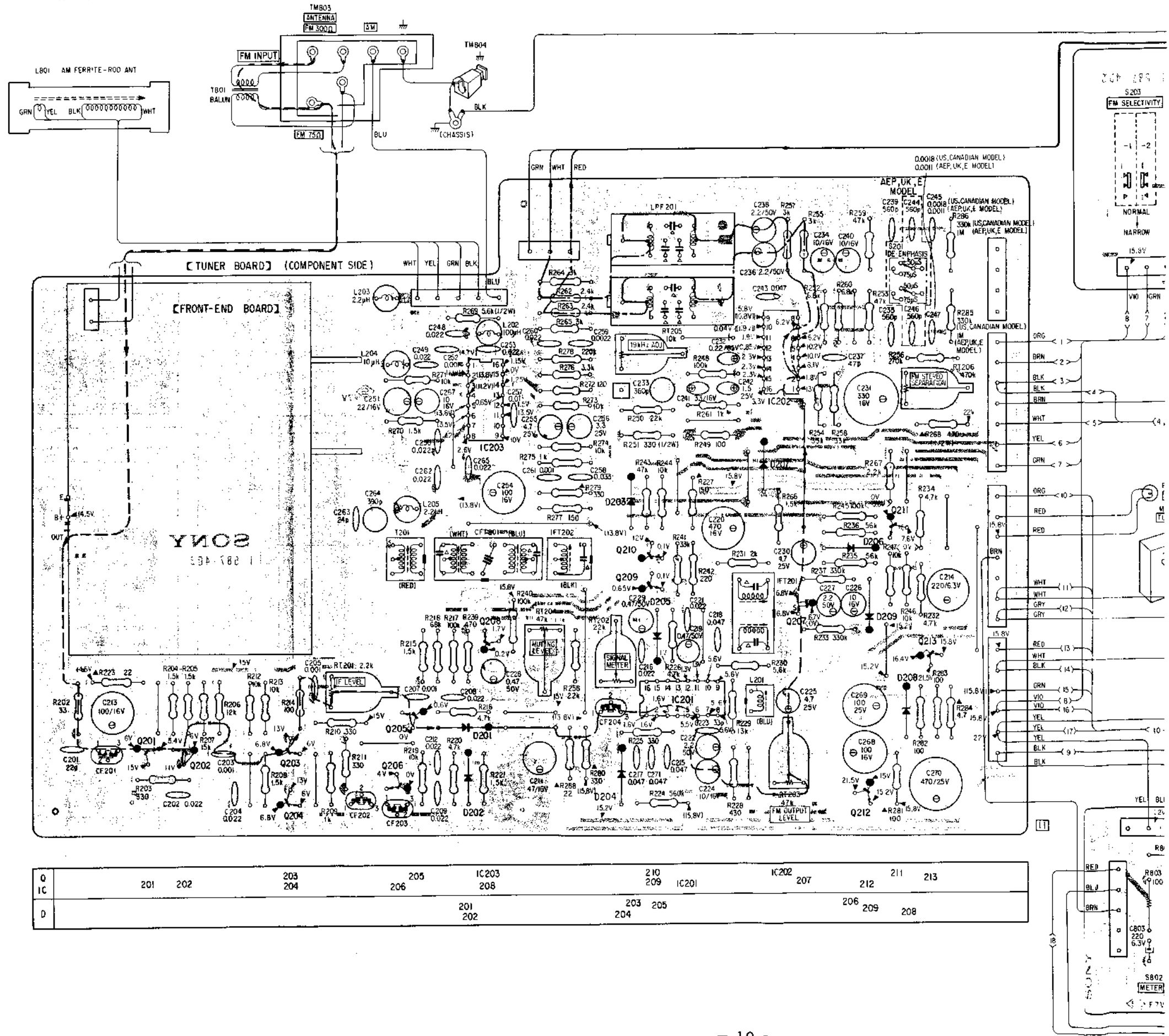

Note:

- : parts extracted from the component side.
- : indicates side identified with part number.
- Color code of sleeving over the end of the jacket.

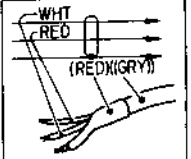

- ▲ : nonflammable resistor.
- B+ pattern
- Signal path
- : L-CH
- : R-CH
- : Common
- () : FUNCTION (S302) - AM
- < > : FM MUTING (S202) ON (no signal input)
- (()) : FM STEREO (Tuned in FM signal)
- no mark: FUNCTION (S302) - FM

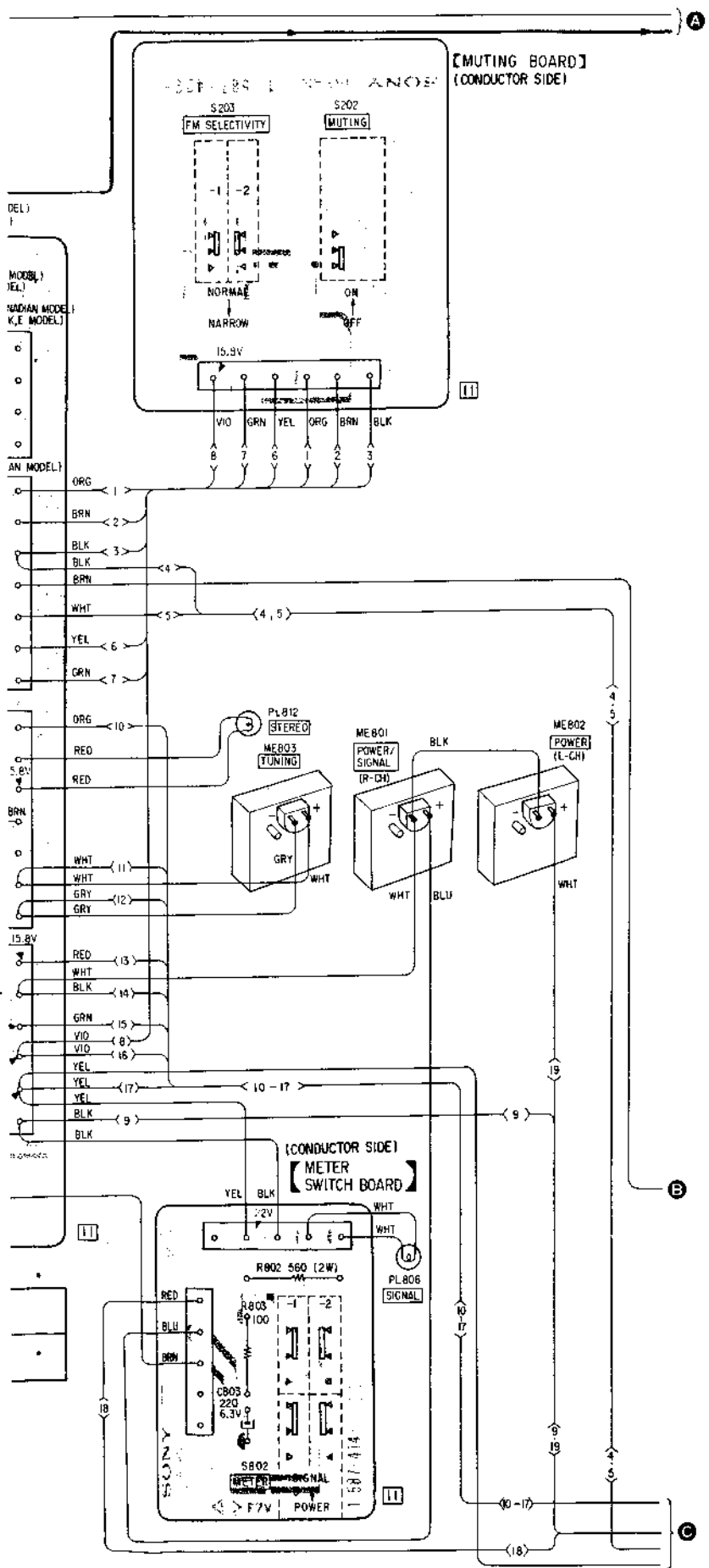

• Replacement Semiconductors

For replacement, use semiconductors except in ().

- | | | |
|----------------------------------|------------------------------------|------------------------------------|
| Q201-204: 2SC710 | Q507, 508, 512 } 2SC1364 (2SC634A) | D201-205, 207 } 1S1555 (1T40) |
| | Q558, 562, 603 } | D502-505, 507-509 } 1S1555 (1T22A) |
| Q205, 206 } 2SC1364 (2SC945) | Q510, 560: 2SD669 (2SD669A) | D206 } 1S1555 |
| Q208-211 } | | D209: |
| Q605 | Q511, 561: 2SB649 (2SB649A) | D208: EQB01-16 (EQA01-17R) |
| Q207: 2SK30A (2SK30A-GR) | | D605: EQB01-10 (EQA01-10R) |
| | Q514, 516 } 2SD736 | D603, 604: EQB01-26 |
| Q303, 353: 2SC1775-E (2SC1775) | Q564, 566 } | |
| | Q515, 517 } 2SB700 | D501, 551: SV04S |
| Q213: 2SD476A (2SC1826) | Q565, 567 } | |
| | IC201: HA1137W | D506, 556: MV12N |
| Q301, 302 } 2SA872-D (2SA872) | IC202: HA1196 | |
| Q351, 352 } 2SA872-D (2SA893) | IC203: LA1240 | D601: S5151 |
| Q501-503 } 2SA896 | | |
| Q551-553 } 2SB647 | IC401, 451: HA1457 | D602: S5151R |
| Q505, 555: 2SA896 | IC501: HA12002 | |
| Q602: 2SB647 | | D607: SIRB10 |
| Q212, 601: 2SD667 | | |
| Q504, 554: 2SC1811 | | |
| | | |
| Q506, 509, 513 } 2SA678 (2SA844) | | |
| Q556, 559, 563 } 2SA678 | | |
| Q604: 2SA678 | | |
| | | |

4. MOUNTING DIAGRAM

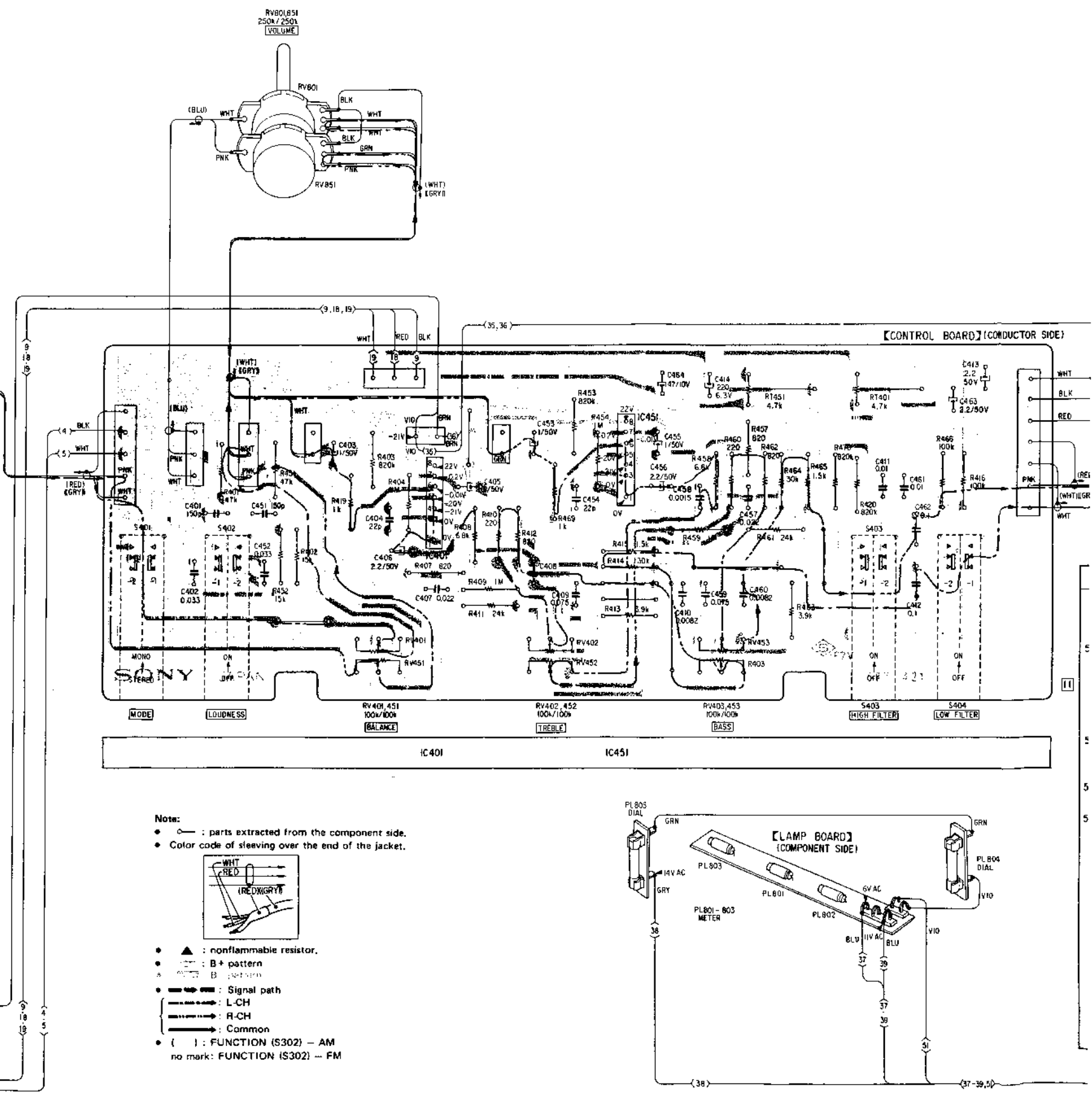
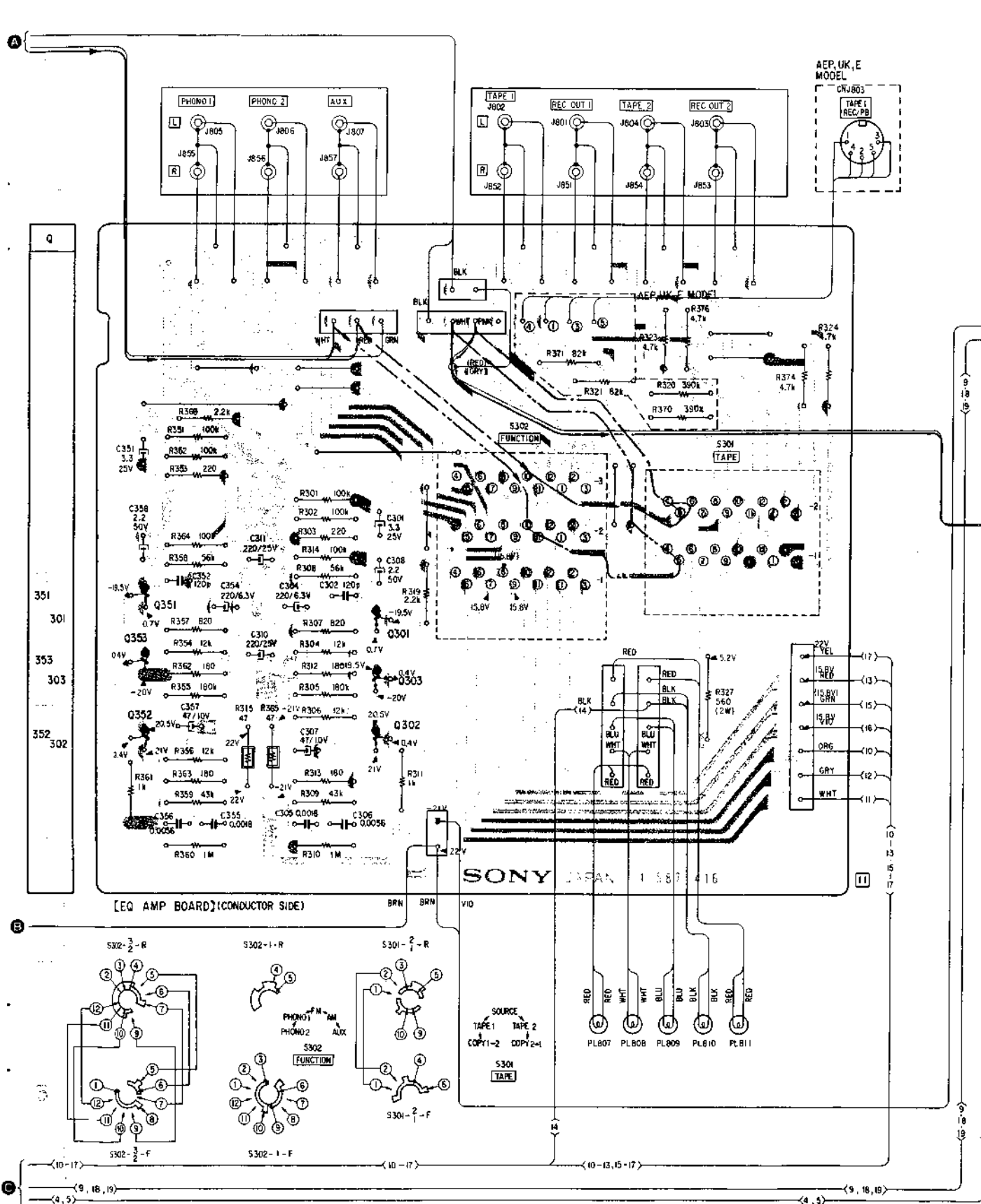

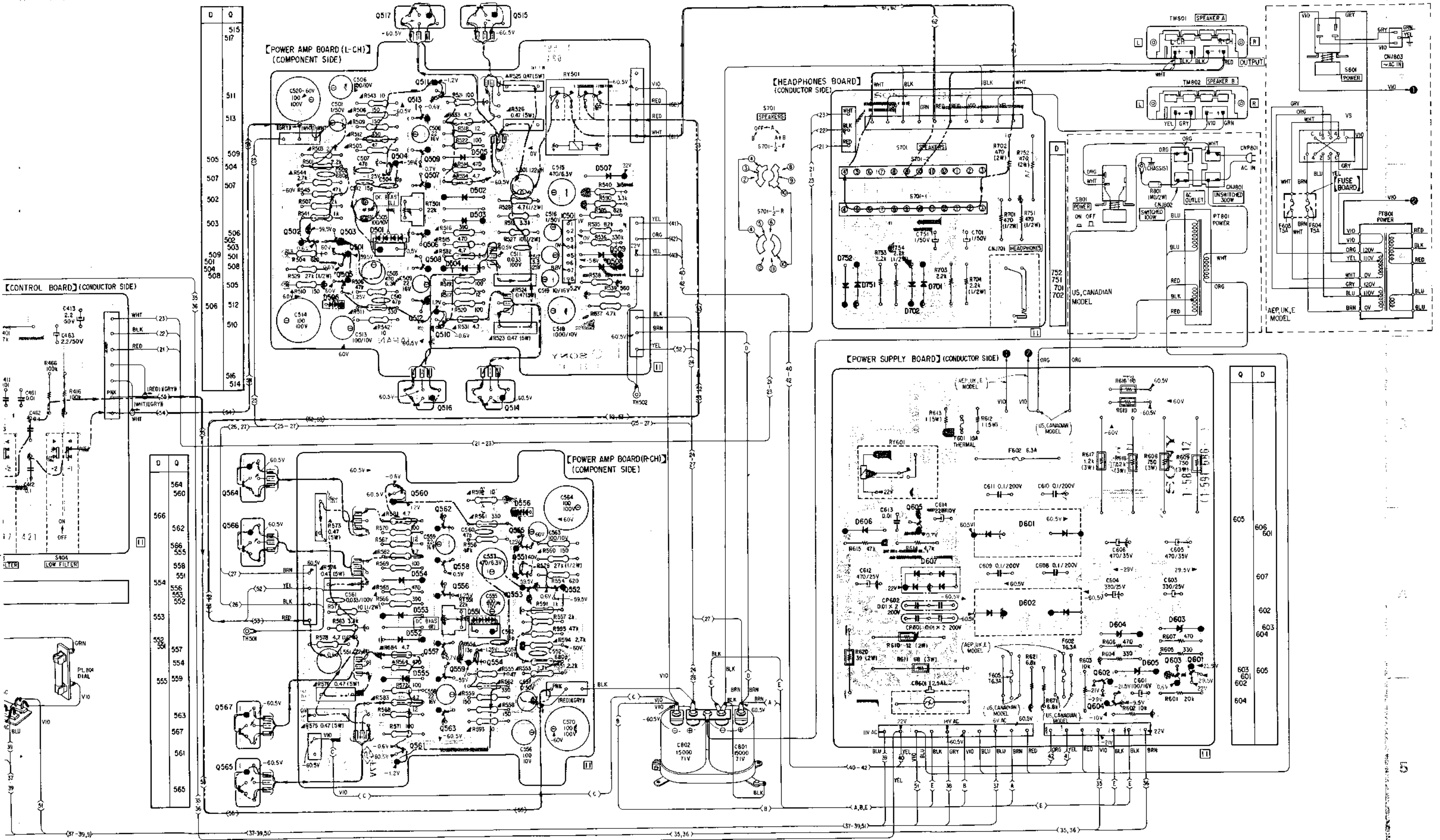

5. SCHEMATIC DIAGRAM

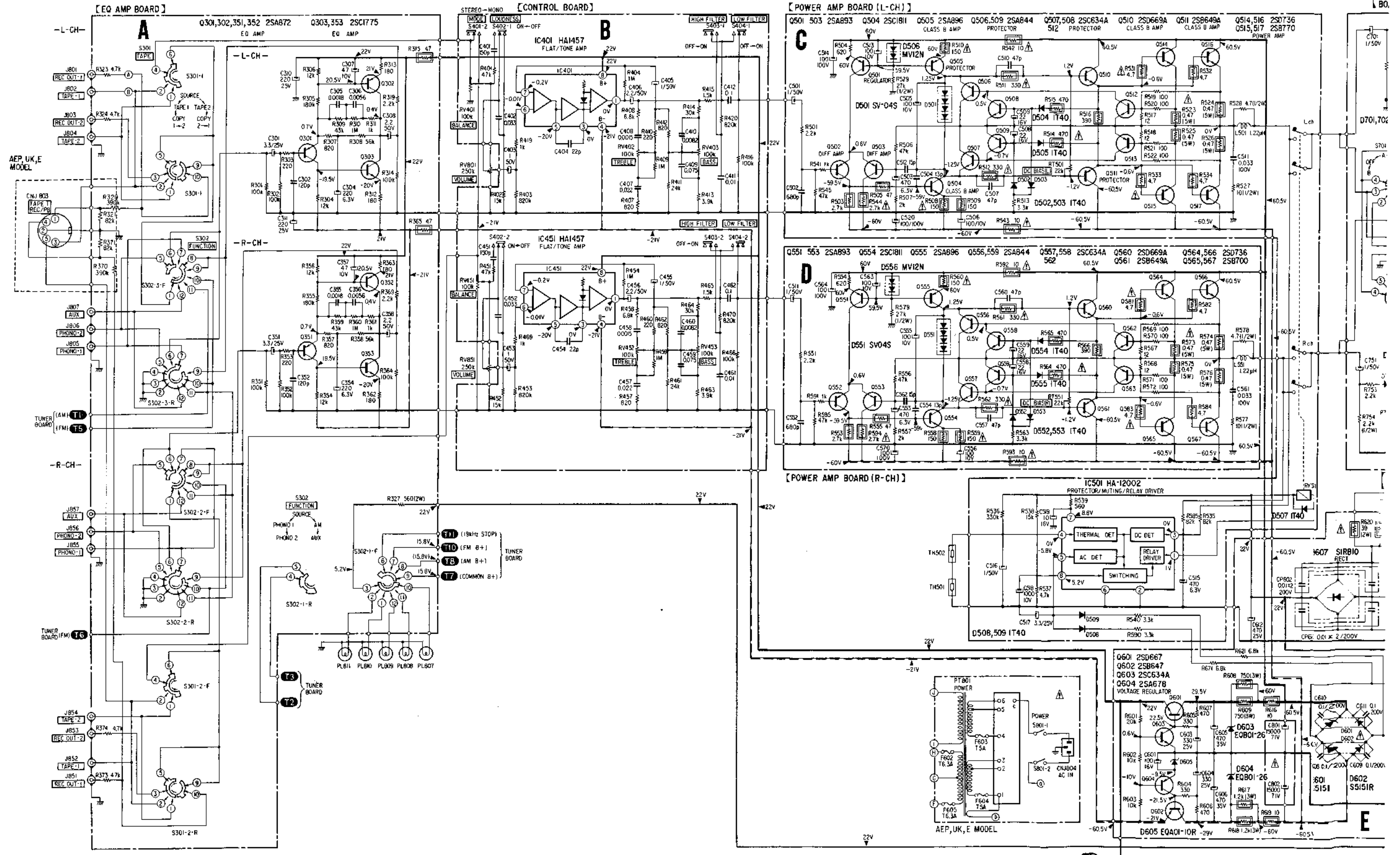

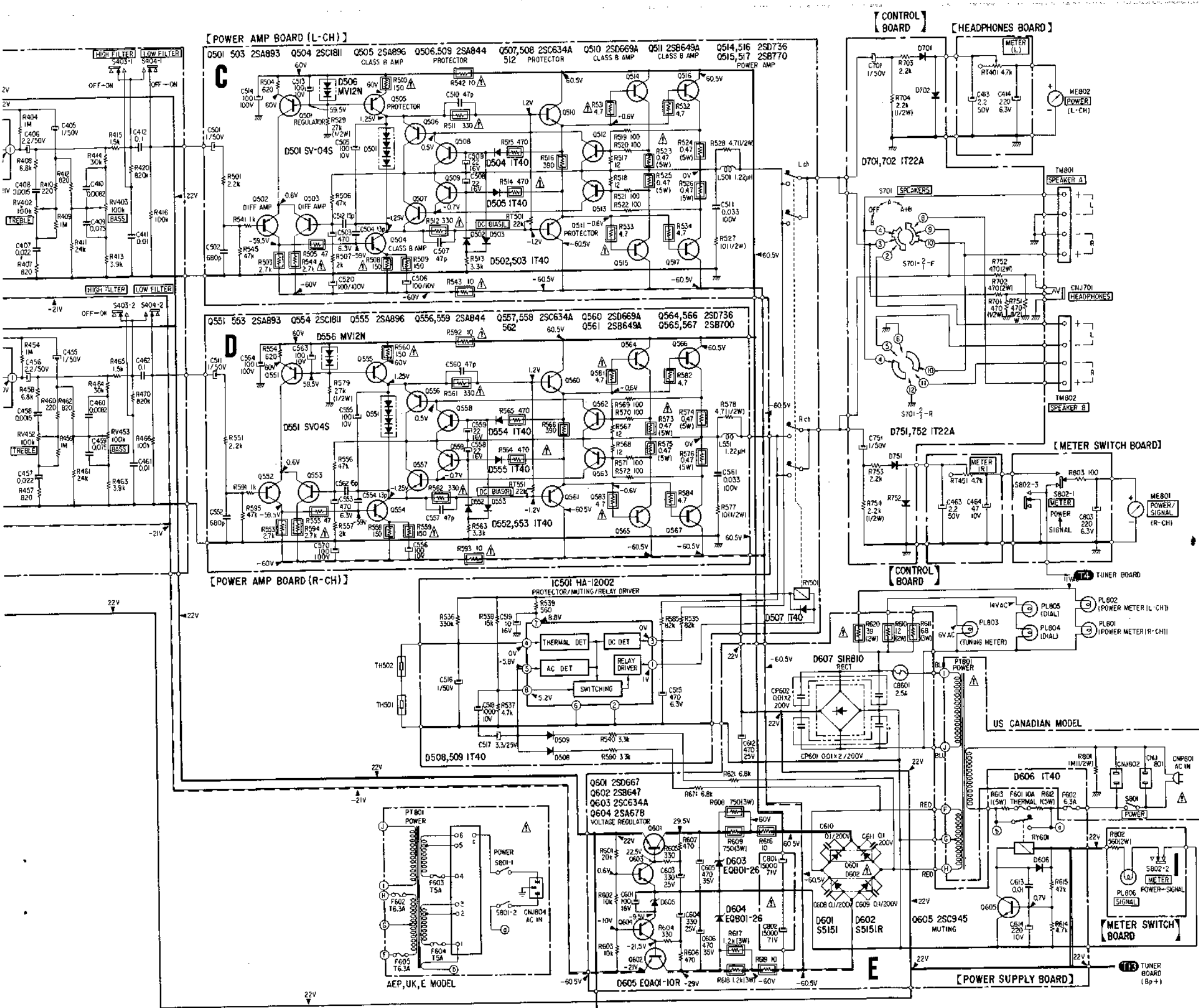

- Note:**
- All capacitors are in μF unless otherwise noted. pF : μF
 - All resistors are in ohms, $\frac{1}{2}\text{W}$ unless otherwise noted. $\text{k}\Omega$: 1000Ω ; $\text{M}\Omega$: $1000\text{k}\Omega$
 - Voltage variations may be noted due to normal production tolerances.
 - : nonflammable resistor.
 - : direct connection to points marked on the chassis.
 - : panel designation.
 - : adjustment for repair.
 - Readings are taken under no-signal conditions with a VOM ($20\text{k}\Omega/\text{V}$).
 - () : FUNCTION (S302) - AM
 - no mark : FUNCTION (S302) - FM
 - : B+ bus.
 - : B- bus.
 - Switch

Ref. No.	Switch	Position
S301-1, 2	TAPE	SOURCE
S302-1 to -3	FUNCTION	SOURCE
S401-1, 2	MODE	STEREO
S402-1, 2	LOUDNESS	OFF
S403-1, 2	HIGH FILTER	OFF
S404-1, 2	LOW FILTER	OFF
S701-1, 2	SPEAKERS	A
S801	POWER	OFF
S802-1 to -3	METER	SIGNAL

Note: The components identified by shading and mark are critical for safety. Replace only with part number specified.

Note: Les composants identifiés par un trame et une marque sont critiques pour la sécurité. Ne les remplacer que par une pièce portant le numéro spécifié.

(1)

- Note:**
- Items with no part number and/or no description are not stocked because they are seldom required for routine service.
 - All screws are Phillips (cross recess) type unless otherwise noted.
 - (-) = slotted head
 - Circled letters (A) to (Z) are applicable to European models only.

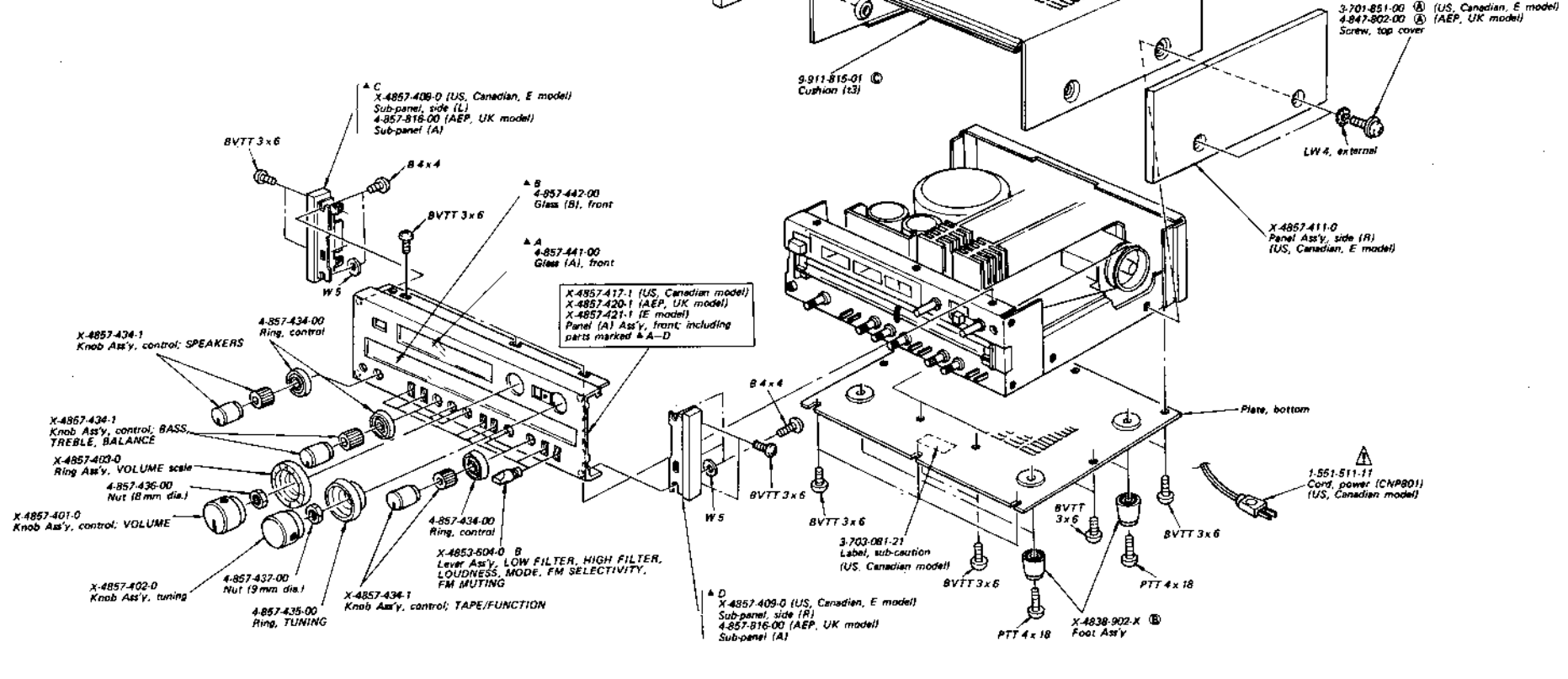

Note: The components identified by shading and mark Δ are critical for safety. Replace only with part number specified.

Note: Les composants identifiés par un trame et une marque Δ sont critiques pour la sécurité. Ne les remplacer que par une pièce portant le numéro spécifié.

(2)

- Note:**
- Items with no part number and/or no description are not stocked because they are seldom required for routine service.
 - All screws are Phillips (cross recess) type unless otherwise noted.
 - (-) = slotted head
 - Circled letters (A) to (Z) are applicable to European models only.

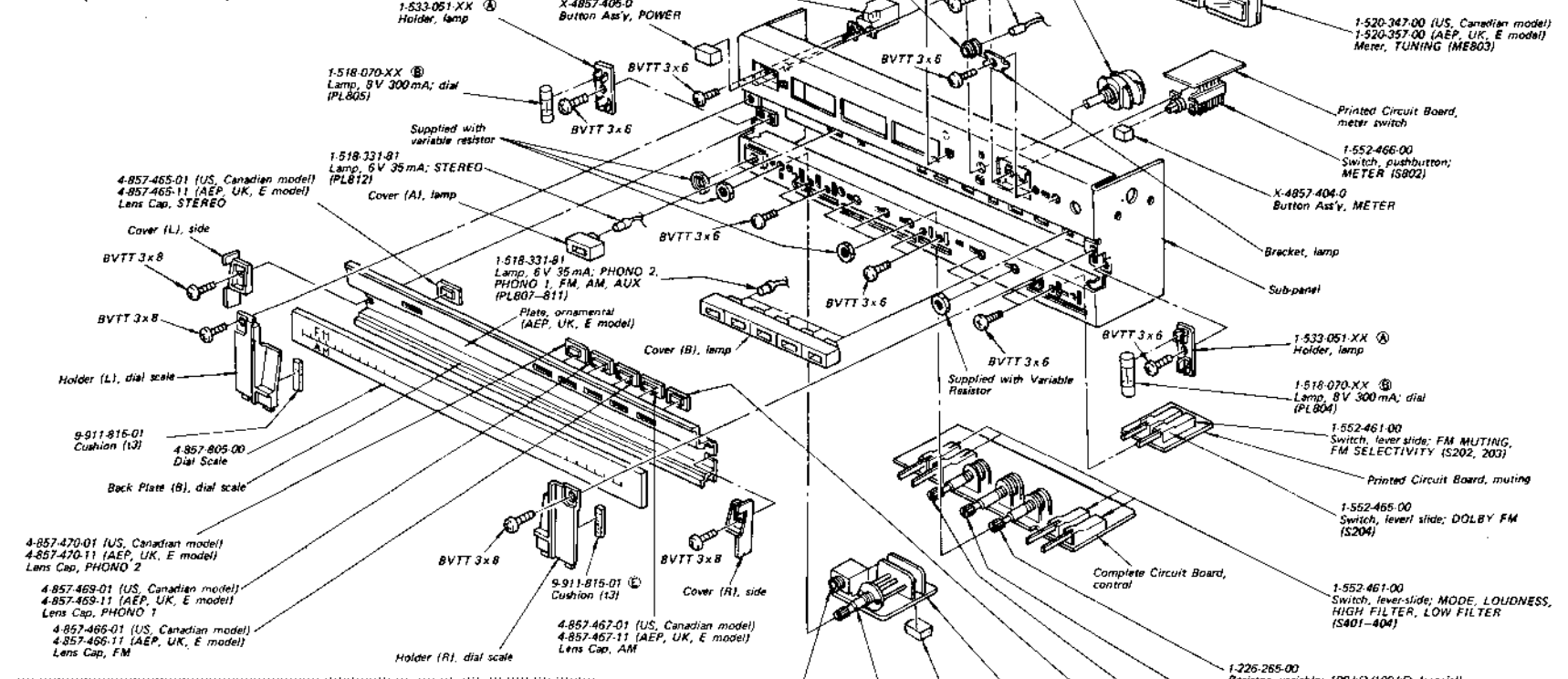

Note: The components identified by shading and mark Δ are critical for safety. Replace only with part number specified.

Note: Les composants identifiés par un trame et une marque Δ sont critiques pour la sécurité. Ne les remplacer que par une pièce portant le numéro spécifié.

- 20 -

- 21 -

A

B

C

D

E

(2)

Note:

- Items with no part number and/or no description are not stocked because they are seldom required for routine service.
- All screws are Phillips (cross recess) type unless otherwise noted.
- (-) = slotted head
- Circled letters (A to Z) are applicable to European models only.

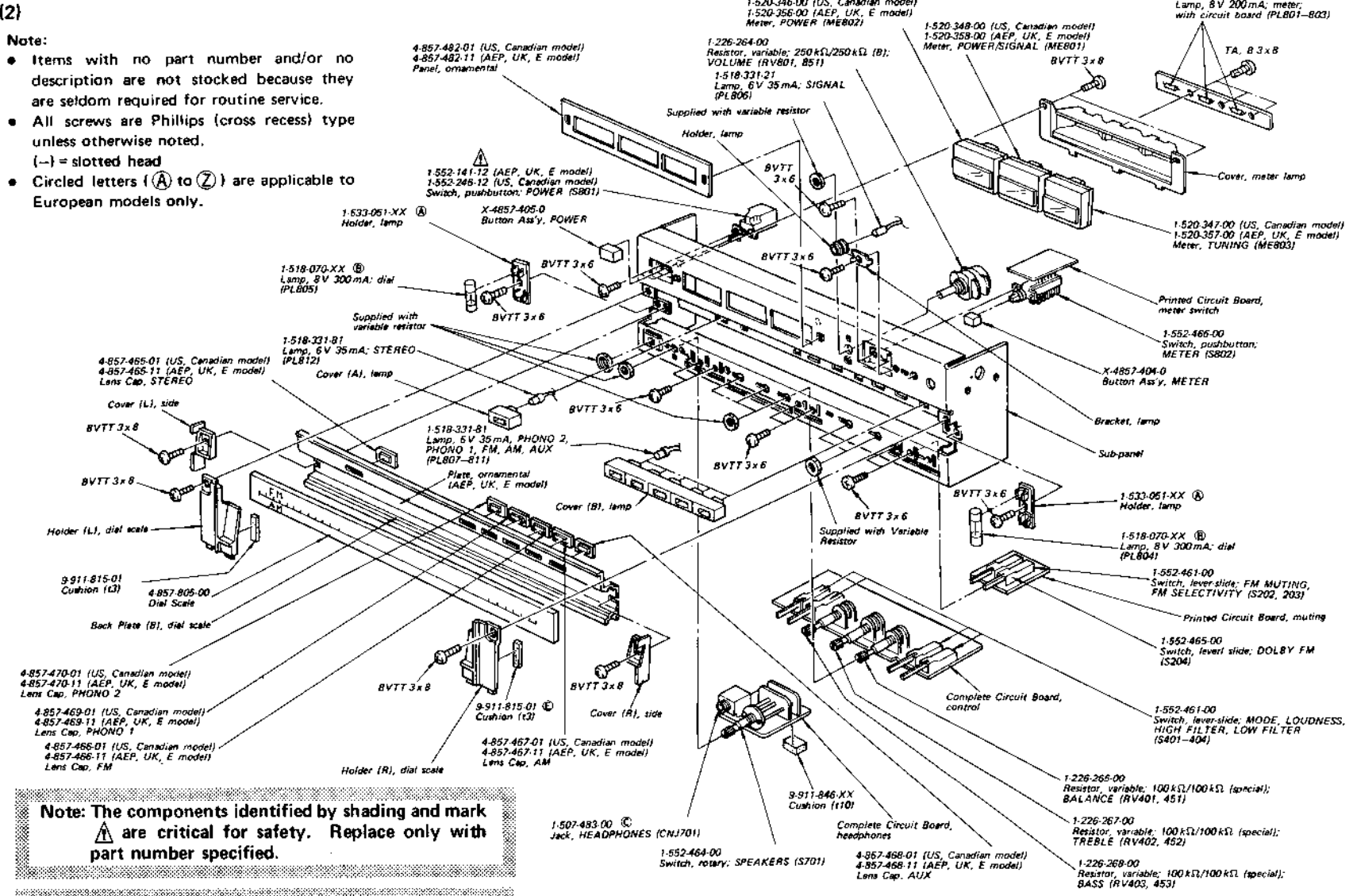

Note: The components identified by shading and mark are critical for safety. Replace only with part number specified.

Note: Les composants identifiés par un trame et une marque sont critiques pour la sécurité. Ne les remplacer que par une pièce portant le numéro spécifié.

A

B

C

D

E

(3)

Note: The components identified by shading and mark are critical for safety. Replace only with part number specified.

Note: Les composants identifiés par un trame et une marque sont critiques pour la sécurité. Ne les remplacer que par une pièce portant le numéro spécifié.

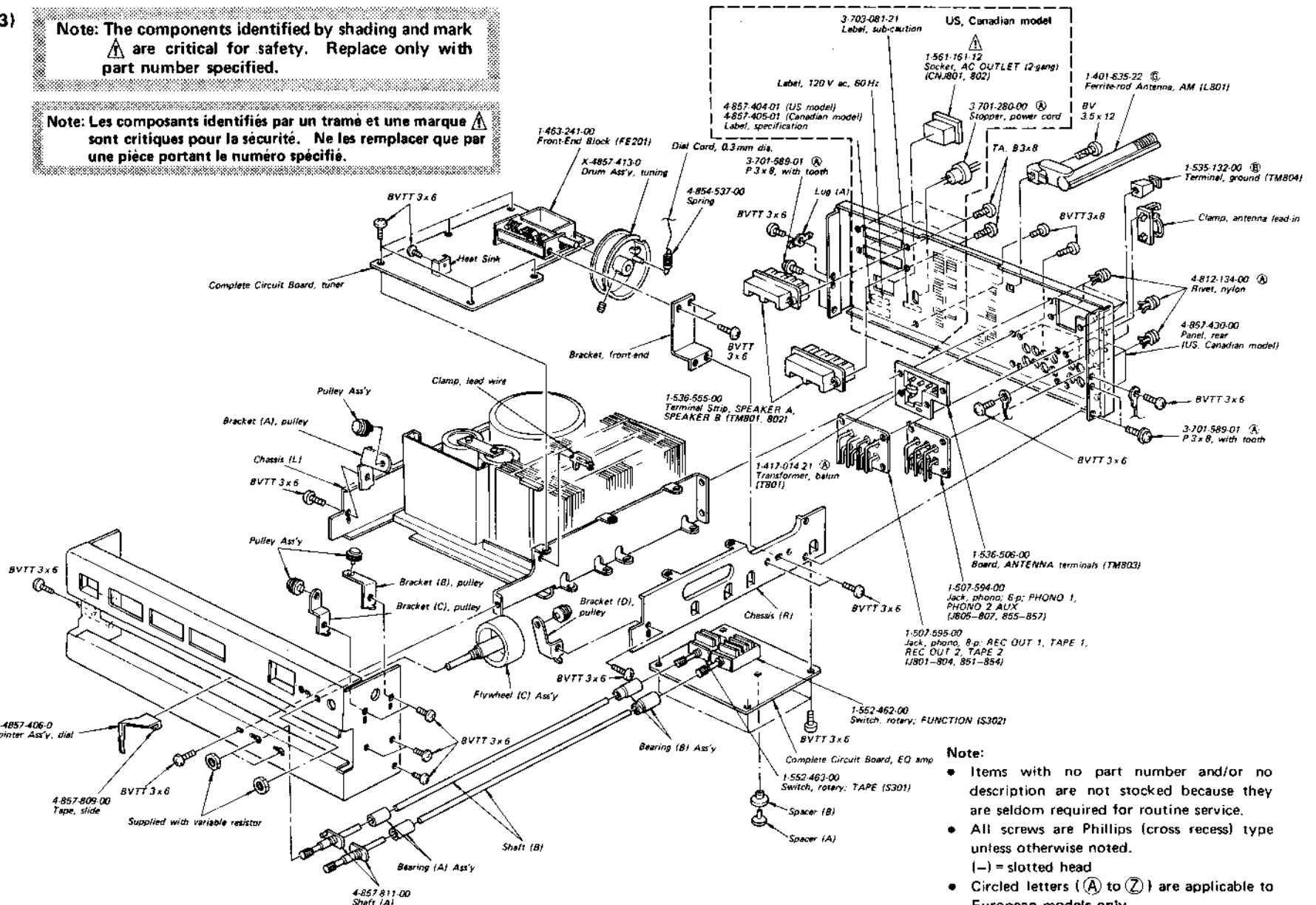

Note:

- Items with no part number and/or no description are not stocked because they are seldom required for routine service.
- All screws are Phillips (cross recess) type unless otherwise noted.
- (-) = slotted head
- Circled letters (A to Z) are applicable to European models only.

STR-V6 STR-V6

21

22

(4)

1

2

- 23 -

3

4

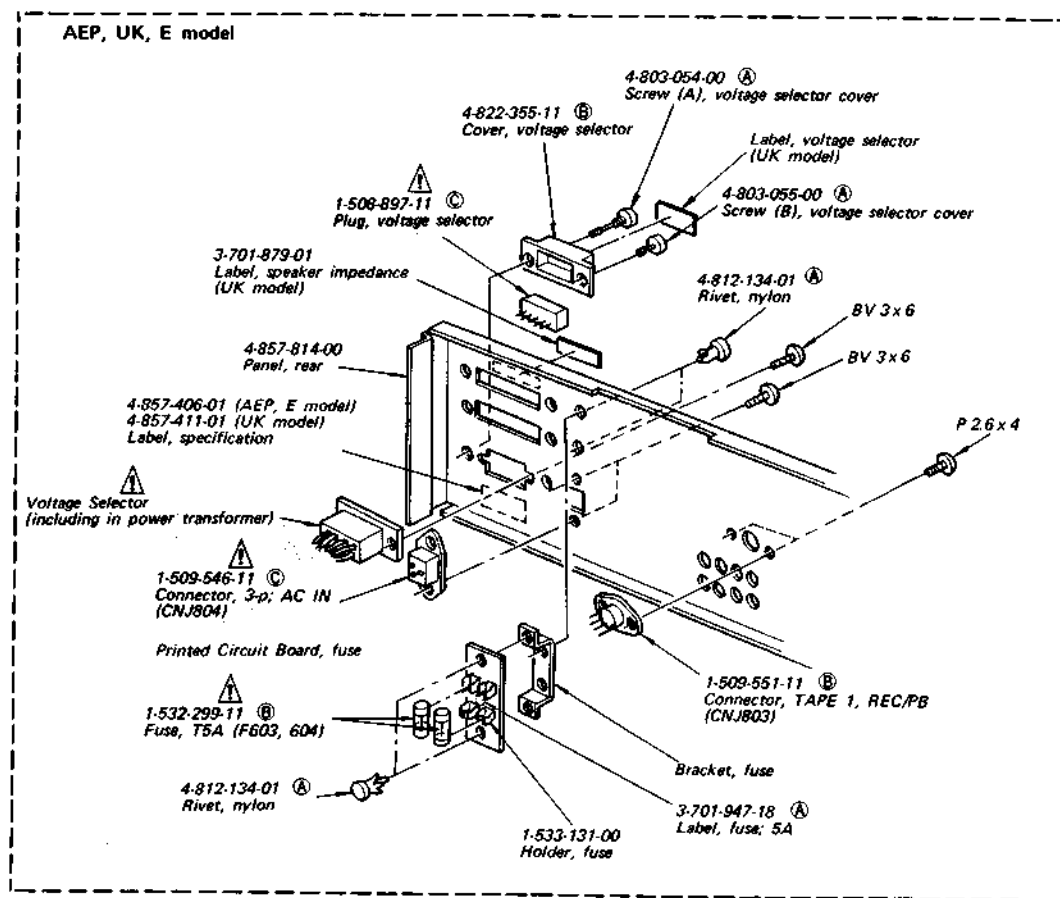
**Note:**

- Items with no part number and/or no description are not stocked because they are seldom required for routine service.
- All screws are Phillips (cross recess) type unless otherwise noted.
(-) = slotted head
- Circled letters (A) to (Z) are applicable to European models only.

Note: The components identified by shading and mark  are critical for safety. Replace only with part number specified.

Note: Les composants identifiés par un trame et une marque  sont critiques pour la sécurité. Ne les remplacer que par une pièce portant le numéro spécifié.

A

B

C

D

E

(5)

Note:

- Items with no part number and/or no description are not stocked because they are seldom required for routine service.
- All screws are Phillips (cross recess) type unless otherwise noted.
(-) = slotted head
- Circled letters (A) to (Z) are applicable to European models only.

1
2
3
4

24

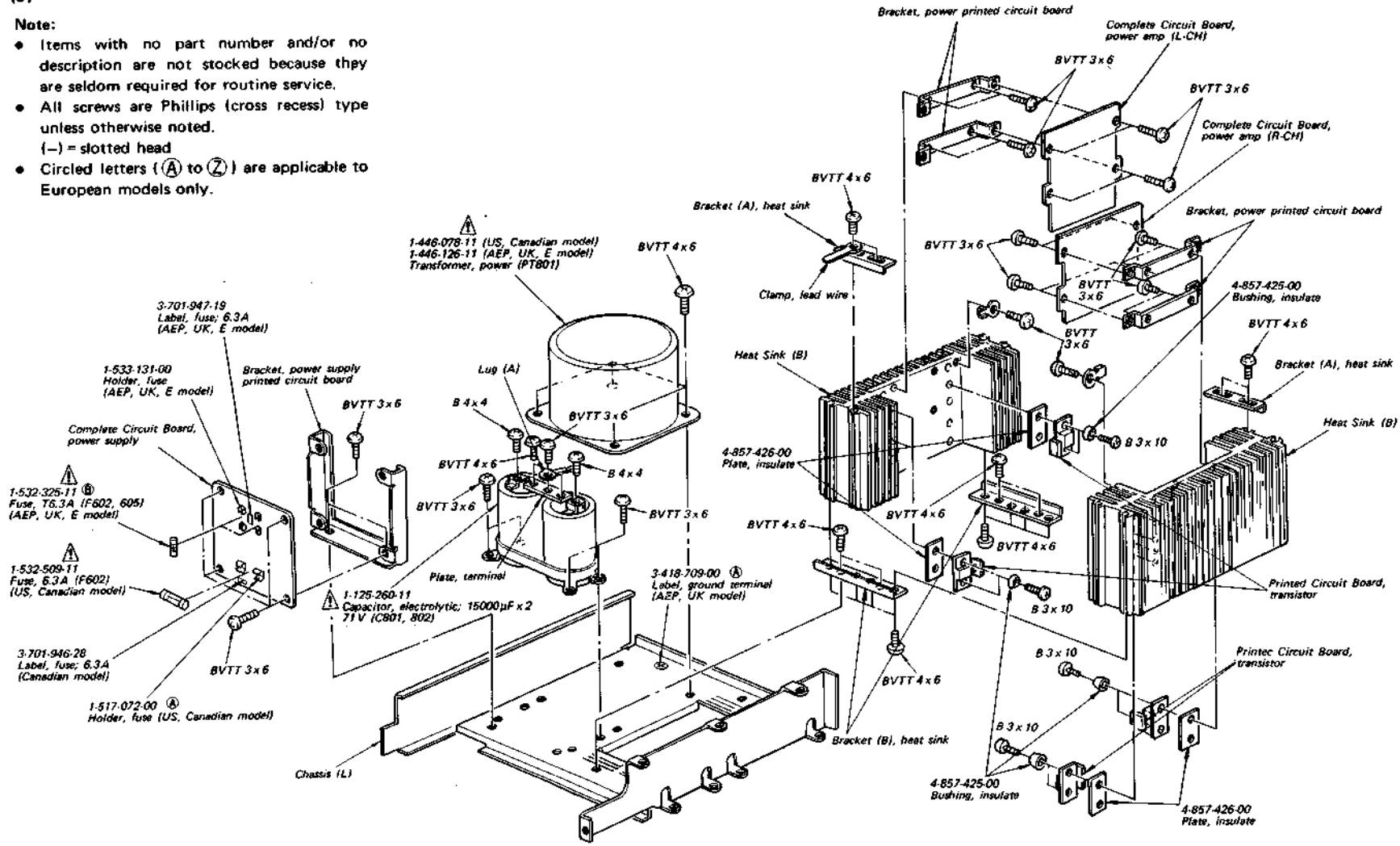

Note: The components identified by shading and mark are critical for safety. Replace only with part number specified.

Note: Les composants identifiés par un trame et une marque sont critiques pour la sécurité. Ne les remplacer que par une pièce portant le numéro spécifié.

Note: Circled letters (A) to (Z) are applicable to European models only.

7. ELECTRICAL PARTS LIST

Ref. No. Part No. Description

SEMICONDUCTORS

Transistors

Q201-204	8-729-671-13	(B) 2SC710
⇒ Q205,206	8-729-663-47	(B) 2SC1364
Q207	8-729-203-04	(B) 2SK30A
⇒ Q208-211	8-729-663-47	(B) 2SC1364
Q212	8-729-366-71	2SD667
⇒ Q213	8-729-307-62	(D) 2SD476A
⇒ Q301,351 Q302,352	8-729-387-27	(B) 2SA872-D
⇒ Q303,353		
⇒ Q501-503 Q551-553	8-729-387-27	(B) 2SA872-D
Q504,554		
Q505,555	8-765-082-20	(C) 2SA896
⇒ Q506,556	8-727-788-00	(B) 2SA678
⇒ Q507,551 Q508,558	8-729-663-47	(B) 2SC1364
⇒ Q509,559		
⇒ Q510,560	8-729-366-92	2SD669
⇒ Q511,561	8-729-364-92	2SB649
⇒ Q512,562	8-729-663-47	(B) 2SC1364
⇒ Q513,563	8-727-788-00	(B) 2SA678
Q514,564	8-729-373-63	2SD736
Q515,565	8-729-370-03	2SB700
Q516,566	8-729-373-63	2SD736
Q517,567	8-729-370-03	2SB700
Q601	8-729-366-71	2SD667
Q602	8-729-364-71	2SB647
⇒ Q603	8-729-663-47	(B) 2SC1364
Q604	8-727-788-00	(B) 2SA678
⇒ Q605	8-729-663-47	(B) 2SC1364

Diodes

⇒ D201-205	8-719-815-55	(B) 1S1555
⇒ D206	8-719-422-21	(A) 1T22AM
⇒ D207	8-719-815-55	(B) 1S1555

⇒: Due to standardization, interchangeable replacements may be substituted for parts specified in the diagrams.

Note: The components identified by shading and mark **⚠** are critical for safety. Replace only with part number specified.

Ref. No. Part No. Description

⇒ D208	8-719-931-16	(B) EQB01-16
D209	8-719-815-55	(B) 1S1555
D501,551	8-719-300-11	(B) SV04S
⇒ D502-505 D552-555	8-719-815-55	(B) 1S1555
D506,556		
⇒ D507-509	8-719-815-55	(B) 1S1555
D601	⚠ 8-719-851-51	(F) S5151
D602	⚠ 8-719-801-51	(F) S5151R
D603,604	8-719-931-26	(B) EQB01-26
⇒ D605	8-719-931-10	(B) EQB01-10
⇒ D606	8-719-815-55	(B) 1S1555
D607	⚠ 8-719-510-10	(C) SIRB10
⇒ D701,751 D702,752	8-719-422-21	(A) 1T22AM

ICs

IC201	8-759-310-37	(H) HA1137W
IC202	8-759-311-96	(G) HA1196
IC203	8-759-812-40	(F) LA1240
IC401,451	8-759-314-57	HA1457
IC501	8-759-320-02	HA12002

COILS

L201	1-459-152-00	(B) Coil with core
L202	1-407-169-XX	(A) 100 μH, microinductor
L203	1-407-182-XX	(A) 2.2 μH, microinductor
L204	1-407-157-XX	(A) 10 μH, microinductor
L205	1-407-182-XX	(A) 2.2 μH, microinductor
L801	1-401-635-22	Ferrite-rod Antenna, MW

TRANSFORMERS

CFT201	1-404-086-00	AM IFT (US, Canadian model)
CFT201	1-404-087-00	AM IFT (AEP, UK, E model)
IFT201	1-404-011-00	(C) FM discriminator
IFT202	1-404-085-00	AM IFT

Note: Les composants identifiés par un trame et une marque **⚠** sont critiques pour la sécurité. Ne les remplacer que par une pièce portant le numéro spécifié.

Note: Circled letters (A) to (Z) are applicable to European models only.

Ref. No.	Part No.	Description
PT801	A 1-446-078-11	Power (US, Canadian model)
PT801	A 1-446-126-11	Power (AEP, UK, E model)
T201	1-405-779-00	Coil, osc
T801	1-417-014-21	A BALUN, antenna matching

CAPACITORS

All capacitors are in μF and ceramic unless otherwise noted. 50WV or less are not indicated except for electrolytics.
p : μF , elect : electrolytic

C201	1-102-967-11	22p	
C202	1-101-924-11	A 0.022	
C203	1-101-918-11	A 0.001	
C204	1-101-924-11	A 0.022	
C205	1-101-918-11	A 0.001	
C207	1-101-918-11	A 0.001	
C208,209	1-101-924-11	A 0.022	
C211	1-121-409-11	A 47	16V elect
C212	1-101-924-11	A 0.022	
C213	1-121-415-11	A 100	16V elect
C214	1-121-419-11	A 220	6.3V elect
C215	1-101-925-11	A 0.047	
C216	1-101-924-11	A 0.022	
C217,218	1-101-925-11	A 0.047	
C219	1-101-924-11	A 0.022	
C220	1-121-415-11	100	16V elect
C221	1-101-924-11	A 0.022	
C222	1-121-450-11	2.2	50V elect
C223	1-102-969-11	C 33p	
C224	1-121-651-11	A 10	16V elect
C225	1-121-395-11	A 4.7	25V elect
C226	1-121-651-11	A 10	16V elect
C227	1-121-450-11	A 2.2	50V elect
C228,229	1-121-726-11	A 0.47	50V elect
C230	1-121-395-11	A 4.7	25V elect
C231	1-123-069-11	A 330	16V elect
C232	1-131-211-11	0.22	35V tantalum
C233	1-104-066-11	360p	polystyrol
C234,236	1-121-651-11	A 10	16V elect

Ref. No.	Part No.	Description
C237	1-101-880-11	A 47p
C238,240	1-121-651-11	A 10 16V elect
C241	1-131-197-11	B 3.3 16V tantalum
C242	1-131-237-11	B 1.5 25V tantalum
C243	1-108-246-12	A 0.047 mylar
C244	1-104-072-11	620p polystyrol (AEP, UK, E model)
C245	1-108-561-12	0.0018 mylar (US, Canadian model)
C245	1-108-556-12	0.0011 mylar (AEP, UK, E model)
C246	1-104-072-11	620p polystyrol (AEP, UK, E model)
C247	1-108-561-12	0.0018 mylar (US, Canadian model)
C247	1-108-556-12	0.0011 mylar (AEP, UK, E model)
C248-250	1-101-924-11	A 0.022
C251	1-121-479-11	A 22 16V elect
C252	1-101-918-11	A 0.001
C253	1-101-924-11	A 0.022
C254	1-123-193-11	100 16V elect
C255	1-121-395-11	A 4.7 25V elect
C256	1-121-392-11	A 3.3 25V elect
C257	1-101-923-11	A 0.01
C258	1-108-244-12	A 0.033 mylar
C259	1-108-230-12	A 0.0022 mylar
C260	1-108-242-12	A 0.022 mylar
C261	1-101-918-11	A 0.001
C262	1-101-924-11	A 0.022
C263	1-102-960-11	A 24p
C264	1-104-067-11	390p polystyrol
C265	1-101-924-11	A 0.022
C267	1-121-651-11	A 10 16V elect
C268	1-123-193-11	100 15V elect
C269	1-121-416-11	A 100 25V elect
C270	1-121-940-11	B 470 25V elect
C271	1-101-925-11	A 0.047
C301,351	1-121-913-11	3.3 25V elect
C302,352	1-102-816-11	A 120p
C304,354	1-121-419-11	A 220 6.3V elect

Note: The components identified by shading and mark **A** are critical for safety. Replace only with part number specified.

Note: Les composants identifiés par un trame et une marque **A** sont critiques pour la sécurité. Ne les remplacer qu'une pièce portant le numéro spécifié.

STR-V6 STR-V6

Note: Circled letters (A to Z) are applicable to European models only.

Ref. No.	Part No.	Description
C305,355	1-108-561-12	0.0018 mylar
C306,356	1-108-573-12	0.0056 mylar
C307,357	1-121-352-11	(A) 47 10V elect
C308,358	1-123-050-11	2.2 50V elect
C310,311	1-121-936-11	(A) 220 25V elect
C401,451	1-101-361-11	(A) 150p
C402,452	1-108-591-12	0.033 mylar
C403,453	1-121-912-11	(A) 1 50V elect
C404,454	1-102-959-11	(A) 22p
C405,455	1-121-912-11	(A) 1 50V elect
C406,456	1-123-050-11	2.2 50V elect
C407,457	1-108-587-12	0.022 mylar
C408,458	1-108-559-12	0.0015 mylar
C409,459	1-108-600-12	0.075 mylar
C410,460	1-108-577-12	0.0082 mylar
C411,461	1-108-579-12	0.01 mylar
C412,462	1-108-603-12	0.1 mylar
C413,463	1-121-450-11	(A) 2.2 50V elect
C414	1-121-419-11	(A) 220 6.3V elect
C464	1-121-352-11	(A) 47 10V elect
C501,551	1-121-391-11	(A) 1 50V elect
C502,552	1-102-116-11	(A) 680p
C503,553	1-121-424-11	(B) 470 6.3V elect
C504,554	1-102-950-11	(A) 13p
C505,555	1-121-414-11	(A) 100 10V elect
C506,556		
C507,557	1-101-880-11	(A) 47p
C508,558	1-121-479-11	(A) 22 16V elect
C509,559		
C510,560	1-101-880-11	(A) 47p
C511,561	1-106-208-12	0.033 100V mylar
C512,562	1-102-951-11	(A) 15p
C513,563	1-121-414-11	(A) 100 10V elect
C514,564	1-123-084-11	(C) 100 100V elect
C515	1-121-424-11	(B) 470 6.3V elect
C516	1-121-391-11	(A) 1 50V elect
C517	1-121-651-11	(A) 10 16V elect
C518	1-121-736-11	(B) 1000 10V elect
C519	1-121-651-11	(A) 10 16V elect
C520,570	1-123-084-11	(C) 100 100V elect

Note: The components identified by shading and mark **A** are critical for safety. Replace only with part number specified.

Ref. No.	Part No.	Description
C601	1-123-193-11	100 16V elect
C603,604	1-123-065-11	(B) 330 25V elect
C605,606	1-121-941-11	(B) 470 35V elect
C608-611	1-108-433-12	(A) 0.1 200V mylar
C612	1-121-940-11	(B) 470 25V elect
C613	1-102-129-11	0.01
C614	1-123-072-11	(A) 220 10V elect
C701,751	1-121-391-11	(A) 1 50V elect
C801,802	(A) 1-123-260-11	(P) 15000 71V elect
C803	1-121-419-11	(A) 220 6.3V elect

RESISTORS

All resistors are in ohms. Common 1/2W carbon resistors are omitted. Refer to the list on page 5 for their part numbers.

R223	(A) 1-211-506-11	(A) 22 1/2W carbon (nonflammable)
R227	(A) 1-211-526-11	(C) 150 1/2W carbon (nonflammable)
R251	1-244-861-11	(A) 330 1/2W carbon
R268	1-211-630-11	(B) 470 1/2W carbon (nonflammable)
R269	1-244-891-11	(A) 5.6k 1/2W carbon
R279,280	(A) 1-211-534-11	(C) 330 1/2W carbon (nonflammable)
R281	(A) 1-211-522-11	(C) 100 1/2W carbon (nonflammable)
R284	(A) 1-211-490-11	(A) 4.7 1/2W carbon (nonflammable)
R288	(A) 1-211-506-11	(A) 22 1/2W carbon (nonflammable)
R315,563	1-211-553-11	(A) 47 1/2W carbon (nonflammable)
R327	1-206-658-11	(A) 560 2W metal oxide (nonflammable)
R503,553	(A) 1-221-553-11	(C) 2.7k 1/2W carbon (nonflammable)
R505,555	(A) 1-211-514-11	(A) 47 1/2W carbon (nonflammable)

Note: Les composants identifiés par un trame et une marque **A** sont critiques pour la sécurité. Ne les remplacer que par une pièce portant le numéro spécifié.

Note: Circled letters (A to Z) are applicable to European models only.

Ref. No.	Part No.	Description
R508-510	(A) 1-211-526-11	(C) 150 1/2W carbon (nonflammable)
R558-560		
R511,561	(A) 1-211-534-11	(C) 330 1/2W carbon (nonflammable)
R512,562		
R514,564	(A) 1-211-538-11	(A) 470 1/2W carbon (nonflammable)
R515,565		
R516,566	(A) 1-211-536-11	(B) 390 1/2W carbon (nonflammable)
R523-526	(A) 1-217-158-11	(A) 0.47 5W metal oxide
R573-576		
R527,577	1-244-825-11	(A) 10 1/2W carbon
R528,578	1-244-817-11	(A) 4.7 1/2W carbon
R529,579	1-244-907-11	(A) 27k 1/2W carbon
R531-534	(A) 1-211-490-11	(A) 4.7 1/2W carbon (nonflammable)
R581-584		
R542,592	(A) 1-211-498-11	(A) 10 1/2W carbon (nonflammable)
R543,593		
R544,594	(A) 1-211-553-11	(C) 2.7k 1/2W carbon (nonflammable)
R555	(A) 1-211-514-11	(A) 47 1/2W carbon (nonflammable)
R608,609	(A) 1-206-722-11	750 3W metal oxide (nonflammable)
R610	(A) 1-206-465-11	(A) 12 2W metal oxide (nonflammable)
R611	(A) 1-206-531-11	68 3W metal oxide (nonflammable)
R612,613	(A) 1-217-160-11	(B) 1 5W metal oxide
R616	(A) 1-211-498-11	(A) 10 1/2W carbon (nonflammable)
R617,618	(A) 1-206-727-11	(B) 1.2k 3W metal oxide (nonflammable)
R619	(A) 1-211-498-11	(A) 10 1/2W carbon (nonflammable)
R620	(A) 1-206-477-11	(A) 39 2W metal oxide (nonflammable)
R701,751	1-244-865-11	(A) 470 1/2W carbon
R702,752	1-206-656-11	(A) 470 2W metal oxide
R704,754	1-244-881-11	(A) 2.2k 1/2W carbon
R801	1-202-719-11	(B) 1M 1/2W composition (US, Canadian model)
R802	1-206-658-11	(A) 560 2W metal oxide

Note: The components identified by shading and mark **A** are critical for safety. Replace only with part number specified.

Ref. No.	Part No.	Description
RT201	1-244-643-XX	(B) 2.2k (B), adjustable
RT202	1-224-646-XX	(B) 22k (B), adjustable
RT203,204	1-224-647-XX	(B) 47k (B), adjustable
RT205	1-224-645-XX	(B) 10k (B), adjustable
RT206	1-224-650-XX	(B) 470k (B), adjustable (US, Canadian model)
RT206	1-222-768-11	470k (B), adjustable (AEP, UK, E model)
RT401,451	1-244-644-XX	(B) 4.7k (B), adjustable
RT501,551	1-244-491-11	(B) 22k (B), adjustable
RV401,451	1-226-265-00	100k/100k, variable; BALANCE
RV402,452	1-226-267-00	100k/100k, variable; TREBLE
RV403,453	1-226-268-00	100k/100k, variable; BASS
RV801,851	1-226-264-00	250k/250k, variable; VOLUME

SWITCHES

S202	1-552-461-00	Lever-slide, FM MUTING
S203	1-552-461-00	Lever-slide, FM SELECTIVITY
S301	1-552-463-00	Rotary, TAPE
S302	1-552-462-00	Rotary, FUNCTION
S401	1-552-461-00	Lever-slide, MODE
S402	1-552-461-00	Lever-slide, LOUDNESS
S403	1-552-461-00	Lever-slide, HIGH FILTER
S404	1-552-461-00	Lever-slide, LOW FILTER
S701	1-552-464-00	Rotary, SPEAKERS
S801	(A) 1-552-246-12	Pushbutton, POWER (US, Canadian model)
S801	(A) 1-552-141-12	(E) Pushbutton, POWER (AEP, UK, E model)
S802	1-552-466-00	Pushbutton, METER

JACKS AND CONNECTORS

CNJ701	1-507-483-00	(C) Jack, HEADPHONES
CNJ801,802	(A) 1-561-161-12	Socket, AC OUTLET (2-gang) (US, Canadian model)
CNJ803	1-509-551-00	(B) Connector, TAPE 1 REC/PB (AEP, UK, E model)
CNJ804	(A) 1-509-546-00	(C) Connector, 3p; AC IN (AEP, UK, E model)

Note: Les composants identifiés par un trame et une marque **A** sont critiques pour la sécurité. Ne les remplacer que par une pièce portant le numéro spécifié.

Note: Circled letters (A to Z) are applicable to European models only.

Note: Circled letters (A to Z) are applicable to European models only.

Ref. No.	Part No.	Description
J801-804, J851-854	1-507-595-00	Jack, 8p; REC OUT 1, TAPE 1, REC OUT 2, TAPE 2
J805-807, J855-857	1-507-594-00	Jack, 6p; PHONO 1, PHONO 2, AUX

LAMPS

PL801-803	1-518-329-00	8V 200mA, with circuit board
PL804,805	1-518-070-XX	(B) 8V 300mA

PL806	1-518-331-21	6V 35mA
PL807	1-518-332-81	6V 35mA
PL808	1-518-333-81	6V 35mA
PL809	1-518-334-71	6V 35mA
PL810	1-518-331-81	6V 35mA

PL811	1-518-330-81	6V 35mA
PL812	1-518-331-81	6V 35mA

FUSES

F601	(A) 1-532-496-11	(C) Thermo 10A
F602	(A) 1-532-509-11	6.3A (US, Canadian model)
F602,605	(A) 1-532-325-11	(B) T6.3A (AEP, UK, E model)
F603,604	(A) 1-532-299-11	(B) T5A (AEP, UK, E model)

METERS

ME801	1-520-348-00	POWER/SIGNAL (US, Canadian model)
ME801	1-520-358-00	POWER/SIGNAL (AEP, UK, E model)
ME802	1-520-346-00	POWER (US, Canadian model)
ME802	1-520-356-00	POWER (AEP, UK, E model)
ME803	1-520-347-00	TUNING (US, Canadian model)
ME803	1-520-357-00	TUNING (AEP, UK, E model)

MISCELLANEOUS

CB601	(A) 1-532-521-11	Circuit Breaker (US, Canadian model)
CB601	(A) 1-532-531-11	(C) Circuit Breaker (AEP, UK, E model)

Ref. No.	Part No.	Description
----------	----------	-------------

CF201-203	1-527-307-XX	Filter, ceramic
-----------	--------------	-----------------

CNP801	(A) 1-551-511-11	Cord, power (US, Canadian model)
--------	------------------	-------------------------------------

CP601,602	1-102-355-11	(A) 0.01 μ F 500V, ceramic
-----------	--------------	--------------------------------

FE201	1-163-241-00	Front End
-------	--------------	-----------

LPF201,202	1-231-360-00	Filter, low-pass
------------	--------------	------------------

RY501	1-515-302-00	Relay
RY601	(A) 1-515-278-12	(F) Relay (AEP, UK model)
RY601	(A) 1-515-278-22	Relay (US, Canadian model)

TH501,551	1-800-427-21	(B) Thermister, positive
-----------	--------------	--------------------------

TM801,802	1-536-555-00	Terminal, push; SPEAKERS
TM803	1-536-506-00	Terminal Strip, ANTENNA
TM804	1-535-132-00	(B) Terminal, push; ground

(A) 1-508-897-11	(C) Plug, voltage selector (AEP, UK, E model)
------------------	--

1-533-051-XX	(A) Holder, lamp
--------------	------------------

1-533-131-11	Holder, fuse (AEP, UK, E model)
--------------	---------------------------------

ACCESSORY AND PACKING MATERIALS

Part No.	Description
X-4490-002-2	(A) Cloth Ass'y, polishing
1-506-113-00	(A) Plug, short
1-506-161-11	(H) Antenna, feeder
(A) 1-534-754-14	Cord, power (E2 model)
(A) 1-534-819-12	Cord, power (UK model)
(A) 1-551-216-11	Cord, power (E1 model)
3-701-020-00	(A) Bag, check sheet
3-701-622-00	(A) Bag, plastic (Canadian, UK model)
3-701-730-00	(B) Bag, plastic; IBM card (US model)
3-770-508-11	Manual, instruction (AEP, UK, E model)
3-770-508-21	Manual, instruction (US model)
3-770-508-21	Manual, instruction (Canadian model)
3-794-257-31	
3-794-233-21	Separate Sheet, consumer products (US model)
4-857-819-00	Cushion, upper
4-857-820-00	Cushion, lower
4-857-821-00	Carton
4-857-826-00	Bag, protection

Note: The components identified by shading and mark (A) are critical for safety. Replace only with part number specified.

Note: Les composants identifiés par un trame et une marque (A) sont critiques pour la sécurité. Ne les remplacer que par une pièce portant le numéro spécifié.

Note: The components identified by shading and mark (A) are critical for safety. Replace only with part number specified.

Note: Les composants identifiés par un trame et une marque (A) sont critiques pour la sécurité. Ne les remplacer que par une pièce portant le numéro spécifié.