

STR-6050

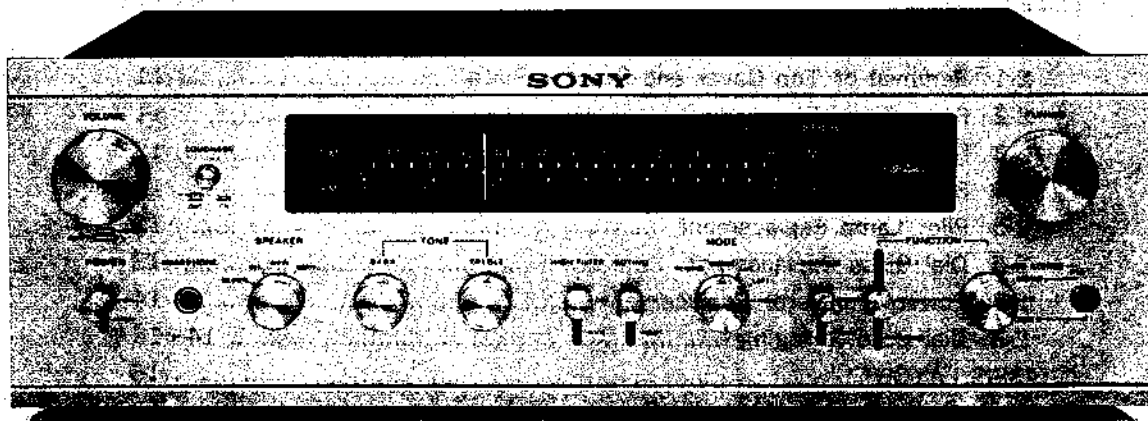

- System :** All Silicon transistor A-M/FM FM stereo receiver
- Semiconductor Complement :** 46 all silicon transistors
(including 3FET's) 34 diodes
- Dynamic Power Output :** 75 watts both channels, 8 ohms (IHF)
- Power Requirement :** AC100, 117, 220, 240V 50/60 Hz
- Power Consumption :** 30 watts at no signal (36VA)
250 watts at rated output (260VA)
- AC Outlet :** Unswitched, 500 watts maximum
- Dimensions :** 17 $\frac{3}{8}$ "(w) \times 5 $\frac{5}{8}$ "(H) \times 13 $\frac{3}{8}$ "(D)
(440 \times 148 \times 345mm)
- Weight :** 20 lb 13 oz (9.45 kg)

SONY® SERVICE MANUAL

TABLE OF CONTENTS

	Page
SECTION 1 CIRCUIT DESCRIPTION	
General Information.....	1
Technical Specifications.....	1
Circuit Description.....	2~6
BLOCK DIAGRAM	7~8
LEVEL DIAGRAM	9~10
SECTION 2 DISASSEMBLY AND REPLACEMENT OF PARTS	
2-1 Removal of Top Cover and Bottom Plate	11
2-2 Front Panel Removal	11
2-3 Removal of Front Panel Assembly	12
2-4 Switch and Binaural Jack Replacement	13
2-5 Pilot Lamp Replacement	13
2-6 Dial Glass Replacement	13
2-7 Power Transistor Replacement.....	14
2-8 Dial Cord Stringing	14~15
CHASSIS LAYOUT	16
SECTION 3 TEST AND ALIGNMENT	
3-1 Front End Alignment.....	17
3-2 FM Discriminator Adjustment	18
3-3 A-M I-F Alignment	19
3-4 A-M Tuner Frequency Coverage and Tracking Alignment	20~21
SCHEMATIC DIAGRAM (Tuner Section)	22~23
SECTION 4 OVERALL ADJUSTMENT AND TEST	
4-1 Discriminator Transformer Adj.	24
4-2 FM Muting Operation Adj.	25
4-3 FM Monaural Distortion Adj.	25
4-4 FM Stereo Distortion Adj.	25
4-5 Channel Separation Adj.	26
4-6 Dial Pointer Calibration.....	26
4-7 Power Amplifier Adj.	26~27
SCHEMATIC DIAGRAM (Audio Section)	28~29
Service Note	30
MOUNTING DIAGRAM	
Front End Section	31~32
FM I-F Board	33~34
A-M I-F Board	35~36
MPX and Equalizer Amplifier Board.....	37~38
Loudness Section	39
Tone Control and Flat Amplifier Board	40~41
Power Amplifier Board	42~43
Power Supply Board	44~45
EXPLODED VIEW	46~48

SECTION 1 GENERAL DESCRIPTION

General Information

FM Tuner

A passive rf circuit and field effect transistor improve the tuner's figure of merit greatly.

A newly designed fm local oscillator circuit provides drift free operation, eliminating the need for automatic frequency control.

The passive rf circuit makes the following possible: Excellent sensitivity and noise figure, low cross-modulation, and high overload capacity.

Seven i-f stages using six piezoelectric resonators ensure high sensitivity, sharp skirt response, and essentially flat response within the selected channel.

An electronic switching system in the multiplex decoder section switches the receiver to stereo or mono automatically, according to the characteristics of the received signal.

The muting circuit eliminates interstation noise to provide smooth and quiet tuning. The high filter decreases the hiss caused by the weak stereo signal.

A-M Tuner

Two piezoelectric resonators are used in the a-m tuner section for high sensitivity and adjacent channel rejection. In addition, one FET is employed to improve AGC response for distortion-less reception.

Control Amplifier

All controls are designed and placed for maximum operating convenience. The amplifier delivers up to 85 watts of dynamic power (42.5 watts per channel) to an 8 ohm load, measured according to IHF standards. The amplifier section consists of a flat amplifier, and a power amplifier with an effective power-transistor protection circuit.

All equalization filtering and tone control functions are performed by passive RC networks, with two feedback stabilized direct coupled amplifiers between them for isolation and gain.

Technical Specifications

Circuit: All silicon transistor A-M/FM Stereo Receiver Superheterodyne, 46 transistors (including 3 Field-Effect Transistors) 34 diodes

FM Section

Antenna: 300 ohms balanced
 Tuning Range: 87-108 MHz
 Usable Sensitivity: 2.0 μ V, IHF
 S/N Ratio: 70 dB, IHF
 Capture Ratio: 2.0 dB, IHF
 Selectivity: 70 dB, IHF
 Frequency Response: 30-15,000 Hz \pm 1 dB
 Image Rejection: 75 dB
 I-F Rejection: 90 dB
 Spurious Rejection: 100 dB
 A-M Suppression: 55 dB
 Harmonic Distortion: Mono 0.4 % at 400 Hz, 100 % modulation

Stereo 0.5 % at 400 Hz, 100 % modulation

FM Stereo Separation: Better than 40 dB at 400 Hz 100 % modulation

Stereo-Auto

Switching Level: 5 microvolts

SCA Suppression: 54 dB

A-M Section

Antenna: Built-in ferrite bar antenna
 External antenna terminals

Tuning Range: 530-1,605 kHz

Sensitivity: 44 dB / μ , built-in antenna
 20 dB / μ , external antenna

S/N Ratio: 50 dB at 5 millivolts

Image Rejection: 47 dB at 600 kHz
 45 dB at 1,400 kHz

Harmonic Distortion: 0.5 % at 5 millivolts input

I-F Rejection: 40 dB at 1,000 kHz

Amplifier Section

Dynamic Power

Output (IHF): 75 watts both channels into 8 ohms

Rated Output: 30 watts per channel into 8 ohms

Speaker Available: 4, 8 or 16 ohms speaker

Power Bandwidth: 30-50,000 Hz

Harmonic Distortion: Less than 0.2 % at rated output
 Less than 0.1 % at 0.5 watts output

IM Distortion: Less than 0.4 % at rated output
 Less than 0.2 % at 0.5 watts output

Frequency Response: AUX, TAPE, 30-50,000 Hz \pm 3 dB
 PHONO, RIAA Standard
 TAPE, NAB Standard

Input Sensitivity and Impedance: AUX 250 mV (100 k Ω)
 TAPE 250 mV (100 k Ω)
 PHONO 2.5 mV (47 k Ω)

S/N Ratio: AUX Better than 90 dB (weighting network "A")
 TAPE Better than 70 dB (weighting network "A")
 PHONO Better than 70dB (weighting network "A")

Recording Output: 250 millivolts, 10 k ohms
 and Impedance

Headphone Output: Accepts all low and high impedance headphones

Tone Control: BASS, \pm 10 dB at 100 Hz

TREBLE, \pm 10 dB at 10,000 Hz

General

Semiconductor 46 all silicon transistors

Complement: (including 3 FET's) 34 diodes

Power Requirement: AC 100, 117, 220, 240 V 60/50Hz

Power Consumption: 30 watts at no signal (36 VA)
 250 watts at rated output (260 VA)

AC Outlet: Unswitched, 500 watts maximum

Dimensions: 17 $\frac{5}{16}$ "(W) \times 5 $\frac{13}{16}$ "(H) \times 13 $\frac{3}{16}$ "(D)

Weight: 20 lb 13 oz (9.45kg)

General

Accessories Supplied: Ribbon Antenna (1)
Phono Plugs, red (2), black (2)
Polishing Cloth (1)
Binaural Plug (1)

Circuit Description

The following describes the functions of all stages and controls. The description follows the signal path and lists stages by their main circuit component symbol number at the left margin. Refer to the block diagram on page 7-8 and the schematic diagram on page 22-23, 28-29.

Front End Section

Stage/Control	Function	Stage/Control	Function
Passive RF Circuit L101, L102, L103	A triple-tuned circuit is employed in this stage between the antenna and rf mixer. The passive coupling circuit contains no active amplifiers. Therefore, it is perfectly linear, and cannot produce distortion and overload components. Thus, the factors that contribute to spurious response are eliminated ahead of the mixer.	Diode Limiters D201 to D206	Limiting is accomplished by diode pairs, connected in parallel and poled in opposite directions. The diodes conduct when the signal across them exceeds the barrier potential of about 0.6 volts in the forward direction. Thus, signal is limited in both directions to 1.2 volts peak to peak. The diodes provide symmetrical limiting.
Local Oscillator Q102	Supplies injection signals to the mixer via L104. The circuit is a modified Hartley type with feedback applied to the emitter from the tap on L104. Temperature changes have little effect on oscillator tuning in this circuit so that this oscillator is extremely stable.	I-F Output Q206	Signal at the base of Q206 has had all amplitude variations removed by the preceding limiters, and only selected signals have been passed by the solid-state filters. Q206 provides power to drive the ratio detector.
Mixer Q101	Rf signals and local oscillator signals are heterodyned in the gate-source junction of Q101 to produce the 10.7 MHz output. IFT 101 is a tuned transformer to develop the i-f output and provide proper selectivity. A low impedance output winding feeds the signal to the i-f section.	Muting Circuit Q208 to Q210 D210, D211	The i-f signal is extracted from the collector of Q204 to drive the muting circuit. Q208 acts as a buffer amplifier to drive the voltage doubler D210, D211. The output of this circuit is a positive dc voltage proportional to carrier level. With the muting switch IN, fm signals of average strength keep Q209 normally saturated, cutting off Q210 and maintaining normal operation. Weak stations and interstation noise can not produce a dc voltage at the base of Q209 sufficient to keep it conducting. This makes Q209 cut off, which in turn saturates Q210. Accordingly, audio output is grounded. With the muting switch OUT, Q209 is kept saturated by placing its base at B+.
I-F Amplifier Q103	This stage amplifies the output of the mixer to drive the following i-f amplifiers.	Tuning Meter	This cuts off Q210, lifting the audio output off ground regardless of the strength of the fm signal. Rv201 adjusts the muting level. An i-f output from the collector of Q204 is coupled through C213 and R252 to D209. This half wave rectifier feeds a dc signal to the Tuning Meter.
I-F Amplifiers Q201 to Q205	These i-f stages are basically RC coupled amplifiers that provide essentially flat response.	Ratio Detector D207, D208.	T201 and the diodes D207 and D208 form a balanced ratio detector that transforms the frequen-
CF201 to CF206	The selectivity of this section is determined by the solid-state filters in the interstage coupling paths. These ceramic filters are made up of two individual sections that operate in a "trapped-energy" mode. The filters provide ex-		

Stage/Control	Function	Stage/Control	Function
Emitter Follower Q207	cy modulated signal into an audio signal. Supplies demodulated signals to the MPX decoder circuit.		filters out audio components so that the input signal is primarily high-frequency noise. This noise signal is amplified by Q404 to drive rectifier D410. When interstation noise is received, the output of D410 is fed back to the base of Q404, and drives Q404 into conduction. This in turn shorts the frequency doubler output to ground, preventing amplification of the incoming signal and, therefore, operation of the 38 kHz amplifier and stereo indicator circuit, Q402 and Q403. When a stereo signal is received, the signal-to-noise ratio increases, reducing the noise signal at the base of Q404. Q404 then cuts off and enables the stereo indicator circuits to operate.
MPX Decoder Section			
Q401	This stage serves two functions. The composite stereo signal is extracted from its emitter circuit and the 19 kHz pilot signal is taken from a tuned circuit at its collector. Signals developed at the collector of Q401 are transformer coupled to a full-wave rectifier D401, D402. The output of these rectifiers is not filtered. They thus produce two positive pulses for each input cycle. Therefore the 19 kHz frequency is effectively doubled by D401 and D402. However, the waveform is not sinusoidal at the base of Q402.		
Frequency Doubler D401, D402,			
38 kHz Amplifier Q402	The 38 kHz pulses produced by D401 and D402 are amplified by Q402. The tank circuit at its collector is tuned to 38 kHz to restore the sinusoidal waveshape to the signal. This signal is then transformer coupled to the bridge-type demodulator to supply its sampling drive.	Multiplex Demodulator D405 to D408	The demodulator circuit employs diodes in a balanced bridge arrangement. This system has the advantage of cancelling residual components of rf (actually 38 kHz signal and some 19 kHz signal as well as higher-order harmonics of these frequencies.) "L" and "R" components are developed at each side of the bridge as the result of the synchronous demodulator, when the tuner is operated in the stereo mode. In the mono mode, D405 and D408 are forward biased and act merely as low value resistances. Under this condition, the monaural signal is applied to both "L" and "R" audio amplifiers respectively.
Stereo Lamp Circuit Q403	The STEREO indicator lights when an fm stereo signal is received. The emitter of Q402 is connected directly to the base of Q403, which is normally cut off. The circuit operates as follows. When a stereo composite signal is applied to the MPX decoder, the 38 kHz pulses produced at the output of the frequency doubler yield a higher average current flowing through Q402. This forces Q403 into conduction lighting the stereo indicator PL904.	Twin T Filter C411, 412 and C414 R416, 417 and R419	Eliminates the carrier component (38 kHz) to prevent carrier leak interference.
Noise Amplifier Q404, D409, D410.	This circuit is employed to prevent the stereo indicator from lighting on interstation noise or distorted sound due to a station not being tuned properly. Noise signals above 19 kHz are extracted at L401 and applied to the base of Q404. The coupling capacitor C421,	A-M Tuner Section Local Oscillator Q305	This stage supplies injection voltage to the mixer via the secondary winding of L303 (Bar Antenna). The circuit is a modified Hartley type with feedback applied to the emitter from the secondary winding of L304 (oscillator coil). Incoming rf signals and local-oscillator signals are heterodyned
		Mixer Q301	

Stage/Control	Function	Stage/Control	Function
	in the base-emitter junction of Q301 to produce the 455 kHz output.		negative feedback technique that provides stable operation during temperature change and good amplification at low frequencies. It also applies the audio signal to the REC OUT terminal for recording.
I-F Amplifier Q302	Q301 and Q302 (FET) form a cascaded amplifier that assure stable processing of the rf and i-f signals.		In addition, RIAA equalization is accomplished in this section when the Function Switch S_1 is in the PHONO position.
	In addition, an ingenious AGC circuit is employed using the FET that makes a large figure of merit possible in a-m reception.		RIAA equalization is achieved by the negative feedback loop containing these components. Please use care when replacing any of them.
IFT301	IFT301 is a tuned transformer for 455 kHz and its low impedance output winding feeds the signal to I-F amplifier Q303.	R517 to R518 and C508 to C511 (R617 to R618 and C608 to C611)	In the TUNER or AUX 1 position of the function switch, feedback is applied through R519 (13 k ohms) and R520 (13 k ohms) respectively to provide a flat response in the preamplifier. Preamplifier gain is about 39 dB at 1 kHz for the phono input. For the tuner and TAPE input, the gain changes to about 22 dB.
I-F Amplifier Q303	This stage is an amplifier that provides essentially flat response.		Signals applied at the AUX 1 and AUX 2 input jacks are attenuated about 39 dB by these resistors. This allows the STR-6050 to accept signals at about 200 mV across these input jacks and amplify them without distortion.
CF301	The selectivity of the stage is determined by two solidstate filters in its output circuit.		Selects the desired mode of operation. This switch may also be used for test purposes. Relation of outputs and Mode Selector positions are summarized in the table.
	Each of these filters is made up of three sections of ceramic material mechanically coupled to each other. The filters provide extremely sharp skirt selectivity and flat response inside the pass-band.	R502, R504 (R602, R604)	The level of signal applied to the power amplifier section is determined by the setting of Rv501 (Rv601), an audio-taper control.
I-F Amplifier Q304	Provides the power to drive diode detector, D302.		Compensates for human hearing characteristics, which vary according to the loudness of the sound. When this switch is set to the "IN" position, high and low frequency components are increased in conjunction with a decreasing volume level.
AGC Circuit R325, R326 C323, C305	The dc component of the detector (D302) output is fed back to the FET i-f amplifier through R325 and R326, C323 and C305 to control the gain of amplifier Q302.	Mode Switch S4	This two-stage amplifier provides a 24 dB voltage gain to increase the signal to the level required at the input of the power amplifier.
Audio Amplifier Section			
Channel Separation Adj. Rv604	This network is connected between the emitters of audio preamplifiers Q501 and Q601, when Function Switch S_2 is in the FM STEREO position. It provides a form of negative feedback between the left and right channels.	Volume Control Rv501 (Rv601)	
	Any residual "L" signals in the "R" channel are cancelled out by the signal from the "L" channel. The same is true of residual "R" signals in the "L" channel. Rv604 is therefore set for maximum channel separation.	Loudness Switch S5 R523, R524 C512, C513 (R623, R624) (C612, C613)	
Preamplifier (Equalizer) Q501, Q502 (Q601, Q602)	Amplifies the small signal produced by the tuner, a cartridge or signals applied to the TAPE input jack, to the level required at the input of the driver section. The circuit employs a complicated	Flat Amplifier Q503 to Q504 (Q603 to Q604)	

Stage/Control	Function
Tone Control Rv502 (Rv602) Rv503 (Rv603)	Rv502 (Rv602) controls treble response. It has a range of ± 10 dB at 10,000 Hz. Rv503 (Rv603) controls bass response. It has a range of ± 10 dB at 100 Hz.
High Filter Switch S6	Eliminates unwanted high-frequency components from the input signal (-6 dB/oct above 8 kHz) in the ON position.

Power Amplifier Section

Flat Amplifier Q701	This is a conventional resistance-coupled amplifier to power the driver stage. R705 (R805) is a load resistance.
Driver Q702	Acts as driver for the complementary circuit, providing sufficient positive and negative voltage swings for the required output power. R712 (R812) is a load resistance.
Complementary Q704 to Q705	These transistors operate as emitter followers to provide the current swings demanded of the output stages. They also provide the necessary phase inversion. Phase inversion is performed by using PNP and NPN type transistors which conduct during alternate half cycles.
DC Bias Adj. Rv702	Determines the amount of current flow through driver transistors Q704 and Q705 and so current flow in the power transistors Q706 and Q707 at zero signal. By adjusting this resistor, the cross-over distortion, which occurs

Stage/Control	Function
Thermo Compensator	The negative temperature coefficient of D701 and D702 performs thermal compensation for bias current in the complementary stage.
Driver Limiter Q703	Q703 limits the negative-going half cycle of the drive voltage applied to the base of Q705 when power consumption at the Q706 or Q707 collector exceeds its safety margin. Since power dissipation at the collector can be considered a function of collector voltage and collector current flow, trigger signal for Q703 is extracted from the collector and emitter of Q707 through R721 and R720. Q703 is forced to conduct when the voltage applied to its base and emitter junction exceeds the barrier voltage. Effective input limiting is performed as follows: Under normal conditions, Q703 is cut off. When excessive current flows in power transistor Q707 or power dissipation at the collector of Q707 exceeds the transistor's safety margin, Q703 turns on and limits the input drive voltage to protect the power transistors. Though Q703 only limits the negative half cycle of voltage it

RECEIVER OUTPUT

Receiver Output Mode Selector Switch Position	SPEAKER OUT; LEFT	SPEAKER OUT; RIGHT	HEADPHONE LEFT	HEADPHONE RIGHT	REC OUT; LEFT	REC OUT; RIGHT
REVERSE	R	L	R	L	L	R
STEREO	L	R	L	R	L	R
L+R	L+R	L+R	L+R	L+R	L+R	L+R
LEFT	L	L	L	L	L	R
RIGHT	R	R	R	R	L	R

Stage/Control	Function
	also prevents excessive current flow in Q706 during the positive half cycle. This occurs because C710 charges during the positive half cycle and the voltage across C710 goes up to nearly B+, and since the negative half cycle cannot discharge C710, the following positive half cycle cannot fully drive Q706.
Click Noise Suppressor D704, C702, C802, C812	To prevent click noise caused by the initial charging current in the power amplifier section. D704 is a varister which operates as a small resistance for audio frequencies but as a constant dc voltage supply for direct current. C812 eliminates the noises caused by the varister.
AC Balance Adj. Rv701 (Rv801)	Determines the center line voltage to obtain a minimum of harmonic distortion at the rated output.
Power Supply Section	
Regulated Power Supply Q901, to Q903 D901	Dc output from the bridged rectifier is filtered by C904 and applied to the series regulator Q902. Transistor Q901 compares a sample of the output voltage, picked off at the junction of R906 and R907, with a reference voltage supplied by the zener diode D901. A change in output voltage, detected by Q901 and amplified by Q903, results in a change in conduction in Q902 that offsets the original voltage shift. The stable dc voltage is supplied to tuner, preamplifier and power amplifier sections.

STR-6050 STR-6050

BLOCK DIAGRAM

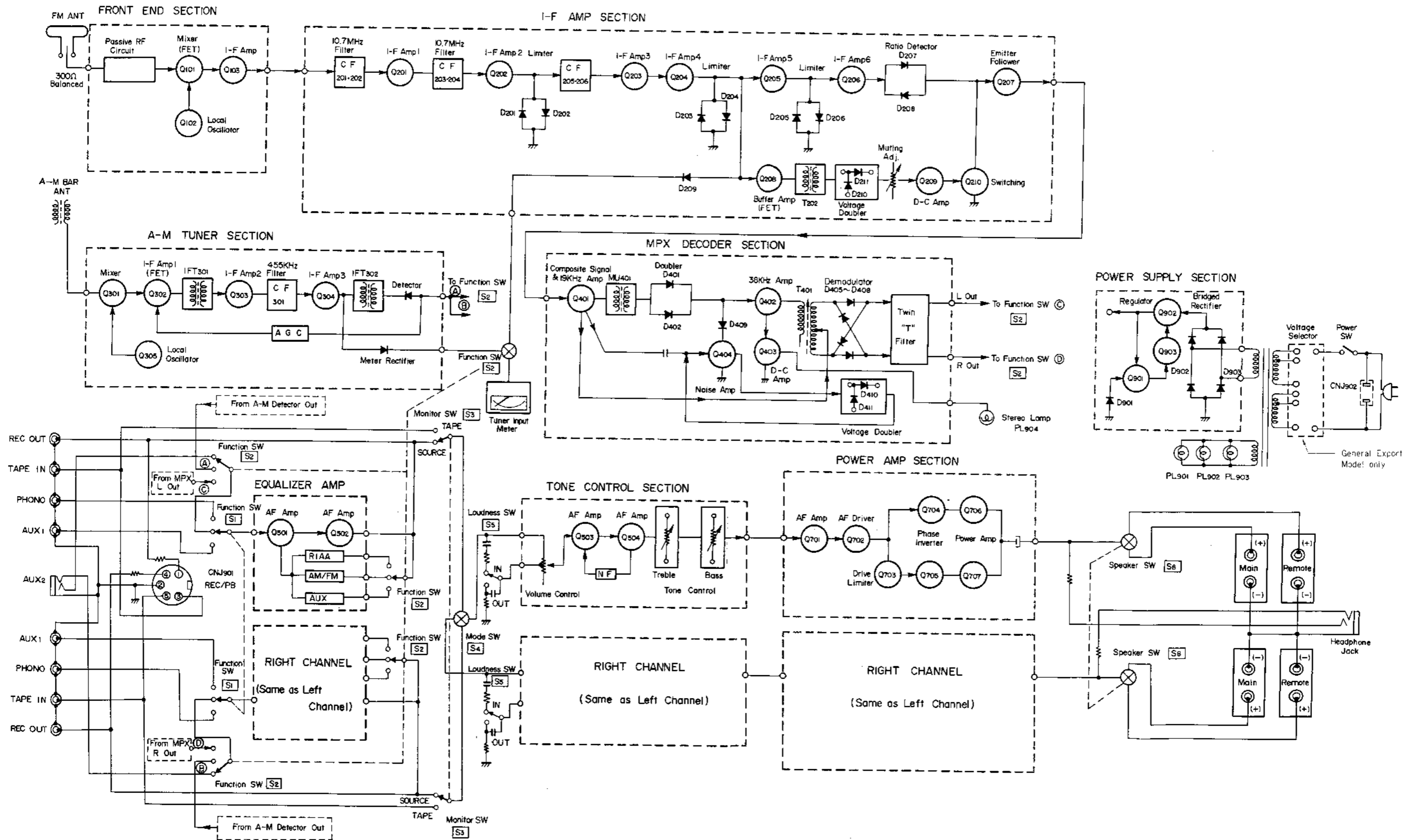

STR-6050

LEVEL DIAGRAM

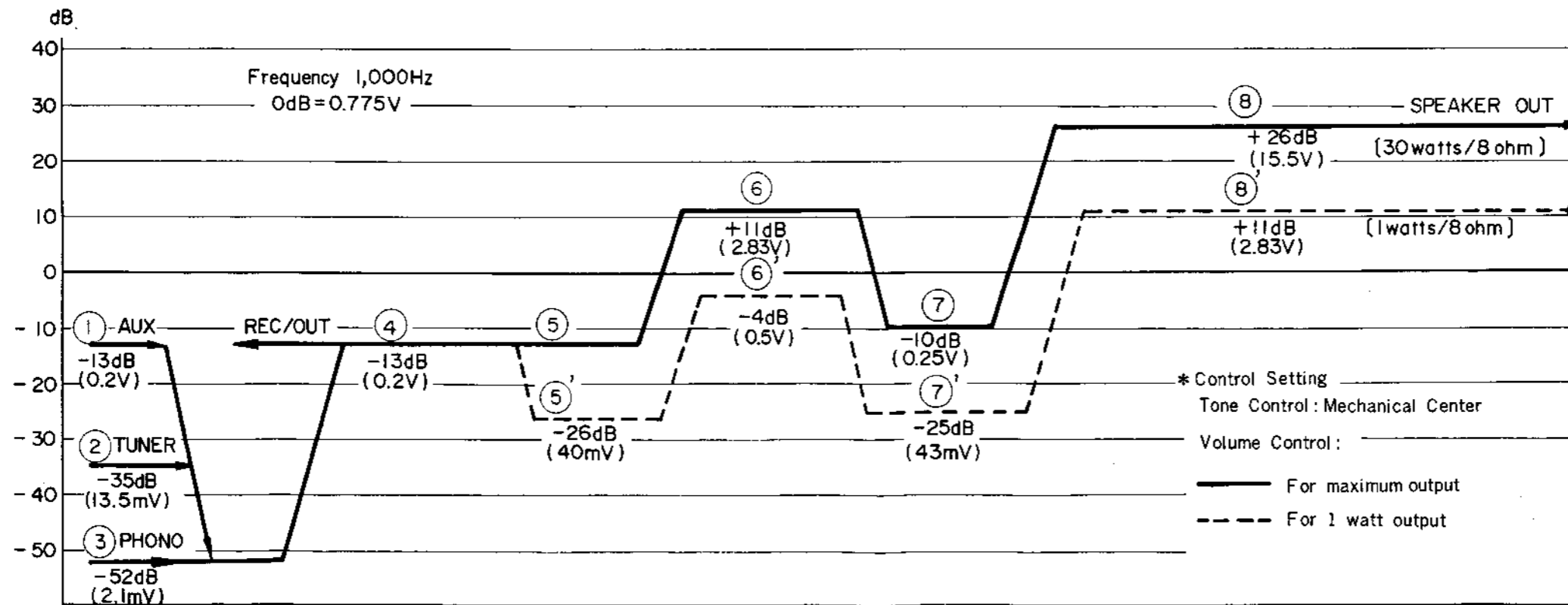
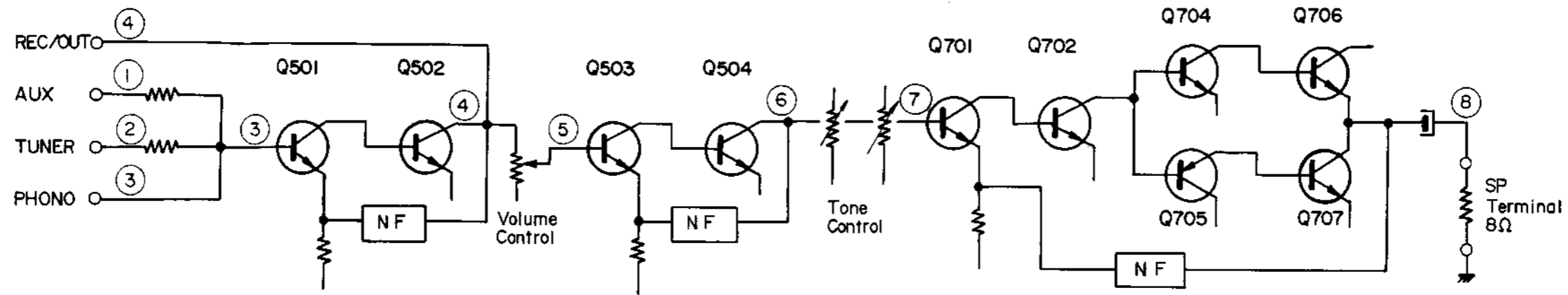

SECTION 2

DISASSEMBLY AND REPLACEMENT OF PARTS

2-1 Removal of Top Cover and Bottom Plate

- (a) Loosen off two machine screws at each side of the receiver and lift off the top cover by pulling it up straight.
- (b) Loosen off five Phillips-Head screws (+RF 3×6) at the bottom of the receiver and pull the bottom plate toward the rear of the receiver. See Fig. 2-1.

2-2 Front Panel Removal

- (a) Remove the top cover. See Section 2-1.
- (b) Remove all control knobs by pulling them out straight.

- (c) Loosen off two screws (+B3×6) one at the right side of the tuning shaft and the other just above the volume control shaft. See Fig. 2-2.

- (d) Loosen off two hex nuts that secure the rotary function switch and speaker switch to the front panel.

Be careful not to scratch or otherwise damage the front panel when loosening the nuts. Place a cover between the front panel and a wrench for protection.

- (e) Take off the front panel.

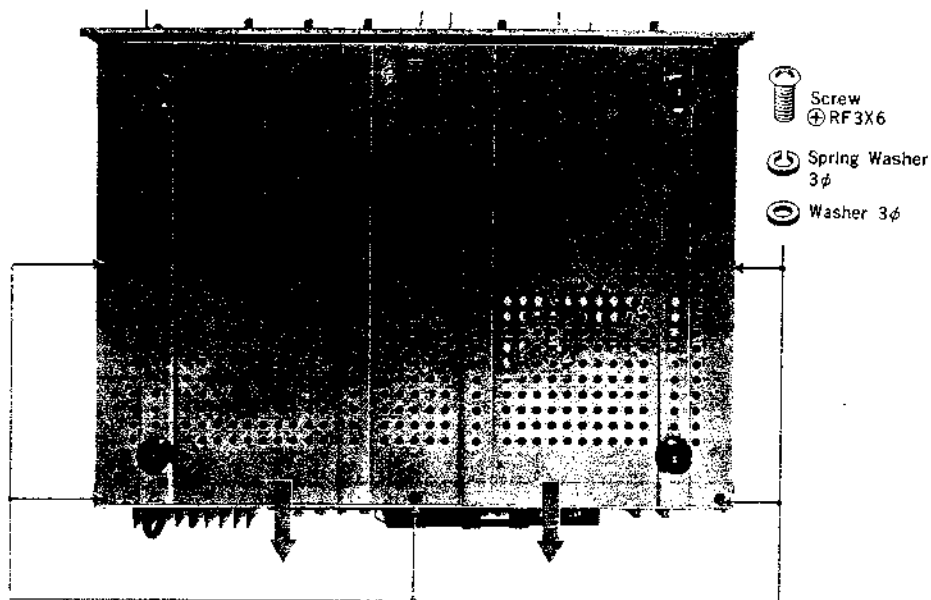

Fig. 2-1 Removal of Bottom Plate

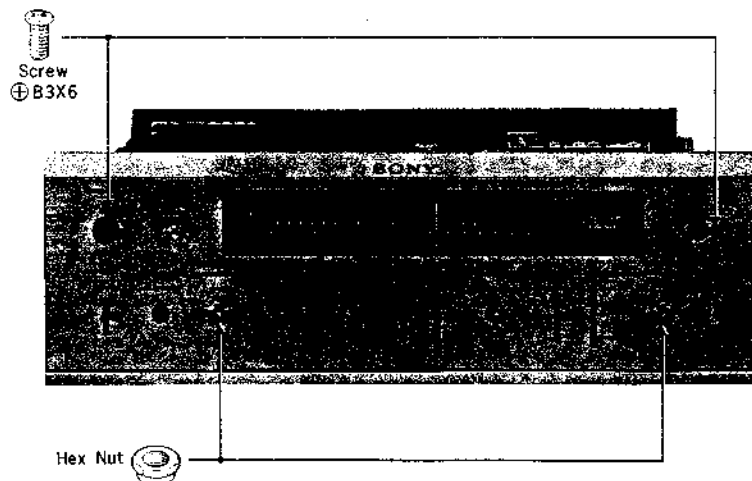

Fig. 2-2 Removal of Front Panel

2-3 Removal of the Front Panel Assembly

The front panel assembly is a vertical member on which the glass dial, switches, tuning meter and pilot lamps are attached.

- (a) Remove the cover, all knobs and the front panel. See Sections 2-1 and 2-2.
- (b) Loosen off two screws (+RF 3 × 6) at each side of the chassis. See Fig. 2-3.
- (c) Unhook the dial cord from the dial pointer tab. Mark the dial pointer position on the dial cord

for the convenience of re-installing the dial pointer in place.

- (d) Remove the volume control and loudness switch by loosening off the hexnut and screw securing the switch to the bracket. See Fig. 2-5.
- (e) Unsolder the lead wires from both dial lamp sockets. The front panel assembly is now free, and can be tilted forward and down as shown in Fig. 2-4.

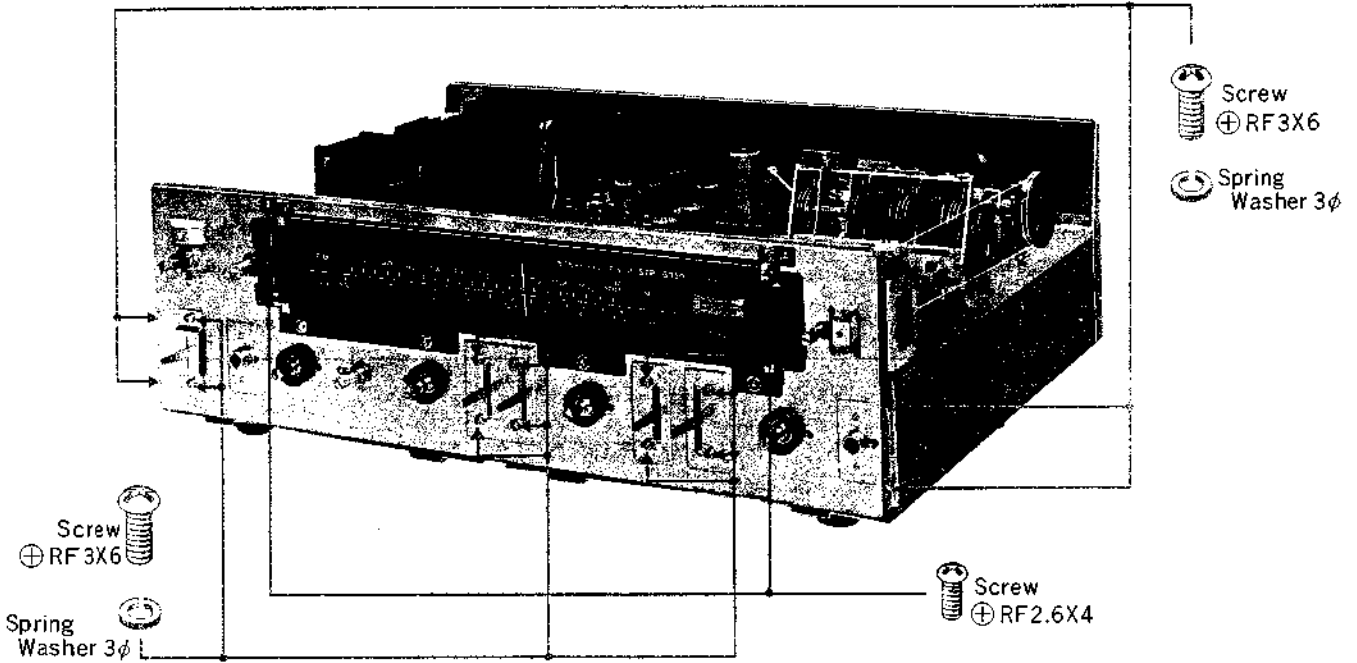

Fig. 2-3 Removal of Front Panel Ass'y (1)

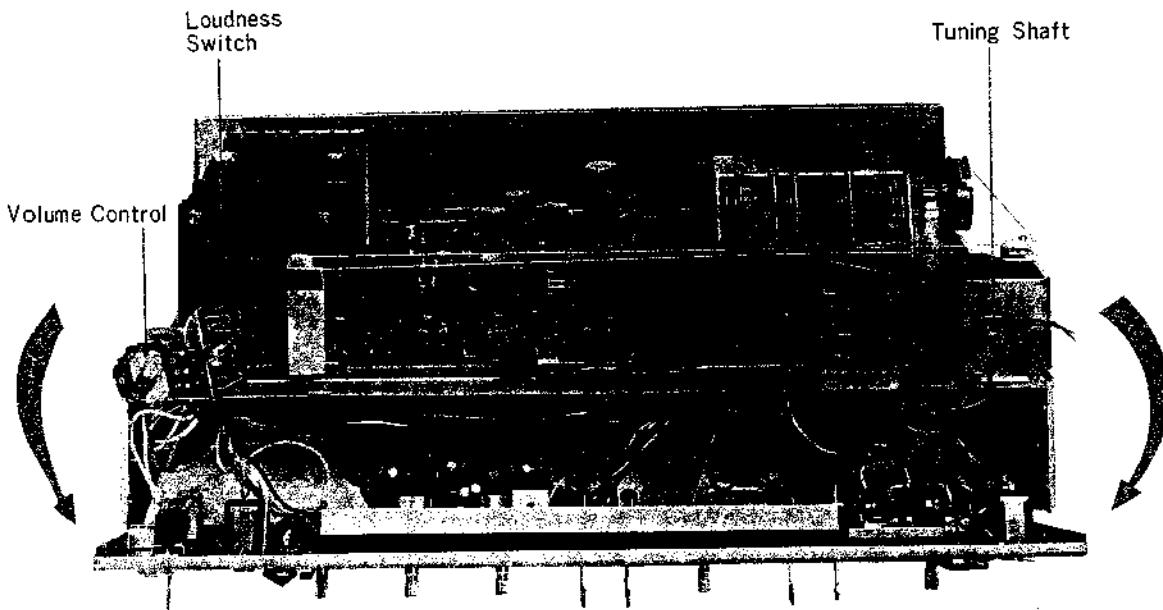

Fig. 2-4 Removal of Front Panel Ass'y (2)

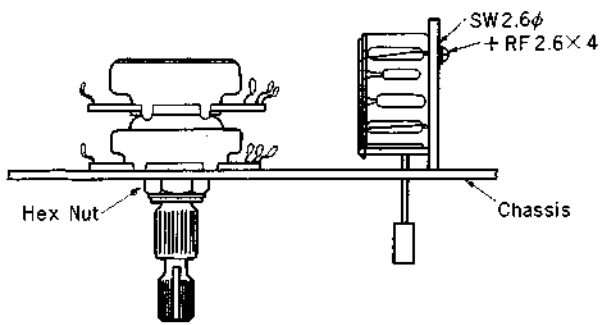

Fig. 2-5 Detail of Volume Control and Loudness Switch

2-4 Switch and Binaural Jack Replacement

To remove switches and binaural jack for replacement, proceed as follows:

- (a) Remove the front panel assembly.
See Section 2-3.
- (b) All switches except the speaker, tone, mode and function switches can be removed by loosening their set screws (+RF 3 × 6).
- (c) To remove the binaural jack, loosen off two screws securing it to the chassis from the back of the front panel assembly.

2-5 Pilot Lamp Replacement

To remove pilot lamp for replacement proceed as follows:

- (a) Unplug the ac cord.
- (b) Remove the top cover. See Section 2-1.

Meter Lamp

- (a) Straighten the tab of lamp socket bracket to permit removal of lamp.
- (b) Grasp the lamp socket with a pair of pliers and slide it off the bracket.
See Fig. 2-6.

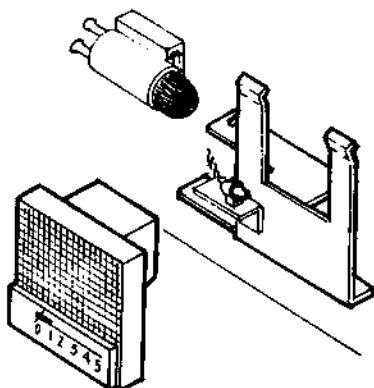

Fig. 2-6 Meter and Stereo Lamp Replacement

- (c) Apply a drop of cement solvent to the point where the lamp is fixed and wait a few seconds for the cement to dissolve.
- (d) Unscrew the lamp from the socket and install a new lamp.

Stereo Lamp

- (a) Remove the bottom plate.
- (b) Loosen off two self-tapping screws (+R 3 × 6) from the tuning meter holder. The stereo lamp is mounted on the tuning meter holder.
- (c) Apply a drop of cement solvent to the point where the lamp is fixed and wait a few seconds for the cement to dissolve.
- (d) Pry out the lamp with a pair of tweezers and install a new lamp.
- (e) Unsolder the old lead wires from the MPX board and resolder the new wires.

Dial Lamp

- (a) Remove the control knobs and front panel.
- (b) Pry out the lamp as you would a cartridge fuse.
- (c) Push a new lamp into the clip.

Tuning Meter Replacement

- (a) Loosen off two self-tapping screws (+R 3 × 6) securing the meter holder to the chassis.
- (b) Unsolder the lead wires, and install a meter.

2-6 Dial Glass Replacement

- (1) Remove the front panel. See Section 2-2.
- (2) Loosen off screws (+RF 2.6 × 4) securing the dial glass bracket to the sub chassis as shown in Fig. 2-7.
- (3) Install a dial glass.

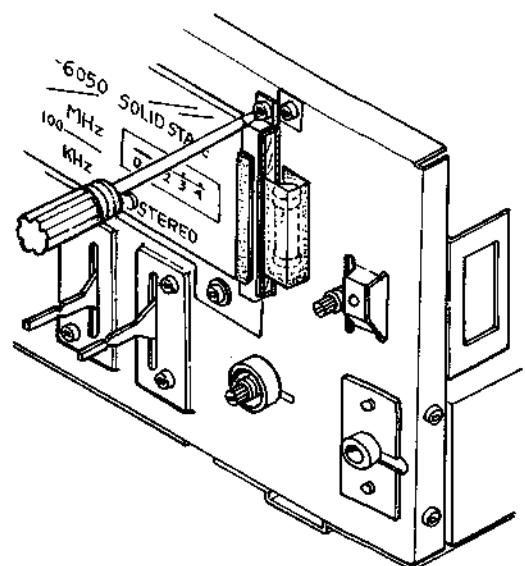

Fig. 2-7 Dial Glass Replacement

2-7 Power Transistor Replacement

- (a) Remove the bottom plate.
- (b) Remove the heat sink by loosening the two screws that secure the heat sink to the chassis from the rear.
- (c) Take the heat sink out of the chassis through the rear panel. Pay attention to the lead wires.
- (d) Remove the power transistor by loosening the two screws (+RF 3×12). See Fig. 2-8.
- (e) When replacing a power transistor, apply a coating of a heat-conducting silicone grease to both sides of the mica. The grease fills the tiny depressions in the mating surfaces, thereby improving heat transfer to the heat sink.

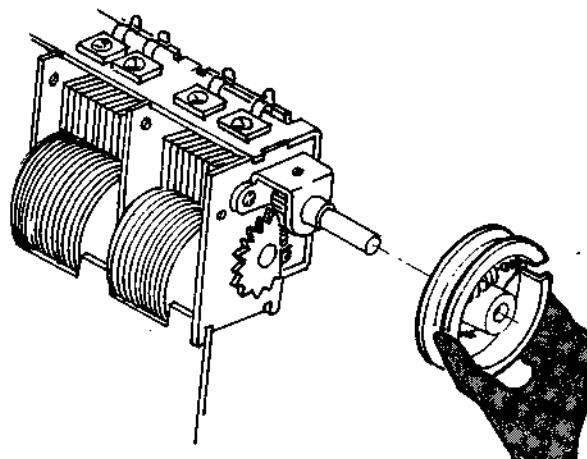

Fig. 2-9 Drive Drum Installation

2-8 Dial Cord Stringing

- (a) Remove the top cover. See Section 2-1.
- (b) Cut a 63 inch (1,600 mm) length of dial cord.
- (c) Remove the tuning capacitor drive drum by loosening the two screws and rotate the tuning capacitor shaft fully clockwise (minimum capacitance position).
- (d) Tie the cord and hook the spring to each hole of the drum, then attach the drum to the shaft of the tuning capacitor as shown in Fig. 2-9 and 2-10.

- (e) After tightening the screws of the drum run the cord through the slot in the rim of the drum and position the cord close to the rear edge of the drum.
- (f) Run the cord under the drum and over the pulley (A) See Fig. 2-12.
- (g) Make three counterclockwise turns around the tuning shaft and run the cord over pulleys (B), (C) and (D).

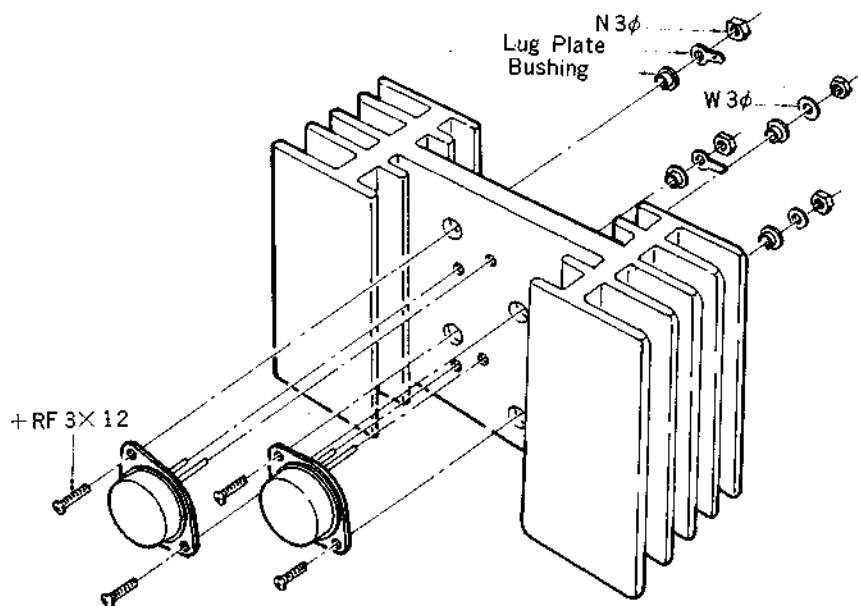

Fig. 2-8 Power Transistor Replacement

- (h) Pull the cord taut and wrap two clockwise turns around the drive drum. See Fig. 2-12.
- (i) Pass the cord through the slot and hook it to the spring, using an eyelet as shown in Fig. 2-11.
- (j) Pull the cord to give it a tension and squeeze the eyelet.
Make a knot and apply a drop of contact cement to the eyelet.

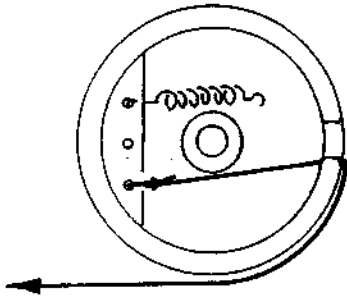

Fig. 2-10 Start Point of Dial Cord

- (k) Put the dial pointer in place, and run the dial cord over and under the tabs at the rear of the dial pointer.
- (l) After completing dial cord threading, and making sure the tuning system works properly put a drop of contact cement on the dial pointer tabs. See Section 4-6, OVERALL ADJUSTMENTS, for accurately locating the dial pointer.

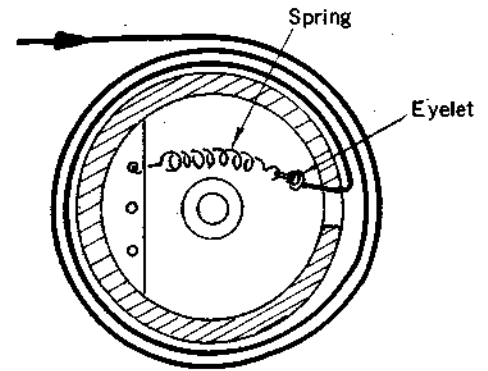

Fig. 2-11 Finish Point of Dial Cord

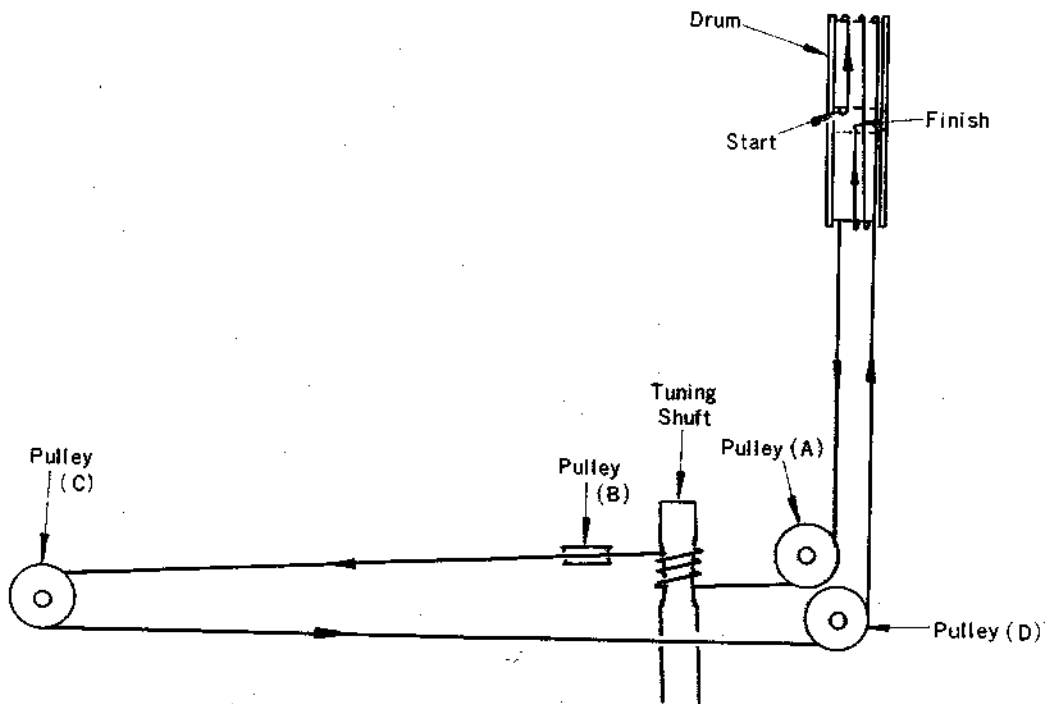
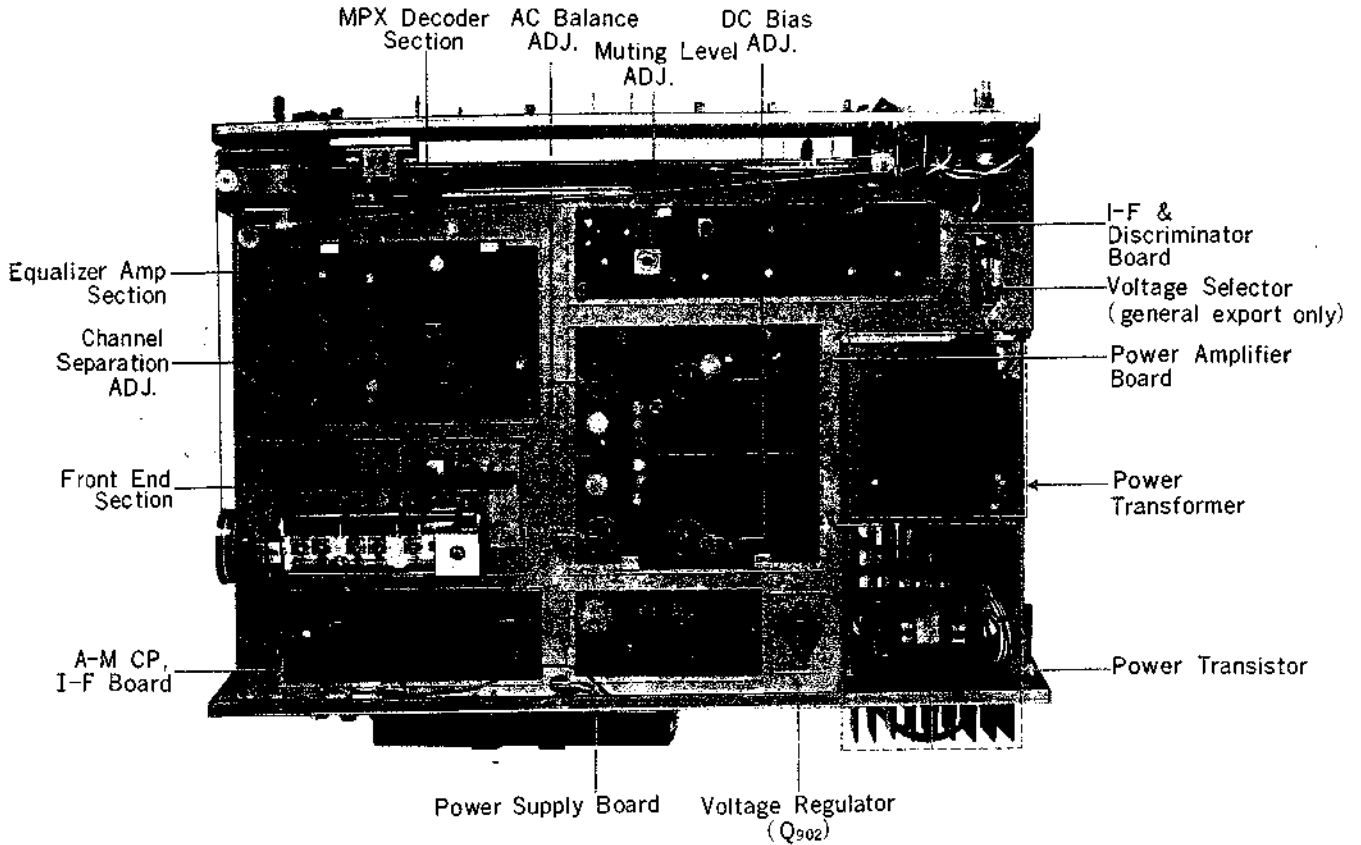

Fig. 2-12 Complete Dial Cord Stringing

STR-6050

CHASSIS LAYOUT

TOP VIEW



BOTTOM VIEW

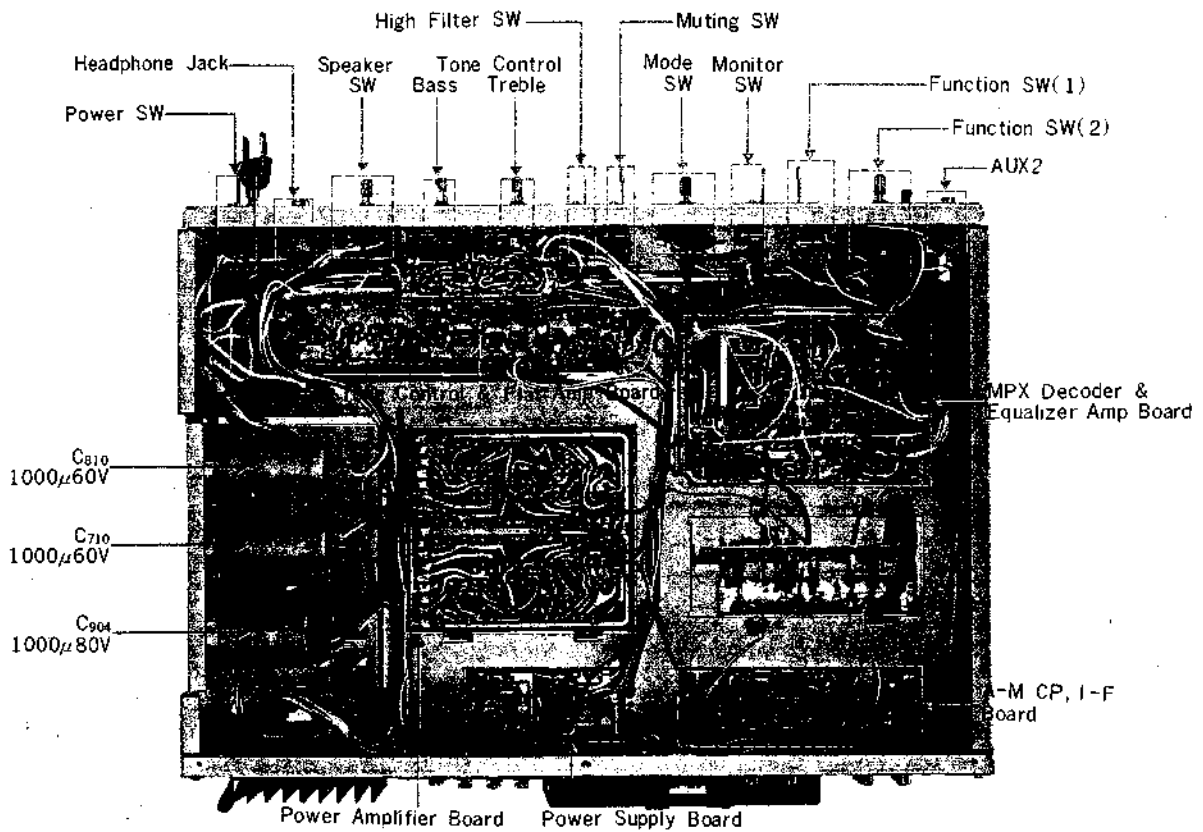

**SECTION 3
TEST AND ALIGNMENT**

FM Section

Caution: Never attempt alignment of the front end section except for frequency coverage and dial calibration adjustments.

Factory adjustments are extremely stable and should not be reset except in unusual circumstances.

Alignment need not be performed when front end FET's have been replaced since changes in FET parameters have little effect upon tuning. In case

an rf stage adjustment is required, ask your nearest SONY Service Station for a complete front end alignment to be performed at a Factory Service Center. Please exercise caution when returning the faulty unit so that it is not damaged in transit. The warranty will not cover damage incurred in this way.

3-1 Front End Alignment

Note: Discriminator alignment should be performed first.

Test Equipment Required:

- (1) FM Standard Signal Generator.
If such a generator is unavailable, off-the-air signals at each end of the band will suffice.
- (2) Dummy Antenna See Fig. 3-1.
- (3) AC VTVM
- (4) Alignment Tools

Preparation

- (1) Remove the chassis cover.
 - (2) Connect the equipment as shown in Fig. 3-2
 - (3) Set the receiver's controls as follows:
 - FUNCTION Selector FM
 - VOLUME Control Minimum
 - MODE Switch STEREO
 - MONITOR Switch SOURCE
- Follow the procedures given in Table 1.

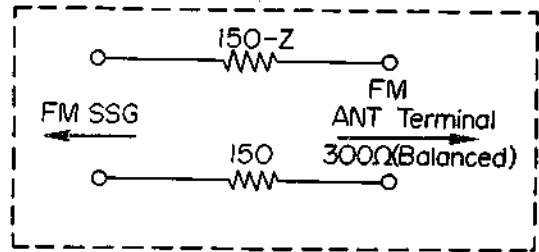

Z : FM SSG Impedance

Fig. 3-1 FM Dummy Antenna

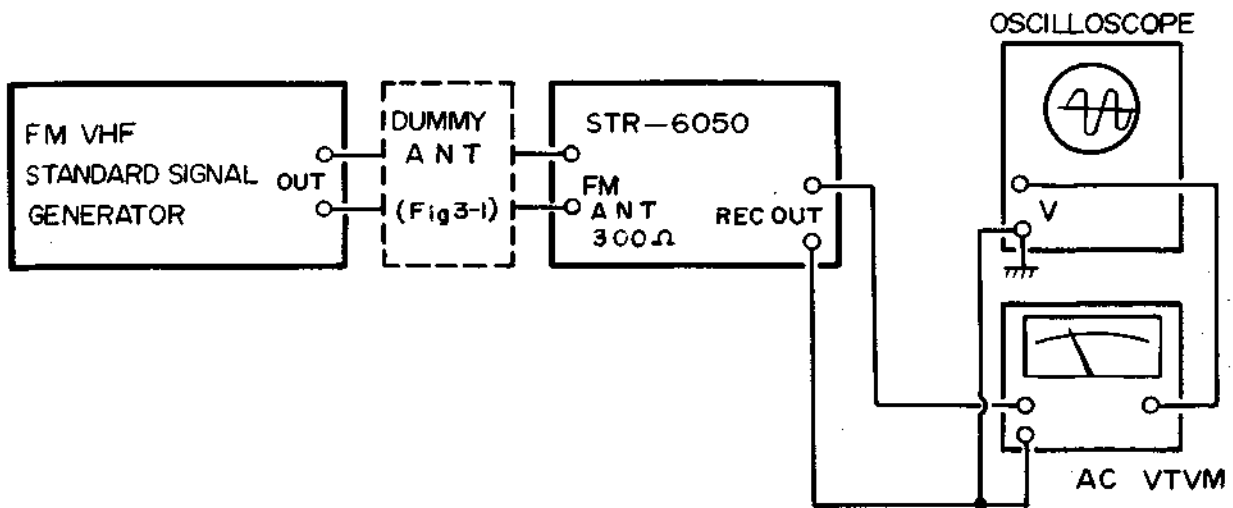

Fig. 3-2 FM Front End Alingment Test Set-up

TABLE I
FM Frequency Coverage Adjustment

Coupling between Front End and SSG	SSG frequency and output	Tuning capacitor	AC VTVM connection	Adjust	Indication
Dummy Antenna Fig. 3-1	86 MHz 400 Hz 30 % Mod 20 dB/ μ	Maximum Capacitance position	REC OUT J504	OSC coil L104 Fig. 3-3	Maximum VTVM reading
Same as above	109.5 MHz 400 Hz 30% Mod 20 dB/ μ	Minimum Capacitance position	REC OUT J504	OSC trimmer CT104 Fig. 3-4	Same as above

Note: Repeat the foregoing procedure several times until accurate dial calibration is observed.

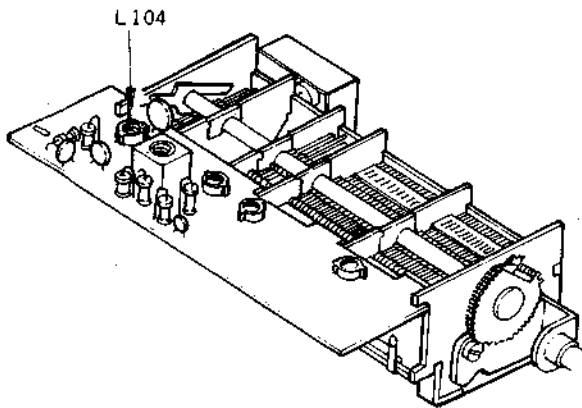

Fig. 3-3 FM OSC Coil L104

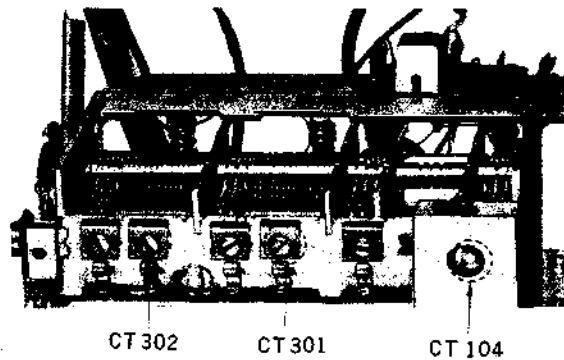

Fig. 3-4 FM OSC Trimmer CT104 and A-M Antenna Trimmer CT302

3-2 FM Discriminator Adjustment

Note: This is a preadjustment procedure for the discriminator section. To obtain optimum operation of the discriminator, follow the overall adjustment 4-1, 4-2, described on page 26. and 27.

Test Equipment Required:

- (1) 10.7 MHz Sweep Generator
 - Center Frequency..... 8 to 12 MHz (variable)
 - Sweep Width..... 800 kHz or more
 - Output Impedance..... 50 or 75 ohms
- (2) Oscilloscope
 - Vertical Sensitivity..... at least 10mV/cm
 - CRT diameter5" or more
- (3) Alignment Tools

Preparation.

- (1) Remove the chassis cover.
- (2) Unsolder the coaxial cable from the input and output terminals of the I-F and Discriminator board.
- (3) Connect the sweep generator output to the input terminal of the I-F and Discriminator board.
- (4) Connect the Oscilloscope to the output terminal of the I-F and Discriminator board.

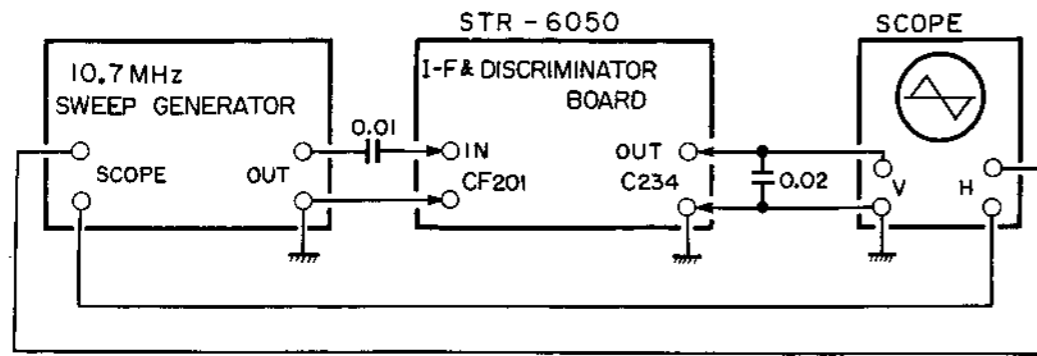

Fig. 3-5 FM Discriminator Adjustment Test Set-up

Procedures:

- (1) With the equipment connected as shown in Fig. 3-5, set the 10.7 MHz Sweep Generator controls as follows:
 Center Frequency.....10.7 MHz
 Sweep Width.....800 kHz or 1.0 MHz
 Output Level.....6 dB/ μ
 Set the receiver controls for fm stereo reception.
 - (2) Adjust the scope controls to provide a visible indication.
- Note:** Two or three outputs will be observed on the scope as the center frequency of the sweep generator varies ± 1 to 2MHz. The output you are looking for has the largest amplitude. Once you get this output, decrease the sweep generator output as low as possible.
- (3) Turn the top core of T201 with the hexagonal-head alignment tool to obtain an "S" curve response as shown in Fig. 3-6.
 - (4) Turn the bottom core of T201 to obtain maximum response.
 - (5) Turn the top core of T201 to equalize negative and positive peakes as shown in Fig. 3-6.
 $a=b=1/2A$
 - (6) Disconnect the sweep generator and make sure that the scope displays only noise.

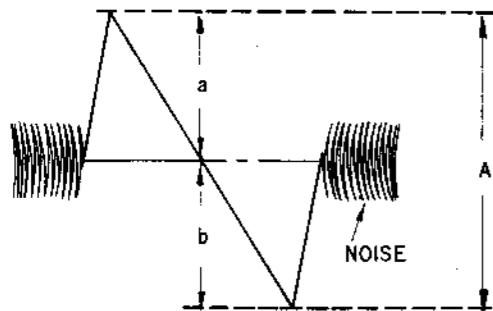

Fig. 3-6 "S" Curve Response

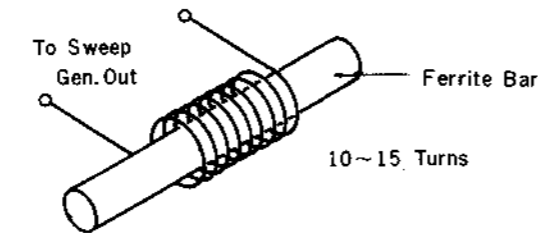

Fig. 3-7 Radiating Antenna

A-M Section

3-3 A-M I-F Alignment

Test Equipment Required:

- (1) 455 kHz Sweep Generator
 Center Frequency455 kHz
 Sweep width ± 35 kHz (variable)
 Output ImpedanceLess than 300 ohms
 Radiating Antenna.....See Fig. 3-7
- (2) Oscilloscope
 Vertical Sensitivityat least 10mV/cm
 CRT Diameter3" or more
- (3) Alignment Tools

Preparation

- (1) Remove the chassis cover.
- (2) Solder a hook-up wire directly to resistor R320 (4.7 k Ω) from the conductor side on the A-M-CP-I-F board as shown in Fig. 3-10.
 Note: Connect the ground lead of the scope as close to R320 as possible.
- (3) Set the receiver's controls as follows.
 VOLUME ControlMinimum position
 FUNCTION SelectorA-M
 MONITOR SwitchSOURCE

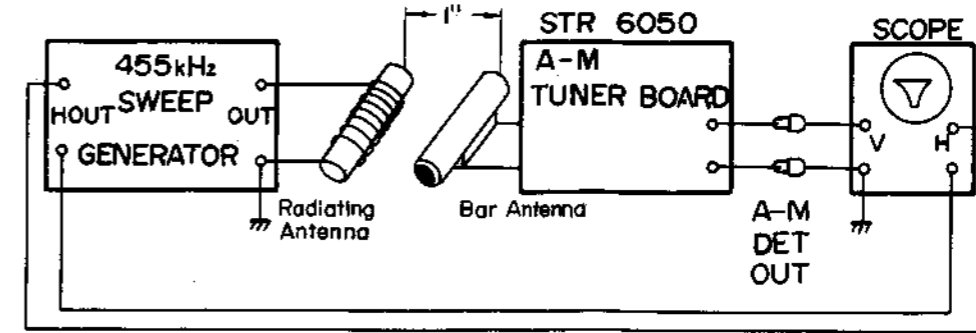

Fig. 3-8 A-M I-F Adjustment Test Set-up

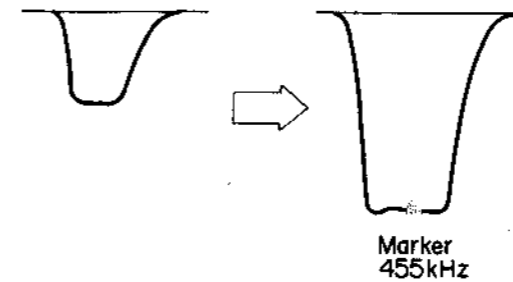

Fig. 3-9 A-M I-F Response

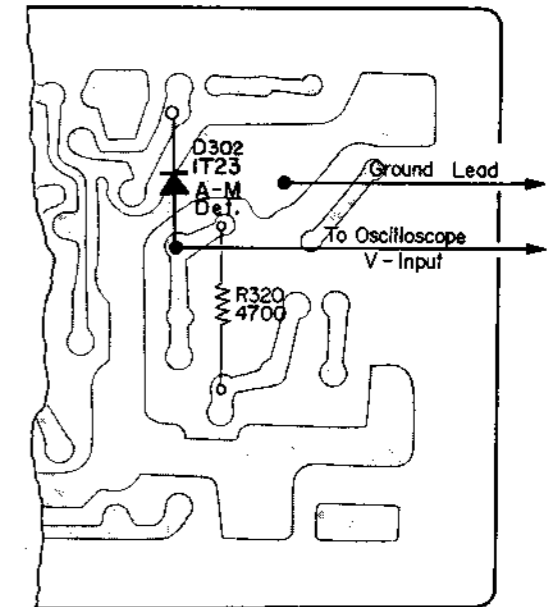

Fig. 3-10 A-M I-F Adjustment Test Point

Procedure:

- (1) With the equipment connected as shown in Fig. 3-8, adjust the sweep generator output as low as possible and set scope controls to provide a visible indication.
- (2) Turn the top core of IFT 301 to obtain a maximum and symmetrical response. See Fig. 3-9.

3-4 A-M Tuner Frequency Coverage and Tracking Alignment

Test Equipment Required:

- (1) A Standard A-m Signal Generator (SSG)
 If such a generator is unavailable, off-the-air signals at each end of the band will suffice.
- (2) Radiating AntennaStandard Loop Antenna
- (3) AC VTVM or Oscilloscope.....Capable of indicating rms voltage of 0.1V or less
- (4) Alignment Tools.

Preparation:

- (1) Remove the chassis cover.
- (2) Set the receiver's controls as follows;
 VOLUME controlMinimum position
 FUNCTION SelectorA-M

Procedures:

With the equipment connected as shown ni Fig. 3-11, follow the procedure given in Table 2.

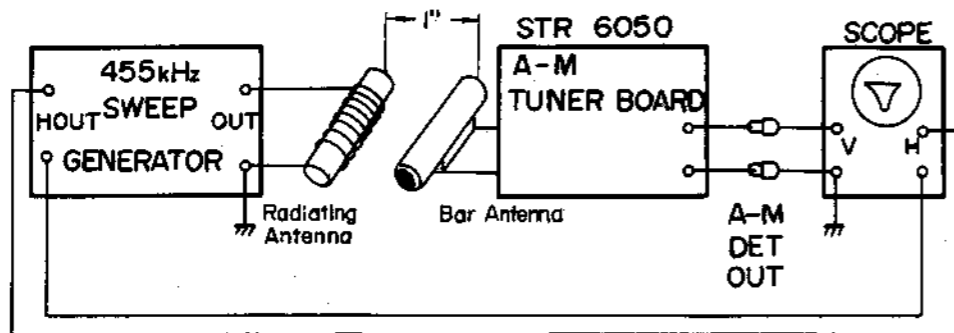

Fig. 3-8 A-M I-F Adjustment Test Set-up

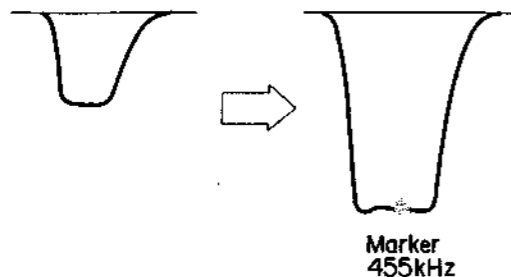

Fig. 3-9 A-M I-F Response

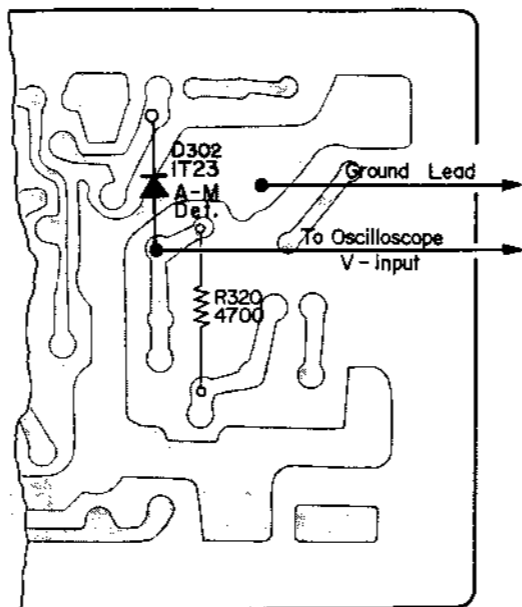

Fig. 3-10 A-M I-F Adjustment Test Point

Procedure :

- (1) With the equipment connected as shown in Fig. 3-8, adjust the sweep generator output as low as possible and set scope controls to provide a visible indication.
- (2) Turn the top core of IFT 301 to obtain a maximum and symmetrical response. See Fig. 3-9.

3-4 A-M Tuner Frequency Coverage and Tracking Alignment

Test Equipment Required :

- (1) A Standard A-m Signal Generator (SSG)
If such a generator is unavailable, off-the-air signals at each end of the band will suffice.
- (2) Radiating AntennaStandard Loop Antenna
- (3) AC VTVM or Oscilloscope.....Capable of indicating rms voltage of 0.1V or less
- (4) Alignment Tools.

Preparation :

- (1) Remove the chassis cover.
- (2) Set the receiver's controls as follows;
VOLUME controlMinimum position
FUNCTION SelectorA-M

Procedures :

With the equipment connected as shown in Fig. 3-11, follow the procedure given in Table 2.

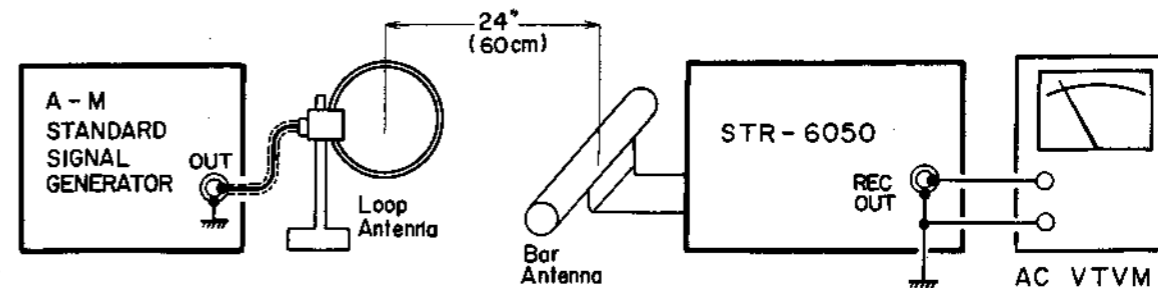

Fig. 3-11 A-M Frequency Coverage and Tracking Adjustment Test Set-up

TABLE 2

Frequency Coverage and Tracking Alignment

Adjustment	SSG Coupling	SSG Frequency and output level	Tuning Capacitor	Connect VTVM	Adjust	Remarks
Frequency Coverage	Loop Antenna	520 kHz 400 Hz 30 % Mod 60 dB/μ+α	Maximum Capacitance	REC OUT J504 (J604)	OSC Coil L304 Fig. 3-12	Adjust to obtain Maximum reading
		1680 kHz Same as above	Minimum Capacitance	Same as above	OSC Trimmer CT301 Fig. 3-4	Same as above

* α=Specified insertion loss of loop antenna (dB)

Note : Repeat the foregoing procedure two or three times until sufficient response is obtained.

Tracking	Loop Antenna	SSG Frequency and output level	Tuning Capacitor	Connect VTVM	Adjust	Remarks
Tracking	Loop Antenna	620 kHz 400 Hz 30 % Mod Output level as low as possible	Tune to 620 kHz signal	REC OUT J504 (J604)	Position of Bar Antenna core L303 Fig. 3-13	Adjust to obtain maximum reading
		1400 kHz Same as above	Tune to 1400 kHz signal	Same as above	Antenna Trimmer CT302 Fig. 3-4	Same as above

Note : Repeat the foregoing procedure two or three times until sufficient response is obtained.

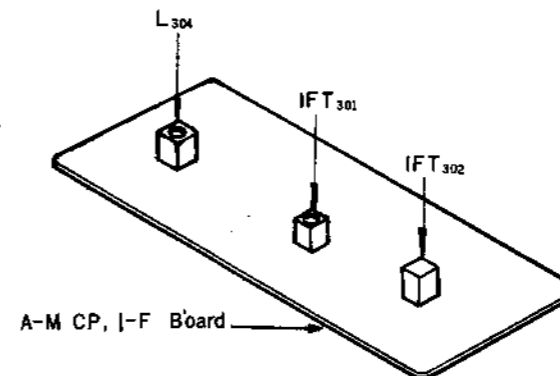

Fig. 3-12 A-M OSC Coil L304

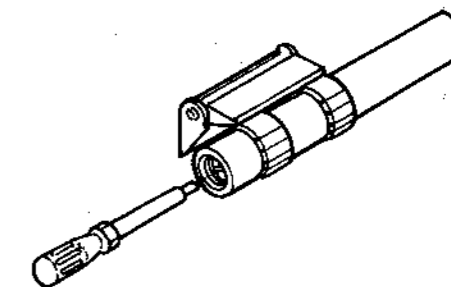
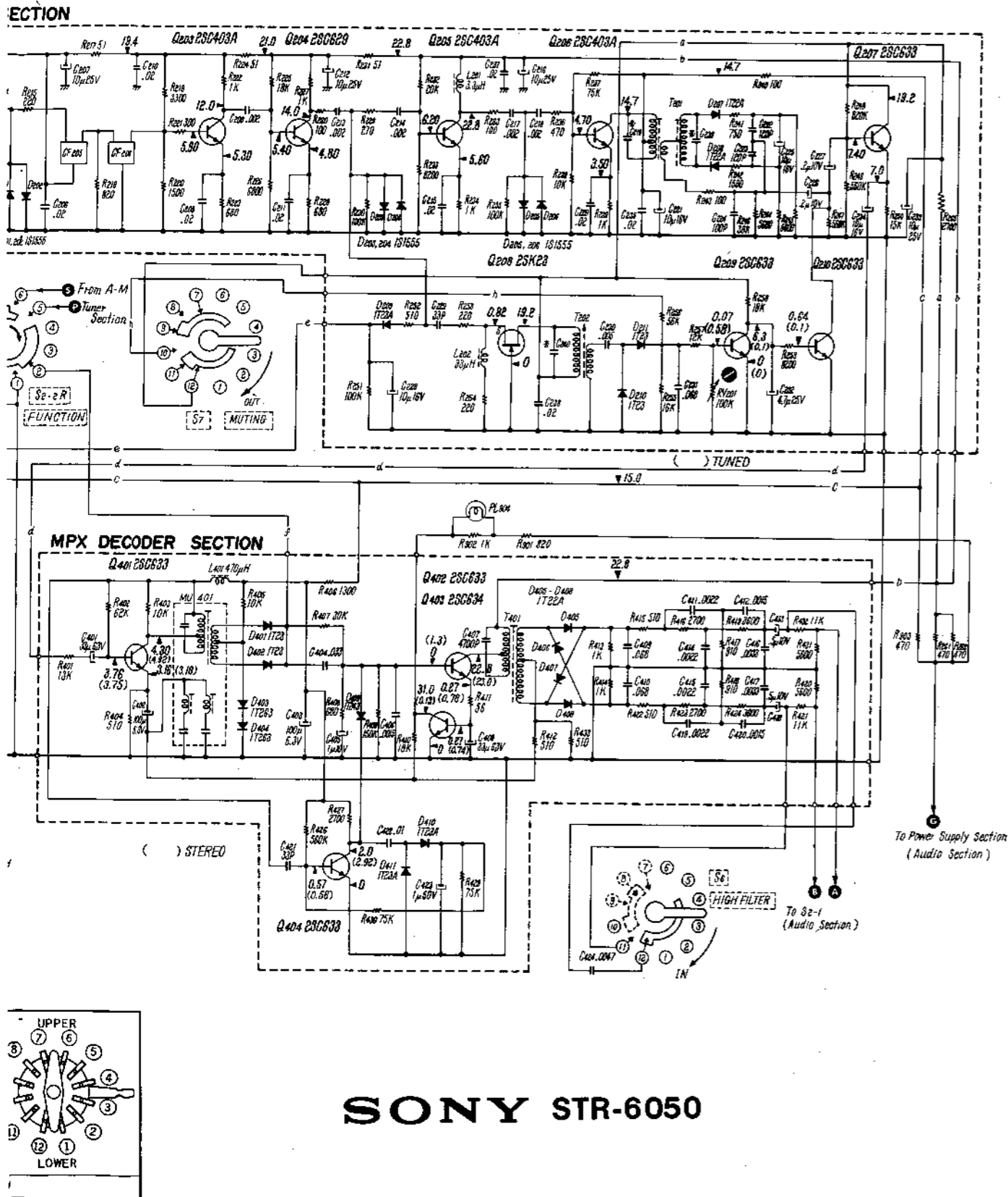

Fig. 3-13 A-M Antenna Core (L303) Adjustment

SECTION 4
OVERALL ADJUSTMENT AND TEST



These "touch-up" adjustments ensure optimum performance.

They also assist in locating troubles.

Test Equipment Required

- (1) Standard FM Signal Generator
- (2) MPX Stereo Signal Generator
- (3) Audio Oscillator
- (4) Distortion Meter with AC VTVM
- (5) Dummy Antenna See Fig. 4-1.
- (6) Oscilloscope
- (7) Alignment Tools

4-1 Discriminator Transformer Adj.

Note: This adjustment should be done before performing any other adjustment.

Preparation:

- (a) Unsolder the connection point of R244 and R245 and connect the null meter (center zero) or dc voltmeter across R244, and R245, and ground. See Fig. 4-2.

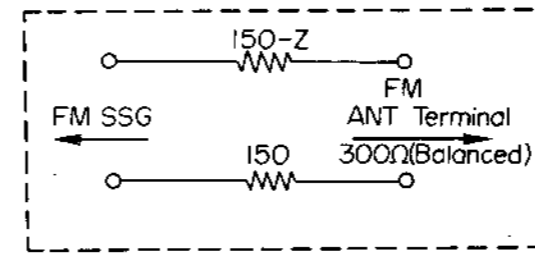

Z : FM SSG Impedance

Fig. 4-1 FM Dummy Antenna

(b) Set the receiver's controls as follows:

FUNCTION SelectorFM
VOLUME ControlMinimum

Procedure:

- (1) With the equipment connected as shown in Fig. 4-3, check that the null meter shows a center-scale reading under no signal condition. If not, turn the top core of T201 (discriminator transformer) slightly to obtain zero reading on the meter.
- (2) In performing the foregoing procedure, be sure that oscilloscope displays only noise.
- (3) Repeat the above mentioned procedure two or three times while changing the tuning position.
- (4) Tune the 98 MHz 400 Hz 30 % Mod. 60 dB/μ signal and be sure that the null meter shows the center position when tuning or detuning the receiver.

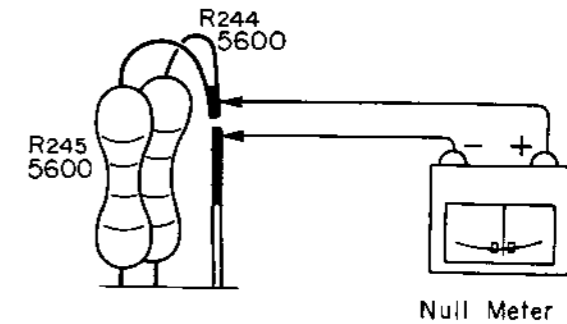

Fig. 4-2 Null Meter Connection Point

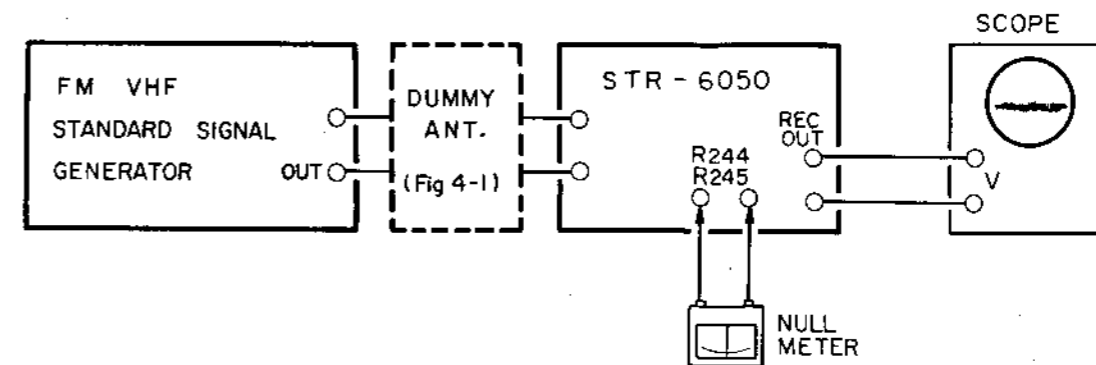
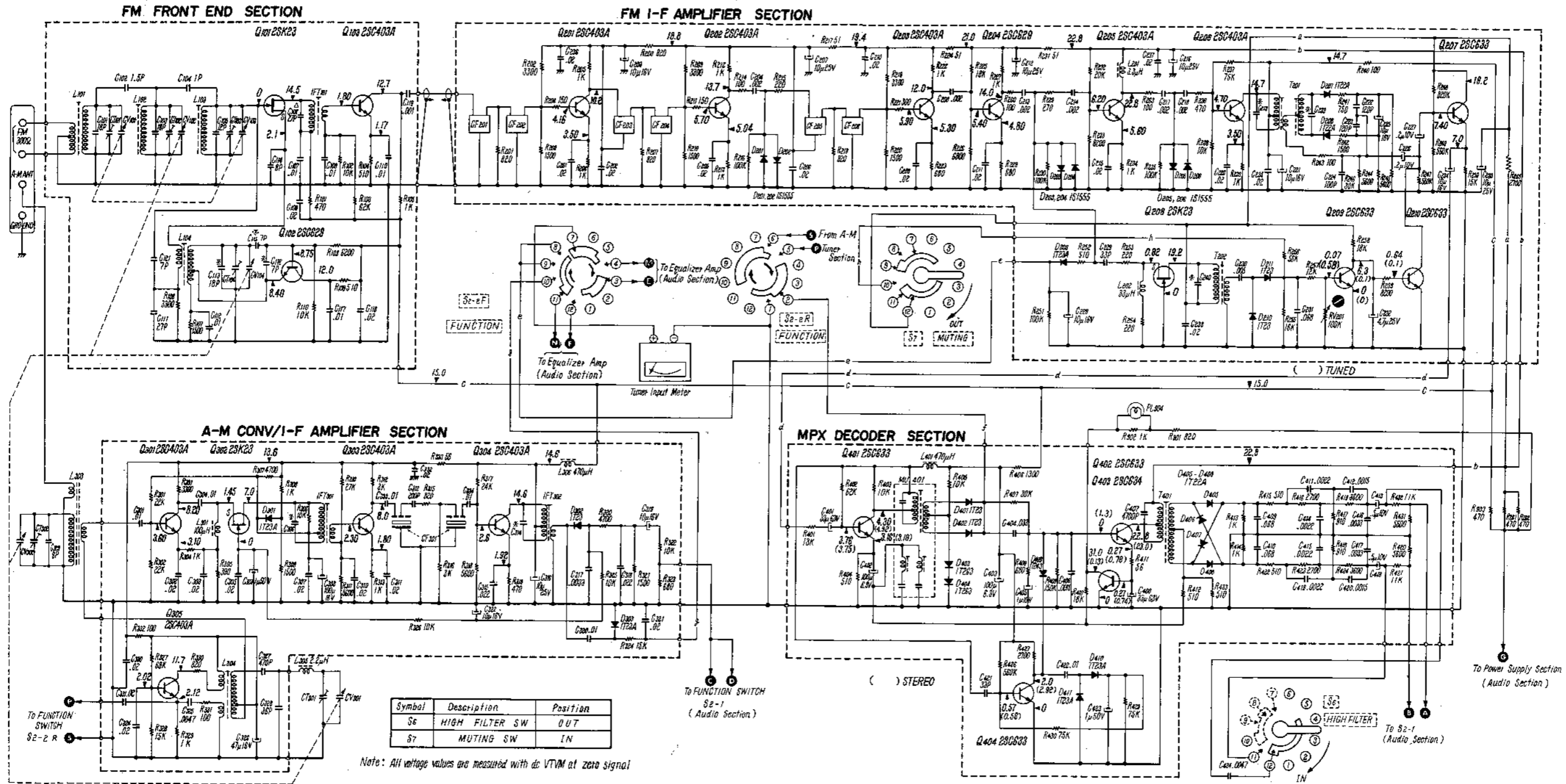

Fig. 4-3 Discriminator Transformer Adjustment Test Set-up

SCHEMATIC DIAGRAM

Tuner Section



Symbol	Description	Position
S6	HIGH FILTER SW	OUT
S7	MUTING SW	IN

Note: All voltage values are measured with dc VTVM at zero signal

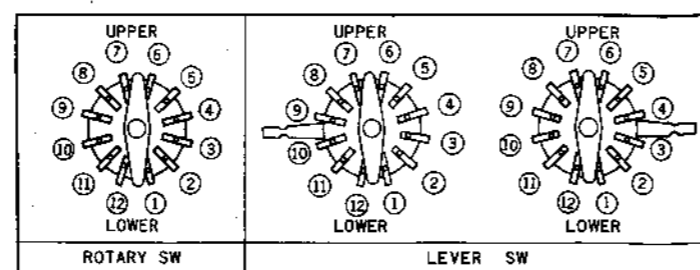
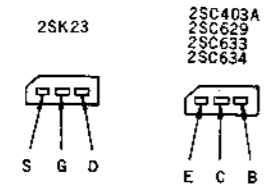

SONY STR-6050

These
formar
They
Test E
(1) S
(2) M
(3) A
(4) I
(5) I
(6) C
(7) A
4-1 D
Note:
for
Prepar
(a)

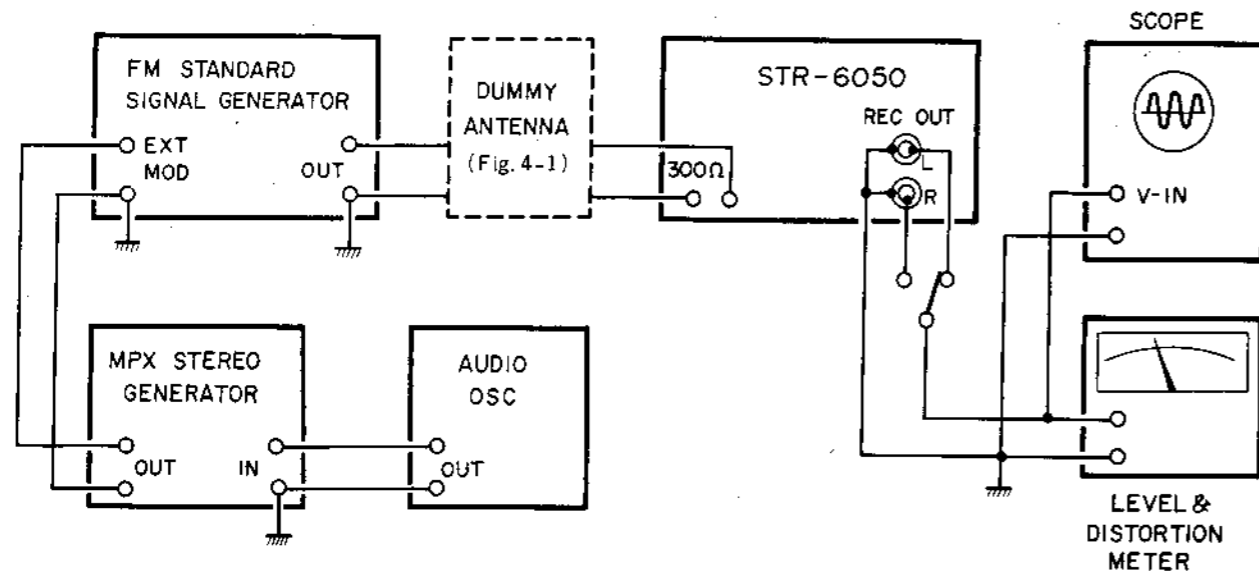

Fig. 4-4 Overall Adjustment Test Set-up

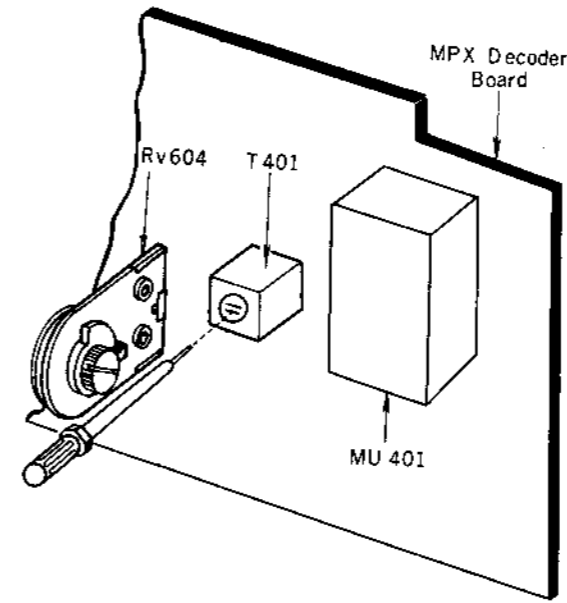

Fig. 4-5 Location of T401 (Switching Transformer) and RV604 (Channel Separation)

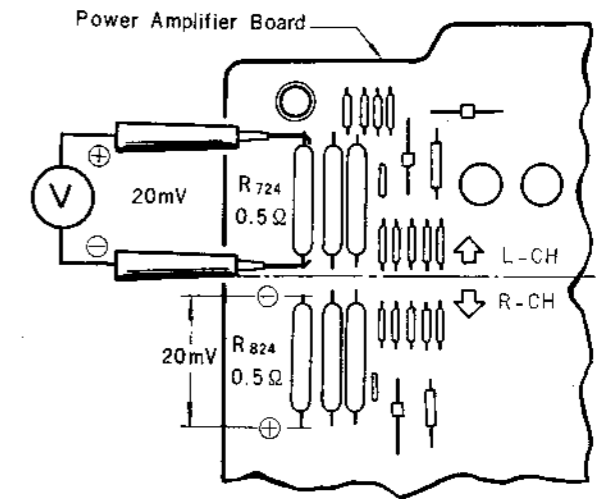

Fig. 4-6 Emitter Voltage Measurement of Power Transistors

4-2 FM Muting Operation Adj.

- Connect the equipment as shown in Fig. 4-4.
- Set the fm signal generator frequency to 98 MHz, 400 Hz, 100 % modulation. Output level: 60 dB/μ
- Set the receiver's controls as follows:
 FUNCTION Selector.....FM STEREO
 MONITOR Switch.....SOURCE
 VOLUME Control.....Minimum
 MUTING Switch.....IN
- Tune the set to obtain maximum tuning meter indication. Turn the core of T202 on the I-F Discriminator board with a non-metallic alignment tool for a maximum dc voltmeter reading at the base of Q209 and be sure that the muting will not take place.
- Decrease the signal generator output and be sure that the muting function is still in operative at an output level of 15±1 dB/μ. Adjust Rv201 (100 k ohms) so that muting takes place when signal strength is decreased below this level.

4-3 FM Monaural Distortion Adj.

- Connect the equipment as shown in Fig. 4-4.
- Set the fm Signal Generator frequency to 98 MHz, 400 Hz, 100 % modulation. Output level: 60 dB/μ
- Set the receiver's controls as described in section 4-2.
- Tune the receiver to 98 MHz and adjust the bottom core of T201 (Discriminator Transformer), primary side, for minimum distortion.

4-4 FM Stereo Distortion Adj.

- Connect the equipment as shown in Fig. 4-4, set the fm signal generator as follows:
 Carrier Frequency98 MHz
 Output level60 dB/μ
 Modulation: Main Channel (400 Hz)45 % (33.75 kHz)
 Sub Channel (38 kHz)45 % (33.75 kHz)
 Pilot Signal (19 kHz)10 % (7.5 kHz)

The above mentioned modulation will be performed by following the next procedure.

- With the equipment connected as shown in Fig. 4-4, set the MPX stereo generator controls as follows:
 MAIN CHANNEL.....OFF
 SUB CHANNEL.....OFF
 19 kHz (PILOT).....ON
 - Adjust the MPX generator output level to obtain a 7.5 kHz deviation on the FM SSG modulation indicator.
 - Reset the MPX stereo generator controls as follows:
 MAIN CHANNEL.....ON
 SUB CHANNEL.....OFF
 19 kHz (PILOT).....OFF
 - Adjust the audio oscillator output control to obtain a 33.75 kHz deviation on the FM SSG modulation indicator.
 - Set all controls to the ON position.
- (2) Measure the distortion on each channel. Turn the core of T401 (switching transformer) in the MPX decoder board to obtain minimum distortion. See Fig. 4-5.

4-5 Channel Separation Adj.

- With the equipment connected as shown in Fig. 4-4, set the signal generator's and receiver's controls to the positions described in the stereo distortion check, Section 4-4.
- Measure the channel separation as follows:
 Record the output level of the left channel when the MPX generator input selector is set to the left channel. Switch the input selector to the right channel, and read the residual signal level in the left channel.
 The output level to residual level ratio represents the separation.
 Adjust Rv604 (1 k-B) (separation Adj.) on the MPX and Preamp board for minimum residual level. Measure the right channel separation, usually there exists about an 8 to 9 dB difference after doing above mentioned procedure.
 Readjust Rv604 for minimum difference between left and right separation. See Fig 4-5.

Note: The output level changes according to the setting of Rv604.

4-6 Dial Pointer Calibration

- Connect the signal generator to the antenna terminals using a dummy antenna.
- Set the generator to 98 MHz (crystal calibrated) 400 Hz 100 % modulation, Output level, 20 dB/μ
- Set the MUTING switch to OFF.
- Tune the set precisely to 98 MHz signal.
- Set the pointer to 98 MHz on the dial.

4-7 Power Amplifier Adj.

Note: To simplify the following description, only the left channel and its related circuitry are described. The right channel is identical except for reference symbol numbers (See schematic diagram)
 This adjustment should be performed after replacing any transistors removed from the power amplifier section.

Caution: To avoid accidental power transistor damage, increase the ac line voltage gradually, using the variable transformer, while measuring the voltage drop across the emitter resistor R724 (0.5 ohm). Be sure that the reading does not exceed 20 mV. See Fig. 4-6.

Preparation:

Set the receiver's controls as follows.

- TONE ControlFlat (center position)
- MODE Switch.....STEREO
- FUNCTION SwitchTAPE
- VOLUME Control.....Fully counterclockwise

(A) Dc Bias Adjustment

Caution: Serious deficiencies in performance, such as thermal runaway of power transistors, will result if this adjustment is set improperly.

- Connect the dc voltmeter across the emitter resistor R724 (0.5 ohm) as shown in Fig. 4-6.
- Turn on the power switch; then increase the line voltage gradually up to the rated value by means of variable transformer.
- Adjust Rv702 (500 ohm-B) to obtain a 20 mV reading on the meter. See Fig. 4-8.

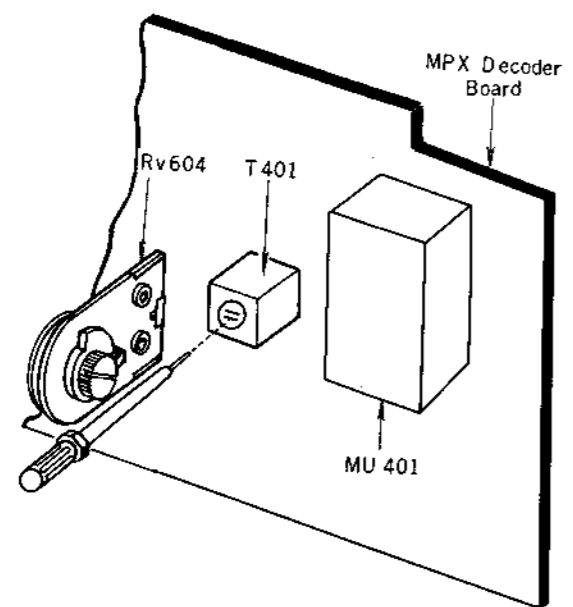

Fig. 4-5 Location of T401 (Switching Transformer) and RV604 (Channel Separation)

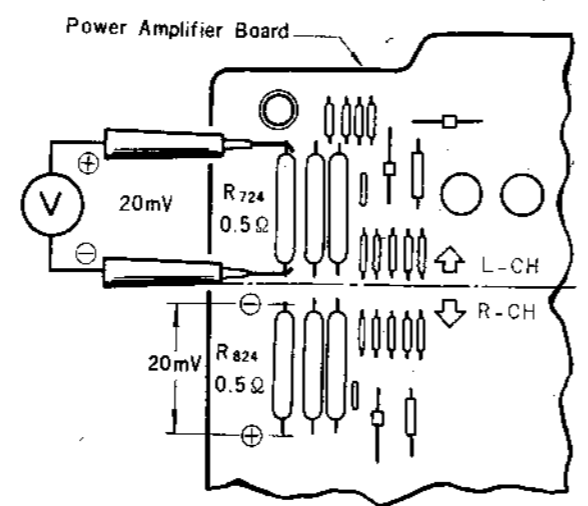

Fig. 4-6 Emitter Voltage Measurement of Power Transistors

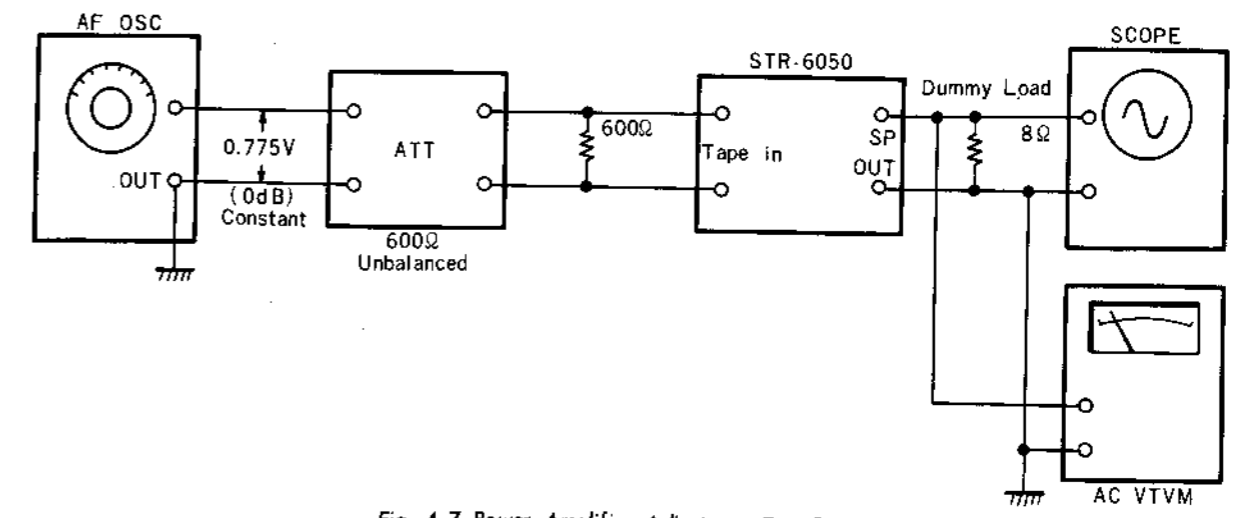

Fig. 4-7 Power Amplifier Adjustment Test Set-up

4-5 Channel Separation Adj.

- With the equipment connected as shown in Fig. 4-4, set the signal generator's and receiver's controls to the positions described in the stereo distortion check, Section 4-4.
- Measure the channel separation as follows:
Record the output level of the left channel when the MPX generator input selector is set to the left channel. Switch the input selector to the right channel, and read the residual signal level in the left channel.
The output level to residual level ratio represents the separation.
Adjust RV604 (1 k-B) (separation Adj.) on the MPX and Preamp board for minimum residual level. Measure the right channel separation, usually there exists about an 8 to 9 dB difference after doing above mentioned procedure.
Readjust RV604 for minimum difference between left and right separation. See Fig 4-5.

Note: The output level changes according to the setting of RV604.

4-6 Dial Pointer Calibration

- Connect the signal generator to the antenna terminals using a dummy antenna.
- Set the generator to 98 MHz (crystal calibrated) 400 Hz 100% modulation, Output level, 20 dB//
- Set the MUTING switch to OFF.
- Tune the set precisely to 98 MHz signal.
- Set the pointer to 98 MHz on the dial.

4-7 Power Amplifier Adj.

Note: To simplify the following description, only the left channel and its related circuitry are described. The right channel is identical except for reference symbol numbers (See schematic diagram)

This adjustment should be performed after replacing any transistors removed from the power amplifier section.

Caution: To avoid accidental power transistor damage, increase the ac line voltage gradually, using the variable transformer, while measuring the voltage drop across the emitter resistor R724 (0.5 ohm). Be sure that the reading does not exceed 20 mV. See Fig. 4-6.

Preparation:
Set the receiver's controls as follows.

- TONE Control Flat (center position)
- MODE Switch STEREO
- FUNCTION Switch TAPE
- VOLUME Control Fully counterclockwise

(A) Dc Bias Adjustment

Caution: Serious deficiencies in performance, such as thermal runaway of power transistors, will result if this adjustment is set improperly.

- Connect the dc voltmeter across the emitter resistor R724 (0.5 ohm) as shown in Fig. 4-6.
- Turn on the power switch; then increase the line voltage gradually up to the rated value by means of variable transformer.
- Adjust RV702 (500 ohm-B) to obtain a 20 mV reading on the meter. See Fig. 4-8.

(B) Ac Balance Adjustment

Note: Serious deficiencies in harmonic distortion at high levels will result if this adjustment is set improperly.

- With the equipment connected as shown in Fig. 4-7, feed a 1 kHz, 0 dB signal to the "TAPE" input terminal through the attenuator.
- Turn the volume control gradually and watch the waveform on the oscilloscope.
Turn the RV701 (100 k ohm-B) to obtain an output waveform such that the positive and negative peaks are clipped at the same time when increasing the volume control. See Fig. 4-8, 4-9.

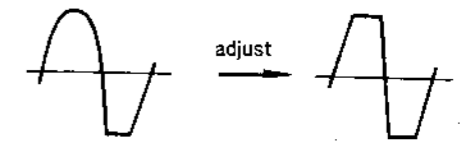

Fig. 4-9 AC Balance Adjustment

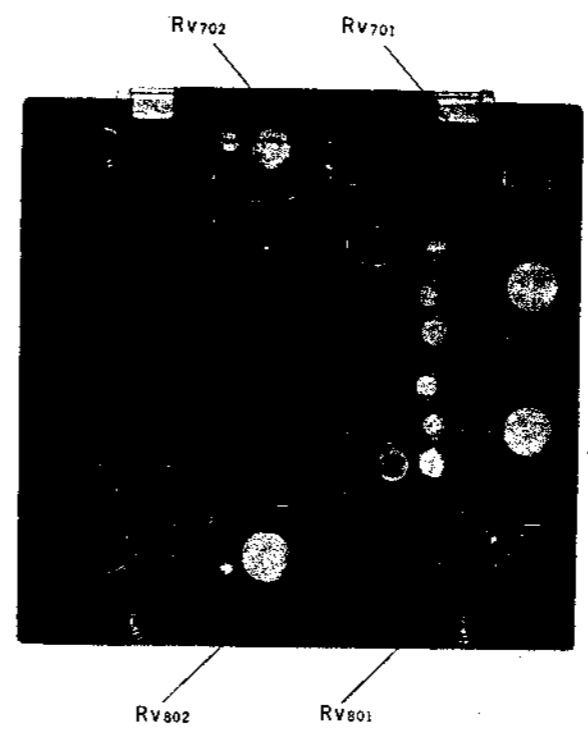
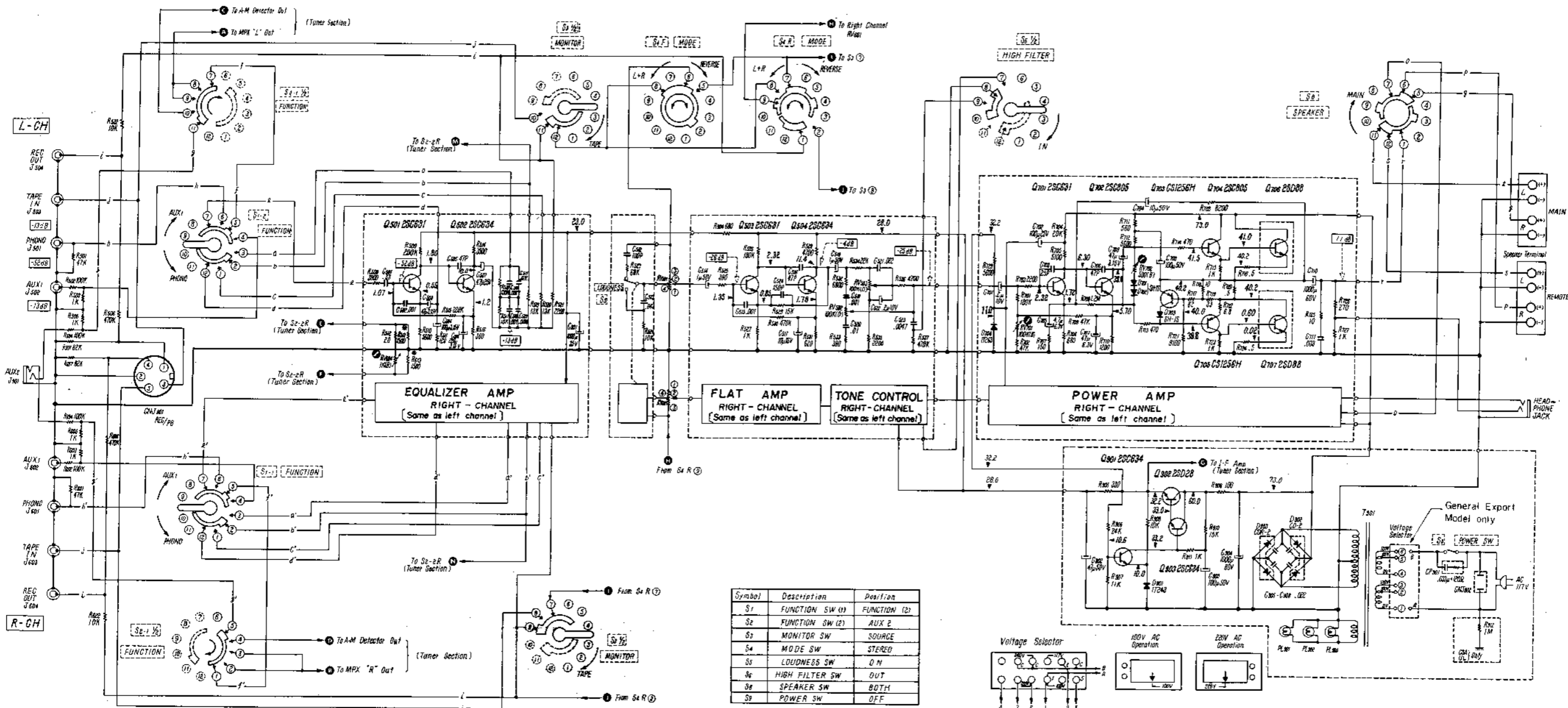

Fig. 4-8 Location of RV702, 802 (DC Bias Adj.) and RV701, 801 (AC Balance Adj.)

SCHEMATIC DIAGRAM

Audio Section



Symbol	Description	Position
S1	FUNCTION SW (1)	FUNCTION (2)
S2	FUNCTION SW (2)	AUX 2
S3	MONITOR SW	SOURCE
S4	MODE SW	STEREO
S5	LOUDNESS SW	DN
S6	HIGH FILTER SW	OUT
S8	SPEAKER SW	BOTH
S9	POWER SW	OFF

Notes: All voltage values are measured with ac VTVM at zero signal
 □ Signal Voltages. Signal Voltages measured with AC VTVM and expressed in dB referred to 0.775 volts under 500mW output.

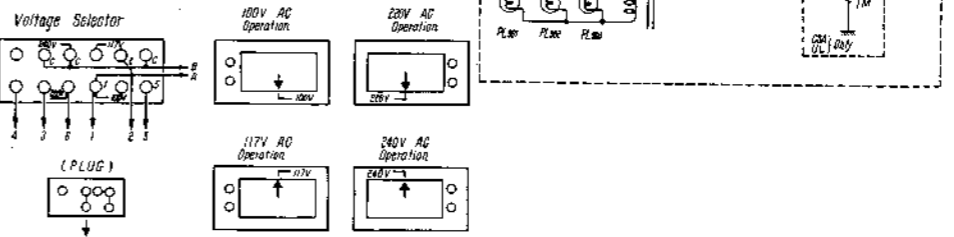
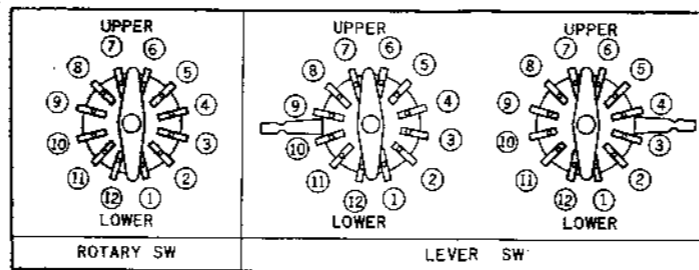
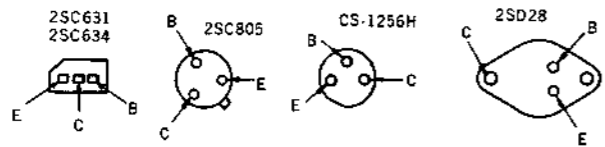

SONY STR-6050

See
The
sign
audi
trace
an /
valu
diag
The
an
sign
ped
four

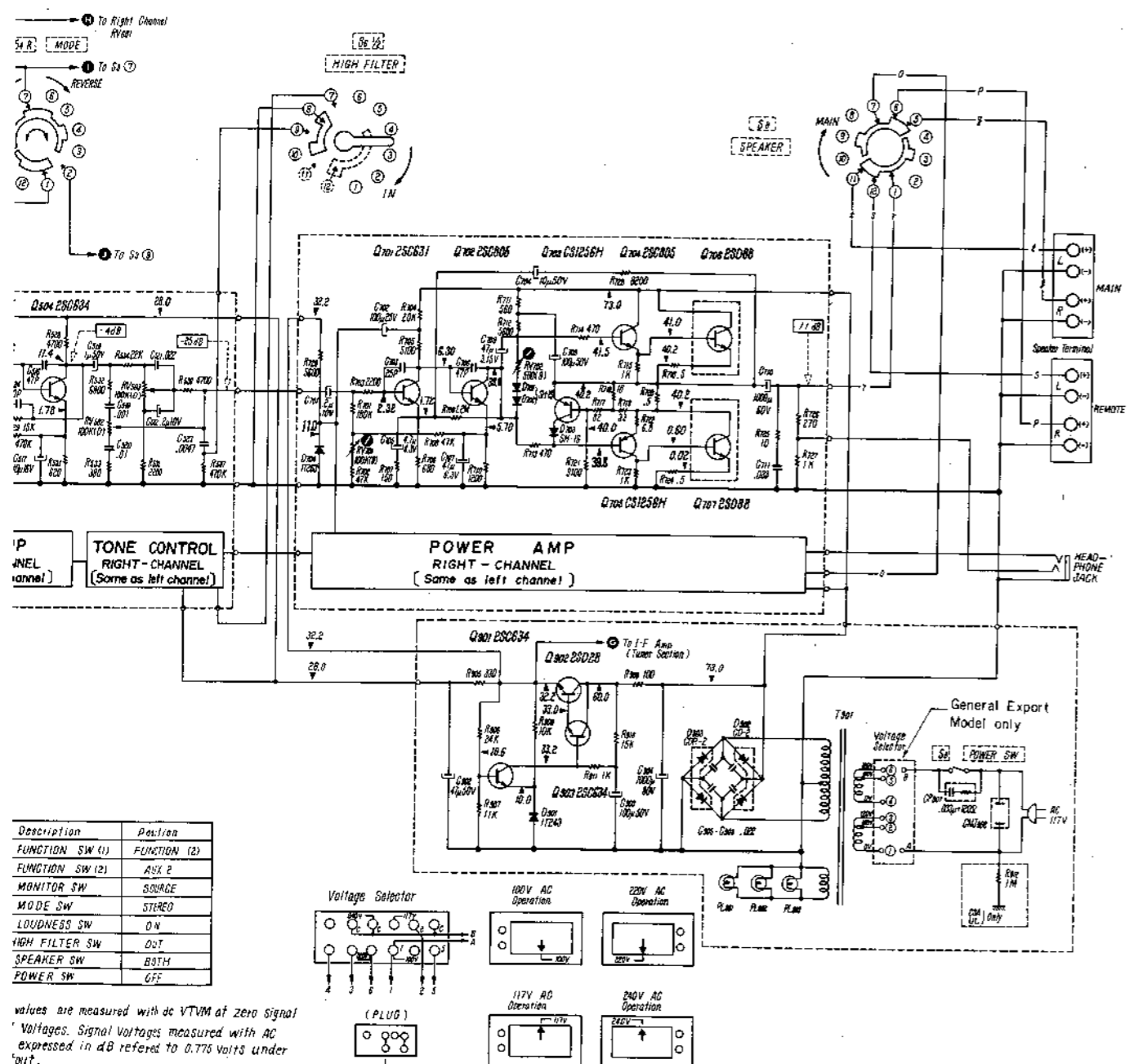

Description	Position
FUNCTION SW (1)	FUNCTION (2)
FUNCTION SW (2)	ASL 2
MONITOR SW	SOURCE
MODE SW	STEREO
LOUDNESS SW	ON
HIGH FILTER SW	OST
SPEAKER SW	BOTH
POWER SW	OFF

values are measured with dc VTVM at zero signal voltages. Signal voltages measured with AC expressed in dB refered to 0.775 volts under put.

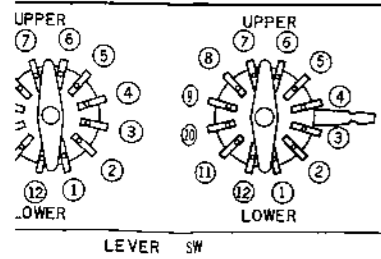

SONY STR-6050

Service Note:

The most effective troubleshooting method is signal tracing. That is, apply a standard rf or audio signal at the antenna or input terminals and trace the signal through the amplifier chain using an AC VTVM or calibrated oscilloscope. Normal values of signal voltages are shown on the level diagram and schematic diagram. The faulty stage usually precedes the point at which an abnormal signal voltage is found. However, signal loss can also result from a short or low impedance at the point where low signal voltage is found.

When the defective stage has been located check dc voltages in the stage. Most current failures will affect resistance checks to locate the fault to a component. In performing voltage check or tracing signal level by dc or ac VTVM, test leads are usually have to touch the component lead after removing the printed board from chassis. Your time will be saved by reforming test lead of your equipment to touch the leads of capacitors, transistors or resistors directly from component side of printed circuit board as shown.

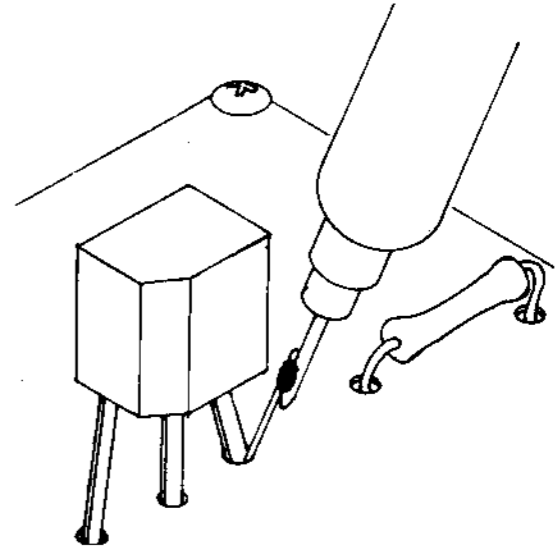
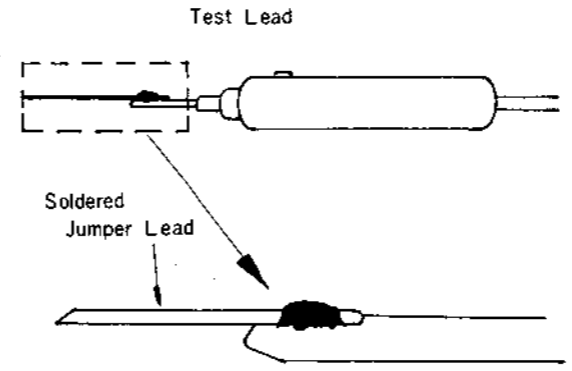

MOUNTING DIAGRAM

F-M I-F Board

- Conductor Side -

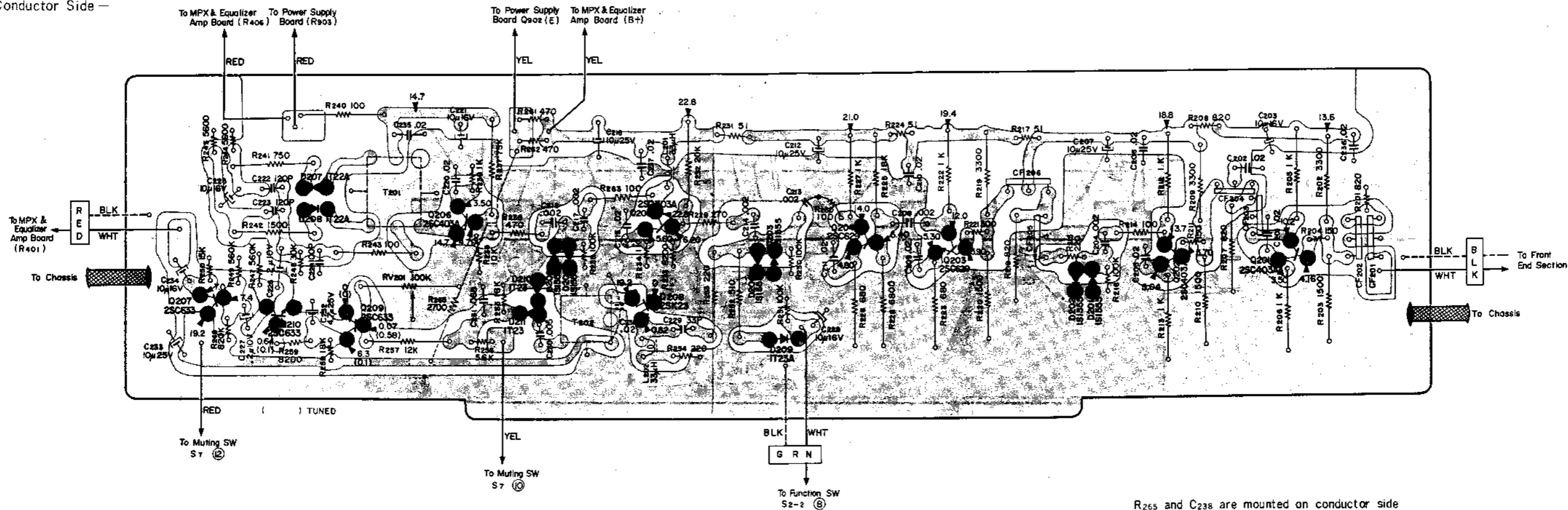

- Component Side -

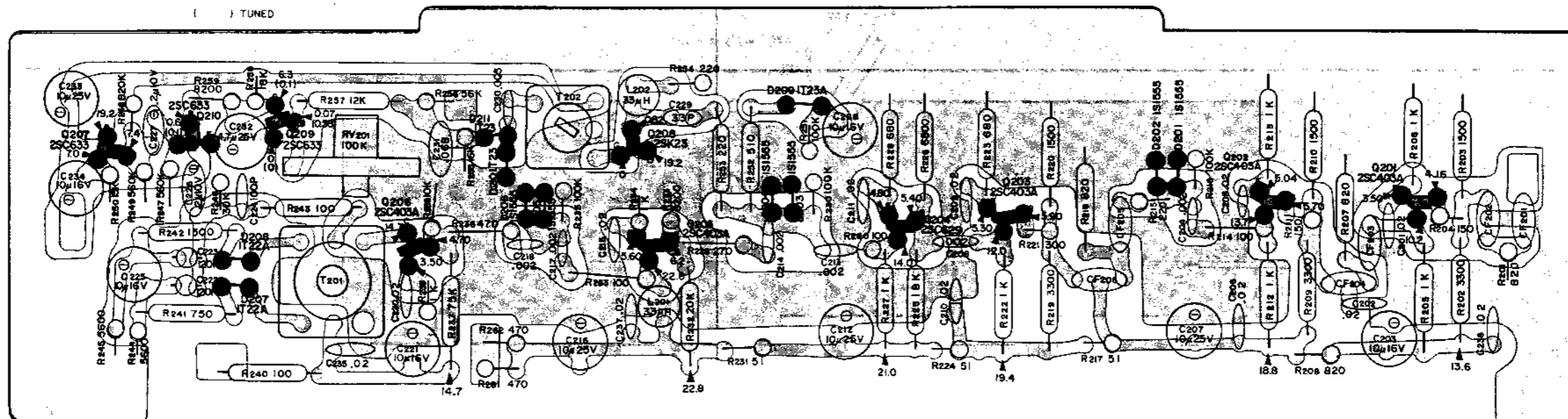

MOUNTING DIAGRAM

A-M I-F Board

— Conductor Side —

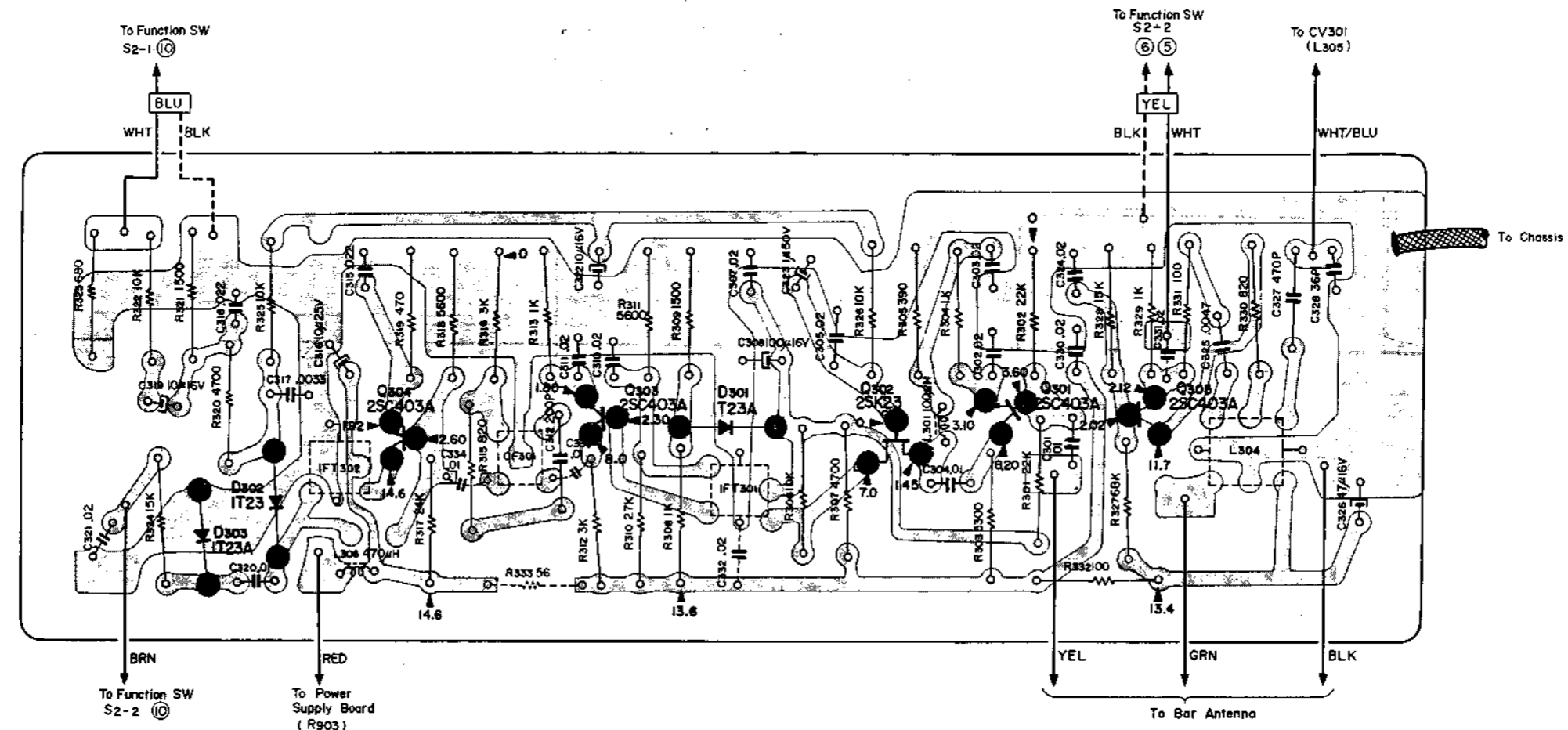

— Component Side —

R333 and C331 to C334 are mounted on conductor side

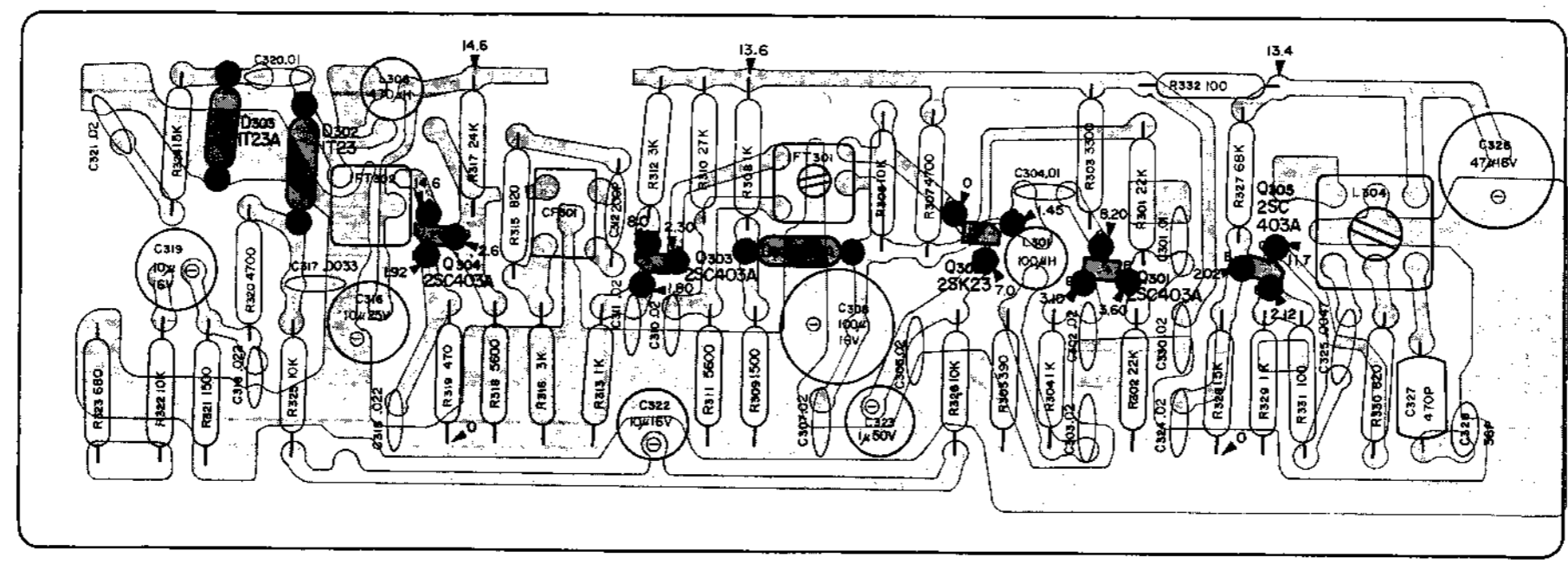

MOUNTING DIAGRAM

MPX and Equalizer Amplifier Board

— Conductor Side —

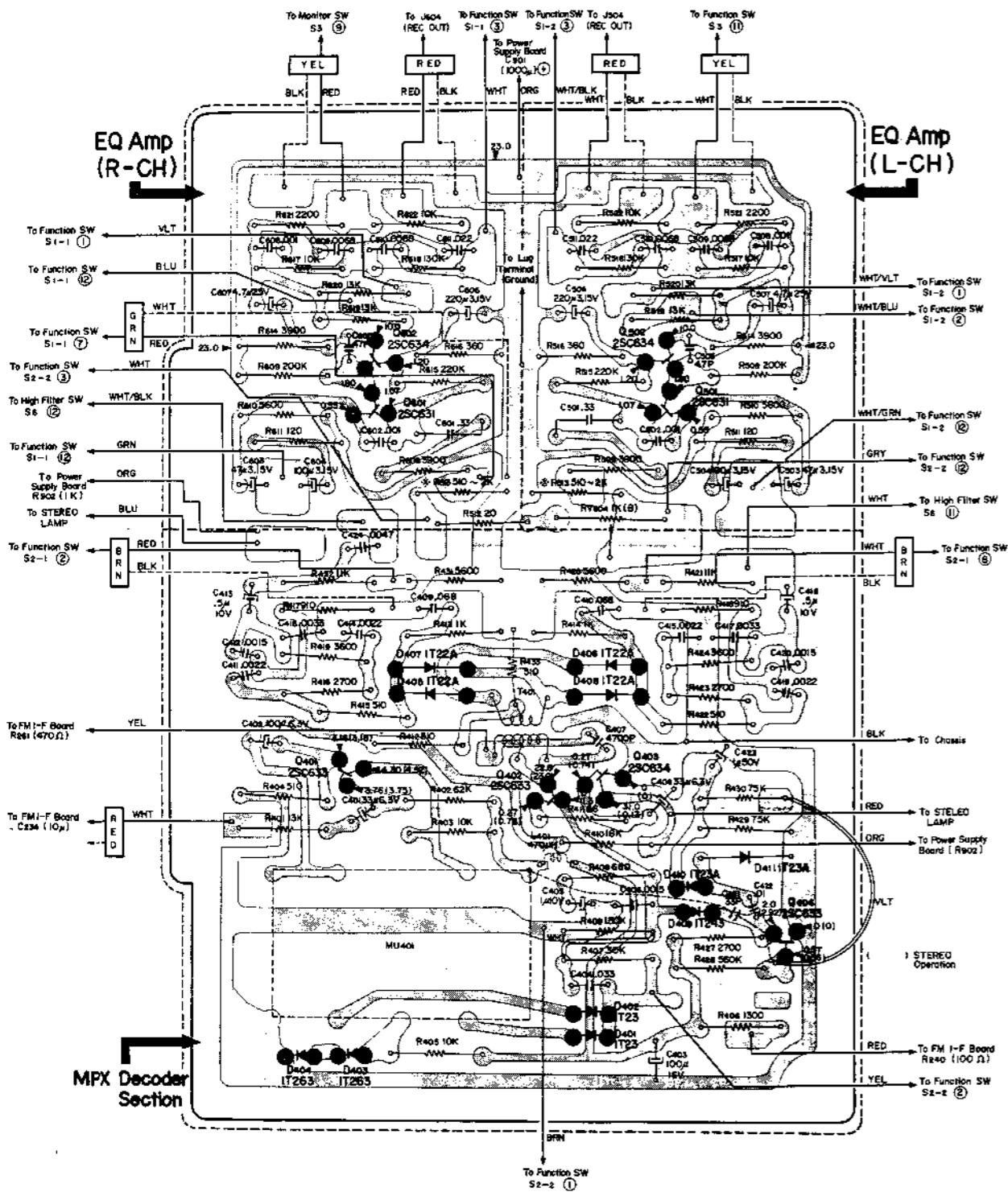

R433, C421 and L401 are mounted on conductor side

* : To be selected

MOUNTING DIAGRAM

MPX and Equalizer Amplifier Board

— Component Side —

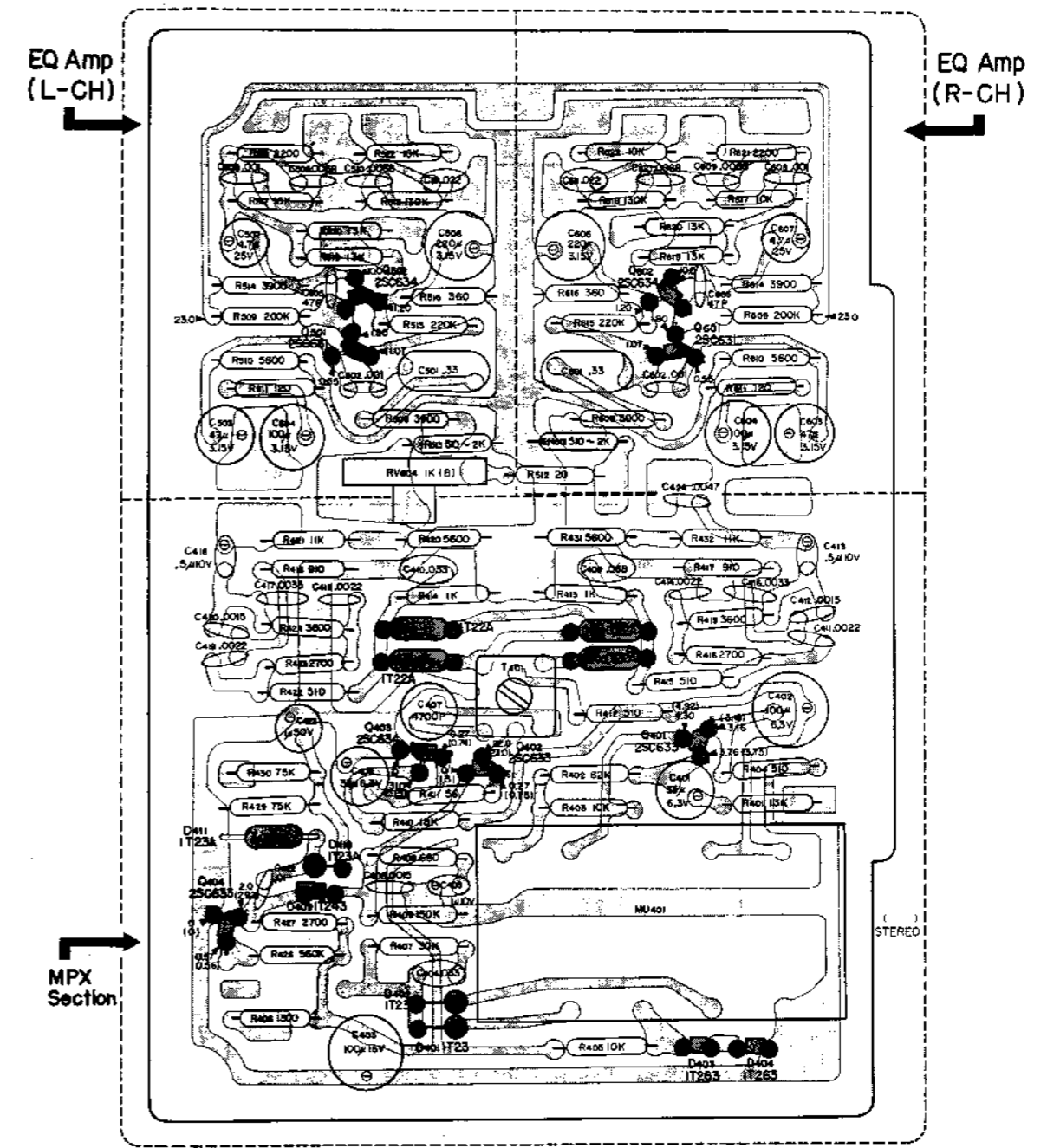

MOUNTING DIAGRAM

Loudness Section

— Conductor Side —

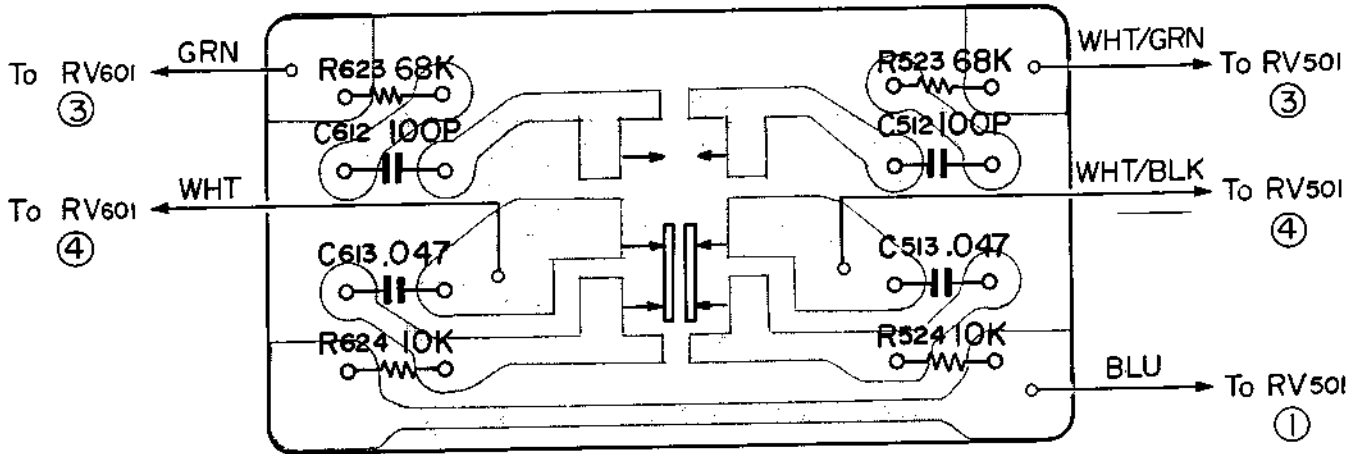

— Conductor Side —

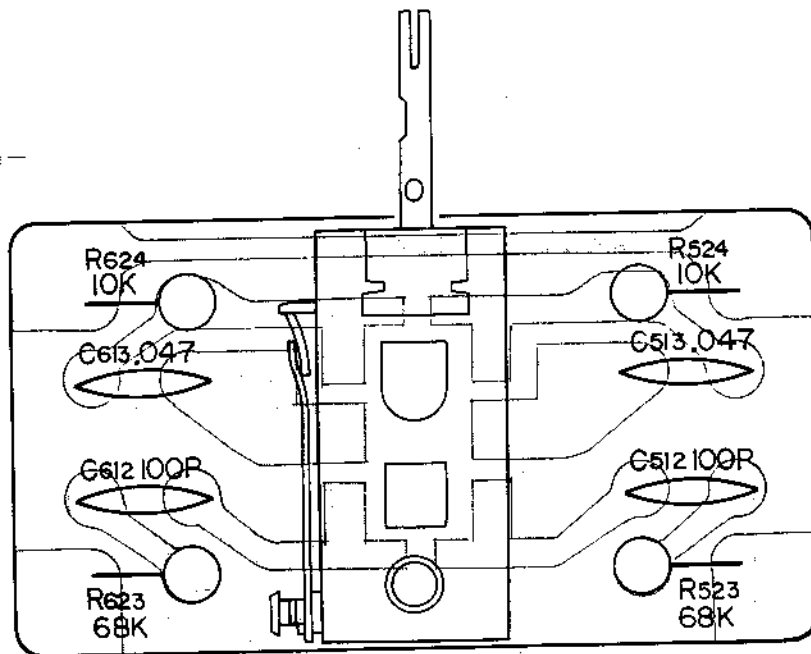

MOUNTING DIAGRAM

Tone Control and Flat Amplifier Board

- Conductor Side -

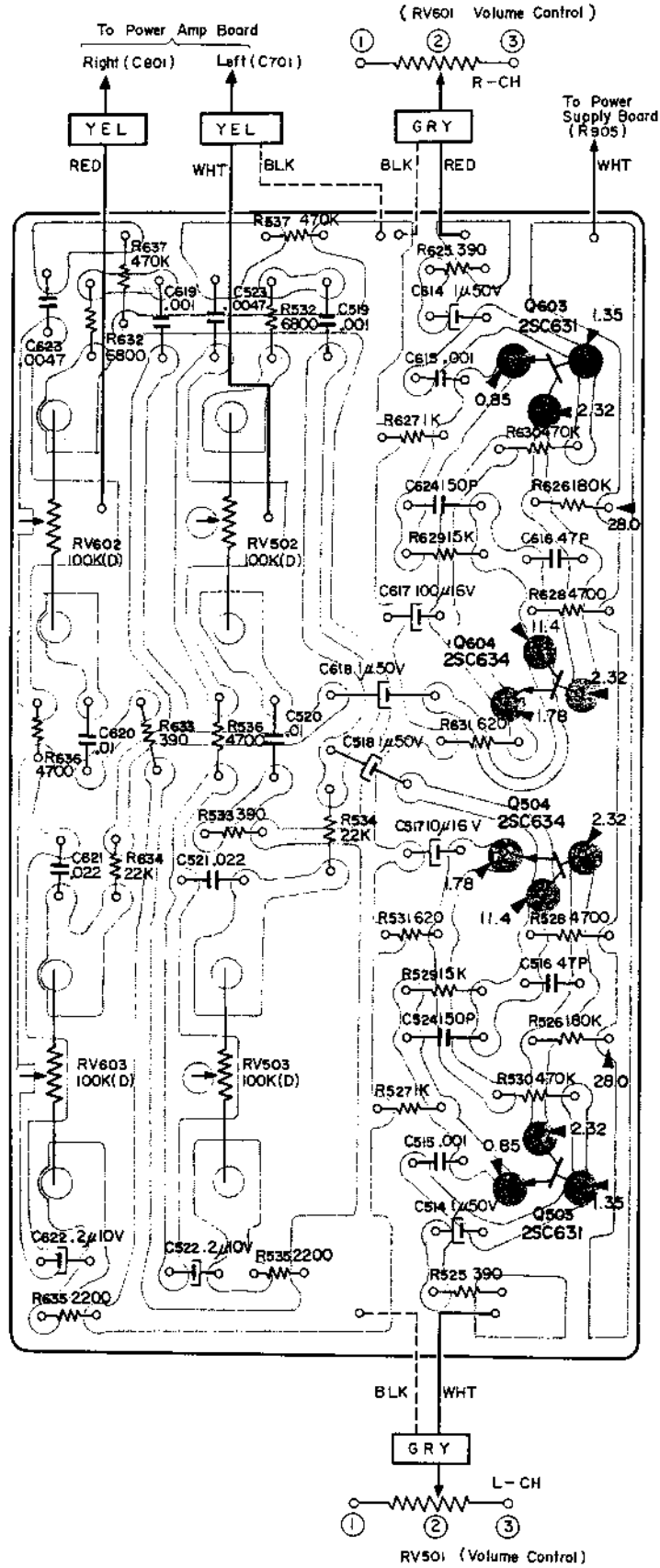

MOUNTING DIAGRAM

Tone Control and Flat Amplifier Board

— Component Side —

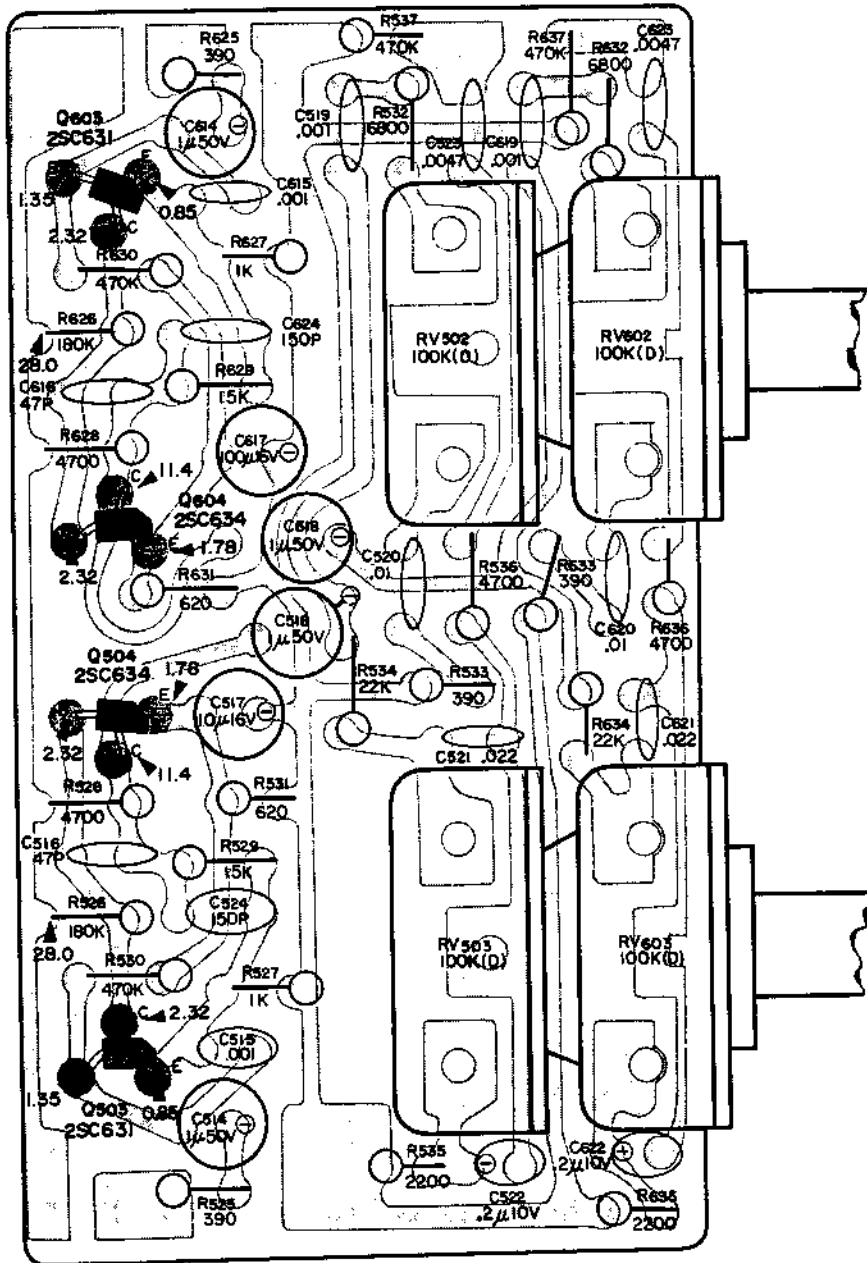

STR-6050

MOUNTING DIAGRAM

Power Amplifier Board

- Conductor Side -

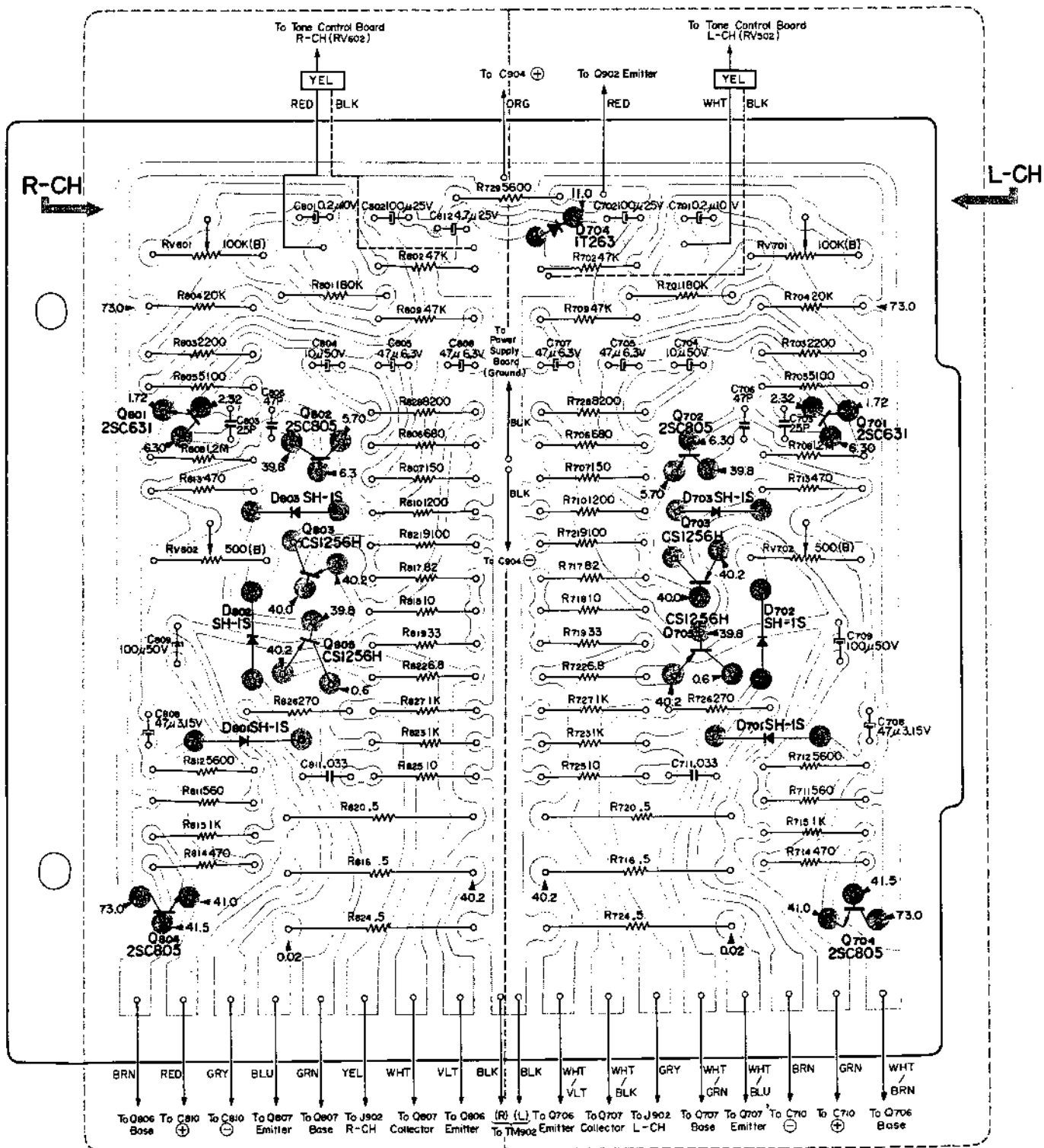

MOUNTING DIAGRAM

Power Amplifier Board

— Component Side —

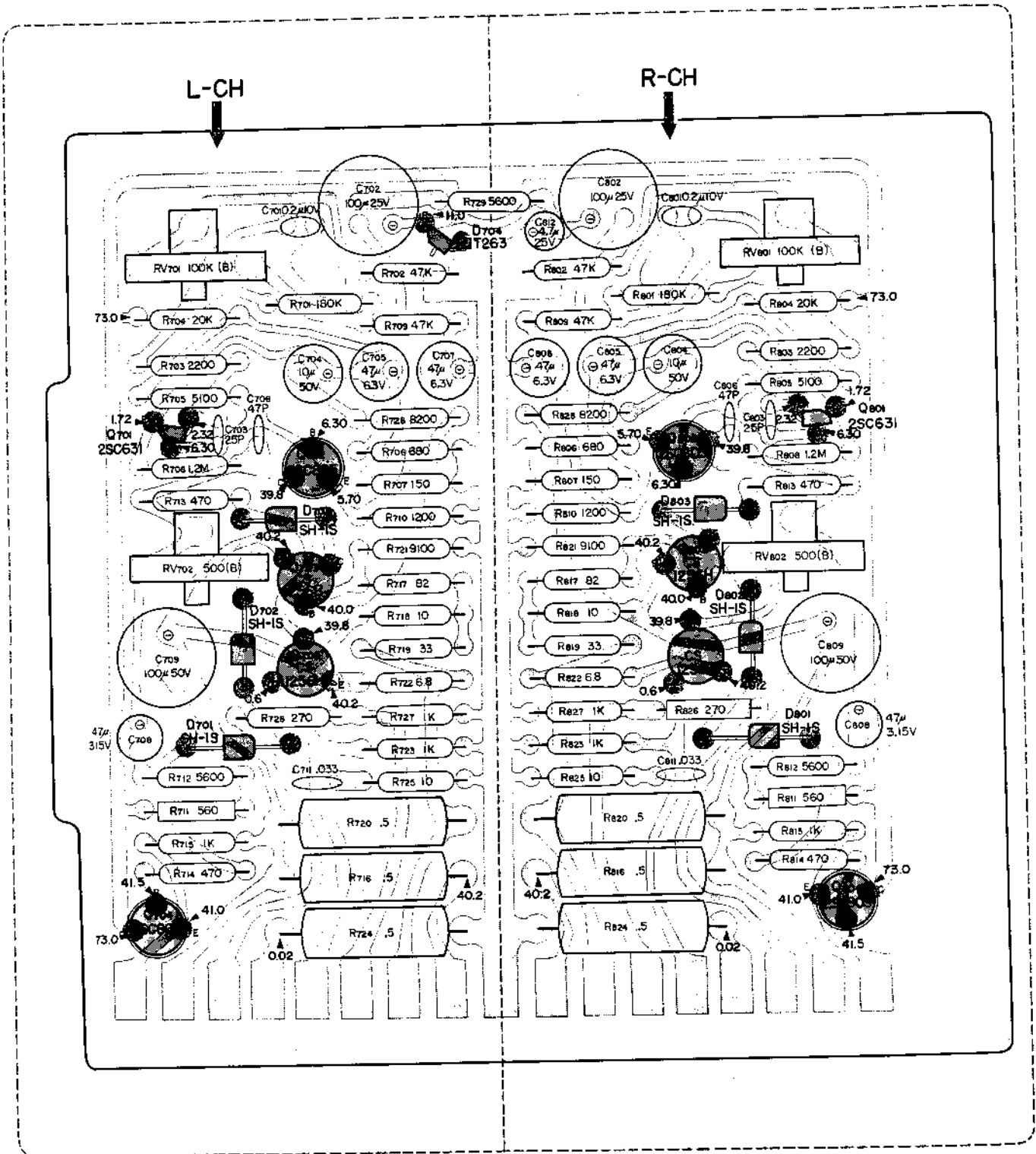

STR-6050

MOUNTING DIAGRAM

Power Supply Board

— Conductor Side —

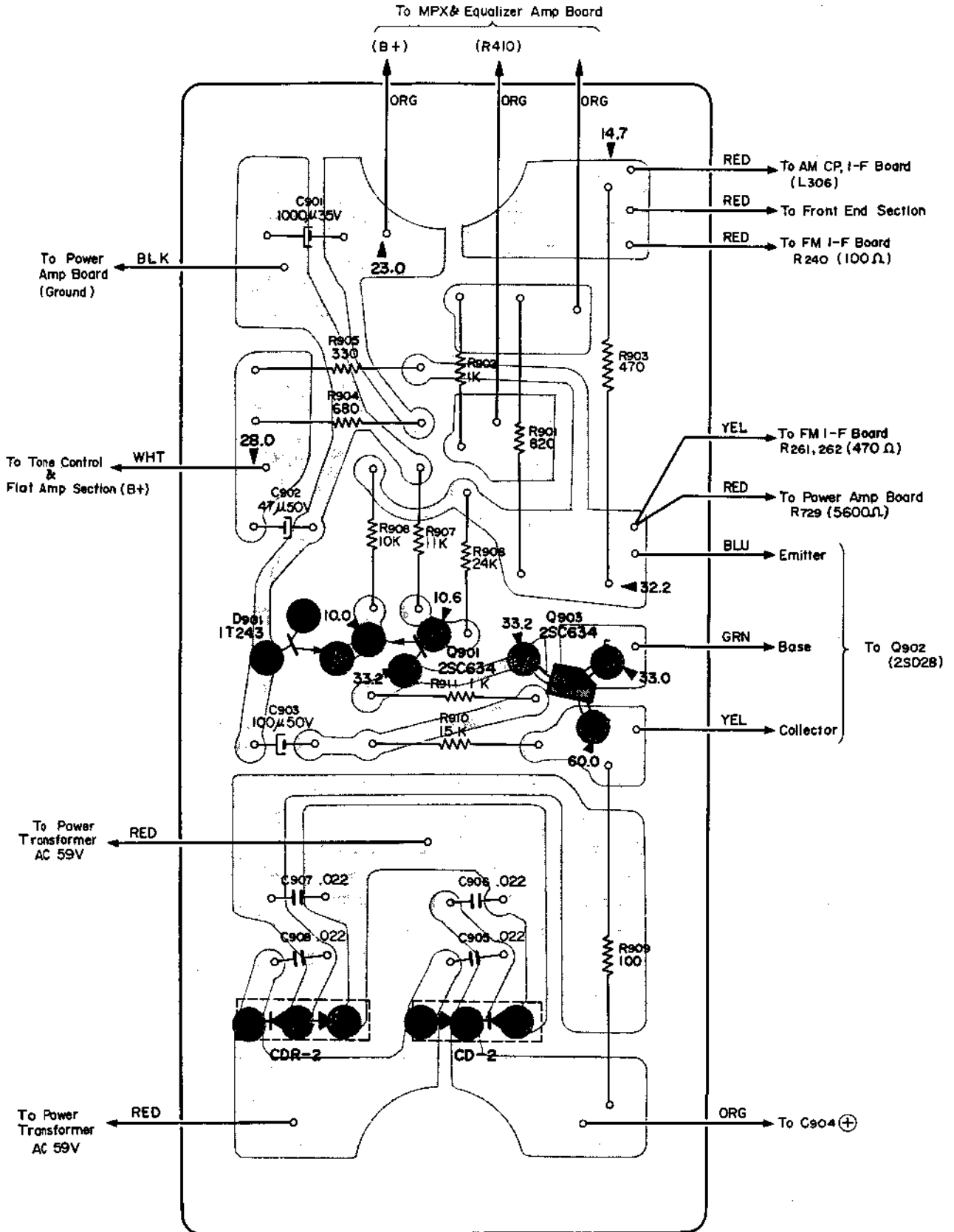

MOUNTING DIAGRAM

Power Supply Board

— Component Side —

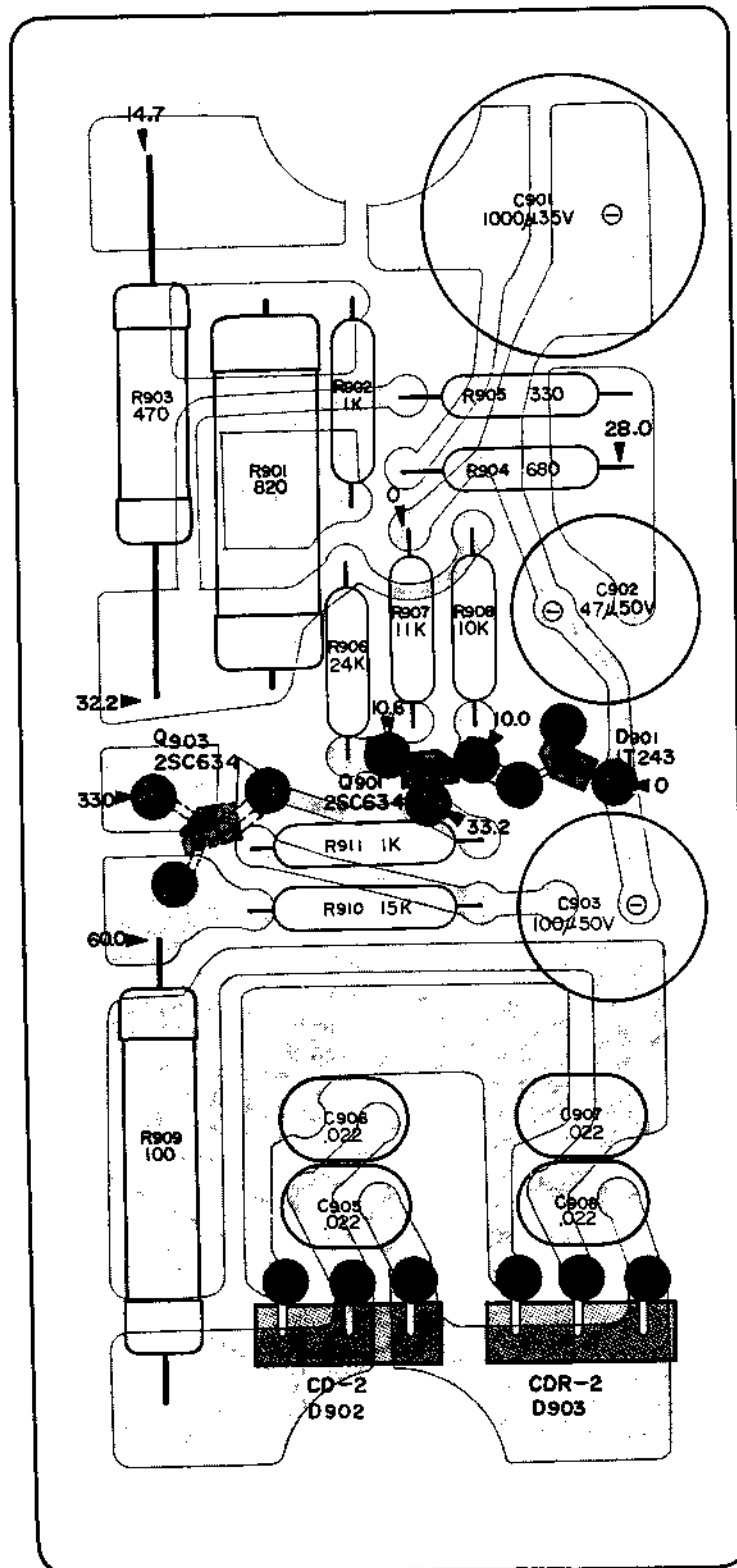

STR-6050

EXPLODED VIEW

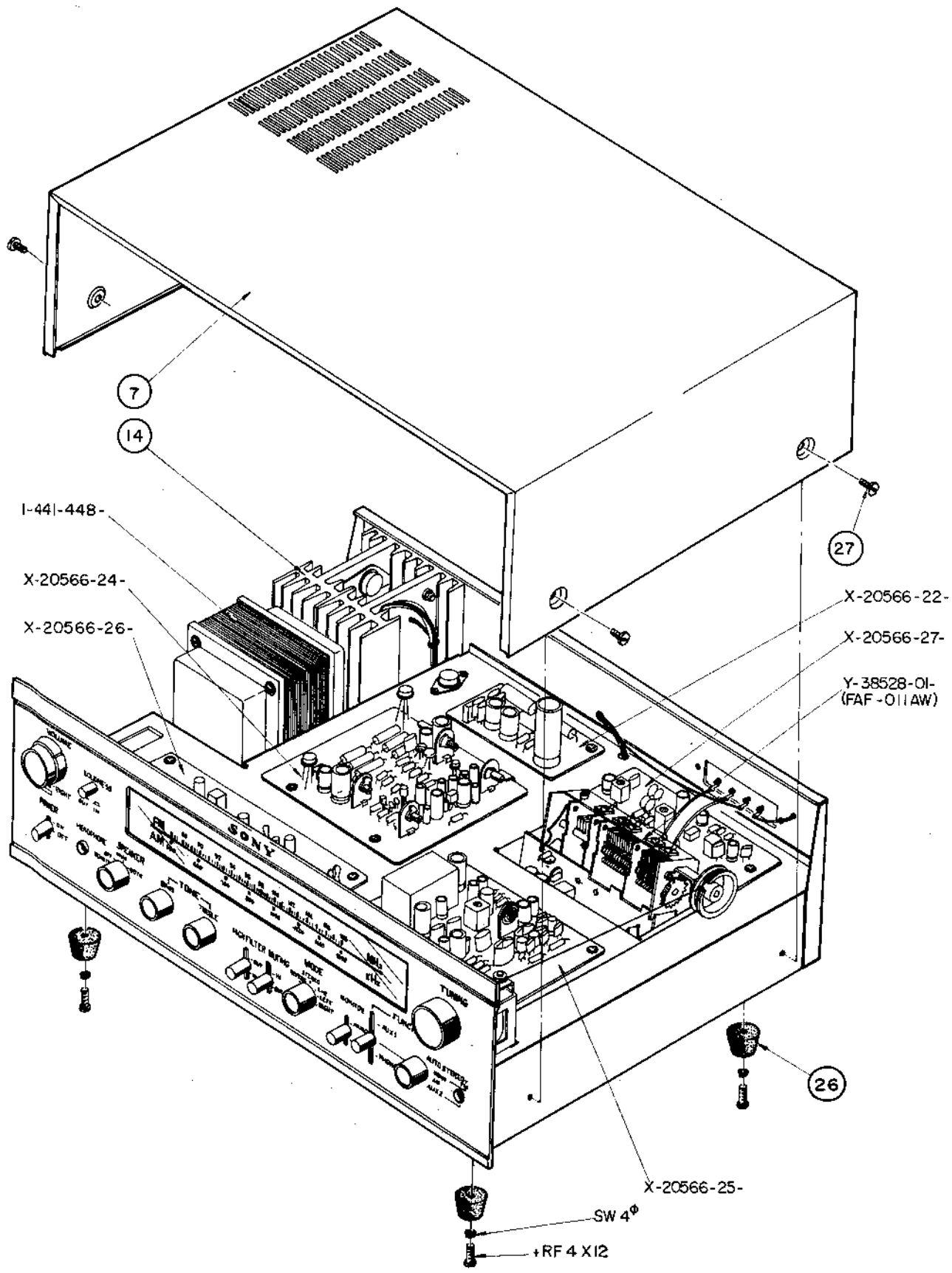

SONY®

STR-6050

SERVICE MANUAL SUPPLEMENT

NO. 1

OCT. '70

Subject: Minor change of Model STR-6050

1. INTRODUCTION

SONY made a change on Model STR-6050 to improve its electrical performance.

2. DESCRIPTION OF THE MODIFICATION

(a) SCA Trap Added

SCA trap has employed to remove the unwanted SCA interference on the MPX decoder board, and some parts has also changed at the same time.

New Parts Added

<i>Reference</i>	<i>Value</i>	<i>Part Number</i>
L402 (trap coil)	22 mH	1-409-181, micro inductor
C426	240 pF	1-107-140, silvered mica
R434	8.2 k ohm	1-244-695

Parts Changed

	<i>Description</i>	<i>Changed to</i>
*MPX decoder section	C421, 33 pF	62 pF (1-101-886), ceramic
	R401, 3 k ohm	8.2 k ohm (1-244-695)

Applicable Serial Number

<i>For USA Model</i>	<i>For Canada Model</i>	<i>For General Export Model</i>
81,501 up to 87,930	70,001 up to 70,832	50,001 up to 58,038

(b) Rectifier D902 Changed

New rectifier diode has employed to increase current capacity.

<i>Description</i>	<i>Changed to</i>
D902, CD-2	5B4

Applicable Serial Number

<i>For USA Model</i>	<i>For Canada Model</i>	<i>For General Export Model</i>
86,754 and later	70,735 and later	57,424 and later

(c) Printed Circuit Board Changed (MPX decoder section)

The MPX decoder's printed circuit board has been modified to place the SCA trap circuit on the component side, and some parts have also changed at the same time. New circuit diagram and mounting diagram are given on pages 5 to 8.

<i>Description</i>	<i>Changed to</i>
MPX board. X-20566-25	X-20566-25-3
C421, 62 pF	30 pF (1-101-871), ceramic
L402, 22 mH (1-409-181)	22 mH (1-407-408)

Applicable Serial Number

<i>For USA Model</i>	<i>For Canada Model</i>	<i>For General Export Model</i>
87,931 and later	70,833 and later	58,039 and later

(d) De-emphasis Changeover Circuit Added

The de-emphasis changeover circuit has employed to change the de-emphasis time constant easily. The specified de-emphasis time constant is 75 microseconds in USA and Canada, 50 micro-seconds in Europe. Refer to schematic diagram on pages 5 to 6.

Parts Added

*MPX decoder section

<i>Reference</i>	<i>Value</i>	<i>Part Number</i>
C427, 428	0.047 μ F, mylar	1-105-681-11
C429, 430	0.022 μ F, mylar	1-105-677-11
S10 (Slide switch)		1-514-524-11

Parts Changed

*MPX decoder section

<i>Description</i>	<i>Changed to</i>
C416, 417, 0.0033 μ F	0.0022 μ F (1-105-665-11) *Note: Mounting position is changed also.
C409, 410, 0.068 μ F	0.01 μ F (1-105-673-11) mylar
R415, 422, 510 ohm	750 ohm (1-244-670)

Applicable Serial Number

<i>For USA Model</i>	<i>For Canada Model</i>	<i>For General Export Model</i>
88,374 and later	70,841 and later	57,602 and later

(e) Fuse Added

A fuse is inserted in the primary side of the power transformer.

<i>Description</i>	<i>Part Number</i>
Fuse (USA, Canada Model)	1-532-213
Fuse (General Export Model)	1-532-250
Terminal strip for fuse mounting	1-536-189

Applicable Serial Number

<i>For USA Model</i>	<i>For Canada Model</i>	<i>For General Export Model</i>
88,058 and later	70,851 and later	57,284 and later

(f) Schematic Diagram (Tuner Section) Changed

According to the circuit modifications as described herein, reference number of resistor and capacitor in the fm i-f and MPX decoder section has changed. The new schematic diagram is given on pages 5 to 6.

Applicable Serial Number

<i>For USA Model</i>	<i>For Canada Model</i>	<i>For General Export Model</i>
87,227 and later	70,742 and later	57,409 and later

(g) Parts Changed

	<i>Description</i>	<i>Changed to</i>
a-m i-f section	R317, 24 k ohm	18 k ohm (1-244-703)
	R320, 4.7 k ohm	1.8 k ohm (1-244-679)
	R324, 15 k ohm	18 k ohm (1-244-703)
power supply section	R907, 11 k ohm	10 k ohm (1-244-697)
	C904, 1000 μ F 80 V	3300 μ 80 V (1-121-560), electrolytic

(h) Service Manual Correction in the Exploded View

<i>Description</i>	<i>Change to</i>	<i>Page</i>
S2 (1-514-506)	(1-514-338)	47
S1 (1-514-338)	(1-514-506)	47

STR-6050 STR-6050

SCHEMATIC DIAGRAM

TUNER SECTION

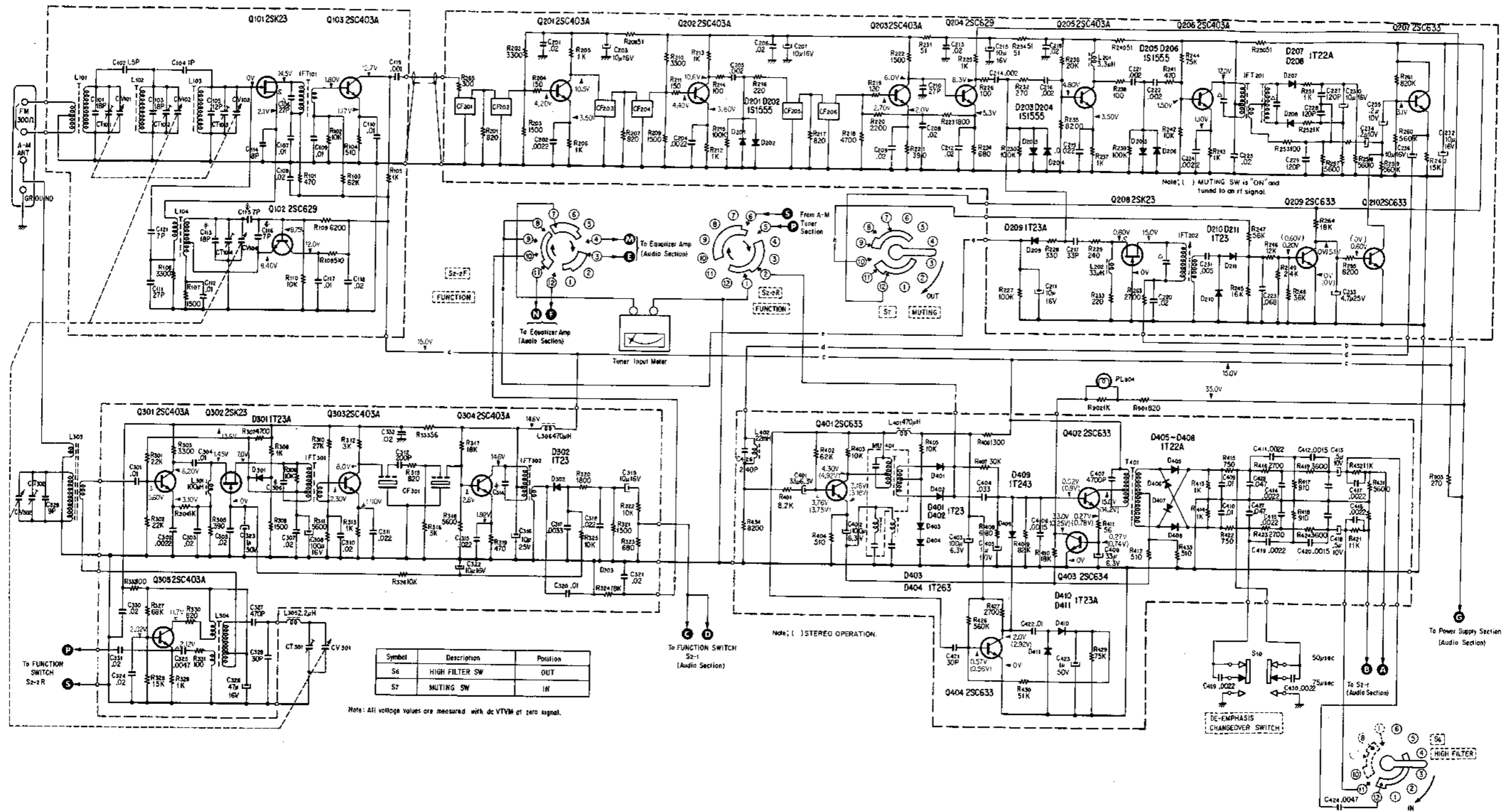

STR-6050 STR-6050

MOUNTING DIAGRAM -MPX and Equalizer Amplifier Board

- Conductor Side -

MOUNTING DIAGRAM -MPX and Equalizer Amplifier Board

- Component Side -

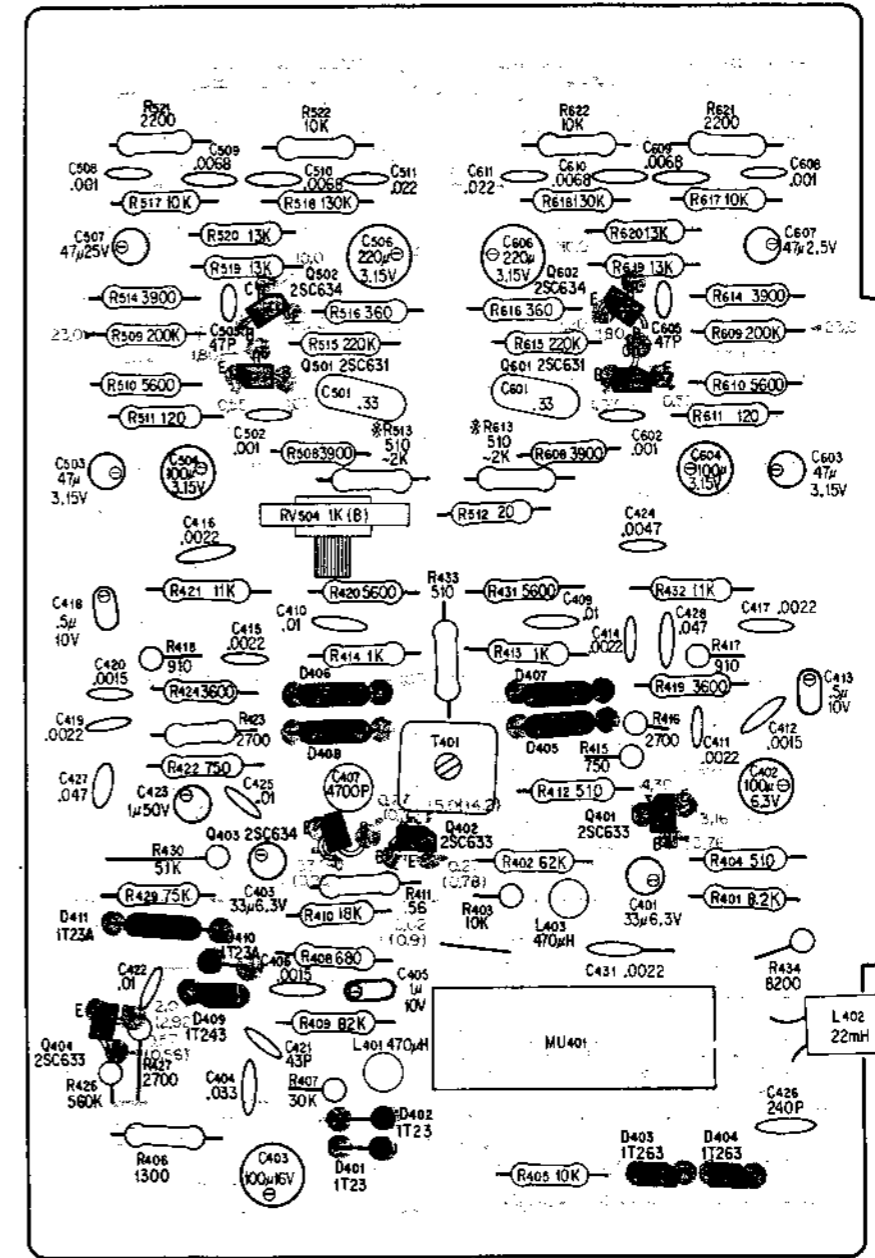
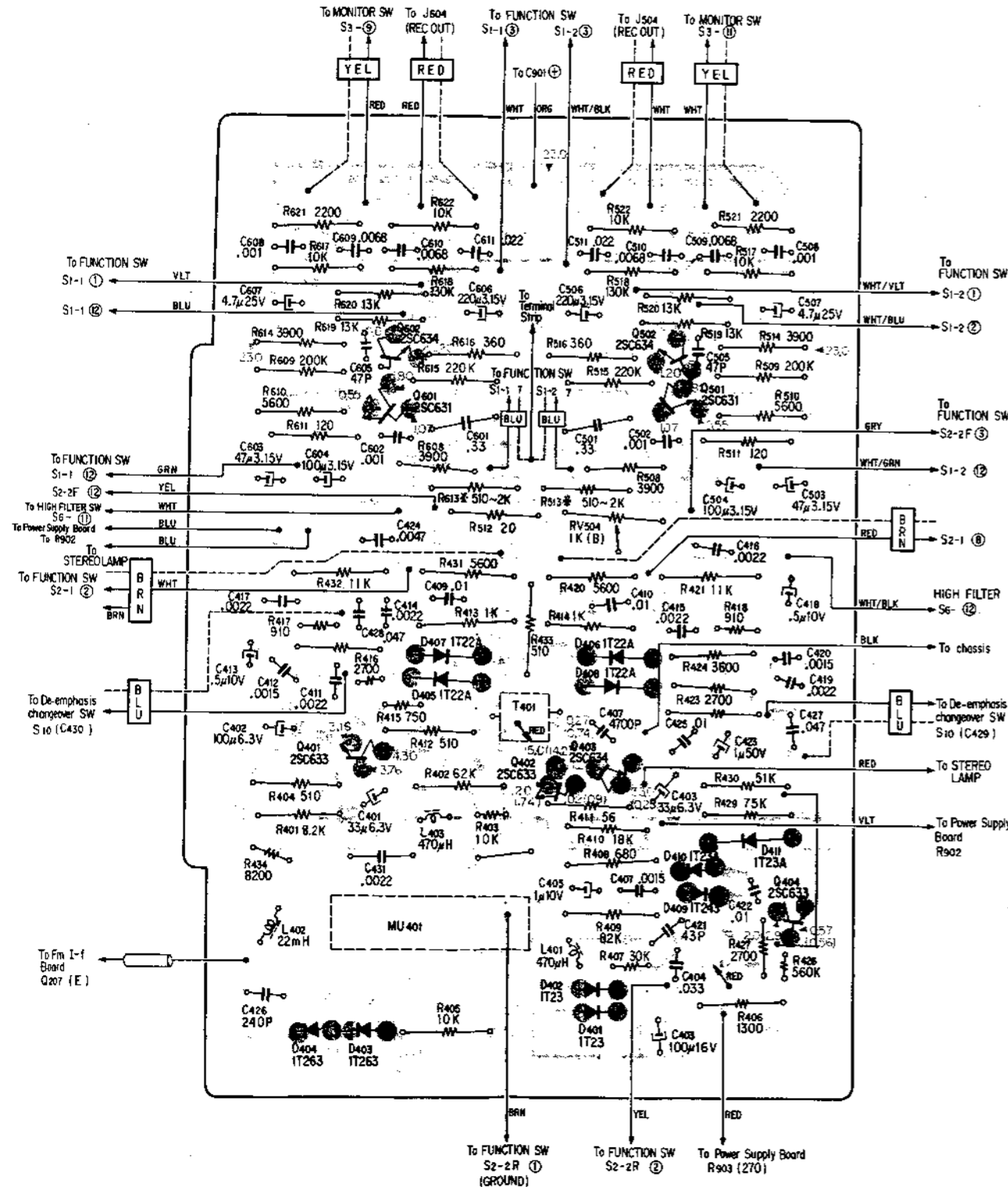

Note: 1. () STEREO OPERATION
 2. R433, C421 and L401 are mounted on conductor side
 * : To be selected

() ; STEREO OPERATION

STR-6050 STR-6050

MOUNTING DIAGRAM— F-M I-F Board

—Conductor Side—

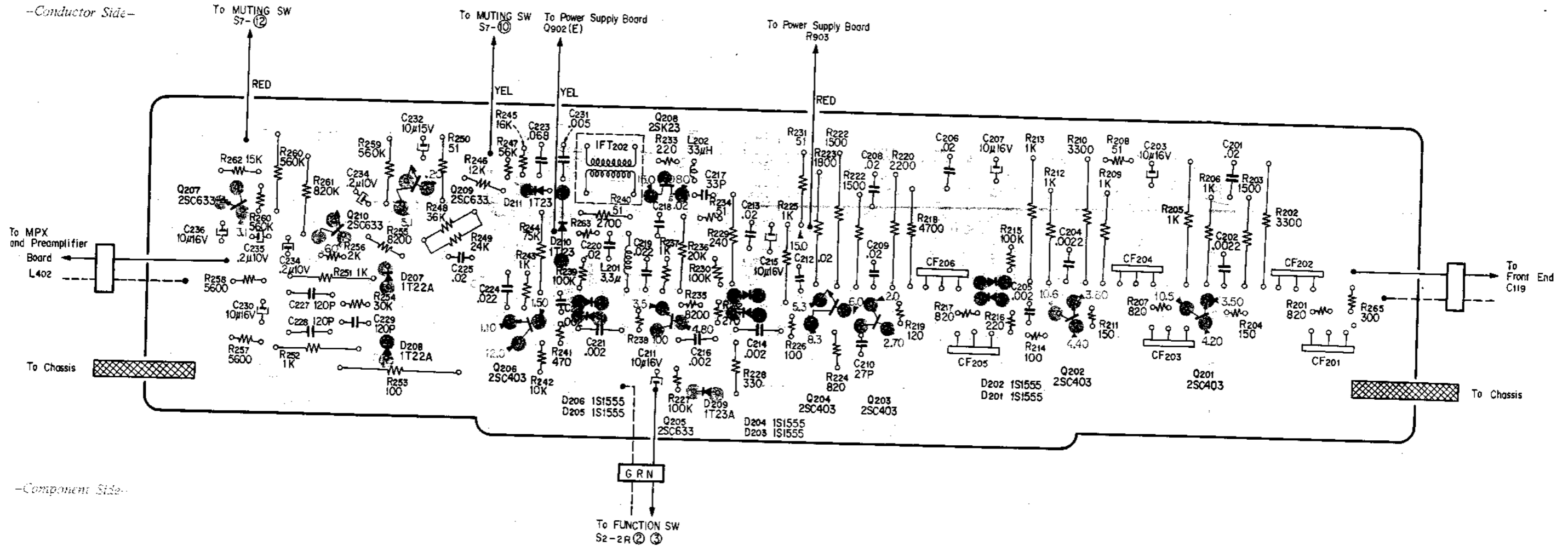

—Component Side—

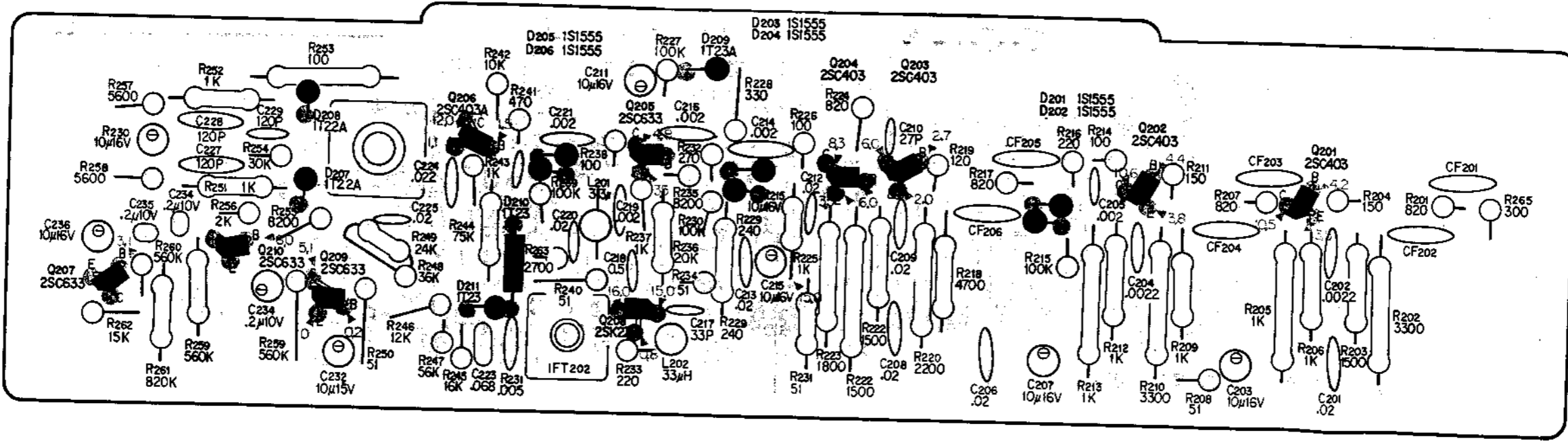

STR-6050 STR-6050

MOUNTING DIAGRAM— A-M I-F Board

—Conductor Side—

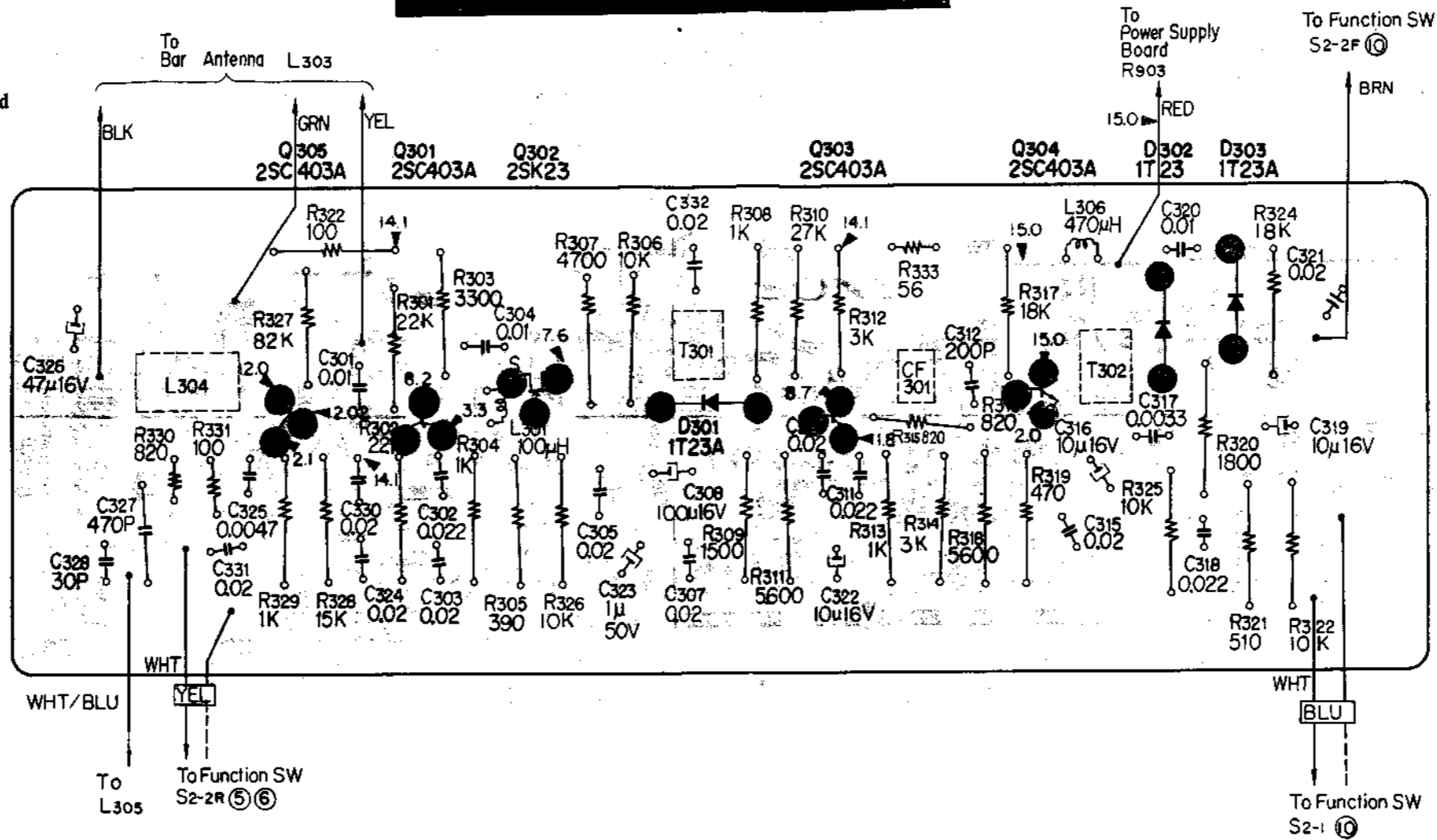

—Component Side—

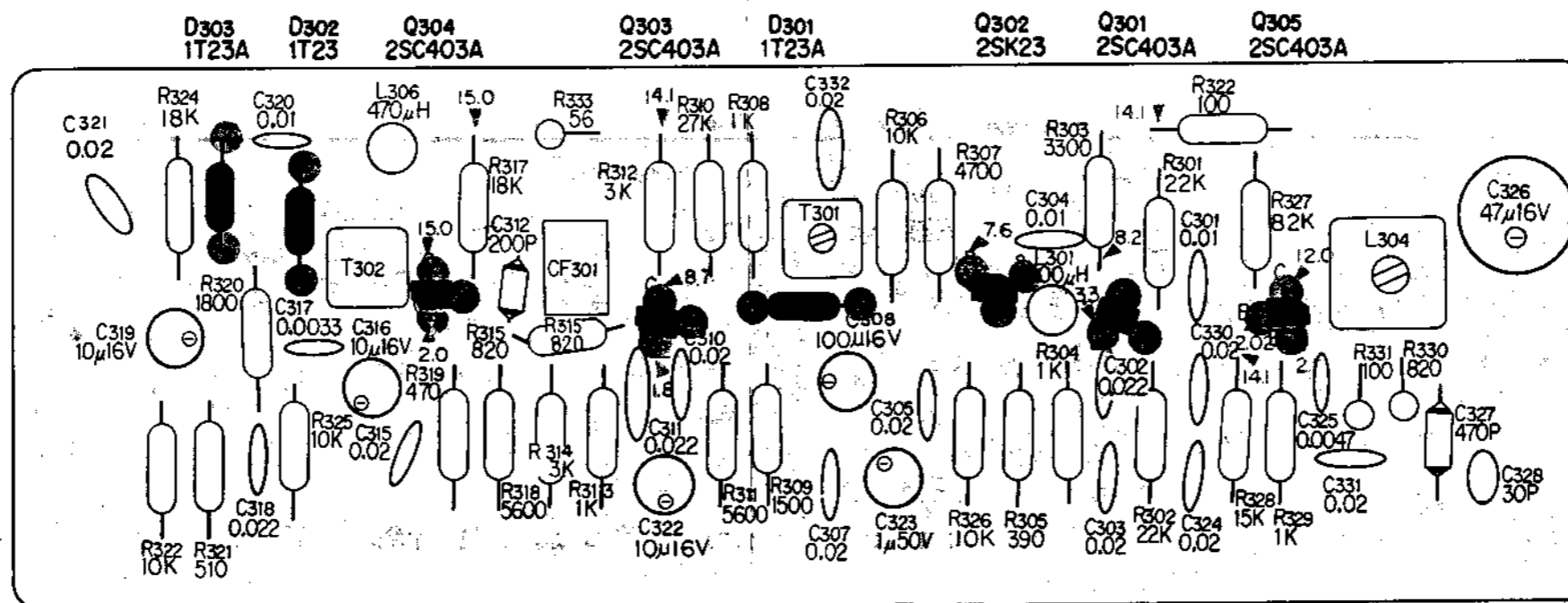

SONY CORPORATION