

STR-5800/5800SD

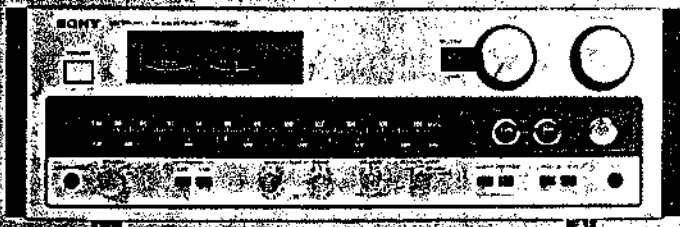

STR-5800

Original

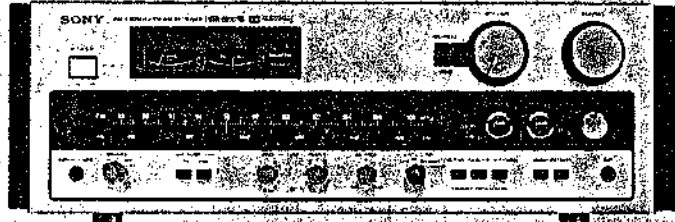

STR-5800SD

DOLBY FM

STR-5800SD

USA Model

Canada Model

STR-5800

AEP Model

FM STEREO/FM-AM RECEIVER

SPECIFICATIONS

GENERAL

Power Requirements: 120 V ac, 60 Hz (USA and Canada Model)
110, 127, 220 or 240 V ac adjustable, 50/60 Hz (AEP Model)

Power Consumption: 190 W (USA Model)
380 VA (Canada Model)
570 W (AEP Model)

AC Outlets: 3 unswitched, total 200 W

Dimensions: Approx.
490 (w) x 170 (h) x 415 (d) mm
19 1/4 (w) x 6 7/16 (h) x 16 1/4 (d) inches
Including projecting parts and controls

Weight: Approx.
15.4 kg, 34 lb (net)
Approx.
17.7 kg, 39 lb (with shipping carton)

FM SECTION

Tuning Range: 87.5 MHz — 108 MHz

Intermediate Frequency: 10.7 MHz

Sensitivity at 50 dB Quieting: 3.5 μ V (MONO)
45 μ V (STEREO)

Sensitivity at 46 dB Quieting: 50 μ V (STEREO) (AEP Model)
(40 kHz deviation)

Usable Sensitivity: IHF 1.7 μ V (MONO)
1.5 μ V, S/N = 26 dB (40 kHz deviation) (AEP Model)

S/N Ratio: 73 dB (MONO)
68 dB (STEREO)

Harmonic Distortion: at 100 Hz
0.2% (MONO)
0.3% (STEREO)
at 1 kHz
0.2% (MONO)
0.3% (STEREO)
at 10 kHz
0.2% (MONO)
0.6% (STEREO)

IM Distortion: 0.2% (MONO)
0.3% (STEREO)

Separation: 35 dB at 100 Hz
40 dB at 1 kHz
35 dB at 10 kHz

Frequency Response: 30 Hz — 15 kHz $+0.2$ dB (USA and Canada Model)
 -1.5 dB
40 Hz — 12.5 kHz $+0.2$ dB (AEP Model)
 -1.0 dB

Capture Ratio: 1.0 dB

AM Suppression Ratio: 54 dB

Image Response Ratio: 75 dB

— Continued on next page —

* STR-5800SD is equipped with DOLBY FM circuit. 'Dolby' and the double-D symbol are the trade marks of Dolby Laboratory Inc. Noise reduction system manufactured under license from Dolby Lab.

Original

SONY
SERVICE MANUAL

STR-5800/5800SD

IF Response Ratio: 100 dB

Spurious Response Ratio: 100 dB

RF Intermodulation: 65 dB

Sub-carrier Product Ratio: 60 dB

Muting Threshold: Approx. 5 μ V

FM DISCRI Output Level: 250 mV, 2,500 Ω , at 1 kHz,
100% modulation

AM SECTION

Tuning Range: 530 kHz — 1,605 kHz

Intermediate Frequency: 455 kHz (USA and Canada Model)
468 kHz (AEP Model)

Usable Sensitivity: 250 μ V/m, built-in ferrite-rod antenna
100 μ V, external antenna
at 1,000 kHz

S/N Ratio: 50 dB at 50 mV/m

Harmonic Distortion: 0.5% at 50 mV/m, 400 Hz

Selectivity: 35 dB

Image Response Ratio: 40 dB at 1,000 kHz

IF Response Ratio: 35 dB at 1,000 kHz

AUDIO AMPLIFIER SECTION

Continuous RMS

Power Output: Both channels driven simultaneously
(rated output) At 20 — 20,000 Hz
(less than 0.2% THD) 55 + 55 W (8 Ω)

At 1 kHz
60 + 60 W (8 Ω) } (AEP Model)
75 + 75 W (4 Ω) }

According to DIN 45500

60 + 60 W (8 Ω) } (AEP Model)
70 + 70 W (4 Ω) }

Dynamic Power Output: 200 W (8 Ω) } (AEP Model)
(IHF constant power supply method) 280 W (4 Ω) }

Power Bandwidth: 10 — 35,000 Hz, IHF (AEP Model)

Damping Factor: 40 at 1 kHz (8 Ω)

Harmonic Distortion: Less than 0.2% at rated output } (AEP Model)
Less than 0.1% at 1 W output }

IM Distortion: Less than 0.2% at rated output
(60 Hz : 7 kHz = 4 : 1) Less than 0.1% at 1 W output

Residual Noise: Less than 0.1 μ W

Frequency Response:

PHONO	RIAA equalization curve ± 0.5 dB
AUX TAPE 1, 2 REC/PB (AEP Model) EXT ADPT	10 — 30,000 Hz $\pm \frac{0}{2}$ dB

Input Sensitivity, Impedance and S/N Ratio:

	Sensitivity	Impedance	S/N	Weighting network
PHONO	2.5 mV	50 k Ω	72 dB	A
AUX TAPE 1, 2 REC/PB (AEP Model) EXT ADPT	250 mV	100 k Ω	90 dB	A

Note: Measured with rated output into 8 Ω loads
(both channels driven simultaneously) at 1 kHz.

Output Level and Impedance:

	Output level	Impedance	Input level
REC OUT 1, 2	250 mV	4.7 k Ω	PHONO 2.5 mV
REC/PB (AEP Model)	40 mV	82 k Ω	AUX TAPE 1, 2 250 mV REC/PB (input) EXT ADPT
EXT ADPT	250 mV	4.7 k Ω	

HEADPHONES: Accepts 8 — 10,000 Ω headphones.
headphones.

SPEAKER: 4 — 16 Ω speakers are suitable.

Tone Controls: BASS ± 10 dB at 100 Hz
TREBLE ± 10 dB at 10 kHz

Filters: HIGH 6 dB/oct. above 6 kHz
LOW 6 dB/oct. below 35 Hz

Acoustic Compensator: LOW +9 dB at 50 Hz
(att. 30 dB) PRESENCE +3 dB at 1 kHz
LOUDNESS +10 dB at 50 Hz
+3 dB at 10 kHz

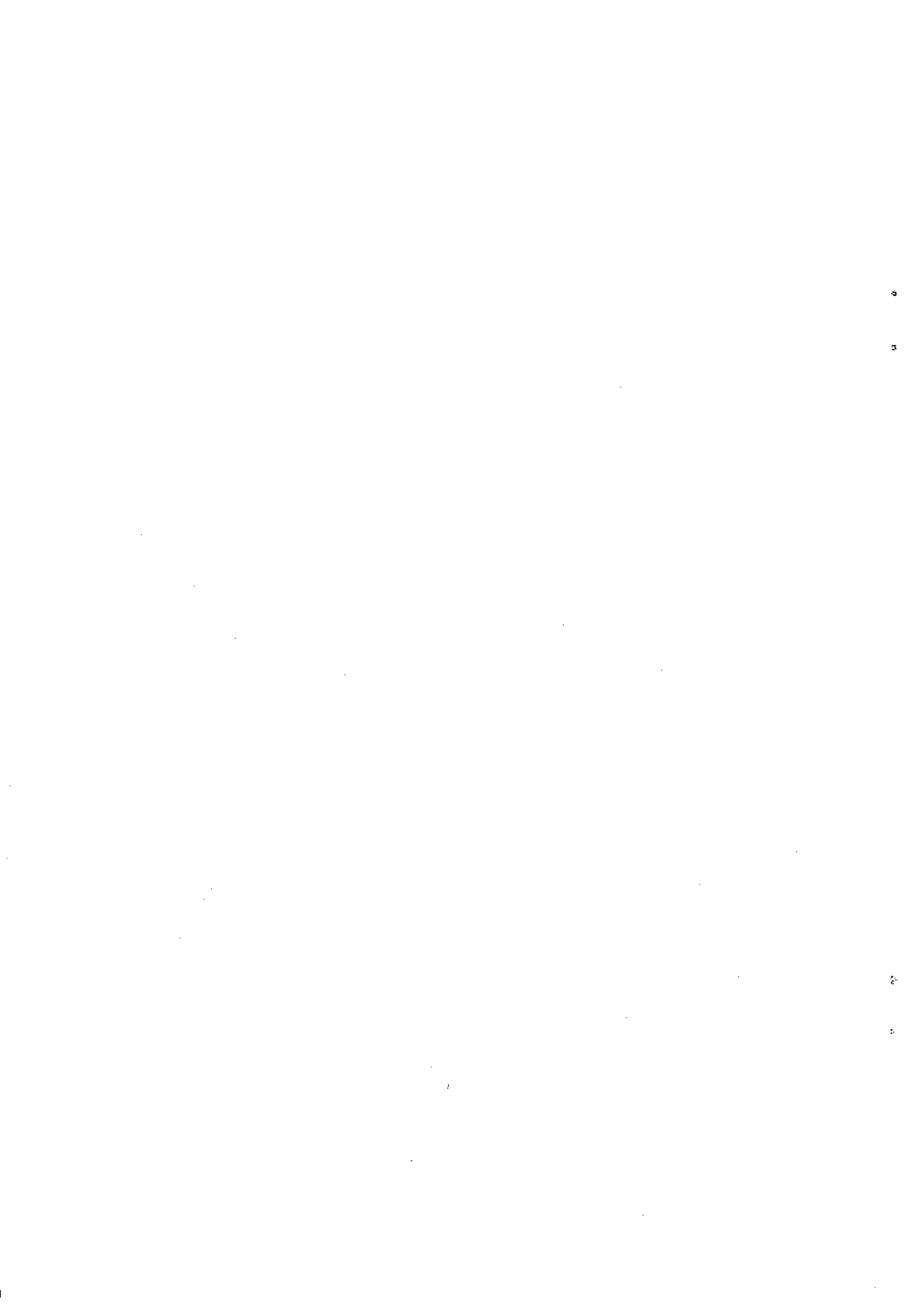

STR-5800/5800SD STR-5800/5800SD

SECTION 1
BLOCK DIAGRAM

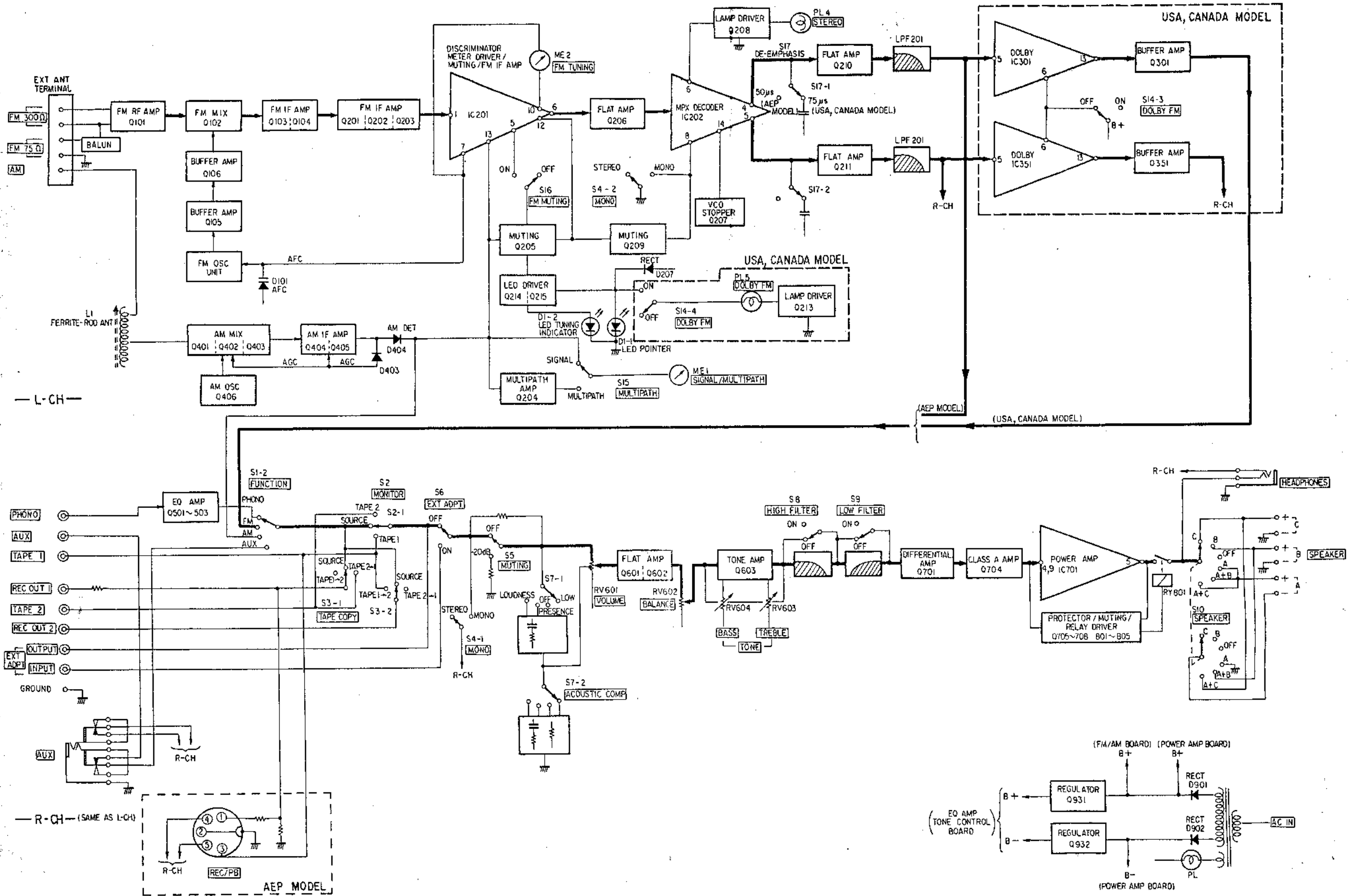

ALIGNMENTS AND ADJUSTMENTS

2-6. DIAL CORD STRINGING

1) Dial Cord Length

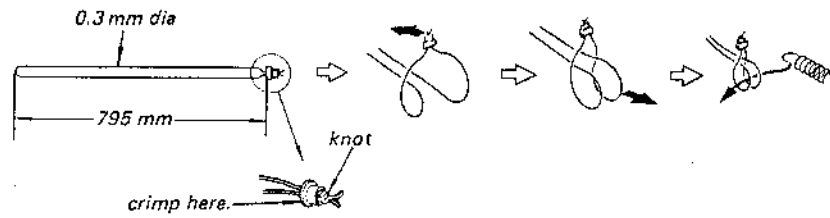

2) Dial Cord Stringing

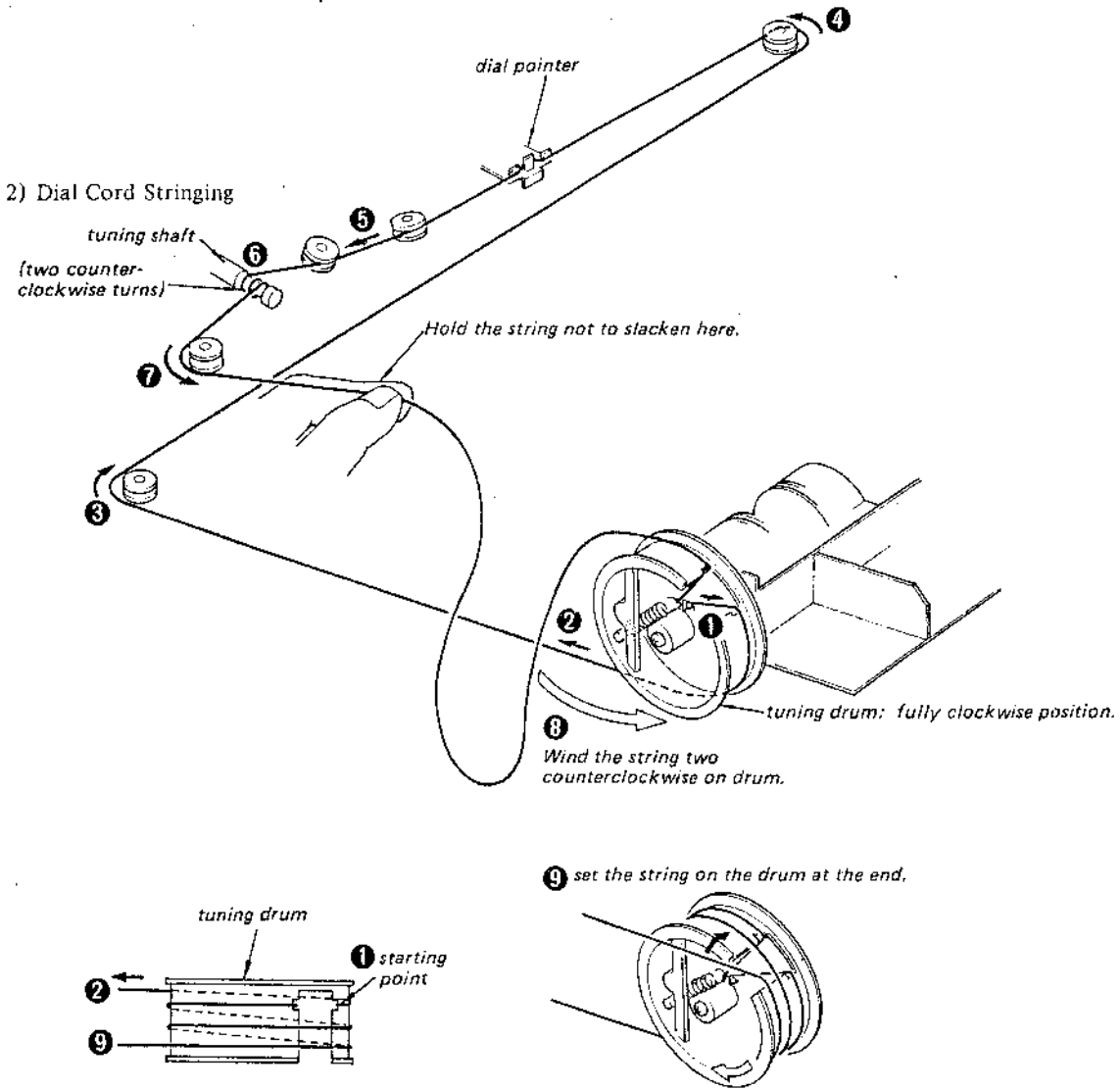

FM FREQUENCY COVERAGE AND TRACKING ALIGNMENT

Never attempt alignment of the fm front-end section for the fm frequency coverage and tracking alignment. If the fm frequency coverage alignment is required, replace the fm front-end board.

In the case of tracking alignment, ask your nearest SONY Service Station to send your set to the Factory Service Center.

AM FREQUENCY COVERAGE AND AM TRACKING ALIGNMENT

Test setup:

FUNCTION selector: AM

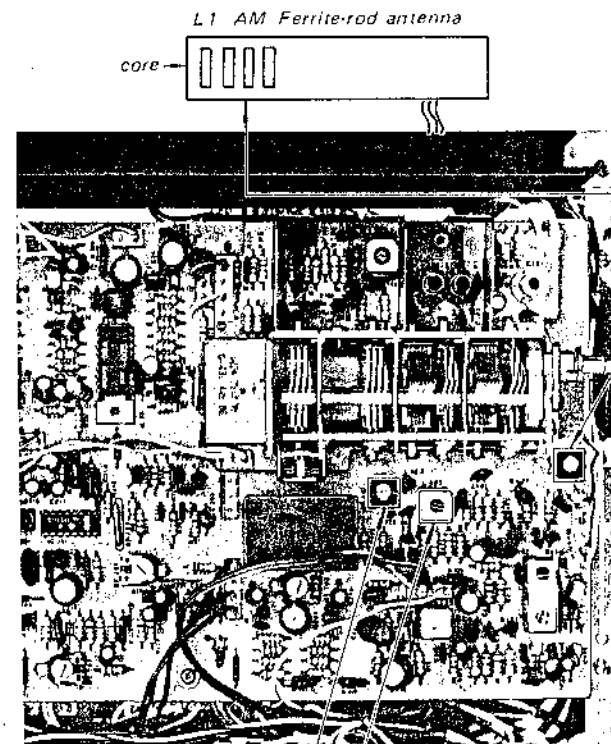
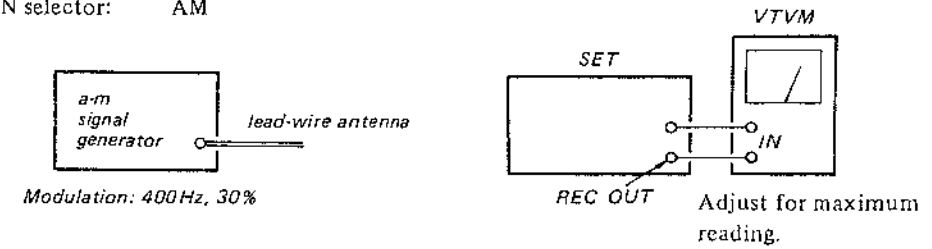

Step	AM TRACKING ALIGNMENT
1	L1 (600 kHz)
2	CT401 (1,400 kHz)

Note: Repeat step 1 and 2 several times, and finish the alignment at step 2.

Step	AM FREQUENCY COVERAGE ALIGNMENT	DIAL INDICATION
1	L402 (520 kHz)	Lower End
2	CT402 (1,680 kHz)	Upper End

Note: Repeat step 1 and 2 several times, and finish the alignment at step 2.

FM OUTPUT LEVEL ADJUSTMENT

Setup:

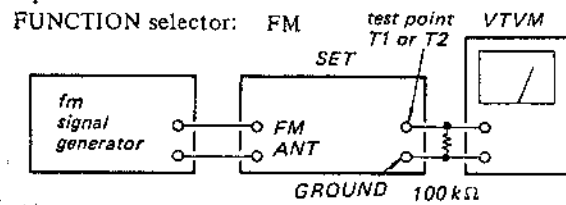

FM Signal Generator Setting:

Carrier frequency: 98 MHz
 Modulation: 400 Hz, 75 kHz deviation (100%)
 Output level: 1 mV (60 dB)

Procedure:

Adjust RT201 for 870 mV on the VTVM.

DISCRIMINATOR ALIGNMENT

Procedure:

- FUNCTION selector: FM
1. Detune the set.
 2. Adjust the secondary side core of IFT201 for zero center on the TUNING meter.

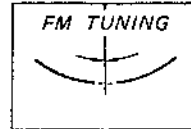

FM IF ALIGNMENT

Setup:

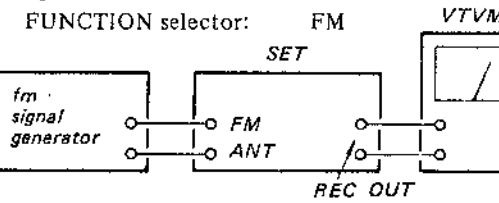

FM Signal Generator Setting:

Carrier frequency: 98 MHz
 Modulation: 400 Hz, 75 kHz deviation (100%)
 Output level: 1 mV (60 dB)

Procedure:

Tune the set to 98 MHz and adjust IFT101 for maximum reading on the VTVM.

MPX ADJUSTMENT

Setup:

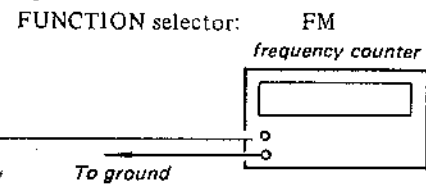

FM Signal Generator Setting:

Carrier frequency: 98 MHz
 Modulation: no modulation
 Output level: 3.2 mV (70 dB)

Procedure:

Adjust RT205 for 19 kHz \pm 100 Hz on the counter with no input signal.

Note: Perform this adjustment after the power switch turned ON and one minute passed.

FM STEREO SEPARATION ADJUSTMENT

Setup:

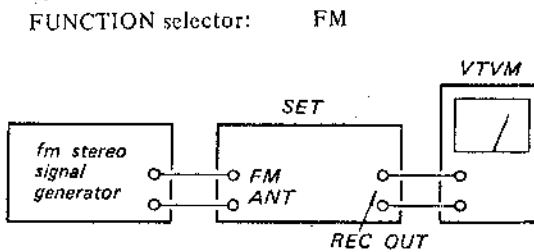

FM Stereo Signal Generator Setting:

Carrier frequency: 98 MHz
 Mode: Stereo
 Audio (400 Hz) Mode: 67.5 kHz (90%)
 Pilot (19 kHz) Mode: 7.5 kHz (10%)

Procedure:

1. Tune the set to 98 MHz.
 2. Set the signal generator channel selector to L-CH.
 3. Connect the VTVM to the REC OUT "L-CH" of the set and read the output level on the VTVM.
 4. Turn the stereo signal generator channel selector from L-CH to R-CH and adjust RT202 for minimum output on the VTVM.
- Note: The output level difference between step 3 and step 4 represents the separation.
5. Connect the VTVM to the REC OUT "R-CH" of the set and read the output level on the VTVM.
 6. Turn the stereo signal generator channel selector from R-CH to L-CH and adjust RT202 for minimum output on the VTVM.
 7. If the separation obtained in step 4 and step 6 differs more than 3 dB in value, readjust RT202 to be less than 3 dB.

MUTING LEVEL ADJUSTMENT

Setup:

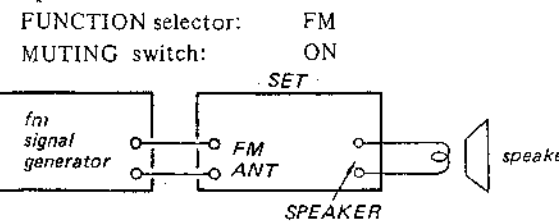

FM Signal Generator Setting:

Carrier frequency: 98 MHz
 Modulation: 400 Hz, 75 kHz deviation (100%)

Procedure:

1. Set the output level of the fm signal generator to 5.6 μ V (15 dB).
2. Adjust R203 for the point that the sound begins to disappear.

SIGNAL METER ADJUSTMENT

Setup:

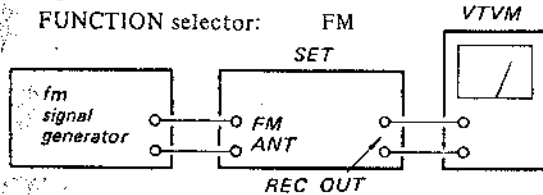

FM Signal Generator Setting:

Carrier frequency: 98 MHz
 Modulation: no modulation
 Output level: 3.2 mV (70 dB)

Procedure:

Tune the set to 98 MHz and adjust RT204 for specified pointer position (See figure below.) on the SIGNAL meter.

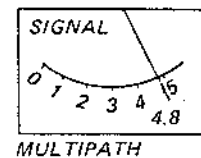

SECTION 4
DIAGRAMS

4-1. MOUNTING DIAGRAM - FRONT-END, FM/AM Boards -
Conductor Side -

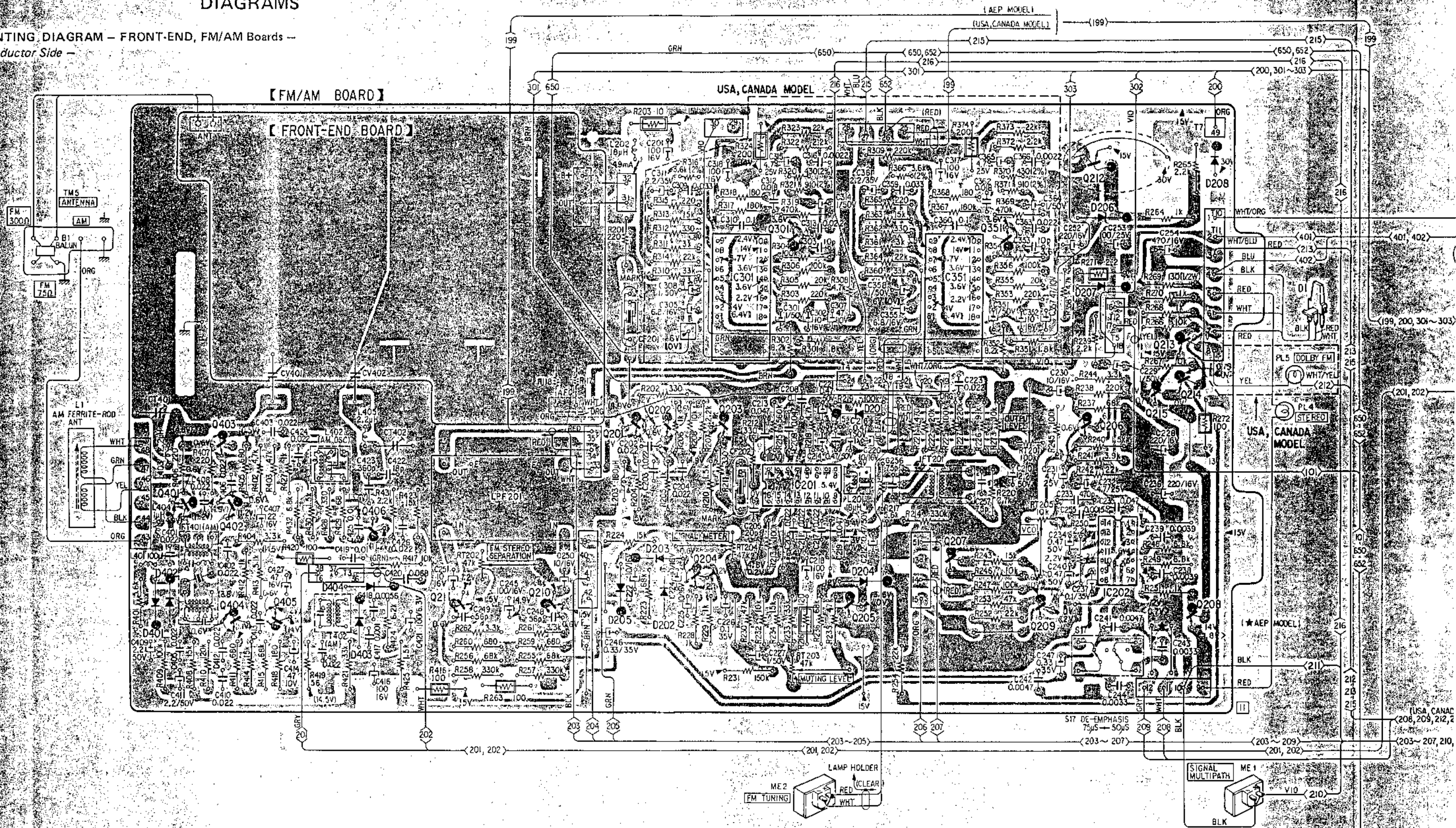

Q & IC	401	403	402 404	405	406	211	210	201	202	204	203	IC301	301	IC201	205	IC351	351	212	206	IC202	215	213	214	208
D	401 402		404	403				205	203	202			201	204				206	207					208

STR-5800/5800SD STR-5800/5800SD

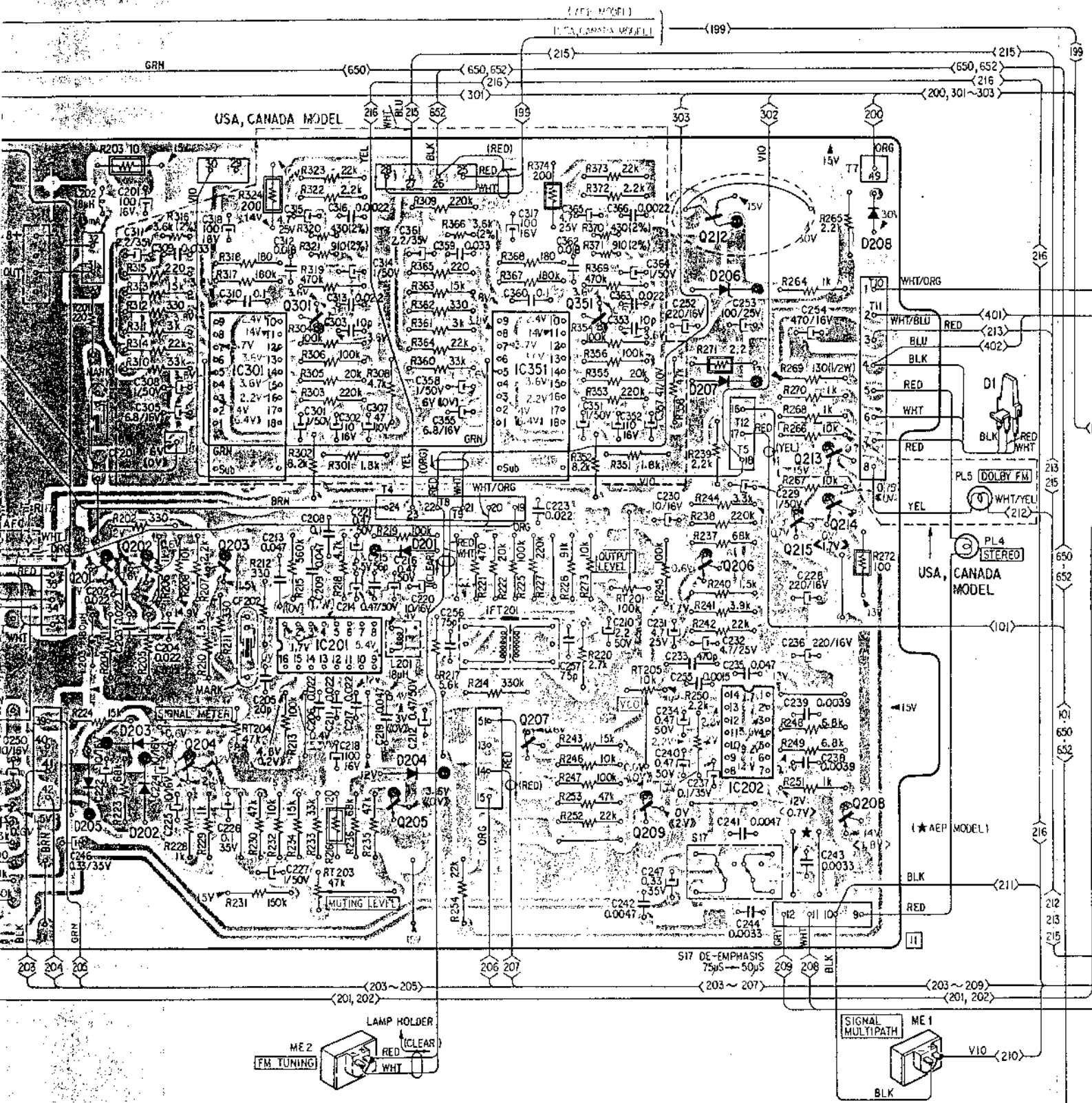

- Q201 ~ 203 : 2SC710
Q405, 406 : 2SC710
- Q208 : 2SA677
- Q204, 205, 207 : 2SC634A
Q209 : 2SC403C
Q401 ~ 404 : 2SC403C
Q206, 210, 211 : 2SC632A
Q301, 351
- Q213 ~ 215 : 2SC945
- Q212 : 2SD291
- D1 : TX312
- D205 : MV203V
- D206 : EQA01-16R
- D207, 208 : 10E2
D201, 403, 404 : 1T22A
D202 ~ 204 : 1T40
- IC201 : HA1137W
- IC202 : HA1156
- IC301, 351 : CX064

Note:

- : B+ pattern
- : nonflammable resistor
- : part number side

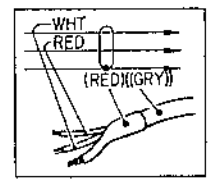

201	202	IC301	301	IC201	205	207	351	212	213	214	208
203	204				209	206	IC202	215	216	208	
205	202			201	204	206	207				

STR-5800/5800SD STR-5800/5800SD

4-2. SCHEMATIC DIAGRAM - FRONT-END, FM/AM Section -

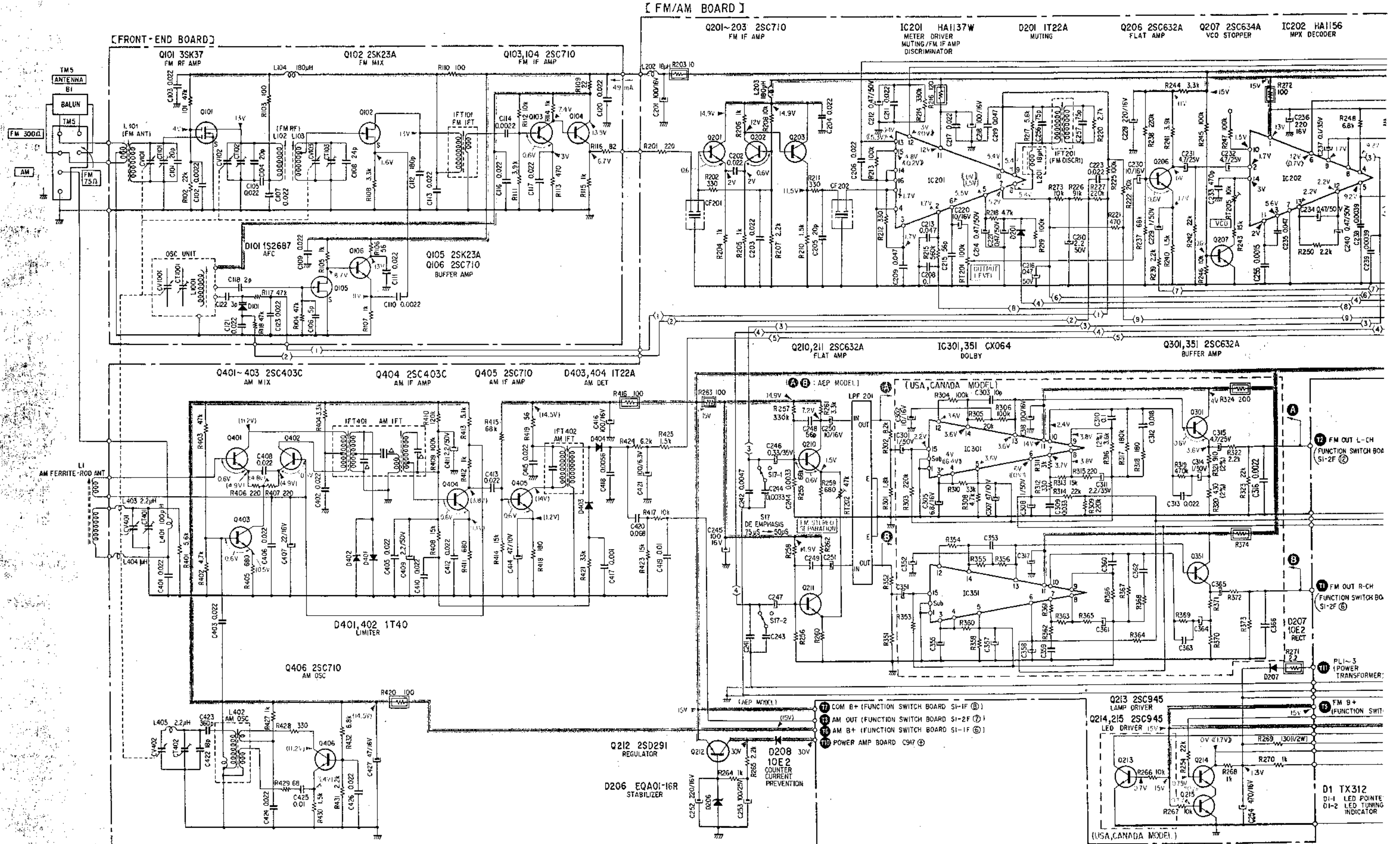

STR-5800/5800SD STR-5800/5800SD

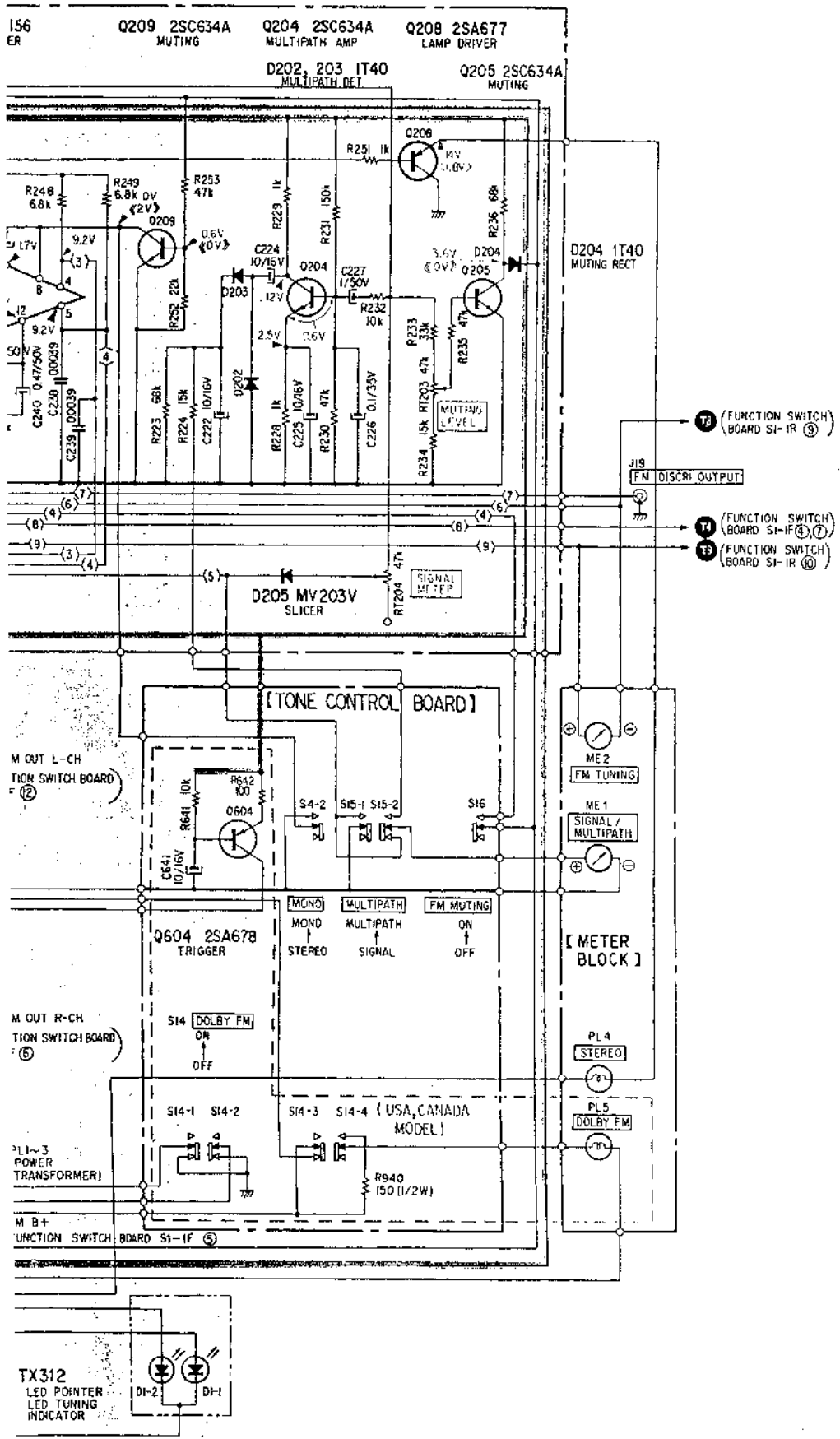

Note:

- All capacitors are in μF unless otherwise noted. 50 or less working volts are omitted except for electrolytic type. $p = \mu\text{F}$.
- All resistors are in Ω , $\frac{1}{2}\text{W}$, unless otherwise noted. $k = 1,000$ $M = 1,000k$
- indicates nonflammable resistor
- indicates internal components
- indicates chassis ground
- (2%) of resistor indicates the tolerance ($\pm 2\%$).
- indicates B+ circuit
- Voltages are DC with respect to ground unless otherwise noted. Readings are taken under no-signal conditions with a VOM (20k Ω /V).
- \llcorner \ggcorner : FM (Tuned in FM signal) \langle \rangle : FM STEREO
- (\llcorner) : DOLBY FM (S14) (\llcorner) : MUTING (S16) (Tuned in FM signal) — ON
- (\llcorner) : MUTING (S16) (no signal input) — ON
- (\llcorner) : FUNCTION (S1) — AM
- no mark: FUNCTION (S1) — FM
- Voltage variations may be noted due to normal production tolerances.
- Voltage between base and emitter are measured with 2.5 V range.
- Switch Mode:

Ref. No.	Switch	Position
S4	MONO	STEREO
S14	DOLBY FM (USA, CANADA MODEL)	OFF
S15	MULTIPATH	SIGNAL
S16	FM MUTING	OFF
S17	DE-EMPHASIS	75 μs

STR-5800/5800SD STR-5800/5800SD

4-3. MOUNTING DIAGRAM - AUDIO Amplifier Boards -
- Conductor Side -

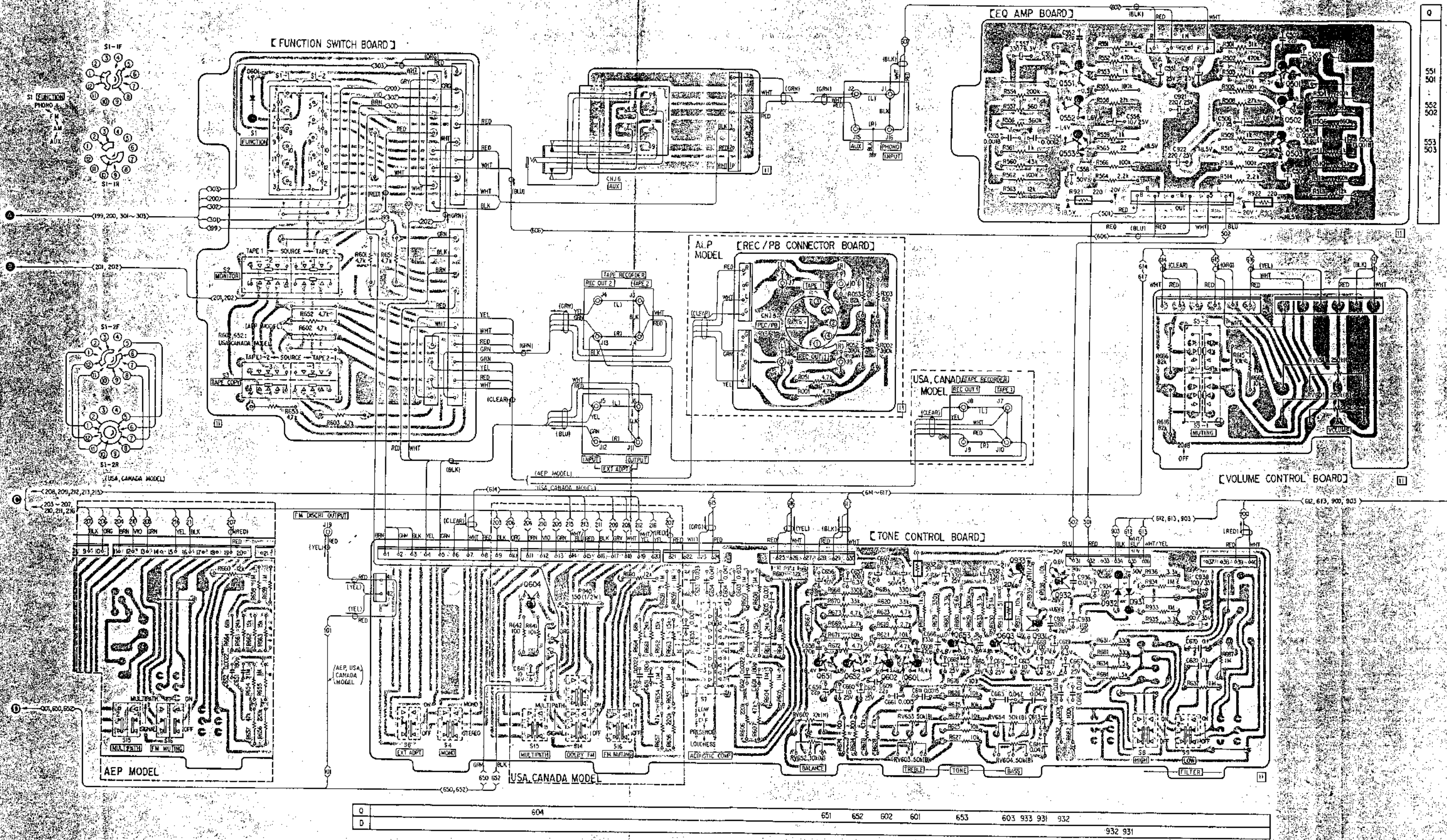

Q
551
552
553

Q 604 651 652 602 601 653 603 933 931 932
D 932 931

STR-5800/5800SD STR-5800/5800SD

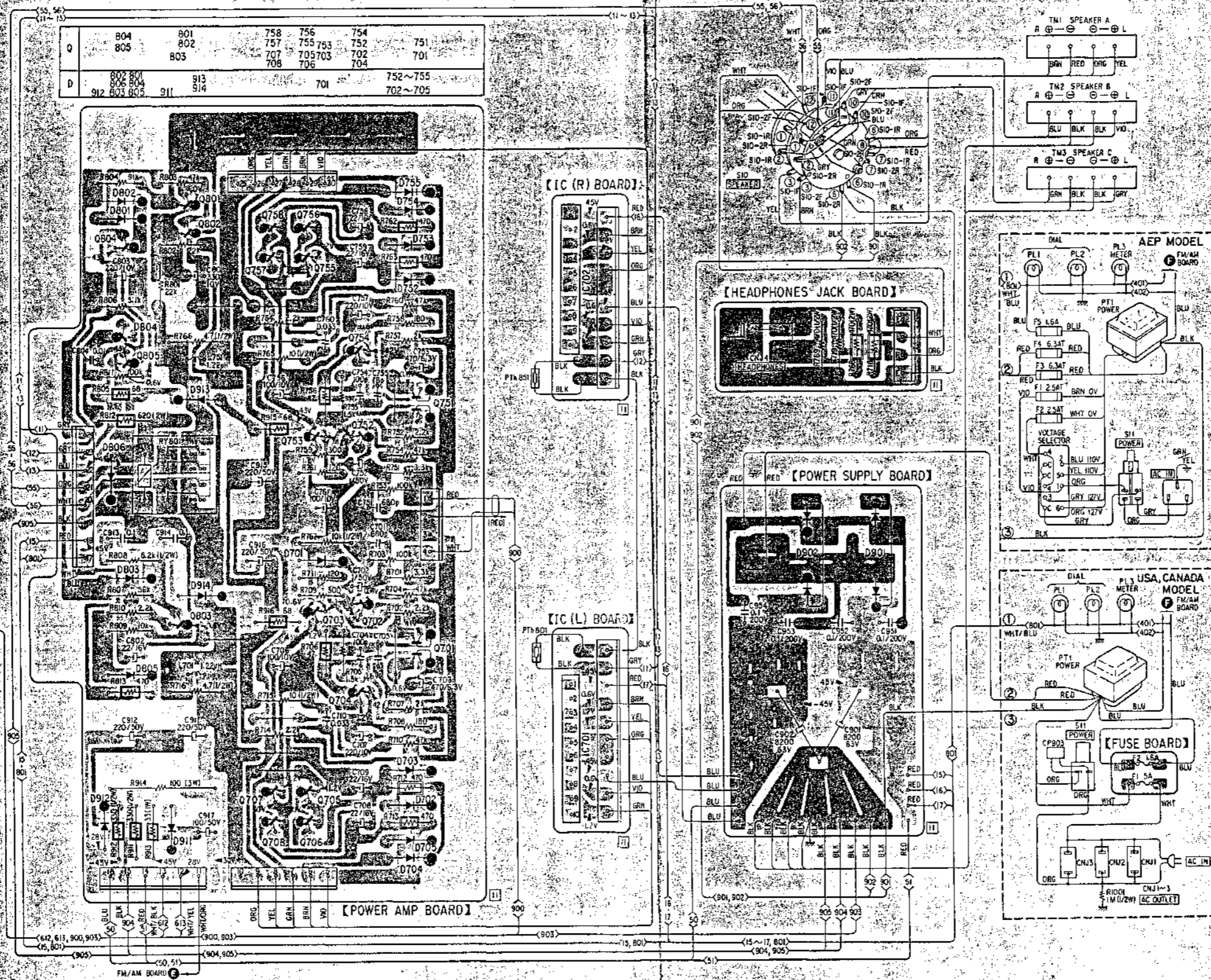

Q501, 551: 2SC1636
Q601, 651:
Q603, 653:
Q706, 756: 2SC632A
Q707, 757:
Q804: 2SC634A

D701: VD1221

D801, 702, 705, 752, 755: 1S1555
D801, 803, 805, 806:
D911, 912: 10E2

Q502, 503, 602, 652:
Q552, 553, 702, 752:
Q705, 755, 804, 708:
Q758, 801~803:
Q933: 2SA677

2SA705
2SA678

D804: 1T243M

Q701, 751: 2SA884

Q703, 753: 2SA896

Q704, 754: 2SC1811
Q805: 2SC1670

Q931: 2SC1124

Q932: 2SA706

IC701, 702: SS120A

Notes:

- B+ pattern
- B- pattern
- nonflammable resistor

4-4. SCHEMATIC DIAGRAM - AUDIO Amplifier Section -

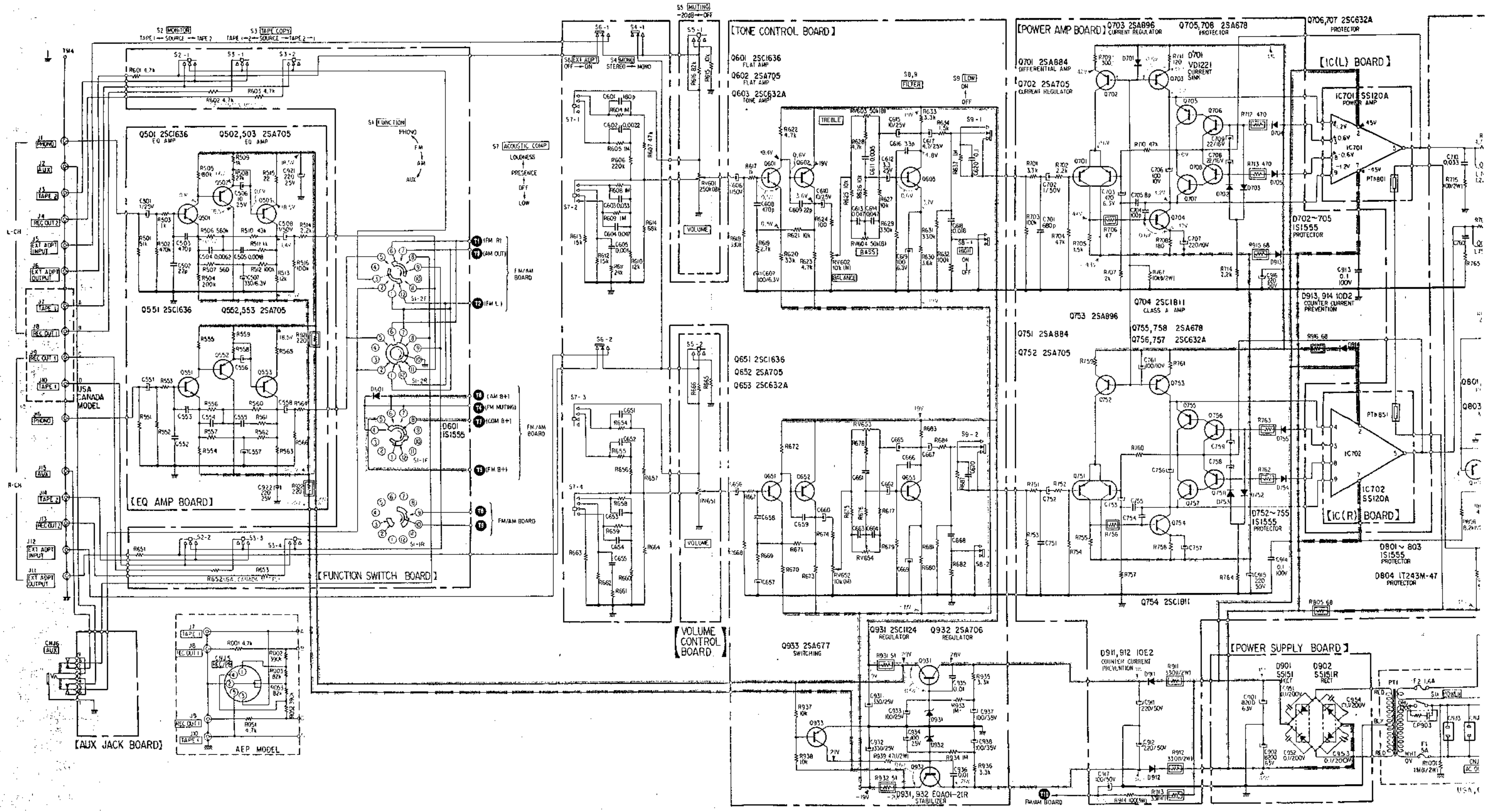

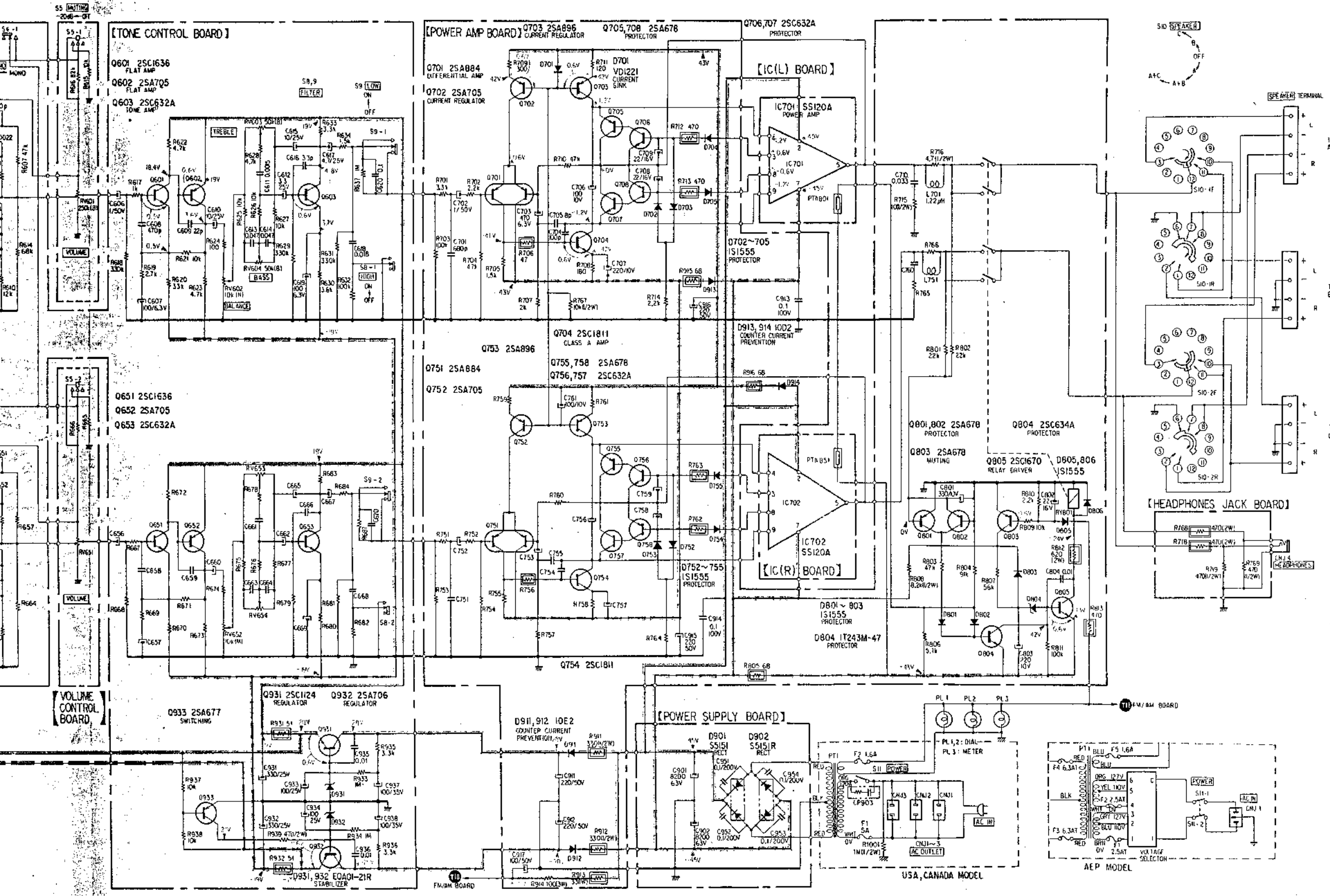

- Note:**
- All capacitors are in μF unless otherwise noted. 50 or less working volts are omitted except for electrolytic type μF .
 - All resistors are in Ω , $\frac{1}{2}\text{W}$, unless otherwise noted. $k = 1,000$ $M = 1,000k$
 - indicates chassis ground.
 - indicates nonflammable resistor.
 - indicates B+ circuit.
 - indicates B- circuit.
 - Voltages are DC with respect to ground unless otherwise noted. Readings are taken under no-signal condition with a VOM (20 $k\Omega/V$).
 - Voltage variations may be noted due to normal production tolerances.
 - Voltage between base and emitter are measured with 2.5 V range.
 - Switch Mode:

Ref. No.	Switch	Position
S1	FUNCTION	FM
S2	MONITOR	SOURCE
S3	TAPE COPY	SOURCE
S4	MONO	STEREO
S5	MUTING	OFF
S6	EXT ADPT	OFF
S7	ACOUSTIC COMP	OFF
S8	HIGH FILTER	OFF
S9	LOW FILTER	OFF
S10	SPEAKER	OFF
S11	POWER	OFF

SECTION 5
EXPLODED VIEWS

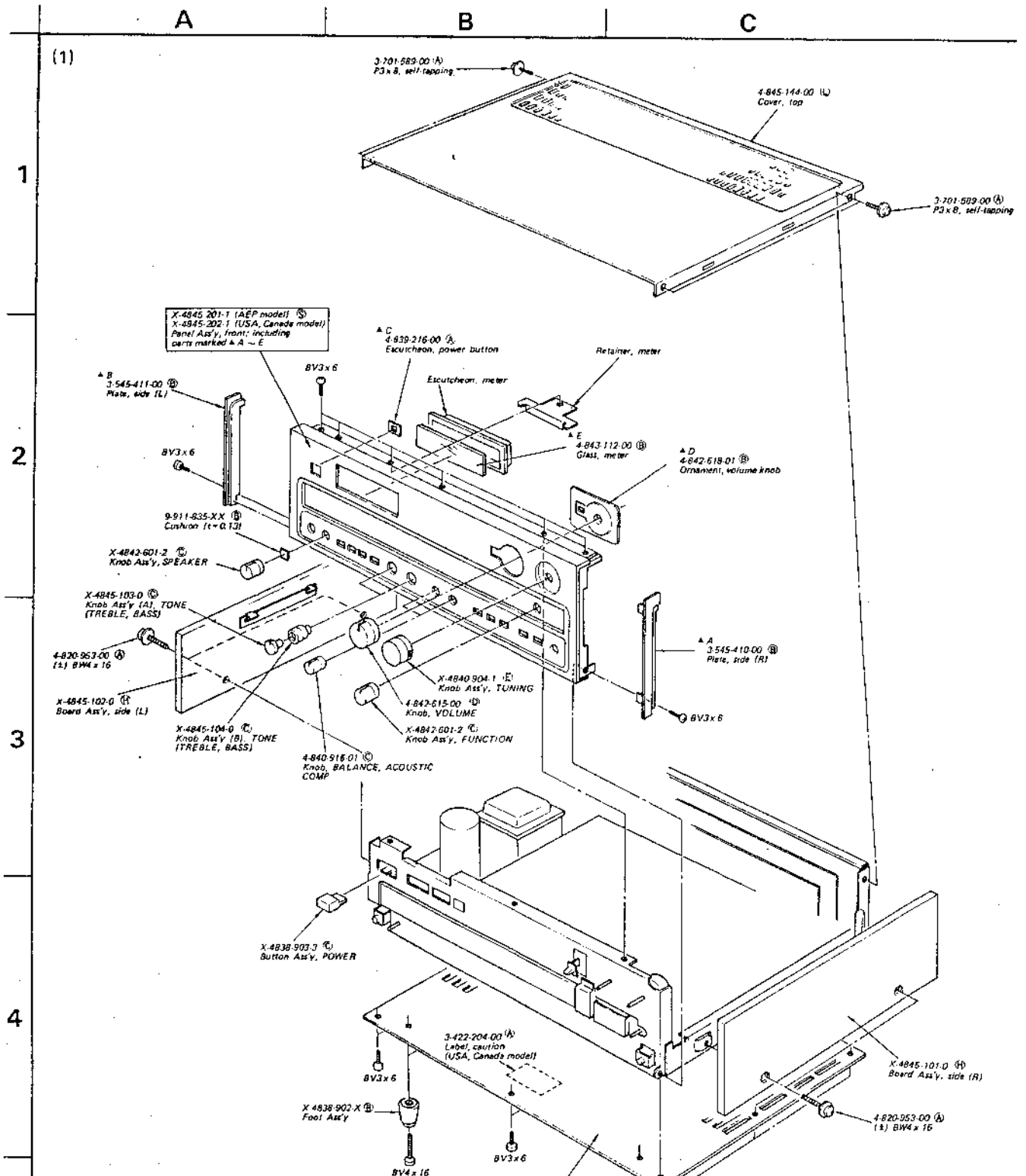

Note:

- Items with no part number and/or no description are not stocked because they are seldom required for routine service.
- All screws are Phillips (cross recess) type unless otherwise noted.
- {-} = slotted head
- [□□] shows the number of coils in spring.
- The circled letters (A) to (Z) are applicable for the European model only.

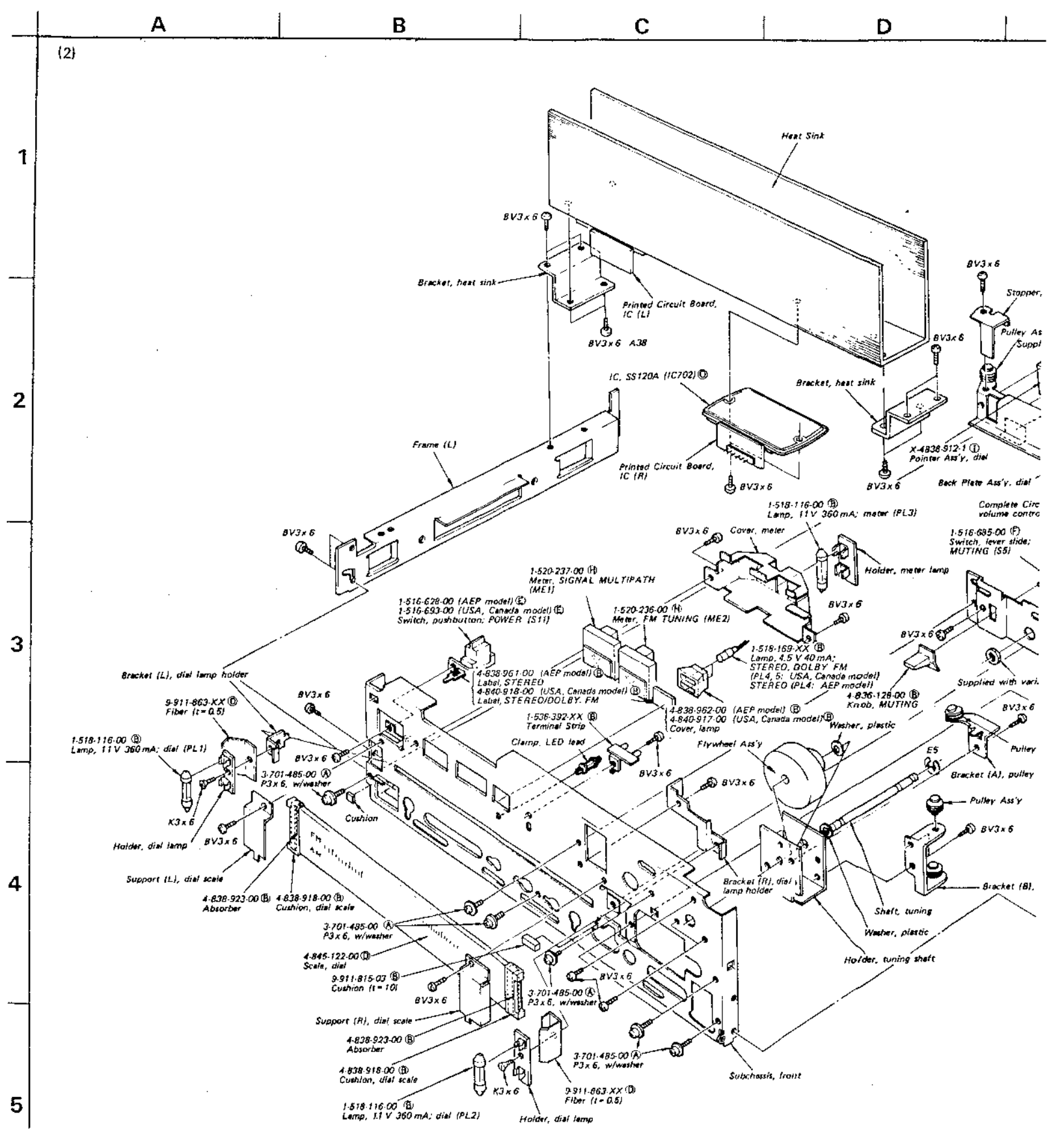

STR-5800/5800SD STR-5800/5800SD

(2)

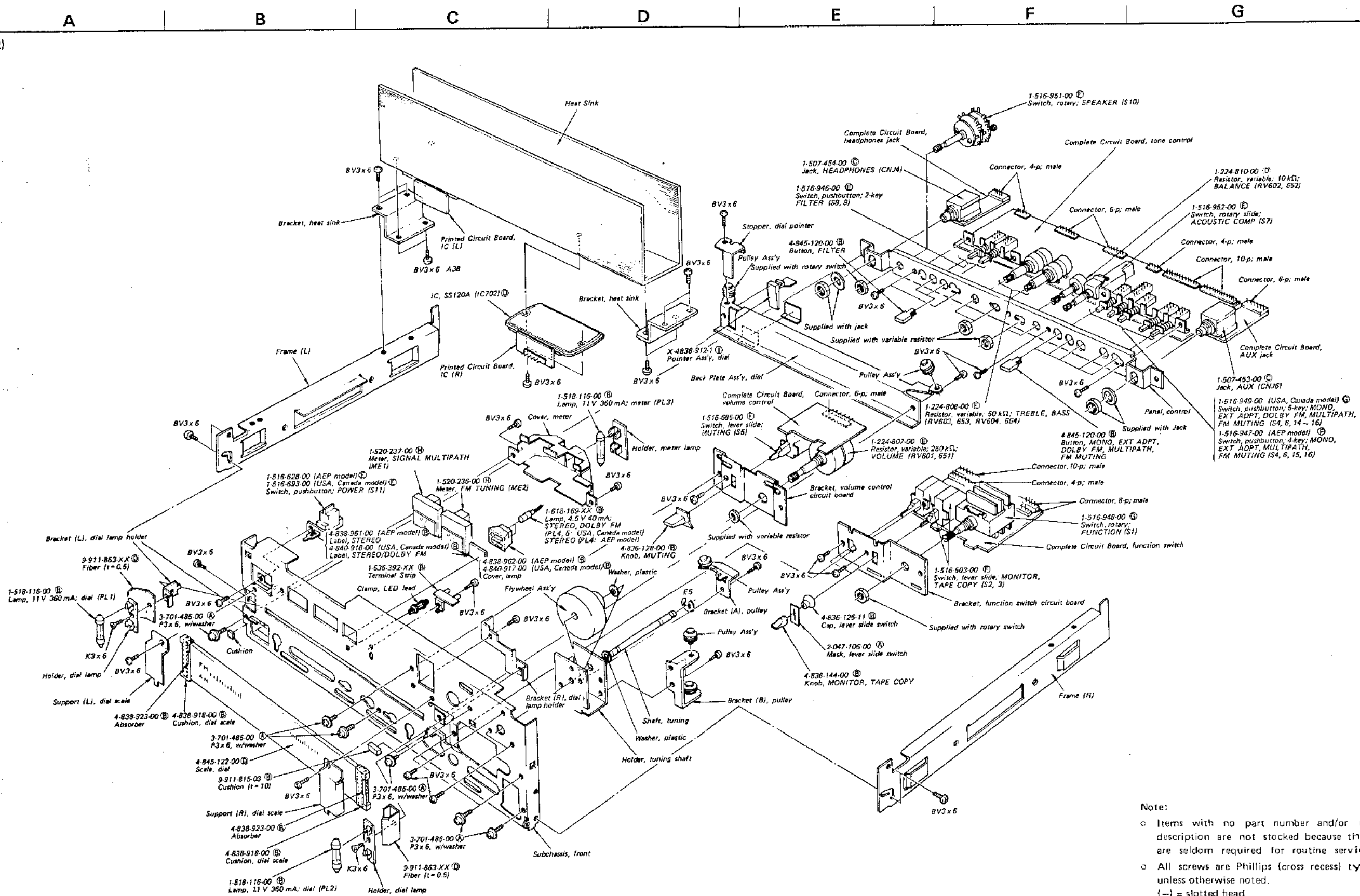

Note:

- Items with no part number and/or no description are not stocked because they are seldom required for routine service.
- All screws are Phillips (cross recess) type unless otherwise noted.
- (-) = slotted head
- (#) shows the number of coils in spring.
- The circled letters (A) to (Z) are applicable for the European model only.

STR-5800/5800SD STR-5800/5800SD

(3)

A B C D E F G

1

2

3

4

5

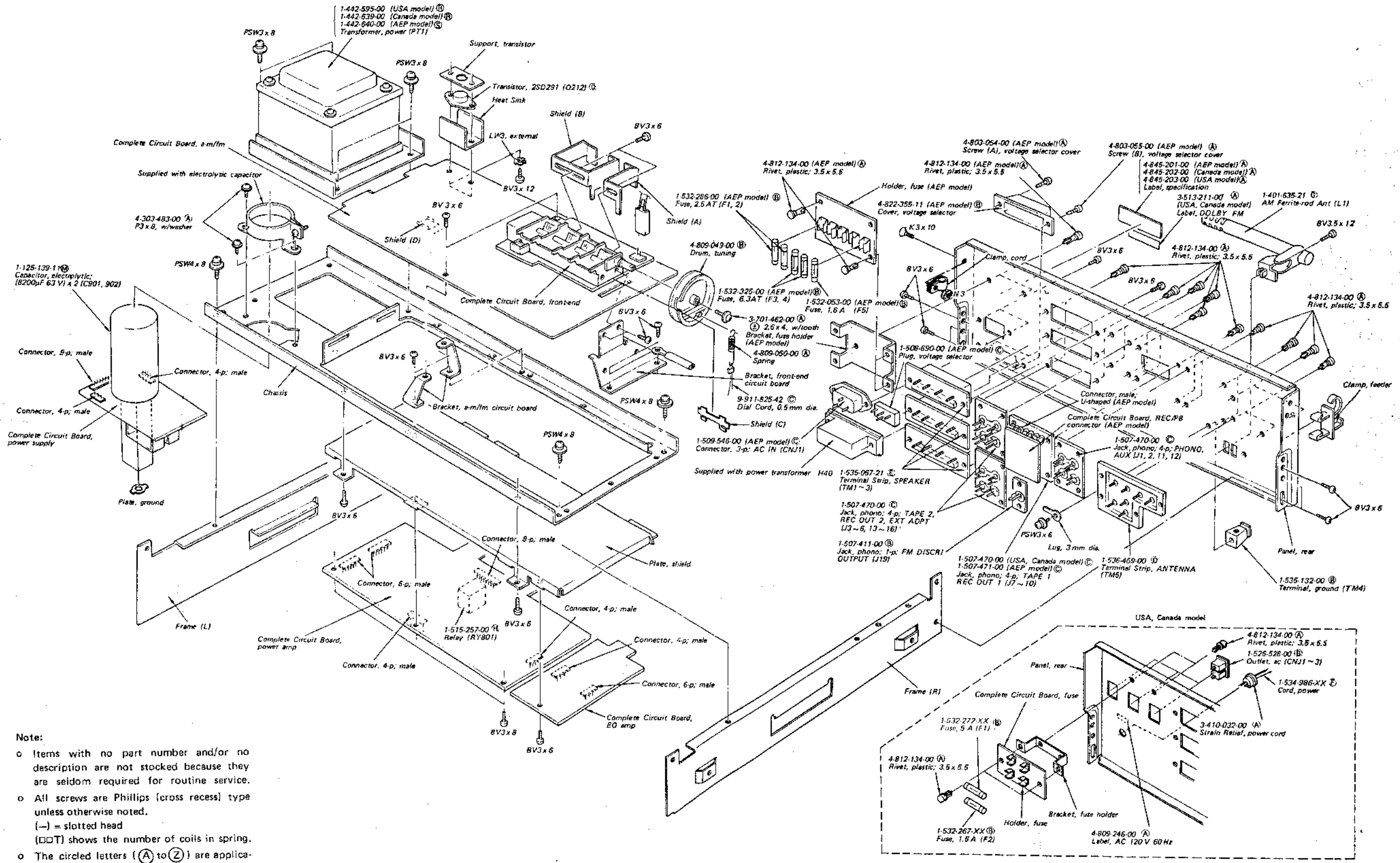

- Note:
- o Items with no part number and/or no description are not stocked because they are seldom required for routine service.
 - o All screws are Phillips (cross recess) type unless otherwise noted.
 - (-) = slotted head
 - (□□T) shows the number of coils in spring.
 - o The circled letters (A) to (Z) are applicable for the European model only.

SECTION 7 ELECTRICAL PARTS LIST

Note: The circled letters (A to Z) are applicable for the European model only.

Note: The circled letters (A to Z) are applicable for the European model only.

Ref. No.	Part No.	Description
SEMICONDUCTORS		
Transistors		
Q101	(E) 3SK37	
Q102	(C) 2SK23A	
Q103, 104	(B) 2SC710	
Q105	(C) 2SK23A	
Q106	(B) 2SC710	
Q201 ~ 203	(B) 2SC710	
Q204, 205	(B) 2SC945	
⇒ Q206	(B) 2SC632A	
Q207	(B) 2SC945	
⇒ Q208	(C) 2SA678	
Q209	(B) 2SC945	
⇒ Q210, 211	(B) 2SC632A	
Q212	(D) 2SD291	
Q213 ~ 215	(B) 2SC945	
⇒ Q301, 351	(B) 2SC632A	
Q401 ~ 404	(B) 2SC403C	
Q405, 406	(B) 2SC710	
Q501, 551	(B) 2SC1636	
Q502, 552	(B) 2SA705	
Q503, 553	(B) 2SA705	
Q601, 651	(B) 2SC1636	
Q602, 652	(B) 2SA705	
Q603, 653	(B) 2SC632A	
Q604	(C) 2SA678	
Q701, 751	(D) 2SA884	
Q702, 752	(B) 2SA705	
Q703, 753	(C) 2SA896	
Q704, 754	(C) 2SC1811	
⇒ Q705, 755	(C) 2SA678	
⇒ Q706, 756	(B) 2SC634A	
⇒ Q707, 757	(B) 2SC634A	
⇒ Q708, 758	(C) 2SA678	
⇒ Q801 ~ 803	(C) 2SA678	
⇒ Q804	(B) 2SC634A	

Ref. No.	Part No.	Description
Q805	(C) 2SC1670	
Q931	(E) 2SC1124	
Q932	(D) 2SA706	
Q933	(C) 2SA678	
ICs		
IC201	(H) HA1137W	
IC202	(J) HA1156	
IC301, 351	(I) CX064	
IC701, 702	(O) SS120A	
D1-1, 1-2	(H) TX312	
D101	(B) 1S2687	
D201	(B) 1T22A	
⇒ D202 ~ 204	(B) 1S1555	
D205	(B) MV203V	
D206	(B) EQA01-16R	
D207, 208	(B) 10E2	
⇒ D401, 402	(B) 1S1555	
D403, 404	(B) 1T22A	
D601	(B) 1S1555	
D701	(B) VD1221	
D702 ~ 705	(B) 1S1555	
D752 ~ 755	(B) 1S1555	
D801 ~ 803	(B) 1S1555	
D804	(B) 1T243M	
D805, 806	(B) 1S1555	
D901	(F) S5151	
D902	(F) S5151R	
D911, 912	(B) 10E2	
D913, 914	(B) 10D2	
⇒ D931, 932	(B) EQB01-21	

THERMISTOR

Pth801, 851 1-800-427-21 (B) Positive

Ref. No.	Part No.	Description
COILS		
L1	1-401-635-21 (C) AM Ferrite-rod Antenna	
L101	1-401-662-00 (B) FM Ant	
L102	1-425-925-00 (B) FM RF	
L103	1-425-926-00 (B) FM RF	
L104	1-407-172-XX (A) Microinductor, 180 μ H	
L201	1-459-152-00 (B) 18 μ H	
L202	1-407-160-XX (A) Microinductor, 18 μ H	
L203	1-407-172-XX (A) Microinductor, 180 μ H	
L401	1-407-169-XX (A) Microinductor, 100 μ H	
L402	1-405-656-00 (B) AM Osc	
L403	1-407-182-XX (A) Microinductor, 2.2 μ H	
L404	1-407-178-XX (A) Microinductor, 1 μ H	
L405	1-407-182-XX (A) Microinductor, 2.2 μ H	

L701, 751 1-420-838-00 (A) 1.2 μ H

TRANSFORMERS

B1	1-417-014-31 (B) Balun	
IFT101	1-403-295-12 (B) FM IFT	
IFT201	1-404-029-00 (C) FM Discriminator	
IFT401	1-404-014-11 (D) AM IFT (USA, Canada models)	
	1-404-014-21 (D) AM IFT (AEP model)	
IFT402	1-403-149-00 (B) AM IFT	
PT1	1-442-595-00 (R) Power (USA model)	
	1-442-639-00 (R) Power (Canada model)	
	1-442-640-00 (S) Power (AEP model)	

FILTERS

CF201, 202	1-527-248-XX (H) Ceramic	
LPF201	1-231-219-00 (D) Low-pass	

CAPACITORS

All capacitors are in μ F and of electrolytic unless otherwise noted. 50 and/or less working voltages are not indicated except for electrolytic type. (p = μ μ F)

Ref. No.	Part No.	Description
C101	1-101-981-11 (A) 20 p	ceramic
C102	1-102-257-11 (A) 0.0022	ceramic
C103	1-101-924-11 (A) 0.022	ceramic
C104	1-101-981-11 (A) 20 p	ceramic
C105	1-101-924-11 (A) 0.022	ceramic
C106	1-102-864-11 (A) 5 p	ceramic
C107	1-101-924-11 (A) 0.022	ceramic
C108	1-102-642-11 (A) 24 p	ceramic
C109	1-101-924-11 (A) 0.022	ceramic
C110	1-101-919-11 (A) 0.0022	ceramic
C111	1-101-924-11 (A) 0.022	ceramic
C112	1-102-848-11 (A) 180 p	ceramic
C113	1-101-924-11 (A) 0.022	ceramic
C114	1-101-919-11 (A) 0.0022	ceramic
C116, 117	1-101-924-11 (A) 0.022	ceramic
C118	1-102-502-11 (A) 2 p	ceramic
C119	(A)	
C120, 121	1-101-924-11 (A) 0.022	ceramic
C122	1-102-503-11 (A) 3 p	ceramic
C123	1-101-924-11 (A) 0.022	ceramic
C201	1-121-415-11 (B) 100 16 V	
C202 ~ 204	1-101-924-11 (A) 0.022	ceramic
C205	1-101-974-11 (A) 20 p	ceramic
C206	1-101-924-11 (A) 0.022	ceramic
C208	1-108-251-12 (B) 0.1	mylar
C209	1-101-925-11 (A) 0.047	ceramic
C210	1-121-450-11 (A) 2.2 50 V	
C211	1-101-924-11 (A) 0.022	ceramic
C212	1-121-726-11 (A) 0.47 50 V	
C213	1-101-925-11 (A) 0.047	ceramic
C214	1-121-726-11 (A) 0.47 50 V	
C215	1-101-884-11 (A) 56 p	ceramic
C216	1-121-726-11 (A) 0.47 50 V	
C217	1-101-924-11 (A) 0.022	ceramic
C218	1-121-415-11 (B) 100 16 V	
C219	1-101-925-11 (A) 0.047	ceramic
C220	1-121-651-11 (A) 10 16 V	
C221	1-121-726-11 (A) 0.47 50 V	
C222	1-121-651-11 (A) 10 16 V	

⇒ : Due to replacement parts, the descriptions are different from the diagrams.

STR-5800/5800SD

Note: The circled letters (A) to (Z) are applicable for the European model only.

Ref. No.	Part No.	Description	
C223	1-101-924-11 (A) 0.022	ceramic	
C224, 225	1-121-651-11 (A) 10	16 V	
C226	1-131-209-11 (B) 0.1	35 V	tantalum
C227	1-121-391-11 (A) 1	50 V	
C228	1-123-068-11 (B) 220	16 V	
C229	1-121-391-11 (A) 1	50 V	
C230	1-121-651-11 (A) 10	16 V	
C231, 232	1-121-395-11 (A) 4.7	25 V	
C233	1-103-717-11 (A) 470p		polystyrol
C234	1-121-726-11 (A) 0.47	50 V	
C235	1-108-246-12 (A) 0.047		mylar
C236	1-123-068-11 (B) 220	16 V	
C237	1-131-209-11 (B) 0.1	35 V	tantalum
C238, 239	1-108-569-12 (B) 0.0039		mylar
C240	1-121-726-11 (A) 0.47	50 V	
C241, 242	1-108-571-12 (A) 0.0047		mylar
C243, 244	1-108-567-12 (A) 0.0033		mylar
C245	1-121-415-11 (B) 100	16 V	
C246, 247	1-131-212-11 (B) 0.33	35 V	tantalum
C248, 249	1-101-884-11 (A) 56 p		ceramic
C250, 251	1-121-651-11 (A) 10	16 V	
C252	1-123-068-11 (B) 220	16 V	
C253	1-121-935-11 (B) 100	25 V	
C254	1-121-939-11 (B) 470	16 V	
C255	1-108-228-12 (A) 0.0015		mylar
C256, 257	1-102-732-11 (A) 75 p		ceramic
USA, Canada models			
C301, 351	1-121-912-11 (A) 1	50 V	
C302, 352	1-121-651-11 (A) 10	16 V	
C303, 353	1-102-947-11 (A) 10 p		ceramic
C305, 355	1-131-198-11 (B) 6.8	16 V	tantalum
C307, 357	1-121-352-11 (A) 47	10 V	
C308, 358	1-121-912-11 (A) 1	50 V	
C309, 359	1-108-244-12 (A) 0.033		mylar
C310, 360	1-108-603-12 (B) 0.1		mylar
C311, 361	1-131-217-11 (B) 2.2	35 V	tantalum
C312, 362	1-108-585-12 (B) 0.018		mylar
C313, 363	1-108-587-12 (A) 0.022		mylar

Ref. No.	Part No.	Description	
USA, Canada models			
C314, 364	1-121-912-11 (A) 1	50 V	
C315, 365	1-121-395-11 (A) 4.7	25 V	
C316, 366	1-108-230-12 (A) 0.0022		mylar
C317, 318	1-121-415-11 (B) 100	16 V	
C401 ~ 403	1-101-924-11 (A) 0.022		ceramic
C405, 406	1-101-924-11 (A) 0.022		ceramic
C407	1-121-479-11 (A) 22	16 V	
C408	1-101-924-11 (A) 0.022		ceramic
C409	1-121-450-11 (A) 2.2	50 V	
C410	1-101-924-11 (A) 0.022		ceramic
C411	1-121-450-11 (A) 2.2	50 V	
C412, 413	1-101-924-11 (A) 0.022		ceramic
C414	1-121-352-11 (A) 47	10 V	
C415	1-101-924-11 (A) 0.022		ceramic
C416	1-121-415-11 (B) 100	16 V	
C417	1-108-227-12 (A) 0.001		mylar
C418	1-108-355-12 (A) 0.0056		mylar
C419	1-108-239-12 (A) 0.01		mylar
C420	1-108-249-12 (A) 0.068		mylar
C421	1-121-413-11 (A) 100	6.3 V	
C422	1-102-953-11 (A) 18 p		ceramic
C423	1-103-714-11 (A) 360 p		polystyrol
C424	1-101-924-11 (A) 0.022		ceramic
C425	1-108-239-12 (A) 0.01		mylar
C426	1-101-924-11 (A) 0.022		ceramic
C427	1-121-409-11 (A) 47	16 V	
C501, 551	1-131-236-11 (B) 1	25 V	tantalum
C502, 552	1-102-959-11 (A) 22 p		ceramic
C503, 553	1-102-114-11 (A) 470 p		ceramic
C504, 554	1-108-574-12 (A) 0.0062		mylar
C505, 555	1-108-561-12 (B) 0.0018		mylar
C506, 556	1-121-398-11 (A) 10	25 V	
C507, 557	1-121-751-11 (B) 330	6.3 V	
C508, 558	1-121-912-11 (A) 1	50 V	
C601, 651	1-102-976-11 (A) 180 p		ceramic
C602, 652	1-108-230-12 (A) 0.0022		mylar
C603, 653	1-108-244-12 (A) 0.033		mylar
C604, 654	1-108-246-12 (A) 0.047		mylar

R-5800/5800SD

Note: The circled letters (A to Z) are applicable for the European model only.

Ref. No.	Part No.	Description
C605, 655	1-108-227-12 (A) 0.001	mylar
C606, 656	1-121-912-11 (A) 1	50 V
C607, 657	1-121-413-11 (A) 100	6.3 V
C608, 658	1-102-114-11 (A) 470p	ceramic
C609, 659	1-102-959-11 (A) 22p	ceramic
C610, 660	1-121-748-11 (A) 10	25 V
C611, 661	1-108-228-12 (A) 0.0015	mylar
C612, 662	1-121-913-11 (A) 3.3	25 V
C613, 663	1-108-246-12 (A) 0.047	mylar
C614, 664		
C615, 665	1-121-748-11 (A) 10	25 V
C616, 666	1-102-963-11 (A) 33p	ceramic
C617, 667	1-121-915-11 (A) 4.7	25 V
C618, 668	1-108-585-12 (A) 0.018	mylar
	(USA, Canada models)	
C619, 669	1-121-413-11 (A) 100	6.3 V
C620, 670	1-108-603-12 (B) 0.1	mylar
C641	1-121-651-11 (A) 10	16 V
	(USA, Canada models)	
C641	1-121-651-11 (A) 10	16 V
C701, 751	1-102-116-11 (A) 680p	ceramic
C702, 752	1-121-912-11 (A) 1	50 V
C703, 753	1-123-077-11 (B) 470	6.3 V
C704, 754	1-102-973-11 (A) 100p	ceramic
C705, 755	1-102-945-11 (A) 8p	ceramic
C706, 756	1-121-414-11 (A) 100	10 V
C707, 757	1-123-072-11 (B) 220	10 V
C708, 758	1-121-479-11 (A) 22	16 V
C709, 759		
C710, 760	1-108-244-12 (A) 0.033	mylar
C761	1-121-414-11 (A) 100	10 V
C801	1-123-073-11 (B) 330	10 V
C802	1-121-479-11 (A) 22	16 V
C803	1-123-072-11 (B) 220	10 V
C804	1-101-004-11 (A) 0.01	ceramic
C901, 902	1-125-139-11 (M) 8,200	63 V
C911, 912	1-121-937-11 (B) 220	50 V
C913, 914	1-108-389-12 (B) 0.1	100 V mylar
C915, 916	1-121-937-11 (B) 220	50 V

Ref. No.	Part No.	Description
C917	1-123-059-11 (B) 100	50 V
C921, 922	1-121-936-11 (B) 20	25 V
C931, 932	1-123-065-11 (B) 30	25 V
C933, 934	1-121-935-11 (B) 100	25 V
C935, 936	1-102-129-11 (A) 0.01	ceramic
C937, 938	1-123-062-11 (B) 100	35 V
C951 ~ 954	1-106-505-12 (B) 1	200 V mylar
CT401, 402	1-141-147-XX (B) 1	trimmer

RESISTORS

All resistors are in ohms. Regular-type 1/4 W carbon resistors are omitted.

Check the schematic diagram for the resistance values.

(k = 1000, M = 1000 k)

R203	1-211-498-11 (A) 10	1/4 W carbon (nonflammable)
R216	1-211-524-11 (A) 120	1/4 W carbon (nonflammable)
R263	1-211-522-11 (A) 100	1/4 W carbon (nonflammable)
R269	1-202-552-11 (A) 330	1/2 W composition
R271	1-217-379-11 (B) 2.2	1/4 W fusible (nonflammable)
R272	1-211-522-11 (A) 100	1/4 W carbon (nonflammable)

USA, Canada models

R316, 366	1-210-871-11 (A) 3.6 k	±2% 1/4 W carbon
R320, 370	1-210-873-11 (A) 430	±2% 1/4 W carbon
R321, 371	1-210-851-11 (A) 910	±2% 1/4 W carbon
R324, 374	1-211-529-11 (A) 200	1/4 W carbon (nonflammable)

R416, 420	1-211-522-11 (A) 100	1/4 W carbon (nonflammable)
R712, 762	1-211-538-11 (A) 470	1/4 W carbon (nonflammable)
R713, 763		
R706, 756	1-211-514-11 (A) 47	1/4 W carbon (nonflammable)
R715, 765	1-202-525-11 (A) 10	1/2 W composition
R716, 766	1-202-517-11 (A) 4.7	1/2 W composition

STR-5800/5800S

Note: The circled letters (A) to (Z) are applicable for the European model only.

Ref. No.	Part No.	Description
R718, 768	1-206-656-11 (A) 470	2W metal-oxide (nonflammable)
R719, 769	1-202-565-11 (A) 470	1/4W composition
R767	1-202-597-11 (A) 10k	1/4W composition
R805	1-211-518-11 (A) 68	1/4W carbon (nonflammable)
R808	1-202-595-11 (A) 5.2k	1/2W composition
R812	1-206-659-11 (A) 620	2W metal-oxide (nonflammable)
R813	1-211-539-11 (A) 470	1/4W carbon (nonflammable)
R911, 912	1-212-994-11 (A) 330	1/4W carbon (nonflammable)
R913	1-213-125-11 (A) 33	1W metal-oxide (nonflammable)
R914	1-207-665-11 (B) 100	3W wirewound (nonflammable)
R915, 916	1-211-518-11 (A) 68	1/4W carbon (nonflammable)
R921, 922	1-211-530-11 (A) 220	1/4W carbon (nonflammable)
R931, 932	1-211-515-11 (A) 51	1/4W carbon (nonflammable)
R939	1-202-541-11 (A) 47	1/2W composition
R940	1-202-553-11 (A) 150	1/2W composition (USA, Canada models)
R1001	1-202-719-11 (A) 1M	1/4W composition (USA, Canada models)
RT201	1-224-648-XX (B) 100k	adjustable
RT202~204	1-224-647-XX (B) 47k	adjustable
RT205	1-224-645-XX (B) 10k	adjustable
RV601, 651	1-224-807-00 (E) 250k	variable, VOLUME
RV602, 652	1-224-810-00 (D) 10k	variable, BALANCE
RV603, 653	1-224-808-00 (E) 50k	variable, TONE
RV604, 654		(TREBLE, BASS)

SWITCHES

S1	1-516-948-00 (G)	Rotary, FUNCTION
S2, 3	1-516-603-00 (F)	Lever Slide, MONITOR, TAPE COPY
S4, 6 S14~16	1-516-949-00 (G)	Pushbutton, 5-key; MONO, EXT ADPT, DOLBY FM, MULTIPATH, FM MUTING (USA, Canada models)

Ref. No.	Part No.	Description
S4, 6, 15, 16	1-516-947-00 (F)	Pushbutton, 5-key; MONO, EXT ADPT, MULTIPATH, FM MUTING (AEP model)
S5	1-516-685-00 (F)	Lever Slide, MUTING
S7	1-516-952-00 (F)	Rotary Slide, ACOUSTIC COMP
S8, 9	1-516-946-00 (E)	Pushbutton, 2-key; FILTER
S10	1-516-951-00 (F)	Rotary, SPEAKER
S11	1-516-628-00 (E)	Pushbutton, POWER (AEP model)
	1-516-693-00 (E)	Pushbutton, POWER (USA, Canada models)
S17	1-516-954-00 (B)	De-emphasis

FUSES

F1	1-532-272-XX (B) 5 A	(USA, Canada models)
F2	1-532-267-XX (B) 1.6 A	(USA, Canada models)
F1, 2	1-532-286-00 (B) 2.5 AT	(AEP model)
F3, 4	1-532-325-00 (B) 6.3 AT	(AEP model)
F5	1-532-053-00 (B) 1.6 A	(AEP model)

JACKS

CNJ1~3	1-526-528-00 (B)	Outlet, ac (USA, Canada models)
CNJ1	1-509-546-00 (C)	Connector, 3-p; AC IN (AEP model)
CNJ4	1-507-454-00 (C)	HEADPHONES
CNJ5	1-509-549-00 (B)	Connector, REC/PB (AEP model)
CNJ6	1-507-453-00 (C)	AUX
J1~6	1-507-470-00 (C)	Phono, 4-p; PHONO, AUX, TAPE 2 REC OUT2, EXT ADPT
J11~16		Phono, 4-p; TAPE 1, REC OUT1 (AEP model)
J7~10	1-507-470-00 (C)	Phono, 4-p; TAPE 1, REC OUT1 (USA, Canada models)
J19	1-507-411-00 (B)	Phono, 1-p; FM DISCRI OUTPUT

MISCELLANEOUS

CP903	1-231-057-31 (B)	Encapsulated Component (USA, Canada models)
ME1	1-520-237-00 (H)	Meter, SIGNAL MULTIPATH
ME2	1-520-236-00 (H)	Meter, FM TUNING
PL1~3	1-518-116-00 (B)	Lamp, 11 V 360 mA; dial, meter
PL4	1-518-169-XX (B)	Lamp, 4.5 V 40 mA; STEREO

Note: The circled letters (A to Z) are applicable for the European model only.

<u>Ref. No.</u>	<u>Part No.</u>	<u>Description</u>
PL5	1-518-169-XX	(B) Lamp, 4.5 V 40 mA; DOLBY FM (USA, Canada models)
RY801	1-515-257-00	(H) Relay
TM1 ~ 3	1-535-057-21	(E) Terminal Strlp, SPEAKER
TM4	1-535-132-00	(B) Terminal, ground
TM5	1-536-469-00	(D) Terminal Strip, ANTENNA

<u>Ref. No.</u>	<u>Part No.</u>	<u>Description</u>
	1-508-690-00	(C) Plug, voltage selector (AEP model)
	1-536-392-XX	(B) Terminal Strip
	1-534-986-XX	(F) Cord, power (USA, Canada models)

ACCESSORIES AND PACKING MATERIALS

<u>Part No.</u>	<u>Description</u>	<u>Part No.</u>	<u>Description</u>
X-4490-002-1	(B) Cloth Ass'y, polishing	3-780-940-11	(H) Manual, instruction (AEP model)
1-501-161-00	(D) Ribbon Antenna, fm	3-780-940-21	(H) Manual, instruction (USA, Canada models)
1-506-113-00	(A) Plug, shorting	3-793-990-31	(A) Manual, instruction; French edition (Canada model)
3-701-020-00	(A) Bag, plastic; instruction manual	4-828-909-00	(B) Bag, plastic; unit
3-701-356-01	(A) Label, tack (Canada model)	4-845-131-00	(C) Cushion
3-701-360-02	(A) Label, tack (AEP model)	4-845-207-00	(H) Carton (USA, Canada models)
3-701-657-01	(A) Label, tack (USA model)	4-845-208-00	(H) Carton (AEP model)