

SL-F30E / UB / EC

RMT-230 / 231

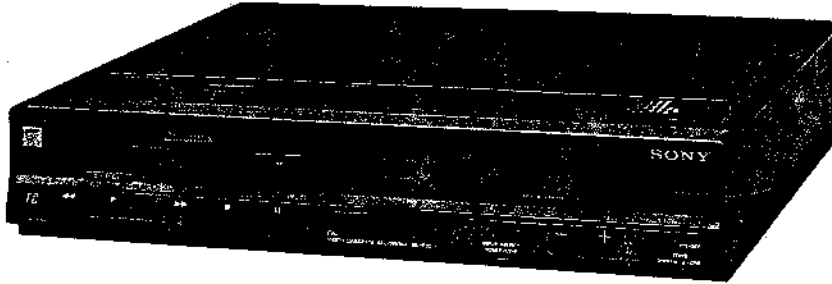

SERVICE MANUAL



AEP Model
UK Model
E Model
REMOTE COMMANDER
RMT-230

EC Model
REMOTE COMMANDER
RMT-231

November, 1984

711B2 CHASSIS

SPECIFICATIONS

This manual contains the adjustment method.

System

Video recording system

Rotary two-head helical scanning

Video signal CCIR standards, PAL colour

Aerial input 75-ohm, asymmetrical aerial socket

Channel coverage

SL-F30EC

VHF: Western European channels

E2-U20

UHF: Western European channels

E21-E68

(Up to 30 programmes can be preset.)

SL-F30E

VHF: Western European channels

E2 - E12

UHF: Western European channels

E21 - E68

(Up to 12 programmes can be preset.)

SL-F30UB

UHF: European channels 21-68

(Up to 12 programmes can be preset.)

RF output signal

UHF channels 30 to 39 (variable)

75 ohms, unbalanced

Video

Input

VIDEO IN: BNC connector

1.0 V $\begin{matrix} +1.0 \\ -0.5 \end{matrix}$ V (p-p)

75 ohms, unbalanced,

sync negative

Output

VIDEO OUT: BNC connector

1.0 V (p-p) ± 0.1 V (p-p)

75 ohms, unbalanced,

sync negative

Horizontal resolution

260 lines

Signal-to-noise ratio

Colour: Better than 40 dB

B/W: Better than 43 dB

Audio

Input

AUDIO IN: phono jack

47 kilohms, -10 dBs

(0 dBs = 0.775 V rms)

Output

AUDIO OUT: phono jack

Load impedance less than

10 kilohms

-10 dBs with 47 kilohms load,

unbalanced

Frequency response

50 Hz to 10 kHz

Signal-to-noise ratio

40 dB

Audio distortion

Less than 4 % at 400 Hz

— Continued on next page —



Beta



VIDEO CASSETTE RECORDER
SONY

Tape transport

Tape speed 18.73 mm/sec.
Maximum recording time
2 hours 10 min. (with Sony L-500
cassette)
3 hours 15 min. (with L-750)
Fast forward/rewind time
Within 5 min. (with L-500)

Timer

Clock Crystal lock
Time indication 24-hour cycle
Timer setting Only for recording
1 event/3 weeks, adjustable for any day
or for all 7 days of the week

General

Power requirements

SL-F30EC: 220 V AC \pm 10 %, 50/60 Hz
SL-F30E (AEP MODEL): 220 V AC \pm 10%,
50/60 Hz
SL-F30E (E MODEL): 110 - 127 V or
220 - 240 V AC adjustable, 50/60 Hz
SL-F30UB: 240 V AC, 50/60 Hz

Power consumption

38 W

Storage temperature

-20° C to + 65° C (-4° F to + 149° F)

Operating temperature

5° C to 40° C (41° F to 104° F)

Dimensions

Approx. 430 × 80 × 382 mm (w/h/d)

(17 × 3¹/₄ × 15¹/₈ inches)

including projecting parts and controls

Weight

Approx. 8.2 kg (18 lbs 1 oz) net

Accessories supplied

75-ohm coaxial cable for recorder to TV
connection (1)

Remote Commander RMT-231 (SL-F30EC) or RMT-230
(SL-F30E, SL-F30UB) with two IEC designation R6
batteries (1)

RF channel adjustment screwdriver (1)

Design and specifications subject to change without
notice.

SAFETY CHECK-OUT

After correcting the original service problem, perform the following
safety checks before releasing the set to the customer:

1. Check the area of your repair for unsoldered or poorly-soldered connections. Check the entire board surface for solder splashes and bridges.
2. Check the interboard wiring to ensure that no wires are "pinched" or contact high-wattage resistors.
3. Look for unauthorized replacement parts, particularly transistors, that were installed during a previous repair. Point them out to the customer and recommend their replacement.
4. Look for parts which, though functioning, show obvious signs of deterioration. Point them out to the customer and recommend their replacement.
5. Check the B+ voltage to see it is at the values specified.

SAFETY-RELATED COMPONENT WARNING !!

COMPONENTS IDENTIFIED BY SHADING AND MARK
▲ ON THE SCHEMATIC DIAGRAMS, EXPLODED
VIEWS AND IN THE PARTS LIST ARE CRITICAL TO
SAFE OPERATION. REPLACE THESE COMPONENTS
WITH SONY PARTS WHOSE PART NUMBERS APPEAR
AS SHOWN IN THIS MANUAL OR IN SUPPLEMENTS
PUBLISHED BY SONY. CIRCUIT ADJUSTMENTS
THAT ARE CRITICAL TO SAFE OPERATION ARE
IDENTIFIED IN THIS MANUAL. FOLLOW THESE PRO-
CEDURES WHENEVER CRITICAL COMPONENTS ARE
REPLACED OR IMPROPER OPERATION IS SUSPECTED.

TABLE OF CONTENTS

<u>Section</u>	<u>Title</u>	<u>Page</u>	<u>Section</u>	<u>Title</u>	<u>Page</u>
1. GENERAL			3-12.	PG Signal Timing Chart	41
1-1.	Model Identification — Specification Label —	4	3-13.	Audio Level Diagram (REC)	42
1-2.	Location and Function of Controls	5	3-14.	Audio Level Diagram (PB)	42
1-3.	Adjusting the TV	8	3-15.	Audio Block Diagram	43
1-4.	TV Station Programming	9	3-16.	Tuner Block Diagram	45
1-5.	Clock Setting	10	3-17.	Timer Block Diagram	47
1-6.	TV Programme Recording	11	3-18-1.	Power Block Diagram (AEP, UK, EC Model)	49
1-7.	Timer-Activated Recording	12	3-18-2.	Power Block Diagram (E Model)	51
1-8.	Quick Timer Recording	14	4. SCHEMATIC DIAGRAM AND PRINTED WIRING BOARDS		
2. DISASSEMBLY			4-1.	Flame Schematic Diagram	55
2-1.	Disassembly of Cabinet	15	4-2.	YC-31, RP-20 Boards	59
2-2.	Removal of the RP-20 Board	16	4-3.	SS-34, RD-20, RD-21, LM-8, FU-25, N, CAPSTAN MOTOR, R, STATOR Boards	67
2-3.	Removal of the TA-22 Board	17	4-4.	TA-22, MT-10, TM-57, TM-58 Boards	75
2-4.	Removal of the YC-31 Board	17	4-5-1.	PS-45, PS-46, PS-69 Boards (AEP, UK, EC Model)	82
2-5.	Removal of the Timer Block	18	4-5-2.	PS-67, PS-76, VS-4 Boards (E Model)	87
2-6.	Removal of the FU-25 Board	18	4-6.	Semiconductors	91
2-7-1.	Removal of the Power Block (AEP, UK, EC Model)	19	4-7.	UHF and Tuner Schematic Diagram (AEP, E Model)	93
2-7-2.	Removal of the Power Block (E Model)	19	4-8.	UHF Tuner Schematic Diagram (UK Model)	93
2-8.	Removal of the FL Cassette Compartment Assembly	20	4-9.	UHF and VHF Tuner Schematic Diagram (EC Model)	94
2-9.	Removal of the Reel Block Assembly	20	5. EXPLODED VIEWS		
2-10.	Internal View	21	5-1.	Front Panel and Cabinet Assemblies	95
3. DIAGRAMS			5-2-1.	Tuner, Timer and Power Assemblies (AEP, UK, EC Model)	96
3-1.	Circuit Boards Location	22	5-2-2.	Tuner, Timer and Power Assemblies (E Model)	97
3-2.	Overall Block Diagram	23	5-3.	Front Loading Assembly	98
3-3.	Video Block Diagram	26	5-4.	Chassis Assembly 1	99
3-4.	System Control Block Diagram	29	5-5.	Chassis Assembly 2	100
3-5.	System Control Interface	31	5-6.	Drum Assembly	101
3-6.	Servo Block Diagram	37	5-7.	Reel Block Assembly	102
3-7.	Capstan Phase System Timing Chart (REC)	39	5-8.	Hardware List	103
3-8.	Capstan Phase System Timing Chart (PB)	39	6. ELECTRICAL PARTS LIST	104	
3-9.	Capstan Speed System Timing Chart	40	7. ADJUSTMENT	123	
3-10.	Drum Phase System Timing Chart	40	REMOTE COMMANDER RMT-230	171	
3-11.	Drum Speed System Timing Chart	41	REMOTE COMMANDER RMT-231	177	

1-1. MODEL IDENTIFICATION
 - Specification Label -

EC MODEL

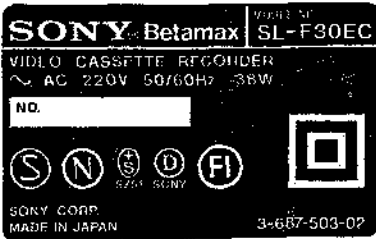

UK MODEL

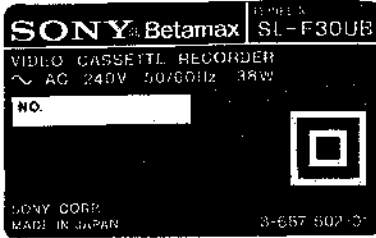

AEP MODEL



E MODEL

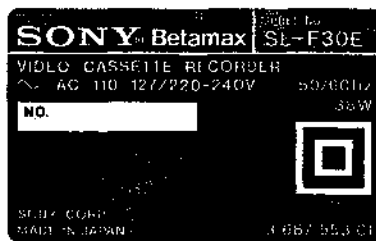

NOTE ON TYPES OF SL-F30EC, SL-F30E AND SL-F30UB

This service manual covers four types of models: SL-F30EC, SL-F30E (AEP), SL-F30E (E) and SL-F30UB.

The principal differences among the models are indicated in the following table. The differences are clearly mentioned in the text as required.

Model	Operating voltage and frequency	Programmable stations	Supplied Remote Commander
SL-F30EC	220V AC, 50/60Hz	30	RMT-231
SL-F30E AEP model	220V AC, 50/60Hz	12	RMT-230
SL-F30E E model	110-127V or 220-240V AC adjustable, 50/60Hz	12	RMT-230
SL-F30UB	240V AC, 50/60Hz	12	RMT-230

For the SL-F30E E model

Before operating the unit to the power source, set the voltage selector at the rear to the appropriate position according to your local power supply.

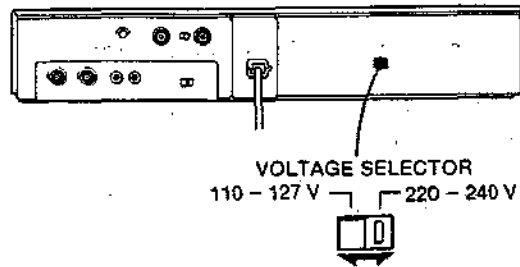

1-2. LOCATION AND FUNCTION OF CONTROLS

Front

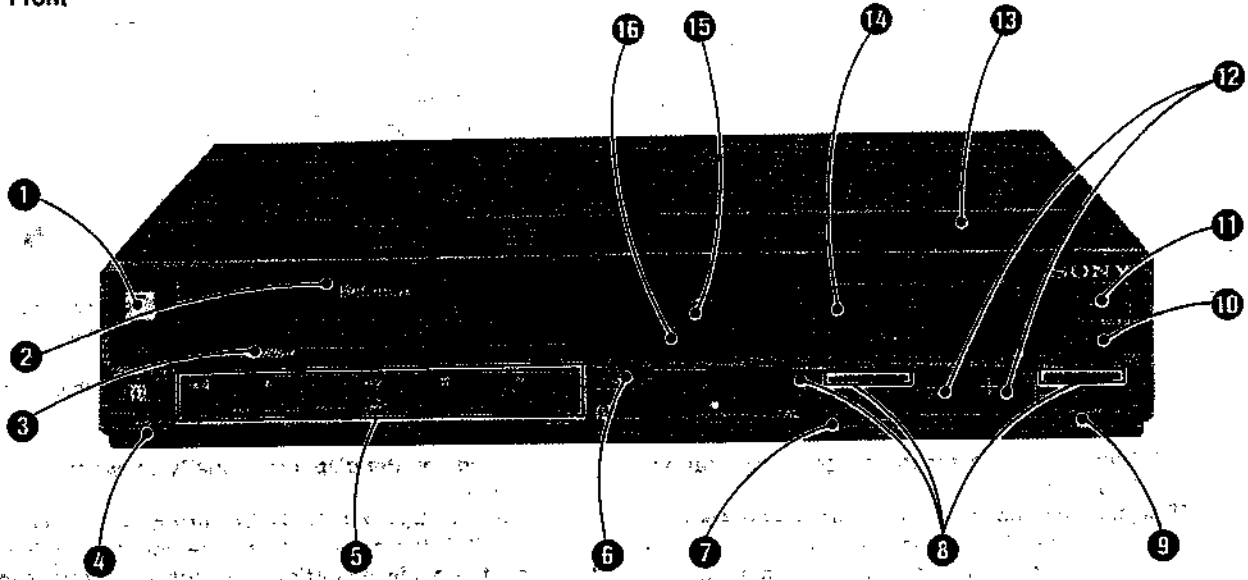

① ON/STANDBY button and indicator

Press to turn on the unit. The indicator will light up. Press again to turn it off.

The timer section will continue to operate and the time will be displayed even if the ON/STANDBY button is off.

② Cassette compartment

Insert a cassette after turning on the recorder. The  indication appears on the display window when a cassette is inside.

③ EJECT button

Press to remove the cassette. This button does not function when the recorder is turned off.

④ TRACKING control

If streaks or snow appear during the playback of a tape recorded on another recorder, turn this knob to obtain the best possible picture.

⑤ Function buttons

◀ **REW** button: Press to rewind the tape. Also used for the reverse picture search, skip scan and auto play operation.

▶ **PLAY** button: Press to play the tape back. Also used for auto play operation.

▶▶ **FF** button: Press to advance the tape rapidly. Also used for the forward picture search and skip scan operation.

■ **STOP** button: Press to stop the tape.

▢ **PAUSE** button: Press to stop the tape for a moment during recording or playback. A still picture will be seen during playback. Press again to release the pause mode.

⑥ RECORD button

Press to start recording.

⑦ INPUT SELECT button

Press to select the programme to be recorded.

LINE: for recording signals connected to the VIDEO IN and AUDIO IN jacks.

TUNER: for recording TV programmes.

⑧ Buttons for clock and timer setting

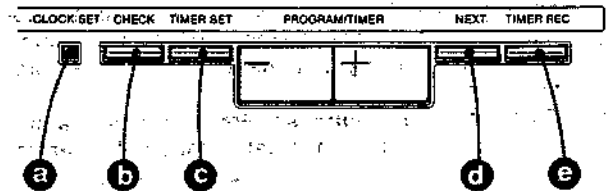

a **CLOCK SET** button: Press to initiate clock setting.

b **CHECK** button: Press to check timer settings.

c **TIMER SET** button: Press to initiate setting of timer recording.

d **NEXT** button: Press to advance to the next item to be set during clock or timer setting.

e **TIMER REC ON/OFF** button: Press to activate timer recording. Press it again to deactivate timer recording or quick timer recording in timer standby mode or while recording.

⑨ TONE selector

Normally, set to HIGH. If the high frequencies of playback sound seem exaggerated, set to LOW.

⑩ QUICK TIMER button

Press to set the recording duration up to 4 hours in units of 30 minutes.

⑪ REMOTE SENSOR

Detects the remote control signal transmitted from the supplied Remote Commander.

12 PROGRAM/TIMER +/- button

Press + to advance or - to reverse the programme numbers. Also used for clock setting and timer setting.

13 Tuning compartment

All the switches and buttons for programming stations are in this compartment.

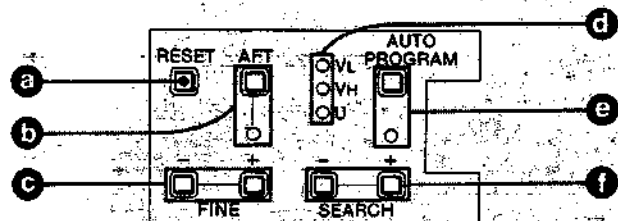

- a **RESET button:** To clear the programmed station, press this button.
- b **AFT button and lamp:** The AFT circuit activates automatically after the stations are tuned and memorized with automatic and manual programming. The AFT lamp will illuminate. If you wish to restore the AFT on the channel which has been finetuned manually with the FINE buttons, press the AFT button.
- c **FINE + and - buttons:** Press to fine tune the station.
- d **Tuning indicator:** (for the SL-F30E and the SL-F30EC) Indicates the tuning band.
- e **AUTO PROGRAM (automatic programming) button and lamp:** To preset the receivable stations automatically, press this button. The corresponding lamp blinks during automatic and manual programming.
- f **SEARCH + and - buttons:** Press to tune in a station. Press the - button to get a station of lower frequency and the + button to get a station of higher frequency.

14 Display window

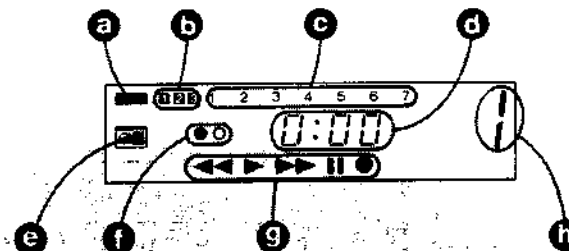

- a **TIMER REC indication:** Shows the recorder is in the timer standby mode. It remains displayed until the timer recording is finished.
- b **Week indications:** Show the week in which the timer recording will take place.
- c **Day of the week indications**
- d **Time and counter display:** Usually shows the present time. When the CLOCK/COUNTER button is pressed to COUNTER, the display shows the counter number.
- e **Cassette-inside indication:** Shows a cassette is inserted.
- f **Turn-on and turn-off setting indications:** The "●" mark shows the display is the turn-on time of the timer recording and the "○" mark shows the turn-off time.
- g **Tape operation mode indications:** Show the engaged tape operation mode: ◀◀ (rewind), ▶▶ (play-back), ▶▶▶ (fast-forward), || (pause) or ● (recording).
- h **Programme number:** Shows the programme number selected with the PROGRAM/TIMER + and - buttons. When the INPUT SELECT button is pressed to LINE to record signals from the VIDEO IN and AUDIO IN jacks, the indication will change to "AU".

15 CLOCK/COUNTER button

Press to set the display to the tape counter. To reset to clock, press it again.

16 CLEAR/RESET button

Press to set the tape counter reading to "0000" when the tape counter is displayed. Also used for changing the timer setting and erasing the memory of the timer setting.

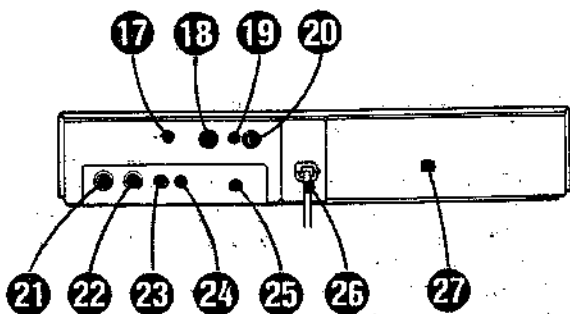

Illustration: SL-F30E E model

17 RF CHANNEL screw

If there is interference on the factory-preset channel for RF output and the signal of this recorder cannot be displayed clearly on the TV screen, adjust this screw with the supplied screwdriver.

18 AERIAL OUT socket

Connect the aerial input of the TV receiver using the supplied cable.

19 DX/LOCAL switch

Normally set this switch to DX. If the TV signal is very strong, set the switch to LOCAL.

20 AERIAL IN socket

Connect the aerial cable.

21 VIDEO OUT jack (BNC type)

Connect to the video input of another video cassette recorder or a video monitor.

22 VIDEO IN jack (BNC type)

Connect to the video output of a camera, another video cassette recorder, etc.

23 AUDIO OUT jack (phono type)

Connect to the audio input of a video monitor or video cassette recorder.

24 AUDIO IN jack (phono type)

Connect to the audio output of a camera or another video cassette recorder.

25 TEST SIGNAL switch

Set to ON to obtain the test pattern for adjusting the TV so that it can receive the signal from the recorder.

26 AC mains lead

27 VOLTAGE SELECTOR (for the SL-F30E E model only)
Set to 110 — 127 V or 220 — 240 V according to your local power line voltage.

1-3. ADJUSTING THE TV

One of the television programme positions must be adjusted to receive the signal from the recorder.

Note that the adjustment is not necessary, however, when the recorder is connected to the video/audio inputs on the TV receiver/monitor.

- 1 After making the connections, press the ON/STANDBY button.
- 2 Make sure that the recorder is in the stop mode.
- 3 Set the TEST SIGNAL switch located at the rear of the recorder to ON. The test signal is transmitted on a channel between UHF channels E30 and E39.
- 4 Turn on the TV and select a programme position which is not being used to receive a TV station. Tune the channel until you see a clear black and white pattern on the TV screen and you hear a continuous tone. This is the recorder's test signal.

—If you are not sure how to adjust your TV, please refer to the TV's instruction manual or consult your dealer.

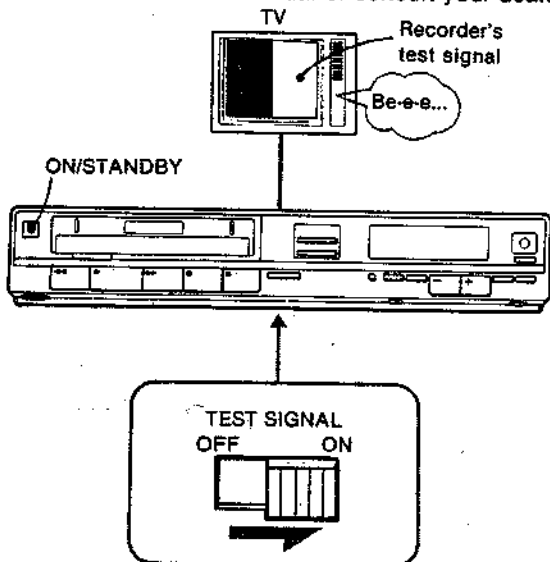

Whenever you use the video recorder, you should set the TV to the programme position selected in this adjustment.

If the test picture is free of disturbance, the TV adjustment is complete. Set the TEST SIGNAL switch to OFF.

If the test picture is not free of disturbance

- 1 Reset the TEST SIGNAL switch to OFF.
- 2 Adjust the channel of the TV to a channel between UHF channels E30 and E39 with the tuning control or the fine tuning control on the TV, so that the TV screen shows no picture and so that a steady rustling sound or no sound is heard.
- 3 Set the TEST SIGNAL switch to ON again.
- 4 Slowly turn the RF CHANNEL screw on the back of the recorder with the supplied screwdriver, until you see an undistorted test pattern on the TV screen.
- 5 Now the TV adjustment is complete. Reset the TEST SIGNAL switch to OFF.

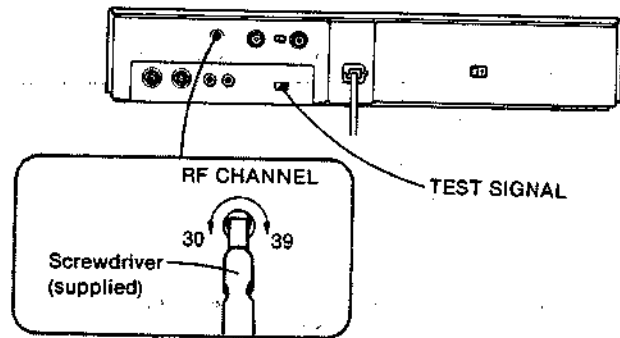

1-4. TV STATION PROGRAMMING

Automatic and manual programming are available. Automatic programming automatically presets receivable stations from the lowest frequency to the highest. Manual programming is useful for presetting selected stations in any desired sequence.

To start programming, turn on the recorder by pressing the ON/STANDBY button and set the INPUT SELECT button to TUNER.

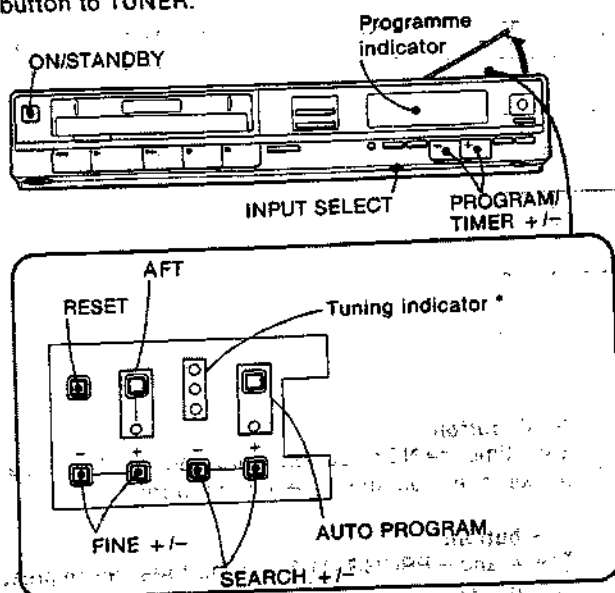

FINE TUNING OF A WEAK STATION

If the picture on a particular programme position is not acceptable, keep the + or - FINE button pressed until the picture becomes clearer. When either of the FINE buttons is pressed, the AFT of the selected station is deactivated and the AFT lamp goes off. To view this particular station, keep the AFT deactivated. (Do not press the AFT button.) When other memorized stations are selected, the AFT automatically activates.

ELIMINATING NOISE ON UNUSED PROGRAMME POSITIONS

Simply press the RESET button. The annoying noise will be eliminated.

*Tuning indicator (for the SL-F30E and the SL-F30EC)
The tuning indicator lights to show the current tuning band.
VL: E2 - E4 and Cable TV S1 - S3 channels
VH: E5 - E12 and Cable TV M1 - M10 and U11 - U20 channels
U: E21 - E68 channels

Note: Cable TV channels are receivable on the SL-F30EC only.

AUTOMATIC PROGRAMMING

Press the AUTO PROGRAM button. Up to 30 receivable stations (for the SL-F30EC) or up to 12 stations (for the SL-F30E and the SL-F30UB) will be preset one by one from programme position 1. When no more stations can be located, programme number "1" will light on the programme indicator and automatic programming will stop.

MANUAL PROGRAMMING

- 1 Press the + or - PROGRAM/TIMER button to select the programme position.
 - + for a higher-numbered programme position
 - for a lower-numbered programme position
- 2 Press the + SEARCH button to locate a station with higher frequency and the - SEARCH button to locate a station with lower frequency. When a station has been received, the search will stop. Press the + or - SEARCH button again, until the desired station is received.

Repeat these steps for all desired stations.

1-5. CLOCK SETTING

When you connect the mains lead to a mains outlet, the clock indicates "0:00" with the two dots blinking.

Example: To set the clock to 7:35 p.m. (19:35) on Tuesday *

*Time Indication

AM			PM						
12:00 (midnight)	1:00	11:00	12:00 (noon)	1:00	2:00		10:00	11:00	
0:00	1:00	11:00	12:00	13:00	14:00		22:00	23:00	

Day Indication

Mo (Monday)	Tu (Tuesday)	We (Wednesday)	Th (Thursday)	Fr (Friday)	Sa (Saturday)	Su (Sunday)
1	2	3	4	5	6	7



CLOCK SET

NEXT

+/- buttons

+ to advance

- to reverse

NEXT button

Each time the NEXT button is pressed, the item to be set blinks to let you know the setting order.

+/- buttons

The + and - PROGRAM/TIMER buttons can be pressed in two ways.

- 1 Press CLOCK SET.

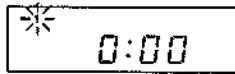

- 2 Set the day by pressing + or -.

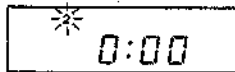

- 3 Press NEXT and set the hour by pressing + or -.

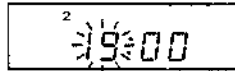

- 4 Press NEXT and set the minute by pressing + or -.

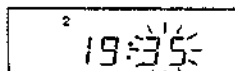

- 5 With an announced time signal, press NEXT. The clock now starts operating, showing the correct time.

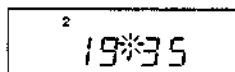

The dots of the colon alternately blink every 30 seconds.



When you hold a button down, the digits will advance continuously until the button is released.



When you press and immediately release a button, the digits will advance by one.

To change the actual clock setting

Press the CLOCK SET button and repeat the clock setting procedure from step 1.

Note

If you have pressed the CLOCK SET button inadvertently, press the NEXT button enough times until the dots of the colon blink.

When power has been interrupted, the time indication reverts to "0:00", showing that the clock must be reset.

1-6. TV PROGRAMME RECORDING

Numbers in the illustration show the sequence of operation.

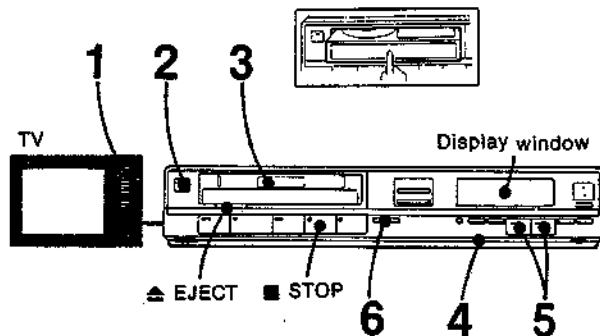

- 1 Turn on the TV and select the programme position for the recorder.
- 2 Press the ON/STANDBY button. The indicator on the button will light up.
- 3 Insert the cassette with the round window to the left. The  indication will appear on the display window.
 - Do not use force when inserting the cassette into the compartment.
- 4 Press the INPUT SELECT button (TUNER) so that a programme number appears on the display window.
- 5 Select the programme to be recorded with the +/- PROGRAM/TIMER buttons.
 - + for higher numbered programmes, and - for lower numbered programmes.
- 6 Press the ● RECORD button. The ● indication will appear on the display window and recording will begin.
 - If the inserted cassette does not have the safety tab, or if the tape is at its end, the cassette will be automatically ejected.

To stop recording, press the ■ STOP button.

To eject the cassette, press the ▲ EJECT button after stopping the recording.

To view another TV programme while recording, simply select the programme you want to view with the TV's programme selector.

When the tape reaches the end during recording, it will be automatically rewound.

Note

The recorder can be automatically turned on by inserting a cassette without pressing the ON/STANDBY button.

CAUTION

Television programmes, films, video tapes and other materials may be copyrighted. Unauthorized recording of such material may be contrary to the provision of the copyright laws.

TO STOP RECORDING MOMENTARILY

Press the ||| button. The ||| indicator will appear on the display window. The TV programme can be seen on the TV, but the picture will not be recorded.

To resume recording, press the ||| button again.

To protect the video heads and the tape, the pause mode will be automatically released after about 8 minutes and recording will stop.

TO KEEP A RECORDED PROGRAMME FROM BEING ACCIDENTALLY ERASED

When a new recording is made on a previously recorded cassette, the previous recording will be automatically erased.

To avoid erasing a recording

Break off the safety tab using a screwdriver or similar object.

To re-record on a cassette which has had the safety tab removed

Cover the slot with a piece of plastic tape.



If you activate the ● RECORD button or the TIMER REC ON/OFF button with a cassette with its safety tab removed inserted, the cassette will be automatically ejected.

1-7. TIMER-ACTIVATED RECORDING

Using the built-in timer, you can make one recording any day or every day, either this week, next week or the week after next.

Possible days for recording

The day you set the timer

Mo	Tu	We	Th	Fr	Sa	Su
			1	2	3	4
5	6	7	8	9	10	11
12	13	14	15	16	17	18
19	20	21	22	23	24	25
26	27	28	29	30		

This week ①
 Next week ②
 The week after next ③

Check before setting the timer

- Is the clock set to the correct day and correct time? Timer setting can only be made after the clock has been set.

- Is a cassette inserted in the recorder?

- Is the cassette long enough to record the program?

- Does the cassette have a safety tab on the bottom?

Note: The timer cannot be set during recording or playback.

TO SET THE TIMER

Example: To record a PROGRAM 2 broadcast from 9:00 AM to 11:25 AM on Friday next week.

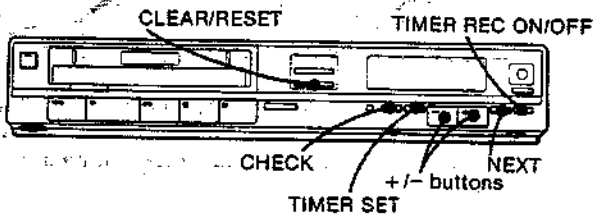

- 1 Press **TIMER SET**.
(If the recorder is off, it will be turned on automatically.)

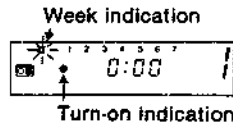

- 2 Set the week by pressing + or -.

Week indication changes:

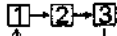

- 3 Press **NEXT** and set the turn-on day by pressing + or -.
Day indication changes:
1234567(everyday) → 1 → 2 → ...7

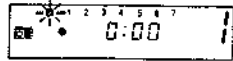

- 4 Press **NEXT** and set the turn-on hour by pressing + or -.

- 5 Press **NEXT** and set the minute by pressing + or -.
(To set to 00 minutes, there is no need to press + or -.)

- 6 Press **NEXT** and set the turn-off hour and minute with + or - as in turn-on time setting.

- 7 Press **NEXT** and select the programme to be recorded with + or -.

To record the signals from the equipment connected to the VIDEO IN jacks, press **INPUT SELECT** so that "AU" indication appears.

- 8 Press **NEXT**.
The display reverts to the current time.

- 9 Press **TIMER REC ON/OFF**.
The **TIMER REC** indication appears and the recorder is turned off.

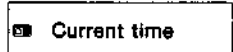
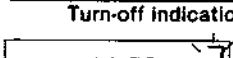
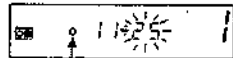
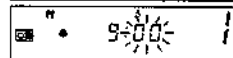
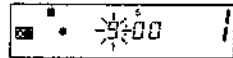

At the preset turn-on time, recording will start automatically and will stop at the preset turn-off time.

Note

If the inserted cassette is at its end or does not have the safety tab, the cassette will be automatically ejected when the **TIMER REC ON/OFF** button is pressed.

ONCE THE **TIMER REC** INDICATION HAS DISPLAYED, NO FUNCTION OF THE RECORDER CAN BE ACTIVATED, except for checking the timer setting.

To operate the recorder after setting the timer for recording, press the **TIMER REC ON/OFF** button so that the **TIMER REC** indication goes off. To reactivate the timer recording standby mode, be sure to press the **TIMER REC ON/OFF** button again.

WHILE SETTING TIMER

To change the preset item

Press the **CLEAR/RESET** button and repeat the timer setting procedure from step 2.

To record to the end of the tape

Set the turn-off time to a time after the tape will reach its end.

BEFORE OR DURING TIMER RECORDING

To check the timer settings

Press the **CHECK** button. Each time the **CHECK** button is pressed, the display will change to the preset turn-on time, the turn-off time, then the current time.

During actual timer recording, only the turn-off time can be checked.

To change the settings

- 1 Press the **TIMER REC ON/OFF** button so that the **TIMER REC** indication goes off.
- 2 Press the **CHECK** button.
- 3 Press the **CLEAR/RESET** button.
- 4 Repeat the timer setting procedure from step 2.

To erase the timer setting

- 1 Press the **TIMER REC ON/OFF** button so that the **TIMER REC** indication goes off.
- 2 Press the **CHECK** button.
- 3 Press the **CLEAR/RESET** button.
- 4 Press the **TIMER SET** button. The setting will be erased from the memory.

Note: When the **TIMER REC** indication is displayed, the timer setting cannot be erased.

If the tape reaches the end during timer recording

The recording will stop and the tape will be rewound to the beginning. Then after about a second, the recorder will be turned off.

To stop the on-going timer recording

Press the **TIMER REC ON/OFF** button so that the **TIMER REC** indication goes off. The unit will be turned off automatically after about a second.

When a power interruption occurs

If the clock shows "0:00" and the dots blink, all the timer settings have been erased. Reset the clock time and the timer settings.

AFTER TIMER RECORDING

When a timer recording is finished, the programming (except the everyday setting) will be deleted automatically.

1-8. QUICK TIMER RECORDING

—To set the recording duration and to turn off the unit automatically

During recording, you can set the recording duration for up to 4 hours in units of 30 minutes by pressing the QUICK TIMER button. After the preset time has elapsed, recording stops and the recorder is turned off automatically.

- 1 Start recording.
- 2 Press the QUICK TIMER button to set the recording duration.
The TIMER REC indication will appear.

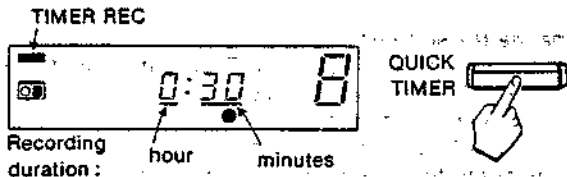

Each time you press the QUICK TIMER button, the indication changes: 0:30 → 1:00 → 1:30 → 2:00 → ... 3:30 → 4:00

As the recording continues, the duration indication decreases minute by minute to 0:00 and the recording stops. The recorder is turned off automatically.

Note

When the TIMER REC indication is displayed, no function of the recorder can be activated.

To extend the recording duration

The on-going recording duration can be extended simply by pressing the QUICK TIMER button.

The duration will be extended in units of 30 minutes with each pressing.

Example: When 2:25 is indicated,

2:25 → 2:30 → 3:00 ...

To cancel the quick timer function.

Press the TIMER REC ON/OFF button so that the TIMER REC indication goes off. The recorder will be turned off automatically after about a second.

SECTION 2 DISASSEMBLY

2-1. DISASSEMBLY OF CABINET

- 1) Remove the four case set screws ① .
- 2) Remove the upper case ② in the direction shown by the arrow A .
- 3) Loosen the eight screws (BVTP3 x 8) ③ .
- 4) Remove the lower case ④ in the direction shown by the arrow B .
- 5) Remove the three screws (BVTP3 x 8) ⑤ .
- 6) Remove the two claws ⑥ in the direction shown by the arrow C , then remove the front panel ⑦ in the direction shown by the arrow D .

Note: Follow the disassembly procedure in the numerical order given.

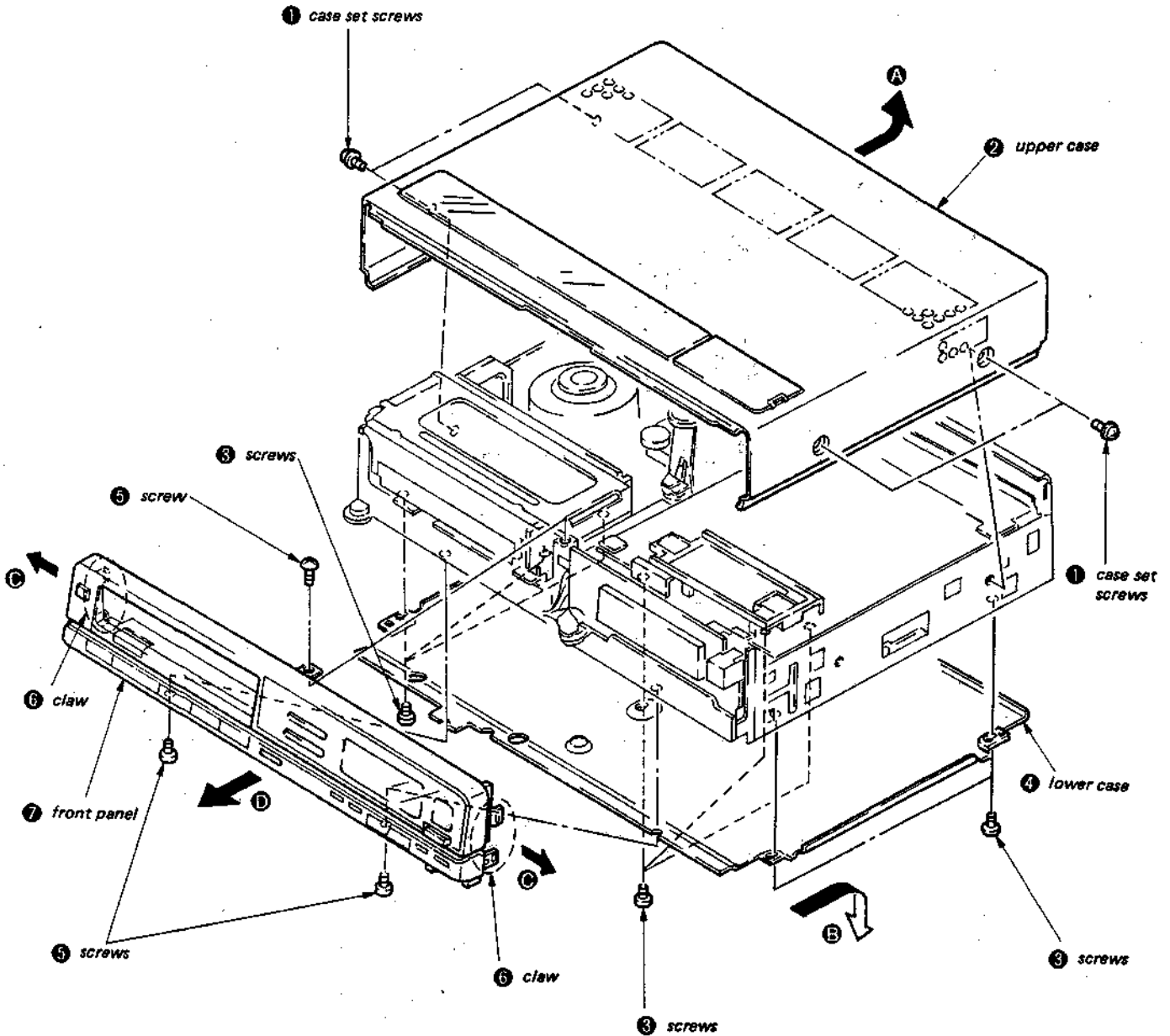

2-2. REMOVAL OF THE RP-20 BOARD

- 1) Pull out the connector CN501 ①.
- 2) Remove the two screws (BVTP3 x 8) ②.
- 3) Pull out the three connectors (CN503, CN504) ③, ④.
- 4) Remove the two shield cases ⑥ in the direction shown by the arrows A and B.

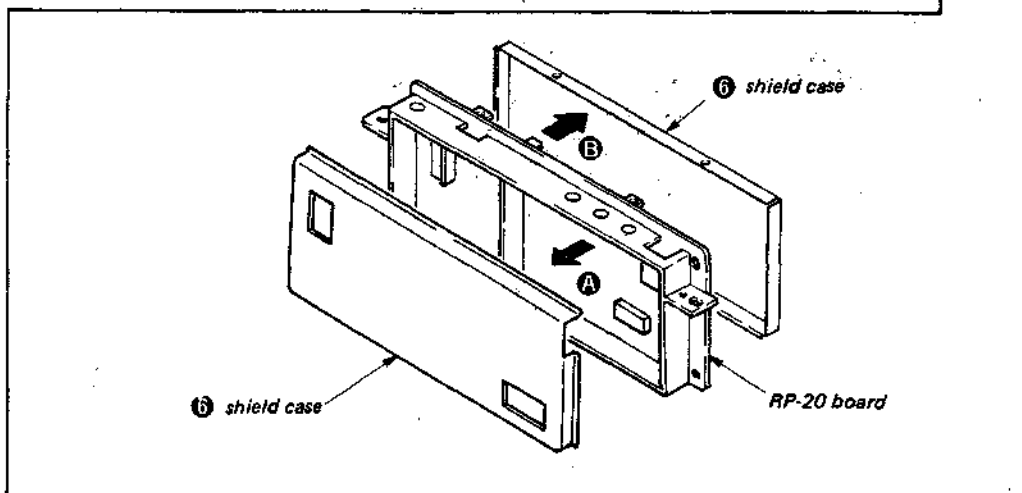
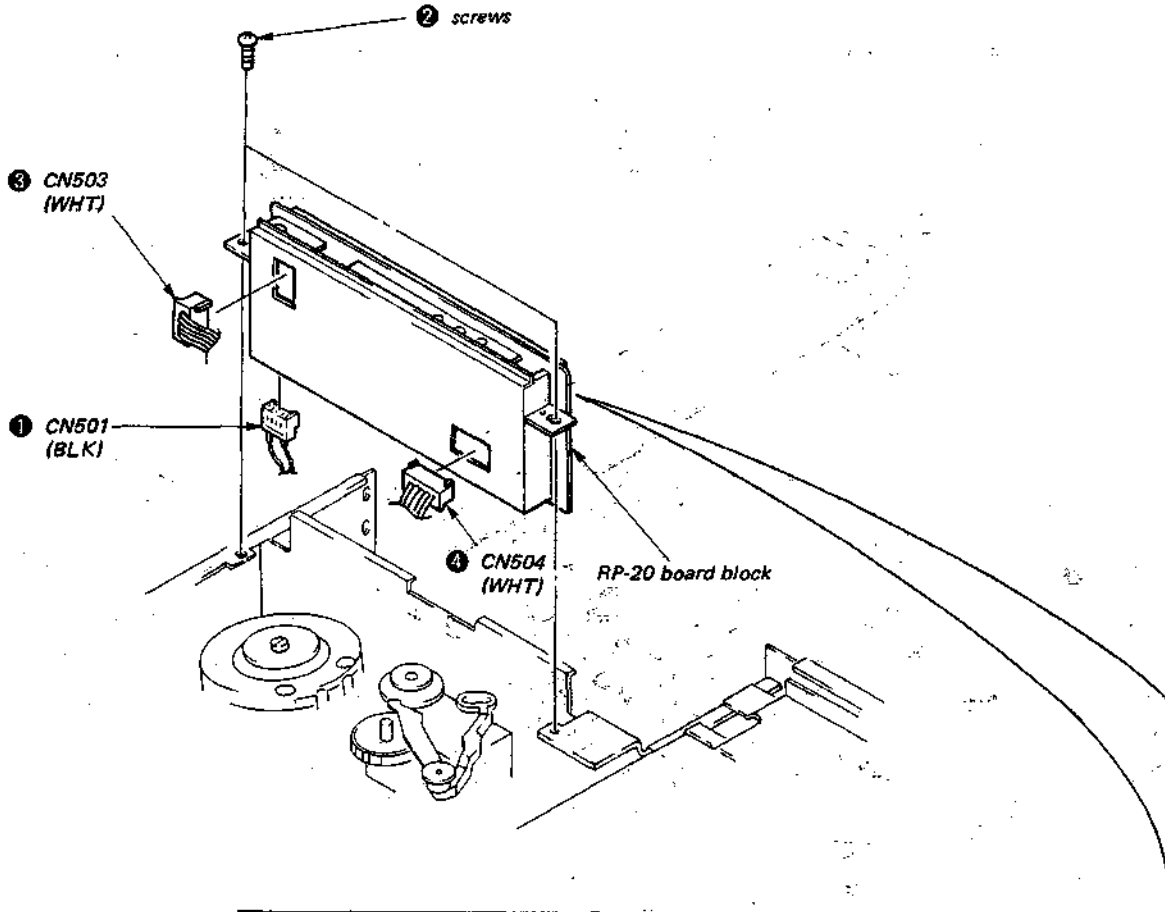

2-3. REMOVAL OF THE TA-22 BOARD

- 1) Remove the two screws (BVTP3 x 8) ①.
- 2) Remove the TA-22 board ② in the direction shown by the arrow.

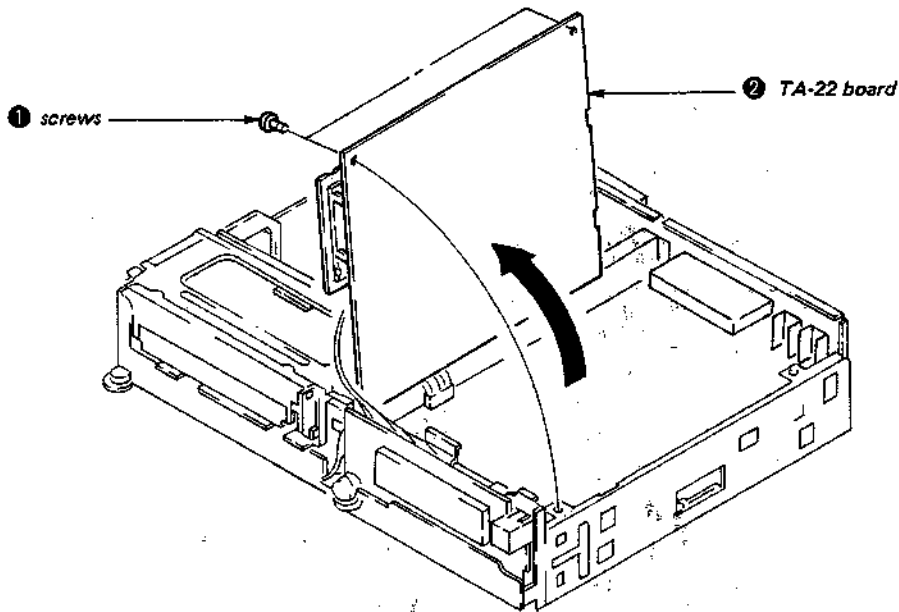

2-4. REMOVAL OF THE YC-31 BOARD

- 1) Stand the set with the left side panel on the bottom.
- 2) Remove the screw (BVTP3 x 8) ①.
- 3) Remove the plate, connector ② in the direction shown by the arrow A.
- 4) Remove the two screws (BVTP3 x 8) ③.
- 5) Remove the YC-31 board ④ in the direction shown by the arrow B.

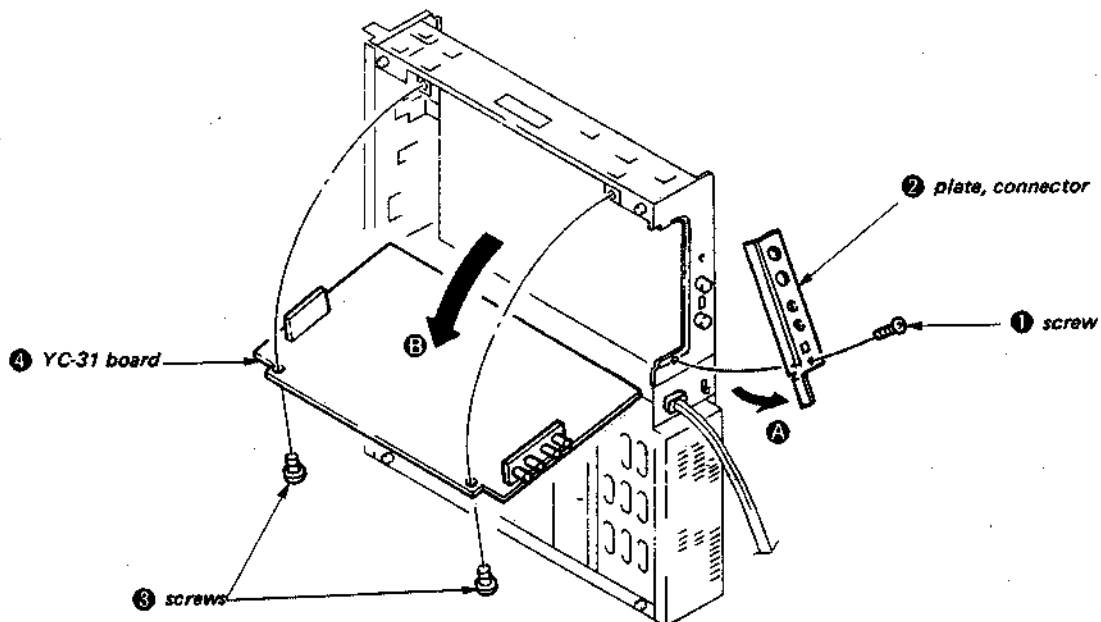

2-5. REMOVAL OF THE TIMER BLOCK

- 1) Remove the screw (BVTP3 x 8) ① .
- 2) Remove the TM-58 board ② in the direction shown by the arrow A .
- 3) Remove the two screws (BVTP3 x 8) ③ .
- 4) Remove the TM-57 board ④ in the direction shown by the arrow B .

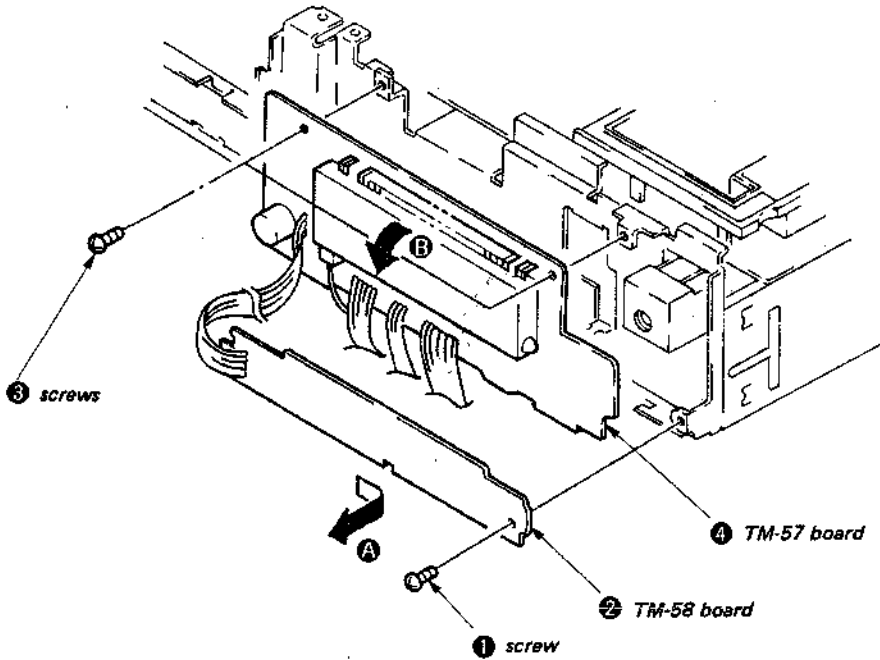

2-6. REMOVAL OF THE FU-25 BOARD

- 1) Remove the screw (BVTP3 x 8) ① .
- 2) Remove the FU-25 board ② in the direction shown by the arrow A ; then remove in the direction shown by the arrow B .

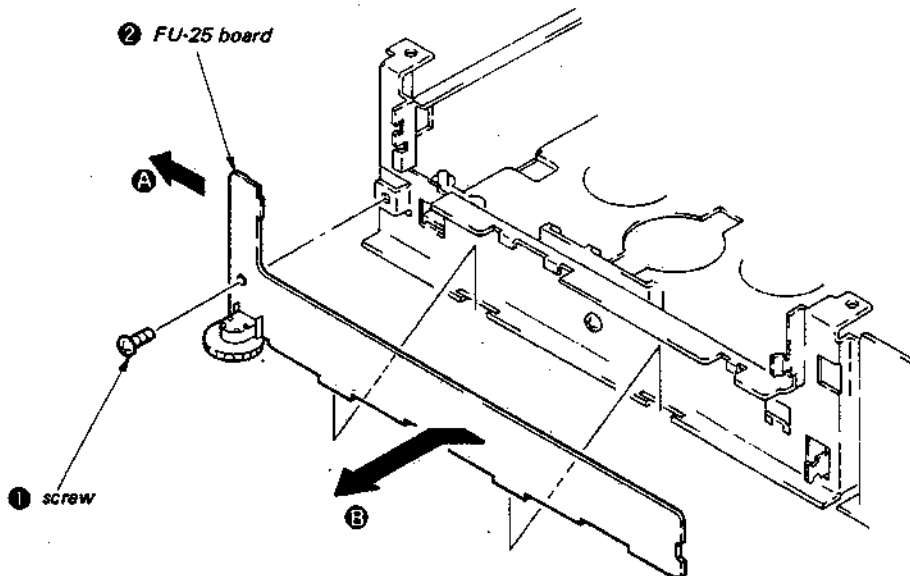

**2-7-1. REMOVAL OF THE POWER BLOCK
(AEP, UK, EC MODEL)**

- 1) Remove the six screws (BVTP3 x 8) ①.
- 2) Pull out the five connectors (CN101, CN102, CN103, CN104, CN106) ②.
- 3) Remove the power block ③ in the direction shown by the arrow.

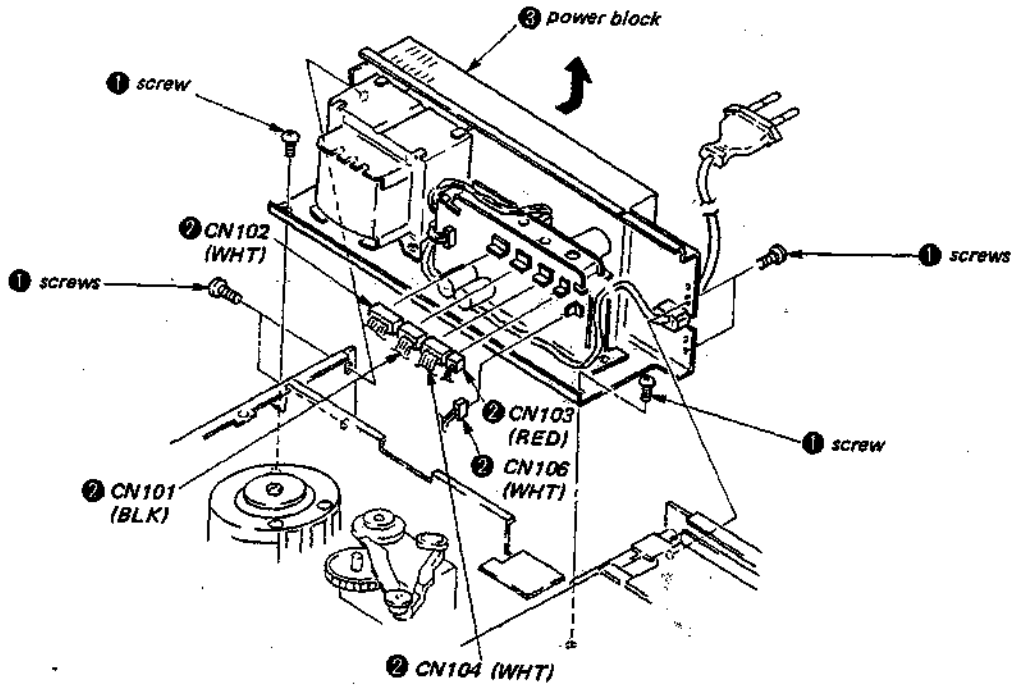

**2-7-2. REMOVAL OF THE POWER BLOCK
(E MODEL)**

- 1) Remove the six screws (BVTP3 x 8) ①.
- 2) Pull out the five connectors (CN001, CN002, CN003, CN004, CN005) ②.
- 3) Remove the power block ③ in the direction shown by the arrow.

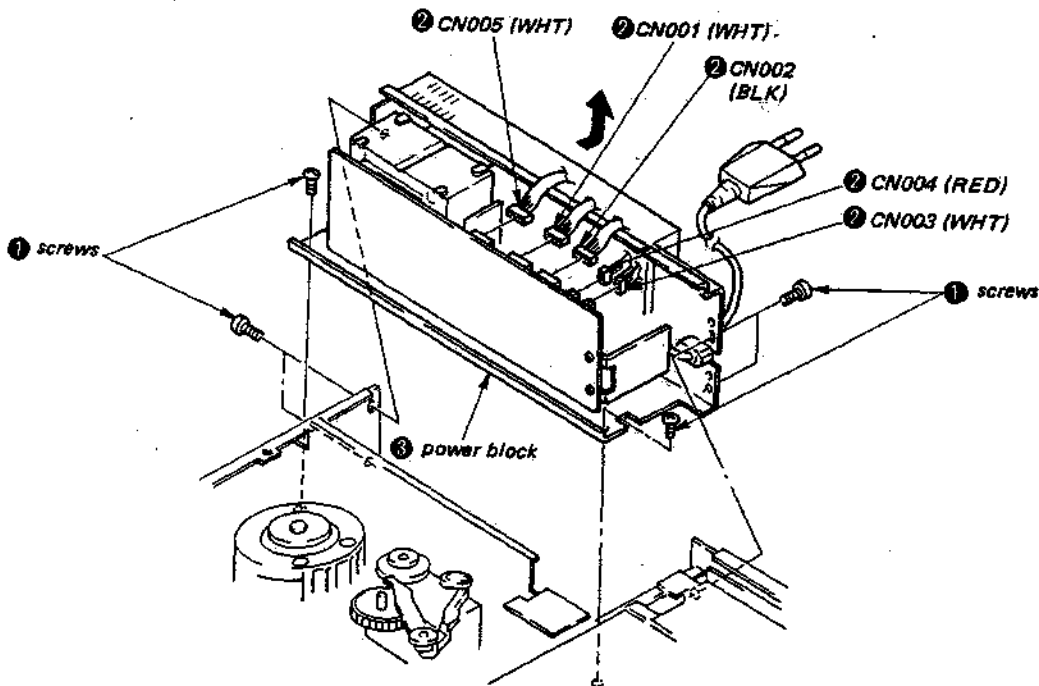

2-8. REMOVAL OF THE FL CASSETTE COMPARTMENT ASSEMBLY

- 1) Remove the four screws (BVTP3 x 8) ① .
- 2) Remove the internal gear flange ② .
- 3) Remove the timing belt (loading belt) ③ .
- 4) Pull out the connector CN606 ④ , on the SS-34 board.
- 5) Remove the FL cassette compartment assembly in the direction shown by the arrow.

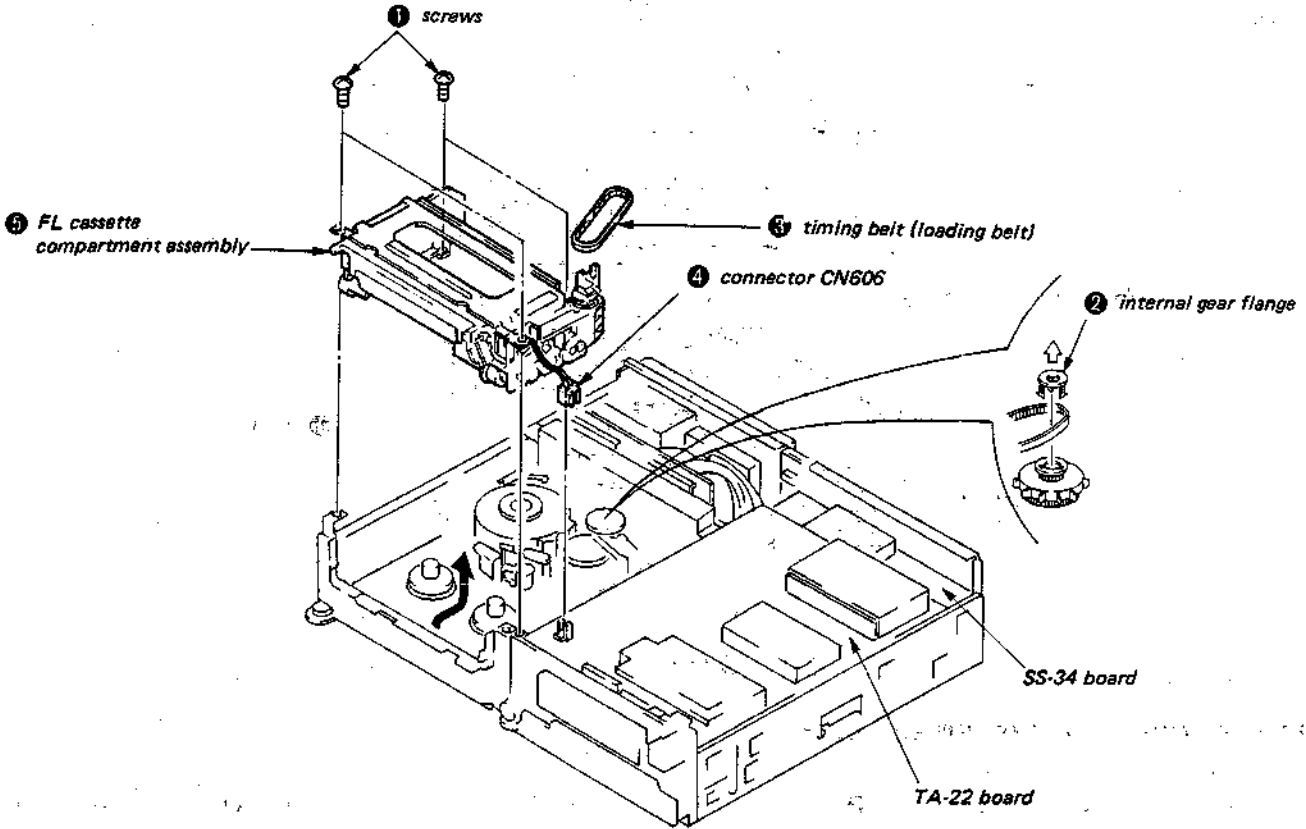

2-9. REMOVAL OF THE REEL BLOCK ASSEMBLY

- 1) Remove the four screws (BVTP3 x 8) ① .
- 2) Remove the reel block assembly ② in the direction shown by the arrow.

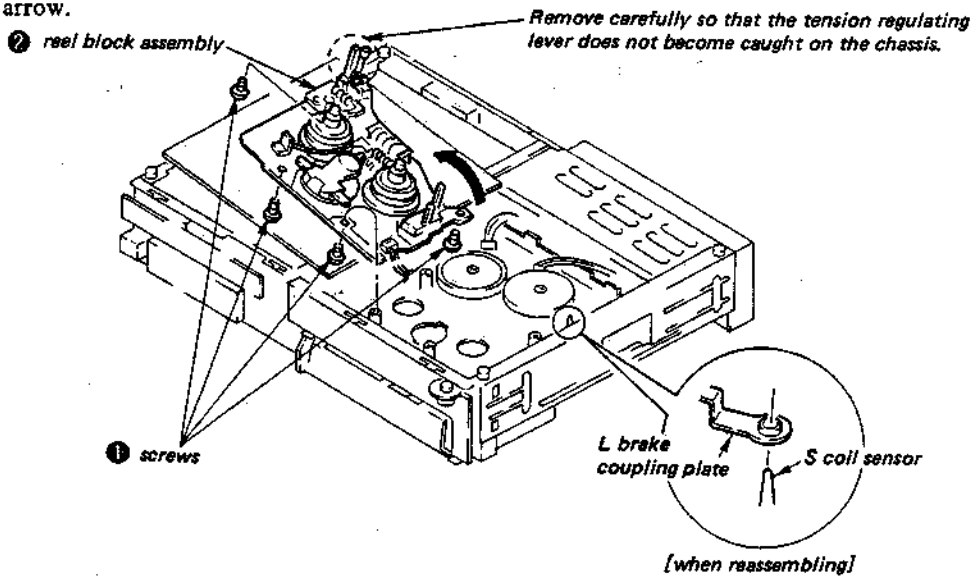

2-10. INTERNAL VIEW
 - Top Side -

E MODEL

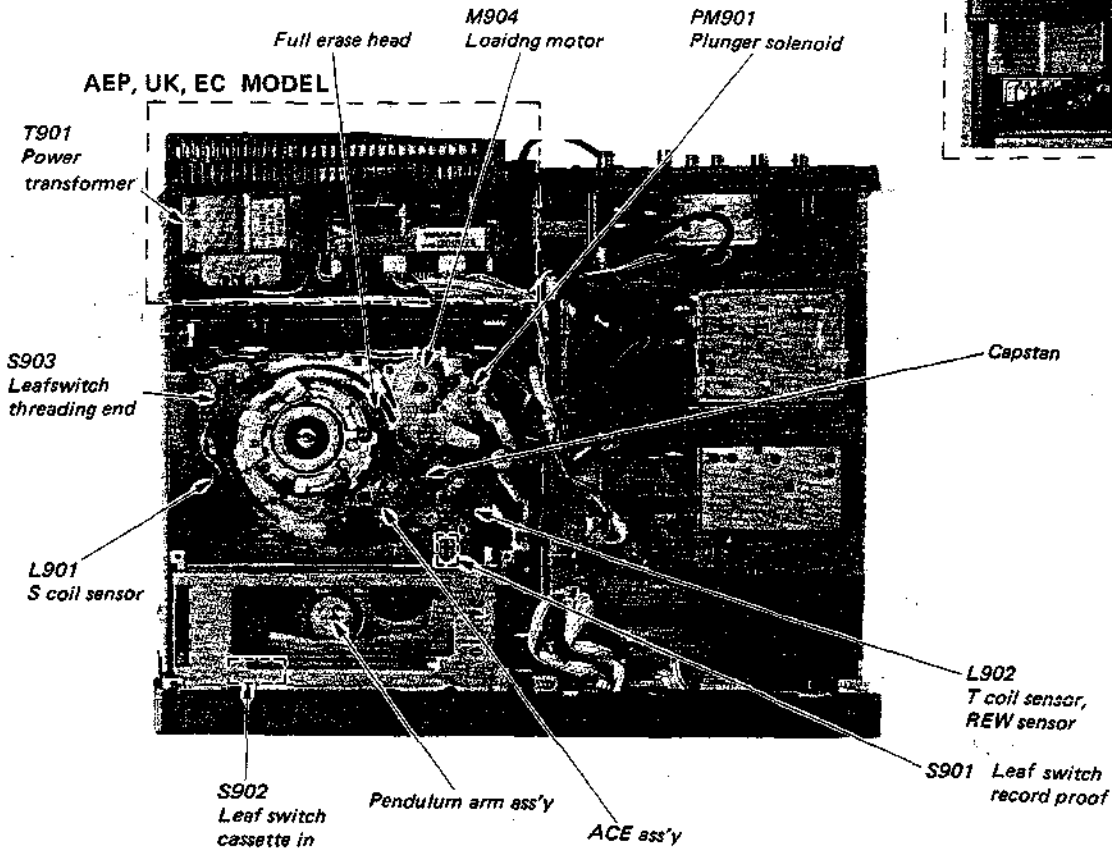
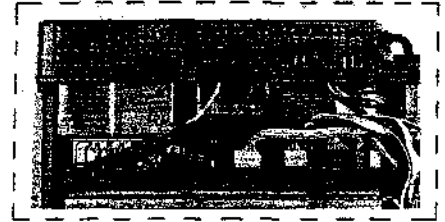

- Bottom Side -

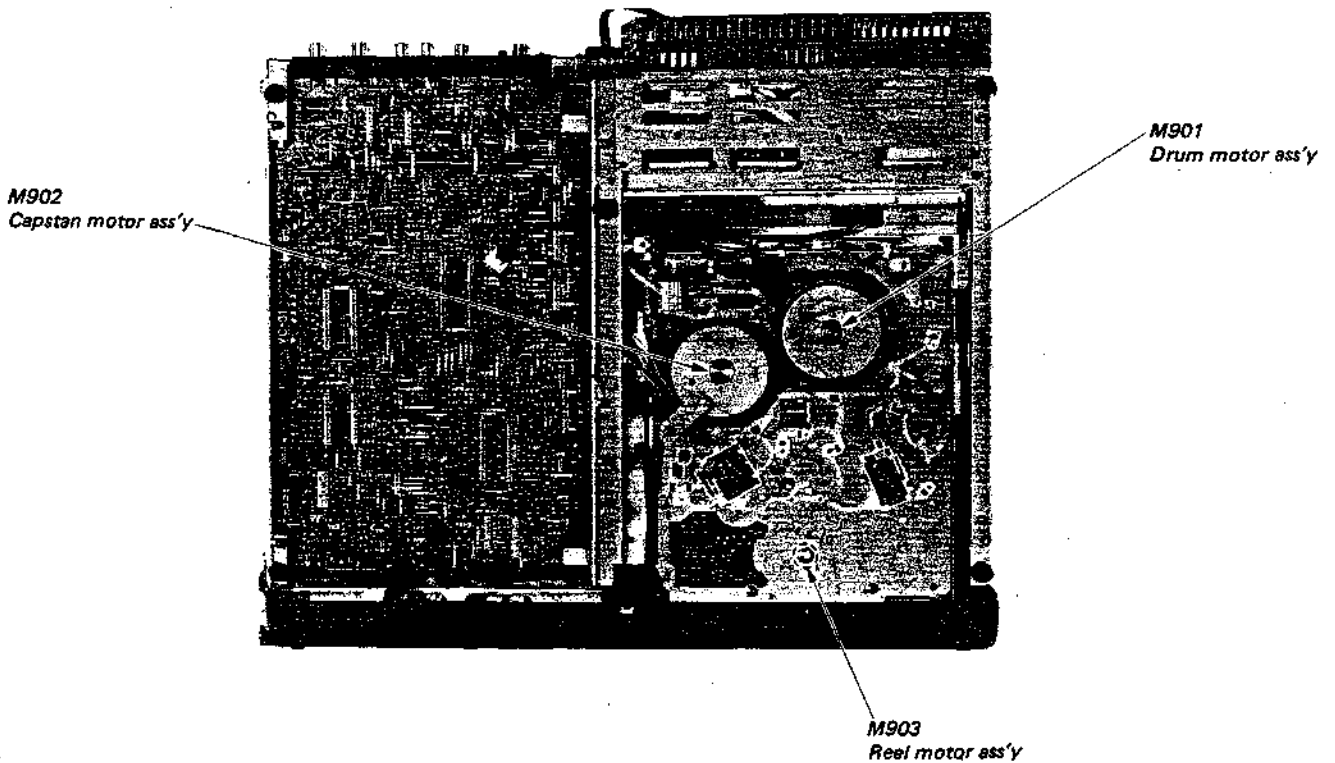

SECTION 3 DIAGRAMS

3-1. CIRCUIT BOARDS LOCATION

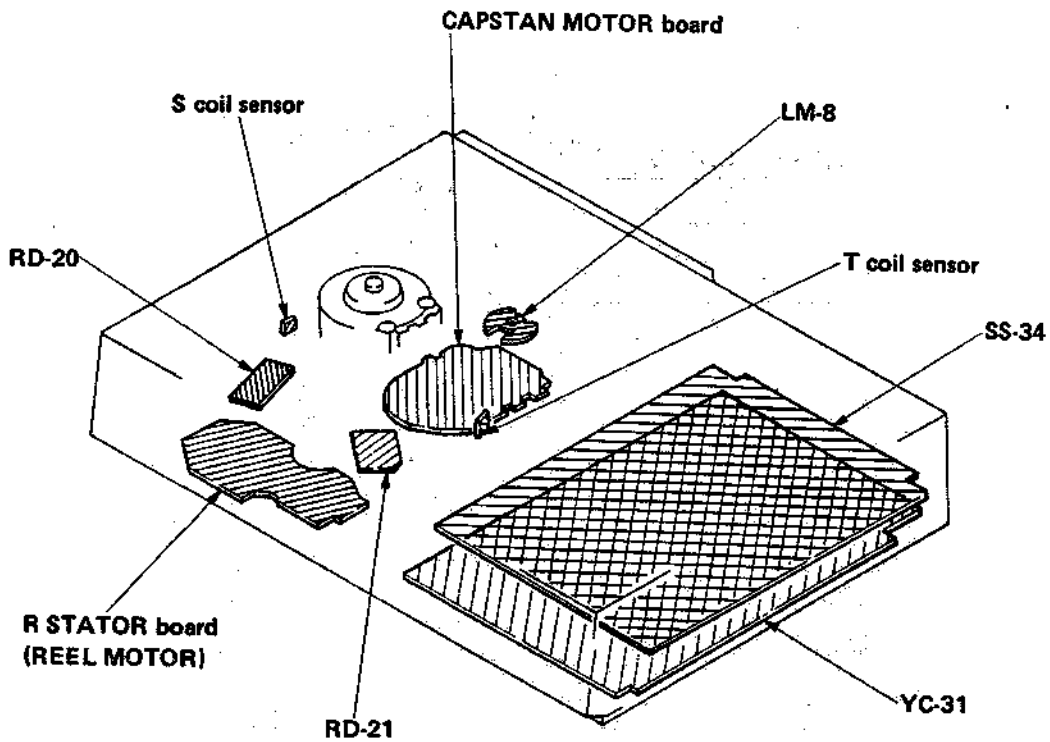
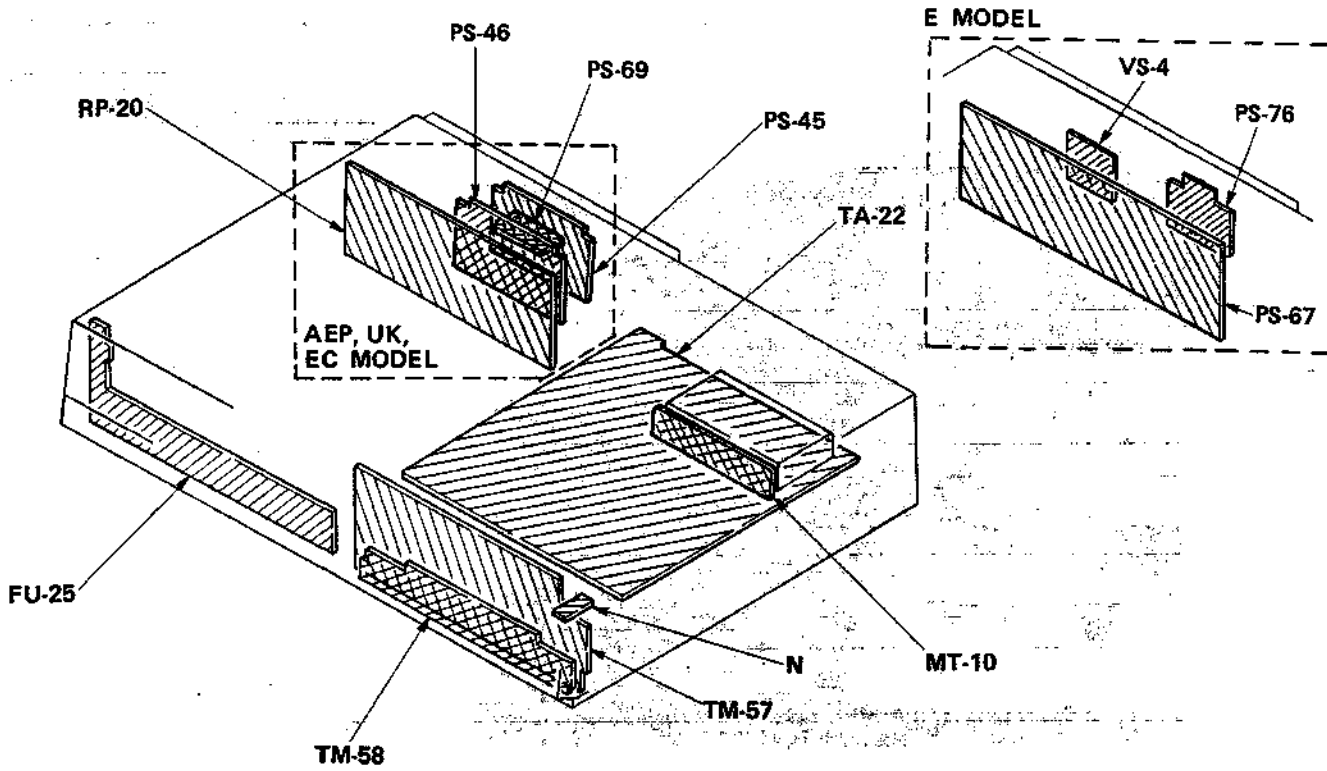

3-2. OVERALL BLOCK DIAGRAM

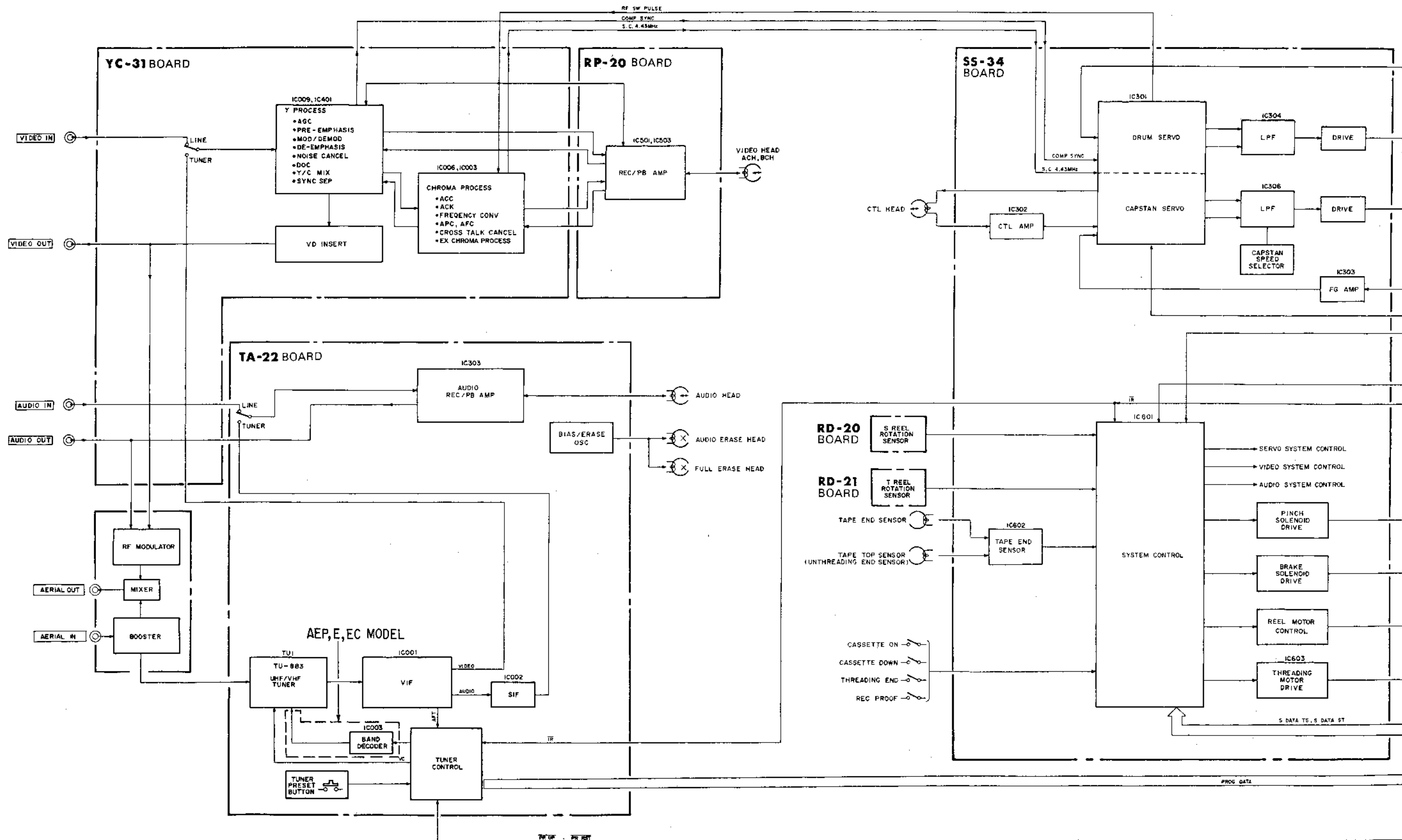

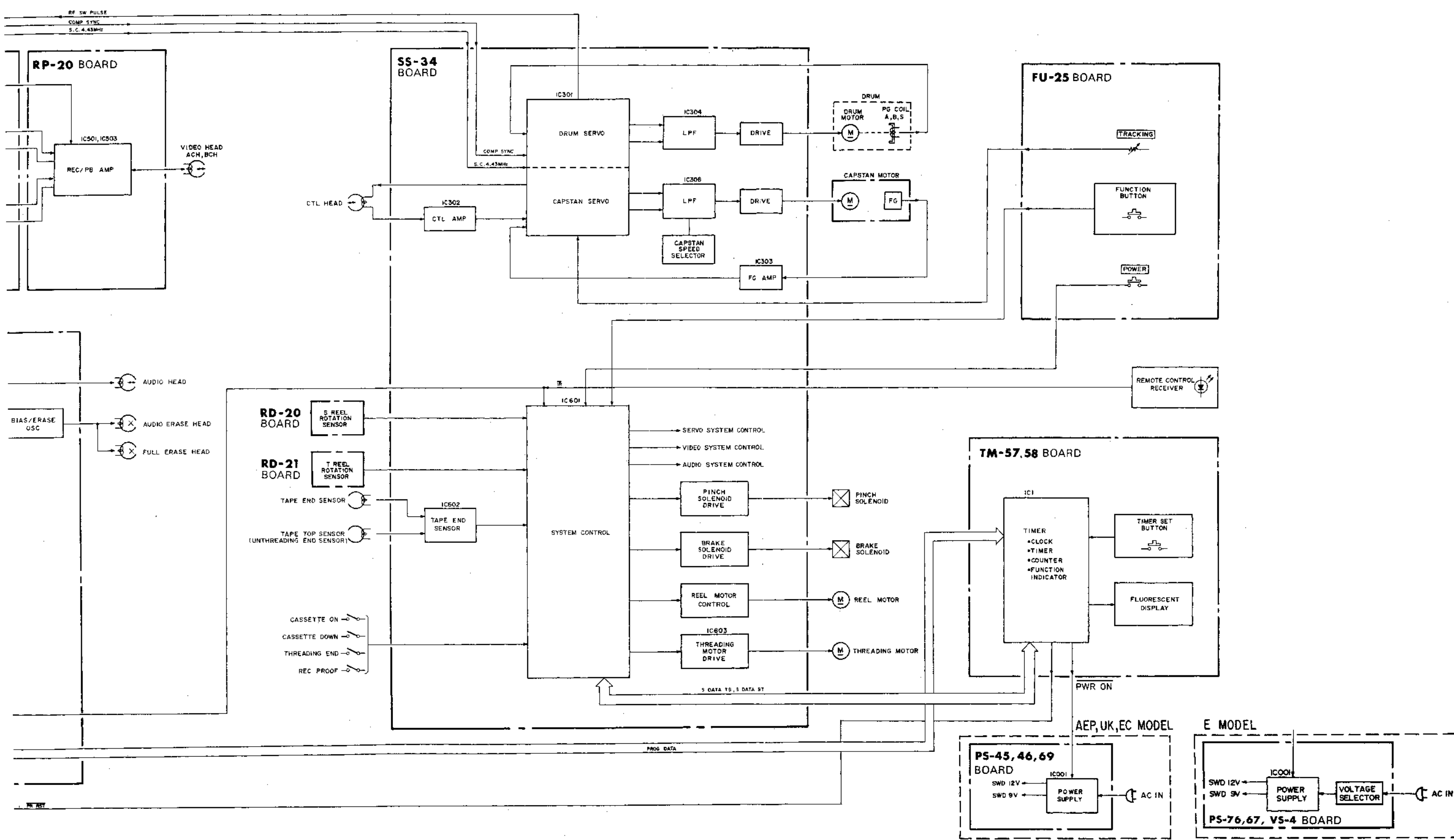

3-4. SYSTEM CONTROL BLOCK DIAGRAM

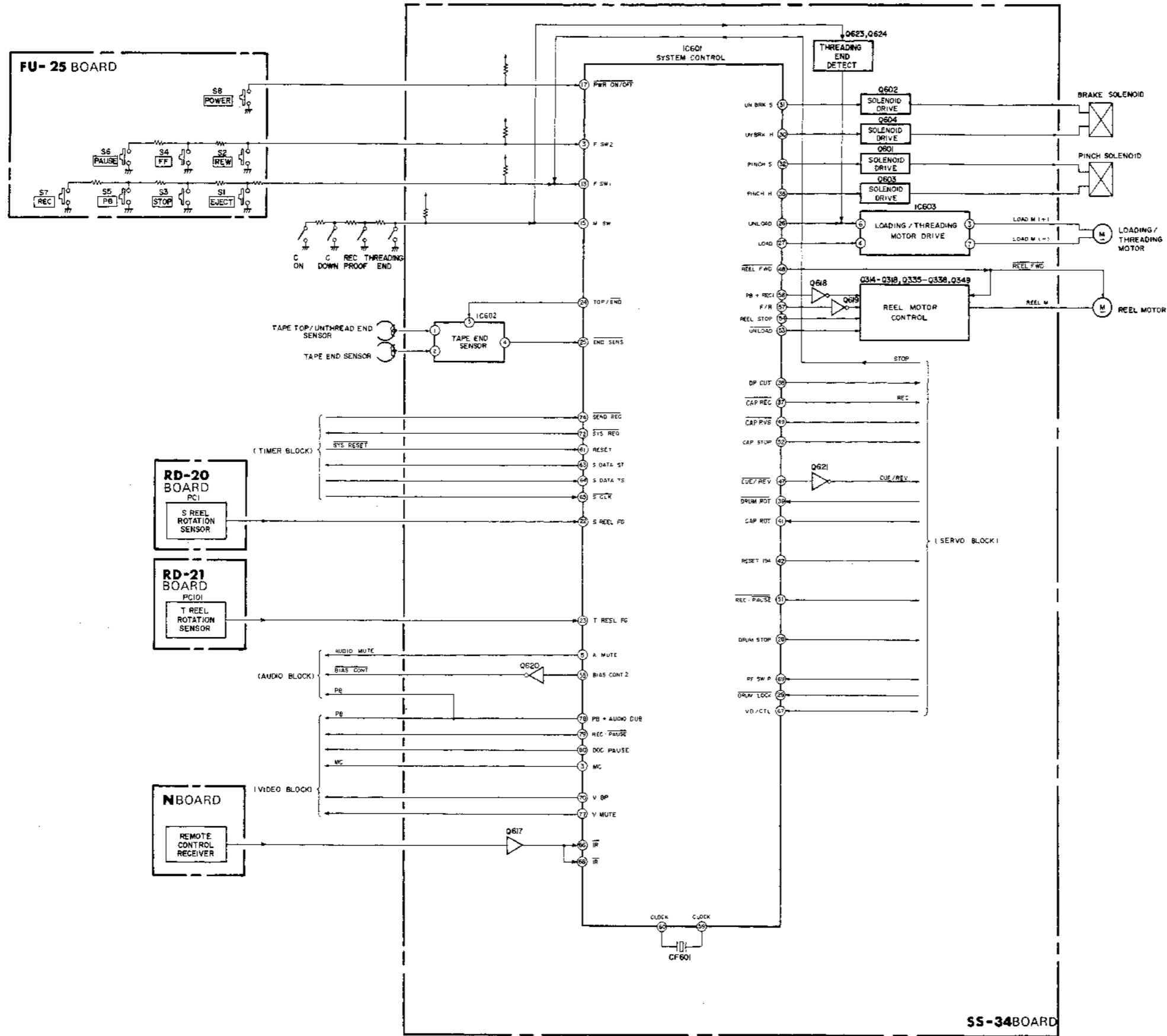

3.5. SYSTEM CONTROL INTERFACE

[SYSTEM CONTROL-VIDEO BLOCK INTERFACE]

SIGNAL	I/O	IC601 Pin No.	STOP	FF	REW	PB	PB PAUSE	PICTURE SEARCH		REC OR TIMER REC	REC PAUSE	WAIT PAUSE	FR SEARCH	
								CUE	REV				CUE	REV
PAUSE	O	①	L	L	L	L	H	L	L	L	H	*2	L	L
MC	O	③	L	L	L	L	H	H	H	L	L	L	H	H
VBP	O	⑦⑩	H	H	H	H	H	H	H	H	H	H	H	H
A' HEAD *1	O	⑦⑥	L	L	L	L	L	L	L	L	L	L	L	L
V MUTE	O	⑦⑦	L	L	L	L	L	L	L	L	L	L	L	L
PB + AUDIO DUB	O	⑦⑧	L	L	L	H	H	H	H	L	L	L	H	H
REC · P	O	⑦⑨	L	L	L	L	L	L	L	H	L	L	L	L
DOC PAUSE *1	O	⑧⑩	L	L	L	L	L	L	L	L	L	L	L	L

*1 : NOT USED

*2 : T = 2(SEC),

50% duty ratio pulse

[SYSTEM CONTROL-SERVO BLOCK INTERFACE]

SIGNAL	I/O	IC601 Pin No.	STOP	FF	REW	PB	PB PAUSE	PICTURE SEARCH		REC OR TIMER REC	REC PAUSE	WAIT PAUSE	FR SEARCH	
								CUE	REV				CUE	REV
S REEL FG	I	②②	H/L	FG	FG	FG	H/L	FG	FG	FG	H/L	H/L	FG	FG
T REEL FG	I	②③	H/L	FG	FG	FG	H/L	FG	FG	FG	H/L	H/L	FG	FG
DRUM STOP	O	②⑧	H	L	L	L	L	L	L	L	L	H	L	L
DRUM LOCK	I	②⑨	L	H	H	H	H	H	H	H	H	L	H	H
BRK ADJ *1	O	③⑥	H	H	H	H	H	H	H	H	H	H	H	H
REC	O	③⑦	L	L	L	L	L	L	L	H	H	L	L	L
DP CUT	O	③⑧	L	L	L	L	L	H	H	L	L	L	H	H
DRUM ROT	I	③⑨	L	H	H	H	H	H	H	H	H	L	H	H
CAP ROT	I	④①	L	L	L	H	H	H	H	H	H	L	L	L
RESET 194	O	④②	L	L	L	L	L	L	L	L	L	L	L	L
CAP CUT	O	④③	L	L	L	L	L	L	L	L	L	L	L	L
PB + REC 2 *1	O	④④	L	L	L	H	H	L	L	H	H	L	L	L
BIAS CONT 1 *1	O	④⑤	L	L	L	L	L	L	L	H	H	L	L	L
CUE/REV	O	④⑦	H	H	H	H	H	L	L	H	H	H	H	H
CAP RVS	O	④⑨	H	H	H	H	H	H	L	H	H	H	H	H
WITHN/N.LESS	I	⑤⑩	H	H	H	H	H	H	H	H	H	H	H	H
REC · P	O	⑤①	H	H	H	H	H	H	H	L	H	H	H	H
CAP STOP	O	⑤②	H	H	H	L	L	L	L	L	L	H	H	H
PAUSE	O	⑤⑥	H	H	H	H	L	H	H	H	L	*2	H	H
VD/CTL	I	⑥⑦	L	PB CTL	PB CTL	PB CTL	L	PB CTL	PB CTL	VD	L	L	PB CTL	PB CTL
RF SW P	I	⑥⑨	H/L	RF SWP	RF SWP	RF SWP	RF SWP	RF SWP	RF SWP	RF SWP	RF SWP	H/L	RF SWP	RF SWP
NOISE P *1	I	⑦⑤	L	L	L	L	L	L	L	L	L	L	L	L

*1 : NOT USED

*2 : T=2(SEC),

50% duty ratio pulse

3-3. VIDEO BLOCK DIAGRAM

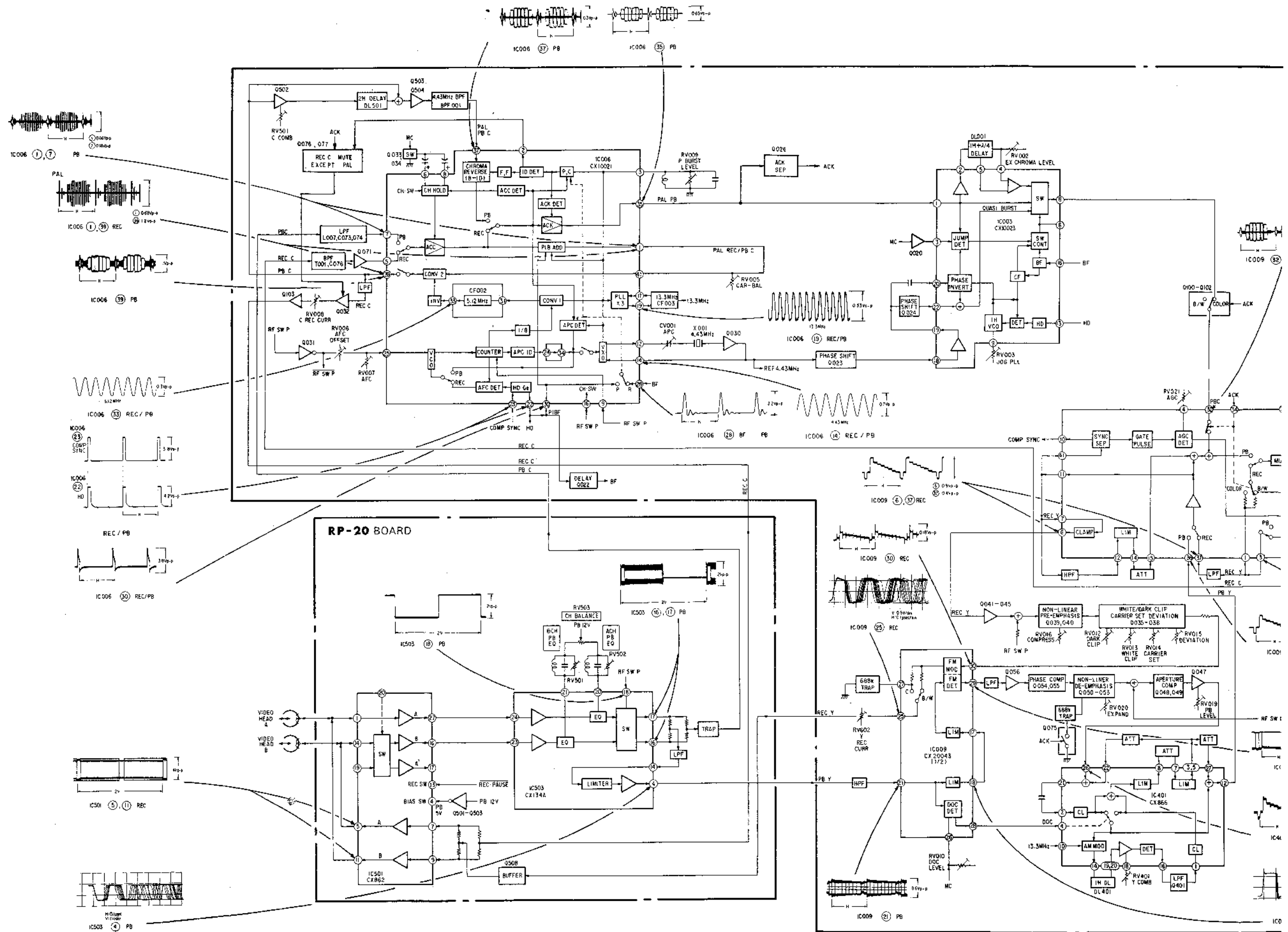

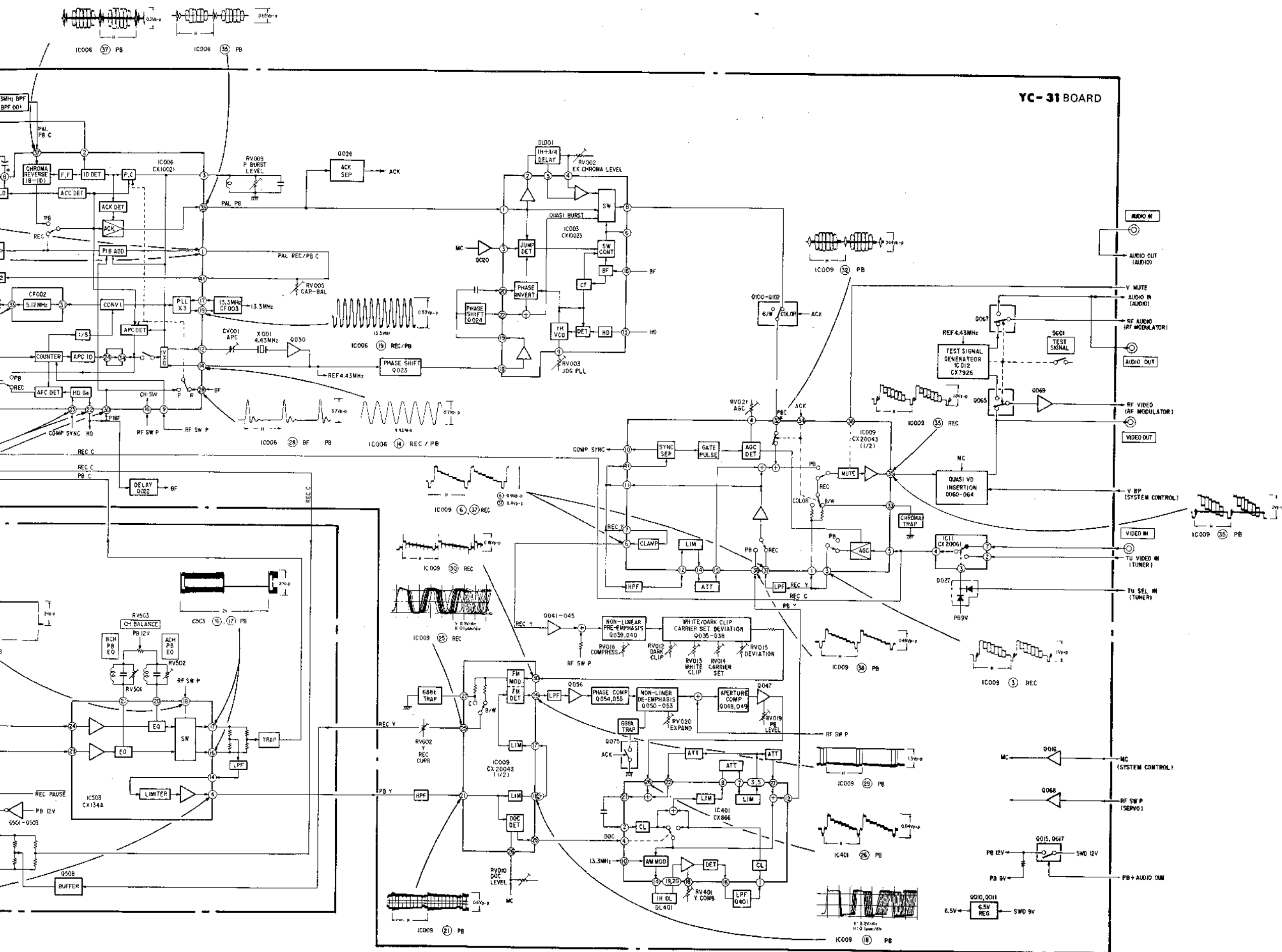

YC-31 BOARD

[SYSTEM CONTROL-REEL MOTOR BLOCK INTERFACE]

SIGNAL	I/O	IC601 Pin No.	EJECTED	LOADING	THREADING	STOP	UN- THREADING	UN- LOADING	FF	REW	PB	PB PAUSE	PICTURE SEARCH		REC	REC PAUSE	FR SEARCH	
													CUE	REV			CUE	REV
CUE/REV	O	47	H	H	H	H	H	H	H	H	H	H	L	L	H	H	H	H
REEL FWD	O	48	L	L	L	L	H	L	L	H	L	L	L	H	L	L	L	H
REEL STOP	O	54	H	H	L	H	L	H	L	L	L	H	L	L	L	H	L	L
F/R	O	57	L	L	L	L	L	L	L	L	L	L	L	L	L	L	H	H
PB + REC 1	O	58	L	L	L	L	L	L	L	L	H	H	L	L	H	H	L	L
UNLOAD	O	53	H	H	H	H	L	H	H	H	H	H	H	H	H	H	H	H

[SYSTEM CONTROL-MECHANISM BLOCK INTERFACE]

SIGNAL	I/O	IC601 Pin No.	EJECTED	LOADING	THREADING	STOP	UN- THREADING	UN- LOADING	FF	REW	PB	PB PAUSE	PICTURE SEARCH		REC	REC PAUSE	FR SEARCH	
													CUE	REV			CUE	REV
MSW *1	I	15	5V	3V	1V (2V)	0V	1V (2V)	3V	0V	0V	0V	0V	0V	0V	0V	0V	0V	0V
TOP/END	O	24	L	L	L	L	H	H	L	H	L	L	L	H	L	L	L	H
END SENS	I	25	H	H/L	H/L	H	H	L	H	H	H	H	H	H	H	H	H	H
UNLOAD	O	26	L	L	L	L	H	H	L	L	L	L	L	L	L	L	L	L
LOAD	O	27	L	H	H	L	L	L	L	L	L	L	L	L	L	L	L	L
UNBRK (H)	O	30	L	L	L	L	L	L	H	H	H	L	H	H	H	L	H	H
UNBRK (S)	O	31	L	L	L	L	L	L	L	L	L	L	L	L	L	L	L	L
PINCH (S)	O	32	L	L	L	L	L	L	L	L	L	L	L	L	L	L	L	L
PINCH (H)	O	35	L	H	L	L	L	H	L	L	H	L	H	H	H	L	L	L

*1 (): THE SAFTY TAB OF THE CASSETTE IS BROKEN

[SYSTEM CONTROL-AUDIO BLOCK INTERFACE]

SIGNAL	I/O	IC601 Pin No.	MODE											FR SEARCH			
			STOP	FF	REW	PB	PB- PAUSE	PICTURE SEARCH		REC OR TIMER REC	REC- PAUSE	WAIT PAUSE	CUE	REV			
								CUE	REV								
AUDIO DUB *1	O	4	L	L	L	L	L	L	L	L	L	L	L	L	L	L	L
A MUTE	O	5	L	L	L	L	H	H	H	L	L	L	L	H	H		
BIAS CONT 2	O	55	L	L	L	L	L	L	L	H	L	L	L	L	L		
PB + AUDIO DUB	O	73	L	L	L	H	H	H	H	L	L	L	L	H	H		

*1 NOT USED

[SYSTEM CONTROL-ITS PERIPHERAL CIRCUIT INTERFACE]

SIGNAL	I/O	IC601 Pin No.	MODE										
			USUAL	PRESSED BUTTON									
				EJECT	STOP	PB	REC	REW	FF	PAUSE	POWER		
F SW 1	I	⑬	5V	0V	1V	2V	3V		-	-	-	-	
F SW 2	I	⑭	5V	-	-	-	-		0V	1V	2V	-	
V HOLD *1	I	⑯	0V - 5V *2	-	-	-	-		-	-	-	-	
POWER ON/OFF	I	⑰	5V	-	-	-	-		-	-	-	0V	
IR	I	⑥⑥, ⑥⑧	5V	-	-	-	-		-	-	-	-	

*1: NOT USED

*2: BY V HOLD VR

[SYSTEM CONTROL-TIMER BLOCK INTERFACE] [TIMER-TUNER INTERFACE (1)]

SIGNAL	I/O	IC601 Pin No.	MODE
			USUAL
S DATA ST	O	⑤③	L
S DATA TS	I	⑤④	L
S CLK	I	⑤⑤	H
SYS REQ	O	⑦②	H
SEND REQ	I	⑦④	H

SIGNAL	I/O	IC001 Pin No.	FL DISPLAY INDICATION		
			PROG. No.	AU	BLANK
P00	I	①	*1	L	L
P01	I	②	*1	L	L
P02	I	③	*1	L	L
P03	I	④	*1	L	L
P10	I	⑤	*1	L	L
P11	I	⑥	*1	L	L
PR RESET	O	⑤⑧	H	H	H
PR UP	O	⑤⑨	H	H	H
PR LOCK	O	⑥⑩	L	L	L
TU SEL	O	⑥①	H	L	L

*1 REFER TO "TIMER-TUNER INTERFACE (2)".

[TIMER-TUNER INTERFACE (2)]

PROG. No.	IC101 INPUT						IC101 OUTPUT (INDICATION)		PROG. No.	IC101 INPUT						IC101 OUTPUT (INDICATION)	
	P11	P10	P03	P02	P01	P00	10 digit	1 digit		P11	P10	P03	P02	P01	P00	10 digit	1 digit
1	H	H	L	L	L	H		1	18*2	L	H	H	L	L	L	1	8
2	H	H	L	L	H	L		2	19*2	L	H	H	L	L	H	1	9
3	H	H	L	L	H	H		3	20*2	H	L	L	L	L	L	2	0
4	H	H	L	H	L	L		4	21*2	H	L	L	L	L	H	2	1
5	H	H	L	H	L	H		5	22*2	H	L	L	L	H	L	2	2
6	H	H	L	H	H	L		6	23*2	H	L	L	L	H	H	2	3
7	H	H	L	H	H	H		7	24*2	H	L	L	H	L	L	2	4
8	H	H	H	L	L	L		8	25*2	H	L	L	H	L	H	2	5
9	H	H	H	L	L	H		9	26*2	H	L	L	H	H	L	2	6
10	L	H	L	L	L	L	1	0	27*2	H	L	L	H	H	H	2	7
11	L	H	L	L	L	H	1	1	28*2	H	L	H	L	L	L	2	8
12	L	H	L	L	H	L	1	2	29*2	H	L	H	L	L	H	2	9
13*2	L	H	L	L	H	H	1	3	0*2	H	H	L	L	L	L		0
14*2	L	H	L	H	L	L	1	4	LINE	L	L	H	H	L	L	A	U
15*2	L	H	L	H	L	H	1	5	BLANK	H	H	H	H	H	H		
16*2	L	H	L	H	H	L	1	6	1-*2	L	H	H	H	H	H	1	
17*2	L	H	L	H	H	H	1	7	2-*2	H	L	H	H	H	H	2	

*2 EC MODEL ONLY

3-6. SERVO BLOCK DIAGRAM

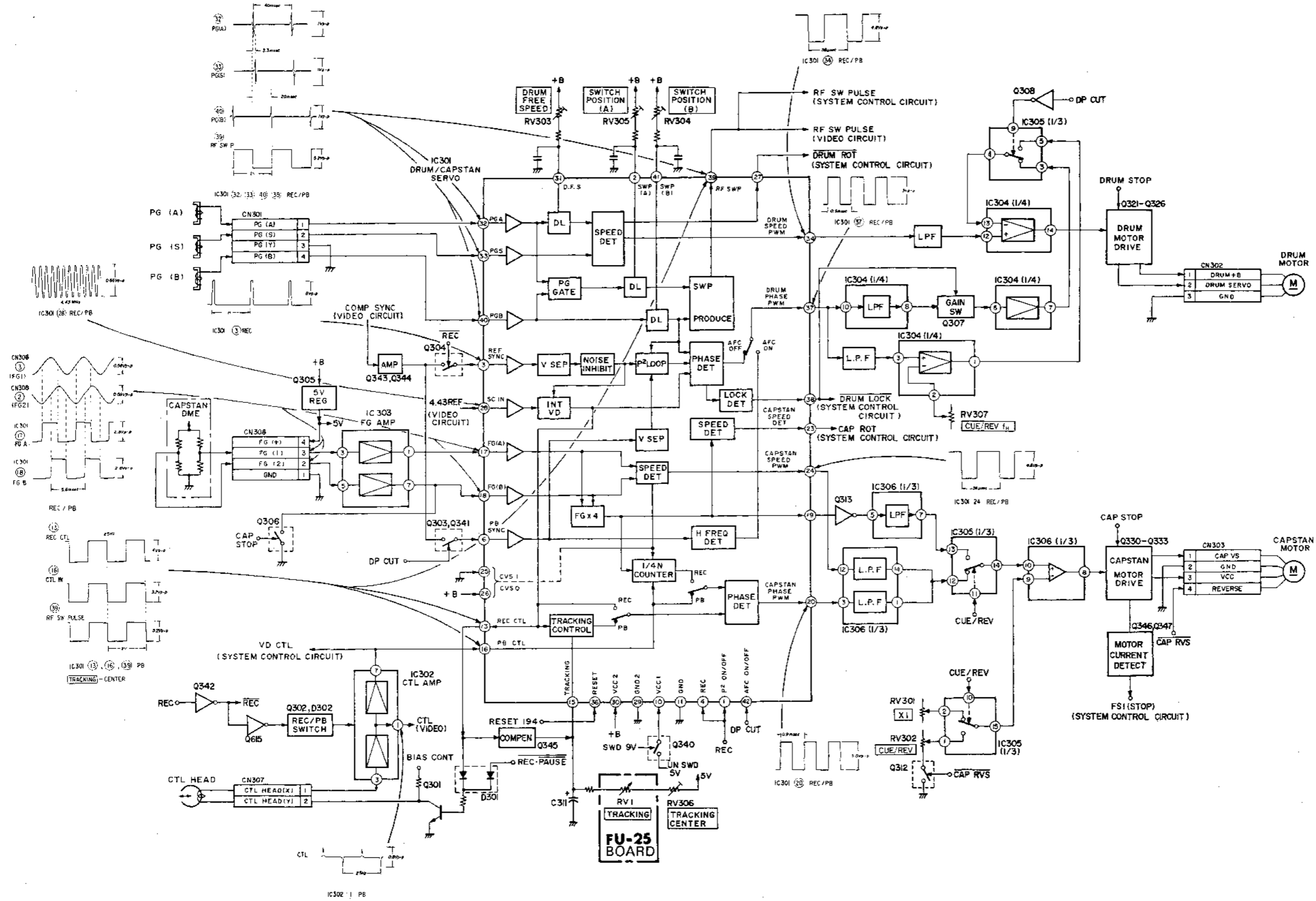

3-7. CAPSTAN PHASE SYSTEM TIMING CHART (REC)

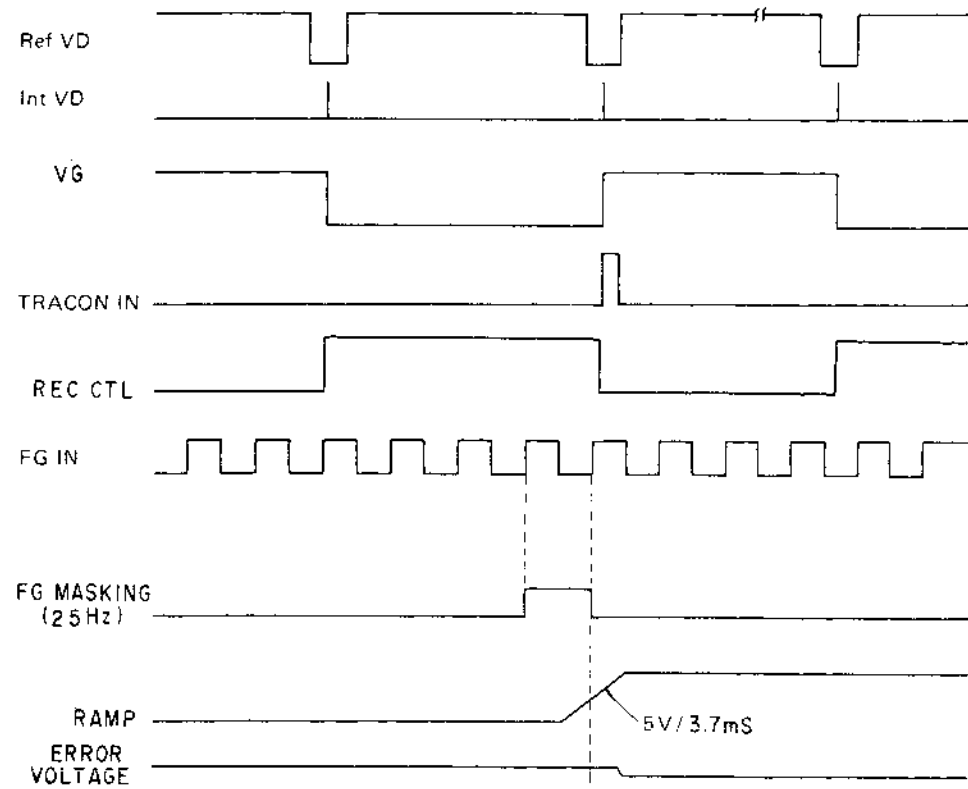

3-8. CAPSTAN PHASE SYSTEM TIMING CHART (PB)

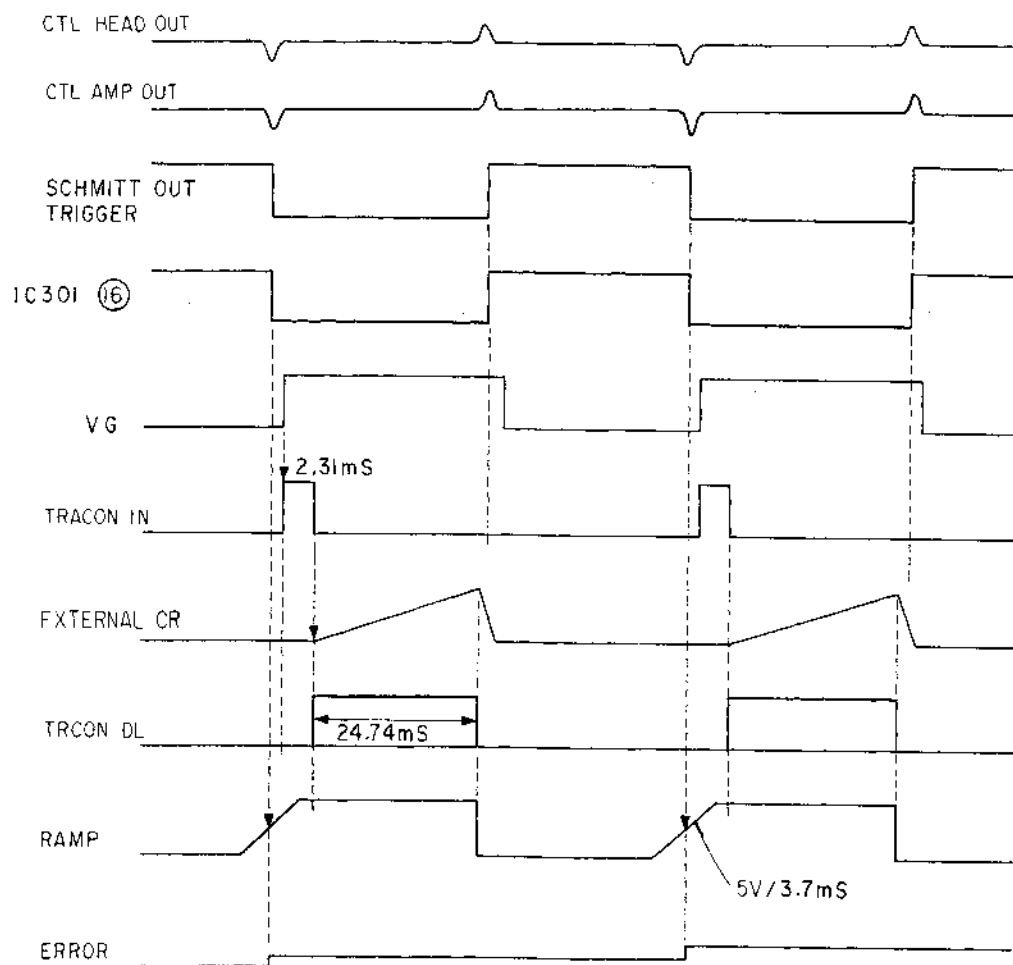

3-9. CAPSTAN SPEED SYSTEM TIMING CHART

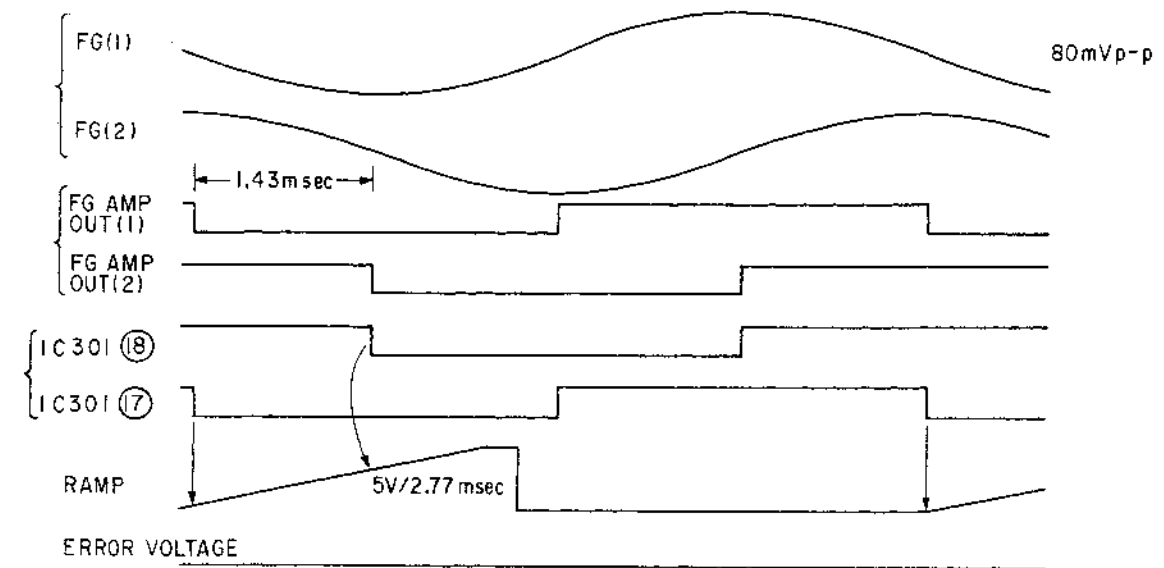

3-10. DRUM PHASE SYSTEM TIMING CHART

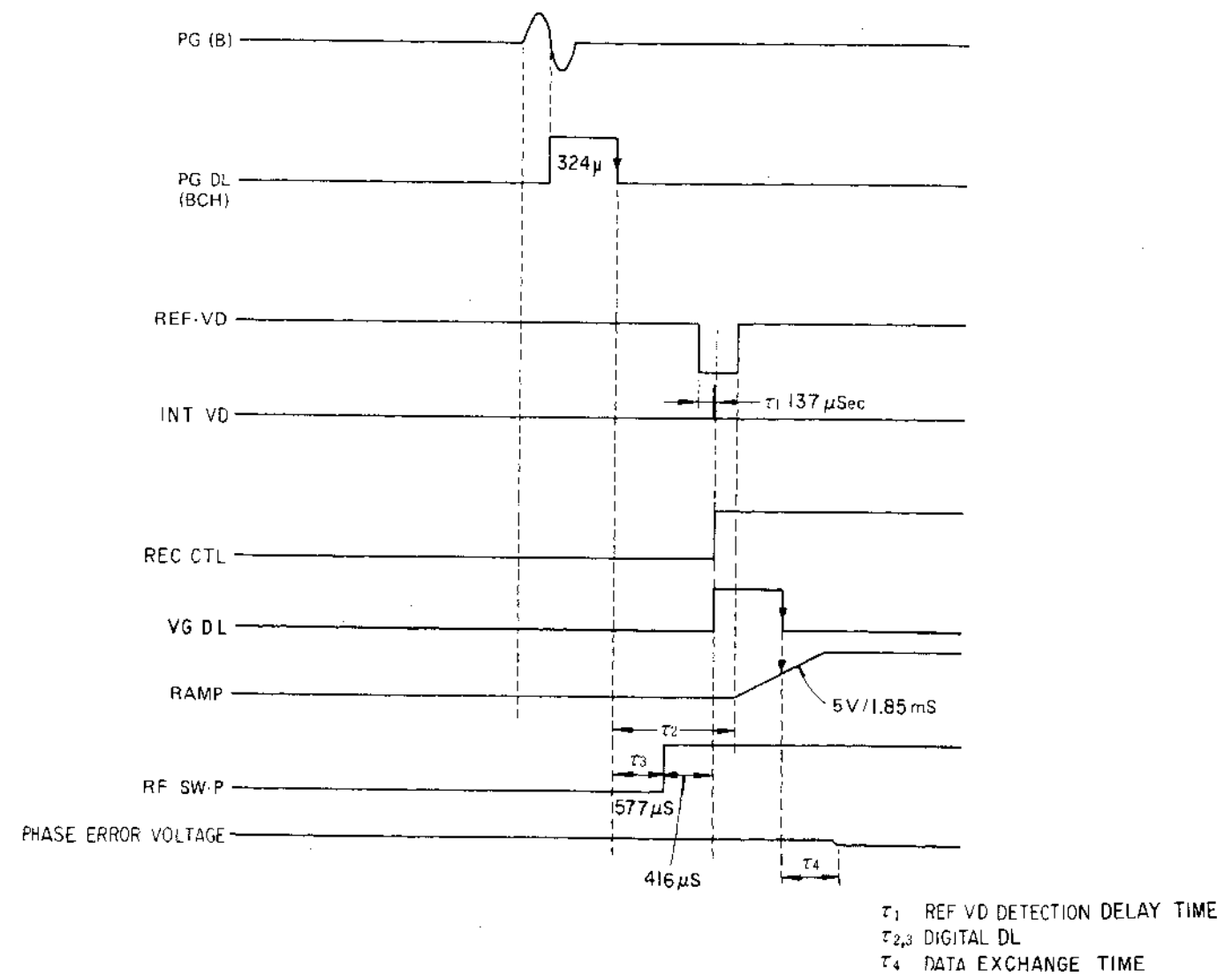

3-11. DRUM SPEED SYSTEM TIMING CHART

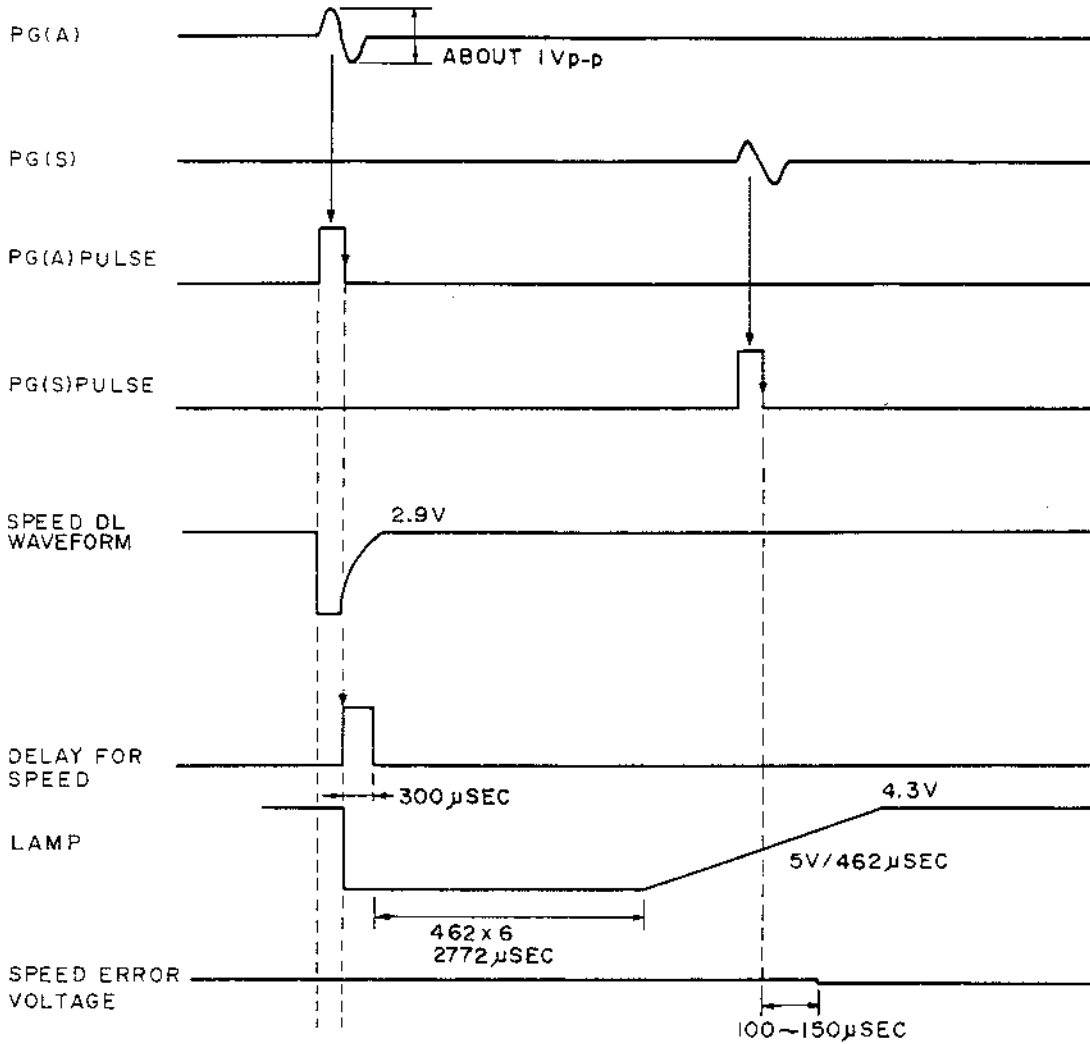

3-12. PG SIGNAL TIMING CHART

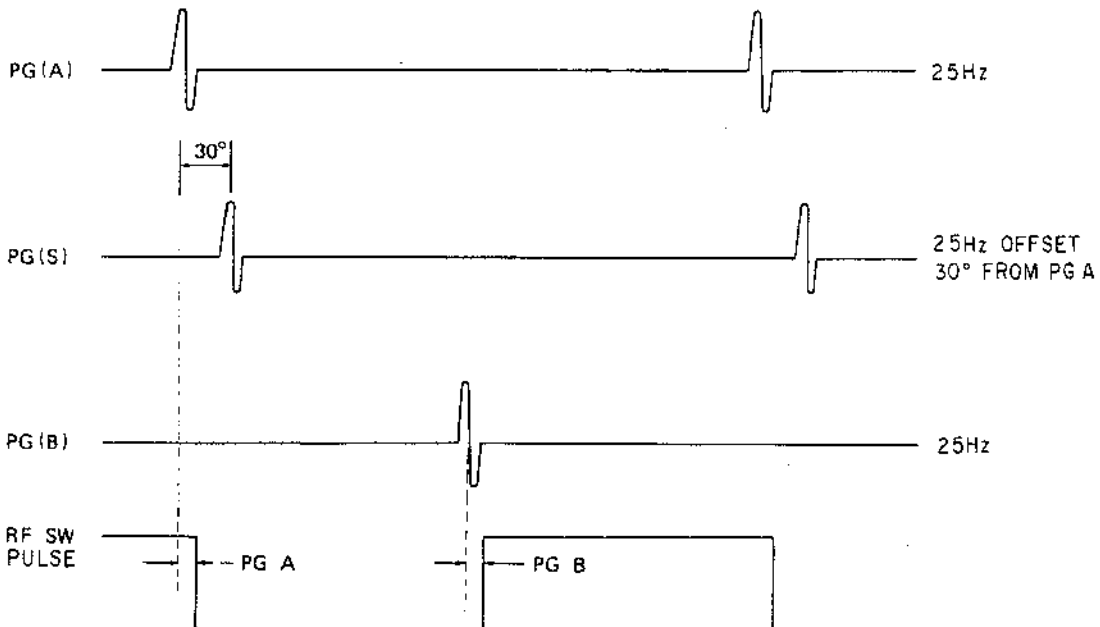

3-13. AUDIO LEVEL DIAGRAM (REC)

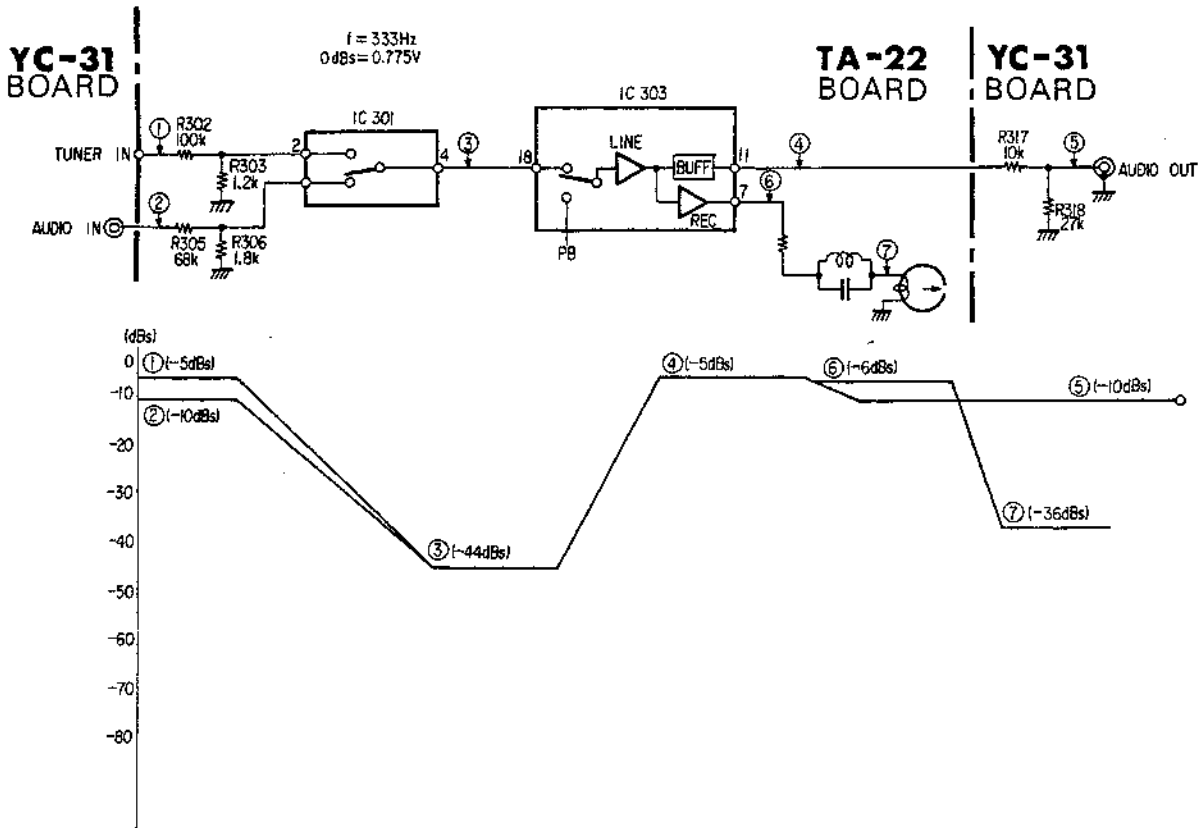

3-14. AUDIO LEVEL DIAGRAM (PB)

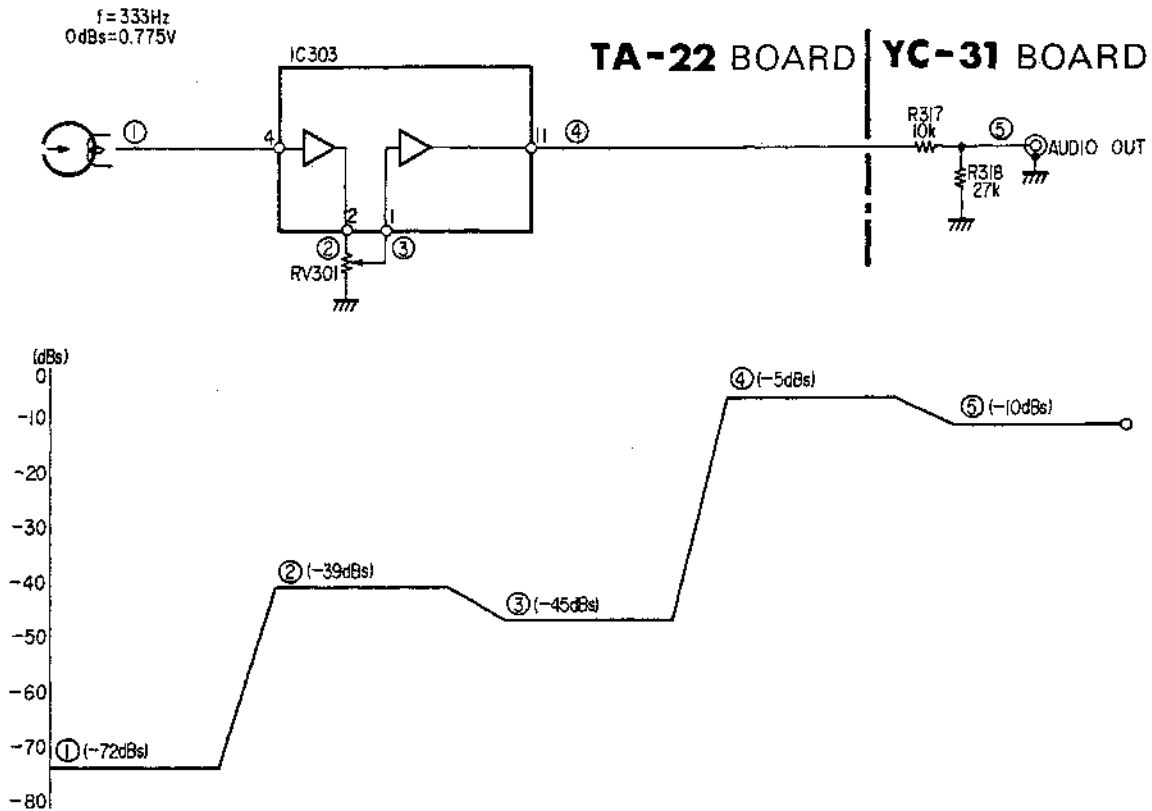

3-15. AUDIO BLOCK DIAGRAM

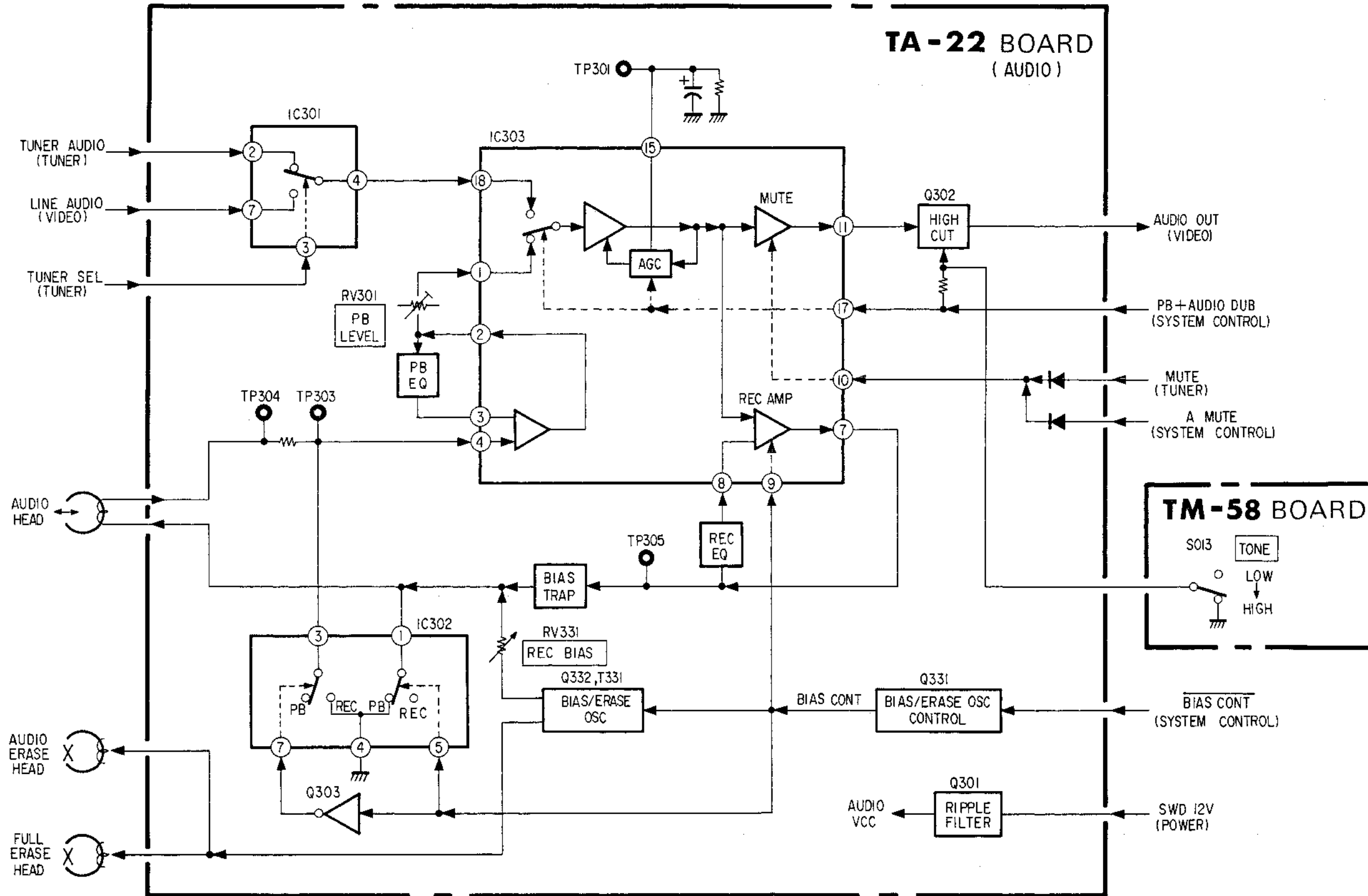

3-16. TUNER BLOCK DIAGRAM

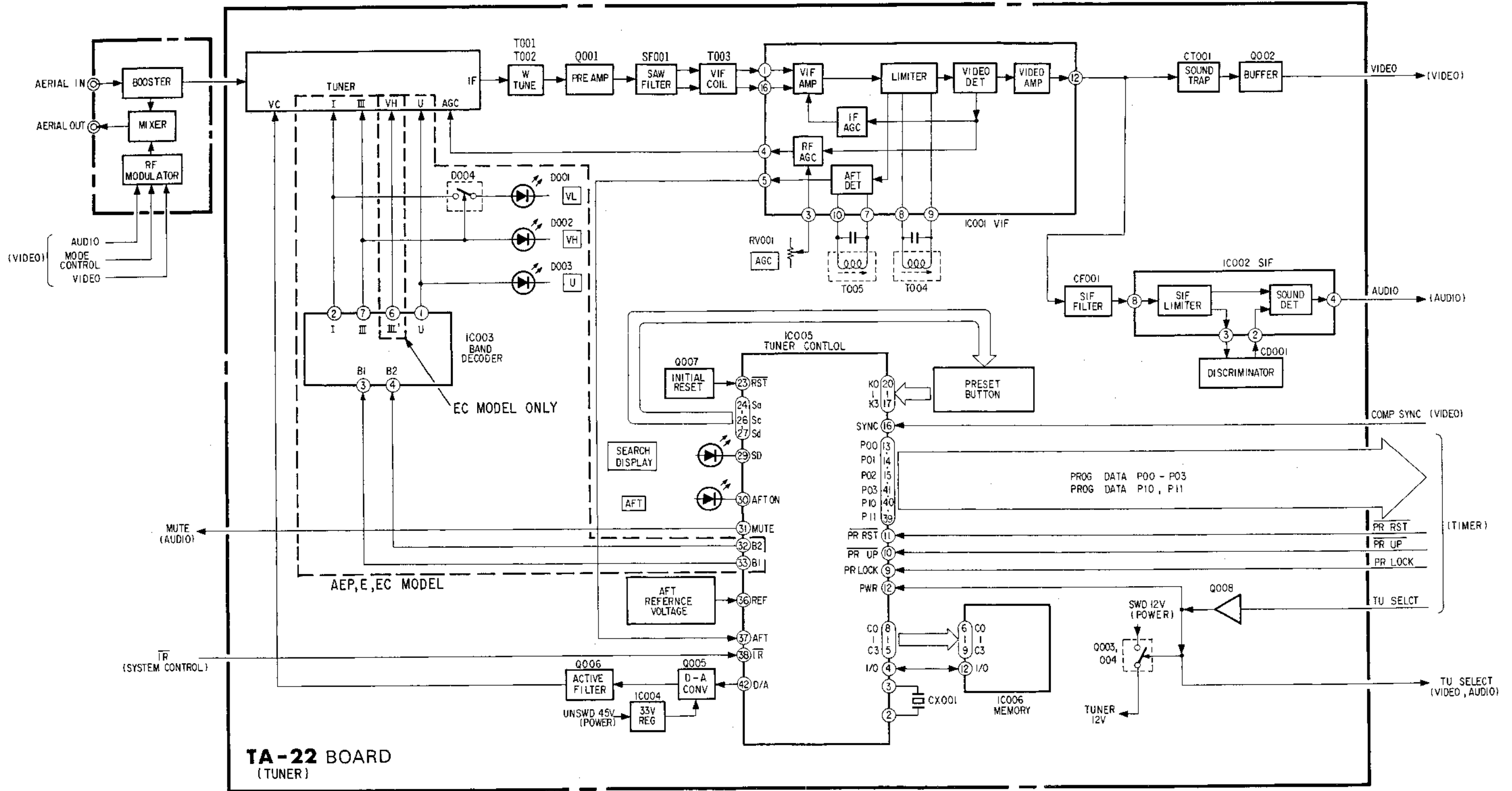

TA-22 BOARD
(TUNER)

3-17. TIMER BLOCK DIAGRAM

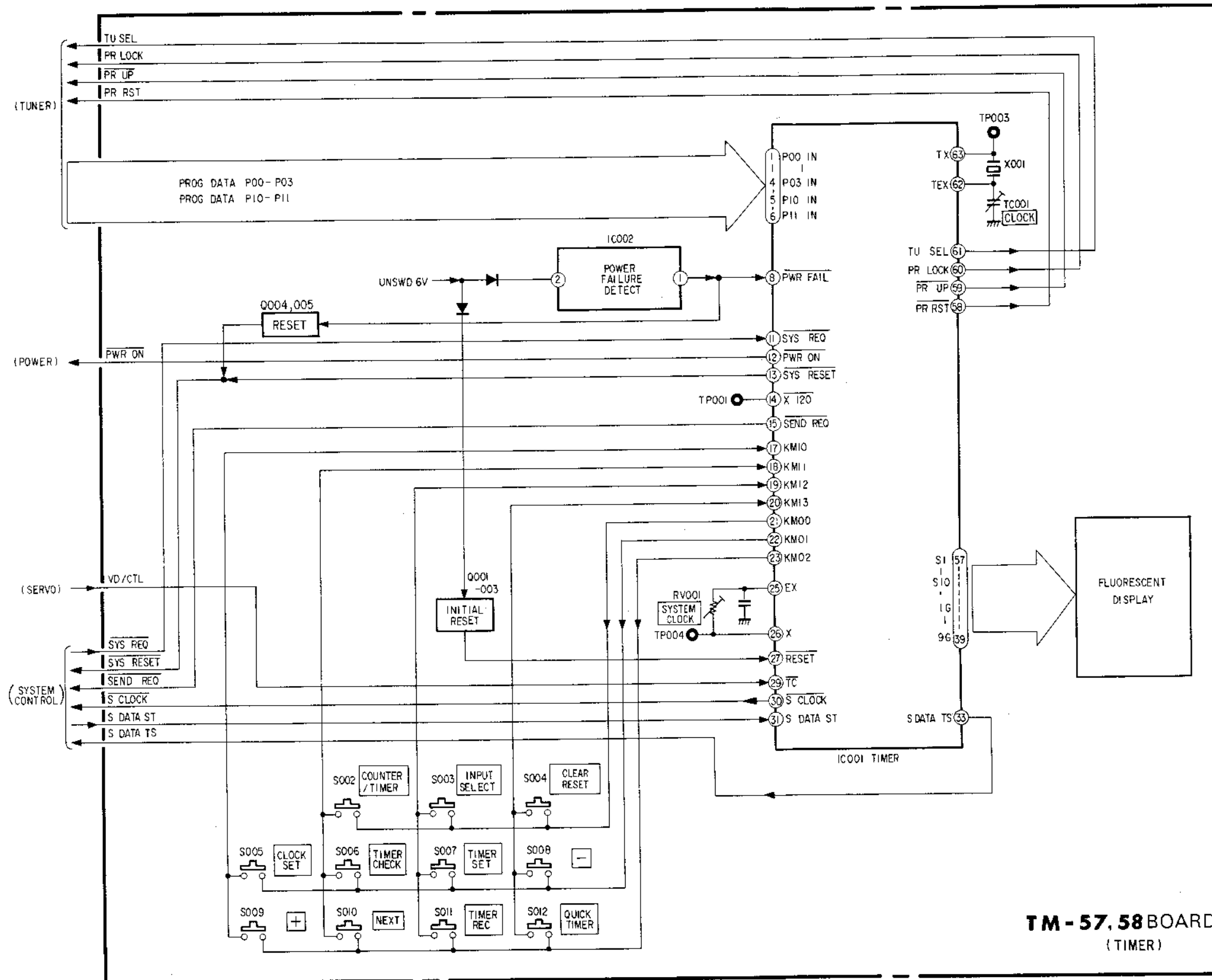

3-18-1. POWER BLOCK DIAGRAM (AEP, UK, EC MODEL)

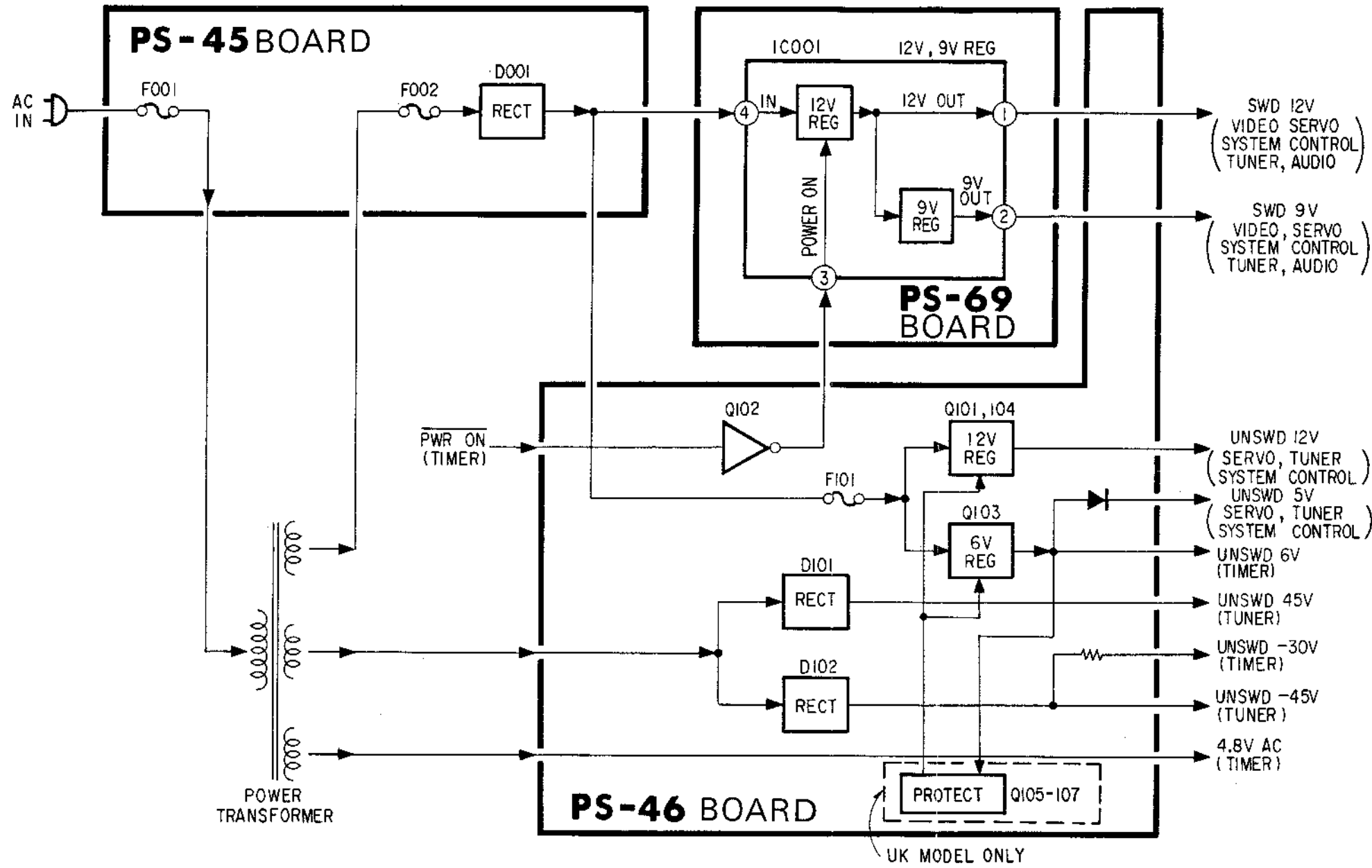

3-18-2. POWER BLOCK DIAGRAM (E MODEL)

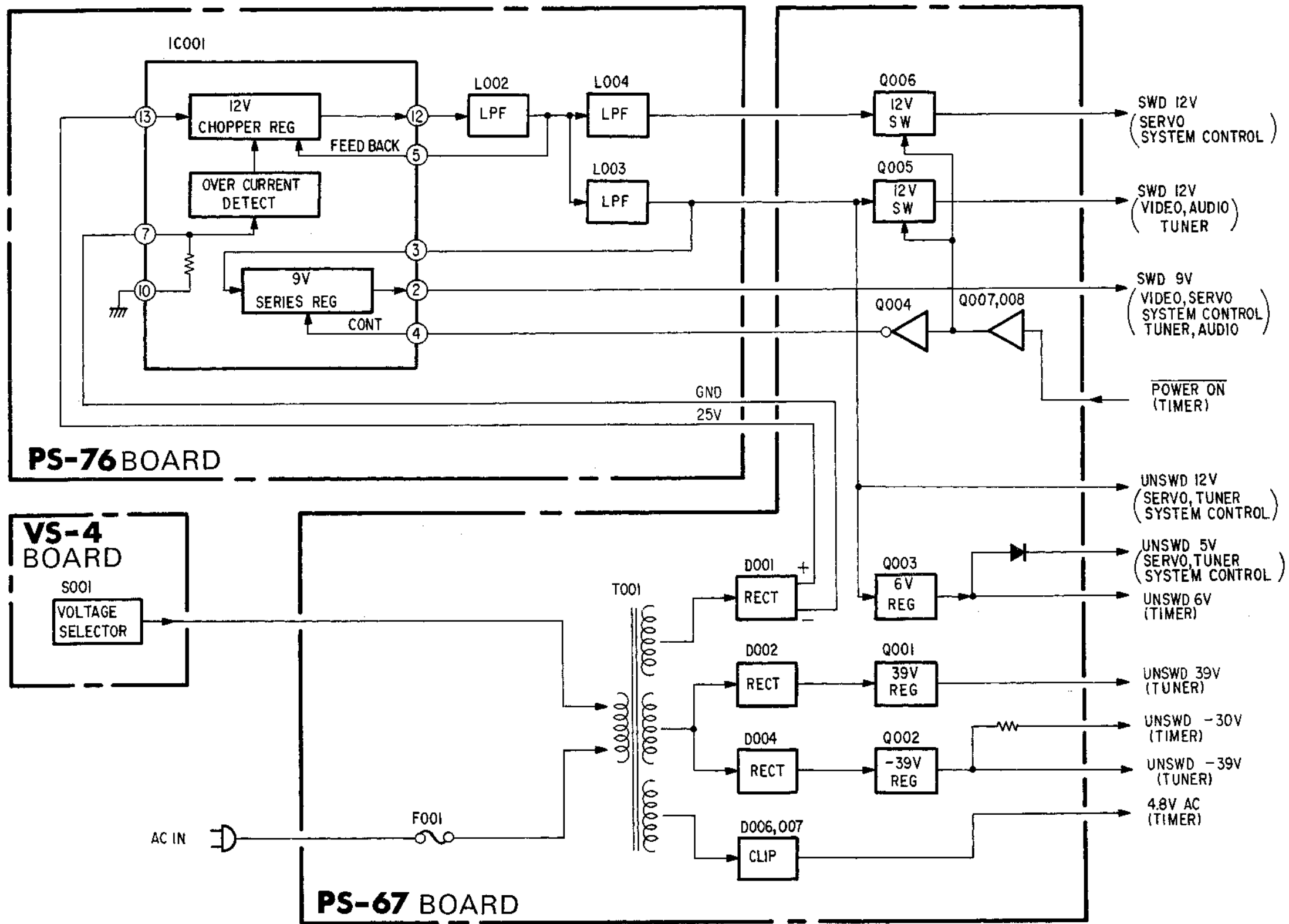

SECTION 4
SCHEMATIC DIAGRAM AND PRINTED WIRING BOARDS

FRAME FRAME

4-1. FRAME SCHEMATIC DIAGRAM

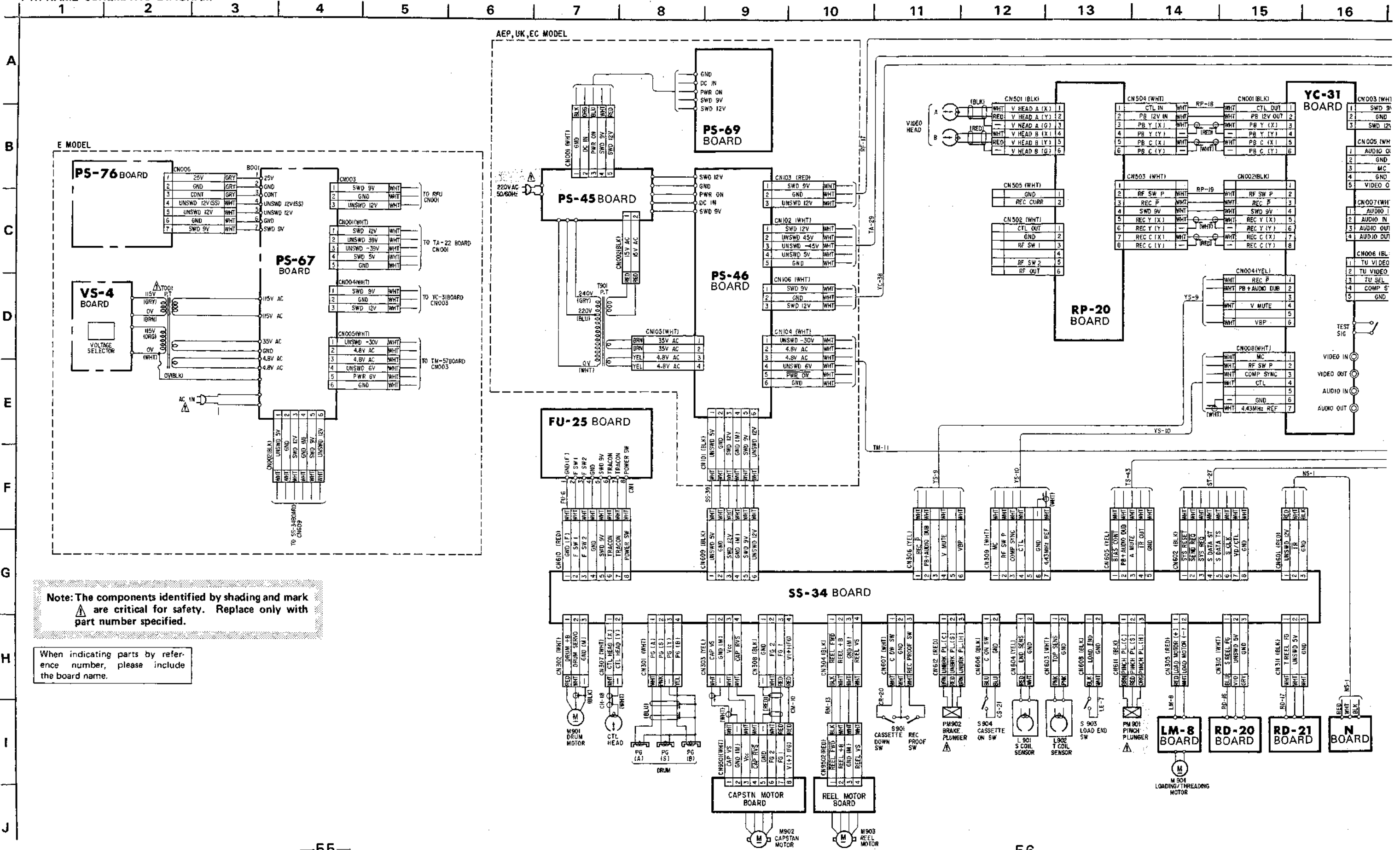

Note: The components identified by shading and mark are critical for safety. Replace only with part number specified.

When indicating parts by reference number, please include the board name.

VIDEO VIDEO

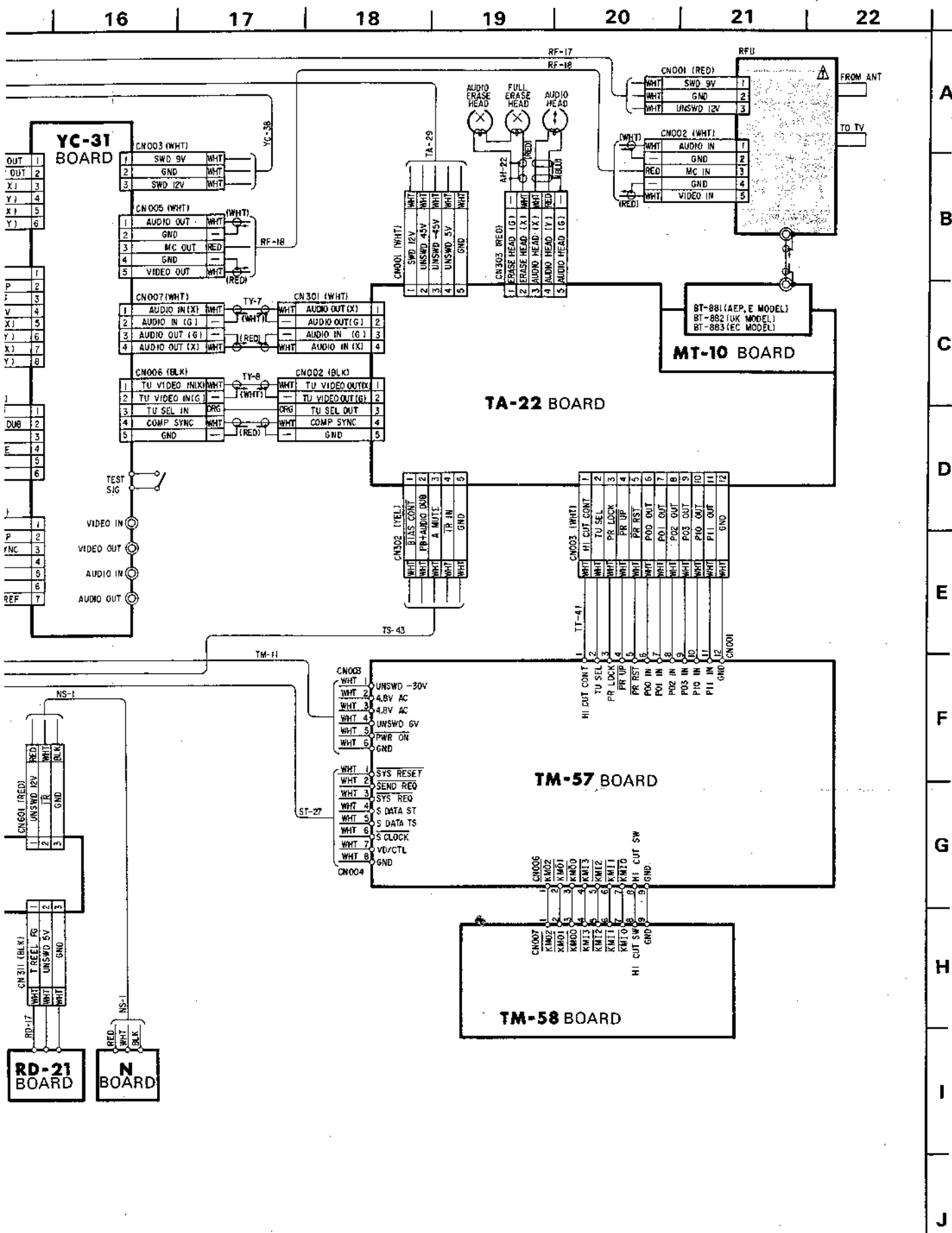

YC-31 BOARD (PAL/SECAM)

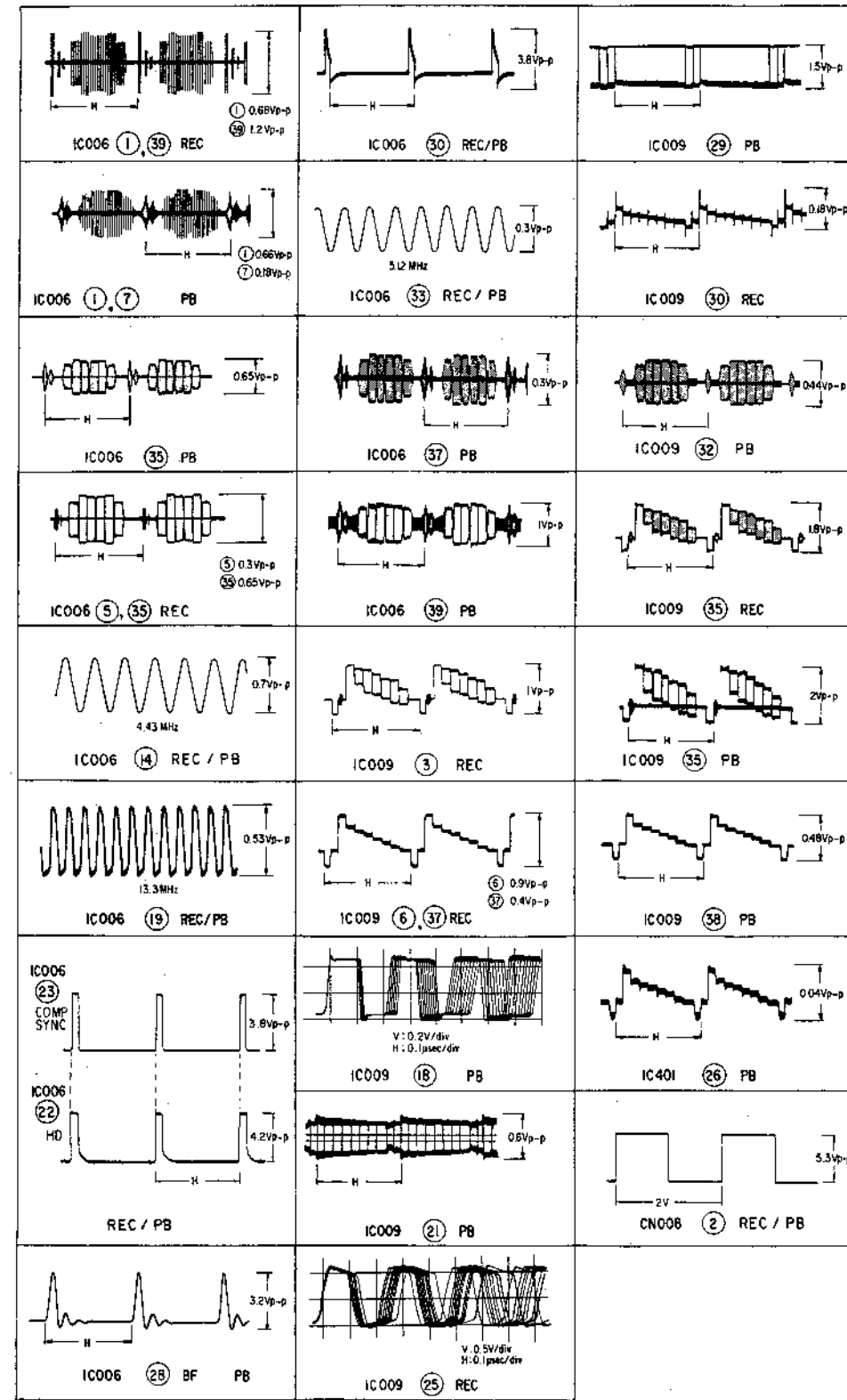

RP-20 BOARD

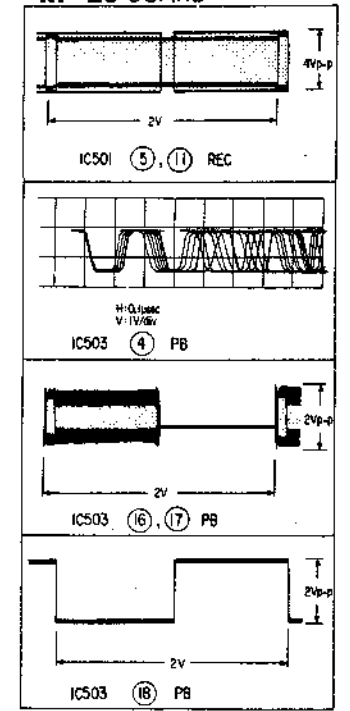

VIDEO VIDEO

4-2. YC-31 (Y, CHROMA SIGNAL PROCESS), RP-20 (VIDEO SIGNAL, REC/PB AMP) PRINTED WIRING BOARDS

— Ref. No. YC-31 BOARD : 1000 series, RP-20 BOARD : 2000 series —

1 2 3 4 5 6 7 8 9 10 11 12 13 14 15 16

A
B
C
D
E
F
G
H
I
J

Q, IC	D	ADJ
075		RV002
052,053,069	031	RV003
047		RV401
064,065,063,062,051,054		RV501
102,048,049		
502,100,03,060,061,104,01	030	LV501
		RV018
050	021,022	
055		RV020
020,401,024,100H	029	
504,503		
023		
C22	018	
		RV021
076,077	044,043	
010,045,040,011		RV602
		RV014
030		RV016
033,034,100,039,071,038,069	019	CV001
	015	RV015
035,036,067	020	RV009
		RV010
037	016	RV012
	017	
026		RV013
056		
101,100,016	036	RV005
	023	
031,015,068		RV006
		RV007
617,103,032	014	RV008
Q, IC	D	ADJ

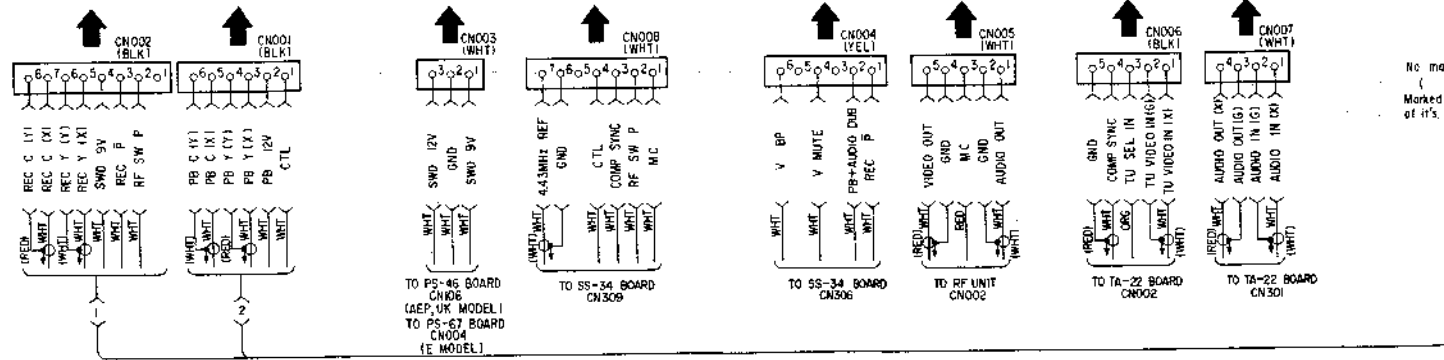
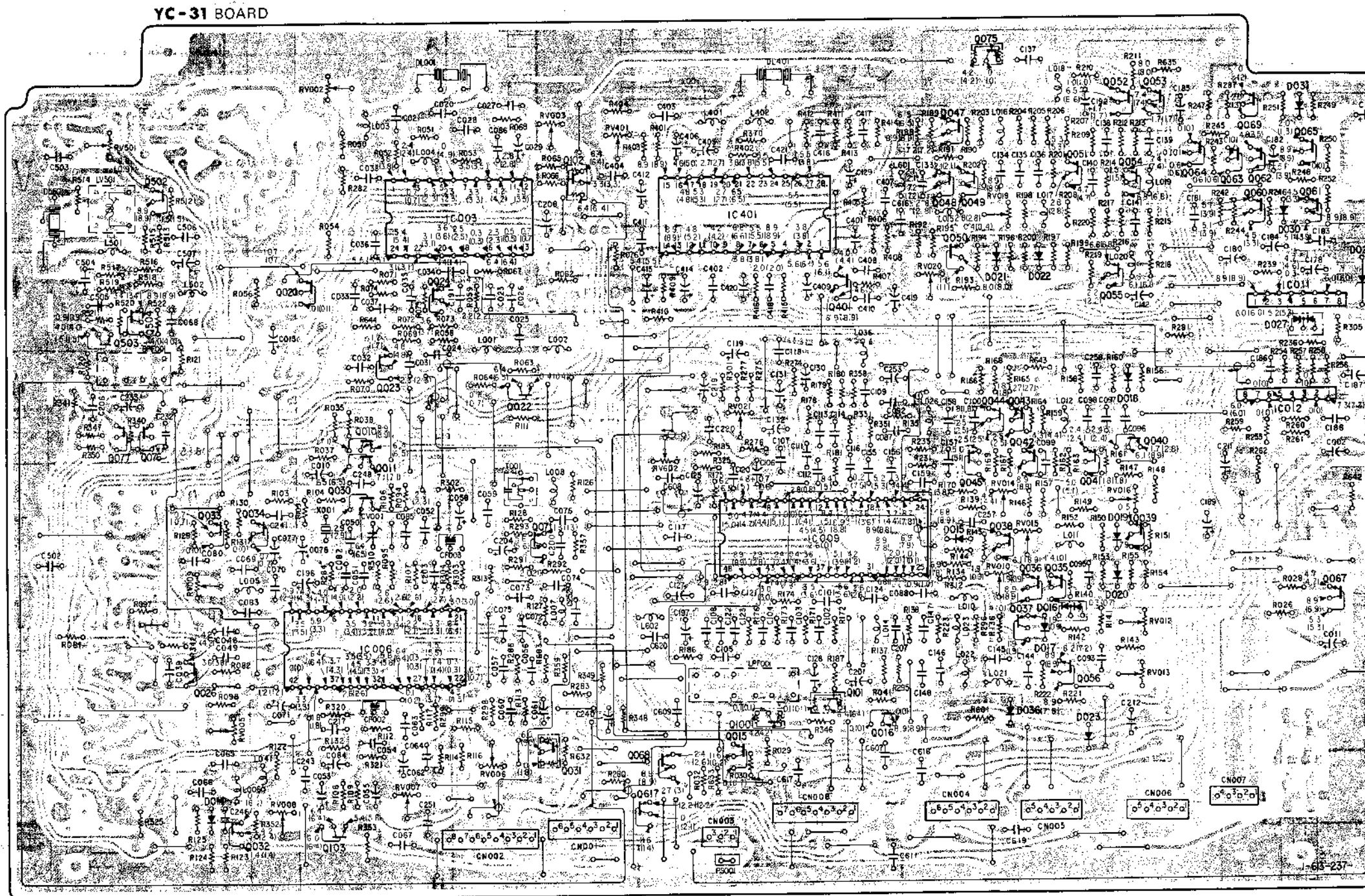

VIDEO VIDEO

16 17 18 19 20 21 22 23 24 25 26 27 28 29 30

Q	IC503	IC501	502,503	508	Q
IC	RV502	RV503	RV501	501	IC
ADJ					ADJ

- Note:**
- — : indicates a lead wire mounted on the component side.
 - — : indicates a lead wire mounted on the printed side.
 - ◐ : soldering side
 - ◑ : B+ pattern

When indicating parts by reference number, please include the board name.

RP-20 BOARD

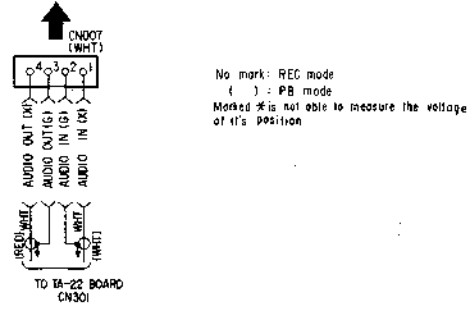
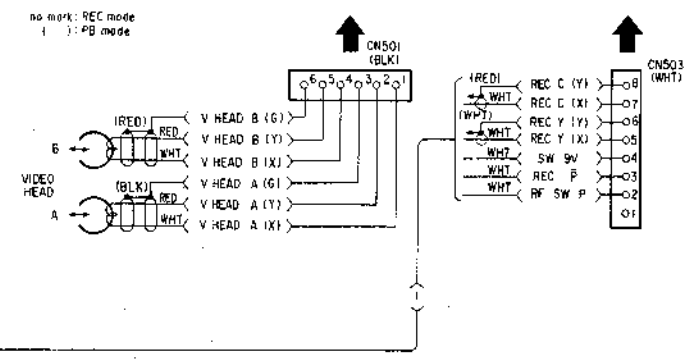
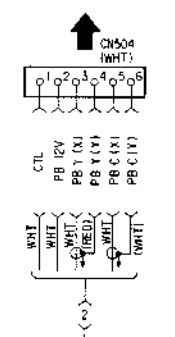
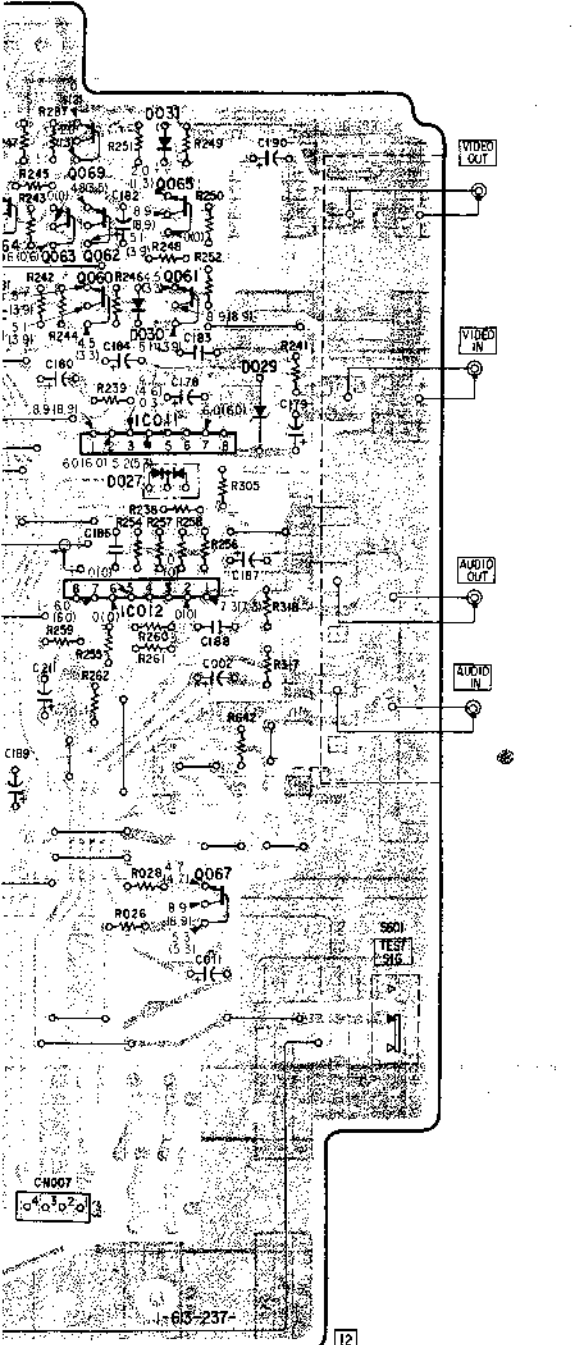
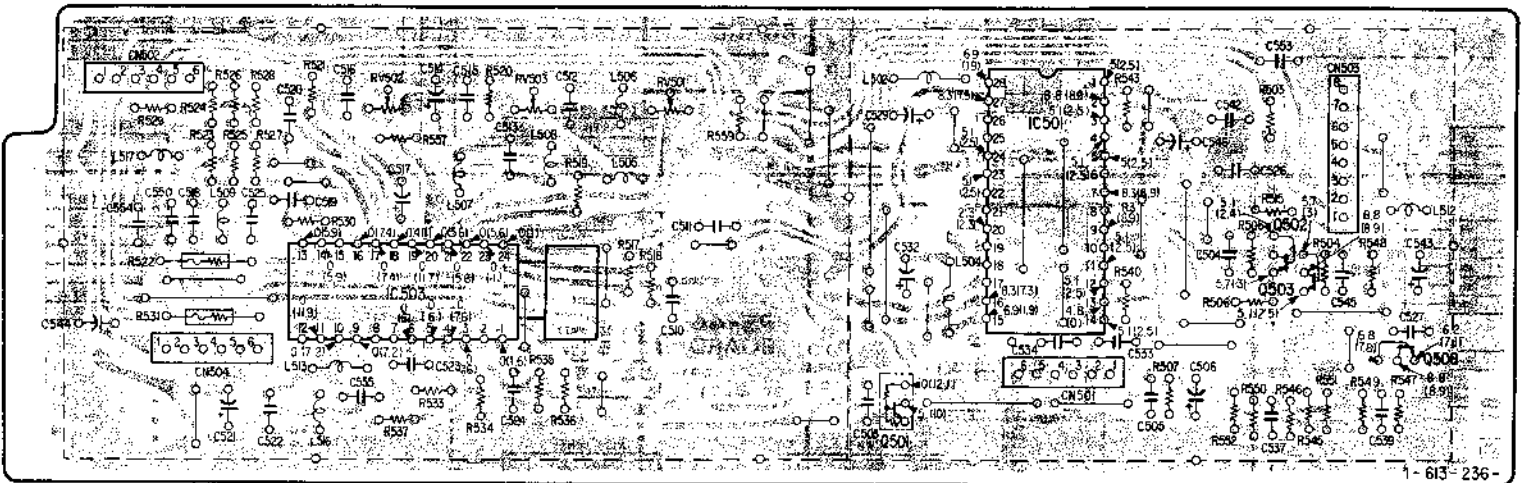





A
B
C
D
E
F
G
H
I
J

VIDEO VIDEO

YC-31 (Y, CHROMA SIGNAL PROCESS), RP-20 (VIDEO SIGNAL, REC/PB AMP) SCHEMATIC DIAGRAM

- Ref. No. YC-31 BOARD : 1000 series, RP-20 BOARD : 2000 series -

Note:

- All resistors are in ohms, 1/8W unless otherwise noted.
- All capacitors are in μF (p:pF) unless otherwise noted.
- 50V or less are not indicated except for electrolytic capacitors.
- All variable and semi fixed resistors have characteristic curve B, unless otherwise noted.
-  : Nonflammable resistor
-  : Fusible resistor
-  : B+ bus.
-  : B- bus.
- The voltage value is reference value between the grounding when the color bar signal is received from a color bar generator.
- The voltage value is measured using a digital tester (10M Ω).

Note: The components identified by shading and mark  are critical for safety. Replace only with part number specified.

When indicating parts by reference number, please include the board name.

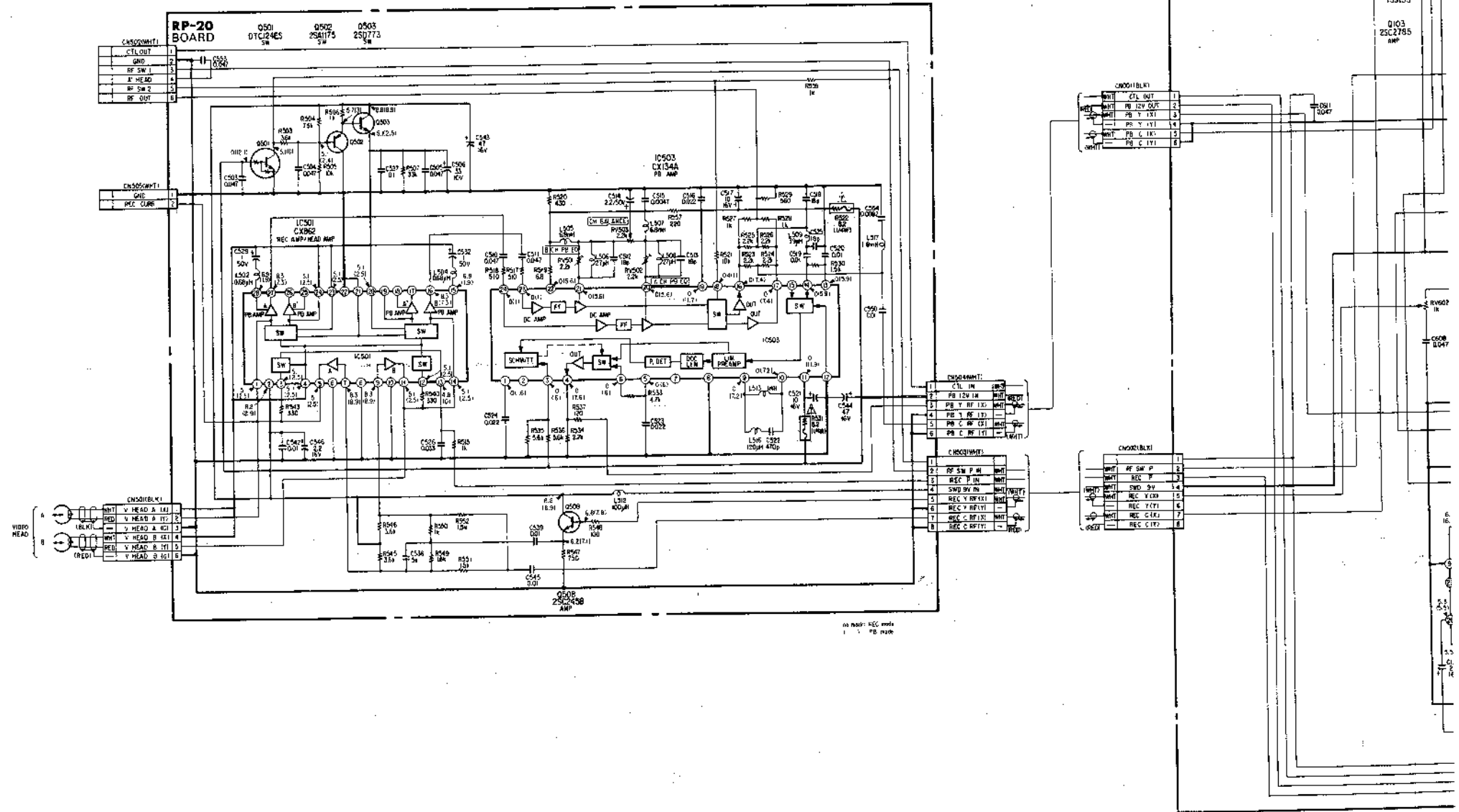

VIDEO VIDEO

15 16 17 18 19 20 21 22 23 24 25 26 27 28 29 30

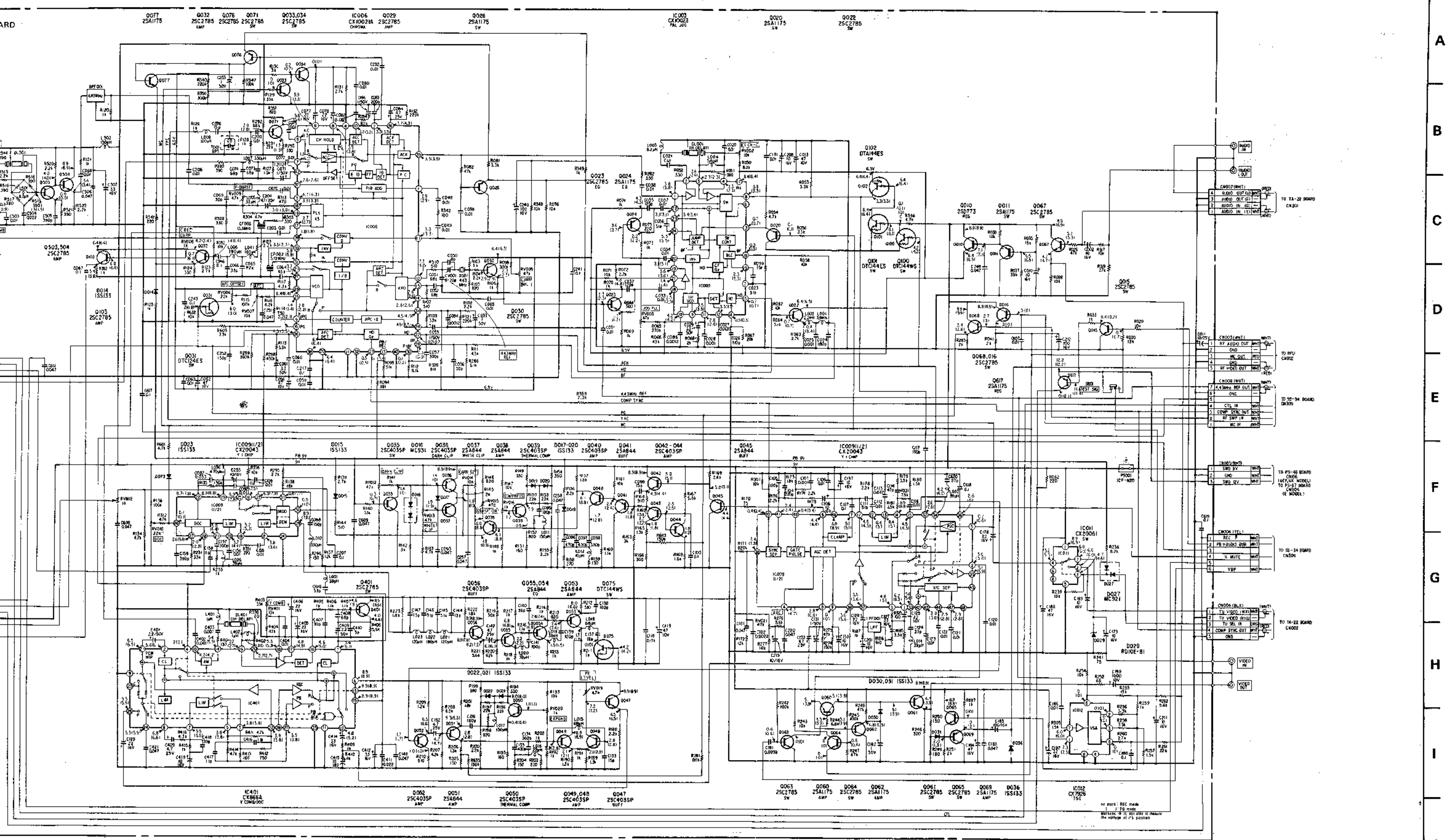

SERVO/SYSTEM CONTROL SERVO/SYSTEM CONTROL

4-3. SS-34 (SYSTEM CONTROL, SERVO), RD-20 (ROTATION DETECTOR), RD-21 (ROTATION DETECTOR), LM-8 (LOADING MOTOR), FU-25 (FUNCTION, TRACKING CONTROL), N (INFRARED AMP), CAPSTAN MOTOR (CAPSTAN MOTOR), R. ST/

- Ref. No. SS-34, RD-20, RD-21 BOARD : 4000 series, LM-8 BOARD : 9000 series, FU-25 BOARD : 8000 series, N BOARD : 8300 series, CAPSTAN MOTOR BOARD : 8200 series, R. STATOR BOARD : 8100 series -

A
B
C
D
E
F
G
H
I
J

- Note:**
- — : indicates a lead wire mounted on the component side.
 - — : indicates a lead wire mounted on the printed side.
 - : soldering side
 - : B+ pattern
 - : component side

Note: The components identified by shading and mark Δ are critical for safety. Replace only with part number specified.

When indicating parts by reference number, please include the board name.

CAPSTAN MOTOR BOARD

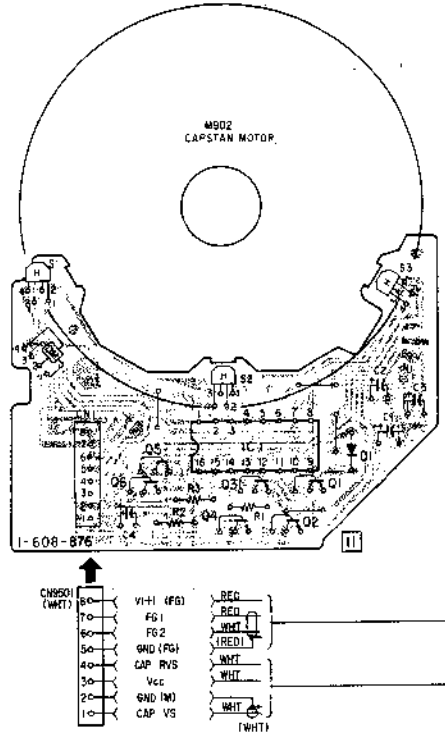

R-STATOR BOARD

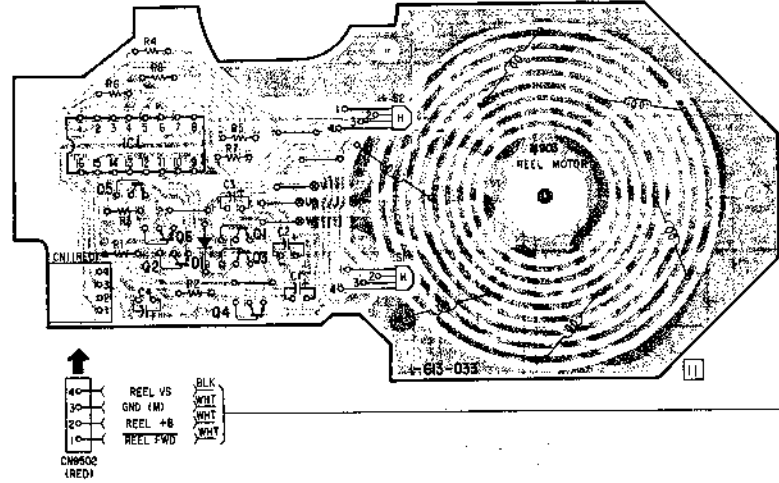

FU-25 BOARD

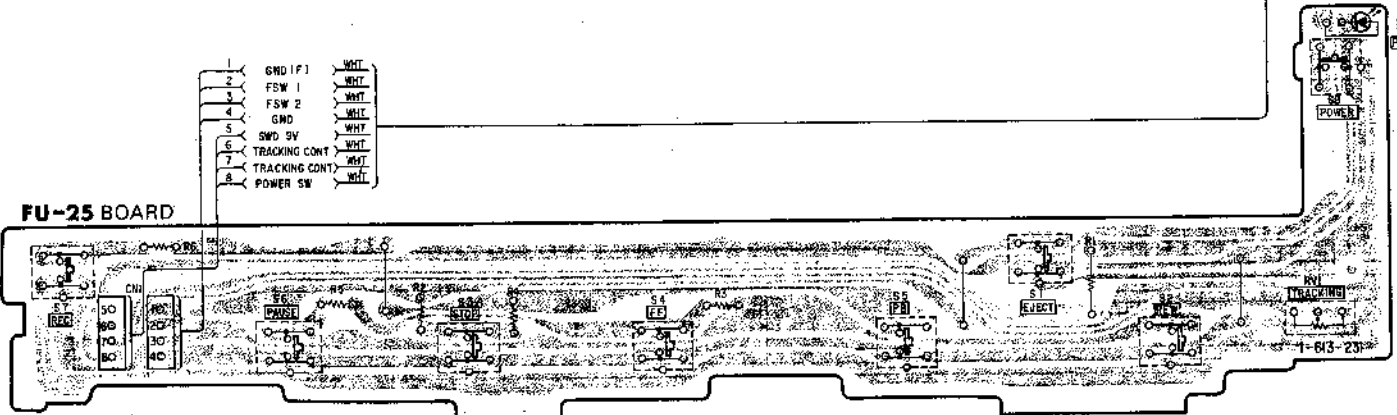

N BOARD

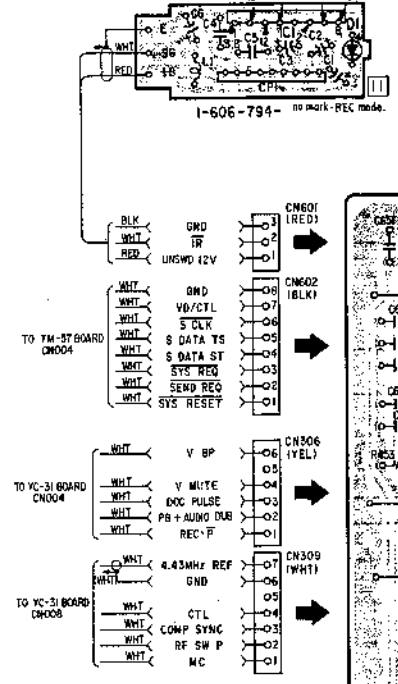

SS-34 BOARD

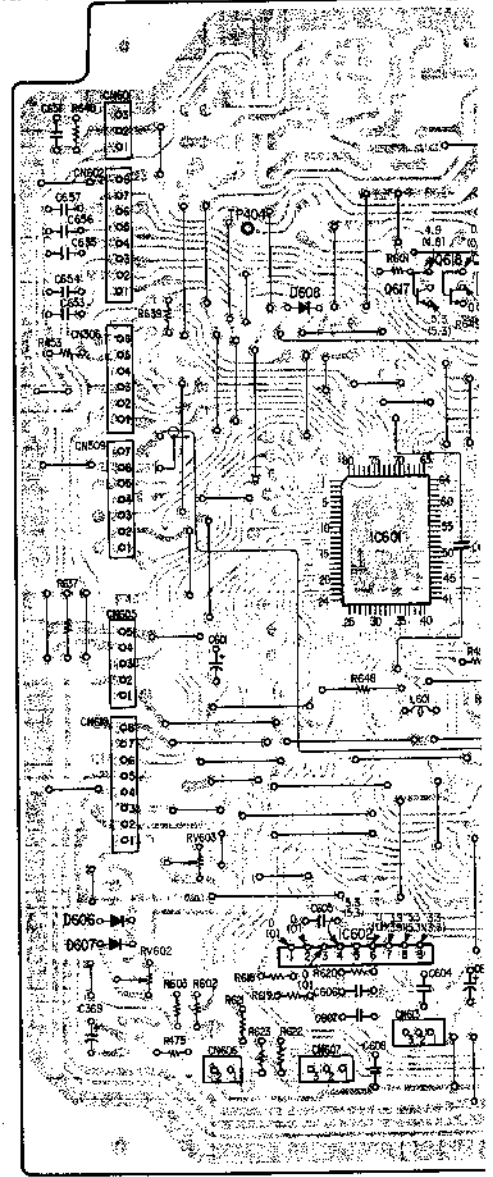

RD-20 BOARD

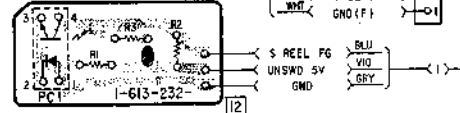

RD-21 BOARD

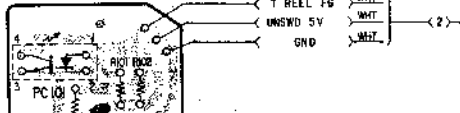

LM-8 BOARD

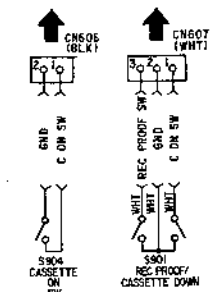
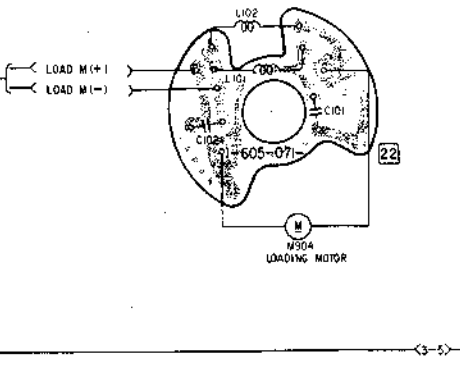

SERVO/SYSTEM CONTROL SERVO/SYSTEM CONTROL

PSTAN MOTOR), R. STATOR (REEL MOTOR) PRINTED WIRING BOARDS

5 16 17 18 19 20 21 22 23 24 25 26 27 28 29 30

BOARD

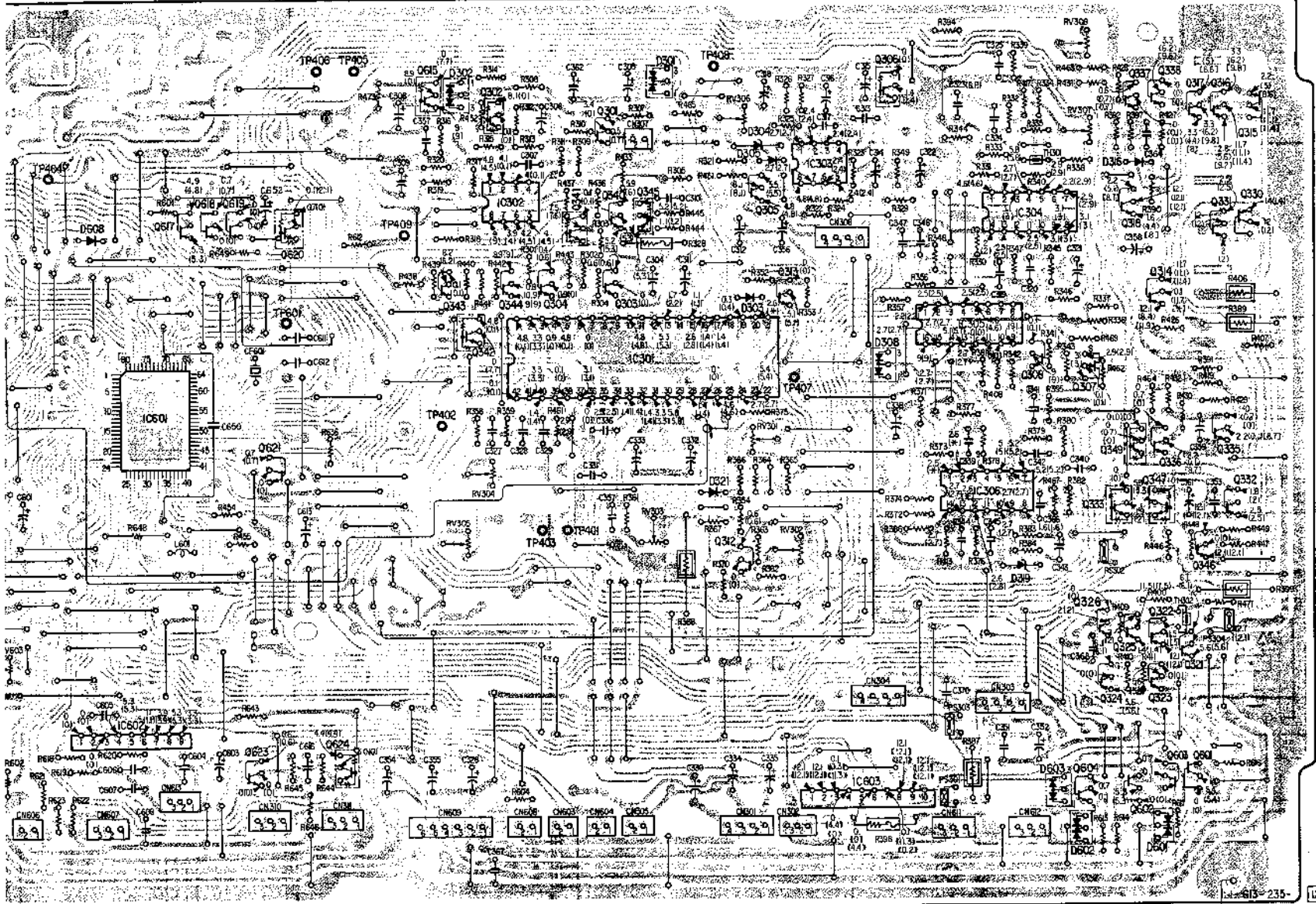

to mark: (RED) GND
 (WHT) FG 2
 (BLK) FG 1
 (YEL) V(+1FG)

to mark: () PB mode
 () CLUE mode
 () FF/REW mode
 () LOADING/THREADING mode
 () EJECT mode
 () REV mode

Marked * is not able to measure the voltage of its position.

Q, IC	D	ADJ, TP
306	301	RV308
616	302	TP408
337,338		TP406,TP405
317,316		RV306
302,303,305	304,316	RV307
IC303	305	TP404
305		TP409
IC302,344	345	
619,620	IC304	
617,618,318,350	341,351	
IC305	308	TP601
308,307	303	TP407
IC301	308	
IC601	335	TP402
349,336	621	RV301
IC306	321	RV304
333,332		TP401
347		RV303
346	319	RV302
312		
326,322		
325		
323		
324		
606	607	
IC602		
623,624	603	
603,601		
604,602		
IC603	601	
	602	

SS-34 BOARD (SERVO/SYSTEM CONTROL)

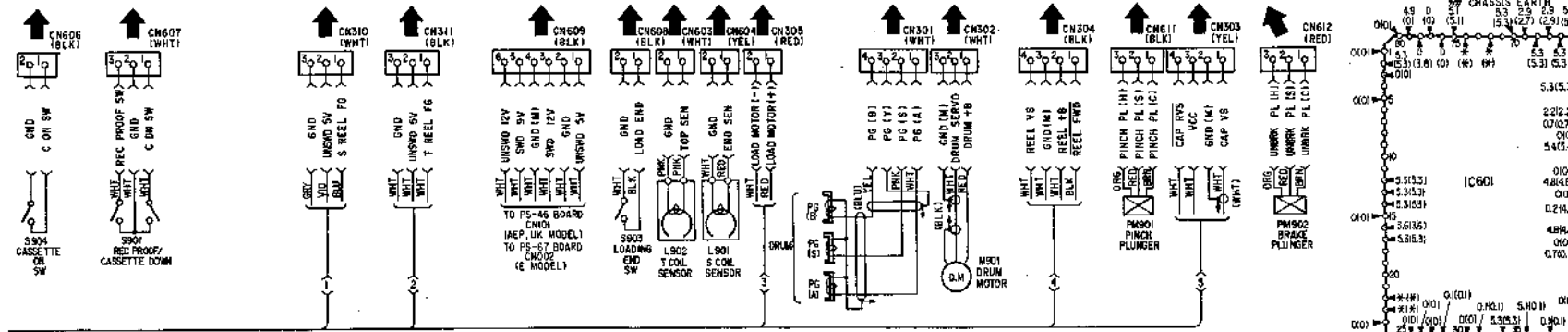
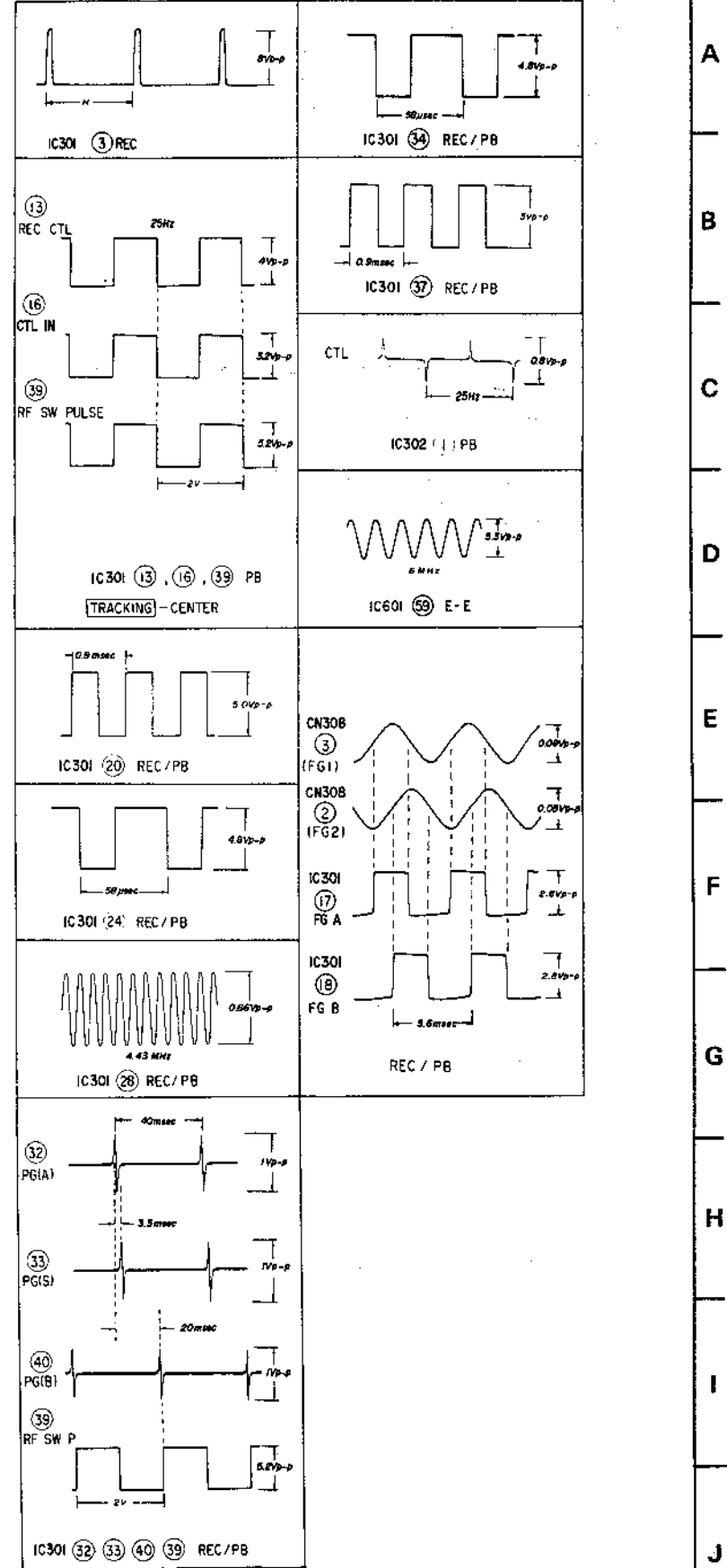

SERVO/SYSTEM CONTROL SERVO/SYSTEM CONTROL

MOTOR), R. STATOR (REEL MOTOR) SCHEMATIC DIAGRAM

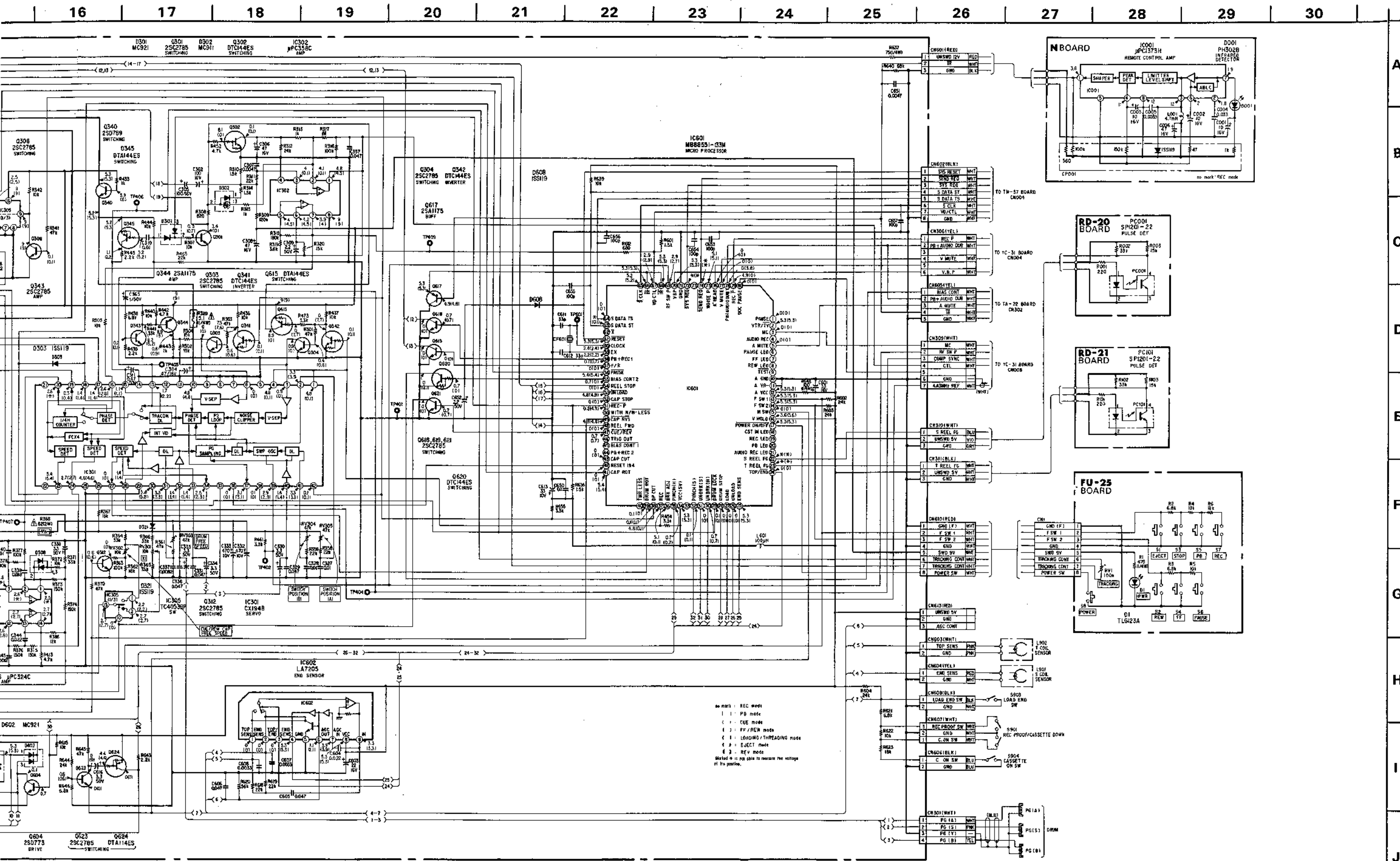

TUNER/TIMER TUNER/TIMER

4-4. TA-22 (VIF, AFT, SIF, AUTO PROGRAM AUDIO), MT-10 (TUNER), TM-57 (TIMER INDICATOR), TM-58 (SWITCH) PRINTED WIRING BOARDS

- Ref. No. TA-22, MT-10 BOARD : 5000 series, TM-57, TM-58 BOARD : 6000 series -

1 2 3 4 5 6 7 8 9 10 11 12 13 14 15 16

A
B
C
D
E
F
G
H
I
J

Q, IC	D	ADJ, TP
IC003		
001	010	
006	004	
	003,002,001	RV001
005	IC004	
IC004	011	
002		TP001
		RV301
IC006		
IC002		
IC005	IC301	TP304
007		RV331
		TP301
	303	TP303
IC303	332	
003,302	009	TP305
008,004,IC302		TP302
	303	013
		TP331
	301,331	302
		304
	301	
Q, IC	D	ADJ, TP

TA-22 BOARD

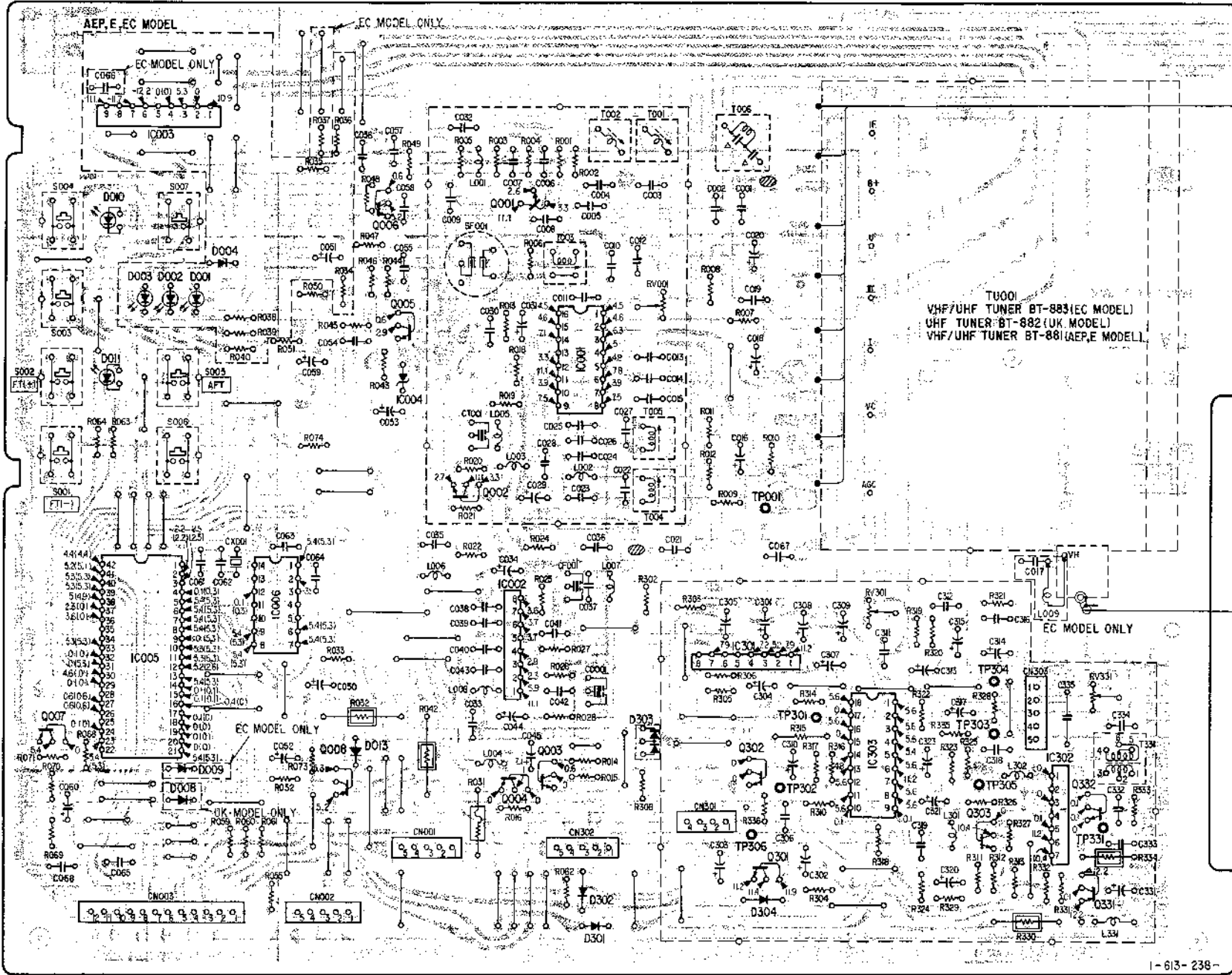

MT-10 BOARD

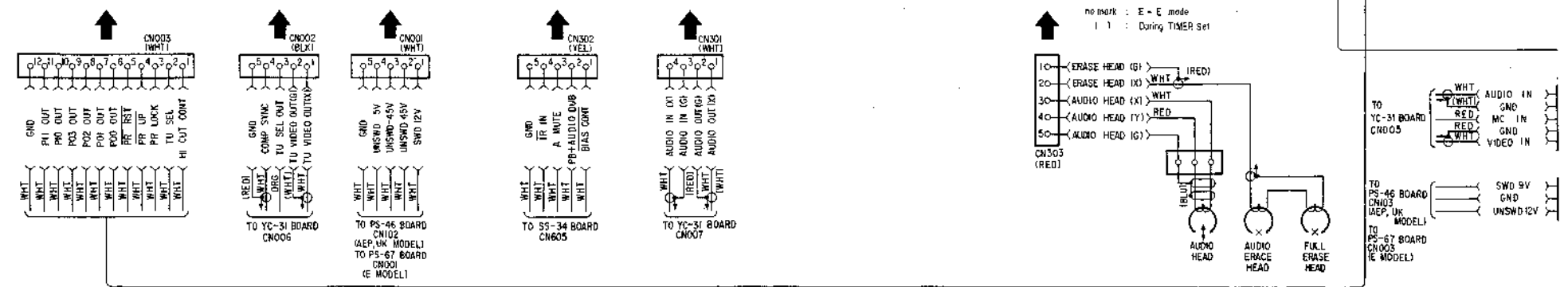
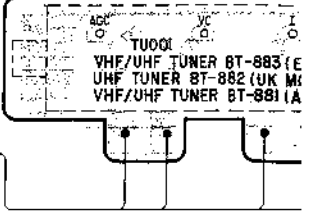

TUNER/TIMER TUNER/TIMER

5 16 17 18 19 20 21 22 23 24 25 26 27 28 29 30

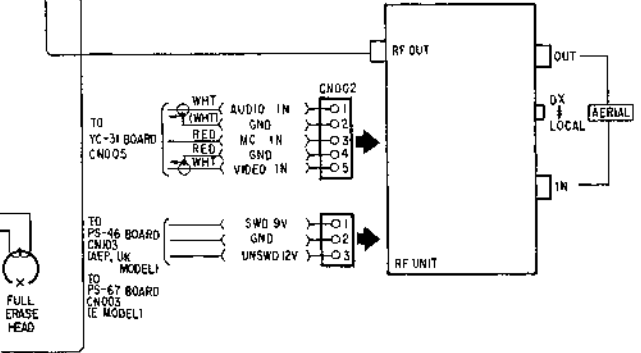
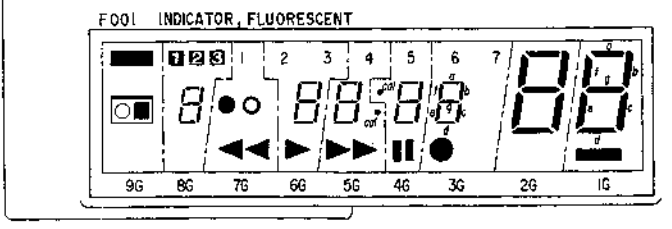
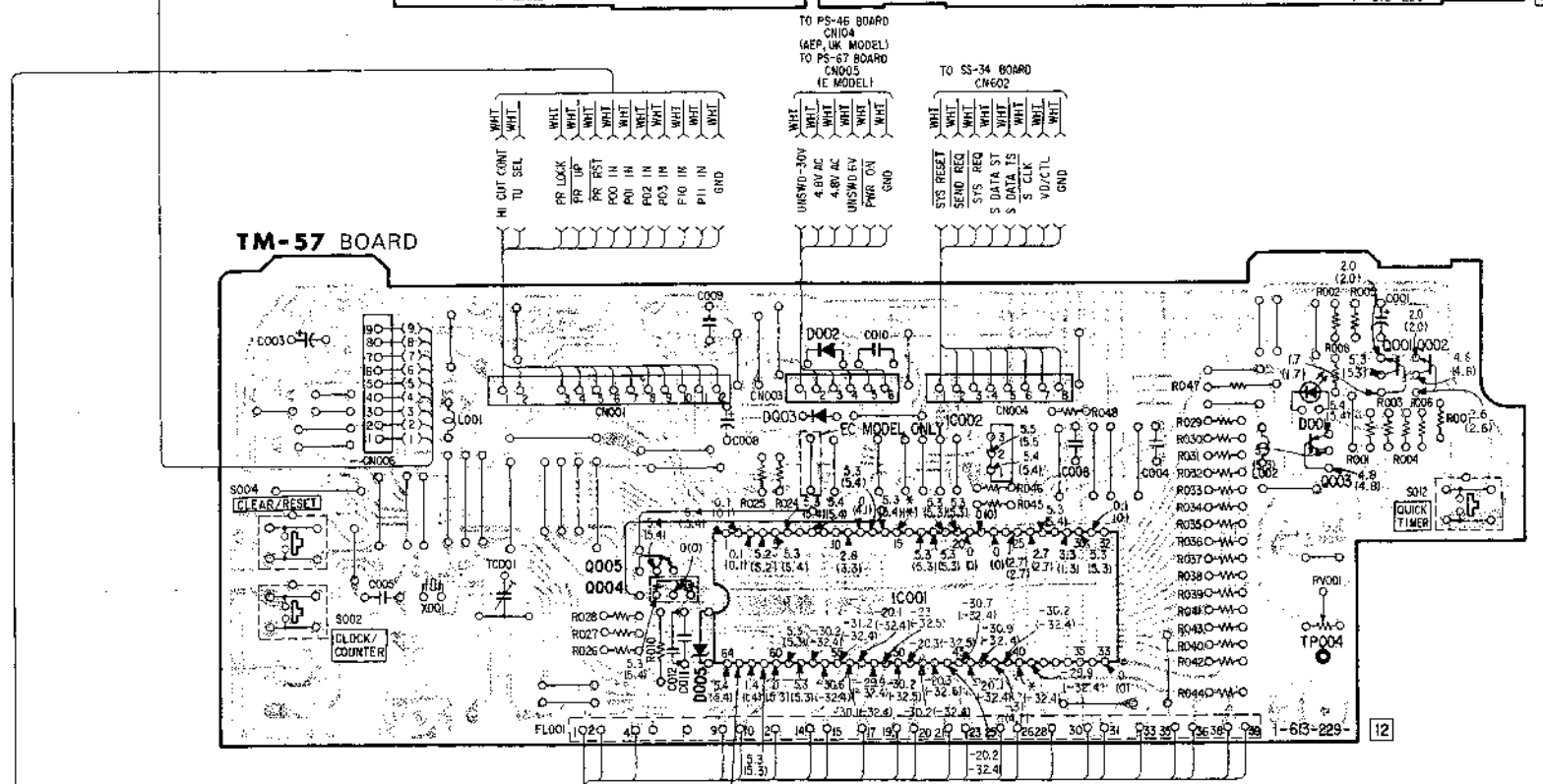
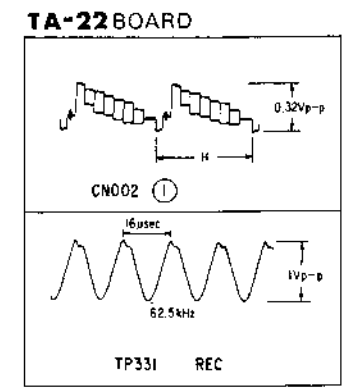
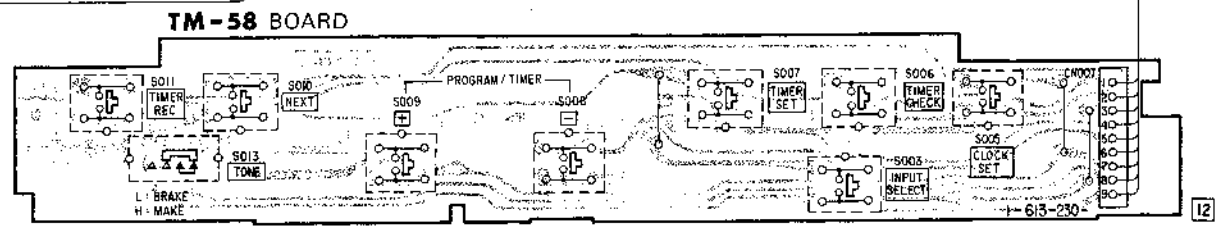
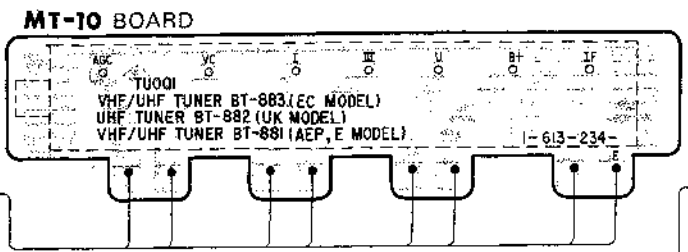

no mark : E-E mode
 I : During TIMER Set
 Marked * is not able to measure the voltage of it's position

- Note:**
- — : indicates a lead wire mounted on the component side.
 - — : indicates a lead wire mounted on the printed side.
 - : soldering side
 - : B+ pattern

When indicating parts by reference number, please include the board name.

A
B
C
D
E
F
G
H
I
J

TUNER/TIMER TUNER/TIMER

TA-22 (VIF, AFT, SIF, AUTO PROGRAM AUDIO), MT-10 (TUNER), TM-57 (TIMER INDICATOR), TM-58 (SWITCH) SCHEMATIC DIAGRAM

- Ref. No. TA-22, MT-10 BOARD : 5000 series, TM-57, TM-58 BOARD : 6000 series -

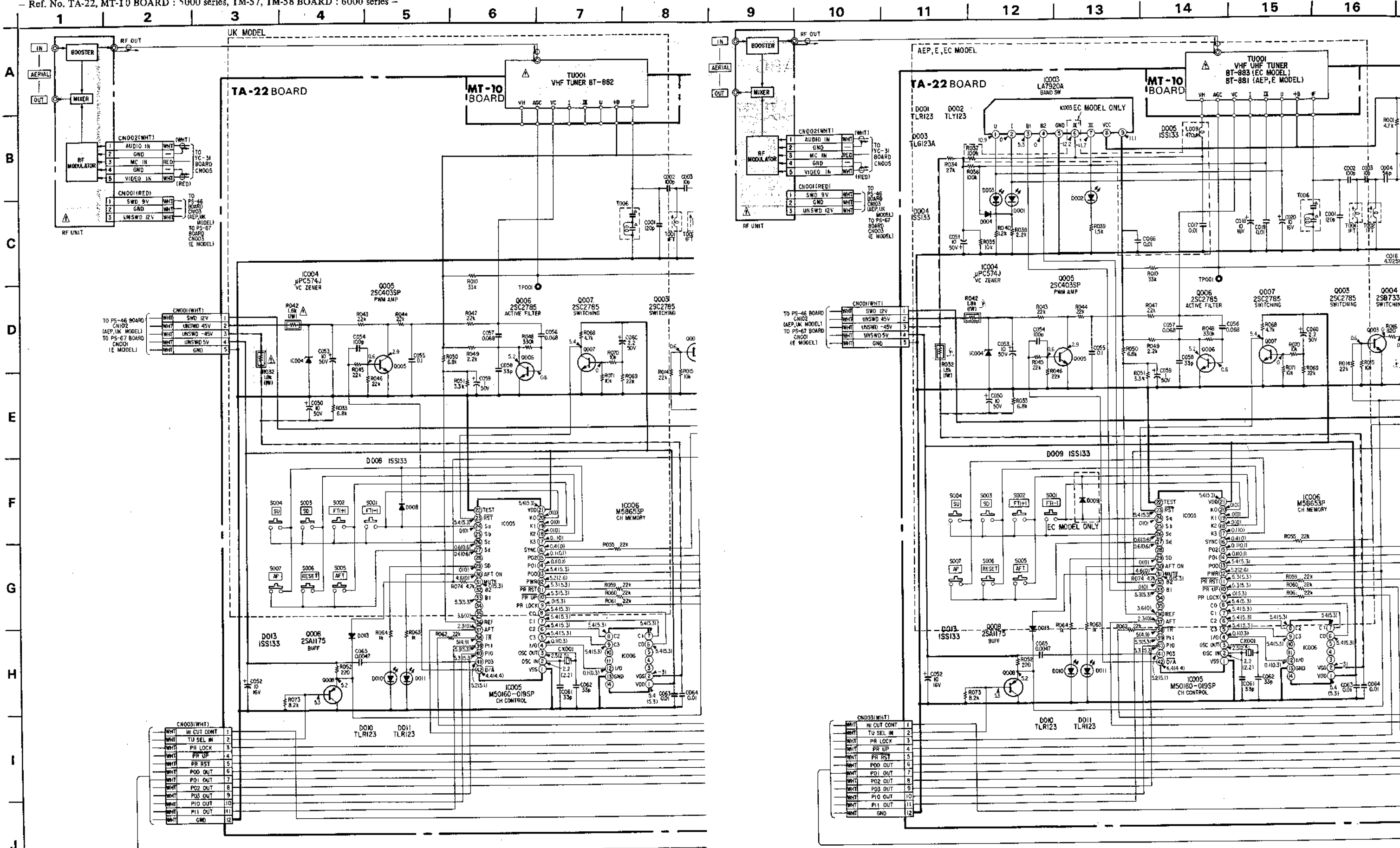

20 21 22 23 24 25 26 27 28 29 30 31 32 33 34 35

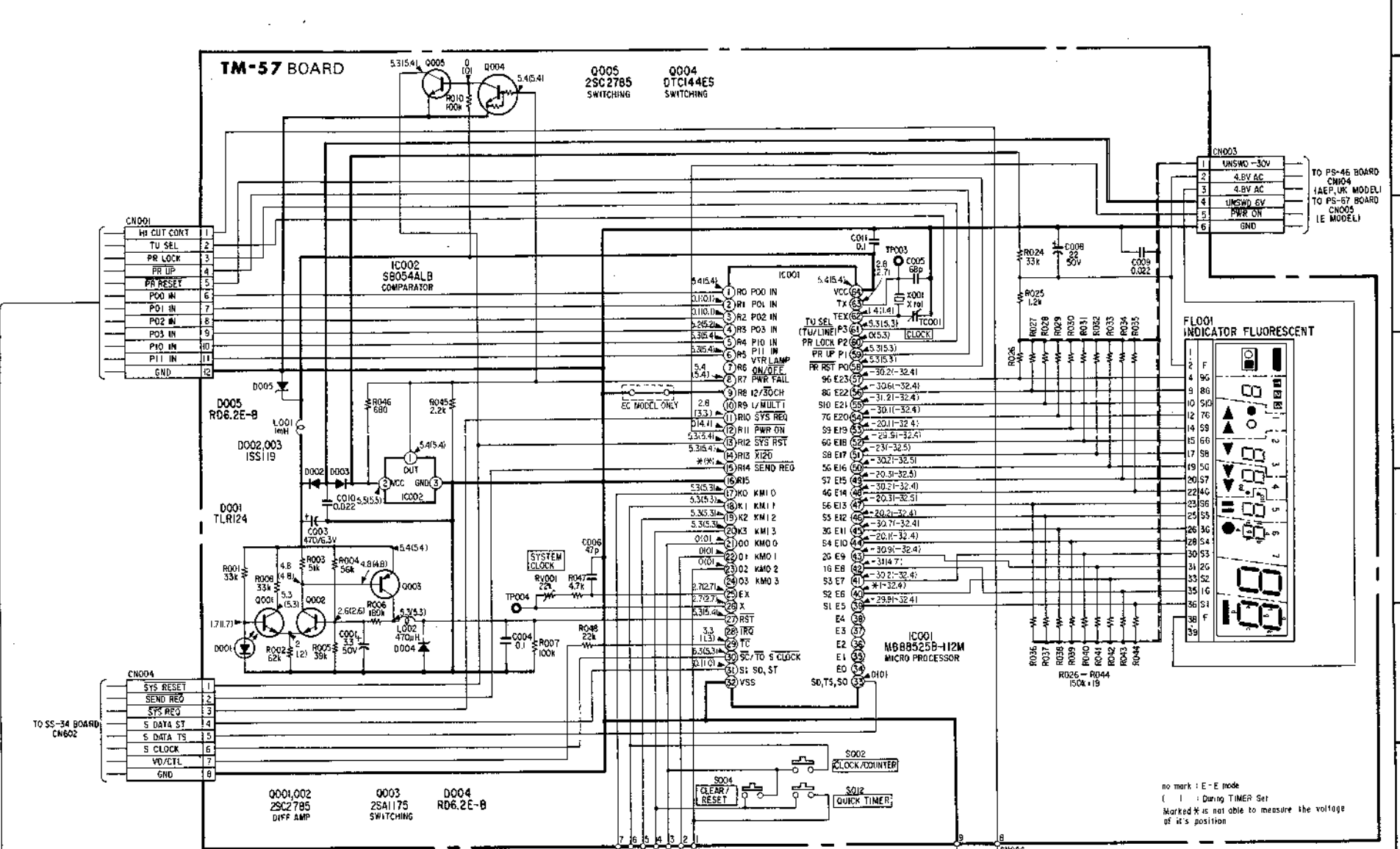
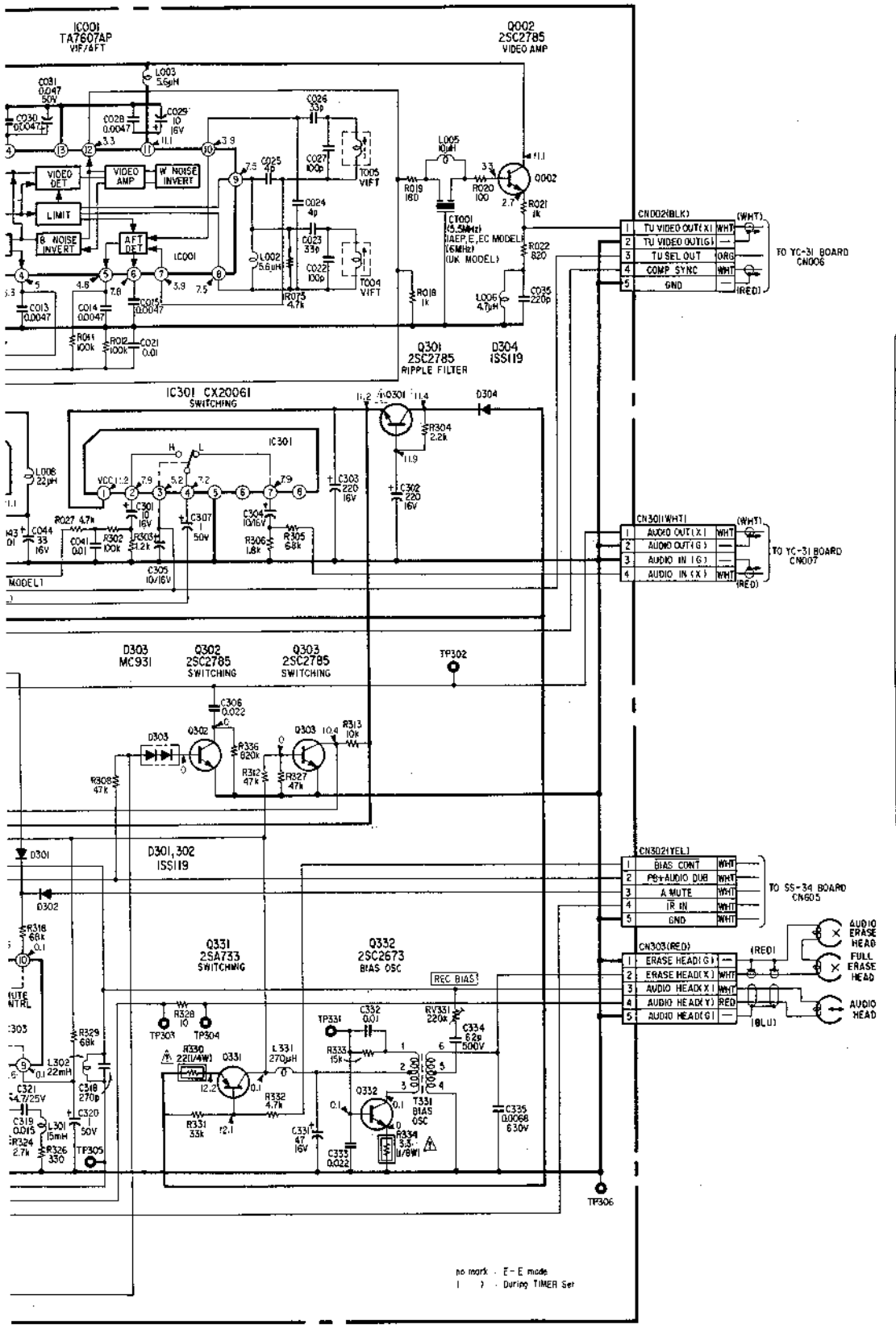

- Note:**
- All resistors are in ohms, 1/6W unless otherwise noted.
 - All capacitors are in μF (p:pF) unless otherwise noted.
 - 50V or less are not indicated except for electrolytic capacitors.
 - All variable and semi-fixed resistors have characteristic curve B, unless otherwise noted.
 - : Nonflammable resistor
 - : Fusible resistor
 - : B+ bus.
 - : B- bus.
 - The voltage value is reference value between the grounding when the color bar signal is received from a color bar generator.
 - The voltage value is measured using a digital tester (10M Ω).

Note: The components identified by shading and mark Δ are critical for safety. Replace only with part number specified.

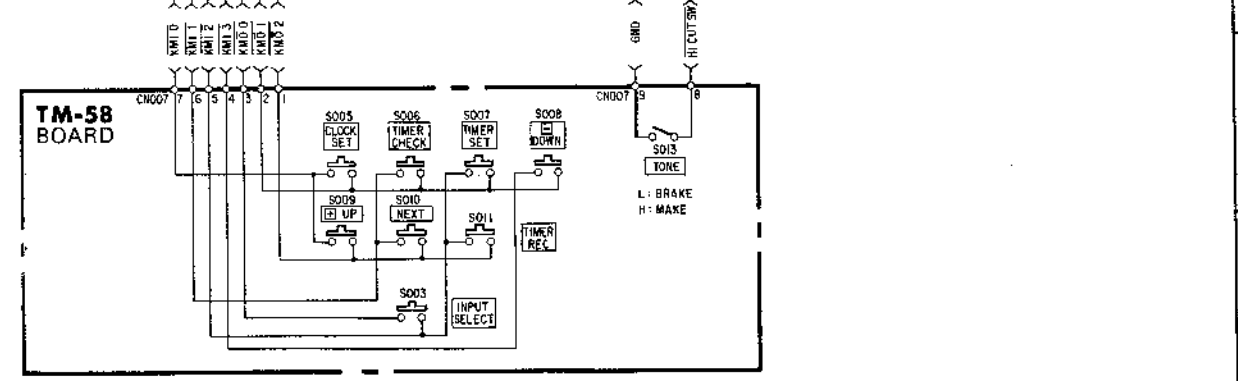

When indicating parts by reference number, please include the board name.

A
B
C
D
E
F
G
H
I
J

POWER SUPPLY

4-5-1. PS-45 (POWER SUPPLY), PS-46 (POWER), PS-69 (REGULATOR) PRINTED WIRING BOARDS... AEP, UK, EC MODEL

- Ref. No. PS-45 BOARD : 7000 series, PS-46, PS-69 BOARD : 7100 series -

1 2 3 4 5 6 7 8 9 10 11 12 13 14 15 16

A
B
C
D
E
F
G
H
I
J

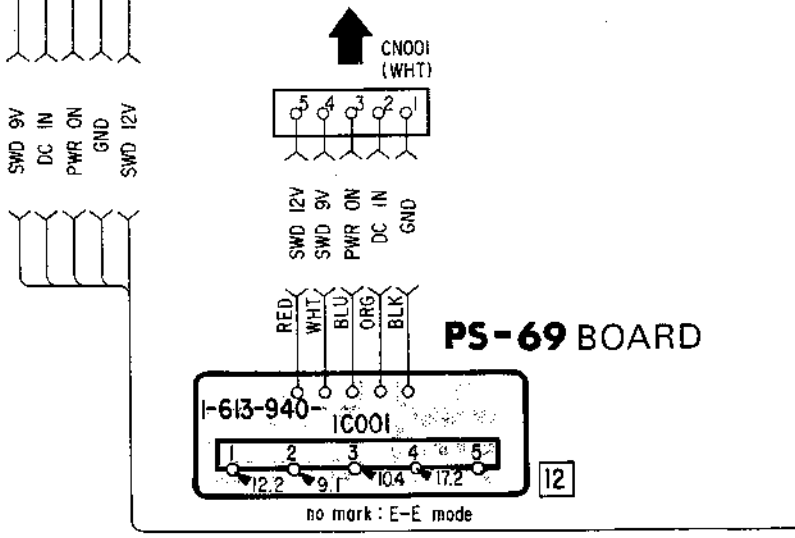
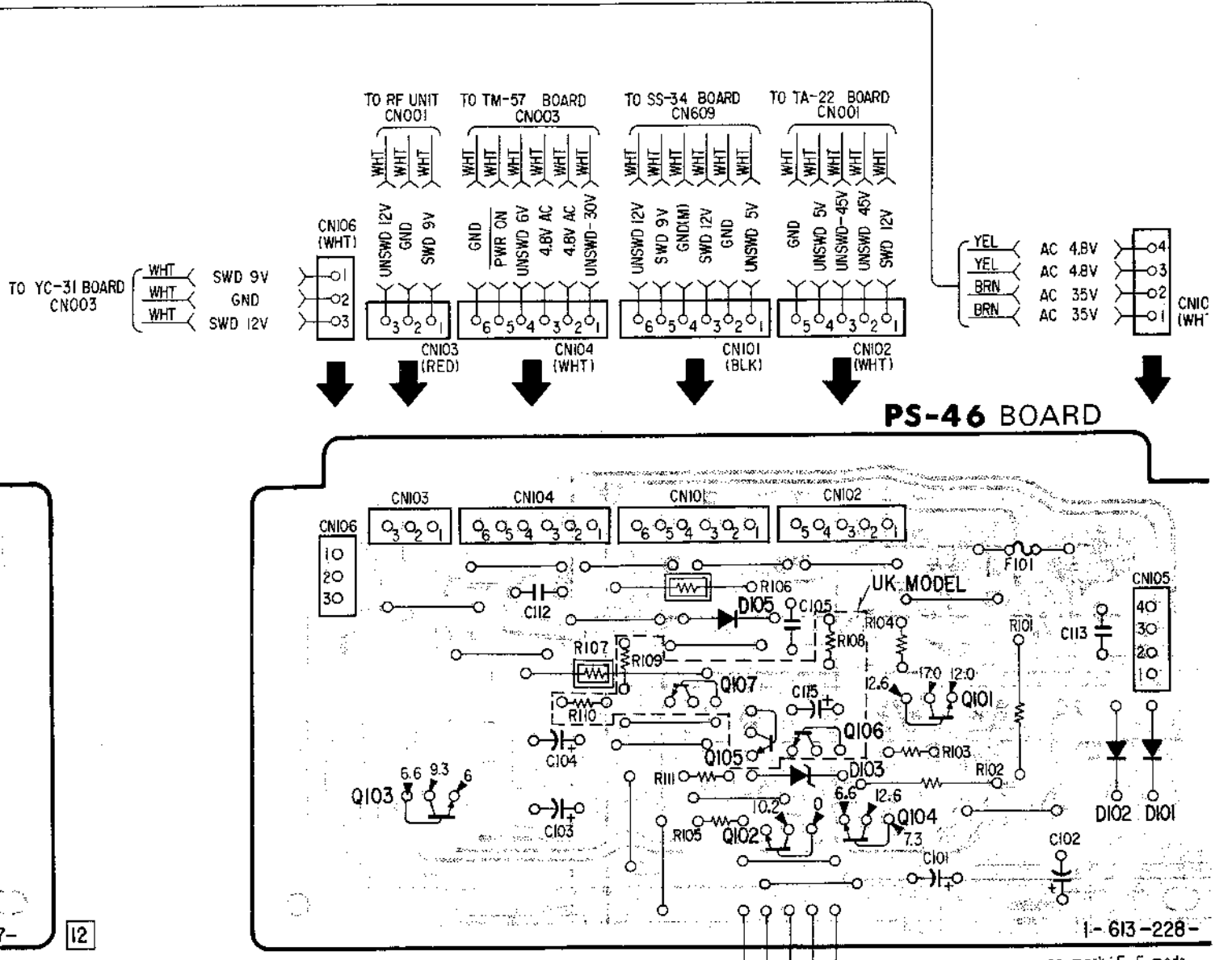
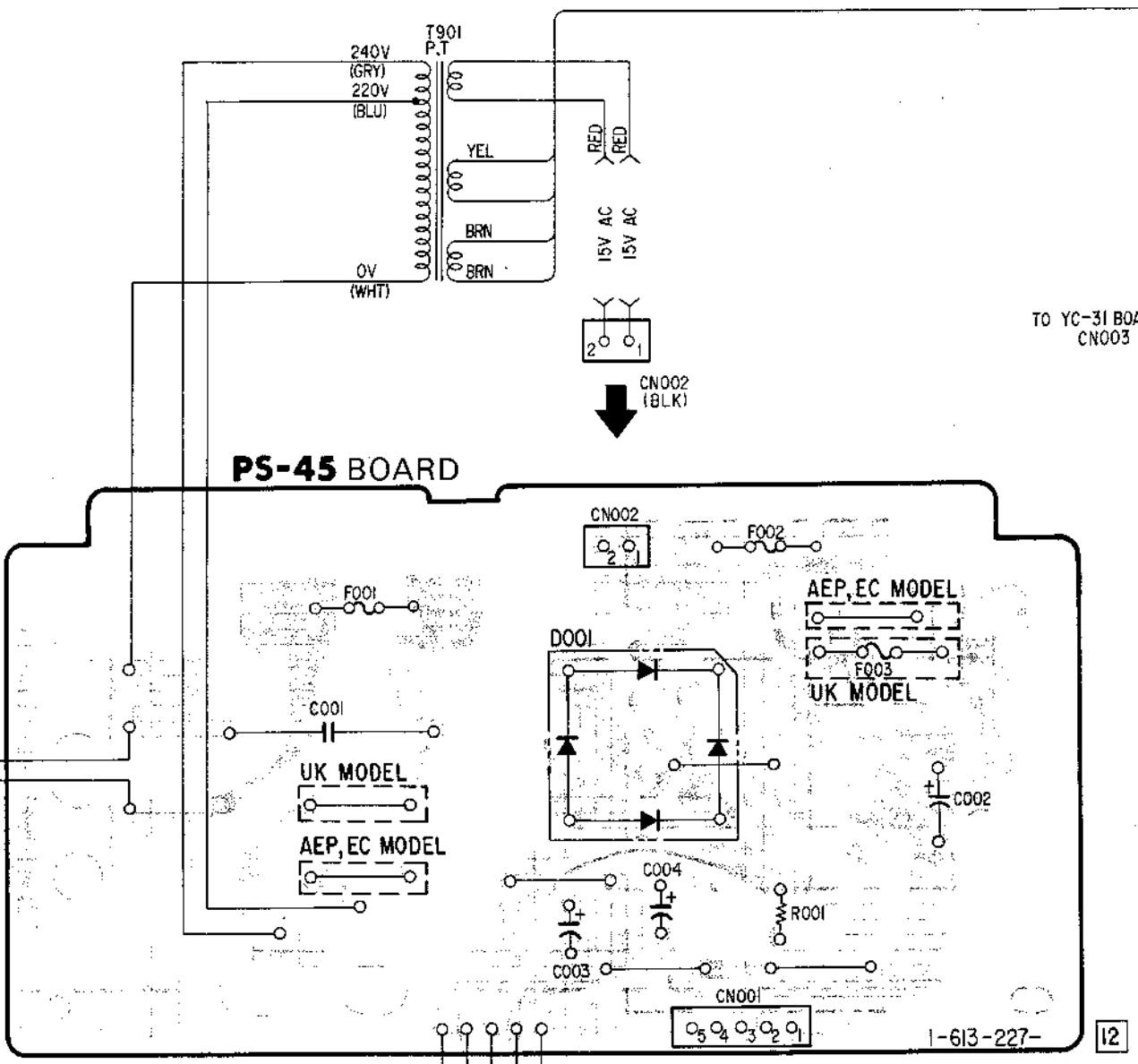

Note:
 • ○ : indicates a lead wire mounted on the component side.
 • ● : indicates a lead wire mounted on the printed side.
 • ○ : soldering side
 • ○ : B+ pattern

When indicating parts by reference number, please include the board name.

13 | 14 | 15 | 16 | 17

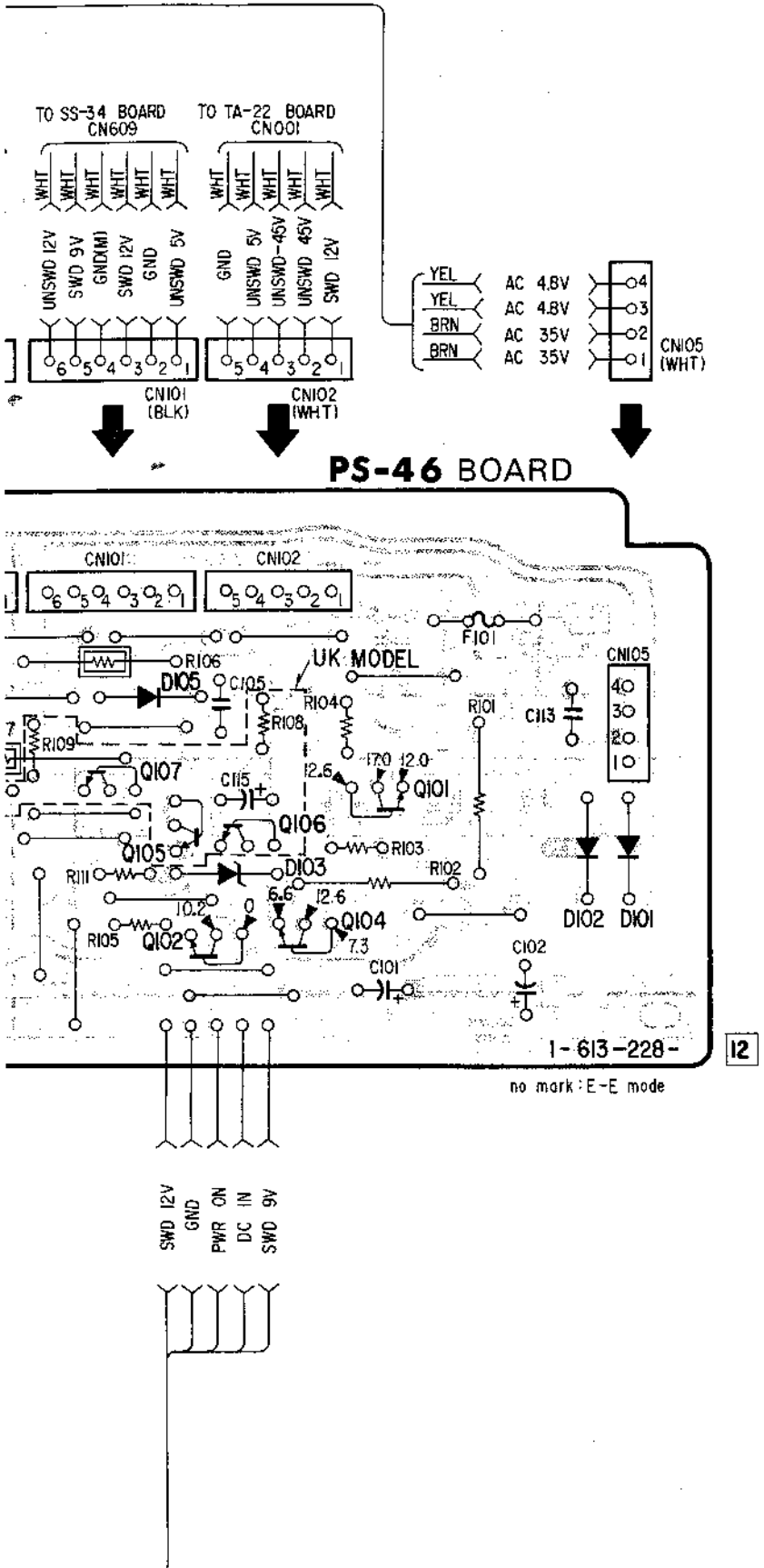

1 | 2 | 3 | 4 | 5 | 6 | 7 | 8 | 9 | 10 | 11

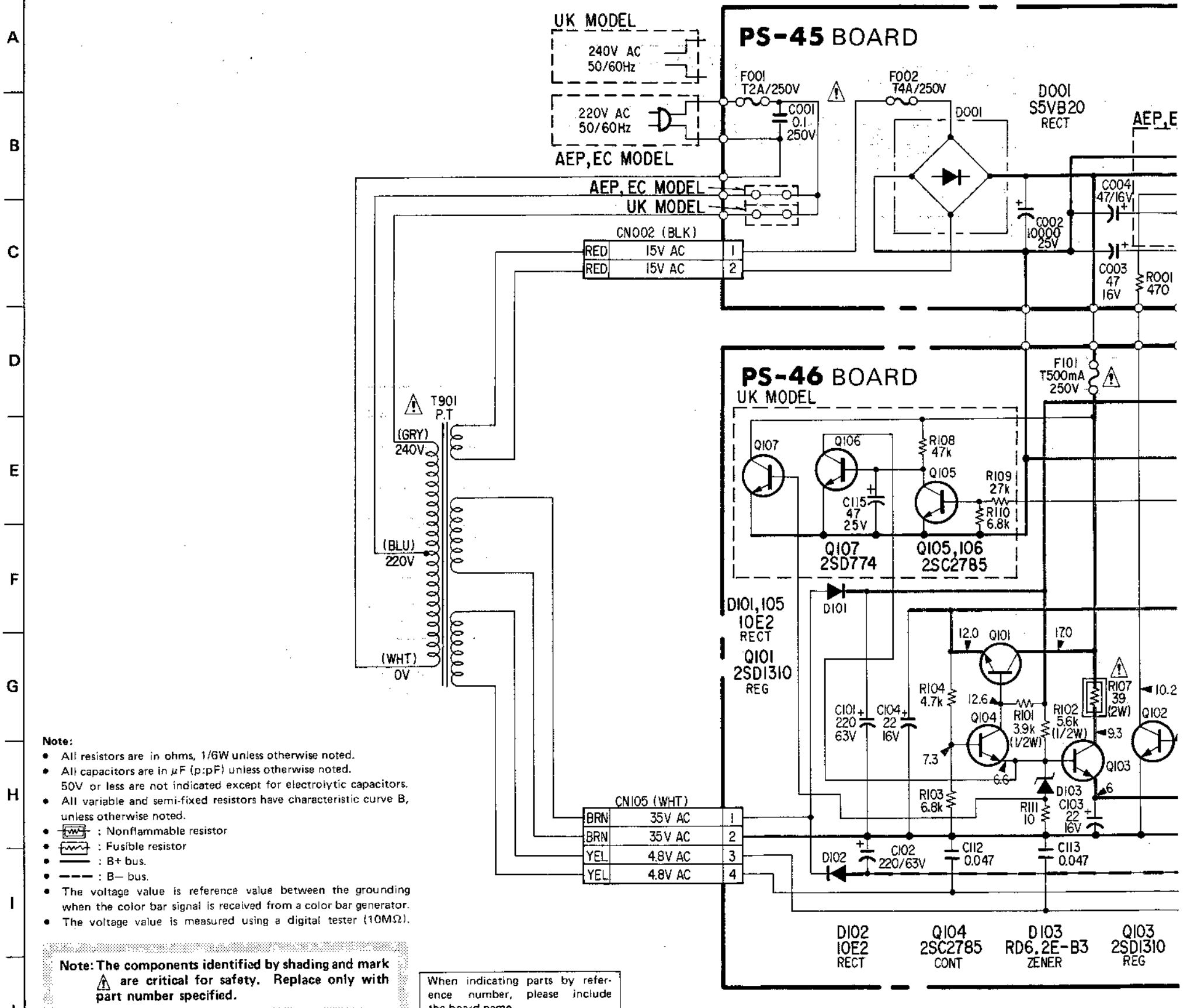

POWER SUPPLY POWER SUPPLY

IPPLY), PS-46 (POWER), PS-69 (REGULATOR) SCHEMATIC DIAGRAM... AEP, UK, EC MODEL

RD : 7000 series, PS-46, PS-69 BOARD : 7100 series -

2 | 3 | 4 | 5 | 6 | 7 | 8 | 9 | 10 | 11 | 12 | 13 | 14 | 15 | 16 | 17

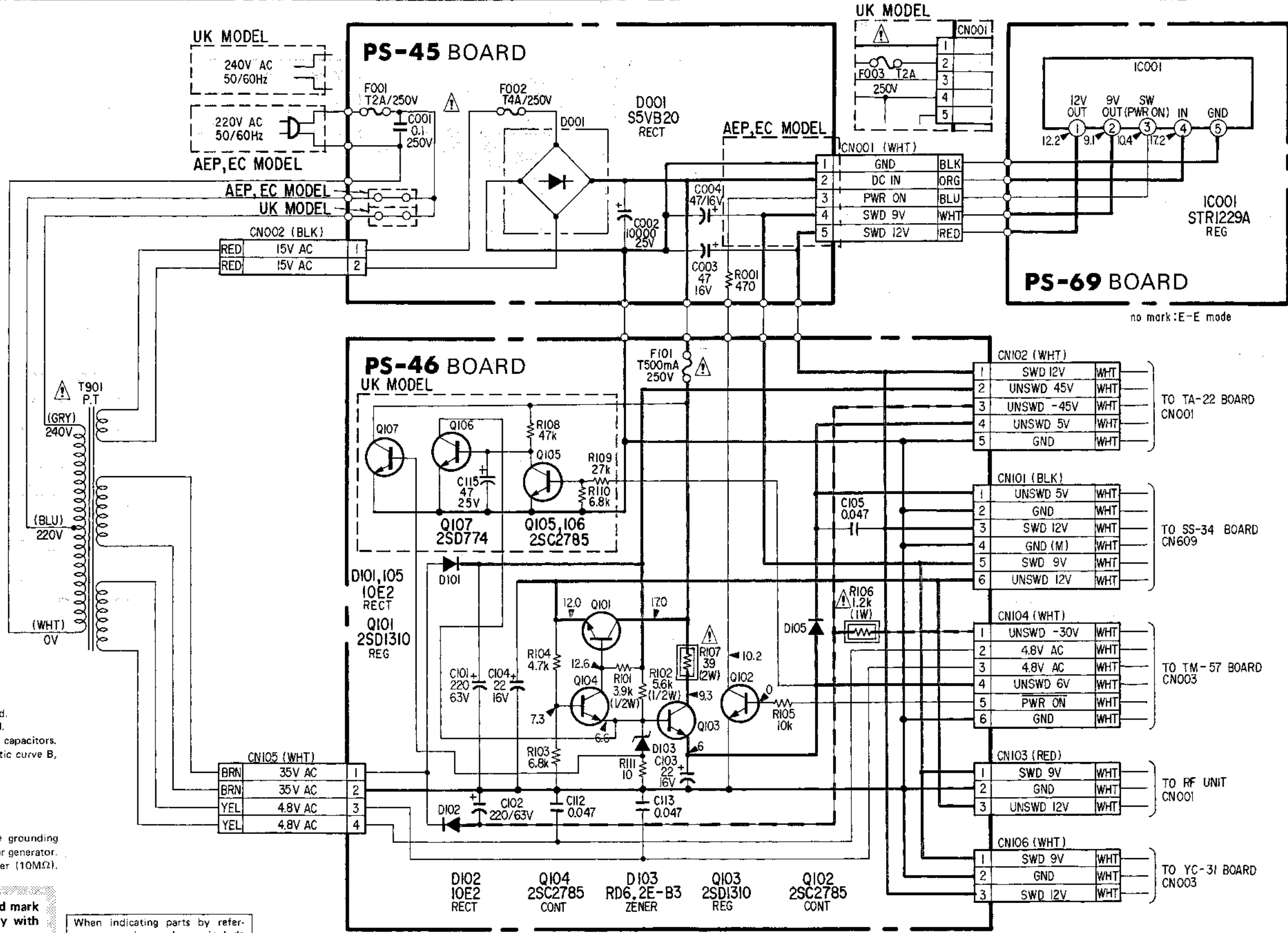

in ohms, 1/6W unless otherwise noted.
 in μF (p:pF) unless otherwise noted.
 not indicated except for electrolytic capacitors.
 semi-fixed resistors have characteristic curve B,
 e noted.
 mmable resistor
 resistor
 s.
 alue is reference value between the grounding
 - bar signal is received from a color bar generator.
 alue is measured using a digital tester (10M Ω).

omponents identified by shading and mark
 critical for safety. Replace only with
 mber specified.

When indicating parts by refer-
 ence number, please include
 the board name.

no mark : E-E mode

POWER SUPPLY POWER SUPPLY

4-5-2. PS-67 (POWER SUPPLY), PS-76 (REGULATOR), VS-4 (VOLTAGE SELECTOR) PRINTED WIRING BOARDS... E MODEL

- Ref. No. PS-67 BOARD : 7200 series, PS-76, VS-4 BOARD : 7300 series -

PS-67 (POWER SUPPLY), PS-76 (REGULATOR),

- Ref. No. PS-67 BOARD : 7200 series, PS-76, VS-4 BOARD

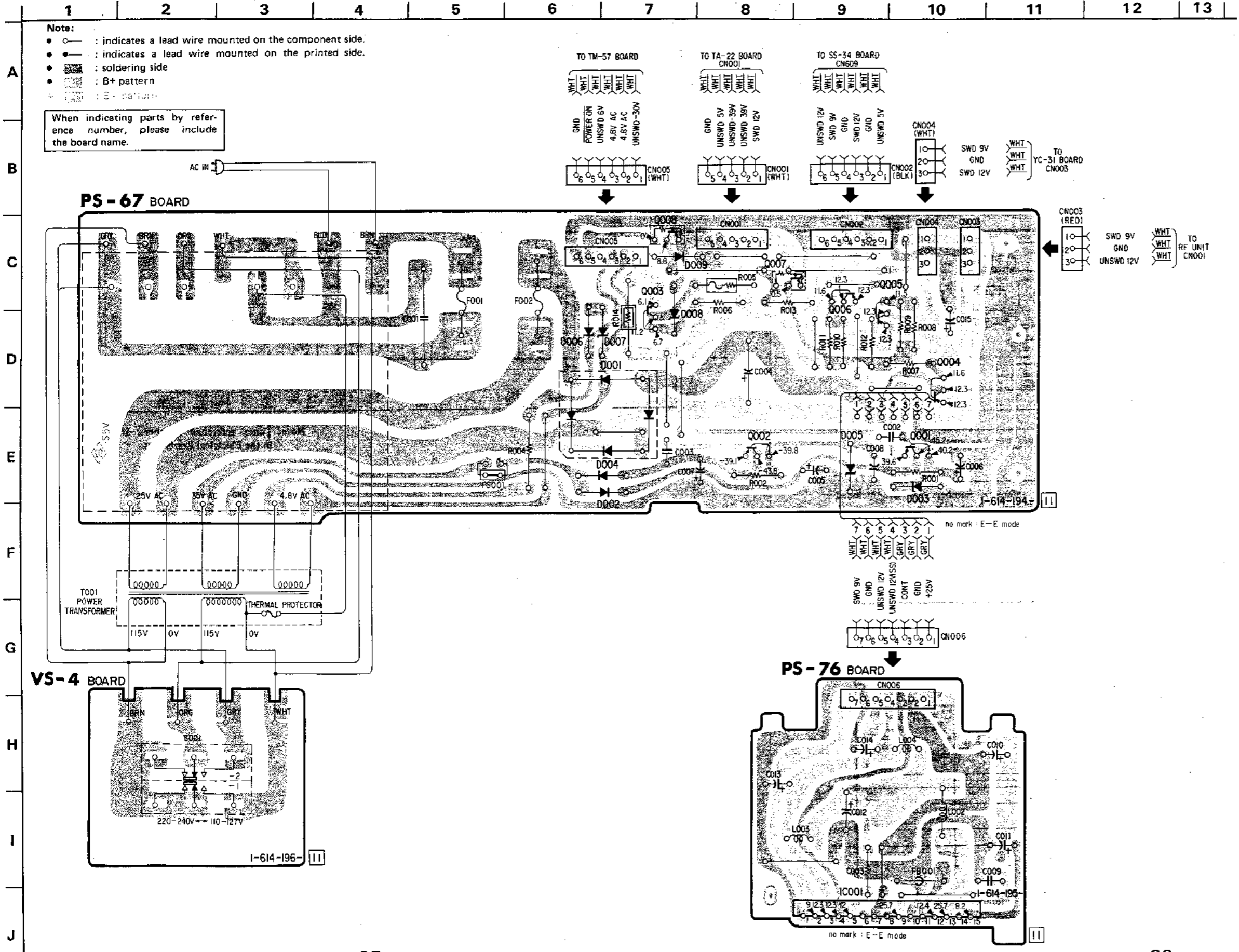

Note:

- : indicates a lead wire mounted on the component side.
- : indicates a lead wire mounted on the printed side.
- : soldering side
- : B+ pattern
- : B- pattern

When indicating parts by reference number, please include the board name.

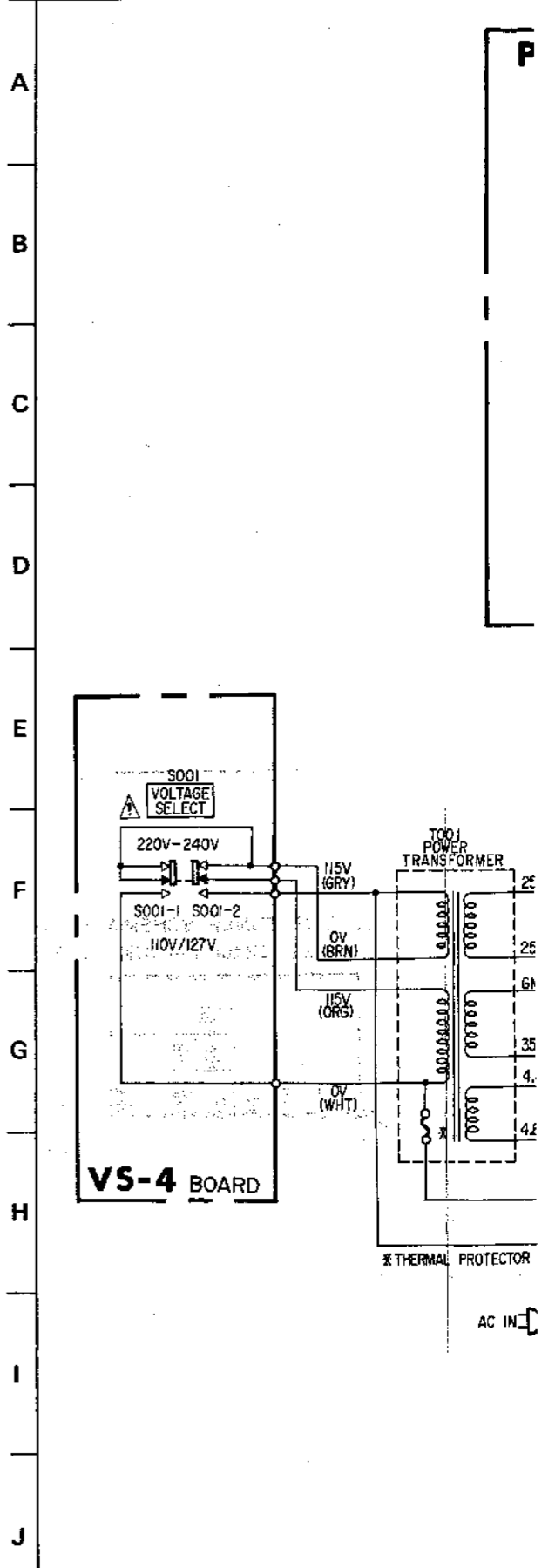

POWER SUPPLY POWER SUPPLY

1), PS-76 (REGULATOR), VS-4 (VOLTAGE SELECTOR) SCHEMATIC DIAGRAM... E MODEL

7200 series, PS-76, VS-4 BOARD : 7300 series -

2 3 4 5 6 7 8 9 10 11 12 13 14 15 16 17

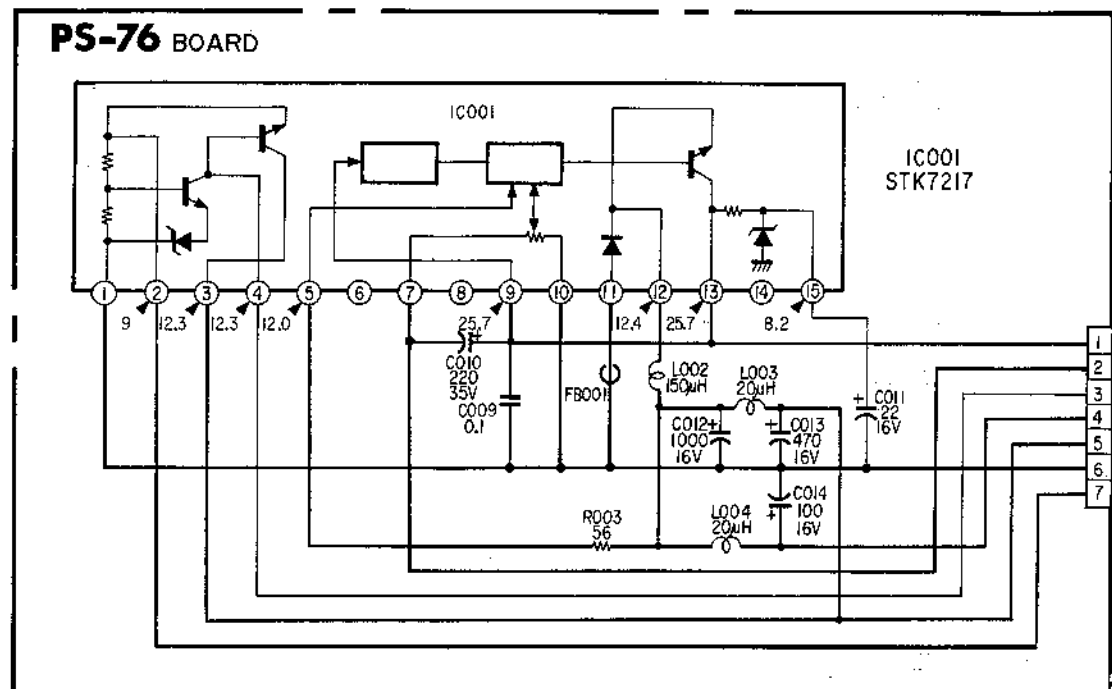

- Note:**
- All resistors are in ohms, 1/4W unless otherwise noted.
 - All capacitors are in μF (μpF) unless otherwise noted.
 - 50V or less are not indicated except for electrolytic capacitors.
 - All variable and semi-fixed resistors have characteristic curve B, unless otherwise noted.
 - : Nonflammable resistor
 - : Fusible resistor
 - : B+ bus.
 - : B- bus.
 - The voltage value is reference value between the grounding when the color bar signal is received from a color bar generator.
 - The voltage value is measured using a digital tester (10M Ω).

Note: The components identified by shading and mark are critical for safety. Replace only with part number specified.

When indicating parts by reference number, please include the board name.

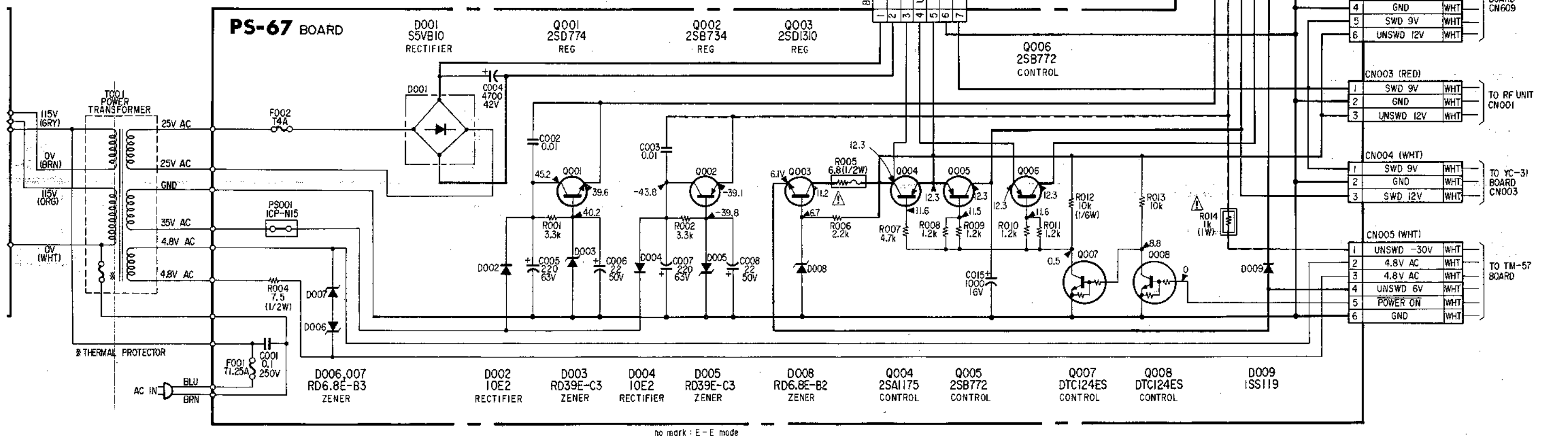

4-6. SEMICONDUCTORS

BA634



BA4558
HA17558
LM358P
NJM4558D
μPC358C
μPC4558C

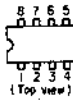

BA5115

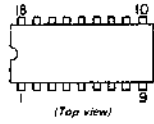

BA7007



CX134A

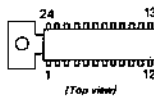

CX862
CX866A
CX866B



CX894
LA7205
LA7920



CX10021A-P
CX10021A-NP
CX1021B-P
CX1021B-NP
CX194B-0
CX194B-5
M50160-019SP

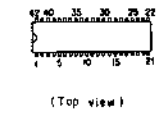

CX10023

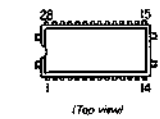

CX20043

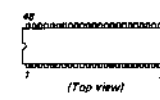

CX20061
CX7926
μPC1373H
μPC1373HA
μPC1391H

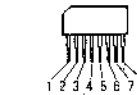

HZT33-02
μPC574J

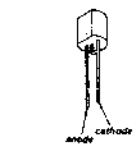

LB1640N

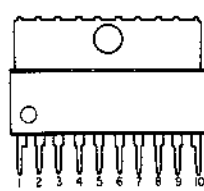

M54543L

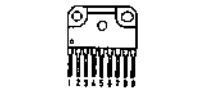

M54570L

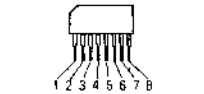

M58653P
MB3614
μPC324C

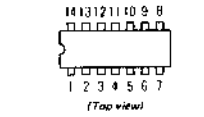

MB88525B-112M

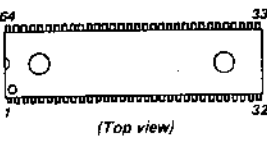

MB8851-133M

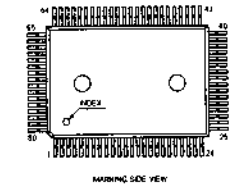

MB84053B
TA7607AP
TC4053BP
μPD4053BC

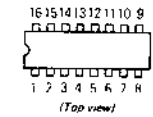

μPC1513HA

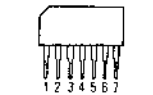

STK7217

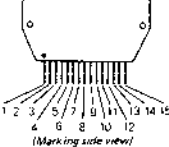

STR-1229A
STR-1229

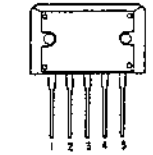

2SA733-K
2SA733-P
2SA844-C
2SA844-D
2SA844-E
2SC1740S

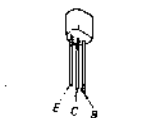

2SA933S
2SA1048
2SA1048-GR
2SA1115
2SC403SP
2SC2458
2SC2603
2SD1310
DTA114ES
DTC124ES
DTC144ES
DTC144WS

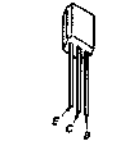

2SA1026

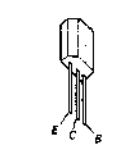

2SA1175
2SC2785

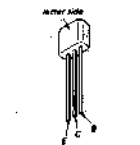

2SB772

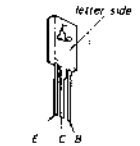

2SB733
2SD773
2SD774

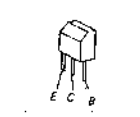

2SB739
2SC1474
2SC1475-13
2SD788
2SD789

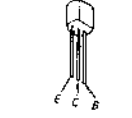

2SC1061
2SC1826
2SC1827
2SD313HP

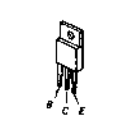

2SC2216
2SC2717

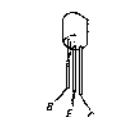

2SC2673

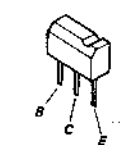

2SD1164

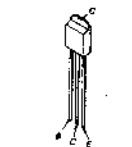

2SK107-2
2SK105A

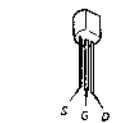

10E2
ERB12-02RK

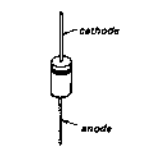

1SS119
1SS133
1SS148

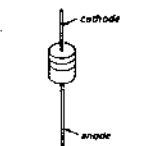

EQA02-06E
EQA02-07A
EQA02-07B1
EQA02-09D
EQA02-10A
EQA02-10B
HZ10E-B1
HZ10E-B2
HZ10E-B3
HZ6.2E-B3
HZ6.8E-B2
HZ6.8E-B3
RD10E-B1
RD10E-B2
RD10E-B3
RD39E-C3
RD39J-N3
RD5.1E-B1
RD5.1E-L1
RD5.1E-L2
RD5.1E-L3
RD6.2E-B
RD6.2E-B3
RD6.8E-B2

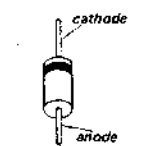

GP08D

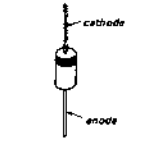

MC911

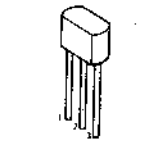

MC921

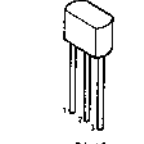

MC931

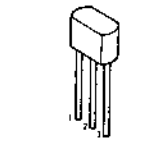

PH302B

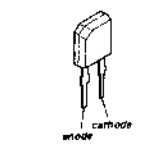

S5VB10
S5VB20

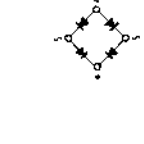
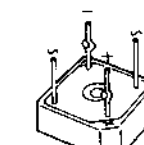

SIB01-02

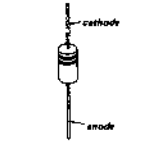

SPI201-22

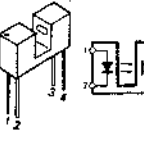

TLG123A
TLR123
TLR124
TLY123

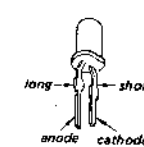

4-7. UHF AN
- BT-881

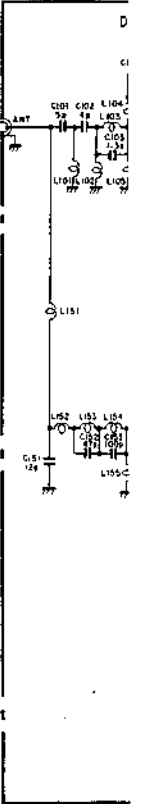

4-8. UHF TU
- BT-882

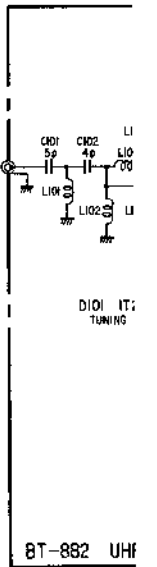

SECTION 5 EXPLODED VIEWS

NOTE:

- Items with no part number and no description are not stocked because they are seldom required for routine service.
- The construction parts of an assembled part are indicated with a collation number in the remark column.
- Items marked "*" are not stocked since they are seldom required for routine service. Some delay should be anticipated when ordering these items.
- The mechanical parts with no reference number in the exploded views are not supplied.

The components identified by shading and mark **Δ** are critical for safety. Replace only with part number specified.

5-1. FRONT PANEL AND CABINET ASSEMBLIES

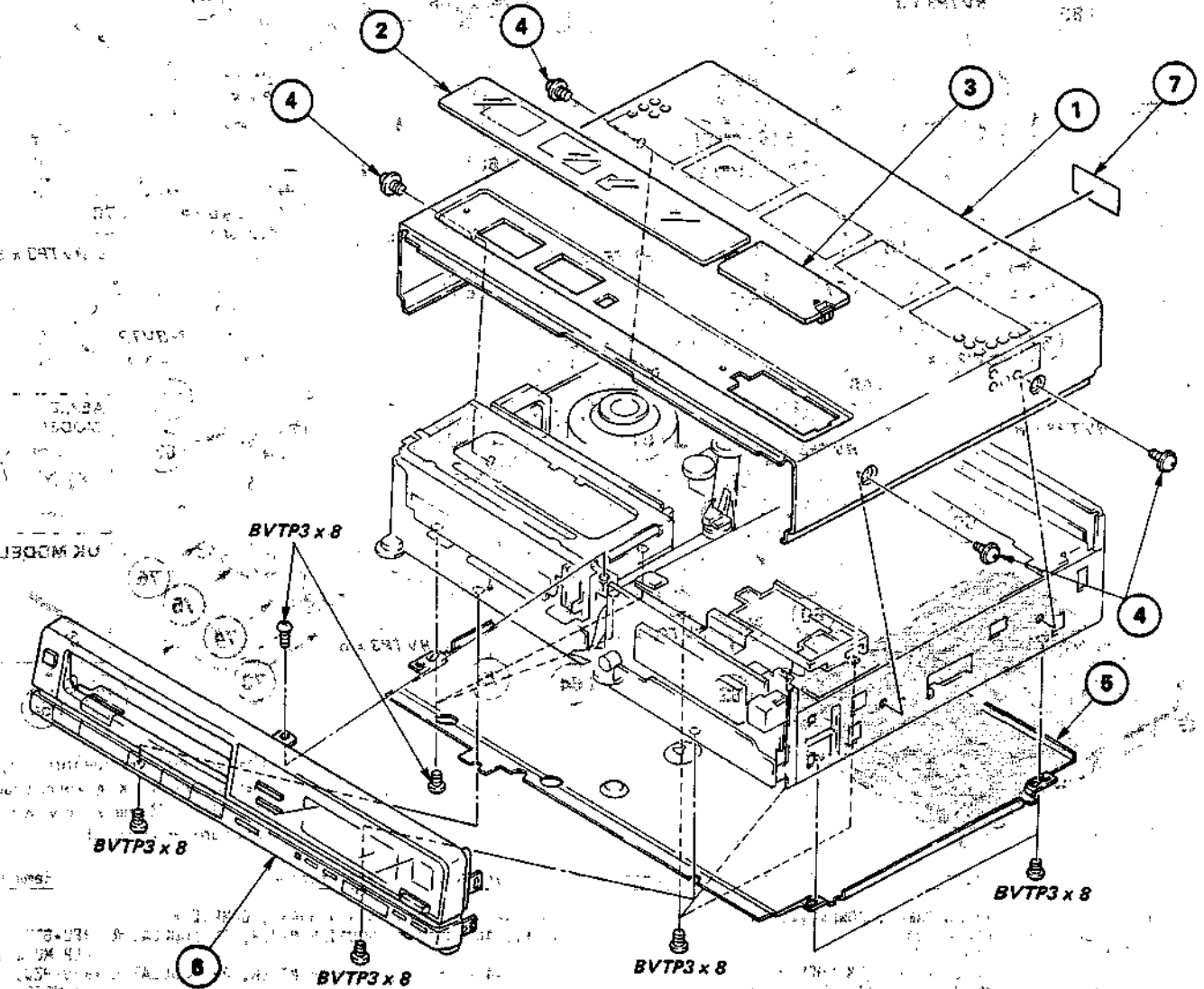

No.	Part No.	Description	Remark	No.	Part No.	Description	Remark
1	X-3687-504-1	CASE ASSY, UPPER (AEP, UK, EC MODEL/GRAY)	2	6	X-3687-513-1	PANEL ASSY, FRONT (EC MODEL/BLUE)	
	X-3687-512-1	CASE ASSY, UPPER (EC MODEL/BLUE)	2		X-3687-514-1	PANEL ASSY, FRONT (EC MODEL/RED)	
	X-3687-517-1	CASE ASSY, UPPER (EC MODEL/WHITE)	2		X-3687-515-1	PANEL ASSY, FRONT (EC MODEL/WHITE)	
	X-3687-519-1	CASE ASSY, UPPER (EC MODEL/RED)	2		X-3687-516-1	PANEL ASSY, FRONT (AEP, E, EC MODEL/SILVER)	
	X-3687-521-1	CASE ASSY, UPPER (AEP, E, EC/SILVER)	2		X-3687-523-1	PANEL ASSY, FRONT (AEP, UK, EC MODEL/GRAY)	
2	3-684-184-01	PLATE, TRANSPARENT		7	*3-687-502-01	LABEL, MODEL NUMBER (UK MODEL)	
3	X-3684-146-1	LID ASSY, PRESET			*3-687-503-01	LABEL, MODEL NUMBER (EC MODEL)	
4	4-886-821-01	SCREW, M3 CASE (GRAY MODEL)			*3-687-553-01	LABEL, MODEL NUMBER (E MODEL)	
	4-886-821-11	SCREW, M3 CASE (SILVER, WHITE, RED, BLUE MODEL)			*3-688-403-01	LABEL, MODEL NUMBER (AEP MODEL)	
5	*X-3684-133-1	PLATE ASSY, BOTTOM					

5-2-1. TUNER, TIMER AND POWER ASSEMBLIES
(AEP, UK, EC MODEL)

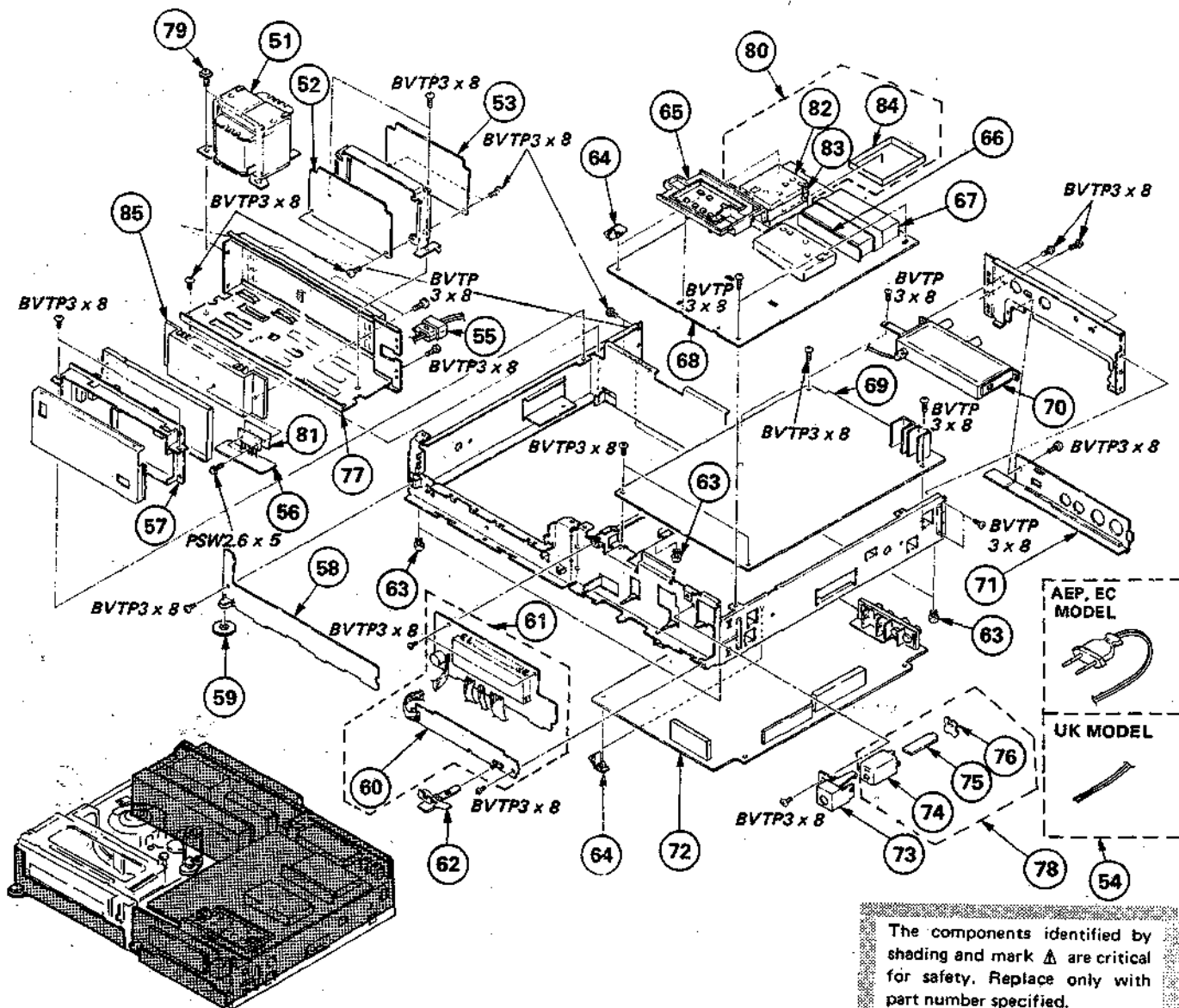

No.	Part No.	Description	Remark
51	Δ 1-447-894-11	TRANSFORMER, POWER (T901)	
52	*1-613-228-12	PS-46 BOARD	
53	*1-613-227-12	PS-45 BOARD	
54	Δ 1-551-884-12	CORD, POWER (UK MODEL)	8 828102
	Δ 1-551-908-41	CORD, POWER (AEP, EC MODEL)	
55	Δ 3-703-244-02	BUSHING, CORD	
56	*1-613-940-12	PS-69 BOARD	
57	*A-6711-565-A	RP-20 BOARD, COMPLETE	
58	*1-613-231-12	FU-25 BOARD	
59	3-684-103-12	KNOB, TRACK CONTROL	
60	*1-613-230-12	TM-58 BOARD	
61	*A-6707-464-A	TM BOARD, COMPLETE (EC MODEL)	60
	*A-6707-468-A	TM BOARD, COMPLETE (AEP, UK MODEL)	
62	3-684-270-11	BUTTON, SELECTION, INPUT	
63	3-670-155-11	LEG	
64	*3-701-832-00	HINGE, CIRCUIT BOARD	
65	X-3687-501-1	COVER ASSY, PRESET	
66	*1-613-234-11	MT-10 BOARD	
67	Δ 1-463-350-12	TUNER, ET (BT-881) (AEP MODEL)	
	Δ 1-463-371-12	TUNER, ET (BT-882) (UK MODEL)	
	Δ 1-463-421-11	TUNER, ET (BT-883) (EC MODEL)	
68	*A-6721-219-A	TA-22 BOARD, COMPLETE (EC MODEL)	66, 67, 80
	*A-6721-220-A	TA-22 BOARD, COMPLETE	66, 67, 80 (AEP, UK MODEL)

No.	Part No.	Description	Remark
69	*A-6715-239-A	SS-34 BOARD, COMPLETE	
70	Δ 1-464-386-11	BOOSTER MIXER, RF MODULATOR (RFU-819)	(AEP MODEL)
	Δ 1-464-387-11	BOOSTER MIXER, RF MODULATOR (RFU-820)	(UK MODEL)
	Δ 1-464-388-11	BOOSTER MIXER, RF MODULATOR (RFU-821)	(EC MODEL)
71	*3-687-535-01	PLATE, CONNECTOR	
72	*A-6711-566-A	YC-31 BOARD, COMPLETE	
73	*3-684-182-01	FRAME, FITTING, RAY CATCHER	
74	*4-342-117-00	CASE, SHIELD (MAIN), R	
75	*1-606-794-00	N BOARD	
76	*4-342-118-00	LID, SHIELD CASE, R	
77	X-3687-502-1	FRAME ASSY, POWER	
78	A-6734-213-A	CATCHER BLOCK ASSY, RAY	74-76
79	4-886-821-11	SCREW, M3 CASE	
80	*X-3687-527-1	LID ASSY, BOTTOM, SHIELD CASE, AU	82-84
81	3-687-589-01	SHEET, RADIATION	
82	*3-687-550-01	CASE (UPPER LID), SHIELD, AU	
83	*3-687-558-01	CASE (MAIN), SHIELD, AU	
84	*3-687-559-01	CASE (BOTTOM LID), SHIELD, AU	
85	*3-687-588-01	HEAT SINK (K) (AEP, UK, EC MODEL)	

5-2.2. TUNER, TIMER AND POWER ASSEMBLIES
(E MODEL)

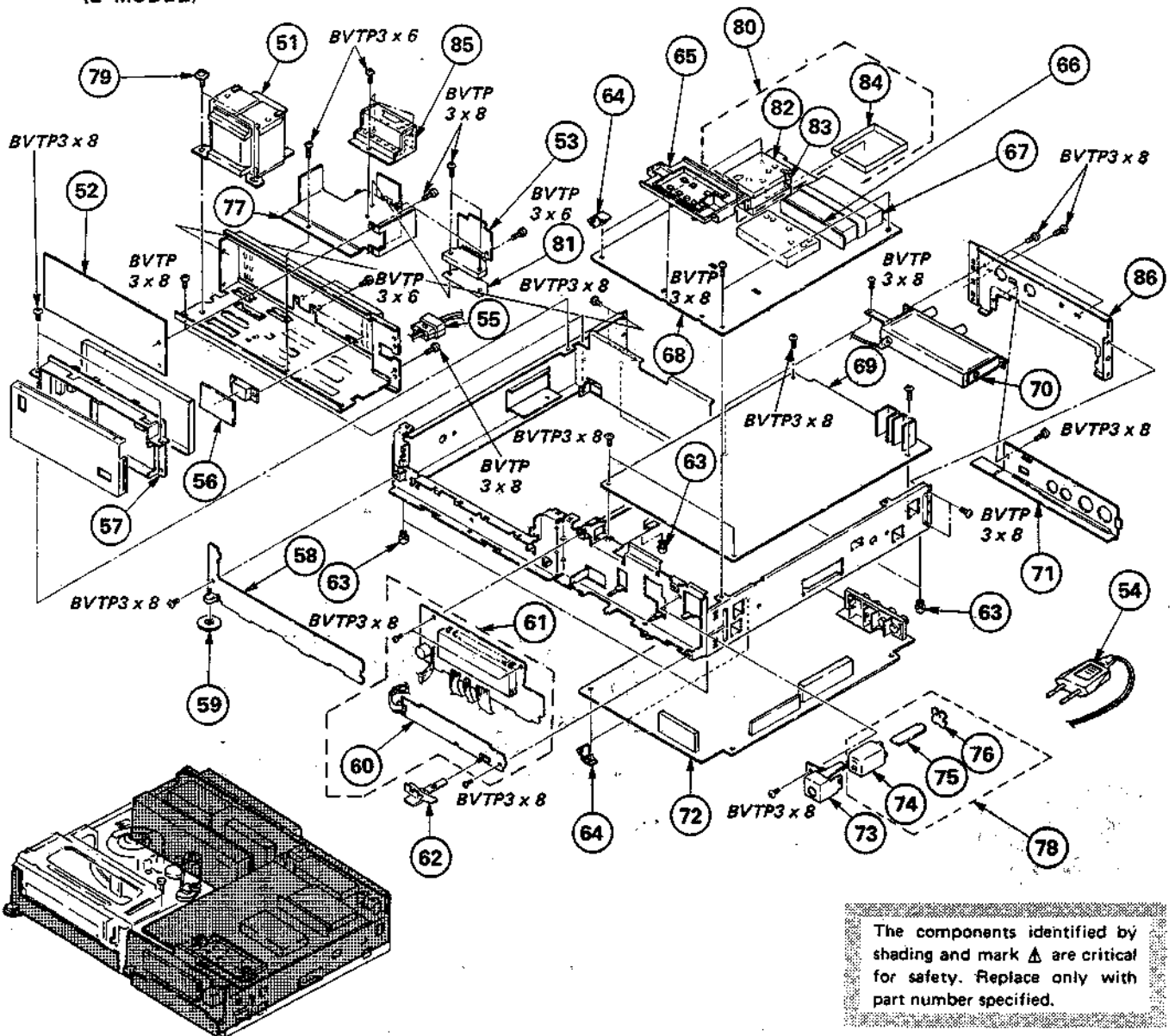

The components identified by shading and mark Δ are critical for safety. Replace only with part number specified.

No.	Part No.	Description	Remark	No.	Part No.	Description	Remark
51	Δ 1-447-985-11	TRANSFORMER, POWER (T901)		69	*A-6715-239-A	SS-34 BOARD, COMPLETE	
52	*A-6729-106-A	PS-67 BOARD, COMPLETE		70	Δ 1-464-386-21	BOOSTER/MIXER, W/F. MODULATOR (RFU-819)	
53	*1-614-195-12	PS-76 BOARD		71	*3-687-535-01	PLATE, CONNECTOR	
54	Δ 1-551-908-11	CORD, POWER		72	*A-6711-578-A	YC-31 BOARD, COMPLETE	
55	Δ 3-703-244-02	BUSHING, CORD		73	*3-684-182-01	FRAME, FITTING, RAY CATCHER	
56	*1-614-196-12	VS-4 BOARD		74	*4-342-117-00	CASE, SHIELD (MAIN), R	
57	*A-6711-565-A	RP-20 BOARD, COMPLETE		75	*1-606-794-00	N BOARD	
58	*1-613-231-12	FU-25 BOARD		76	*4-342-118-00	LID, SHIELD CASE, R	
59	3-684-103-11	KNOB, TRACK CONTROL		77	*3-687-595-01	HEAT SINK	
60	*1-613-230-11	TM-58 BOARD		78	A-6734-213-A	CATCHER BLOCK ASSY, RAY	74-76
61	*A-6707-468-A	TM BOARD, COMPLETE	60	79	4-886-821-11	SCREW, M3 CASE	
62	3-684-270-11	BUTTON, SELECTION, INPUT		80	*X-3687-527-1	LID ASSY, BOTTOM, SHIELD CASE, AU	82-84
63	3-670-155-11	LEG		81	3-687-592-01	SHEET, RADIATION	
64	*3-701-832-00	HINGE, CIRCUIT BOARD		82	*3-687-550-01	CASE (UPPER LID), SHIELD, AU	
65	X-3687-501-1	COVER ASSY, PRESET		83	*3-687-558-01	CASE (MAIN), SHIELD, AU	
66	*1-613-234-11	MT-10 BOARD		84	*3-687-559-01	CASE (BOTTOM LID), SHIELD, AU	
67	Δ 1-463-350-12	TUNER, ET (BT-881)		85	*3-687-541-02	CASE, SHIELD	
68	*A-6721-222-A	TA-22 BOARD, COMPLETE	66, 67, 80	86	*3-687-594-01	PLATE, JACK	

5-3. FRONT LOADING ASSEMBLY

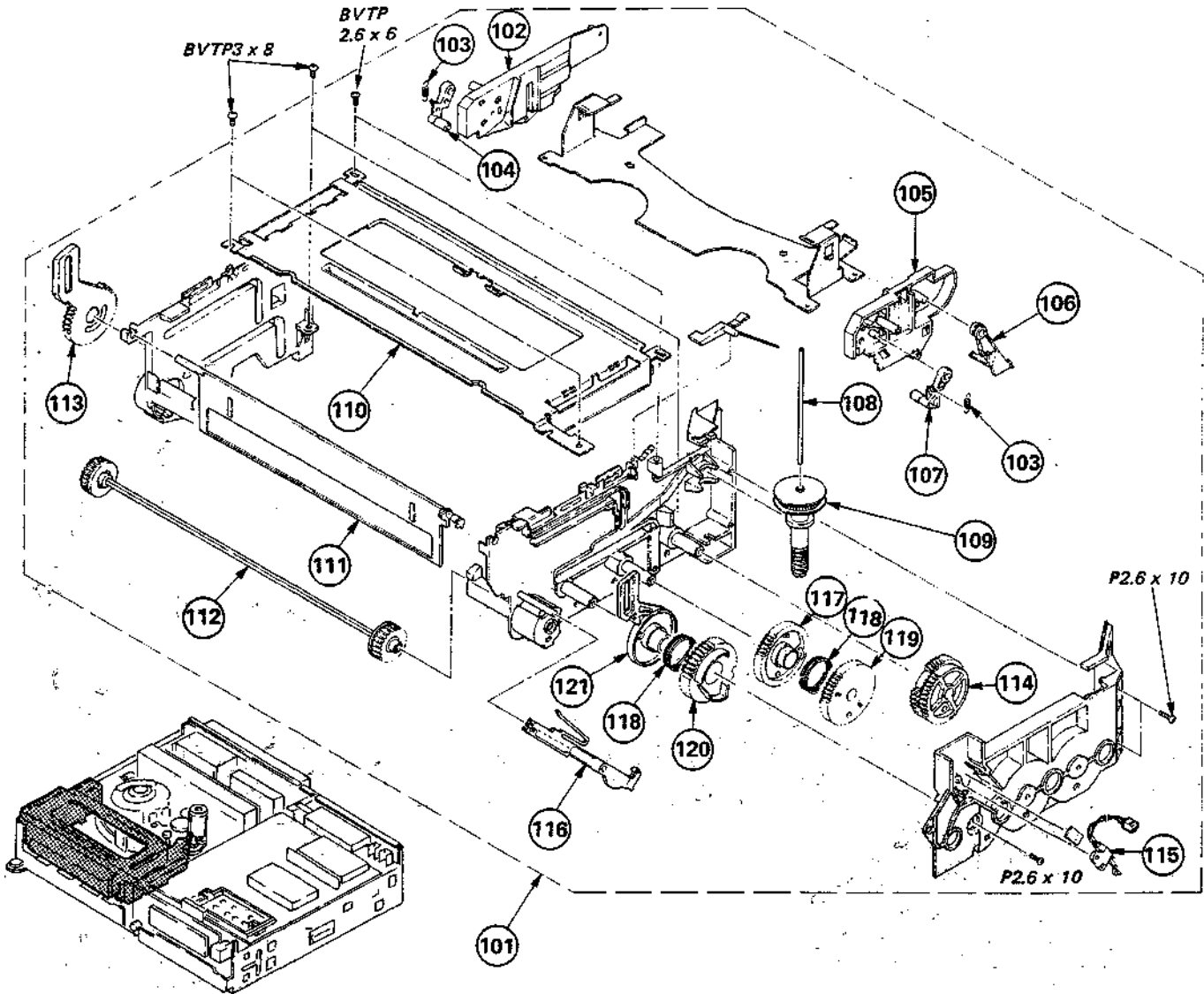

No.	Part No.	Description	Remark	No.	Part No.	Description	Remark
101	A-6751-186-A	LOADING BLOCK ASSY, FRONT	102-121	112	X-3684-116-1	SHAFT ASSY, MIDWAY GEAR	
102	*X-3684-117-1	PLATE ASSY, SIDE, BASE (LEFT)		113	*3-684-166-01	ARM (LEFT), DRIVING	
103	3-684-258-01	SPRING, TENSION		114	X-3684-123-1	GEAR ASSY, DRIVING	
104	X-3684-125-1	RETAINER (LEFT) ASSY, CASSETTE		115	1-554-840-11	SWITCH, LEAF (CASSETTE ON)(S904)	
105	*X-3684-118-1	PLATE ASSY, SIDE, RIGHT		116	3-684-162-01	ARM, SWITCHING, DOOR	
106	*3-684-108-01	ARM, LID OPEN		117	3-684-111-01	GEAR (B), LIMITER	
107	X-3684-124-1	RETAINER (RIGHT) ASSY, CASSETTE		118	3-684-115-01	SPRING	
108	3-679-123-00	SHAFT, GEAR, WORM		119	3-684-109-01	GEAR (A), LIMITER	
109	3-684-164-01	GEAR, WORM		120	3-684-163-01	GEAR, DRIVING ARM	
110	*3-684-195-01	PLATE, TOP		121	3-684-165-01	ARM (RIGHT), DRIVING	
111	3-684-168-01	DOOR					

5-4. CHASSIS ASSEMBLY 1

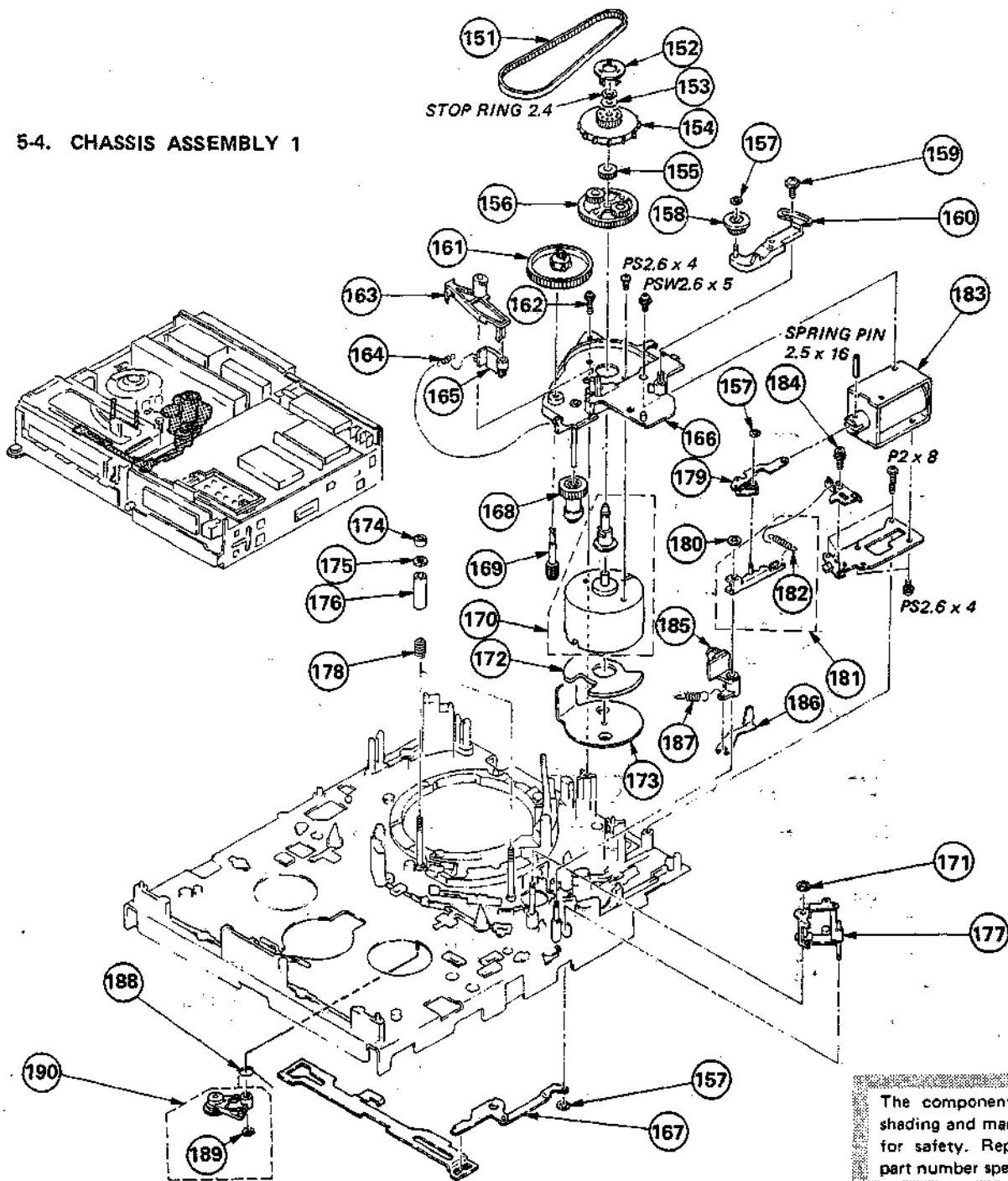

No.	Part No.	Description	Remark	No.	Part No.	Description	Remark
151	3-684-264-01	BELT, TIMING		171	3-669-596-00	WASHER (2.3), STOPPER	
152	3-684-152-01	FLANGE, INTERNAL GEAR		172	*1-605-071-00	LM-8 BOARD	
153	3-683-454-01	WASHER, POLYETHYLENE		173	*3-669-613-00	INSULATOR, L MOTOR	
154	3-684-178-01	GEAR, INTERNAL		174	3-669-318-21	NUT, ADJUSTMENT, GUIDE	
155	3-679-104-05	GEAR		175	3-684-135-01	WASHER (UPPER), GUIDE, #7, 8	
156	X-3679-111-0	CARRIER ASSY		176	3-684-133-01	SLEEVE, GUIDE, #7, 8	
157	3-669-465-00	WASHER (1.5), STOPPER		177	X-3684-113-1	ARM ASSY, PINCH PRESS	
158	3-684-151-01	GEAR		178	3-684-290-01	SPRING, COMPRESSION	
159	3-681-231-00	SCREW (+PW 2.6X8), TAPPING		179	X-3684-109-1	ARM ASSY, PINCH SOLENOID	
160	X-3684-119-1	ARM ASSY, GEAR		180	3-669-595-00	WASHER (2), STOPPER	
161	3-679-115-00	GEAR (LARGE), LOADING		181	*X-3684-112-1	ARM ASSY, PINCH LIMITER	182
162	3-669-480-11	+ PTPWH 2		182	3-515-170-00	SPRING, TENSION	
163	3-684-167-01	ARM, STOPPER		183	Δ 1-454-349-41	SOLENOID, PLUNGER (PINCH) (PM901)	
164	3-684-227-01	SPRING, TENSION		184	3-669-607-00	+PSW (SMALL ROUND) 2.6	
165	3-684-116-01	LIMITER, STOPPER		185	1-464-329-31	SENSOR, T COIL (L902)	
166	X-3684-129-1	CHASSIS ASSY, PLANET GEAR		186	*3-684-119-01	LINK, TAKE-UP SENSOR	
167	*X-3684-114-1	LEVER ASSY, COMMUNICATION		187	3-684-157-04	SPRING (T SENSOR), TENSION	
168	X-3669-321-0	GEAR (C) ASSY		188	3-681-154-00	SPRING, TORSION	
169	3-679-114-00	GEAR (SMALL), LOADING		189	3-701-436-11	WASHER, 1.6	
170	X-3679-268-1	MOTOR ASSY, L (LOADING/THREADING) (MS04)		190	X-3687-503-1	ARM ASSY, REVIEW BRAKE	189

5-5. CHASSIS ASSEMBLY 2

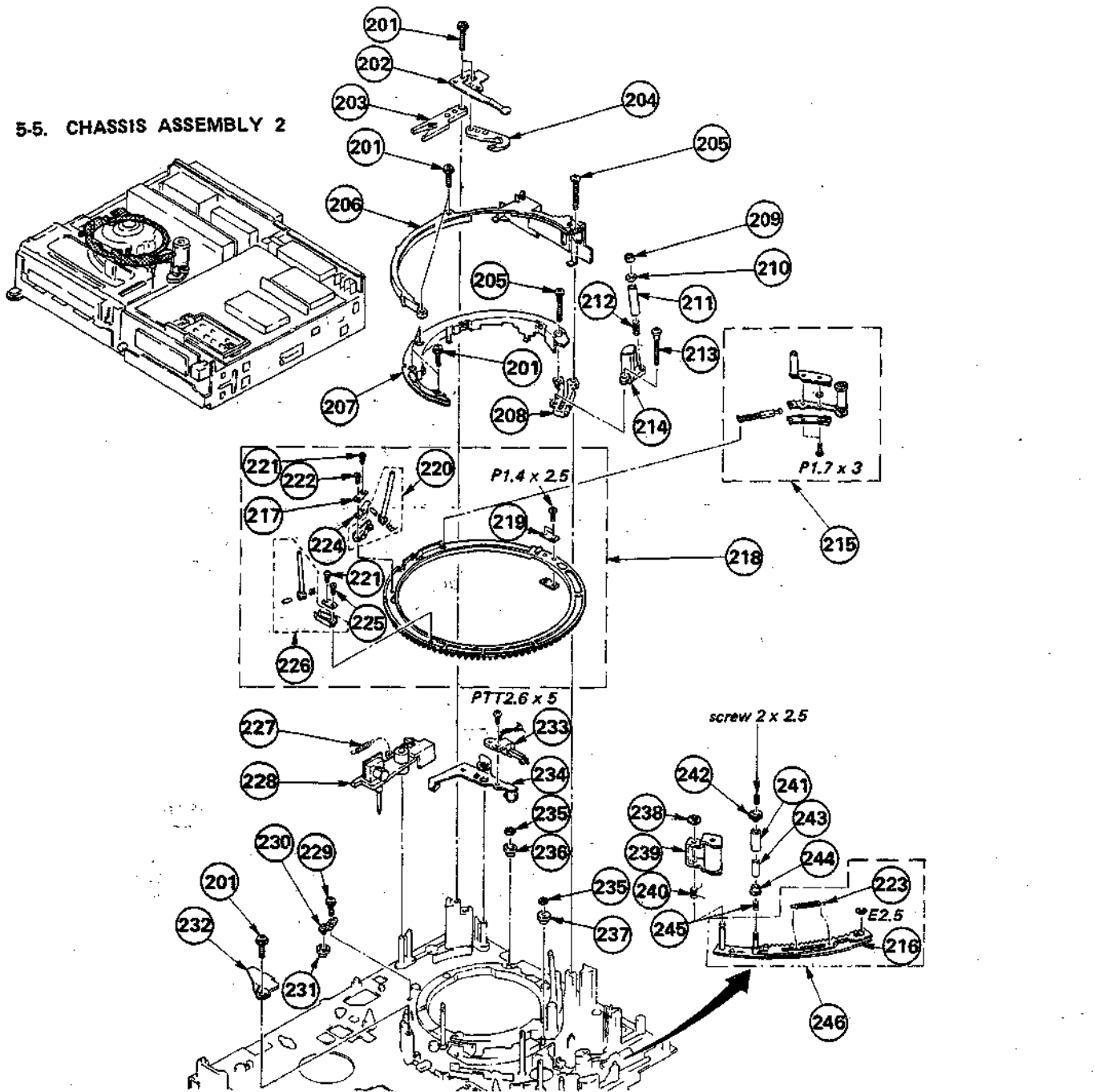

No.	Part No.	Description	Remark	No.	Part No.	Description	Remark
201	3-669-480-11	+ PTPMH 2		224	3-672-583-00	SPRING	
202	*3-684-158-01	PLATE, GROUND, TAPE GUIDE		225	3-672-586-00	SCREW (1.4X3), TAPPING	
203	*3-669-618-00	PLATE (2), ADJUST		226	*X-3669-429-0	HOLDER BLOCK ASSY, #2 GUIDE	
204	*3-672-507-00	PLATE (3-1), ADJUSTMENT		227	3-684-161-01	SPRING (S SENSOR), TENSION	
205	3-669-466-21	SCREW (M 2.6)		228	1-464-330-11	SENSOR, S COIL (L901)	
206	3-684-217-01	GUIDE (2), SHUTTLE		229	3-669-607-31	+PSW (SMALL ROUND) (2.6)	
207	*3-679-290-00	GUIDE (1-YA), SHUTTLE		230	*X-3669-329-0	PLATE ASSY, ADJUSTMENT	
208	*X-3679-263-1	BASE ASSY, SLANT		231	3-669-360-00	ROLLER, RING	
209	3-669-446-00	NUT, GUIDE, NO. 6		232	3-669-476-04	PLATE, GUIDE	
210	3-679-910-00	FLANGE (S), GUIDE, NUMBER 6		233	1-554-840-11	SWITCH, LEAF (THREADING END) (S903)	
211	3-669-445-00	SPACER, GUIDE, NO. 6		234	*X-3684-130-1	ARM ASSY, LOCK	
212	3-669-615-00	SPRING, COMPRESSION		235	3-669-465-00	WASHER (1.5), STOPPER	
213	3-669-606-00	SCREW (2.6)		236	3-669-630-00	ROLLER (C), RING	
214	8-825-508-10	HEAD, FE (FULL ERASE HEAD)		237	3-669-597-00	ROLLER (B), RING	
215	A-6750-158-8	SHUTTLE (2) BLOCK ASSY		238	3-669-596-00	WASHER (2.3), STOPPER	
216	*X-3679-265-1	SLIDER ASSY (2), T		239	X-3679-264-1	ARM ASSY, PINCH ROLLER	
217	*3-669-472-02	RETAINER, SPRING, LEAF		240	3-683-441-01	SPRING	
218	X-3679-150-0	RING (YA) ASSY, S LOADING	217, 219-222 224-226	241	3-676-649-11	ROLLER (#9), GUIDE	
219	*3-669-616-00	RETAINER		242	3-676-650-00	FLANGE (UPPER) (#9), GUIDE	
220	*X-3669-430-0	HOLDER BLOCK ASSY, #3 GUIDE		243	3-672-559-00	SLEEVE, GUIDE	
221	3-669-478-00	SCREW (1X3), TAPPING		244	3-672-558-00	FLANGE (LOWER) (#9), GUIDE	
222	3-669-479-11	SCREW (1.4X3.5), TAPPING		245	3-669-452-00	SPRING, COMPRESSION	
223	3-549-014-00	SPRING, TENSION		246	A-6750-165-A	GEAR ASSY, SLIDER	216, 223

5-6. DRUM ASSEMBLY

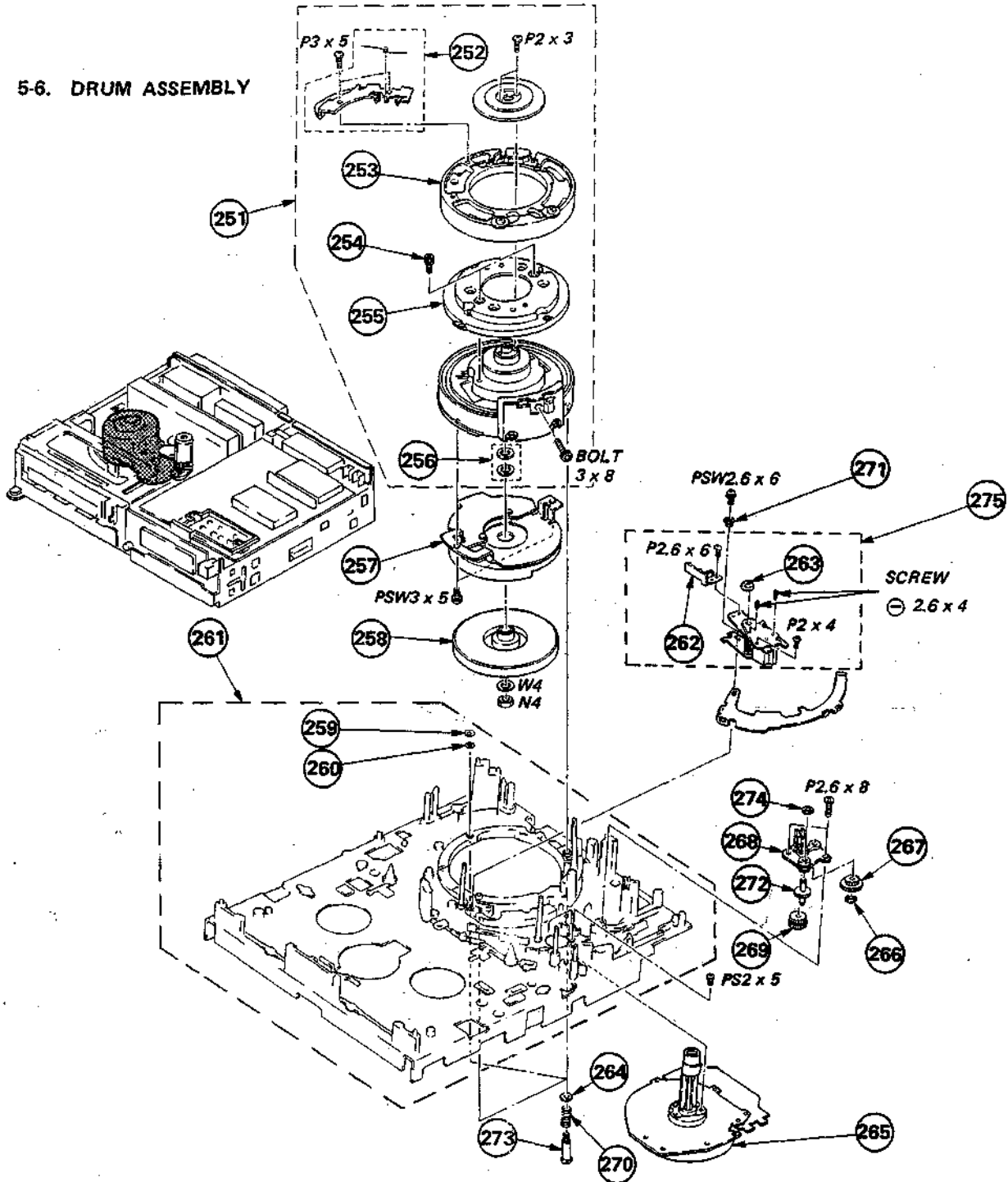

No.	Part No.	Description	Remark	No.	Part No.	Description	Remark
251	A-6050-187-A	DRUM ASSY (DSH-35A-R)	252-256	264	3-669-600-11	WASHER, FLAT(3.5)	
252	A-6760-066-B	SPRING ASSY, TAPE RETAINER		265	8-838-080-01	MOTOR, DC(BHF-1908B)(CAPSTAN MOTOR)(M902)	
253	A-6760-138-A	DRUM ASSY, UPPER		266	3-669-465-00	WASHER (1.5), STOPPER	
254	3-669-157-00	BOLT (WASHER)(2.6X8)		267	3-669-337-00	GEAR (D)	
255	A-6762-122-A	DISK ASSY		268	X-3679-147-0	CHASSIS (B) ASSY, DRIVE GEAR	
256	X-3669-105-0	SPACE BLOCK ASSY		269	3-669-338-00	GEAR (E)	
257	X-2621-204-2	STATOR ASSY, D		270	3-429-123-00	SPRING	
258	X-2621-202-0	ROTOR ASSY, D		271	3-684-247-01	BUSHING, ACE	
259	3-669-646-00	SPACER, DRUM		272	X-3684-166-1	GEAR(F) ASSY(C)	
260	3-669-646-11	SPACER, DRUM		273	3-669-302-00	SCREW, FITTING	
261	*X-3687-505-1	CHASSIS ASSY, MECHANICAL	259, 260	274	3-669-595-00	WASHER (2), STOPPER	
262	3-684-140-01	PROTECTOR		275	A-6761-075-A	ACE ASSY	262, 263
263	*3-684-246-02	NUT, ADJUSTMENT, HEIGHT, ACE					

5-7. REEL BLOCK ASSEMBLY

The components identified by shading and mark Δ are critical for safety. Replace only with part number specified.

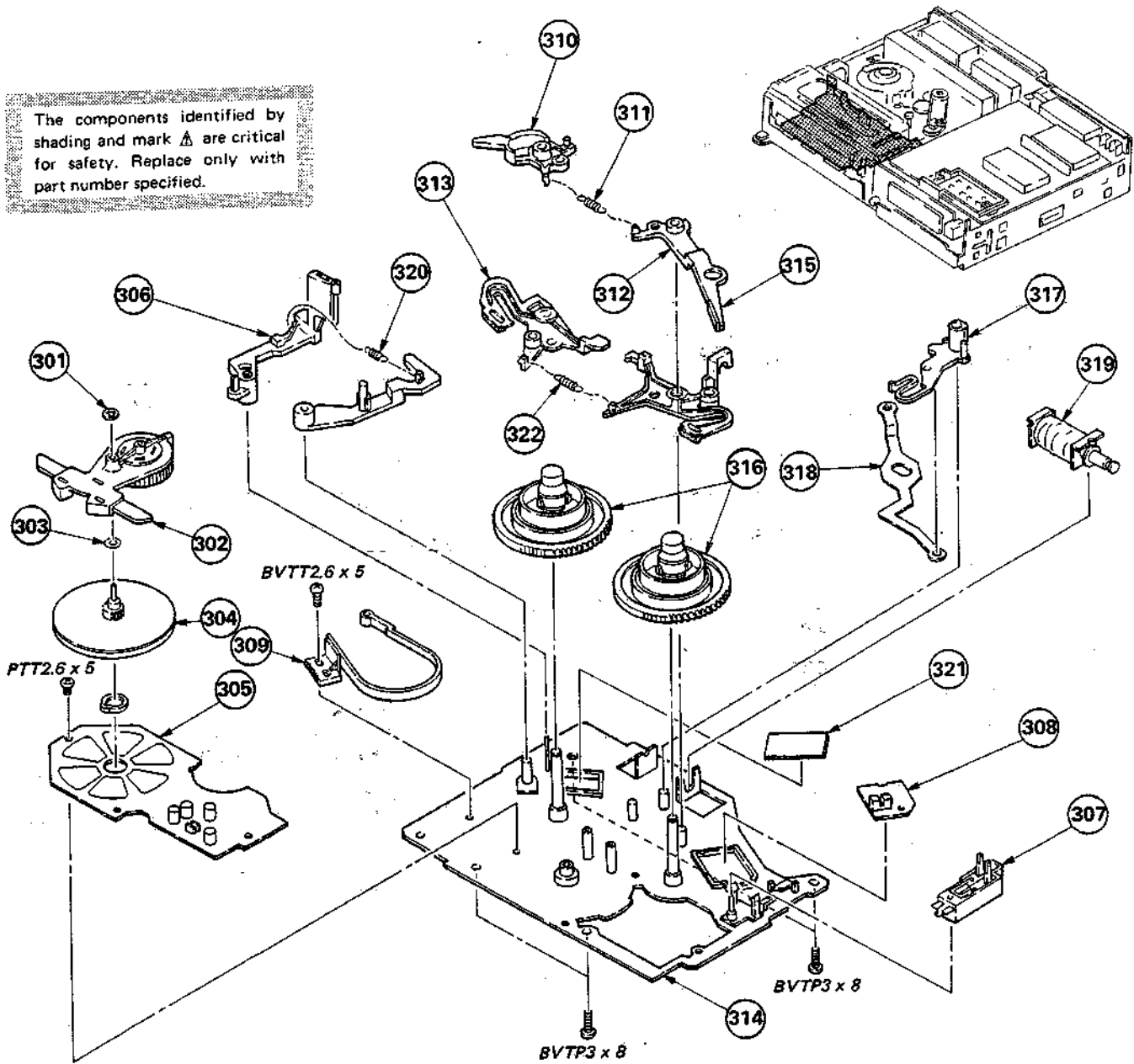

No.	Part No.	Description	Remark	No.	Part No.	Description	Remark
301	3-669-595-00	WASHER (2), STOPPER		312	X-3684-137-1	BRAKE ASSY, T SOFT	
302	A-6759-074-A	ARM BLOCK ASSY, PENDULUM		313	X-3684-107-1	BRAKE ASSY, SUPPLY	
303	3-679-318-00	WASHER, PENDULUM ARM		314	*X-3684-131-1	CHASSIS ASSY, SUB	
304	X-2622-201-0	ROTOR ASSY, R		315	X-3684-108-1	BRAKE ASSY, TAKE-UP	
305	*A-4910-049-A	R STATOR BOARD, COMPLETE (REEL MOTOR) (M903)		316	X-3684-106-1	TABLE ASSY, REEL	
306	X-3684-121-1	LEVER ASSY, TENSION REGULATOR		317	3-684-193-01	ARM, PENDULUM STOPPER	
307	1-554-839-11	SWITCH, LEAF (2 GANG) (S901) (REC PROOF/CASSETTE DOWN)		318	*3-684-183-01	LINK, L	
308	*1-613-233-12	RD-21 BOARD		319	Δ 1-454-371-31	SOLENOID, "PLUNGER" (BRAKE) (PM902)	
309	X-3679-120-0	BAND ASSY, TENSION REGULATOR		320	3-679-151-00	SPRING, TENSION	
310	3-684-192-01	ARM, BRAKE, SUPPLY SOFT		321	*1-613-232-12	RD-20 BOARD	
311	3-684-235-01	SPRING, TENSION		322	3-685-772-01	SPRING, TENSION	

5.8. HARDWARE LIST

SCREW

7-621-770-67 SCREW +P 2.6X6
7-621-759-35 +PSW, 2.6X5
7-621-759-85 +PSW, 2.6X12
7-621-759-95 +PSW, 2.6X14
7-627-551-28 SCREW, PRECISION +P 1.4X2.5

7-627-552-38 SCREW, PRECISION +P 1.7X3
7-627-553-18 SCREW, PRECISION +P 2X2
7-627-553-47 SCREW, PRECISION +P 2X4
7-628-253-15 SCREW +PS 2X5
7-628-253-95 SCREW +PS 2.6X4

7-628-254-15 SCREW +PS 2.6X6
7-682-548-04 SCREW +P 3X8
7-685-134-14 SCREW +P 2.6X8 TYPE2 NON-SLIT
7-685-135-14 SCREW +P 2.6X10 TYPE2 NON-SLIT
7-685-645-71 SCREW +BVTP 3X6 TYPE2 IT-3

7-685-645-81 SCREW +BVTP 3X6 TYPE2
7-685-646-71 SCREW +BVTP 3X8 TYPE2 IT-3
7-685-646-79 SCREW +BVTP 3X8 TYPE2 IT-3
7-685-646-81 SCREW +BVTP 3X8 TYPE2
7-685-646-89 SCREW +BVTP 3X8 TYPE2

7-685-648-71 SCREW +BVTP 3X12 TYPE2 IT-3
7-685-648-81 SCREW +BVTP 3X12 TYPE2
7-685-790-04 SCREW +PTT 2.6X4 (S)
7-685-791-04 SCREW +PTT 2.6X5 (S)
7-685-791-04 SCREW +BVTT 2.6X5 (S)

SET-SCREW

7-621-710-25 SET-SCREW, SLOT 2X3 CONE POINT
7-621-731-08 SET-SCT, HEX. 2X2.5, FLAT POINT
7-621-732-08 SET-SCT, HEX. 2X3 FLAT POINT
7-683-174-21 SET-SCREW, SLOT 3X4 CONE POINT

RING

7-624-118-01 RING, RETAINING E-2.5
7-624-190-61 STOP RING 2.4, TYPE-CS

TAPPING

7-685-105-14 TPG +P 2X8, TYPE 2, NON-SLIT

R STATOR TM

NOTE:
The components identified by shading and mark Δ are critical for safety. Replace only with part number specified.

When indicating parts by reference number, please include the board name.

- Due to standardization, replacements in the parts list may be different from the parts specified in the diagrams or the components used on the set.
 - All variable and adjustable resistors have characteristic curve B, unless otherwise noted.
 - Items marked "*" are not stocked since they are seldom required for routine service. Some delay should be anticipated when ordering these items.
- RESISTORS**
- All resistors are in ohms
 - F : nonflammable
- CAPACITORS**
- MF : μ F, PF : μ μ F
- COILS**
- MMH : mH, UH : μ H

Ref.No	Part No.	Description	Remark
*A-4910-049-A	R STATOR BOARD, COMPLETE (REEL MOTOR)		

*1-560-460-00	PIN, CONNECTOR 4P		
<u>CAPACITOR</u>			
C1	1-123-821-00	ELECT 47MF	20% 16V
C2	1-123-821-00	ELECT 47MF	20% 16V
C3	1-123-821-00	ELECT 47MF	20% 16V
C4	1-123-821-00	ELECT 47MF	20% 16V
<u>DIODE</u>			
D1	8-719-941-48	DIODE 1N4148TP	
<u>IC</u>			
IC1	8-759-108-77	IC CX877	
<u>TRANSISTOR</u>			
Q1	8-729-100-01	TRANSISTOR 2SD992-N	
Q2	8-729-100-01	TRANSISTOR 2SD992-N	
Q3	8-729-100-01	TRANSISTOR 2SD992-N	
Q4	8-729-100-01	TRANSISTOR 2SD992-N	
Q5	8-729-100-01	TRANSISTOR 2SD992-N	
Q6	8-729-100-01	TRANSISTOR 2SD992-N	
<u>RESISTOR</u>			
R1	1-247-823-00	CARBON 470 5%	1/6W
R2	1-247-823-00	CARBON 470 5%	1/6W
R3	1-247-823-00	CARBON 470 5%	1/6W
R4	1-247-829-00	CARBON 820 5%	1/6W
R5	1-247-871-00	CARBON 47K 5%	1/6W
R6	1-247-871-00	CARBON 47K 5%	1/6W
R7	1-247-871-00	CARBON 47K 5%	1/6W
R8	1-247-871-00	CARBON 47K 5%	1/6W
<u>DIODE</u>			
S1	8-719-810-31	DIODE THS103-1	
S2	8-719-810-31	DIODE THS103-1	

*A-6707-464-A	TM BOARD, COMPLETE (EC MODEL)		

*A-6707-468-A	TM BOARD, COMPLETE (AEP, E, UK MODEL)		

<u>CAPACITOR</u>			
C001	1-123-382-00	ELECT 3.3MF	20% 50V
C003	1-125-299-00	DOUBLE LAYERS 47000MF	5.5V
C004	1-161-773-00	CERAMIC 0.1MF	20% 25V
C005	1-102-525-00	CERAMIC 68PF	5% 50V
C006	1-102-852-00	CERAMIC 47PF	5% 50V

Ref.No	Part No.	Description	Remark
C008	1-123-357-00	ELECT 22MF	20% 50V
C009	1-161-055-00	CERAMIC 0.022MF	10% 50V
C010	1-161-055-00	CERAMIC 0.022MF	10% 50V
C011	1-161-773-00	CERAMIC 0.1MF	20% 25V
C012	1-123-308-00	ELECT 220MF	20% 10V
<u>DIODE</u>			
D001	8-719-812-31	DIODE TLR123	
D002	8-719-911-19	DIODE 1SS119	
D003	8-719-911-19	DIODE 1SS119	
D004	8-719-162-07	DIODE RD6.2E-B	
D005	8-719-162-07	DIODE RD6.2E-B	
<u>FLUORESCENT INDICATOR</u>			
FL001	1-519-322-11	INDICATOR, FLUORESCENT	
<u>IC</u>			
IC001	8-759-911-09	IC MB88525B-112M	
IC002	8-759-913-41	IC S-8054ALB	
<u>COIL</u>			
L001	1-407-492-00	MICRO INDUCTOR 1MMH	
L002	1-407-177-XX	MICRO INDUCTOR 470UH	
<u>TRANSISTOR</u>			
Q001	8-729-245-83	TRANSISTOR 2SC2458	
Q002	8-729-245-83	TRANSISTOR 2SC2458	
Q003	8-729-204-83	TRANSISTOR 2SA1048-GR	
Q004	8-729-900-89	TRANSISTOR DTC144ES	
Q005	8-729-245-83	TRANSISTOR 2SC2458	
<u>RESISTOR</u>			
R001	1-247-867-00	CARBON 33K 5%	1/6W
R002	1-247-874-00	CARBON 62K 5%	1/6W
R003	1-247-872-00	CARBON 51K 5%	1/6W
R004	1-247-873-00	CARBON 56K 5%	1/6W
R005	1-247-869-00	CARBON 39K 5%	1/6W
R006	1-247-885-00	CARBON 180K 5%	1/6W
R007	1-247-879-00	CARBON 100K 5%	1/6W
R008	1-247-867-00	CARBON 33K 5%	1/6W
R010	1-247-879-00	CARBON 100K 5%	1/6W
R024	1-247-867-00	CARBON 33K 5%	1/6W
R025	1-247-833-00	CARBON 1.2K 5%	1/6W
R026	1-247-883-00	CARBON 150K 5%	1/6W
R027	1-247-883-00	CARBON 150K 5%	1/6W
R028	1-247-883-00	CARBON 150K 5%	1/6W
R029	1-247-883-00	CARBON 150K 5%	1/6W
R030	1-247-883-00	CARBON 150K 5%	1/6W
R031	1-247-883-00	CARBON 150K 5%	1/6W
R032	1-247-883-00	CARBON 150K 5%	1/6W
R033	1-247-883-00	CARBON 150K 5%	1/6W
R034	1-247-883-00	CARBON 150K 5%	1/6W
R035	1-247-883-00	CARBON 150K 5%	1/6W

Ref.No	Part No.	Description	Remark
L513	1-407-717-00	MICRO INDUCTOR 1MMH	
L516	1-408-422-00	MICRO INDUCTOR 120UH	
L517	1-407-495-00	MICRO INDUCTOR 1.8MMH	
<u>TRANSISTOR</u>			
Q501	8-729-900-36	TRANSISTOR DTC124ES	
Q502	8-729-204-83	TRANSISTOR 2SA1048-GR	
Q503	8-729-177-43	TRANSISTOR 2SD774	
Q508	8-729-245-83	TRANSISTOR 2SC2458	
<u>RESISTOR</u>			
R503	1-247-844-00	CARBON 3.6K 5% 1/6W	
R504	1-247-852-00	CARBON 7.5K 5% 1/6W	
R505	1-247-855-00	CARBON 10K 5% 1/6W	
R506	1-247-831-00	CARBON 1K 5% 1/6W	
R507	1-247-867-00	CARBON 33K 5% 1/6W	
R515	1-247-831-00	CARBON 1K 5% 1/6W	
R517	1-247-824-00	CARBON 510 5% 1/6W	
R518	1-247-824-00	CARBON 510 5% 1/6W	
R519	1-247-779-00	CARBON 6.8 5% 1/6W	
R520	1-247-822-00	CARBON 430 5% 1/6W	
R521	1-247-855-00	CARBON 10K 5% 1/6W	
R522	1-247-855-00	FUSIBLE 3.2A 5% 1/4W 250V	
R523	1-247-839-00	CARBON 2.2K 5% 1/6W	
R524	1-247-839-00	CARBON 2.2K 5% 1/6W	
R525	1-247-839-00	CARBON 2.2K 5% 1/6W	
R526	1-247-839-00	CARBON 2.2K 5% 1/6W	
R527	1-247-831-00	CARBON 1K 5% 1/6W	
R528	1-247-831-00	CARBON 1K 5% 1/6W	
R529	1-247-825-00	CARBON 560 5% 1/6W	
R530	1-247-835-00	CARBON 1.5K 5% 1/6W	
R531	1-247-855-00	FUSIBLE 3.2A 5% 1/4W 250V	
R533	1-247-847-00	CARBON 4.7K 5% 1/6W	
R534	1-247-839-00	CARBON 2.2K 5% 1/6W	
R535	1-247-849-00	CARBON 5.6K 5% 1/6W	
R536	1-247-849-00	CARBON 5.6K 5% 1/6W	
R537	1-247-809-00	CARBON 120 5% 1/6W	
R540	1-247-819-00	CARBON 330 5% 1/6W	
R543	1-247-819-00	CARBON 330 5% 1/6W	
R545	1-247-844-00	CARBON 3.6K 5% 1/6W	
R546	1-247-844-00	CARBON 3.6K 5% 1/6W	
R547	1-247-828-00	CARBON 750 5% 1/6W	
R548	1-247-807-00	CARBON 100 5% 1/6W	
R549	1-247-831-00	CARBON 1K 5% 1/6W	
R550	1-247-831-00	CARBON 1K 5% 1/6W	
R551	1-247-835-00	CARBON 1.5K 5% 1/6W	
R552	1-247-835-00	CARBON 1.5K 5% 1/6W	
R557	1-247-815-00	CARBON 220 5% 1/6W	
R559	1-247-855-00	CARBON 10K 5% 1/6W	
<u>VARIABLE RESISTOR</u>			
RV501	1-228-920-00	RES, ADJ, CARBON 2.2K	
RV502	1-228-920-00	RES, ADJ, CARBON 2.2K	

Ref.No	Part No.	Description	Remark
RV503	1-228-920-00	RES, ADJ, CARBON 2.2K	

	*A-6711-578-A	YC-31 BOARD, COMPLETE	

	*1-536-870-11	TERMINAL BOARD, CONTROL PANEL	
<u>BAND PASS FILTER</u>			
BPF001	1-235-098-00	FILTER, BAND PASS	
<u>CAPACITOR</u>			
C002	1-123-356-00	ELECT 10MF 20% 16V	
C010	1-123-356-00	ELECT 10MF 20% 16V	
C011	1-123-356-00	ELECT 10MF 20% 25V	
C020	1-101-004-00	CERAMIC 0.01MF 50V	
C021	1-101-004-00	CERAMIC 0.01MF 50V	
C023	1-101-882-00	CERAMIC 51PF 5% 50V	
C024	1-130-047-00	FILM 180PF 5% 50V	
C025	1-106-172-00	MYLAR 0.001MF 5% 50V	
C026	1-101-059-00	CERAMIC 510PF 5% 50V	
C027	1-161-045-00	CERAMIC 0.0033MF 10% 25V	
C028	1-106-172-00	MYLAR 0.001MF 50V	
C029	1-123-382-00	ELECT 3.3MF 20% 50V	
C031	1-101-004-00	CERAMIC 0.01MF 50V	
C032	1-102-816-00	CERAMIC 120PF 5% 50V	
C033	1-101-004-00	CERAMIC 0.01MF 50V	
C034	1-101-004-00	CERAMIC 0.01MF 50V	
C035	1-102-816-00	CERAMIC 120PF 5% 50V	
C036	1-101-882-00	CERAMIC 51PF 5% 50V	
C037	1-101-004-00	CERAMIC 0.01MF 50V	
C038	1-101-004-00	CERAMIC 0.01MF 50V	
C039	1-101-004-00	CERAMIC 0.01MF 50V	
C048	1-101-004-00	CERAMIC 0.01MF 50V	
C049	1-101-004-00	CERAMIC 0.01MF 50V	
C050	1-102-865-00	CERAMIC 8PF 0.5PF 50V	
C051	1-102-525-00	CERAMIC 68PF 5% 50V	
C052	1-102-525-00	CERAMIC 68PF 5% 50V	
C053	1-123-380-00	ELECT 1MF 20% 50V	
C054	1-161-040-00	CERAMIC 0.0012MF 10% 25V	
C055	1-123-380-00	ELECT 1MF 20% 50V	
C056	1-102-962-00	CERAMIC 30PF 5% 50V	
C057	1-102-981-00	CERAMIC 300PF 5% 50V	
C058	1-123-306-00	ELECT 47MF 20% 10V	
C059	1-101-004-00	CERAMIC 0.01MF 50V	
C060	1-108-579-00	MYLAR 0.01MF 5% 50V	
C061	1-123-382-00	ELECT 3.3MF 20% 50V	
C062	1-123-306-00	ELECT 47MF 20% 10V	
C063	1-101-004-00	CERAMIC 0.01MF 50V	
C064	1-102-521-00	CERAMIC 43PF 5% 50V	
C065	1-102-527-00	CERAMIC 82PF 5% 50V	
C066	1-102-518-00	CERAMIC 33PF 5% 50V	

The components identified by shading and mark **▲** are critical for safety. Replace only with part number specified.

When indicating parts by reference number, please include the board name.

Ref.No	Part No.	Description			Remark	Ref.No	Part No.	Description			Remark
C067	1-161-025-00	CERAMIC	0.1MF	10%	25V	C129	1-123-330-00	ELECT	22MF	20%	16V
C068	1-101-004-00	CERAMIC	0.01MF		50V	C130	1-123-356-00	ELECT	10MF	20%	16V
C069	1-102-962-00	CERAMIC	30PF	5%	50V	C131	1-123-380-00	ELECT	1MF	20%	50V
C070	1-101-004-00	CERAMIC	0.01MF		50V	C132	1-123-369-00	ELECT	4.7MF	20%	25V
C071	1-123-380-00	ELECT	1MF	20%	50V	C133	1-102-851-00	CERAMIC	15PF	5%	50V
C072	1-101-004-00	CERAMIC	0.01MF		50V	C134	1-102-821-00	CERAMIC	360PF	5%	50V
C073	1-102-525-00	CERAMIC	68PF	5%	50V	C135	1-102-823-00	CERAMIC	430PF	5%	50V
C074	1-102-525-00	CERAMIC	68PF	5%	50V	C136	1-102-976-00	CERAMIC	180PF	5%	50V
C075	1-101-004-00	CERAMIC	0.01MF		50V	C137	1-102-513-00	CERAMIC	18PF	5%	50V
C076	1-102-951-00	CERAMIC	15PF	5%	50V	C138	1-102-529-00	CERAMIC	100PF	5%	50V
C077	1-123-330-00	ELECT	22MF	20%	16V	C139	1-102-530-00	CERAMIC	120PF	5%	50V
C078	1-123-330-00	ELECT	22MF	20%	16V	C140	1-102-519-00	CERAMIC	36PF	5%	50V
C080	1-101-004-00	CERAMIC	0.01MF		50V	C141	1-102-529-00	CERAMIC	100PF	5%	50V
C082	1-161-024-00	CERAMIC	0.082MF	10%	25V	C142	1-123-369-00	ELECT	4.7MF	20%	25V
C083	1-102-977-00	CERAMIC	200PF	5%	50V	C144	1-102-511-00	CERAMIC	13PF	5%	50V
C084	1-123-369-00	ELECT	4.7MF	20%	25V	C145	1-102-522-00	CERAMIC	51PF	5%	50V
C085	1-101-004-00	CERAMIC	0.01MF		50V	C146	1-102-522-00	CERAMIC	51PF	5%	50V
C086	1-108-557-00	MYLAR	0.0012MF	5%	50V	C147	1-102-511-00	CERAMIC	13PF	5%	50V
C087	1-161-057-00	CERAMIC	0.033MF	10%	25V	C148	1-101-006-00	CERAMIC	0.047MF		50V
C088	1-101-361-00	CERAMIC	150PF	5%	50V	C155	1-101-004-00	CERAMIC	0.01MF		50V
C092	1-101-004-00	CERAMIC	0.01MF		50V	C156	1-101-004-00	CERAMIC	0.01MF		50V
C093	1-101-006-00	CERAMIC	0.047MF		50V	C157	1-102-981-00	CERAMIC	300PF	5%	50V
C095	1-102-976-00	CERAMIC	180PF	5%	50V	C158	1-102-948-00	CERAMIC	11PF	5%	50V
C096	1-102-824-00	CERAMIC	470PF	5%	50V	C159	1-102-822-00	CERAMIC	390PF	5%	50V
C097	1-102-823-00	CERAMIC	430PF	5%	50V	C178	1-123-330-00	ELECT	22MF	20%	16V
C098	1-102-820-00	CERAMIC	330PF	5%	50V	C179	1-123-356-00	ELECT	10MF	20%	16V
C099	1-102-851-00	CERAMIC	15PF	5%	50V	C180	1-123-332-00	ELECT	47MF	20%	16V
C100	1-161-025-00	CERAMIC	0.1MF	10%	25V	C181	1-106-186-00	MYLAR	0.0039MF	5%	50V
C101	1-108-595-00	MYLAR	0.047MF	5%	50V	C182	1-123-380-00	ELECT	1MF	20%	50V
C102	1-161-043-00	CERAMIC	0.0022MF	10%	25V	C183	1-101-006-00	CERAMIC	0.047MF		50V
C103	1-106-172-00	MYLAR	0.001MF	5%	50V	C184	1-123-332-00	ELECT	47MF	20%	16V
C104	1-102-977-00	CERAMIC	200PF	5%	50V	C185	1-123-333-00	ELECT	100MF	20%	16V
C105	1-102-973-00	CERAMIC	100PF	5%	50V	C186	1-101-004-00	CERAMIC	0.01MF		50V
C106	1-123-356-00	ELECT	10MF	20%	16V	C187	1-123-330-00	ELECT	22MF	20%	16V
C107	1-161-025-00	CERAMIC	0.1MF	10%	25V	C188	1-161-025-00	CERAMIC	0.1MF	10%	25V
C108	1-101-004-00	CERAMIC	0.01MF		50V	C189	1-123-356-00	ELECT	10MF	20%	16V
C109	1-101-004-00	CERAMIC	0.01MF		50V	C190	1-123-311-00	ELECT	1000MF	20%	10V
C111	1-101-882-00	CERAMIC	51PF	5%	50V	C191	1-101-004-00	CERAMIC	0.01MF		50V
C112	1-101-004-00	CERAMIC	0.01MF		50V	C192	1-123-369-00	ELECT	4.7MF	20%	25V
C113	1-101-006-00	CERAMIC	0.047MF		50V	C196	1-123-380-00	ELECT	1MF	20%	50V
C114	1-101-880-00	CERAMIC	47PF	5%	50V	C197	1-123-356-00	ELECT	10MF	20%	16V
C116	1-101-004-00	CERAMIC	0.01MF		50V	C200	1-101-004-00	CERAMIC	0.01MF		50V
C117	1-101-361-00	CERAMIC	150PF	5%	50V	C201	1-123-356-00	ELECT	10MF	20%	16V
C118	1-101-004-00	CERAMIC	0.01MF		50V	C203	1-101-004-00	CERAMIC	0.01MF		50V
C119	1-123-306-00	ELECT	47MF	20%	10V	C204	1-123-369-00	ELECT	4.7MF	20%	25V
C120	1-101-004-00	CERAMIC	0.01MF		50V	C206	1-101-004-00	CERAMIC	0.01MF		50V
C121	1-101-004-00	CERAMIC	0.01MF		50V	C207	1-161-025-00	CERAMIC	0.1MF	10%	25V
C122	1-101-004-00	CERAMIC	0.01MF		50V	C208	1-123-356-00	ELECT	10MF	20%	16V
C123	1-101-004-00	CERAMIC	0.01MF		50V	C211	1-123-356-00	ELECT	10MF	20%	16V
C124	1-102-518-00	CERAMIC	33PF	5%	50V	C212	1-123-333-00	ELECT	100MF	20%	16V
C125	1-123-330-00	ELECT	22MF	20%	16V	C217	1-161-025-00	CERAMIC	0.1MF	10%	25V
C127	1-123-318-00	ELECT	33MF	20%	16V	C219	1-123-356-00	ELECT	10MF	20%	16V
C128	1-123-330-00	ELECT	22MF	20%	16V	C220	1-161-059-00	CERAMIC	0.047MF	10%	25V

When indicating parts by reference number, please include the board name.

Ref.No	Part No.	Description	Remark
C232	1-101-004-00	CERAMIC 0.01MF	50V
C233	1-123-380-00	ELECT 1MF	20% 50V
C240	1-123-307-00	ELECT 100MF	20% 10V
C241	1-161-025-00	CERAMIC 0.1MF	10% 25V
C243	1-161-025-00	CERAMIC 0.1MF	10% 25V
C246	1-161-025-00	CERAMIC 0.1MF	10% 25V
C248	1-161-059-00	CERAMIC 0.047MF	10% 25V
C251	1-161-059-00	CERAMIC 0.047MF	10% 25V
C252	1-101-081-00	CERAMIC 130PF	5% 50V
C253	1-123-356-00	ELECT 10MF	20% 16V
C257	1-161-059-00	CERAMIC 0.047MF	10% 25V
C258	1-161-059-00	CERAMIC 0.047MF	10% 25V
C401	1-123-381-00	ELECT 2.2MF	20% 50V
C402	1-101-001-00	CERAMIC 0.001MF	50V
C403	1-101-001-00	CERAMIC 0.003MF	50V
C404	1-101-004-00	CERAMIC 0.01MF	50V
C405	1-123-330-00	ELECT 22MF	20% 16V
C406	1-123-330-00	ELECT 22MF	20% 16V
C407	1-102-962-00	CERAMIC 30PF	5% 50V
C408	1-101-888-00	CERAMIC 68PF	5% 50V
C409	1-123-381-00	ELECT 2.2MF	20% 50V
C410	1-102-936-00	CERAMIC 3PF	0.25PF 50V
C411	1-101-005-00	CERAMIC 0.022MF	50V
C412	1-123-318-00	ELECT 33MF	20% 16V
C414	1-123-318-00	ELECT 33MF	20% 16V
C415	1-123-356-00	ELECT 10MF	20% 16V
C416	1-102-948-00	CERAMIC 11PF	5% 50V
C417	1-102-948-00	CERAMIC 11PF	5% 50V
C418	1-102-965-00	CERAMIC 39PF	5% 50V
C419	1-123-356-00	ELECT 10MF	20% 16V
C420	1-123-369-00	ELECT 4.7MF	20% 25V
C421	1-101-006-00	CERAMIC 0.047MF	50V
C502	1-101-004-00	CERAMIC 0.01MF	50V
C503	1-101-004-00	CERAMIC 0.01MF	50V
C504	1-101-005-00	CERAMIC 0.022MF	50V
C505	1-102-822-00	CERAMIC 390PF	5% 50V
C506	1-101-006-00	CERAMIC 0.047MF	50V
C507	1-123-318-00	ELECT 33MF	20% 16V
C607	1-101-004-00	CERAMIC 0.01MF	50V
C608	1-161-059-00	CERAMIC 0.047MF	10% 25V
C609	1-101-006-00	CERAMIC 0.047MF	50V
C611	1-101-006-00	CERAMIC 0.047MF	50V
C616	1-102-518-00	CERAMIC 33PF	5% 50V
C617	1-161-025-00	CERAMIC 0.1MF	10% 25V
C618	1-161-025-00	CERAMIC 0.1MF	10% 25V
C619	1-161-025-00	CERAMIC 0.1MF	10% 25V
C620	1-102-516-00	CERAMIC 27PF	5% 50V
<u>FILTER</u>			
CF002	1-527-875-00	FILTER, CERAMIC	
CF003	1-527-849-00	FILTER, CERAMIC	

Ref.No	Part No.	Description	Remark
<u>CONNECTOR</u>			
CN001	*1-560-894-00	PIN, CONNECTOR 6P	
CN002	*1-560-896-00	PIN, CONNECTOR 8P	
CN003	*1-560-891-00	PIN, CONNECTOR 3P	
CN004	*1-560-894-00	PIN, CONNECTOR 6P	
CN005	*1-560-893-00	PIN, CONNECTOR 5P	
CN006	*1-560-893-00	PIN, CONNECTOR 5P	
CN007	*1-560-892-00	PIN, CONNECTOR 4P	
CN008	*1-560-895-00	PIN, CONNECTOR 7P	
<u>TRIMMER</u>			
CV001	1-141-275-00	CAP, TRIMMER	
<u>DIODE</u>			
D014	8-719-911-19	DIODE 1SS119	
D015	8-719-911-19	DIODE 1SS119	
D016	8-719-000-12	DIODE MC931	
D017	8-719-911-19	DIODE 1SS119	
D018	8-719-911-19	DIODE 1SS119	
D019	8-719-911-19	DIODE 1SS119	
D020	8-719-911-19	DIODE 1SS119	
D021	8-719-911-19	DIODE 1SS119	
D022	8-719-911-19	DIODE 1SS119	
D023	8-719-911-19	DIODE 1SS119	
D027	8-719-000-06	DIODE MC921	
D029	8-719-100-57	DIODE RD10E-B2	
D030	8-719-911-19	DIODE 1SS119	
D031	8-719-911-19	DIODE 1SS119	
D036	8-719-911-19	DIODE 1SS119	
<u>DELAY LINE</u>			
DL001	1-415-313-00	DELAY LINE (1H)	
DL401	1-415-352-11	DELAY LINE, 1H	
DL501	1-415-282-00	DELAY LINE	
<u>IC</u>			
IC003	8-759-201-68	IC CX10023	
IC006	8-759-203-99	IC CX10021B-NP	
IC009	8-759-101-62	IC CX20043	
IC011	8-752-006-10	IC CX20061	
IC012	8-759-979-26	IC CX7926	
IC401	8-758-662-00	IC CX866B	
<u>COIL</u>			
L001	1-407-499-00	MICRO INDUCTOR 3.9MMH	
L002	1-407-496-00	MICRO INDUCTOR 2.2MMH	
L003	1-408-408-00	MICRO INDUCTOR 8.2UH	
L004	1-408-406-00	MICRO INDUCTOR 5.6UH	
L005	1-408-415-00	MICRO INDUCTOR 33UH	
L006	1-408-428-00	MICRO INDUCTOR 390UH	
L007	1-408-427-00	MICRO INDUCTOR 330UH	

When indicating parts by reference number, please include the board name.

Ref.No	Part No.	Description	Remark	Ref.No	Part No.	Description	Remark
L008	1-408-421-00	MICRO INDUCTOR 100UH		Q038	8-729-384-46	TRANSISTOR 2SA844-C	
L010	1-408-427-00	MICRO INDUCTOR 330UH		Q039	8-729-603-30	TRANSISTOR 2SC403SP-3	
L011	1-408-423-00	MICRO INDUCTOR 150UH		Q040	8-729-603-30	TRANSISTOR 2SC403SP-3	
L012	1-408-409-00	MICRO INDUCTOR 10UH		Q041	8-729-384-46	TRANSISTOR 2SA844-C	
L014	1-408-416-00	MICRO INDUCTOR 39UH		Q042	8-729-603-30	TRANSISTOR 2SC403SP-3	
L015	1-408-419-00	MICRO INDUCTOR 68UH		Q043	8-729-603-30	TRANSISTOR 2SC403SP-3	
L016	1-408-413-00	MICRO INDUCTOR 22UH		Q044	8-729-603-30	TRANSISTOR 2SC403SP-3	
L017	1-408-423-00	MICRO INDUCTOR 150UH		Q045	8-729-384-46	TRANSISTOR 2SA844-C	
L018	1-408-419-00	MICRO INDUCTOR 68UH		Q047	8-729-603-30	TRANSISTOR 2SC403SP-3	
L019	1-408-416-00	MICRO INDUCTOR 39UH		Q048	8-729-603-30	TRANSISTOR 2SC403SP-3	
L020	1-408-416-00	MICRO INDUCTOR 39UH		Q049	8-729-603-30	TRANSISTOR 2SC403SP-3	
L021	1-408-422-00	MICRO INDUCTOR 120UH		Q050	8-729-603-30	TRANSISTOR 2SC403SP-3	
L022	1-408-424-00	MICRO INDUCTOR 180UH		Q051	8-729-384-46	TRANSISTOR 2SA844-C	
L023	1-408-422-00	MICRO INDUCTOR 120UH		Q052	8-729-603-30	TRANSISTOR 2SC403SP-3	
L026	1-408-416-00	MICRO INDUCTOR 39UH		Q053	8-729-384-46	TRANSISTOR 2SA844-C	
L036	1-408-429-00	MICRO INDUCTOR 470UH		Q054	8-729-384-46	TRANSISTOR 2SA844-C	
L041	1-408-424-00	MICRO INDUCTOR 180UH		Q055	8-729-384-46	TRANSISTOR 2SA844-C	
L401	1-408-397-00	MICRO INDUCTOR 1UH		Q056	8-729-603-30	TRANSISTOR 2SC403SP-3	
L402	1-408-397-00	MICRO INDUCTOR 1UH		Q060	8-729-204-83	TRANSISTOR 2SA1048-GR	
L501	1-408-408-00	MICRO INDUCTOR 8.2UH		Q061	8-729-245-83	TRANSISTOR 2SC2458	
L502	1-408-423-00	MICRO INDUCTOR 150UH		Q062	8-729-204-83	TRANSISTOR 2SA1048-GR	
L601	1-408-416-00	MICRO INDUCTOR 39UH		Q063	8-729-245-83	TRANSISTOR 2SC2458	
L602	1-408-416-00	MICRO INDUCTOR 39UH		Q064	8-729-245-83	TRANSISTOR 2SC2458	
<u>LOW PASS FILTER</u>				Q065	8-729-245-83	TRANSISTOR 2SC2458	
LPF001	1-235-097-00	FILTER, LOW PASS		Q067	8-729-245-83	TRANSISTOR 2SC2458	
<u>VARIABLE COIL</u>				Q068	8-729-245-83	TRANSISTOR 2SC2458	
LV501	1-407-569-00	COIL, VARIABLE 10UH		Q069	8-729-204-83	TRANSISTOR 2SA1048-GR	
<u>IC LINK</u>				Q071	8-729-245-83	TRANSISTOR 2SC2458	
PS001A 1-432-685-00 IC LINK IC 0.8A				Q075	8-729-900-85	TRANSISTOR DTC144WS	
<u>TRANSISTOR</u>				Q076	8-729-204-83	TRANSISTOR 2SA1048-GR	
Q010	8-729-177-43	TRANSISTOR 2SD774		Q077	8-729-245-83	TRANSISTOR 2SC2458	
Q011	8-729-204-83	TRANSISTOR 2SA1048-GR		Q100	8-729-900-85	TRANSISTOR DTC144WS	
Q015	8-729-245-83	TRANSISTOR 2SC2458		Q101	8-729-900-89	TRANSISTOR DTC144ES	
Q016	8-729-245-83	TRANSISTOR 2SC2458		Q102	8-729-900-65	TRANSISTOR DTA144ES	
Q020	8-729-204-83	TRANSISTOR 2SA1048-GR		Q103	8-729-245-83	TRANSISTOR 2SC2458	
Q022	8-729-245-83	TRANSISTOR 2SC2458		Q401	8-729-245-83	TRANSISTOR 2SC2458	
Q023	8-729-245-83	TRANSISTOR 2SC2458		Q502	8-729-245-83	TRANSISTOR 2SC2458	
Q024	8-729-204-83	TRANSISTOR 2SA1048-GR		Q503	8-729-245-83	TRANSISTOR 2SC2458	
Q026	8-729-204-83	TRANSISTOR 2SA1048-GR		Q504	8-729-245-83	TRANSISTOR 2SC2458	
Q030	8-729-245-83	TRANSISTOR 2SC2458		Q617	8-729-205-02	TRANSISTOR 2SA1150	
Q031	8-729-900-36	TRANSISTOR DTC124ES		<u>RESISTOR</u>			
Q032	8-729-245-83	TRANSISTOR 2SC2458		R026	1-247-871-00	CARBON	47K 5% 1/6W
Q033	8-729-245-83	TRANSISTOR 2SC2458		R028	1-247-855-00	CARBON	10K 5% 1/6W
Q034	8-729-245-83	TRANSISTOR 2SC2458		R029	1-247-855-00	CARBON	10K 5% 1/6W
Q035	8-729-603-30	TRANSISTOR 2SC403SP-3		R030	1-247-867-00	CARBON	33K 5% 1/6W
Q036	8-729-603-30	TRANSISTOR 2SC403SP-3		R032	1-247-815-00	CARBON	220 5% 1/6W
Q037	8-729-384-46	TRANSISTOR 2SA844-C		R035	1-247-859-00	CARBON	15K 5% 1/6W
				R037	1-247-869-00	CARBON	39K 5% 1/6W
				R038	1-247-837-00	CARBON	1.8K 5% 1/6W
				R041	1-247-838-00	CARBON	2K 5% 1/6W
				R050	1-247-853-00	CARBON	8.2K 5% 1/6W
				R051	1-247-821-00	CARBON	390 5% 1/6W

The components identified by shading and mark **A** are critical for safety. Replace only with part number specified.

When indicating parts by reference number, please include the board name.

Ref.No	Part No.	Description	Remark	Ref.No	Part No.	Description	Remark
R052	1-247-819-00	CARBON	330 5% 1/6W	R134	1-247-847-00	CARBON	4.7K 5% 1/6W
R053	1-247-843-00	CARBON	3.3K 5% 1/6W	R135	1-247-883-00	CARBON	150K 5% 1/6W
R054	1-247-847-00	CARBON	4.7K 5% 1/6W	R136	1-247-879-00	CARBON	100K 5% 1/6W
R056	1-247-867-00	CARBON	33K 5% 1/6W	R137	1-247-857-00	CARBON	12K 5% 1/6W
R058	1-247-865-00	CARBON	10K 5% 1/6W	R138	1-247-861-00	CARBON	18K 5% 1/6W
R059	1-247-859-00	CARBON	15K 5% 1/6W	R139	1-247-841-00	CARBON	2.7K 5% 1/6W
R062	1-247-855-00	CARBON	10K 5% 1/6W	R140	1-247-867-00	CARBON	33K 5% 1/6W
R063	1-247-841-00	CARBON	2.7K 5% 1/6W	R141	1-247-831-00	CARBON	1K 5% 1/6W
R064	1-247-848-00	CARBON	5.1K 5% 1/6W	R142	1-247-842-00	CARBON	3K 5% 1/6W
R065	1-247-889-00	CARBON	270K 5% 1/6W	R143	1-247-847-00	CARBON	4.7K 5% 1/6W
R066	1-247-870-00	CARBON	43K 5% 1/6W	R144	1-247-824-00	CARBON	510 5% 1/6W
R067	1-247-862-00	CARBON	20K 5% 1/6W	R145	1-247-838-00	CARBON	2K 5% 1/6W
R068	1-247-838-00	CARBON	2K 5% 1/6W	R146	1-247-829-00	CARBON	820 5% 1/6W
R069	1-247-831-00	CARBON	1K 5% 1/6W	R147	1-247-855-00	CARBON	10K 5% 1/6W
R070	1-247-831-00	CARBON	1K 5% 1/6W	R148	1-247-831-00	CARBON	1K 5% 1/6W
R071	1-247-855-00	CARBON	10K 5% 1/6W	R149	1-247-819-00	CARBON	330 5% 1/6W
R072	1-247-841-00	CARBON	2.7K 5% 1/6W	R150	1-247-863-00	CARBON	22K 5% 1/6W
R073	1-247-831-00	CARBON	1K 5% 1/6W	R151	1-247-812-00	CARBON	160 5% 1/6W
R074	1-247-831-00	CARBON	1K 5% 1/6W	R152	1-247-829-00	CARBON	820 5% 1/6W
R075	1-247-815-00	CARBON	220 5% 1/6W	R153	1-247-863-00	CARBON	22K 5% 1/6W
R076	1-247-855-00	CARBON	10K 5% 1/6W	R154	1-247-821-00	CARBON	390 5% 1/6W
R081	1-247-843-00	CARBON	3.3K 5% 1/6W	R155	1-247-839-00	CARBON	2.2K 5% 1/6W
R082	1-247-871-00	CARBON	47K 5% 1/6W	R156	1-247-839-00	CARBON	2.2K 5% 1/6W
R094	1-247-869-00	CARBON	39K 5% 1/6W	R157	1-247-837-00	CARBON	1.8K 5% 1/6W
R095	1-247-872-00	CARBON	51K 5% 1/6W	R158	1-247-817-00	CARBON	270 5% 1/6W
R098	1-247-890-00	CARBON	300K 5% 1/6W	R159	1-247-810-00	CARBON	130 5% 1/6W
R103	1-247-831-00	CARBON	1K 5% 1/6W	R160	1-247-832-00	CARBON	1.1K 5% 1/6W
R104	1-247-839-00	CARBON	2.2K 5% 1/6W	R161	1-247-855-00	CARBON	10K 5% 1/6W
R105	1-247-829-00	CARBON	820 5% 1/6W	R162	1-247-835-00	CARBON	1.5K 5% 1/6W
R106	1-247-831-00	CARBON	1K 5% 1/6W	R163	1-247-842-00	CARBON	3K 5% 1/6W
R107	1-247-824-00	CARBON	510 5% 1/6W	R164	1-247-830-00	CARBON	910 5% 1/6W
R108	1-247-839-00	CARBON	2.2K 5% 1/6W	R165	1-247-834-00	CARBON	1.3K 5% 1/6W
R109	1-247-867-00	CARBON	33K 5% 1/6W	R166	1-247-818-00	CARBON	300 5% 1/6W
R111	1-247-846-00	CARBON	4.3K 5% 1/6W	R167	1-247-849-00	CARBON	5.6K 5% 1/6W
R112	1-247-854-00	CARBON	9.1K 5% 1/6W	R168	1-247-836-00	CARBON	1.6K 5% 1/6W
R113	1-247-843-00	CARBON	3.3K 5% 1/6W	R169	1-247-840-00	CARBON	2.4K 5% 1/6W
R114	1-247-828-00	CARBON	750 5% 1/6W	R170	1-247-804-00	CARBON	75 5% 1/6W
R115	1-247-879-00	CARBON	100K 5% 1/6W	R171	1-247-901-00	CARBON	820K 5% 1/6W
R116	1-247-853-00	CARBON	8.2K 5% 1/6W	R172	1-247-857-00	CARBON	12K 5% 1/6W
R117	1-247-846-00	CARBON	4.3K 5% 1/6W	R173	1-247-861-00	CARBON	18K 5% 1/6W
R120	1-247-831-00	CARBON	1K 5% 1/6W	R174	1-247-839-00	CARBON	2.2K 5% 1/6W
R121	1-247-831-00	CARBON	1K 5% 1/6W	R175	1-247-831-00	CARBON	1K 5% 1/6W
R122	1-247-839-00	CARBON	2.2K 5% 1/6W	R176	1-247-839-00	CARBON	2.2K 5% 1/6W
R123	1-247-841-00	CARBON	2.7K 5% 1/6W	R178	1-247-839-00	CARBON	2.2K 5% 1/6W
R124	1-247-819-00	CARBON	330 5% 1/6W	R179	1-247-843-00	CARBON	3.3K 5% 1/6W
R125	1-247-831-00	CARBON	1K 5% 1/6W	R180	1-247-835-00	CARBON	1.5K 5% 1/6W
R126	1-247-831-00	CARBON	1K 5% 1/6W	R181	1-247-835-00	CARBON	1.5K 5% 1/6W
R127	1-247-835-00	CARBON	1.5K 5% 1/6W	R185	1-247-843-00	CARBON	3.3K 5% 1/6W
R128	1-247-831-00	CARBON	1K 5% 1/6W	R186	1-247-830-00	CARBON	910 5% 1/6W
R129	1-247-867-00	CARBON	33K 5% 1/6W	R187	1-247-831-00	CARBON	1K 5% 1/6W
R130	1-247-842-00	CARBON	3K 5% 1/6W	R188	1-247-839-00	CARBON	2.2K 5% 1/6W
R131	1-247-841-00	CARBON	2.7K 5% 1/6W	R189	1-247-834-00	CARBON	1.3K 5% 1/6W
R132	1-247-887-00	CARBON	220K 5% 1/6W	R190	1-247-834-00	CARBON	1.3K 5% 1/6W

When indicating parts by reference number, please include the board name.

Ref.No	Part No.	Description	Remark	Ref.No	Part No.	Description	Remark
R191	1-247-831-00	CARBON	1K 5% 1/6W	R258	1-247-852-00	CARBON	7.5K 5% 1/6W
R192	1-247-831-00	CARBON	1K 5% 1/6W	R259	1-247-831-00	CARBON	1K 5% 1/6W
R193	1-247-855-00	CARBON	10K 5% 1/6W	R260	1-247-841-00	CARBON	2.7K 5% 1/6W
R194	1-247-819-00	CARBON	330 5% 1/6W	R261	1-247-863-00	CARBON	22K 5% 1/6W
R195	1-247-812-00	CARBON	160 5% 1/6W	R262	1-247-849-00	CARBON	5.6K 5% 1/6W
R196	1-247-863-00	CARBON	22K 5% 1/6W	R274	1-247-883-00	CARBON	150K 5% 1/6W
R197	1-247-863-00	CARBON	22K 5% 1/6W	R275	1-247-871-00	CARBON	47K 5% 1/6W
R198	1-247-829-00	CARBON	820 5% 1/6W	R276	1-247-849-00	CARBON	5.6K 5% 1/6W
R199	1-247-821-00	CARBON	390 5% 1/6W	R277	1-247-855-00	CARBON	10K 5% 1/6W
R200	1-247-839-00	CARBON	2.2K 5% 1/6W	R280	1-247-821-00	CARBON	390 5% 1/6W
R201	1-247-837-00	CARBON	1.8K 5% 1/6W	R281	1-247-883-00	CARBON	150K 5% 1/6W
R202	1-247-831-00	CARBON	1K 5% 1/6W	R282	1-247-819-00	CARBON	330 5% 1/6W
R203	1-247-815-00	CARBON	220 5% 1/6W	R283	1-247-831-00	CARBON	1K 5% 1/6W
R204	1-247-811-00	CARBON	150 5% 1/6W	R284	1-247-877-00	CARBON	82K 5% 1/6W
R205	1-247-811-00	CARBON	150 5% 1/6W	R286	1-247-846-00	CARBON	5.1K 5% 1/6W
R206	1-247-834-00	CARBON	1.3K 5% 1/6W	R287	1-247-831-00	CARBON	1K 5% 1/6W
R207	1-247-874-00	CARBON	62K 5% 1/6W	R291	1-247-863-00	CARBON	22K 5% 1/6W
R208	1-247-874-00	CARBON	62K 5% 1/6W	R292	1-247-875-00	CARBON	68K 5% 1/6W
R209	1-247-833-00	CARBON	1.2K 5% 1/6W	R293	1-247-819-00	CARBON	330 5% 1/6W
R210	1-247-824-00	CARBON	510 5% 1/6W	R295	1-247-839-00	CARBON	2.2K 5% 1/6W
R211	1-247-831-00	CARBON	1K 5% 1/6W	R296	1-247-811-00	CARBON	150 5% 1/6W
R212	1-247-824-00	CARBON	510 5% 1/6W	R298	1-247-894-00	CARBON	430K 5% 1/6W
R213	1-247-829-00	CARBON	820 5% 1/6W	R299	1-247-892-00	CARBON	360K 5% 1/6W
R214	1-247-831-00	CARBON	1K 5% 1/6W	R301	1-247-855-00	CARBON	10K 5% 1/6W
R215	1-247-831-00	CARBON	1K 5% 1/6W	R302	1-247-819-00	CARBON	330 5% 1/6W
R216	1-247-832-00	CARBON	1.1K 5% 1/6W	R303	1-247-819-00	CARBON	330 5% 1/6W
R217	1-247-831-00	CARBON	1K 5% 1/6W	R304	1-247-847-00	CARBON	4.7K 5% 1/6W
R218	1-247-831-00	CARBON	1K 5% 1/6W	R305	1-247-835-00	CARBON	1.5K 5% 1/6W
R219	1-247-866-00	CARBON	30K 5% 1/6W	R312	1-247-847-00	CARBON	4.7K 5% 1/6W
R220	1-247-874-00	CARBON	62K 5% 1/6W	R313	1-247-823-00	CARBON	470 5% 1/6W
R221	1-247-849-00	CARBON	5.6K 5% 1/6W	R317	1-247-855-00	CARBON	10K 5% 1/6W
R222	1-247-837-00	CARBON	1.8K 5% 1/6W	R318	1-247-865-00	CARBON	27K 5% 1/6W
R223	1-247-837-00	CARBON	1.8K 5% 1/6W	R320	1-247-878-00	CARBON	91K 5% 1/6W
R231	1-247-867-00	CARBON	33K 5% 1/6W	R321	1-247-887-00	CARBON	220K 5% 1/6W
R235	1-247-831-00	CARBON	1K 5% 1/6W	R325	1-247-807-00	CARBON	100 5% 1/6W
R236	1-247-853-00	CARBON	8.2K 5% 1/6W	R331	1-247-852-00	CARBON	7.5K 5% 1/6W
R239	1-247-855-00	CARBON	10K 5% 1/6W	R340	1-247-887-00	CARBON	220K 5% 1/6W
R241	1-247-804-00	CARBON	75 5% 1/6W	R341	1-247-815-00	CARBON	220 5% 1/6W
R242	1-247-879-00	CARBON	100K 5% 1/6W	R342	1-247-807-00	CARBON	100 5% 1/6W
R243	1-247-855-00	CARBON	10K 5% 1/6W	R346	1-247-847-00	CARBON	4.7K 5% 1/6W
R244	1-247-851-00	CARBON	6.8K 5% 1/6W	R347	1-247-879-00	CARBON	100K 5% 1/6W
R245	1-247-879-00	CARBON	100K 5% 1/6W	R348	1-247-855-00	CARBON	10K 5% 1/6W
R246	1-247-871-00	CARBON	47K 5% 1/6W	R349	1-247-831-00	CARBON	1K 5% 1/6W
R247	1-247-871-00	CARBON	47K 5% 1/6W	R350	1-247-890-00	CARBON	300K 5% 1/6W
R248	1-247-818-00	CARBON	300 5% 1/6W	R351	1-247-815-00	CARBON	220 5% 1/6W
R249	1-247-813-00	CARBON	180 5% 1/6W	R352	1-247-855-00	CARBON	10K 5% 1/6W
R250	1-247-811-00	CARBON	150 5% 1/6W	R353	1-247-831-00	CARBON	1K 5% 1/6W
R251	1-247-838-00	CARBON	2K 5% 1/6W	R357	1-247-829-00	CARBON	820 5% 1/6W
R252	1-247-803-00	CARBON	68 5% 1/6W	R358	1-247-855-00	CARBON	10K 5% 1/6W
R254	1-247-855-00	CARBON	10K 5% 1/6W	R359	1-247-839-00	CARBON	2.2K 5% 1/6W
R255	1-247-858-00	CARBON	13K 5% 1/6W	R370	1-247-790-00	CARBON	20 5% 1/6W
R256	1-247-843-00	CARBON	3.3K 5% 1/6W	R401	1-247-810-00	CARBON	130 5% 1/6W
R257	1-247-835-00	CARBON	1.5K 5% 1/6W	R402	1-247-808-00	CARBON	110 5% 1/6W

When indicating parts by reference number, please include the board name.

YC-31 SS-34

Ref.No	Part No.	Description			
R403	1-247-867-00	CARBON	33K	5%	1/6W
R404	1-247-871-00	CARBON	47K	5%	1/6W
R405	1-247-831-00	CARBON	1K	5%	1/6W
R406	1-247-832-00	CARBON	1.1K	5%	1/6W
R407	1-247-832-00	CARBON	1.1K	5%	1/6W
R408	1-247-849-00	CARBON	5.6K	5%	1/6W
R409	1-247-831-00	CARBON	1K	5%	1/6W
R410	1-247-831-00	CARBON	1K	5%	1/6W
R411	1-247-847-00	CARBON	4.7K	5%	1/6W
R412	1-247-828-00	CARBON	750	5%	1/6W
R413	1-247-812-00	CARBON	160	5%	1/6W
R414	1-247-847-00	CARBON	4.7K	5%	1/6W
R415	1-247-831-00	CARBON	1K	5%	1/6W
R416	1-247-846-00	CARBON	4.3K	5%	1/6W
R510	1-247-824-00	CARBON	510	5%	1/6W
R512	1-247-847-00	CARBON	4.7K	5%	1/6W
R513	1-247-863-00	CARBON	22K	5%	1/6W
R514	1-247-821-00	CARBON	390	5%	1/6W
R515	1-247-839-00	CARBON	2.2K	5%	1/6W
R516	1-247-821-00	CARBON	390	5%	1/6W
R517	1-247-821-00	CARBON	390	5%	1/6W
R518	1-247-821-00	CARBON	390	5%	1/6W
R519	1-247-821-00	CARBON	390	5%	1/6W
R520	1-247-839-00	CARBON	2.2K	5%	1/6W
R521	1-247-821-00	CARBON	390	5%	1/6W
R522	1-247-839-00	CARBON	2.2K	5%	1/6W
R525	1-247-843-00	CARBON	3.3K	5%	1/6W
R601	1-247-847-00	CARBON	4.7K	5%	1/6W
R603	1-247-843-00	CARBON	3.3K	5%	1/6W
R632	1-247-855-00	CARBON	10K	5%	1/6W
R633	1-247-831-00	CARBON	1K	5%	1/6W
R635	1-247-883-00	CARBON	150K	5%	1/6W
R643	1-247-883-00	CARBON	150K	5%	1/6W
R644	1-247-818-00	CARBON	300	5%	1/6W
VARIABLE RESISTOR					
RV002	1-228-748-00	RES, ADJ, CARBON	10K		
RV003	1-228-750-00	RES, ADJ, CARBON	47K		
RV005	1-228-750-00	RES, ADJ, CARBON	47K		
RV006	1-228-749-00	RES, ADJ, CARBON	22K		
RV007	1-228-748-00	RES, ADJ, CARBON	10K		
RV008	1-228-745-00	RES, ADJ, CARBON	1K		
RV009	1-228-996-00	RES, ADJ, METAL GLAZE	47K		
RV010	1-228-749-00	RES, ADJ, CARBON	22K		
RV012	1-228-750-00	RES, ADJ, CARBON	47K		
RV013	1-228-750-00	RES, ADJ, CARBON	47K		
RV014	1-228-748-00	RES, ADJ, CARBON	10K		
RV015	1-228-989-00	RES, ADJ, METAL GLAZE	470		
RV016	1-228-745-00	RES, ADJ, CARBON	1K		
RV019	1-228-993-00	RES, ADJ, METAL GLAZE	4.7K		
RV020	1-228-745-00	RES, ADJ, CARBON	1K		
RV021	1-228-750-00	RES, ADJ, CARBON	47K		
RV401	1-228-994-00	RES, ADJ, METAL GLAZE	10K		

Remark	Ref.No	Part No.	Description	Remark
	RV501	1-228-989-00	RES, ADJ, METAL GLAZE 470	
	RV602	1-228-990-00	RES, ADJ, METAL GLAZE 1K	
		SWITCH		
	S601	1-553-725-21	SWITCH, SLIDE	
		TRANSFORMER		
	T001	1-426-093-00	COIL, REC C BPT	
		CRYSTAL		
	X001	1-527-345-00	CRYSTAL, OSC	

		*A-6715-239-A SS-34 BOARD, COMPLETE		

		*3-681-170-00 HEAT SINK, S		
		*3-846-049-11 PIN, LEAD		
		7-621-770-87 SCREW +B 2.6X5		
		CAPACITOR		
	C304	1-123-332-00	ELECT 47MF 20% 16V	
	C305	1-123-333-00	ELECT 100MF 20% 16V	
	C306	1-123-332-00	ELECT 47MF 20% 16V	
	C307	1-130-479-00	MYLAR 0.0047MF 5% 50V	
	C308	1-123-332-00	ELECT 47MF 20% 16V	
	C309	1-123-381-00	ELECT 2.2MF 20% 50V	
	C310	1-161-013-00	CERAMIC 0.01MF 10% 25V	
	C311	1-127-477-00	ELECT(SOLID) 0.47MF 5% 25V	
	C312	1-123-332-00	ELECT 47MF 20% 16V	
	C313	1-161-059-00	CERAMIC 0.047MF 10% 25V	
	C314	1-131-357-00	TANTALUM 4.7MF 20% 25V	
	C315	1-123-381-00	ELECT 2.2MF 20% 50V	
	C316	1-131-357-00	TANTALUM 4.7MF 20% 25V	
	C317	1-161-059-00	CERAMIC 0.047MF 10% 25V	
	C318	1-123-381-00	ELECT 2.2MF 20% 50V	
	C319	1-161-013-00	CERAMIC 0.01MF 10% 25V	
	C320	1-161-054-00	CERAMIC 0.018MF 10% 25V	
	C321	1-123-356-00	ELECT 10MF 20% 16V	
	C322	1-123-330-00	ELECT 22MF 20% 16V	
	C323	1-124-429-00	ELECT 0.68MF 20% 50V	
	C324	1-161-059-00	CERAMIC 0.047MF 10% 25V	
	C325	1-161-059-00	CERAMIC 0.047MF 10% 25V	
	C326	1-123-330-00	ELECT 22MF 20% 16V	
	C327	1-130-483-00	MYLAR 0.01MF 5% 50V	
	C328	1-130-483-00	MYLAR 0.01MF 5% 50V	
	C329	1-161-059-00	CERAMIC 0.047MF 10% 25V	
	C330	1-123-382-00	ELECT 3.3MF 20% 50V	
	C331	1-161-059-00	CERAMIC 0.047MF 10% 25V	
	C332	1-123-310-00	ELECT 470MF 20% 10V	
	C333	1-123-310-00	ELECT 470MF 20% 10V	
	C334	1-123-382-00	ELECT 3.3MF 20% 50V	

When indicating parts by reference number, please include the board name.

Ref.No	Part No.	Description			Remark
C335	1-123-382-00	ELECT	3.3MF	20%	50V
C336	1-161-059-00	CERAMIC	0.047MF	10%	25V
C337	1-130-482-00	MYLAR	0.0082MF	5%	50V
C338	1-123-382-00	ELECT	3.3MF	20%	50V
C339	1-161-054-00	CERAMIC	0.018MF	10%	25V
C340	1-161-013-00	CERAMIC	0.01MF	10%	25V
C341	1-161-013-00	CERAMIC	0.01MF	10%	25V
C342	1-161-054-00	CERAMIC	0.018MF	10%	25V
C343	1-127-479-51	ELECT(SOLID)	1MF	5%	25V
C344	1-161-055-00	CERAMIC	0.022MF	10%	25V
C345	1-161-104-00	CERAMIC	0.0012MF	10%	25V
C346	1-161-054-00	CERAMIC	0.018MF	10%	25V
C347	1-161-054-00	CERAMIC	0.018MF	10%	25V
C351	1-161-057-00	CERAMIC	0.033MF	10%	25V
C352	1-123-381-00	ELECT	2.2MF	20%	50V
C353	1-161-057-00	CERAMIC	0.033MF	10%	25V
C354	1-123-343-00	ELECT	33MF	20%	25V
C355	1-123-343-00	ELECT	33MF	20%	25V
C356	1-123-308-00	ELECT	220MF	20%	6.3V
C357	1-161-059-00	CERAMIC	0.047MF	10%	25V
C358	1-123-333-00	ELECT	100MF	20%	16V
C359	1-123-617-00	ELECT	10MF	20%	16V
C361	1-123-821-00	ELECT	47MF	20%	16V
C362	1-123-333-00	ELECT	100MF	20%	16V
C364	1-161-059-00	CERAMIC	0.047MF	10%	25V
C365	1-123-380-00	ELECT	1MF	20%	50V
C366	1-161-013-00	CERAMIC	0.01MF	10%	25V
C367	1-161-059-00	CERAMIC	0.047MF	10%	25V
C368	1-161-043-00	CERAMIC	0.0022MF	10%	50V
C370	1-161-063-00	CERAMIC	0.1MF	20%	25V
C601	1-123-318-00	ELECT	33MF	20%	16V
C603	1-123-330-00	ELECT	22MF	20%	16V
C604	1-161-055-00	CERAMIC	0.022MF	10%	25V
C605	1-161-059-00	CERAMIC	0.047MF	10%	25V
C606	1-161-059-00	CERAMIC	0.047MF	10%	25V
C607	1-129-794-00	FILM	0.0033MF	5%	100V
C608	1-129-794-00	FILM	0.0033MF	5%	100V
C611	1-102-518-00	CERAMIC	33PF	5%	50V
C612	1-102-518-00	CERAMIC	33PF	5%	50V
C613	1-123-318-00	ELECT	33MF	20%	10V
C616	1-123-382-00	ELECT	3.3MF	20%	50V
C650	1-161-773-00	CERAMIC	0.1MF	20%	25V
C651	1-161-047-00	CERAMIC	0.0047MF	10%	25V
C652	1-123-381-00	ELECT	2.2MF	20%	50V
C653	1-102-973-00	CERAMIC	100PF	5%	50V
C654	1-102-973-00	CERAMIC	100PF	5%	50V
C655	1-102-973-00	CERAMIC	100PF	5%	50V
C656	1-102-973-00	CERAMIC	100PF	5%	50V
C657	1-102-973-00	CERAMIC	100PF	5%	50V
<u>FILTER</u>					
CF601	1-527-992-11	OSCILLATOR, CERAMIC			

Ref.No	Part No.	Description	Remark
<u>CONNECTOR</u>			
CN301	*1-560-892-00	PIN, CONNECTOR 4P	
CN302	*1-560-466-00	PIN, CONNECTOR 3P	
CN303	*1-560-892-00	PIN, CONNECTOR 4P	
CN304	*1-560-892-00	PIN, CONNECTOR 4P	
CN305	*1-560-890-00	PIN, CONNECTOR 2P	
CN306	*1-560-894-00	PIN, CONNECTOR 6P	
CN307	*1-560-890-00	PIN, CONNECTOR 2P	
CN308	*1-560-892-00	PIN, CONNECTOR 4P	
CN309	*1-560-895-00	PIN, CONNECTOR 7P	
CN310	*1-560-891-00	PIN, CONNECTOR 3P	
CN311	*1-560-891-00	PIN, CONNECTOR 3P	
CN601	*1-560-891-00	PIN, CONNECTOR 3P	
CN602	*1-560-896-00	PIN, CONNECTOR 8P	
CN603	*1-560-890-00	PIN, CONNECTOR 2P	
CN604	*1-560-890-00	PIN, CONNECTOR 2P	
CN605	*1-560-893-00	PIN, CONNECTOR 5P	
CN606	*1-560-890-00	PIN, CONNECTOR 2P	
CN607	*1-560-891-00	PIN, CONNECTOR 3P	
CN608	*1-560-890-00	PIN, CONNECTOR 2P	
CN609	*1-560-894-00	PIN, CONNECTOR 6P	
CN610	*1-560-896-00	PIN, CONNECTOR 8P	
CN611	*1-560-891-00	PIN, CONNECTOR 3P	
CN612	*1-560-891-00	PIN, CONNECTOR 3P	
CN613	*1-560-466-00	PIN, CONNECTOR 3P	
<u>DIODE</u>			
D301	8-719-000-06	DIODE MC921	
D302	8-719-000-04	DIODE MC911	
D303	8-719-911-19	DIODE 1S5119	
D304	8-719-101-50	DIODE RD5.1E-L2	
D305	8-719-911-19	DIODE 1S5119	
D308	8-719-000-12	DIODE MC931	
D316	8-719-911-19	DIODE 1S5119	
D319	8-719-100-29	DIODE RD5.1E-B1	
D321	8-719-911-19	DIODE 1S5119	
D601	8-719-000-06	DIODE MC921	
D602	8-719-000-06	DIODE MC921	
D603	8-719-000-04	DIODE MC911	
D608	8-719-911-19	DIODE 1S5119	
<u>IC</u>			
IC301	8-751-941-05	IC CX194B-5	
IC302	8-759-135-80	IC UPC358C	
IC303	8-759-145-58	IC UPC4558C	
IC304	8-759-132-40	IC UPC324C	
IC305	8-759-240-53	IC TC4053BP	
IC306	8-759-132-40	IC UPC324C	
IC601	8-759-911-08	IC M888551-133M	
IC602	8-759-800-72	IC LA7205	
IC603	8-759-600-24	IC M54543L	

When indicating parts by reference number, please include the board name.

Ref.No	Part No.	Description	Remark	Ref.No	Part No.	Description	Remark
<u>COIL</u>							
L601	1-407-492-00	MICRO INDUCTOR 1MMH		Q615	8-729-900-69	TRANSISTOR DTA144WS	
<u>IC LINK</u>				Q617	8-729-204-83	TRANSISTOR 2SA1048-GR	
PS301A	1-532-637-00	LINK, IC, 1A		Q618	8-729-245-83	TRANSISTOR 2SC2458	
PS302A	1-532-679-00	LINK, IC, 0.6A		Q619	8-729-245-83	TRANSISTOR 2SC2458	
PS303A	1-532-605-00	LINK, IC, 0.4A		Q620	8-729-900-89	TRANSISTOR DTC144ES	
PS304A	1-532-637-00	LINK, IC, 1A		Q621	8-729-245-83	TRANSISTOR 2SC2458	
<u>TRANSISTOR</u>				Q623	8-729-245-83	TRANSISTOR 2SC2458	
Q301	8-729-245-83	TRANSISTOR 2SC2458		Q624	8-729-900-61	TRANSISTOR DTA144ES	
Q302	8-729-900-89	TRANSISTOR DTC144ES		<u>RESISTOR</u>			
Q303	8-729-245-83	TRANSISTOR 2SC2458		R301	1-247-871-00	CARBON	47K 5% 1/6W
Q304	8-729-245-83	TRANSISTOR 2SC2458		R302	1-247-859-00	CARBON	15K 5% 1/6W
Q305	8-729-245-83	TRANSISTOR 2SC2458		R303	1-247-871-00	CARBON	47K 5% 1/6W
Q306	8-729-900-89	TRANSISTOR DTC144ES		R304	1-247-859-00	CARBON	15K 5% 1/6W
Q307	8-729-200-20	TRANSISTOR 2SK107-2		R305	1-247-855-00	CARBON	10K 5% 1/6W
Q308	8-729-245-83	TRANSISTOR 2SC2458		R307	1-247-855-00	CARBON	10K 5% 1/6W
Q312	8-729-245-83	TRANSISTOR 2SC2458		R308	1-247-829-00	CARBON	820 5% 1/6W
Q313	8-729-245-83	TRANSISTOR 2SC2458		R309	1-247-881-00	CARBON	120K 5% 1/6W
Q314	8-729-204-83	TRANSISTOR 2SA1048-GR		R310	1-247-835-00	CARBON	1.5K 5% 1/6W
Q315	8-729-316-16	TRANSISTOR 2SC1061		R311	1-247-863-00	CARBON	22K 5% 1/6W
Q316	8-729-245-83	TRANSISTOR 2SC2458		R312	1-247-864-00	CARBON	24K 5% 1/6W
Q317	8-729-245-83	TRANSISTOR 2SC2458		R313	1-247-831-00	CARBON	1K 5% 1/6W
Q318	8-729-245-83	TRANSISTOR 2SC2458		R314	1-247-835-00	CARBON	1.5K 5% 1/6W
Q321	8-729-177-43	TRANSISTOR 2SD774		R315	1-247-829-00	CARBON	820 5% 1/6W
Q322	8-729-204-83	TRANSISTOR 2SA1048-GR		R316	1-247-879-00	CARBON	100K 5% 1/6W
Q323	8-729-805-13	TRANSISTOR 2SC1475-13		R317	1-247-903-00	CARBON	1M 5% 1/6W
Q324	8-729-117-54	TRANSISTOR 2SA1175		R318	1-247-885-00	CARBON	180K 5% 1/6W
Q325	8-729-245-83	TRANSISTOR 2SC2458		R319	1-247-844-00	CARBON	3.6K 5% 1/6W
Q326	8-729-245-83	TRANSISTOR 2SC2458		R320	1-247-859-00	CARBON	15K 5% 1/6W
Q330	8-729-316-16	TRANSISTOR 2SC1061		R321	1-247-845-00	CARBON	3.9K 5% 1/6W
Q331	8-729-245-83	TRANSISTOR 2SC2458		R322	1-247-903-00	CARBON	1M 5% 1/6W
Q332	8-729-204-83	TRANSISTOR 2SA1048-GR		R323	1-247-855-00	CARBON	10K 5% 1/6W
Q333	8-729-900-89	TRANSISTOR DTC144ES		R324	1-247-831-00	CARBON	1K 5% 1/6W
Q335	8-729-245-83	TRANSISTOR 2SC2458		R325	1-247-903-00	CARBON	1M 5% 1/6W
Q336	8-729-245-83	TRANSISTOR 2SC2458		R326	1-247-831-00	CARBON	1K 5% 1/6W
Q337	8-729-245-83	TRANSISTOR 2SC2458		R327	1-247-855-00	CARBON	10K 5% 1/6W
Q338	8-729-245-83	TRANSISTOR 2SC2458		R328	1-212-850-00	FUSIBLE	5A 250V
Q340	8-729-177-43	TRANSISTOR 2SD774		R329	1-247-857-00	CARBON	12K 5% 1/6W
Q341	8-729-900-89	TRANSISTOR DTC144ES		R330	1-247-859-00	CARBON	15K 5% 1/6W
Q342	8-729-900-89	TRANSISTOR DTC144ES		R331	1-247-847-00	CARBON	4.7K 5% 1/6W
Q343	8-729-245-83	TRANSISTOR 2SC2458		R332	1-247-873-00	CARBON	56K 5% 1/6W
Q344	8-729-204-83	TRANSISTOR 2SA1048-GR		R333	1-247-900-00	CARBON	750K 5% 1/6W
Q345	8-729-900-65	TRANSISTOR DTA144ES		R334	1-247-867-00	CARBON	33K 5% 1/6W
Q346	8-729-204-83	TRANSISTOR 2SA1048-GR		R335	1-247-867-00	CARBON	33K 5% 1/6W
Q347	8-729-900-89	TRANSISTOR DTC144ES		R336	1-247-856-00	CARBON	11K 5% 1/6W
Q349	8-729-900-89	TRANSISTOR DTC144ES		R337	1-247-855-00	CARBON	10K 5% 1/6W
Q601	8-729-116-42	TRANSISTOR 2SD1164		R338	1-247-842-00	CARBON	3K 5% 1/6W
Q602	8-729-116-42	TRANSISTOR 2SD1164		R339	1-247-843-00	CARBON	3.3K 5% 1/6W
Q603	8-729-177-43	TRANSISTOR 2SD774		R340	1-247-825-00	CARBON	560 5% 1/6W
Q604	8-729-177-43	TRANSISTOR 2SD774		R341	1-247-871-00	CARBON	47K 5% 1/6W
				R342	1-247-855-00	CARBON	10K 5% 1/6W
				R343	1-247-865-00	CARBON	27K 5% 1/6W
				R344	1-247-872-00	CARBON	51K 5% 1/6W

The components identified by shading and mark **A** are critical for safety. Replace only with part number specified.

When indicating parts by reference number, please include the board name.

Ref.No	Part No.	Description	Remark	Ref.No	Part No.	Description	Remark
R345	1-247-865-00	CARBON	27K 5% 1/6W	R413	1-247-847-00	CARBON	4.7K 5% 1/6W
R346	1-247-848-00	CARBON	5.1K 5% 1/6W	R417	1-247-837-00	CARBON	1.8K 5% 1/6W
R347	1-247-887-00	CARBON	220K 5% 1/6W	R419	1-247-855-00	CARBON	10K 5% 1/6W
R348	1-247-887-00	CARBON	220K 5% 1/6W	R426	1-247-831-00	CARBON	1K 5% 1/6W
R349	1-247-845-00	CARBON	3.9K 5% 1/6W	R427	1-247-863-00	CARBON	22K 5% 1/6W
R352	1-247-871-00	CARBON	47K 5% 1/6W	R428	1-247-863-00	CARBON	22K 5% 1/6W
R353	1-247-867-00	CARBON	33K 5% 1/6W	R429	1-247-848-00	CARBON	5.1K 5% 1/6W
R354	1-247-855-00	CARBON	10K 5% 1/6W	R430	1-247-859-00	CARBON	15K 5% 1/6W
R355	1-247-887-00	CARBON	220K 5% 1/6W	R431	1-247-867-00	CARBON	33K 5% 1/6W
R356	1-247-871-00	CARBON	47K 5% 1/6W	R432	1-247-871-00	CARBON	47K 5% 1/6W
R357	1-247-871-00	CARBON	47K 5% 1/6W	R433	1-247-831-00	CARBON	1K 5% 1/6W
R358	1-247-863-00	CARBON	22K 5% 1/6W	R436	1-247-855-00	CARBON	10K 5% 1/6W
R359	1-247-863-00	CARBON	22K 5% 1/6W	R437	1-247-855-00	CARBON	10K 5% 1/6W
R361	1-247-871-00	CARBON	47K 5% 1/6W	R438	1-247-851-00	CARBON	6.8K 5% 1/6W
R362	1-247-861-00	CARBON	18K 5% 1/6W	R439	1-247-839-00	CARBON	2.2K 5% 1/6W
R363	1-247-879-00	CARBON	100K 5% 1/6W	R440	1-247-855-00	CARBON	10K 5% 1/6W
R364	1-247-867-00	CARBON	33K 5% 1/6W	R441	1-247-867-00	CARBON	33K 5% 1/6W
R365	1-247-867-00	CARBON	33K 5% 1/6W	R442	1-247-847-00	CARBON	4.7K 5% 1/6W
R366	1-247-867-00	CARBON	33K 5% 1/6W	R443	1-247-831-00	CARBON	1K 5% 1/6W
R367	1-247-859-00	CARBON	15K 5% 1/6W	R444	1-247-855-00	CARBON	10K 5% 1/6W
R368	1-206-482-00	METAL OXIDE	62 5% 2W F	R445	1-247-839-00	CARBON	2.2K 5% 1/6W
R370	1-247-871-00	CARBON	47K 5% 1/6W	R446	1-247-851-00	CARBON	6.8K 5% 1/6W
R371	1-247-867-00	CARBON	33K 5% 1/6W	R447	1-247-855-00	CARBON	10K 5% 1/6W
R372	1-247-855-00	CARBON	10K 5% 1/6W	R448	1-247-863-00	CARBON	22K 5% 1/6W
R373	1-247-883-00	CARBON	150K 5% 1/6W	R449	1-247-871-00	CARBON	47K 5% 1/6W
R374	1-247-883-00	CARBON	150K 5% 1/6W	R451	1-247-815-00	CARBON	220 5% 1/6W
R375	1-247-883-00	CARBON	150K 5% 1/6W	R452	1-247-847-00	CARBON	4.7K 5% 1/6W
R376	1-247-883-00	CARBON	150K 5% 1/6W	R453	1-247-843-00	CARBON	3.3K 5% 1/6W
R377	1-247-879-00	CARBON	100K 5% 1/6W	R454	1-247-843-00	CARBON	3.3K 5% 1/6W
R378	1-247-879-00	CARBON	100K 5% 1/6W	R455	1-247-843-00	CARBON	3.3K 5% 1/6W
R379	1-247-879-00	CARBON	100K 5% 1/6W	R461	1-247-843-00	CARBON	3.3K 5% 1/6W
R380	1-247-879-00	CARBON	100K 5% 1/6W	R462	1-247-903-00	CARBON	1M 5% 1/6W
R381	1-247-867-00	CARBON	33K 5% 1/6W	R463	1-247-871-00	CARBON	47K 5% 1/6W
R382	1-247-867-00	CARBON	33K 5% 1/6W	R464	1-247-871-00	CARBON	47K 5% 1/6W
R383	1-247-897-00	CARBON	560K 5% 1/6W	R465	1-247-863-00	CARBON	22K 5% 1/6W
R384	1-247-897-00	CARBON	560K 5% 1/6W	R467	1-247-847-00	CARBON	4.7K 5% 1/6W
R386	1-247-857-00	CARBON	12K 5% 1/6W	R469	1-247-863-00	CARBON	22K 5% 1/6W
R387	1-246-981-00	CARBON	4.7 5% 1/8W F	R471	1-247-825-00	CARBON	560 5% 1/6W
R389	1-212-366-00	METAL OXIDE	75 5% 1/4W F	R473	1-247-843-00	CARBON	3.3K 5% 1/6W
R390	1-247-855-00	CARBON	10K 5% 1/6W	R601	1-247-835-00	CARBON	1.5K 5% 1/6W
R391	1-247-845-00	CARBON	3.9K 5% 1/6W	R602	1-247-864-00	CARBON	24K 5% 1/6W
R392	1-247-819-00	CARBON	330 5% 1/6W	R603	1-247-864-00	CARBON	24K 5% 1/6W
R394	1-247-832-00	CARBON	1.1K 5% 1/6W	R604	1-247-864-00	CARBON	24K 5% 1/6W
R397	1-247-831-00	CARBON	1K 5% 1/6W	R612	1-247-827-00	CARBON	680 5% 1/6W
R398	1-212-849-00	REFUSIBLE	0.004 5% 1/4W F	R614	1-247-845-00	CARBON	3.9K 5% 1/6W
R399	1-212-360-00	METAL OXIDE	75 5% 1/4W F	R615	1-247-855-00	CARBON	10K 5% 1/6W
R400	1-247-828-00	CARBON	750 5% 1/6W	R616	1-247-845-00	CARBON	3.9K 5% 1/6W
R406	1-212-360-00	METAL OXIDE	75 5% 1/4W F	R617	1-247-855-00	CARBON	10K 5% 1/6W
R407	1-247-847-00	CARBON	4.7K 5% 1/6W	R618	1-215-454-00	METAL	24K 1% 1/6W
R408	1-247-843-00	CARBON	3.3K 5% 1/6W	R619	1-247-863-00	CARBON	22K 5% 1/6W
R409	1-247-838-00	CARBON	2K 5% 1/6W	R620	1-247-873-00	CARBON	56K 5% 1/6W
R410	1-247-847-00	CARBON	4.7K 5% 1/6W	R621	1-247-851-00	CARBON	6.8K 5% 1/6W
R411	1-247-855-00	CARBON	10K 5% 1/6W	R622	1-247-855-00	CARBON	10K 5% 1/6W

The components identified by shading and mark **Δ** are critical for safety. Replace only with part number specified.

When indicating parts by reference number, please include the board name.

Ref.No	Part No.	Description	Remark
R623	1-247-861-00	CARBON 18K 5% 1/6W	
R636	1-247-835-00	CARBON 1.5K 5% 1/6W	
R637	1-247-104-00	CARBON 75 5% 1/4W	
R639	1-247-855-00	CARBON 10K 5% 1/6W	
R640	1-247-875-00	CARBON 68K 5% 1/6W	
R643	1-247-839-00	CARBON 2.2K 5% 1/6W	
R644	1-247-864-00	CARBON 24K 5% 1/6W	
R645	1-247-871-00	CARBON 47K 5% 1/6W	
R646	1-247-851-00	CARBON 6.8K 5% 1/6W	
R648	1-247-107-00	CARBON 100 5% 1/4W	

VARIABLE RESISTOR

RV301	1-228-994-00	RES, ADJ, METAL GLAZE 10K
RV302	1-228-994-00	RES, ADJ, METAL GLAZE 10K
RV303	1-228-996-00	RES, ADJ, METAL GLAZE 47K
RV304	1-228-750-00	RES, ADJ, CARBON 47K
RV305	1-228-750-00	RES, ADJ, CARBON 47K
RV306	1-228-750-00	RES, ADJ, CARBON 47K
RV307	1-228-991-00	RES, ADJ, METAL GLAZE 2.2K
RV308	1-228-991-00	RES, ADJ, METAL GLAZE 2.2K

THERMISTOR

TH301	1-800-200-00	THERMISTOR S-3K
TH302	1-800-198-XX	THERMISTOR S-1K

*1-613-231-12 FU-25 BOARD

DIODE

D001	8-719-812-33	DIODE TLG123A
------	--------------	---------------

RESISTOR

R001	1-247-123-00	CARBON 470 5% 1/4W
R002	1-247-851-00	CARBON 6.8K 5% 1/6W
R003	1-247-851-00	CARBON 6.8K 5% 1/6W
R004	1-247-855-00	CARBON 10K 5% 1/6W
R005	1-247-855-00	CARBON 10K 5% 1/6W
R006	1-247-861-00	CARBON 18K 5% 1/6W

VARIABLE RESISTOR

RV001	1-230-421-11	RES, VAR, CARBON 100K
-------	--------------	-----------------------

SWITCH

S001	1-554-174-00	SWITCH, KEY BOARD
S002	1-554-174-00	SWITCH, KEY BOARD
S003	1-554-174-00	SWITCH, KEY BOARD
S004	1-554-174-00	SWITCH, KEY BOARD
S005	1-554-174-00	SWITCH, KEY BOARD
S006	1-554-174-00	SWITCH, KEY BOARD
S007	1-554-174-00	SWITCH, KEY BOARD
S008	1-554-174-00	SWITCH, KEY BOARD

Ref.No	Part No.	Description	Remark
*A-6721-219-A		TA-22 BOARD, COMPLETE (EC MODEL) *****	
*A-6721-220-A		TA-22 BOARD, COMPLETE (UK MODEL) *****	
*A-6721-222-A		TA-22 BOARD, COMPLETE (AEP, E MODEL) *****	
*1-556-934-00		CABLE, PIN (EC MODEL)	
*3-662-227-00		HOLDER (R-3), LED (AEP, E, EC MODEL)	
*3-662-383-00		BAND, RETAINER, TUNER	
*3-674-390-00		HOLDER (B), LED	
*3-687-523-01		LID, UPPER, SHIELD CASE, TU	
*3-687-524-01		LID, BOTTOM, SHIELD CASE, TU	
*3-687-525-01		CASE (MAIN), SHIELD, TU	
*3-687-550-01		CASE (UPPER LID), SHIELD, AU	
*3-687-558-01		CASE (MAIN), SHIELD, AU	
*3-687-559-01		CASE (BOTTOM LID), SHIELD, AU	
*4-336-029-00		PLATE, SHIELD	

CAPACITOR

C001	1-102-530-00	CERAMIC 120PF 5% 50V
C002	1-102-529-00	CERAMIC 100PF 5% 50V
C003	1-102-508-00	CERAMIC 10PF 0.5PF 50V
C004	1-102-523-00	CERAMIC 56PF 5% 50V
C006	1-102-125-00	CERAMIC 0.0047MF 10% 50V
C007	1-102-125-00	CERAMIC 0.0047MF 10% 50V
C008	1-102-125-00	CERAMIC 0.0047MF 10% 50V
C009	1-102-125-00	CERAMIC 0.0047MF 10% 50V
C010	1-102-125-00	CERAMIC 0.0047MF 10% 50V
C011	1-102-125-00	CERAMIC 0.0047MF 10% 50V
C012	1-102-125-00	CERAMIC 0.0047MF 10% 50V
C013	1-102-125-00	CERAMIC 0.0047MF 10% 50V
C014	1-102-125-00	CERAMIC 0.0047MF 10% 50V
C015	1-102-125-00	CERAMIC 0.0047MF 10% 50V
C016	1-123-369-00	ELECT 4.7MF 20% 25V
C017	1-161-013-00	CERAMIC 0.01MF 20% 25V (EC MODEL)
C018	1-123-356-00	ELECT 10MF 20% 16V (AEP, E, EC MODEL)
C019	1-161-013-00	CERAMIC 0.01MF 20% 25V (AEP, E, EC MODEL)
C020	1-123-356-00	ELECT 10MF 20% 16V (AEP, E, EC MODEL)
C021	1-102-129-00	CERAMIC 0.01MF 10% 50V
C022	1-102-529-00	CERAMIC 100PF 5% 50V
C023	1-102-518-00	CERAMIC 33PF 5% 50V
C024	1-102-504-00	CERAMIC 4PF 0.25PF 50V
C025	1-102-504-00	CERAMIC 4PF 0.25PF 50V
C026	1-102-518-00	CERAMIC 33PF 5% 50V
C027	1-102-529-00	CERAMIC 100PF 5% 50V
C028	1-102-125-00	CERAMIC 0.0047MF 10% 50V
C029	1-123-356-00	ELECT 10MF 20% 16V

When indicating parts by reference number, please include the board name.

Ref.No	Part No.	Description	Remark	Ref.No	Part No.	Description	Remark
C030	1-102-125-00	CERAMIC	0.0047MF 10% 50V	C314	1-123-318-00	ELECT 33MF 20% 16V	
C031	1-123-379-00	ELECT	0.47MF 20% 50V	C315	1-123-380-00	ELECT 1MF 20% 50V	
C032	1-101-004-00	CERAMIC	0.01MF 50V	C316	1-130-471-00	MYLAR 0.001MF 5% 50V	
C033	1-101-004-00	CERAMIC	0.01MF 50V	C317	1-123-380-00	ELECT 1MF 20% 50V	
C034	1-123-318-00	ELECT	33MF 20% 16V	C318	1-102-111-00	CERAMIC 270PF 10% 50V	
C035	1-102-978-00	CERAMIC	220PF 5% 50V	C319	1-130-485-51	MYLAR 0.015MF 5% 50V	
C036	1-102-959-00	CERAMIC	22PF 5% 50V	C320	1-123-380-00	ELECT 1MF 20% 50V	
C037	1-102-959-00	CERAMIC	22PF 5% 50V	C321	1-123-369-00	ELECT 4.7MF 20% 25V	
C038	1-101-004-00	CERAMIC	0.01MF 50V	C323	1-123-607-00	ELECT 0.1MF 20% 50V	
C039	1-101-004-00	CERAMIC	0.01MF 50V	C331	1-123-332-00	ELECT 47MF 20% 16V	
C040	1-161-030-00	CERAMIC	0.0047MF 20% 25V	C332	1-161-013-00	CERAMIC 0.01MF 10% 25V	
C041	1-161-013-00	CERAMIC	0.01MF 20% 25V	C333	1-161-055-00	CERAMIC 0.022MF 10% 25V	
C042	1-102-959-00	CERAMIC	22PF 5% 50V	C334	1-107-166-00	MICA 62PF 5% 500V	
C043	1-101-004-00	CERAMIC	0.01MF 50V	C335	1-129-712-00	FILM 0.0068MF 10% 630V	
C044	1-123-318-00	ELECT	33MF 20% 16V	<u>CERAMIC DISCRIMINATOR</u>			
C045	1-123-318-00	ELECT	33MF 20% 16V (UK, EC MODEL)	CDD01	1-404-380-00	DISCRIMINATOR, CERAMIC 5.5MHZ (AEP, E, EC MODEL)	
C045	1-124-118-00	ELECT	220MF 20% 16V (AEP, E MODEL)	CDD01	1-404-407-00	DISCRIMINATOR, CERAMIC 6MHZ (UK MODEL)	
C050	1-123-356-00	ELECT	10MF 20% 50V	<u>FILTER</u>			
C051	1-123-356-00	ELECT	10MF 20% 50V (AEP, E, EC MODEL)	CF001	1-527-263-00	CERAMIC FILTER (5.5MHZ) (AEP, E, EC MODEL)	
C052	1-123-356-00	ELECT	10MF 20% 16V	CF001	1-527-262-00	CERAMIC FILTER (6MHZ) (UK MODEL)	
C053	1-123-356-00	ELECT	10MF 20% 50V	<u>CONNECTOR</u>			
C054	1-102-973-00	CERAMIC	100PF 5% 50V	CN001	*1-560-893-00	PIN, CONNECTOR 5P	
C055	1-130-495-51	MYLAR	0.1MF 5% 50V	CN002	*1-560-893-00	PIN, CONNECTOR 5P	
C056	1-130-493-00	MYLAR	0.068MF 5% 50V	CN003	*1-560-900-00	PIN, CONNECTOR 12P	
C057	1-130-493-00	MYLAR	0.068MF 5% 50V	CN301	*1-508-797-00	PIN, CONNECTOR 4P	
C058	1-102-963-00	CERAMIC	33PF 5% 50V	CN302	*1-560-893-00	PIN, CONNECTOR 5P	
C059	1-123-380-00	ELECT	1MF 20% 50V	CN303	*1-508-743-00	PIN, CONNECTOR 5P	
C060	1-123-381-00	ELECT	2.2MF 20% 50V	<u>TRIMMER</u>			
C061	1-102-518-00	CERAMIC	33PF 5% 50V	CT001	1-404-134-00	TRAP, CERAMIC (5.5MHZ) (AEP, E, EC MODEL)	
C062	1-102-518-00	CERAMIC	33PF 5% 50V	CT001	1-409-333-00	TRAP, CERAMIC (6MHZ) (UK MODEL)	
C063	1-101-004-00	CERAMIC	0.01MF 50V	<u>CERAMIC</u>			
C064	1-101-004-00	CERAMIC	0.01MF 50V	CX001	1-527-822-00	OSCILLATOR, CERAMIC	
C065	1-102-125-00	CERAMIC	0.0047MF 10% 50V	<u>DIODE</u>			
C066	1-101-004-00	CERAMIC	0.01MF 50V (AEP, E, EC MODEL)	D001	8-719-812-31	DIODE TLR123	
C067	1-101-006-00	CERAMIC	0.047MF 50V	D002	8-719-812-32	DIODE TLY123	
C068	1-101-006-00	CERAMIC	0.047MF 50V	D003	8-719-812-33	DIODE TLG123A	
C301	1-123-356-00	ELECT	10MF 20% 16V	D004	8-719-911-19	DIODE 1SS119	
C302	1-123-321-00	ELECT	220MF 20% 16V	D008	8-719-911-19	DIODE 1SS119 (UK MODEL)	
C303	1-123-321-00	ELECT	220MF 20% 16V	D009	8-719-911-19	DIODE 1SS119 (EC MODEL)	
C304	1-123-356-00	ELECT	10MF 20% 16V	D010	8-719-812-31	DIODE TLR123	
C305	1-123-356-00	ELECT	10MF 20% 16V	D011	8-719-812-31	DIODE TLR123	
C306	1-130-487-00	MYLAR	0.022MF 5% 50V	D013	8-719-911-19	DIODE 1SS119	
C307	1-123-380-00	ELECT	1MF 20% 50V	D301	8-719-911-19	DIODE 1SS119	
C308	1-123-380-00	ELECT	1MF 20% 50V				
C309	1-123-318-00	ELECT	33MF 20% 16V				
C310	1-123-306-00	ELECT	47MF 20% 6.3V				
C311	1-130-491-51	MYLAR	0.047MF 5% 50V				
C312	1-130-483-00	MYLAR	0.01MF 5% 50V				
C313	1-123-318-00	ELECT	33MF 20% 16V				

When indicating parts by reference number, please include the board name.

Ref.No	Part No.	Description	Remark	Ref.No	Part No.	Description	Remark
D302	8-719-911-19	DIODE 1SS119		R009	1-247-877-00	CARBON 82K 5% 1/6W	
D303	8-719-000-12	DIODE MC931		R010	1-247-867-00	CARBON 33K 5% 1/6W	
D304	8-719-911-19	DIODE 1SS119		R011	1-247-879-00	CARBON 100K 5% 1/6W	
<u>IC</u>				R012	1-247-879-00	CARBON 100K 5% 1/6W	
IC001	8-759-276-07	IC TA7607AP		R013	1-247-901-00	CARBON 820K 5% 1/6W	
IC002	8-759-193-91	IC UPC1391H		R014	1-247-863-00	CARBON 22K 5% 1/6W	
IC003	8-759-800-12	IC LA7920 (AEP, E, EC MODEL)		R015	1-247-855-00	CARBON 10K 5% 1/6W	
IC004	8-759-157-40	IC UPC574J		R016	1-247-829-00	CARBON 820 5% 1/6W	
IC005	8-759-602-05	IC M50160-019SP		R018	1-247-831-00	CARBON 1K 5% 1/6W	
IC006	8-759-600-66	IC M58653P		R019	1-247-813-00	CARBON 180 5% 1/6W	
IC301	8-752-006-10	IC CX20061		R020	1-247-807-00	CARBON 100 5% 1/6W	
IC302	8-759-101-73	IC UPC1513HA		R021	1-247-831-00	CARBON 1K 5% 1/6W	
IC303	8-759-911-23	IC BA5115		R022	1-247-829-00	CARBON 820 5% 1/6W	
<u>COIL</u>				R024	1-247-831-00	CARBON 1K 5% 1/6W	
L001	1-408-591-00	MICRO INDUCTOR 1UH		R025	1-247-831-00	CARBON 1K 5% 1/6W	
L002	1-408-600-00	MICRO INDUCTOR 5.6UH		R026	1-247-817-00	CARBON 270 5% 1/6W	
L003	1-408-600-00	MICRO INDUCTOR 5.6UH		R027	1-247-847-00	CARBON 4.7K 5% 1/6W	
L004	1-408-615-00	MICRO INDUCTOR 100UH		R028	1-247-821-00	CARBON 390 5% 1/6W	
L005	1-408-603-00	MICRO INDUCTOR 10UH		R029	1-212-849-00	FUSIBLE 4.7 5% 1/4W F	
L006	1-408-599-00	MICRO INDUCTOR 4.7UH		R032	1-213-146-00	METAL OXIDE 1.8K 5% 1W F	
L007	1-408-606-00	MICRO INDUCTOR 18UH		R033	1-247-851-00	CARBON 6.8K 5% 1/6W	
L008	1-408-607-00	MICRO INDUCTOR 22UH		R034	1-247-865-00	CARBON 27K 5% 1/6W	
L009	1-407-177-XX	MICRO INDUCTOR 470UH (EC MODEL)		R035	1-247-855-00	CARBON 10K 5% (AEP, E, EC MODEL)	
L301	1-407-963-00	MICRO INDUCTOR 15MMH				(AEP, E, EC MODEL)	
L302	1-408-221-00	MICRO INDUCTOR 22MMH		R036	1-247-879-00	CARBON 100K 5% 1/6W	
L331	1-407-710-00	MICRO INDUCTOR 270UH				(AEP, E, EC MODEL)	
<u>TRANSISTOR</u>				R037	1-247-879-00	CARBON 100K 5% 1/6W	
Q001	8-729-203-28	TRANSISTOR 2SC2216				(EC MODEL)	
Q002	8-729-245-83	TRANSISTOR 2SC2458		R038	1-247-839-00	CARBON 2.2K 5% 1/6W	
Q003	8-729-245-83	TRANSISTOR 2SC2458				(AEP, E, EC MODEL)	
Q004	8-729-113-32	TRANSISTOR 2SB733		R039	1-247-835-00	CARBON 1.5K 5% 1/6W	
Q005	8-729-603-50	TRANSISTOR 2SC403SP				(AEP, E, EC MODEL)	
Q006	8-729-245-83	TRANSISTOR 2SC2458		R040	1-247-833-00	CARBON 1.2K 5% 1/6W	
Q007	8-729-245-83	TRANSISTOR 2SC2458				(AEP, E, EC MODEL)	
Q008	8-729-204-83	TRANSISTOR 2SA1048-GR		R042	1-213-146-00	METAL OXIDE 1.8K 5% 1W F	
Q301	8-729-178-54	TRANSISTOR 2SC2785		R043	1-247-863-00	CARBON 22K 5% 1/6W	
Q302	8-729-245-83	TRANSISTOR 2SC2458		R044	1-247-863-00	CARBON 22K 5% 1/6W	
Q303	8-729-245-83	TRANSISTOR 2SC2458		R045	1-247-863-00	CARBON 22K 5% 1/6W	
Q331	8-729-173-37	TRANSISTOR 2SA733-P		R046	1-247-863-00	CARBON 22K 5% 1/6W	
Q332	8-729-967-32	TRANSISTOR 2SC2673		R047	1-247-863-00	CARBON 22K 5% 1/6W	
<u>RESISTOR</u>				R048	1-247-891-00	CARBON 330K 5% 1/6W	
R001	1-247-847-00	CARBON 4.7K 5% 1/6W		R049	1-247-839-00	CARBON 2.2K 5% 1/6W	
R002	1-247-839-00	CARBON 2.2K 5% 1/6W		R050	1-247-851-00	CARBON 6.8K 5% 1/6W	
R003	1-247-815-00	CARBON 220 5% 1/6W		R051	1-247-843-00	CARBON 3.3K 5% 1/6W	
R004	1-247-813-00	CARBON 180 5% 1/6W		R052	1-247-815-00	CARBON 220 5% 1/6W	
R005	1-247-819-00	CARBON 330 5% 1/6W		R055	1-247-863-00	CARBON 22K 5% 1/6W	
R006	1-247-837-00	CARBON 1.8K 5% 1/6W		R059	1-247-863-00	CARBON 22K 5% 1/6W	
R007	1-247-835-00	CARBON 1.5K 5% 1/6W		R060	1-247-863-00	CARBON 22K 5% 1/6W	
R008	1-247-839-00	CARBON 2.2K 5% 1/6W		R061	1-247-863-00	CARBON 22K 5% 1/6W	
				R062	1-247-863-00	CARBON 22K 5% 1/6W	
				R063	1-247-831-00	CARBON 1K 5% 1/6W	
				R064	1-247-831-00	CARBON 1K 5% 1/6W	

The components identified by shading and mark Δ are critical for safety. Replace only with part number specified.

When indicating parts by reference number, please include the board name.

Ref.No	Part No.	Description	Remark
R068	1-247-847-00	CARBON	4.7K 5% 1/6W
R069	1-247-863-00	CARBON	22K 5% 1/6W
R070	1-247-855-00	CARBON	10K 5% 1/6W
R071	1-247-855-00	CARBON	10K 5% 1/6W
R073	1-247-853-00	CARBON	8.2K 5% 1/6W (UK, EC MODEL)
R074	1-247-847-00	CARBON	4.7K 5% 1/6W
R075	1-247-847-00	CARBON	4.7K 5% 1/6W
R302	1-247-879-00	CARBON	100K 5% 1/6W
R303	1-247-833-00	CARBON	1.2K 5% 1/6W
R304	1-247-839-00	CARBON	2.2K 5% 1/6W
R305	1-247-875-00	CARBON	68K 5% 1/6W
R306	1-247-837-00	CARBON	1.8K 5% 1/6W
R308	1-247-871-00	CARBON	47K 5% 1/6W
R310	1-247-843-00	CARBON	3.3K 5% 1/6W
R311	1-247-855-00	CARBON	10K 5% 1/6W
R312	1-247-871-00	CARBON	47K 5% 1/6W
R313	1-247-855-00	CARBON	10K 5% 1/6W
R314	1-247-875-00	CARBON	68K 5% 1/6W
R315	1-210-825-00	SOLID	3.3M 5% 1/4W
R316	1-247-883-00	CARBON	150K 5% 1/6W
R317	1-247-863-00	CARBON	22K 5% 1/6W
R318	1-247-875-00	CARBON	68K 5% 1/6W
R319	1-247-859-00	CARBON	15K 5% 1/6W
R320	1-247-891-00	CARBON	330K 5% 1/6W
R321	1-247-827-00	CARBON	680 5% 1/6W
R322	1-247-887-00	CARBON	220K 5% 1/6W
R323	1-247-863-00	CARBON	22K 5% 1/6W
R324	1-247-841-00	CARBON	2.7K 5% 1/6W
R325	1-247-859-00	CARBON	15K 5% 1/6W
R326	1-247-819-00	CARBON	330 5% 1/6W
R327	1-247-871-00	CARBON	47K 5% 1/6W
R328	1-247-783-00	CARBON	10 5% 1/6W
R329	1-247-875-00	CARBON	68K 5% 1/6W
R330	1-246-873-11	CARBON	22 5% 1/4W
R331	1-247-867-00	CARBON	33K 5% 1/6W
R332	1-247-847-00	CARBON	4.7K 5% 1/6W
R333	1-247-859-00	CARBON	15K 5% 1/6W
R334	1-246-980-00	CARBON	3.3 5% 1/4W
R335	1-247-855-00	CARBON	10K 5% 1/6W
R336	1-247-901-00	CARBON	820K 5% 1/6W

VARIABLE RESISTOR

RV001	1-228-746-00	RES, ADJ, CARBON 2.2K
RV301	1-228-749-00	RES, ADJ, CARBON 22K
RV331	1-228-998-00	RES, ADJ, METAL GLAZE 220K

SWITCH

S001	1-553-997-00	SWITCH, KEY BOARD
S002	1-553-997-00	SWITCH, KEY BOARD
S003	1-553-997-00	SWITCH, KEY BOARD
S004	1-553-997-00	SWITCH, KEY BOARD
S005	1-553-997-00	SWITCH, KEY BOARD

Ref.No	Part No.	Description	Remark
S006	1-553-997-00	SWITCH, KEY BOARD	
S007	1-553-997-00	SWITCH, KEY BOARD	
<u>FILTER</u>			
SF001	1-404-345-00	SAWF (UK MODEL)	
SF001	1-404-433-00	SAWF (AEP, E, EC MODEL)	
<u>TRANSFORMER</u>			
T001	1-404-476-00	COIL, IF	
T002	1-404-476-00	COIL, IF	
T003	1-404-428-00	VIFT	
T004	1-404-427-00	VIFT	
T005	1-404-427-00	VIFT	
T331	1-433-275-00	TRANSFORMER, BIAS OSCILLATOR	

*1-613-234-11 MT-10 BOARD			

<u>TUNER</u>			
TU001A	1-463-350-12	TUNER, (BT-881) (AEP, E MODEL)	
TU001A	1-463-371-12	TUNER, (BT-882) (UK MODEL)	
TU001A	1-463-421-11	TUNER, (BT-883) (EC MODEL)	

*1-613-233-12 RD-21 BOARD			

<u>DIODE</u>			
PC101	8-719-913-41	DIODE SPI201-22	
<u>RESISTOR</u>			
R101	1-247-815-00	CARBON	220 5% 1/6W
R102	1-247-867-00	CARBON	33K 5% 1/6W
R103	1-247-859-00	CARBON	15K 5% 1/6W

*1-613-232-12 RD-20 BOARD			

<u>DIODE</u>			
PC001	8-719-913-41	DIODE SPI201-22	
<u>RESISTOR</u>			
R001	1-247-815-00	CARBON	220 5% 1/6W
R002	1-247-867-00	CARBON	33K 5% 1/6W
R003	1-247-859-00	CARBON	15K 5% 1/6W

The components identified by shading and mark **Δ** are critical for safety. Replace only with part number specified.

When indicating parts by reference number, please include the board name.

N PS-45 PS-46

Ref.No	Part No.	Description	Remark
	*1-606-794-00	N BOARD *****	
<u>CAPACITOR</u>			
C001	1-123-617-00	ELECT 10MF 20% 16V	
C002	1-123-617-00	ELECT 10MF 20% 16V	
C003	1-123-617-00	ELECT 10MF 20% 16V	
C004	1-161-057-00	CERAMIC 0.033MF 10% 25V	
C005	1-106-184-00	MYLAR 0.0033MF 5% 50V	
C006	1-123-821-00	ELECT 47MF 20% 16V	
<u>DIODE</u>			
D001	8-719-110-32	DIODE PH302B	
<u>IC</u>			
IC001	8-759-102-84	IC UPC1373HA	
<u>COIL</u>			
L001	1-404-310-00	COIL	

	*1-613-227-12	PS-45 BOARD (AEP, UK, EC MODEL) *****	
	1-533-162-00	HOLDER, FUSE	
<u>CAPACITOR</u>			
C001	1-123-617-00	ELECT 10MF 20% 16V	
C002	1-125-298-00	ELECT (BLOCK) 10000MF 20% 25V	
C003	1-123-332-00	ELECT 47MF 20% 16V	
C004	1-123-332-00	ELECT 47MF 20% 16V	
<u>CONNECTOR</u>			
CN001	*1-560-893-00	PIN, CONNECTOR 5P	
CN002	*1-560-890-00	PIN, CONNECTOR 2P	
<u>DIODE</u>			
D001	8-719-110-32	DIODE PH302B	
<u>FUSE</u>			
F001	1-532-203-11	FUSE, TIME-LAG T2A 250V	
F002	1-532-360-11	FUSE, TIME-LAG TAA 250V	
F003	1-532-203-11	FUSE, TIME-LAG T2A 250V (UK MODEL)	
<u>RESISTOR</u>			
R001	1-247-823-00	CARBON 470 5% 1/6W	

Ref.No	Part No.	Description	Remark
	*1-613-228-12	PS-46 BOARD (AEP, UK, EC MODEL) *****	
	1-533-162-00	HOLDER, FUSE	
	*3-660-552-00	HEAT SINK	
	7-685-646-71	SCREW +8VTP 3X10 TYPE2 IT-3	
<u>CAPACITOR</u>			
C101	1-123-375-00	ELECT 220MF 20% 63V	
C102	1-123-375-00	ELECT 220MF 20% 63V	
C103	1-123-330-00	ELECT 22MF 20% 16V	
C104	1-123-330-00	ELECT 22MF 20% 16V	
C105	1-161-059-00	CERAMIC 0.047MF 10% 25V	
C112	1-161-059-00	CERAMIC 0.047MF 10% 25V	
C113	1-161-059-00	CERAMIC 0.047MF 10% 25V	
C115	1-123-332-00	ELECT 47MF 20% 25V (UK MODEL)	
<u>CONNECTOR</u>			
CN101	*1-560-894-00	PIN, CONNECTOR 6P	
CN102	*1-560-893-00	PIN, CONNECTOR 5P	
CN103	*1-560-891-00	PIN, CONNECTOR 3P	
CN104	*1-560-894-00	PIN, CONNECTOR 6P	
CN105	*1-560-892-00	PIN, CONNECTOR 4P	
CN106	*1-560-891-00	PIN, CONNECTOR 3P	
<u>DIODE</u>			
D101	8-719-200-02	DIODE 10E2	
D102	8-719-200-02	DIODE 10E2	
D103	8-719-100-39	DIODE RD6.2E-83	
D105	8-719-200-02	DIODE 10E2	
<u>FUSE</u>			
F001	1-532-203-11	FUSE, TIME-LAG T2A 250V	
<u>TRANSISTOR</u>			
Q101	8-729-316-16	TRANSISTOR 2SC1061	
Q102	8-729-245-83	TRANSISTOR 2SC2458	
Q103	8-729-316-16	TRANSISTOR 2SC1061	
Q104	8-729-178-54	TRANSISTOR 2SC2785	
Q105	8-729-245-83	TRANSISTOR 2SC2458 (UK MODEL)	
Q106	8-729-245-83	TRANSISTOR 2SC2458 (UK MODEL)	
Q107	8-729-177-43	TRANSISTOR 2SD774 (UK MODEL)	
<u>RESISTOR</u>			
R101	1-244-887-51	CARBON 3.9K 5% 1/2W	
R102	1-244-891-51	CARBON 5.6K 5% 1/2W	
R103	1-247-851-00	CARBON 6.8K 5% 1/6W	
R104	1-247-847-00	CARBON 4.7K 5% 1/6W	
R105	1-247-855-00	CARBON 10K 5% 1/6W	
R106	1-213-144-00	METAL OXIDE 1.2K 5% 1/4W F	
R107	1-206-477-00	METAL OXIDE 39 5% 1/2W F	

The components identified by shading and mark **Δ** are critical for safety. Replace only with part number specified.

When indicating parts by reference number, please include the board name.

Ref.No	Part No.	Description	Remark
R108	1-247-871-00	CARBON 47K 5% 1/6W	(UK MODEL)
R109	1-247-866-00	CARBON 27K 5% 1/6W	(UK MODEL)
R110	1-247-851-00	CARBON 6.8K 5% 1/6W	(UK MODEL)
R111	1-247-783-00	CARBON 10 5% 1/6W	

 *1-613-940-12 PS-69 BOARD (AEP, UK, EC MODEL)

IC

IC001 8-749-912-29 IC STR1229

 *A-6729-106-A PS-67 BOARD, COMPLETE (E MODEL)

1-533-162-00 HOLDER, FUSE

CAPACITOR

C001	1-130-710-00	FILM 0.1M 20% 250V
C002	1-161-013-00	CERAMIC 0.01MF 10% 25V
C003	1-161-013-00	CERAMIC 0.01MF 10% 25V
C004	1-124-362-00	ELECT 4700MF 20% 42V
C005	1-123-375-00	ELECT 220MF 20% 63V
C006	1-123-357-00	ELECT 22MF 20% 50V
C007	1-123-375-00	ELECT 220MF 20% 63V
C008	1-123-357-00	ELECT 22MF 20% 50V
C015	1-123-324-00	ELECT 1000MF 20% 16V

CONNECTOR

CN001	*1-560-893-00	PIN, CONNECTOR 5P
CN002	*1-560-894-00	PIN, CONNECTOR 6P
CN003	*1-560-891-00	PIN, CONNECTOR 3P
CN004	*1-560-891-00	PIN, CONNECTOR 3P
CN005	*1-560-894-00	PIN, CONNECTOR 6P

DIODE

D002	8-719-200-02	DIODE 10E2
D003	8-719-101-31	DIODE RD39E-C3
D004	8-719-200-02	DIODE 10E2
D005	8-719-101-31	DIODE RD39E-C3
D006	8-719-100-42	DIODE RD6.8E-B3
D007	8-719-100-42	DIODE RD6.8E-B3
D008	8-719-100-41	DIODE RD6.8E-B2
D009	8-719-911-19	DIODE ISS119

FUSE

F001	1-532-285-11	FUSE, TENE-LAG T1.25A 250V
F002	1-532-350-11	FUSE, TENE-LAG T4A 250V

Ref.No	Part No.	Description	Remark
<u>IC LINK</u>			

~~PS001A 1-532-679-00 LINK STR1016A~~

TRANSISTOR

Q001	8-729-177-43	TRANSISTOR 2SD774
Q002	8-729-113-33	TRANSISTOR 2SB733-4
Q003	8-729-103-33	TRANSISTOR 2SD1310
Q004	8-729-204-83	TRANSISTOR 2SA1048-GR
Q005	8-729-177-23	TRANSISTOR 2SB772
Q006	8-729-177-23	TRANSISTOR 2SB772
Q007	8-729-900-36	TRANSISTOR DTC124ES
Q008	8-729-900-36	TRANSISTOR DTC124ES

RESISTOR

R001	1-246-485-00	CARBON 3.3K 5% 1/4W
R002	1-246-485-00	CARBON 3.3K 5% 1/4W
R004	1-244-822-51	CARBON 7.5 5% 1/2W
R005	1-212-954-51	FUSIBLE 6.8 5% 1/2W
R006	1-247-139-00	CARBON 2.2K 5% 1/4W
R007	1-247-147-00	CARBON 4.7K 5% 1/4W
R008	1-247-133-00	CARBON 1.2K 5% 1/4W
R009	1-247-133-00	CARBON 1.2K 5% 1/4W
R010	1-247-133-00	CARBON 1.2K 5% 1/4W
R011	1-247-133-00	CARBON 1.2K 5% 1/4W
R012	1-247-855-00	CARBON 10K 5% 1/6W
R013	1-247-155-00	CARBON 10K 5% 1/4W
R014	1-213-143-00	METAL OXIDE 1K 5% 1/2W

 *1-614-195-11 PS-76 BOARD (E MODEL)

CAPACITOR

C009	1-161-025-00	CERAMIC 0.1MF 10% 25V
C010	1-123-346-00	ELECT 220MF 20% 35V
C011	1-123-330-00	ELECT 22MF 20% 16V
C012	1-123-850-51	ELECT 1000MF 20% 16V
C013	1-123-323-00	ELECT 470MF 20% 16V
C014	1-123-333-00	ELECT 100MF 20% 16V

CONNECTOR

CN006 *1-560-895-00 PIN, CONNECTOR 7P

FERRITE BEAD

FB001 1-543-236-11 BEAD, FERRITE

IC

IC001 8-749-972-17 IC STK7217

The components identified by shading and mark **A** are critical for safety. Replace only with part number specified.

When indicating parts by reference number, please include the board name.

PS-76

VS-4

LM-8

Ref.No	Part No.	Description	Remark
<u>COIL</u>			
L002	1-421-701-11	COIL, CHOKE 150UH	
L003	1-408-944-00	COIL, CHOKE	
L004	1-408-944-00	COIL, CHOKE	
<u>RESISTOR</u>			
R003	1-247-101-00	CARBON 56 5% 1/4W	

*1-614-196-11 VS-4 BOARD (E MODEL)

<u>SWITCH</u>			
S001	1-553-011-00	SWITCH, POWER VOLTAGE SELECTION	

*1-605-071-00 LM-8 BOARD

<u>CAPACITOR</u>				
C101	1-161-057-00	CERAMIC	0.033MF	10% 50V
C102	1-161-057-00	CERAMIC	0.033MF	10% 50V

<u>COIL</u>			
L101	1-408-120-00	MICRO INDUCTOR 18UH	
L102	1-408-120-00	MICRO INDUCTOR 18UH	

MISCELLANEOUS

A-6761-075-A	ACE ASSY		
▲ 1-464-386-11	BOOSTER MIXER, RF MODULATOR (RFU-819)		
▲ 1-464-386-21	BOOSTER MIXER, RF MODULATOR (RFU-819)	(AEP MODEL)	
▲ 1-464-387-11	BOOSTER MIXER, RF MODULATOR (RFU-820)	(UK MODEL)	
▲ 1-464-388-11	BOOSTER MIXER, RF MODULATOR (RFU-821)	(EC MODEL)	
▲ 1-551-884-12	CORD, POWER (UK MODEL)		
▲ 1-551-908-11	CORD, POWER (E MODEL)		
▲ 1-551-908-41	CORD, POWER (AEP, EC MODEL)		
8-825-508-10	HEAD, FE (FULL ERASE HEAD)		
L901	1-464-330-11	SENSOR, S COIL	
L902	1-464-329-11	SENSOR, T COIL	
M902	8-838-080-01	MOTOR, DC (BHF-1908B) (CAPSTAN MOTOR)	
M903	*A-4910-049-A	R STATOR BOARD, COMPLETE (REEL MOTOR)	
M904	X-3679-268-1	MOTOR ASSY, L (LOADING/THREADING)	
PM901	▲ 1-454-349-41	SOLENOID, PLUNGER (PINCH)	
PM902	▲ 1-454-371-31	SOLENOID, PLUNGER (BRAKE)	

Ref.No	Part No.	Description	Remark
S901	1-554-839-11	SWITCH, LEAF (2 GANG) (REC PROOF/CASSETTE DOWN)	
S903	1-554-840-11	SWITCH, LEAF (THREADING END)	
S904	1-554-840-11	SWITCH, LEAF (CASSETTE ON)	
T901	▲ 1-447-894-11	TRANSFORMER, POWER (AEP, UK, EC MODEL)	
T901	▲ 1-447-985-11	TRANSFORMER, POWER (E MODEL)	

ACCESSORIES AND PACKING MATERIALS

Part No.	Description	Remark
A-6765-565-A	COMMANDER ASSY RMT-230/SILVER (AEP, E, UK MODEL)	
A-6765-638-A	COMMANDER ASSY RMT-230/GRAY (AEP, E, UK MODEL)	
A-6765-566-A	COMMANDER ASSY RMT-231/SILVER (EC MODEL)	
A-6765-639-A	COMMANDER ASSY RMT-231/GRAY (EC MODEL)	
A-6765-641-A	COMMANDER ASSY RMT-231/RED (EC MODEL)	
1-556-893-00	CORD ASSY, COAXIAL	
3-656-301-00	SCREWDRIVER, CONTROL	
*3-677-503-00	SHEET, PROTECTION	
3-681-287-01	LID, ACCESSORY CASE	
3-684-259-01	CASE, ACCESSORY	
*3-687-580-01	CUSHION (UPPER)	
*3-687-581-01	CUSHION (LOWER)	
*3-687-583-01	INDIVIDUAL CARTON (UK/GRAY MODEL)	
*3-687-587-01	INDIVIDUAL CARTON (EC/GRAY MODEL)	
*3-687-587-11	INDIVIDUAL CARTON (EC/SILVER MODEL)	
*3-687-587-21	INDIVIDUAL CARTON (EC/WHITE MODEL)	
*3-687-587-31	INDIVIDUAL CARTON (EC/RED MODEL)	
*3-687-587-41	INDIVIDUAL CARTON (EC/BLUE MODEL)	
*3-688-401-01	INDIVIDUAL CARTON (E/SILVER MODEL)	
*3-688-402-01	INDIVIDUAL CARTON (AEP/SILVER MODEL)	
*3-688-402-11	INDIVIDUAL CARTON (AEP/GRAY MODEL)	
3-760-103-11	MANUAL, INSTRUCTION (AEP, E, EC MODEL) (ENGLISH, FRENCH, DUTCH, SPANISH)	
3-760-103-61	MANUAL, INSTRUCTION (AEP, EC MODEL) (GERMAN, SWEDISH, ITALIAN)	
3-760-103-71	MANUAL, INSTRUCTION (UK MODEL) (ENGLISH)	

The components identified by shading and mark ▲ are critical for safety. Replace only with part number specified.

When indicating parts by reference number, please include the board name.

SECTION 7 ADJUSTMENT

TABLE OF CONTENTS

<u>Section</u>	<u>Title</u>	<u>Page</u>	<u>Section</u>	<u>Title</u>	<u>Page</u>
1.	PREPARATION FOR MECHANICAL SECTION CHECK, ADJUSTMENT AND REPLACEMENT		3-7-3.	Checking and Adjustment of the Cassette Door Assembly	139
1-1.	Disassembly of Cabinet	124	3-7-4.	Mounting the FL Cassette Compartment Assembly	139
1-2.	Removal of the RP-20 Board	125	3-8.	Removal of the No. 2 and No. 3 Guides	
1-3.	Removal of the TA-22 Board	126	3-8-1.	Removal of the No. 2 Guide	140
1-4.	Removal of the YC-31 Board	126	3-8-2.	Removal of the No. 3 Guide	140
1-5-1.	Removal of the Power Block (AEP, UK, EC Model)	127	3-9.	Replacement and Adjustment of the S Threading Ring	
1-5-2.	Removal of the Power Block (E Model)	127	3-9-1.	Preparation to Remove the S Threading Ring Removal of the ACE Assembly, FE Head and Threading Motor	141
1-6.	Operation of the Unit With the FL Cassette Compartment Removed		3-9-2.	Removal of the S Threading Ring	143
1-6-1.	How to put the Unit into Threading Completed Mode when the FL Cassette Compartment is Removed	128	3-9-3.	S Threading Ring Mounting and Position Adjustment	144
1-6-2.	Playback Without Cassette Installed	128	3-10.	Pinch Snap-Fit Limiter Gap Check and Adjustment	145
1-6-3.	How to put in Recording Mode Without Cassette Installed	128	3-11.	Threading End Switch and T Coil Sensor	
1-7.	How to Load, Thread, Unload and Unthread With the Power Off	129	3-11-1.	Threading End Switch (TE Switch) Position Check and Adjustment	146
1-7-1.	Manual Loading and Unloading	129	3-11-2.	T Coil Sensor Mounting and Operation Check	147
1-7-2.	Manual Threading and Unthreading	129	3-12.	Removal and Adjustment of the Reel Block Assembly	
1-8.	Tools and Fixtures Required For Servicing	130	3-12-1.	Removal of the Reel Block Assembly	148
2.	PERIODIC CHECK AND MAINTENANCE		3-12-2.	Adjustment of the Position of the Tension Regulation Lever	148
2-1.	Post-Repair Maintenance		3-13.	Adjustment of the Forward Back Tension	149
2-1-1.	Cleaning of Rotating Head Disk Assembly	131	3-14.	Adjustment of the Forward Torque	149
2-1-2.	Cleaning of the Tape Movement System	131	4.	TAPE PATH ADJUSTMENT	
2-1-3.	Cleaning the Drive System	131	4-1.	Tracking Adjustment	150
2-2.	Periodic Check Items	132	4-1-1.	Preparation for Adjustment	151
3.	CHECK, ADJUSTMENT AND REPLACEMENT PROCEDURES		4-1-2.	Entrance Side Adjustment	151
3-1.	Replacement of Rotating Head Disk Assembly		4-1-3.	Exit Side Adjustment	153
3-1-1.	Removal of the Rotating Head Disk Assembly	133	4-2.	Adjustments After Replacement of the Ace Assembly	
3-1-2.	Mounting of the Rotating Head Disk Assembly	133	4-2-1.	Exit Side Tracking Adjustment	154
3-2.	Video Head Dihedral Check and Adjustment	134	4-2-2.	CTL Head (ACE Assembly) Position Adjustment	155
3-3.	Replacement and Adjustment of the Drum Assembly		4-2-3.	Audio Head (ACE Assembly) Azimuth Adjustment	156
3-3-1.	Replacement of the Drum Assembly	135	4-2-4.	Audio Head (ACE Assembly) Height Adjustment	156
3-3-2.	Adjustment of the Motor Gap when Replacing the Drum Assembly	136	4-3.	How to Inspect the Tape Traveling When Adjusting the Tape Path	157
3-4.	Replacement of the Capstan Motor		5.	ELECTRICAL ALIGNMENT	
3-4-1.	Removal of the Capstan Motor	136	5-1.	Power Supply Check	160
3-5.	Removal of the S Coil Sensor	137	5-1-1.	AEP, UK, EC Model (PS-46 Board)	160
3-6.	Removal of the FL Cassette Compartment Assembly	137	5-1-2.	E Model (PS-67 Board)	160
3-7.	Adjustment of the FL Cassette Compartment		5-2.	System Control Check (SS-34 Board)	160
3-7-1.	Adjustment of the Position of the Right Gear of the FL Cassette Compartment Assembly	138	5-3.	Servo System Alignment	
3-7-2.	Cassette ON Switch Operation Check and Adjustment	138	5-3-1.	Drum Servo System Alignment	160
			5-3-2.	Capstan Servo System Alignment	161
			5-4.	PAL Video System Alignment	163
			5-4-1.	Playback System Alignment	163
			5-4-2.	Record System Alignment	165
			5-5.	Audio System Adjustment (TA-22 Board)	167
			5-6.	Tuner System Adjustment (TA-22 Board)	168
			5-7.	Timer System Adjustment (TM-57 Board)	168

1. PREPARATION FOR MECHANICAL SECTION CHECK, ADJUSTMENT AND REPLACEMENT

1-1. DISASSEMBLY OF CABINET

- 1) Remove the four case set screws ①.
- 2) Remove the upper case ② in the direction shown by the arrow A.
- 3) Loosen the eight screws (BVTP3 x 8) ③.
- 4) Remove the lower case ④ in the direction shown by the arrow B.
- 5) Remove the three screws (BVTP3 x 8) ⑤.
- 6) Remove the two claws ⑥ in the direction shown by the arrow C, then remove the front panel ⑦ in the direction shown by the arrow D.

Note: Follow the disassembly procedure in the numerical order given.

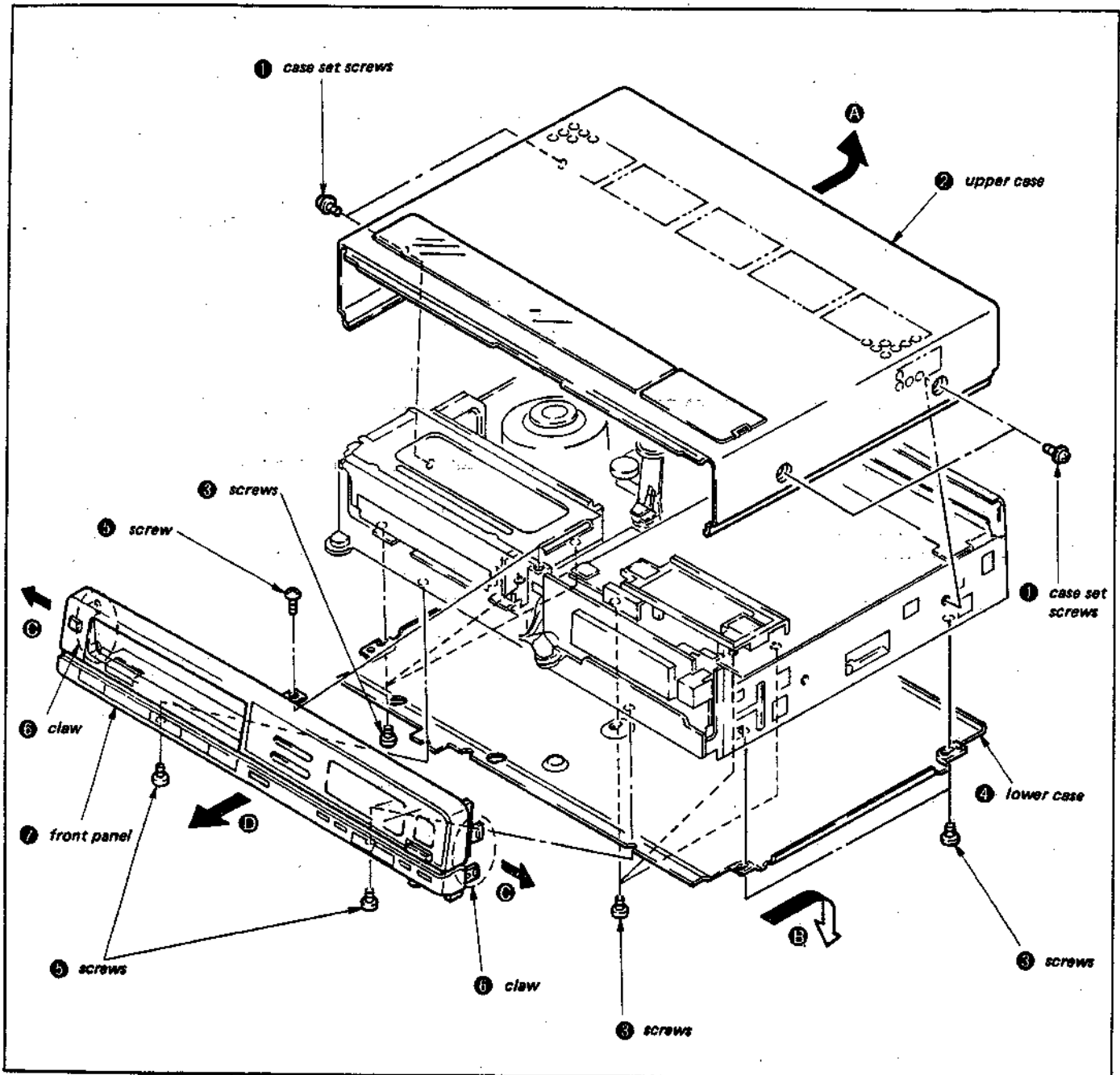

Fig. 1-1. Disassembly of Cabinet

1-2. REMOVAL OF THE RP-20 BOARD

- 1) Pull out the connector CN501 ① .
- 2) Remove the two screws (BVTP3 x 8) ② .
- 3) Pull out the three connectors (CN503, CN504) ③ , ④ .
- 4) Remove the two shield cases ⑤ in the direction shown by the arrows A and B .

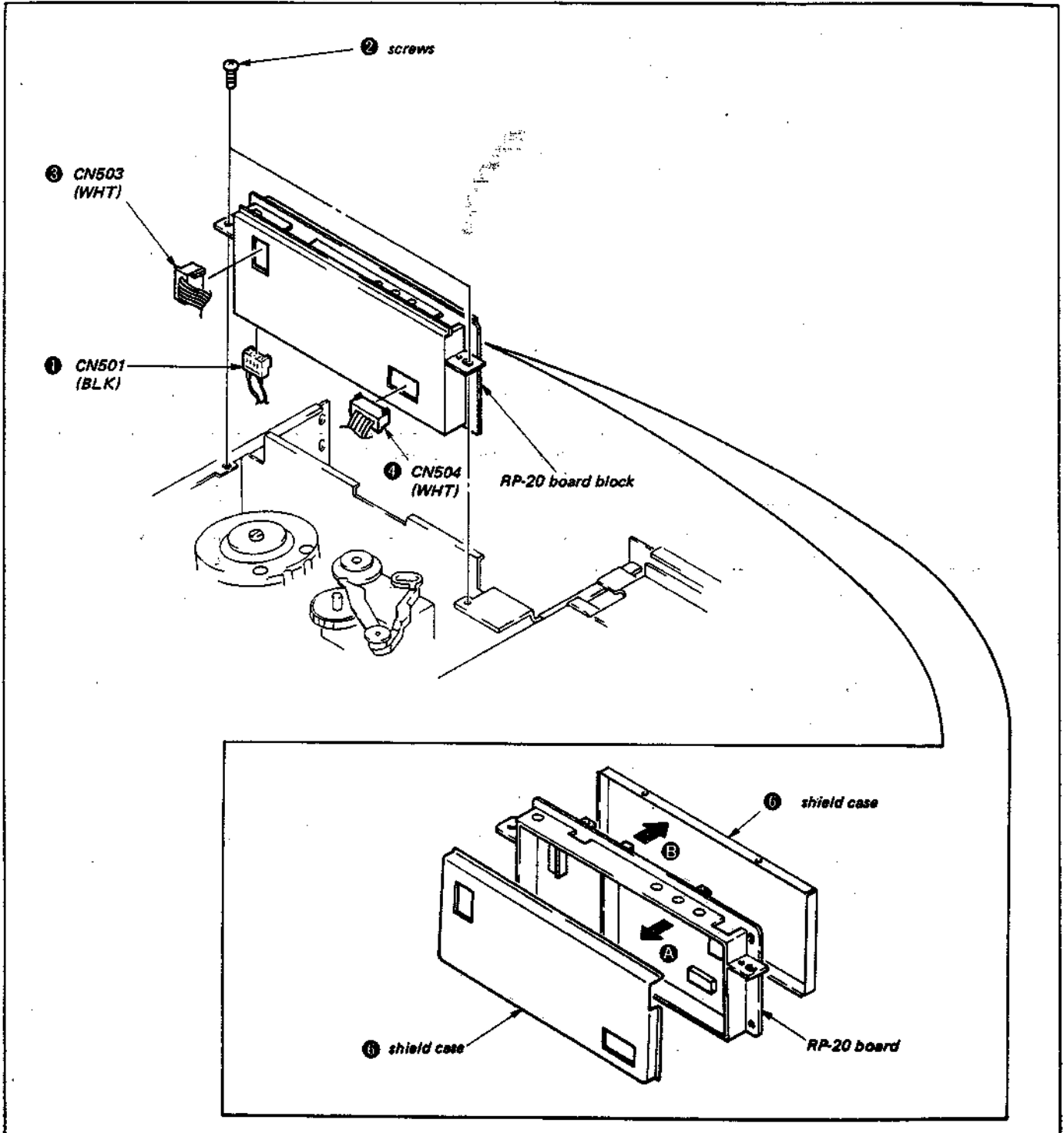

Fig. 1-2. Removal of the RP-20 Board

1-3. REMOVAL OF THE TA-22 BOARD

- 1) Remove the two screws (BVTP3 x 8) ①.
- 2) Remove the TA-22 board ② in the direction shown by the arrow.

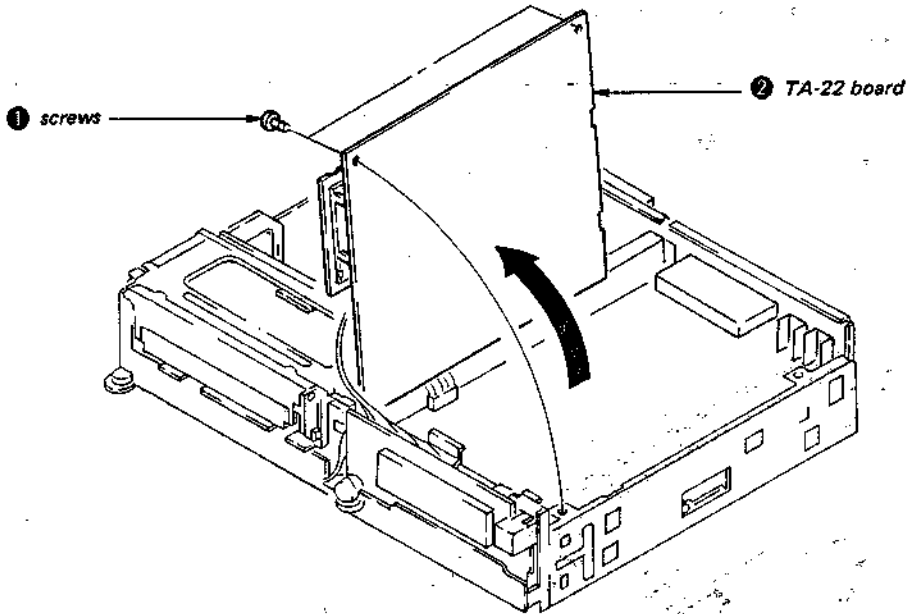

Fig. 1-3. Removal of the TA-22 Board

1-4. REMOVAL OF THE YC-31 BOARD

- 1) Stand the set with the left side panel on the bottom.
- 2) Remove the screw (BVTP3 x 8) ①.
- 3) Remove the plate, connector ② in the direction shown by the arrow A.
- 4) Remove the two screws (BVTP3 x 8) ③.
- 5) Remove the YC-31 board ④ in the direction shown by the arrow B.

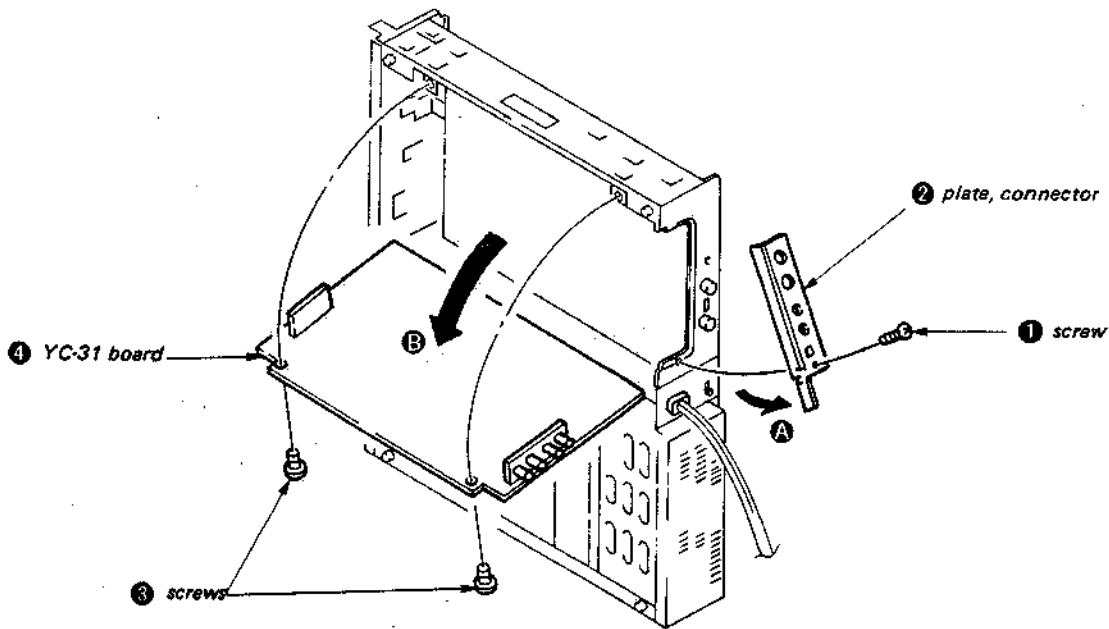

Fig. 1-4. Removal of the YC-31 Board

**1-5-1. REMOVAL OF THE POWER BLOCK
(AEP, UK, EC MODEL)**

- 1) Remove the six screws (BVTP3 x 8) ①.
- 2) Pull-out the five connectors (CN101, CN102, CN103, CN104, CN106) ②.
- 3) Remove the power block ③ in the direction shown by the arrow.

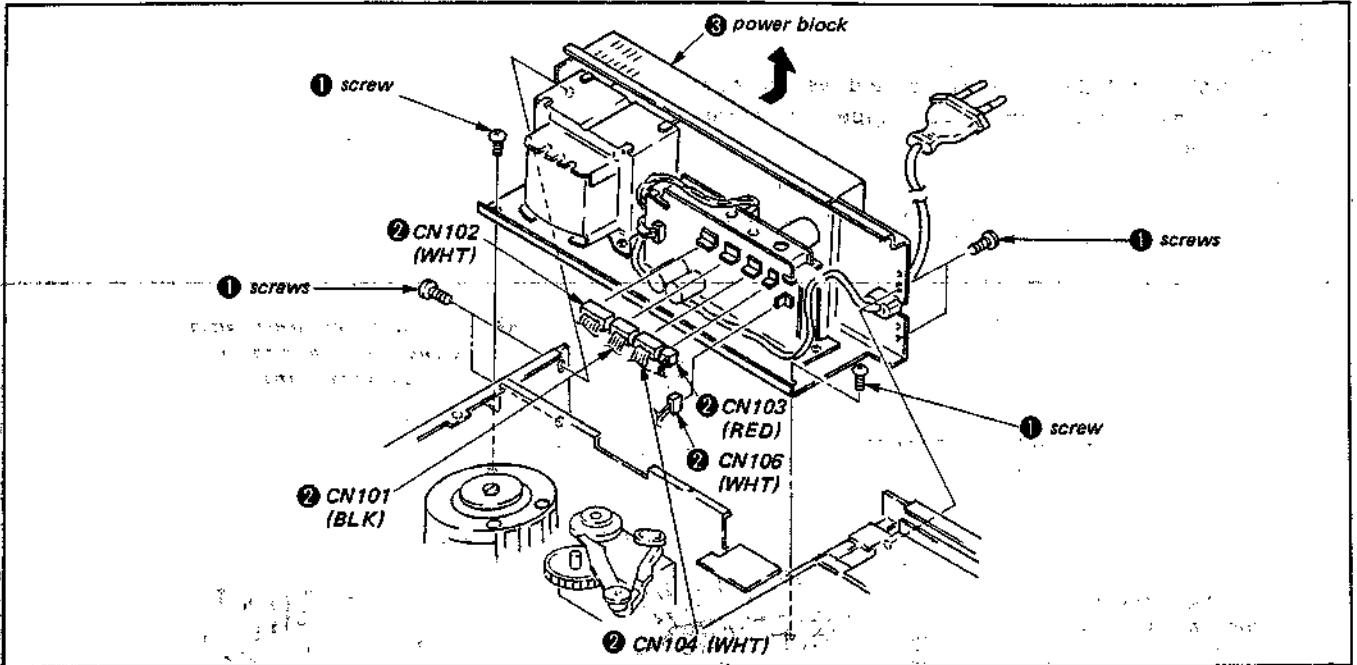

Fig. 1-5-1. Removal of the power block

**1-5-2. REMOVAL OF THE POWER BLOCK
(E MODEL)**

- 1) Remove the six screws (BVTP3 x 8) ①.
- 2) Pull out the five connectors (CN001, CN002, CN003, CN004, CN005) ②.
- 3) Remove the power block ③ in the direction shown by the arrow.

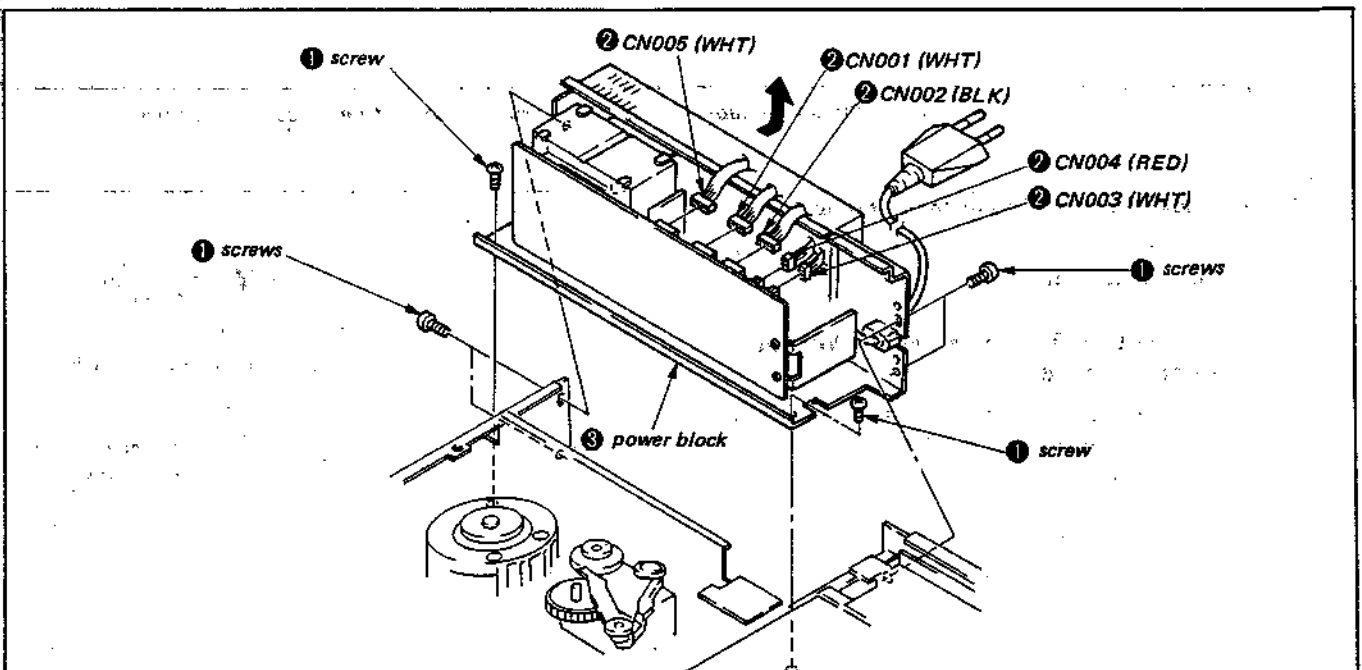

Fig. 1-5-2. Removal of the power block

1-6. OPERATION OF THE UNIT WITH THE FL CASSETTE COMPARTMENT REMOVED

1-6-1. How to Put the Unit into Threading Completed Mode when the FL Cassette Compartment is Removed

- 1) Connect ordinary screwdriver to short the leaf switch (cassette-on switch).

Note:

Be careful that the ordinary screwdriver do not touch any other parts (use tape or other insulation).

- 2) Press the cassette-down switch and leave it pressed in. When the power button is turned ON, threading starts.

* Refer to 3-6 for instructions on how to remove the FL cassette compartment.

[How to EJECT in this condition]

- Press the EJECT button. When unthreading is completed and the internal gear starts to turn, turn the power OFF.

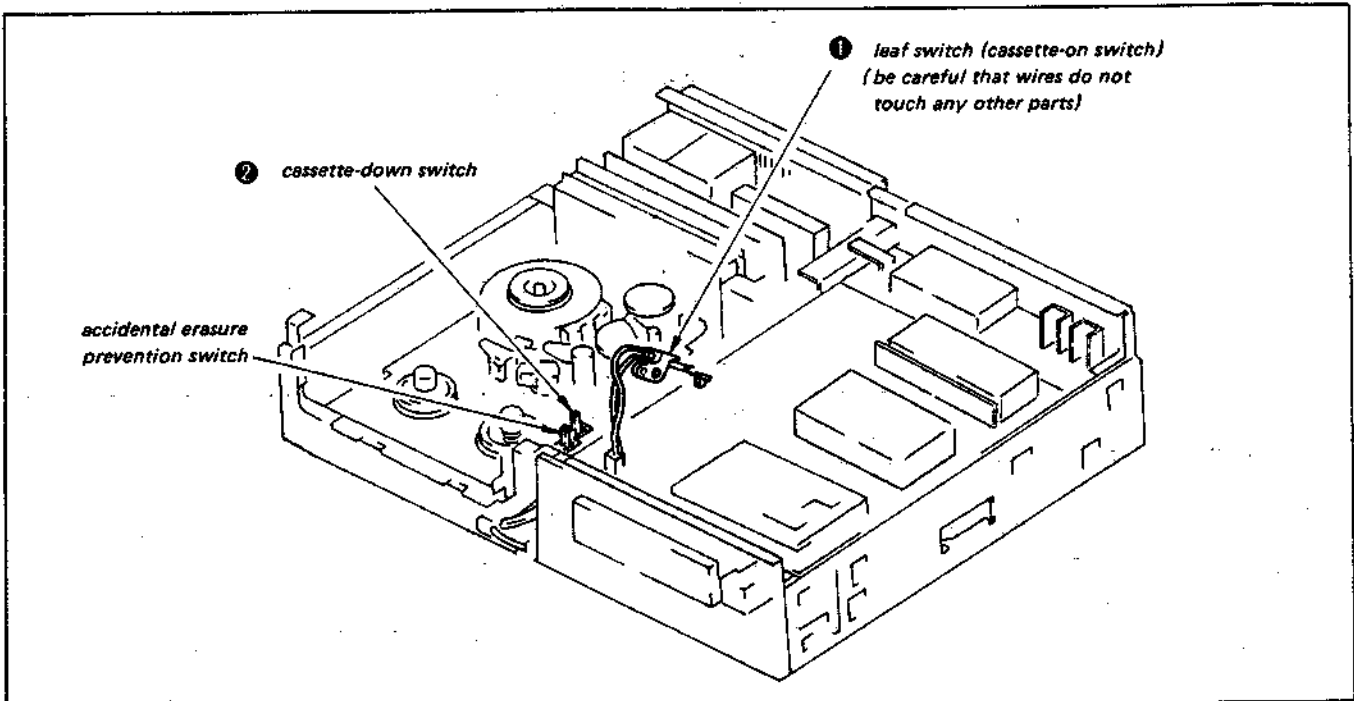

Fig. 1-6. How to thread the tape when the FL cassette compartment has been removed

1-6-2. Playback Without Cassette Installed

Complete threading by the procedure described in 1-6-1, then press the playback button.

1-6-3. How to Put in Recording Mode Without Cassette Installed

1. Thread by the procedure in 1-6-1 then press the accidental erasure prevention switch shown in Fig. 1-7.
2. With the accidental erasure prevention switch pressed down, press the recording button.

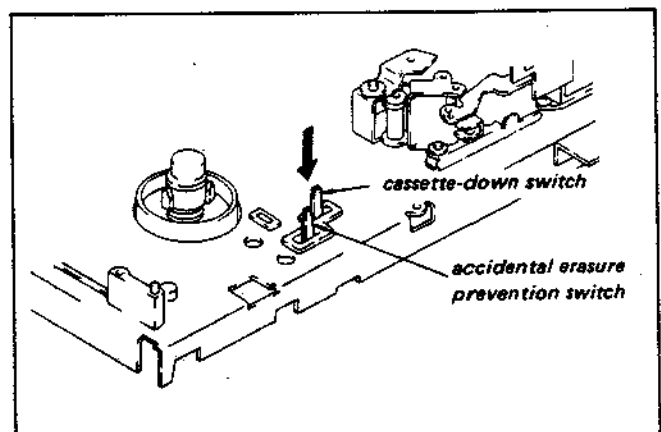

Fig. 1-7. How to put the recorder in recording mode with the FL cassette compartment removed

3-9. REPLACEMENT AND ADJUSTMENT OF THE S THREADING RING

3-9-1. Preparation to Remove the S Threading Ring Removal of the ACE Assembly, FE Head and Threading Motor (Fig. 3-18)

- 1) Remove the cross-recessed head screw.
- 2) Remove the No. 6 guide nut.
- 3) Remove the No. 6 washer.
- 4) Remove the No. 6 guide spacer.
- 5) Remove the compression coil spring.
- 6) Remove the 2 guide adjustment screws, then remove the ACE assembly and the FE head.

Note:

Since the ACE assembly and the FE head are connected by a lead wire, be careful when removing them. It is not necessary to remove the compression coil spring below the ACE assembly, but be careful not to use it.

- 7) Remove the 3 screws, then remove the threading motor assembly by pulling it up and out.

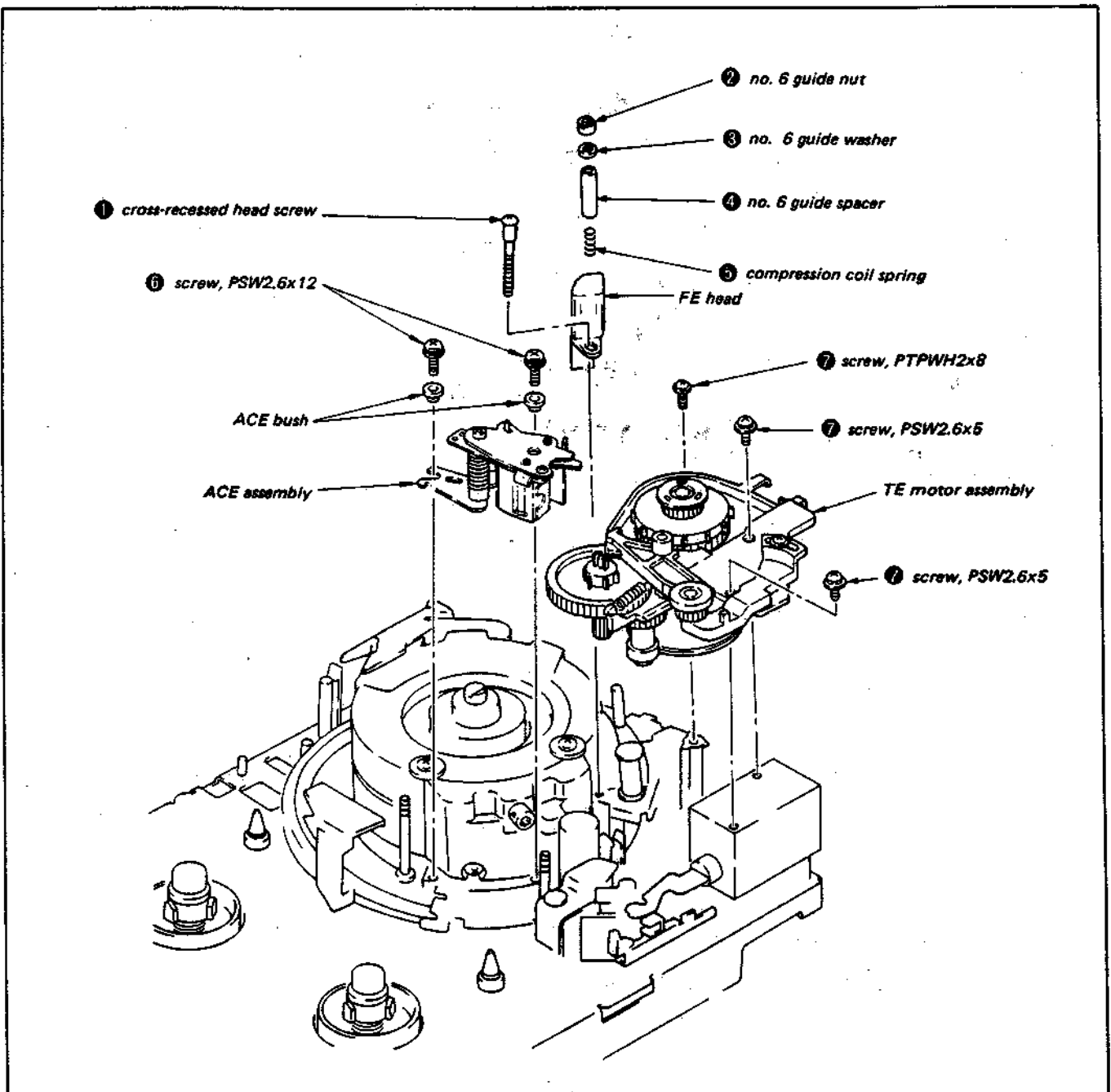

Fig. 3-18. Removal of the ACE assembly, FE head and TE motor assembly.

Removal of Miscellaneous Parts (Fig. 3-19)

Proceeding in the same manner as in replacement of the drum assembly, measure the width of the gap between the upper drum and the adjusting plates (Fig. 3-5).

- 1) Remove the screw, then remove the tape guide ground plate and adjusting plates 1 and 2.
- 2) Remove the two screws, then remove the tape holder assembly.
- 3) Remove the screw, then remove the guide plate.
- 4) Remove the 2 PTPWH2x8 screws and the M2.6 screw, then remove shuttle guide 2.

- 5) Remove the 3 PTPWH2x8 screws and the M2.6 screw. Then remove the 2 claws holding shuttle guide 1-YA in place, and finally remove shuttle guide 1-YA.
- 6) Remove the slant base assembly.
- 7) Remove the BVTT2.6x6 screw, then remove the pinch liner link.

Note:

After removing the guide plate, do not thread or unthread a tape with the shuttle guide mounted.

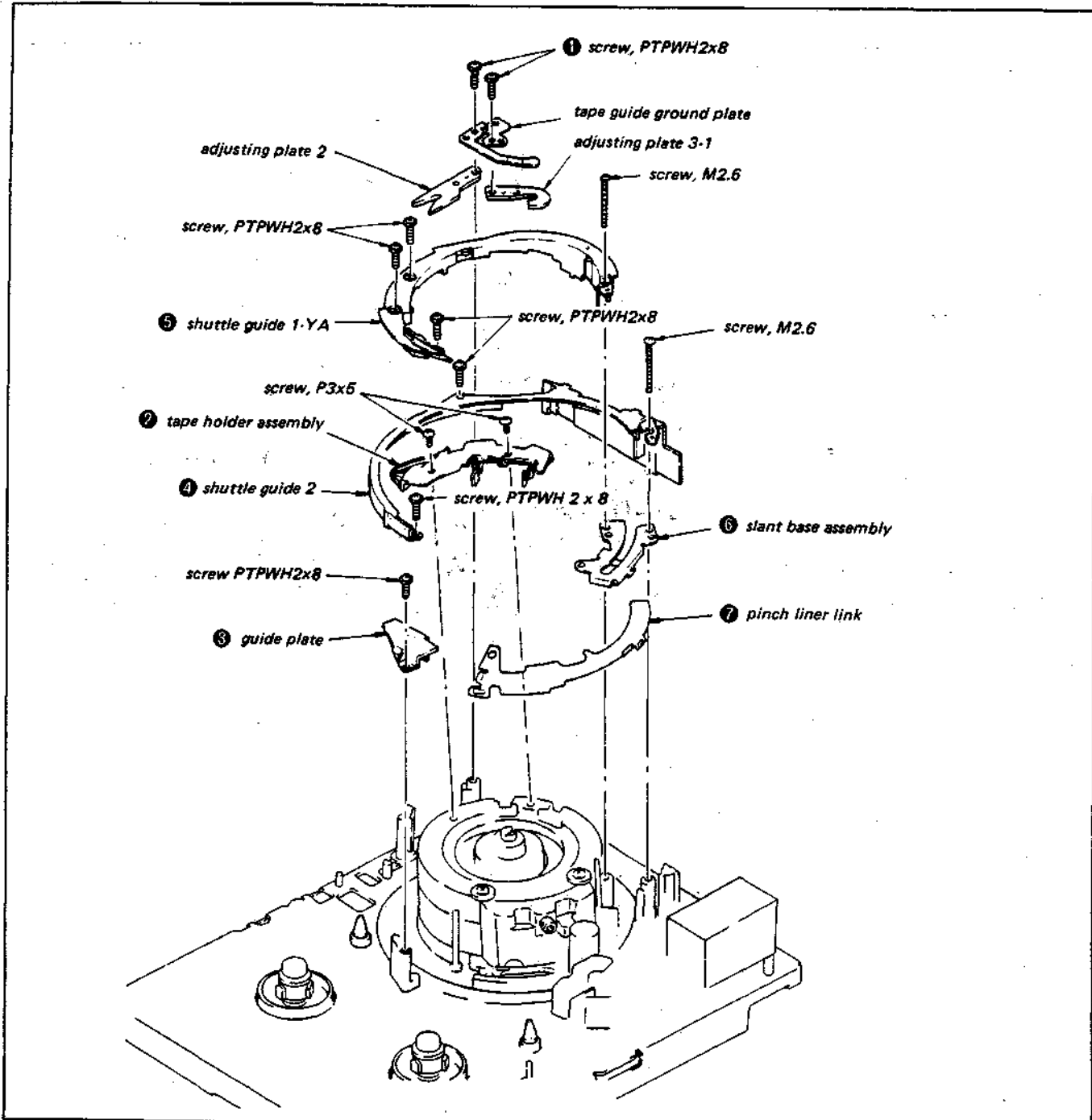

Fig. 3-19. Removal of miscellaneous parts

3-9-2. Removal of the S Threading Ring (Fig. 3-20)

- 1) Turn the stop washer and remove the ring roller (B) and (C).
- 2) Remove the screw, then remove the ring roller adjustment plate.
- 3) Remove the S threading ring.

Note:

Once a stop washer has been removed, do not use it again.

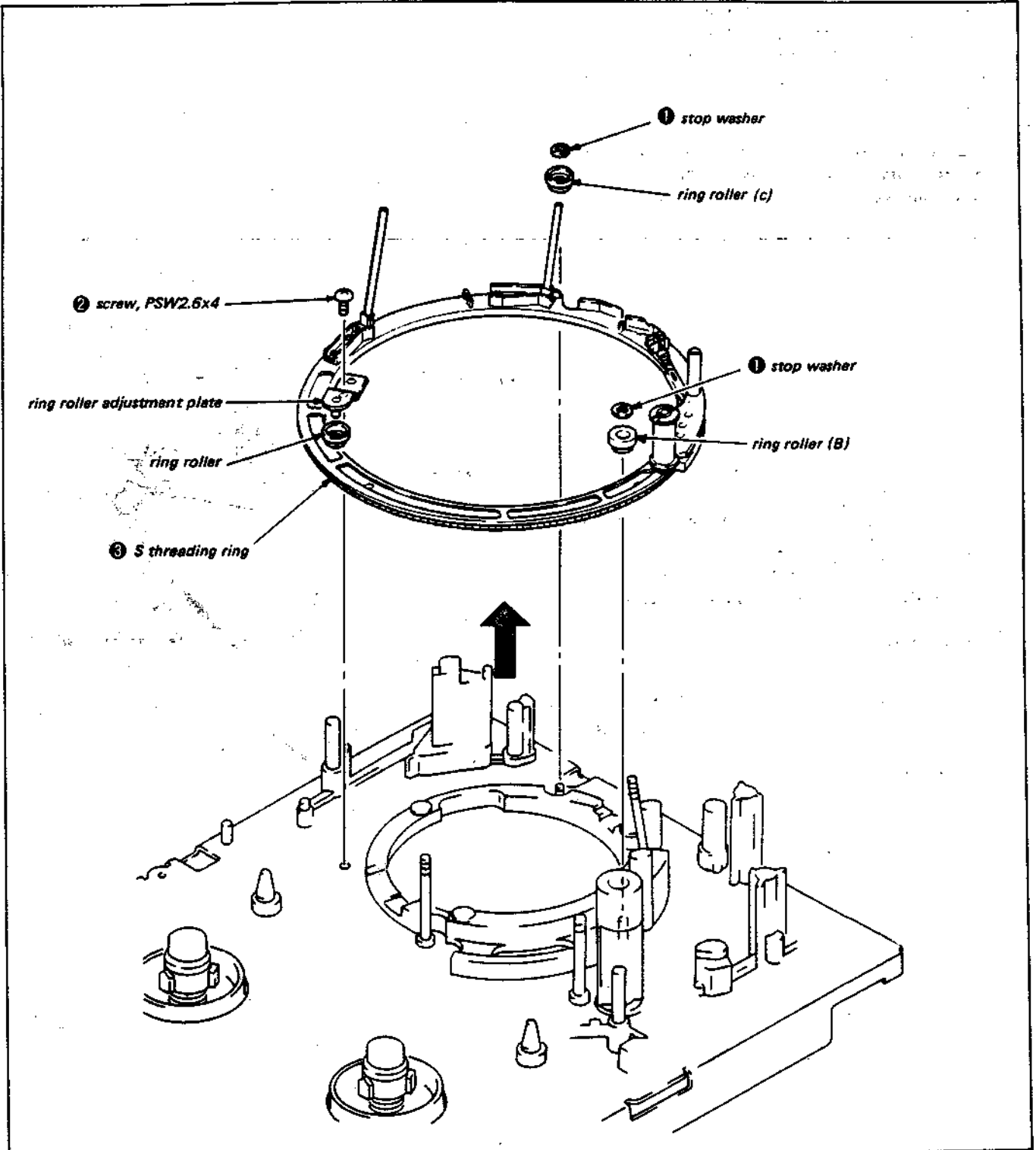

Fig. 3-20. Removal of the S threading ring

3-9-3. S Threading Ring Mounting and Position Adjustment (Fig. 3-21)

- 1) Set the slider gear assembly in the unthreading completed position.
(Slider gear assembly set so that it is up against part T slider stop mold.)
- 2) In this condition, fit the threading ring into place, match the chassis hole (3ϕ) of part A with the S threading ring hole (1.5ϕ), and mesh with the drive gear teeth.
- 3) Attach ring roller (B) and fix in place with a stop washer.
- 4) Attach the ring roller, and fix in place with the adjustment plate.

Note:

After replacement and mounting are completed, adjust the ACE assembly as explained in the section on tape path adjustment.

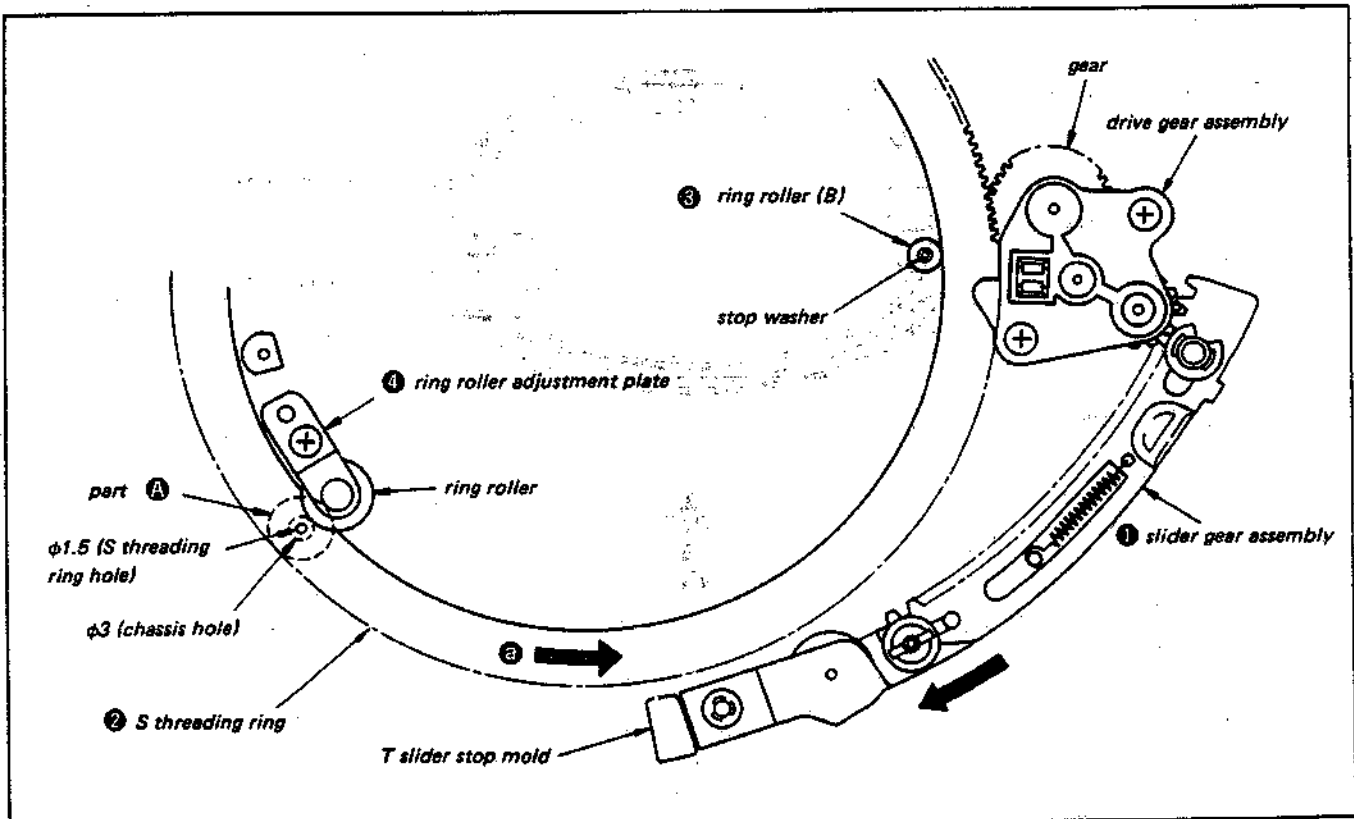

Fig. 3-21. S threading ring position adjustment

3-11-2. T Coil Sensor Mounting and Operation Check

[Method of checking]

Confirm that T coil sensor link ① is pressed and T coil sensor ② moves in the direction of arrow ③ when the T slider gear assembly is moved in the direction of arrow ④.

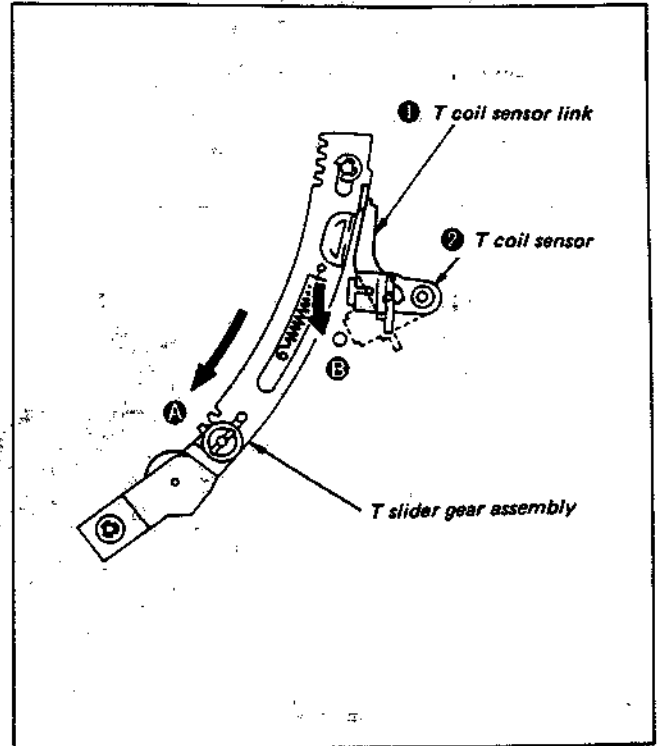

Fig. 3-25. T coil sensor operation check.

[Method of mounting]

- 1) Place T coil sensor link in the prescribed position.
- 2) Match up the T coil sensor hole with the chassis shaft ④ and insert. Place so that it engages with T coil sensor link.
- 3) Hook the tension coil spring on the T coil sensor and chassis claw.

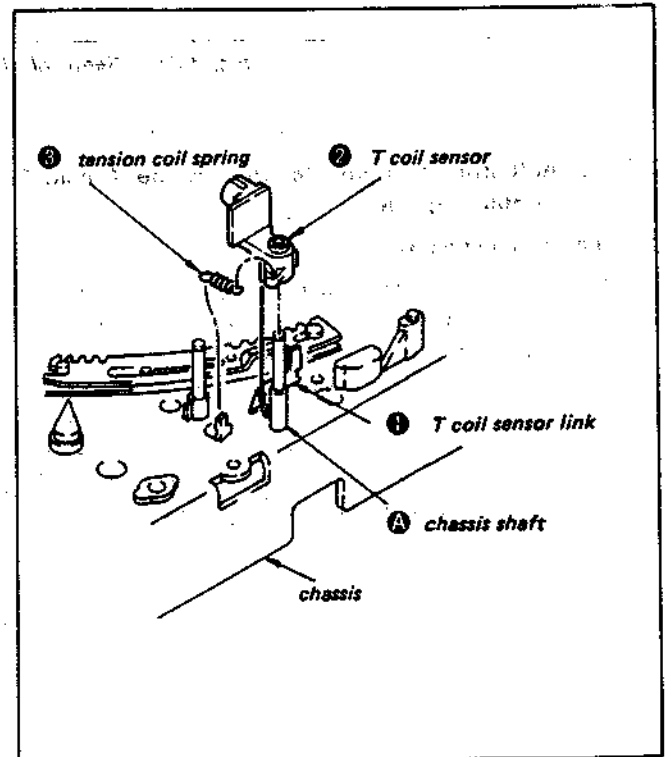

Fig. 3-26 T coil sensor link and T coil sensor mounting.

3-12. REMOVAL AND ADJUSTMENT OF THE REEL BLOCK ASSEMBLY

3-12-1. Removal of the Reel Block Assembly

- 1) Remove the four screws (BVTP3 x 8) ①.
- 2) Remove the reel block assembly ② in the direction shown by the arrow.

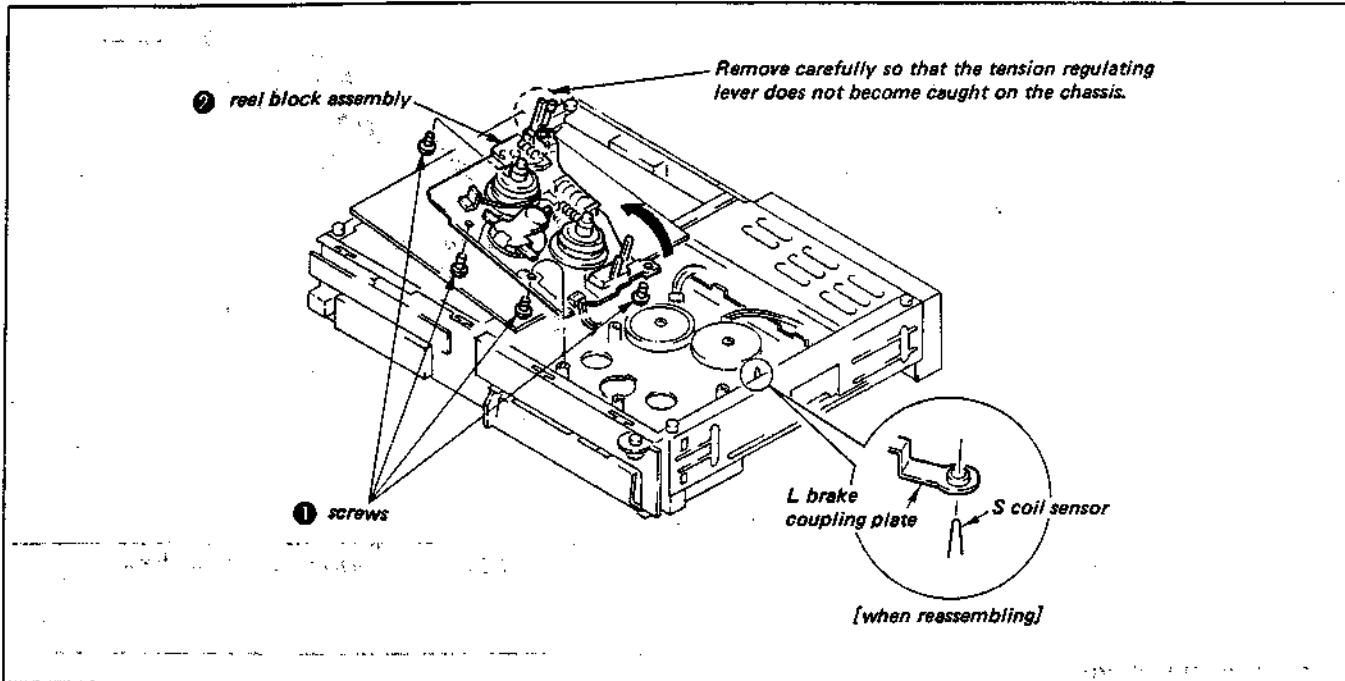

Fig. 3-27 Removal of the reel block assembly

3-12-2. Adjustment of the Position of the Tension Regulating Lever

[Method of adjustment]

- 1) Put the unit in playback mode.
- 2) Loosen the adjustment spring until the tape guide pin of the tension regulating lever assembly is positioned to the outside of the outer circumference of shuttle guide 2, as shown in Fig. 3-28. Then adjust by moving the tension regulating band assembly in the direction of arrow A.
- 3) After adjustment, tighten the adjustment screw, being careful that the tension regulating band assembly does not move.

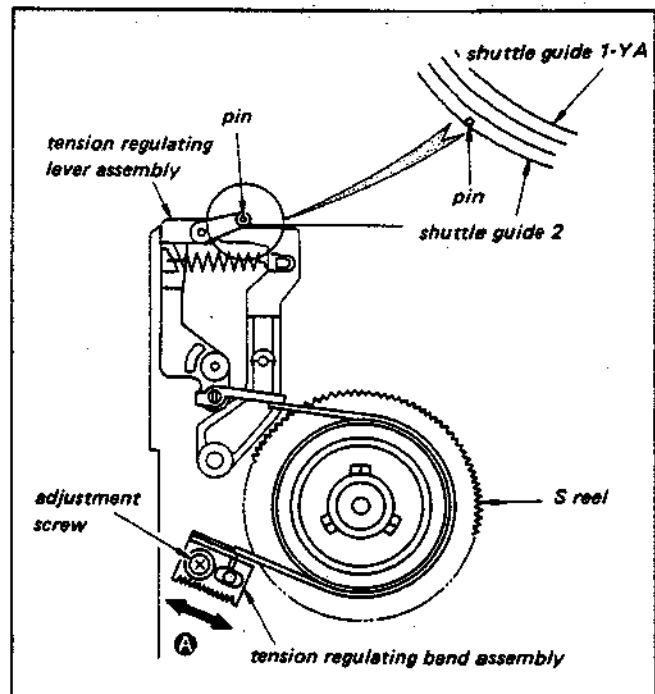

Fig. 3-28 Adjustment of the position of the tension regulating lever

3-10. PINCH SNAP-FIT LIMITER GAP CHECK AND ADJUSTMENT

[Method of checking]

- 1) Set in the threading completed condition.
- 2) With the plunger pushed in all the way, confirm that the thickness of the pinch snap-fit limiter gap is 0.4 mm to 0.6 mm. If it is not, adjust as explained under [method of adjustment] below.

[Method of adjustment]

- 1) With the pinch solenoid in the absorbed condition (when the plunger is pushed in all the way), loosen the adjustment screw.
- 2) Press the pinch limiter adjustment plate in the direction of arrow **a** with an ordinary screwdriver, as in section **A** in the diagram, and adjust until the thickness of the gap in 0.4 mm to 0.6 mm.
Tighten the adjustment screw and then lock it to fix everything in place.

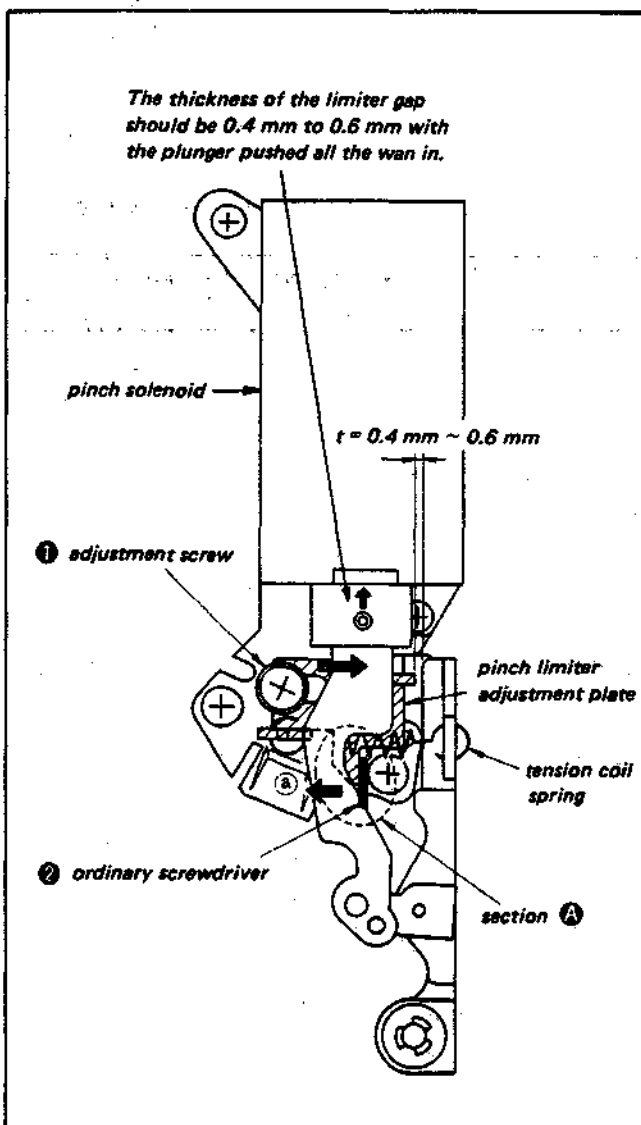

Fig. 3-22. Pinch snap-fit limiter gap adjustment plate

3-11. THREADING END SWITCH AND T COIL SENSOR

3-11-1. Threading End Switch (TE Switch) Position Check and Adjustment

[Method of checking]

Turn the S threading ring manually. Check to make sure that, when the lock roller moves from above the straight line part of the notch in the ring (Fig. 3-23 section A) to 1/3 of the way down it and back, the TE switch turns ON and OFF.

If the lock roller has to move outside of this range before the switch will turn ON and OFF, adjust as explained below.

[Method of adjustment]

- 1) Set the lock roller between the top of the notch in the S threading ring and 1/3 of the way down it, turn the TE switch in the direction of the arrow and, when the switch turns ON, fix the TE switch in place.
- 2) When the adjustment is completed, repeat the check as described above [method of checking].

[Removal]

- 1) Remove the tension coil spring that is attached to the S coil sensor assembly, then remove the S coil sensor.
- 2) Remove the lock arm assembly in the direction of arrow A.

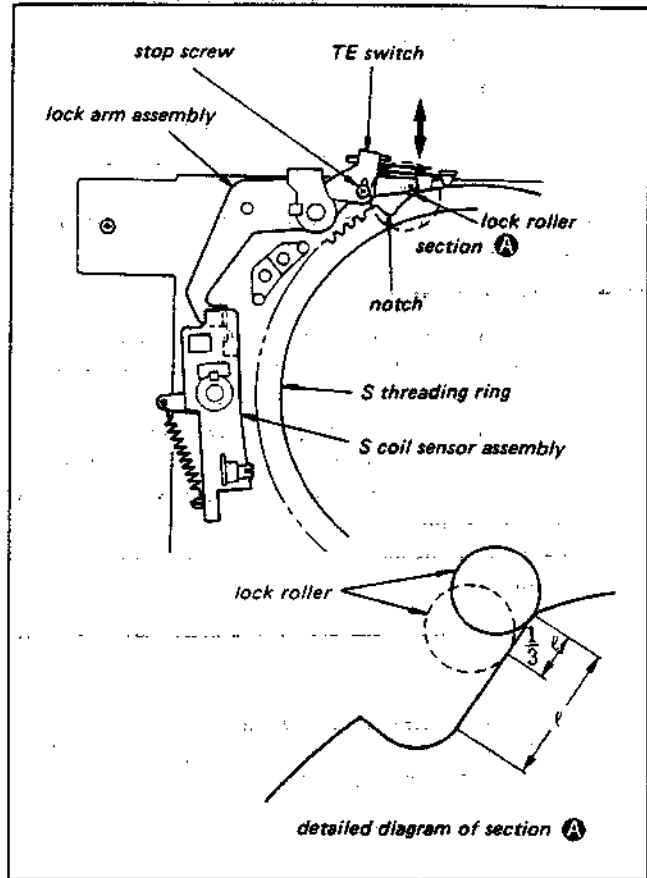

Fig. 3-23. TE switch position adjustment

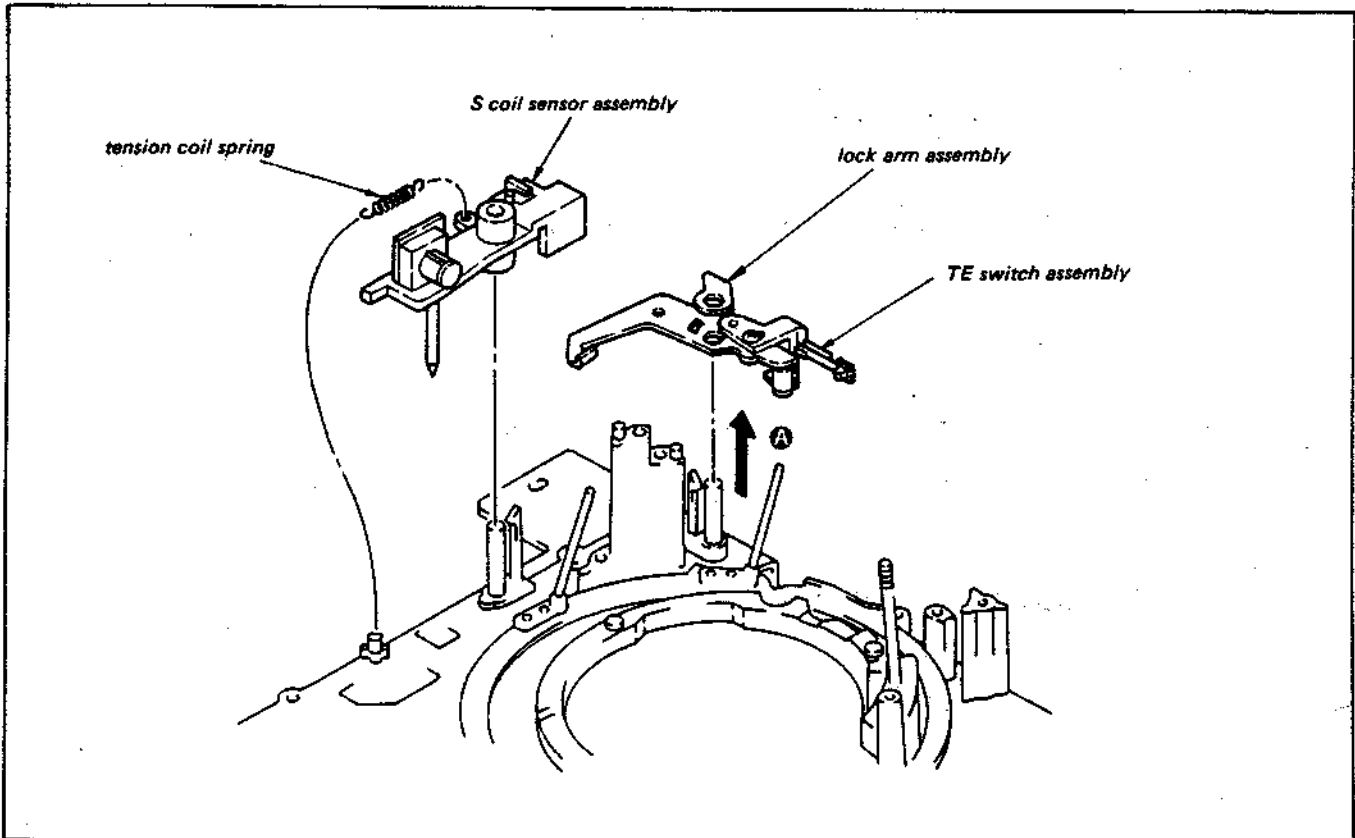

Fig. 3-24. Removal of the TE switch assembly and lock arm assembly

1-7. HOW TO LOAD, THREAD, UNLOAD AND UNTHREAD WITH THE POWER OFF

1-7-1. Manual Loading and Unloading

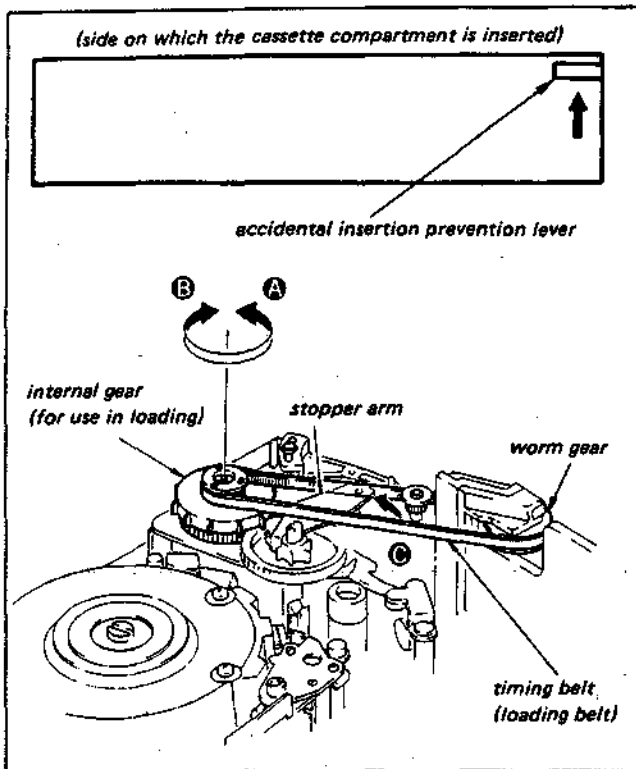

Fig. 1-8. Manual loading and unloading

- 1) Release the right accidental insertion prevention lever inside the cassette compartment, then press the stopper arm in the direction of arrow **B** and release the internal gear stop.
- 2) Turn the internal gear manually in the direction of arrow **A** until loading is completed.
- 3) To unload, turn the internal gear in the direction of arrow **B**.

Note:

When the loading belt has been removed, load and unload by turning the worm gear manually.

1-7-2. Manual Threading and Unthreading

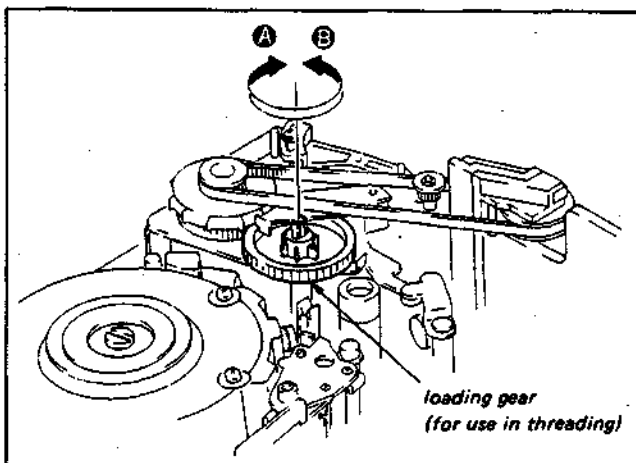

Fig. 1-9. Manual threading and unthreading

- 1) Turn the loading gear in the direction of arrow **A** until loading is completed.
- 2) To unthread, turn the loading gear in the direction of arrow **B**.

Note:

Always turn the loading gear sideways by hand. Never use a screwdriver or other tool.

1-8. TOOLS AND FIXTURES REQUIRED FOR SERVICING

Ref.No.	Name	Part Code	Carved Jig No.	Use and Remarks
J-1	Torque Measurement Tape	J-6080-003-C	SL-0003C	forward torque and back tension measurement
J-2	Parallel Plate	J-6086-570-A	SL-0657	audio/CTL head lateral adjustment capstan shaft vertical adjustment
J-3	Dental Mirror (handle) Dental Mirror (mirror)	J-6080-029-A J 6080 030 1	SL-5052	tape path and tape traveling adjustment check
J-4	Alignment Tape (KR5-2H)	8-969-995-52	---	tracking, overall adjustment of picture quality, etc.
J-5	Cleaning Fluid	Y-2031-001-0	---	
J-6	Thickness Gauge	9-911-053-00	---	
J-7	Chamois Cloth	2-034-697-00	---	cleaning
J-8	Head Demagnetizer	widely available	---	demagnetization of video head and audio head
J-9	Cleaning Cassette Tape	8-888-004-00	---	video head cleaning
J-10	Dihedral Adjustment Screw	J-6080-013-A	SL-0013	video dihedral adjustment

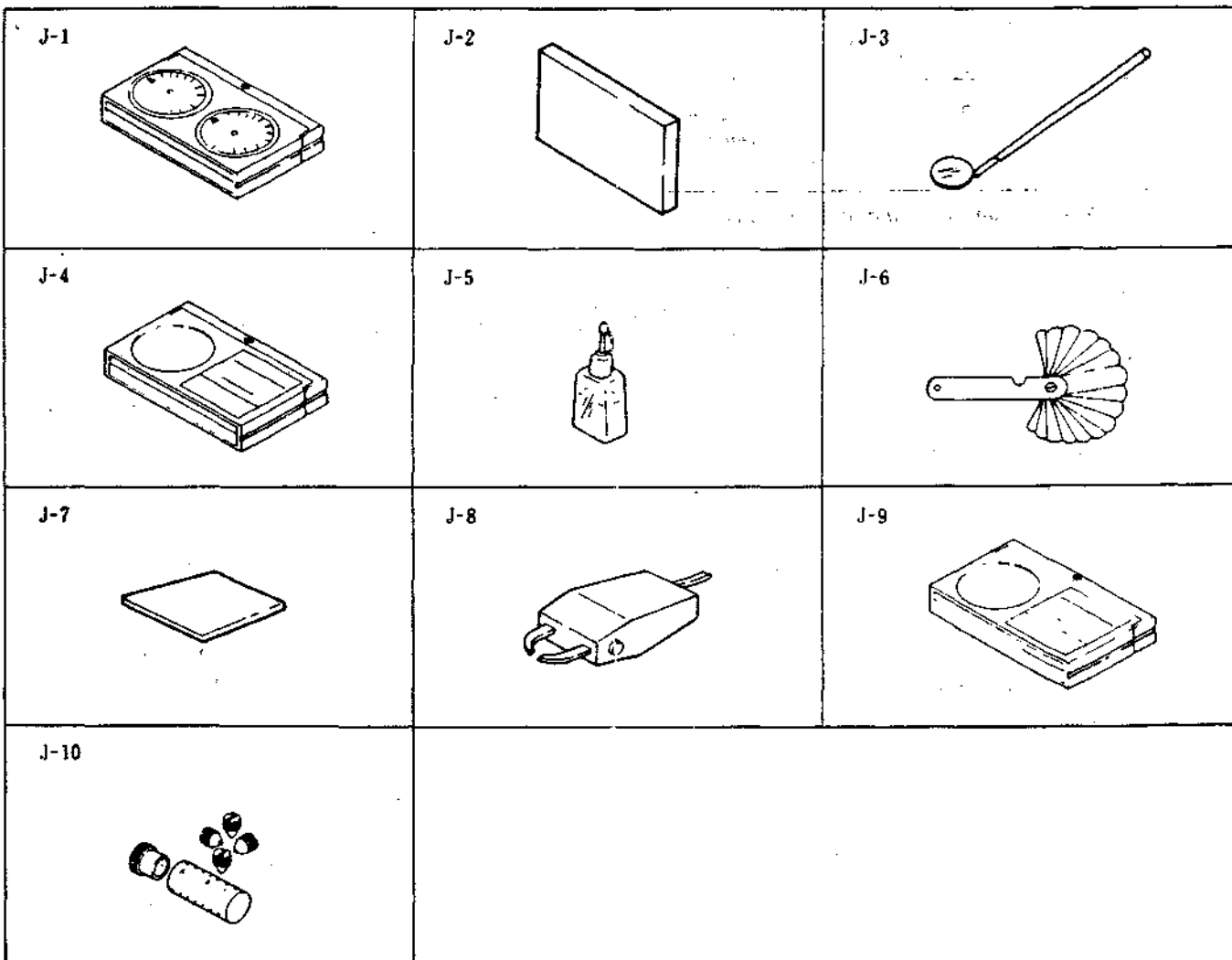

Fig. 1-10. Tools and fixtures required for servicing

2. PERIODIC CHECK AND MAINTENANCE

In order to obtain the best performance from this unit and make full use of its capabilities, and to extend the life of the unit and tapes, it is recommended that the following periodic checks and maintenance be performed.

2-1. POST-REPAIR MAINTENANCE

The following must be done after every repair regardless of how many hours the user has operated the machine.

2-1-1. Cleaning of Rotating Head Disk Assembly

- 1) Press a chamois cloth (Jig Ref. No. J-7) which has been dipped in cleaning fluid (Jig Ref. No. J-5) lightly against the rotating drum assembly, then do the cleaning by slowly rotating the rotating head disk by hand. (Never try to clean by using the motor to turn it.)
- 2) Never try to clean by moving the chamois cloth at a right angle to the head tip. There is a very great danger of damaging the head tip if this is done.

2-1-2. Cleaning of the Tape Movement System

- 1) Clean the surfaces which the tape contacts during its movement (tape guide, drum assembly surface, capstan, pinch roller, etc.) with a chamois cloth that has been dipped in cleaning fluid.

2-1-3. Cleaning the Drive System

- 1) Clean the driving parts with a cloth that has been dipped in cleaning fluid.

parts requiring cleaning

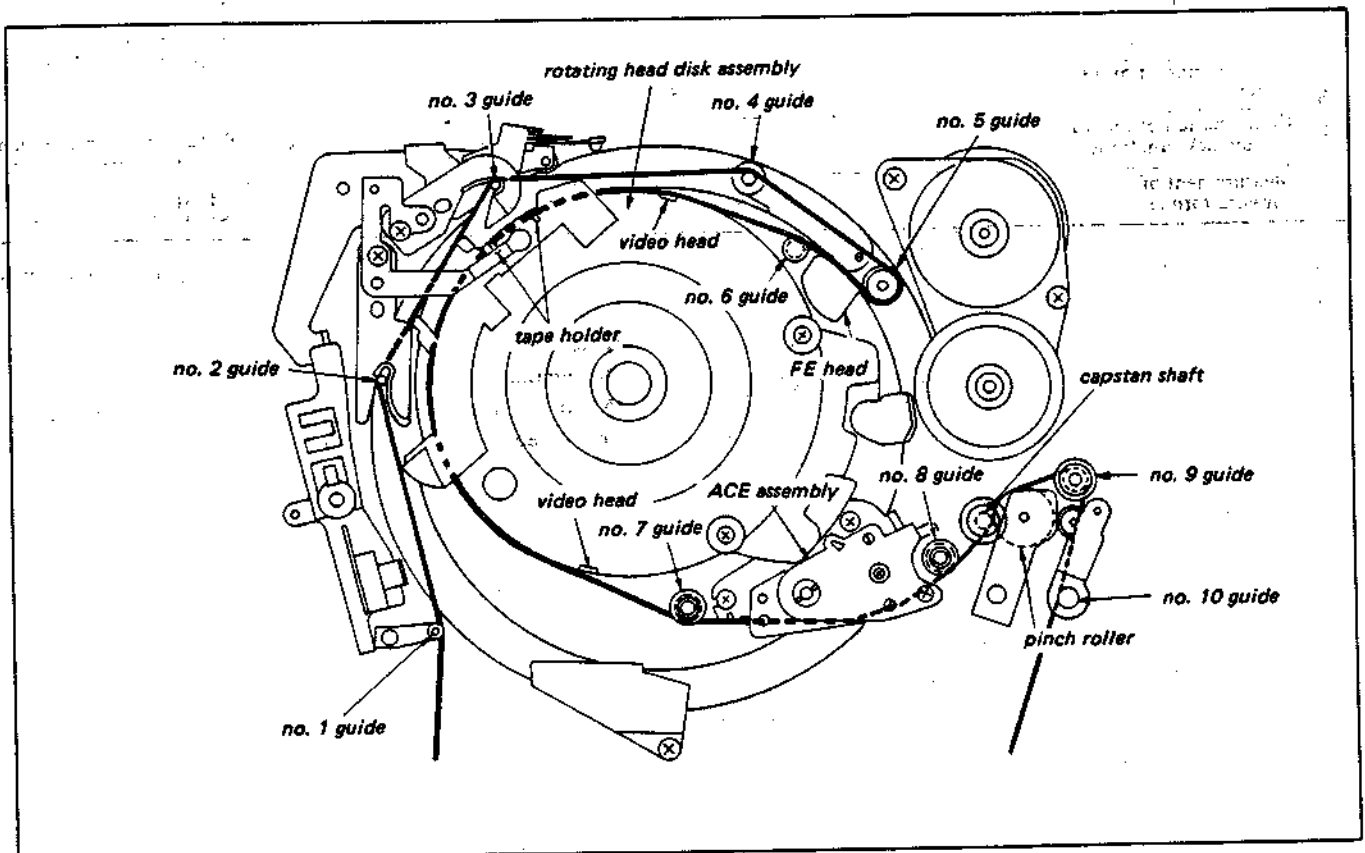

Fig. 2-1. Parts requiring cleaning

2-2. PERIODIC CHECK ITEMS

Perform the maintenance and check listed on the table below, according to user's operating hours.

Maintenance & Check		Operating Hours (H)											Remarks
		Replacement Part No.	500	1,000	1,500	2,000	2,500	3,000	3,500	4,000	4,500	5,000	
Tape Trans- Portation System	Cleaning of tape transportation system	—	○	○	○	○	○	○	○	○	○	○	This cleaning must be done whenever a repair is made.
	Cleaning and degaussing of ACE ass'y	—	○	○	○	○	○	○	○	○	○	○	
	Cleaning & degaussing of video disk ass'y	—	○	○	○	○	○	○	○	○	○	○	
Driving System	Loading belt (synchro belt)	3-684-264-01	☆	☆	☆	☆	☆	☆	☆	☆	☆	☆	This cleaning must be done whenever a repair is made.
	Cleaning of iron core and opening of solenoid	—	-	-	-	○	-	-	-	○	-	-	Wipe iron core and opening of solenoid with dry cloth.
Performance Confirmation	Abnormal sound		☆	☆	☆	☆	☆	☆	☆	☆	☆	☆	Adjust or replace the section which causes abnormal sound.
	Measurement of FWD back tension		-	☆	-	☆	-	☆	-	☆	-	☆	Confirmation must be made according to 3-13. Specified value: adjust to 31 - 35 g·cm (When measured with torque cassette tape)
	Confirmation of brake system		-	☆	-	☆	-	☆	-	☆	-	☆	
	Confirmation of record & playback functions		☆	☆	☆	☆	☆	☆	☆	☆	☆	☆	Perform the confirmation whenever repair is made.
	Measurement of forward torque		☆	☆	☆	☆	☆	☆	☆	☆	☆	☆	Adjust to 80 ± 5 g·cm (SL-0003C)

○ Cleaning ☆ Replacement ☆ Confirmation

Note:

On overhaul

When overhauling the unit, replace parts as indicated in the above table.

3. CHECK, ADJUSTMENT AND REPLACEMENT PROCEDURES

3-1. REPLACEMENT OF ROTATING HEAD DISK ASSEMBLY

3-1-1. Removal of the Rotating Head Disk Assembly (Fig. 3-1)

- 1) Remove the two screws that hold the damper assembly in place, then remove the damper assembly.
- 2) Use a hexagonal wrench to remove the hexagonal socket bolt that holds the upper drum assembly in place, then remove the upper drum assembly.

Note:

Turn the upper drum to remove, being careful not to move the adjusting plate. Movement of the adjusting plate will have a great effect on the tape path, so caution is required.

- 3) Unsolder the rotating head disk relay plate (4 red and white leads).
- 4) Remove the two hexagonal socket bolts holding rotating head disk assembly ⑤ in place, then remove the rotating head disk assembly.

Note:

Be careful not to touch the head tip with the hand or bang anything against it.

3-1-2. Mounting of the Rotating Head Disk Assembly (Fig. 3-1)

- 1) Insert rotating head disk ⑤ in place, being careful of the direction so that the red and white leads are in the right places.
- 2) Tighten hexagonal socket bolt ④ and solder the lead wires.

Note:

Be careful to solder the lead wires correctly and not to break any wires.

- 3) Attach the upper drum, being careful (as during removal) not to move the adjusting plate. While pressing the two points that determine the height, tighten hexagonal socket bolt ②.

Note:

When inserting the upper drum, be careful that it does not touch the head tip.

Note:

When replacing the rotating drum head, it can happen that the rotating head disk assembly will be hard to remove. In such a case, remove it using the method explained below (Fig. 3-2).

- 1) Remove the hexagonal socket bolts that hold the rotating head disk assembly in place.
- 2) When the head disk is jammed on tight and is hard to remove, screw the hexagonal socket bolts removed in step ① into the threaded holes removed from the original holes by 90°. Tighten them a little at a time.

The head disk will be lifted up by the two screws and will come off easily.

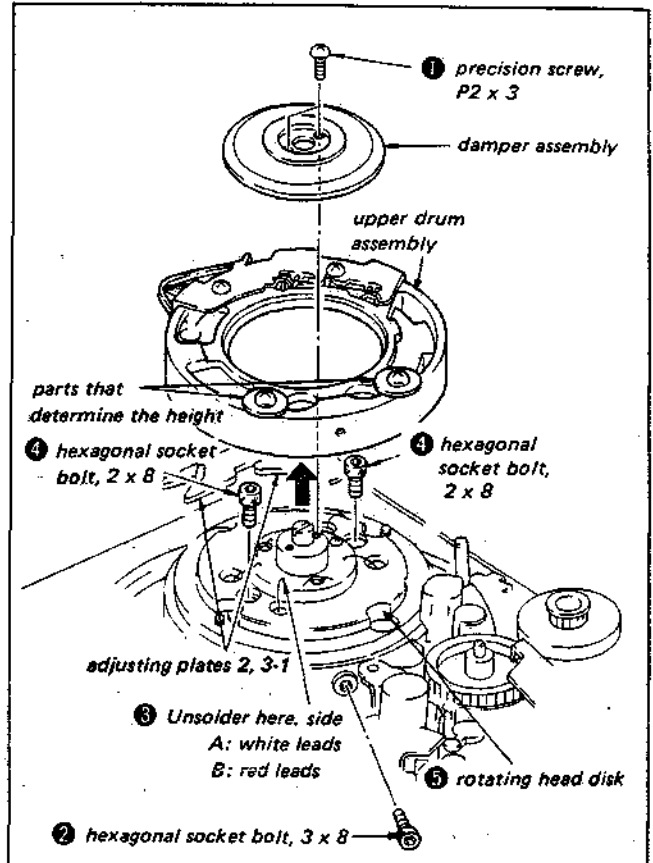

Fig. 3-1. Removal of the rotating head disk assembly I

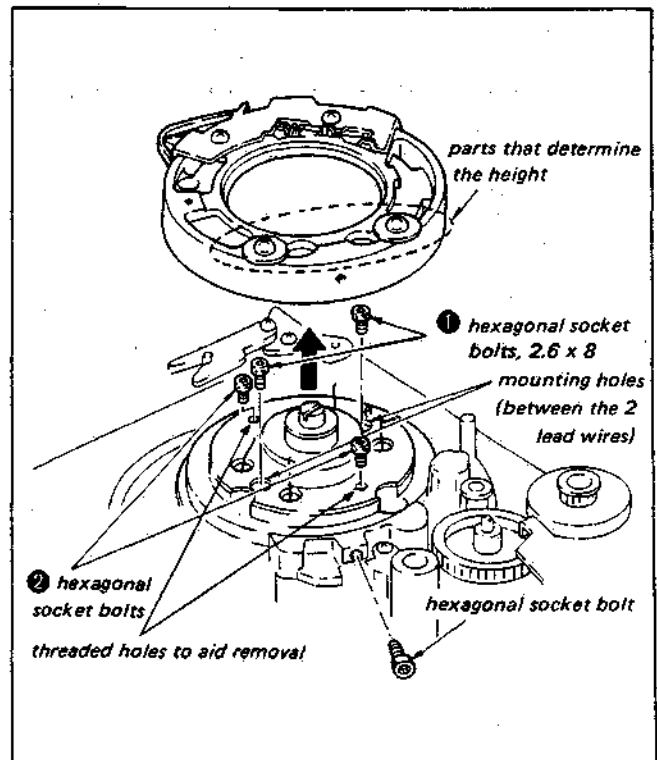

Fig. 3-2. Removal of the rotating head disk assembly II

3-2. VIDEO HEAD DIHEDRAL CHECK AND ADJUSTMENT

This adjustment is generally unnecessary, but it is sometimes necessary when the video head disk is replaced. (The video head disk used for maintenance has been precision adjusted at the factory using a microscope and almost never needs to be readjusted.)

When judging whether the video head dihedral angle is correct, the alignment tape is played back. When this is done the tracking control knob must be in the centering position. If the check is done with this knob in other than the center click position (if the tracking is off-center), even if the dihedral angle is correct the picture will be reproduced as if it were off.

Before this adjustment is performed, the ACE assembly position adjustment (refer to the section where the tape path adjustment is described) must be completed.

[Method of checking]

With the tracking control knob set to the center click position, play back the monoscope section of the alignment tape. Check to see if any of the vertical monoscope lines immediately below the switching pulse are reproduced double. If not, the dihedral angle is correct and does not have to be adjusted. If so, perform the adjustment as explained below.

[Method of adjustment]

- 1) As shown in Fig. 3-3, screw two dihedral angle adjustment screws (Jig Ref. No. J-10) into the adjustment screw holes on the side on which the red lead wires from the video head are connected, until the top of the screw is level with the video head disk. (If they are not screwed in far enough, the video head disk will not turn past the point where the top of the adjustment screw strikes the upper drum. Conversely, if it is screwed in too far, the head base will be moved, throwing the video head dihedral angle way off.)

Note:

The side on which the white lead wires are connected is the reference side and must not be moved.

- 2) Screw one of the two adjustment screws in a little bit farther until resistance is felt. Beyond this point, turning the screw still farther will move the video head, adjusting the dihedral angle.
- 3) With the adjustment screws in place, play the monoscope signal section of the alignment tape and see how the lines are reproduced. If the vertical lines are split apart more than before, turn the screw which was screwed in more tightly counterclockwise to loosen it, then adjust by tightening the other screw.
- 4) After the adjustment is completed, remove the adjustment screws and play the tape again to reconfirm that the adjustment is correct.

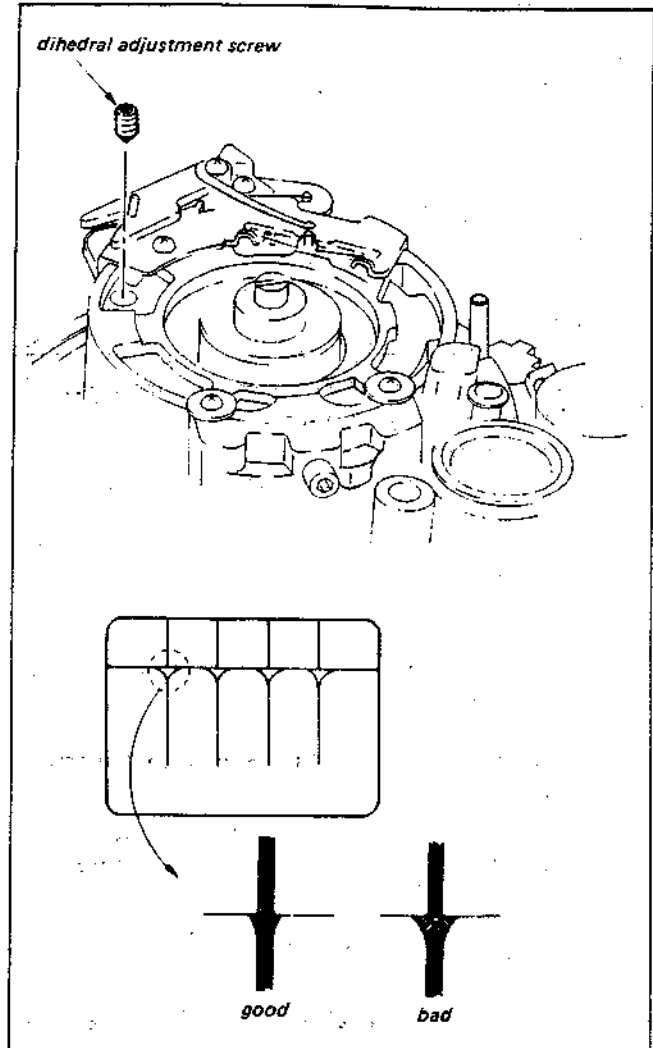

Fig. 3-3. Video head dihedral adjustment

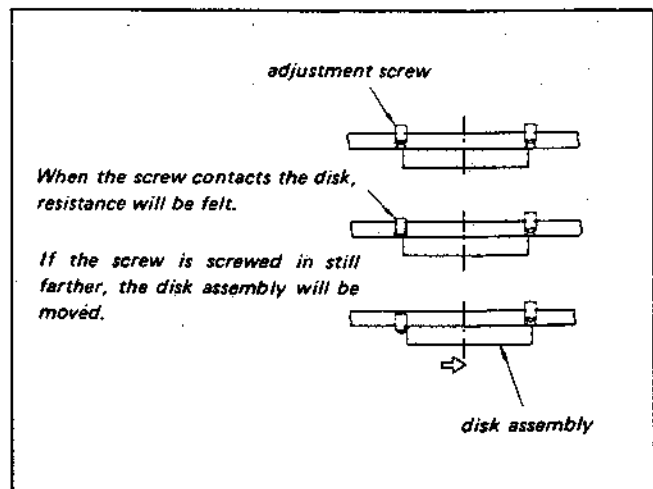

Fig. 3-4.

3-3. REPLACEMENT AND ADJUSTMENT OF THE DRUM ASSEMBLY

3-3-1. Replacement of the Drum Assembly

- 1) Measure gap **A** between adjusting plate 2 and the upper drum holder section and record the measurement.
Note:
 The position where the adjusting plate is mounted has a large effect on the tape path, so this measurement must be performed.
- 2) Measure gap **B** between adjusting plate 3-1 and the upper drum holder section, and record the measurement.
Note:
 The position where the adjusting plate is mounted has a large effect on the tape path, so this measurement must be performed.
- 3) Remove the screws shown in Fig. 3-5, then remove the tape guide ground plate and adjusting plates 2 and 3-1.
- 4) Remove the 3 connectors from the rear of the chassis as shown in Fig. 3-6.
- 5) Remove the 3 drum mounting screws from the rear of the chassis, then remove the main body of the drum assembly. After the replacement has been completed, adjust the drum path.

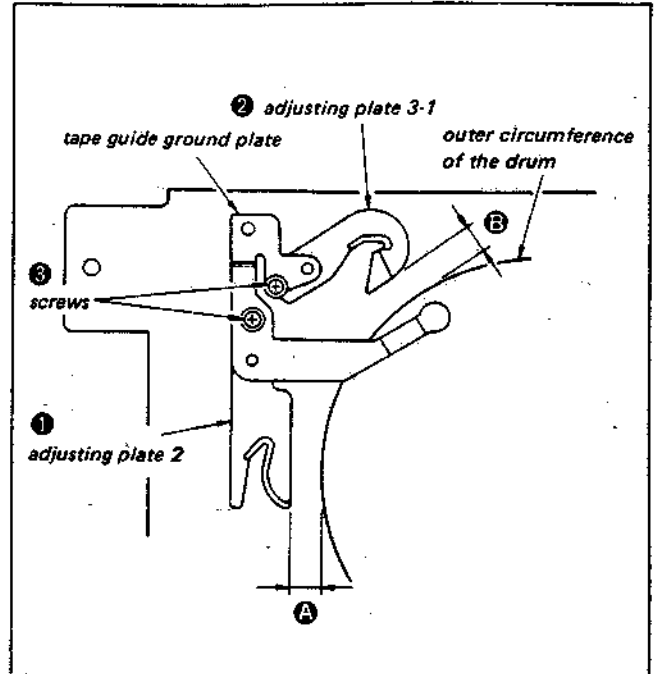

Fig. 3-5. Measurement of the position of adjusting plates 2 and 3-1

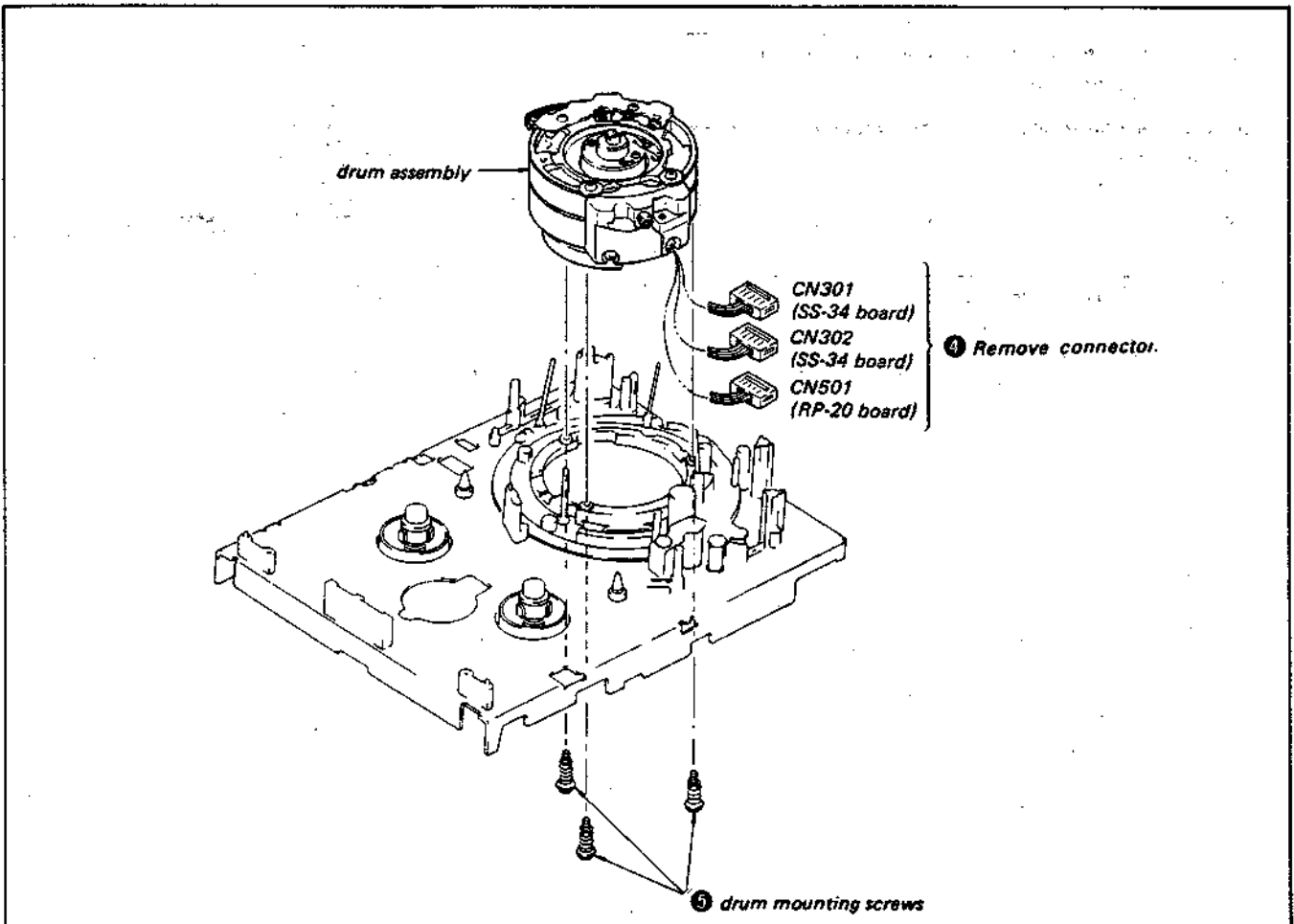

Fig. 3-6. Removal of the drum assembly

3-3-2. Adjustment of the Motor Gap when Replacing the Drum Assembly

After replacing the drum assembly, adjust the gap between the motor rotor and the coil to 0.3 mm to 0.6 mm (Fig. 3-7).

[Procedure]

- 1) When re-assembling the drum, use the spacers which were removed to produce a gap of between 0.3 mm and 0.6 mm. Measure the gap using the gauge that comes with the drum for assembly and maintenance use. One side of the gauge is 0.3 mm and the other side is 0.6 mm. If the gap is adjusted correctly, the 0.3 mm side should fit in and the 0.6 mm side should not.
- 2) If this fails to give the correct gap width, do not use the spacers which were removed; instead, use a combination of the 4 0.3 mm accessory spacers to obtain the correct width.

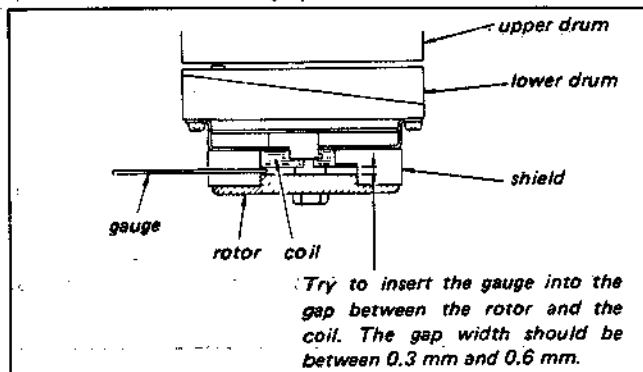

Fig. 3-7. Checking the motor gap width after replacing the drum assembly

Removal of the stator and rotor when replacing the drum

- 1) Remove the nut and washer.
- 2) Remove the rotor from the stator.
- 3) Remove the 2 screws, then remove the stator from the main body of the drum.

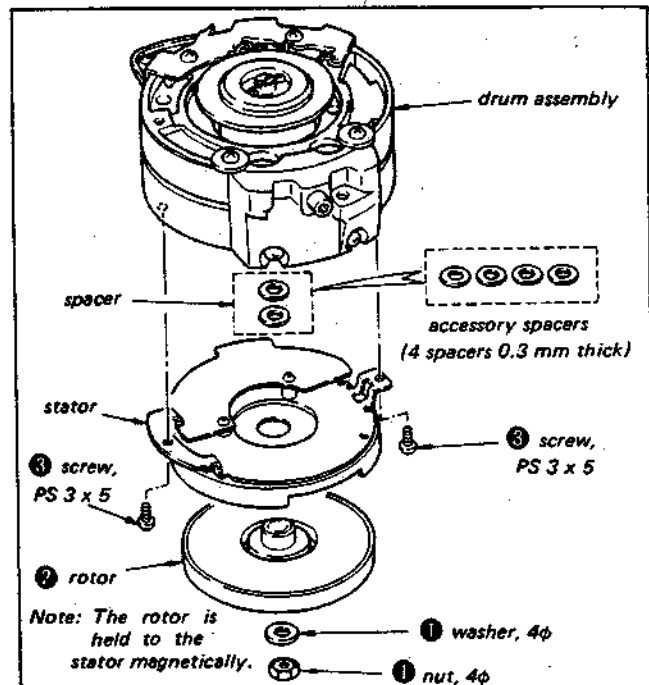

Fig. 3-8. Removal of the stator and rotor when replacing the drum

3-4. REPLACEMENT OF THE CAPSTAN MOTOR

3-4-1. Removal of the Capstan Motor (Fig. 3-9)

- Remove the three screws ❶ then remove the capstan motor from the rear of the mechanical chassis.

Note:

When the capstan motor has been removed or replaced, check the tape path once.

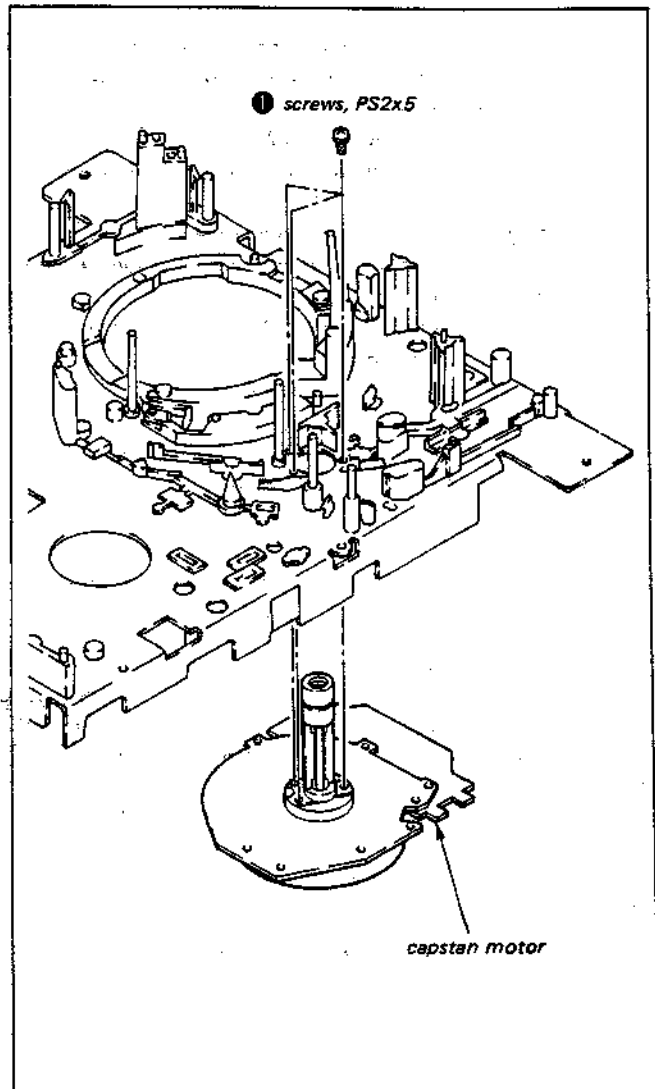

Fig. 3-9 Removal of the capstan motor

3-5. REMOVAL OF THE S COIL SENSOR (Fig. 3-10)

- 1) Remove the spring.
- 2) Remove the claw in the direction of arrow **A**, then pull the S coil sensor out.
- 3) Pull out the connector from CN604 on SS-34 board.

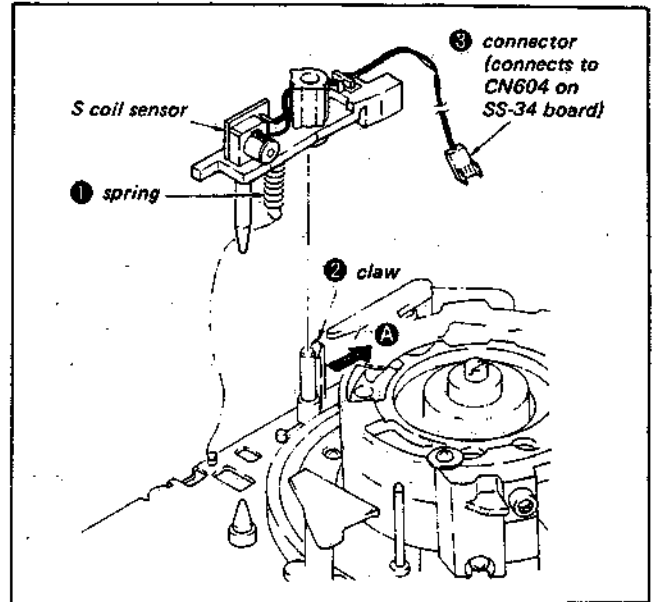

Fig. 3-10. Removal of the S coil sensor

3-6. REMOVAL OF THE FL CASSETTE COMPARTMENT ASSEMBLY (Fig. 3-11)

- 1) Remove the four screws (BVTP3 x 8) (1).
- 2) Remove the internal gear flange (2).
- 3) Remove the timing belt (loading belt) (3).
- 4) Pull out the connector CN606 (4), on the SS-34 board.
- 5) Remove the FL cassette compartment assembly in the direction shown by the arrow.

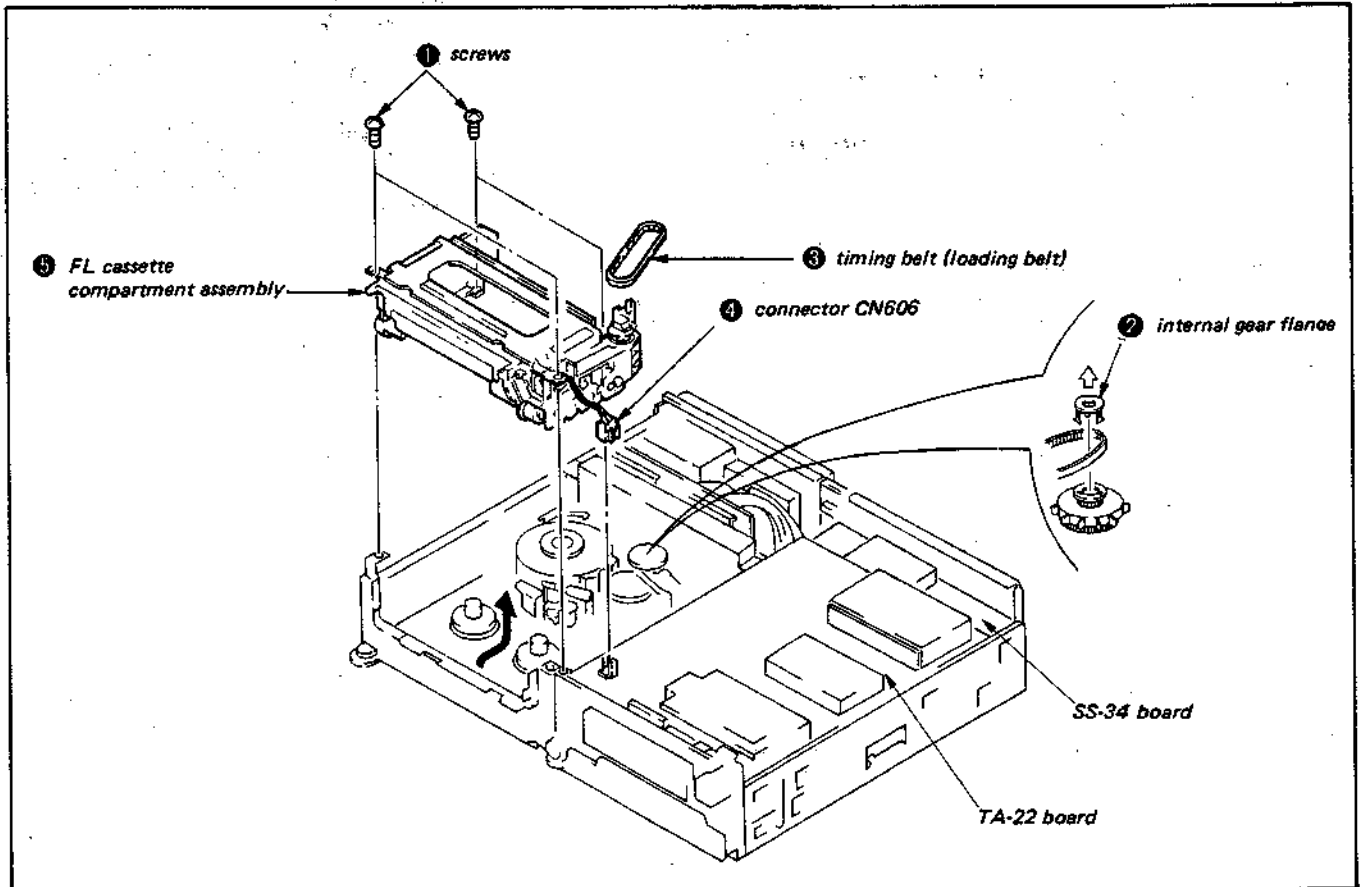

Fig. 3-11. Removal of the FL cassette compartment assembly

3-7. ADJUSTMENT OF THE FL CASSETTE COMPARTMENT

3-7-1. Adjustment of the Position of the Right Gear of the FL Cassette Compartment Assembly

In the FL cassette compartment assembly, the cassette holder must always move parallel to the mechanical chassis. The gear system is used to control the amount by which the cassette holder advances so that this will be the case. Consequently, if the gears in this section slip out of mesh, the next time the unit is assembled the gear mesh must be adjusted to the correct position; otherwise the cassette will not feed properly.

[Adjustment of the gear positions]

- 1) Get a positioning rod about 200 mm long and 1.5 mm in diameter ready.
- 2) While passing the positioning rod through the combination of the drive arm right and cassette ON cam, fit the latter on the right side plate. Similarly, fit the drive arm left onto the left side plate.
- 3) Similarly, while passing the positioning rod through the worm wheel, fit the latter onto the right side plate.
- 4) Similarly, while passing the positioning rod through the combination of the limiter gear and cassette OFF cam, fit the latter onto the right side plate.

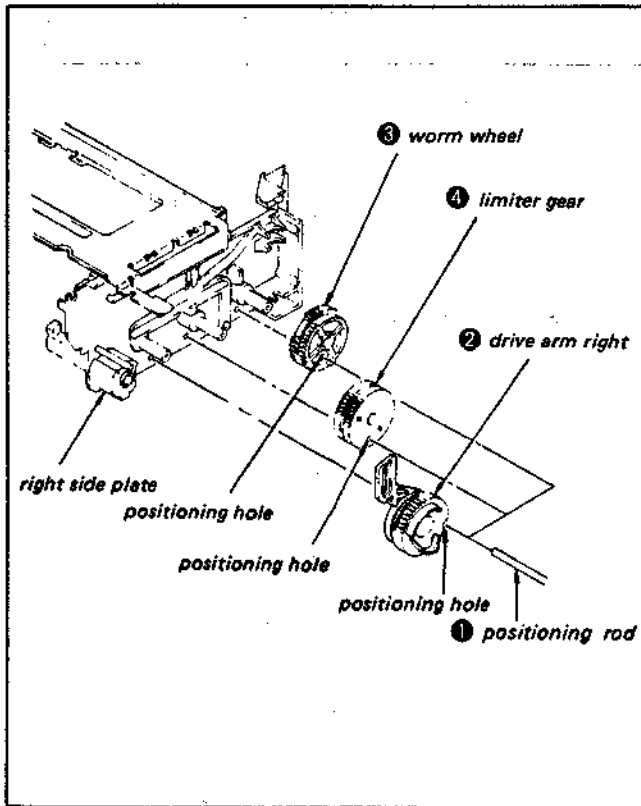

Fig. 3-12. Positioning of the FL cassette compartment gears

3-7-2. Cassette ON Switch Operation Check and Adjustment

[Method of checking]

When inserting a cassette into the FL cassette compartment assembly, confirm that as the cassette is inserted, the leafswitch comes ON when the center of the drive roller is 8 to 13 mm from the end of the guide groove, as shown in Fig. 3-13.

[Method of adjustment]

Bend the tip of the cassette ON switch in the direction of the arrow.

Adjust so that the cassette ON switch comes ON when the above distance is 8 to 13 mm, and finally tighten the screw.

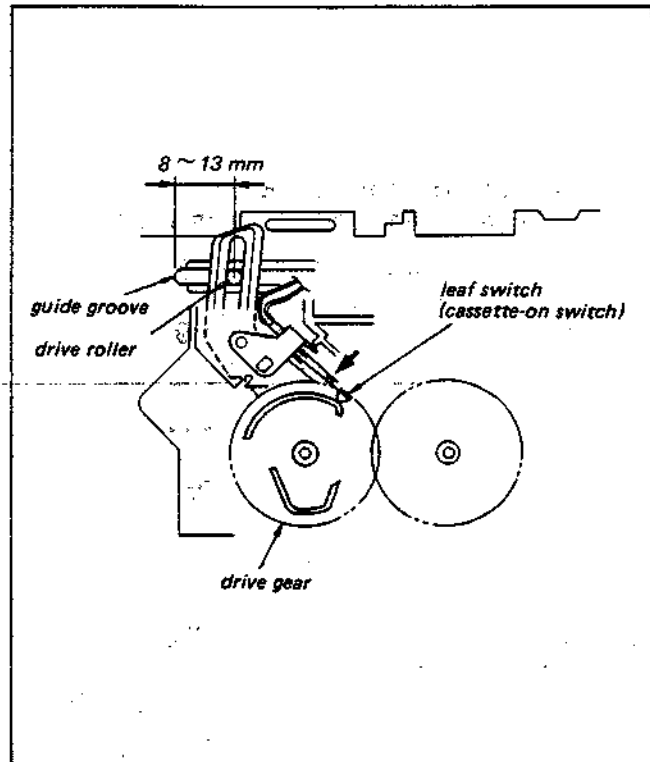

Fig. 3-13. Cassette ON switch operation check and adjustment

3-8. REMOVAL OF THE No. 2 AND No. 3 GUIDES

3-8-1. Removal of the No. 2 Guide

- 1) Remove the 1x3 tap-in screw.
- 2) Remove the 1.4x3 tap-in screw.
- 3) Remove the No. 2 guide assembly.

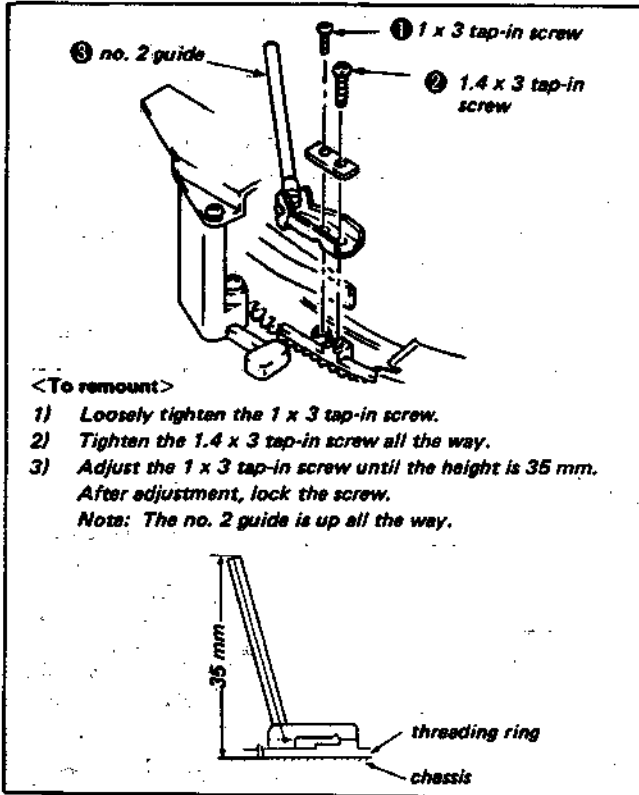

Fig. 3-16. Removal of the no. 2 guide

3-8-2. Removal of the No. 3 Guide

- 1) Remove the 1x3 tap-in screw.
- 2) Remove the 1.4x3.5 tap-in screw.
- 3) Remove the limiter spring.
- 4) Remove the No. 3 guide assembly.

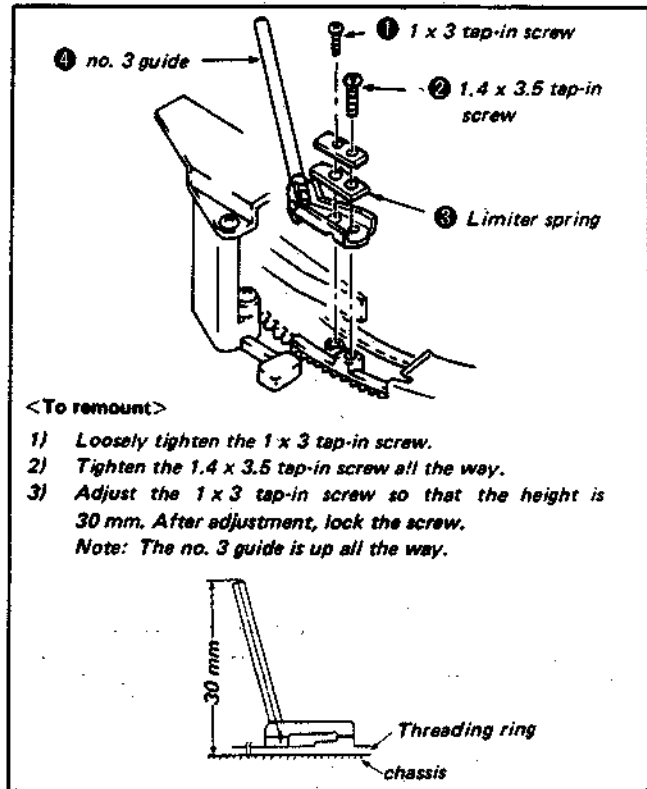

Fig. 3-17. Removal of the no. 3 guide

3-7-3. Checking and Adjustment of the Cassette Door Assembly

[Method of checking]

With the door opening and closing arm returned all the way in the direction of arrow **A**, check to make sure that the door is vertical.

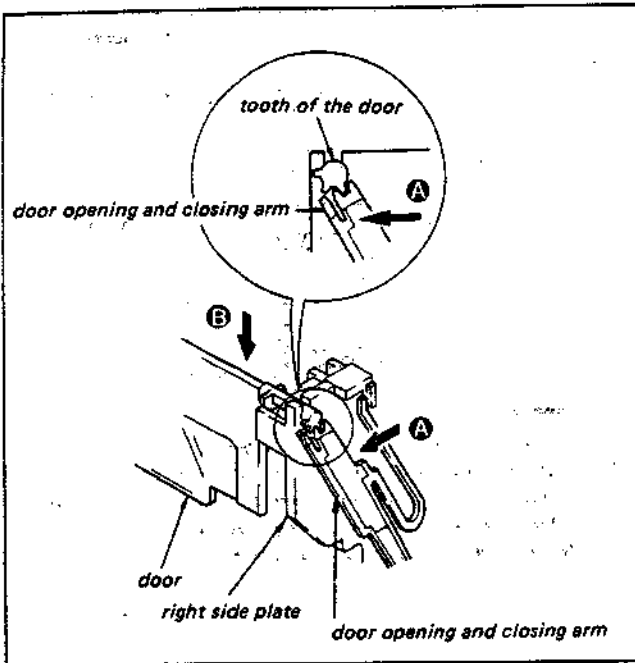

Fig. 3-14. Adjustment of the position of the cassette door assembly

[Method of adjustment]

check to make sure that the door opening and closing rack plate has returned all the way. Then, close the door together in the direction of arrow **B** so that it is vertical, and mesh the gears.

3-7-4. Mounting the FL Cassette Compartment Assembly (Fig. 3-15)

- 1) Hook the two holes of the FL cassette compartment assembly onto the mechanical chassis, then place the compartment in the specified position on the chassis.
- 2) Loosely tighten the 4 mounting screws of the FL cassette compartment assembly. Move the FL cassette compartment assembly forward and backward with respect to the mechanical chassis, set it in the correct position, then tighten the mounting screws all the way.
- 3) Connect the timing belt (loading belt) between the threading motor and the worm gear, then hold it in place with the internal gear flange.
- 4) Press the tension roller arm in the direction of the arrow to adjust the tension of the timing belt (loading belt), then fix it in place with the arm fixing screw.
- 5) Insert the harness sticking out from the FL cassette compartment into connector CN606 on SS-34 board.

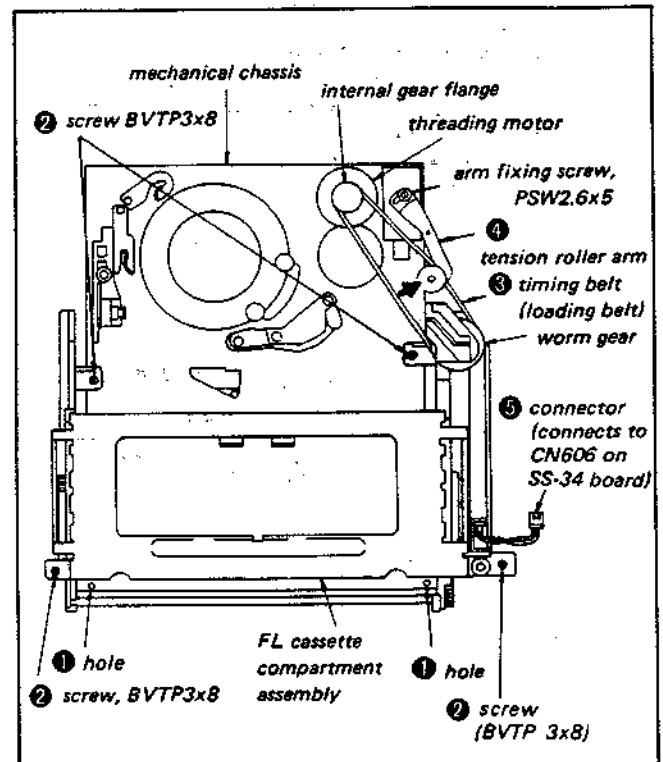

Fig. 3-15. Mounting the FL cassette compartment assembly

3-13. ADJUSTMENT OF THE FORWARD BACK TENSION

[Method of measurement]

- 1) Insert the torque cassette (SL-0003C) and put the unit in playback mode.
- 2) Read the value on the meter on the S reel side after the needle has gone around about once.

The correct value is 31 g·cm – 35 g·cm

Notes:

- i) The set must be perfectly level during this measurement.
- ii) After the measurement, the tape can become slack when the stop button is pressed. If this happens set the unit in forward mode to take up the slack before removing the tape.

[Method of adjustment]

Move the position of the tension coil spring that is hooked on the tension regulating lever assembly in the direction of arrow

- Ⓐ until the measured value falls within the correct range.

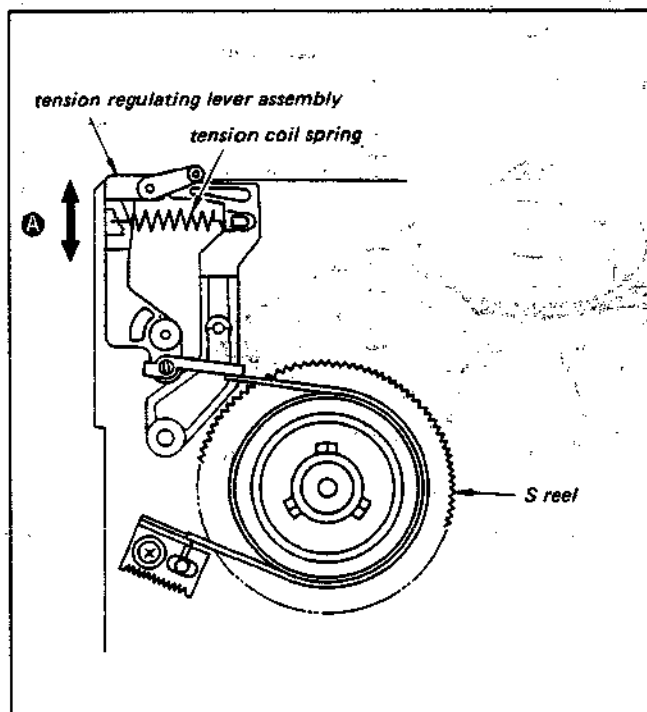

Fig. 3-29 Adjustment of the back tension

3-14. ADJUSTMENT OF THE FORWARD TORQUE

[Method of measurement]

- 1) Insert the torque cassette (SL-0003C) and start to record a telecast.
- 2) Read the value on the meter on the T reel side after the needle has gone around about once. The correct range is 80g·cm ± 5g·cm.

[Method of adjustment]

- 1) Remove the front panel.
- 2) Turn potentiometer RV308 on SS-34 board to adjust the torque until its value falls within the correct range.

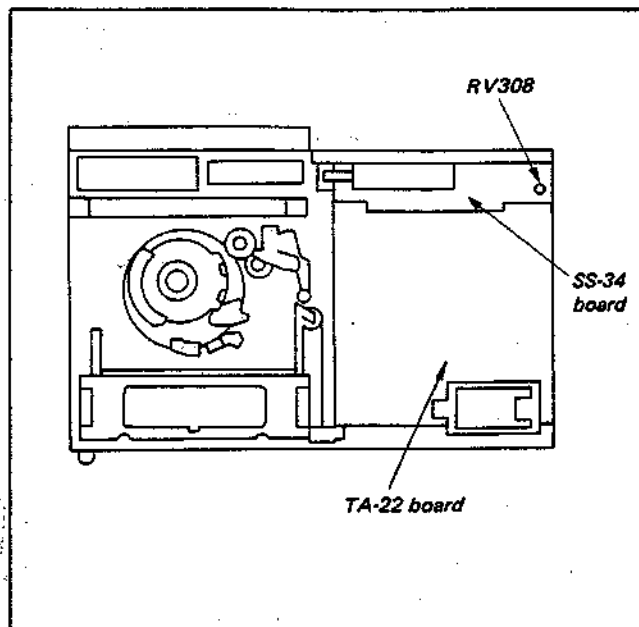

Fig. 3-30. Adjustment of the forward torque

Note:

When the forward torque is weakened during the measurement the tape can become slack, in which case the set will go into emergency stop mode. In such a case, the only switches that will work are the cassette eject switch and the power switch. It is necessary to temporarily remove the cassette, or to turn the power OFF and back ON.

4. TAPE PATH ADJUSTMENT

4-1. TRACKING ADJUSTMENT

This adjustment has a large effect on the picture quality in each mode and on the interchangeability of tapes, so it should be done carefully.

4-1-1. Preparation for adjustment

4-1-2. Adjustment on the entrance side

4-1-3. Adjustment on the exit side

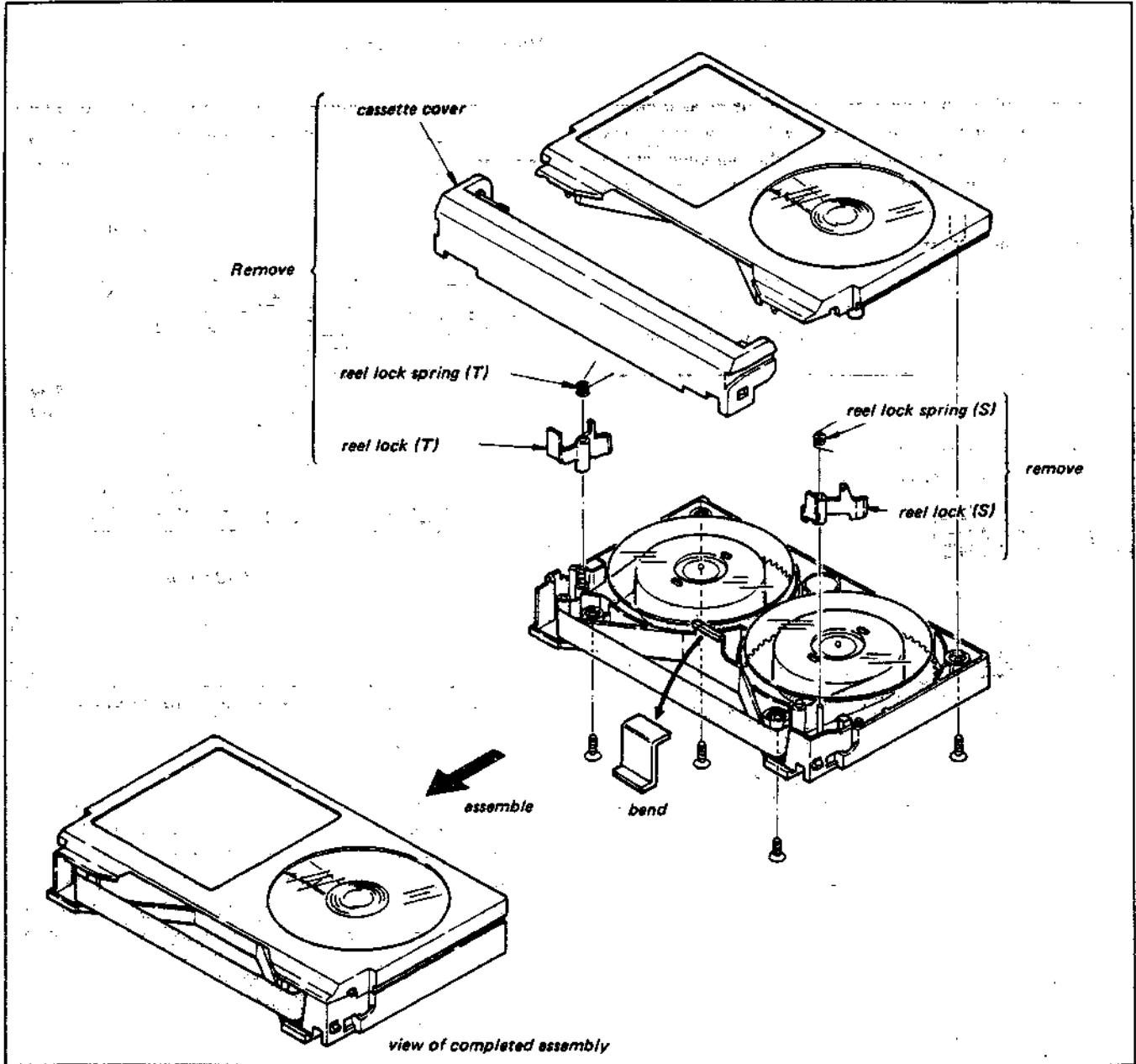

Fig. 4-1.

4-1-1. Preparation for Adjustment

- 1) Remove the cassette cover of the alignment tape in accordance with Fig. 4-1.
- 2) Clean the surface contacted by traveling tape (tape guide, drum tape trailing surface capstan shaft pitch roller, ACE FE head surface) with a chamois cloth dipped in methanol.
- 3) Connect the oscilloscope as follows:
Channel 1: Pin ⑥ of CN502 (RP-20 board)
External trigger: Pin ③ of CN502 (RP-20 board)
- 4) Play back the 1 kHz signal on the tracking section of the alignment tape.
- 5) Confirm that the oscilloscope radio frequency output waveform is flat and that the amplitude is a maximum. (Turn the tracking knob right and left to increase and decrease the amplitude while the waveform remains flat.) When the amplitude of the waveform is a maximum, confirm that the fluctuations and contact of the radio frequency output waveform meet the standards given in Fig. 4-2. If they do not, go through the procedure given in step 6).
- 6) If the entrance waveform cannot be made flat, as shown in Fig. 4-3 (a), by turning the tracking knob, go through the "entrance side adjustment" described in 4-1-2; if the exit waveform shown in Fig. 4-3 (b) cannot be made flat, go through the "exit side adjustment" in 4-1-3.

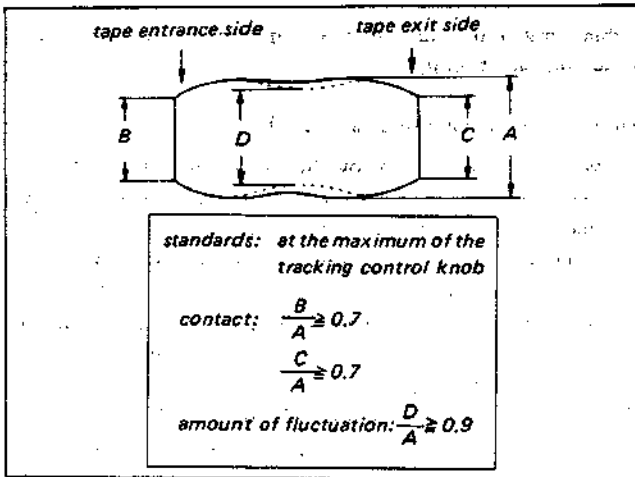

Fig. 4-2.

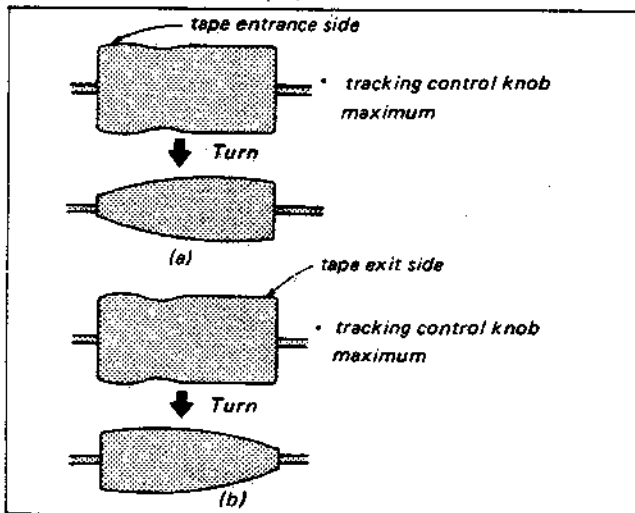

Fig. 4-3.

4-1-2. Entrance Side Adjustment

Whenever the entrance side adjustment is performed, the exit side adjustment must also be performed. The various tape guides and adjustment positions are shown in Fig. 4-5.

- 1) Turn the No. 6 guide counterclockwise to free the movement of the tape as it enters the drum.
- 2) Turn the tracking control knob to the right until the amplitude of the waveform is about 60% of its maximum.
- 3) Loosen No. 5 guide lock screw ① and turn the No. 5 guide until the entrance waveform sticks up a little above flat, as shown in the figure below. Then tighten the No. 5 guide lock screw (Fig. 4-6).

Note:

After tightening No. 5 guide lock screw ①, confirm that it is as in the figure below.

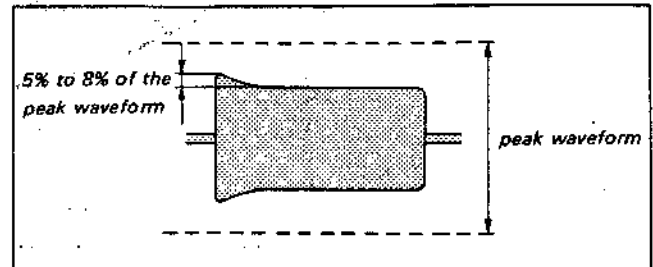

Fig. 4-4.

- 4) Next, lower the No. 6 guide until the waveform is flat.
- 5) Press the tape down between the No. 4 and No. 5 guide with a finger to lower the entrance side radio frequency waveform, then let go and confirm that the waveform returns to what it was before.
- 6) In this condition, check the clearance and curl of the No. 5 guide. If there are clearance and curl, adjust as explained in subsequent sections.

Note:

The tape tension between the No. 3, No. 4 and No. 5 guides must be balanced. If it is not, adjust the tilt of the No. 3 and No. 5 guides.

If the waveform cannot be made to look as shown in Fig. 4-4, or if when the tape is pressed and released on the entrance side it takes time for the waveform to return to what it was before, or if it does not return to what it was before, adjust according to the instructions given below.

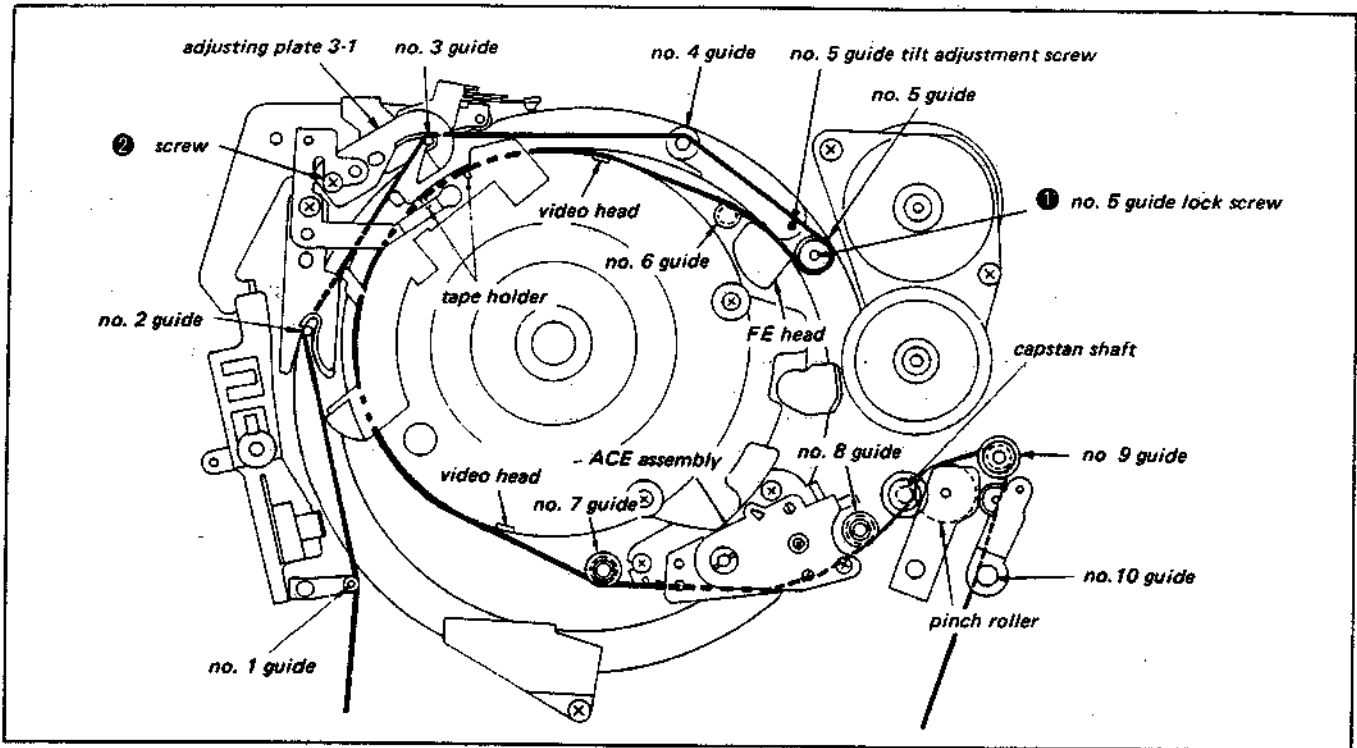

Fig. 4-5. Tape guide layout diagram

[What to do when the waveform entrance output will not rise]

- 1) Check to see if the up-down tension between the No. 3, No. 4 and No. 5 guides is uniform. If it is not, adjust the tilt of the No. 3 and No. 5 guides.

Note:

The lower flange of the No. 4 guide must not protrude.

- 2) Raise the lower flange of the No. 4 guide to raise the entrance output.

Note:

It is sufficient to raise the lower flange of the No. 4 guide to 0.4 mm from its lowest position (within a rotation angle of 360°).

- 3) If the operation performed in step 2) fails to raise the waveform output, turn the No. 5 guide tilt adjustment screw slightly to the left, and the entrance output should rise.

[What to do when the waveform entrance output will not drop]

- 1) Remove the adjusting plate 3-1 of the No. 3 guide from the drum. Just before the lower tension of the tape becomes slack, tighten screw ②.
- 2) If the tape is in contact with the lower flange of the No. 4 guide, lower the flange. If the tape is sticking up from the lower flange, adjust the tilt of the No. 5 guide so that the tape does not stick up from the lower flange of the No. 4 guide.

[What to do when there is a clearance in the No. 5 guide]

Turn the No. 4 guide counterclockwise to run the tape upward and eliminate the clearance in the No. 5 guide.

Note:

At this time make sure that a large curl is not produced below the No. 4 guide.

[What to do when there is a curl]

- 1) When there is a gap below the No. 4 guide: Just before the lower tension on the tape becomes slack, move adjusting plate 3-1 of the No. 3 guide to the outside.
- 2) When there is not a gap below the No. 4 guide (when there is a curl below the No. 4 guide):
 - i) Check to see if the No. 4 guide has been raised up too high. If it has been raised up too high, turn the adjusting plate clockwise to lower the No. 4 guide.
 - ii) If the curl still has not been removed after i), tighten the No. 5 guide tilt adjustment screw in the clockwise direction until the curl is removed.

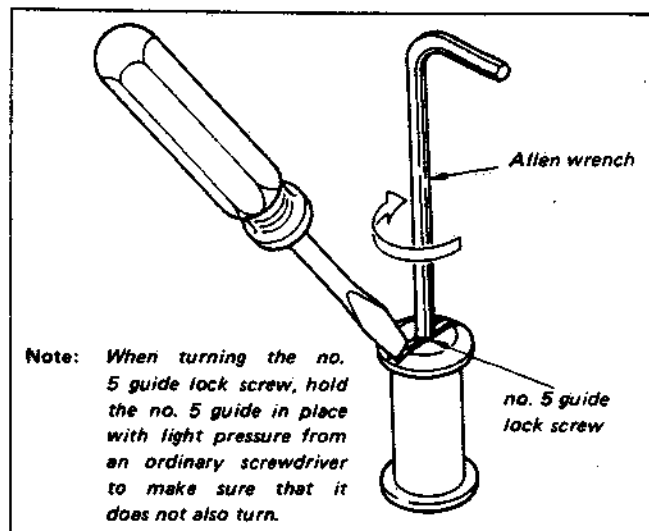

Note: When turning the no. 5 guide lock screw, hold the no. 5 guide in place with light pressure from an ordinary screwdriver to make sure that it does not also turn.

Fig. 4-6.

4-1-3. Exit Side Adjustment

- 1) Connect the oscilloscope to pin ⑥ of CN502 (RP-20 board). Connect the external trigger to pin ③ of CN502.
- 2) Play the tracking section of the alignment tape. Adjust the tracking knob to reduce the amplitude of the radio frequency output waveform to 60% of its maximum level.
- 3) Watch the radio frequency output waveform when the No. 7 and No. 8 guides are raised (by turning the respective guide nuts counterclockwise) to let the tape run free. This waveform is called to exit free waveform.

Note:

Be careful not to raise the guides too far. They should be raised only about 0.2 to 0.3mm.

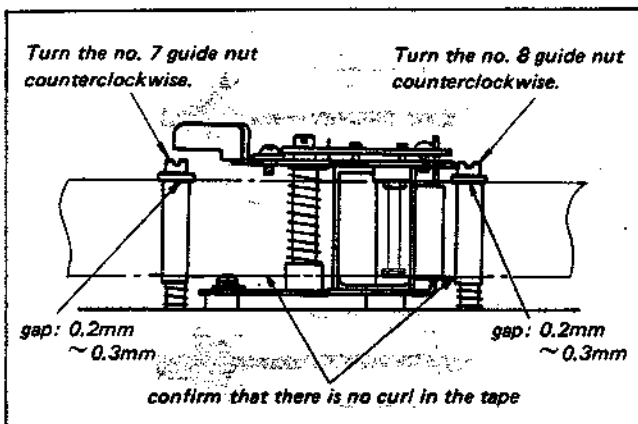

Fig. 4-7.

- 4) At this time, confirm that the exit free waveform is within the range shown in Fig 4-8(a) and (b).
 - If it is outside of this range, adjust according to the procedure in 4-3.

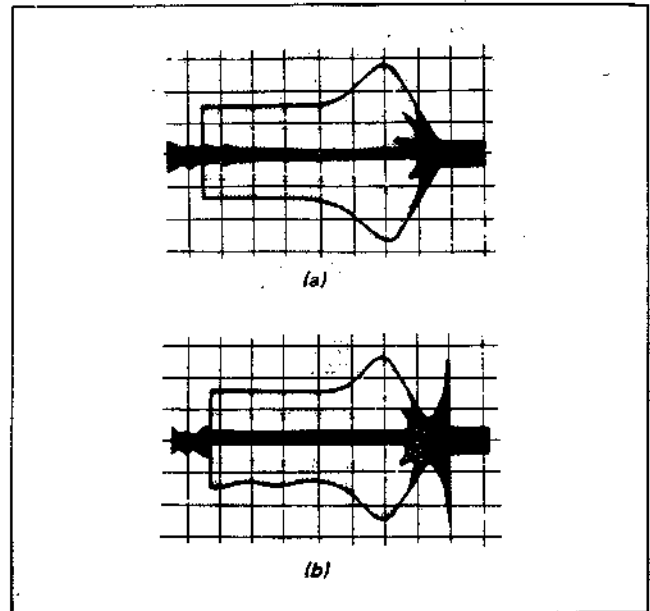

Fig. 4-8.

- 5) Turn the No. 7 guide nut clockwise until the waveform is flat.
- 6) Turn the No. 8 guide nut clockwise until the No. 8 guide is lined up with the tape (just before the waveform starts to change lower the guide until there is no curl).
- 7) During playback, confirm that no curl occurs in the No. 7 guide or the No. 8 guide.
- 8) During review confirm that no curl or clearance occurs in the No. 8 guide. If there is a curl or clearance, adjust using the No. 9 guide. After adjustment, lock the guide nut.

4-2. ADJUSTMENTS AFTER REPLACEMENT OF THE ACE ASSEMBLY

After removal or replacement of the ACE assembly perform the adjustments listed below.

- 4-2-1. Exit side tracking adjustment
- 4-2-2. CTL head (ACE assembly) position adjustment
- 4-2-3. Audio head (ACE assembly) azimuth adjustment
- 4-2-4. Audio head (ACE assembly) height adjustment

4-2-1. Exit Side Tracking Adjustment

- 1) Set the parallel plate (SL-0657 in the list of fixtures and tools) up against the unit as shown in Fig. 4-9, and turn the tilt adjustment screw to adjust the audio head vertically.

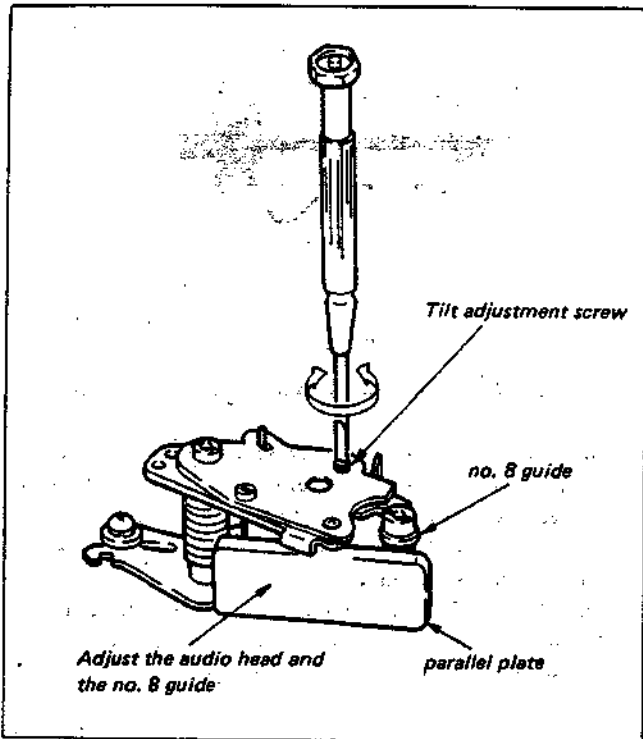

Fig. 4-9.

- 2) Connect the oscilloscope to pin ⑥ of connector CN502 (RP-20 board). Connect the external trigger to pin ③ of CN502.
- 3) Play the tracking section of the alignment tape. Adjust the tracking knob until the radio frequency output waveform amplitude is reduced to about 60% of its maximum level.
- 4) Raise the No. 7 and No. 8 guides (turn the respective guide nuts counterclockwise) and observe the radio frequency exit free waveform when the tape runs free.

Note:

Be careful not to raise the guide too far. Raise it about 0.2 to 0.3 mm.

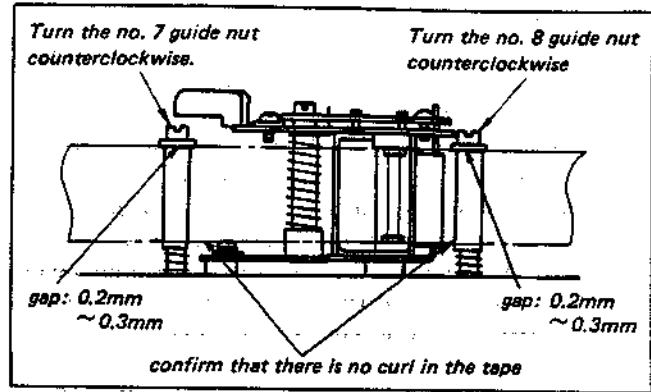

Fig. 4-10.

- 5) At this time, confirm that the exit free waveform is within the range shown in Fig. 4-11(a) and (b).

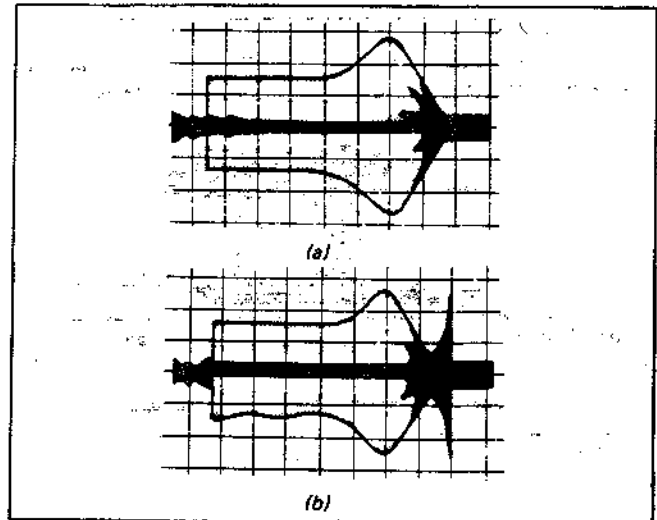

Fig. 4-11.

[When the waveform is outside this range]

- When the waveform is outside this range and has the form shown in Fig. 4-12, turn the tilt adjustment screw clockwise to adjust until the waveform is within the required range.

Note:

Complete the adjustment by turning the adjustment screw in the direction of tightening (clockwise).

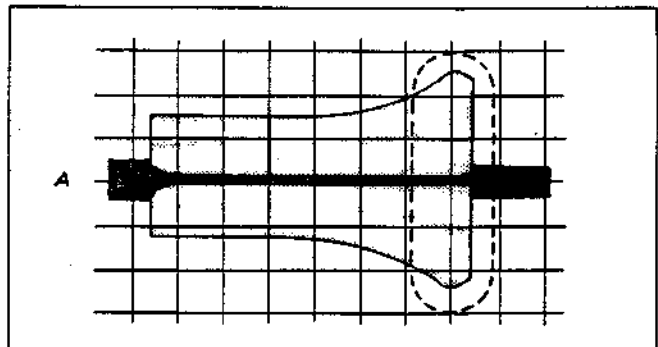

Fig. 4-12.

- When the exit free waveform is outside of the required range and has the form shown in Fig. 4-13, turn the tilt adjustment screw counterclockwise to produce waveform A (Fig. 4-12), then turn it clockwise to bring the waveform within the required range.

Note:

Finish the adjustment by turning the adjustment screw in the direction of tightening (clockwise).

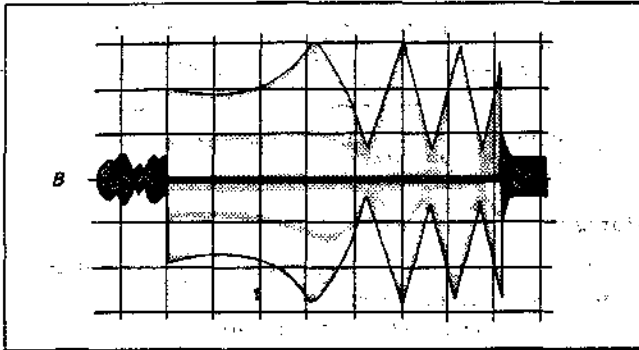

Fig. 4-13.

- Turn the No. 7 guide nut clockwise to flatten the waveform.
- Turn the No. 8 guide nut clockwise to line the No. 8 guide up with the tape (lower it so that there is no curl just before the waveform starts to change).
- If the radio frequency waveform is as shown in Fig. 4-12 on the exit side, repeat the adjustment.

4-2-2. CTL Head (ACE Assembly) Position Adjustment

This adjustment includes the mechanical CTL head mounting position adjustment and the electrical tracking control center adjustment. The tracking control center adjustment is to be performed first, followed by the mechanical adjustment of the head mounting position.

[Connections]

- Playback

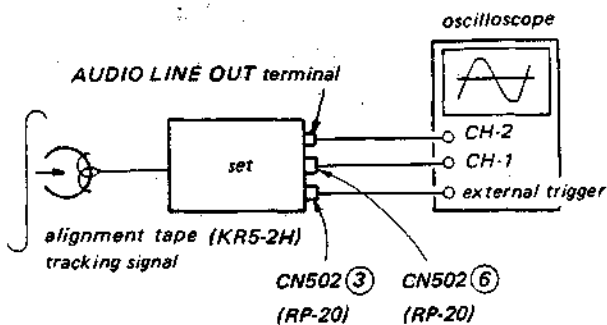

[Method of adjustment]

- Play the tracking signal section of the alignment tape.
- Turn the tracking control knob clockwise or counterclockwise to the center click position. Confirm that the amplitude of the radio frequency output signal is at its maximum level. Also confirm that the audio signal 0 level position occurs at the location of the channel B waveform. If the necessary standards are not met follow the procedure in 3).

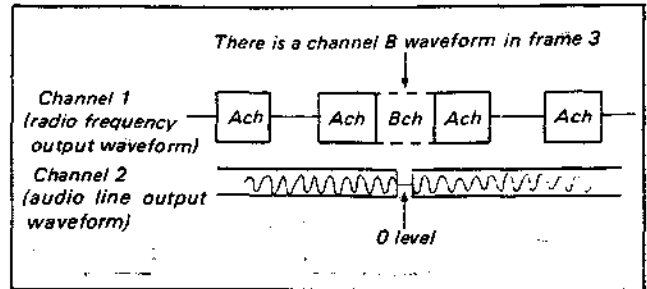

Fig. 4-14.

- Tracking center adjustment
Refer to electrical adjustment 3) in section 5-3-2.
- CTL head position adjustment
 - Set the tracking control knob at the center click position.
 - Loosen the 2 ACE assembly position adjustment screws, then use a tool such as an ordinary screwdriver to slide the ACE assembly to where the radio frequency output waveform amplitude becomes a maximum.
 - Play the color bar signal on the alignment tape and check the picture quality.
 - Tighten the position adjustment screws, then lock them.

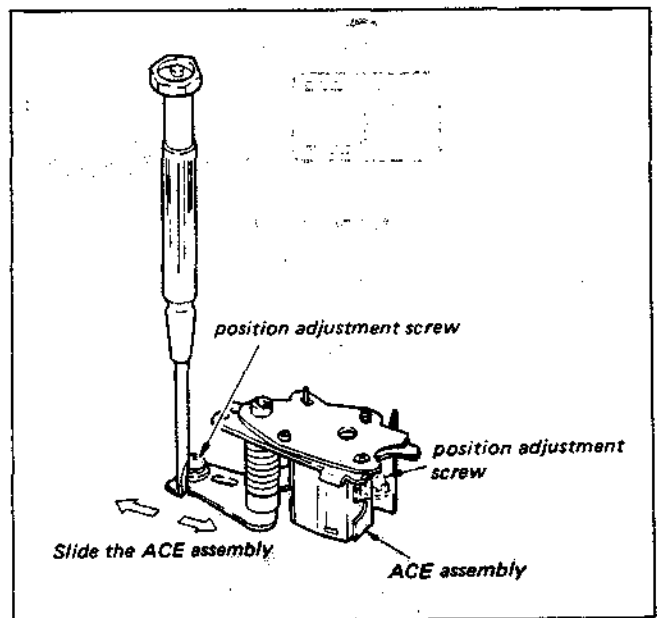
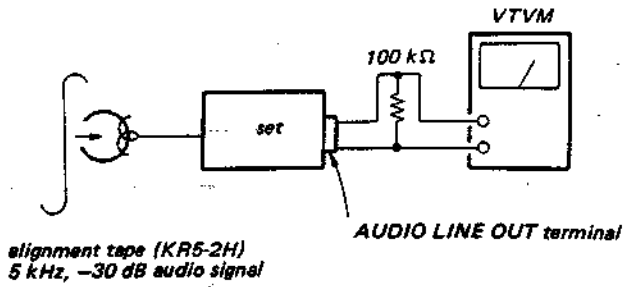

Fig. 4-15.

4-2-3. Audio head (ACE Assembly) Azimuth Adjustment

[Connections]

- 1) Playback



[Method of adjustment]

- 1) Play the 5kHz, -30dB audio signal section (RF sweep section) of the alignment tape.
- 2) Adjust the azimuth adjustment screw until the output level (VTVM indication) is a maximum.

Note:

Complete the adjustment by turning the adjustment screw in the direction of tightening (clockwise).

- 3) After adjustment, lock the adjustment screw.

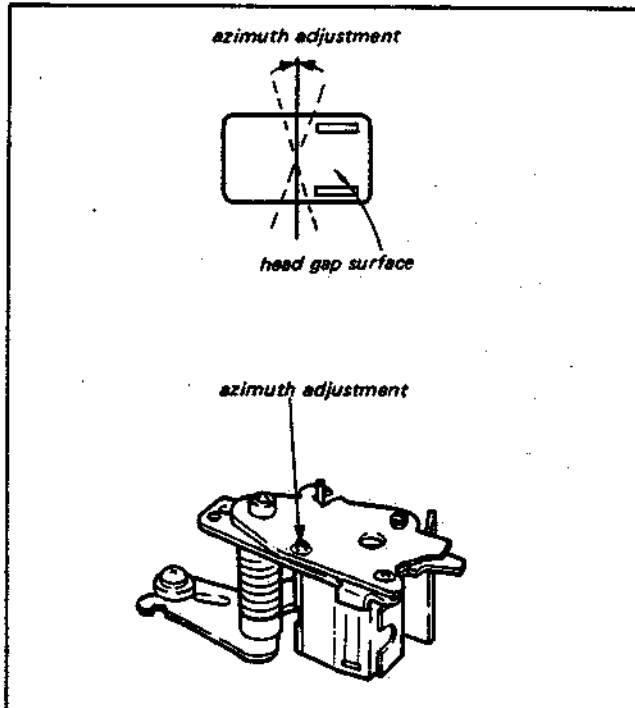

Fig. 4-16.

4-2-4. Audio Head (ACE Assembly) Height Adjustment

[Condition]

This adjustment must only be performed after the exit side tracking adjustment has been completed.

[Connections]

- 1) Playback

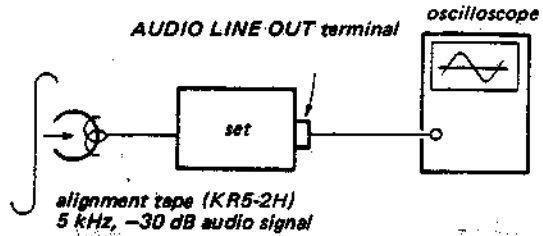

[Method of adjustment]

- 1) Play the 5kHz, -30dB audio signal section (RF sweep section) of the alignment tape.
- 2) Adjust the height adjustment nut so that the amplitude of the audio line output waveform (5 kHz) becomes a maximum.

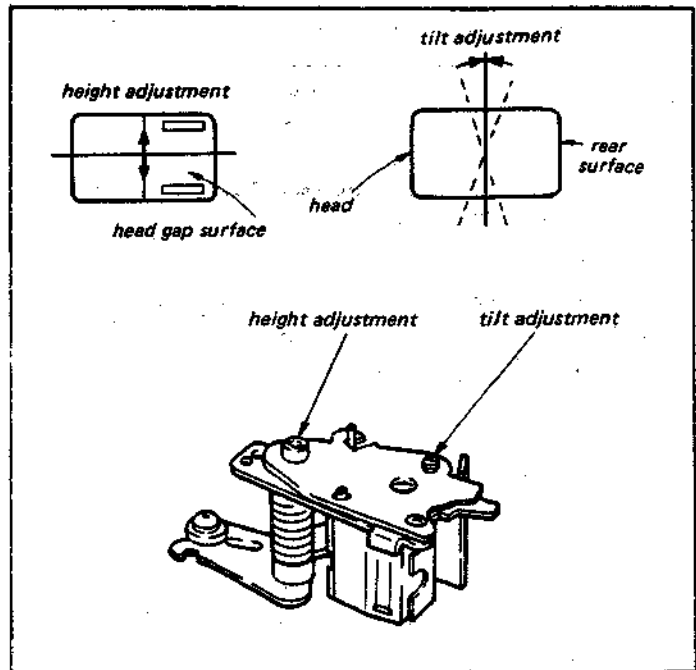

Fig. 4-17.

4-3. HOW TO INSPECT THE TAPE TRAVELING WHEN ADJUSTING THE TAPE PATH

Adjust and check the tape path using the alignment tape following the adjustment guide, then check the tape travel using the procedure below.

- 1) Get one L-830 reel ready (these are widely available commercially). Remove the cassette cover referring to Fig 4-1 of the adjustment guide.
- 2) Run the L-830 tape in playback mode and check the following points.

i) Entrance side

Confirm that the tape contacts the upper flange of the No. 5 and No. 6 guides and the lower flange of the No. 4 guide, and is not damaged or bent. (Some tape curl is allowed but the tape must not be creased.) (Fig. 4-18)

ii) Exit side

Confirm that the tape does not contact the upper flange of the No. 7 guide or the No. 8 guide, or the upper or lower flange of the No. 10 guide, and is not scratched. (Some tape curl is allowed but the tape must not be creased.) (Fig. 4-19)

- iii) If the tape was found to not be running correctly in step ii), readjust the tape path using the alignment tape, following the adjustment guide.

If the tape is not running correctly on the entrance side, refer to section 4-1-2 of the adjustment guide.

If the tape is not running correctly on the exit side, refer to section 4-1-3 of the adjustment guide.

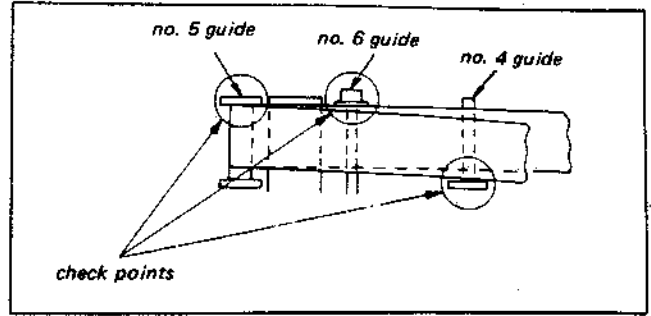

Fig. 4-18.

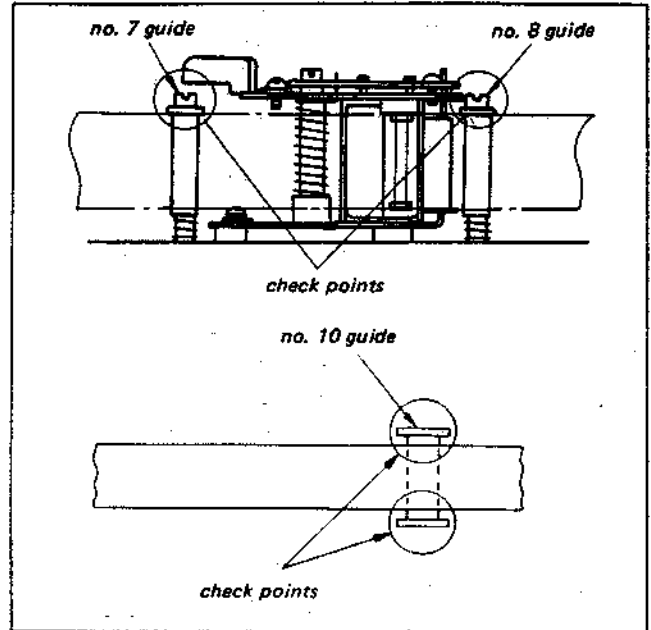

Fig. 4-19.

5. ELECTRICAL ALIGNMENT

All the electrical alignment can be performed by using the equipment mentioned below, the alignment tape, and the PAL colour bar signal (100%).

[Equipment Required]

- (1) PAL Colour Monitor TV
- (2) Oscilloscope, Dual-trace, Bandwidth... more than 10 MHz with delay mode
- (3) Frequency Counter
- (4) PAL Colour-Bar Generator
- (5) Digital voltmeter
- (6) Audio Signal Generator
- (7) Audio level meter (VTVM)
- (8) Attenuator
- (9) Alignment Tape, type: KR5-2H, Code No. 8-969-995-52
- (10) Alignment Tool (Adjusting screwdriver for semi-fixed resistors and coils)
Jig No. SL-0001, Code No. J-6080-001-A

[Setup for Alignment]

The antenna should be connected correctly to the antenna input terminal of the videocassette recorder.

It is important that the video output signal satisfies the specification because the telecast signal received by the incorporated tuner of the videocassette recorder is utilized as the adjustment signal of the machine. The incorporated tuner should be set to the channel with the best reception. The video signal should be checked with an oscilloscope connected to VIDEO OUT (BNC connector). Verify that the sync signal amplitude is approx. 0.3 Vp-p and the video signal amplitude is approx. 0.7 Vp-p at peak. Adjust the fine tuning while observing the signal and the TV screen so that the burst signal amplitude becomes approx. $0.3V \pm 0.1 Vp-p$. Also confirm that there is not spikes observed at the sync signal portion. (See Fig. 5-1.)

The video (colour bar) signal for the alignment is shown in Fig. 5-1.

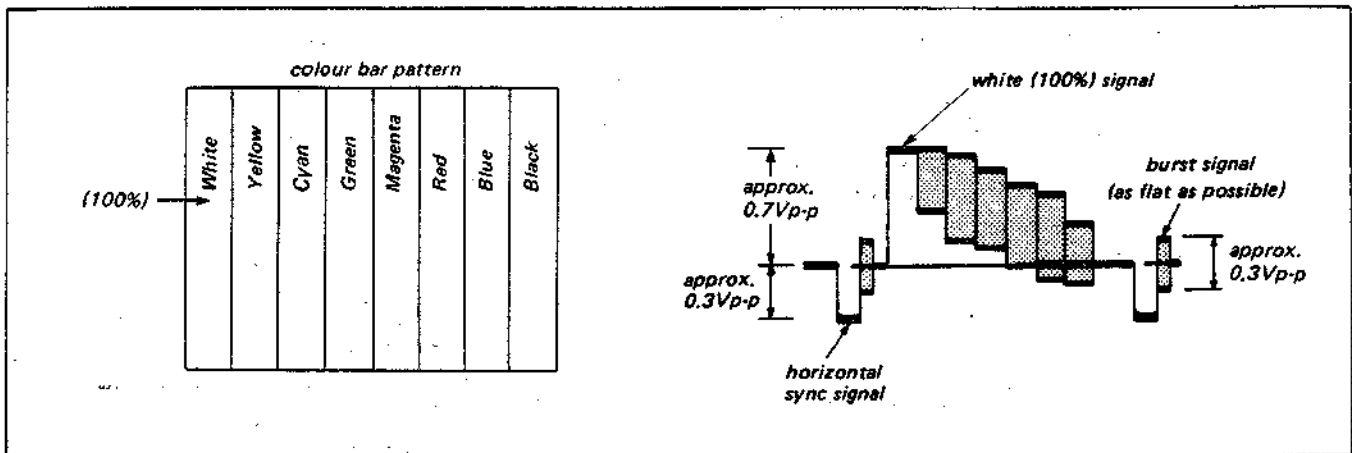

Fig. 5-1. Video (colour-bar) signal

[Alignment Tape]

KR5-2H

	Video signal	Audio signal	Playing time	Use for
1.	Colour bars	3 kHz - 5 dB	5 min	General performance, tape speed checks, switching position adjustment.
2.	Monoscope	333 Hz - 25 dB	5 min	Video head dihedral, audio level adjustment.
3.	RF sweep	5 kHz - 25 dB	5 min	Video, audio frequency characteristics, audio azimuth adjustment marker: 1, 2, 3.58, 4.5, 5.2 MHz
4.	Tracking 1 MHz (CH-B) *1 (Channel B is inserted in every 3 frames.)	1 kHz - 5 dB *2 (Signal is dropped out in the positions where channel B is inserted.)	5 min	Tracking, Audio height adjustments CTL Position check (Check if *1 and *2 are the same position.)

[Alignment Tool for Semi-fixed Variable Resistors and Coils]

Semi-fixed variable resistors and inductances should be adjusted with the alignment tool exclusively prepared for the adjustment of the components. A common screwdriver is too large for adjusting the components from the conductor side of a printed circuit board.

The metal blade of the alignment tool is used for variable resistors and trimmer capacitors and the plastic tip is used for variable inductances.

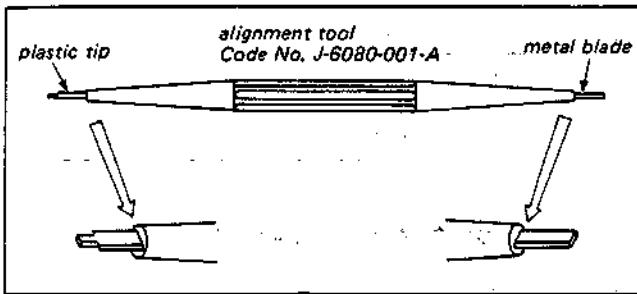

Fig. 5-2. Alignment tool

[Required levels and Impedances of Input and Output]

Video

Input VIDEO IN: BNC connector
 $1 \text{ Vp-p} \begin{matrix} +1.0 \\ -0.5 \end{matrix} \text{ Vp-p}$
 75Ω unbalanced, sync negative

VIDEO OUT: BNC connector
 $1 \text{ Vp-p} \pm 0.1 \text{ Vp-p}$
 75Ω unbalanced, sync negative

Audio

Input AUDIO IN: phono jack
 47 kΩ, -10 dBs
 (0 dBs = 0.775V rms)

Output AUDIO OUT: phono jack
 Load impedance less than 10 kΩ
 -10 dBs with 47 kΩ load unbalanced

[Colour Bar Signal]

The 100% colour bar signal recorded on the Alignment tape is shown in Fig. 5-3.

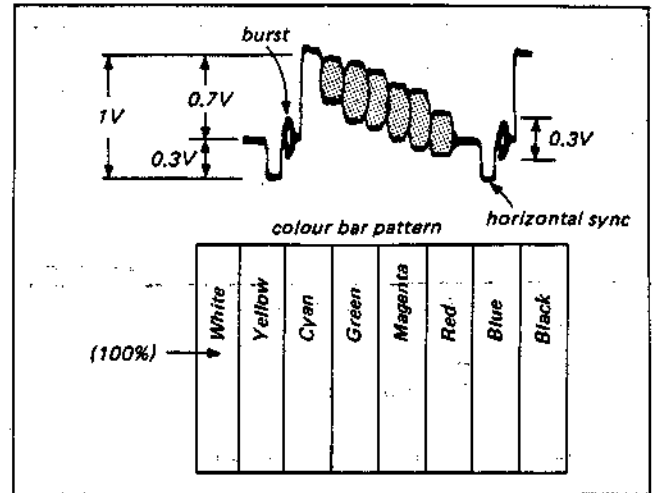
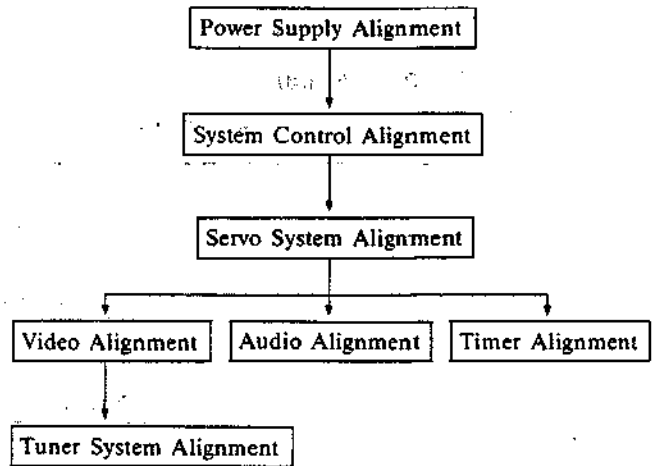

Fig. 5-3. Colour bar signal recorded on the alignment tape

[Adjustment procedure]

Adjust in the order given below.



5-1. POWER SUPPLY CHECK

5-1-1. AEP, UK, EC MODEL (PS-46 Board)

Measure in E-E mode (power supply switch ON).

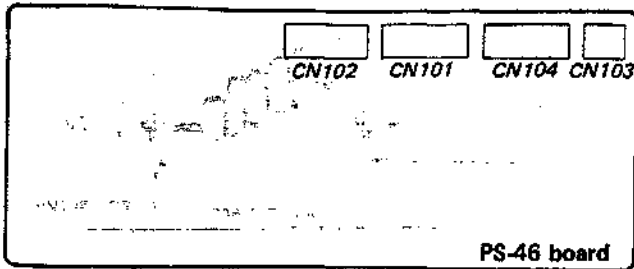

Fig. 5-4. Component layout

1. UN 12V Check
Pin ⑥ of CN101 shall be $12 \pm 0.5V$
2. SW 12V Check
Pin ③ of CN101 shall be $12.2 \pm 0.2V$
3. SW 9V Check
Pin ⑤ of CN101 shall be $9.0 \pm 0.2V$
4. UN 5V Check
Pin ① of CN101 shall be $5.1 \pm 0.5V$
5. UN 45V Check
Pin ② of CN102 shall be $44 \pm 3V$
6. UN -45V Check
Pin ③ of CN102 shall be $-44 \pm 3V$

5-1-2. E MODEL (PS-67 Board)

Measure in E-E mode (power supply switch ON).

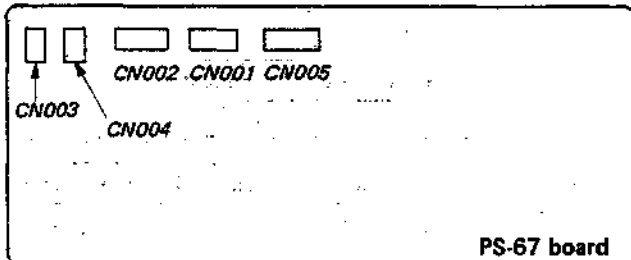

Fig. 5-4. Component layout

1. UN 12V Check
Pin ⑥ of CN002 shall be $12 \pm 0.5V$.
2. SW 12V Check
Pin ① of CN001 shall be $12.2 \pm 0.2V$.
Pin ③ of CN002 shall be $12.2 \pm 0.2V$.
3. SW 9V Check
Pin ⑤ of CN002 shall be $9.0 \pm 0.2V$.
4. UN 5V Check
Pin ④ of CN001 shall be $5.0 \pm 0.5V$.
5. UN 39V Check
Pin ② of CN001 shall be $39 \pm 2V$.
6. UN -39V Check
Pin ③ of CN001 shall be $-39 \pm 2V$.

5-2. SYSTEM CONTROL CHECK (SS-34 Board)

1. Clock Frequency Check

Mode: E-E
Signal: None
Frequency counter: Pin ⑥ of IC601
Check: $f: 6\text{ MHz}$

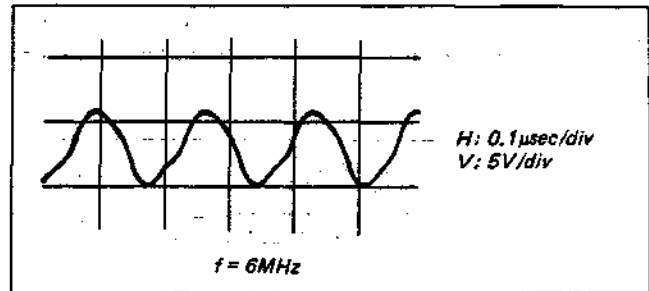

Fig. 5-5.

5-3. SERVO SYSTEM ALIGNMENT

Alignment Sequence

1. Drum servo system alignment
2. Capstan servo system alignment

5-3-1. Drum Servo System Alignment

1) Drum Free Speed Adjustment (SS-34 Board)

Mode: Playback
Signal: Alignment tape colour bar, or monoscope
Oscilloscope: CH-1 TP405 (Pin ⑬ of IC301)
CH-2 TP402 (Pin ⑳ of IC301)

[Alignment method]

Adjust to $553\ \mu\text{sec} \pm 10\ \mu\text{sec}$ with RV303.

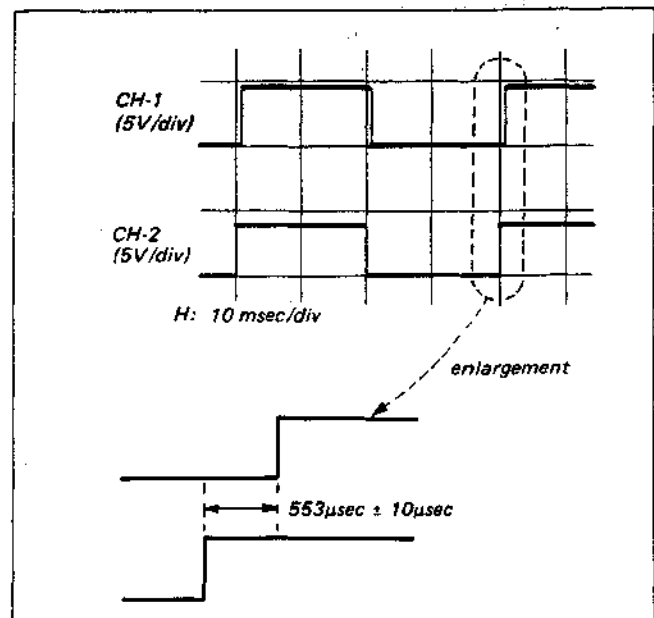

Fig. 5-6. Drum free speed adjustment

- 2) RF Switching Position Adjustment (SS-34 Board)
 Mode: Playback
 Signal: Alignment tape colour bar or monoscope
 Oscilloscope: CH-1 TP402 (Pin ③ of IC301)
 CH-2 Pin ④ of IC301

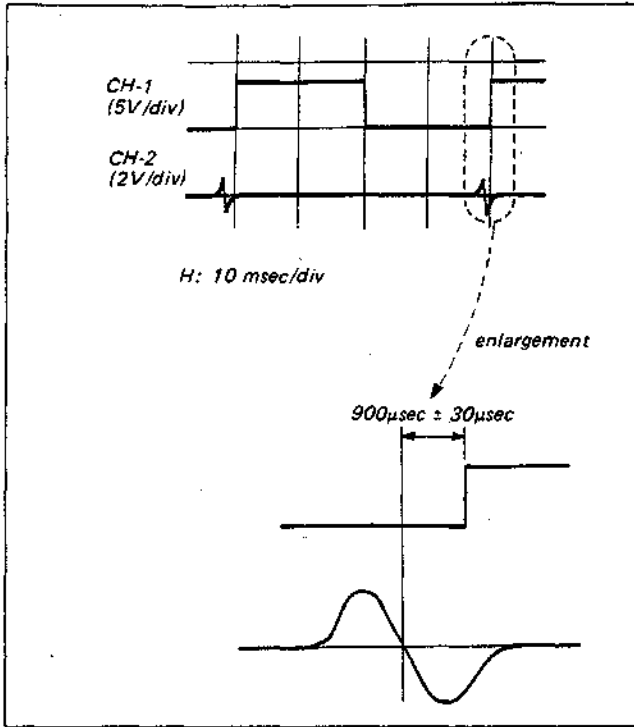

Fig. 5-7. RF switching position adjustment (1)

[Adjustment method]

- i) Adjust to $900\mu\text{sec} \pm 30\mu\text{sec}$ with RV304 (See Fig. 5-7.)
- ii) Change connection of CH-2 only to Pin ③ of IC301.
- iii) Adjust to $900\mu\text{sec} \pm 30\mu\text{sec}$ with RV305 (See Fig. 5-8.)

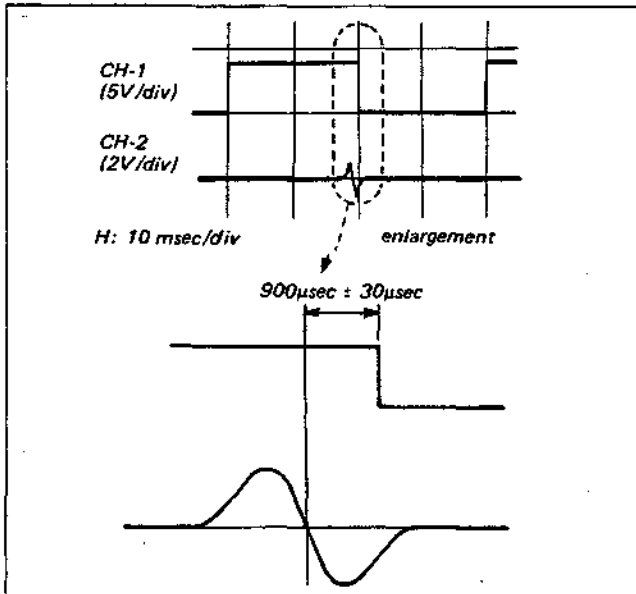

Fig. 5-8. RF switching position adjustment (2)

- 3) PICTURE SEARCH, f_H Adjustment (SS-34 Board)
 Mode: PICTURE SEARCH (FWD)
 Signal: Alignment tape colour bar or monoscope
 Frequency counter: Pin ③ of CN309 (TP404)

[Adjustment method]

Adjust to $64\mu\text{sec} \pm 0.3\mu\text{sec}$ with RV307.

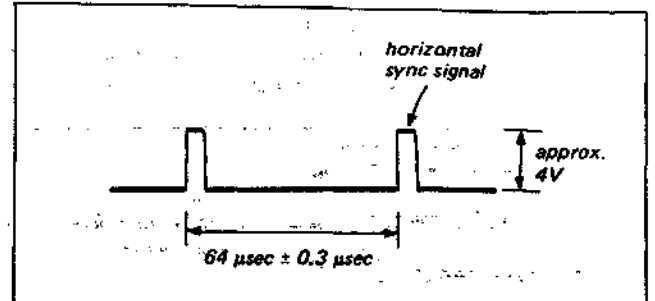

Fig. 5-9. PICTURE SEARCH, drum free speed adjustment

5-3-2. Capstan Servo System Alignment

- 1) Capstan Free Speed Adjustment (SS-34 Board)
 Mode: playback
 Signal: Alignment tape colour bar or monoscope
 Oscilloscope: TP407 (Pin ② of IC301)

[Adjustment method]

Adjust the duty (ratio for A and B) to $50\% \pm 5\%$ with the RV301.

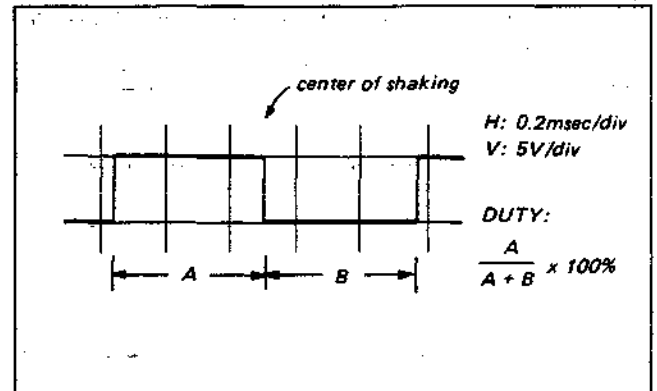

Fig. 5-10. Capstan free speed adjustment

2) PICTURE SEARCH, Capstan Free Speed Adjustment (SS-34 Board)

Mode: PICTURE SEARCH (FWD)

Signal: Alignment tape colour bar or monoscope

[Adjustment method]

- i) Set up the picture search (forward) mode and adjust with RV302 so that the progression of noise bars becomes as slow as possible.
- ii) Set up the picture search (reverse) mode and check that noise bars do not progress very quickly.

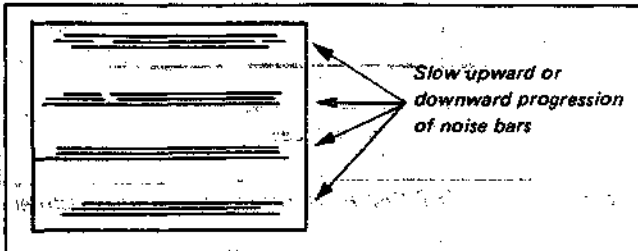

Fig. 5-11. PICTURE SEARCH, capstan free speed adjustment

3) Tracking Center Adjustment (SS-34 Board)

Mode: Playback

Signal: Alignment tape colour bar, or monoscope

Oscilloscope: CH-1 TP405 (Pin 13 of IC301)

CH-2 TP406 (Pin 15 of IC301)

[Adjustment method]

- i) Set the TRACKING knob to the center click position.
- ii) Adjust to $7.05 \text{ msec} \pm 0.05 \text{ msec}$ with RV306. (See Fig. 5-12.)

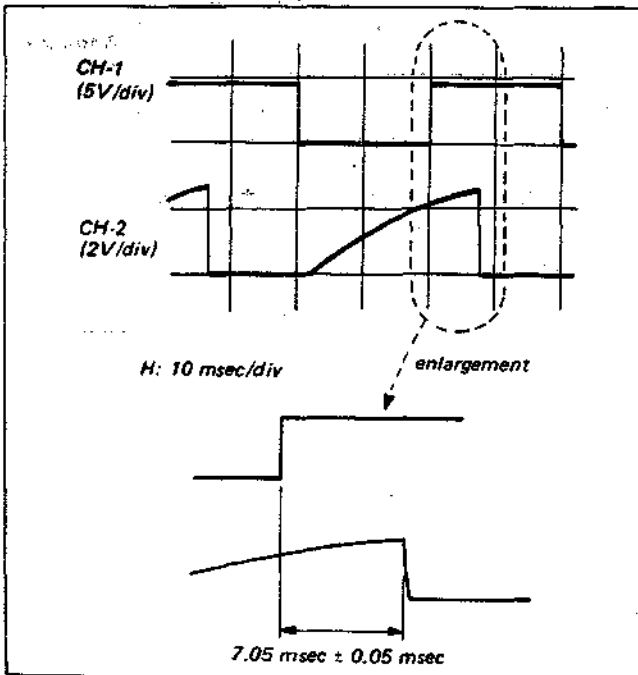

Fig. 5-12. Tracking center adjustment

5-4. PAL VIDEO SYSTEM ALIGNMENT

As a rule, first the playback system is aligned with an alignment tape to check that it operates normally, then the recording system is aligned.

The alignment sequence is shown below. The Y signal and chroma signal systems are aligned for both playback and recording systems.

Colour video signal supplied by the PAL colour bar generator is used as video input signal for video system alignment in the record mode. Check that the sync and colour burst signals conform to the specifications designated in "Set-up for Alignment" in Fig 5-1.

5-4-1. Playback System Alignment

1. Playback frequency characteristic adjustment
2. Expand adjustment
3. Playback video level adjustment
4. Y-comb adjustment
5. Dropout compensator adjustment
6. AFC adjustment
7. AFC offset adjustment
8. 4.43MHz REF adjustment
9. Chroma comb filter adjustment
10. Carrier balance adjustment
11. JOG PLL adjustment
12. JOG exchange chroma level adjustment

5-4-2. Record System Alignment

1. Sync AGC adjustment
2. Compress adjustment
3. Carrier set adjustment.
4. Deviation adjustment
5. Dark clip and white clip adjustment
6. Y record current adjustment
7. Pilot burst signal level adjustment
8. Chroma record current adjustment

5-4-1. Playback System Alignment

1) Playback Frequency Characteristic Adjustment (RP-20 Board)

- Adjust both the A and B channels.
 - The B channel indicated by ().
- Mode: Playback
Signal: Alignment tape RF sweep
Oscilloscope: Pin ⑥ of CN502
External trigger: Pin ③ of CN502

[Adjustment method]

- i) Turn tracking knob to maximum output.
- ii) Adjust RV503 to make the 2MHz amplitude of A and B channels equal. (See Fig. 5-16)
- iii) Set the trigger slope to $- (+)$.
- iv) Adjust the 5.2MHz amplitude to $1/2 - 2/3$ of the 2MHz amplitude with RV502 (RV501).

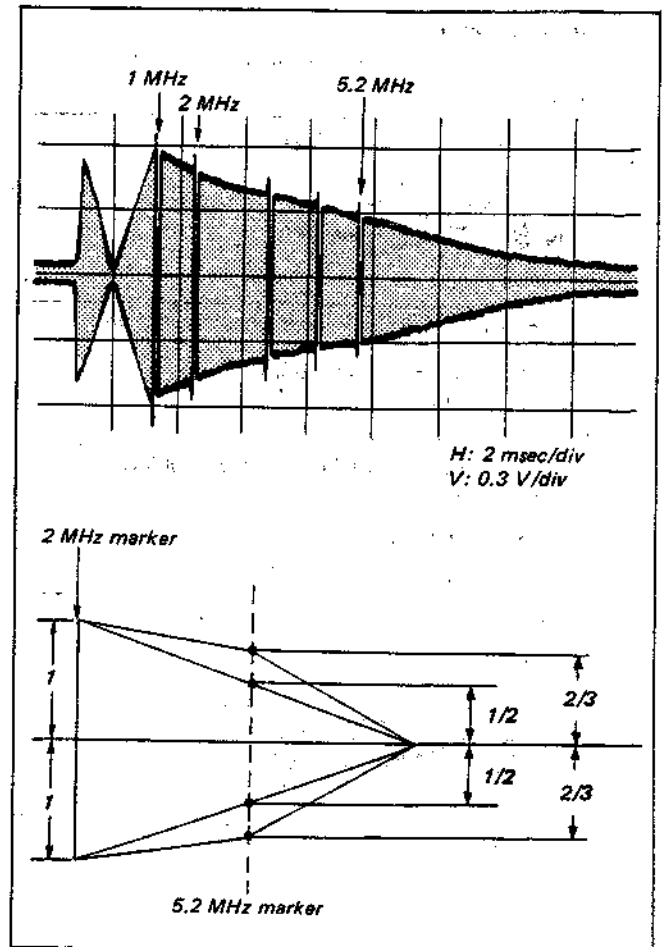

Fig. 5-16. Playback amplifier frequency characteristic adjustment.

2) Expand Adjustment (YC-31 Board)

- Mode: Playback
Signal: Colour bar
Digital voltmeter: See Fig. 5-17.

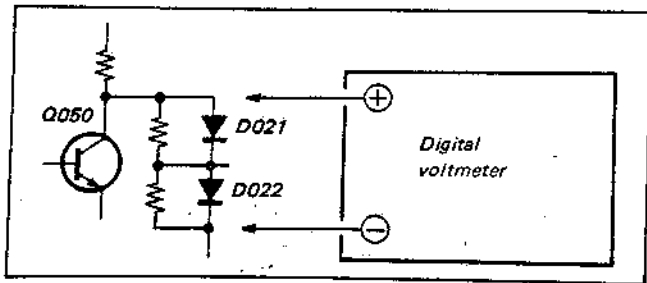

Fig. 5-17.

[Adjustment method]

- i) Adjust to 0.45 ± 0.01 Vdc with RV020.

3) Playback Video Level Adjustment (YC-31 Board)

Mode: Playback

Signal: Alignment tape colour bar

Oscilloscope: VIDEO OUT (75Ω terminated) on YC-31 Board

[Adjustment method]

- i) Adjust to $1.0V \pm 0.05V_{p-p}$ with RV019 on YC-31 Board.

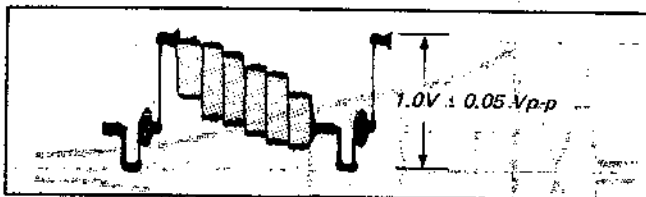

Fig. 5-18. Playback video level adjustment

4) Y-Comb Adjustment (YC-31 Board)

Mode: Playback

Signal: Colour bar

Oscilloscope: Pin ⑧ of IC401 (Attach 100kΩ resistor to tip of probe (10:1)).

[Adjustment method]

- i) Adjust RV401 for minimum output.

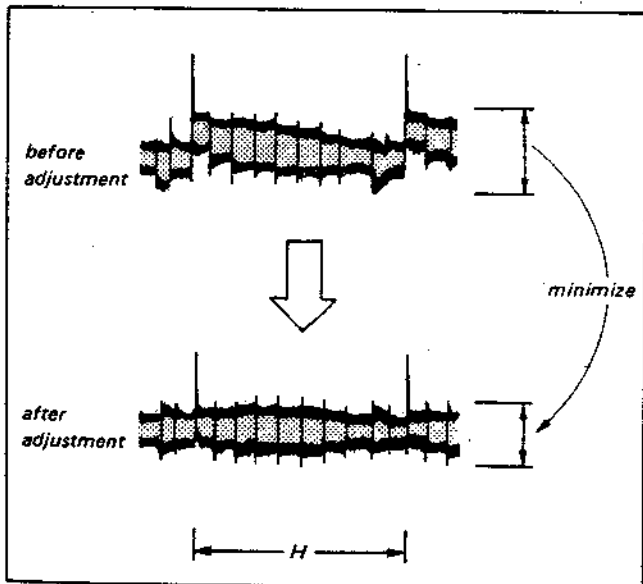

Fig. 5-19. Y-comb adjustment

5) Dropout Compensator Threshold Adjustment (YC-31 Board)

Mode: Playback

Signal: A recorded tape with dropouts

[Adjustment method]

- i) Turn RV010 fully clockwise (⌚) as seen from the pattern side. In this state, dropouts appear on the monitor screen.
- ii) Slowly turn RV010 counterclockwise (⌚) and set to make the dropouts disappear.
- iii) Rewind the tape and verify that the dropouts described in (i) above have disappeared.

6) AFC Adjustment (YC-31 Board)

Mode: E-E

Signal: Colour bar

Oscilloscope: Pin ⑳ of IC006

[Adjustment method]

- i) Adjust to $4.50V_{dc} \pm 0.01$ Vdc with RV007.

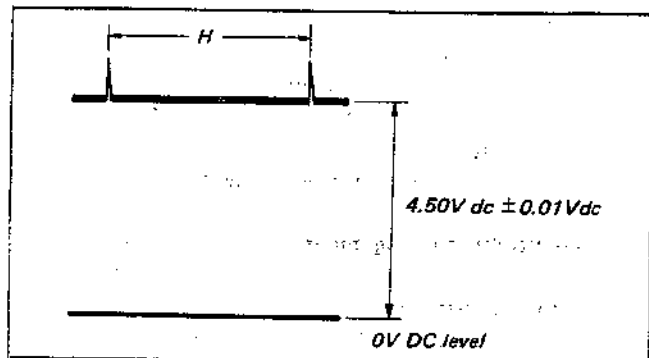

Fig. 5-20. AFC adjustment

7) AFC Offset Adjustment (YC-31 Board)

Mode: Record

Signal: Colour bar

Oscilloscope: Pin ⑳ of IC006

[Adjustment method]

- i) Adjust RV006 so that the fluctuation of DC level is minimum.
- ii) After this adjustment, check the AFC adjustment.

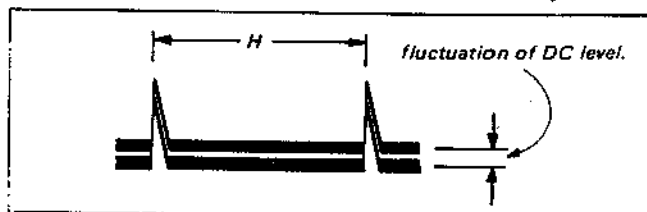

Fig. 5-21. AFC offset adjustment

8) 4.43MHz REF. adjustment (YC-31 Board)

Mode: PB

Signal: Colour bar

Frequency counter: Pin ⑭ of IC006

[Adjustment method]

- i) Adjust to $4.433619MHz \pm 5$ Hz with CV001.

9) Chroma Comb Filter Adjustment (YC-31 Board)

Mode: Playback
Signal: Alignment tape colour bar
Adjust while observing the monitor TV screen.

[Adjustment method]

- i) Minimize beats with RV501 and LV501.

10) Carrier Balance Adjustment (YC-31 Board)

Mode: Playback
Signal: Alignment tape colour bar
Adjust while observing the monitor TV screen.

[Adjustment method]

- i) Minimize beats with RV005.

11) JOG PLL Adjustment (YC-31 Board)

Mode: E-E
Signal: Colour bar
Oscilloscope: Pin ⑩ of IC003

[Adjustment method]

- Adjust to $20\mu\text{sec} \pm 1\mu\text{sec}$ with RV003. (See Fig. 5-28.)

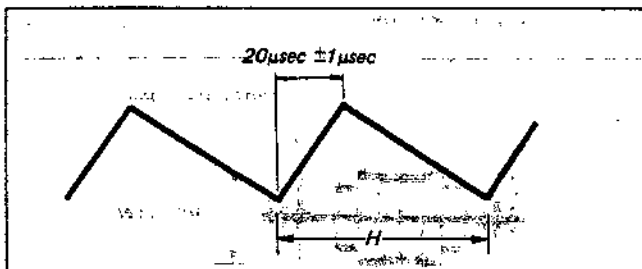

Fig. 5-22. JOG PLL adjustment

12) JOG Exchange Chroma level Adjustment (YC-31 Board)

Mode: PB· PAUSE (STILL)
Signal: colour bar
Oscilloscope: Pin ⑧ of IC003

[Adjustment method]

- i) Adjust RV002 so that the fluctuation of level is minimum.

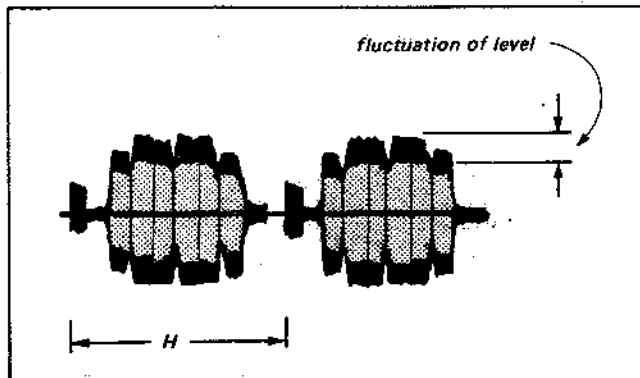

Fig. 5-23. JOG EXCH. C. level adjustment

5-4-2. Record System Alignment

1) Sync AGC Adjustment (YC-31 Board)

Mode: E-E
Oscilloscope: VIDEO OUT (75Ω terminated)
Signal: Colour bar (V : S = 7 : 3)

[Adjustment method]

- i) Adjust to $1.0V \pm 0.05V_{p-p}$ with RV021.

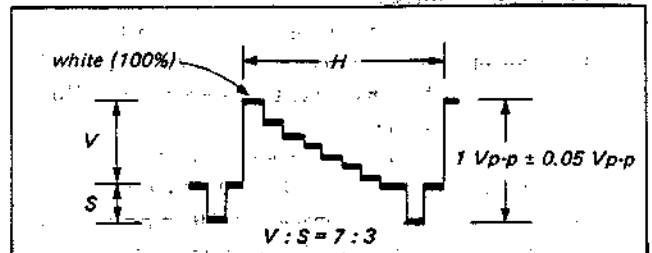

Fig. 5-24. Sync AGC adjustment

2) Compress Adjustment (YC-31 Board)

Mode: E-E
Signal: None
Digital voltmeter: See Fig. 5-25.

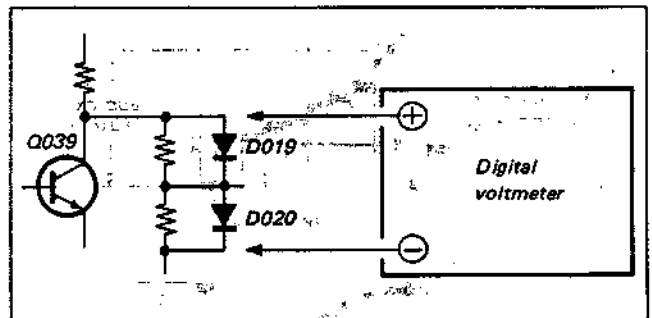

Fig. 5-25.

[Adjustment method]

- i) Adjust to $0.3V \pm 0.01V_{dc}$ with RV016.

3) Carrier Set Adjustment (YC-31 Board)

Mode: E-E
Signal: None
Frequency counter: Pin ⑮ of IC009

[Adjustment method]

- 1) Adjust to $3.8\text{MHz} \pm 0.04\text{MHz}$ with RV014.

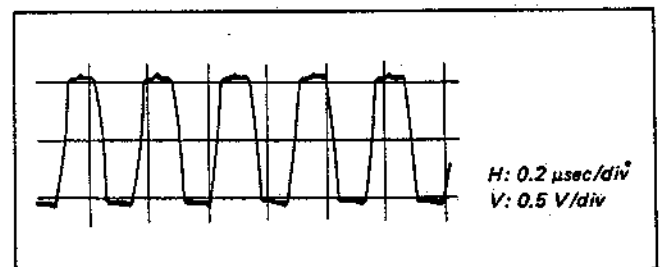

Fig. 5-26. Carrier set adjustment

4) Deviation Adjustment (YC-31 Board)

- The playback system adjustment and the carrier set adjustment in Paragraph 3) above must be completed before making this adjustment.

Mode: Self-recording and playback
 Signal: Colour bar
 Oscilloscope: Collector of Q038, VIDEO OUT (75Ω terminated)

[Adjustment method]

- Supply the colour bar signal and set up E-E mode.
- Connect the oscilloscope to Collector of Q038.
- Adjust the Y signal level to 0.4Vp-p with RV015.
- Set up RECORD mode.
- Playback the recorded section of the tape.
- Connect the oscilloscope to VIDEO OUT.
- Check that the video signal level is 1.0 Vp-p \pm 0.05 Vp-p. if the level is outside of this range. repeat Steps iv) through vi) above adjusting with RV015 until the standard value is obtained.

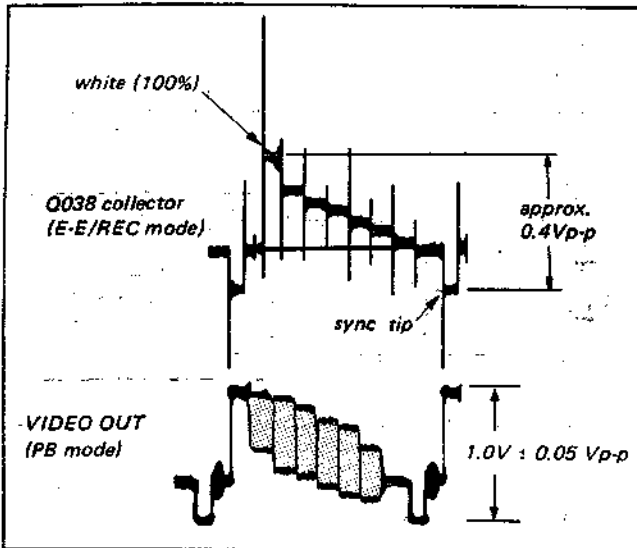

Fig. 5-27. Deviation adjustment

5) Dark Clip and White Clip Adjustment (YC-31 Board)

Mode: E-E
 Signal: None
 Frequency counter: Pin ② of IC009

[Adjustment method]

- Connect a jumper wire between the base of Q041 and ground.
- Adjust to 2.82MHz \pm 0.1MHz with RV012.
- Check that the voltage of the collector of Q038 is 1.5V \pm 0.3V dc.
- Remove the jumper wire.
- Connect a jumper wire between the base of Q041 and the 9V line (collector of Q042).
- Adjust to 6.66MHz \pm 0.1MHz with RV013.
- Remove the jumper wire.

6) Y Record Current Adjustment (YC-31 Board)

Mode: Record
 Signal: Colour bar
 Oscilloscope: Pin ⑤ of CN002

[Adjustment method]

- Adjust to 450mV \pm 20mVp-p with RV602.

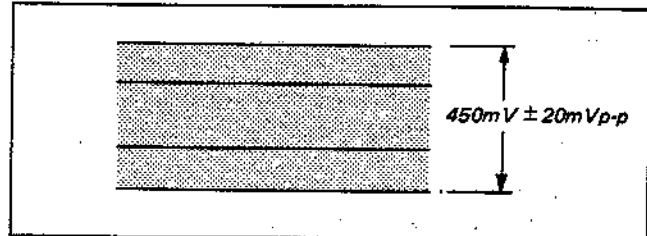

Fig. 5-28. Y record current adjustment

7) Pilot Burst Signal Level Adjustment (YC-31 Board)

Mode: E-E
 Signal: Colour bar
 Oscilloscope: Pin ① of IC006

[Adjustment method]

- Align the pilot burst signal with the chroma signal level using RV009.

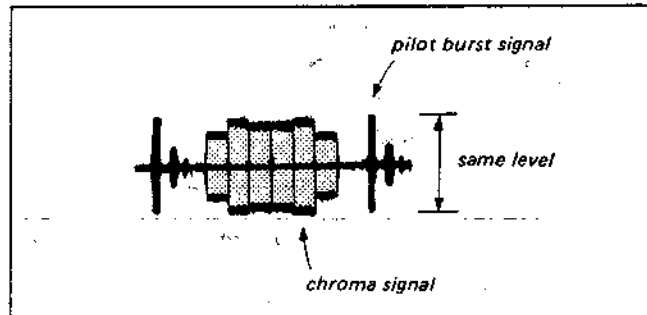

Fig. 5-29. Pilot burst signal level adjustment

8) Chroma Record Current Adjustment (YC-31 Board)

Mode: E-E
 Signal: Colour bar
 Oscilloscope: Pin ⑦ of CN002

[Adjustment method]

- Adjust to 180mV \pm 10mVp-p with RV008.

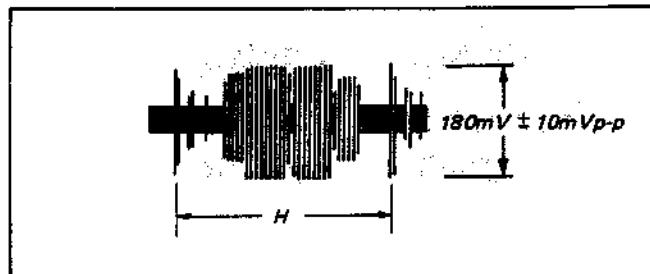

Fig. 5-30. Chroma record current adjustment

5-5. AUDIO SYSTEM ADJUSTMENT (TA-22 Board)

Use a Dynamicron tape for adjustments.

[Connection of Related Equipment]

Note: Set the INPUT SELECT switch to LINE.
Set the TONE switch to HIGH.

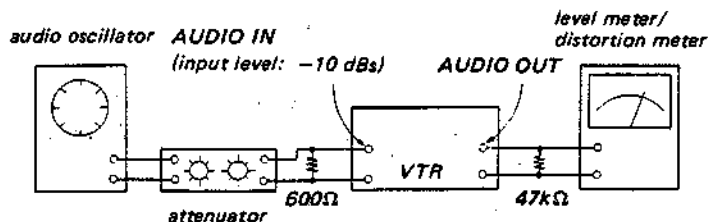

[Adjustment method]

1. ACE head adjustment... See "Mechanical Adjustment"
2. Playback frequency characteristic check
3. Playback output level adjustment
4. Bias oscillator check
5. Record bias adjustment
6. Record level check
7. Overall frequency characteristic check
8. Overall S/N check
9. Overall distortion check

1. ACE Head Adjustment

Refer to "Mechanical Adjustment"

2. Playback Frequency Characteristic Check

- (1) Play back 333 Hz and 5 kHz from the alignment tape and check that the level difference between 333Hz and 5kHz is within 0dB \pm 1dB.

3. Playback Output Level Adjustment

- (1) Play back 333 Hz from the alignment tape and adjust so that the output level is -30 dB \pm 0.5 dB with RV301.

4. Bias Oscillator Check

- (1) Set the input signal level to zero and set up the RECORD mode.
- (2) Connect a frequency counter to Pin ② of CN303. The reading should be 65kHz \pm 6.5kHz.

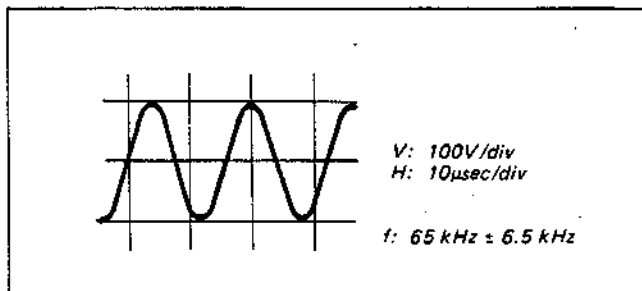

Fig. 5-31. Bias oscillator check

5. Record Bias Adjustment

Check that "Playback frequency characteristic check has been made.

- (1) Connect TP301 and TP306 (GND) with a jumper wire so as to turn off the AGC operation.
- (2) Supply a 333 Hz signal.
- (3) Set up the E-E mode and adjust the oscillator output level so that the level meter reading is -30 dBs.
- (4) Record signals.
- (5) Supply a frequency of 7 kHz and perform Steps (3) and (4) above.
- (6) Play back the recorded section of the tape and check that the output level at 7 kHz is ± 1 dB relative to the output level at 333 Hz. If the level is outside this range, repeat Steps (2) through (5) adjusting with RV331 until the standard is met.
- (7) Remove the jumper wire after making the adjustment.

6. Record Level Check

- (1) Supply a 333Hz signal at -10 dBs.
- (2) Set up the E-E mode.
- (3) Check that the output level is -10 dBs ± 3 dB.
- (4) Record signals.
- (5) Play back the recorded section of the tape and check that the output level is -9 dBs ± 3 dB.

7. Overall Frequency Characteristic Check

- (1) Connect TP301 and TP306 (GND) with a jumper wire so as to turn off the AGC operation.
- (2) Connect a 333 Hz signal.
- (3) Set up the E-E mode and adjust the oscillator output level so that the level meter reading is -30 dBs.
- (4) Record signals.
- (5) Change the frequency to 50 Hz, 100 Hz, 7 kHz and 10 kHz and repeat Steps (3) and (4).
- (6) Play back the recorded section of the tape and verify that the level is within the specification.

Standard values: With reference to the 333 Hz playback output level.

50 Hz	+2.5	-10	dB
100 Hz	+2.5	-3	dB
7 kHz	+2.5	-2.5	dB
10 kHz	+2.5	-6	dB

- (7) If the specified values cannot be attained, perform 5 again. "Record Bias Adjustment".
- (8) Remove the jumper wire after making the adjustment.

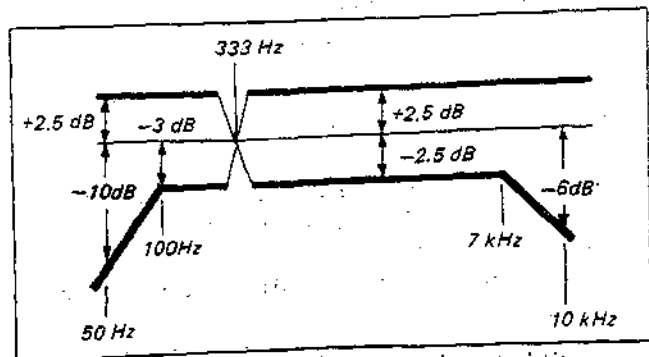

Fig. 5-32. Overall frequency characteristic

8. Overall S/N Check

- (1) Supply a 333 Hz signal at -10 dBs.
- (2) Record signals.
- (3) Set the input signal level to zero and record signals.
- (4) Play back the recorded section of the tape and check that the output level difference is greater than 38 dB.

9. Overall Distortion Check

- (1) Supply a 333 Hz signal at -10 dBs.
- (2) Record signals.
- (3) Play back the recorded section of the tape and verify that the distortion is below 4%.

5-6. TUNER SYSTEM ADJUSTMENT (TA-22 Board)

1) Tuner AGC Adjustment

- (1) Set the DX/LOCAL switch on the rear panel to DX.
- (2) Input RF signals (West Germany model: 52dBμ /75Ω terminated, other models: 55dBμ/75Ω terminated) from a colour bar generator, etc.
- (3) Connect a digital voltmeter to TP001 (Pin ④ of IC001).
- (4) Adjust RV001 to 7.2V ± 0.1V dc.

2) AFT Adjustment

- (1) Input RF signals, and press FINE + or FINE - button finely for the best picture quality, while watching the monitor screen.
- (2) Connect a digital voltmeter to pin ⑤ of IC001.
- (3) Adjust T005 to 6V dc.
- (4) Press AFT button to turn on the AFT operation, receive each channel and check to make sure that there is no beat or picture disturbance.

5-7. TIMER SYSTEM ADJUSTMENT (TM-57 Board)

1) Clock Adjustment

- (1) Connect a frequency counter to pin ③ of IC001.
- (2) Adjust oscillation period (T) with TC001 so the value will be as follows.

$$T = (30.51750 + 0.000015 \times C_p) \mu\text{sec} \pm 0.0001 \mu\text{sec}$$

C_p : Probe capacity (PF) of the frequency counter

2) System Clock Adjustment

- (1) Connect a frequency counter to pin ⑥ of IC001.
- (2) Adjust oscillation frequency (f) to the following value with RV001.

$$f = (2.60 - 0.0041 \times C_p) \text{MHz} \pm 0.05 \text{MHz}$$

C_p : Probe capacity (PF) of the frequency counter

YC-31 BOARD (CONDUCTOR SIDE)

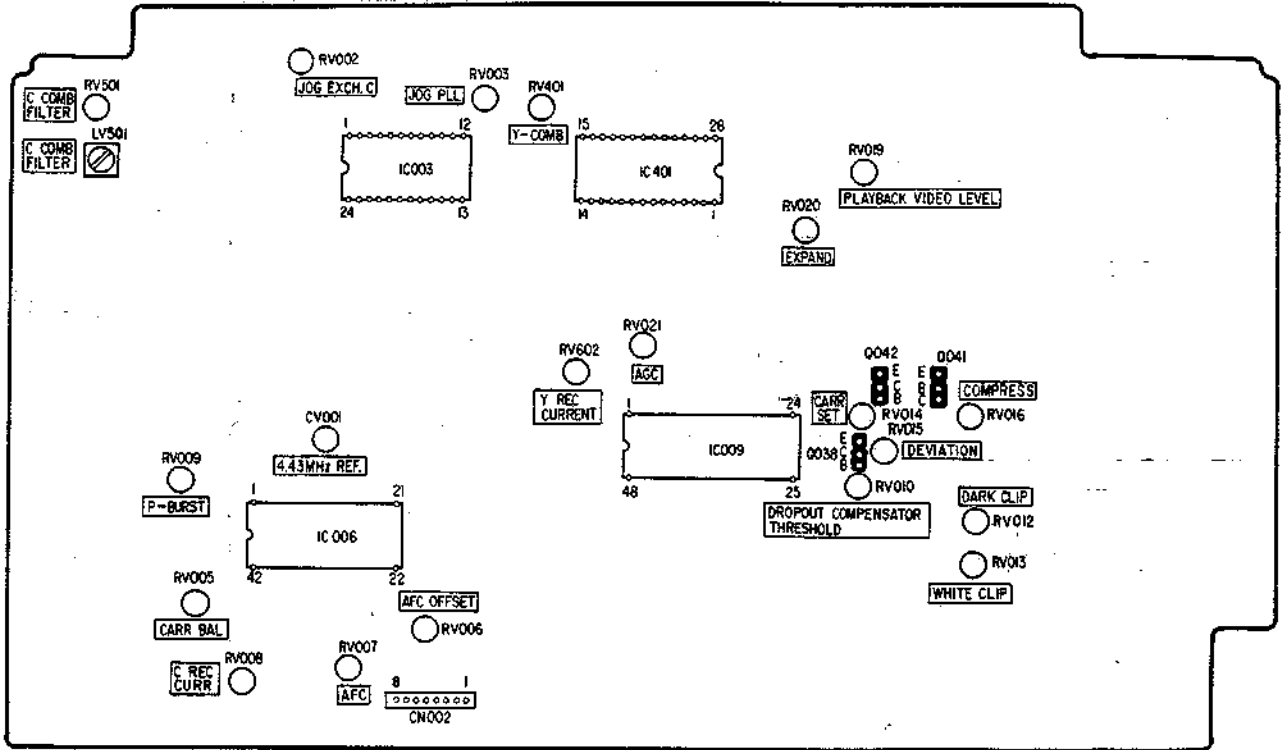

SS-34 BOARD (COMPONENT SIDE)

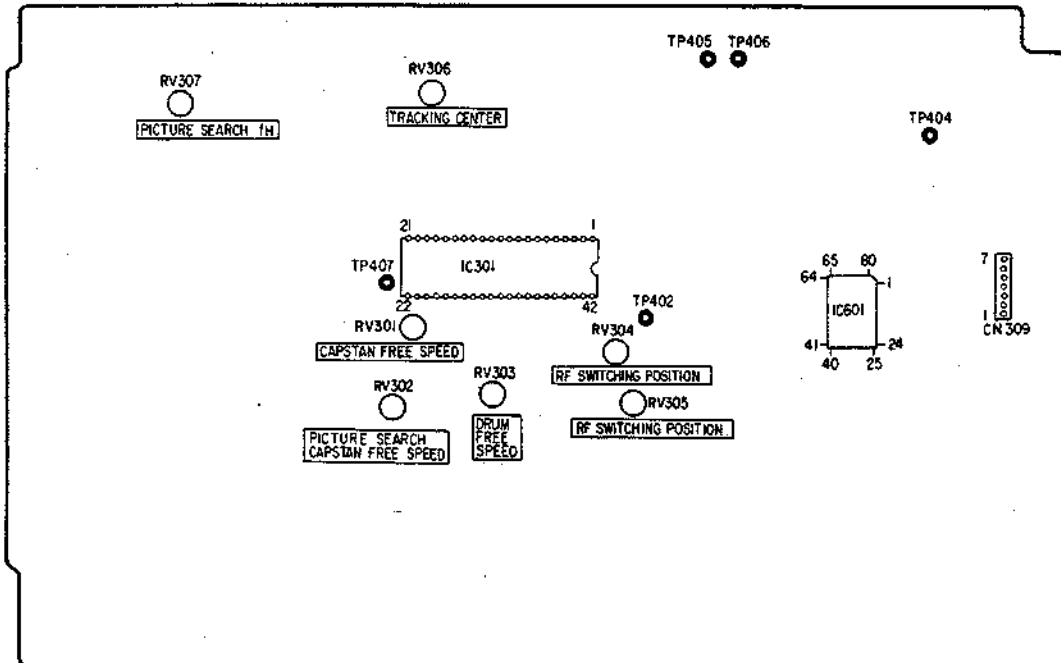

TA-22 BOARD (COMPONENT SIDE)

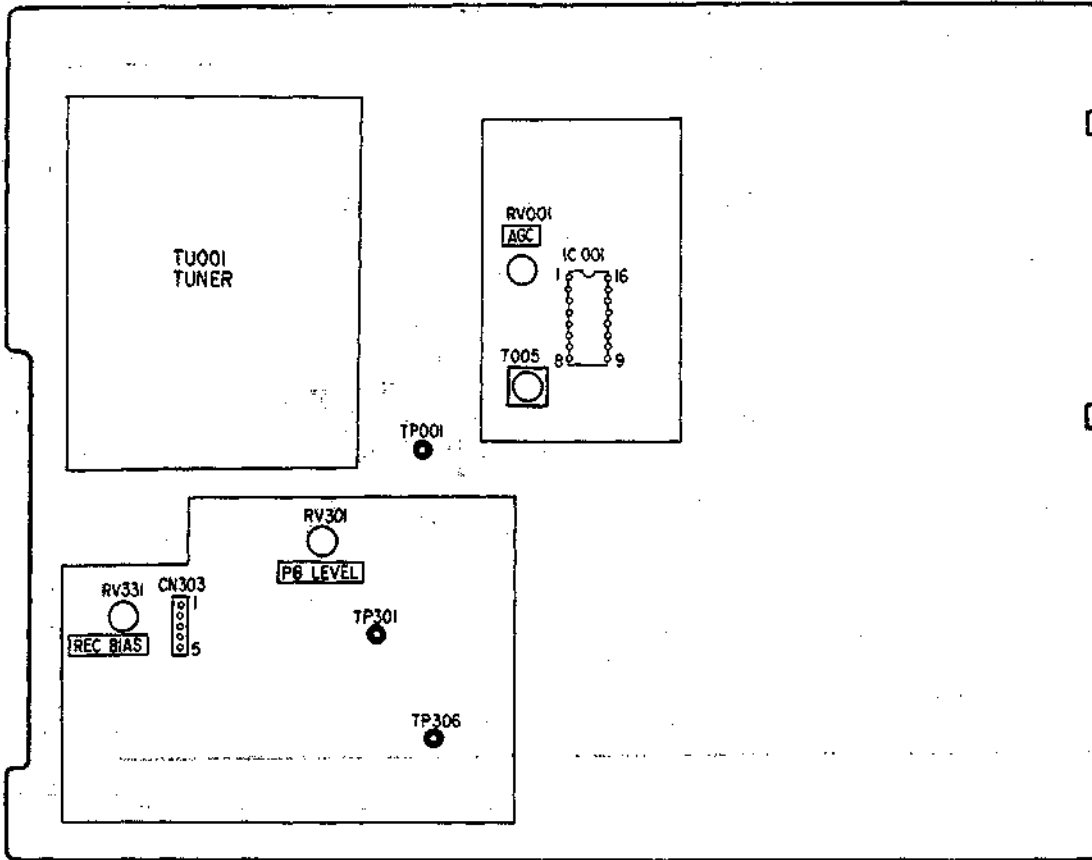

RP-20 BOARD (COMPONENT SIDE)

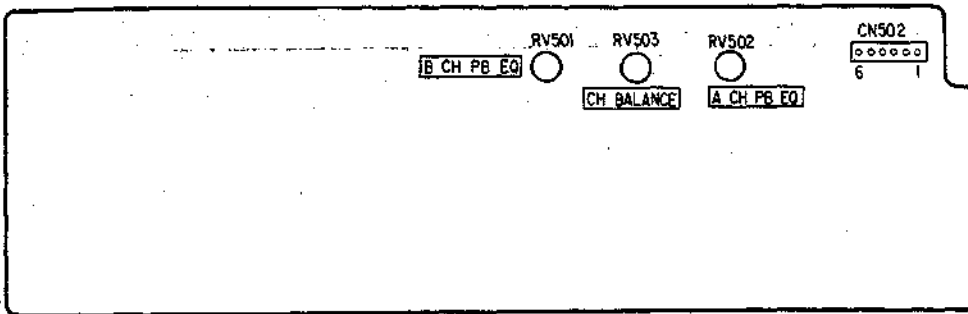

TM-57 BOARD (COMPONENT SIDE)

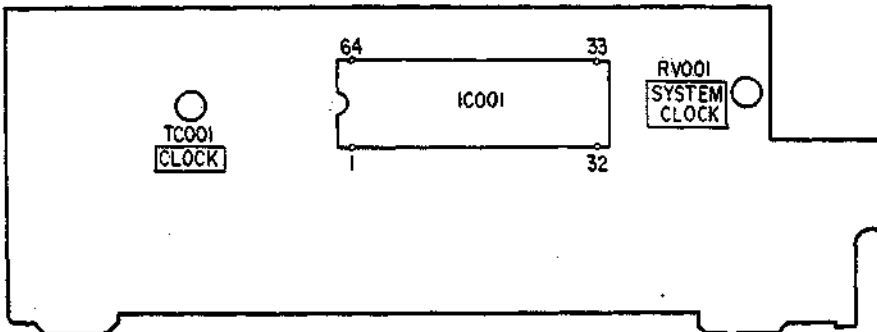

RMT-230

SERVICE MANUAL

AEP Model
UK Model
E Model



SPECIFICATIONS

Remote Commander RMT-230	
Remote control system	Infrared control
Power requirements	3V DC, 2 IEC designation R6 batteries (size AA)
Dimensions	Approx. 45 × 20 × 175 mm (w/h/d) (1 3/4 × 3/4 × 7 inches)
Weight	incl. projecting parts and controls Approx. 105 g (3.7 oz) incl. batteries

Disassembly

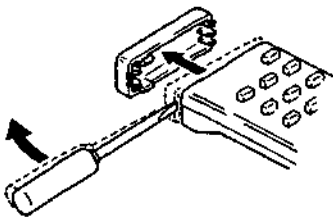

① Remove the front panel by prying up with a screwdriver.

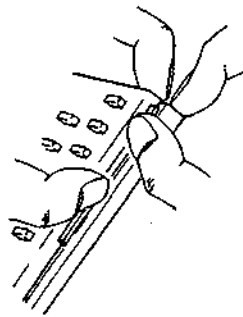

② While pulling the lower case outward, lift the upper case and free the claw.

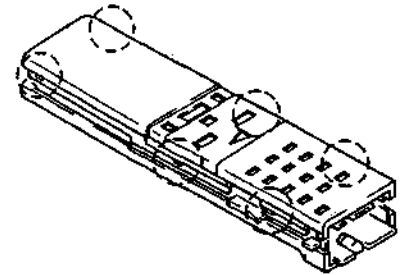

③ Free all 6 claws similarly.

REMOTE COMMANDER
SONY®

1. REMOTE CONTROL OPERATION

You can control almost all the functions of this video cassette recorder from your armchair using the supplied Remote Commander.

BATTERY INSERTION

- 1 Open the lid.

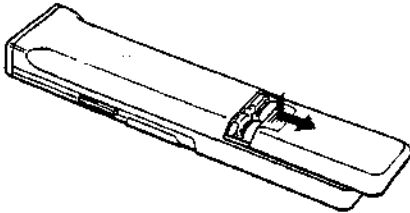

- 2 Insert two IEC designation R6 batteries with correct polarity.

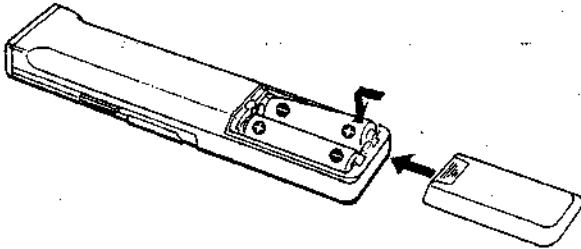

- 3 Close the lid firmly.

Battery life

In normal operation, batteries will last for about six months. If the range of the Remote Commander becomes noticeably short, replace the batteries with new ones. When the batteries are exhausted, the remote function indicator will not light when the buttons on the Commander are pressed.

If the Commander is not to be used for a long period of time, remove the batteries to avoid possible damage from battery leakage.

Notes

- There should be no obstacles between the Commander and the REMOTE SENSOR of the recorder.
- The shorter the distance between the Commander and the recorder, the wider the angle within which the recorder can be controlled.

OPERATION

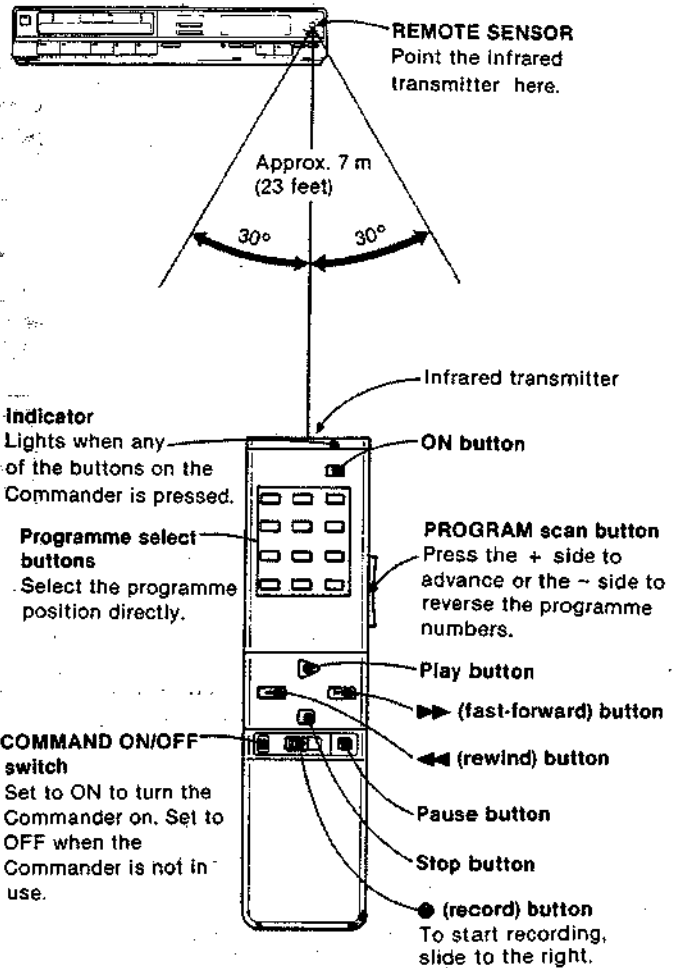

1 2 3 4 5 6 7

2. PRINTED WIRING BOARDS
 - Conductor Side -

A
B
C
D
E
F
G
H
I
J

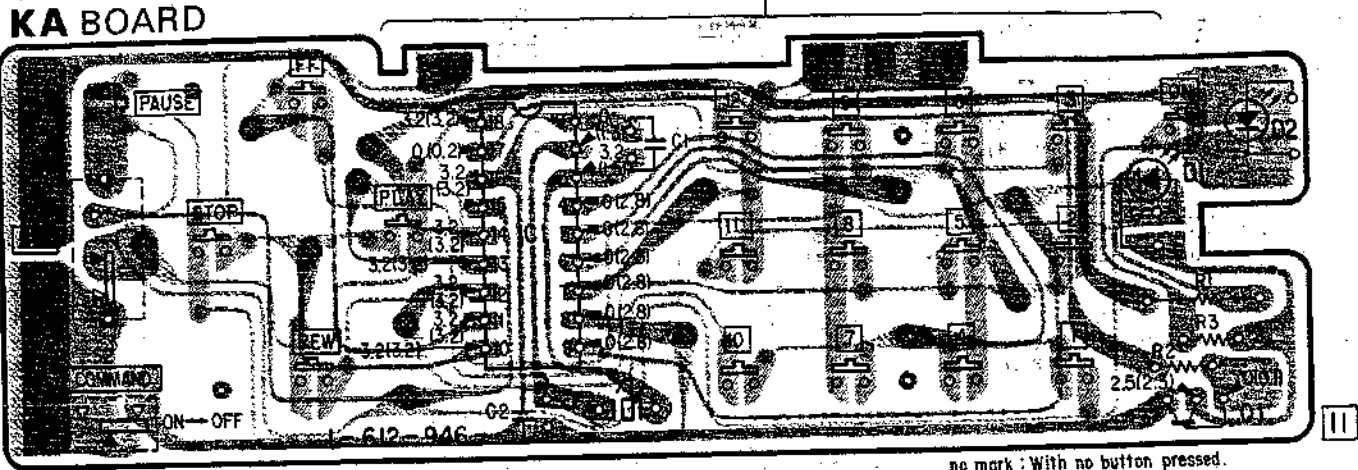
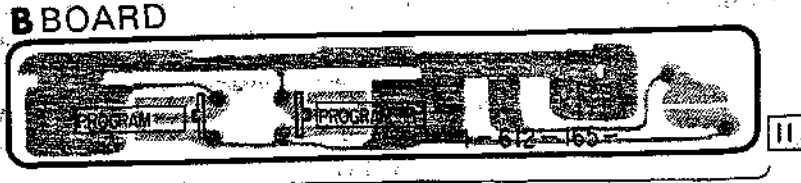

- Note:**
- ○ : indicates a lead wire mounted on the component side.
 - ● : indicates a lead wire mounted on the printed side.
 - ⊗ : Through hole.
 - [stippled] : soldering side.
 - [cross-hatched] : B+ pattern
 - [diagonal lines] : component side
 - [horizontal lines] : Carbon pattern.

3 SCHEMATIC DIAGRAM

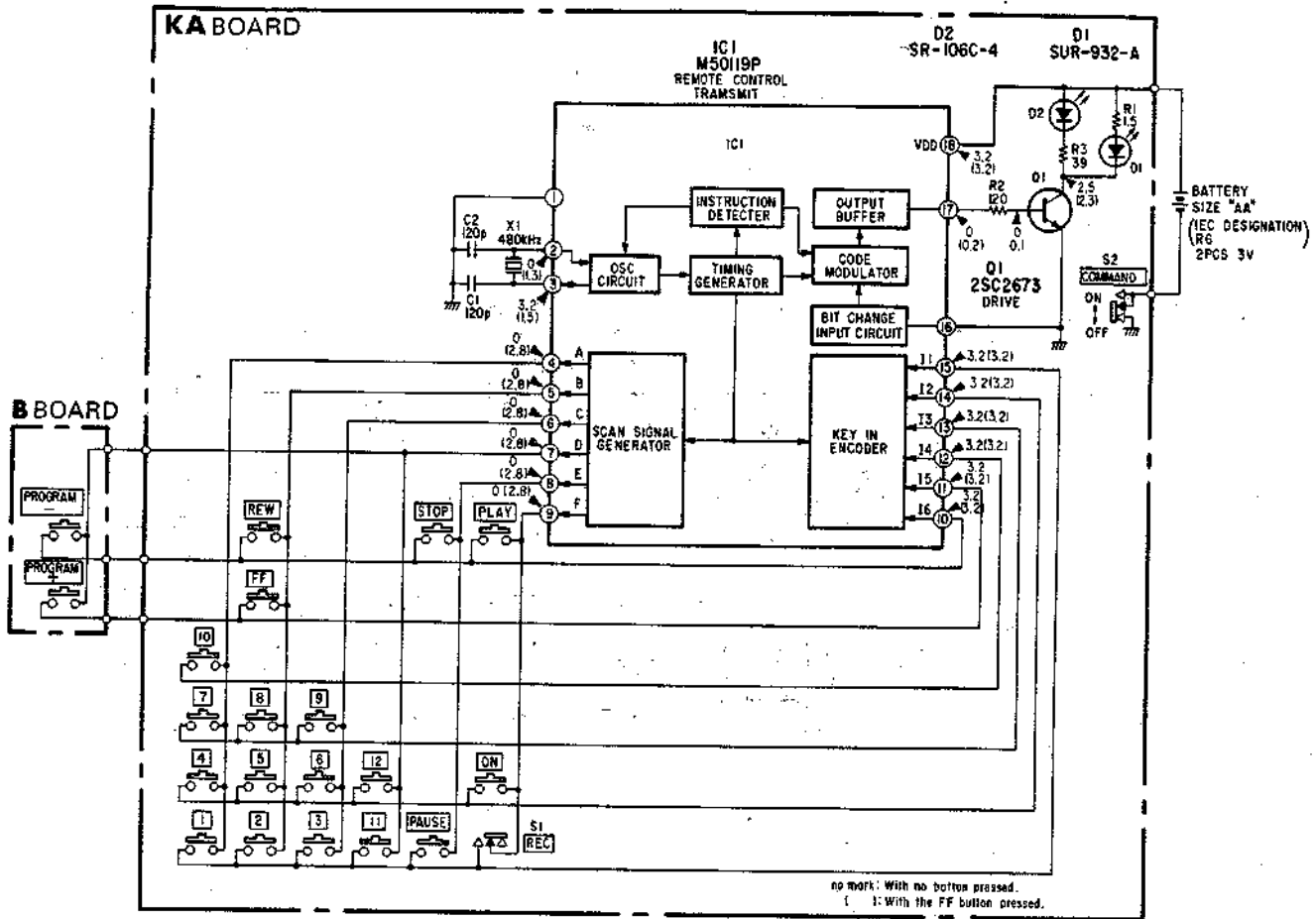

no mark: With no button pressed.
 1: With the FF button pressed.

Note:

- All resistors are in ohms, 1/6W unless otherwise noted.
- All capacitors are in μF (p:pF) unless otherwise noted.
- 50V or less are not indicated except for electrolytic capacitors.
- --- : B+ bus.
- The voltage value is measured using a digital tester (10M Ω).

When indicating parts by reference number, please include the board name.

SEMICONDUCTORS

M50119P

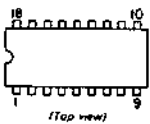

2SC2673



SLR932A



SR106C



4. EXPLODED VIEW

NOTE:

- Items with no part number and no description are not stocked because they are seldom required for routine service.
- The construction parts of an assembled part are indicated with a collation number in the remark column.
- Items marked "*" are not stocked since they are seldom required for routine service. Some delay should be anticipated when ordering these items.
- The mechanical parts with no reference number in the exploded views are not supplied.

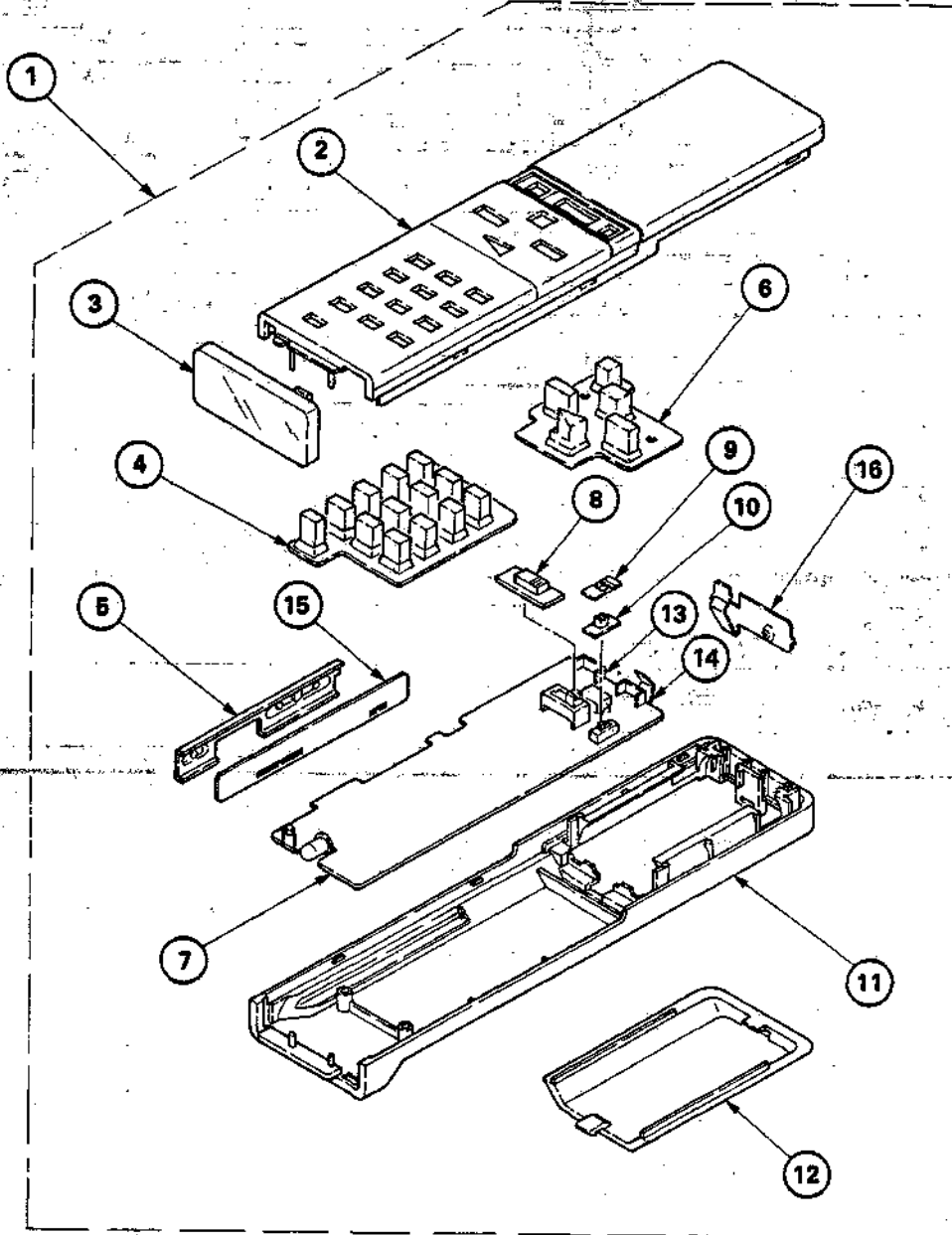

No.	Part No.	Description	Remark	No.	Part No.	Description	Remark
1	A-6765-565-A	COMMANDER ASSY RMT-230/SILVER	2-16	8	2-387-101-01	BUTTON, RECORDING	
	A-6765-638-A	COMMANDER ASSY RMT-230/GRAY	2-16	9	2-387-113-11	PLATE, COLOR	
2	2-383-130-01	CASE (UPPER), COMMANDER RMT-230/SILVER		10	2-383-127-01	BUTTON, SLIDE	
	2-383-130-61	CASE (UPPER), COMMANDER RMT-230/GRAY		11	2-387-123-01	CASE (LOWER), COMMANDER (GRAY/SILVER)	
3	2-387-107-01	PANEL, COMMANDER (FRONT)		12	2-387-105-01	COVER, BATTERY (GRAY/SILVER)	
4	2-383-128-01	RUBBER (A), CONTACT		13	2-387-104-01	TERMINAL (B), BATTERY	
5	2-389-303-01	RUBBER (B), CONTACT		14	2-387-103-01	TERMINAL (A), BATTERY	
6	2-383-129-01	RUBBER (C), CONTACT		15	*1-612-165-11	B BOARD	
7	*1-612-946-11	KA BOARD		16	4-350-925-00	TERMINAL (C), BATTERY	

5. ELECTRICAL PARTS LIST

NOTE:

The components identified by shading and mark **A** are critical for safety. Replace only with part number specified.

When indicating parts by reference number, please include the board name.

- Due to standardization, replacements in the parts list may be different from the parts specified in the diagrams or the components used on the set.
 - All variable and adjustable resistors have characteristic curve B, unless otherwise noted.
 - Items marked "*" are not stocked since they are seldom required for routine service. Some delay should be anticipated when ordering these items.
- CAPACITORS**
- MF : μ F, PF : $\mu\mu$ F
- COILS**
- MMH : mH, UH : μ H
 - F : nonflammable
- RESISTORS**
- All resistors are in ohms
 - F : nonflammable

Ref.No	Part No.	Description	Remark		
	*1-612-946-11	KA BOARD *****			
	2-387-103-01	TERMINAL (A), BATTERY			
	2-387-104-01	TERMINAL (B), BATTERY			
<u>CAPACITOR</u>					
C1	1-102-107-00	CERAMIC	120PF	10%	50V
C2	1-102-107-00	CERAMIC	120PF	10%	50V
<u>DIODE</u>					
D1	8-719-912-39	DIODE SLR-932A			
D2	8-719-100-06	DIODE SR106C			
<u>IC</u>					
IC1	8-759-600-07	IC M50119P			
<u>TRANSISTOR</u>					
Q1	8-729-967-32	TRANSISTOR 2SC2673			
<u>RESISTOR</u>					
R1	1-246-405-25	CARBON	1.5	5%	1/4W
R2	1-246-772-00	CARBON	120	5%	1/8W
R3	1-246-766-00	CARBON	39	5%	1/8W
<u>SWITCH</u>					
S1	1-554-364-00	SWITCH, SLIDE			
S2	1-553-977-00	SWITCH, SLIDE			
<u>CRYSTAL</u>					
X1	1-527-476-00	OSCILLATOR, CERAMIC			

	*1-612-165-11	B BOARD *****			

RMT-231

SERVICE MANUAL

EC Model



SPECIFICATIONS

Remote Commander RMT-231	
Remote control system	Infrared control
Power requirements	3V dc, 2 IEC designation R6 batteries (size AA)
Dimensions	Approx. 45 × 20 × 175 mm (w/h/d) (1 3/4 × 3/4 × 7 inches)
Weight	incl. projecting parts and controls Approx. 105 g (3.7 oz) incl. batteries

Disassembly

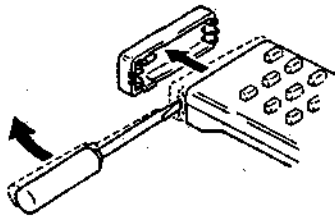

① Remove the front panel by prying up with a screwdriver.

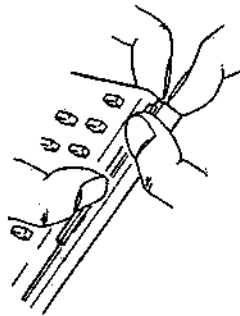

② While pulling the lower case outward, lift the upper case and free the claw.

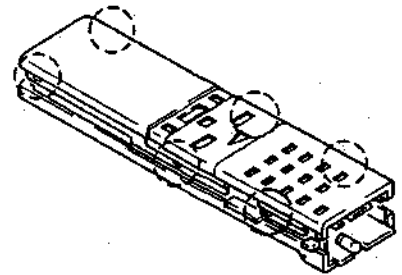

③ Free all 6 claws similarly.

REMOTE COMMANDER
SONY®

1. REMOTE CONTROL OPERATION

You can control almost all the functions of this video cassette recorder from your armchair using the supplied Remote Commander.

BATTERY INSERTION

- 1 Open the lid.

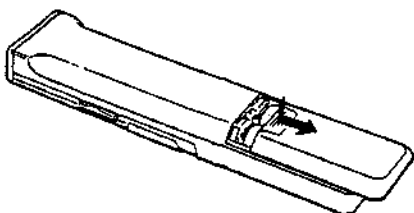

- 2 Insert two IEC designation R6 batteries with correct polarity.

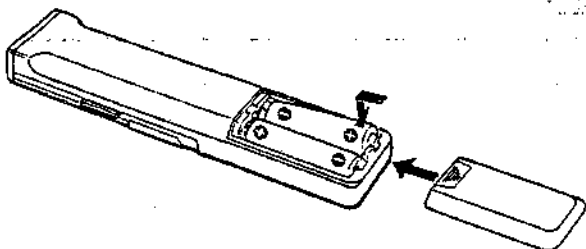

- 3 Close the lid firmly.

Battery life

In normal operation, batteries will last for about six months. If the range of the Remote Commander becomes noticeably short, replace the batteries with new ones. When the batteries are exhausted, the remote function indicator will not light when the buttons on the Commander are pressed.

If the Commander is not to be used for a long period of time, remove the batteries to avoid possible damage from battery leakage.

Notes

- There should be no obstacles between the Commander and the REMOTE SENSOR of the recorder.
- The shorter the distance between the Commander and the recorder, the wider the angle within which the recorder can be controlled.

OPERATION

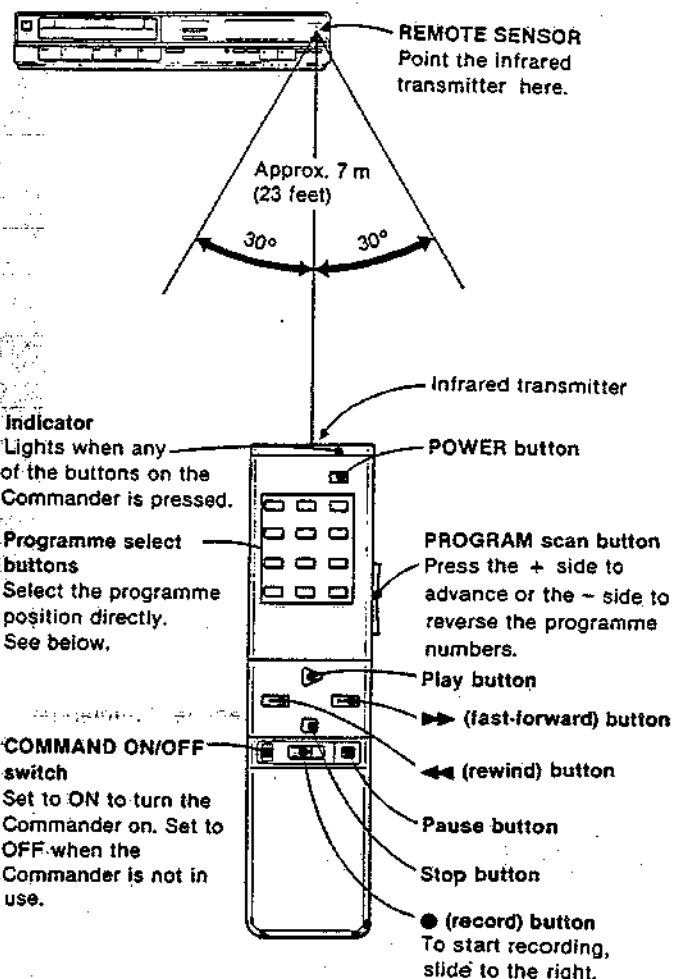

How to press the programme select buttons

SL-F30EC

For programmes 1 through 9, press the corresponding single-digit button.

For 10 through 19, press "1-" for the tens-digit and then the corresponding single-digit button.

For 20 through 29, press "2-" and then the corresponding single-digit button.

For 30, press "0".

- If you do not press a single-digit button within several seconds after pressing "1-" or "2-", the previous programme position will be recalled.

SL-F30E

Press the corresponding button, 1 through 12.

1

2

3

4

5

6

7

2. PRINTED WIRING BOARDS

- Conductor Side -

A

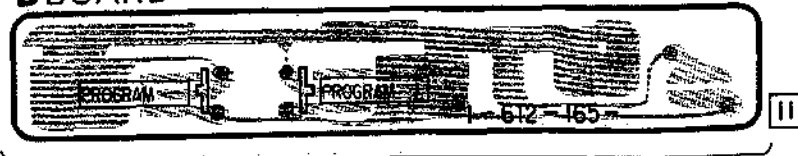
B BOARD

II

B

C

KA BOARD

D

E

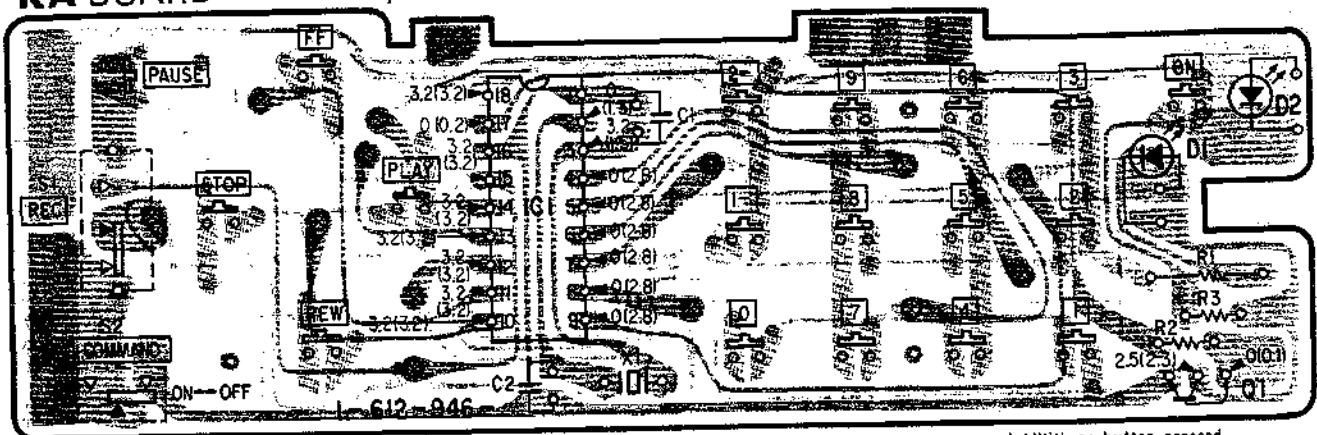

II

no mark : With no button pressed.

() : With the FF button pressed.

Note:

- ○ — : indicates a lead wire mounted on the component side.
- — : indicates a lead wire mounted on the printed side.
- ⊗ : Through hole.
- ◻ : soldering side
- ◻ : B+ pattern
- ◻ : component side
- ◻ : Carbon pattern.

F

G

H

I

J

3. SCHEMATIC DIAGRAM

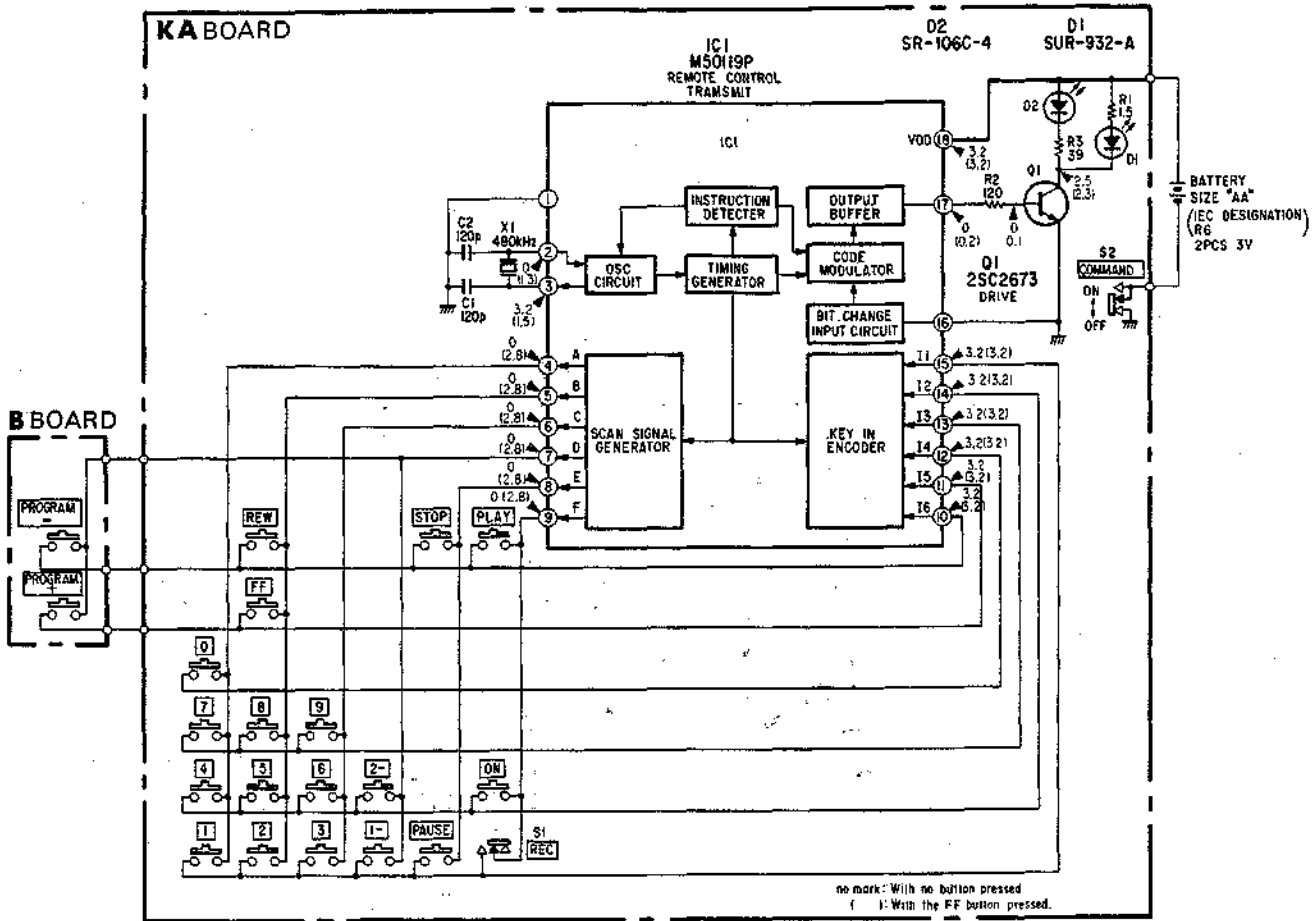

Note:

- All resistors are in ohms, 1/6W unless otherwise noted.
- All capacitors are in μF (p:pF) unless otherwise noted.
- 50V or less are not indicated except for electrolytic capacitors.
- —: B+ bus.
- The voltage value is measured using a digital tester (10M Ω).

When indicating parts by reference number, please include the board name.

SEMICONDUCTORS

M50119P

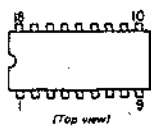

2SC2673



SLR932A



SR106C



4. EXPLODED VIEW

NOTE:

- Items with no part number and no description are not stocked because they are seldom required for routine service.
- The construction parts of an assembled part are indicated with a collation number in the remark column.
- Items marked "*" are not stocked since they are seldom required for routine service. Some delay should be anticipated when ordering these items.
- The mechanical parts with no reference number in the exploded views are not supplied.

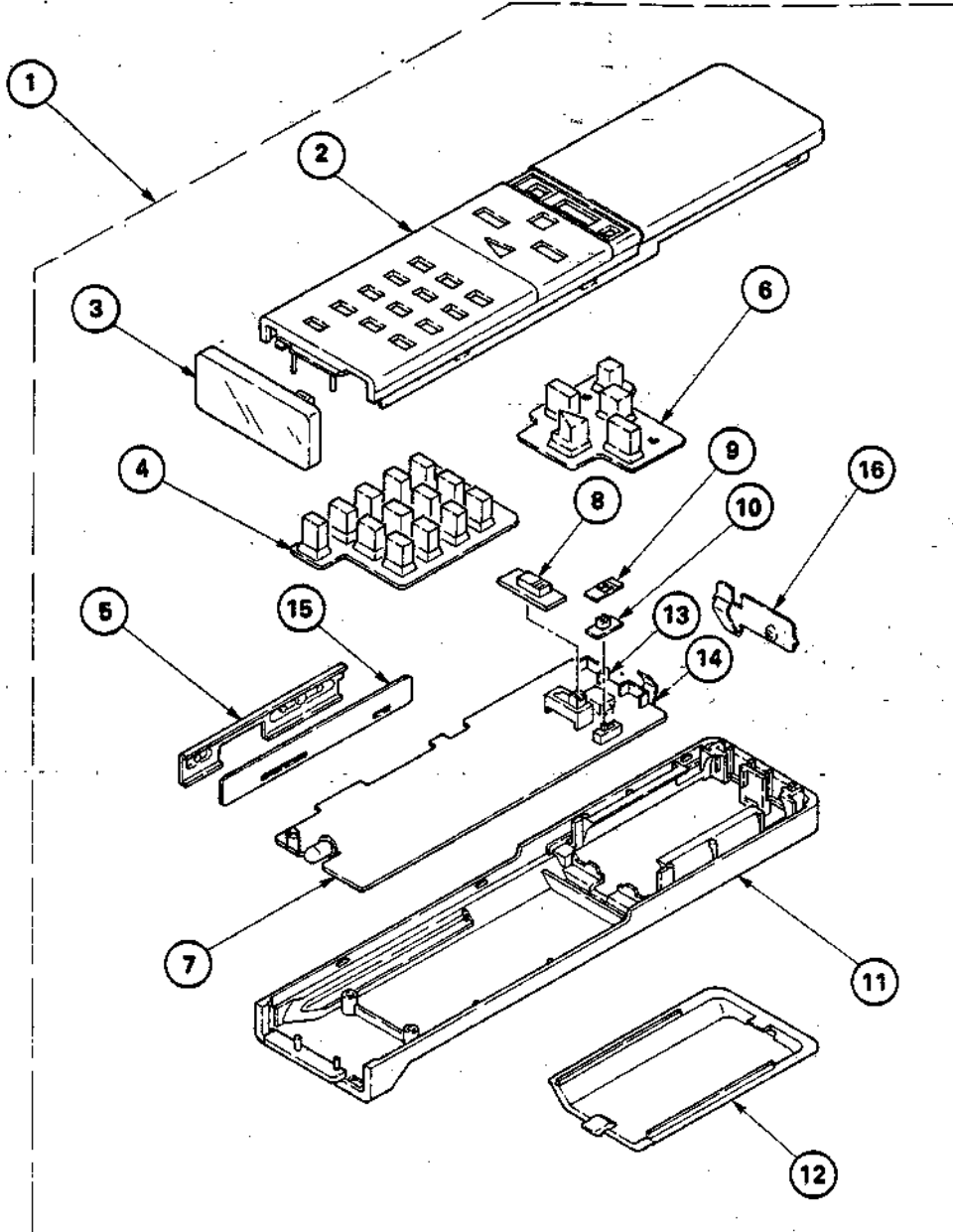

No.	Part No.	Description	Remark	No.	Part No.	Description	Remark
1	A-6765-566-A	COMMANDER ASSY RMT-231/SILVER	2-16	8	2-387-101-01	BUTTON, RECORDING	
	A-6765-639-A	COMMANDER ASSY RMT-231/GRAY	2-16	9	2-387-113-11	PLATE, COLOR	
	A-6765-641-A	COMMANDER ASSY RMT-231/RED	2-16	10	2-383-127-01	BUTTON, SLIDE	
2	2-383-130-11	CASE (UPPER), COMMANDER RMT-231/SILVER		11	2-387-123-01	CASE (LOWER), COMMANDER (GRAY/SILVER)	
	2-383-130-21	CASE (UPPER), COMMANDER RMT-231/GRAY			2-387-123-21	CASE (LOWER), COMMANDER (RED)	
	2-383-130-41	CASE (UPPER), COMMANDER RMT-231/RED		12	2-387-105-01	COVER, BATTERY (GRAY/SILVER)	
3	2-387-107-01	PANEL, COMMANDER (FRONT)			2-387-105-21	COVER, BATTERY (RED)	
4	2-383-128-01	RUBBER (A), CONTACT		13	2-387-104-01	TERMINAL (B), BATTERY	
5	2-389-303-01	RUBBER (B), CONTACT		14	2-387-103-01	TERMINAL (A), BATTERY	
6	2-383-129-01	RUBBER (C), CONTACT		15	*1-612-165-11	B BOARD	
7	*1-612-946-11	KA BOARD		16	4-350-925-00	TERMINAL (C), BATTERY	

5. ELECTRICAL PARTS LIST

NOTE:

The components identified by shading and mark **A** are critical for safety. Replace only with part number specified.

When indicating parts by reference number, please include the board name.

- Due to standardization, replacements in the parts list may be different from the parts specified in the diagrams or the components used on the set.
- Items marked "*" are not stocked since they are seldom required for routine service. Some delay should be anticipated when ordering these items.

- All variable and adjustable resistors have characteristic curve B, unless otherwise noted.

RESISTORS

- All resistors are in ohms
- F : nonflammable

CAPACITORS

- MF : μ F, PF : $\mu\mu$ F

COILS

- .MMH : mH, UH : μ H

Ref.No	Part No.	Description	Remark
	*1-612-946-11	KA BOARD *****	
	2-387-103-01	TERMINAL (A), BATTERY	
	2-387-104-01	TERMINAL (B), BATTERY	
<u>CAPACITOR</u>			
C1	1-102-107-00	CERAMIC 120PF 10% 50V	
C2	1-102-107-00	CERAMIC 120PF 10% 50V	
<u>DIODE</u>			
D1	8-719-912-39	DIODE SLR-932A	
D2	8-719-100-06	DIODE SR106C	
<u>IC</u>			
IC1	8-759-600-07	IC M50119P	
<u>TRANSISTOR</u>			
Q1	8-729-967-32	TRANSISTOR 2SC2673	
<u>RESISTOR</u>			
R1	1-246-405-25	CARBON 1.5 5% 1/4W	
R2	1-246-772-00	CARBON 120 5% 1/8W	
R3	1-246-766-00	CARBON 39 5% 1/8W	
<u>SWITCH</u>			
S1	1-554-364-00	SWITCH, SLIDE	
S2	1-553-977-00	SWITCH, SLIDE	
<u>CRYSTAL</u>			
X1	1-527-476-00	OSCILLATOR, CERAMIC	

	*1-612-165-11	B BOARD *****	
