

SONY.

VIDEOCASSETTE PLAYER

PVW-2600P

SERVICE MANUAL

Vol.1 1st Edition

Serial No.10001 and Higher

BETACAM SP
2000PRO

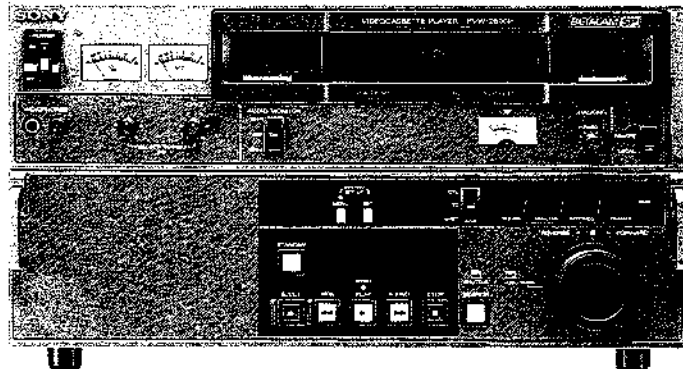

このマニュアルに記載されている事柄の著作権は当社にあり、説明内容は機器購入者の使用を目的としています。
従って、当社の許可なしに無断で複写したり、説明内容(操作、保守等)と異なる目的で本マニュアルを使用することを禁止します。

The material contained in this manual consists of information that is the property of Sony Corporation and is intended solely for use by the purchasers of the equipment described in this manual.

Sony Corporation expressly prohibits the duplication of any portion of this manual or the use thereof for any purpose other than the operation or maintenance of the equipment described in this manual without the express written permission of Sony Corporation.

Le matériel contenu dans ce manuel consiste en informations qui sont la propriété de Sony Corporation et sont destinées exclusivement à l'usage des acquéreurs de l'équipement décrit dans ce manuel. Sony Corporation interdit formellement la copie de quelque partie que ce soit de ce manuel ou son emploi pour tout autre but que des opérations ou entretiens de l'équipement à moins d'une permission écrite de Sony Corporation.

Das in dieser Anleitung enthaltene Material besteht aus Informationen, die Eigentum der Sony Corporation sind, und ausschließlich zum Gebrauch durch den Käufer der in dieser Anleitung beschriebenen Ausrüstung bestimmt sind.

Die Sony Corporation untersagt ausdrücklich die Vervielfältigung jeglicher Teile dieser Anleitung oder den Gebrauch derselben für irgendeinen andere Zweck als die Bedienung oder Wartung der in dieser Anleitung beschriebenen Ausrüstung ohne ausdrückliche schriftliche Erlaubnis der Sony Corporation.

TABLE OF CONTENTS

Volume-1

1. INSTALLATION

1-1. Operational Environment	1-1
1-2. Installation	1-1
1-2-1. Installation Space	1-1
1-2-2. Installation Setup and Adjustment	1-2
1-3. Operating Voltage	1-2
1-4. Matching Connectors and Cables	1-3
1-5. Input/Output Signals of the Connectors	1-4
1-6. Select Switch Setting on the Board	1-7
1-7. System Control Setup	1-12
1-7-1. Setup Menu	1-12
1-7-2. Setup Operation	1-14
1-7-3. Main Menu	1-16
1-7-4. System Menu	1-18
1-8. Rack Mounting	1-24
1-9. Supplied Accessories	1-25
1-10. Optional Accessories	1-25
1-11. Setting Check Sheet	1-26

2. SERVICE INFORMATION

2-1. Specifications	2-1
2-2. Main Parts Location	2-3
2-2-1. Location of Printed Circuit Board	2-3
2-2-2. Location of Mechanical Parts /Components	2-4
2-2-3. Location of Sensor (1)	2-4
2-2-4. Location of Sensor (2)---Cassette Compartment	2-5
2-2-5. Function of the Cassette Plug and Tub	2-6
2-3. Error Message	2-7
2-4. Printed Circuit Board	2-21
2-5. Removal of Cabinet	2-22
2-6. Removal/Installation of Cassette Compartment	2-23
2-7. Removal of Power Supply Block	2-24
2-8. Removal/Installation of Lower Control Panel Ass'y	2-24
2-9. Tilt the Lower Control Panel	2-25
2-10. Removal of Connector Panel	2-25
2-11. Note for Check and Maintenance of Printed Circuit Board	2-25
2-12. Extension Board	2-25
2-13. Notes on Repair Parts	2-26
2-13-1. Notes on Repair Parts	2-26
2-13-2. Replacement Procedure for Chip Parts	2-26

2-13-3. Removal of PLCC IC	2-27
2-13-4. Replacement of Fuse	2-27
2-14. How to Operate the Unit Without Cassette Tape	2-28
2-15. Take Out the Cassette Tape in Slacking	2-29
2-16. Cleaning When Heads Clogged	2-30
2-17. Replacement of Boards	2-31
2-17-1. SW-444 Board	2-31
2-17-2. VR-117 Board	2-32
2-17-3. MA-44 Board	2-32
2-17-4. DP-138 Board	2-33
2-17-5. VR-116 Board	2-34
2-17-6. PTC-42 Board	2-34
2-18. Removal/Installation of Detection Switch	2-35
2-18-1. Removal of MC Sensor	2-35
2-19. Precaution in Replacement of DR-118 Board	2-35
2-20. Fixture	2-36
2-21. Introduction to Circuit	2-38
2-21-1. Outline of the Betacam Method	2-38

3. MAINTENANCE MODE

3-1. Video System Check Mode (A0 : Video Check)	3-3
3-2. Servo System Check Mode (B0 : Servo Check)	3-5
3-3. Servo System Adjustment Mode (B1 : Servo Adjust)	3-21
3-4. Other Check Mode (F : Others)	3-34

4. INSPECTION AND MAINTENANCE

4-1. Hours Meter	4-1
4-2. Maintenance After Repairs	4-2
4-2-1. Cleaning Procedure of Video Head	4-2
4-2-2. Cleaning Procedure of Stationary Heads	4-2
4-2-3. Cleaning Procedure of Tape Movement Areas	4-2
4-3. Periodic Maintenance Table	4-3

5. REPLACEMENT OF MAJOR PARTS

5-1. General Information for Part Replacement and Adjustment	5-1
5-1-1. Index for Adjustment Item	5-4
5-2. Upper Drum Assembly Replacement	5-5
5-2-1. Upper Drum Eccentricity Adjustment	5-9
5-3. Drum Assembly Replacement	5-11
5-3-1. Drum Motor Operation Check	5-15

5-4. Drum Ground Shaft Assembly Replacement	5-17
5-5. Pinch Roller Assembly Replacement	5-18
5-6. Cleaning Roller Assembly Replacement	5-20
5-6-1. Cleaning Roller Block Position Adjustment	5-21
5-7. Brake Lining Assembly Replacement	5-22
5-7-1. Reel Brake Clearance Check	5-24
5-7-2. Reel Brake Release Amount Adjustment	5-25
5-8. Tape Guide Replacement	5-26
5-8-1. TG-4 Tape Guide Roller Replacement	5-27
5-8-2. Other Tape Guide Rollers Replacement	5-28
5-9. Cleaning Solenoid Replacement	5-30
5-10. Reel Table Replacement	5-31
5-10-1. Cassette Pillar (S) Height Adjustment	5-32
5-10-2. Reel Table Height Adjustment	5-34
5-10-3. Reel Rotation Detector Position Adjustment	5-36
5-11. Reel Motor Plate Replacement	5-38
5-12. Reel Motor Replacement	5-41
5-12-1. Reel Motor Shaft Slantness Adjustment	5-44
5-12-2. Reel Motor Operation Check	5-46
5-12-3. Reel FG Duty Adjustment	5-47
5-12-4. S Reel Offset/Friction Adjustment	5-48
5-12-5. S Reel Torque Adjustment	5-50
5-12-6. T Reel Offset/Friction Adjustment	5-52
5-12-7. T Reel Torque Adjustment	5-54
5-13. Reel Position Motor Replacement	5-56
5-13-1. Reel Position Motor Operation Check	5-57
5-14. Reel Position Sensor Replacement	5-58
5-15. Threading Motor Replacement	5-59
5-15-1. Threading Motor Operation Check	5-60
5-16. S Slider Assembly Replacement	5-62
5-17. T Slider Assembly Replacement	5-65
5-18. P Slider Assembly Replacement	5-69
5-19. S Tension Regulator Arm Assembly Replacement	5-72
5-19-1. S Tension Regulator Arm Operating Position Adjustment	5-74
5-19-2. S Tension Sensor Sensitivity Adjustment	5-78
5-19-3. FWD Back Tension Adjustment	5-84
5-19-4. REV Back Tension Adjustment	5-87
5-20. T Tension Regulator Arm Assembly Replacement	5-91
5-20-1. T Tension Regulator Arm Operating Position Adjustment	5-93

5-20-2. T Tension Sensor Sensitivity Adjustment	5-97
5-21. Pinch Press Block Replacement	5-100
5-22. Pinch Solenoid Replacement	5-101
5-22-1. Pinch Solenoid Position Adjustment	5-104
5-23. Threading Ring Replacement	5-106
5-24. Threading Gear Replacement	5-110
5-25. CTL Head Replacement	5-115
5-26. AUDIO/TC Head Replacement	5-117
5-27. Capstan Motor Replacement	5-120
5-27-1. Capstan Motor Operation Check	5-122
5-27-2. Capstan FG Duty Adjustment	5-123
5-27-3. Capstan Speed Adjustment	5-125

6. TAPE RUN ALIGNMENT

6-1. General Information for Tape Run Adjustment	6-1
6-2. Audio/TC Head Zenith Adjustment	6-4
6-3. Tape Running Adjustment	6-6
6-4. Confirmation of Video Tracking	6-8
6-4-1. Video Tracking Adjustment (1)	6-10
6-4-2. Video Tracking Adjustment (2)	6-14
6-4-3. Video Tracking Adjustment (3)	6-18
6-5. CTL Head Height Adjustment	6-20
6-6. CTL Head Position Adjustment	6-22
6-7. Audio Head Height Adjustment	6-24
6-8. Audio Head Phase Adjustment	6-26
6-9. Audio Head Head-to-Tape Contact Adjustment	6-28
6-10. TC Head Position Adjustment	6-30
6-11. Audio Level Adjustment (in REV Mode)	6-32
6-12. RF Switching Position Adjustment	6-34
6-13. Video Head Dihedral Check	6-36
6-14. Picture Splitting Compensation Adjustment	6-37

7. GENERAL INFORMATION FOR ELECTRICAL ADJUSTMENT

7-1. Adjustment Component Index	7-1
7-2. Required Equipment	7-4
7-3. Test Signal	7-5

8. POWER SUPPLY AND SYSTEM CONTROL ALIGNMENT

8-1. Switching Regulator Voltage Check	8-1
8-2. Character Position Adjustment	8-1

9. SERVO SYSTEM ALIGNMENT

- 9-1. Search Dial Assembly Sensor Duty Adjustment9-2

10. AUDIO/TIME CODE SYSTEM ALIGNMENT

- 10-1. Audio PB Dolby Off Frequency Response Adjustment10-7
 - 10-1-1. CH-1 Audio PB Dolby Off Frequency Response Adjustment10-7
 - 10-1-2. CH-2 Audio PB Dolby Off Frequency Response Adjustment10-8
 - 10-1-3. CH-1 Audio PB Dolby Off Metal Frequency Response Adjustment10-9
 - 10-1-4. CH-1 Audio PB Phase Adjustment10-10
 - 10-1-5. CH-2 Audio PB Dolby Off Metal Frequency Response Adjustment10-12
 - 10-1-6. CH-2 Audio PB Phase Adjustment10-13
- 10-2. Search Mode Audio PB Level Check10-14
 - 10-2-1. CH-1 Search Mode Audio Oxide/Metal PB Level Check10-14
 - 10-2-2. CH-2 Search Mode Audio Oxide/Metal PB Level Check10-14
- 10-3. Audio Meter Adjustment10-14
- 10-4. Audio Monitor Out Level Check10-15
 - 10-4-1. CH-1 Audio Monitor Out Level Check10-15
 - 10-4-2. CH-2 Audio Monitor Out Level Check10-15
- 10-5. Headphones Level Check10-16

11. VIDEO SYSTEM ALIGNMENT

- 11-1. VP Board (RF, DM System) Adjustment11-15
 - 11-1-1. Y PB RF Level Adjustment (Metal)11-15
 - 11-1-2. RF Meter Adjustment (Metal)11-15
 - 11-1-3. Y PB RF Level Adjustment (Oxide)11-16
 - 11-1-4. C PB RF Level Adjustment (Metal)11-17
 - 11-1-5. C PB RF Level Adjustment (Oxide)11-17
 - 11-1-6. Y and C Demodulator Gain Adjustment (Metal).....11-18
 - 11-1-7. Y/C Demodulator Gain Adjustment (Oxide).....11-19
 - 11-1-8. Y and C Limiter Balance Adjustment ..11-20
 - 11-1-9. Y and C Demodulator Balance Adjustment11-24
 - 11-1-10. Y and C OMC Adjustment (Metal)11-28

- 11-1-11. Y and C OMC Adjustment (Oxide)11-29
- 11-1-12. PB Y Frequency Response Adjustment (Metal)11-30
- 11-1-13. PB Y Frequency Response Adjustment (Oxide)11-31
- 11-1-14. PB C Frequency Response Adjustment (Metal)11-32
- 11-1-15. PB C Frequency Response Adjustment (Oxide)11-33
- 11-1-16. Y DOC Sensitivity Adjustment11-35
- 11-1-17. C DOC Sensitivity Adjustment11-36
- 11-2. TBC Board Adjustment11-38
 - 11-2-1. Y and C TBC Input Level Check11-38
 - 11-2-2. Y TBC Output Level and Gain Adjustment11-39
 - 11-2-3. C TBC Output Level and Gain Adjustment11-40
 - 11-2-4. Y and C Normal VCO Adjustment11-42
 - 11-2-5. INT SC Frequency Adjustment11-43
 - 11-2-6. U-V Axis Phase (B-Y, R-Y Phase) Adjustment11-44
 - 11-2-7. TBC Tracking Adjustment11-45
- 11-3. VP Board (VO, EN System) Adjustment11-46
 - 11-3-1. ENC Y Level Adjustment11-46
 - 11-3-2. COMPONENT 2 and 1 Y OUT Level Adjustment11-47
 - 11-3-3. S-VIDEO OUT Y Level Adjustment ..11-47
 - 11-3-4. VIDEO OUT 1 and 2 Y Level Adjustment11-48
 - 11-3-5. VIDEO OUT 3 and MONITOR OUT Y Level Adjustment11-48
 - 11-3-6. COMPONENT 2 and 1 R-Y OUT Level Adjustment11-49
 - 11-3-7. COMPONENT 2 and 1 B-Y OUT Level Adjustment11-50
 - 11-3-8. COMPONENT 2 B-Y CF ID Level Adjustment11-51
 - 11-3-9. COMPONENT 2 Y VISC Level Adjustment11-52
 - 11-3-10. VIDEO OUT 1 ENC SC Leak Adjustment11-53
 - 11-3-11. VIDEO OUT 1 Chroma Level Adjustment11-54
 - 11-3-12. VIDEO OUT 1 Burst Level Adjustment11-54
 - 11-3-13. VIDEO OUT 2 Chroma Level and Burst Level Check11-55
 - 11-3-14. VIDEO OUT 3 Chroma Level and Burst Level Check11-56

11-3-15. MONITOR OUT Chroma Level and Burst Level Check	11-57
11-3-16. S-VIDEO OUT Chroma Level and Burst Level Check	11-58

12. VIDEO OVERALL ALIGNMENT

12-1. Y and C PB RF Frequency Response Adjustment	12-11
12-2. Noise Reduce Adjustment	12-12
12-3. Y and C BID Level Check	12-13
12-4. Y and C WCK Frequency Adjustment	12-15
12-5. Y and C Error Offset Adjustment	12-16
12-6. INT REF. VIDEO OUT Level Adjustment	12-16
12-7. PB Video Phase Adjustment	12-17
12-8. PB Composite Y/C Delay Adjustment (Metal/Oxide)	12-20
12-9. PB Component Y/C Delay Adjustment (Metal/Oxide)	12-22
12-10. Encode CF Phase Adjustment	12-24
12-11. Reference CF Phase Adjustment	12-26
12-12. VISC Lock in Adjustment	12-28
12-13. VISC Regen Phase Adjustment	12-30
12-14. VISC Tracking Check	12-32
12-15. H Shift Check	12-33
12-16. No Burst REF IN Check	12-34
12-17. INT SCH Phase Adjustment	12-35
12-18. DUB OUT REF IN Check	12-36
12-19. Play Back Component Linearity Check	12-36

13. SIMPLE ALIGNMENT

(This section will be available as a supplement.)

Volume-2

14. BLOCK DIAGRAM

15. BOARD LAYOUT

16. SCHEMATIC DIAGRAM

17. SEMICONDUCTOR PIN ASSIGNMENT

18. REPLACEABLE PARTS & OPTIONAL FIXTURE

19. CHANGED PARTS

INSTALLATION

SECTION 1 INSTALLATION

Be sure to install the PVW-2600P in locations satisfying the required operational environment described below to assure the PVW-2600P's superior performance and to maintain the excellent serviceability and accessibility.

1-1. OPERATIONAL ENVIRONMENT

- Operating temperature : +5 °C to +40 °C
(Good air circulation is essential to prevent internal heat build-up. Place the unit in location with sufficient air circulation. Do not block the ventilation holes on the cabinet and the rear panel.)
- Humidity : 80% or less
- Storage temperature : -20 °C to +60 °C
- Locations to avoid :
 - Areas where the unit will be exposed to direct sunlight or any other strong lights.
 - Dusty areas or areas where it is subject to vibration.
 - Areas with strong electric or magnetic fields.
 - Areas near heat sources.

1-2. INSTALLATION

1-2-1. Installation Space

- (1) The rear side must be at least 40 cm away from the walls for ventilation and maintenance.
- (2) When the unit is operated on a desk or similar condition, assure that the clearance above the unit is at least 40 cm to provide accessibility to the printed circuit boards and other mechanical parts. Note that it is not necessary to provide the space when the unit is mounted in a rack since the printed circuit boards can be repaired after it is pulled out.

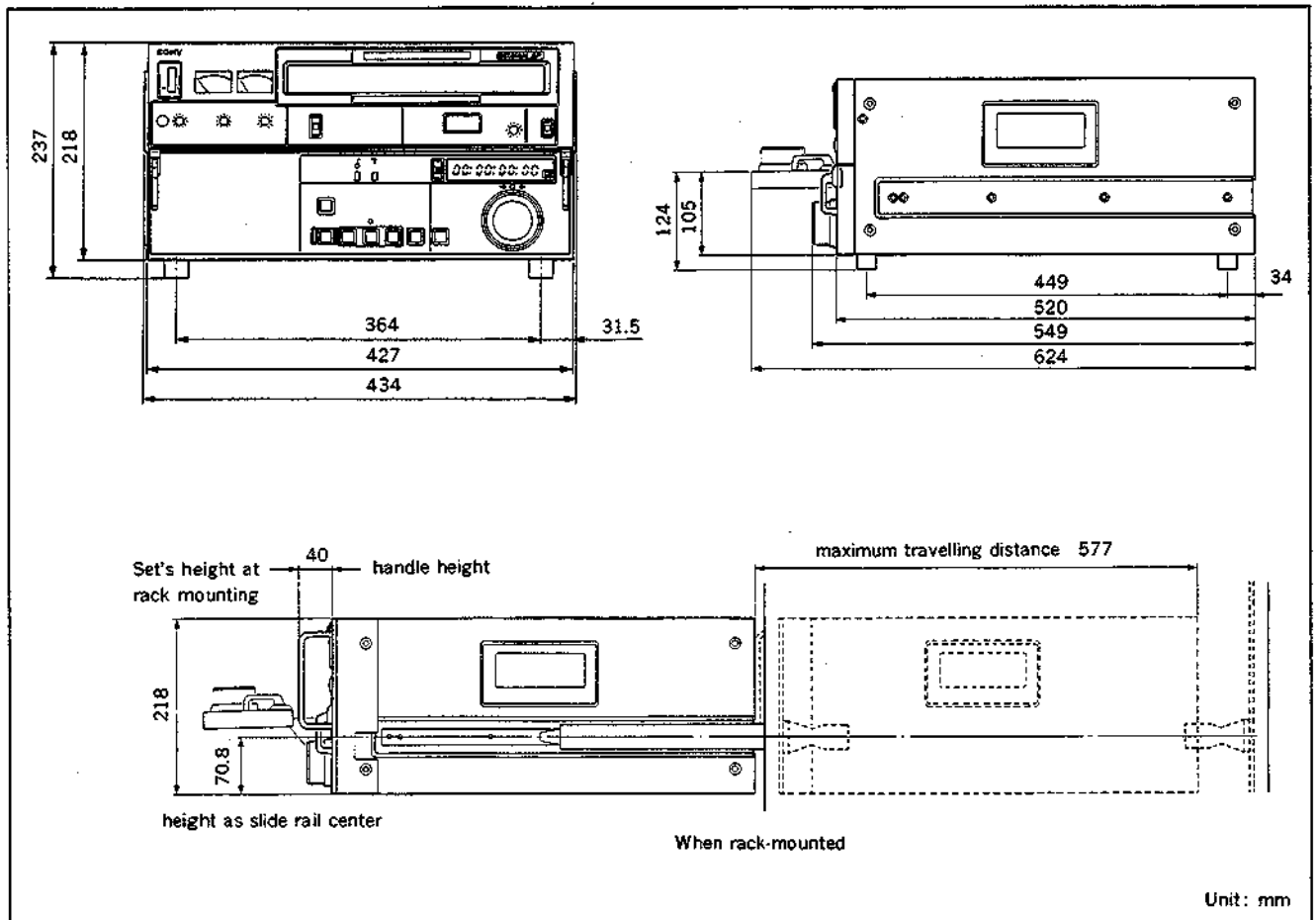

1-2-2. Installation Setup and Adjustment

When the unit is installed, be sure to perform the following setup and adjustment. If the adjustment is not performed, the unit may not operate properly.

Refer to the operation manual "Chapter 3 Setting Up the Unit" for setup and adjustment.

- (1) 75 Ω termination switch setting : 75 Ω ON/OFF

Further, under the applications, perform the following setup and adjustment.

- In case of performing time code editing.
 - (1) Time code reader mode setting
- In case of using as editing system.
 - (1) Put the reference video signal to REF. VIDEO IN connector.
 - (2) H system phase adjustment
 - (3) SC system phase adjustment

1-3. OPERATING VOLTAGE

- Power voltage : 90-264 V ac
- Power frequency : 48-64 Hz
- Power consumption : 130 W

1-4. MATCHING CONNECTORS AND CABLES

When external cables are connected to the connector on a connector panel during maintenance, the hardware listed below (or equivalents) must be used.

PVW-2600P side Connector	Matching Connector/Cable	
Panel Indication	Connector/Cable	Sony Part No.
VIDEO INPUT REF. VIDEO	BNC, MALE	1-560-069-11
VIDEO OUTPUT 1/2/3 REF. VIDEO COMPONENT 2 (Y, R-Y, B-Y)	BNC, MALE	1-560-069-11
COMPONENT 1	PLUG, 12P, MALE	1-560-995-00
DUB (U-matic)	PLUG, 7P, MALE	1-508-948-00
S-VIDEO	VDC-3 (3 m) VDC-5 (5 m) YC-15V (1.5 m)	optional accessory
AUDIO OUTPUT CH-1/CH-2/MONITOR	XLR 3P, FEMALE	1-508-083-00
TIME CODE OUT	BNC, MALE	1-560-069-11
MONITOR	RECTANGULAR, 8P, MALE	1-506-161-00
TBC REMOTE	CONNECTOR, D-SUB 15P, FEMALE and JUNCTION SHELL, 15P	1-561-610-21 1-561-929-00
REMOTE	CONNECTOR, D-SUB 9P, MALE and JUNCTION SHELL, 9P	1-560-651-00 1-561-749-00
	RCC-5G (5 m) RCC-10G (10 m) RCC-30G (30 m)	optional accessory

1-5. INPUT/OUTPUT SIGNALS OF THE CONNECTORS

INPUT

REF VIDEO : BNC×2 (bridging connection)
Black burst or composite video 1.0 ± 0.3 V p-p, 75 Ω (ON/OFF), sync negative

OUTPUT

REF VIDEO : BNC
Black burst, 75 Ω , sync negative

VIDEO OUTPUT 1/2/3 : BNC×3
Composite video, 1.0 V p-p, 75 Ω , sync negative
Superimposed time code etc. output from VIDEO OUTPUT 3, as specified by CHARACTER switch on a sub control panel.

COMPONENT 1 : Circular 12 pin
Y : 1.0 V p-p, 75 Ω , sync negative
R-Y : 0.7 V p-p, 75 Ω
B-Y : 0.7 V p-p, 75 Ω

COMPONENT 2 : BNC×3
Y : 1.0 V p-p, 75 Ω , sync negative
R-Y : 0.7 V p-p, 75 Ω
B-Y : 0.7 V p-p, 75 Ω

DUB (U-matic)
(with an optional
BKW-2030) : Circular 7 pin
Y : 0.5 V p-p (75 Ω load)
C : 0.5 V p-p (75 Ω load)

S-VIDEO : Circular 4 pin
Y : 1.0 V p-p, 75 Ω , sync negative
C : 0.7 V p-p, 75 Ω (burst 0.286 V p-p)

AUDIO OUTPUT CH-1/2/MONITOR : XLR 3P×3
+4 dBu (600 Ω load), low impedance, balanced
(0 dBu=0.775 V rms)

TIME CODE OUT : BNC
2.2 V p-p (600 Ω load), unbalanced

HEADPHONES : Stereo phone jack
-14 dBu max. (8 Ω load)
(0 dBu=0.775 V rms)

TBC REMOTE

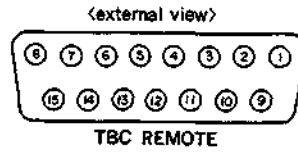

Pin No.	Description	Operating Voltage	IN/OUT
1	SYNC CONTROL	-5 V to +5 V	IN
2	HUE CONTROL	-5 V to +5 V	IN
3	SC CONTROL	-5 V to +5 V	IN
4	VIDEO LEVEL CONTROL	-5 V to +5 V	IN
5	SETUP CONTROL	-5 V to +5 V	IN
6	CHROMA LEVEL CONTROL	-5 V to +5 V	IN
7	-12 V	-12 V	OUT
8	GND	—	IN/OUT
9	FRAME GND	—	IN/OUT
10	N C	—	—
11	N C	—	—
12	N C	—	—
13	Y/C DELAY CONTROL	-5 V to +5 V	IN
14	N C	—	—
15	+12 V	+12 V	OUT

MONITOR

Pin No.	Output Signal
1	AUDIO MONITOR OUT (X)
2	VIDEO OUT (X)
3	—
4	—
5	AUDIO MONITOR OUT (G)
6	VIDEO OUT (G)
7	—
8	—

<external view>

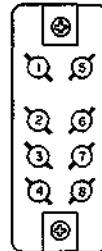

MONITOR

- VIDEO : 1.0 V p-p, 75 Ω , sync negative
Superimposed time code etc. output as specified by
sub control panel switches.
- AUDIO : -5 dBu (47 k Ω load), unbalanced
(0 dBu=0.775 V rms)

REMOTE

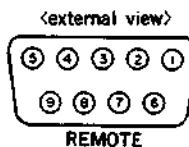

Pin No.	Controlling Device	Controlled Device
1	Frame Ground	Frame Ground
2	Receive A	Transmit A
3	Transmit B	Receive B
4	Transmit Common	Receive Common
5	—	—
6	Receive Common	Transmit Common
7	Receive B	Transmit B
8	Transmit A	Receive A
9	Frame Ground	Frame Ground

S-VIDEO

Pin No.	Description
1	Y (G)
2	C (G)
3	Y (X)
4	C (X)

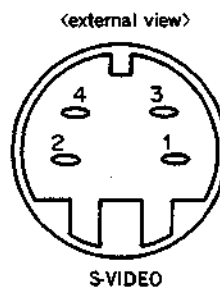

1-6. SELECT SWITCH SETTING ON THE BOARD

AU-148 board

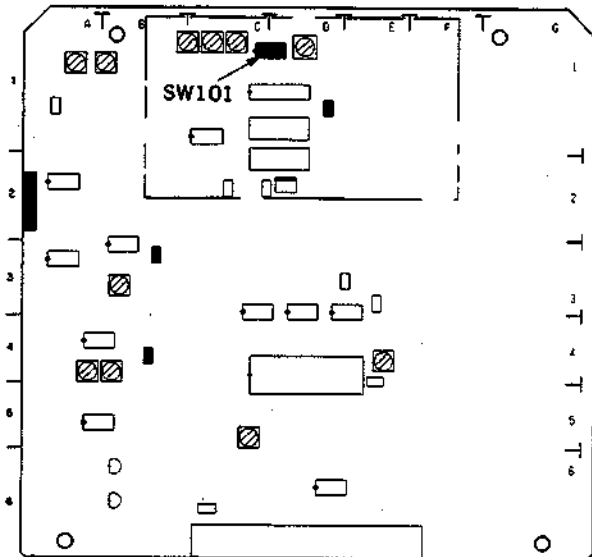

SW101 (C-1/AU-148): AUDIO HEAD TUNE ADJ SW

By coupling with LV101 on the AU-148 board, adjust the CH-1 head amp high frequency response (head vibration). (Refer to Section 10-1.)

This switch is used in audio head tune adjustment. If the switch setting is changed when this adjustment is not performed, audio frequency response may be failed.

When the unit is shipped, this switch is set to the position based on the adjustment condition.

AU-149 board

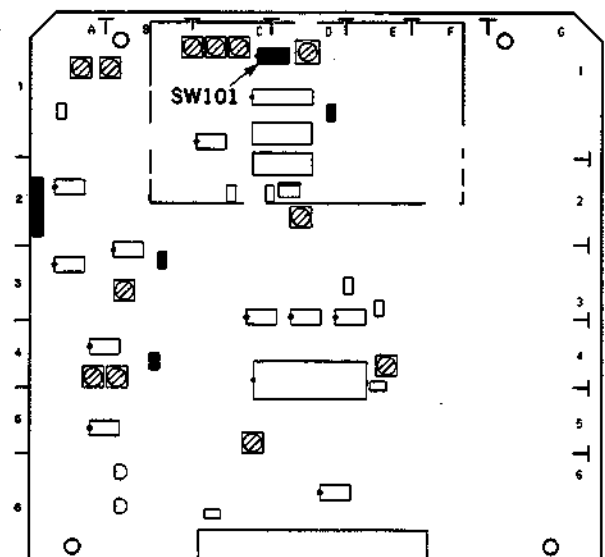

SW101 (C-1/AU-149): AUDIO HEAD TUNE ADJ SW

By coupling with LV101 on the AU-149 board, adjust the CH-2 head amp high frequency response (head vibration). (Refer to Section 10-1.)

This switch is used in audio head tune adjustment. If the switch setting is changed when this adjustment is not performed, audio frequency response may be failed.

When the unit is shipped, this switch is set to the position based on the adjustment condition.

SS-48 board

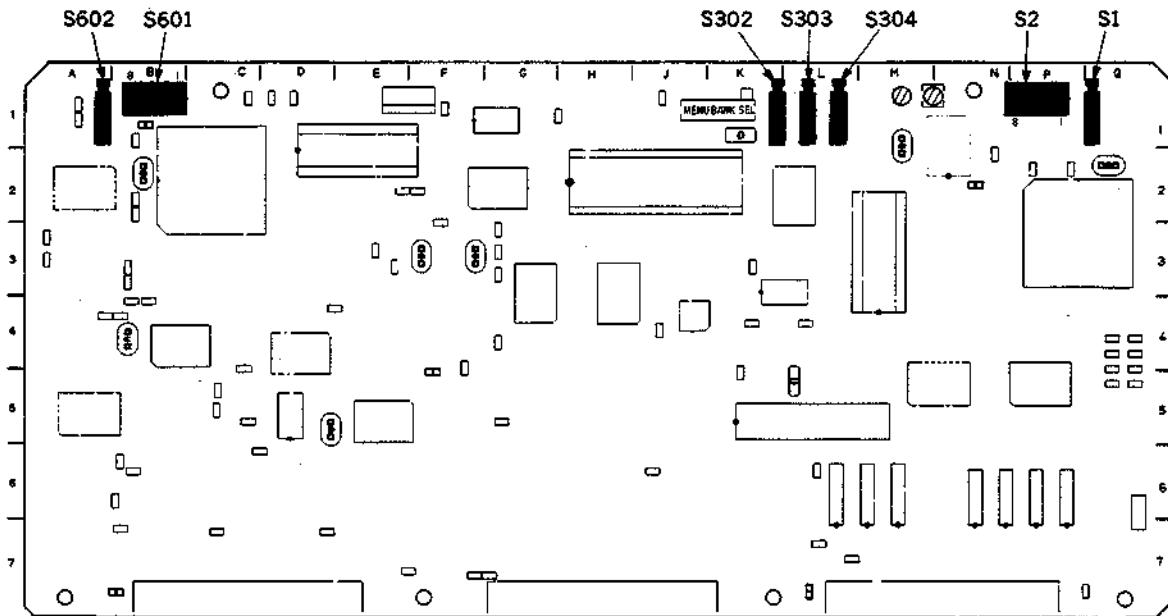

S1 (Q-1/SS-48): SY/SV RESET SW

When this switch is pressed, systems are initialized as the POWER is turned ON.

S2 (P-1/SS-48): SY DIP SW

S2-1 (P-1/SS-48): factory use

When the unit is shipped, this switch is set to OPEN.

S2-2 (P-1/SS-48): factory use

When the unit is shipped, this switch is set to OPEN.

S2-3 (P-1/SS-48): factory use

When the unit is shipped, this switch is set to OPEN.

S2-4 (P-1/SS-48): factory use

When the unit is shipped, this switch is set to OPEN.

S2-5 (P-1/SS-48): factory use

When the unit is shipped, this switch is set to OPEN.

S2-6 (P-1/SS-48): factory use

When the unit is shipped, this switch is set to OPEN.

S2-7 (P-1/SS-48): factory use

When the unit is shipped, this switch is set to OPEN.

S2-8 (P-1/SS-48): KEY BOARD SELECT

This switch should be set to CLOSE.

When the unit is shipped, this switch is set to CLOSE.

S302 (K-1/SS-48): ADJ (+) SW

When this switch is pressed, the unit is put into the maintenance mode, or execute a menu. (Refer to Section 3 Maintenance Mode.)

S303 (L-1/SS-48): ADJ (-) SW

In the maintenance mode, when this switch is pressed, you can return a menu display or mode display, or finish the maintenance mode. (Refer to Section 3 Maintenance Mode.)

S304 (L-1/SS-48): Does not use.

S601 (B-1/SS-48): SV DIP SW

S601-1 (B-1/SS-48): factory use

When the unit is shipped, this switch is set to OPEN.

S601-2 (B-1/SS-48): factory use

When the unit is shipped, this switch is set to OPEN.

S601-3 (B-1/SS-48): factory use

When the unit is shipped, this switch is set to OPEN.

S601-4 (B-1/SS-48): SERVO ADJUST

Set this switch to ON (CLOSE), when perform the servo system adjustment mode (B1: SERVO ADJUST) in the maintenance mode. (Refer to Section 3-3.)

When the unit is shipped, this switch is set to OFF (OPEN).

S601-5 (B-1/SS-48): factory use

When the unit is shipped, this switch is set to OPEN.

S601-6 (B-1/SS-48): factory use

When the unit is shipped, this switch is set to OPEN.

S601-7 (B-1/SS-48): SERVO CHECK

Set this switch to ON (CLOSE) to perform the servo system check mode (B0: SERVO CHECK) in the maintenance mode. (Refer to Section 3-2.)

When the unit is shipped, this switch is set to OFF (OPEN).

S601-8 (B-1/SS-48):

This switch is for selecting the initial data.

OPEN: NOVDRAM data

CLOSE: ROM data

When the unit is shipped, this switch is set to OPEN.

S602 (A-1/SS-48): REEL POSITION SELECT SW

When this switch is pressed, reel tables are moved to large or small position forcibly.

The reel tables are moved toggle by pressing the switch.

TBC-18 board

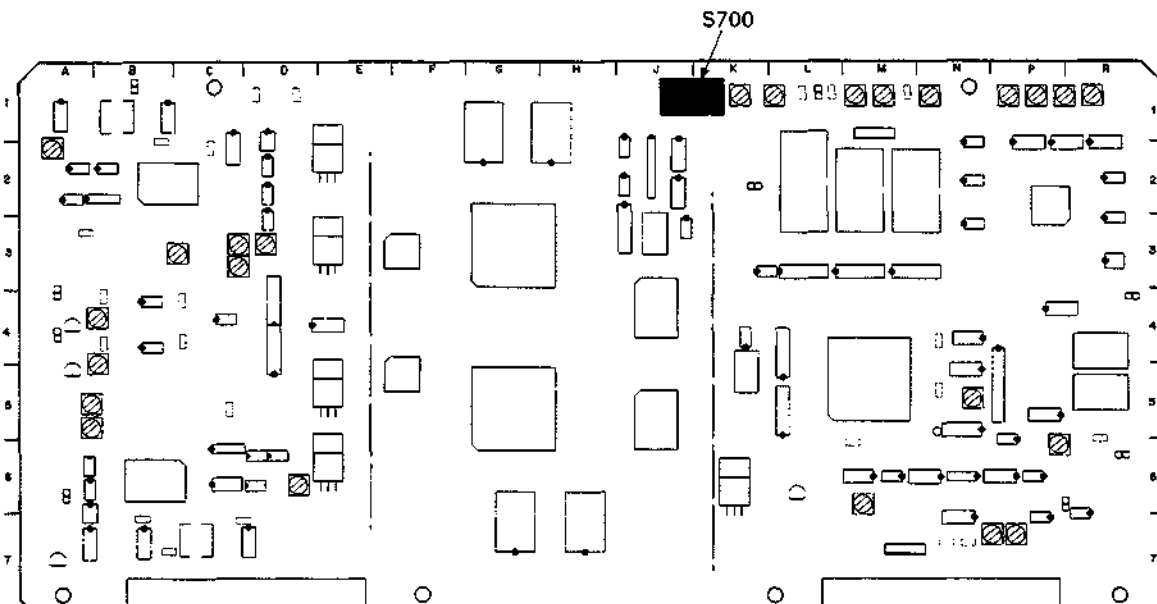

S700-1 (J-1/TBC-18): LEVEL REF SW

This switch is used for Y/C level adjustment. (Refer to Section 11-2-2 and 11-2-3.)

When this switch is set to ON, reference level signal of internal data is output and D/A, A/D level can be adjusted.

When the adjustment is completed, this switch is surely set to OFF.

When the unit is shipped, this switch is set to OFF.

S700-2 (J-1/TBC-18): factory use

When the unit is shipped, this switch is set to OFF.

S700-3 (J-1/TBC-18): Y MUTE SW

This switch is for muting the Y signal of TBC output.

When this switch is set to ON, the Y signal of all video output is muted and is not output.

When the unit is shipped, this switch is set to OFF.

S700-4 (J-1/TBC-18): C MUTE SW

This switch is for muting the R-Y, B-Y signal of TBC output.

When this switch is set to ON, the R-Y, B-Y signal of COMPONENT 1/2 OUT are muted and are not output. And the chroma signal of COMPOSITE VIDEO OUT is muted, is not output. (The color burst is not muted and is output.)

When the unit is shipped, this switch is set to OFF.

S700-5 (J-1/TBC-18): COMB SW

The R-Y, B-Y signal of TBC output is filtered by simple comb filter with this switch.

If there is the H step difference which is not-correctable by LCC(Line Crawl Canceller) on the PB video signal, this switch is set to ON.

When this switch is set to ON, this signal is corrected by comb filter.

When this switch is set to OFF, the PB video signal is corrected by LCC only.

When the unit is shipped, this switch is set to OFF.

S700-6 (J-1/TBC-18): VISC TEST SW

This switch is for VISC phase check and adjustment. (Refer to Section 12-11.)

When this switch is set to ON, the VISC of TBC input is out to TBC output as it is. So this is useful for adjustment.

This switch is set to OFF in usual, the regenerated VISC is out to COMPONENT 1/2 OUT.

When the unit is shipped, this switch is set to OFF.

S700-7 (J-1/TBC-18): factory use

When the unit is shipped, this switch is set to OFF.

S700-8 (J-1/TBC-18): factory use

When the unit is shipped, this switch is set to OFF.

VP-33 board

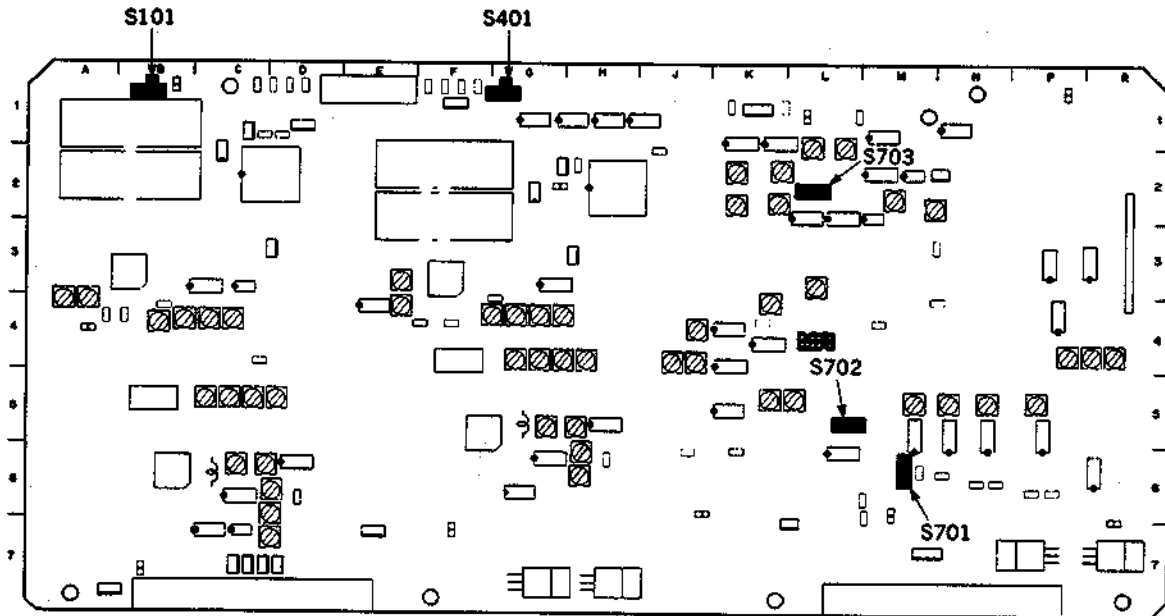

S101 (B-1/VP-33): Y RF AGC ON/OFF SW

When this switch is set to OFF, AGC is set to OFF.

This switch is set to ON in usual.

When the unit is shipped, this switch is set to ON.

S401 (G-1/VP-33): C RF AGC ON/OFF SW

When this switch is set to OFF, AGC is set to OFF.

This switch is set to ON in usual.

When the unit is shipped, this switch is set to ON.

S701 (M-6/VP-33): VISC MUTE ON/OFF SW

The VISC which is inserted in the 11th line of COMPONENT Y signal and output to COMPONENT 1/2 OUT is muted or not by this switch.

When the unit is shipped, this switch is set to OFF. (VISC is inserted.)

S702 (L-5/VP-33): ENC CHROMA MUTE SW

The chroma signal of COMPOSITE VIDEO OUT (including color burst) is on or off by this switch. (The signal of COMPONENT OUT is not affected by this switch.)

When the unit is shipped, this switch is set to OFF (color mode).

S703 (L-2/VP-33): CF ID SW

The CF ID inserted in the 15th line of COMPONENT B-Y signal is output or not to COMPONENT 1/2 OUT by this switch.

When the unit is shipped, this switch is set to ON (CF ID is inserted).

1-7. SYSTEM CONTROL SETUP

Various select switches are provided on the control panel, sub control panel, and printed circuit board in the unit. (Refer to Section 1-6 "Select Switch Setting on the Board".)

For the system control items described below, the reference control settings "setup" can be set with menus according to the system.

1-7-1. Setup Menu

The setup menu has Main Menu and System Menu.

The each menu contains the following items.

1. Main Menu

ITEM-000 SERIES : OPERATIONAL KEY PARAMETER

- 001 : PREROLL TIME
- 002 : CHARACTER H-POSITION
- 003 : CHARACTER V-POSITION
- 005 : DISPLAY INFORMATION SELECT
- 006 : LOCAL FUNCTION ENABLE
- 007 : TAPE TIMER DISPLAY
- 009 : CHARACTER TYPE
- 010 : CHARACTER H SIZE
- 011 : CHARACTER V SIZE

2. System Menu

ITEM-100 SERIES : OPERATIONAL PARAMETER

- 101 : SELECTION FOR SEARCH DIAL ENABLE
- 102 : MAXIMUM TAPE SPEED
- 104 : AUDIO MUTING TIME
- 105 : REF VIDEO MISSING ALARM
- 106 : CAPSTAN LOCK

ITEM-200 SERIES : INTERFACE OF ROMOTE CONTROL

- 202 : CF FLAG REPLY

ITEM-300 SERIES : EDITING PARAMETER

- 302 : CAPSTAN RE-LOCKING DIRECTION
- 307 : AUTO-DELETION FOR INCONSISTENT DATA

ITEM-400 SERIES : PREROLL PARAMETER

- 401 : FUNCTION MODE AFTER CUE-UP
- 402 : TIME REFERENCE FOR PREROLL
- 403 : AUTOMATIC PREROLL REFERENCE ENTRY

ITEM-500 SERIES : TAPE PROTECTION PARAMETER

- 501 : STILL TIMER
- 502 : TAPE PROTECTION MODE FROM SEARCH
- 503 : TAPE PROTECTION MODE FROM STOP
- 504 : DRUM ROTATION IN STANDBY OFF

ITEM-700 SERIES : VIDEO CONTROL PARAMETER

703 : BLANK LINE SELECT

**ITEM-900 SERIES : ADJUSTMENT USE ONLY
(FACTORY USE PARAMETER)**

901 : AUDIO NR IN SP MODE

902 : EMERGENCY TAPE PROTECTION

1-7-2. Setup Operation

The setup conditions appears in the time counter on the control panel and video monitor display.

The time counter display indicates the item number, and data number only.

The informations about the item and data can be superimposed on a video monitor display connected to the VIDEO OUTPUT 3 connector or MONITOR OUT connector on the connector panel of the unit. However the CHARACTER switch on the sub control panel must be set to ON.

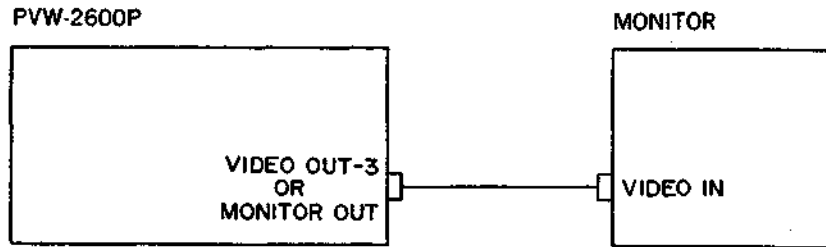

1. Put the unit into setup menu mode.

Press the SYSTEM SET-UP MENU button on the sub control panel.

time counter display
001 - 05

monitor display

```

SETUP MENU
*001:P-ROLL TIME - 5 s
002:CHARA H-POS - 1E
003:CHARA V-POS - 7A
005:DISPLAY SEL - T&sta
006:LOCAL ENA - st&ej
007:TAPE TIMER - +-12H
009:CHARA TYPE - white
010:CHARA HSIZE - x1
011:CHARA VSIZE - x1
101:SEARCH ENA - dial
102:MAX SPEED - X42
  
```

2. Select the item.

Push the search dial, and the unit enters the JOG mode.

Rotate the search dial on the control panel.

Rotate the dial clockwise to display higher-numbered items, and counterclockwise to display lower-numbered items.

time counter display
005 - 0

monitor display

```

SETUP MENU
001:P-ROLL TIME - 5 s
002:CHARA H-POS - 1E
003:CHARA V-POS - 7A
005:DISPLAY SEL - T&sta
*006:LOCAL ENA - st&ej
007:TAPE TIMER - +-12H
009:CHARA TYPE - white
010:CHARA HSIZE - x1
011:CHARA VSIZE - x1
101:SEARCH ENA - dial
102:MAX SPEED - X42
  
```

3. Change the data.

Pressing the SEARCH button, rotate the search dial.

Rotate the dial clockwise to display higher-numbered data, and counterclockwise to display lower-numbered data.

After changing the data, release the SEARCH button to select the data.

time counter display

006 - 2

monitor display

```
SETUP  ITEM-006  
  
LOCAL FUNCTION  
ENABLE  
  
all enable
```

This is displayed during pressing the SEARCH button.

Repeat Step 2 and 3 until you are satisfied with the settings of all menu items.

When changes are cancelled and restored to the former settings, press the SYSTEM SET-UP MENU button.

4. Save the data, and finish the setup menu mode.

Press the SET button on the sub control panel.

- The setup data is saved to a nonvolatile memory (NV-RAM) and remains even if the POWER switch is turned off.

Restoring the factory settings

If it is wishing to be restored all data to the factory setting, press the MENU button of the SYSTEM-UP on the sub control panel and press the RESET button at the upper right of the time counter.

1-7-3. Main Menu

The numbers enclosed with in the data column indicate the factory preset settings.

ITEM-000 SERIES : OPERATIONAL KEY PARAMETER

ITEM		DATA		Description
No.	ITEM	No.	DATA	
001	PREROLL TIME	00	0 sec	Set the preroll time to between 0 and 15 seconds in steps of 1 second. A preroll time of at least 3 seconds is recommended when using this unit for editing.
		01	1 sec	
		02	2 sec	
		03	3 sec	
		04	4 sec	
		<input type="text" value="05"/>	<input type="text" value="5 sec"/>	
		06	6 sec	
		07	7 sec	
		08	8 sec	
		09	9 sec	
		10	10 sec	
		11	11 sec	
		12	12 sec	
		13	13 sec	
		14	14 sec	
		15	15 sec	
002	CHARACTER H-POSITION	00		Adjust the horizontal position of the characters superimposed on the signal output from the VIDEO OUTPUT 3 connector or MONITOR connector. The hexadecimal value "00" is for the far left of the screen and "57" (decimal 87) for the far right. Increasing the value moves the position of the characters to the right. It is possible to place the character to 88 positions.
		<input type="text" value="1E"/>		
		57		
003	CHARACTER V-POSITION	00		Adjust the vertical position of the characters superimposed on the signal output from the VIDEO OUTPUT 3 connector or MONITOR connector. The hexadecimal value "00" is for the top of the screen and "94" (decimal 148) for the bottom. Increasing the value lowers the position of the screen. It is possible to place the character to 149 positions.
		<input type="text" value="7A"/>		
		94		
005	DISPLAY INFORMATION SELECT	<input type="text" value="0"/>	<input type="text" value="time data & status"/>	Determines the data output from the VIDEO OUTPUT 3 connector or MONITOR connector when the CHARACTER ON/OFF switch on the sub control panel to ON. 0 : Timer information and VTR status. 1 : Timer information and users bit. 2 : Timer information and CTL. 3 : Timer information (LTC and VITC). 4 : Timer information only (LTC or VITC).
		1	time data & UB	
		2	time data & CTL	
		3	time data & time data	
		4	time data & only	

ITEM		DATA		Description
No.	ITEM	No.	DATA	
006	LOCAL FUNCTION ENABLE	0 1 2	all disable stop & eject all enable	Determines which buttons on the control panel are enabled, when the unit is set to the REMOTE mode. 0: All of the switches/buttons are disabled. 1: Only the STOP and EJECT buttons are enabled. 2: All of the switches/buttons are enabled.
007	TAPE TIMER DISPLAY	0 1	+/-12H 24H	Determines whether the CTL counter should display 12-hour or 24-hour time. 0: 12-hour time. 1: 24-hour time.
009	CHARACTER TYPE	0 1 2 3		Determines the type of superimposed characters output from the VIDEO OUTPUT 3 connector or MONITOR connector. 0: White letters on a black background. 1: Black letters on a white background. 2: Black outline letters. 3: White outline letters.
010	CHARACTER H SIZE	01 02		Determines the horizontal size of superimposed characters output from the VIDEO OUTPUT 3 connector or MONITOR connector. 01: Standard 02: Twice standard size
011	CHARACTER V SIZE	01 02 03 04		Determines the vertical size of superimposed characters output from the VIDEO OUTPUT 3 connector or MONITOR connector. 01: Standard size 02: Twice standard size 03: 3 times standard size 04: 4 times standard size

1-7-4. System Menu

The numbers enclosed with in the data column indicate the factory preset settings.

ITEM-100 SERIES : OPERATIONAL PARAMETER

ITEM		DATA		Description
No.	ITEM	No.	DATA	
101	SELECTION FOR SEARCH DIAL ENABLE	<input type="text" value="0"/> 1	<input type="text" value="dial direct"/> via search key	Determines when the unit is put into search mode. 0: When the search dial is rotated, the unit is put into the search mode from any mode. 1: When the SEARCH button is pressed, the unit is put into the search mode.
102	MAXIMUM TAPE SPEED	0 <input type="text" value="1"/> 2	X42 <input type="text" value="X42 (shuttle X24)"/> X24	Sets the maximum tape speed for fast forward and rewind, and the maximum tape speed selectable with the search dial. 0: 42 times normal speed. 1: 42 times normal speed for fast forward and rewind, and 24 times normal speed for the search dial in shuttle mode. 2: 24 times normal speed.
104	AUDIO MUTING TIME	<input type="text" value="00"/> 01 02 03 04 05 06 07 08 09 10	<input type="text" value="OFF"/> 0.1 sec 0.2 sec 0.3 sec 0.4 sec 0.5 sec 0.6 sec 0.7 sec 0.8 sec 0.9 sec 1.0 sec	Determines the muting time of an audio signal when the unit enters the playback mode from stop or still mode to playback mode. Can be set to any value between 0 and 1.0 second, in steps of 0.1 second.
105	REF VIDEO MISSING ALARM	<input type="text" value="0"/> 1	<input type="text" value="off"/> on	Issue warning if reference video signals are not being supplied through the REF,VIDEO connector. 0: Does not issue warning. 1: Warns by flashing the STOP button.
106	CAPSTAN LOCK	<input type="text" value="0"/> 1 2 3 4	<input type="text" value="switch select"/> 2F 2F/4F 4F 8F	Selects the capstan servo lock mode. 0: Use the setting of the CAPSTAN LOCK switch on the sub control panel. 1: Always 2F, regardless of CAPSTAN LOCK switch setting on the sub control panel. 2: Always 2F/4F, regardless of CAPSTAN LOCK switch setting on the sub control panel. 3: Always 4F, regardless of CAPSTAN LOCK switch setting on the sub control panel. 4: Always 8F, regardless of CAPSTAN LOCK switch setting on the sub control panel.

ITEM-200 SERIES : INTERFACE OF REMOTE CONTROL

ITEM		DATA		Description
No.	ITEM	No.	DATA	
202	CF FLAG REPLY	0 1	8F 4/8F	Determines the status of color frame which is sent to remote controller. 0 : 8FD 1 : 4/8FD

ITEM-300 SERIES : EDITING PARAMETER

(Items concerning operational settings when you use this unit as a player in an editing system.)

ITEM		DATA		Description
No.	ITEM	No.	DATA	
302	CAPSTAN RE-LOCKING DIRECTION	0 1	deceleration acceleration	Determines whether capstan servo lock mode is deceleration mode or acceleration mode, when the CAPSTAN LOCK switch on the sub control panel is set to 4FD. 0 : Capstan servo locks in deceleration mode. 1 : Capstan servo locks in acceleration mode.
307	AUTO-DELETION FOR INCONSISTENT DATA	0 1 2	manual neg & excess neg	Determines the mode what happens when an erroneous edit point, such as an OUT point located before an IN point, or excessive edit points are set. 0 : Issue a warning by flashing the DELETE indicator on the recorder (PVW-2800P). The operator must manually delete the excessive unnecessary edit points or correct the erroneous edit point. 1 : When a incorrect edit point is set, the previously set edit point is deleted automatically. When excessive edit points are set, the previously set edit point is deleted automatically. 2 : When a incorrect edit point is set, the previously set edit point is deleted automatically. When excessive edit points are set, the DELETE indicator on the recorder (PVW-2800P) flashes to issue a warning. NOTE : Delete edit points by pressing the DELETE button simultaneously with one of the IN/OUT or AUDIO IN/OUT buttons. (These buttons are on the recorder (PVW-2800P)) Edits cannot be executed if the DELETE indicator on the recorder (PVW-2800P) is flashing.

ITEM-400 SERIES : PREROLL PARAMETER

(Items concerning operational settings when you use this unit as a player in an editing system.)

ITEM		DATA		Description
No.	ITEM	No.	DATA	
401	FUNCTION MODE AFTER CUE-UP	<input type="checkbox"/> 0 1	<input type="checkbox"/> stop <input type="checkbox"/> still	Determines the unit's mode after cue-up. 0 : Stop mode. 1 : Still mode. (Search mode.)
402	TIME REFERENCE FOR PREROLL	<input type="checkbox"/> 0 1	<input type="checkbox"/> CTL <input type="checkbox"/> TC	When a tape with the time code signal containing a discontinuous point is used and discontinuous point is prerolled, determines whether the time code signal preceding the point is advanced and prerolled using a CTL signal. 0 : Interpolate with a CTL signal. 1 : Does not interpolate with a CTL signal. NOTE: When "0" is selected, maximum tape speed during cue-up or preroll is limited to 10 times normal speed.
403	AUTOMATIC PREROLL REFERENCE ENTRY	<input type="checkbox"/> 0 1	<input type="checkbox"/> disable <input type="checkbox"/> enable	Determines whether the IN point is entered by pressing only the PREROLL button on the recorder (PVW-2800P) when it is not entered during preroll operation. 0 : Does not enter the IN point automatically. 1 : Enters the IN point automatically.

ITEM-500 SERIES : TAPE PROTECTION PARAMETER

ITEM		DATA		Description
No.	ITEM	No.	DATA	
501	STILL TIMER	00	0.5 sec	<p>If the unit remains in stop or still mode for a certain period of time, it is put automatically into tape protection mode in order to prevent from head clogging and tape damage.</p> <p>This item determines the transition time of the tape stop to tape protection mode. The time may set to one of the 16 values, ranging between 0.5 second to 30 minutes.</p>
		01	5 sec	
		02	10 sec	
		03	20 sec	
		04	30 sec	
		05	40 sec	
		06	50 sec	
		07	1 min	
		08	2 min	
		09	3 min	
		10	4 min	
		11	5 min	
		12	6 min	
		13	7 min	
		14	8 min	
		15	30 min	
502	TAPE PROTECTION MODE FROM SEARCH	0	step fwd	<p>When the time in the still mode during search mode (JOG/SHUTTLE) set using Item 501 passes, the unit enters the tape protection mode. This item determines the tape protection mode setting.</p> <p>0: When the time designated by Item 501 passes, the tape is sent repeatedly for 2 seconds at 1/30 times normal speed in the forward direction.</p> <p>1: When the designated time passes, the unit enters the standby off mode.</p> <p>2: When the designated time passes, the unit enters the tension release mode.</p>
		1	standby off	
		2	tension release	
503	TAPE PROTECTION MODE FROM STOP	0	standby off	<p>When the time in the stop mode set using Item 501 passes, the unit enters the tape protection mode. This item determines the tape protection mode setting.</p> <p>0: When the designated time passes, the unit enters the standby off mode.</p> <p>1: When the designated time passes, the unit enters the tension release mode.</p>
		1	tension release	
504	DRUM ROTATION IN STANDBY OFF	0	off	<p>Determines whether the head drum stops rotating in standby OFF mode.</p> <p>0: Drum stops rotating.</p> <p>1: Drum keeps rotating.</p>
		1	on	

ITEM-700 SERIES : VIDEO CONTROL PARAMETER

* To choose line for setup menu "Item 703", rotate the search dial while pressing the STOP button on the control panel.

ITEM		DATA		Description
No.	ITEM	No.	DATA	
703*	BLANK LINE SELECT	9,322 } 22,335 line <input type="checkbox"/> 0 2	<input type="checkbox"/> blank throu	Determines blanking lines for the V-blanking period of output video signals. Each of the lines from 9,322 to 23,336 may be set ON or OFF separately. 0 : Blanking ON 1 : Half blanking at line 23,336. 2 : Blanking OFF
		23,336 line <input type="checkbox"/> 1 2	<input type="checkbox"/> half throu	

ITEM-900 SERIES : ADJUSTMENT USE ONLY (FACTORY USE PARAMETER)

The items below are not displayed on the normal operation to avoid the erroneous operation.

To display "Item 901" or "Item 902", turn the SEARCH dial while pressing the PLAY button in setup menu mode.

The two items are used exclusively for adjustment. After adjustment is completed, the menu data should be returned to the factory setting.

ITEM		DATA		Description
No.	ITEM	No.	DATA	
901	AUDIO NR IN SP MODE	0 1	on switch select	<p>This item is used exclusively for audio system adjustment. After adjustment is completed, be sure to return the menu data to the factory setting "0".</p> <p>The Dolby NR control is selected when a metal particle tape is used for recording and playback.</p> <p>0: Turned ON at all times when the metal particle tape is used.</p> <p>1: Turned ON or OFF using the DOLBY NR switch on the sub control panel.</p> <p>NOTE: When an oxide tape is used, set using the DOLBY NR switch on the sub control panel irrespective of this setting.</p>
902	EMERGENCY TAPE PROTECTION	0 1	enable disable	<p>This item is used exclusively for servo system and mechanical adjustments. After adjustment is completed, be sure to return the menu data to the factory setting "0".</p> <p>When the unit detects an error in the tape transport system, selects whether tape protection is done or not.</p> <p>0: Tape protection is done.</p> <p>1: Tape protection is not done.</p> <p>NOTE: When "1" is selected, the auto off lamp goes on and off.</p>

1-8. RACK MOUNTING

The unit can be mounted in a 19-inch standard rack.
It is recommended to use the following kit.

Rack Mount Kit : RMM-110 (optional accessory)
or
RACK-MOUNT SLIDES : MODEL 305
slide length 558.8 mm
(ACCURIDE)

Note for rack mounting :

- When several units are mounted in a rack, it is recommended to install a fan for ventilation. Good air circulation is essential to prevent internal heat build-up in a rack (5 °C to 40 °C must be met for all units).
- Never remove a upper panel and lower panel during rack mounting.
- Be sure to secure the rack to the floor to avoid accidents when a unit is pulled out.

1. Remove the five screws on right and left side panels.
And install the Inner Members of the rails to the right and left side panels with the screws removed.

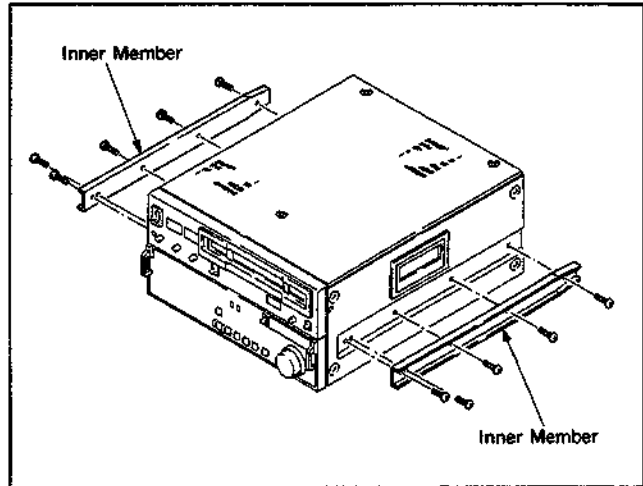

2. Remove the four feet on the lower panel.
If the unit is mounted in the rack with the feet attached, they will contact the lower and the upper portions of the rack and the unit cannot be pulled from the rack.
3. Install the Outer Member Bracket of the slide rail to the rack. Adjust the distance from the edge of the slide rail to the outside of the rack so that it meets the required specification.

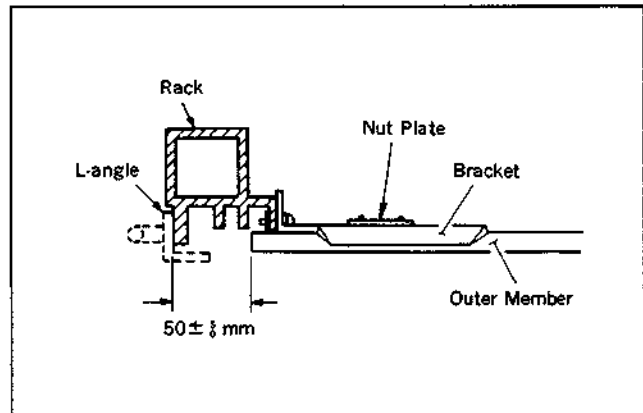

- Remove the two screws (B4×6) on the right and left side panels. (Be careful not to lose these four screws.)

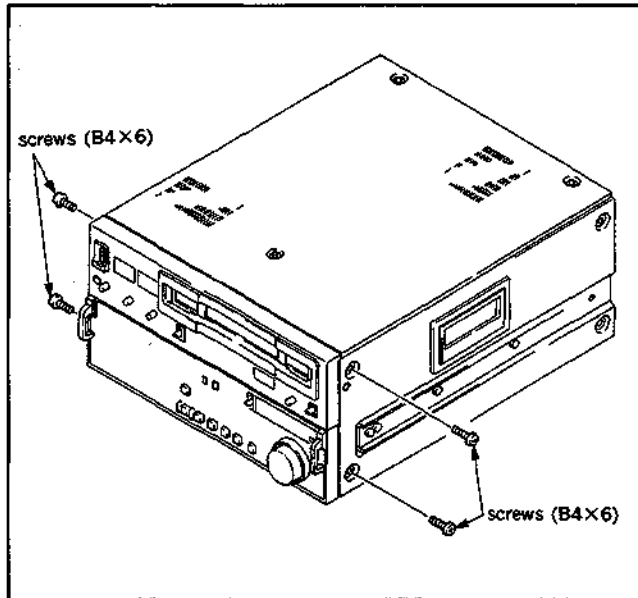

- Install the Handle Brackets to the holes described in step (4) with the supplied screws (PSW4×16) for these brackets.

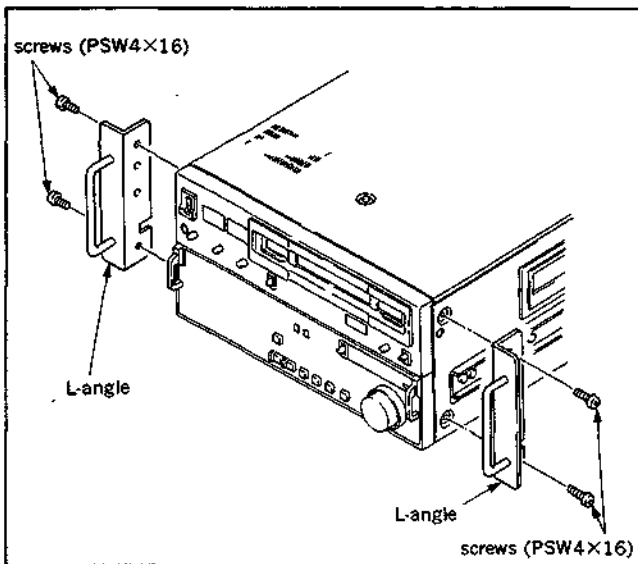

(NOTE) Never use screws PSW4×16 to install the right and left side panels. Be sure to install the panels with the screws B4×6 removed in step 4. Screws for L angles are longer than the ones of side panels. Therefore, using the screws PSW4×16 may cause trouble in the unit.

1-9. SUPPLIED ACCESSORIES

- AC power code (1)
- 9-pin remote cable RCC-5G (1)
- PSW4×16 screws for rack mounting (4)
- Operation manual (1)

1-10. OPTIONAL ACCESSORIES

- U-matic dubbing output kit : BKW-2030
- Control panel extension kit : BKW-2010
- Control panel case : BK-803
- TBC remote control unit : BK-2006
BVR-50P
- Rack mount kit : RMM-110
This kit is used to mount the unit in a standard 19-inch rack.
- 12-pin dubbing cable : VDC-C5
- 7-pin dubbing cable : VDC-5
- Cleaning cassette tape : BCT-5CLN

1-11. SETTING CHECK SHEET

It is recommended to check the setup conditions such as switch, setup menu under the application.

And it is recommended to copy this sheet and write down and keep, when maintenance or changing the use condition.

If the unit is used in editing room, changing the system combination very often, several sheet based on the combination is useful.

This is to help the trouble during editing such as setting.

CONTROL PANEL

AUDIO MONITOR CH1 MIX CH2
 LOCAL/REMOTE LOCAL REMOTE
 CH1 PB VOL MANUAL AUTO
 CH2 PB VOL MANUAL AUTO

SUB CONTROL PANEL

DOLBY NR ON OFF
 CHARACTER ON OFF
 TC LTC AUTO VITC
 CAPSTAN LOCK 2FD 2/4FD 4FD 8FD
 TBC CONTROL REMOTE LOCAL
 VIDEO PRESET MANUAL
 CHROMA PRESET MANUAL
 SET UP PRESET MANUAL
 Y/C DELAY PRESET MANUAL

CONNECTOR PANEL

REF. VIDEO 75 Ω ON OFF

SETUP MENU

ITEM	factory setting	setting
001 PREROLL TIME	05	
002 CHARACTER H-POSITION	1E	
003 CHARACTER V-POSITION	7A	
005 DISPLAY INFORMATION SELECT	0	
006 LOCAL FUNCTION ENABLE	1	
007 TAPE TIMER DISPLAY	0	
009 CHARACTER TYPE	0	
010 CHARACTER H SIZE	01	
011 CHARACTER V SIZE	01	
101 SELECTION FOR SEARCH DIAL ENABLE	0	
102 MAXIMUM TAPE SPEED	1	
104 AUDIO MUTING TIME	00	
105 REF VIDEO MISSING ALARM	0	
106 CAPSTAN LOCK	0	
202 CF FLAG REPLY	0	
302 CAPSTAN RE-LOCKING DIRECTION	1	
307 AUTO-DELETION FOR INCONSISTENT DATA	0	
401 FUNCTION MODE AFTER CUE-UP	0	
402 TIME REFERENCE FOR PREROLL	0	
403 AUTOMATIC PREROLL REFERENCE ENTRY	0	

ITEM		factory setting	setting
501 STILL TIMER		14	
502 TAPE PROTECTION MODE FROM SEARCH		0	
503 TAPE PROTECTION MODE FROM STOP		0	
504 DRUM ROTATION IN STANDBY OFF		0	
703 BLANK LINE SELECT	9,322	0	
	10,323		
	11,324		
	12,325		
	13,326		
	14,327		
	15,328		
	16,329		
	17,330		
	18,331		
	19,332		
20,333			
21,334			
22,335			
23,336	1		
901 AUDIO NR IN SP MODE		0	
902 EMERGENCY TAPE PROTECTION		0	

SWITCH ON BOARD

board	switch	factory setting	setting
AU-148 board	SW101 AUDIO HEAD TUNE ADJ SW (CH-1)	Dependent on adjustment	
AU-149 board	SW101 AUDIO HEAD TUNE ADJ SW (CH-2)	Dependent on adjustment	
SS-48 board	S2-1 factory use	OFF (OPEN)	
	S2-2 factory use	OFF (OPEN)	
	S2-3 factory use	OFF (OPEN)	
	S2-4 factory use	OFF (OPEN)	
	S2-5 factory use	OFF (OPEN)	
	S2-6 factory use	OFF (OPEN)	
	S2-7 factory use	OFF (OPEN)	
	S2-8 KEY BOARD SELECT	ON (CLOSE)	
	S601-1 factory use	OFF (OPEN)	
	S601-2 factory use	OFF (OPEN)	
	S601-3 factory use	OFF (OPEN)	
	S601-4 SERVO ADJUST	OFF (OPEN)	
	S601-5 factory use	OFF (OPEN)	
	S601-6 factory use	OFF (OPEN)	
S601-7 SERVO CHECK	OFF (OPEN)		
S601-8 NOVRAM/ROM DATA SELECT SW	OFF (OPEN)		

board	switch	factory setting	setting
TBC-18 board	S700-1 LEVEL REF SW	OFF	
	S700-2 factory use	OFF	
	S700-3 Y MUTE SW	OFF	
	S700-4 C MUTE SW	OFF	
	S700-5 COMB SW	OFF	
	S700-6 VISC TEST SW	OFF	
	S700-7 factory use	OFF	
	S700-8 factory use	OFF	
VP-33 board	S101 Y RF AGC ON/OFF SW	ON	
	S401 C RF AGC ON/OFF SW	ON	
	S701 VISC MUTE ON/OFF SW	OFF	
	S702 ENC CHROMA MUTE SW	OFF	
	S703 CF ID SW	ON	

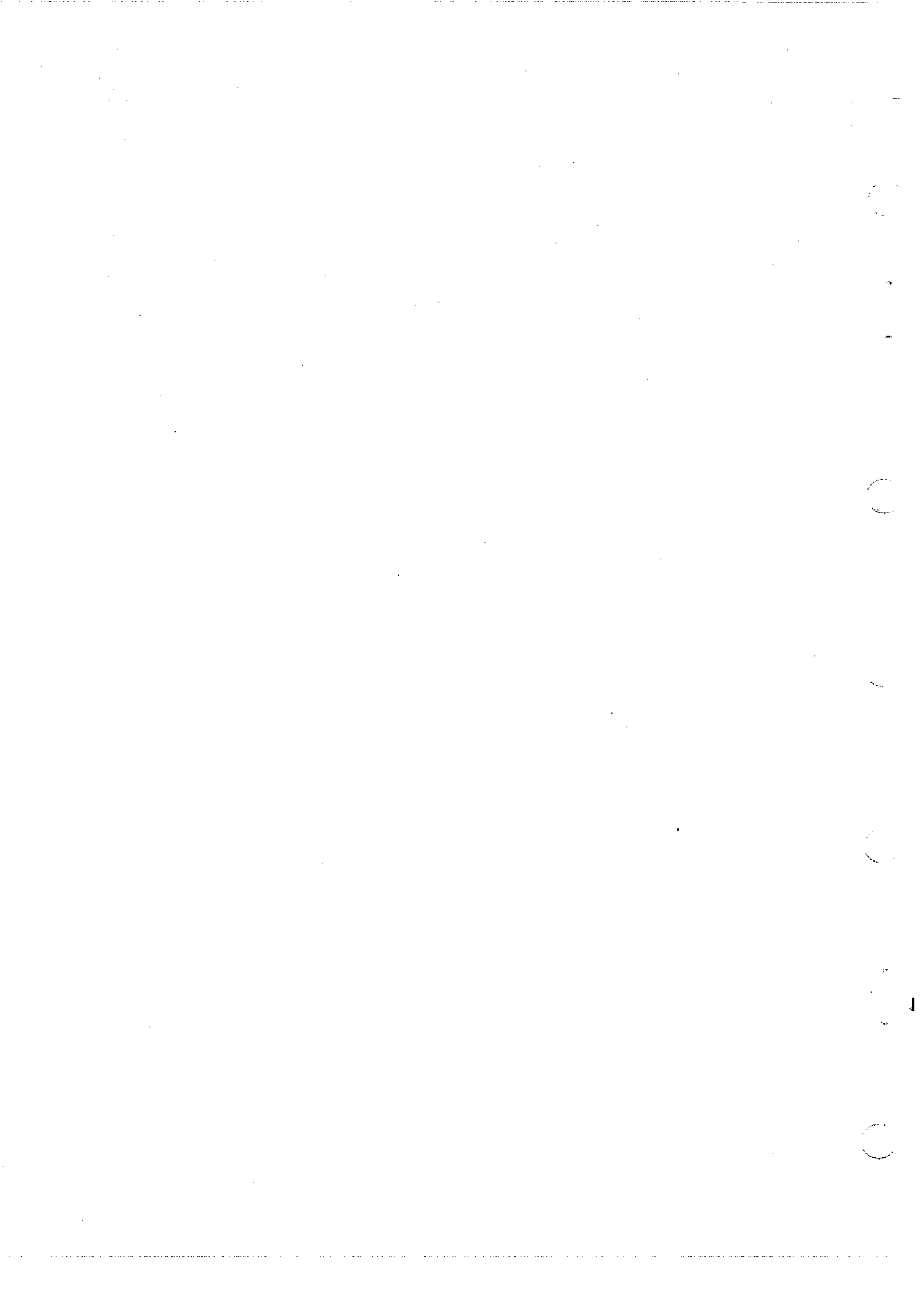

SERVICE INF.

SECTION 2 SERVICE INFORMATION

2-1. SPECIFICATIONS

GENERAL

Power requirements	: 220-240 V ac, 50/60 Hz
Operating voltage	: 90-264 V
Power consumption	: 130 W
Operating temperature	: +5 °C to +40 °C
Storage temperature	: -20 °C to +60 °C
Humidity	: 80% or less
Weight	: 24.5 kg
Dimensions	: 427×237×520 mm (w/h/d, excluding the projections)
Normal tape speed	: 101.51 mm/s
Maximum playback time	: 100 min or longer with BCT-90ML cassette
Fast forward/rewind time	: 180 s or less with BCT-90ML cassette
Search speed	

Shuttle mode : Still, 0.03, 0.1, 0.2, 0.5, 1, 3, 5, 10, 24 and * 42 times normal speed, forward and reverse.
* 42 times ; by setting in setup menu ITEM-102.

Jog mode : Variable from still to normal speed, forward and reverse.

Recommended cassette tape	: 1/2-inch Betacam or Betacam SP cassette
Metal tapes	: BCT-5M/10M/20M/30M/ BCT-5ML/10ML/20ML/30ML/60ML/90ML or equivalent
Oxide tapes	: BCT-5G/10G/20G/30G/ BCT-5GL/10GL/20GL/30GL/60GL/90GL or equivalent

Video

(recording)/play back	Luminance	FM
	Chrominance	FM (Compressed time division multiplexed)

		Metal tape	Oxide tape
Band width	Luminance	25 Hz to 5.5 MHz $\begin{matrix} +0.5 \\ -4.0 \end{matrix}$ dB	25 Hz to 4.0 MHz $\begin{matrix} +0.5 \\ -6.0 \end{matrix}$ dB
	Color difference	R-Y : 25 Hz to 2.0 MHz $\begin{matrix} +0.5 \\ -3.0 \end{matrix}$ dB	R-Y : 25 Hz to 1.5 MHz $\begin{matrix} +0.5 \\ -3.0 \end{matrix}$ dB
		B-Y : 25 Hz to 2.0 MHz $\begin{matrix} +0.5 \\ -3.0 \end{matrix}$ dB	B-Y : 25 Hz to 1.5 MHz $\begin{matrix} +0.5 \\ -3.0 \end{matrix}$ dB
S/N	Luminance (component)	48 dB or greater	46 dB or greater
	Chrominance	AM : 48 dB or greater PM : 48 dB or greater	AM : 48 dB or greater PM : 48 dB or greater
K-factor (2T pulse)		2 % or less	3 % or less
DG		3 % or less	3 % or less
DP		3° or less	3° or less
Y/C delay		20 ns or less	

* When play back a standard tape.

Audio

(Audio recording)

AC Bias

	Metal tape	Oxide tape
Frequency response	50 Hz to 15 kHz $\begin{matrix} +1.5 \\ -3.0 \end{matrix}$ dB	50 Hz to 15 kHz ± 3.0 dB
Signal to noise ratio (at peak level*, weighted CCIR468-3)	68 dB or greater (with dolby NR)	62 dB or greater (with dolby NR)
Distortion factor (THD) (Reference level, 1 kHz)	1% or less	2% or less
Wow & flutter	0.1% rms or less	

* Peak level: +8 dB above the operation level

Processor adjustment range

Video level : ± 3 dB
 Chroma level : ± 3 dB
 Setup level : 0-100 mV
 System SC phase : 360° p-p
 System sync phase : $\begin{matrix} +3 \\ -1 \end{matrix}$ μ s
 Y/C delay : ± 50 ns

*Dolby noise reduction manufactured under licence from
 Dolby Laboratories Licensing Corporation. "DOLBY"
 and the double-D symbol  are trademarks of Dolby
 Laboratories Licensing Corporation.

2-2. MAIN PARTS LOCATION

2-2-1. Location of Printed Circuit Board

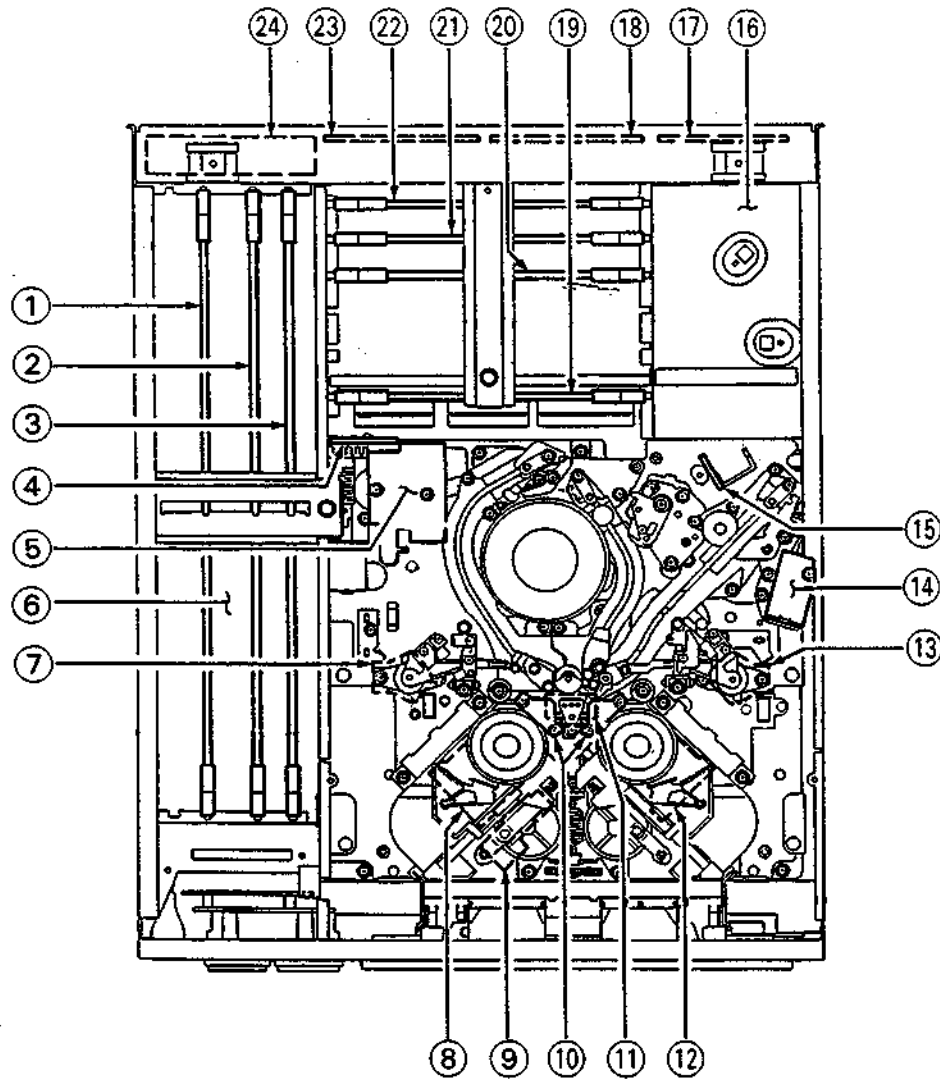

- | | |
|----------------|-----------------------|
| ① VP-33 board | ⑬ TR-73 board |
| ② TBC-18 board | ⑭ PD-56 board |
| ③ SS-48 board | ⑮ DS-31 board |
| ④ PTC-54 board | ⑯ Switching regulator |
| ⑤ PTC-49 board | ⑰ AC-133 board |
| ⑥ MB-322 board | ⑱ CP-167 board |
| ⑦ TR-73 board | ⑲ RP-57 board |
| ⑧ RM-82 board | ⑳ AU-148 board |
| ⑨ PTC-42 board | ㉑ AU-149 board |
| ⑩ DE-15 board | ㉒ AU-150 board |
| ⑪ PTC-55 board | ㉓ CP-166 board |
| ⑫ RM-82 board | ㉔ RM-93 board |

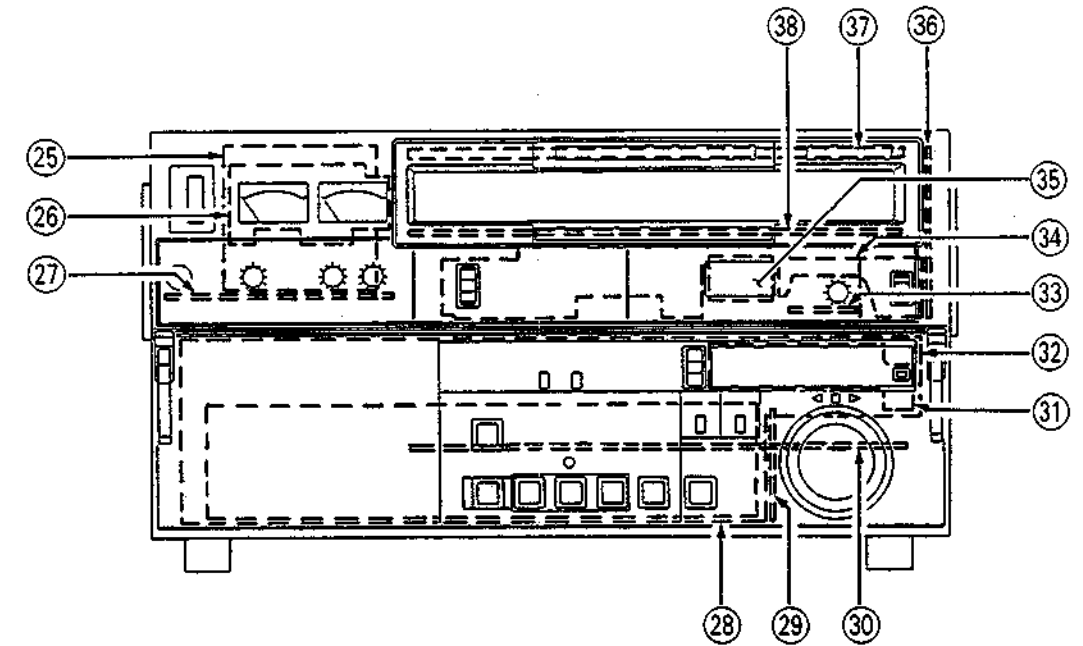

- | | |
|----------------|--------------------------------------|
| ⑳ MA-44 board | ㉒ KY-210 board |
| ㉑ DP-138 board | ㉓ VR-117 board |
| ㉒ VR-116 board | ㉔ SW-444 board |
| ㉓ HC-14 board | ㉕ DP-159 board |
| ㉔ PTC-39 board | ㉖ CL-25 board (cassette compartment) |
| ㉕ DR-118 board | ㉗ LP-57 board (cassette compartment) |
| ㉖ DP-139 board | ㉘ PC-62 board (cassette compartment) |

INDEX

- | | |
|---------------------|---|
| AC-133 board⑰ | PD-56 board⑭ |
| AU-148 board⑳ | PTC-39 board㉒ |
| AU-149 board㉑ | PTC-42 board⑨ |
| AU-150 board㉒ | PTC-49 board⑤ |
| CL-25 board㉖ | PTC-54 board④ |
| CP-166 board㉓ | PTC-55 board⑪ |
| CP-167 board⑱ | RM-82 board⑧ : [Supply side] ; ⑫ : [Take-up side] |
| DE-15 board⑩ | RM-93 board㉔ |
| DP-138 board㉑ | RP-57 board⑲ |
| DP-139 board㉒ | SS-48 board③ |
| DP-159 board⑤ | SW-444 board㉔ |
| DR-118 board㉕ | TBC-18 board② |
| DS-31 board⑮ | TR-73 board⑦ : [Supply side] ; ⑬ : [Take-up side] |
| HC-14 board㉓ | VP-33 board① |
| KY-210 board㉒ | VR-116 board㉒ |
| LP-57 board㉗ | VR-117 board㉓ |
| MA-44 board㉑ | switching regulator⑯ |
| MB-322 board⑥ | |
| PC-62 board㉘ | |

2-2-2. Location of Mechanical Parts/Components

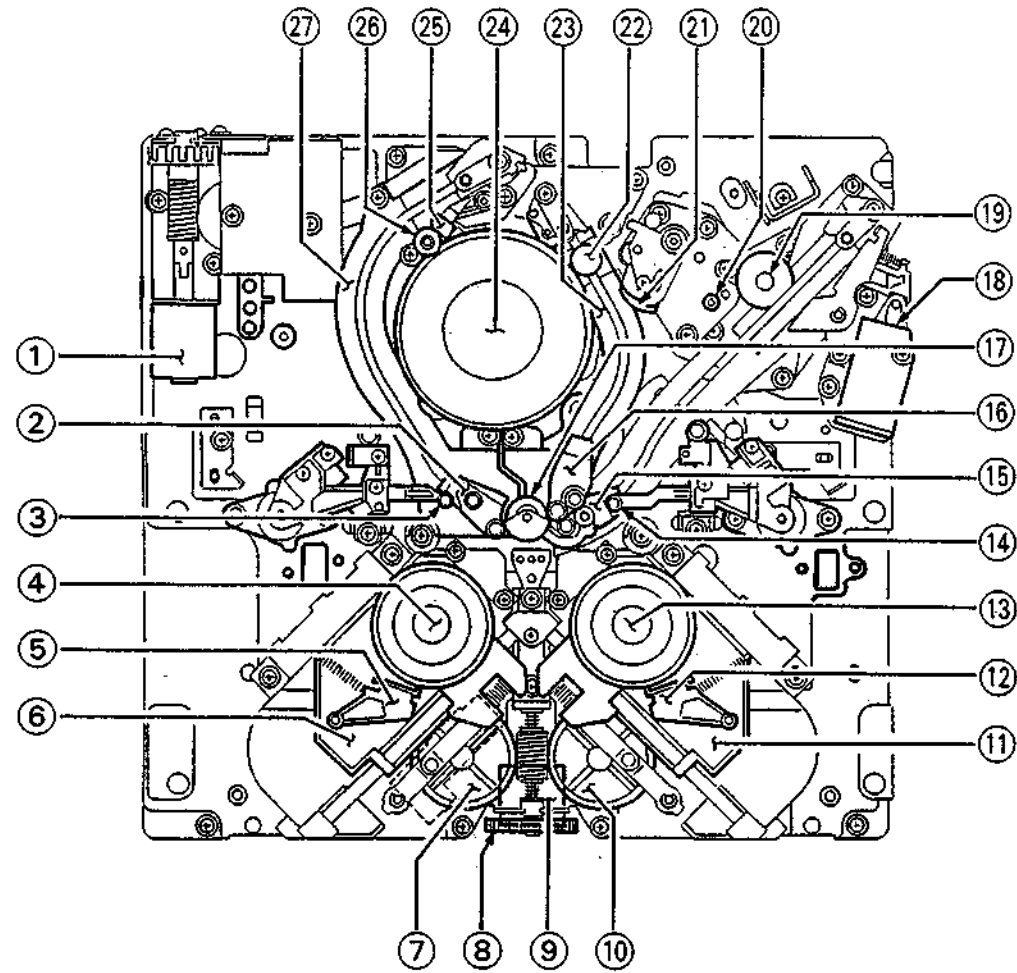

- | | |
|---------------------------|-------------------|
| ① Threading motor | ⑮ P slider |
| ② S slider | ⑯ T slider |
| ③ S tension regulator arm | ⑰ Pinch roller |
| ④ S reel table | ⑱ Pinch solenoid |
| ⑤ S brake | ⑲ Capstan shaft |
| ⑥ S reel motor plate | ⑳ TG-6 tape guide |
| ⑦ S worm wheel | ㉑ Audio/TC head |
| ⑧ Reel shift driver gear | ㉒ Cleaning roller |
| ⑨ Reel shift motor | ㉓ T rail |
| ⑩ T worm wheel | ㉔ Head drum |
| ⑪ T reel motor plate | ㉕ CTL head |
| ⑫ T brake | ㉖ TG-4 tape guide |
| ⑬ T reel table | ㉗ S rail |
| ⑭ T tension regulator arm | |

2-2-3. Location of Sensor (1)

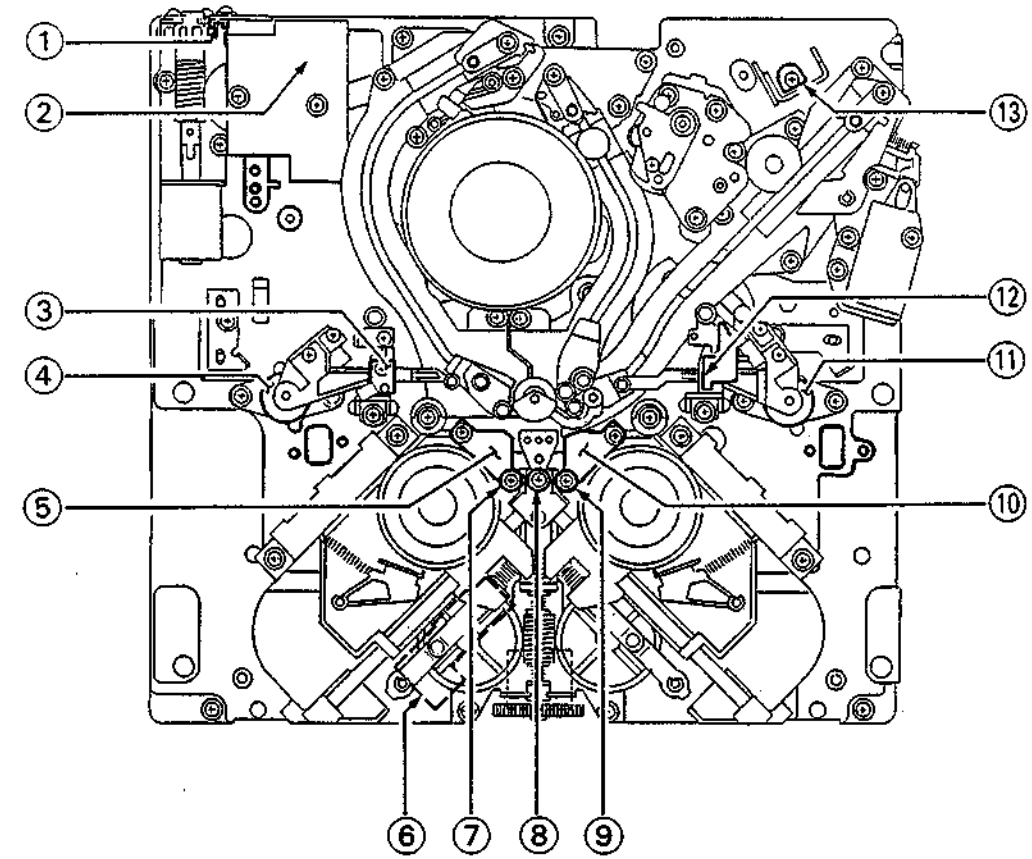

- ① Threading motor rotation detection sensor
Threading motor rotation detection sensor detects the rotation speed of the threading motor. The FG output signal of this sensor inputs to servo circuit, and controls the threading speed to protect the tape from damage.

- ② Threading-end/unthreading-end detection sensor
This sensor detects whether the threading ring reaches the threading-end or unthreading-end position.
- ③ Tape end sensor
During tape travelling in the FWD direction, tape end sensor detects the end of tape.
- ④ S tension regulator arm sensor
During playback, S tension regulator arm activates to keep a constant tape tension.
S tension regulator arm sensor detects the position of the S tension regulator arm.
- ⑤ S reel rotation detection sensor
S reel rotation detection sensor detects the rotation of the S reel table.
The FG output signal of this sensor inputs to servo circuit, and controls the rotation speed and torque of the reel motor.
- ⑥ Reel L/S position sensor
This sensor detects whether the reel table moves to the correct position according to the size of the inserted cassette tape.
- ⑦ Reel hub diameter detection sensor
The reel hub diameter varies depending on the length of the tape wound on a cassette tape. The reel hub diameter detection sensor detects the reel hub diameter using a tub on the back side of the cassette tape.
The output signal of this sensor inputs to servo circuit, and controls the rotation speed and torque of the reel motor.
- ⑧ Oxide tape/metal particle tape detection sensor
This sensor detects whether an oxide tape or metal particle tape is being inserted to the unit using a tub on the back side of the cassette tape.
- ⑨ Video tape thickness detection sensor
This sensor detects the thickness of the wound tape that is being inserted to the unit using a tub on the back side of the cassette tape.
- ⑩ T reel rotation detection sensor
T reel rotation detection sensor detects the rotation of the T reel table.
The FG output signal of this sensor inputs to servo circuit, and controls the rotation speed and torque of the reel motor.
- ⑪ T tension regulator arm sensor
During playback, T tension regulator arm activates to keep a constant tape tension.
T tension regulator arm sensor detects the position of the T tension regulator arm.
- ⑫ Tape beginning sensor
During tape travelling in the FWD direction, tape beginning sensor detects the beginning of tape.
- ⑬ Condensation sensor
This sensor detects whether the moisture condensation occurs in the unit.

2-2-4. Location of Sensor (2).....Cassette Compartment

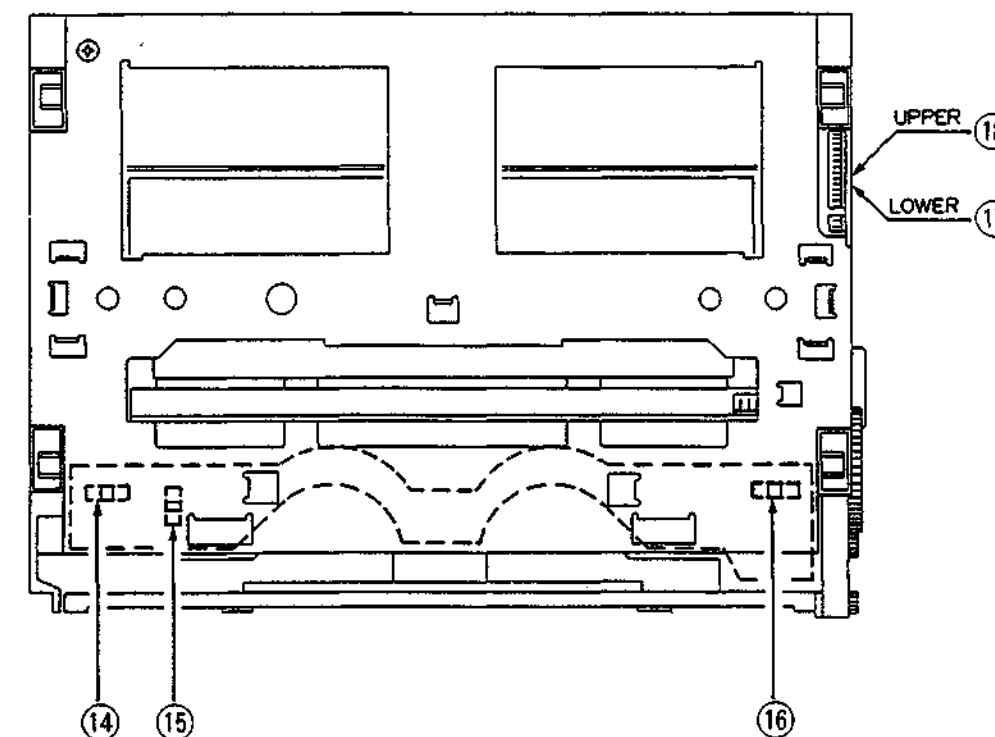

- ⑭ Cassette-in sensor (L)
This sensor detects whether a cassette is being inserted.
- ⑮ Cassette L/S size detection sensor
This sensor detects whether the inserted cassette tape is an L size or S size.
- ⑯ Cassette-in sensor (R)
This sensor detects whether a cassette is being inserted.
- ⑰ Cassette-down (2) sensor
- ⑱ Cassette-down (1) sensor
(1) sensor detects the position of the cassette compartment by using the combination of ON/OFF operation of these sensors and cassette-in sensor.

2-2-5. Function of the Cassette Plug and Tab

As shown in the figure below, plugs and tabs are provided at the back side of the cassette tape.

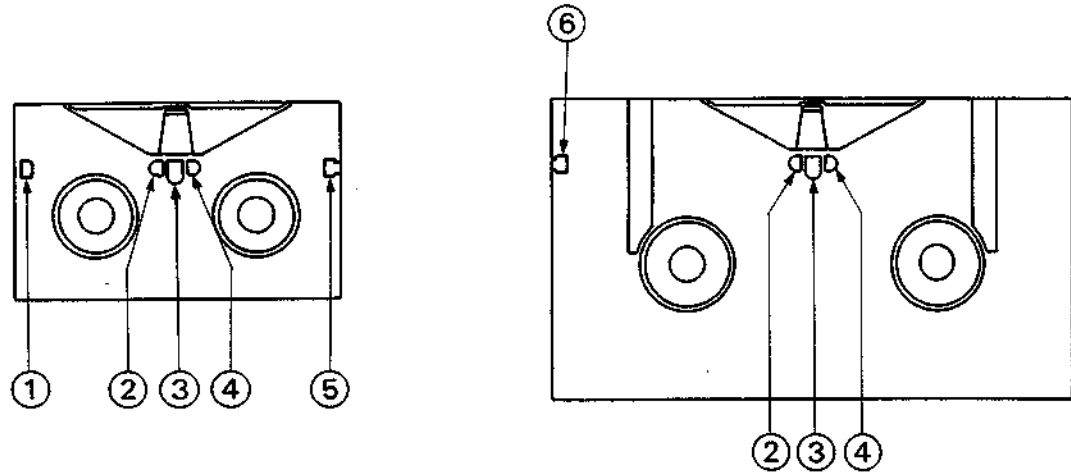

- ① S cassette Miss-REC tab (for oxide tape)
- ② Video tape thickness detection tab
- ③ Oxide/metal particle tape detection tab
- ④ Reel hub diameter detection tab
- ⑤ S cassette Miss-REC plug (for metal particle tape)
- ⑥ L cassette Miss-REC plug

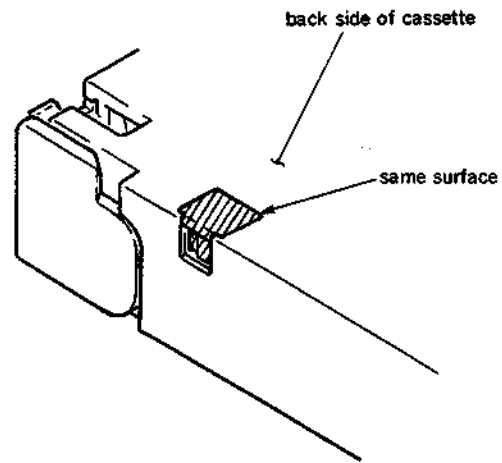

Fig. 1

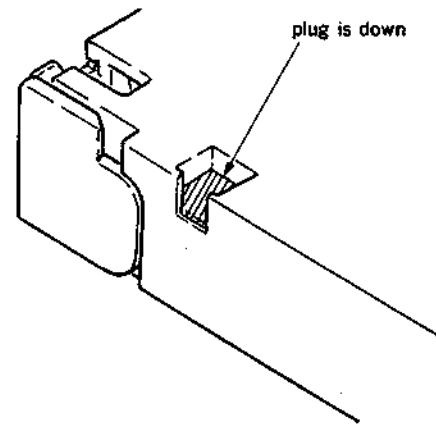

Fig. 2

The presence or absence of these plugs and tabs determines the cassette status as shown in the table below.

Plug and tab	Cassette status with plugs and tabs	Cassette status without plugs and tabs
S cassette Miss-REC tab (for oxide tape)	Can be recorded (refer to Fig.1).	Cannot be recorded (refer to Fig.2).
S cassette Miss-REC plug (for metal particle tape)		
L cassette Miss-REC plug		
Tape thickness detection tab	A 20 μm thick tape is wound on the cassette.	A 15 μm thick tape is wound on the cassette.
Oxide/metal particle tape detection tab	An oxide tape is wound on the cassette.	A metal particle tape is wound on the cassette.
Reel hub diameter detection tab	For small hub	For large hub

(NOTE) This unit cannot record.

2-3. ERROR MESSAGE

This unit features self-diagnostics.

When trouble is detected, an error code is displayed immediately in the time counter display on the control panel, an error code and message are displayed on the video monitor display.

Furthermore, as for the interface error (error code 92,93), interface object which error occurred replaced by sub error message on the video monitor display.

(To display error code and message on the monitor, the monitor must be connected to the VIDEO OUTPUT 3 connector or MONITOR OUT connector, and the CHARACTER switch on the sub control panel must be set to ON.)

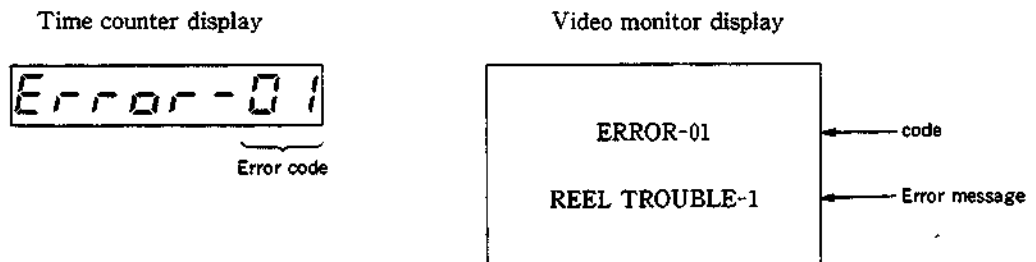

code	error message	description	detection
01	REEL TROUBLE-1	The slack of the tape is detected during threading or unthreading, and then tape protection is done.	Detected when the ratio of the FG frequency at a supply reel, take-up reel and threading ring is less than the specified value.
02	REEL TROUBLE-2	The slack or breaking of the tape is detected in search, fast forward, or rewind mode, and then tape protection is done.	Detected when the ratio of the FG frequency at a supply reel and take-up reel is less than the specified value.
03	REEL TROUBLE-3	The slack or breaking of the tape is detected in recording or playback mode, or either of the lock of the supply or take-up reel is detected, and then tape protection is done.	Detected when the FG frequency at a supply or take-up reel is zero (0), or when the tension detected from a tension sensor is less than 15 g.
04	REEL TROUBLE-4	It is detected that the tape does not run at the speed of designation in fast forward or rewind mode, and then tape protection is done.	Depends on the comparison between the tape speed using the FG frequency at supply and take-up reels and the designated speed.
05	REEL TROUBLE-5	It is detected that the supply or take-up reel cannot stop with a cassette is not inserted, or detected that over current has been flowing to supply and take-up reels.	Detected using the FG frequency or current at supply and take-up reels.
06	TAPE TENSION ERROR	When excessive tension is detected, tape protection is done.	Detected when the tension detected from a tension sensor is more than 55 g.
07	CAPSTAN TROUBLE	It is detected that the tape does not run at the speed of designation in play or search mode, and tape protection is done.	Detected at the tape speed detected from the FG frequency at a capstan motor.
08	DRUM TROUBLE	It is detected that drum motor rotation is not normal, and then tape protection is done.	Detected when the drum speed obtained from the speed FG of the drum motor is less than the specified value.
09	TH/UNTH MOTOR TIME OUT	It is detected that threading or unthreading is not completed, and then tape protection is done.	Detected when threading or unthreading is not completed within ten seconds after it is started.

code	error message	description	detection
0A	THREADING TROUBLE	It is detected that threading cannot be done, and then tape protection is done.	Detected when the tape beginning sensor is acted during threading after the short FF mode is automatically entered three times.
10	HUMID	Condensation is detected.	Detected using a condensation sensor.
11	TAPE BEGINNING/END SENSOR TROUBLE	The tape beginning or end sensor operation is defective.	Detected when the tape beginning and end are detected at the same time.
12	TAPE BEGINNING SENSOR TROUBLE	The tape beginning sensor operation is defective.	Detected when the tape beginning continues for more than seven seconds.
13	TAPE END SENSOR TROUBLE	The tape end sensor operation is defective.	Detected when the tape end continues for more than seven seconds.
14	FAN MOTOR TROUBLE	The operation of the fan motor is defective.	Detected according to the period of a ripple noise at the fan motor terminal.
20	CASSETTE COMPARTMENT MOTOR LOCK	It is detected that cassette up/down operation is not completed, and then tape protection is done.	Detected when cassette up/down operation is not completed within four seconds after it is started.
21	REEL TABLE MOTOR LOCK	It is detected that driving of the L position to S position or the S position to L position in the reel table is not completed, and then tape protection operation is done.	Detect when reel table driving is not completed within four seconds after it is started.
22	REEL TABLE SENSOR TROUBLE	The operation of the L/S position detection sensor of the reel table is defective.	Detected when the L and S positions are detected at the same time.
90	KEY INTERFACE ERROR	The interface between the keyboard and system control is defective.	Detected when no interface signal is sent from the system control to the keyboard.
91	1/2 VD NOT EXIST	No 1/2 VD signal input to system control is detected.	Detected when no 1/2 VD signal input to system control.
92	INTERNAL SERIAL INTERFACE ERROR sub error message HC TBC	The serial interface between the HC-14 board, TBC-18 board and system control is defective. HC : IC1/HC-14 TBC : IC717/TBC-18	Detected when no interface signal is sent from the each board to the system control three times continuously.
93	CPU INITIALIZE ERROR sub error message servo (main) servo (sub) time code	The interface between the time code and system control, or the servo and system control is defective when the POWER switch is turned ON. servo (main) : IC604/SS-48 servo(sub) : IC710/SS-48 time code : IC403/SS-48	Detected when the interface signal from the time code or servo system to the system control when the POWER switch is turned ON is defect.
96	SY NV-RAM TROUBLE	The operational defect of the NV-RAM (setup menu data) is detected on the HC-14 board. Then, reset the data in the NV-RAM to the condition at exfactory.	Detected by the NV-RAM data's checksum.
97	SV NV-RAM TROUBLE	The operational defect of the NV-RAM (servo adjustment data) is detected on the DR-118 board.	Detected by the NV-RAM data's checksum.

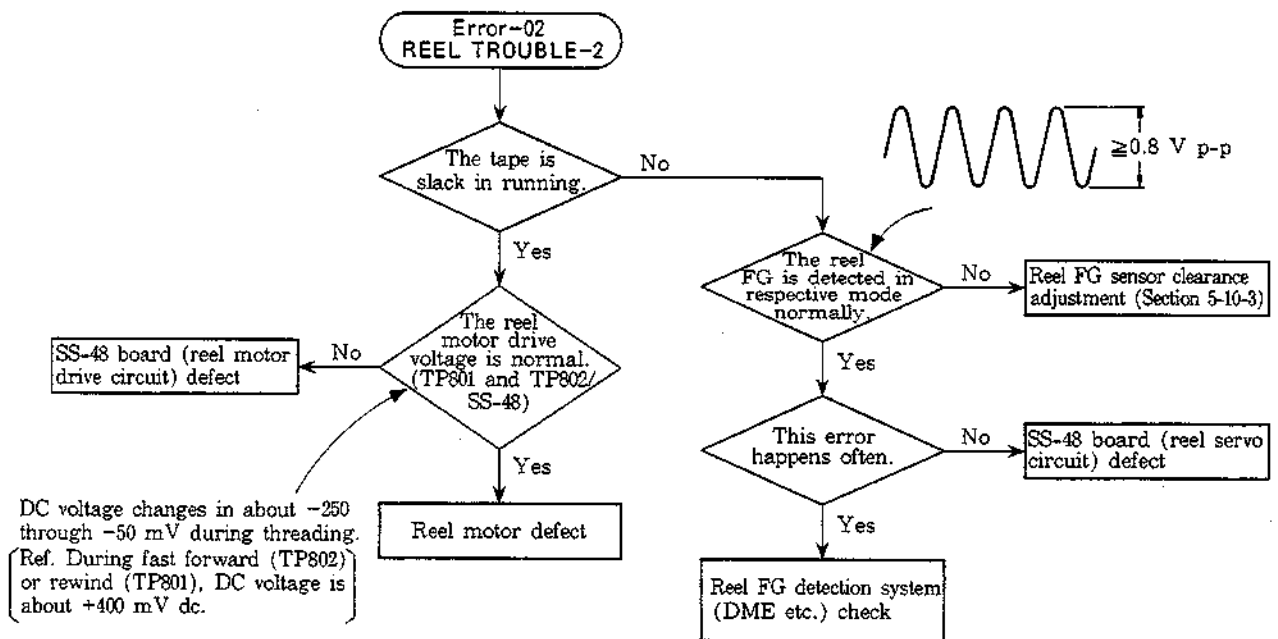
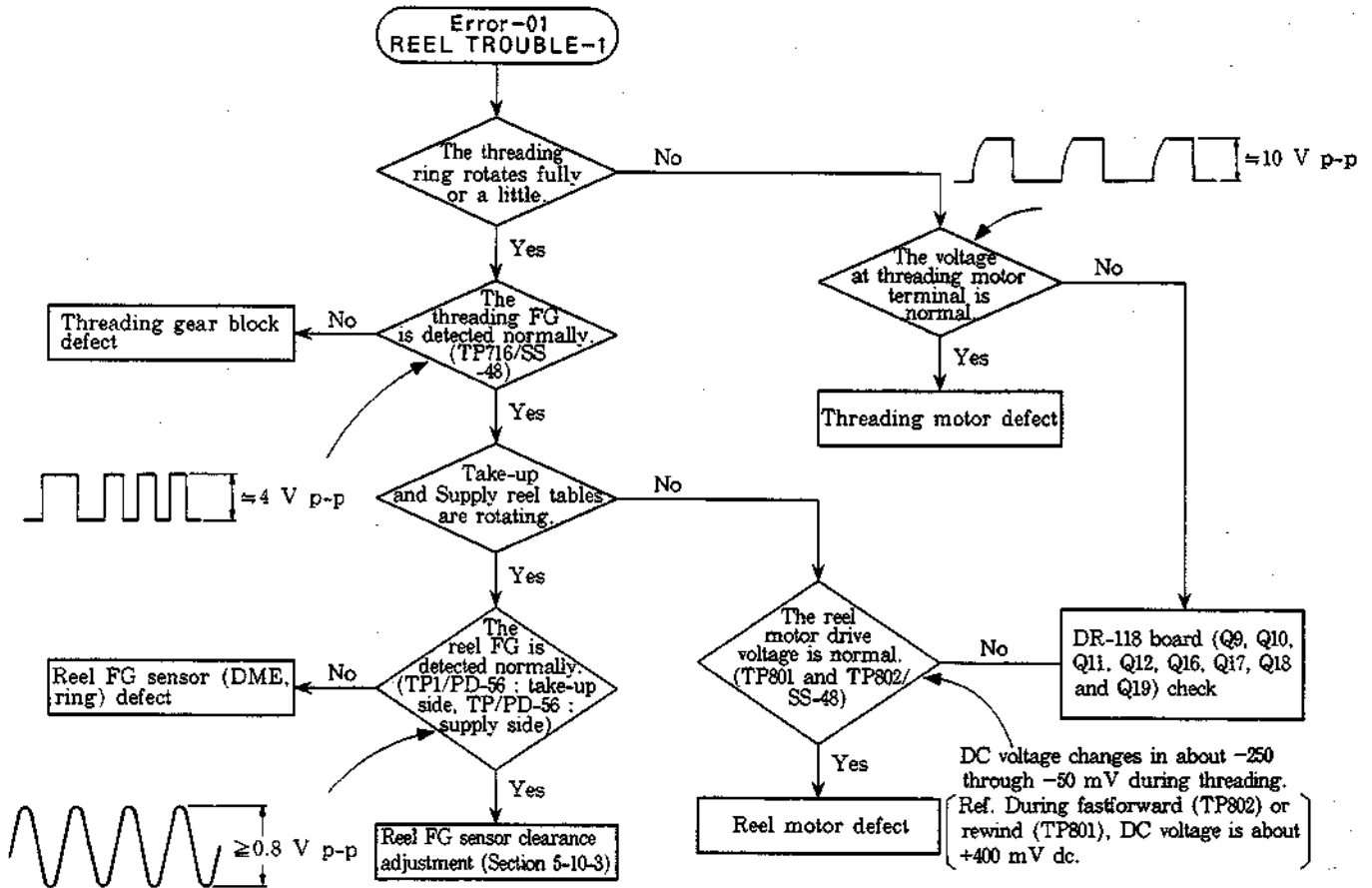

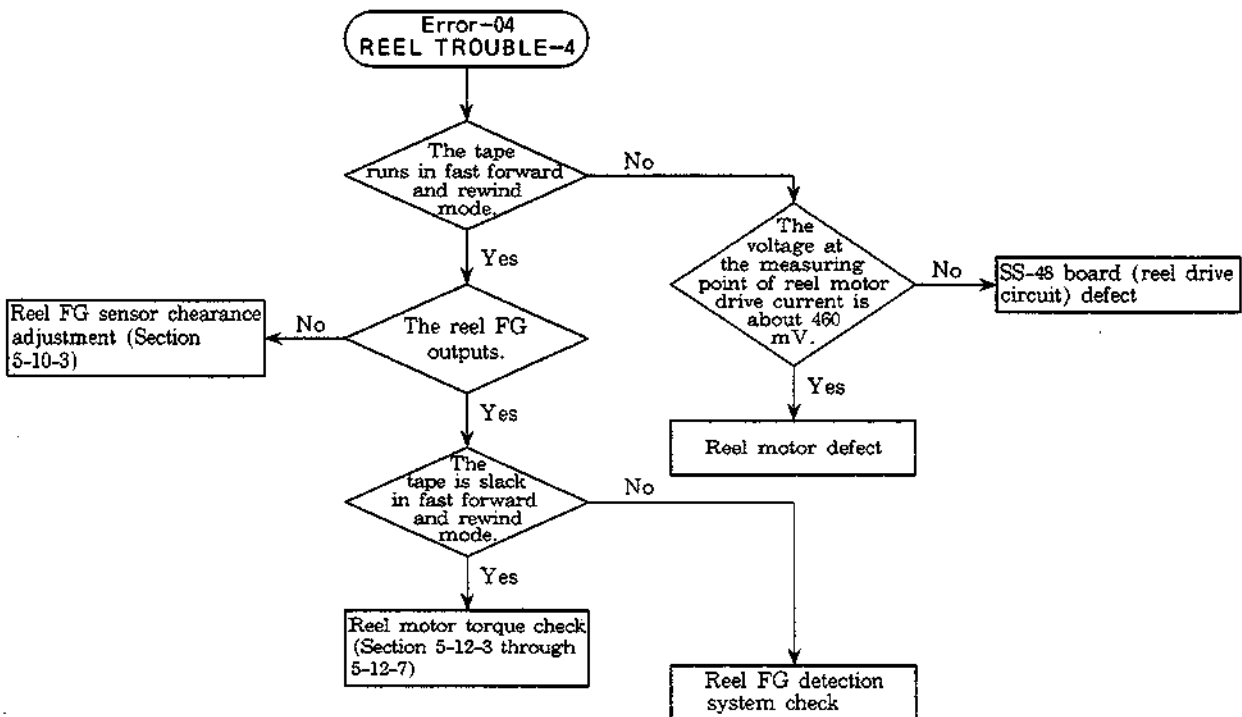
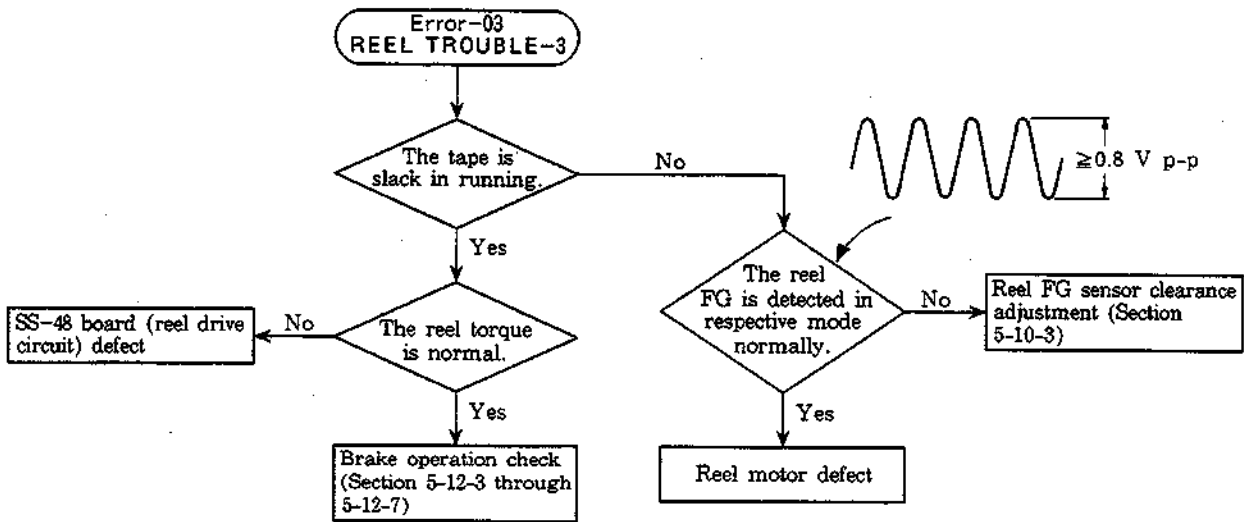

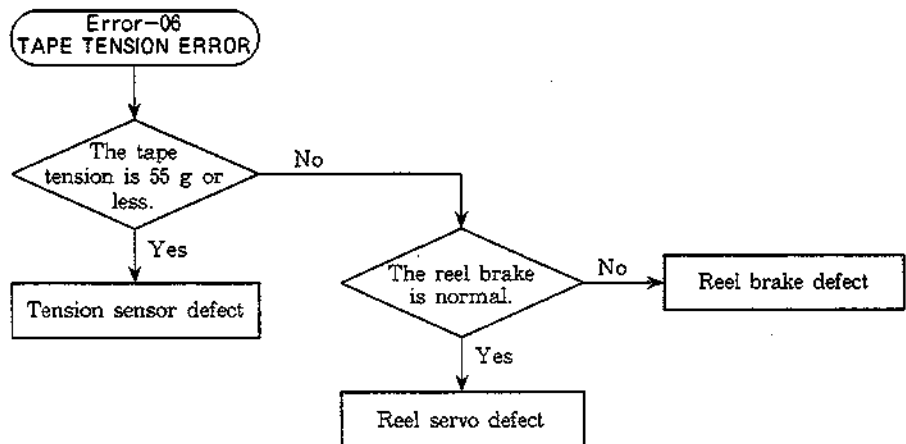
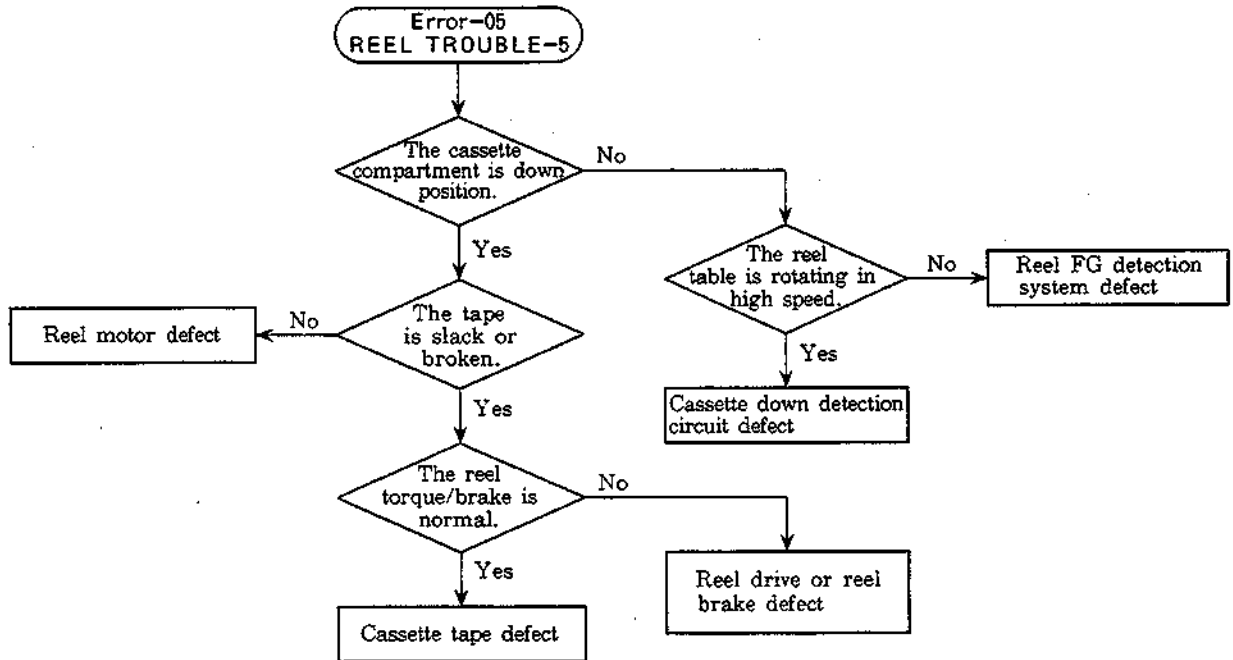

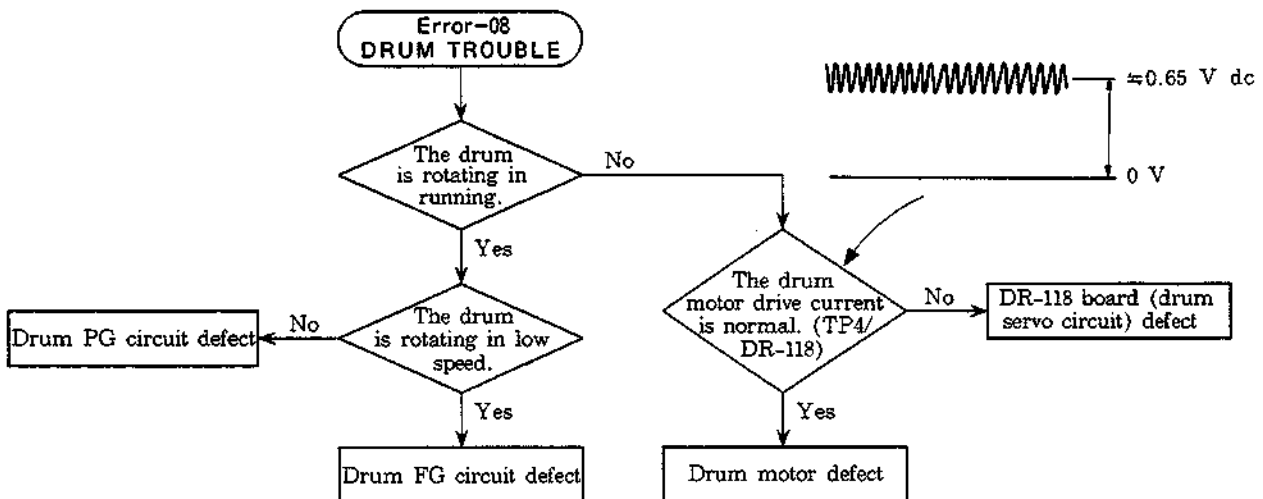
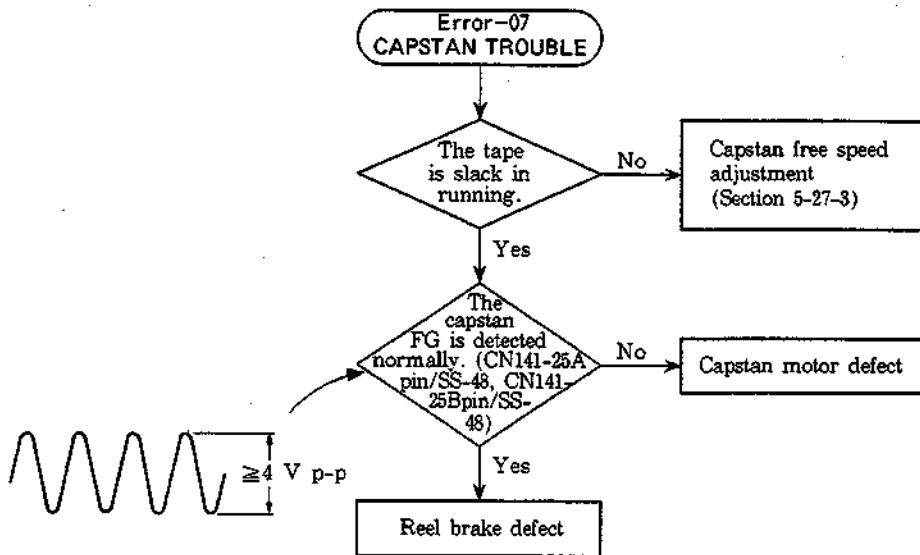

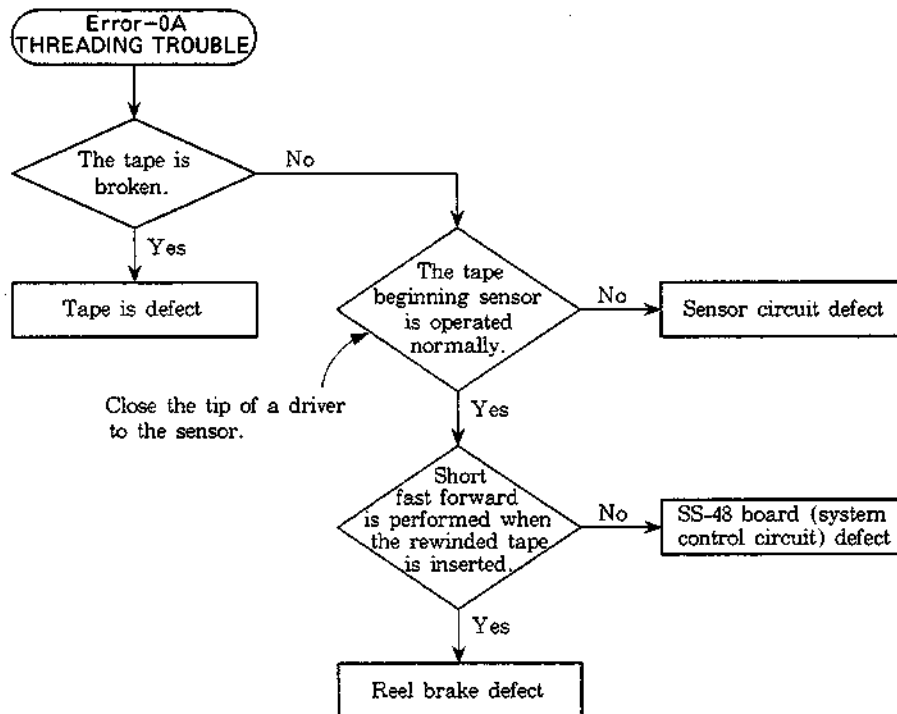
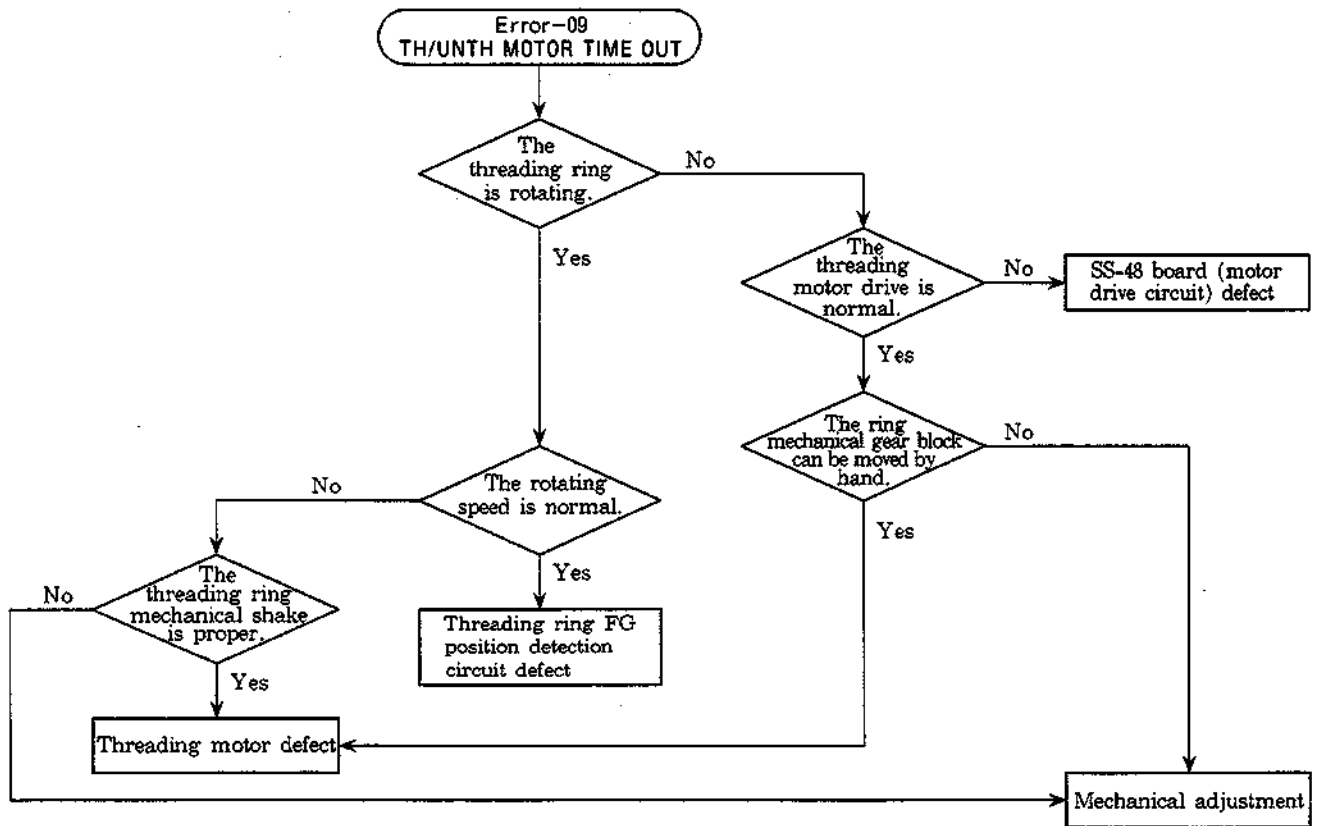

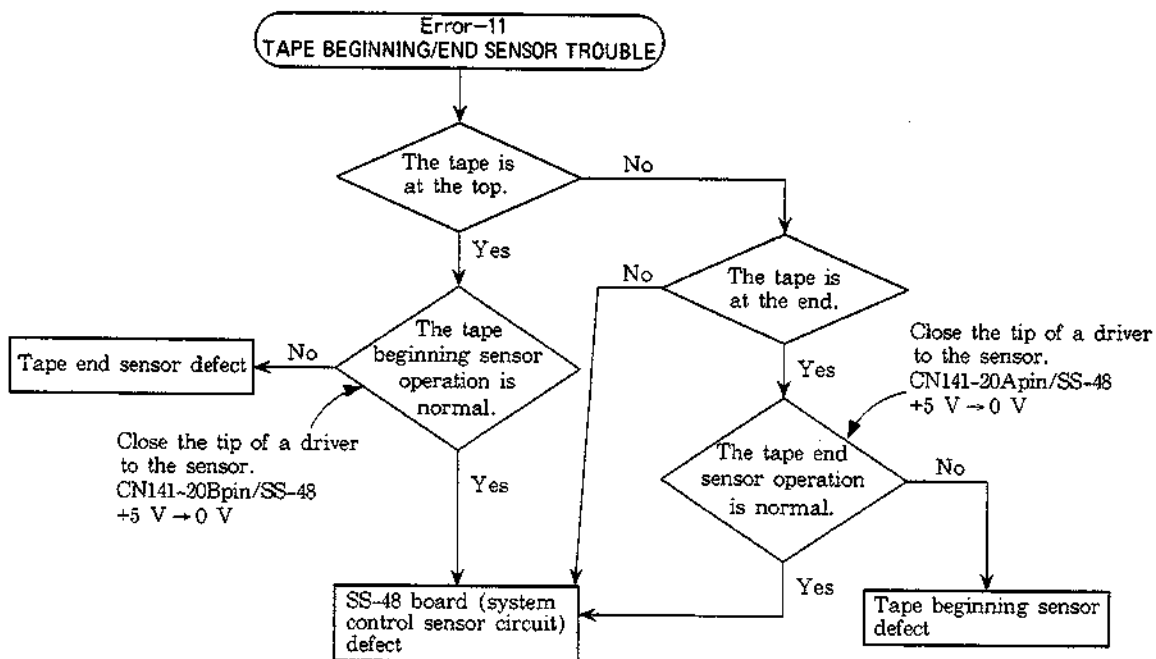
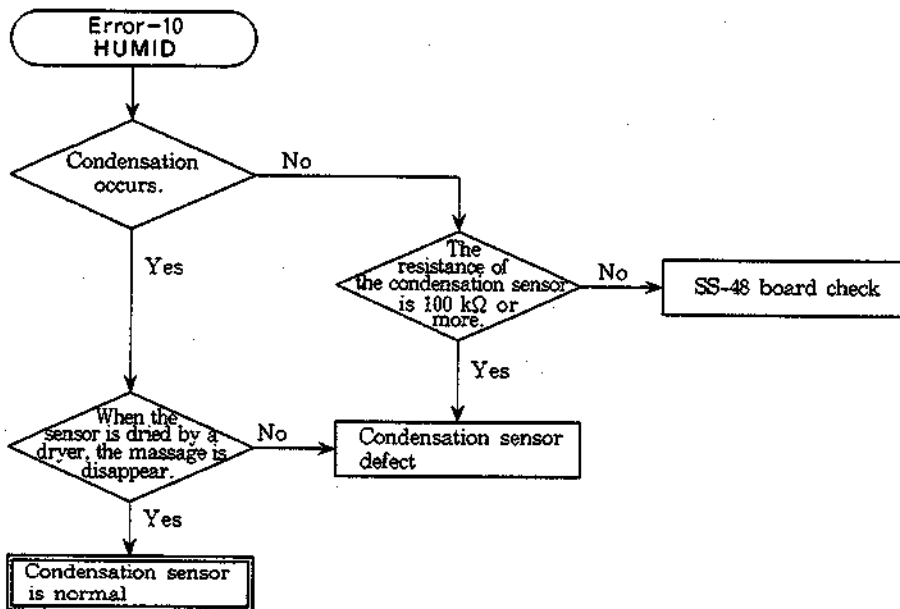

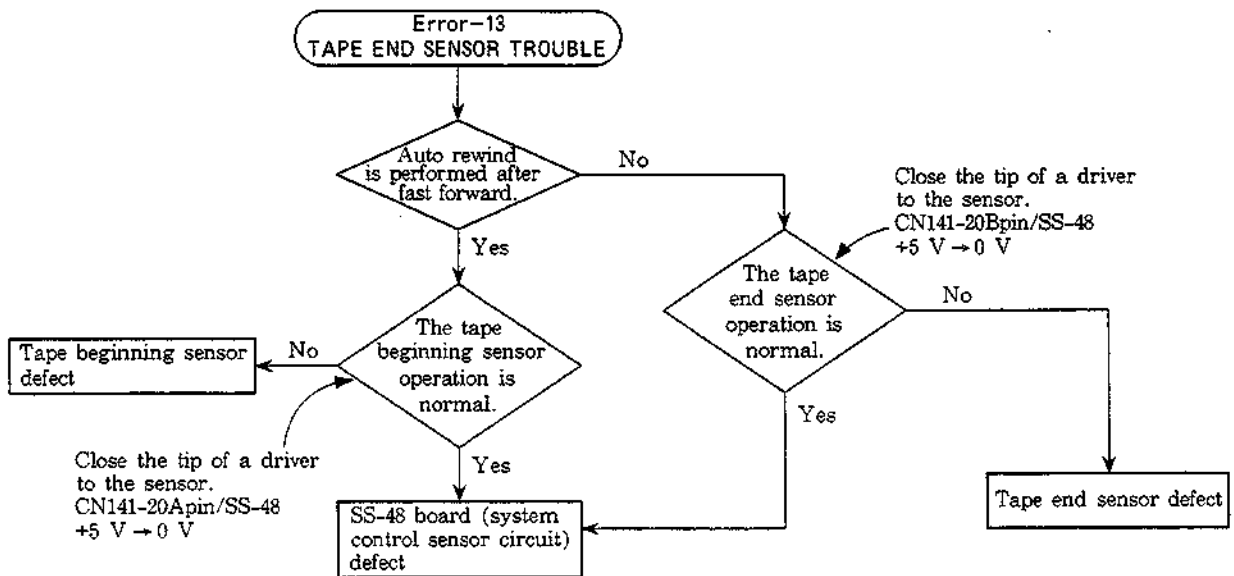
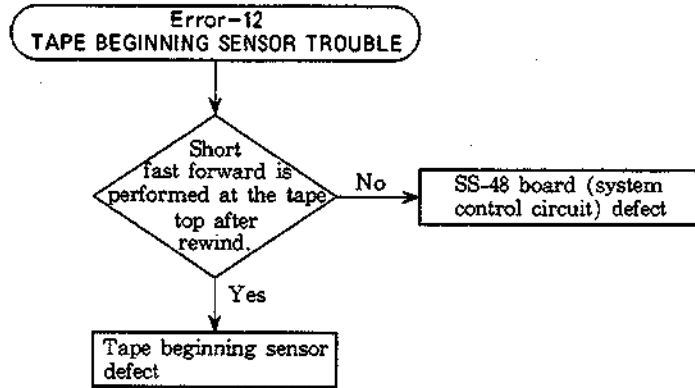

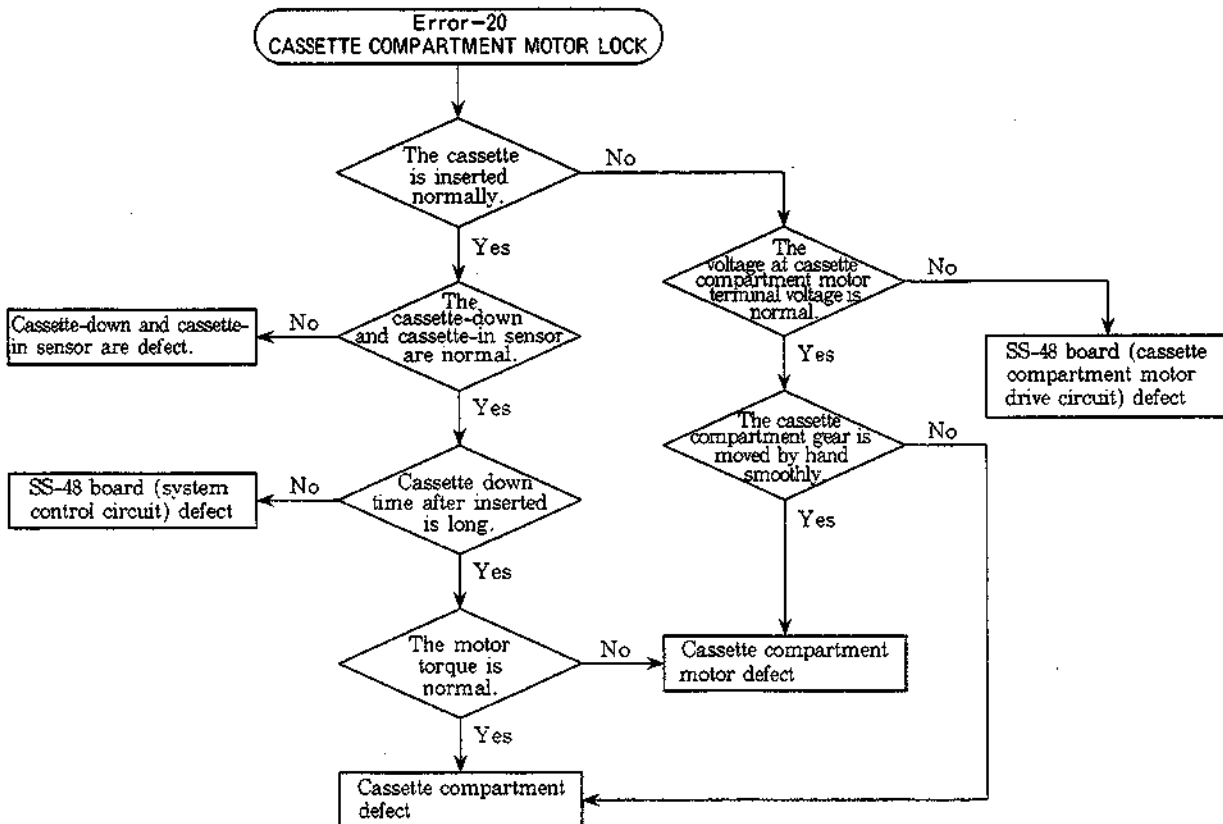
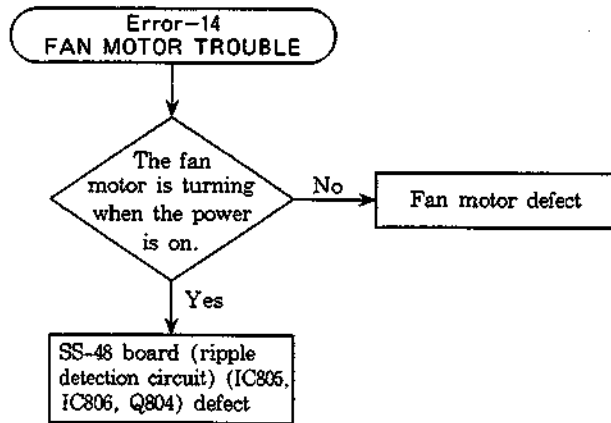

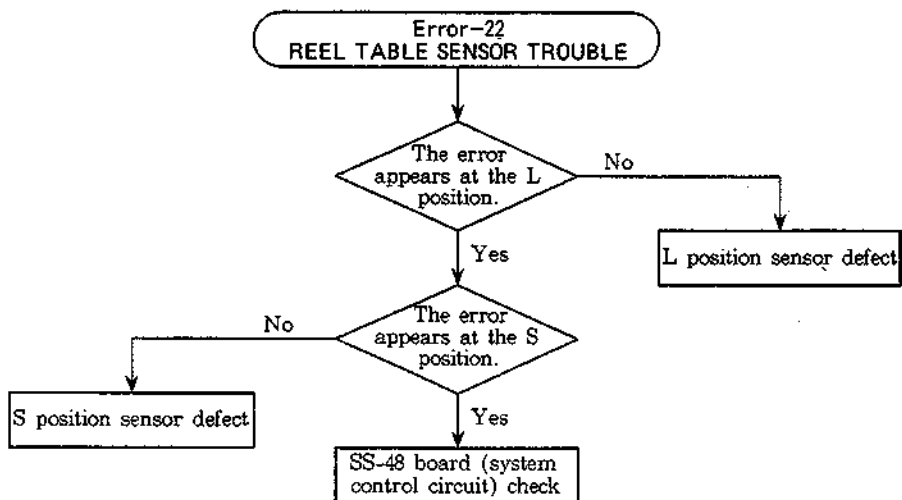
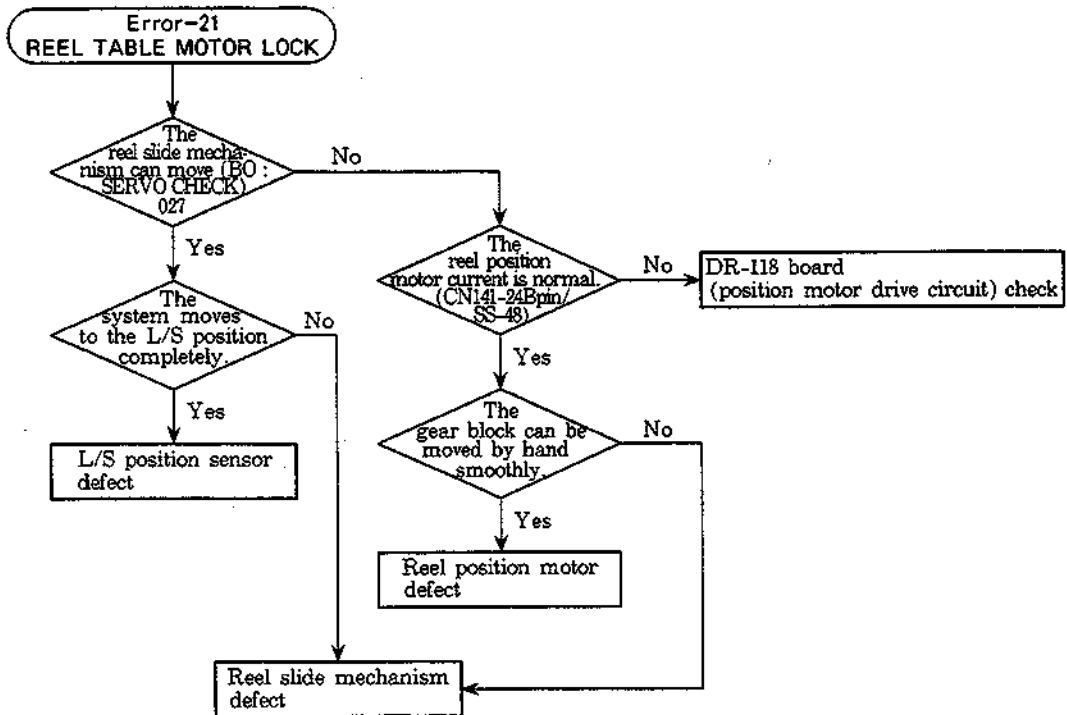

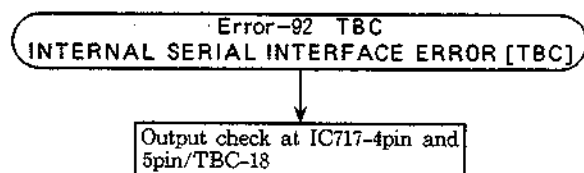
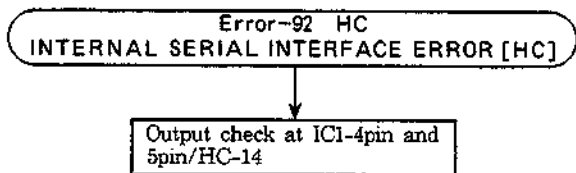
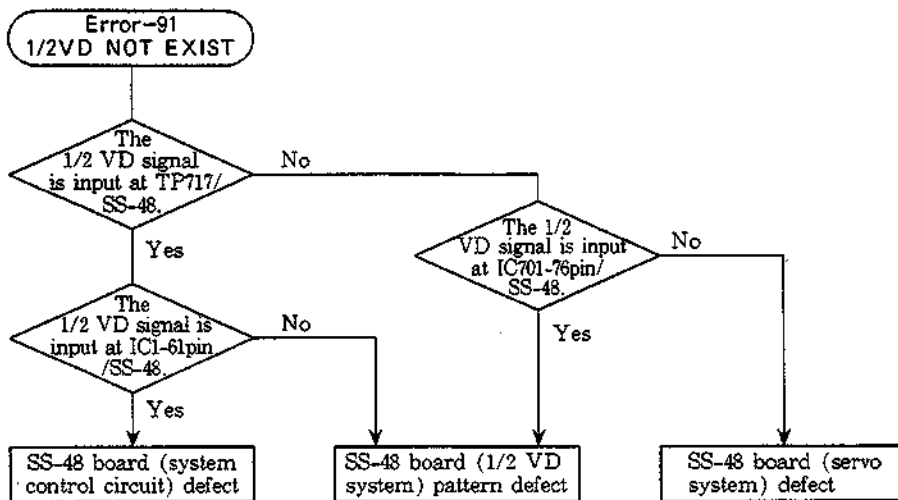
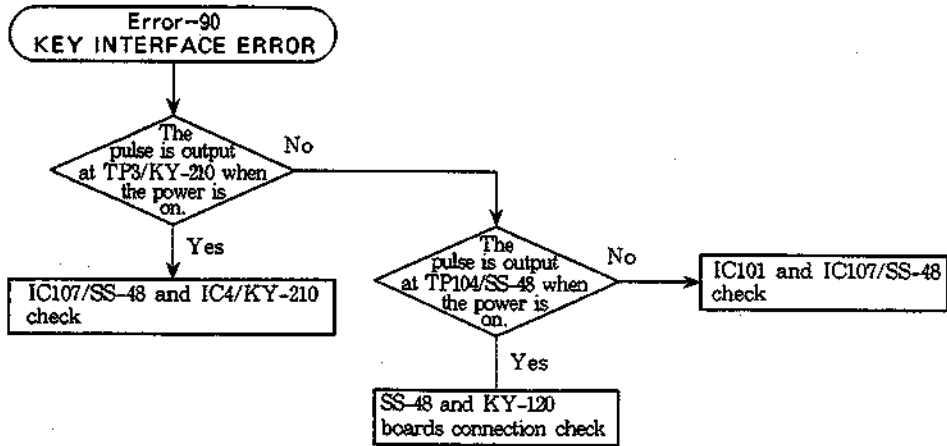

Error-93 servo(main)
CPU INITIALIZE ERROR [servo(main)]

The clock pulse is normal at IC604-1pin/SS-48. (20 MHz, 3.1 Vp-p)

No
SS-48 board (X601, C628, C629, IC604-16pin, +5 V) check

The reset pulse is normal at IC604-21pin/SS-48 when the power is on.

No
IC4/SS-48 (reset pulse circuit) check

IC604/SS-48 check

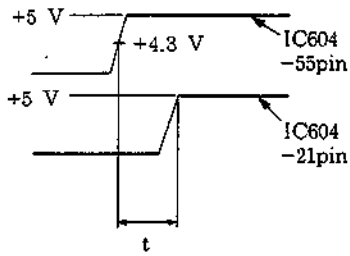

POWER ON
340 ms ≤ t ≤ 700 ms

Error-93 servo(sub)
CPU INITIALIZE ERROR [servo(sub)]

The clock pulse is normal at IC710-34pin/SS-48. (16 MHz, 4.2 Vp-p)

No
SS-48 board (X702, C713, C714, IC710-72pin, +5 V) check

The reset pulse is normal at IC710-32pin/SS-48 when the power is on.

No
IC4/SS-48 (reset pulse circuit) check

IC710/SS-48 check

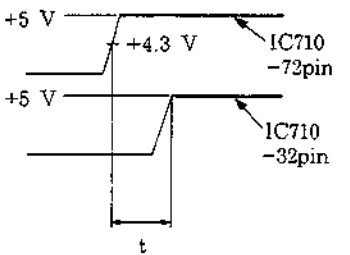

POWER ON
340 ms ≤ t ≤ 700 ms

Error-93 time code
CPU INITIALIZE ERROR [time code]

The clock pulse is normal at IC403-33pin/SS-48. (8 MHz, 4.3 V p-p)

No

SS-48 board (X401, C405, C406, IC403-64pin, +5 V) check

Yes

The reset pulse is normal at IC403-22pin/SS-48 when the power is on.

No

IC4/SS-48 (reset pulse circuit) check

Yes

IC403/SS-48 check

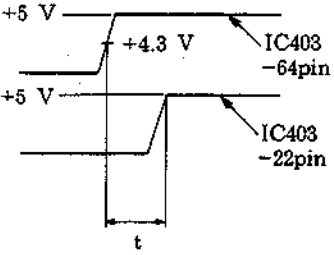

POWER ON
 $340 \text{ ms} \leq t \leq 700 \text{ ms}$

Error-96
SV NV-RAM TROUBLE

Output check at IC1/HC-14

Error-97
SV NV-RAM TROUBLE

DR-118 board (IC51, IC52, IC53) check

2-4. PRINTED CIRCUIT BOARD

SYSTEM	BOARD	CIRCUIT FUNCTION
VIDEO	RP-57AP VP-33AP TBC-18P CP-166A VR-117A	RF PB Amplifier Y/C PB Process (PB RF EQ, Demod, Encode, Y-RF Envelope DET), Composite Out Driver Time Base Corrector, CTDM (Expand) Output Connector, Component Out Driver Tracking Control
AUDIO	AU-148AP AU-149AP AU-150A CP-167A DP-138A VR-116A MA-44A	CH-1 PB Process, Dolby System CH-2 PB Process, Dolby System Mode Control, LTC PB Output Connector, Line Amplifier Level Meter, Back Light PB Level Control, Headphone Volume Control Meter Driver, Headphone Amplifier
SERVO/ SYSTEM CONTROL/ TIME CODE	SS-48P KY-210A DP-139A DR-118A CL-25 DE-15 DS-31 HC-14C PC-62 PD-56 PTC-39 PTC-42 PTC-49 PTC-54 PTC-55 RM-82 RM-93A SW-444A TR-73	System Control, Servo System Main, Time Code Reader, Character Generator Keyboard Time Code Display Motor Driver, Solenoid Driver, Sensor Input, Tension Amplifier, FG Amplifier, CTL PB, Adjust Data Storage Cassette Compartment (Cassette Loading Begin/Near-end Sensor, LP-57 Connection) Reel FG Condensation Sensor Sub-control Panel Cassette In/Large Cassette Sensor Pinch/Cleaning Solenoid Connection, Reel FG check Search Dial Cassette Size Sensor Threading Motor Threading FG Cassette Information Sensor (Tape Thickness, Reel Hub Diameter, Metal/Oxide) Reel Motor TBC/9P Remote Connector Select Switch, Indicator, RF Level Meter S/T Tension Sensor
OTHERS	AC-133 DP-159A LP-57 MB-322A	AC Line Filter, Fuse RF Meter Back Light Cassette Illumination Mother Board

2-5. REMOVAL OF CABINET

Turn the POWER switch to OFF during removal.

Left Side Panel

1. Remove a carrying handle.
2. Remove four screws (4×6) and remove a left side panel.

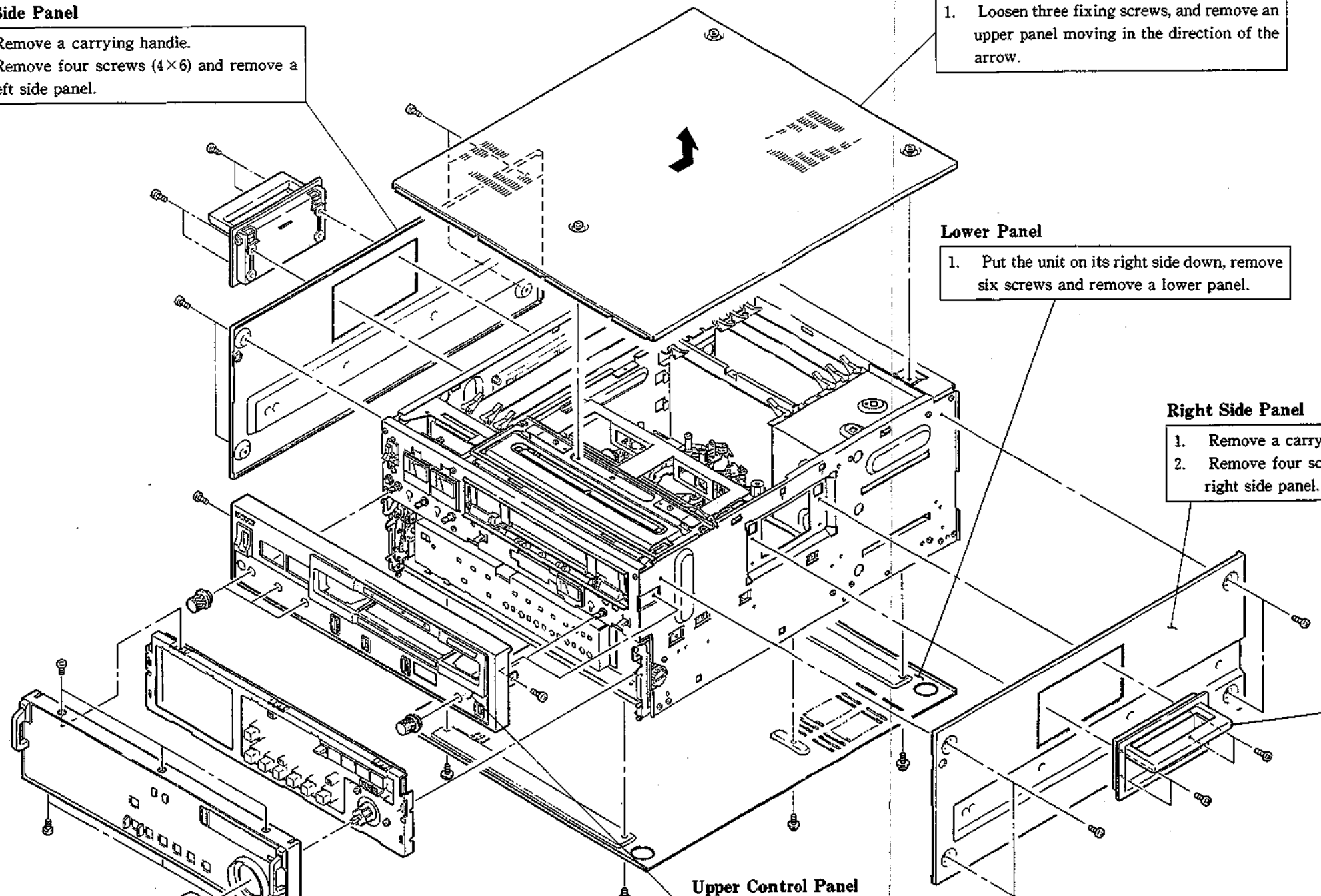

Upper Panel

1. Loosen three fixing screws, and remove an upper panel moving in the direction of the arrow.

Lower Panel

1. Put the unit on its right side down, remove six screws and remove a lower panel.

Right Side Panel

1. Remove a carrying handle.
2. Remove four screws (4×6) and remove a right side panel.

Carrying Handle

1. Remove four screws (3×6) and remove a carrying handle.

Lower Control Panel

1. Remove a lower control panel ass'y from the unit. (Refer to Section 2-8.)
2. Remove the each three screws (3×6) at the top and bottom on the lower control panel ass'y.
3. Remove the screw on a search dial (3×5) and remove a dial knob, then remove the lower control panel.

Upper Control Panel

1. Remove a upper panel.
2. Remove the four control knobs on a upper control panel.
3. Remove the each one screw (3×6) at the left and right of the upper control panel.
Insert your fingers in the space between the upper control panel and chassis, and remove the upper control panel as shown in the figure 1.
4. When installing, insert the claws of the upper control panel into the lack of chassis, then fix the panel with the screws as shown in the figure 2.

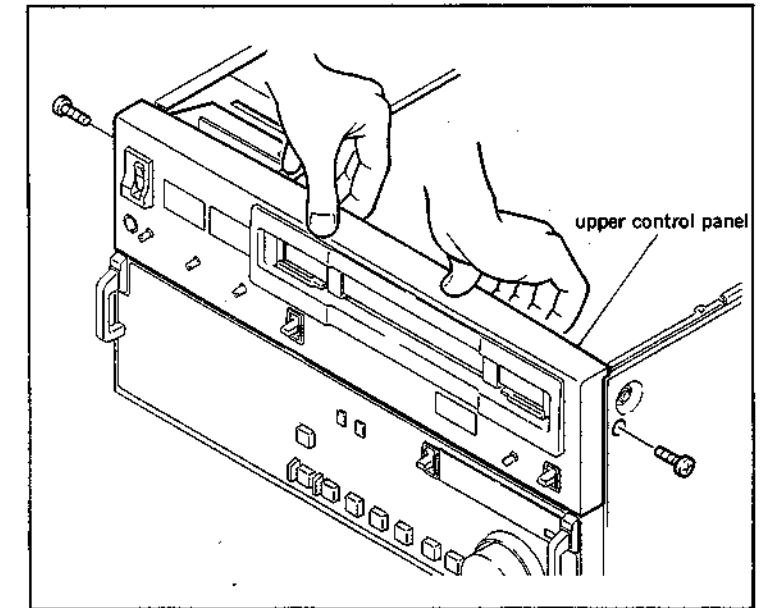

Figure 1

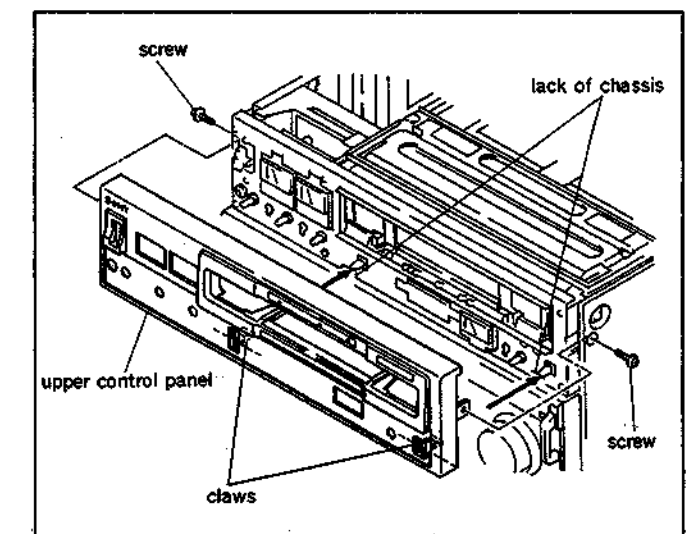
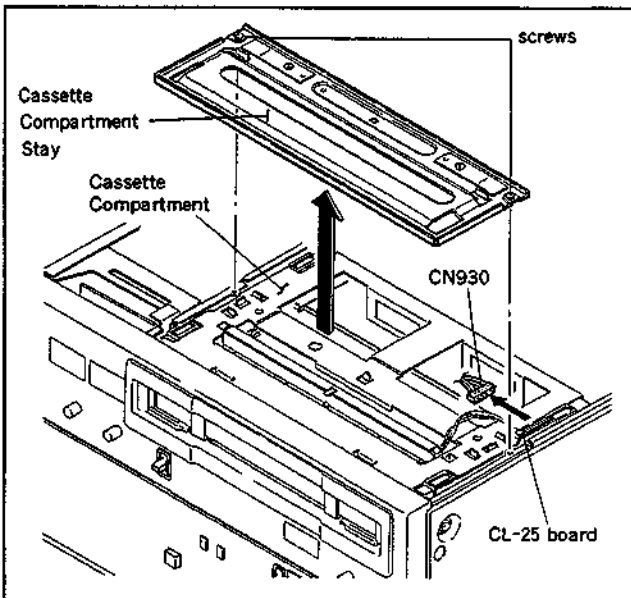

Figure 2

2-6. REMOVAL/INSTALLATION OF CASSETTE COMPARTMENT

• Removal

1. Turn the POWER OFF.
2. Loosen three screws and remove an upper panel. (Refer to Section 2-5.)
3. Loosen the two screws shown in the figure and remove a Cassette Compartment Stay. These screws are retained on the Stay, so they don't get out of the Stay.
4. Disconnect the connector CN930 on the CL-25 board at the upper right of the Cassette Compartment.



5. Slide up the Cassette Compartment raising up the rear part as shown in the figure. Lift up the Cassette Compartment slowly.

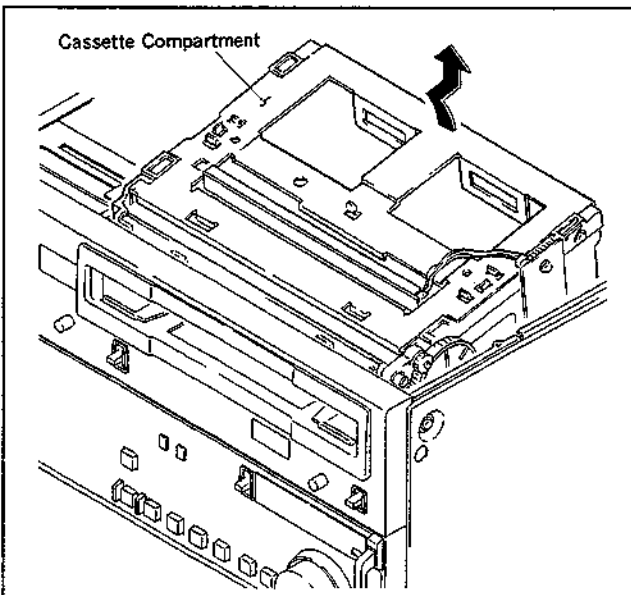

• Installation

6. Set the harness of the connector(CN930) disconnected in step (4) so it is not put between chassis. Install the Cassette Compartment inserting slantingly in the direction as shown in the figure.
(Note) In this time, confirm that the four legs of the Cassette Compartment for fixing the position are in the holes of the mechanical chassis for fixing the position.

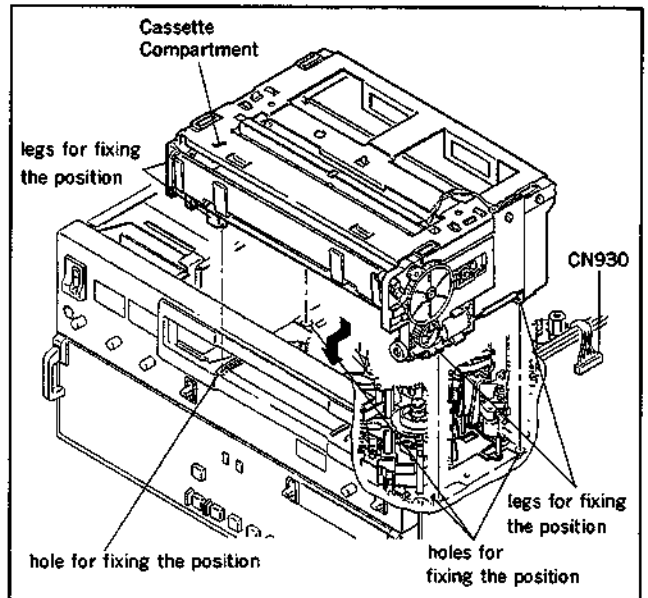

7. After confirming that the Cassette Compartment is fixed to the chassis, install the Cassette Compartment Stay and connect the connector CN930 of the CL-25 board.

2-7. REMOVAL OF POWER SUPPLY BLOCK

1. Turn the POWER OFF.
2. Put the unit on its right side down and remove six screws and remove a lower panel.
3. Disconnect the four connectors (CN1, CN2, CN3, and CN4) shown in the figure.

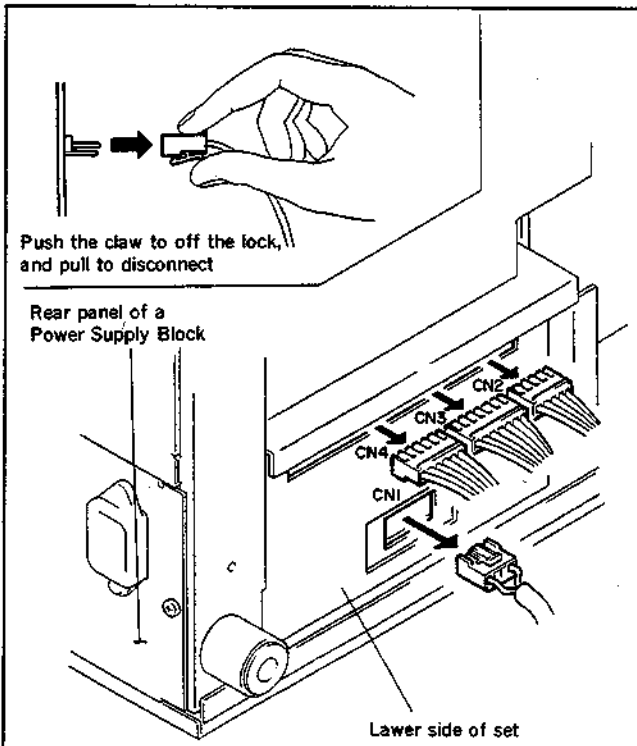

4. Remove the two screws at the top and bottom on the rear panel of a Power Supply Block and remove the rear panel.

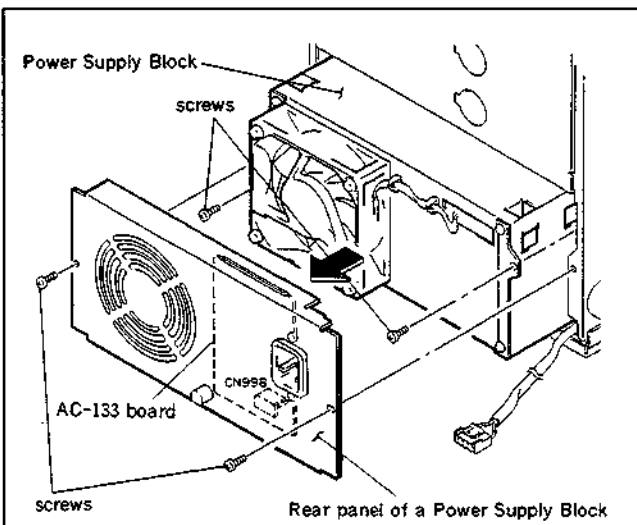

5. Disconnect the connector CN998 on the AC-133 board.
6. Remove the two screws at the top and bottom diagonal and slide the Power Supply Block not to catch the harnesses, and remove the Power Supply Block.

2-8. REMOVAL/INSTALLATION OF LOWER CONTROL PANEL ASS'Y

• Removal

1. Fix a lower control panel ass'y at 90 degrees (Refer to section 2-9.), disconnect the connector CN552 on the HC-14 board of a sub control panel.
2. Loosen the two black screws (3×10) on the lower control panel ass'y shown in the figure. (Loosen the screws until screw's top are exposed from the lack of the lower control panel ass'y.)

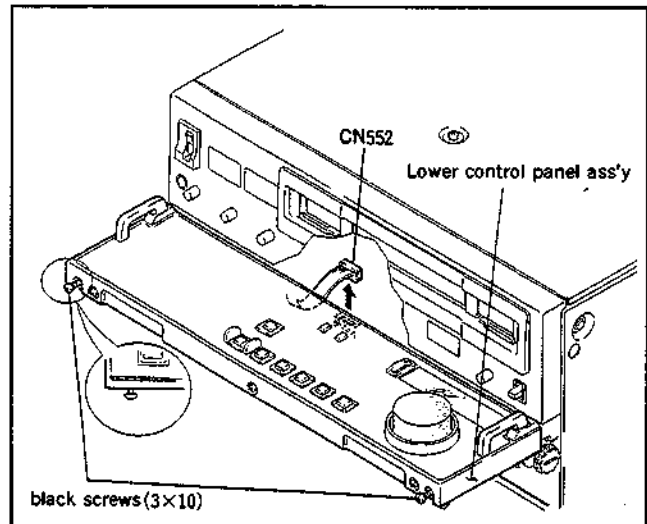

3. While pushing the loosen black screws in the direction of the arrow, remove the lower control panel ass'y from arms.

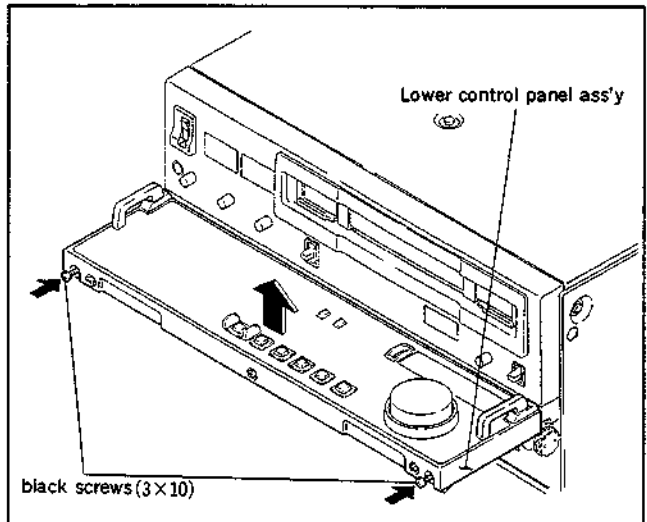

• Installation

4. Connect the harness of the lower control panel ass'y to the connector CN552 on the HC-14 board of the sub control panel.
5. Fix the arms at 45 degrees, set the lacks of the lower control panel ass'y to the claws of the arms and insert the ass'y until you can hear the click. Then fix the ass'y with screws.

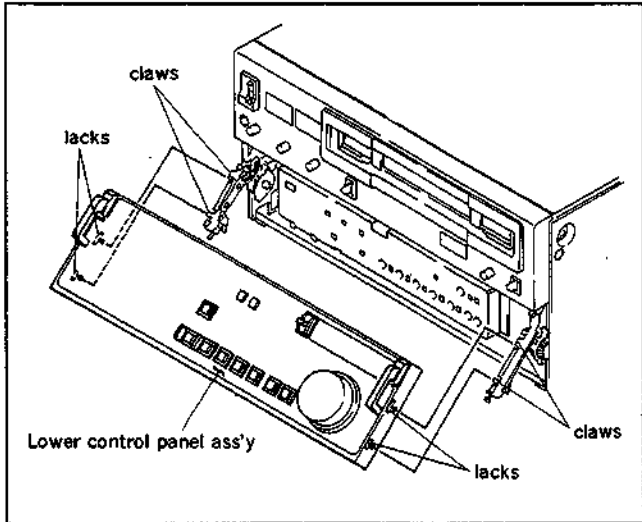

2-9. TILT THE LOWER CONTROL PANEL

1. Raise the panel to the desired angle.
2. While pressing the levers at the right and left sides of the panel, pull the panel up until it stops.
3. Tighten the screws on the right and left sides inside the panel by turning them clockwise.
4. While pressing the levers, lower the panel to the desired angle.
5. In case of change the angle, loosen the screws and try again from step 1.

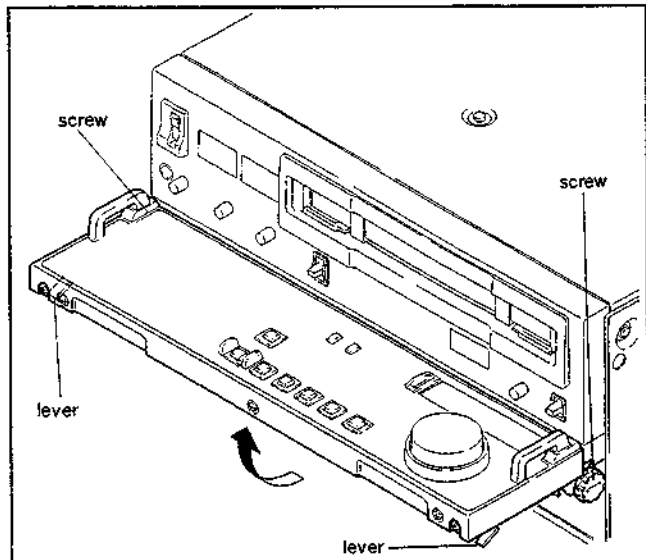

2-10. REMOVAL OF CONNECTOR PANEL

1. Turn the POWER OFF.
2. Remove the six screws indicated ⇒ at the top and bottom on the connector panel, then remove the connector panel not to stretch the harnesses as shown in the figure.

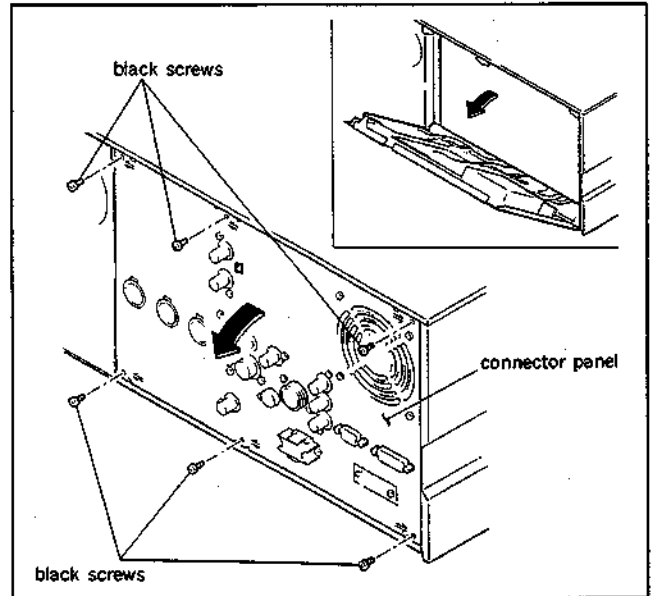

2-11. NOTE FOR CHECK AND MAINTENANCE OF PRINTED CIRCUIT BOARD

Be sure to turn the POWER OFF before removing or inserting the printed circuit boards.

2-12. EXTENSION BOARD

Two extension boards are supplied as optional accessory for check and adjustment of some printed circuit boards. Insert the extension board into the chassis of a unit and connect the circuit board to be checked or adjusted to the end of the extension board.

Extension board	Connectable Printed Circuit Boards
EX-286 A-6766-389-A	VP-33, TBC-18, SS-48
EX-287 J-6338-130-A	AU-148, AU-149, AU-150, RP-57

2-13. NOTES ON REPAIR PARTS

2-13-1. Notes on Repair Parts

(1) Safety Related Components Warning

Components marked with Δ on the schematic diagrams, exploded views and electrical spare parts list are critical to safe operation. Replace these components with Sony parts whose part numbers appear in this manual or in service bulletins and service manual supplements published by Sony.

(2) Standardization of Parts

Repair parts supplied from Sony Parts Center may not be always identical with the parts which actually in use due to "accommodating the improved parts and/or engineering changes" or "standardization of genuine parts".

This manual's exploded views and electrical spare parts list are indicating the part numbers of "the standardized genuine parts at present".

(3) Change of Parts

Regarding engineering parts changes, refer to Section 19 "CHANGED PARTS".

(4) Stock of Parts

Parts marked with "o" SP (Supply Code) column of the spare parts list are not normally required for routine service work. Orders for parts marked with "o" will be processed, but allow for additional delivery time.

(5) Units for Capacitors and Resistors

The following units may be assumed in schematic diagrams, electrical parts list and exploded views unless otherwise specified.

Capacitors : μF

Resistors : Ω

2-13-2. Replacement Procedure for Chip Parts

Required Tools

Soldering iron : 20 W If possible, use a soldering iron tip heat-controller at 270 ± 10 °C.

Braided wire : SOLDER TAUL or equivalent
Sony part No. 7-641-300-81

Solder : 0.6 mm dia. is recommended.

Tweezers

Soldering Conditions

Soldering iron temperature : 270 ± 10 °C.

Soldering time : less than two seconds per a pin.

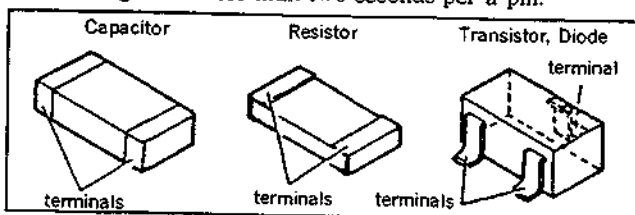

• Resistor and Capacitor Replacement

- (1) Place the soldering iron tip onto the chip part and heat it up until the solder is melted. When the solder is melted, slide the chip part aside.
- (2) Make sure that there is no pattern peeling, damage and/or bridges around the desoldering positions.
- (3) After removing the chip part, presolder the area, in which the new chip part is to be placed, with a thin layer of solder.
- (4) Place new chip part in the desired position and solder both ends.

NOTE: Once a chip part has been removed, never use it again.

• Transistor and Diode Replacement

- (1) Cut the terminals of the chip part with a nipper.
- (2) Remove the cut leads.
- (3) Make sure that there is no pattern peeling, damage and/or bridges around the desoldering positions.
- (4) After removing the chip part, presolder the area, in which the new chip part is to be placed, with a thin layer of solder.
- (5) Place new chip part in the desired position and solder the terminals.

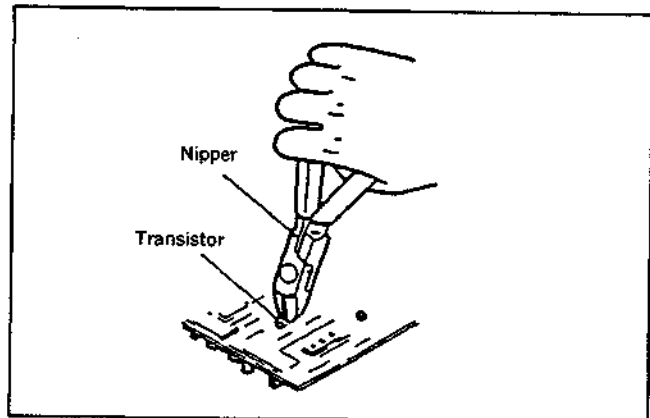

• IC Replacement

- (1) Using the braided wire, "SOLDER TAUL" Sony Part No. 7-641-300-81, remove the solder around the pins of the IC-chip to be removed.
- (2) While heating up the pins, remove the pins one by one using sharp-pointed tweezers.
- (3) Make sure that there is no pattern peeling, damage and/or bridges around the desoldering positions.
- (4) After removing the chip part, presolder the area, in which the new chip part is to be placed, with a thin layer of solder.
- (5) Place new chip part in the desired position and solder the pins.

2-13-3. Removal of PLCC IC

The Extraction Tool is useful for removing the IC (PLCC type) inserted into an IC socket. This is useful for all sizes of ICs of 20 pins through 124 pins.

Extraction Tool (for PLCC socket)
Sony Part No. J-6035-070-A

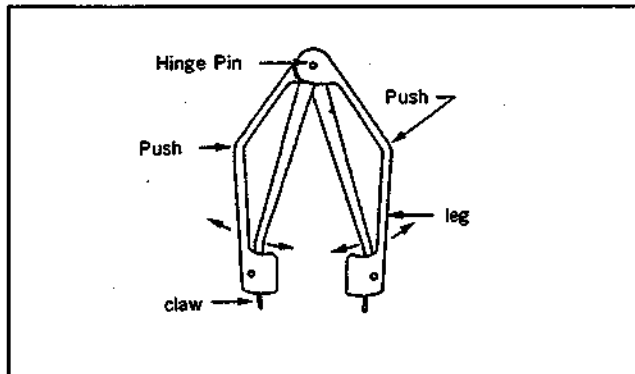

NOTE : • Never pull chips of IC upward with the Extraction Tool.

• Never hold the Extraction Tool on a strong force.

- (1) Adjust width so that the claws of the tool are matched to the socket of an IC.

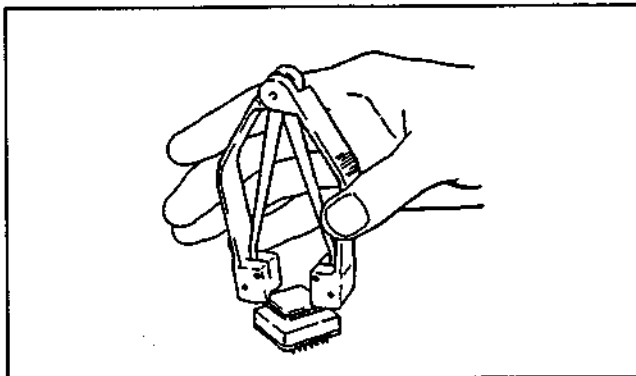

- (2) Insert the claws of the tool into the slots of the socket, and then press the tool against the socket so that the A portion shown in the figure contact to the socket.

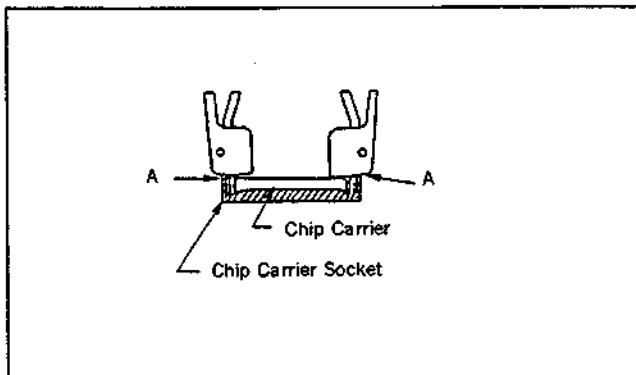

- (3) Hold the tool as shown in the figure. The socket is pressed on a little force to downward.

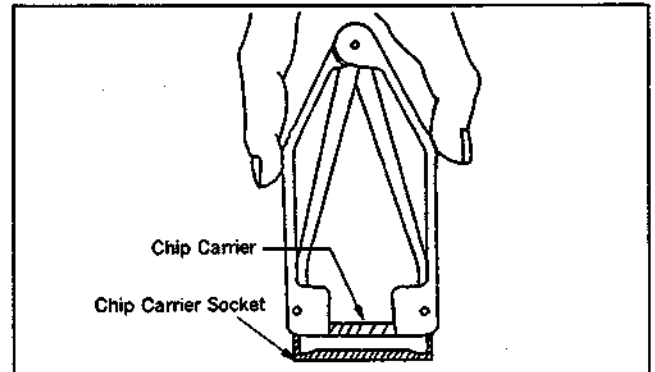

- (4) Pinch the tool, so the legs of the tool are straightened. At that time, the claws pinch the chips of the IC and pull the IC upward.
- (5) After pulling the IC, loosen the force of the fingers, and take off the chip.

2-13-4. Replacement of Fuse

A power fuse is mounted on the AC-133 board. If the fuse has blown, first remedy cause of trouble, and replace the fuse.

- (1) Turn the POWER OFF.
- (2) Remove the two screws at the top and bottom on the rear panel of the Power Supply Block and remove the rear panel.

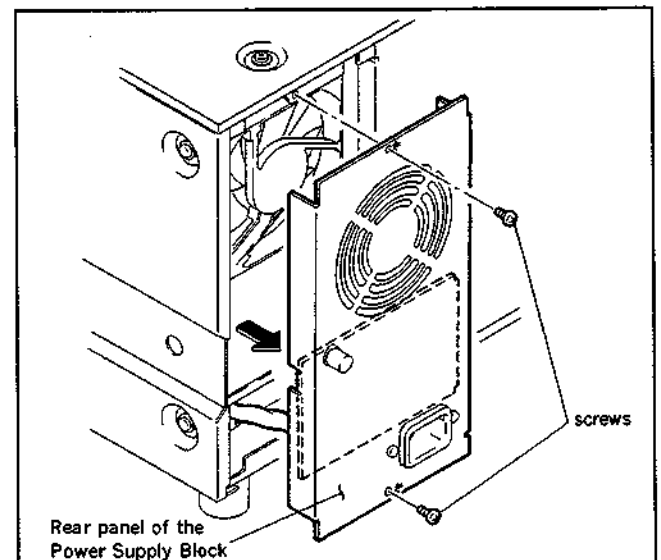

- (3) Disconnect the connector CN998 on the AC-133 board and remove a screw.

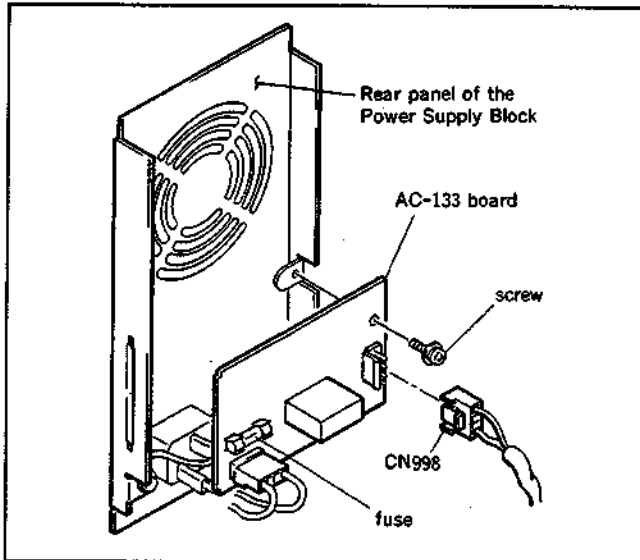

- (4) Remove the solder around the pins of the fuse on the B side of the AC-133 board using the braided wire "SOLDER TAUL" and replace the fuse.

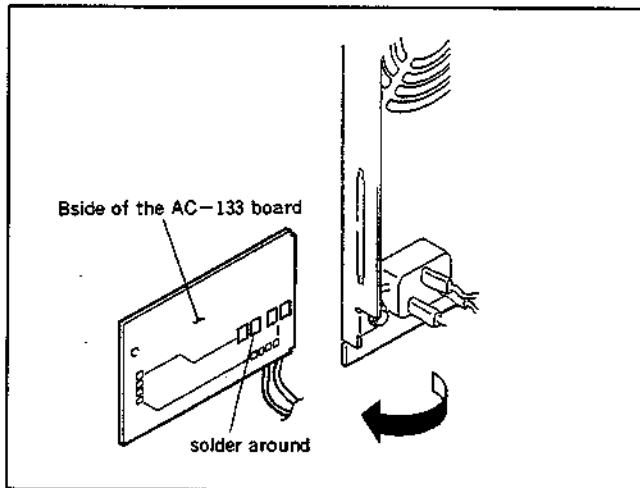

2-14. HOW TO OPERATE THE UNIT WITHOUT CASSETTE TAPE

When some mechanical alignments are performed, it may be operated the unit without inserting a cassette tape. The following procedures are described about the operation of the unit without installing a Cassette Compartment.

1. Threading

Turn the POWER ON.

After the reel motor and upper drum are rotated, the supply tension arm, take-up tension arm, supply slider, take-up slider and pinch roller slider begin to move, and the unit is put into threading mode.

The tension arm and three sliders move to the regular positions, and threading is completed.

It is said that this threading completed state is STOP mode.

2. Playback

Set the setup menu "Item 902" to 1. (At this time, tape protection mode is off.)

Press the PLAY button in threading completed state. A pinch roller is pressed to the capstan shaft, and the unit is put into PLAY mode.

If the PLAY button is pressed during the threading, the pinch roller is pressed to a capstan shaft after threading is completed, and the unit is put into PLAY mode.

NOTE: After adjustment is completed, set the setup menu "Item 902" to 0.

3. Unthreading

Press the EJECT button in threading completed state. A supply slider, take-up slider and pinch roller slider begin to move, and the unit is put into unthreading mode.

Three sliders move to the regular positions, and unthreading is completed.

4. Search

Set the setup menu "Item 902" to 1. (At this time, tape protection mode is off.)

Rotate a search dial to forward or reverse direction in threading completed state. A pinch roller is pressed to a capstan shaft, and the unit is put into search mode in the direction and the speed decided by the search dial.

If setup menu "Item 101" is set to 1, press the SEARCH button and rotate the search dial in threading completed state. Then the unit is put into search mode.

NOTE: After adjustment is completed, set the setup menu "Item 902" to 0.

5. Fast forward and rewind

Set the setup menu "Item 902" to 1. (At this time, tape protection mode is off.)

Press the F.FWD button or REW button in threading completed state. Then the unit is put into fast forward or rewind mode.

NOTE : After adjustment is completed, set the setup menu "Item 902" to 0.

2-15. TAKE OUT THE CASSETTE TAPE IN SLACKING

When the tape in the unit is slacked, take out the cassette tape by the following procedures carefully so that the tape is not damaged.

1. Turn the POWER OFF.
2. Remove the upper panel. (Refer to Section 2-5.)
3. Turn the rotation detection pulley of a Threading Motor Block counterclockwise until the supply tension arm, take-up tension arm, supply slider, take-up slider and pinch roller slider are threading completed state.

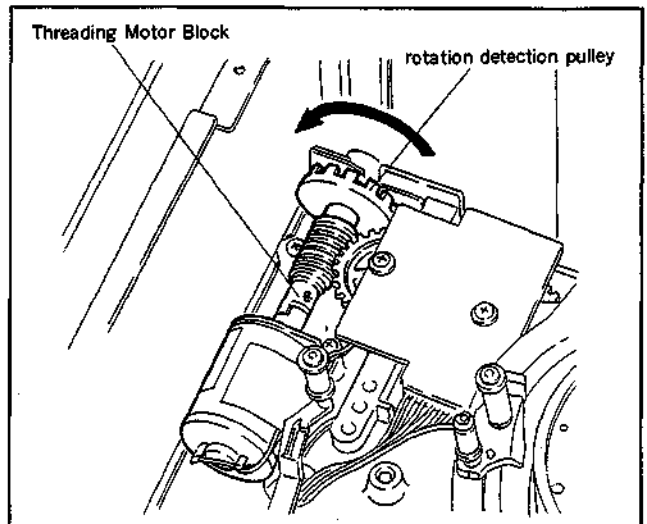

4. Remove the Cassette Compartment Stay. (Refer to Section 2-6.)
5. Disconnect the connector CN930 on the CL-25 board of the Cassette Compartment. (Refer to Section 2-6.)
6. Remove the lower control panel ass'y. (Refer to Section 2-8.)
7. Remove the sub cover.
8. Turn the motor pulley shown in the figure in the direction of the arrow.

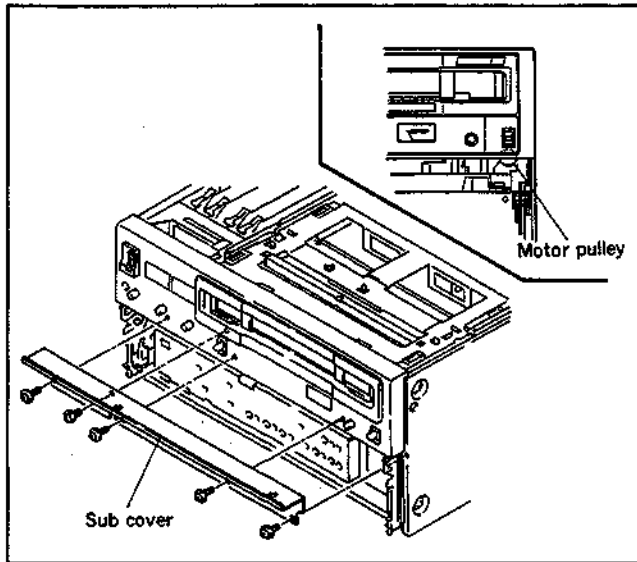

9. While holding a cassette lid by hand to prevent it closing so that the cassette compartment moves up. (Stop rotating the pulley just before the cassette compartment begins to move to the surface.)
10. Take out the cassette compartment slowly from the unit while holding the cassette lid.
11. Wind the tape into the cassette by turning a reel hub with a finger and close the cassette lid.

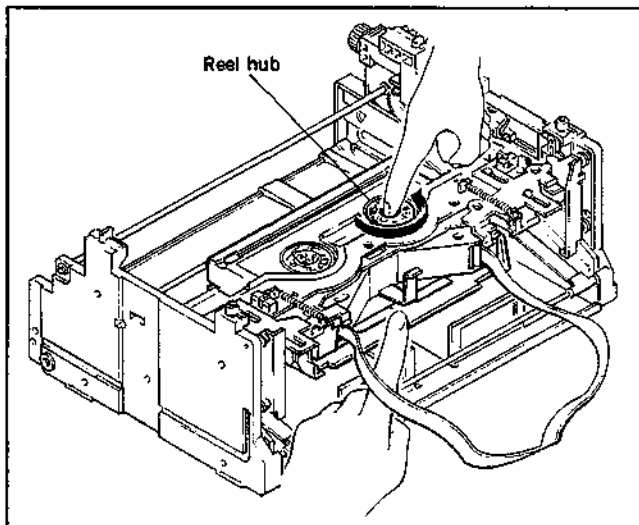

12. Remove the cassette tape from the cassette compartment.
13. Turn the pulley described in Step 8 so that the stage of the cassette compartment moves the cassette out position.
14. Install the cassette compartment to the unit.
15. Connect the connector (CN930), then install the Cassette Compartment Stay.

NOTE : Locate the cause of the trouble and remedy the problem, before the POWER switch is turned ON.

2-16. CLEANING WHEN HEADS CLOGGED

If the video head is clogged, clean the head as the following procedures.

• Cleaning by cleaning cassette

1. Insert the cleaning cassette BCT-5CLN in the unit, and press the PLAY button at once.
 - NOTE :** • Make sure to use the cleaning cassette BCT-5CLN. If the cleaning is performed by other cleaning cassette, not the BCT-5CLN, unusual friction or damage of the video head may occurred.
 - Press the PLAY button immediately after inserting the cleaning cassette BCT-5CLN in the unit.
2. After using the cleaning tape in play mode for 5 seconds, press the EJECT button.
 - NOTE :** • Make sure to press the EJECT button not STOP button.
 - Do not put the unit in play mode more than 5 seconds.
 - Do not use the cleaning cassette with rewind.
3. Confirm that the head clog is clear.

If the video head is clogged after Step 2, clean the video head as following procedure.

• Cleaning by cleaning piece

1. Hold the cleaning piece moisten with cleaning fluid against the heads gently.
2. Slowly rotate the upper drum in the direction of head's rotation with a finger and clean the video head.
 - NOTE :** • Do not move the cleaning piece in a vertical direction. This will damage the video head.
 - Be sure to turn the POWER ON, when cleaning is performed.

2-17. REPLACEMENT OF BOARDS

2-17-1. SW-444 Board

- (1) Turn the POWER OFF.
- (2) Loosen three screws and remove the upper panel. (Refer to Section 2-5.)
- (3) Remove four control knobs and two screws and remove the upper control panel. (Refer to Section 2-5.)
- (4) Remove the Cassette Compartment. (Refer to Section 2-6.)
- (5) Remove the two screws (3×6) shown in the figure and remove the SC guide ass'y.

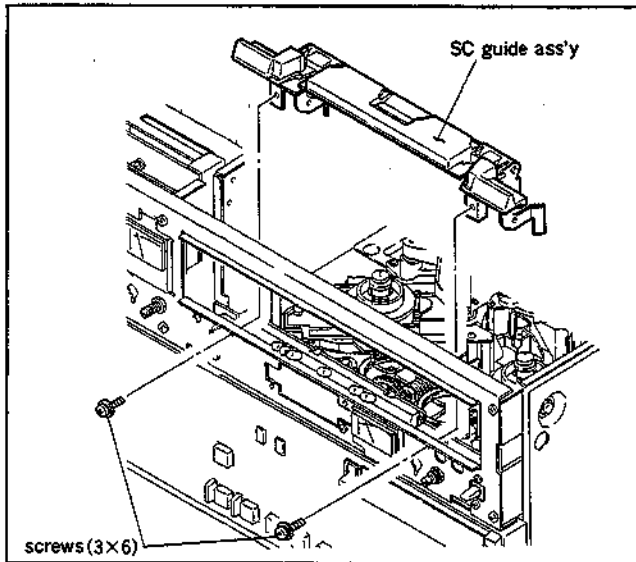

- (6) Disconnect the connector (CN501) of the VR-117 board while holding the board.
- (7) Remove the seven screws (2.6×4) shown in the figure and remove the SW-444/DP-159 boards.

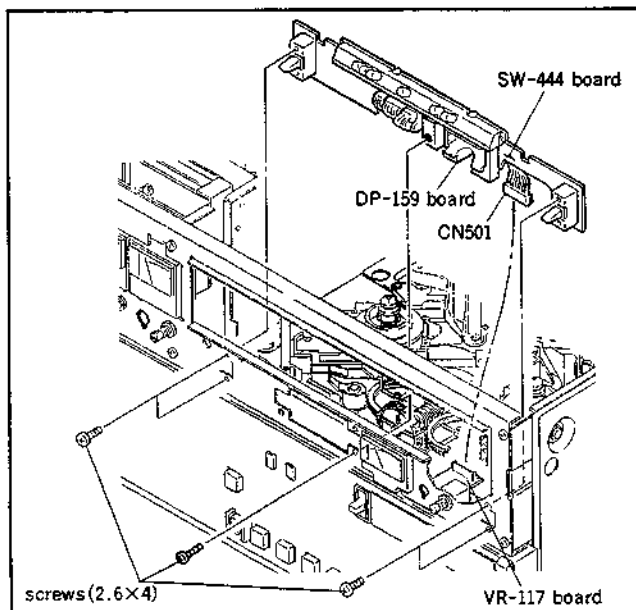

- (8) Pull off the plastic meter housing of the DP-159 board from the notch of the SW-444 board.

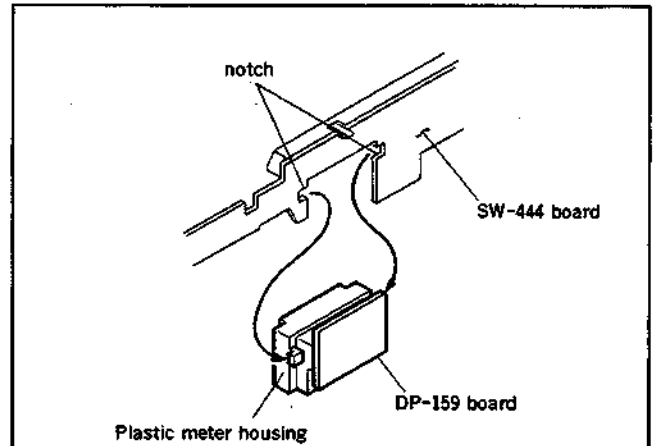

- (9) Disconnect the four connectors (CN510, CN511, CN512 and CN513) of the SW-444 board.

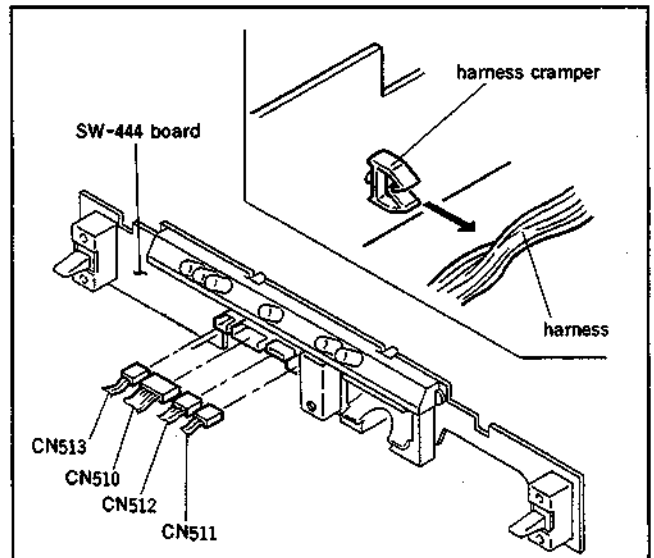

- (10) Remove the harness from the crammer and remove the SW-444 board.

2-17-2. VR-117 Board

- (1) Turn the POWER OFF.
- (2) Loosen three screws and remove the upper panel. (Refer to Section 2-5.)
- (3) Remove four control knobs and two screws and remove the upper control panel. (Refer to Section 2-5.)
- (4) Remove the Cassette Compartment. (Refer to Section 2-6.)
- (5) Remove the two screws (3×6) shown in the figure and remove the SC guide ass'y.

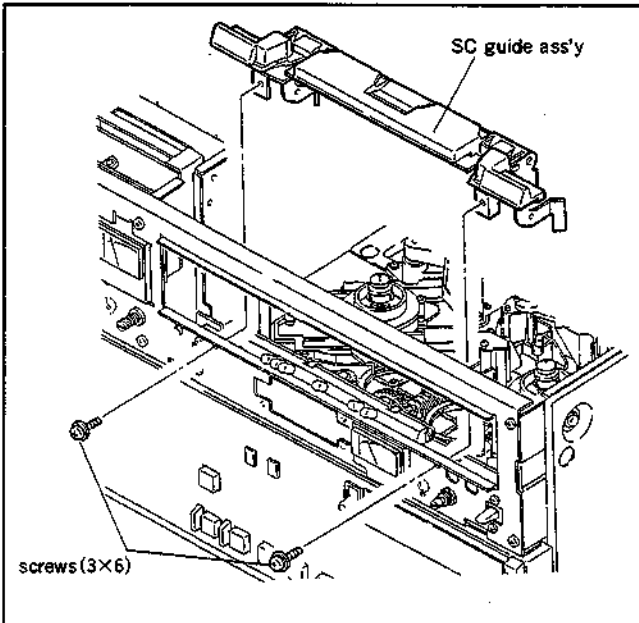

- (6) Disconnect the connectors (CN501 and CN502) of the VR-117 board while holding the board.

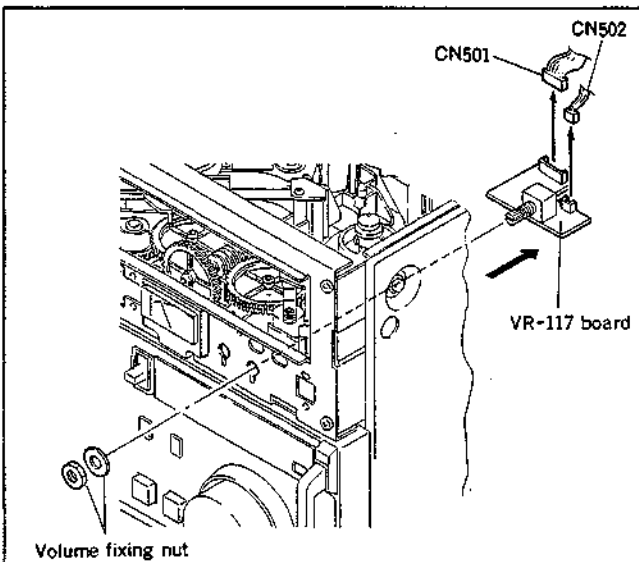

- (7) Remove a volume fixing nut from the control panel side and remove the VR-117 board.

2-17-3. MA-44 Board

• Removal

- (1) Turn the POWER OFF.
- (2) Loosen three screws and remove the upper panel. (Refer to Section 2-5.)
- (3) Remove four control knobs and two screws and remove the upper control panel. (Refer to Section 2-5.)
- (4) Remove the six screws (3×6) shown in the figure and remove the control panel chassis.

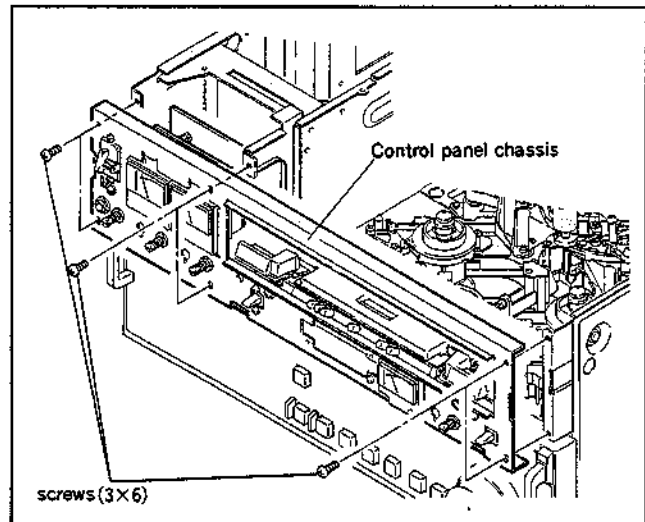

- (5) Disconnect the four connectors (CN408, CN409, CN410 and CN411) of the MA-44 board.
- (6) Push and remove the white nylon locks fixing the MA-44 board with a pincers from the board.
- (7) Disconnect the connector (CN405) connected to the VR-116 board and remove the MA-44 board.

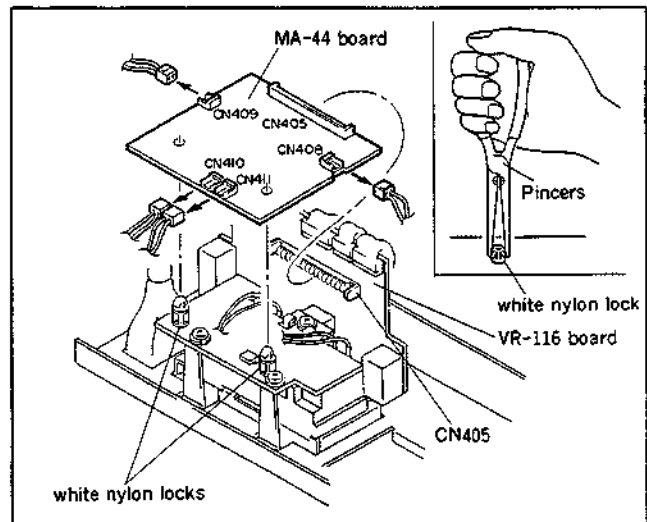

• **Installation**

- (8) Connect the MA-44 board to the connector (CN405) of the VR-116 board and insert the white nylon locks to the board.
- (9) Connect the four connectors (CN408, CN409, CN410 and CN411) and push two audio level meters into the chassis from the control panel side.

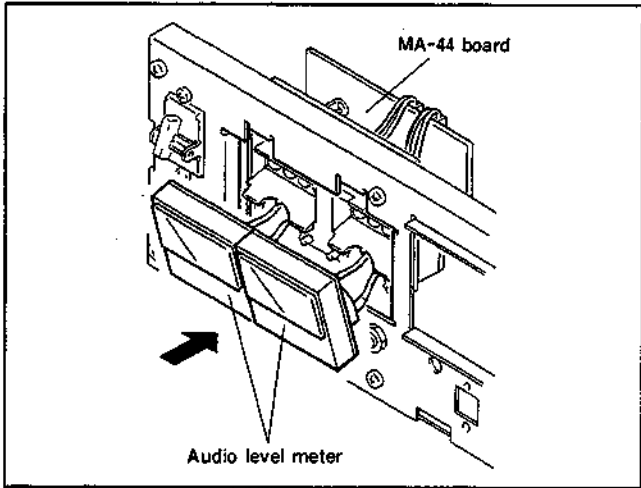

2-17-4. DP-138 Board

• **Removal**

- (1) Turn the POWER OFF.
- (2) Loosen three screws and remove the upper panel. (Refer to Section 2-5.)
- (3) Remove four control knobs and two screws and remove the upper control panel. (Refer to Section 2-5.)
- (4) Remove six screws and the control panel chassis and remove the MA-44 board. (Refer to Section 2-17-3.)
- (5) Remove the three screws of the DP-138 board and remove the board.

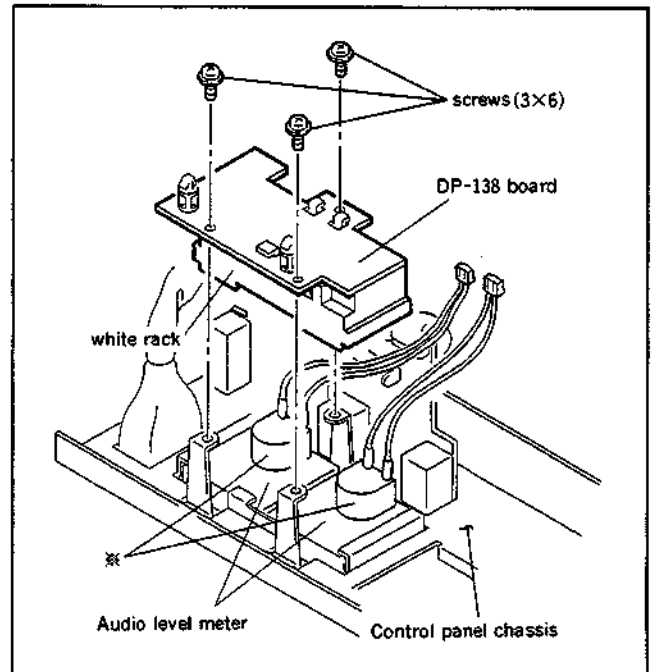

• **Installation**

- (6) Set the white rack of the DP-138 board and * portion of the audio level meters as shown in the figure above and fasten the DP-138 board by the screws.
- (7) Install the MA-44 board and connect the four connectors (CN408, CN409, CN410 and CN411).
- (8) Push the audio level meters into the chassis from the control panel side.

2-17-5. VR-116 Board

- (1) Turn the POWER OFF.
- (2) Loosen three screws and remove the upper panel. (Refer to Section 2-5.)
- (3) Remove four control knobs and two screws and remove the upper control panel. (Refer to Section 2-5.)
- (4) Remove six screws and the control panel chassis and remove the MA-44 board. (Refer to Section 2-17-3.)
- (5) Disconnect the four connectors (CN400, CN401, CN402, and CN407) of the VR-116 board.

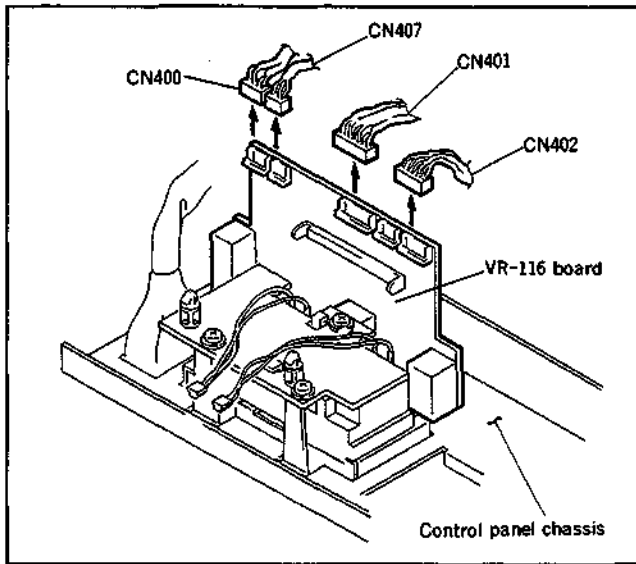

- (6) Remove four volume fixing nuts from the control panel side and remove the VR-116 board.

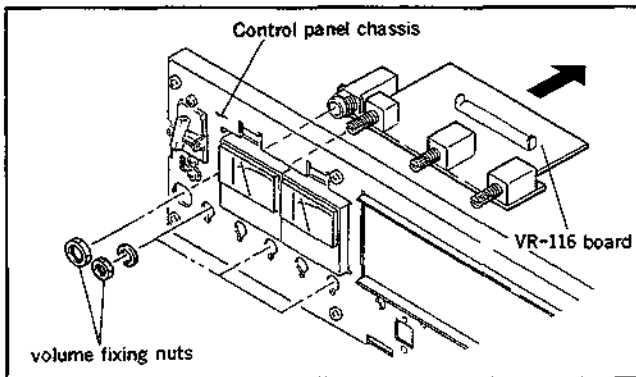

2-17-6. PTC-42 Board

- (1) Turn the POWER OFF.
- (2) Put the unit right side down and remove six screws and remove the lower panel.
- (3) Remove two screws and remove the PTC-42 board.
- (4) Disconnect the connector CN924.

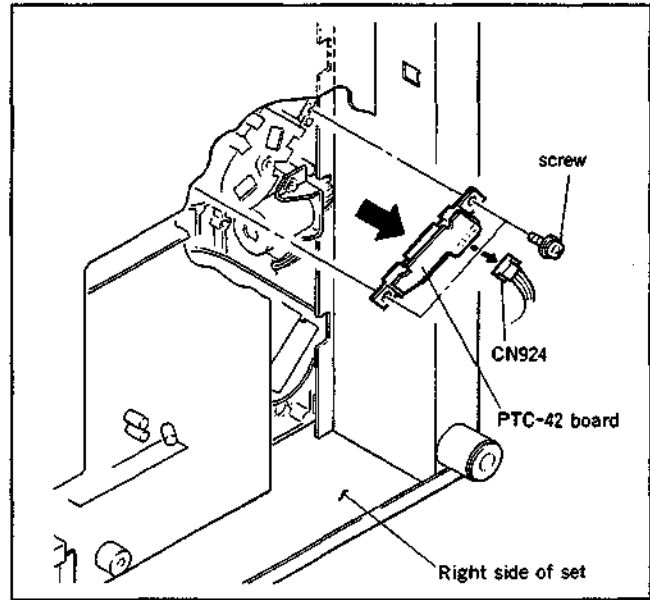

2-18. REMOVAL/INSTALLATION OF DETECTION SWITCH

2-18-1. Removal of MC Sensor

1. Remove the Cassette Compartment. (Refer to Section 2-6.)
2. Position the reel table at the center or large cassette position.
3. Remove the two screws shown in the figure and remove the MC sensor ass'y.

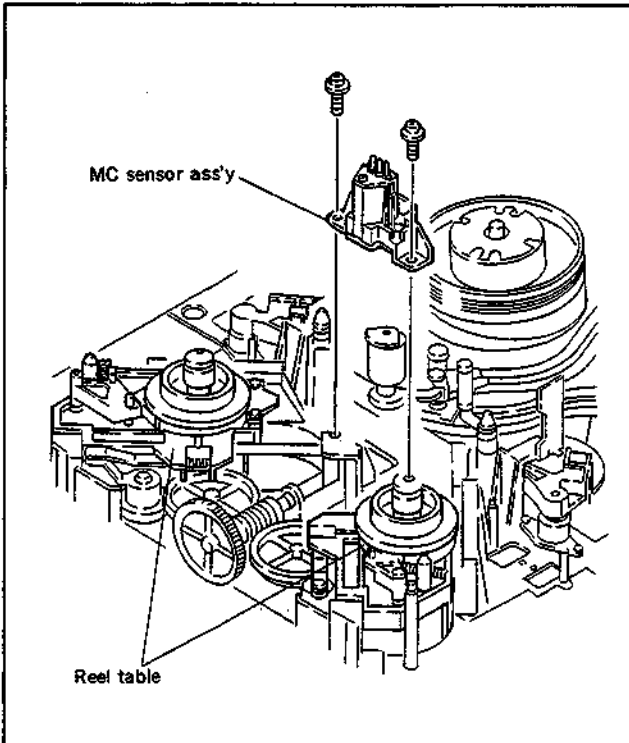

4. Remove the two screws from the reverse side of the MC sensor ass'y and remove the PTC-55 board.
5. Disconnect the connector CN922 on the PTC-55 board.

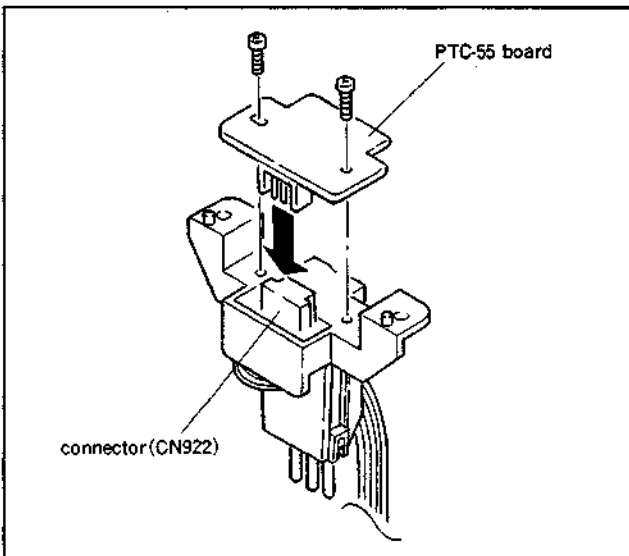

2-19. PRECAUTION IN REPLACEMENT OF DR-118 BOARD

NOVRAM CXXK1013P (IC51, IC52 and IC53) are mounted on the DR-118 board to save the data of servo system adjustment.

When the DR-118 board is replaced, pull out the NOVRAM (IC51, IC52 and IC53) and mount them on the new DR-118 board.

If not mounting them to the new board, servo system may not be operated normally.

NOTE : The IC51, 52 and 53 are not mounted on the boards which are in stock as service parts.

2-20. FIXTURE

Fig. No	Part No.	Description	For Use
1	A-6766-389-A	Extention Board (L), EX-286	VP-33, TBC-18, SS-48 Board extention
2	J-6001-820-A	Drum Eccentricity Gauge (3)	Upper drum eccentricity adjustment
3	J-6001-830-A	Drum Eccentricity Gauge (2)	
4	J-6001-840-A	Drum Eccentricity Gauge (1)	
5	J-6031-830-A	Multi Connector Cable (DOBNC)	
6	J-6035-070-A	Extraction Tool (for PLCC socket)	Extraction of IC (PLCC type)
7	J-6080-008-A	Cassette Reference Plate	Reel table height adjustment
8	J-6080-011-A	Reel Table Tension Gauge	Brake torque adjustment
9	J-6080-029-A	Adjustment Mirror	
10	J-6080-840-A	Adjustment Mirror	Tape path adjustment
11	J-6086-570-A	Reference Flat Plate	Audio/TC head slantness adjustment
12	J-6087-000-A	Drum Eccentricity Gauge (5)	Upper drum eccentricity adjustment
13	J-6320-870-A	Reel Motor Shaft Slantness Check Fixture	Reel motor shaft slantness check and adjustment
14	J-6152-450-A	Wire Clearance Check Gauge	Clearance check
15	J-6320-680-A	Reel Table Height Gauge	Reel table height adjustment
16	J-6320-880-A	Cassette Base Plate (L)	Reel table height adjustment
17	J-6321-500-A	Tape Guide Adjustment Driver	Tape guide height adjustment
18	J-6322-370-A	Tension Regulator Position Adjustment Fixture	Tension regulator position adjustment
19	J-6325-530-A	Drum Eccentricity Gauge (6)	Upper drum eccentricity adjustment
20	J-6327-850-A	Dial Tension Gauge	Measuring torques
21	J-6327-930-A	Tension Measurement Tape	Tension arm sensitivity/position adjustment
23	J-6338-130-A	Extention Board (S), EX-287	AU-148, AU-149, AU-150, RP-57 Board extention
24	2-034-697-00	Cleaning Piece	Cleaning
25	7-661-018-18	Oil	
26	7-662-001-41	Molyton Grease, No.320 (30 g Bottle)	
27	7-662-010-04	Grease, SGL-505 (20 g)	
28	7-700-736-01	L-Shaped Hexagonal Wrench (d : 1.27 mm)	
29	7-700-736-05	L-Shaped Hexagonal Wrench (d : 1.5 mm)	
30	7-700-736-06	L-Shaped Hexagonal Wrench (d : 0.89 mm)	
31	7-732-050-20	Tension Scale (50 g full scale)	Tension adjustment
32	7-732-050-30	Tension Scale (100 g full scale)	
33	8-960-096-51	Alignment Tape, CR2-1B PS	Servo and Tracking alignments (metal particle tape)
34	8-960-096-86	Alignment Tape, CR8-1B PS	Audio alignment (oxide tape)
35	8-960-096-91	Alignment Tape, CR5-1B PS	Video and Audio alignments (metal particle tape)
36	8-960-098-44	Alignment Tape, CR5-2A PS	Video, Servo and Power Supply/System Control alignments (oxide tape)
37	8-960-098-45	Alignment Tape, CR8-1A PS	Audio alignment (oxide tape)
38	9-911-053-00	Thickness Gauge	Clearance check
39	9-919-573-01	Cleaning Fluid	Cleaning
40	standard product	TENVELOMETER (T2-H7-UMC)	Back tension adjustment

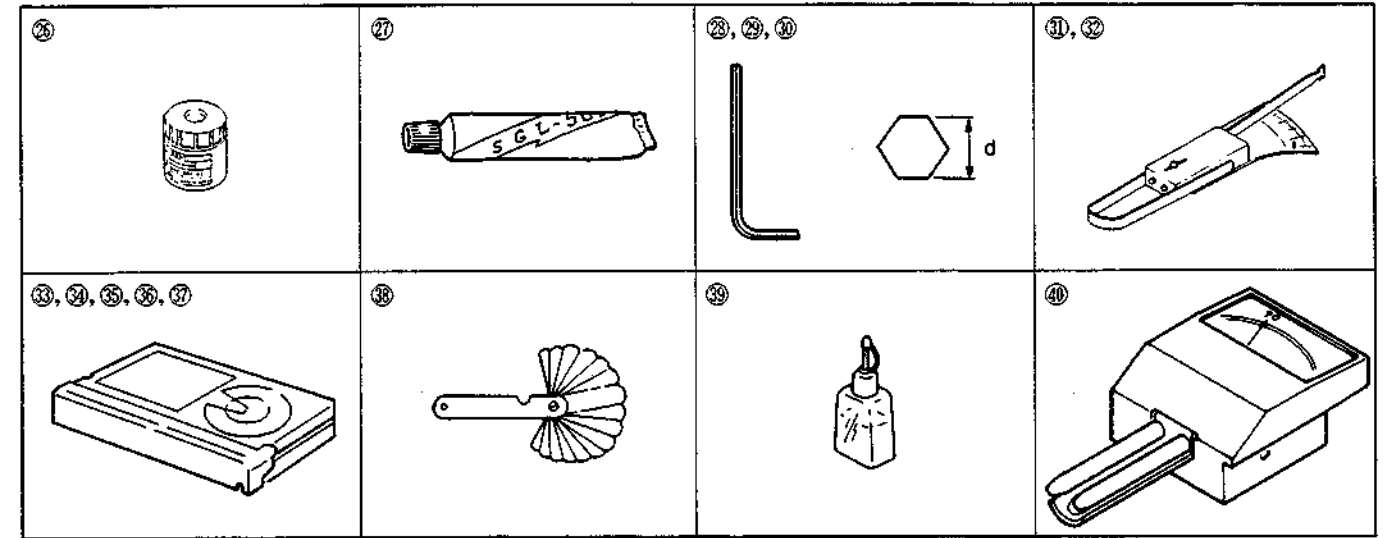
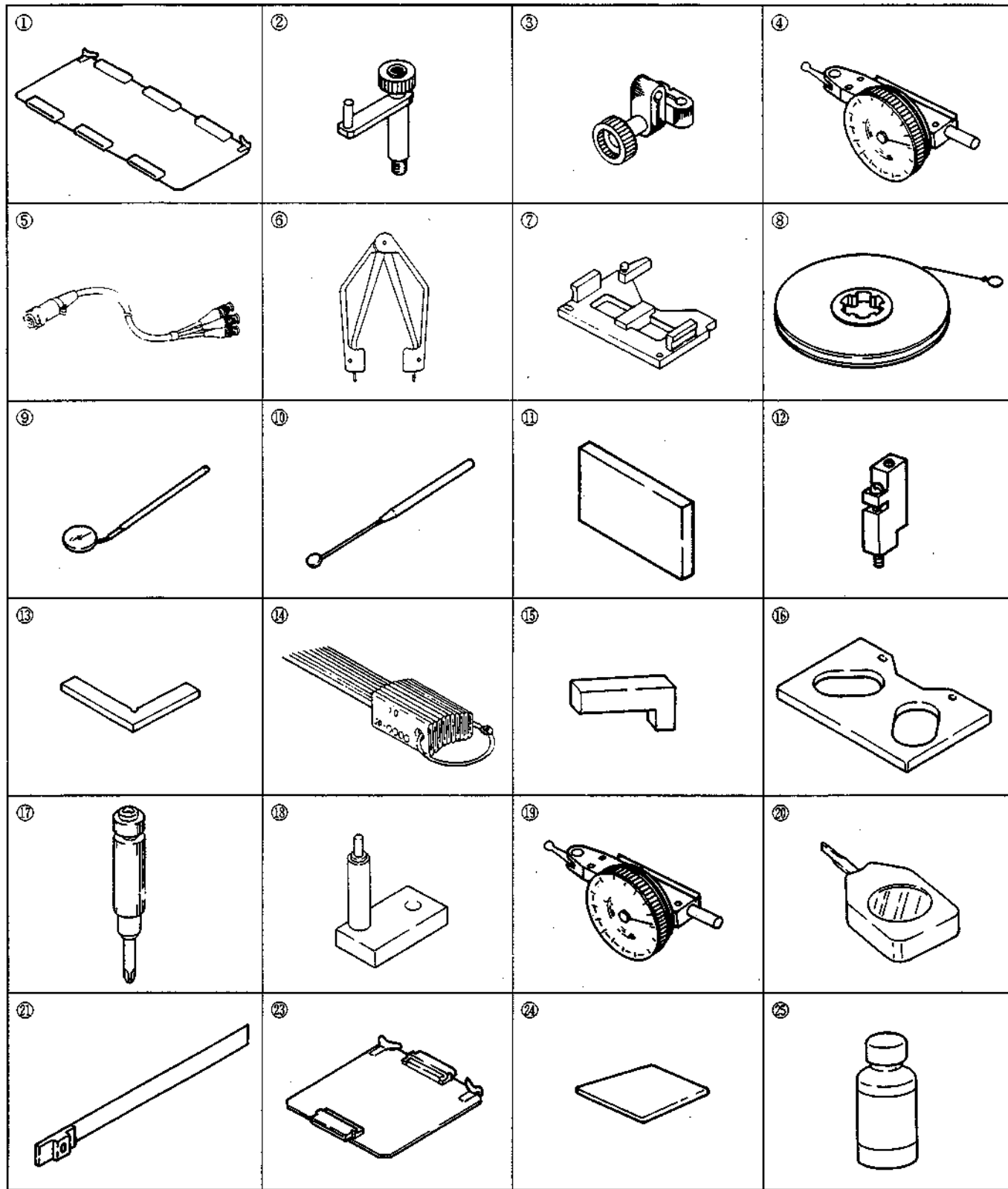

TENDEL and TENDELOMETER are registered trademark of TENDEL Corp., Campbell, CA U.S.A.

2-21. INTRODUCTION TO CIRCUIT

2-21-1. Outline of The Betacam Method

The Betacam recording method was developed for the purpose of ENG (Electronic News Gathering) and EFP (Electronic Field Production). Therefore, the primary object of its development is to make it compact and to have good quality of portrait enough to use broadcast.

As for recording system, all processes are disposed as component signal. Consequently, composite input signals are replaced as Y, B-Y or R-Y and disposed.

The process is shown as fig.1. After A/D converting, the input signals are separated as Y/C, converted as component signal at decoder. The converted each signal is send to process of luminance signal (Y) system, B-Y and R-Y send to process of chroma signal (C) system. After that, Y-signal which added synchronized signal is FM-modulated and recorded at Y-R/P head. On the other side, chroma signal add B-Y and CFID (Color Framing ID), and is time-compressed to record within the time of 1H. The process is read back alternately R-Y by the double-pulsed clock of memory-write, then time-compressed to half. This compressed signal is called CTDM signal. The chroma signal resulted in CTDM signal is FM-modulated after phase adjustment with Y signal, recorded at C-R/P head.

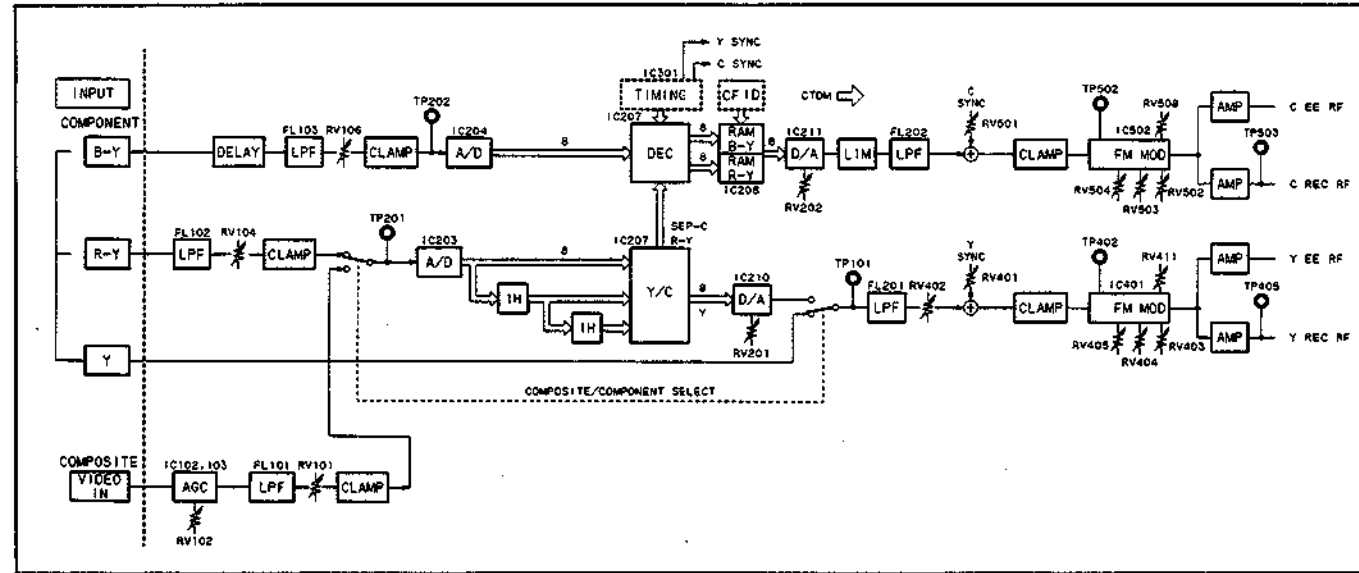

Fig. 1

As shown in fig.2, Y signal and CTDM chroma signal are recorded on respective track at R/P head of each Y/C at the same time.

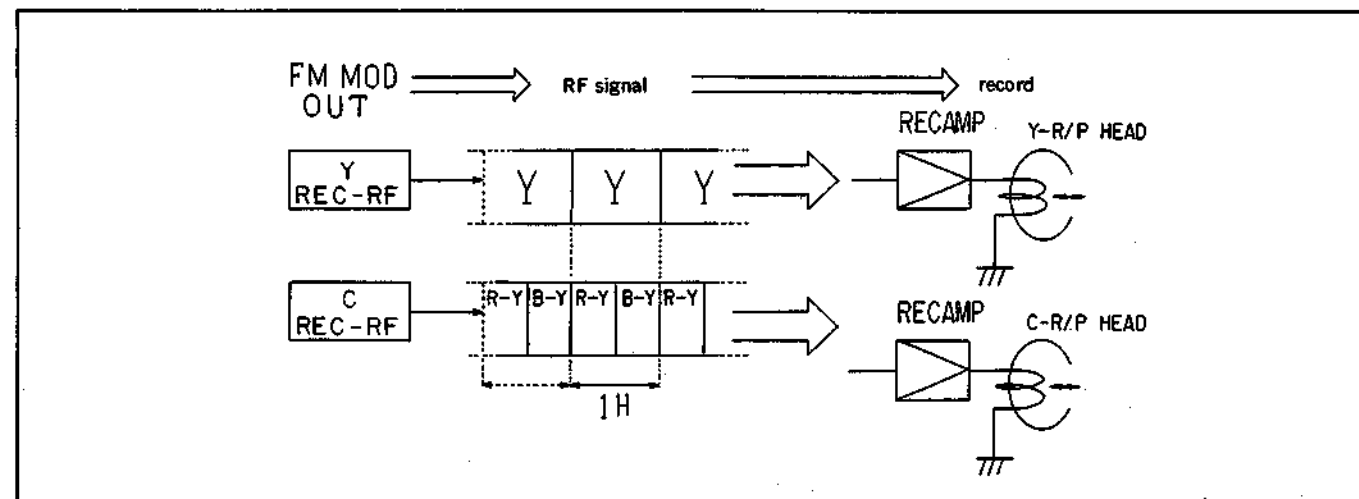

Fig. 2

The Betacam recording pattern that 2CH of audio, Time code (LTC) and CTL signal are added to video signal is shown in fig. 3.

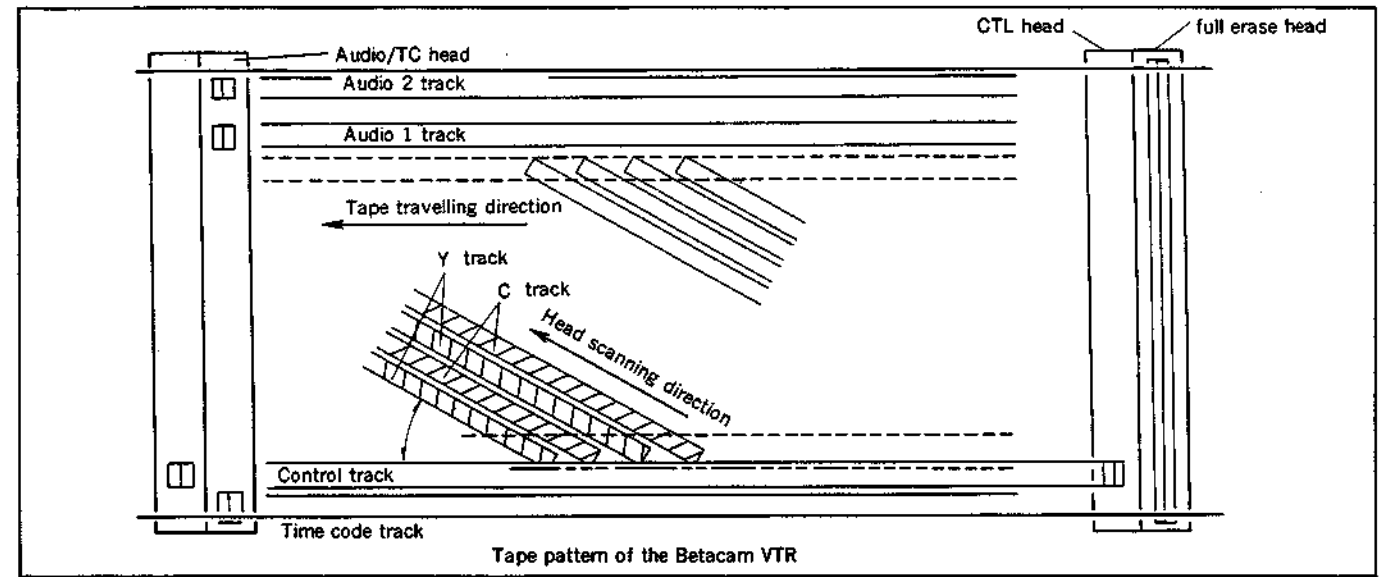

Fig. 3

In the playback system, playback the tape which is recorded using above mentioned process, and then return to original signal using the reversing process. PVW-2600P is a player, so that it is only provided the following playback system.

At the process of play system, as shown in fig.4, RF signal from Y-R/P head is sent to circuit of TBC after FM demodulated and deemphasized through preamplifier and equalizer. On the other side, chroma signal from C-RP head enter the circuit of TBC after FM demodulated through preamplifier and equalizer. At the circuit of TBC, both of Y and C signal are revised of time axis (revice of jitter element) and drop out (DO process), and at the same time, CTDM chroma signal is expanded in time and returned to B-Y or R-Y signal. Next, the signals are encoded to color-differential, composite or Y/C signal at encoder and output after added burst and sync that are remade at circuit of TBC.

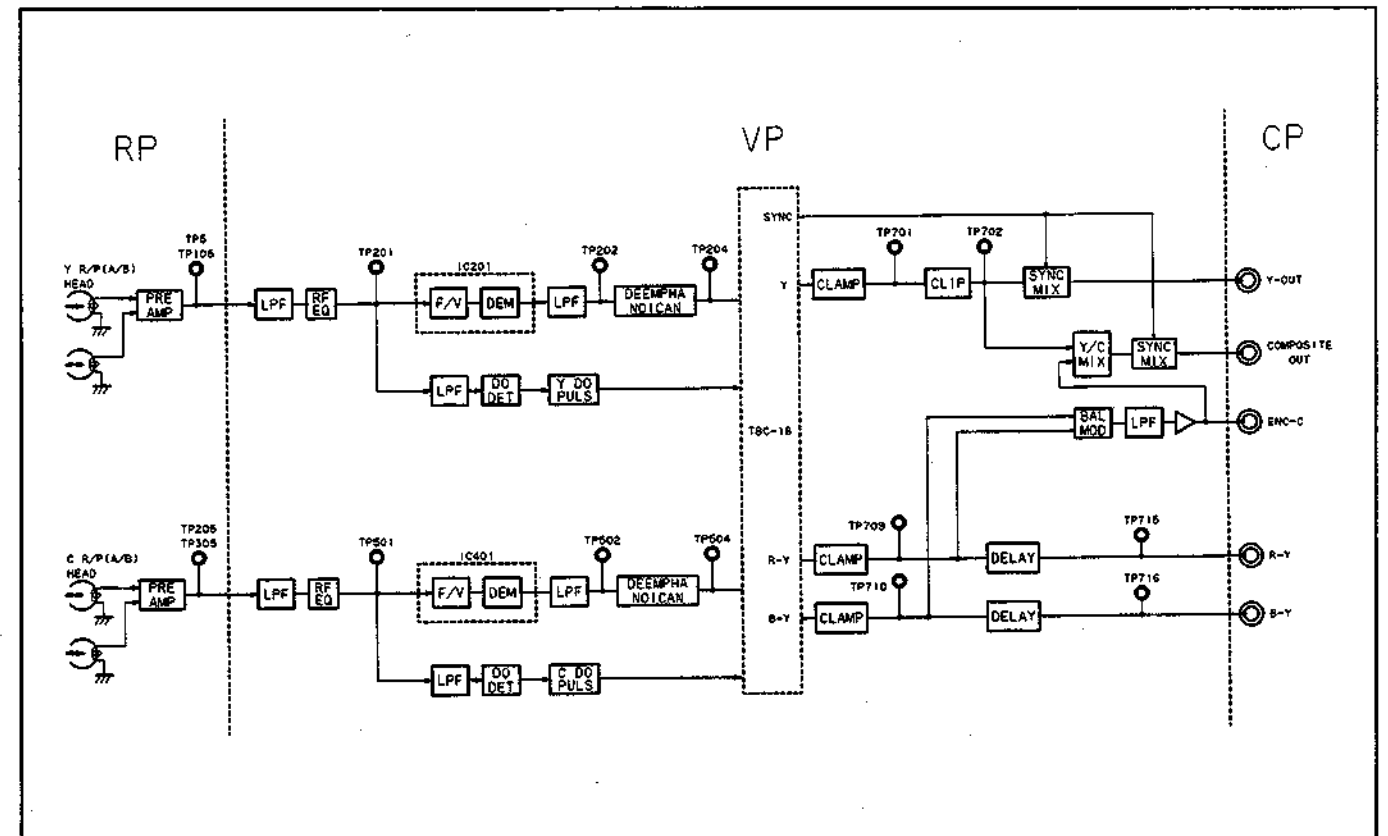

Fig. 4

MAINTENANCE MODE

SECTION 3 MAINTENANCE MODE

This equipment provides the maintenance mode which is necessary when performing maintenance.

The maintenance mode has following modes of four kinds. Each mode consists of several menus and sub menus.

Contents of the maintenance mode are displayed in the video monitor which is connected with VIDEO OUTPUT 3 connector or MONITOR connector.

MODE	MENU	SUB MENU
A0 : VIDEO CHECK	A001 : TBC thru pass(Y) A002 : TBC thru pass(C) A003 : TEST SIG. GEN	—————
B0 : SERVO CHECK	B01 : INPUT CHECK	B011 : CASSETTE SW B012 : CASSETTE COMP. SW B013 : TOP/END SENSOR B014 : DEW SENSOR
	B02 : MOTOR CHECK	B021 : S REEL B022 : T REEL B023 : THREADING B024 : CASSETTE COMP. B025 : CAPSTAN MOTOR B026 : DRUM MOTOR B027 : REEL POSITION
	B03 : PLUNGER SOL. CHECK	B031 : PINCH ROLLER B032 : S REEL BRAKE B033 : T REEL BRAKE B034 : CLEANING ROLLER
	B04 : REEL/CAPSTAN MOTOR & FG CHECK	—————
B1 : SERVO ADJUST	B101 : B102-B108 ADJ. B102 : S REEL FG DUTY B103 : T REEL FG DUTY B104 : CAPSTAN FG DUTY B105 : S REEL OFFSET/FRIC B106 : T REEL OFFSET/FRIC B107 : S REEL TORQUE B108 : T REEL TORQUE B109 : CAPSTAN SPEED B110 : RF SWITCHING POS. B111 : TRACKING CENTER B112 : S TENSION SENSOR B113 : T TENSION SENSOR B114 : PICTURE SPLITTING B115 : FWD TENSION B116 : REV TENSION B117 : NV RAM CONTROL	—————
F : OTHERS	F00 : rom version F01 : front panel check F02 : F03 : F04 : syscon panel check F05 : CF data check F06 : memory check	—————

Following switches on the SS-48 board or search dial are used so as to execute the maintenance mode.

SS-48 board

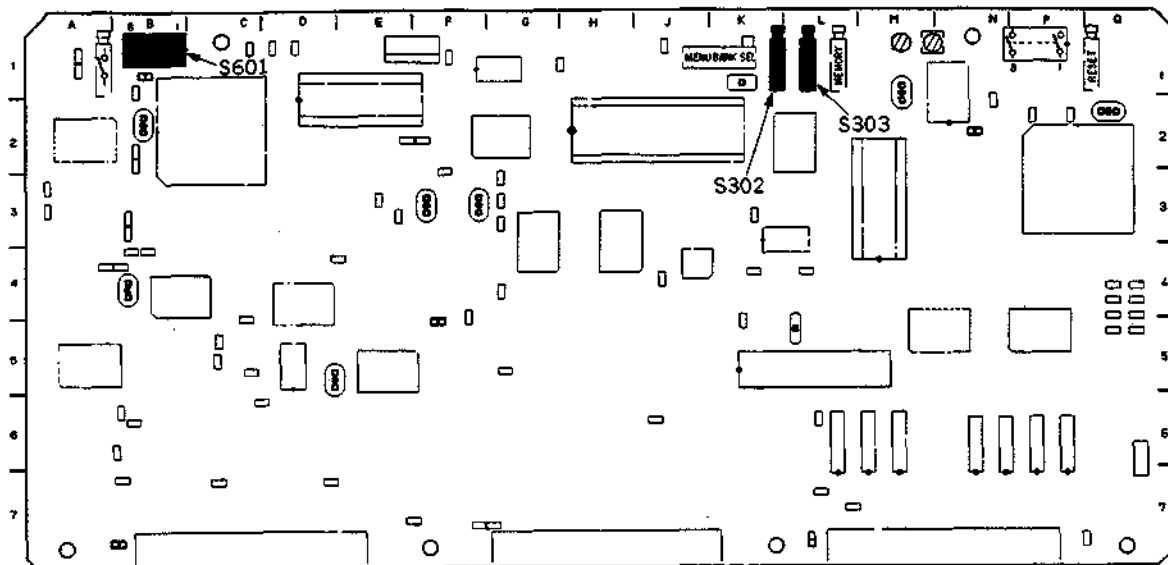

S601-4 (B-1) : SERVO ADJUST SW

Set this switch to ON (CLOSE) when executing the servo system adjustment mode (B1 : SERVO ADJUST) in the maintenance mode.

S601-7 (B-1) : SERVO CHECK SW

Set this switch to ON (CLOSE) when executing the servo system check adjustment mode (B0 : SERVO CHECK) in the maintenance mode.

S302 (K-1) : ADJ (+) SW

Press this switch when entering into the maintenance mode. Also press this switch when executing the menu which is selected by search dial.

S303 (L-1) : ADJ (-) SW

Press this switch when returning to the menu picture or mode picture of the maintenance mode. Also press this switch when closing the maintenance mode.

Search Dial : Select a menu or sub menu in the jog mode.

How to enter the maintenance mode

1. When performing the servo system check mode (B0 : SERVO CHECK), turn OFF the POWER, and then set S601-7 switch on the SS-48 board to ON (CLOSE). When performing the servo system adjustment mode (B1 : SERVO ADJUST), turn OFF the POWER, and then set S601-4 switch to ON (CLOSE).
NOTE: Omit this step when performing the video system check mode (A0 : VIDEO CHECK) or others check mode (F : OTHERS).
2. Turn ON the POWER, and press S302 switch on the SS-48 board to display modes on the monitor.
3. Press the search dial to put the unit into the jog mode, then move the * mark to a desired mode which is displayed on the monitor.
4. Press S302 switch on the SS-48 board to select the * marked mode.

How to close the maintenance mode

5. Press S303 switch on the SS-48 board.
When S601-7 or S601-4 switch on the SS-48 board is set to ON (CLOSE) at step 1, turn OFF the POWER, and reset the switch to OFF (OPEN).

3-1. VIDEO SYSTEM CHECK MODE (A0 : VIDEO CHECK)

Video system is checked automatically or semiautomatically in this mode.

• Procedure

1. Press S302 switch on the SS-48 board.
Then the unit enters into the maintenance mode. Modes of four kinds are displayed on the monitor.
2. Press the search dial for put the unit into the jog mode, and move the * mark to "A0 : VIDEO CHECK" mode which is displayed on the monitor.
3. Press S302 switch on the SS-48 board.
Then "A0 : VIDEO CHECK" mode is selected, and menus are displayed on the monitor.
4. Move the * mark to a desired menu by the search dial (jog mode).
5. Press S302 switch on the SS-48 board, and execute the * marked menu.
Then check is executed automatically.
6. "OK !!" is displayed on the monitor when the check finishes.
If the result of the check is NG, "NG!!" is displayed on the monitor.
In this case, check the related circuit.
7. Press S303 switch on the SS-48 board to return to the menu picture.
8. If there are other menus wishing to be checked, repeat the step 4 to 7.
9. When all the checks are performed, press S303 switch twice to return to the mode picture.
10. When closing the maintenance mode, press S303 switch on the SS-48 board.

```
MAINTENANCE MODE
* A0 : VIDEO CHECK
  B0 : SERVO CHECK
  B1 : SERVO ADJUST
  F  : OTHERS
```

```
VIDEO CHECK MODE
*A001:TBC thru pass (Y)
A002:TBC thru pass (C)
A003:TEST SIG. GEN
```

A001 : TBC thru pass (Y)

This mode checks whether the digital system (Y) on the TBC-18 board acts normally or not, automatically.

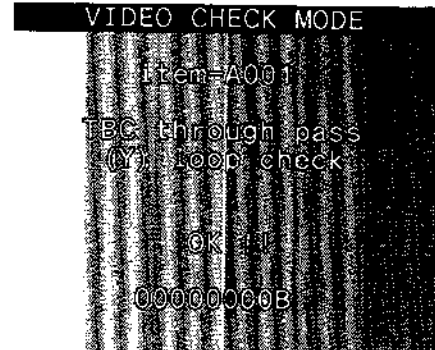

In case of NG

If "NG" is displayed, watch the error indication on the lower on the monitor.

There is unusual on the bit indicated "1". Check the DATA bit indicated "1" of IC501, 503, 504 and 507 on the TBC-18 board.

ex: unusual bit

↓
00100000B
(MSB) (LSB)

A002 : TBC thru pass (C)

This mode checks whether the digital system (C) on the TBC-18 board acts normally or not, automatically.

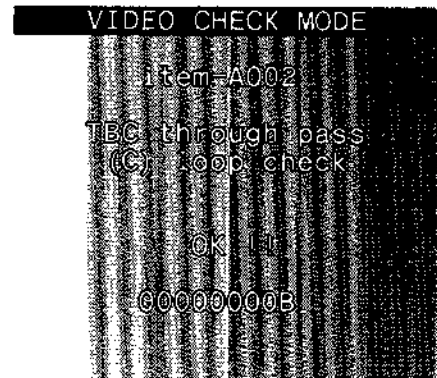

In case of NG

If "NG!!" is displayed, watch the error indication on the lower on the monitor.

There is unusual on the bit indicated "1". Check the DATA bit indicated "1" of IC501, 503, 504 and 507 on the TBC-18 board.

ex: unusual bit

↓
00100000B
(MSB) (LSB)

A003 : TEST SIG. GEN

The built-in test signal generator acts, and the video signal is output from VIDEO OUT 1/2/3, COMPONENT OUT 1/2 and S-VIDEO OUT connectors.

By connecting the signal to the VP-33 board can be checked.

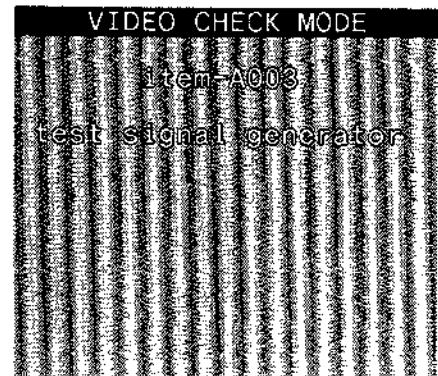

3-2. SERVO SYSTEM CHECK MODE (B0 : SERVO CHECK)

Servo system is checked automatically or semiautomatically in this mode.

• Procedure

1. Turn OFF the POWER, and set S601-7 switch on the SS-48 board to ON (CLOSE).
2. Turn ON the POWER.
3. Press S302 switch on the SS-48 board. Then the unit enters into the maintenance mode. Modes of four kinds are displayed on the monitor.
4. Press the search dial to put the unit into the jog mode, then move the * mark to "B0 : SERVO CHECK" which is a mode displayed on the monitor.

```
MAINTENANCE MODE
A0 : VIDEO CHECK
* B0 : SERVO CHECK
B1 : SERVO ADJUST
F : OTHERS
```

5. Press S302 switch on the SS-48 board. Then "B0 : SERVO CHECK" mode is selected, and menus are displayed on the monitor.
6. Move the * mark to a desired menu by the search dial (Jog mode).

```
SERVO CHECK
*B01: INPUT CHECK
B02: MOTOR CHECK
B03: PLUNGER SOL. CHECK
B04: REEL/CAPSTAN MOTOR
      & FG CHECK
```

7. Press S302 switch on the SS-48 board. Then the sub menus are displayed further.

```
SERVO CHECK
INPUT CHECK
*B011: CASSETTE SW
B012: CASSETTE COMP. SW
B013: TOP/END SENSOR
B014: DEW SENSOR
```

8. Move the * mark to a desired sub menu by the search dial (jog mode).

9. Press S302 switch on the SS-48 board, and execute the * marked sub menu.

(Refer to each page of menu item about a method of check.)

While the sub menu is being performed, the keyboard operation is possible by pressing S302 on the SS-48 board. (Character displays on the monitor continuously.)

Then, mechanical operation is possible in the maintenance mode.

In this state, the key board operation is returned to the state of the maintenance mode by pressing S303 on the SS-48 board.

10. When check is finished, press S303 switch on the SS-48 board to return to the submenu picture. Or, press switch SW303 twice to return to the menu picture.
11. If there are other menus or submenus wishing to be checked, repeat the step 4 to 10.
12. When all the checks are performed, press S303 switch on the SS-48 board three times to return to the mode picture.
13. When closing the maintenance mode, press S303 on the SS-48 board. Next, turn OFF the POWER, and reset S601-7 switch on the SS-48 board to OFF (OPEN).

B01 : INPUT CHECK

The sub menus of the "B01 : INPUT CHECK" are explained here.

```
SERVO CHECK
INPUT CHECK

*B011: CASSETTE SW
B012: CASSETTE COMP. SW
B013: TOP/END SENSOR
B014: DEW SENSOR
```

(1) B011 : CASSETTE SW

This mode checks the function of the cassette switch (sensor).

```
SERVO CHECK
INPUT CHECK

B011: CASSETTE SW
SW1: LARGE/SMALL HUB
SW2: METAL/OXIDE TAPE
SW3: TAPE THICKNESS

      1  2  3
      └──┴──┬──┘
S-reel          T-reel
```

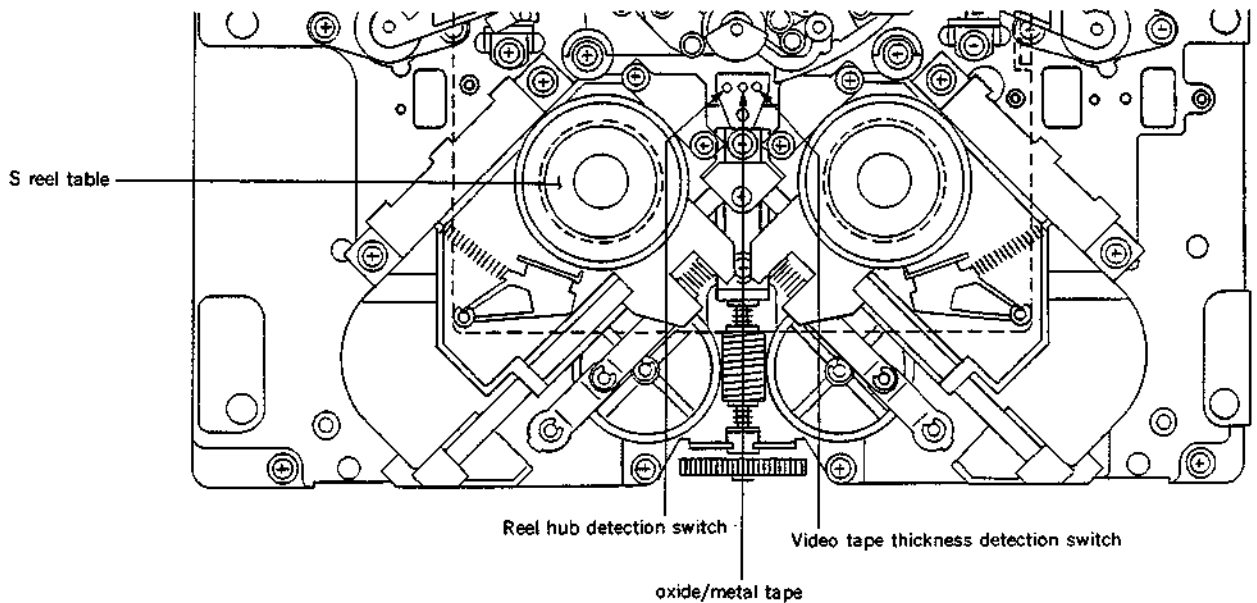

1. Press the reel hub detection switch (sensor) with finger.
Confirm that ■ is displayed on the "1" which is in the monitor picture.

```
SERVO CHECK
INPUT CHECK

B011: CASSETTE SW
SW1: LARGE/SMALL HUB
SW2: METAL/OXIDE TAPE
SW3: TAPE THICKNESS

  1  2  3
  ─  ─  ─
S-reel  T-reel
```

2. Press the oxide/metal tape detection switch (sensor) with finger.
Confirm that ■ is displayed on the "2" which is in the monitor picture.

```
SERVO CHECK
INPUT CHECK

B011: CASSETTE SW
SW1: LARGE/SMALL HUB
SW2: METAL/OXIDE TAPE
SW3: TAPE THICKNESS

  1  2  3
  ─  ─  ─
S-reel  T-reel
```

3. Press the video tape thickness detection sensor with finger.
Confirm that ■ is displayed on the "3" which is in the monitor picture.

```
SERVO CHECK
INPUT CHECK

B011: CASSETTE SW
SW1: LARGE/SMALL HUB
SW2: METAL/OXIDE TAPE
SW3: TAPE THICKNESS

  1  2  3
  ─  ─  ─
S-reel  T-reel
```

In case of NG

If ■ isn't displayed on the appointed number, check the sensor on the PTC-55 board and the sensor input circuit (DR-118 board).

(2) B012: CASSETTE COMP. SW

This mode checks the function of the Cassette Compartment switch (sensor).

Push up the cassette window with finger

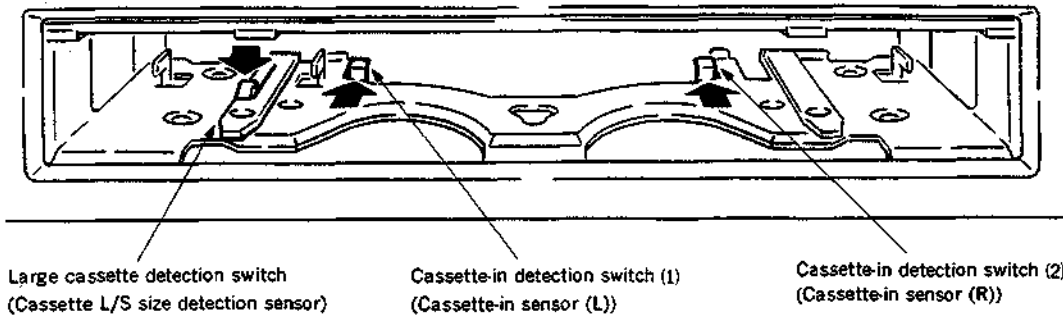

1. Press the cassette-in detection switch (1) (cassette-in sensor (L)) with finger.
Confirm that ■ is displayed on the "1" which is in the monitor picture.

```
SERVO CHECK  
INPUT CHECK  
  
B012: CASSETTE COMP. SW  
SW1: CASSETTE IN SW 1  
SW2: CASSETTE IN SW 2  
SW3: LARGE CASSETTE SW  
  
  1  2  3  
  └─┘ └─┘ └─┘
```

2. Press the cassette-in detection switch (2) (cassette-in sensor (R)) with finger.
Comfirm that ■ is displayed on the "2" which is in the monitor picture.

```
SERVO CHECK  
INPUT CHECK  
  
B012: CASSETTE COMP. SW  
SW1: CASSETTE IN SW 1  
SW2: CASSETTE IN SW 2  
SW3: LARGE CASSETTE SW  
  
  1  2  3  
  └─┘ └─┘ └─┘
```

3. Press the large cassette detection switch (cassette L/S size detection sensor) with finger.
Comfirm that ■ is displayed on the "3" which is in the monitor picture.

```
SERVO CHECK  
INPUT CHECK  
  
B012: CASSETTE COMP. SW  
SW1: CASSETTE IN SW 1  
SW2: CASSETTE IN SW 2  
SW3: LARGE CASSETTE SW  
  
  1  2  3  
  └─┘ └─┘ └─┘
```

In case of NG

If ■ is not displayed on the appointed number, check the sensor on the PC-62 board and the sensor input circuit (DR-118 board).

(3) B013: TOP/END SENSOR

This mode checks the function of the tape beginning/end sensor.

```
SERVO CHECK
INPUT CHECK
B013:TOP/END SENSOR

TOP SENSOR : OFF
END SENSOR : OFF
```

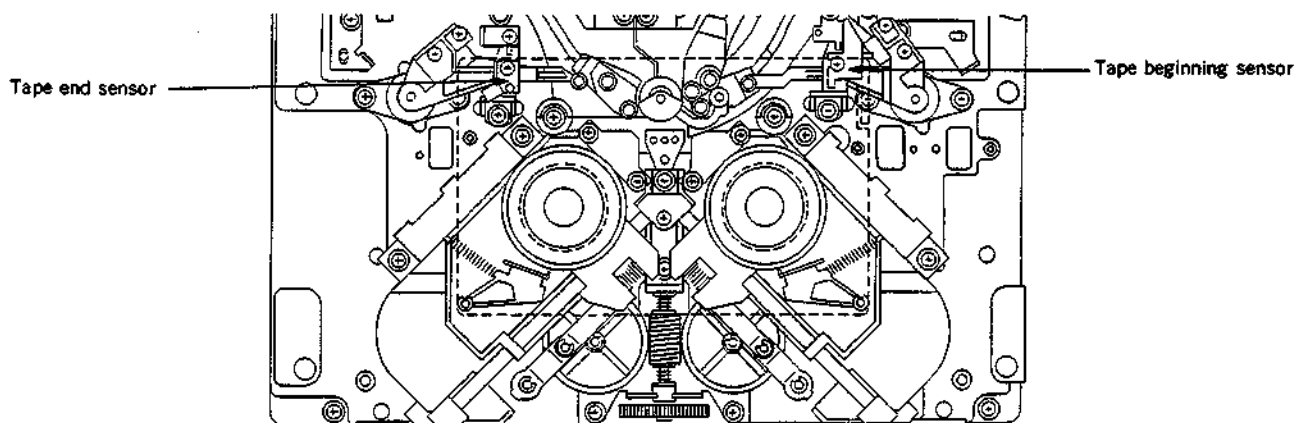

1. Draw a screw driver up to the tape beginning sensor. Confirm that "TOP SENSOR: OFF" which is in the monitor picture changes into "TOP SENSOR: ON!".

```
SERVO CHECK
INPUT CHECK
B013:TOP/END SENSOR

TOP SENSOR : ON!
END SENSOR : OFF
```

2. Draw a screw driver up to the tape end sensor. Confirm that "END SENSOR: OFF" which is in the monitor picture changes into "END SENSOR: ON!".

```
SERVO CHECK
INPUT CHECK
B013:TOP/END SENSOR

TOP SENSOR : OFF
END SENSOR : ON!
```

In case of NG

If "OFF" does not change into "ON!", check that the tape beginning/end sensor is normal or not, individually. And check the tape beginning/end sensor circuit (DR-118 board).

(4) B014: DEW SENSOR

This mode checks the function of the dew (condensation) sensor.

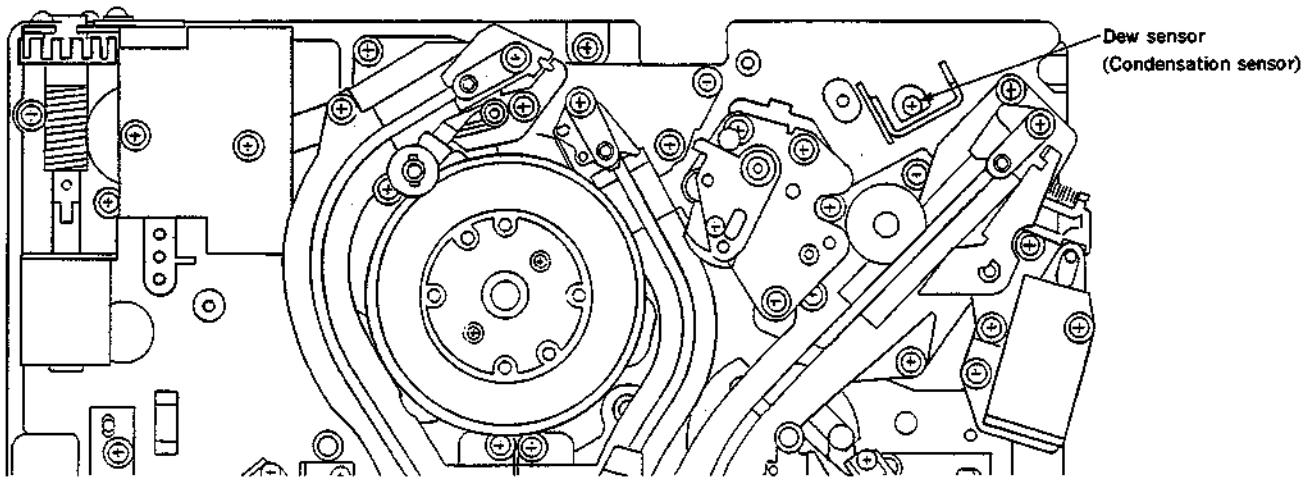

1. Touch the dew sensor (condensation sensor) softly with a wet applicator.
Confirm that "DRY" which is in the monitor picture changes into "WET!".



2. Mop the moisture of the dew sensor (condensation sensor) with a dry applicator, or blow the sensor with a blower to evaporate.
Confirm that "WET!" which is in the monitor picture changes into "DRY".

In case of NG

If "DRY" does not change to "WET!" when the dew sensor (condensation sensor) is damped, check that condensation sensor is normal or not, individually.

And check the dew sensor amplifier (DS-31 board).

B02: MOTOR CHECK

The sub menus of the "B02: Motor Check" are explained here.

```
SERVO CHECK
MOTOR CHECK
*B021:S REEL
B022:T REEL
B023:THREADING
B024:CASSETTE COMP.
B025:CAPSTAN MOTOR
B026:DRUM MOTOR
B027:REEL POSITION
```

(1) B021: S REEL

This mode checks the rotation of the S reel motor.

Set the search dial to the jog mode, and turn it in the direction of forward and reverse. Confirm that the S reel motor rotates in the dial appointed direction, after the brake solenoid inhaled to release the reel brake.

```
SERVO CHECK
MOTOR CHECK
B021:S REEL MOTOR

TURN JOG DIAL
    IN JOG MODE

SW303(SS-48): RETURN
```

In case of NG

If inhalation of the brake solenoid is soundless and the S reel motor does not rotate in the dial appointed direction, check the reel motor driver circuit (DR-118 board).

(2) B022: T REEL

This mode checks the rotation of the T reel motor.

Set the search dial to the jog mode, and turn in the direction of forward and reverse.

Confirm that the T reel motor rotates in the dial appointed direction, after the brake solenoid inhaled to release the reel brak.

```
SERVO CHECK
MOTOR CHECK
B022:T REEL MOTOR

TURN JOG DIAL
    IN THE JOG MODE

SW303(SS-48): RETURN
```

In case of NG

If inhalation of the brake solenoid is soundless, and the T reel motor does not rotate in the dial appointed direction, check the reel motor driver circuit (DR-118 board).

(3) B023 : THREADING

This mode checks the rotation of the threading motor and threading-end/unthreading-end sensor.

1. Set the search dial to the jog mode, and turn it in the direction of forward.
Confirm that S slider, T slider and P slider are threaded, and "THREAD END" is displayed in the monitor picture.
2. Turn the search dial in the direction of reverse.
Confirm that S slider, T slider and P slider are unthreaded, and "UNTHREAD END" is displayed in the monitor picture.

In case of NG

If the threading motor does not rotate, "....." is displayed on the monitor after finishing threading, or "UNTHREAD END" is not displayed in the monitor picture after finishing unthreading, confirm that whether the threading motor and sensor on the PTC-49 board are normal or not. Also, check the loading motor driver circuit, loading FG amplifier circuit (DR-118 board), and loading TOP/END switch.

```
SERVO CHECK
MOTOR CHECK
B023:TREADING MOTOR

*** UNTHREAD END ***

TURN JOG DIAL
    IN JOG MODE
FWD:THREAD, REV:UNTH

SW303(SS-48) : RETURN
```

```
SERVO CHECK
MOTOR CHECK
B023:TREADING MOTOR

*** THREAD END ***

TURN JOG DIAL
    IN JOG MODE
FWD:THREAD, REV:UNTH

SW303(SS-48) : RETURN
```

```
SERVO CHECK
MOTOR CHECK
B023:TREADING MOTOR

*** UNTHREAD END ***

TURN JOG DIAL
    IN JOG MODE
FWD:THREAD, REV:UNTH

SW303(SS-48) : RETURN
```

```
SERVO CHECK
MOTOR CHECK
B023:TREADING MOTOR

.....

TURN JOG DIAL
    IN JOG MODE
FWD:THREAD, REV:UNTH

SW303(SS-48) : RETURN
```

(4) B024: CASSETTE COMP.

This mode checks the cassette compartment motor.

Press S302 switch on the SS-48 board.
Confirm that cassette compartment goes down.
Confirm that cassette compartment goes up when pressing
S302 switch again. (The display on the monitor changes in the
reverse order when it going down.)

```
SERV CHECK
MOTOR CHECK
B024: CASSETTE COMP. MOTOR

UP

SW302 (SS-48) : CHECK
SW303 (SS-48) : RETURN
```

```
SERV CHECK ✓
MOTOR CHECK
B024: CASSETTE COMP. MOTOR

HORIZ.

SW302 (SS-48) : CHECK
SW303 (SS-48) : RETURN
```



```
SERV CHECK
MOTOR CHECK
B024: CASSETTE COMP. MOTOR

VERT.

SW302 (SS-48) : CHECK
SW303 (SS-48) : RETURN
```



```
SERV CHECK
MOTOR CHECK
B024: CASSETTE COMP. MOTOR

DOWN

SW302 (SS-48) : CHECK
SW303 (SS-48) : RETURN
```

In case of NG
If the display in the monitor doesn't change, check the cassette
compartment motor and the sensor input circuit (DR-118
board).

(5) B025 : CAPSTAN MOTOR

This mode checks the direction of the rotation of the capstan motor.

1. Press S302 switch on the SS-48 board.
Confirm that "FORWORD...OK" is displayed in the monitor picture.

2. Press S302 switch on the SS-48 board again.
Confirm that "REVERSE...OK" is displayed in the monitor picture.

In case of NG

If the display on the monitor does not change, check the capstan motor and the capstan motor driver circuit (DR-118 board).

```
SERVO CHECK
MOTOR CHECK
B025:CAPSTAN MOTOR

SW302(SS-48): CHECK
SW303(SS-48): RETURN
```

```
SERVO CHECK
MOTOR CHECK
B025:CAPSTAN MOTOR

FORWARD...OK

SW302(SS-48): CHECK
SW303(SS-48): RETURN
```

```
SERVO CHECK
MOTOR CHECK
B025:CAPSTAN MOTOR

REVERSE...OK

SW302(SS-48): CHECK
SW303(SS-48): RETURN
```

(6) B026 : DRUM MOTOR

This mode checks the rotation of the drum motor.

- SPEED : Confirm that the display on the monitor changes into "OK".
- PHASE : Confirm that the display on the monitor changes into "LOCK".
- PG : Confirm that the display on the monitor changes into "EXIST".

In case of NG

If the display on the monitor does not change, check the drum motor, drum motor driver circuit, drum FG amplifier circuit, and drum PG amplifier circuit (DR-118 board).

```
SERVO CHECK
MOTOR CHECK
B026:DRUM MOTOR

SPEED :    NG
PHASE :    UNLOCK
PG      :    NO EXIST

SW303 (SS-48) : RETURN
```



```
SERVO CHECK
MOTOR CHECK
B026:DRUM MOTOR

SPEED :    OK
PHASE :    LOCK
PG      :    EXIST

SW303 (SS-48) : RETURN
```

(7) B027 : REEL POSITION MOTOR

This mode checks the action of the reel position motor and the function of the reel L/S position sensor.

Press S302 switch on the SS-48 board.
Confirm that the reel table moves S-POSITION to L-POSITION, and the display changes.

```
SERVO CHECK
MOTOR CHECK
B027:REEL POSITION MOTOR

S-POSITION

SW302(SS-48) : CHECK
SW303(SS-48) : RETURN
```

```
SERVO CHECK
MOTOR CHECK
B027:REEL POSITION MOTOR

.....

SW302(SS-48) : CHECK
SW303(SS-48) : RETURN
```



```
SERVO CHECK
MOTOR CHECK
B027:REEL POSITION MOTOR

L-POSITION

SW302(SS-48) : CHECK
SW303(SS-48) : RETURN
```

In case of NG
If the reel table does not move and the display on the monitor does not change, check the reel shift motor, reel L/S position sensor (PTC-42 board) and reel position motor driver circuit (DR-118 board).

B03 : PLUNGER SOL. CHECK

The submenus of the "B03 : PLUNGER SOL. CHECK" are explained here.

(1) B031 : PINCH ROLLER

This mode checks the action of the pinch roller solenoid.

1. Press S302 switch on the SS-48 board.
Confirm with a sound that the pinch solenoid is set to ON.
2. Press S303 switch on the SS-48 board.
Then the voltage which is supplied to pinch solenoid is set to OFF. And the monitor picture returns to the sub menu picture.
3. Push the pinch lever in the direction of the pinch solenoid lightly.
Then iron core of the pinch solenoid is back to the original position.

In case of NG

If there is no sound that the pinch solenoid is set to ON, and the monitor picture does not change, check the pinch solenoid and circuit.

(2) B032 : S REEL BRAKE

This mode checks the action of the S reel brake solenoid.

1. Press S302 switch on the SS-48 board.
Confirm with a sound that the S reel brake solenoid is set to ON.
2. Press S303 switch on the SS-48 board.
Then iron core of the S reel brake solenoid is back to the original position. And the monitor picture returns to the sub menu picture.

In case of NG

If there is no sound that S reel brake solenoid is set to ON, and the monitor picture does not change, check the S reel brake solenoid, reel brake plunger and driver circuit (DR-118 board).

```
SERVO CHECK
PLUNGER SOLENOID CHECK
*B031: PINCH ROLLER
B032: S REEL BRAKE
B033: T REEL BRAKE
B034: CLEANING ROLLER
```

```
SW302(SS-48) : SOL. ON
SW303(SS-48) : RETURN
```

```
SERVO CHECK
PLUNGER SOLENOID
B031: PINCH ROLLER
```

```
SW303(SS-48) :
SOLENOID OFF & RETURN
```

```
SERVO CHECK
PLUNGER SOLENOID
B032: S REEL BRAKE
```

```
SW303(SS-48) :
SOLENOID OFF & RETURN
```

(3) B033 : T REEL BRAKE

This mode checks the action of the T reel brake solenoid.

1. Press S302 switch on the SS-48 board.
Confirm with a sound that the T reel brake solenoid is set to ON.
2. Press S303 switch on the SS-48 board.
Then iron core of the T reel brake solenoid is back to the original position. And the monitor picture returns to the sub menu picture.

In case of NG

If there is no sound that the T reel brake solenoid is set to ON, and the monitor picture doesn't change, check the T reel brake solenoid, reel brake plunger and driver circuit (DR-118 board).

(4) B034 : CLEANING ROLLER

This mode checks the action of the cleaning roller solenoid.

1. Press S302 switch on the SS-48 board.
Confirm that the cleaning roller solenoid is set to ON, and the cleaning roller is pressed to drum.
2. Press S302 switch on the SS-48 board.
Then the cleaning roller solenoid is set to OFF, and the cleaning roller is separated from the drum. And the monitor picture returns to the sub menu picture.

In case of NG

If the cleaning roller is not pressed to the drum, check the cleaning roller solenoid and solenoid drive circuit (DR-118 board).

SERVO CHECK
PLUNGER SOLENOID
B033:T REEL BRAKE

SW303(SS-48) :
SOLENOID OFF & RETURN

SERVO CHECK
PLUNGER SOLENOID
B034:CLEANING ROLLER

SW303(SS-48) :
SOLENOID OFF & RETURN

B04: REEL/CAPSTAN MOTOR & FG CHECK

When pressig S302 on the SS-48 board, the following check is performed automatically.

- S REEL FG/MOTOR CHECK
- T REEL FG/MOTOR CHECK
- CAPSTAN FG/MOTOR CHECK
- S REEL FRICTION/OFFSET
- T REEL FRICTION/OFFSET
- S REEL MOTOR TORQUE
- T REEL MOTOR TORQUE

When all the check are performed, and all are normal, "COMPLETE" is displayed in the monitor picture.

In case of NG

If the contents of the trouble are displayed on the monitor, check the relative circuit of the trouble.

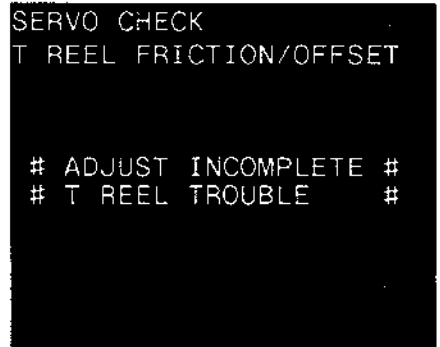
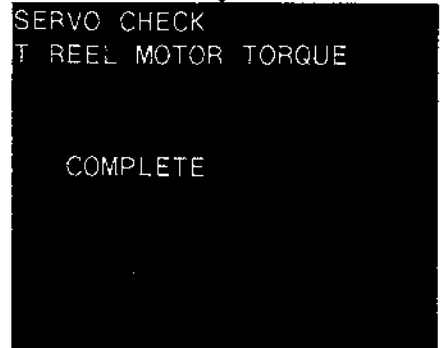
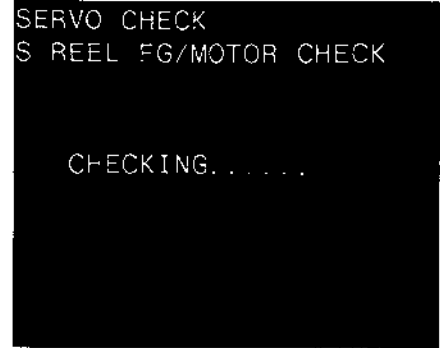

3-3. SERVO SYSTEM ADJUSTMENT MODE (B1 : SERVO ADJUST)

Servo system is adjusted automatically or semiautomatically in this mode.

• Procedure

1. Turn OFF the POWER, and set S601-4 switch on the SS-48 board to ON (CLOSE).
2. Turn ON the POWER.
3. Press the EJECT button to put the unit into the EJECT mode.
NOTE: If the unit is not set to the EJECT mode, the servo system adjustment mode does not run.
4. Press S302 switch on the SS-48 board.
Then the unit enters into the maintenance mode. Modes of four kinds are displayed on the monitor.
5. Press the search dial to put the unit into the jog mode, and move the * mark to "B1 : SERVO ADJUST" which is a mode displayed on the monitor.

```
MAINTENANCE MODE
A0 : VIDEO CHECK
B0 : SERVO CHECK
* B1 : SERVO ADJUST
F : OTHERS
```

6. Press S302 switch on the SS-48 board.
Then "B1 : SERVO ADJUST" mode is selected, and menus are displayed on the monitor.

```
SERVO ADJUST
*B101:B102-B108 ADJ.
B102:S REEL FG DUTY
B103:T REEL FG DUTY
B104:CAPSTAN FG DUTY
B105:S REEL OFFSET/FRIC
B106:T REEL OFFSET/FRIC
B107:S REEL TORQUE
B108:T REEL TORQUE
B109:CAPSTAN SPEED
CONTINUE
```

```
SERVO ADJUST (CONTNUED)
*B110:RF SWITCHING POS.
B111:TRACKING CENTER
B112:S TENSION SENSOR
B113:T TENSION SENSOR
B114:PICTURE SPLITTING
B115:FWD TENSION
B116:REV TENSION
B117:NV RAM CONTROL
```

7. Move the * mark to a desired menu by the search dial (jog mode).
8. Press S302 switch on the SS-48 board, and execute the * marked menu.

(Refer to each page of menu about a method of adjustment.)

9. When all the adjustments are performed, press S303 switch on the SS-48 board to return to the menu picture.

NOTE: To have the NV RAM memorize the adjustment data after an adjustment is performed, execute the "B117: NV RAM control".

Also it is possible to have the NV RAM memorize all the adjustment data after multi adjustments are performed. At that time, execute the "B117: NV RAM CONTROL" after all adjustments are performed.

10. If there are other menus wishing to be adjusted, repeat the step 7 to 9.
11. When all the adjustments are performed, press S303 switch on the SS-48 board to return to the mode picture.

NOTE: Have NV RAM memorize the adjustment data.

12. Turn OFF the POWER, and reset S601-4 on the SS-48 board to OFF (OPEN).

B101: B102-B108 ADJ

Adjustments of B102 to B108 menus are performed automatically.

Confirm that adjustment is performed, and "COMPLETE" is displayed.

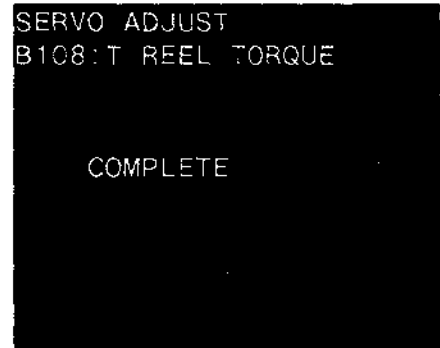

In case of NG

"ADJUST INCOMPLETE" and contents of the trouble are displayed on the monitor.

In this case, check the relative circuit of the trouble.

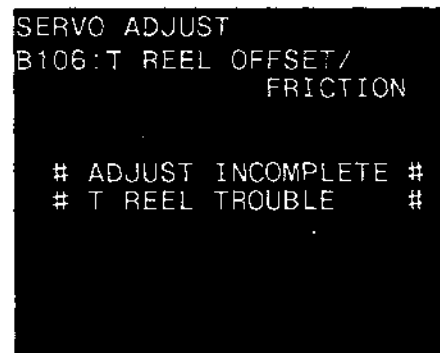

B102: S REEL FG DUTY

This mode adjusts the S reel FG duty.
Confirm that adjustment is performed, and "COMPLETE" is displayed.

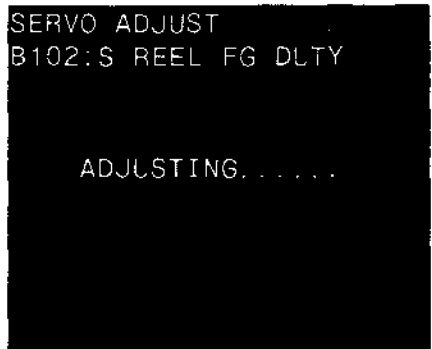

In case of NG
If "ADJUST INCOMPLETE" and contents of the trouble are displayed on the monitor, check the reel FG amplifier circuit and the reel motor driver circuit (DR-118 board, SS-48 board).

B103: T REEL FG DUTY

This mode adjusts the T reel FG duty.

Confirm that adjustment is performed, and "COMPLETE" is displayed.

```
SERVO ADJUST  
B103:T REEL FG DUTY
```

```
ADJUSTING.....
```



```
SERVO ADJUST  
B103:T REEL FG DUTY
```

```
COMPLETE
```

In case of NG

If "ADJUST INCOMPLETE" and contents of the trouble are displayed on the monitor, check the reel FG amplifier circuit and the reel motor driver circuit (DR-118 board, SS-48 board).

B104: CAPSTAN FG DUTY

This mode adjusts the capstan FG duty.

Confirm that adjustment is performed, and "COMPLETE" is displayed.

```
SERVO ADJUST  
B104:CAPSTAN FG DUTY
```

```
ADJUSTING.....
```



```
SERVO ADJUST  
B104:CAPSTAN FG DUTY
```

```
COMPLETE
```

In case of NG

If "ADJUST INCOMPLETE" and contents of the trouble are displayed on the monitor, check the capstan motor driver circuit (DR-118 board) and the capstan FG amplifier circuit (SS-48 board).

B105 : S REEL OFFSET/FRIC

This mode adjusts the S reel offset/friction.

Confirm that adjustment is performed, and "COMPLETE" is displayed.

```
SERVO ADJUST  
B105:S REEL OFFSET/  
FRICION  
  
ADJUSTING.....
```



```
SERVO ADJUST  
B105:S REEL OFFSET/  
FRICION  
  
COMPLETE
```

In case of NG

If "ADJUST INCOMPLETE" and contents of the trouble are displayed on the monitor, adjust the S reel FG duty again (B102 : S REEL FG DUTY). And check the reel motor driver circuit (DR-118 board).

B106 : T REEL OFFSET/FRIC

This mode adjusts the T reel offset/friction. Confirm that adjustment is performed, and "COMPLETE" is displayed.

```
SERVO ADJUST  
B106:T REEL OFFSET/  
FRICION  
  
ADJUSTING.....
```



```
SERVO ADJUST  
B106:T REEL OFFSET/  
FRICION  
  
COMPLETE
```

In case of NG

If "ADJUST INCOMPLETE" and contents of the trouble are displayed on the monitor, adjust the T reel FG duty again (B103 : T REEL FG DUTY). And check the reel motor driver circuit (DR-118 board).

B107: S REEL TORQUE

This mode adjusts the S reel torque.

Confirm that adjustment is performed and "COMPLETE" is displayed.

```
SERVO ADJUST  
B107:S REEL TORQUE  
  
ADJUSTING.....
```



```
SERVO ADJUST  
B107:S REEL TORQUE  
  
COMPLETE
```

In case of NG

If "ADJUST INCOMPLETE" and contents of the trouble are displayed on the monitor, adjust the S reel FG duty again (B102: S REEL FG DUTY). And check the reel motor driver circuit (DR-118 board).

B108: T REEL TORQUE

This mode adjusts the T reel torque.

Confirm that adjustment is performed, and "COMPLETE" is displayed.

```
SERVO ADJUST  
B108:T REEL TORQUE  
  
ADJUSTING.....
```



```
SERVO ADJUST  
B108:T REEL TORQUE  
  
COMPLETE
```

In case of NG

If "ADJUST INCOMPLETE" and contents of the trouble are displayed on the monitor, adjust the T reel FG duty again (B103: T REEL FG DUTY). And check the reel motor driver circuit (DR-118 board).

B109 : CAPSTAN SPEED

This mode adjusts the capstan free speed.

Insert an alignment tape CR2-1B PS, and press the play button.

NOTE: Be sure to use an alignment tape CR2-1B PS.

It may display "COMPLETE" even after the adjustment which is played back by other alignment tape. But when not using the alignment tape which is regulated tape speed strictly, it is impossible to get correct adjustment data.

Confirm that adjustment is performed, and "COMPLETE" is displayed.

The cassette tape is ejected automatically.

In case of NG

If "ADJUST INCOMPLETE" and contents of the trouble are displayed on the monitor, check the capstan FG amplifier, capstan motor drive and CTL amplifier circuit (DR-118 board).

```
SERVO ADJUST
B109:CAPSTAN FREE SPEED
```

```
SET
CR2-1
ALIGNMENT TAPE
AND PUSH PLAY KEY
```

```
SERVO ADJUST
B109:CAPSTAN FREE SPEED
```

```
ADJUSTING.....
```



```
SERVO ADJUST
B109:CAPSTAN FREE SPEED
```

```
COMPLETE
```

B110: RF SWITCHING POS.

This mode adjusts the RF switching position.

Insert an alignment tape CR2-1B PS, and press the play button.

NOTE: Be sure to use an alignment tape CR2-1B PS.

Do not use other alignment tape.

Confirm that adjustment is performed, and "COMPLETE" is displayed.

The cassette tape is ejected automatically.

In case of NG

If "ADJUST INCOMPLETE" and contents of the trouble are displayed on the monitor, check that the played alignment tape was CR2-1B PS or not. And check the DO pulse circuit.

```
SERVO ADJUST  
B110:RF SWITCHING POS.
```

```
SET  
CR2-1 or CR2-2  
ALIGNMENT TAPE  
AND PUSH PLAY KEY
```

```
SERVO ADJUST  
B110:RF SWITCHING POS.
```

```
ADJUSTING.....
```



```
SERVO ADJUST  
B110:RF SWITCHING POS.
```

```
COMPLETE
```

B111: TRACKING CENTER

This mode adjusts the tracking center.

1. Insert an alignment tape CR5-1B PS, and playback the color bars signal portion (0:00-4:55).
2. Set the tracking adjustment control on the control panel to **FIXED**.
3. Move the * mark to "READY!" in the monitor picture with the search dial.
4. Press S302 on the SS-48 board.
5. Confirm that adjustment is performed, and "COMPLETE" is displayed.

```
SERVO ADJUST  
B111:TRACKING CENTER
```

```
SET  
ANY ALIGNMENT TAPE  
AND PUSH PLAY KEY
```

```
SERVO ADJUST  
B111:TRACKING CENTER
```

```
SET TRACKING VR  
TO CENTER CLICK
```

```
*NOT READY  
READY !
```

```
SERVO ADJUST  
B111:TRACKING CENTER
```

```
SET TRACKING VR  
TO CENTER CLICK
```

```
NOT READY  
*READY !
```

```
SERVO ADJUST  
B111:TRACKING CENTER
```

```
COMPLETE
```

In case of NG

If "ADJUST INCOMPLETE" and contents of the trouble are displayed on the monitor, check the tracking volume circuit.

B112: S TENSION SENSOR

This mode adjusts the sensor of the S tension regulator.
Use fixtures in this adjustment.
Refer to section 5-19-2 about a method of adjustment.

```
SERVO ADJUST  
B112:S TENSION SENSOR  
  
SET  
TENSION TOOL at 45g  
ON STANDBY OFF MODE,  
AND PUSH PLAY KEY  
  
*NOT READY  
READY !
```

B113: T TENSION SENSOR

This mode adjusts the sensor of the T tension regulator.
Use fixtures in this adjustment.
Refer to section 5-20-2 about a method of adjustment.

```
SERVO ADJUST  
B113:T TENSION SENSOR  
  
PUSH PLAY KEY  
  
*NOT READY  
READY !
```

B114: PICTURE SPLITTING

This mode adjusts the picture splitting.

NOTE: This mode is performed only when the picture splitting is serious.

1. Connect the video monitor to TP202 (D-2) on the VP-33 board using the BNC clip cable.
2. Set the monitor as following.
 - H DELAY
 - AFC FAST
 - INT SYNC

NOTE: It is impossible to observe with the video monitor which captured the H sync strongly by the AFC circuit in the monitor.

3. Insert an alignment tape CR5-2A PS, and playback the monoscope signal portion. (13:00-15:00).
4. Press S302 on the SS-48 board and measure the picture splitting portion (A portion of the figure) in the monitor. If the A is 1.5 μ s or more (2.4 scales in H direction on the monoscope), the following steps should be performed.

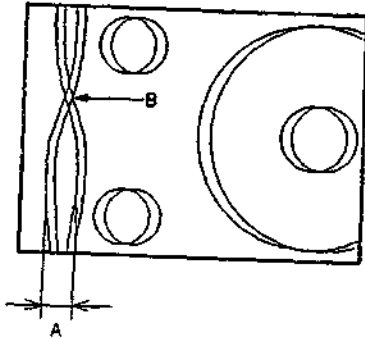

5. Memorize the cross point of the picture splitting portion (B portion of the above figure) in the monitor, and press S302 on the SS-48 board.

NOTE: It is easy to memorize by putting a adhesive tape on the monitor.

6. Turn the search dial, and position the cross point at the memorized position in step 5, and press S302 on the SS-48 board.
7. Turn the search dial to make least the picture splitting, and press S302 on the SS-48 board.
8. Confirm that adjustment is performed, and "COMPLETE" is displayed.

In case of NG

If "ADJUST INCOMPLETE" and contents of the trouble are displayed on the monitor, check the drum FG amplifier circuit and drum motor drive circuit.

SERVO ADJUST
B114: PICTURE SPLITTING

SET
CR5-2A
ALIGNMENT TAPE
AND PUSH PLAY KEY

SERVO ADJUST
B114: PICTURE SPLITTING

MEMORIZE POSITION OF
PICTURE SPLITTING

CANCEL: SW303 (SS-48)
FINISH: SW302 (SS-48)

SERVO ADJUST
B114: PICTURE SPLITTING

TURN JOG DIAL FOR SHIFT
-ING THE LARGE SPLITTING
TO THE SAME POSITION
OF MEMORIED POSITION
CANCEL: SW303 (SS-48)
FINISH: SW302 (SS-48)

SERVO ADJUST
B114: PICTURE SPLITTING

TURN JOG DIAL FOR
REDUCING PICTURE
SPLITTING

CANCEL: SW303 (SS-48)
FINISH: SW302 (SS-48)

B115: FWD TENSION

This mode adjusts the FWD back tension.
Use fixtures in this adjustment.
Refer to section 5-19-3 about a method of adjustment.

```
SERVO ADJUST
B115:FWD TENSION

SET CASSETTE
AND DRUM TENSION TOOL
ON STANDBY OFF MODE,
AND PUSH PLAY KEY
*NOT READY
READY !
```

B116: REV TENSION

This mode adjusts the REV back tension.
Use fixtures in this adjustment.
Refer to section 5-19-4 about a method of adjustment.

```
SERVO ADJUST
B116:REV TENSION

SET CASSETTE
AND DRUM TENSION TOOL
ON STANDBY OFF MODE,
AND PUSH SEARCH KEY
*NOT READY
READY !
```

B117: NV RAM CONTROL

This mode installs the adjustment data to NVRAM.

When having all the adjustment data installed

Move the * mark to "SAVE ALL ADJ. DATA" with search dial, and press S302 switch on the SS-48 board.

When returning all the adjusted data to the condition that the unit is shipped

Move the * mark to "LOAD FACTORY DATA" with search dial, and press S302 switch on the SS-48 board.

"SAVE COMPLETE" is displayed on the monitor after the data is installed.

After "SAVE COMPLETE" was displayed, press S303 on the SS-48 board to return to the menu picture. Or press S303 twice to return to the mode picture.

```
SERVO ADJUST
B117:NV RAM CONTROL

*NO OPERATION
SAVE ALL ADJ. DATA
LOAD FACTORY DATA
```

3-4. OTHER CHECK MODE (F : OTHERS)

In this mode, it is able to check the ROM version, switch of the control panel/sub control panel and CF data.

• Procedure

1. Press S302 switch on the SS-48 board.
Then the unit enters into the maintenance mode.
Modes of four kinds are displayed on the monitor.
2. Press the search dial to put the unit into the jog mode, and move the * mark to "F : OTHERS" which is a mode displayed on the monitor.

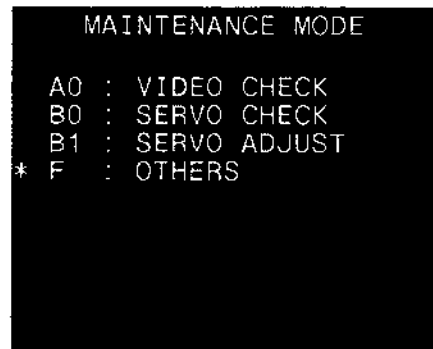

3. Press S302 switch on the SS-48 board.
Then "F : OTHERS" mode is selected, and menus are displayed on the monitor.

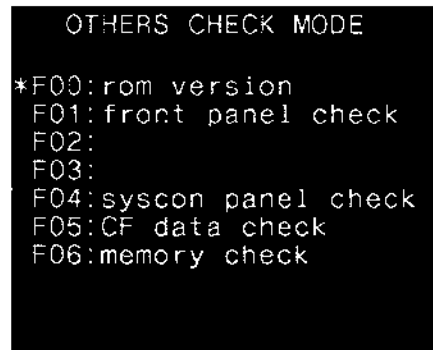

4. Move the * mark to a desired menu with the search dial (jog mode).
5. Press S302 switch on the SS-48 board, and execute the * marked menu.
6. When check is performed, press S303 switch on the SS-48 board to return to the menu picture.
7. If there are other menus wishing to be checked, repeat the step 4 to 6.
8. When all the checks are performed, press S303 switch on the SS-48 board to return to the mode picture.

F00: rom version

In this mode, rom version is displayed.

SYSCON: IC7 on the SS-48 board
SERVO (main): IC604 on the SS-48 board
SERVO (sub): IC710 on the SS-48 board
TIME CODE: IC403 on the SS-48 board

```
OTHERS CHECK MODE  
PAL  
player without DT  
SYSCON : V1.04  
SERVO (main) : V1.11  
SERVO (sub) : V1.00  
TIME CODE : V1.01
```

F01: front panel check

This mode checks the function of the switch which is on the control panel.

```
OTHERS CHECK MODE  
RMT SW : local  
VIDEO SEL :  
LIMITER :
```

RMT SW : Operate the LOCAL/REMOTE switch, and confirm that the monitor display changes to the set position.

F04 : syscon panel check

This mode checks the function of the switch which is on the sub control panel.

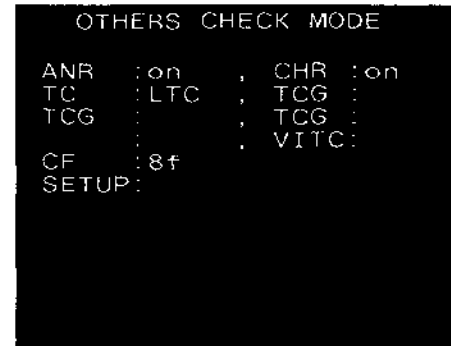

- ANR : Operate the DOLBY NR switch, and confirm that the monitor display changes to the set position.
- CHR : Operate the CHARACTER switch, and confirm that the monitor display changes to the set position.
- TC : Operate the TC switch, and confirm that the monitor display changes to the set position.
- CF : Operate the CAPSTAN LOCK switch, and confirm that the monitor display changes to the set position.
- SETUP: Press the SETUP SET switch, and confirm that its mode is displayed on the monitor.

F05 : CF data check

- REF ID : The field number for reference TBC is displayed.
- PB ID : The field number of play back video signal in play back mode is displayed, and the difference between the field number and REF ID is displayed. (field number : 0 through 7)
- OUT ID : The field number of the composite video signal from the VTR is displayed, and the difference between the field number and REF ID is displayed. (field number : 0 through 7)
- CF select : The CF select of the VTR is displayed.
- VIDEO PHASE : Whether the video phase by CF ID is IN phase or OUT phase is displayed. When the video phase is OUT phase, the output video signal is shifted H by 70 ns. (VISC has nothing to do with this display.)

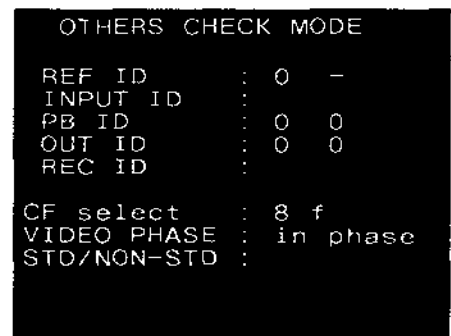

F06 : memory check

factory use

PERIODIC CHECK

SECTION 4 INSPECTION AND MAINTENANCE

4-1. HOURS METER

The Hours Meter is installed on the sub control panel.

It is recommended to perform inspection and maintenance based on the Hours Meter.

NOTE: The Hours Meter has a built-in battery. The Hours Meter should be replaced every five years.

When replacing the Hours Meter, it is recommended to note down the total hours and times displayed for inspection and maintenance later.

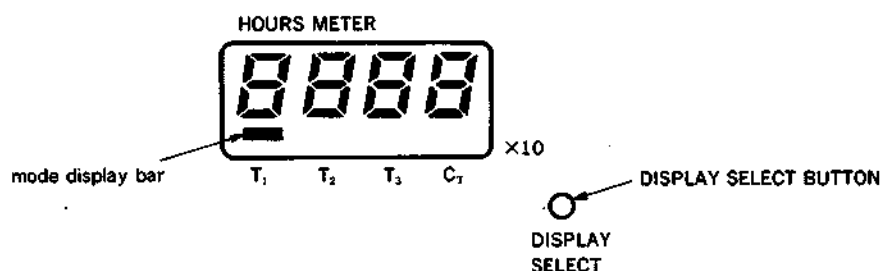

The Hours Meter has four kinds of display modes. The total operation hours or total times of operations is displayed in each mode.

To select the display mode, push the DISPLAY SELECT button at the side of the Hours Meter.

NOTE: The actual operation hours or times are equal to the displayed value multiplied by 10.

mode	contents	The unit operation status in every mode.	
		light a mode display bar	blink a mode display bar
T₁ : OPERATION	Displays the total hours that the power of the unit has been turned on.	POWER OFF	POWER ON
T₂ : DRUM RUNNING	Displays the total rotation hours of the drum in threading end mode.	• POWER OFF • POWER ON in mode other than threading end.	Drum is rotating in threading end mode.
T₃ : TAPE RUNNING	Displays the total running hours of the tape in fast forward, rewind, playback and search modes (except for stop and standby).	• POWER OFF • POWER ON in mode other than fast forward, rewind, playback or search.	Tape is running in fast forward, rewind, playback or search.
C₁ : THREADING	Displays the total times of threading and unthreading operations.	_____	Every time if the POWER is ON or OFF.

Example: This display indicates that the total rotation hours of the drum is 1500 hours in threading end mode.

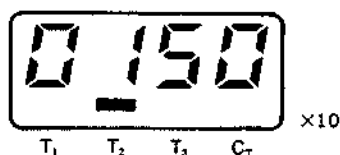

4-2. MAINTENANCE AFTER REPAIRS

Perform the following maintenance after repairs regardless of the unit operating hours.

1. Video heads and stationary heads cleaning. (Refer to Section 4-2-1. and 4-2-2.)
2. Tape movement area cleaning. (Refer to Section 4-2-3.)

NOTE: Wait until the cleaning fluid evaporates completely before inserting a cassette tape.

4-2-1. Cleaning Procedure of Video Head

Press a cleaning piece moistened with cleaning fluid and turn a drum slowly with hand.

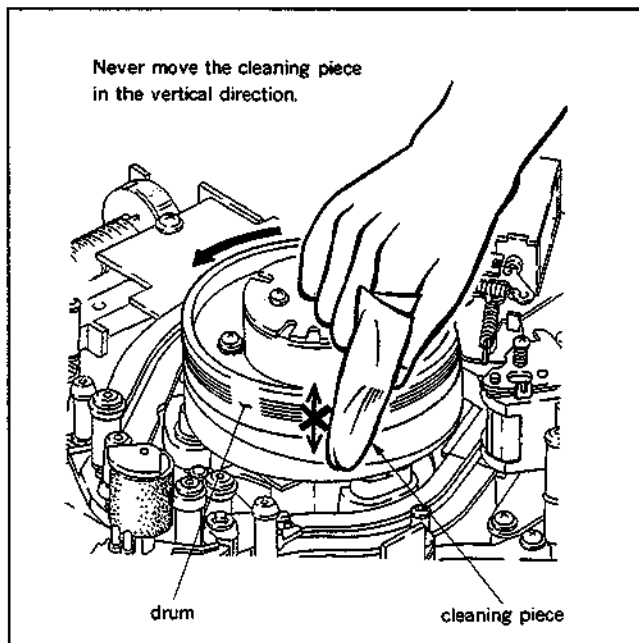

NOTE:

- Never move the cleaning piece in the vertical direction of a head tip.
- Clean the head with the power off.

4-2-2. Cleaning Procedure of Stationary Heads

Clean with a cleaning piece moistened with cleaning fluid.

4-2-3. Cleaning Procedure of Tape Movement Areas

Wipe the tape bearing surfaces (of a tape guide, drum, capstan and pinch roller) with a cleaning piece moistened with cleaning fluid.

4-3. PERIODIC MAINTENANCE TABLE

It is recommended to perform the periodic maintenance in order to obtain correct function and higher performance, and also to extend the life of tape and unit.

Perform the periodic maintenance referring to T2 : DRUM RUNNING mode shown in hours meter.

○ mark : Execute

△ mark : Confirm. if not, replace or adjust

Item	1000H	2000H	3000H	4000H	5000H	6000H	Replacement	Q'ty	Remarks
Tape running system									
Tape running surface cleaning	○	○	○	○	○	○			
Tape running confirmation/adjustment	△	△	△	△	△	△			
Cleaning roller replacement	○	○	○	○	○	○	X-3675-858-1 ROLLER SUB ASSY, C	1pc	
Upper drum assembly replacement	○	○	—	○	○	—	A-6762-463-A UPPER DRUM ASSY, DBR-28-R	1pc	(Note 1)
Servo automatic adjustment (B110) execute	○	○	○	○	○	○			
Servo automatic adjustment (B111) execute	○	○	○	○	○	○			
Video tracking confirmation/adjustment	△	△	△	△	△	△			
Drum assembly replacement	—	—	○	—	—	○	A-6050-841-A DRUM ASSY, DBH-28A-R	1pc	
Tape guide roller rotation confirmation/ replacement	△	△	△	△	△	△	X-3166-431-1 ROLLER (TG-6) ASSY, TAPE X-3166-037-1 ROLLER (M) ASSY, TAPE X-3166-052-1 ROLLER (S-T) ASSY, TAPE X-3166-320-1 TG-5 ASSY X-3166-386-1 TG-4 (IP) ASSY	1pc 4pcs 2pcs 1pc 1pc	
Tape guide flange wearing confirmation/ replacement	△	△	△	△	△	△	3-173-172-01 FLANGE, LOWER 3-173-176-01 NUT, ADJUSTMENT 3-174-315-01 FLANGE (UPPER) 3-174-316-01 FLANGE (LOWER)	2pcs 4pcs 5pcs 4pcs	
Bearing for cleaning roller replacement	—	○	—	○	—	○	3-669-443-01 BEARING, BALL	2pcs	
Audio/TC head replacement	—	—	○	—	—	○	8-825-776-61 HEAD, EPS244-2103E	1pc	
CTL head replacement	—	—	○	—	—	○	8-825-776-41 HEAD, PS244-21C	1pc	
Drive system									
Pinch roller replacement	○	○	○	○	○	○	X-3166-040-3 ARM ASSY, PINCH	1pc	
Brake shoe replacement	—	—	○	—	—	○	X-3717-205-1 LINING ASSY, C	2pcs	
Drum ground shaft replacement	—	—	○	—	—	○	X-3166-376-1 GROUND ASSY, SHAFT	1pc	
Pinch solenoid replacement	—	—	○	—	—	○	1-454-338-00 SOLENOID	1pc	
Cleaning solenoid replacement	—	—	○	—	—	○	1-454-372-11 SOLENOID	1pc	
Brake solenoid replacement	—	—	○	—	—	○	1-454-417-41 SOLENOID	2pcs	
Reel motor replacement	—	—	○	—	—	○	A-6737-207-A RM ASSY	2pcs	
Capstan motor replacement	—	—	○	—	—	○	8-835-445-01 MOTOR, DC SCV-0301A	1pc	
Threading motor replacement	—	—	○	—	—	○	8-835-179-01 MOTOR, DC MCB2B15	1pc	
Mechanical operation confirmation									
Abnormal noise	△	△	△	△	△	△			
Servo automatic adjustment (B101) execute	○	○	○	○	○	○			
Servo automatic adjustment (B109) execute	○	○	○	○	○	○			
Servo check menu execute	○	○	○	○	○	○			
FWD back tension confirmation/adjustment	△	△	△	△	△	△			
REV back tension confirmation/adjustment	△	△	△	△	△	△			
Cassette compartment operation confirmation	△	△	△	△	△	△			
Reel brake clearance confirmation	—	—	△	—	—	△			
Reel brake release amount confirmation	—	—	△	—	—	△			
Electrical confirmation									
System control operation confirmation	△	△	△	△	△	△			
Audio specifications confirmation	△	△	△	△	△	△			
Video specifications confirmation	△	△	△	△	△	△			

Note 1: The video head life is greatly affected by operating ambient condition and tape.

Note 2: It is recommended to replace the fun motor on the connector panel every 10,000 hours is operation mode shown in hours meter.

SONY®

VIDEOCASSETTE PLAYER

PVW-2600P

SERVICE MANUAL

SUPPLEMENT-1

Please replace your manual with this SUPPLEMENT-1.

SUBJECT

SECTION 4 INSPECTION AND MAINTENANCE

(Revised the periodic maintenance table of Inspection and Maintenance to obtain correct function and higher performance, and also to extend the life of tape and unit.)

BETACAM SP
2000 PRO

4-3. PERIODIC MAINTENANCE TABLE

It is recommended to perform the periodic maintenance in order to obtain correct function and higher performance, and also to extend the life of tape and unit.

○ mark : Execute
 △ mark : Confirm. if not, replace or adjust

Perform the periodic maintenance referring to T2 : DRUM RUNNING mode shown in hours meter.

Item	750H	1500H	2250H	3000H	3750H	4500H	5250H	6000H	Replacement	Q'ty	Remarks
Tape running system											
Tape running surface cleaning	○	○	○	○	○	○	○	○			
Tape running confirmation/adjustment	△	△	△	△	△	△	△	△			
Cleaning roller replacement	○	○	○	○	○	○	○	○	X-3675-858-1 ROLLER SUB ASSY, C	1pc	
Upper drum assembly replacement	○	○	○	—	○	○	○	—	A-6762-463-A UPPER DRUM ASSY, DBR-28-R	1pc	(Note 1)
Servo automatic adjustment (B110) execute	○	○	○	○	○	○	○	○			
Servo automatic adjustment (B111) execute	○	○	○	○	○	○	○	○			
Video tracking confirmation/adjustment	△	△	△	△	△	△	△	△			
Drum assembly replacement	—	—	—	○	—	—	—	○	A-6050-841-A DRUM ASSY, DBH-28A-R	1pc	
Tape guide roller rotation confirmation/replacement	△	△	△	△	△	△	△	△	X-3166-431-1 ROLLER (TG-6) ASSY, TAPE X-3166-037-1 ROLLER (M) ASSY, TAPE X-3166-052-1 ROLLER (S-T) ASSY, TAPE X-3166-320-1 TG-5 ASSY X-3166-386-1 TG-4 (IP) ASSY	1pc 4pcs 2pcs 1pc 1pc	
Tape guide flange wearing confirmation/replacement	△	△	△	△	△	△	△	△	3-173-172-01 FLANGE, LOWER 3-173-176-01 NUT, ADJUSTMENT 3-174-315-01 FLANGE (UPPER) 3-174-316-01 FLANGE (LOWER)	2pcs 4pcs 5pcs 4pcs	
Bearing for cleaning roller replacement	—	○	—	○	—	○	—	○	3-669-443-01 BEARING, BALL	2pcs	
Audio/TC head replacement	—	—	—	○	—	—	—	○	8-825-776-61 HEAD, EPS244-2103E	1pc	
CTL head replacement	—	—	—	○	—	—	—	○	8-825-776-41 HEAD, PS244-21C	1pc	
Drive system											
Pinch roller replacement	○	○	○	○	○	○	○	○	X-3166-040-3 ARM ASSY, PINCH	1pc	
Brake shoe replacement	—	—	—	○	—	—	—	○	X-3717-205-1 LINING ASSY, C	2pcs	
Drum ground shaft replacement	—	—	—	○	—	—	—	○	X-3166-376-1 GROUND ASSY, SHAFT	1pc	
Pinch solenoid replacement	—	—	—	○	—	—	—	○	1-454-338-00 SOLENOID	1pc	
Cleaning solenoid replacement	—	—	—	○	—	—	—	○	1-454-372-11 SOLENOID	1pc	
Brake solenoid replacement	—	—	—	○	—	—	—	○	1-454-417-41 SOLENOID	2pcs	
Reel motor replacement	—	—	—	○	—	—	—	○	A-6737-207-A RM ASSY	2pcs	
Capstan motor replacement	—	—	—	○	—	—	—	○	8-835-445-01 MOTOR, DC SCV-0301A	1pc	
Threading motor replacement	—	—	—	○	—	—	—	○	8-835-179-01 MOTOR, DC MCB2B15	1pc	
Mechanical operation confirmation											
Abnormal noise	△	△	△	△	△	△	△	△			
Servo automatic adjustment (B101) execute	○	○	○	○	○	○	○	○			
Servo automatic adjustment (B109) execute	○	○	○	○	○	○	○	○			
Servo check menu execute	○	○	○	○	○	○	○	○			
FWD back tension confirmation/adjustment	△	△	△	△	△	△	△	△			
REV back tension confirmation/adjustment	△	△	△	△	△	△	△	△			
Cassette compartment operation confirmation	△	△	△	△	△	△	△	△			
Reel brake clearance confirmation	—	—	—	△	—	—	—	△			
Reel brake release amount confirmation	—	—	—	△	—	—	—	△			
Electrical confirmation											
System control operation confirmation	△	△	△	△	△	△	△	△			
Audio specifications confirmation	△	△	△	△	△	△	△	△			
Video specifications confirmation	△	△	△	△	△	△	△	△			

Note 1 : The video head life is greatly affected by operating ambient condition and tape.

Note 2 : It is recommended to replace the fun motor on the connector panel every 10,000 hours is operation mode shown in hours meter.

REPLACEMENT/ADJ.

SECTION 5 REPLACEMENT OF MAJOR PARTS

5-1. GENERAL INFORMATION FOR PART REPLACEMENT AND ADJUSTMENT

1. Cassette Compartment

When performing part replacement and mechanical adjustment, remove a cassette compartment from the unit unless otherwise specified.

Removing procedure :

- 1) Remove three fixing screws of an upper panel, and remove the upper panel.
- 2) Disconnect a connector of a cassette compartment.
- 3) Loosen two fixing screws of a cassette compartment stay. These fixing screws have retainers, then they can not remove from the cassette compartment stay.
- 4) Remove the cassette compartment from the unit.

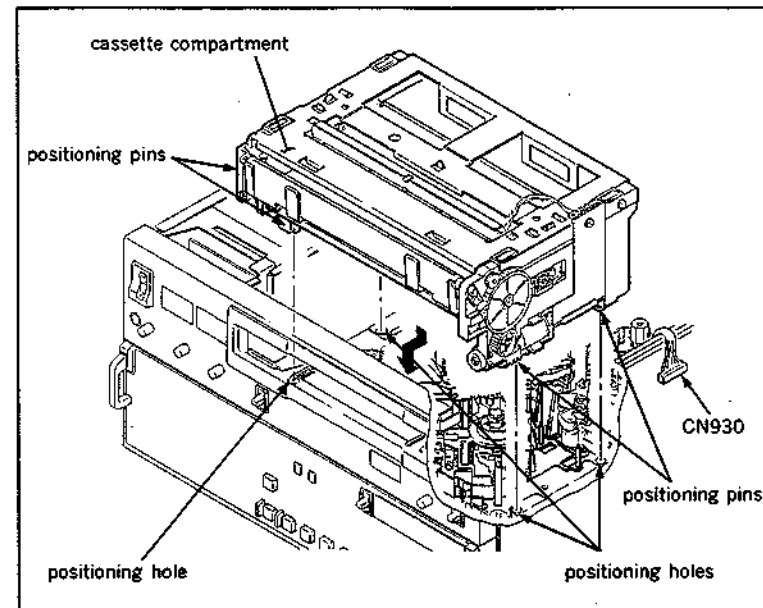

2. To Operate the Unit without Installing Cassette Compartment

When disconnect a connector of the cassette compartment, the protection circuit operates. However the unit can operate by performing the following procedures, even if the cassette compartment is removed from the unit.

- 1) Turn the POWER to OFF.
- 2) Put Bit4 of S601 on SS-48P board in CLOSE state.

By this operation, the protection circuit stops its operation, and the unit can operate normally without inserting a cassette tape or without installing the cassette compartment.

Note : After adjustment is completed, be sure to put Bit4 of S601 on SS-48P board in OPEN state.

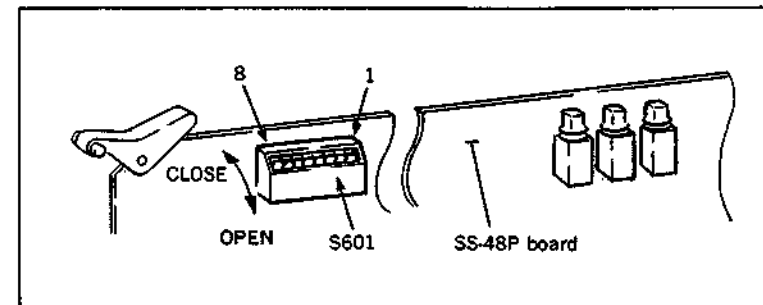

3. Maintenance Menu

This unit has a Maintenance Menu mode for video system and servo system operation check and adjustment.

Check and adjustment procedures are described in this manual, perform according to this procedures.

In maintenance menu mode, the following switches are mainly used.

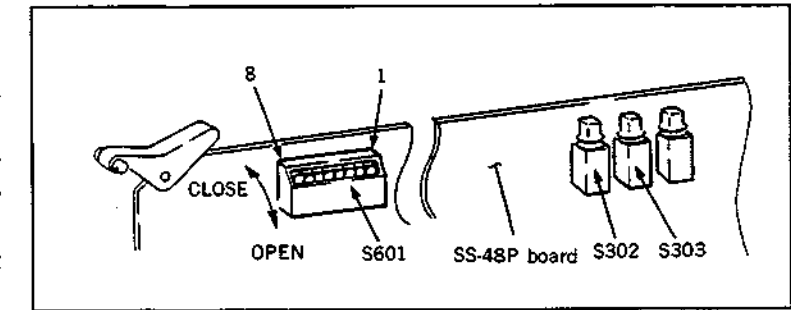

Bit4 of S601 :

This switch is used in SERVO ADJUST mode. Before performing the SERVO ADJUST mode, put this switch in CLOSE state.

After the SERVO ADJUST mode is completed, put it in OPEN state.

When this switch is in CLOSE state, the protection circuit stops its operation.

Bit7 of S601 :

This switch is used in SERVO CHECK mode. Before performing the SERVO CHECK mode, put this switch in CLOSE state.

After the SERVO CHECK mode is completed, put it in OPEN state.

S302 :

Push this switch, then mode, menu or sub-menu of the SERVO CHECK/SERVO ADJUST is executed.

S303 :

Push this switch, then menu or sub-menu of the SERVO CHECK/SERVO ADJUST is returned to the previous state.

4. Index for Replacement Part
(alphabetical order)

(Top portion of the unit)

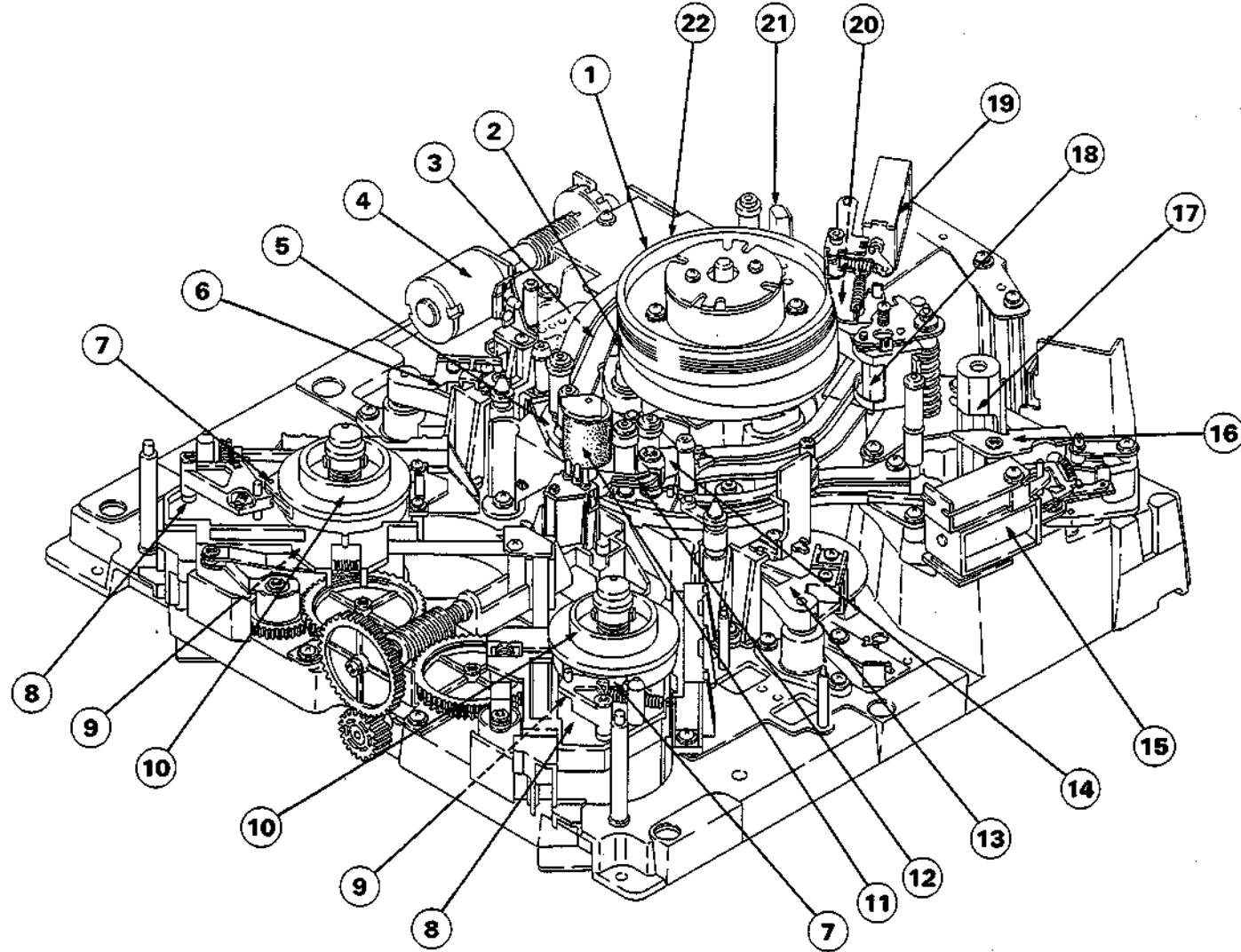

No.	Description	Section No.	Page	No.	Description	Section No.	Page
18	Audio/TC head	5-26	5-117	8	Reel motor plate	5-11	5-38
7	Brake lining assembly	5-7	5-22	10	Reel table	5-10	5-31
17	Capstan motor	5-27	5-120	5	S slider assembly	5-16	5-68
20	Cleaning roller assembly	5-6	5-20	6	S tension regulator arm assembly	5-19	5-72
19	Cleaning solenoid	5-9	5-30	-	Tape guide	5-8	5-26
21	CTL head	5-25	5-115	22	Threading gear	5-24	5-110
2	Drum assembly	5-3	5-11	4	Threading motor	5-15	5-59
16	Pinch press block	5-21	5-100	3	Threading ring	5-23	5-106
11	Pinch roller assembly	5-5	5-18	14	T slider assembly	5-17	5-65
15	Pinch solenoid	5-22	5-101	13	T tension regulator arm assembly	5-20	5-91
12	P slider assembly	5-18	5-69	1	Upper drum assembly	5-2	5-5
9	Reel motor	5-12	5-41				

(Bottom portion of the unit)

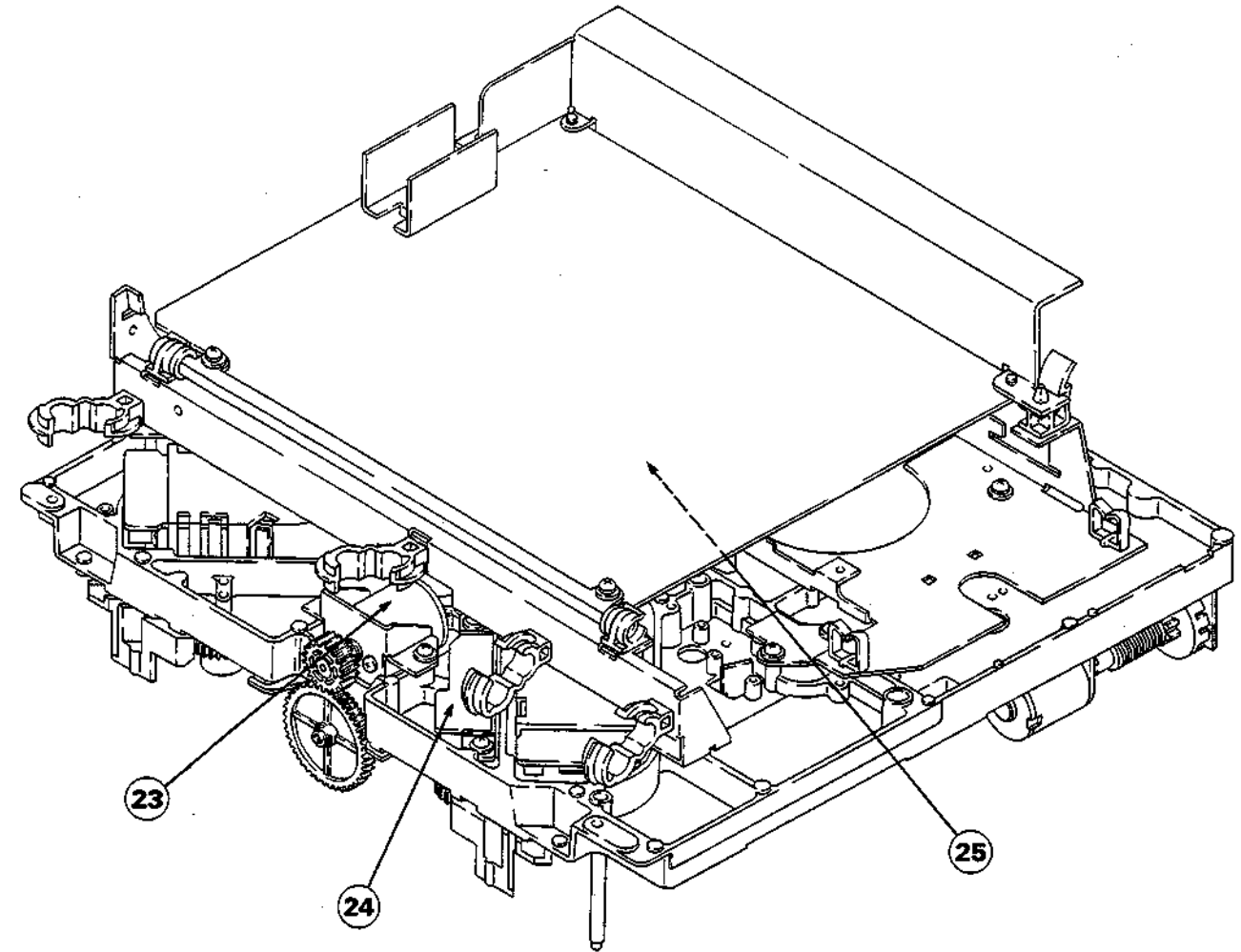

No.	Description	Section No.	Page
25	Drum ground shaft assembly	5-4	5-17
23	Reel position motor	5-13	5-56
24	Reel position sensor	5-14	5-58

5. Oil

Apply only the specified oil when oiling is required for replacing parts and/or adjustment. If a different oil is used, major malfunctions may be caused due to differences in oil viscosity and ingredients.

SONY part number : 7-661-018-18

If oil is used that has been mixed with dust, shafts and bearings may be damaged, causing major malfunctions.

One drop of oil is defined as follows :

About the amount that will adhere to the end of a stick 2 mm in diameter, as shown in the figure.

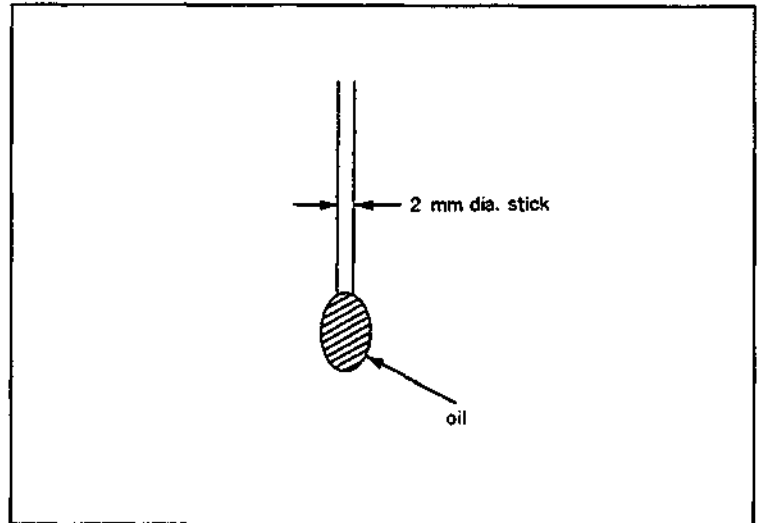

6. Grease

Smear only the specified grease product to sliding part. If a different grease is used, major malfunctions may be caused due to differences in viscosity and ingredients.

Major malfunctions may also be caused by using grease that has been mixed with dust.

Amounts of grease to smear

Smear just enough grease to create a thin film on the surface of the part. Any grease that adheres to other surrounding parts must be removed with gauze or soft cloth.

7. Tension measurement tape

Prepare the following tool :

J-6327-930-A

This tension measurement tape uses a S tension regulator arm operating position adjustment, T tension regulator arm operating position adjustment and S tension sensor sensitivity adjustment.

How to create the tension measurement tape.

- 1) Cut a video tape as shown in the figure.
- 2) Make a loop while inserting two pieces of pencil as shown in the figure, and stick a video tape.

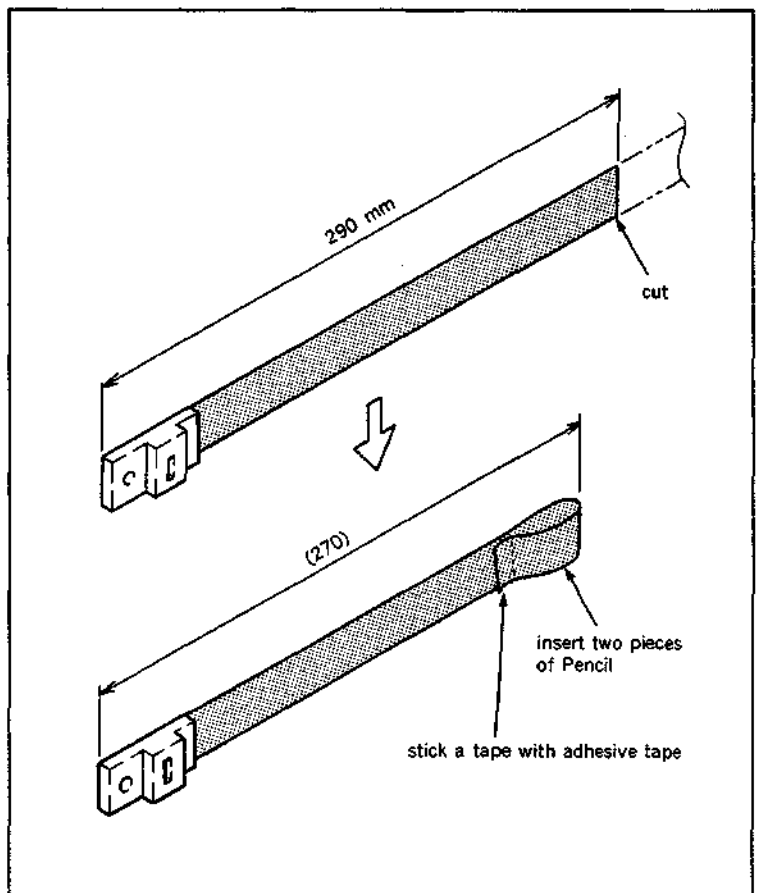

5-1-1. Index for Adjustment Item
 (alphabetical order)
 (except tape path system alignment)

Adjustment Item	Section No.	Page
Audio/TC head zenith adjustment	6-2	6-4
Capstan FG duty adjustment	5-27-2	5-123
Capstan speed adjustment	5-27-3	5-125
Capstan motor operation check	5-27-1	5-122
Cassette pillar (S) height adjustment	5-10-1	5-32
Cleaning roller block position adjustment	5-6-1	5-21
Drum motor operation check	5-3-1	5-15
FWD back tension adjustment	5-19-3	5-84
Pinch solenoid position adjustment	5-22-1	5-104
Reel brake clearance check	5-7-1	5-24
Reel brake release amount adjustment	5-7-2	5-25
Reel FG duty adjustment	5-12-3	5-47
Reel motor operation check	5-12-2	5-46
Reel motor shaft slantness adjustment	5-12-1	5-44
Reel position motor operation check	5-13-1	5-57
Reel rotation detector position adjustment	5-10-3	5-36
Reel table height adjustment	5-10-2	5-34
REV back tension adjustment	5-19-4	5-87
S reel offset/friction adjustment	5-12-4	5-48
S reel torque adjustment	5-12-5	5-50
S tension regulator arm operating position adjustment	5-19-1	5-74
S tension sensor sensitivity adjustment	5-19-2	5-78
Threading motor operation check	5-15-1	5-60
T reel offset/friction adjustment	5-12-6	5-52
T reel torque adjustment	5-12-7	5-54
T tension sensor sensitivity adjustment	5-20-2	5-97
T tension regulator arm operating position adjustment	5-20-1	5-93
Upper drum eccentricity adjustment	5-2-1	5-9

5-2. UPPER DRUM ASSEMBLY REPLACEMENT

- The upper drum assembly is a periodic replacement part. It is recommended to be replaced periodically based on the periodic maintenance table.
- When the video heads are worn or damaged, replace an upper drum assembly.
- When the upper drum assembly is removed, if a spacer is placed on the flange, be sure to leave it in place on the flange. If the spacer is lost or replaced with one of a different thickness, the height of the video head from its reference surface will be changed, making it impossible to get interchangeability.

Tools

Cleaning piece : 2-034-697-00
Cleaning fluid : 9-919-573-01

Replacement flow chart

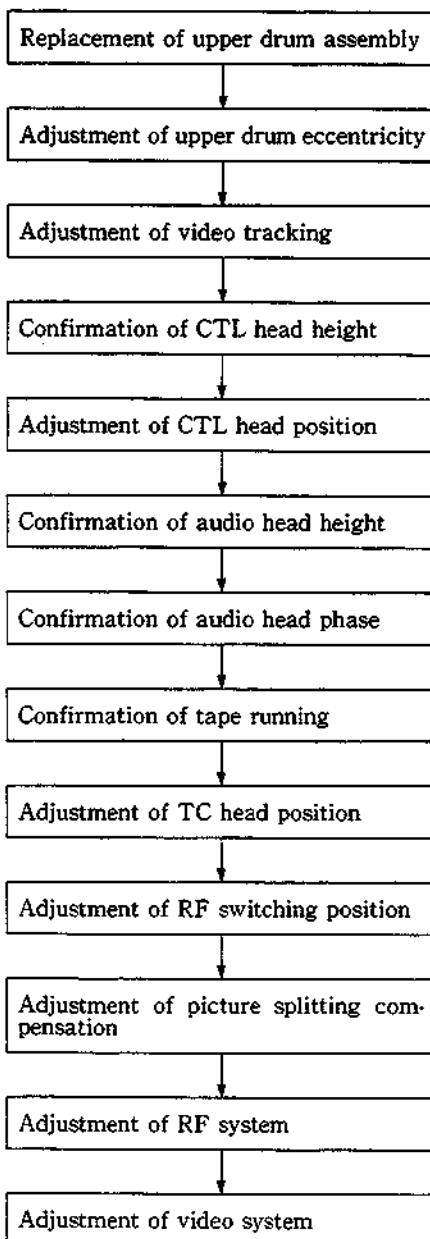

Removal

1. Hold claws of the upper part of a TG-4 tape guide roller using tweezers, and remove a fly wheel.

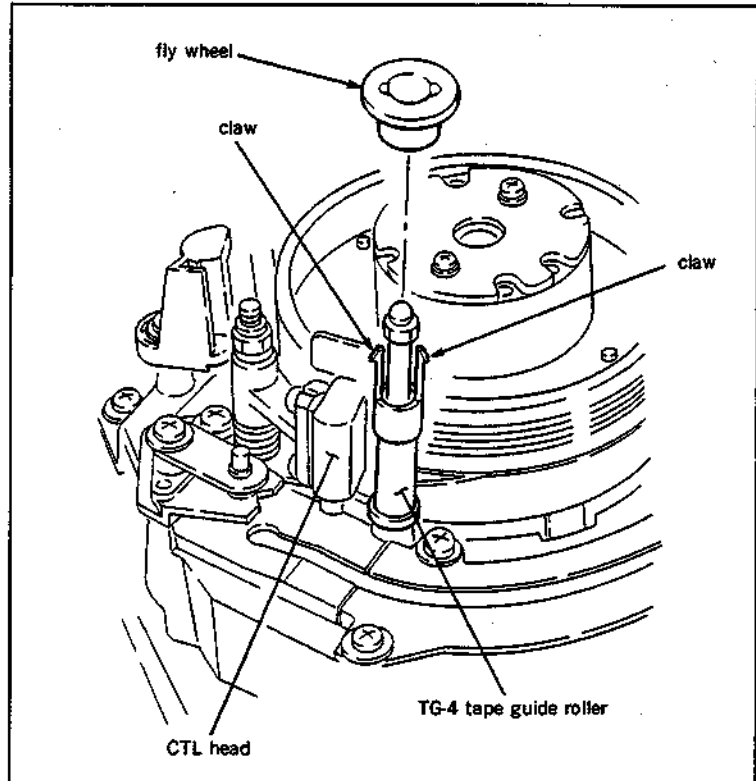

2. Unsolder eight leads of the video heads soldered to FL-107 board in the drum's center.
3. Rotate an upper drum assembly by hand, and set the video heads away from TG-4, CTL head, stationary guide and cleaning roller.

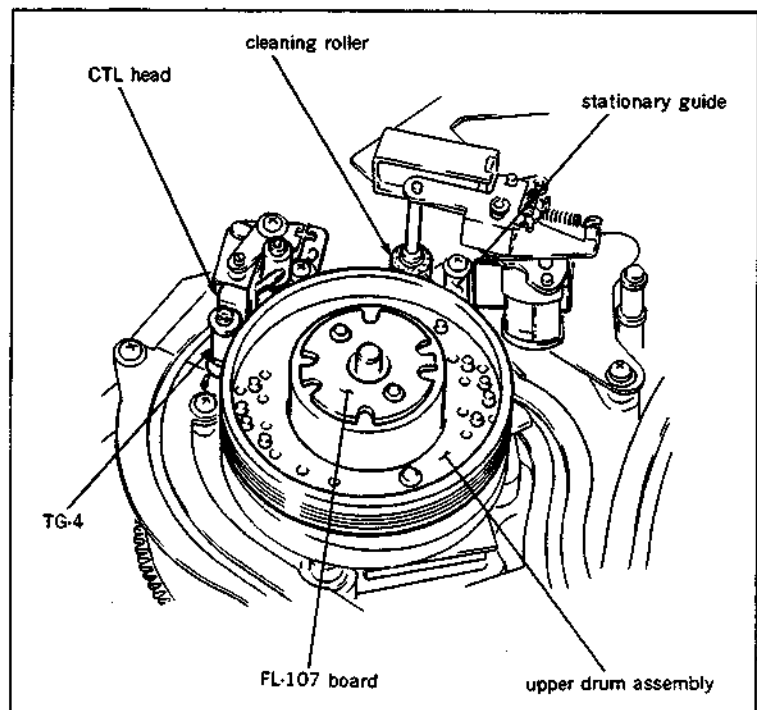

- Remove two screws holding the upper drum assembly, and lift the upper drum assembly straight up to remove. At this time the washers with tooth also come off together.

Note : Never contact the upper drum assembly to the TG-4, CTL head, stationary guides and cleaning roller when removing the upper drum assembly.

Installation

- Clean the flange surface of a lower drum and the installation surface of a new upper drum assembly with a cleaning piece moistened with cleaning fluid.
- As shown in the figure, place orange and white lead wires of the upper drum assembly as the C-A indicated side of the printed "A" side on FL-107 board and put it on the flange, then secure it with two screws snugly, but do not tighten.

Note 1 : When placing the upper drum assembly on the lower drum, never make a scratch or otherwise damage on the tape surface and video heads of the upper drum assembly.

Note 2 : Never contact the upper drum assembly to the TG-4, CTL head, stationary guides and cleaning roller when installing the upper drum assembly on the flange.

Note 3 : When placing the upper drum assembly on the flange, pay particular attention to install in the correct position.

- Solder eight lead wires of the upper drum assembly to FL-107 board.

Reference :

Marking on FL-107 board	Color of wire of the upper drum assembly
C-A-O	orange
C-A-W	white
Y-A-W	white
Y-A-B	blue
C-B-O	orange
C-B-R	red
Y-B-R	red
Y-B-B	blue

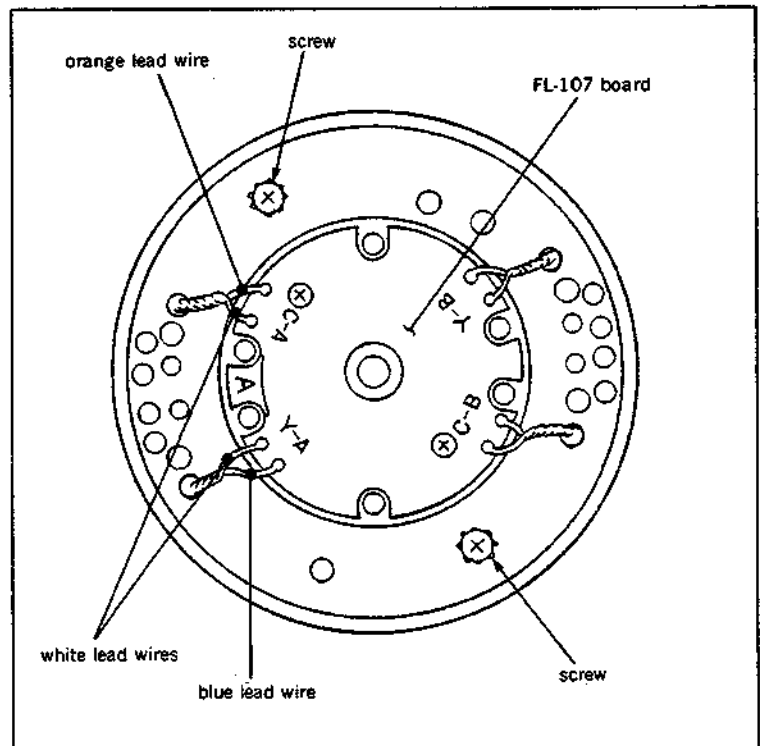
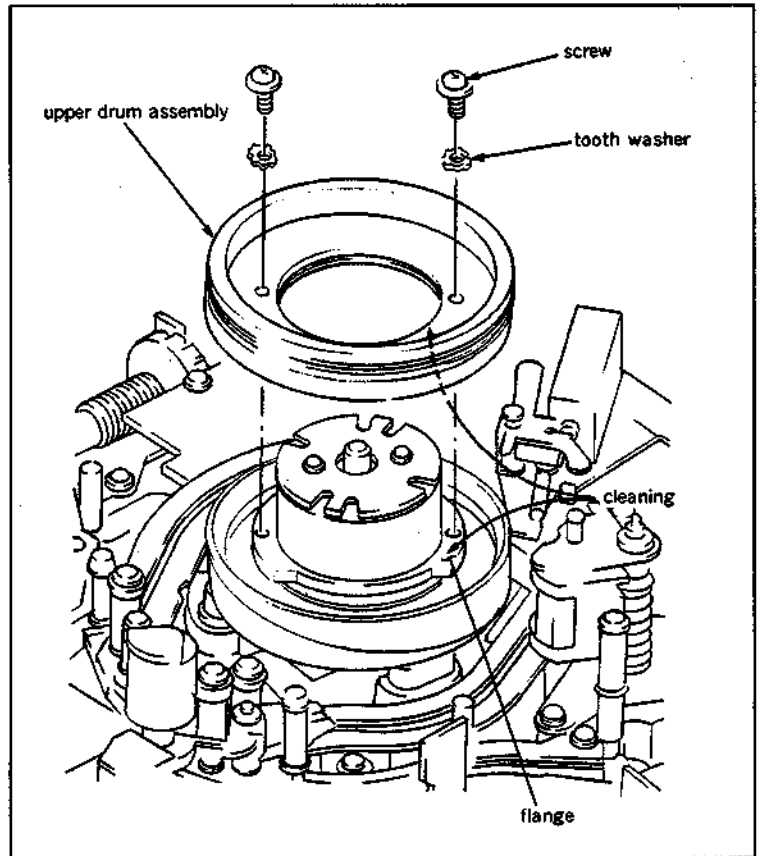

Adjustments after replacement

8. Perform upper drum eccentricity adjustment.
(Refer to Section 5-2-1.)
9. Perform video tracking adjustment.
(Refer to Section 6-4.)
10. Perform confirmation of CTL head height.
(Refer to Section 6-5.)
11. Perform CTL head position adjustment.
(Refer to Section 6-6.)
12. Perform confirmation of audio head height.
(Refer to Section 6-7.)
13. Perform confirmation of audio head phase.
(Refer to Section 6-8.)
14. Perform confirmation of tape running.
(Refer to Section 6-3.)
15. Perform TC head position adjustment.
(Refer to Section 6-10.)
16. Align two claws of the upper part of the TG-4 tape guide roller and two grooves of the fly wheel, then install the fly wheel to the TG-4 tape guide roller.
Make sure that the fly wheel is surely locked, after the installation.
17. Perform RF switching position adjustment.
(Refer to Section 6-12.)
18. Perform picture splitting compensation adjustment. (Refer to Section 6-14.)
19. Perform RF system adjustment.
20. Perform video system adjustment.

5-2-1. Upper Drum Eccentricity Adjustment

- Be sure to perform an upper drum eccentricity adjustment, when the upper drum is replaced.

Tools

Upper drum eccentricity gauge(2) : J-6001-830-A

Upper drum eccentricity gauge(3) : J-6001-820-A

Upper drum eccentricity gauge(5) : J-6087-000-A

Upper drum eccentricity gauge(6) : J-6325-530-A

or(1): J-6001-840-A

Cleaning piece : 2-034-697-00

Cleaning fluid : 9-919-573-01

Assemble the upper drum eccentricity gauges as shown in the figure.

For reference :

Drum eccentricity adjustment gauge (J-6080-038-A) and dial gauge holder (J-6080-039-A) are able to use for the upper drum eccentricity adjustment instead of to use drum eccentricity gauges (2), (3) and (5).

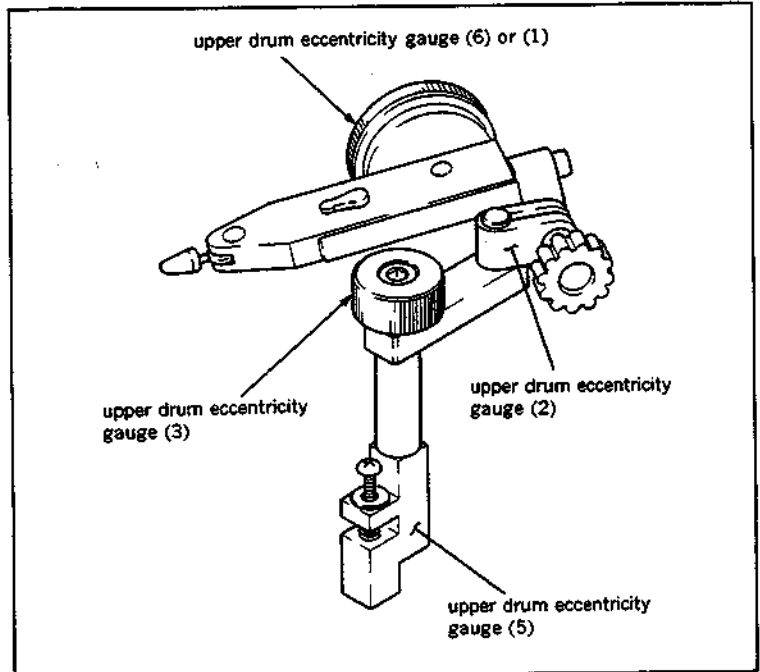

Adjustment

1. Clean the pointer of the assembled upper drum eccentricity gauges with a cleaning piece moistened with cleaning fluid.

Note : The tape running surface of the upper drum may be damaged if the gauge is used with dirt or dust adhering to the pointer.

2. Install the assembled upper drum eccentricity gauges to the screw hole shown in the figure.

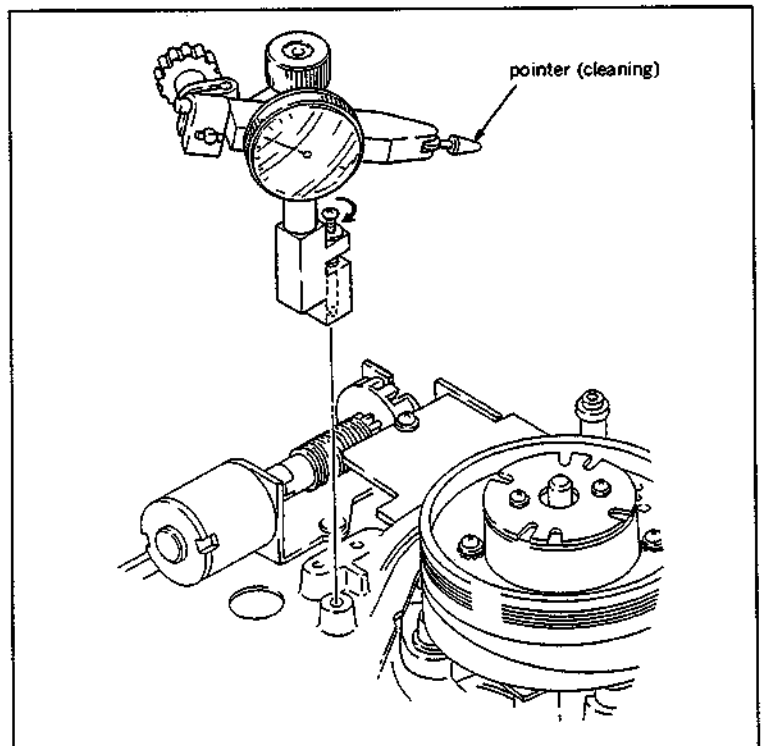

3. Adjust the position of the gauge so that the pointer is positioned about 5 mm away from the upper edge of the upper drum assembly.

Note : Pay particular attention not to touch the pointer to the video heads.

4. Turn the upper drum slowly in the clockwise direction. Make sure that the pointer deviation indicated in one full turn of the upper drum satisfies the specification.

Specification : $3 \mu\text{m}$ or less.

If the specification is satisfied, perform step (6) and later.

If the specification is not satisfied, perform step (5) and later.

5. Perform if the specification is not satisfied :
 - (1) Turn the upper drum slowly in the clockwise direction, and make sure that the amount of the pointer deviation.
 - (2) Turn the upper drum slowly in the clockwise direction, and stop the turning at the place where the least pointer deviation is indicated.
 - (3) Adjust the position of the upper drum to about one-half the amount of the pointer deviation by pressing with finger against the upper edge of the upper drum assembly at a point 180 degrees opposed to the contact point of pointer. If no movement is produced by this adjustment, slightly loosen two screws of the upper drum assembly. If the movement occurs too readily, tighten two screws slightly.
 - (4) Make sure that the deviation of the eccentricity again to satisfies the specification.
6. Tighten two screws alternately and gradually (tightening torque : $78.5 \text{ N}\cdot\text{cm}$ { $8 \text{ kgf}\cdot\text{cm}$ }).
7. Make sure that the eccentricity of the upper drum to satisfy the specification.
8. Remove the upper drum eccentricity gauges.

Note : Take care not to contact the pointer with the video heads.

9. Clean the video heads and tape running surface of the upper drum assembly with a cleaning piece moistened with cleaning fluid. After cleaning, be sure to wipe the cleaned surface two to three times with a dry cloth.

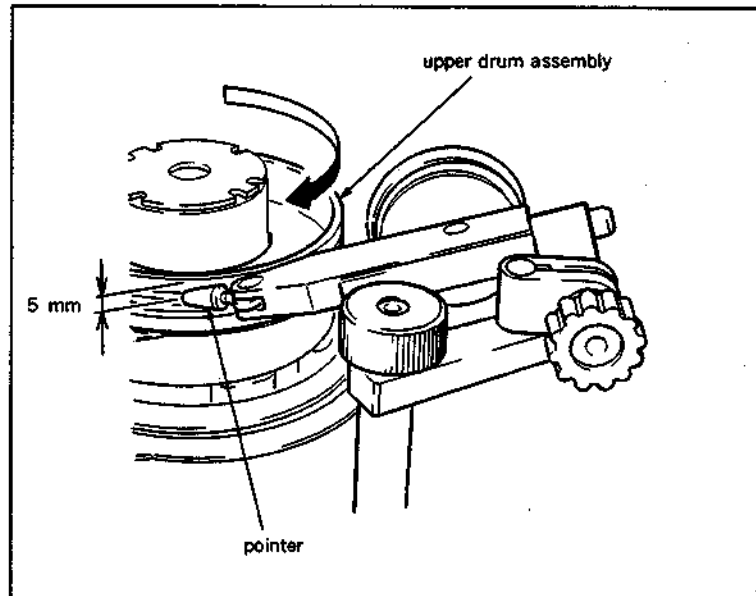

5-3. DRUM ASSEMBLY REPLACEMENT

- A drum assembly is a periodic replacement part. It is recommended to replace periodically based on the periodic maintenance table.
- It is necessary to replace the drum assembly in the following cases :
 - (1) The lead surface of a lower drum is worn, and a correct RF waveform cannot be obtained even when tracking adjustment is performed.
 - (2) The lower drum's lead surface and tape running surface of the lower drum are scratched and cannot be repaired.
 - (3) The drum shaft bearings are out of life, resulting in noise or jitter that makes it impossible to maintain the performance of the unit.
- When replacing the drum assembly, replace an upper drum assembly at the same time.

Tools

- Cleaning piece : 2-034-697-00
- Cleaning fluid : 9-919-573-01

Replacement flow chart

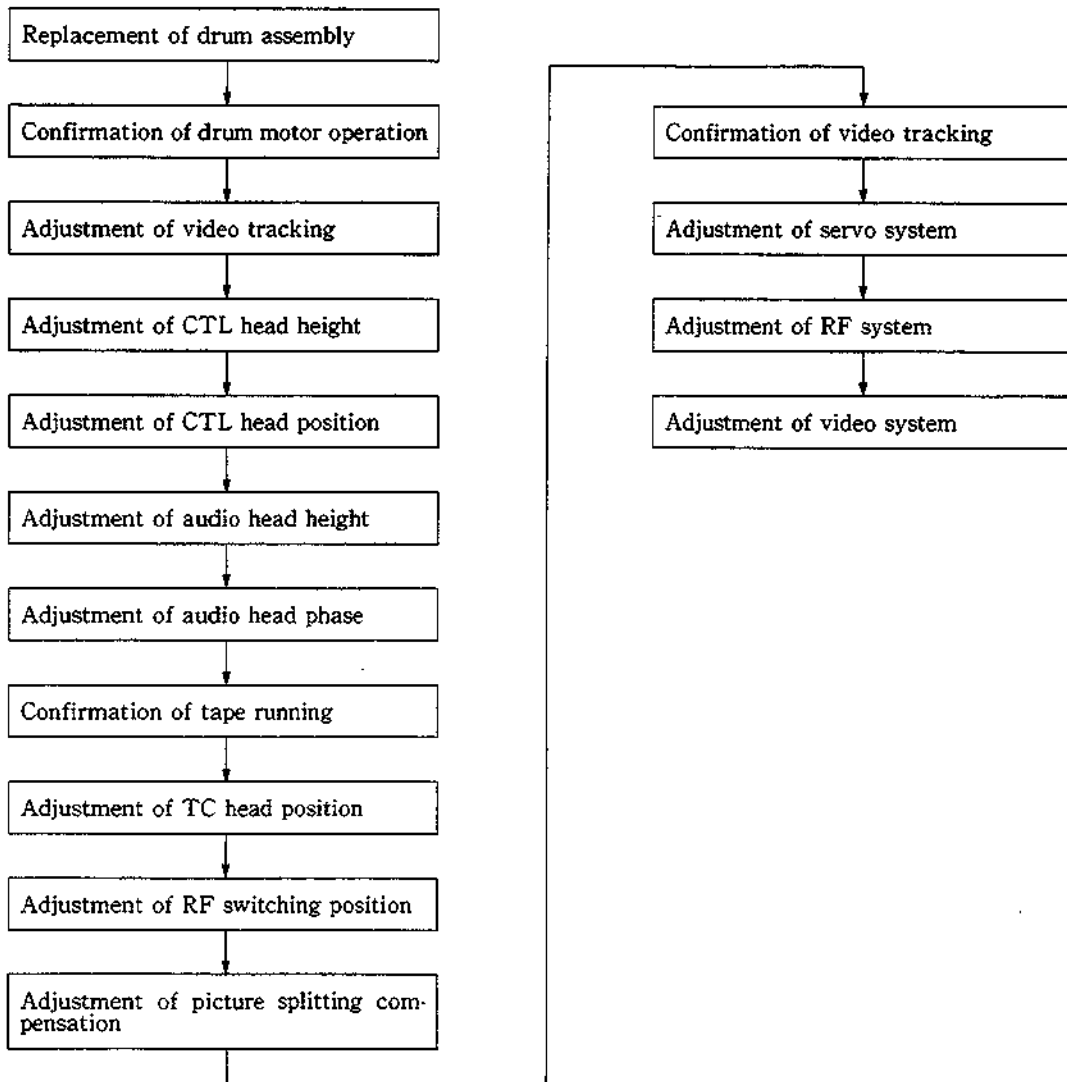

Removal

1. Remove a cleaning roller assembly.
(Refer to steps (1) and (2) in Section 5-6.)
2. Remove a fly wheel of the upper part of a TG-4 tape guide roller. (Refer to step (1) in Section 5-2.)
3. Remove an AU head cover. At this time, the harness clumper of the drum comes off together.

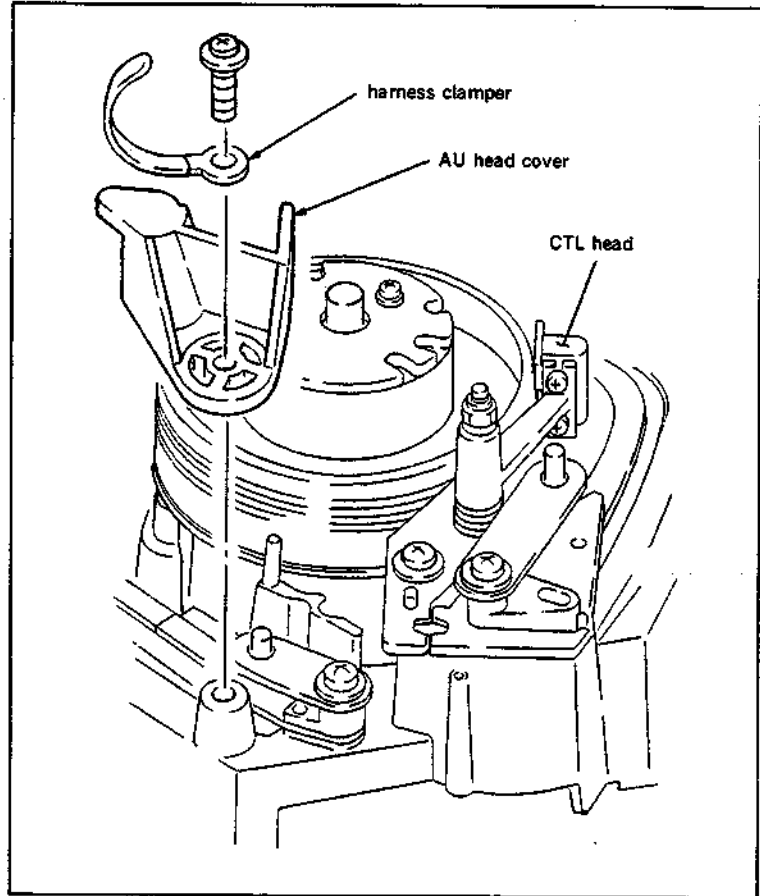

4. Open DR-118A board.
5. Disconnect two connectors CN968 and CN969 connected to a drum assembly.
6. Hold the drum assembly from the unit surface by hand, and remove three screws from back side of the unit which are installing the drum assembly.

Note 1 : Hold the drum assembly with hands to prevent it from dropping.

Note 2 : Be careful not to damage the guides and other parts surrounding the drum assembly.

7. Remove the drum assembly from the unit.

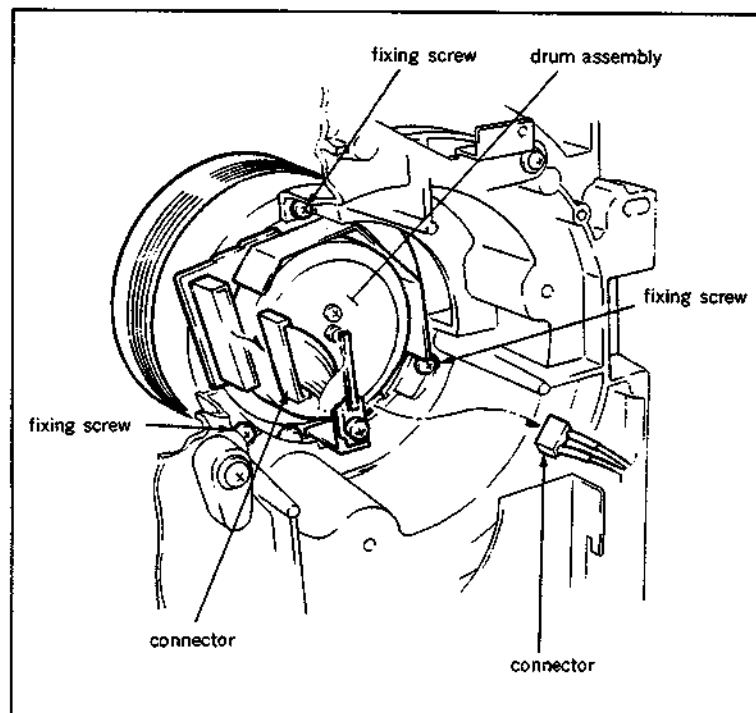

Installation

8. Clean the new drum assembly mounting surface and the chassis with cleaning piece moistened with cleaning fluid.
9. Install the drum assembly to the chassis while putting two guide pins of the chassis into the guide holes which are on the lower side of the new drum assembly.

Note 1: Pay particular attention not to cause damages to the tape running surface of the upper drum, video heads, lower drum's tape running surface and lead of the lower drum.

Note 2: Pay particular attention not to cause damages by contacting the guides and other parts surrounding the drum assembly.

10. Tighten the drum assembly with three screws.
11. Connect two connectors CN968 and CN969 to drum assembly.
12. Clean the tape running surface of the drum assembly with a cleaning piece moistened with cleaning fluid. After cleaning, be sure to clean the cleaned surface two or three times with a soft dry cleaning piece.

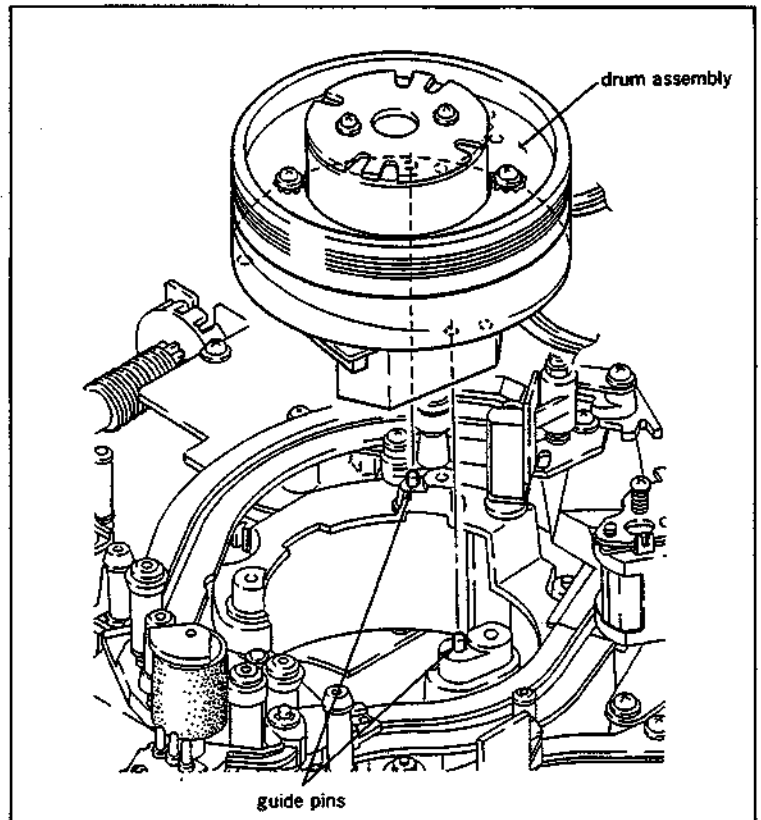

Adjustments after replacement

13. Perform confirmation of drum motor operation. (Refer to Section 5-3-1.)
14. Perform video tracking adjustment. (Refer to Section 6-4.)
15. Perform CTL head height adjustment. (Refer to Section 6-5.)
16. Perform CTL head position adjustment. (Refer to Section 6-6.)
17. Perform audio head height adjustment. (Refer to Section 6-7.)
18. Perform audio head phase adjustment. (Refer to Section 6-8.)
19. Perform confirmation of tape running. (Refer to Section 6-3.)
20. Perform TC head position adjustment. (Refer to Section 6-10.)
21. Install the AU head cover together with the drum harness clumper.
22. Install the fly wheel to the upper part of the TG-4 tape guide roller. (Refer to step (15) in Section 5-2.)
23. Install the cleaning roller assembly. (Refer to steps (7) and (8) in Section 5-6.)
24. Perform cleaning roller block position adjustment. (Refer to Section 5-6-1.)
25. Perform RF switching position adjustment. (Refer to Section 6-12.)
26. Perform picture splitting compensation adjustment. (Refer to Section 6-14.)
27. Perform confirmation of video tracking. (Refer to Section 6-4.)
28. Perform servo system adjustment.
29. Perform RF system adjustment.
30. Perform video system adjustment.

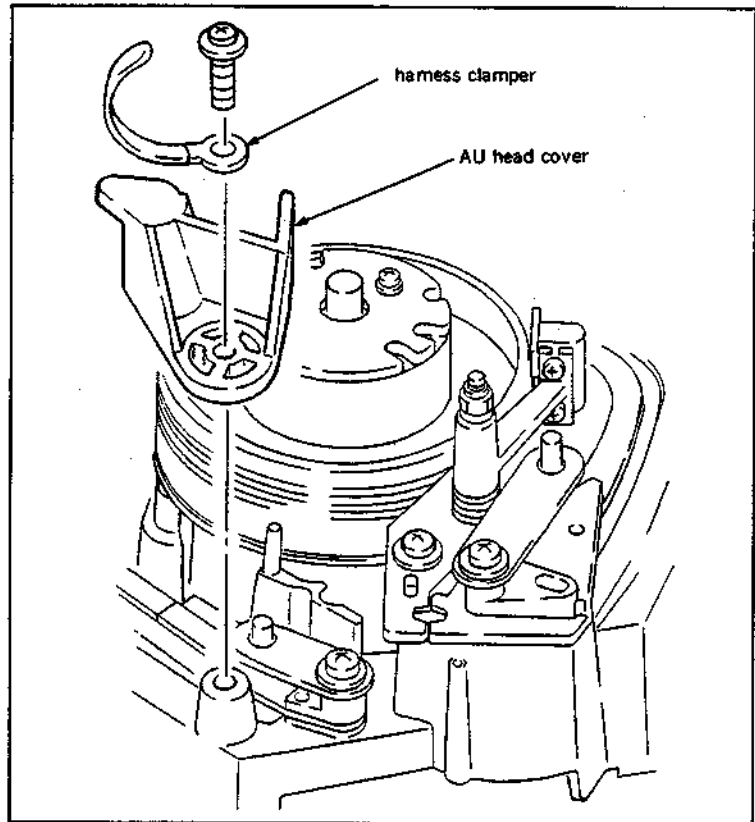

5-3-1. Drum Motor Operation Check

- Be sure to perform the drum motor operation check when a drum assembly is replaced.

Preparation

Connect a video monitor with VIDEO OUTPUT 3 connector or MONITOR connector, and display characters.

Check

1. Put Bit7 of S601 on SS-48P board in CLOSE state, and turn the POWER to ON.
2. Press S302 and put the unit into maintenance mode.
3. Press the search dial to enter the jog mode, and move * mark to "BO: SERVO CHECK" which is displaying on the monitor screen with the search dial.
4. Press S302 on SS-48P board to select "SERVO CHECK" mode.
5. Move * mark to "BO2: MOTOR CHECK" which is displaying on the monitor screen with the search dial.
6. Press S302 on SS-48P board to select "MOTOR CHECK" menu.
7. Move * mark to "BO26: DRUM MOTOR" which is displaying on the monitor screen with the search dial.
8. Press S302 on SS-48P board and to execute "DRUM MOTOR" sub-menu.
9. Check the followings appears on the monitor screen :
 "SPEED : OK"
 "PHASE : LOCK"
 "PG : EXIST"
 If above messages are not displayed, check that four connectors connected with the drum assembly are inserted surely.
 If above messages are still not displayed, check the drum driver circuit, drum FG amplifier circuit and drum PG amplifier circuit (on DR-118A board).
10. Press S303 on SS-48P board, and check that the drum rotation stops.
11. Press S303 twice on SS-48P board to return to the mode screen.
12. Turn the POWER to OFF, and put Bit7 of S601 on SS-48P board in OPEN state.

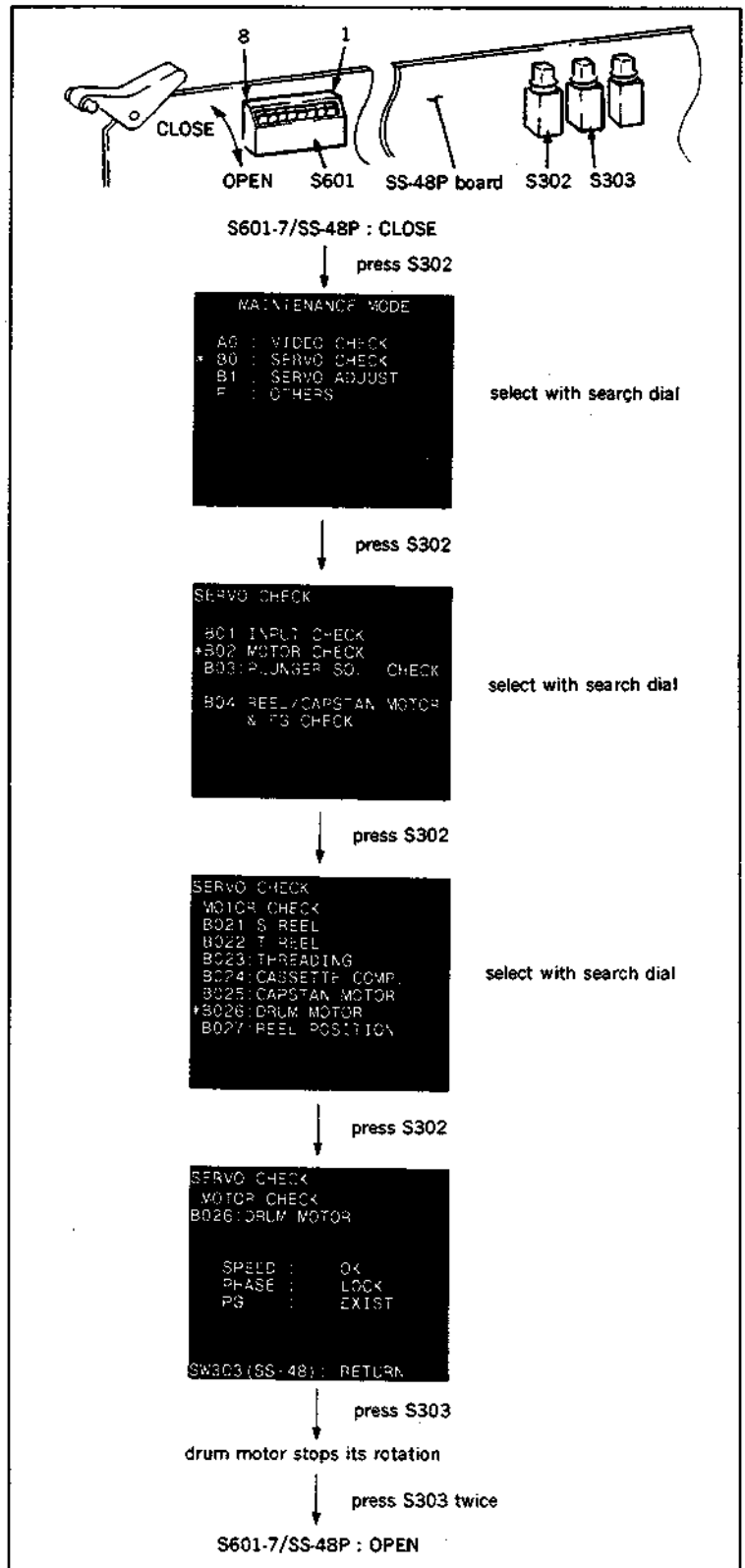

5-4. DRUM GROUND SHAFT ASSEMBLY REPLACEMENT

- The drum ground shaft assembly is a periodic replacement part. It is recommended to replace periodically based on the periodic maintenance table.
- When a drum ground shaft becomes worn, white noise may appear on the monitor screen. In this case, replace the drum ground shaft.
- Do not apply excessive force or try to bend the drum ground shaft assembly.

Tools

- Cleaning piece : 2-034-697-00
Cleaning fluid : 9-919-573-01

Removal

1. Remove a fixing screw of a drum ground shaft assembly, and remove the drum ground shaft assembly.

Installation

2. Clean a projection of a new drum ground shaft assembly with a cleaning piece moistened with cleaning fluid. After cleaning, be sure to clean the cleaned surface two or three times with a soft dry cleaning piece.

Note: When cleaning the drum ground shaft assembly, never apply excessive force or try to bend the drum ground shaft assembly.

3. Clean the mounting place of the drum and the installation surface on the new drum ground shaft assembly with a cleaning piece moistened with cleaning fluid.
4. Install the new drum ground shaft assembly as the projection on its end to be located in the center of the drum ground shaft touching the surface of the lower part of the drum.

Note: When installing the drum ground shaft assembly, never apply excessive force or try to bend it.

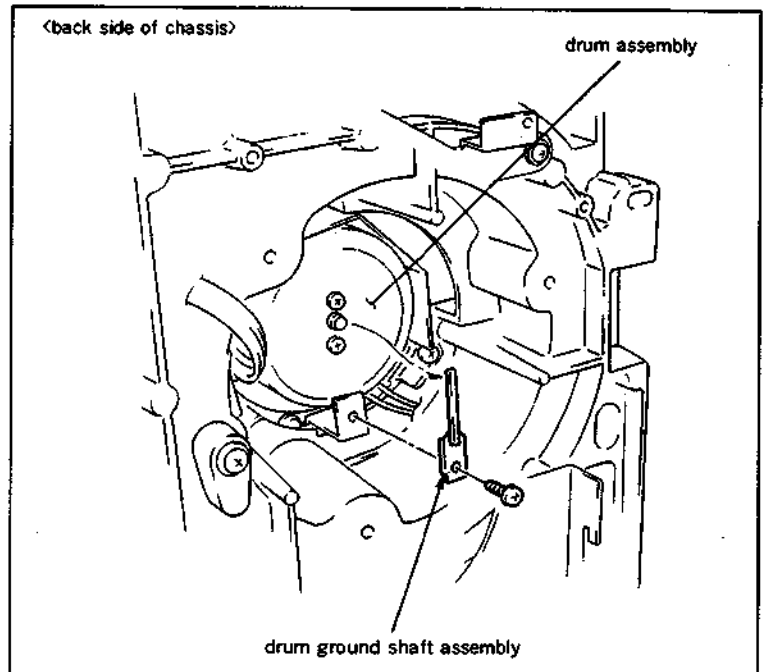

5-5. PINCH ROLLER ASSEMBLY REPLACEMENT

- The pinch roller assembly is a periodic replacement part. It is recommended to be replaced periodically based on the periodic maintenance table.
- When a pinch roller assembly is worn or damaged, replace the pinch arm assembly.

Replacement flow chart

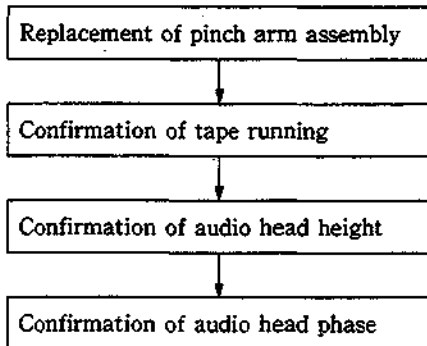

Tool

- Cleaning piece : 2-034-697-00
- Cleaning fluid : 9-919-573-01

Removal

1. Remove a cassette compartment.
2. Turn the POWER to ON.
3. Turn the POWER to OFF when a pinch roller comes to a position in front of a TG-6 tape guide.
4. Remove an E-ring on the upper part of a pinch arm assembly, and remove the pinch arm assembly from a P slider assembly.

Note : Do not remove a polyslider washer and spring at the bottom of the pinch arm assembly.

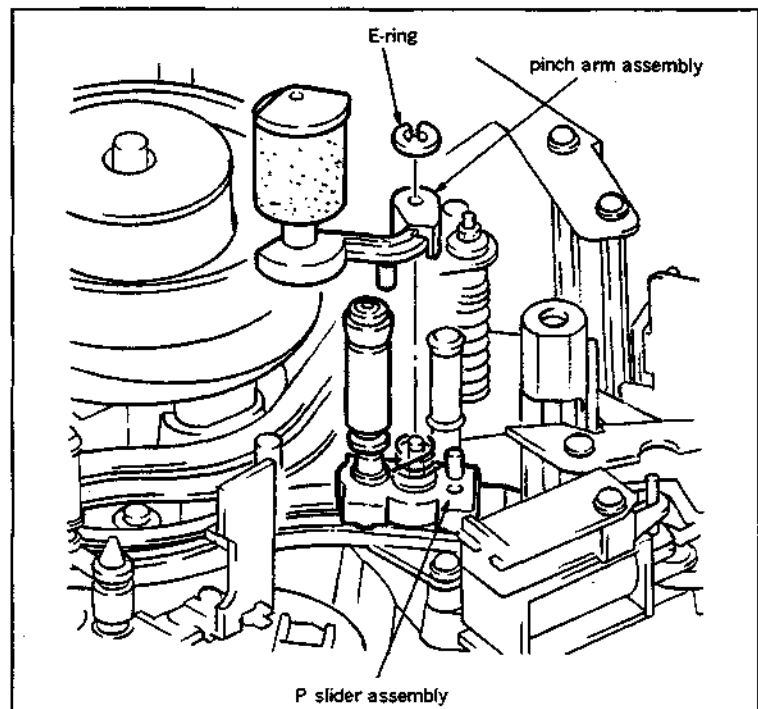
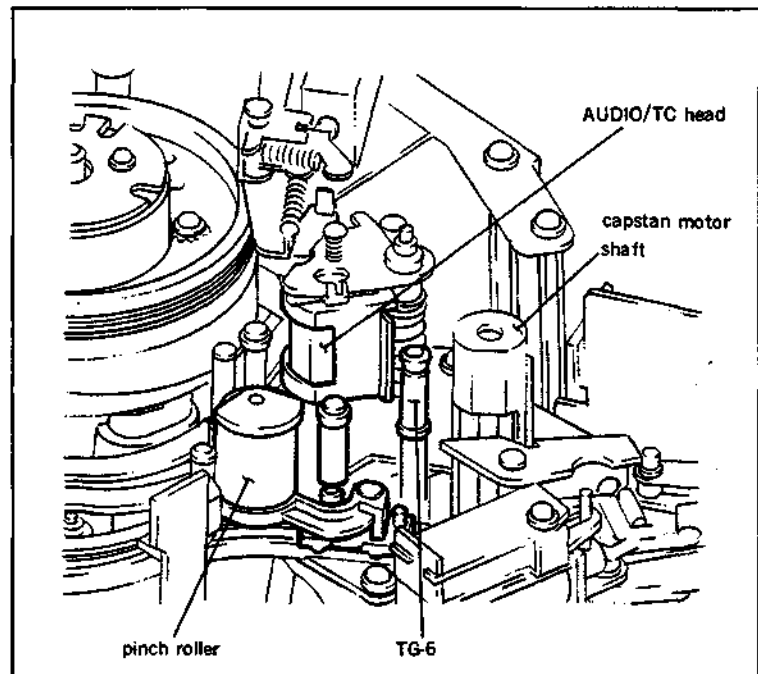

Installation

5. Rub surface of the installing shaft of the pinch arm assembly with cotton swab moistened with oil, in other words, apply about a half of drop oil to the shaft.
6. Set a spring as shown in the figure, and install a new pinch arm assembly and fasten it to the P slider assembly with E-ring.

Note 1: Install a spring so that the long bar is to the shaft on the P slider assembly, and the short bar is to the pinch arm assembly.

Note 2: Using tweezers to install the spring will help to easy installation.

7. Push the pinch arm assembly toward the TG-6 tape guide with finger, then release the finger and make sure that it returns smoothly to its original position.

Clean the new pinch roller with a cleaning piece moistened with cleaning fluid.

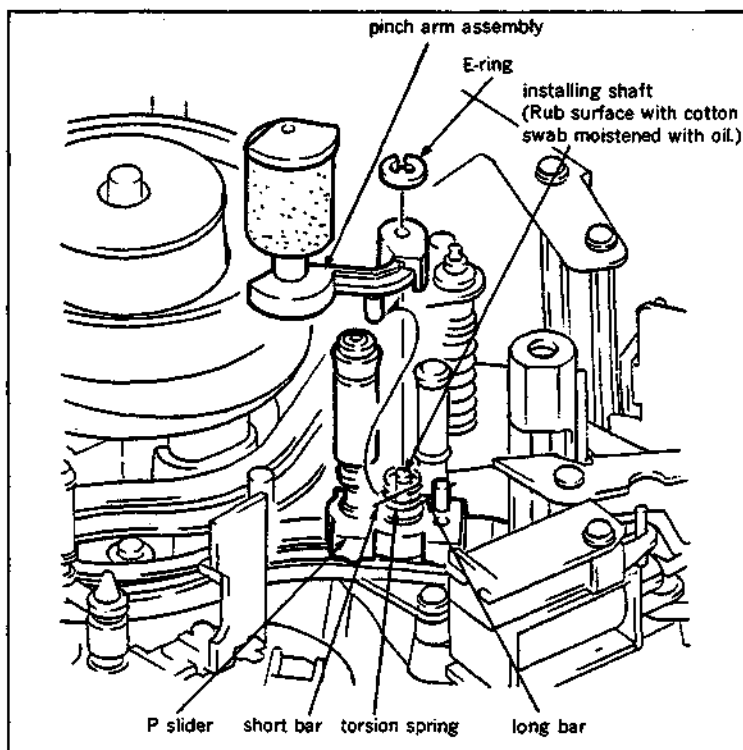

Adjustment after replacement

8. Perform confirmation of tape running.
(Refer to Section 6-3.)
9. Perform confirmation of video tracking.
(Refer to Section 6-4.)
10. Perform confirmation of audio head height.
(Refer to Section 6-7.)
11. Perform confirmation of audio head phase.
(Refer to Section 6-8.)

5-6. CLEANING ROLLER ASSEMBLY REPLACEMENT

- The the cleaning roller assembly is a periodic replacement part. It is recommended to replaced periodically based on the periodic maintenance table.

Replacement flow chart

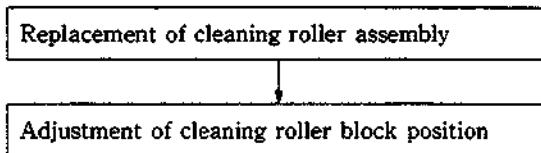

Removal

1. Disconnect a connector of a cleaning solenoid from CN916 on PD-56 board which is positioned on a pinch solenoid block.
2. Remove two screws holding a cleaning roller block, and remove it.

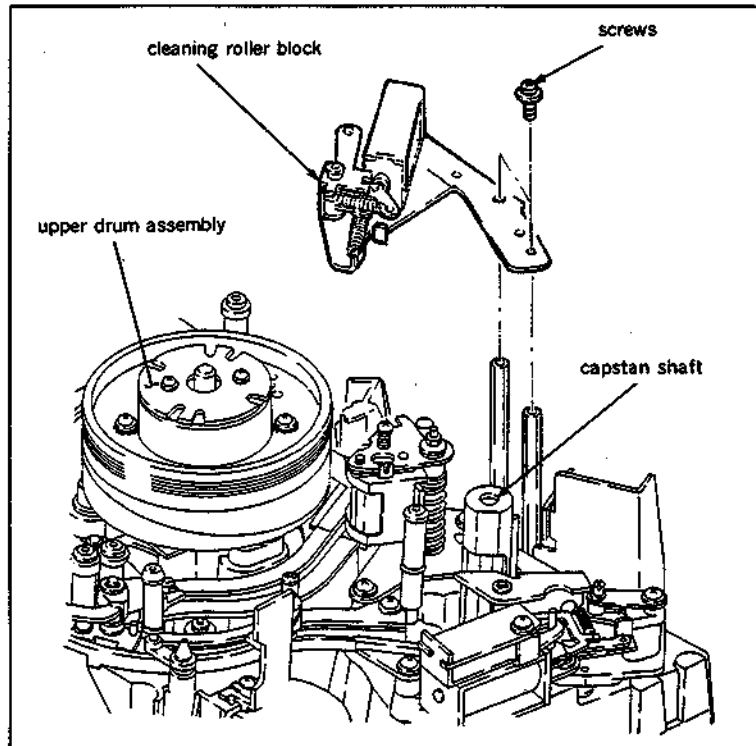

3. Remove a shaft cap of a cleaning roller, and remove a cleaning roller assembly.

Installation

4. Install bearings to the both side of a new cleaning roller assembly, and insert the assembled cleaning roller assembly and a spacer to the shaft in the order as shown in the figure.
5. Install the shaft cap to the top of the shaft.
6. Make sure that the cleaning roller rotates smoothly when rotating the cleaning roller with hand.
7. Install the cleaning roller block to the shafts with two screws snugly, but do not tighten.
8. Connect connector CN916 of the cleaning solenoid on PD-56 board.

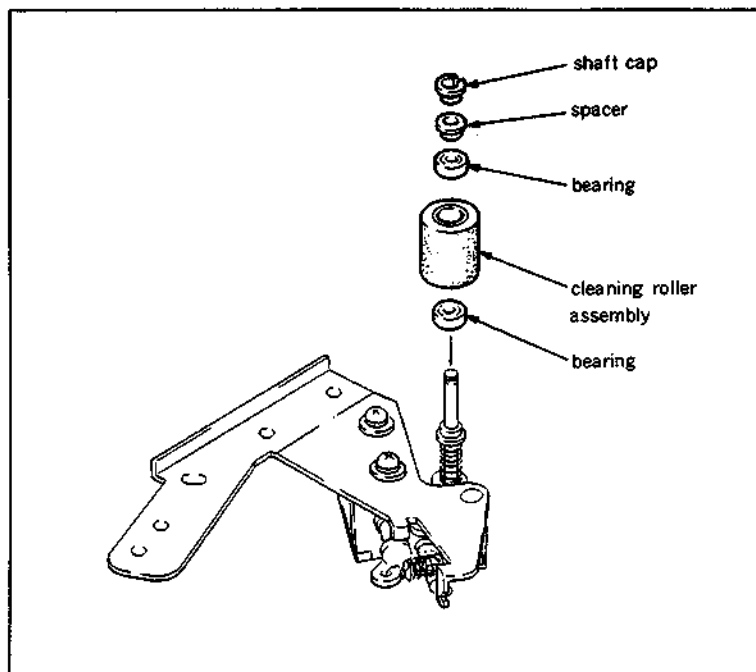

Adjustment after replacement

9. Perform cleaning roller block position adjustment. (Refer to Section 5-6-1.)

5-6-1. Cleaning Roller Block Position Adjustment

- Be sure to perform a cleaning roller block position adjustment, when the cleaning roller block is removed.

Adjustment

1. Install a cleaning roller block to the shafts with two screws snugly, but do not tighten.
2. While pushing an iron core of a cleaning roller solenoid in the direction of arrow (energized position), adjust the position of the cleaning roller block so that the clearances between a pin of a lever C and C main arm satisfy the specification 1. Then tighten it with two screws.
3. Visually check the clearance between a drum and cleaning roller satisfy the specification 2.
4. Turn the POWER to ON, then the unit put into threading mode automatically. While the cleaning solenoid is energized in threading mode, visually check that the clearances between the pin of the lever C and C main arm satisfy the specification 1. If the specification is not satisfied, readjust the cleaning roller block position so that the specification 1 is satisfied.

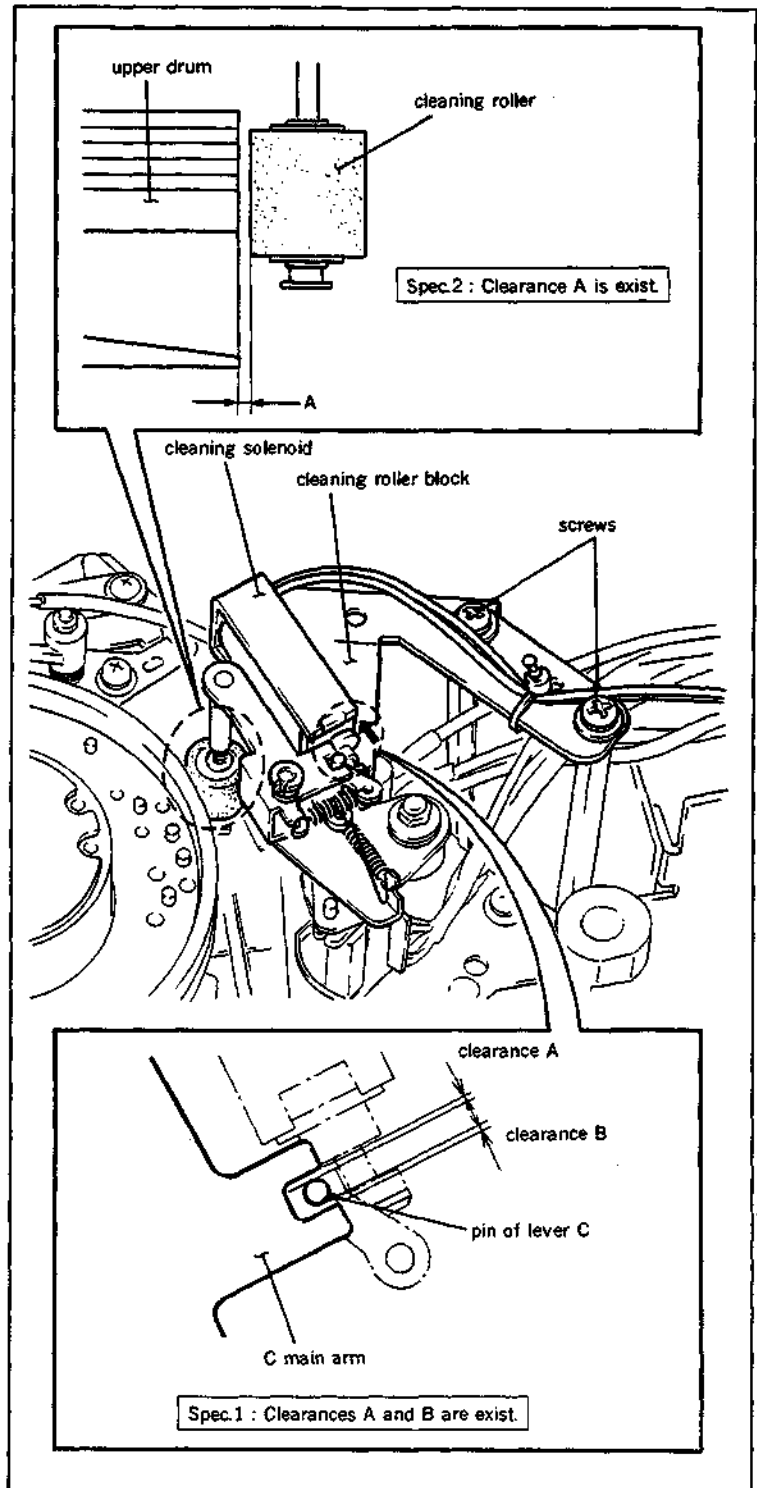

5-7. BRAKE LINING ASSEMBLY REPLACEMENT

- When the POWER is OFF, T reel brake lining and S reel brake lining are pressed against the take-up reel table and supply reel table.

When the POWER is turned ON, the S and T reel brake linings are released.

The reel brake linings still released even at PLAY, STOP, REW, F.FWD, SEARCH and REV modes.

Press the EJECT button to put into the EJECT mode. Few seconds later after the EJECT mode is completed, the S and T reel brake linings are pressed against the reel tables.

Replacement flow chart

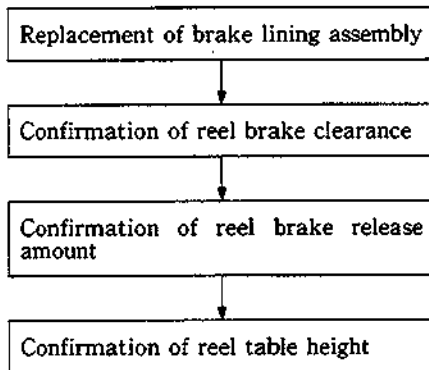

If the reel brake release amount does not satisfy the specification, and then reel brake release amount adjustment is performed, be sure to perform the following adjustments:

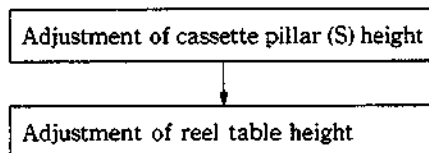

Removal and installation

1. Remove a reel table. (Refer to steps from (1) to (6) in Section 5-10.)
2. Unhook a spring of a brake block as shown in the figure from a motor plate assembly.
3. Remove an E-ring that holds the brake block, and remove it.
4. Unhook a spring in the brake block as shown in the figure and remove a lining assembly.
5. Assemble a new lining assembly in the reversing the order of steps (2) to (4).
6. Install the reel table to the reel shaft.

Note : Two fixing screws must be fasten after the reel table height check is completed.

Adjustment after replacement

7. Perform confirmation of reel brake clearance. (Refer to Section 5-7-1.)
8. Perform confirmation of brake release amount. (Refer to steps from (1) to (3) in Section 5-7-2.)
9. Perform confirmation of reel table height. (Refer to steps from (1) to (8) in Section 5-10-2.)

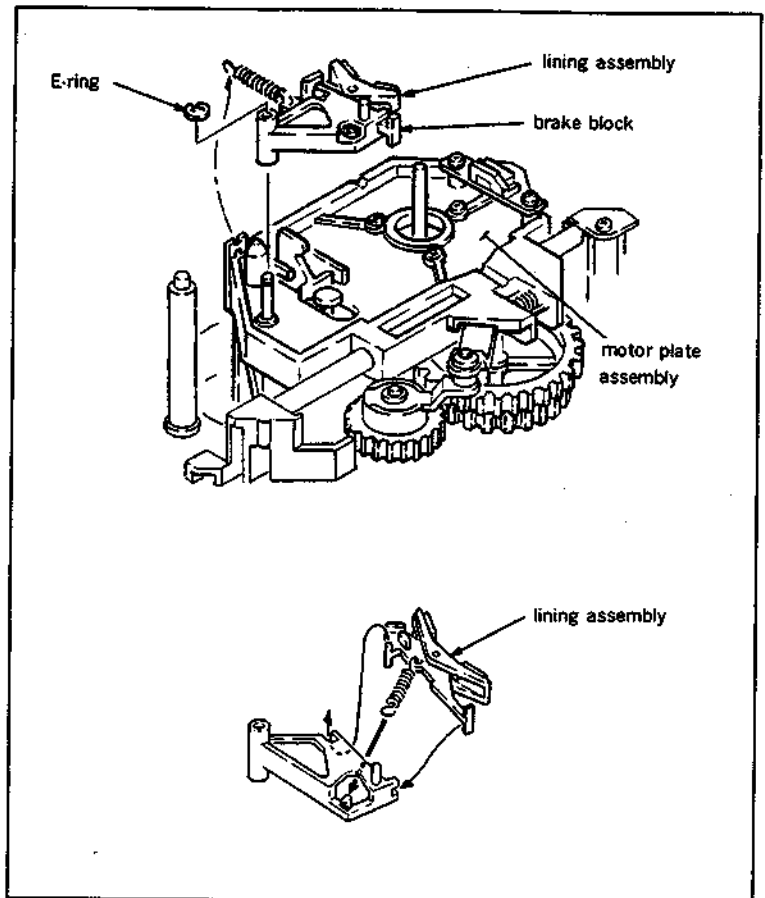

5-7-1. Reel Brake Clearance Check

- Be sure to perform a reel brake clearance check, when the brake lining assembly is removed.

Check

1. Make sure that there is a clearance between a brake arm block and boss when a take-up reel table is turned counterclockwise direction by fingers.
If there is no clearance, replace the lining assembly.
2. Make sure that there is a clearance between a brake arm block and boss when a supply reel table is turned clockwise direction by fingers.
If there is no clearance, replace the lining assembly.

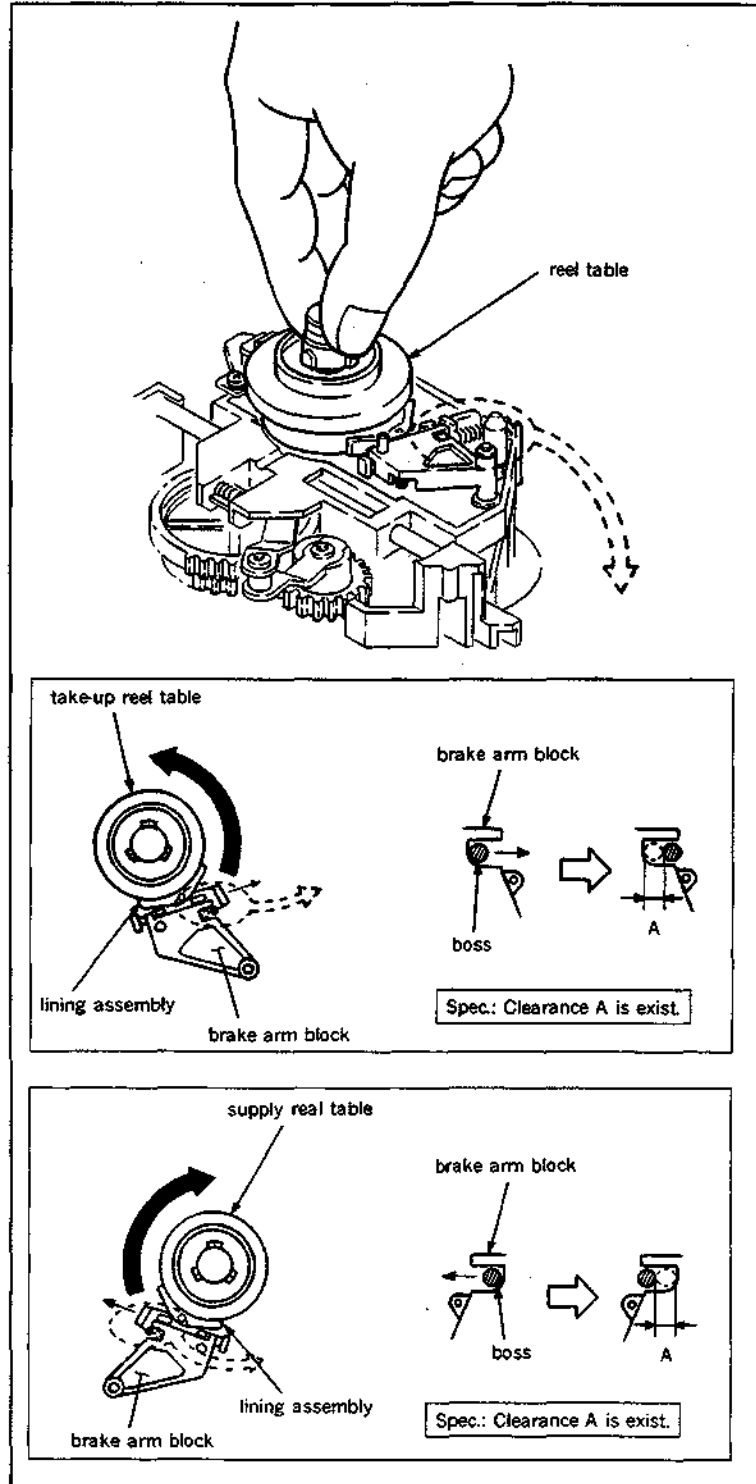

5-7-2. Reel Brake Release Amount Adjustment

- Be sure to perform a reel brake release amount check, when the brake lining assembly is replaced.
- Be sure to perform a reel brake release amount adjustment, after the brake solenoid is replaced or removed.

Check

1. Turn the POWER to ON.
2. Make sure that a T brake lining assembly doesn't touch a take-up reel table while the take-up reel table is rotating. (Specification 1) (For reference : clearance is 0.6 to 1.8 mm.)
If the specification is not satisfied, perform the adjustment step (4) and later.
2. Make sure that a S brake lining assembly doesn't touch a supply reel table while the supply reel table is rotating. (Specification 2) (For reference : clearance is 0.6 to 1.8 mm.)
If the specification is not satisfied, perform the adjustment step (4) and later.

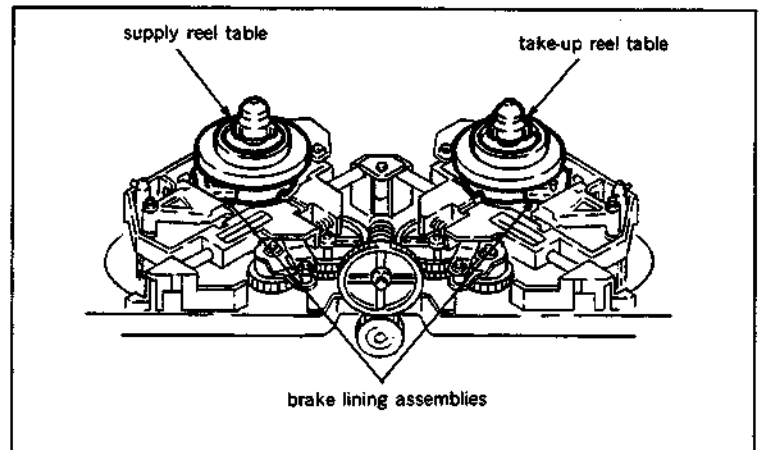

Adjustment

4. Turn the POWER to OFF.
5. Remove a reel motor plate. (Refer to steps from (1) to (6) in Section 5-11.)
6. Loosen two screws which hold a brake solenoid $\frac{1}{2}$ to 1 turn.
7. Adjust the brake solenoid position by pushing down an iron core of the brake solenoid to energized position so that there is a clearance between the reel table and brake lining assembly.

Specification : There is a clearance (0.6 to 1.8 mm) between the reel table and brake lining assembly when the solenoid is energized position.

8. Tighten two fixing screws of the brake solenoid.
9. Reconfirm that there is a clearance between the reel table and brake lining assembly when pushing down the iron core of the brake solenoid to energized position.
10. Assemble the reel motor plate in the reversing the order of steps (1) to (6) in Section 5-11.
11. Perform the following adjustment after adjustment :
Perform cassette pillar (S) height check. (Refer to steps from (1) to (6) in Section 5-10-1.)
Perform reel table height check. (Refer to steps from (1) to (8) in Section 5-10-2.)

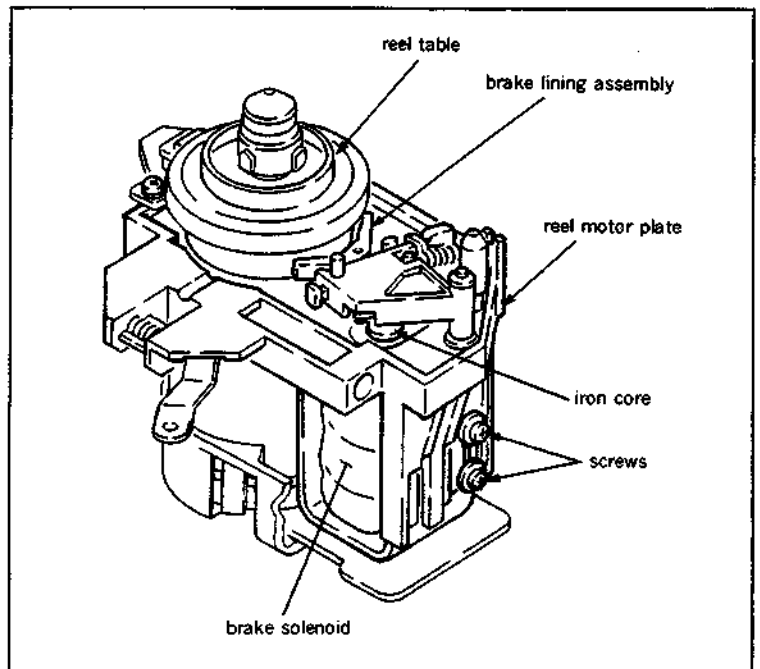

5-8. TAPE GUIDE REPLACEMENT

- This section describes the replacement procedure for the tape guide roller.
- All the replacement procedures for the tape guide rollers are the same except TG-4 tape guide roller.
- Pay particular attention not to cause damage to the tape guide roller as the tape guide roller touches the tape.

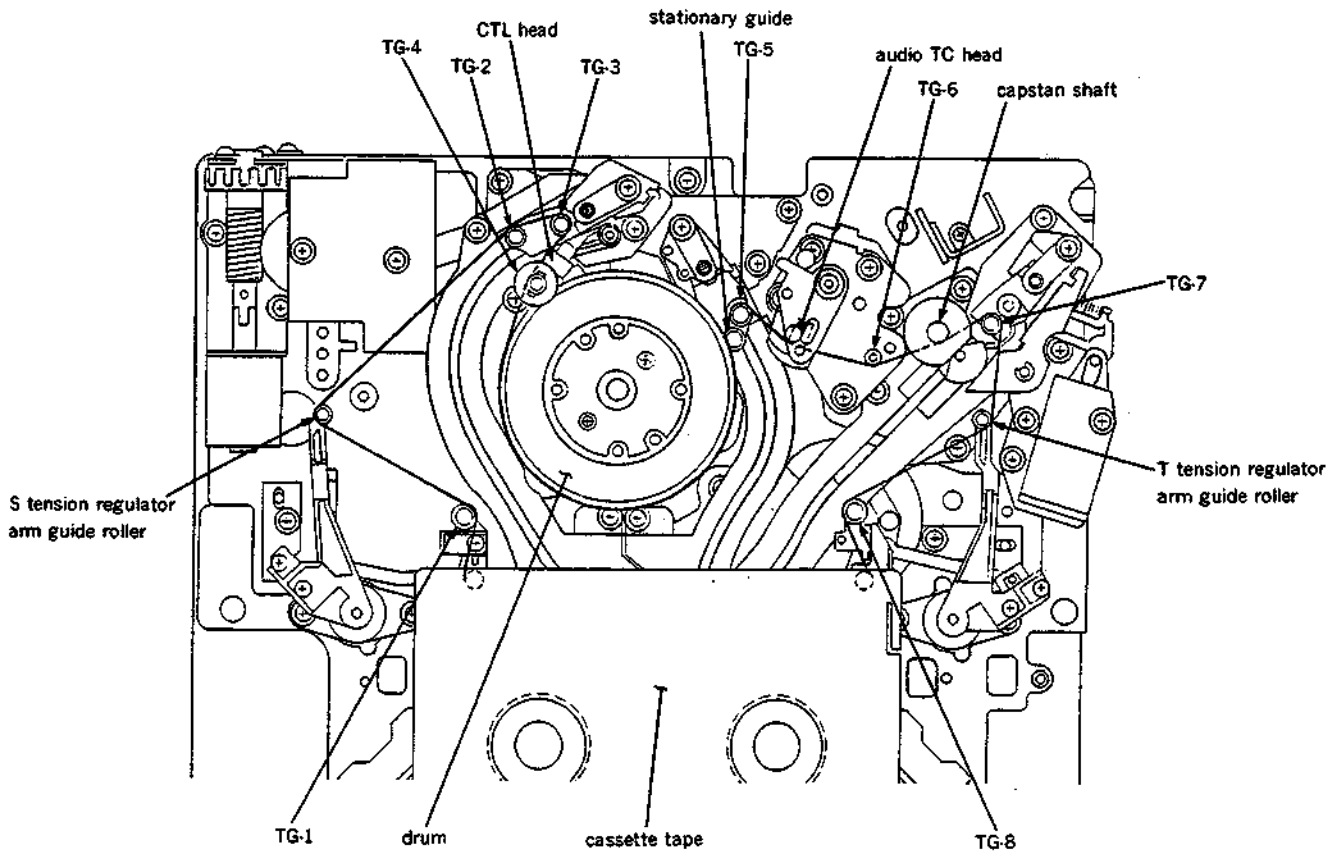

<This figure shows that the unit is in the threading end state.>

5-8-1. TG-4 Tape Guide Roller Replacement

Tools

Cleaning piece : 2-034-697-00

Cleaning fluid : 9-919-573-01

Replacement flow chart

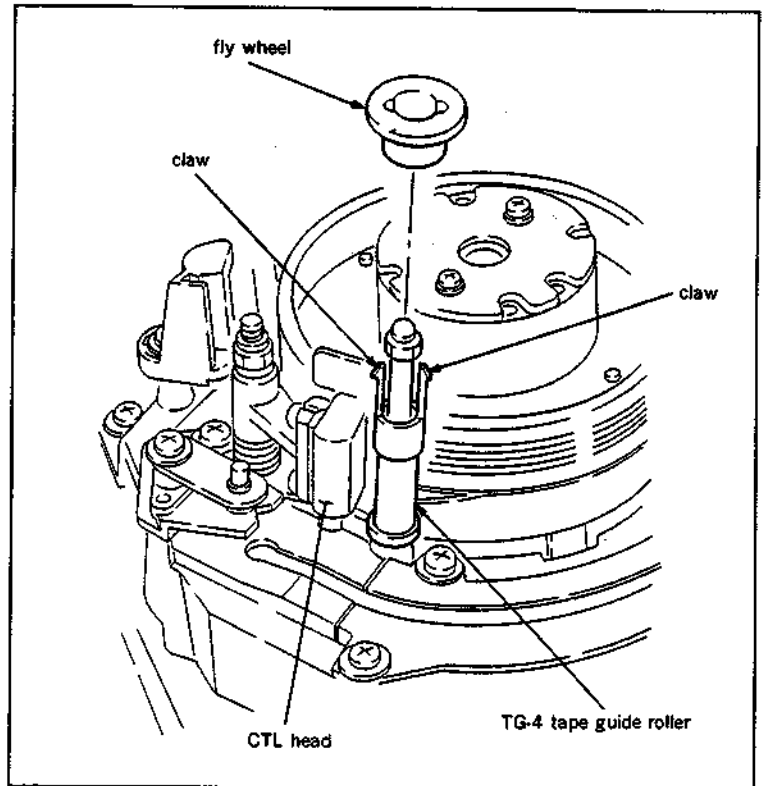
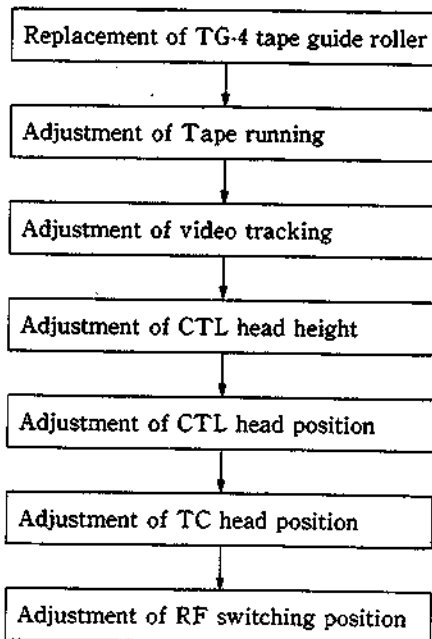

Removal

1. Rotate an upper drum assembly by hand, and set the video heads away from a TG-4 tape guide roller.
2. Hold claws of the upper part of the TG-4 tape guide roller using tweezers, and remove a fly wheel.

- Unscrew a nut on the upper part of the TG-4 tape guide roller, and remove a bearing holder and TG-4 tape guide roller.

Note :Pay particular attention not to cause damage to the upper drum assembly during removal.

Installation

- Install a new TG-4 tape guide roller and bearing holder, and then tighten the nut.
- Make sure that the TG-4 tape guide roller rotates smoothly when rotating it by hand.
- Clean the TG-4 tape guide roller with a cleaning piece moistened with cleaning fluid.
- Align two claws of the upper part of the TG-4 tape guide roller and the two grooves of the fly wheel, then install the fly wheel to the TG-4 tape guide roller.
Make sure that the fly wheel is surely locked, after the installation.

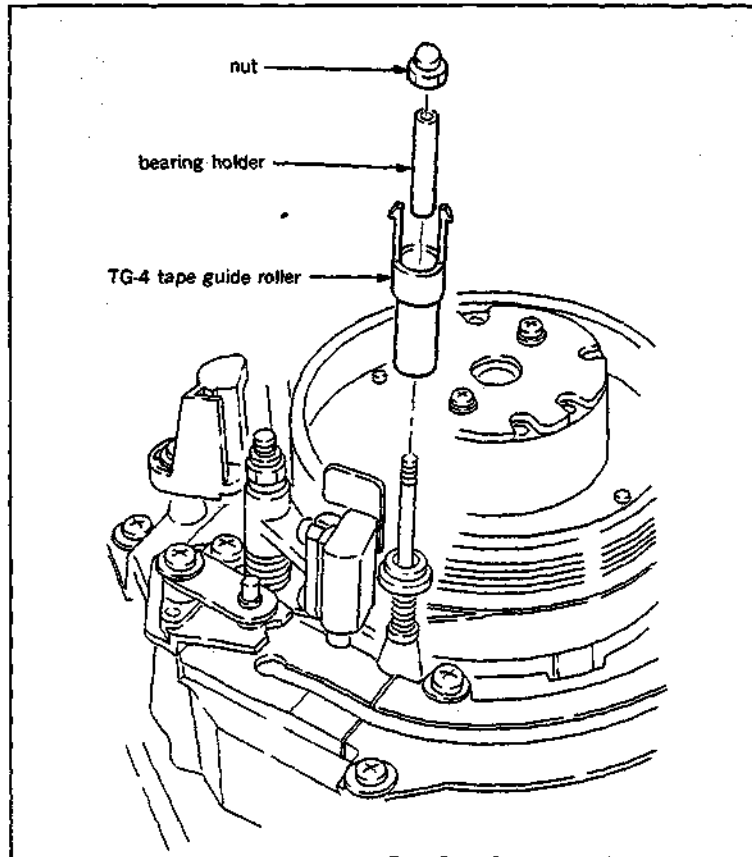

Adjustment after replacement

- Perform tape running adjustment. (Refer to Section 6-3.)
- Perform video tracking adjustment. (Refer to Section 6-4.)
- Perform CTL head height adjustment. (Refer to Section 6-5.)
- Perform CTL head position adjustment. (Refer to Section 6-6.)
- Perform TC head position adjustment. (Refer to Section 6-10.)
- Perform RF switching position adjustment. (Refer to Section 6-12.)

5-8-2. Other Tape Guide Rollers Replacement

Tools

- Cleaning piece : 2-034-697-00
- Cleaning fluid : 9-919-573-01
- Tape guide adjustment driver : J-6321-500-A

Replacement flow chart

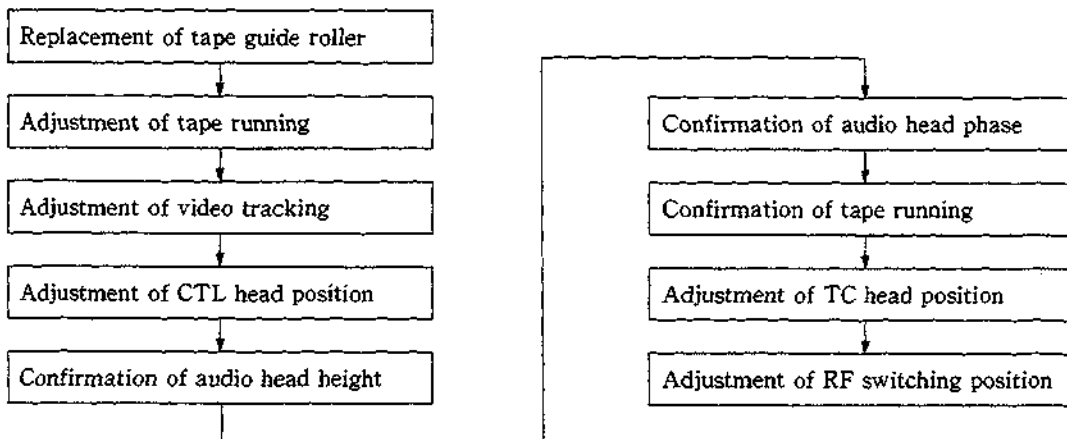

Removal

1. Make sure that the unit is in unthreading end mode.
2. Loosen locking screw of the upper part of the tape guide roller for one to two turns with a tape guide adjustment driver.

Note : Pay particular attention not to cause damage to other tape guide rollers.

3. Rotate an upper flange of the tape guide, and remove it from a tape guide shaft.
4. Remove a tape guide roller.

Installation

5. Install a new tape guide roller and upper flange.

Note : Pay particular attention not to cause damage to other tape guide rollers during installation.

6. Tighten tentatively the locking screw of the upper part of the tape guide with the tape guide adjustment driver.
7. Make sure that the tape guide roller rotates smoothly when rotating the tape guide roller with hand.
8. Clean the tape guide roller, upper flange and lower flange with a cleaning piece moistened with cleaning fluid.

Adjustment after replacement

9. Perform tape running adjustment.
(Refer to Section 6-3.)
10. Perform video tracking adjustment.
(Refer to Section 6-4.)
11. Perform CTL head position adjustment.
(Refer to Section 6-6.)
12. Perform confirmation of audio head height.
(Refer to Section 6-7.)
13. Perform confirmation of audio head phase.
(Refer to Section 6-8.)
14. Perform confirmation of tape running.
(Refer to Section 6-3.)
15. Perform TC head position adjustment.
(Refer to Section 6-10.)
16. Perform RF switching position adjustment.
(Refer to Section 6-12.)

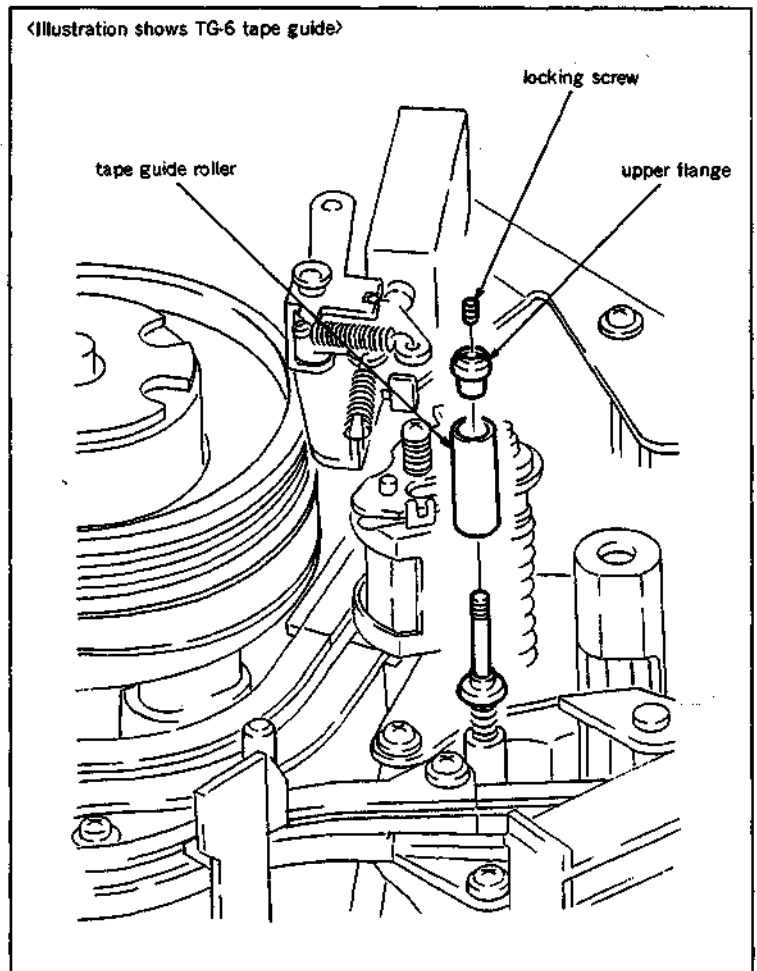

5-9. CLEANING SOLENOID REPLACEMENT

Replacement flow chart

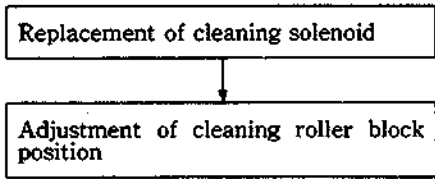

Removal

1. Disconnect connector of a cleaning solenoid from CN916 on PD-56 board which is positioned on a pinch solenoid block.
2. Remove two screws holding a cleaning roller block, and remove the cleaning roller block.
3. Remove two screws holding the cleaning solenoid, and remove the cleaning solenoid.

Installation

4. Install a new solenoid to a cleaning base assembly with two washers and screws while inserting a boss of a cleaning lever (2) into the groove of an iron core of the solenoid.

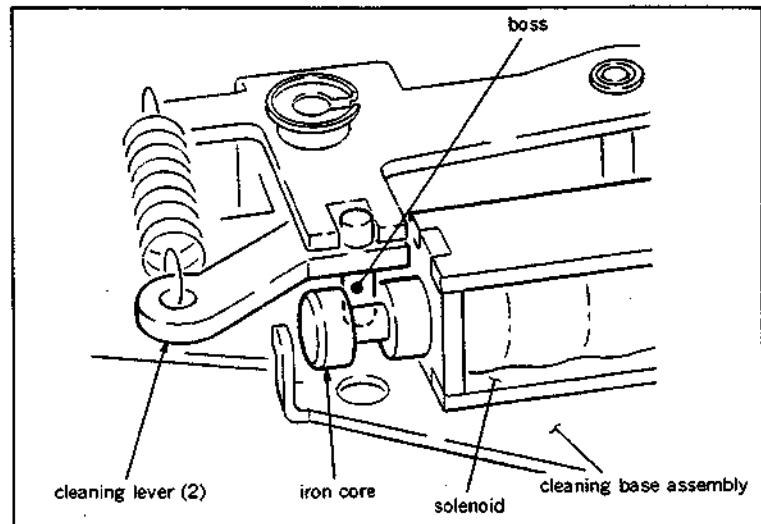
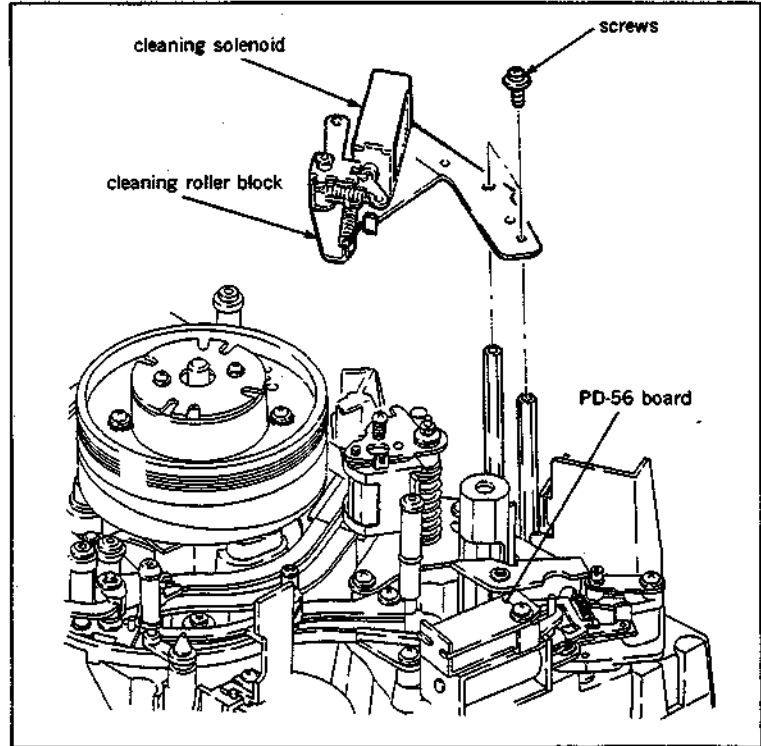

5. Tighten the cleaning roller block to the studs with two screws, but do not tighten.
6. Connect the connector CN916 of the cleaning solenoid to PD-56 board.

Adjustment after replacement

7. Perform cleaning roller block position adjustment. (Refer to Section 5-6-1.)

5-10. REEL TABLE REPLACEMENT

Tools

- Cleaning piece : 2-034-697-00
- Cleaning fluid : 9-919-573-01
- L shaped wrench (across flat has 1.5 mm)
: 7-700-736-05

Replacement flow chart

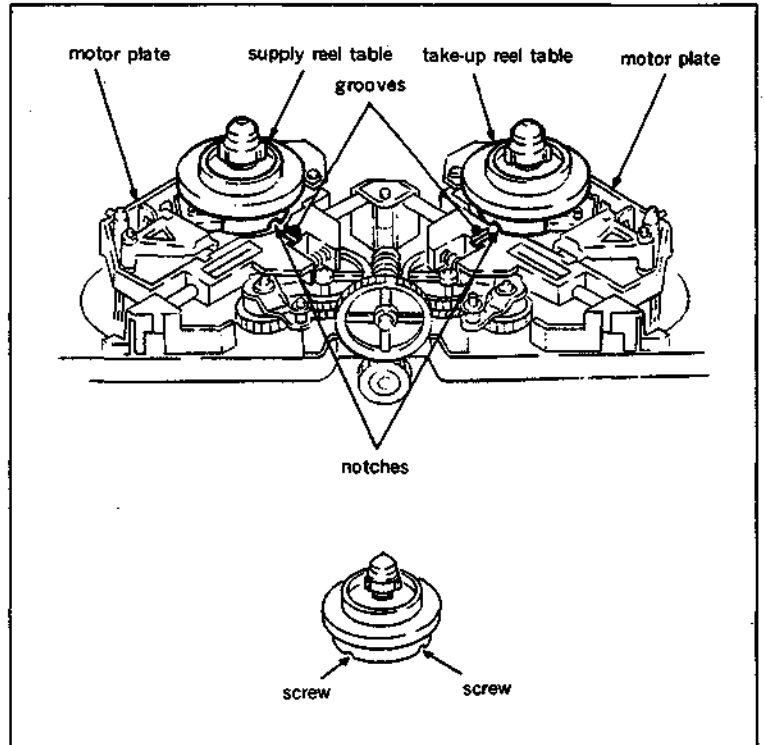
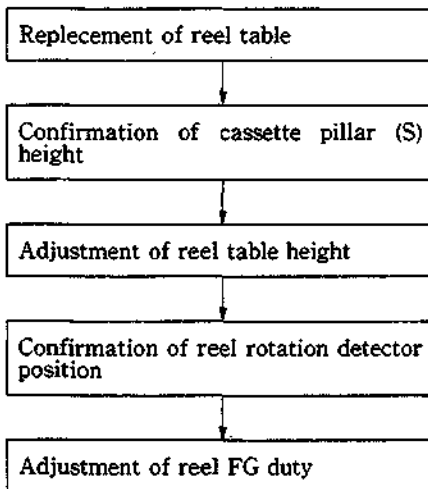

Removal

1. Align one of the notch at the lower part of a reel table to a groove of a motor plate by rotating the reel table by hand.
2. Insert the L shaped wrench along with the groove of the motor plate, and put it into the screw hole at the lower part of the reel table.
3. Loosen a fixing screw of the reel table for two to three turns.
4. Rotate the reel table more, and align the other notch at the lower part of the reel table to the groove of the motor plate.
5. Repeat the above steps (2) and (3) in order to loosen the fixing screw of the reel table.
6. Remove the reel table from the motor plate assembly.

Note :A polyslider washer for reel table height adjustment is inserted at the lower part of the bearing of the reel table.

Pay particular attention not to lose the polyslider washer when removing the reel table as the polyslider washer may be stuck with the lower part of the reel table.

Installation

7. Clean a new reel table with a cleaning piece moistened with cleaning fluid, and install it to a reel motor shaft.

Note :Tighten two fixing screws after the reel table height check is performed.

Adjustment after replacement

8. Perform confirmation of cassette pillar (S) height. (Refer to steps from (1) to (6) in Section 5-10-1.)
9. Perform reel table height adjustment. (Refer to Section 5-10-2.)
10. Perform reel rotation detector position adjustment. (Refer to steps from (1) to (5) in Section 5-10-3.)
11. Perform reel FG duty adjustment. (Refer to Section 5-12-3.)

5-10-1. Cassette Pillar (S) Height Adjustment

Tools

Cassette reference plate (L) : J-6320-880-A
Cleaning piece : 2-034-697-00
Cleaning fluid : 9-919-573-01
Adjustment mirror : J-6080-029-A
L shaped wrench (across flat has 1.5 mm) : 7-700-736-05

Check

1. Make sure that the unit is in unthreading end mode.
2. Clean surface of the cassette reference plate (L) with a cleaning piece moistened with cleaning fluid.
3. Place the cassette reference plate (L) on four cassette pillars.

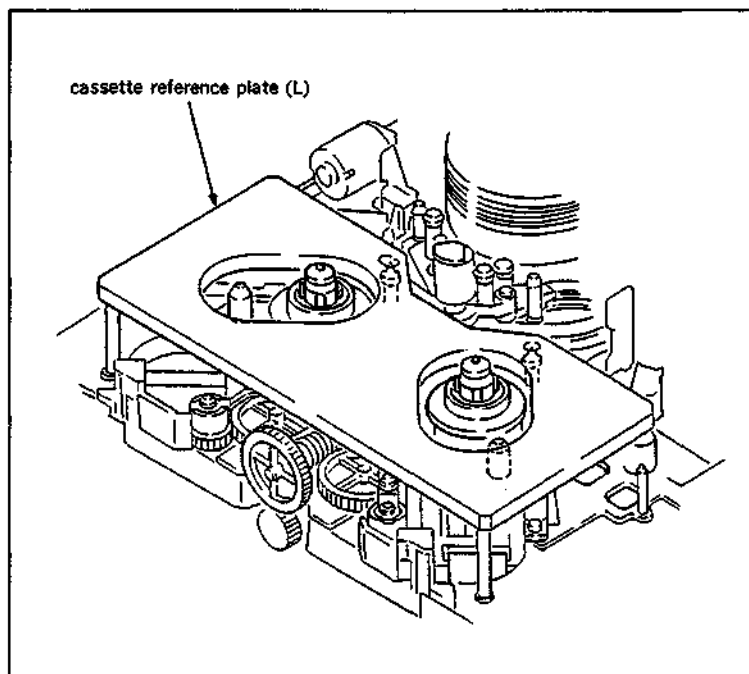

4. Place the supply and take-up reel tables to the intermediate position between S cassette position and L cassette position by rotating a drive gear by fingers as shown in the figure. Make sure that the S cassette pillar and T cassette pillar are positioned under the cassette reference plate (L) as shown in the figure. (The S cassette pillar and T cassette pillar should not be seen from the upper part of the unit.)
5. Turn over the cassette reference plate (L) and place it on four cassette pillars.
6. Check with adjustment mirror that there are no clearances between the cassette reference plate (L) and S cassette pillar, and T cassette pillar.
If the specifications are not satisfied, perform the following adjustment.

Adjustment

7. Loosen a fixing screw of the S cassette pillar and/or T cassette pillar 1/2 to one turn with the L shaped wrench.
8. Lift the S cassette pillar and/or T cassette pillar, and contact it with the cassette reference plate (L).
Tighten a fixing screw with L shaped wrench under this condition.
9. Make sure that the specification is satisfied.

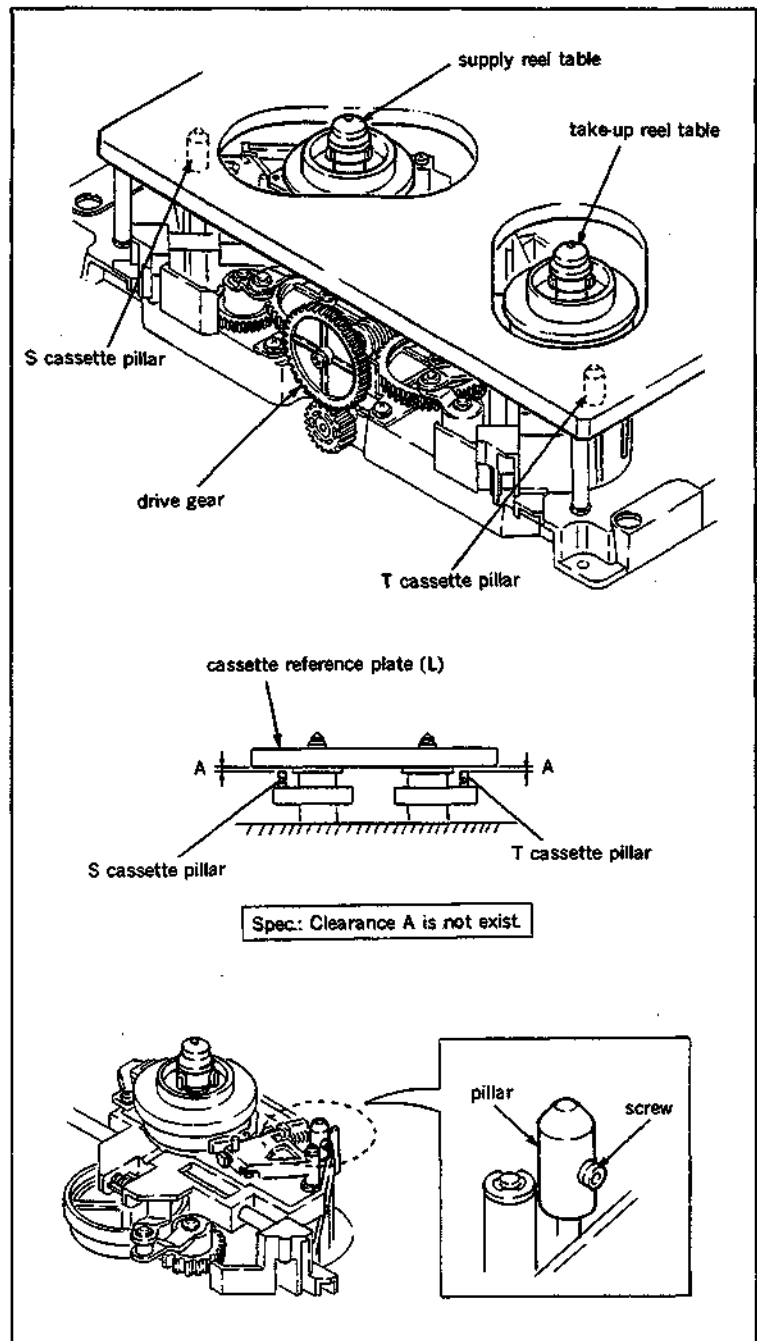

5-10-2. Reel Table Height Adjustment

- This adjustment is not necessary in general, however, perform when a reel motor is replaced or a reel table is removed or replaced.
- In order to obtain stabilized tape running, supply reel table should be placed in the position 0.13mm higher than the reel table height adjusted with a gauge.
- Pay particular attention to perform this adjustment as it is to be the reference for the tape running system.

Tools

Cassette reference plate (L):	J-6320-880-A
Reel table height gauge	: J-6320-680-A
Cleaning piece	: 2-034-697-00
Cleaning fluid	: 9-919-573-01
L shaped wrench (across flat has 1.5 mm)	: 7-700-736-05

Check

1. Make sure that the unit is in unthreading end mode.
2. Rotate a drive gear by fingers so that a reel table is placed to the L cassette position.
3. Clean the surface of the cassette reference plate (L) with a cleaning piece moistened with cleaning fluid.
4. Place the cassette reference plate (L) on four cassette pillars.
5. Clean the surface of the reel table height gauge with a cleaning piece moistened with cleaning fluid.
6. Move the reel table height gauge from three directions of arrows towards supply reel table or take-up reel table, and make sure that the specifications are satisfied.

Specification 1 : * marked portion (passing side) as shown in the figure of the gauge runs over the flange of the reel table.

Specification 2 : ** marked portion (no passing side) as shown in the figure of the gauge is blocked at the flange of the reel table.

7. Rotate the drive gear by fingers so that the reel table is placed to the S cassette position.
8. Perform step (6) and make sure that the specifications are satisfied.

If any specification is not satisfied, perform step (9) and later, and repeat the adjustment at both L cassette position and S cassette position until the specifications are satisfied. If the specification is satisfied, at both positions, perform step (11) and later.

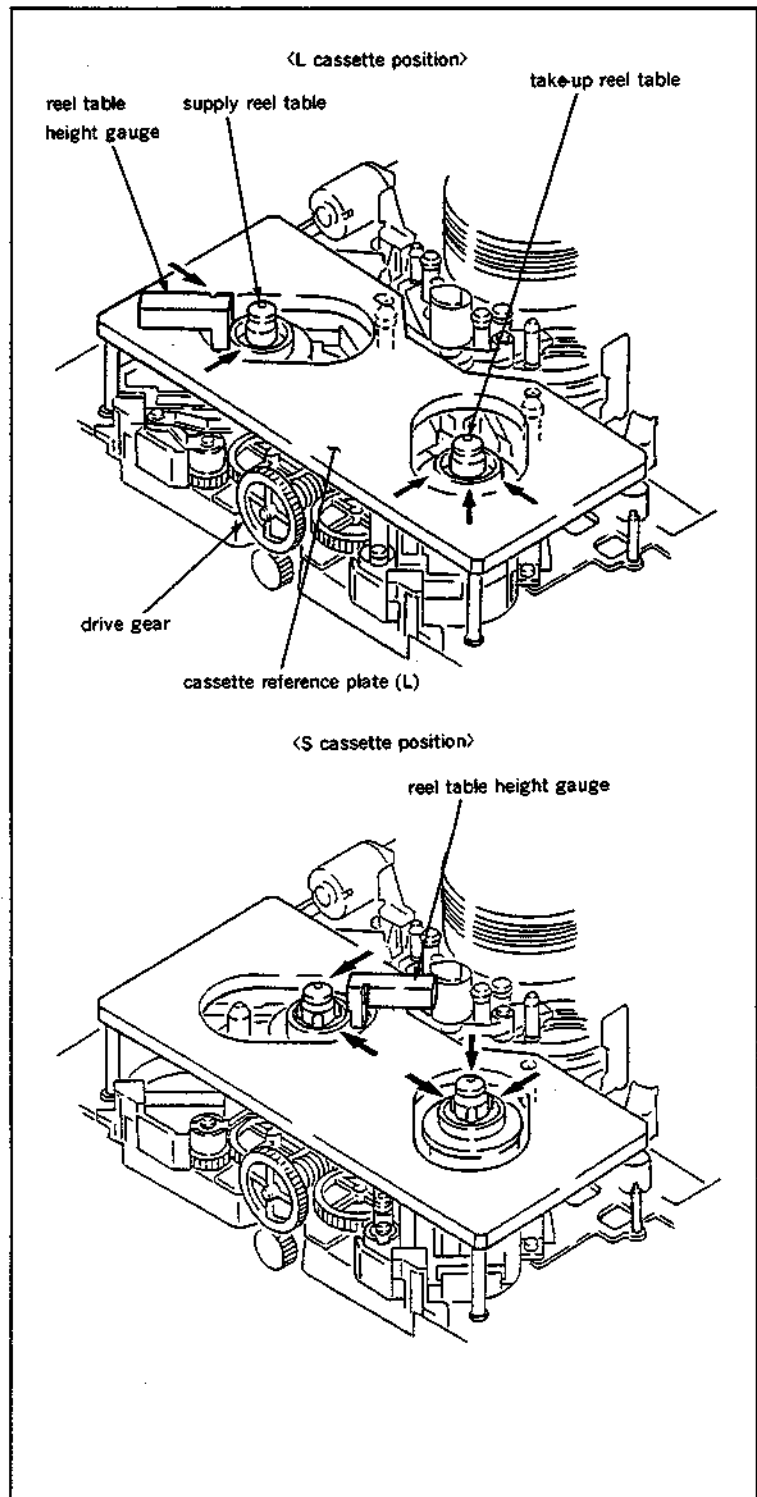

Adjustment

9. Remove the reel table.
10. Adjust the height of the reel table with polyslider washer installed into the reel motor shaft until the specifications are satisfied at both L cassette position and S cassette position.

Polyslider washer for adjustment use:

4 mm dia. 0.13 mm thick : Part No. 3-701-441-01

4 mm dia. 0.25 mm thick : Part No. 3-701-441-11

4 mm dia. 0.5 mm thick : Part No. 3-701-441-21

11. After step (10) is completed, remove the supply reel table tentatively, and add one 0.13 mm thick polyslider washer below the reel table.
12. Tighten two fixing screws of the reel table with the L shaped wrench while pressing the supply reel table and/or take-up reel table slightly towards down. (Refer to steps from (1) to (5) in Section 5-10.)

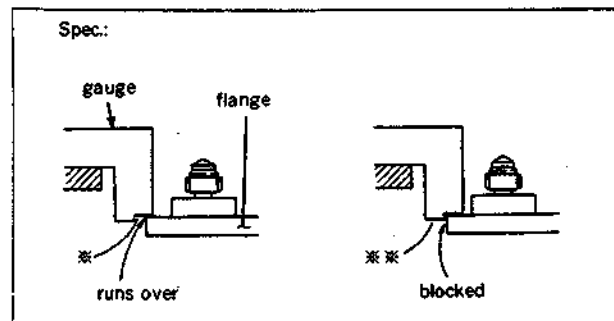
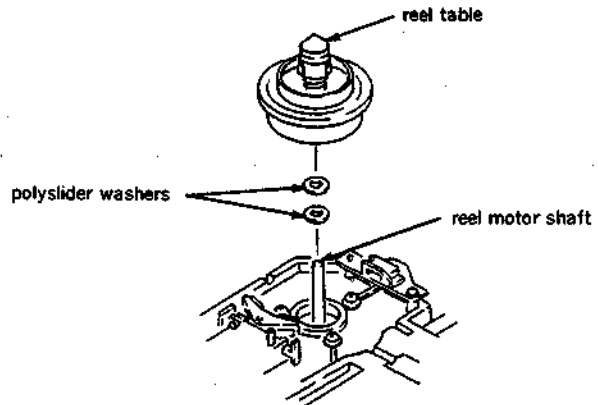

5-10-3. Reel Rotation Detector Position Adjustment

- Be sure to perform this adjustment when a reel rotation detector is replaced.
- Be sure to perform the confirmation when a reel motor and/or reel table is replaced.
- Adjustment of a supply reel rotation detector and take-up reel rotation detector take the same procedure.

Tools

Oscilloscope

Wire clearance gauge : J-6152-450-A

Check

1. Connect the oscilloscope to PD-56 board on a pinch solenoid block as follows :
S : TP1/PD-56 board
T : TP2/PD-56 board
2. Put Bit7 of S601 on SS-48P board in CLOSE state.
3. Turn the POWER to ON.
4. Press S602 on SS-48P board. (Reel table begins to rotate.)
5. Make sure that the test point output satisfies the specification 1.
Make sure that a clearance between a reel table and reel rotation detector satisfies the specification 2.

Specification 1 : No distortion in the waveform as well as 0.4 Vp-p or more.

Specification 2 : A clearance between the reel table and reel rotation detector is more than 0.1 mm.

When both specifications 1 and 2 are satisfied, perform step (6) and later.

When either specifications 1 or 2 is not satisfied, perform step (17) and later.

6. Turn the POWER to OFF.
7. Turn the POWER to ON again, and press S302 and put the unit into maintenance mode.
8. Press the search dial to enter the jog mode, and move * mark to "B0: SERVO CHECK" which is displaying on the monitor screen.
9. Press S302 on SS-48P board to select "SERVO CHECK" mode.
10. Move * mark to "B02: MOTOR CHECK" which is displaying on the monitor screen with the search dial.
11. Press S302 on SS-48P board to select "MOTOR CHECK" menu.
12. Move * mark to "B021 : S REEL" or "B022 : T REEL" which is displaying the sub-menu on the monitor screen with the search dial.

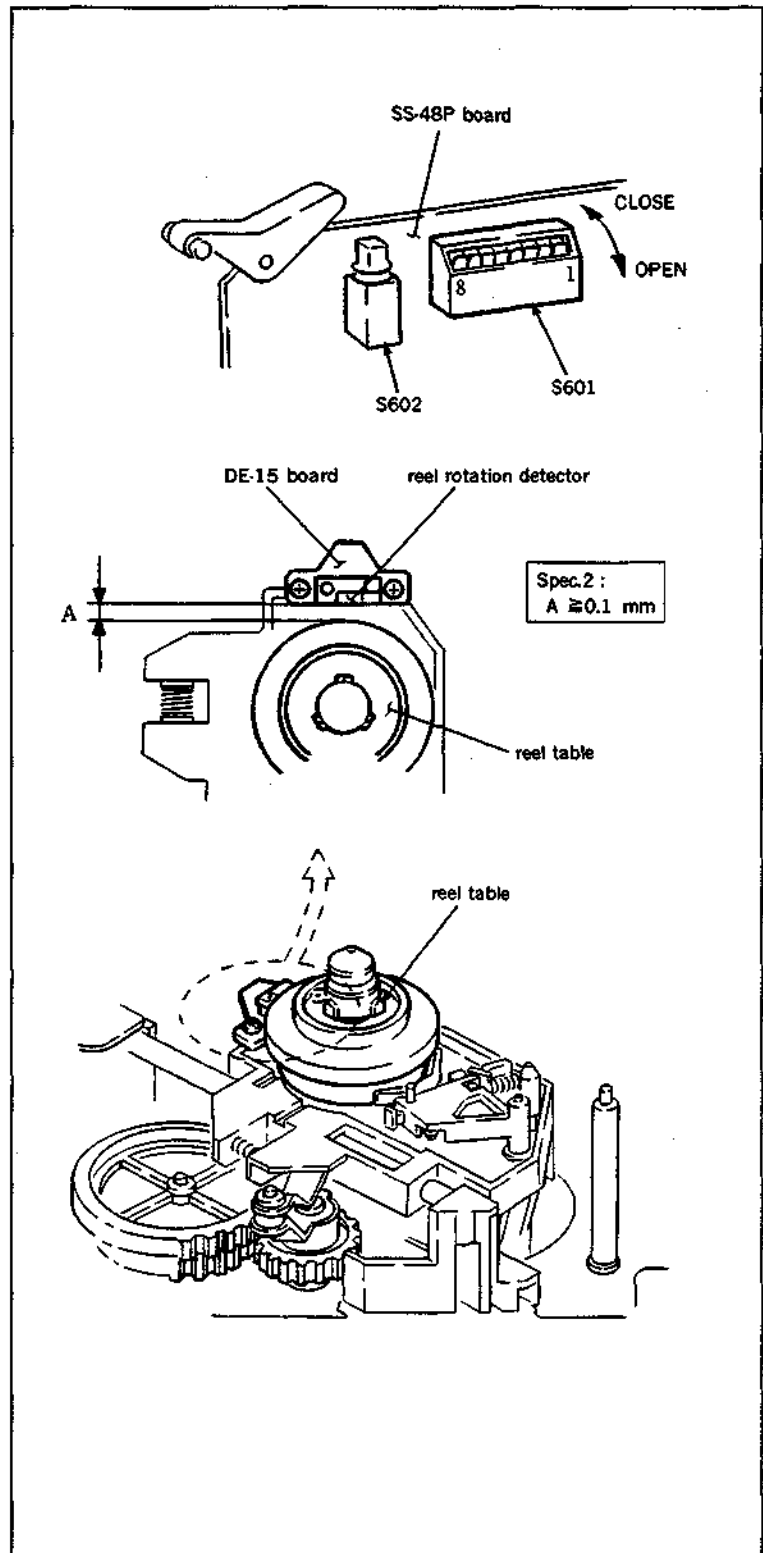

13. Press S302 on SS-48P board and execute S REEL" or T REEL" sub-menu.
14. When the search dial rotates in the jog mode, make sure that the test point output satisfies the specification 3.

Specification 3 : 0.4 V p-p or more (no distortion)

If the specification 3 is satisfied, perform step (15) and later.

If the specification 3 is not satisfied, perform step (17) and later.

15. Turn the POWER to OFF.
16. Put Bit7 of S601 on SS-48P board in OPEN state.

Adjustment

17. Loosen a fixing screw of DE-15 board holding the reel rotation detector for one to two turns.
18. Insert the paper which two folded such as of this service manual between the reel table and reel rotation detector, and press the reel rotation detector slightly towards the reel table. Then tighten a fixing screw.
19. Pull out the folded paper, and make sure that a sheet of paper is easily inserted in this space.
20. Perform the check procedures and make sure that all of the three specifications 1 to 3 are satisfied.
If all of the three specifications are not satisfied, adjust the position of DE-15 board again.
21. Perform reel FG duty adjustment.
(Refer to Section 5-12-3.)

OK

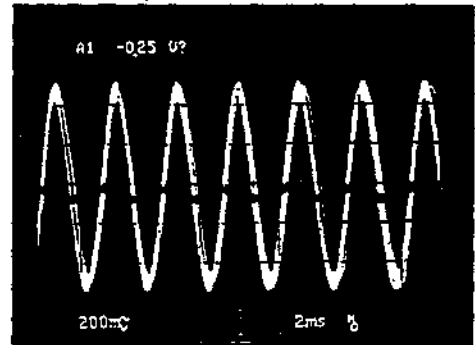

NG
narrower
clearance

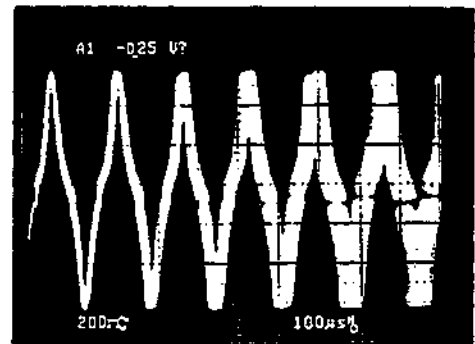

NG
wider
clearance

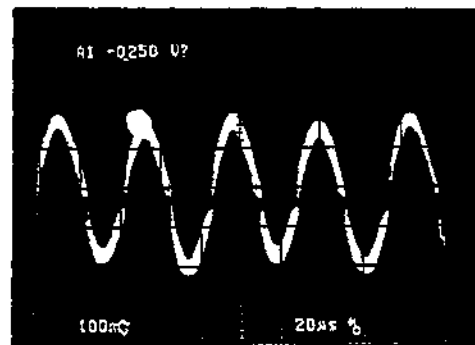

5-11. REEL MOTOR PLATE REPLACEMENT

• Replacement of supply reel motor plate and take-up reel motor plate take the same procedure.

Tools

Cleaning piece	: 2-034-697-00
Cleaning fluid	: 9-919-573-01
L shaped wrench (across flat has 1.5 mm)	
	: 7-700-736-05
Grease (SGL-505)	: 7-662-010-04

Replacement flow chart

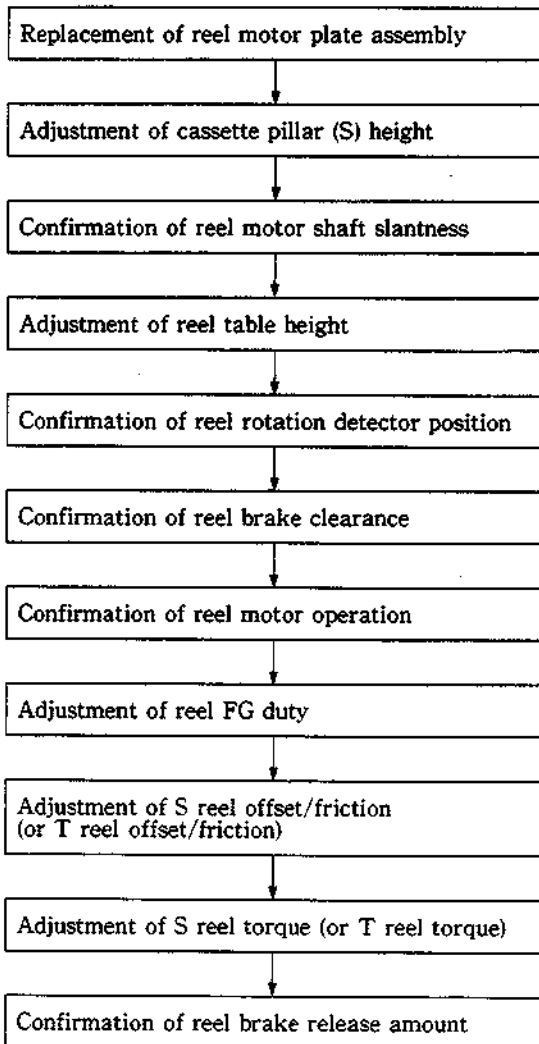

Removal

1. Disconnect a flat cable of a reel motor board (RM-82 board) connected with DR-118A board.
2. Remove an E-ring holding a crank arm (B) of a reel motor plate assembly.

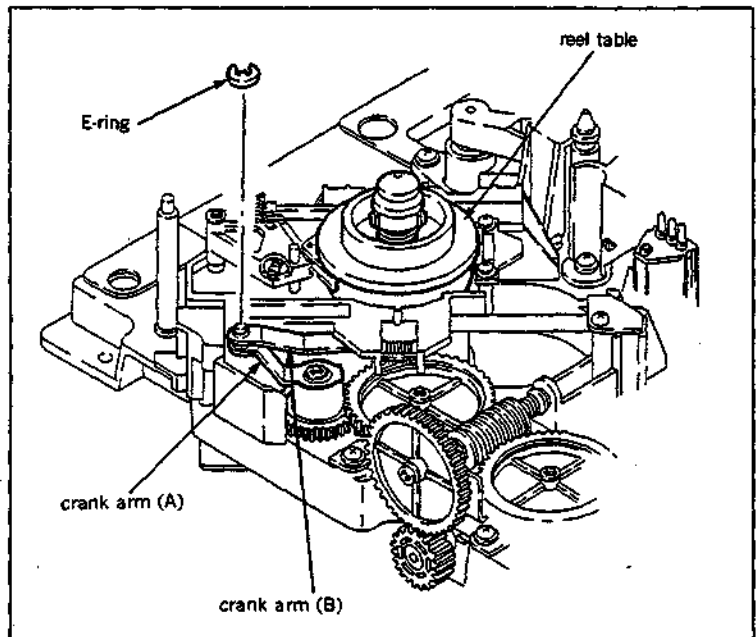

3. Remove a reel table. (Refer to the steps from (1) to (6) in Section 5-10.)
4. Remove a screw shown in the figure, and remove a slide shaft holder bracket.
5. Push a slide shaft towards the direction of arrow and remove it from the reel motor plate assembly.

Note : Pay particular attention not to cause damage to the slide shaft during removal.

6. Lift the reel motor plate assembly, and disconnect the flat cable of the reel motor board (RM-82 board).

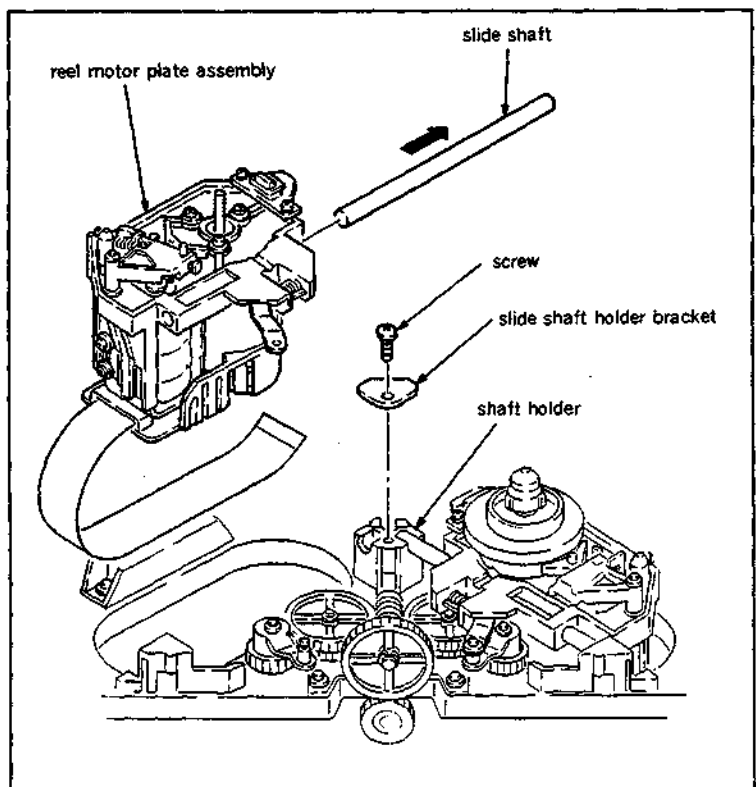

Installation

7. Clean the hole where the slide shaft to be inserted of a new reel motor plate assembly with a cleaning piece moistened with cleaning fluid.
8. Clean the slide shaft with a cleaning piece moistened with cleaning fluid.

9. Connect the flat cable to the connector of RM-82 board of the new reel motor plate assembly.
10. Insert the slide shaft to the reel motor plate assembly and install it to the unit.

Note :Pay particular attention not cause damage to the slide shaft during installation.

11. After putting the slide shaft into a shaft holder, install the slide shaft bracket with a screw.
Smear grease very lightly to the place of the slide shaft shown in the figure.
13. Make sure that the reel motor plate assembly moves smoothly when moving it by hand towards S cassette and L cassette positions.
14. Install the crank arm (B) to a crank arm (A) on the chassis with an E-ring.
15. Install the reel table to a reel shaft.

Note :Tighten two fixing screws after the adjustment of reel table height.

16. Connect the flat cable of the reel motor board (RM-82 board) with DR-118A board.

Adjustment after replacement

17. Perform cassette pillar (S) height adjustment. (Refer to Section 5-10-1.)
18. Perform confirmation of reel motor shaft slantness adjustment. (Refer to steps from (1) to (7) in Section 5-12-1.)
19. Perform reel table height adjustment. (Refer to Section 5-10-2.)
20. Perform confirmation of reel rotation detector position adjustment. (Refer to steps from (1) to (5) in Section 5-10-3.)
21. Perform confirmation of reel brake clearance adjustment. (Refer to Section 5-7-1.)
22. Perform confirmation of reel motor operation. (Refer to Section 5-12-2.)
23. Perform reel FG duty adjustment. (Refer to Section 5-12-3.)
24. Perform S reel offset/friction (or T reel offset/friction) adjustment. (Refer to Section 5-12-4 or 5-12-6.)
25. Perform S reel torque (or T reel torque) adjustment. (Refer to Section 5-12-5 or 5-12-7.)
26. Perform confirmation of reel brake release amount adjustment. (Refer to steps from (1) to (3) in Section 5-7-2.)

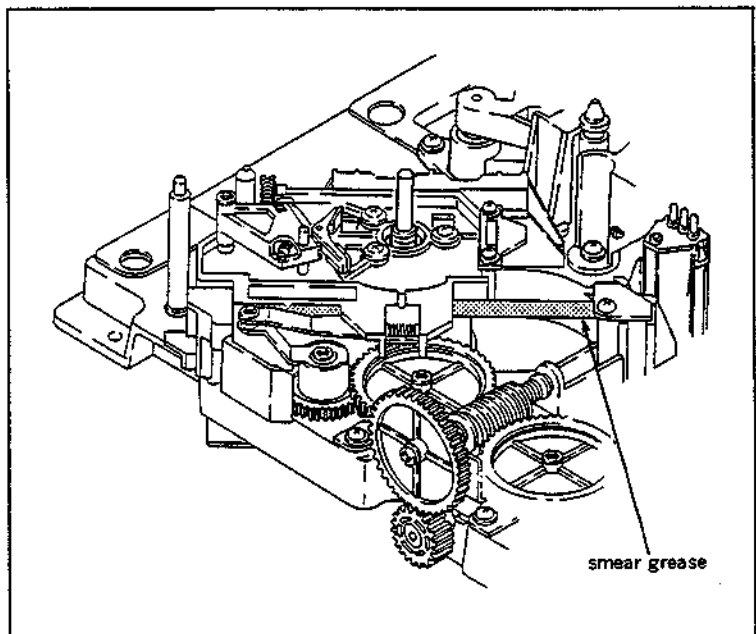
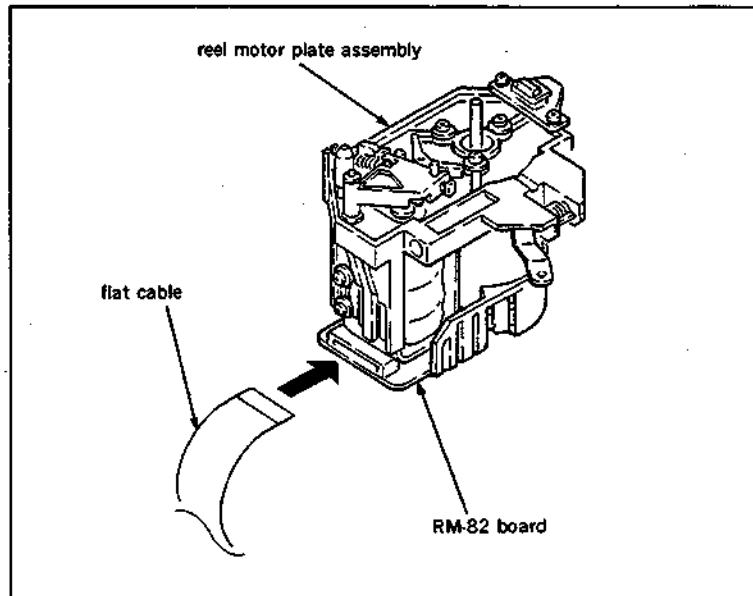

5-12. REEL MOTOR REPLACEMENT

- Replacement of supply reel motor and take-up reel motor take the same procedure.
- Perform the replacement of a reel motor as an assembled part instead of as a component part.

Tools

Cleaning piece : 2-034-697-00
Cleaning fluid : 9-919-573-01
L shaped wrench (across flat has 1.5 mm)
: 7-700-736-05

Replacement flow chart

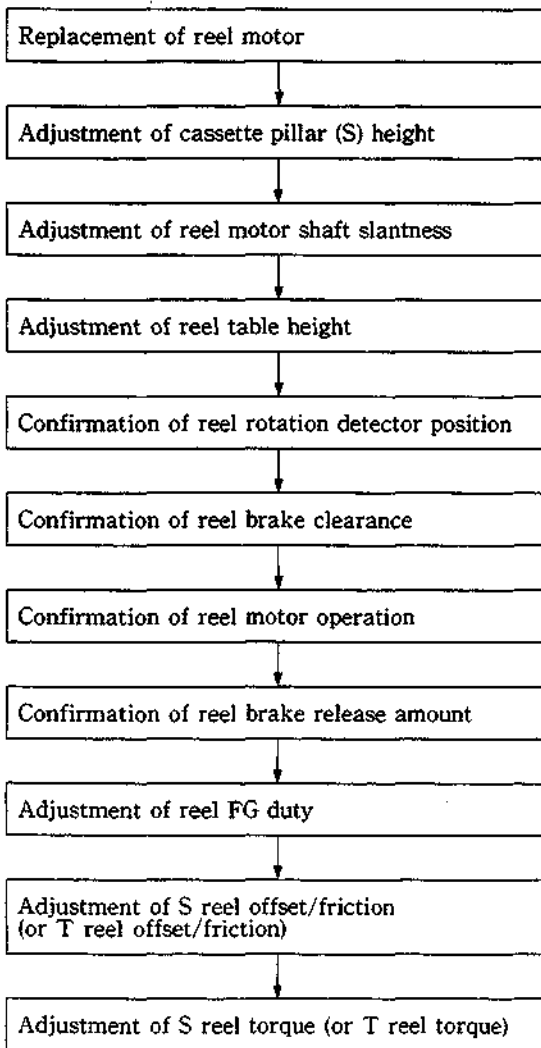

Removal

1. Remove a reel table. (Refer to steps from (1) to (6) in Section 5-10.)
2. Disconnect a flat cable of a reel motor board (RM-82 board) connected with DR-118 board.
3. Disconnect three connectors CN923, CN926 and CN927 of the reel motor board (RM-82 board).
4. Remove three screws shown in the figure, and remove a reel motor assembly.

Note 1 : Hold the reel motor assembly to avoid dropping.

Note 2 : Pay particular attention not to lose the spacer using for slantness adjustment since it comes off with the reel motor assembly when its removal.

5. Remove a polyslider washer which is used for the reel table height adjustment from the reel motor shaft.

Installation

6. Clean the surfaces of a new reel motor assembly and reel motor plate assembly with a cleaning piece moistened with cleaning fluid.
7. Install the new reel motor assembly as in the direction shown in the figure with three screws.
8. Connect three connectors CN923, CN926 and CN927 to RM-82 board.
9. Insert the flat cable to RM-82 board.
10. Install the reel table to the reel motor shaft.

Note : Tighten two screws after adjustment of the reel table height.

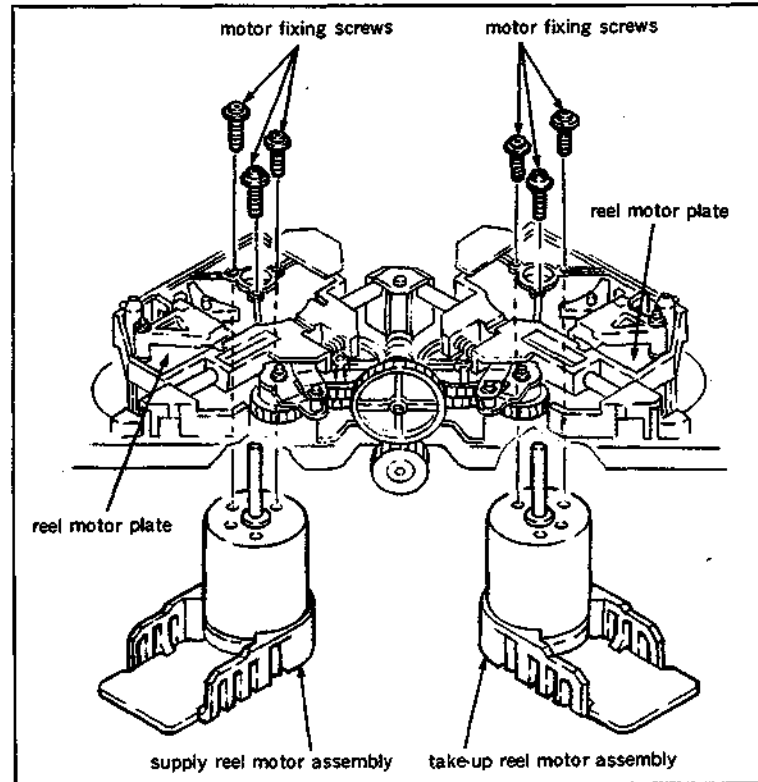

Adjustment after replacement

11. Perform confirmation of cassette pillar (S) height adjustment. (Refer to steps from (1) to (6) in Section 5-10-1.)
12. Perform reel motor shaft slantness adjustment. (Refer to Section 5-12-1.)
13. Perform reel table height adjustment. (Refer to Section 5-10-2.)
14. Perform confirmation of reel rotation detector position adjustment. (Refer to steps from (1) to (5) in Section 5-10-3.)
15. Perform confirmation of reel brake clearance. (Refer to Section 5-7-1.)
16. Perform confirmation of reel motor operation. (Refer to Section 5-12-2.)
17. Perform confirmation of reel brake release amount. (Refer to steps (1) to (3) in Section 5-7-2.)
18. Perform reel FG duty adjustment. (Refer to Section 5-12-3.)
19. Perform S reel offset/friction (or T reel offset/friction) adjustment. (Refer to Section 5-12-4 or 5-12-6.)
20. Perform S reel torque (or T reel torque) adjustment. (Refer to Section 5-12-5 or 5-12-7.)

5-12-1. Reel Motor Shaft Slantness Adjustment

- Supply reel motor shaft slantness adjustment and take-up reel motor shaft slantness adjustment take the same procedure.
- This adjustment is not necessary in general, however, be sure to perform it when a reel motor and reel motor plate assembly are replaced.
- If this adjustment is not performed correctly, it may cause the occurrence of noise due to a contact of reel hub to a case in a cassette tape, or damage to the tape due to the incorrect tape running.
- In the following adjustment, it is described under the condition that a reel table is already removed from a reel motor shaft.

Tools

Cassette reference plate (L): J-6320-880-A	
Reel motor shaft slantness check tool	
	: J-6320-870-A
Cleaning piece	: 2-034-697-00
Cleaning fluid	: 9-919-573-01
Wire clearance gauge	: J-6152-450-A

Check

1. Make sure that the unit is in unthreading end mode.
2. Clean the surfaces of the cassette reference plate (L) and reel motor shaft slantness check tool with a cleaning piece moistened with cleaning fluid.
3. Rotate a drive gear by fingers so that a reel table is placed to the L cassette position.
4. Place the cassette reference plate (L) on four cassette pillars.
5. Move the reel motor shaft slantness check tool from three directions of arrows towards supply reel motor shaft or take-up reel motor shaft, and make sure that the clearance between the reel motor shaft and slantness check tool satisfies the specification 1 using the wire clearance gauge.

Specification 1: Upper or lower clearance between the reel motor shaft and slantness check tool is 0.03 mm or less.

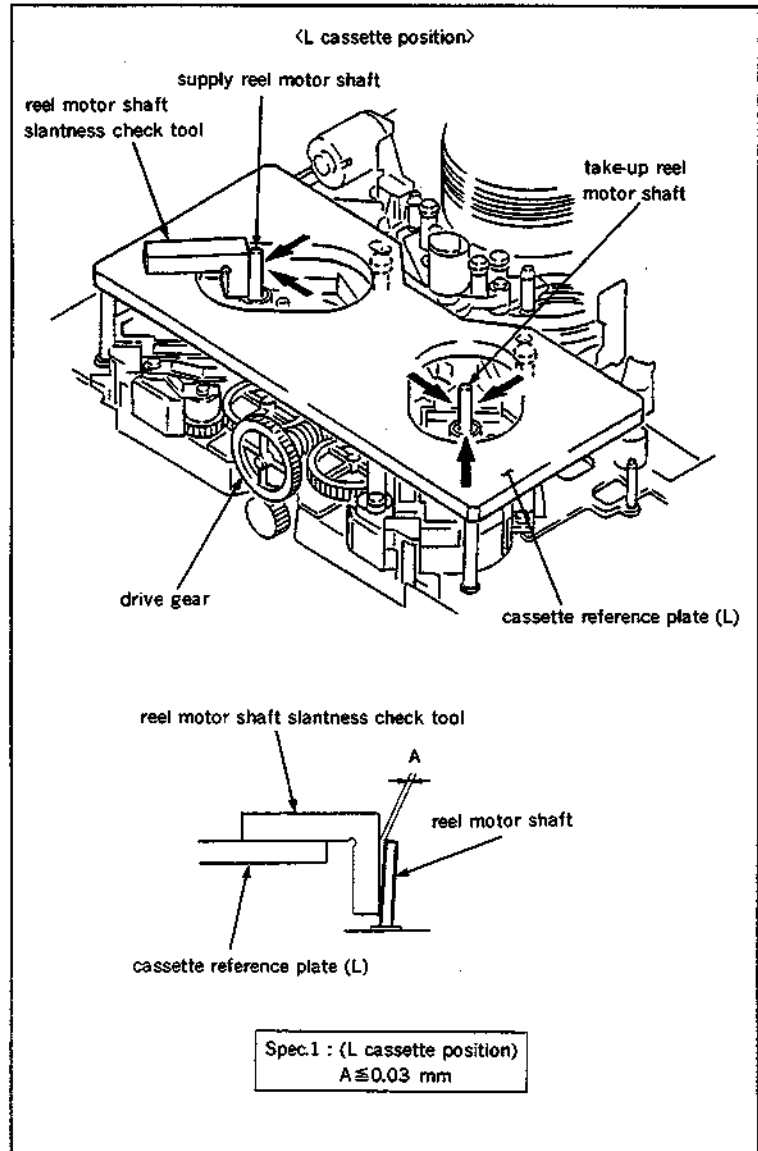

6. Rotate the drive gear by fingers so that the reel table is placed to the S cassette position.
7. Perform step (5), and make sure that the clearance between the reel motor shaft and slantness check tool satisfies the specification 2.

Specification 2 : Upper or lower clearance between the reel motor shaft and slantness check tool is 0.1 mm or less.

If any specification is not satisfied, perform step (8) and later until the specifications are satisfied at the both positions of the L cassette and S cassette.

Adjustment

8. Bend an adjustment spacer as shown in the figure.

Adjustment spacer : 3-717-625-01

9. Loosen screws that hold the reel motor for one to two turns.
10. Pick the adjustment spacer with tweezers, and insert it between the chassis at the fixing screw and motor through a square hole by a screw on the reel motor plate assembly.
11. Tighten screws which hold the reel motor, and make sure that the specification is satisfied.

Repeat the steps from (9) to (11) until the specification is satisfied.

12. Perform the following adjustment after the adjustment:

Reel table heigh adjustment (Refer to Section 5-10-2.)

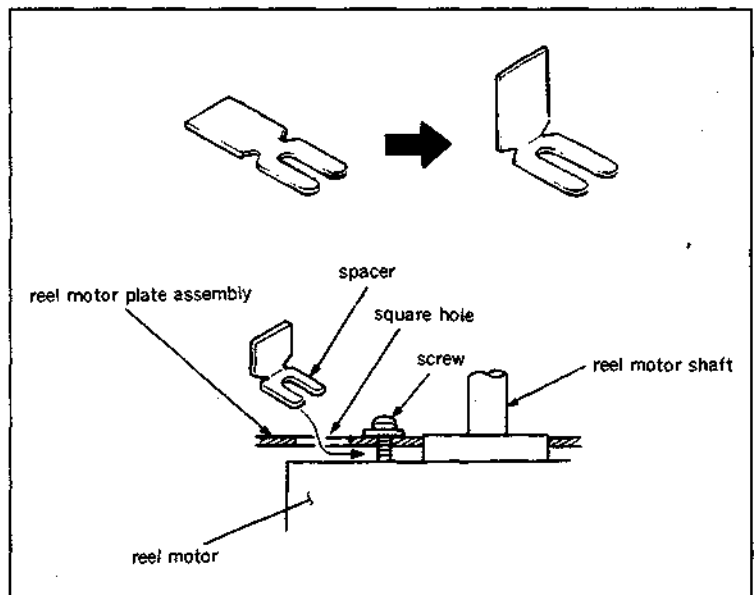
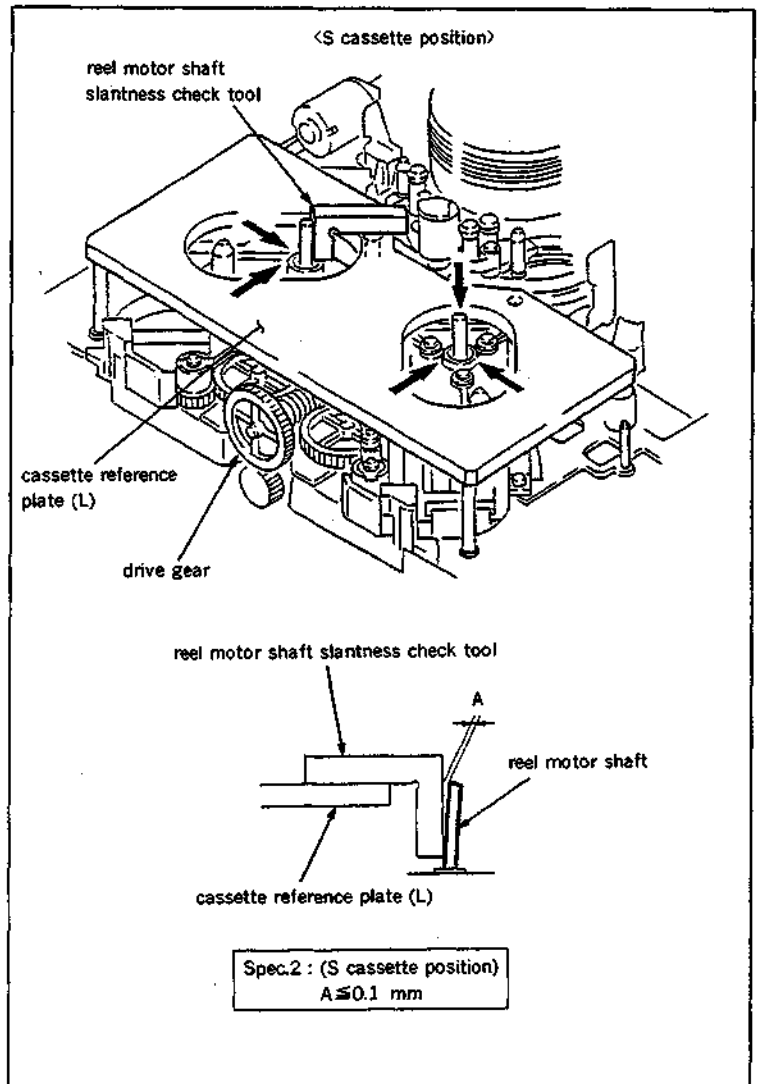

5-12-2. Reel Motor Operation Check

• Be sure to perform the reel motor operation check when a reel motor is replaced.

Preparation

Connect a video monitor with VIDEO OUTPUT 3 connector or MONITOR connector, and display characters.

Check

1. Put Bit7 of S601 on SS-48P board in CLOSE state.
2. Turn the POWER to ON. Push S302 and put the unit into maintenance mode.
3. Press the search dial to enter the jog mode, and move * mark to "BO : SERVO CHECK" which is displaying on the monitor screen with the search dial.
4. Press S302 on SS-48P board to select "SERVO CHECK" mode.
5. Move * mark to "BO2 : MOTOR CHECK" which is displaying on the monitor screen with the search dial.
6. Press S302 on SS-48P board to select "MOTOR CHECK" menu.
7. Move * mark to "BO21: S REEL" or "BO22: T REEL" which is displaying on the monitor screen with the search dial.
8. Press S302 on SS-48P board and to execute "BO21 : S REEL" or "BO22 : T REEL" sub-menu.
9. The message "TURN JOG DIAL IN JOG MODE" will appear on the monitor screen. When rotating the search dial at jog mode, make sure that the reel brake is released, and the reel table rotates in the same direction with the search dial. If the reel table does not rotate correctly, check the reel motor driver circuit (on DR-118A board). After confirming the correct reel table rotation, press S303 twice on SS-48P board to return to the mode screen.
10. After confirmation, turn the POWER to OFF, and put Bit7 of S601 on SS-48P board in OPEN state.

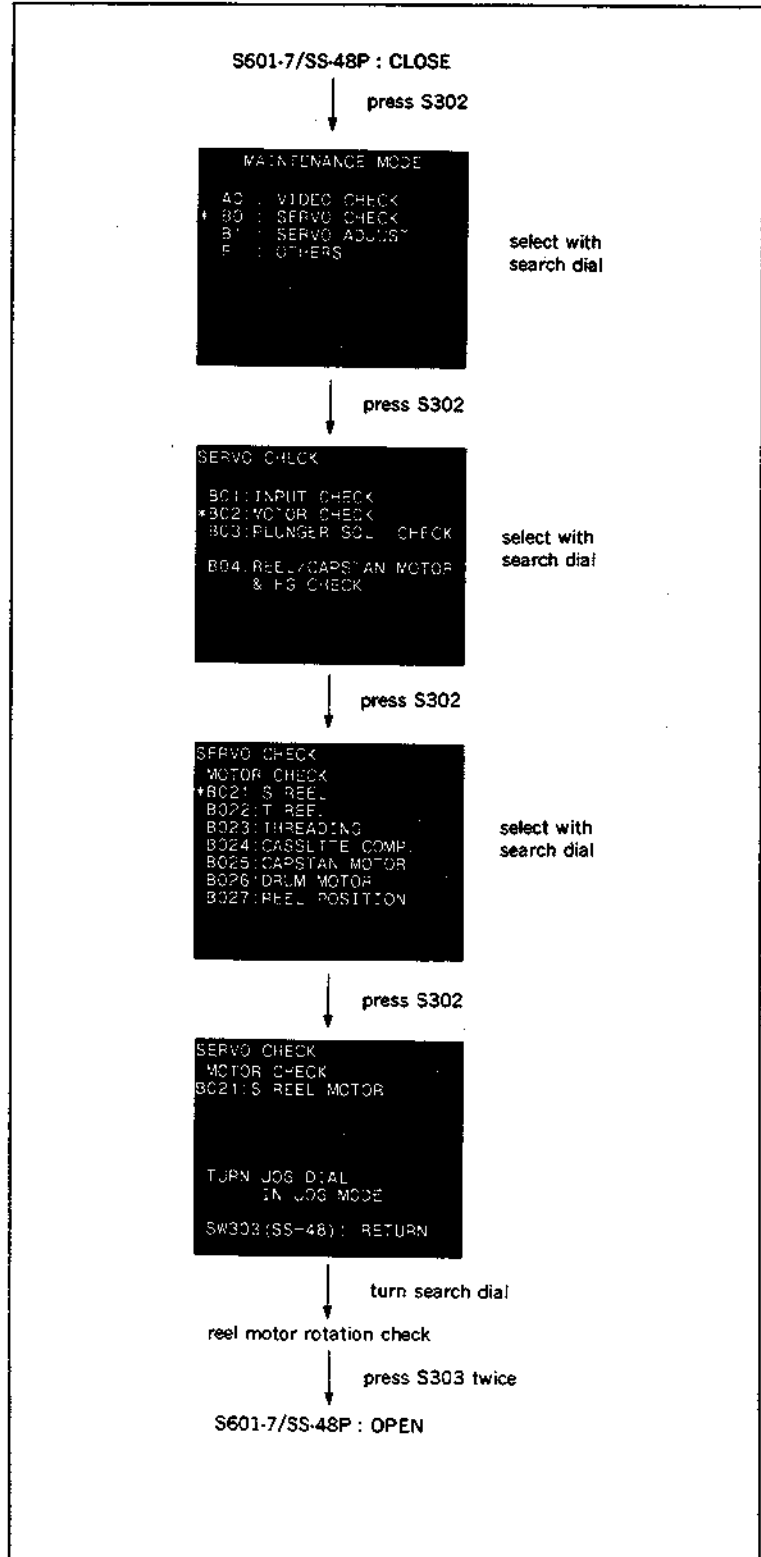

5-12-3. Reel FG Duty Adjustment

- Be sure to perform the reel FG duty adjustment when a supply or take-up reel motor is replaced.

Preparation

Connect a video monitor with VIDEO OUTPUT 3 connector or MONITOR connector, and display characters.

Check

1. Make sure that the unit is in EJECT mode. (The automatic adjustment dose not accept the mode other than EJECT.)
2. Put Bit4 of S601 on SS-48P board in CLOSE state. Push S302 and put the unit into maintenance mode.
3. Press the search dial to enter the jog mode, and move * mark to "B1: SERVO ADJUST" which is displaying on the monitor screen with the search dial.
4. Press S302 on SS-48P board to select "SERVO ADJUST" mode.
5. Move * mark to the following menu which is displaying on the monitor screen with the search dial.
When a S reel motor is replaced, move * mark to "B102 : S REEL FG DUTY."
When a T reel motor is replaced, move * mark to "B103 : T REEL FG DUTY."
6. Press S302 on SS-48P board to execute "S REEL FG DUDY" or "T REEL FG DUTY" menu.
7. Confirm that the message "COMPLETE" is displayed on the monitor screen.
When "COMPLETE" is displayed on the monitor screen, press S303 on SS-48P board to return to the menu screen.
8. Move * mark to "B117 : NV RAM CONTROL" which is displaying on the monitor screen with the search dial.

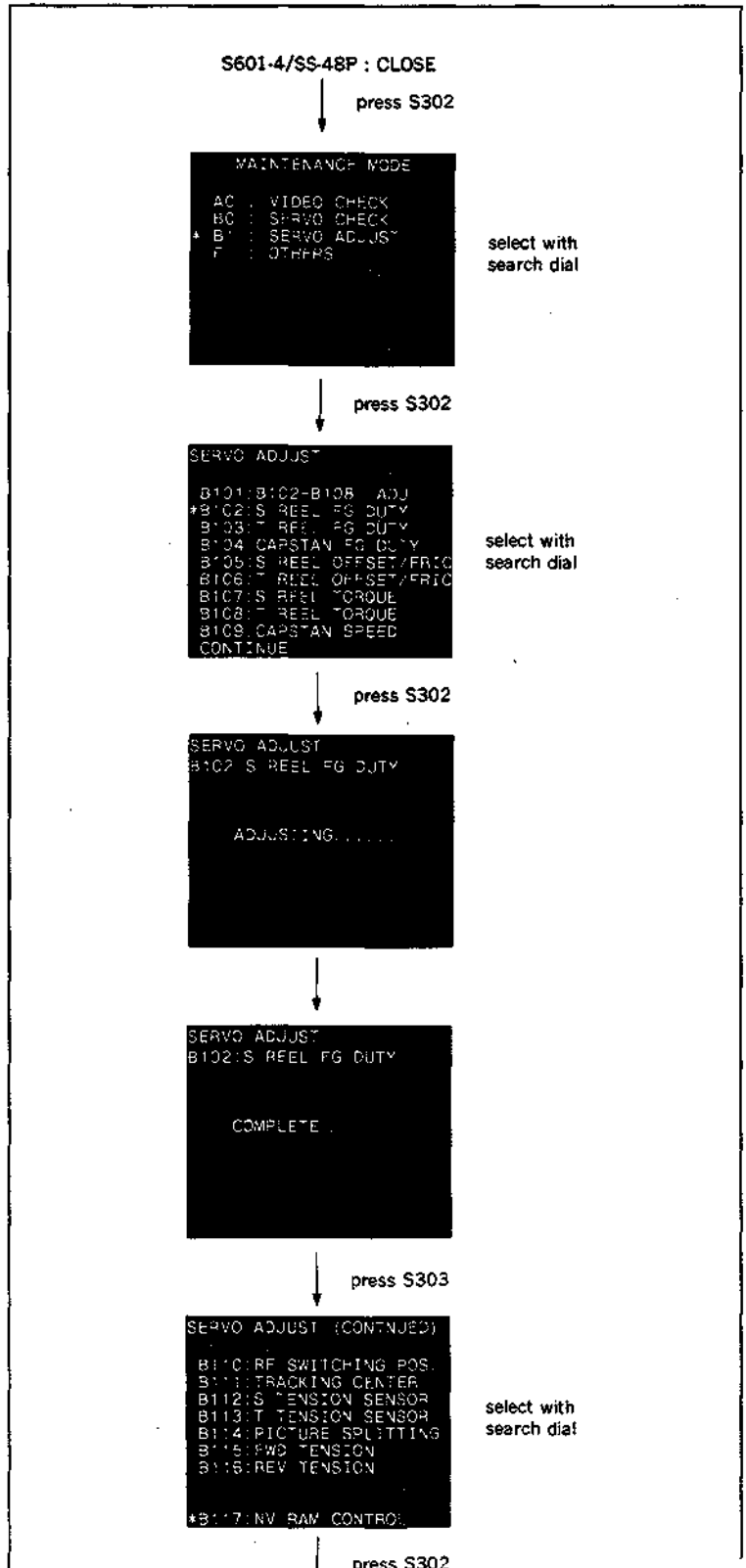

9. Press S302 on SS-48P board to execute "NV RAM CONTROL" menu.
10. Move * mark to "SAVE ALL ADJ. DATA" with the search dial.
11. Press S302 on SS-48P board. Data will be stored on the NOV RAM.
12. When "SAVE COMPLETE" is displayed on the monitor screen, press S303 twice on SS-48P board to return to the mode screen.

Note 1: When "INCOMPLETE" appears on the monitor screen in step (7), press S303 on SS-48 board to return to the menu screen. Check the reel rotation detector, reel FG amplifier circuit and reel motor drive circuit (on DR-118A board and SS-48P board).

Note 2: When the "SERVO ADJUST" mode is completed, turn the POWER to OFF and put Bit4 of S601 on SS-48P board in OPEN state.

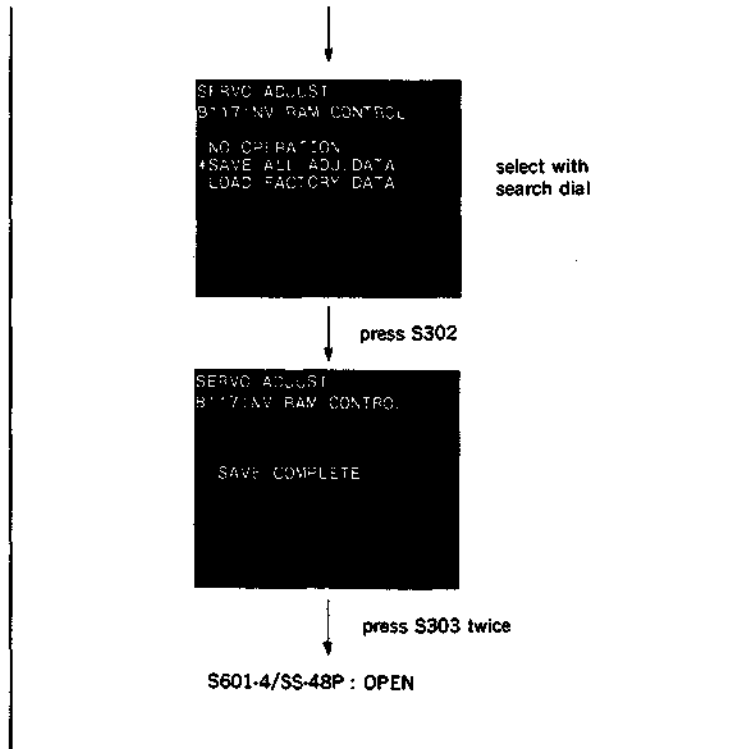

5-12-4. S Reel Offset/Friction Adjustment

- Be sure to perform the S reel offset/friction adjustment when a supply reel motor is replaced.

Preparation

Connect a video monitor with VIDEO OUTPUT 3 connector or MONITOR connector, and display characters.

Check

1. Make sure that the unit is in EJECT mode. (The automatic adjustment does not accept the mode other than EJECT.)
2. Put Bit4 of S601 on SS-48P board in CLOSE state. Push S302 and put the unit into maintenance mode.
3. Press the search dial to enter the jog mode, and move * mark to "B1: SERVO ADJUST" which is displaying on the monitor screen with the search dial.
4. Press S302 on SS-48P board to select "SERVO ADJUST" mode.
5. Move * mark to "B105: S REEL OFFSET/FRIC" which is displaying on monitor screen with the search dial.
6. Press S302 on SS-48P board to execute "S REEL OFFSET/FRIC".

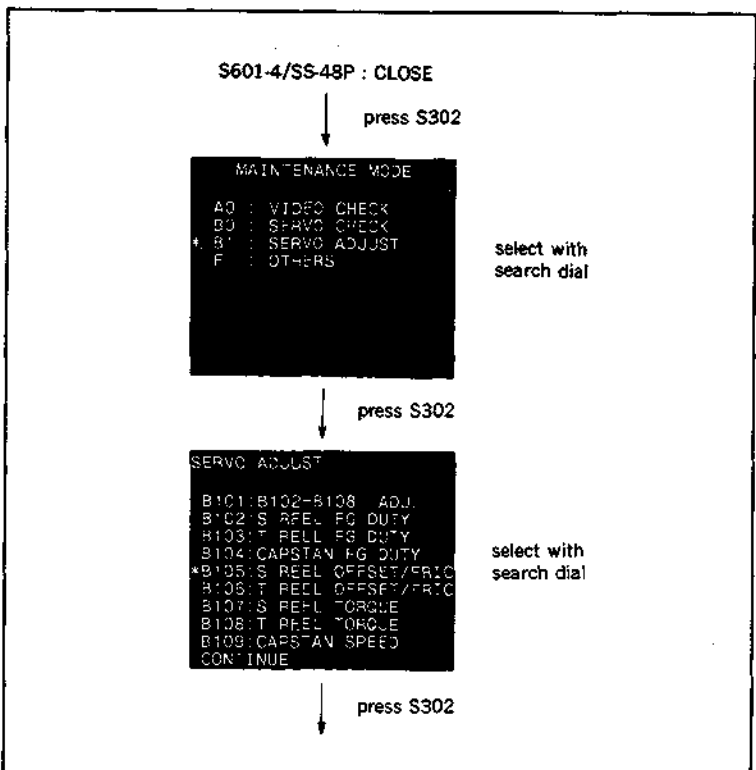

7. Confirm that the message "COMPLETE" is displayed on the monitor screen.
When "COMPLETE" is displayed on the monitor screen, press S303 on SS-48P board to return to the menu screen.
8. Move * mark to "B117 : NV RAM CONTROL" which is displaying on the monitor screen with the search dial.
9. Press S302 on SS-48P board to execute "NV RAM CONTROL" menu.
10. Move * mark to "SAVE ALL ADJ. DATA" with the search dial.
11. Press S302 on SS-48P board. Data will be stored on the NOV RAM.
12. When "SAVE COMPLETE" is displayed on the monitor screen, press S303 twice on SS-48P board to return to the mode screen.

Note 1: When "INCOMPLETE" appears on the monitor screen in step (7), press S303 on SS-48P board to return to the menu screen.

Check the reel motor, reel FG duty adjustment and reel motor drive circuit (on DR-118A board).

Note 2: When the "SERVO ADJUST" mode is completed, turn the POWER to OFF and put Bit4 of S601 on SS-48P board in OPEN state.

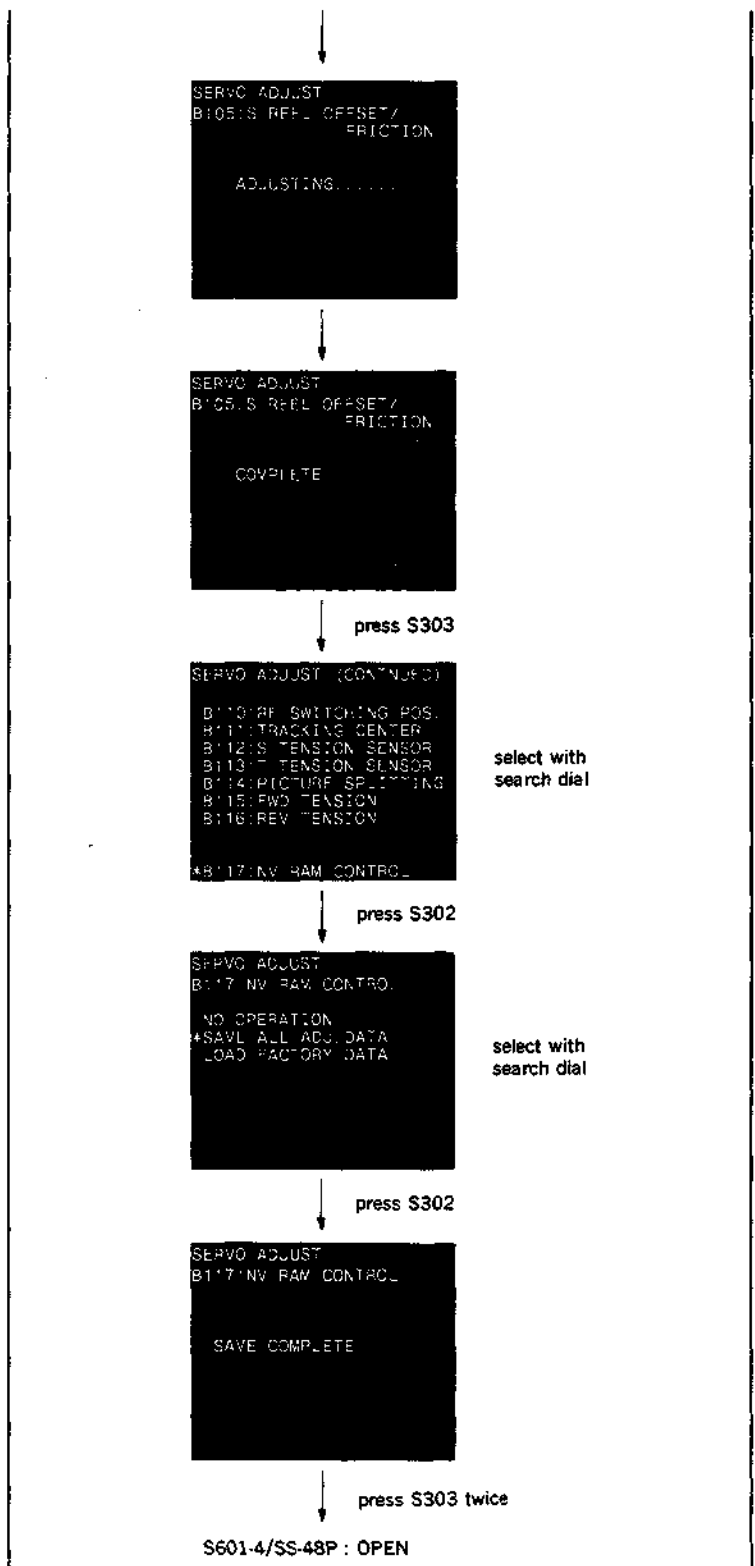

5-12-5. S Reel Torque Adjustment

- Be sure to perform the S reel torque adjustment when a supply reel motor is replaced.

Preparation

Connect a video monitor with VIDEO OUTPUT 3 connector or MONITOR connector, and display characters.

Check

1. Make sure that the unit is in EJECT mode. (The automatic adjustment dose not accept the mode other than EJECT.)
2. Put Bit4 of S601 on SS-48P board in CLOSE state. Push S302 and put the unit into maintenance mode.
3. Press the search dial to enter the jog mode, and move * mark to "B1: SERVO ADJUST" which is displaying on the monitor screen with the search dial.
4. Press S302 on SS-48P board to select "SERVO ADJUST" mode.
5. Move * mark to "B107: S REEL TORQUE" which is displaying on monitor screen with the search dial.
6. Press S302 on SS-48P board to execute "S REEL TORQUE".
7. Confirm that the message "COMPLETE" is displayed on the monitor screen. When "COMPLETE" is displayed on the monitor screen, press S303 on SS-48P board to return to the menu screen.
8. Move * mark to "B117 : NV RAM CONTROL" which is displaying on the monitor screen with the search dial.
9. Press S302 on SS-48P board to execute "NV RAM CONTROL" menu.

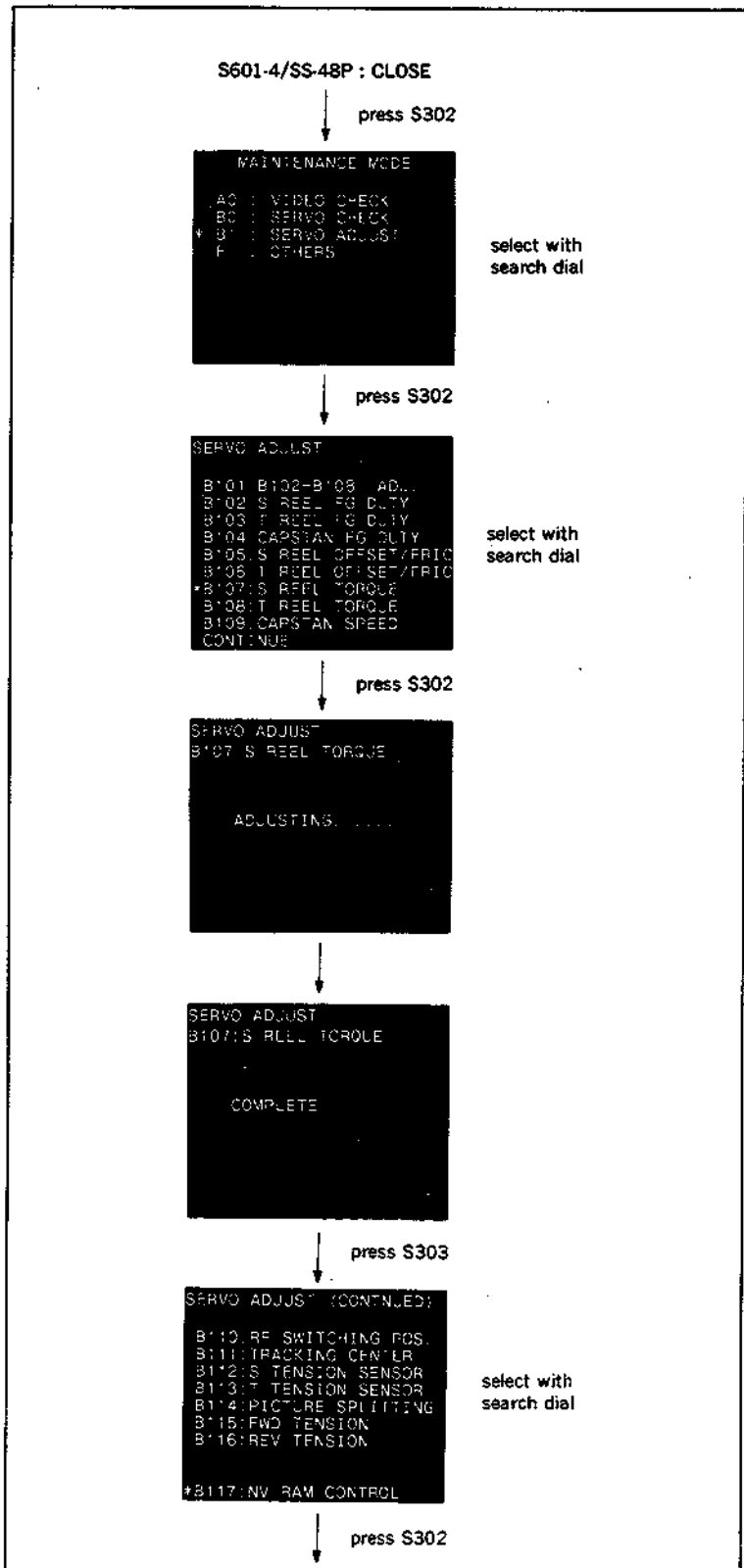

10. Move * mark to "SAVE ALL ADJ. DATA" with the search dial.
11. Press S302 on SS-48P board. Data will be stored on the NOV RAM.
12. When "SAVE COMPLETE" is displayed on the monitor screen, press S303 twice on SS-48P board to return to the mode screen.

Note 1: When "INCOMPLETE" appears on the monitor screen in step (7), press S303 on SS-48P board to return to the menu screen. Perform reel FG duty adjustment. Check the reel motor drive circuit (on DR-118A board).

Note 2: When the "SERVO ADJUST" mode is completed, turn the POWER to OFF and put Bit4 of S601 on SS-48P board in OPEN state.

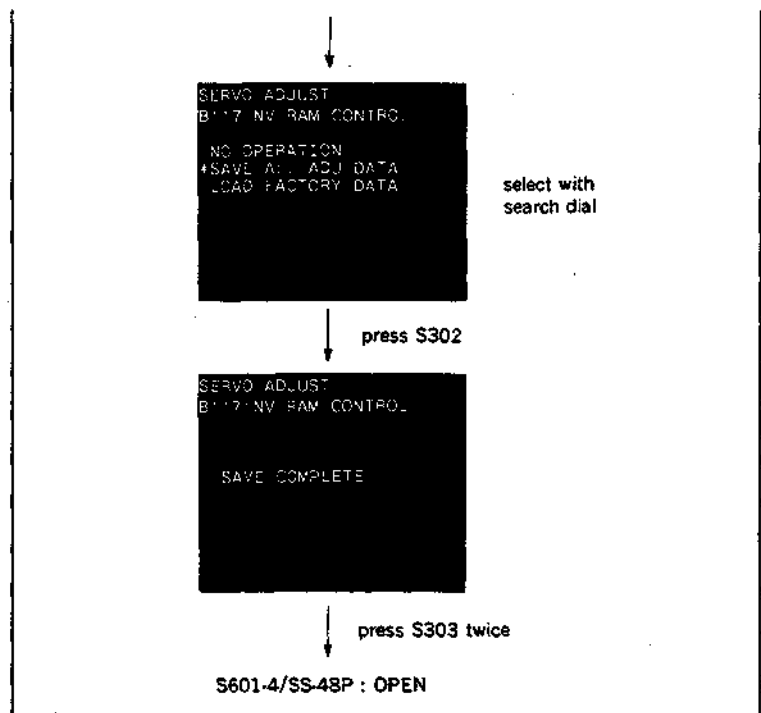

5-12-6. T Reel Offset/Friction Adjustment

- Be sure to perform the T reel offset/friction adjustment when a take-up reel motor is replaced.

Preparation

Connect a video monitor with VIDEO OUTPUT 3 connector or MONITOR connector, and display characters.

Check

1. Make sure that the unit is in EJECT mode. (The automatic adjustment dose not accept the mode other than EJECT.)
2. Put Bit4 of S601 on SS-48P board in CLOSE state. Push S302 and put the unit into maintenance mode.
3. Press the search dial to enter the jog mode, and move * mark to "B1: SERVO ADJUST" which is displaying on the monitor screen with the search dial.
4. Press S302 on SS-48P board to select "SERVO ADJUST" mode.
5. Move * mark to "B106: T REEL OFFSET/FRIC" which is displaying on monitor screen with the search dial.
6. Press S302 on SS-48P board to execute "T REEL OFFSET/FRIC".
7. Confirm that the message "COMPLETE" is displayed on the monitor screen. When "COMPLETE" is displayed on the monitor screen, press S303 on SS-48P board to return to the menu screen.
8. Move * mark to "B117 : NV RAM CONTROL" which is displaying on the monitor screen with the search dial.
9. Press S302 on SS-48P board to execute "NV RAM CONTROL" menu.
10. Move * mark to "SAVE ALL ADJ. DATA" with the search dial.
11. Press S302 on SS-48P board. Data will be stored on the NOV RAM.
12. When "SAVE COMPLETE" is displayed on the monitor screen, press S303 twice on SS-48P board to return to the mode screen.

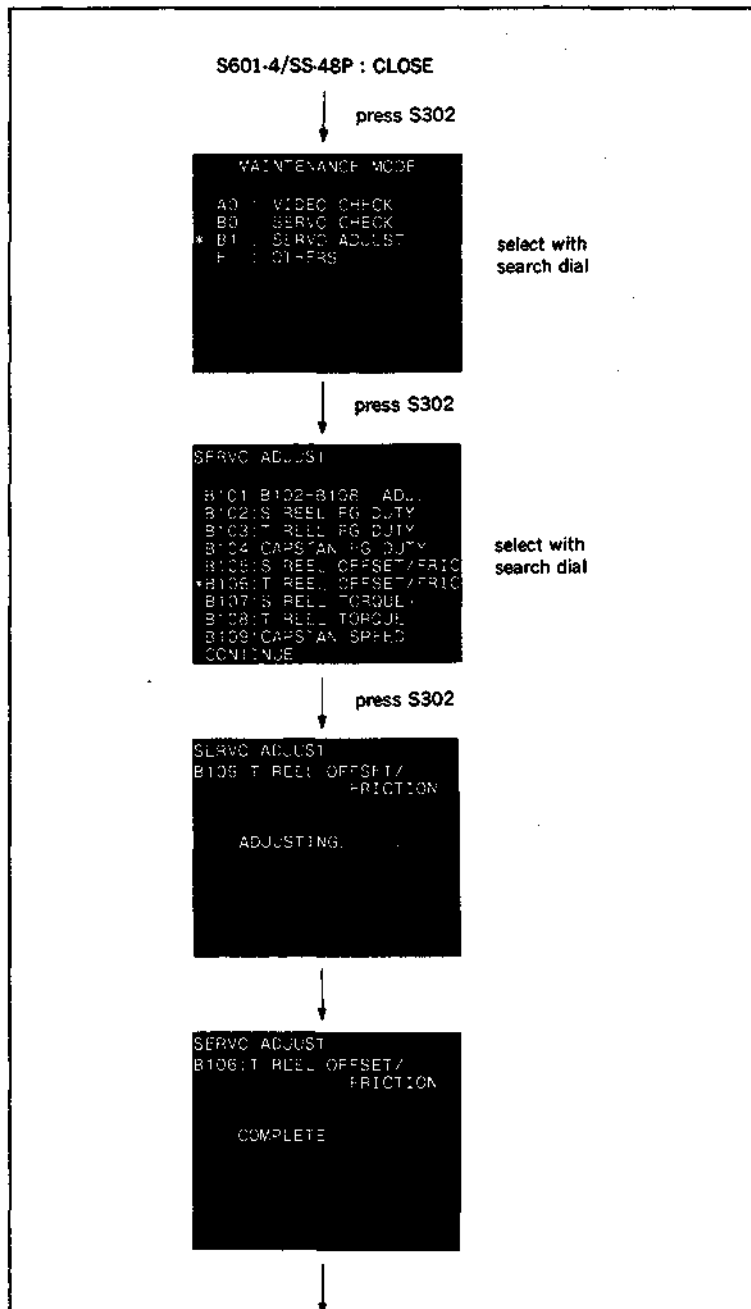

Note 1: When "INCOMPLETE" appears on the monitor screen in step (7), press S303 on SS-48P board to return to the menu screen.

Check the reel motor, reel FG duty adjustment and reel motor drive circuit (on DR-118A board).

Note 2: When the "SERVO ADJUST" mode is completed, turn the POWER to OFF and put Bit4 of S601 on SS-48P board in OPEN state.

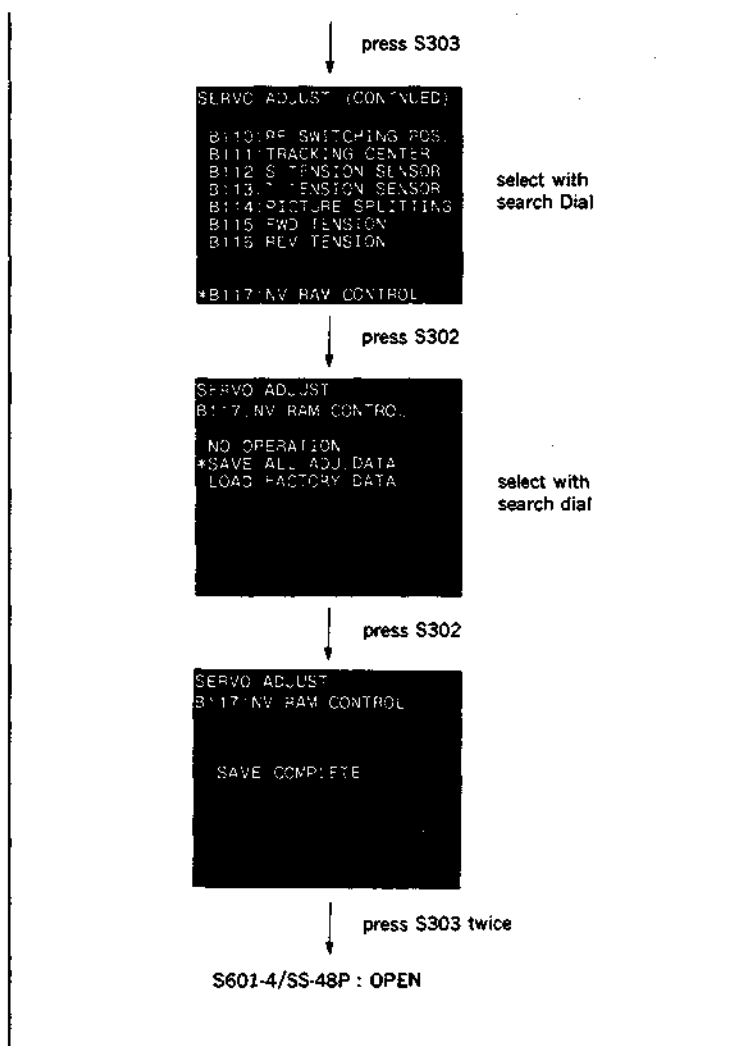

5-12-7. T Reel Torque Adjustment

- Be sure to perform the T reel torque adjustment when a take-up reel motor is replaced.

Preparation

Connect a video monitor with VIDEO OUTPUT 3 connector or MONITOR connector, and display characters.

Check

1. Make sure that the unit is in EJECT mode. (The automatic adjustment dose not accept the mode other than EJECT.)
2. Put Bit4 of S601 on SS-48P board in CLOSE state. Push S302 and put the unit into maintenance mode.
3. Press the search dial to enter the jog mode, and move * mark to "B1: SERVO ADJUST" which is displaying on the monitor screen with the search dial.
4. Press S302 on SS-48P board to select "SERVO ADJUST" mode.
5. Move * mark to "B108: T REEL TORQUE" which is displaying on monitor screen with the search dial.
6. Press S302 on SS-48P board to execute "T REEL TORQUE".
7. Confirm that the message "COMPLETE" is displayed on the monitor screen. When "COMPLETE" is displayed on the monitor screen, press S303 on SS-48P board to return to the menu screen.
8. Move * mark to "B117 : NV RAM CONTROL" which is displaying on the monitor screen with the search dial.

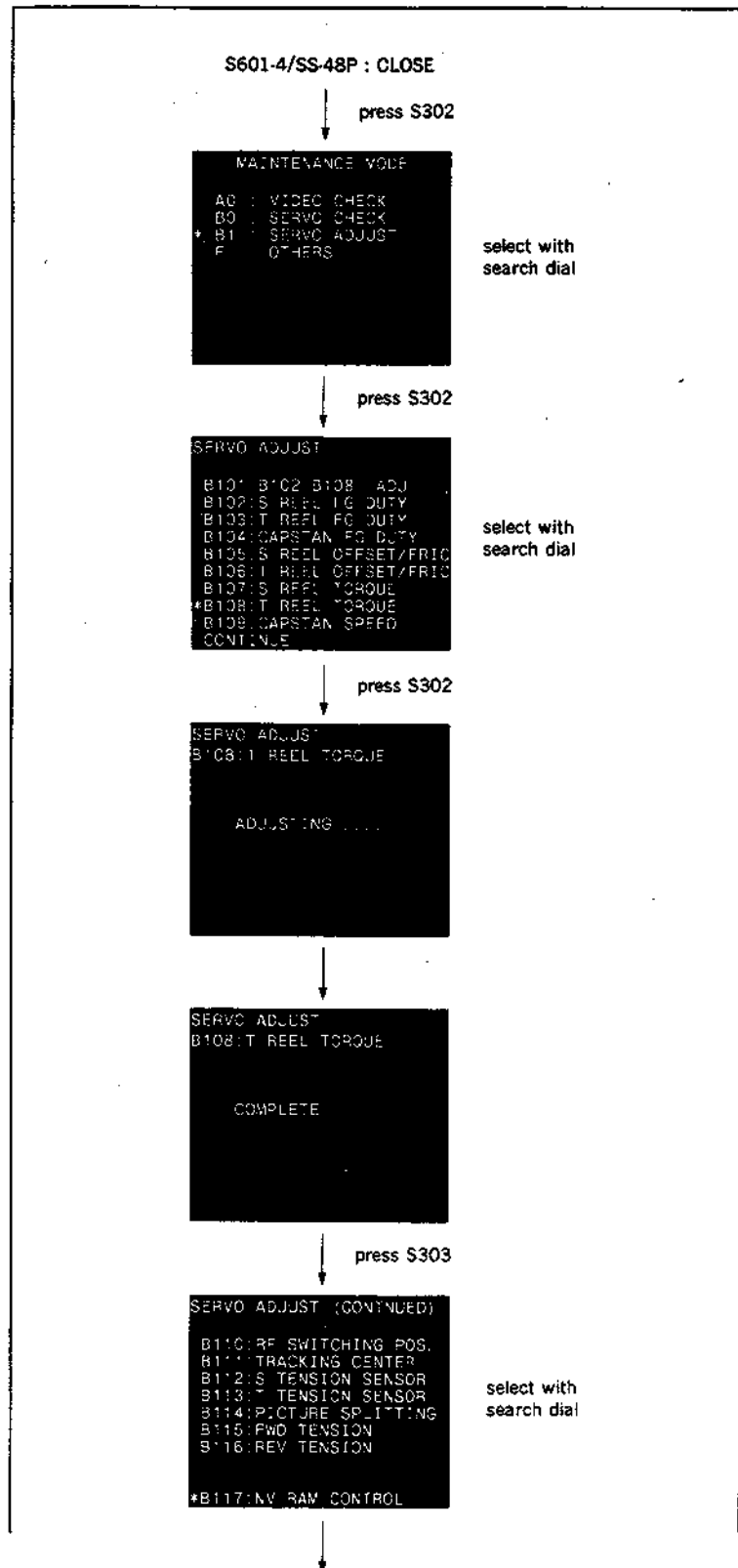

9. Press S302 on SS-48P board to execute "NV RAM CONTROL" menu.
10. Move * mark to "SAVE ALL ADJ. DATA" with the search dial.
11. Press S302 on SS-48P board. Data will be stored on the NOV RAM.
12. When "SAVE COMPLETE" is displayed on the monitor screen, press S303 twice on SS-48P board to return to the mode screen.

Note 1: When "INCOMPLETE" appears on the monitor screen in step (7), press S303 on SS-48P board to return to the menu screen. Perform reel FG duty adjustment. Check the reel motor drive circuit (on DR-118A board).

Note 2: When the "SERVO ADJUST" mode is completed, turn the POWER to OFF and put Bit4 of S601 on SS-48P board in OPEN state.

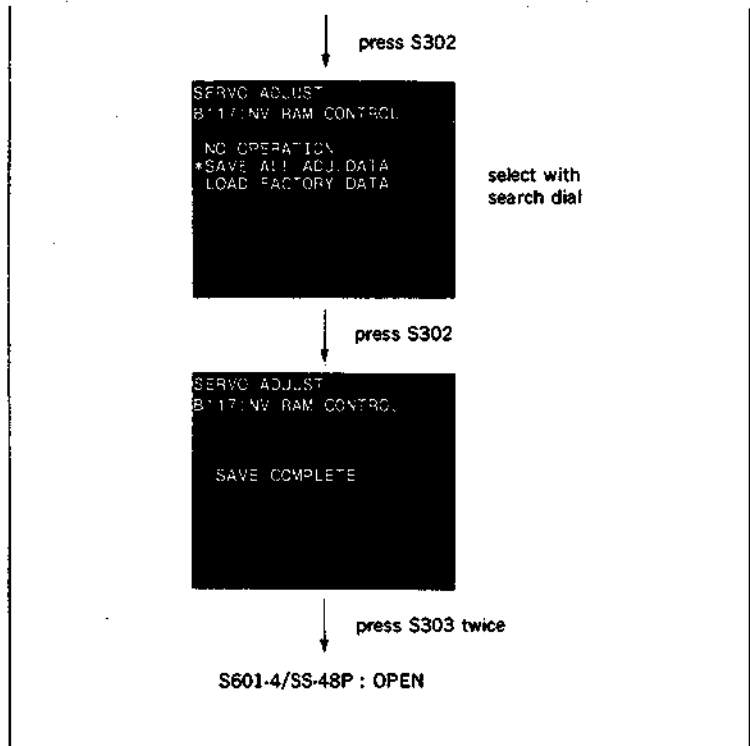

5-13. REEL POSITION MOTOR REPLACEMENT

Tools

- L shaped wrench (across flat has 0.89 mm)
: 7-700-736-06
- Wire clearance gauge : J-6152-450-A

Replacement flow chart

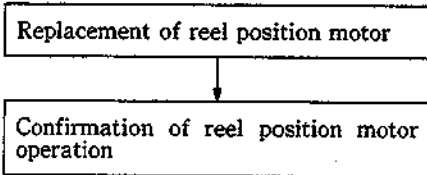

Removal

1. Open DR-118A board.
2. Disconnect a connector CN315 of the reel position motor from DR-118A board.
3. Remove two screws shown in the figure, and remove a reel position motor block.
4. Loosen two setscrews of a gear M, and remove the gear M from the reel position motor shaft.
5. Remove two screws, and remove a reel position motor.
6. Unsolder two lead wires of the reel position motor.

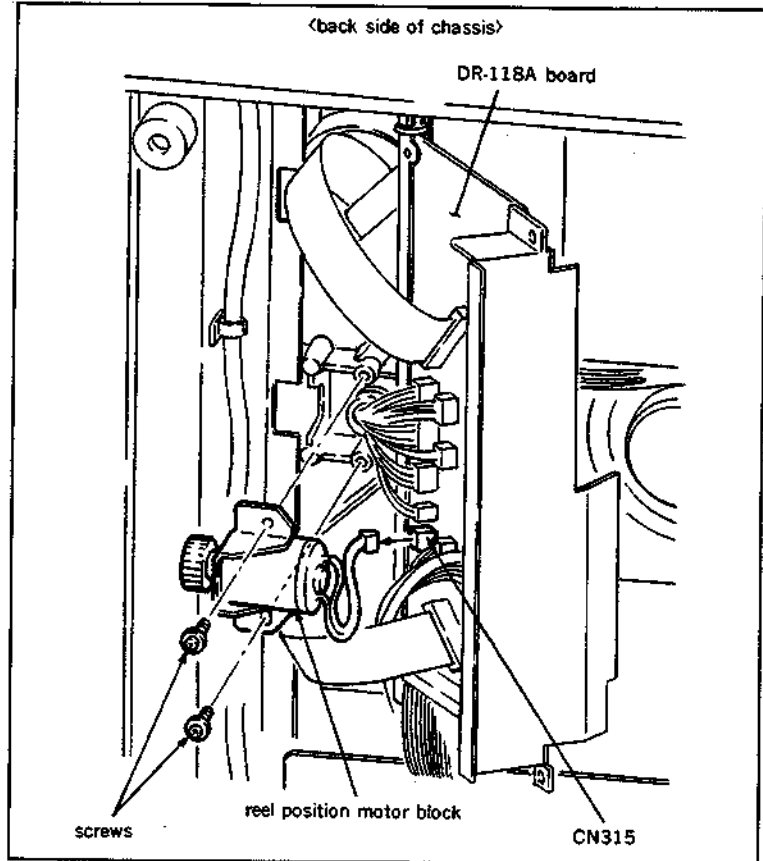

Installation

7. Solder two lead wires unsoldered in step (6) to a new reel position motor.
Solder a yellow lead wire to + terminal
8. Install the new reel position motor to a motor mounting bracket as the yellow lead wire faces in the direction of a S reel table.
9. Insert the gear M to the reel position motor shaft.
10. Put the wire clearance gauge (0.5 mm) between the gear M and boss of the motor, and tighten two setscrews while pressing the gear M towards the motor side.
11. Install the reel position motor block to the chassis with two screws.
12. Connect the reel position motor connector to CN315 on DR-118A board.

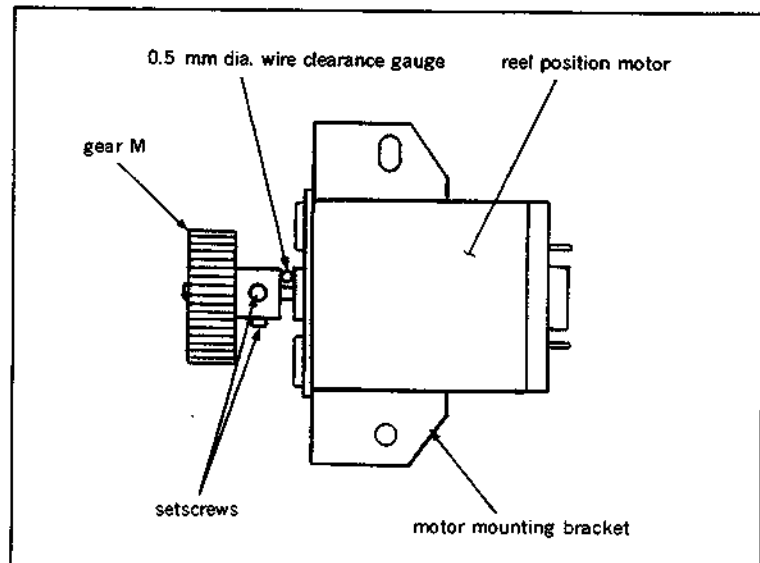

Adjustment after replacement

13. Perform confirmation of reel position motor operation. (Refer to Section 5-13-1.).

5-13-1. Reel Position Motor Operation Check

- Be sure to perform the reel position motor operation check when a reel position motor is replaced.

Preparation

Connect a video monitor with VIDEO OUTPUT 3 connector or MONITOR connector, and display characters.

Check

1. Put Bit7 of S601 on SS-48P board in CLOSE state.
2. Turn the POWER to ON. Push S302 and put the unit into maintenance mode.
3. Press the search dial to enter the jog mode, and move * mark to "BO: SERVO CHECK" which is displaying on the monitor screen with the search dial.
4. Press S302 on SS-48P board to select "SERVO CHECK" mode.
5. Move * mark to "BO2: MOTOR CHECK" which is displaying on the monitor screen with the search dial.
6. Press S302 on SS-48P board to select "MOTOR CHECK" menu.
7. Move * mark to "BO27: REEL POSITION" which is displaying on the monitor screen with the search dial.
8. Press S302 on SS-48P board to execute "REEL POSITION" sub-menu.
9. Press S302 on SS-48P board, make sure that a reel table moves.
When the reel table is positioned to the S cassette position, confirm that the message "S-POSITION" is displayed on the monitor screen.
When the reel table is positioned to the L cassette position, confirm that the message "L-POSITION" is displayed on the monitor screen.
If the message does not appear on the monitor screen, check the reel position motor driver circuit (on DR-118A board) and reel position switch operates normally.
10. Press S303 twice on SS-48P board to return to the mode screen.
11. After confirmation, turn the POWER to OFF, and put Bit7 of S601 on SS-48P board in OPEN state.

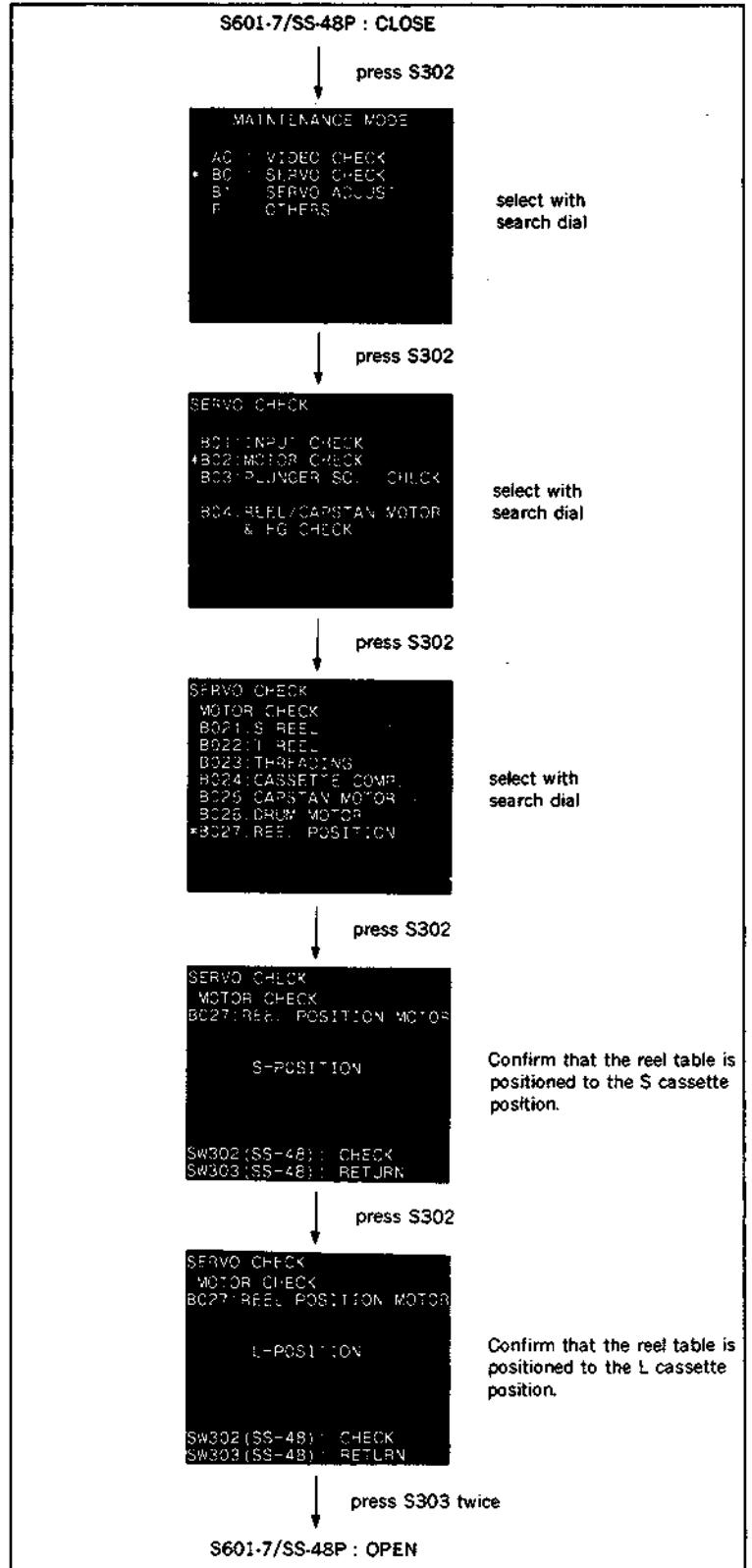

5-14. REEL POSITION SENSOR REPLACEMENT

Replacement flow chart

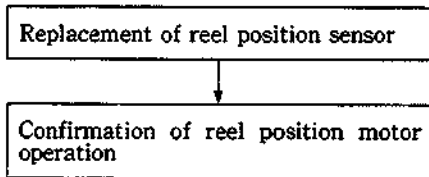

Removal

1. Open DR-118A board.
2. Remove two screws that holds PTC-42 board where a reel position sensors are mounted.
3. Disconnect connector CN924 while lifting PTC-42 board.

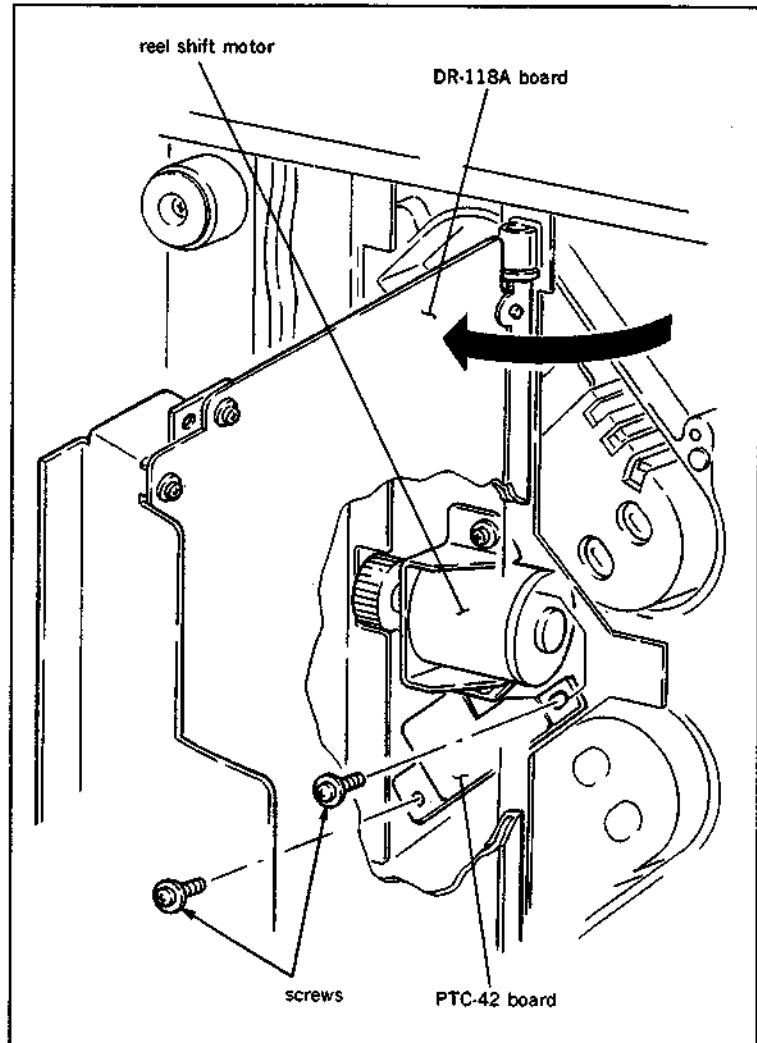

Installation

4. Mount a new reel position sensor to match a polarity that is silk screened on the printed circuit board.
5. Connect connector CN924 to PTC-42 board, and install it to the chassis.

Adjustment after replacement

6. Perform reel position motor operation check.
(Refer to Section 5-13-1.)

5-15. THREADING MOTOR REPLACEMENT

Tools

- L shaped wrench (across flat has 1.27 mm)
: 7-700-736-01
- Wire clearance gauge : J-6152-450-A

Replacement flow chart

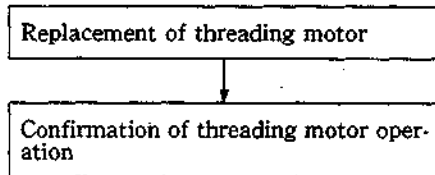

Removal

1. Disconnect connectors CN903 and CN902 from PTC-49 board.
2. Remove two screws shown in the figure, and remove a threading motor block.

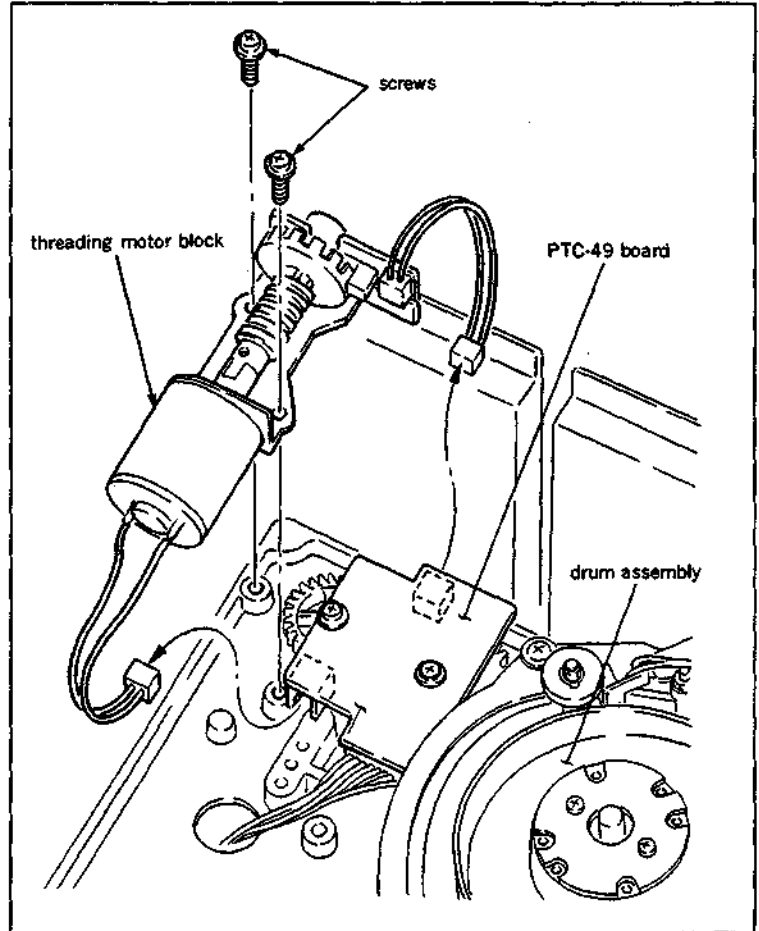

3. Loosen a setscrew of a joint (1) with L shaped wrench.
4. Remove two screws, and remove a threading motor.
5. Unsolder two lead wires from the threading motor.

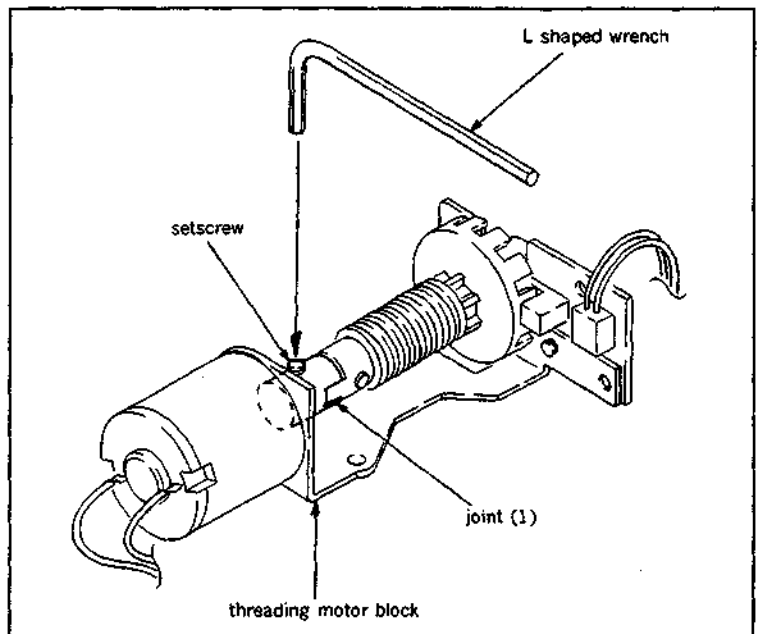

Installation

- Solder two lead wires which are unsoldered in step (5) to a new threading motor.

Note :Solder brown lead wire to plus terminal.

- After a threading motor shaft is pass through a hole of the threading motor bracket, and insert the joint (1) to the motor shaft.
- Install the threading motor to the threading motor bracket with two screws so that the following two requirements are satisfied:
 - The brown lead wire must face in the direction of the drum when installing to the threading motor bracket.
 - Engage the joint (1) with the joint (2) of the worm assembly.
- Install the joint (1) to the motor shaft with a setscrew so that the clearance between the joints (1) and (2) satisfies the specification.
- Make sure that the threading motor rotation detection ring rotates smoothly when it is turned by fingers.
- Install the threading motor block to chassis with two screws.
- Connect the connectors CN903 and CN902 to PTC-49 board.

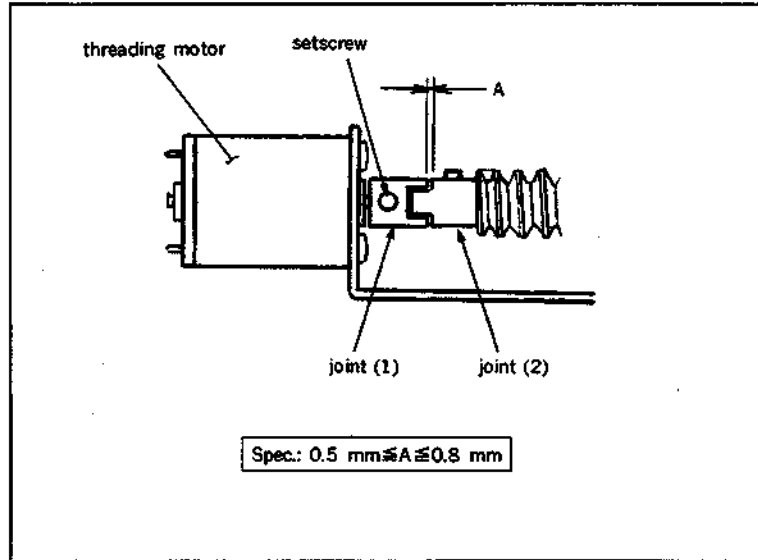

Adjustment after replacement

- Perform threading motor operation check. (Refer to Section 5-15-1.)

5-15-1. Threading Motor Operation Check

- Be sure to perform the theading motor operation check when a threading motor is replaced.

Preparation

Connect a video monitor with VIDEO OUTPUT 3 connector or MONITOR connector, and display characters.

Check

- Put Bit7 of S601 on SS-48P board in CLOSE state.
- Turn the POWER to ON. Push S302 and put the unit into maintenance mode.
- Press the search dial to enter the jog mode, and move * mark to "BO: SERVO CHECK" which is displaying on the monitor screen with the search dial.

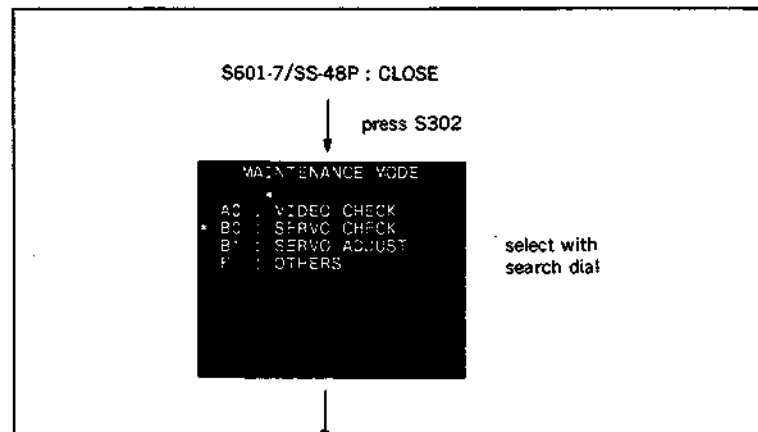

4. Press S302 on SS-48P board to select "SERVO CHECK" mode.
5. Move * mark to "BO2: MOTOR CHECK" which is displaying on the monitor screen with the search dial.
6. Press S302 on SS-48P board to select "MOTOR CHECK" menu.
7. Move * mark to "BO23: THREADING" which is displaying on the monitor screen with the search dial.
8. Press S302 on SS-48P board to execute "THREADING" sub-menu.
9. Message "TURN JOG DIAL IN JOG MODE, FWD : THREAD, REV : UNTH" will appear on the monitor screen.
Then turn the search dial to the direction of FWD according to the message, make sure that the threading motor rotates in the threading direction, and message on the screen changes into "THREAD END".
10. Turn the search dial to the direction of REV. Make sure that the threading motor rotates in the unthreading direction, and message on the screen changes into "UNTHREAD END".
If the message does not appear, check the loading motor drive circuit, loading FG amplifier (on DR-118A board) and to make sure that the loading TOP/END switch operates normally.
11. Press S303 twice on SS-48P board to return to the mode screen.
12. After confirmation, turn the POWER to OFF, and put Bit7 of S601 on SS-48P board in OPEN state.

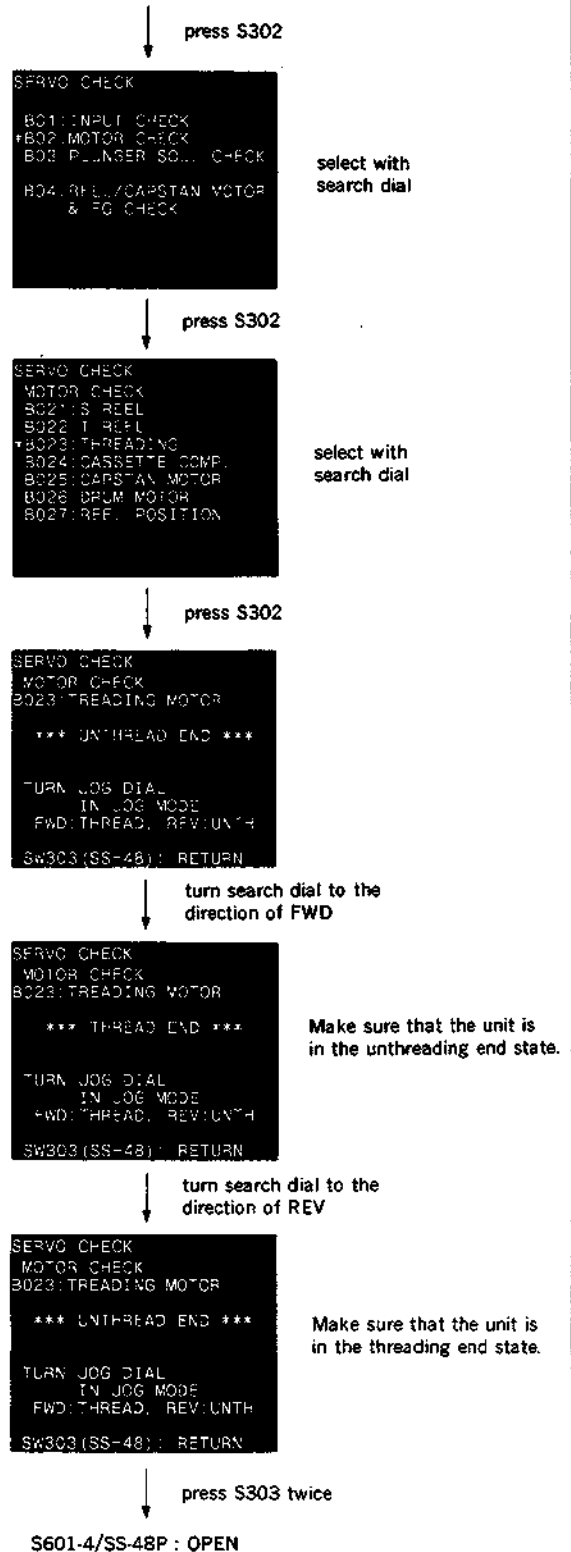

5-16. S SLIDER ASSEMBLY REPLACEMENT

Tools

Cleaning piece : 2-034-697-00
Cleaning fluid : 9-919-573-01
Molyton grease : 7-662-001-41

Replacement flow chart

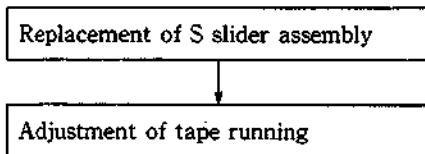

Removal

1. Turn a threading motor rotation detection ring of a threading motor block in the clockwise direction by fingers looking it from the front, and put a S slider assembly to 5 mm back from the threading completion mode. At this time S, T and P slider assemblies are moved on ST base and P base.
2. Unhook an end sensor harness as shown in the figure from a clammer of a S rail.
3. Remove four screws that holds the S rail, and remove the S rail.

Note: Pay particular attention not to cause damage to a drum and tape guide during removal.

4. Hold the S slider assembly with hand and turn the motor rotation detection ring of the threading motor block in the counterclockwise direction by fingers until the S joint installation shaft on a threading ring comes to the position as shown in the figure.

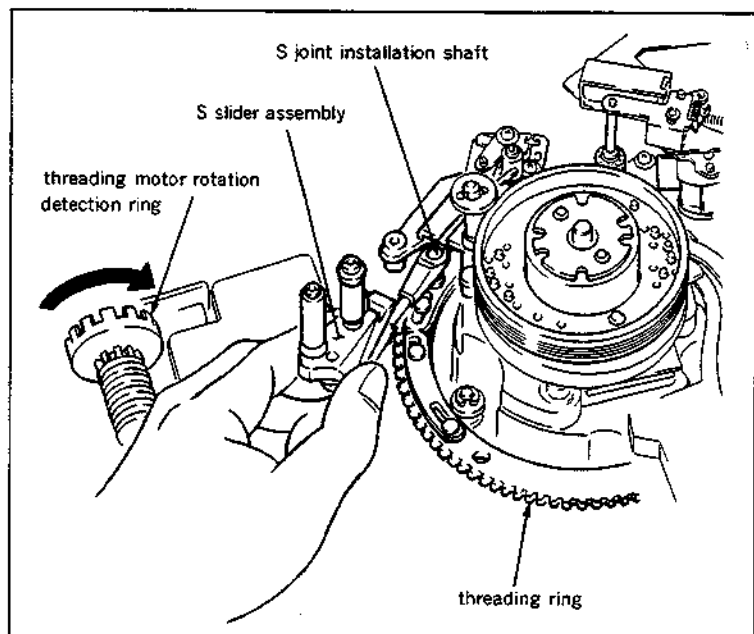
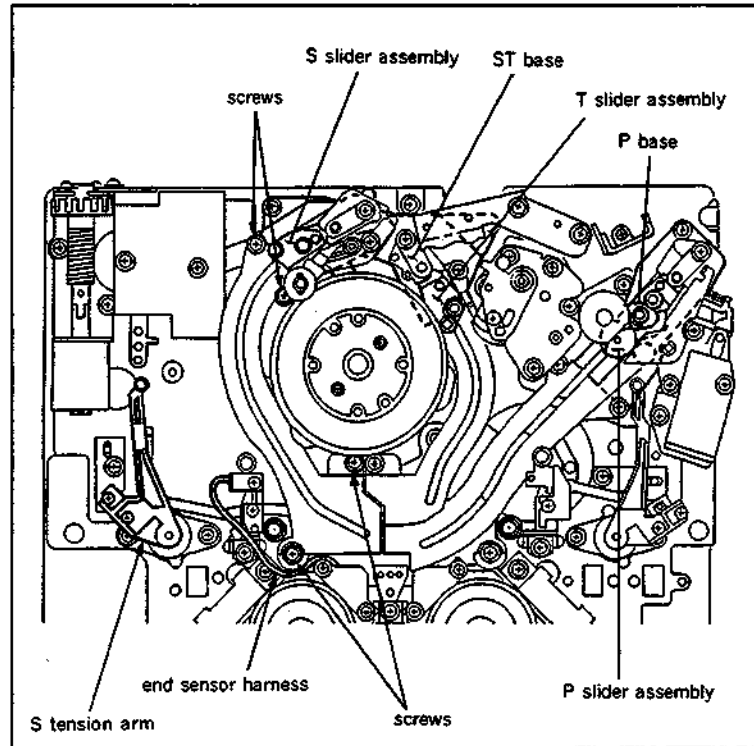

- Remove the S joint from a shaft on the threading ring, and remove the S slider assembly from the unit.

Note: Pay particular attention not to cause damage to the drum during removal.

- Remove the S joint from the S slider assembly.

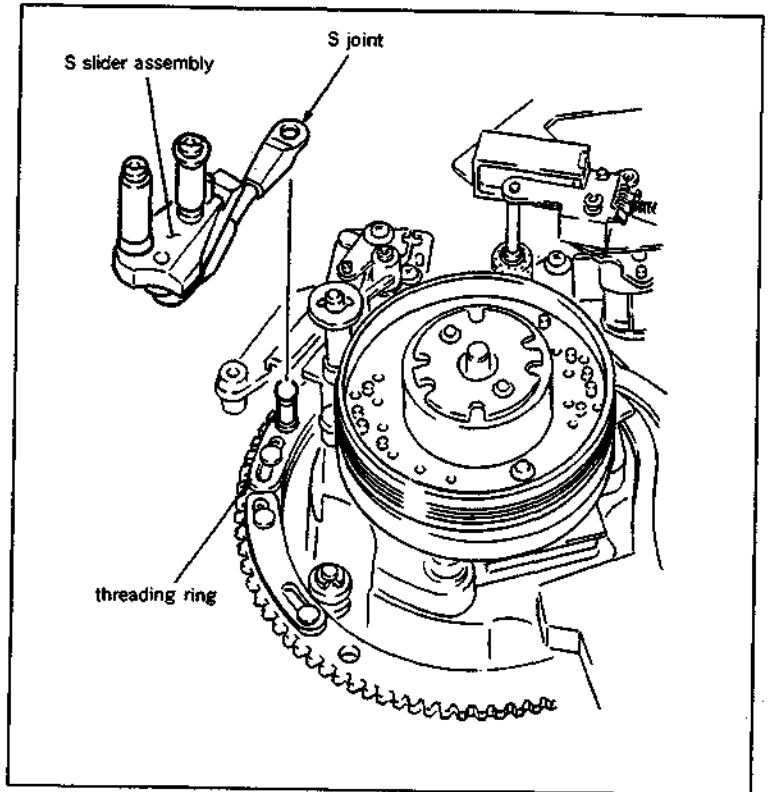

Installation

- Clean the contacting surfaces of the S rail with the S slider assembly with a cleaning piece moistened with cleaning fluid.
- Clean the contacting surfaces of a new S slider assembly with the S rail with a cleaning piece moistened with cleaning fluid.
- Insert the S joint to the S slider assembly as show in the figure.

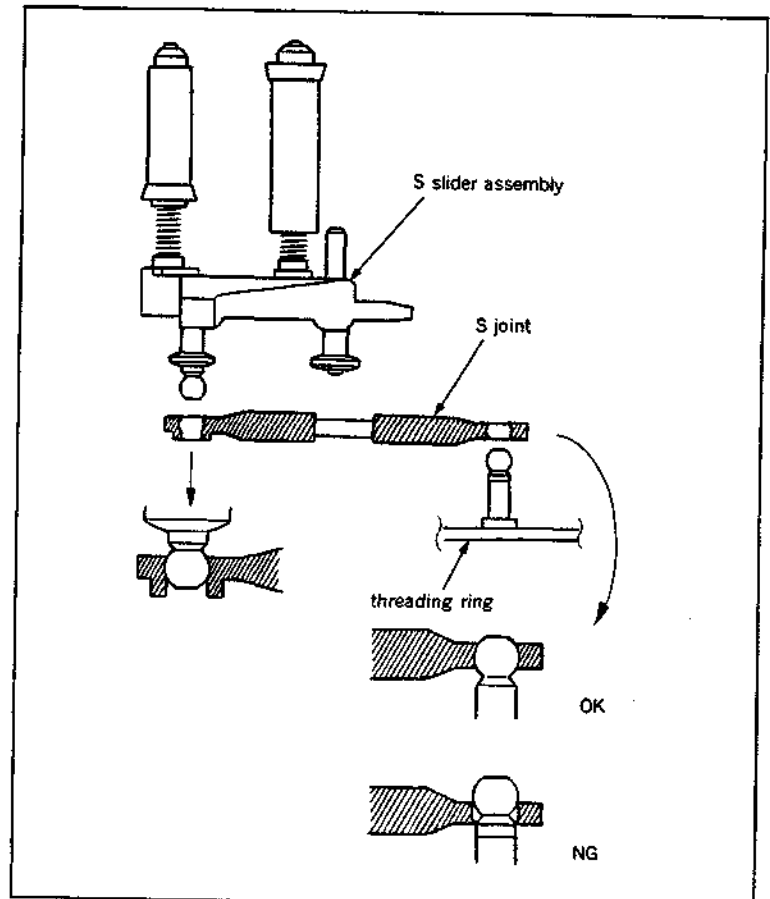

10. Insert the other end of the S joint into the shaft on the threading ring.
11. Hold the S slider assembly with hand and turn the motor rotation detection ring of the threading motor block in the clockwise direction by fingers, and insert the S slider assembly into the groove of the ST base.
12. Install the S rail to the chassis with four screws.

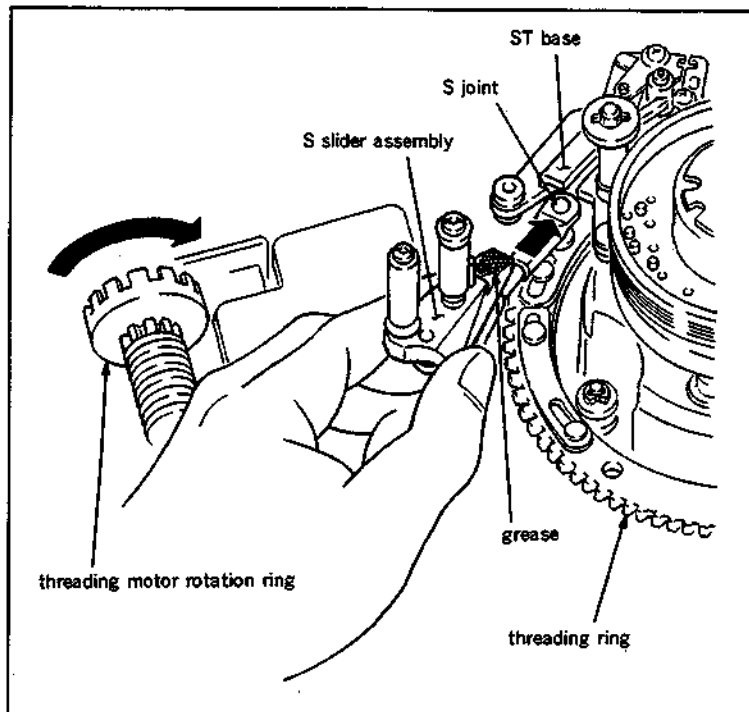

- Note 1 :** Pay particular attention not to cause damage to the drum and the tape guide.
- Note 2 :** When installing the S rail, push the S rail in the direction of the arrows so that align the width of groove of the ST base and S rail.

13. After turning the motor rotation detection ring in the counterclockwise direction with fingers, and smear a molyton grease slightly to the part as shown in the figure.

- Note 1 :** Do not smear the grease to the rail.
- Note 2 :** Pay particular attention not to smear grease to the tape guide and drum, etc. when smearing grease. If it is smeared by mistake, wipe it off completely with a cleaning piece moistened with cleaning fluid.

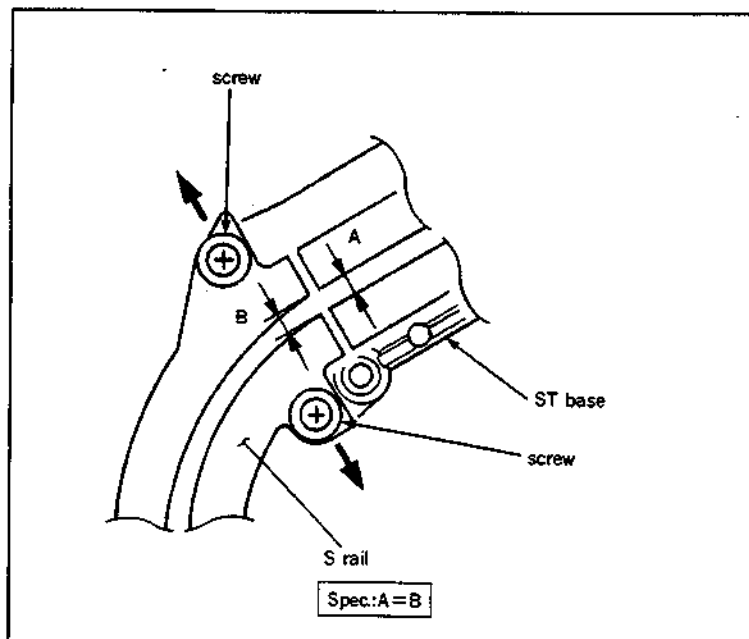

14. Turn the motor rotation detection ring in the clockwise and counterclockwise directions by fingers, and make sure that the S slider assembly moves smoothly.

Adjustment after replacement

15. Perform tape running adjustment. (Refer to Section 6-3.)

5-17. T SLIDER ASSEMBLY REPLACEMENT

Tools

Cleaning piece : 2-034-697-00
Cleaning fluid : 9-919-573-01
Molyton grease : 7-662-001-41

Replacement flow chart

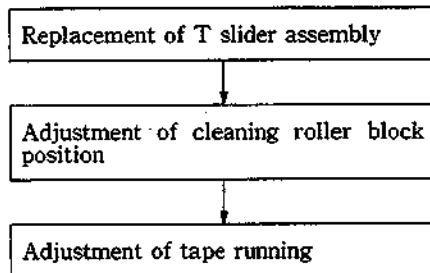

Removal

1. Remove a cleaning roller block. (Refer to steps (1) and (2) in Section 5-6.)
2. Remove an AU head cover. At this time, the harness clamber of the drum comes off together. (Refer to step (3) in Section 5-3.)
3. Rotate a drive gear by fingers so that a reel table is placed to the L cassette position.
4. Turn a threading motor rotation detection ring of a threading motor block in the clockwise direction by fingers looking it from the front, and put a T slider assembly to 5 mm back from the threading completion mode. At this time S, T and P slider assemblies are moved on ST base and P base.
5. Unhook a tape beginning sense harness from a T rail.
6. Remove five screws that holds the T rail, and remove the T rail.

Note :Pay particular attention not to cause damage to a drum and tape guide during removal.

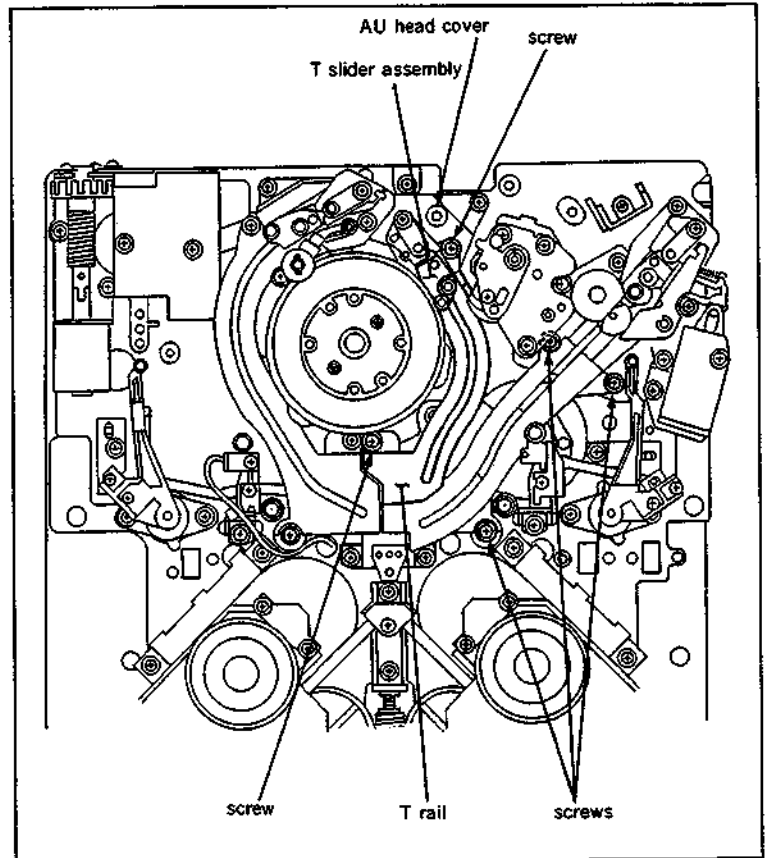

7. Remove the P joint of a P slider assembly from a shaft on the threading ring.
8. Hold the T slider assembly with hand and turn the motor rotation detection ring of the threading motor block in the counterclockwise direction by fingers until the T joint installation shaft on the threading ring comes to the position as shown in the figure.

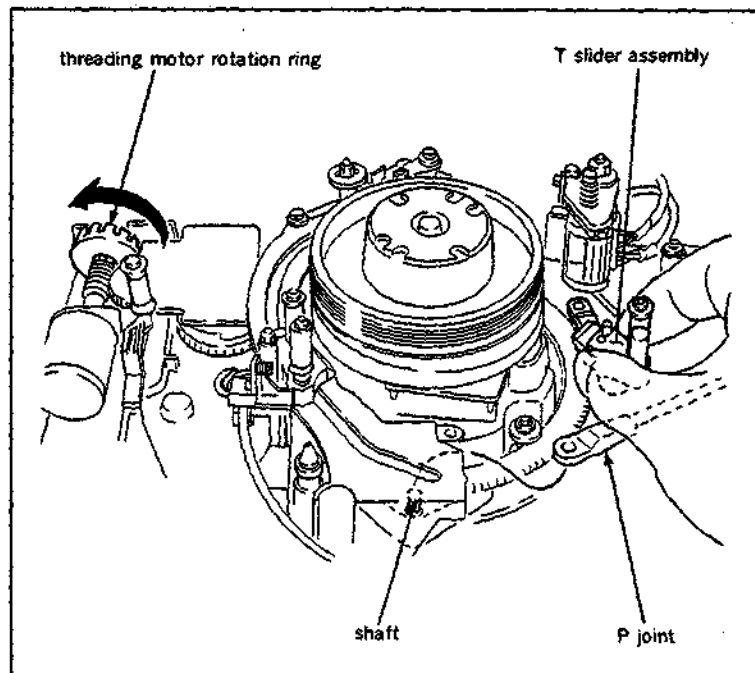

9. Remove the T joint from the shaft on the threading ring, and remove the T slider assembly from the unit.

Note : Pay particular attention not to cause damage to the drum during removal.

10. Remove the T joint from the T slider assembly.

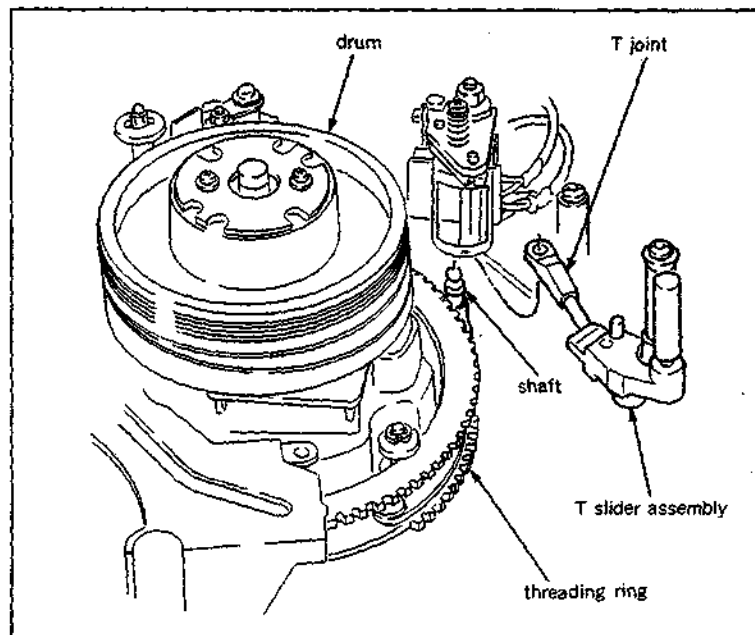

Installation

11. Clean the contacting surfaces of the T rail with the T slider assembly with a cleaning piece moistened with cleaning fluid.
12. Clean the contacting surfaces of a new T slider assembly with the T rail with a cleaning piece moistened with cleaning fluid.
13. Insert the T joint to the T slider assembly as show in the figure.

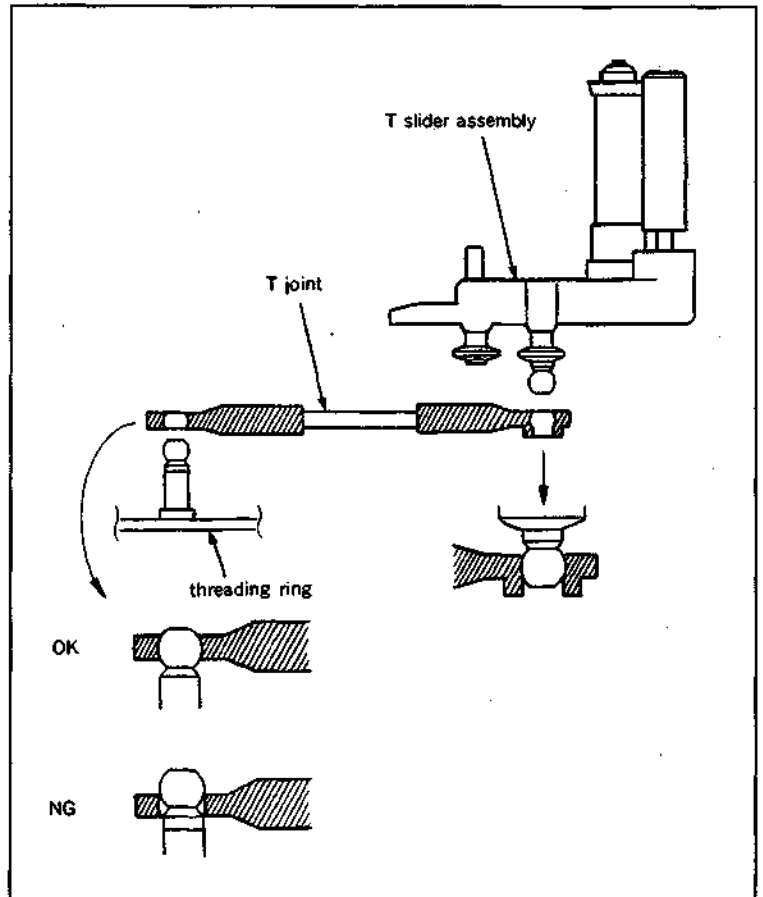

14. Insert the other end of the T joint into a shaft on the threading ring.
15. Hold the T slider assembly with hand and turn the motor rotation detection ring of the threading motor block in the counterclockwise direction by fingers, and insert the T slider assembly into the groove of the ST base.
16. Insert the P joint into the shaft on the threading ring.

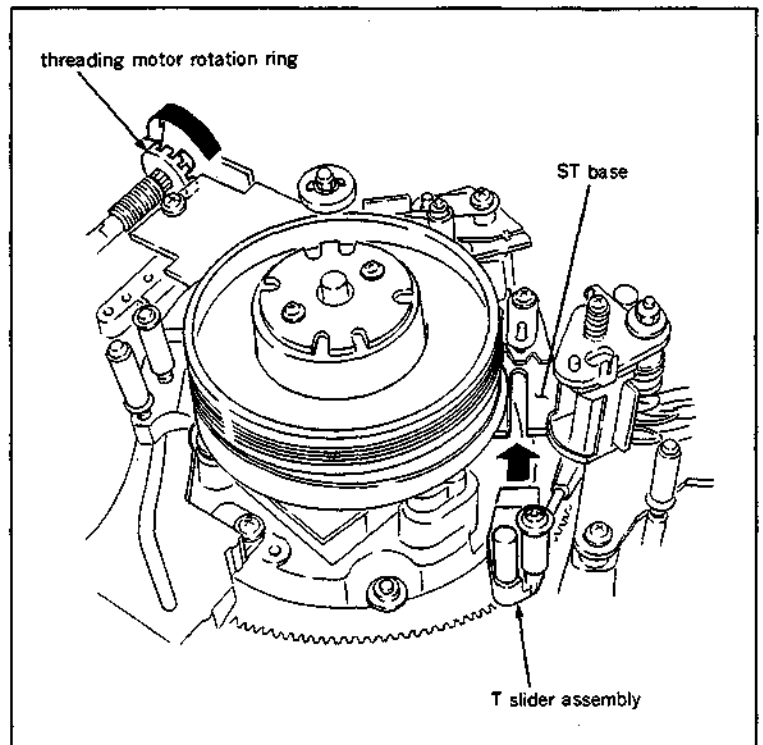

17. Install the T rail to the chassis with five screws.

Note 1 : Pay particular attention not to cause damage to the drum and the tape guide.

Note 2 : When installing the T rail, align the width of groove of the ST base and T rail.

Note 3 : When fastening the T rail with the screw shown in the figure, pay particular attention not to twist the T rail.

18. After turning the motor rotation detection ring in the counterclockwise direction with fingers, and smear a molyton grease slightly to the part as shown in the figure.

Note 1 : Do not smear the grease to the rail.

Note 2 : Pay particular attention not to smear grease to the tape guide and drum, etc. when smearing grease. If it is smeared by mistake, wipe it off completely with a cleaning piece moistened with cleaning fluid.

19. Turn the motor rotation detection ring in the clockwise and counterclockwise directions by fingers, and make sure that the T slider assembly moves smoothly.
20. Install the AU head cover together with the drum harness clasper.
21. Install the cleaning roller block. (Refer to steps(7) and (8) in Section 5-6.)

Adjustment after replacement

22. Perform cleaning roller block position adjustment. (Refer to Section 5-6-1.)
23. Perform tape running adjustment. (Refer to Section 6-3.)

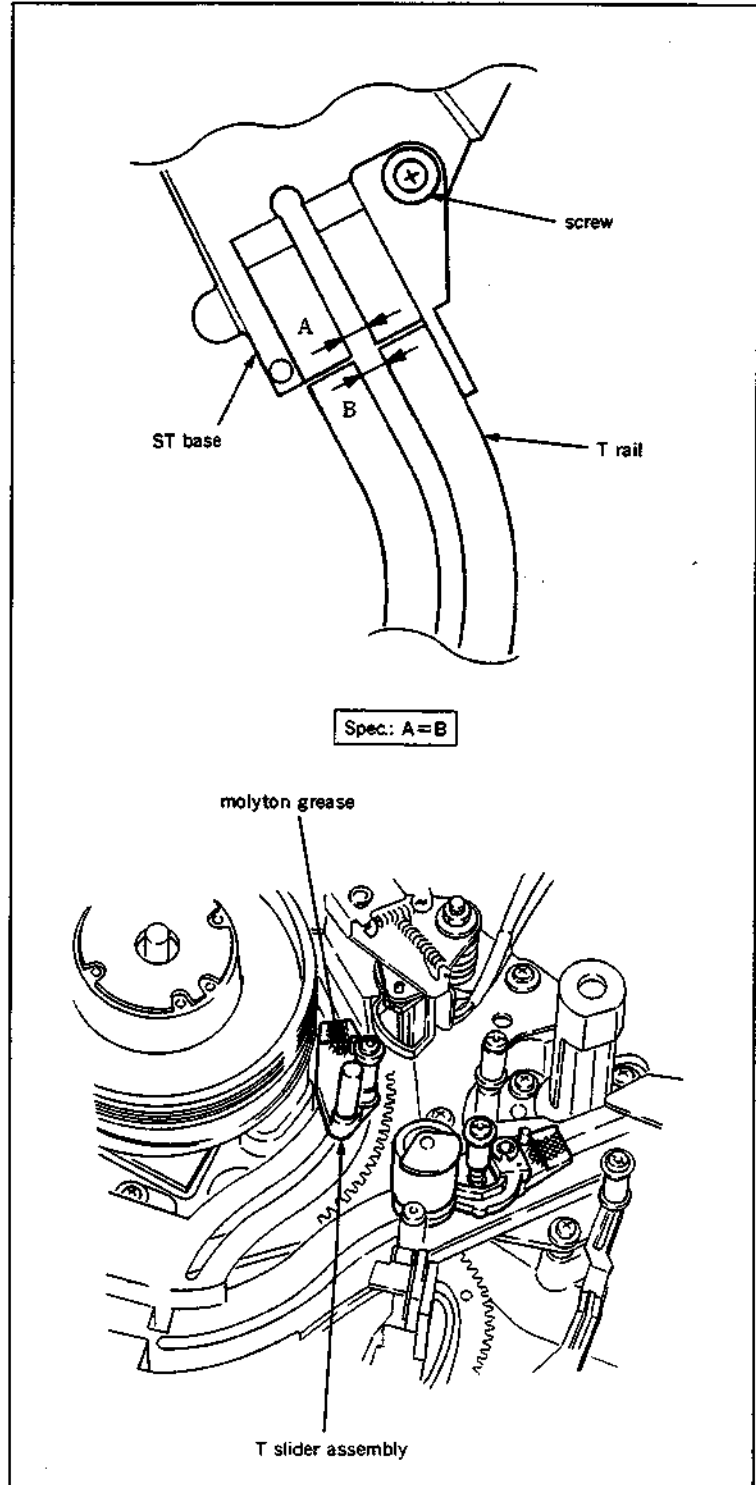

5-18. P SLIDER ASSEMBLY REPLACEMENT

Tools

Cleaning piece : 2-034-697-00
Cleaning fluid : 9-919-573-01
Molyton grease : 7-662-001-41

Replacement flow chart

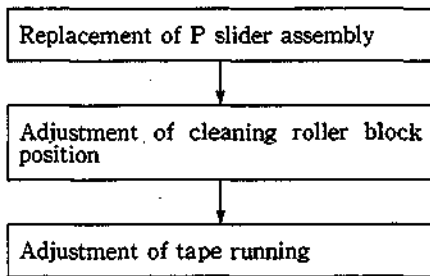

Removal

1. Remove a cleaning roller block. (Refer to steps (1) and (2) in Section 5-6.)
2. Remove an AU head cover. At this time, the harness clamber of the drum comes off together. (Refer to step (3) in Section 5-3.)
3. Rotate a drive gear by fingers so that a reel table is placed to the L cassette position.
4. Turn a threading motor rotation detection ring of a threading motor block in the clockwise direction by fingers looking it from the front, and put a P slider assembly to 5 mm back from the threading completion mode. At this time S, T and P slider assemblies are moved on ST base and P base.
5. Unhook a tape beginning sensor harness from a T rail, and remove five screws that holds the T rail, and remove it. (Refer to step (6) in Section 5-17.)

Note :Pay particular attention not to cause damage to a drum and tape guide during removal.

6. Remove a P joint which connects the P slider assembly with a threading ring from a shaft on the threading ring.
7. Remove the P joint from the P slider assembly.

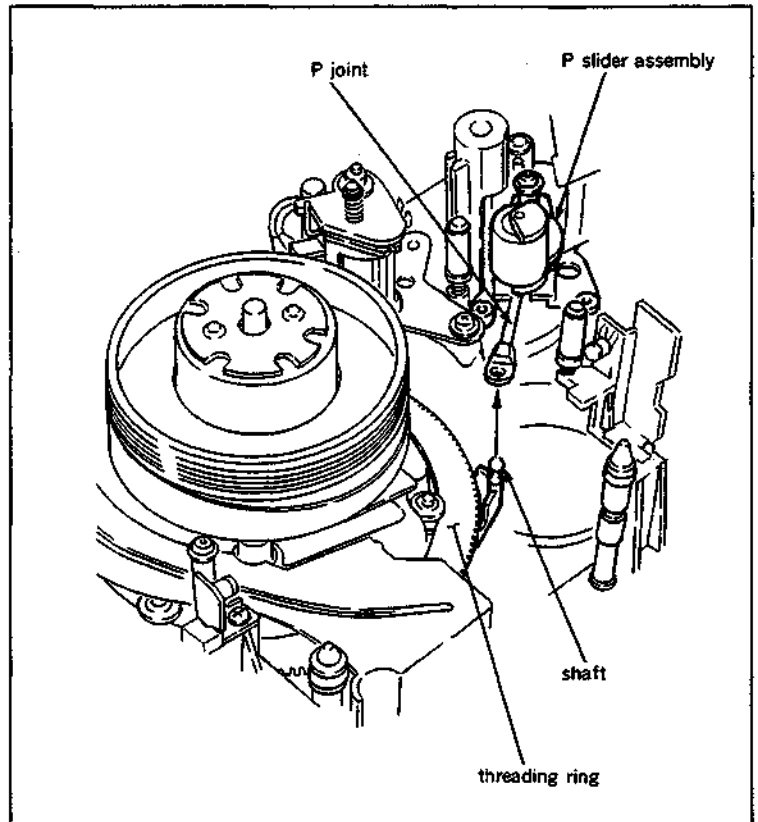

Installation

8. Clean the contacting surfaces of the T rail with the T slider assembly and P slider assembly with a cleaning piece moistened with cleaning fluid.
9. Clean the contacting surfaces of a new P slider assembly with the T rail with a cleaning piece moistened with cleaning fluid.
10. Insert the P joint to the P slider assembly as shown in the figure.

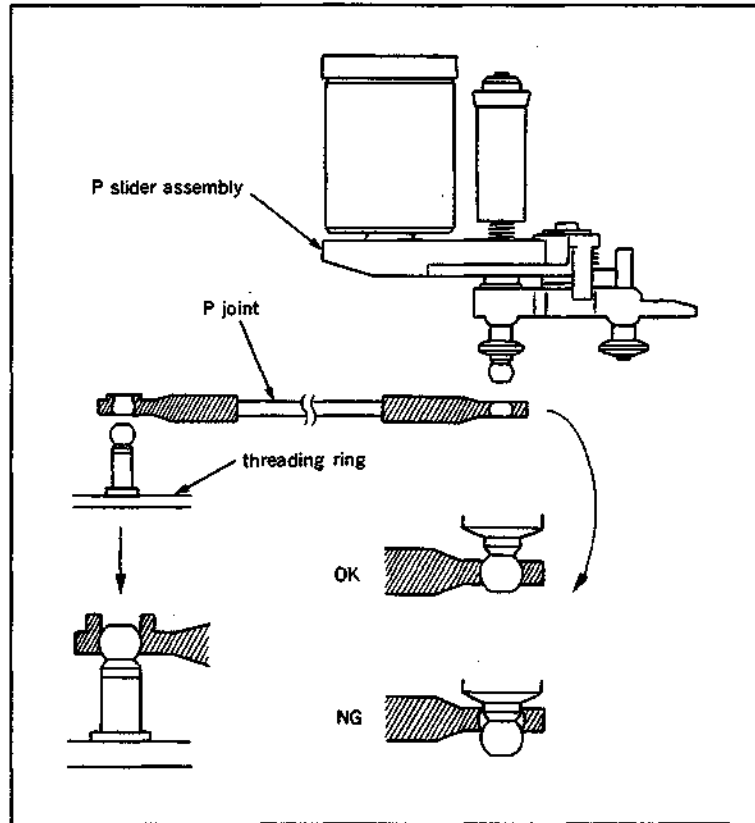

11. Insert the P slider assembly into the groove of the ST base as shown in the figure.

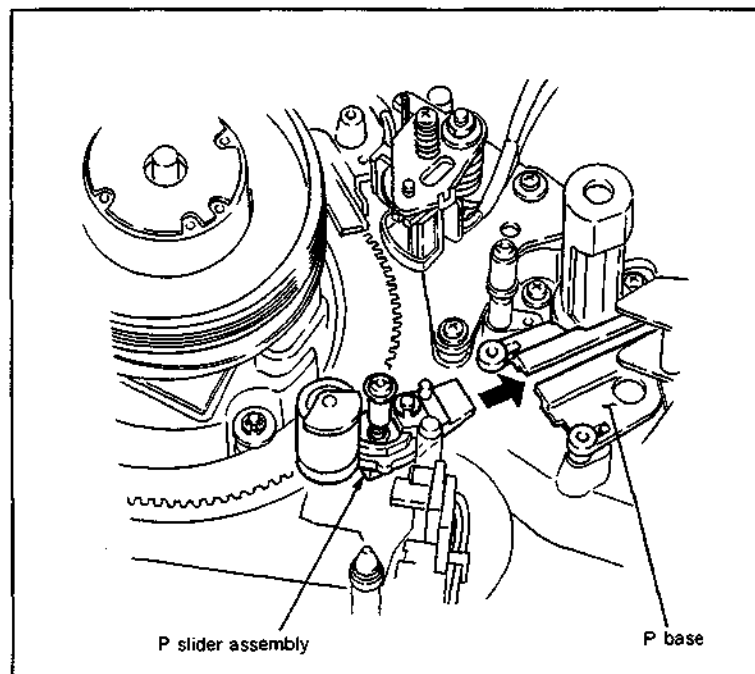

12. Insert the P joint into the shaft on the threading ring.
13. Install the T rail to the chassis with five screws.

Note 1 : Pay particular attention not to cause damage to the drum and the tape guide.

Note 2 : When installing the T rail, align the width of groove of the ST base and T rail.

Note 3 : When fastening the T rail with the screw shown in the figure, pay particular attention not to twist the T rail.

14. After turning the motor rotation detection ring in the counterclockwise direction with fingers, and smear a molyton grease slightly to the part as shown in the figure.

Note 1 : Do not smear the grease to the rail.

Note 2 : Pay particular attention not to smear grease to the tape guide and drum, etc. when smearing grease. If it is smeared by mistake, wipe it off completely with a cleaning piece moistened with cleaning fluid.

15. Turn the motor rotation detection ring in the clockwise and counterclockwise directions by fingers, and make sure that the P slider assembly moves smoothly.
16. Install the AU head cover together with the drum harness clamper.
17. Install the cleaning roller block. (Refer to steps (7) and (8) in Section 5-6.)

Adjustment after replacement

18. Perform cleaning roller block position adjustment. (Refer to Section 5-6-1.)
19. Perform tape running adjustment. (Refer to Section 6-3.)

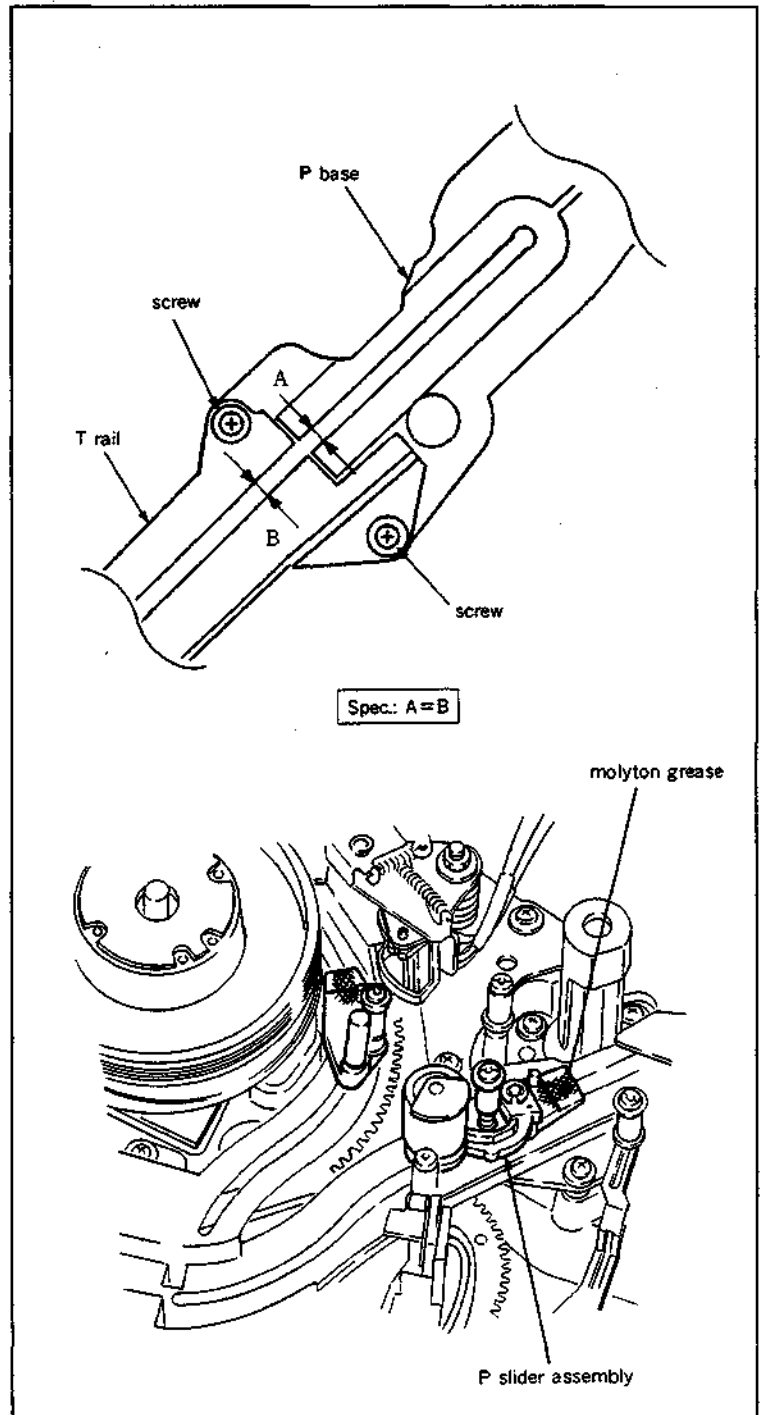

5-19. S TENSION REGULATOR ARM ASSEMBLY REPLACEMENT

Tool

L shaped wrench (across flat has 0.89 mm)
: 7-700-736-06

Replacement flow chart

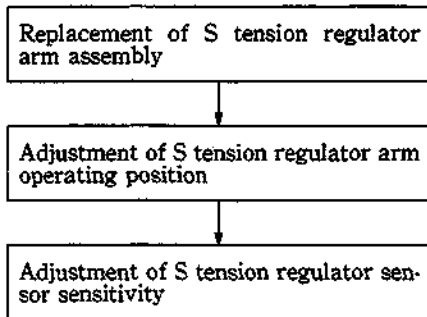

(Be sure to replace a T tension regulator arm and TR-73 board which places under the T tension regulator arm at the back side of the chassis in this step, if necessary.)

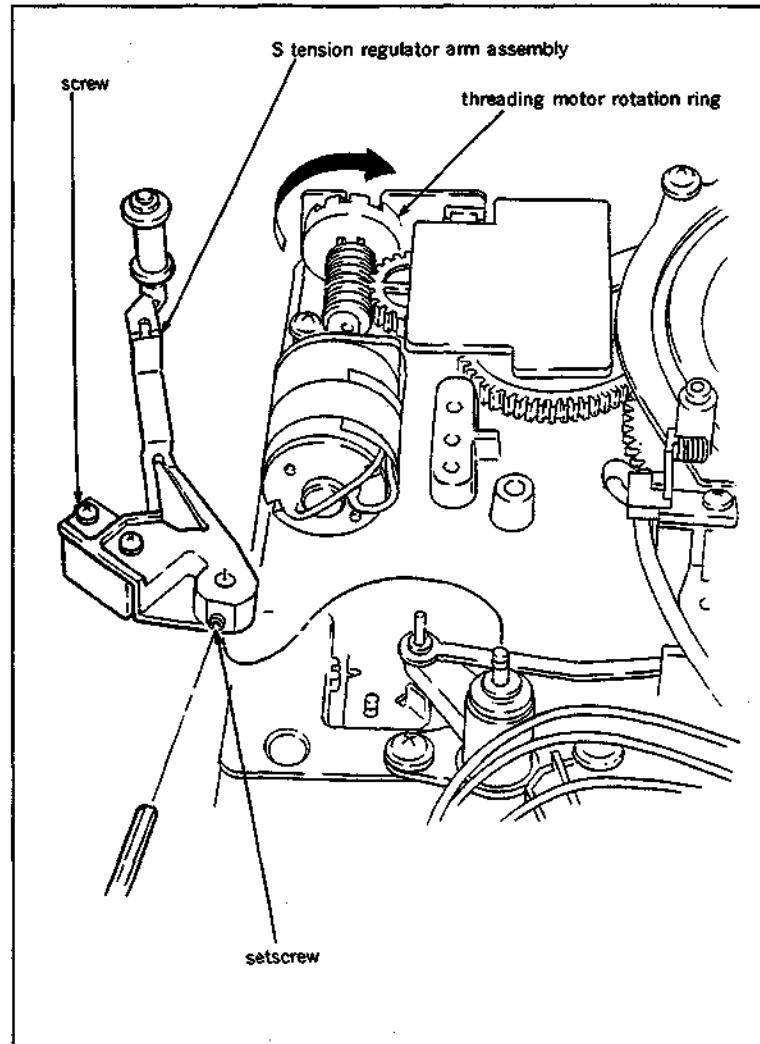
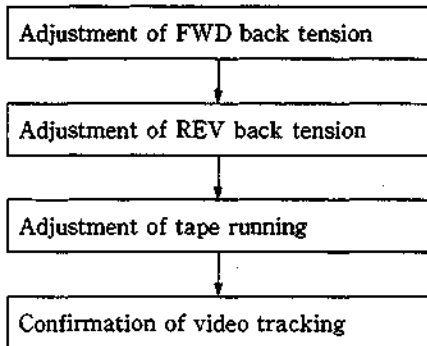

Removal

1. Turn a threading motor rotation detection ring of a threading motor block in the clockwise direction by fingers looking from the front, and put the unit into the threading completion mode.
2. Loosen a setscrew shown in the figure holding a S tension regulator arm assembly, and lift the S tension regulator arm assembly straight up to remove.

Installation

3. Install a new S tension regulator arm assembly to a shaft of a tension regulator base so that a protector, plate spring and shaft of a drive arm are assembled as shown in the figure, and tighten a setscrew.

Adjustment after replacement

4. Perform S tension regulator arm operating position adjustment. (Refer to step (2) and later in Section 5-19-1.)
5. Perform S tension sensor sensitivity adjustment. (Refer to Section 5-19-2.)
6. Perform FWD back tension adjustment. (Refer to Section 5-19-3.)
7. Perform REV back tension adjustment. (Refer to Section 5-19-4.)
8. Perform tape running adjustment. (Refer to Section 6-3.)
9. Perform confirmation of video tracking adjustment. (Refer to Section 6-4.)

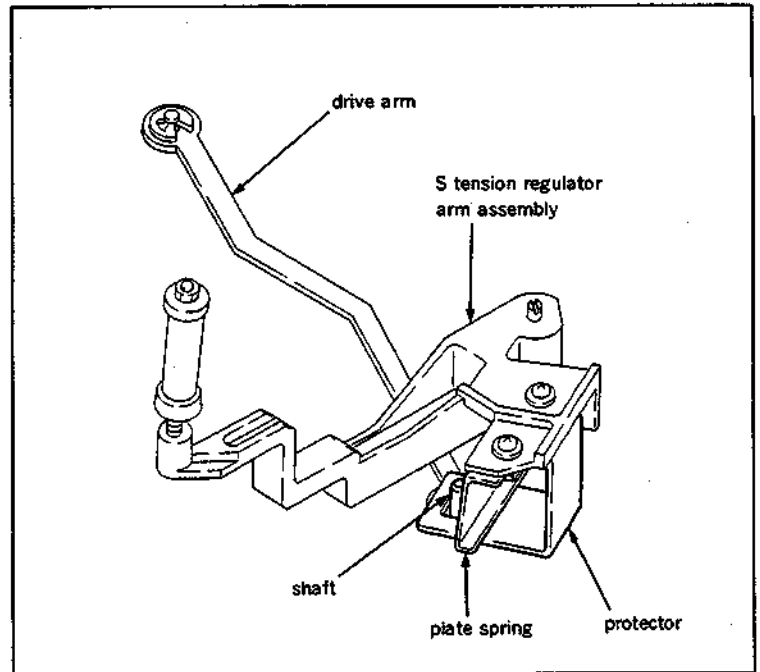

5-19-1. S Tension Regulator Arm Operating Position Adjustment

- Be sure to perform this adjustment without installing a cassette compartment.

Tools

Cassette reference plate (L): J-6320-880-A
Tension regulator positioning tool : J-6322-370-A
Dial tension gauge (50 g) : J-6327-850-A
Tension measurement tape : Refer to Section 5-1.
Wire clearance gauge : J-6152-450-A
Cleaning piece : 2-034-697-00
Cleaning fluid : 9-919-573-01

Check

1. Install a tension regulator positioning tool onto the place, with its fixing screw while turning the tool in the direction of the arrow.

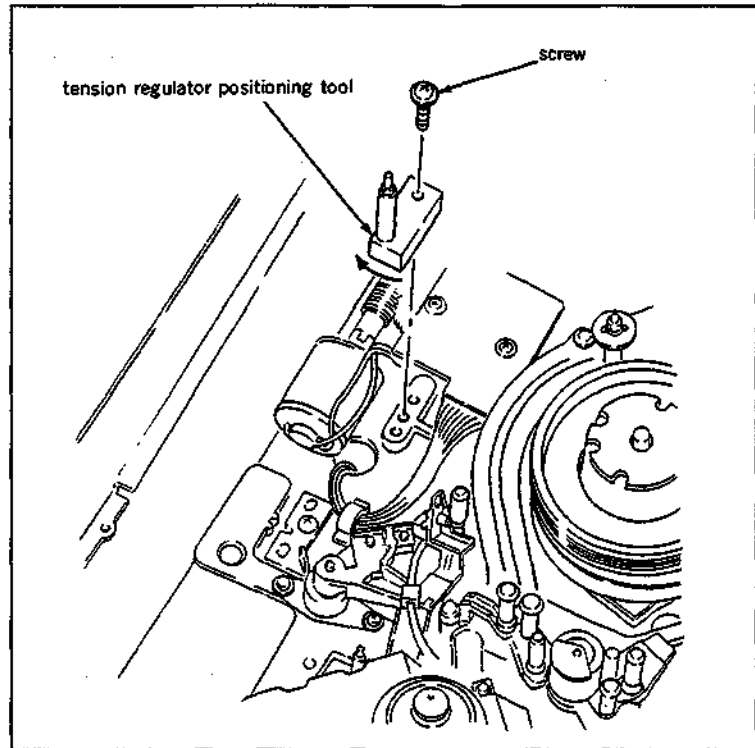

2. Put Bit4 of S601 on SS-48P board in CLOSE state.
3. Confirm that a reel table is in S cassette position. When it is in L cassette position, turn the POWER to ON once, change it to S cassette position, according to the Maintenance Menu "B027: REEL POSITION"
4. Place the cassette reference plate (L) on four cassette pillars.
5. Turn the POWER to ON. A threading ring rotates automatically, and put the unit into the threading completion mode. Press STANDBY button to be in STANDBY OFF mode, and stop the rotation of a drum.
6. Put one end of the tension measurement tape into TG-3 tape guide on a S slider assembly as shown in the figure.
7. Thread the tension measurement tape as shown in the figure.
8. Put the tip of the dial tension gauge into the holder of the tension measurement tape.

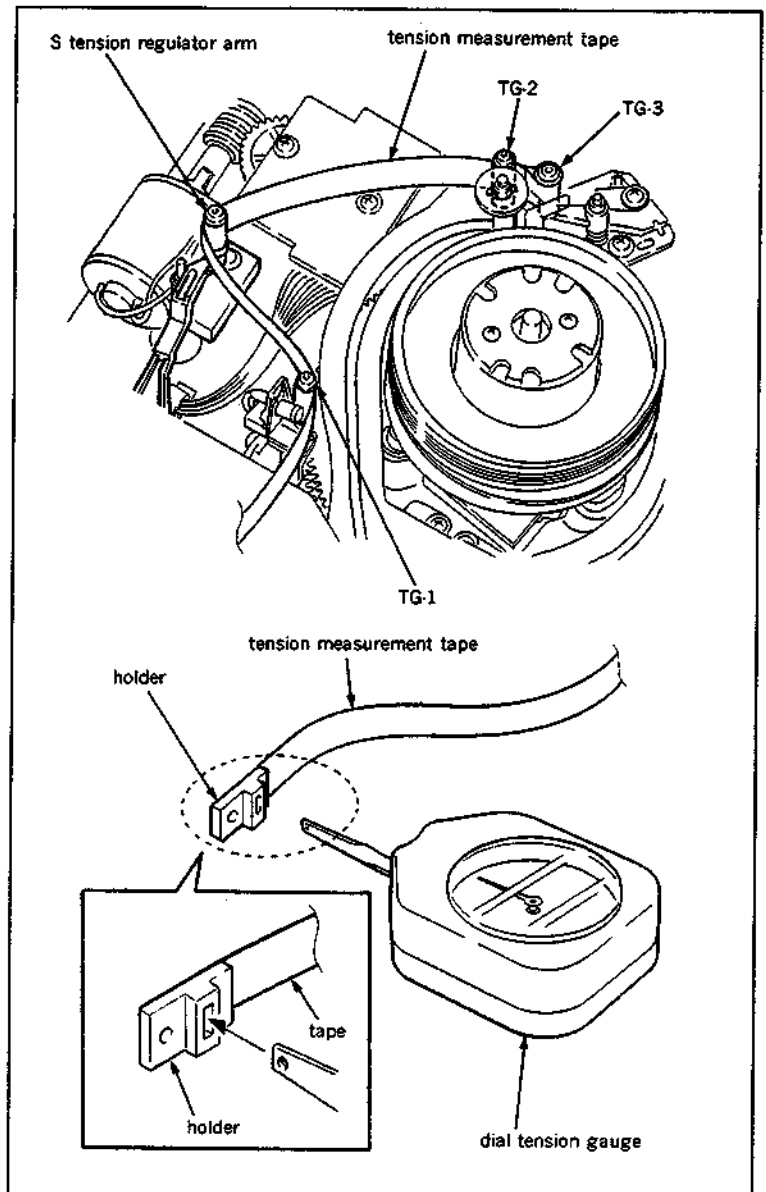

9. Place the dial tension gauge on the cassette reference plate (L), and move the gauge along the cassette reference plate (L) in the direction shown in the figure until the indication of the gauge shows 42 g.

Note 1 : Confirm that the tension measurement tape is placed on every tape guide roller properly.

Note 2 : Pull the tension measurement tape in the perpendicular direction to the cassette reference plate (L).

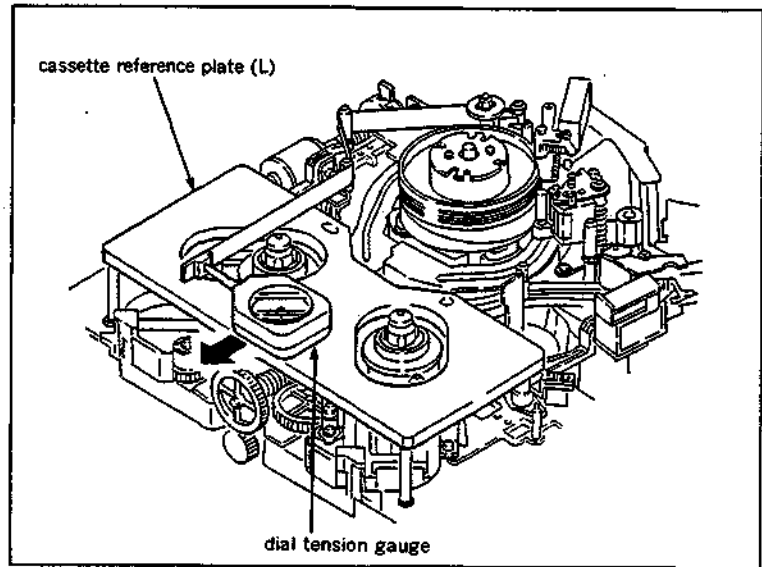

10. When the indication of the gauge is 42 g, confirm that the side surface of the S tension regulator arm is located within the range of the tension regulator positioning tool as shown in the figure.

If the specification is satisfied, perform step (16) and later.

If the specification is not satisfied, perform step (11) and later.

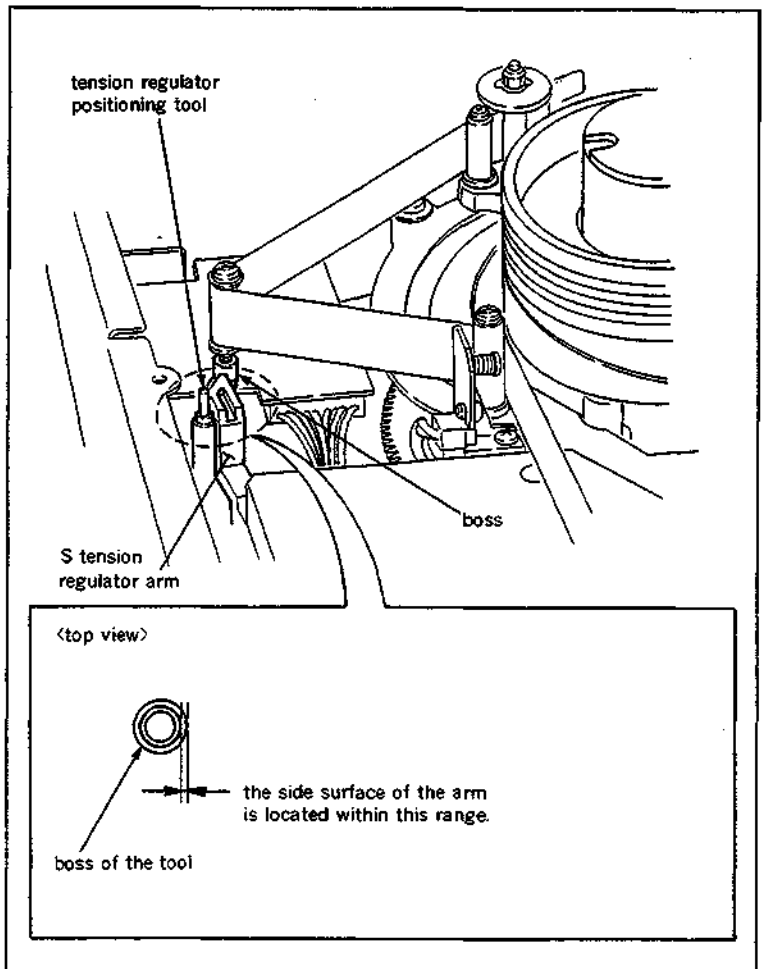

Adjustment

11. Loosen a fixing screw of a S stopper for 1/3 to 1/2 turn.
12. Perform step (9).
13. While keeping the state of step (9), insert a 3 mm flatblade screwdriver into notch of the S stopper, and adjust position of the S stopper so that the specification is satisfied.
14. Tighten the fixing screw of the S stopper.
15. Reconfirm that the specification is satisfied according to the check procedure.
16. After adjustment, take out the tension measurement tape from the unit, and press EJECT button to put into the unthreading completion mode, then take out the cassette reference plate (L).
17. Turn the POWER to OFF, and put Bit4 of S601 on SS-48 board in OPEN state.
18. Remove the tension regulator positioning tool.
19. Clean the tape running surfaces of TG-1, TG-2, TG-3 and tension regulator roller with a cleaning piece moistened with cleaning fluid.

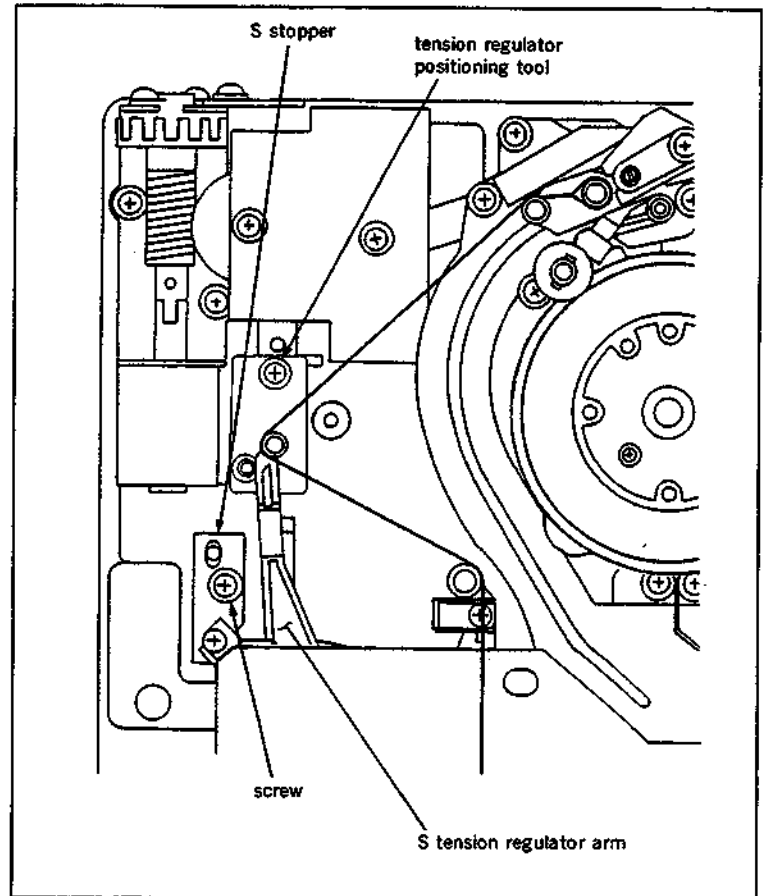

5-19-2. S Tension Sensor Sensitivity Adjustment

- It is impossible to only confirm whether S tension sensor sensitivity is being properly adjusted. Be sure to adjust S tension sensor sensitivity as the following procedures below, and save the adjustment data in NOV RAM.
- Be sure to perform this adjustment after removing a cassette compartment.

Tools

- Cassette reference plate : J-6080-008-A
 Dial tension gauge (50 g) : J-6327-850-A
 Tension measurement tape : Refer to Section 5-1.
 L shaped wrench (across flat has 0.89 mm)
 : 7-700-736-06

Preparation

Connect a video monitor with VIDEO OUTPUT 3 connector or MONITOR connector, and display characters.

Adjustment

1. Turn the POWER to OFF, and put Bit4 of S601 on SS-48P board in CLOSE state.
2. Confirm that a reel table is in S cassette position. When it is in L cassette position, turn the POWER to ON once, change it to S cassette position, according to the Maintenance Menu "B027 : REEL POSITION"
3. Loosen a setscrew of a S tension regulator arm assembly for 1/4 to 1/3 turn.
4. Turn the POWER to ON. When the POWER is turned ON, threading automatically starts. Press EJECT button to put the unit in EJECT completion mode.
5. Push S302 and put the unit into maintenance mode.
6. Press the search dial to enter the jog mode, and move * mark to "B1: SERVO ADJUST" which is displaying on the monitor screen with the search dial.
7. Press S302 on SS-48P board to select "SERVO ADJUST" mode.
8. Move * mark to "B112: S TENSION SENSOR" which is displaying on the monitor screen with the search dial.
9. Press S302 on SS-48P board to execute "S TENSION SENSOR" menu.
10. Place a cassette reference plate on four cassette pillars.

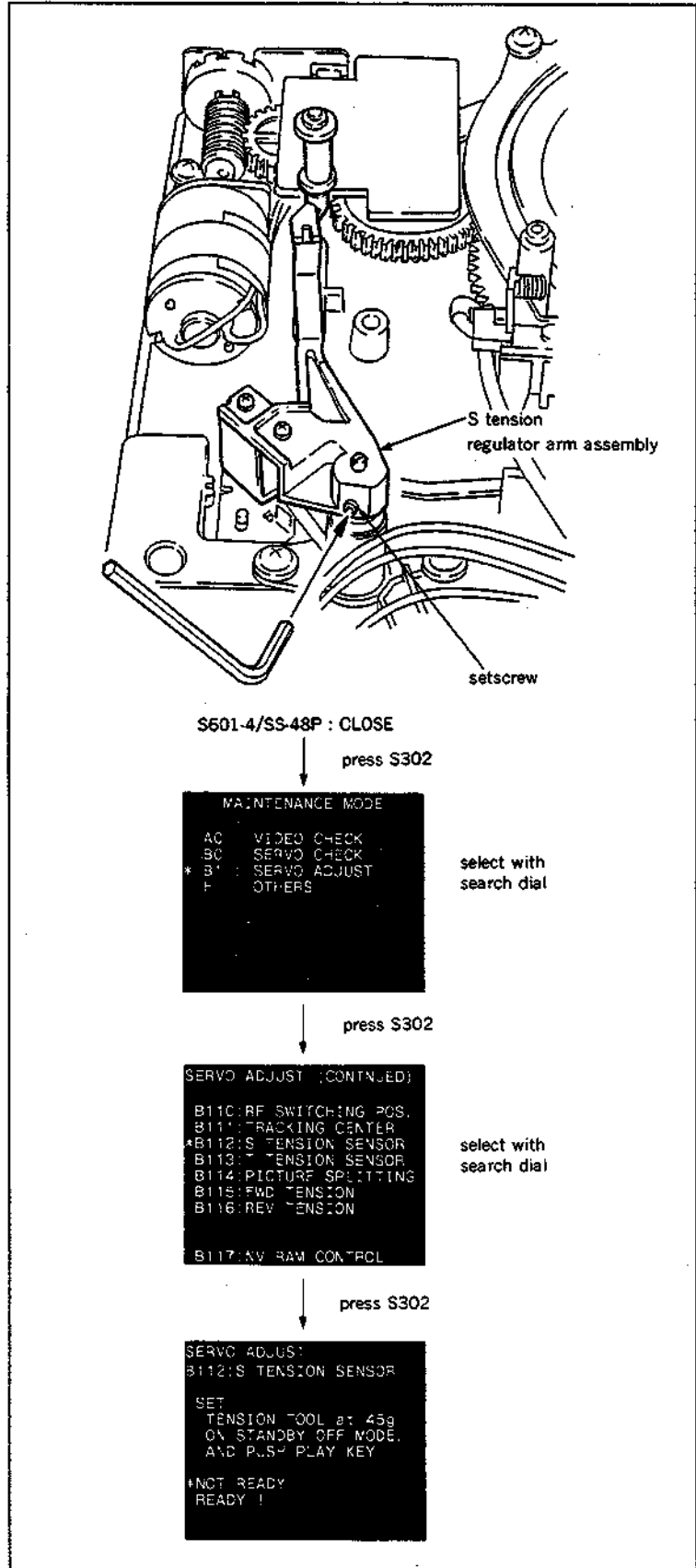

11. Press STOP button to put the unit into the threading completion mode. Then press STANDBY button to be in STANDBY OFF mode, and stop the rotation of a drum.
12. Put one end of the tension measurement tape into TG-3 tape guide on a S slider assembly as shown in the figure.
13. Thread the special made tension measuring tape as shown in the figure.
14. Put the tip of the dial tension gauge into the holder of the special made tension measuring tape.

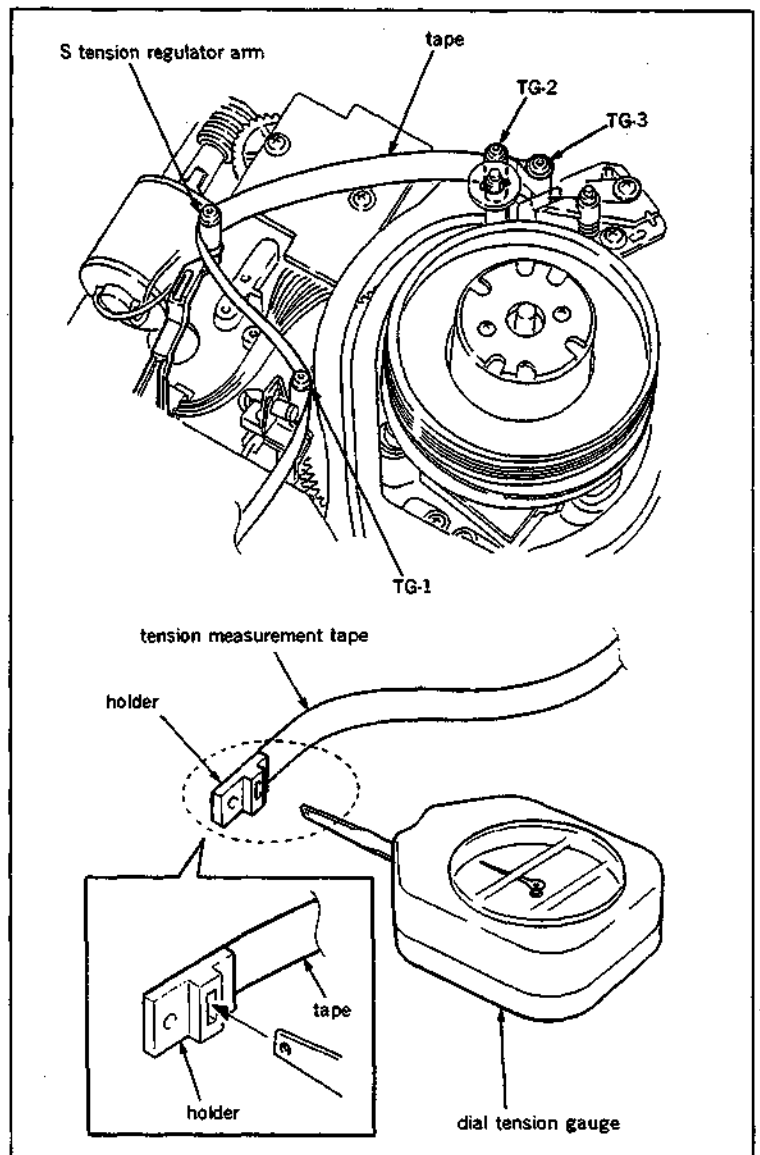

15. Place the dial tension gauge on the cassette reference plate, and move the gauge along the cassette reference plate in the direction shown in the figure until the indication of the gauge shows 45 g.

Note 1 : Confirm that the tension measurement tape is placed on every tape guide roller properly.

Note 2 : Pull the tension measurement tape in the perpendicular direction to the cassette reference plate.

Note 3 : Keep the condition of step (15) when performing steps (16) through (20).

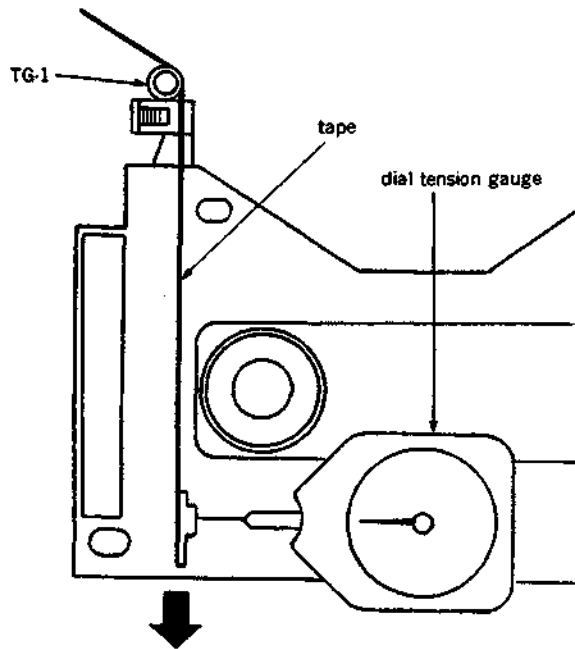
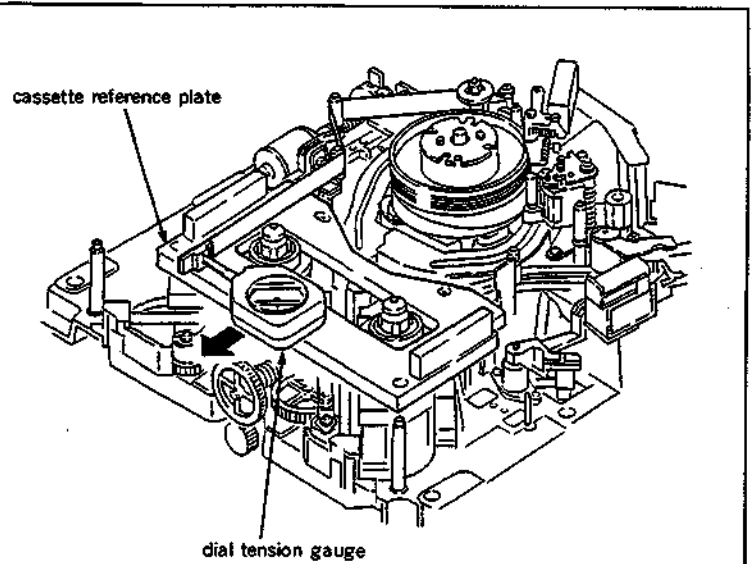

Pull the tape in the perpendicular direction to the cassette reference plate.

press PLAY button

```

SERVO ADJUST
BIPOLAR TENSION SENSOR
SF-
TENSION TOOL at 45g
ON STANDBY OFF MODE.
AND PUSH PLAY KEY
NOT READY
*READY
  
```

select with search dial

press S302

16. Press PLAY button.
17. Move * mark to "READY" which is displaying on the monitor screen with the search dial.
18. Press S302 on SS-48P board.
19. First, use a flatblade screwdriver to rotate the adjusting screw of the S tension regulator arm assembly clockwise slowly until the display on the monitor screen changes (turn three to four rotation).
Then rotate the adjusting screw slowly until data displayed on the monitor screen changes to values between -10 and 10, and the data must be kept in increasing state.

Note 1 : Make sure to rotate the flatblade screwdriver clockwise.

Note 2 : While adjusting screw is rotated, the data will keep on increasing and decreasing. In this adjustment, the data must be kept in increasing state and adjusted to meet the specification.

For example : 0001, 0002, 0003, 0004,... data shown in monitor screen is increasing.

0002, 0001, 0000, -0001,...data shown in monitor screen is decreasing.

20. While the condition of step (15) is being kept, tighten a setscrew of the S tension regulator arm assembly.

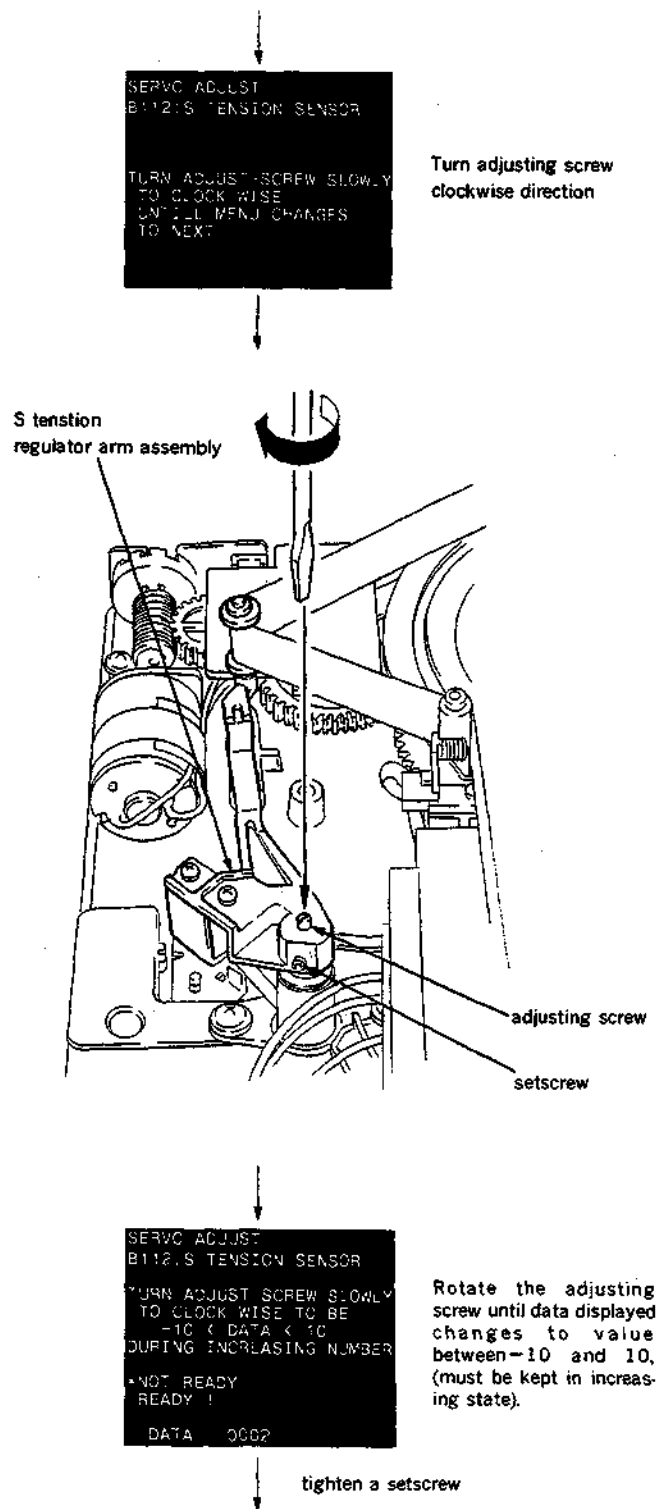

21. Move * mark to "READY" which is displaying on the monitor screen with the search dial.
22. Press S302 on SS-48P board.
23. After pressing STOP button, press STANDBY button to be in STANDBY OFF mode, and stop the rotation of a drum.
24. Place the dial tension gauge on the cassette reference plate, and move the gauge along the cassette reference plate in the direction shown in the figure until the indication of the gauge shows 25 g.

Note 1 : Confirm that the tension measurement tape is placed on every tape guide roller properly.

Note 2 : Pull the tension measurement tape in the perpendicular direction to the cassette reference plate.

Note 3 : Keep the condition of step (24) when performing steps (25) through (27).

25. Press PLAY button.
26. Move * mark to "READY" which is displaying on the monitor screen with the search dial.
27. Press S302 on SS-48P board.
28. After pressing STOP button, press STANDBY button to be in STANDBY OFF mode, and stop the rotation of a drum.
29. Take out the dial tension gauge, tension measurement tape and cassette reference plate from the unit.
30. Press EJECT button to put into the unthreading completion mode.

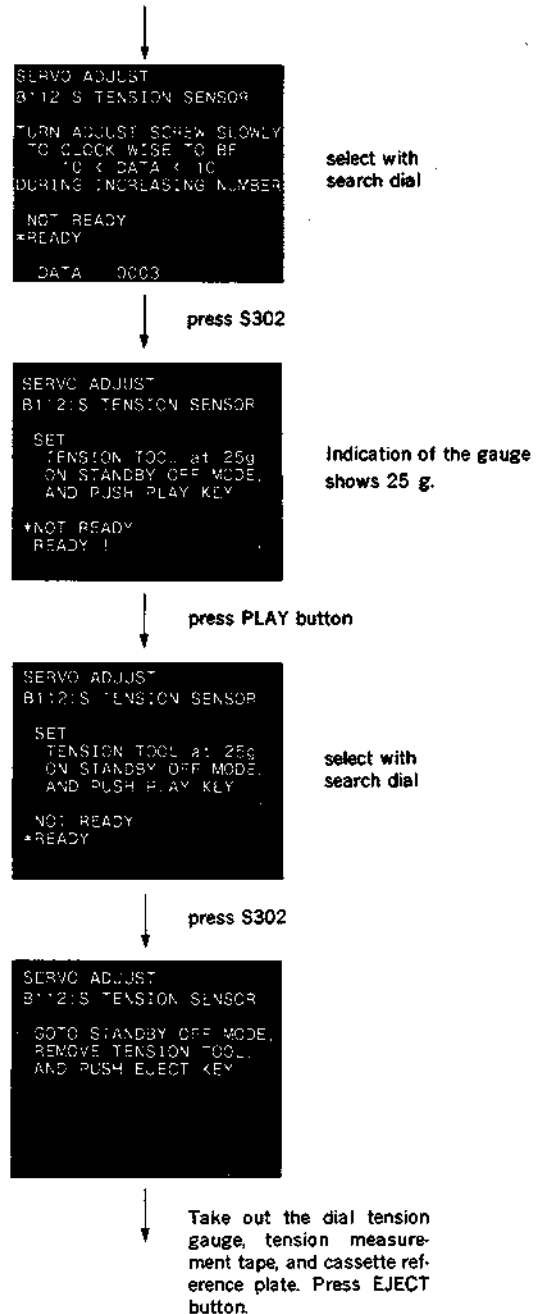

31. Move * mark to "B117 : NV RAM CONTROL" which is displaying on the monitor screen with the search dial.
32. Press S302 on SS-48P board to execute "NV RAM CONTROL" menu.
33. Move * mark to "SAVE ALL ADJ. DATA" with the search dial.
34. Press S302 on SS-48P board. Data will be stored on the NOV RAM.
35. When "SAVE COMPLETE" is displayed on the monitor screen, press S303 twice on SS-48P board to return to the mode screen.
36. Turn the POWER to OFF and put Bit4 of S601 on SS-48P board in OPEN state.

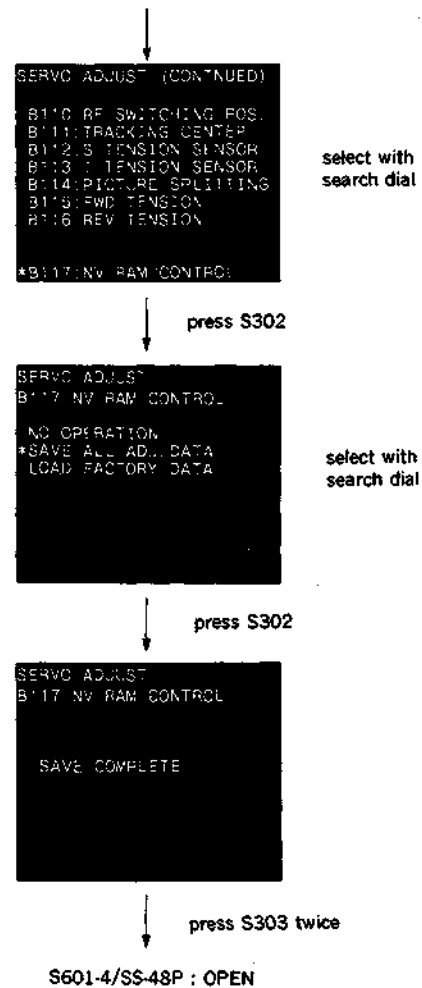

5-19-3. FWD Back Tension Adjustment

- Make sure to perform this adjustment with a cassette compartment is installed.

Tools

Cassette tape BCT-30M
Drum tension tool (Recommended to use TENTELOMETER U2-H7-UMC).

Preparation

Connect a video monitor with VIDEO OUTPUT 3 connector or MONITOR connector, and display characters.

Check

1. Put the unit into EJECT mode.
2. Turn the POWER to OFF, and put Bit4 of S601 on SS-48P board in CLOSE state.
3. Turn the POWER to ON. Push S302 on SS-48P board and put the unit into maintenance mode.
4. Press the search dial to enter the jog mode, and move * mark to "B1 : SERVO ADJUST" which is displaying on the monitor screen with the search dial.
5. Press S302 on SS-48P board to select "SERVO ADJUST" mode.
6. Move * mark to "B115: FWD TENSION" which is displaying on the monitor screen with the search dial.
7. Press S302 on SS-48P board to execute "FWD TENSION" menu.
8. Insert a BCT-30M cassette tape at about 3 minutes portion from the tape beginning.

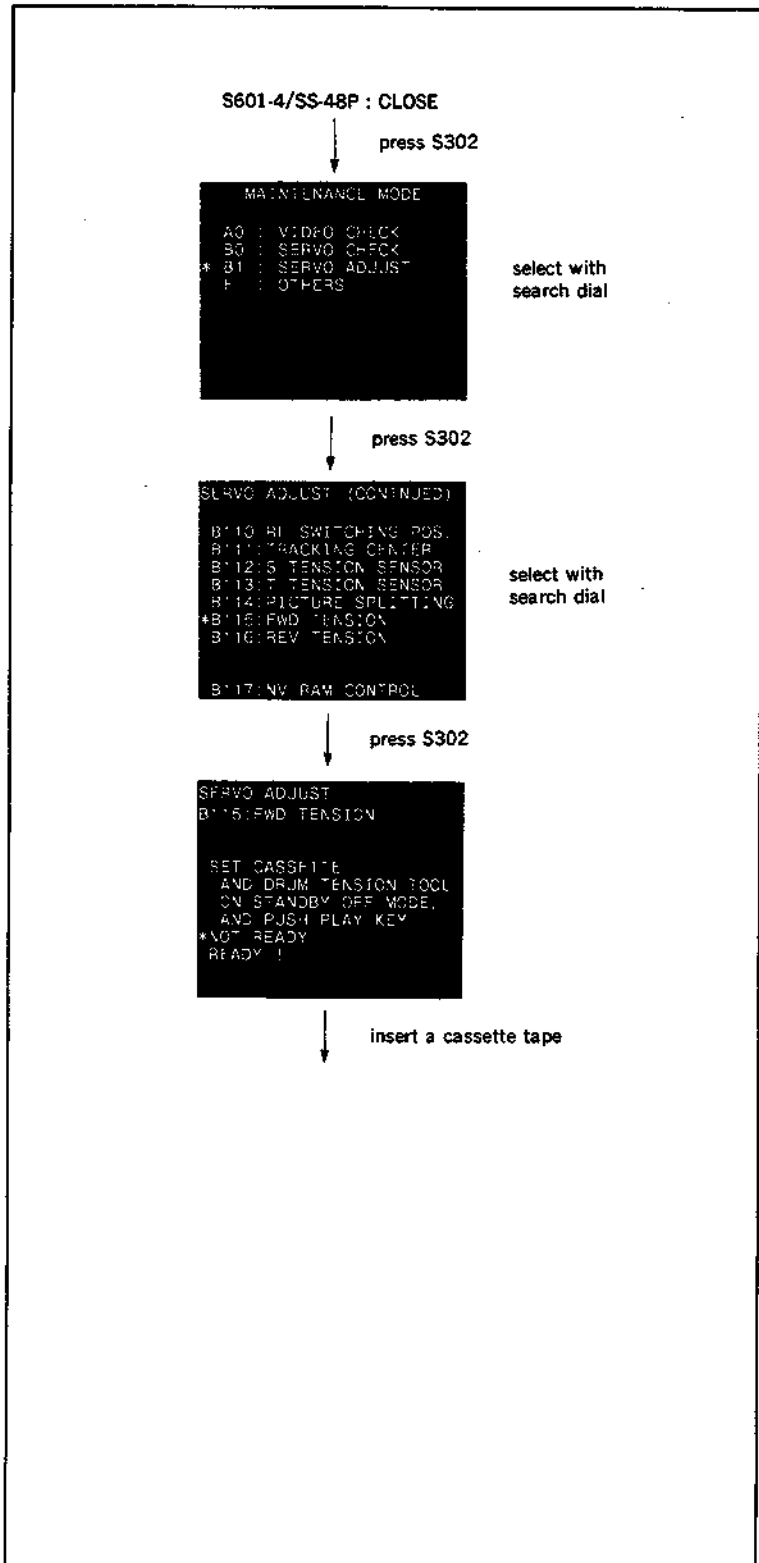

9. Hold a drum tension tool (TENVELOMETER), and insert it into the appointed portion as shown in the figure.

set the drum tension tool in this portion.

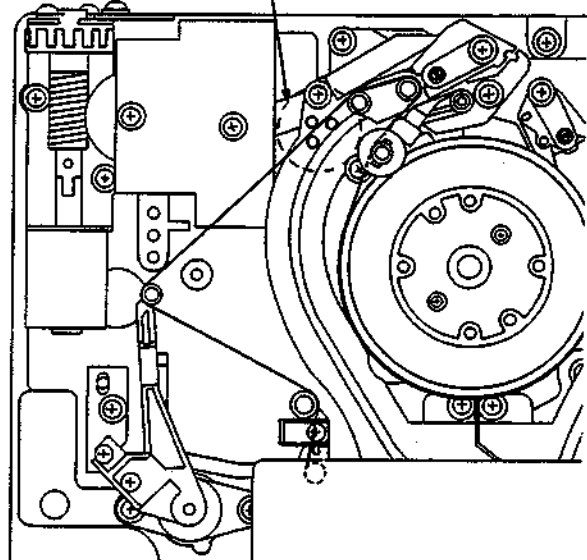

drum tension tool (TENVELOMETER)

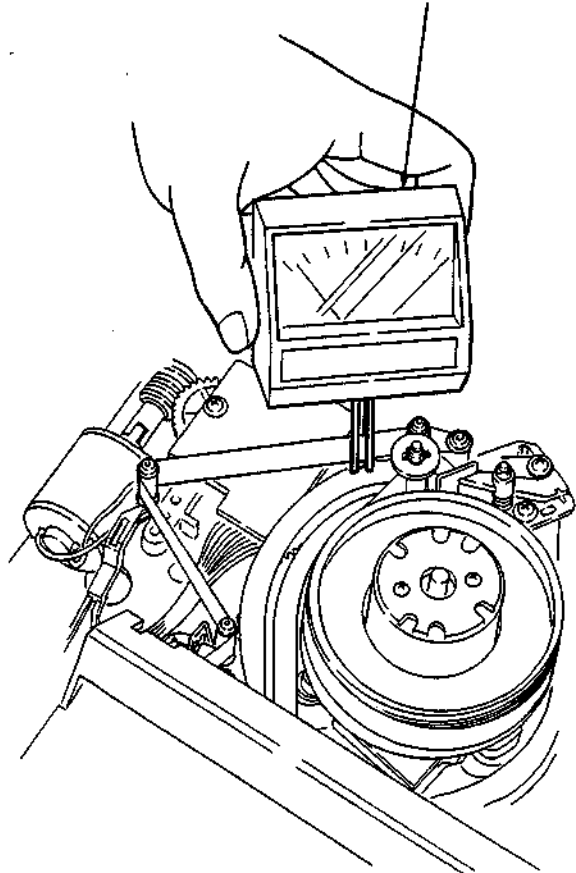

10. Put the unit into Play mode.

Note : Adjust the slantness of the drum tension tool so that the tape runs smoothly without waving between the S tension regulator arm and TG-2 tape guide.

11. Move * mark to "READY" which is displaying on the monitor screen with the search dial.
12. Confirm that the values of the drum tension tool meet the specification.

Specification : 41 g to 45 g.

(The value which is displaying on the monitor screen means the FWD back tension value at the drum entrance side.)

If not to meet the specification, perform step (13) and later.

Adjustment

13. Perform steps from (1) to (11).
14. Press S302 on SS-48P board.
15. Rotate search dial until the value of drum tension tool meets the specification.
16. If meet the specification, push S302 on SS-48P board.
17. Remove drum tension tool and then push EJECT button, take out the cassette tape.
18. Move * mark to "B117 : NV RAM CONTROL" which is displaying on the monitor screen with the search dial.
19. Press S302 on SS-48P board to execute "NV RAM CONTROL" menu.
20. Move * mark to "SAVE ALL ADJ. DATA" with the search dial.
21. Press S302 on SS-48P board. Data will be stored on the NOV RAM.
22. When "SAVE COMPLETE" is displayed on the monitor screen, press S303 twice on SS-48P board to return to the mode screen.
23. Turn the POWER to OFF and put Bit4 of S601 on SS-48P board in OPEN state.

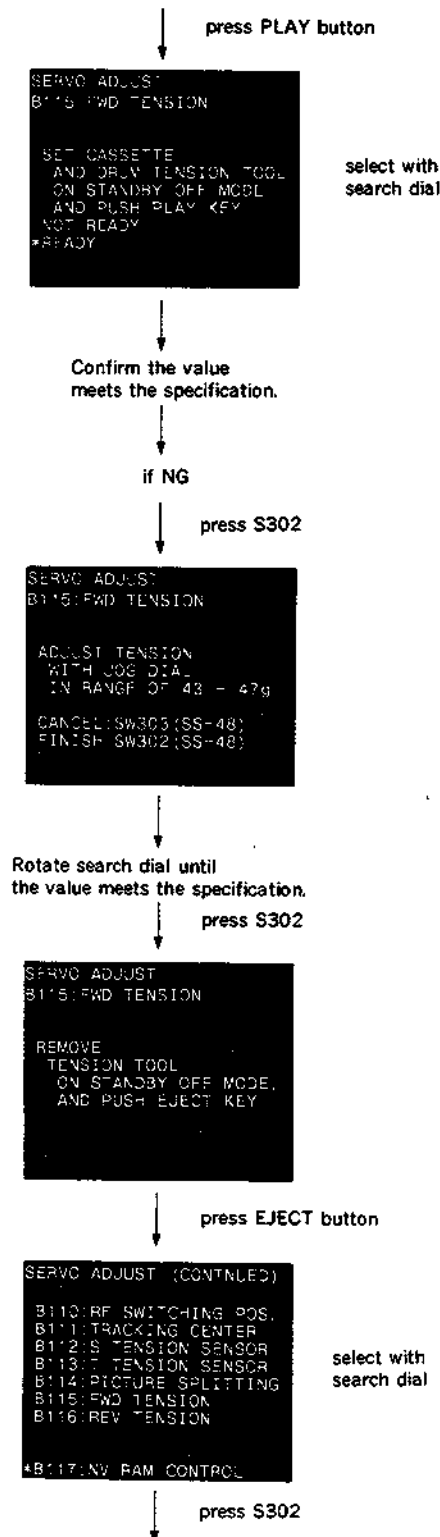

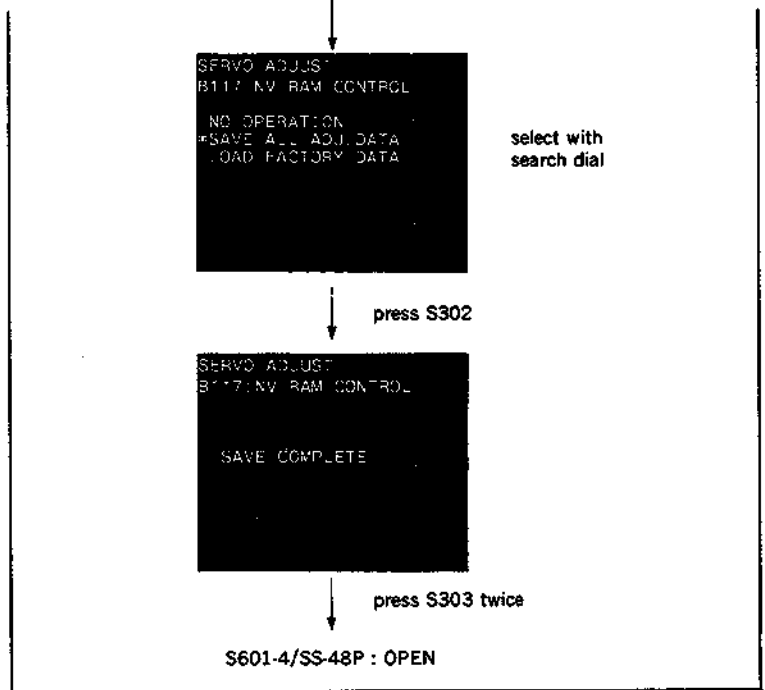

5-19-4. REV Back Tension Adjustment

- Make sure to perform this adjustment with a cassette compartment is installed.

Tools

Cassette tape BCT-30M
Drum tension tool (Recommended to use TENTELOMETER U2-H7-UMC).

Preparation

Connect a video monitor with VIDEO OUTPUT 3 connector or MONITOR connector, and display characters.

Check

1. Put the unit into EJECT mode.
2. Turn the POWER to OFF, and put Bit4 of S601 on SS-48P board in CLOSE state.
3. Turn the POWER to ON. Push S302 on SS-48P board and put the unit into maintenance mode.
4. Press the search dial to enter the jog mode, and move * mark to "B1 : SERVO ADJUST" which is displaying on the monitor screen with the search dial.
5. Press S302 on SS-48P board to select "SERVO ADJUST" mode.
6. Move * mark to "B116: REV TENSION" which is displaying on the monitor screen with the search dial.

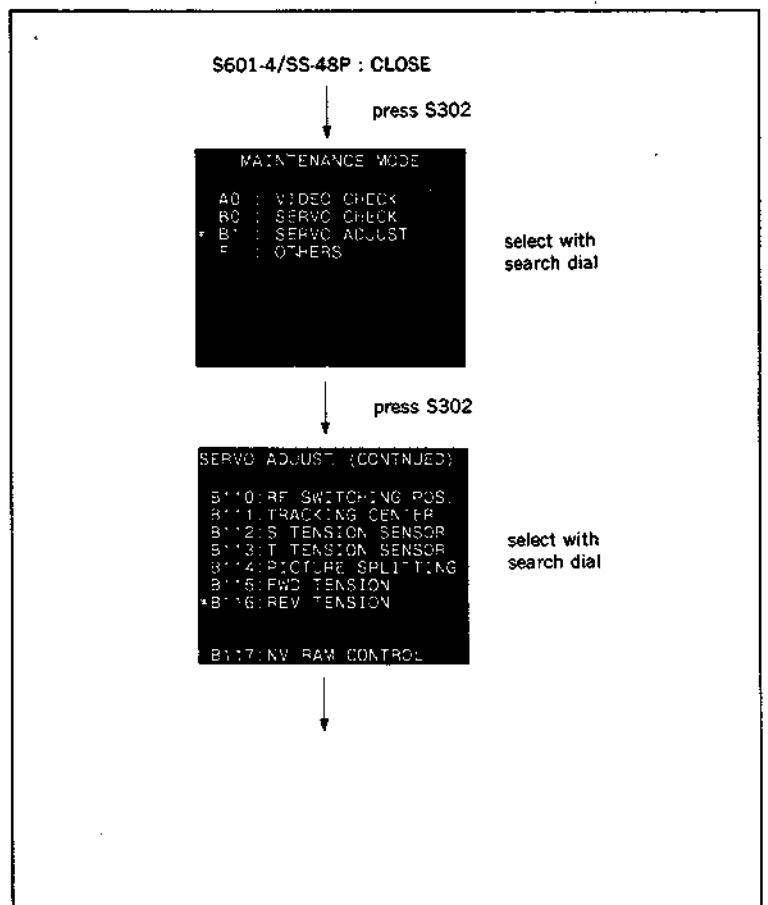

7. Press S302 on SS-48P board to execute "REV TENSION" menu.
8. Insert a BCT-30M cassette tape at about 3 minutes portion from the tape beginning.
9. Hold a drum tension tool, and insert it into the appointed portion as shown in the figure.

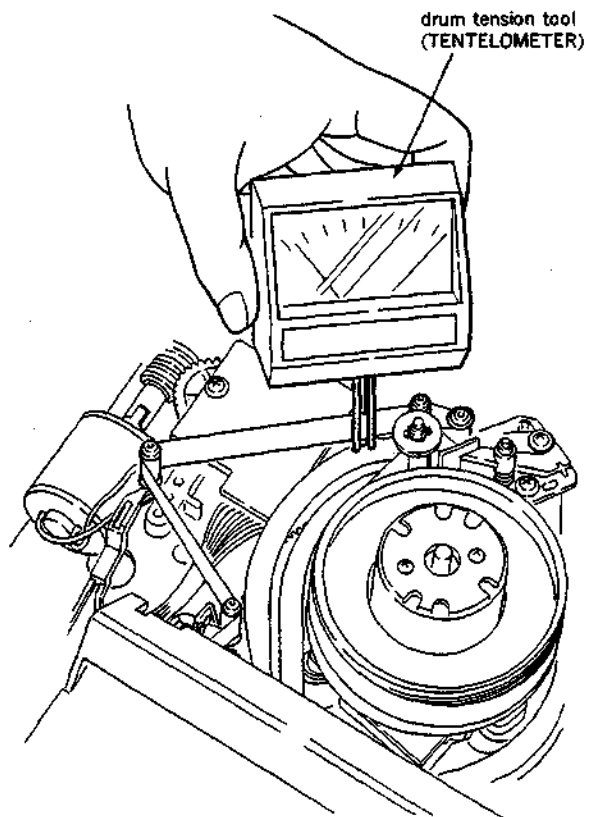
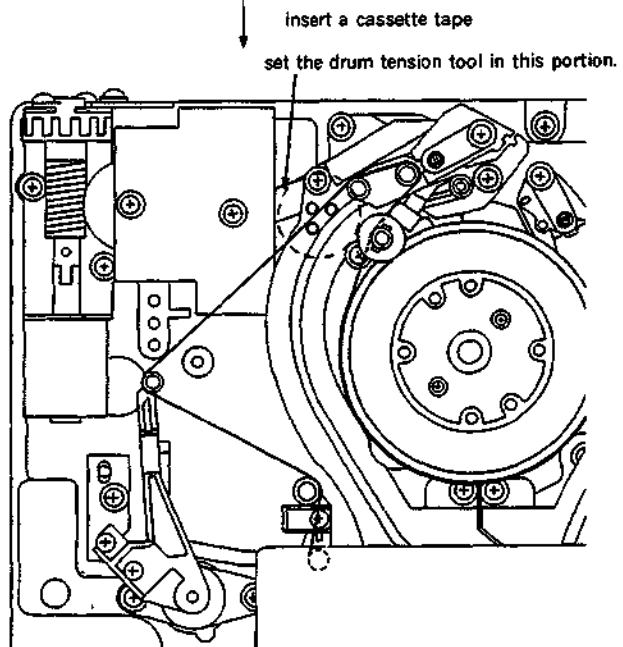
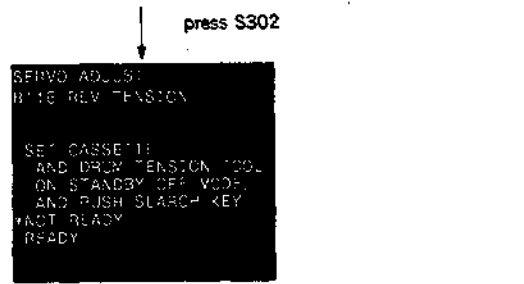

10. Press SEARCH button.

Note: Adjust the slantness of the drum tension tool so that the tape is placed without twisting between the S tension regulator arm and TG-2 tape guide.

11. Move * mark to "READY" which is displaying on the monitor screen with the search dial.
12. Confirm that the values of the drum tension tool satisfy the specification.

Specification: 28 g to 34 g.

(The value which is displaying on the monitor screen means the REV back tension value at the drum entrance side.)

If the specification is not satisfied, perform step (13) and later.

Adjustment

13. Perform steps from (1) to (11).
14. Press S302 on SS-48P board.
15. Rotate search dial until the value of drum tension tool satisfies the specification.
16. If the specification is satisfied, press S302 on SS-48P board.
17. Remove drum tension tool and then press EJECT button, take out the cassette tape.
18. Move * mark to "B117 : NV RAM CONTROL" which is displaying on the monitor screen with the search dial.
19. Press S302 on SS-48P board to execute "NV RAM CONTROL" menu.
20. Move * mark to "SAVE ALL ADJ. DATA" with the search dial.
21. Press S302 on SS-48P board. Data will be stored on the NOV RAM.
22. When "SAVE COMPLETE" is displayed on the monitor screen, press S303 twice on SS-48P board to return to the mode screen.
23. Turn the POWER to OFF and put Bit4 of S601 on SS-48P board in OPEN state.

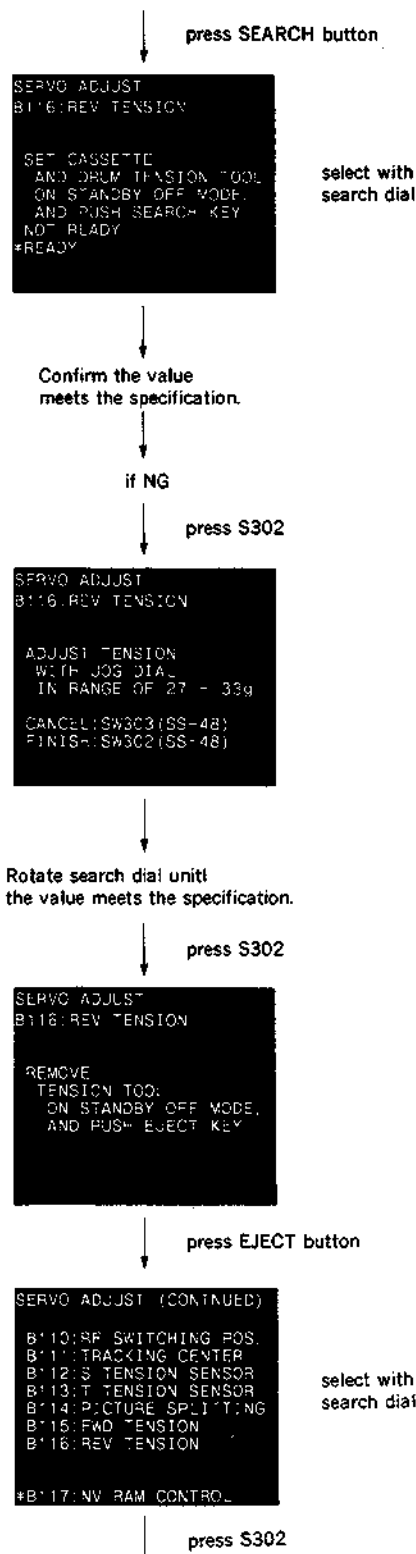

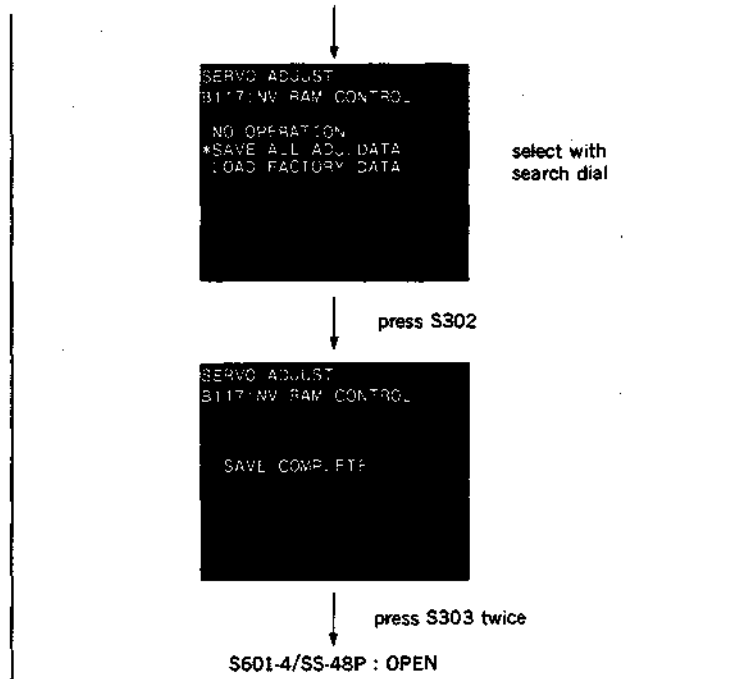

5-20. T TENSION REGULATOR ARM ASSEMBLY REPLACEMENT

Tool

L shaped wrench (across flat has 0.89 mm)
: 7-700-736-06

Replacement flow chart

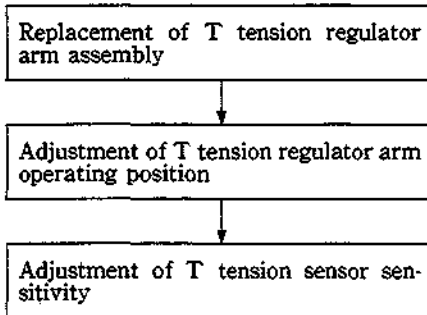

(Be sure to replace a S tension regulator arm and TR-73 board which places under the S tension regulator arm at the back side of the chassis in this step, if necessary.)

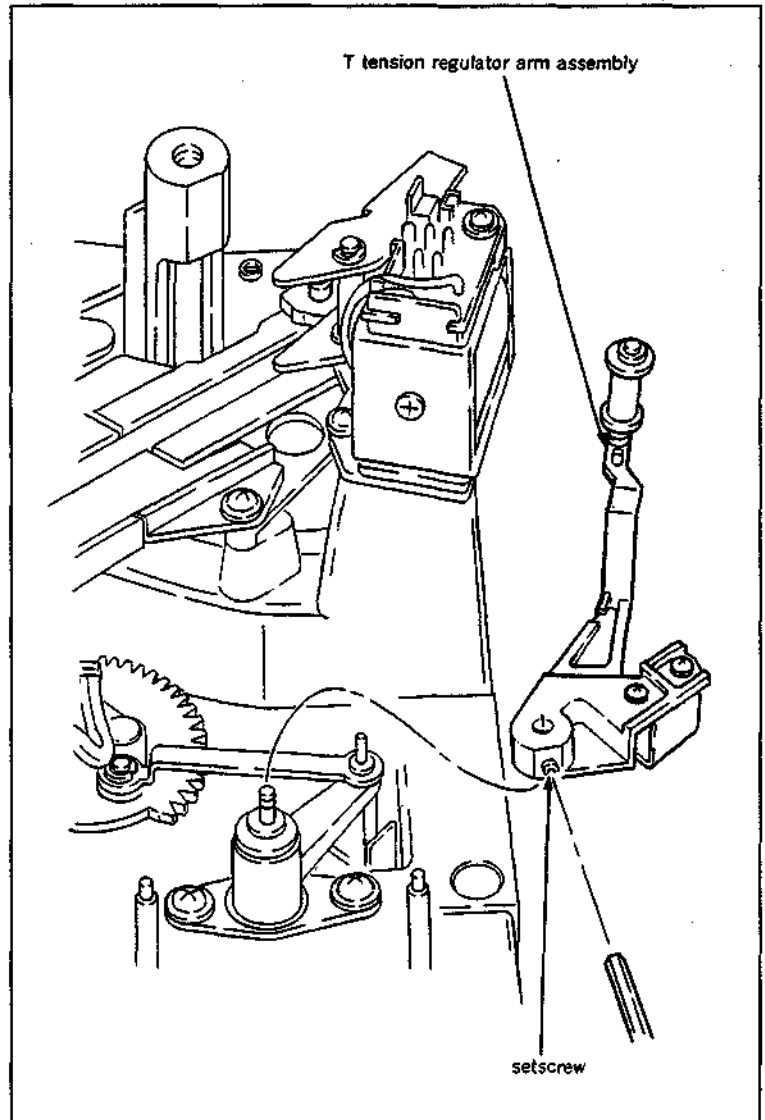
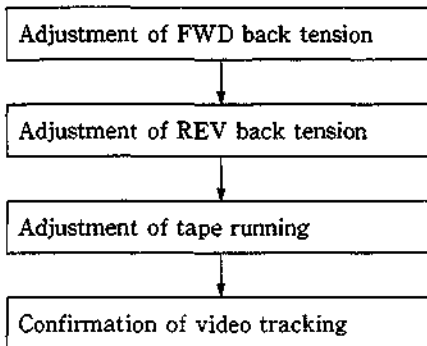

Removal

1. Turn a threading motor rotation detection ring of a threading motor block in the clockwise direction by fingers looking from the front, and put the unit into the threading completion mode.
2. Loosen a setscrew shown in the figure holding a T tension regulator arm assembly, and lift the T tension regulator arm assembly straight up to remove.

Installation

3. Install a new T tension regulator arm assembly to a shaft of a tension regulator base so that a protector, plate spring and shaft of a drive arm are assembled as shown in the figure, and tighten a setscrew.

Adjustment after replacement

4. Perform T tension regulator arm operating position adjustment. (Refer to step (10) and later in Section 5-20-1.)
5. Perform T tension sensor sensitivity adjustment. (Refer to Section 5-20-2.)
6. Perform FWD back tension adjustment. (Refer to Section 5-19-3.)
7. Perform REV back tension adjustment. (Refer to Section 5-19-4.)
8. Perform tape running adjustment. (Refer to Section 6-3.)
9. Perform confirmation of video tracking. (Refer to Section 6-4.)

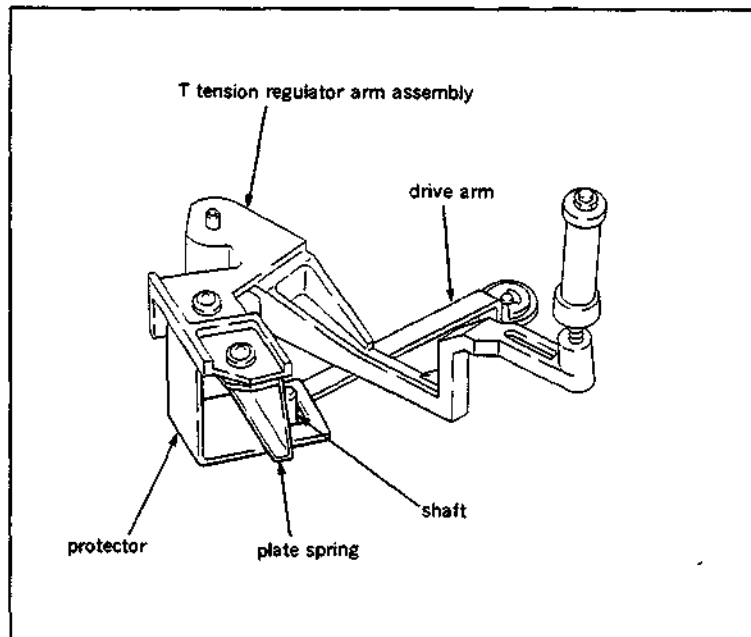

5-20-1. T Tension Regulator Arm Operating Position Adjustment

- Be sure to perform this adjustment without installing a cassette compartment.

Tools

Cassette reference plate (L):	J-6320-880-A
Dial tension gauge (50 g) :	J-6327-850-A
Tension measurement tape :	Refer to Section 5-1.
Wire clearance gauge :	J-6152-450-A
Cleaning piece :	2-034-697-00
Cleaning fluid :	9-919-573-01

Check

1. Confirm that a reel table is in S cassette position. When it is in L cassette position, turn the POWER to ON once, change it to S cassette position, according to the Maintenance Menu "B027: REEL POSITION"
2. Turn the POWER to OFF, and place the cassette reference plate (L) on four cassette pillars.
3. Turn a threading motor rotation detection ring of a threading motor block in the clockwise direction by fingers looking it from the front, and put a P slider assembly to 30 mm back from the threading completion mode.
4. Put one end of the tension measurement tape into TG-6 tape guide as shown in the figure.
5. Thread the tension measurement tape as shown in the figure.
6. Turn a threading motor rotation detection ring of a threading motor block in the clockwise direction by fingers looking it from the front, and put a P slider assembly to the threading completion mode.

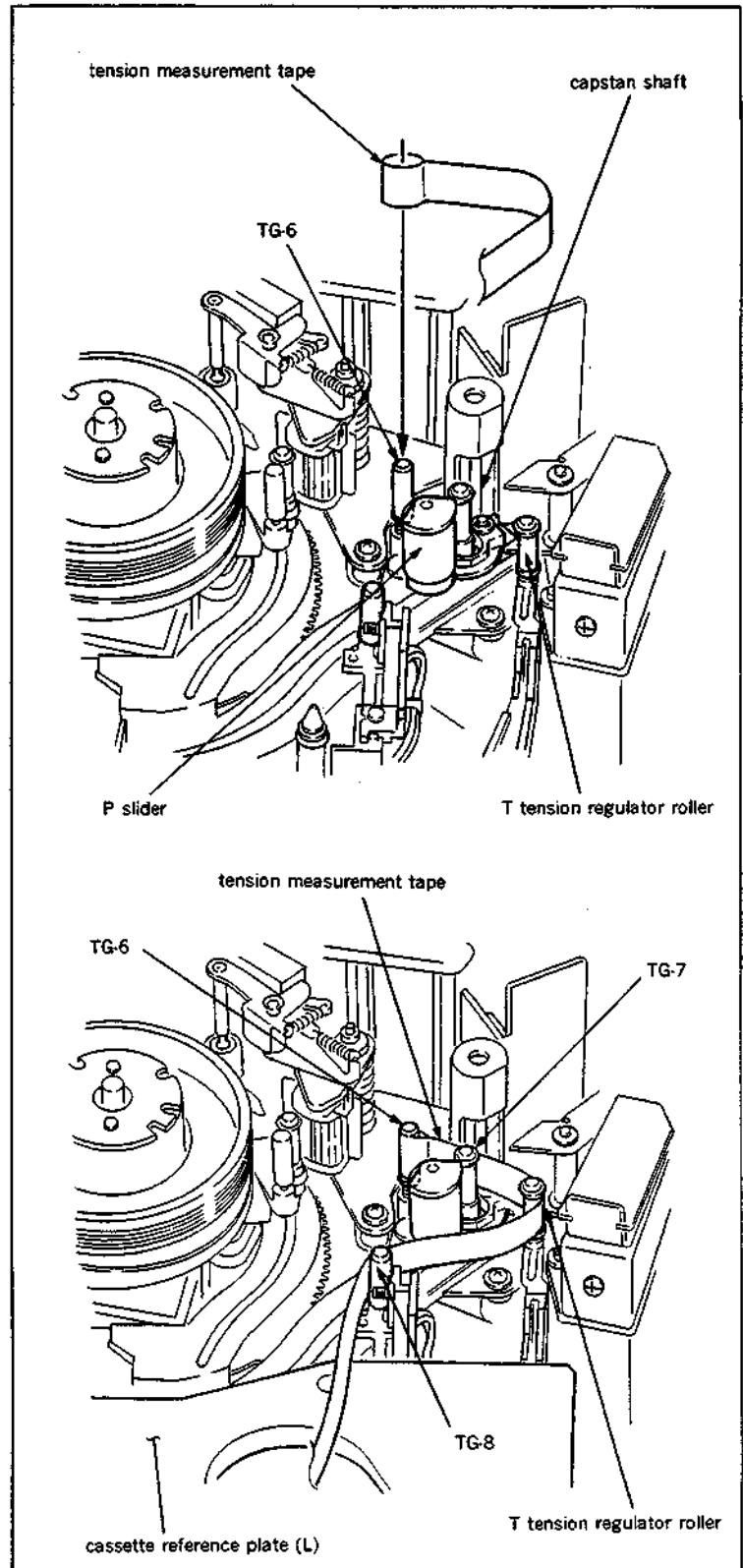

7. Put the tip of the dial tension gauge into the holder of the tension measurement tape.
8. Place the dial tension gauge on the cassette reference plate (L), and move the gauge along the cassette reference plate (L) in the direction shown in the figure until the indication of the gauge shows 20 g.

Note 1 : Confirm that the tension measurement tape is placed on every tape guide roller properly.

Note 2 : Pull the tension measurement tape in the perpendicular direction to the cassette reference plate (L).

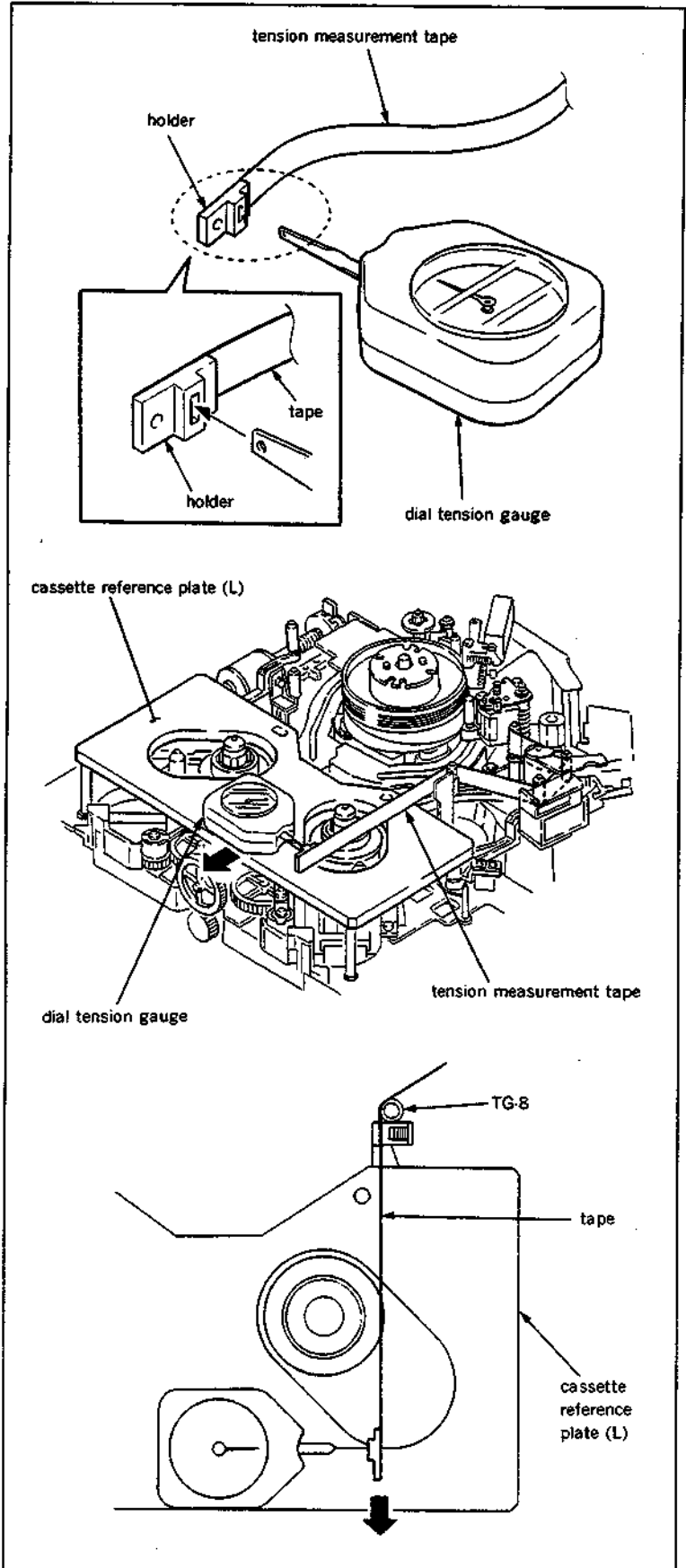

9. When the indication of the gauge is 20 g, confirm that the clearance between a T tension regulator arm and pinch solenoid base satisfy the specification as shown in the figure.

If the specification is satisfied, perform step (15) and later.

If the specification is not satisfied, perform step (10) and later.

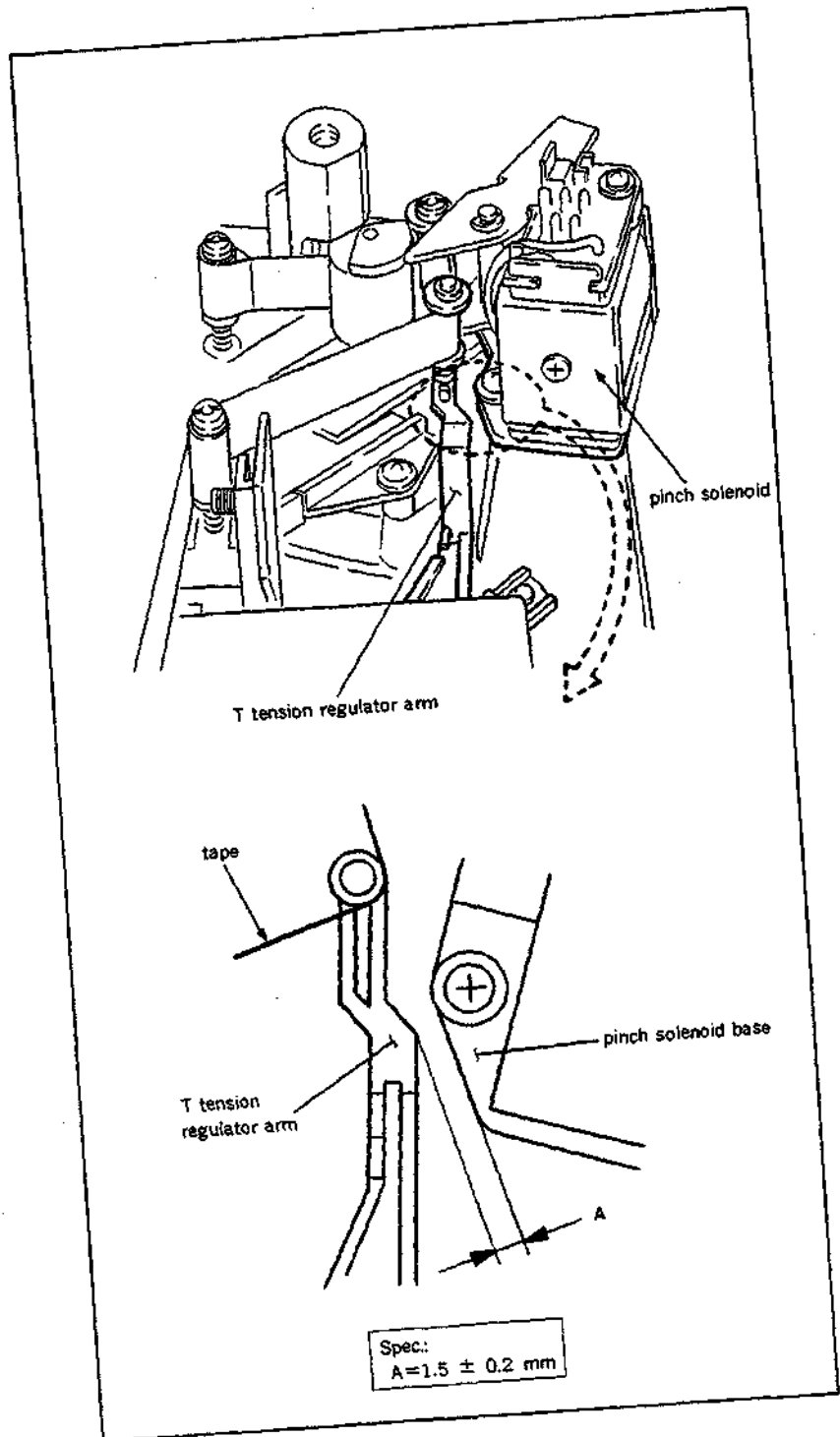

Adjustment

10. Loosen a fixing screw of a T stopper for 1/3 to 1/2 turn.
11. Perform step (8).
12. While keeping the state of step (8), insert a 3 mm flatblade screwdriver into notch of the T stopper, and adjust position of the T stopper so that the specification is satisfied.
13. Tighten the fixing screw of the S stopper.
14. Reconfirm that the specificatin is satisfied according to the check procedure.
15. After adjustment, turn a threading motor rotation detection ring of a threading motor block in the counterclockwise direction by fingers looking it from the front, and put the P slider assmbly to 30 mm back from the threading completion mode.
16. Take out the tension measurement tape from the unit.
17. Turn the POWER to ON, and press EJECT button to put the unit into the unthreading end mode. Take out the cassette reference plate (L).

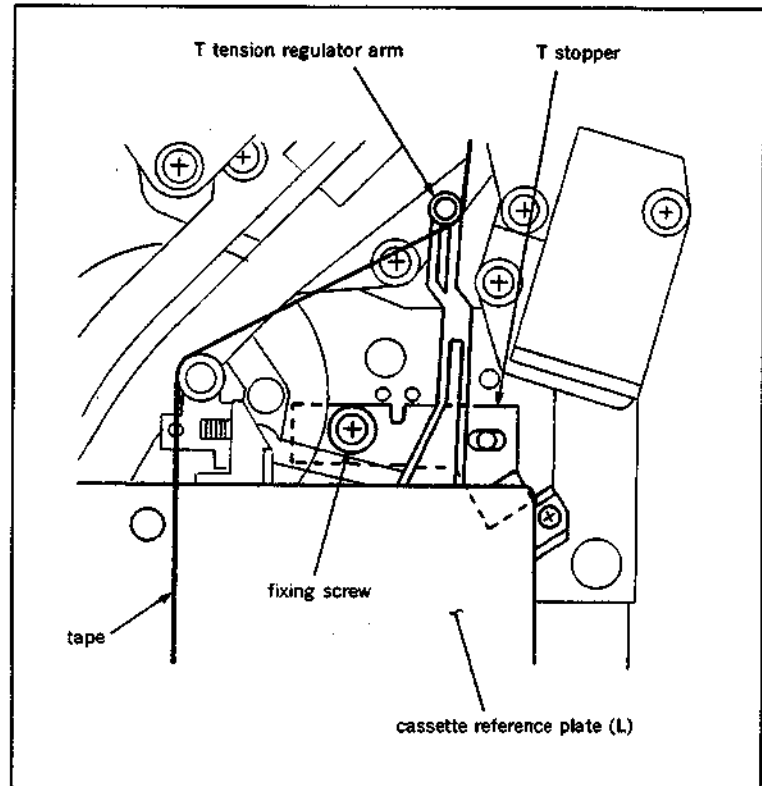

5-20-2. T Tension Sensor Sensitivity Adjustment

- It is impossible to only confirm whether T tension sensor sensitivity is being properly adjusted. Be sure to adjust T tension sensor sensitivity as the following procedures below, and save the adjustment data in NOV RAM.
- Be sure to perform this adjustment after removing a cassette compartment.

Tool

L shaped wrench (across flat has 0.89 mm)
: 7-700-736-06

Preparation

Connect a video monitor with VIDEO OUTPUT 3 connector or MONITOR connector, and display characters.

Adjustment

1. Turn the POWER to OFF, and put Bit4 of S601 on SS-48P board in CLOSE state.
2. Turn the POWER to ON. When the POWER is turned ON, threading automatically starts. Press EJECT button to put the unit in EJECT completion mode.
3. Loosen a setscrew of a T tension regulator arm assembly for 1/4 to 1/3 turn.
4. Push S302 and put the unit into maintenance mode.
5. Press the search dial to enter the jog mode, and move * mark to "B1: SERVO ADJUST" which is displaying on the monitor screen with the search dial.
6. Press S302 on SS-48P board to select "SERVO ADJUST" mode.
7. Move * mark to "B113: T TENSION SENSOR" which is displaying on the monitor screen with the search dial.
8. Press S302 on SS-48P board to execute "T TENSION SENSOR" menu.
9. Press PLAY button to put the unit in PLAY mode.
10. Move * mark to "READY" which is displaying on the monitor screen with the search dial.
11. Press S302 on SS-48P board.

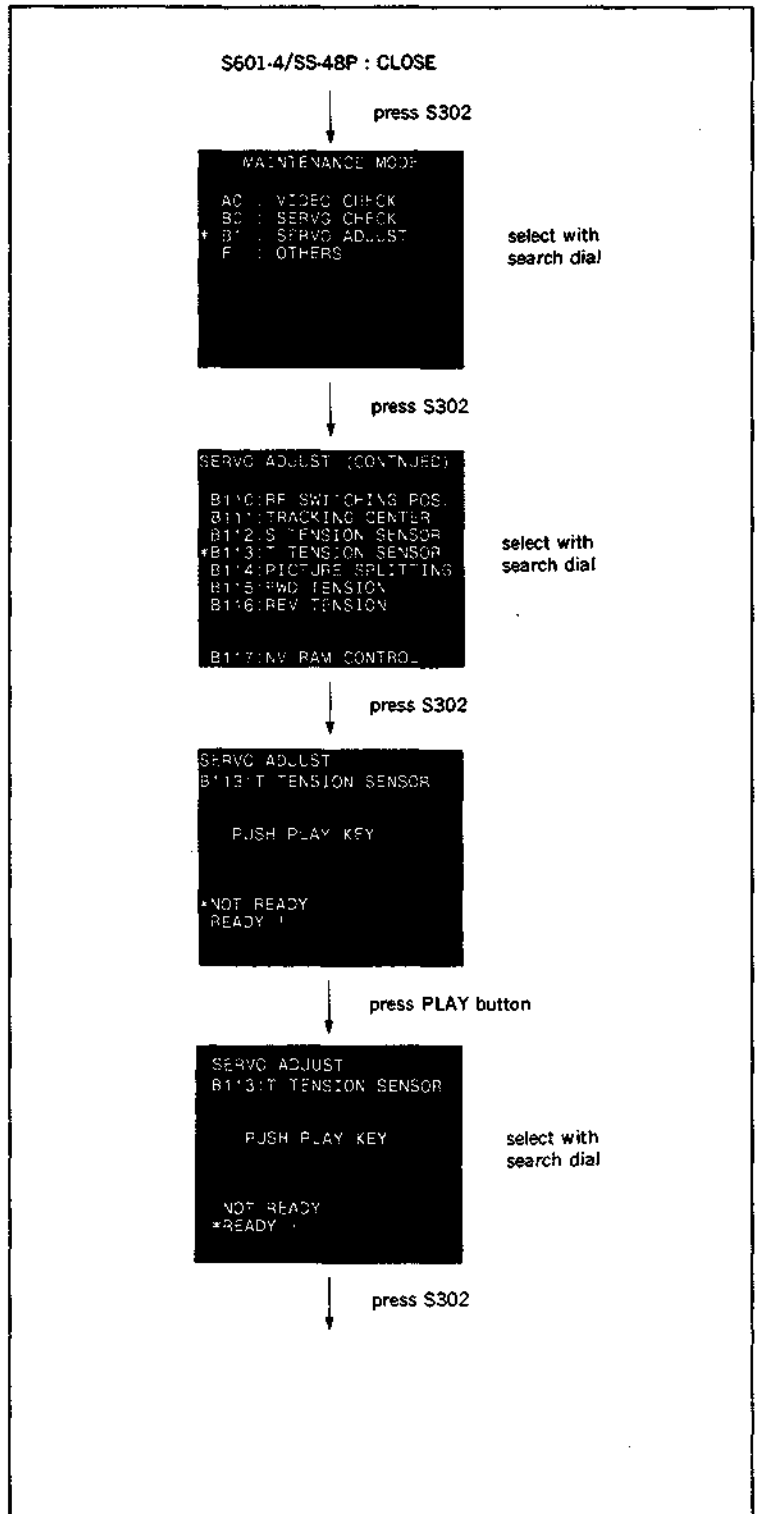

12. First, use a flatblade screwdriver to rotate the adjusting screw of the T tension regulator arm assembly counterclockwise slowly until the display on the monitor screen changes (turn three to four rotation).
Then rotate the adjusting screw slowly until data displayed on the monitor screen changes to values between -10 and 10, and the data must be kept in increasing state.

Note 1 :Make sure to rotate the flatblade screwdriver counterclockwise.

Note 2 :While adjusting screw is rotated, the data will keep on increasing and decreasing. In this adjustment, the data must be kept in increasing state and adjusted to meet the specification.

For example : 0001, 0002, 0003, 0004,... data shown in the monitor screen is increasing.

0002, 0001, 0000, -0001,...data shown in the monitor screen is decreasing.

13. Tighten a setscrew of the T tension regulator arm assembly.

Note :Be extremely careful because of take-up reel table is rotating in high speed.

14. After tightening the setscrew, confirm that the data shown in the monitor screen remains within the range of the specification when the T tension regulator arm is moved right and left with fingers.

15. Move * mark to "READY" which is displaying on the monitor screen with the search dial.

16. Press S302 on SS-48P board.

17. Press EJECT button to put the unit into the unthreading completion mode.

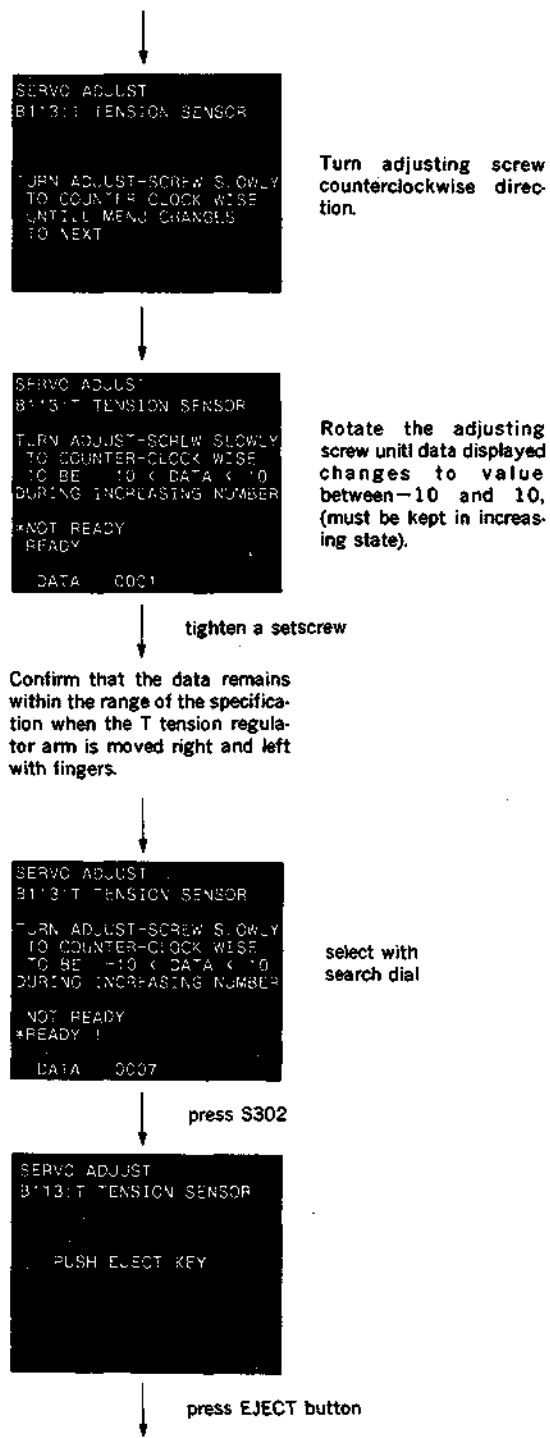

18. Press S303 on SS-48P board to menu screen.
19. Move * mark to "B117 : NV RAM CONTROL" which is displaying on the monitor screen with the search dial.
20. Press S302 on SS-48P board to execute "NV RAM CONTROL" menu.
21. Move * mark to "SAVE ALL ADJ. DATA" with the search dial.
22. Press S302 on SS-48P board. Data will be stored on the NOV RAM.
23. When "SAVE COMPLETE" is displayed on the monitor screen, press S303 twice on SS-48P board to return to the mode screen.
24. Turn the POWER to OFF and put Bit4 of S601 on SS-48P board in OPEN state.

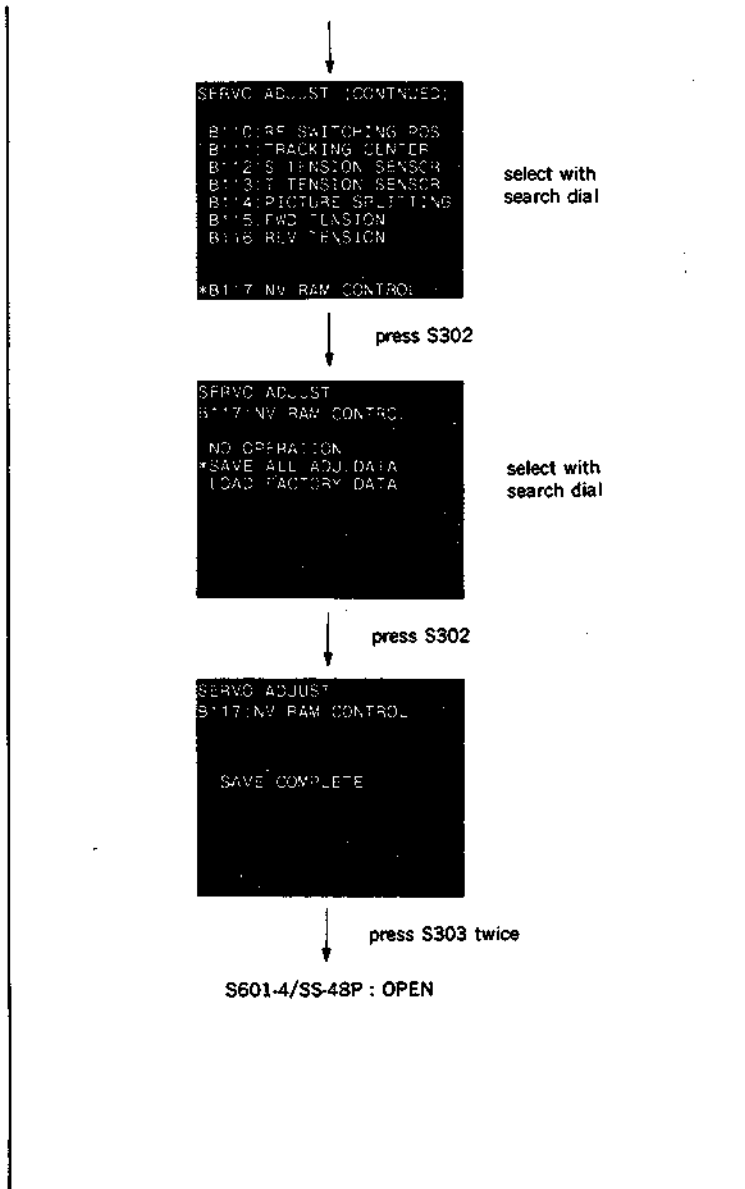

5-21. PINCH PRESS BLOCK REPLACEMENT

Replacement Flow Chart

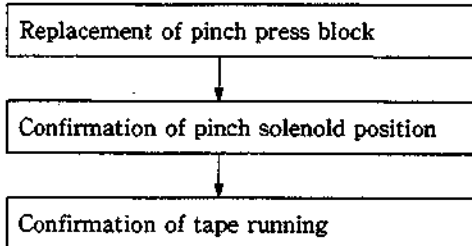

Removal

1. Put the unit into unthreading end mode.
2. Disconnect three connectors CN914, CN915 and CN916 from PD-56 board.
3. Remove two screws installing a pinch press block and remove it from the unit.

Installation

4. Install a new pinch press block with two screws to the unit.
5. Connect three connectors CN914, CN915 and CN916 to PD-56 board.

Adjustment after replacement

6. Perform confirmation of pinch solenoid position. (Refer to steps (1) to (9) in Section 5-22-1.)
7. Perform confirmation of tape running. (Refer to Section 6-3.)

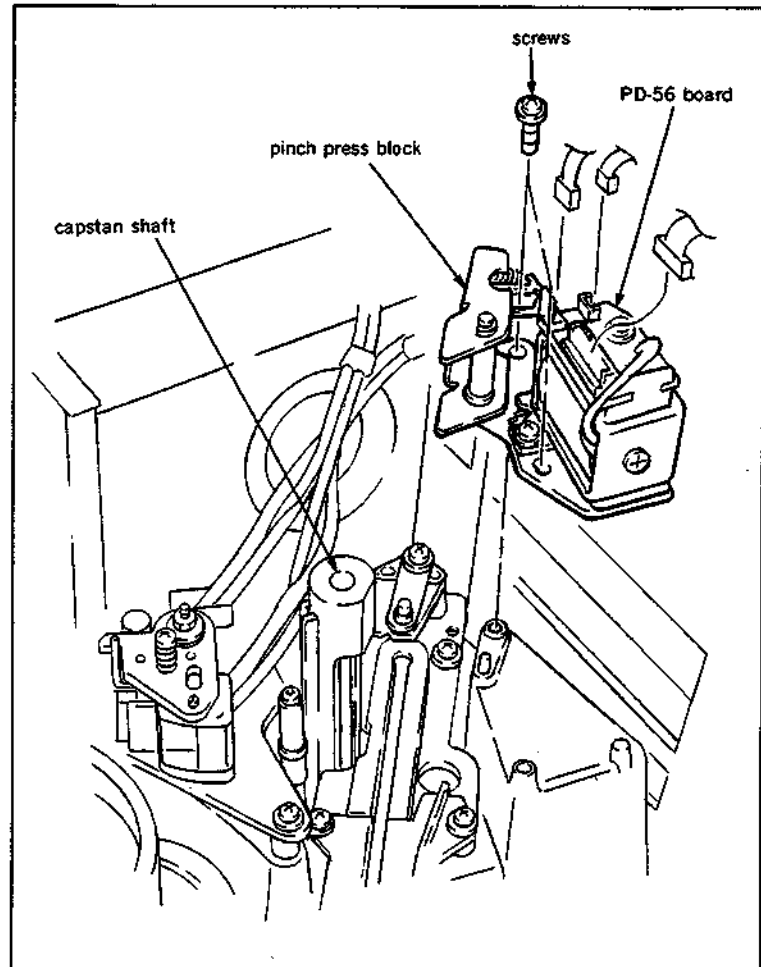

5-22. PINCH SOLENOID REPLACEMENT

Replacement flow chart

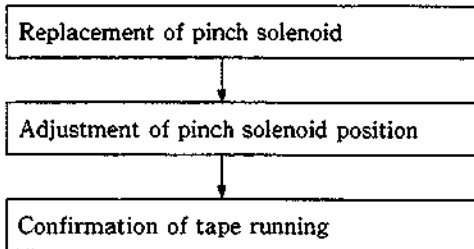

Removal

1. Put the unit into unthreading end mode.
2. Disconnect three connectors CN914, CN915 and CN916 from PD-56 board.
3. Remove two screws installing a pinch press block and remove it from the unit. (Refer to step (3) in Section 5-21.)
4. Remove PD-56 board and board mounting bracket.

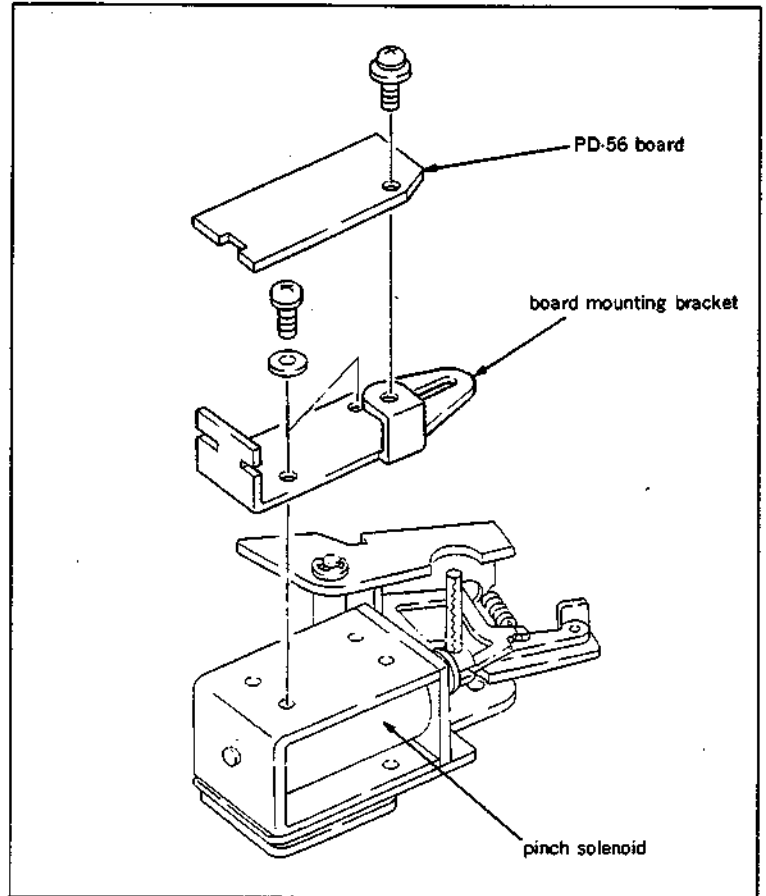

5. Remove a spring pin from an iron core of a solenoid.

Note :A compression spring comes off at the same time. Be careful not to lose it.

6. Remove two screws shown in the figure on the bottom side of the pinch press block and remove the solenoid.

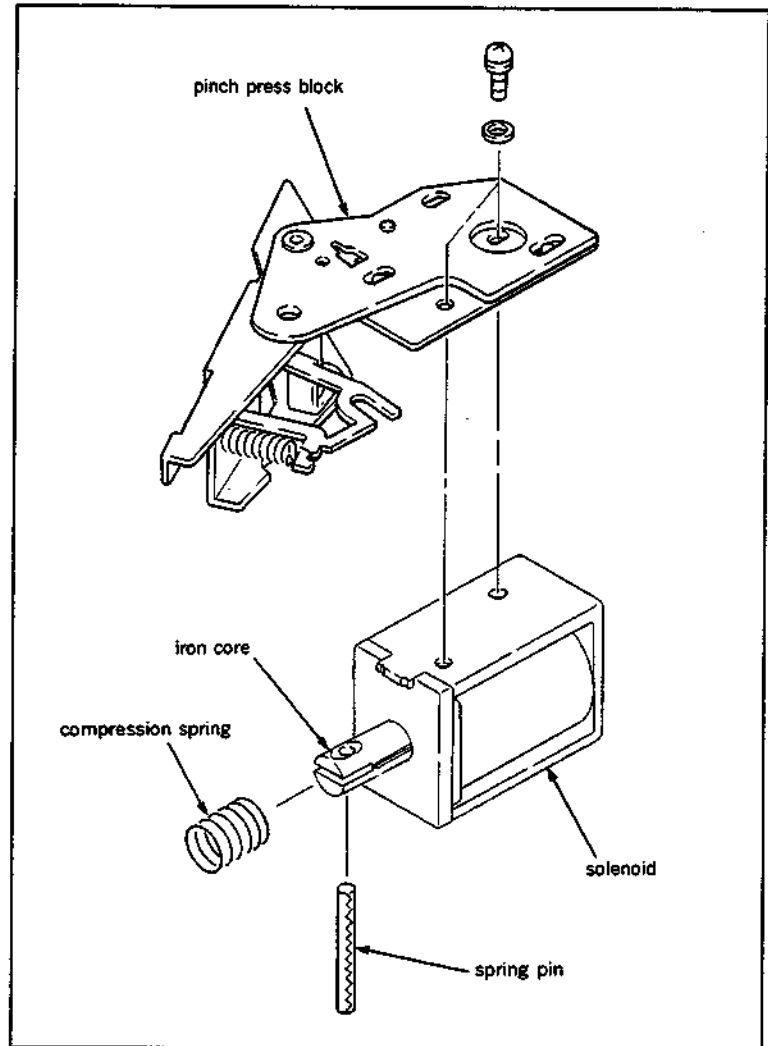

Installation

7. Insert the spring pin into an new iron core so that the edge of the spring pin is the same positioned as outer surface of the iron core as shown in the figure.

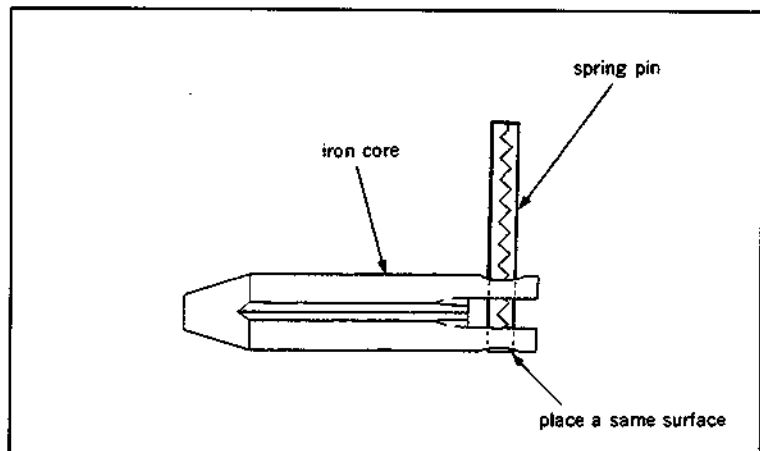

8. Insert the compression spring through longer part of the iron core as shown in the figure, and engage the groove of the pinch press sub arm with the spring pin shown in the figure. Insert the assembled iron core into the hole of the solenoid.
9. Install the new pinch solenoid into the pinch press block with two screws and washers.
10. After putting the spring pin through the longitudinal hole of the board mounting bracket, install the board mounting bracket with two screws and washers.
11. Install PD-56 board.
12. Install the pinch press block to the unit with two screws.
13. Connect CN914, CN915 and CN916 to PD-56 board.

Adjustment after Replacement

14. Perform pinch solenoid position adjustment. (Refer to Section 5-22-1.)
15. Perform confirmation of tape running. (Refer to Section 6-3.)

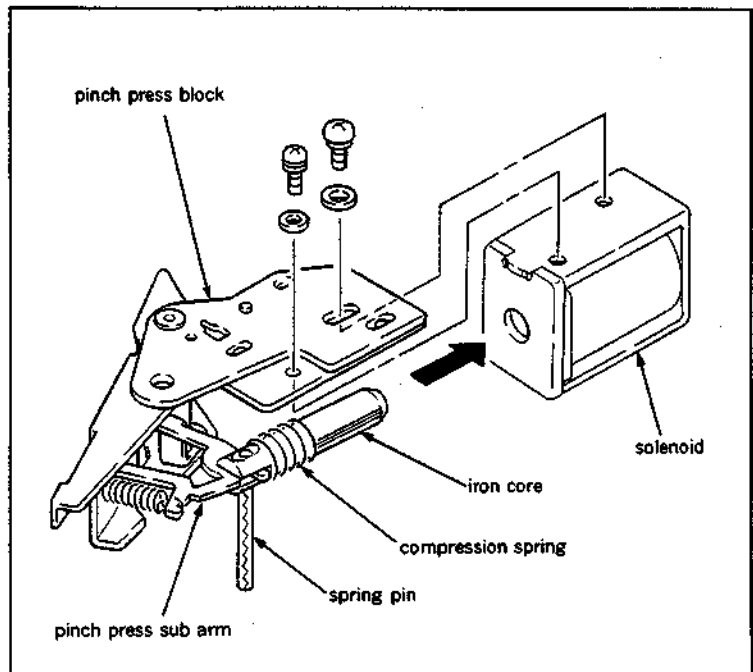

5-22-1. Pinch Solenoid Position Adjustment

- Make sure to perform this adjustment when a pinch press block and/or pinch solenoid is removed or replaced.

Tool

Wire clearance gauge : J-6152-450-A

Preparation

Connect a video monitor with VIDEO OUTPUT 3 connector or MONITOR connector, and display characters.

Check

1. Put Bit7 of S601 on SS-48P board in CLOSE state.
2. Turn the POWER to ON, and push S302 to put the unit into maintenance mode.
3. Press the search dial to enter the jog mode, and move * mark to "B0: SERVO CHECK" which is displaying on the monitor screen with the search dial.
4. Press S302 on SS-48P board to select "SERVO CHECK" mode.
5. Move * mark to "B03: PLUNGER SOL. CHECK" which is displaying on the monitor screen with the search dial.
6. Press S302 on SS-48P board to select "PLUNGER SOL. CHECK" menu.
7. Move * mark to "B031: PINCH ROLLER" which is displaying on the monitor screen with the search dial.
8. Press S302 on SS-48P board to put the pinch solenoid into the energized state.
9. Confirm that the clearance between a pinch press arm and pinch press sub arm satisfy the specification as shown in the figure.

If the specification is satisfied, perform step (13) and later.

If the specification is not satisfied, perform step (10) and later.

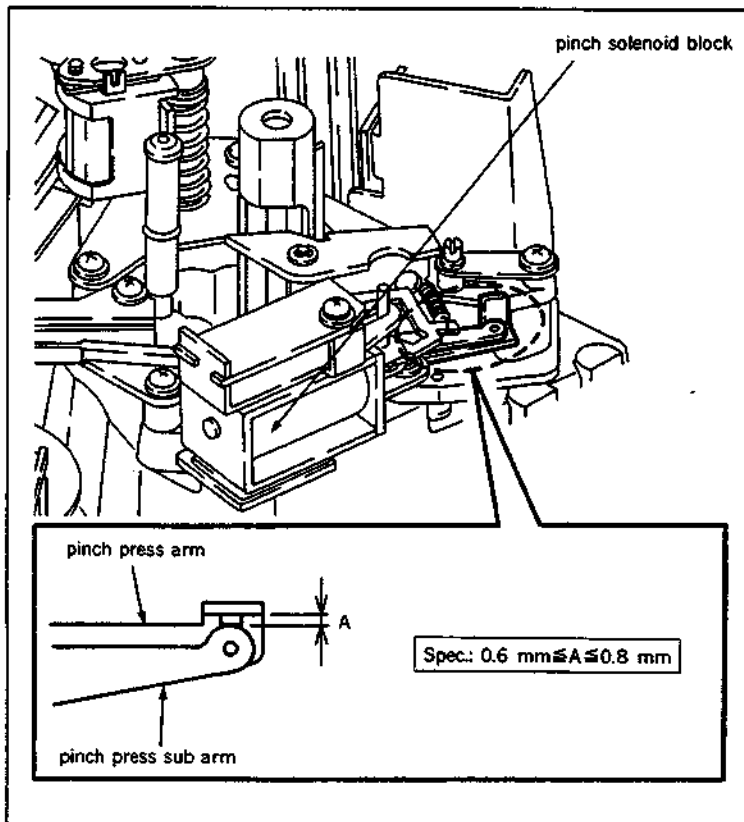

Adjustment

10. Loosen a screw of the pinch solenoid base for 1/2 to 1 turn.
11. Insert a 3 mm flatblade screwdriver into the notch of the pinch solenoid base, and adjust the position of the pinch solenoid to satisfy the specification.
12. After tightening a screw, reconfirm the specification.
13. Press S302 on SS-48P board to put the pinch solenoid into off state.
14. Press S303 twice on SS-48P board to return to the mode screen.
15. Turn the POWER to OFF after adjustment, and put Bit7 of S601 on SS-48P board in OPEN state.

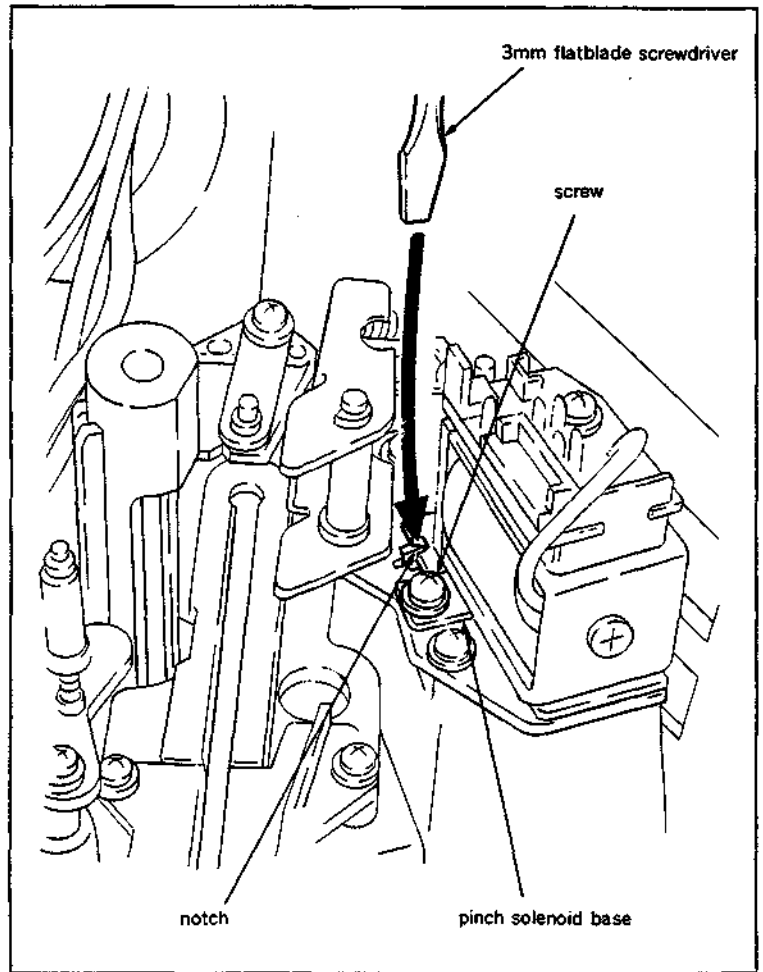

5-23. THREADING RING REPLACEMENT

- It is quite rare to replace a threading ring. In case the replacement is necessary, be extremely careful with the gear engagement adjustment of the threading ring and threading gear described in step (3).
- If the adjustment is not done correctly, tape can't thread in the correct position.

Replacement flow chart

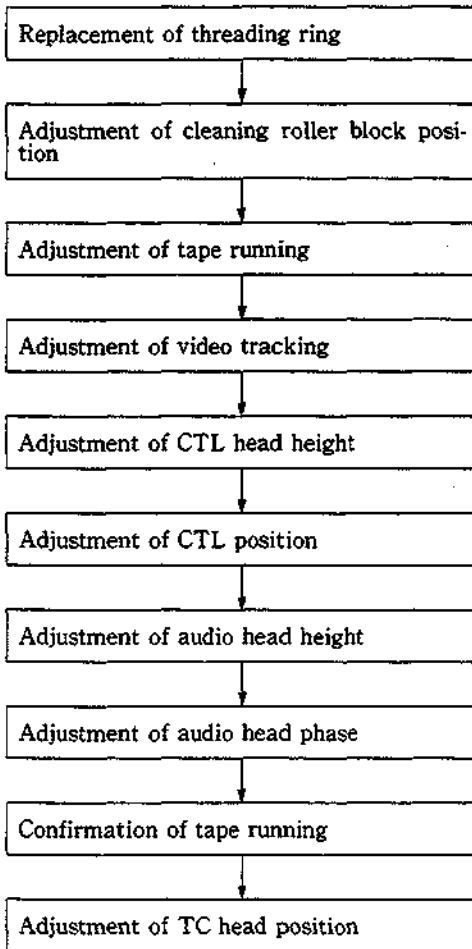

Tools

- Cleaning piece : 2-034-697-00
- Cleaning fluid : 9-919-573-01

Removal

1. Remove a cleaning roller block.
(Refer to steps (1) and (2) in Section 5-6.)
2. Remove an AU head cover. At this time, the harness clamber of the drum comes off together. (Refer to step (3) in Section 5-3.)
3. Place a reel table to the L cassette position.
4. Remove a S rail and S slider assembly.
(Refer to steps (1) to (6) in Section 5-16.)
5. Remove a T rail and T slider assembly.
(Refer to steps (5) to (9) in Section 5-17.)
6. Remove a P slider assembly. (Refer to step (6) in Section 5-18.)
7. Disconnect connectors from a drum which are connected to RP board.
8. Remove two screws of a ST base assembly, and place it on the power block.

Note : Be careful not to loose or tighten the adjustment screws of a S adjustment bracket and T adjustment bracket, and also not to change height of a CTL head and TG-4 tape guide on the ST base assembly. It is recommended to cover the CTL head with gauze to prevent make damage of tape running surface of the CTL head.

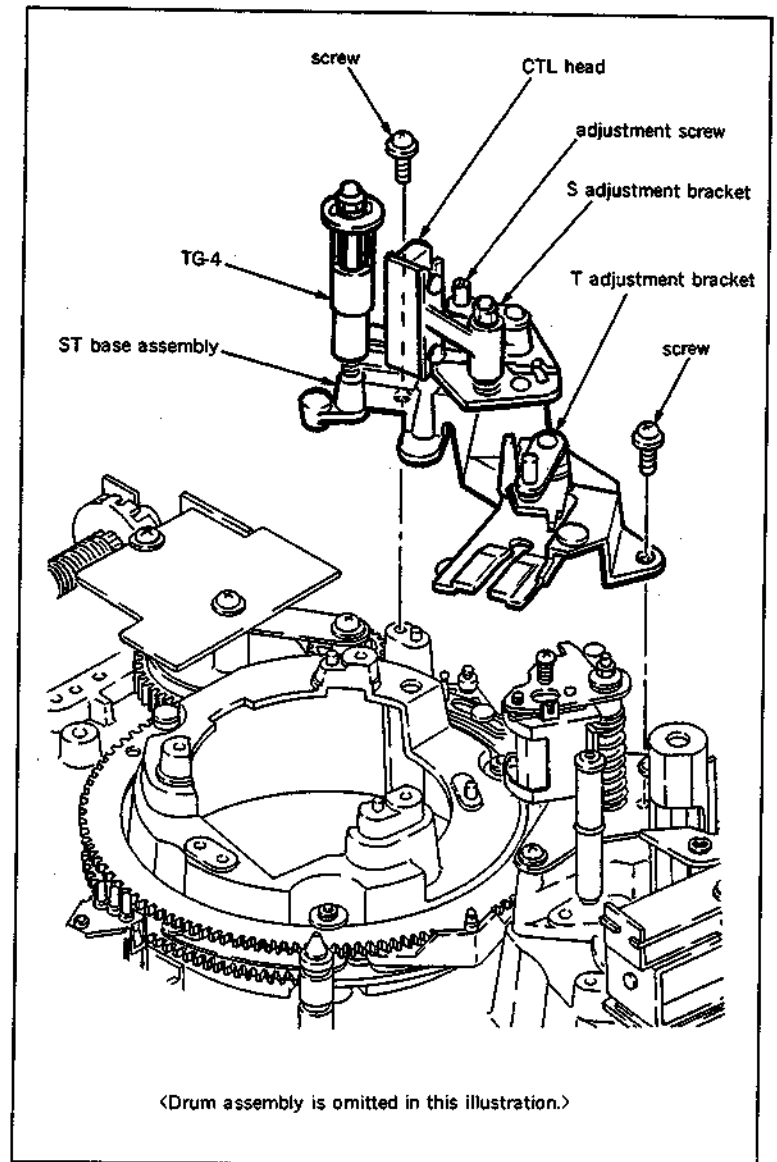

9. Turn a threading motor rotation detection ring of a threading motor block by fingers looking it from the front so that match hole "A" of a S threading ring, hole "B" of a T threading ring and in the concave "C" on the slant chassis.

Note 1 : This operation is the important point when installing a new threading ring.

Note 2 : Be extremely careful not to move the threading gear of the threading gear block when performing following step (13).

10. Remove three E-rings on the upper part of a ring roller holding the threading ring.

11. When three ring roller (B)s are removed, then the S threading ring can be removed, and three ring roller (A)s are removed, the T threading ring can be removed.

Installation

12. Clean the inside of a new threading ring to be replaced with the cleaning piece moistened with cleaning fluid.

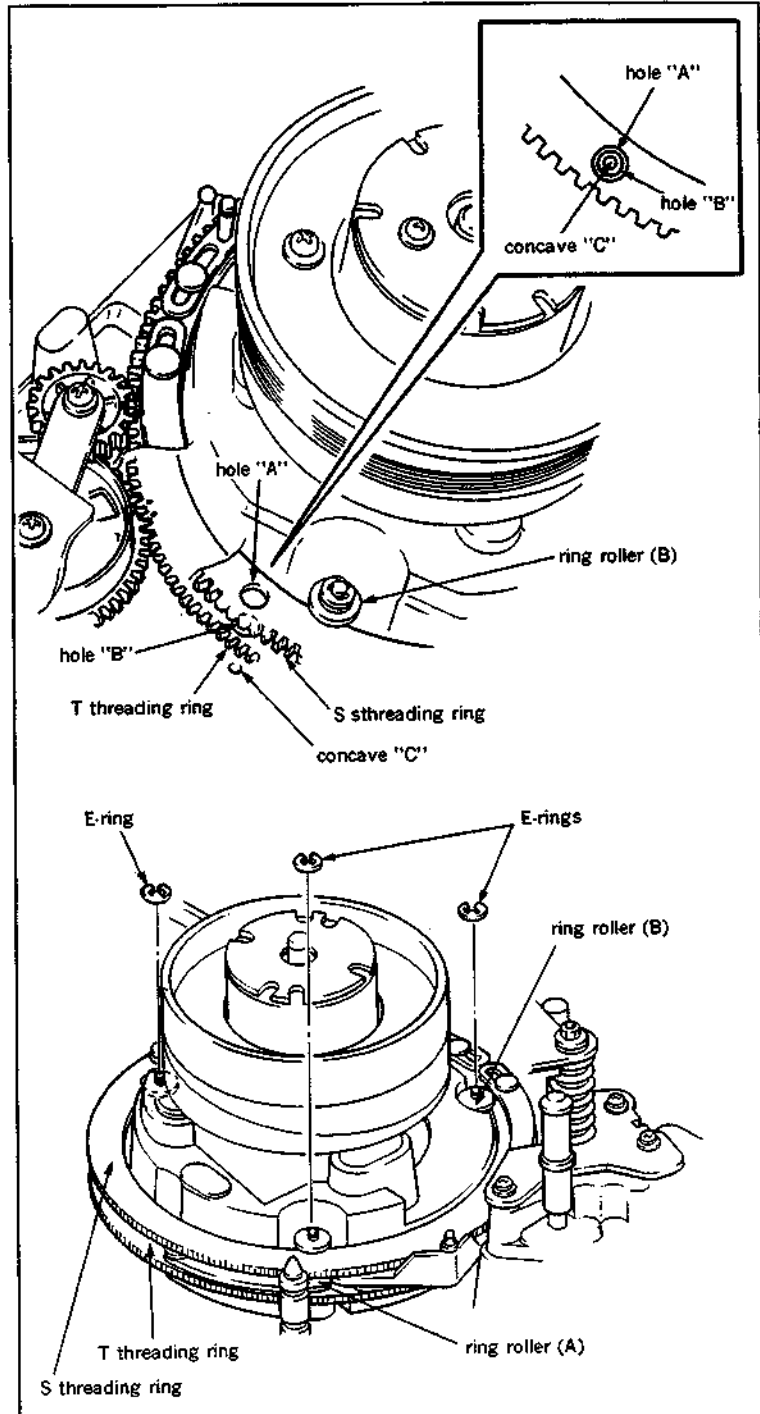

13. Install the T threading ring so that engage two marks on the teeth of the T threading ring with a mark on the tooth of the main gear as shown in the figure. Then insert the ring roller (A).
- Install the S threading ring so that engage two marks on the teeth of the S threading ring with a mark on the tooth of the gear S as shown in the figure. Then install the ring roller (B). Make sure that the hole "A" of the S threading ring, hole "B" of the T threading ring and in the concave "C" on the slant chassis are the same position.
14. Install three E-rings to each point on the shaft of the ring roller.
15. Make sure that the threading ring rotates smoothly, when turning the threading motor rotation detection ring of a threading motor block by fingers.
16. Turn the threading motor rotation detection ring of a threading motor block with finger, and place the threading ring to the point of 5 mm back from the threading completion mode.
17. Assemble the ST base assembly, P slider assembly, T slider assembly, T rail, S slider assembly and T rail in the reversing the order of steps (4) to (8).
18. Turn the POWER to ON, make sure that the threading operates properly and smoothly.
19. Insert a cassette tape, and make sure that the tape threads to the normal position.

Adjustment after replacement

20. Perform cleaning roller block position adjustment. (Refer to Section 5-6-1.)
21. Perform tape running adjustment. (Refer to Section 6-3.)
22. Perform video tracking adjustment. (Refer to Section 6-4.)
23. Perform CTL head height adjustment. (Refer to Section 6-5.)
24. Perform CTL head position adjustment. (Refer to Section 6-6.)
25. Perform audio head height adjustment. (Refer to Section 6-7.)
26. Perform audio head phase adjustment. (Refer to Section 6-8.)
27. Perform confirmation of tape running. (Refer to Section 6-3.)
28. Perform TC head position adjustment. (Refer to Section 6-10.)

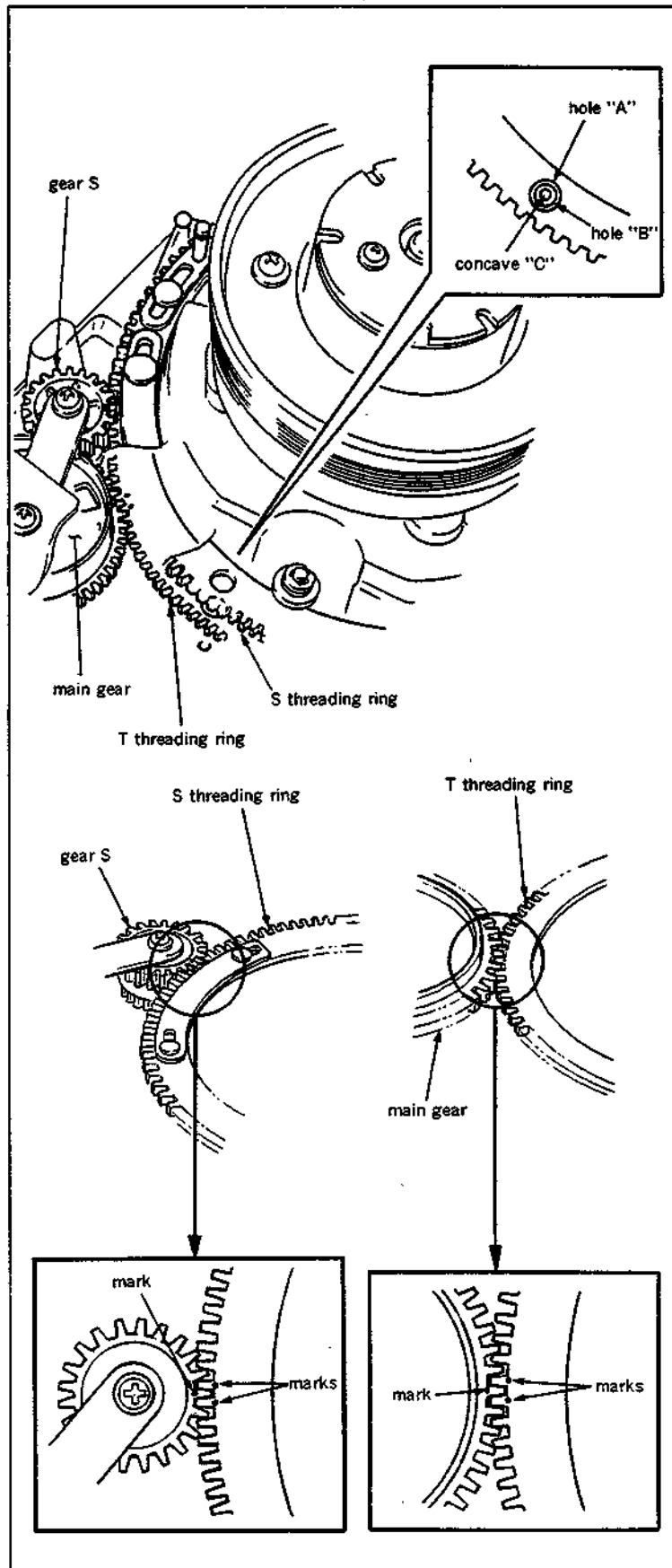

5-24. THREADING GEAR REPLACEMENT

- When a threading gear is replaced, be extremely careful with the gear engagement adjustment of the threading ring and threading gear.
- If this adjustment is not done correctly, tape can't thread in the correct position.

Tools

Cleaning piece : 2-034-697-00

Cleaning fluid : 9-919-573-01

Cassette tape (BCT 20M)

Replacement flow chart

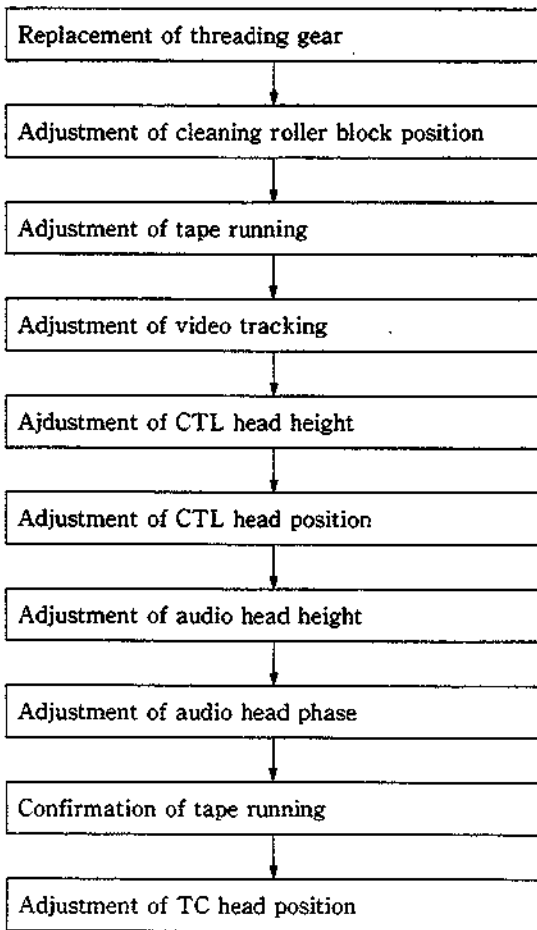

Removal

1. Remove a cleaning roller block. (Refer to steps (1) and (2) in Section 5-6.)
2. Remove an AU head cover. At this time, the harness clamber of the drum comes off together. (Refer to step (3) in Section 5-3.)
3. Place a reel table to the L cassette position.
4. Remove a S rail and S slider assembly. (Refer to steps (1) to (6) in Section 5-16.)
5. Remove a T rail and T slider assembly. (Refer to steps (5) to (9) in Section 5-17.)
6. Remove a P slider assembly. (Refer to step (6) in Section 5-18.)
7. Disconnect connectors from a drum which are connected to RP board.
8. Remove two screws of a ST base assembly, and place it on the power block.

Note :Be careful not to loose or tighten the adjustment screws of a S adjustment bracket and T adjustment bracket, and also not to change height of a CTL head and TG-4 tape guide on the ST base assembly.

It is recommended to cover the CTL head with gauze to prevent make damage of tape running surface of the CTL head.

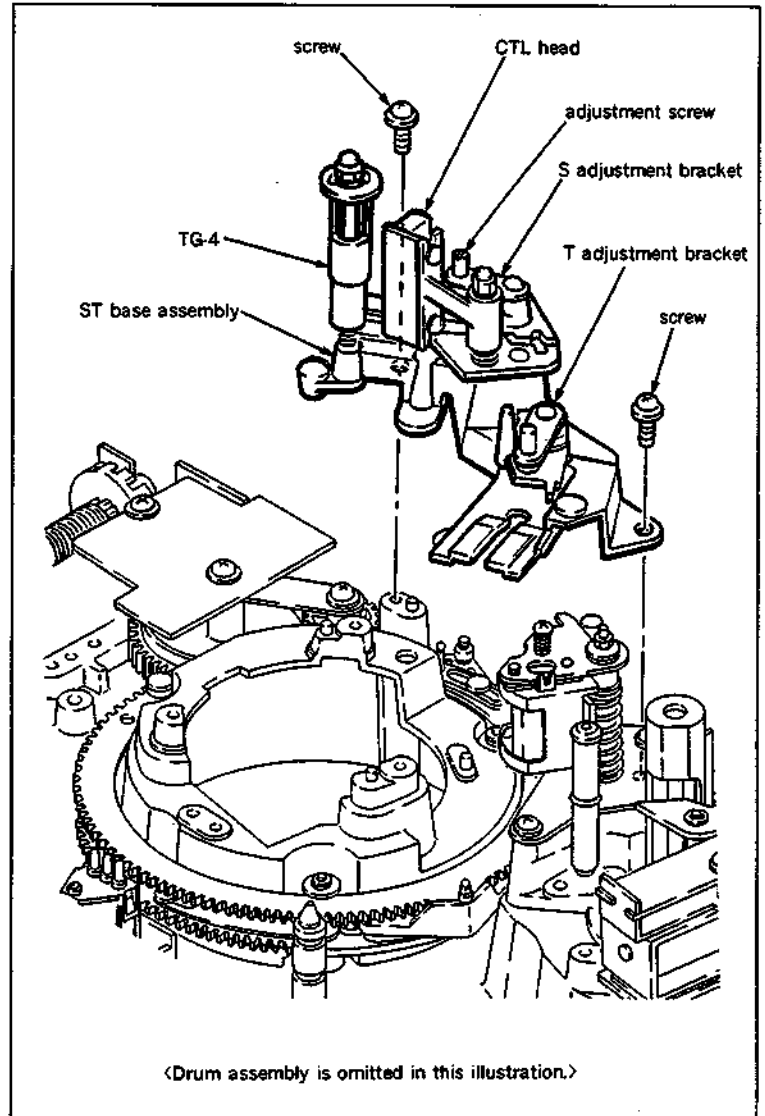

9. Turn a threading motor rotation detection ring of a threading motor block by fingers looking it from the front so that match hole "A" of a S threading ring, hole "B" of a T threading ring and in the concave "C" on the slant chassis.

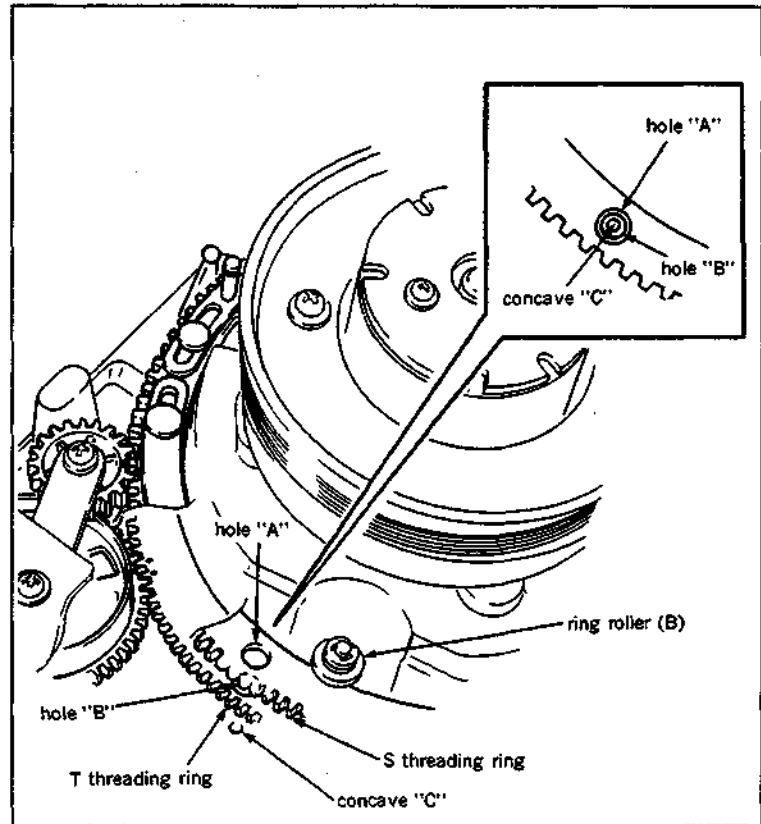

10. Disconnect connectors CN901, CN902 and CN903 from PTC-49 board. Remove two screws of PTC-49 board and remove it from the unit.
11. Remove a screw of a reinforcement bracket, and remove it.
12. Remove a worm wheel, S gear and main gear from the unit.

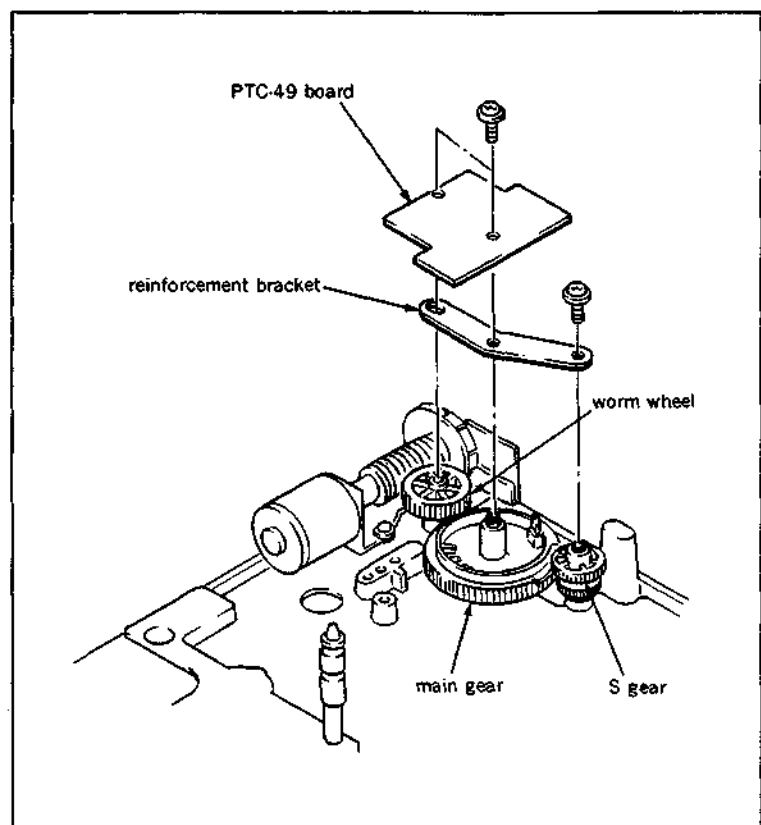

Installation

Note 1 : Install the worm wheel and S gear after performing following step (14) main gear engagement adjustment.

Note 2 : When install the S gear, perform following step (15) S gear engagement adjustment.

13. Clean installation shaft for the gear, and hole of the gear with cleaning piece moistened with cleaning fluid.

14. Install the main gear and perform the main gear engagement adjustment.

(1) Make sure that the hole "A" of the S threading ring, hole "B" of the T threading ring and in the concave "C" on the slant chassis are the same position.

(2) Install the main gear so that engage two marks on the teeth of the T threading ring with a mark on the tooth of the main gear as shown in the figure.

15. Install the S gear and perform the S gear engagement adjustment.

(1) Make sure that the hole "A" of the S threading ring, hole "B" of the T threading ring and in the concave "C" on the slant chassis are the same position.

(2) Install the S gear so that engage two marks on the teeth of the S threading ring with a mark on the tooth of the S gear as shown in the figure.

16. Install the worm wheel.

17. Install the reinforcement bracket.

18. Connect connectors CN901, CN902 and CN903 to PTC-49 board, and install PTC-49 board to the unit.

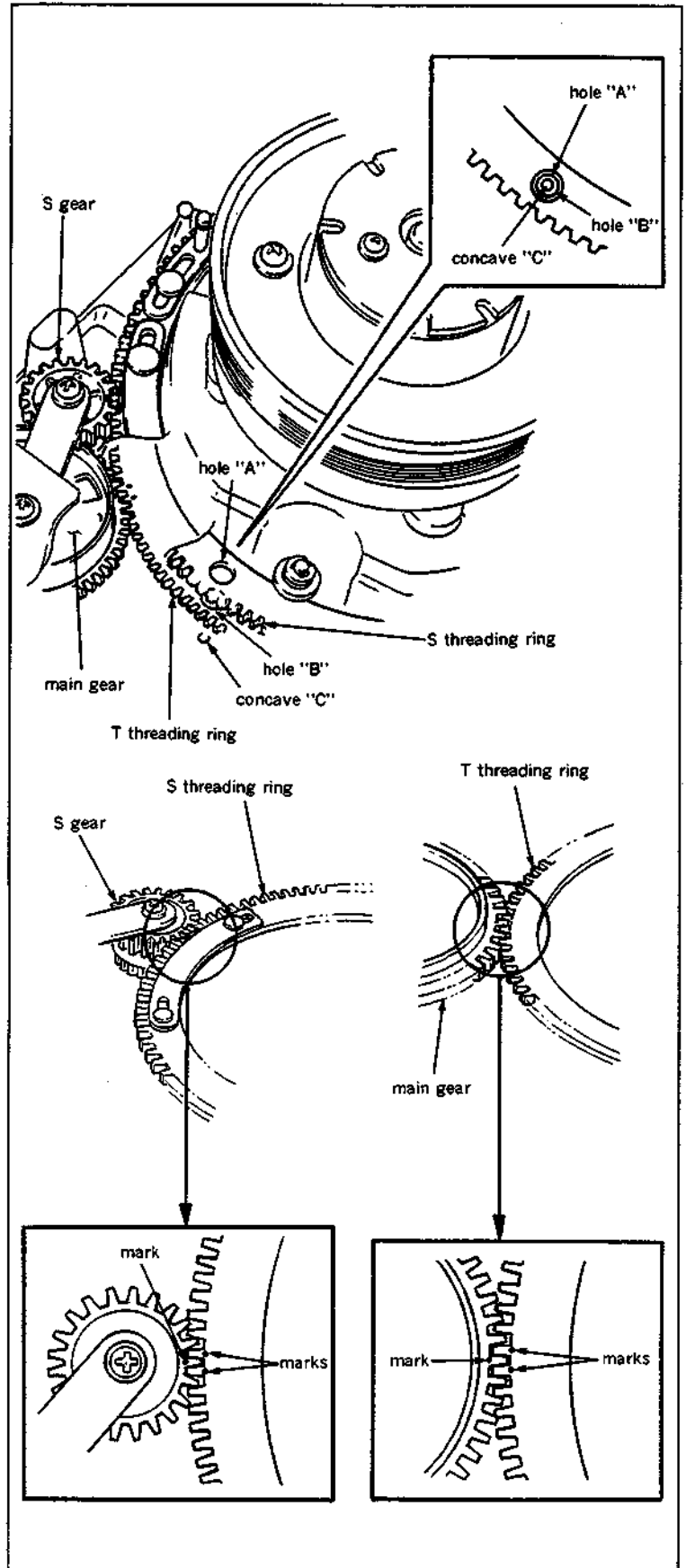

19. Turn the threading motor rotation detection ring of a threading motor block with finger, and place the threading ring to the point of 5 mm back from the threading completion mode.
20. Assemble the ST base assembly, P slider assembly, T slider assembly, T rail, S slider assembly and T rail in the reversing the order of steps (4) to (8).
21. Turn the POWER to ON, make sure that the threading operates properly and smoothly.
22. Insert a cassette tape, and make sure that the tape threads to the normal position.

Adjustment after replacement

23. Perform cleaning roller block position adjustment. (Refer to Section 5-6-1.)
24. Perform tape running adjustment. (Refer to Section 6-3.)
25. Perform video tracking adjustment. (Refer to Section 6-4.)
26. Perform CTL head height adjustment. (Refer to Section 6-5.)
27. Perform CTL head position adjustment. (Refer to Section 6-6.)
28. Perform audio head height adjustment. (Refer to Section 6-7.)
29. Perform audio head phase adjustment. (Refer to Section 6-8.)
30. Perform confirmation of tape running. (Refer to Section 6-3.)
31. Perform TC head position adjustment. (Refer to Section 6-10.)

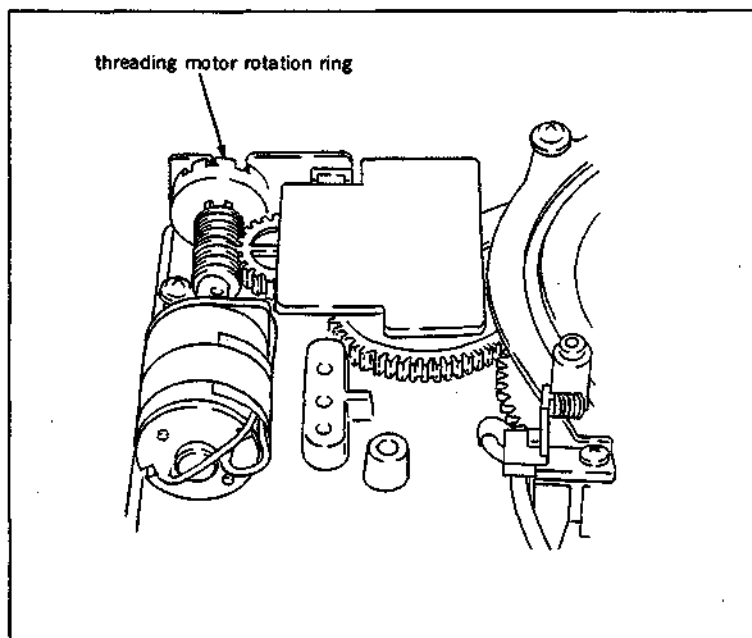

5-25. CTL HEAD REPLACEMENT

Tools

- Cleaning piece : 2-034-697-00
- Cleaning fluid : 9-919-573-01

Replacement flow chart

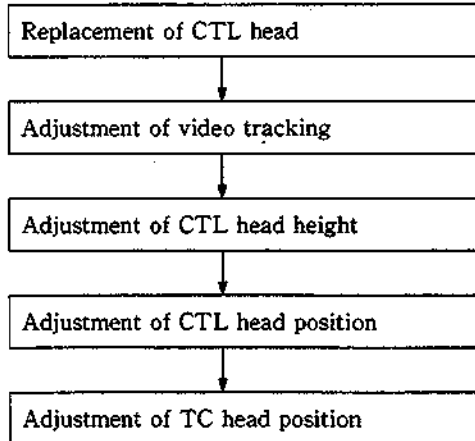

Removal

1. Rotate an upper drum assembly by hand, and set the video heads away from a CTL head.
2. Unsolder two lead wires from the CTL head.
3. Loosen a screw shown in the figure, remove the CTL head block from the unit.

Note :Never contact the CTL head to the upper drum assembly when removing the CTL head.

4. Loosen two screws at the bottom of the head, and remove the CTL head.

Installation

5. Clean a CTL head side bracket and the installation surface of a new CTL head with a cleaning piece moistened with cleaning fluid.
6. Install the CTL head with two screws.
7. Install the assembled CTL head block to the unit.

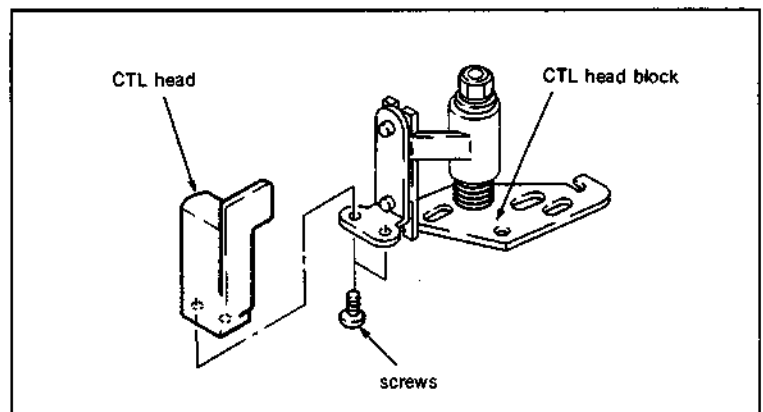
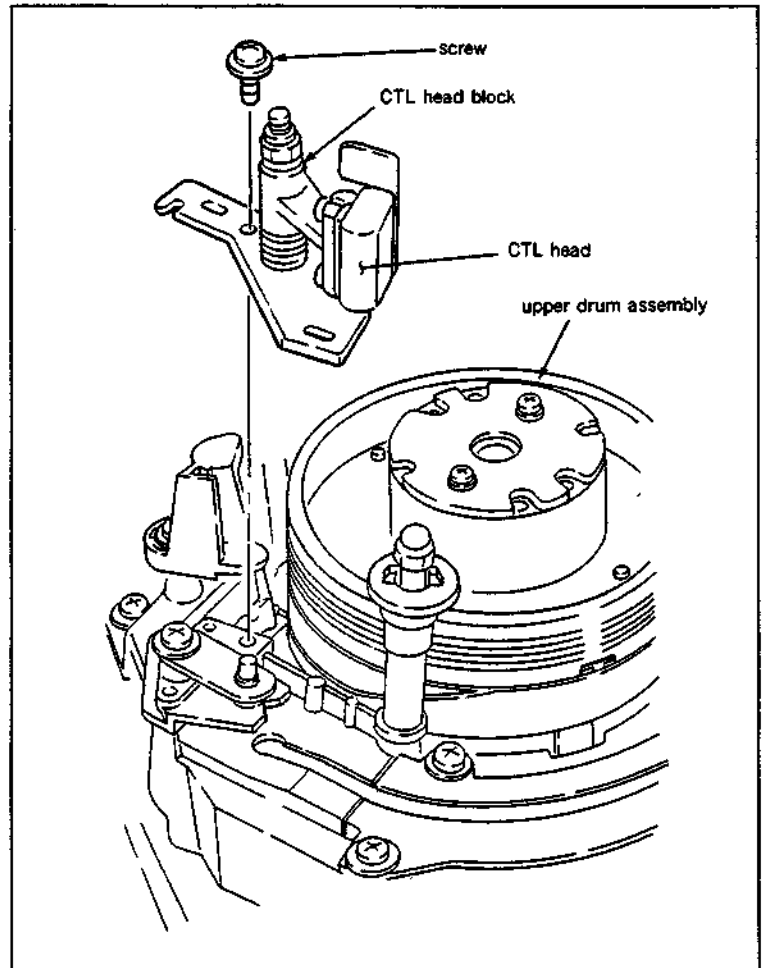

8. Solder two lead wires to the CTL head.

Note :Solder red lead wire to left side, and white lead wire to right side looking it from the front.

9. Clean the CTL head and TG-4 tape guide with cleaning piece moistened with cleaning fluid.

Adjustment after replacement

10. Perform video tracking adjustment.
(Refer to Section 6-4.)
11. Perform CTL head height adjustment.
(Refer to Section 6-5.)
12. Perform CTL head position adjustment.
(Refer to Section 6-6.)
13. Perform TC head position adjustment.
(Refer to Section 6-10.)

5-26. AUDIO/TC HEAD REPLACEMENT

Tools

- Cleaning piece : 2-034-697-00
Cleaning fluid : 9-919-573-01

Replacement flow chart

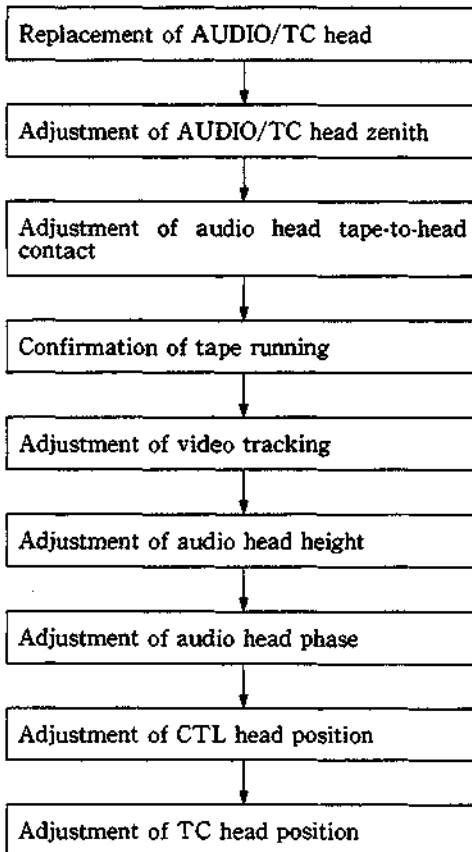

Removal

1. Remove a cleaning roller, block. (Refer to steps (1) and (2) in Section 5-6.)
2. Remove an AU head cover. At this time, the harness clamber of the drum comes off together. (Refer to step (3) in Section 5-3.)
3. Disconnect connectors from an AUDIO/TC head which connected with AU-148AP board, AU-149AP board and AU-150P board.
4. Remove the head harness from the harness clamber.
5. Remove three screws which hold the AUDIO/TC head block, and remove the head block from the unit.

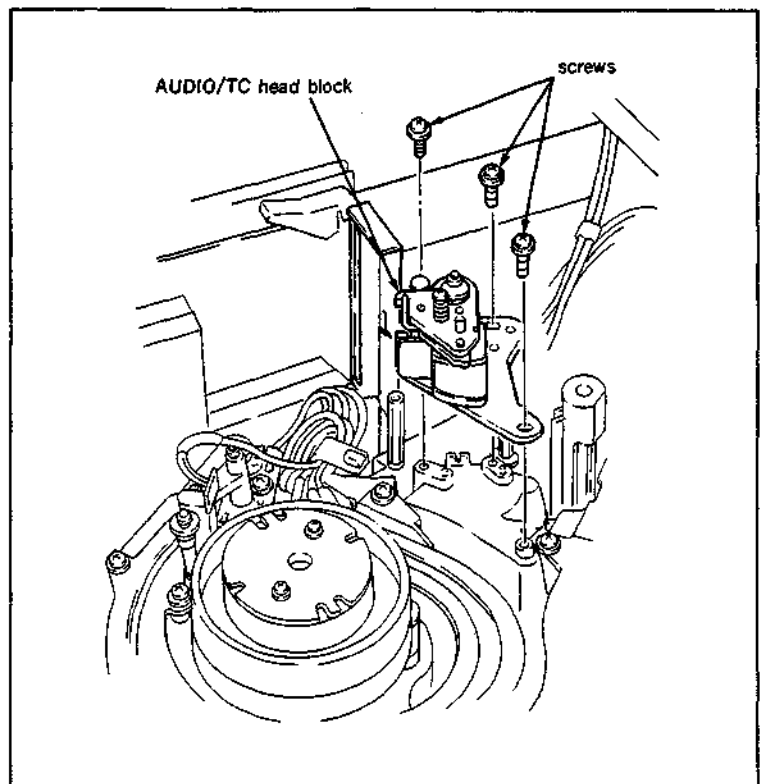

- Remove a screw as shown in the figure, and remove the AUDIO/TC head unit from a RP adjustment bracket.

Note 1 : When removing the screw, pay particular attention not to lose a spacer, compression spring and washer which come off with the screw.

Note 2 : Do not loosen or tighten the two set-screws.

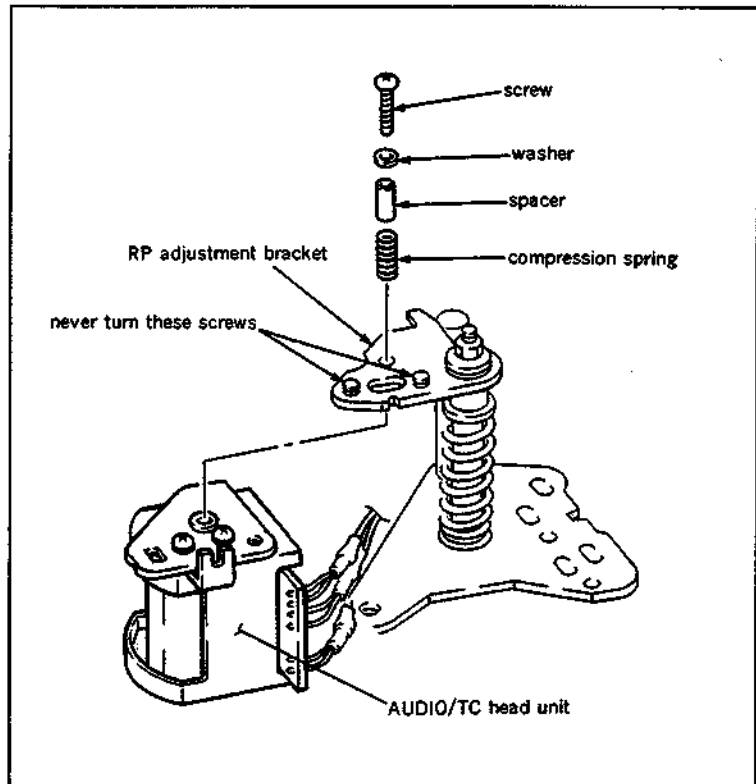

- Unsolder all lead wires which connected with the head board.
- Remove two screws as shown in the figure and remove the AUDIO/TC head.

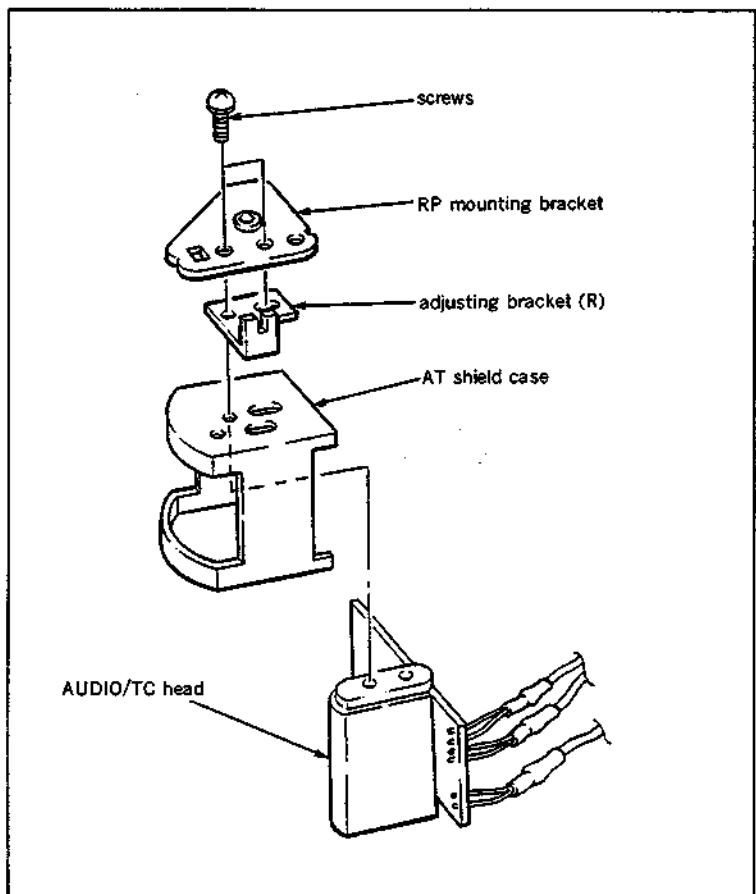

Installation

9. Clean the installing surface of a new AUDIO/TC head with a cleaning piece moistened with cleaning fluid.
10. Install the AUDIO/TC head, adjusting bracket (R) and RP mounting bracket to the holes on an AT shield case as shown in the figure with two screws.
11. Solder the connectors and lead wires to the AUDIO/TC head board.
To face in front of the head,
From the top
White (with yellow tube)
Red (with yellow tube)
White (with red tube)
Red (with red tube)
White (with white tube)
Red (with white tube)
12. Install the assembled AUDIO/TC head unit to the RP adjustment bracket.
13. Clean the tape running surface of the AUDIO/TC head with a cleaning piece moistened with cleaning fluid.
14. Install the AUDIO/TC head block with three screws.

Adjustment after replacement

15. Perform AUDIO/TC head zenith adjustment.
(Refer to Section 6-2.)
16. Perform AUDIO head tape-to-head contact adjustment. (Refer to Section 6-9.)
17. Perform confirmation of tape running.
(Refer to Section 6-3.)
18. Perform video tracking adjustment.
(Refer to Section 6-4.)
19. Perform audio head height adjustment.
(Refer to Section 6-7.)
20. Perform audio head phase adjustment.
(Refer to Section 6-8.)
21. Perform CTL head position adjustment.
(Refer to Section 6-6.)
22. Perform TC head position adjustment.
(Refer to Section 6-10.)

5-27. CAPSTAN MOTOR REPLACEMENT

Tools

Cleaning piece : 2-034-697-00

Cleaning fluid : 9-919-573-01

Replacement flow chart

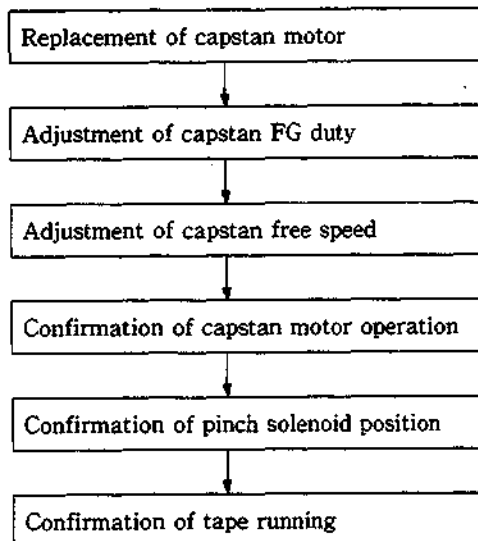

Removal

1. Make sure that the unit is into unthreading end mode.
2. Set the unit up with the left side panel to the bottom.
3. Open DR-118 board.
4. Disconnect a connector of a capstan motor at the back side of the unit.
5. Disconnect three connectors CN914, CN915 and CN916 which connected with PD-56 board on the pinch press block.
6. Remove two screws which holding a pinch press block, and remove it from the chassis. (Refer to Section 5-22.)
7. Remove three fixing screws of the capstan motor from the top of the unit while holding the capstan motor with hand from the back side of the unit.

Note 1 : Hold the capstan motor with hands to prevent it dropping.

Note 2 : Pay particular attention not to cause damage to the tape guide around the capstan motor.

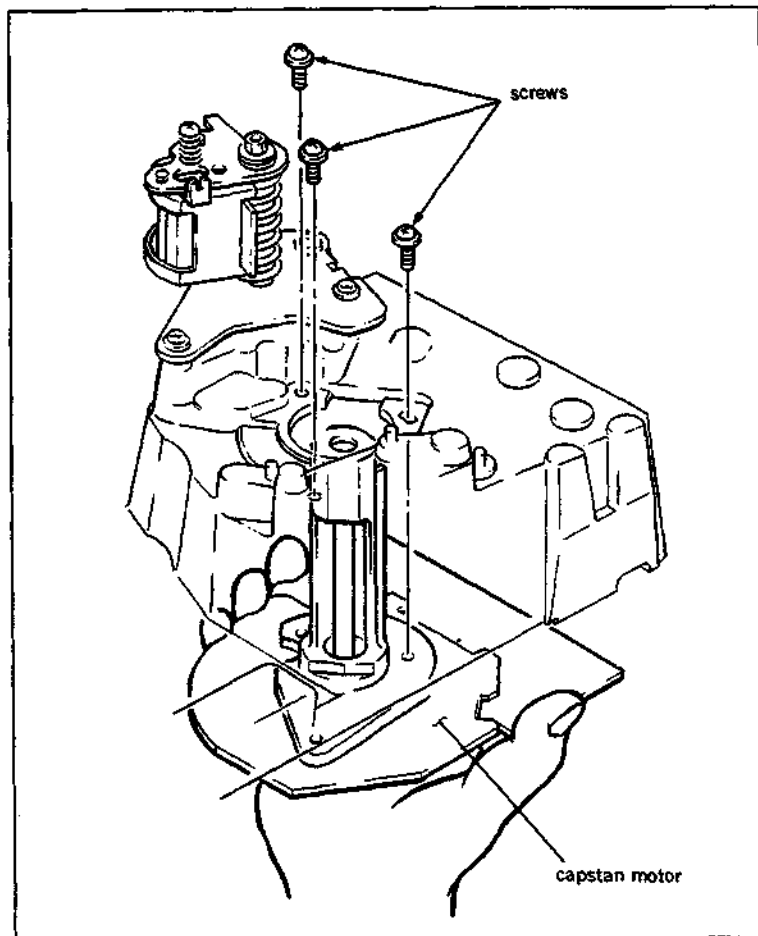

Installation

8. Clean the installing surfaces of a new capstan motor and the chassis with a cleaning piece moistened with cleaning fluid.
9. Install the capstan motor to the chassis.

Note 1 :Pay particular attention not to cause damage to the capstan shaft.

Note 2 :Pay particular attention not to cause damage to the tape guide around the capstan motor.

10. Install the capstan motor with three screws.
11. Connect the capstan motor connector.
12. Close DR-118A board, and place the unit to the original position.
13. Clean the capstan shaft with a cleaning piece moistened with cleaning fluid.
14. Install the pinch press block to the chassis with two screws.
15. Connect three connectors CN914, CN915 and CN916 with PD-56 board.

Adjustment after replacement

16. Perform capstan FG duty adjustment.
(Refer to Section 5-27-2.)
17. Perform capstan speed adjustment.
(Refer to Section 5-27-3.)
18. Perform confirmation of capstan motor operation. (Refer to Section 5-27-1.)
19. Perform confirmation of pinch solenoid position. (Refer to steps (1) to (4) in Section 5-22-1.)
20. Perform confirmation of tape running.
(Refer to Section 6-3.)

5-27-1. Capstan Motor Operation Check

• Be sure to perform the capstan motor operation check when a capstan motor is replaced.

Preparation

Connect a video monitor with VIDEO OUTPUT 3 connector or MONITOR connector, and display characters.

Check

1. Put Bit7 of S601 on SS-48P board in CLOSE state, and press S302 to put the unit into maintenance mode.
2. Press the search dial to enter the jog mode, and move * mark to "BO : SERVO CHECK" which is displaying on the monitor screen with the search dial.
3. Press S302 on SS-48P board to select "SERVO CHECK" mode.
4. Move * mark to "BO2: MOTOR CHECK" which is displaying on the monitor screen with the search dial.
5. Press S302 on SS-48P board to select "MOTOR CHECK" menu.
6. Move * mark to "BO25: CAPSTAN MOTOR" which is displaying on the monitor screen with the search dial.
7. Press S302 on SS-48P board to execute "CAPSTAN MOTOR" sub-menu.
8. Press S302 on SS-48P board after "BO25: CAPSTAN MOTOR" is appeared on the monitor screen.
Make sure that "FORWARD...OK" is appeared on the monitor screen.
9. Press S302 on SS-48P board again.
Make sure that "REVERSE..." appears and then "REVERSE...OK" is displayed on the monitor screen.
If the above message does not appear, check the capstan motor drive circuit (on DR-118A board).
10. Press S303 twice on SS-48P board to return to the mode screen.

Note :In order to finish "SERVO CHECK" mode in the maintenance mode, turn the POWER switch to OFF, and put Bit7 of S601 on SS-48P board in OPEN state.

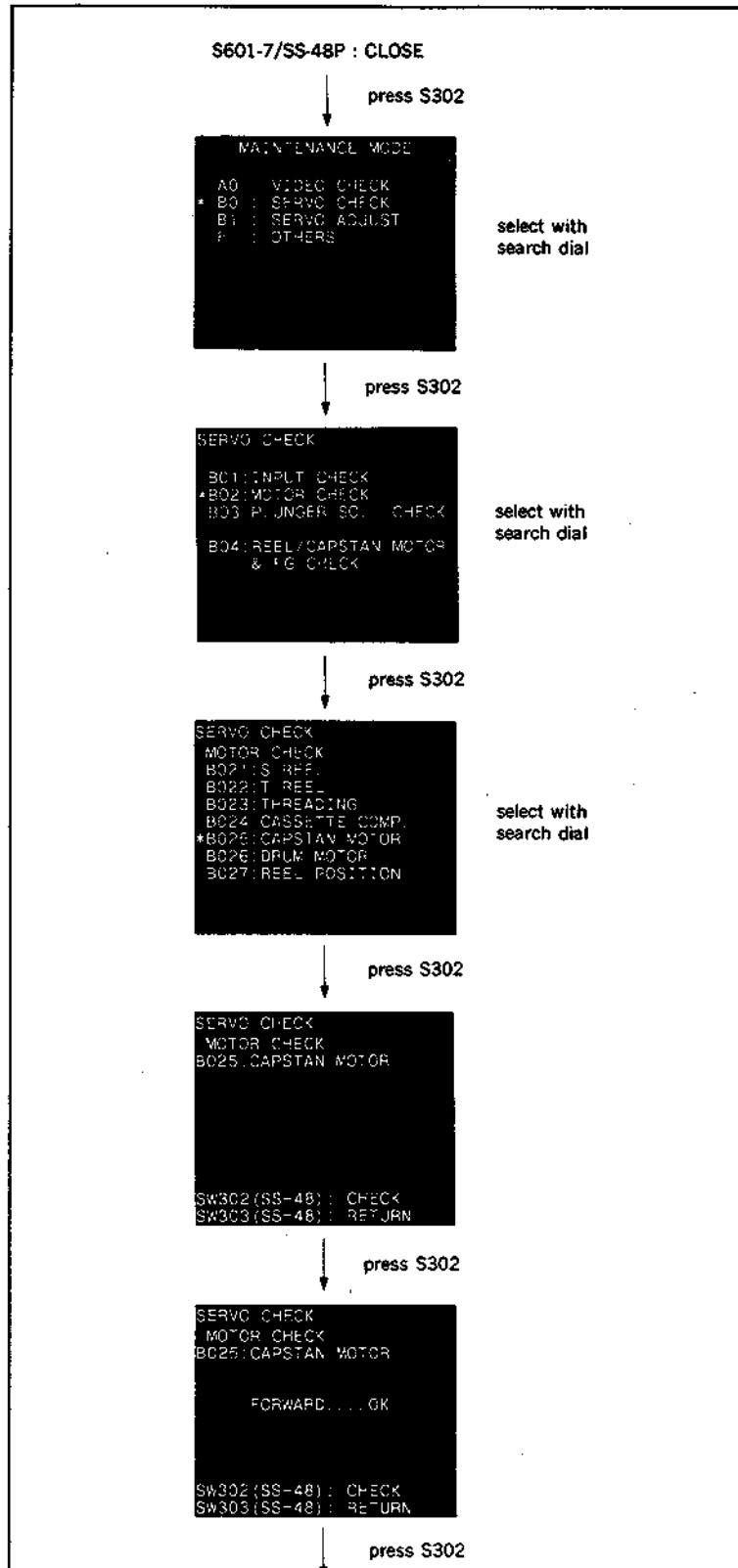

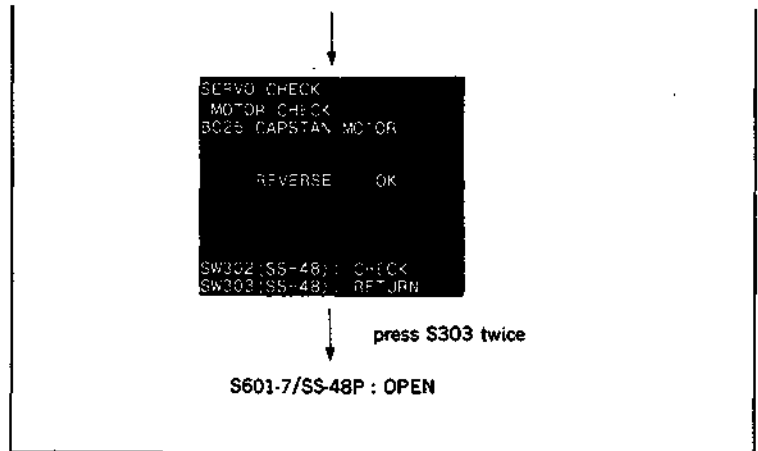

5-27-2. Capstan FG Duty Adjustment

- Be sure to perform the capstan FG duty adjustment when the capstan motor is replaced.

Preparation

Connect a video monitor with VIDEO OUTPUT 3 connector or MONITOR connector, and display characters.

Check

1. Make sure that the unit is in EJECT mode. (The automatic adjustment dose not accept the mode other than EJECT.)
2. Put Bit4 of S601 on SS-48P board in CLOSE state. Push S302 and put the unit into maintenance mode.
3. Press the search dial to enter the jog mode, and move * mark to "B1: SERVO ADJUST" which is displaying on the monitor screen with the search dial.
4. Press S302 on SS-48P board to select "SERVO ADJUST" mode.
5. Move * mark to "B104: CAPSTAN FG DUTY" which is displaying on the monitor screen with the search dial.
6. Press S302 on SS-48P board to execute "CAPSTAN FG DUTY".
7. Confirm that the message "COMPLETE" is displayed on the monitor screen. When "COMPLETE" is displayed on the monitor screen, press S303 on SS-48P board to return to the menu screen.

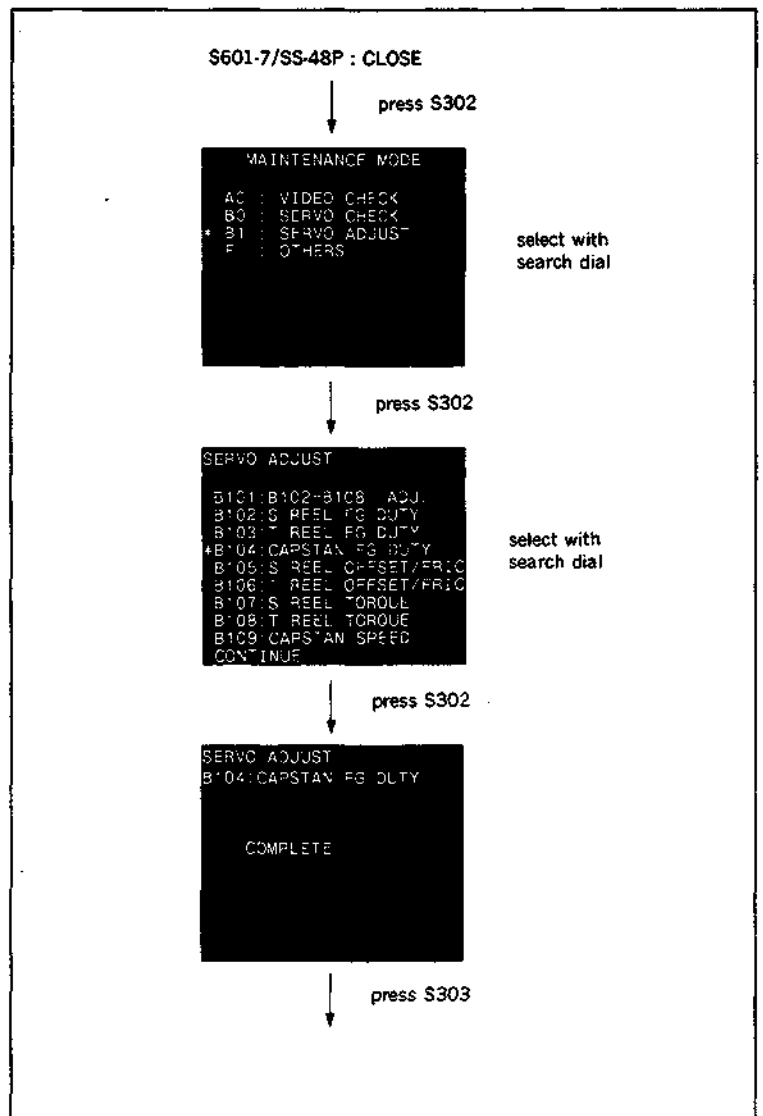

8. Move * mark to "B117 : NV RAM CONTROL" which is displaying on the monitor screen with the search dial.
9. Press S302 on SS-48P board to execute "NV RAM CONTROL" menu.
10. Move * mark to "SAVE ALL ADJ. DATA" with the search dial.
11. Press S302 on SS-48P board. Data will be stored on the NOV RAM.
12. When "SAVE COMPLETE" is displayed on the monitor screen, press S303 twice on SS-48P board to return to the mode screen.

Note 1 :When "INCOMPLETE" appears on the monitor screen in step (7), press S303 on SS-48P board to return to the menu screen.

Check the capstan motor drive circuit (on DR-118A board) and capstan FG amplifier circuit (on SS-48P board).

Note 2 :When the "SERVO ADJUST" mode is completed, turn the POWER to OFF and put Bit4 of S601 on SS-48P board in OPEN state.

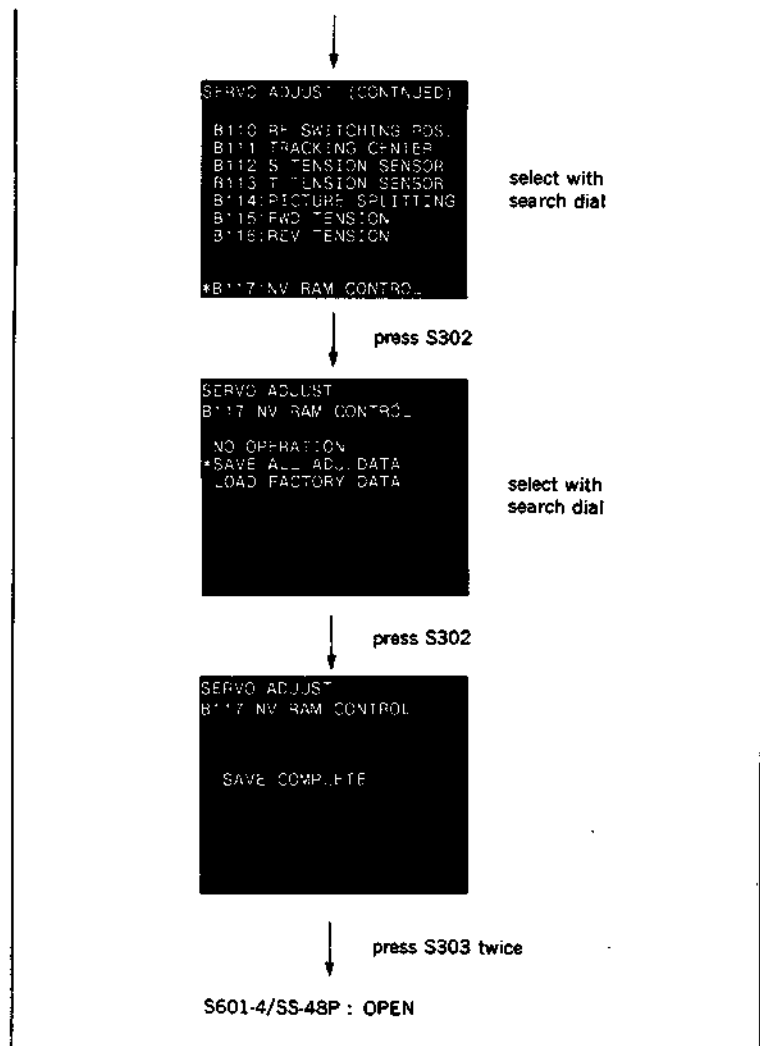

5-27.3. Capstan Speed Adjustment

• Be sure to perform the capstan speed adjustment when the capstan motor is replaced.

Preparation

Connect a video monitor with VIDEO OUTPUT 3 connector or MONITOR connector, and display characters.

Tool

Alignment tape CR2-1B PS : 8-960-096-51

Check

1. Make sure that the unit is in EJECT mode. (The automatic adjustment dose not accept the mode other than EJECT.)
2. Put Bit4 of S601 on SS-48P board in CLOSE state. Push S302 and put the unit into maintenance mode.
3. Press the search dial to enter the jog mode, and move * mark to "B1 : SERVO ADJUST" which is displaying on the monitor screen with the search dial.
4. Press S302 on SS-48P board to select "SERVO ADJUST" mode.
5. Move * mark to "B109: CAPSTAN SPEED" which is displaying on monitor screen with the search dial.
6. Press S302 on SS-48P board to execute "CAPSTAN FREE SPEED" menu.
7. A message "SET CR2-1 ALIGNMENT TAPE AND PUSH PLAY KEY" will be displayed on the monitor screen.
8. Insert an alignment tape CR2-1B PS, and press PLAY button.
9. Confirm that the message "COMPLETE" is displayed on the monitor screen. When "COMPLETE" is displayed on the monitor screen, press S303 on SS-48P board to return to the menu screen.

Note: When "INCOMPLETE" appears on the monitor screen in step (9), press S303 on SS-48P board to return to the menu screen. Then press EJECT button and take out the alignment tape, then check if the alignment tape is CR2-1B PS.

If it is OK, check the capstan motor drive circuit (on DR-118A board) and capstan FG amplifier circuit (on SS-48P board).

10. Move * mark to "B117 : NV RAM CONTROL" which is displaying on the monitor screen with the search dial.

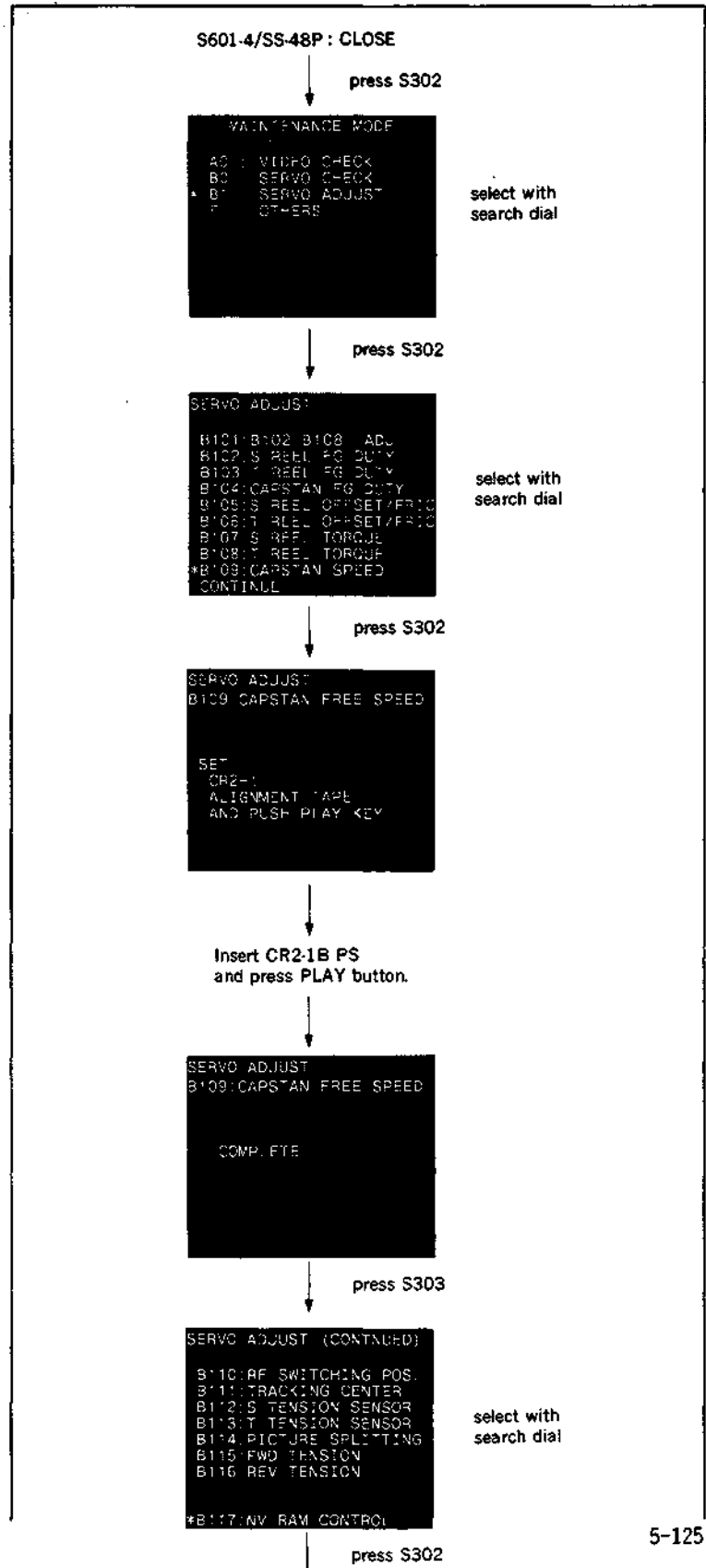

11. Press S302 on SS-48P board to execute "NV RAM CONTROL" menu.
12. Move * mark to "SAVE ALL ADJ. DATA" with the search dial.
13. Press S302 on SS-48P board. Data will be stored on the NOV RAM.
14. When "SAVE COMPLETE" is displayed on the monitor screen, press S303 twice on SS-48P board to return to the mode screen.
15. Press EJECT button and take out the alignment tape.
16. Turn the POWER to OFF and put Bit4 of S601 on SS-48P board in OPEN state.

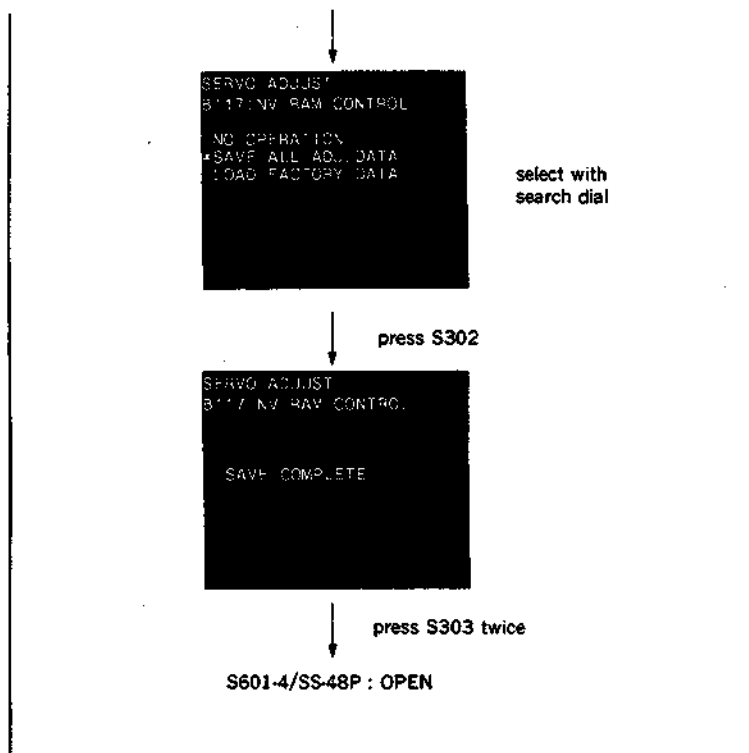

TAPE RUN

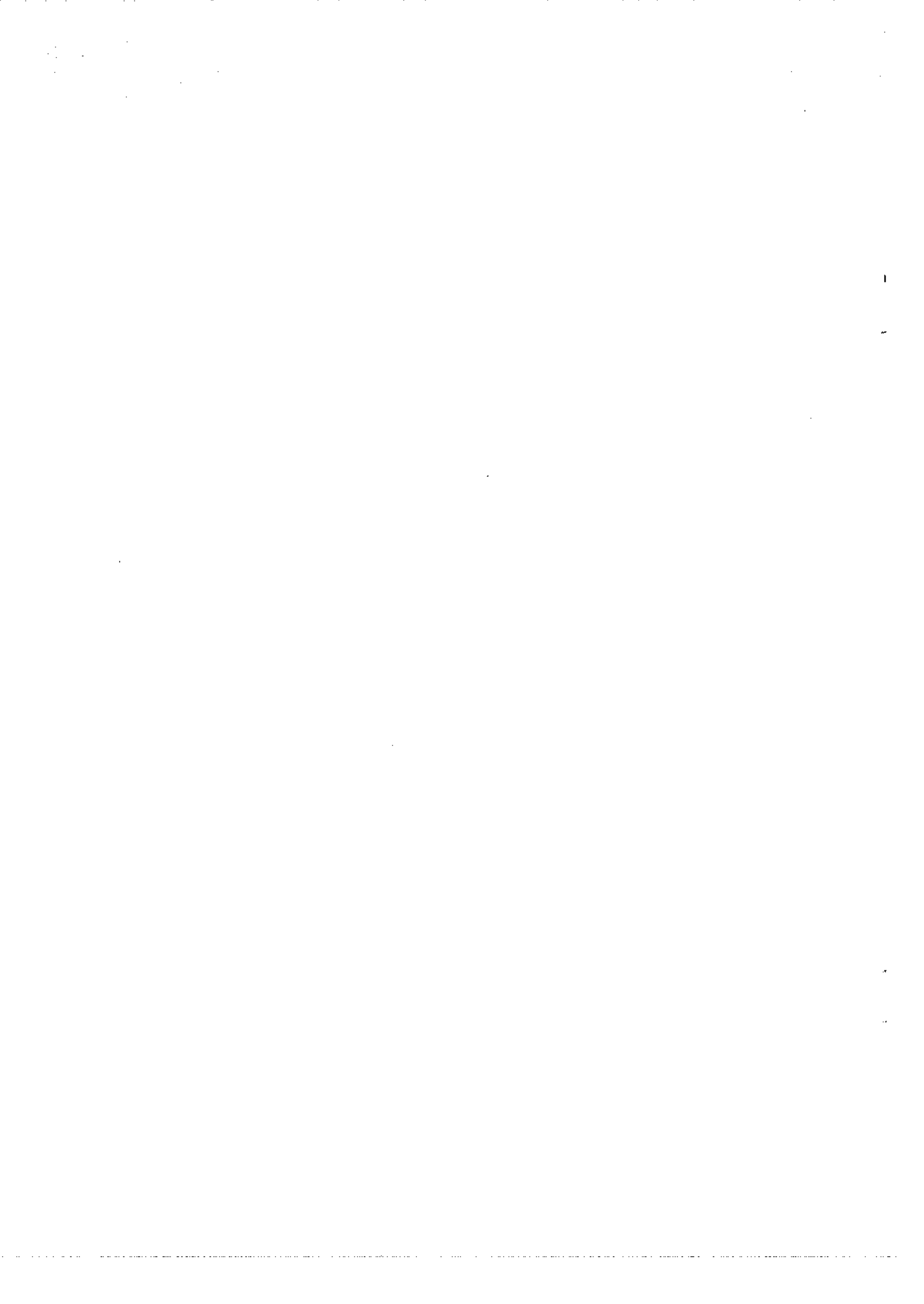

SECTION 6 TAPE RUN ALIGNMENT

6-1. GENERAL INFORMATION FOR TAPE RUN ADJUSTMENT

1. HOW TO MAKE A CASSETTE TAPE (ALIGNMENT TAPE) WITHOUT LID

The check and adjustment cannot be performed if a cassette tape lid is installed. Remove the cassette tape lid as follows :

- (1) Remove four screws on the back of the cassette tape as shown in the figure, and remove an upper half of the cassette.
- (2) Remove the lock mechanism parts and the springs both at left and right sides, and remove the cassette lid from the upper half.
- (3) Install the upper half on the lower half with four screws from the back side.

2. ALIGNMENT TAPE

The alignment tapes used for tape run adjustment are as follows :

CR2-1B PS : 8-960-096-51

CR5-2A PS : 8-960-098-44

CR8-1A PS : 8-960-098-45

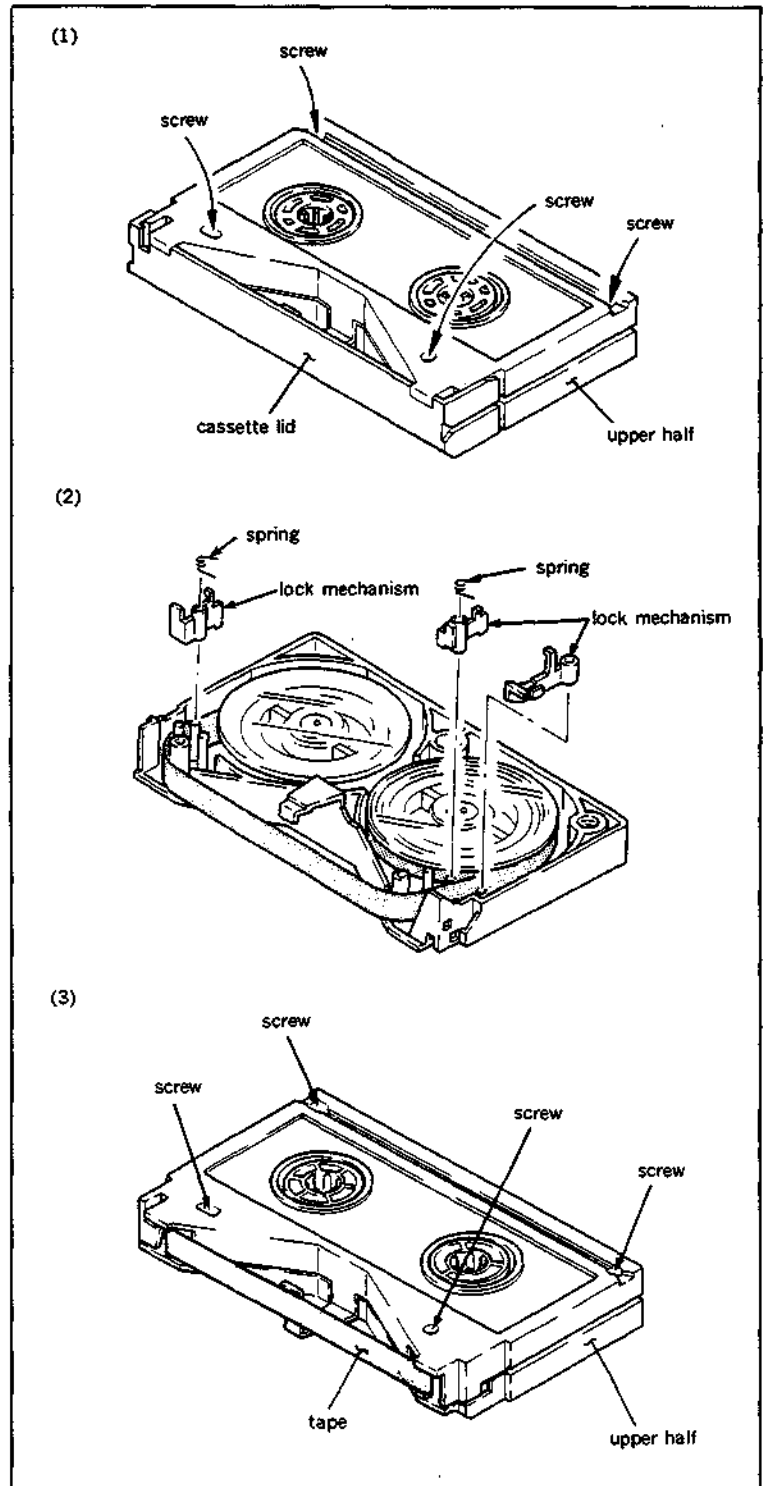

3. TAPE GUIDE ADJUSTMENT DRIVER

During tracking adjustment, rotate the flange on the tape guide in order to obtain the most desirable tape path. At that time, use the tape guide adjustment driver.

Tape guide adjustment driver : J-6321-500-A
Here is the explanation about how to use the tape guide adjustment driver.

- (1) Align A portion (flatblade) with the groove of the tape guide flange.
- (2) Fix knob C, rotate knob B, and loosen locking screw.
- (3) Align the tip of knob B with the hole of locking screw of the tape guide. Fix knob B and rotate knob C. Then, the upper flange of the tape guide is rotated.
- (4) In order to tighten the locking screw of the tape guide flange, firstly, fix the knob C, then rotate the knob B. (Tightening torque: 9.8 to 11.7 N·cm {1.0 to 1.2 kgf·cm})

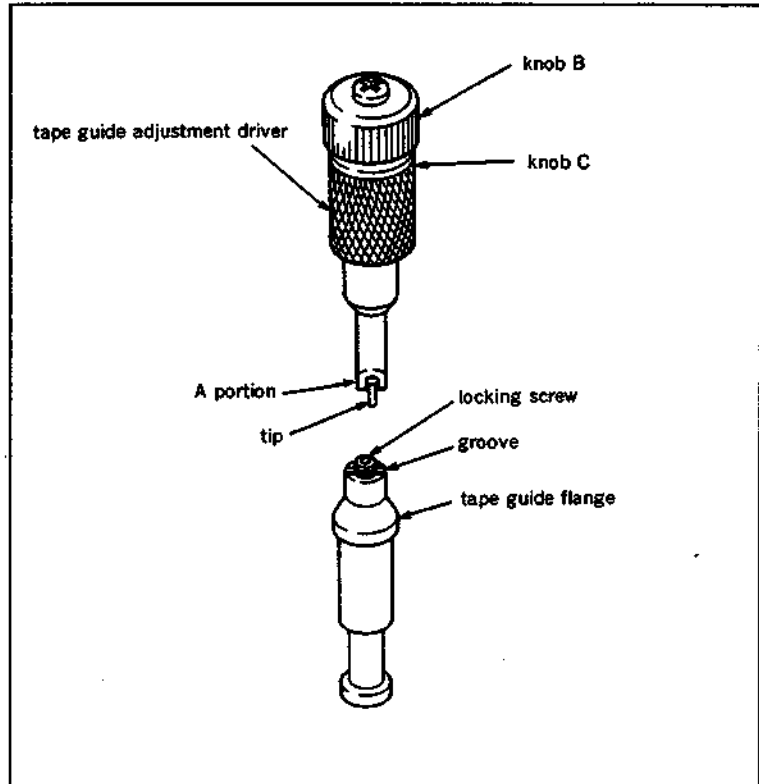

4. CASSETTE COMPARTMENT

Install the cassette compartment in the unit before performing the tape run adjustment. This enables more accurate adjustment.

5. LOCATION OF HEADS AND TAPE GUIDES

The location of heads and tape guides listed up in the adjustment item is shown in the figure.

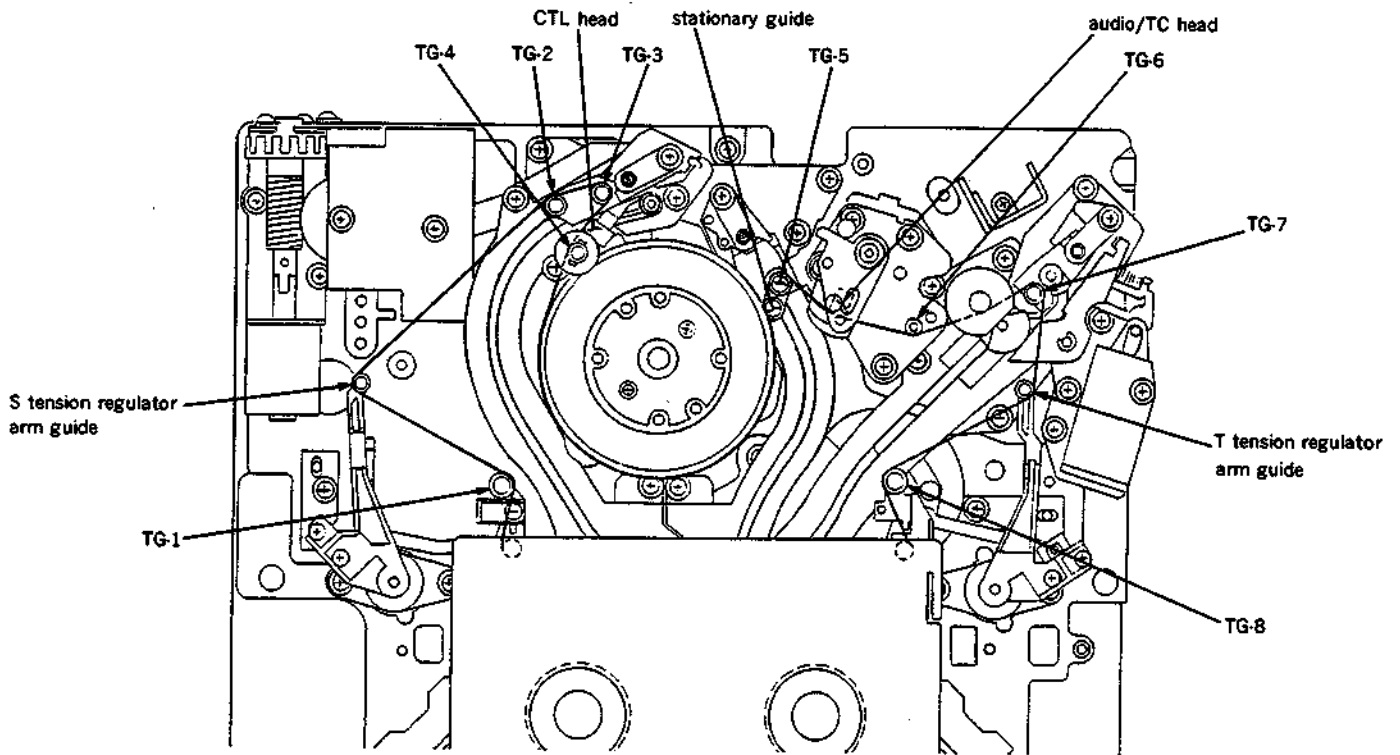

6-2. AUDIO/TC HEAD ZENITH ADJUSTMENT

Tools

Cleaning piece : 2-034-697-00
Cleaning fluid : 9-919-573-01
Flatness plate : J-6086-570-A

Adjustment flow chart

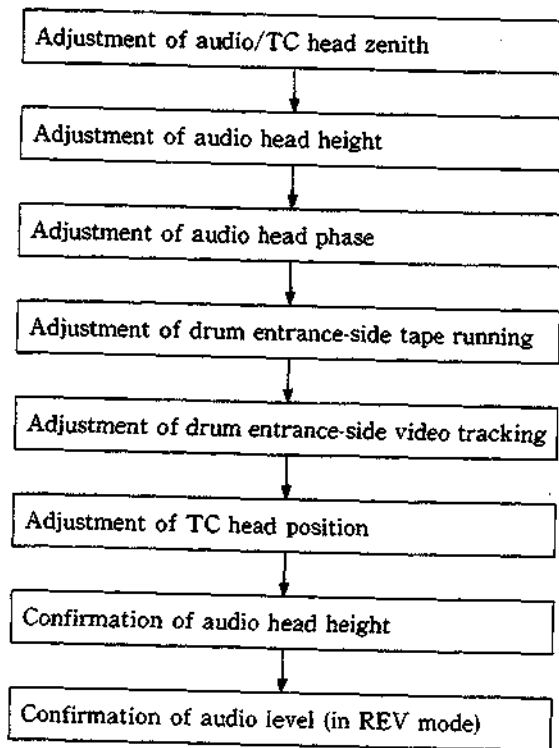

Check

1. Put the unit into unthreading end mode.
2. Place the flatness plate to a TG-6 tape guide, then push it slightly against an audio/TC head.

Note :Pay particular attention not to scratch the tape contacting surface of the audio/TC head.

3. While pressing the flatness plate against the TG-6 tape guide with finger, push the upper part of the flatness plate in front of the audio/TC head softly with fingers of the other hand. Then, push the lower part of the flatness plate in front of the audio/TC head softly with fingers of the other hand.

Specification : The flatness plate must not move when pushed the upper part. (In other words, no clearance shall exist between the flatness plate and head.)

The flatness plate must not move or a little move when pushed the lower part.

The clearance between the flatness plate and head (moving distance) is acceptable less than 0.05 mm.

• The confirmation procedure of 0.05 mm clearance :

- (1) Turn the zenith adjustment screw in counterclockwise so that the flatness plate must not move when pushed the upper and lower parts.
- (2) Turn the zenith adjustment screw in clockwise 50 degrees, the 0.05 mm clearance between the flatness plate and head exists.

If the specification is satisfied, perform steps (5) and later.

If the specification is not satisfied, perform steps (4) and later.

Adjustment

4. In case clearance is observed at lower part, turn the zenith adjustment screw in counterclockwise to satisfy the above specification. In case clearance is observed at upper part, turn the zenith adjustment screw in clockwise to satisfy the above specification.
5. Clean the audio/TC head and TG-6 tape guide with a cleaning piece moistened with cleaning fluid.
6. Perform audio head height adjustment. (Refer to Section 6-7.)
7. Perform audio head phase adjustment. (Refer to Section 6-8.)
8. Perform drum exit-side tape running adjustment. (Refer to Section 6-3.)
9. Perform drum exit-side video tracking adjustment. (Refer to Section 6-4.)
10. Perform TC head position adjustment. (Refer to Section 6-10.)
11. Perform reconfirmation of audio head height. (Refer to steps (1) through (3) in Section 6-7.)
12. Perform confirmation of audio level (in REV mode). (Refer to Section 6-11.)

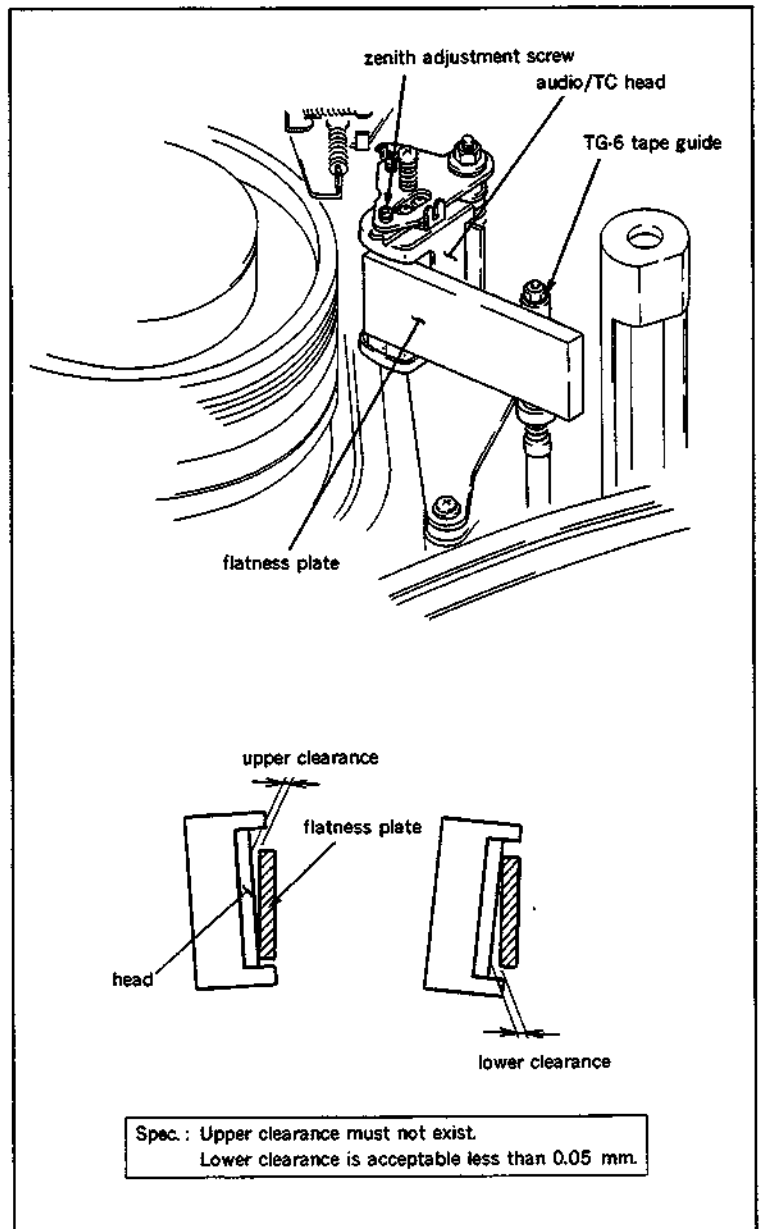

6-3. TAPE RUNNING ADJUSTMENT

- Adjustment of tape run is extremely important and critical adjustment for the purpose of running the tape in the most appropriate state. If this adjustment is not adequate, there is a possibility to damage the tape or cause serious damage to the unit.

Take utmost care in performing adjustment.

- Perform this adjustment with the cassette compartment installed in the unit. By this way, accurate adjustment will be possible without difficulty as a service operation.

Tools

Cleaning piece	: 2-034-697-00
Cleaning fluid	: 9-919-573-01
Tape guide adjustment driver	: J-6321-500-A
Adjustment mirror	: J-6080-029-A
Oxide tape without lid (BCT-30G)	
Metal tape without lid (BCT-90ML)	

Adjustment flow chart

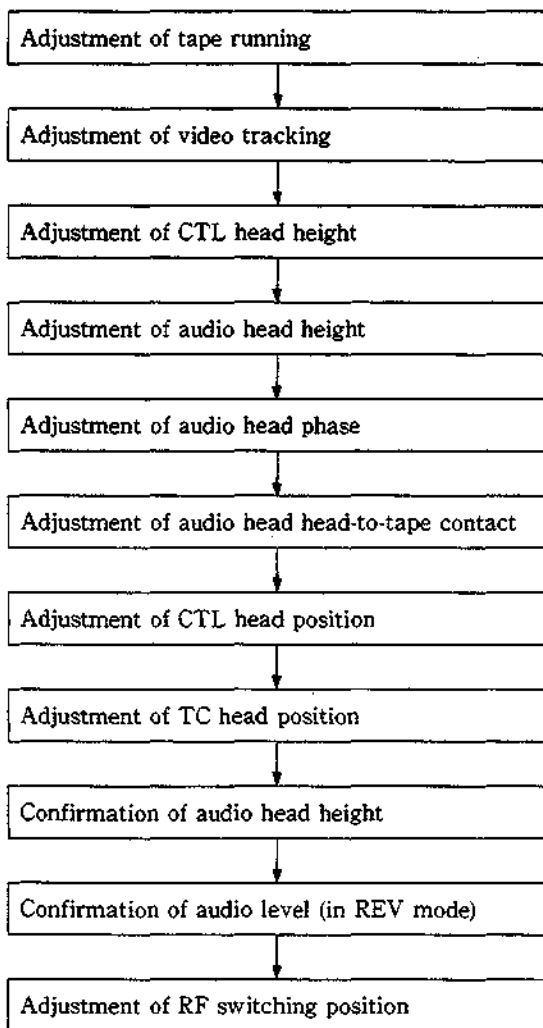

Check

1. Clean the tape running surface of the tape guides, drum and video heads with a cleaning piece moistened with cleaning fluid.
2. Insert an oxide tape without lid (BCT-30G) into the unit.
3. Put the unit into PLAY mode.
4. Make sure using the adjustment mirror that the tape running condition satisfies the specification.
5. Put the unit into REV X1 mode.
6. Make sure using the adjustment mirror that the tape running condition satisfies the specification.
7. Put the unit into FWD X5 and F.FWD modes.
8. Make sure using the adjustment mirror that the tape running condition satisfies the specification.
9. Put the unit into REV X5 and REW modes.
10. Make sure using the adjustment mirror that the tape running condition satisfies the specification.
11. Make sure that the specification is satisfied when the unit is changed from STOP mode to F.FWD mode, STOP mode to REW mode, STOP mode to PLAY mode, STOP mode to FWD X5 mode, or STOP mode to REV X5 mode.
12. Press the EJECT button, take out the oxide tape without lid (BCT-30G), and insert the metal particle tape without lid (BCT-90ML) into the unit.
13. Perform steps (3) through (11) and confirm that the specifications are satisfied.

Adjustment

14. Loosen the locking screw at the upper part of the tape guide that does not satisfy the specification two to three turns using the tape guide adjustment driver.
 15. Turn the adjustment nut or the upper flange of the tape guide, and adjust the height of the tape guide so that the specification is satisfied. Tighten the locking screw after adjustment is completed.
- Note:** The specification may not be satisfied by the above adjustment when an S slider assembly or T slider assembly is replaced. In this case, turn the slantness adjustment screw for the S slider assembly or T slider assembly in accordance with the procedure described in the video tracking adjustment. (Refer to Section 6-4-2 or 6-4-3.)
16. Perform video tracking adjustment. (Refer to Section 6-4.)
 17. Perform CTL head height adjustment. (Refer to Section 6-5.)
 18. Perform audio head height adjustment. (Refer to Section 6-7.)
 19. Perform audio head phase adjustment. (Refer to Section 6-8.)
 20. Perform audio head head-to-tape contact adjustment. (Refer to Section 6-9.)

21. Perform CTL head position adjustment. (Refer to Section 6-6.)
22. Perform TC head position adjustment. (Refer to Section 6-10.)
23. Perform reconfirmation of audio head height. (Refer to steps (1) through (3) in Section 6-7.)
24. Perform confirmation of audio level (in REV mode). (Refer to Section 6-11.)
25. Perform RF switching position adjustment. (Refer to Section 6-12.)

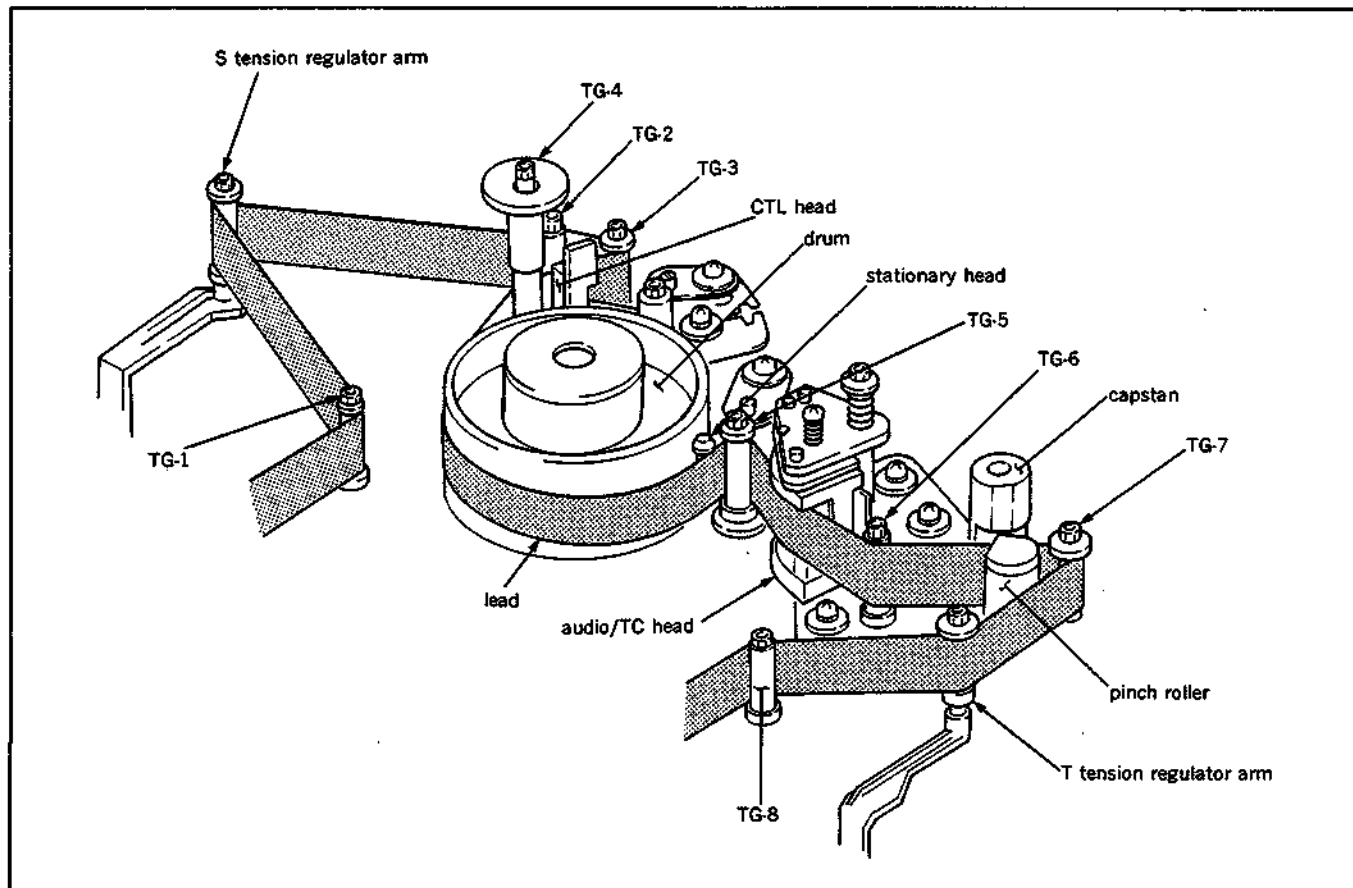

Specification

Drum entrance side

- 1) The tape runs in contact with the lead of drum entrance side without any curl.
- 2) The upper edge of the tape runs in contact with the upper flange of the TG-3 tape guide. (If a tape curl exists, it is acceptable to the extent of 1/10 of the tape width.)
- 3) The lower edge of the tape runs in contact with the lower flange of the TG-2 tape guide. When the unit just put into the REV mode, the lower edge of the tape runs in contact with the lower flange without curl. (If a tape curl exists, it is acceptable to the extent of 1/10 of the tape width.)
- 4) The tape runs in the center of the guide roller of the S tension arm. (In modes other than PLAY, if a tape curl exists at the upper or lower flange, it is acceptable to the extent of 1/10 of the tape width.)
- 5) There shall be no uneven tape tension in the area between the TG-4 and TG-3, the TG-2 and guide roller of S tension arm, and the guide roller of S tension arm and TG-1.

Drum exit side

- 6) The tape runs in contact with the lead of drum exit side without any curl.
- 7) The upper edge of the tape runs in contact with the upper flange of the TG-5 tape guide. (If a tape curl exists, it is acceptable to the extent of 1/10 of the tape width.)
- 8) The lower edge of the tape runs in contact with the lower flange of the TG-6 tape guide. However, in PLAY, F.FWD, and REW modes, the lower flange of the tape guide must not rotate. (If a tape curl exists, it is acceptable to the extent of 1/10 of the tape width.)
- 9) The upper edge of the tape runs in contact with the upper flange of the TG-7 tape guide. (If a tape curl exists, it is acceptable to the extent of 1/10 of the tape width.)
- 10) The tape runs in the center of the guide roller of the T tension arm. (In modes other than PLAY, if a tape curl exists at the upper or lower flange, it is acceptable to the extent of 1/10 of the tape width.)
- 11) There shall be no uneven tape tension in the area between the TG-5 and TG-6, the TG-6 and capstan shaft, the capstan shaft and TG-7, the TG-7 and guide roller of T tension arm, and the guide roller of T tension arm and TG-8.

6-4. CONFIRMATION OF VIDEO TRACKING

- Adjustment of video tracking is extremely important. If this adjustment is not adequate, the tape interchangeability is influenced significantly.
Take utmost care in performing adjustment.
- Perform this adjustment with the cassette compartment installed in the unit. By this way, accurate adjustment will be possible without difficulty as a service operation.

Tools

- Cleaning piece : 2-034-697-00
- Cleaning fluid : 9-919-573-01
- Alignment tape without lid (CR2-1B PS)
: 8-960-096-51
- Adjustment mirror : J-6080-029-A
- Dualtrace oscilloscope

Adjustment flow chart

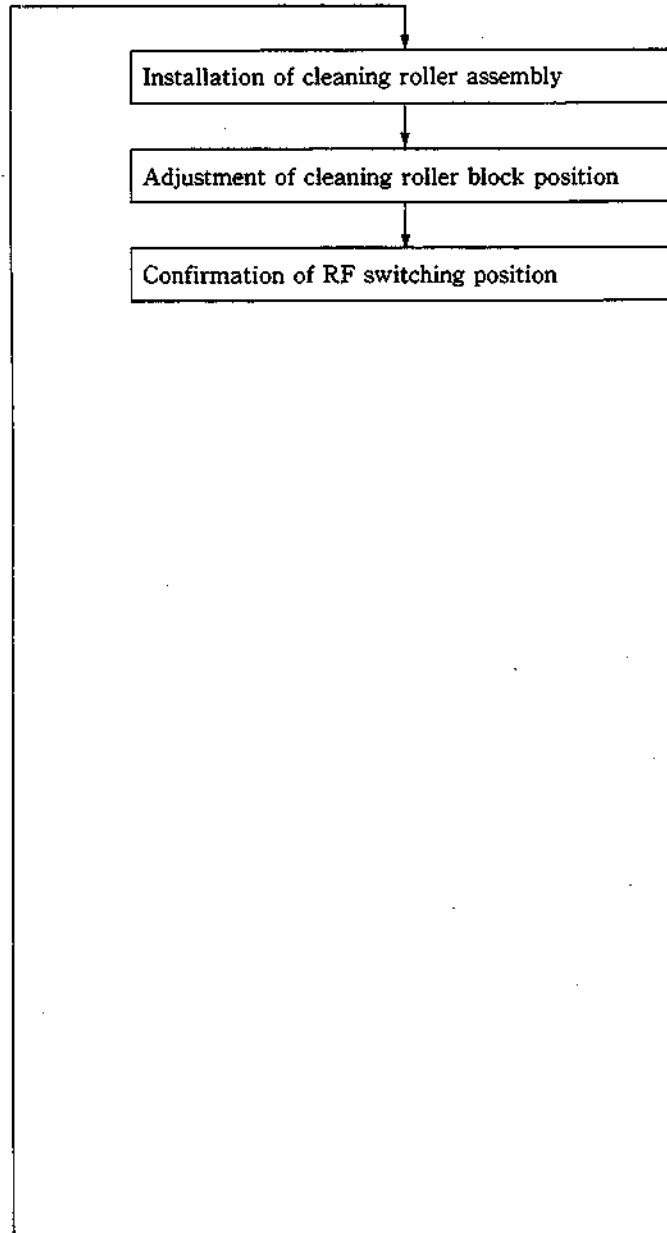
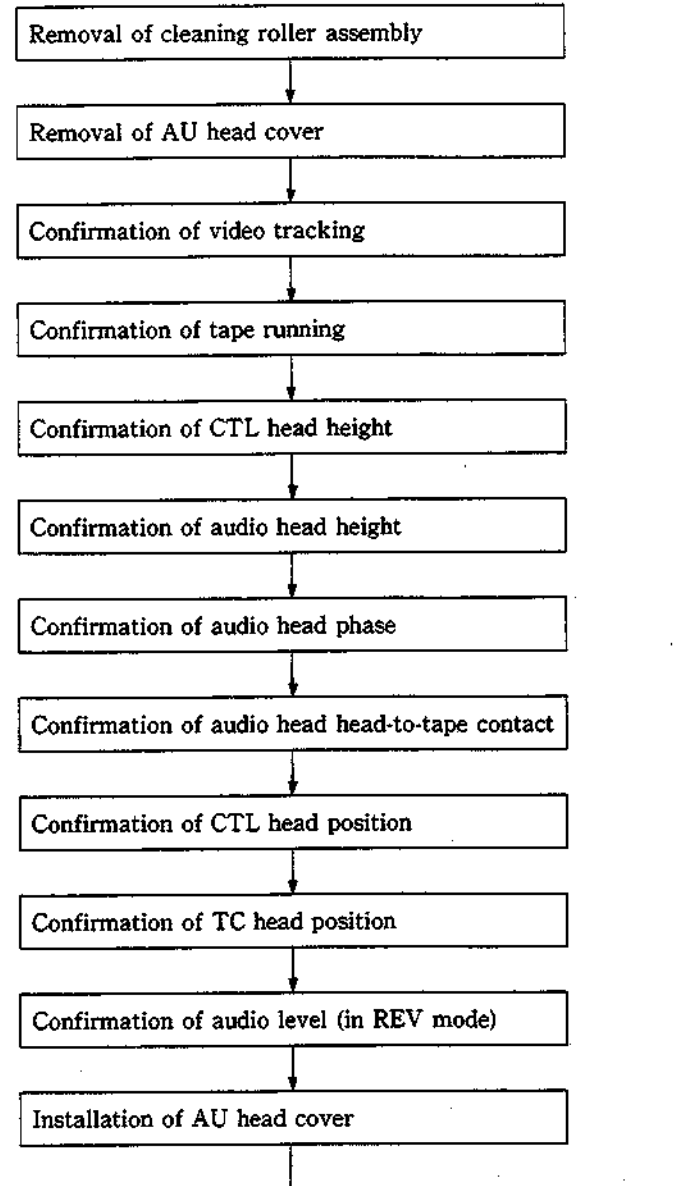

Preparation

1. Remove a cleaning roller assembly. (Refer to steps (1) and (2) in Section 5-6.)
2. Remove an AU head cover. (Refer to step (3) in Section 5-3.)

Check

1. Clean the tape running surface of the tape guides, drum, and video heads with a cleaning piece moistened with cleaning fluid.
2. Connect the oscilloscope as follows.
CH-1 : TP101/VP-33AP board
(Address : Side A, D-1) (Y-RF signal)
CH-2 : TP1/VP-33AP board
(Address : Side A, D-1) (Switching pulse)
TRIG : CH-2
3. Insert an alignment tape without lid (CR2-1B PS) into the unit and put the unit into PLAY mode.
4. Make sure that the RF envelope waveform increases/decreases keeping its flat shape when the tracking control is turned.
5. Make sure that the head-to-tape contact waveform and fluctuation satisfy the required specifications when the RF envelope waveform is maximized.

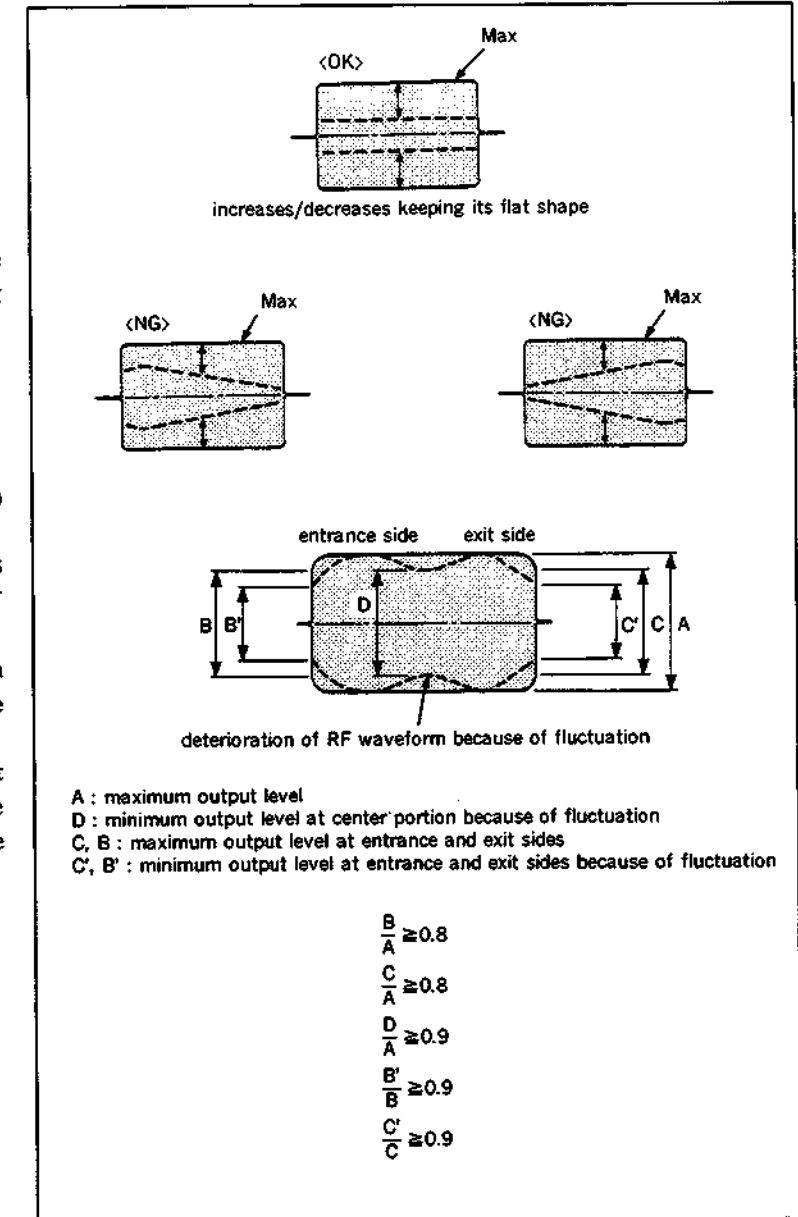

6. Put the unit into REV X1 mode.
7. Make sure that the head-to-tape contact waveform satisfies the specifications when the RF envelope waveform is maximized.
8. Put the unit into REW and F.FWD modes, and change the mode from STOP to F.FWD modes, and from STOP to REW modes. At that time, make sure that no head-to-tape contact waveform lacking exists in the RF envelope waveform.

If the specification is satisfied, perform steps (9) and later.

If the specification is not satisfied, perform the adjustment in accordance with Sections 6-4-1, 6-4-2, or 6-4-3.

9. Make sure that the tape running state in each tape guide satisfy the specification. (Refer to Section 6-3.)
10. Perform CTL head height adjustment. (Refer to Section 6-5.)
11. Perform audio head height adjustment. (Refer to Section 6-7.)
12. Perform audio head phase tentative adjustment. (Refer to Section 6-8.)
13. Perform audio head head-to-tape contact adjustment. (Refer to Section 6-9.)
14. Perform reconfirmation of audio head height. (Refer to steps (1) through (3) in Section 6-7.)
15. Perform audio head phase adjustment. (Refer to Section 6-8.)
16. Perform CTL head position adjustment. (Refer to Section 6-6.)
17. Perform TC head position adjustment. (Refer to Section 6-10.)
18. Perform reconfirmation of audio head height. (Refer to steps (1) through (3) in Section 6-7.)
19. Perform confirmation of audio level (in REV mode). (Refer to Section 6-11.)
20. Install the AU head cover. (Refer to step (2) in Section 5-3.)
21. Install the cleaning roller assembly. (Refer to steps (7) and (8) in Section 5-6.)
22. Perform cleaning roller block position adjustment. (Refer to Section 5-6-1.)
23. Perform RF switching position adjustment. (Refer to Section 6-12.)

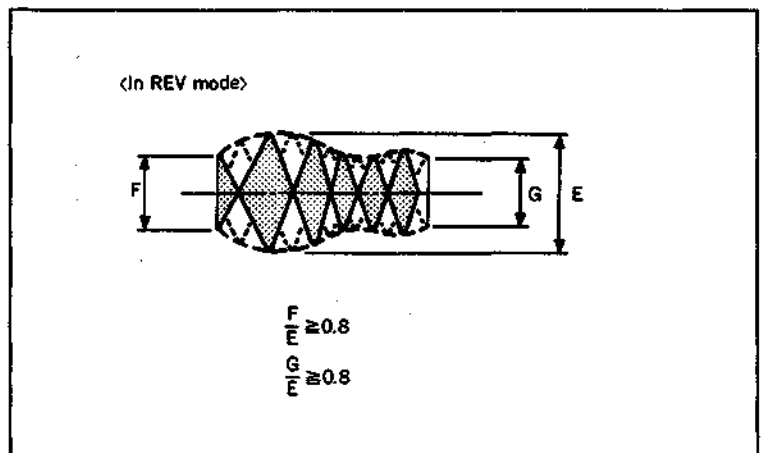

Preparation

1. Remove a cleaning roller assembly. (Refer to steps (1) and (2) in Section 5-6.)
2. Remove an AU head cover. (Refer to step (3) in Section 5-3.)

Adjustment

- Perform steps (1) through (6), and steps (31) and later when performing the tracking adjustment on the drum entrance side.
- Perform steps (1) and (2), and steps (17) and later when performing the tracking adjustment on the drum exit side.

1. Clean the tape running surface of the tape guides, drum, and video heads with a cleaning piece moistened with cleaning fluid.
2. Connect the oscilloscope as follows.
 CH-1 : TP101/VP-33AP board
 (Address : Side A, D-1) (Y-RF signal)
 CH-2 : TP1/VP-33AP board
 (Address : Side A, D-1) (Switching pulse)
 TRIG : CH-2

3. Hold claws of the upper part of a TG-4 tape guide roller using tweezers, and remove a fly wheel. (Refer to Section 5-2.)
4. Loosen the locking screws at the upper part of a TG-3 and TG-2 tape guide rollers one to two turns using a tape guide adjustment driver.
5. Insert an alignment tape CR2-1B PS and put the unit into PLAY mode.
6. Turn the tracking control so that the RF envelope waveform is 70 % to 80 % of the maximum output.
7. Turn the adjustment nut of the TG-2 tape guide so that the lower flange of the TG-2 tape guide does not come in contact with the lower edge of the tape.
8. Turn the upper flange of the TG-3 tape guide so that the RF envelope waveform on the entrance side is flat.
9. Turn the adjustment nut of the TG-2 tape guide so that the lower flange of the TG-2 tape guide comes in contact with the lower edge of the tape.

10. Turn the tracking control so that the RF envelope waveform is the maximum output. Make sure that the head-to-tape contact of the RF envelope waveform on the drum entrance side and the fluctuation satisfy the specification. Make sure that no tape curl to occur at the tape guide flanges of the TG-2 and TG-3 using an adjustment mirror. (If tape curl can not be removed, it is acceptable as far as the maximum limit shown in the figure.)

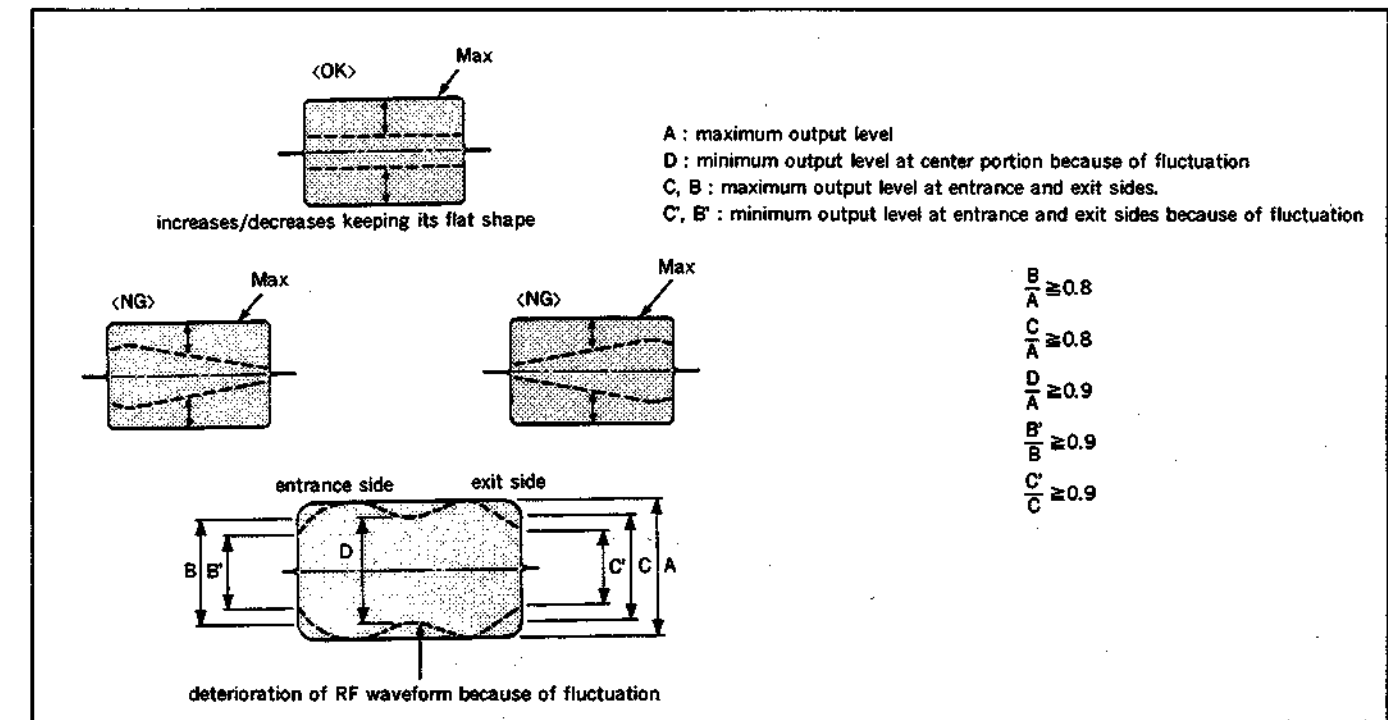
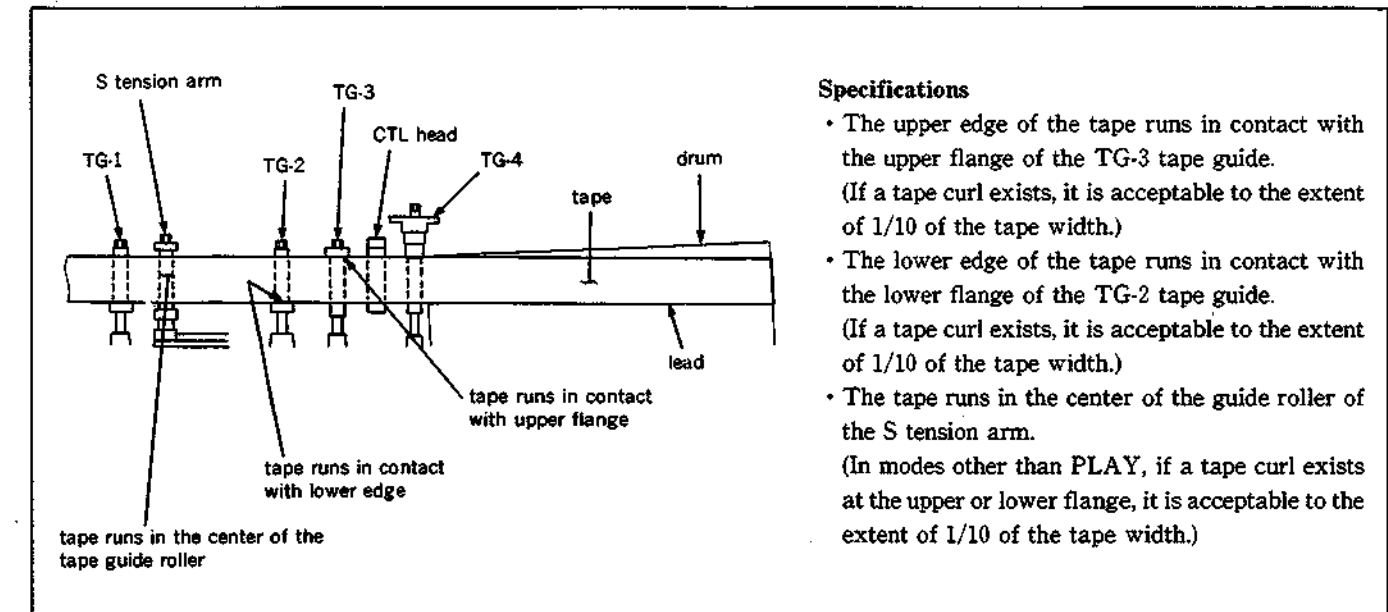
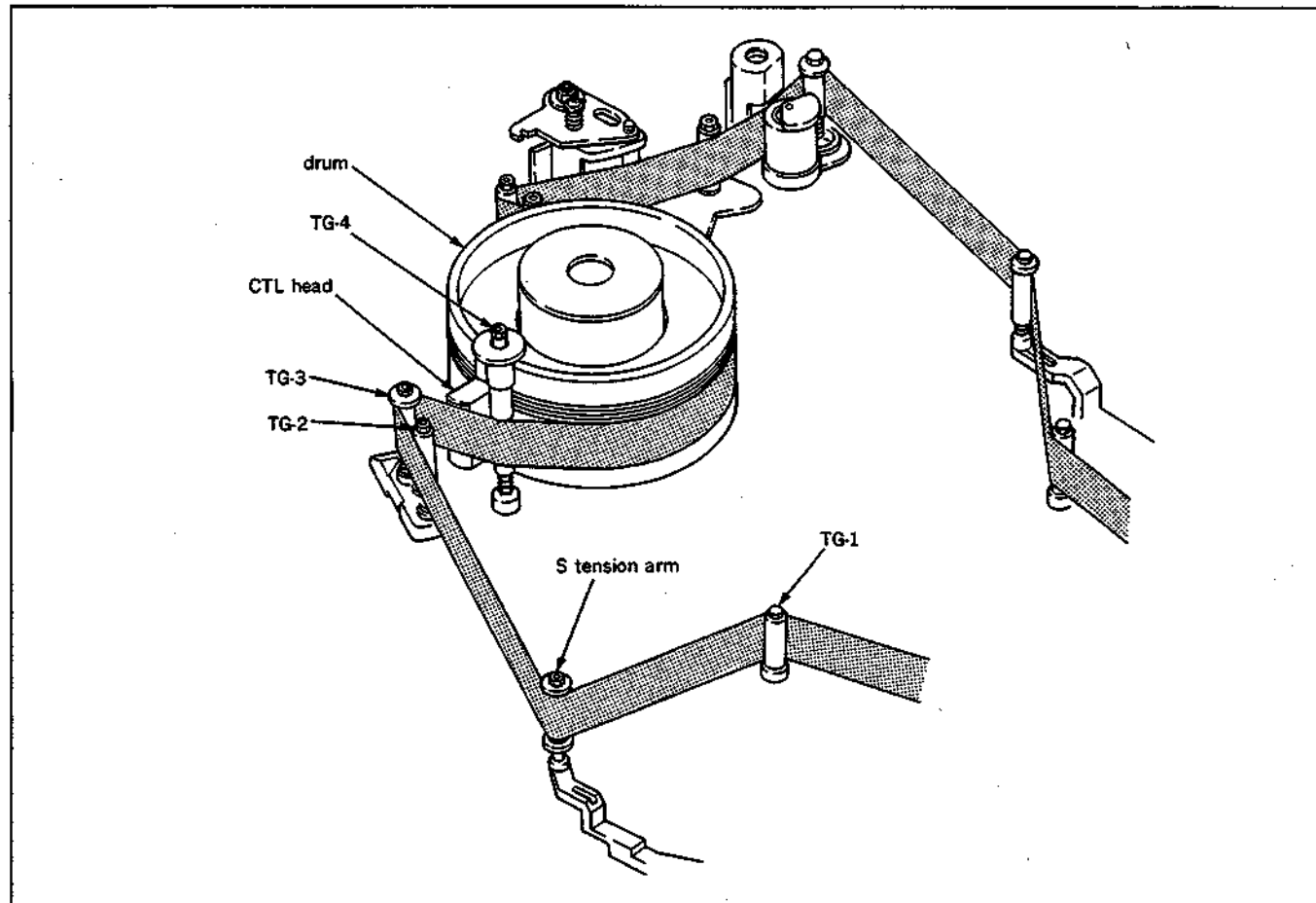

11. Put the unit into REV X1 mode.

At that time, make sure that the tape curl at the lower flange of the TG-2 tape guide satisfies the specification below.

Specification : No tape curl to occur at the lower flange.

(If tape curl can not be removed, it is acceptable to the extent of 1/10 of the tape width.)

If the specification is not satisfied, perform the adjustment in accordance with the following procedure.

- Loosen the locking screw of the guide roller of the S tension regulator one to two turns using a tape guide adjustment driver.
- Put the unit into PLAY mode.
- Rotate the upper flange so that the tape runs in the center of the guide roller of the S tension regulator.
- Put the unit into REV X1 mode.
- Turn the upper flange of the guide roller of the S tension regulator and adjustment nut of the TG-2 tape guide for fine adjustment so that the specification is satisfied.
- Put the unit into PLAY mode again. Make sure that the head-to-tape contact of the RF envelope waveform and fluctuation satisfy the specification, and that the tape running at the TG-2 tape guide and guide roller of the S tension regulator satisfy the specification described on the right column. If the specification is not satisfied, readjust repeatedly so that the specification is satisfied in both PLAY and REV modes.

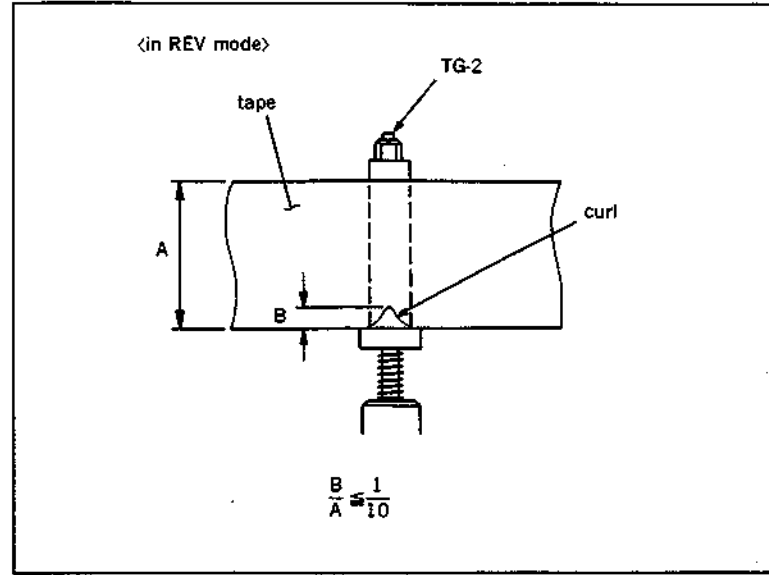

- Put the unit into REV X1 mode and turn the tracking control so that the RF envelope waveform is the maximum output.
- Make sure that the head-to-tape contact of the RF envelope waveform in REV X1 mode satisfies the specification.
- Tighten the locking screws of each tape guide using a tape guide adjustment driver.
- Perform steps (4) through (9) in Section 6-4, and make sure that the head-to-tape contact of the RF envelope waveform and fluctuation satisfy the specification.
- Install the fly wheel to the TG-4 tape guide roller. Make sure that the fly wheel is surely locked, after installation.

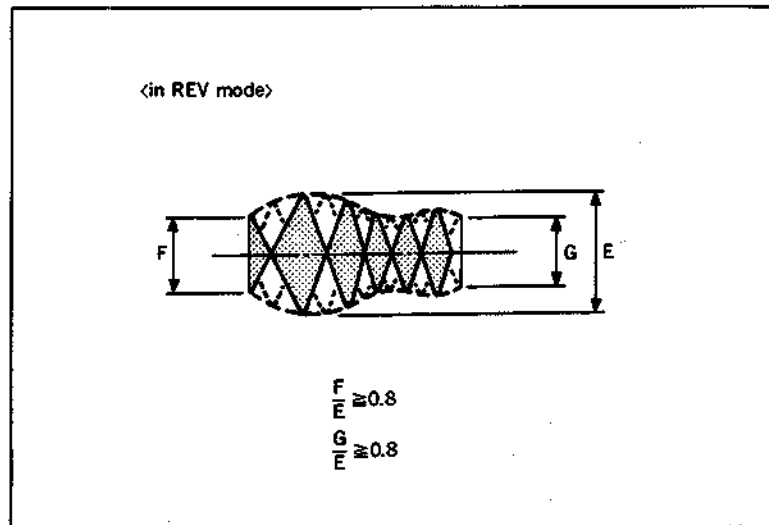

If the RF envelope waveform on the drum entrance side and tape running do not satisfy the specification even in the above procedure, replace the drum assembly.

Steps (17) and later describe the tracking adjustment on the drum exit side.

- Loosen the locking screws at the upper part of the TG-5, TG-6, and TG-7 tape guide rollers one to two turns using a tape guide adjustment driver.
 - Insert the alignment tape CR2-1B PS and put the unit into PLAY mode.
 - Turn the tracking control so that the RF envelope waveform is 70% to 80% of the maximum output.
 - Turn the adjustment nut of the TG-6 tape guide so that the lower flange of the TG-6 tape guide does not come in contact with the lower edge of the tape.
 - Turn the upper flange of the TG-7 tape guide so that the upper flange of the tape guide does not come in contact with the upper edge of the tape.
 - Turn the upper flange of the TG-5 tape guide so that the RF envelope waveform on the exit side is flat. If tape curl can not be removed in the upper flange of the TG-5 tape guide when the RF envelope waveform is flat, make sure that the zenith of an audio/TC head. (Refer to Section 6-2.)
 - Turn the adjustment nut of the TG-6 tape guide so that the lower flange of the TG-6 tape guide does not come in contact with the lower edge of the tape.
 - Put the unit into REV X1 mode. At that time, make sure that the clearance between the lower flange of the TG-6 tape guide and tape satisfies the specification.
- Specification :** The clearance between the lower flange and lower edge of the tape should be more than 0.2 mm.
- Turn the upper flange of the TG-7 tape guide so that the upper flange of the TG-7 tape guide slightly comes in contact with the upper edge of the tape.

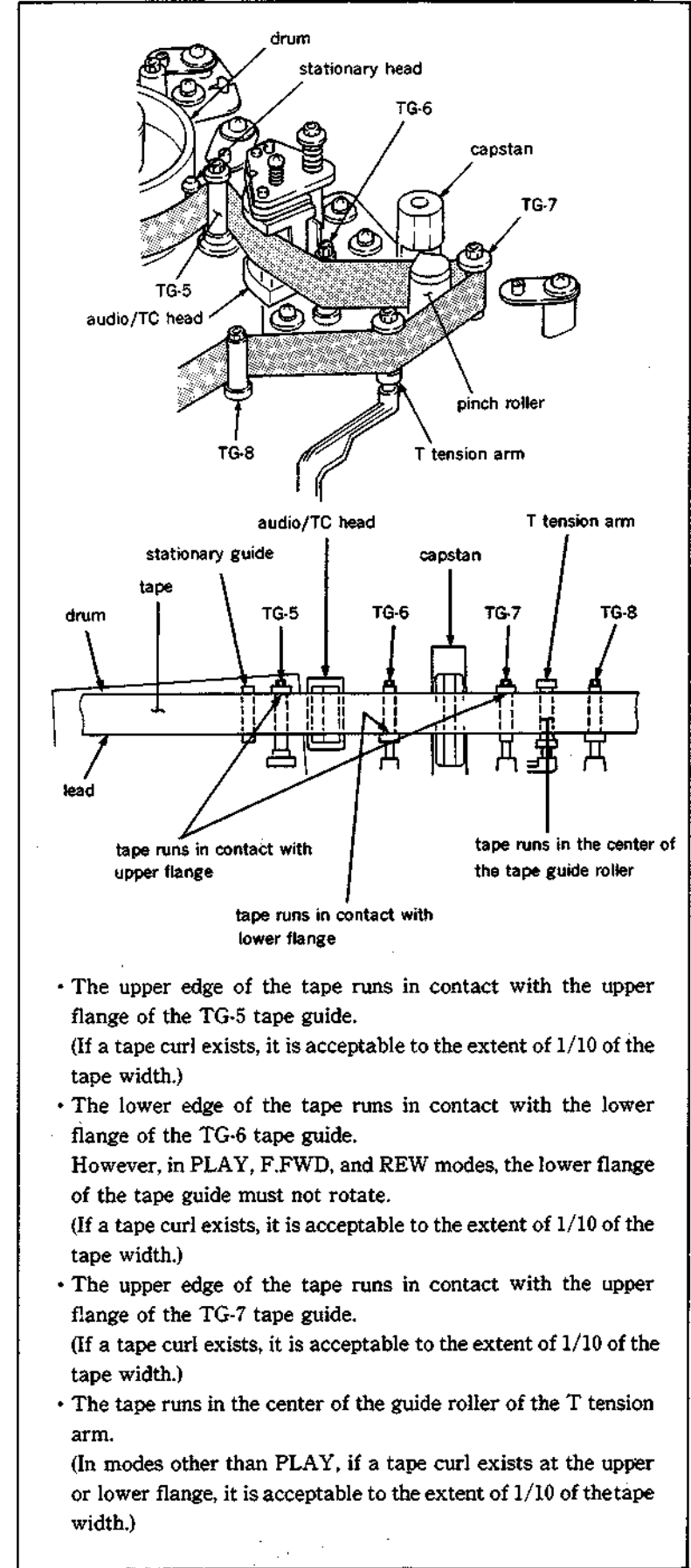

26. Turn the tracking control so that the RF envelope waveform is the maximum output. Make sure that the head-to-tape contact of the RF envelope waveform on the drum exit side and the fluctuation satisfy the specification.

Make sure that no tape curl to occur at the tape guide flanges of the TG-5, TG-6 and TG-7 using the adjustment mirror.

(If tape curl can not be removed, it is acceptable as far as the maximum limit shown in the figure.)

27. Make sure that the head-to-tape contact of the RF envelope waveform in REV X1 mode satisfies the specification.

28. Tighten the locking screws of each tape guide using a tape guide adjustment driver.

29. Perform steps (4) through (9) in Section 6-4, and make sure that the head-to-tape contact of the RF envelope waveform and fluctuation satisfy the specification.

If the RF envelope waveform on the drum exit side and the tape running do not satisfy the specification even in the above procedure, replace the drum assembly.

30. Make sure that the tape running at each tape guide satisfy the specification.

(Refer to Section 6-3.)

31. Perform CTL head height adjustment.

(Refer to Section 6-5.)

32. Perform audio head height adjustment.

(Refer to Section 6-7.)

33. Perform audio head phase adjustment.

(Refer to Section 6-8.)

34. Perform CTL head position adjustment.

(Refer to Section 6-6.)

35. Perform TC head position adjustment.

(Refer to Section 6-10.)

36. Perform reconfirmation of audio head height.

(Refer to steps (1) through (3) in Section 6-7.)

37. Perform confirmation of audio level (in REV mode). (Refer to Section 6-11.)

38. Install the AU head cover.

(Refer to step (23) in Section 5-3.)

39. Install the cleaning roller assembly.

(Refer to steps (7) and (8) in Section 5-6.)

40. Perform cleaning roller block position adjustment. (Refer to Section 5-6-1.)

41. Perform RF switching position adjustment. (Refer to Section 6-12.)

<in REV mode>

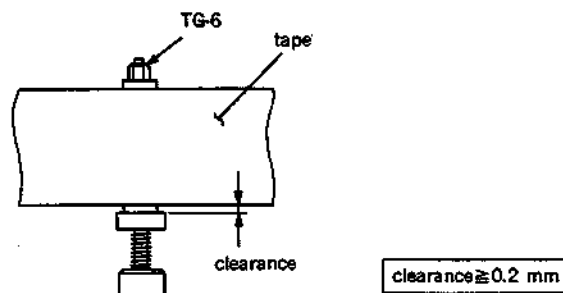

<in REV mode>

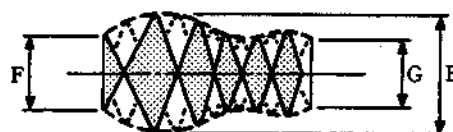

$$\frac{F}{E} \approx 0.8$$

$$\frac{G}{E} \approx 0.8$$

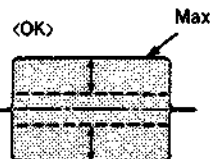

increases/decreases keeping its flat shape

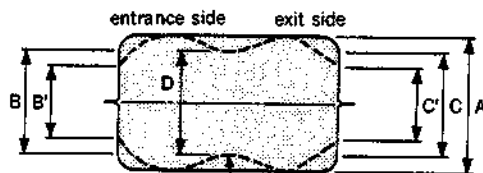

deterioration of RF waveform because of fluctuation

A : maximum output level
 D : minimum output level at center portion because of fluctuation
 C, B : maximum output level at entrance and exit sides
 C', B' : minimum output level at entrance and exit sides because of fluctuation

$$\frac{B}{A} \approx 0.8$$

$$\frac{C}{A} \approx 0.8$$

$$\frac{D}{A} \approx 0.9$$

$$\frac{B'}{B} \approx 0.9$$

$$\frac{C'}{C} \approx 0.9$$

6-4-2. Video Tracking Adjustment (2)

- This section describes how to adjust the video tracking when an S slider assembly is replaced.
- Adjustment of video tracking is extremely important. If this adjustment is not adequate, the tape interchangeability is influenced significantly.
Take utmost care in performing adjustment.
- Perform this adjustment with the cassette compartment installed in the unit. By this way, accurate adjustment will be possible without difficulty as a service operation.

Tools

Cleaning piece	: 2-034-697-00
Cleaning fluid	: 9-919-573-01
Alignment tape without lid (CR2-1B PS)	: 8-960-096-51
Tape guide adjustment driver	: J-6321-500-A
Adjustment mirror	: J-6080-029-A
Dualtrace oscilloscope	

Adjustment flow chart

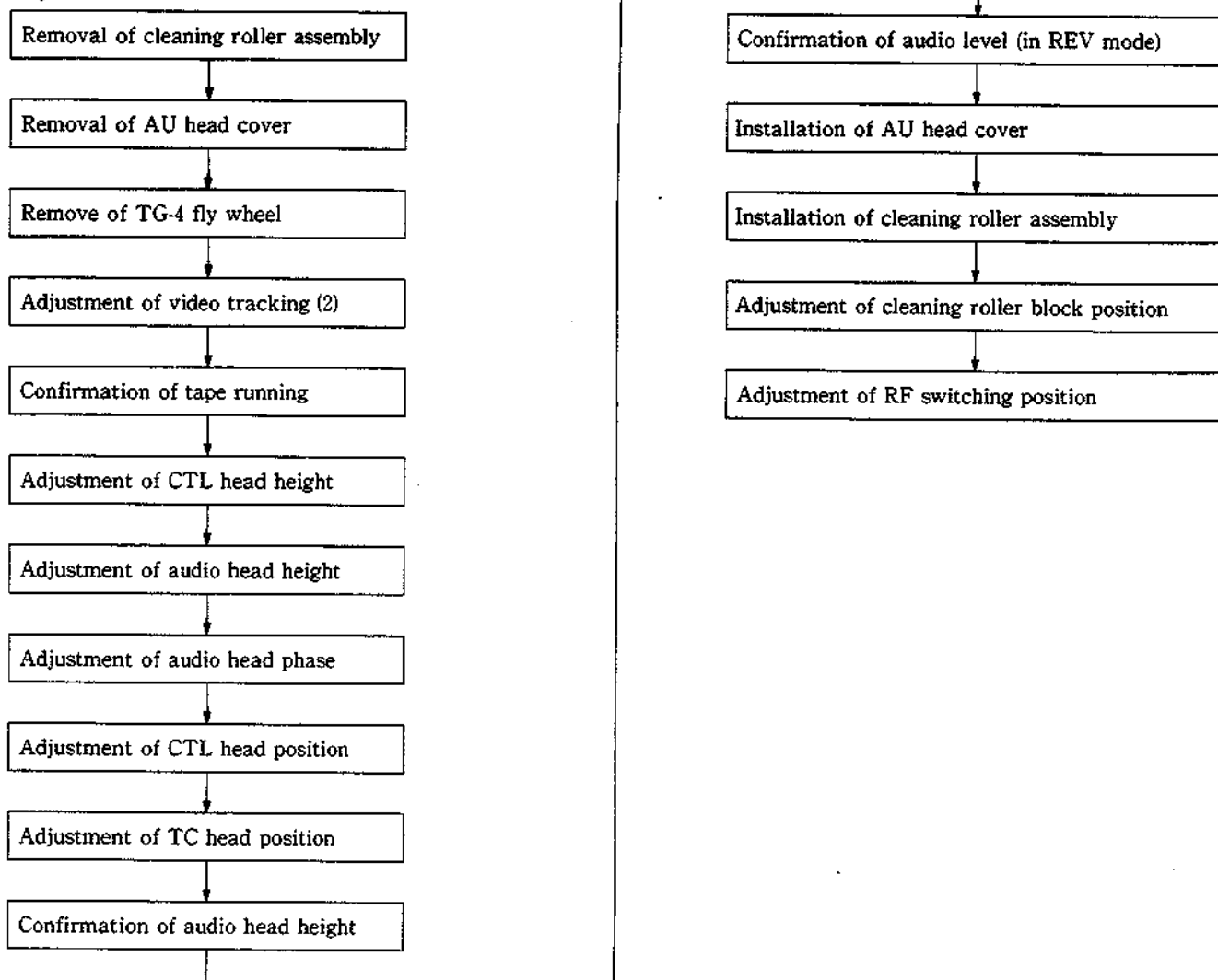

Preparation

1. Remove a cleaning roller assembly.
(Refer to steps (1) and (2) in Section 5-6.)
2. Remove an AU head cover.
(Refer to step (3) in Section 5-3.)

Adjustment

1. Hold claws of the upper part of a TG-4 tape guide roller using tweezers, and remove a fly wheel. (Refer to Section 5-2.)
2. Clean the tape running surface of the tape guides, drum, and video heads with a cleaning piece moistened with cleaning fluid.
3. Connect the oscilloscope as follows.
CH-1 : TP101/VP-33AP board
(Address : Side A, D-1) (Y-RF signal)
CH-2 : TP1/VP-33AP board
(Address : Side A, D-1) (Switching pulse)
TRIG : CH-2

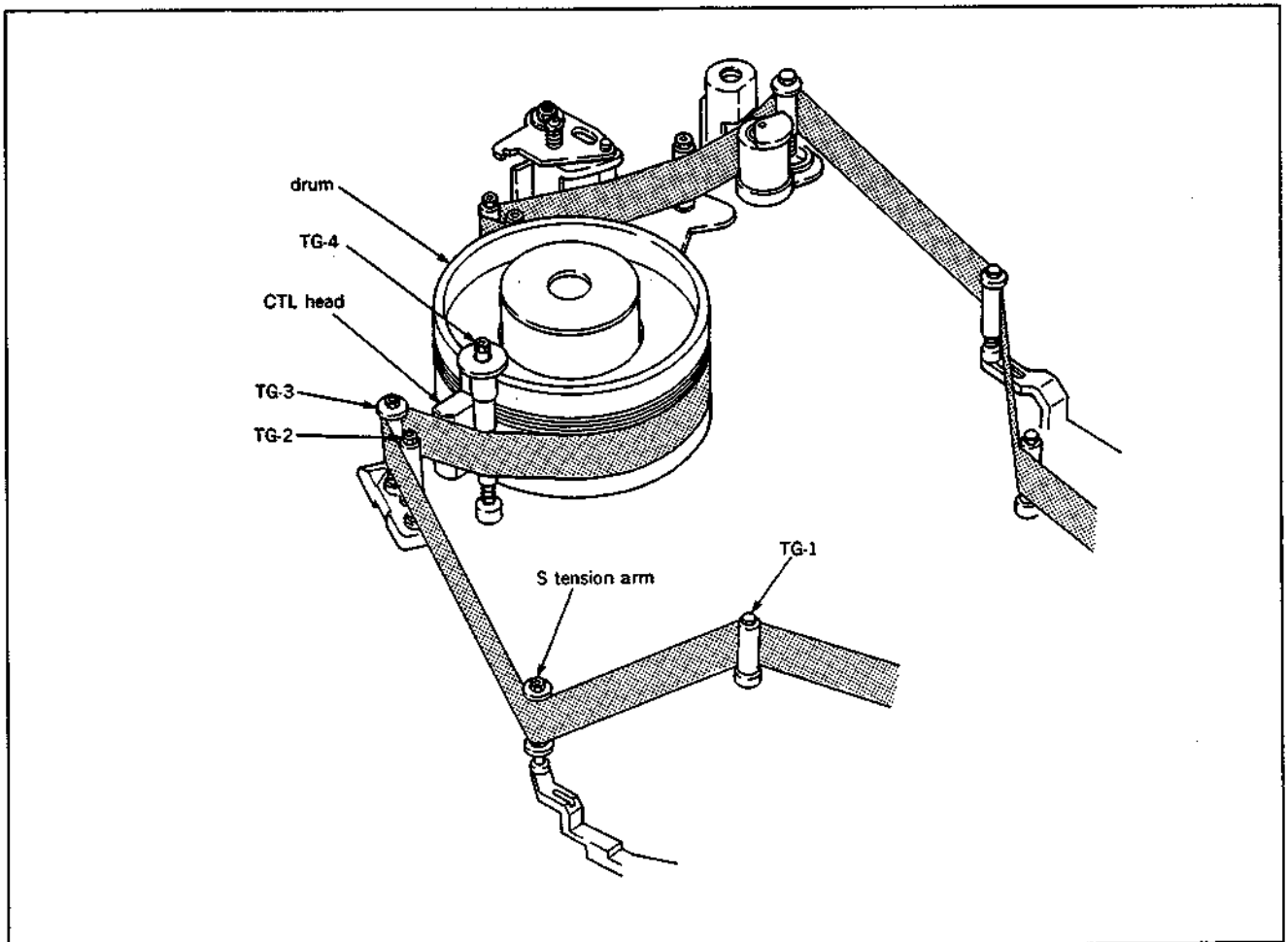

4. Loosen the locking screws at the upper part of a TG-3 tape guide roller, TG-2 tape guide roller and S tension arm one to two turns using a tape guide adjustment driver.
5. Insert an alignment tape CR2-1B PS and put the unit into PLAY mode.
6. Turn the adjustment nut of the TG-2 tape guide so that a clearance occurs between the lower flange of the TG-2 tape guide and the lower edge of the tape.
7. Turn the upper flange of the TG-3 tape guide so that a clearance occurs between the upper flange of the TG-3 tape guide and the upper edge of the tape.
8. Fine adjust the height of the tape guide of the S tension arm so that the tape runs in the center of the tape guide of the S tension arm.
9. Make sure that the tape runs in contact with the tape guide flanges of the TG-2, TG-3, TG-4, and S tension arm.
10. Turn the tracking control so that the RF envelope waveform on the drum exit side is maximum.
11. Make sure that the RF waveform satisfies the specification as shown in the figure.
If the specification is not satisfied, perform the adjustment as follows :
 - 1) Turn the slantness adjustment screw for an S slider assembly in counterclockwise in the range not exceeding 90 degrees to satisfy the specification.
12. Turn the upper flange of the TG-3 tape guide so that it comes in contact with the upper edge of the tape and so that the RF envelope waveform is flat.
13. Turn the tracking control so that the RF envelope waveform is 70% to 80% of the maximum output.
14. Turn the adjustment nut of the TG-2 tape guide so that the lower flange of the TG-2 tape guide comes in contact with the lower edge of the tape.

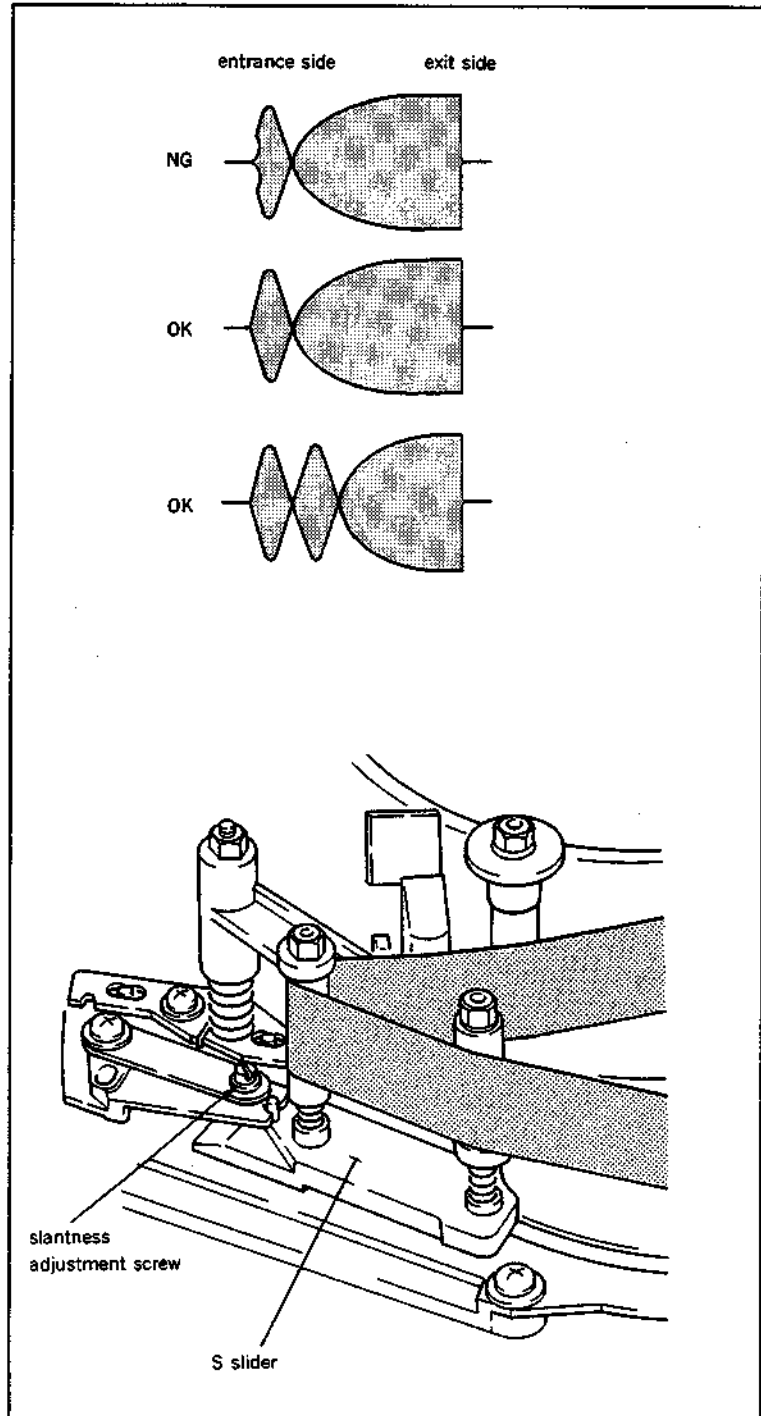

15. Fine adjust the height of the tape guide of the S tension arm so that the tape runs in the center of the tape guide of the S tension arm.
16. Turn the tracking control so that the RF envelope waveform is the maximum output. Make sure that the head-to-tape contact of the RF envelope waveform on the drum entrance side and fluctuation satisfy the specification.

Make sure that no tape curl to occur at the tape guide flanges of the TG-2 and TG-3 using an adjustment mirror.

(If tape curl can not be removed, it is acceptable as far as the maximum limit shown in the figure.)

17. Put the unit into REV X1 mode.

At that time, make sure that the tape curl at the lower flange of the TG-2 tape guide satisfies the specification below.

Specification : No tape curl to occur at the lower flange.
(If tape curl can not be removed, it is acceptable to the extent of 1/10 of the tape width.)

If the specification is not satisfied, perform the adjustment in accordance with the following procedure.

- 1) Put the unit into REV X1 mode.
- 2) Turn the upper flange of the guide roller of the S tension arm and adjustment nut of the TG-2 tape guide for fine adjustment so that the specification is satisfied.
- 3) Put the unit into PLAY mode again. Make sure that the head-to-tape contact of the RF envelope waveform and fluctuation satisfy the specification, and that the tape running at the TG-2 tape guide and guide roller of the S tension arm satisfy the specification described on the right column.

If the specification is not satisfied, readjust repeatedly so that the specification is satisfied in both PLAY and REV modes.

18. Put the unit into REV X1 mode and make sure that the head-to-tape contact of the RF envelope waveform in REV X1 mode satisfies the specification.

- The upper edge of the tape runs in contact with the upper flange of the TG-3 tape guide.
(If a tape curl exists, it is acceptable to the extent of 1/10 of the tape width.)
- The lower edge of the tape runs in contact with the lower flange of the TG-2 tape guide.
(If a tape curl exists, it is acceptable to the extent of 1/10 of the tape width.)
- The tape runs in the center of the guide roller of the S tension arm.
(In modes other than PLAY, if a tape curl exists at the upper or lower flange, it is acceptable to the extent of 1/10 of the tape width.)

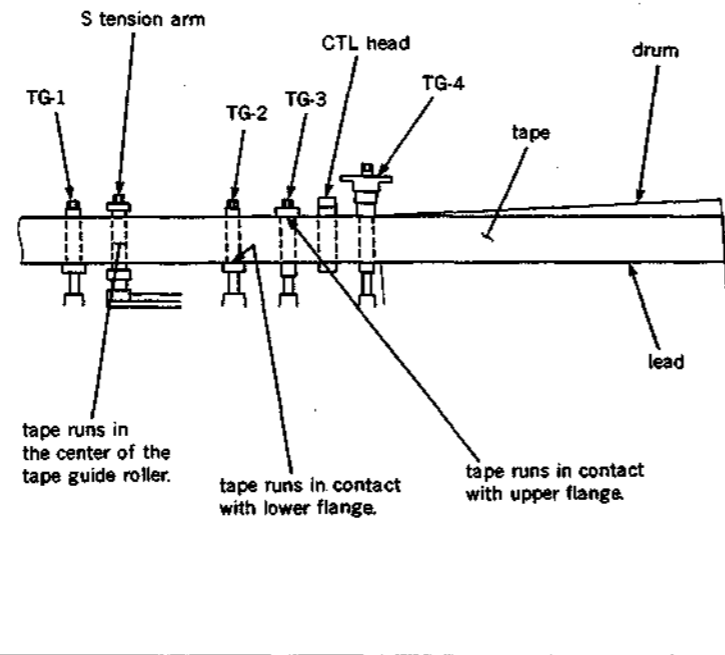

19. Tighten the locking screws of each tape guide using a tape guide adjustment driver.
20. Perform steps (4) through (9) in Section 6-4, and make sure that the head-to-tape contact of the RF envelope waveform and fluctuation satisfy the specification.
21. Install the fly wheel to the TG-4 tape guide roller. Make sure that the fly wheel is surely locked, after installation.
22. Make sure that the tape running at each tape guide satisfy the specification.
(Refer to Section 6-3.)
23. Perform CTL head height adjustment.
(Refer to Section 6-5.)
24. Perform audio head height adjustment.
(Refer to Section 6-7.)
25. Perform audio head phase adjustment.
(Refer to Section 6-8.)
26. Perform CTL head position adjustment.
(Refer to Section 6-6.)
27. Perform TC head position adjustment.
(Refer to Section 6-10.)
28. Perform reconfirmation of audio head height.
(Refer to steps (1) through (3) in Section 6-7.)
29. Perform confirmation of audio level (in REV mode).
(Refer to Section 6-11.)
30. Install the AU head cover.
(Refer to step (2) in Section 5-3.)
31. Install the cleaning roller assembly.
(Refer to steps (7) and (8) in Section 5-6.)
32. Perform cleaning roller block position adjustment.
(Refer to Section 5-6-1.)
33. Perform RF switching position adjustment.
(Refer to Section 6-12.)

(in REV mode)

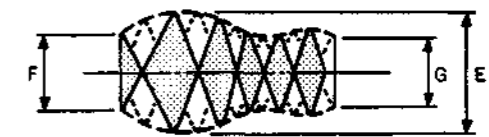

$$\frac{F}{E} \approx 0.8$$

$$\frac{G}{E} \approx 0.8$$

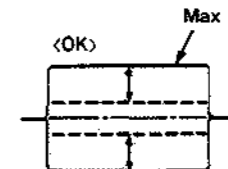

increases/decreases keeping its flat shape

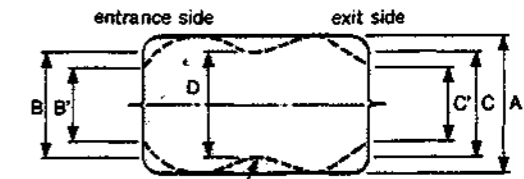
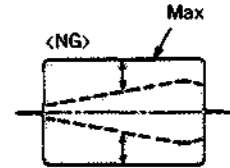
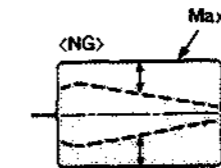

deterioration of RF waveform because of fluctuation

A : maximum output level
D : minimum output level at center portion because of fluctuation
C, B : maximum output level at entrance and exit sides
C', B' : minimum output level at entrance and exit sides because of fluctuation

$$\frac{B}{A} \approx 0.8$$

$$\frac{C}{A} \approx 0.8$$

$$\frac{D}{A} \approx 0.9$$

$$\frac{B'}{B} \approx 0.9$$

$$\frac{C'}{C} \approx 0.9$$

6-4-3. Video Tracking Adjustment (3)

- This section describes how to adjust the video tracking when an T slider assembly is replaced.
- Adjustment of video tracking is extremely important. If this adjustment is not adequate, the tape interchangeability is influenced significantly.
Take utmost care in performing adjustment.
- Perform this adjustment with the cassette compartment installed in the unit. By this way, accurate adjustment will be possible without difficulty as a service operation.

Tools

Cleaning piece	: 2-034-697-00
Cleaning fluid	: 9-919-573-01
Alignment tape without lid (CR2-1B PS)	
	: 8-960-096-51
Tape guide adjustment driver	: J-6321-500-A
Adjustment mirror	: J-6080-029-A
Dualtrace oscilloscope	

Adjustment flow chart

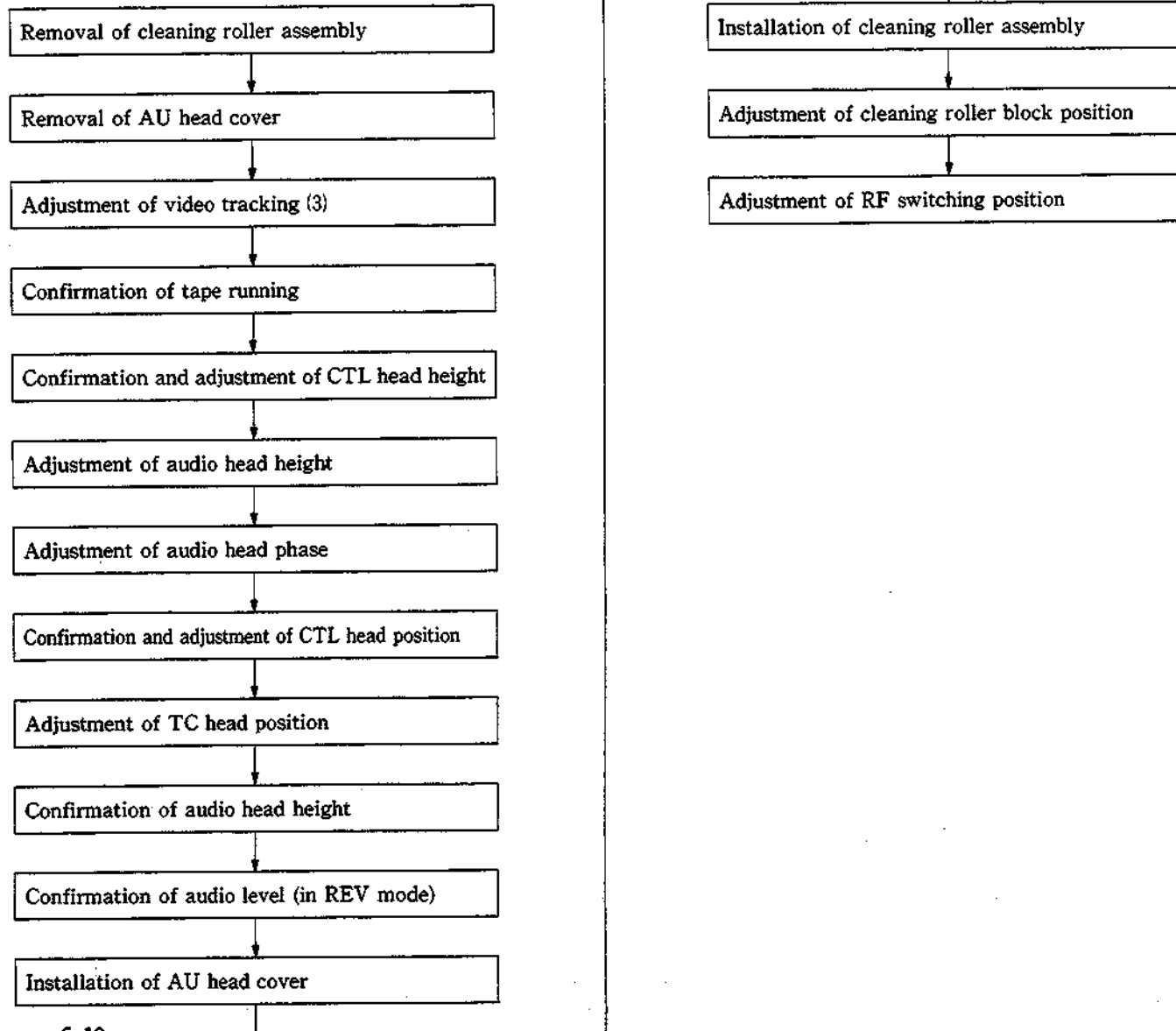

Preparation

1. Remove a cleaning roller assembly.
(Refer to steps (1) and (2) in Section 5-6.)
2. Remove an AU head cover.
(Refer to step (3) in Section 5-3.)

Adjustment

1. Clean the tape running surface of the tape guides, drum, and video heads with a cleaning piece moistened with cleaning fluid.
2. Connect the oscilloscope as follows.
CH-1 : TP101/VP-33AP board
(Address : Side A, D-1) (Y-RF signal)
CH-2 : TP1/VP-33AP board
(Address : Side A, D-1) (Switching pulse)
TRIG : CH-2
3. Loosen the locking screws at the upper part of a TG-5 tape guide roller, TG-6 tape guide roller, TG-7 tape guide roller and T tension arm one to two turns using a tape guide adjustment driver.
4. Insert an alignment tape CR2-1B PS and put the unit into PLAY mode.
5. Turn the upper flange of the TG-5 tape guide so that a clearance occurs between the upper flange of the TG-5 tape guide and the upper edge of the tape.
6. Turn the adjustment nut of the TG-6 tape guide so that a clearance occurs between the lower flange of the TG-6 tape guide and the lower edge of the tape.
7. Turn the upper flange of the TG-7 tape guide so that a clearance occurs between the upper flange of the TG-7 tape guide and the upper edge of the tape.
8. Fine adjust the height of the tape guide of the T tension arm so that the tape runs in the center of the tape guide of the T tension arm.
9. Make sure that the tape runs in contact with the tape guide flanges of the TG-5, TG-6, TG-7, and T tension arm.
10. Turn the tracking control so that the RF envelope waveform on the drum entrance side is maximum.
11. Make sure that the RF envelope waveform satisfies the specification as shown in the figure.

- If the specification is not satisfied, perform the adjustment as follows :
- 1) Turn the slantness adjustment screw for a T slider assembly in counterclockwise in the range not exceeding 30 degrees to satisfy the specification.

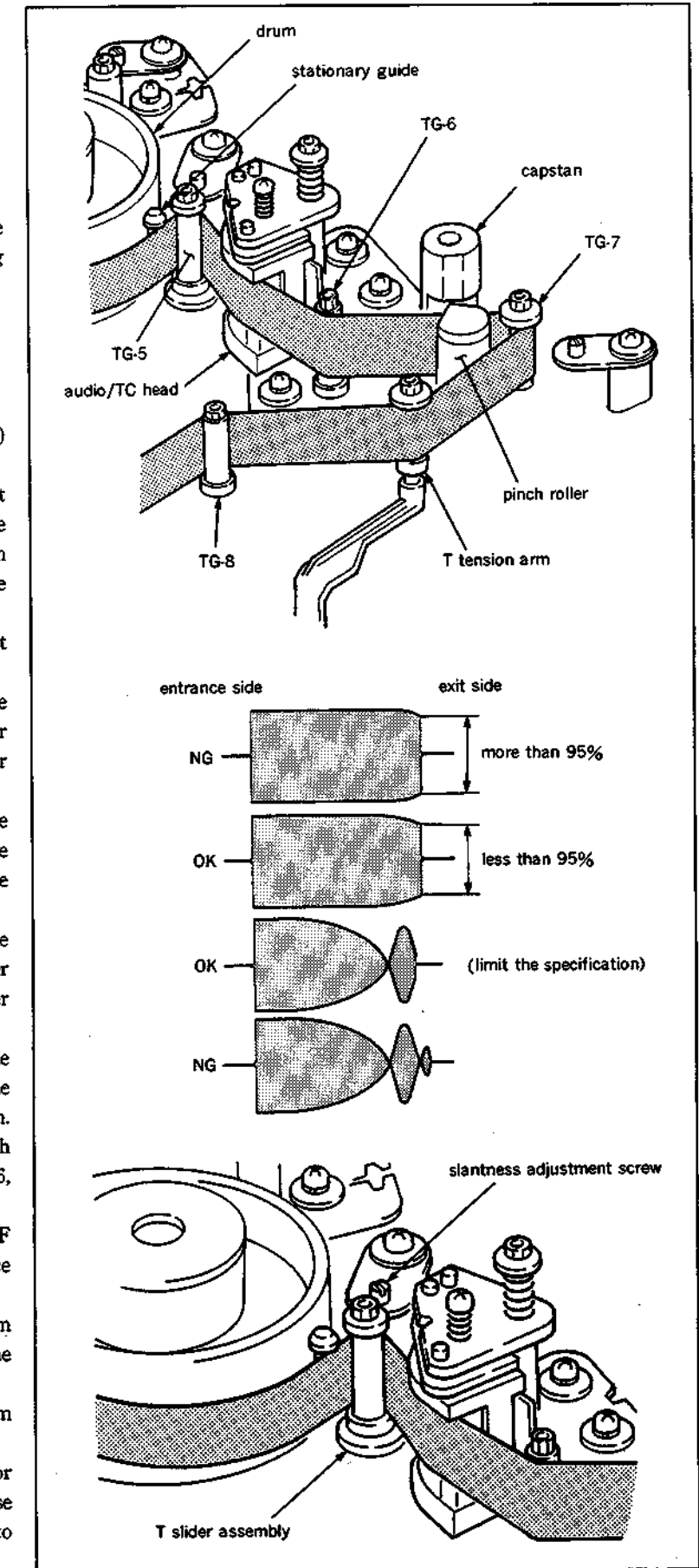

12. Turn the upper flange of the TG-5 tape guide so that it comes in contact with the upper edge of the tape and so that the RF envelope waveform is flat.
13. Turn the tracking control so that the RF envelope waveform is 70% to 80% of the maximum output.
14. Turn the adjustment nut of the TG-6 tape guide so that the lower flange of the TG-6 tape guide comes in contact with the lower edge of the tape.
15. Put the unit into REV X1 mode.
At that time, make sure that the clearance between the lower flange of the TG-6 tape guide and tape satisfies the specification.

Specification : The clearance between the lower flange and lower edge of the tape should be more than 0.2 mm.

16. Turn the upper flange of the TG-7 tape guide so that the upper flange of the TG-7 tape guide slightly comes in contact with the upper edge of the tape.
17. Fine adjust the height of the tape guide of the T tension arm so that the tape runs in the center of the tape guide of the T tension arm.
18. Turn the tracking control so that the RF envelope waveform is the maximum output. Make sure that the head-to-tape contact of the RF envelope waveform on the drum exit side and fluctuation satisfy the specification. Make sure that no tape curl to occur at the tape guide flanges of the TG-5, TG-6 and TG-7 using an adjustment mirror.
(If tape curl can not be removed, it is acceptable as far as the maximum limit shown in the figure.)

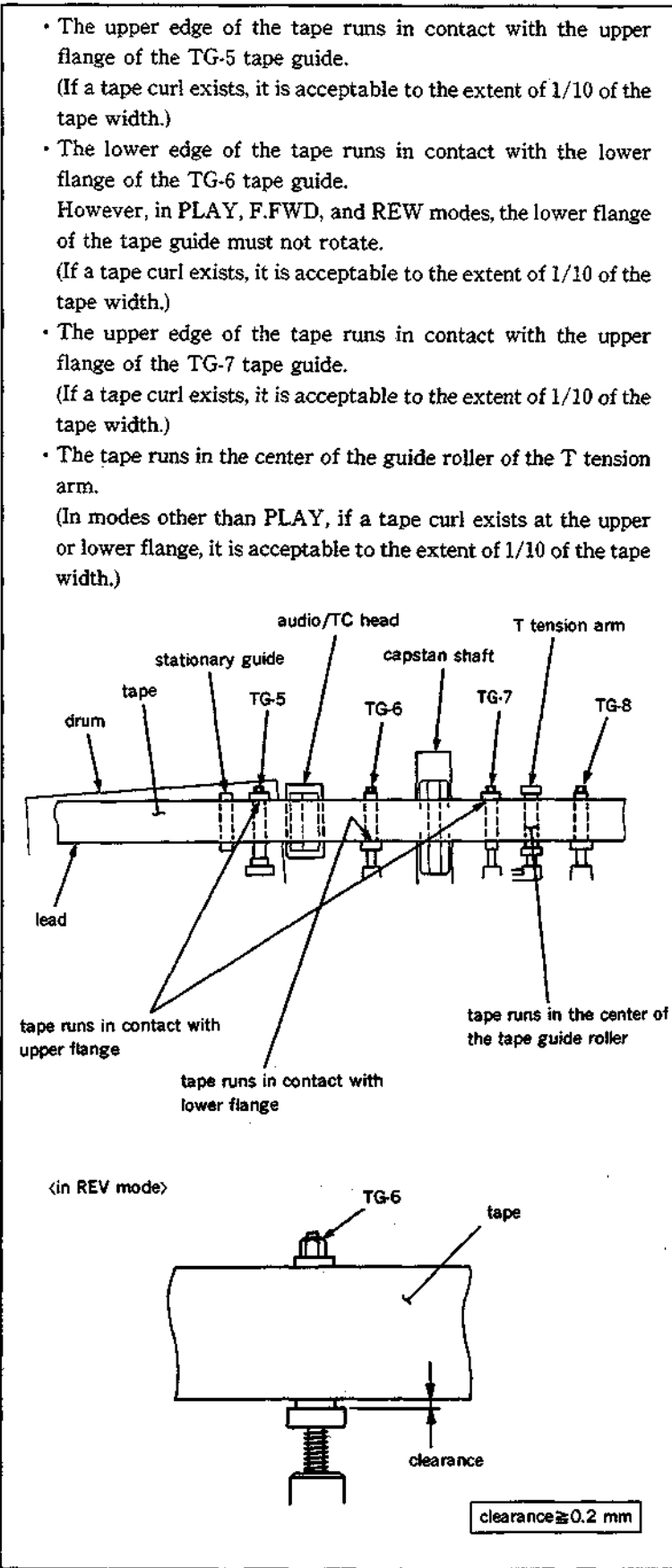

19. Make sure that the head-to-tape contact of the RF envelope waveform in REV X1 mode satisfies the specification.
20. Tighten the locking screws of each tape guide using a tape guide adjustment driver.
21. Perform steps (4) through (9) in Section 6-4, and make sure that the head-to-tape contact of the RF envelope waveform and fluctuation satisfy the specification.
22. Make sure that the tape running at each tape guide satisfy the specification.
(Refer to Section 6-3.)
23. Perform CTL head height adjustment.
(Refer to Section 6-5.)
24. Perform audio head height adjustment.
(Refer to Section 6-7.)
25. Perform audio head phase adjustment.
(Refer to Section 6-8.)
26. Perform CTL head position adjustment.
(Refer to Section 6-6.)
27. Perform TC head position adjustment.
(Refer to Section 6-10.)
28. Perform reconfirmation of audio head height.
(Refer to steps (1) through (3) in Section 6-7.)
29. Perform confirmation of audio level (in REV mode).
(Refer to Section 6-11.)
30. Install the AU head cover. (Refer to step (2) in Section 5-3.)
31. Install the cleaning roller assembly.
(Refer to steps (7) and (8) in Section 5-6.)
32. Perform cleaning roller block position adjustment. (Refer to Section 5-6-1.)
33. Perform RF switching position adjustment.
(Refer to Section 6-12.)

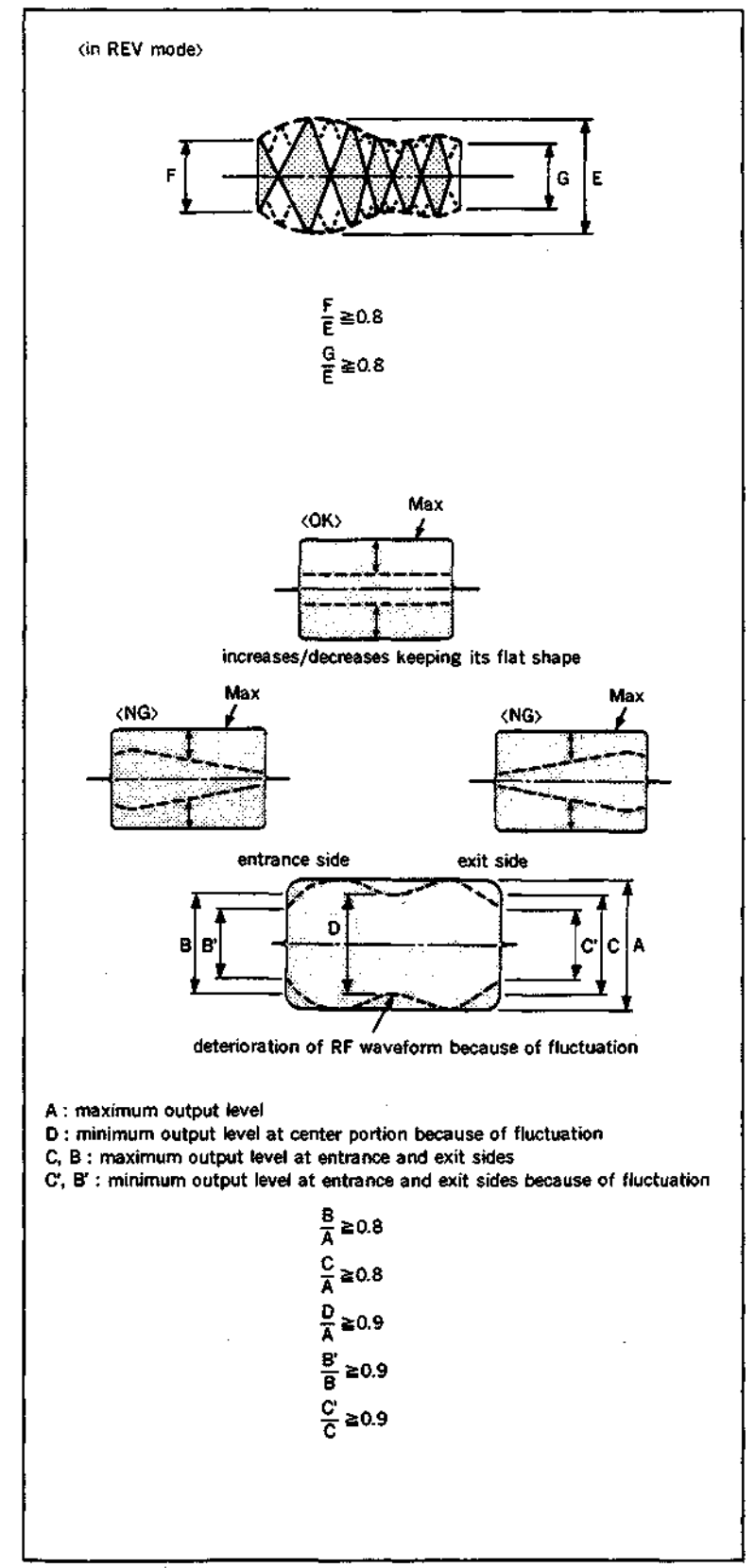

6-5. CTL HEAD HEIGHT ADJUSTMENT

Tools

Alignment tape CR8-1A PS : 8-960-098-45

Dualtrace oscilloscope

Box screwdriver (Across flat has 5.5 mm)

Adjustment flow chart

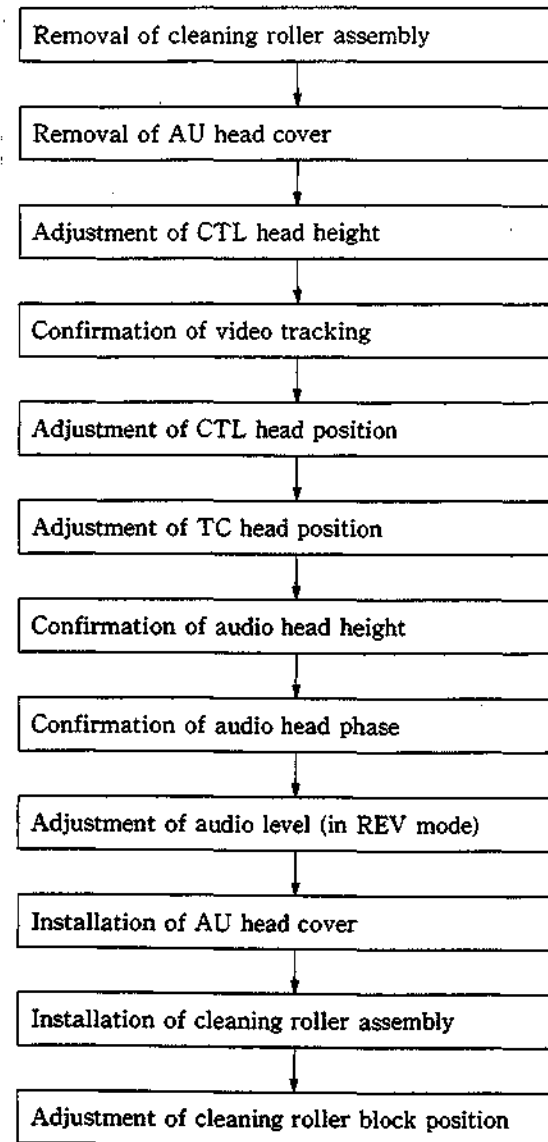

Preparation

1. Remove a cleaning roller assembly.
(Refer to steps (1) and (2) in Section 5-6.)
2. Remove an AU head cover.
(Refer to step (3) in Section 5-3.)

Check

1. Connect the oscilloscope as follows.
CH-1 : TP606/SS-48P board
(Address : Side A, A-1) (CTL signal)
2. Insert an alignment tape CR8-1A PS into the unit and play back the portion where 1 kHz signal has been recorded on a CTL track.
3. Make sure that the level goes down when the portion (between a CTL head and TG-4 tape guide) of the tape shown in the figure is pressed down or pushed up slightly.
If the level goes up, perform steps (4) and later.
If the level goes down, perform steps (5) and later.

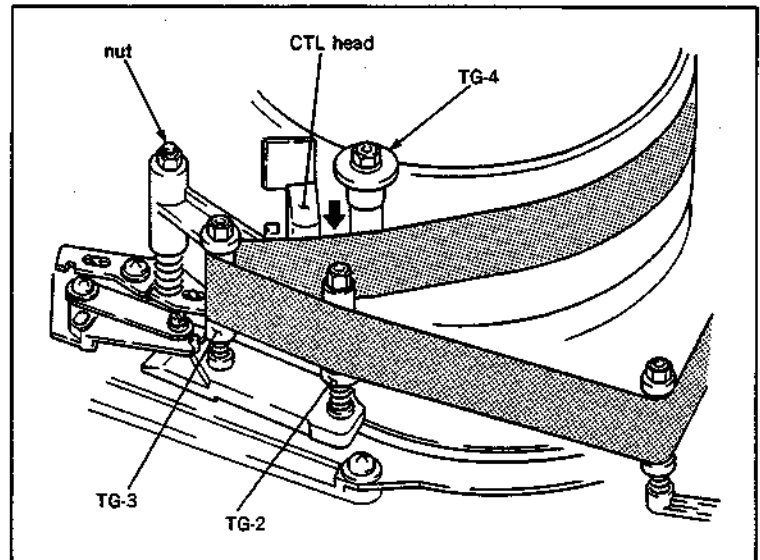

Adjustment

4. In case the level goes up when the tape is pressed down :
 - (1) Turn the nut shown in the figure in counterclockwise using a box screwdriver so that the output waveform is maximum.In case the level goes up when the tape is pushed up :
 - (1) Turn the nut shown in the figure in clockwise using a box screwdriver so that the output waveform is maximum.
5. Make sure that the video tracking on the drum entrance side satisfied the specification.
(Refer to Section 6-4.)
6. Perform CTL head position adjustment.
(Refer to Section 6-6.)
7. Perform TC head position adjustment.
(Refer to Section 6-10.)
8. Perform confirmation of audio head height.
(Refer to steps (1) through (3) in Section 6-7.)
9. Perform confirmation of audio head phase.
(Refer to steps (1) through (4) in Section 6-8.)
10. Perform audio level adjustment (in REV mode). (Refer to Section 6-11.)
11. Install the AU head cover. (Refer to step (2) in Section 5-3.)
12. Install the cleaning roller assembly.
(Refer to steps (7) and (8) in Section 5-6.)
13. Perform cleaning roller block position adjustment. (Refer to Section 5-6-1.)

6-6. CTL HEAD POSITION ADJUSTMENT

- Adjustment of CTL head position is extremely important. If this adjustment is not adequate, the tape interchangeability is influenced significantly.
Take utmost care in performing adjustment.
- Perform this adjustment with the cassette compartment installed in the unit.

Tools

Alignment tape CR2-1B PS : 8-960-096-51
Dualtrace oscilloscope

Adjustment flow chart

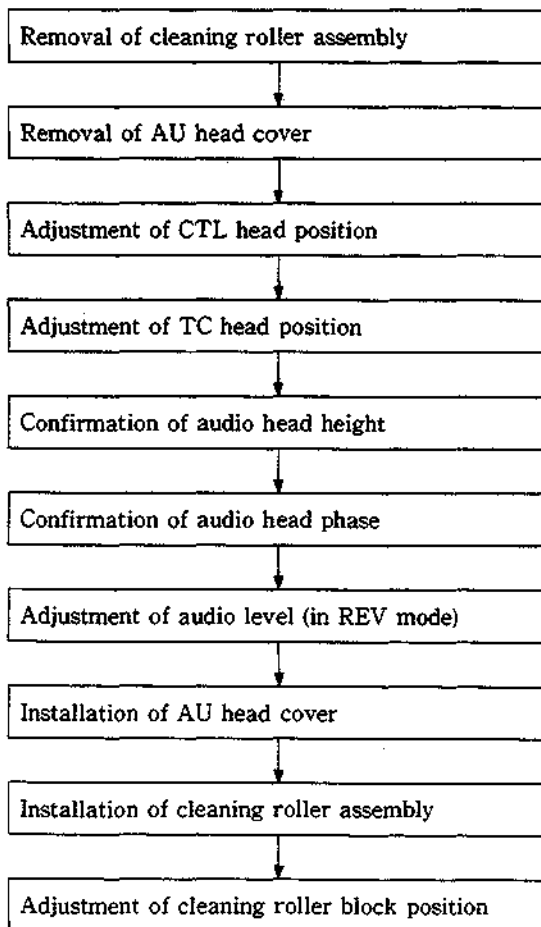

Preparation

1. Remove a cleaning roller assembly.
(Refer to steps (1) and (2) in Section 5-6.)
2. Remove an AU head cover.
(Refer to step (3) in Section 5-3.)

Check

1. Connect the oscilloscope as follows.
CH-1 : TP606/SS-48P board
(Address : Side A, A-1) (CTL signal)
CH-2 : TP1/VP-33AP board
(Address : Side A, D-1) (Switching pulse)
TRIG : CH-2
2. Insert an alignment tape CR2-1B PS into the unit and put the unit into PLAY mode.
3. Turn the tracking control and confirm that the output in the center of the RF envelope waveform is maximum when it is set to the FIX position.
If the specification is satisfied, perform steps (9) and later.
If the specification is not satisfied, perform steps (4) and later.

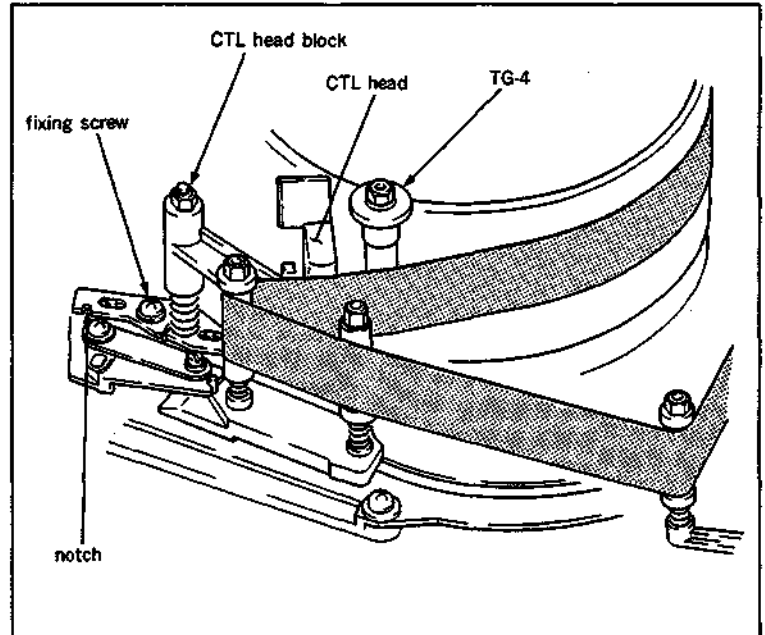

Adjustment

4. Turn the tracking control and set it to the FIX position.
5. Loosen a fixing screw of the CTL head block by 1/4 to 1/2 turn.
6. Insert a 3 mm flatbladed screwdriver into the notch of the CTL head block and adjust the CTL head block position so that the center level of the RF envelope waveform is maximized.
7. Tighten a fixing screw of the CTL head block.
8. Make sure that the specification is satisfied in accordance with the check procedures.
9. Perform TC head position adjustment.
(Refer to Section 6-10.)
10. Perform confirmation of audio head height.
(Refer steps (1) through (3) in Section 6-7.)
11. Perform confirmation of audio head phase.
(Refer to steps (1) through (4) in Section 6-8.)
12. Perform audio level adjustment (in REV mode). (Refer to Section 6-11.)
13. Install the AU head cover. (Refer to step (3) in Section 5-3.)
14. Install the cleaning roller assembly.
(Refer to steps (7) and (8) in Section 5-6.)
15. Perform cleaning roller block position adjustment. (Refer to Section 5-6-1.)

6-7. AUDIO HEAD HEIGHT ADJUSTMENT

Tools

Alignment tape CR8-1A PS : 8-960-098-45

Dualtrace oscilloscope

Box screwdriver (Across flat has 5.5 mm)

Adjustment flow chart

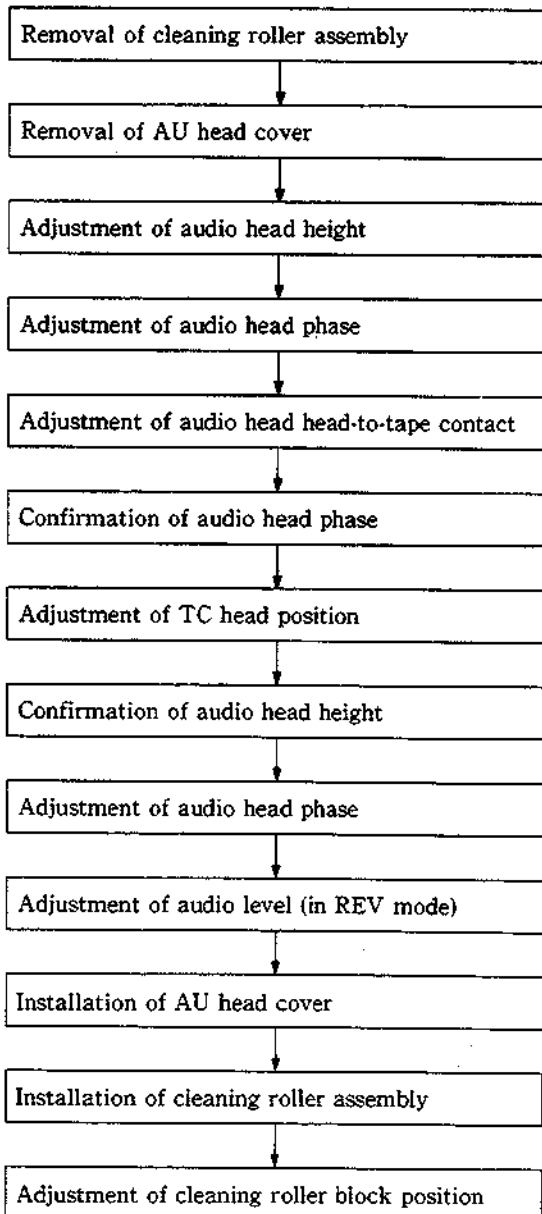

Preparation

1. Remove a cleaning roller assembly.
(Refer to steps (1) and (2) in Section 5-6.)
2. Remove an AU head cover.
(Refer to step (3) in Section 5-3.)

Check

1. Connect the oscilloscope as follows.
CH-1 : TP103/AU-148AP board
(Address : Side A, E-3) (AUDIO CH-1)
CH-2 : TP103/AU-149AP board
(Address : Side A, E-3) (AUDIO CH-2)
2. Insert an alignment tape CR8-1A PS into the unit and play back the 1 kHz 0 VU (0 : 00 to 2 : 55) audio signal portion recorded in the last portion.
3. Make sure that the level goes down when the portion (between an audio head and TG-6 tape guide) of the tape shown in the figure is pressed down or pushed up.
If the level goes up, perform steps (4) and later.
If the level goes down, perform steps (5) and later.

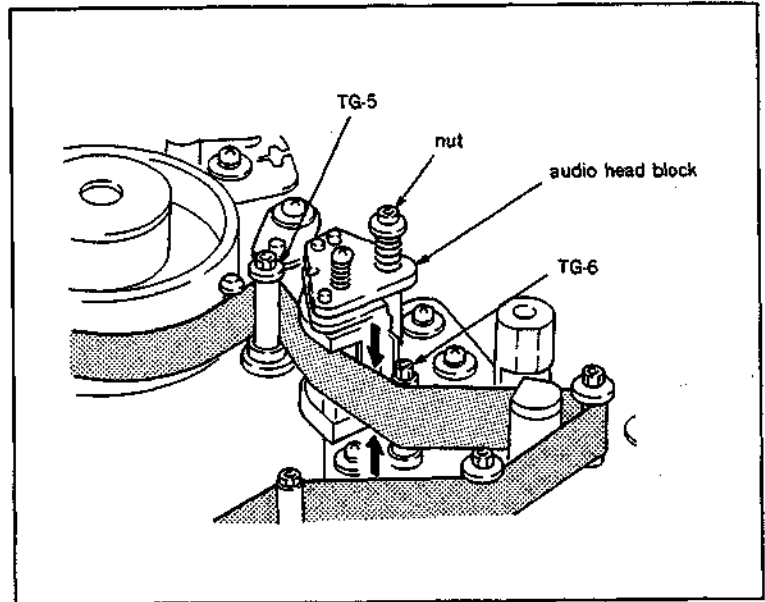

Adjustment

4. In case the level goes up when the tape is pressed down :
 - (1) Turn the nut shown in the figure in counterclockwise using a box screwdriver so that the output waveform is maximum.In case the level goes up when the tape is pushed up :
 - (1) Turn the nut shown in the figure in clockwise using a box screwdriver so that the output waveform is maximum.
5. Perform audio head phase adjustment.
(Refer to Section 6-8.)
6. Perform audio head head-to-tape contact adjustment. (Refer to Section 6-9.)
7. Perform confirmation of audio head phase.
(Refer to steps (1) through (4) in Section 6-8.)
8. Perform TC head position adjustment.
(Refer to Section 6-10.)
9. Perform confirmation of audio head height.
(Refer to steps (2) and (3) in Section 6-7.)
10. Perform confirmation of audio head phase.
(Refer to steps (1) through (4) in Section 6-8.)
11. Perform audio level adjustment (in REV mode). (Refer to Section 6-11.)
12. Install the AU head cover. (Refer to step (3) in Section 5-3.)
13. Install the cleaning roller assembly.
(Refer to steps (7) and (8) in Section 5-6.)
14. Perform cleaning roller block position adjustment. (Refer to Section 5-6-1.)

6-8. AUDIO HEAD PHASE ADJUSTMENT

Tools

Alignment tape CR8-1A PS : 8-960-098-45

Dualtrace oscilloscope

Adjustment flow chart

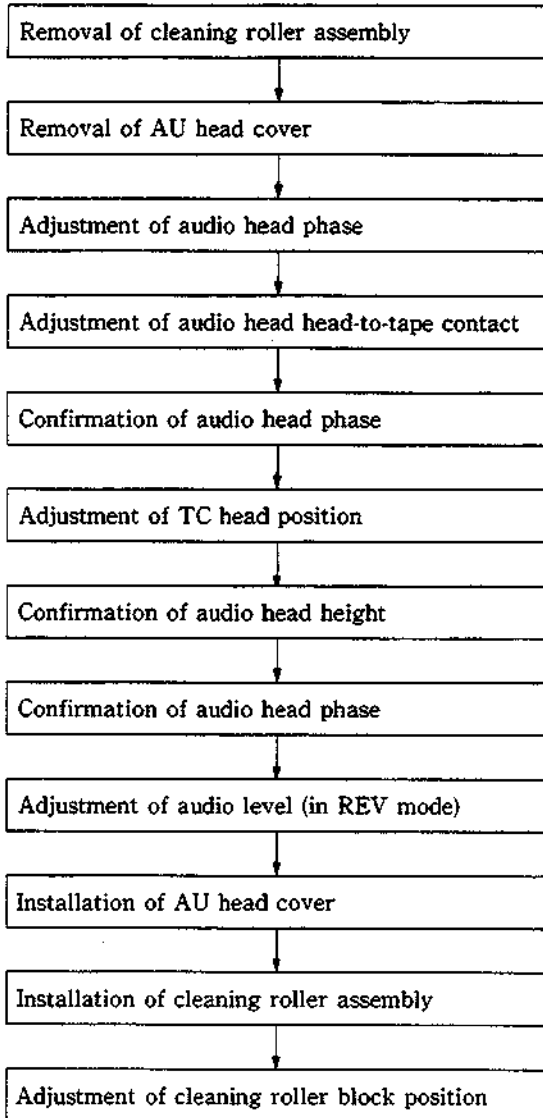

Preparation

1. Remove a cleaning roller assembly.
(Refer to steps (1) and (2) in Section 5-6.)
2. Remove an AU head cover.
(Refer to step (3) in Section 5-3.)

Check

1. Connect the oscilloscope as follows.
CH-1 : C138 (-) terminal on AU-148AP board
(Address : Side A, A-3) (AUDIO CH-1)
CH-2 : C138 (-) terminal on AU-149AP board
(Address : Side A, A-3) (AUDIO CH-2)
2. Insert an alignment tape CR8-1A PS into the unit and play back the 10 kHz, -10 dB (3 : 00 to 4 : 55) audio signal portion.
3. Adjust the scope for horizontal and vertical amplitude to 6 cm of a lissajous waveform.
4. Make sure that the vertical amplitude at the center of the horizontal direction satisfies the specification.

Then, strike the portion of a RP bracket shown in the figure lightly with the tip of a screwdriver and make sure that the phase in this case satisfies the specification.

If the specification is satisfied, perform steps (6) and later.

If the specification is not satisfied, perform steps (5) and later.

Adjustment

5. Turn the adjustment screw shown in the figure so that the specification is satisfied.
6. Perform step (4) in the check procedure, then perform reconfirmation of audio head phase.
7. Perform audio head head-to-tape contact adjustment. (Refer to Section 6-9.)
8. Perform step (4) in the check procedure, then perform reconfirmation of audio head phase.
9. Perform TC head position adjustment.
(Refer to Section 6-10.)
10. Perform confirmation of audio head height.
(Refer to steps (1) through (3) in Section 6-7.)
11. Perform step (4) in the check procedure, then perform reconfirmation of audio head phase.
12. Perform audio level adjustment (in REV mode). (Refer to Section 6-11.)
13. Install the AU head cover.
(Refer to step (2) in Section 5-3.)
14. Install the cleaning roller assembly.
(Refer to steps (7) and (8) in Section 5-6.)

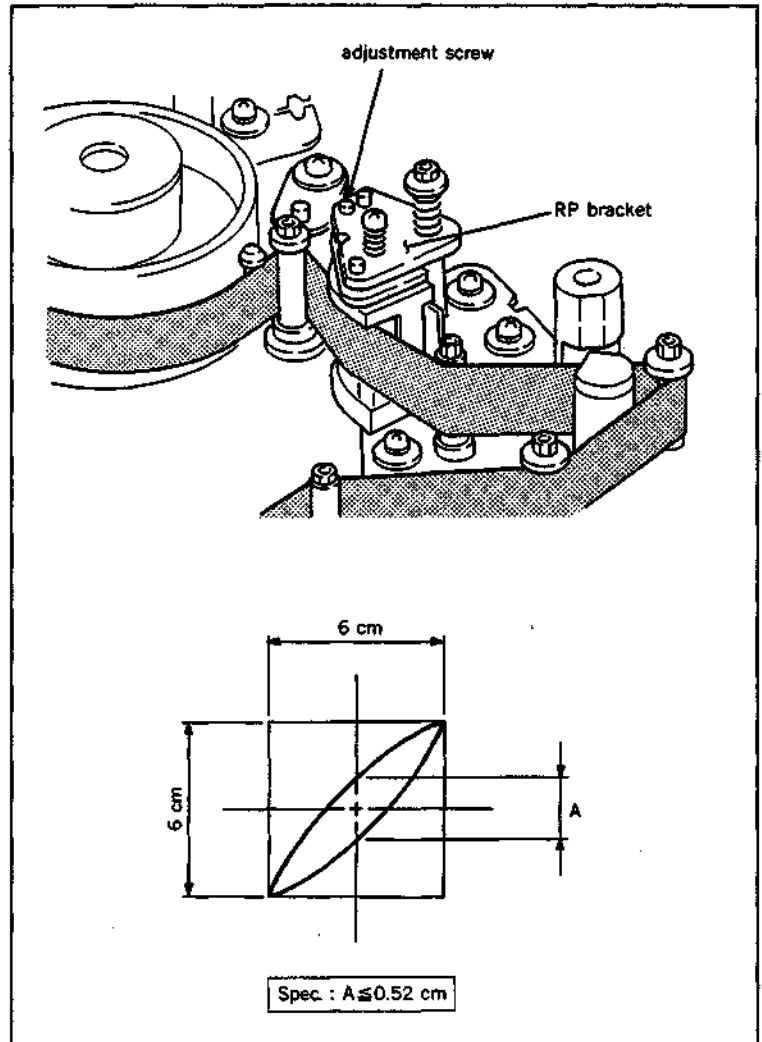

6-9. AUDIO HEAD HEAD-TO-TAPE CONTACT ADJUSTMENT

Tools

Alignment tape CR8-1A PS: 8-960-098-45

Audio level meter

Tension scale : 7-732-050-20

Adjustment flow chart

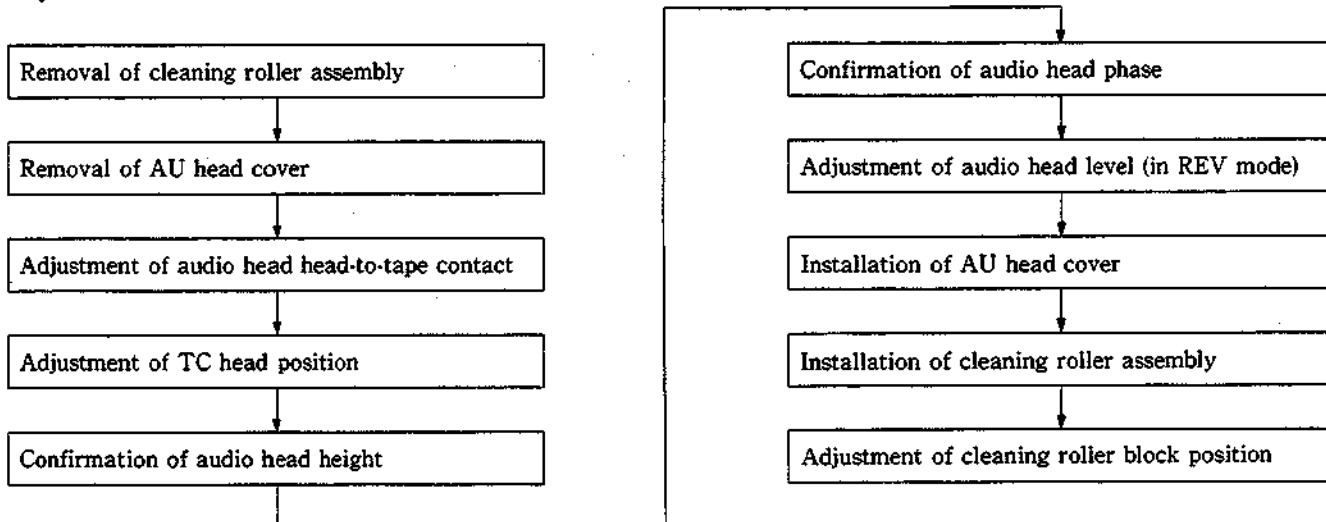

Preparation

1. Remove a cleaning roller assembly.
(Refer to steps (1) and (2) in Section 5-6.)
2. Remove an AU head cover.
(Refer to step (3) in Section 5-3.)

Check

1. Connect the oscilloscope as follows.
CH-1 : AUDIO OUT CH-1 connector on the connector panel
CH-2 : AUDIO OUT CH-2 connector on the connector panel
2. Insert an alignment tape CR8-1A PS into the unit and play back the 10 kHz, -10 dB (3 : 00 to 4 : 55) audio signal portion.

3. Push the upper part of the tape between an audio head and TG-6 tape guide slightly in the direction shown by the arrow. Push the upper part of the tape between the audio head and TG-5 tape guide slightly in the direction shown by the arrow. Make sure that the change in a level satisfies specification 1 in both channels.

Specification 1 : The change in a level must be less than 0.3 dB.

4. Put the tension scale on the portion of a S tension arm shown in the figure, and push it in the direction shown by the arrow until 20 g is indicated. Make sure that the change in a level satisfies specification 2 in both channels.

Specification 2 : The change in a level must be less than 0.3 dB.

If specifications 1 and 2 are satisfied, perform step (9).

If specification 1 or 2 is satisfied, perform steps (5) and later.

Adjustment

5. Loosen two fixing screws of the head shown in the figure by 1/4 to 1/2 turn.
6. Insert a 3 mm flatbladed screwdriver into the notch of an adjustment plate R shown in the figure and adjust the head-to-tape contact so that the level is maximum.
7. Tighten two screws of the head.
8. Make sure that the specification is satisfied in accordance with the check procedure.
9. Perform TC head position adjustment. (Refer to Section 6-10.)
10. Perform confirmation of audio head height. (Refer to steps (1) through (3) in Section 6-7.)
11. Perform confirmation of audio head phase. (Refer to steps (1) through (4) in Section 6-8.)
12. Perform audio level adjustment (in REV mode). (Refer to Section 6-11.)
13. Install the AU head cover. (Refer to step (3) in Section 5-3.)
14. Install the cleaning roller assembly. (Refer to steps (7) and (8) in Section 5-6.)
15. Perform cleaning roller block position adjustment. (Refer to Section 5-6-1.)

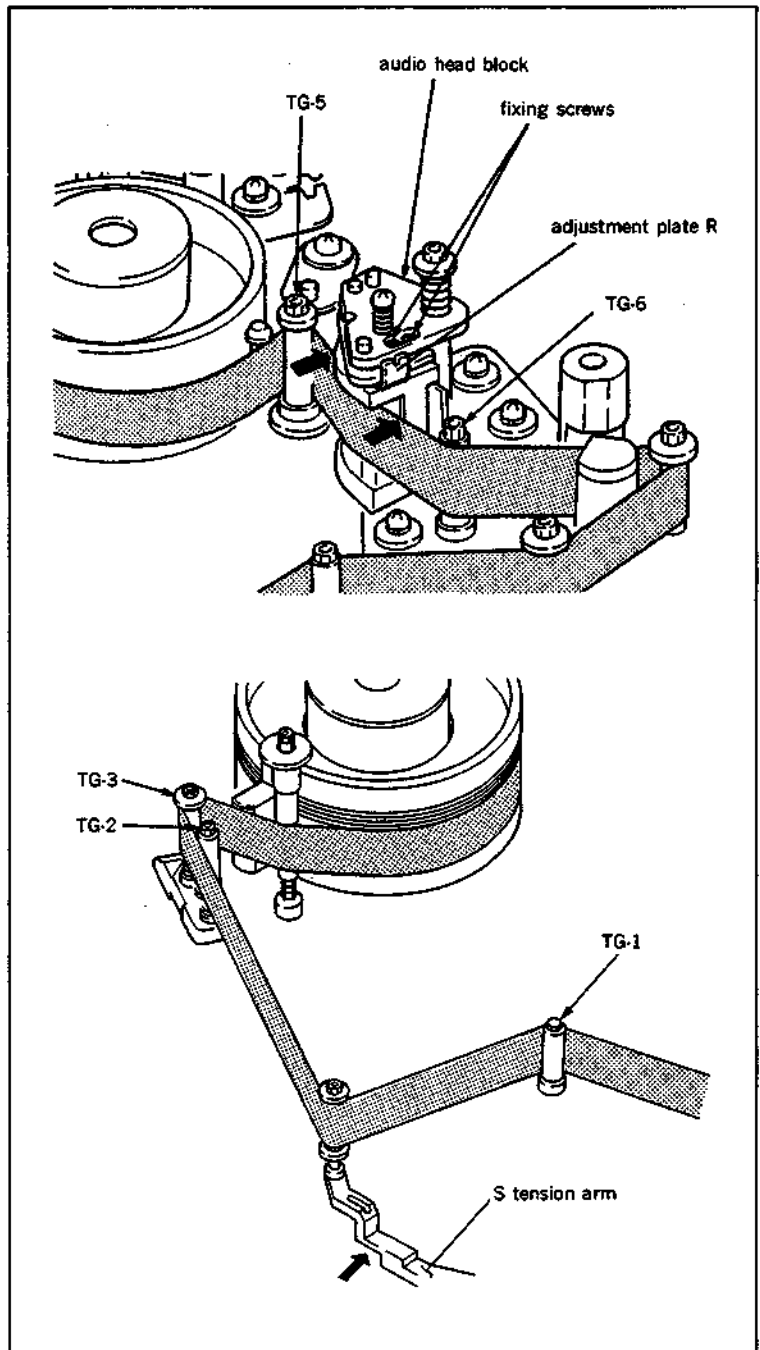

6-10. TC HEAD POSITION ADJUSTMENT

Tools

Alignment tape CR2-1B PS : 8-960-096-51
Dualtrace oscilloscope

Adjustment flow chart

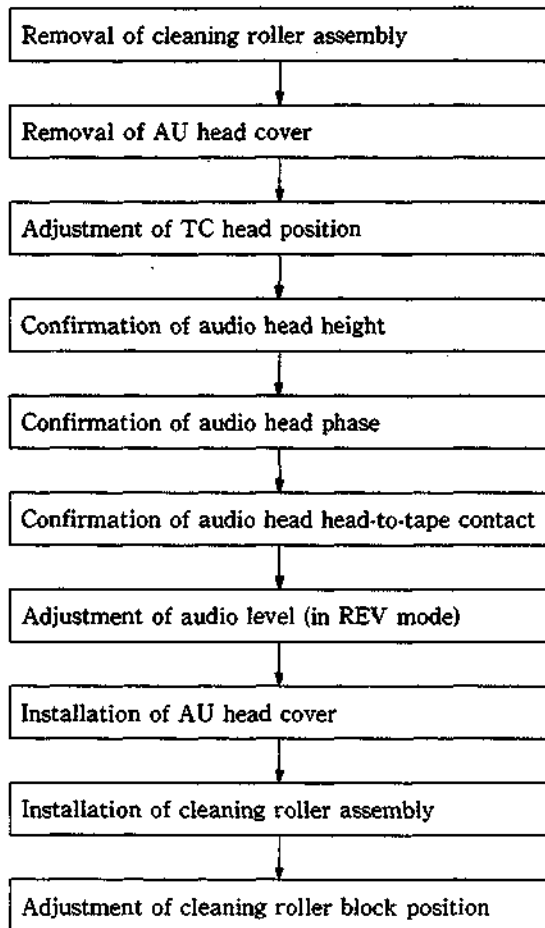

Preparation

1. Remove a cleaning roller assembly.
(Refer to steps (1) and (2) in Section 5-6.)
2. Remove an AU head cover.
(Refer to step (3) in Section 5-3.)

Check

1. Connect the oscilloscope as follows.
CH-1 : TP606/SS-48P board
(Address : Side A, A-1) (CTL signal)
CH-2 : TP3/AU-150A board
(Address : Side A, B-3) (TC signal)
TRIG : TP1/VP-33AP board
(Address : Side A, D-1)
(Switching pulse)
2. Insert an alignment tape CR2-1B PS into the unit and put the unit into PLAY mode.
3. Make sure that the positional relationship between at the rising edge of a CTL signal and at the falling edge of a TC signal satisfy the specification.
If the specification is satisfied, perform steps (8) and later.
If the specification is not satisfied, perform steps (4) and later.

Adjustment

4. Loosen three fixing screws of an audio/TC head block by 1/4 to 1/2 turn.
5. Insert a 3 mm flatbladed screwdriver into the notch of the audio/TC head block shown in the figure and adjust the audio/TC head block position so that the specification is satisfied.
6. Tighten three screws of the audio/TC head block.
7. Make sure that the specification is satisfied in accordance with the check procedure.
8. Perform confirmation of audio head height. (Refer to steps (1) through (3) in Section 6-7.)
9. Perform confirmation of audio head phase. (Refer to steps (1) through (4) in Section 6-8.)
10. Perform confirmation of audio head head-to-tape contact. (Refer to steps (1) through (4) in Section 6-9.)
11. Perform audio level adjustment (in REV mode). (Refer to Section 6-11.)
12. Install the AU head cover. (Refer to step (2) in Section 5-3.)
13. Install the cleaning roller assembly. (Refer to steps (7) and (8) in Section 5-6.)
14. Perform cleaning roller block position adjustment. (Refer to Section 5-6-1.)

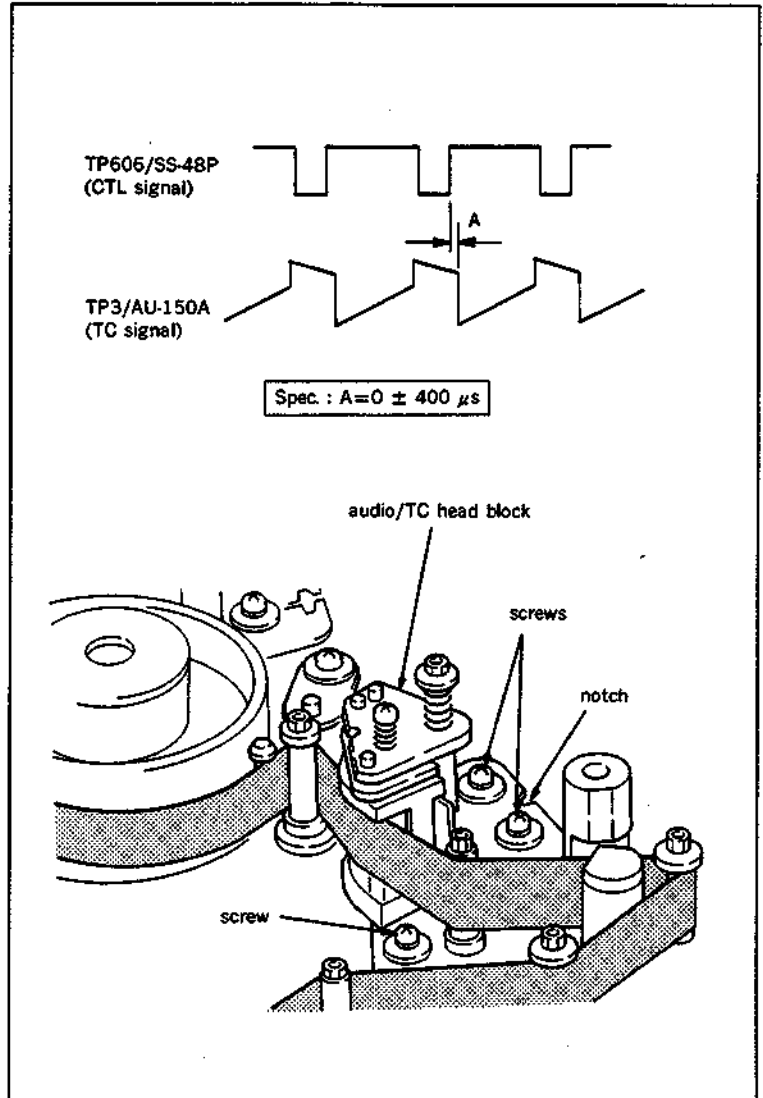

6-11. AUDIO LEVEL ADJUSTMENT (IN REV MODE)

Tools

Alignment tape CR8-1A PS : 8-960-098-45
 Tape guide adjustment driver: J-6321-500-A
 Adjustment mirror : J-6080-029-A
 Audio level meter

Adjustment flow chart

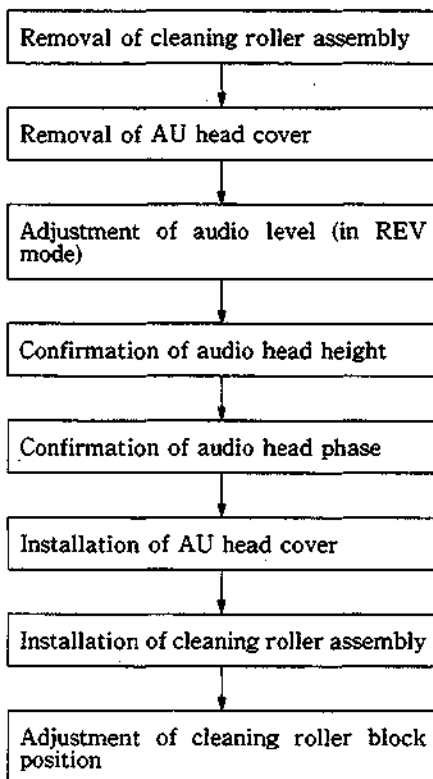

Preparation

1. Remove a cleaning roller assembly.
(Refer to steps (1) and (2) in Section 5-6.)
2. Remove an AU head cover.
(Refer to step (3) in Section 5-3.)

Check

1. Connect the oscilloscope as follows.
 CH-1 : AUDIO OUT CH-1 connector on the connector panel
 CH-2 : AUDIO OUT CH-2 connector on the connector panel

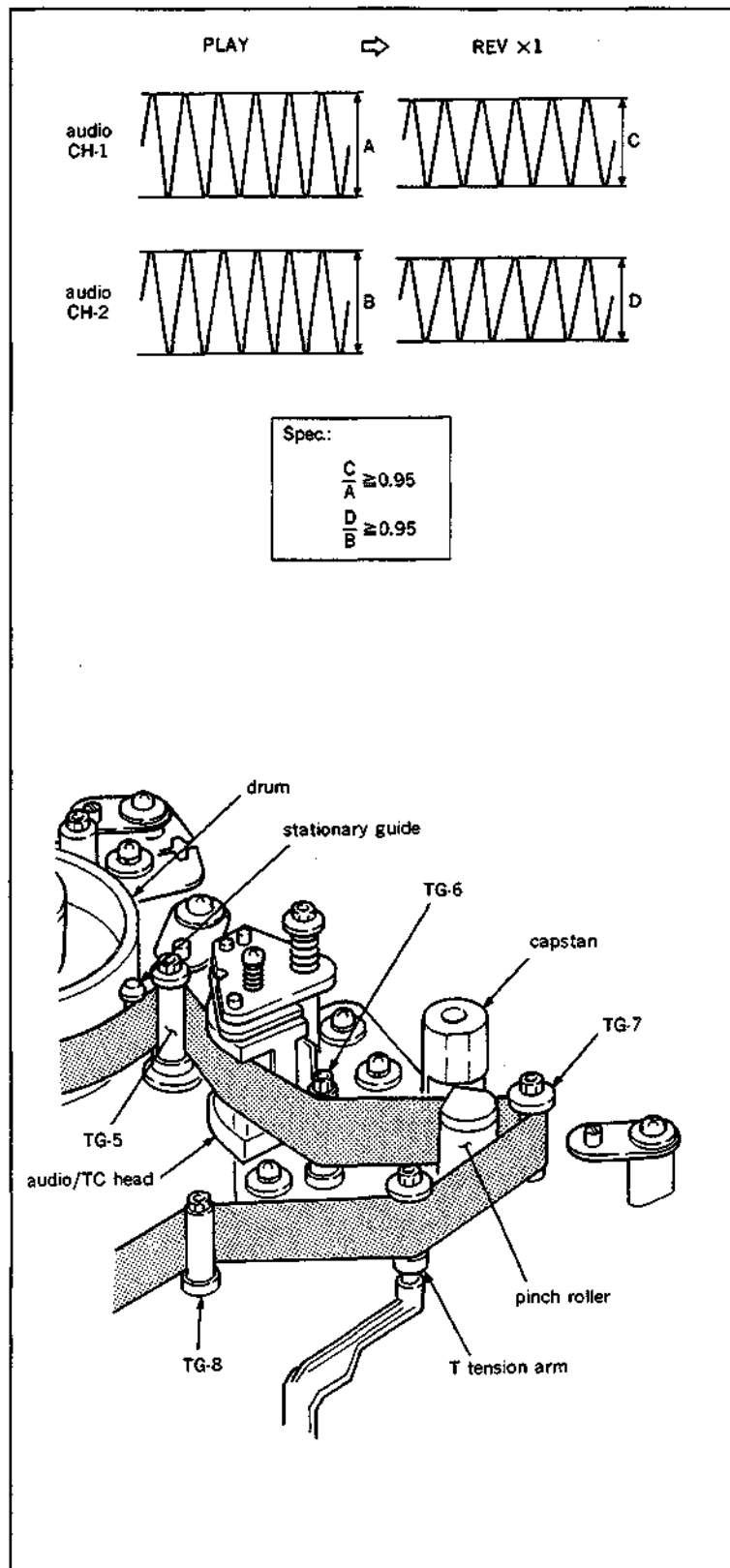

2. Insert an alignment tape CR8-1A PS into the unit, and play back the 10 kHz, -10 dB audio signal portion, and memorize the CH-1 and CH-2 levels. (The CH-1 level is defined as A, and the CH-2 level as B.)
3. Put the unit into REV X1 mode.
4. Make sure that the CH-1 and CH-2 levels satisfy the specification below. (The CH-1 level is defined as C, and the CH-2 level as D.)

Specification :

CH-1 : C/A level must be more than 0.95.

CH-2 : D/B level must be more than 0.95.

If the specification is not satisfied, perform steps (5) and later.

Adjustment

5. Loosen the locking screw at the upper part of a TG-7 tape guide two to three turns using a tape guide adjustment driver.
6. Fine adjust the height of the TG-7 tape guide so that the specification is satisfied in REV X1 mode.
7. Put the unit into PLAY, REV X1, F.FWD and REW modes, and change the mode from STOP to F.FWD modes, and from STOP to REW modes.
Using an adjustment mirror, make sure that the tape running at the flanges of the TG-6, TG-7, and T tension arm satisfy the specification in every mode.
8. Perform confirmation of audio head height. (Refer to steps (1) through (3) in Section 6-7.)
9. Perform confirmation of audio head phase. (Refer to steps (1) through (4) in Section 6-8.)
10. Install the AU head cover. (Refer to step (2) in Section 5-3.)
11. Install the cleaning roller assembly. (Refer to steps (7) and (8) in Section 5-6.)
12. Perform cleaning roller block position adjustment. (Refer to Section 5-6-1.)

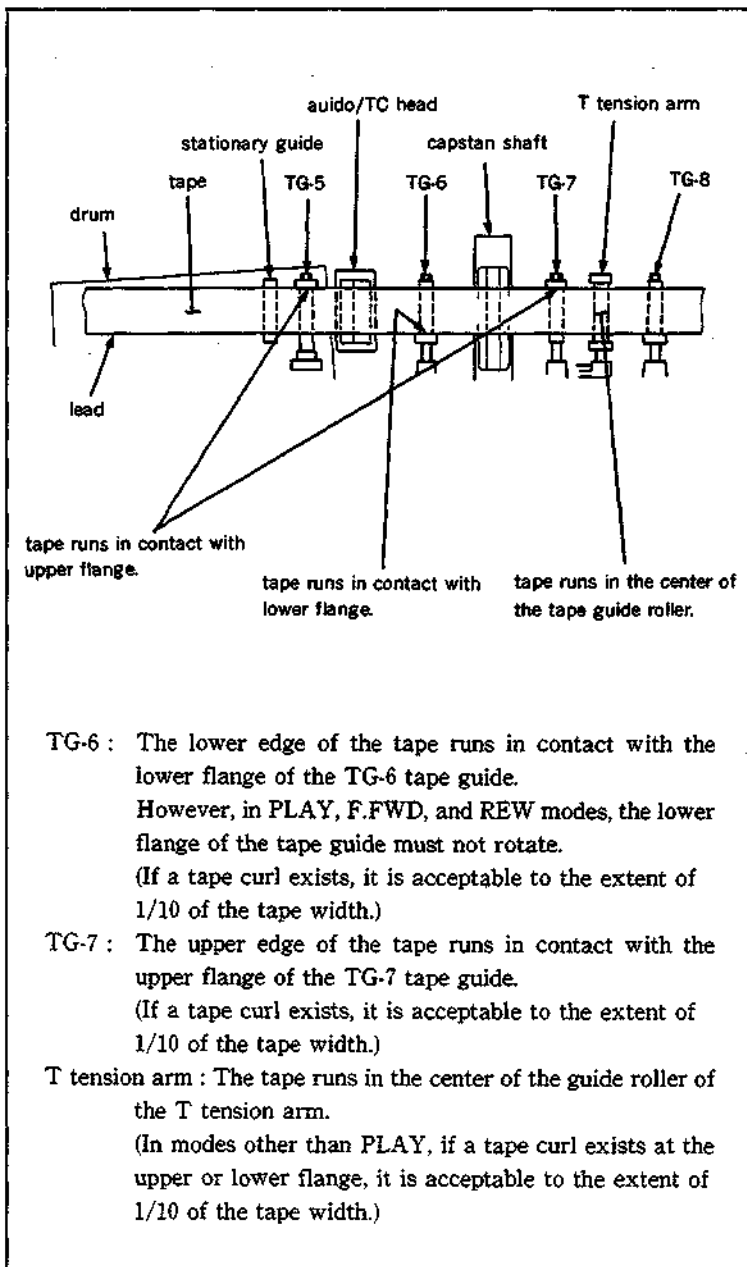

6-12. RF SWITCHING POSITION ADJUSTMENT

Perform this RF switching position adjustment when a video tracking adjustment is performed.

Preparation

Connect a video monitor with VIDEO OUTPUT 3 connector or MONITOR connector, and display characters.

Tool

Alignment tape CR2-1B PS : 8-960-096-51

Check

1. Make sure that the unit is in EJECT mode. (The automatic adjustment does not accept the mode other than EJECT.)
2. Put Bit4 of S601 on SS-48P board in CLOSE state. Press S302 and put the unit into maintenance mode.
3. Press the search dial to enter the jog mode, and move * mark to "B1 : SERVO ADJUST" which is displaying on the monitor screen with the search dial.
4. Press S302 on SS-48P board to select "SERVO ADJUST" mode.
5. Move * mark to "B110: RF SWITCHING POS." which is displaying on the monitor screen with the search dial.
6. Press S302 on SS-48P board to execute "RF SWITCHING POS." menu.
7. Confirm that the message "SET CR2-1 OR CR2-2 ALIGNMENT TAPE AND PUSH PLAY KEY" is displayed on the monitor screen.
8. Insert an alignment tape CR2-1B PS and press the PLAY button.
9. Make sure that the message "COMPLETE" is displayed on the monitor screen. When "COMPLETE" is displayed on the monitor screen, press S303 on SS-48P board to return to the menu screen.
10. Move * mark to "B117: NV RAM CONTROL" which is displaying on the monitor screen with the search dial.
11. Press S302 on SS-48P board to execute "NV RAM CONTROL" menu.
12. Move * mark to "SAVE ALL ADJ. DATA" with the search dial.
13. Press S302 on SS-48P board. Data will be stored on the NOV RAM.
14. When "SAVE COMPLETE" is displayed on the monitor screen, press S303 twice on SS-48P board to return to the mode screen.

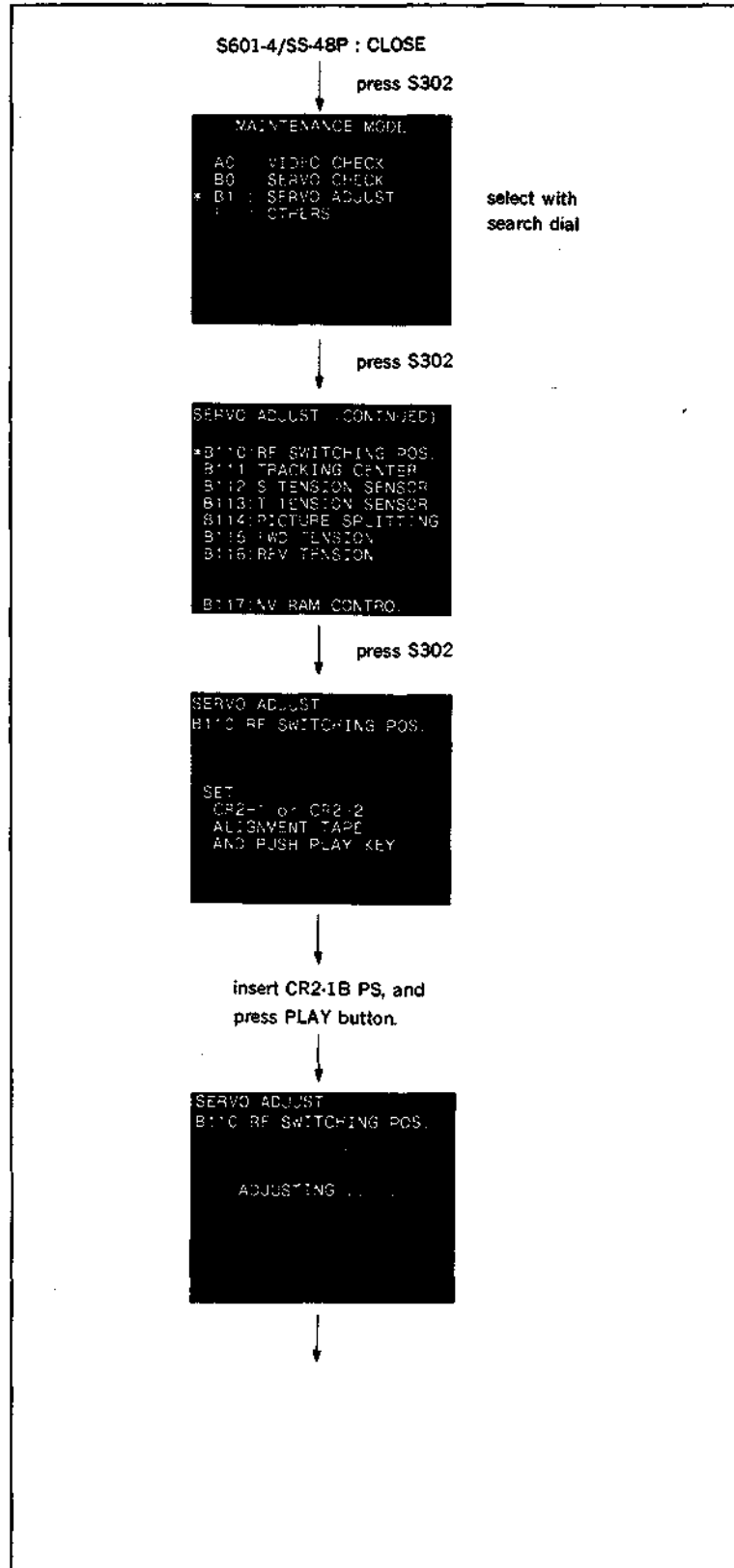

Note: When "INCOMPLETE" appears on the monitor screen in step (9), press S303 on SS-48P board to return to the menu screen. After that, press the EJECT button, take out the alignment tape, and make sure that it is CR2-1B PS.

15. Press the EJECT button and take out the alignment tape.
16. Turn the POWER to OFF and put Bit4 of S601 on SS-48P board to OPEN state.

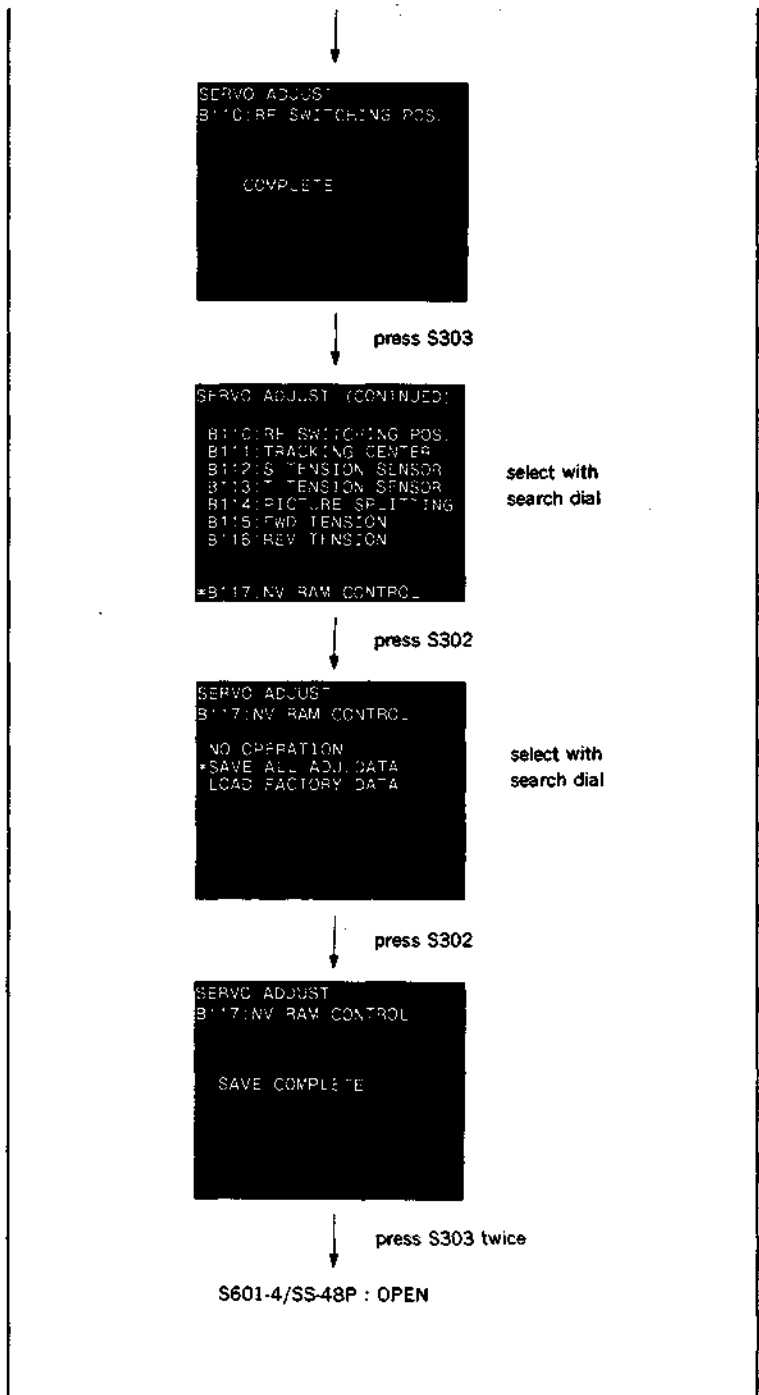

6-13. VIDEO HEAD DIHEDRAL CHECK

The video head dihedral of an upper drum assembly and drum assembly for service part is precisely adjusted at the factory. No adjustment is thus required. Perform only the check.

Tools

Alignment tape CR5-2A PS : 8-960-098-44

Monitor TV

Check flow chart

Confirmation of video head dihedral

Check

1. Connect a monitor TV to TP204 on VP-33AP board.
2. Insert an alignment tape CR5-2A PS into the unit and play back the monoscope signal portion.
3. Make sure if the vertical line of the monoscope signal just beneath a switching pulse is played back in double lines instead of a single line.

Make sure that the space of the double line is within 10 times of width of the vertical line.

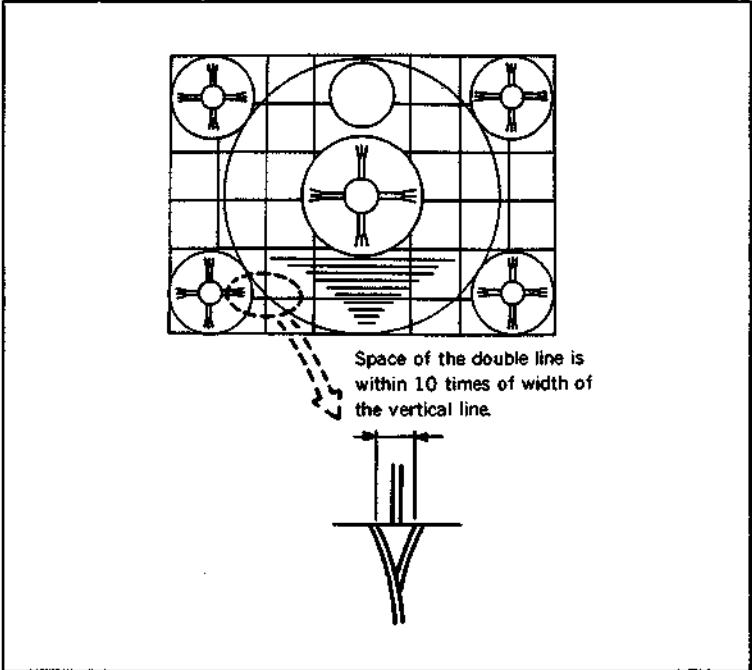

6-14. PICTURE SPLITTING COMPENSATION ADJUSTMENT

This picture splitting compensation adjustment is usually not required.

Picture splitting is rarely detected on the monitor TV that is connected to the connector on the connector panel. Perform this adjustment only when the picture splitting is detected. The picture splitting is the phenomenon shown in the figure.

Tools

Conventional monitor TV for checking
Alignment tape CR5-2A PS : 8-960-098-44
For adjustment purpose, monitor TV (Use a monitor whose AFC lock is slow.)

Adjustment flow chart

Adjustment of picture splitting compensation

Check

1. Connect a conventional monitor TV to the connector on the connector panel.
2. Insert an alignment tape CR5-2A PS into the unit and play back the monoscope signal portion.
3. Check whether picture splitting is detected on the monitor TV.

Specification : 1.5 μ s or less

If picture splitting is detected, perform steps (4) and later.

Adjustment

4. Connect a monitor TV for adjustment purpose to TP202 on VP-33AP board.
5. Connect a conventional monitor TV with VIDEO OUTPUT 3 connector or MONITOR connector on the connector panel.
6. Put the monitor TV into H DELAY, AFC FAST, and SYNC INT modes.
7. Make sure that the unit is in EJECT mode.
8. Put Bit4 of S601 on SS-48P board to CLOSE state. Press S302 and put the unit into maintenance mode.
9. Press the search dial to enter the jog mode, and move * mark to "B1 : SERVO ADJUST" which is displaying on the monitor screen with the search dial.
10. Press S302 on SS-48P board to select "SERVO ADJUST" mode.
11. Move * mark to "B114: PICTURE SPLITTING" in the menu which is displaying on the monitor screen with the search dial.

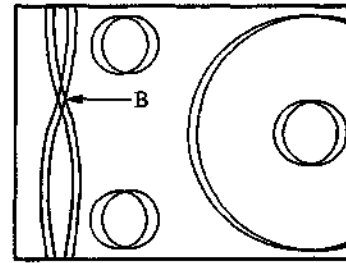

S601-4/SS-48P:CLOSE

press S302

```

MAINTENANCE MODE
AD : VIDEO CHECK
BG : SERVO CHECK
* B1 : SERVO ADJUST
F : OTHERS
    
```

select with search dial

press S302

```

SERVO ADJUST (CONTINUED)
B110:RH SWITCHING POS.
B111:TRACKING CENTER
B112:S TENSION SENSOR
B113:T TENSION SENSOR
* B114:PICTURE SPLITTING
B115:FWD TENSION
B116:REV TENSION

B117:LV PAM CONTROL
    
```

select with search dial

press S302

```

SERVO ADJUST
B114:PICTURE SPLITTING

SET
CR5-2A
ALIGNMENT TAPE
AND PUSH PLAY KEY
    
```

insert CR5-2A PS, and press PLAY button.

12. Press S302 on SS-48P board to execute "PICTURE SPLITTING" menu.
13. Insert an alignment tape CR5-2A PS into the unit and play back the monoscope signal portion.
14. Mark the "B" position shown in the figure on the monitor screen with felt pen.
15. Press S302 on SS-48P board.
16. Turn the search dial so that the picture splitting cross-point position of a picture played back on the monitor screen coincides with the position marked in step (14).
17. Press S302 on SS-48P board.
18. Turn the search dial so that minimize the picture splitting, and press S302 on SS-48P board.
19. Make sure that the message "COMPLETE" is displayed on the monitor screen that is connected with VIDEO OUTPUT 3 connector or MONITOR connector.
20. When "COMPLETE" is displayed on the monitor screen, press S303 on SS-48P board to return to the menu screen.
21. Move * mark to "B117 : NV RAM CONTROL" which is displaying on the monitor screen with the search dial.
22. Press S302 on SS-48P board to execute "NV RAM CONTROL" menu.
23. Move * mark to "SAVE ALL ADJ. DATA" with the search dial.
24. Press S302 on SS-48P board. Data will be stored on the NOV RAM.
25. When "SAVE COMPLETE" is displayed on the monitor screen, press S303 twice on SS-48P board to return to the mode screen.

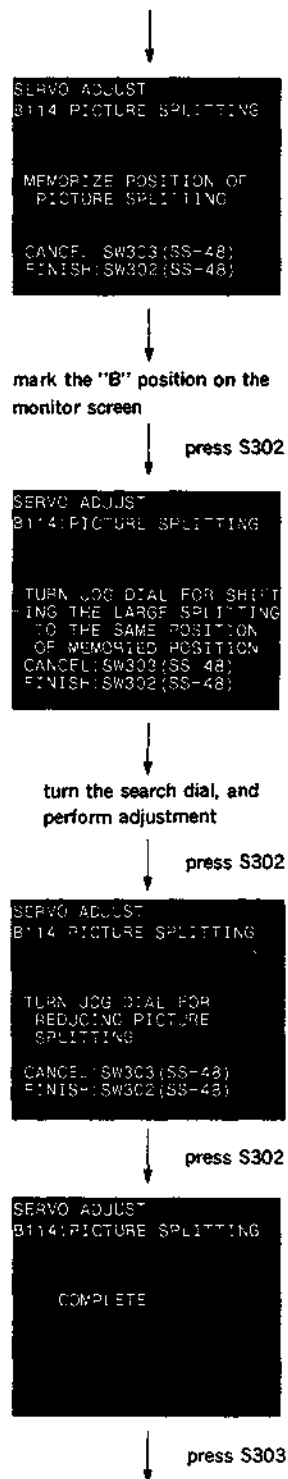

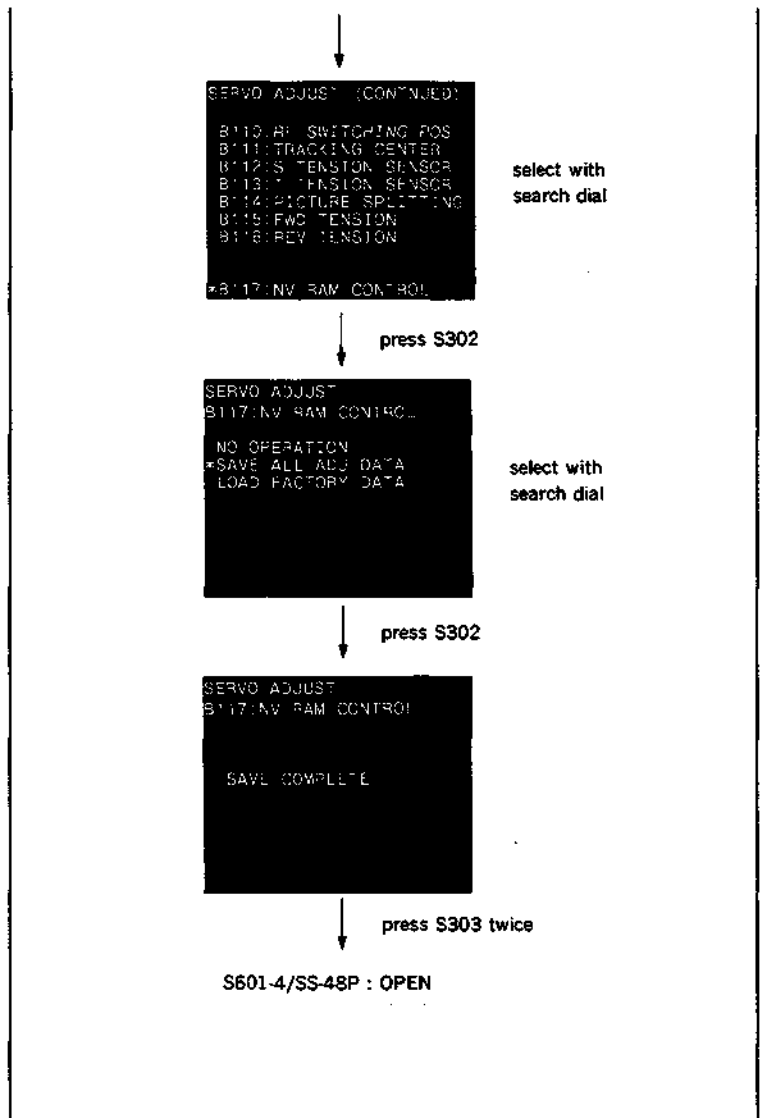

E-ALIGNMENT INF.

SECTION 7 GENERAL INFORMATION FOR ELECTRICAL ADJUSTMENT

7-1. ADJUSTMENT COMPONENT INDEX

AU-148 board

RV101	HEAD TUNE	10-7
RV102	OXIDE F.RESP.	10-7
RV103	METAL F.RESP.	10-9
RV104	METAL PB LEVEL	10-9
RV105	STEREO PHASE	10-10
RV106	PB LEVEL	10-7
RV201	DOLBY EN INPUT LEVEL	10-7
RV204	PB PRESET LEVEL	10-7
SW101	HEAD TUNE C SELECT SW	10-7

AU-149 board

RV101	HEAD TUNE	10-8
RV102	OXIDE F.RESP.	10-8
RV103	METAL F.RESP.	10-12
RV104	METAL PB LEVEL	10-12
RV105	STEREO PHASE	10-13
RV106	PB LEVEL	10-8
RV201	DOLBY EN INPUT LEVEL	10-8
RV204	PB PRESET LEVEL	10-8
SW101	HEAD TUNE C SELECT SW	10-8

MA-44 board

RV1	CH1 METER LEVEL	10-14
RV2	CH2 METER LEVEL	10-14

PTC-39 board

RV1	DME	9-3
RV2	DME	9-3

RP-57 board

RV4	YA PB RF F.RESP.	12-11
RV104	YB PB RF F.RESP.	12-11
RV204	CA PB RF F.RESP.	12-11
RV304	CB PB RF F.RESP.	12-11

SS-48 board

CV401	CHARA SIZE	8-1
-------	------------	-----

CV402	MENU SIZE	8-1
-------	-----------	-----

TBC-18 board

LV300	Y ERR VOLT	11-42
LV400	C ERR VOLT	11-42
RV100	Y GAIN	11-39
RV200	C GAIN	11-40
RV301	Y PHASE	12-18
RV302	Y ERR CLP	12-16
RV303	Y TR GAIN	11-45
RV307	Y FREQ	12-15
RV400	Y/C DELAY	12-20
RV401	OXIDE DELAY	12-21
RV402	C ERR CLIP	12-16
RV403	C FREQ	12-15
RV500	VIDEO LEVEL	11-39
RV501	CHROMA LEVEL	11-40
RV700	SYNC LEVEL	12-16
RV701	SYNC PHASE	12-35
RV702	UV OFFSET (AM NOISE)	11-44
RV703	VISC P	12-28
RV704	VISC R	12-30
RV705	BURST LEVEL	12-16
RV706	POSI EDGE	12-12
RV707	NEGA EDGE	12-12
RV708	INT SC	12-35
RV709	1ST FIELD	12-26
RV710	HUE	11-44
RV711	4Fsc FREQ.	11-43

VP-33 board

RV102	YA OXIDE F.RESP.	11-31
RV103	YB OXIDE F.RESP.	11-31
RV106	YA METAL F.RESP.	11-30
RV107	YB METAL F.RESP.	11-30
RV108	Y OXIDE RF	11-16
RV109	Y METAL RF	11-15
RV111	VIDEO METER	11-15
RV112	Y METAL DO	11-35
RV113	Y OXIDE DO	11-35
RV201	Y LIMITER BALANCE	11-20
RV202	Y METAL OMC	11-28
RV203	Y OXIDE OMC	11-29
RV204	Y METAL DEMOD GAIN	11-18
RV205	Y OXIDE DEMOD GAIN	11-19
RV206	Y DEMOD BALANCE	11-24

RV402	CA OXIDE F.RESP.	11-33
RV403	CB OXIDE F.RESP.....	11-33
RV406	CA METAL F.RESP.	11-32
RV407	CB METAL F.RESP.	11-32
RV408	C OXIDE RF	11-17
RV409	C METAL RF	11-17
RV412	C METAL DO	11-36
RV413	C OXIDE DO	11-36
RV501	C LIMITER BALANCE	11-22
RV502	C METAL OMC	11-28
RV503	C OXIDE OMC	11-29
RV504	C METAL DEMOD GAIN	11-18
RV505	C OXIDE DEMOD GAIN	11-19
RV506	C DEMOD BALANCE	11-26
RV701	PRE Y LEVEL	11-46
RV703	Y OUT LEVEL	11-47
RV704	S VIDEO Y LEVEL	11-47
RV705	VIDEO OUT LEVEL	11-48
RV706	VIDEO OUT SYNC	11-48
RV707	S VIDEO SYNC	11-47
RV708	Y OUT SYNC	11-47
RV709	VIDEO 3 LEVEL	11-48
RV712	BURST LEVEL	11-54
RV713	V SC LEAK	11-53
RV714	U SC LEAK	11-53
RV715	ENC B-Y LEVEL	11-54
RV716	ENC R-Y LEVEL	11-54
RV718	CF ADJ	12-25
RV719	VISC LEVEL	11-52
RV720	VISC DC	11-52
RV721	R-Y DELAY	12-22
RV722	R-Y LEVEL	11-49
RV723	B-Y DELAY	12-22
RV724	B-Y LEVEL	11-50
RV725	ID(+)LEVEL	11-51
RV726	ID(-)LEVEL	11-51

7-2. REQUIRED EQUIPMENT

VIDEO system equipments

Equipment		Equivalent	Note
Oscilloscope		TEKTRONIX 2445	more than 150 MHz
Signal Generator	Component	TEKTRONIX TSG-300(BETACAM SP SPEC.)	(for BETACAM SP)
	Composite	TEKTRONIX 1411	
	Digital Composite	TEKTRONIX 271	SCH reference
Network Analyzer		ANRITSU MS-420B	use together with head coupling tool
Waveform Monitor	Component	TEKTRONIX WFM300/WFM300A/1781R	component signal W/F
	Composite	TEKTRONIX 1481C/1751/1781R	with SCH meter
Spectrum analyzer		ADVANTEST R4131B/D	
Picture Monitor			
Head Coupling Tool			
Frequency Counter		ADVANTEST TR5821AK	
Blank Tape (Oxide)		BCT-20G	standard products
Blank Tape (Metal)		BCT-20M	standard products
Alignment Tape		CR5-1B PS(PART No. 8-960-096-91)	refer to Section 11, 12 Video System Alignment
Alignment Tape		CR5-2A PS(PART No. 8-960-098-44)	refer to Section 11, 12 Video System Alignment

AUDIO/TIME CODE system equipments

Equipment		Equivalent	Note
Oscilloscope		TEKTRONIX 2445	
Composite Signal Generator		TEKTRONIX 1411	
Picture Monitor			
Audio Level Meter		HP 3400A	
Alignment Tape		CR8-1A PS(PART No. 8-960-098-45)	refer to Section 10 Audio/Time Code System Alignment
		CR8-1B PS(PART No. 8-960-096-86)	

Others

Equipment		Equivalent	Note
Digital Voltmeter		ADVANTEST TR6845	refer to 8-1. switching regulator adjustment

7-3. TEST SIGNAL

1. 100% COLOR BARS

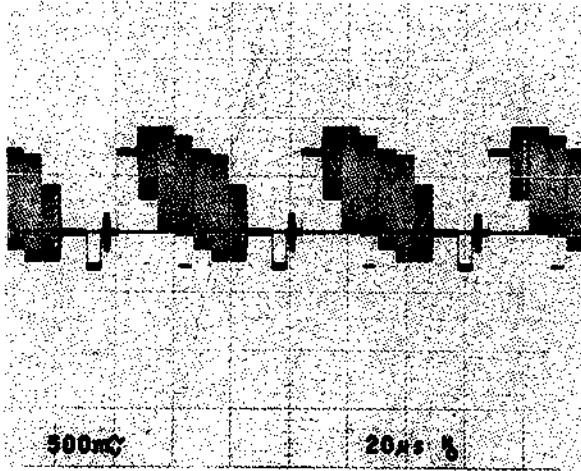

4. 50% FLAT FIELD

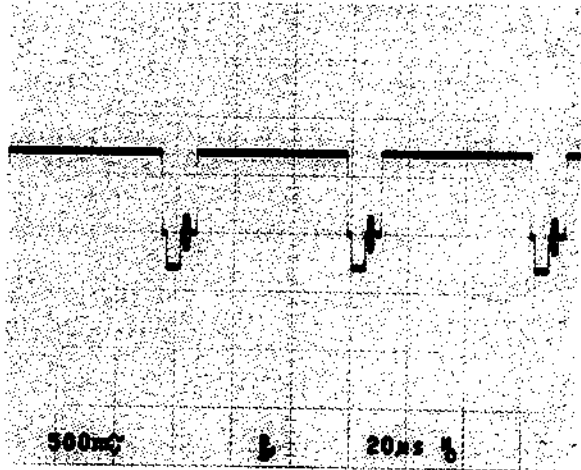

2. 75% COLOR BARS

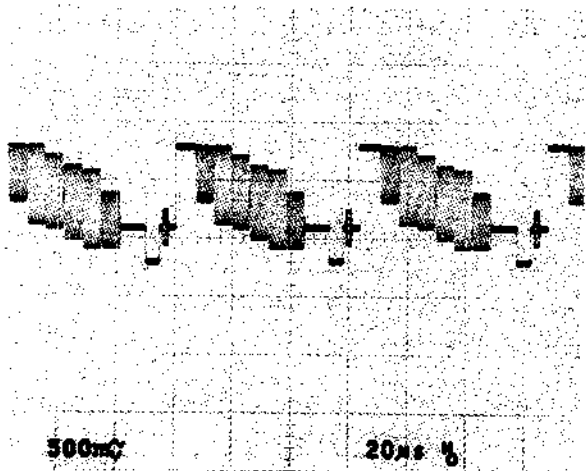

5. PULSE & BAR (COMPONENT) 2T(Y)

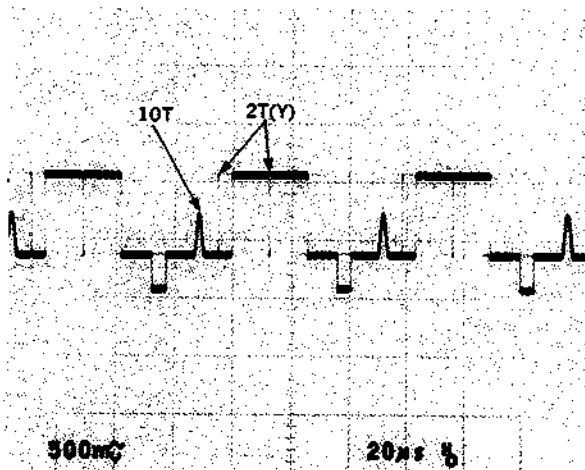

3. 60% MULTI BURST

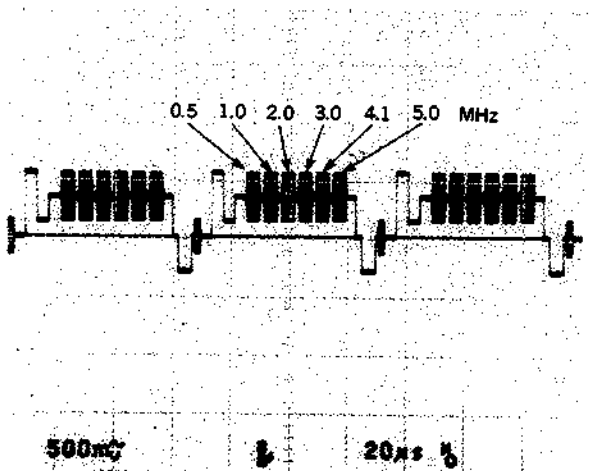

6. PULSE & BAR (COMPONENT) 2T, 4T (Y)

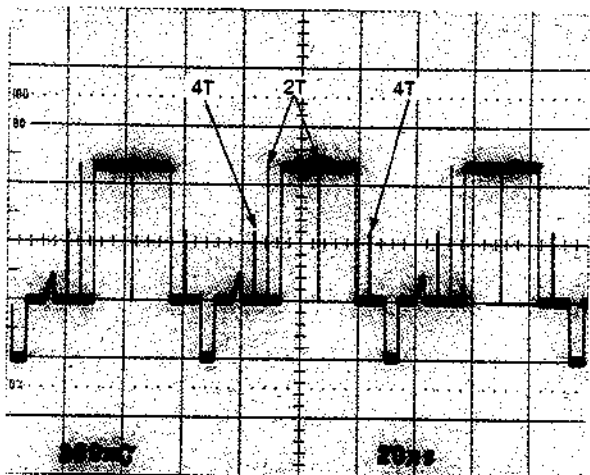

7. PULSE & BAR (COMPOSITE) 2T

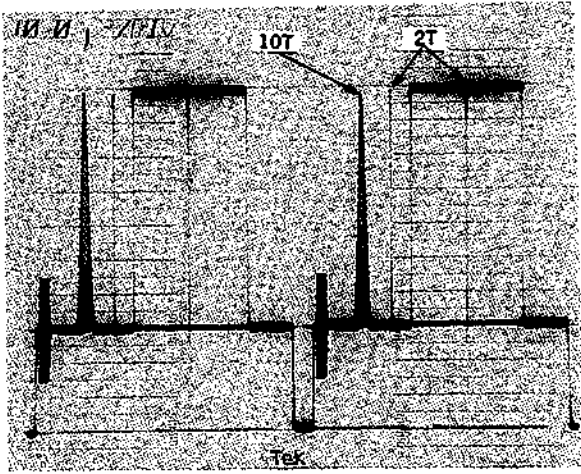

9. 100% NARROW LINE SWEEP (200 kHz-5.5 MHz)

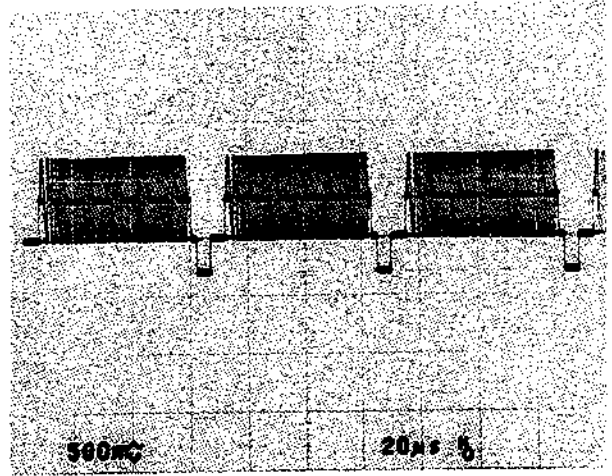

8. 50% BOWTIE

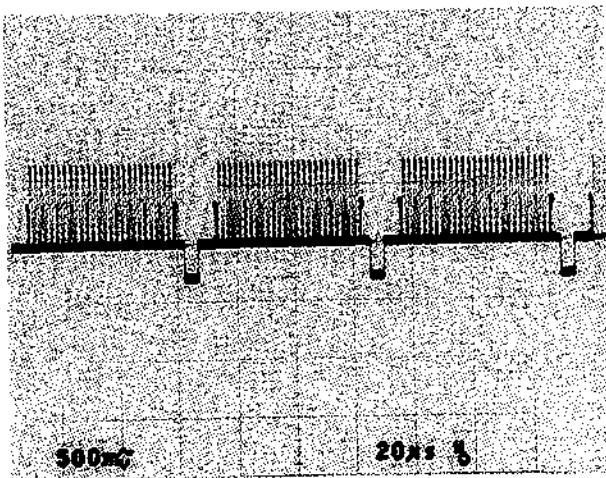

10. BLACK BURST

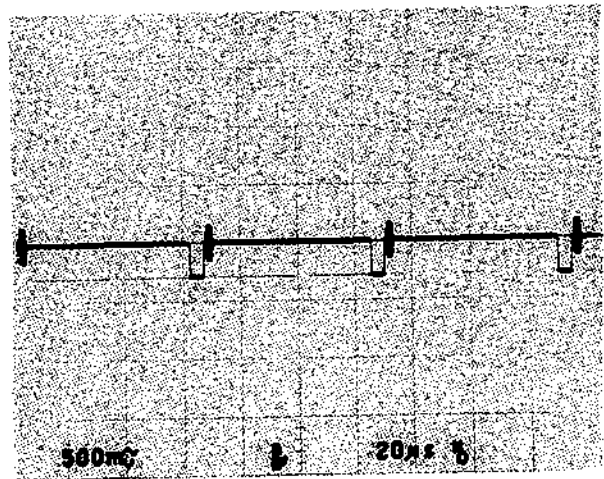



POWER/SYSCON

SECTION 8 POWER SUPPLY AND SYSTEM CONTROL ALIGNMENT

[Equipment Required]

- Digital Voltmeter (ADVANTEST TR6845)
- Picture Monitor
- Alignment Tape CR5-2A PS (Part No. 8-960-098-44)

Contents

TIME min s	VIDEO TRACK
0: 00	75% Color Bars
3: 00	60% Multi Burst Y: 0.5,1.0,2.0,3.0,4.1,4.5 MHz C: 0.2,0.5,1.0,1.5,2.0 MHz
6: 00	50% Bowtie & 10T
9: 00	Pulse & Bar
11: 00	Quad Phase
13: 00	C-Monoscope Switching position is shifted.
15: 00	

8-1. SWITCHING REGULATOR VOLTAGE CHECK

Machine conditions for adjustment	Specifications	Adjustment
<ul style="list-style-type: none"> • Set the bit 1 through 8 of S601 (B-1) on the SS-48 board to ON. NOTE: When checking, be careful not to short between connector pins. • After adjustment is completed, set the bit 1 through 8 of S601 (B-1) on the SS-48 board to OFF. 	Use the digital voltmeter CN139-46pin/SS-48 +5.1±0.25 V CN139-44pin/SS-48 +8.0 ^{+1.0} _{-0.8} V CN139-42pin/SS-48 -5.1 ^{+0.25} _{-0.8} V CN141-5Apin/SS-48 -13.0 ^{+0.5} _{-0.75} V CN141-4Apin/SS-48 +13.0±0.5 V	(CHECK)

8-2. CHARACTER POSITION ADJUSTMENT

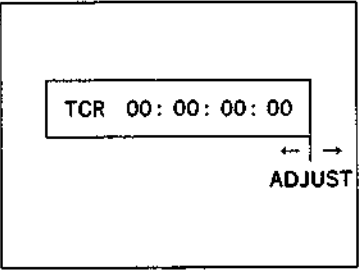
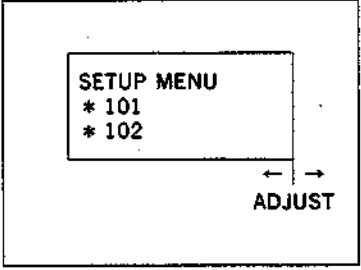
Machine conditions for adjustment	Specifications	Adjustment
Step 1 <ul style="list-style-type: none"> • Connect the picture monitor to VIDEO OUTPUT 3 connector. • CHARACTER switch (sub control panel): ON • CTL/TC/U-BIT switch (control panel): CTL • Play back the C-monoscope signal (13:00—15:00) portion of the alignment tape CR5-2A PS. 	Adjust the CTL character display, and position the right side frame at the same scale which positioned the left side frame in the monoscope picture on the monitor. 	CV401/SS-48(M-1)
Step 2 <ul style="list-style-type: none"> • Press the SYSTEM SET-UP MENU button on the sub control panel once. 	Adjust the setup menu display, and position the right side frame at the same scale which positioned the left side frame in the monoscope picture on the monitor. 	CV402/SS-48(M-1)
<ul style="list-style-type: none"> • After adjustment is completed, press the SYSTEM SET-UP MENU button and display the original picture. 		

SS-48 board

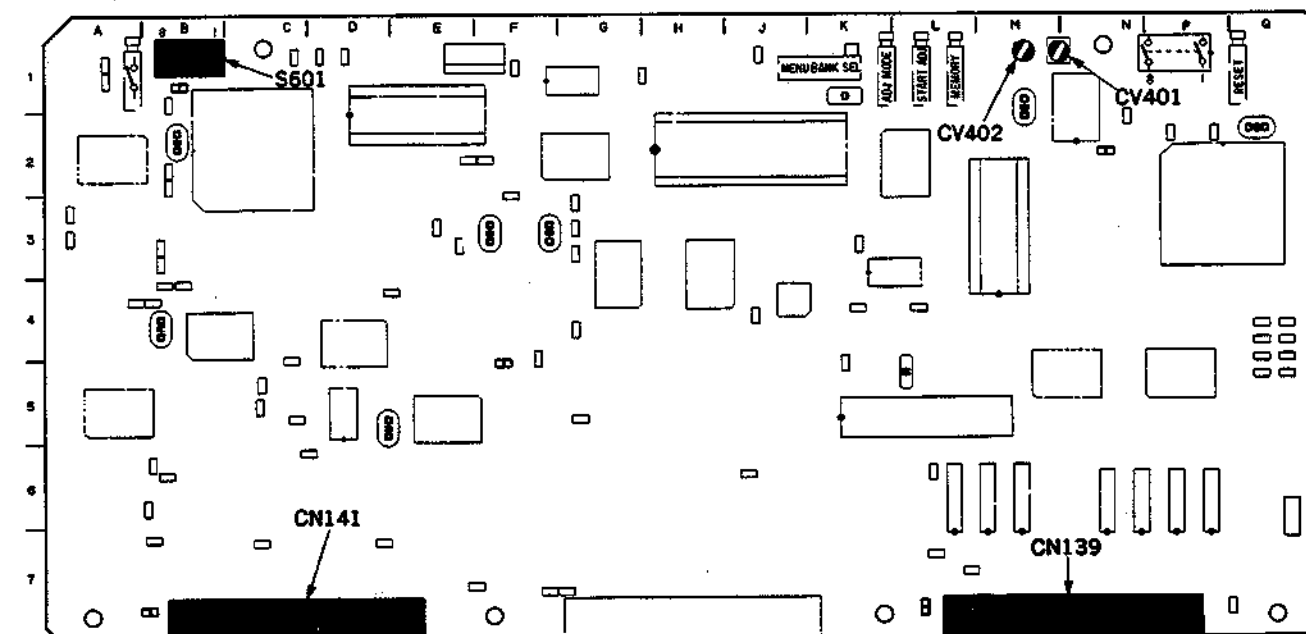

SERVO

SECTION 9 SERVO SYSTEM ALIGNMENT

NOTE: There are relative items about servo system alignment in section 3,5 and 6.
If necessary, refer to them.

[Equipment Required]

- Oscilloscope (TEKTRONIX 2445 or equivalent)
- Picture Monitor
- Alignment Tape CR2-1B PS (Part No. 8-960-096-51)

Contents

VIDEO TRACK	AUDIO TRACK	TIME CODE TRACK	CTL
Y; 4MHz Signal C; 5MHz Signal	Blank	Blank	CTL

- Alignment Tape CR5-1B PS (Part No. 8-960-096-91)

Contents

TIME min s	VIDEO TRACK	AFM
0: 00	RF Sweep Marker 1,2,4,6,8,10,12 MHz	No-Signal
2: 00	60% H Sweep (CTDM) Marker 0.5,1,2,3,4,5 MHz	
5: 00	Pulse & Bar (CTDM)	
8: 00	Multi Burst Y: 0.5,1,2,4,5,5.5 MHz C: 0.2, 0.5,1,1.5,2 MHz	
11: 00	Pulse & Bar	
14: 00	100% Color Bars	400 Hz SINE WAVE 25 kHz DEVIATION
16: 30		75 kHz DEVIATION
17: 00	50% Bowtie & 10T	No-Signal
19: 00	Line 17A	
22: 00	Quad Phase	
24: 00	50% Flat Field	
26: 00	100% Color Bars with Dropout	
28: 00	Composite H Sweep with VISC	
30: 00		

• Alignment Tape CR5-2A PS (Part No. 8-960-098-44)

Contents

TIME min. s	VIDEO TRACK
0: 00	75% Color Bars
3: 00	60% Multi Burst Y: 0.5,1.0,2.0,3.0,4.1,4.5 MHz C: 0.2,0.5,1.0,1.5,2.0 MHz
6: 00	50% Bowtie & 10T
9: 00	Pulse & Bar
11: 00	Quad Phase
13: 00	C-Monoscope Switching position is shifted.
15: 00	

9-1. SEARCH DIAL ASSEMBLY SENSOR DUTY ADJUSTMENT

NOTE: This adjustment should be only performed if any parts are replaced on the PTC-39 board or if any RV is moved unintentionally.

Preparation:

- (1) Remove the lower control panel ass'y. (Refer to Section 2-8.)
- (2) Remove the rubber of a search dial. Then remove the screw on the dial and pull out the dial knob.
- (3) Remove three screws on the lower control panel and remove the search dial.
- (4) Remove one screw on the side of the search dial and remove a plastic cover.
- (5) Install the lower control panel on the unit.
- (6) Install the dial knob and rubber.
- (7) Connect the harness to the connector CN1 on the PTC-39 board passing the hole of the control panel.
- (8) Solder the test terminal for connecting a probe to CN1-2pin, 3pin and 6pin on the PTC-39 board.
- (9) Fix the search dial on the control panel using an adhesive tape, so you can operate the dial by one hand.
- (10) After adjustment is completed, install the dial and the panel.

Fig. 1

Fig. 2

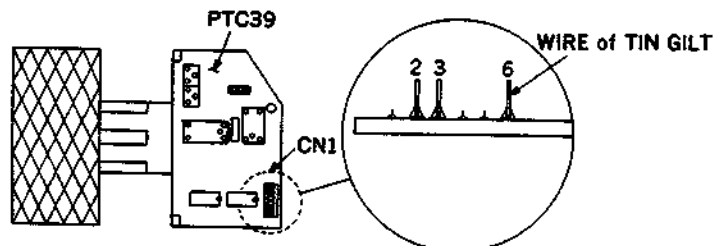
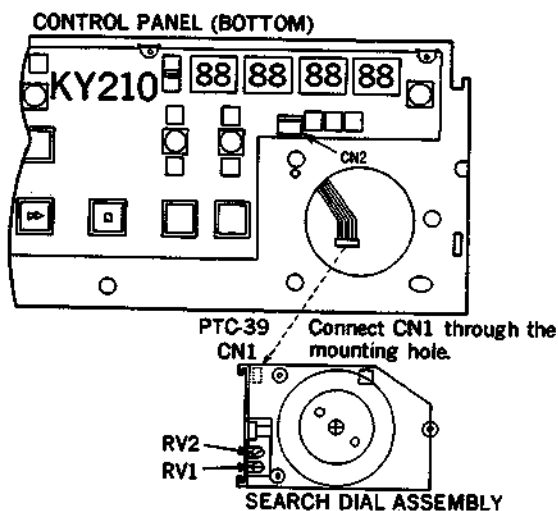

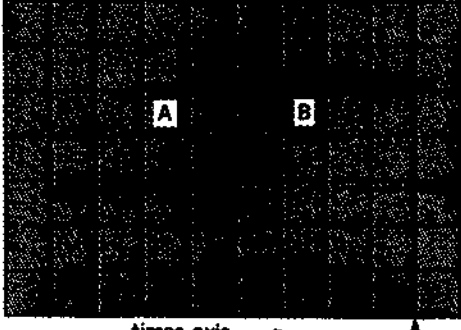
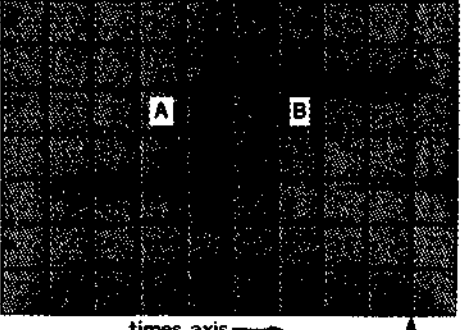
Machine conditions for adjustment	Specifications	Adjustment
<p>Step 1</p> <ul style="list-style-type: none"> • Connect the HOT side of the probe of the oscilloscope to CN1-2pin on the PTC-39 board of the search dial ass'y and the GND side to CN1-6pin. • Press the search dial to put the unit into jog mode. • Oscilloscope VOLTS/div: 2 V SEC/div: 2 ms TRIGGER/SLOPE: - • Turn the H position control of the oscilloscope to position the rising of the beam at the first graduation from the left of the scale. • Turn and keep the search dial in the reverse direction at the settled speed. • Adjust the turning speed of the oscilloscope so that the waveform has one cycle of 8 graduations on the scale. 	<p>Adjust to a width of 8 graduations.</p>  <p>A: B=4.2: 3.8 (±5%)</p>	<p>RV2/PTC-39</p>
<p>Step 2</p> <ul style="list-style-type: none"> • Connect the HOT side of the probe of the oscilloscope to CN1-3pin on the PTC-39 board and the GND side to CN1-6pin. • Press the search dial to put the unit into jog mode. • Oscilloscope VOLTS/div: 2 V SEC/div: 2 ms TRIGGER/SLOPE: - • Turn the H position control of the oscilloscope to position the rising of the beam at the first graduation from the left of the scale. • Turn and keep the search dial in the forward direction at the settled speed. • Adjust the turning speed of the oscilloscope so that the waveform has one cycle of 8 graduations on the scale. 	<p>Adjust to a width of 8 graduations.</p>  <p>A: B=4.2: 3.8 (±5%)</p>	<p>RV1/PTC-39</p>

AUDIO/TC

SECTION 10 AUDIO/TIME CODE SYSTEM ALIGNMENT

[Equipment Required]

- Oscilloscope (TEKTRONIX 2445 or equivalent)
- Signal Generator
 Composite SG (TEKTRONIX 1411 or equivalent)
- Audio Level Meter
- Picture Monitor
- Alignment Tape CR8-1A PS (Part No. 8-960-098-45)

Contents

TIME min s	AUDIO TRACK
0: 00	1 kHz, 0 VU* ¹
2: 55	Blank
3: 00	10 kHz, -10 VU
4: 55	Blank
5: 00	1 kHz, -20 VU
5: 55	Blank
6: 00	40 Hz, 7, 10, 15 kHz, -20 VU* ²
7: 55	Blank
8: 00	1 kHz, 0 VU
10: 00	CTL TRACK 1 kHz, 0 VU

- * 1. When this tape is reproduced in the audio reference level check or adjustment, the output level (0 dB) should be corrected according to the correction value as follows.

Example: Correction value = -0.5 dB

Output level = 0 dB - 0.5 dB = -0.5 dB

- * 2. When this tape is reproduced in the audio frequency response check or adjustment, the output level should be corrected according to the correction value.

[Connection]

Connect some equipments as following CONNECTION 1 or CONNECTION 2 unless otherwise specified.

CONNECTION 1.

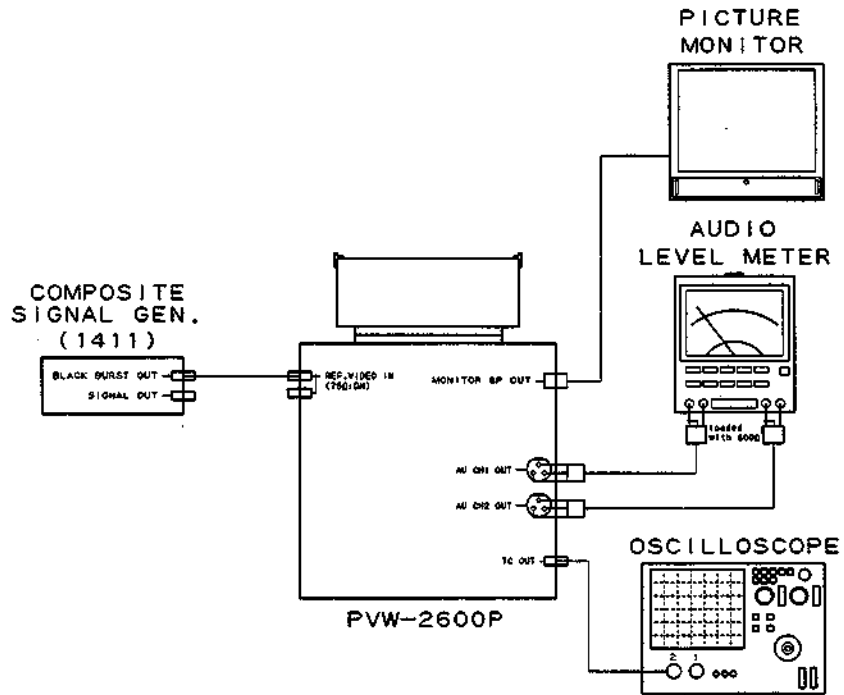

CONNECTION 2.

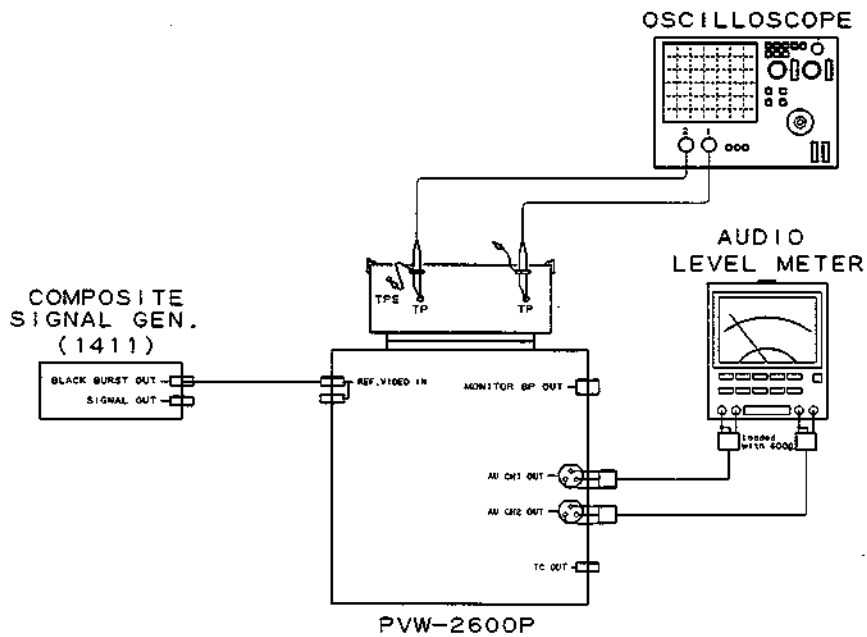

SECTION 10 AUDIO/TIME CODE SYSTEM ALIGNMENT

[Equipment Required]

- Oscilloscope (TEKTRONIX 2445 or equivalent)
- Signal Generator
Composite SG (TEKTRONIX 1411 or equivalent)
- Audio Level Meter
- Picture Monitor
- Alignment Tape CR8-1A PS (Part No. 8-960-098-45)

Contents

TIME min s	AUDIO TRACK
0: 00	1 kHz, 0 VU ^{*1}
2: 55	Blank
3: 00	10 kHz, -10 VU
4: 55	Blank
5: 00	1 kHz, -20 VU
5: 55	Blank
6: 00	40 Hz, 7, 10, 15 kHz, -20 VU ^{**2}
7: 55	Blank
8: 00	1 kHz, 0 VU CTL TRACK 1 kHz, 0 VU
10: 00	

- * 1. When this tape is reproduced in the audio reference level check or adjustment, the output level (0 dB) should be corrected according to the correction value as follows.

Example: Correction value = -0.5 dB

Output level = 0 dB - 0.5 dB = -0.5 dB

- * 2. When this tape is reproduced in the audio frequency response check or adjustment, the output level should be corrected according to the correction value.

• Alignment Tape CR8-1B PS (Part No. 8-960-096-86)

Contents

TIME min s	AUDIO TRACK	VIDEO TRACK	CTL TRACK
0: 00	1 kHz, 0 VU**	Black Burst	CTL
2: 30	Blank (only Bias)	Black Burst	CTL
	15 kHz, 0 VU	Black Burst	CTL
5: 00	1 kHz, -20 VU	Black Burst	CTL
6: 00	40 Hz, -20 VU**	Black Burst	CTL
6: 30	7 kHz, -20 VU**		
7: 00	10 kHz, -20 VU**		
7: 30	15 kHz, -20 VU**		
8: 00	1 kHz 0 VU		
10: 00		—	1 kHz sine wave

- * 1. When this tape is reproduced in the audio reference level check or adjustment, the output level (0 dB) should be corrected according to the correction value as follows.

Example: Correction value = -0.5 dB

Output level = 0 dB - 0.5 dB = -0.5 dB

- * 2. When this tape is reproduced in the audio frequency response check or adjustment, the output level should be corrected according to the correction value.

[Switch/Setup menu/Volume Setting]

This setting should not be changed in position unless otherwise specified.

Terminate the output of the AUDIO OUT connector at 600 Ω unless otherwise specified.

<Control Panel>

upper

AUDIO MONITOR: MIX

CH1 PB VOL: PUSH(PRESET)

CH2 PB VOL: PUSH(PRESET)

HEADPHONES VOL: MIN

<Sub Control Panel>

DOLBY NR: OFF

[Connection]

Connect some equipments as following CONNECTION 1 or CONNECTION 2 unless otherwise specified.

CONNECTION 1.

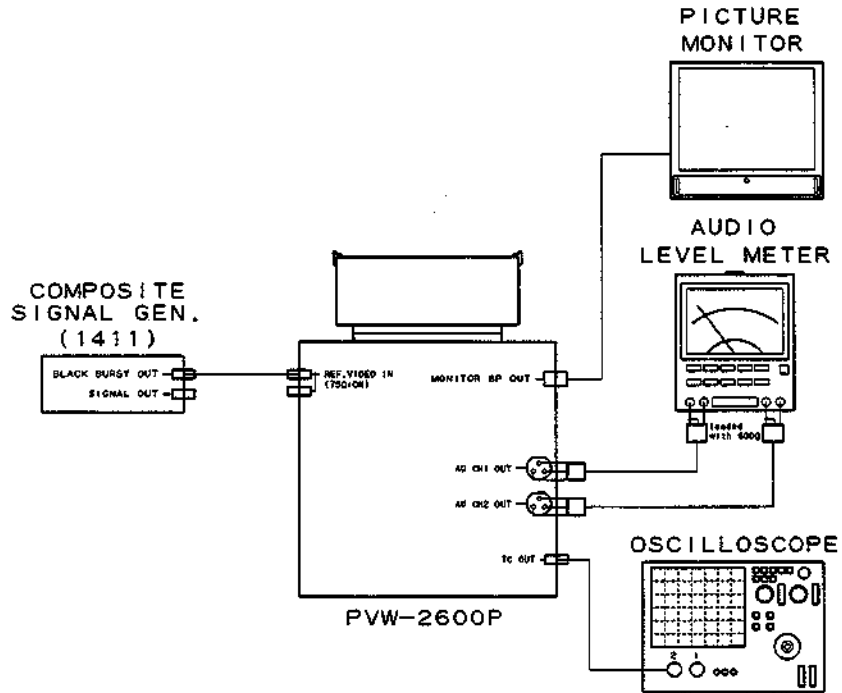

CONNECTION 2.

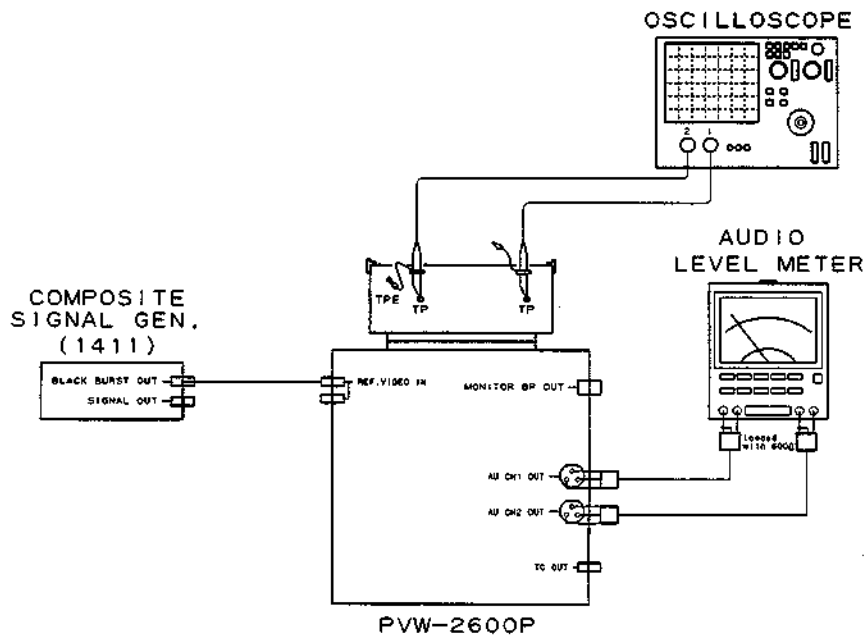

CONNECTION 3.

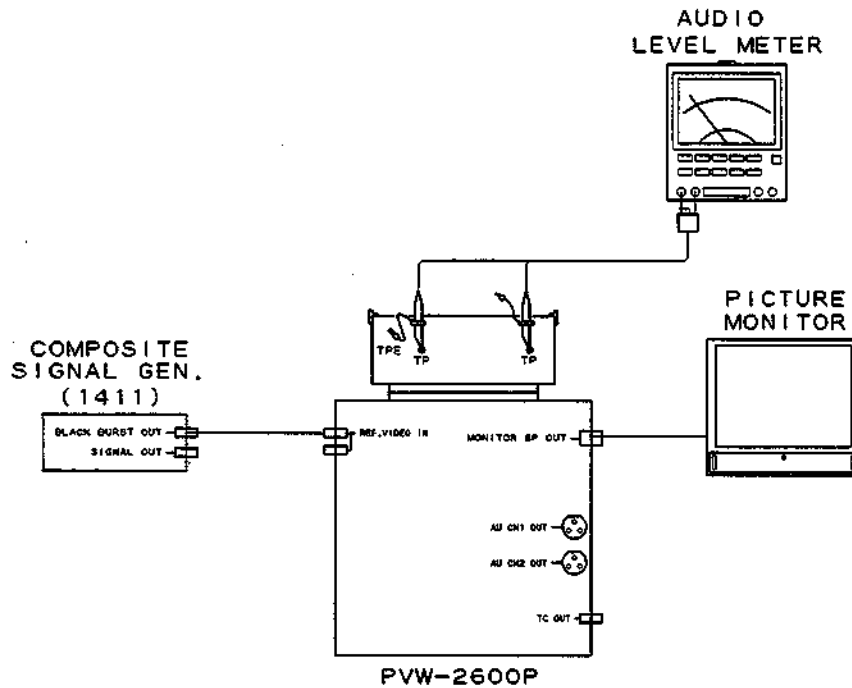

[Preparations and Notes on Alignment]

• Preparations

Cleaning of stationary heads

Clean two stationary heads by the cleaning piece moistened with cleaning fluid. After the fluid blow off, wipe off the heads by a dry cloth or cleaning piece.

• Notes for alignment

- Level fluctuation at 15 kHz in PB is permitted by 0.5 dB.
- When the alignment tape is played back, specification should be corrected according to the correction value mentioned in the tape level.
- The alignment tape is used within the limits of about 50 times and recommend to manage by marking.

AUDIO SYSTEM LEVEL DIAGRAM
 PB MODE(CR8-1A,1 kHz 0 VU PORTION)
 PB LEVEL CONTROL=PRESET

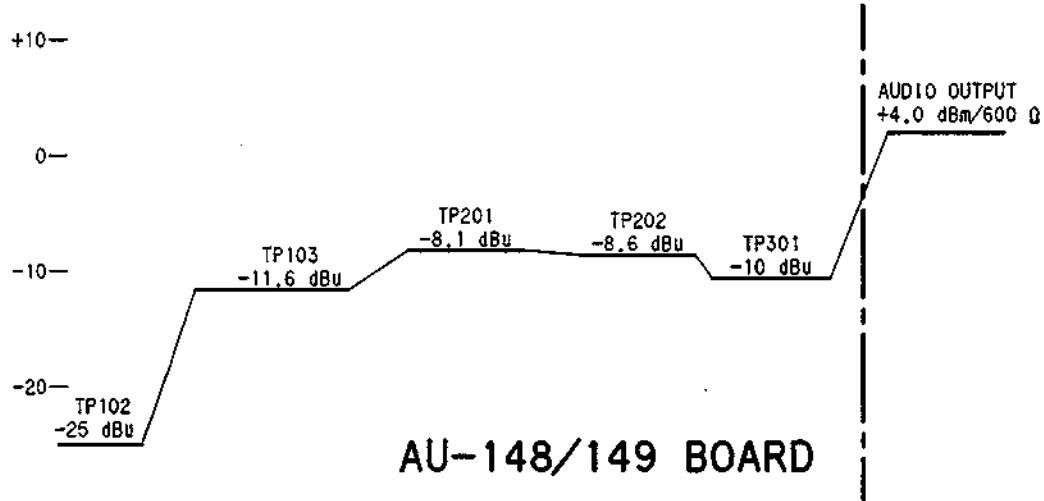

BOARD	TEST POINT	LEVEL		MODE
		-dBu	mV rms	
AU148/149	TP102	-25.0	43.6	PB
AU148/149	TP103	-11.6	203.7	PB
AU148/149	TP201	-8.1	304.8	PB
AU148/149	TP202	-8.6	287.8	PB
AU148/149	TP301	-10.0	245.0	PB
CP167	AUDIO OUT	*+4.0 dBm	1227.7	PB

*----600 Ω TERMINATED

AU-148/149 board (A Side)

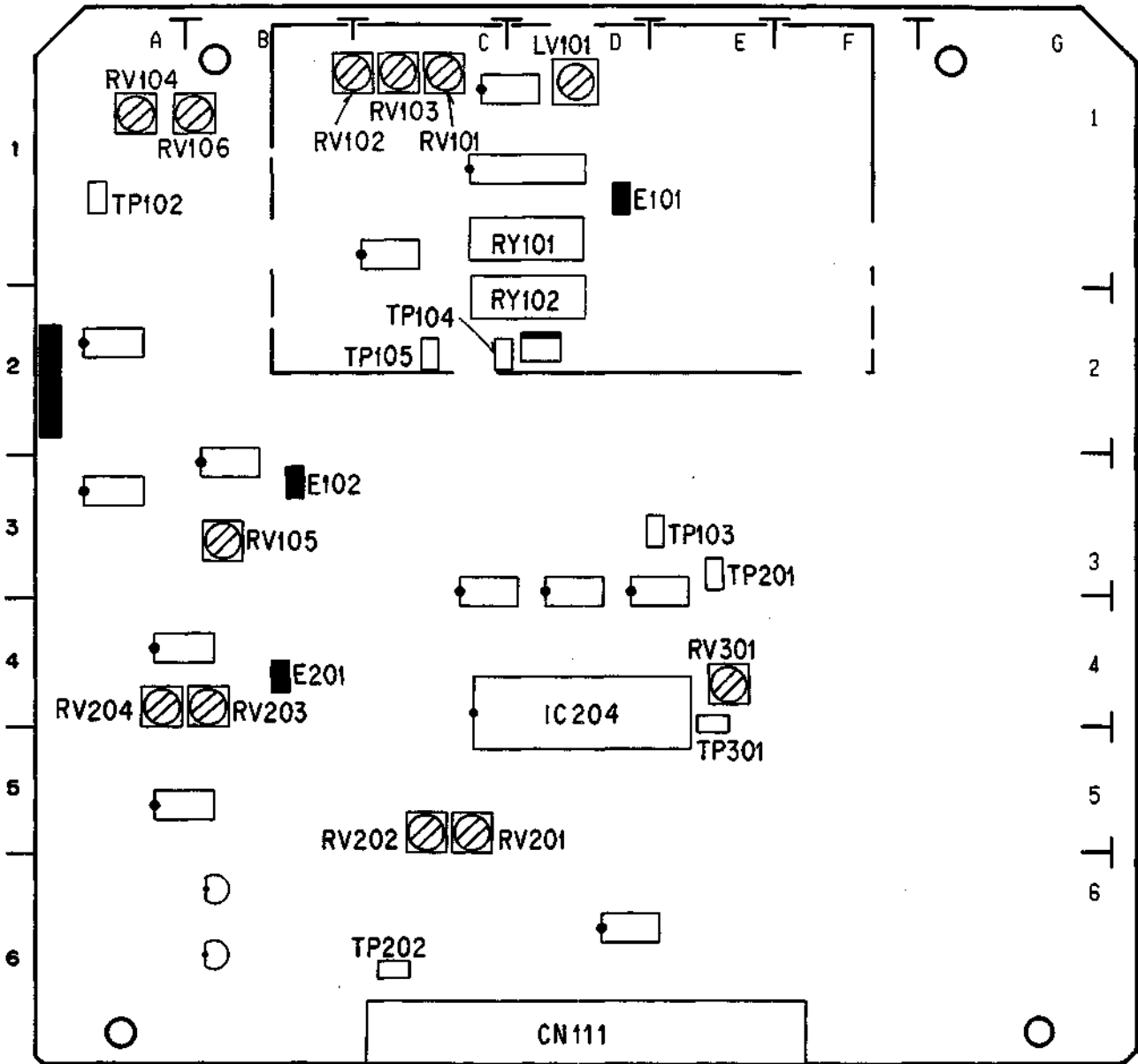

MA-44 board (A Side)

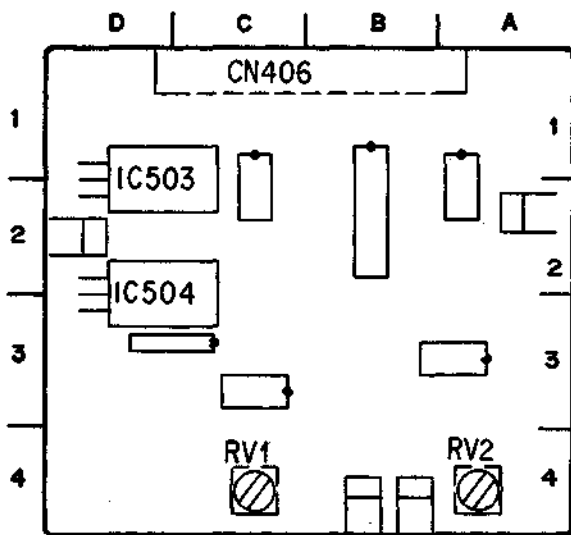

10-1. AUDIO PB DOLBY OFF FREQUENCY RESPONSE ADJUSTMENT

10-1-1. CH-1 Audio PB Dolby Off Frequency Response Adjustment

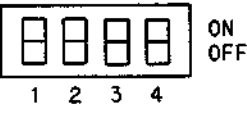
Preparations for adjustment	Specifications	Adjustments												
<p>Step 1</p> <p>RV201</p>  <ul style="list-style-type: none"> RV201/AU-148 (C-5) should indicate in the direction of 3 o'clock. Play back the 1 kHz, 40 Hz, 7 kHz, 10 kHz and 15 kHz (-20 VU) signal portion (5:00-7:55) of the alignment tape CR8-1A PS. 	<p>CH1 AUDIO OUT</p> <table border="1"> <thead> <tr> <th>FREQUENCY [Hz]</th> <th>OUTPUT LEVEL [dB]</th> </tr> </thead> <tbody> <tr> <td>40</td> <td>0^{+0.7}_{-2.5}</td> </tr> <tr> <td>1 k</td> <td>0(REF)</td> </tr> <tr> <td>7 k</td> <td>0±0.5</td> </tr> <tr> <td>10 k</td> <td>0^{+0.5}_{-0.7}</td> </tr> <tr> <td>15 k</td> <td>0^{+0.5}_{-1.2}</td> </tr> </tbody> </table>	FREQUENCY [Hz]	OUTPUT LEVEL [dB]	40	0 ^{+0.7} _{-2.5}	1 k	0(REF)	7 k	0±0.5	10 k	0 ^{+0.5} _{-0.7}	15 k	0 ^{+0.5} _{-1.2}	<p>High-Frequency</p> <p>● RV101/AU-148 (C-1)</p> <p>Low-Frequency</p> <p>● RV102/AU-148 (C-1)</p> <p>Adjust alternately</p> <p>If the specification of the high frequency is not satisfied, change SW101/AU-148 (C-1) board.</p>  <p>Set SW101/AU-148 and SW101/AU-149 at the same position and then perform the adjustment.</p> <p>CONNECTION 1</p>
FREQUENCY [Hz]	OUTPUT LEVEL [dB]													
40	0 ^{+0.7} _{-2.5}													
1 k	0(REF)													
7 k	0±0.5													
10 k	0 ^{+0.5} _{-0.7}													
15 k	0 ^{+0.5} _{-1.2}													
<p>Step 2</p> <ul style="list-style-type: none"> Play back the 1 kHz, 0 VU signal portion (0:00-2:55) of the alignment tape CR8-1A PS. 	<p>TP301/AU-148 (E-4)</p> <p>-10.00±0.05 dBu</p>	<p>● RV106/AU-148 (B-1)</p> <p>CONNECTION 1</p>												
<p>Step 3</p> <ul style="list-style-type: none"> Play back the 1 kHz, 0 VU signal portion (0:00-2:55) of the alignment tape CR8-1A PS. 	<p>CH1 AUDIO OUT</p> <p>+4.0±0.1 dBm</p>	<p>● RV204/AU-148 (A-4)</p> <p>CONNECTION 1</p>												

NOTE: If SW101/AU-148 was changed, perform Section 10-1-4. CH-1 Audio PB Phase Adjustment.

AU-148/149 board

APPLICATION: 10-1-1.

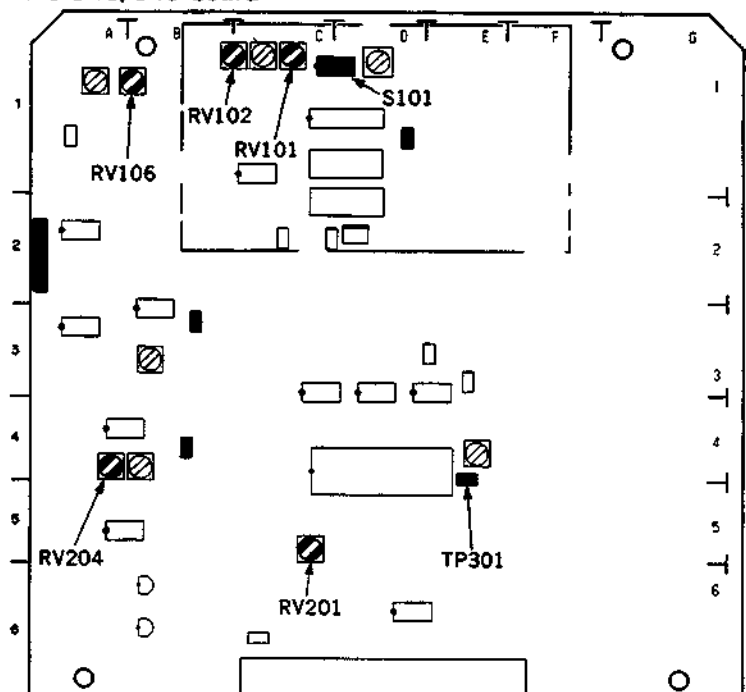

10-1-2. CH-2 Audio PB Dolby Off Frequency Response Adjustment

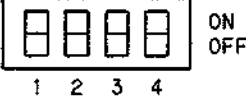
Preparations for adjustment	Specifications	Adjustments												
<p>Step 1</p>  <ul style="list-style-type: none"> RV201/AU-149 (C-5) should indicate in the direction of 3 o'clock. Play back the 1 kHz, 40 Hz, 7 kHz, 10 kHz and 15 kHz (-20 VU) signal portion (5: 00-7: 55) of the alignment tape CR8-1A PS. 	<p>CH2 AUDIO OUT</p> <table border="1" data-bbox="542 392 981 616"> <thead> <tr> <th>FREQUENCY [Hz]</th> <th>OUTPUT LEVEL [dB]</th> </tr> </thead> <tbody> <tr> <td>40</td> <td>0 $\begin{smallmatrix} +0.7 \\ -2.5 \end{smallmatrix}$</td> </tr> <tr> <td>1 k</td> <td>0(REF)</td> </tr> <tr> <td>7 k</td> <td>0\pm0.5</td> </tr> <tr> <td>10 k</td> <td>0 $\begin{smallmatrix} +0.5 \\ -0.7 \end{smallmatrix}$</td> </tr> <tr> <td>15 k</td> <td>0 $\begin{smallmatrix} +0.5 \\ -1.2 \end{smallmatrix}$</td> </tr> </tbody> </table>	FREQUENCY [Hz]	OUTPUT LEVEL [dB]	40	0 $\begin{smallmatrix} +0.7 \\ -2.5 \end{smallmatrix}$	1 k	0(REF)	7 k	0 \pm 0.5	10 k	0 $\begin{smallmatrix} +0.5 \\ -0.7 \end{smallmatrix}$	15 k	0 $\begin{smallmatrix} +0.5 \\ -1.2 \end{smallmatrix}$	<p>High-Frequency ●RV101/AU-149 (C-1) Low-Frequency ●RV102/AU-149 (C-1) Adjust alternately If the specification of the high frequency is not satisfied, change SW101/AU-148 (C-1) board.</p>  <p>Set SW101/AU-148 and SW101/AU-149 at the same position and then perform the adjustment.</p> <p>CONNECTION 1</p>
FREQUENCY [Hz]	OUTPUT LEVEL [dB]													
40	0 $\begin{smallmatrix} +0.7 \\ -2.5 \end{smallmatrix}$													
1 k	0(REF)													
7 k	0 \pm 0.5													
10 k	0 $\begin{smallmatrix} +0.5 \\ -0.7 \end{smallmatrix}$													
15 k	0 $\begin{smallmatrix} +0.5 \\ -1.2 \end{smallmatrix}$													
<p>Step 2</p> <ul style="list-style-type: none"> Play back the 1 kHz, 0 VU signal portion (0: 00-2: 55) of the alignment tape CR8-1A PS. 	<p>TP301/AU-149 (E-4) -10.00\pm0.05 dBu</p>	<p>●RV106/AU-149 (B-1) CONNECTION 1</p>												
<p>Step 3</p> <ul style="list-style-type: none"> Play back the 1 kHz, 0 VU signal portion (0: 00-2: 55) of the alignment tape CR8-1A PS. 	<p>CH2 AUDIO OUT +4.0\pm0.1 dBm</p>	<p>●RV204/AU-149 (A-4) CONNECTION 1</p>												

NOTE: If SW101/AU-149 was changed, perform Section 10-1-6. CH-2 Audio PB Phase Adjustment.

AU-148/149 board

APPLICATION: 10-1-2.

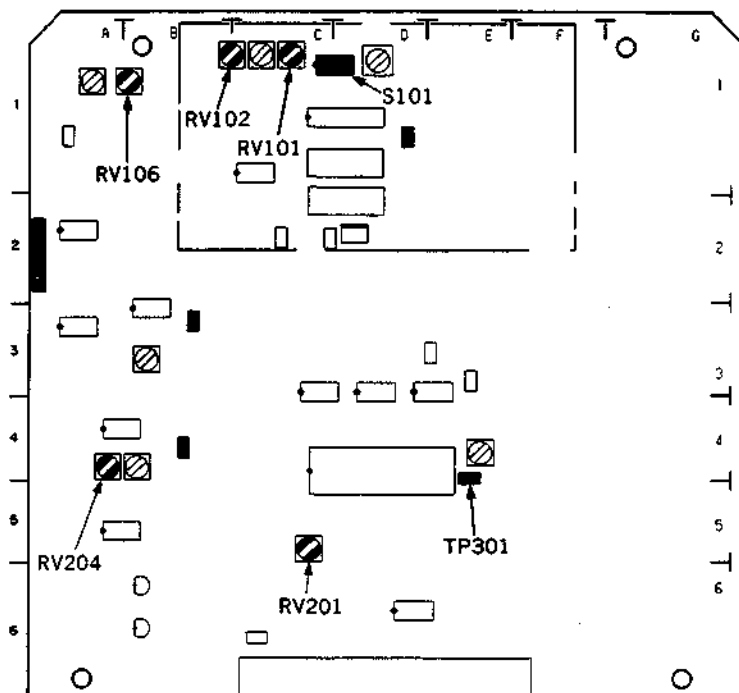

10-1-3. CH-1 Audio PB Dolby Off Metal Frequency Response Adjustment

Preparations for adjustment	Specifications	Adjustments								
Step 1 • Play back the 1 kHz, 40 Hz, 7 kHz, 10 kHz and 15 kHz (-20 VU) signal portion (6: 00-8: 00) of the alignment tape CR8-1B PS.	CH1 AUDIO OUT <table border="1"> <thead> <tr> <th>FREQUENCY [Hz]</th> <th>OUTPUT LEVEL [dB]</th> </tr> </thead> <tbody> <tr> <td>1 k</td> <td>0 (REF)</td> </tr> <tr> <td>10 k</td> <td>0 ±0.2</td> </tr> <tr> <td>15 k</td> <td>-0.8 ±0.5</td> </tr> </tbody> </table>	FREQUENCY [Hz]	OUTPUT LEVEL [dB]	1 k	0 (REF)	10 k	0 ±0.2	15 k	-0.8 ±0.5	High-Frequency ● RV103/AU-148 (C-1) CONNECTION 1
FREQUENCY [Hz]	OUTPUT LEVEL [dB]									
1 k	0 (REF)									
10 k	0 ±0.2									
15 k	-0.8 ±0.5									
Step 2 • Play back the 1 kHz, 0 VU signal portion (0: 00-2: 30) of the alignment tape CR8-1B PS.	CH1 AUDIO OUT +4.0 ±0.1 dBm	Middle-Frequency ● RV104/AU-148 (A-1) CONNECTION 1								

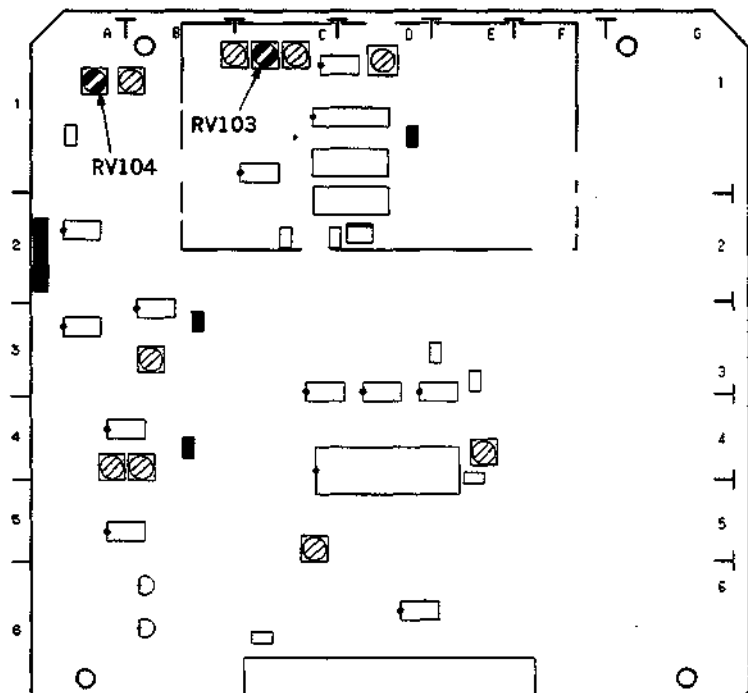

APPLICATION: 10-1-3.

AU-148/149 board

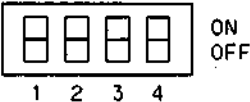

10-1-4. CH-1 Audio PB Phase Adjustment

Before the adjustment, Audio Head Phase Adjustment in Section 6-8 should be completed.

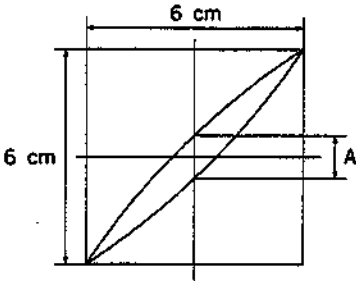
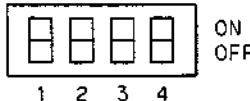
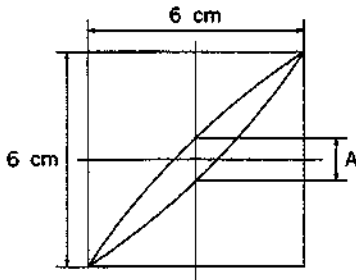
Preparations for adjustment	Specifications	Adjustments
<p>Step 1</p> <ul style="list-style-type: none"> • Connect the CH1 probe of the oscilloscope to CH2 AUDIO OUT connector. (HOT side to 2 pin, and GND side to 3 pin) • Connect the CH2 probe of the oscilloscope to CH1 AUDIO OUT connector. (HOT side to 2 pin, and GND side to 3 pin) • Set the oscilloscope to X-Y mode. • Write down the setting of SW101 bit1 through bit4 (C-1) on the AU-148 and AU-149 boards.  <ul style="list-style-type: none"> • Set SW101 on the AU-148 board and SW101 on the AU-149 board to all OFF.  <ul style="list-style-type: none"> • Play back the 10 kHz, -10 VU signal portion (3: 00-4: 55) of the alignment tape CR8-1A. 	<p>CH1 AUDIO OUT (CH2 probe: Y axis) CH2 AUDIO OUT (CH1 probe: X axis) Lissajous waveform of the oscilloscope</p>  <p>The lissajous waveform should point from the bottom-left to the top-right corner area. $A \leq 0.5 \text{ cm } (\pm 5' \text{ or less})$</p> <p>If the specification is not satisfied, perform Audio Head Phase Adjustment in Section 6-8.</p>	<p>(Check)</p> <p>CONNECTION 2</p>
<p>Step 2</p> <ul style="list-style-type: none"> • Extend the AU-148 board by extension board. • Reset SW101 on the AU-148 board to the memorized position in Step 1.  <ul style="list-style-type: none"> • Play back the 10 kHz, -10 VU signal portion (3: 00-4: 55) of the alignment tape CR8-1A. 	 <p>The lissajous waveform should point from the bottom-left to the top-right corner area. $A \leq 0.5 \text{ cm } (\pm 5' \text{ or less})$</p>	<p>RV105/AU-148 (B-3)</p> <p>CONNECTION 2</p>

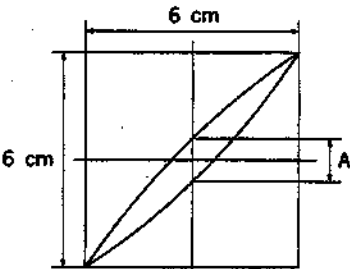
Preparations for adjustment	Specifications	Adjustments
<p>Step 3</p> <ul style="list-style-type: none"> • Disconnect the extension board. • Play back the 10kHz, -10VU signal portion (3:00-4:55) of the alignment tape CR8-1A. <p>NOTE: Confirm that SW101 on the AU-148 and AU-149 boards are set to the memorized position in Step 1.</p> <div style="display: flex; align-items: center; margin-top: 10px;"> <div style="border: 1px solid black; padding: 2px; margin-right: 5px;"> <div style="width: 10px; height: 10px; background-color: white; margin-bottom: 2px;"></div> <div style="width: 10px; height: 10px; background-color: white; margin-bottom: 2px;"></div> <div style="width: 10px; height: 10px; background-color: white; margin-bottom: 2px;"></div> <div style="width: 10px; height: 10px; background-color: white; margin-bottom: 2px;"></div> </div> <div style="margin-right: 5px;">ON</div> <div style="margin-right: 5px;">OFF</div> </div> <div style="display: flex; justify-content: space-around; width: 100px; margin-top: 5px;"> 1234 </div>	<div style="text-align: center; margin-bottom: 20px;">  </div> <p>The lissajous waveform should point from the bottom-left to the top-right corner area.</p> <p style="text-align: center;">$A \leq 0.5 \text{ cm } (\pm 5' \text{ or less})$</p> <p>If the specification is not satisfied, perform CH-2 Audio PB Phase Adjustment in section 10-1-6.</p>	<p>(Check)</p>

APPLICATION: 10-1-4.

AU-148/149 board

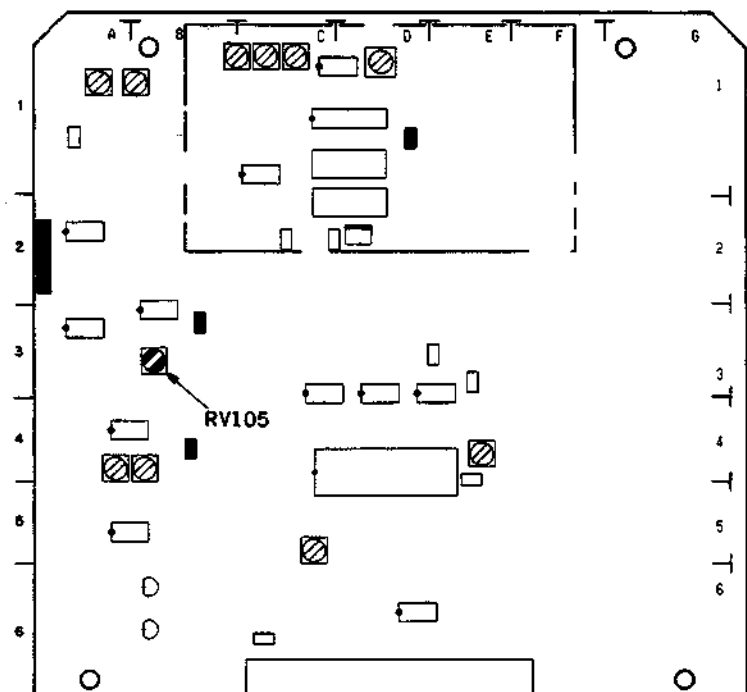

10-1-5. CH-2 Audio PB Dolby Off Metal Frequency Response Adjustment

Preparations for adjustment	Specifications	Adjustments								
Step 1 • Play back the 1 kHz, 40 Hz, 7 kHz, 10 kHz and 15 kHz (-20 VU) signal portion (6: 00-8: 00) of the alignment tape CR8-1B PS.	CH2 AUDIO OUT <table border="1"> <thead> <tr> <th>FREQUENCY [Hz]</th> <th>OUTPUT LEVEL [dB]</th> </tr> </thead> <tbody> <tr> <td>1 k</td> <td>0 (REF)</td> </tr> <tr> <td>10 k</td> <td>0 ±0.2</td> </tr> <tr> <td>15 k</td> <td>-0.8 ±0.2</td> </tr> </tbody> </table>	FREQUENCY [Hz]	OUTPUT LEVEL [dB]	1 k	0 (REF)	10 k	0 ±0.2	15 k	-0.8 ±0.2	High-Frequency ● RV103/AU-149 (C-1) CONNECTION 1
FREQUENCY [Hz]	OUTPUT LEVEL [dB]									
1 k	0 (REF)									
10 k	0 ±0.2									
15 k	-0.8 ±0.2									
Step 2 • Play back the 1 kHz, 0 VU signal portion (0: 00-2: 30) of the alignment tape CR8-1B PS.	CH2 AUDIO OUT +4.0 ±0.1 dBm	Middle-Frequency ● RV104/AU-149 (A-1) CONNECTION 1								

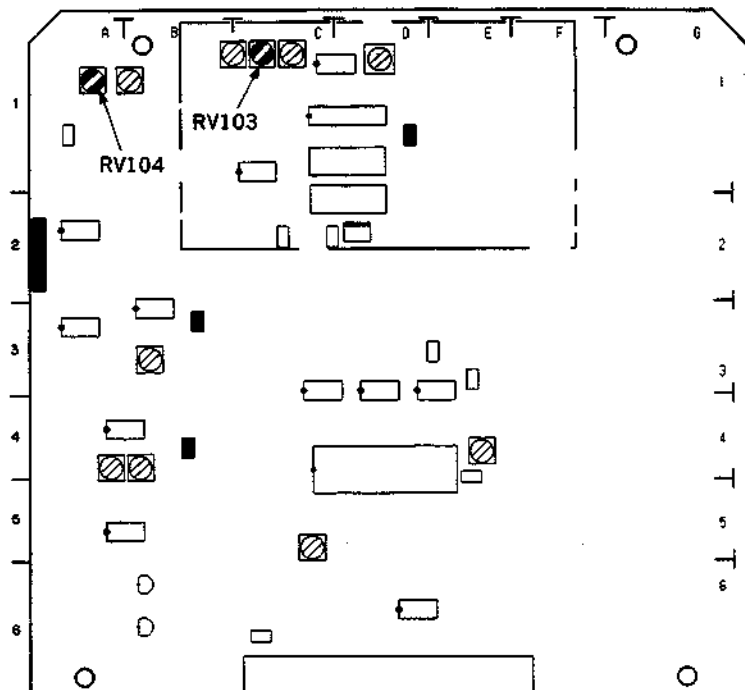

APPLICATION: 10-1-5.

AU-148/149 board

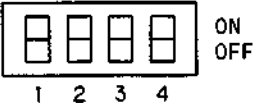

10-1-6. CH-2 Audio PB Phase Adjustment

Before the adjustment, Audio Head Phase Adjustment in Section 6-8 should be completed.

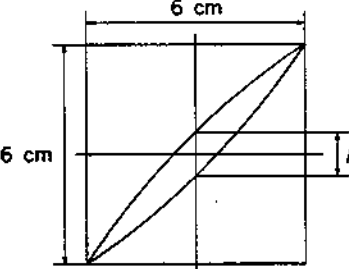
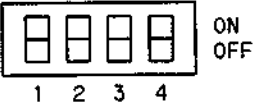
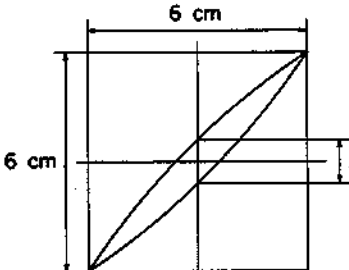
Preparations for adjustment	Specifications	Adjustments
<p>Step 1</p> <ul style="list-style-type: none"> Connect the CH1 probe of the oscilloscope to CH1 AUDIO OUT connector. (HOT side to 2 pin, and GND side to 3 pin) Connect the CH2 probe of the oscilloscope to CH2 AUDIO OUT connector. (HOT side to 2 pin, and GND side to 3 pin) Set the oscilloscope to X-Y mode. Write down the setting of SW101 bit1 through bit4 (C-1) on the AU-148 and AU-149 boards.  <ul style="list-style-type: none"> Set SW101 on the AU-148 board and SW101 on the AU-149 board to all OFF.  <ul style="list-style-type: none"> Play back the 10 kHz, -10 VU signal portion (3: 00-4: 55) of the alignment tape CR8-1A. 	<p>CH1 AUDIO OUT (CH1 probe: X axis) CH2 AUDIO OUT (CH2 probe: Y axis) Lissajous waveform of the oscilloscope</p>  <p>The lissajous waveform should point from the bottom-left to the top-right corner area. $A \leq 0.5 \text{ cm } (\pm 5' \text{ or less})$</p> <p>If the specification is not satisfied, perform Audio Head Phase Adjustment in Section 6-8.</p>	(Check)
<p>Step 2</p> <ul style="list-style-type: none"> Extend the AU-149 board by extension board. Reset SW101 on the AU-149 board to the memorized position in Step 1.  <ul style="list-style-type: none"> Play back the 10 kHz, -10 VU signal portion (3: 00-4: 55) of the alignment tape CR8-1A. 	 <p>The lissajous waveform should point from the bottom-left to the top-right corner area. $A \leq 0.5 \text{ cm } (\pm 5' \text{ or less})$</p>	<p>CONNECTION 2</p> <p>RV105/AU-149 (B-3)</p>

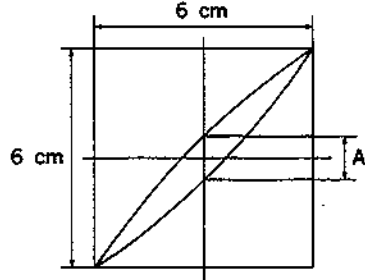
Preparations for adjustment	Specifications	Adjustments
<p>Step 3</p> <ul style="list-style-type: none"> Disconnect the extension board. Play back the 10 kHz, -10 VU signal portion (3: 00-4: 55) of the alignment tape CR8-1A. <p>NOTE: Confirm that SW101 on the AU-148 and AU-149 boards are set to the memorized position in Step 1.</p> 	 <p>The lissajous waveform should point from the bottom-left to the top-right corner area. $A \leq 0.5 \text{ cm } (\pm 5' \text{ or less})$</p> <p>If the specification is not satisfied, perform CH-1 Audio PB Phase Adjustment in section 10-1-4.</p>	(Check)

APPLICATION: 10-1-6.

AU-148/149 board

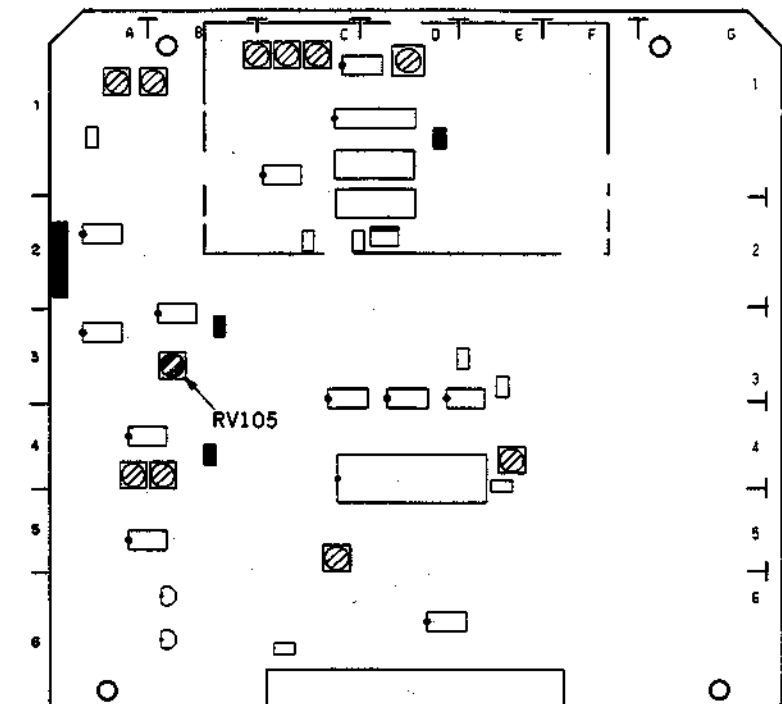

10-2. SEARCH MODE AUDIO PB LEVEL CHECK

10-2-1. CH-1 Search Mode Audio OXIDE/METAL PB Level Check

Preparations for adjustment	Specifications	Adjustments
<ul style="list-style-type: none"> Rewind the 1 kHz, 0 VU signal portion (0:00—2:55) of the alignment tape CR8-1A PS and 1 kHz, 0 VU signal portion (0:00—2:30) of the alignment tape CR8-1B PS (10 times normal speed). 	CH1 AUDIO OUT +10.0 dBm or less	(Check) CONNECTION 1

10-2-2. CH-2 Search Mode Audio OXIDE/METAL PB Level Check

Preparations for adjustment	Specifications	Adjustments
<ul style="list-style-type: none"> Rewind the 1 kHz, 0 VU signal portion (0:00—2:55) of the alignment tape CR8-1A PS and 1 kHz, 0 VU signal portion (0:00—2:30) of the alignment tape CR8-1B PS (10 times normal speed). 	CH2 AUDIO OUT +10.0 dBm or less	(Check) CONNECTION 1

10-3. AUDIO METER ADJUSTMENT

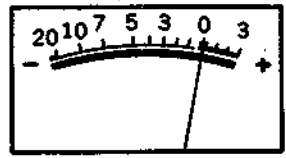
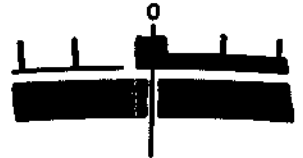
Preparations for adjustment	Specifications	Adjustments
<ul style="list-style-type: none"> Play back the 1 kHz, 0 VU signal portion (0:00—2:55) of the alignment tape CR8-1A PS. 	CH1/CH2 VU METER   The pointer should indicate zero. Correct the adjustment position of the pointer by using correction value which is listed on the label of the alignment tape.	CH1 Ⓞ RV1/MA-44 (C-4) CH2 Ⓞ RV2/MA-44 (A-4) CONNECTION 1

APPLICATION: 10-3.

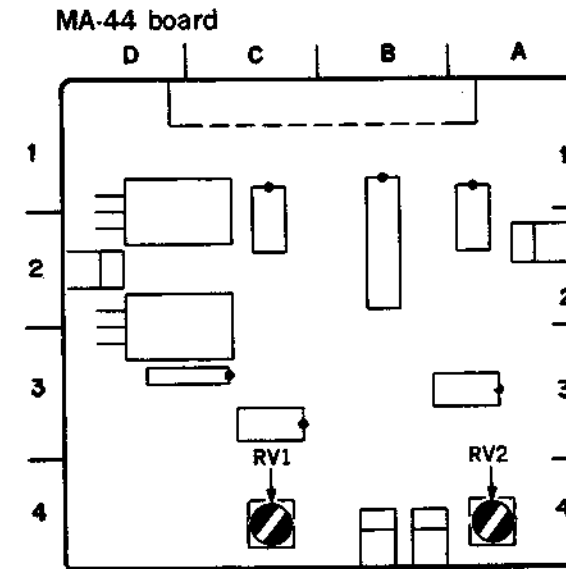

10-4. AUDIO MONITOR OUT LEVEL CHECK

10-4-1. CH-1 Audio Monitor Out Level Check

Preparations for adjustment	Specifications	Adjustments
<ul style="list-style-type: none"> • AUDIO MONITOR switch (control panel): MIX • Pull the CH1 PB level control on the control panel, then fully turn it counterclockwise. (MIN) • Play back the 1 kHz, 0 VU signal portion (0:00—2:55) of the alignment tape CR8-1B PS. 	<p style="text-align: center;">AUDIO MONITOR OUT</p> <p style="text-align: center;">+4.0±0.5 dBm</p>	<p style="text-align: center;">(Check)</p>

10-4-2. CH-2 Audio Monitor Out Level Check

Preparations for adjustment	Specifications	Adjustments
<ul style="list-style-type: none"> • AUDIO MONITOR switch (control panel): MIX • Pull the CH2 PB level control on the control panel, then fully turn it counterclockwise. (MIN) • Play back the 1 kHz, 0 VU signal portion (0:00—2:55) of the alignment tape CR8-1B PS. 	<p style="text-align: center;">AUDIO MONITOR OUT</p> <p style="text-align: center;">+4.0±0.5 dBm</p>	<p style="text-align: center;">(Check)</p>

10-5. HEADPHONES LEVEL CHECK

Preparations for adjustment	Specifications	Adjustments
<p>Step 1</p> <ul style="list-style-type: none"> • Connect a stereo phone jack between the HEADPHONES jack on a control panel and a audio level meter. (terminated by 8 Ω) • Turn the HEADPHONES volume level control on a control panel counterclockwise fully (MIN). • Play back the 1 kHz, 0 VU signal portion (0: 00—2: 55) of the alignment tape CR8-1A PS. 	<p>HEADPHONES connector OUT (CH1/CH2)</p> <p style="text-align: center;">-70 dBu or less</p>	<p>(Check)</p>
<p>Step 2</p> <ul style="list-style-type: none"> • Turn the HEADPHONES volume level control clockwise fully (MAX). • Play back the 1 kHz, 0 VU signal portion (0: 00—2: 55) of the alignment tape CR8-1A PS. 	<p>HEADPHONES connector OUT (CH1/CH2)</p> <p style="text-align: center;">-16±2 dBu</p>	<p>(Check)</p>
<p>Step 3</p> <ul style="list-style-type: none"> • Play back the 1 kHz, 0 VU signal portion (0: 00—2: 55) of the alignment tape CR8-1A PS. 	<p>HEADPHONES connector OUT (CH1/CH2)</p> <p>CH1:</p> <p style="text-align: center;">-16±2 dBu</p> <p>CH2:</p> <p style="text-align: center;">-60 dBu or less</p>	<p>(Check)</p>
<p>Step 4</p> <ul style="list-style-type: none"> • AUDIO MONITOR select switch (control panel): CH1 • Play back the 1 kHz, 0 VU signal portion (0: 00—2: 55) of the alignment tape CR8-1A PS. 	<p>HEADPHONES connector OUT (CH1/CH2)</p> <p>CH1/CH2</p> <p style="text-align: center;">-16±2 dBu</p>	<p>(Check)</p>
<p>Step 5</p> <ul style="list-style-type: none"> • AUDIO MONITOR select switch (control panel): CH2 • Play back the 1 kHz, 0 VU signal portion (0: 00—2: 55) of the alignment tape CR8-1A PS. • After adjustment is completed, set the AUDIO MONITOR select switch to MIX, and set the PB level controls to mechanical center. 	<p>HEADPHONES connector OUT (CH1/CH2)</p> <p>CH1/CH2</p> <p style="text-align: center;">-70 dBu or less</p>	<p>(Check)</p>

VIDEO



SECTION 11 VIDEO SYSTEM ALIGNMENT

[Equipment Required]

- Oscilloscope (TEKTRONIX 2445 or equivalent)
 - Signal Generator
 - Composite SG (TEKTRONIX 1411 or equivalent)
 - Waveform Monitor
 - Component (TEKTRONIX WFM300/WFM300A/1781R or equivalent)
 - Composite (TEKTRONIX 1481C/1751/1781R or equivalent)
 - Spectrum Analyzer (ADVANTEST R4131 B/D or equivalent)
 - Picture Monitor
 - Frequency Counter
 - Blank Tape (oxide) BCT-20G
 - Blank Tape (metal) BCT-20M
- NOTE:** "Blank Tape" indicates a cassette tape on which no video/audio signals are recorded.
- Alignment Tape CR5-2A PS (part No. 8-960-098-44)

Contents

TIME min s	VIDEO TRACK
0: 00	75% Color Bars
3: 00	60% Multi Burst Y: 0.5,1.0,2.0,3.0,4.1,4.5 MHz C: 0.2,0.5,1.0,1.5,2.0 MHz
6: 00	50% Bowtie & 10T
9: 00	Pulse & Bar
11: 00	Quad Phase
13: 00	C-Monoscope Switching position is shifted.
15: 00	

• Alignment Tape CR5-1B PS (Part No. 8-960-096-91)

Contents

TIME min s	VIDEO TRACK	AFM
0: 00	RF Sweep Marker 1,2,4,6,8,10,12 MHz	No-Signal
2: 00	60% H Sweep (CTDM) Marker 0.5,1,2,3,4,5 MHz	
5: 00	Pulse & Bar (CTDM)	
8: 00	Multi Burst Y: 0.5,1,2,4,5,5.5 MHz C: 0.2, 0.5,1,1.5,2 MHz	
11: 00	Pulse & Bar	
14: 00	100% Color Bars	400 Hz Sine Wave 25 kHz Deviation
16: 30		75 kHz Deviation
17: 00	50% Bowtie & 10T	No-Signal
19: 00	Line 17A	
22: 00	Quad Phase	
24: 00	50% Flat Field	
26: 00	100% Color Bars with Dropout	
28: 00	Composite H Sweep with VISC	
30: 00		

[Switch/Setup menu Setting]

This setting should not be changed in position unless otherwise specified.

<Control Panel>

upper
LOCAL/REMOTE: LOCAL
lower
CTL/TC/U-BIT: TC

<Sub Control Panel>

CHARACTER: ON
TC: LTC
CAPSTAN LOCK: 8 FD
TBC CONTROL: LOCAL
VIDEO: PRESET
CHROMA: PRESET
SET UP: PRESET
Y/C DELAY: PRESET

[Connection]

Connect some equipment as following unless otherwise specified.

CONNECTION 1 SG 1411/Waveform Monitor WFM-300 (A)/Oscilloscope/Picture Monitor

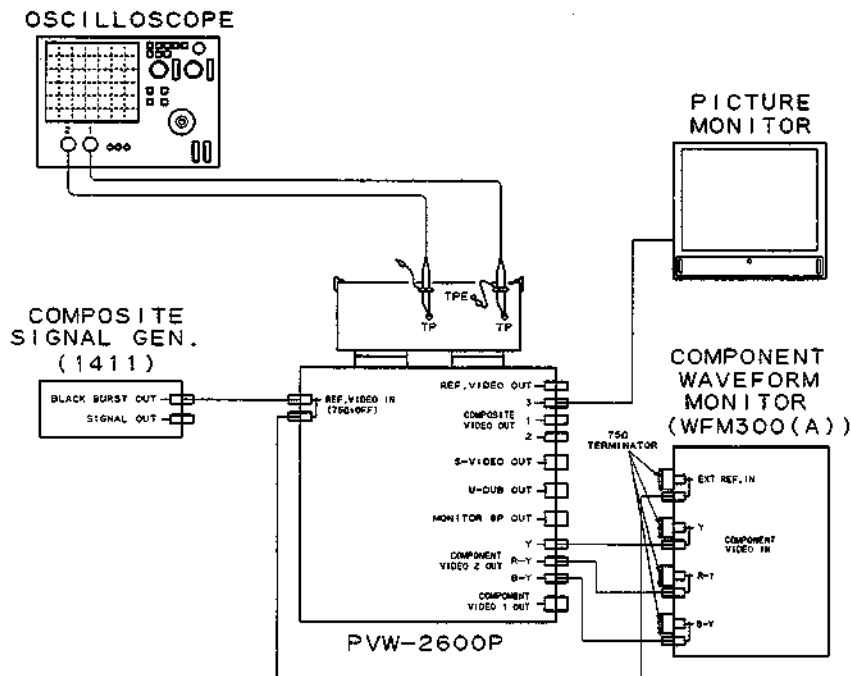

CONNECTION 2 SG1411/Waveform Monitor1751/Oscilloscope/Picture Monitor

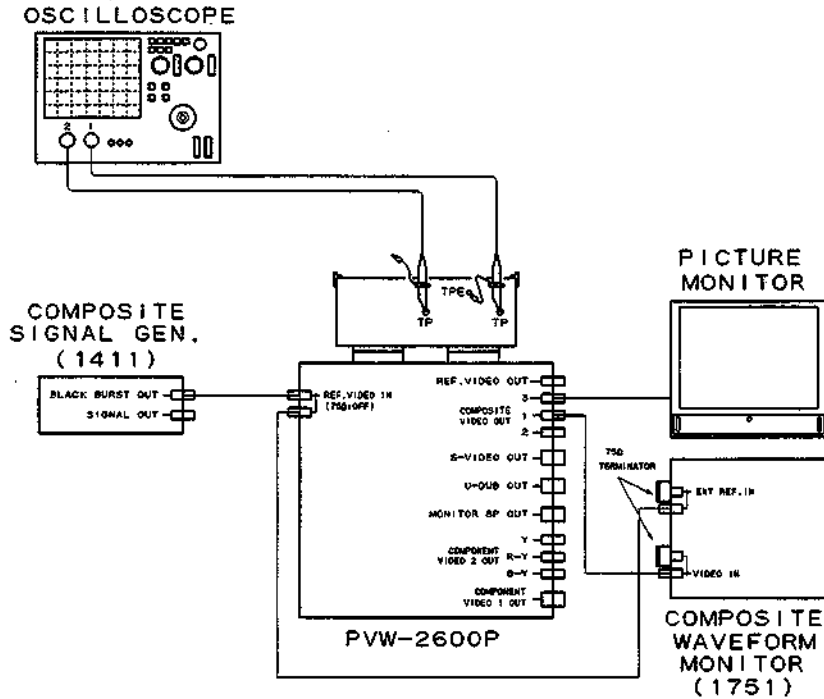

[Preparations and Notes on Alignment]

Making the cable for measuring S-VIDEO input/output level

S-terminal (Y/C) convert cable (BNC x 2) is necessary to measuring S-VIDEO input/output level.

Preparation: S-S terminal connection cable about 5 meters in length (standard product) (SONY YC-50KV)

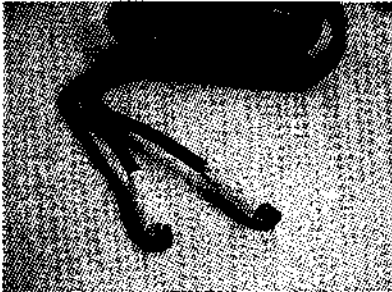

1. Cut the cable in half.
2. Tear and strip the cover of the cable with a cutter.
3. Strip the cover of the shield wire with a nipper.
4. Check the Y/C core wire with a tester.
5. Solder the BNC terminal for Y signal to the shield wire of Y signal in the cable and the BNC terminal for C signal to the shield wire of C signal. (Check the continuity with a tester.)

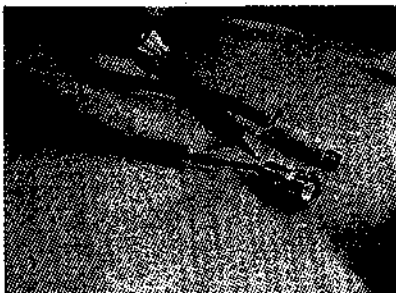

S-VIDEO
Cable connector IN/OUT

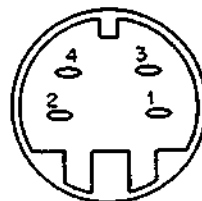

1	: Y (G)
2	: C (G)
3	: Y (X)
4	: C (X)

VP-33 board (A side)

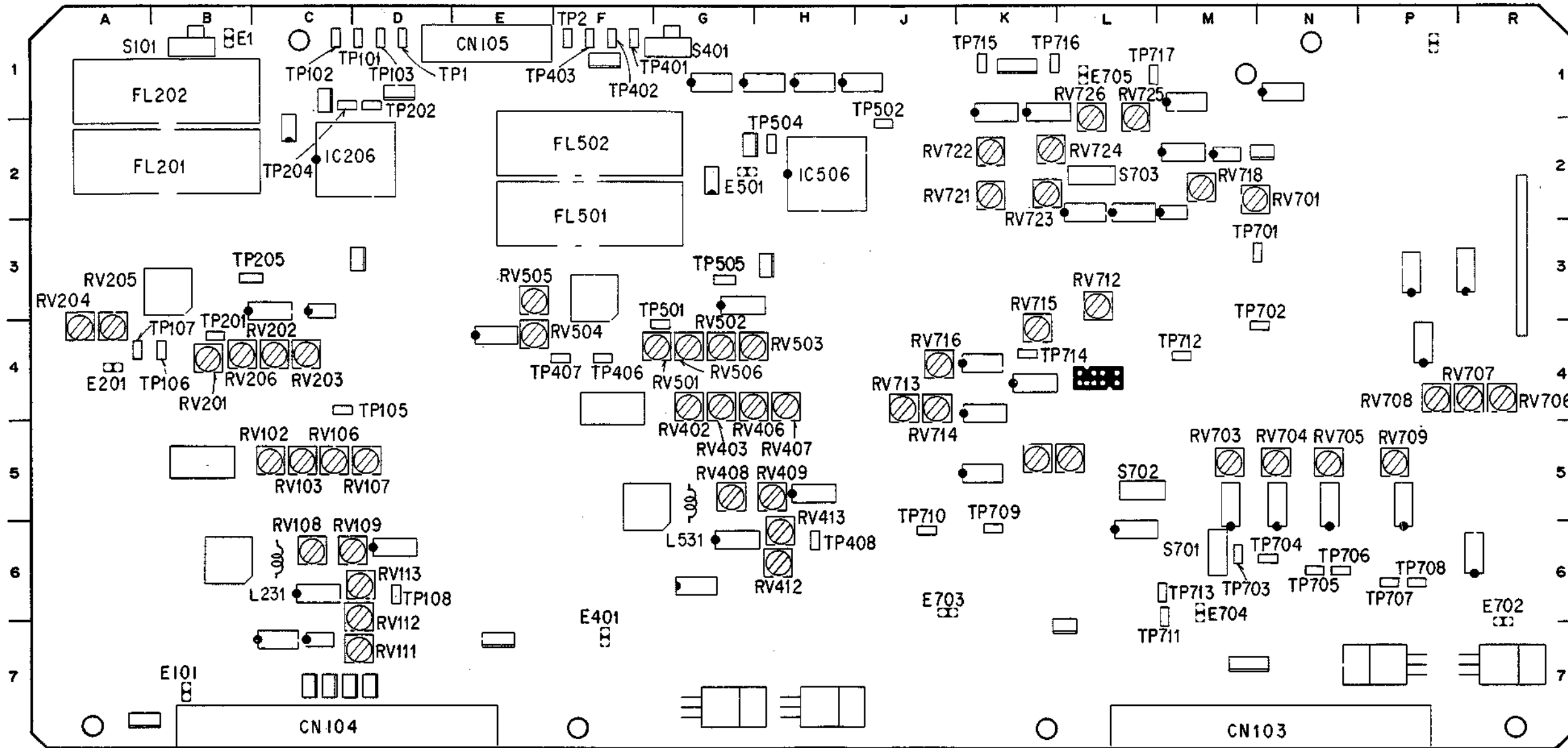

TBC-18 board (A side)

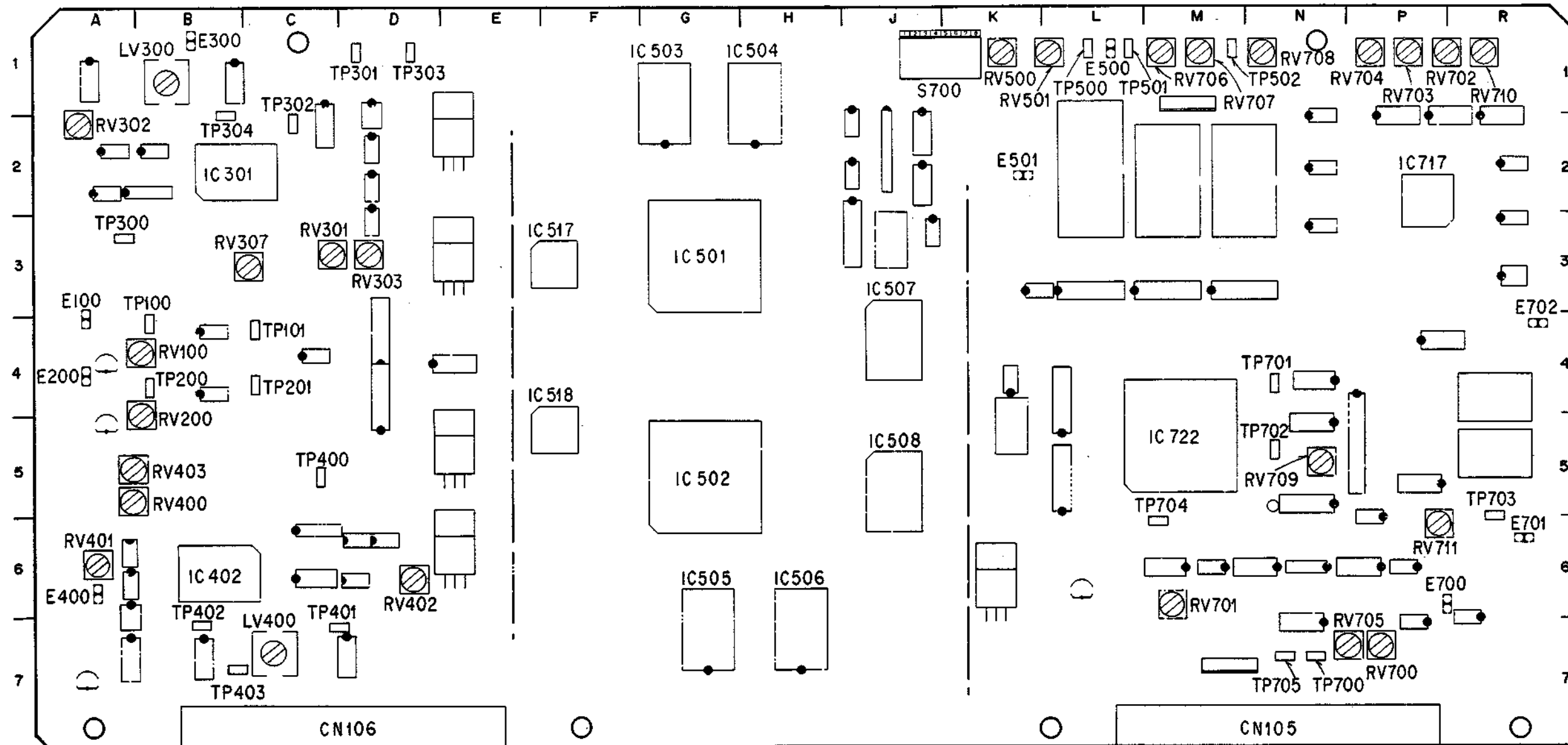

RP-57 board (A side)

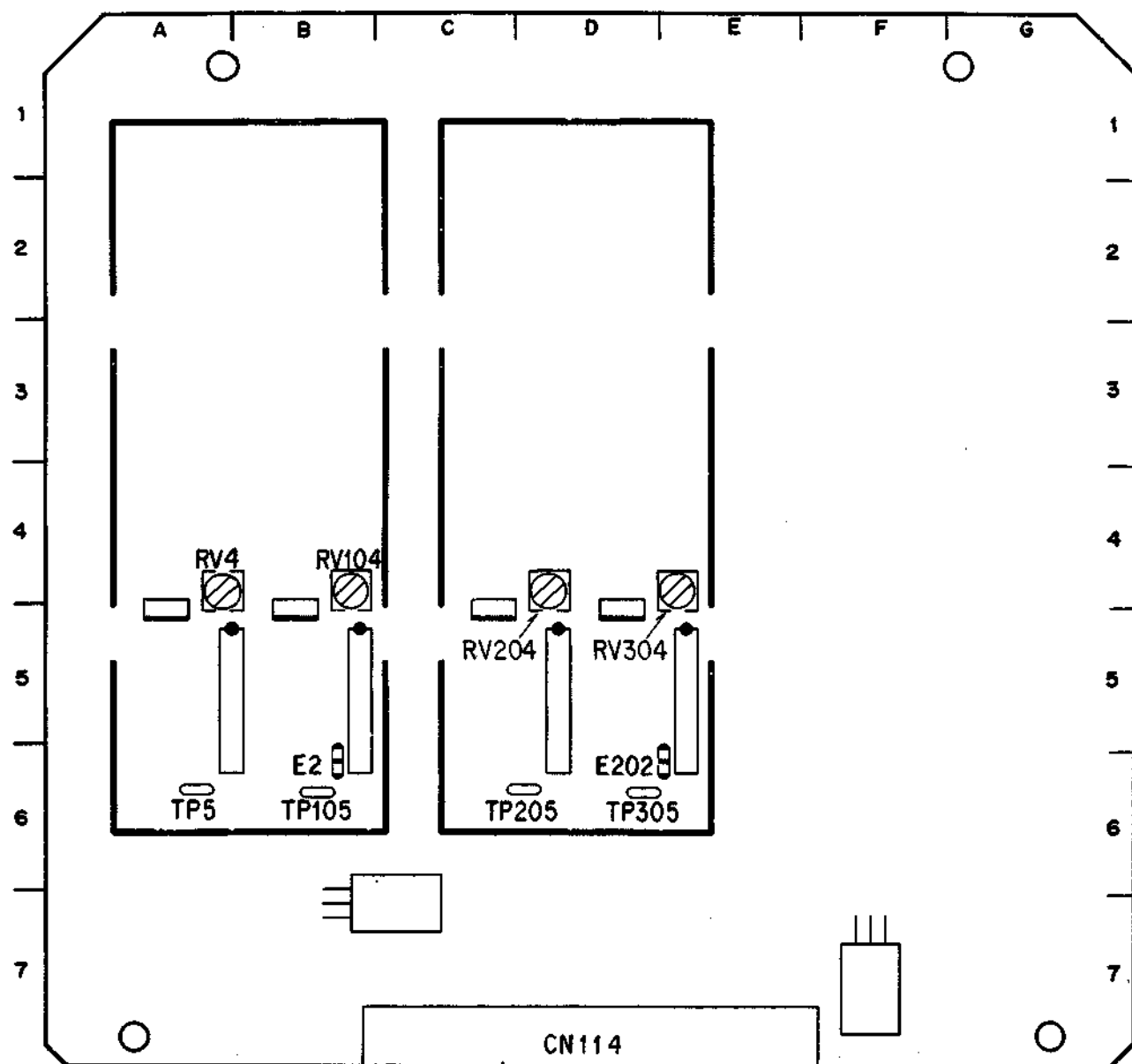

VP-33 board Block Diagram

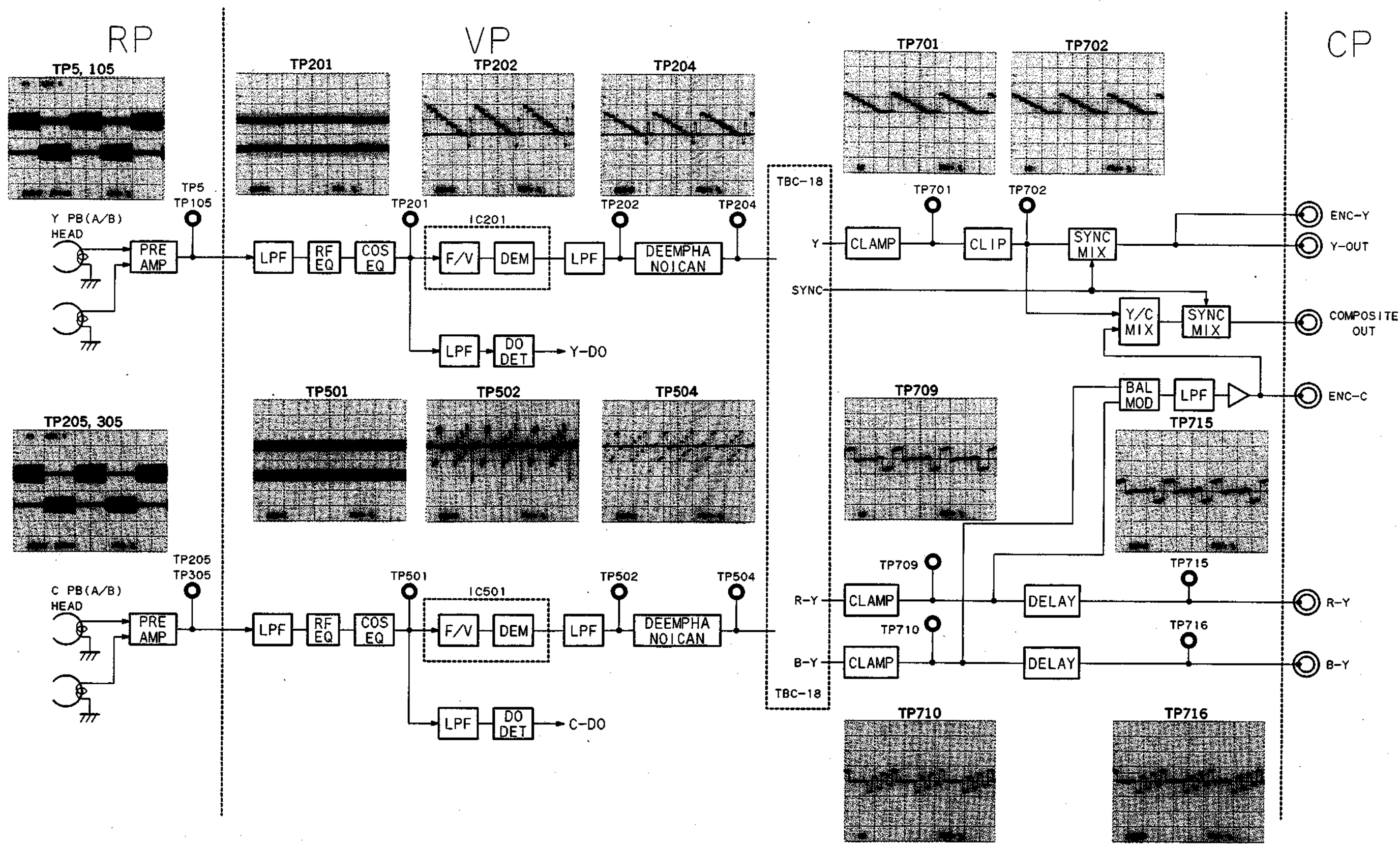

TBC board Block Diagram

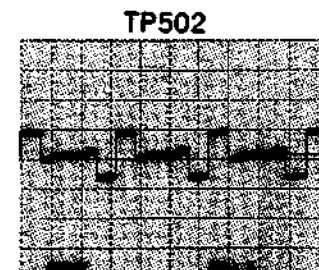
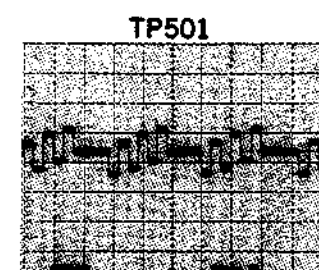
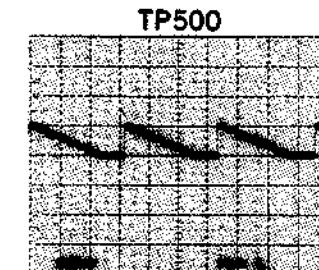
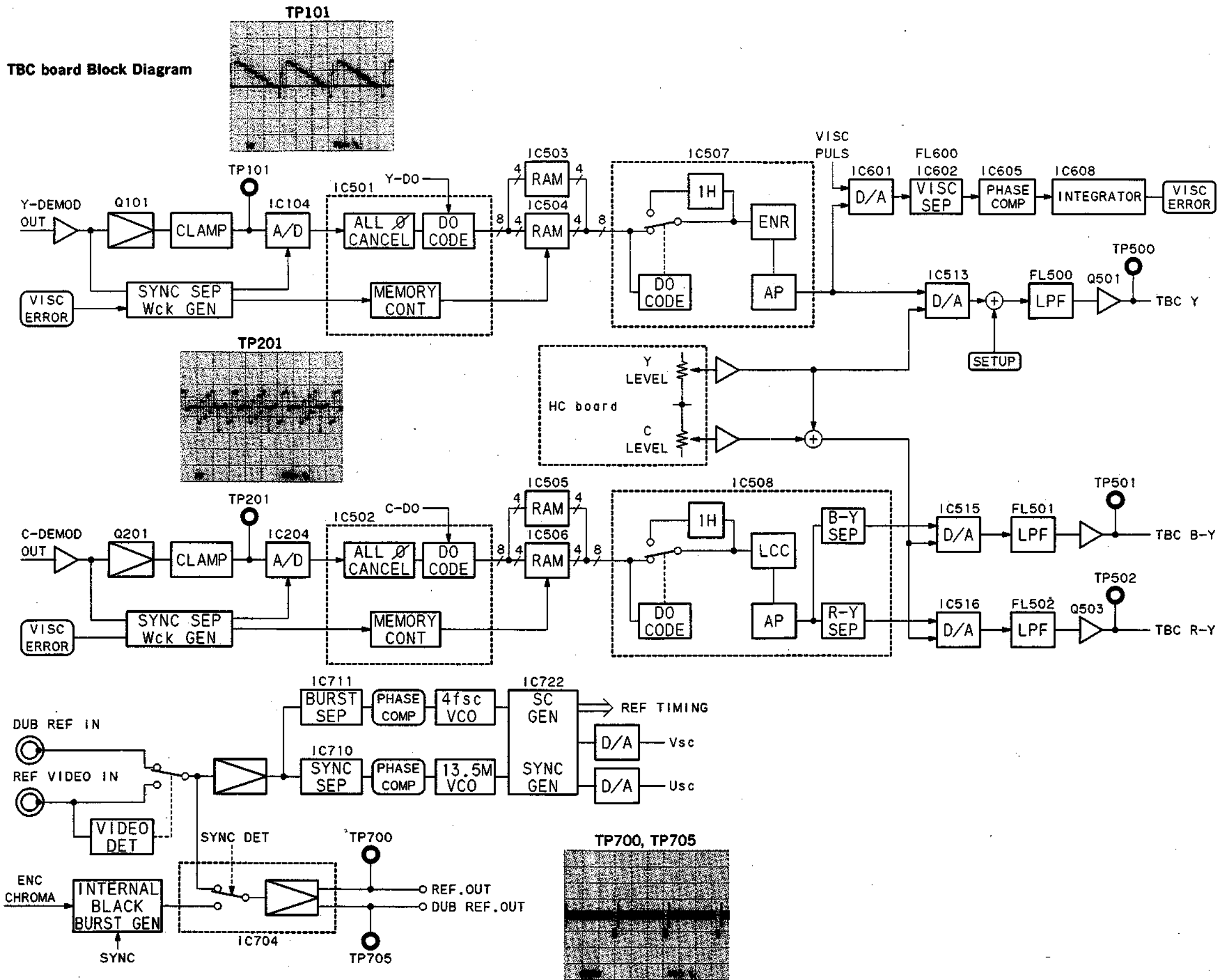

11-1. VP BOARD (RF, DM SYSTEM) ADJUSTMENT

11-1-1. Y PB RF Level Adjustment (Metal)

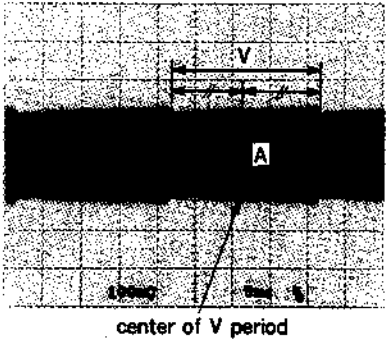
Preparations for adjustment	Specifications	Adjustments
<ul style="list-style-type: none"> • Play back the flat field signal portion (24:00—26:00) of the alignment tape CR5-1B PS. • Turn the tracking control on a control panel so that the pointer of the RF meter indicates the maximum RF level. <p>NOTE : S101/VP-33 (B-1): ON (S101: Y RF AGC SW)</p>	<p>TP106/VP-33 (B-4)</p> <p>Waveform of the oscilloscope</p>  <p>center of V period</p> <p>A=200±10 mV p-p</p>	<p>RV109/VP-33 (D-6)</p> <p>TRIG: TP1/VP-33 (D-1)</p> <p>CONNECTION 1</p>

11-1-2. RF Meter Adjustment (Metal)

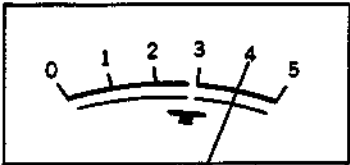
Preparations for adjustment	Specifications	Adjustments
<ul style="list-style-type: none"> • Play back the flat field signal portion (24:00—26:00) of the alignment tape CR5-1B PS. • Turn the tracking control on a control panel so that the pointer of the RF meter indicates the maximum RF level. 	<p>RF meter/control panel</p>  <p>The pointer of the meter should indicate 4.</p>	<p>RV111/VP-33 (D-7)</p> <p>CONNECTION 1</p>

VP-33 board

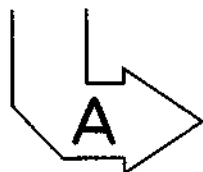
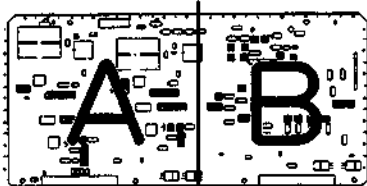

APPLICATION: 11-1-1.
11-1-2.

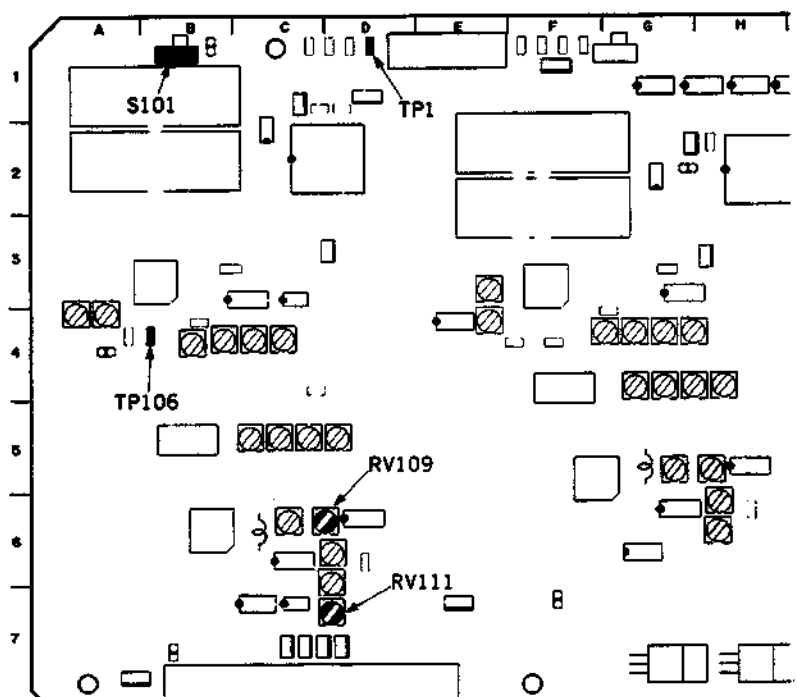

11-1-3. Y PB RF Level Adjustment (Oxide)

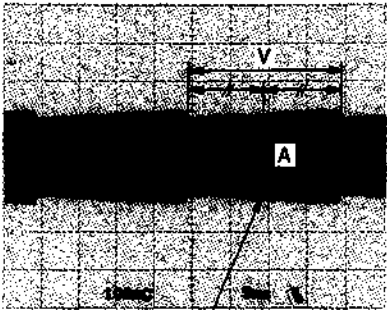
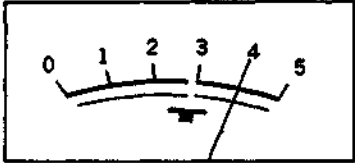
Preparations for adjustment	Specifications	Adjustments
<ul style="list-style-type: none"> • Play back the color bars signal portion (0:00—3:00) of the alignment tape CR5-2A PS. • Turn the tracking control on a control panel so that the pointer of the RF meter indicates the maximum RF level. 	<p>TP106/VP-33 (B-4)</p> <p>Waveform of the oscilloscope</p>  <p>center of V period</p> <p>$A = 200 \pm 10$ mV p-p</p>	<p>RV108/VP-33 (C-6)</p> <p>TRIG: TP1/VP-33 (D-1)</p> <p>CONNECTION 1</p>
<p>NOTE : S101/VP-33 (B-1): ON (S101: Y RF AGC SW)</p>	<p>RF meter/control panel</p>  <p>The pointer of the meter should indicate 4.0 ± 0.5.</p>	<p>(Check)</p>

VP-33 board

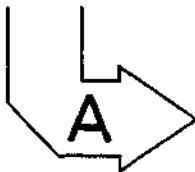
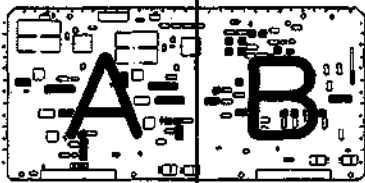

APPLICATION: 11-1-3.

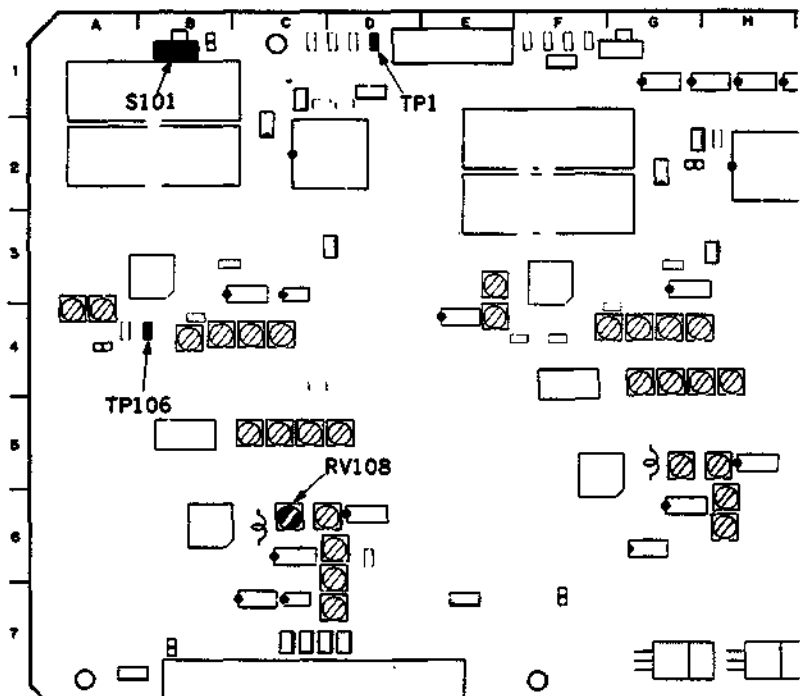

11-1-4. C PB RF Level Adjustment (Metal)

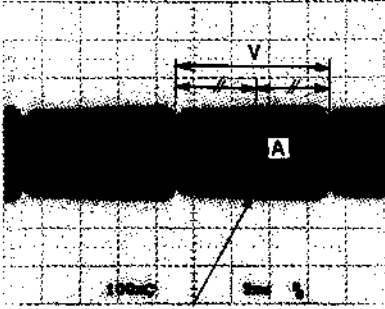
Preparations for adjustment	Specifications	Adjustments
<ul style="list-style-type: none"> • Play back the flat field signal portion (24:00—26:00) of the alignment tape CR5-1B PS. • Turn the tracking control on a control panel so that the pointer of the RF meter indicates the maximum RF level. <p>NOTE : S401/VP-33 (G-1): ON (S401 : C RF AGC SW)</p>	<p>TP406/VP-33 (F-4)</p> <p>Waveform of the oscilloscope</p>  <p>center of V period A=200±10 mV p-p</p>	<p>RV409/VP-33 (H-5)</p> <p>TRIG: TP2/VP-33 (F-1)</p> <p>CONNECTION 1</p>

11-1-5. C PB RF Level Adjustment (Oxide)

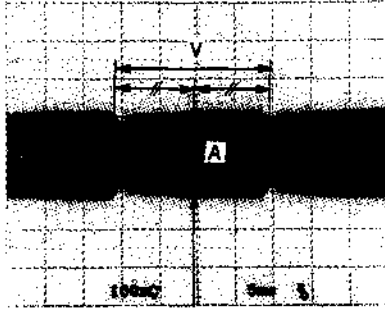
Preparations for adjustment	Specifications	Adjustments
<ul style="list-style-type: none"> • Play back the color bars signal portion (0:00—3:00) of the alignment tape CR5-2A PS. • Turn the tracking control on a control panel so that the pointer of the RF meter indicates the maximum RF level. <p>NOTE : S401/VP-33 (G-1): ON (S401 : C RF AGC SW)</p>	<p>TP406/VP-33 (F-4)</p> <p>Waveform of the oscilloscope</p>  <p>center of V period A=200±10 mV p-p</p>	<p>RV408/VP-33 (G-5)</p> <p>TRIG: TP2/VP-33 (F-1)</p> <p>CONNECTION 1</p>

VP-33 board

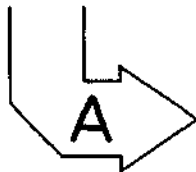
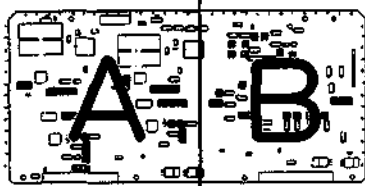

APPLICATION : 11-1-4.
11-1-5.

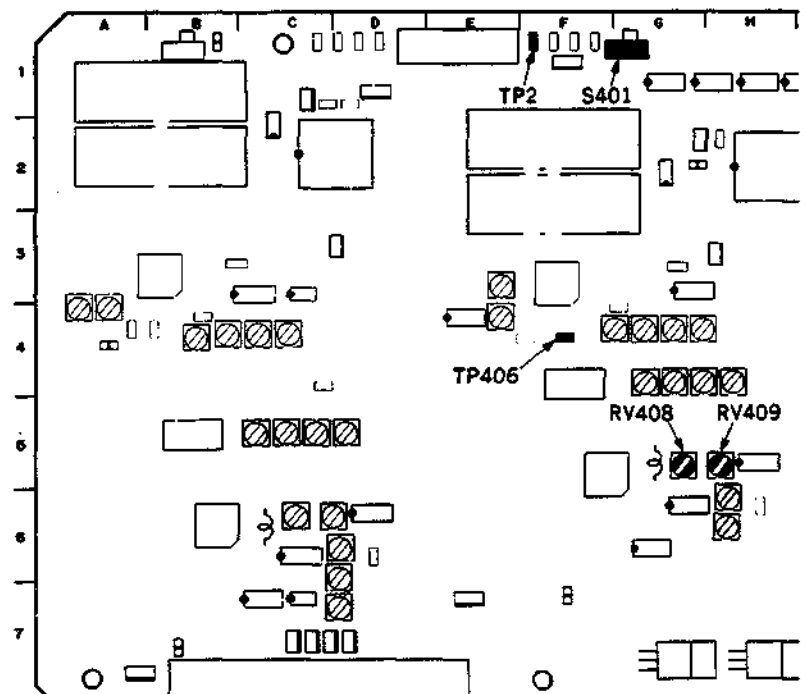

11-1-6. Y and C Demodulator Gain Adjustment (Metal)

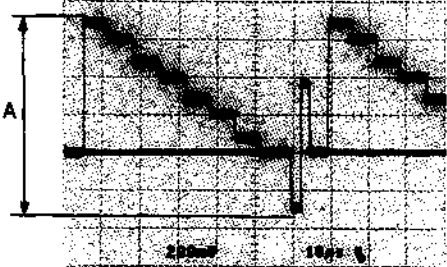
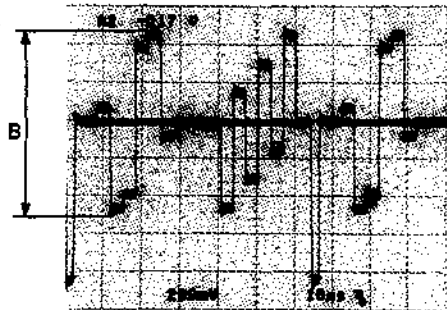
Preparations for adjustment	Specifications	Adjustments
<ul style="list-style-type: none"> • Play back the color bars signal portion (14:00—17:00) of the alignment tape CR5-1B PS. 	<p>TP204/VP-33 (C-1) Waveform of the oscilloscope</p>  <p>$A = 1.0 \pm 0.02 \text{ V pp}$</p>	<p>(A) (Y METAL DM GAIN) RV204/VP-33 (A-4)</p> <p>TRIG: TP204/VP-33 (C-1)</p> <p>CONNECTION 1</p>
	<p>TP504/VP-33 (H-2) Waveform of the oscilloscope</p>  <p>$B = 933 \pm 20 \text{ mV pp}$</p>	<p>(B) (C DM GAIN) RV504/VP-33 (E-3)</p> <p>TRIG: TP504/VP-33 (H-2)</p> <p>CONNECTION 1</p>

VP-33 board

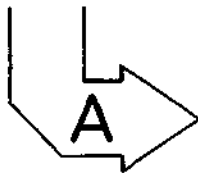
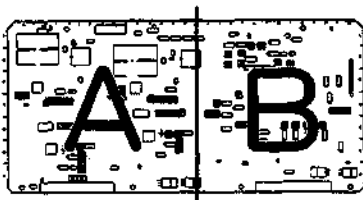

APPLICATION: 11-1-6.

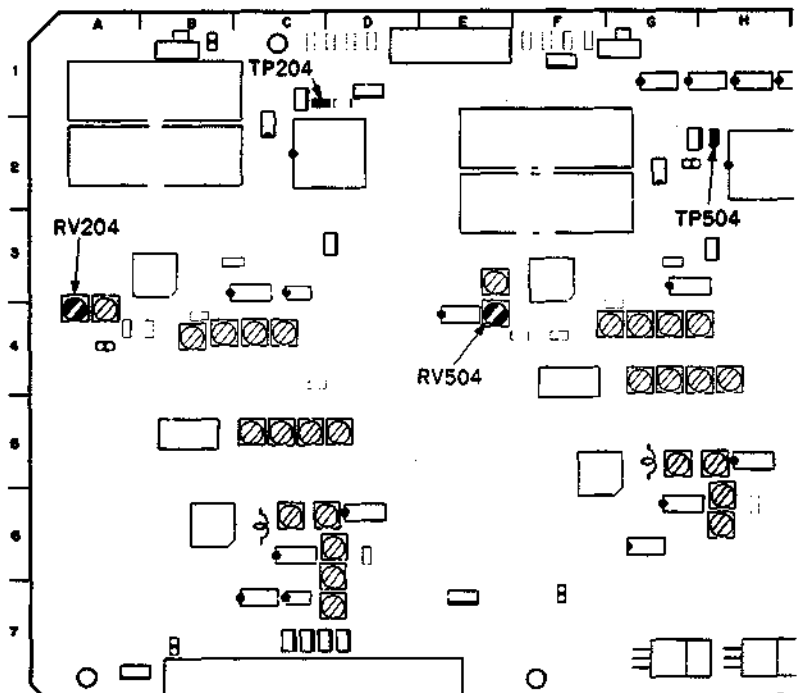

11-1-7. Y/C Demodulator Gain Adjustment (Oxide)

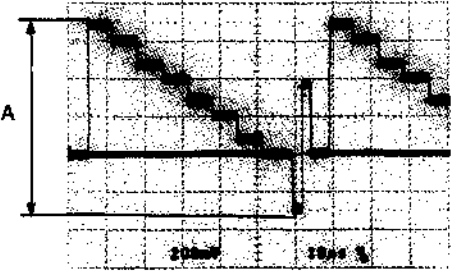
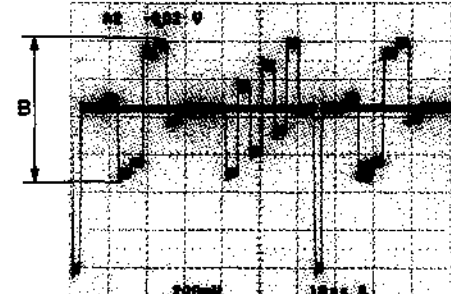
Preparations for adjustment	Specifications	Adjustments
<p>Step 1</p> <ul style="list-style-type: none"> • Play back the color bars signal portion (0:00—3:00) of the alignment tape CR5-2A PS. 	<p>TP204/VP-33 (C-1)</p> <p>Waveform of the oscilloscope</p>  <p>$A = 1.00 \pm 0.02 \text{ V pp}$</p>	<p>(A) (Y OXIDE DM GAIN) ⓄRV205/VP-33 (A-4)</p> <p>TRIG: TP1/VP-33 (D-1)</p> <p>CONNECTION 1</p>
<p>Step 2</p> <ul style="list-style-type: none"> • Play back the color bars signal portion (0:00—3:00) of the alignment tape CR5-2A PS. 	<p>TP504/VP-33 (H-2)</p> <p>Waveform of the oscilloscope</p>  <p>$B = 700 \pm 20 \text{ mV pp}$</p>	<p>(B) (C OXIDE DM GAIN) ⓄRV505/VP-33 (E-3)</p> <p>TRIG: TP504/VP-33 (H-2)</p> <p>CONNECTION 1</p>

VP-33 board

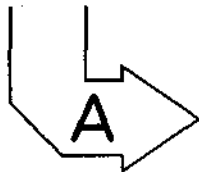
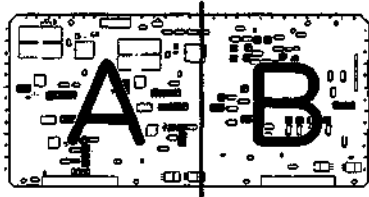

APPLICATION: 11-1-7.

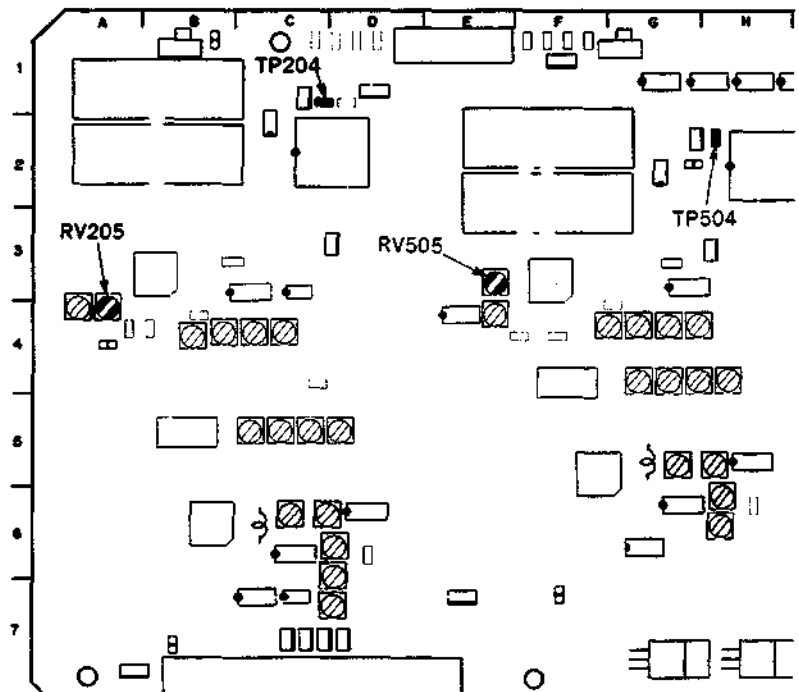

11-1-8. Y and C Limiter Balance Adjustment

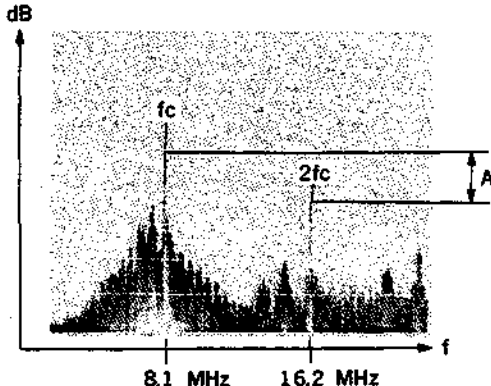
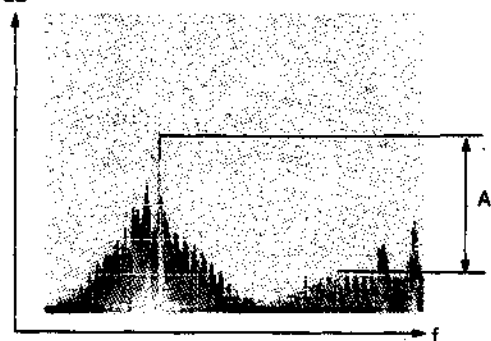
Preparations for adjustment	Specifications	Adjustments
<ul style="list-style-type: none"> • Play back the flat field signal portion (24:00—26:00) of the alignment tape CR5-1B PS. • Connect a spectrum analyzer to OUTPUT terminal of a oscilloscope. 	<p>TP201/VP-33 (B-4) Picture of the spectrum analyzer</p> <p>Before adjustment</p>  <p style="text-align: center;">8.1 MHz 16.2 MHz</p> <p style="text-align: center;">↓</p> <p>After adjustment</p>  <p style="text-align: center;">$A \geq 35 \text{ dB}$</p>	<p>(A) (Y LIMITER BALANCE) RV201/VP-33 (B-4)</p> <p>TRIG: TP1/VP-33 (D-1)</p>

Continues to the next page.

VP-33 board

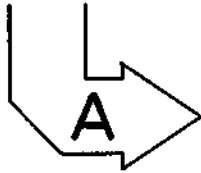
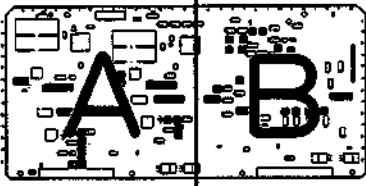

APPLICATION: 11-1-8.

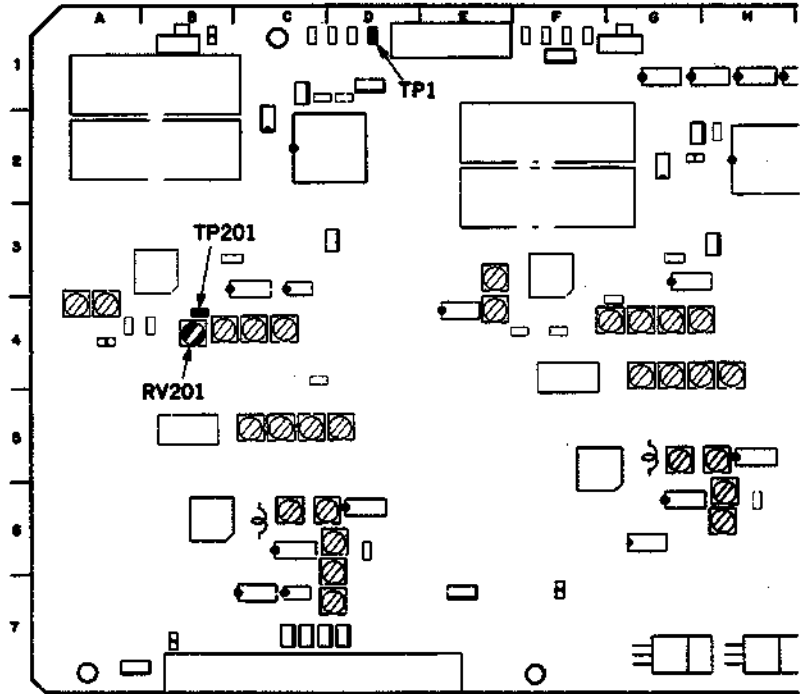

[CONNECTION]

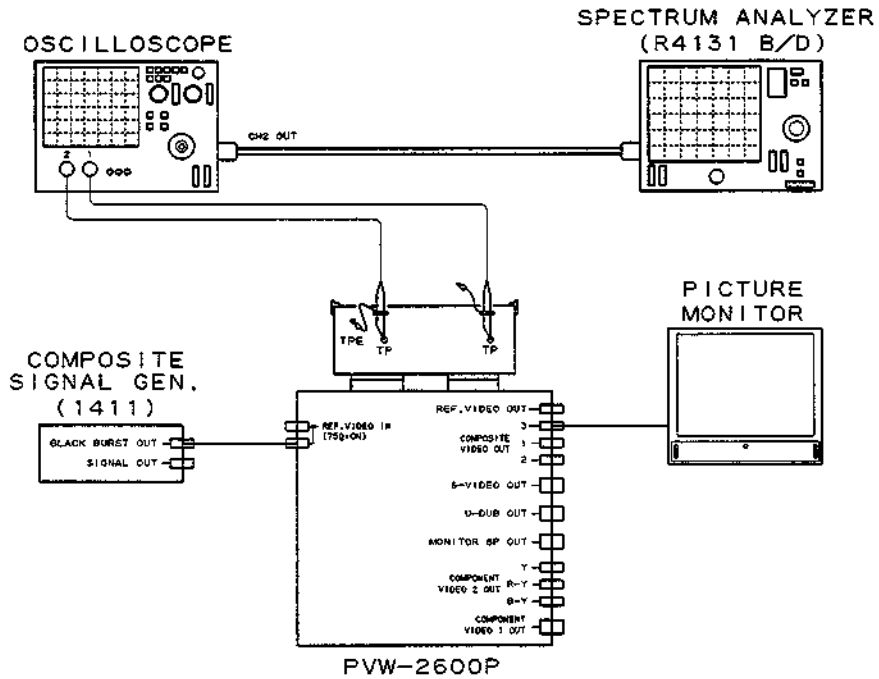

11-1-8. Y and C Limiter Balance Adjustment (Continued)

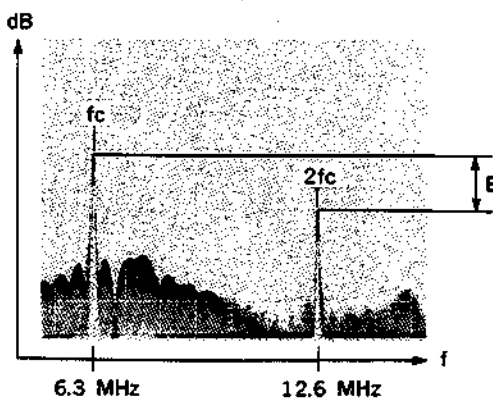
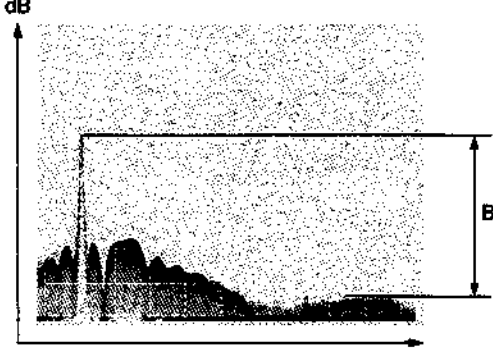
Preparations for adjustment	Specifications	Adjustments
<ul style="list-style-type: none"> • Play back the flat field signal portion (24:00—26:00) of the alignment tape CR5-1B PS. • Connect a spectrum analyzer to OUTPUT terminal of a oscilloscope. 	<p>TP501/VP-33 (G-4) Picture of the spectrum analyzer</p> <p style="text-align: center;">Before adjustment</p>  <p style="text-align: center;">↓</p> <p style="text-align: center;">After adjustment</p>  <p style="text-align: center;">$B \geq 40 \text{ dB}$</p>	<p>(B) (C LIMITER BALANCE) RV501/VP-33 (G-4)</p> <p style="text-align: right;">TRIG: TP2/VP-33 (F-1)</p>

VP-33 board

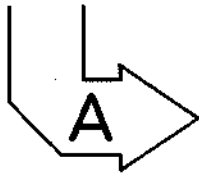
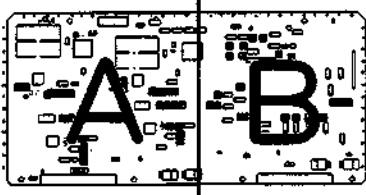

APPLICATION: 11-1-8.

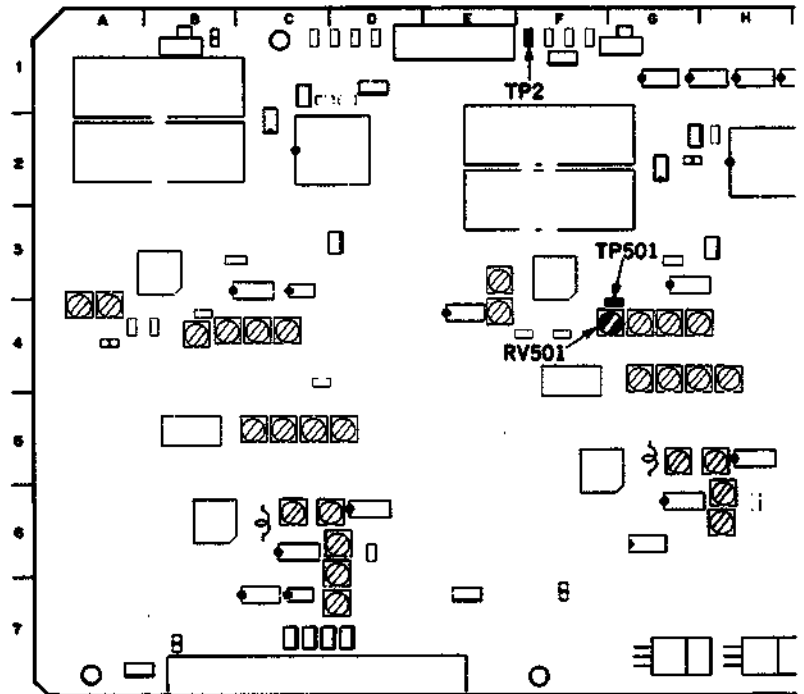

[CONNECTION]

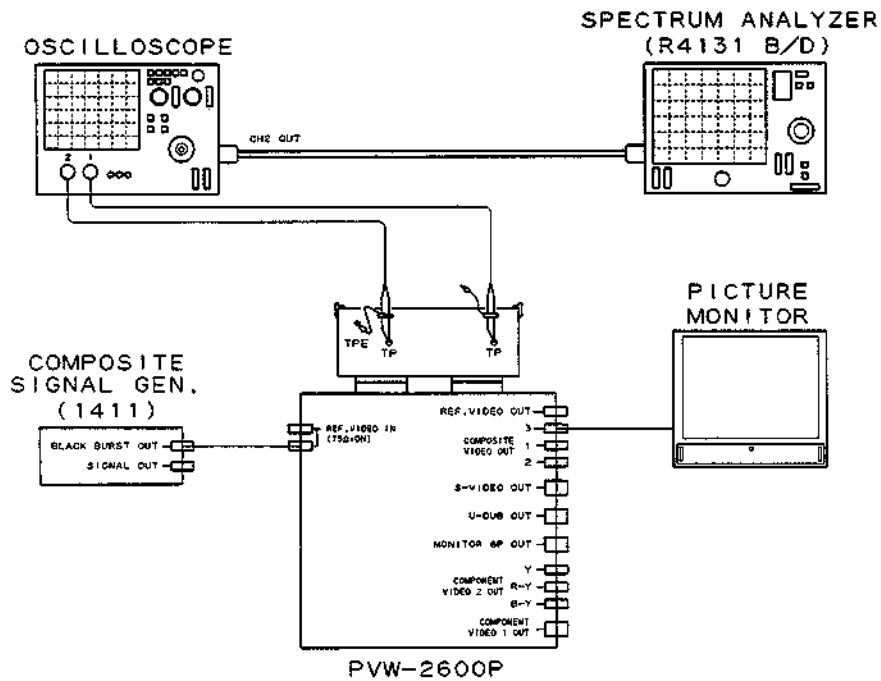

11-1-9. Y and C Demodulator Balance Adjustment

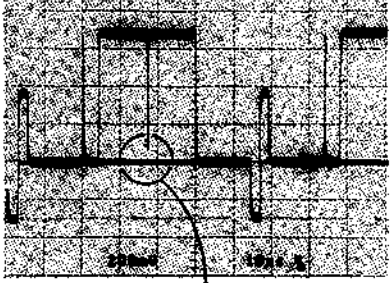
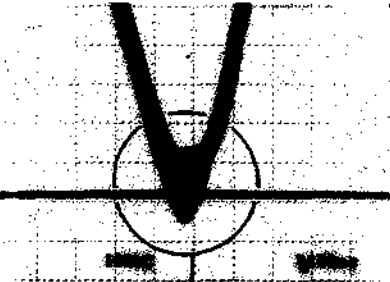
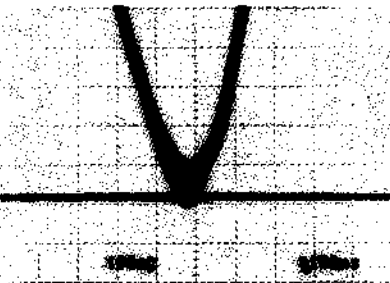
Preparations for adjustment	Specifications	Adjustments
<p>• Play back the pulse & bar signal portion (5:00—8:00) of the alignment tape CR5-1B PS.</p>	<p>TP204/VP-33 (C-1) Waveform of the oscilloscope</p>  <p>Before adjustment</p>  <p>Minimize the moiré.</p> <p>After adjustment</p> 	<p>(A) (Y DEMOD BALANCE) ⊗ RV206/VP-33 (B-4)</p> <p>TRIG: TP300/TBC-18 (A-3) CONNECTION 1</p>

Continues to the next page.

VP-33 board

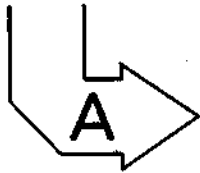
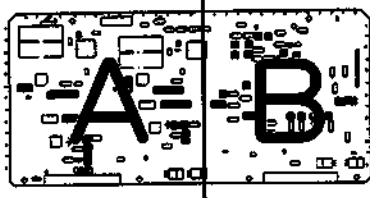

APPLICATION: 11-1-9.

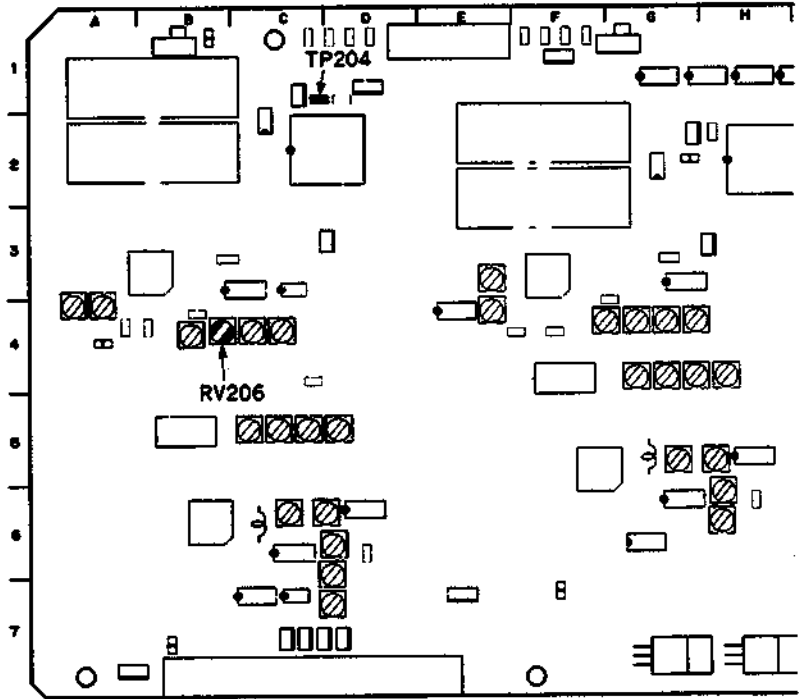

TBC-18 board

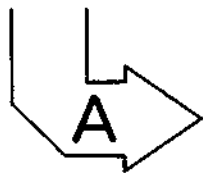
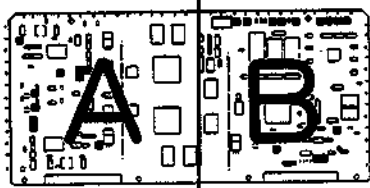

APPLICATION: 11-1-9.

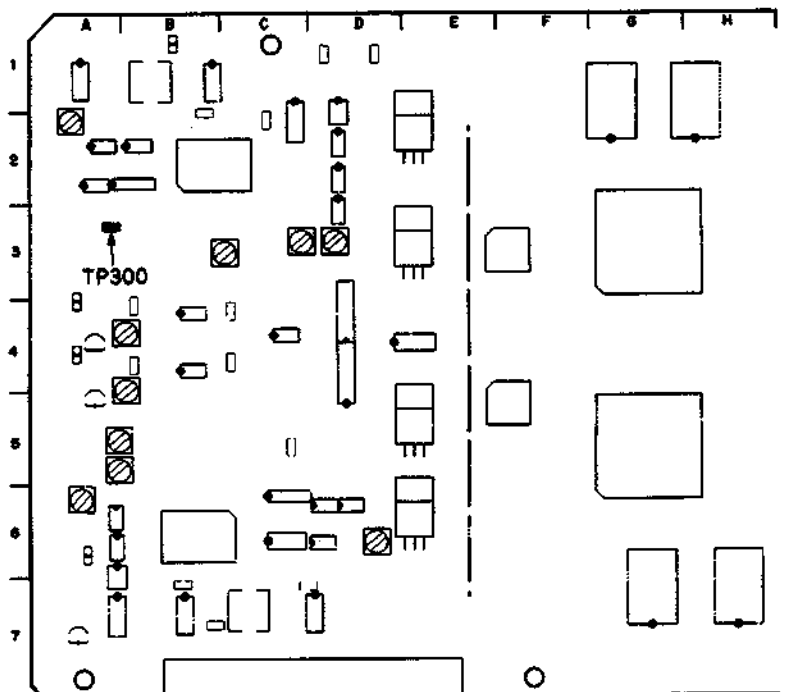

11-1-9. Y and C Demodulator Balance Adjustment (Continued)

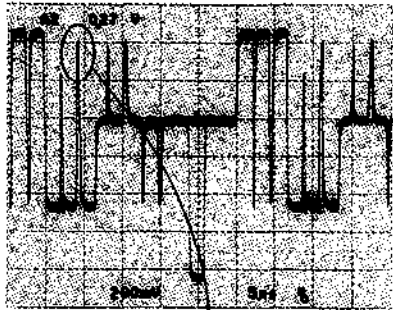
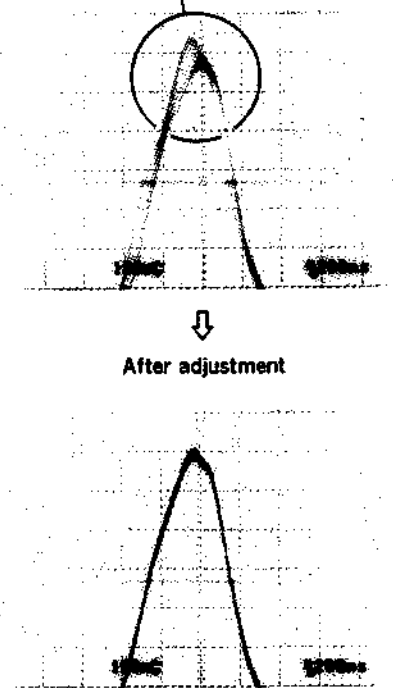
Preparations for adjustment	Specifications	Adjustments
<p>• Play back the pulse & bar signal portion (5:00—8:00) of the alignment tape CR5-1B PS.</p>	<p>TP504/VP-33 (H-2) Waveform of the oscilloscope</p>  <p>Before adjustment Minimize the moiré.</p>  <p>After adjustment</p>	<p>(B) (C DEMOD BALANCE) ● RV506/VP-33 (G-4)</p> <p>TRIG: TP400/TBC-18 (C-5) CONNECTION 1</p>

VP-33 board

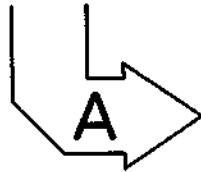
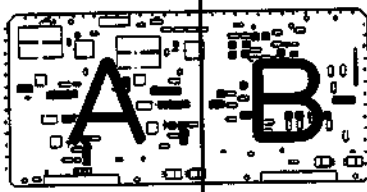

APPLICATION: 11-1-9.

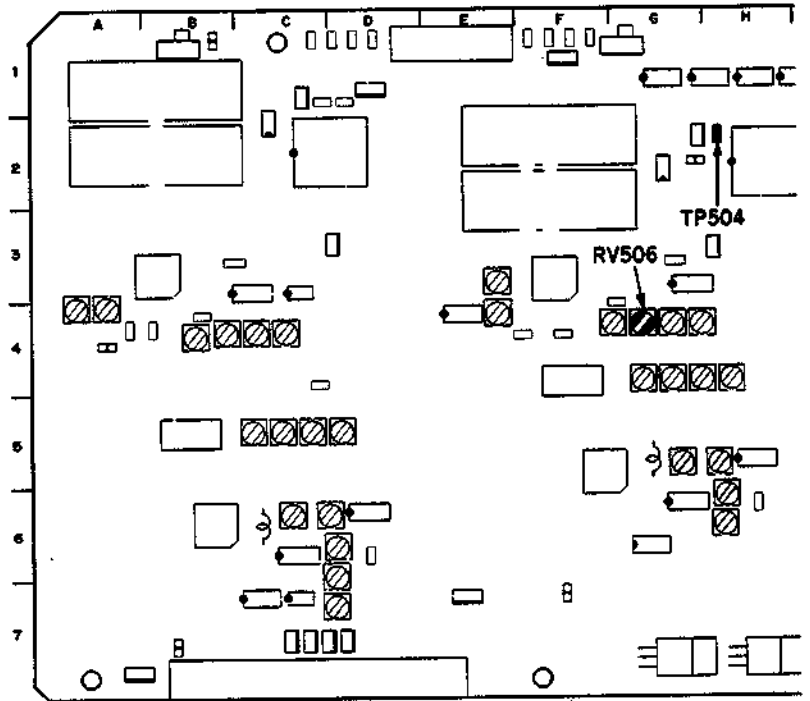

TBC-18 board

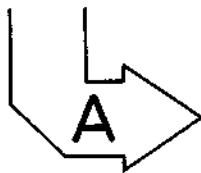
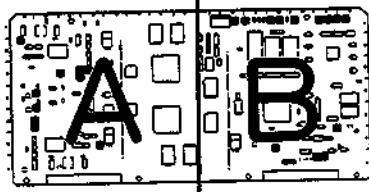

APPLICATION: 11-1-9.

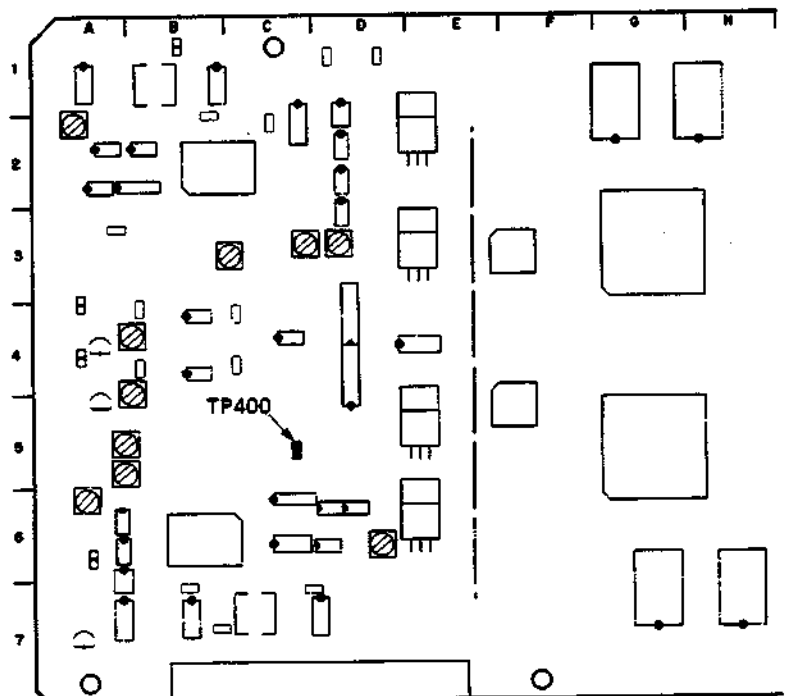

11-1-10. Y and C OMC Adjustment (Metal)

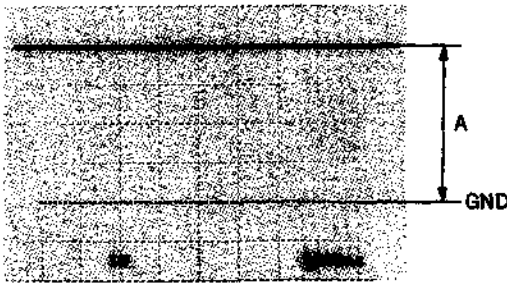
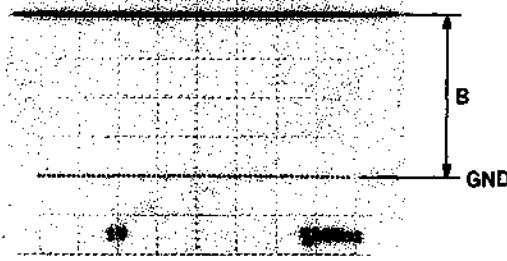
Preparations for adjustment	Specifications	Adjustments
<ul style="list-style-type: none"> • Insert a blank tape BCT-20M (metal) • PLAY mode 	<p>TP205/VP-33 (C-3) Waveform of the oscilloscope</p>  <p style="text-align: center;">$A = 4.0 \pm 0.1 \text{ V dc}$</p>	<p>(A) (Y METAL OMC) ⊙ RV202/VP-33 (C-4)</p> <p>CONNECTION 1</p>
	<p>TP505/VP-33 (G-3) Waveform of the oscilloscope</p>  <p style="text-align: center;">$B = 4.1 \pm 0.1 \text{ V dc}$</p>	<p>(B) (C METAL OMC) ⊙ RV502/VP-33 (G-4)</p> <p>CONNECTION 1</p>

VP-33 board

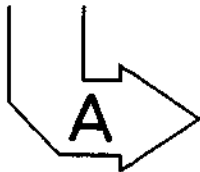
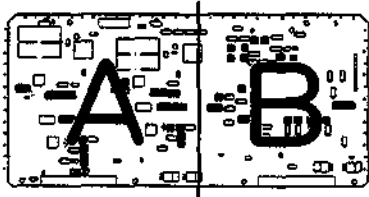

APPLICATION: 11-1-10.

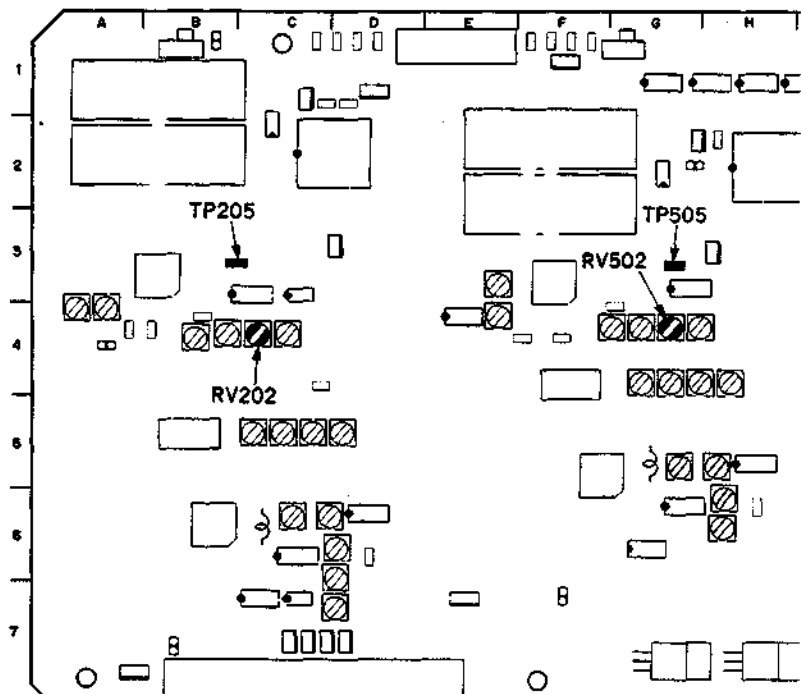

11-1-11. Y and C OMC Adjustment (Oxide)

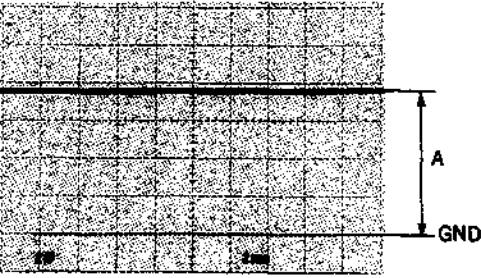
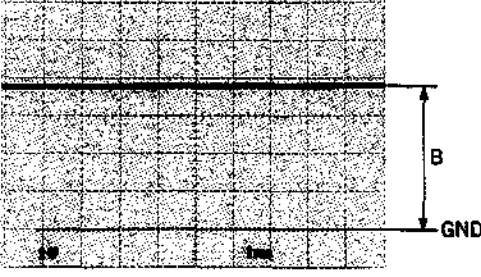
Preparations for adjustment	Specifications	Adjustments
<ul style="list-style-type: none"> • Insert a blank tape BCT-20G (oxide). • PLAY mode 	<p>TP205/VP-33 (B-3) Waveform of the oscilloscope</p>  <p style="text-align: center;">$A = 3.8 \pm 0.1 \text{ V dc}$</p>	<p>(A) (Y OXIDE OMC) ●RV203/VP-33 (C-4)</p> <p>CONNECTION 1</p>
	<p>TP505/VP-33 (G-3) Waveform of the oscilloscope</p>  <p style="text-align: center;">$B = 3.8 \pm 0.1 \text{ V dc}$</p>	<p>(B) (C OXIDE OMC) ●RV503/VP-33 (G-4)</p> <p>CONNECTION 1</p>

VP-33 board

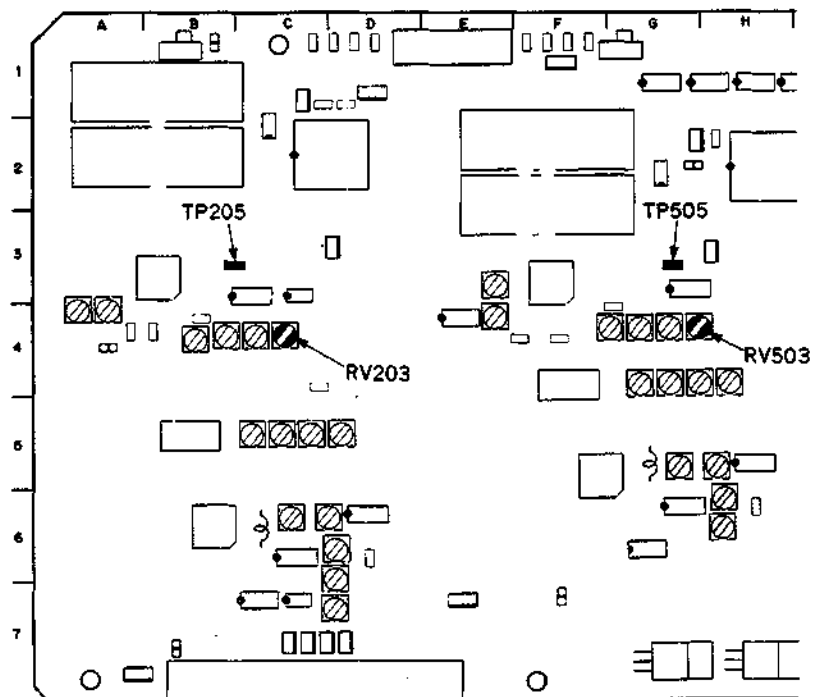
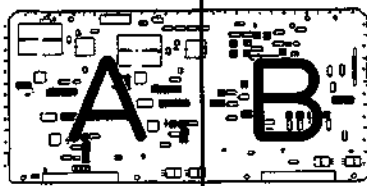

APPLICATION: 11-1-11.

11-1-12. PB Y Frequency Response Adjustment (Metal)

Preparations for adjustment	Specifications	Adjustments
<ul style="list-style-type: none"> • Play back the multi burst signal portion (8:00–11:00) of the alignment tape CR5-1B PS. • Connect a waveform monitor to COMPONENT 2 OUTPUT connector. 	<p>COMPONENT 2 Y OUT Waveform of the waveform monitor</p>  <p>(1) 0.5 MHz reference 100% (or 0 dB) 4.0 MHz=100% (101 through 99%) (0±0.1 dB)</p> <p>(2) Check the levels for following frequencies. 0.5 MHz=reference 1.0 MHz=100% (105 through 96%) (0±0.4 dB) 2.0 MHz=100% (105 through 96%) (0±0.4 dB) 5.0 MHz= 89% (105 through 96%) (-1.0±0.6 dB) 5.5 MHz= 73% (80 through 67%) (-2.7±0.8 dB)</p> <p>(3) Flicker should not be on the monitor picture.</p>	<p>CH-A: ●RV106/VP-33 (C-5) CH-B: ●RV107/VP-33 (D-5)</p> <p>TRIG: REF. VIDEO OUT</p> <p>CONNECTION 1</p>

VP-33 board

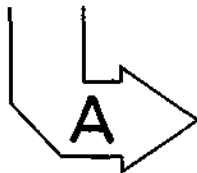
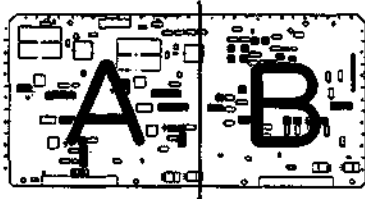

APPLICATION: 11-1-12.

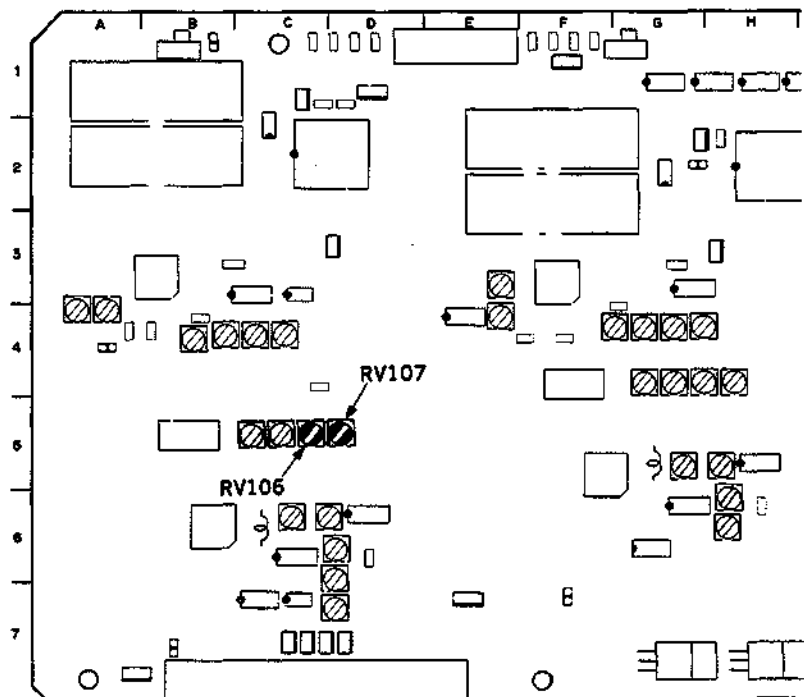

11-1-13. PB Y Frequency Response Adjustment (Oxide)

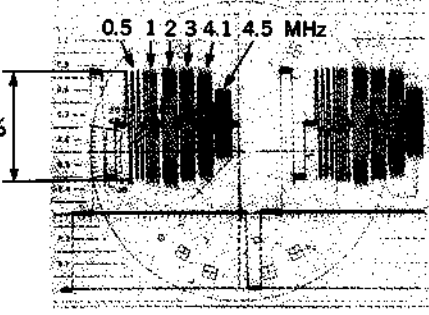
Preparations for adjustment	Specifications	Adjustments
<ul style="list-style-type: none"> • Play back the multi burst signal portion (3:00 — 6:00) of the alignment tape CR5-2A PS. • Connect a waveform monitor to COMPONENT 2 OUTPUT connector. 	<p>COMPONENT 2 Y OUT Waveform of the waveform monitor</p>  <ol style="list-style-type: none"> (1) 0.5 MHz reference 100% (or 0 dB) 3.0 MHz = 89% (94 through 84%) (-1.0±0.5 dB) (2) Check the levels for following frequencies. 0.5 MHz = reference 1.0 MHz = 100% (105 through 96%) (0±0.4 dB) 2.0 MHz = 100% (105 through 86%) (0±0.4 dB) 4.1 MHz = 71% (87 through 56%) (-3.0 ±0.8 dB) (3) Flicker should not be on the monitor picture. 	<p>CH-A: ●RV102/VP-33 (C-5) CH-B: ●RV103/VP-33 (C-5)</p> <p>TRIG: REF VIDEO OUT</p> <p>CONNECTION 1</p>

VP-33 board

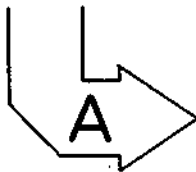

APPLICATION: 11-1-13.

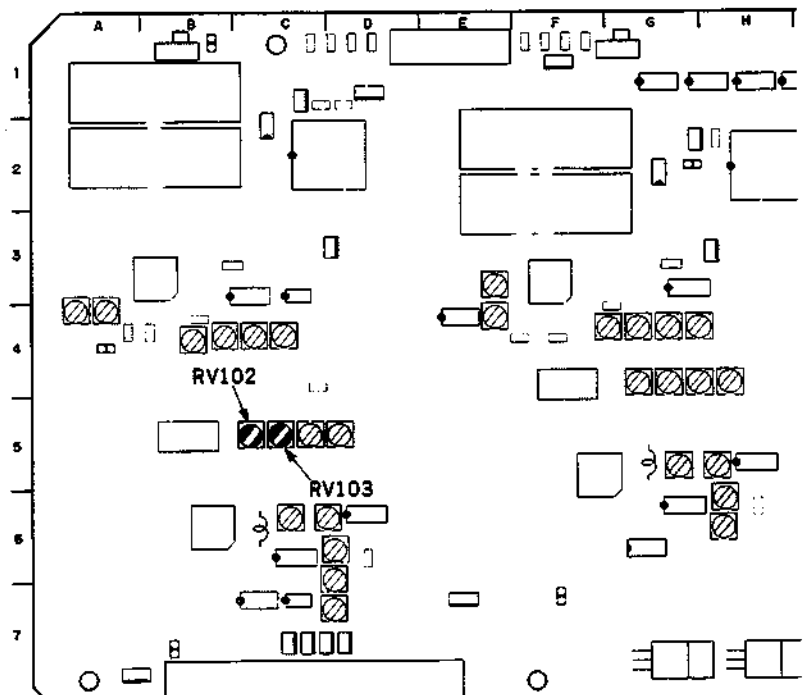

11-1-14. PB C Frequency Response Adjustment (Metal)

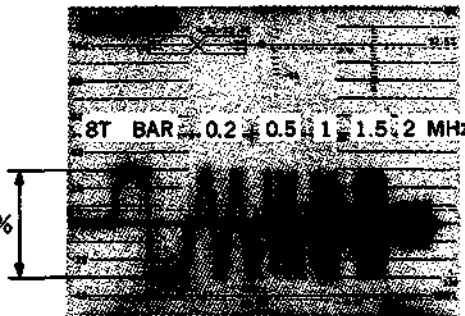
Preparations for adjustment	Specifications	Adjustments
<ul style="list-style-type: none"> • Play back the multi burst signal portion (8:00—11:00) of the alignment tape CR5-1B PS. • Connect a waveform monitor to COMPONENT 2 OUTPUT connector. 	<p>COMPONENT 2 R-Y OUT/B-Y OUT Waveform of the waveform monitor</p>  <p>(1) R-Y 8T BAR reference 100% (or 0 dB) 1.5 MHz = 94% (98 through 91%) (-0.5±0.3 dB)</p> <p>(2) Check the levels for following frequencies. 0.2 MHz = 100% (105 through 96%) (0±0.4 dB) 0.5 MHz = 100% (105 through 96%) (0±0.4 dB) 1.0 MHz = 100% (105 through 96%) (0±0.4 dB) 2.0 MHz = 84% (91 through 72%) (-1.8±1.0 dB)</p> <p>(3) Check that the waveform of B-Y satisfies the specifications above. If it doesn't, perform fine adjustments so that both waveforms of R-Y and B-Y satisfy the specifications.</p>	<p>CH-A: ●RV406/VP-33 (G-4) CH-B: ●RV407/VP-33 (H-4)</p> <p>TRIG: REF. VIDEO OUT</p> <p>CONNECTION 1</p>

VP-33 board

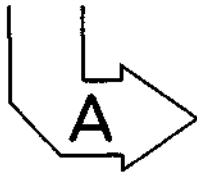
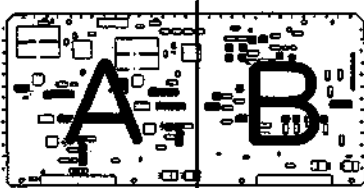

APPLICATION: 11-1-14.

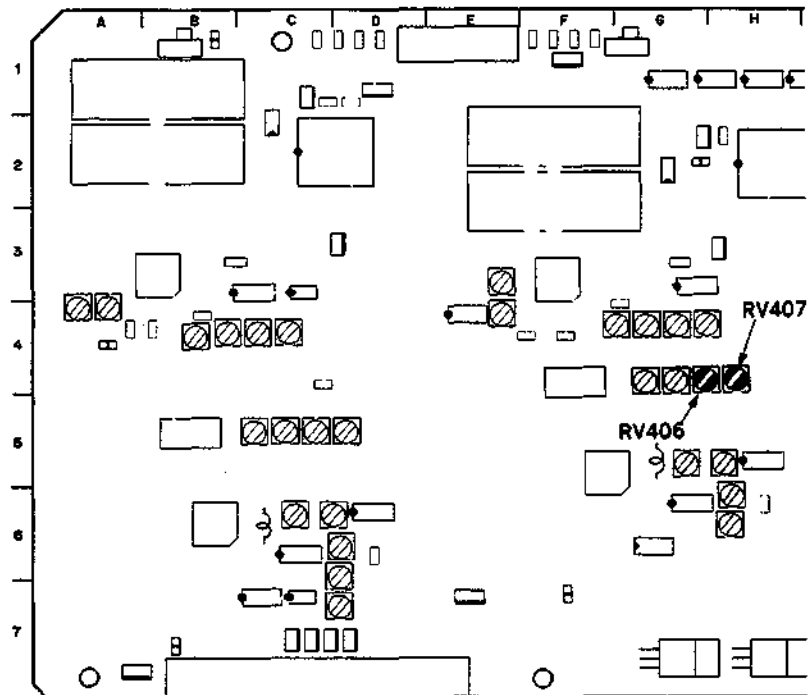

11-1-15. PB C Frequency Response Adjustment (Oxide)

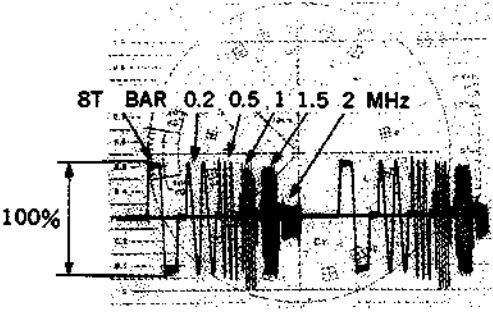
Preparations for adjustment	Specifications	Adjustments
<ul style="list-style-type: none"> • Play back the multi burst signal portion (3:00—6:00) of the alignment tape CR5-2A PS. • Connect a waveform monitor to COMPONENT 2 OUTPUT connector. 	<p>COMPONENT 2 R-Y OUT/B-Y OUT Waveform of the waveform monitor</p>  <p>(1) R-Y. 8T BAR reference 100% (or 0dB) 1.0 MHz = 94% (98 through 91%) (-0.5±0.3 dB)</p> <p>(2) Check the levels for following frequencies. 0.2 MHz = 100% (105 through 96%) (0±0.4 dB) 0.5 MHz = 100% (105 through 96%) (0±0.4 dB) 1.5 MHz = 84% (97 through 73%) (-1.5±1.2 dB)</p> <p>(3) Check that the waveform of B-Y satisfies the specifications above. If it does not, change the specification of section 11-1-11. Y and C OMC Adjustment (RV503) from 3.8 V dc into 3.7 V dc, then adjust again.</p>	<p>CHA: RV402/VP-33 (G-4) CH-B: RV403/VP-33 (G-4)</p> <p>TRIG: REF. VIDEO OUT</p> <p>CONNECTION 1</p>

VP-33 board

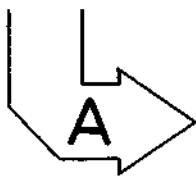
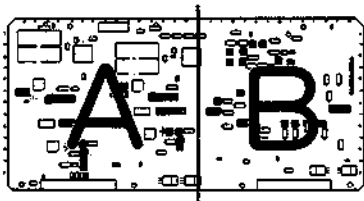

APPLICATION: 11-1-15.

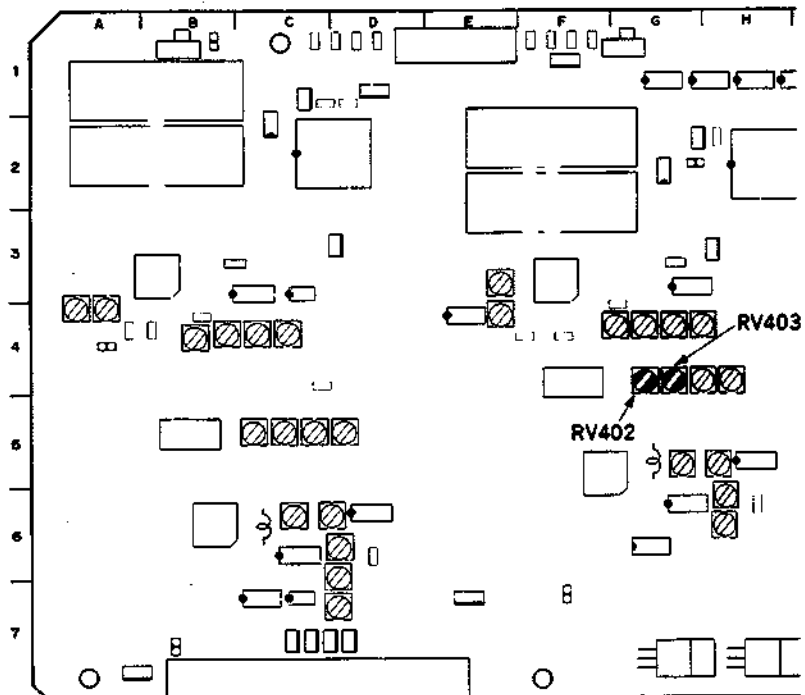

VP-33 board

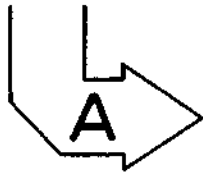

APPLICATION: 11-1-16.

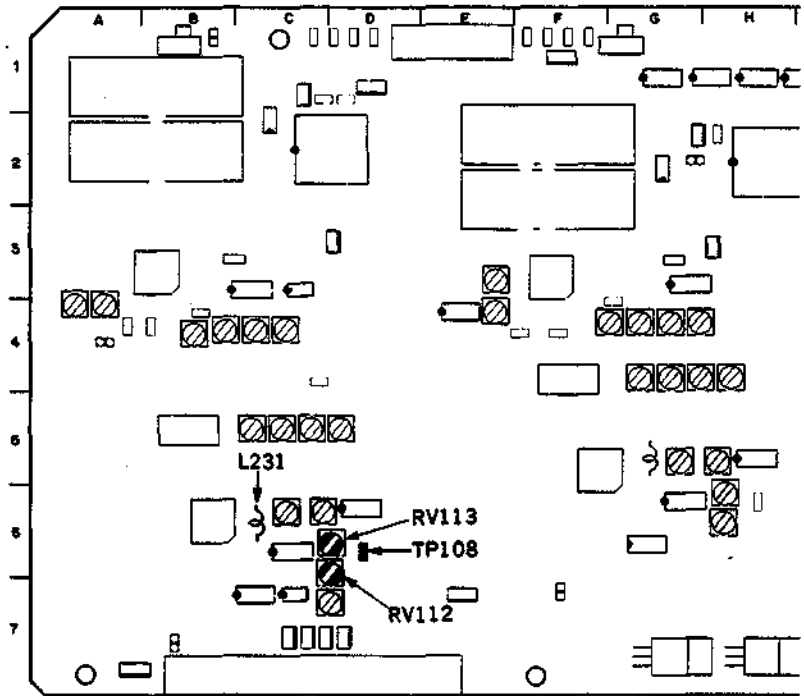

11-1-16. Y DOC Sensitivity Adjustment

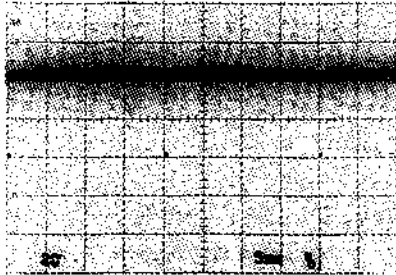
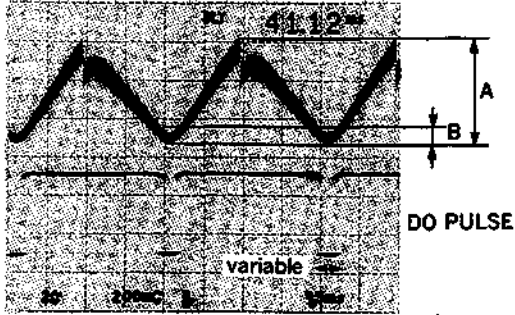
Preparations for adjustment	Specifications	Adjustments
<p>Step 1</p> <ul style="list-style-type: none"> • Play back the color bars signal portion (0:00—3:00) of the alignment tape CR5-2A PS. 	<p>L231/VP-33 (C-6)</p> <p>Waveform of the oscilloscope</p>  <p>ENVELOPE DC level</p> <p>Maximize the DC level</p>	<p>TRACKING control /control panel</p> <p>CONNECTION 1</p>
<p>Step 2</p> <ul style="list-style-type: none"> • JOG (still) mode 	<p>CH-1: L231/VP-33 (C-6) CH-2: TP108/VP-33 (D-6)</p> <p>Waveform of the oscilloscope</p>  <p>DO PULSE</p> <p>variable</p> <p>$B/A=1/5$</p> <p>Adjust so that the value of the DO detective level B stated above, after jog (still) was adjusted so that the high and low noises of monitor picture are equal.</p>	<p>Y OXIDE DO: RV113/VP-33 (D-6)</p> <p>TRIG: TP108/VP-33 (D-6)</p> <p>CONNECTION 1</p>

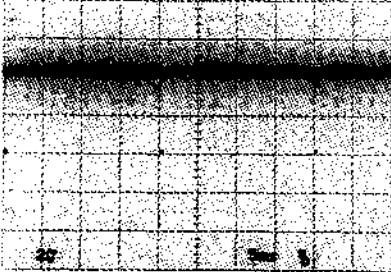
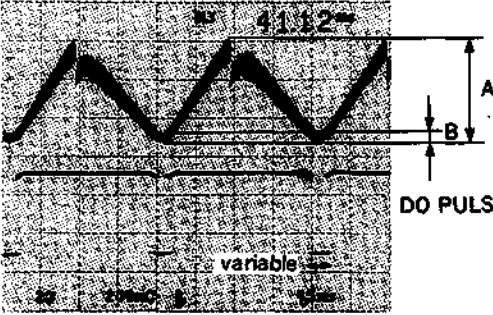
Preparations for adjustment	Specifications	Adjustments
<p>Step 3</p> <ul style="list-style-type: none"> • Play back the color bars signal portion (14:00—17:00) of the alignment tape CR5-1B PS. 	<p>LV531/VP-33 (G-5)</p> <p>Waveform of the oscilloscope</p>  <p>ENVELOPE DC level</p> <p>Maximize the DC level</p>	<p>TRACKING control /control panel</p> <p>CONNECTION 1</p>
<p>Step 4</p> <ul style="list-style-type: none"> • JOG (still) mode 	<p>CH-1: L531/VP-33 (G-5)</p> <p>CH-2: TP408/VP-33 (H-6)</p> <p>Waveform of the oscilloscope</p>  <p>DO PULSE</p> <p>variable</p> <p>$B/A=1/10$</p> <p>Adjust so that the value of the DO detective level B stated above, after jog (still) was adjusted so that the high and low noises of monitor picture are equal.</p>	<p>C METAL DO: RV412/VP-33 (H-6)</p> <p>TRIG: TP408/VP-33 (H-6)</p> <p>CONNECTION 1</p>
<p>Step 5</p> <ul style="list-style-type: none"> • Play back the dropout signal portion (26:00—28:00) of the alignment tape CR5-1B PS. 	<p>Check that the dropout portion on the monitor picture is corrected.</p>	<p>(Check)</p>

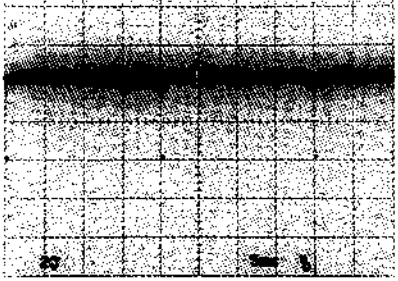
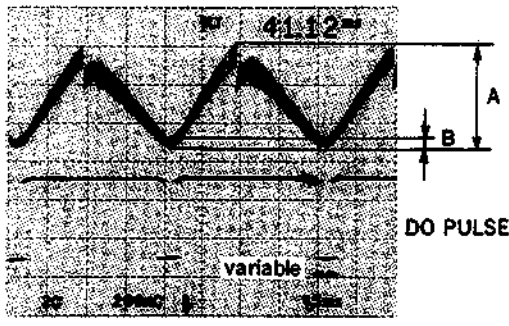
Preparations for adjustment	Specifications	Adjustments
<p>Step 3</p> <ul style="list-style-type: none"> • Play back the color bars signal portion (14:00—17:00) of the alignment tape CR5-1B PS. 	<p>L231/VP-33 (C-6)</p> <p>Waveform of the oscilloscope</p>  <p>ENVELOPE DC level</p> <p>Maximize the DC level</p>	<p>TRACKING control /control panel</p> <p>CONNECTION 1</p>
<p>Step 4</p> <ul style="list-style-type: none"> • JOG (still) mode 	<p>CH-1: L231/VP-33 (C-6)</p> <p>CH-2: TP108/VP-33 (D-6)</p> <p>Waveform of the oscilloscope</p>  <p>DO PULSE</p> <p>variable</p> <p>$B/A=1/8$</p> <p>Adjust so that the value of the DO detective level B stated above, after jog (still) was adjusted so that the high and low noises of monitor picture are equal.</p>	<p>Y METAL DO: RV112/VP-33 (D-6)</p> <p>TRIG: TP108/VP-33 (D-6)</p> <p>CONNECTION 1</p>
<p>Step 5</p> <ul style="list-style-type: none"> • Play back the dropout signal portion (26:00—28:00) of the alignment tape CR5-1B PS. 	<p>Check that the dropout portion on the monitor picture is corrected.</p>	<p>(Check)</p>

11-1-17. C DOC Sensitivity Adjustment

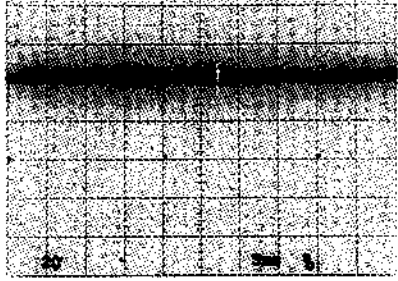
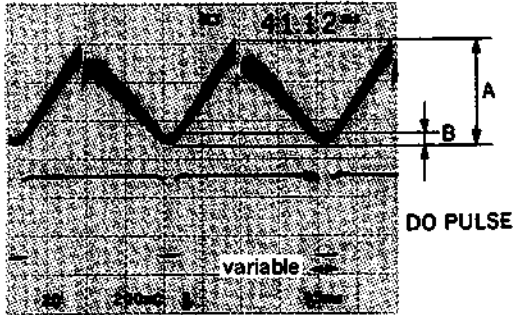
Preparations for adjustment	Specifications	Adjustments
<p>Step 1</p> <ul style="list-style-type: none"> • Play back the color bars signal portion (0:00—3:00) of the alignment tape CR5-2A PS. 	<p>LV531/VP-33 (G-5)</p> <p>Waveform of the oscilloscope</p>  <p>ENVELOPE DC level</p> <p>Maximize the DC level</p>	<p>TRACKING control /control panel</p> <p>CONNECTION 1</p>
<p>Step 2</p> <ul style="list-style-type: none"> • JOG (still) mode 	<p>CH-1: L531/VP-33 (G-5)</p> <p>CH-2: TP408/VP-33 (H-6)</p> <p>Waveform of the oscilloscope</p>  <p>41.12</p> <p>A</p> <p>B</p> <p>DO PULSE</p> <p>variable</p> <p>$B/A=1/6$</p> <p>Adjust so that the value of the DO detective level B stated above, after jog (still) was adjusted so that the high and low noises of monitor picture are equal.</p>	<p>C OXIDE DO: RV413/VP-33 (H-6)</p> <p>TRIG: TP408/VP-33 (H-6)</p> <p>CONNECTION 1</p>

VP-33 board

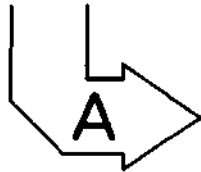
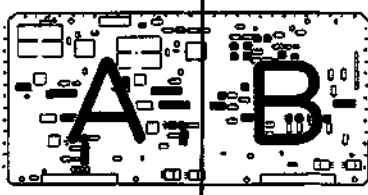

APPLICATION: 11-1-17.

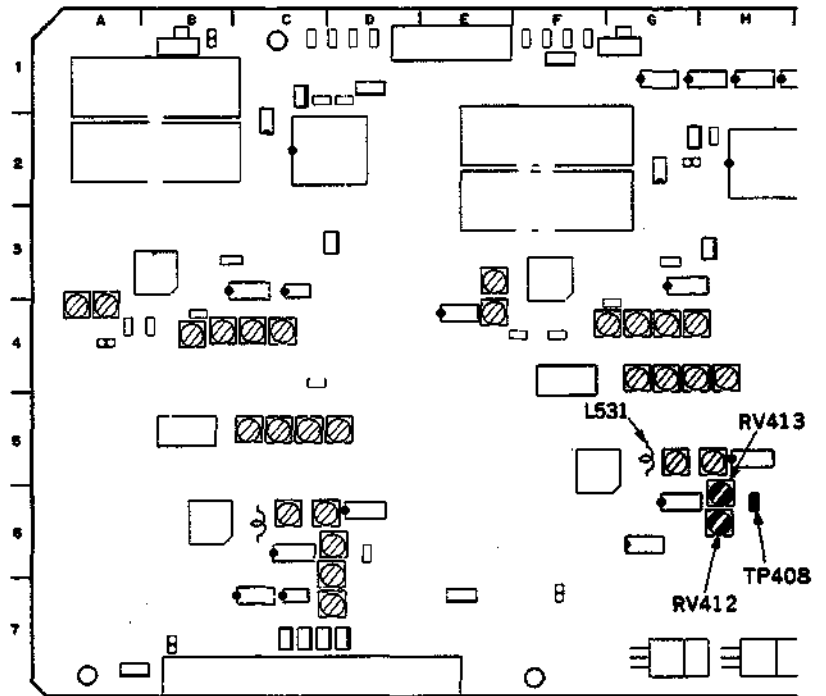

11-2. TBC BOARD ADJUSTMENT

11-2-1. Y and C TBC Input Level Check

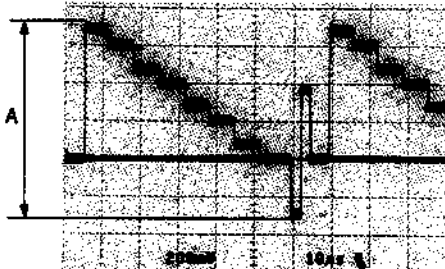
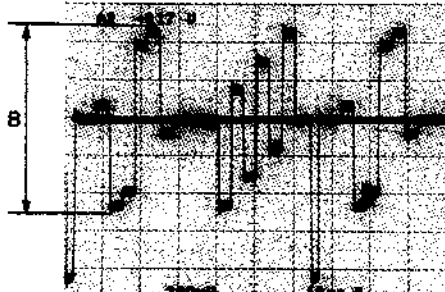
Preparations for adjustment	Specifications	Adjustments
<p>• Play back the color bars signal portion (14:00—17:00) of the alignment tape CR5-1B PS.</p>	<p>TP100/TBC-18 (B-4)</p> <p>Waveform of the oscilloscope</p>  <p>$A = 1.0 \pm 0.1 \text{ V p-p}$</p>	<p>(A) (Y IN Check)</p> <p>TRIG: TP300/TBC-18 (A-3)</p> <p>CONNECTION 1</p>
	<p>TP200/TBC-18 (B-4)</p> <p>Waveform of the oscilloscope</p>  <p>$B = 0.933 \pm 0.10 \text{ V p-p}$</p>	<p>(B) (C IN Check)</p> <p>TRIG: TP400/TBC-18 (C-5)</p> <p>CONNECTION 1</p>

TBC-18 board

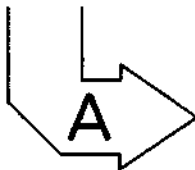
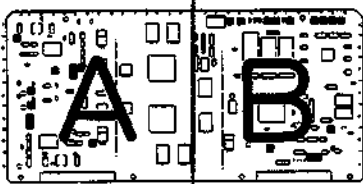

APPLICATION: 11-2-1.

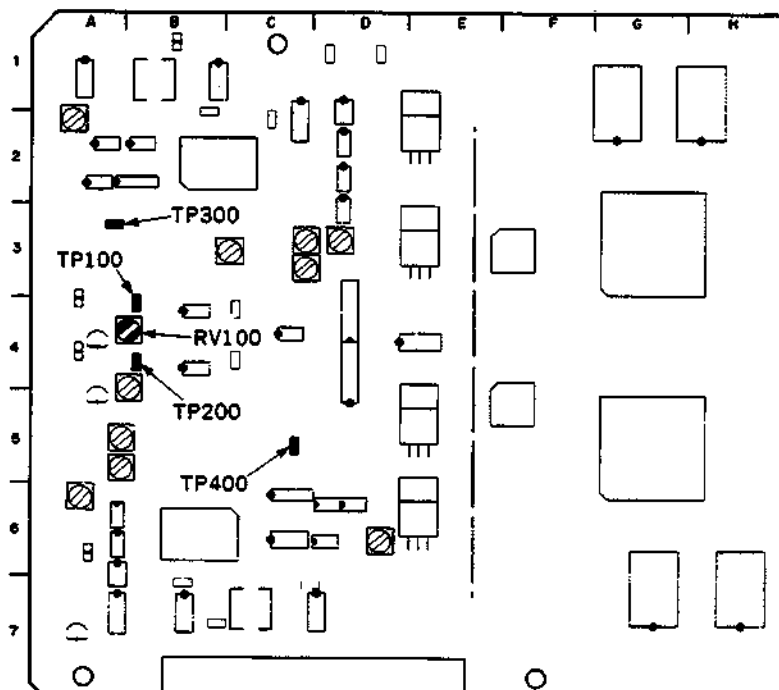

11-2-2. Y TBC Output Level and Gain Adjustment

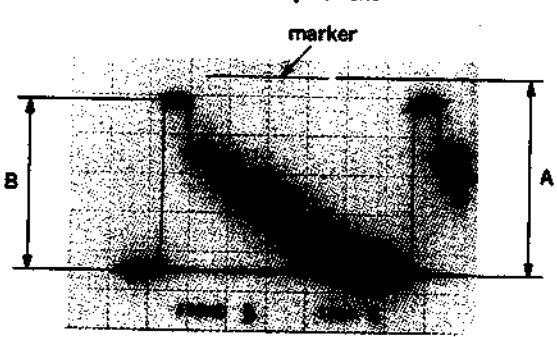
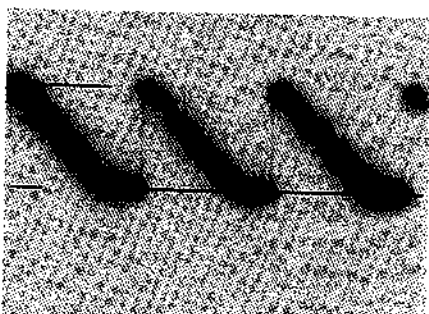
Preparations for adjustment	Specifications	Adjustments
<ul style="list-style-type: none"> • Play back the color bars signal portion (14:00—17:00) of the alignment tape CR5-1B PS. • Set S700-1 (LEVEL REF) (J-1) on the TBC-18 board to ON. <p>NOTE: Bright the oscilloscope, otherwise the marker of the reference level may be missed.</p> <ul style="list-style-type: none"> • After adjustment is completed, set S700-1/TBC-18 to OFF. 	<p>TP500 (Y OUT)/TBC-18 (L-1)</p> <p>Waveform of the oscilloscope</p> <p>Before adjustment</p>  <p>After adjustment</p>  <p>$A=0.50 \pm 0.01$ V p-p $B=0.50 \pm 0.01$ V p-p</p>	<p>(A) (VIDEO LEVEL) ● RV500/TBC-18 (K-1) (B) (Y GAIN) ● RV100/TBC-18 (B-4)</p> <p>TRIG: VIDEO OUT CONNECTION 1</p>

TBC-18 board

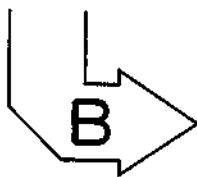
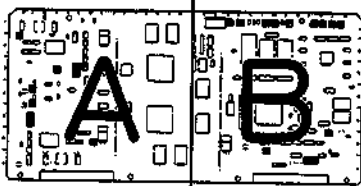

APPLICATION: 11-2-2.

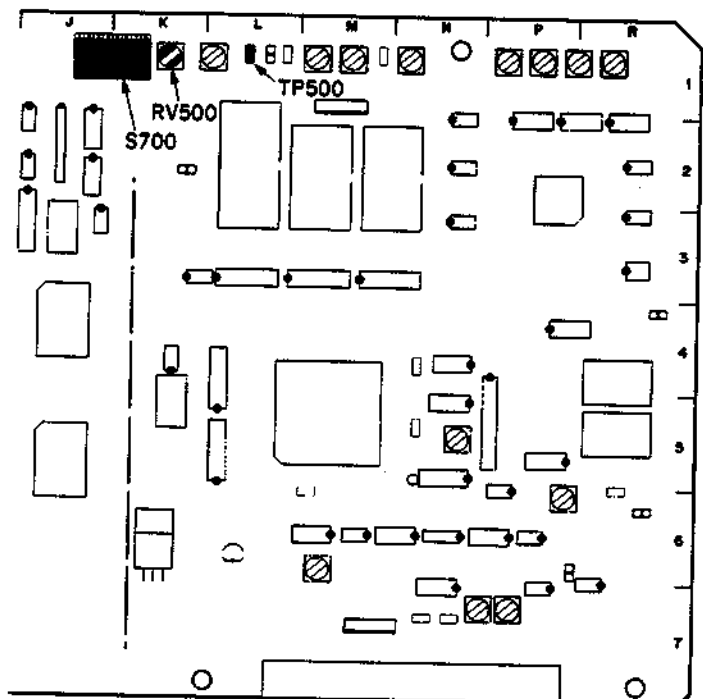

11-2-3. C TBC Output Level and Gain Adjustment

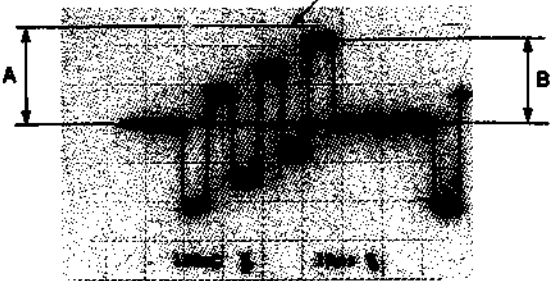
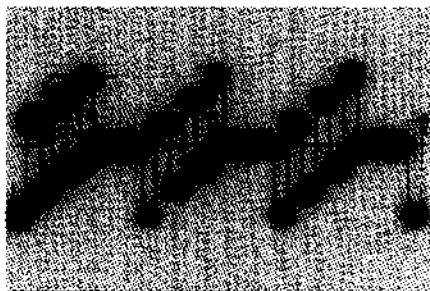
Preparations for adjustment	Specifications	Adjustments
<ul style="list-style-type: none"> • Play back the color bars signal portion (14:00—17:00) of the alignment tape CR5-1B PS. • Set S700-1 (LEVEL REF) (J-1) on the TBC-18 board to ON. <p>NOTE: Bright the oscilloscope, otherwise the marker of the reference level may be missed.</p>	<p>TP501 (B-Y OUT)/TBC-18 (L-1)</p> <p>Waveform of the oscilloscope</p> <p>Before adjustment</p>  <p>marker</p> <p>↓</p> <p>After adjustment</p>  <p>$A = 0.336 \pm 0.010 \text{ V p-p}$</p> <p>$B = 0.336 \pm 0.010 \text{ V p-p}$</p>	<p>(A) (CHROMA LEVEL)</p> <p>● RV501/TBC-18 (L-1)</p> <p>(B) (C GAIN)</p> <p>● RV200/TBC-18 (B-4)</p> <p>TRIG: VIDEO OUT</p> <p>CONNECTION 1</p>

TBC-18 board

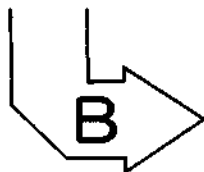
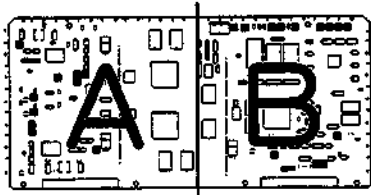

APPLICATION: 11-2-3.

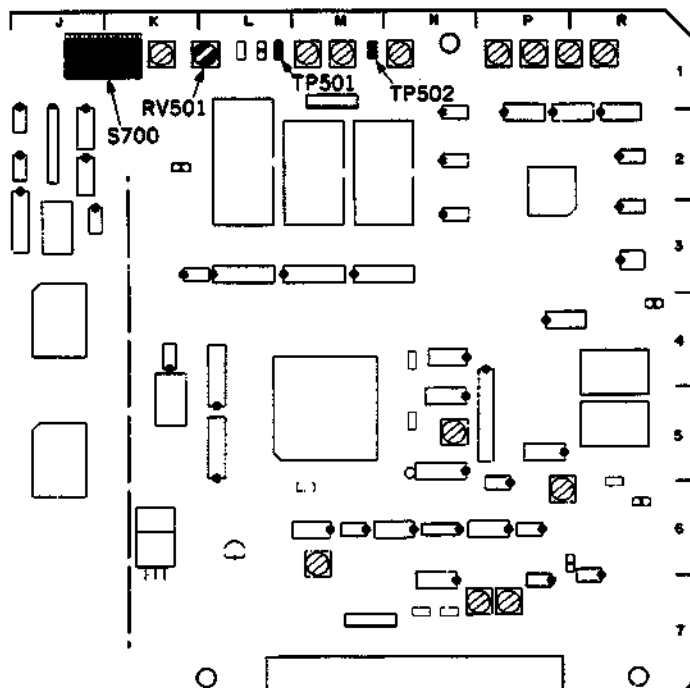

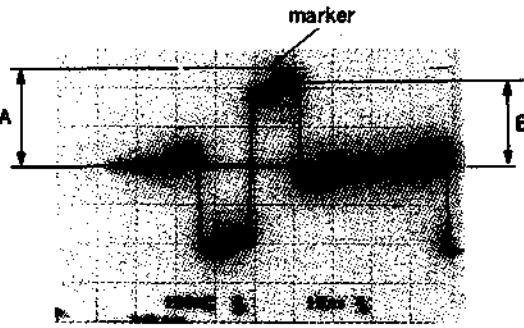
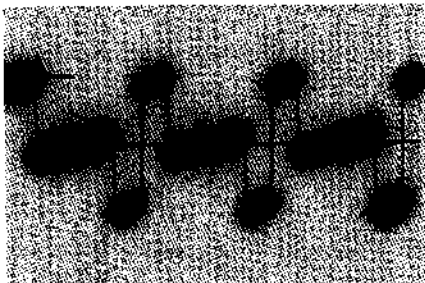
Preparations for adjustment	Specifications	Adjustments
<ul style="list-style-type: none"> • Play back the color bars signal portion (14:00—17:00) of the alignment tape CR5-1B PS. • Set S700-1 (LEVEL REF)(J-1) on the TBC-18 board to ON. <p>NOTE: Bright the oscilloscope, otherwise the marker of the reference level may be missed.</p> <ul style="list-style-type: none"> • After adjustment is completed, set S700-1/TBC-18 to OFF. 	<p>TP502 (R-Y OUT)/TBC-18 (M-1) Waveform of the oscilloscope</p> <p>Before adjustment</p>  <p>marker</p> <p>After adjustment</p>  <p>$A=0.336\pm 0.010$ V p-p $B=0.336\pm 0.020$ V p-p</p>	<p>(Check)</p> <p>TRIG: VIDEO OUT CONNECTION 1</p>

TBC-18 board

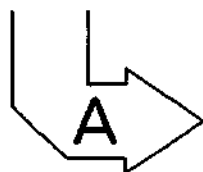
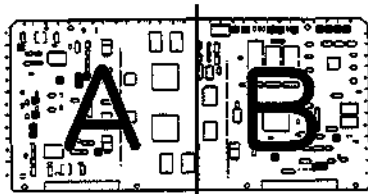

APPLICATION: 11-2-3.

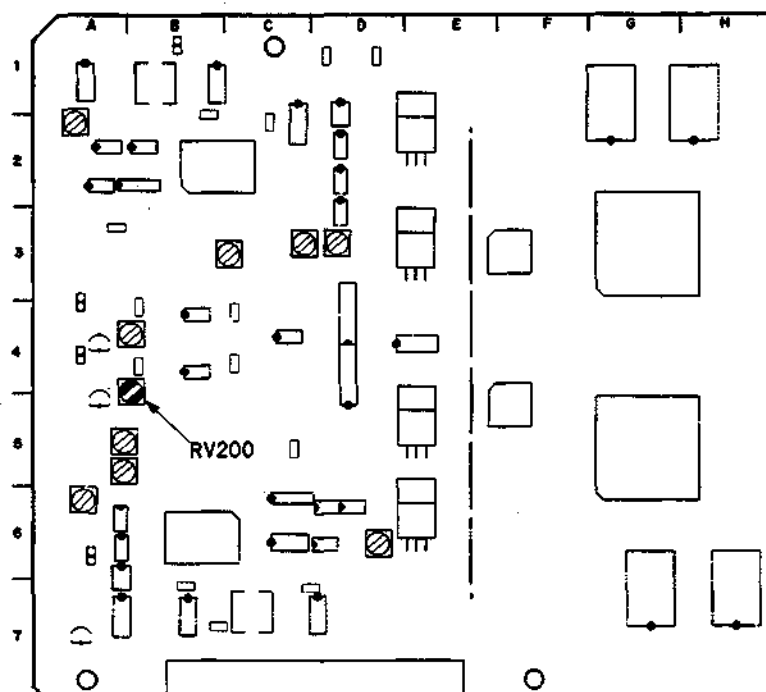

11-2-4. Y and C Normal VCO Adjustment

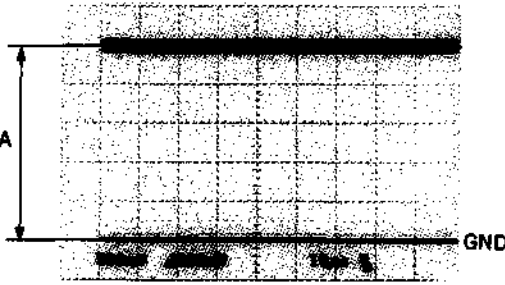
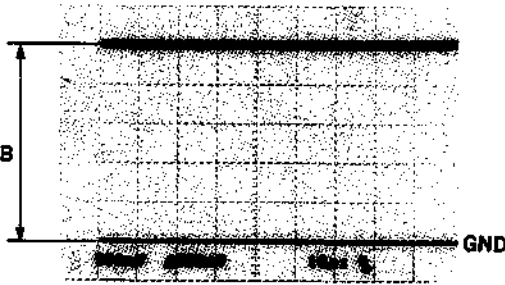
Preparations for adjustment	Specifications	Adjustments
<p>• Play back the color bars signal portion of (14:00—17:00) the alignment tape CR5-1B PS.</p>	<p>TP301/TBC-18 (D-1) Waveform of the oscilloscope</p>  <p>A=2.50±0.05 V dc</p>	<p>(A) (Y ERR VOLT) ⊗LV300/TBC-18 (B-1)</p> <p>TRIG: VIDEO OUT CONNECTION 1</p>
	<p>TP401/TBC-18 (D-7) Waveform of the oscilloscope</p>  <p>B=2.50±0.05 V dc</p>	<p>(B) (C ERR VOLT) ⊗LV400/TBC-18 (C-7)</p> <p>TRIG: VIDEO OUT CONNECTION 1</p>

TBC-18 board

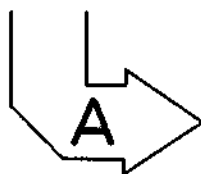
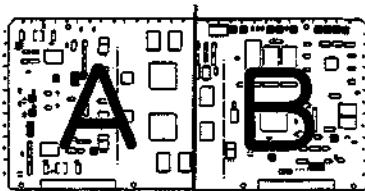

APPLICATION: 11-2-4.

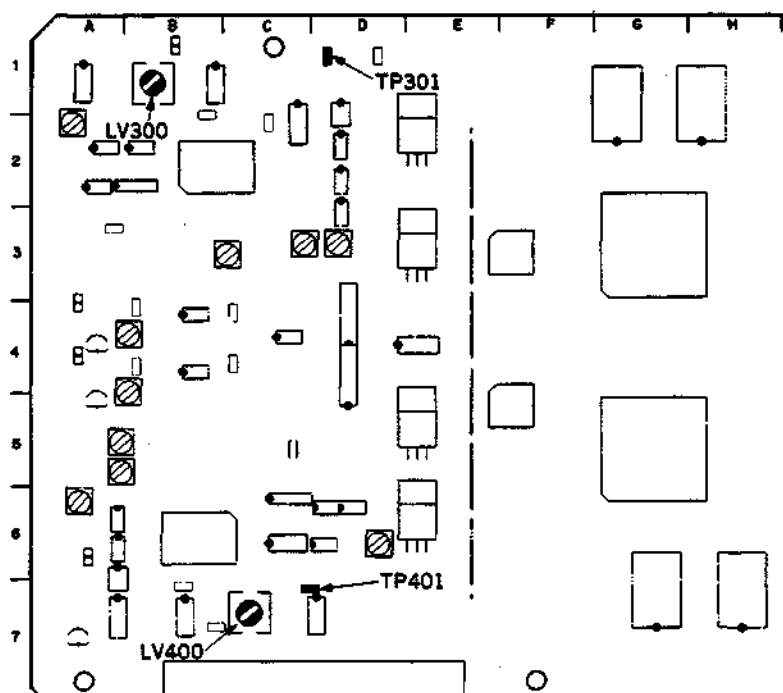

11-2-5. INT SC Frequency Adjustment

[CONNECTION]

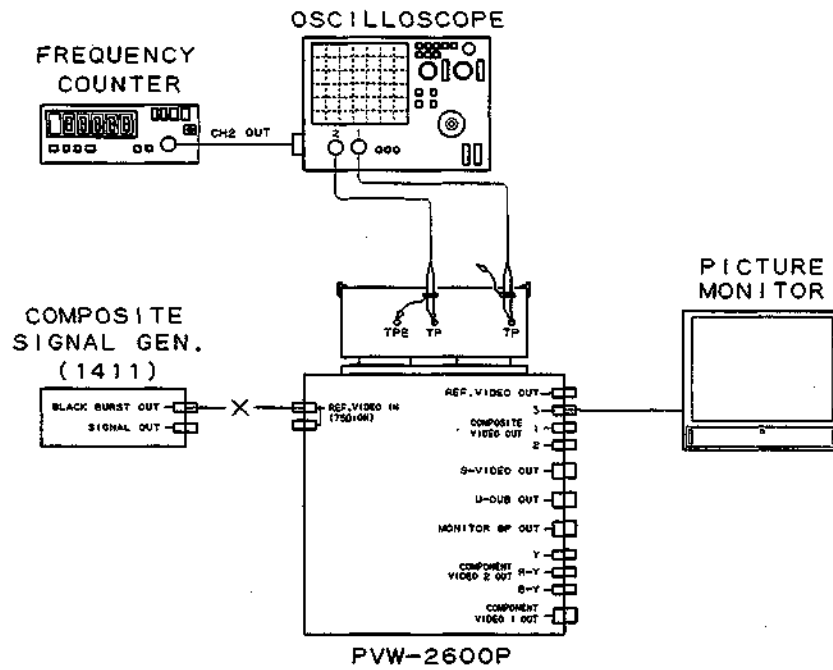

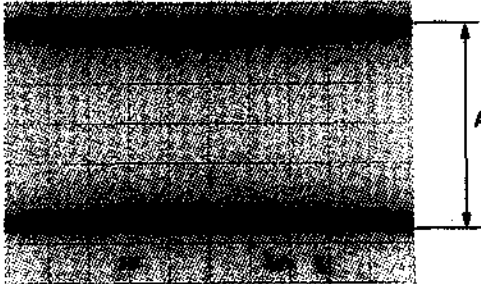
Preparations for adjustment	Specifications	Adjustments
<ul style="list-style-type: none"> • Play back the color bars signal portion (14:00—17:00) of a alignment tape CR5-1B PS. • Connect the frequency counter to the OUTPUT terminal of oscilloscope. • Disconnect the REF VIDEO INPUT connector. 	<p>TP701/TBC-18 (N-4) Waveform of the oscilloscope</p>  <p>$A = 5.0^{+0.2}_{-0.5} \text{ V p-p}$</p>	<p>(Check)</p> <p>TRIG: TP701/TBC-18 (N-4)</p>
<ul style="list-style-type: none"> • After adjustment is completed, connect the REF VIDEO INPUT connector. 	<p>TP701/TBC-18 (N-4) Frequency counter</p> <p>$f = 4,433,618 \pm 10 \text{ Hz}$</p>	<p>(4FSC FREQ) RV711/TBC-18 (P-6)</p>

TBC-18 board

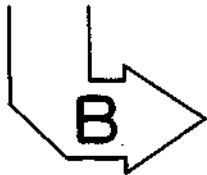
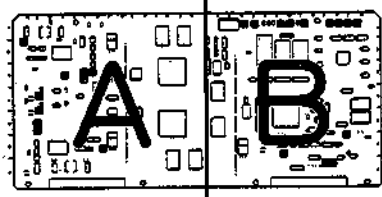

APPLICATION: 11-2-6.

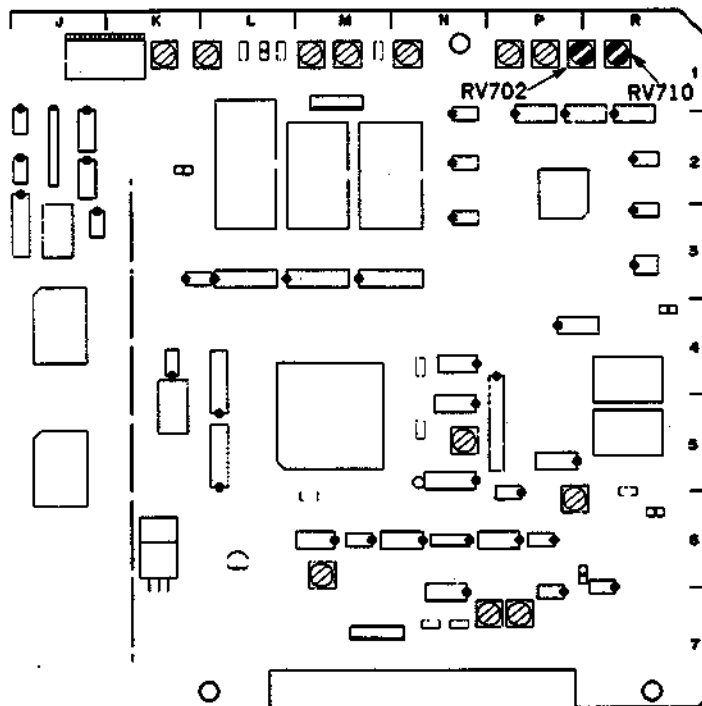

TBC-18 board

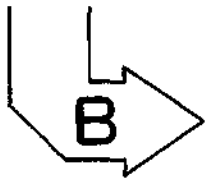
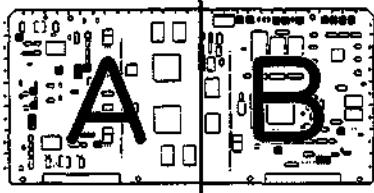

APPLICATION: 11-2-5.

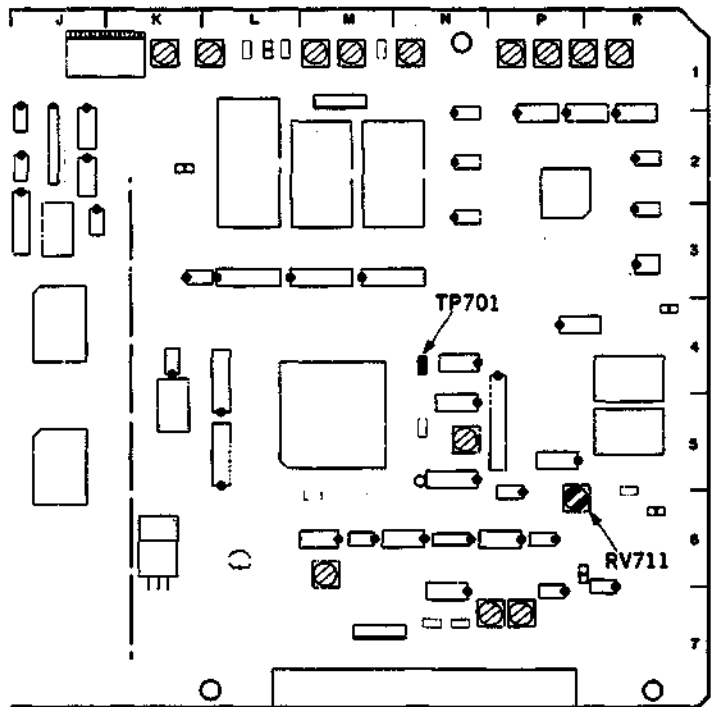

11-2-6. U—V Axis Phase (B-Y, R-Y Phase) Adjustment

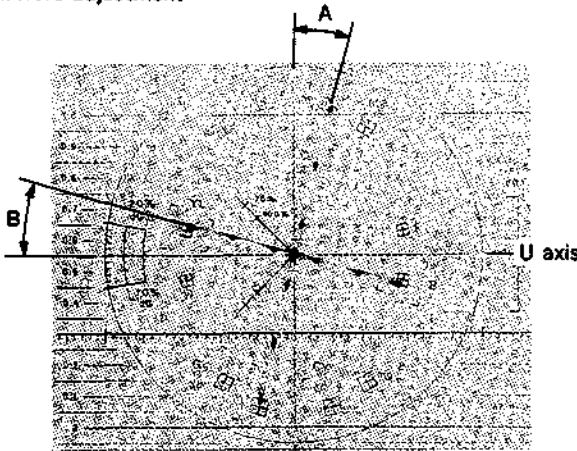
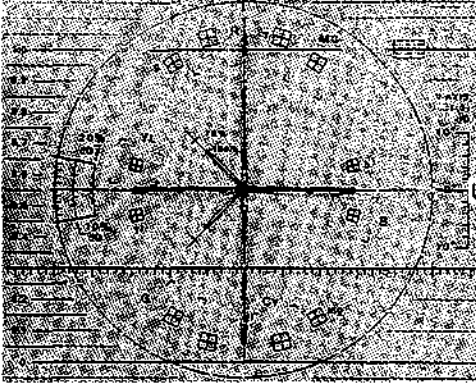
Preparations for adjustment	Specifications	Adjustments
<ul style="list-style-type: none"> • Play back the Quad Phase signal portion (22:00—24:00) of the alignment tape CR5-1B PS. • Connect a vectorscope to VIDEO OUT 1 connector. 	<p>VIDEO OUT 1 Picture of the vectorscope Before adjustment</p>  <p>After adjustment</p>  <p>(A) Set the dot of the burst on the right position on the scale. (B) Set the dots of the B—Y on the U axis of the vector scope. $B=0\pm 1^\circ$ (C) Set the dots of the R—Y on the V axis of the vector scope. $C=0\pm 1^\circ$</p>	<p>(A) Burst PHASE control/vectorscope</p> <p>(B) U axis (HUE) RV710/TBC-18 (R-1)</p> <p>(C) V axis (U/V OFFSET) RV702/TBC-18 (R-1)</p> <p>TRIG: REF. VIDEO</p> <p>CONNECTION 2</p>

11-2-7. TBC Tracking Adjustment

Preparations for adjustment	Specifications	Adjustments
Step 1	<ul style="list-style-type: none"> Fully turn RV303 counterclockwise. 	(Y TR GAIN) ●RV303/TBC-18 (D-3)
Step 2 <ul style="list-style-type: none"> Play back the color bars signal portion (14:00—17:00) of the alignment tape CR5-1B PS. Shuttle mode (24 times normal speed in forward and reverse) 	monitor display <ul style="list-style-type: none"> The picture of 24 times normal speed appears. If the picture does not appear, turn RV303 clockwise gradually so that the picture appear. 	(Tracking check)

TBC-18 board

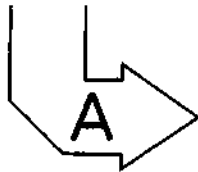
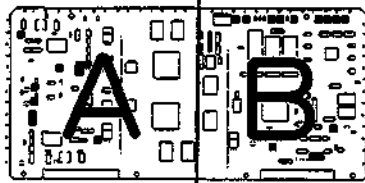

APPLICATION: 11-2-7.

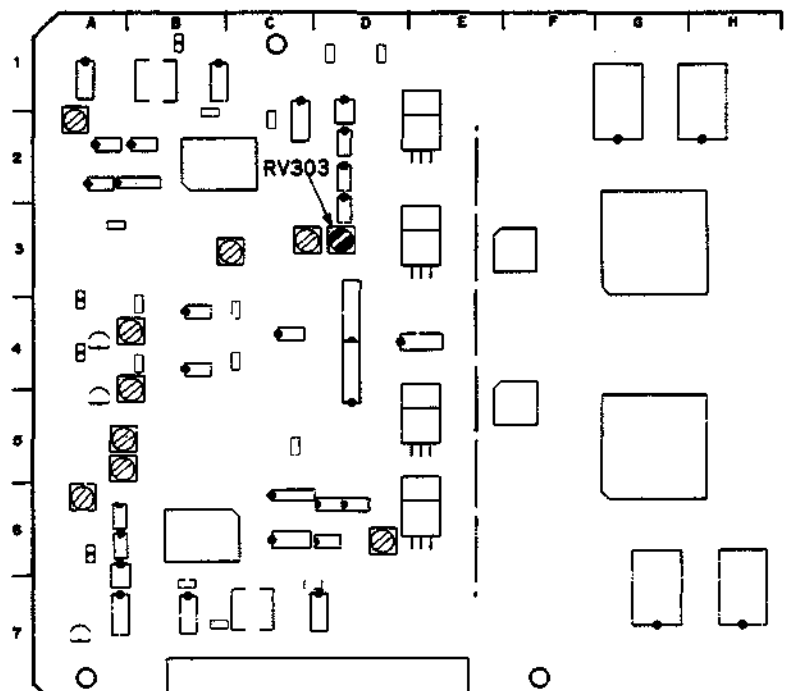

11-3. VP BOARD (VO, EN SYSTEM) ADJUSTMENT

11-3-1. ENC Y Level Adjustment

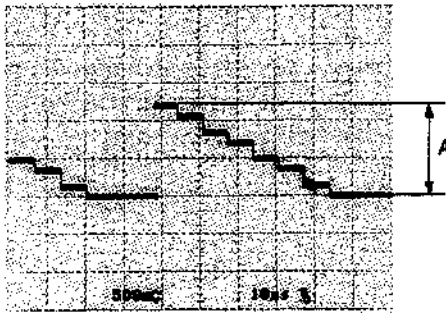
Preparations for adjustment	Specifications	Adjustments
<ul style="list-style-type: none"> • Play back the color bars signal portion (14:00—17:00) of the alignment tape CR5-1B PS. 	<p>TP701/VP-33 (N-3)</p> <p>Waveform of the oscilloscope</p>  <p>$A = 1.20 \pm 0.02 \text{ V p-p}$</p>	<p>RV701/VP-33 (M-2)</p> <p>TRIG: REF VIDEO</p> <p>CONNECTION 1</p>

VP-33 board

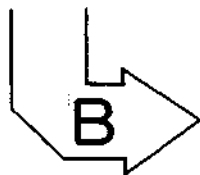
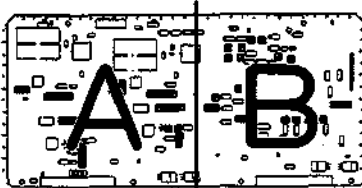

APPLICATION: 11-3-1.

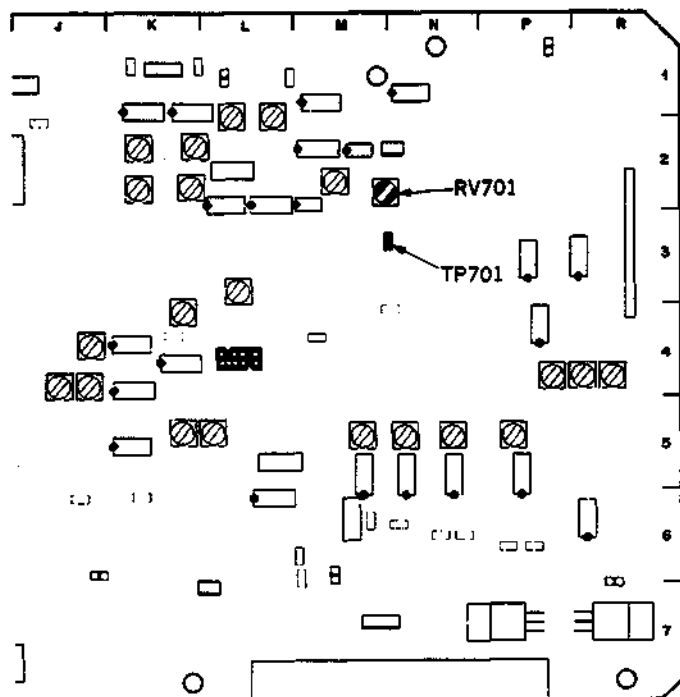

11-3-2. COMPONENT 2 and 1 Y OUT Level Adjustment

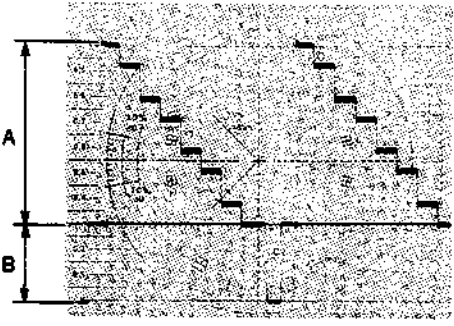
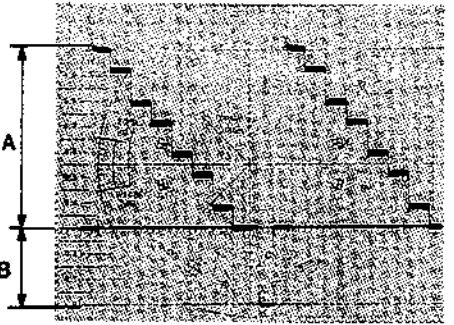
Preparations for adjustment	Specifications	Adjustments
<ul style="list-style-type: none"> • Play back the color bars signal portion (14:00—17:00) of the alignment tape CR5-1B PS. <p>Step 1</p> <ul style="list-style-type: none"> • Connect a waveform monitor to COMPONENT 2 Y OUTPUT connector. 	<p>COMPONENT 2 Y OUT</p> <p>Waveform of the waveform monitor</p>  <p>$A=0.700\pm0.007$ V p-p $B=0.300\pm0.003$ V p-p</p>	<p>(A) (Y) ①RV703/VP-33 (M-5) (B) (Y SYNC) ①RV708/VP-33 (P-4)</p> <p>TRIG: REF. VIDEO</p> <p>CONNECTION 1</p>
<p>Step 2</p> <ul style="list-style-type: none"> • Connect the waveform monitor to the Y terminal (1-2 (G)) of COMPONENT 1 OUTPUT connector. (using a multi connector cable DOBNC.) 	<p>COMPONENT 1 (Y) OUT</p> <p>Waveform of the waveform monitor</p>  <p>$A=0.700\pm0.007$ V p-p $B=0.300\pm0.003$ V p-p</p>	<p>(Check)</p> <p>TRIG: REF. VIDEO</p> <p>CONNECTION 1</p>

11-3-3. S-VIDEO OUT Y Level Adjustment

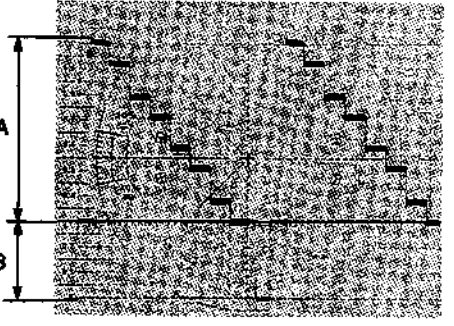
Preparations for adjustment	Specifications	Adjustments
<ul style="list-style-type: none"> • Play back the color bars signal portion (14:00—17:00) of the alignment tape CR5-1B PS. • Connect a waveform monitor to the Y terminal (3-1 (G)) of S-VIDEO OUTPUT connector. 	<p>S-VIDEO (Y) OUT</p> <p>Waveform of the waveform monitor</p>  <p>$A=0.700\pm0.007$ V p-p $B=0.300\pm0.003$ V p-p</p>	<p>(A) (S/Y) ①RV704/VP-33 (N-5) (B) (S VIDEO SYNC) ①RV707/VP-33 (R-4)</p> <p>TRIG: REF. VIDEO</p> <p>CONNECTION 1</p>

11-3-5. VIDEO OUT 3 and MONITOR OUT Y Level Adjustment

[CONNECTION]

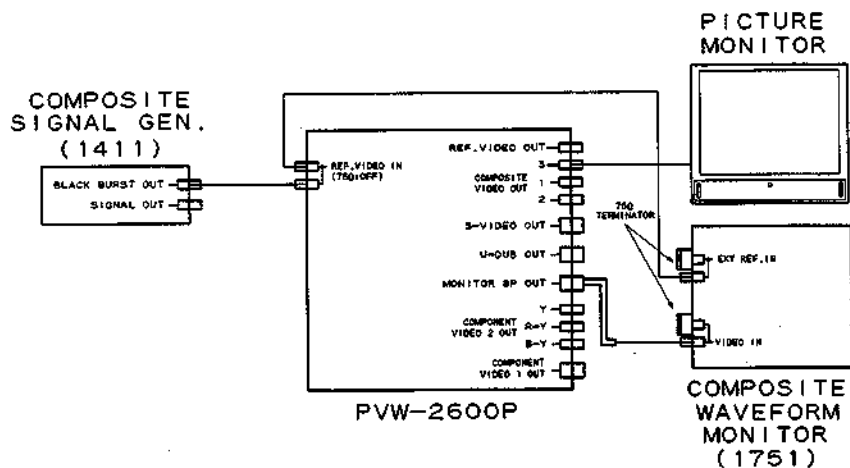

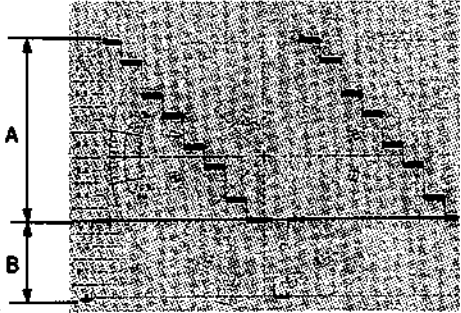
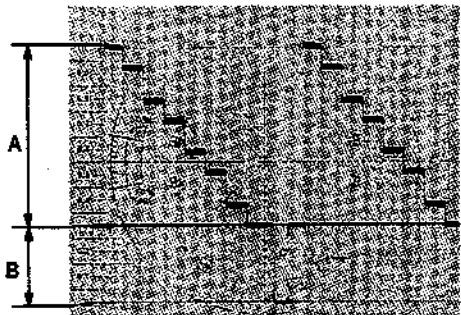
Preparations for adjustment	Specifications	Adjustments
<ul style="list-style-type: none"> • Play back the color bars signal portion (14:00—17:00) of the alignment tape CR5-1B PS. • Set S702 (CHROMA) (L-5) on the VP-33 board to OFF. <p>Step 1</p> <ul style="list-style-type: none"> • Connect a waveform monitor to VIDEO OUT 3 connector. 	<p>VIDEO OUT 3 Waveform of the waveform monitor</p>  <p>$A = 0.700 \pm 0.007 \text{ V p-p (adjustment)}$ $B = 0.300 \pm 0.003 \text{ V p-p (check)}$</p>	<p>(A) (VIDEO 3) RV709/VP-33 (P-5) (B) (Check)</p> <p>TRIG: REF. VIDEO</p>
<p>Step 2</p> <ul style="list-style-type: none"> • Connect the waveform monitor to the TV terminal (2-6 (G)) of MONITOR OUTPUT (TV-SP) connector. <p>• After adjustment is completed, set S702/VP-33 to ON.</p>	<p>MONITOR (TV) OUT Waveform of the waveform monitor</p>  <p>$A = 0.700 \pm 0.007 \text{ V p-p}$ $B = 0.300 \pm 0.003 \text{ V p-p}$</p>	<p>(Check)</p> <p>TRIG: REF. VIDEO</p>

VP-33 board

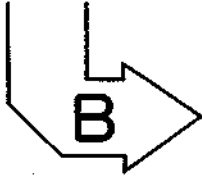
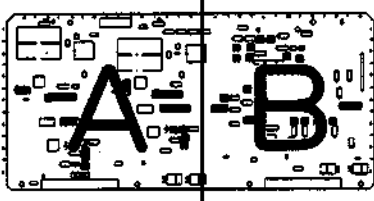

APPLICATION: 11-3-2.
11-3-3.

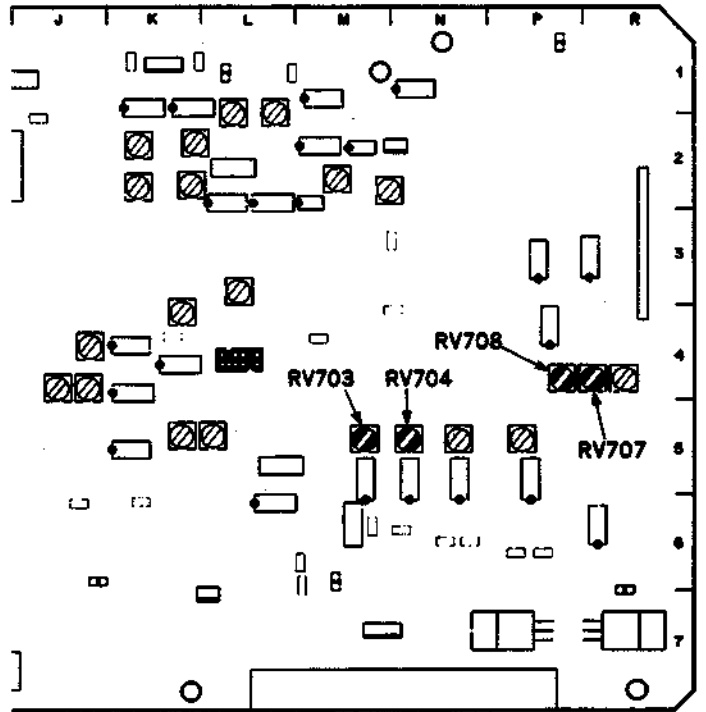

11-3-4. VIDEO OUT 1 and 2 Y Level Adjustment

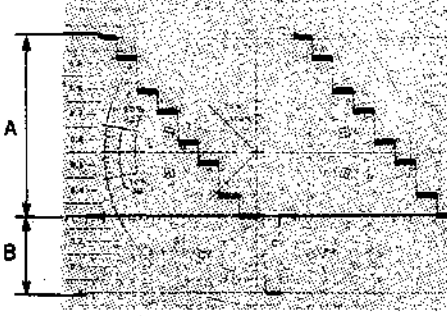
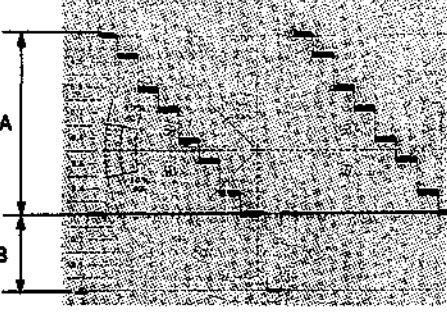
Preparations for adjustment	Specifications	Adjustments
<ul style="list-style-type: none"> • Play back the color bars signal portion (14:00—17:00) of the alignment tape CR5-1B.PS. • Set S702 (CHROMA) (L-5) on the VP-33 board to OFF. <p>Step 1</p> <ul style="list-style-type: none"> • Connect a waveform monitor to VIDEO OUT 1 connector. 	<p>VIDEO OUT 1</p> <p>Waveform of the waveform monitor</p>  <p>A=0.700±0.007 V p-p B=0.300±0.003 V p-p</p>	<p>(A) (VIDEO) ●RV705/VP-33 (N-5) (B) (VIDEO SYNC) ●RV706/VP-33 (R-4)</p> <p>TRIG: REF. VIDEO</p> <p>CONNECTION 2</p>
<p>Step 2</p> <ul style="list-style-type: none"> • Connect the waveform monitor to VIDEO OUT 2 connector. <p>• After adjustment is completed, set S702/VP-33 to ON.</p>	<p>VIDEO OUT 2</p> <p>Waveform of the waveform monitor</p>  <p>A=0.700±0.007 V p-p B=0.300±0.003 V p-p</p>	<p>(Check)</p> <p>TRIG: REF. VIDEO</p> <p>CONNECTION 2</p>

VP-33 board

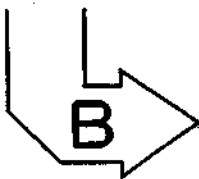
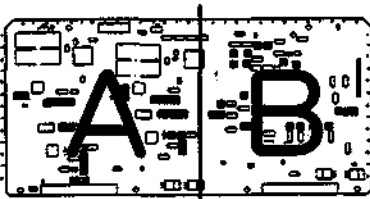

APPLICATION: 11-3-4.
11-3-5.

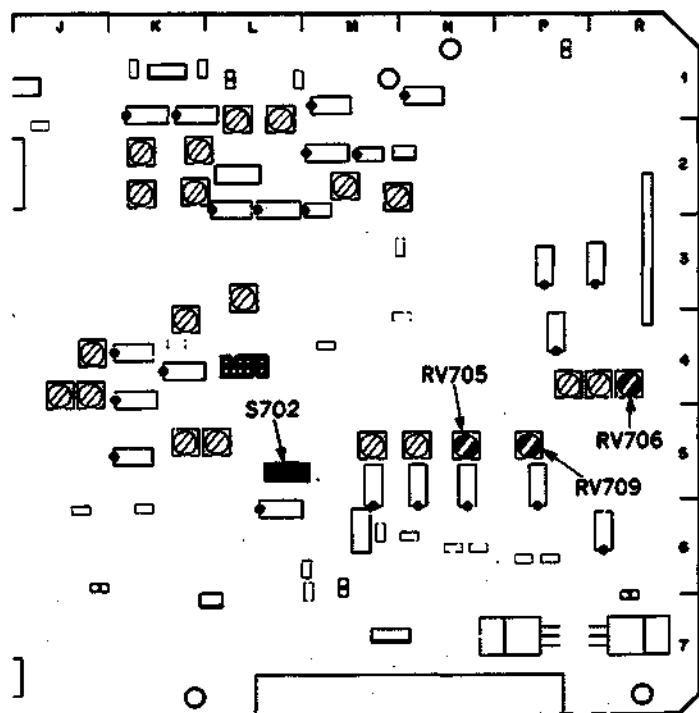

11-3-6. COMPONENT 2 and 1 R-Y OUT Level Adjustment

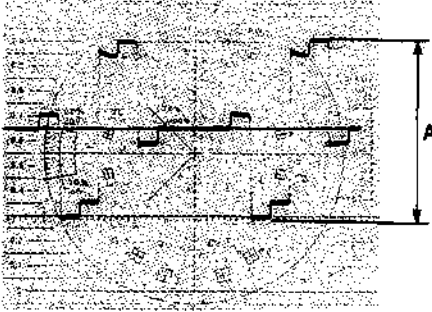
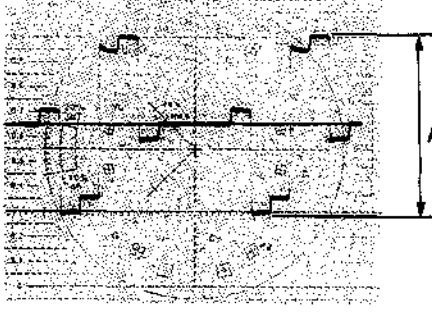
Preparations for adjustment	Specifications	Adjustments
<p>• Play back the color bars signal portion (14:00—17:00) of the alignment tape CR5-1B PS.</p> <p>Step 1</p> <p>• Connect a waveform monitor to COMPONENT 2 R-Y OUTPUT connector.</p>	<p>COMPONENT 2 R-Y OUT Waveform of the waveform monitor</p>  <p>$A=0.7000\pm0.0035$ V p-p</p>	<p>RV722/VP-33 (K-2)</p> <p>TRIG: REF. VIDEO</p> <p>CONNECTION 1</p>
<p>Step 2</p> <p>• Connect the waveform monitor to R-Y terminal (3-4 (G)) of COMPONENT 1 OUTPUT connector. (using a multi connector cable DOBNC)</p>	<p>COMPONENT 1 (R-Y) OUT Waveform of the waveform monitor</p>  <p>$A=0.700\pm0.007$ V p-p</p>	<p>(Check)</p> <p>TRIG: REF. VIDEO</p> <p>CONNECTION 1</p>

VP-33 board

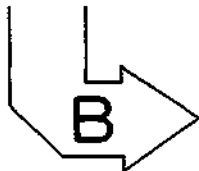
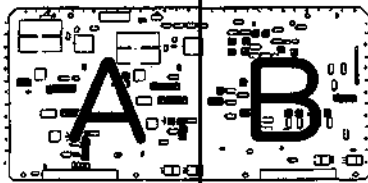

APPLICATION: 11-3-6.

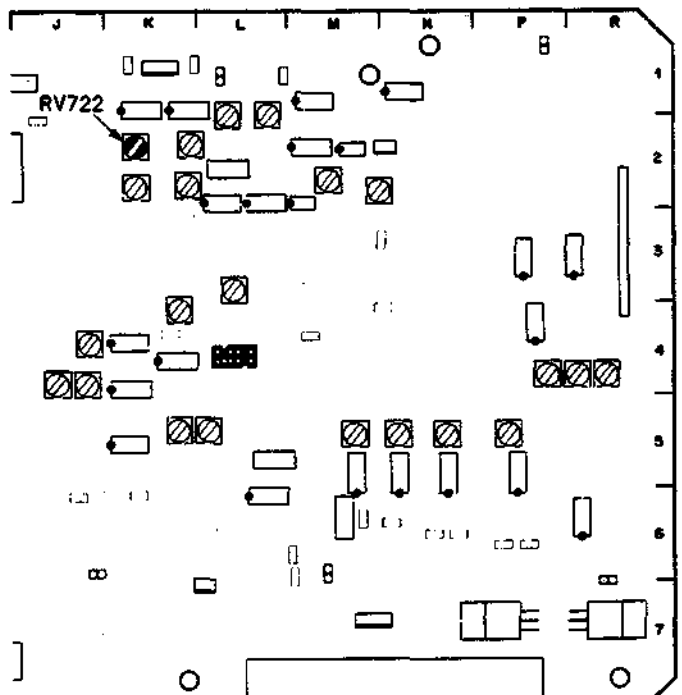

11-3-7. COMPONENT 2 and 1 B-Y OUT Level Adjustment

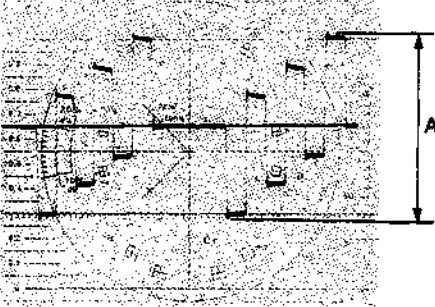
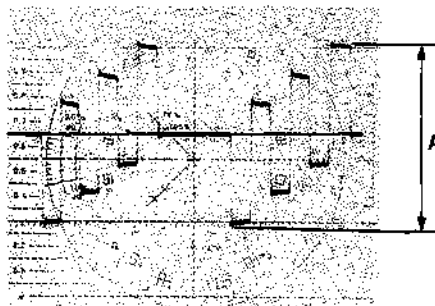
Preparations for adjustment	Specifications	Adjustments
<p>• Play back the color bars signal portion (14:00—17:00) of the alignment tape CR5-1B PS.</p> <p>Step 1</p> <p>• Connect a waveform monitor to COMPONENT 2 B-Y OUTPUT connector.</p>	<p>COMPONENT 2 B-Y OUT Waveform of the waveform monitor</p>  <p>$A = 0.7000 \pm 0.0035 \text{ V p-p}$</p>	<p>RV724/VP-33 (K-2)</p> <p>TRIG: REF. VIDEO</p> <p>CONNECTION 1</p>
<p>Step 2</p> <p>• Connect the waveform monitor to B-Y terminal (5-6 (G)) of COMPONENT 1 OUTPUT connector. (using a multi connector cable DOBNC)</p>	<p>COMPONENT 1 (B-Y) OUT Waveform of the waveform monitor</p>  <p>$A = 0.700 \pm 0.007 \text{ V p-p}$</p>	<p>(Check)</p> <p>TRIG: REF. VIDEO</p> <p>CONNECTION 1</p>

VP-33 board

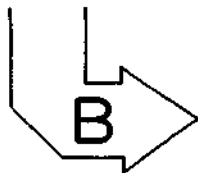
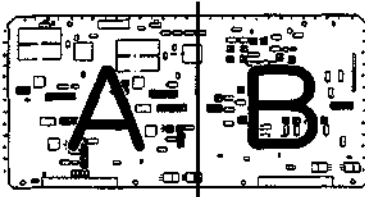

APPLICATION: 11-3-7.

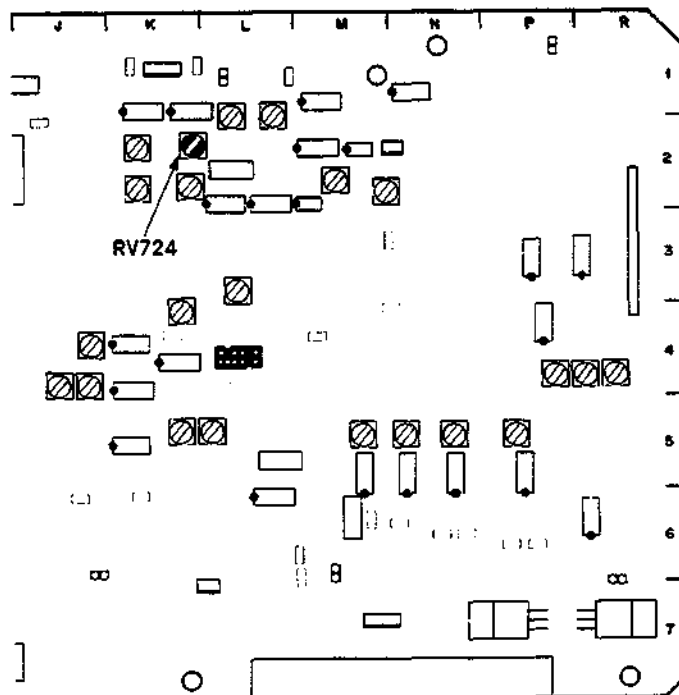

11-3-8. COMPONENT 2 B-Y CF ID Level Adjustment

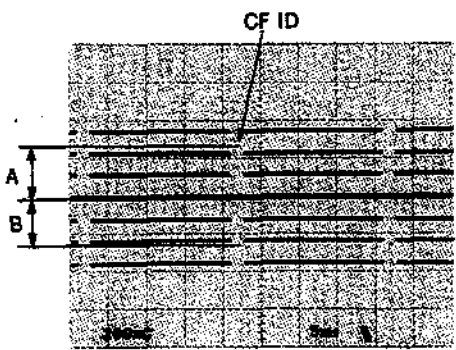
Preparations for adjustment	Specifications	Adjustments
<ul style="list-style-type: none"> • Play back the color bars signal portion (14:00—17:00) of the alignment tape CR5-1B PS. • Set S703 (CF ID) (L-2) on the VP-33 board to ON. • CAPSTAN LOCK switch (sub control panel): 8FD • Connect a waveform monitor to COMPONENT 2 B-Y OUTPUT connector. 	<p>COMPONENT 2 B-Y OUT</p> <p>Waveform of the oscilloscope</p>  <p>CF ID</p> <p>A</p> <p>B</p> <p>(1) $A=0.2625\pm 0.010$ V $B=0.2625\pm 0.010$ V</p> <p>(2) Check that CF ID pulse will disappear when the CAPSTAN LOCK switch is set to 2FD. After that, set the switch to 8FD.</p>	<p>(A) (ID (+)) ⓄRV725/VP-33 (L-1)</p> <p>(B) (ID (-)) ⓄRV726/VP-33 (L-1)</p> <p>TRIG: TP2/VP-33 (F-1)</p> <p>CONNECTION 1</p>

VP-33 board

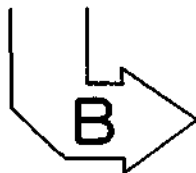
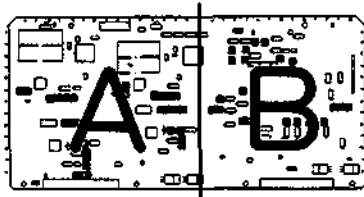

APPLICATION: 11-3-8.

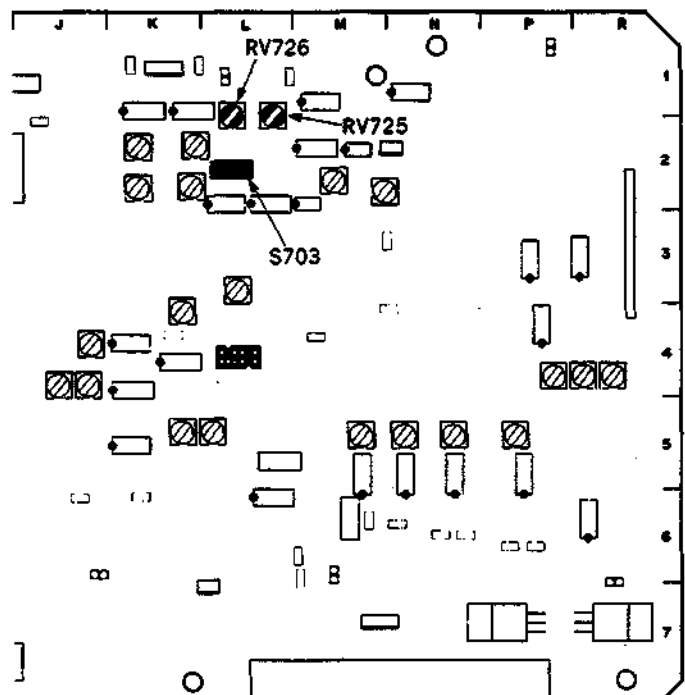

11-3-9. COMPONENT 2 Y VISC Level Adjustment

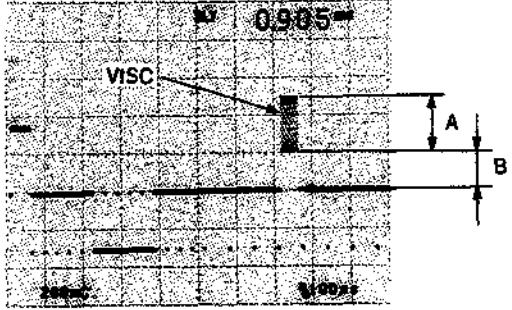
Preparations for adjustment	Specifications	Adjustments
<ul style="list-style-type: none"> • Play back the composite V sweep signal portion with VISC (28:00—30:00) of the alignment tape CR5-1B PS. • CAPSTAN LOCK switch (sub control panel): 8FD • Connect a oscilloscope that terminated CH-1 by 75 Ω to COMPONENT 2 Y OUTPUT connector. 	<p>COMPONENT 2 Y OUT Waveform of the oscilloscope</p>  <p>(1) $A=300\pm 10$ mV $B=200\pm 5$ mV</p> <p>(2) Check that CF ID pulse will disappear when the CAPSTAN LOCK switch is set to 8FD. After that, set the switch to 8FD.</p>	<p>(A) (VISC LEVEL) ●RV719/VP-33 (K-5)</p> <p>(B) (VISC DC) ●RV720/VP-33 (L-5)</p> <p>TRIG: TP2/VP-33 (F-1)</p> <p>CONNECTION 1</p>

VP-33 board

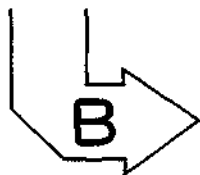
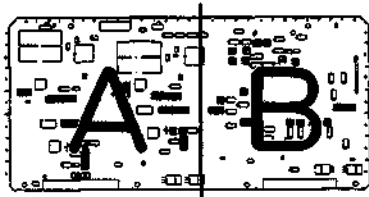

APPLICATION: 11-3-9.

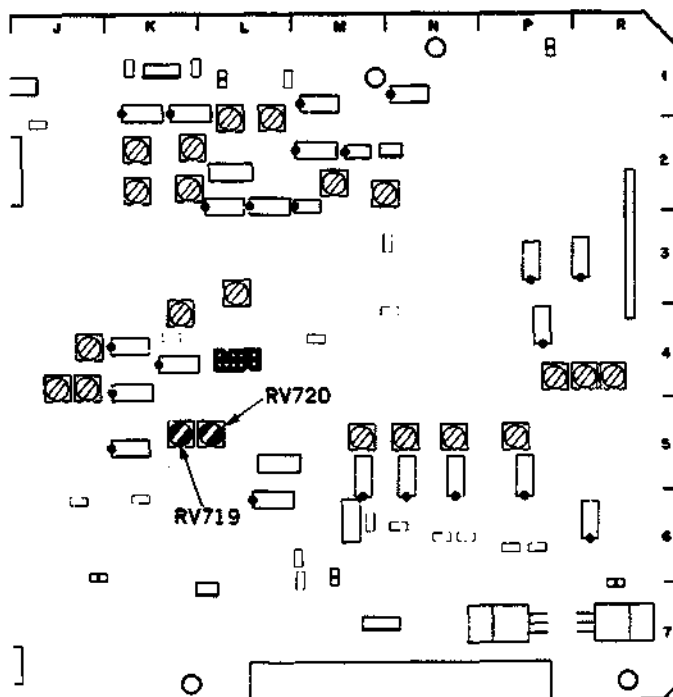

11-3-10. VIDEO OUT 1 ENC SC Leak Adjustment

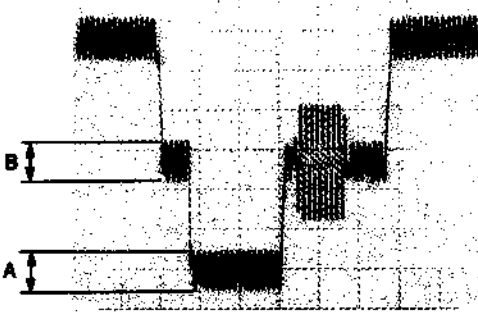
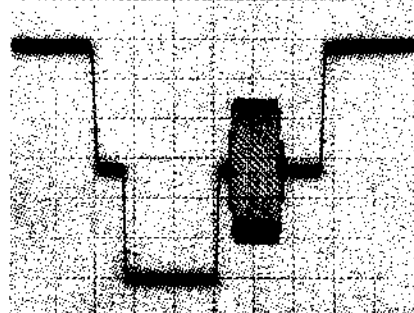
Preparations for adjustment	Specifications	Adjustments
<ul style="list-style-type: none"> • Play back the flat field signal portion (24:00—26:00) of the alignment tape CR5-1B PS. • Connect a waveform/vector monitor to VIDEO OUT 1 connector. • Set the time axis of the waveform monitor to magnification mode. 	<p>VIDEO OUT 1 WFM mode</p> <p>Before adjustment</p>  <p>After adjustment</p>  <p>Minimize the A. (less than 10 mV p-p) Minimize the B. (less than 10 mV p-p)</p>	<p>(A) (U SC LEAK) ●RV714/VP-33 (J-4)</p> <p>(B) (V SC LEAK) ●RV713/VP-33 (J-4)</p> <p>Adjust alternately.</p> <p>TRIG: REF. VIDEO</p> <p>CONNECTION 2</p>

VP-33 board

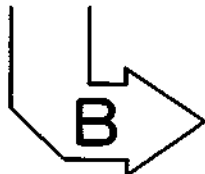
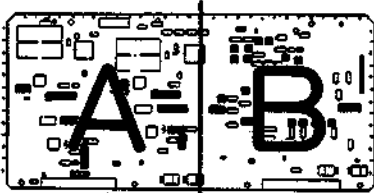

APPLICATION : 11-3-10.

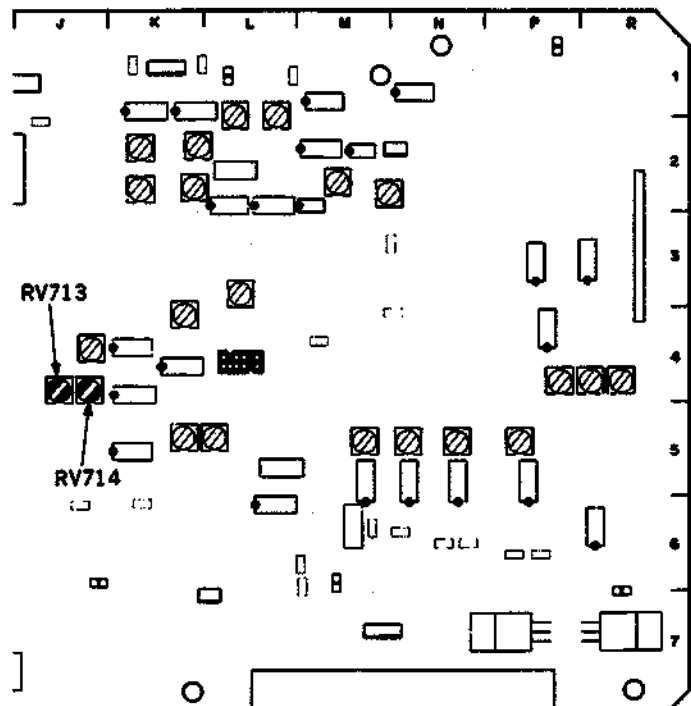

11-3-12. VIDEO OUT 1 Burst Level Adjustment

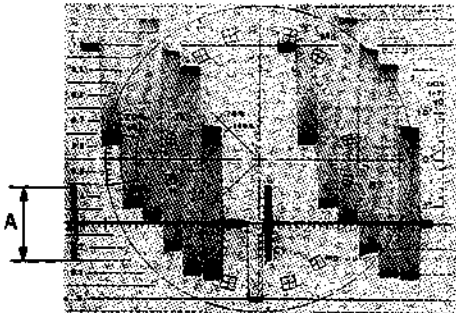
Preparations for adjustment	Specifications	Adjustments
<ul style="list-style-type: none"> • Play back the color bars signal portion (14:00–17:00) of the alignment tape CR5-1B PS. • Connect a waveform monitor to VIDEO OUT 1 connector. 	<p>VIDEO OUT 1 Waveform of the waveform monitor</p>  <p>A=300±3 mV p-p</p>	<p>RV712/VP-33 (L-3)</p> <p>TRIG: REF. VIDEO</p> <p>CONNECTION 2</p>

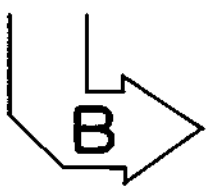
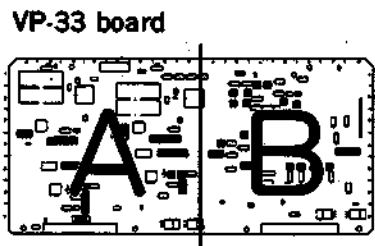

APPLICATION: 11-3-12.

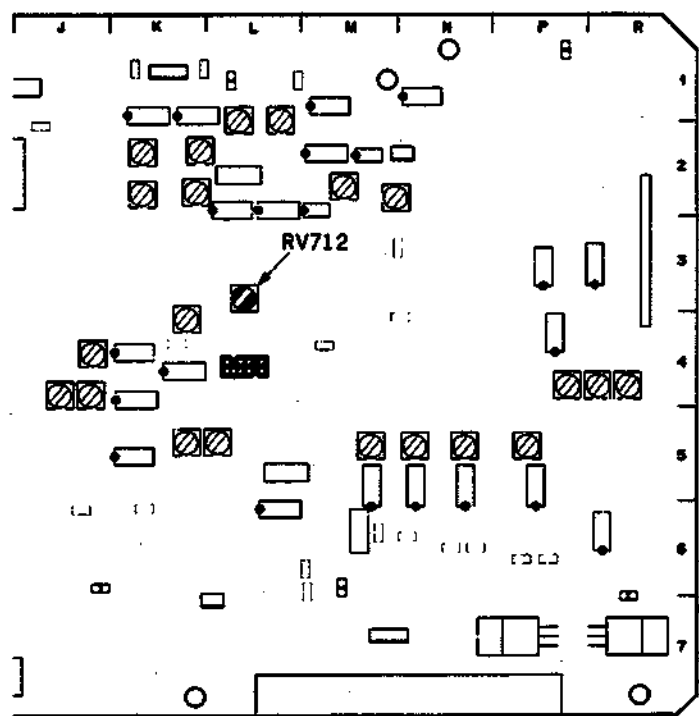

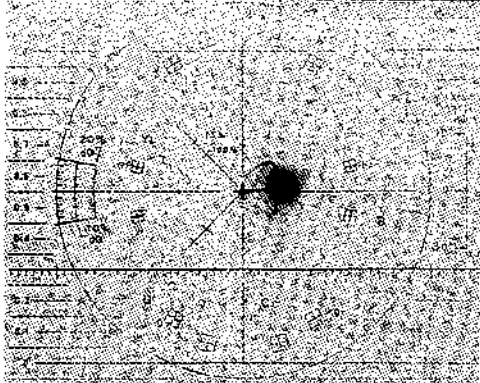
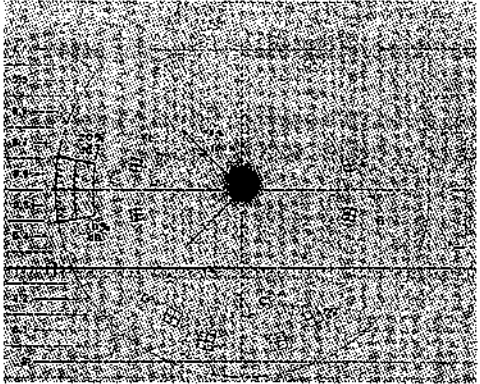
Preparations for adjustment	Specifications	Adjustments
<ul style="list-style-type: none"> • Play back the flat field signal portion (24:00—26:00) of the alignment tape CR5-1B PS. • Connect a waveform/vector monitor to VIDEO OUT 1 connector. • Set the time axis of the waveform monitor to magnification mode. 	<p>VIDEO OUT 1 SCH mode</p> <p style="text-align: center;">Before adjustment</p>  <p style="text-align: center;">↓</p> <p style="text-align: center;">After adjustment</p>  <p>Maximum the gain of the vectorscope and check the dot is at center.</p>	<p>(Check)</p> <p>TRIG: REF. VIDEO</p> <p>CONNECTION 2</p>

11-3-11. VIDEO OUT 1 Chroma Level Adjustment

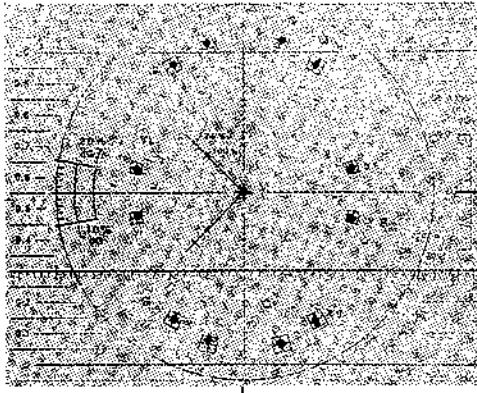
Preparations for adjustment	Specifications	Adjustments
<ul style="list-style-type: none"> • Play back the color bars signal portion (14:00—17:00) of the alignment tape CR5-1B PS. • Connect a vectorscope to VIDEO OUT 1 connector. 	<p>VIDEO OUT 1 Picture of the vectorscope</p>  <p>(A) Set the dot of the burst on the right position on the scale. All dots should be inside the \square mark on the vectorscope by adjust RV716 and RV715 alternately.</p>	<p>(A) Burst PHASE control/vectorscope</p> <p>(B) V axis (ENC R—Y) ●RV716/VP-33 (J-4)</p> <p>(C) U axis (ENC R—Y) ●RV715/VP-33 (K-4)</p> <p>TRIG: REF. VIDEO</p> <p>CONNECTION 2</p>

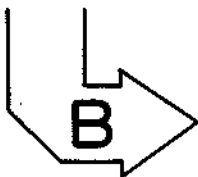
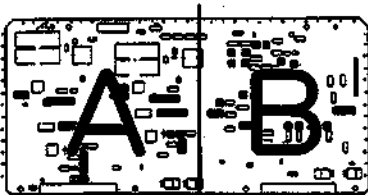

VP-33 board

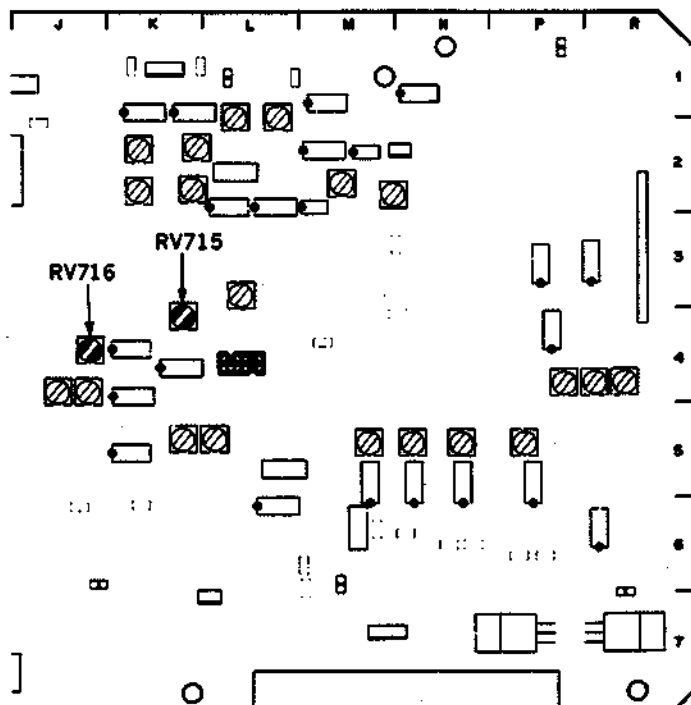

APPLICATION: 11-3-11:

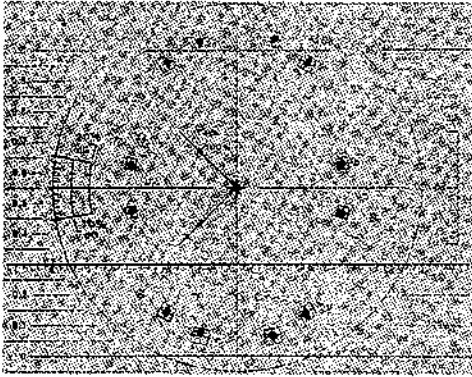

11-3-13. VIDEO OUT 2 Chroma Level and Burst Level Check

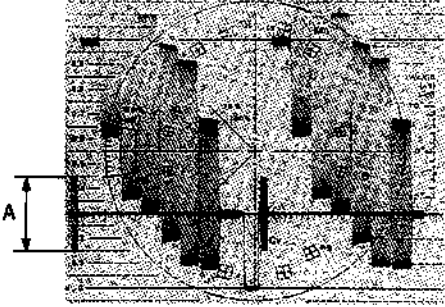
Preparations for adjustment	Specifications	Adjustments
<ul style="list-style-type: none"> • Play back the color bars signal portion (14:00—17:00) of the alignment tape CR5-1B PS. • Connect a waveform/vector monitor to VIDEO OUT 2 connector. <p>Step 1</p> <ul style="list-style-type: none"> • Use the waveform/vector monitor as a vectorscope, set the dot of the burst on the right position on the scale by PHASE control. 	<p>VIDEO OUT 2 Picture of the vectorscope</p>  <p>All dots should be inside the  mark on the vectorscope.</p>	<p>(Chroma level check)</p> <p>TRIG: REF. VIDEO CONNECTION 2</p>
<p>Step 2</p> <ul style="list-style-type: none"> • Use the waveform/vector monitor as a waveform monitor. 	<p>VIDEO OUT 2 Waveform of the waveform monitor</p>  <p>$A=300\pm 6$ mV p-p</p>	<p>(Burst level check)</p> <p>TRIG: REF. VIDEO CONNECTION 2</p>

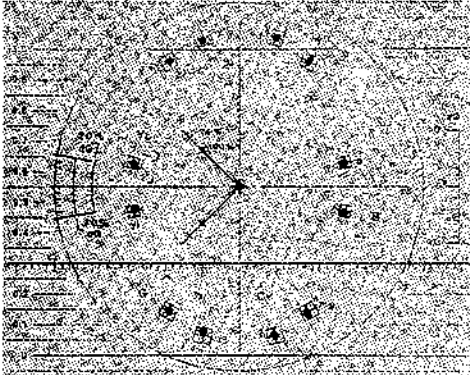
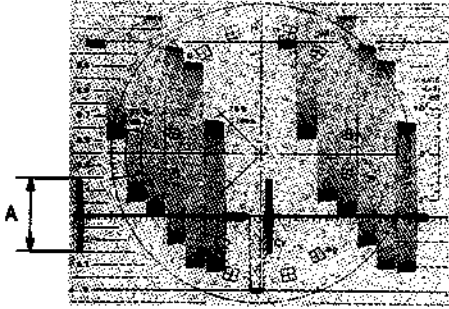

11-3-14. VIDEO OUT 3 Chroma Level and Burst Level Check

Preparations for adjustment	Specifications	Adjustments
<ul style="list-style-type: none"> • Play back the color bars signal portion (14:00—17:00) of the alignment tape CR5-1B PS. • Connect a waveform/vector monitor to VIDEO OUT 3 connector. <p>Step 1</p> <ul style="list-style-type: none"> • Use the waveform/vector monitor as a vectorscope, set the dot of the burst on the right position on the scale by PHASE control. 	<p>VIDEO OUT 3</p> <p>Picture of the vectorscope</p>  <p>All dots should be inside the \boxplus mark on the vectorscope.</p>	<p>(Chroma level check)</p> <p>TRIG: REF. VIDEO</p> <p>CONNECTION 2</p>
<p>Step 2</p> <ul style="list-style-type: none"> • Use the waveform/vector monitor as a waveform monitor. 	<p>VIDEO OUT 3</p> <p>Waveform of the waveform monitor</p>  <p>$A=300\pm 6$ mV p-p</p>	<p>(Burst level check)</p> <p>TRIG: REF. VIDEO</p> <p>CONNECTION 2</p>

11-3-15. MONITOR OUT Chroma Level and Burst Level Check

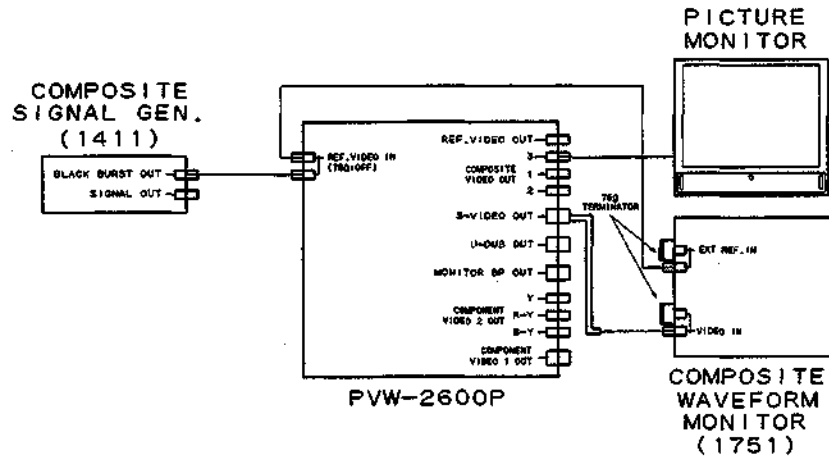
[CONNECTION]

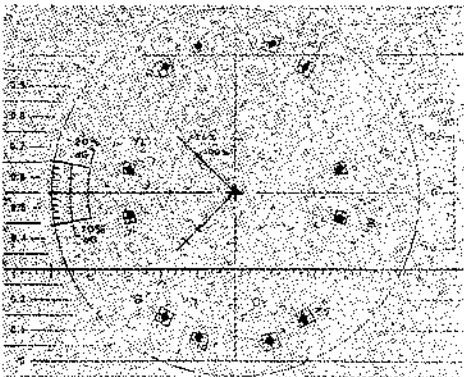

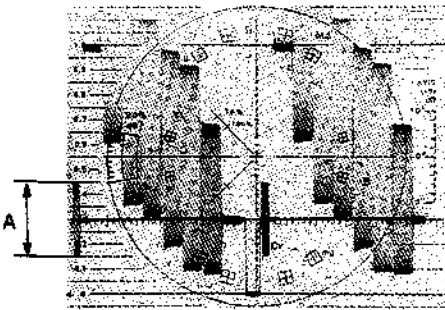

Preparations for adjustment	Specifications	Adjustments
<ul style="list-style-type: none"> • Play back the color bars signal portion (14:00--17:00) of the alignment tape CR5-1B PS. • Connect a waveform/vector monitor to the TV terminal (2-6(G)) of MONITOR OUT (TV-SP) connector. <p>Step 1</p> <ul style="list-style-type: none"> • Use the waveform/vector monitor as a vectorscope, set the dot of the burst on the right position on the scale by PHASE control. 	<p>MONITOR OUT Picture of the vectorscope</p>  <p>All dots should be inside the double size area of the  mark on the vectorscope.</p>	<p>(Chroma level check)</p> <p>TRIG: REF. VIDEO</p>
<p>Step 2</p> <ul style="list-style-type: none"> • Use the waveform/vector monitor as a waveform monitor. 	<p>MONITOR OUT Waveform of the waveform monitor</p>  <p>$A=300\pm 15$ mV p-p</p>	<p>(Burst level check)</p> <p>TRIG: REF. VIDEO</p>

11-3-16. S-VIDEO OUT Chroma Level and Burst Level Check

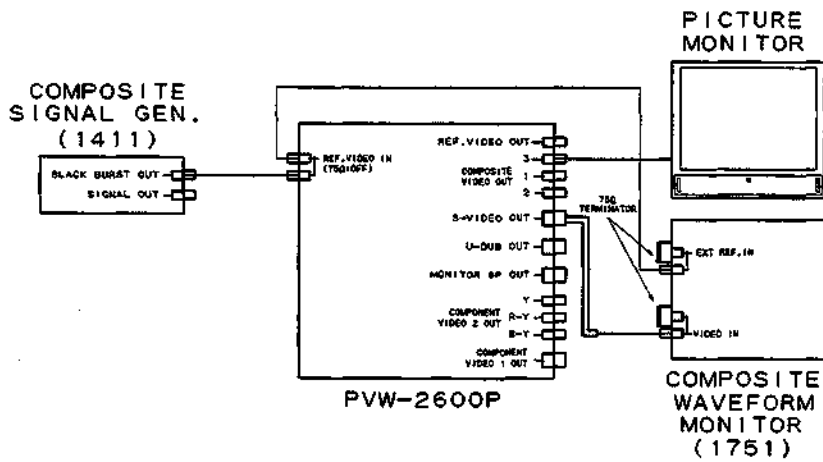
[CONNECTION]

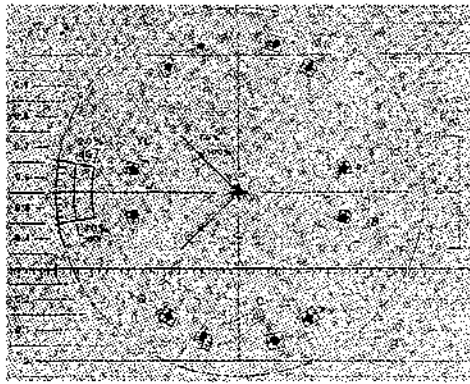

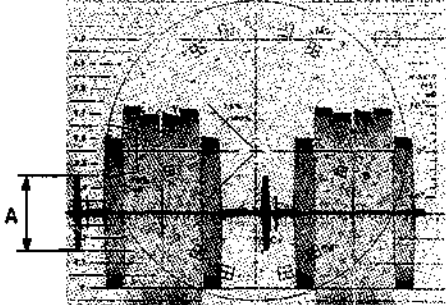
Preparations for adjustment	Specifications	Adjustments
<ul style="list-style-type: none"> • Play back the color bars signal portion (14:00~17:00) of the alignment tape CR5-1B PS. • Connect a waveform/vector-monitor to the C terminal (4-2G) of S-VIDEO OUT connector. <p>Step 1</p> <ul style="list-style-type: none"> • Use the waveform/vector monitor as a vectorscope, set the dot of the burst on the right position on the scale by PHASE control. 	<p>S-VIDEO C OUT Picture of the vectorscope</p>  <p>All dots should be inside the triple size area of the  mark on the vectorscope.</p>	<p>(Chroma level check)</p> <p>TRIG: REF. VIDEO</p>
<p>Step 2</p> <ul style="list-style-type: none"> • Use the waveform/vector monitor as a waveform monitor. 	<p>S-VIDEO C OUT Waveform of the waveform monitor</p>  <p>$A = 300 \pm 45 \text{ mV p-p}$</p>	<p>(Burst level check)</p> <p>TRIG: REF. VIDEO</p>

VIDEO OVERALL

SECTION 12 VIDEO OVERALL ALIGNMENT

[Equipment Required]

- Oscilloscope (TEKTRONIX 2445 or equivalent)
- Signal Generator
 - Component SG (TEKTRONIX TSG-300 or equivalent)
 - Composite SG (TEKTRONIX 1411 or equivalent)
 - Digital Composite (TEKTRONIX TSG-271 or equivalent)
- Network Analyzer (ANRITSU MS-420B or equivalent)
- Waveform Monitor
 - Component (TEKTRONIX WFM300/WFM300A/1781R or equivalent)
 - Composite (TEKTRONIX 1481C/1751/1781R or equivalent)
- Spectrum Analyzer (ADVANTEST R4131 B/D or equivalent)
- Picture Monitor
- Head Coupling Tool
- Alignment Tape CR5-2A PS (part No. 8-960-098-44)

Contents

TIME min s	VIDEO TRACK
0: 00	75% Color Bars
3: 00	60% Multi burst Y: 0.5,1.0,2.0,3.0,4.1,4.5 MHz C: 0.2, 0.5,1.0,1.5,2.0 MHz
6: 00	50% Bowtie & 10T
9: 00	Pulse & bar
11: 00	Quad phase
13: 00	C-Monoscope (Switching Position is shifted.)
15: 00	

• Alignment Tape CR5-1B PS (part No. 8-960-096-91)

Contents

TIME min s	VIDEO TRACK	AFM
0: 00	RF Sweep Marker 1,2,4,6,8,10,12 MHz	No-Signal
2: 00	60% H. Sweep (CTDM) Marker 0.5,1,2,3,4,5 MHz	
5: 00	Pulse & Bar (CTDM)	
8: 00	Multi Burst Y: 0.5,1,2,4,5,5.5 MHz C: 0.2, 0.5,1,1.5,2 MHz	
11: 00	Pulse & Bar	
14: 00	100% Color Bars	
16: 30		75 kHz Deviation
17: 00	50% Bowtie & 10T	No-Signal
19: 00	Line 17A	
22: 00	Quad Phase	
24: 00	50% Flat Field	
26: 00	100% Color Bars with dropout	
28: 00	Composite H. Sweep with VISC	
30: 00		

[Switch/Setup menu Setting]

This setting should not be changed in position unless otherwise specified.

<Control Panel>

upper
 LOCAL/REMOTE : LOCAL
 lower
 CTL/TC/U-BIT : TC

<Sub Control Panel>

CHARACTER : ON
 TC : LTC
 CAPSTAN LOCK : 8FD
 TBC CONTROL : LOCAL
 VIDEO : PRESET
 CHROMA : PRESET
 SET UP : PRESET
 Y/C DELAY : PRESET

[Connection]

Connect some equipment as following unless otherwise specified.

CONNECTION1

SG 1411/Waveform Monitor WFM-300 (A)/Oscilloscope/Picture Monitor

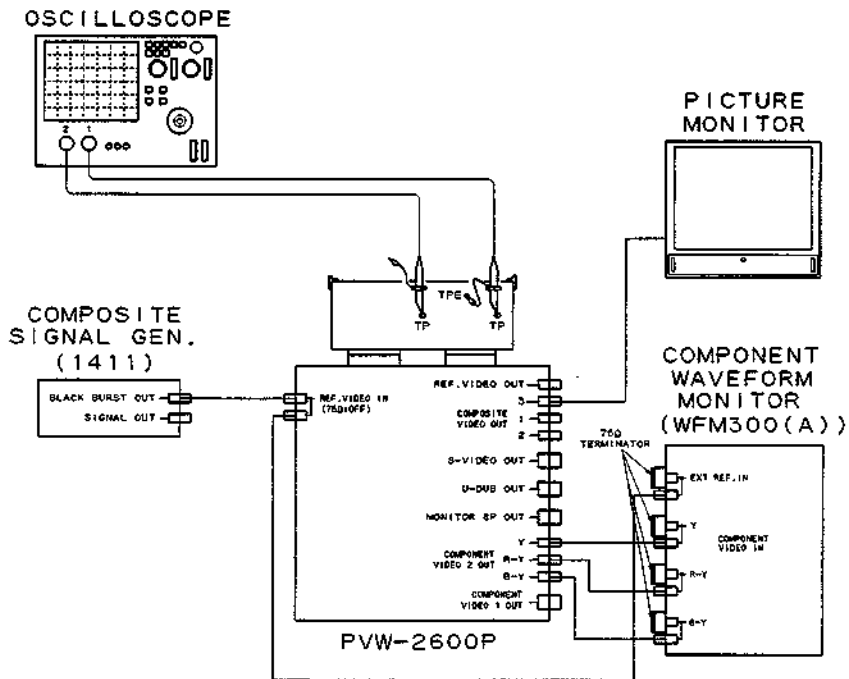

CONNECTION2

SG 1411/waveform Monitor 1751/Oscilloscope/Picture Monitor

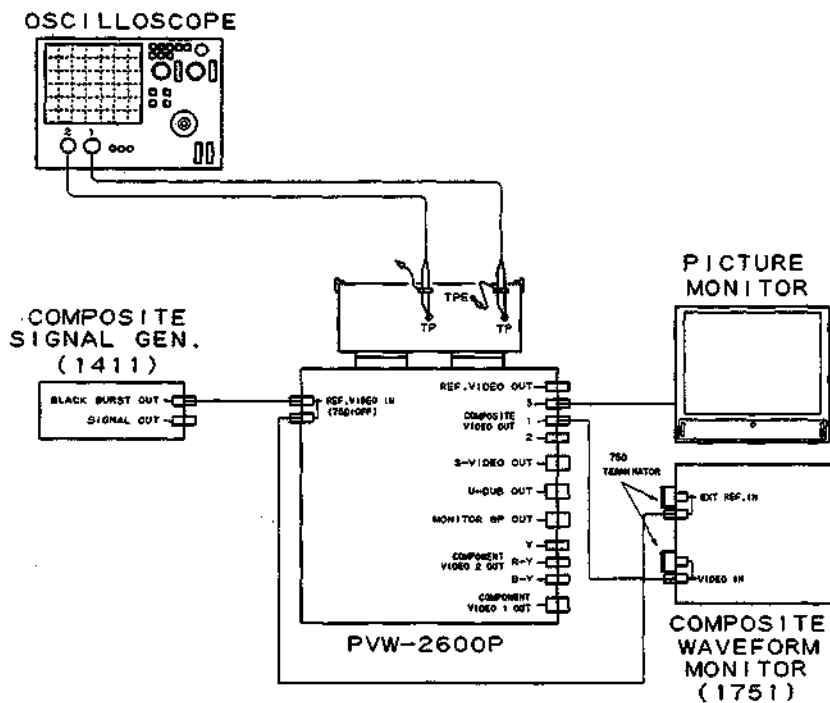

VP-33 board (A SIDE)

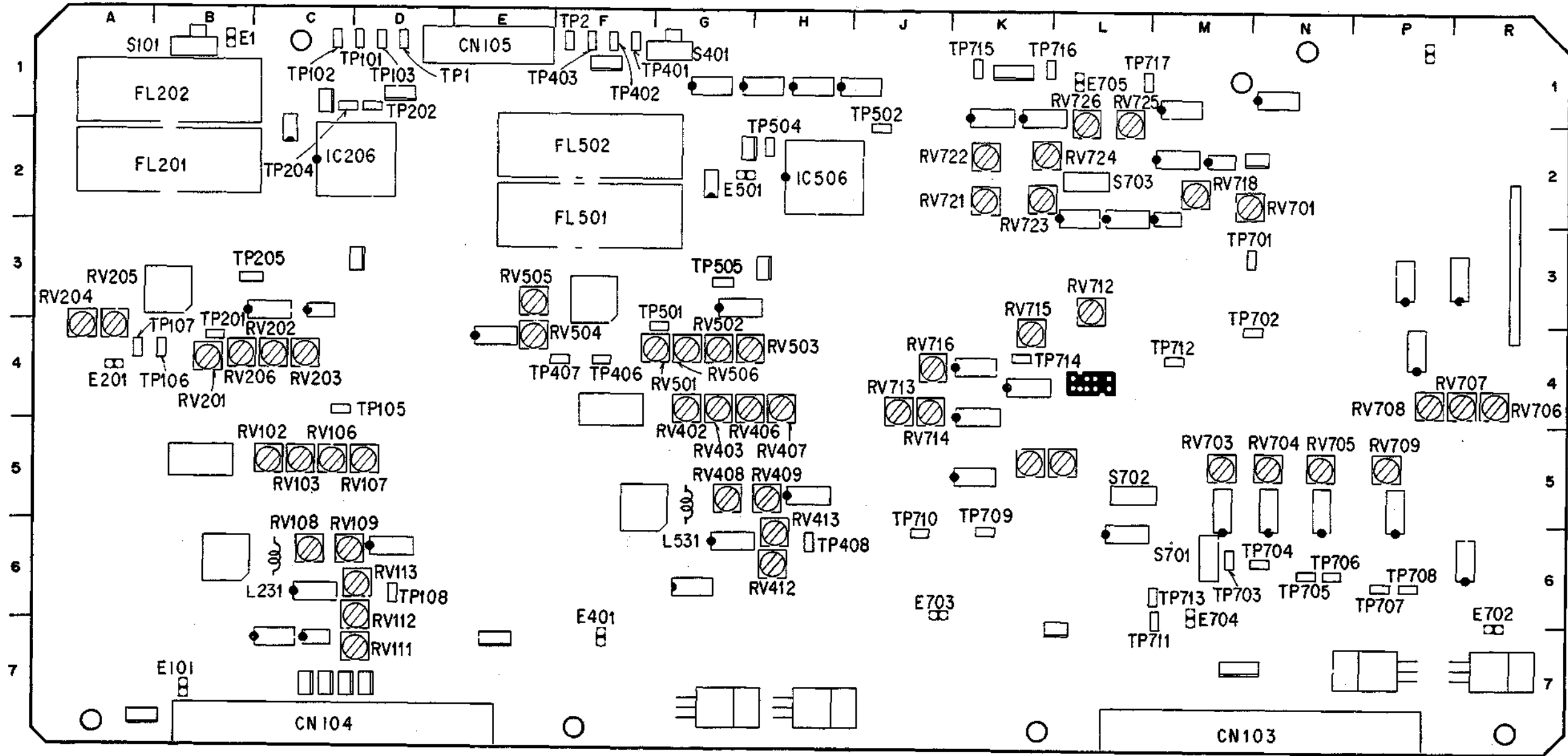

TBC-18 board (A SIDE)

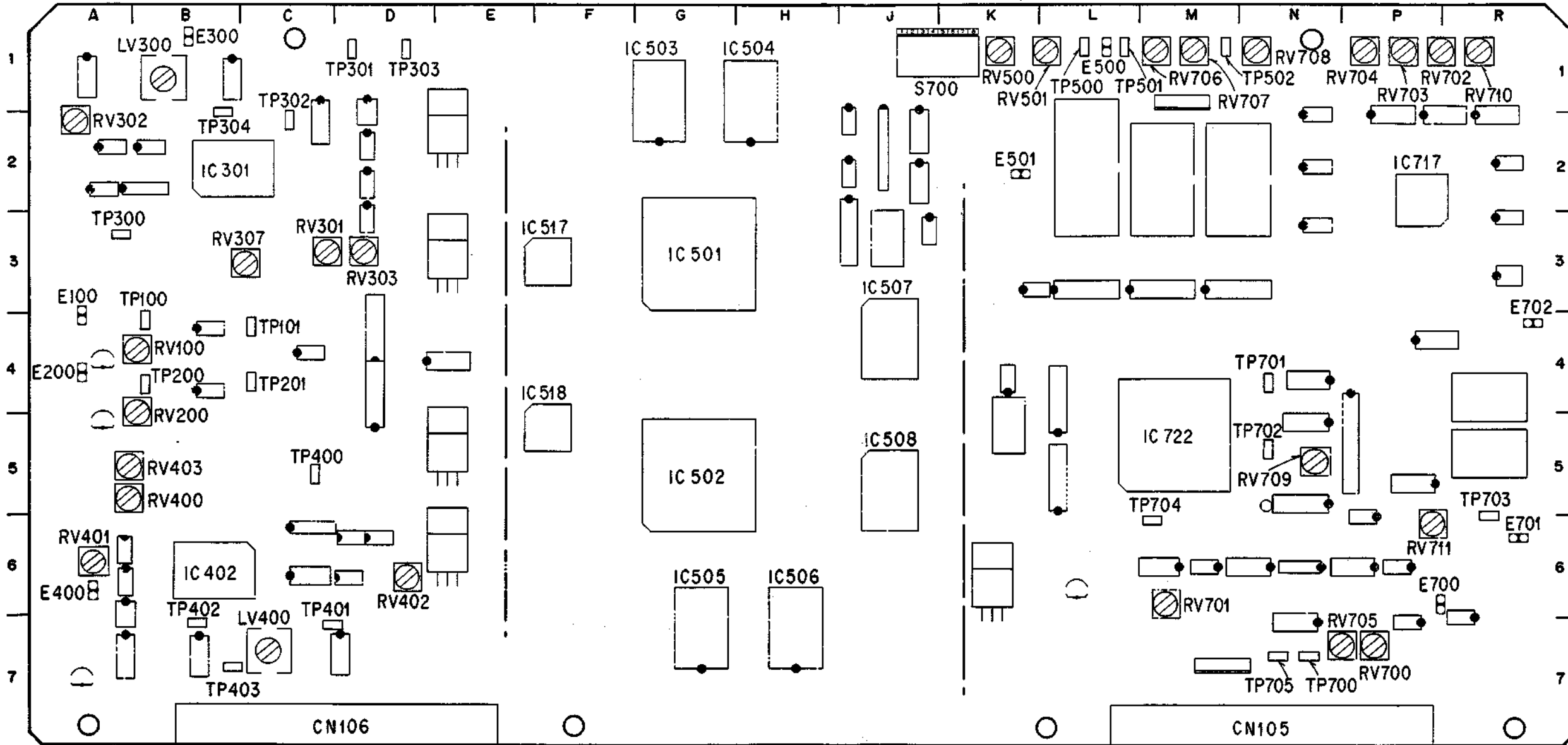

RP-57 board (A SIDE)

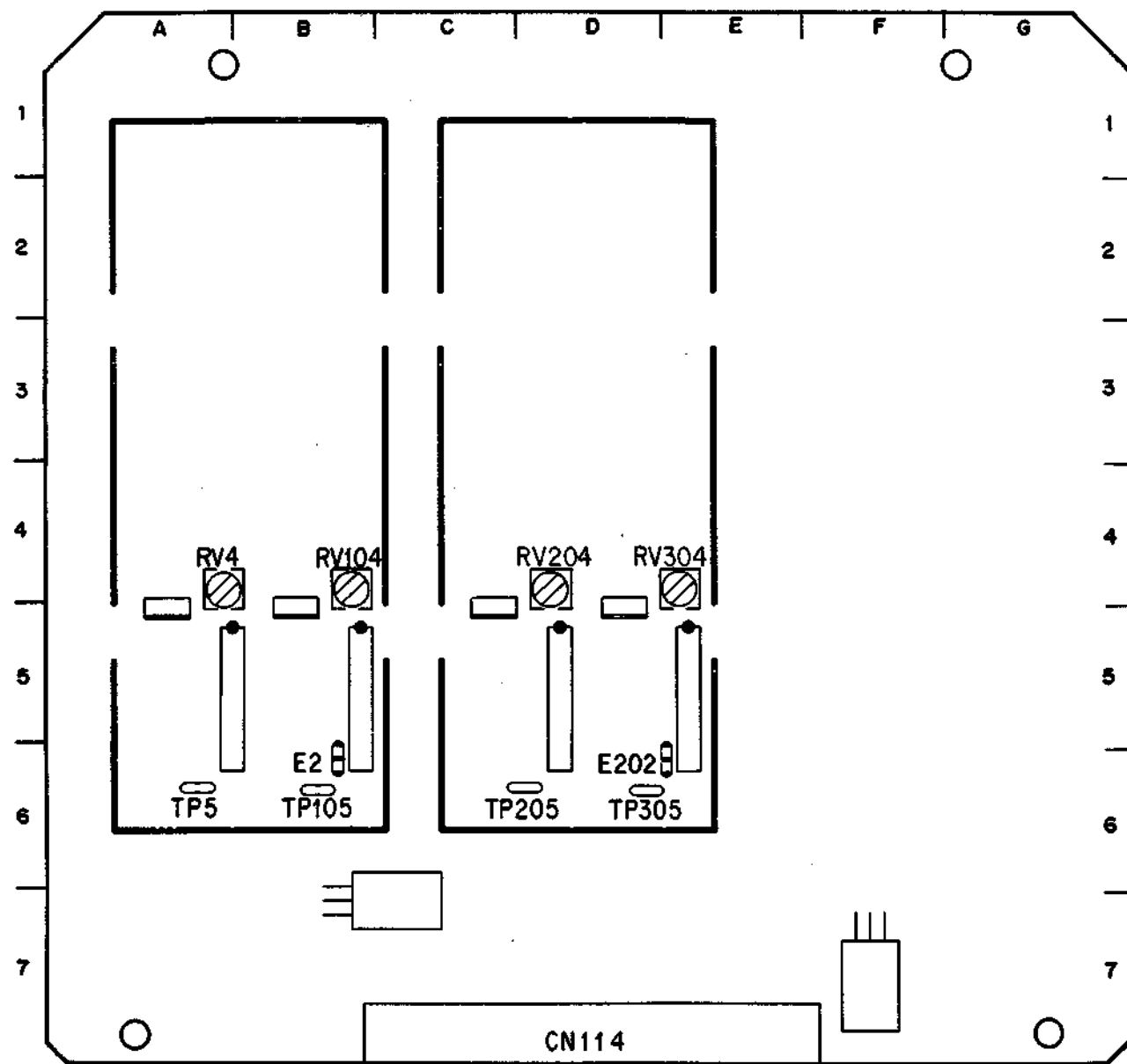

12-1. Y and C PB RF FREQUENCY RESPONSE ADJUSTMENT

[CONNECTION]

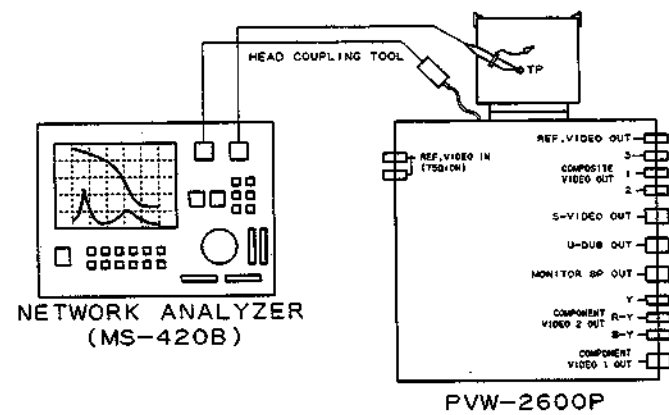

APPLICATION: 12-1.

RP-57 board

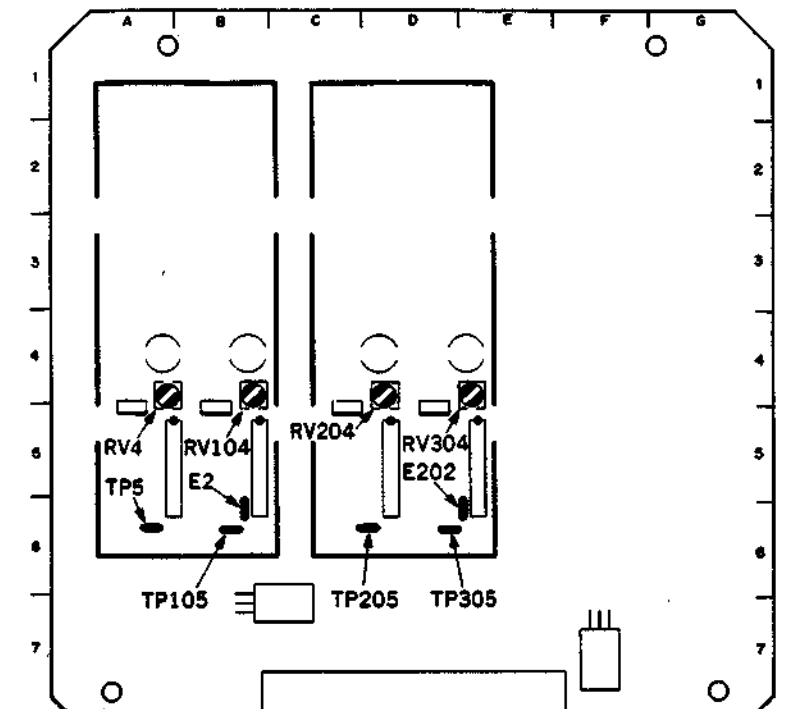







Preparations for adjustment	Specifications	Adjustments
<ul style="list-style-type: none"> • Attach a head coupling tool to the drum. Depending on the channel to be adjusted, replace the tool to the head for its channel. • Depending on the channel to be adjusted, connect the INPUT probe of a network analyzer to the test point for its channel. • Use the network analyzer in the following modes: RECALL-5 for Y adjustment RECALL-6 for C adjustment 	<p>CH-A: TP5-E2(GND)/RP-57(A-6)(B-6) CH-B: TP105-E2(GND)/RP-57(B-6)(B-6) Picture of the network analyzer</p> <p>10 MHz A = -1.5 ± 1.0 dB B = -2 ± 3 ns</p>	<p>(Y PB RF F. RESP.) CH-A: ●RV4/RP-57(A-4) CH-B: ●RV104/RP-57(B-4)</p>
	<p>CH-A: TP205-E202(GND)/RP-57(D-6)(E-6) CH-B: TP305-E202(GND)/RP-57(D-6)(E-6) Picture of the network analyzer</p> <p>10 MHz A = -3 ± 1 dB B = -5 ± 3 ns</p>	<p>(C PB RF F. RESP.) CH-A: ●RV204/RP-57(D-4) CH-B: ●RV304/RP-57(E-4)</p>

NOTE: This adjustment is impossible without a network analyzer.

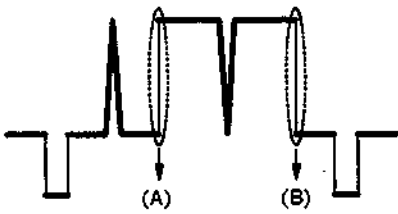
If any of RV4, RV104, RV204 and RV304 is moved unintentionally, as a temporary measure, set the volume to the same mechanical position as any other volume which is not moved.

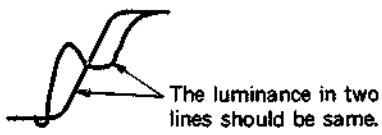
12-2. NOISE REDUCE ADJUSTMENT

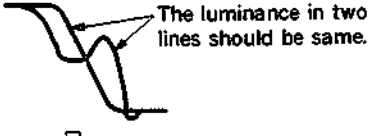
- Before performing this adjustment, use tape aligned by the PVW-2800P.
- INPUT SELECT switch: COMPOSITE
- Supply a pulse & bar signal (-1.5 dB) to the PVW-2800P's VIDEO INPUT connector.
- Record the pulse & bar signal.

Preparations for adjustment	Specifications	Adjustments
<ul style="list-style-type: none"> • Play back the pulse & bar signal that is recorded on tape by PVW-2800P as mentioned above. • Connect the waveform monitor to the COMPONENT 2 Y OUTPUT connector. • Set S700-2 (ENR TEST) (J-1) on the TBC-18 board to ON. 	<p>COMPONENT 2 Y OUT waveform of the waveform monitor</p>  <p>Expanded</p> <p>(A) Confirm that rising edge changes as below, and set to (OK) position.</p> <p>(NG) </p> <p>(OK) </p> <p>(NG) </p> <p>(B) Confirm that falling edge changes as below, and set to (OK) position.</p> <p>(NG) </p> <p>(OK) </p> <p>(NG) </p>	<p>(A) (POSITIVE EDGE) ● RV706/TBC-18 (M-1)</p> <p>(B) (NEGATIVE EDGE) ● RV707/TBC-18 (M-1)</p> <p>TRIG: INT/WFM CONNECTION 1</p>
<ul style="list-style-type: none"> • After adjustment is completed, set S700-2 to OFF. 		

TBC-18 board

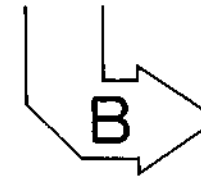
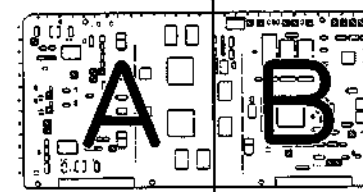

APPLICATION: 12-2.

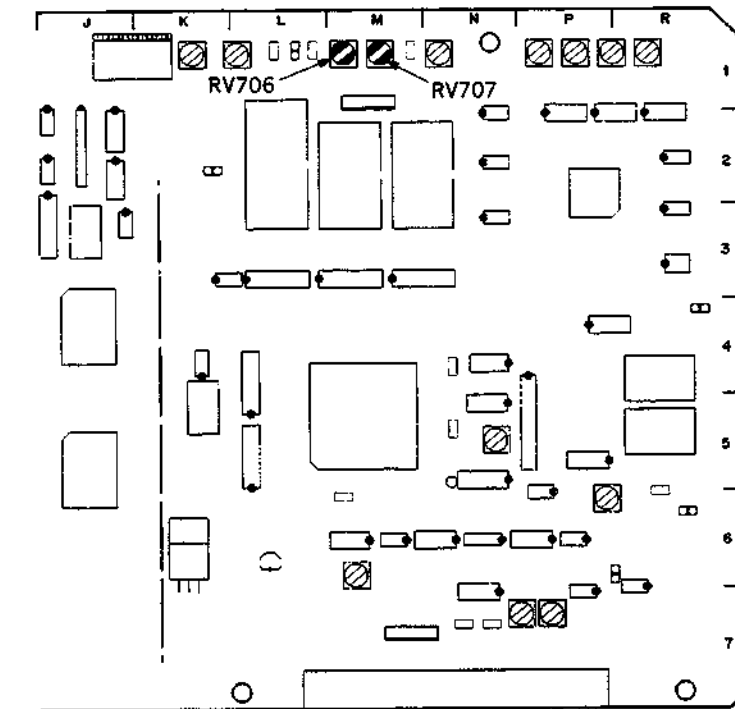

12-3. Y and C BID LEVEL CHECK

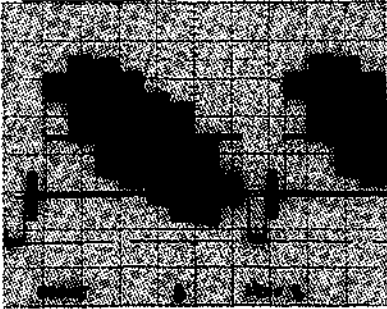
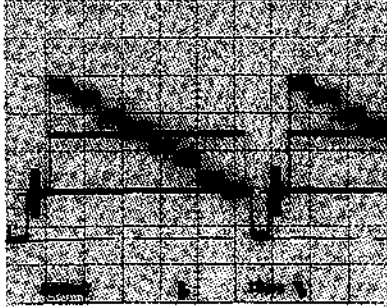
Preparations for adjustment	Specifications	Adjustments
<ul style="list-style-type: none"> • Play back the color bars signal portion (14:00—17:00) of the alignment tape CR5-1B PS. • Connect a waveform/vector monitor to VIDEO OUT 1 connector. • Connect a color-monitor to MONITOR OUT (TV-SP) connector. <p>Step1</p> <ul style="list-style-type: none"> • Check using the color monitor. • (Reference) Check using the waveform/vector monitor as a waveform monitor. 	<p>MONITOR OUT picture of the color monitor (Reference) Waveform of the waveform monitor (VIDEO OUT 1)</p> <p style="text-align: center;">shuttle mode: +10 times speed</p>  <p style="text-align: center;">shuttle mode: +24 times speed</p>  <p>Check the following conditions in shuttle mode:</p> <ol style="list-style-type: none"> (1) When set to the speed multiplied by $-10, -1, +1, +10$: Colored picture should appear on the color monitor. (2) When set to the speed multiplied by $-24, +24$: Black and white picture should appear on the color monitor. 	<p>(Y BID Level Check)</p> <p>TRIG: REF.VIDEO</p> <p>CONNECTION 2</p>

Continues to the next page.

12-3. Y and C BID LEVEL CHECK (Continued)

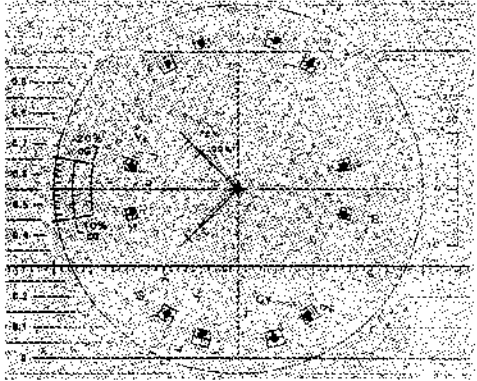
Preparations for adjustment	Specifications	Adjustments
<ul style="list-style-type: none"> • Play back the color bars signal portion (14:00—17:00) of the alignment tape CR5-1B PS. • Connect a waveform/vector monitor to VIDEO OUT 1 connector. • Connect a color monitor to MONITOR OUT (TV-8P) connector. <p>Step2</p> <ul style="list-style-type: none"> • Use the waveform/vector monitor as a vectorscope. Set the dot of the burst on the right position on the scale. 	<p>VIDEO OUT 1</p> <p>Picture of the vectorscope</p>  <p>Check the following conditions in shuttle mode:</p> <p>(1) When set to the speed multiplied by $-10, -1, +1, +10$: All dots should be inside the double size area of the respective \boxtimes mark on the vectorscope.</p> <p>(2) When set to the speed multiplied by $-24, +24$: All the dots should disappear.</p>	<p>(C BID Level Check)</p> <p>TRIG: REF.VIDEO</p> <p>CONNECTION 2</p>

12-4. Y and C WCK FREQUENCY ADJUSTMENT

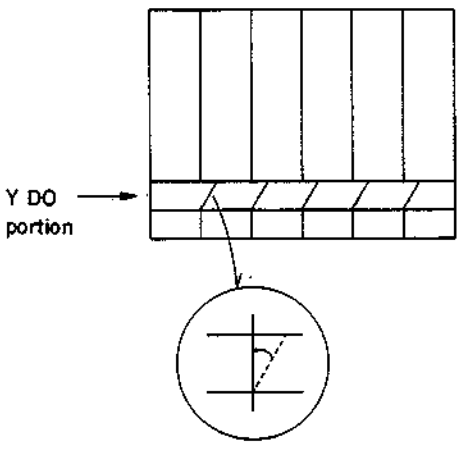
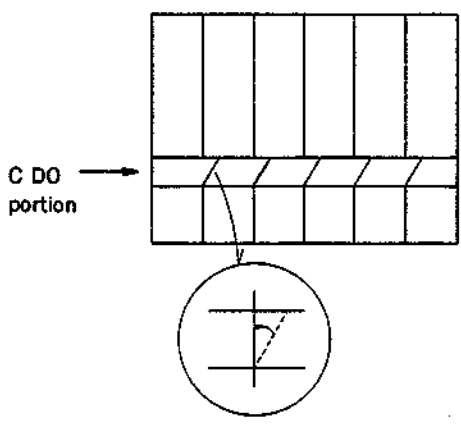
Preparations for adjustment	Specifications	Adjustments
<p>Step1</p> <ul style="list-style-type: none"> • Set S700-4 (COLOR MUTE) on the TBC-18 board to ON. • Play back the color bars signal with dropout portion (26: 00—28: 00) of the alignment tape CR5-1B PS. • Connect a monitor TV to the VIDEO OUT 3 connector. <p>• After adjustment is completed, set S700-4 on the TBC-18 board to OFF.</p>	<p>VIDEO OUT 3 Picture on the monitor TV</p>  <p>Adjust to a straight line.</p>	<p>(Y WCK Adjustment)</p> <p>(Y FREQ)</p> <p>●RV307/TBC-18 (C-3)</p> <p>TRIG: REF. VIDEO</p> <p>CONNECTION 2</p>
<p>Step2</p> <ul style="list-style-type: none"> • Set S700-3 (Y MUTE) on the TBC-18 board to ON. • Play back the color bars signal with dropout portion (26: 00—28: 00) of the alignment tape CR5-1B PS. • Connect a monitor TV to the VIDEO OUT 3 connector. <p>• After adjustment is completed, set S700-3 on the TBC-18 board to OFF.</p>	<p>VIDEO OUT 3 Picture on the monitor TV</p>  <p>Adjust to a straight line.</p>	<p>(C WCK Adjustment)</p> <p>(C FREQ)</p> <p>●RV403/TBC-18 (A-5)</p> <p>TRIG: REF. VIDEO</p> <p>CONNECTION 1</p>

TBC-18 board

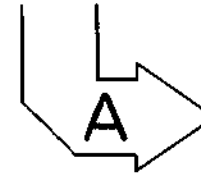
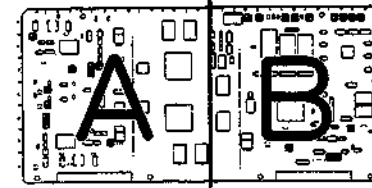

APPLICATION: 12-4.

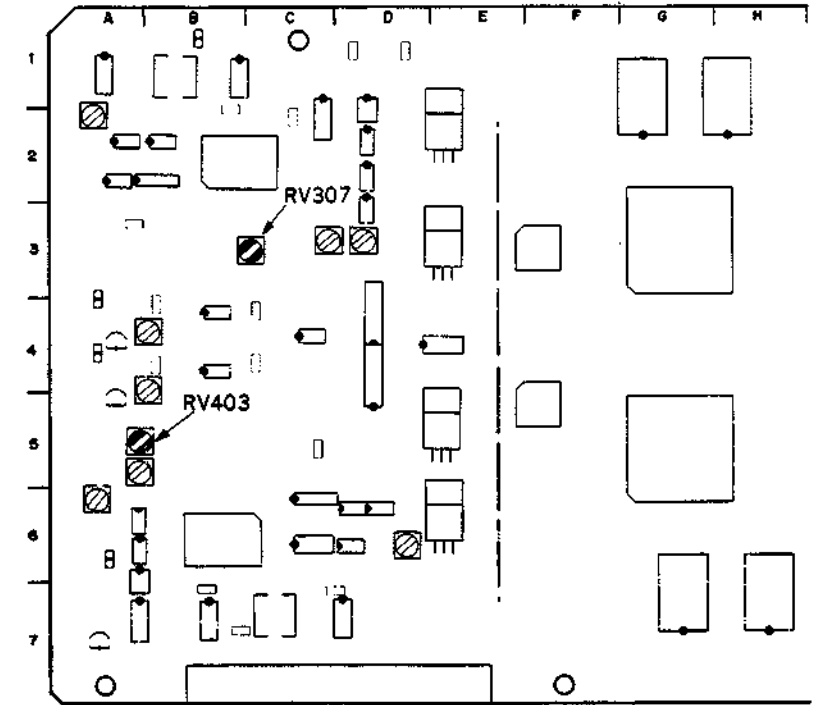

TBC-18 board

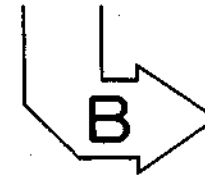
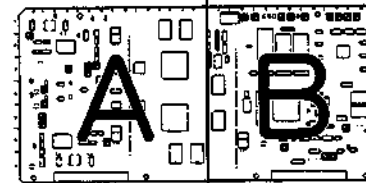

APPLICATION: 12-4.

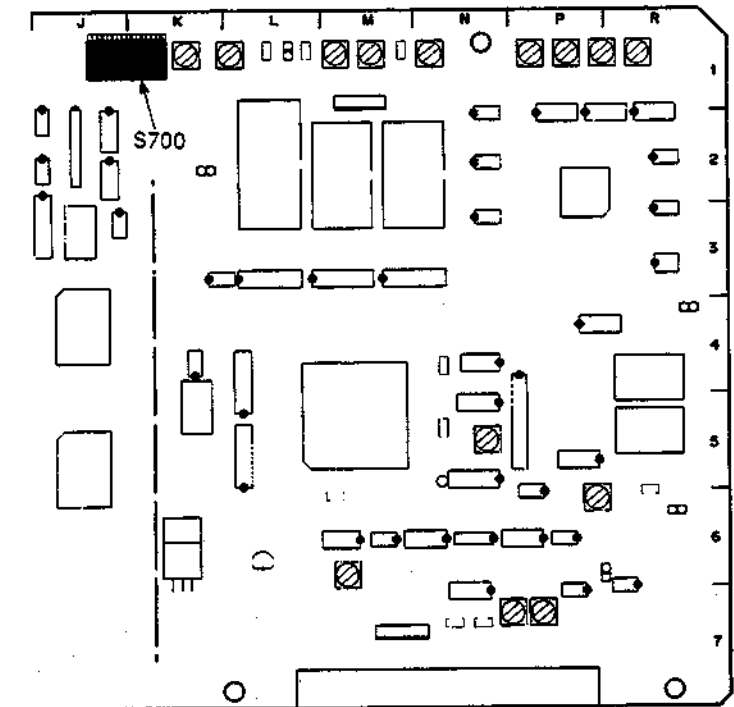

12-5. Y and C ERROR OFFSET ADJUSTMENT

Preparations for adjustment	Specifications	Adjustments
<ul style="list-style-type: none"> Play back the color bars signal with drop out portion (26:00—28:00) of the alignment tape CR5-1B PS. CHARACTER switch (sub control panel): OFF Connect a monitor TV to VIDEO OUT 1 connector. 	<p>Monitor display</p> <p>C DO portion Y DO portion</p> <p>(A) The Y DO portions should disappear on the monitor display by RV302. (B) The C DO portions should disappear on the monitor display by RV402.</p>	<p>(A) (Y ERR CLIP) RV302/TBC-18(A-2) (B) (C ERR CLIP) RV402/TBC-18(D-6)</p> <p>CONNECTION 1</p>
<ul style="list-style-type: none"> After adjustment is completed, set the CHARACTER switch to ON. 		

TBC-18 board

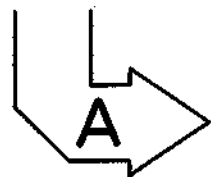
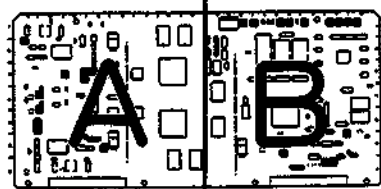

APPLICATION: 12-5.

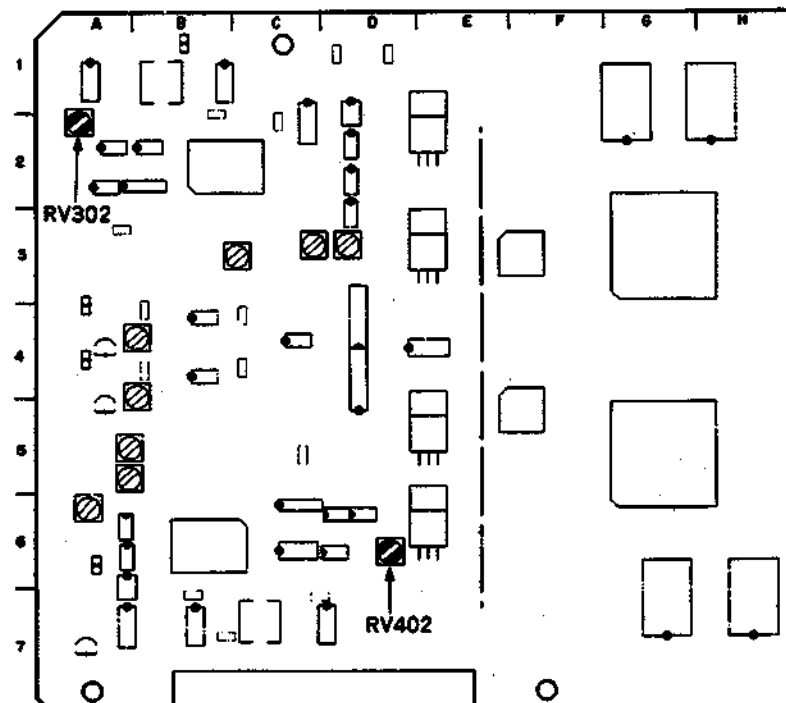

12-6. INT REF. VIDEO OUT LEVEL ADJUSTMENT

Preparations for adjustment	Specifications	Adjustments
<ul style="list-style-type: none"> Connect a waveform monitor to REF. VIDEO OUTPUT connector. Disconnect the REF. VIDEO INPUT connector to put the unit into INT REF. mode. 	<p>REF. VIDEO OUT Waveform of the waveform monitor</p> <p>A=300±1.5 mV p-p B=300±1.5 mV p-p</p>	<p>(A) (SYNC LEVEL) RV700/TBC-18(P-7) (B) (BURST LEVEL) RV705/TBC-18(P-7)</p> <p>TRIG: REF.VIDEO CONNECTION 2</p>
<ul style="list-style-type: none"> After adjustment is completed, connect the REF VIDEO INPUT connector. 		

TBC-18 board

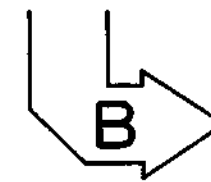
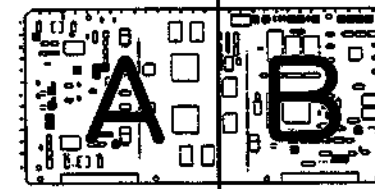

APPLICATION: 12-6.

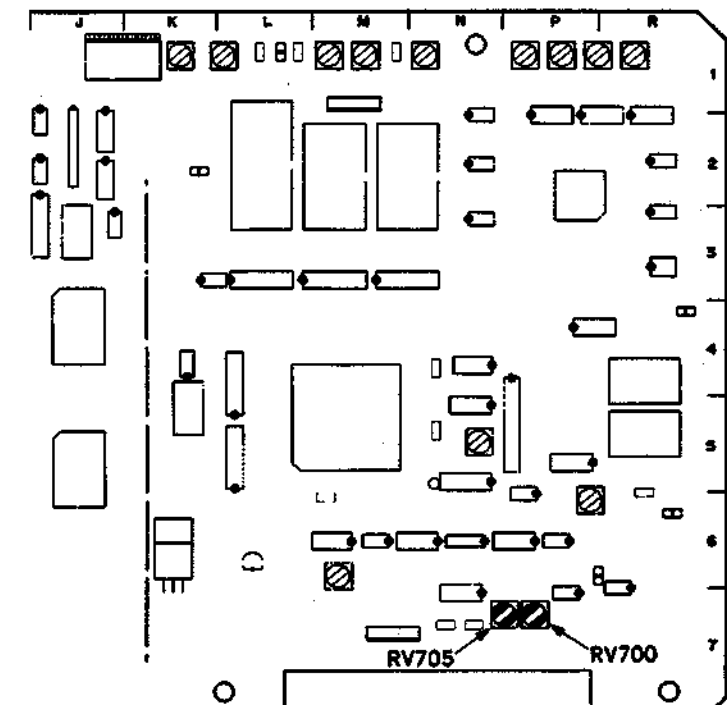

12-7. PB VIDEO PHASE ADJUSTMENT

[CONNECTION]

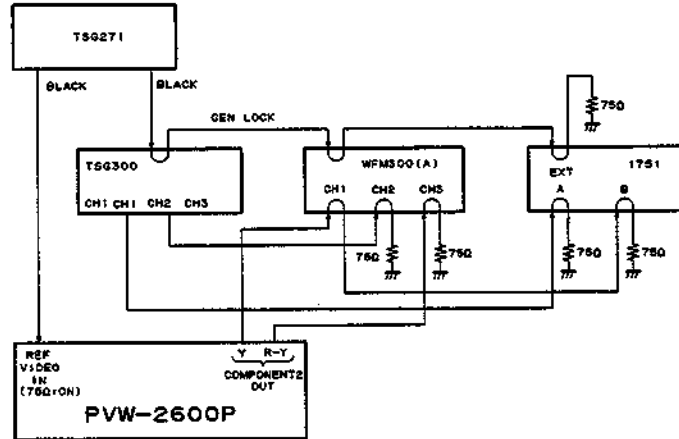

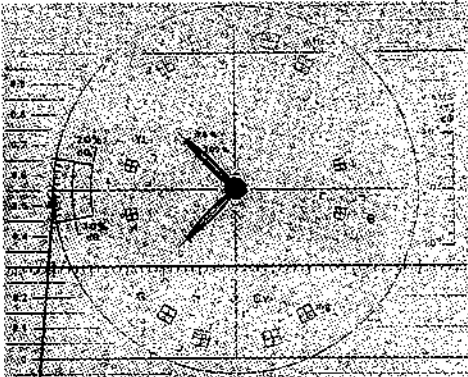
Preparations for adjustment	Specifications	Adjustments
<ul style="list-style-type: none"> • CAPSTAN LOCK switch (sub control panel): 2FD • Connect the CH-A of a waveform/vector monitor to the CH-1 (Y) of a component signal generator. • Turn the signal of the component signal generator into bowtie signal. • Play back the bowtie signal portion (17:00—19:00) of the alignment tape CR5-1B PS. <p>Step 1</p> <ul style="list-style-type: none"> • Use the waveform/vector monitor as a vectorscope. 	<p>COMPONENT2 Y OUT Picture of the vectorscope</p>  <p>CH-A → CH-B SYNC</p> <ol style="list-style-type: none"> 1. Set the SYNC control on the sub control panel to the mechanical center. 2. Use 1751's PHASE control to adjust the SYNC phase of CH-A as shown above. 3. Change the CH-A to CH-B of 1751. Then, make the SYNC phase of CH-B coincides with the SYNC phase of CH-A with the SYNC control on the sub control panel. (Note: The dot position should be adjusted in the direction of the shortest movement.) 	<p>SYNC control /sub control panel</p> <p>TRIG: EXT/WFM</p>

Continues to the next page.

12-7. PB VIDEO PHASE ADJUSTMENT (continued)

[CONNECTION]

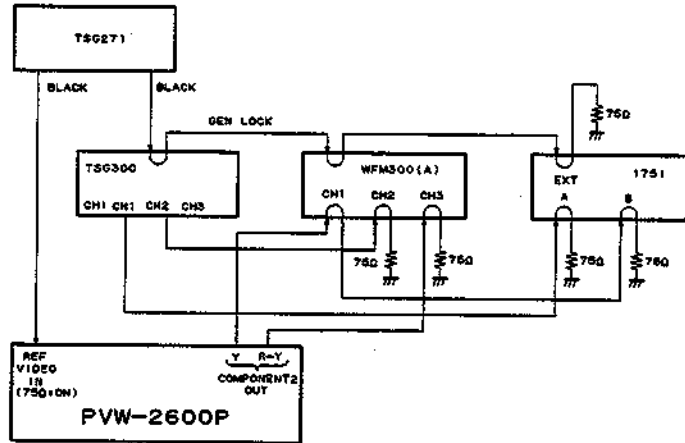

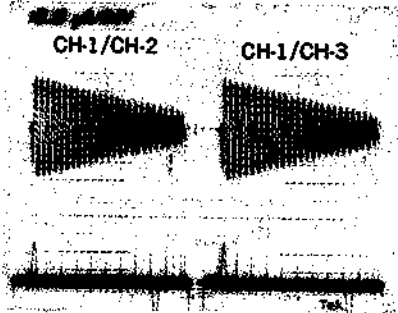
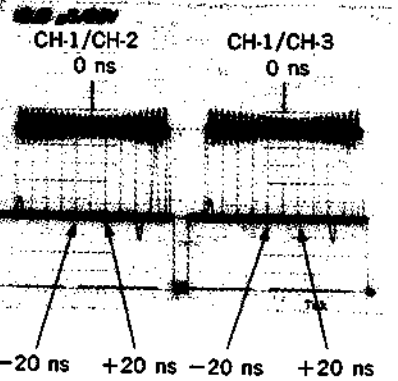
Preparations for adjustment	Specifications	Adjustments
<ul style="list-style-type: none"> • CAPSTAN LOCK switch (sub control panel): 2FD • Connect the CH-A of a waveform/vector monitor to the CH-1 (Y) of a component signal generator. • Turn the signal of the component signal generator into bowtie signal. • Play back the bowtie signal portion (17:00–19:00) of the alignment tape CR5-1B PS. <p>Step2 Set the waveform monitor to BOWTIE mode.</p>	<p>COMPONENT 2 Y OUT BOWTIE mode/PARADE of the waveform monitor</p> <p>Before adjustment</p>  <p style="text-align: center;">↓</p> <p>After adjustment</p>  <p>Set the BOWTIE DIP points (cross points of the CH-1/CH-2 and CH-1/CH-3) on the center marker. 0 ± 10 ns</p>	<p>(Y PHASE) ● RV301/TBC-18(C-3)</p> <p>TRIG: EXT/WFM</p>

TBC-18 board

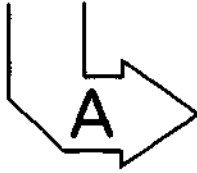
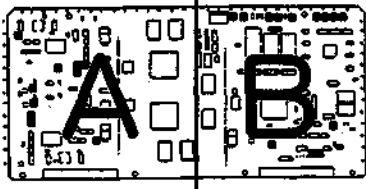

APPLICATION: 12-7.

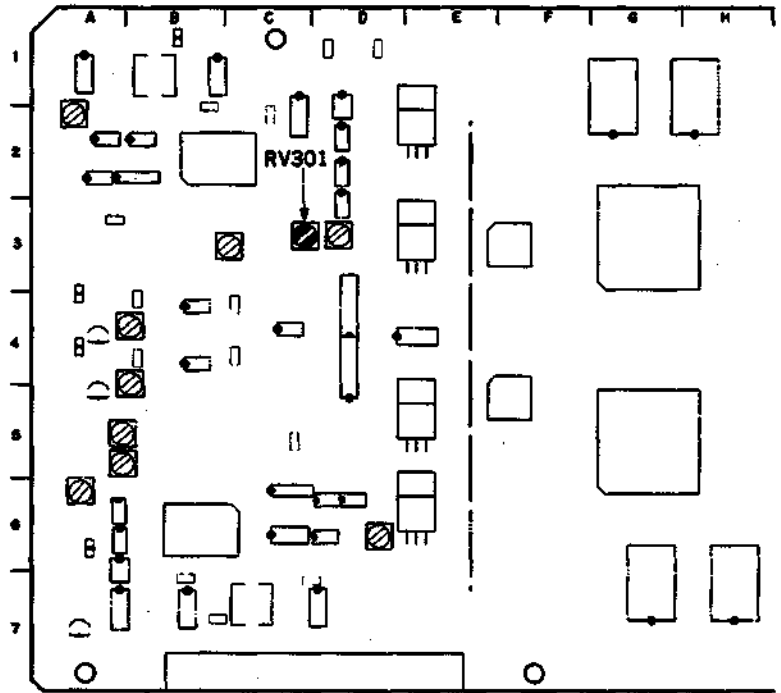

12-8. PB COMPOSITE Y/C DELAY ADJUSTMENT (METAL/OXIDE)

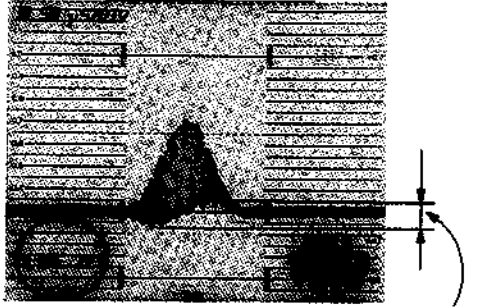
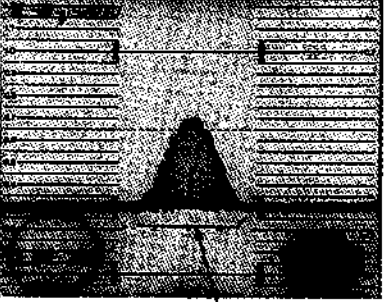
Preparations for adjustment	Specifications	Adjustments
<ul style="list-style-type: none"> • CAPSTAN LOCK switch (sub control panel): 2FD • Connect a waveform monitor to VIDEO OUT 1 connector. <p>Step1</p> <ul style="list-style-type: none"> • Play back the 10T pulse of bowtie signal portion (17:00—19:00) of the alignment tape CR5-1B PS. • Select 195 line with the line selector of the waveform monitor. 	<p>VIDEO OUT 1 Waveform of the waveform monitor</p> <p>Before adjustment</p>  <p>↓</p> <p>After adjustment</p>  <p>TRIG: INT/WFM</p> <p>CONNECTION 2</p>	<p>(Metal)</p> <p>●RV400/TBC-18(A-5)</p>

TBC-18 board

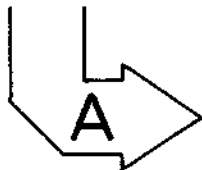
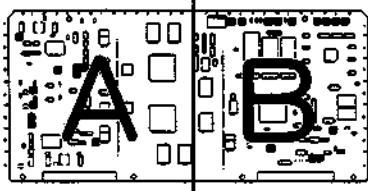

APPLICATION: 12-8. Step1

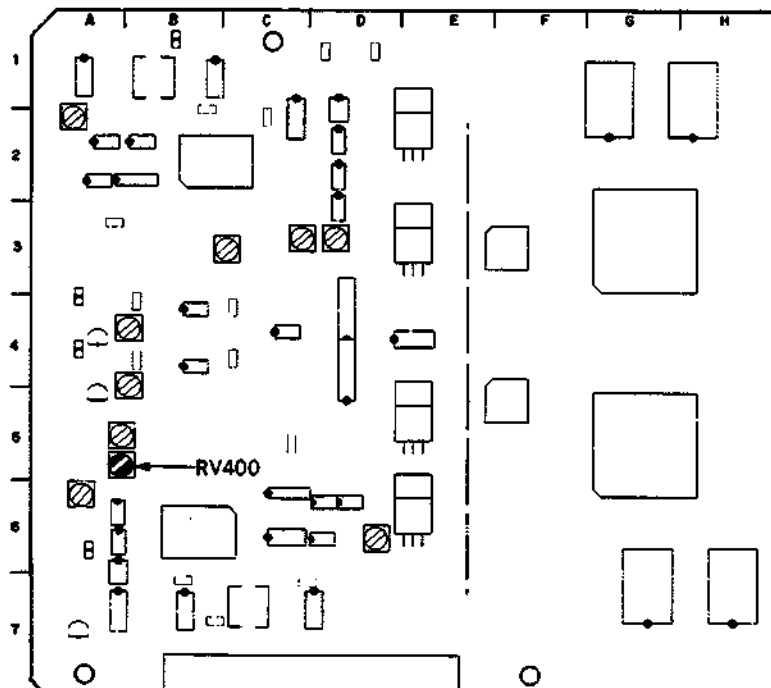

12-9. PB COMPONENT Y/C DELAY ADJUSTMENT (METAL/OXIDE)

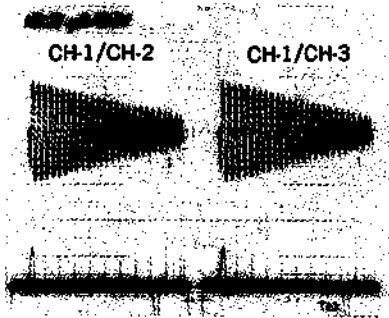
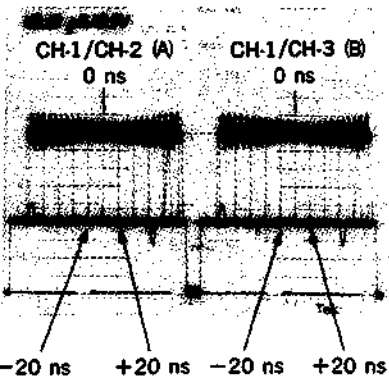
Preparations for adjustment	Specifications	Adjustments
<p>Step1</p> <ul style="list-style-type: none"> • Play back the bowtie signal portion (17:00—19:00) of the alignment tape CR5-1B PS. 	<p>COMPONENT 2 OUT BOWTIE mode/PARADE of the waveform monitor</p> <p>Before adjustment</p>  <p>After adjustment</p>  <p>Set the each BOWTIE DIP point of (A) and (B) on the center marker.</p> <p style="text-align: center;">0 ± 10 ns</p>	<p>(Metal)</p> <p>(A) (B-Y DELAY) ●RV723/VP-33(K-2)</p> <p>(B) (R-Y DELAY) ●RV721/VP-33(K-2)</p> <p>TRIG: EXT/WFM</p> <p>CONNECTION 1</p>
<p>Step2</p> <ul style="list-style-type: none"> • Play back the bowtie signal portion (6:00—9:00) of the alignment tape CR5-2A PS. 	<p>COMPONENT 2 OUT BOWTIE mode of the waveform monitor</p> <p>The BOWTIE DIP point on CH-1/CH-2 and on CH-1/CH-3 should coincide with the center marker within the following range:</p> <p style="text-align: center;">0 ± 18 ns</p>	<p>(Oxide check)</p> <p>TRIG: EXT/WFM</p> <p>CONNECTION 1</p>

VP-33 board

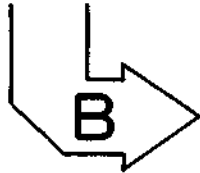
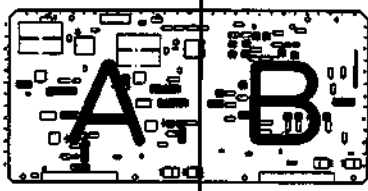

APPLICATION: 12-9.

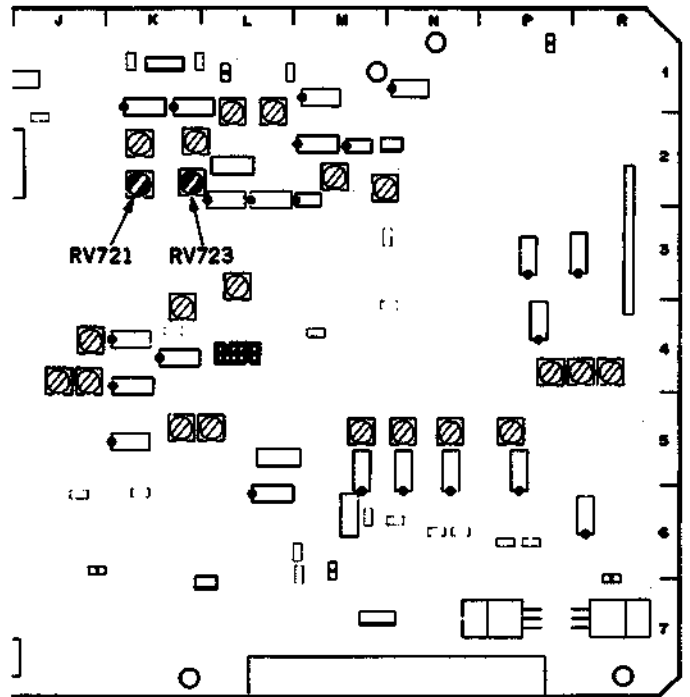

12-10. ENCODE CF PHASE ADJUSTMENT

[CONNECTION]

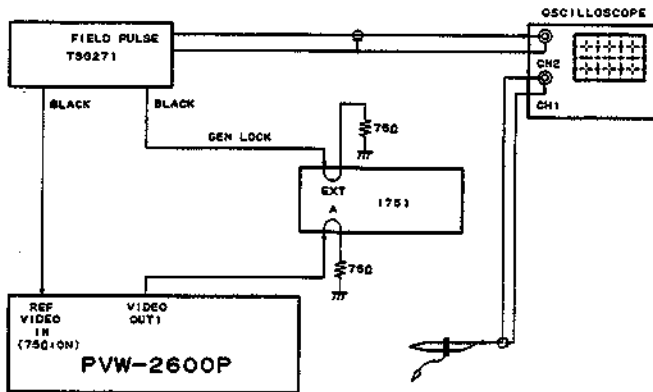

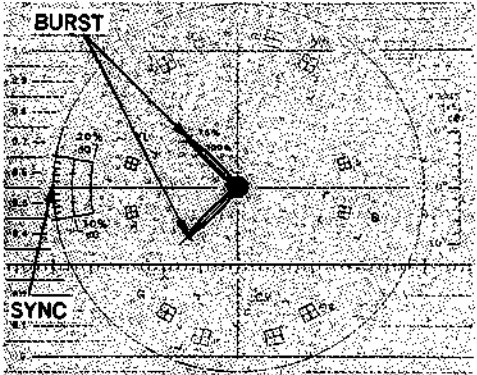

Preparations for adjustment	Specifications	Adjustments
<ul style="list-style-type: none"> • Play back the color bars signal portion (14:00—17:00) of the alignment tape CR5-18 PS. • SC control (sub control panel): mechanical center 	<p>Step1 VIDEO OUT 1 Picture of the vectorscope</p>  <p>(A) Set the dot of the burst on the normal position on the scale.</p> <p>(B) The SYNC should be in the same phase as the burst (SCH=0°).</p> <p>TRIG: EXT/WFM</p>	<p>(A) Burst Adjustment PHASE Control/Vectorscope</p> <p>(B) SYNC Adjustment SYNC control/sub control panel</p>

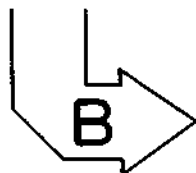
VP-33 board

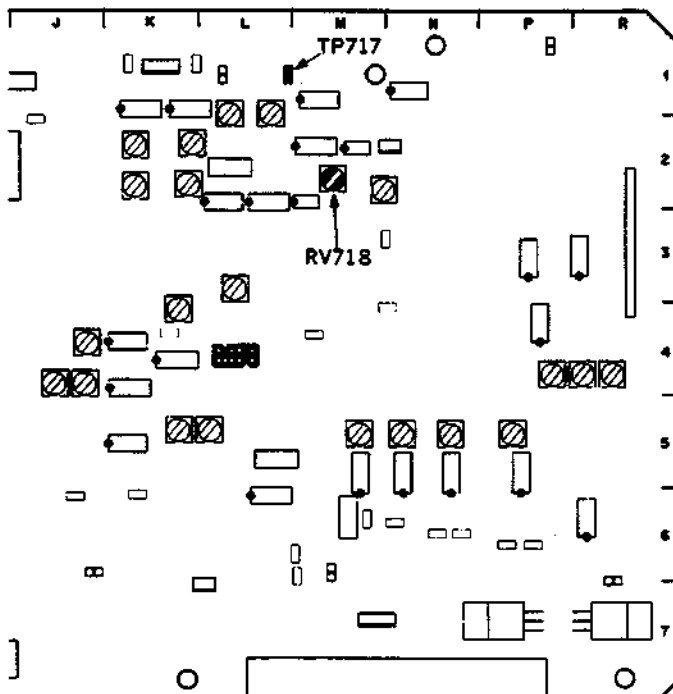

APPLICATION: 12-10. Step2

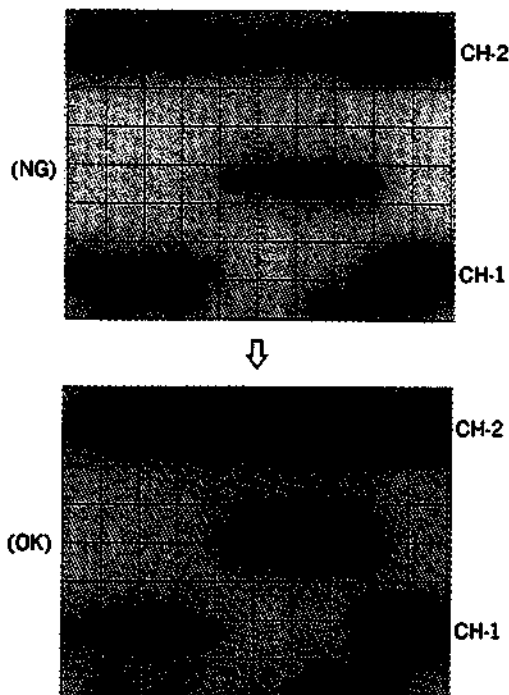

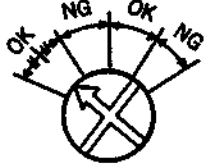
Preparations for adjustment	Specifications	Adjustments
<ul style="list-style-type: none"> • Play back the color bars signal portion (14:00—17:00) of the alignment tape CR5-1B PS. • SC control (sub control panel): mechanical center 	<p>Step2</p> <p>CH-1: TP717/VP-33(L-1) CH-2: FRAME PULSE terminal/TSG271</p> <p>Waveform of the oscilloscope</p>  <p>(1) Turn RV718 counterclockwise fully.</p> <p>(2) When RV718 is turned clockwise gradually, the phase condition between CH1 and CH2 changes from NG to OK or OK to NG.</p> <p>(3) In case of the pattern of change is started to NG as shown in waveform picture, set RV718 to mechanical center of range of first OK. NG → OK → NG → OK</p>  <p>↑ the mechanical center of this range</p> <p>(4) In case of the pattern of change is started to OK as shown in waveform picture, set RV718 to mechanical center of range of first OK. OK → NG → OK → NG</p>  <p>↑ the mechanical center of this range</p> <p>* If the range of first OK is extremely narrow, set to mechanical center of range of second OK.</p>	<p>(CF ADJ) RV718/VP-33(M-2)</p> <p>TRIG: CH-2</p>

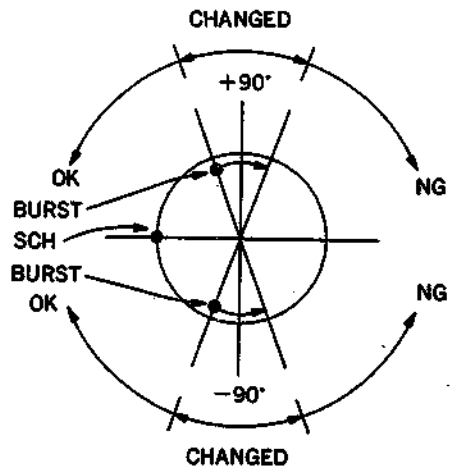
Preparations for adjustment	Specifications	Adjustments
<ul style="list-style-type: none"> • Play back the color bars signal portion (14:00—17:00) of the alignment tape CR5-1B PS. 	<p>Step3</p> <p>While monitoring the burst phase with the vectorscope described in Step1, observe the CF phase for normal/inverted condition by the oscilloscope waveforms described in Step2.</p> <p>Check whether the adjustment position is in the center of the OK range or not. Use the SC control on the sub control panel to move the burst phase $\pm 90^\circ$ or more. Verify the following conditions are met:</p>  <p>The CF phase changes from OK to NG within the range of $+90 \pm 20^\circ$.</p> <p>The CF phase changes from NG to OK within the range of $-90 \pm 20^\circ$.</p> <p>If the specification is not satisfied, check the deviation from the specification and perform the adjustment in Step 2, then perform Step3 and confirm.</p> <p>Repeat this procedure until the specification is satisfied.</p>	<p>(Adjustment Position Check)</p>

12-11. REFERENCE CF PHASE ADJUSTMENT

[CONNECTION]

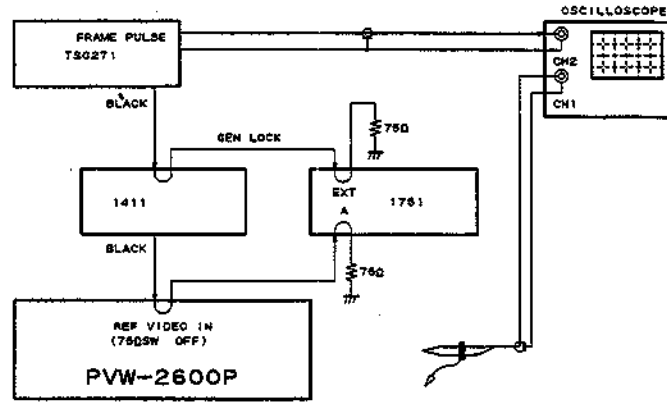

Preparations for adjustment	Specifications	Adjustments
<p>• Connect the equipments as shown in the upper figure.</p>	<p>Step1 REF VIDEO IN through out Picture of the vectorscope</p> <p>(A) Set the dot of the burst on the right position on the scale. (B) The SYNC should be in the same direction as the burst (SCH=0°).</p>	<p>(A) SYNC Adjustment PHASE Control/Vectorscope</p> <p>(B) Burst Adjustment SC control/1411</p> <p>TRIG: EXT/WFM</p>

TBC-18 board

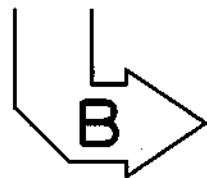
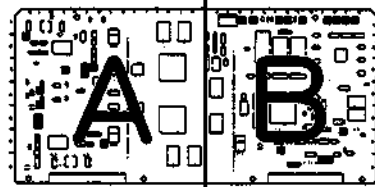

APPLICATION: 12-11. Step2

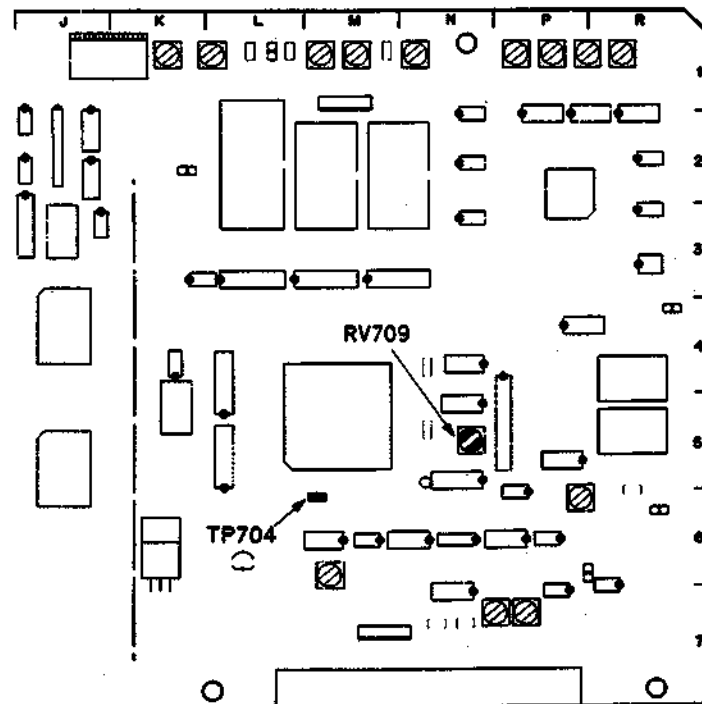

Preparations for adjustment	Specifications	Adjustments
	<p>Step2 CH-1: TP704(1ST FIELD)/TBC-18(M-6) CH-2: FIELD PULSE terminal/TSG271 Waveform of the oscilloscope</p>	<p>(1ST FIELD) RV709/TBC-18(N-5)</p> <p>(1) Turn RV709 counterclockwise fully. (2) When RV709 is turned clockwise gradually, the phase condition between CH1 and CH2 changes from NG to OK or OK to NG. (3) In case of the pattern of change is started to NG as shown in waveform monitor, set RV709 to mechanical center of range of first OK. NG → OK → NG → OK ↑ the mechanical center of this range</p> <p>(4) In case of the pattern of change in started OK as shown in waveform monitor, set RV709 to mechanical center of range of first OK. OK → NG → OK → NG ↑ the mechanical center of this range</p> <p>* If the range of first OK is extremely narrow, set to mechanical center of range of second OK.</p> <p>TRIG: CH-1</p>

Preparations for adjustment	Specifications	Adjustments
	<p>Step3</p> <p>While monitoring the burst phase with the vectorscope described in Step1, observe the CF phase for normal/inverted condition by the oscilloscope waveforms described in Step2.</p> <p>Check whether the adjustment position is in the center of the OK range or not. Use SC control on the 1411 to move the burst phase $\pm 90^\circ$ or more. Verify the following conditions are met:</p> <div data-bbox="598 772 1029 1243" data-label="Diagram"> </div> <p>The CF phase changes from OK to NG within the range of $+90 \pm 20^\circ$.</p> <p>The CF phase changes from NG to OK within the range of $-90 \pm 20^\circ$.</p> <p>If the specification is not satisfied, check the deviation from the specification and perform the adjustment in Step2, then perform Step3 and confirm.</p> <p>Repeat this procedure until the specification is satisfied.</p>	<p>(Adjustment Position Check)</p>

12-12. VISC LOCK IN ADJUSTMENT

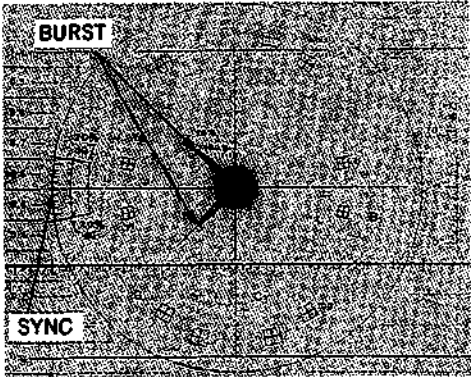
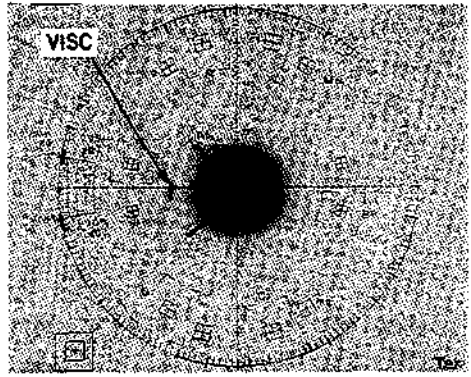
Preparations for adjustment	Specifications	Adjustments
<p>• Connect a waveform/vector monitor to VIDEO OUT 1 connector.</p> <p>• Set the S700-6 (VISC TEST)(K-1) on TBC-18 board to ON.</p> <p>Step1</p> <p>• Play back the composite V sweep signal with VISC portion (28:00—30:00) of the alignment tape CR5-1B PS.</p> <p>• CAPSTAN LOCK switch (sub control panel): 8FD</p>	<p>VIDEO OUT1</p> <p>Picture of the vectorscope (1751 vector mode)</p> <p>(A)</p>  <p>(B, C)</p>  <p>(LINE 8)</p> <p>(A) The SYNC and burst should be in same phase.</p> <p>(B) Check that the VISC is within $\pm 45^\circ$, when the CAPSTAN LOCK switch is set to 2FD.</p> <p>(C) Set the CAPSTAN LOCK switch to 8FD, then align the VISC in the same direction of the burst.</p>	<p>(A) SYNC Adjustment SYNC control/ sub control panel</p> <p>(B) Burst Adjustment SC control/ sub control panel</p> <p>(C) (VISC P) ●RV703/TBC-18(P-1)</p> <p>TRIG: INT/WFM</p> <p>CONNECTION 2</p>
<p>Step2</p> <p>• Set the S700-6(K-1) on the TBC-18 board to OFF.</p>	<p>Check that the VISC should disappear.</p>	<p>TRIG: INT/WFM</p> <p>CONNECTION 2</p>

TBC-18 board

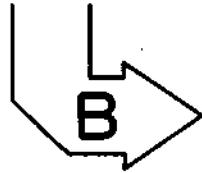
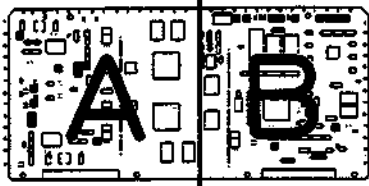

APPLICATION: 12-12

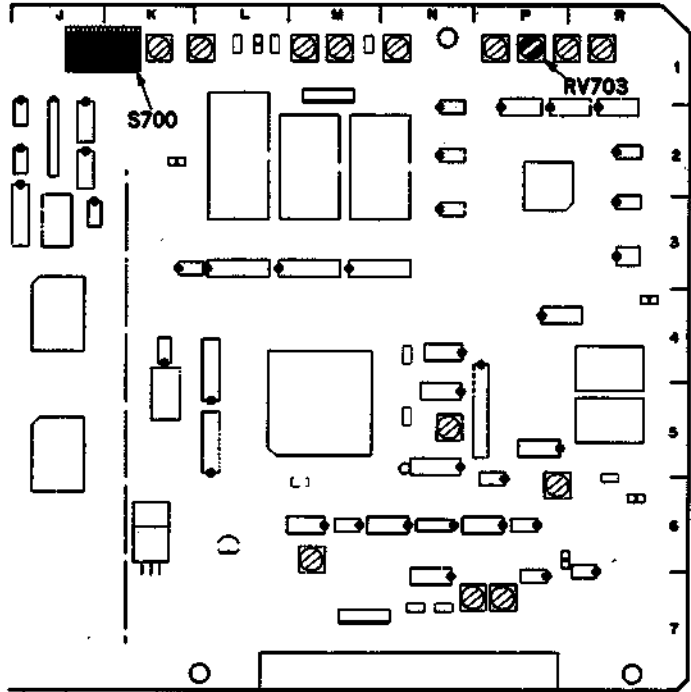

12-13. VISC REGEN PHASE ADJUSTMENT

[CONNECTION]

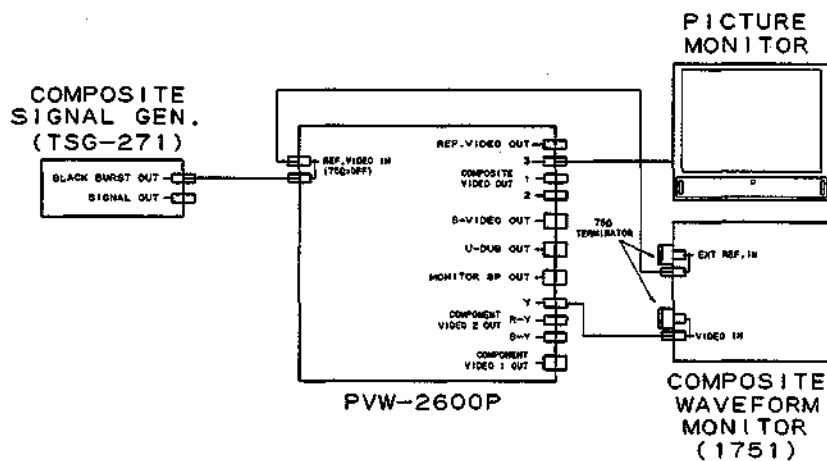

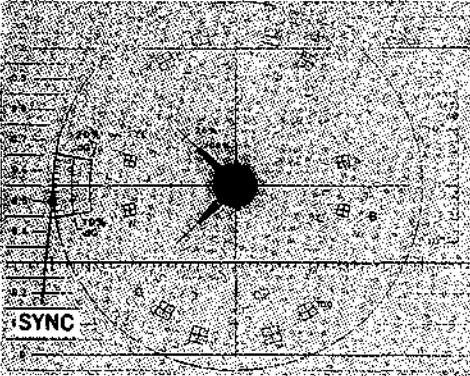
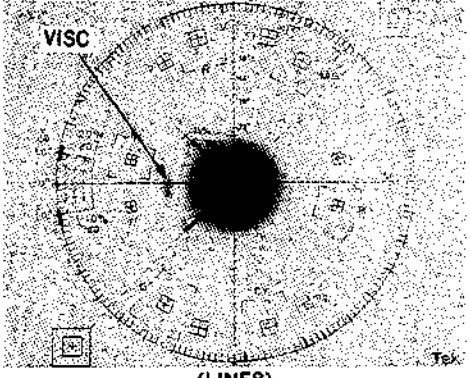
Preparations for adjustment	Specifications	Adjustments
<ul style="list-style-type: none"> • Connect a waveform/vector monitor to COMPONENT 2 Y OUT • Play back the composite V sweep signal with VISC portion (28:00—30:00) of the alignment tape CR5-1B PS. • CAPSTAN LOCK switch (sub control panel): 8FD 	<p>COMPONENT 2 Y OUT Picture of the vectorscope</p> <p>(A)</p>  <p>(B)</p>  <p>(LINE8)</p> <p>(A) The SYNC dot should be on the normal position. (B) The VISC should be in the same phase as the SYNC.</p>	<p>(A) SYNC Adjustment PHASE Control/Vectorscope</p> <p>(B) (VISC R) ●RV704/TBC-18(P-1)</p> <p>TRIG: INT/WFM</p>

TBC-18 board

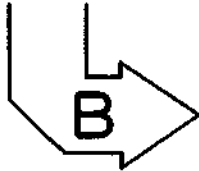
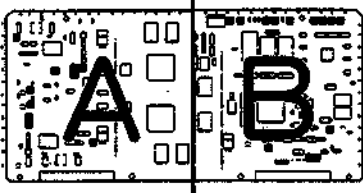

APPLICATION: 12-13.

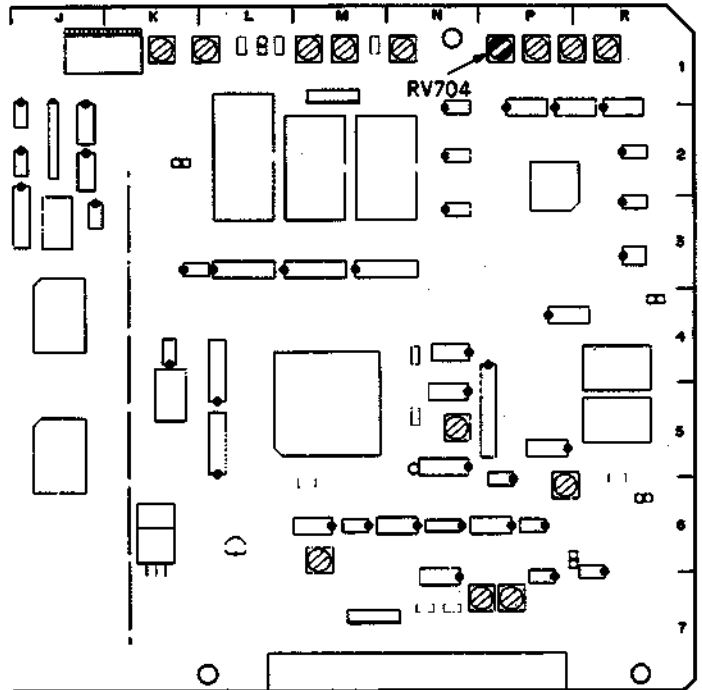

12-14. VISC TRACKING CHECK

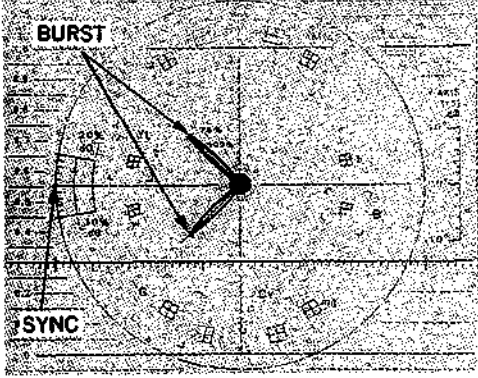
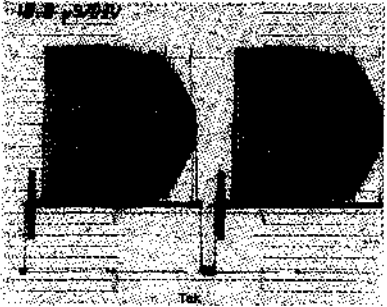
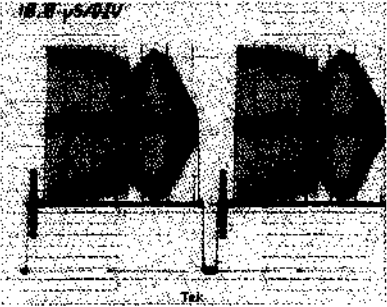
Preparations for adjustment	Specifications	Adjustments
<ul style="list-style-type: none"> • Connect a waveform/vector monitor to VIDEO OUT 1 connector. • Play back the composite V sweep signal with VISC portion (28:00—30:00) of the alignment tape CR5-1B PS. • CAPSTAN LOCK switch (sub control panel): 8FD 	<p>Step1 VIDEO OUT 1 Picture of the vectorscope</p>  <p>The SYNC and burst should be in the same phase (SCH=0°).</p>	<p>(SYNC Adjustment) SYNC control/sub control panel</p> <p>(Burst Adjustment) SC control/sub control panel</p> <p>TRIG: INT/WFM</p> <p>CONNECTION 2</p>
	<p>Step2 VIDEO OUT 1 Switch the mode from play back to stop and then back to play back, and observe the waveform of the waveform monitor.</p> <p>OK</p>  <p>NG</p>  <p>Perform this procedure five times. The waveform observed should be accepted each time this is made.</p>	<p>(Tracking Check)</p> <p>TRIG: INT/WFM</p> <p>CONNECTION 2</p>

12-15. H SHIFT CHECK

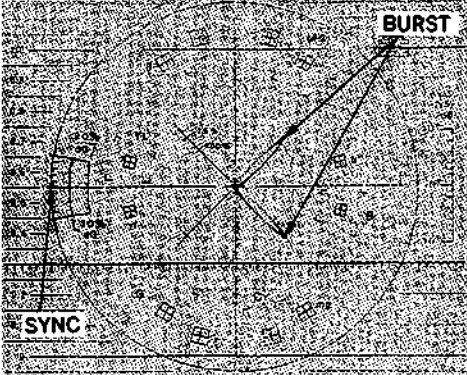
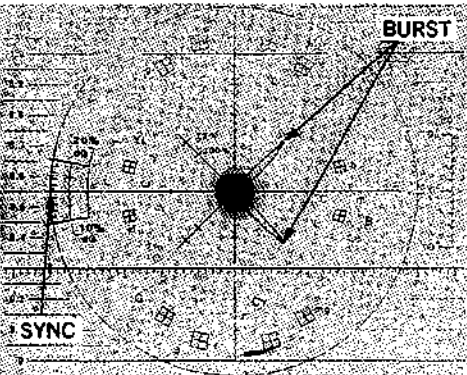
Preparations for adjustment	Specifications	Adjustments						
<ul style="list-style-type: none"> • Connect a waveform/vector monitor to VIDEO OUT 1 connector. • Connect a monitor TV to VIDEO OUT 3 connector. • Play back the composite V sweep signal with VISC portion (28:00—30:00) of the alignment tape CR5-1B PS. 	<p>Step1 VIDEO OUT The SYNC and burst should be in the same phase. (SCH=0°)</p>  <p>When setting the CAPSTAN LOCK switch on the sub control panel between 2FD and 8FD, the monitor TV screen should present no H shift.</p>	<p>(SYNC Adjustment) SYNC control/sub control panel</p> <p>(Burst Adjustment) SC control/sub control panel</p> <p>TRIG: INT/WFM</p> <p>CONNECTION 2</p>						
	<p>Step2 VIDEO OUT Invert the burst phase on the vectorscope.</p>  <p>When setting the CAPSTAN LOCK switch on the sub control panel between 2FD and 8FD, the monitor TV screen should H shift as follows:</p> <table border="0" style="margin-left: 40px;"> <tr> <td>CAP.SW.</td> <td>2FD</td> <td>8FD</td> </tr> <tr> <td>picture shift</td> <td>left side</td> <td>right side</td> </tr> </table> <p>After check is completed, set the CAPSTAN LOCK switch to 8FD. Then use the SC control to return to the state defined in Step 1.</p>	CAP.SW.	2FD	8FD	picture shift	left side	right side	<p>(Burst Phase) SC control/sub control panel</p> <p>TRIG: INT/WFM</p> <p>CONNECTION 2</p>
CAP.SW.	2FD	8FD						
picture shift	left side	right side						

12-16. NO BURST REF IN CHECK

Preparations for adjustment	Specifications	Adjustments
<ul style="list-style-type: none"> • Supply a video signal without burst to REF. VIDEO INPUT connector. • Connect a monitor TV to VIDEO OUT connector. • Play back the composite V sweep signal with VISC portion (28:00—30:00) of the alignment tape CR5-1B PS. • CAPSTAN LOCK switch (sub control panel): 8FD 	<p>VIDEO OUT Picture of the monitor TV</p> <p style="text-align: center;">H Shift is not done. (H shift repeatedly to the right and left is delinquent.)</p>	<p>(H Shift Check)</p> <p style="text-align: right;">CONNECTION 2</p>

12-17. INT SCH PHASE ADJUSTMENT

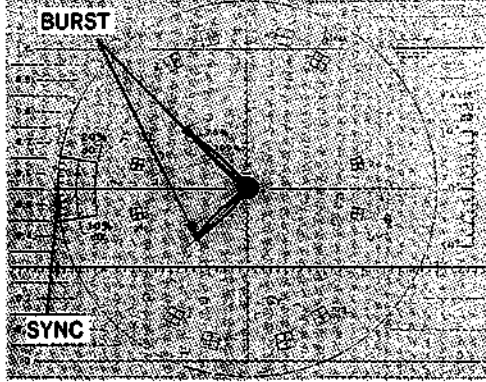
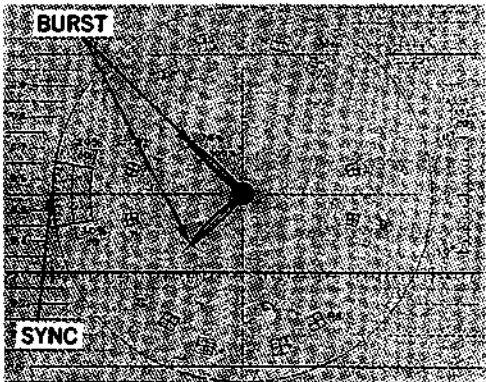
Preparations for adjustment	Specifications	Adjustments
<ul style="list-style-type: none"> • Disconnect the REF. VIDEO INPUT connector and put the unit into INT REF. mode. • Connect CH-A of a vectorscope to VIDEO OUT 1 connector, and CH-B to REF. VIDEO OUT connector. 	<p>Step1 VIDEO OUT 1 Vectorscope CH-A</p>  <p>(A) Set the dot of the burst on the normal position on the scale. (B) The SYNC should be in the same phase as the burst (SCH=0°).</p>	<p>(A) Burst Adjustment PHASE control/Vectorscope</p> <p>(B) (INT SC) ●RV708/TBC-18(N-1)</p> <p>TRIG: INT/WFM</p> <p>CONNECTION 2</p>
<ul style="list-style-type: none"> • After adjustment is completed, connect the REF. VIDEO INPUT connector. 	<p>Step2 REF.VIDEO OUT Vectorscope CH-B</p>  <p>(A) Set the dot of the burst on the normal position on the scale. (B) The SYNC should be in the same phase as the burst (SCH=0°).</p>	<p>(A) Burst Adjustment PHASE Control/Vectorscope</p> <p>(B) (SYNC PHASE) ●RV701/TBC-18(M-6)</p> <p>TRIG: INT/WFM</p> <p>CONNECTION 2</p>

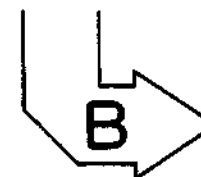
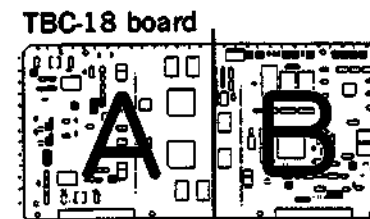

APPLICATION: 12-17.

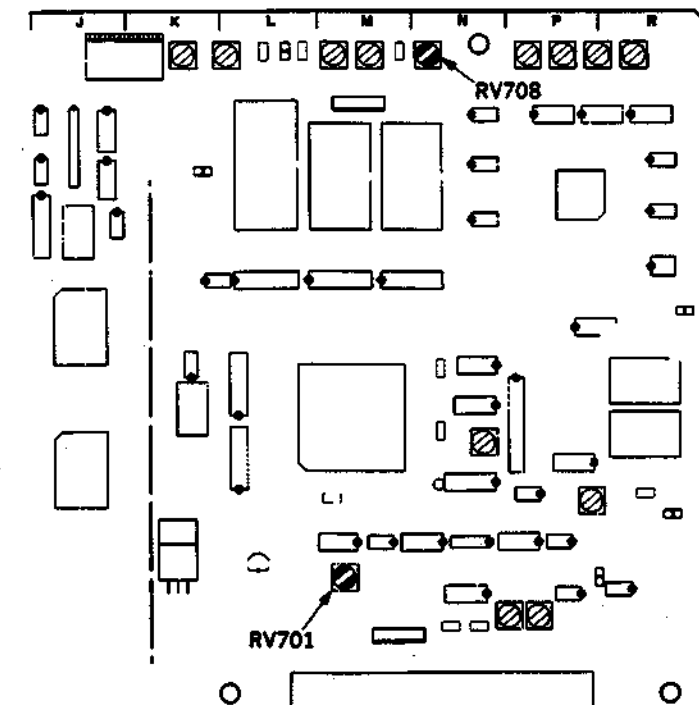

12-18. DUB OUT REF IN CHECK

[CONNECTION]

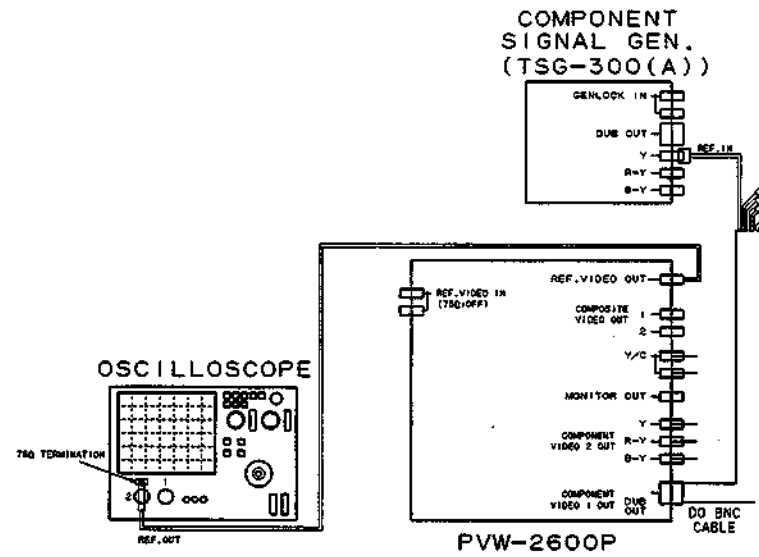

Preparations for adjustment	Specifications	Adjustments
<ul style="list-style-type: none"> Supply a component color bar Y signal to the REF IN terminal (DUB OUT REF IN terminal) (9-10 (G)) of COMPONENT 1 OUTPUT connector. (Using a multi connector cable DOBNC.) Connect the oscilloscope to the REF. VIDEO connector which is terminated at 75Ω. Disconnect a REF. VIDEO INPUT connector. After check is completed, connect the REF. VIDEO INPUT connector. 	<p>DUB IN REF OUT (terminated by 75Ω) Waveform of the oscilloscope</p> <p>(1) $A = 300 \pm 30$ mV p-p (2) Only Y signal of the color bar should appear.</p>	<p>(DUB REF Operation Check)</p> <p>TRIG: INT</p> <p>CONNECTION 2</p>

12-19. PLAY BACK COMPONENT LINEARITY CHECK

Preparations for adjustment	Specifications	Adjustments
<ul style="list-style-type: none"> Play back the LINE 17A signal portion (19:00—22:00) of the alignment tape CR5-1B PS. Connect a waveform monitor 1781R to COMPONENT 2 Y OUTPUT connector. Waveform monitor 1781R: DIFF/WFM mode 	<p>COMPONENT 2 Y OUT waveform of the waveform monitor</p> <p>the maximum in the five pulses the minimum in the five pulses</p> <p>$A \leq 2.8\%$</p>	<p>(Y Linearity Check)</p> <p>TRIG: REF. VIDEO</p> <p>CONNECTION 1</p>
<ul style="list-style-type: none"> Play back the QUAD PHASE signal portion (22:00—24:00) of the alignment tape CR5-1B PS. Connect a waveform monitor 1781R to COMPONENT 2 R-Y OUTPUT and B-Y OUTPUT connector. Waveform monitor 1781R: DIFF/PARADE mode 	<p>COMPONENT 2 Y OUT waveform of the waveform monitor</p> <p>max min</p> <p>(1) as compared with R-Y OUT $A \leq 3.8\%$</p> <p>(2) as compared with B-Y OUT $A \leq 3.8\%$</p>	<p>(Y Linearity Check)</p> <p>TRIG: REF. VIDEO</p> <p>CONNECTION 1</p>