

# PS-X50

*AEP Model  
E Model  
Canadian Model  
US Model*



## STEREO TURNTABLE SYSTEM

### SPECIFICATIONS

#### GENERAL

<b>Power Requirements:</b>	120, 220V ac adjustable, 50/60Hz (AEP, E model) 120V ac, 60Hz (Canadian, US model)
<b>Power Consumption:</b>	12W (AEP, E model) 8W (Canadian, US model)
<b>Dimensions:</b>	Approx. 480(w) x 165(h) x 420(d) mm 18 <sup>1</sup> / <sub>16</sub> x 6 <sup>1</sup> / <sub>2</sub> x 16 <sup>9</sup> / <sub>16</sub> inches including projecting parts and controls
<b>Weight:</b>	Approx. 11.5kg, 25 lb 6 oz (net) Approx. 13kg, 28 lb 11 oz (in shipping carton)

#### TURNTABLE

<b>Platter:</b>	32 cm (12 <sup>5</sup> / <sub>8</sub> inches) diecasting aluminum-alloy
-----------------	--

#### SAFETY RELATED COMPONENT WARNING !!

COMPONENTS IDENTIFIED BY SHADING AND MARK  ON THE SCHEMATIC DIAGRAMS, EXPLODED VIEWS AND IN THE PARTS LIST ARE CRITICAL TO SAFE OPERATION. REPLACE THESE COMPONENTS WITH SONY PARTS WHOSE PART NUMBERS APPEAR AS SHOWN IN THIS MANUAL OR IN SUPPLEMENTS PUBLISHED BY SONY.

ATTENTION AU COMPOSANT AYANT RAPPORT A LA SÉCURITÉ !

LES COMPOSANTS IDENTIFIÉS PAR UN TRAMÉ ET UNE MARQUE  SUR LES DIAGRAMMES SCHEMATIQUES, LES VUES EXPLOSÉES ET LA LISTE DES PIÈCES SONT CRITIQUES POUR LA SÉCURITÉ DE FONCTIONNEMENT. NE REMPLACER CES COMPOSANTS QUE PAR DES PIÈCES SONY DONT LES NUMÉROS SONT DONNÉS DANS CE MANUEL OU DES SUPPLÉMENTS PUBLIÉS PAR SONY.

<b>Motor:</b>	Linear BSL (brushless and slotless) motor
<b>Drive System:</b>	Direct drive, crystal lock control system
<b>Speed:</b>	33 <sup>1</sup> / <sub>3</sub> rpm, 45 rpm
<b>Starting Characteristics:</b>	Comes to nominal speed within a second revolution (33 <sup>1</sup> / <sub>3</sub> rpm)
<b>Wow and Flutter:</b>	±0.045% (DIN) (AEP, E model) 0.025% (WRMS)
<b>S/N Ratio:</b>	75dB (DIN-B)
<b>Load Characteristics:</b>	0% at 150g tracking force
<b>Automatic System:</b>	Arm return reject

#### TONEARM

<b>Type:</b>	Statically balanced, universal
<b>Pivot-to-Stylus Length:</b>	235mm, 9 <sup>1</sup> / <sub>4</sub> inches
<b>Overall Arm Length:</b>	330mm, 13 inches
<b>Overhang:</b>	14 mm, <sup>9</sup> / <sub>16</sub> inch
<b>Tracking Error:</b>	+2°27', -1°30'
<b>Tracking Force Adjustment Range:</b>	0-2.5g
<b>Shell Weight:</b>	11g
<b>Cartridge Weight Range:</b> (including shell weight)	11-19.5g 19-27.5g (with extra weight)

# SONY®

## SERVICE MANUAL

# PS-X50

AEP Model  
E Model  
Canadian Model  
US Model



## STEREO TURNTABLE SYSTEM

### SPECIFICATIONS

#### GENERAL

**Power Requirements:** 120, 220V ac adjustable, 50/60Hz  
(AEP, E model)  
120V ac, 60Hz (Canadian, US model)

**Power Consumption:** 12W (AEP, E model)  
8W (Canadian, US model)

**Dimensions:** Approx. 480(w) x 165(h) x 420(d) mm  
18<sup>5</sup>/<sub>16</sub> x 6<sup>1</sup>/<sub>2</sub> x 16<sup>9</sup>/<sub>16</sub> inches  
including projecting parts and controls

**Weight:** Approx. 11.5kg, 25 lb 6 oz (net)  
Approx. 13kg, 28 lb 11 oz (in shipping carton)

#### TURNTABLE

**Platter:** 32 cm (12<sup>5</sup>/<sub>8</sub> inches)  
diecasting aluminum-alloy

#### SAFETY-RELATED COMPONENT WARNING!!

COMPONENTS IDENTIFIED BY SHADING AND MARK ON THE SCHEMATIC DIAGRAMS, EXPLODED VIEWS AND IN THE PARTS LIST ARE CRITICAL TO SAFE OPERATION. REPLACE THESE COMPONENTS WITH SONY PARTS WHOSE PART NUMBERS APPEAR AS SHOWN IN THIS MANUAL OR IN SUPPLEMENTS PUBLISHED BY SONY.

ATTENTION AU COMPOSANT AYANT RAPPORT  
À LA SÉCURITÉ !

LES COMPOSANTS IDENTIFIÉS PAR UN TRAMÉ ET UNE MARQUE SUR LES DIAGRAMMES SCHEMATIQUES, LES VUES EXPLOSÉES ET LA LISTE DES PIÈCES SONT CRITIQUES POUR LA SÉCURITÉ DE FONCTIONNEMENT. NE REMPLACER CES COMPOSANTS QUE PAR DES PIÈCES SONY DONT LES NUMÉROS SONT DONNÉS DANS CE MANUEL OU DES SUPPLÉMENTS PUBLIÉS PAR SONY.

**Motor:** Linear BSL (brushless and slotless) motor

**Drive System:** Direct drive, crystal lock control system

**Speed:** 33 <sup>1</sup>/<sub>3</sub> rpm, 45 rpm

**Starting Characteristics:** Comes to nominal speed within a second revolution (33 <sup>1</sup>/<sub>3</sub> rpm)

**Wow and Flutter:** ± 0.045% (DIN) (AEP, E model)  
0.025% (WRMS)

**S/N Ratio:** 75dB (DIN-B)

**Load Characteristics:** 0% at 150g tracking force

**Automatic System:** Arm return reject

#### TONARM

**Type:** Statically balanced, universal

**Pivot-to-Stylus Length:** 235mm, 9 <sup>1</sup>/<sub>4</sub> inches

**Overall Arm Length:** 330mm, 13 inches

**Overhang:** 14 mm, <sup>9</sup>/<sub>16</sub> inch

**Tracking Error:** +2°27', -1°30'

**Tracking Force Adjustment Range:** 0-2.5g

**Shell Weight:** 11g

**Cartridge Weight Range:** 11-19.5g  
(including shell weight) 19-27.5g (with extra weight)

## PS-X50

### SERVICING NOTE

1. Perform the checking of the adjustment a few minutes after the power switch is turned on.
2. When replacing the pilot lamp of automatic-return detection, adjust the automatic-return adjustment (13 page).
3. Platter handling.
4. When adjusting the set, confirm that the transit screws are removed.

bottom view of platter

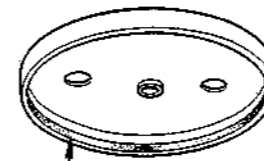

Be sure not to spoil the magnetic coating (dark brown color).

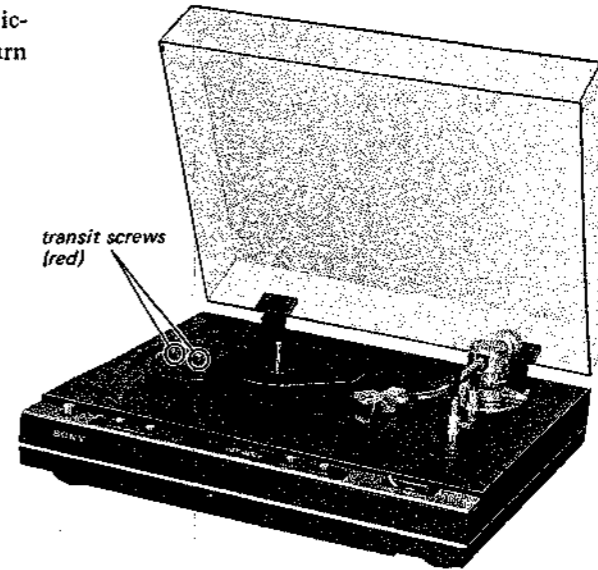

transit screws (red)

### MODEL IDENTIFICATIONS

#### - Specification Label -

#### US, Canadian model

<b>SONY</b>	STEREO TURNTABLE SYSTEM	
	MODEL NO. PS-X50	
	AC 120V 60Hz	BW
	SERIAL NO. _____	MADE IN JAPAN

#### AEP, E model

<b>SONY</b>	STEREO TURNTABLE SYSTEM	
	MODEL NO. PS-X50	
	~120, 220V 50/60Hz 12W	
	SERIAL NO. _____	MADE IN JAPAN

### MODEL IDENTIFICATIONS

#### - Power Cord -

E1 model: euro-plug  
1-551-530-11

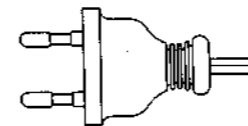

E2 model: parallel-blade plug  
1-551-473-31

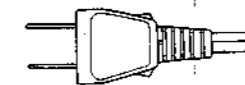

# SONY

## SERVICE MANUAL

SECTION 1  
OUTLINE

1. BLOCK DIAGRAM

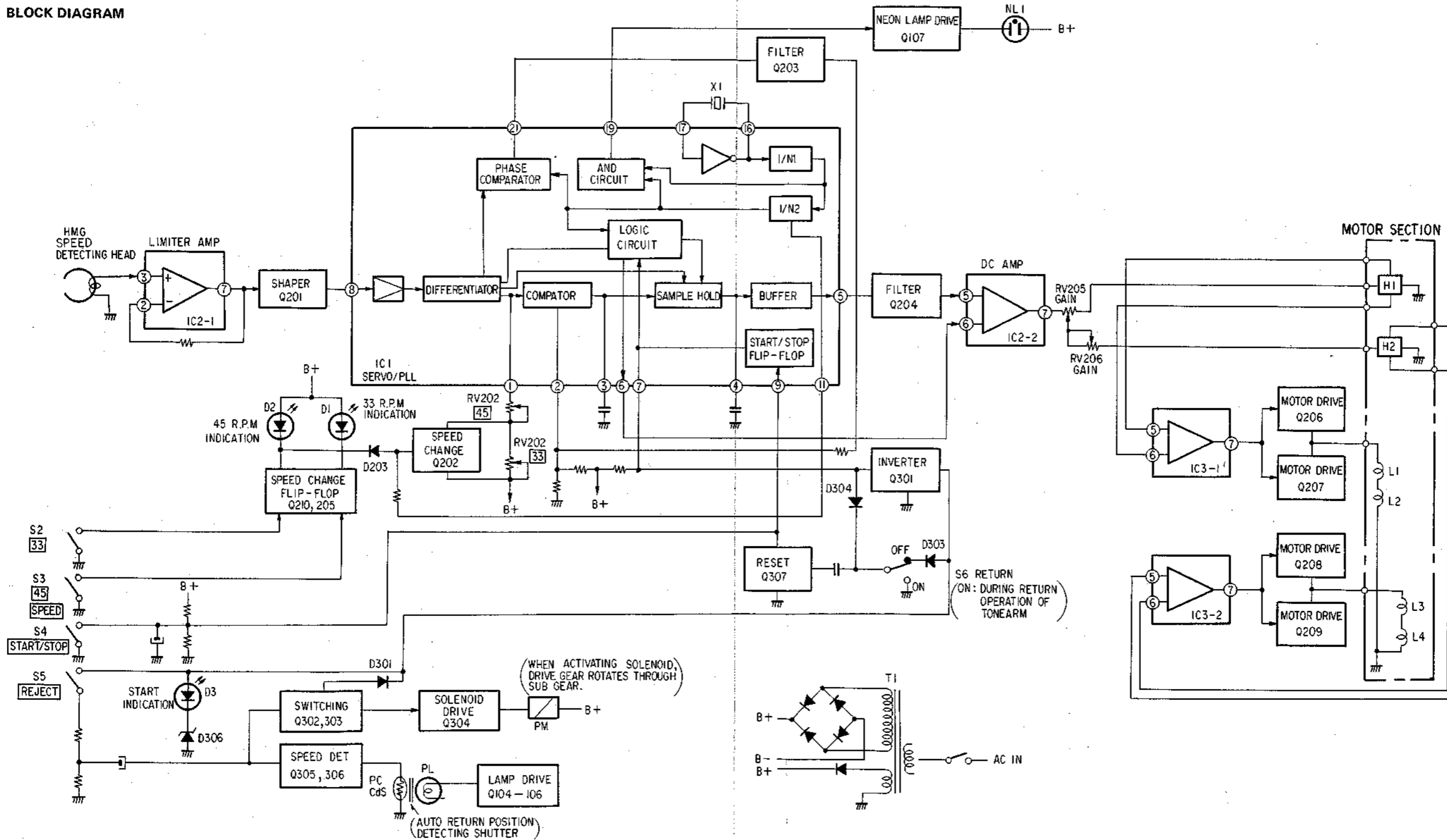

SECTION 2  
DISASSEMBLY

PS-X50 PS-X50

- Follow the disassembly procedure in the numerical order given.

Remove the dust cover, turntable sheet and turntable.

BOTTOM PLATE REMOVAL

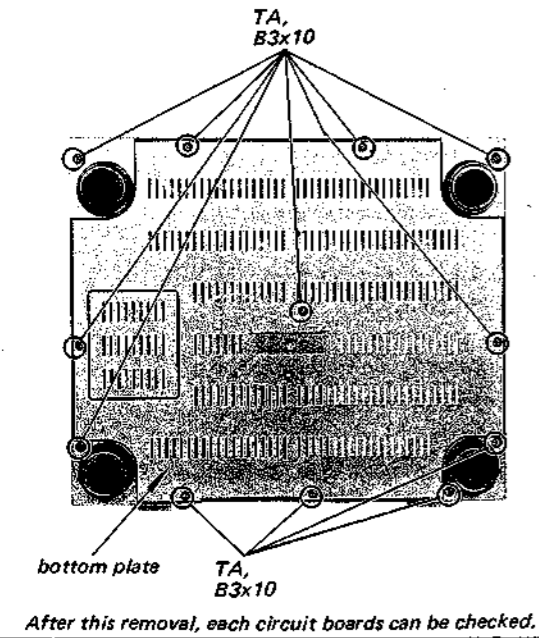

TONELARM REMOVAL (1)

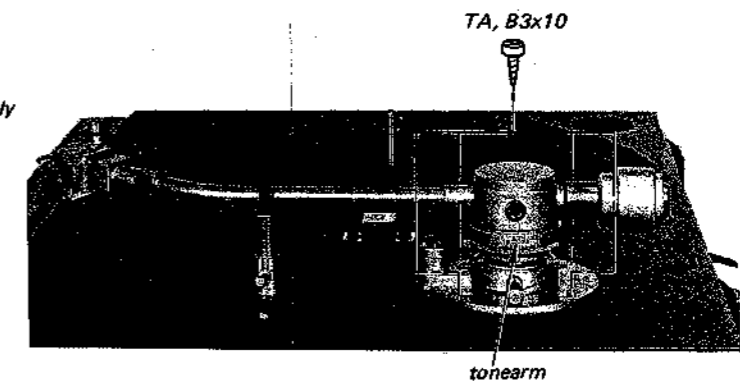
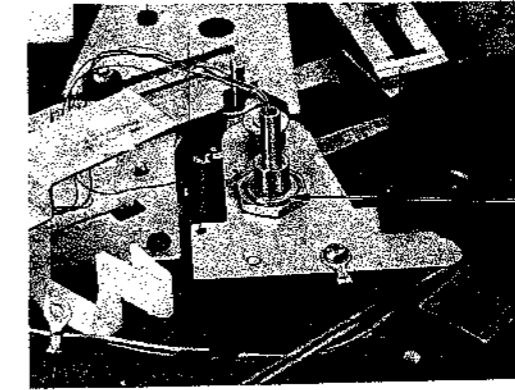
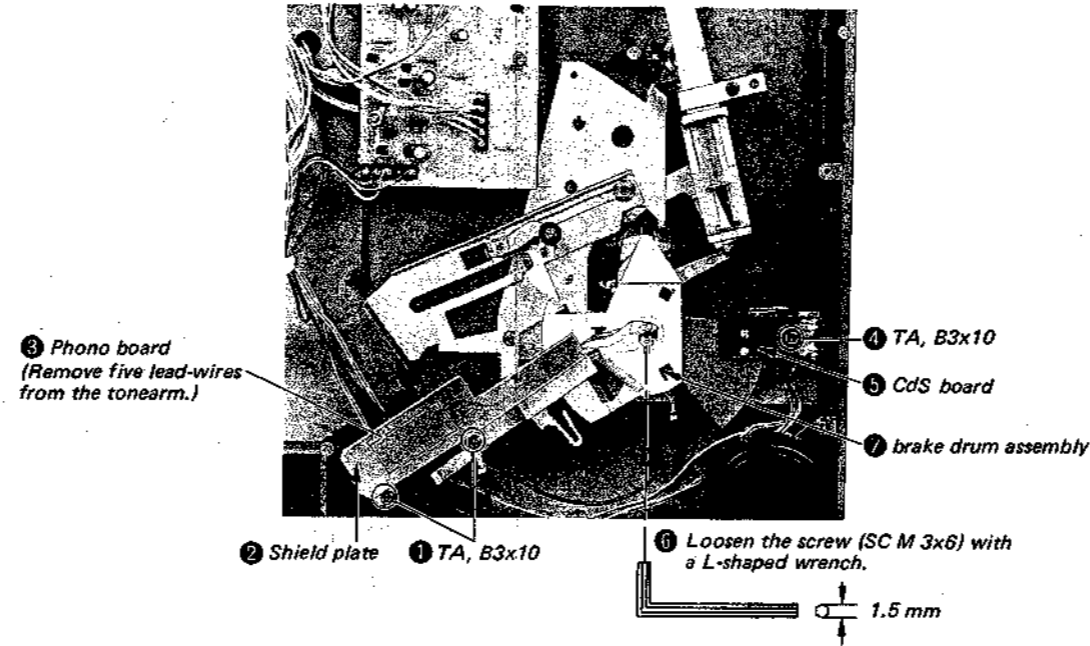

SPEED SWITCH (S2, 3), START/STOP SWITCH (S4) AND REJECT SWITCH (S5) REMOVAL

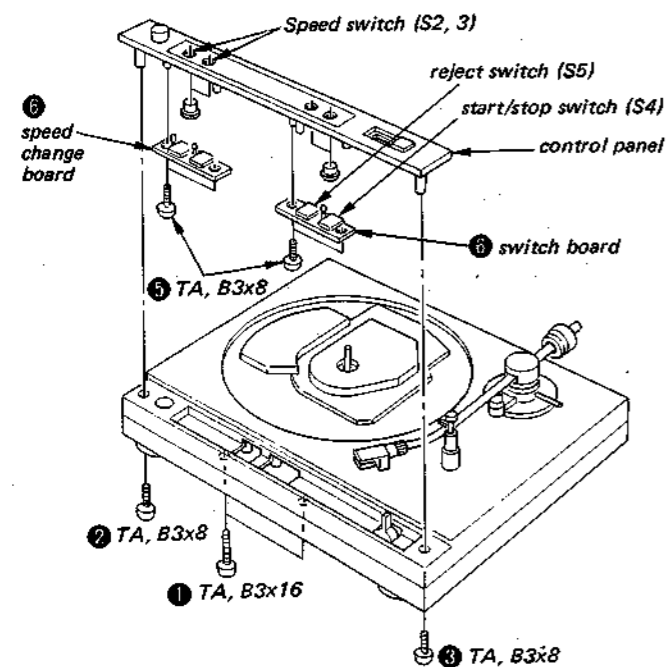

NEON LAMP (NL1) AND POWER SWITCH (S1) REMOVAL

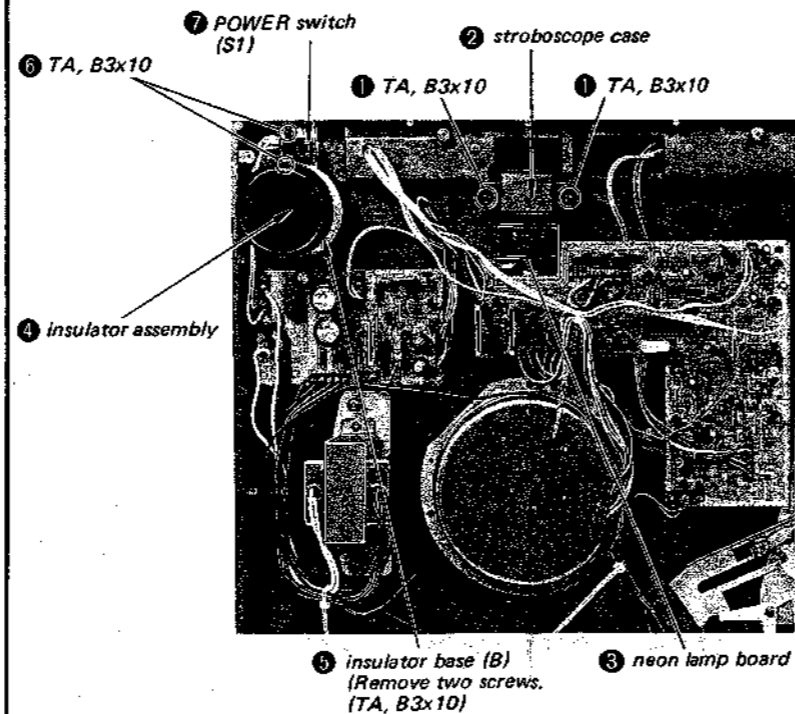

TOP COVER REMOVAL

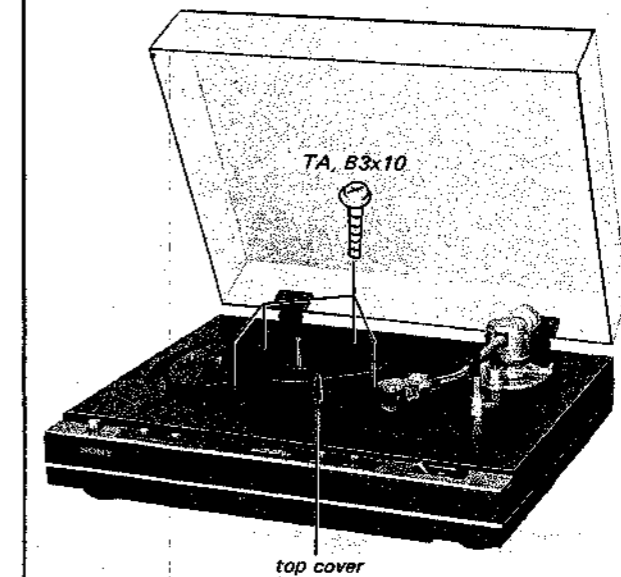

After this removal, drive gear, miniature switch (S6), solenoid (PM) and motor can be replaced.

TONEARM REMOVAL (2)

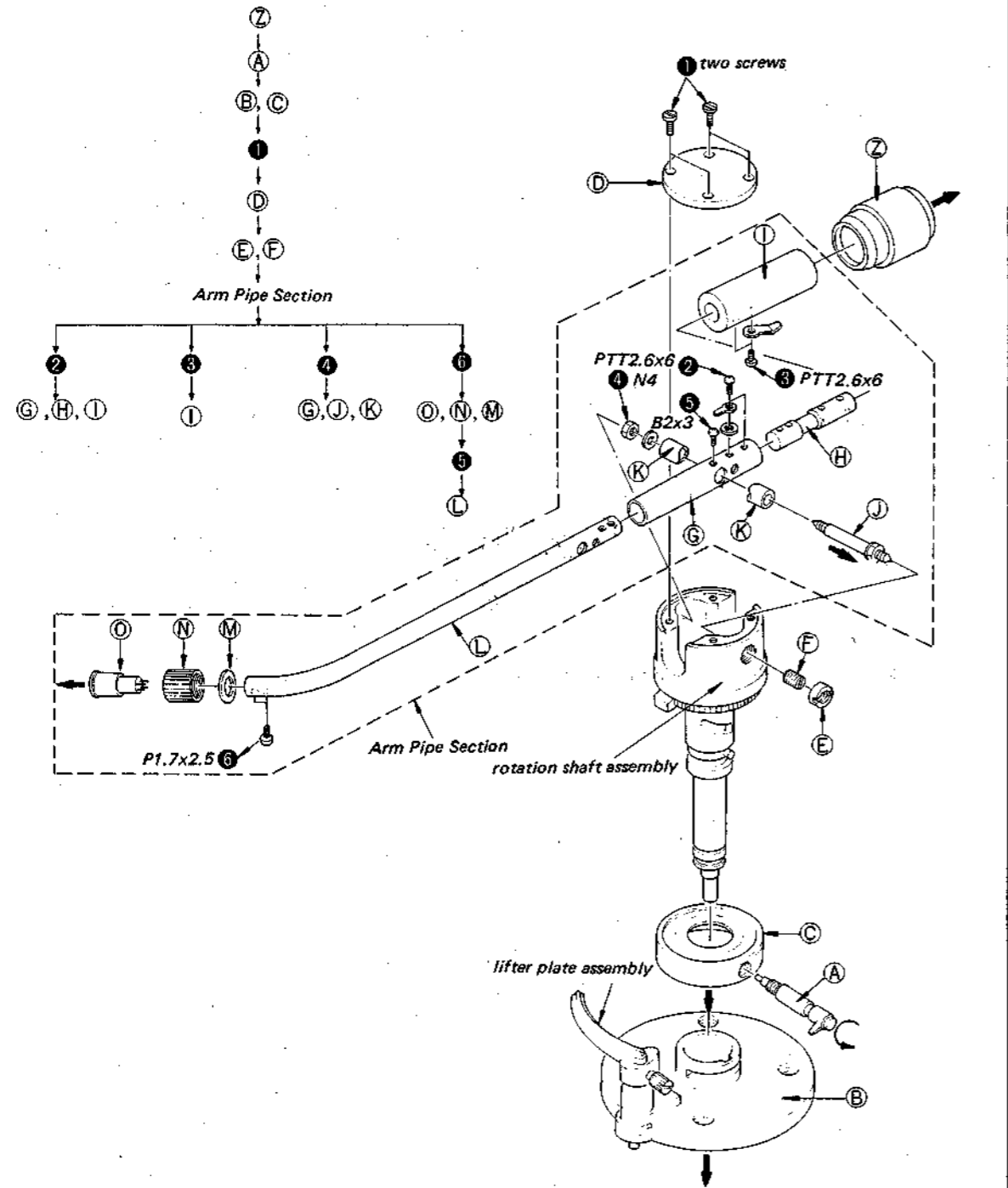

AUTOMATIC RETURN DETECTING LAMP (PL) REPLACEMENT

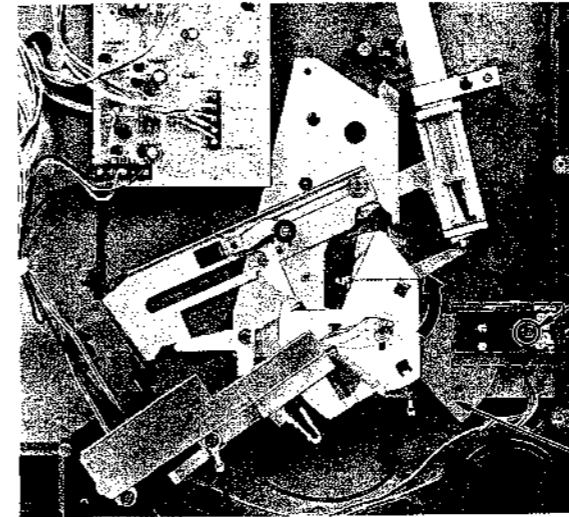

- 1 TA, B3x10
  - 2 CdS board
  - 3 Set the tonearm to center spindle side.
  - 4 Remove the lamp from the lamp holder.
- Shutter (attached to the brake drum)

BRAKE MAGNET INSTALLATION

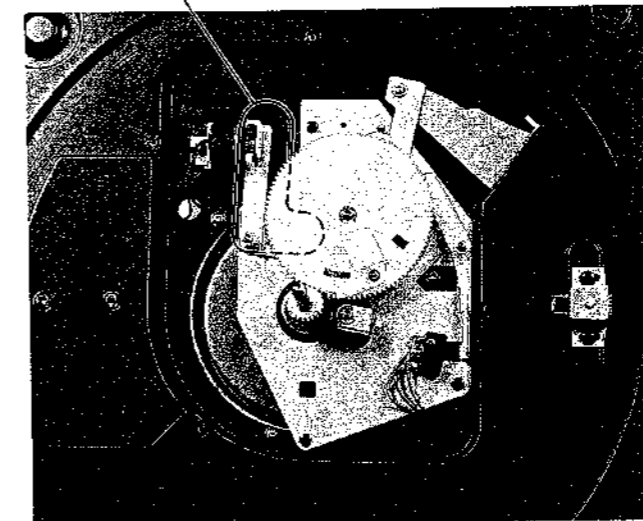
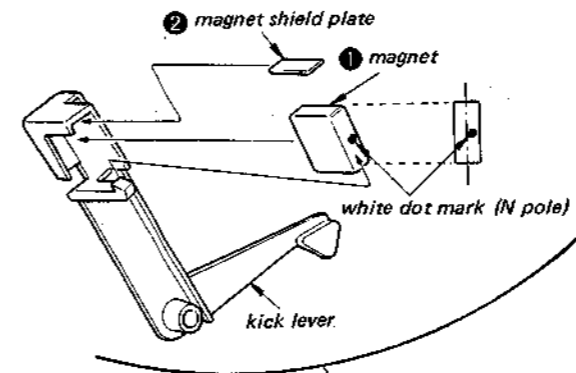

**SOLENOID (PM) INSTALLATION**

Install the solenoid (PM) parallel to **A** line.

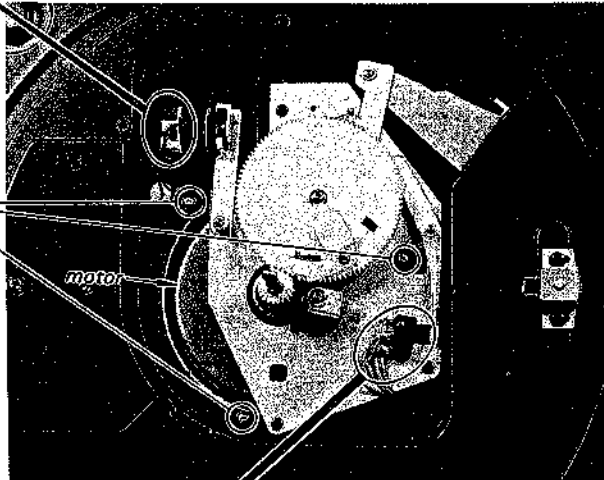
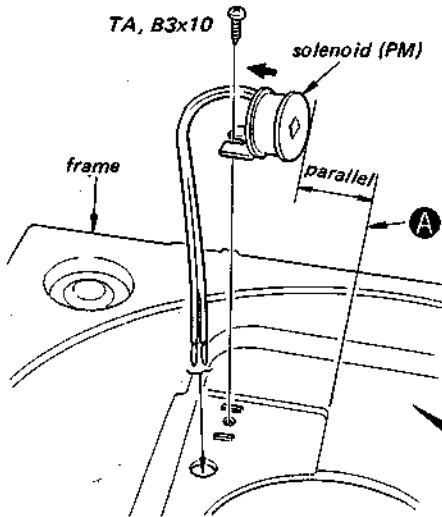

**MOTOR REMOVAL**

1. Remove the motor lead-wires from the servo amp/ system control/PLL board.
2. Remove three screws (PSW 3x12).
3. Remove the motor.

**RETURN SWITCH (S6) INSTALLATION**

Install the return switch (S6).

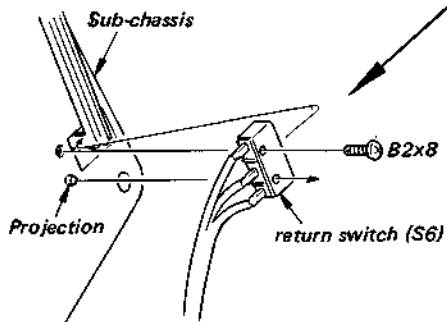

**ARM LIFTER MECHANISM**

The arm lifter mechanism of this set uses silicone-oil as damper of between the lifter cam assembly and the lifter base assembly.

If the arm lifter moves down too quickly, apply silicone-oil in the numerical order given.

1. Perform the tonearm removal (1).
2. Remove the lifter base assembly.
3. Remove E3 and the lifter cam assembly from the lifter base assembly.
4. Wipe off the silicone-oil on the lifter cam assembly and lifter base assembly.
5. Apply silicone-oil (7-661-012-15) on the lifter cam assembly.
6. Install the lifter cam assembly on the lifter base assembly.

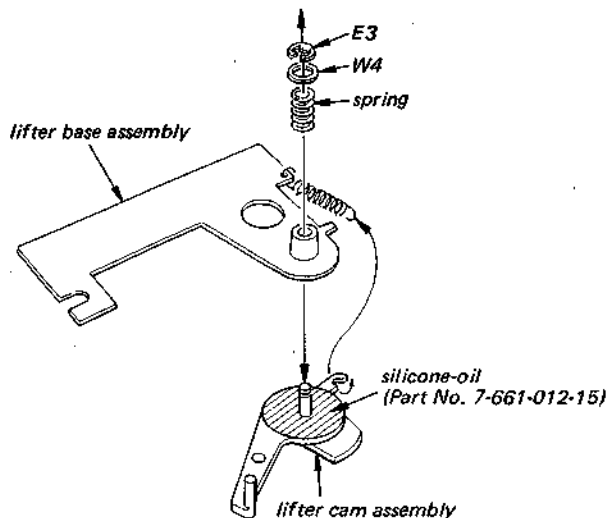
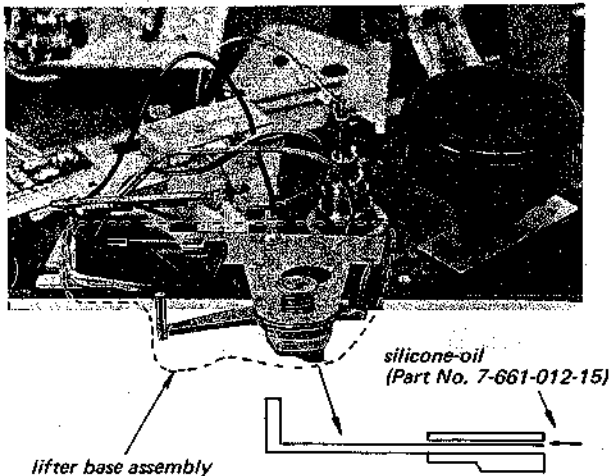

**BRAKE DRUM ASSEMBLY INSTALLATION**

1. Thread the lead wires of tonearm in the brake drum assembly.
2. Insert the brake drum assembly in the rotation shaft of tonearm.
3. Place the boss of brake drum assembly as shown below and fix the brake drum assembly with screw.
4. Perform the automatic return position adjustment (Refer to the electrical adjustment on page 13).

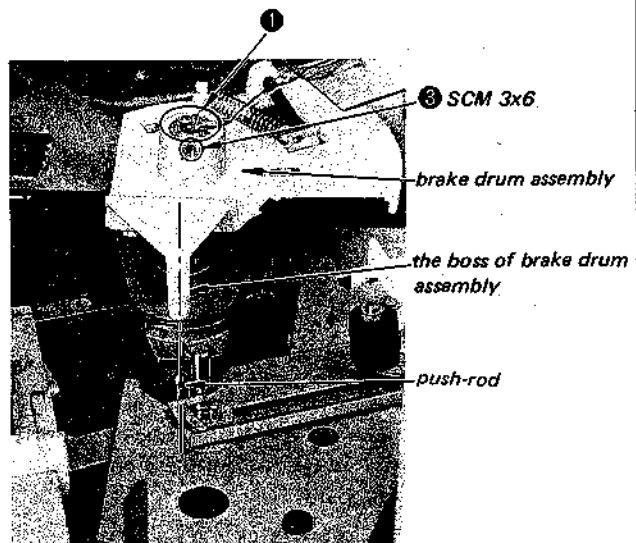

**TONARM INSTALLATION**

**1. LEAD WIRE THREADING (1)**

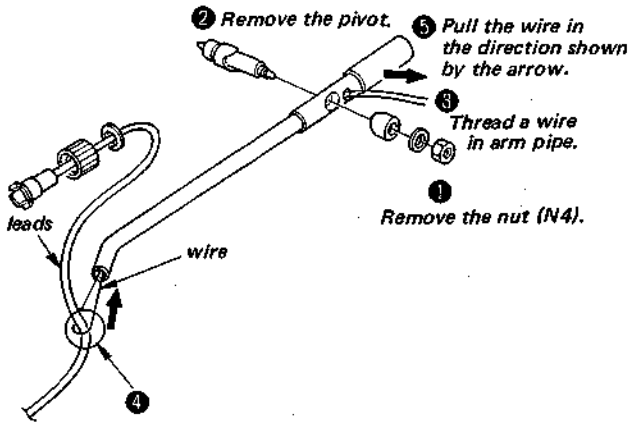

**2. LEAD WIRE THREADING (2)**

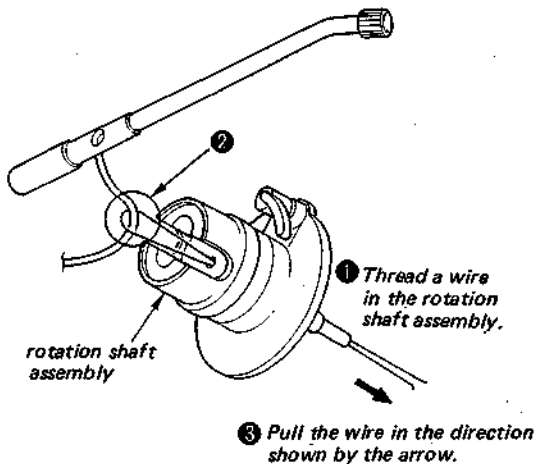

**3. PIVOT NEEDLE INSTALLATION**

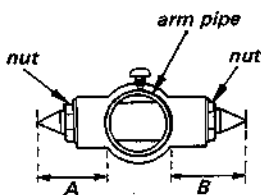

Turn the nuts so that A is equal to B.

**4. ARM PIPE INSTALLATION**

- 1) Loosen the pivot-locking nuts and the pivot bearings.
- 2) Install the pivot needle to the pivot bearings as shown in Fig. A.
- 3) Tighten the pivot bearings temporarily as shown in Fig. B.

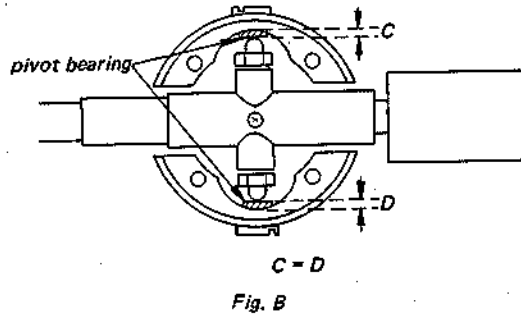
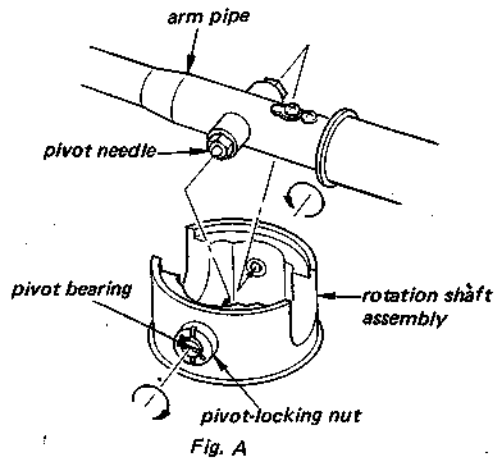

- 4) Install the tonearm on the set and perform the longitudinal balance adjustment.
- 5) Adjust the pivot bearings so that the tonearm sinks 3mm when the 20mg weight is placed on the shell as shown in Fig. C and the tonearm is in a horizontally balanced position when the weight is removed. (Fig. D)

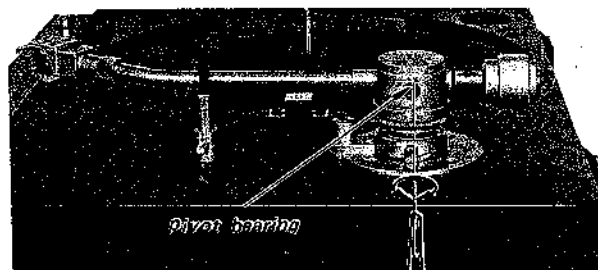
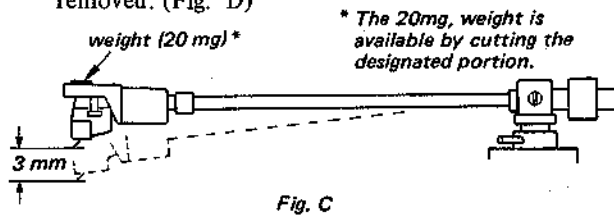
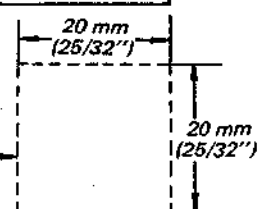

Fig. D

20 mg weight for tonearm balance adjustment





**CARTRIDGE WIRE REPLACEMENT**

**1. CARTRIDGE WIRE CONNECTION**

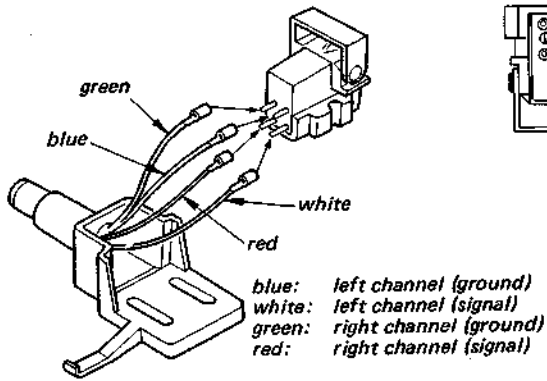

**2. CARTRIDGE INSTALLATION**

Install the cartridge into the shell with the mounting screws so that the distance between the shell end and the stylus tip is 49mm ( $1\frac{15}{16}$  inches).

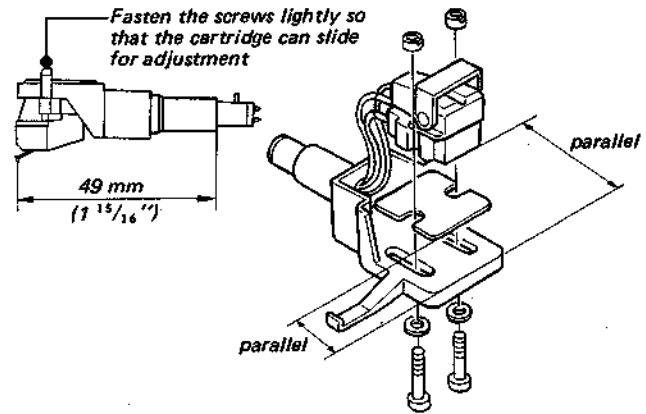

**SECTION 3  
ADJUSTMENTS**

**3-1. MECHANICAL ADJUSTMENT**

**Stylus Height Adjustment**

1. Bring the tonearm above the record.
2. Lift the cueing lever up and make sure that the clearance between the stylus tip and the record is 5–9 mm ( $\frac{3}{16}$ – $\frac{3}{8}$  inches).
3. If necessary, loosen the lifter plate adjustment screw and adjust the lifter height.

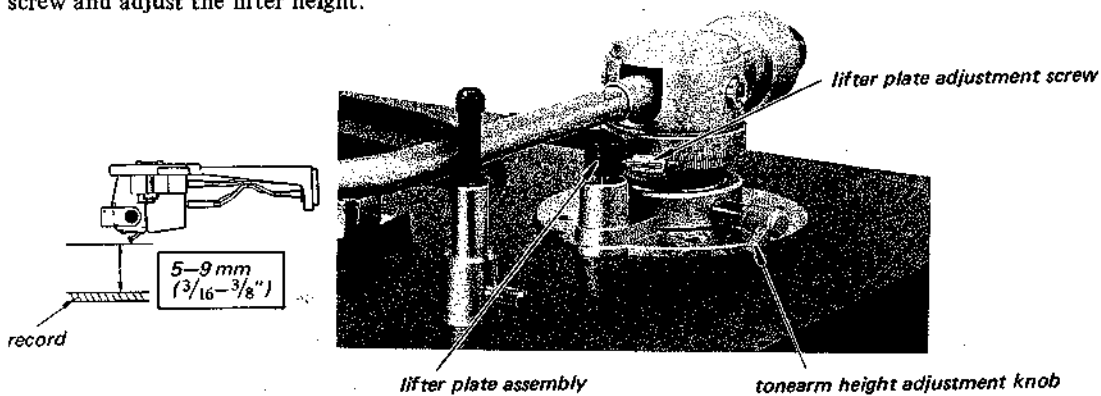

3.2. ELECTRICAL ADJUSTMENT

Voltage Adjustment

Adjust RV101 for 13.5 V dc reading on the VOM (A), and -13.5 V dc reading on the VOM (B).

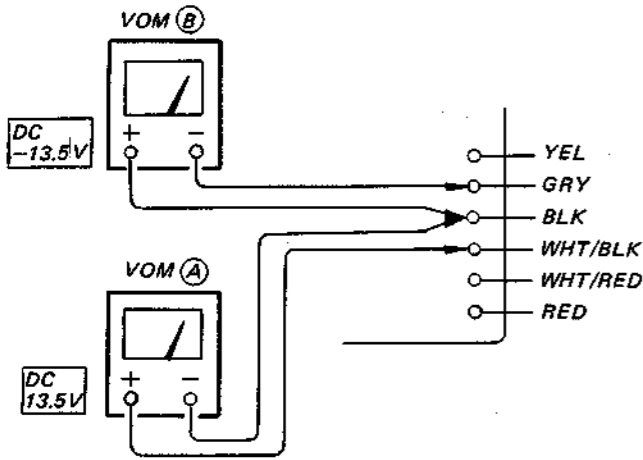

RV101

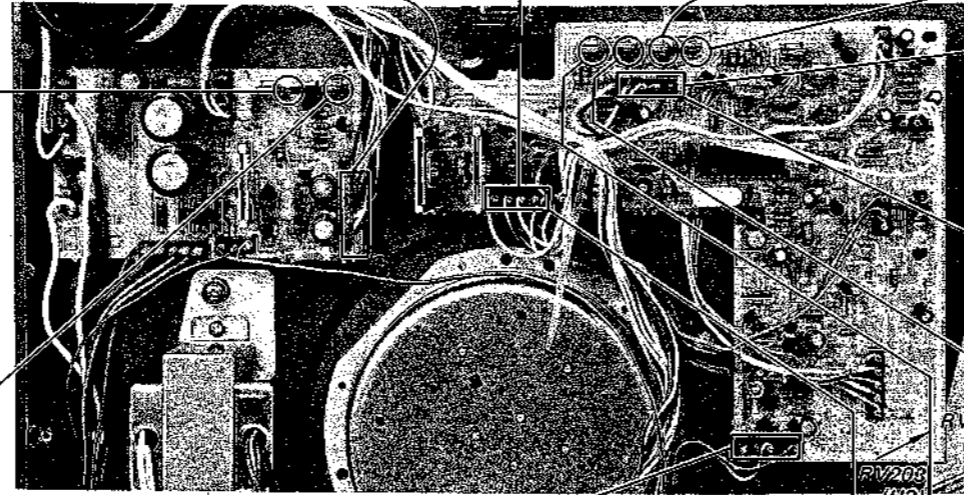

RV102

Automatic Return Adjustment

1. Set the power switch on.
2. Set the tonearm to the center spindle side.
3. Adjust RV102 for 1.1 V dc reading on the VOM (C).

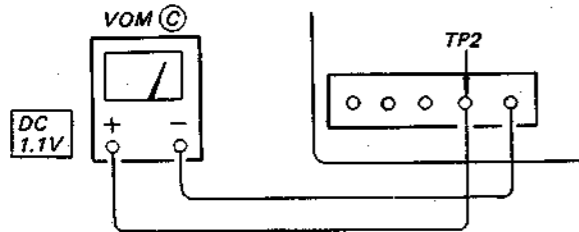

4. Set the stylus position as shown below. Adjust the shutter adjustment screw for 7.3 V dc reading on the VOM (C).

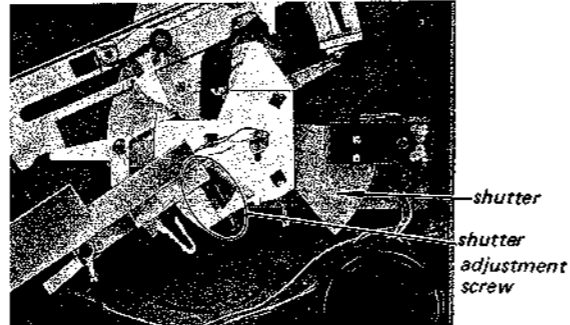
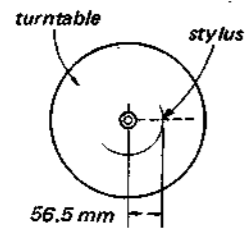

5. Set the test record (YFSB-6, BAND 2, 33 rpm).
6. Turn the shutter adjustment screw so that tonearm starts to return at count of 15-16.
7. Set the test record (YFSB-6, BAND 3, 33 rpm).
8. Adjust RV102 for the tonearm starts to return at only 1kHz playback signal is heard.
9. If RV102 is turned, readjust steps 4 to 7 several times.

Hall Device Gain Adjustment (33<sup>1</sup>/<sub>3</sub> rpm)

1. Disconnect the white lead wire and connect the regulated power supply as shown below.

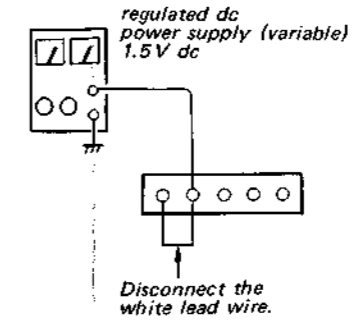

2. Connect VTVM to H1 and adjust RV205 for 1.9 V ac reading on VTVM.
3. Connect VTVM to H2 and adjust RV206 for 1.9 V ac reading on VTVM.

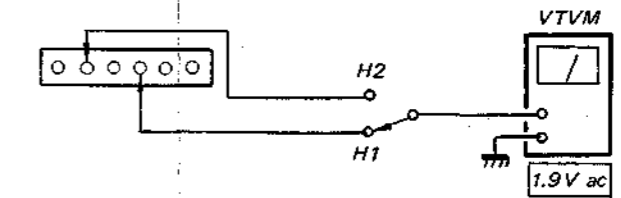

Motor Amp Offset Adjustment (33<sup>1</sup>/<sub>3</sub> rpm)

1. Disconnect the white lead wire and connect the regulated power supply as shown below.

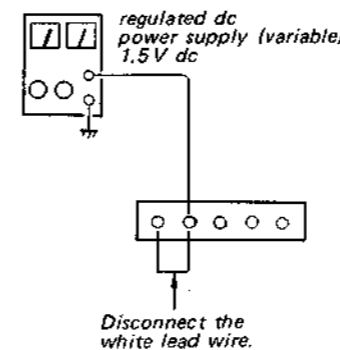

2. Connect VTVM or oscilloscope to H1 and adjust RV204 for 0 V dc VTVM reading or the waveform on oscilloscope as shown below.
3. Connect VTVM or oscilloscope to H2 and adjust RV203 for 0 V dc VTVM reading or the waveform on oscilloscope as shown below.

Waveform on Oscilloscope:

Note: Set the sweep time to longer for easy checking the waveform.

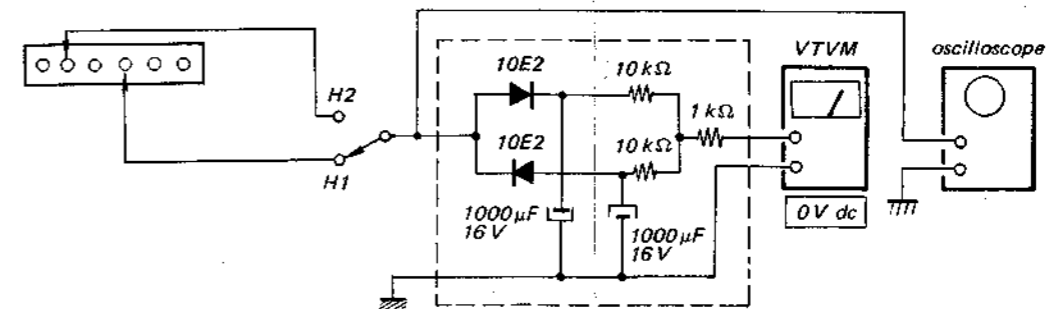
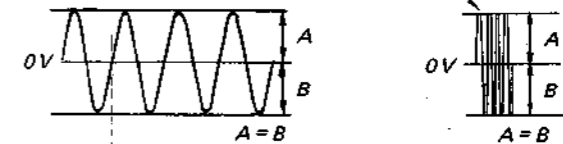

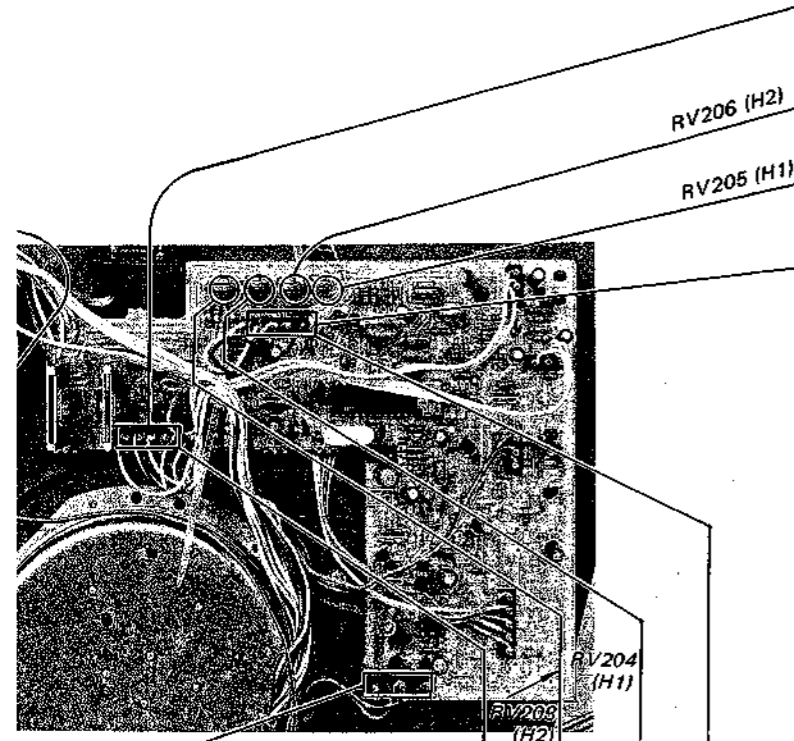

### Hall Device Gain Adjustment (33 1/3 rpm)

1. Disconnect the white lead wire and connect the regulated power supply as shown below.

2. Connect VTVM to H1 and adjust RV205 for 1.9 V ac reading on VTVM.
3. Connect VTVM to H2 and adjust RV206 for 1.9 V ac reading on VTVM.

### Turntable Speed Adjustment

1. Set the SPEED switch (S2, 3) to "45" position.

2. Reference waveform: + **Note:** Waveform must appear ⊕ side.

3. If the correct waveform does not appear, adjust RV202 (45 rpm).
4. Set the SPEED switch (2, 3) to "33" position.

5. Reference waveform: + **Note:** Waveform must appear ⊕ side.

6. If the correct waveform does not appear, adjust RV201 (33 rpm) so that the stroboscope pattern appears stationary.

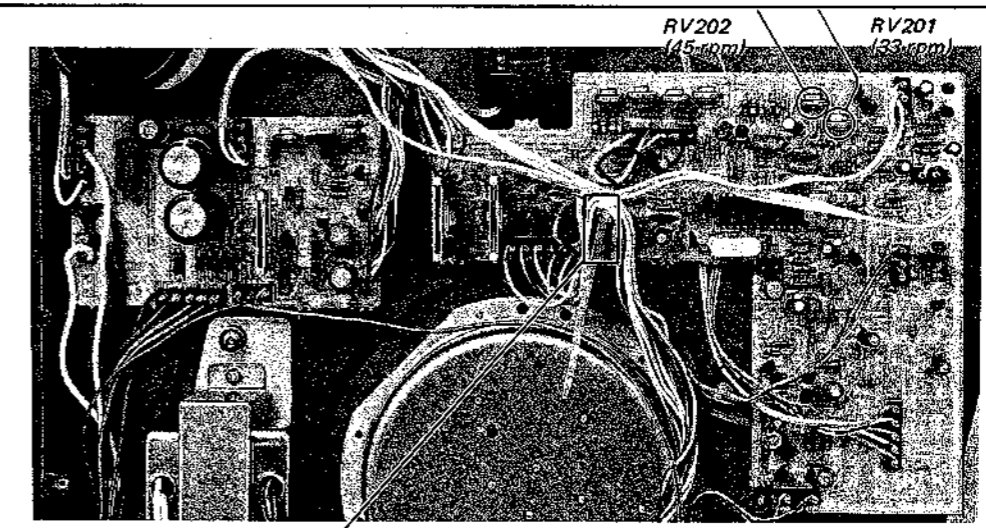

### Motor Amp Offset Adjustment (33 1/3 rpm)

1. Disconnect the white lead wire and connect the regulated power supply as shown below.

2. Connect VTVM or oscilloscope to H1 and adjust RV204 for 0 V dc VTVM reading or the waveform on oscilloscope as shown below.
3. Connect VTVM or oscilloscope to H2 and adjust RV203 for 0 V dc VTVM reading or the waveform on oscilloscope as shown below.

Waveform on Oscilloscope:

**Note:** Set the sweep time to longer for easy checking the waveform.

### Speed Detecting Head Output Level Adjustment

Power switch: ON

1. Adjust the position of the head so that the VTVM reading is more than 15 mV ac at 33 1/3 rpm.
2. Make sure that the head does not touch the turntable and tighten the screws securely.

**Note:** The clearance between the magnet coated rim and the speed detecting head is more than 0.3 mm.

—Adjustment Location—

4-1. MOUNTING DIAGRAM

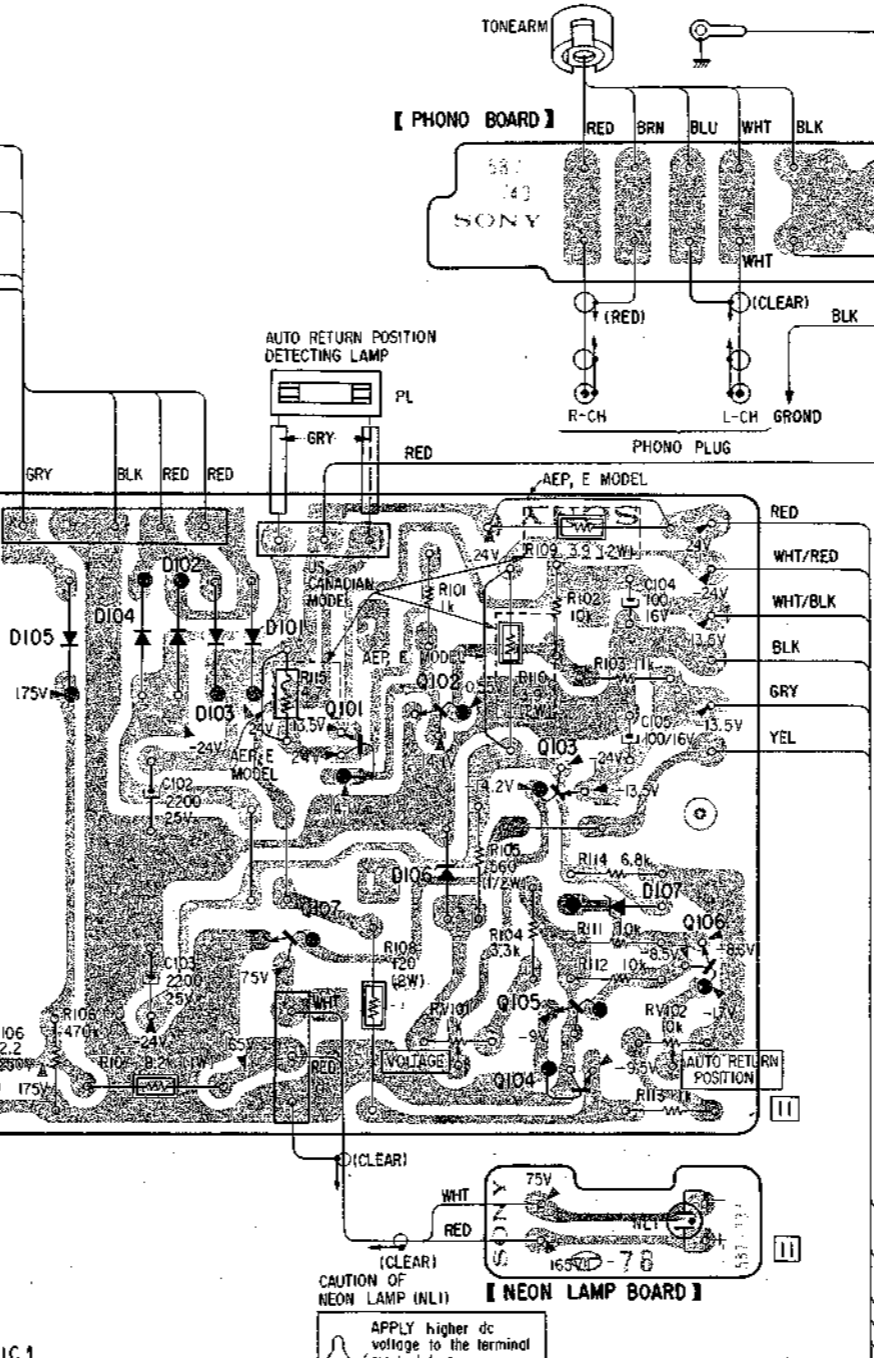
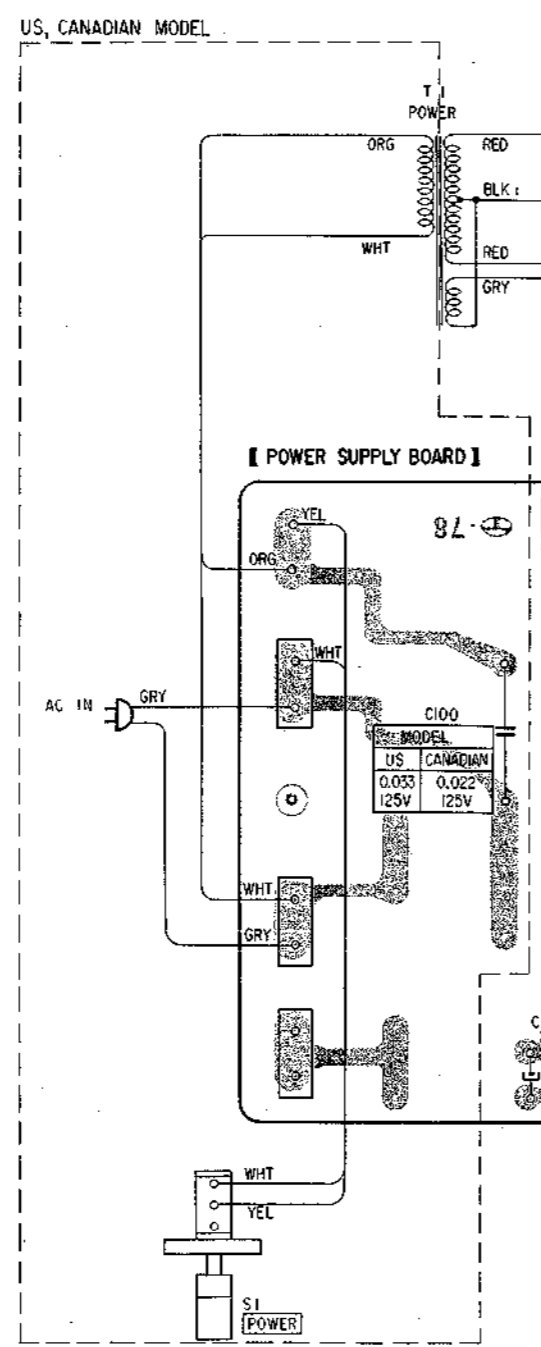
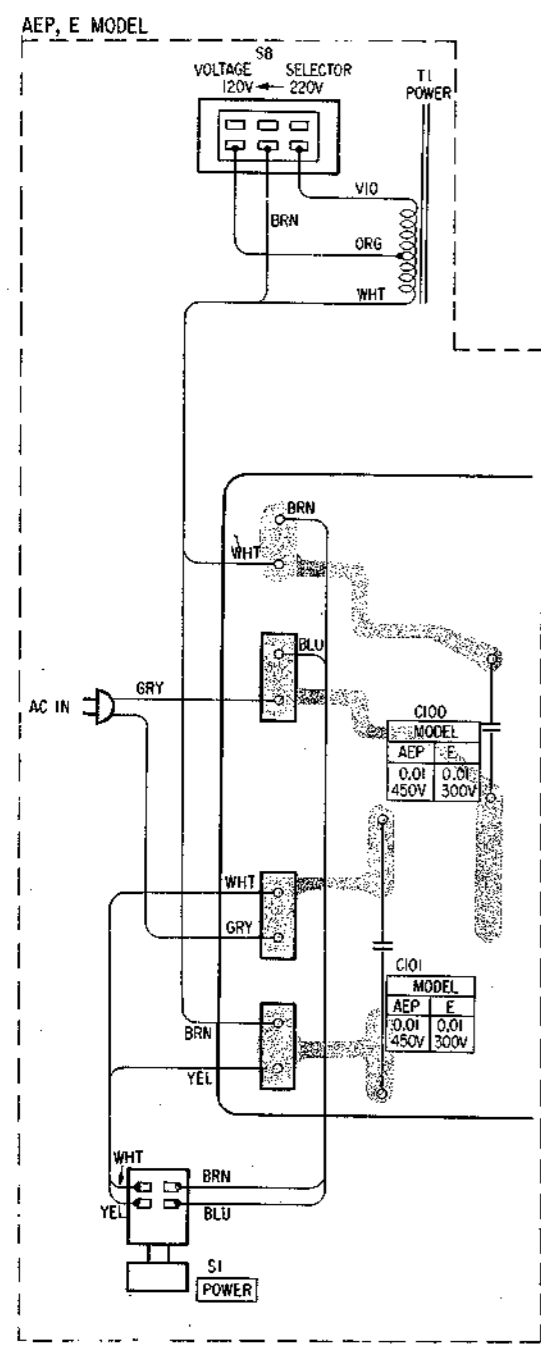

- B+ pattern
- B- pattern
- parts extracted from the component side.
- Color code of sleeving over the end of the jacket.

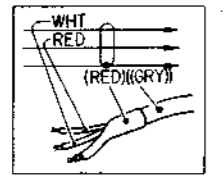

Q	IC	107	101	102	103,105	106	206	207	208	209	IC3	IC2	201
D		105	104,102,103,101	106	107	2	1		3			201	

D E F G H I J K

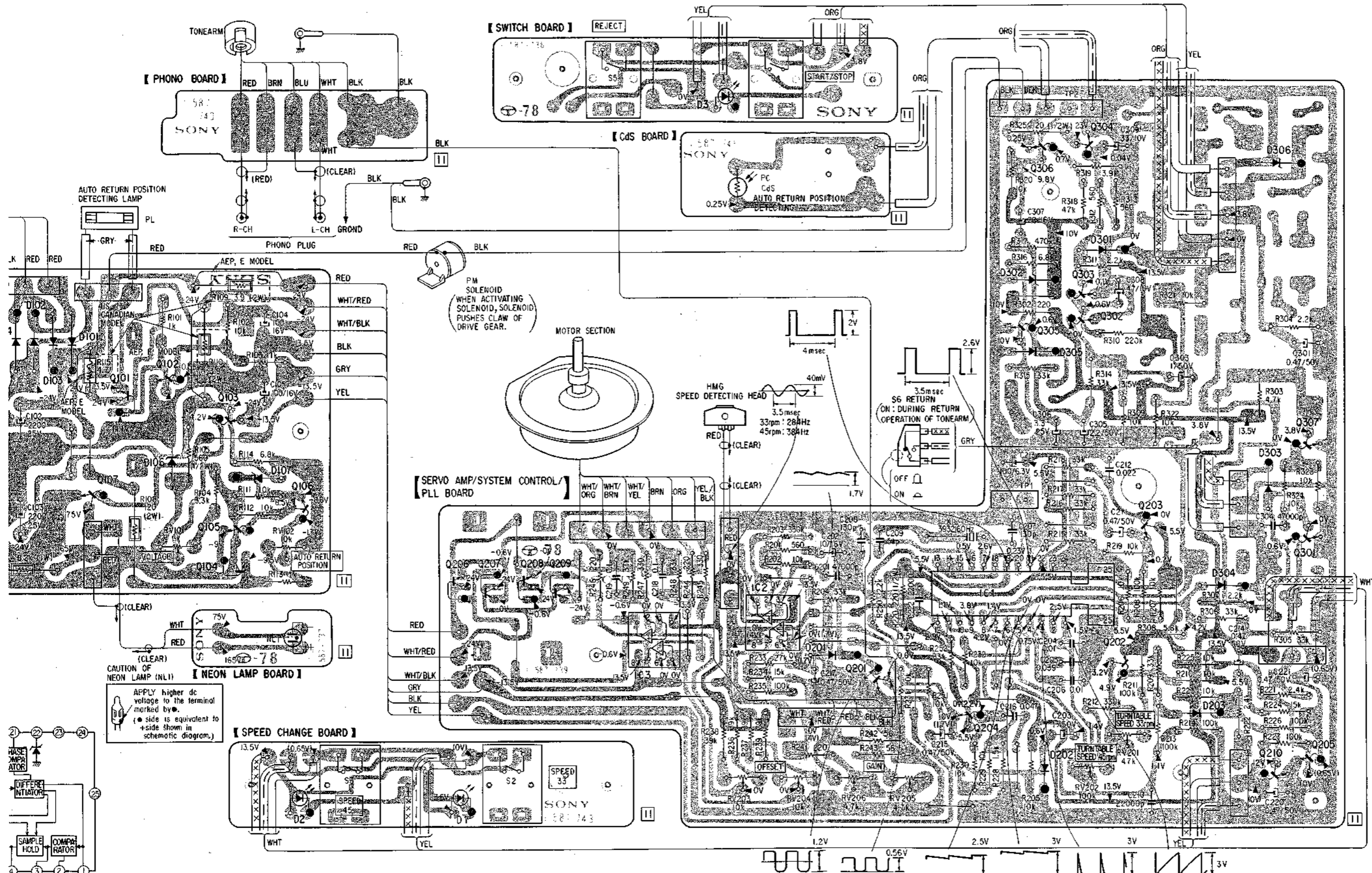

107	101	102	103,105 104	106	206	207	208	209	IC3	IC2	201	204	IC1	306 305	303 302	304 202	203	210 301 205	Q IC
104,102,103,101	106	107	2							3	201			302 305,202	301		203	304 306 303	0

4-2. SCHEMATIC DIAGRAM

[SERVO AMP / SYSTEM CONTROL / PLL BOARD]

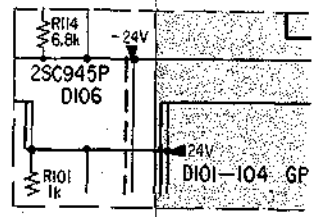
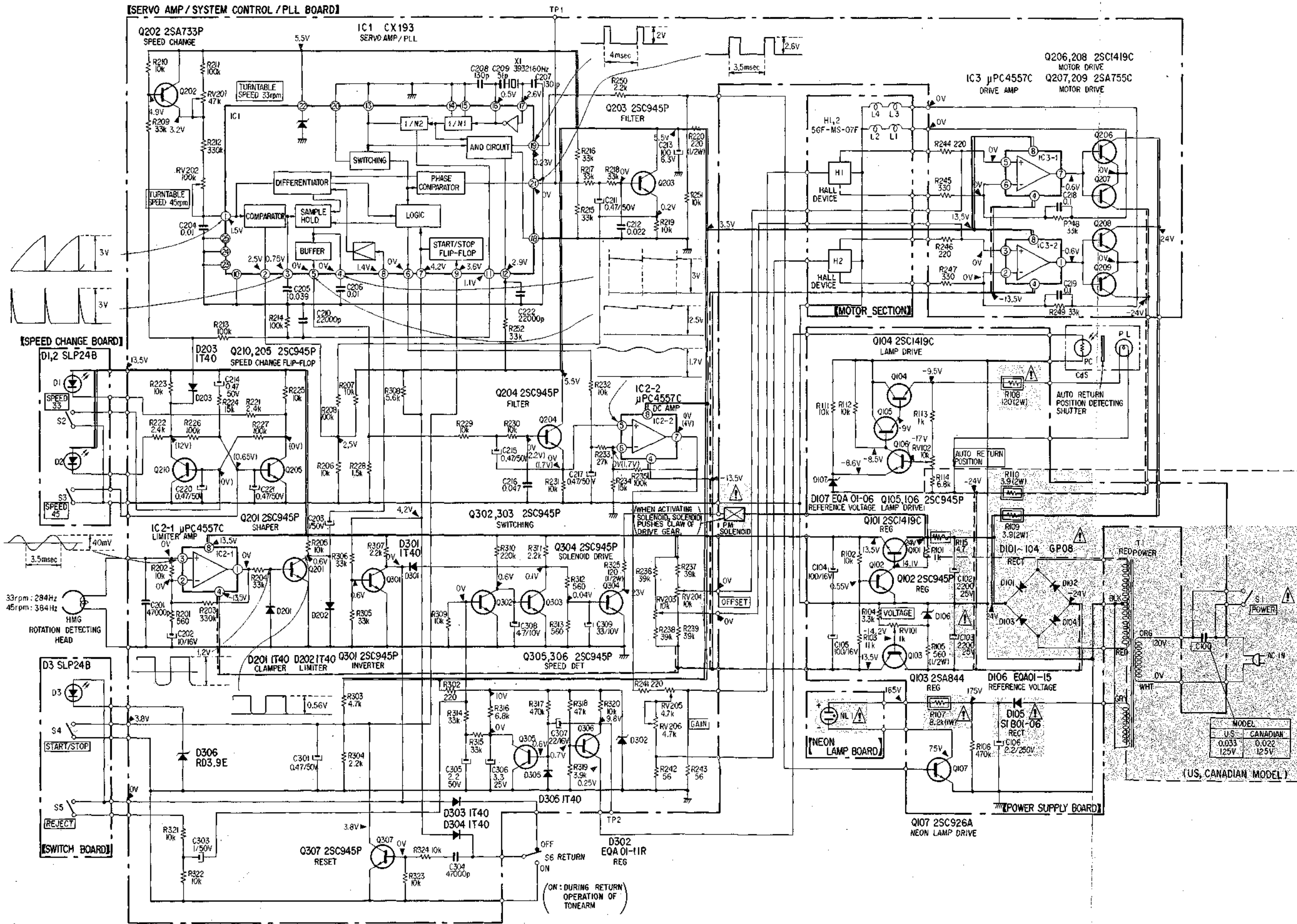

MODEL	
U.S.	CANADIAN
0.033	0.022
125V	125V

(U.S. CANADIAN MODEL)

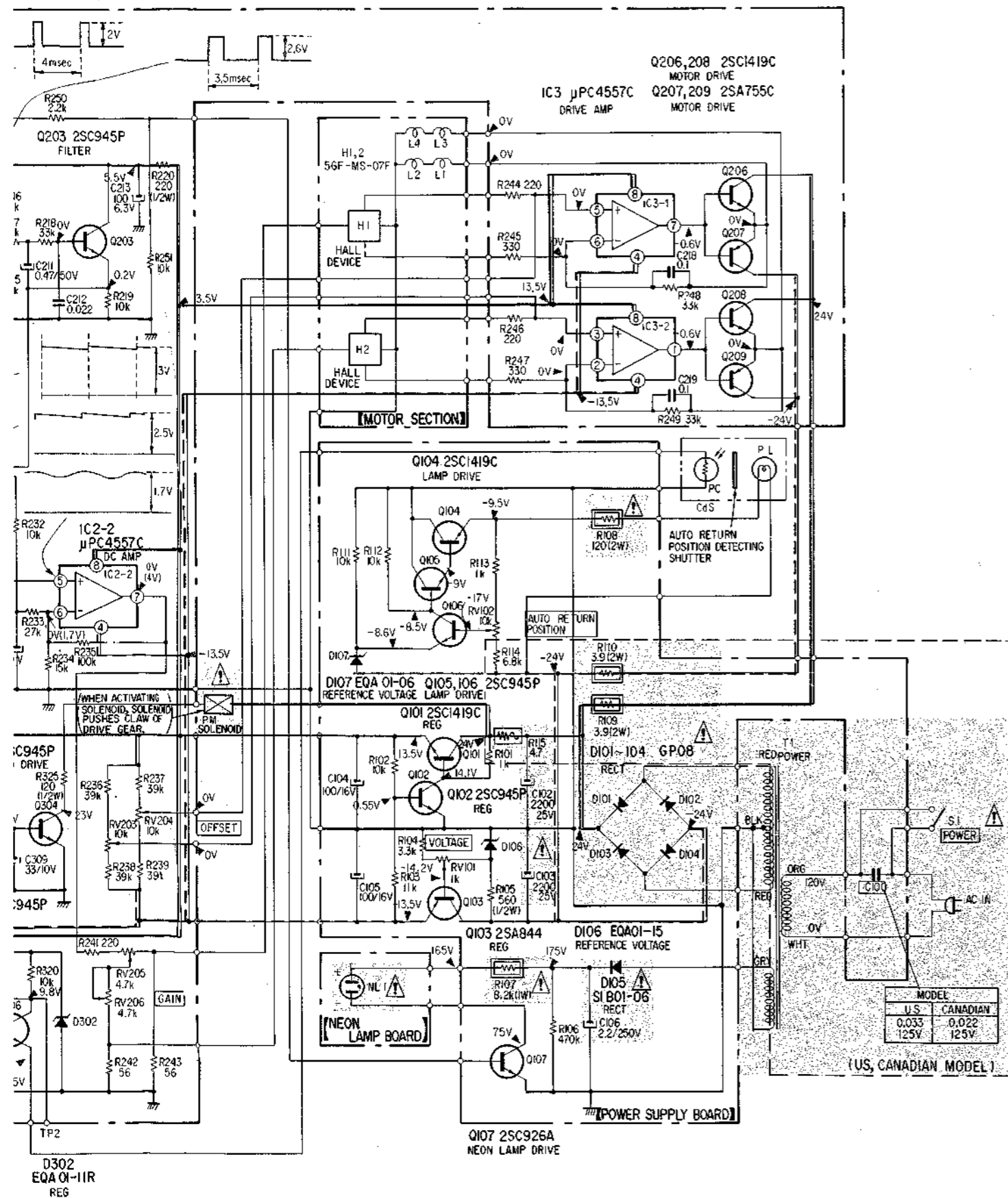

- All capacitors are in  $\mu$ F unless otherwise noted. pF :  $\mu$ F
  - All resistors are in ohms,  $\frac{1}{4}$  W unless otherwise noted. k $\Omega$  : 1000  $\Omega$ ; M $\Omega$  : 1000 k $\Omega$
  - : nonflammable resistor.
  - : fusible resistor.
  - : panel designation.
  - : adjustment for repair.
  - All variable and adjustable resistors have characteristic curve B, unless otherwise noted.
  - : B + bus.
  - : B - bus.
  - Reading are taken with a VOM (20 k $\Omega$ /V).
- No mark: With POWER switch (S1) set to on and tonearm on arm rest.  
 ( ) : With SPEED switch set to 33, POWER switch (S1) set to on, and tonearm on arm rest.

• Switch

Ref. No.	Switch	Position
S1	POWER	OFF
S2	SPEED 33	OFF
S3	SPEED 45	OFF
S4	START/STOP	OFF
S5	REJECT	OFF
S6	RETURN	OFF
S8	VOLTAGE SELECTOR (AEP, E model)	220V

Note: The components identified by shading and mark are critical for safety. Replace only with part number specified.

Note: Les composants identifiés par un trame et une marque sont critiques pour la sécurité. Ne les remplacer que par une pièce portant le numéro spécifié.

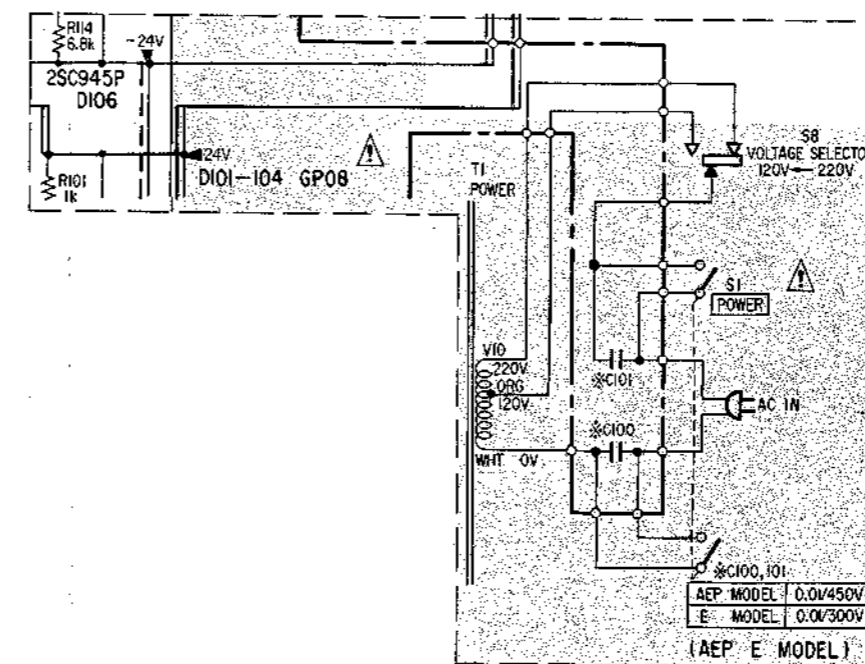

• Replacement Semiconductors

For replacement, use semiconductors except in ( ).

Q101, 104  
Q206, 209) 2SC1061(2SC1419C) D1-3: SLP24B

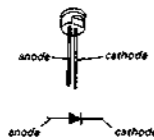
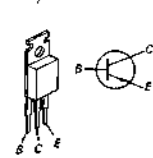

Q102, 105  
Q106, 201  
Q203-205  
Q210  
Q301-307) 2SC1364(2SC948P)

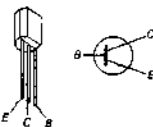

D101-104: 10E2(GP08)

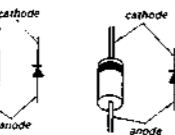

Q103: 2SA678(2SA844)

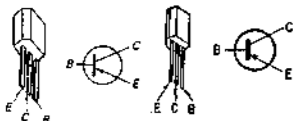

D105: 10D6(SIB01-06)

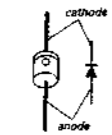

D106: EQB01-15(EQA01-15)  
D107: EQB01-06(EQA01-06)  
D302: EQB01-11Z(EQA01-11R)

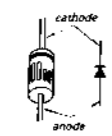

Q107: 2SC926A

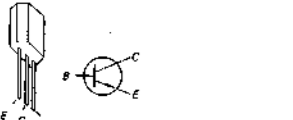

D201-203  
D301  
D303-305  
D307  
D308: RD4.3E(RD3.9E)

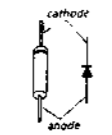

Q202: 2SA678(2SA733P)

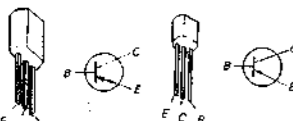

Q207, 209: 2SA671(2SA755C)

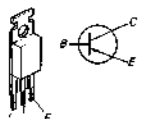

H1, 2: 5GF-MS-07F



IC1: CX193

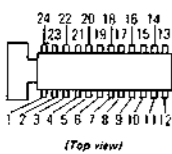

IC2, 3: μPC4557C

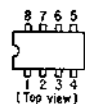

SECTION 5  
EXPLODED VIEWS

5-1.

5-2.

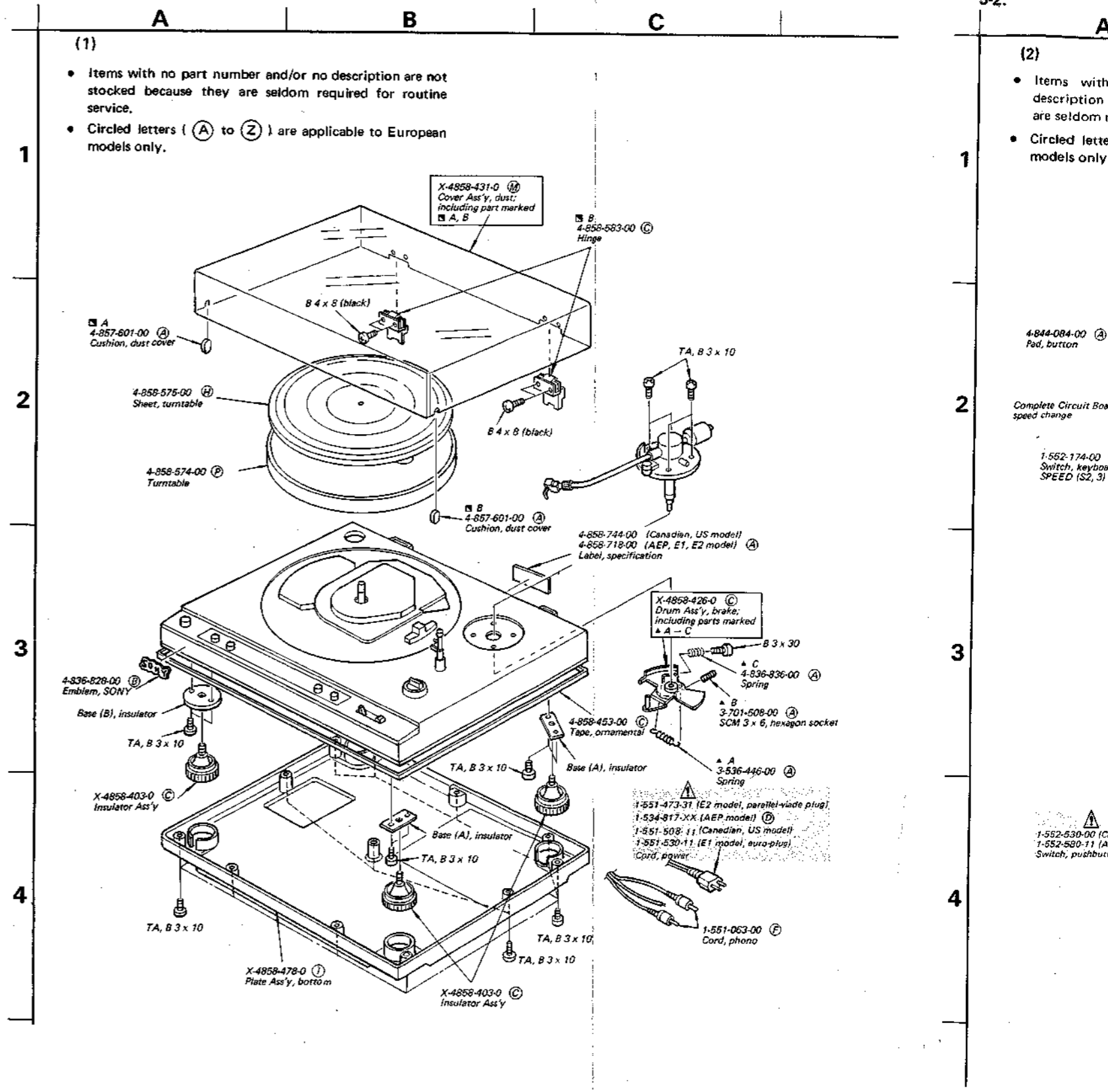

- (1)
- Items with no part number and/or no description are not stocked because they are seldom required for routine service.
  - Circled letters (A to Z) are applicable to European models only.

- (2)
- Items with description are seldom required.
  - Circled letter models only.

Note: The components identified by shading and mark **A** are critical for safety. Replace only with part number specified.

Note: Les composants identifiés par un trame et une marque **A** sont critiques pour la sécurité. Ne les remplacer que par une pièce portant le numéro spécifié.

Note: The **A** part





5-3.

A

B

C

D

(3)

- Items with no part number and/or no description are not stocked because they are seldom required for routine service.
- Circled letters (A) to (Z) are applicable to European models only.

1

2

3

4

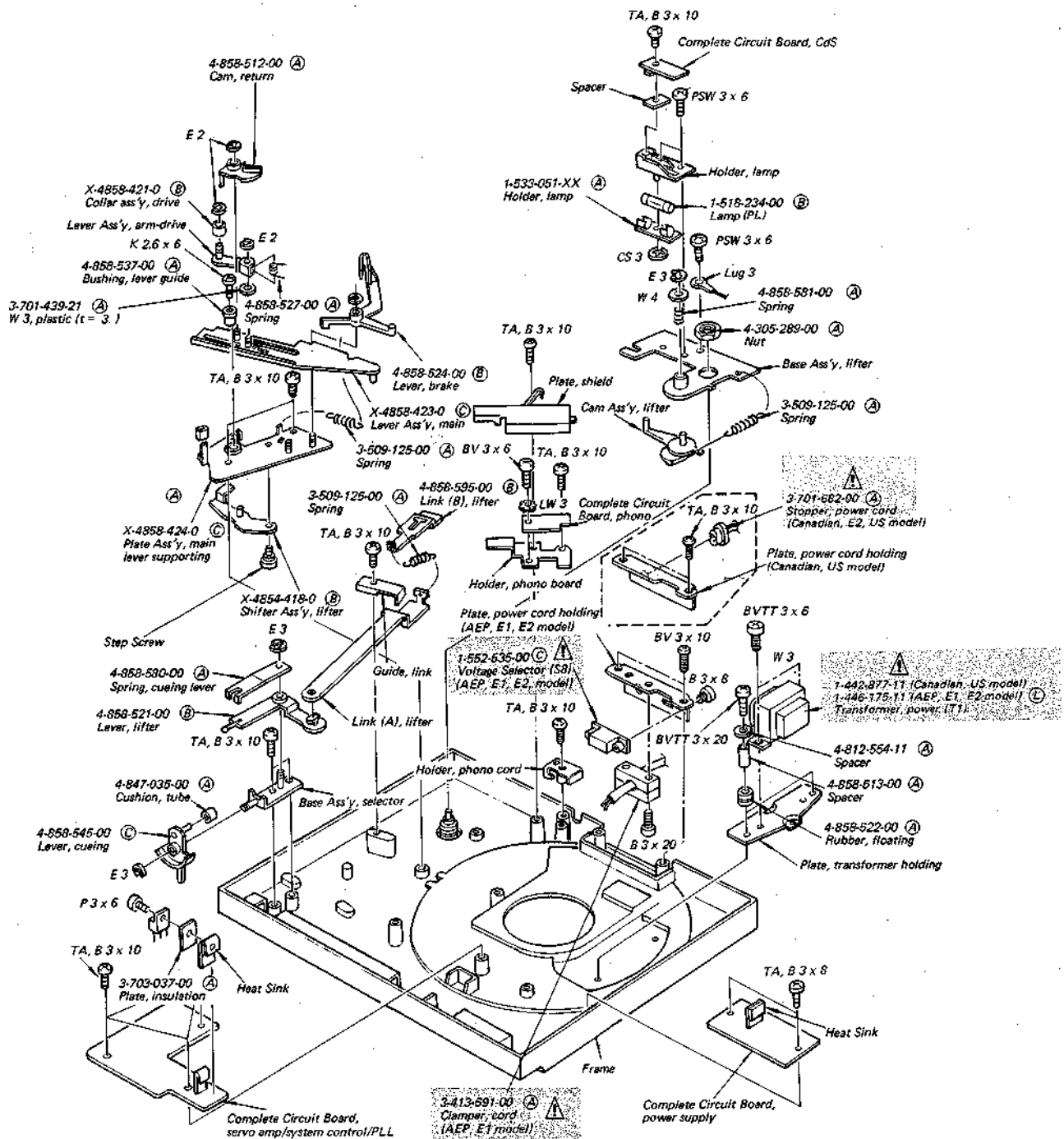

Note: The components identified by shading and mark  are critical for safety. Replace only with part number specified.

Note: Les composants identifiés par un tramé et une marque  sont critiques pour la sécurité. Ne les remplacer que par une pièce portant le numéro spécifié.

5-4.

A

B

C

D

(4)

- Items with no part number and/or no description are not stocked because they are seldom required for routine service.
- Circled letters (A to Z) are applicable to European models only.

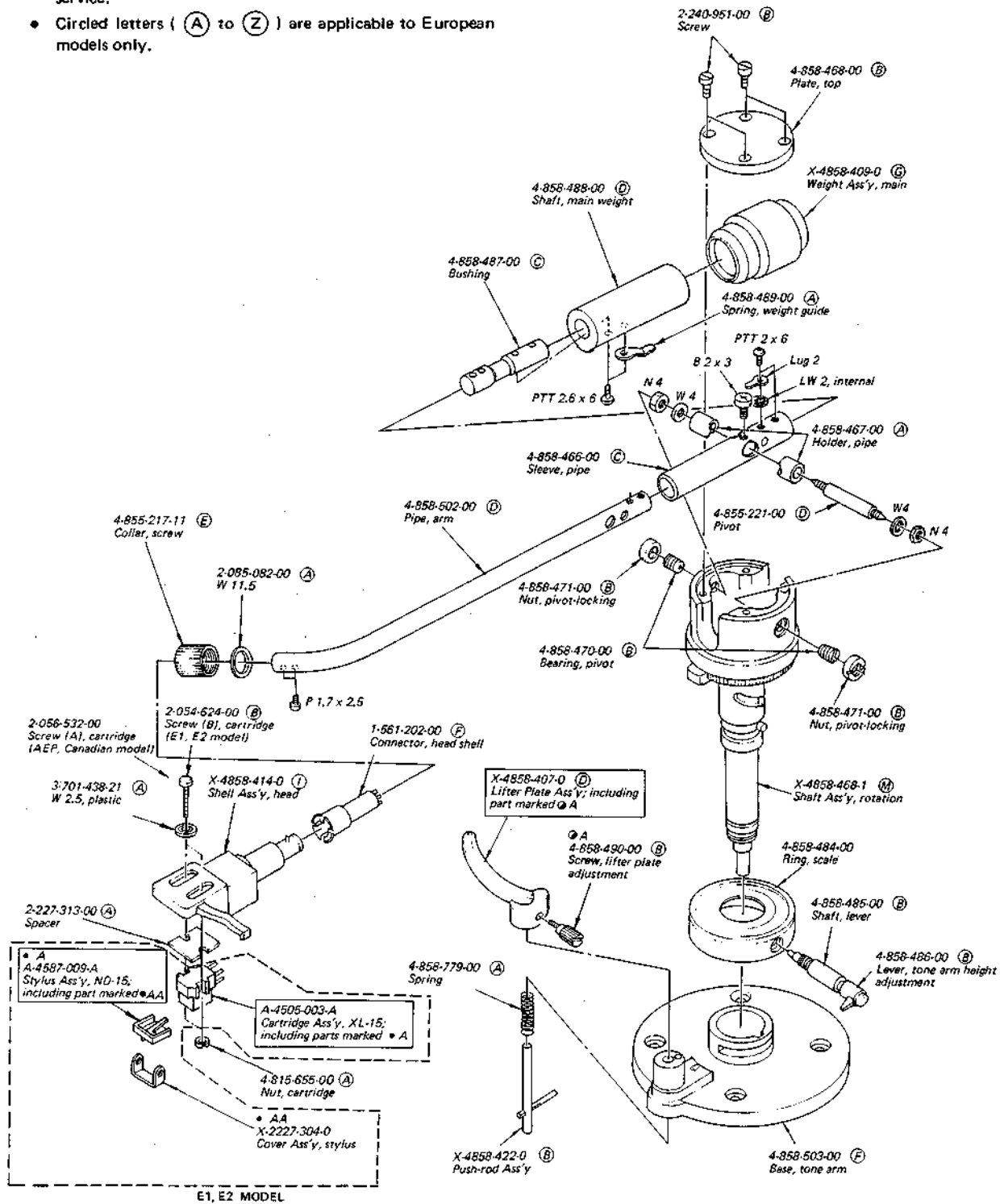

SECTION 6  
ELECTRICAL PARTS LIST

• Circled letters (A) to (Z) are applicable to European models only.

5. ELECTRICAL PARTS LIST

Ref. No.	Part No.	Description
<b>SEMICONDUCTORS</b>		
<b>Transistors</b>		
⇒ Q101	8-729-316-12	(D) 2SC1061
⇒ Q102	8-729-663-47	(B) 2SC1364
⇒ Q103	8-727-788-00	(B) 2SA678
⇒ Q104	8-729-316-12	(D) 2SC1061
⇒ Q105, 106	8-729-663-47	(B) 2SC1364
Q107	8-720-950-03	(C) 2SC926A
⇒ Q201	8-729-663-47	(B) 2SC1364
⇒ Q202	8-727-788-00	(B) 2SA678
⇒ Q203-205	8-729-663-47	(B) 2SC1364
⇒ Q206	8-729-316-12	(D) 2SC1061
⇒ Q207	8-729-317-12	(E) 2SA671
⇒ Q208	8-729-316-12	(D) 2SC1061
⇒ Q209	8-729-317-12	(E) 2SA671
⇒ Q210	8-729-663-47	(B) 2SC1364
⇒ Q301-307	8-729-663-47	(B) 2SC1364
<b>ICs</b>		
IC1	8-751-930-00	(K) CX193
IC2, 3	8-759-145-57	(C) μPC4557C
<b>Diodes</b>		
D1-3	8-719-900-24	(C) SLP24B
⇒ D101-104	8-719-200-02	(B) 10E2
⇒ D105	8-719-210-06	(B) 10D6
⇒ D106	8-719-931-15	(B) EQB01-15
⇒ D107	8-719-931-06	(B) EQB01-06
⇒ D201-203	8-719-815-55	(B) 1S1555
⇒ D301	8-719-815-55	(B) 1S1555
⇒ D302	8-719-930-11	(B) EQB01-11Z
⇒ D303-305	8-719-815-55	(B) 1S1555
⇒ D306	8-719-143-07	(B) RD4.3E
⇒ D307	8-719-815-55	(B) 1S1555
HI, H2	8-719-905-07	(D) 5GF-MS-07F
<b>TRANSFORMERS</b>		
T1	1-442-877-11	Transformer, power (Canadian, US model)
T1	1-446-175-11	(L) Transformer, power (AEP, E1, E2 model)

• ⇒ : Due to standardization, interchangeable replacements may be substituted for parts specified in the diagrams.

Ref. No.	Part No.	Description
<b>CAPACITORS</b>		
• All capacitors are in μF and ceramic unless otherwise noted. 50WV or less are not indicated except for electrolytics. p : μF, elect : electrolytic.		
C100	1-108-750-11	(A) 0.033 125V mylar (US model)
C100	1-130-098-00	(A) 0.022 125V polyethylene (Canadian model)
C100, 101	1-115-148-00	(C) 0.01 451V paper (AEP model)
C100, 101	1-108-779-00	(A) 0.01 300V polyethylene (E1/E2 model)
C102, 103	1-123-047-00	(B) 2200 32V elect
C104, 105	1-121-415-00	(A) 100 16V elect
C106	1-123-027-00	(B) 2.2 250V elect
C201	1-101-925-00	(A) 47,000p
C202	1-121-651-00	(A) 10 16V elect
C203	1-121-391-00	(A) 1 50V elect
C204	1-108-804-00	(A) 0.01 mylar
C205	1-108-360-00	(A) 0.039 mylar
C206	1-108-804-00	(A) 0.01 mylar
C207, 208	1-101-081-00	(A) 130p
C209	1-102-491-00	(A) 51p
C210	1-101-924-00	(A) 22,000p
C211	1-121-726-00	(A) 0.47 50V elect
C212	1-108-242-00	(A) 0.022 mylar
C213	1-121-413-00	(A) 100 6.3V elect
C214, 215	1-121-726-00	(A) 0.47 50V elect
C216	1-108-812-00	(A) 0.047 mylar
C217	1-121-726-00	(A) 0.47 50V elect
C218, 219	1-108-870-00	(A) 0.1 mylar
C220, 221	1-121-726-00	(A) 0.47 50V elect
C222	1-101-924-00	(A) 22,000p
C301	1-121-726-00	(A) 0.47 50V elect
C303	1-121-391-00	(A) 1 50V elect
C304	1-101-925-00	(A) 47,000p
C305	1-121-450-00	(A) 2.2 50V elect
C306	1-121-392-00	(A) 3.3 25V elect
C307	1-121-726-00	(A) 22 16V elect
C308	1-121-352-00	(A) 47 10V elect
C309	1-121-402-00	(A) 33 10V elect

Note: Les composants identifiés par un trame et une marque **A** sont critiques pour la sécurité. Ne les remplacer que par une pièce portant le numéro spécifié.

Note: The components identified by shading and mark **A** are critical for safety. Replace only with part number specified.

Ref. No. Part No. Description

Ref. No.	Part No.	Description
<b>RESISTORS</b>		
• All resistors are in ohms. Common 1/4 W carbon resistors are omitted. Refer to the list on the last page for their part numbers.		
All variable and adjustable resistors have characteristic curve B, unless otherwise noted.		
kΩ : 1000 Ω, MΩ : 1000 kΩ		
R105	1-244-867-00	(A) 560 1/2 W carbon
R107	1-213-154-00	(B) 8.2K 1 W metal oxide (nonflammable)
R108	1-206-642-00	(A) 120 2 W metal oxide (nonflammable)
R109, 110	1-212-948-00	(A) 3.9 1/2 W fusible (Canadian, US model)
R115	1-217-383-00	(B) 4.7 1/2 W fusible (Canadian, US model)
R220	1-244-857-00	(A) 220 1/2 W carbon
R325	1-244-851-00	(A) 120 1/2 W
RV101	1-244-631-00	(B) 1K adjustable VOLTAGE
RV102	1-244-645-XX	(B) 10K adjustable AUTO RETURN
RV201	1-224-636-00	(A) 47K adjustable SPEED
RV202	1-224-648-XX	(B) 100K adjustable SPEED
RV203, 204	1-224-645-XX	(B) 10K adjustable OFFSET
RV205, 206	1-224-633-00	(B) 4.7K adjustable GAIN
<b>SWITCHES</b>		
S1	1-552-530-00	(A) Push button, POWER (Canadian, US model)
S1	1-552-580-11	(C) Push button, POWER (AEP, E1, E2 model)
S2-5	1-552-174-00	(B) Keyboard, SPEED, START/STOP, REPEAT
S6	1-552-414-00	(B) Miniature, RETURN
S8	1-552-535-00	(C) Voltage Selector (AEP, E1, E2 model)
<b>MISCELLANEOUS</b>		
M	A-4608-058-A	(P) Motor Ass'y.
NL1	1-519-152-00	(B) Lamp, neon
HMG	1-534-123-00	(K) Head, speed detecting
PL	1-518-234-00	(B) Lamp 6V 100mA
PM	1-454-196-00	(B) Solenoid
X1	1-527-380-00	(C) Crystal 3932160Hz
	1-452-059-00	(B) Magnet
	1-533-051-XX	(A) Holder, lamp

Note: The components identified by shading and mark **A** are critical for safety. Replace only with part number specified.

• Circled letters (A) to (Z) are applicable to European models only.

1-534-817-XX	(D) Cord, power (AEP model)
1-551-063-00	(E) Cord, phone
1-551-473-31	(A) Cord, power (E2 model) (parallel-blade plug)
1-551-508-11	(A) Cord, power (Canadian, US model)
1-551-530-11	(A) Cord, power (E1 model) (euro plug)
1-561-202-00	(F) Connector, head shell
1-800-652-00	(C) CdS

ACCESSORIES & PACKING MATERIALS

Part No.	Description
A-4505-003-A	Cartridge Ass'y, XL-15 (E1, E2 model)
X-4858-409-0	(C) Weight Ass'y, main
X-4858-414-0	(I) Shell Ass'y, head
2-011-002-00	(A) Bag, plastic (AEP, Canadian model)
2-054-624-00	Screw (B), cartridge (E1, E2 model)
2-056-532-00	(B) Screw (A), cartridge (AEP, Canadian model)
2-224-081-00	(B) Screw (E), cartridge (AEP, Canadian model)
2-227-313-00	(A) Spacer
3-701-438-21	(A) W2.6, plastic (AEP, Canadian, US model)
3-701-613-00	(A) Bag, plastic (for extra weight)
3-701-616-00	(A) Bag, plastic (for shell, main weight)
3-701-630-00	(A) Bag, plastic
3-701-634-00	(A) Bag, plastic
3-701-806-00	(A) Adaptor, 45 rpm
3-770-541-11	Manual, instruction (AEP, E1, E2 model)
3-770-541-21	Manual, instruction (Canadian, US model)
3-794-265-11	Sheet, XL-15 (E1, E2 model)
3-794-288-31	Manual, instruction; French (Canadian model)
4-815-655-00	(A) Nut (A), cartridge
4-858-483-00	(C) Extra Weight
4-858-585-00	(C) Cushion, right
4-858-586-00	(C) Cushion, left
4-858-587-00	(B) Case, accessory
4-858-588-00	(C) Bag, protection
4-858-590-00	(C) Box, accessory
4-858-593-00	(A) Cushion, main weight shaft
4-858-734-00	(F) Carton

Note: Les composants identifiés par un trame et une marque **A** sont critiques pour la sécurité. Ne les remplacer que par une pièce portant le numéro spécifié.

1/4 WATT CARBON RESISTORS <sup>(A)</sup> Note: Circled letter (A) is applicable to European models only.

Ω	Part No.	Ω	Part No.	Ω	Part No.	Ω	Part No.	Ω	Part No.	Ω	Part No.	Ω	Part No.
1.0	1-246-401-00	10	1-246-425-00	100	1-246-449-00	1.0k	1-246-473-00	10k	1-246-497-00	100k	1-246-521-00	1.0M	1-246-545-00
1.1	1-246-402-00	11	1-246-426-00	110	1-246-450-00	1.1k	1-246-474-00	11k	1-246-498-00	110k	1-246-522-00	1.1M	1-210-814-00
1.2	1-246-403-00	12	1-246-427-00	120	1-246-451-00	1.2k	1-246-475-00	12k	1-246-499-00	120k	1-246-523-00	1.2M	1-210-815-00
1.3	1-246-404-00	13	1-246-428-00	130	1-246-452-00	1.3k	1-246-476-00	13k	1-246-500-00	130k	1-246-524-00	1.3M	1-210-816-00
1.5	1-246-405-00	15	1-246-429-00	150	1-246-453-00	1.5k	1-246-477-00	15k	1-246-501-00	150k	1-246-525-00	1.5M	1-210-817-00
1.6	1-246-406-00	16	1-246-430-00	160	1-246-454-00	1.6k	1-246-478-00	16k	1-246-502-00	160k	1-246-526-00	1.6M	1-210-818-00
1.8	1-246-407-00	18	1-246-431-00	180	1-246-455-00	1.8k	1-246-479-00	18k	1-246-503-00	180k	1-246-527-00	1.8M	1-210-819-00
2.0	1-246-408-00	20	1-246-432-00	200	1-246-456-00	2.0k	1-246-480-00	20k	1-246-504-00	200k	1-246-528-00	2.0M	1-210-820-00
2.2	1-246-409-00	22	1-246-433-00	220	1-246-457-00	2.2k	1-246-481-00	22k	1-246-505-00	220k	1-246-529-00	2.2M	1-210-821-00
2.4	1-246-410-00	24	1-246-434-00	240	1-246-458-00	2.4k	1-246-482-00	24k	1-246-506-00	240k	1-246-530-00	2.4M	1-244-754-00
2.7	1-246-411-00	27	1-246-435-00	270	1-246-459-00	2.7k	1-246-483-00	27k	1-246-507-00	270k	1-246-531-00	2.7M	1-244-755-00
3.0	1-246-412-00	30	1-246-436-00	300	1-246-460-00	3.0k	1-246-484-00	30k	1-246-508-00	300k	1-246-532-00	3.0M	1-244-756-00
3.3	1-246-413-00	33	1-246-437-00	330	1-246-461-00	3.3k	1-246-485-00	33k	1-246-509-00	330k	1-246-533-00	3.3M	1-244-757-00
3.6	1-246-414-00	36	1-246-438-00	360	1-246-462-00	3.6k	1-246-486-00	36k	1-246-510-00	360k	1-246-534-00	3.6M	1-244-758-00
3.9	1-246-415-00	39	1-246-439-00	390	1-246-463-00	3.9k	1-246-487-00	39k	1-246-511-00	390k	1-246-535-00	3.9M	1-244-759-00
4.3	1-246-416-00	43	1-246-440-00	430	1-246-464-00	4.3k	1-246-488-00	43k	1-246-512-00	430k	1-246-536-00	4.3M	1-244-760-00
4.7	1-246-417-00	47	1-246-441-00	470	1-246-465-00	4.7k	1-246-489-00	47k	1-246-513-00	470k	1-246-537-00	4.7M	1-244-761-00
5.1	1-246-418-00	51	1-246-442-00	510	1-246-466-00	5.1k	1-246-490-00	51k	1-246-514-00	510k	1-246-538-00	5.1M	1-244-762-00
5.6	1-246-419-00	56	1-246-443-00	560	1-246-467-00	5.6k	1-246-491-00	56k	1-246-515-00	560k	1-246-539-00		
6.2	1-246-420-00	62	1-246-444-00	620	1-246-468-00	6.2k	1-246-492-00	62k	1-246-516-00	620k	1-246-540-00		
6.8	1-246-421-00	68	1-246-445-00	680	1-246-469-00	6.8k	1-246-493-00	68k	1-246-517-00	680k	1-246-541-00		
7.5	1-246-422-00	75	1-246-446-00	750	1-246-470-00	7.5k	1-246-494-00	75k	1-246-518-00	750k	1-246-542-00		
8.2	1-246-423-00	82	1-246-447-00	820	1-246-471-00	8.2k	1-246-495-00	82k	1-246-519-00	820k	1-246-543-00		
9.1	1-246-424-00	91	1-246-448-00	910	1-246-472-00	9.1k	1-246-496-00	91k	1-246-520-00	910k	1-246-544-00		

HARDWARE NOMENCLATURE

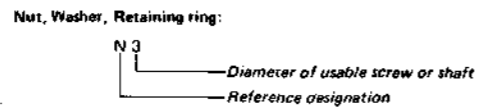
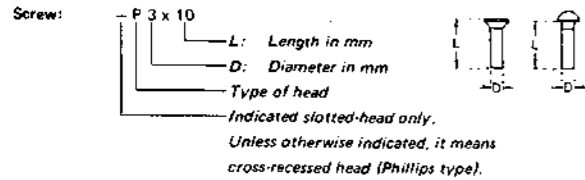

Reference Designation	Shape	Description	Remarks
SCREWS			
P		pan-head screw	binding-head (B) screw for replacement
PWH		pan-head screw with washer face	binding-head (B) screw and flat washer for replacement
PS PSP		pan-head screw with spring washer	binding-head (B) screw and spring washer for replacement
PSW PSPW		pan-head screw with spring and flat washers	binding-head (B) screw and spring and flat washers for replacement
R		round-head screw	binding-head (B) screw for replacement
K		flat-countersunk-head screw	
RK		oval-countersunk-head screw	
B		binding-head screw	
T		truss-head screw	binding-head (B) screw for replacement
F		flat-filister-head screw	
RF		filister-head screw	
BV		brazer-head screw	

Reference Designation	Shape	Description	Remarks
SELF-TAPPING SCREWS			
TA		self-tapping screw	ex: TA, P 3 x 10
PTP		pan-head self-tapping screw	binding-head self-tapping (TA, B) screw for replacement
PTPWH		pan-head self-tapping screw with washer face	binding-head self-tapping (TA, B) screw and flat washer for replacement
PTTWH		pan-head thread-rolling screw with washer face	binding-head (B) screw and flat washer for replacement
SET SCREWS			
SC		set screw	
SC		hexagon-socket set screw	ex: SC 2.6 x 4, hexagon socket
NUT			
N		nut	
WASHERS			
W		flat washer	
SW		spring washer	
LW		internal-tooth lock washer	ex: LW3, internal
LW		external-tooth lock washer	ex: LW3, external
RETAINING RINGS			
E		retaining ring	
G		grip-type retaining ring	