

PS-T30

*AEP Model
E Model
Canadian Model*



STEREO TURNTABLE SYSTEM

SPECIFICATIONS

GENERAL

Power Requirements: 120 or 220 V ac adjustable, 50/60 Hz (AEP, E model)
120 V ac, 60 Hz (Canadian model)

Power Consumption: 8 W (AEP, E model)
6 W (Canadian model)

Dimensions: Approx. 445 (w) x 145 (h) x 400 (d) mm
17 1/2 (w) x 5 3/4 (h) x 15 3/4 (d) inches
including projecting parts and controls

Weight: Approx. 7 kg, 15 lb 6 oz (net)
8.4 kg, 18 lb 8 oz (in shipping carton)

TURNTABLE

Platter: 31.3 cm, 12 5/16 inches dia., aluminum-alloy diecast

Motor: Linear BSL (brushless and slotless) motor

Drive System: Direct drive

Speeds: 33 1/3 rpm, 45 rpm

Pitch Control Range: ± 4 %

Wow and Flutter: ± 0.05 % (DIN)
0.03 % (WRMS)

S/N Ratio: 70 dB (DIN-B)

Automatic System: Lead-in, return, reject, repeat

— Continued on the next page —

ATTENTION AU COMPOSANT AYANT RAPPORT
À LA SÉCURITÉ !

LES COMPOSANTS IDENTIFIÉS PAR UN TRAMÉ ET
UNE MARQUE  SUR LES DIAGRAMMES SCHÉ-
MATIQUES, LES VUES EXPLOSÉES ET LA LISTE
DES PIÈCES SONT CRITIQUES POUR LA SÉCURITÉ
DE FONCTIONNEMENT. NE REMPLACER CES
COMPOSANTS QUE PAR DES PIÈCES SONY DONT
LES NUMÉROS SONT DONNÉS DANS CE MANUEL
OU DES SUPPLÉMENTS PUBLIÉS PAR SONY.

SAFETY-RELATED COMPONENT WARNING !!
COMPONENTS IDENTIFIED BY SHADING AND MARK
 ON THE SCHEMATIC DIAGRAMS, EXPLODED
VIEWS AND IN THE PARTS LIST ARE CRITICAL TO
SAFE OPERATION. REPLACE THESE COMPONENTS
WITH SONY PARTS WHOSE PART NUMBERS APPEAR
AS SHOWN IN THIS MANUAL OR IN SUPPLEMENTS
PUBLISHED BY SONY.

SONY[®]
SERVICE MANUAL

PS-T30

TONEARM

Type: Statically balanced, universal
Arm Length: 300 mm, 11 $\frac{7}{8}$ inches, overall
216.5 mm, 8 $\frac{1}{2}$ inches, pivot-to-stylus
Overhang: 16.5 mm, $\frac{3}{4}$ inches
Tracking Error: +3°, -1°
Tracking-force
Adjustment Range: 0-3 g
Shell Weight: 7.5 g
Cartridge Weight Range: 12 - 19 g
(with head shell)

MODEL IDENTIFICATION

- Specification Label -

Canadian model

SONY [®]	STEREO TURNTABLE SYSTEM
	MODEL NO, PS-T30
	AC 120V 60Hz 6W
	SERIAL NO. _____
	MADE IN JAPAN

AEP, E model

SONY [®]	STEREO TURNTABLE SYSTEM
	MODEL NO, PS-T30
	~120, 220V 50/60Hz 8W
	SERIAL NO. _____
	MADE IN JAPAN



1-2. CIRCUIT DESCRIPTION (See Fig. 1-5)

Motor Servo System is explained in Block Diagram Fig. 1-1.

Apply the voltage V_i to the motor coil to rotate at a given speed ω , soon the motor reaches the speed ω .

When any change occurs in the rotational speed, a detector reads the amount of the error and the feedback circuit produces the voltage V_f required to correct the speed, returning V_f to the input.

Servo System works to keep the speed constant by adding or subtracting a voltage change V_f of the output to the input V_i .

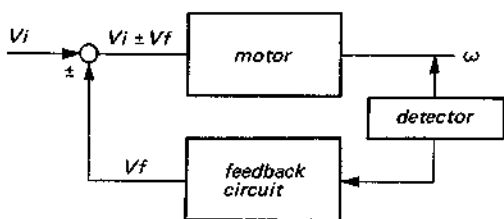

Fig. 1-1

The servo motor employs the frequency generator (FG) as a detector and the feedback circuit as shown in Fig. 1-2.

The signal voltage generated in FG is fed to the limiter amplifier to eliminate the voltage fluctuation, and in the next stage of the frequency discriminator the variation of the frequency is converted into the voltage proportioned to the rotational speed.

This voltage is rectified, amplified by DC amplifier and supplied to the motor.

The reference frequencies detected by the multi-gap head (MGH) are 284Hz at 33rpm and 384Hz at 45 rpm.

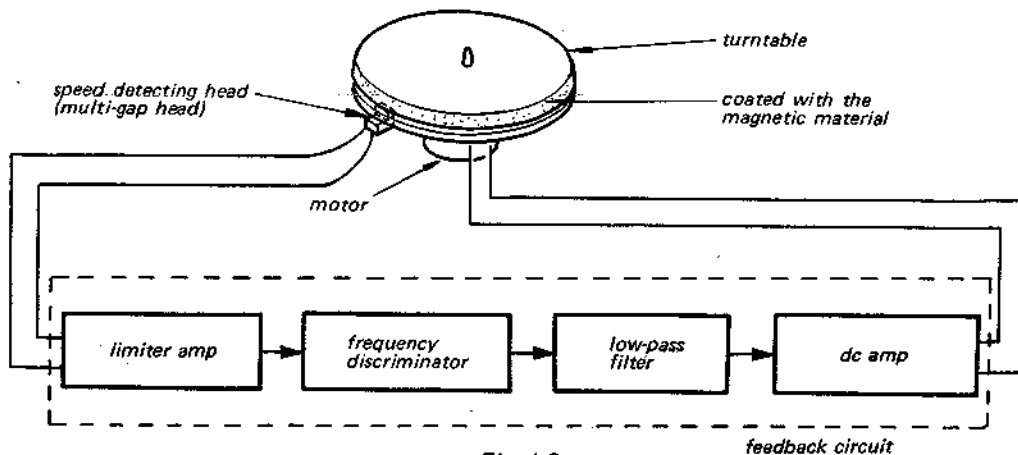

Fig. 1-2

Limiter IC1-1

1. Once the turntable starts to rotate, an output signal is produced by the MG head.
2. Although the MG head output signal is a sine wave, there is some fluctuation in amplitude. Therefore, above a certain level, this sine wave is changed into a constant-amplitude square wave.

Q101

Q101 amplifies the output signal from IC1-1 and converts it into a square wave by clipping.

Differential Circuit C102, R103

The square wave signal on the collector of Q101 is changed to a triangular wave by C102 and R103. The differentiated (triangular) pulse triggers the sawtooth wave generator transistor (Q102).

Sawtooth Wave Generator Circuit Q102, C103

While Q102 is turned off, C103 is charged up through R104. When the positive trigger pulse is applied to the base of Q102, Q102 turns on and then C103 discharges instantly through Q102.

After discharging, C103 is recharged, resulting in the Q103 base forming a sawtooth wave signal.

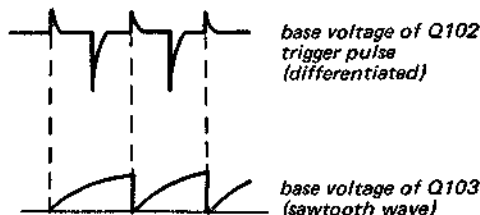

Fig. 1-3

Comparator Q103, Q104

The sawtooth wave signal is applied to the comparator circuit formed by Q103 and Q104.

The base of Q104 is biased by the bleeder resistors RV302, R301, RV301 (RV303, R302, RV301) and R107. Since, the emitter voltage of Q103 is determined by the reference voltage, Q103 will turn on when its base voltage (sawtooth wave) exceeds the total voltage (emitter voltage plus V_{BE}).

Then, a negative pulse will appear on the collector of Q103. Consequently, if the rotational speed slows down, the frequency of the sawtooth wave will be low.

When the output negative pulse width increases, the period of the time Q103 turns on becomes long.

Buffer Amp Q105

Q105 serves as a phase converter which feeds the positive pulse signal to the next stage.

Integrator (Low-pass Filter)

The low-pass filter (composed of R109, R110, R111, C104, C105 and C106) serves as an integrator which converts the pulse signal into dc voltage in proportion to the pulse width.

IC1-2

IC1-2 is also the low-pass filter and amplifies dc voltage.

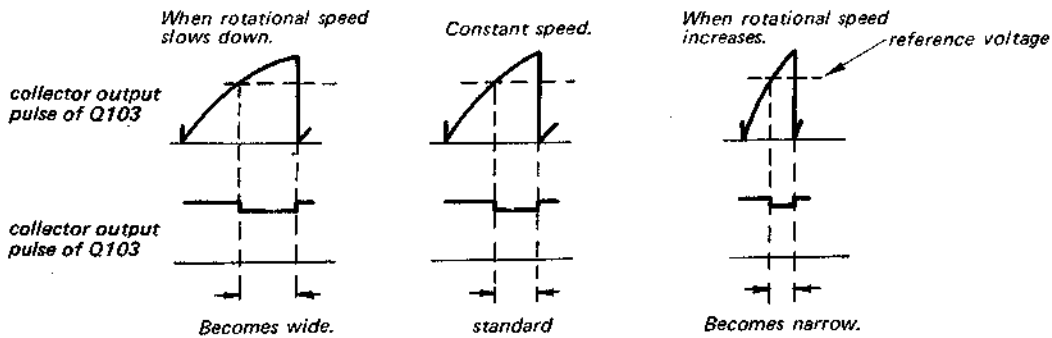

Fig. 1-4

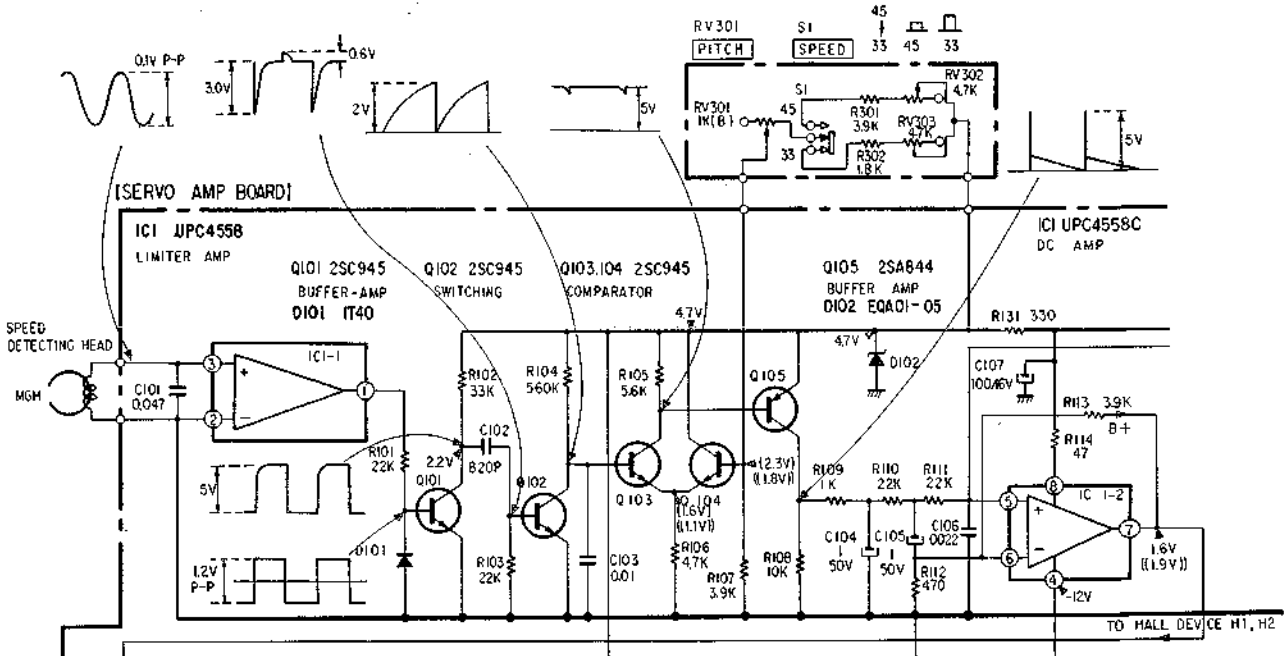

Fig. 1-5

SPEED Control

1. The selection of the speed 33/45 rpm can be done by turning the switch S1 which selects the value of the bleeder resistor connected to the base of Q104.
2. Since the base voltage of Q104 at 33 rpm is designed higher than the one at 45 rpm, the emitter voltage of Q104 at 33 rpm is higher than the one at 45 rpm.
3. When the switch S1 is changed to the speed 45 rpm from 33 rpm, the pulse width on the collector of Q103 becomes wide as illustrated in Fig. 1-6.

Therefore, DC voltage obtained through the low-pass filter rises and the motor speed increases.

Finally, the motor reaches the speed of 45 rpm and keeps the constant speed of 45 rpm.

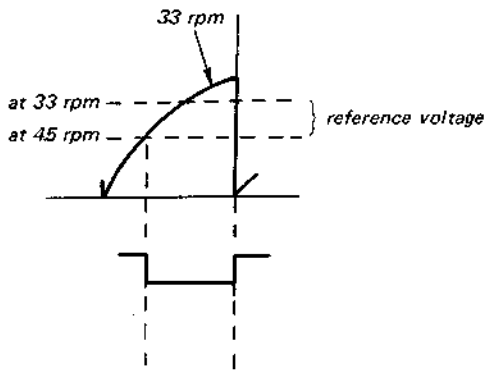

Fig. 1-6

Servo System

Any change in the rotational speed of the motor can be corrected in the servo circuit and the motor speed is kept constant.

The servo system works as follows.

1. When the speed of the motor slows down, the frequency of the signal generated by the speed detecting head (multi-gap head) becomes low and the pulse width obtained from the comparator becomes wide.
2. Consequently, dc voltage through the low-pass filter increases, the motor speed increases and reaches the given speed.

Hall Motor

This model is equipped with the newly developed BSL (brush and slotless) dc servo motor, which has the following major advantages.

- Extremely uniform torque.
- All-electronic switching (no mechanical contacts used at all), resulting very little noise.
- Extremely stable performance, and long operational life.

1. Hall Element

The magnetic field strength is converted into electrical signals by employing the Hall Effect.

Hall Effect: When a metal strip is placed with its plane perpendicular to a magnetic field and an electric current flows longitudinally through the strip, a potential difference is developed across the strip at right angles to the current flow and to the magnetic field.

The potential is proportional to amounts of the current and a strength of the magnetic field.

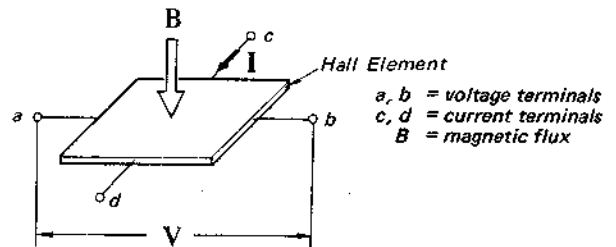

Fig. 1-7

When the N pole approaches. When the S pole approaches.

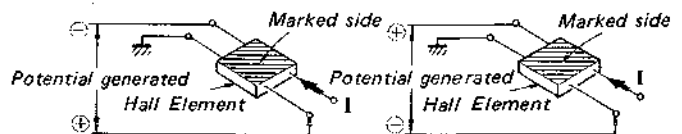

Fig. 1-8

2. Exploded View

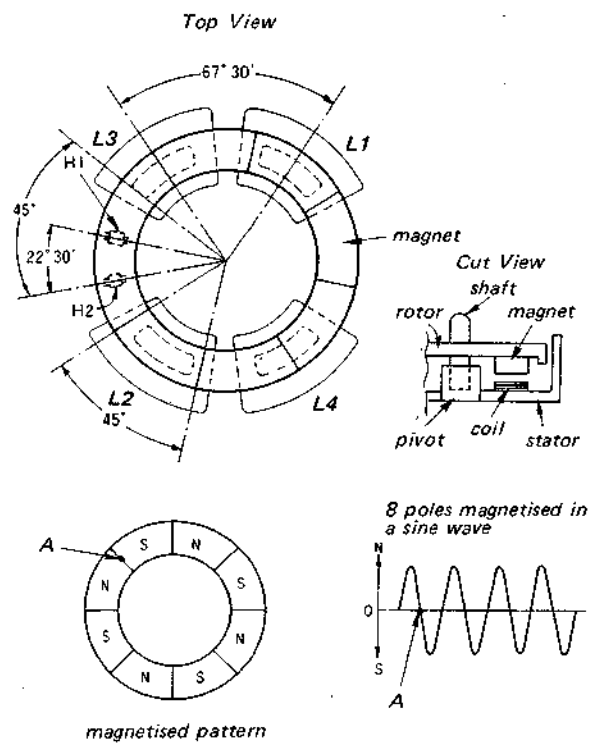

Fig. 1-9

- The motor coils L1 and L2 (L3 and L4) form a pair, in series.
- In order to change the phase of two signals by 90°, Hall elements H1 and H2 are positioned 22°30' apart.
- In order to change the phase of two signals fed to L1 and L3 (L2 and L4) by 90°, coils are positioned at 67°30' apart.
- The center angle of the coil is 45° so that the coil can face the magnets of which 8 poles are positioned every 45° apart.
- The angle between the Hall Element and the coil is 45° so that the flux peak of the coil comes to the flux peak of the magnet.

3. Generation of Rotational Force

According to the Fleming's left-hand rule, the force generated in the motor coil is in the counterclockwise direction, but since the coils are fixed so that the magnet (rotor) rotates clockwise.

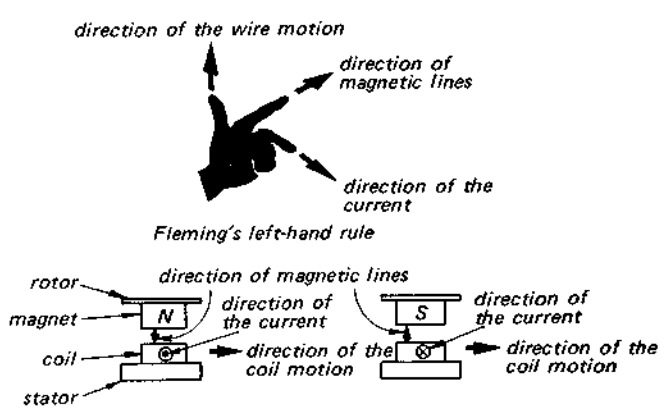

Fig. 1-10

When the Hall Element H2 faces the N pole of the magnet, H2 generates voltage. The voltage is amplified by IC2-2 and fed to Q108, which also amplifies and supplies the current in L3 and L4. The coils (L3 and L4) produce the magnetic field that creates the rotational force of the rotor.

When the Hall element H1 faces the N pole, the current flows in L1 and L2, and the rotor rotates in the direction shown by the arrow.

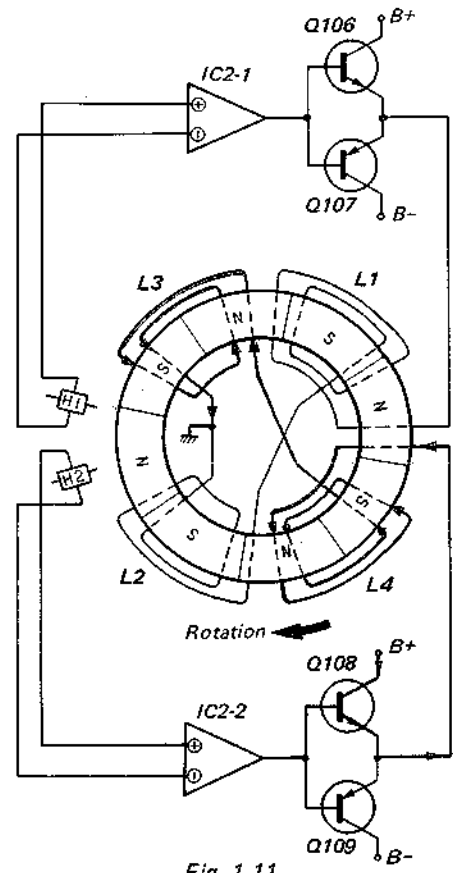

Fig. 1-11

Likewise, when the Hall Element H2 faces the S pole, the current flows in L3 and L4. The rotor rotates in the direction shown by the arrow.

When the Hall element H1 faces the S pole, the current flows in L1 and L2, and the rotor is also forced to rotate in the same direction.

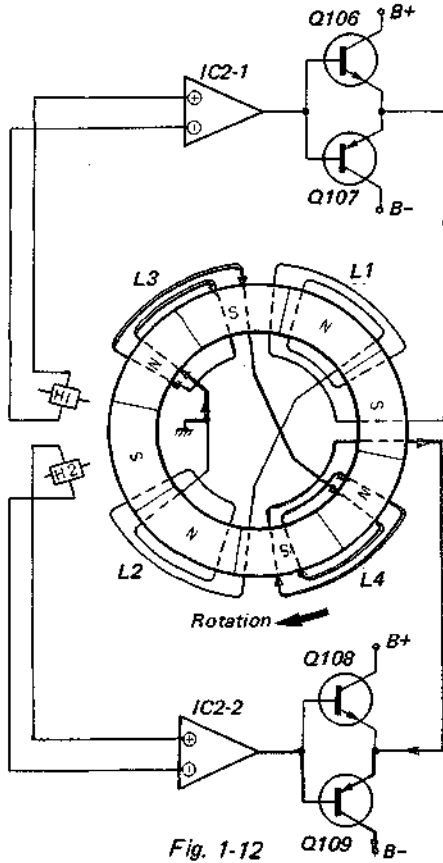

Fig. 1-12

Hence, N and S poles are repeatedly positioned oppositely to the Hall Elements H1 and H2 every $22^{\circ}30'$ of a rotation, thereby generating the voltages in these elements and resulting in the production of a current in the motor coils, and subsequent rotation of the motor.

The phase relationship between coils L1, L2 and L3, L4 are as follows:

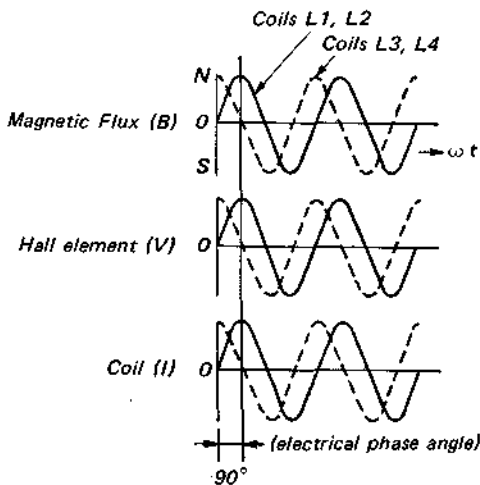

Fig. 1-13

4. Torque

A motor torque is proportional to a strength of magnetic flux (B) and amounts of current which flows in coils.

$$\text{Therefore, } F = B I$$

When the rotor which is magnetized in a sine wave pattern rotates, the Hall elements detect the variation of the magnetic flux ($B_1 = B_0 \sin \omega t$).

This controlled current ($I_1 = I_0 \sin \omega t$) is supplied to one coil.

On the other hand, the current, which leads the phase angle by 90° , is supplied to the other coil. Thus, $B_2 = B_0 \sin (\omega t + 90^{\circ}) = B_0 \cos \omega t$.

$$I_2 = I_0 \sin (\omega t + 90^{\circ}) = I_0 \cos \omega t$$

And, when both torques ($F_1 = B_1 I_1, F_2 = B_2 I_2$) are produced simultaneously, their combined torque is constant as shown by the following formula.

$$\begin{aligned} F &= F_1 + F_2 \\ &= B_1 I_1 + B_2 I_2 \\ &= B_0 I_0 \sin^2 \omega t + B_0 I_0 \cos^2 \omega t \\ &= B_0 I_0 (\sin^2 \omega t + \cos^2 \omega t) \\ &= B_0 I_0 \text{ constant} \end{aligned}$$

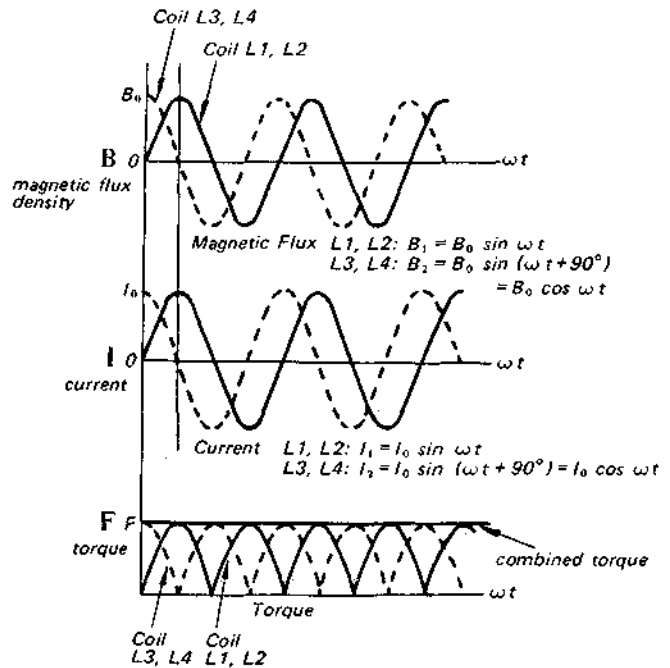

Accordingly, it can be said that this motor is theoretically a linear-drive motor with no torque fluctuations.

Fig. 1-14

System Control Circuit

1. START Operation (See Fig. 1-15)

- a. When the START/STOP switch (S2) is pushed, Q110, Q111 and Q112 conduct for a moment. This turns Q113 off and the solenoid (PM) on.
- b. A positive voltage is applied to the terminal ⑤ of IC1-2 by off-state of Q113 and the turntable starts rotating.

- c. The center gear is engaged with the pawl of drive gear by means of the solenoid (PM), and the drive gear starts rotating. (The tonearm moves toward the lead-in groove of the record.)
- d. The stop switch (S3) is mechanically pushed when the drive gear rotates, and Q113 does not conduct while the tonearm is not on the tonearm rest. Accordingly, the turntable keeps on rotating.

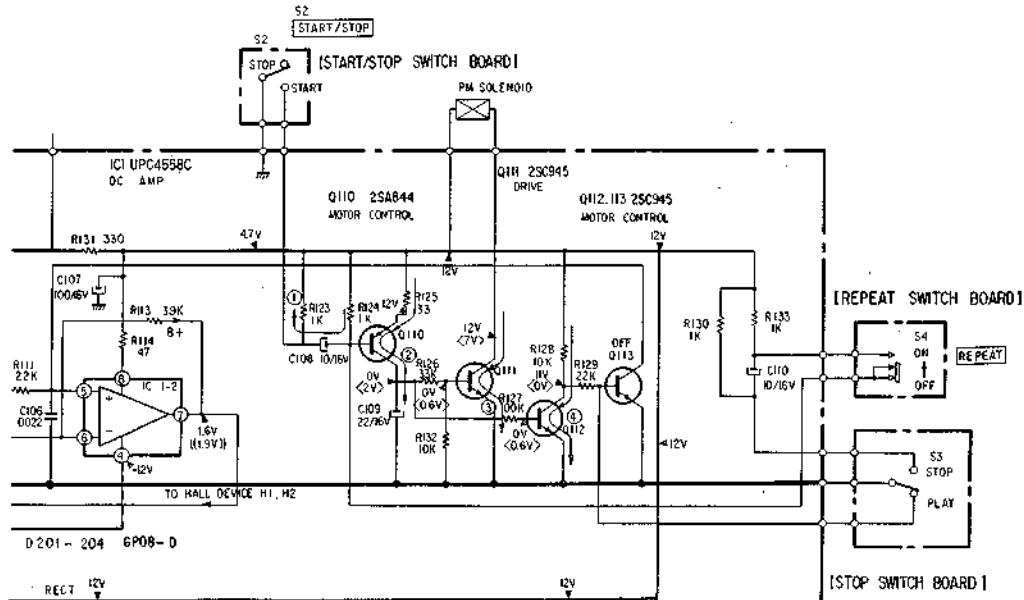

Fig. 1-15

2. STOP Operation (See Fig. 1-16)

- a. When the START/STOP switch (S2) is pushed during play, Q110 and Q111 conduct for a moment. This activates the solenoid (PM).
- b. The center gear is engaged with the pawl of drive gear by means of the solenoid, and

- c. When the drive gear stops rotating, the stop switch (S3) mechanically returns to the original position, and Q113 conducts.
- d. The terminal ⑤ of IC1-2 is grounded via Q113 and the turntable stops rotating.

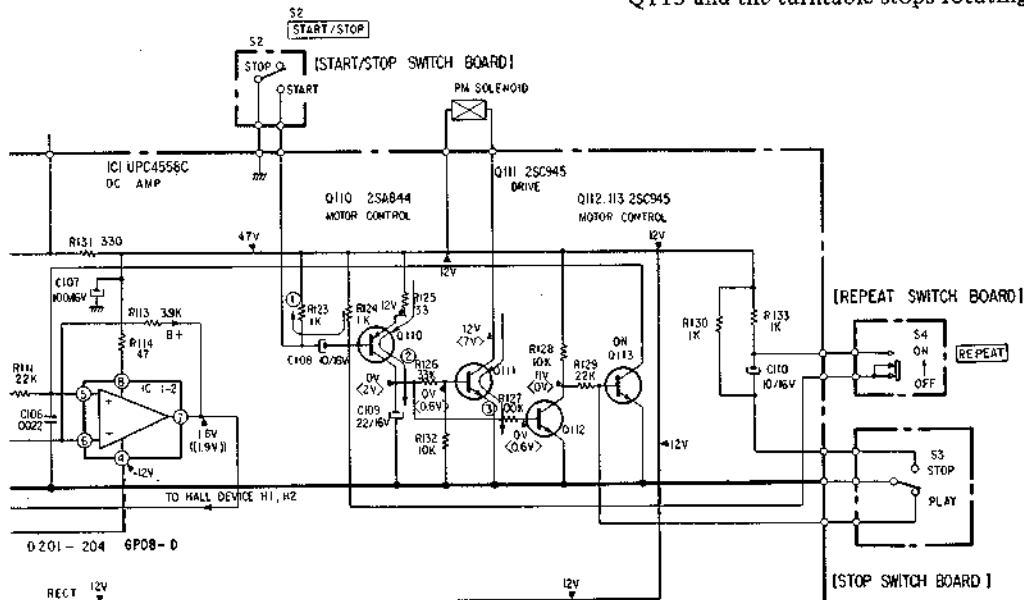

Fig. 1-16

3. REPEAT Operation (See Fig. 1-17)

- a. When the tonearm enters the out-of groove of the record, the drive gear rotates and the unit starts the return operation.
- b. The stop switch (S3) mechanically returns to the original (stop) position when the unit ends the return operation.
- c. Q110, Q111 and Q112 conduct, if the REPEAT switch (S4) is pressed. The solenoid (PM) is activated by on-state of Q111.
- d. The base voltage of Q113 is grounded through Q112 and Q113 does not conduct.
- e. A positive voltage is applied to the terminal ⑤ of IC1-2, and the turntable keeps on rotating.

- f. The center gear is engaged with the pawl of drive gear by the solenoid (PM), and the drive gear starts rotating. (The tonearm moves toward the lead-in groove of the record.)
- g. When the drive gear rotates, the stop switch (S3) is mechanically pushed and Q113 does not conduct while the tonearm is not on the tonearm rest.
- h. While the REPEAT switch (S4) is pushed, the unit repeats the play as described in procedures a to g.
- i. The unit stops the repeat operation when the REPEAT switch (S4) is released.

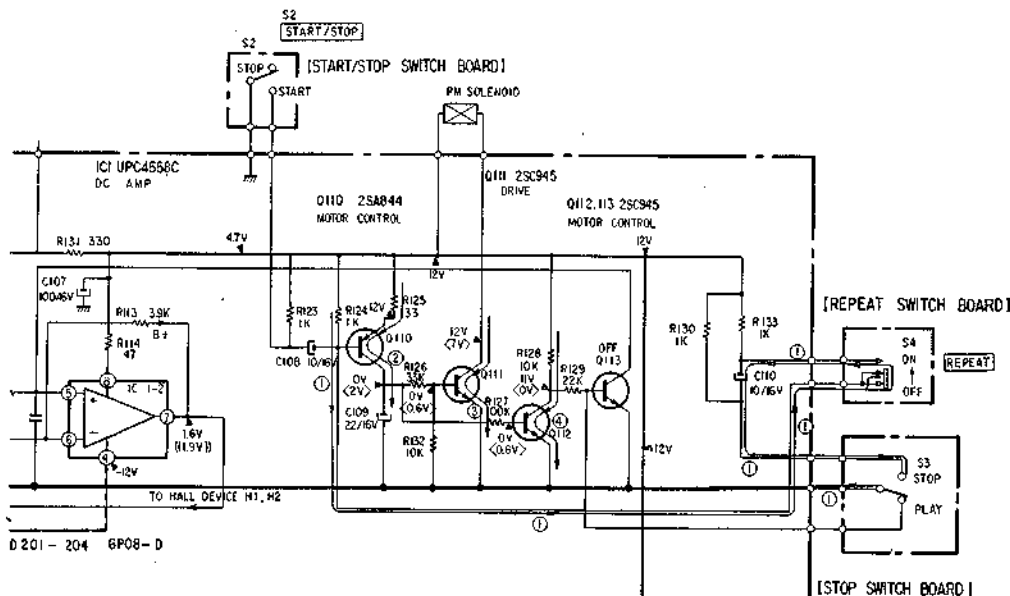
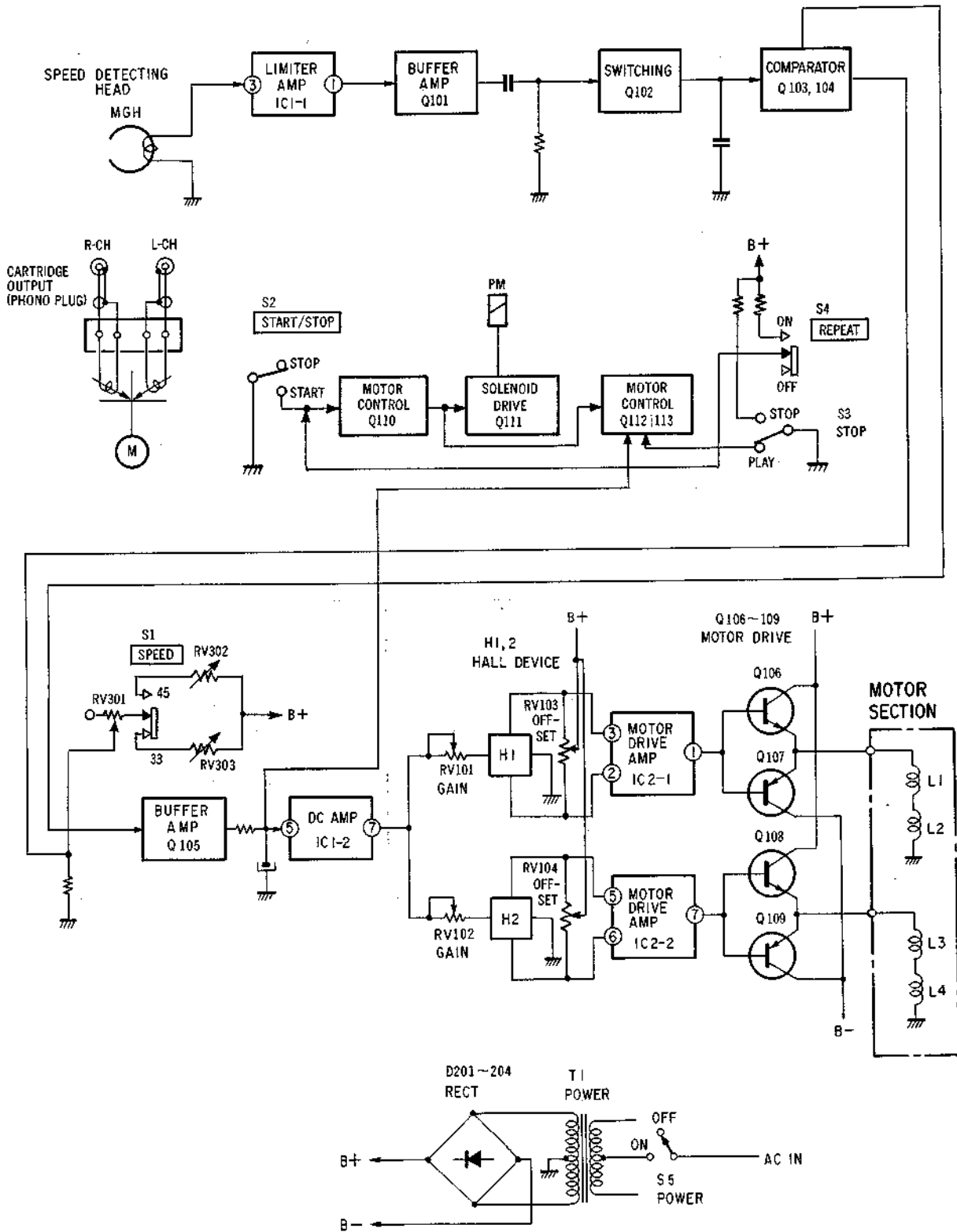

Fig. 1-17

1-2. BLOCK DIAGRAM



SECTION 2 DISASSEMBLY

2-1. REMOVAL

- Follow the disassembly procedure in the numerical order given.

DUST COVER REMOVAL

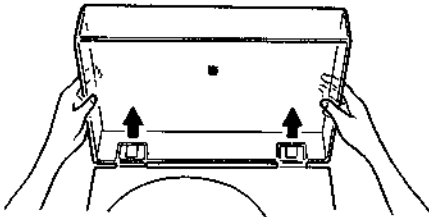

Fig. 2-1

BOTTOM COVER REMOVAL

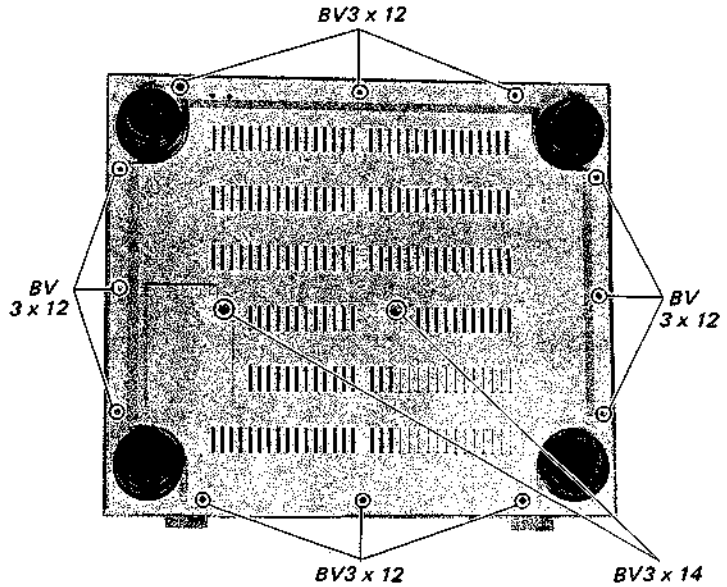

Fig. 2-4

TURNTABLE AND UPPER COVER REMOVAL

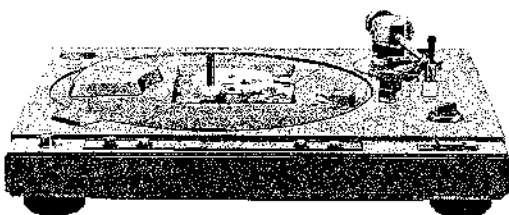
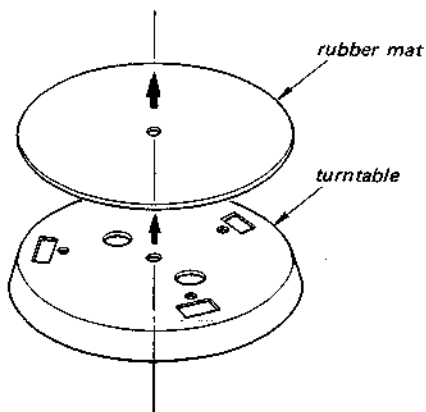

Fig. 2-2

1. Press the upper cover in the direction of the arrow ① and unhook the two hooks on the right.
2. Push up the upper cover in the direction of the arrow ②.

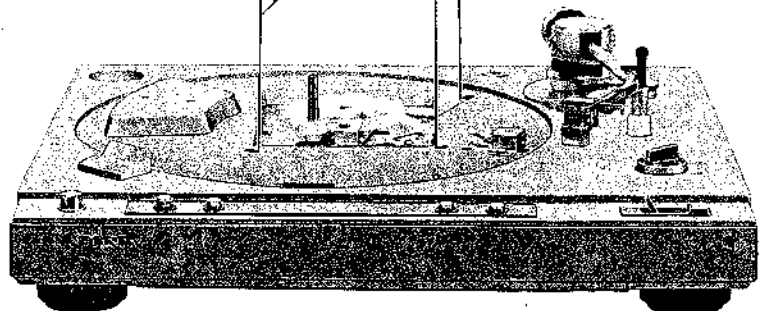
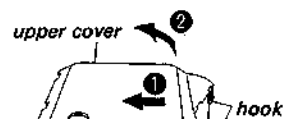

Fig. 2-3

SERVO AMP BOARD, MOTOR SECTION REMOVAL

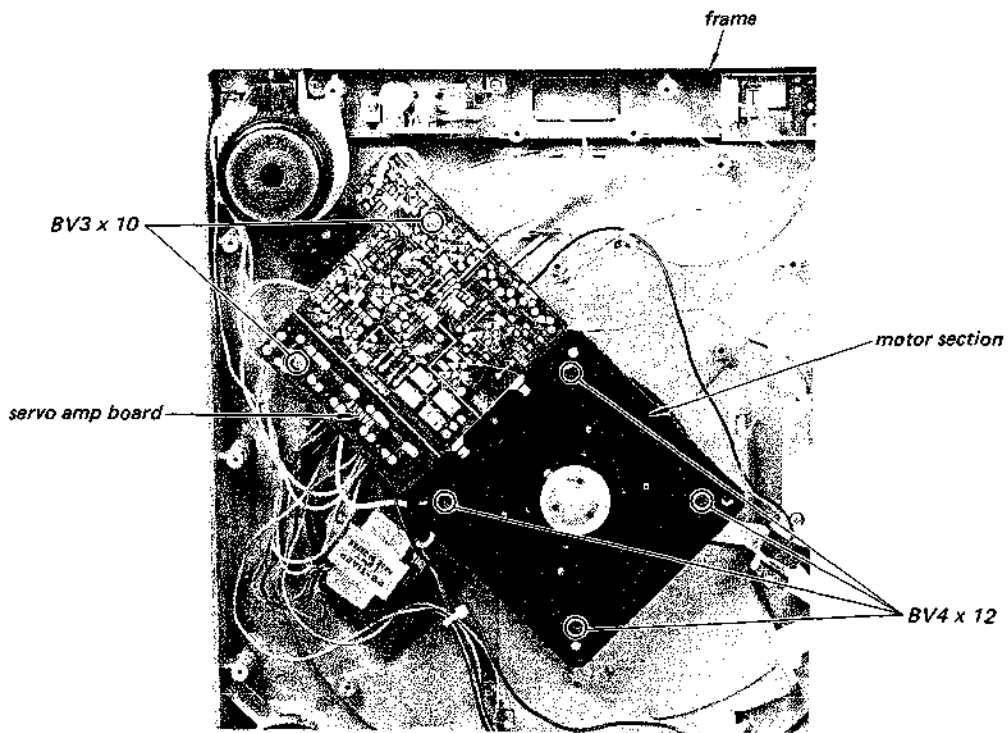

Fig. 2-5

POWER SWITCH REMOVAL

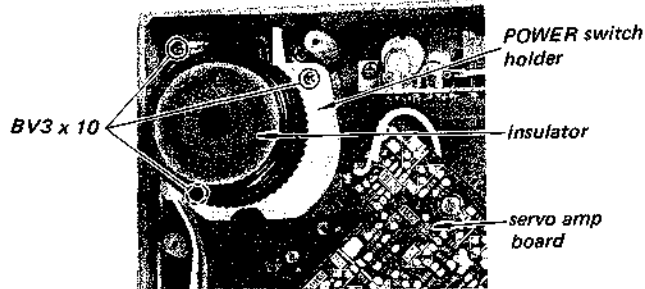

Fig. 2-6

SWITCH REMOVAL

- Pitch Control
- SPEED Switch (S1)
- START/STOP Switch (S2)
- REPEAT Switch (S4)

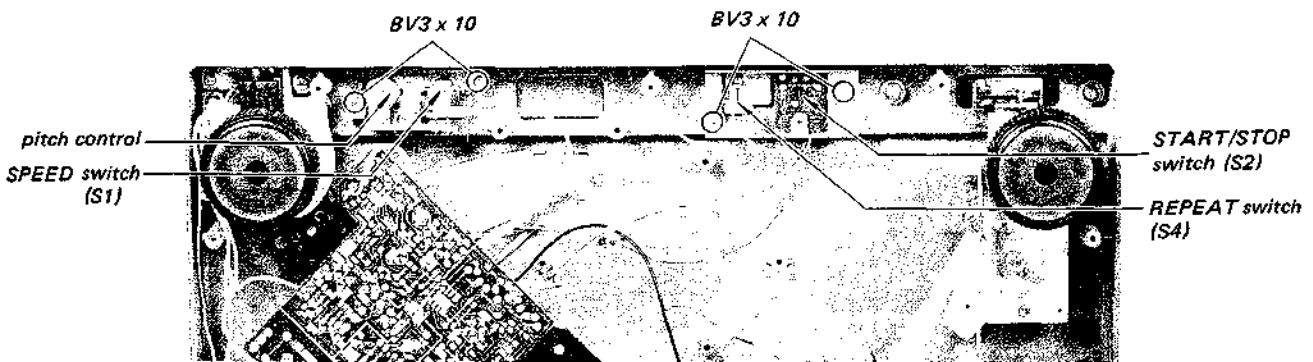

Fig. 2-7

TONEARM REMOVAL

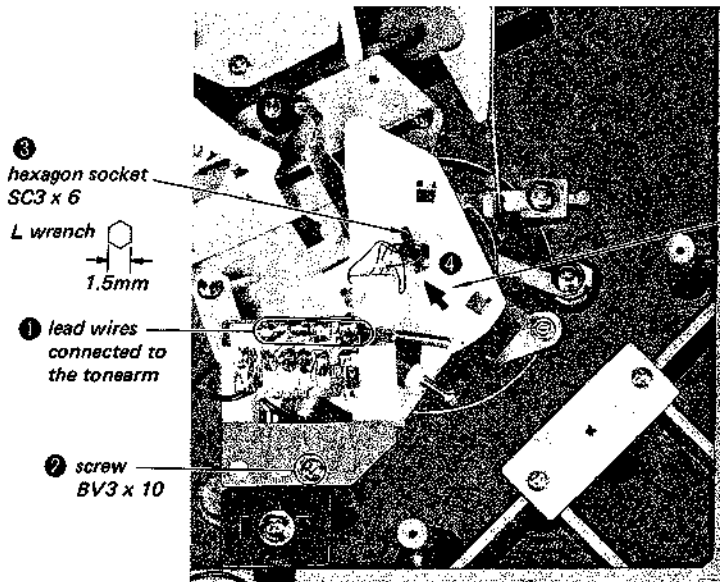

Fig. 2-8

- 1 Unsolder the five lead wires connected to the tonearm.
- 2 Remove the screw BV3 x 10 on the phono circuit board holder.
- 3 Loosen the hexagon socket set screw.
- 4 Remove the brake drum ass'y in the direction of the arrow.
- 5 Remove E12 and remove the tonearm in the direction of the arrow.

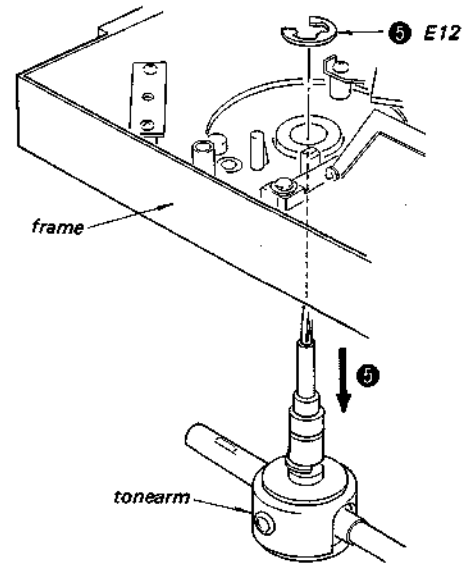

Fig. 2-9

IFC KNOB ASSEMBLY INSTALLATION

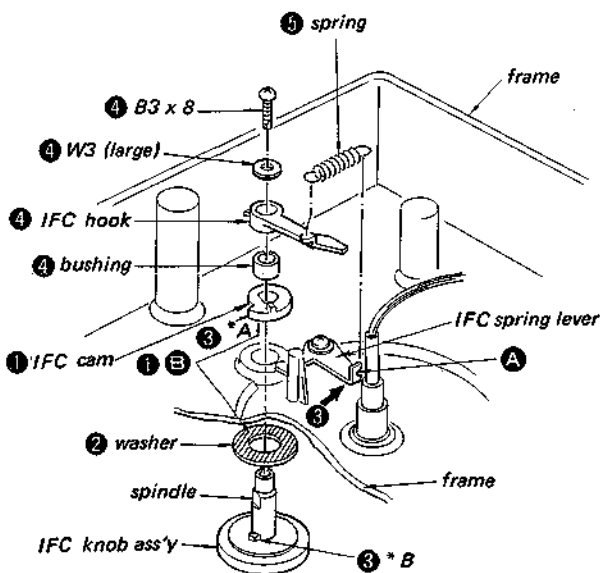

Fig. 2-10

- 1 Smear the shaded portion (E) of the washer and the IFC cam with grease.
- 2 Install a washer in the IFC knob ass'y.
- 3 Set the marked point (*A) of the IFC cam as shown in Fig. 2-10. Install it through the frame and set it with the IFC cam. Be sure that the two marked points (*A & *B) coincides. (Place the IFC spring lever in the direction of the arrow when performing this installation.)
- 4 Place the bushing, IFC hook and washer (W3) on the spindle and fasten them with screw B3 x 8.
- 5 Connect the IFC hook and the IFC spring lever with a spring and apply a bond at point A of the lever.
- 6 After the installation has been completed, be sure that the IFC hook moves on its own.

BRAKE DRUM INSTALLATION

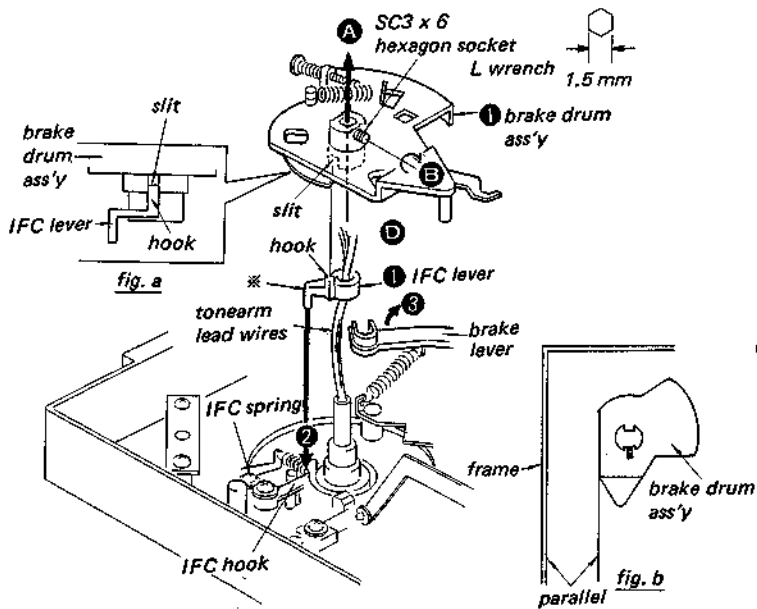

Fig. 2-11

- ① Place the lead wires through the IFC lever and the brake drum ass'y. Pull them out in the direction of the arrow **A**.
- ② Set the marked portion (*) of the IFC lever between the IFC spring lever and the IFC hook. Install the IFC lever in the direction of the arrow **2**.
- ③ Push the brake lever in the direction of the arrow **3** and match the slitted part with the hook on the IFC lever. (See fig. a)
- ④ Adjust the position of the drum so that the straight side runs parallel with the frame. Fix the drum by turning the set screw (SC3 x 6) in the direction of the arrow **B**.

SUB GEAR AND CLUTCH ASS'Y INSTALLATION

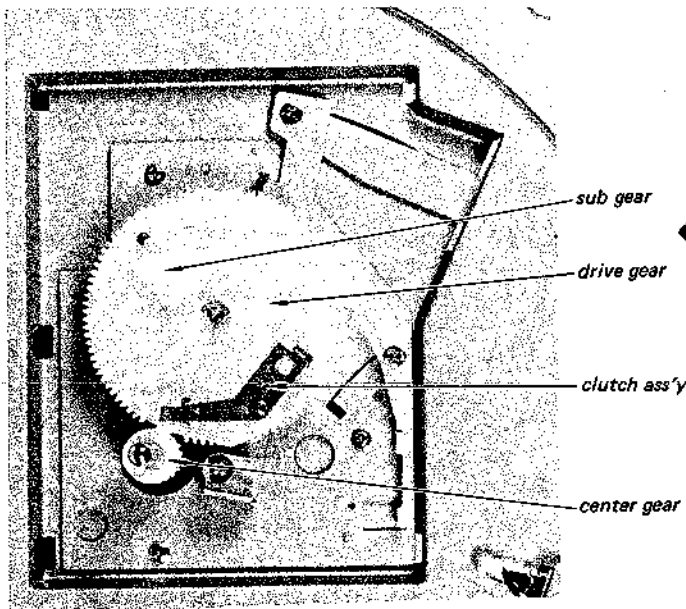

Fig. 2-13

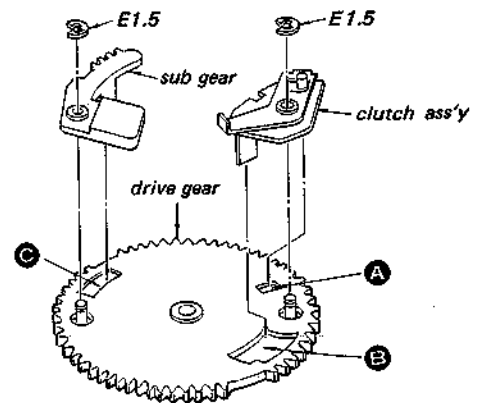

Fig. 2-12

- ① Set the sub gear in hole **C** and fasten with E1.5.
- ② Set the clutch ass'y in hole **A** and **B** and fasten with E1.5.
- ③ After installation has been completed, make sure that they move on its own.

MOTOR INSTALLATION

The motor and the servo amp board are assembled together. If found defective, disassemble the motor block as shown in Fig. 2-13 and repair it.

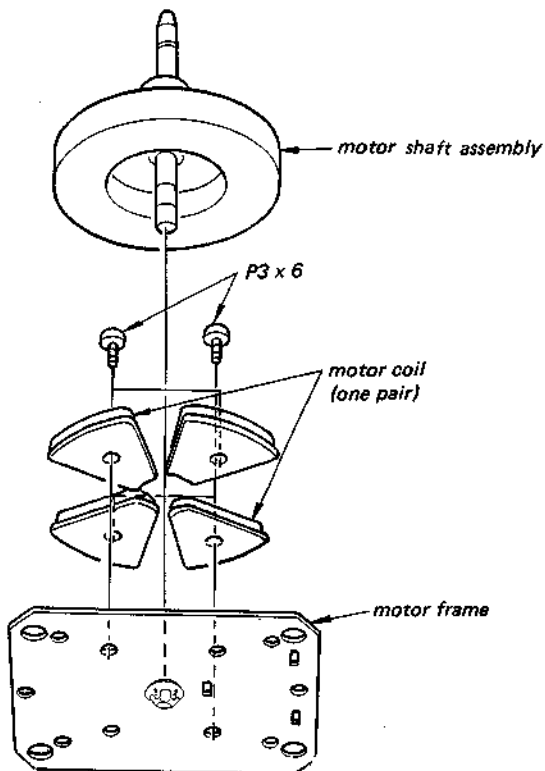

Fig. 2-13

1. When the motor shaft is replaced, apply two drops of the SONY oil (OL-2KA) in the pivot and apply grease to the parts marked by * in Fig. 2-14.
2. When the motor bearing and the thrust retainer plate are replaced, apply two drops of the SONY oil (OL-2KA) in the pivot.

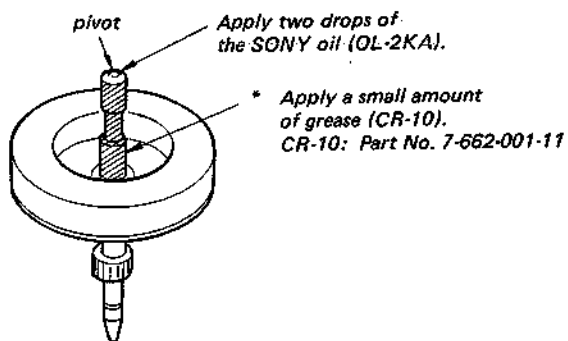

Fig. 2-14.

- 3. Insert the motor shaft assembly slowly in the motor bearing so that the motor shaft is not attracted by strong magnetic field strength.
- 4. The motor coils are composed of two pairs.
 - a). Mount the coils on the motor frame so that the boss of the coil is placed in the hole of the frame as illustrated in Fig. 2-15.
 - b). Push the coils in the arrowed direction and tighten the screws.
 - c). Lay the leads of the coils as shown in Fig. 2-16 and fix the leads in the slot between the portions marked by * in Fig. 2-17.

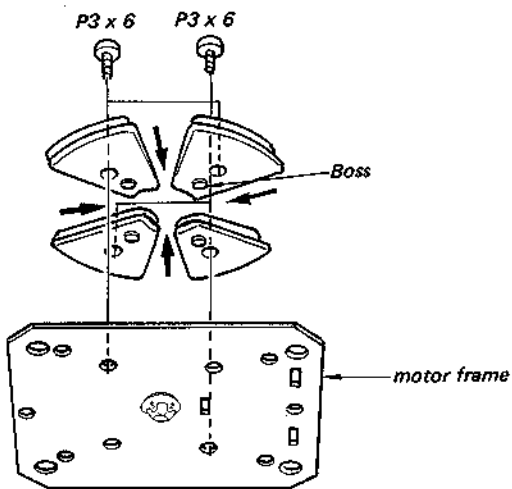

Fig. 2-15

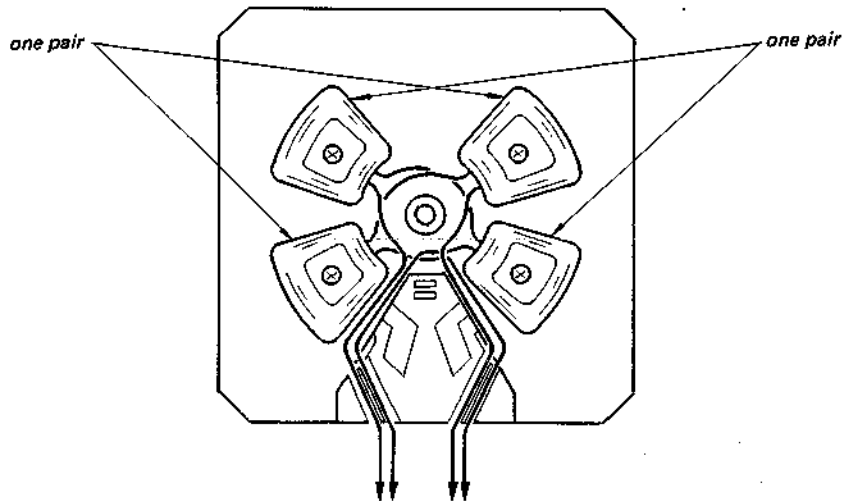

Fig. 2-16

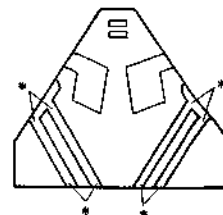
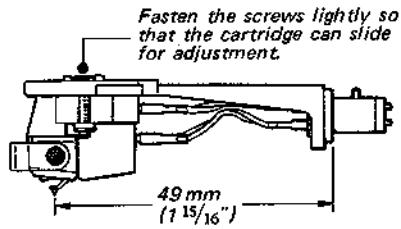

Fig. 2-17

CARTRIDGE INSTALLATION

Install the cartridge into the shell with the mounting screws so that the distance between the shell end and the stylus tip is 49 mm (1 15/16 inches).



LEAD WIRE CONNECTION

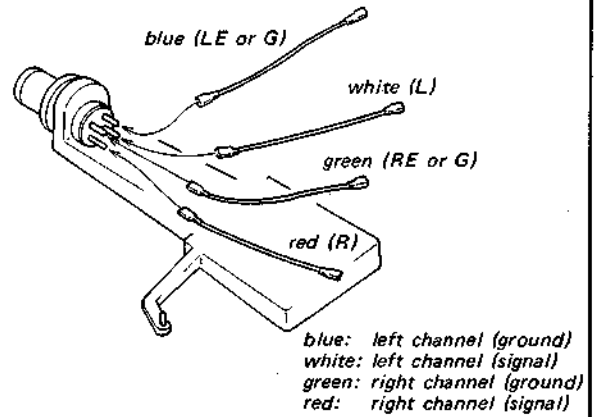

SECTION 3 ADJUSTMENTS

3-1 MECHANICAL ADJUSTMENTS

Automatic Return Position Adjustment

- Unplug the power cord.
- 1. Remove the rubber mat and the platter.
- 2. Put the tonearm on the arm rest.
- 3. Turn the center shaft clockwise by hand and turn the drive gear one turn by engaging the center gear with the drive gear. Then place the drive gear in the disengaging position.
- 4. Push the clutch (B) in the direction shown by the arrow and place the clutch (A) and clutch (B) as shown below:

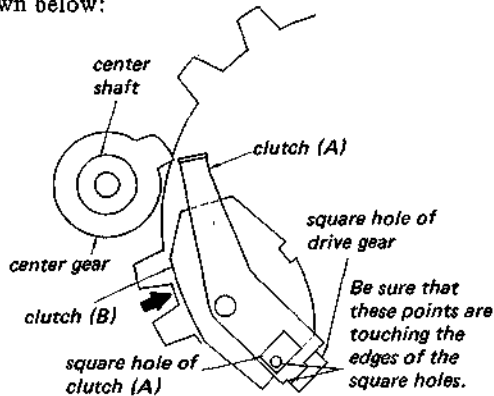

- 5. Put the return adjustment scale (Part No. 9-911-814-01) on the center shaft.
- 6. Move the tonearm toward the center shaft by hand so that the clutch (A) is positioned as shown below and confirm that the stylus is located on the hatched area of the return adjustment scale.

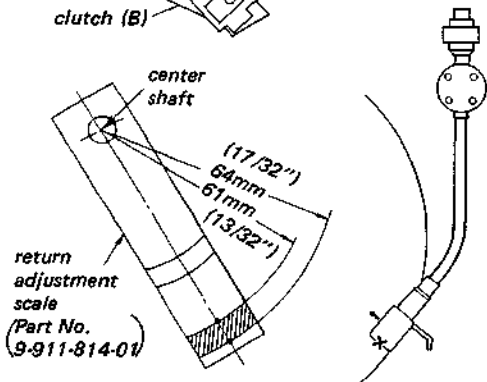
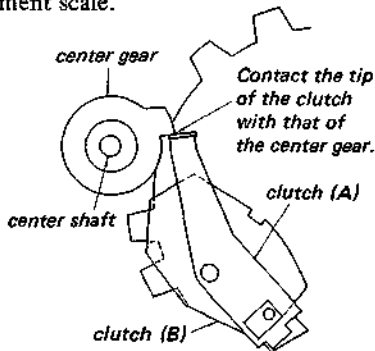

- 7. If necessary, adjust the adjustment screw.

Stylus Position	Adjustment Screw
outside of hatched area	clockwise
inside of hatched area	counterclockwise
on hatched area	correct

- 8. Play the automatic-return test record (YFSC-16, A side "C-3") and confirm that the tonearm returns at count 4 to II.

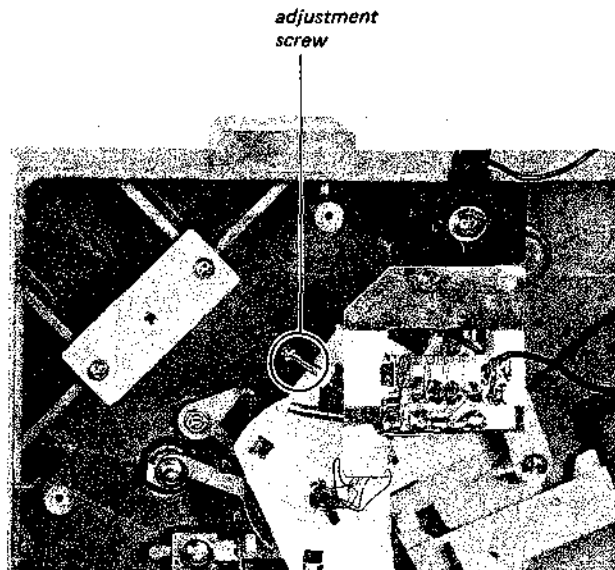

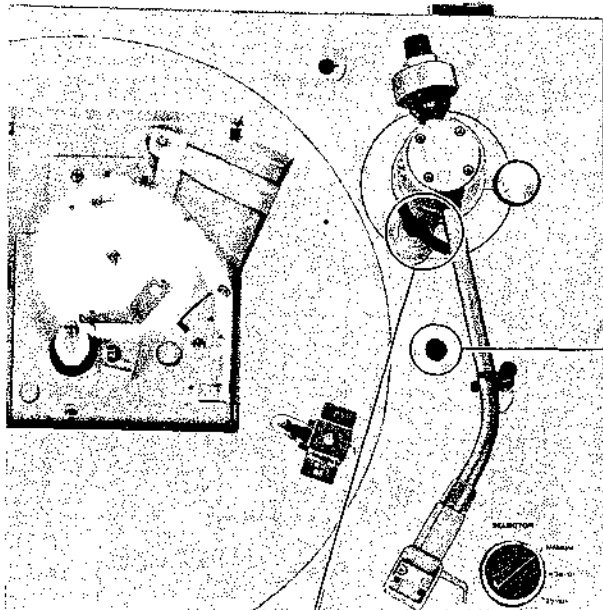

Arm Lifter Height Adjustment

- Unplug the power cord.

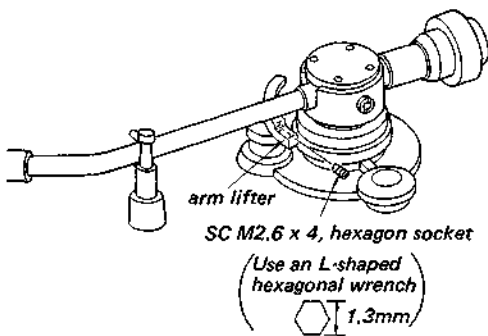

The clearance between the stylus tip and the record on the rubber mat should be 7-11mm (5/16 - 7/16").

Stylus Drop-point Adjustment

- Remove the cap from the adjustment hole.

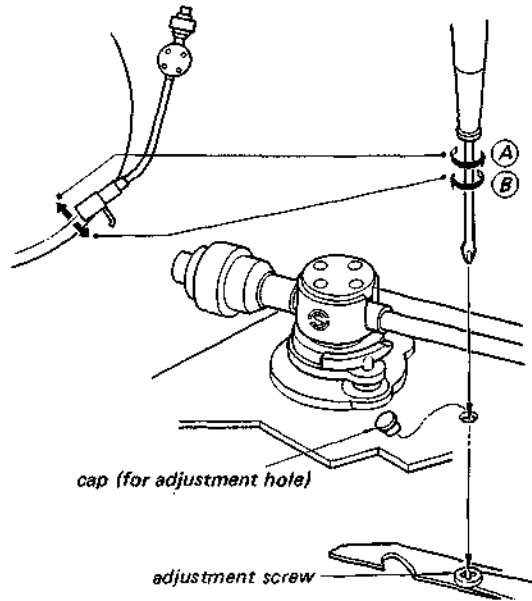

1. Set the record size selector lever to the 30 (12") position and make sure that the stylus gets down on the specified point of the test record.
test record: YFSC-16

Record size selector lever position	Count of drop-point
30 (12")	4 to 16
25 (10")	6 to 24
17 (7")	7 to 25

2. If necessary, insert the screw-driver into the hole and adjust the drop-point by turning the adjustment screw.

To change the drop-point inward:

Turn the adjustment screw slightly counterclockwise (A)

To change the drop-point outward:

Turn the adjustment screw slightly clockwise (B)

3. Once it is properly adjusted with a 30 cm (12") record, the drop-point will be correct for 17 cm (7") and 25 cm (10") records as well.

Note: The stylus drop-point is changed to about 12 mm (1/2") by one turn of the adjustment screw.

3-2. ELECTRICAL ADJUSTMENTS

Turntable Speed Adjustment

If correct speeds cannot be obtained by adjusting the PITCH control, adjust RV303 (33 rpm) and RV302 (45 rpm) at the bottom of the case through corresponding adjustment hole.

1. Place the record player as illustrated for easy access to the adjustment hole.
2. Set the record size selector knob to the MANUAL position and push the START/STOP switch.
3. Set the PITCH control knob at the center position.
4. Adjust RV303 (33 rpm) and RV302 (45 rpm) so that the stroboscope pattern appears stationary.

Note:

Even after adjustment, the stroboscope pattern might be seen moving. This is because line-frequency variation affects neon lamp or fluorescent lamp which is operated on power line. The rotational speed of the incorporated motor or turntable is always maintained constant regardless line frequency variation.

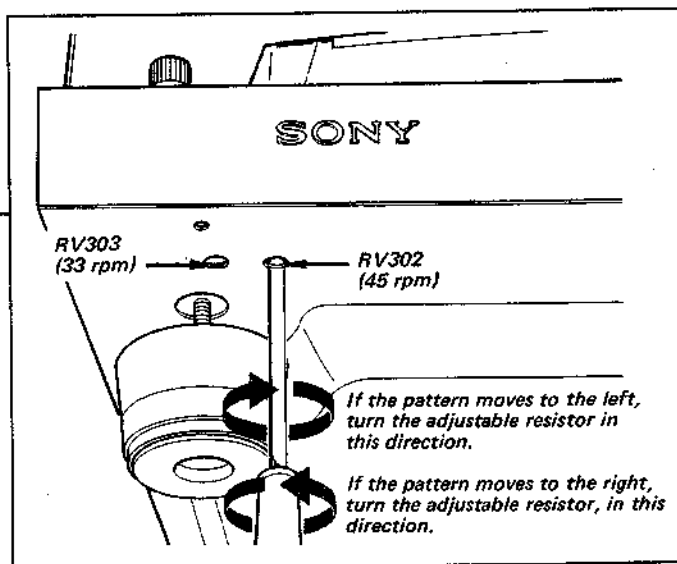
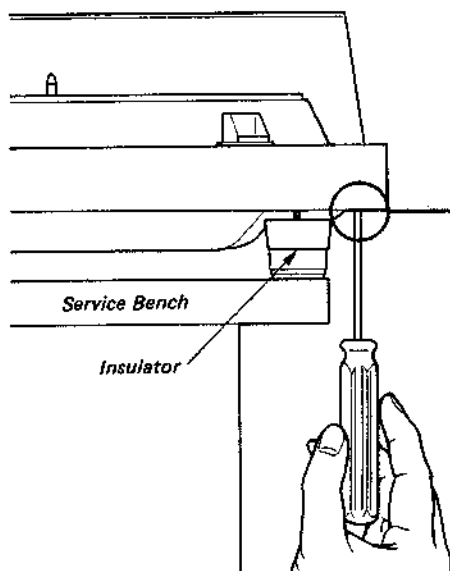

Speed-Detecting Head Output Adjustment

1. Adjust the position of the speed-detecting head by loosening two screws (TA, B3 x 10) as shown in the picture so that the VTVM reading is more than 20mV ac at 33 rpm.
2. Make sure that the head does not touch the turntable and tighten the screws securely.

Note:

- Maladjustment results in abnormal wow-flutter characteristics.
- The clearance between the magnet-coated rim and the speed-detecting head is more than 0.3mm.

Reference:

Adjust the position of the speed-detecting head by inserting a card (approx. 0.3mm thick) between the magnetic coating of the turntable and the speed-detecting head.

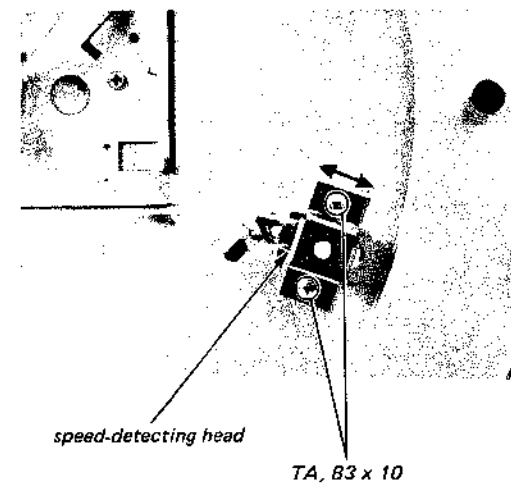
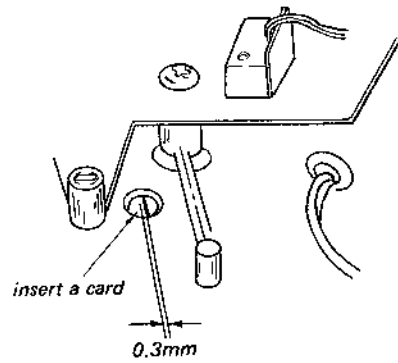

Hall Device Gain Adjustment (33 rpm)

1. Unsolder the bridged portion on the pattern and connect the regulated power supply as shown below.

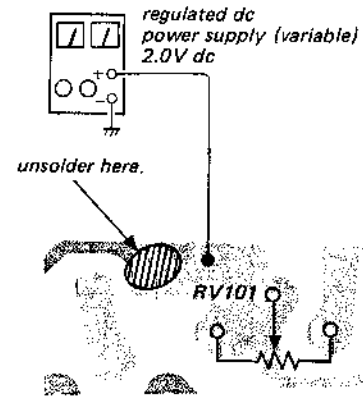

2. Connect VTVM to H1 and adjust RV101 for 2.5V ac reading on VTVM.
3. Connect VTVM to H2 and adjust RV102 for 2.5V ac reading on VTVM.

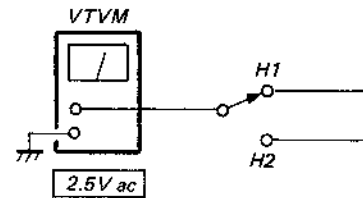

Reference:

VTVM reading (ac) should be 1.25 times the power supply voltage (dc). If a dry battery (1.6V dc) is used instead of regulated power supply, VTVM reading should be 2.0V ac.

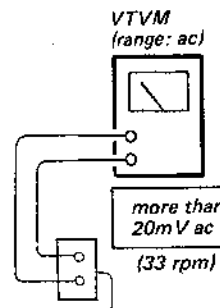
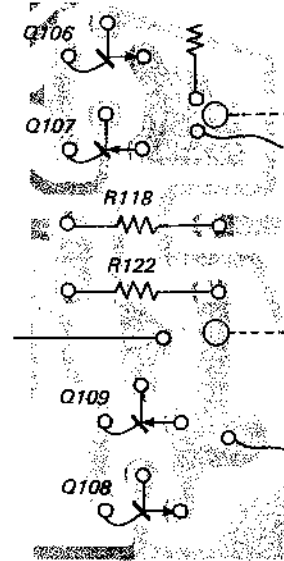

Motor Amp Offset Adjustment (33 rpm)

1. Unsolder the bridged portion on the pattern and connect the regulated power supply as shown on the right.
2. Connect VTVM or oscilloscope to H1 and adjust RV103 for 0V dc VTVM reading or the waveform on oscilloscope as shown in Fig. A.
3. Connect VTVM or oscilloscope to H2 and adjust RV104 for 0V dc VTVM reading or the waveform on oscilloscope as shown in Fig. A.

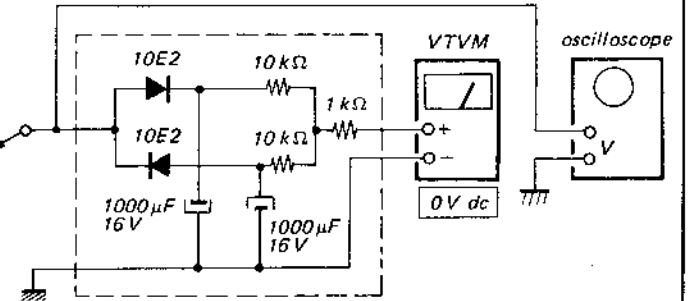
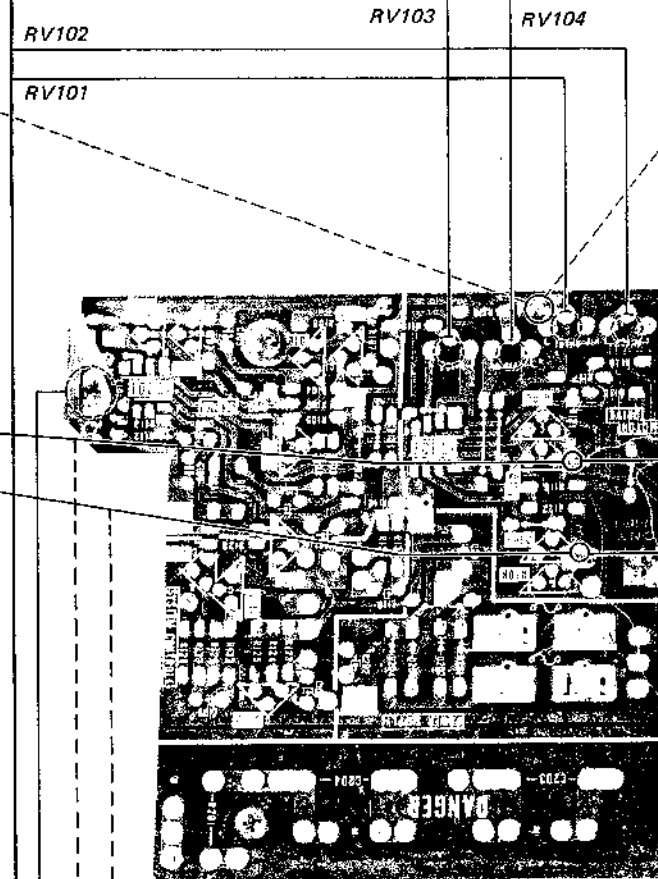
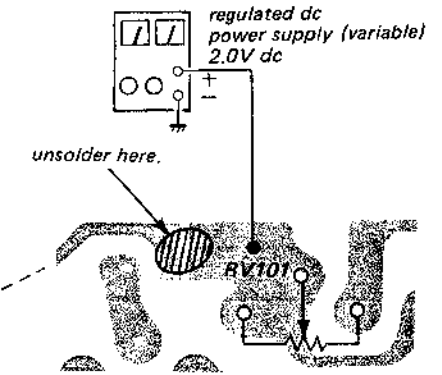

Note: Set the sweep time longer as for easy waveform checking.

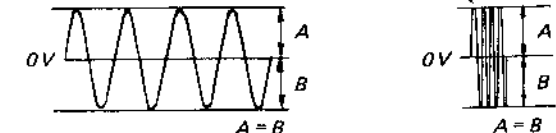

Fig. A Waveform on oscilloscope

SECTION 4
DIAGRAMS

4-1. MOUNTING DIAGRAM -- Conductor Side --

• Replacement Semiconductors

For replacement, use semiconductors except in ().

Q101, 102, 103 : 2SC1364 (2SC945)
Q104, 112, 113

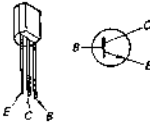

D101: 1S1555 (1T40)

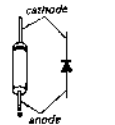

Q105, 110: 2SA678 (2SA844)

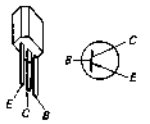

D102: EOB01-05 (EQA01-05)

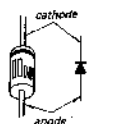

Q106, 108: 2SC1475 (2SD571)

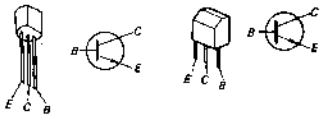

Q107, 109: 2SA684 (2SB605)

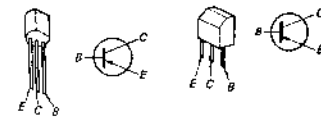

Q111: 2SC1364 (2SC945)

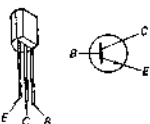

D201-204: 10E2 (GP08-D)

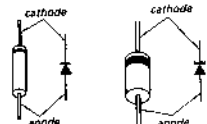

IC1, 2: μPC4558C

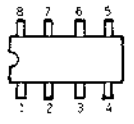

H1, 2: 5GF-MS-07F



(Top View)

Note:

- All capacitors are in μF unless otherwise noted. pF : μF
- All resistors are in ohms, 1/4 W unless otherwise noted. kΩ : 1000 Ω; MΩ : 1000 kΩ
- : nonflammable resistor.
- : direct connection to points marked on the chassis
- : panel designation.
- : adjustment for repair.
- Readings are taken with a VOM (20 kΩ/V).
- () : 33 rpm
- (|) : 45 rpm
- < > : the moment the START switch is pushed.
- no mark: 33, 45 rpm

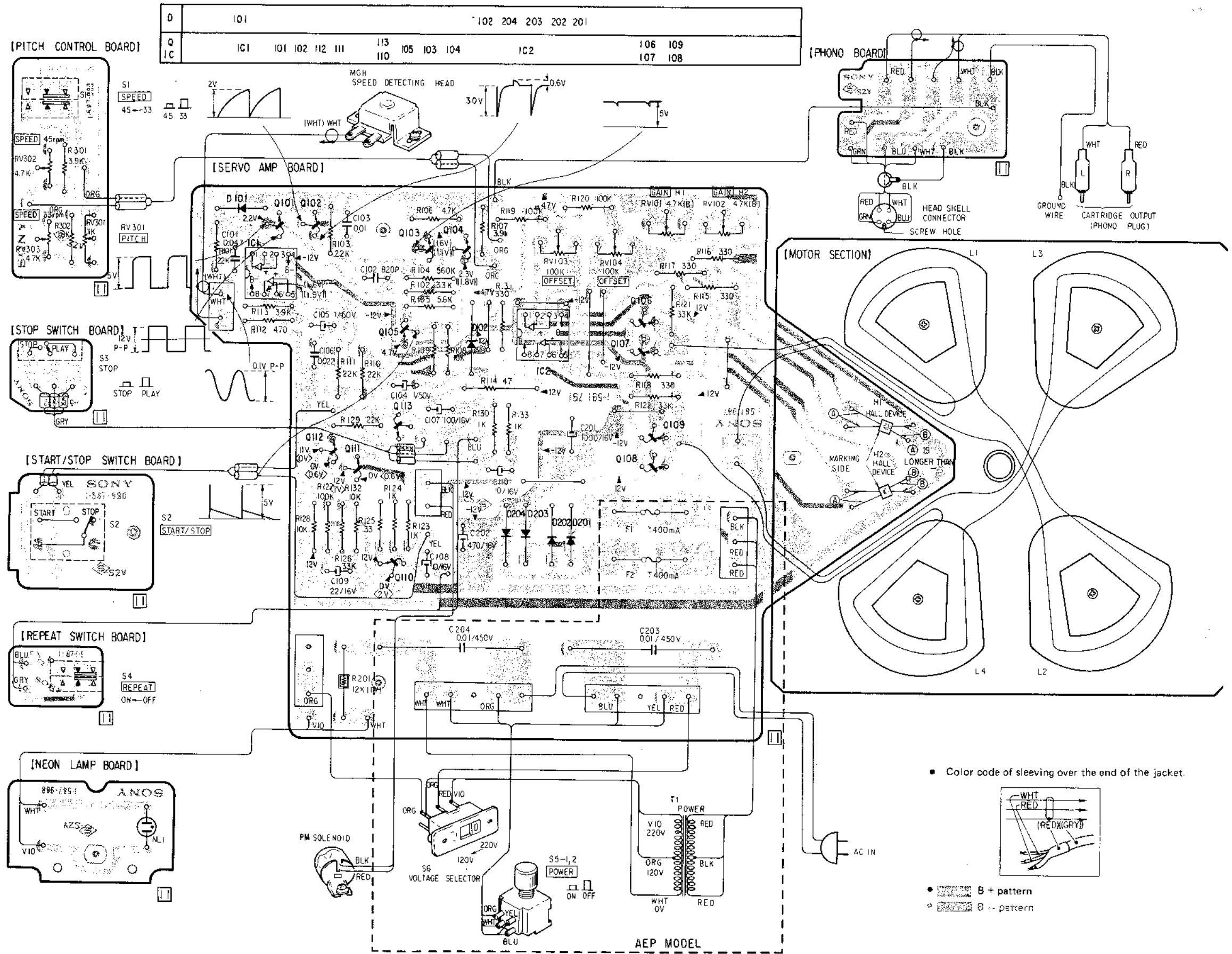

- Color code of sleeving over the end of the jacket.

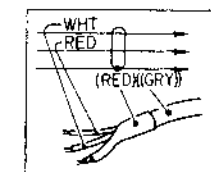

- B + pattern
- B - pattern

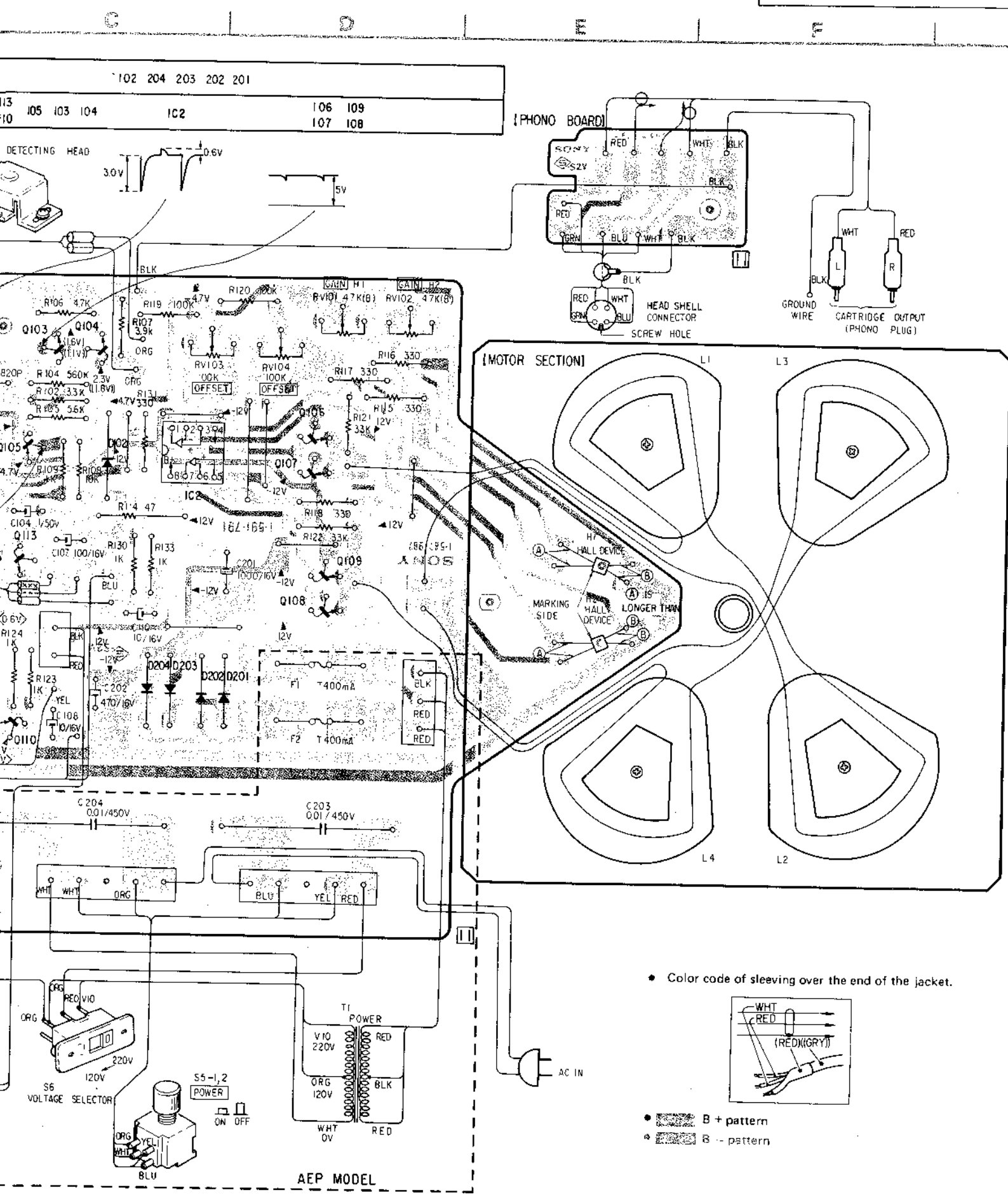

AEP MODEL

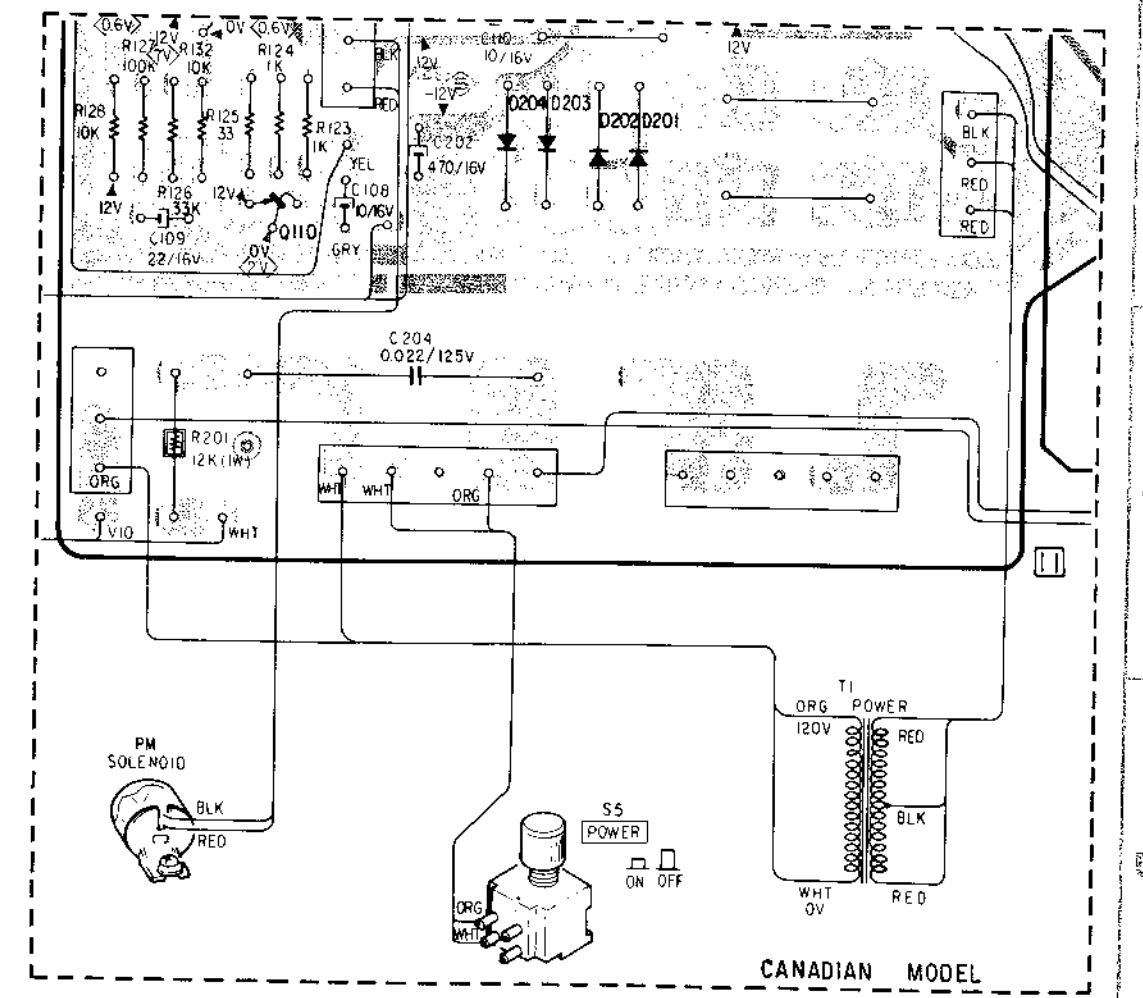
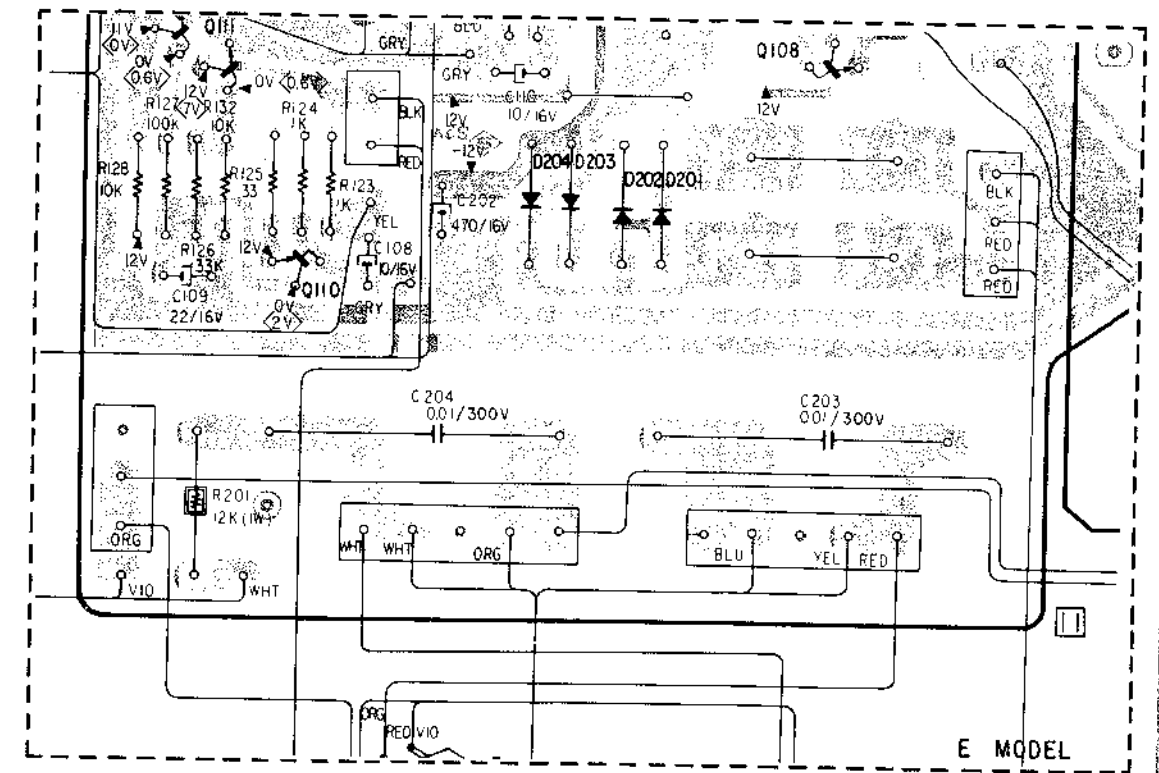

4.2. SCHEMATIC DIAGRAM

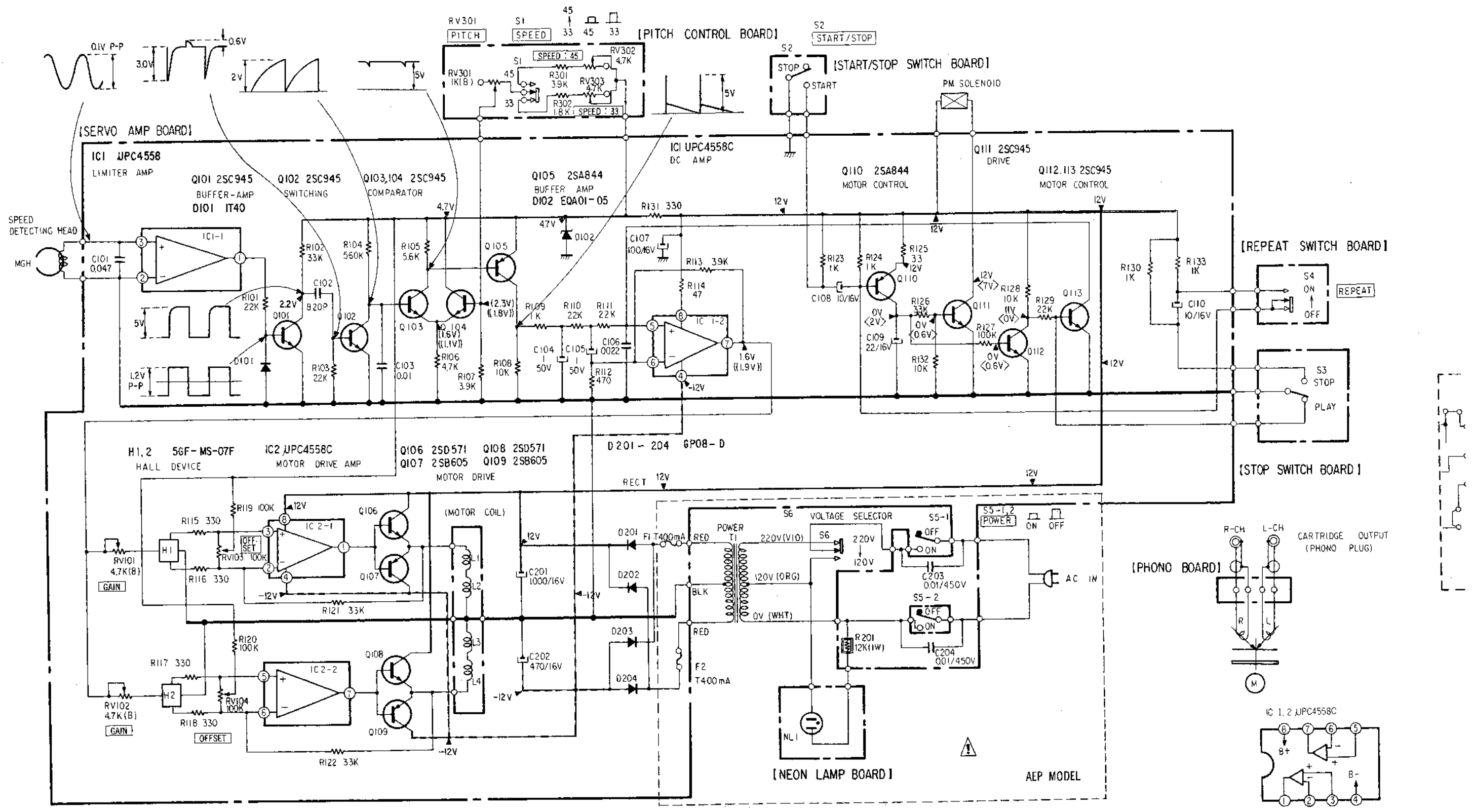

Note: The components identified by shading and mark ⚠ are critical for safety. Replace only with part number specified.

Note: Les composants identifiés par un trame et une marque ⚠ sont critiques pour la sécurité. Ne les remplacer que par une pièce portant le numéro spécifié.

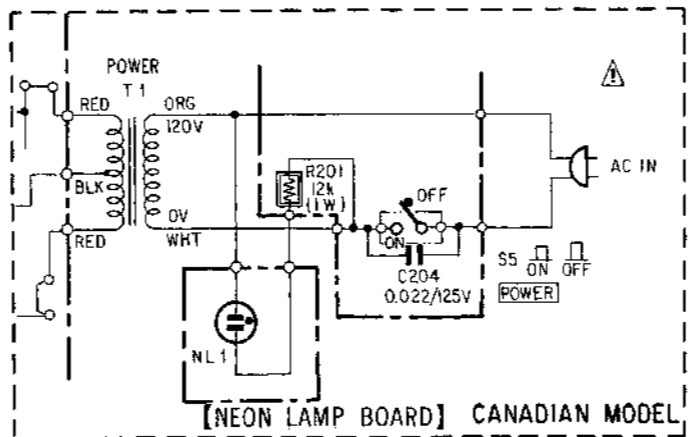
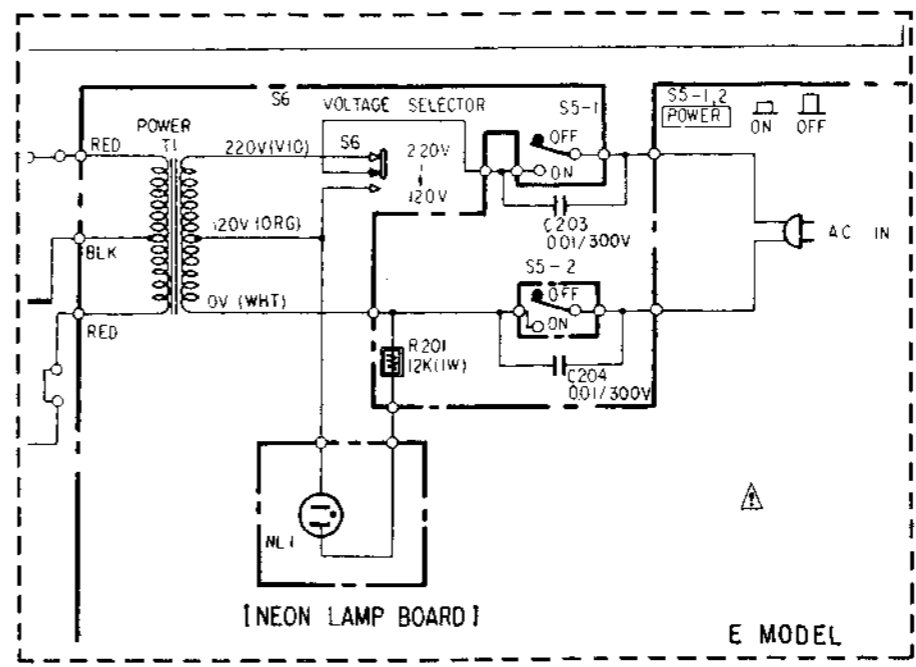
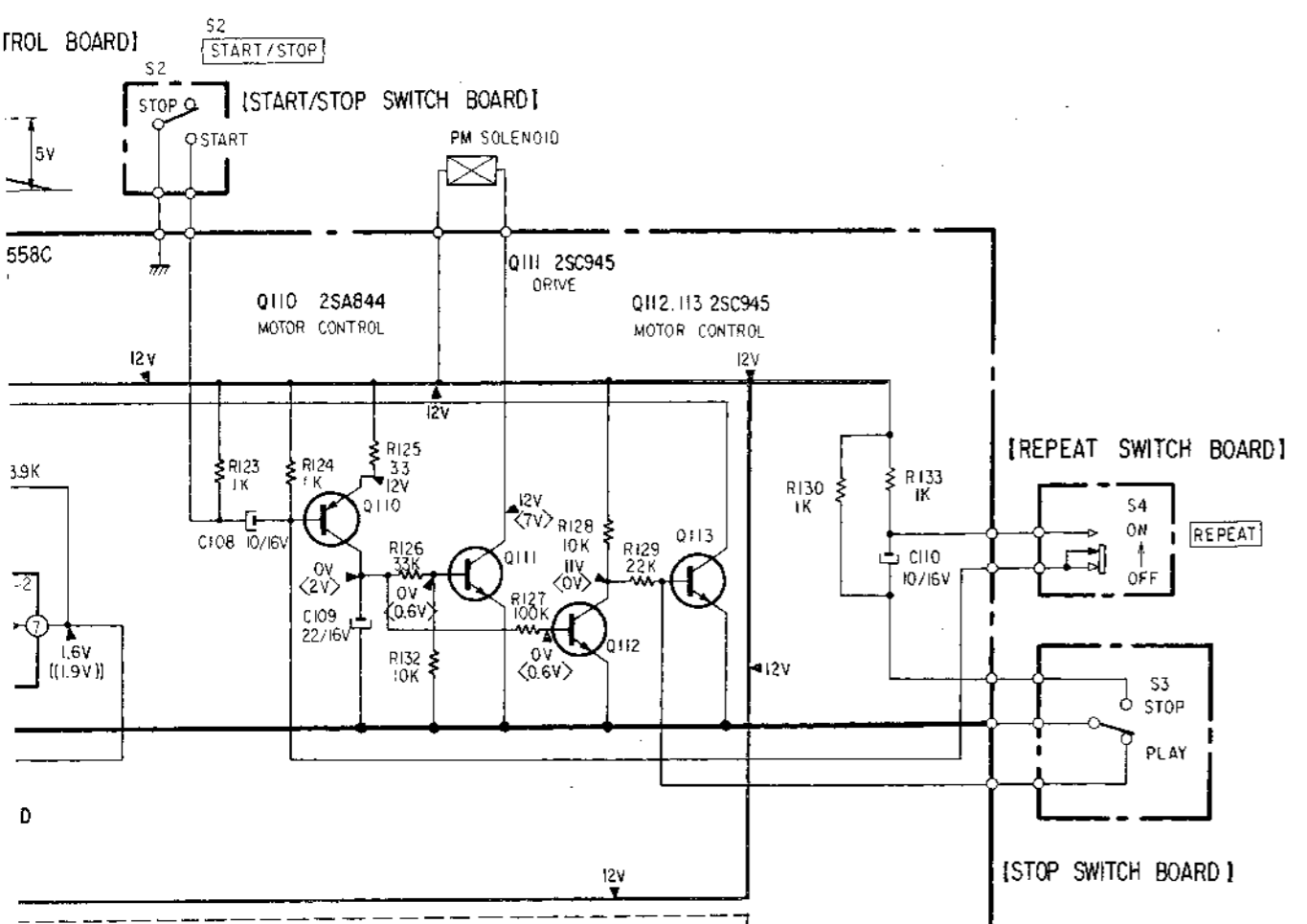

- Note:**
- All capacitors are in μF unless otherwise noted. pF : μF , 50WV or less are not indicated except for electrolytics.
 - All resistors are in ohms, $\frac{1}{2}\text{W}$ unless otherwise noted. k Ω : 1000 Ω , M Ω : 1000k Ω
 - All variable and adjustable resistors have characteristic curve B, unless otherwise noted.
 - — : B+ bus.
 - □ : panel designation.
 - □ : adjustment for repair.
 - — : B- bus.
 - : nonflammable resistor.
 - : direct connection to points marked on the chassis.

- Readings are taken with a VOM (20k Ω /V).
- () : 33 rpm
- (()) : 45 rpm
- < > : the moment the START switch is pushed.
- no mark : 33, 45 rpm
- Switch

No.	Description	Mode
S1	SPEED	33 rpm
S2	START/STOP	STOP
S3	STOP	PLAY
S4	REPEAT	NO REPEAT
S5	POWER	OFF
S6	VOLTAGE SELECT	220V

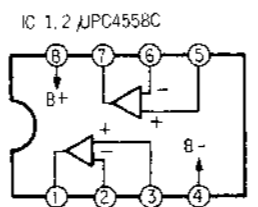
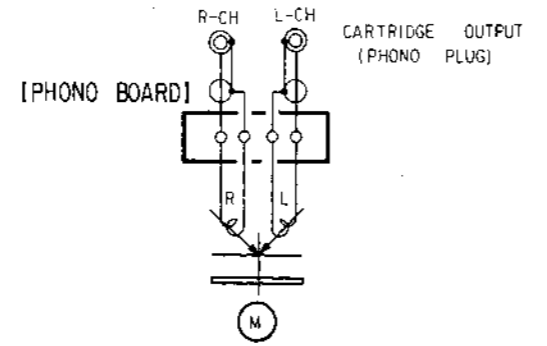
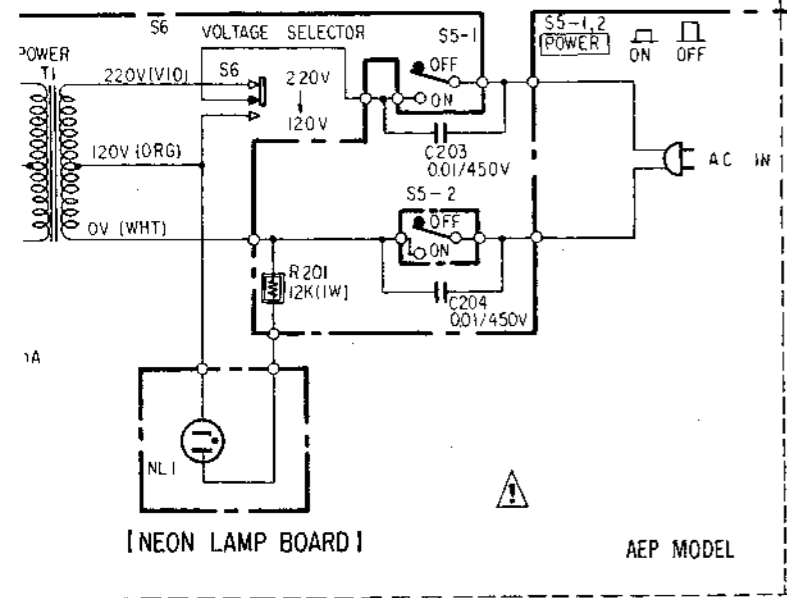

SECTION 5
EXPLODED VIEWS

5-1.

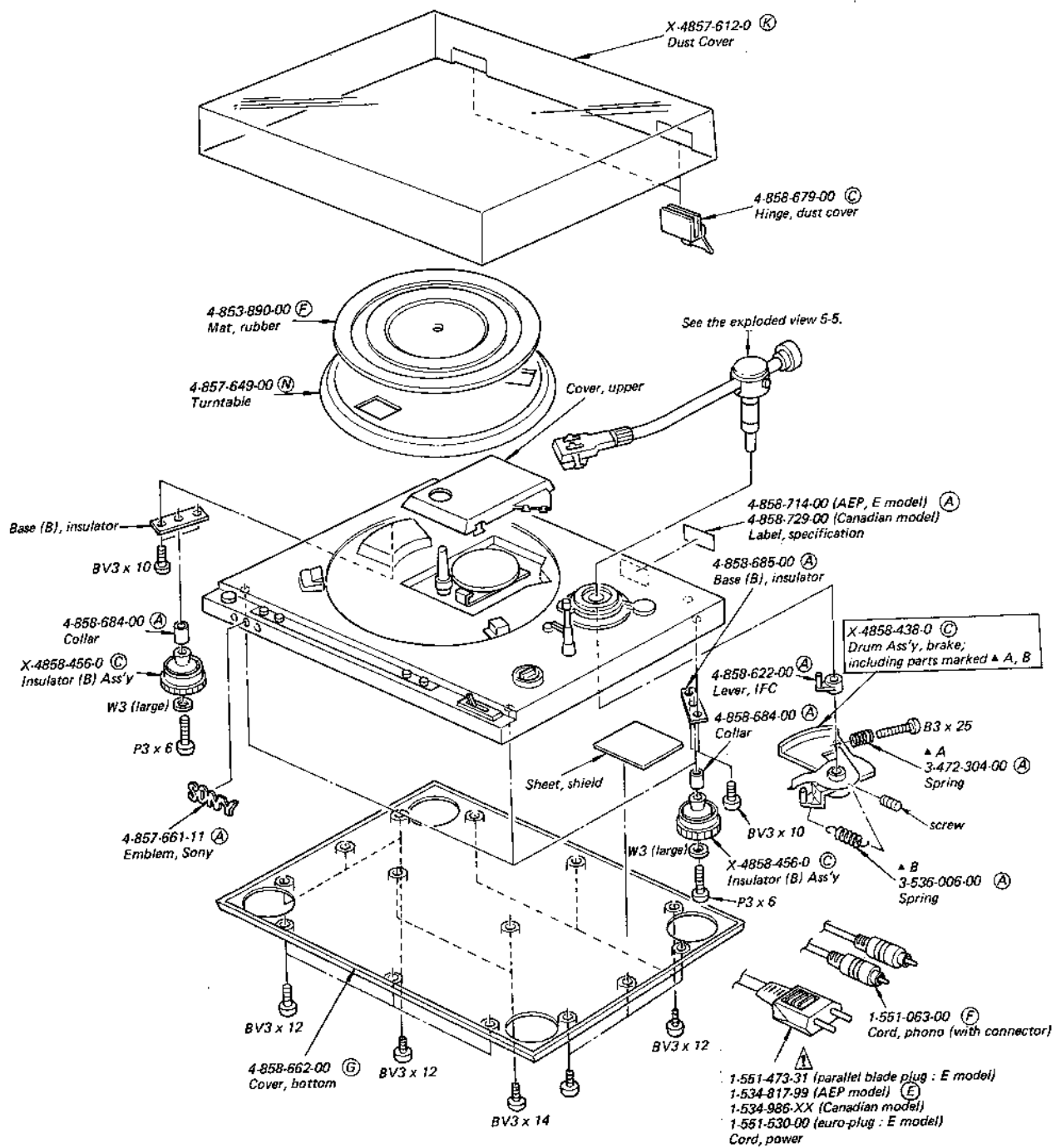

Note: The components identified by shading and mark are critical for safety. Replace only with part number specified.

Note: Les composants identifiés par un tramé et une marque sont critiques pour la sécurité. Ne les remplacer que par une pièce portant le numéro spécifié.

Note:

- Items with no part number and/or no description are not stocked because they are seldom required for routine service.
- All screws are Phillips (cross recess) type unless otherwise noted. (-) = slotted head
- Circled letters (A to Z) are applicable to European models only.

5-2.

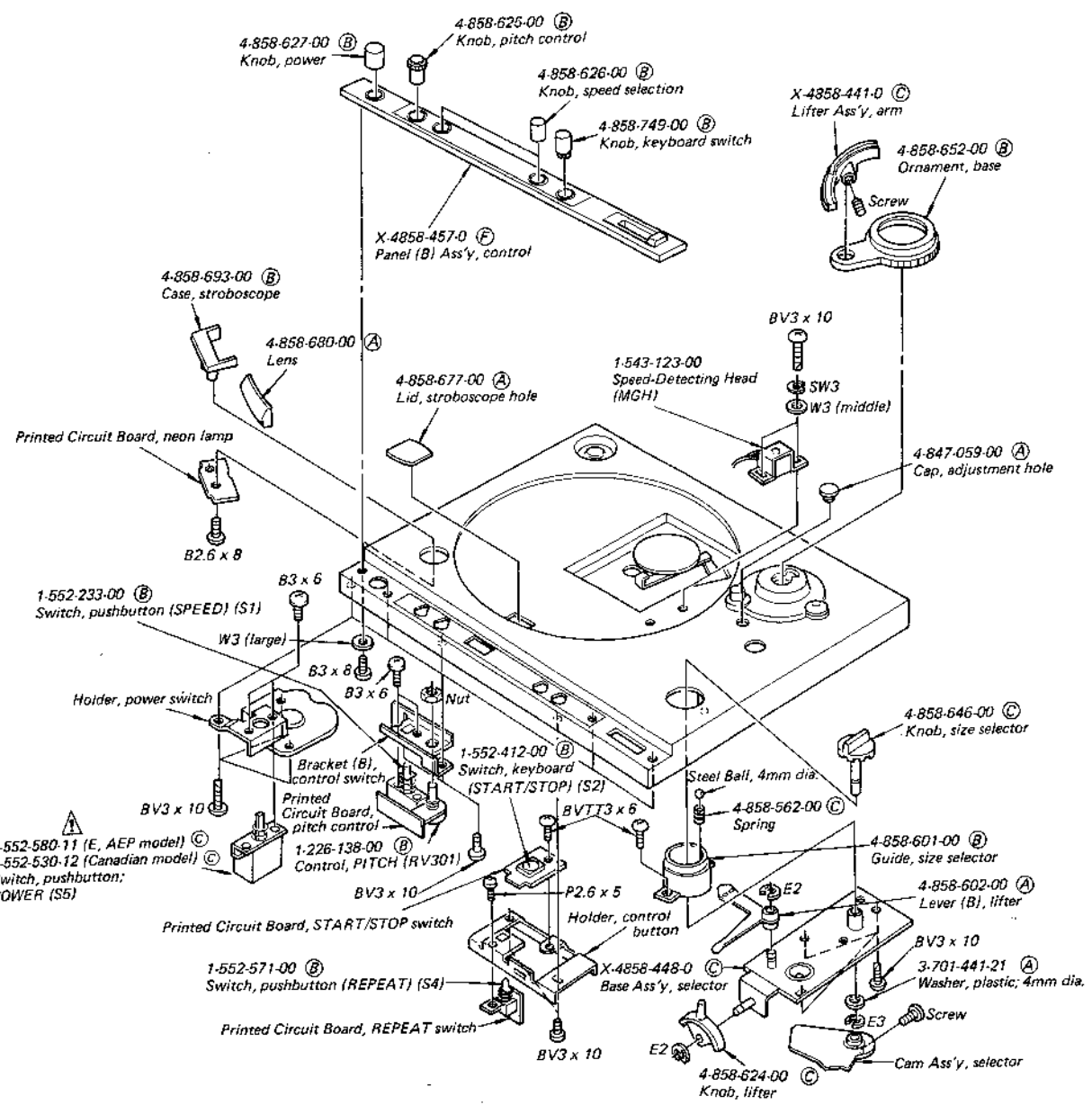

Note: The components identified by shading and mark are critical for safety. Replace only with part number specified.

Note: Les composants identifiés par un tramé et une marque sont critiques pour la sécurité. Ne les remplacer que par une pièce portant le numéro spécifié.

Note:

- Items with no part number and/or no description are not stocked because they are seldom required for routine service.
- All screws are Phillips (cross recess) type unless otherwise noted. (-) = slotted head
- Circled letters (A to Z) are applicable to European models only.

A B C D

5-2.

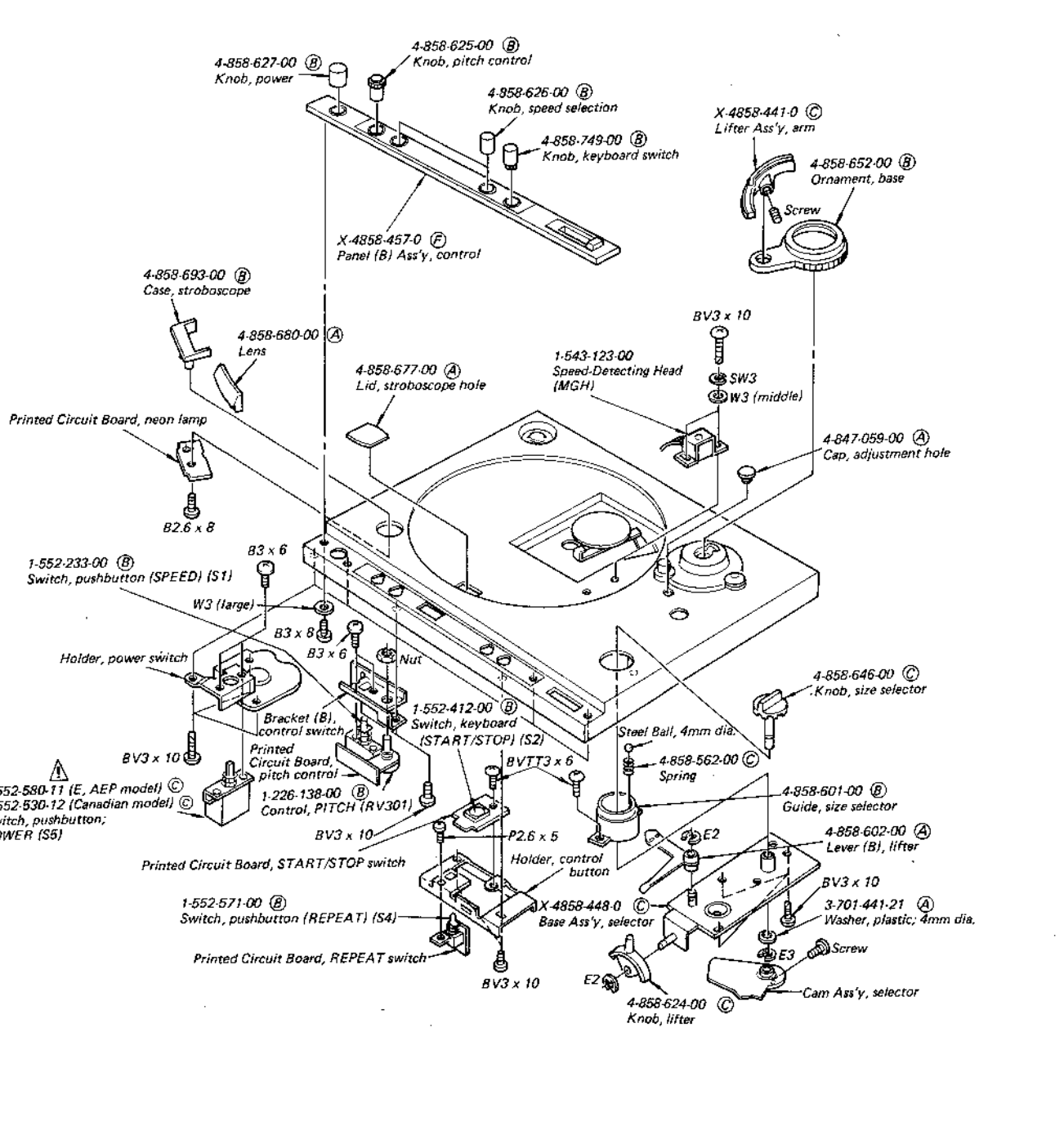

Note: The components identified by shading and mark **A** are critical for safety. Replace only with part number specified.

Note: Les composants identifiés par un trame et une marque **A** sont critiques pour la sécurité. Ne les remplacer que par une pièce portant le numéro spécifié.

- Note:
- Items with no part number and/or no description are not stocked because they are seldom required for routine service.
 - All screws are Phillips (cross recess) type unless otherwise noted. (-) = slotted head
 - Circled letters (A to Z) are applicable to European models only.

A B C D

5-3.

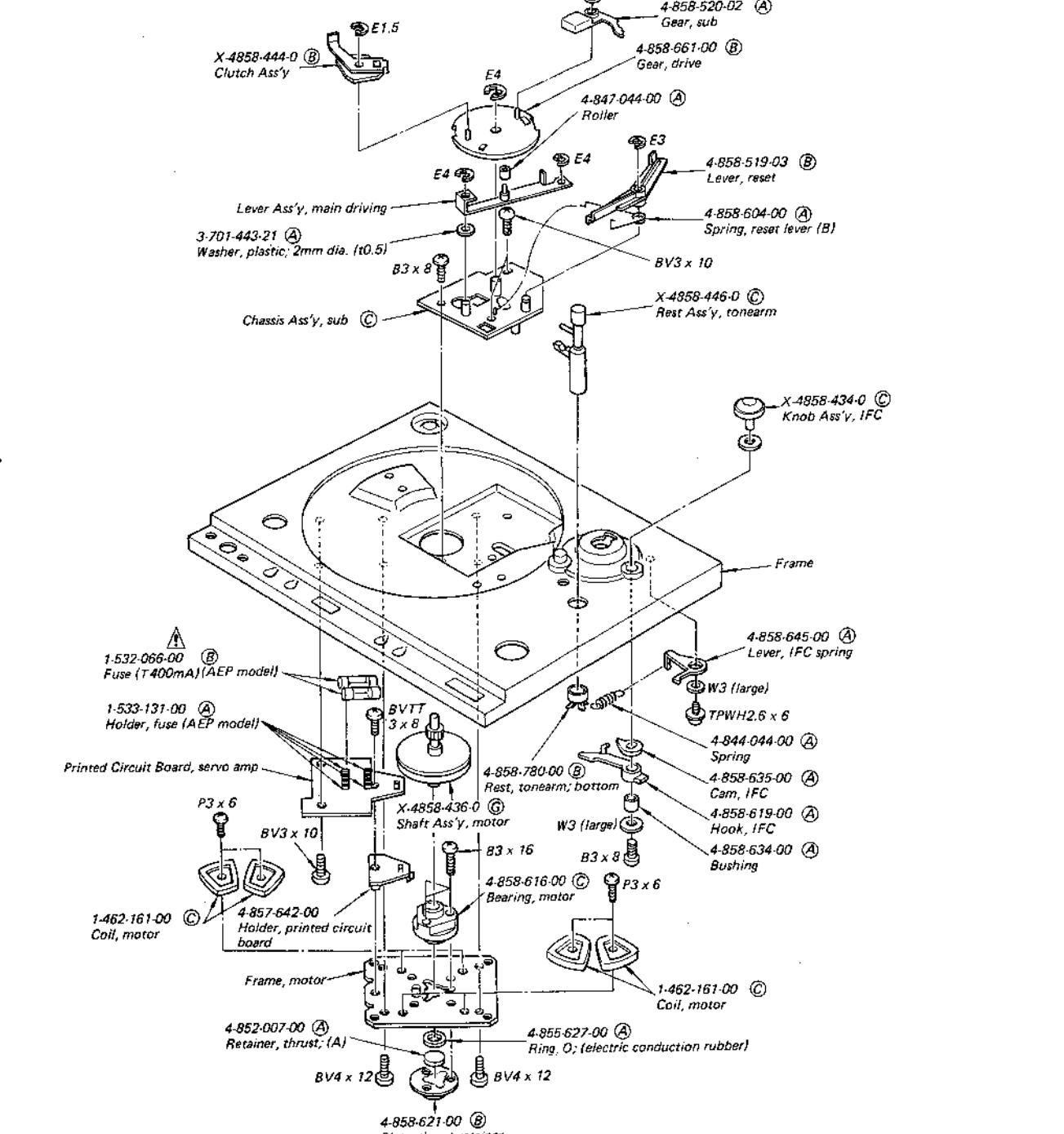

Note: The components identified by shading and mark **A** are critical for safety. Replace only with part number specified.

Note: Les composants identifiés par un trame et une marque **A** sont critiques pour la sécurité. Ne les remplacer que par une pièce portant le numéro spécifié.

- Note:
- Items with no part number and/or no description are not stocked because they are seldom required for routine service.
 - All screws are Phillips (cross recess) type unless otherwise noted. (-) = slotted head
 - Circled letters (A to Z) are applicable to European models only.

5-4.

1

2

3

4

5

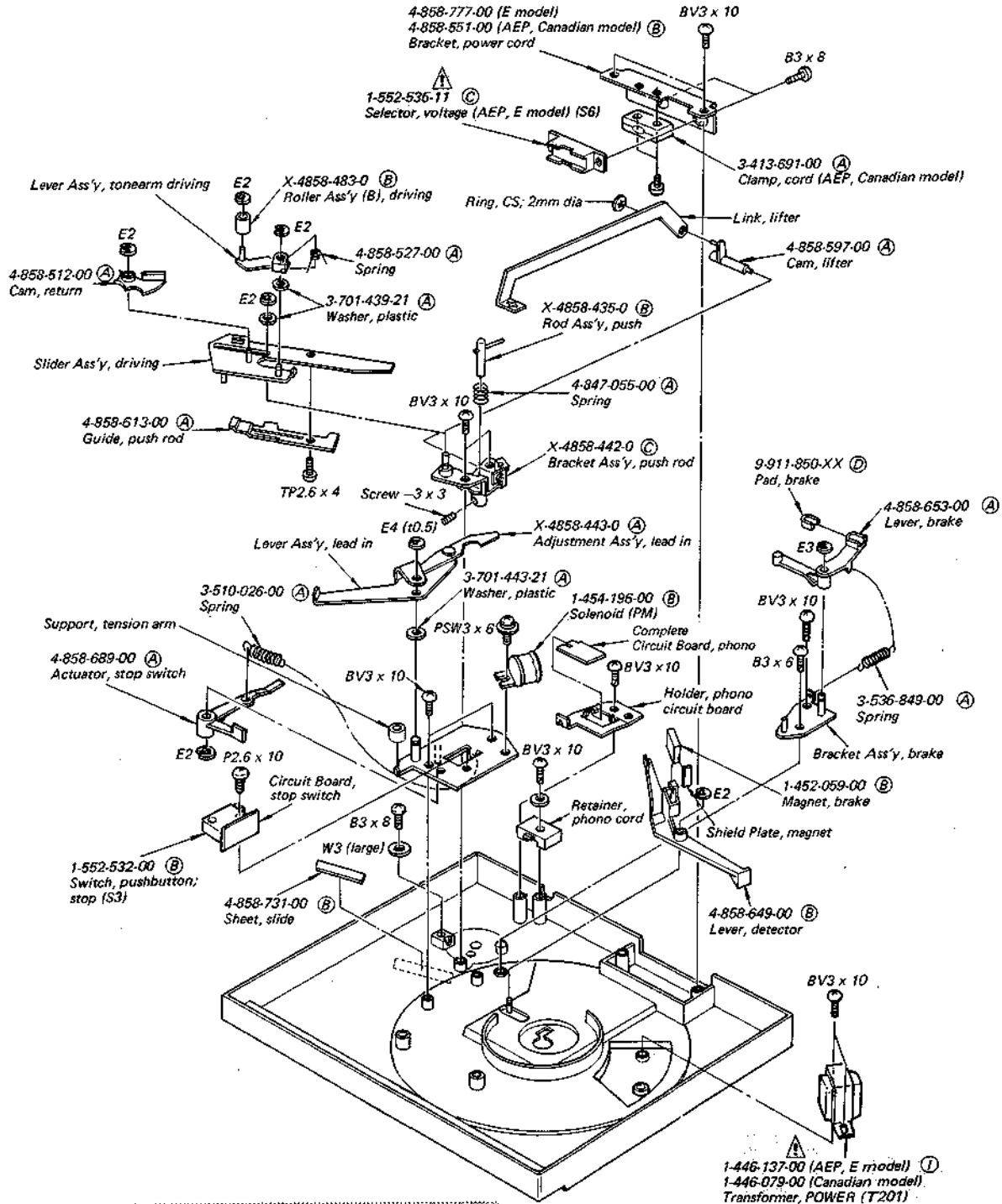

Note: The components identified by shading and mark are critical for safety. Replace only with part number specified.

Note: Les composants identifiés par un trame et une marque sont critiques pour la sécurité. Ne les remplacer que par une pièce portant le numéro spécifié.

Note:

- Items with no part number and/or no description are not stocked because they are seldom required for routine service.
- All screws are Phillips (cross recess) type unless otherwise noted.
(-) = slotted head
- Circled letters (A to Z) are applicable to European models only.

5-5.

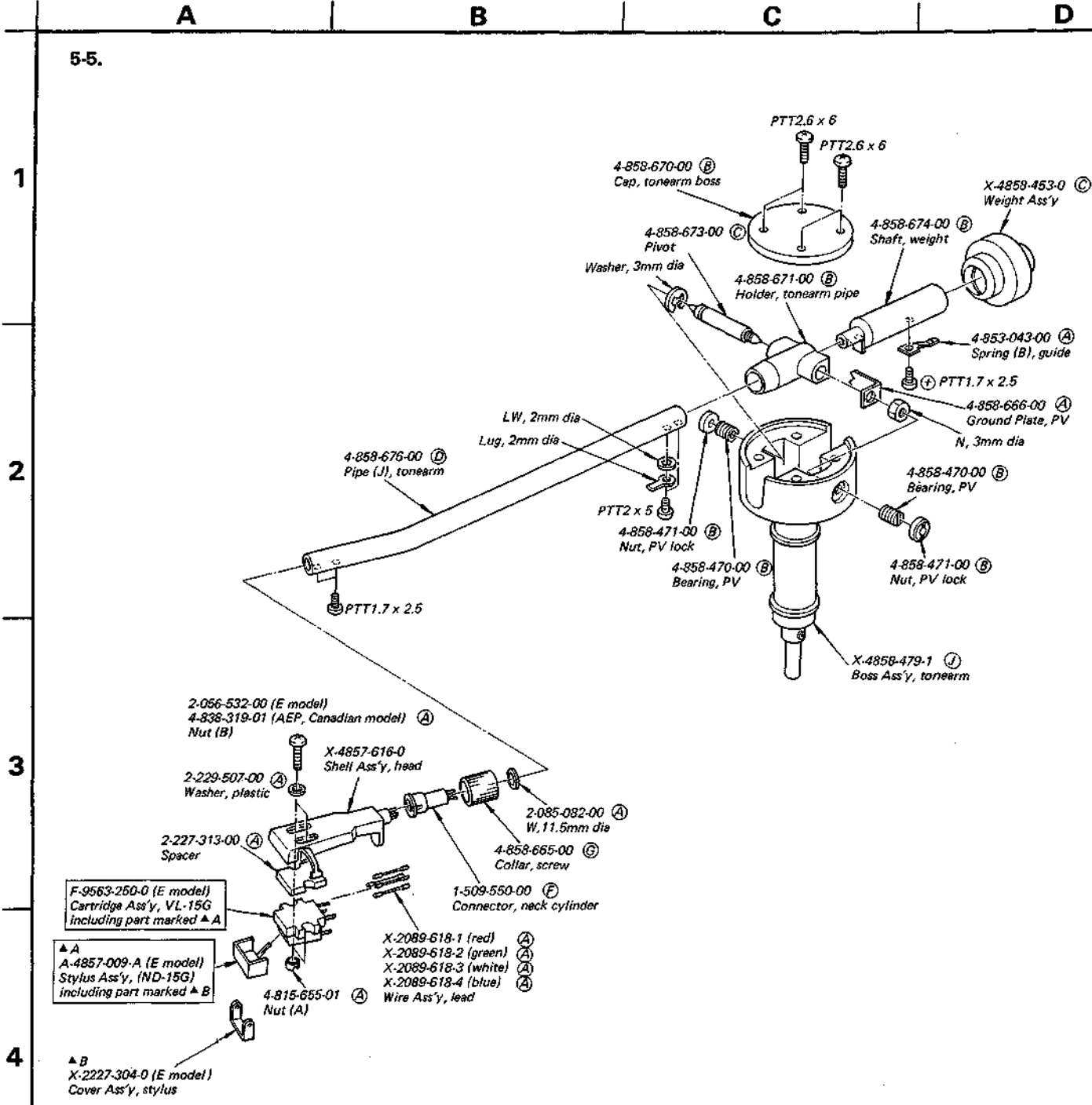

Note:

- Items with no part number and/or no description are not stocked because they are seldom required for routine service.
- All screws are Phillips (cross recess) type unless otherwise noted.
(-) = slotted head
- Circled letters (A to Z) are applicable to European models only.

**SECTION 6
ELECTRICAL PARTS LIST**

• Circled letters (**A** to **Z**) are applicable to European models only.

Ref. No. Part No. Description

SEMICONDUCTORS

Transistors

⇒ Q101-104 ⇒ Q112, 113)	8-729-663-47	(B)	2SC1364		
⇒ Q105, 110	8-727-788-00	(B)	2SA678		
⇒ Q106, 108	8-760-413-10	(B)	2SC1475		
⇒ Q107, 109	8-729-468-43	(B)	2SA684		
⇒ Q111	8-729-663-47	(B)	2SC1364		

IC

IC1, 2	8-759-145-58	(D)	μPC4558C		
--------	--------------	-----	----------	--	--

Diodes

⇒ D101	8-719-931-05	(A)	1S1555		
⇒ D102	8-719-815-55	(B)	EQB01-05		
⇒ D201-204	8-719-200-02	(B)	10E2		

Hall Device

H1, 2	8-719-905-07	(C)	5GF-MS-07F		
-------	--------------	-----	------------	--	--

COILS

L1-4	1-462-161-00	(C)	Coil, motor		
------	--------------	-----	-------------	--	--

TRANSFORMERS

T1	△1-446-079-00		Transformer, POWER (Canadian model)		
	△1-446-137-00	(I)	Transformer, POWER (AEP, E model)		

CAPACITORS

All capacitors are in μF and ceramic unless otherwise noted.
50WV or less are not indicated except for electrolytics.
pF : μF, elect : electrolytic

C101	1-101-925-00	(A)	0.047		
C102	1-102-117-00	(A)	820p		
C103	1-108-804-00	(A)	0.01		mylar
C104, 105	1-121-952-00	(A)	1	50V	elect
C106	1-161-034-00	(A)	0.022		
C107	1-121-415-00	(A)	100	16V	elect
C108	1-121-651-00	(A)	10	16V	elect

Ref. No. Part No. Description

C109	1-121-479-00	(A)	22	16V	elect
C110	1-121-651-00	(A)	10	16V	elect
C201	1-121-944-00	(E)	1000	16V	elect
C202	1-121-939-00	(B)	470	16V	elect
C203	△1-108-779-00		0.01	300V	paper
			(E model)		
C203	△1-115-148-00	(C)	0.01	450V	paper
			(AEP model)		
C204	△1-108-779-00	(B)	0.01	300V	paper
			(E model)		
C204	△1-115-148-00	(C)	0.01	450V	paper
			(AEP model)		
C204	△1-130-098-00		0.022	125V	mylar
			(Canadian model)		

RESISTORS

All resistors are in ohms. Common 1/4W carbon resistors are omitted.

R201	△1-213-156-00	(B)	12k	1W	metal oxide
RV101,102	1-224-633-00	(B)	4.7k, adjustable; gain		
RV103,104	1-224-637-00	(B)	100k, adjustable; offset		
RV301	1-226-138-00	(B)	1k, variable; PITCH		
RV302,303	1-224-633-00	(B)	4.7k, adjustable; speed		

SWITCHES

S1	1-552-233-00	(C)	Pushbutton, SPEED		
S2	1-552-412-00	(B)	Keyboard, START/STOP		
S3	1-552-532-00	(B)	Pushbutton, stop		
S4	1-552-571-11	(B)	Pushbutton, REPEAT		
S5	△1-552-531-11	(C)	Pushbutton, POWER		(Canadian, AEP model)
S5	△1-552-580-00		Pushbutton, POWER (E model)		
S6	△1-552-535-00	(C)	Selector, voltage (AEP, E model)		

MISCELLANEOUS

F1, 2	△1-532-066-00	(A)	Fuse, (AEP model)		
MGH	1-543-123-00	(K)	Speed-Detecting Head		
NL1	△1-519-135-00	(C)	Lamp, neon		
PM	1-454-196-00	(B)	Solenoid		
	1-452-059-00	(B)	Magnet, brake		

• ⇒: Due to standardization, interchangeable replacements may be substituted for parts specified in the diagrams.

Note: Les composants identifiés par un trame et une marque △ sont critiques pour la sécurité. Ne les remplacer que par une pièce portant le numéro spécifié.

Note: The components identified by shading and mark △ are critical for safety. Replace only with part number specified.

- Circled letters (A to Z) are applicable to European models only.

<u>Part No.</u>	<u>Description</u>
1-509-550-00	(F) Connector, neck cylinder
1-533-131-00	(A) Holder, fuse (AEP model)
(A) 1-534-817-99	(E) Cord, power (AEP model)
(A) 1-534-986-XX	Cord, power (Canadian model)
1-551-063-00	(F) Cord, phono (with connector)
(A) 1-551-530-00	Cord, power; euro-plug (E model)
(A) 1-551-473-31	Cord, power; parallel blade plug (E model)

ACCESSORIES & PACKING MATERIALS

<u>Part No.</u>	<u>Description</u>
A-4857-009-A	Stylus Ass'y, ND-15G (E model) including;
X-2227-304-0	Cover Ass'y, stylus
F-9563-250-0	Cartridge Ass'y, VL-15G (E model) including;
A-4857-009-A	Stylus Ass'y, ND-15G
3-701-616-00	(A) Bag, polyethylene; Shell, Main Weight
3-701-630-00	(A) Bag, polyethylene
3-701-634-00	(A) Bag, polyethylene; TT
3-701-806-00	(A) Adaptor, 45
3-770-601-11	(D) Manual, instruction (AEP, E model)
3-794-297-31	Manual, instruction (Canadian model)
3-770-601-21	
3-793-395-14	(B) Gauge, tracking error
3-794-263-11	(A) Leaflet, PS; VL-32G (AEP model)
3-794-295-00	Leaflet, PS; VL-15G (E model)
4-847-314-00	(C) Bag, polyethylene, (main)
4-848-002-00	(A) Cushion, arm pipe
4-857-655-00	(A) Plate (A), protection
4-858-407-00	(A) Adjustor, drop-point
4-858-587-00	(B) Case, accessory
4-858-593-00	(A) Cushion, weight bar
4-858-739-00	(E) Carton
4-858-740-00	(C) Cushion (right)
4-858-741-00	(C) Cushion (left)
4-858-748-00	(C) Box, accessory

Note: Les composants identifiés par un tramé et une marque **A** sont critiques pour la sécurité. Ne les remplacer que par une pièce portant le numéro spécifié.

Note: The components identified by shading and mark **A** are critical for safety. Replace only with part number specified.

STEREO TURNTABLE SYSTEM

PS-T30

AEP Model
E Model
Canadian Model

CORRECTION

Correct the service manual as shown below.

No. 1

September, 1979

 : corrected portion

Page 32
EXPLODED VIEW
5-3.

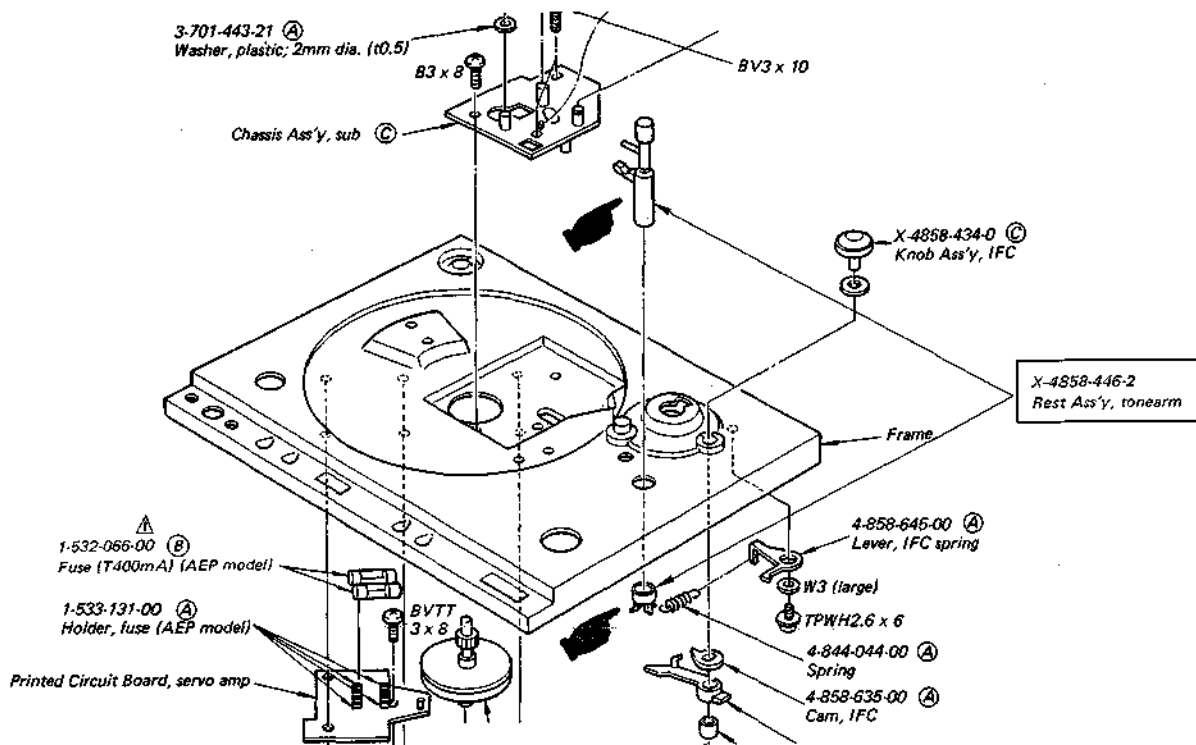

Sony Corporation

© 1979

SONY

SERVICE MANUAL