

PS-Q3A

SERVICE MANUAL

6846
 US Model
 Canadian Model
 AEP Model
 UK Model
 E Model

- PS-Q3A differs from PS-Q3 in following parts.
- Refer to the PS-Q3 Service Manual previously issued for the information not contained here. (2053)

No.	Part No.	Description
48	4-885-133-00	(SILVER)..BUTTON,POWER
48	4-885-133-21	(BLACK)...BUTTON,POWER
50	4-885-136-00	(SILVER)..BUTTON,S/S
50	4-885-136-21	(BLACK)...BUTTON,S/S
78	4-905-536-01	LABEL,SWITCH
92	4-905-514-21	(US,Canadian,AEP,UK)(SILVER)PANEL,ORNAMENTAL
92	4-905-514-31	(US,Canadian,AEP,UK)(BLACK)PANEL,ORNAMENTAL
92	4-905-514-01	(E)(SILVER)..PANEL,ORNAMENTAL
92	4-905-514-41	(E)(BLACK)...PANEL,ORNAMENTAL
94	*4-905-537-01	(US,Canadian)..LABEL,MODEL NUMBER
94	*4-905-535-01	(AEP).....LABEL,MODEL NUMBER
94	*4-905-540-01	(UK).....LABEL,MODEL NUMBER
94	*4-905-538-01	(E).....LABEL,MODEL NUMBER
96	4-905-522-21	(SILVER)..PANEL,CONTROL
96	4-905-522-31	(BLACK)...PANEL,CONTROL
98	4-905-539-01	(SILVER)..FRAME
98	4-905-539-11	(BRACK)...FRAME
147	X-4905-503-1	(SILVER)..COVER ASSY,DUST
147	X-4905-503-4	(BLACK)...COVER ASSY,DUST
212	4-905-533-11	(US,Canadian,AEP,UK)INDIVIDUAL CARTON
212	4-905-533-21	(E).....INDIVIDUAL CARTON

NOTE:
 - Items marked " * " are not stocked since they are seldom required for routine service. Some delay should be anticipated when ordering these items.

• MODEL IDENTIFICATION

— Specification Label —

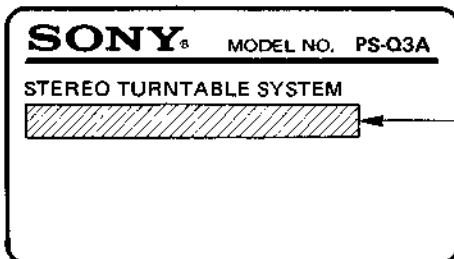

US, Canadian model: AC : 120V 60 Hz 3W
 AEP model: AC : 220V ~ 50/60 Hz 3W
 UK model: AC : 240V ~ 50/60 Hz 3W
 E model: AC : 110 - 120V, 220 - 240V ~ 50/60 Hz 3W

STEREO TURNTABLE SYSTEM
SONY®



9-951-690-11

Sony Corporation

English
 85C06110-1
 Printed in Japan
 © 1985



6846

PS-Q3

SERVICE MANUAL

*US Model
Canadian Model
AEP Model
UK Model
E Model*



SPECIFICATIONS

Turntable

Platter	7.8 cm (3 ¹ / ₈ in.), zinc-alloy diecast
Motor	DC motor
Drive system	Belt drive
Control system	Electro governor servo control system
Speed	33 ¹ / ₃ rpm, 45 rpm
Wow and flutter	0.12% (WRMS)
Signal-to-noise ratio	58 dB (DIN-B)
Automatic system	Lead-in, return, reject

Tonearm

Type	Dynamic balanced low mass type
------	-----------------------------------

Cartridge

Type	Moving magnet type
Frequency response	10 to 20,000 Hz
Channel separation	20 dB at 1 kHz
Load impedance	50 kilohms
Tracking force	2 g
Stylus	Sony ND-143G (0.6 mil diamond)
Weight	3.4 g

General

Power requirements	US, Canadian model: 120 V ac, 60 Hz AEP model: 220 V ac, 50/60 Hz UK model: 240 V ~ ac, 50/60 Hz E model: 110 - 120, 220 - 240 V ~ ac, 50/60 Hz
Power consumption	3 W
Dimensions	Approx. 215 x 235 x 58 mm (w/h/d) (8 ¹ / ₂ x 9 ³ / ₈ x 2 ³ / ₈ in.) including projecting parts and controls
Weight	Approx. 2.3 kg (5 lbs 2 oz) net Approx. 3.0 kg (6 lbs 10 oz), in shipping carton

ATTENTION AU COMPOSANT AYANT RAPPORT
À LA SÉCURITÉ!

LES COMPOSANTS IDENTIFIÉS PAR UNE TRAME ET
UNE MARQUE  SUR LES DIAGRAMMES SCHE-
MATIQUES ET LA LISTE DES PIÈCES SONT CRITIQUES
POUR LA SÉCURITÉ DE FONCTIONNEMENT. NE REM-
PLACER CES COMPOSANTS QUE PAR DES PIÈCES
SONY DONT LES NUMÉROS SONT DONNÉS DANS CE
MANUEL OU DANS LES SUPPLÉMENTS PUBLIÉS PAR
SONY.

SAFETY-RELATED COMPONENT WARNING!!

COMPONENTS IDENTIFIED BY SHADING AND MARK
 ON THE SCHEMATIC DIAGRAMS AND IN THE
PARTS LIST ARE CRITICAL TO SAFE OPERATION.
REPLACE THESE COMPONENTS WITH SONY PARTS
WHOSE PART NUMBERS APPEAR AS SHOWN IN THIS
MANUAL OR IN SUPPLEMENTS PUBLISHED BY SONY.



STEREO TURNTABLE SYSTEM
SONY®

AUD

SAFETY CHECK-OUT (US Model)

After correcting the original service problem, perform the following safety check before releasing the set to the customer:

Check the antenna terminals, metal trim, "metallized" knobs, screws, and all other exposed metal parts for AC leakage. Check leakage as described below.

LEAKAGE TEST

The AC leakage from any exposed metal part to earth ground and from all exposed metal parts to any exposed metal part having a return to chassis, must not exceed 0.5 mA (500 microamperes). Leakage current can be measured by any one of three methods.

1. A commercial leakage tester, such as the Simpson 229 or RCA WT-540A. Follow the manufacturers' instructions to use these instruments.
2. A battery-operated AC milliammeter. The Data Precision 245 digital multimeter is suitable for this job.
3. Measuring the voltage drop across a resistor by means of a VOM or battery-operated AC voltmeter. The "limit" indication is 0.75 V, so analog meters must have an accurate low-voltage scale. The Simpson 250 and Sanwa SH-63Trd are examples of a passive VOM that is suitable. Nearly all battery operated digital multimeters that have a 2 V AC range are suitable. (See Fig. A)

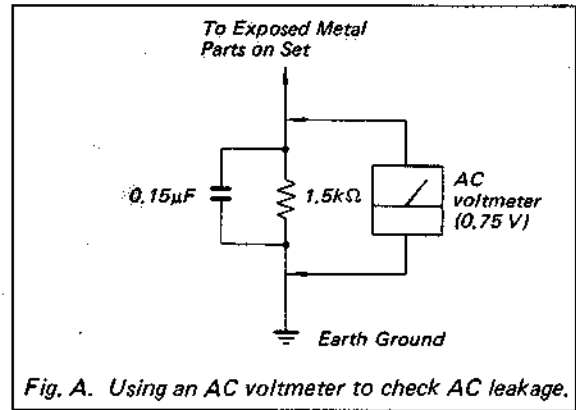
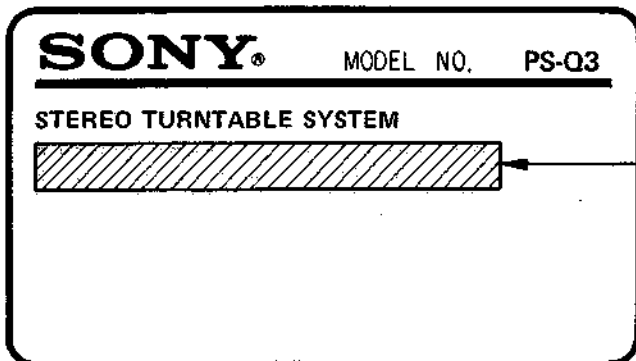

Fig. A. Using an AC voltmeter to check AC leakage.

MODEL IDENTIFICATION

— Specification Label —



US, Canadian model: AC: 120 V 60 Hz 3 W
 AEP model: AC: 220 V ~ 50/60 Hz 3 W
 UK model: AC: 240 V ~ 50/60 Hz 3 W
 E model: AC: 110 - 120, 220 - 240 V ~ 50/60 Hz 3 W

SECTION 1
OUTLINE

1-1. PARTS LOCATION

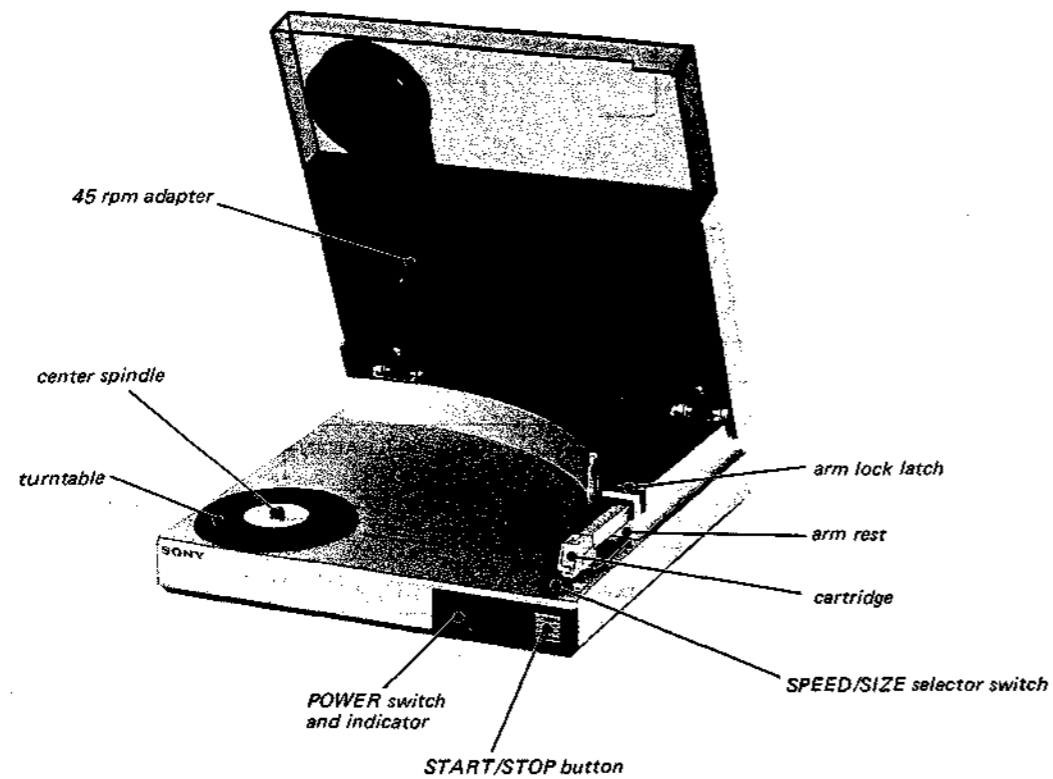

1-2. MECHANISM DESCRIPTION
AUTOMATIC OPERATION MODE
1. REST

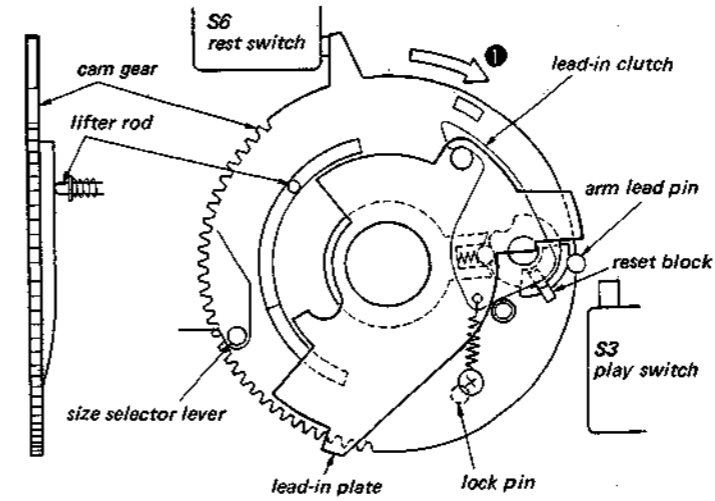

- Cam gear stops, pressing the rest switch.
- The lifter rod is in the "arm lifted" state.
- The arm lead pin is in the rest position.
- ① The arm drive motor (M1) is driven when the START/STOP switch is pressed, and the cam gear turns. Then the turntable motor (M2) goes on.

2. DROP POINT

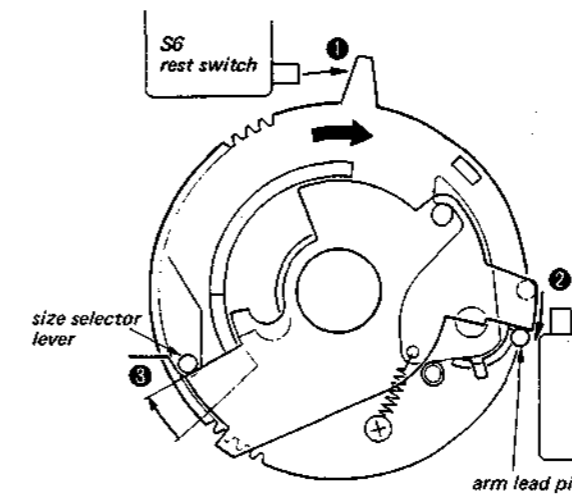

- ① S6 goes off.
- ② The arm lead pin is pressed and the arm moves inward.
- ③ The lead-in plate hits the size selector lever, and the arm movement stops. (drop point)

3. LEAD-IN CLUTCH RELEASE

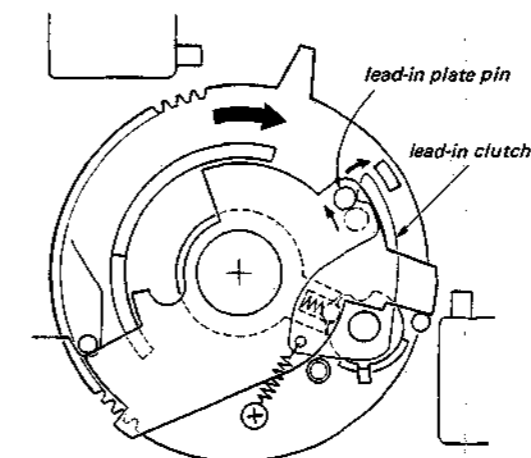

- Since the lead-in plate stops and the cam gear turns, the lead-in clutch comes off of the lead-in plate pin.

4. ARM DOWN

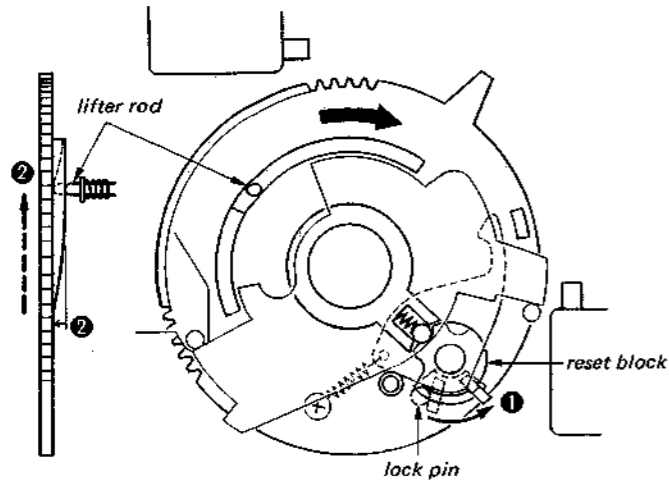

- 1 The claw of the reset block hits the lock pin (chassis side), and the reset block is set.
- 2 The lifter rod traces the slope of the cam gear, and the arm is lowered.

5. PLAYING RECORD

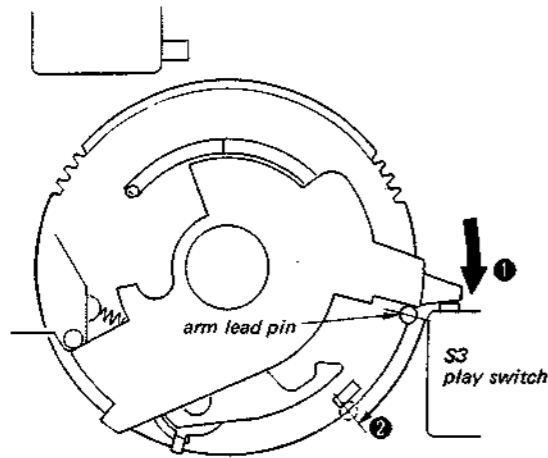

- 1 S3 goes on and the cam gear stops. Record playing starts.
- 2 The arm moves inward as the record plays, and the arm lead pin moves.

6. RETURN

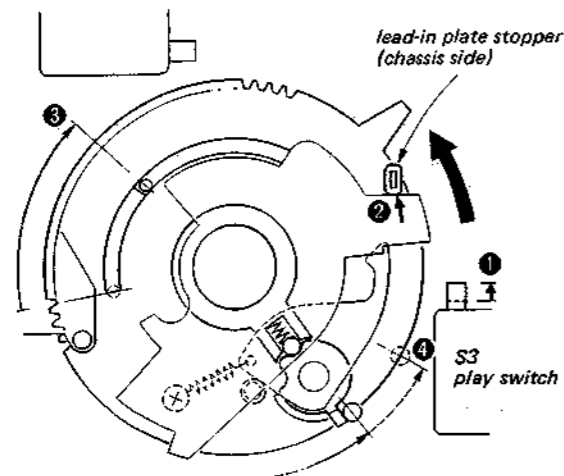

- When record playing ends, the end detector detects it. Then arm drive motor (M1) is driven, and the cam gear turns counterclockwise.
- 1 S3 goes off.
 - 2 The lead-in plate is moved back to the rest position.
 - 3 The lifter rod goes up and the arm is lifted.
 - 4 The arm lead pin is pressed by the reset block and the arm returns.

7. REST

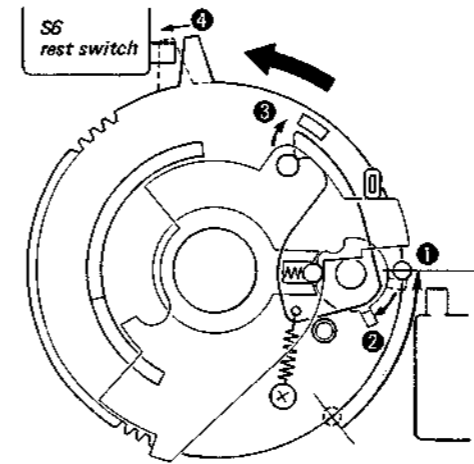

- 1 The arm is pressed till the arm rest position.
- 2 The arm lead pin stops and the reset block is reset.
- 3 The lead-in cam is locked.
- 4 S6 goes on and the cam gear stops. The turntable motor (M2) goes off. (Rest mode)

1-3. CIRCUIT DESCRIPTION

IC102's (SYSTEM CONTROLLER IC TC9305P-009) TERMINAL FUNCTIONS

PIN NO.		IN/OUT	TIMING CHART
1	GND		Ground terminal
2	OSC		Terminal for clock OSC
3	CLOCK		
4	START/STOP	INPUT	
5	REST	INPUT	
6	PLAY	INPUT	
7	END DET	INPUT	
8	SIZE SELECT	INPUT	
11	SIZE 30	OUTPUT	
12	SIZE 17	OUTPUT	
13	ARM OUT	OUTPUT	
14	ARM IN	OUTPUT	
15	TT MOTOR	OUTPUT	
16	VDD		Power supply terminal

SECTION 2 DISASSEMBLY

Note: Follow the disassembly procedure in the numerical order given.

Frame

- ① Pull off the cartridge.
- ② Remove the eight screws +BVTP3 x 12

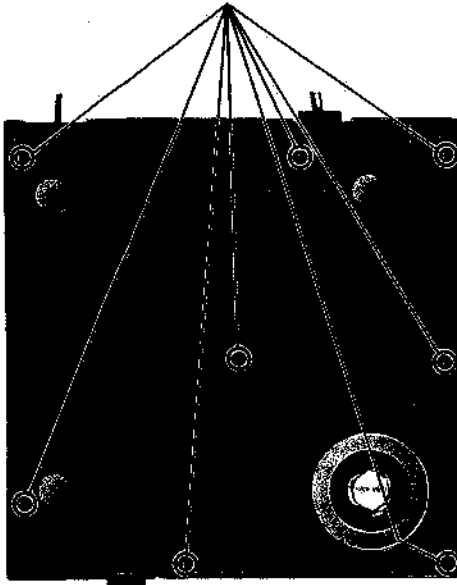

- ④ Set the player system normal position, turntable side facing top.
- ⑤ Lift up the frame slowly and remove it by letting the tonearm pass through the opening in the frame.

- ③ Remove the bottom cover.

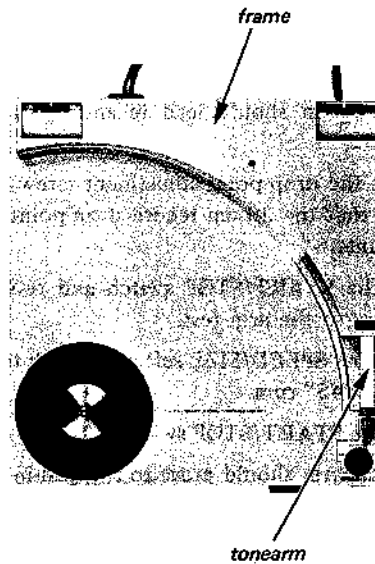

NOTE ON REASSEMBLING CAM GEAR

When reassembling, make sure the protrusion of the cam gear does not land on the lever of the REST switch (S6). When it does, push the lever in to clear the landing.

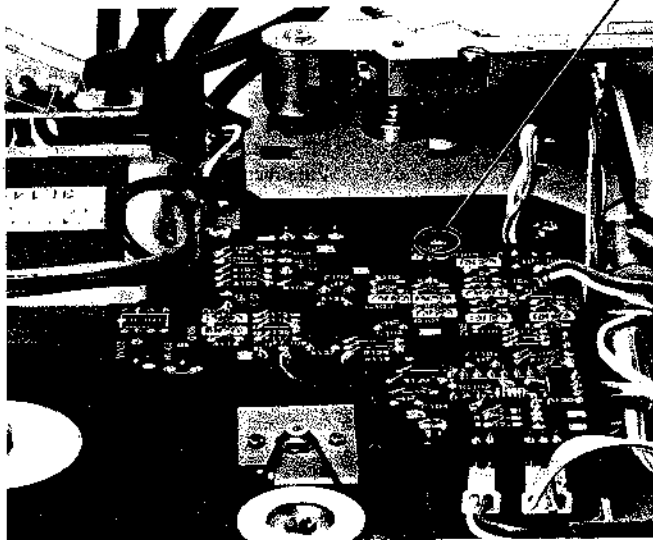

SECTION 3 ADJUSTMENTS

3-1. MECHANICAL ADJUSTMENTS

Drop Point Adjustment

1. Set the test record (YFSC-16) on the turntable.
2. Select the SPEED/SIZE selector switch to "30" cm and "33" rpm.
3. Turn on the POWER switch. The LED indicator lights.
4. Push the START/STOP switch.
5. The tonearm should lead in and play the record.
6. Adjust the drop point adjustment screw in such a way that the 30 cm record drop point is 7 to 15 counts.
7. Push the START/STOP switch and return the tonearm to the arm rest.
8. Select the SPEED/SIZE selector switch to "17" cm and "45" rpm.
9. Push the START/STOP switch.
10. The tonearm should move to the lead-in groove of 17 cm record and play the record.
At this time, the 17 cm record drop point should be 6 to 24 counts. If the drop point is not in the above range, adjust the drop point adjustment screw again.
11. Select the SPEED/SIZE selector switch to "30" cm and "33" rpm again. Make sure that the 30 cm record drop point. Adjust the drop point if necessary.

Return Point Adjustment

1. Put the return point adjustment record (YFSC-16) on the turntable.
2. Select the SPEED/SIZE selector switch to "30" cm and "33" rpm.
3. Move the tonearm to the start position of the return point groove by hand.
4. Turn on the POWER switch. The LED indicator lights.
5. Push the START/STOP switch to play the record.
6. Adjust the return point adjustment screw in such a way that the tonearm returns at the 30 cm record return point 10 – 13 counts.
7. Select the SPEED/SIZE selector switch to "17" cm and "33" rpm. (The tonearm is on the arm reset.)
8. Move the tonearm to the start position of the 17 cm record return point groove by hand.
9. Push the START/STOP switch. The tonearm should down to the record groove and play the record.
10. The tonearm should stop playing the record and return to the arm rest at the 17 cm record return point 14 – 17 counts.
Readjust the return point adjustment screw finely if necessary.
11. Select the SPEED/SIZE selector switch to "30" cm and "33" rpm. Make sure that the 30 cm record return point again.

Caution: If the record play is started under "30" cm selected by the SPEED/SIZE selector switch, the SPEED/SIZE selector switch can be changed from "30" cm to "17" cm during playing the record. However, if the record play is started under "17" cm, the SPEED/SIZE selector switch can not be changed to "30" cm during playing the record.

return point adjustment screw



drop point adjustment screw

Reduce count (CCW)  Increase count (CW)

3-2. ELECTRICAL ADJUSTMENTS

Stylus Pressure Adjustment

1. Turn on the POWER switch. Push the START/STOP switch to let the tonearm lead in.
2. Turn off the POWER switch.
3. Adjust the stylus pressure at the range of 1.8 ± 0.3 g by changing the compression spring hooking position under the tonearm at horizontal.

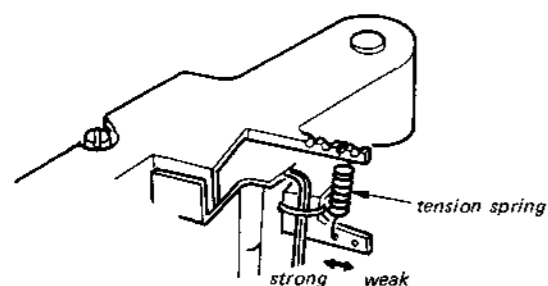

Stylus Height Adjustment

1. The tonearm is on the arm rest and UP condition.
2. Adjust the clearance between the tonearm top surface and subframe inside surface by the stylus height adjustment screw to 0.5 - 1.0 mm.
3. After the adjustment 2, make sure that the tonearm top surface does not touch with the subframe inside surface by leading in and returning the tonearm.

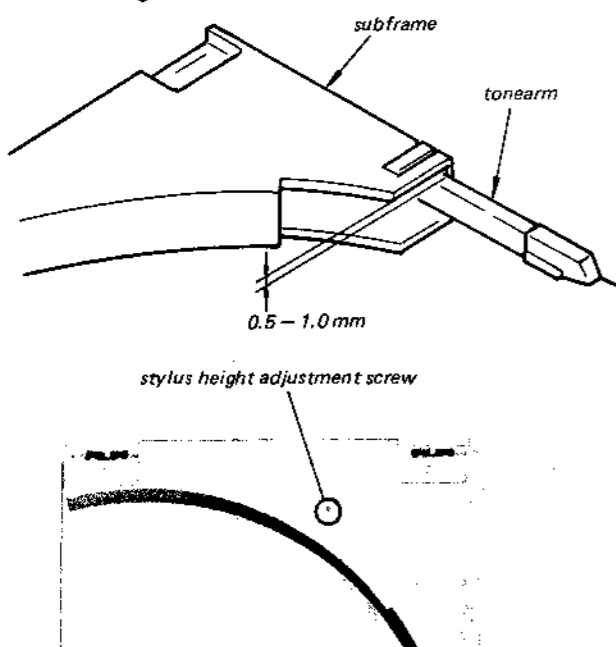

Power Voltage Adjustment

Setting:

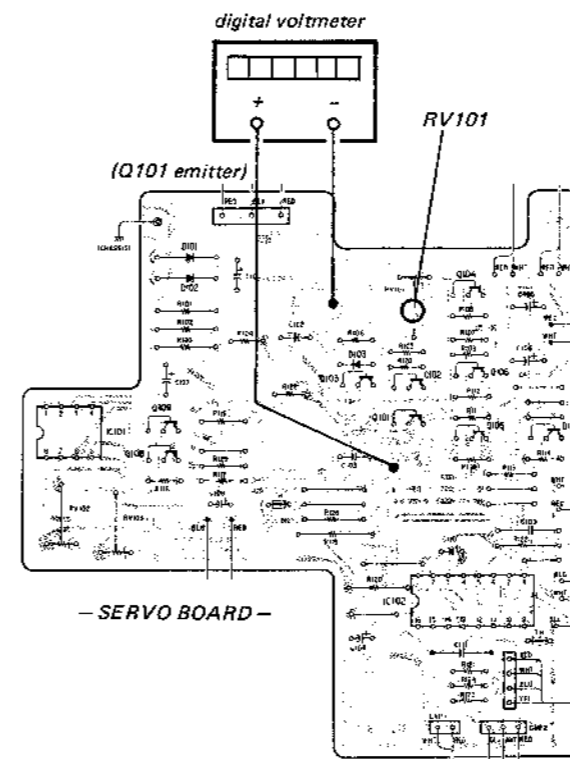

Procedure:

1. Turn on the POWER switch. (STOP mode)
2. Adjust RV101 for $3.1 \text{ V} \pm 0.1 \text{ V}$ on the digital voltmeter.

Speed Adjustment

Setting:

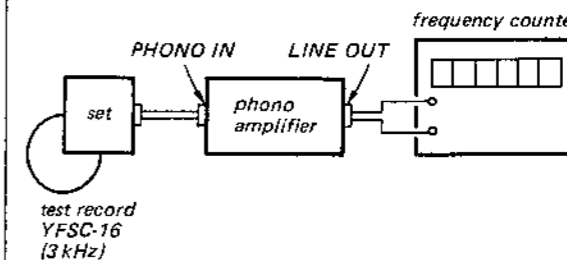

Procedure:

1. Select the SPEED/SIZE selector switch to "30" cm and "33" rpm.
2. Play 3 kHz signal in the test record.
3. Adjust RV102 for $3,000 \text{ Hz} \pm 9 \text{ Hz}$ on the counter.
4. Select the SPEED/SIZE selector switch to "30" cm and "45" rpm.
5. Play 3 kHz signal in the test record.
6. Adjust RV103 for $4,050 \text{ Hz} \pm 12 \text{ Hz}$ on the counter.

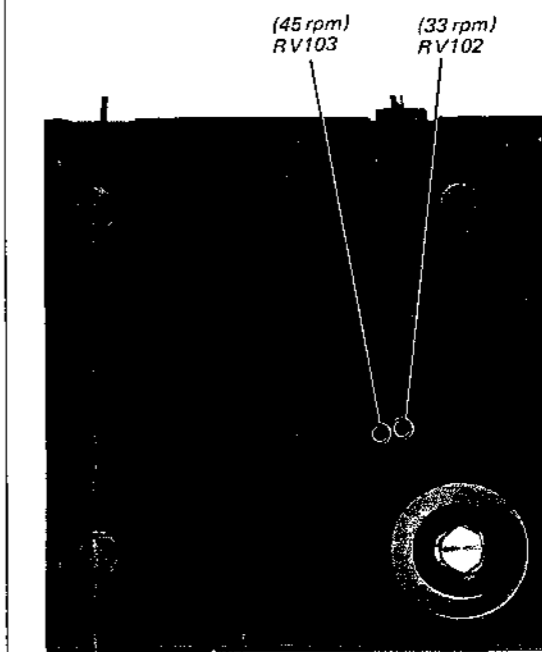

3-2. ELECTRICAL ADJUSTMENTS

Power Voltage Adjustment

Setting:

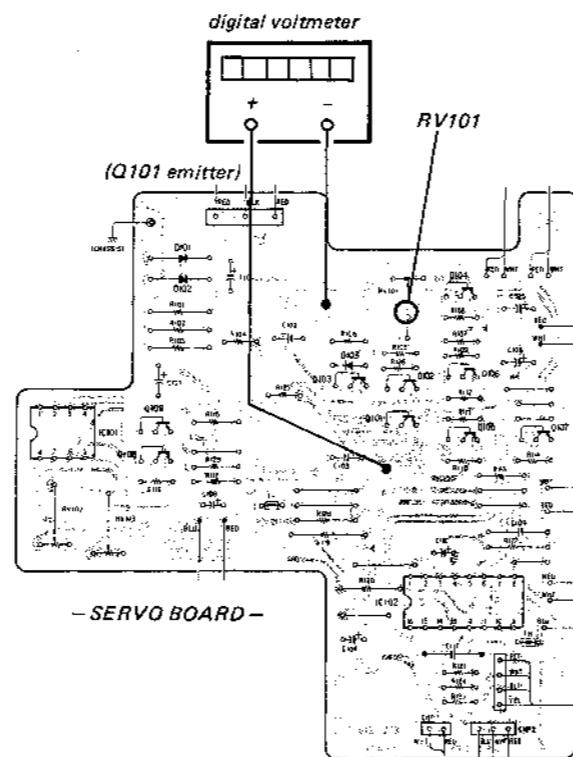

Procedure:

1. Turn on the POWER switch. (STOP mode)
2. Adjust RV101 for 3.1 V \pm 0.1 V on the digital voltmeter.

Speed Adjustment

Setting:

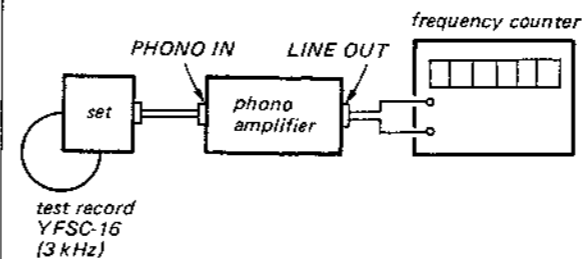

Procedure:

1. Select the SPEED/SIZE selector switch to "30" cm and "33" rpm.
2. Play 3 kHz signal in the test record.
3. Adjust RV102 for 3,000 Hz \pm 9 Hz on the counter.
4. Select the SPEED/SIZE selector switch to "30" cm and "45" rpm.
5. Play 3 kHz signal in the test record.
6. Adjust RV103 for 4,050 Hz \pm 12 Hz on the counter.

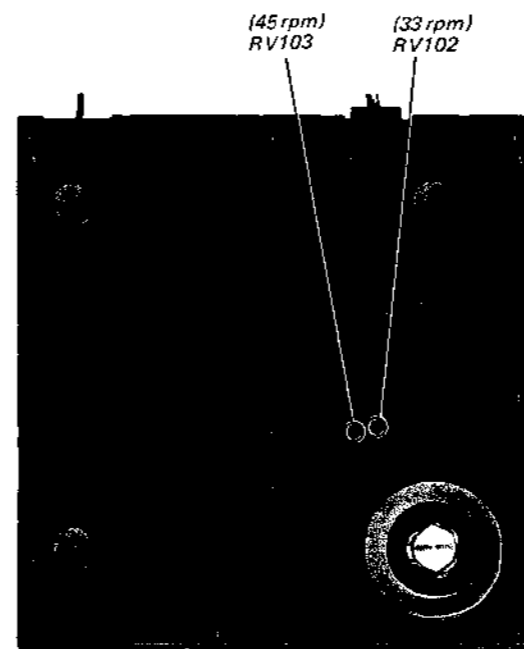

SECTION 4 DIAGRAMS

4-1. MOUNTING DIAGRAM

Q	IC101	109 108		103	102 101	104 106 105 IC102	107		401 402	Q
D		101 102		103				301	401 402	D

A
B
C
D
E
F
G
H
I
J

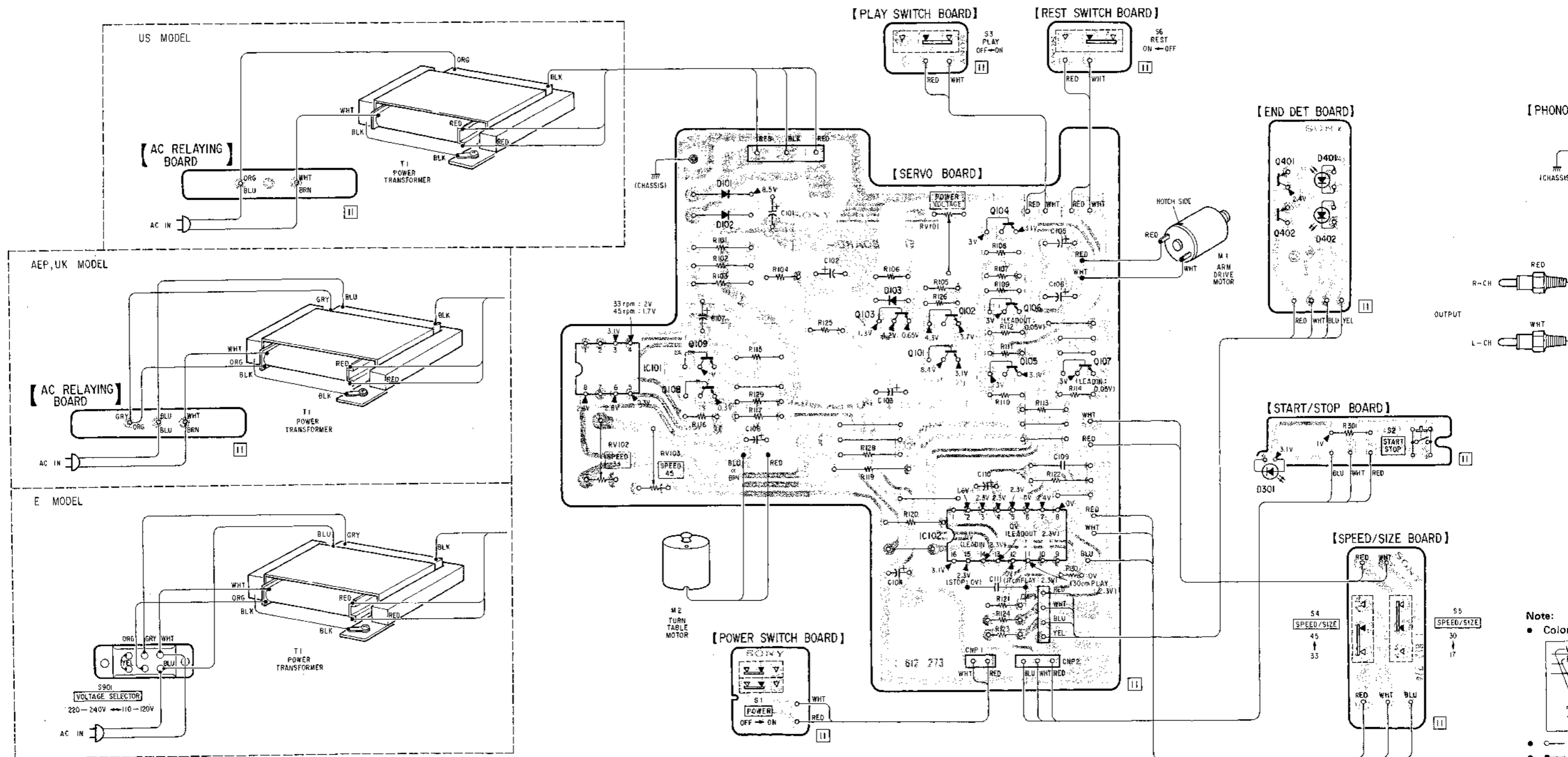

Note:
• Color

Q IC	IC101	I09 I08		I03	I02 I01	I04 I05 IC102	I07		401 402	Q IC
D		I01 I02		I03				301	401 402	D

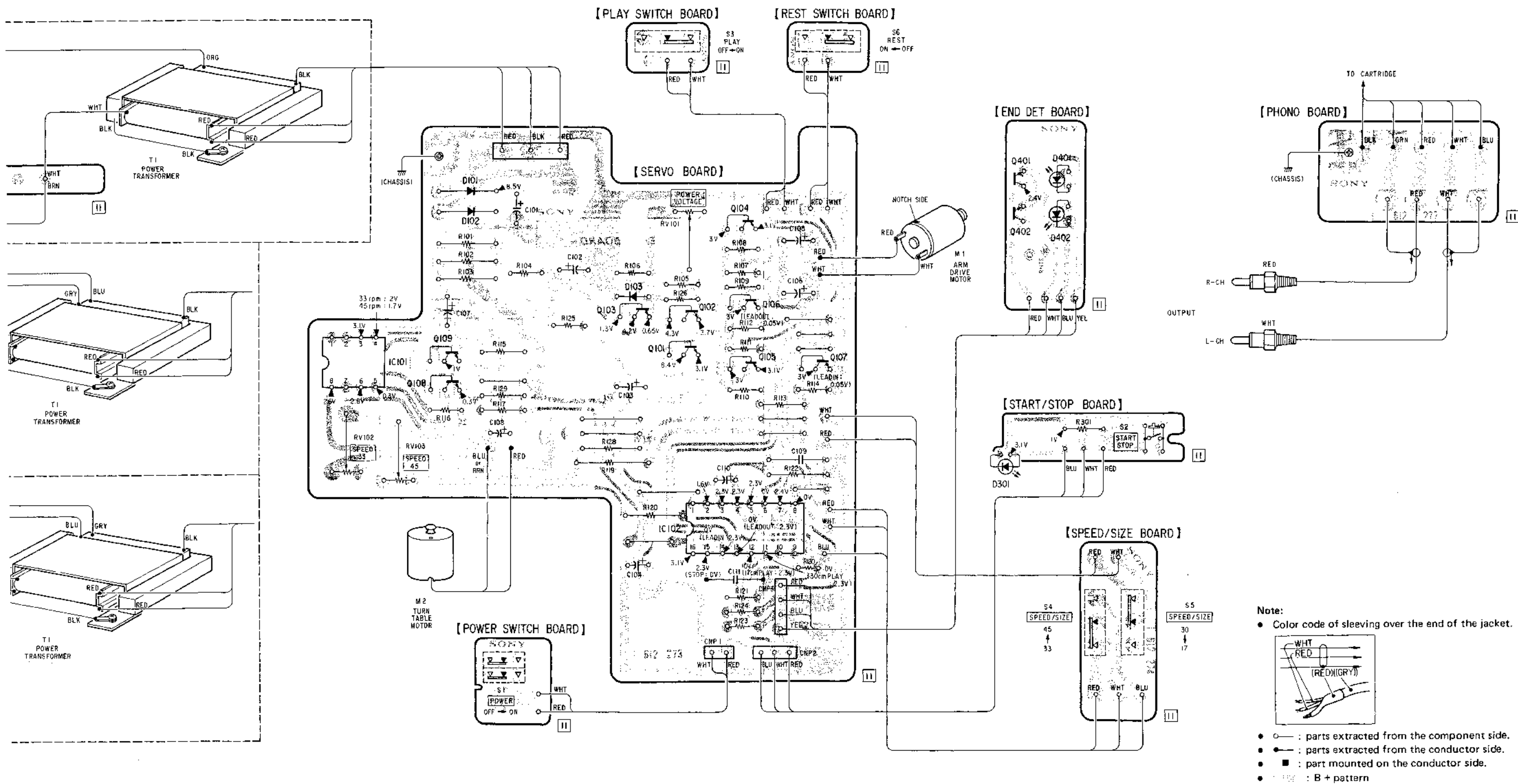

Note:

- Color code of sleeving over the end of the jacket.

- : parts extracted from the component side.
- : parts extracted from the conductor side.
- : part mounted on the conductor side.
- ⊕ : B + pattern

4-2. SCHEMATIC DIAGRAM

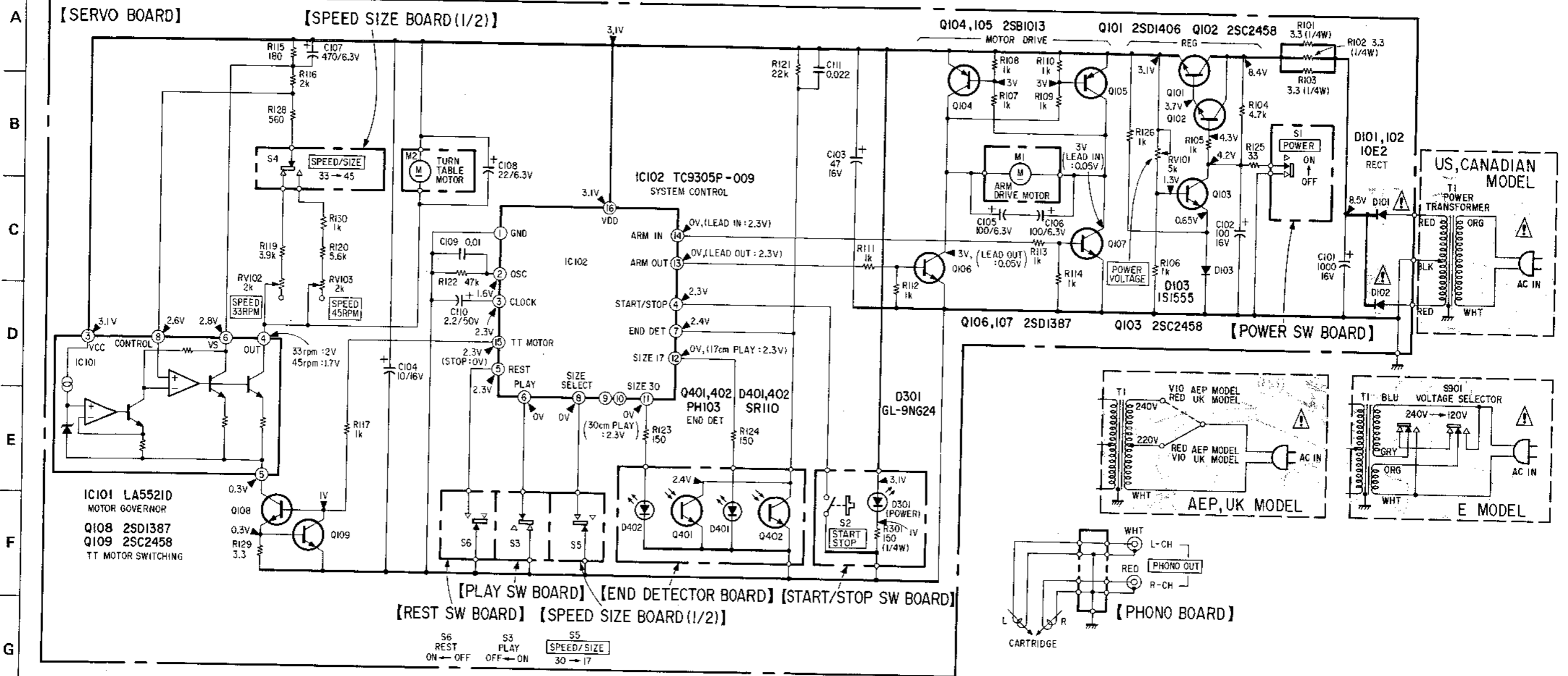

• Semiconductor Lead Layouts

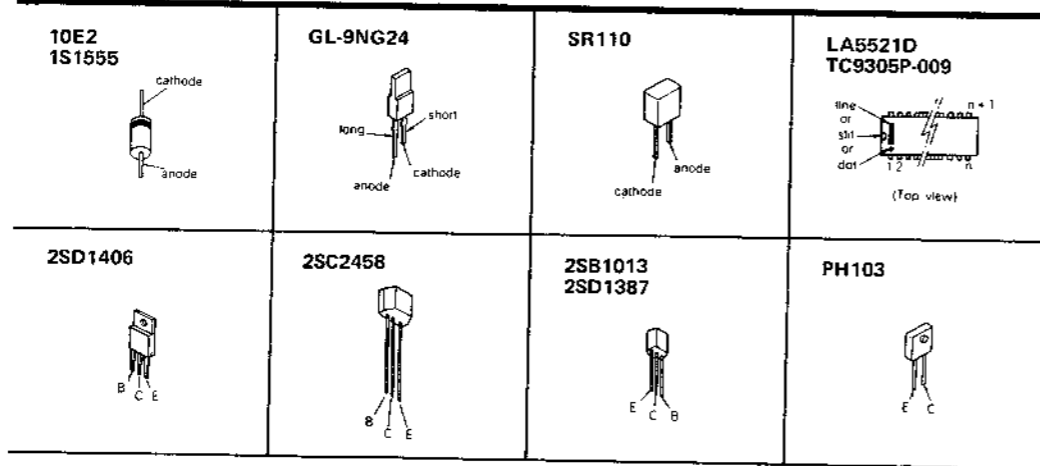

Note:

- All capacitors are in μF unless otherwise noted. pF: μpF . 50WV or less are not indicated except for electrolytics and tantalums.
- All resistors are in ohms, $\frac{1}{4}$ W unless otherwise noted. k Ω : 1000 Ω , M Ω : 1000 k Ω .
- Panel designation.
- Adjustment for repair.
- B+ bus.
- Readings are taken under 30 cm PLAY mode with a VOM (50 k Ω /V).
- Switches

Ref. No.	Switch	Position
S1	POWER	OFF
S2	START/STOP	OFF
S3	PLAY	ON
S4	SPEED/SIZE (45 RPM/33 RPM)	33 RPM
S5	SPEED/SIZE (17 cm/30 cm)	30 cm
S6	REST	OFF

Note: The components identified by shading and mark are critical for safety. Replace only with part number specified.

Note: Les composants identifiés par une trame et une marque sont critiques pour la sécurité. Ne les remplacer que par une pièce portant le numéro spécifié.

SECTION 5
EXPLODED VIEWS AND PARTS LIST

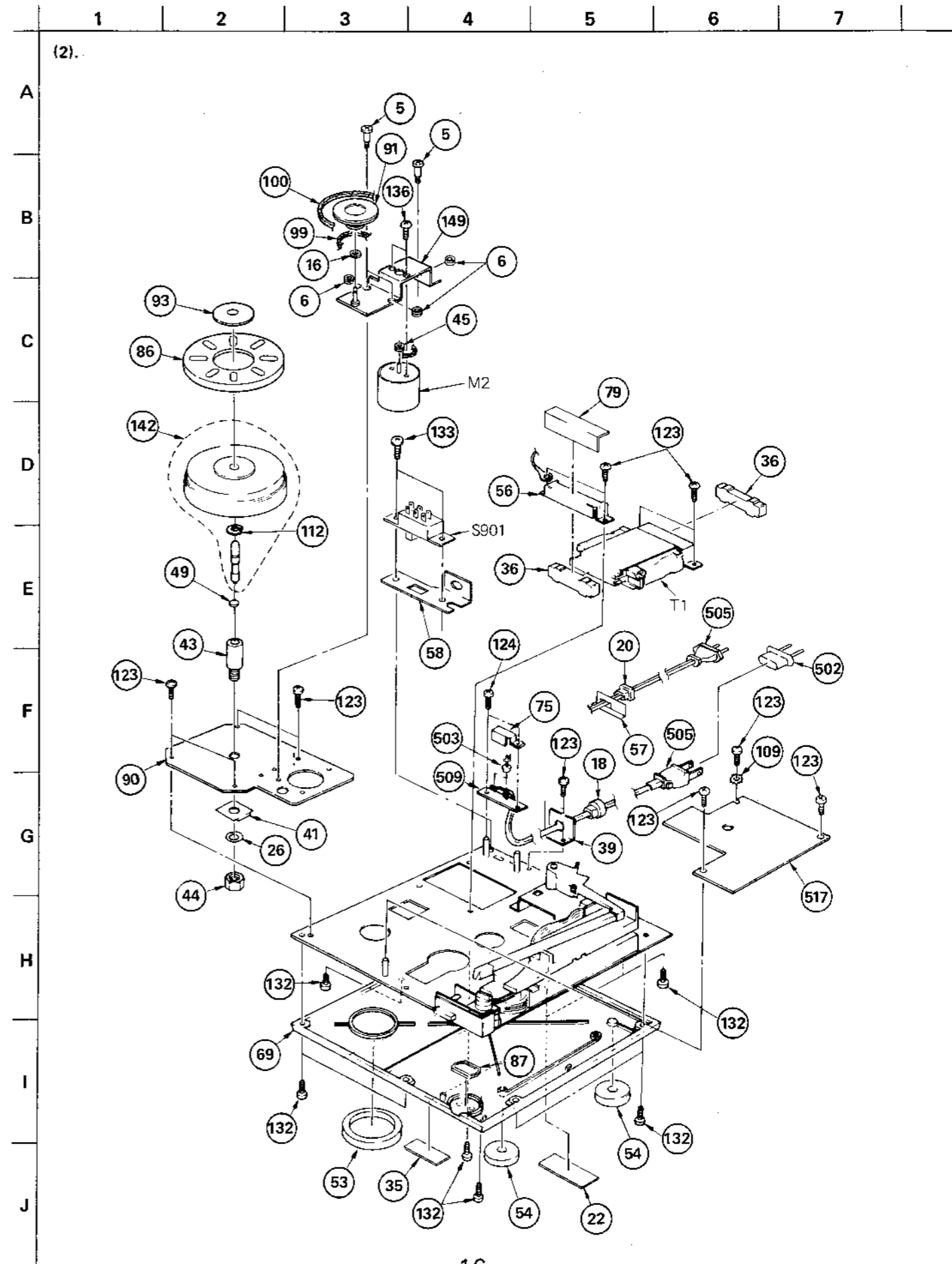
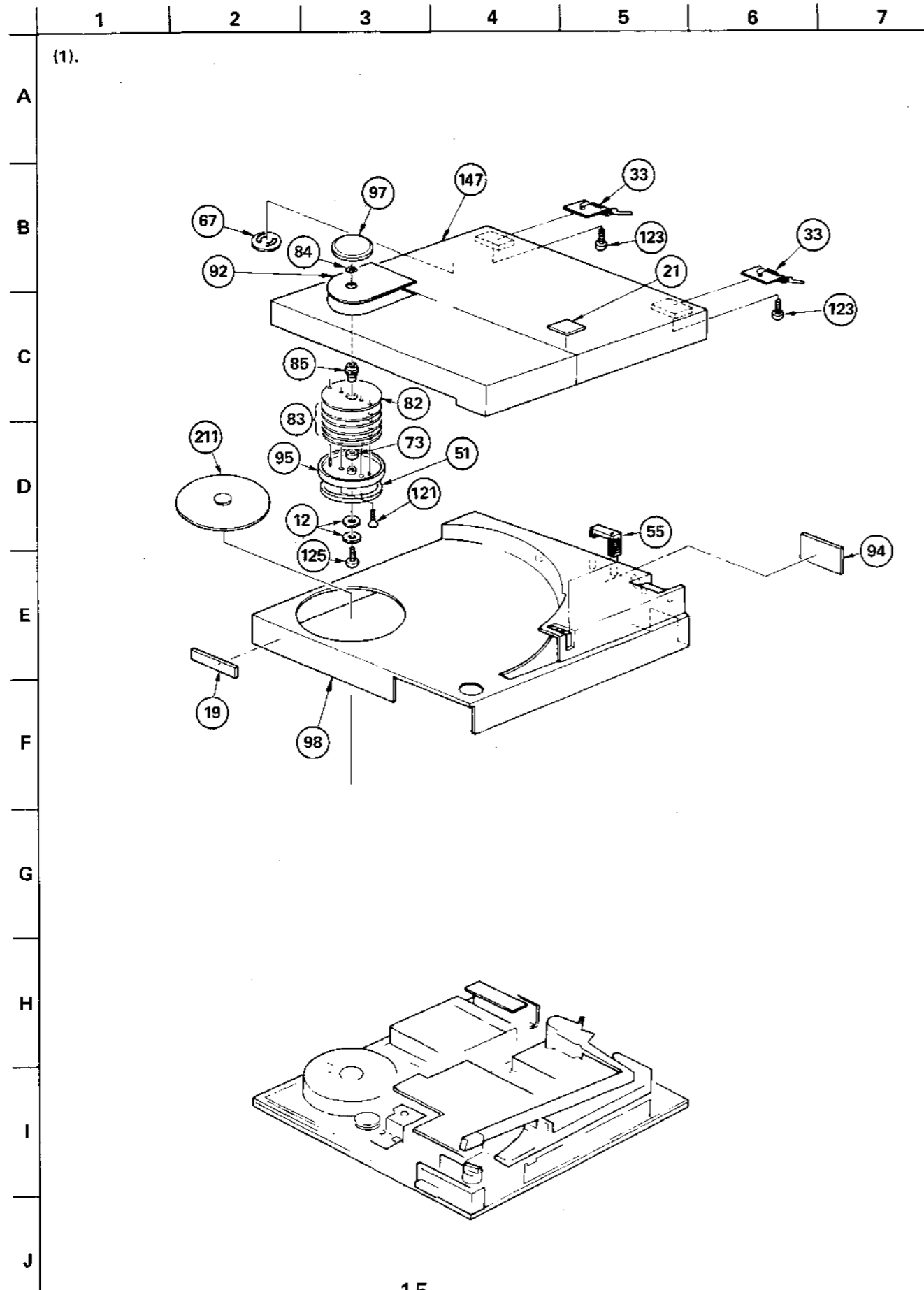

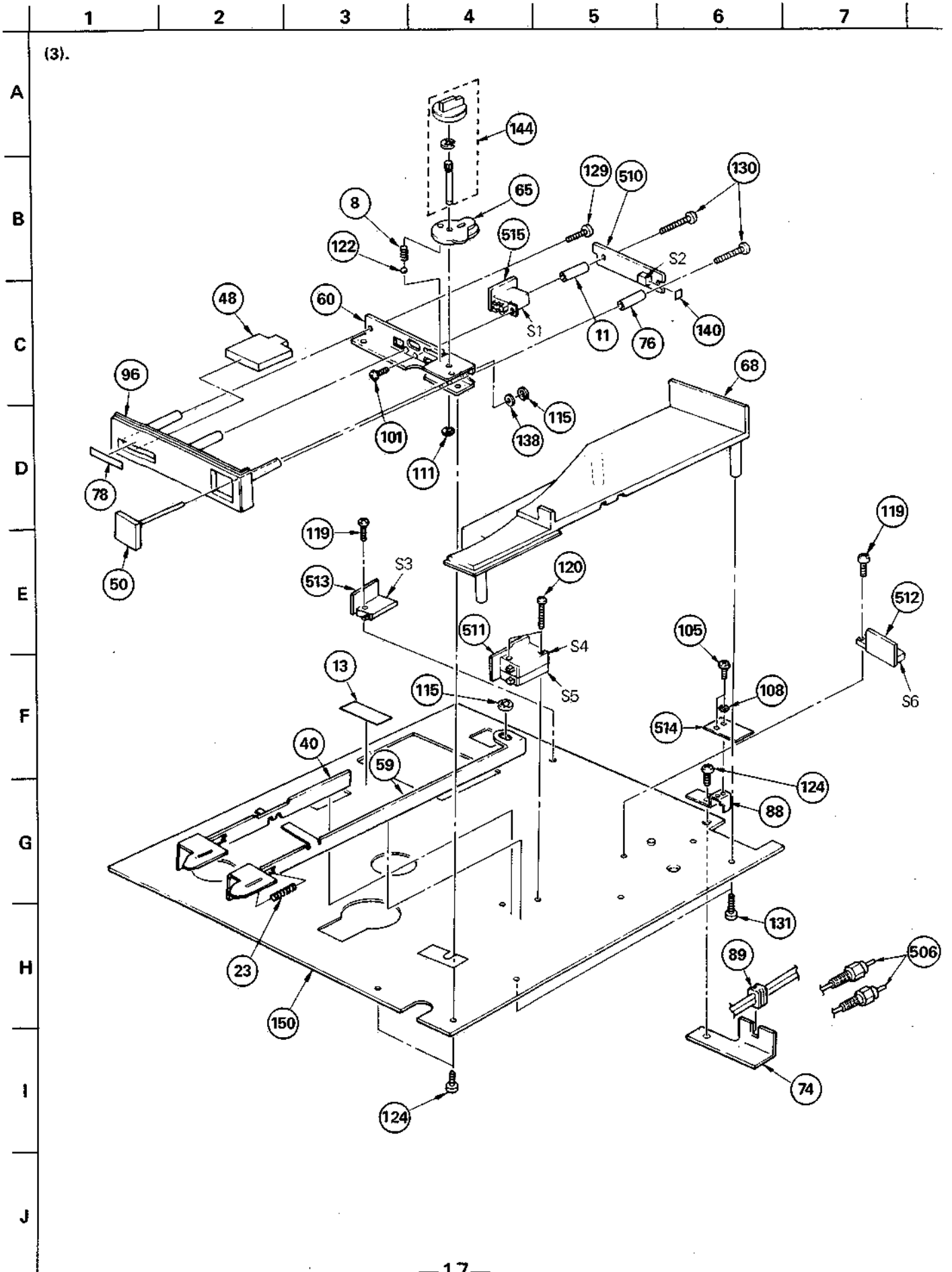

1 2 3 4 5 6 7

(4).

A
B
C
D
E
F
G
H
I
J

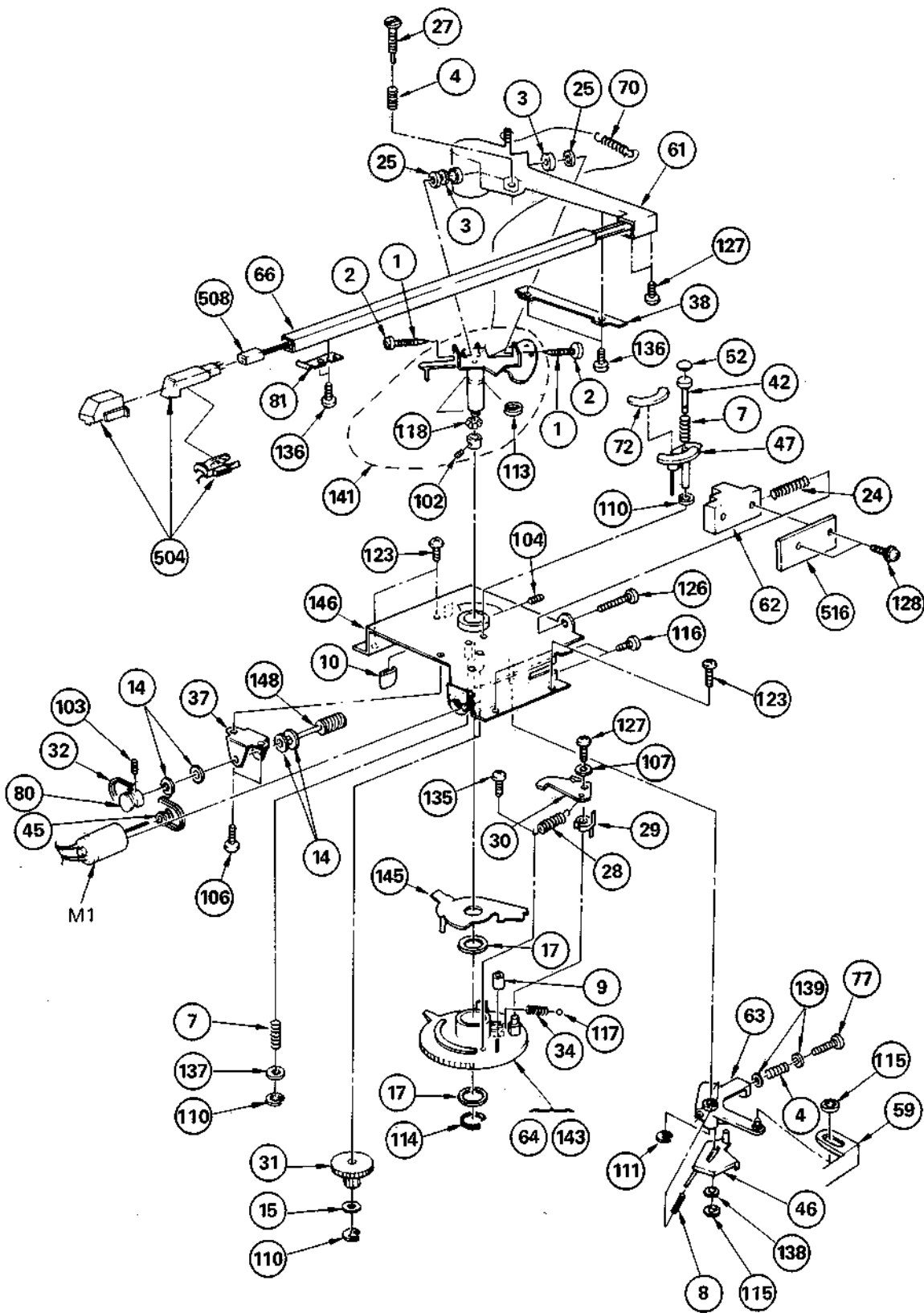

GENERAL SECTION		
No.	Part No.	Description
1	2-203-518-61	SCREW, PIVOT
2	2-203-519-00	NUT (A), LOCK, PIVOT
3	2-203-530-00	DAMPER
4	3-549-887-00	SPRING, COIL, COMPRISION
5	3-570-027-00	SCREW, MOTOR
6	3-570-118-00	CUSHION, MOTOR
7	3-573-150-00	SPRING, COMPRESSION
8	3-576-098-00	SPRING, COMPRESSION
9	3-579-008-00	RUBBER (S1), BRAKE
10	3-579-032-00	RUBBER, BRAKE
11	♣;3-654-056-00	SPACER (2.6X7)
12	3-663-748-00	WASHER, SUS
13	3-701-030-00	LABEL, SERIAL NUMBER
14	3-701-437-11	WASHER
15	3-701-437-21	WASHER
16	3-701-438-21	WASHER
17	3-701-448-21	WASHER, POLYETHYLENE
18	3-701-682-00	(US,Canadian)...STOPPER, CORD
19	3-701-690-00	(UK)...LABEL (MADE IN JAPAN)
20	3-703-244-00	(AEP,UK)...BUSHING, CORD
21	3-703-705-01	STICKER, SONY SYMBOL (30)
22	♣;3-703-845-01	(US,Canadian)..LABEL (N)(U/C), MAIN CAUTION
23	4-838-324-00	SPRING, COMPRESSION
24	4-861-965-00	SPRING, COMPRESSION
25	4-863-604-00	BEARING, PIVOT
26	4-870-945-00	RING (P9), O
27	♣;4-873-347-00	SHAFT, ADJUSTMENT, HIGH
28	4-877-850-00	SPRING, TENSION
29	♣;4-879-717-00	RESET BLOCK
30	4-879-718-00	CLUTCH, LEAD-IN
31	4-879-727-00	GEAR
32	4-879-751-00	BELT
33	4-879-761-11	HINGE
34	4-879-762-00	SPRING, COMPRESSION
35	♣;4-881-683-00	(E).....LABEL, VOLTAGE
36	♣;4-885-101-00	RUBBER, HOLDING, TRANSFORMER
37	♣;4-885-103-00	SUPPORT, WORM SHAFT
38	♣;4-885-106-00	PLATE, LOWER, ARM
39	♣;4-885-107-00	(US,Canadian)...BRACKET (A), POWER CORD
40	♣;4-885-108-00	LEVER, SWITCH
41	4-885-110-00	SPACER
42	4-885-117-00	SHAFT, BRAKE
43	4-885-125-00	BEARING, MOTOR
44	4-885-126-00	NUT
45	4-885-130-00	PULLEY

GENERAL SECTION		
No.	Part No.	Description
46	4-885-131-00	PLATE, ADJUSTMENT
47	4-885-132-00	BLOCK, UP END DOWN
48	4-885-133-11	BUTTON, POWER
49	4-885-135-11	RETAINER, THRUST
50	4-885-136-00	BUTTON, S/S
51	4-885-138-00	CUSHION
52	4-885-139-00	PAD, BRAKE
53	4-885-143-00	SPACER (A), LEG
54	4-885-144-00	SPACER (B), LEG
55	4-885-145-00	PIECE, ARM LOCK
56	♣;4-885-156-00	PLATE, HOLDING, TRANSFORMER
57	♣;4-885-158-00	(AEP,UK)...BRACKET (B), POWER CORD
58	♣;4-885-159-00	(E).....BRACKET (C), POWER CORD
59	♣;4-885-163-00	LEVER, SELECT
60	♣;4-885-164-00	BRACKET, CONTROL BLOCK
61	4-885-166-11	JOINT, PIPE
62	4-885-169-00	BLOCK, END ADJUSTMENT
63	4-885-170-00	LEVER, SELECTION
64	4-885-171-00	GEAR, CAM
65	4-885-172-00	CAM, SELECTION
66	4-885-173-00	PIPE, ARM
67	4-885-174-00	HOLDER, ADAPTOR
68	♣;4-885-176-12	(RED).....FRAME, SUB
68	♣;4-885-176-41	(BLACK).....FRAME, SUB
68	♣;4-885-176-51	(SILVER)...FRAME, SUB
69	♣;4-885-178-07	(AEP,UK)...PLATE, BOTTOM
69	♣;4-885-178-16	(E).....PLATE, BOTTOM
69	♣;4-885-178-26	(US,Canadian)...PLATE, BOTTOM
70	4-885-182-00	SPRING, TENSION
71	
72	4-885-184-00	FELT, UP AND DOWN
73	4-885-186-00	BEARING, RADIAL
74	♣;4-885-188-00	PLATE (B), JACK
75	♣;4-885-197-00	(US,Canadian,AEP,UK)...PROTECTOR
76	♣;4-885-199-00	SPACER
77	4-885-204-00	SCREW, R
78	4-885-213-00	(AEP)...LABEL, STAND-BY
79	♣;4-885-214-00	(E).....PROTECTOR, POWER
80	♣;4-885-215-00	PULLEY
81	4-885-217-00	SPRING, LEAF
82	♣;4-905-501-01	PLATE (A), WEIGHT
83	♣;4-905-502-01	PLATE (B), WEIGHT
84	♣;4-905-503-01	NUT, PLATE
85	4-905-504-01	SLEEVE, CENTER
86	4-905-505-01	SHEET, ROTOR
87	♣;4-905-506-01	ADAPTOR, SLIT

NOTE:

- The mechanical parts with no reference number in the exploded views are not supplied.
- Items marked "♣" are not stocked since they are seldom required for routine service. Some delay should be anticipated when ordering these items.
- Due to standardization, parts with part numbers (Δ-ΔΔΔ-ΔΔΔ-XX or Δ-ΔΔΔΔ-ΔΔΔ-X) may be different from those used in the set.
- If there are two or more same circuits in a set such as a stereophonic machine, only typical circuit parts may be indicated and capacitors and resistors in other same circuits may be omitted.

CAPACITORS:

- All capacitors are in μF. Common capacitors are omitted. Refer to the following lists for their part numbers.
- MF:μF, PF:μμF.

COILS:

- MMH : mH, UH : μH

SEMICONDUCTORS

- In each case, U : μ, for example:
 UA.... : μA...., UPA.... : μPA...., UPC.... : μPC....
 UPD.... : μPD....

GENERAL SECTION

No.	Part No.	Description
88	♣;4-905-507-01	BRACKET, PC BOARD, PHONO
89	4-905-508-01	BUSHING, CORD
90	♣;4-905-509-01	BASE, MOTOR
91	4-905-511-01	PULLEY
92	4-905-514-01	(SILVER, RED)...PLATE, ORNAMENTAL
92	4-905-514-11	(BLACK)...PLATE, ORNAMENTAL
93	4-905-517-01	RING, ROTOR
94	4-905-518-01	(US,Canadian)...LABEL, MODEL NUMBER
94	4-905-519-01	(E)...LABEL, MODEL NUMBER
94	4-905-527-01	(UK)...LABEL, MODEL NUMBER
94	4-905-528-01	(AEP)...LABEL, MODEL NUMBER
95	4-905-521-01	CASE, WEIGHT
96	4-905-522-01	(BLACK)...PANEL, CONTROL
96	4-905-522-12	(RED)...PANEL, CONTROL
97	4-905-523-01	CAP, ORNAMENT
98	4-905-526-01	(SILVER)...FRAME
98	4-905-526-11	(BLACK)...FRAME
98	4-905-526-22	(RED)...FRAME
99	4-905-529-01	BELT, MOTOR
100	4-905-531-01	BELT, ROTOR
101	7-621-255-25	SCREW +P 2X4
102	7-621-712-17	SET-SCREW, SLOT 2.6X2 CUP POINT
103	7-621-731-08	SET-SCT, HEX. 2X2.5, FLAT POINT
104	7-621-734-09	SET-SCT, HEX. 2.6X3
105	7-621-772-18	SCREW +B 2X4
106	7-621-775-10	SCREW +B 2.6X4
107	7-623-105-12	W 2, MIDDLE
108	7-623-420-07	LW 2, TYPE B
109	7-623-422-07	LW 3, TYPE B
110	7-624-102-04	STOP RING 1.5, TYPE -E
111	7-624-104-04	STOP RING 2.0, TYPE -E
112	7-624-109-04	STOP RING 5.0, TYPE -E
113	7-624-133-44	STOP RING 9, TYPE-CE
114	7-624-133-74	STOP RING 12, TYPE-CE
115	7-624-190-81	STOP RING 2, TYPE-CS
116	7-627-553-38	SCREW, PRECISION +P 2X3
117	7-671-113-02	STEAL, BALL 3
118	7-671-151-01	STAINLESS, BALL 1/16INCH
119	7-621-770-XX	SCREW +P 2.6X8
120	7-621-775-88	SCREW +P 2.6X16
121	7-682-250-09	SCREW +K 3X12
122	7-621-113-01	BALL, STEAL
123	7-682-546-04	SCREW +BVTT 3X5 (S)
124	7-682-546-09	SCREW +B 3X5
125	7-682-550-09	SCREW +B 3X12

GENERAL SECTION

No.	Part No.	Description
126	7-682-551-04	SCREW +P 3X14
127	7-685-102-19	SCREW +P 2X4 TYPE2 SLIT
128	7-685-104-14	SCREW +P 2X6 TYPE2 NON-SLIT
129	7-685-134-14	SCREW +P 2.6X8 TYPE2 NON-SLIT
130	7-685-138-11	SCREW +P 2.6X16 TYPE2 NON-SLIT
131	7-685-647-14	SCREW +BVTP 3X10 TYPE2 N-S
132	7-685-648-19	SCREW +BVTP 3X12 TYPE2 N-S
133	7-685-751-09	(E)...SCREW +BVTT 3X6
134	7-685-772-04	SCREW +PTT 1.7X2, TYPE1
135	7-685-780-01	SCREW +PTT 2X3 (S)
136	7-685-799-04	SCREW +PTT 1.7X2.5
137	7-688-001-01	W 2, SMALL
138	7-688-001-11	W 2, MIDDLE
139	7-688-003-01	W 3, SMALL
140	9-911-863-XX	SPACER (A)
141	A-4607-016-A	ROTARY BLOCK ASSY
142	A-4608-283-A	ROTOR (V) ASSY
143	A-4609-027-A	GEAR ASSY, CAM
144	A-4611-130-A	KNÖB ASSY, SELECTOR
145	♣;X-4885-101-0	PLATE ASSY, LEAD-IN
146	♣;X-4885-103-0	CHASSIS ASSY, SUB
147	X-4885-107-6	(BLACK)...COVER ASSY, DUST
147	X-4885-107-7	(SILVER)...COVER ASSY, DUST
147	X-4885-107-8	(RED)...COVER ASSY, DUST
148	♣;X-4885-111-0	GEAR ASSY, WORM
149	X-4905-502-1	BRACKET ASSY, MOTOR
150	♣;X-4905-505-1	(US,Canadian,AEP,UK)...CHASSIS ASSY (B)
150	X-4905-504-1	(E)...CHASSIS ASSY (A)

NOTE:

- The mechanical parts with no reference number in the exploded views are not supplied.
- Items marked "♣" are not stocked since they are seldom required for routine service. Some delay should be anticipated when ordering these items.
- Due to standardization, parts with part numbers (Δ-ΔΔΔ-ΔΔΔ-XX or Δ-ΔΔΔΔ-ΔΔΔ-X) may be different from those used in the set.
- If there are two or more same circuits in a set such as a stereophonic machine, only typical circuit parts may be indicated and capacitors and resistors in other same circuits may be omitted.

CAPACITORS:

- All capacitors are in μF. Common capacitors are omitted. Refer to the following lists for their part numbers.
- MF:μF, PF:μμF.

COILS

- MMH : mH, UH : μH

SEMICONDUCTORS

- In each case, U : μ, for example:
- UA...: μA..., UPA...: μPA..., UPC...: μPC,
- UPD...: μPD...

ACCESSORY & PACKING MATERIAL

No.	Part No.	Description
201	3-701-630-00	BAG, POLYETHYLENE
202	3-773-862-11	(Canadian, AEP, UK)...MANUAL, INSTRUCTION
202	3-773-862-21	(US).....MANUAL, INSTRUCTION
202	3-773-862-41	(E).....MANUAL, INSTRUCTION
203	3-795-557-11	INSTRUCTION, TURNTABLE SPACER
204	3-849-119-00	BAG, PROTECTION
205	4-885-163-00	ADAPTOR, 45
206	4-885-190-00	STOPPER, ARM
207	4-885-192-00	SHEET, PROTECTION
208	4-885-193-00	SHEET, PROTECTION
209	4-885-205-00	CUSHION (FRONT)
210	4-885-206-00	CUSHION (REAR)
211	4-885-212-00	SPACER, TURNTABLE
212	4-905-533-01	INDIVIDUAL CARTON

ELECTRICAL PARTS

Ref.No.	Part No.	Description
501	♣;1-508-800-13	U TYPE BASE POST 3P
502	♣;1-526-565-00	(E)...AC PLUG ADAPTOR
503	1-535-416-00	TERMINAL
504	1-549-113-00	CARTRIDGE
505	♣;1-534-817-XX	(AEP)...CORD, POWER, EURO PLUG
505	♣;1-551-506-XX	(US, Canadian)...CORD, POWER
505	♣;1-551-472-00	(E).....CORD, POWER
505	♣;1-551-884-00	(UK).....CORD, POWER
506	1-551-294-00	CORD
507	
508	1-556-504-00	CONNECTOR, PLUG IN TYPE
509	♣;1-608-536-00	PC BOARD, PRIMARY TRANSLATION
510	♣;1-609-930-00	PC BOARD, S/S SW
511	♣;1-612-274-11	PC BOARD, SPEED SIZE
512	♣;1-612-275-11	PC BOARD, REST SW
513	♣;1-612-276-11	PC BOARD, PLAY SW
514	♣;1-612-277-11	PC BOARD, PHONO
515	♣;1-612-479-11	PC BOARD, POWER SW
516	♣;1-612-480-11	PC BOARD, END DETECTION
517	♣;A-4619-238-A	MOUNTED PCB, SERVO
C101	1-123-324-00	ELECT 1000MF 20% 16V
C102	1-123-333-00	ELECT 100MF 20% 16V
C103	1-123-821-00	ELECT 47MF 20% 16V
C104	1-123-617-00	ELECT 10MF 20% 16V
C105	1-123-661-00	ELECT 100MF 20% 6.3V
C106	1-123-661-00	ELECT 100MF 20% 6.3V
C107	1-123-298-00	ELECT 470MF 20% 6.3V
C108	1-123-618-00	ELECT 22MF 20% 6.3V
C109	1-162-113-00	CERAMIC 0.01MF 30% 16V
C110	1-123-612-00	ELECT 2.2MF 20% 50V
C111	1-161-494-00	CERAMIC 0.022MF 30% 25V
CNP1	♣;1-564-111-00	PIN, CONNECTOR 2P
CNP2	♣;1-564-112-21	PIN, CONNECTOR 3P
CNP3	♣;1-564-113-11	PIN, CONNECTOR 4P
D101	♣;8-719-200-02	DIODE 10E2
D102	♣;8-719-200-02	DIODE 10E2
D103	8-719-815-55	DIODE 1S1555
D301	8-719-909-31	DIODE GL-9NG24
D401	8-719-101-11	DIODE SR110
D402	8-719-101-11	DIODE SR110
IC101	8-759-801-08	IC LA5521D
IC102	8-759-202-48	IC TC9305P-009
M1	1-541-217-00	MOTOR, ARM DRIVE
M2	8-835-106-01	MOTOR (DNR-6901A), TURN TABLE

NOTE:

- The mechanical parts with no reference number in the exploded views are not supplied.
- Items marked "♣" are not stocked since they are seldom required for routine service. Some delay should be anticipated when ordering these items.
- Due to standardization, parts with part numbers (Δ-ΔΔΔ-ΔΔΔ-XX or Δ-ΔΔΔΔ-ΔΔΔ-X) may be different from those used in the set.
- If there are two or more same circuits in a set such as a stereophonic machine, only typical circuit parts may be indicated and capacitors and resistors in other same circuits may be omitted.

CAPACITORS:

All capacitors are in μF. Common capacitors are omitted. Refer to the following lists for their part numbers.
MF:μF, PF:μμF.

COILS

MH : mH, UH : μH

SEMICONDUCTORS

In each case, U : μ, for example:
UA...: μA..., UPA...: μPA..., UPC...: μPC,
UPD...: μPD...

The components identified by shading and mark ♣ are critical for safety. Replace only with part number specified.

Les composants identifiés par une trame et une marque ♣ sont critiques pour la sécurité. Ne les remplacer que par une pièce portant le numéro spécifié.

ELECTRICAL PARTS

Ref.No.	Part No.	Description
Q101	8-729-201-78	TRANSISTOR 2SD1406
Q102	8-729-245-83	TRANSISTOR 2SC2458
Q103	8-729-245-83	TRANSISTOR 2SC2458
Q104	8-729-801-83	TRANSISTOR 2S81013
Q105	8-729-801-83	TRANSISTOR 2SB1013
Q106	8-729-801-93	TRANSISTOR 2SD1387
Q107	8-729-801-93	TRANSISTOR 2SD1387
Q108	8-729-801-93	TRANSISTOR 2SD1387
Q109	8-729-245-83	TRANSISTOR 2SC2458
Q401	8-729-101-13	TRANSISTOR PH103
Q402	8-729-101-13	TRANSISTOR PH103
R101	1-246-413-00	CARBON 3.3 5% 1/4W
R102	1-246-413-00	CARBON 3.3 5% 1/4W
R103	1-246-413-00	CARBON 3.3 5% 1/4W
R104	1-247-847-00	CARBON 4.7K 5% 1/6W
R105	1-247-831-00	CARBON 1K 5% 1/6W
R106	1-247-831-00	CARBON 1K 5% 1/6W
R107	1-247-831-00	CARBON 1K 5% 1/6W
R108	1-247-831-00	CARBON 1K 5% 1/6W
R109	1-247-831-00	CARBON 1K 5% 1/6W
R110	1-247-831-00	CARBON 1K 5% 1/6W
R111	1-247-831-00	CARBON 1K 5% 1/6W
R112	1-247-831-00	CARBON 1K 5% 1/6W
R113	1-247-831-00	CARBON 1K 5% 1/6W
R114	1-247-831-00	CARBON 1K 5% 1/6W
R115	1-247-813-00	CARBON 180 5% 1/6W
R116	1-247-838-00	CARBON 2K 5% 1/6W
R117	1-247-831-00	CARBON 1K 5% 1/6W
R119	1-247-845-00	CARBON 3.9K 5% 1/6W
R120	1-247-849-00	CARBON 5.6K 5% 1/6W
R121	1-247-863-00	CARBON 22K 5% 1/6W
R122	1-247-871-00	CARBON 47K 5% 1/6W
R123	1-247-811-00	CARBON 150 5% 1/6W
R124	1-247-811-00	CARBON 150 5% 1/6W
R125	1-247-795-00	CARBON 33 5% 1/6W
R126	1-247-831-00	CARBON 1K 5% 1/6W
R128	1-247-825-00	CARBON 560 5% 1/6W
R129	1-247-771-00	CARBON 3.3 5% 1/6W
R130	1-247-831-00	CARBON 1K 5% 1/6W
R301	1-246-453-00	CARBON 150 5% 1/4W
RV101	1-226-235-00	RES, ADJ, CARBON 5K
RV102	1-226-234-00	RES, ADJ, CARBON 2K (33RPM)
RV103	1-226-234-00	RES, ADJ, CARBON 2K (45RPM)

ELECTRICAL PARTS

Ref.No.	Part No.	Description
S1	1-553-909-00	SWITCH, PUSH (1 KEY)(POWER)
S2	1-553-856-00	SWITCH, KEY BOARD (START/STOP)
S3	1-552-532-00	SWITCH, PUSH
S4	1-552-532-00	SWITCH, PUSH (SPEED/SIZE) (45RPM/33RPM)
S5	1-552-532-00	SWITCH, PUSH (SPEED/SIZE) (17cm/30cm)
S6	1-552-532-00	SWITCH, PUSH
S001	△ 1-552-535-00	(E) SWITCH, POWER & VOLTAGE CHANGE
T1	△ 1-447-435-00	(UC, Canadian) TRANSFORMER, POWER
T1	△ 1-447-438-00	(AEP, UK) TRANSFORMER, POWER
T1	△ 1-447-437-00	(E) TRANSFORMER, POWER

NOTE:

- The mechanical parts with no reference number in the exploded views are not supplied.
- Items marked "♣" are not stocked since they are seldom required for routine service. Some delay should be anticipated when ordering these items.
- Due to standardization, parts with part numbers (Δ-ΔΔΔ-ΔΔΔ-XX or Δ-ΔΔΔ-ΔΔΔ-X) may be different from those used in the set.
- If there are two or more same circuits in a set such as a stereophonic machine, only typical circuit parts may be indicated and capacitors and resistors in other same circuits may be omitted.

CAPACITORS:

All capacitors are in μF. Common capacitors are omitted. Refer to the following lists for their part numbers.
MF:μF, PF:μμF.

COILS

MMH : mH, UH : μH

SEMICONDUCTORS

In each case, U : μ, for example:
UA... : μA..., UPA... : μPA..., UPC... : μPC.,
UPD... : μPD...

The components identified by shading and mark △ are critical for safety. Replace only with part number specified.

Les composants identifiés par une trame et une marque △ sont critiques pour la sécurité. Ne les remplacer que par une pièce portant le numéro spécifié.