

PS-LX430/430C/431/431N/433

SERVICE MANUAL

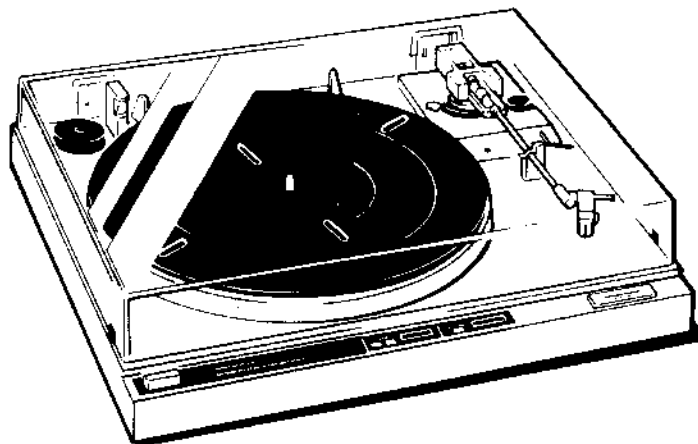

PS-LX430:
US Model

PS-LX430C:
US Model
Canadian Model

PS-LX431:
AEP Model
UK Model
E Model

PS-LX431N:
US Model

PS-LX433:
US Model

SPECIFICATIONS

Turntable

Platter	30.0 cm (12 in.), aluminum-alloy diecast
Motor	DC servo motor
Drive system	Belt drive
Control system	DC servo control system
Speed	33 $\frac{1}{3}$ rpm, 45 rpm
Start-up time	Comes to nominal speed within $\frac{1}{2}$ rotation (33 $\frac{1}{3}$ rpm)
Wow and flutter	0.045% (WRMS)
Signal-to-noise ratio	70 dB (DIN-B)
Automatic system	Lead-in, return, reject, repeat, record size selection
Suspension system	High elasticity gel insulator

Tonearm

PS-LX430/430C/433:

Type	Statically balanced
Pivot-to-stylus length	216.5 mm (8 $\frac{1}{2}$ in.)
Usable cartridge	Plug-in type, 6 g Sony VL-45G
Tracking error	+3, -1

PS-LX431/431N:

Type	Dynamically balanced
Pivot-to-stylus length	216.5 mm (8 $\frac{1}{2}$ in.)
Overhang	16.5 mm ($\frac{22}{32}$ in.)
Tracking error	+3, -1

Cartridge

PS-LX430C: VL-45G

Type	Moving magnet type
Frequency response	20 Hz to 20 kHz
Channel separation	20 dB at 1 kHz
Output voltage	3.5 mV at 1 kHz, 5 cm/sec.
Load impedance	50 to 100 kilohms
Tracking force	1.25 g
Stylus	Sony ND-145G (conical 0.6 mil diamond)
Weight	6 g
PS-LX430/LX433	Not supplied

PS-LX431: VL-42G

Type	Moving magnet type
Frequency response	20 Hz to 20 kHz
Channel separation	16 dB at 1 kHz
Output voltage	2.5 mV at 1 kHz, 5 cm/sec.
Load impedance	50 to 100 kilohms
Tracking force	2 g
Stylus	Sony ND-142G (conical 0.6 mil diamond)
Weight	8 g

— Continued on page 2 —

ATTENTION AU COMPOSANT AYANT RAPPORT
À LA SÉCURITÉ!

LES COMPOSANTS IDENTIFIÉS PAR UNE TRAME ET UNE MARQUE  SUR LES DIAGRAMMES SCHEMATIQUES ET LA LISTE DES PIÈCES SONT CRITIQUES POUR LA SÉCURITÉ DE FONCTIONNEMENT. NE REMPLACER CES COMPOSANTS QUE PAR DES PIÈCES SONY DONT LES NUMÉROS SONT DONNÉS DANS CE MANUEL OU DANS LES SUPPLÉMENTS PUBLIÉS PAR SONY.

SAFETY-RELATED COMPONENT WARNING!!

COMPONENTS IDENTIFIED BY SHADING AND MARK  ON THE SCHEMATIC DIAGRAMS AND IN THE PARTS LIST ARE CRITICAL TO SAFE OPERATION. REPLACE THESE COMPONENTS WITH SONY PARTS WHOSE PART NUMBERS APPEAR AS SHOWN IN THIS MANUAL OR IN SUPPLEMENTS PUBLISHED BY SONY.

STEREO TURNTABLE SYSTEM

SONY®

AUD

PS-LX430/430C/431/431N/433

General

Power requirements	US, Canadian model: 120 V ac, 60 Hz AEP model: 220 V ac, 50/60 Hz UK model: 240 V ac, 50/60 Hz
Power consumption	7 W
Dimensions	PS-LX430/430C/431/433: Approx. 430 x 100 x 360 mm (w/h/d) (17 x 4 x 14 1/4 inches) incl. projecting parts and controls PS-LX431N: Approx. 430 x 110 x 360 mm (w/h/d) (17 x 4 3/8 x 14 in.) including projecting parts and controls
Weight	PS-LX430/430C/431/433: Approx. 3.5 kg (7 lbs 12 oz), net Approx. 4.5 kg (9 lbs 10 oz), in shipping carton PS-LX431N: Approx. 2.9 kg (6 lb 7 oz) net

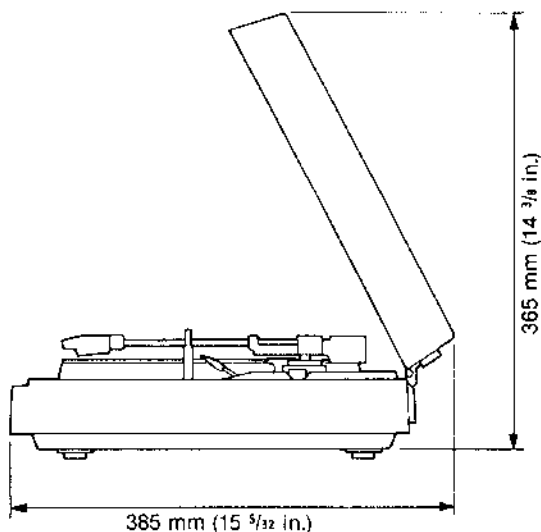

(PS-LX431N: Dust cover is not supplied)

MODEL IDENTIFICATION

— Specification Label —

PS-LX430, PS-LX430C, PS-LX433

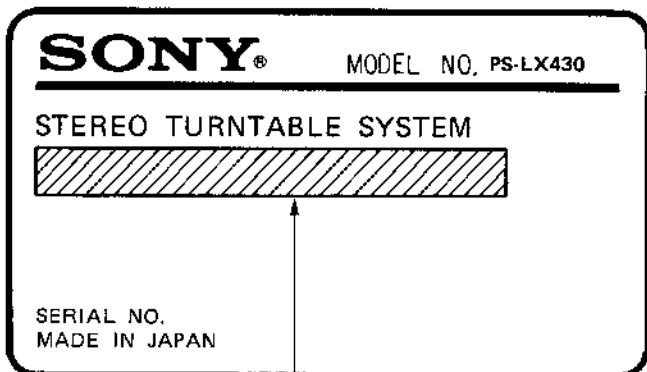

US, Canadian model: AC: 120V – 60 Hz 7W

PS-LX431, PS-LX431N

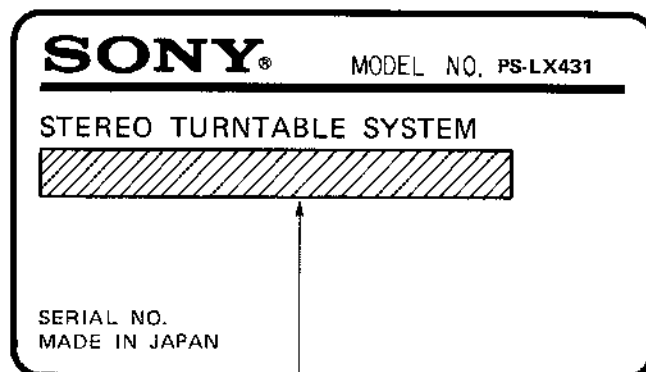

US model: AC: 120V – 60 Hz 7W
AEP, UK model: AC: 220V – 50/60 Hz 7W
E model: AC: 110 – 220V, 220 – 240V 50/60 Hz 7W,

SAFETY CHECK-OUT (US Model)

After correcting the original service problem, perform the following safety check before releasing the set to the customer:

Check the antenna terminals, metal trim, "metallized" knobs, screws, and all other exposed metal parts for AC leakage. Check leakage as described below.

LEAKAGE TEST

The AC leakage from any exposed metal part to earth ground and from all exposed metal parts to any exposed metal part having a return to chassis, must not exceed 0.5 mA (500 microampers). Leakage current can be measured by any one of three methods.

1. A commercial leakage tester, such as the Simpson 229 or RCA WT-540A. Follow the manufacturers' instructions to use these instruments.
2. A battery-operated AC milliammeter. The Data Precision 245 digital multimeter is suitable for this job.
3. Measuring the voltage drop across a resistor by means of a VOM or battery-operated AC voltmeter. The "limit" indication is 0.75 V, so analog meters must have an accurate low-voltage scale. The Simpson 250 and Sanwa SH-63Trd are examples of a passive VOM that is suitable. Nearly all battery operated digital multimeters that have a 2 V AC range are suitable. (See Fig. A)

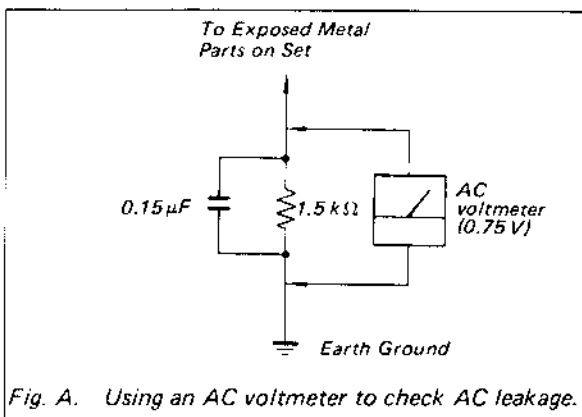
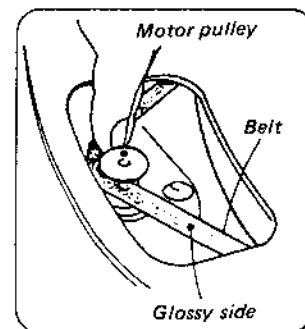

Fig. A. Using an AC voltmeter to check AC leakage.

CAUTION ON INSTALLING BELT

When installing belt, glossy should be faced outside.



SECTION 1
OUTLINE

1-1. PARTS IDENTIFICATION

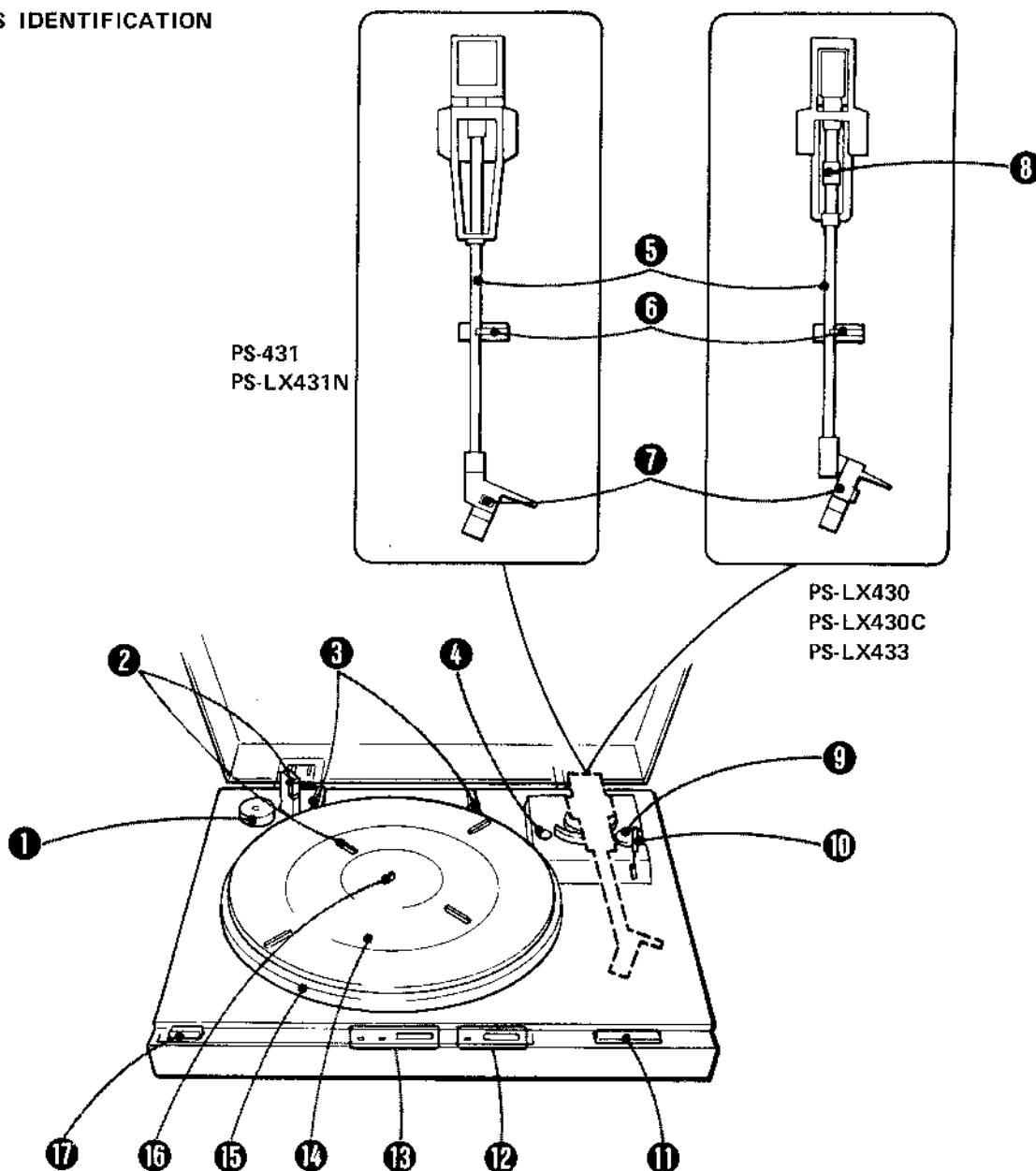

- ❶ 45-rpm adaptor
- ❷ Auto-record-size selection holes and lamp
- ❸ Disc centering guides
- ❹ Drop point adjustment hole
- ❺ Tonearm
- ❻ Arm rest
- ❼ Cartridge (not supplied with US, Canadian certain models of PS-LX430/LX433)
- ❽ Sub-weight

❾ ANTI-SKATING compensator

Normally, set it at the center position. If the stylus is driven inward when the tone arm is lowered to the lead-in groove, turn the ANTI-SKATING compensator to ⊕. If the stylus is driven outward, turn the ANTI-SKATING compensator to ⊖.

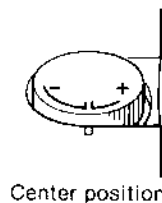

10 **▼/▼ (cueing) lever**
Used to lift or lower the tonearm.

11 **START/STOP button**

12 **REPEAT button and indicator**

13 **SPEED selector and indicators**
Set the SPEED selector according to the speed of the record to be played. For 45-rpm records, depress the selector when a 45 rpm record is to be played. For a 33 $\frac{1}{3}$ records, press it again.

14 **Rubber mat**

15 **Turntable platter**

16 **Center spindle**

17 **POWER switch**

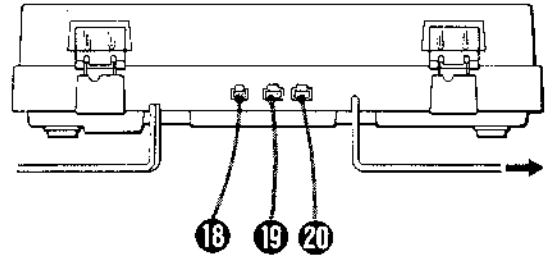

18 **SYNC connector**
Connect to the SYNC connector of the optional Sony tape deck equipped with a 3-pin flat connector.

19 **CONTROL S IN connector**
Connect to the CONTROL S OUT or REMOTE OUT connector of an optional Sony system control tuner or receiver for whole audio system remote control.

20 **CONTROL S OUT connector**
Connect to the CONTROL S IN or REMOTE OUT connector of Sony audio equipment equipped with a 4-pin remote control connector for remote control operation.

1-2. BLOCK DIAGRAM

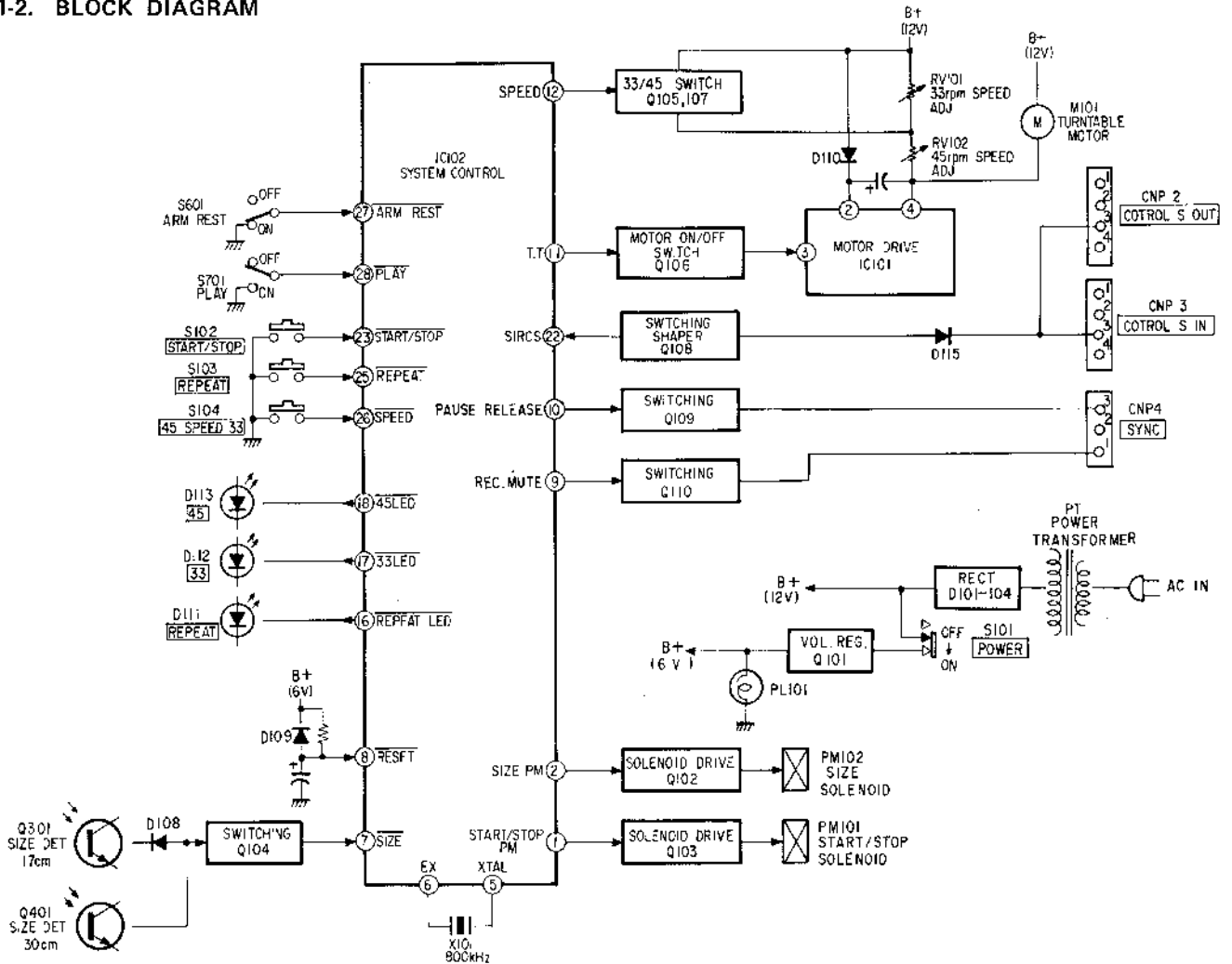

2-1. REMOVAL

- Follow the disassembly procedure in the numerical order given.

Remove bottom plate.
(PTPWH 3 x 12 9 pcs)

TURNTABLE MOTOR (M101)

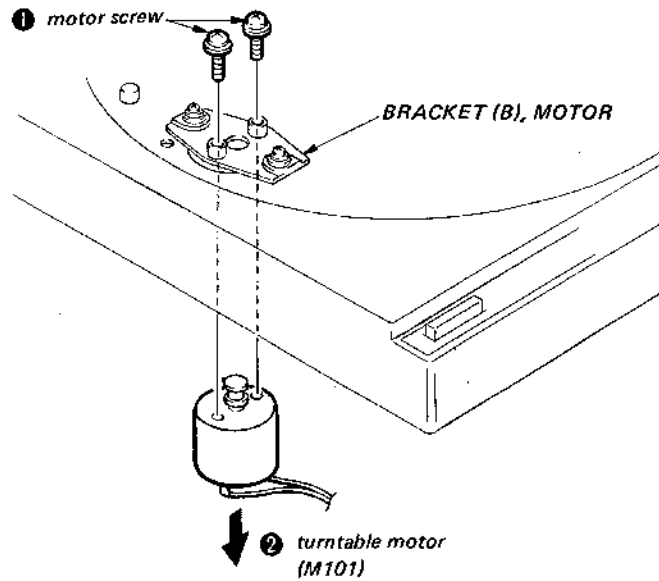

S/S SW BOARD

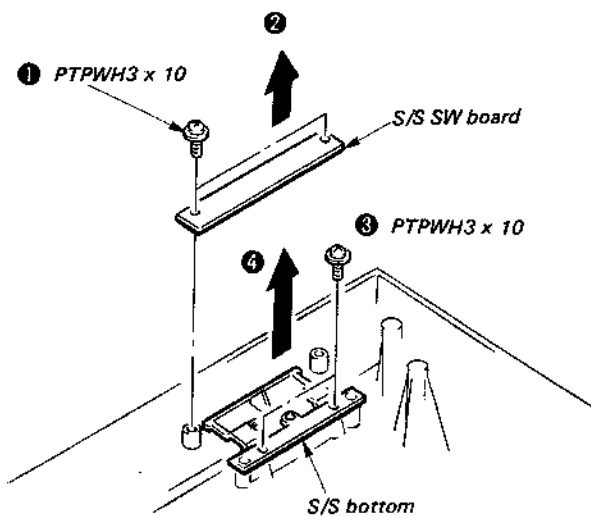

LAMP BOARD

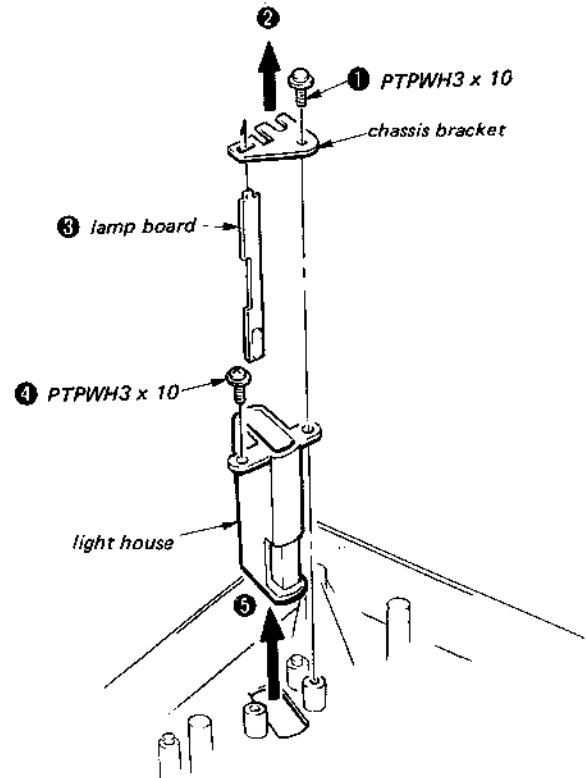

SYSTEM CONTROL (A) BOARD

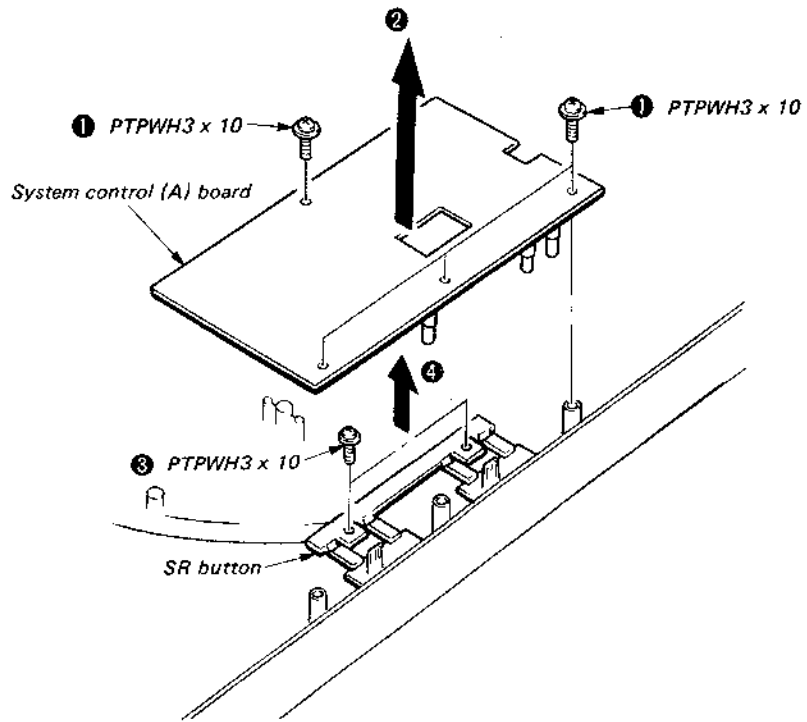

SYSTEM CONTROL (B) BOARD

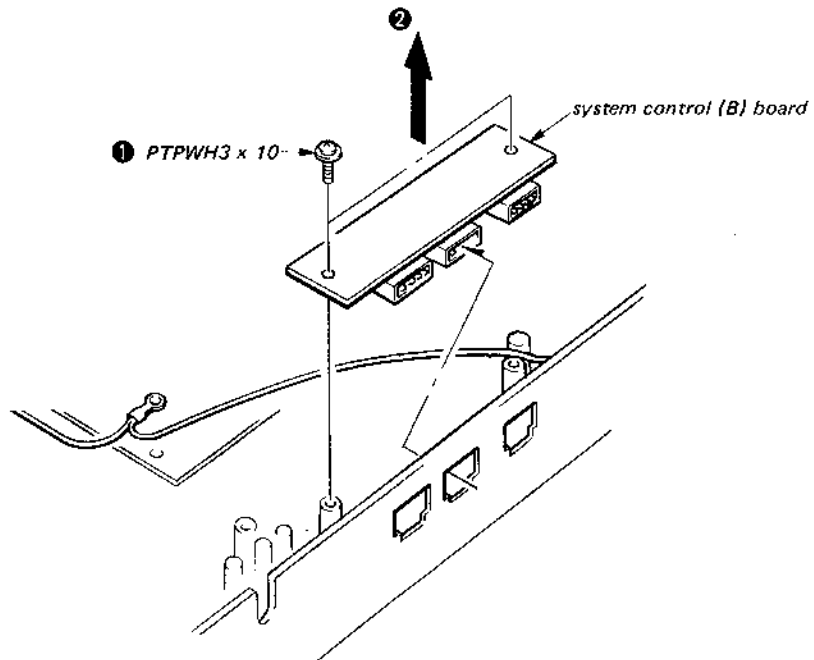

2.2. INSTALLATION

PUSH ROD, LIFTER LEVER

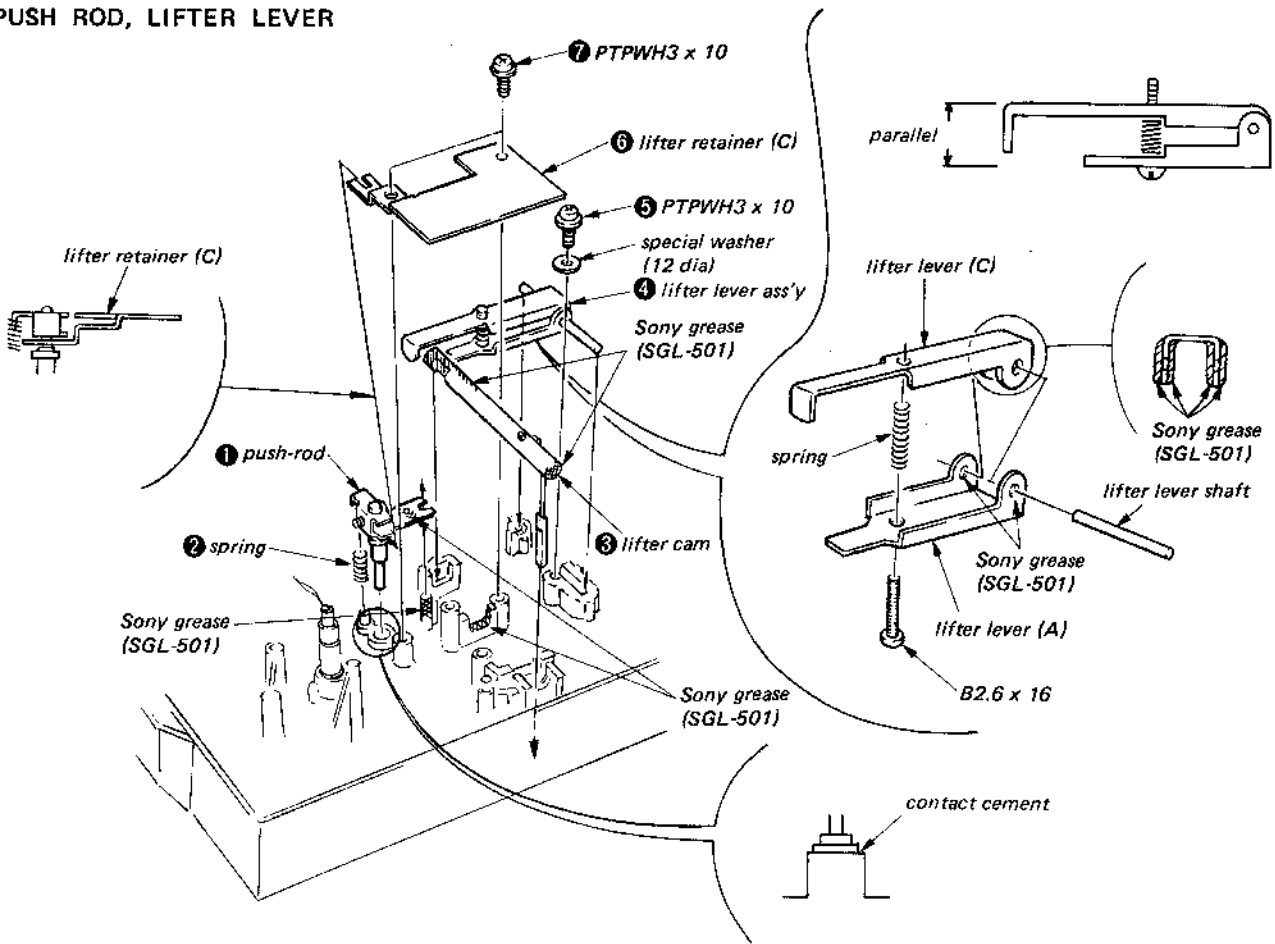

Caution for installation:

When the push rod is replaced, apply silicon oil (viscosity: 500,000 cs) to the push rod as illustrated below.

Caution:

When lubricating, rotate and move the push rod up and down a few times.

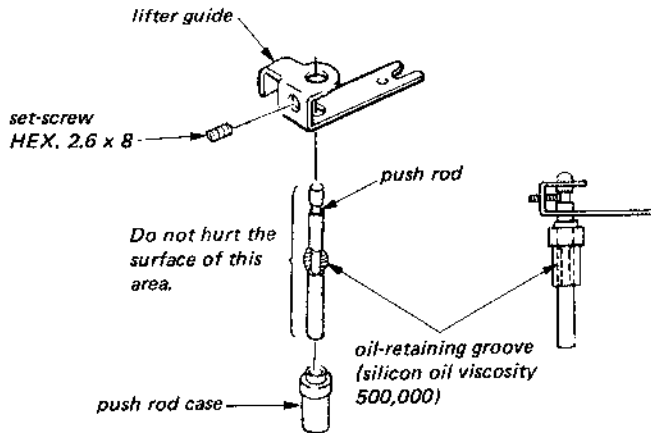

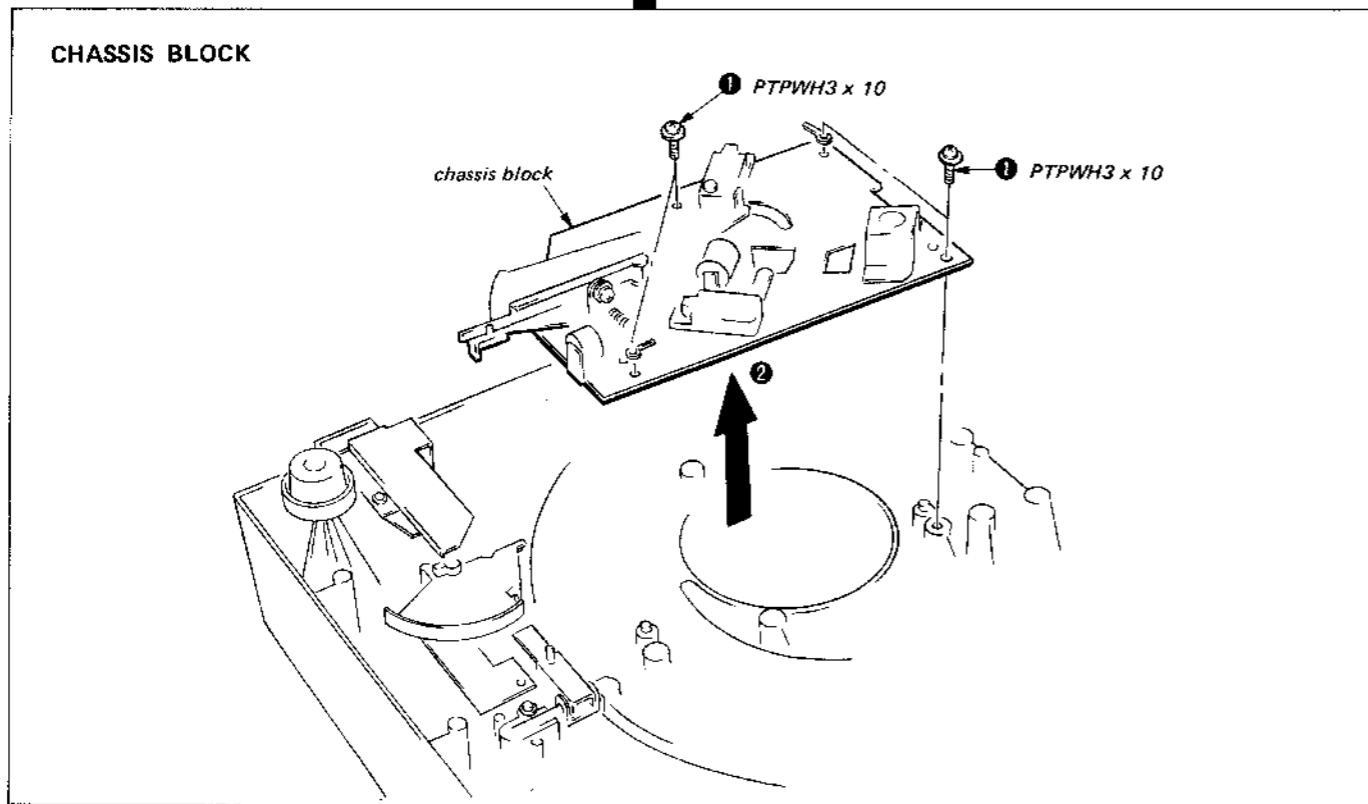
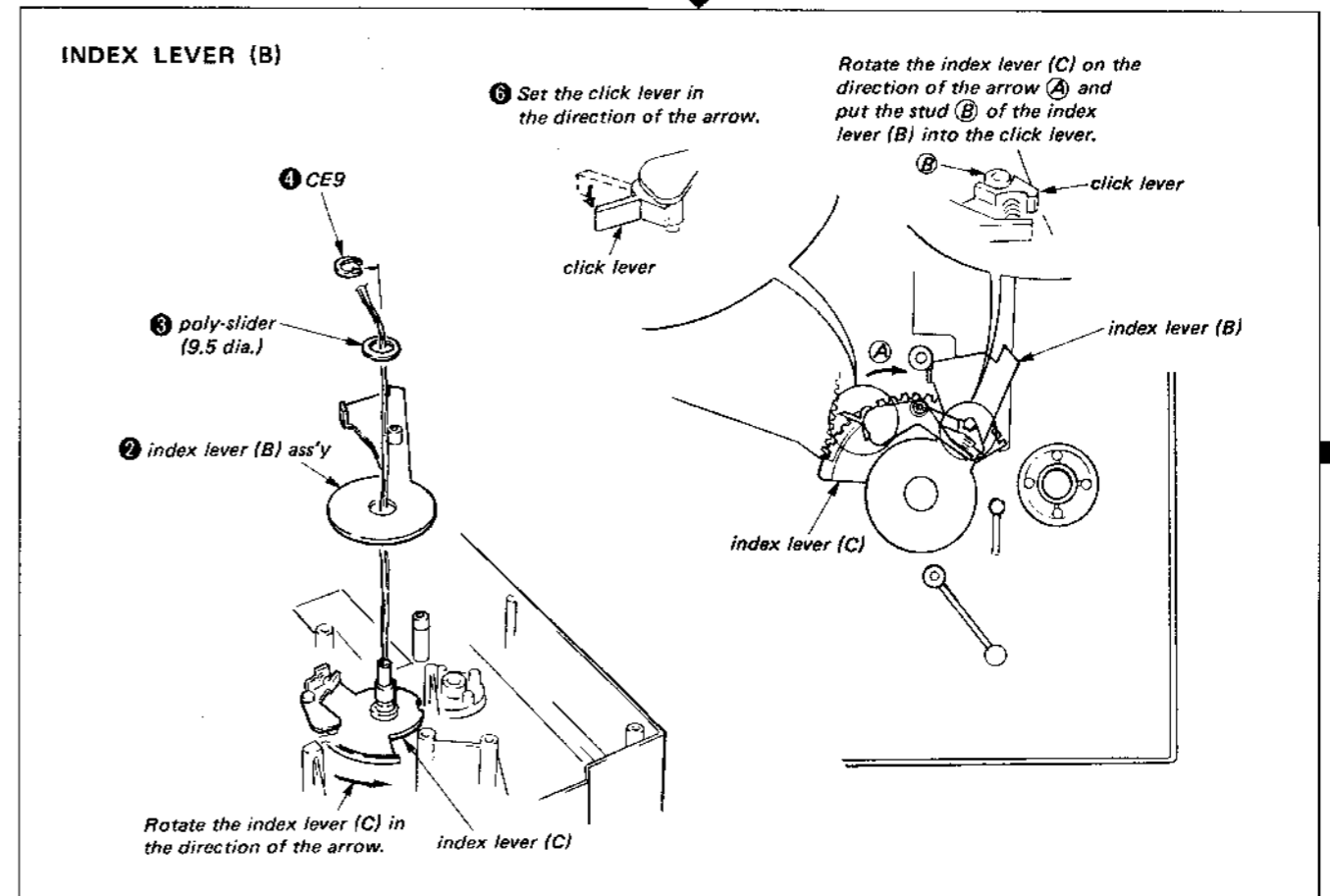
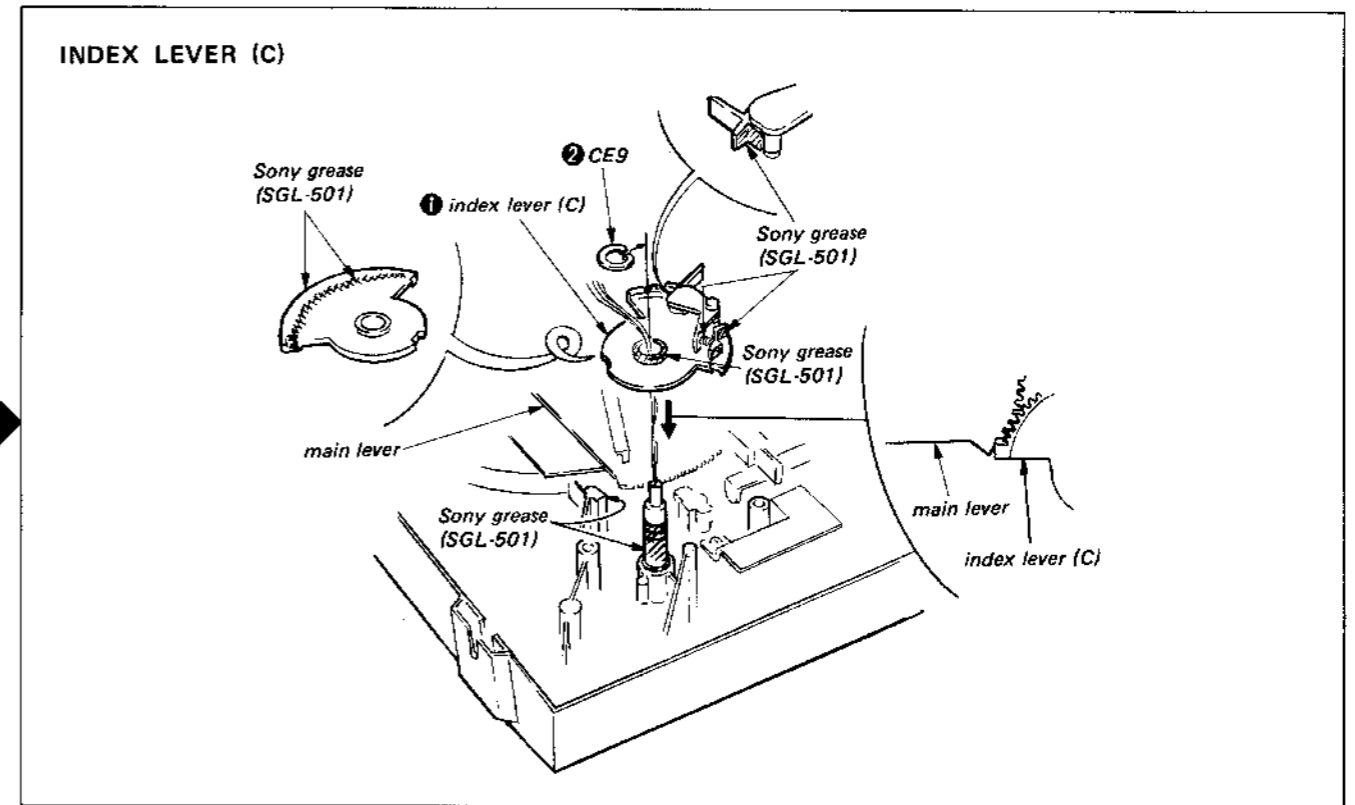
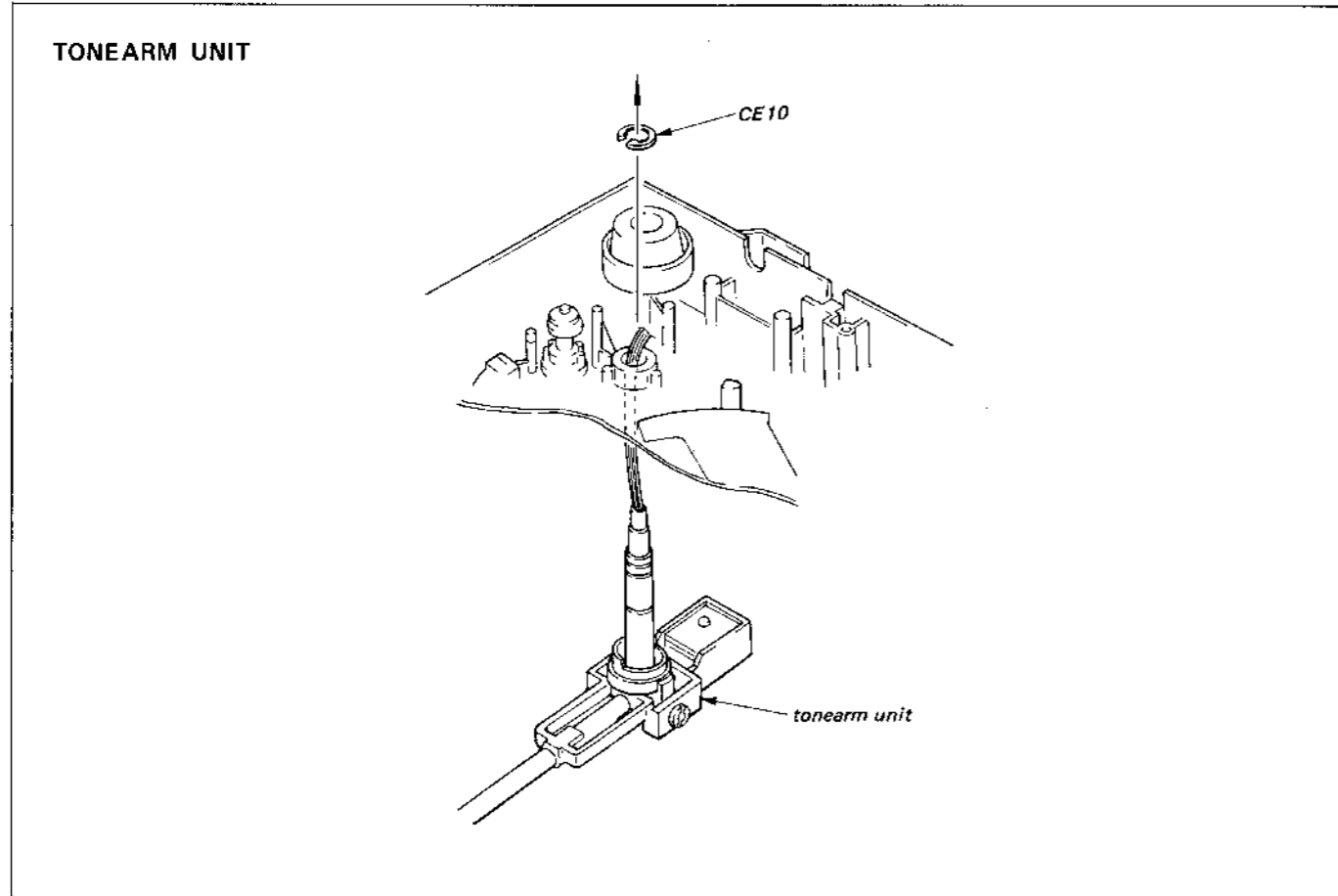

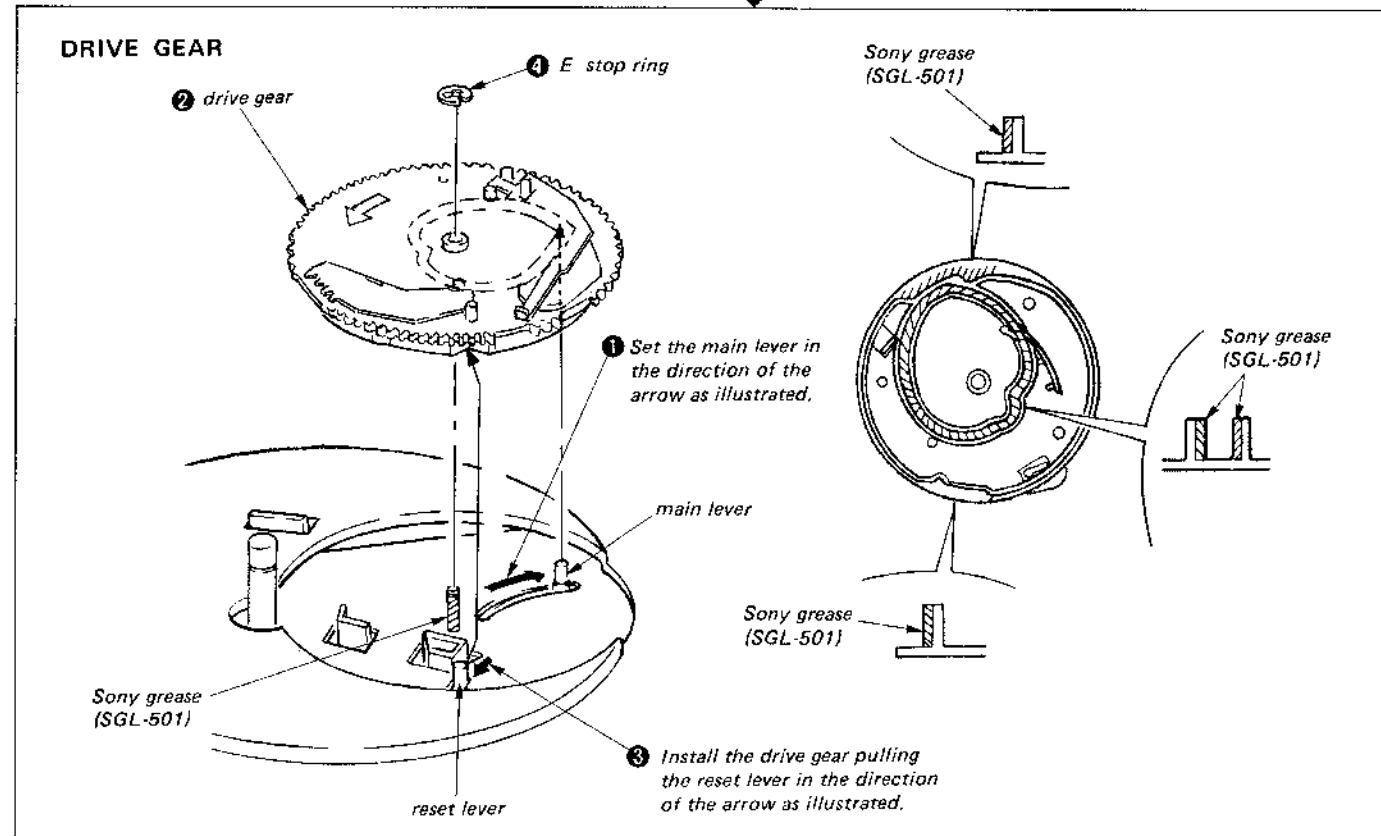
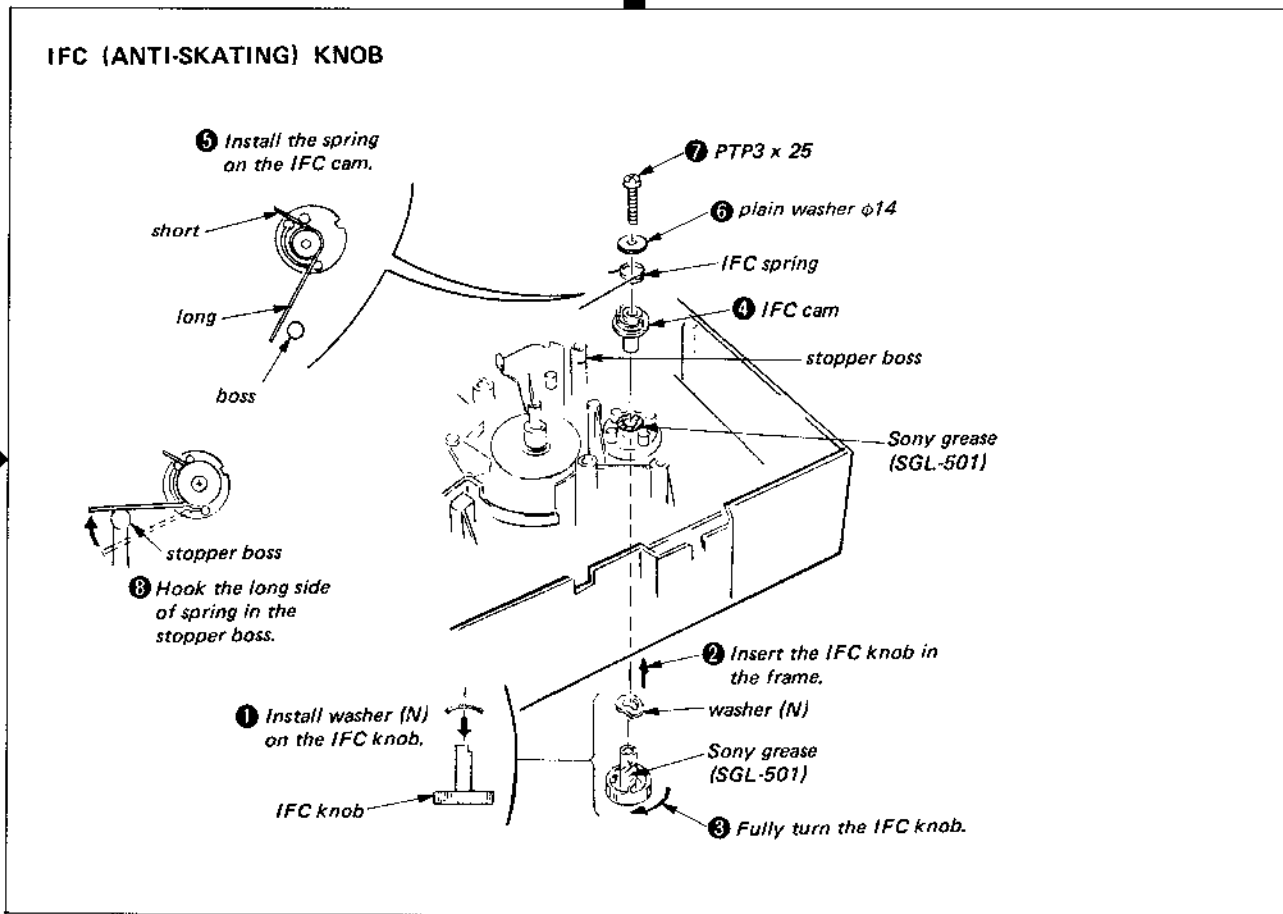
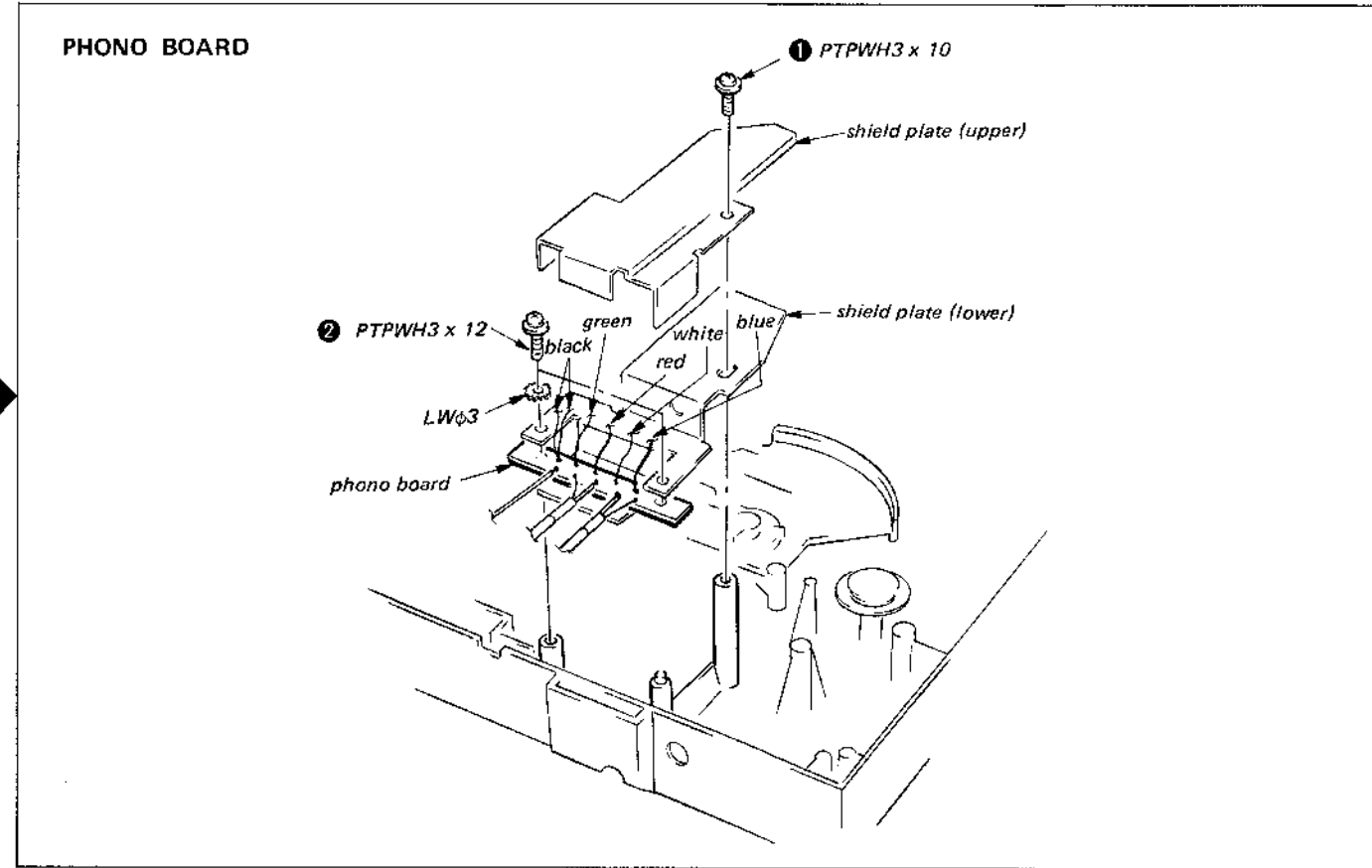
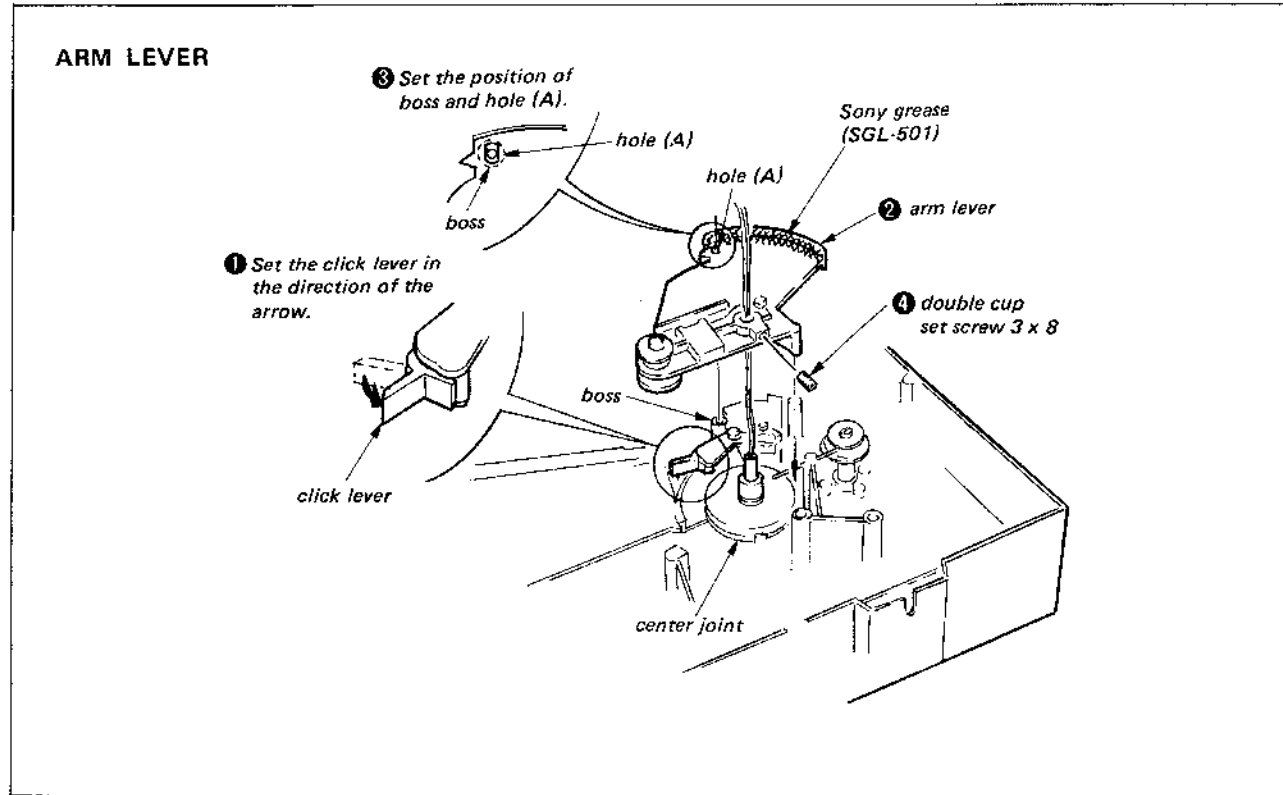

TONEARM (PS-LX431)

1. LEAD WIRE INSTALLATION

- 1-1. Pass piano wire with lead wires through pipe as shown in Fig. A.
- 1-2. Pass piano wire with lead wires through center joint assy as shown in Fig. B.

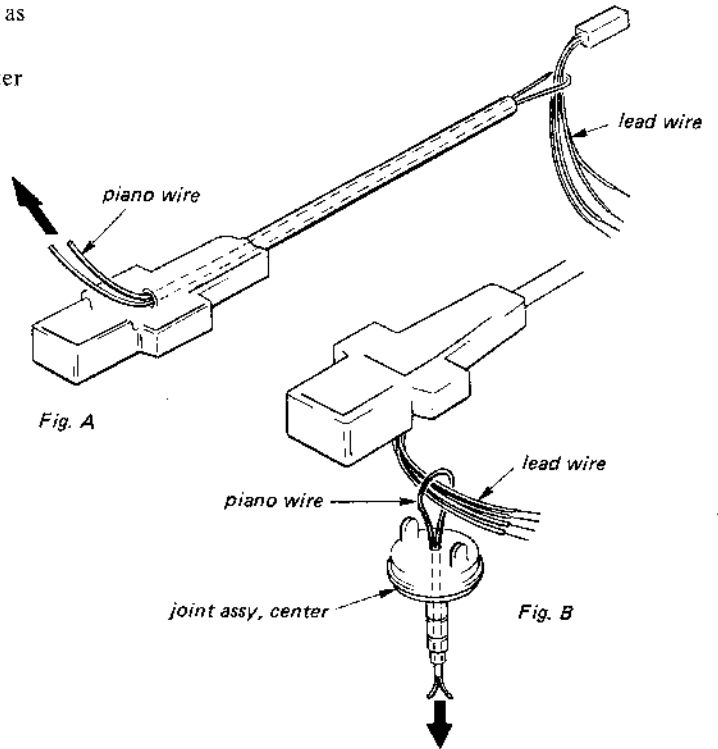

2. ARM PIPE REMOVAL

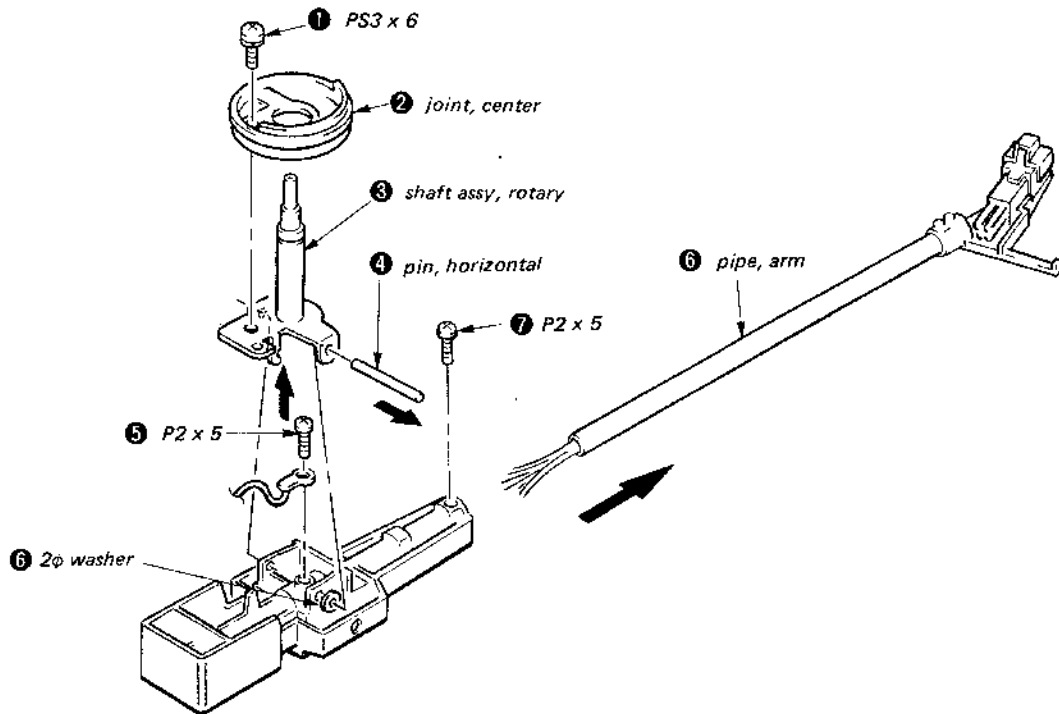

TONARM (PS-LX430, 433)

1. LEAD WIRE INSTALLATION

- 1-1. Pass piano wire with lead wires through pipe as shown in Fig. A.
- 1-2. Pass piano wire with lead wires through center joint assy as shown in Fig. B.

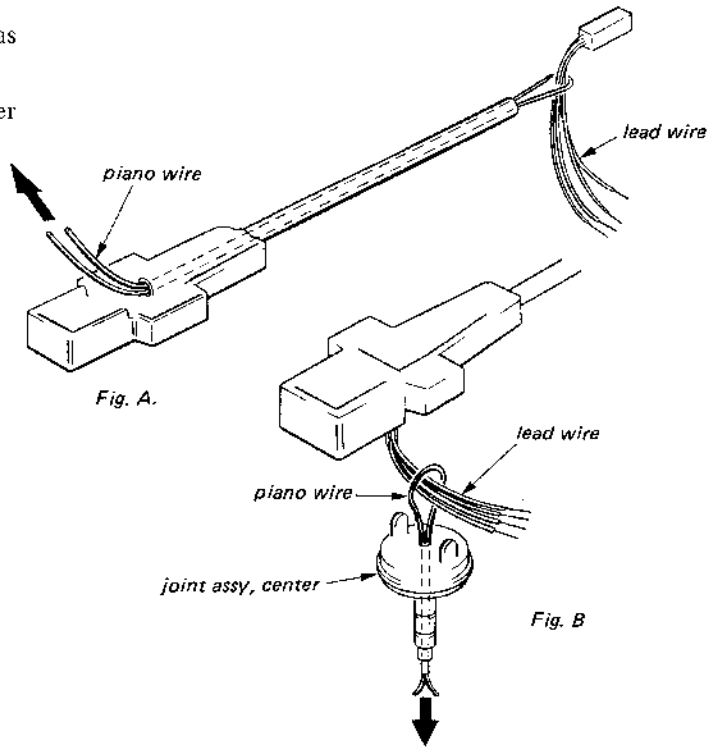

2. ARM PIPE REMOVAL

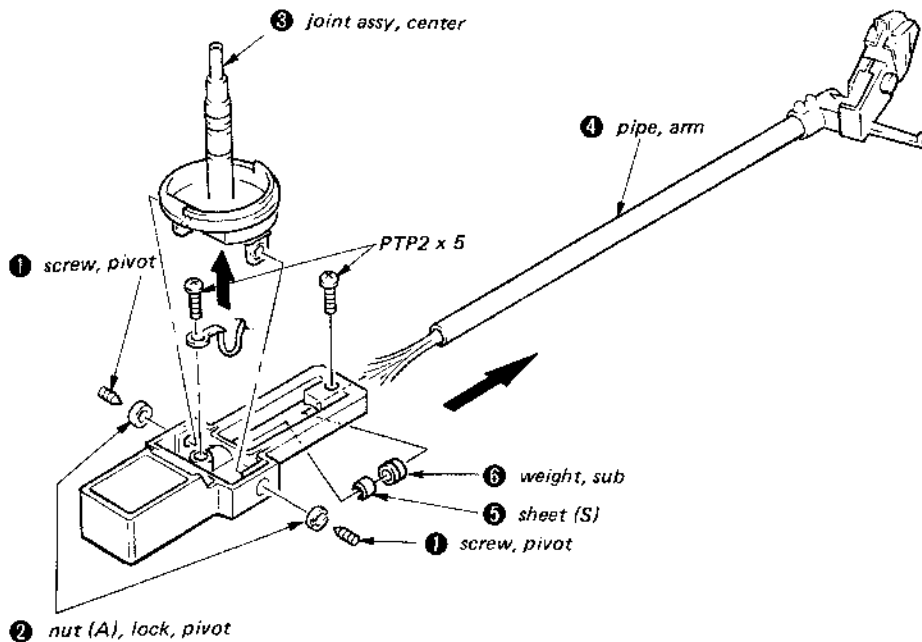

SECTION 3
ADJUSTMENTS

3-1. MECHANICAL ADJUSTMENTS

Longitudinal Sensitivity Adjustment (PS-LX430/430C/433)

1. Install the cartridge and slide the sub weight at \ominus side.
2. Place a weight of about 5g on the pipe joint.
3. Adjust the weight position so that the arm is balanced.
4. Place a weight of about 150mg on the cartridge (right over the stylus).
5. Adjust the pivot screw so that the stylus tip goes down 5mm or more.

Note: If the pivot screw is secured excessively, the pivot bearing may be damaged.

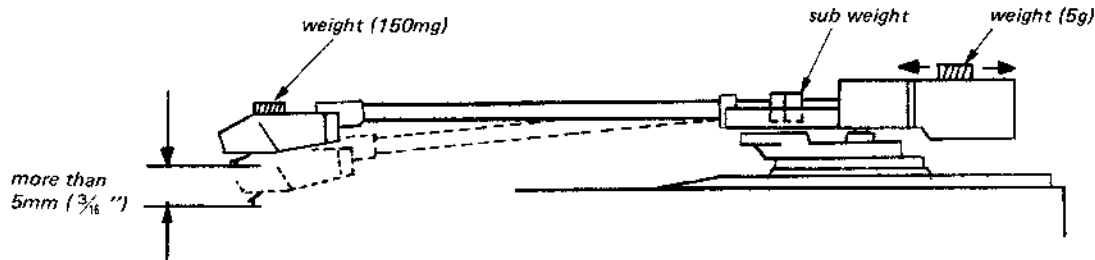
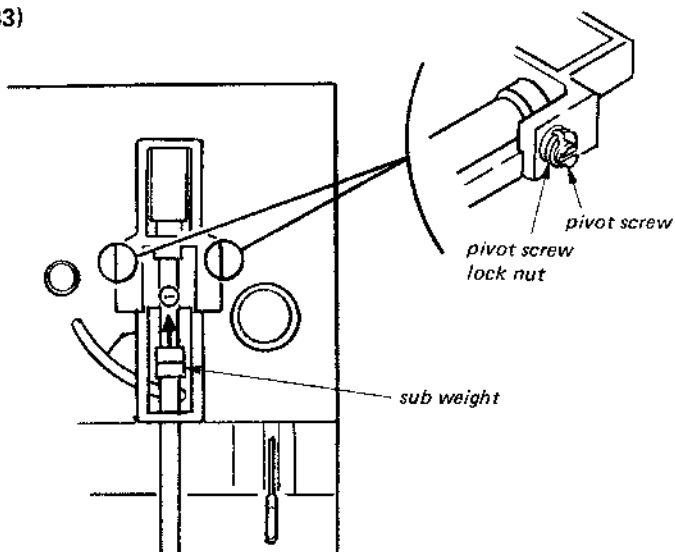

Stylus Force Adjustment (PS-LX431)

1. Turn the adjustment screw to obtain zero balance.
2. Turn the adjustment screw again so that the stylus force becomes 2g on the stylus force gauge.

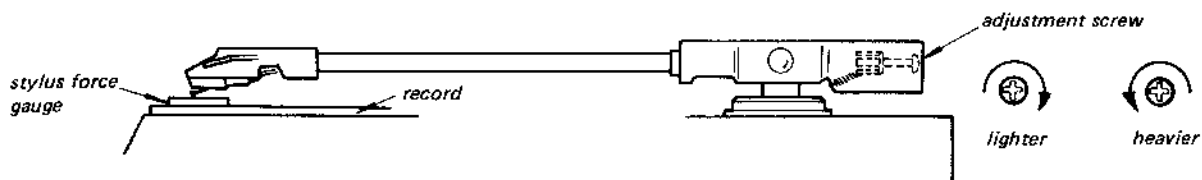

Shell's Horizontal Balance Adjustment

Loosen the neck cylinder screw and adjust so that section A (shell slant) is less than 0.5mm.

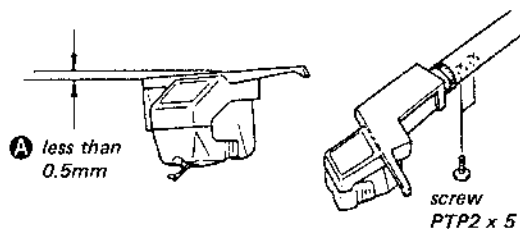

Brake Lever Position Adjustment

1. Rotate the drive gear in the direction of the arrow by hand, and set the reset lever for reset position (shown the Fig. 1).
Then, confirm that the size lever is contact with chassis lightly (shown in the Fig. 2, **A**).
2. Adjust the adjustment screw so that a gap becomes in $0.3 \pm 0.2\text{mm}$ (shown in the Fig. 3).
3. After the adjustment, lock the adjustment screw with locking compound.

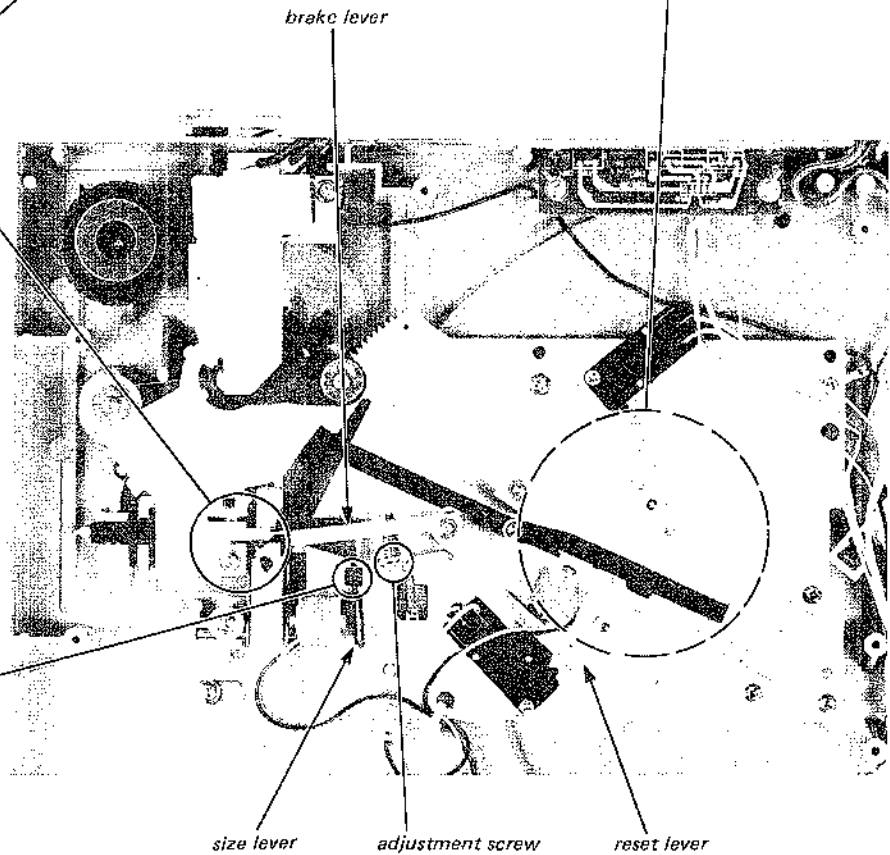
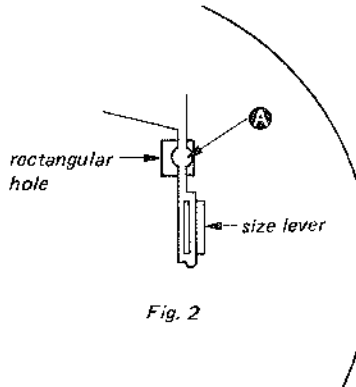
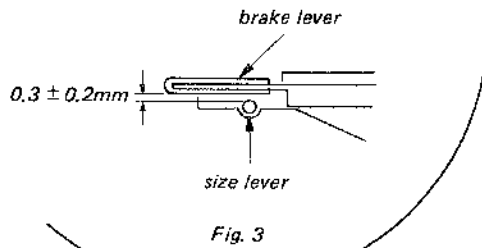
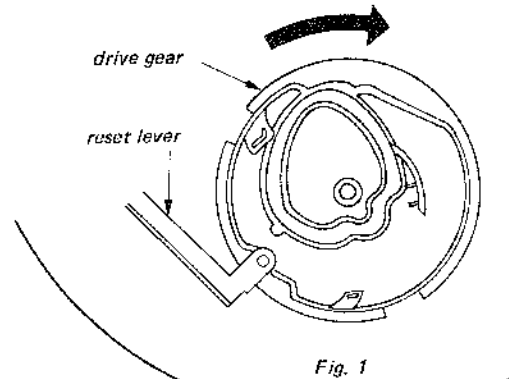

Stylus Height Adjustment

Note: Perform both adjustment for manual and automatic operations.

1. Automatic

- 1) Put a test record on the mat.
- 2) Depress the lifter lever to make a lifterdown mode.
- 3) Move the tonearm to out of groove at record by hand.
- 4) Rotate the turntable by hand and at make tonearm lead-in.
- 5) Move the tonearm to out of groove of record by hand again.
- 6) Rotate the turntable by hand and make the tonearm.
- 7) Then, loosen the adjustment screw (A) and adjust the height of the tonearm lifter so that the stylus height becomes in 4 – 8mm.
- 8) Rotate the turntable by hand slowly and move the tonearm to the most outer groove of record.
- 9) Confirm that stylus height becomes in 4–8mm.

2. Manual

- 1) Put a test record on the mat.
- 2) Move the tonearm to out of groove of record by hand.
- 3) Rotate the turntable by hand and make the tonearm lead-in.
- 4) Raise the lifter lever to make a lifter-up mode.
- 5) Move the tonearm until most outer groove of record by hand.
- 6) Adjust the adjustment screw (B) so that the stylus height becomes in 4–8mm.
- 7) Move the tonearm to the out of groove of record by hand.
Confirm that stylus height becomes in 4–8mm.
- 8) Rotate the turntable by hand and return the tonearm to arm rest.
- 9) After the adjustment, lock the portion (A) with suitable locking compound.

- Note:**
- Stylus height difference should be within 2mm, between automatic and manual operation. When the arm returns.
 - The tonearm should be not contact with the top part of the rest when the tonearm returns.

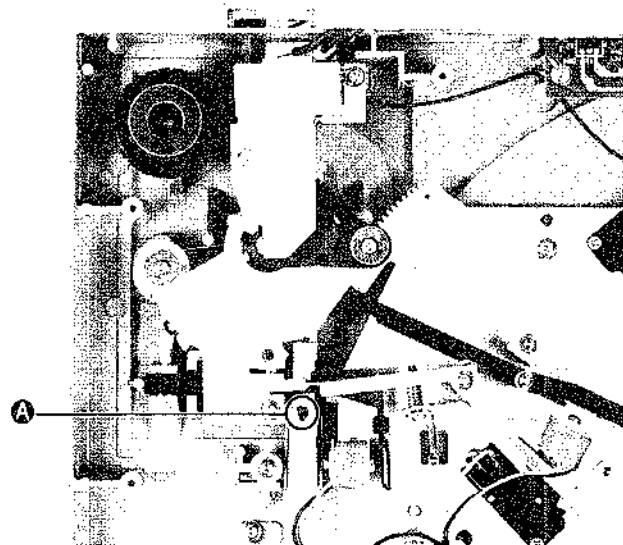
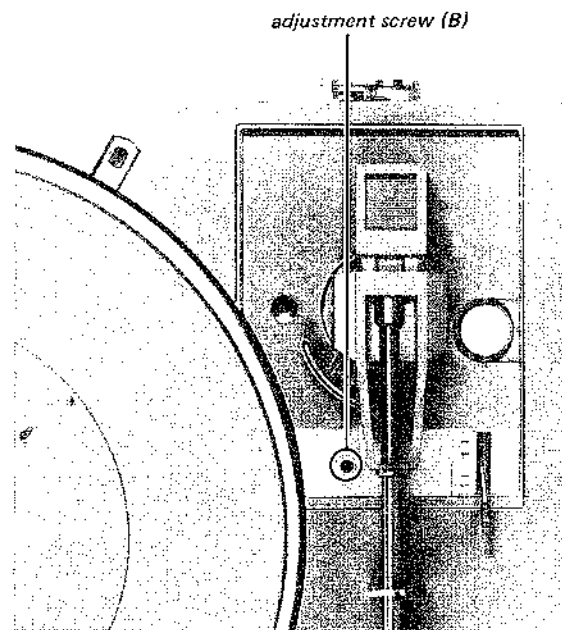
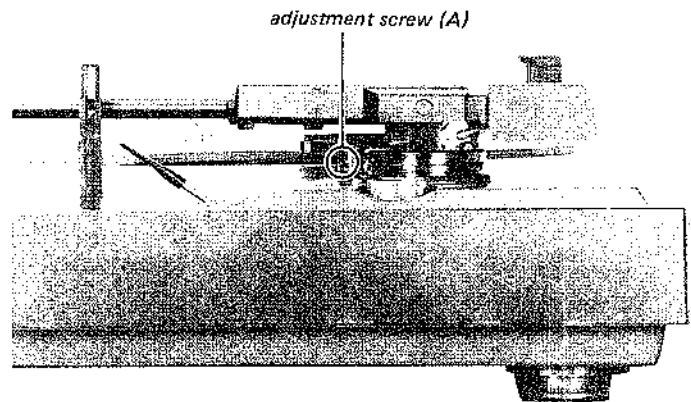

Stylus Drop-point Adjustment

Note: Stylus force adjustment should be completed.

1. Put a test record YFSC-16 on the mat.
2. Set the SPEED switch to 33.
3. Press the START/STOP button.
4. By using a screwdriver, turn the adjustment screw so that the stylus tip drops on the record at the 4-16 counts position.

Note: The proper adjustment for a 30cm record is also correct for a 17cm record.

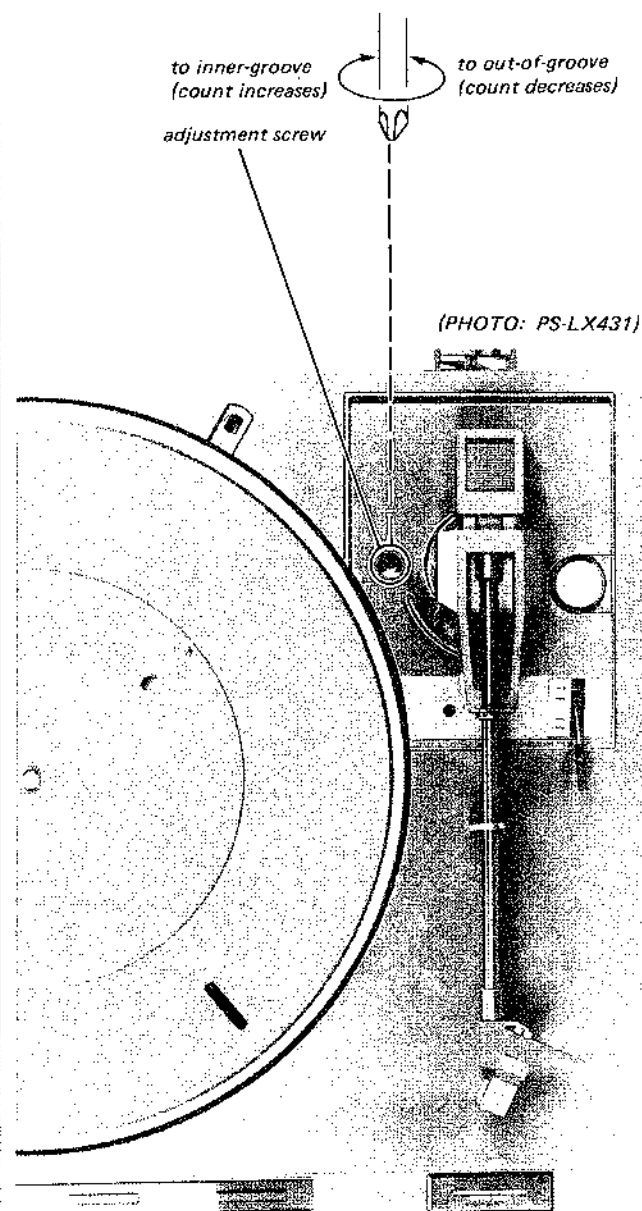

3-2. ELECTRICAL ADJUSTMENT

Speed Adjustment

Note: Be sure to perform 45rpm adjustment before 33rpm.

1. Put a stroboscope board on the mat.
2. Set the SPEED switch to 45.
Press the START/STOP button.
Adjust RV102 so that the stripped pattern of stroboscope board is stationary.
3. Set the SPEED switch to 33.
Adjust RV101 in the same way.

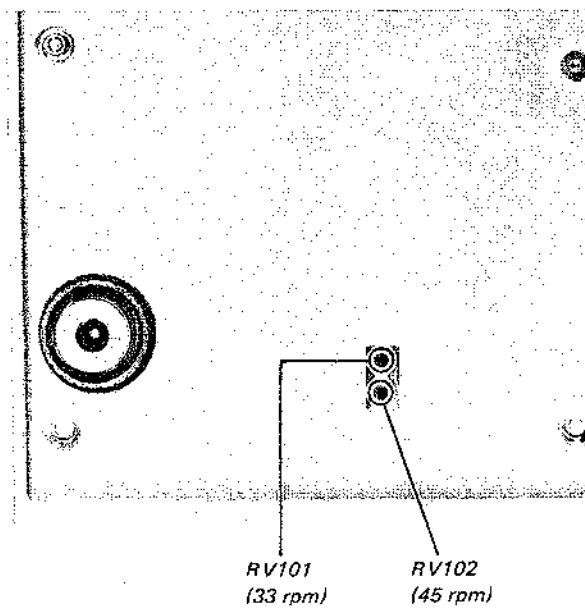

1 2 3 4 5 6 7 8 9 10 11 12 13 14 15 16 17 18 19

4-1. MOUNTING DIAGRAM

— Conductor Side —

• Semiconductor Lead Layouts

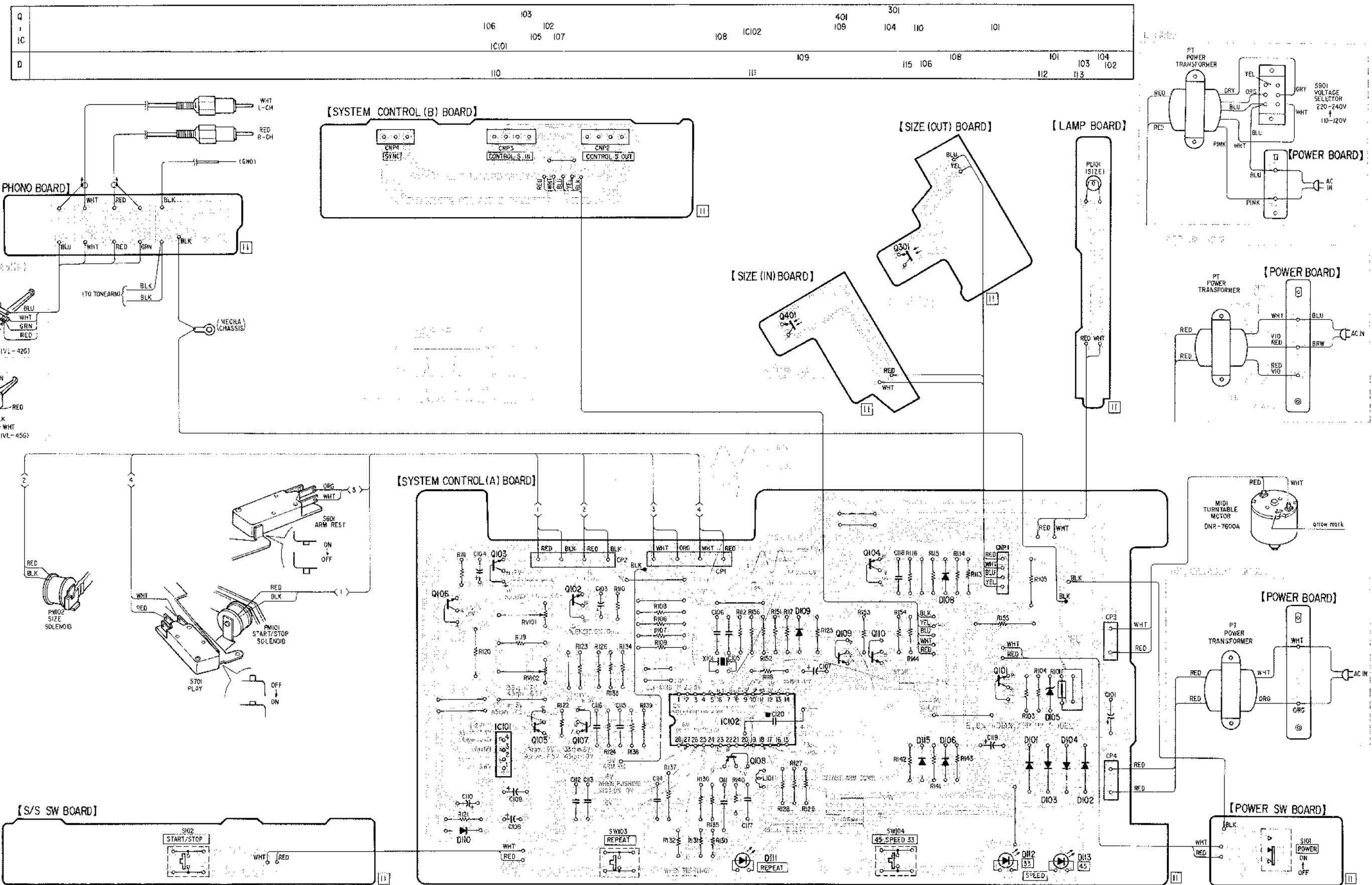
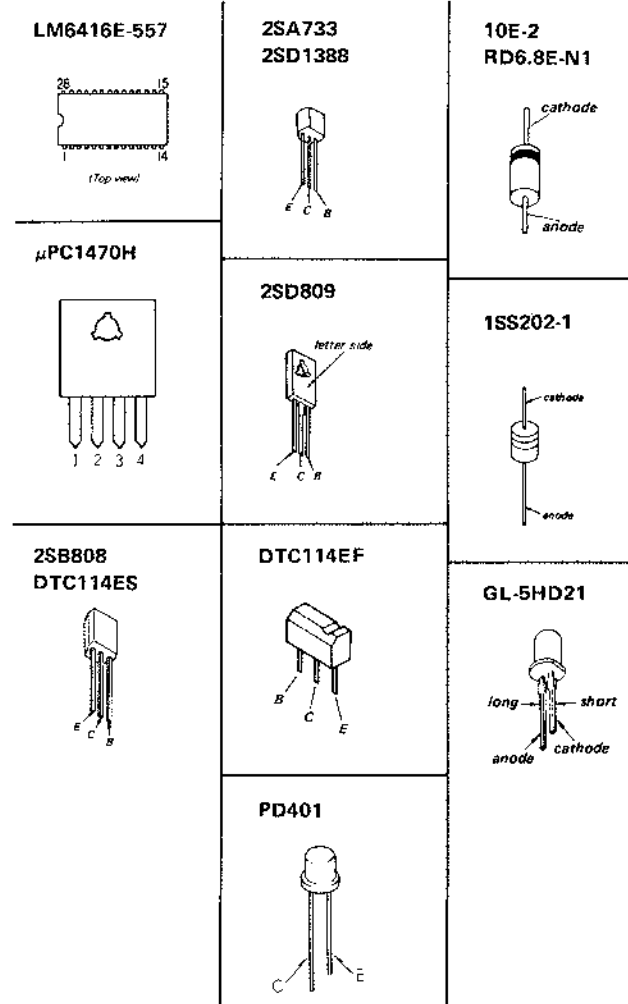

Note:
• Color code of sleeving over the end of the jacket.

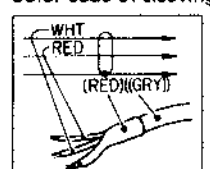

• ○ : parts extracted from the component side.

4-2. SCHEMATIC DIAGRAM

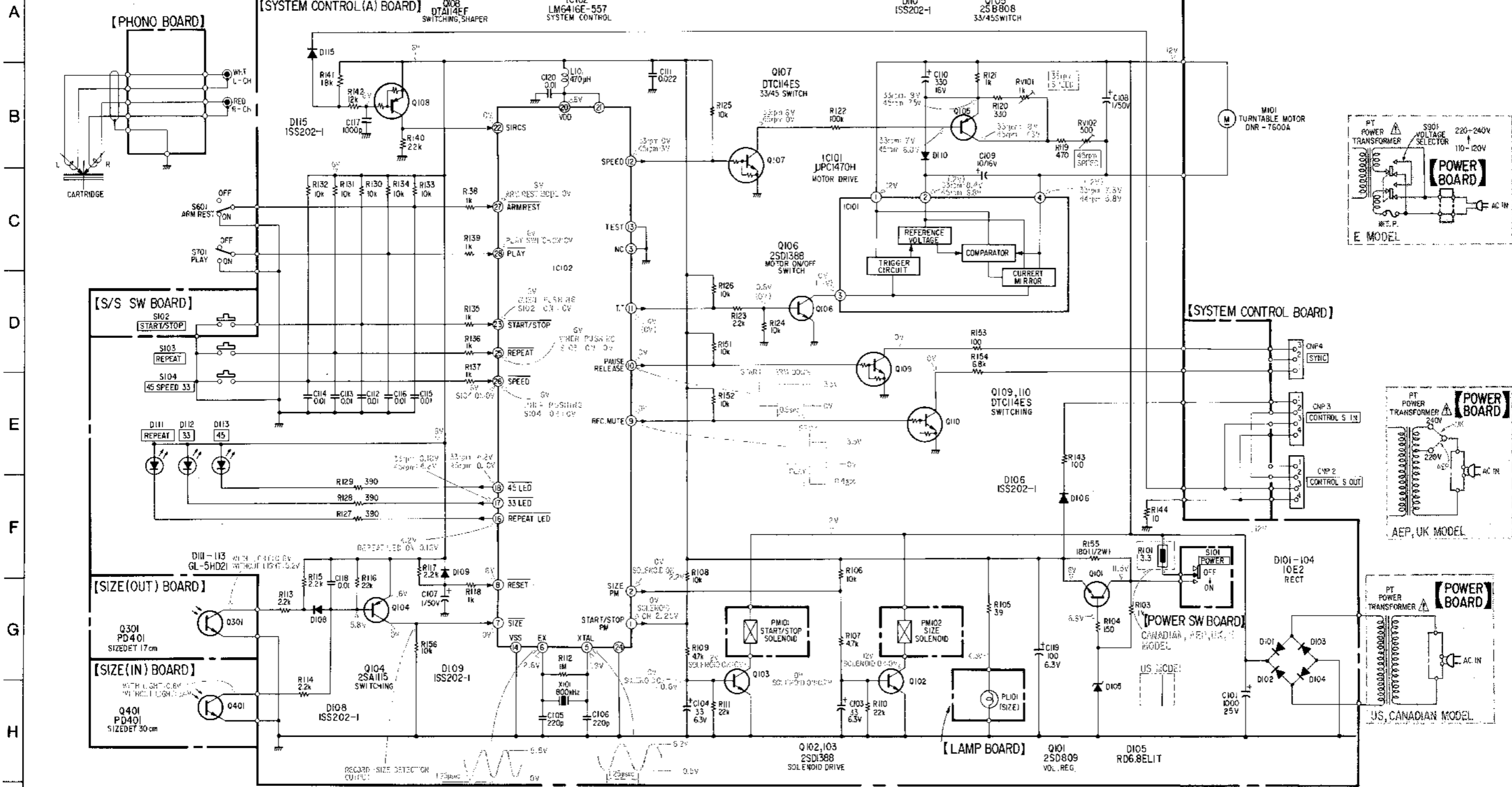

- Note:**
- All capacitors are in μF unless otherwise noted. pF : μF 50 WV or less are not indicated except for electrolytics and tantalums.
 - All resistors are in Ω and $\frac{1}{4}\text{W}$ or less unless otherwise specified.

- Voltages are dc with respect to ground unless otherwise noted.
- Readings are taken under no-signal conditions with a VOM (50k Ω/V).
- No mark: STOP
- | : PLAY
- Voltage variations may be noted due to normal production tolerances.

• Switch

Ref. No.	Switch	Position
S101	POWER	OFF
S102	START/STOP	OFF
S103	REPEAT	OFF
S104	SPEED	OFF
S601	ARM REST	ON
S701	PLAY	OFF

Note: The components identified by shading and mark are critical for safety. Replace only with part number specified.

Note: Les composants identifiés par une trame et une marque sont critiques pour la sécurité. Ne les remplacer que par une pièce portant le numéro spécifié.

[IC102 (LM6416E-557) PIN FUNCTIONS]

IC102 (LM6416E-557) is an N-MOS 4 bit micro-computer for control integrating ROM, RAM, ALU, I/O port, timer, clock generator and etc., into 1-chip.

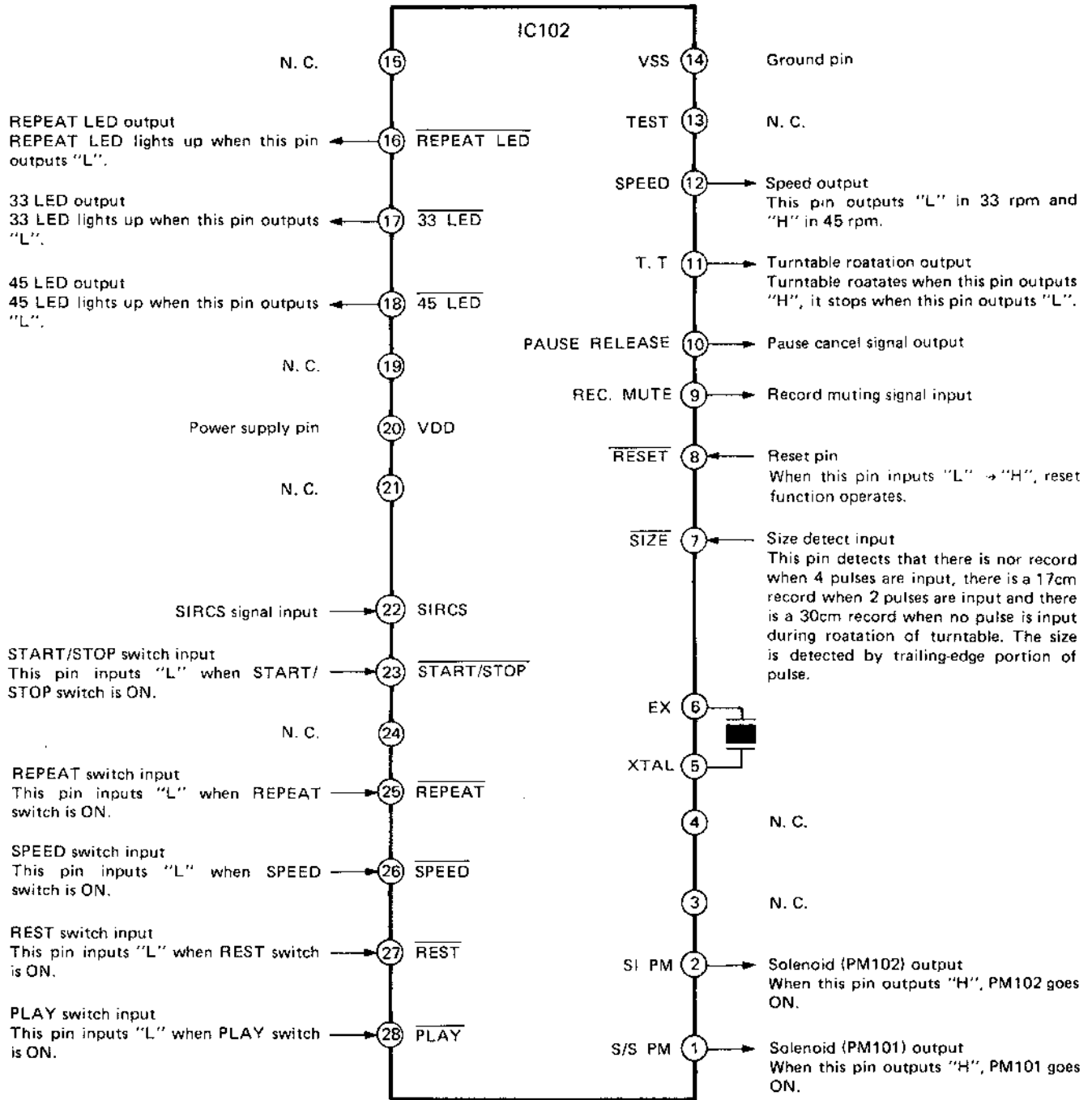

SECTION 5 EXPLODED VIEWS AND PARTS LIST

NOTE:

- The mechanical parts with no reference number in the exploded views are not supplied.
- Items marked " * " are not stocked since they are seldom required for routine service. Some delay should be anticipated when ordering these items.
- The construction parts of an assembled part are indicated with a collation number in the remark column.

The components identified by shading and mark **A** are critical for safety. Replace only with part number specified.

Les composants identifiés par une trame et une marque **A** sont critiques pour la sécurité. Ne les remplacer que par une pièce portant le numéro spécifié.

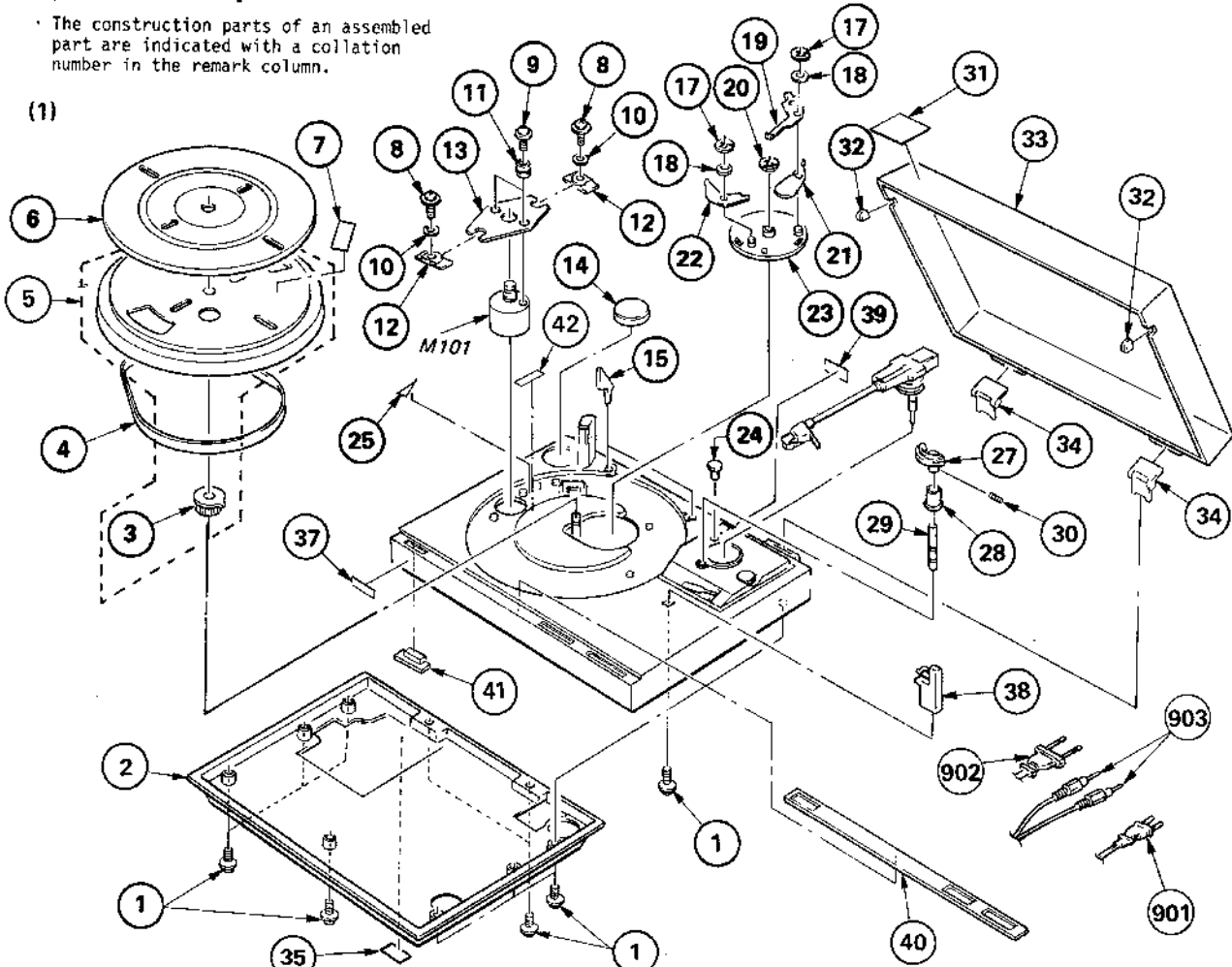



No.	Part No.	Description	Remarks
1	3-703-136-00	SCREW, TAPPING +PTPHW 3X12	
2	4-889-532-01	(PS-LX431:AEP,UK,E)...PLATE, BOTTOM	
	4-889-532-11	(PS-LX430,LX430(C),LX431(N), LX433:US,Canadian)...PLATE, BOTTOM	
3	4-868-052-00	GEAR, CENTER	
4	4-890-655-01	BELT	
5	X-4861-615-1	TURNTABLE ASSY	
6	4-903-470-01	(PS-LX430(C),LX431:Canadian,AEP,UK,E) ...SHEET, TURNTABLE	
	4-903-470-11	(PS-LX430,LX430(C),LX431(N),LX433:US) ...SHEET, TURNTABLE	
7	*4-909-004-01	LABEL, CAUTION, GEAR	
8	3-703-137-00	SCREW, TAPPING +PTPHW 3X10	
9	4-909-062-01	SCREW, MOTOR	
10	*4-301-647-00	WASHER, SPECIAL, 12	
11	4-909-061-01	CUSHION, MOTOR	
12	4-908-120-01	RUBBER, FLOATING	
13	*4-908-151-01	BRACKET (C), MOTOR	
14	3-701-806-00	(PS-LX430,LX430(C),LX431,LX433) ...ADAPTOR, 45, (E)	
15	4-874-262-00	(PS-LX430,LX430(C),LX431,LX433) ...GUIDE, RECORD	
17	7-624-190-81	STOP RING 2, TYPE-CS	
18	7-623-105-15	W 2, MIDDLE	
19	4-874-254-00	CLUTCH (S)	
20	7-624-106-04	STOP RING 3.0, TYPE -E	
21	4-874-232-00	CLUTCH (R)	
22	4-874-279-00	CLUTCH (L)	
23	4-890-524-00	GEAR (S), DRIVE	
24	4-874-260-11	CAP, BLIND	
25	3-703-680-00	(US)...LABEL, CAUTION, SUB, NEW J1	
27	X-4903-302-1	PLATE ASSY, UP AND DOWN	

No.	Part No.	Description	Remarks
28	*4-874-218-00	CASE, PUSH ROD	
29	4-881-688-00	ROD, PUSH	
30	7-621-738-08	SET-SCT, HEX. 2.6X4, FLAT POINT	
31	3-703-705-41	STICKER, SONY SYMBOL (30)	
32	4-876-304-00	(PS-LX430,430(C),LX431,LX433) ...CUSHION, DUST COVER	
33	X-4903-415-1	(PS-LX430,LX430(C),LX431:SMOKED) ...COVER ASSY, DUST	
	X-4903-417-1	(PS-LX433:TRANSPARENCY)...COVER ASSY, DUST	
34	4-857-653-00	(PS-LX430,430(C),LX431,LX433) ...HINGE, DUST COVER	
35	4-876-344-00	(AEP,UK)...LABEL, CAUTION POWER CORD	
37	3-701-690-00	(UK)...LABEL (MADE IN JAPAN)	
38	X-4874-212-X	REST ASSY, ARM	
39	4-903-456-01	(PS-LX431:UK)...LABEL, MODEL NUMBER	
	4-903-457-01	(PS-LX431:AEP)...LABEL, MODEL NUMBER	
	*4-903-459-01	(PS-LX430,LX430(C):US,Canadian) ...LABEL, MODEL NUMBER	
	4-903-460-01	(PS-LX433:US)...LABEL, MODEL NUMBER	
	4-903-472-01	(PS-LX431(N):US)...LABEL, MODEL NUMBER	
	4-903-458-01	(PS-LX431:E)...LABEL, MODEL NUMBER	
40	4-903-440-41	(PS-LX431(N))...PANEL, CONTROL	
	4-903-440-51	(PS-LX431)...PANEL, CONTROL	
	4-903-440-61	(PS-LX430,LX430(C))...PANEL, CONTROL	
	4-903-440-71	(PS-LX433)...PANEL, CONTROL	
41	4-875-501-00	GUIDE, POWER KNOB	
42	*4-881-683-01	(E)...LABEL, VOLTAGE	
901	1-551-506-XX	(US,Canadian)...CORD, POWER	
	1-556-562-00	(UK)...CORD, POWER	
	1-551-472-23	(E)...CORD, POWER	
902	1-551-908-11	(AEP)...CORD, POWER, EULO PLUG	
923	1-551-294-00	CORD (WITH PLUG)	
M101	8-835-126-01	MOTOR, DC (DNR-7600A)	

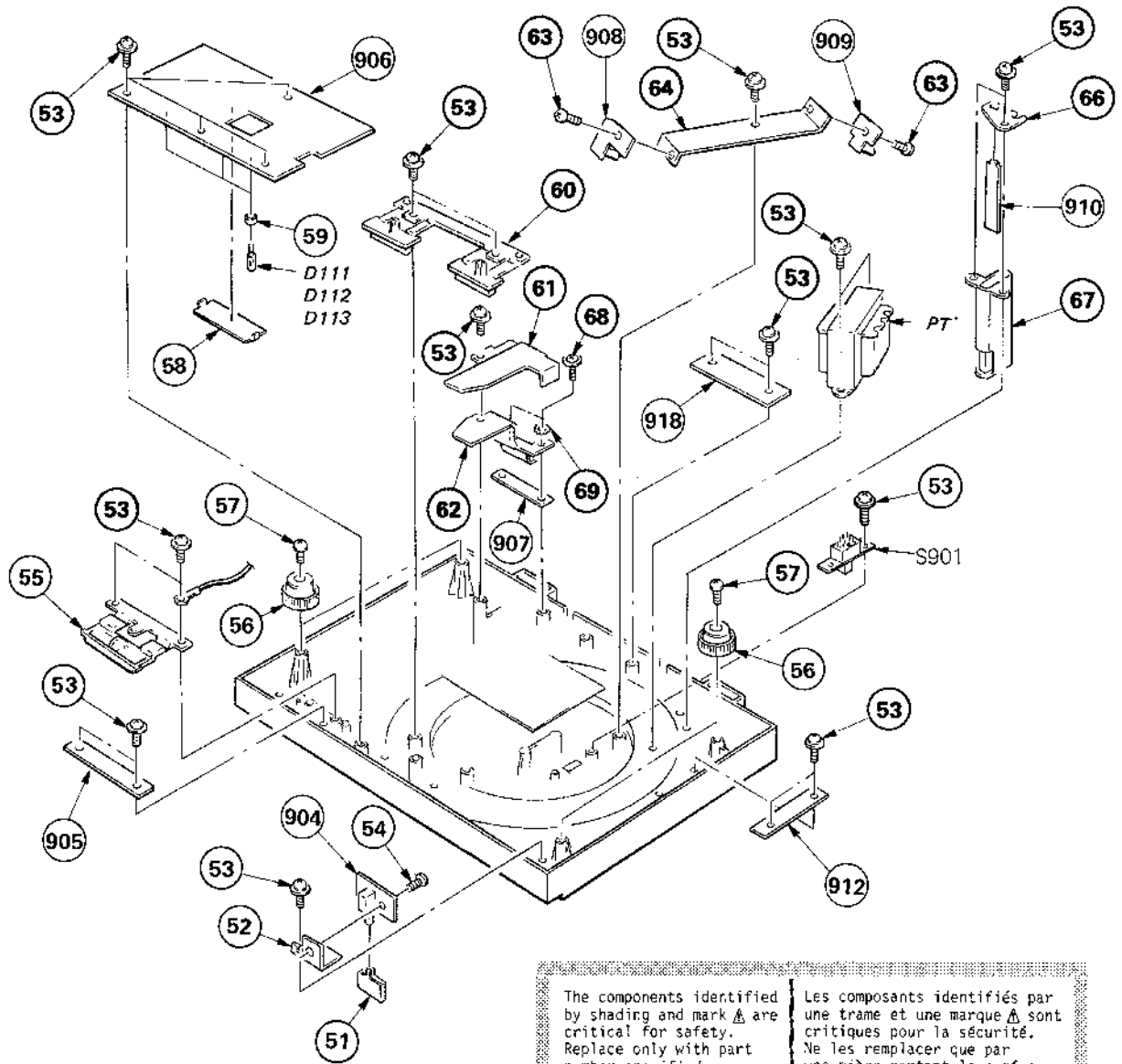
(2)



The components identified by shading and mark  are critical for safety. Replace only with part number specified.

Les composants identifiés par une trame et une marque  sont critiques pour la sécurité. Ne les remplacer que par une pièce portant le numéro spécifié.

No.	Part No.	Description	Remarks	No.	Part No.	Description	Remarks
51	4-903-436-11	BUTTON, POWER		68	3-703-136-00	SCREW, TAPPING +PTPWH 3X12	
52	*4-903-437-01	BRACKET, SWITCH		69	7-623-422-07	LW 3, TYPE B	
53	3-703-137-00	SCREW, TAPPING +PTPWH 3X10		904	*1-615-858-11	PC BOARD, POWER SW	
54	7-621-775-00	SCREW +B 2.6X4		905	*1-615-857-11	PC BOARD, S/S SW	
55	4-903-441-11	BUTTON (S.S)		906	*A-4619-269-A	(PS-LX430,LX430(C),LX431(N),LX433:US)	
56	X-4903-301-1	INSULATOR ASSY			A-4619-270-A	(PS-LX430(C)Canadian)	...MOUNTED PCB, SYSTEM CONTROL
57	3-703-136-00	SCREW, TAPPING +PTPWH 3X12			A-4619-271-A	(PS-LX431:AEP,UK)	...MOUNTED PCB, SYSTEM CONTROL
58	*4-903-450-01	PLATE (P), SHIELD		907	*1-615-860-11	PC BOARD, PHONO	
59	*4-901-657-00	SPACER (A), LED		908	*1-615-863-11	PC BOARD, SIZE (IN)	
60	4-903-443-01	BUTTON (SR)		909	*1-615-862-11	PC BOARD, SIZE (OUT)	
61	*4-889-526-01	PLATE (UPPER), SHIELD		910	*1-615-859-11	PC BOARD, LAMP	
62	*4-889-524-01	PLATE (LOWER), SHIELD		912	*1-615-861-11	PC BOARD, POWER	
63	7-685-750-04	SCREW +PTT 3X5 (S)		S901	.1-552-635-00	(E)... SWITCH, VOLTAGE SELECT	
64	*4-903-454-01	BRACKET (B), SENSOR		PT	.1-448-195-11	(US,Canadian)...TRANSFORMER, POWER	
66	*4-874-255-00	BRACKET, CHASSIS		PT	.1-448-196-11	(AEP,UK).....TRANSFORMER, POWER	
67	X-4874-213-7	HOUSE ASSY, LIGHT		PT	.1-448-426-11	(E).....TRANSFORMER, POWER	

(3)

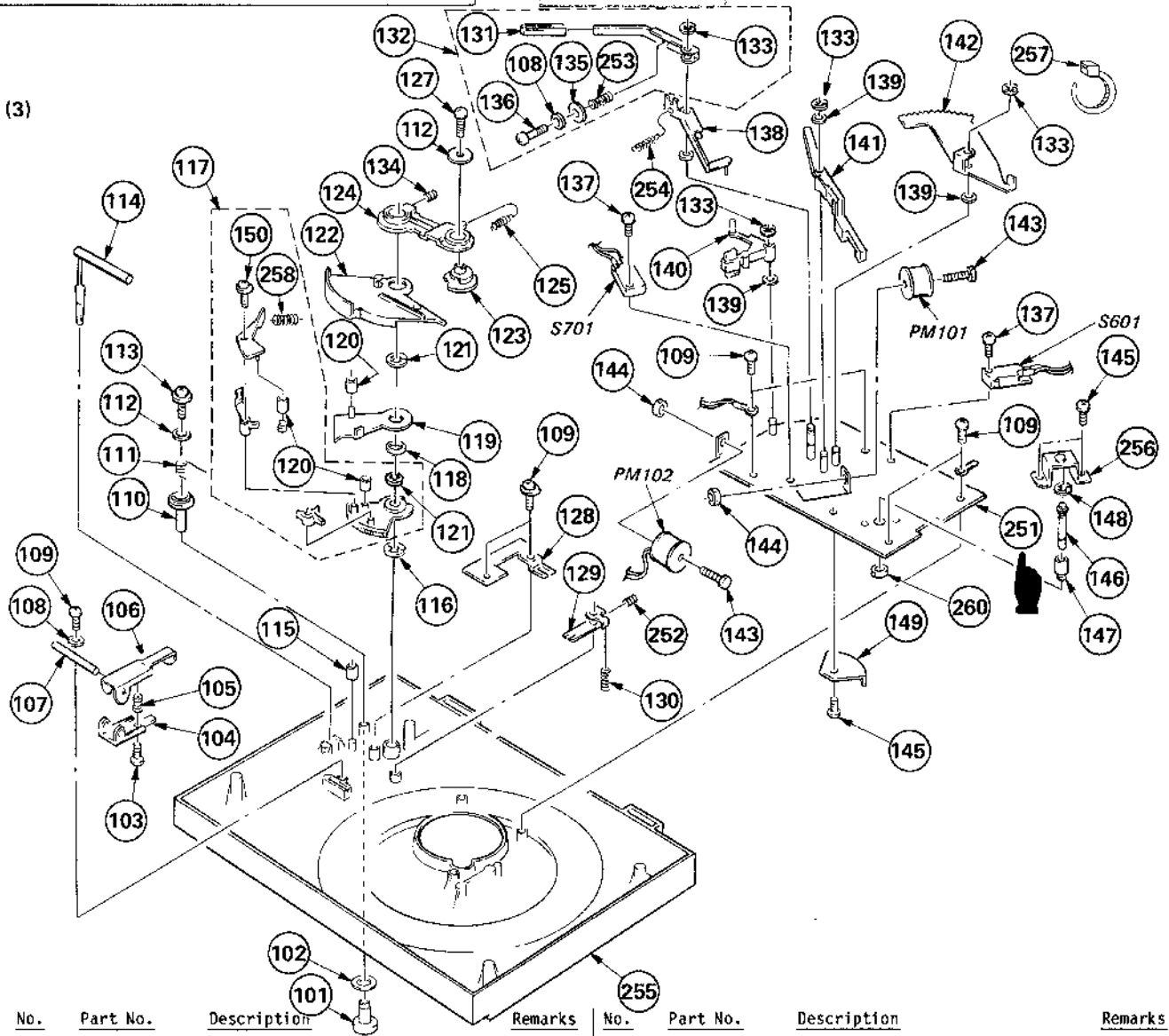

No.	Part No.	Description	Remarks	No.	Part No.	Description	Remarks
101	4-881-633-00 4-903-333-01	(PS-LX431,LX431(N))....KNOB (I), IFC (PS-LX430,LX430(C),LX433)...KNOB, IFC		131	4-874-275-00	PAD, BRAKE	
102	4-844-041-11	WASHER, (N)		132	*X-4874-206-0	LEVER ASSY, BRAKE	
103	7-621-775-80	SCREW +B 2.6X16		134	3-701-509-00	SET SCREW, DOUBLE CUP 3X8	
104	*4-880-501-00	LEVER (A), LIFTER		135	4-812-654-00	WASHER	
105	4-880-503-00	SPRING, COMPRESSION		136	7-682-110-01	SCREW +P 3X18	
106	*4-881-659-00	LEVER (C), LIFTER		137	7-685-755-01	SCREW +PTT 3X14 (S)	
107	*4-861-940-00	SHAFT, LIFTER LEVER		138	*X-4874-205-0	LEVER ASSY, RESET	
108	*4-301-647-00	WASHER, SPECIAL, 12		139	3-701-441-21	WASHER	
109	3-703-137-00	SCREW, TAPPING +PTPW 3X10		140	X-4874-204-0	LEVER ASSY, SIZE	
110	4-903-409-01	CAM, IFC		141	X-4874-203-7	LEVER ASSY, CLUTCH	
111	4-874-250-00	SPRING		142	*X-4874-202-0	LEVER ASSY, MAIN	
112	0-056-028-00	WASHER, PLAIN, 14 DIA.		143	4-874-234-00	CORE	
114	4-877-824-00	CAM, LIFTER		144	7-622-207-05	N 2.6, TYPE 2	
113	7-685-152-21	SCREW PTPWH 3X25 TYPE 2		145	7-682-546-04	SCREW +BVTT 3X5 (S)	
115	4-852-841-00	TUBE		146	4-889-523-01	SHAFT, CENTER	
116	7-624-133-54	STOP RING 10, TYPE-CE		147	4-909-022-01	BEARING (B)	
117	X-4881-610-0	LEVER (C) ASSY, INDEX		148	7-624-133-34	STOP RING 8, TYPE-CE	
118	4-911-107-01	POLY-SLIDER (DIA. 9.5)(LARGE)		149	*4-903-438-01	PLATE, RESET	
119	*X-4874-209-0	LEVER (B) ASSY, INDEX		150	7-687-202-21	TOTSU PTPWH 2X4, TYPE 2, SLIT	
120	4-874-259-00	RUBBER, SHOCK ABSORBING		251	*X-4903-405-1	CHASSIS ASSY	
121	7-624-133-44	STOP RING 9, TYPE-CE		252	7-621-741-09	SET-SCT HEX. 2.6X8 WP	
122	4-874-223-00	LEVER (A), ARM		253	4-876-322-00	SPRING, COMPRESSION (BRAKE)	
123	4-874-231-00	CAM, ECCENTRIC		254	4-876-346-00	SPRING, TENSION (RESET)	
124	4-874-277-00	LEVER (B), ARM		255	4-903-444-41	FRAME	
125	3-548-124-00	SPRING, TENSION		256	*4-909-021-01	BRACKET, BEARING	
126	4-844-041-00	WASHER, (N)		257	3-701-748-00	CLAMP	
127	7-685-145-14	SCREW +P 3X6 TYPE2 SLIT		260	4-909-084-01	NUT, BEARING	
128	*4-903-410-01	RETAINER (C), LIFTER		PM101	1-454-394-21	SOLENOID, PLUNGER	
129	*4-876-317-00	GUIDE, LIFTER		PM201	1-454-394-21	SOLENOID, PLUNGER	
130	4-903-331-01	SPRING (LIFTER), COMPRESSION		S601	1-570-489-11	SWITCH, MICRO (ARM,REST)(PLAY)	
				S701	1-570-489-11	SWITCH, MICRO (ARM,REST)(PLAY)	

(4) PS-LX431, PS-LX431N

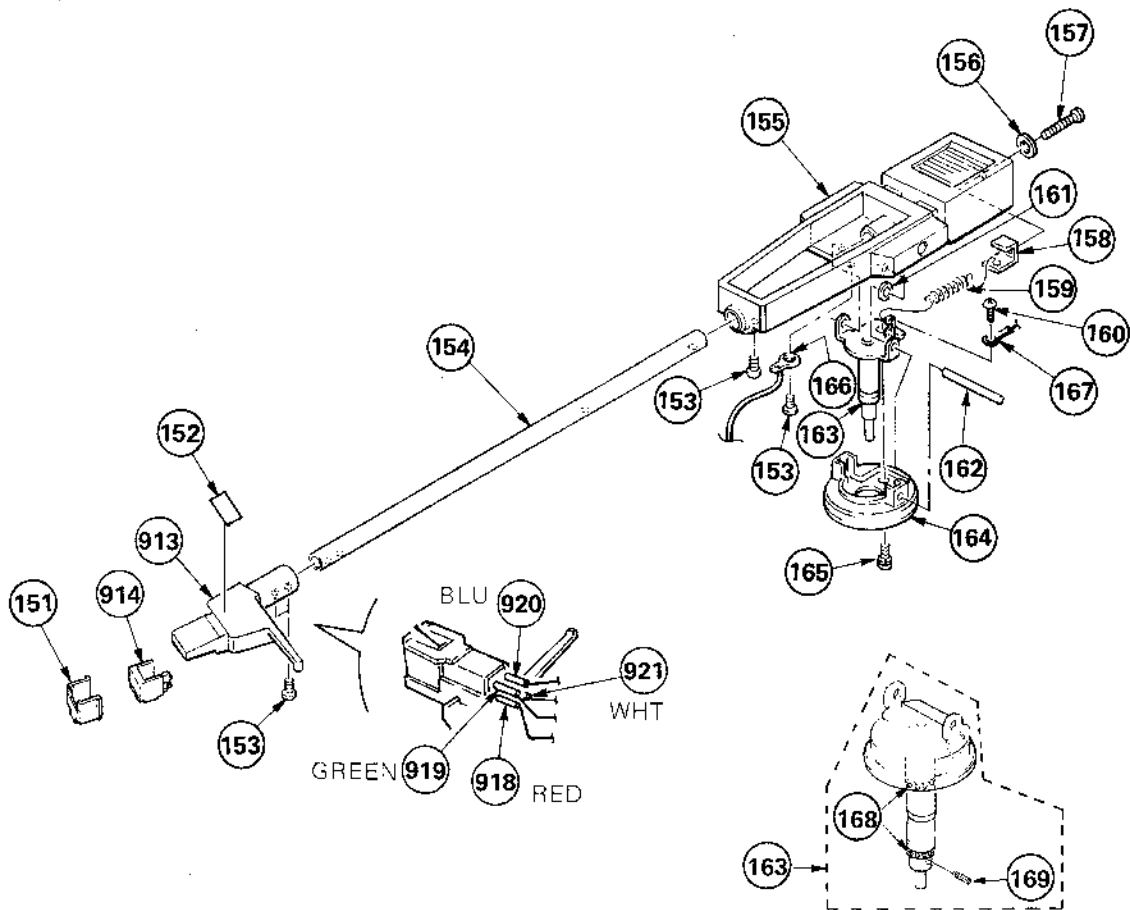

No.	Part No.	Description	Remarks	No.	Part No.	Description	Remarks
151	3-706-613-00	PROTECTOR		163	X-4881-614-0	ROTOR ASSY	
152	3-706-612-00	LABEL, CARTRIDGE		164	4-880-631-11	JOINT, CENTER	
153	7-685-103-2	SCREW +P 2X5 TYPE2 SLIT		165	7-682-647-01	SCREW +PS 3X6	
154	4-889-528-11	PIPE, ARM		166	7-623-505-01	LUG, 2	
155	4-889-529-11	JOINT, PIPE		167	7-623-508-01	LUG, 3	
156	7-688-003-13	W 3, MIDDLE		168	7-671-151-01	STAINLESS, BALL 1/16INCH	
157	7-682-555-09	SCREW +B 3X30		169	7-621-712-17	SET-SCREW, SLOT 2.6X2 CUP POINT	
158	4-868-016-01	HOOK, SPRING		913	1-549-109-21	CARTRIDGE (WITH SHELL) (VL-42G) 151, 152, 914	
159	4-889-510-00	SPRING, TENSION		914	3-706-614-11	SHELL	
160	7-682-545-09	SCREW +B 3X4		918	1-557-042-11	{RED}.....LEAD (WITH TERMINAL)	
161	3-701-437-01	WASHER, 2		919	1-557-042-21	{GRN}.....LEAD (WITH TERMINAL)	
162	4-880-619-00	PIN, HORIZONTAL		920	1-557-042-31	{BLU}.....LEAD (WITH TERMINAL)	
				921	1-557-042-41	{WHT}.....LEAD (WITH TERMINAL)	

PS-LX430/430C/431/431N/433

(5) PS-LX430/430C/433

(PS-LX430/LX433: Cartridge is not supplied with US, Canadian certain models)

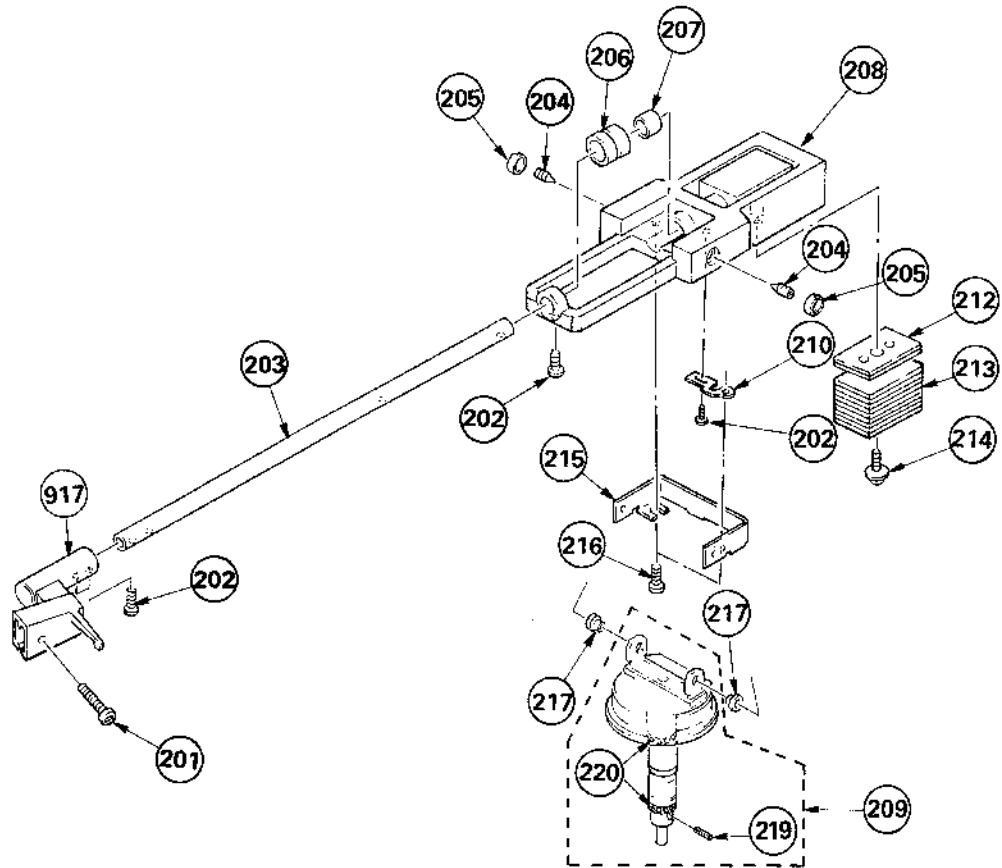

No.	Part No.	Description	Remarks
201	4-887-481-01	SCREW (B), CARTRIDGE FITTING	
202	7-685-103-29	SCREW +P 2X5 TYPE2 SLIT	
203	4-903-307-11	PIPE, ARM	
204	2-203-518-61	SCREW, PIVOT	
205	2-203-519-00	NUT (A), LOCK, PIVOT	
206	*4-903-312-11	WEIGHT, SUB	
207	*4-903-308-01	SHEET (S)	
208	4-903-336-11	JOINT, PIPE	
209	X-4881-611-2	JOINT ASSY, CENTER	
210	*4-889-539-01	(PS-LX430,LX430(C),LX433:BLACK) ...PLATE, GROUND	

No.	Part No.	Description	Remarks
212	*4-903-350-01	WEIGHT, SUPPORT	
213	4-877-810-00	WEIGHT	
214	7-687-234-21	SCREW, TOTSU PTPWH 2.6X8, TYPE2	
215	*4-881-628-00	REINFORCEMENT (A)	
216	7-685-105-29	SCREW +P 2X8 TYPE2 SLIT	
217	4-881-618-00	BEARING, PIVOT	
219	7-621-712-17	SET-SCREW, SLOT 2.6X2 CUP POINT	
220	7-671-151-01	STAINLESS, BALL 1/16 INCH	
915	1-549-117-21	CARTRIDGE (VL-45G)	
917	*1-562-517-41	CONNECTOR(WITH HEAD SHELL) 4P	

SECTION 6
ELECTRICAL PARTS LIST

NOTE:

- Items marked " * " are not stocked since they are seldom required for routine service. Some delay should be anticipated when ordering these items.
- If there are two or more same circuits in a set such as a stereophonic machine, only typical circuit parts may be indicated and capacitors and resistors in other same circuits may be omitted.

CAPACITORS:

MF:μF, PF:μμF.

RESISTORS

- All resistors are in ohms.
- F : nonflammable

COILS

MMH : mH, UH : μH

SEMICONDUCTORS





In each case, U : μ, for example:

UA...: μA..., UPA...: μPA..., UPC...: μPC, UPD...: μPD...



The components identified by shading and mark  are critical for safety. Replace only with part number specified.

Les composants identifiés par une trame et une marque  sont critiques pour la sécurité. Ne les remplacer que par une pièce portant le numéro spécifié.

ELECTRICAL PARTS

Ref.No.	Part No.	Description
901	 .1-551-506-XX	(US,Canadian)...CORD, POWER
	 .1-556-562-00	(UK).....CORD, POWER
	 .1-551-472-23	(E).....CORD, POWER
902	 .1-551-908-11	(AEP)....CORD, POWER, EULO PLUG
904	*1-615-858-11	PC BOARD, POWER SW
905	*1-615-857-11	PC BOARD, S/S SW
906	*A-4619-269-A	(PS-LX430,LX430(C),LX431(N),LX433:US) ...MOUNTED PCB, SYSTEM CONTROL
	A-4619-270-A	(PS-LX430(C)Canadian) ...MOUNTED PCB, SYSTEM CONTROL
	A-4619-271-A	(PS-LX431:AEP,UK) ...MOUNTED PCB, SYSTEM CONTROL
907	*1-615-860-11	PC BOARD, PHONO
908	*1-615-863-11	PC BOARD, SIZE (IN)
909	*1-615-862-11	PC BOARD, SIZE (OUT)
910	*1-615-859-11	PC BOARD, LAMP
912	*1-615-861-11	PC BOARD, POWER
913	1-549-109-21	CARTRIDGE (WITH SHELL)
914	3-706-614-11	SHELL
915	1-549-117-21	CARTRIDGE (VL-456)
917	*1-562-517-41	CONNECTOR(WITH HEAD SHELL) 4P
918	1-557-042-11	(RED)...LEAD (WITH TERMINAL)
919	1-557-042-21	(GRN)...LEAD (WITH TERMINAL)
920	1-557-042-31	(BLU)...LEAD (WITH TERMINAL)
921	1-557-042-41	(WHT)...LEAD (WITH TERMINAL)
923	1-551-294-00	CORD (WITH PLUG)
C101	1-123-337-00	ELECT 1000MF 20% 25V
C103	1-123-646-00	ELECT 33MF 20% 6.3V
C104	1-123-646-00	ELECT 33MF 20% 6.3V
C105	1-162-286-31	CERAMIC 220PF 10% 50V
C106	1-162-286-31	CERAMIC 220PF 10% 50V
C107	1-123-611-00	ELECT 1MF 20% 50V
C108	1-123-611-00	ELECT 1MF 20% 50V
C109	1-123-617-00	ELECT 10MF 20% 16V
C110	1-123-322-00	ELECT 330MF 20% 16V
C111	1-161-494-00	CERAMIC 0.022MF 30% 25V
C112	1-162-306-31	CERAMIC 0.01MF 30% 16V
C113	1-162-306-31	CERAMIC 0.01MF 30% 16V
C114	1-162-306-31	CERAMIC 0.01MF 30% 16V
C115	1-162-306-31	CERAMIC 0.01MF 30% 16V
C116	1-162-306-31	CERAMIC 0.01MF 30% 16V
C117	1-162-294-31	CERAMIC 0.001MF 10% 50V
C118	1-162-306-31	CERAMIC 0.01MF 30% 16V
C119	1-123-661-00	ELECT 220MF 20% 6.3V
C120	1-162-306-31	CERAMIC 0.01MF 30% 16V

ELECTRICAL PARTS

Ref.No.	Part No.	Description
CP1	*1-508-801-00	U TYPE BASE POST 4P
CP2	*1-508-801-00	U TYPE BASE POST 4P
CP3	*1-508-799-00	BASE POST (U TYPE)
CP4	*1-508-799-00	BASE POST (U TYPE)
CNP1	*1-564-706-11	PIN, CONNECTOR (SMALL TYPE) 4P
CNP2	*1-564-980-11	PIN, CONNECTOR 4P (CONTROL S OUT)
CNP3	*1-564-980-11	PIN, CONNECTOR 4P (CONTROL S IN)
CNP4	1-564-358-00	PIN, CONNECTOR 3P (SYNC)
D101	8-719-200-02	DIODE 10E2
D102	8-719-200-02	DIODE 10E2
D103	8-719-200-02	DIODE 10E2
D104	8-719-200-02	DIODE 10E2
D105	8-719-102-76	DIODE RD6.8EW1
D106	8-719-107-94	DIODE 1SS202-1
D108	8-719-107-94	DIODE 1SS202-1
D109	8-719-107-94	DIODE 1SS202-1
D110	8-719-107-94	DIODE 1SS202-1
D111	8-719-906-58	DIODE GL-5HD21
D112	8-719-906-58	DIODE GL-5HD21
D113	8-719-906-58	DIODE GL-5HD21
D115	8-719-107-94	DIODE 1SS202-1
IC101	8-759-103-35	IC UPC1470H
IC102	8-759-801-85	IC LM6416E-557
L101	1-407-177-XX	MICRO INDUCTOR 470UH
M101	8-835-126-01	MOTOR, DC (DNR-7600A)
PL101	1-518-268-00	LAMP, PILOT 4.5V 40MA
PM101	1-454-394-21	SOLENOID, PLUNGER
PM201	1-454-394-21	SOLENOID, PLUNGER
PT	 .1-448-195-11	(US,Canadian)...TRANSFORMER, POWER
PT	 .1-448-196-11	(AEP,UK).....TRANSFORMER, POWER
PT	 .1-448-425-11	(E).....TRANSFORMER, POWER
Q101	8-729-180-93	TRANSISTOR 2SD809
Q102	8-729-802-34	TRANSISTOR 2SD1388
Q103	8-729-802-34	TRANSISTOR 2SD1388
Q104	8-729-173-37	TRANSISTOR 2SA733-P
Q105	8-729-800-83	TRANSISTOR 2SB808
Q106	8-729-802-34	TRANSISTOR 2SD1388
Q107	8-729-900-80	TRANSISTOR DTC114ES
Q108	8-729-900-38	TRANSISTOR DTA114EF
Q109	8-729-900-80	TRANSISTOR DTC114ES
Q110	8-729-900-80	TRANSISTOR DTC114ES
Q301	8-729-902-39	TRANSISTOR PD401
Q401	8-729-902-39	TRANSISTOR PD401

ELECTRICAL PARTS

Ref.No.	Part No.	Description
R101	1-806-883-11	{Canadian,AEP,UK}...THERMISTOR (POSITIVE)
R103	1-247-831-00	CARBON 1K 5% 1/6W
R104	1-247-811-00	CARBON 150 5% 1/6W
R105	1-247-695-11	CARBON 39 5% 1/4W
R106	1-249-429-11	CARBON 10K 5% 1/6W
R107	1-249-425-11	CARBON 4.7K 5% 1/6W
R108	1-249-429-11	CARBON 10K 5% 1/6W
R109	1-249-425-11	CARBON 4.7K 5% 1/6W
R110	1-249-433-11	CARBON 22K 5% 1/6W
R111	1-249-433-11	CARBON 22K 5% 1/6W
R112	1-247-903-00	CARBON 1M 5% 1/6W
R113	1-249-421-11	CARBON 2.2K 5% 1/6W
R114	1-249-421-11	CARBON 2.2K 5% 1/6W
R115	1-249-421-11	CARBON 2.2K 5% 1/6W
R116	1-249-433-11	CARBON 22K 5% 1/6W
R117	1-249-421-11	CARBON 2.2K 5% 1/6W
R118	1-247-831-00	CARBON 1K 5% 1/6W
R119	1-214-721-00	METAL 470 1% 1/4W
R120	1-214-717-00	METAL 330 1% 1/4W
R121	1-247-831-00	CARBON 1K 5% 1/6W
R122	1-247-879-00	CARBON 100K 5% 1/6W
R123	1-249-421-11	CARBON 2.2K 5% 1/6W
R124	1-249-429-11	CARBON 10K 5% 1/6W
R125	1-249-429-11	CARBON 10K 5% 1/6W
R126	1-249-429-11	CARBON 10K 5% 1/6W
R127	1-247-821-00	CARBON 390 5% 1/6W
R128	1-247-821-00	CARBON 390 5% 1/6W
R129	1-247-821-00	CARBON 390 5% 1/6W
R130	1-249-429-11	CARBON 10K 5% 1/6W
R131	1-249-429-11	CARBON 10K 5% 1/6W
R132	1-249-429-11	CARBON 10K 5% 1/6W
R133	1-249-429-11	CARBON 10K 5% 1/6W
R134	1-249-429-11	CARBON 10K 5% 1/6W
R135	1-247-831-00	CARBON 1K 5% 1/6W
R136	1-247-831-00	CARBON 1K 5% 1/6W
R137	1-247-831-00	CARBON 1K 5% 1/6W
R138	1-247-831-00	CARBON 1K 5% 1/6W
R139	1-247-831-00	CARBON 1K 5% 1/6W
R140	1-249-433-11	CARBON 22K 5% 1/6W
R141	1-249-432-11	CARBON 18K 5% 1/6W
R142	1-247-857-00	CARBON 12K 5% 1/6W
R143	1-247-807-00	CARBON 100 5% 1/6W
R144	1-247-783-00	CARBON 10 5% 1/6W
R151	1-249-429-11	CARBON 10K 5% 1/6W
R152	1-249-429-11	CARBON 10K 5% 1/6W
R153	1-247-807-00	CARBON 100 5% 1/6W
R154	1-247-851-00	CARBON 6.8K 5% 1/6W
R155	1-247-742-11	CARBON 180 5% 1/2W
R156	1-249-429-11	CARBON 10K 5% 1/6W
RV101	1-226-233-00	RES, ADJ, CARBON 1K
RV102	1-226-232-00	RES, ADJ, CARBON 500
S601	1-570-489-11	SWITCH, MICRO {ARM,REST}{PLAY}
S701	1-570-489-11	SWITCH, MICRO {ARM,REST}{PLAY}
S901	1-552-535-00	{E}....SWITCH, VOLTAGE SELECT

ELECTRICAL PARTS

Ref.No.	Part No.	Description
SW101	1-553-909-00	SWITCH, PUSH (1 KEY){POWER}
SW102	1-554-541-12	SWITCH, KEY BOARD (START/STOP)
SW103	1-554-541-12	SWITCH, KEY BOARD (REPEAT)
SW104	1-554-541-12	SWITCH, KEY BOARD (SPEED)
X101	1-567-342-11	OSCILLATOR, CERAMIC
ACCESSORY & PACKING MATERIAL		
Part No.	Description	
△ 1-526-565-12	{E}...ADAPTOR, AC PLUG	
1-556-372-41	{PS-LX430,LX430(C),LX431,LX433} ...CORD, CONNECTION (4 CORE)	
1-557-109-21	{PS-LX430,LX430(C),LX431,LX433} ...CORD, CONNECTION	
1-558-233-11	{PS-LX430,LX430(C),LX431,LX433}...CORD (WITH CONNECTOR){SIRCS} 4P	
1-558-649-11	{PS-LX430,LX430(C),LX431,LX433}...CORD (WITH CONNECTOR) 3P	
3-701-630-00	{PS-LX430,LX430(C),LX431,LX433} ...BAG, POLYETHYLENE	
3-701-634-00	BAG, POLYETHYLENE	
3-701-806-01	ADAPTOR, 45RPM	
3-703-450-01	{PS-LX430,LX430(C),LX433:US}...INSTRUCTION	
3-795-753-21	{PS-LX430,LX433}...INSTRUCTION	
3-703-845-01	{US,Canadian}...LABEL {N}{U/C}, MAIN CAUTION	
3-765-235-11	{PS-LX431:AEP,UK,E}...MANUAL, INSTRUCTION	
3-765-235-21	{PS-LX430,LX430(C),LX433:US,Canadian} ...MANUAL, INSTRUCTION	
3-765-235-31	{PS-LX430(C):Canadian}...MANUAL, INSTRUCTION	
3-765-235-41	{PS-LX431:AEP}...MANUAL, INSTRUCTION	
3-794-123-11	LABEL, CAUTION	
4-862-043-00	CUSHION, ARM	
4-874-262-00	{PS-LX430,LX430(C),LX431,LX433}...GUIDE, RECORD	
4-876-352-00	SHEET, PROTECTION	
4-881-698-00	{PS-LX430,LX430(C),LX431,LX433} ...PLATE, PROTECTION	
4-889-536-01	{PS-LX430,LX430(C),LX431,LX433}...CUSHION (LEFT)	
4-889-540-02	{PS-LX431(N)}...CUSHION (LEFT)	
4-889-537-01	{PS-LX430,LX430(C),LX431,LX433}...CUSHION(RIGHT)	
4-889-541-02	{PS-LX431(N)}...CUSHION(RIGHT)	
4-889-538-01	HOLDER, TURNTABLE	
4-889-544-01	{PS-LX431(N)}...SPACER	
4-903-422-00	{PS-LX430,LX430(C),LX433}...HOLDER, ARM	
*4-903-452-01	SPACER, CLUTCH	
4-903-468-01	{PS-LX431}...INDIVIDUAL CARTON	
4-903-468-11	{PS-LX430}...INDIVIDUAL CARTON	
4-903-468-21	{PS-LX430(C)}...INDIVIDUAL CARTON	
4-903-468-31	{PS-LX433}...INDIVIDUAL CARTON	

The components identified by shading and mark △ are critical for safety. Replace only with part number specified.

Les composants identifiés par une trame et une marque △ sont critiques pour la sécurité. Ne les remplacer que par une pièce portant le numéro spécifié.