

# SERVICE MANUAL

*US Model  
AEP Model  
UK Model  
E Model*



## SPECIFICATIONS

### Turntable

Platter	29 cm (11½ in.), aluminum-alloy diecast
Motor	Linear torque BSL (brushless and slotless) motor
Drive system	Direct drive
Control system	Quartz lock control system
Speed	33⅓ rpm, 45 rpm
Wow and flutter	0.03% (WRMS)*, 0.035% (WRMS)
Signal-to-noise ratio	75 dB (DIN-B)
Automatic system	Lead-in, return, reject, repeat, tonearm up/down, record size selection
Load characteristics	0 to 1.5g tracking force (at lead-in groove of a record)
Speed deviation	Within ±0.003%

### Tonearm

Type	Linear tracking tonearm
Pivot-to-stylus length	75 mm (3 in.)
Tracking error	+0.1°
Tracking force adjustment range	1.25 ± 0.25 g
Cartridge	plug-in type, 6 g

### General

Power requirements	120 V ac, 60 Hz (US model)
	220 V ac, 50/60 Hz (AEP model)
	240 V ac, 50/60 Hz (UK model)
	110–220 V, 120–240 V ac, 50/60 Hz (E model)
Power consumption	10 W
Dimensions	Approx. 430 × 96 × 382 mm (w/h/d)
	(17 × 3⅞ × 15⅓ in.)
Weight	including projecting parts and controls
	Approx. 7.5 kg (16 lbs 9 oz), net
	Approx. 9.3 kg (20 lbs 8 oz), in shipping carton

### Cartridge VL-45G (supplied only with partial US model)

Type	Moving magnet
Frequency response	10 Hz to 20 kHz
Channel separation	23 dB at 1 kHz
Output voltage	3.5 mV at 1 kHz, 5 cm/sec., 45°
Load impedance	47 to 100 kilohms
Tracking force	1.0 to 1.5 g (1.25 g recommended)
Stylus	Sony ND-145G
Weight	6 g

### Cartridge XL-250G (supplied only with AEP, UK, E model)

Type	Moving magnet
Frequency response	10 Hz to 20 kHz
Channel separation	23 dB at 1 kHz
Output voltage	5 mV at 1 kHz, 5 cm/sec., 45°
Load impedance	50 kΩ to 100 kΩ
Tracking force	1.0 to 1.5 g (1.25 g recommended)
Stylus	Sony ND-250G
Weight	6 g

### SAFETY-RELATED COMPONENT WARNING!!

COMPONENTS IDENTIFIED BY SHADING AND MARK  ON THE SCHEMATIC DIAGRAMS AND IN THE PARTS LIST ARE CRITICAL TO SAFE OPERATION. REPLACE THESE COMPONENTS WITH SONY PARTS WHOSE PART NUMBERS APPEAR AS SHOWN IN THIS MANUAL OR IN SUPPLEMENTS PUBLISHED BY SONY.

STEREO TURNTABLE SYSTEM  
**SONY**®

**AUD**



**SAFETY CHECK-OUT (US Model)**

After correcting the original service problem, perform the following safety check before releasing the set to the customer:

Check the antenna terminals, metal trim, "metallized" knobs, screws, and all other exposed metal parts for AC leakage. Check leakage as described below.

**LEAKAGE TEST**

The AC leakage from any exposed metal part to earth ground and from all exposed metal parts to any exposed metal part having a return to chassis, must not exceed 0.5 mA (500 microamperes). Leakage current can be measured by any one of three methods.

1. A commercial leakage tester, such as the Simpson 229 or RCA WF-540A. Follow the manufacturers' instructions to use these instruments.
2. A battery-operated AC milliammeter. The Data Precision 245 digital multimeter is suitable for this job.

3. Measuring the voltage drop across a resistor by means of a VOM or battery-operated AC voltmeter. The "limit" indication is 0.75 V, so analog meters must have an accurate low-voltage scale. The Simpson 250 and Sanwa SH-63Trd are examples of a passive VOM that is suitable. Nearly all battery operated digital multimeters that have a 2V AC range are suitable. (See Fig. A)

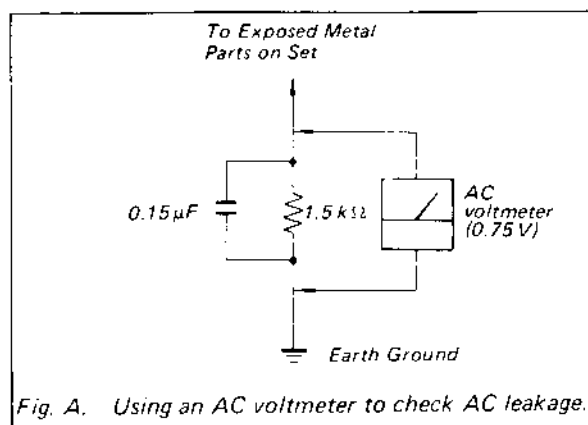

**MODEL IDENTIFICATION**

Specification Label

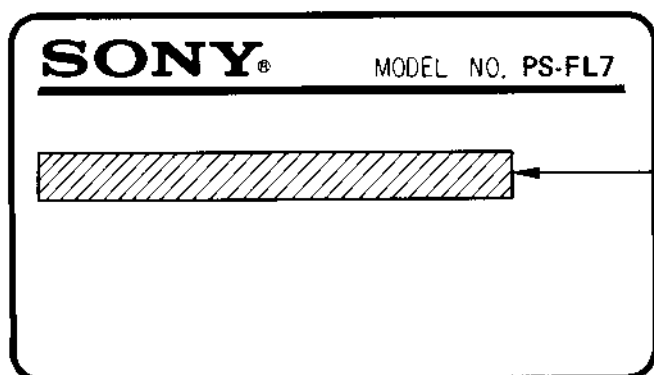

- US model: AC: 120V ~ 60Hz 10W
- AEP model: AC: 220V ~ 50/60Hz 10W
- UK model: AC: 240V ~ 50/60Hz 10W
- E model: AC: 110-220V, 220-240V ~ 50/60Hz 10W

## NOTES ON REPAIR

## — When removing the bottom plate —

- When POWER switch (S401) turns ON with bottom plate removed, loading motor (M701) continues to rotate and does not stop. But, it is not broken.

1. When POWER switch (S401) turns ON with TABLE END switch (S701 or S702) pressed, loading motor (M701) does not rotate.
2. When TABLE END switch (S701 or S702) is pressed according to the rotating direction of loading motor (M701), the motor stops even if the motor is rotating (See the figure below).
3. System control IC checks the condition of TABLE END switch by pressing ARM TRANSPORT ( ◀ , ▶ ), ARM LIFTER ( ▼ , ▲ ), START/STOP button.

When operation buttons are pressed, be sure to keep TABLE END switch (S701 or S702) pressed. If not, key input can not be found.

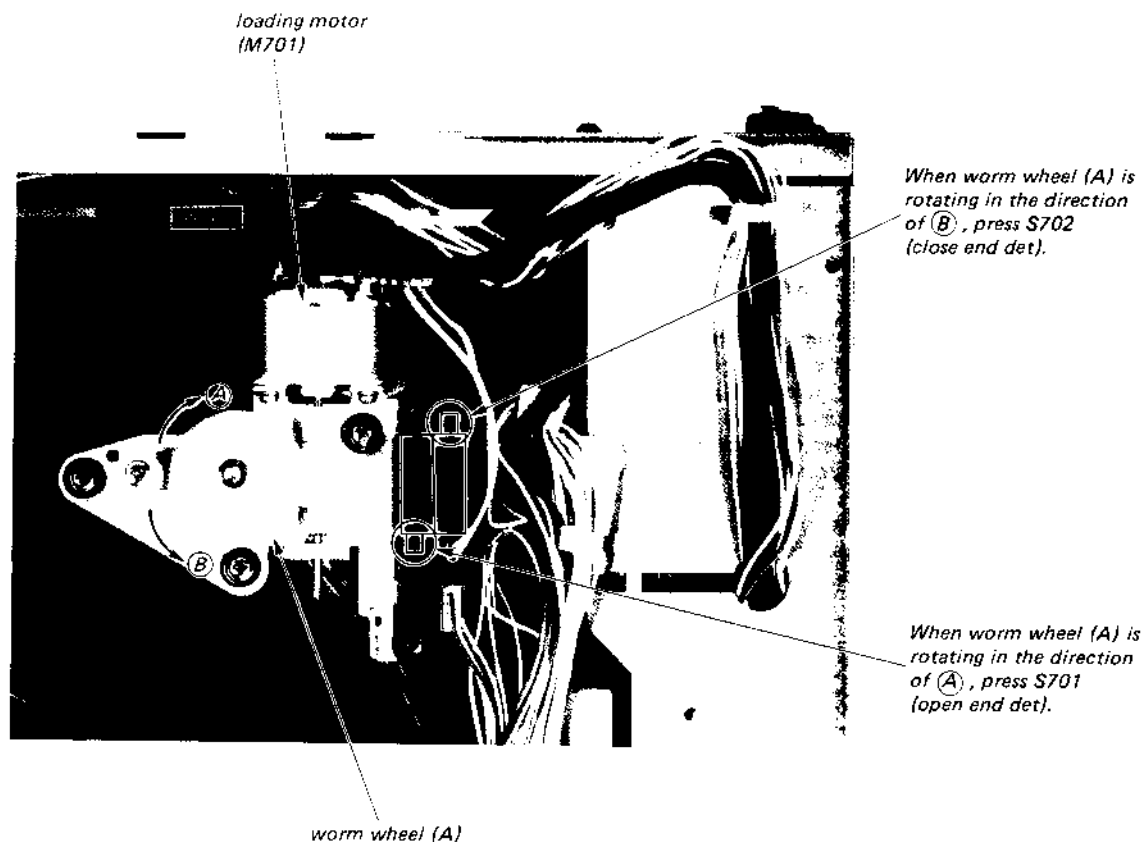

## SECTION 1 OUTLINE

### 1-1. FEATURES

#### **Unique modular turntable system**

When you touch the OPEN/CLOSE button, the turntable module will smoothly slide out. Other audio components can be positioned on top of the turntable cabinet.

#### **Servo-controlled linear tracking tonearm**

Compared with a pivoted tonearm, a linear tracking arm has a very small tracking error (which means greatly reduced harmonic distortion) and almost no pressure on the inside wall of the groove (which means improved tracking ability and channel separation).

#### **A microprocessor controls four motors**

The movement of the turntable, the tonearm and the turntable module is controlled by a microprocessor. When you press the START/STOP button, the module will close, the turntable will rotate and the tonearm will lower onto the record. The tonearm up/down is controlled by its own linear motor to obtain quiet movement.

#### **Fully automatic system**

With the module closed, automatic record play and stylus up/down are operated by the "feather-touch" function buttons on the front panel. The record size is automatically set by a photo sensor system.

#### **Muting system**

A muting system activates when the tonearm is lifted and deactivates after the tonearm lowers onto a record so there is no need to turn the amplifier volume down every time a stylus is placed on a record.

#### **Quartz lock servo system**

The turntable maintains accurate and drift-free speed by referring to a frequency generated by a very stable quartz oscillator.

#### **Linear torque BSL motor**

Direct drive system with Sony's unique BSL (brushless and slotless) motor which has an extremely low noise level and whose smoothness virtually eliminates wow and flutter. Its high torque assures a quick start to 33 $\frac{1}{3}$  rpm after only a half revolution.

#### **Synchronized operation with the Sony cassette decks**

When the tonearm lowers onto the lead-in groove of a record, the cassette deck stand-by mode is released and the record mode assumed. This synchronized operation is possible with Sony cassette decks equipped with a remote control jack which is connected with the Sony RM-65 synchro remote control unit.

#### **Wireless remote control operation**

Using the optional RM-44 or RM-S410 system remote controller, start/stop play and tonearm up/down can be remotely controlled.

## 1-2. LOCATION AND FUNCTION OF CONTROLS

Each number in the text is keyed to that of the photo.  
The photo shows the assembled turntable.

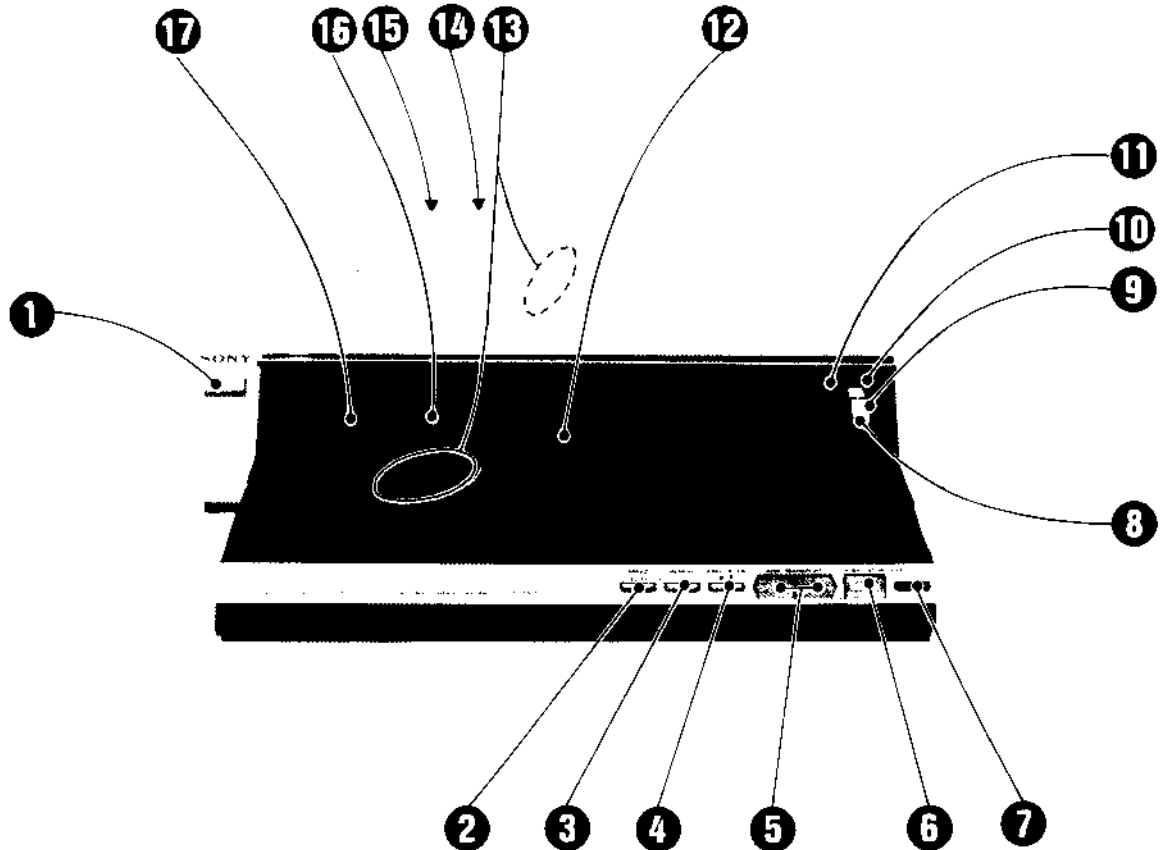

### ❶ POWER switch

Press to turn on the power. To turn the power off, press it again.

### ❷ SPEED selector and indicators

Press this button when a 45 rpm record is to be played. Press it again for a 33 $\frac{1}{3}$  rpm record. Corresponding indicator lights up.

### ❸ REPEAT button and indicator

Press this button to repeat play. The indicator lights up. To cancel the repeat play, press this button again.

### ❹ ▼ ▼ ARM LIFTER button

This button lifts and lowers the tonearm. When the tonearm is lowered, the turntable starts rotating.

### ❺ ARM TRANSPORT buttons

To move the tonearm inward, press the < button, and to move outward, the > button. The tonearm is raised and continues to move while the button is pressed. The tonearm will stop when the button is released. For fine adjustments, press and immediately release the appropriate button.

### ❻ START/STOP button and indicator

Press to start the record playing. To stop during play, press it again.

### ❼ OPEN/CLOSE button

With one touch of this button the turntable module automatically opens for loading a record. With another touch the module automatically closes.

### ❽ Cartridge

### ❾ Cartridge locking screw

### ❿ Tonearm

### ⓫ Tonearm position indicator

### ⓬ Center spindle

### ⓭ Auto-record-size selection holes and LEDs

### ⓮ Remote control connector (rear)

### ⓯ Synchro remote control jack (rear)

### ⓰ Rubber mat

### ⓱ Turntable

1-3. BLOCK DIAGRAM

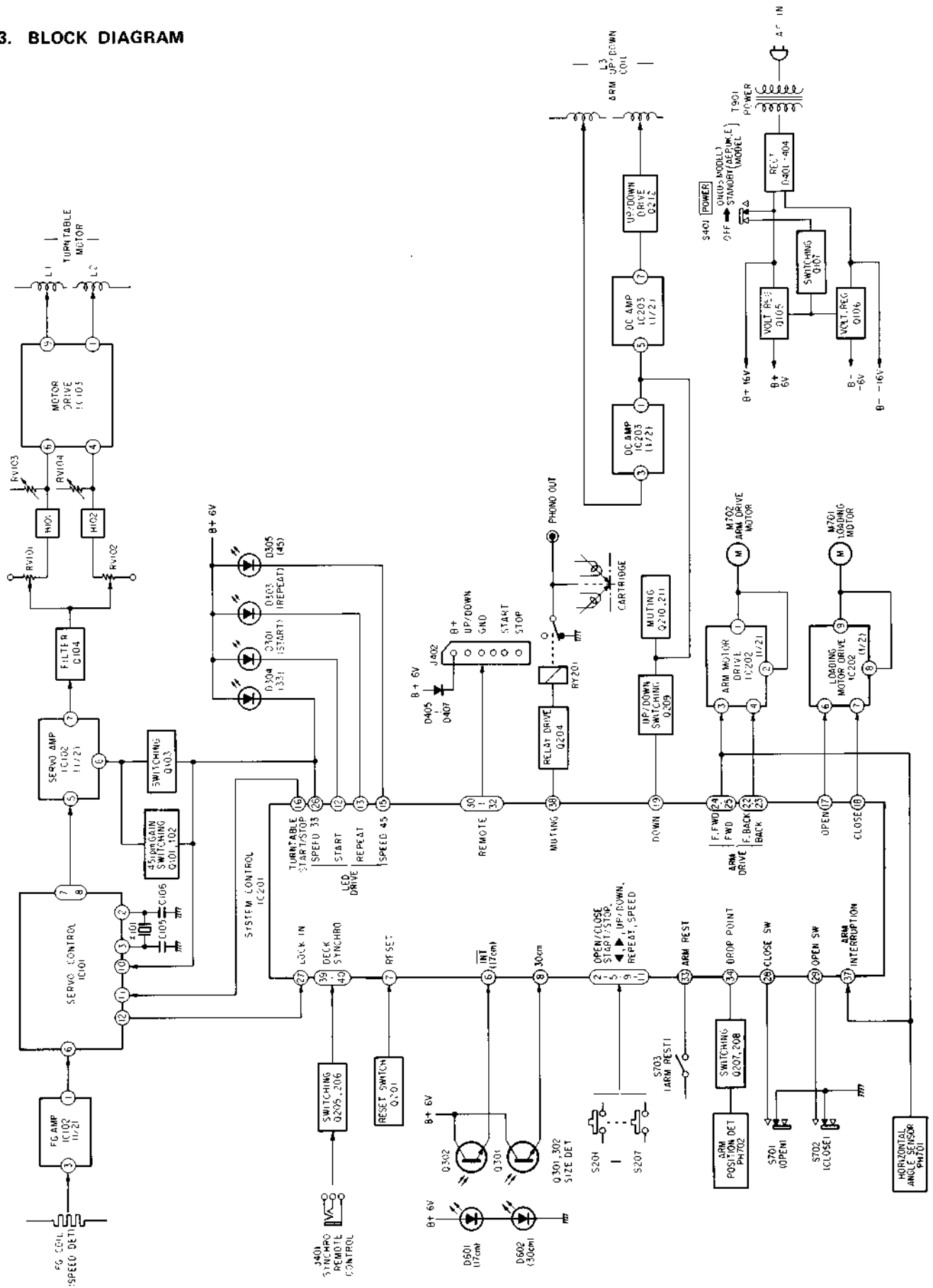

SECTION 2  
DISASSEMBLY

2-1. REMOVAL Note: Follow the disassembly procedure in the numerical order given.

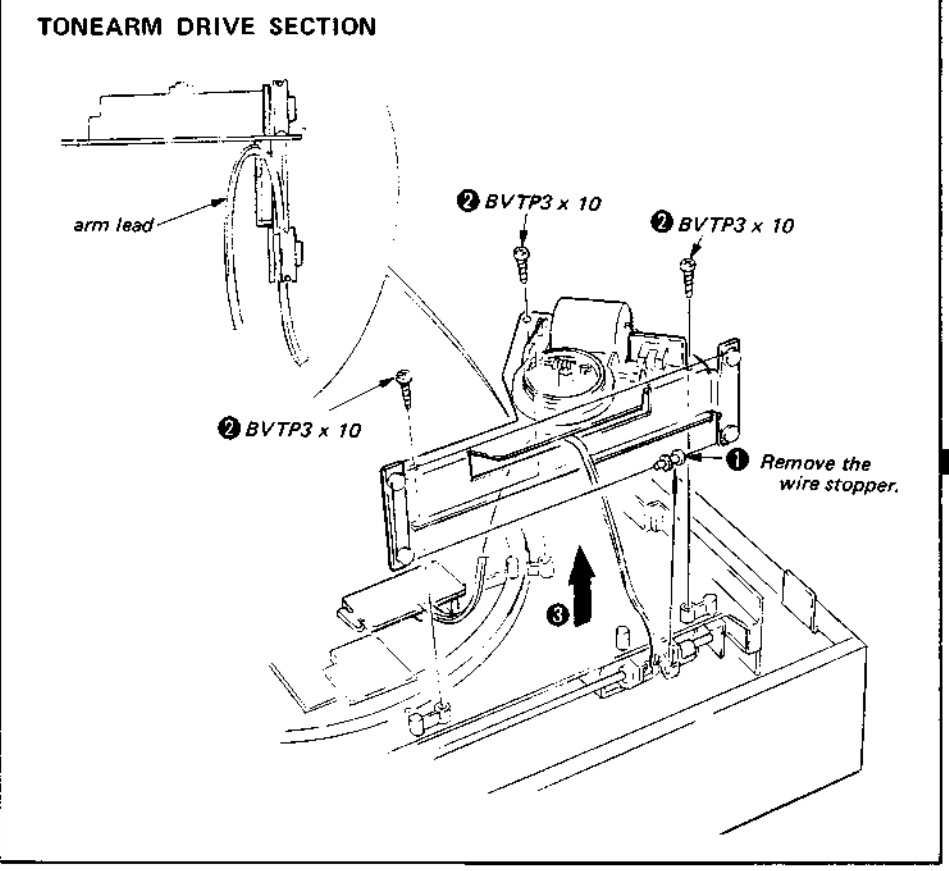
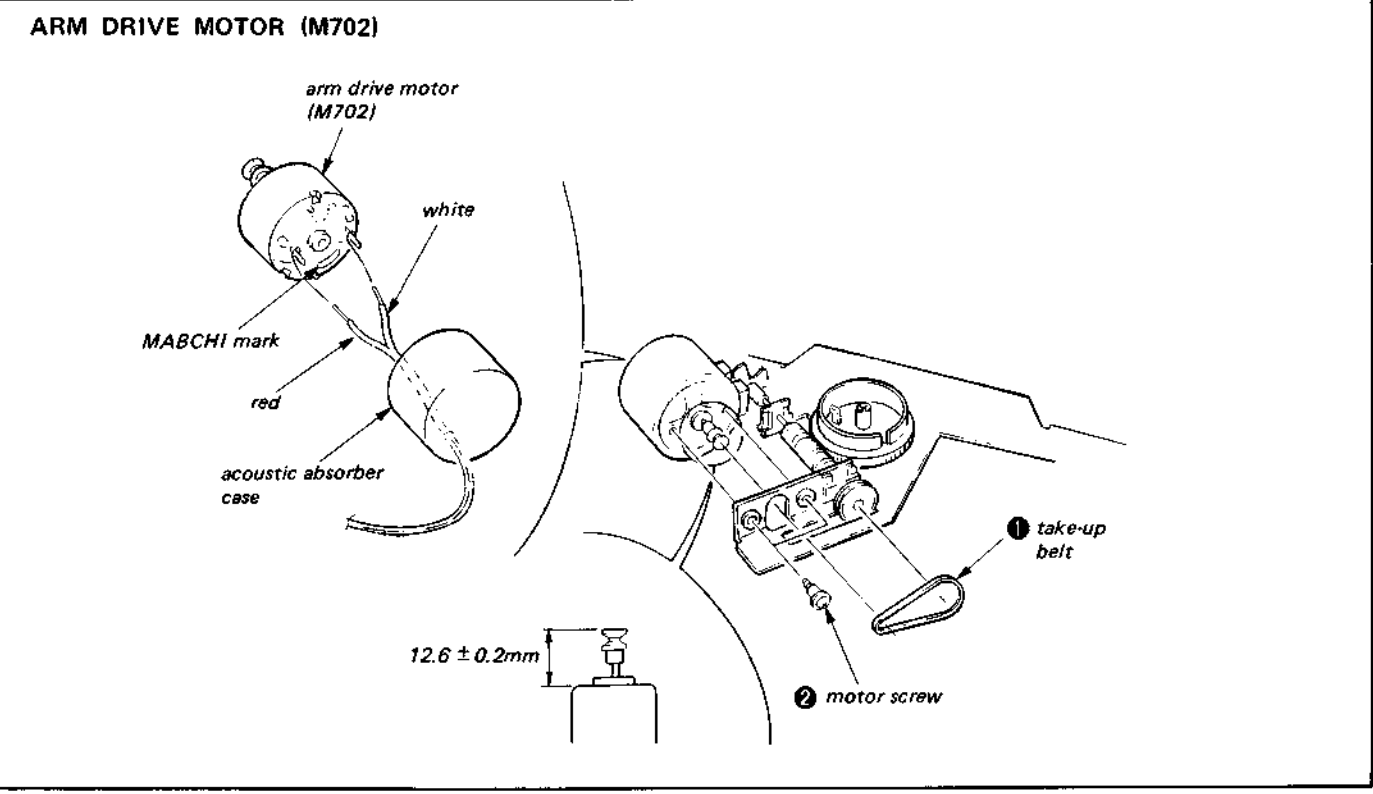
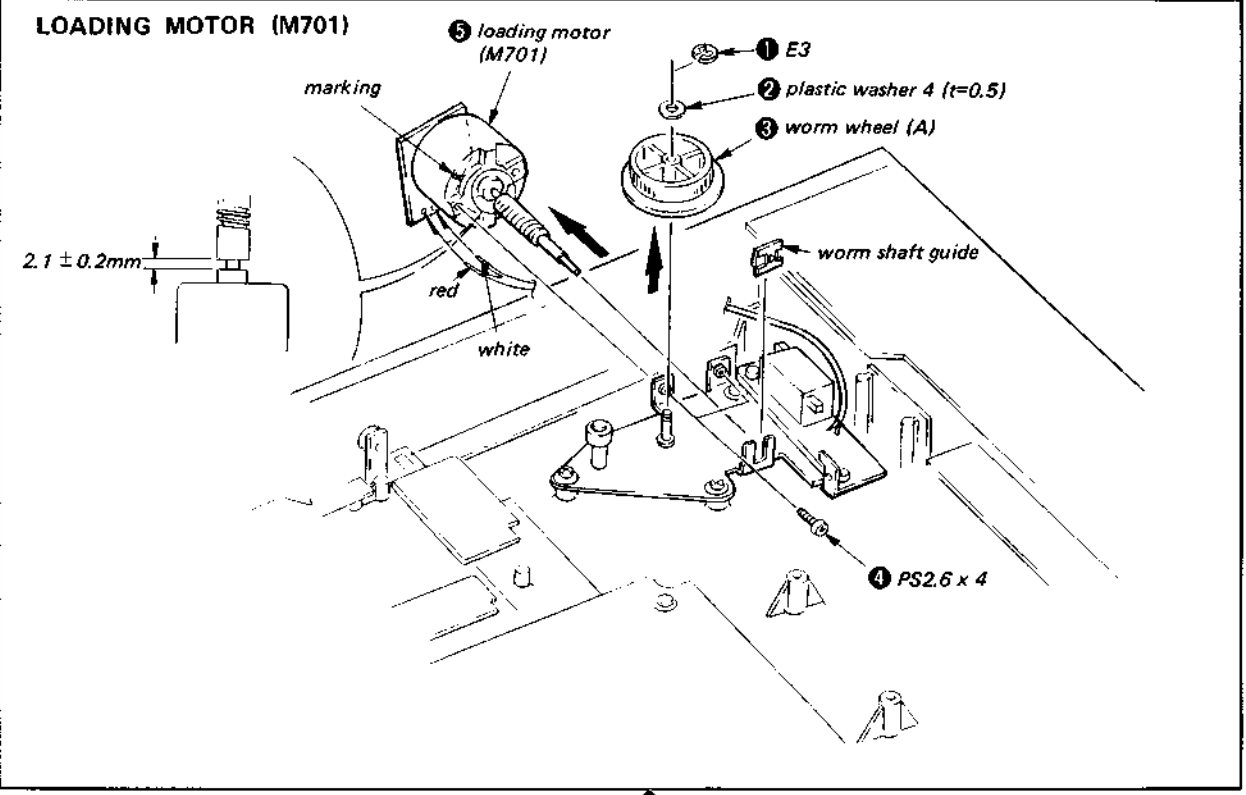
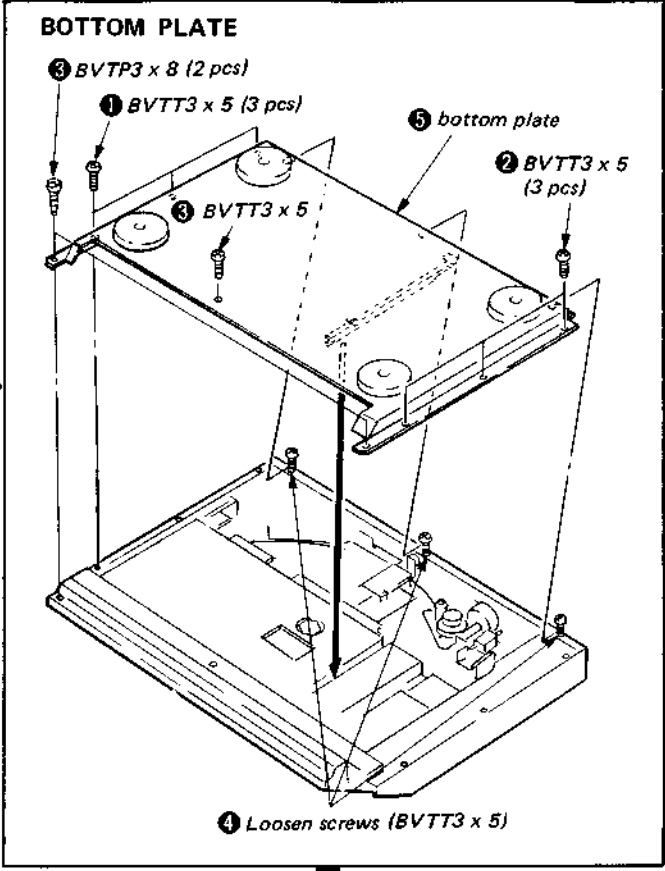
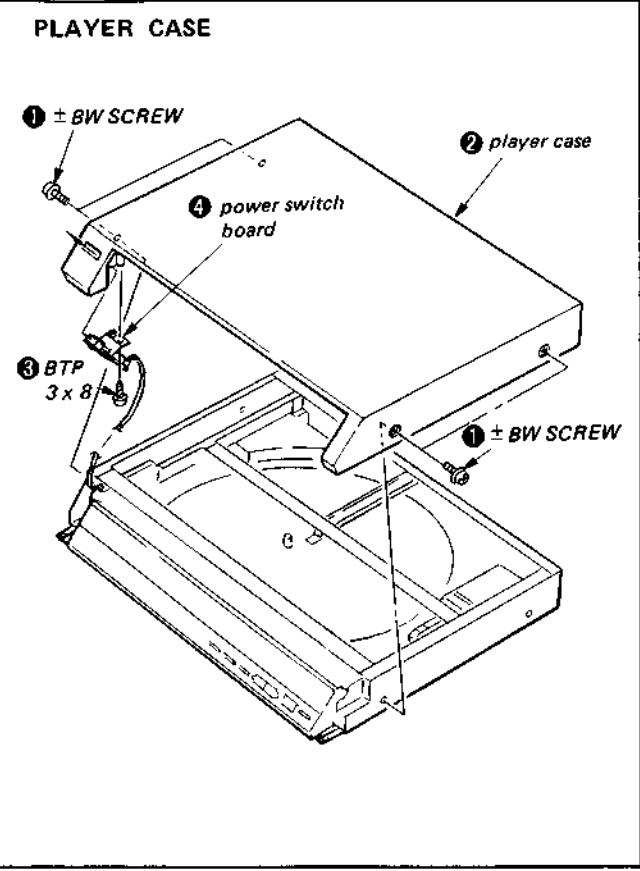

TONEARM DRIVE CORD STRINGING (See page 14.)

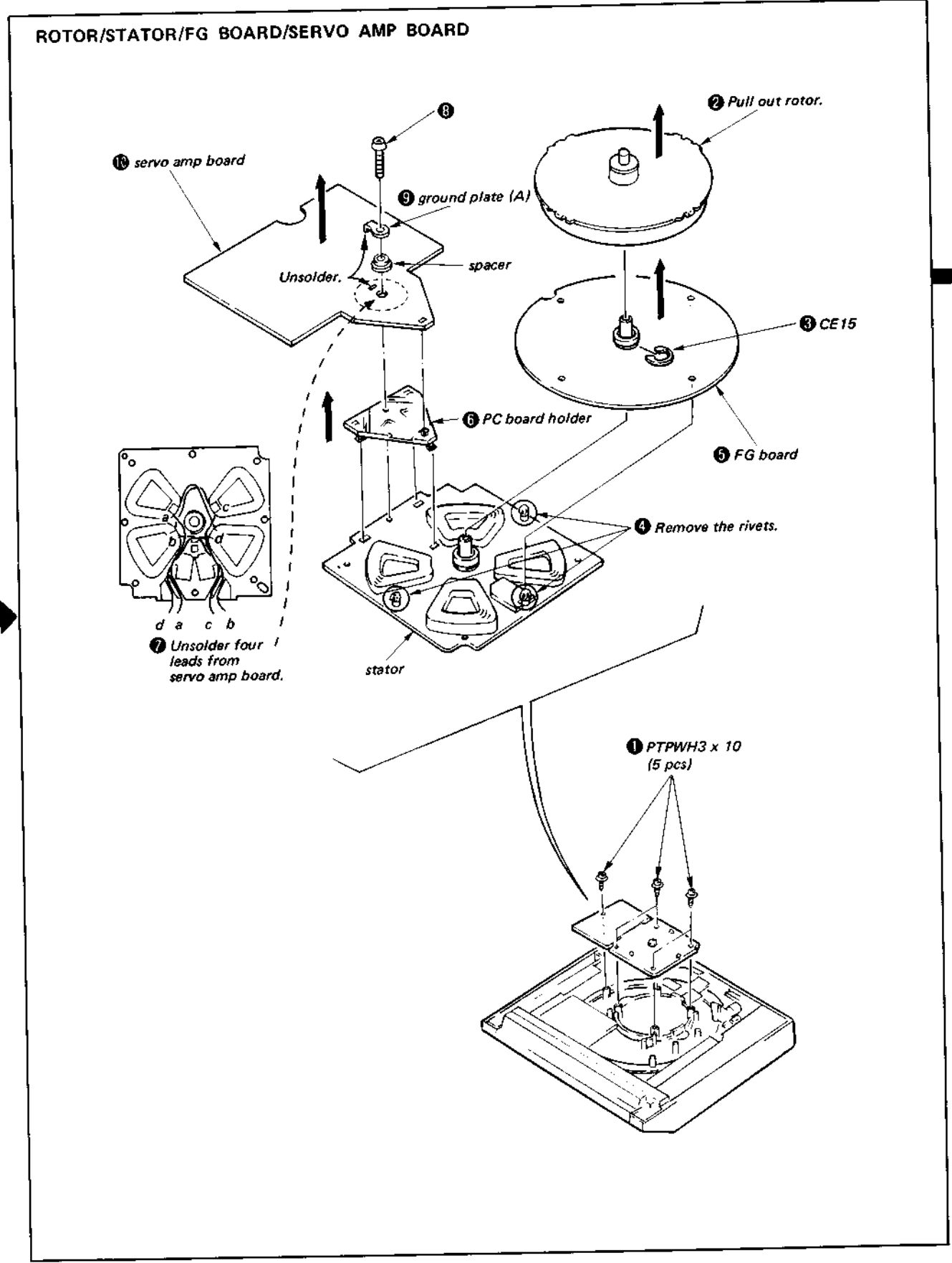
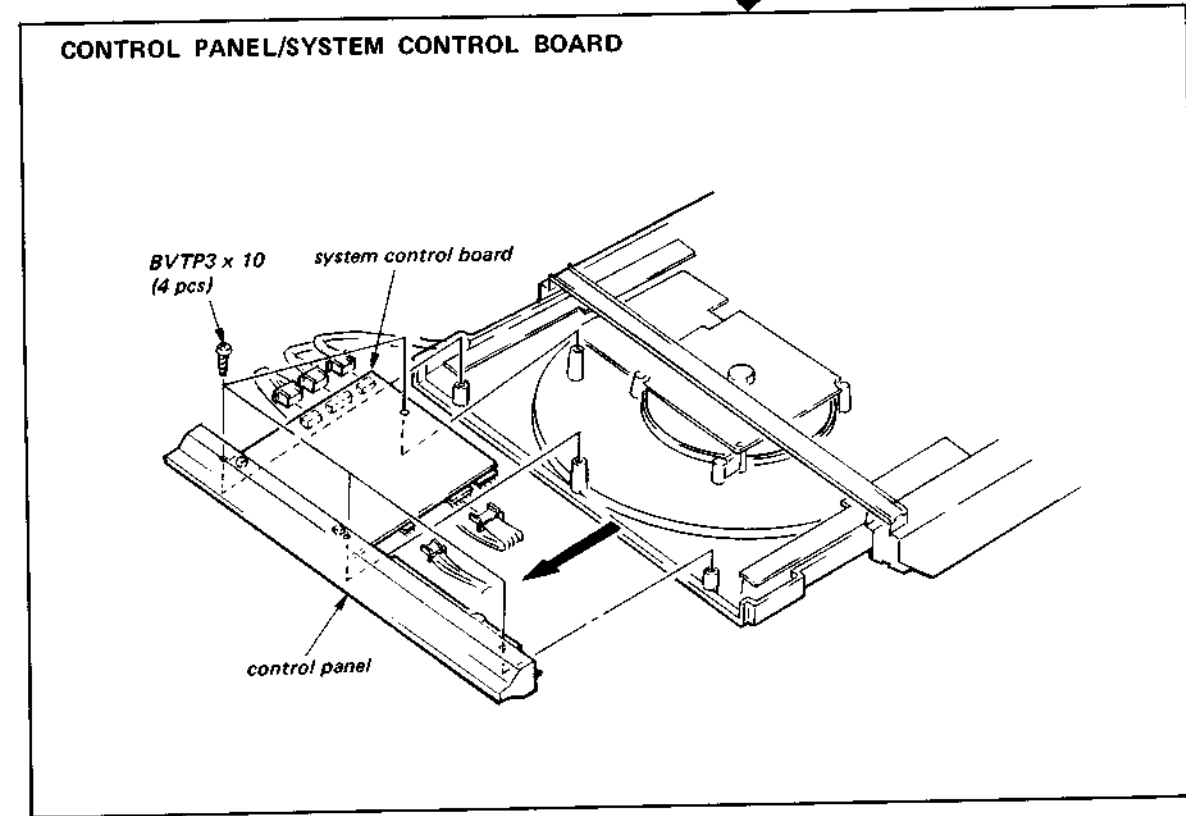
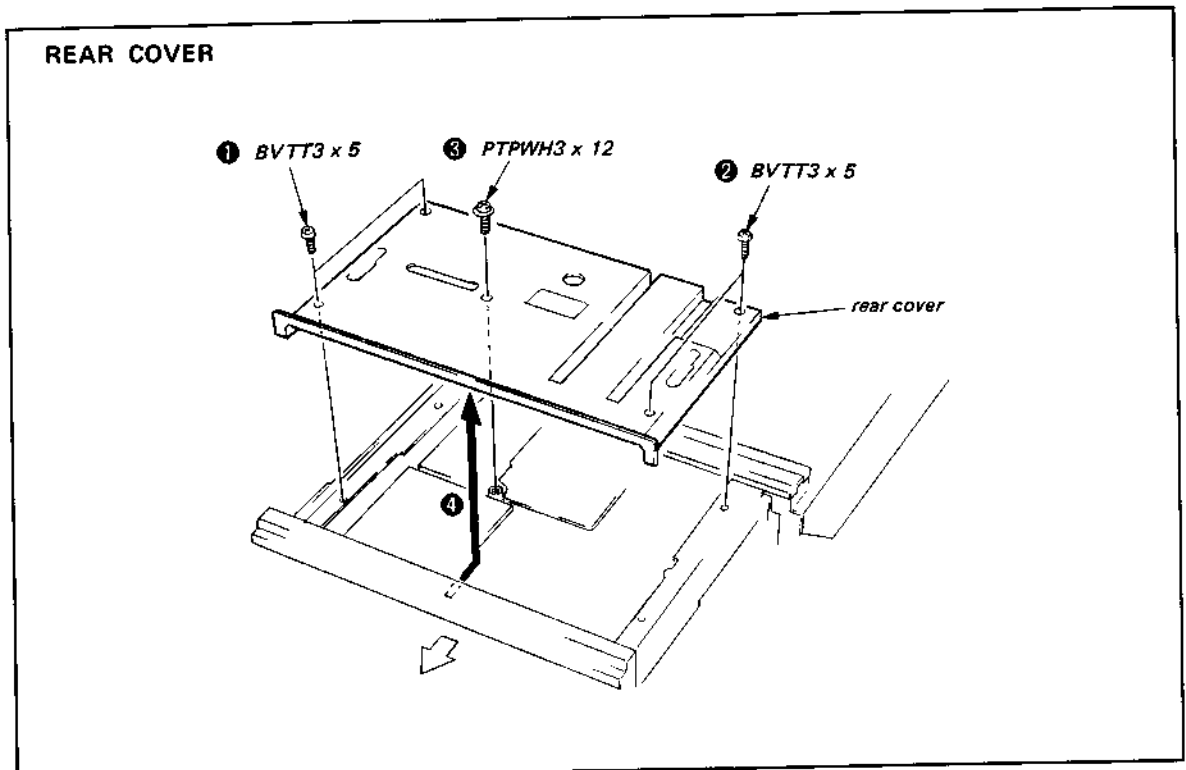



Remove the player case  
(See page 7.).

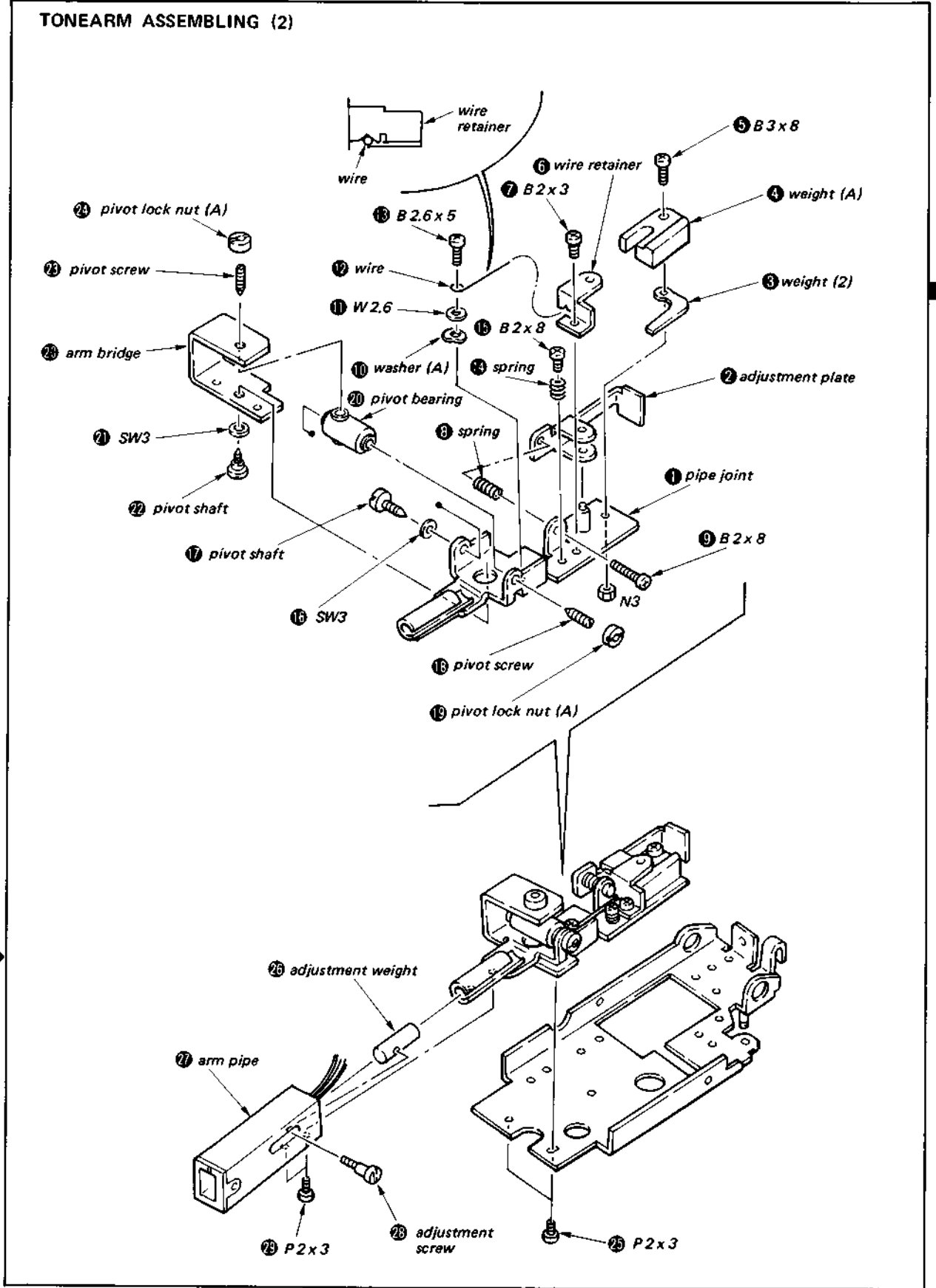
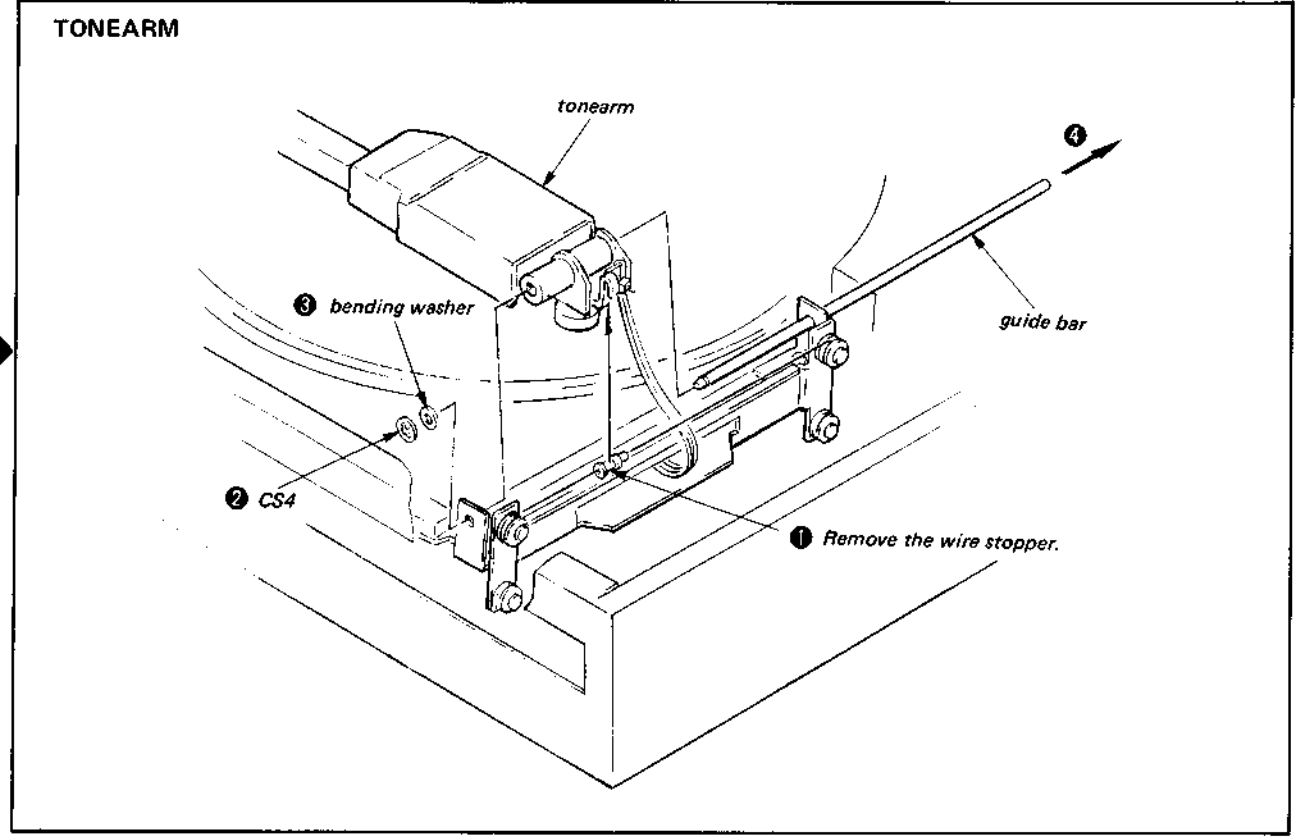

2-2. TONEARM ASSEMBLING

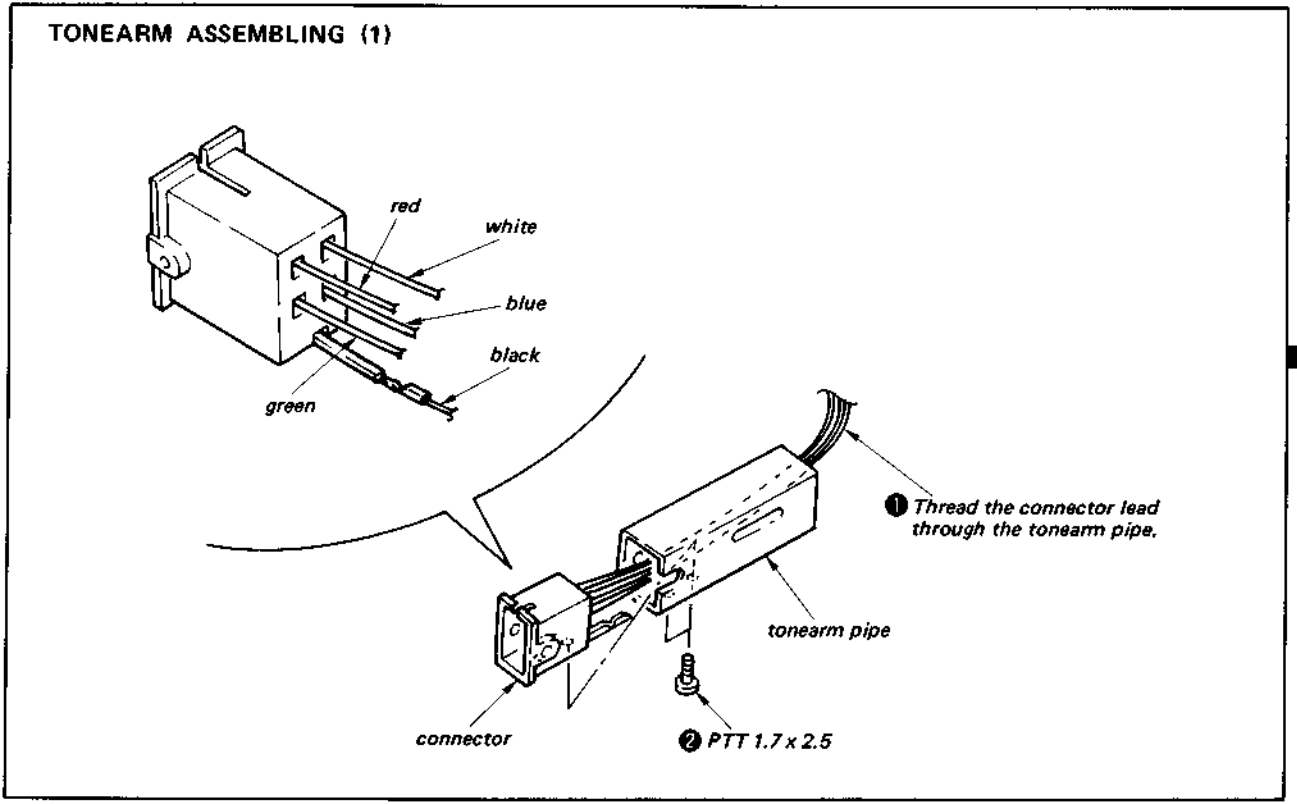

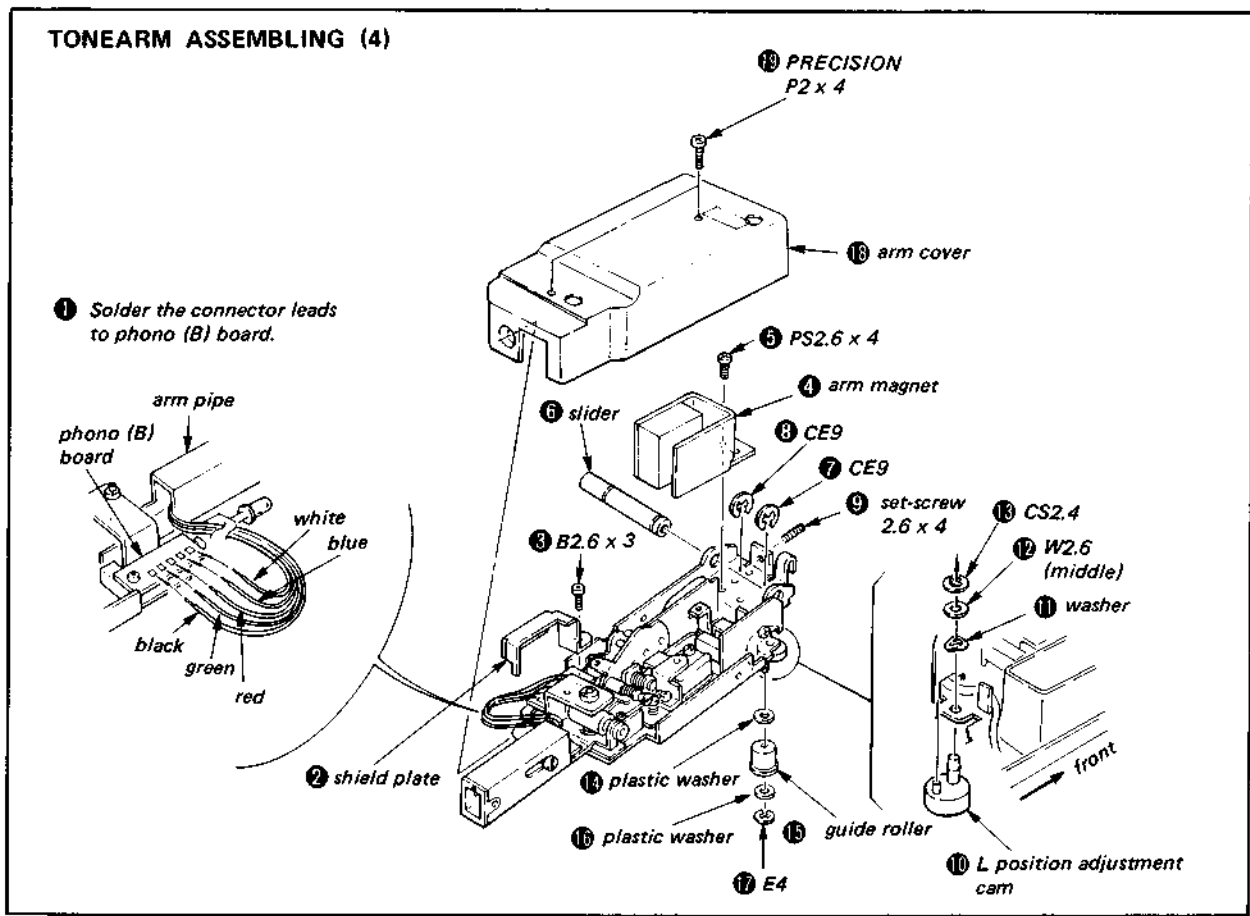
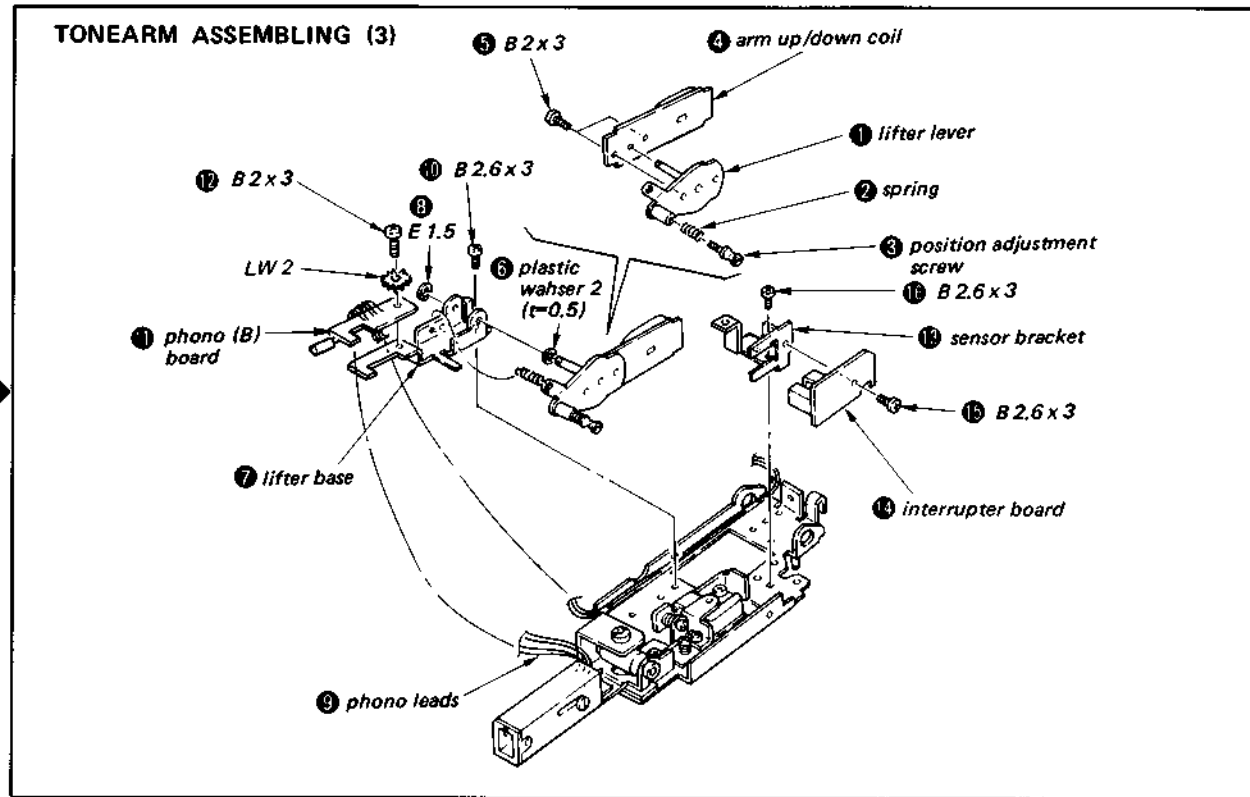

### 2.3. TONEARM DRIVE CORD STRINGING

#### (1) Preparation

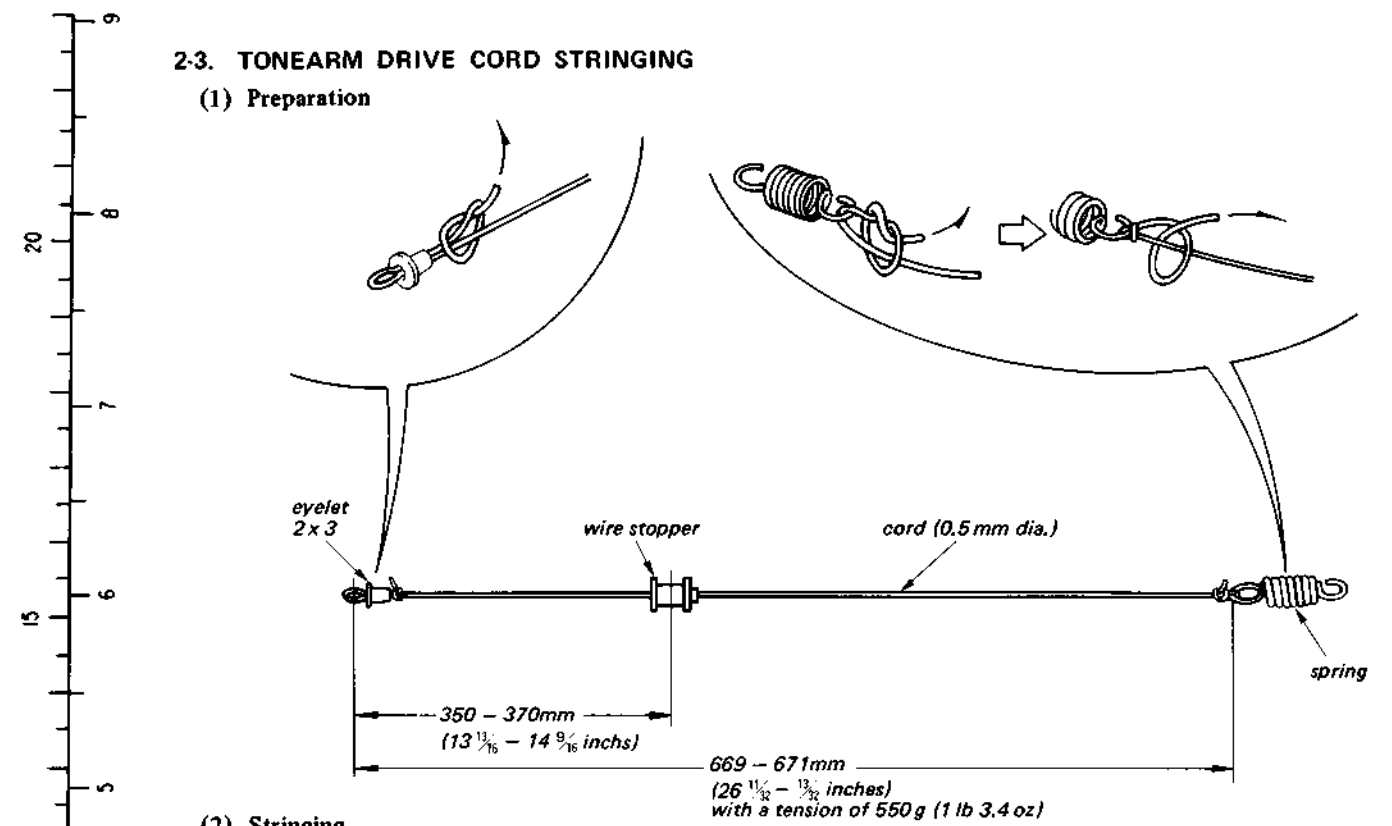

#### (2) Stringing

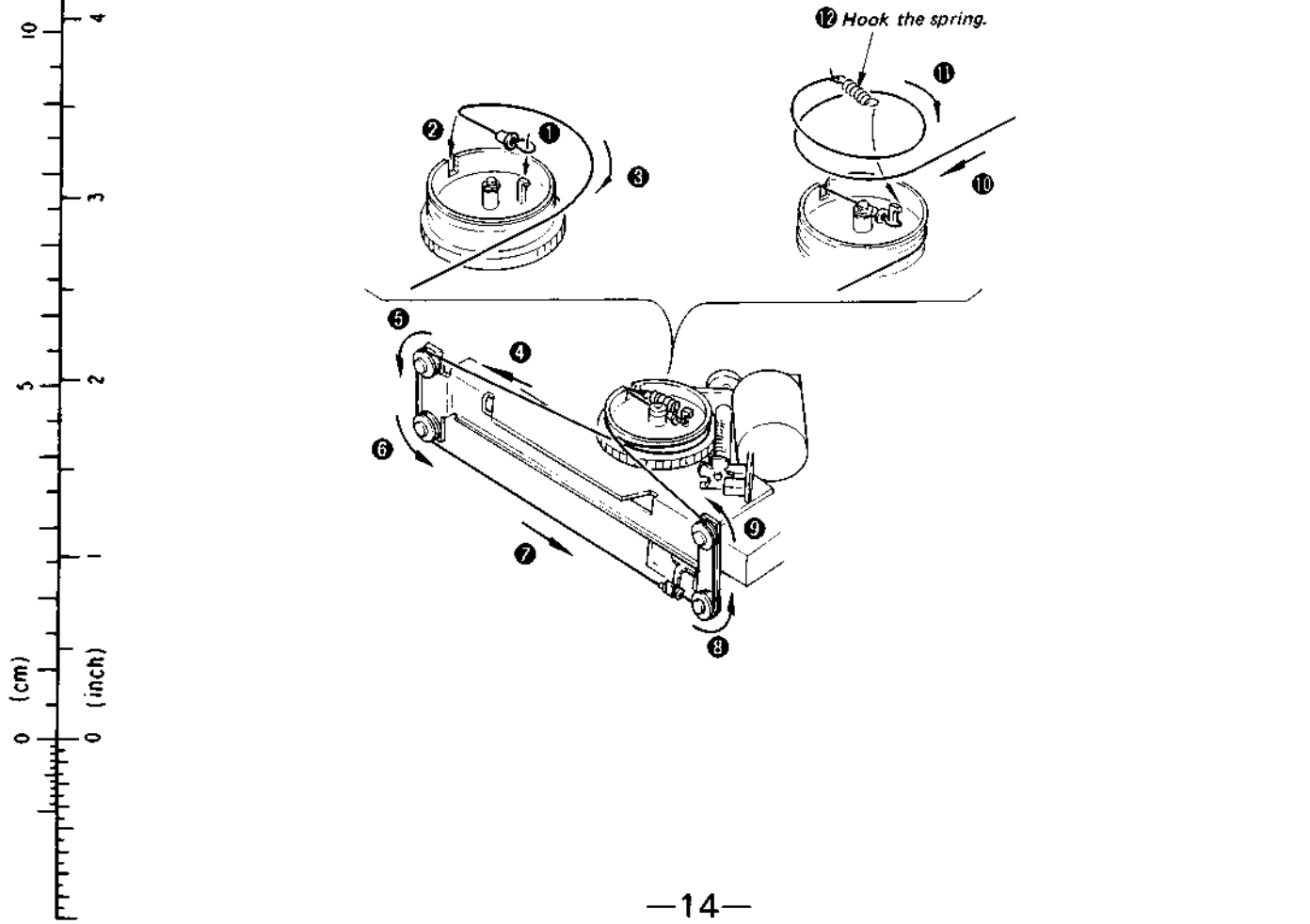

## SECTION 3 ADJUSTMENTS

### 3-1. MECHANICAL ADJUSTMENTS

#### Stylus Height Adjustment

1. Put a record.
2. Press ARM TRANSPORT button (◀) and move the arm outside the record.
3. Make sure that clearance (A) is 4 - 8 mm ( $\frac{3}{16}$  -  $\frac{5}{16}$  inches). If necessary, adjust the stylus height adjustment screw.

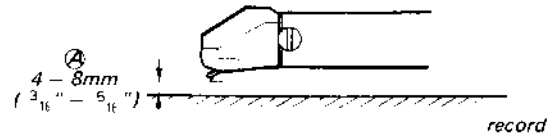

#### GENERAL NOTE:

Do not let a strong light get in the groove of photo interruptor during mechanical adjustment. Otherwise, misoperation of stoppage or moving may occur to the tonearm base.

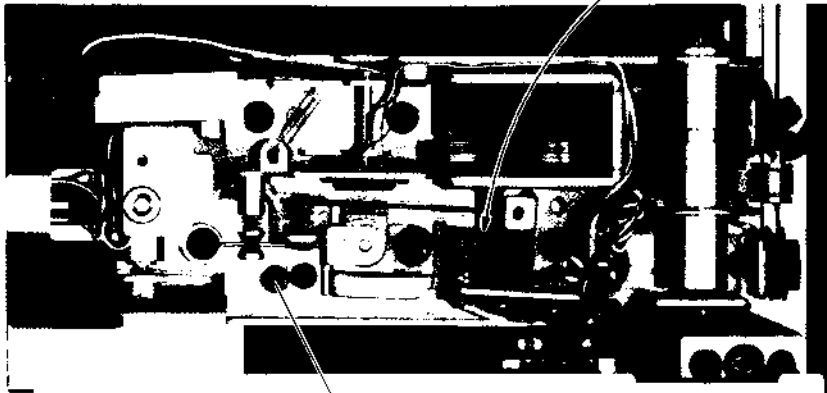

up      down

#### Lifter Height Adjustment

Adjust the lifter height adjustment screw so that the arm up/down coil position is 0 - 0.5 mm (0" -  $\frac{1}{32}$ ") as shown below.

*lifter height adjustment screw*

*lifter*

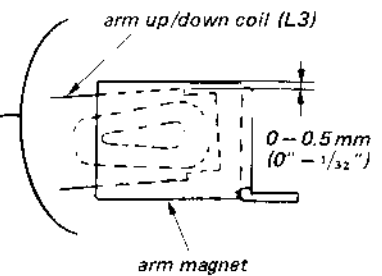
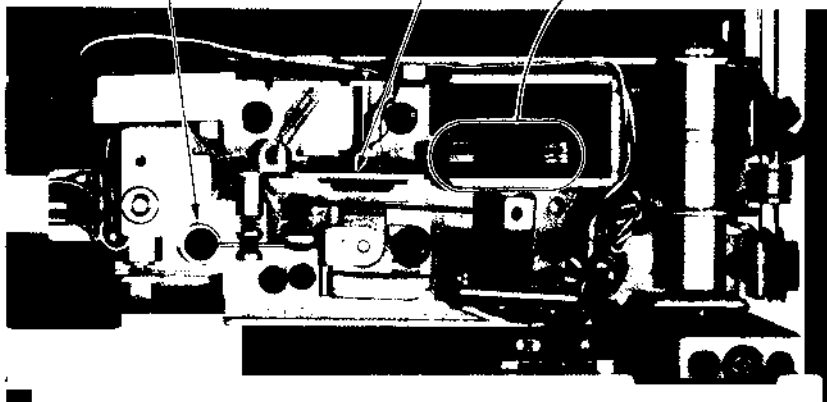

**Tracking Error Adjustment**

- (1) Place a test record (YFSC-16) on the turntable and press the START/STOP button for lead-in.
- (2) Adjust with the adjustment screw so that the tonearm base does not move just after the tonearm goes down.
- (3) After completing step (2), cause the tonearm to lead in, and then go UP after the tonearm base moves.
- (4) Check the count at this time, and then check that the difference in count when the tonearm goes down again is within 0 to -2 counts.

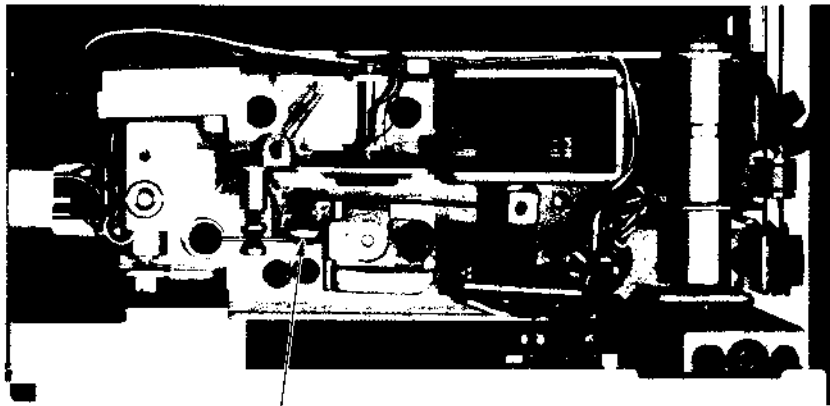

*tracking error adjustment screw*

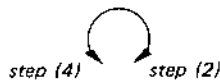

**- Adjustment Direction -**

For (2) when the arm base moves, turn to the right.

For (4) when the difference in count is too large, turn to the left.

**Drop Point (30 cm) Adjustment**

- (1) Place a test record (YFSC-16) on the turntable and press the START/STOP button for lead-in.
- (2) Adjust the L position adjustment cam so that the drop point at this time is within the specification.

Specification: 8 - 14 counts

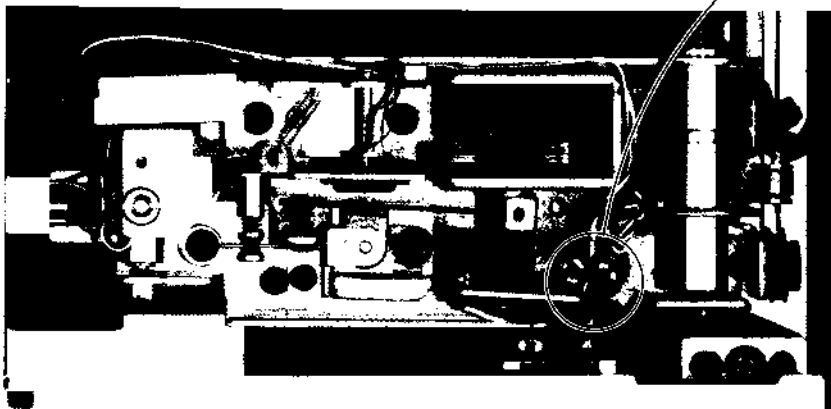
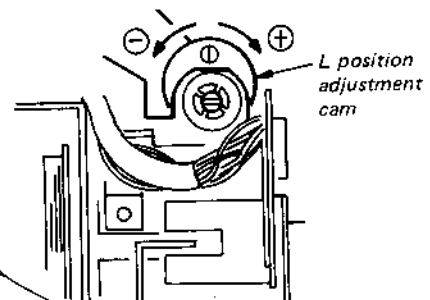

3-2. ELECTRICAL ADJUSTMENTS

Arm Interrupter Adjustment

1. If the pattern (A) is soldered, unsolder the pattern (A).
2. Set the arm fully rightward.  
(Be sure that the interrupter for tracking error detection is fully opened.)

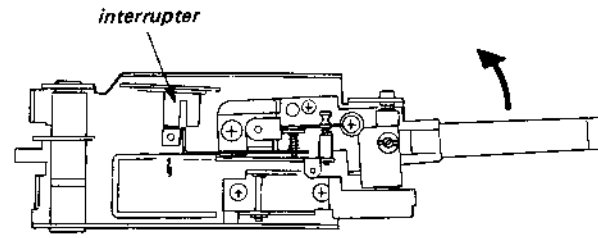

3. Read the voltage on the VOM. If the reading is more than 0.6V, solder the pattern (A).

Adjustment Location: system control board

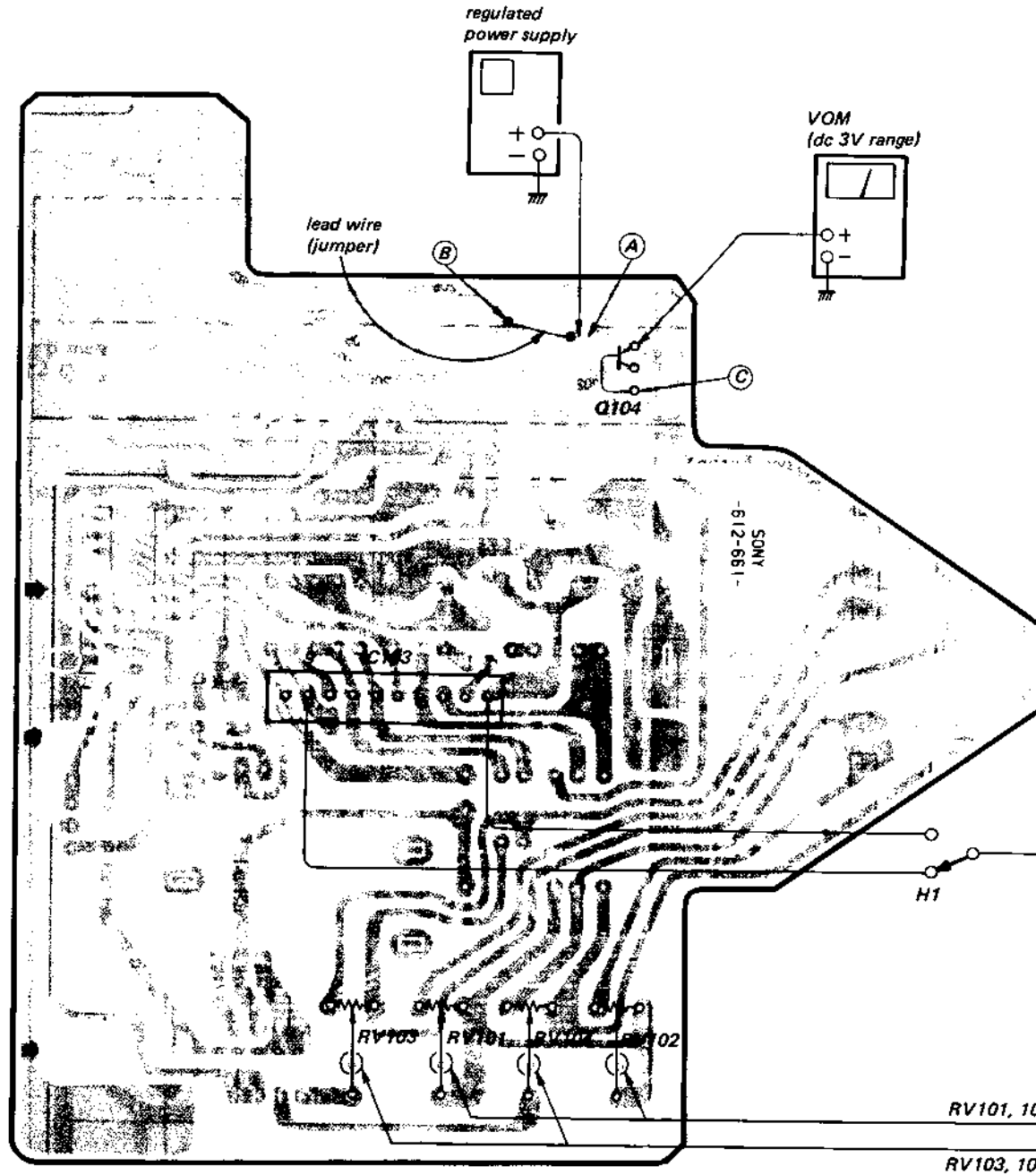
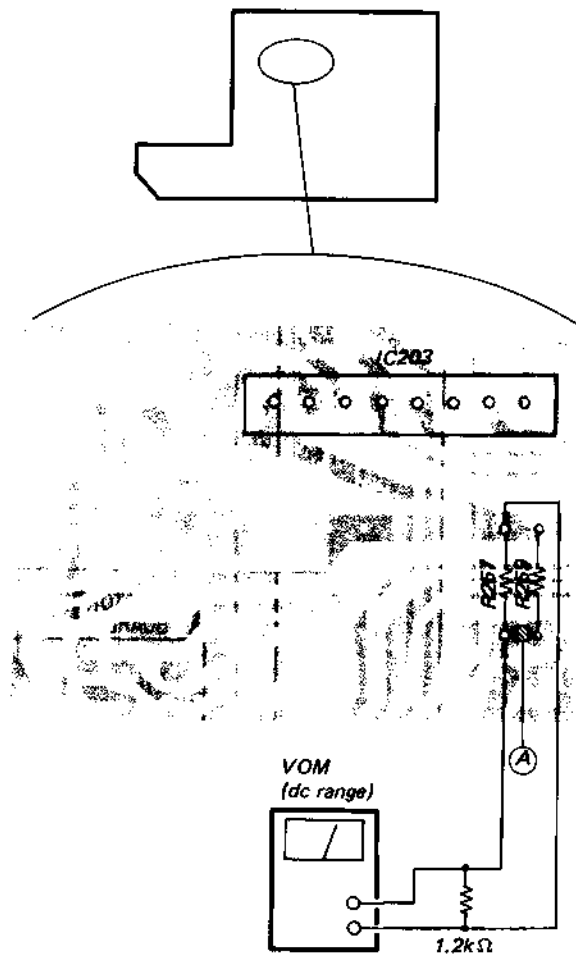

Gain/Offset Adjustment

1. Connect the pattern (A) to (B), and apply regulated power supply (0V DC) to point (C).
2. Connect a VOM to the emitter of Q104, and adjust the regulated power supply voltage for 1V DC.
3. Adjust RV101 (H1) and RV102 (H2) so that the terminal voltage of IC103 (9) (H1) and (1) (H2) are 4Vp-p. . . . . Gain Adjustment
4. Adjust RV103 (H1) and RV104 (H2) so that the terminal waveforms of IC103 (9) (H1) and (1) (H2) are as shown below (or so that DC potential is 0V). . . . . Offset Adjustment
5. After adjustment, remove the lead wire connecting pattern (A) to (B).

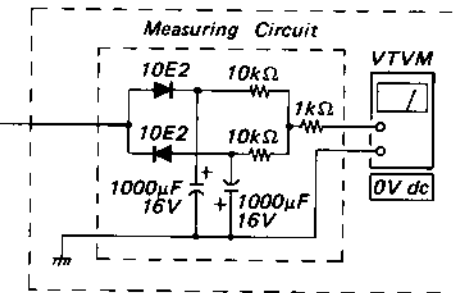
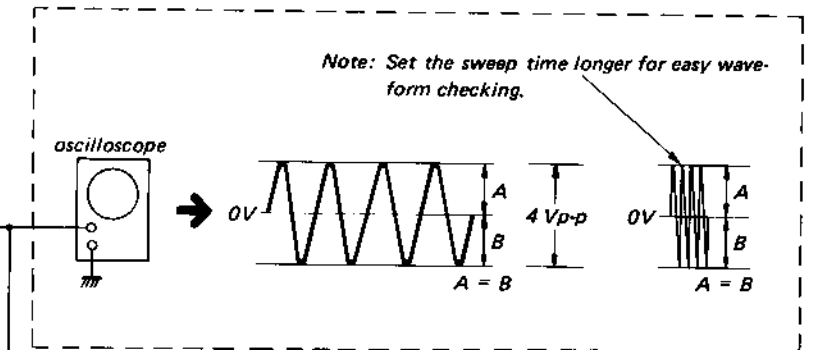

4-1. MOUNTING DIAGRAM

- Conductor Side -

SECTION 4  
DIAGRAMS

PS-FL7 PS-FL7

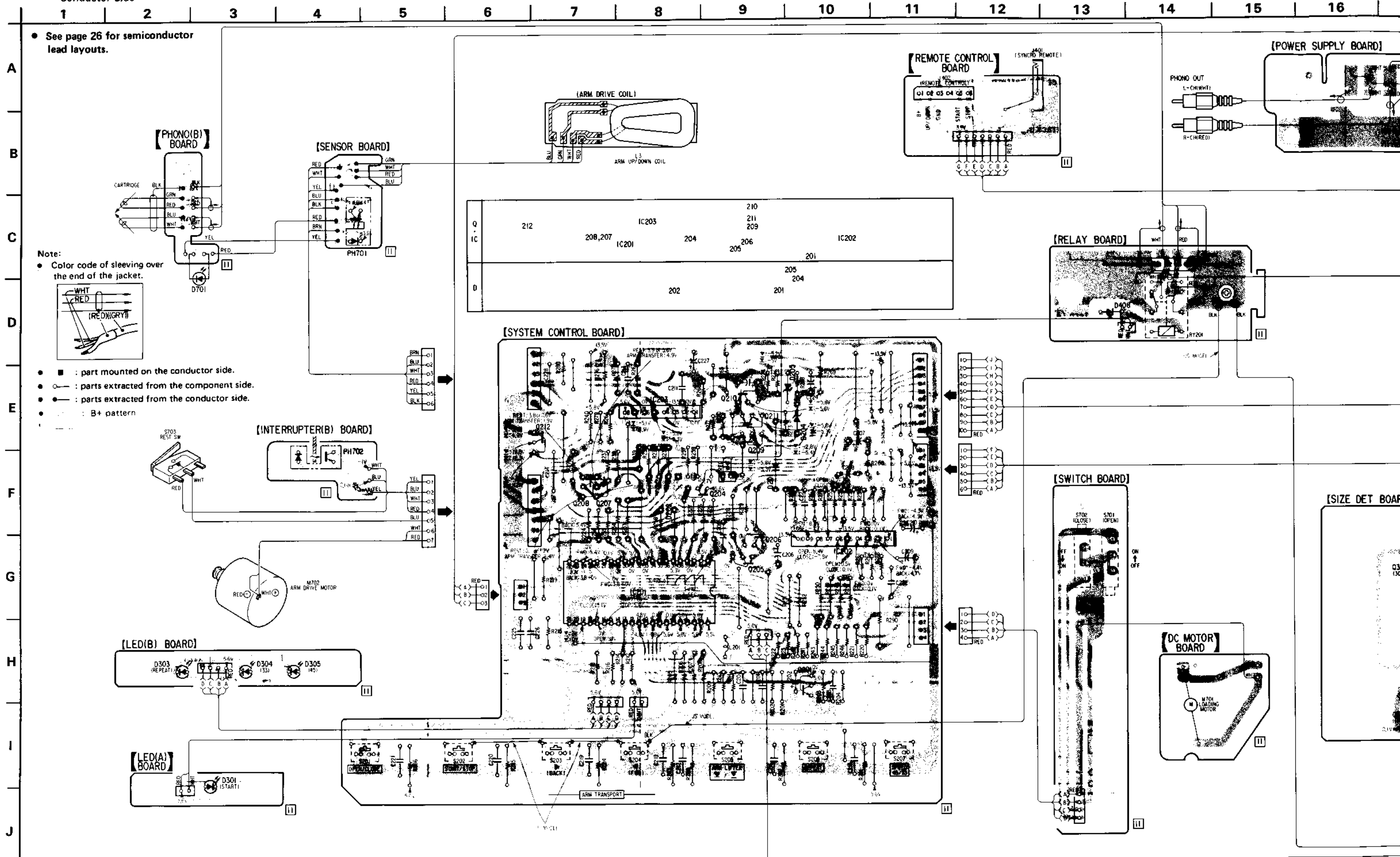

• See page 26 for semiconductor lead layouts.

Note:  
• Color code of sleeving over the end of the jacket.

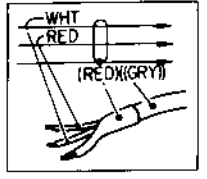

- ■ : part mounted on the conductor side.
- ○ : parts extracted from the component side.
- ● : parts extracted from the conductor side.
- - - - : B+ pattern

15 16 17 18 19 20 21 22 23 24 25 26 27 28 29 30

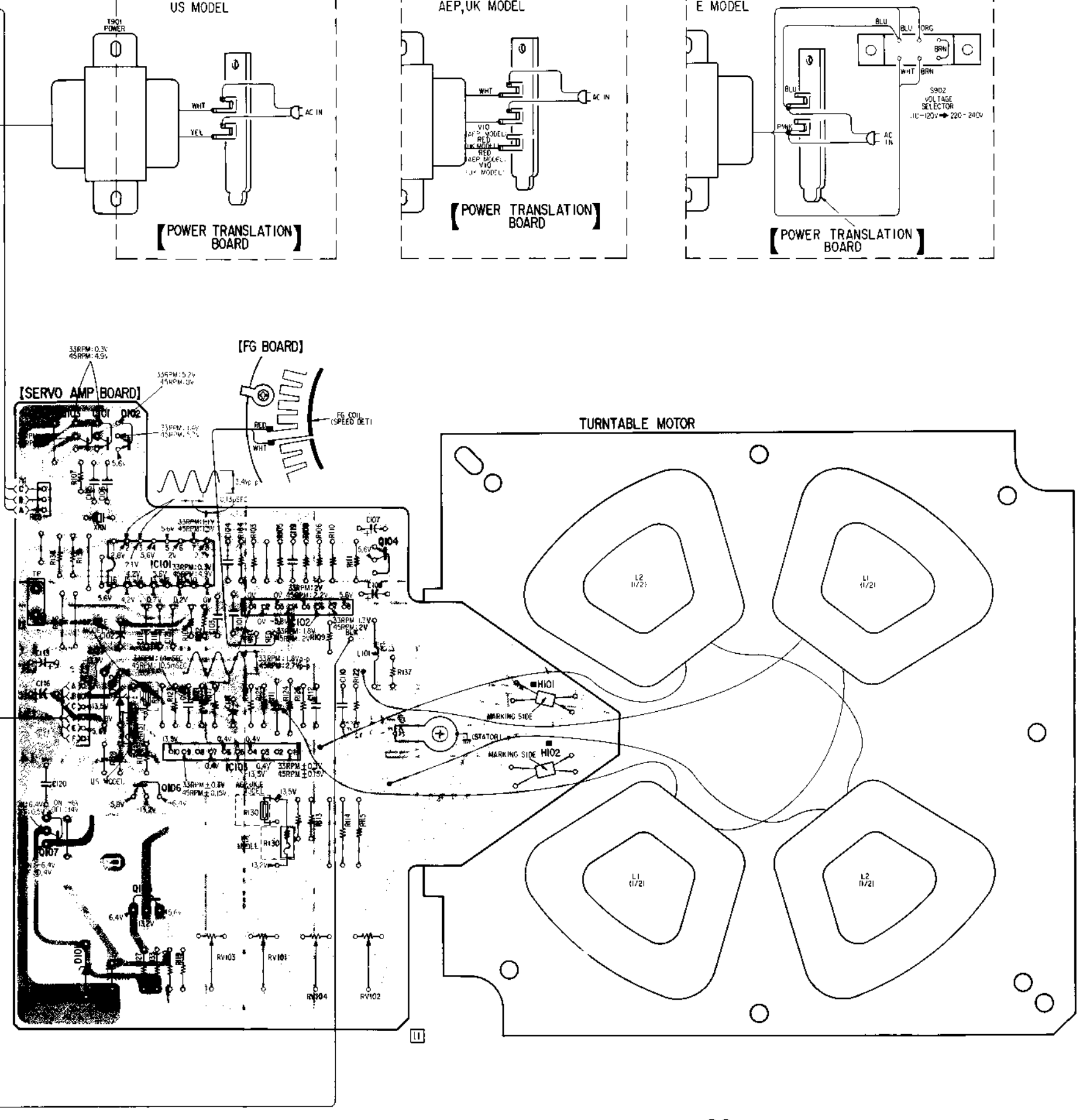
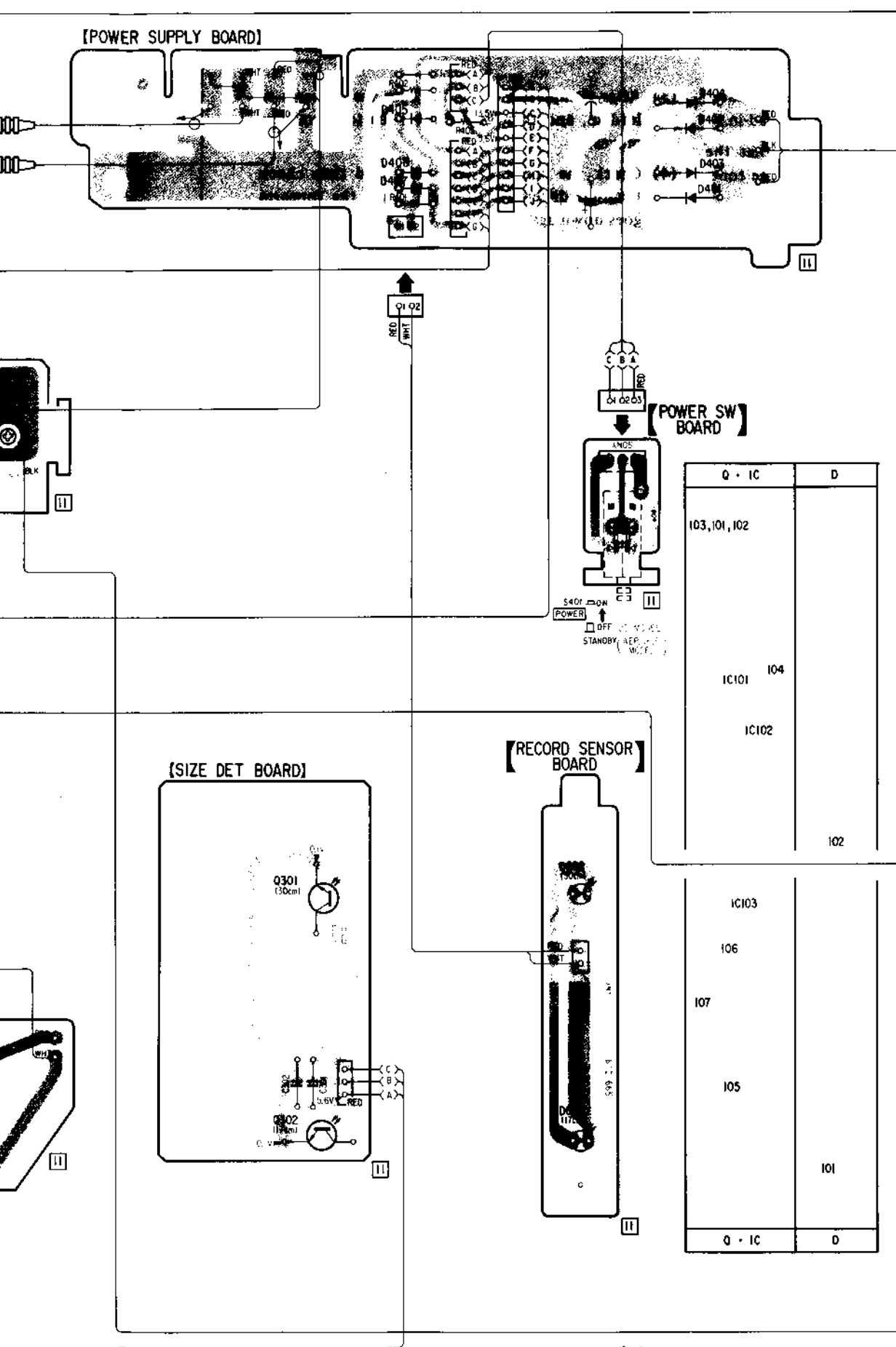

Q • IC	D
103, 101, 102	
IC101	104
IC102	
	102
IC103	
106	
107	
105	
	101
Q • IC	D

A  
B  
C  
D  
E  
F  
G  
H  
I  
J

4-2. SCHEMATIC DIAGRAM

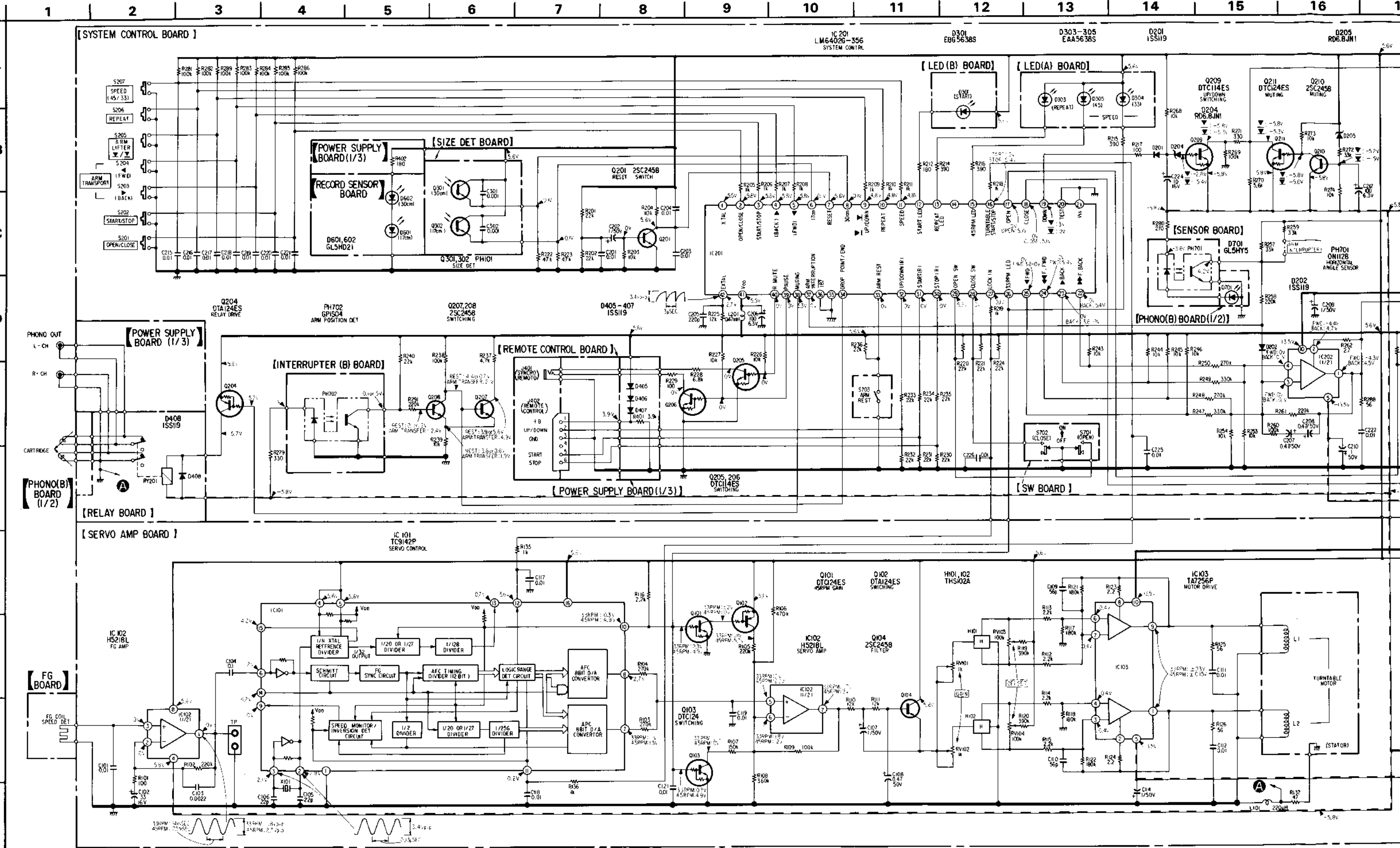



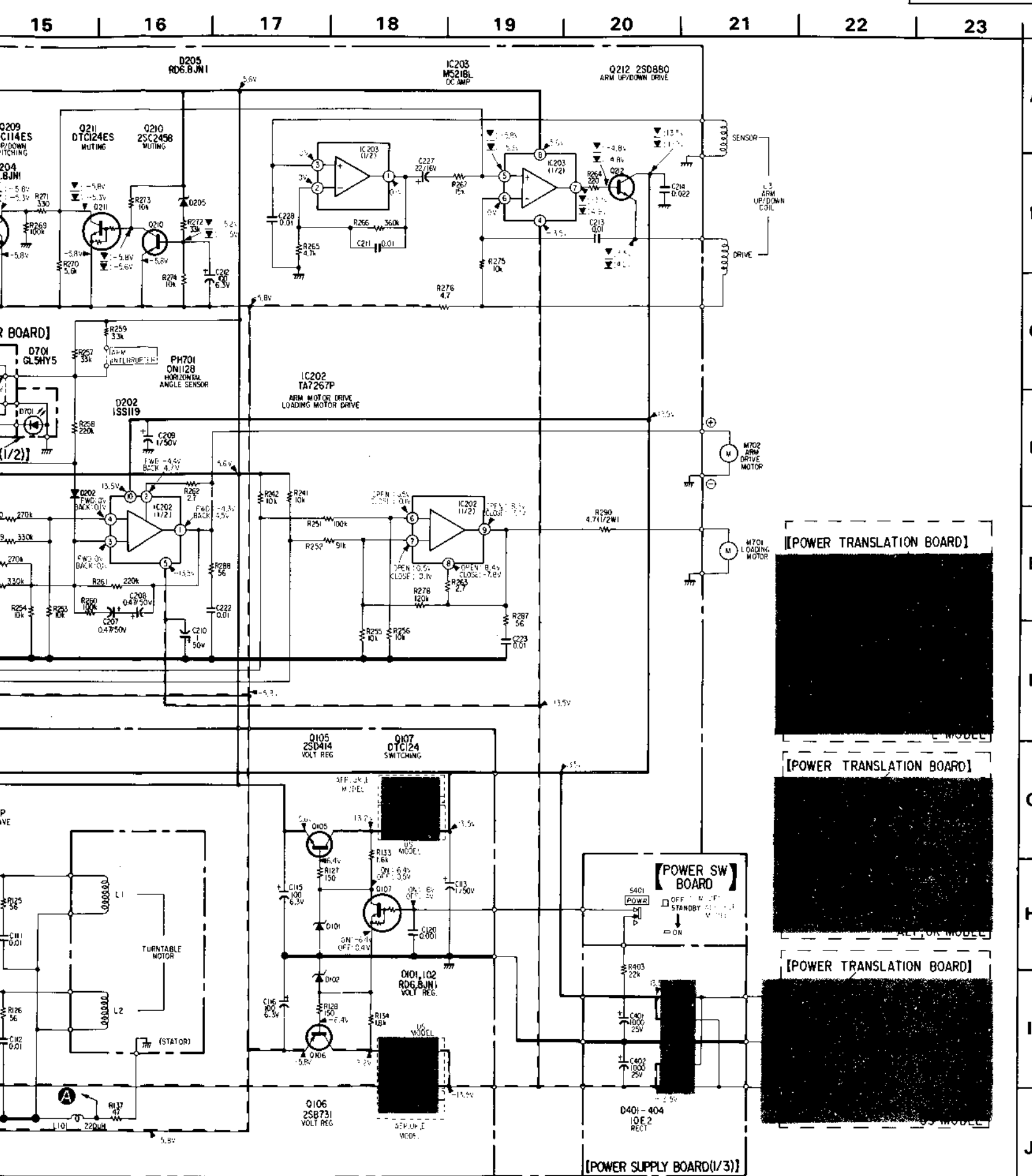

A  
B  
C  
D  
E  
F  
G  
H  
I  
J

● Semiconductor Lead Layouts

<p><b>LM6402G-356</b> <b>TC9142P</b></p> <p>(Top view)</p>	<p><b>PH101</b></p>
<p><b>M5218L</b></p>	<p><b>10E-2</b> <b>1SS119</b></p>
<p><b>TA7256P</b></p> <p>(Marking side view)</p>	<p><b>THS102A</b></p>
<p><b>DTC124ES</b> <b>DTA124ES</b> <b>2SC2458</b> <b>DTC114ES</b></p> <p>letter side</p>	<p><b>ON1128</b></p>
<p><b>2SD809</b> <b>2SB731</b></p> <p>letter side</p>	<p><b>GL-5HD21</b> <b>GL-5HY5</b> <b>EBG5638S</b> <b>EAA5638S</b></p>
<p><b>2SD880</b></p>	<p><b>GP-1S04</b></p>

- Note:**
- All capacitors are in  $\mu F$  unless otherwise noted. pF :  $\mu F$ , 50WV or less are not indicated except for electrolytics and tantalums.
  - All resistors are inohms, 1/6W unless oterhrsie noted. k $\Omega$  : 1000 $\Omega$ , M $\Omega$  : 1000k $\Omega$
  - : fusible resistor.
  - : adjustment for repair.
  - : B+ bus.
  - : B- bus.
  - Readings are taken under no-signal conditions with a VOM (50k $\Omega$ /V).
  - Voltage variations may be noted due to normal production tolerances.

• Switch

Ref. No.	Switch	Position
S201	OPEN/CLOSE	—
S202	START/STOP	—
S203	▶ (BACK)	OFF
S204	◀ (FWD)	OFF
S205	ARM LIFTER	—
S206	REPEAT	OFF
S207	SPEED	—
S401	POWER	OFF
S701	Open	OFF
S702	Close	OFF
S703	Arm rest	OFF
S902	VOLTAGE SELECTOR	110 - 120V

Note: Voltages are measured with a VOM (50k $\Omega$ /V).

Note: The components identified by shading and mark are critical for safety. Replace only with part number specified.

[POWER TRANSLATION BOARD]

[POWER TRANSLATION BOARD]

[POWER TRANSLATION BOARD]

[POWER TRANSLATION BOARD]

[POWER SW BOARD]

[POWER SUPPLY BOARD(1/3)]

SECTION 5  
EXPLODED VIEWS AND PARTS LIST

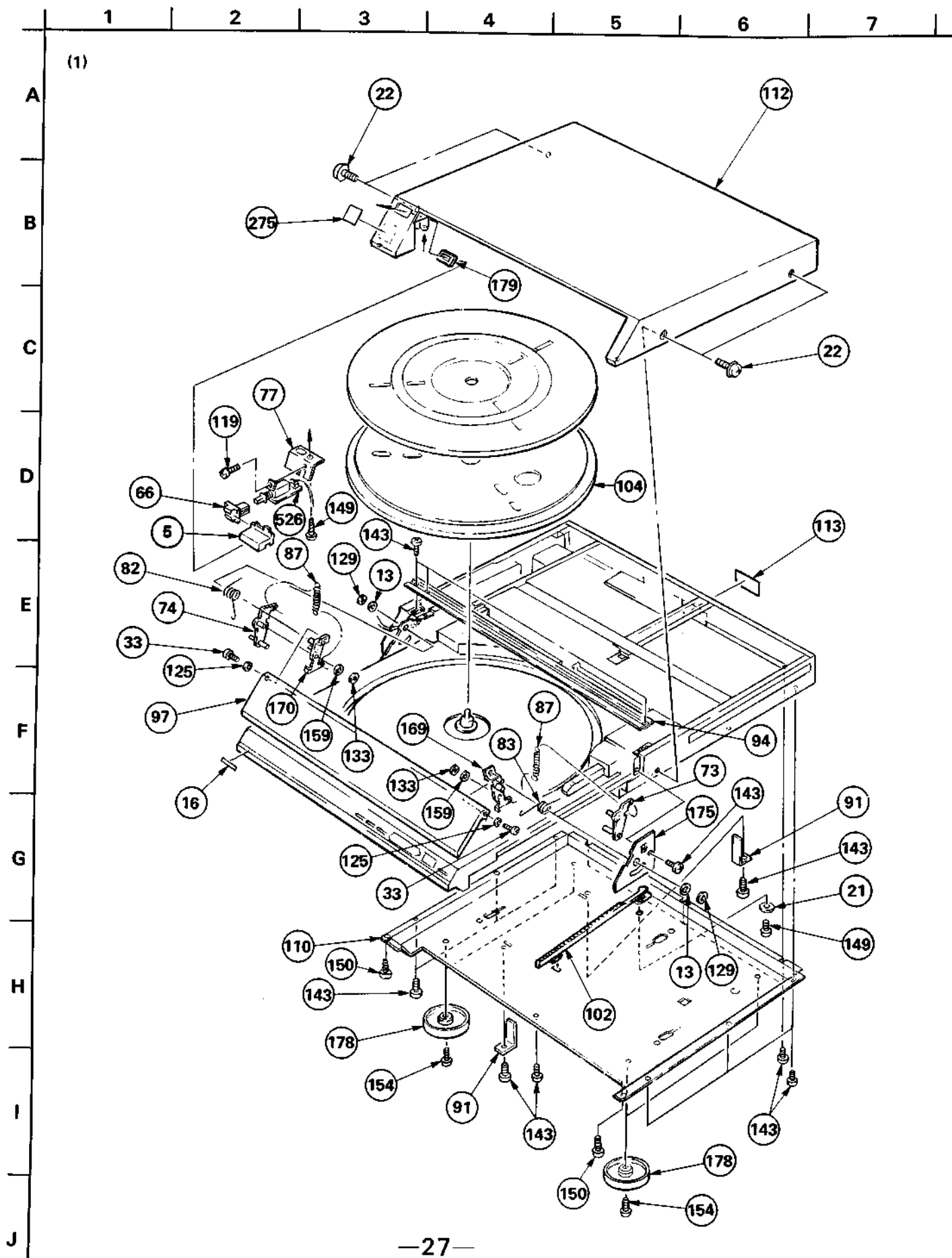

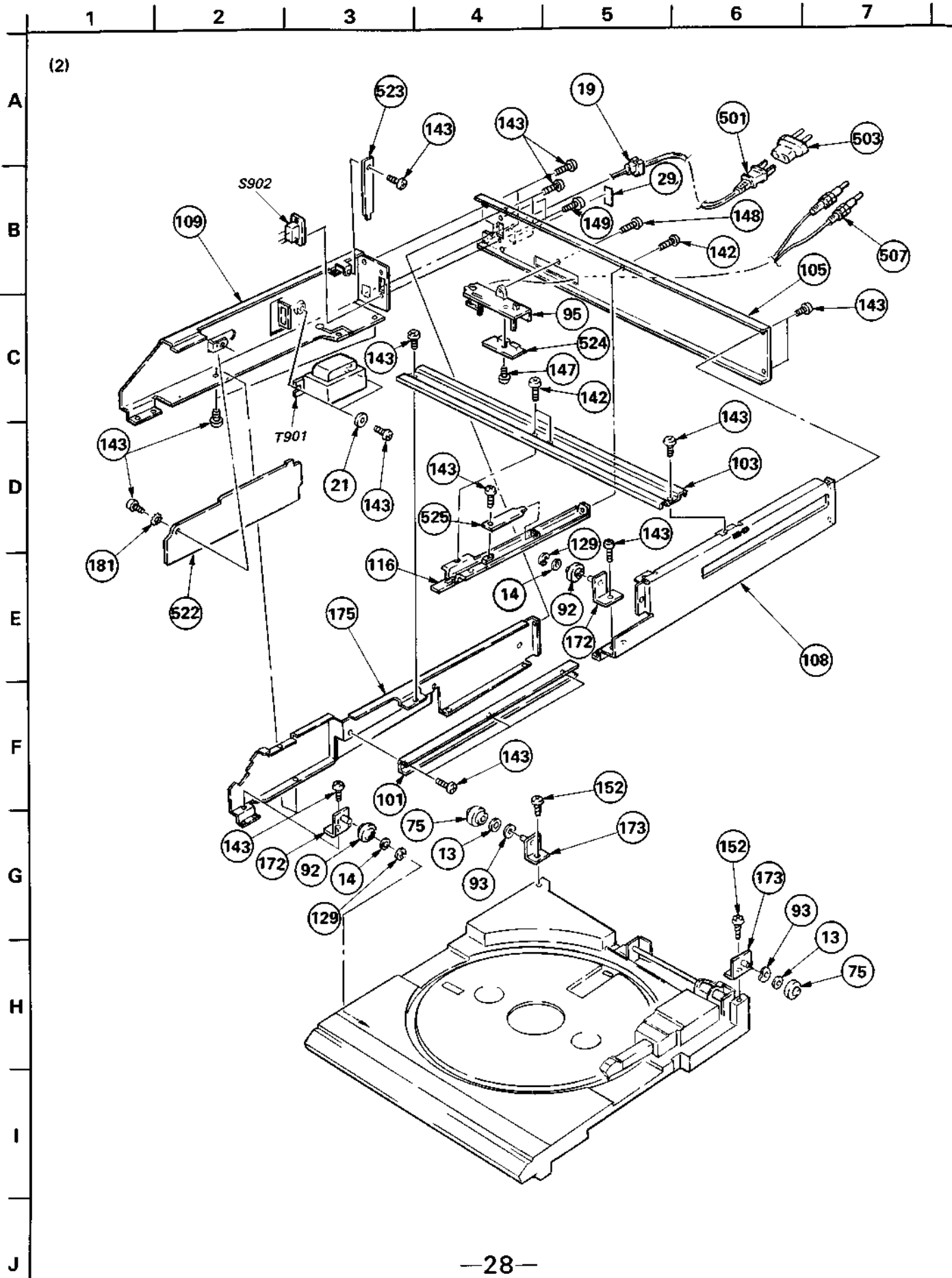

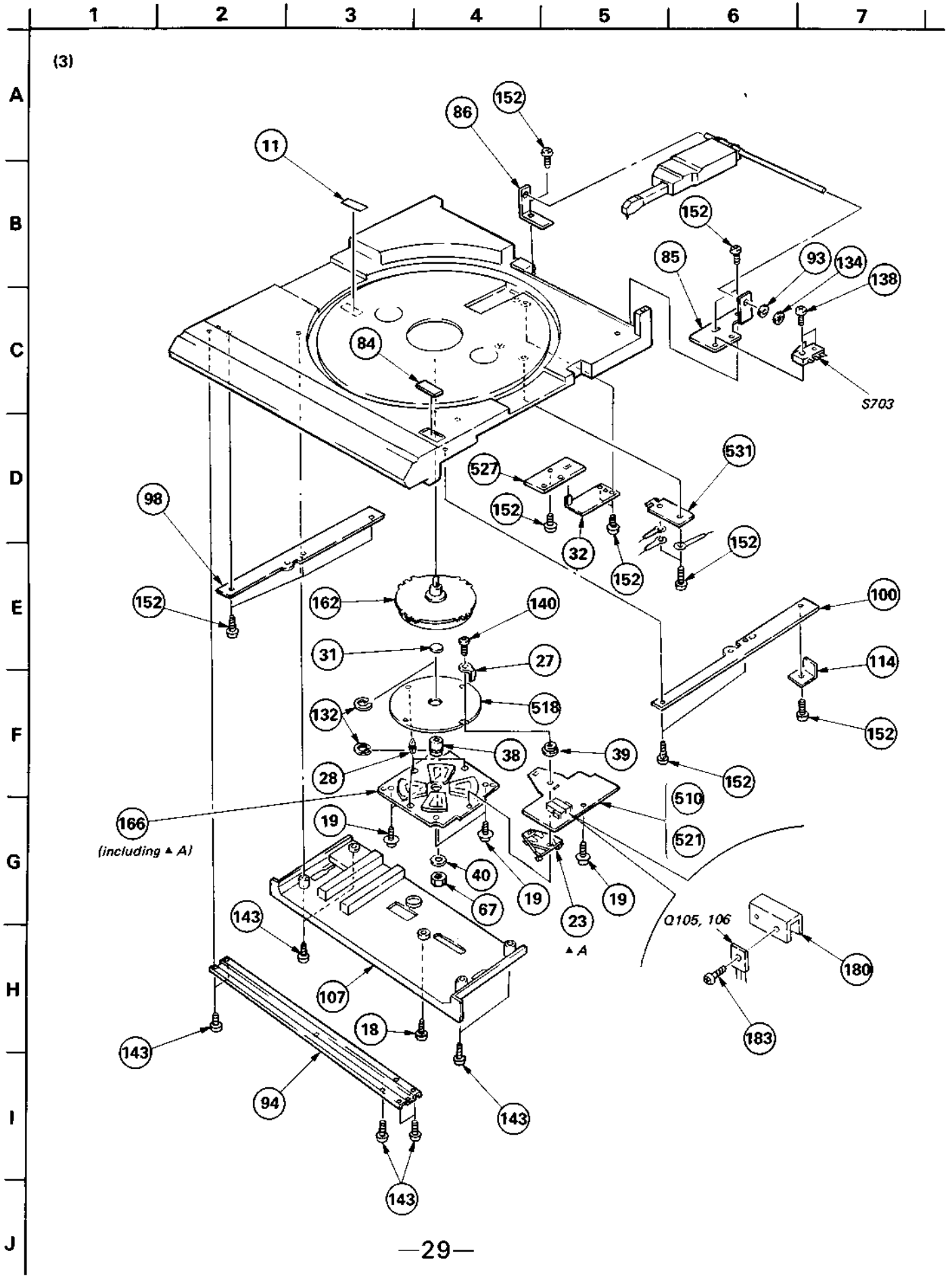

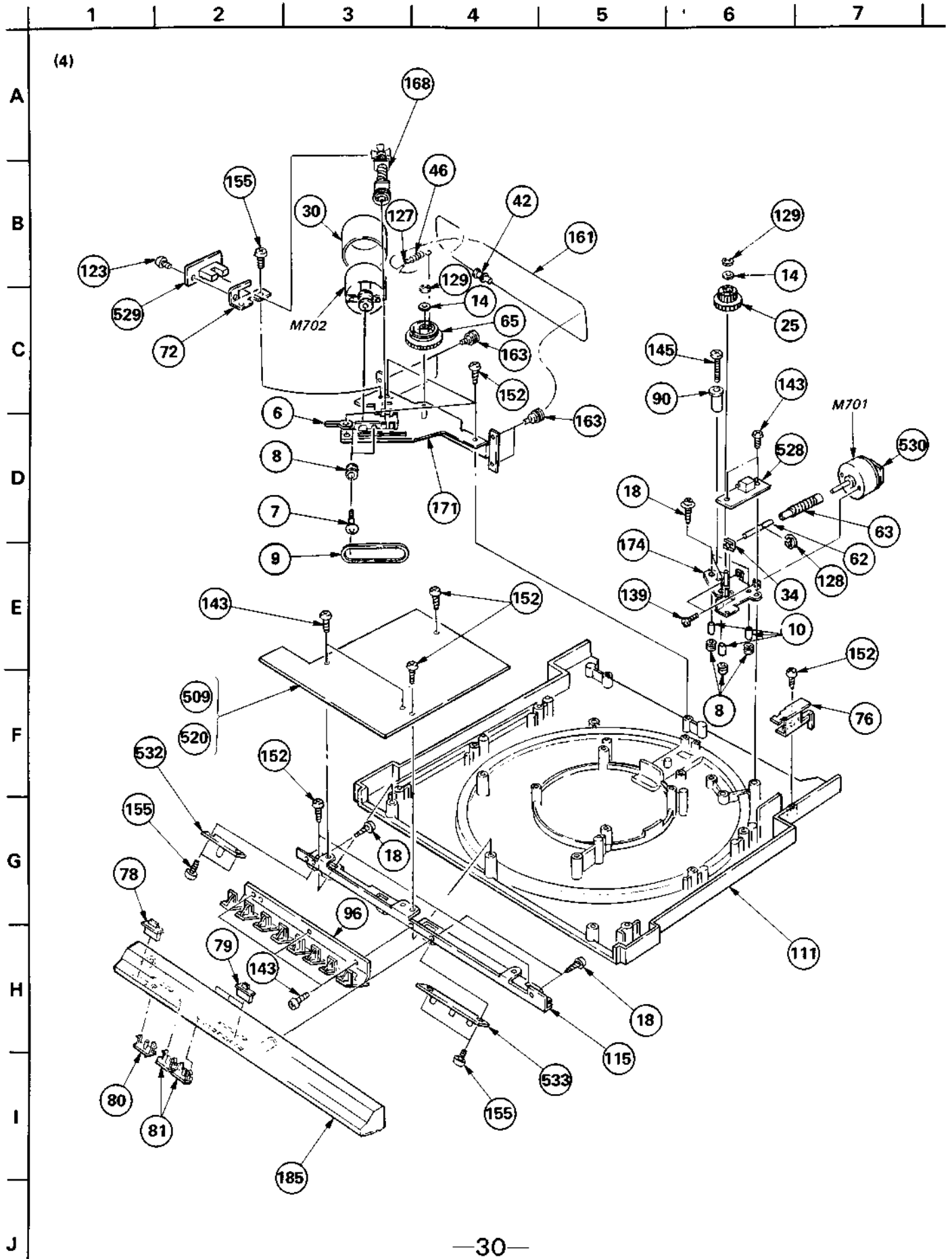

1 2 3 4 5 6 7

A  
B  
C  
D  
E  
F  
G  
H  
I  
J

(5)

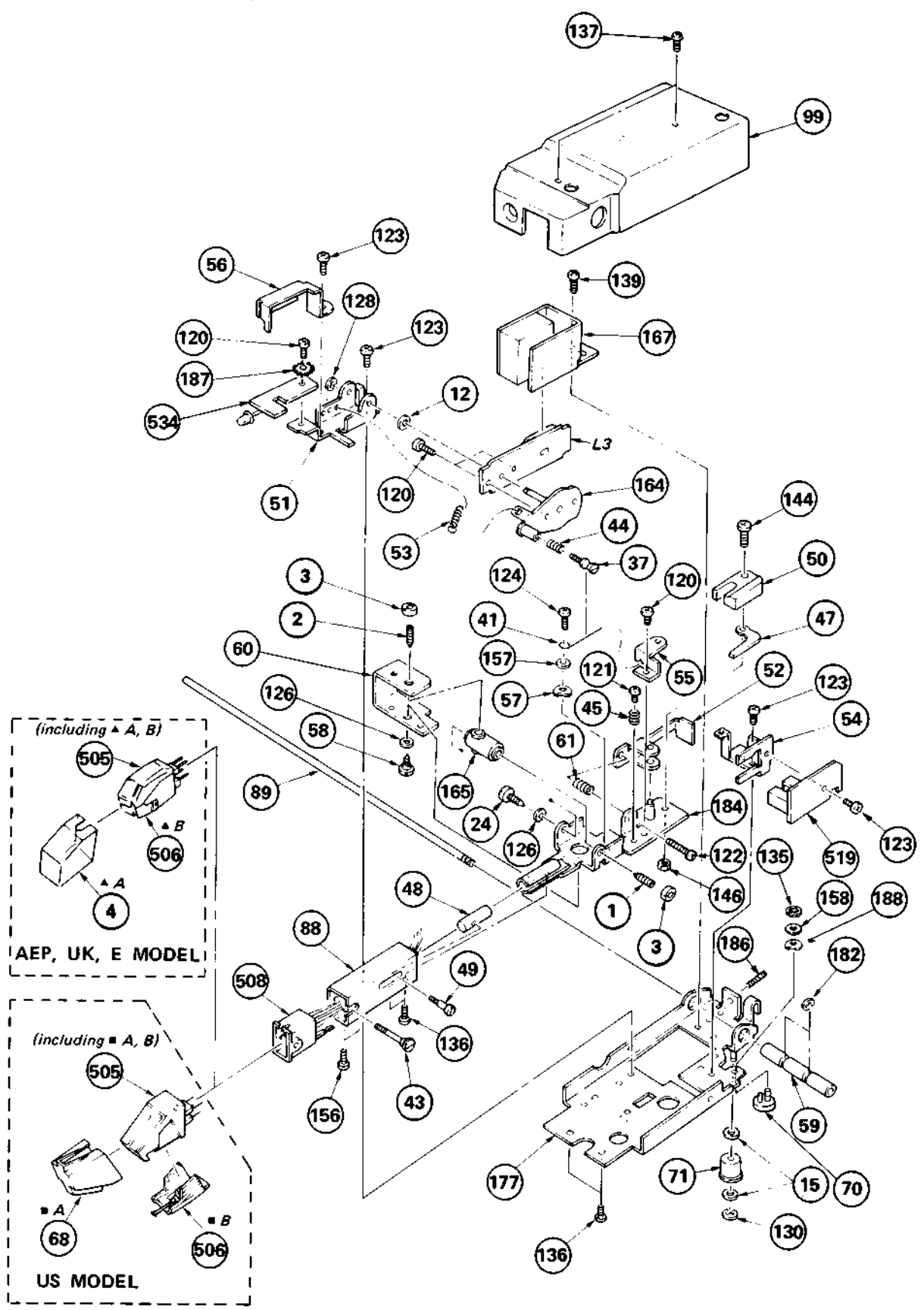

GENERAL SECTION

No.	Part No.	Description
1	2-203-518-61	SCREW, PIVOT
2	2-203-518-71	SCREW, PIVOT
3	2-203-519-00	NUT (A), LOCK, PIVOT
4	2-231-824-01	(AEP,UK,E)...COVER, STYLUS
5	3-318-911-01	(SILVER)...KNOB (POWER.L), T MOLD
5	3-318-911-11	(BLACK)...KNOB (POWER.L), T MOLD
6	3-460-077-00	CLAMP, WIRE
7	3-570-027-00	SCREW, MOTOR
8	3-570-118-00	CUSHION, MOTOR
9	3-573-122-00	BELT, TAKE-UP
10	3-654-058-00	SPACER 3X3
11	3-701-030-00	LABEL, SERIAL NUMBER
12	3-701-437-21	WASHER
13	3-701-441-11	WASHER
14	3-701-441-21	WASHER
15	3-701-443-11	WASHER
16	3-701-690-00	(UK)...LABEL (MADE IN JAPAN)
17	3-701-748-00	CLAMP
18	3-703-136-00	SCREW, PTPWH 3X12
19	3-703-137-00	SCREW, PTPWH 3X10
20	3-703-244-00	(AEP,UK)...BUSHING, CORD
20	3-703-571-00	(US,E)...BUSHING (S), CORD
21	4-301-647-00	WASHER, SPECIAL
22	4-820-330-51	(SILVER)...SCREW, BW, PLUS MINUS
22	4-820-330-61	(BLACK)...SCREW, BW, PLUS MINUS
23	4-857-642-00	HOLDER, PC BOARD
24	4-877-816-00	SHAFT, PIVOT
25	4-879-514-00	WHEEL (A), WORM
26	.....	
27	4-881-629-00	PLATE (A), GROUND
28	4-881-636-11	SUPPORT (TMD), PC
29	4-881-683-00	(E)...LABEL, VOLTAGE
30	4-882-233-00	CASE, ACOUSTIC ABSORBER
31	4-885-135-00	RETAINER, THRUST
32	4-885-535-00	SUPPORT, TRANSPORT
33	4-885-599-00	SCREW, FITTING, REINFORCEMENT
34	4-885-703-00	GUIDE, WORM SHAFT
35	.....	
36	4-885-704-03	PULLEY, MOTOR
37	4-885-706-04	SCREW, ADJUSTMENT, POSITION
38	4-885-724-00	BEARING
39	4-885-727-00	SPACER
40	4-885-728-00	PACKING
41	4-885-737-00	WIRE
42	4-885-744-00	STOPPER, WIRE
43	4-885-746-00	SCREW, FITTING, CARTRIDGE

NOTE:

- The mechanical parts with no reference number in the exploded views are not supplied.
- Items marked " ♣ " are not stocked since they are seldom required for routine service. Some delay should be anticipated when ordering these items.
- Due to standardization, parts with part numbers (Δ-ΔΔΔ-ΔΔΔ-XX or Δ-ΔΔΔΔ-ΔΔΔ-X) may be different from those used in the set.
- If there are two or more same circuits in a set such as a stereophonic machine, only typical circuit parts may be indicated and capacitors and resistors in other same circuits may be omitted.

GENERAL SECTION

No.	Part No.	Description
44	4-885-764-02	SPRING, COMPRESSION
45	4-885-766-00	SPRING, COMPRESSION
46	4-885-767-00	SPRING, TENSION
47	4-885-768-00	WEIGHT (2)
48	4-885-770-00	WEIGHT, ADJUSTMENT
49	4-885-771-00	SCREW, ADJUSTMENT
50	4-887-310-00	WEIGHT (A)
51	4-887-437-01	BASE, LIFTER
52	4-887-438-01	PLATE, ADJUSTMENT
53	4-887-439-01	SPRING, TENSION
54	4-887-440-01	BRACKET, SENSOR
55	4-887-444-01	RETAINER, WIRE
56	4-887-446-01	PLATE, SHIELD
57	4-887-448-01	WASHER (A)
58	4-887-449-01	SHAFT, PIVOT
59	4-887-451-01	SLIDER
60	4-887-454-11	BRIDGE, ARM
61	4-887-461-01	SPRING, COMPRESSION
62	4-888-902-00	SHAFT (A), WORM
63	4-888-904-00	WORM (A)
64	4-888-959-00	DISK, SLIT
65	4-888-960-00	WHEEL, WORM
66	4-902-831-01	JOINT (G), KNOB
67	4-903-330-01	NUT (TMD), BEARING
68	4-903-347-01	(US)...COVER, STYLUS
69	.....	
70	4-905-802-01	CAM, L POSITION ADJUSTMENT
71	4-905-804-01	ROLLER, GUIDE
72	4-905-805-01	BRACKET (B), SENSOR
73	4-905-806-01	LEVER (B,R), PANEL
74	4-905-807-01	LEVER (B,L), PANEL
75	4-905-811-01	ROLLER (B), GUIDE
76	4-905-813-01	PLATE, READ WIRE
77	4-905-814-01	BRACKET, POWER SWITCH
78	4-905-820-11	KNOB (A)
79	4-905-820-01	(SILVER)...KNOB (A)
79	4-905-820-21	(BLACK)...KNOB (A)
80	4-905-821-01	(SILVER)...KNOB, SS
80	4-905-821-11	(BLACK)...KNOB, SS
81	4-905-822-01	(SILVER)...KNOB, TRANSPORT
81	4-905-822-11	(BLACK)...KNOB, TRANSPORT
82	4-905-824-01	SPRING, TORSION
83	4-905-824-11	SPRING, TORSION
84	4-905-827-01	LABEL
85	4-905-830-01	BRACKET (RIGHT), GUIDE BAR
86	4-905-831-01	BRACKET (LEFT), GUIDE BAR
87	4-905-832-01	SPRING, TENSION

CAPACITORS:

MF:μF, PF:μμF.

RESISTORS

- All resistors are in ohms.
- F : nonflammable

COILS

MMH : mH, UH : μH

SEMICONDUCTORS

In each case, U : μ, for example:

UA...: μA..., UPA...: μPA..., UPC...: μPC,

UPD...: μPD...

GENERAL SECTION

No.	Part No.	Description
88	4-905-834-01	PIPE, ARM
89	♣;4-905-835-01	BAR, GUIDE
90	4-905-837-01	GUIDE, RACK
91	♣;4-905-838-01	PLATE, FUNCTION, LOADING SWITCH
92	4-905-841-01	ROLLER (A), GUIDE
93	4-905-842-01	WASHER, BENDING
94	♣;4-905-843-01	REINFORCEMENT (LOWER)
95	4-905-844-01	BOARD, TERMINAL, REMOTE CONTROL
96	4-905-845-01	KNOB (R), CONTROL
97	4-905-846-01	PANEL, FRONT
98	♣;4-905-847-01	GUIDE (C)
99	♣;4-905-848-01	COVER, ARM
100	♣;4-905-850-01	GUIDE (A)
101	♣;4-905-851-01	GUIDE (B)
102	4-905-853-01	PLATE, RACK
103	♣;4-905-854-01	REINFORCEMENT (UPPER)
104	4-905-855-01	TURNTABLE
105	♣;4-905-856-01	(US,AEP,UK)...PANEL, BACK
105	♣;4-905-856-11	(E).....PANEL, BACK
106	.....	
107	♣;4-905-857-01	COVER, REAR
108	♣;4-905-862-01	PLATE (R), SIDE
109	♣;4-905-863-01	(US,AEP,UK)...PLATE (L), SIDE
109	♣;4-905-863-12	(E).....PLATE (L), SIDE
110	♣;4-905-865-01	PLATE, BOTTOM
111	♣;4-905-866-01	FRAME
112	4-905-867-01	(SILVER/US)...CASE, PLAYER
112	4-905-867-21	(BLACK/US)...CASE, PLAYER
112	4-905-867-32	(AEP,UK,E)...CASE, PLAYER
113	4-905-801-01	(US)...LABEL, MODEL NUMBER
113	4-905-870-01	(AEP)...LABEL, MODEL NUMBER
113	4-905-871-01	(E).....LABEL, MODEL NUMBER
113	4-905-872-01	(UK)...LABEL, MODEL NUMBER
114	♣;4-905-873-01	PLATE, STOPPER
115	♣;4-905-875-01	BRACKET, CONTROL PANEL
116	♣;4-905-877-01	BRACKET, SENSOR
117	7-621-255-10	SCREW +P 2X3
118	7-621-736-09	SET-SCT, HEX. 2.6X5
119	7-621-759-35	+PSW, 2.6X5
120	7-621-772-00	SCREW +B 2X3
121	7-621-772-30	SCREW +B 2X6
122	7-621-772-40	SCREW +B 2X8
123	7-621-775-00	SCREW +B 2.6X3
124	7-621-775-20	SCREW +B 2.6X5
125	7-623-207-22	SW 2.6, TYPE 2
126	7-623-208-22	SW 3, TYPE 2
127	7-623-616-01	EYELET, 2X3

NOTE:

- The mechanical parts with no reference number in the exploded views are not supplied.
- Items marked " ♣ " are not stocked since they are seldom required for routine service. Some delay should be anticipated when ordering these items.
- Due to standardization, parts with part numbers (Δ-ΔΔΔ-ΔΔΔ-XX or Δ-ΔΔΔΔ-ΔΔΔ-X) may be different from those used in the set.
- If there are two or more same circuits in a set such as a stereophonic machine, only typical circuit parts may be indicated and capacitors and resistors in other same circuits may be omitted.

GENERAL SECTION

No.	Part No.	Description
128	7-624-102-04	STOP RING 1.5, TYPE -E
129	7-624-106-04	STOP RING 3.0, TYPE -E
130	7-624-108-04	STOP RING 4.0, TYPE -E
131	7-624-133-24	STOP RING 7, TYPE-CE
132	7-624-133-94	STOP RING 15, TYPE-CE
133	7-624-190-11	STOP RING 3, TYPE-CS
134	7-624-190-31	STOP RING 4, TYPE-CS
135	7-624-190-61	STOP RING 2.4, TYPE-CS
136	7-627-553-37	SCREW, PRECISION +P 2X3
137	7-627-553-47	SCREW, PRECISION +P 2X4
138	7-627-553-98	SCREW, PRECISION +P 2X8
139	7-628-253-95	SCREW +PS 2.6X4
140	7-682-149-13	SCREW +P 3X10
141	7-682-544-04	SCREW +B 3X3
142	7-682-545-04	SCREW +B 3X4
143	7-682-546-04	SCREW +BVTT 3X5 (S)
144	7-682-548-09	SCREW +B 3X8
145	7-682-553-04	SCREW +B 3X20
146	7-684-023-04	N 3, TYPE 2
147	7-685-133-21	SCREW +P 2.6X6 TYPE2 SLIT
148	7-685-145-14	SCREW +BTP 3X6 TYPE2 N-S
149	7-685-546-14	SCREW +BTP 3X8 TYPE2 N-S
150	7-685-646-19	SCREW +BVTP 3X8 TYPE2 N-S
151	7-685-647-14	SCREW +BVTP 3X10 TYPE2 N-S
152	7-685-647-21	SCREW +BVTP 3X10 TYPE2 SLIT
153	7-685-648-11	SCREW +BVTP 3X12 TYPE2 N-S
154	7-685-751-09	SCREW +BVTT 3X6 (S)
155	7-685-790-04	SCREW +BVTT 2.6X4 (S)
156	7-685-799-04	SCREW +PTT 1.7X2.5
157	7-688-002-01	W 2.6, SMALL
158	7-688-002-11	W 2.6, MIDDLE
159	7-688-003-12	W 3, MIDDLE
160	9-910-999-33	(US)...LABEL, IDENTIFICATION
161	9-911-825-42	STRING, TETRON DIAL (0.5MM)
162	A-4608-232-A	ROTOR ASSY
163	X-4856-325-0	PULLEY ASSY
164	♣;X-4887-409-1	LEVER ASSY, LIFTER
165	X-4887-411-1	BEARING ASSY, PIVOT
166	X-4887-413-1	STATOR ASSY
167	X-4887-415-1	MAGNET ASSY, ARM
168	X-4888-902-4	WORM ASSY
169	♣;X-4905-801-1	LEVER (A,R) ASSY, PANEL
170	♣;X-4905-802-1	LEVER (A,L) ASSY, PANEL
171	♣;X-4905-803-1	BRACKET ASSY, ARM MOTOR
172	♣;X-4905-804-1	BRACKET (A) ASSY, GUIDE ROLLER
173	♣;X-4905-805-1	BRACKET (B) ASSY, GUIDE ROLLER
174	♣;X-4905-806-1	BRACKET ASSY, LOADING GEAR
175	♣;X-4905-807-1	PLATE (C) ASSY, SIDE

CAPACITORS:

MF:μF, PF:μμF.

RESISTORS

• All resistors are in ohms.

• F : nonflammable

COILS

• MMH : mH, UH : μH

SEMICONDUCTORS

In each case, U : μ, for example:

UA...: μA..., UPA...: μPA..., UPC...: μPC,

UPD...: μPD...



## GENERAL SECTION

No.	Part No.	Description
176	♣;X-4905-808-1	BRACKET (R) ASSY, PANEL LEVER
177	♣;X-4905-809-1	BASE ASSY, ARM
178	X-4905-813-1	INSULATOR ASSY
179	3-318-916-01	ESCUTCHEON (B), POWER KNOB
180	♣;4-885-562-11	HEAT SINK
181	7-623-422-07	WASHER, LW 3
182	7-624-133-44	STOPRING 9, TYPE-CE
183	7-682-547-09	SCREW +B 3X6
184	X-4887-414-1	JOINT ASSY, PIPE
185	X-4905-811-1	(SILVER)...PANEL ASSY, CONTROL
185	X-4905-812-1	(BLACK)...PANEL ASSY, CONTROL
186	7-627-735-09	SET-SCREW, WP 2.6X4
187	7-623-420-07	WASHER, LW 2
188	4-904-236-01	WASHER

## ACCESSORY & PACKING MATERIAL

No.	Part No.	Description
251	3-565-234-00	BAG, PROTECTION
252	3-610-931-11	SPACER, SHAFT, DRUM, HEAD
253	3-701-308-00	LABEL, PRODUCT COLOR
254	3-701-630-00	BAG, POLYETHYLENE
255	3-701-632-00	BAG, POLYETHYLENE
256	3-701-806-00	ADAPTOR, 45, (E)
257	3-773-928-11	(AEP,UK,E)...MANUAL, INSTRUCTION
258	3-773-928-21	(US)...MANUAL, INSTRUCTION
259	3-773-928-41	(AEP)...MANUAL, INSTRUCTION
260	3-795-753-21	(US)...INSTRUCTION
261	4-808-459-91	SCREW (B), MOTOR LOCK
262	4-880-101-00	PLATE, PROTECTION
263	4-885-746-00	SCREW, FITTING, CARTRIDGE
264	4-905-825-01	PLATE (A), LOCK, TRANSPORT
265	4-905-828-01	PLATE (B), LOCK, TRANSPORT
266	4-905-860-11	SHEET, TURNTABLE
267	4-905-868-01	CUSHION (RIGHT)
268	4-905-869-01	CUSHION (LEFT)
269	4-905-876-01	(US)...SCREW, TRANSPORT
270	4-905-878-01	HOLDER, TURNTABLE
271	4-905-879-11	(AEP,UK,E)...LABEL, CAUTION
272	4-905-879-21	(US)...LABEL, CAUTION
273	4-905-880-11	LABEL, SERVICING NOTE
274	4-905-881-01	PLATE, PROTECTION
275	X-4887-405-1	(US)...SCREW ASSY, CARTRIDGE
276	4-905-874-01	INDIVIDUAL CARTON
277	4-905-872-01	(US)...INDIVIDUAL CARTON
278	3-703-713-01	STICKER, SONY SYMBOL (10)
279	3-773-928-01	(UK,E)...MANUAL, INSTRUCTION
280	3-773-928-31	(UK,E)...MANUAL, INSTRUCTION

### NOTE:

- The mechanical parts with no reference number in the exploded views are not supplied.
- Items marked "♣" are not stocked since they are seldom required for routine service. Some delay should be anticipated when ordering these items.
- Due to standardization, parts with part numbers (Δ-ΔΔΔ-ΔΔΔ-XX or Δ-ΔΔΔΔ-ΔΔΔ-X) may be different from those used in the set.
- If there are two or more same circuits in a set such as a stereophonic machine, only typical circuit parts may be indicated and capacitors and resistors in other same circuits may be omitted.

### CAPACITORS:

MF:μF, PF:μμF.

### RESISTORS

- All resistors are in ohms.
- F: nonflammable

### COILS

MMH: mH, UH: μH

### SEMICONDUCTORS

In each case, U: μ, for example:

UA...: μA..., UPA...: μPA..., UPC...: μPC,

UPD...: μPD...

## ELECTRICAL PARTS

Ref.No.	Part No.	Description
501	Δ.1-534-817-XX	(AEP)...CORD, POWER
501	Δ.1-551-884-00	(UK)...CORD, POWER
501	Δ.1-551-472-00	(E)...CORD, POWER
501	Δ.1-551-506-XX	(US)...CORD, POWER
502	♣;1-508-799-00	BASE POST (U TYPE)
503	Δ.1-526-565-00	(E)...AC PLUG ADAPTOR
504	♣;1-535-116-00	TERMINAL
505	1-549-117-00	(US)...CARTRIDGE (VL-45G)
505	A-4505-089-C	(AEP,UK,E)...CARTRIDGE COMPLETE ASSY (XL-250G)
506	1-549-118-11	(US)...STYLUS ASSY, ND-145G
506	A-4587-071-C	(AEP,UK,E)...STYLUS ASSY, ND-250G
507	1-551-294-00	CORD, SHIELD (WITH PIN)
508	1-556-552-00	CONNECTOR (PLUG IN TYPE)
509	♣;A-4616-015-A	MOUNTED PCB, SYSTEM CONTROL
510	♣;A-4619-243-A	(US)...MOUNTED PCB, SERVO AMPLIFIER
510	♣;A-4619-244-A	(AEP,UK,E)...MOUNTED PCB, SERVO AMPLIFIER
511	♣;1-564-113-11	PIN, CONNECTOR 4P
512	♣;1-564-115-00	PIN, CONNECTOR 6P
513	♣;1-564-116-00	PIN, CONNECTOR 7P
514	♣;1-564-496-11	PIN, CONNECTOR 3P
515	1-564-497-11	PIN, CONNECTOR 4P
516	♣;1-564-499-11	PIN, CONNECTOR 6P
517	♣;1-564-502-11	PIN, CONNECTOR 10P
518	♣;1-608-883-00	PC BOARD, FG
519	♣;1-612-356-11	PC BOARD, SENSOR
520	♣;1-612-660-11	PC BOARD, SYSCON
521	♣;1-612-661-11	PC BOARD, SERVO AMP
522	♣;1-612-662-11	PC BOARD, POWER SUPPLY
523	♣;1-612-663-11	PC BOARD, POWER TRANSLATION
524	♣;1-612-664-11	PC BOARD, REMOTE CONTROL
525	♣;1-612-665-11	PC BOARD, RECORD SENSOR
526	♣;1-612-666-11	PC BOARD, POWER SW
527	♣;1-612-667-11	PC BOARD, SIZE DETECTION
528	♣;1-612-668-11	PC BOARD, SW
529	♣;1-612-669-11	PC BOARD, INTERRUPTER (B)
530	♣;1-612-670-11	PC BOARD, DC MOTOR
531	♣;1-612-671-11	PC BOARD, RELAY
532	♣;1-612-672-11	PC BOARD, LED (A)
533	♣;1-612-673-11	PC BOARD, LED (B)
534	♣;1-612-721-11	PC BOARD, PHONO (B)
535	♣;1-612-944-11	PC BOARD, POWER SW
C101	1-162-113-00	CERAMIC 0.01MF 30% 16V
C102	1-123-318-00	ELECT 33MF 20% 16V
C103	1-162-111-00	CERAMIC 0.0022MF 30% 25V

The components identified by shading and mark Δ are critical for safety. Replace only with part number specified.

ELECTRICAL PARTS						
Ref.No.	Part No.	Description				
C104	1-161-974-00	CERAMIC	0.1MF	0	16V	
C105	1-162-052-00	CERAMIC	22PF	5%	50V	
C106	1-162-052-00	CERAMIC	22PF	5%	50V	
C107	1-123-380-00	ELECT	1MF	20%	50V	
C108	1-123-379-00	ELECT	0.47MF	20%	50V	
C109	1-162-031-00	CERAMIC	56PF	5%	50V	
C110	1-162-031-00	CERAMIC	56PF	5%	50V	
C111	1-162-113-00	CERAMIC	0.01MF	30%	16V	
C112	1-162-113-00	CERAMIC	0.01MF	30%	16V	
C113	1-123-611-00	ELECT	1MF	20%	50V	
C114	1-123-611-00	ELECT	1MF	20%	50V	
C115	1-123-661-00	ELECT	100MF	20%	6.3V	
C116	1-123-661-00	ELECT	100MF	20%	6.3V	
C117	1-162-113-00	CERAMIC	0.01MF	30%	16V	
C118	1-162-113-00	CERAMIC	0.01MF	30%	16V	
C119	1-162-113-00	CERAMIC	0.01MF	30%	16V	
C120	1-162-110-00	CERAMIC	0.001MF	10%	50V	
C121	1-162-113-00	CERAMIC	0.01MF	30%	16V	
C201	1-162-113-00	CERAMIC	0.01MF	30%	16V	
C202	1-123-611-00	ELECT	1MF	20%	50V	
C203	1-162-113-00	CERAMIC	0.01MF	30%	16V	
C204	1-162-113-00	CERAMIC	0.01MF	30%	16V	
C205	1-162-102-00	CERAMIC	220PF	10%	50V	
C206	1-123-661-00	ELECT	100MF	20%	6.3V	
C207	1-123-379-00	ELECT	0.47MF	20%	50V	
C208	1-123-379-00	ELECT	0.47MF	20%	50V	
C209	1-123-611-00	ELECT	1MF	20%	50V	
C210	1-123-611-00	ELECT	1MF	20%	50V	
C211	1-162-113-00	CERAMIC	0.01MF	30%	16V	
C212	1-123-307-00	ELECT	100MF	20%	6.3V	
C213	1-162-113-00	CERAMIC	0.01MF	30%	16V	
C214	1-161-494-00	CERAMIC	0.022MF	5%	25V	
C215	1-162-113-00	CERAMIC	0.01MF	30%	16V	
C216	1-162-113-00	CERAMIC	0.01MF	30%	16V	
C217	1-162-113-00	CERAMIC	0.01MF	30%	16V	
C218	1-162-113-00	CERAMIC	0.01MF	30%	16V	
C219	1-162-113-00	CERAMIC	0.01MF	30%	16V	
C220	1-162-113-00	CERAMIC	0.01MF	30%	16V	
C221	1-162-113-00	CERAMIC	0.01MF	30%	16V	
C222	1-162-113-00	CERAMIC	0.01MF	30%	16V	
C223	1-162-113-00	CERAMIC	0.01MF	30%	16V	
C224	1-123-617-00	ELECT	10MF	20%	16V	
C225	1-162-113-00	CERAMIC	0.01MF	30%	16V	
C226	1-162-113-00	CERAMIC	0.01MF	30%	16V	
C227	1-123-330-00	ELECT	22MF	20%	16V	

ELECTRICAL PARTS						
Ref.No.	Part No.	Description				
C228	1-162-113-00	CERAMIC	0.01MF	30%	16V	
C301	1-162-110-00	CERAMIC	0.001MF	10%	50V	
C302	1-162-110-00	CERAMIC	0.001MF	10%	50V	
C401	1-123-349-00	ELECT	1000MF	20%	25V	
C402	1-123-349-00	ELECT	1000MF	20%	25V	
D101	8-719-103-36	DIODE	RD6.8JN1			
D102	8-719-103-36	DIODE	RD6.8JN1			
D201	8-719-911-19	DIODE	1SS119			
D202	8-719-911-19	DIODE	1SS119			
D204	8-719-103-36	DIODE	RD6.8JN1			
D205	8-719-103-36	DIODE	RD6.8JN1			
D301	8-719-913-49	DIODE	EBG5638S			
D303	8-719-913-47	DIODE	EAA5638S			
D304	8-719-913-47	DIODE	EAA5638S			
D305	8-719-913-47	DIODE	EAA5638S			
D401	▲.8-719-200-02	DIODE	10E-2			
D402	▲.8-719-200-02	DIODE	10E-2			
D403	▲.8-719-200-02	DIODE	10E-2			
D404	▲.8-719-200-02	DIODE	10E-2			
D405	8-719-911-19	DIODE	1SS119			
D406	8-719-911-19	DIODE	1SS119			
D407	8-719-911-19	DIODE	1SS119			
D408	8-719-911-19	DIODE	1SS119			
D601	8-719-906-58	DIODE	GL-5HD21			
D602	8-719-906-58	DIODE	GL-5HD21			
D701	8-719-900-57	DIODE	GL-5HY5			
H101	8-719-800-17	DIODE	THS102A			
H102	8-719-800-17	DIODE	THS102A			
PH701	8-719-411-28	DIODE	ON1128			
PH702	8-719-918-74	DIODE	GP-1S04			
IC101	8-759-201-58	IC	TC9142P			
IC102	8-759-600-02	IC	M5218L			
IC103	8-759-202-01	IC	TA7256P			
IC201	8-759-801-03	IC	LM6402G-356			
IC202	8-759-202-01	IC	TA7256P			
IC203	8-759-600-02	IC	M5218L			
J401	1-507-813-00	JACK, SYNCRO REMOTE				
J402	◆;1-560-317-00	CONNECTOR PIN 6P				
L3	1-422-162-11	COIL, ARM UP/DOWN				
L101	1-408-579-00	MICRO INDUCTOR 220UH				
L201	1-408-908-00	MICRO INDUCTOR 470UH				
M701	1-541-163-00	MOTOR, LOADING				
M702	A-4608-291-A	MOTOR ASSY, ARM DRIVE				

NOTE:

- The mechanical parts with no reference number in the exploded views are not supplied.
- Items marked "◆" are not stocked since they are seldom required for routine service. Some delay should be anticipated when ordering these items.
- Due to standardization, parts with part numbers (A-ΔΔΔ-ΔΔΔ-XX or A-ΔΔΔΔ-ΔΔΔ-X) may be different from those used in the set.
- If there are two or more same circuits in a set such as a stereophonic machine, only typical circuit parts may be indicated and capacitors and resistors in other same circuits may be omitted.

CAPACITORS:

MF:μF, PF:μμF.

RESISTORS

- All resistors are in ohms.
- F : nonflammable

COILS

MMH : mH, UH : μH

SEMICONDUCTORS

In each case, U : μ, for example:  
 UA... : μA... , UPA... : μPA... , UPC... : μPC,  
 UPD... : μPD...

The components identified by shading and mark ▲ are critical for safety. Replace only with part number specified.

ELECTRICAL PARTS

Ref.No.	Part No.	Description
Q101	8-729-900-36	TRANSISTOR DTC124ES
Q102	8-729-900-63	TRANSISTOR DTA124ES
Q103	8-729-900-36	TRANSISTOR DTC124ES
Q104	8-729-245-83	TRANSISTOR 2SC2458
Q105	8-729-180-93	TRANSISTOR 2SD809
Q106	8-729-173-13	TRANSISTOR 2SB731
Q107	8-729-900-36	TRANSISTOR DTC124ES
Q201	8-729-245-83	TRANSISTOR 2SC2458
Q204	8-729-900-63	TRANSISTOR DTA124ES
Q205	8-729-900-80	TRANSISTOR DTC114ES
Q206	8-729-900-80	TRANSISTOR DTC114ES
Q207	8-729-245-83	TRANSISTOR 2SC2458
Q208	8-729-245-83	TRANSISTOR 2SC2458
Q209	8-729-900-80	TRANSISTOR DTC114ES
Q210	8-729-245-83	TRANSISTOR 2SC2458
Q211	8-729-900-36	TRANSISTOR DTC124ES
Q212	8-729-288-02	TRANSISTOR 2SD880
Q301	8-729-101-01	TRANSISTOR PH101
Q302	8-729-101-01	TRANSISTOR PH101
R101	1-247-807-00	CARBON 100 5% 1/6W
R102	1-247-887-00	CARBON 220K 5% 1/6W
R103	1-247-889-00	CARBON 270K 5% 1/6W
R104	1-247-889-00	CARBON 270K 5% 1/6W
R105	1-247-887-00	CARBON 220K 5% 1/6W
R106	1-247-895-00	CARBON 470K 5% 1/6W
R107	1-247-883-00	CARBON 150K 5% 1/6W
R108	1-247-892-00	CARBON 360K 5% 1/6W
R109	1-247-879-00	CARBON 100K 5% 1/6W
R110	1-247-857-00	CARBON 12K 5% 1/6W
R111	1-247-857-00	CARBON 12K 5% 1/6W
R112	1-247-839-00	CARBON 2.2K 5% 1/6W
R113	1-247-839-00	CARBON 2.2K 5% 1/6W
R114	1-247-839-00	CARBON 2.2K 5% 1/6W
R115	1-247-839-00	CARBON 2.2K 5% 1/6W
R116	1-247-839-00	CARBON 2.2K 5% 1/6W
R117	1-247-885-00	CARBON 180K 5% 1/6W
R118	1-247-885-00	CARBON 180K 5% 1/6W
R119	1-247-893-00	CARBON 390K 5% 1/6W
R120	1-247-893-00	CARBON 390K 5% 1/6W
R121	1-247-885-00	CARBON 180K 5% 1/6W
R122	1-247-885-00	CARBON 180K 5% 1/6W
R123	1-247-767-00	CARBON 2.2 5% 1/6W
R124	1-247-767-00	CARBON 2.2 5% 1/6W
R125	1-247-801-00	CARBON 56 5% 1/6W
R126	1-247-801-00	CARBON 56 5% 1/6W
R127	1-247-811-00	CARBON 150 5% 1/6W
R128	1-247-811-00	CARBON 150 5% 1/6W

NOTE:

- The mechanical parts with no reference number in the exploded views are not supplied.
- Items marked " \* " are not stocked since they are seldom required for routine service. Some delay should be anticipated when ordering these items.
- Due to standardization, parts with part numbers (Δ-ΔΔΔ-ΔΔΔ-XX or Δ-ΔΔΔΔ-ΔΔΔ-X) may be different from those used in the set.
- If there are two or more same circuits in a set such as a stereophonic machine, only typical circuit parts may be indicated and capacitors and resistors in other same circuits may be omitted.

ELECTRICAL PARTS

Ref.No.	Part No.	Description
R130	Δ.1-217-383-00	(US)...FUSIBLE 4.7 5% 1/4W F
R130	Δ.1-806-882-11	(AEP,UK,E)...THERMISTOR
R131	Δ.1-217-383-00	(US)...FUSIBLE 4.7 5% 1/4W F
R131	Δ.1-806-883-11	(AEP,UK,E)...THERMISTOR
R133	1-247-836-00	CARBON 1.6K 5% 1/6W
R134	1-247-837-00	CARBON 1.8K 5% 1/6W
R135	1-247-831-00	CARBON 1K 5% 1/6W
R136	1-247-831-00	CARBON 1K 5% 1/6W
R137	1-247-799-00	CARBON 47 5% 1/6W
R201	1-247-863-00	CARBON 22K 5% 1/6W
R202	1-247-863-00	CARBON 22K 5% 1/6W
R203	1-247-855-00	CARBON 10K 5% 1/6W
R204	1-247-855-00	CARBON 10K 5% 1/6W
R205	1-247-831-00	CARBON 1K 5% 1/6W
R206	1-247-831-00	CARBON 1K 5% 1/6W
R207	1-247-831-00	CARBON 1K 5% 1/6W
R208	1-247-831-00	CARBON 1K 5% 1/6W
R209	1-247-831-00	CARBON 1K 5% 1/6W
R210	1-247-831-00	CARBON 1K 5% 1/6W
R211	1-247-831-00	CARBON 1K 5% 1/6W
R212	1-247-813-00	CARBON 180 5% 1/6W
R214	1-247-821-00	CARBON 390 5% 1/6W
R215	1-247-821-00	CARBON 390 5% 1/6W
R216	1-247-821-00	CARBON 390 5% 1/6W
R217	1-247-807-00	CARBON 100 5% 1/6W
R218	1-247-831-00	CARBON 1K 5% 1/6W
R219	1-247-831-00	CARBON 1K 5% 1/6W
R220	1-247-863-00	CARBON 22K 5% 1/6W
R221	1-247-863-00	CARBON 22K 5% 1/6W
R222	1-247-871-00	CARBON 47K 5% 1/6W
R223	1-247-871-00	CARBON 47K 5% 1/6W
R224	1-247-863-00	CARBON 22K 5% 1/6W
R225	1-247-857-00	CARBON 12K 5% 1/6W
R226	1-247-855-00	CARBON 10K 5% 1/6W
R227	1-247-855-00	CARBON 10K 5% 1/6W
R228	1-247-851-00	CARBON 6.8K 5% 1/6W
R229	1-247-807-00	CARBON 100 5% 1/6W
R230	1-247-863-00	CARBON 22K 5% 1/6W
R231	1-247-863-00	CARBON 22K 5% 1/6W
R232	1-247-863-00	CARBON 22K 5% 1/6W
R233	1-247-863-00	CARBON 22K 5% 1/6W
R234	1-247-863-00	CARBON 22K 5% 1/6W
R235	1-247-863-00	CARBON 22K 5% 1/6W
R236	1-247-863-00	CARBON 22K 5% 1/6W
R237	1-247-847-00	CARBON 4.7K 5% 1/6W
R238	1-247-879-00	CARBON 100K 5% 1/6W

CAPACITORS:

MF:μF, PF:μμF.

RESISTORS

All resistors are in ohms.

F : nonflammable

COILS

MMH : mH, UH : μH

SEMICONDUCTORS

In each case, U : μ, for example:

UA...: μA..., UPA...: μPA..., UPC...: μPC,

UPD...: μPD...

The components identified by shading and mark Δ are critical for safety. Replace only with part number specified.

## ELECTRICAL PARTS

Ref.No.	Part No.	Description			
R239	1-247-855-00	CARBON	10K	5%	1/6W
R240	1-247-863-00	CARBON	22K	5%	1/6W
R241	1-247-855-00	CARBON	10K	5%	1/6W
R242	1-247-855-00	CARBON	10K	5%	1/6W
R243	1-247-855-00	CARBON	10K	5%	1/6W
R244	1-247-855-00	CARBON	10K	5%	1/6W
R245	1-247-855-00	CARBON	10K	5%	1/6W
R246	1-247-855-00	CARBON	10K	5%	1/6W
R247	1-247-891-00	CARBON	330K	5%	1/6W
R248	1-247-889-00	CARBON	270K	5%	1/6W
R249	1-247-891-00	CARBON	330K	5%	1/6W
R250	1-247-889-00	CARBON	270K	5%	1/6W
R251	1-247-879-00	CARBON	100K	5%	1/6W
R252	1-247-878-00	CARBON	91K	5%	1/6W
R253	1-247-855-00	CARBON	10K	5%	1/6W
R254	1-247-855-00	CARBON	10K	5%	1/6W
R255	1-247-855-00	CARBON	10K	5%	1/6W
R256	1-247-855-00	CARBON	10K	5%	1/6W
R257	1-247-867-00	CARBON	33K	5%	1/6W
R258	1-247-887-00	CARBON	220K	5%	1/6W
R259	1-247-867-00	CARBON	33K	5%	1/6W
R260	1-247-879-00	CARBON	100K	5%	1/6W
R261	1-247-887-00	CARBON	220K	5%	1/6W
R262	1-247-769-00	CARBON	2.7	5%	1/6W
R263	1-247-769-00	CARBON	2.7	5%	1/6W
R264	1-247-815-00	CARBON	220	5%	1/6W
R265	1-247-847-00	CARBON	4.7K	5%	1/6W
R266	1-247-892-00	CARBON	360K	5%	1/6W
R267	1-247-859-00	CARBON	15K	5%	1/6W
R268	1-247-855-00	CARBON	10K	5%	1/6W
R269	1-247-879-00	CARBON	100K	5%	1/6W
R270	1-247-849-00	CARBON	5.6K	5%	1/6W
R271	1-247-819-00	CARBON	330	5%	1/6W
R272	1-247-867-00	CARBON	33K	5%	1/6W
R273	1-247-855-00	CARBON	10K	5%	1/6W
R274	1-247-855-00	CARBON	10K	5%	1/6W
R275	1-247-855-00	CARBON	10K	5%	1/6W
R276	1-247-775-00	CARBON	4.7	5%	1/6W
R278	1-247-881-00	CARBON	120K	5%	1/6W
R279	1-247-819-00	CARBON	330	5%	1/6W
R280	1-247-817-00	CARBON	270	5%	1/6W
R281	1-247-879-00	CARBON	100K	5%	1/6W
R282	1-247-879-00	CARBON	100K	5%	1/6W
R283	1-247-879-00	CARBON	100K	5%	1/6W
R284	1-247-879-00	CARBON	100K	5%	1/6W

## ELECTRICAL PARTS

Ref.No.	Part No.	Description			
R285	1-247-879-00	CARBON	100K	5%	1/6W
R286	1-247-879-00	CARBON	100K	5%	1/6W
R287	1-247-801-00	CARBON	56	5%	1/6W
R288	1-247-801-00	CARBON	56	5%	1/6W
R289	1-247-879-00	CARBON	100K	5%	1/6W
R290	1-247-188-00	CARBON	4.7	5%	1/2W
R291	1-247-887-00	CARBON	220K	5%	1/6W
R401	1-247-845-00	CARBON	3.9K	5%	1/6W
R402	1-247-813-00	CARBON	180	5%	1/6W
R403	1-247-863-00	CARBON	22K	5%	1/6W
RV101	1-226-233-00	RES, ADJ, CARBON	1K		
RV102	1-226-233-00	RES, ADJ, CARBON	1K		
RV103	1-226-239-00	RES, ADJ, CARBON	100K		
RV104	1-226-239-00	RES, ADJ, CARBON	100K		
RY201	1-515-519-00	RELAY			
S201	1-554-088-00	SWITCH, KEY BOARD, OPEN/CLOSE			
S202	1-554-088-00	SWITCH, KEY BOARD, START/STOP			
S203	1-554-088-00	SWITCH, KEY BOARD, BACK			
S204	1-554-088-00	SWITCH, KEY BOARD, FWD			
S205	1-554-088-00	SWITCH, KEY BOARD, ARM LIFTER			
S206	1-554-088-00	SWITCH, KEY BOARD, REPEAT			
S207	1-554-088-00	SWITCH, KEY BOARD, SPEED			
S401	1-552-928-00	SWITCH, POWER			
S701	1-554-205-00	SWITCH, PUSH, OPEN			
S702	1-554-205-00	SWITCH, PUSH, CLOSE			
S703	1-554-921-11	SWITCH, MICRO, ARM REST			
S902	△.1-552-535-00	(E)....SWITCH, VOLTAGE SELECTOR			
T901	△.1-447-811-11	(US).....TRANSFORMER, POWER			
T901	△.1-447-812-11	(AEP,UK)...TRANSFORMER, POWER			
T901	△.1-447-813-11	(E).....TRANSFORMER, POWER			
X101	1-567-259-11	VIBRATOR, CRYSTAL			

## NOTE:

- The mechanical parts with no reference number in the exploded views are not supplied.
- Items marked " \* " are not stocked since they are seldom required for routine service. Some delay should be anticipated when ordering these items.
- Due to standardization, parts with part numbers (Δ-ΔΔΔ-ΔΔΔ-XX or Δ-ΔΔΔΔ-ΔΔΔ-X) may be different from those used in the set.
- If there are two or more same circuits in a set such as a stereophonic machine, only typical circuit parts may be indicated and capacitors and resistors in other same circuits may be omitted.

## CAPACITORS:

MF:μF, PF:μμF.

## RESISTORS

All resistors are in ohms.

F : nonflammable

## COILS

MMH : mH, UH : μH

## SEMICONDUCTORS

In each case, U : μ, for example:

UA...: μA..., UPA...: μPA..., UPC...: μPC,

UPD...: μPD...

The components identified by shading and mark △ are critical for safety. Replace only with part number specified.