

PS-2250 TTS-2250

AEP and EP Model



DIRECT DRIVE TURNTABLE SYSTEM

SPECIFICATIONS

General

Speeds:	33 ¹ / ₃ , 45 rpm ± 4 %, adjustable
Turntable drive:	Direct drive system
Wow and flutter: (weighted)	Less than 0.07 % (DIN 45507) Less than 0.04 % (WRMS)
Signal-to-noise ratio: (weighted)	Greater than 58 dB (JIS) Greater than 67 dB (DIN 45544)
Motor:	AC servo-controlled motor
Turntable platter:	310 mm (12 ³ / ₁₆ ") dia, 1.5 kg (3 lb 5 oz) diecasted aluminium
Start-up-time:	Less than 2.5 seconds
Power consumption:	15 watts
Power requirements:	110, 127, 220 and 240 V ac, 50/60 Hz
Dimensions:	
PS-2250	490 mm (width) x 185 mm (height) x 395 mm (depth) 19 ⁹ / ₃₂ " (width) x 7 ⁹ / ₃₂ " (height) x 15 ¹ / ₃₂ " (depth)
TTS-2250	328 mm (width) x 146 mm (height) x 357 mm (depth) 12 ²⁹ / ₃₂ " (width) x 5 ³ / ₄ " (height) x 14 ¹ / ₁₆ " (depth)

Net weight: 11.3 kg (24 lb 15 oz), PS-2250
7.5 kg (16 lb 9 oz), TTS-2250

Shipping weight: 14 kg (30 lb 14 oz), PS-2250
10 kg (22 lb), TTS-2250

Tonearm (PUA-114)

Type:	Static balanced
Arm length: (Pivot-To-Stylus)	245 mm (9 ²¹ / ₃₂ ")
Over hang:	14 mm (9 ⁹ / ₁₆ ")
Stylus force adjustment range:	0 to 3 g, 0.1 g increments
Anti-skating force compensation range:	0 to 3 g, 0.5 g increments
Tonearm height precise adjustment range:	4.65 cm ~ 5.15 cm (1 ²⁷ / ₃₂ ") ~ (2 ¹ / ₃₂ ")
Cartridge weight range:	4 g to 11 g CW-50 (optional counterweight) 10 g ~ 17 g
Shell-head weight:	10.5 g

SONY®

SERVICE MANUAL

TABLE OF CONTENTS

<u>Section</u>	<u>Title</u>	<u>Page</u>
1.	TECHNICAL DESCRIPTION	
1-1.	Technical Specifications	1
1-2.	Principle of ac Servo System	1
1-3.	Block Diagram	4
2.	DISASSEMBLY AND REPLACEMENT	
2-1.	Top Cover Removal	5
2-2.	Bottom Plate Removal	5
2-3.	Turntable Base Removal	5
2-4.	Servo Amplifier Chassis Removal	6
2-5.	Servo Amplifier Cover Removal	6
2-6.	Power Supply Chassis Removal	6
2-7.	Motor Replacement	6
2-8.	Microswitch Replacement	7
2-9.	Strobe Lamp Replacement	8
2-10.	Power Transistor Replacement	8
2-11.	Tonearm Assembly Removal	8
2-12.	Tonearm Base Removal	8
2-13.	Tonearm Lifter Replacement	9
2-14.	Bias Cord Stringing	9
3.	ADJUSTMENT PROCEDURES	
3-1.	Speed Adjustment	10
3-2.	Tonearm Height Adjustment	10
3-3.	Stylus-Force and Anti-Skating Force Adjustment	10
3-4.	Lateral Balance Adjustment	11
3-5.	Lubrication	11
4.	DIAGRAMS	
4-1.	Wiring/Mounting Diagram – AEP Model –	13
4-2.	Wiring/Mounting Diagram – EP Model –	15
4-3.	Schematic Diagram	17
4-4.	Mounting Diagram	19
5.	EXPLODED VIEWS	20
6.	REPACKING	24
7.	ELECTRICAL PARTS LIST	26

SECTION 1

TECHNICAL DESCRIPTION

1-1. TECHNICAL SPECIFICATIONS

Technical specifications for PS-2250/TTS-2250 are listed in TABLE 1.

Note: TTS-2250 is a turntable unit only.

TABLE 1. TECHNICAL SPECIFICATIONS

	General
Speeds:	33-1/3, 45 rpm $\pm 4\%$, adjustable
Turntable drive:	Direct drive system
Wow and flutter: (weighted)	Less than 0.07 % (DIN 45507) Less than 0.04 % (WRMS)
Signal-to-noise ratio: (weighted)	Greater than 58 dB (JIS) Greater than 67 dB (DIN 45544)
Motor:	AC servo-controlled motor
Turntable platter:	310 mm (12-3/16") dia, 1.5 kg (3 lb 5 oz) diecasted aluminium
Start-up-time:	Less than 2.5 seconds
Power consumption:	15 watts
Power requirements:	110, 127, 220 and 240 V ac, (GEP Model) 50/60 Hz 100, 120, 220 and 240 V ac, (General Export Model) 50/60 Hz
Dimensions:	
PS-2250	490 mm (width) x 185 mm (height) x 395 mm (depth) 19-9/32" (width) x 7-9/32" (height) x 15-11/32" (depth)
TTS-2250	328 mm (width) x 146 mm (height) x 357 mm (depth) 12-29/32" (width) x 5-3/4" (height) x 14-1/16" (depth)
Net weight:	11.3 kg (24 lb 15 oz), PS-2250 7.5 kg (16 lb 9 oz), TTS-2250
Shipping weight:	14 kg (30 lb 14 oz), PS-2250 10 kg (22 lb), TTS-2250
Tonearm (PUA-114)	
Type:	Static balanced
Arm length: (Pivot-To-Stylus)	245 mm (9-21/32")
Over hang:	14 mm (9/16")

Stylus force
adjustment range: 0 to 3 g. 0.1 g increments

Anti-skating force
compensation
range: 0 to 3 g. 0.5 g increments

Tonearm height
precise adjustment
range: 4.65 cm \sim 5.15 cm
(1-27/32") \sim (2-1/32")

Cartridge weight
range: 4 g to 11 g
CW-50 (optional counterweight)
10 g \sim 17 g

Shell-head weight: 10.5 g

1-2. PRINCIPLE OF AC SERVO SYSTEM

Fig. 1-1 shows a simplified diagram of the ac servo system employed in this set. Since the ac motor speed is proportional to the applied ac voltage, it is controlled by varying the applied voltage (E_m) to the motor. This is effectively performed by means of series resistor R_v .

In practice, series resistor R_v is replaced by the diode-bridge circuit and collector-emitter impedance of a power transistor as illustrated in Fig. 1-2. Note that the diode-bridge determines only the direction of the ac current which flows in the power transistor.

Motor speed is converted into ac signal by means of a direct-coupled frequency generator. The servo amplifier compares this signal against a very stable dc reference voltage, and then controls the collector-emitter impedance of power transistor. Any error in motor speed results in a correction voltage supplied to the motor.

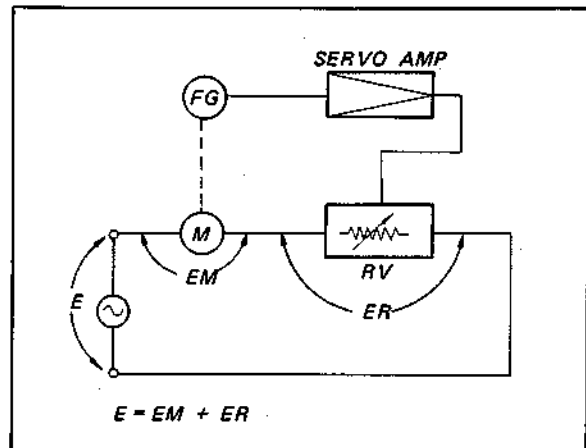

Fig. 1-1. Principle of ac servo system

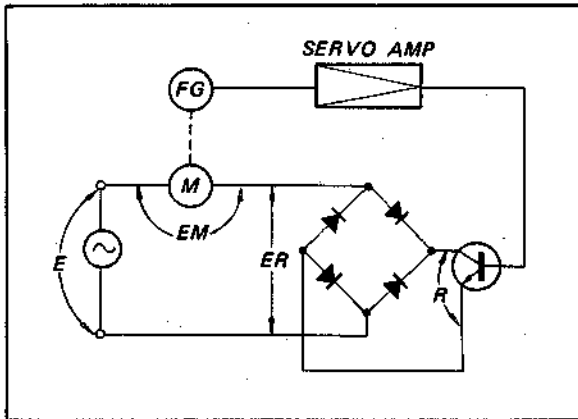

Fig. 1-2. Practical ac servo system

Stage/Control

Function

Start Operation

When the power switch is turned on, Q06 in the base circuit of Q07 is cutoff. As a result, C8 in the collector circuit is charged through R27, R8, VR2, R10, VR1 and R9 when the 33 rpm button is depressed. Note that VR2 and R10 is shorted during 45 rpm operation. Q07 is forced into conduction when C8 is charged up to some specified voltage. As a result the following conditions exist:

<u>Q09</u>	<u>Q010</u>	<u>Q011</u>	<u>Q3</u>	<u>Q4</u>	<u>Q5</u>	<u>Q6</u>
OFF	OFF	ON	ON	ON	ON	ON

and a large enough ac voltage is applied to the motor so the motor starts to revolve rapidly.

Correct Speed Condition

Frequency generator

When the motor starts to revolve, the frequency generator (F.G.) generates ac voltage whose frequency is proportional to the motor speed. As the frequency generator is directly coupled to the shaft of the drive motor, it converts motor speed into frequency.

Differential amplifier Q1, Q2

Q1 and Q2 form a differential amplifier which amplifies the input FG signal to the level required for the following limiter circuit.

Note that the output is extracted from collector circuit of Q1 and Q2, and then fed to the flip-flop stage through diode limiter D1 and D2.

Stage/Control

Function

Diode limiter D1, D2

Removes all amplitude variations from the signal. Each diode conducts when the signal across it exceeds the barrier potential (0.6 V) in a forward biased condition. Thus, the output signal is limited to about 1.2 V peak-to-peak.

Flip-flop circuit Q01, Q02

Q01 and Q02 form a flip-flop circuit which generates square output in accordance with the input trigger signal (limiter's output).

The flip-flop output is extracted at collector circuit of Q02 and then fed to the buffer amplifier stages.

Buffer/phase inverter Q03, Q04, Q05

Q03, Q04 and Q05 form a buffer amplifier stage. Note that Q03 and Q05 are emitter followers but, Q04 acts as a phase inverter.

Differentiation circuit C7, R012

Square wave output at the emitter circuit of Q05 is converted into spike pulses through the differentiator circuit (formed by C7 and R012) to trigger the following saw-tooth wave generator (Q06).

Saw-tooth wave generator Q06, C8, R9, VR1, R10, VR2

Q06 and RC components (C8, R9, VR1, R10, VR2) in the collector circuit form a saw-tooth wave generator. Note that the frequency of the saw-tooth wave is determined by the RC time constants in the collector circuit.

Voltage comparator Q07, Q08

The saw-tooth is fed to the voltage comparator formed by Q07 and Q08. Q08 is forward biased through the FINE control (VR3 paralleled by R12) R11 and R28. The current flow in Q08 is controlled by the FINE control (VR3), which varies its base-emitter voltage. Q07 conducts only when the base voltage becomes higher than the emitter voltage which is determined by the current flow in Q08. Note that the emitter voltage of Q08 serves as a reference voltage.

Referring to Fig. 1-3, the comparator operates as follows: At time T1 a saw-tooth signal is applied to the base of Q07.

At time T2 the voltage at the base of Q07 is sufficient to turn on Q07 generating a negative pulse.

Note that the pulse width is determined by saw-tooth signal waveform.

<u>Stage/Control</u>	<u>Function</u>	<u>Stage/Control</u>	<u>Function</u>
Buffer/phase inverter Q09, Q010, Q011	Q09 and Q011 is an emitter follower but Q010 acts as a phase inverter providing a positive pulsating signal to the following stages.		
Low pass filter /buffer amplifier	Buffer amplifier Q3 and an RC network consisting of R15, C11, R16, C12, C13 R17 and C14 comprise a low-pass filter having a sharp rolloff characteristic. Notice that this stage acts as an integrator, converting the input positive pulses into a dc voltage proportional to the input pulse width.		interval between trigger pulses causes lower saw-tooth wave height, which in turn yeilds a shorter "ON" period for comparator Q07. Therefore, the output pulse width at the emitter circuit of Q011 becomes shorter, reducing the positive bias upon Q4. As a result, the collector-emitter impedance of Q6 increases, reducing the motor speed. Conversely, if the motor speed becomes slower, the collector-emitter impedance of Q6 decreases, increasing the motor speed.
Dc amplifiers Q4, Q5, Q6	Dc output from the low-pass filter is applied to the base of Q4. As Q4, Q5 and Q6 are directly coupled, a change in input dc voltage alters the conduction of Q6, controlling the voltage applied to the motor.	Power supply D8, D9 C17, C19 D7	A positive 12 volts for the system is provided by the full-wave rectifier consisting of D8 and D9, filter capacitors C19, C17 and zener diode D7.
		Speed selector switch S1	Speed changeover operation is performed by changing the saw-tooth wave frequency as previously described. Since the saw-tooth wave frequency is determined by the RC time constant in the collector circuit of Q06, a speed selector switch is connected in parallel with VR2 and R10. A smaller time constant results in faster motor speed and vice versa. So S1 is open when the speed selector switch is set to 33-1/3 rpm.

Servo Operation

When, by any cause, the motor speed becomes slightly faster or slower than the specified value, the servo system works as follows:

Referring to Fig. 1-3, assume that the motor speed becomes faster. The FG output signal frequency becomes higher, resulting in a shorter interval between pulses for triggering the saw-tooth wave generator. The shorter

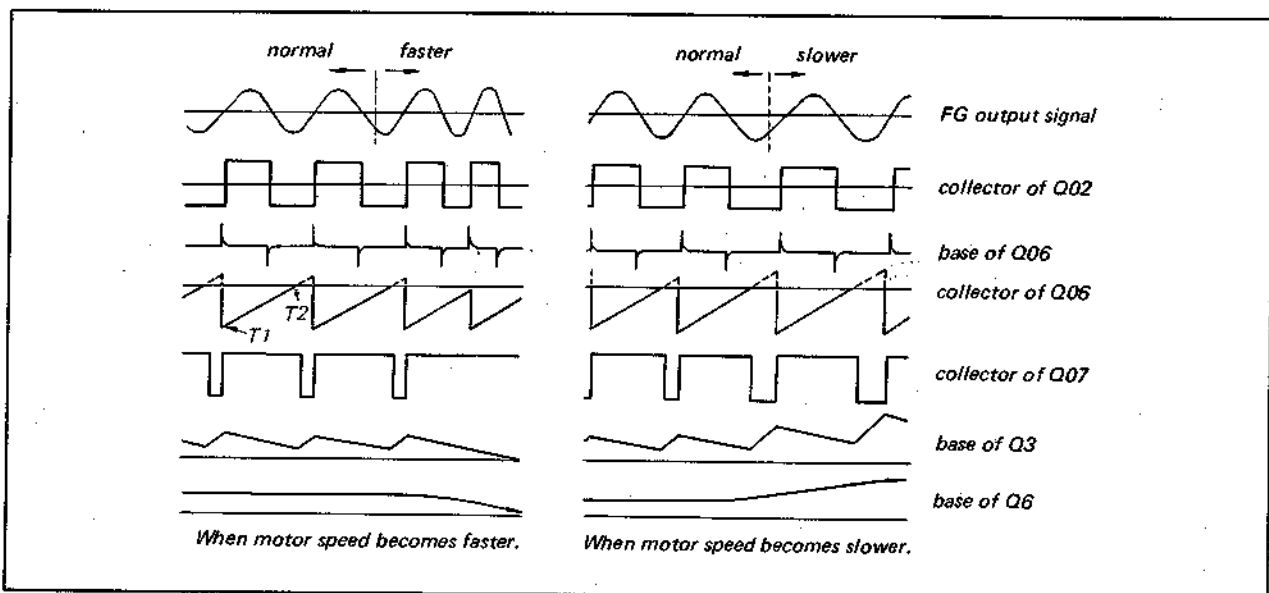
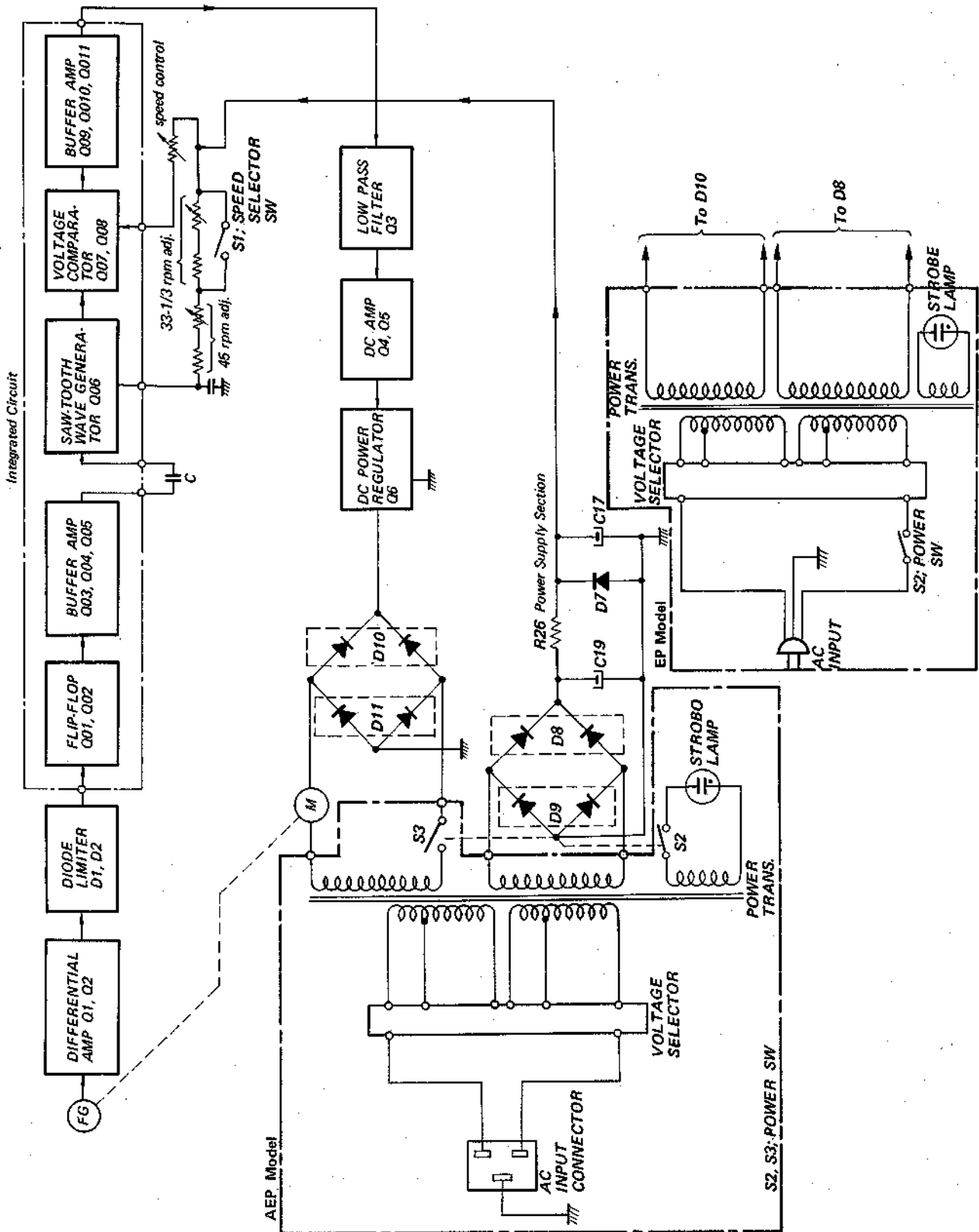

Fig. 1-3. Waveforms on servo control circuit

1-3. BLOCK DIAGRAM



SECTION 2 DISASSEMBLY AND REPLACEMENT

WARNING

Unplug the ac power cord before starting any disassembly or replacement procedures.

CAUTION

To avoid damage to the stylus while performing the following procedures, make sure that the stylus protecting cover is in place.

2-1. TOP COVER REMOVAL

1. Open the top cover, and then push the upper hinge toward the left to release the lock as shown in Fig. 2-1.
2. Carefully lift the top cover straight up. This frees the top cover.

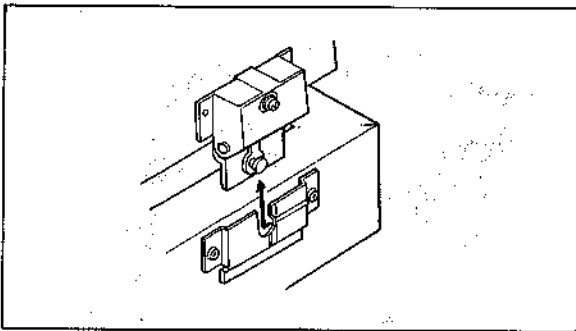

Fig. 2-1. Top cover removal

2-2. BOTTOM PLATE REMOVAL

1. Flip the wooden case upside down. Place it on a soft protective pad, and then remove the six screws (⊕ PS 3 x 16) securing the bottom plate to the wooden case as shown in Fig. 2-2. This frees the bottom plate.

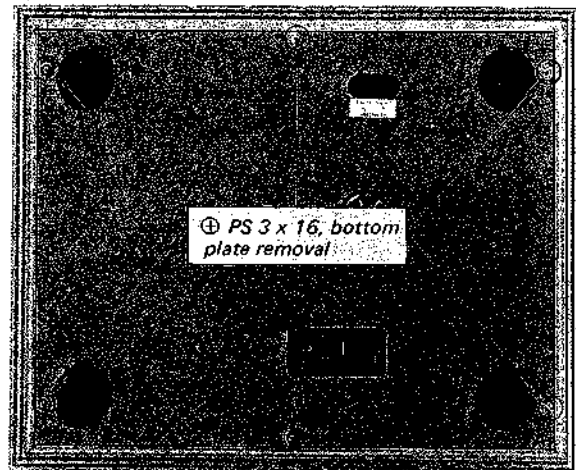

Fig. 2-2. Bottom plate removal

2-3. TURNTABLE BASE REMOVAL

Preparation

1. Remove the bottom plate as described in Procedure 2-2.
2. – Up to serial No. 50,550 – (AEP Model Only)
Disconnect 4-p AMPLOK connector from bottom of the turntable and then remove the top cover as described in Procedure 2-1.
– Serial No. 50,551 and later –
(AEP Model Only)
Disconnect 4-p connector from bottom of the turntable and then remove the top cover as described in Procedure 2-1.

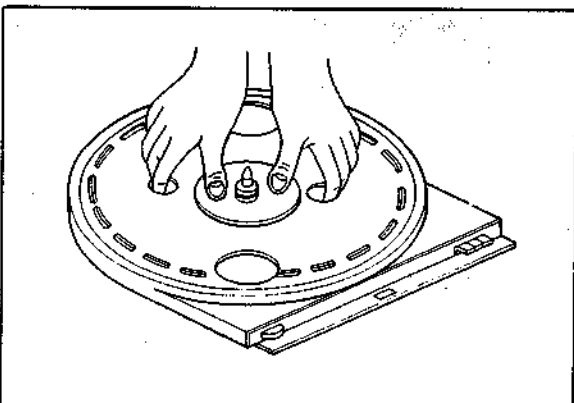

Fig. 2-3. Turntable removal

Procedure

1. Remove the rubber mat from the turntable, and then insert your fingers into the two holes of the turntable with both thumbs placed on the center spindle as shown in Fig. 2-3.
2. Carefully lift the turntable straight up.
3. Remove the three screws (⊕ P 5 x 16) and two screws (⊕ PS 4 x 20) securing the turntable base to the wooden case. This frees the turntable base. See Fig. 2-4.

Note: The turntable base may not be easily removable due to the rubber washer inserted between the turntable base and the wooden case. In this case, gently push the motor end from the bottom.

4. Flip the turntable base upside down. Place a support between the turntable base and the service bench to keep pressure off the motor spindle.

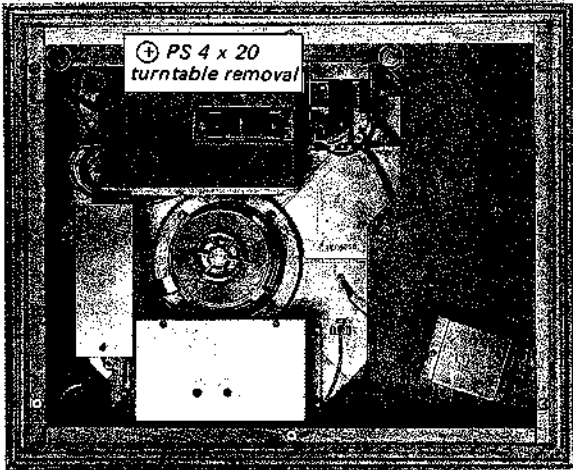

Fig. 2-4. Turntable base removal

2-4. SERVO AMPLIFIER CHASSIS REMOVAL

1. Remove the turntable base as described in Procedure 2-3.
2. Remove the four screws (⊕ PS 4 x 6) securing the chassis to the turntable base as shown in Fig. 2-5. This frees the chassis.

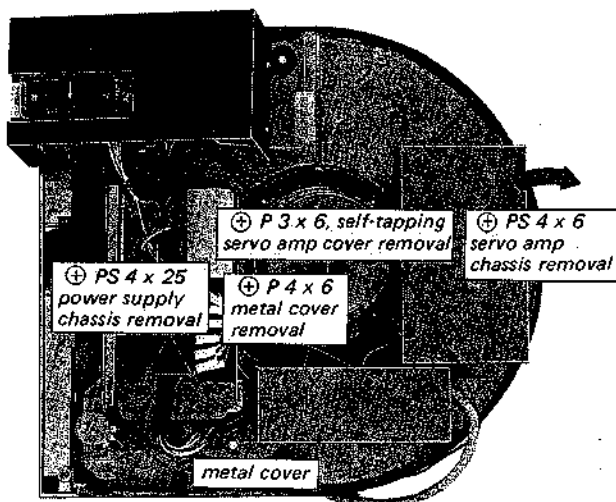

Fig. 2-5. Bottom view

2-5. SERVO AMPLIFIER COVER REMOVAL

1. Remove the servo amplifier chassis as described in Procedure 2-4.
2. Remove the two self-tapping screws (⊕ P 3 x 6) securing the servo amplifier cover as shown in Fig. 2-5, and then slide it in the direction shown by the arrow as illustrated. This frees the cover.

2-6. POWER SUPPLY CHASSIS REMOVAL

Note: The power supply chassis is an angled member on which the power transformer, power transistor and fuse holder are attached.

1. Remove the turntable base as described in Procedure 2-3.
2. Remove the two screws (⊕ PS 4 x 8) and securing the power transformer cover to the heat sink as shown in Fig. 2-6, if necessary.
3. Remove the three screws (⊕ PS 4 x 25) securing the chassis to the turntable base or the bracket, as shown in Fig. 2-5. This frees the power supply chassis.

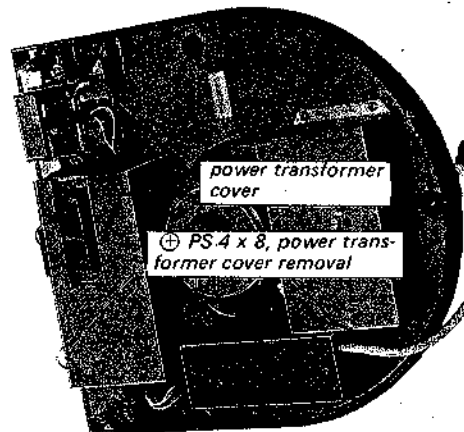

Fig. 2-6. Power transformer cover removal

2-7. MOTOR REPLACEMENT

1. Remove the turntable base as described in Procedure 2-3.
2. Remove the two self-tapping screws (⊕ P 4 x 6) securing the metal cover over the terminal strip as shown in Fig. 2-5.
3. Unsolder the motor lead wires at the terminal strip, and then remove the four screws (⊕ PS 4 x 12) securing the motor to the turntable base from the top as shown in Fig. 2-7.
4. Install the replacement motor.

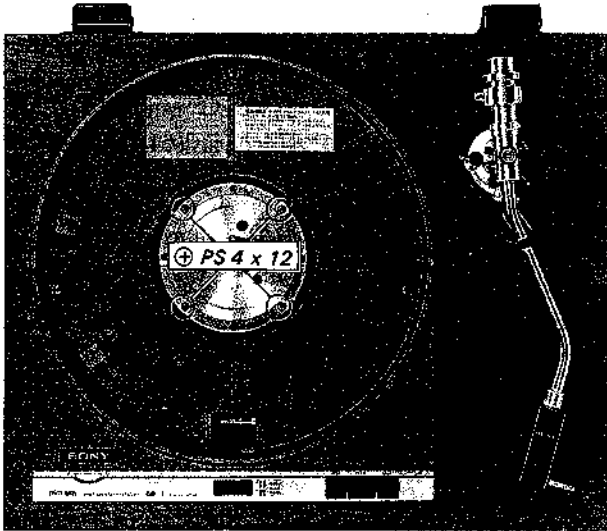

Fig. 2-7. Motor removal

CAUTION

Electromagnetic brake adjustment (clearance between turntable and magnet mounted on turntable base) should be performed as follows after replacing the motor :

1. First of all, confirm that the turntable does not touch with the magnet on the turntable base (See Fig. 2-8). If it does, adjust the magnet height by replacing its mounting plate.

Three kind of mounting plate are available as specified in table below. To remove the magnet and mounting plate, apply a few drops of cement solvent to them.

Description	Thickness of plate (mm)	Part Number
Mounting plate,	1.6	4-808-445-02
magnet	1.0	4-808-445-11
	0.5	4-808-445-21

2. Set the turntable for 33-1/3 rpm operation, and then measure the voltage applied to the motor at the 5-p terminal strip as shown in Fig. 2-9. It should be within the limits of 21 ± 2 volts ac. If not, readjust the clearance between the turntable and the magnet by replacing the mounting plate as previously described.

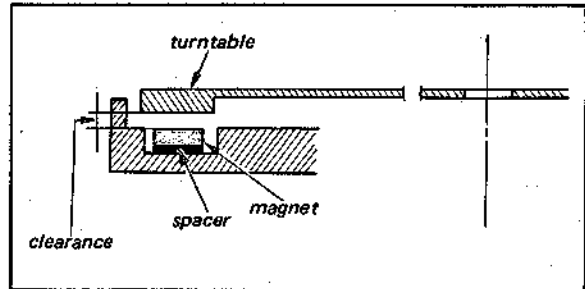

Fig. 2-8. Electromagnetic brake adjustment

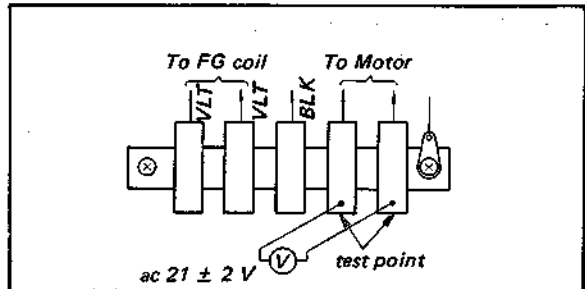

Fig. 2-9. Test point for electromagnetic brake adjustment

2-8. MICROWITCH REPLACEMENT

1. Remove the turntable base as described in Procedure 2-3.
2. Unhook the spring pressing the microswitch holding shaft against its bracket. Carefully draw out the microswitches along with their holding shaft as shown in Fig. 2-10.
3. Remove the retaining rings at one side of the shaft, and then replace the defective microswitch as shown in Fig. 2-10. To reassemble, reverse the aforementioned procedure.

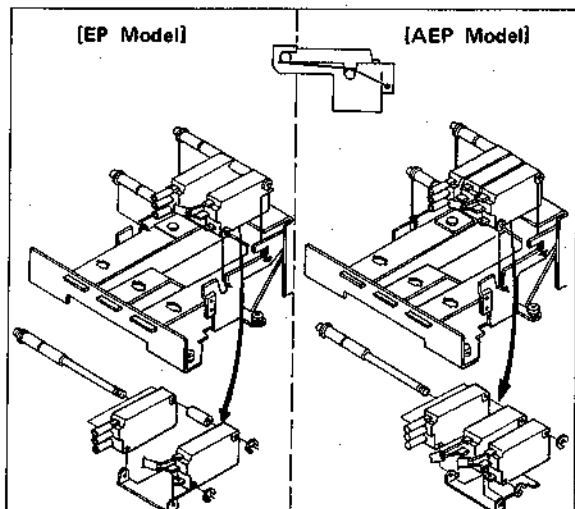

Fig. 2-10. Microswitch replacement

2-9. STROBE LAMP REPLACEMENT

1. Remove the turntable base as described in Procedure 2-3.
2. Remove the four screws (⊕ PS 4 x 8) securing the strobe unit to the turntable base. Pull out the unit.
3. Unhook the retaining spring from the lamp cover and then apply a drop of cement solvent to the lamp. Wait a few seconds, and then push out the defective lamp as shown in Fig. 2-11.

CAUTION

Too much cement solvent may cause damage to the unit. Only a few drops are required to dissolve the rubber-base adhesive.

4. Install a new strobe lamp. Take care that the glowing side (front) of the lamp is positioned as shown in Fig. 2-11

Note: Apply a drop of rubber-base adhesive to the rear side of the lamp when installing the lamp.

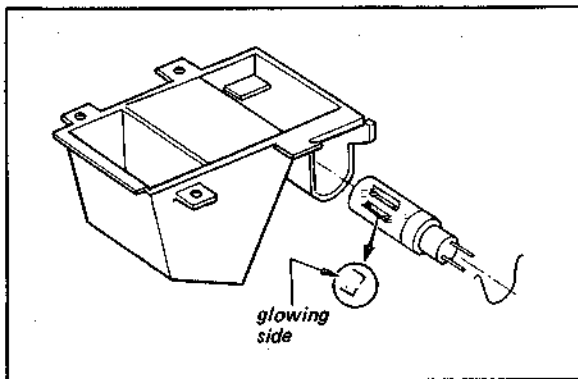

Fig. 2-11. Strobe lamp removal and installation

2-10. POWER TRANSISTOR REPLACEMENT

1. Remove the power supply chassis as described in Procedure 2-6.
2. Remove the screw (⊕ P 3 x 10) securing the power transistor to the heat sink.
3. Cut the emitter and base leads of the defective power transistor with a diagonal cutter. This prevents mica-washer damage when removing the defective power transistor.

4. When replacing the power transistor, apply a coating of heat-transferring grease to both sides of the insulation mica washer. Any excess grease squeezed out when the mounting screw is tightened should be wiped off with a clean cloth. This prevents it from accumulating conductive dust particles that might eventually cause a short.

2-11. TONEARM ASSEMBLY REMOVAL

1. Remove the shell head.
2. Remove the bottom plate as described in Procedure 2-2.
3. Unsolder the leads from the terminal beneath the turntable base (See Fig. 2-12).

The lead wires are coded as follows:

- White L-CH
- Blue L-CH (ground)
- Red R-CH
- Green R-CH (ground)

4. Remove the hexagon nut securing the tonearm base to the wooden case. This frees the tonearm assembly.

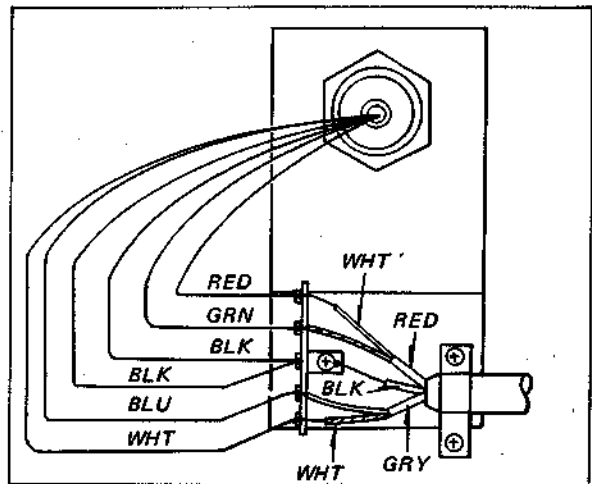

Fig. 2-12. Lead wire connection

2-12. TONEARM BASE REMOVAL

1. Remove the tonearm assembly as described in Procedure 2-11.
2. Remove the lock lever by turning it counter-clockwise.

3. The tonearm base can be removed by turning the tonearm height adjustment ring counter-clockwise while holding the base.
4. When reassembling the base, care should be taken that the lock lever meets with the slot on the tonearm shaft as shown in Fig. 2-13.

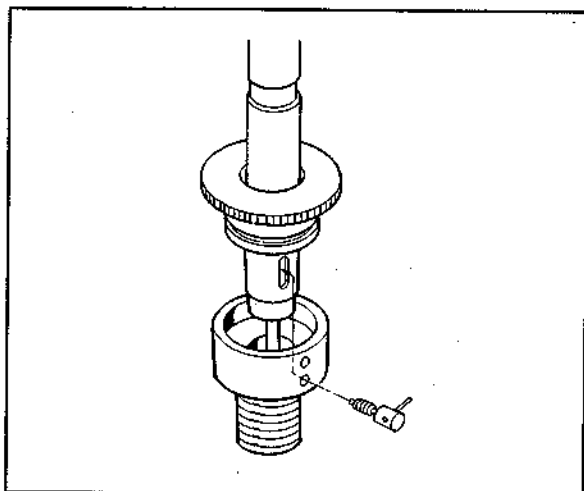

Fig. 2-13. Tonearm reinstallation

2-13. TONEARM LIFTER REPLACEMENT

1. Remove the tonearm assembly as described in Procedure 2-11.
2. Remove the screw (⊖ F 1.7 x 3) securing the lifting tab to the top of the lifter piston as shown in Fig. 2-14.
3. Loosen the screw (⊖ F 2.6 x 8) securing the lifter to the lifter base as shown in Fig. 2-14, and then depress the lifter gently. This frees the lifter.

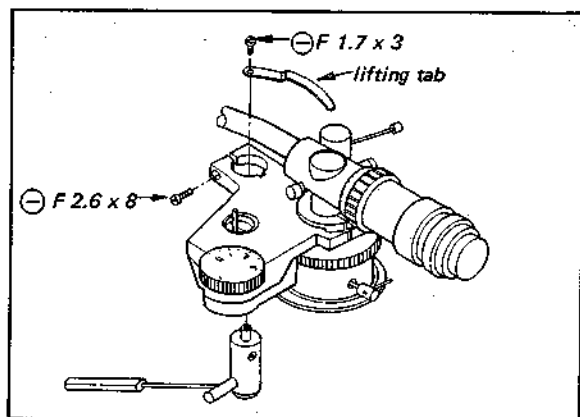

Fig. 2-14. Tonearm lifter replacement

4. Install the replacement lifter.
5. After replacing the lifter, adjust the cueing-height so that the clearance between the stylus tip and the turntable becomes 7 mm (9/32") to 9 mm (23/64") when the cueing lever is set to the "up" position.

2-14. BIAS CORD STRINGING

In case the bias cord string breaks, it must be replaced with a new bias cord assembly. (Part. No. X-20850-07-0)

Tools required:

1. Thin copper wire, 0.2 mm diameter
2. Razor blade
3. Contact cement

Procedure:

1. Remove the contact cement on the plastic ring and anti-skate cantilever.
2. Thread the thin copper wire through the opening of the anti-skating compensator ring as shown in Fig. 2-15, and then hook it to one end of the new bias cord assembly.
3. Gently pull the copper wire. This completes the bias-cord threading.
4. Hook the doubled end of the cord to the tab on the anti-skating compensator ring and the anti-skate cantilever, and then apply a drop of contact cement to it.

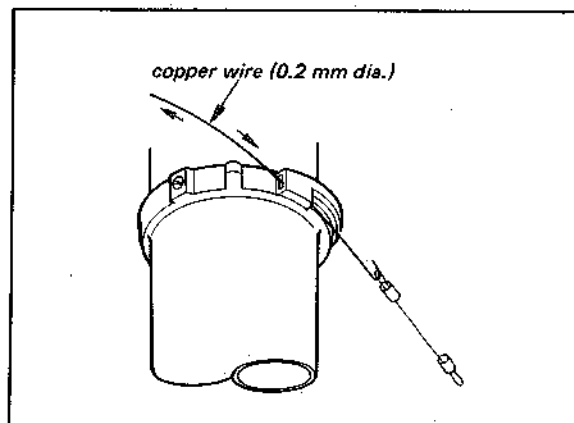

Fig. 2-15. Bias cord stringing

SECTION 3 ADJUSTMENT PROCEDURES

3-1. SPEED ADJUSTMENT

Note: Correct operating speed should be obtained when the front-panel speed control is at or near the midrange setting. If not, readjustment is needed.

Procedure:

1. Set the fine speed control to mid position.
2. Place the turntable in the horizontal position.
3. Set the 33/45 control to the 45 position, and then turn adjustable resistor VR1 (See Fig. 3-1) to obtain the correct strobe indication.
4. After completing the 45 rpm adjustment, proceed to the 33 rpm adjustment as previously described, except turning adjustable resistor VR2 (See Fig. 3-1).

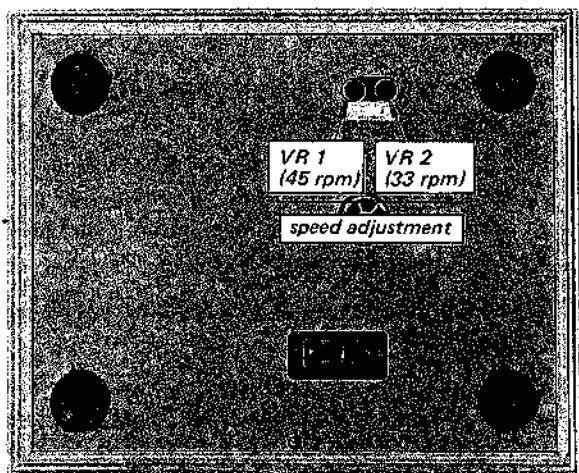

Fig. 3-1. Speed adjustment

3-2. TONEARM HEIGHT ADJUSTMENT

1. Release the locking lever at the tonearm base by turning it counterclockwise as shown in Fig. 3-2.
2. Tonearm height can be adjusted by turning the tonearm height adjustment ring on the tonearm base as shown in Fig. 3-2.

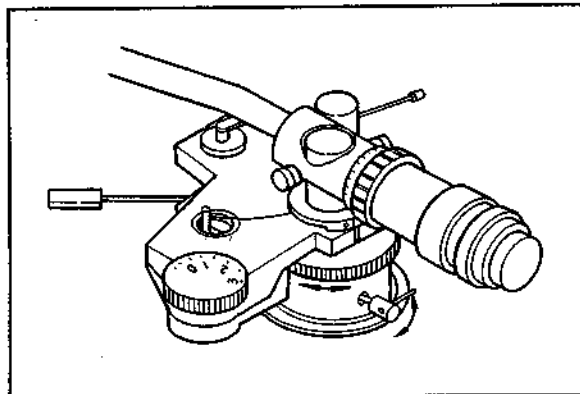

Fig. 3-2. Tonearm height adjustment

3-3. STYLUS-FORCE AND ANTI-SKATING FORCE ADJUSTMENT

1. Set the anti-skating compensator to its "0" position.
2. Release the tonearm from its arm rest. Make sure the tonearm floats freely.
3. Set the stylus force gauge to its "0" position.
4. Horizontally balance the tonearm by sliding the counter weight at the rear of the tonearm. Notice that the vernier weight is provided for precise adjustment. See Fig. 3-3.
5. Turn the stylus-force knob to obtain the proper (recommended) value of stylus force.
6. Set the anti-skating compensator to match the value set in Step 5.

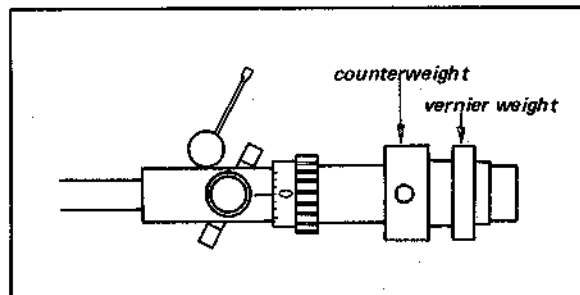

Fig. 3-3. Tonearm balance adjustment

3-4. LATERAL BALANCE ADJUSTMENT

1. Set the anti-skating compensator to its "0" position.
2. Release the tonearm from its arm rest, and then horizontally balance the tonearm.
3. Slowly lift the rear side of cabinet approximately 40 mm and observe the movement of the tonearm.
4. Slide the lateral balance weight towards the same direction as the tonearm movement until lateral balance is obtained. (See Fig. 3-4).

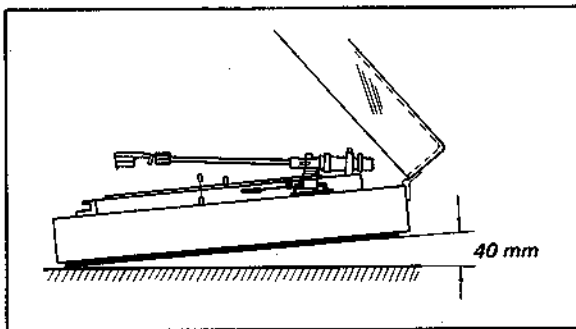

Fig. 3-4. Lateral balance adjustment

3-5. LUBRICATION

Lubricate the turntable shaft once a year. Use the SONY OL-2K oil supplied.

Remove the top of the turntable shaft by turning it counterclockwise, and then apply two or three drops of oil to the opening of the shaft as shown in Fig. 3-5.

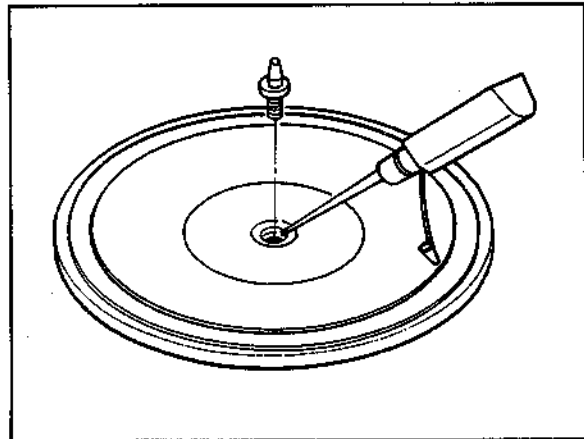
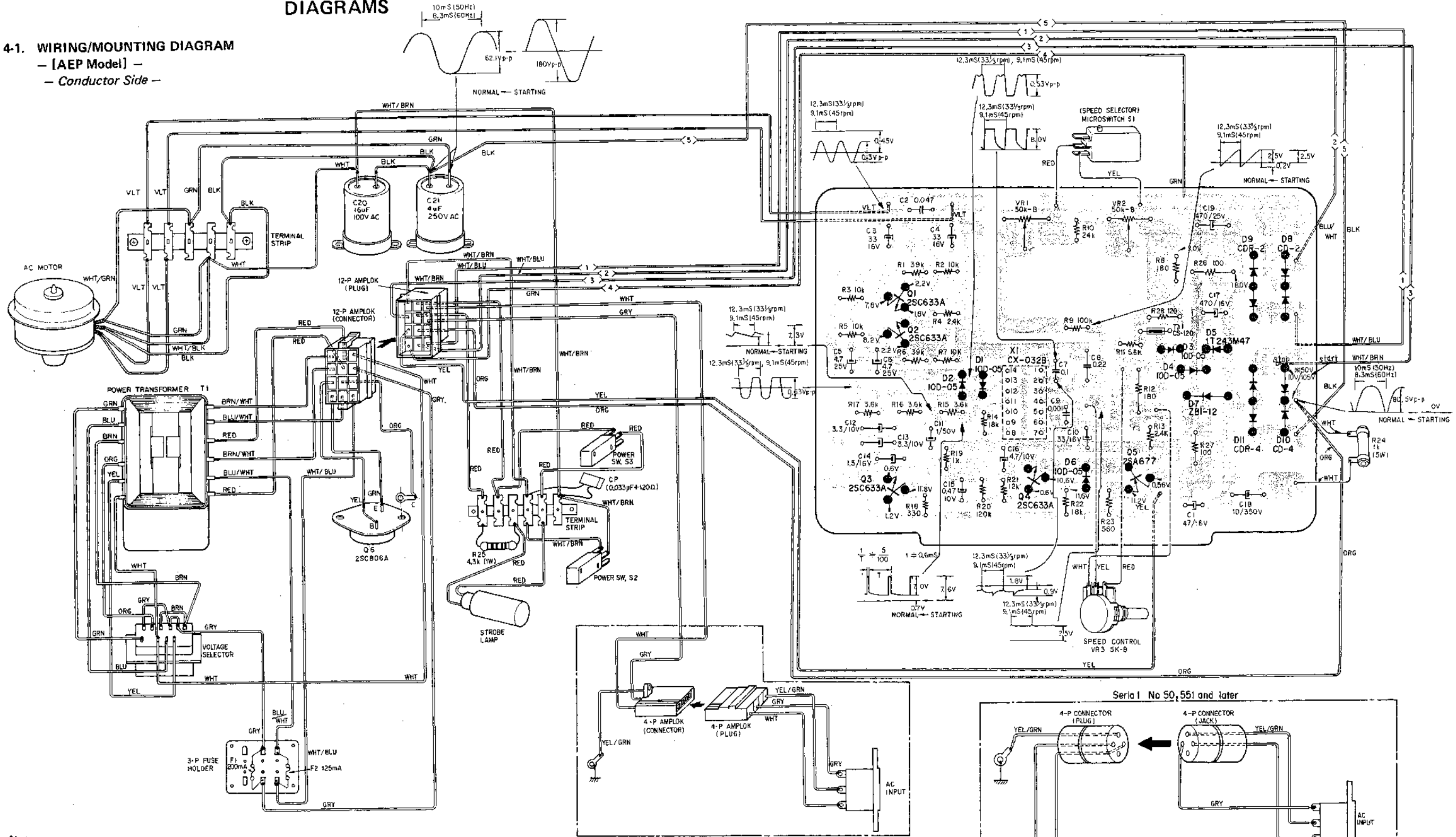

Fig. 3-5. Lubrication

PS-2250 TTS-2250 PS-2250 TTS-2250

**SECTION 4
DIAGRAMS**

4-1. WIRING/MOUNTING DIAGRAM
- [AEP Model] -
- Conductor Side -



Note:
All resistance values are in ohms. k = 1000, M = 1000 k
All capacitance values are in μF except as indicated with p, which means μF .
All voltages represent an average value and should hold within $\pm 20\%$.
All voltages are dc measured with a VOM (DC 20 k ohms/V) at no signal.
* $33\frac{1}{3}$ or 45 rpm operation.

There are two wiring diagrams due to lead wire color UP to Serial No 50,550 and strobo lamp connection changes as shown in 4-1, and 4-2.

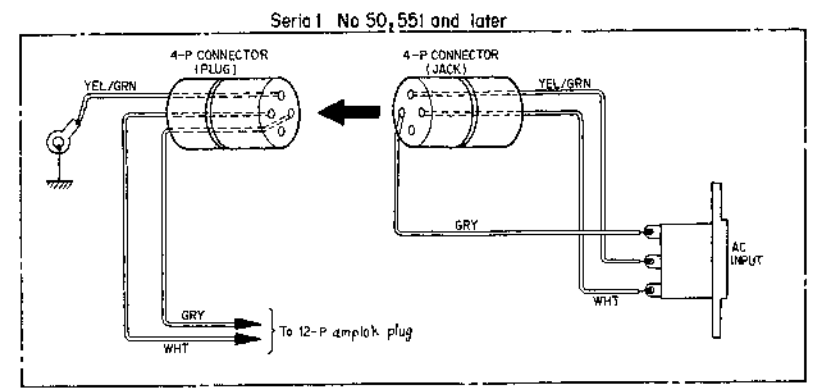

PS-2250 PS-2250
TTS-2250 TTS-2250

4-2. WIRING/MOUNTING DIAGRAM

— [EP Model] —
 — Conductor Side —

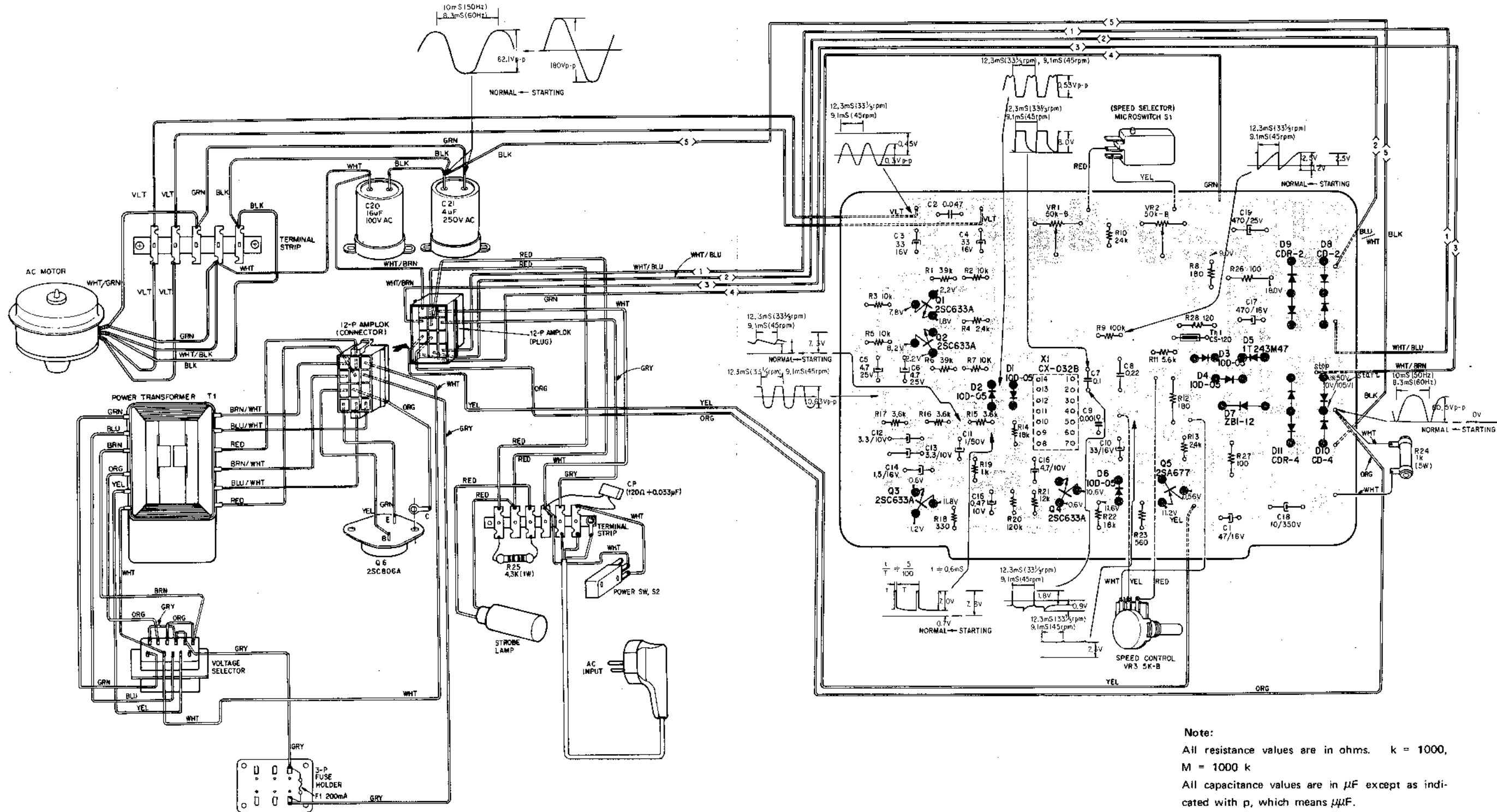

Note:
 All resistance values are in ohms. k = 1000,
 M = 1000 k
 All capacitance values are in μF except as indicated with p, which means μF .
 All voltages represent an average value and should hold within $\pm 20\%$.
 All voltages are dc measured with a VOM (DC 20 k ohms/V) at no signal.
 * $33\frac{1}{3}$ or 45 rpm operation.

**PS-2250 PS-2250
TTS-2250 TTS-2250**

4-3. SCHEMATIC DIAGRAM

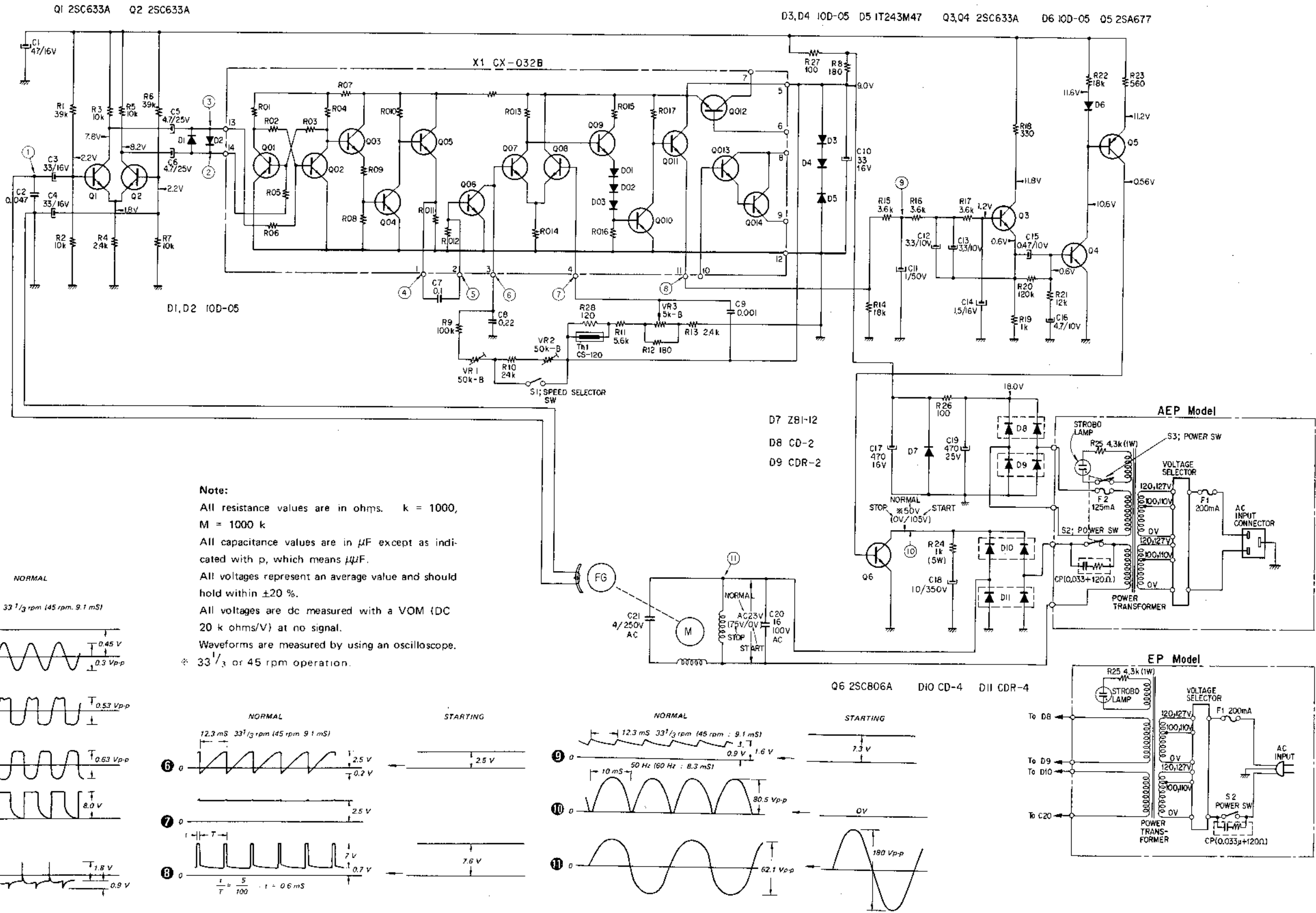

Note:
 All resistance values are in ohms. k = 1000, M = 1000 k
 All capacitance values are in μ F except as indicated with p, which means pF.
 All voltages represent an average value and should hold within $\pm 20\%$.
 All voltages are dc measured with a VOM (DC 20 k ohms/V) at no signal.
 Waveforms are measured by using an oscilloscope.
 * $33\frac{1}{3}$ or 45 rpm operation.

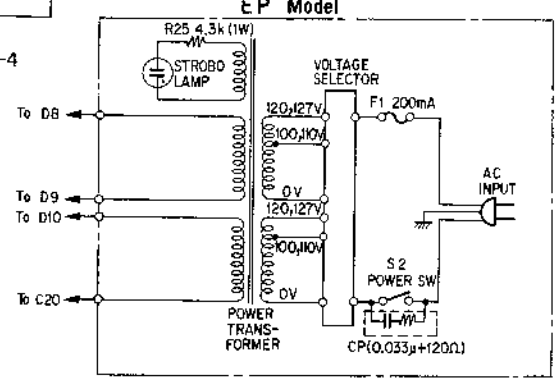
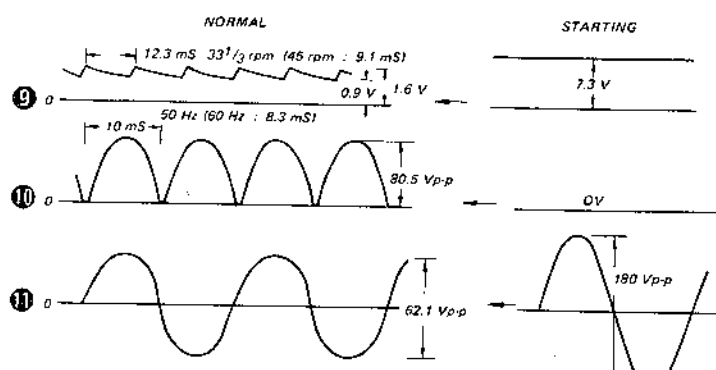
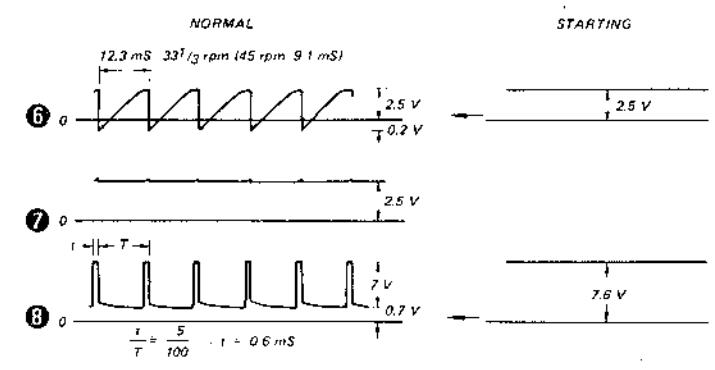
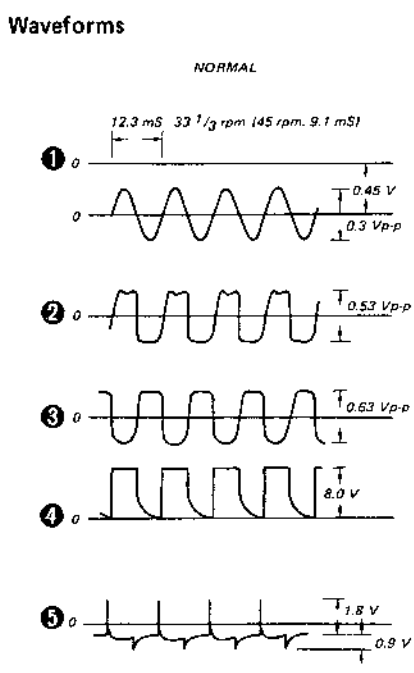

SECTION 5
EXPLODED VIEWS

4-4. MOUNTING DIAGRAM
 — Component Side —

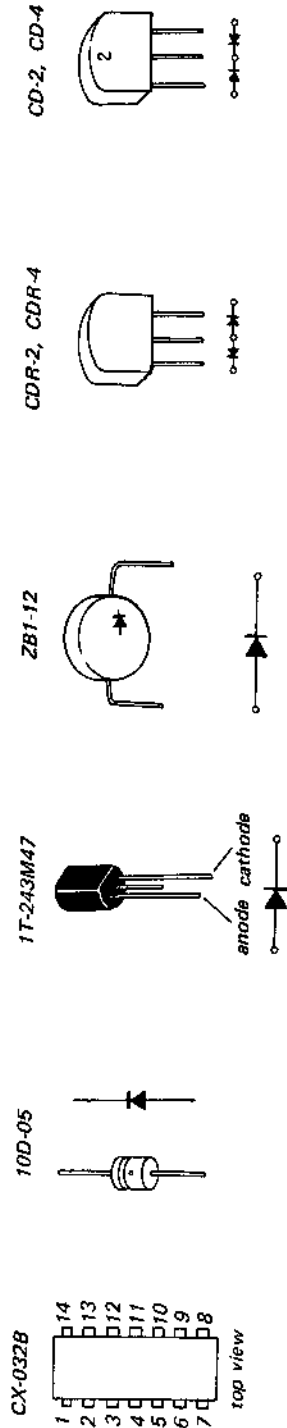
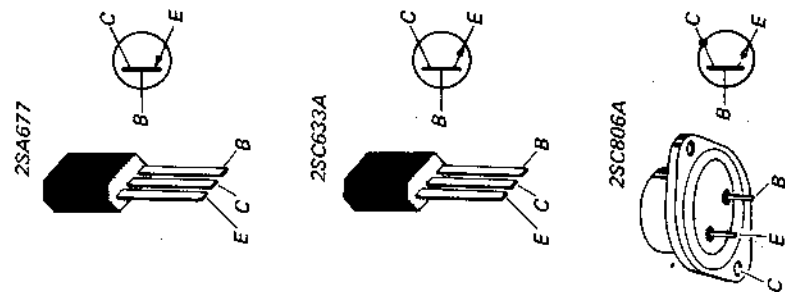
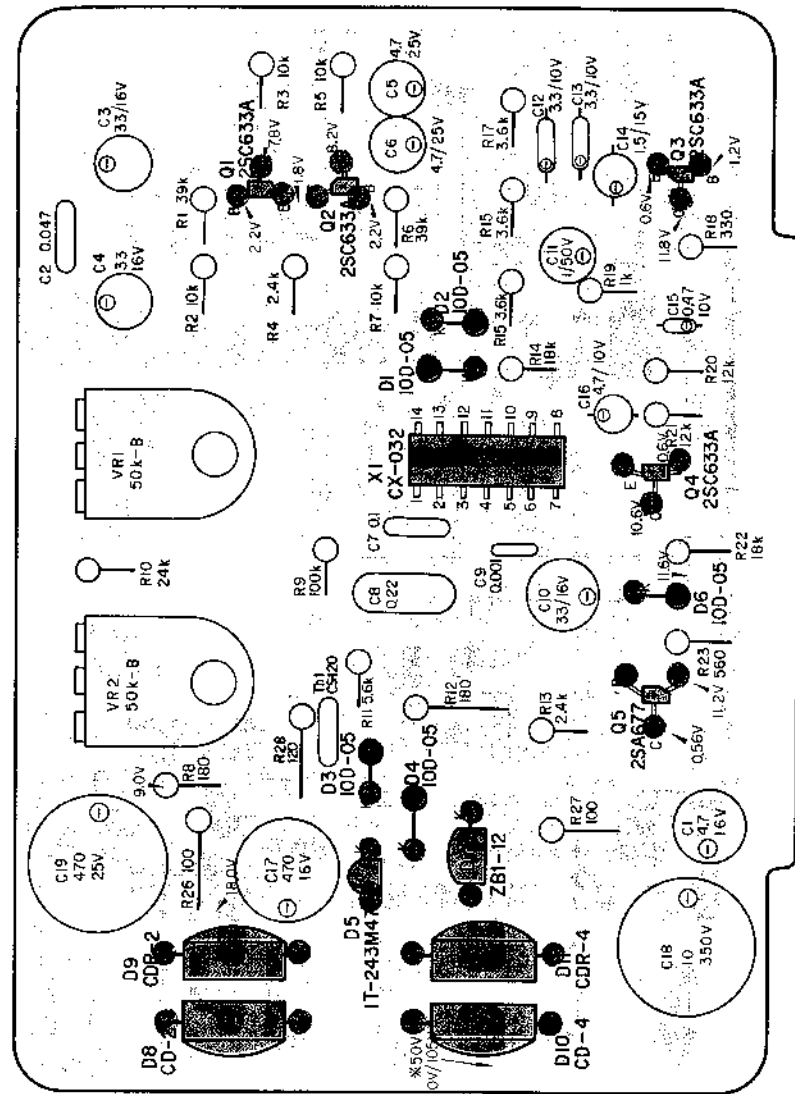

(1) The following chart will help you to decipher the hardware codes given in the exploded views.

— Hardware Nomenclature —

P - Pan Head Screw		SC - Set Screw	
PS - Pan Head Screw with Spring Washer		E - Retaining Ring (E Washer)	
K - Flat Countersunk Head Screw		W - Washer	
B - Binding Head Screw		SW - Spring Washer	
RK - Oval Countersunk Head Screw		LW - Lock Washer	
T - Truss Head Screw		N - Nut	
R - Round Head Screw			
F - Flat Fillister Head Screw			

— Example —

⊕ P 3x10

Length in mm (L)

Diameter in mm (D)

Type of Head

(2) To simplify the exploded view, the part numbers of normal screws, nuts, washers, and retaining rings are not expressed but summarized in the table below.

HARDWARES

Part No.	Description	Part No.	Description
7-621-255-25	⊕ P 2 x 4 screw	7-682-149-13	⊕ P 3 x 10 screw
7-621-255-62	⊕ P 2 x 10 screw	7-682-150-13	⊕ P 3 x 12 screw
7-621-259-58	⊕ P 2.6 x 8 screw	7-682-152-01	⊕ P 3 x 16 screw
7-621-303-22	⊖ F 1.7 x 3 screw	7-682-153-05	⊕ P 3 x 20 screw
7-621-305-42	⊖ F 2 x 6 screw	7-682-178-01	⊕ P 5 x 16 screw
7-621-659-18	⊕ RK 2.6 x 3 screw	7-682-254-15	⊕ K 3 x 25 screw
7-621-712-27	⊖ 2.6 x 3 screw, set	7-682-461-13	⊕ T 4 x 8 screw
7-621-843-47	⊕ R 3.1 x 16 screw, wood	7-682-647-01	⊕ PS 3 x 6 screw
7-621-843-68	⊕ R 3.1 x 25 screw, wood	7-682-660-01	⊕ PS 4 x 6 screw
7-621-844-28	⊕ R 3.1 x 8 screw, wood	7-682-661-01	⊕ PS 4 x 8 screw
7-622-105-02	2 mm dia. nut	7-682-663-01	⊕ PS 4 x 12 screw
7-622-307-01	2.6 mm dia. nut	7-682-667-01	⊕ PS 4 x 25 screw
7-623-108-17	3 mm dia. washer (middle)	7-683-128-03	⊖ 2 x 5 screw, set
7-623-110-11	4 mm dia. washer (middle)	7-683-145-00	⊖ 4 x 4 screw, set
7-623-208-12	3 mm dia. washer, spring	7-684-023-00	3 mm dia. nut
7-623-408-01	3 mm dia. lock washer, external tooth	7-685-102-21	⊕ P 2 x 4 screw, self-tapping
7-623-508-11	3 mm dia. lug	7-685-144-01	⊕ P 3 x 5 screw, self-tapping
7-624-101-01	1.2 mm dia. retaining ring	7-685-145-01	⊕ P 3 x 6 screw, self-tapping
7-624-105-01	2.3 mm dia. retaining ring	7-685-146-01	⊕ P 3 x 8 screw, self-tapping
7-626-301-01	1.6 x 6 pin	7-685-148-01	⊕ P 3 x 12 screw, self-tapping
7-671-102-01	1.6 mm dia. steel ball	7-685-158-01	⊕ P 4 x 6 screw, self-tapping
7-671-112-01	2 mm dia. steel ball	7-685-159-01	⊕ P 4 x 8 screw, self-tapping
7-682-146-03	⊕ P 3 x 5 screw		

SECTION 6 REPACKING

The PS-2250's and TTS-2250's original shipping carton and packing materials are the ideal containers for shipping the unit. However to secure the maximum

protection, the PS-2250 and TTS-2250 must be repacked in these materials precisely as before. The proper repacking procedures are shown in Figures 6-1 and 6-2.

— [PS-2250] —

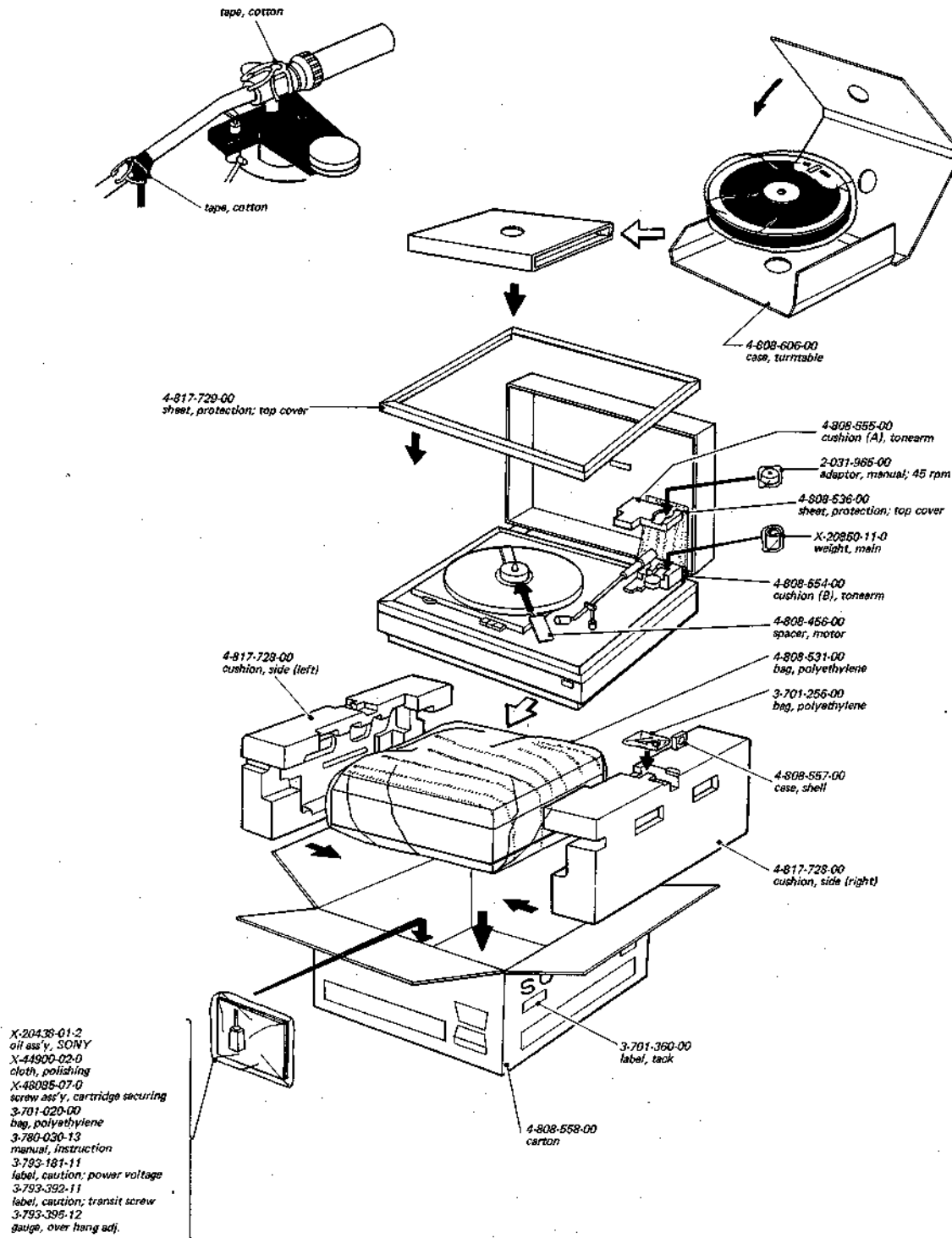

Fig. 6-1. Repacking

Neuigkeiten sind besonders dort hoch zu bewerten, wo Neuigkeiten bislang Seltenheit sind.

Neu: Direkt-Antrieb im SONY PS-2250.

Seit Jahren bewegt sich der technische Fortschritt bei Schallplattenspielern in engen Grenzen. Um Motor, Reibrad, Riemen oder beides, dazu um mehr oder weniger Rumpeln und Tonhöhen-Schwankungen.

SONY hat sich mit Erreichtem noch nie zufrieden gegeben.

Jetzt gibt es Laufwerke, bei denen der Motor direkt auf der Antriebsachse unter dem Teller sitzt – keine Reibräder, keine Riemen mehr.

Dieser Wechselstrom-Motor braucht keine Übersetzung, er treibt – elektronisch kontrolliert – als Langsamläufer den Plattenteller direkt.

Das Ergebnis: Kein Rumpeln mehr: Rumpelgeräuschspannungsabstand mindestens 67 dB (DIN 45544). Keine Tonhöhen-Schwankungen mehr: Tonhöhen-Schwankungen weniger als 0,04% wrms = 0,07% DIN 45507 (Neutrale Messung: 0,042% nach DIN 45507). Die Soll-Geschwindigkeiten von 33 $\frac{1}{3}$ und 45 U/min. werden von der elektronischen Servo-Kontrolle präzise eingehalten, eine elektronische (nicht mechanische) Nachregulierung von $\pm 4\%$ ist zusätzlich möglich.

Auch eine Audio-Kette ist nur so stark wie ihr schwächstes Glied. Deshalb sollten Sie an der Nahtstelle zwischen hochwertiger Schallplatten-Aufnahme-Technik und hochwertiger SONY Wiedergabe-Technik keine Kompromisse machen. Der SONY PS-2250 schließt diese Lücke.

Wollen Sie zu einem der 390 Experten gehören? Dann wenden Sie sich an Ihren HiFi-Fachhändler.

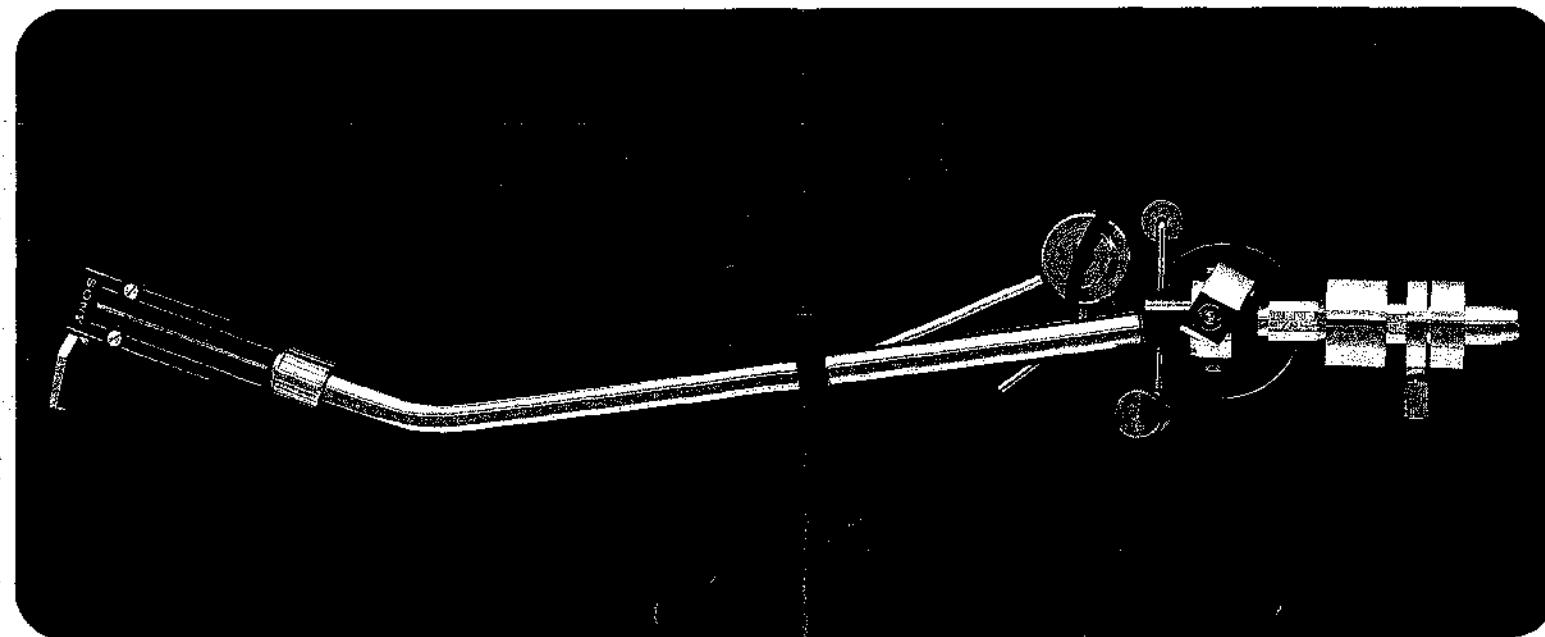
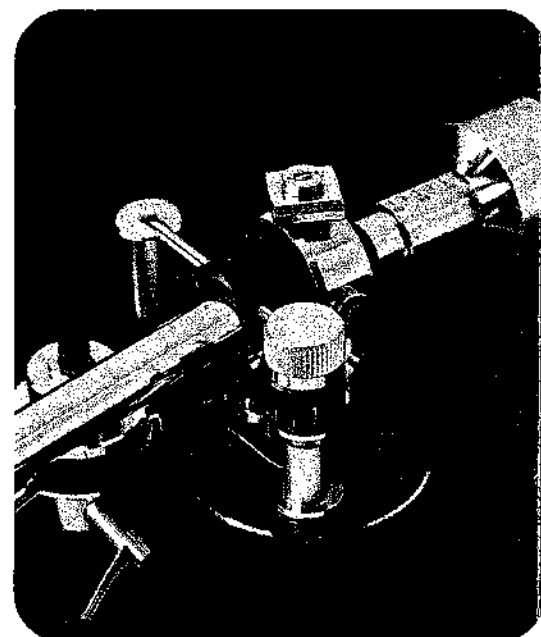
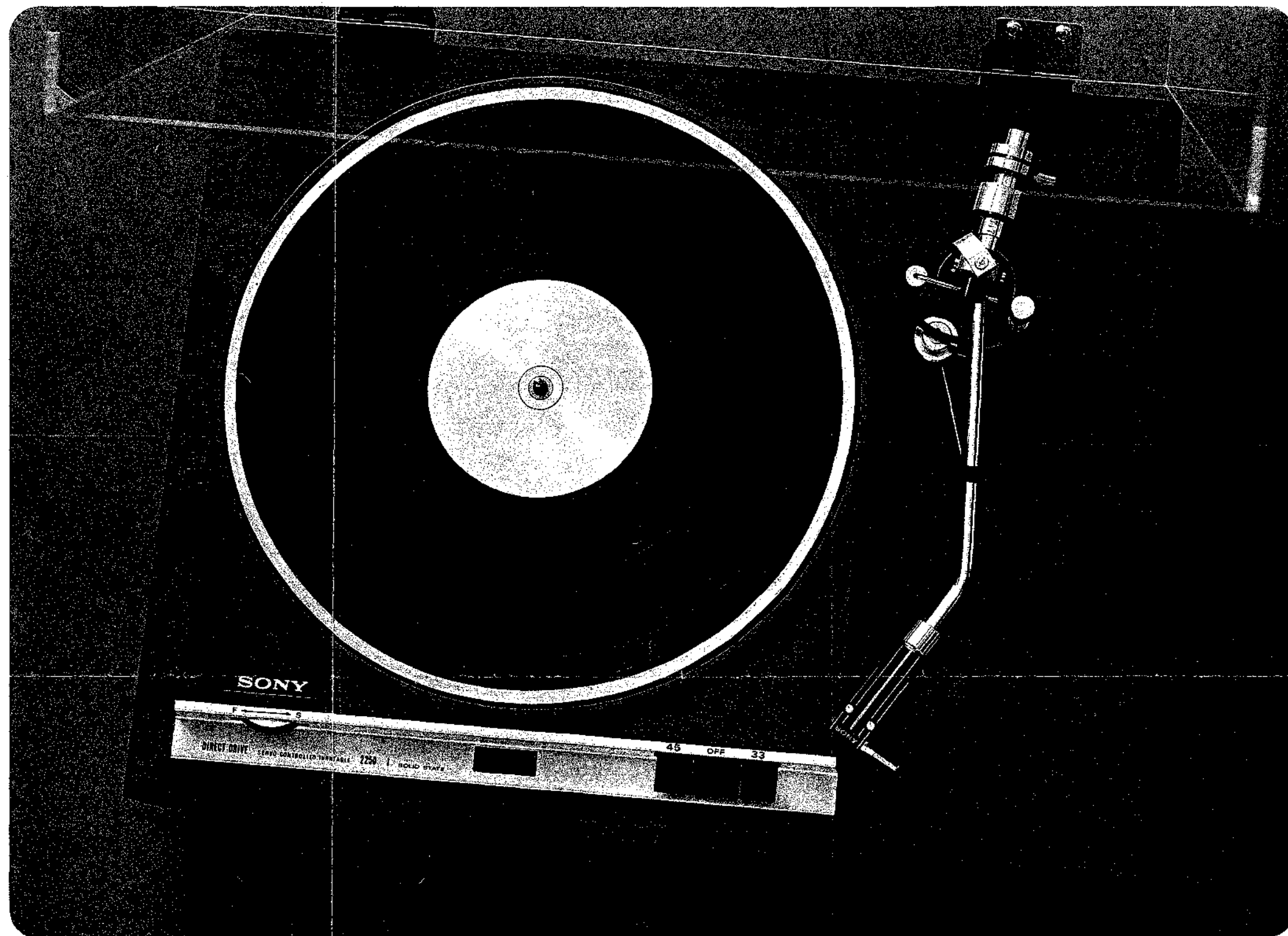

Plattenspieler-Laufwerk SONY TTS-2250

1. Der TTS-2250 ist ein Stereo-Plattenspieler mit dem neu entwickelten „SONY-Wechselstrommotor für direkten Antrieb und Servosteuerung“.
2. Der rumpelfreie Plattenteller mit 31 cm Durchmesser verwendet den direkten Achsantrieb durch langsamlaufenden servogesteuerten Wechselstrommotor.
3. Äußerst niedrige Gleichlaufschwankungen, unter $\pm 0,04\%$ (wrms, bewerteter Effektivwert).

4. Hoher Rumpel-Geräuschspannungs-Abstand von mindestens 67 dB (DIN).
5. Wahl der Drehzahl und Feineinstellung der Drehzahl werden durch den Servoverstärker gesteuert.
6. Drehzahlregelbereich $\pm 4\%$.

Tonarme SONY PUA-1500 S/1500 L (siehe Abbildung Innenseite unten)

Präzisions-Tonarm für höchste Ansprüche in kurzer oder langer Ausführung.

1. Extrem geringe Lagerreibung. Kardanische Aufhängung des Armes.
2. Statisch ausbalanciert in vertikaler Richtung.
3. Lateral ausbalanciert, daher unabhängig von der Neigung des Plattenteilers oder von Verwerfung der Plattenoberfläche.
4. Einstellung der Anti-Scating-Kraft durch neuartige Korrektur: Eine Vorrichtung sorgt dafür, daß die Kompensation bei allen Plattentradien immer konstant bleibt. Es tritt weder Über- noch Unterkompensation wie bei anderen Tonarmen auf.

5. Einstellung des Gegengewichts und Auflagedrucks durch Fein- und Grobgewicht vereinfacht.
6. Flüssigkeitsgedämpfte Absenkvorrichtung und leichte Tonabnehmerschale aus Aluguß. Gewicht nur 10,5 Gramm.
7. Auflagedruck einstellbar zwischen 0-3 Gramm. Gewicht des Tonabnehmers ausgleichbar zwischen 3,5 und 20 Gramm.
8. Zentralloch-Befestigung des Tonarmes, daher leichter Aufbau.

	PUA-1500 S	PUA-1500 L
Überhang:	15 mm	13 mm
Kröpfungswinkel:	22° 13'	18° 39'

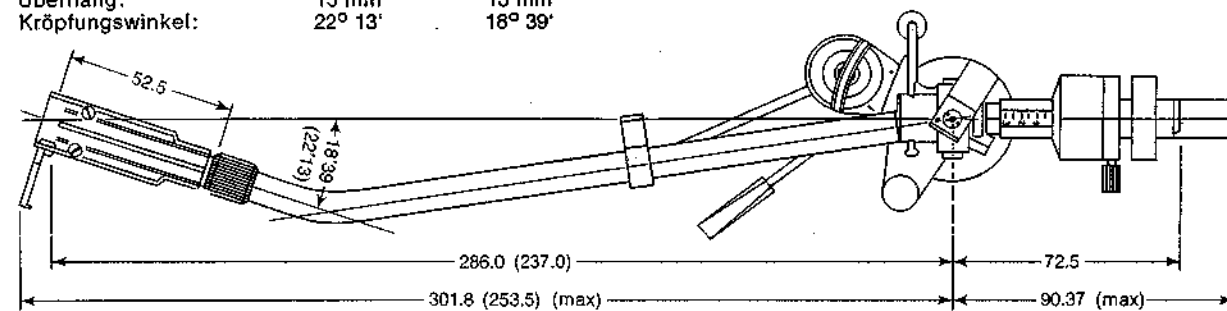

Werte in Klammern: PUA-1500 S

Zum Plattenspieler PS-2250 gehören:

Laufwerk TTS-2250,
Tonarm PUA-1500 S (kurze Ausführung)
Klarsichthaube DU-2250
Zarge TAC-2250

Alle Teile sind einzeln lieferbar.

Die Zarge ist in NN oder weiß erhältlich.

Ausführung B: Mit Montage-Ausschnitt passend zum Tonarm SONY PUA-1500 S

Ausführung O: Ohne Montage-Ausschnitt. Verwendbar für Tonarm SONY PUA-1500 L (lange Ausführung) oder Tonarme anderer Fabrikate.

Bei Einbau langer Tonarme wie SONY PUA-1500 L kann die Haube DU-2250 nicht verwendet werden.

SONY GmbH
5 Köln 30
Mathias-Brüggen-Str. 70-72

SONY
Wegbereiter für die audio-visuelle
Zukunft.

SONY sucht 390 HiFi-Experten.

Für den Direkt-Antrieb im SONY PS-2250.

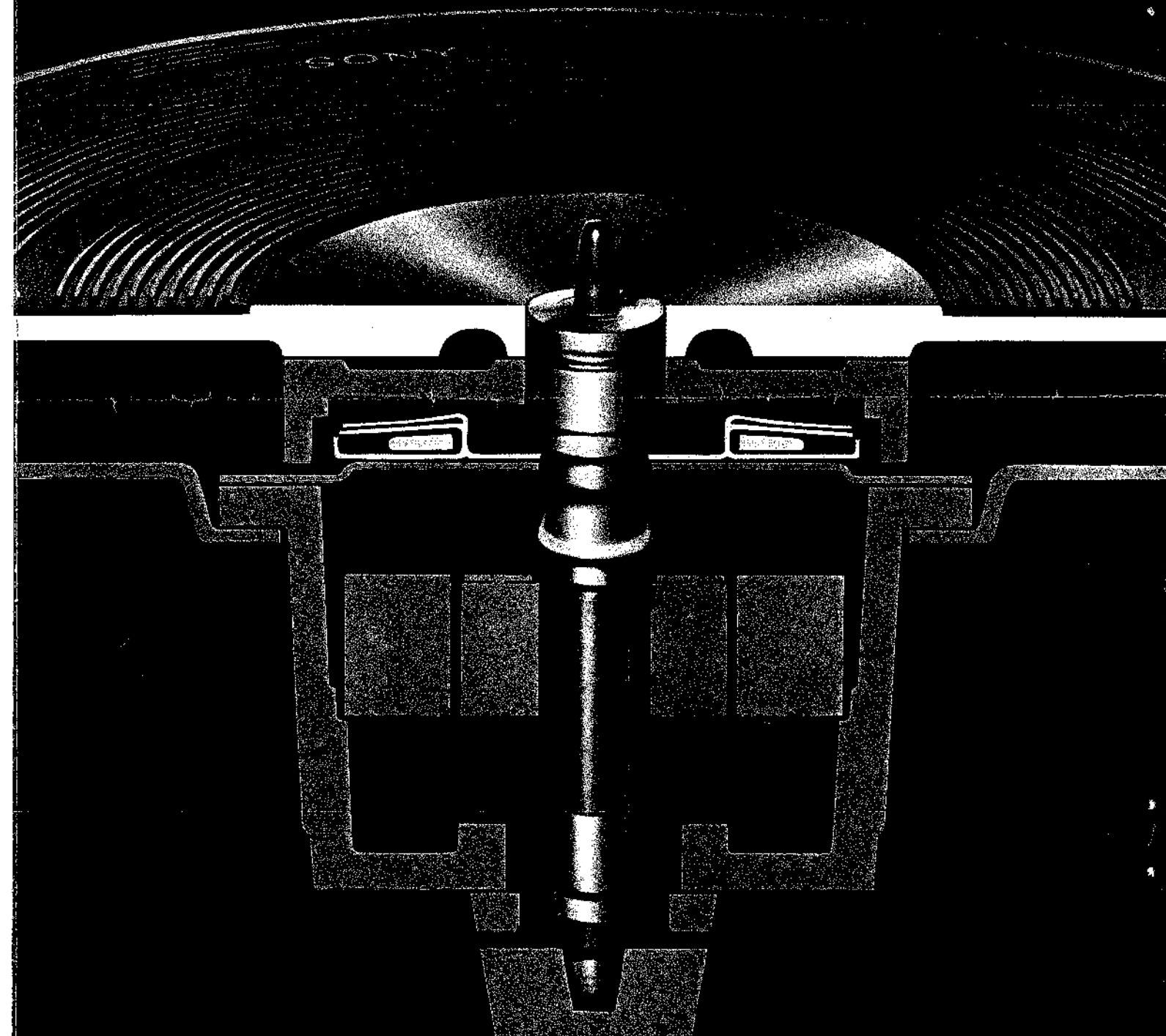

- [TTS-2250] -

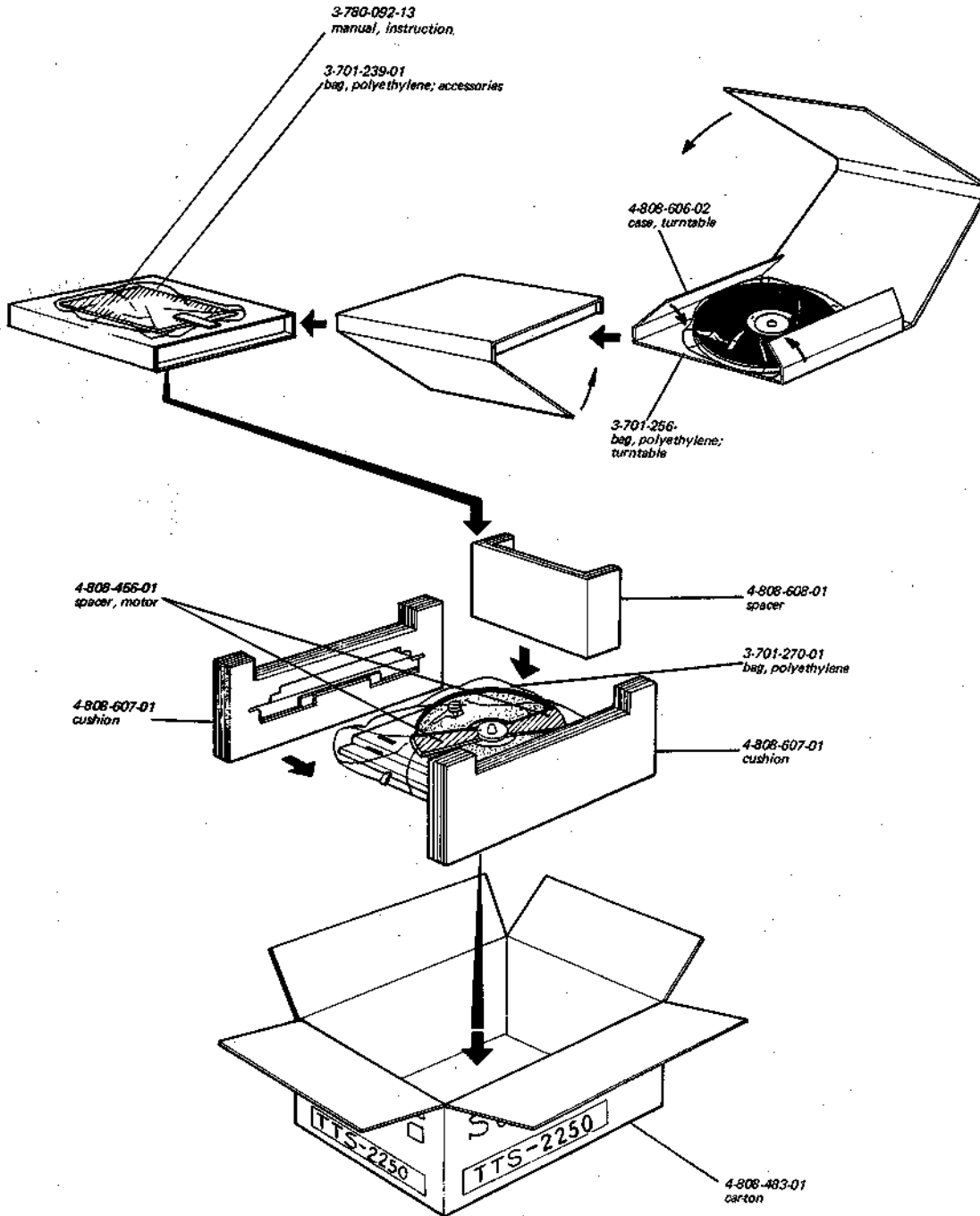

Fig. 6-2. Repacking

SECTION 7

ELECTRICAL PARTS LIST

<u>Ref. No.</u>	<u>Part No.</u>	<u>Description</u>	<u>Ref. No.</u>	<u>Part No.</u>	<u>Description</u>
COMPLETE CIRCUIT BOARD					
	8-982-637-22	servo amplifier circuit board			
SEMICONDUCTORS					
D1		diode, 10D-05	R2	1-242-697	10 k
D2		diode, 10D-05	R3	1-242-697	10 k
D3		diode, 10D-05	R4	1-242-682	2.4 k
D4		diode, 10D-05	R5	1-242-697	10 k
D5		diode, 1T243M47	R6	1-242-711	39 k
D6		diode, 10D-05	R7	1-242-697	10 k
D7		diode, ZB1-12	R8	1-242-655	180
D8		diode, CD-2	R9	1-242-721	100 k
D9		diode, CDR-2	R10	1-242-706	24 k
D10		diode, CD-4	R11	1-242-691	5.6 k
D11		diode, CDR-4	R12	1-242-655	180
Q1		transistor, 2SC633A	R13	1-242-682	2.4 k
Q2		transistor, 2SC633A	R14	1-242-703	18 k
Q3		transistor, 2SC633A	R15	1-242-686	3.6 k
Q4		transistor, 2SC633A	R16	1-242-686	3.6 k
Q5		transistor, 2SA677	R17	1-242-686	3.6 k
Q6		transistor, 2SC806A	R18	1-242-661	330
Th1		thermistor, CS-120	R19	1-242-673	1 k
X1	8-750-321-00	IC, CX-032B	R20	1-242-723	120 k
TRANSFORMER					
T1	1-441-799-00	transformer, power	R21	1-242-699	12 k
CAPACITORS					
All capacitance values are in μF , except as indicated with p, which means μM F.					
C1	1-121-409	47 $\pm 10\%$ 16 V electrolytic	R22	1-242-703	18 k
C2	1-105-681-12	0.047 $\pm 10\%$ 50 V mylar	R23	1-242-667	560
C3	1-121-403	33 $\pm 10\%$ 16 V electrolytic	R24	1-205-521	1 k $\pm 5\%$ 5 W wire wound
C4	1-121-403	33 $\pm 10\%$ 16 V electrolytic	R25	1-210-273	4.3 k 1 W
C5	1-121-395	4.7 $\pm 10\%$ 25 V electrolytic	R26	1-244-849	100 $\frac{1}{2}$ W
C6	1-121-395	4.7 $\pm 10\%$ 25 V electrolytic	R27	1-242-649	100
C7	1-105-685-12	0.1 $\pm 10\%$ 50 V mylar	R28	1-242-651	120
C8	1-105-689-12	0.22 $\pm 10\%$ 50 V mylar	VR1	1-222-781	50 k(B) adjustable
C9	1-105-661-12	0.001 $\pm 10\%$ 50 V mylar	VR2	1-222-781	50 k (B), adjustable
CJ0	1-121-403	33 $\pm 10\%$ 16 V electrolytic	VR3	1-221-727	5 k (B), variable
C11	1-121-391	1 $\pm 10\%$ 50 V electrolytic	SWITCHES		
C12	1-127-025	3.3 $\pm 20\%$ 10 V solid aluminum	S1	1-514-423-11	switch, micro (SPEED SELECTOR)
C13	1-127-025	3.3 $\pm 20\%$ 10 V solid aluminum	S2	1-514-423-11	switch, micro (POWER)
C14	1-131-157	1.5 $\pm 20\%$ 16 V tantalum	S3	1-514-423-11	switch, micro (POWER) (AEP Model only)
C15	1-127-022	0.47 $\pm 20\%$ 10 V solid aluminum	MISCELLANEOUS		
C16	1-131-140	4.7 $\pm 20\%$ 10 V tantalum	CP	1-231-057-12	encapsulated component, 120 Ω + 0.033 μF
C17	1-121-426	470 $\pm 10\%$ 16 V electrolytic		1-452-049-00	magnet
C18	1-121-180	10 $\pm 20\%$ 350 V electrolytic		1-526-165-11	voltage selector
C19	1-121-733	470 $\pm 10\%$ 25 V electrolytic		1-509-445-11	connector, ac input (3-p) (AEP Model only)
C20	1-121-922	16 $\pm 20\%$ 100 V electrolytic		1-509-434-22	amplok, 12-p (socket)
C21	1-117-088	4 $\pm 10\%$ 250 V MP		1-508-451-31	amplok, 12-p (plug) (AEP Model)
RESISTORS					
All resistors are in ohms, $\pm 5\%$, $\frac{1}{4}$ W and carbon type unless otherwise indicated.					
R1	1-242-711	39 k		1-508-461-51	amplok, 12-p (plug) (EP Model)
				1-508-461-31	amplok, 4-p (socket) (AEP Model only) (Up to serial No. 50,550)
				1-506-203-71	amplok, 4-p (plug) (AEP Model only) (Up to serial No. 50,550)
				1-519-058-21	lamp, strobo
			F1	1-532-074-11	fuse, 200 mA
			F2	1-532-149-11	fuse, 125 mA (AEP Model only)
				1-533-026-31	holder, fuse; 3-p
				1-534-550-12	connection cord, with phono plugs
				1-536-213-12	terminal strip, D-5p
				1-536-268-12	terminal strip, D-6p
				1-507-288-11	socket, 4-p (AEP Model only) (serial No. 50,551 and later)
				1-506-197-11	plug, 4-p (AEP Model only) (serial No. 50,551 and later)

SONY CORPORATION