

# PS-313FA

*AEP Model  
E Model*



## FULL AUTOMATIC STEREO TURNTABLE SYSTEM

### SPECIFICATIONS

#### GENERAL

**Power Requirements:** 120 or 220V ac adjustable, 50/60 Hz (AEP model)  
110, 120, 220 or 240V ac adjustable, 50/60 Hz (E model)

**Power Consumption:** 6W

**Dimensions:** Approx. 450 (w) x 135 (h) x 385 (d) mm  
17<sup>3</sup>/<sub>4</sub> (w) x 5<sup>3</sup>/<sub>8</sub> (h) x 15<sup>1</sup>/<sub>4</sub> (d) inches  
including projecting parts and controls

**Weight:** Approx. 7.5 kg, 16 lb 9 oz (net)  
8.8 kg, 19 lb 6 oz (with shipping carton)

#### TURNTABLE

**Platter:** 32.6 cm (12<sup>7</sup>/<sub>8</sub> inches) dia.  
Aluminum-alloy diecast

**Motor:** DC servo-controlled motor  
(brushless and slotless)

**Drive System:** Direct drive

**Speed:** 33<sup>1</sup>/<sub>3</sub>, 45 rpm

**Wow and Flutter:** 0.03% (WRMS)  
± 0.045% (DIN)

**S/N Ratio:** 70 dB

**Pitch Control Range:** ± 3%

#### TO NEARM

**Type:** Statically balanced, universal

**Arm Length:** 300 mm, 11<sup>3</sup>/<sub>4</sub> inches, overall  
216.5 mm, 8<sup>1</sup>/<sub>2</sub> inches, pivot to stylus

**Overhang:** 16.5 mm, 2<sup>1</sup>/<sub>2</sub> inches

**Tracking Error:** +3°, -1°

**Tracking-force Adjustment Range:** 0-3 g

**Shell Weight:** 7.5 g

**Cartridge Weight Range:** 4-12 g

- Continued on page 2 -

#### SAFETY RELATED COMPONENT WARNING!!

COMPONENTS IDENTIFIED BY SHADING AND MARK  ON THE SCHEMATIC DIAGRAMS, EXPLODED VIEWS AND IN THE PARTS LIST ARE CRITICAL TO SAFE OPERATION. REPLACE THESE COMPONENTS WITH SONY PARTS WHOSE PART NUMBERS APPEAR AS SHOWN IN THIS MANUAL OR IN SUPPLEMENTS PUBLISHED BY SONY.

# SONY<sup>®</sup>

## SERVICE MANUAL

## CARTRIDGE (VL-34G)

- Type: Moving magnet type
- Frequency Response: 10–30,000Hz
- Channel Separation: 25 dB at 1 kHz
- Output Voltage: 3 mV at 1 kHz, 5 cm/sec, 45°
- Load Impedance: 50 k $\Omega$
- Tracking Force: 1.5–2.5 g (2 g recommended)
- Stylus: Sony ND-134G (conical 0.6 mil diamond)
- Weight: 5.5 g

## MODEL IDENTIFICATION

– Specification Label –

### E model

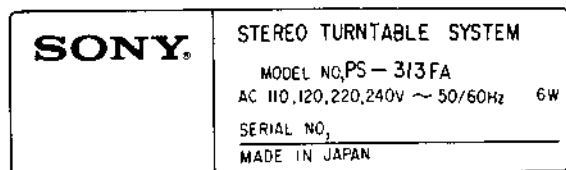

### AEP model

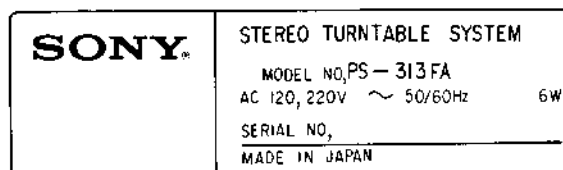

– Power Cord (E model) –

euro-plug (1-534-817-XX)

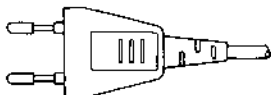

parallel blade plug (1-551-472-00)



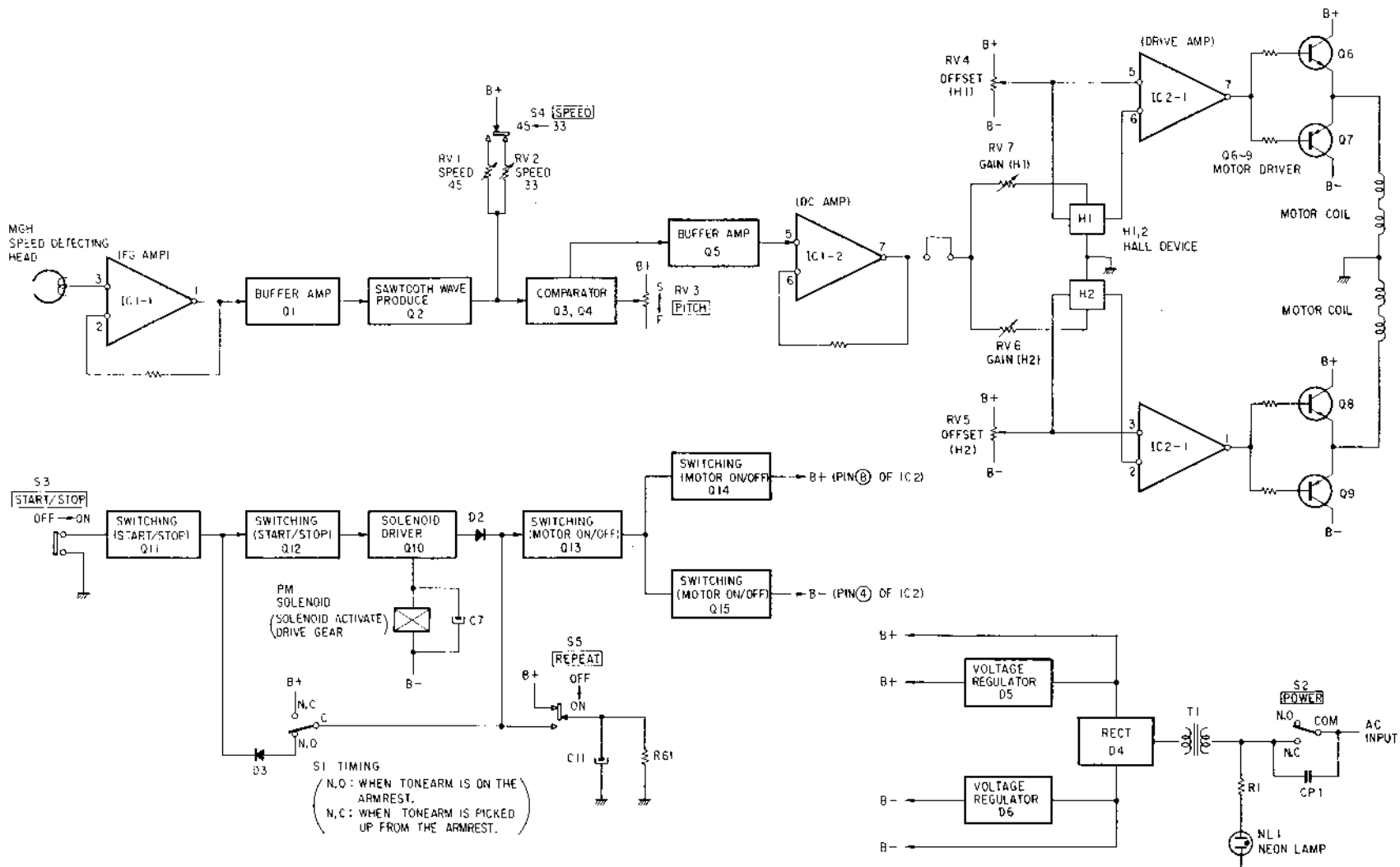

1-1. BLOCK DIAGRAM

SECTION 1  
OUTLINE

1-2. MECHANICAL OPERATION

A) Automatic Start Operation (1)

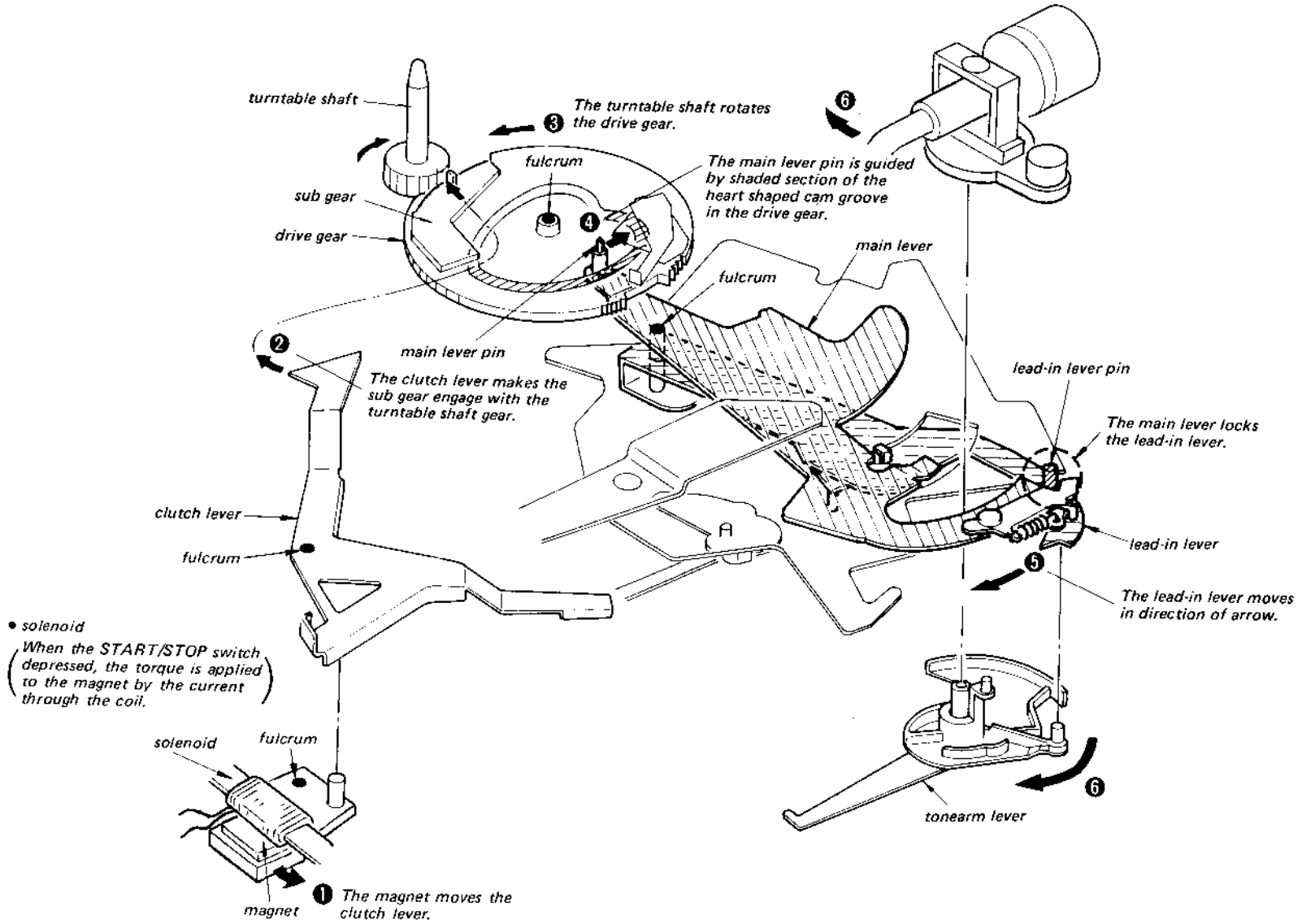

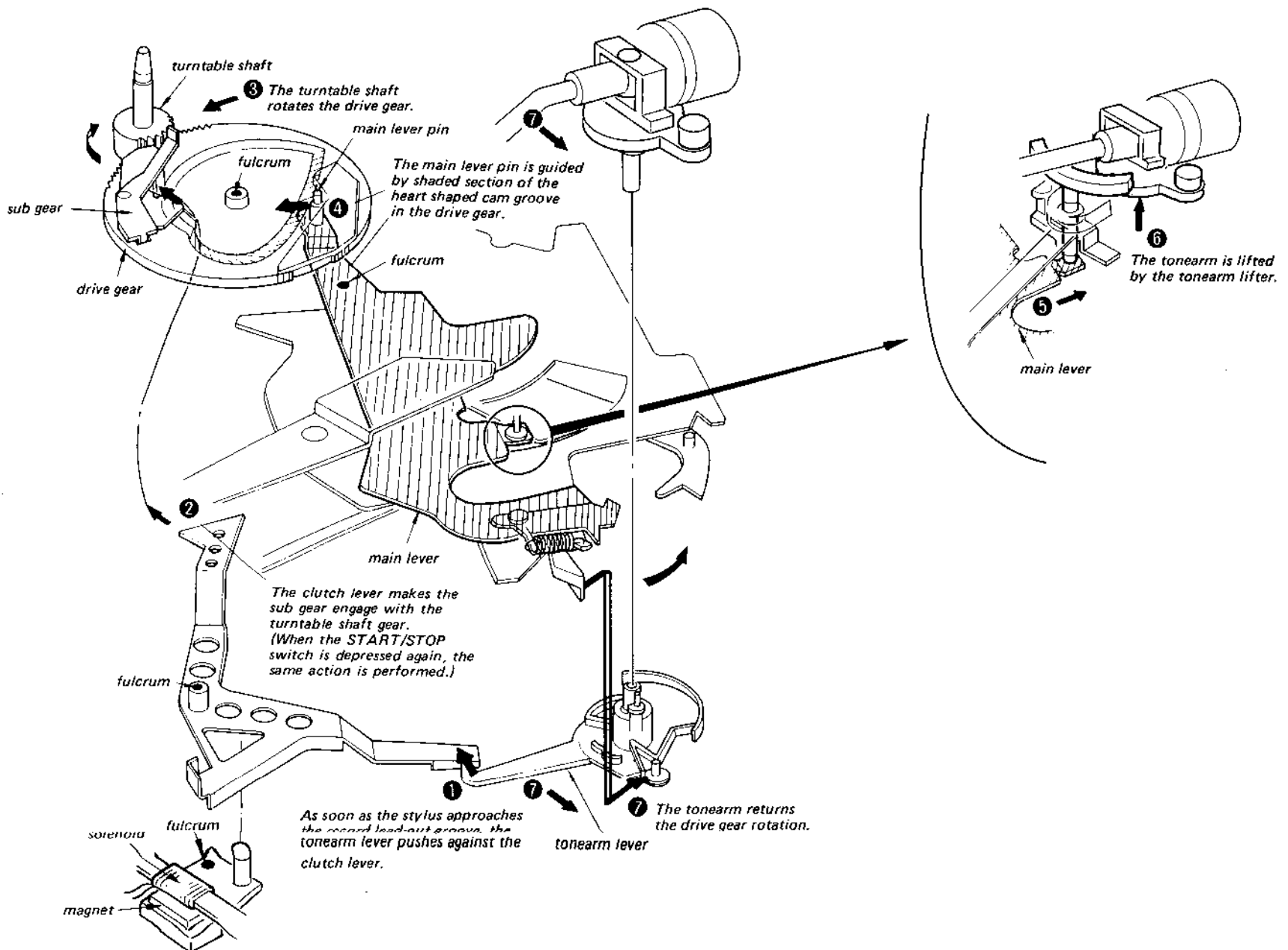
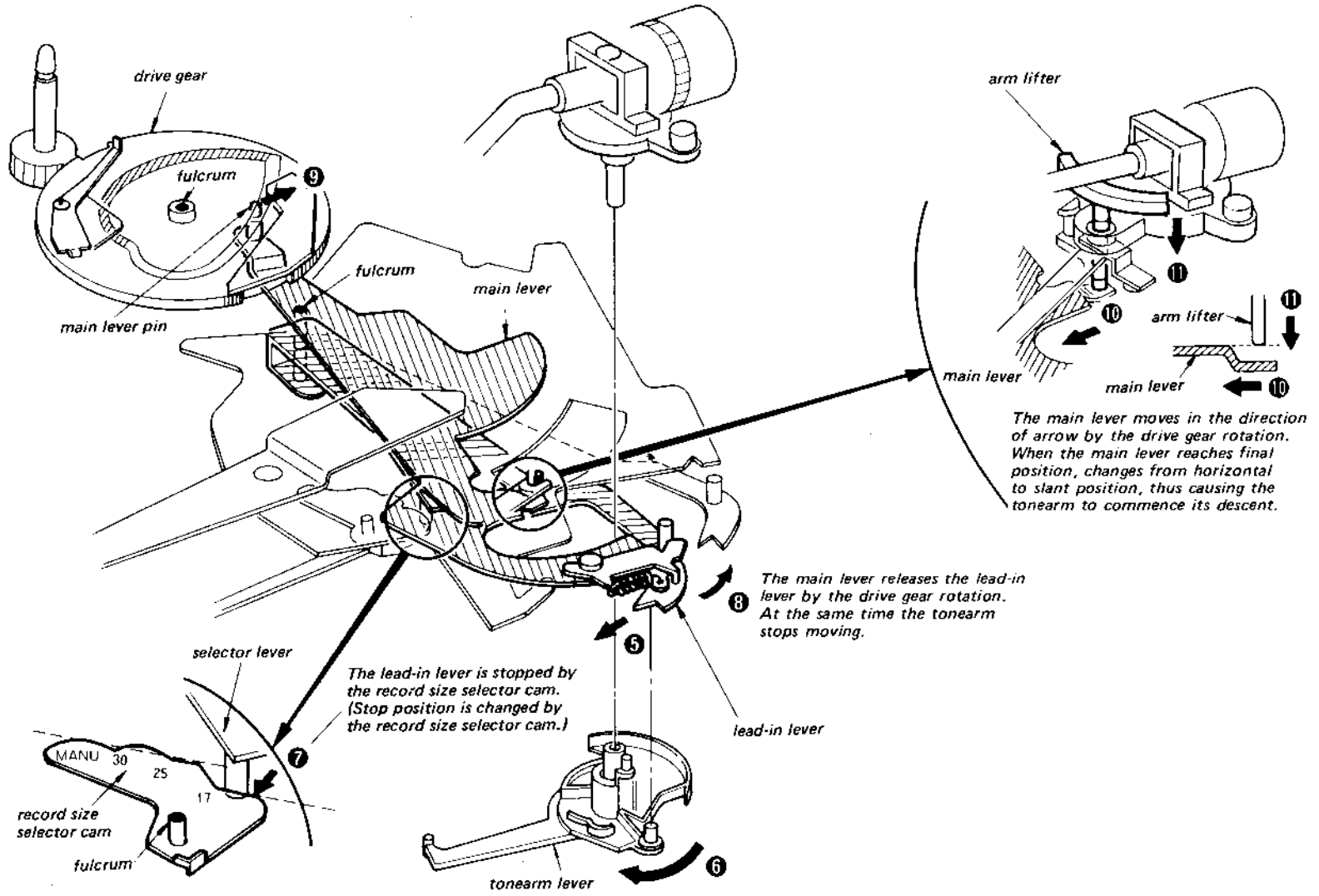

1-3. ELECTRICAL DESCRIPTION

Operation When the START/STOP Button is Pushed

1. When the START/STOP button (S3) is pushed, the current temporarily flows via route ①, turning on Q11 (route ②). Q12 turns on at the same time (route ③).
2. When the current flows via route ③, the bias voltage is applied to Q10, turning it on (route ④). At the same time Q13 turns on (route ⑤). This provides bias voltage to Q14 and Q15 by (route ⑤), which then conduct. The power supply is fed to IC2 (route ⑥), and the turntable starts rotating.
3. The solenoid is actuated via route ④ and pushes out the drive-gear pawl. The drive gear rotates half a turn by the rotation of the turntable (for lead-in motion).
4. When the drive gear rotates and starts the lead-in motion, the timing switch (S1) changes to the N.C. position and the current flows via route ⑦ to keep Q13 conducting. The turntable continues to turn.
5. When the tonearm enters the out-of record groove, the clutch lever is pushed by the arm lever, pushing out the drive-gear pawl. (When the START/STOP button (S3) is pushed while playing, the solenoid is actuated via route ④ and the drive-gear pawl is pushed out.)
6. The drive gear rotates half a turn by the drive-gear pawl (for return motion) as the turntable rotates.
7. The timing switch (S1) changes the N.O. position by the mechanism when the tonearm completes the return motion. When the REPEAT switch (S5) is off, Q13 is turned off because no current flows via route ⑦. Provided with no bias, Q14 and Q15 do not conduct. Thus the power supply to IC2 is cut out and the turntable stops rotating.

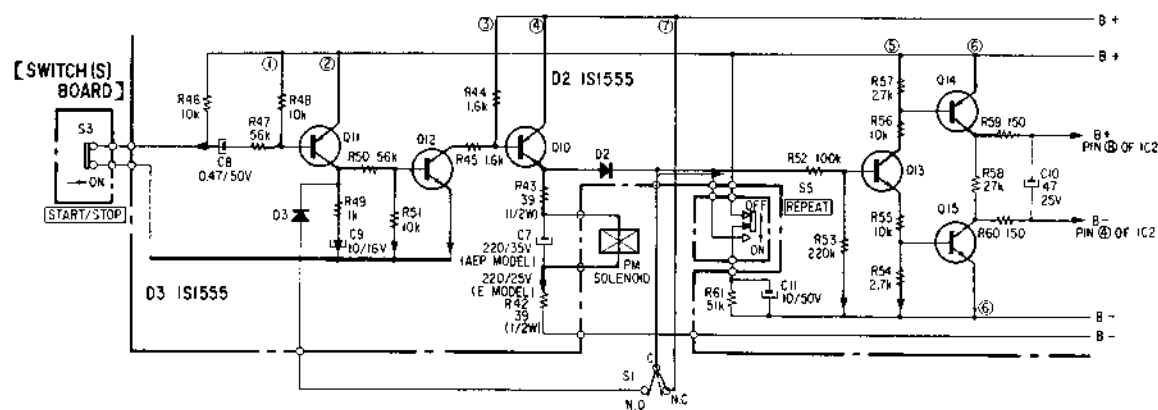

Operation When the REPEAT Switch is ON

- 1-6. The same as when the START/STOP button is pushed.
7. C11 is charged via route ⑦ while the tonearm is on the arm rest (when S1 is in the N.C. position).
8. When the tonearm ends the return motion, the timing switch (S1) changes to N.O. position
9. The drive gear rotates half a turn by the rotation of the turntable (for lead-in motion). Q13 keeps conducting at the same time by the discharge (route ⑧) of C11. The turntable continues to rotate. Q12 and Q10 turn on via route ⑧, thus actuating the solenoid. (route ⑨).

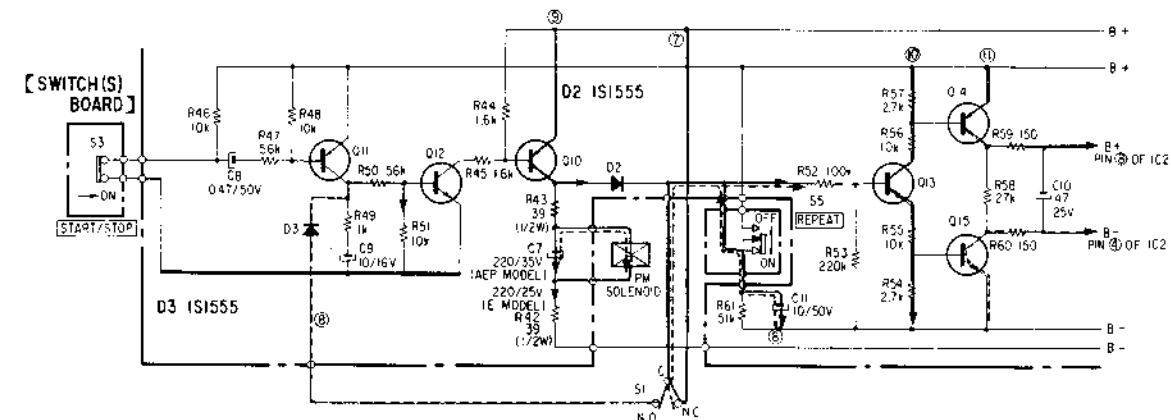

## SECTION 2 DISASSEMBLY

### REPAIR CAUTION

- Platter handling

*backside of platter*

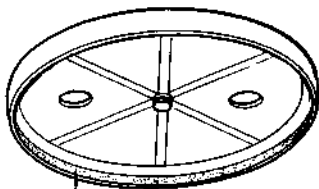

*Be sure not to spoil the magnetic coating. (dark brown color)*

- Platter installation

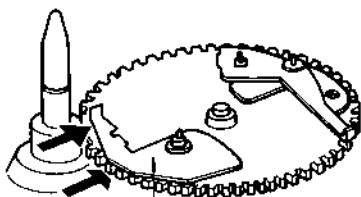

*Be sure that the metal plate does not protrude outside the white gear.*

- Do not connect the power cord and remove the platter.

**Note:**  
Follow the disassembly procedure in the numerical order given.

### BOTTOM PLATE REMOVAL

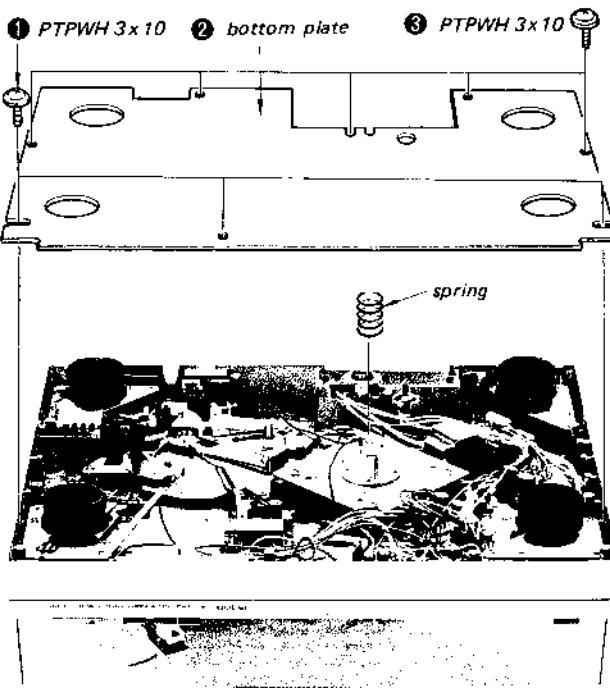

### SERVO AMP CIRCUIT BOARD REMOVAL



① PTPWH 3x8

② servo amp circuit board

**TONEARM REMOVAL**

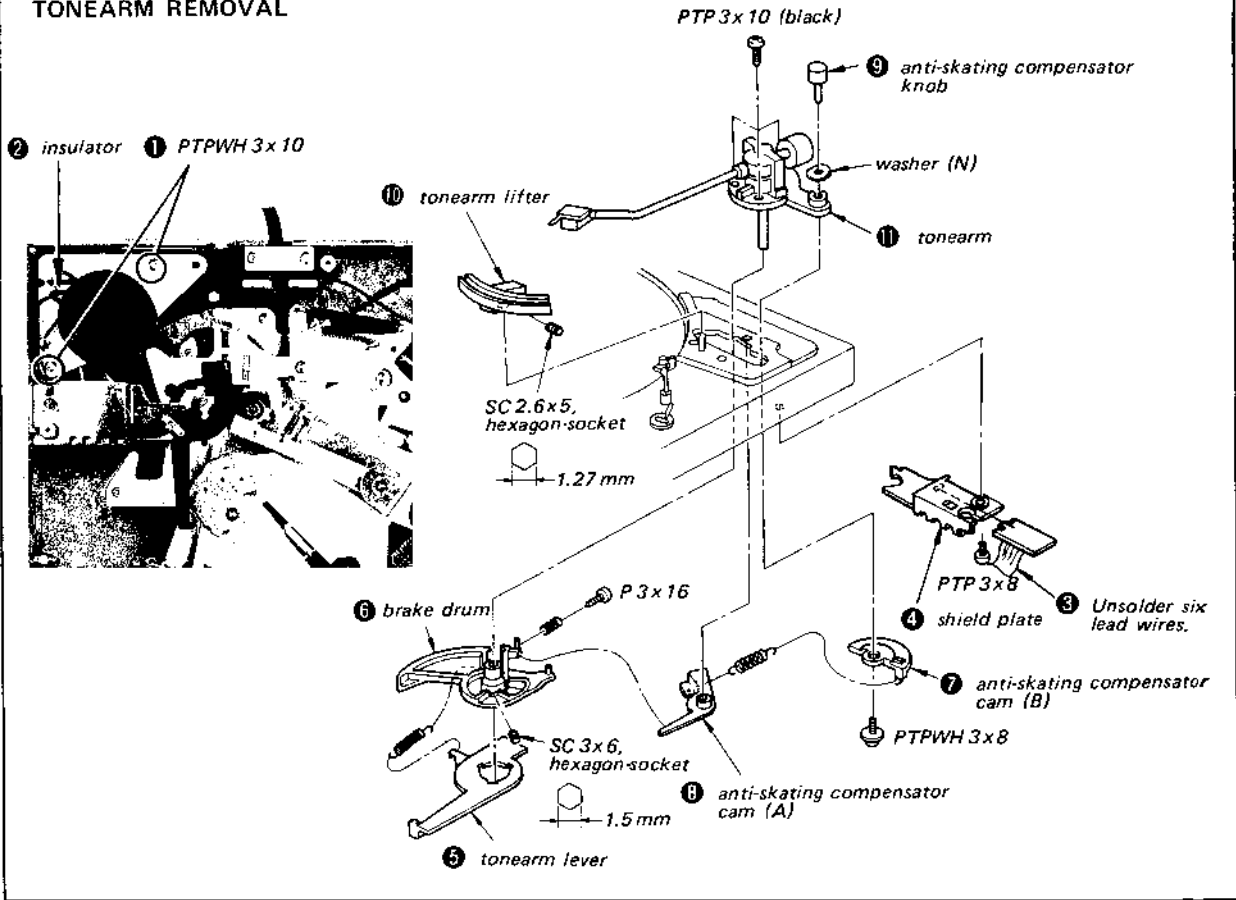

**PUSH-ROD REMOVAL**

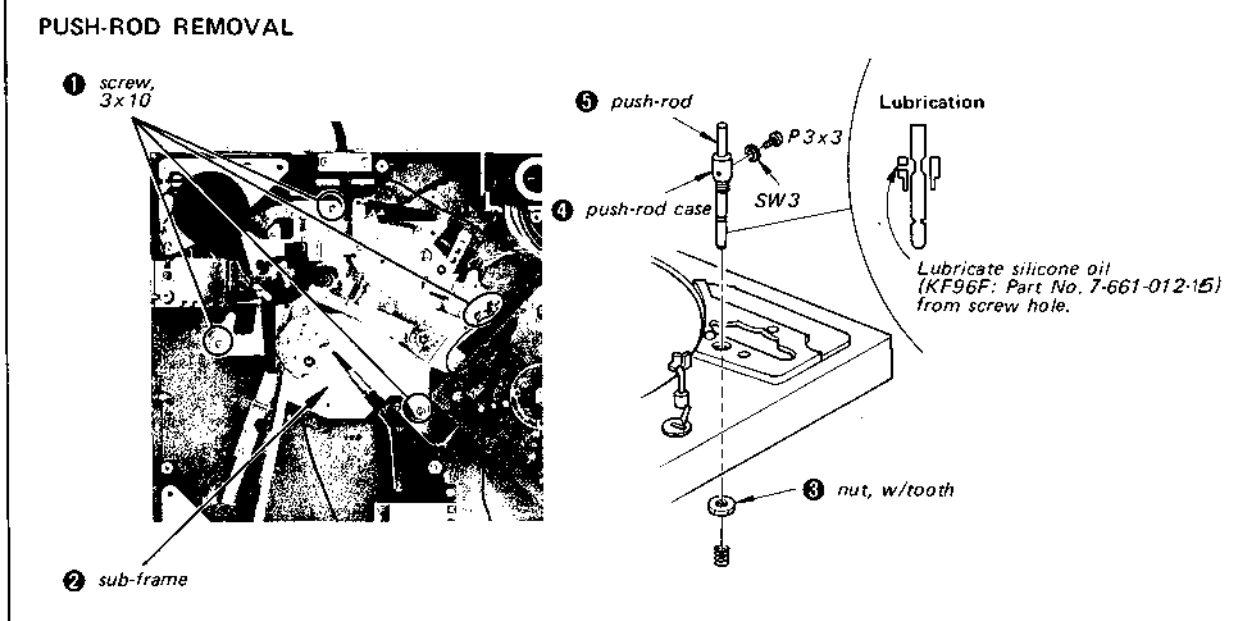



MOTOR REMOVAL

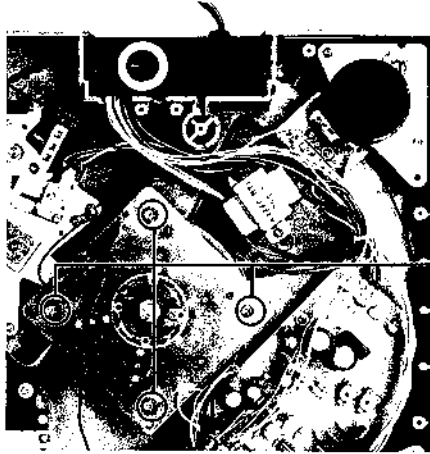

1 Remove four screws (BVTP4x12).

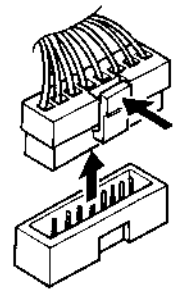
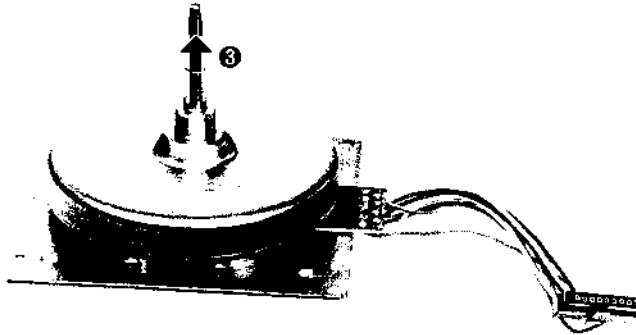

2 Pull out the connector by pushing in.

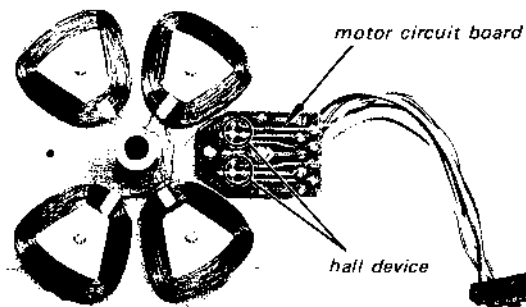

### CARTRIDGE REPLACEMENT

Install the cartridge into the shell with the mounting screws so that the distance between the shell end and the stylus tip is 49 mm (1 <sup>15</sup>/<sub>16</sub> inches).

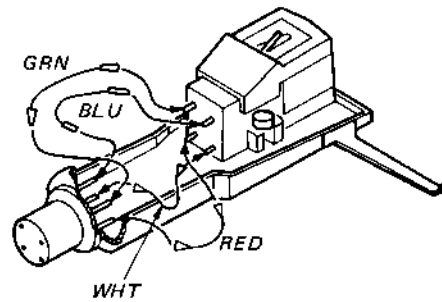
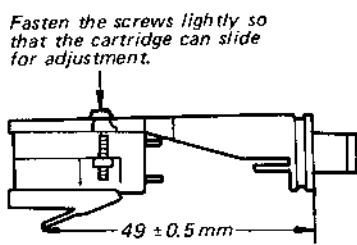

blue: left channel ground  
white: left channel signal  
green: right channel ground  
red: right channel signal

SECTION 3  
ADJUSTMENT

3-1. MECHANICAL ADJUSTMENTS

**Stylus Height Adjustment**  
(POWER switch: OFF)

1. Set the record on the turntable.
2. Set the record size selector to MANUAL position.
3. Automatic Operation
  - 1) Bring the tonearm to last groove of the record.
  - 2) Rotate the turntable clockwise slowly by hand, and the tonearm is lifted up automatically.
  - 3) Make sure that the clearance between the stylus tip and the record is 4-12 mm ( $\frac{3}{16}$ - $\frac{7}{16}$  inches).
  - 4) If necessary, loosen the set screw and adjust the lifter height.

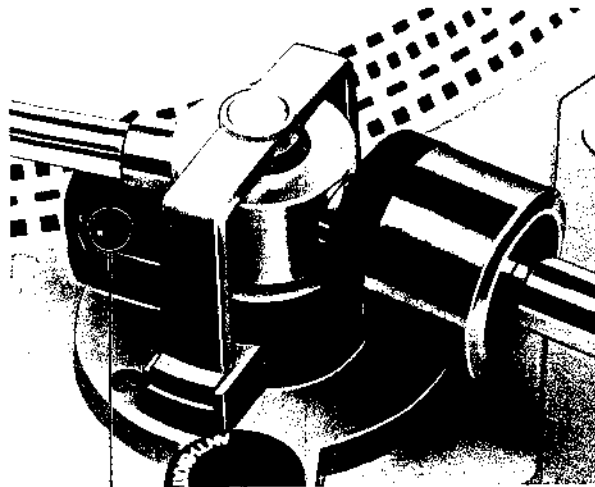

SC 2.6x5,  
hexagon-socket

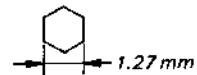

4. Manual Operation
  - 1) Bring the tonearm to center groove of the record.
  - 2) Lift the cueing lever and make sure that the clearance between the stylus tip and the record is 4-12 mm ( $\frac{3}{16}$ - $\frac{7}{16}$  inches).
  - 3) If necessary, adjust the lifter height by turning the adjustment screw as shown below.

turning direction	lifter height
clockwise	up
counterclockwise	down

**Automatic Return Position Adjustment**  
(POWER switch: ON)

1. Set the test record (YFSB-6) on the turntable.
2. Before this adjustment, automatic return must be done.
3. Bring the tonearm to the return test groove of the record.
4. Make sure that the tonearm starts to return at count of 15-17.
5. If necessary, adjust the automatic return position by turning the adjustment screw as shown below.

turning direction	count of return position
clockwise	18
counterclockwise	1

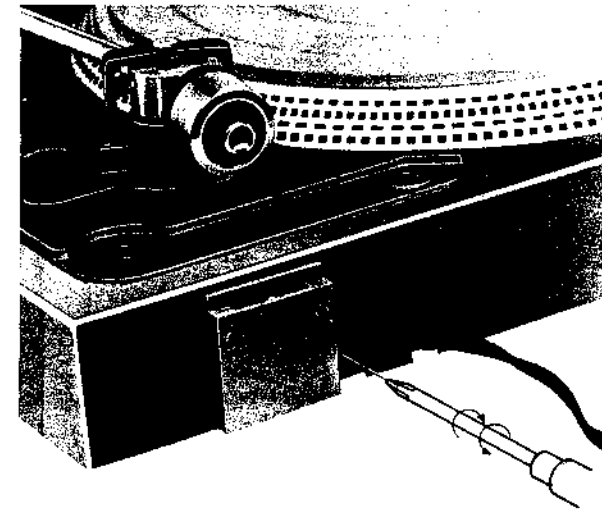

adjustment screw

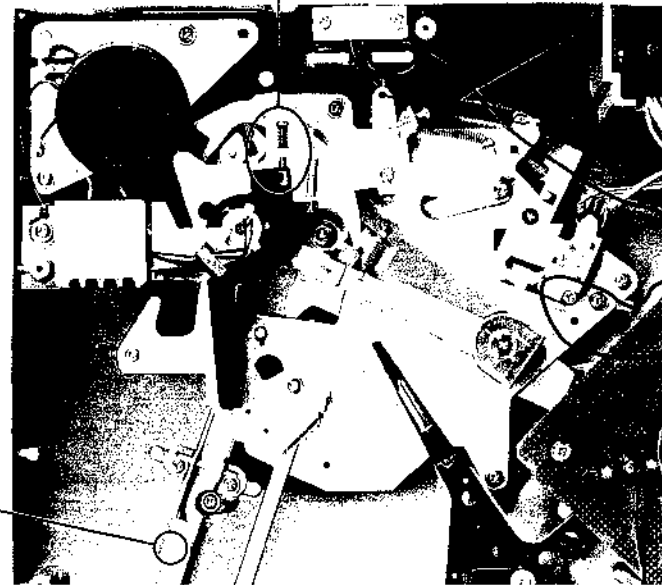

**Stylus Drop-point Adjustment**  
(POWER switch: ON)

1. Set the test record (YFSC-16) on the turntable.
2. Set the record size selector knob to the 30 (12") position and make sure that the stylus gets down on the specified point of the test record.

Specification:

Record size selector position	Count of drop-point
30 (12")	6 to 10

3. If necessary, insert the screwdriver into the hole and adjust the drop-point by turning the adjustment screw.

To change the drop-point inward:  
Turn the adjustment screw slightly counterclockwise **A**

To change the drop-point outward:  
Turn the adjustment screw slightly clockwise **B**

4. Once it is properly adjusted with a 30 cm (12") record, the drop-point will be correct for 17 cm (7") and 25 cm (10") records as well.

**Note:** The stylus drop-point is changed to about 12 mm ( $\frac{1}{2}$ ") by one turn of the adjustment screw.

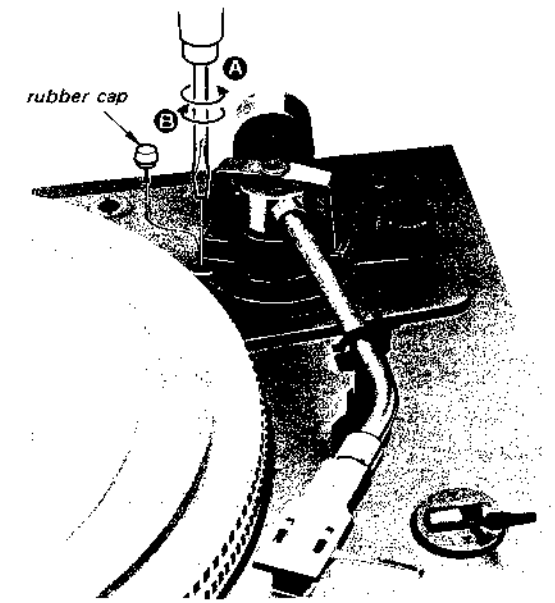

**Brake Drum Position Adjustment**  
(POWER switch: OFF)

1. Rotate the drive gear counterclockwise by hand and set the main lever pin as shown below.

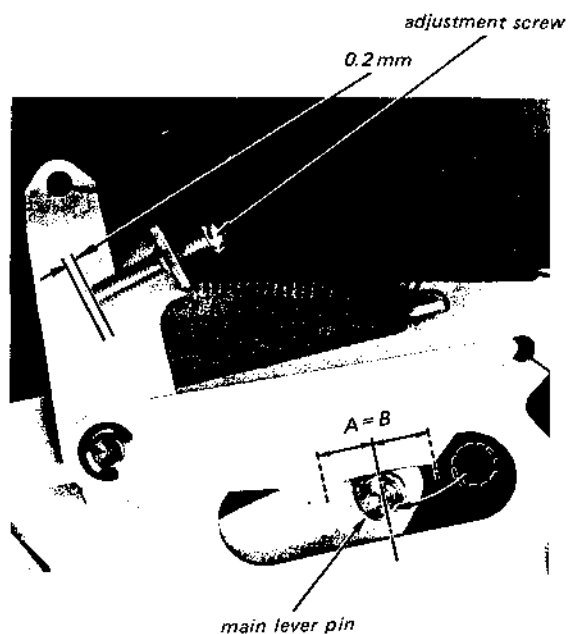

2. Contact the brake lever (1) to the brake drum by loosening the adjustment screw.
3. While pressing the brake lever (1) to the brake drum, tighten the adjustment screw fully clockwise.
4. Then, turn the adjustment screw counterclockwise about 1 turn.

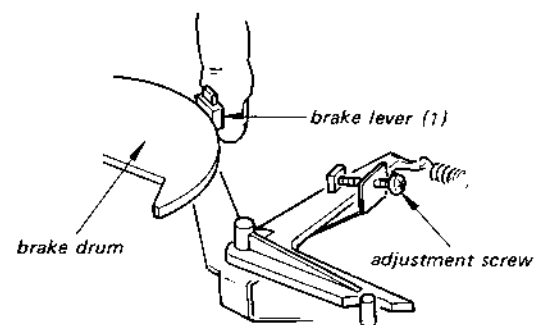

**Reset Adjustment**

If the tonearm returns during play without depressing the START/STOP button, adjust the tension of the spring by hooking the spring to stronger position as shown below.

position	tension
①	weak ↑ ↓ strong
②	
③	

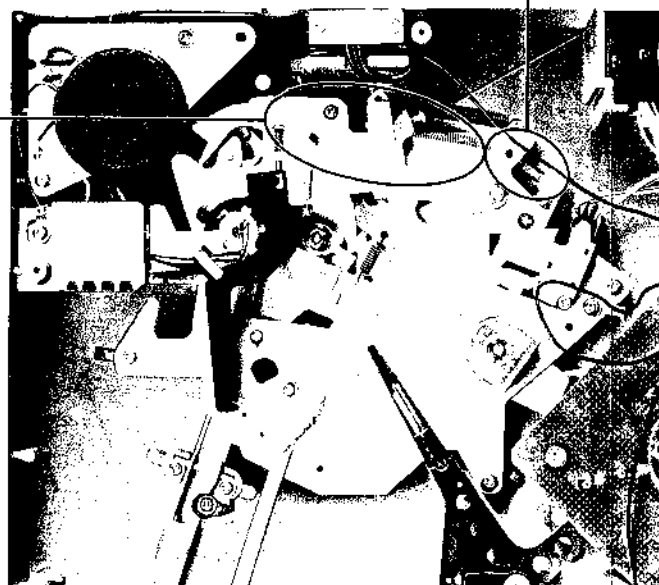
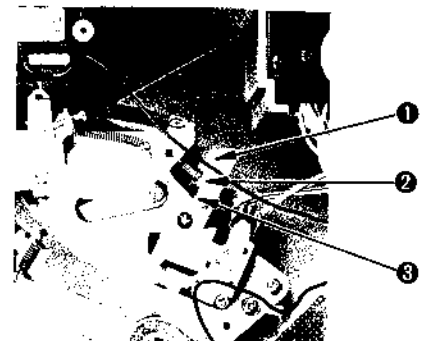

**Speed Detecting Head Output Level Adjustment**

Before this adjustment, set the speed detecting head on the head holder as shown below.

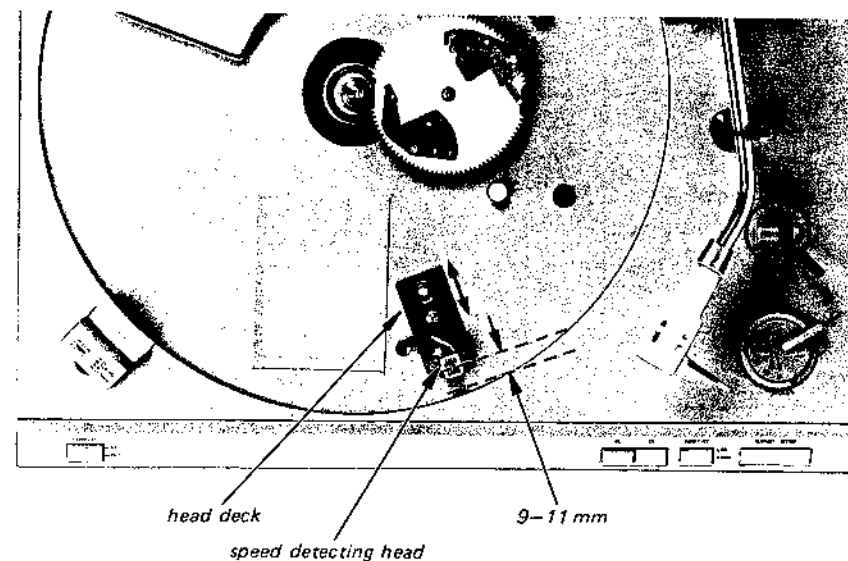

1. Adjust the position of the head holder so that the VTVM reading is 10-50 mV ac at 33 1/3 rpm.
2. Make sure that the head does not touch the turntable and tighten the screws securely.

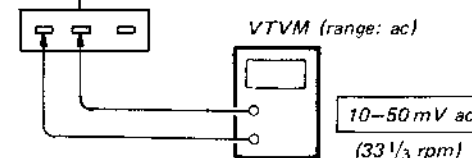
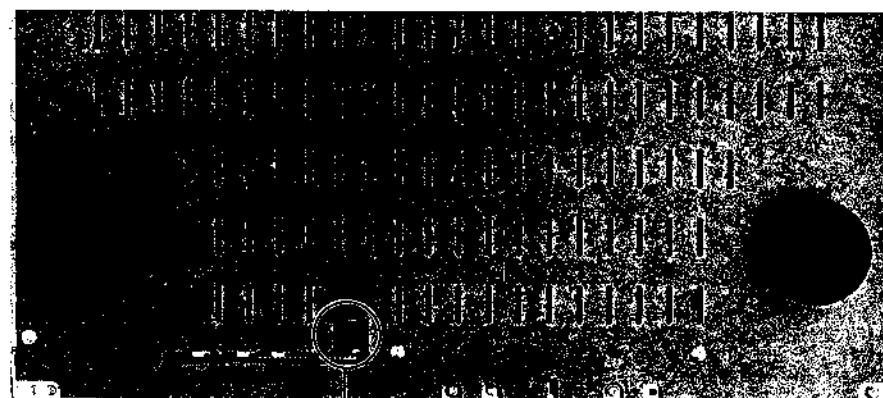

**Note:** The clearance between the magnet coated rim and the speed detecting head is more than 0.3 mm.

3-2. ELECTRICAL ADJUSTMENTS

**Turntable Speed Adjustment**

If correct speed cannot be obtained by adjusting the PITCH control, adjust RV1 (45) and RV2 (33).

1. Set the PITCH control knob to the mechanical-mid position.
2. Set the SPEED selector switch to "33" position and adjust RV2 so that the stroboscope pattern appears stationary.
3. Set the SPEED selector switch to "45" position and adjust RV1 so that the stroboscope pattern appears stationary.

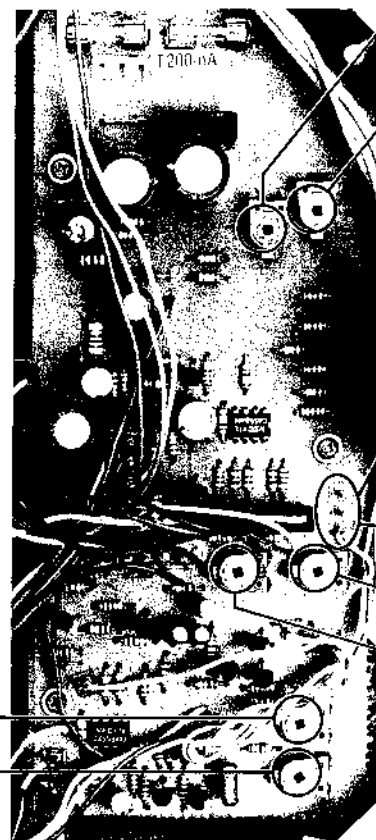

**Motor Amp Offset Adjustment (33 1/3 rpm)**

1. Disconnect the orange lead wire and connect the regulated power supply as shown below.
2. Connect VTVM or oscilloscope to H1 and adjust RV4 for 0V dc VTVM reading or the waveform on oscilloscope as shown below.
3. Connect VTVM or oscilloscope to H2 and adjust RV5 for 0V dc VTVM reading or the waveform on oscilloscope as shown below.

Waveform on Oscilloscope:

**Note:** Set the sweep time to longer for easy checking the waveform.

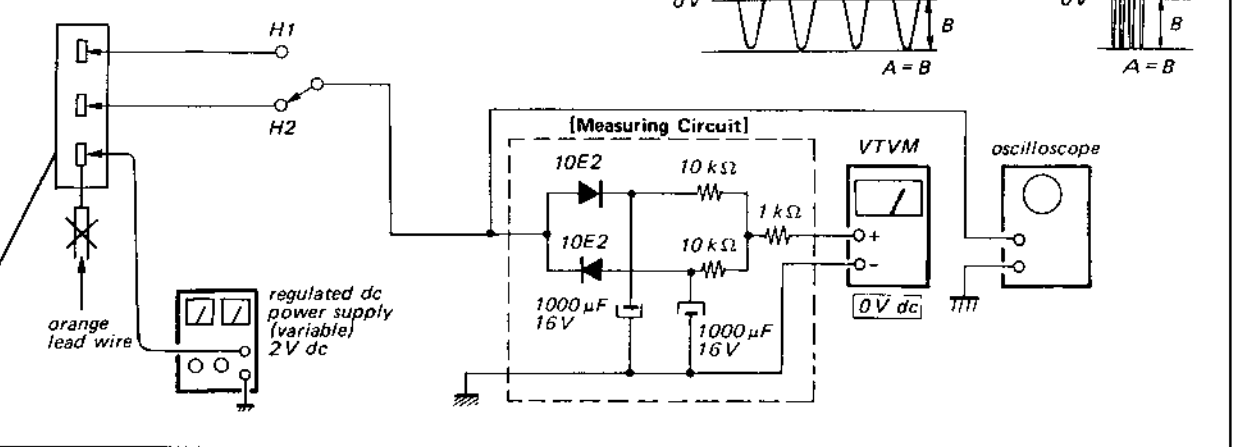
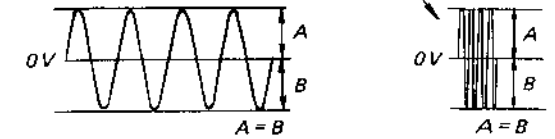

**Hall Device Gain Adjustment (33 1/3 rpm)**

1. Disconnect the orange lead wire and connect the regulated power supply as shown.
2. Connect VTVM to H1 and adjust RV7 for 2.3V ac reading on VTVM.
3. Connect VTVM to H2 and adjust RV6 for 2.3V ac reading on VTVM.

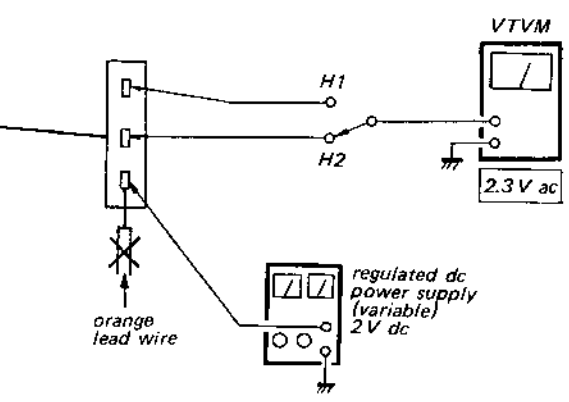

SECTION 4  
DIAGRAMS

Motor Amp Offset Adjustment (33 1/3 rpm)

1. Disconnect the orange lead wire and connect the regulated power supply as shown below.
2. Connect VTVM or oscilloscope to H1 and adjust RV4 for 0V dc VTVM reading or the waveform on oscilloscope as shown below.
3. Connect VTVM or oscilloscope to H2 and adjust RV5 for 0V dc VTVM reading or the waveform on oscilloscope as shown below.

Waveform on Oscilloscope:

Note: Set the sweep time to longer for easy checking the waveform.

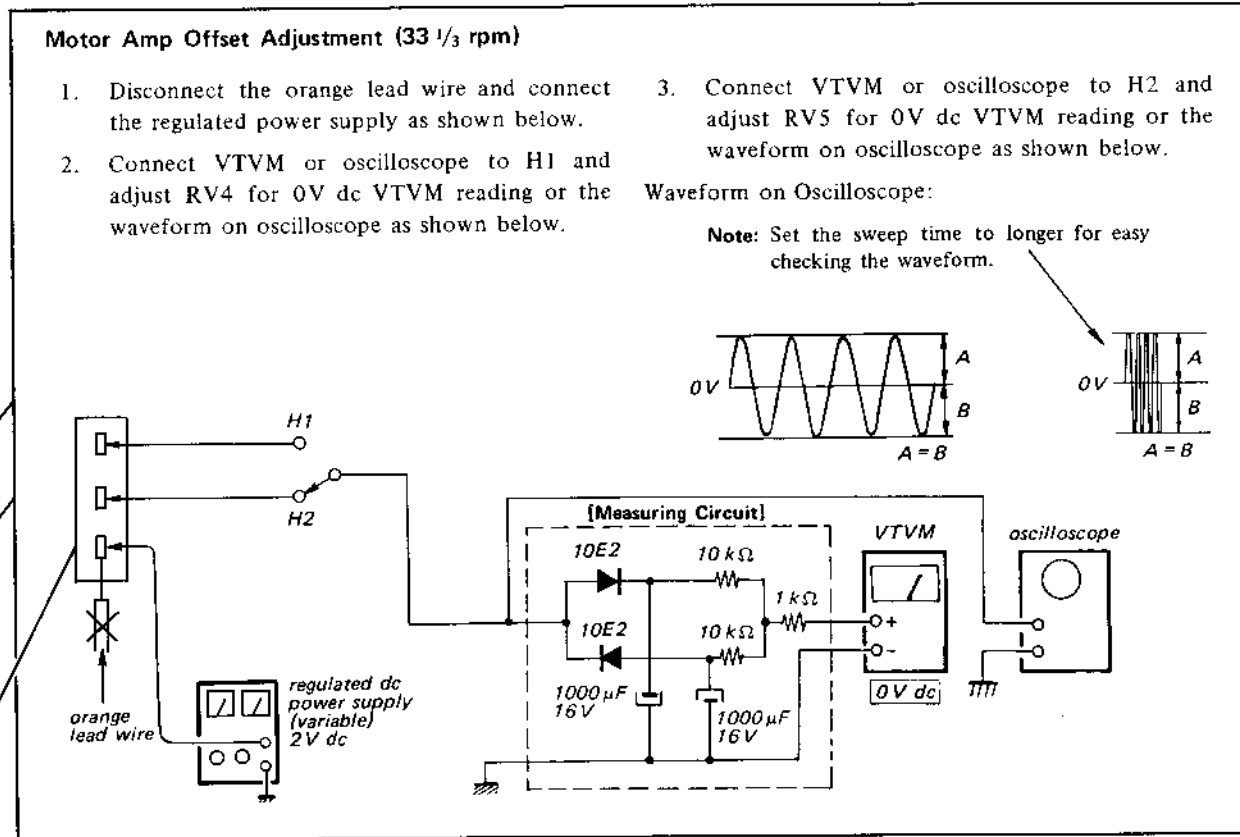
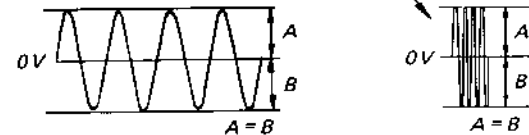

Hall Device Gain Adjustment (33 1/3 rpm)

1. Disconnect the orange lead wire and connect the regulated power supply as shown.
2. Connect VTVM to H1 and adjust RV7 for 2.3V ac reading on VTVM.
3. Connect VTVM to H2 and adjust RV6 for 2.3V ac reading on VTVM.

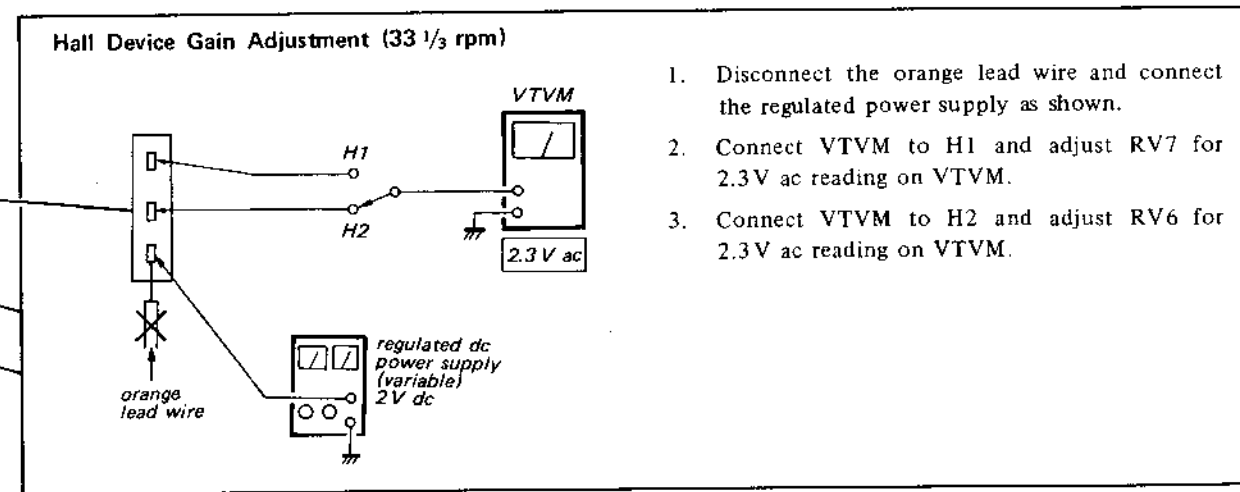

4-1. MOUNTING DIAGRAM

(Phono Board)

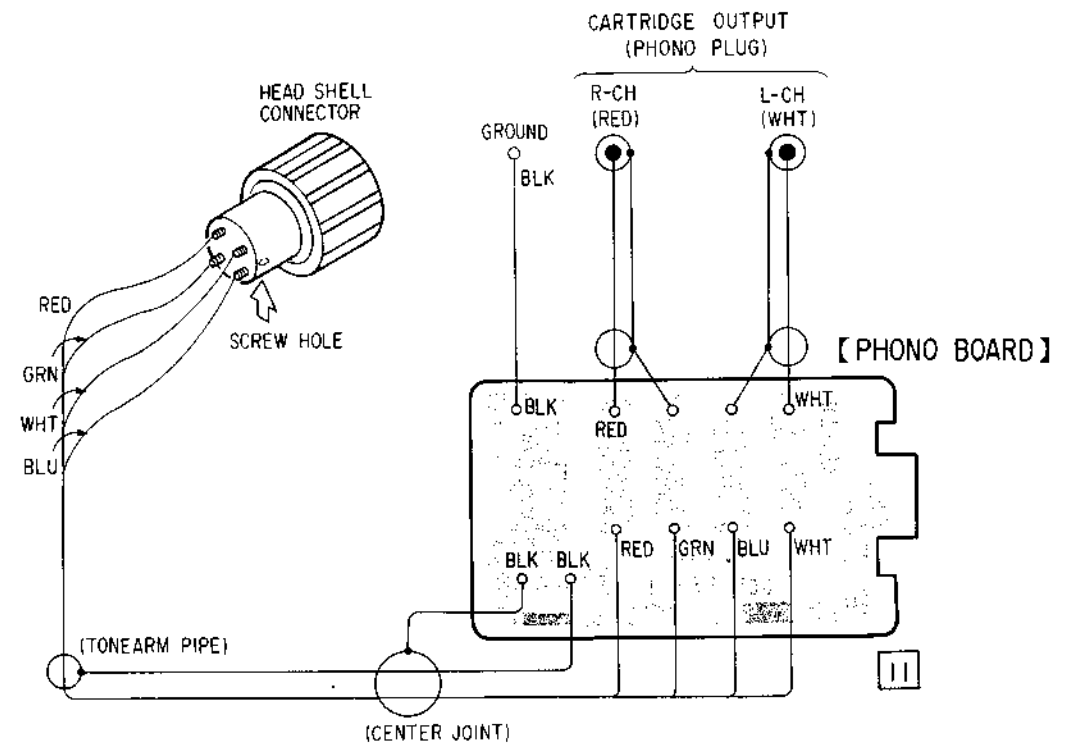

4-2. SCHEMATIC DIAGRAM

(Phono Board)

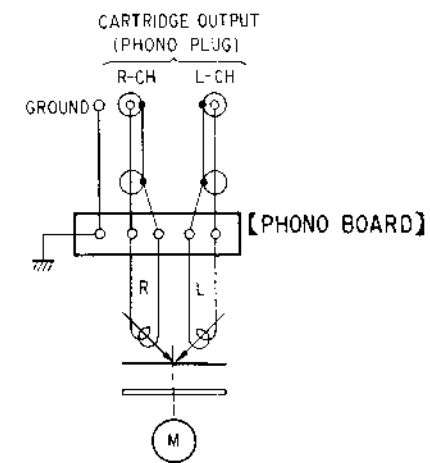

4-3. MOUNTING DIAGRAM

— Conductor Side —

Replacement Semiconductors

For replacement, use semiconductors except in ( ).

Q1-4 }  
Q12, 13 } 2SC1364 (2SC945)  
Q15 }

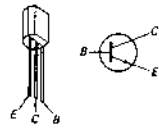

Q5, 11, 14: 2SA678 (2SA733)

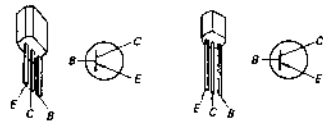

Q6, 8: 2SD414 IC1, 2: μPC4558C

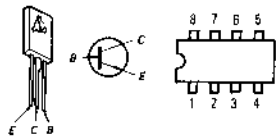

Q7, 9: 2SB548

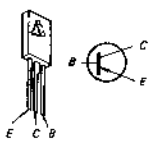

Q10: 2SB605 D1-3: 1S1555

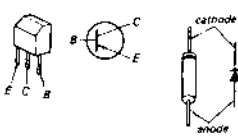

D4: S1RB10 D5, 6: EQB01-11Z (EQA01-11S)

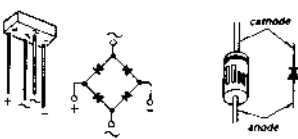

H1, 2: F1409 (HALL8)

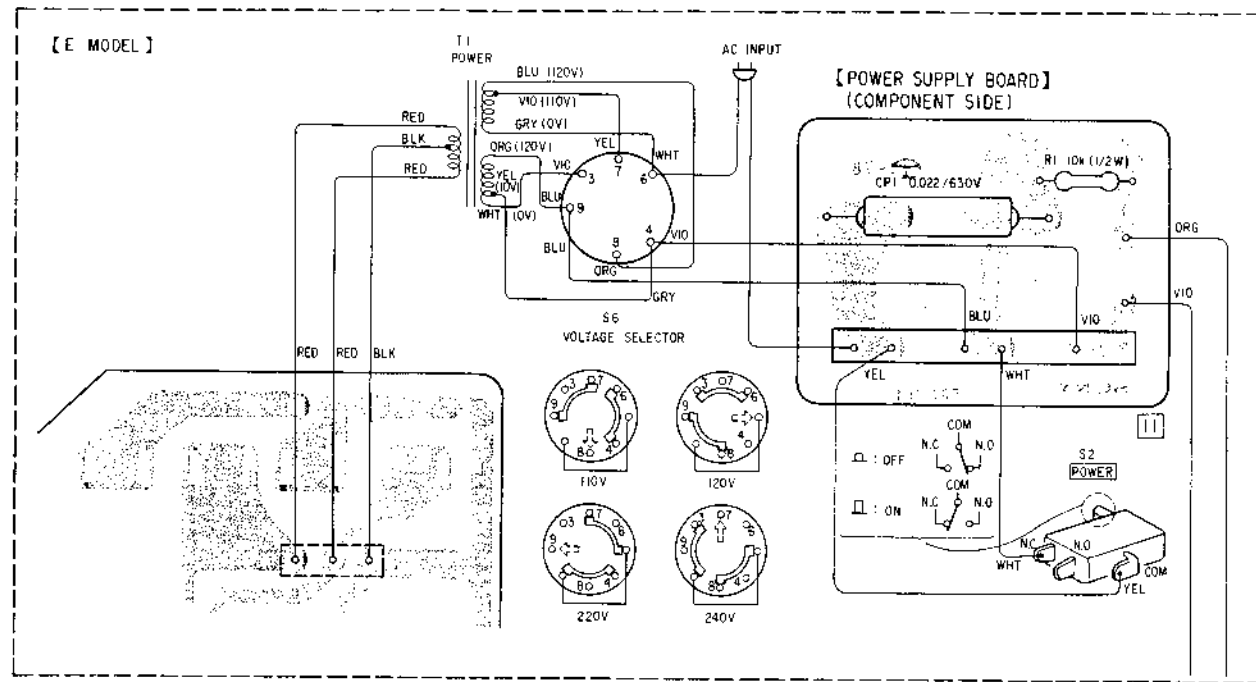
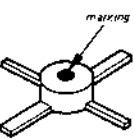

- Note:
- — : parts extracted from the component side.
  - ⋯ : B+ pattern.
  - ⋯ : pattern.
  - Signal Path
  - : FG signal
  - : control signal
  - Voltages are dc with respect to ground unless otherwise noted.
  - Readings are taken under no signal conditions with a VOM (20 kΩ/V).
  - ( ) : 45 rpm
  - [ ] : At the moment when the START/STOP button is depressed
  - ( ) : STOP
  - no mark : 33 rpm
  - All variable and adjustable resistors have characteristic curve B, unless otherwise noted.

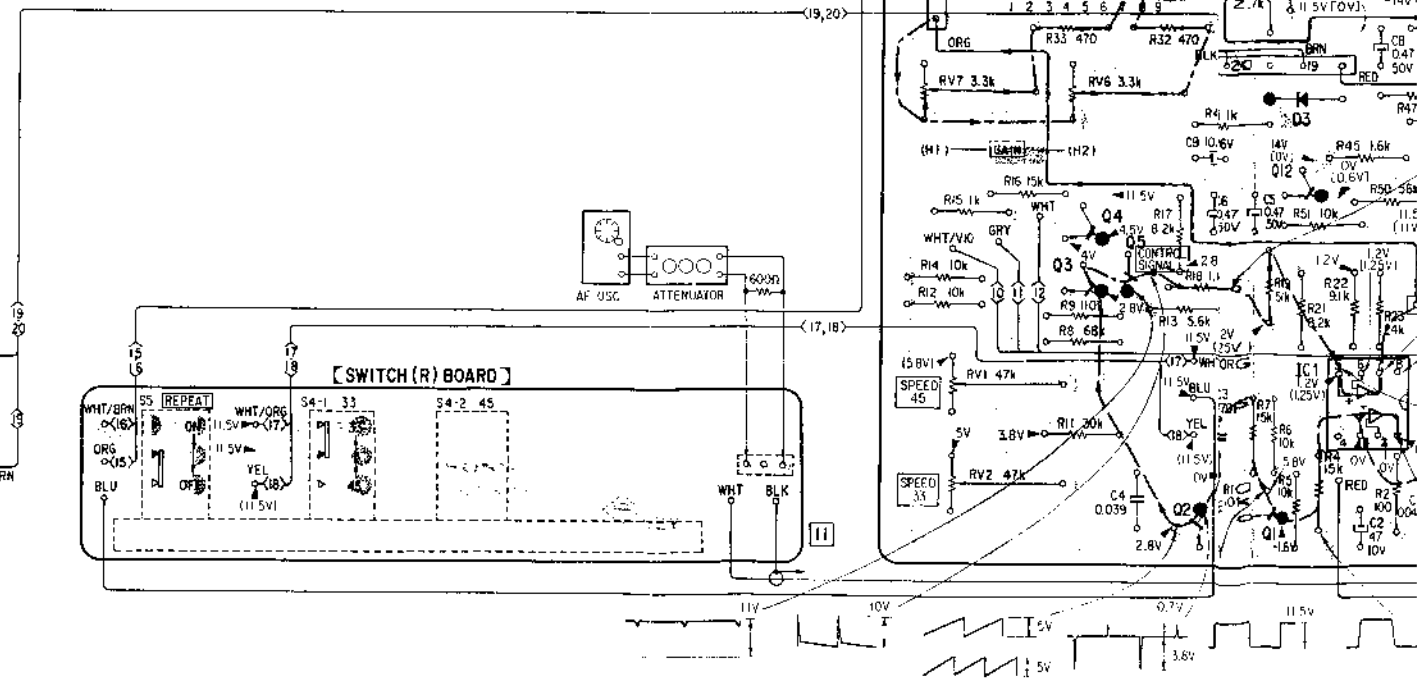
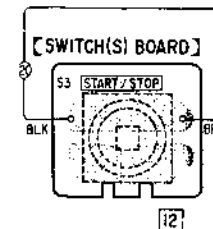

PS-313FA PS-313FA

Q	9,7	4, IC2	15	13	12	IC1	10
IC	8,6	3	5	2, 14	1	11	11
D			4	6	2	5	1

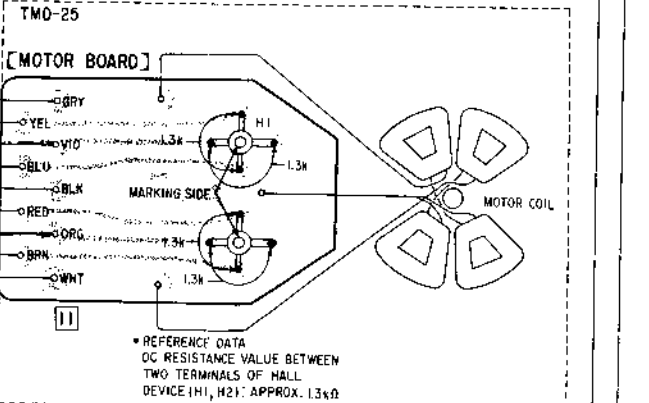
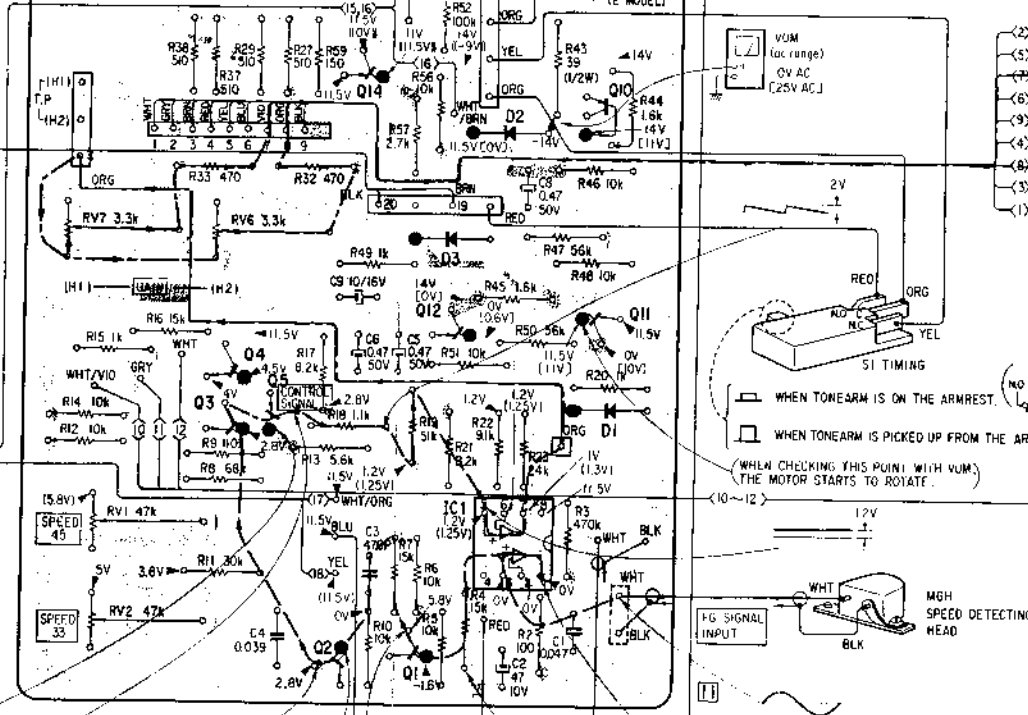
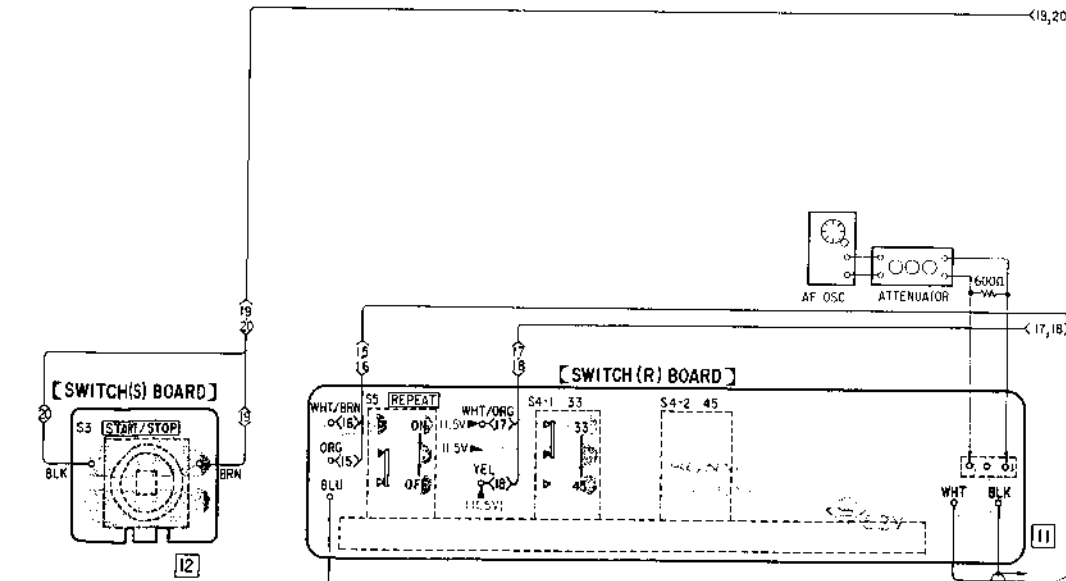
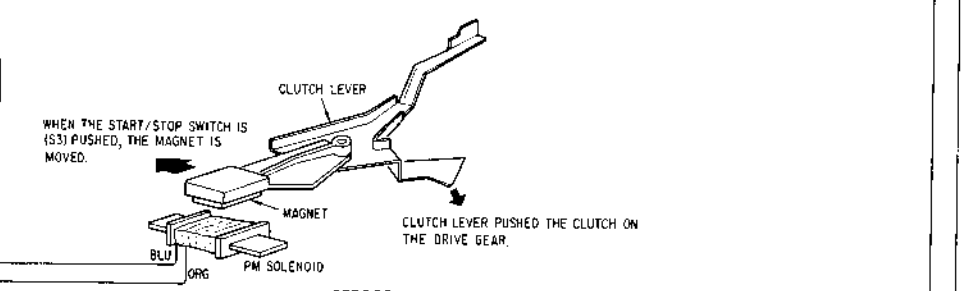
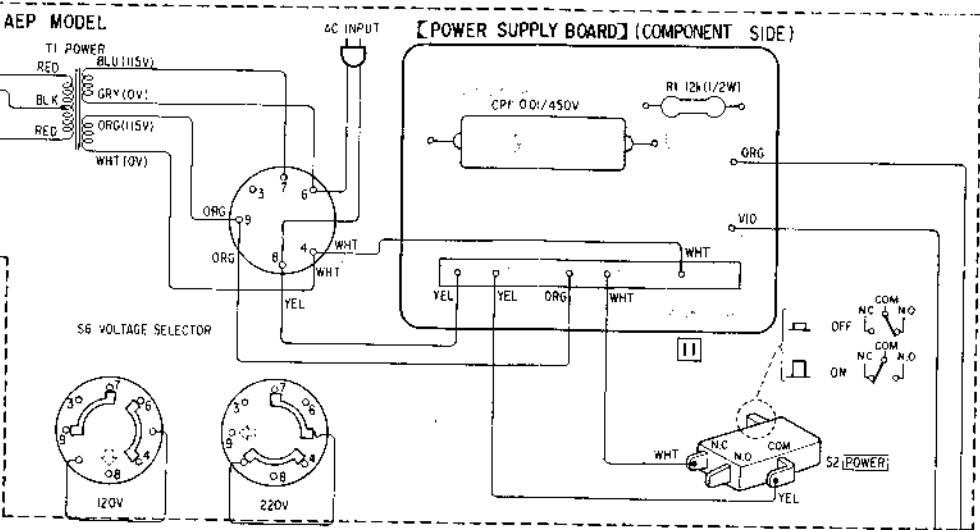
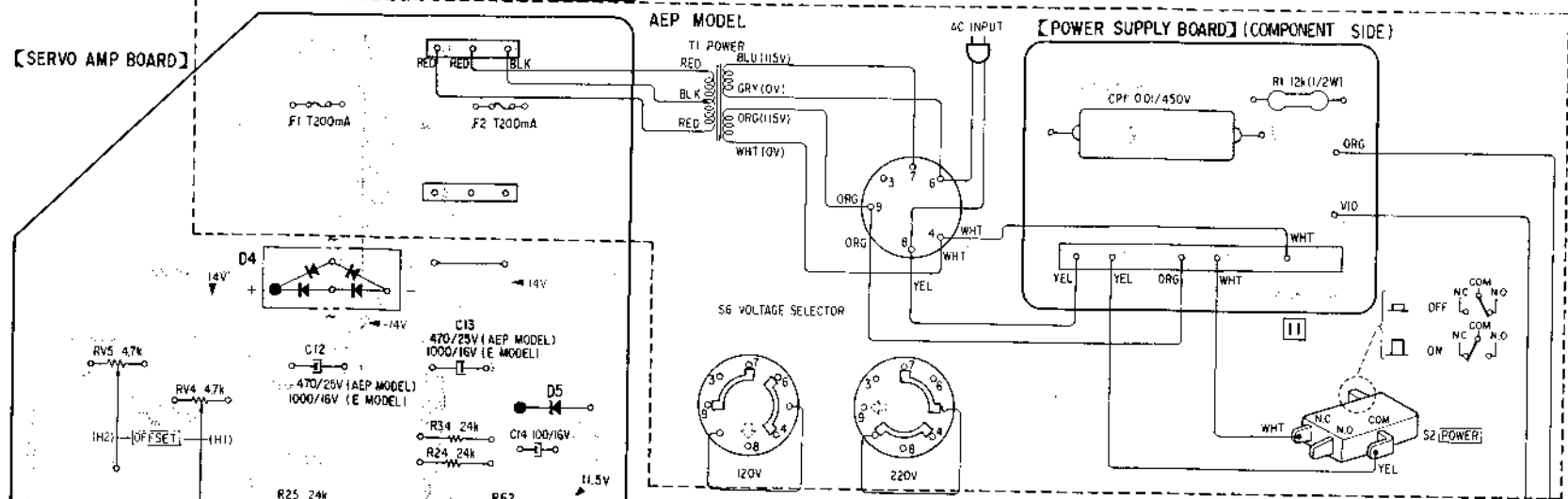
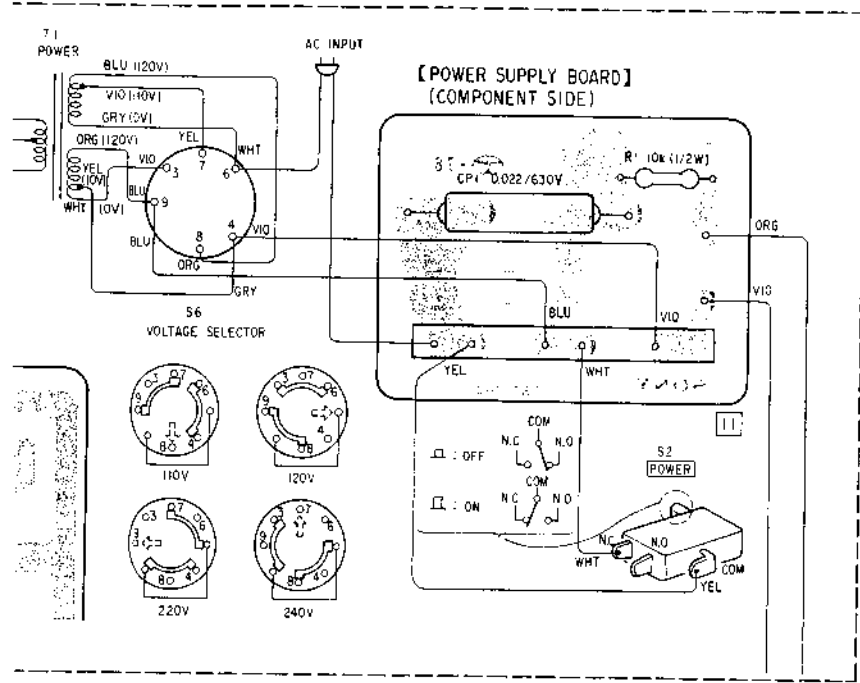



4-4. SCHEMATIC DIAGRAM

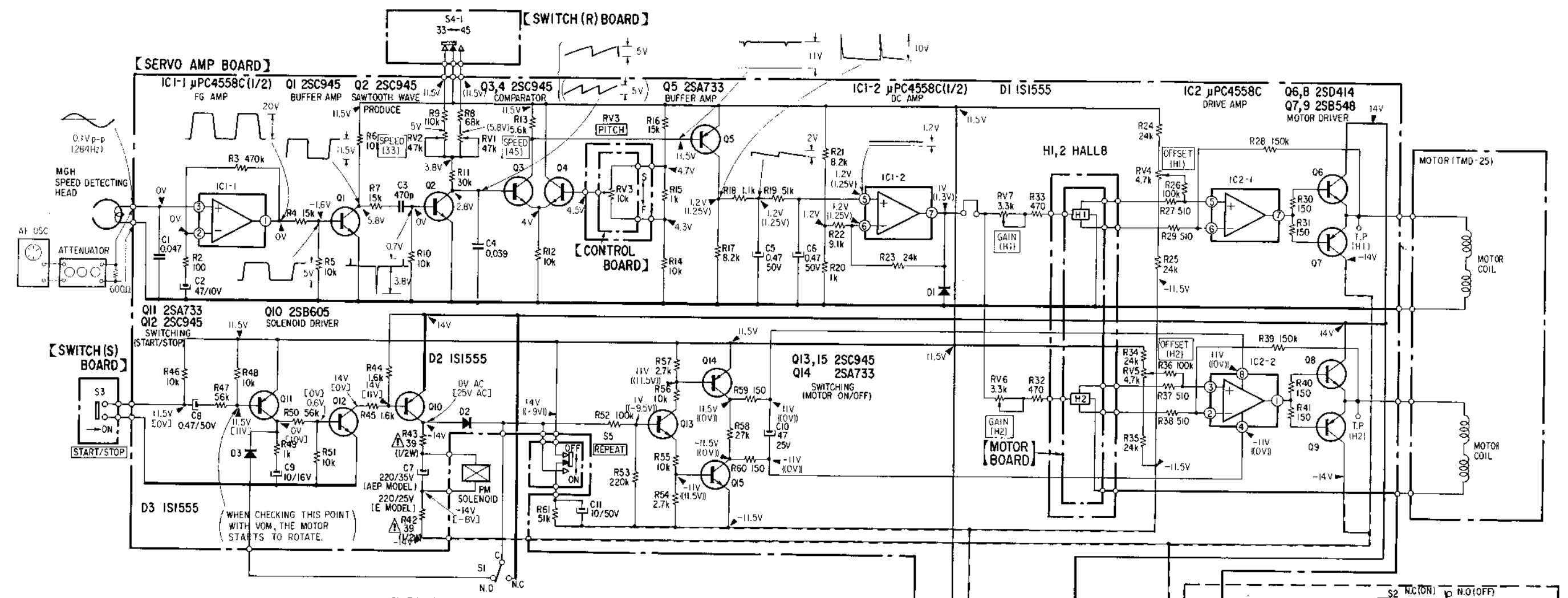

- Note:**
- All capacitors are in  $\mu\text{F}$  unless otherwise noted.  $\text{pF} = \mu\text{F} \times 10^{-6}$ . 50WV or less are not indicated except for electrolytics.
  - All resistors are in ohms,  $\frac{1}{4}\text{W}$  unless otherwise noted.  $\text{k}\Omega = 1000\Omega$ ,  $\text{M}\Omega = 1000\text{k}\Omega$ .
  - All variable and adjustable resistors have characteristic curve B, unless otherwise noted.
  - B+ bus.
  - - - B- bus.
  - : panel designation.
  - : adjustment for repair.
  - Voltages are dc with respect to ground unless otherwise noted.
  - Readings are taken under no signal conditions with a VOM (20  $\text{k}\Omega/\text{V}$ ):
    - ( ) : 45 rpm
    - | | : At the moment when the START/STOP button is depressed
    - ( | ) : STOP
  - no mark: 33 rpm
  - Voltage variations may be noted due to normal production tolerances.
  - Switch

Ref. No.	Switch	Position
S1	timing	N.O
S2	POWER	N.C
S3	START/STOP	OFF
S4	SPEED	33
S5	REPEAT	OFF
S6	VOLTAGE SELECTOR	

**SI TIMING**  
 N.O: WHEN TONEARM IS ON THE ARM REST.  
 N.C: WHEN TONEARM IS PICKED UP FROM THE ARM REST.

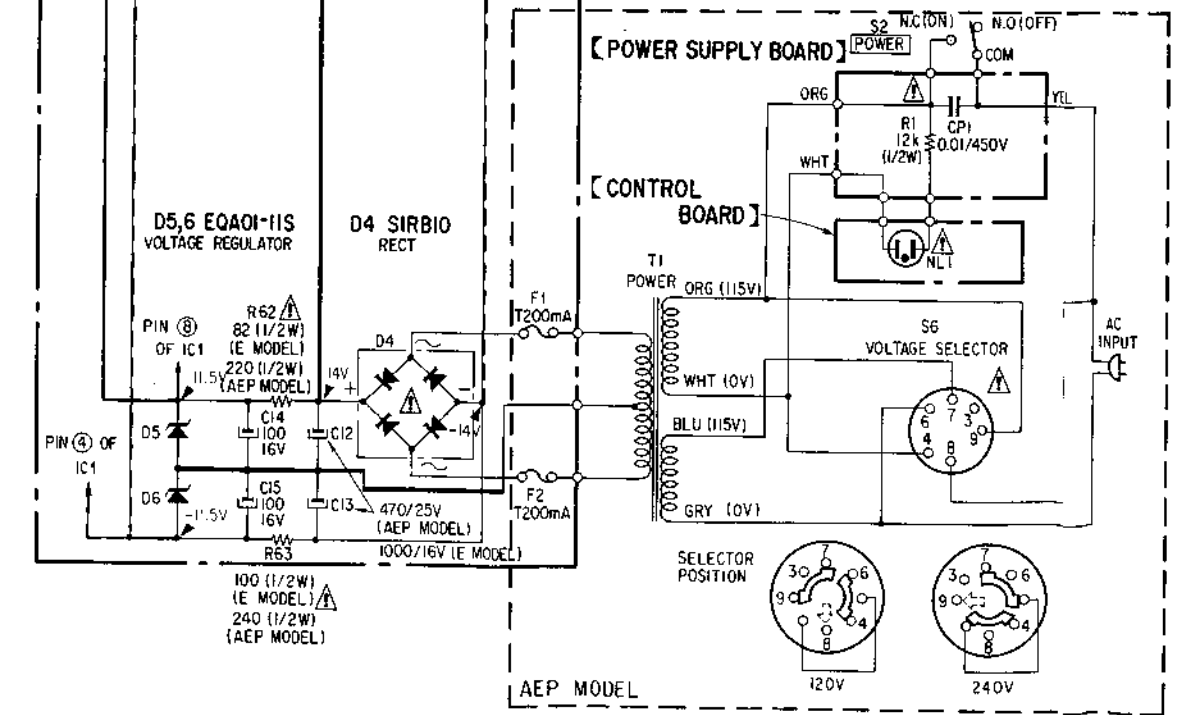
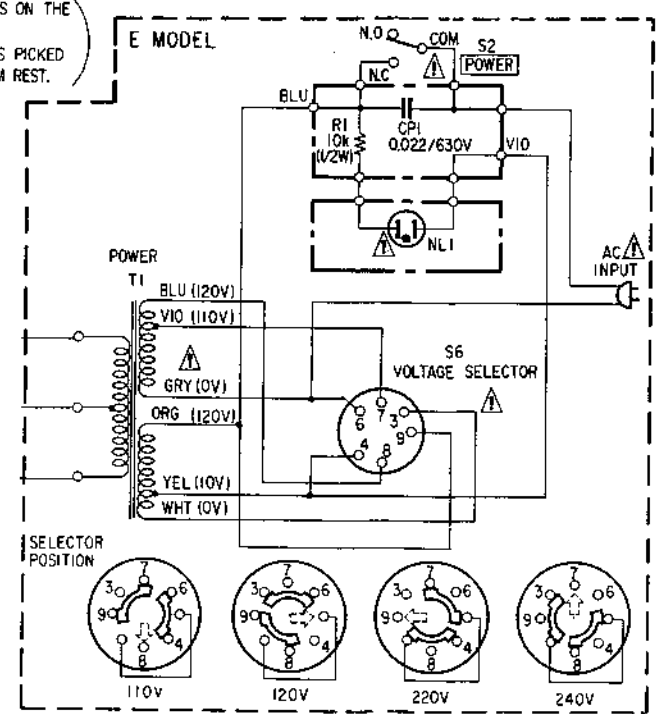

## SECTION 5 EXPLODED VIEWS

**PS-313FA PS-313FA**

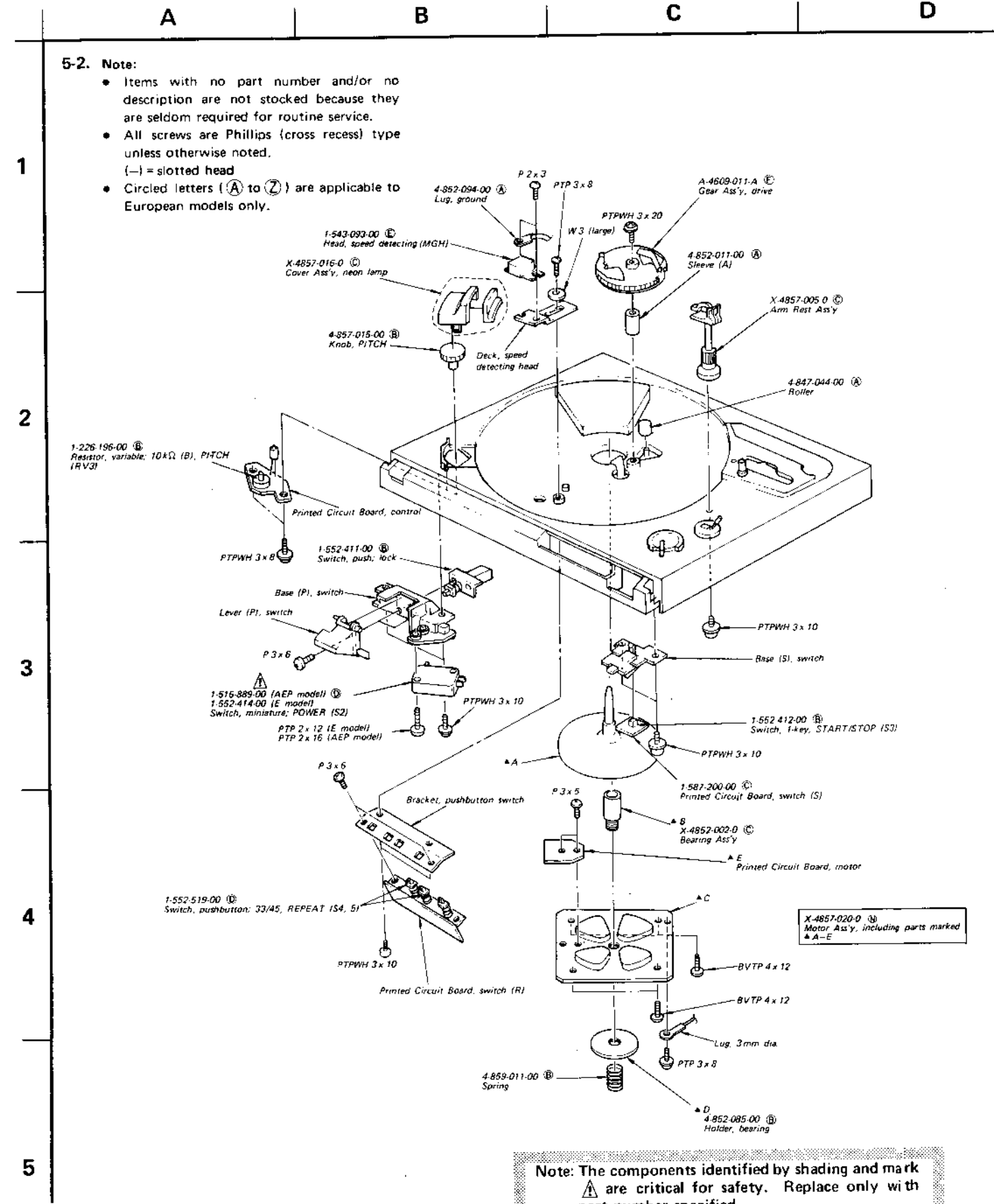
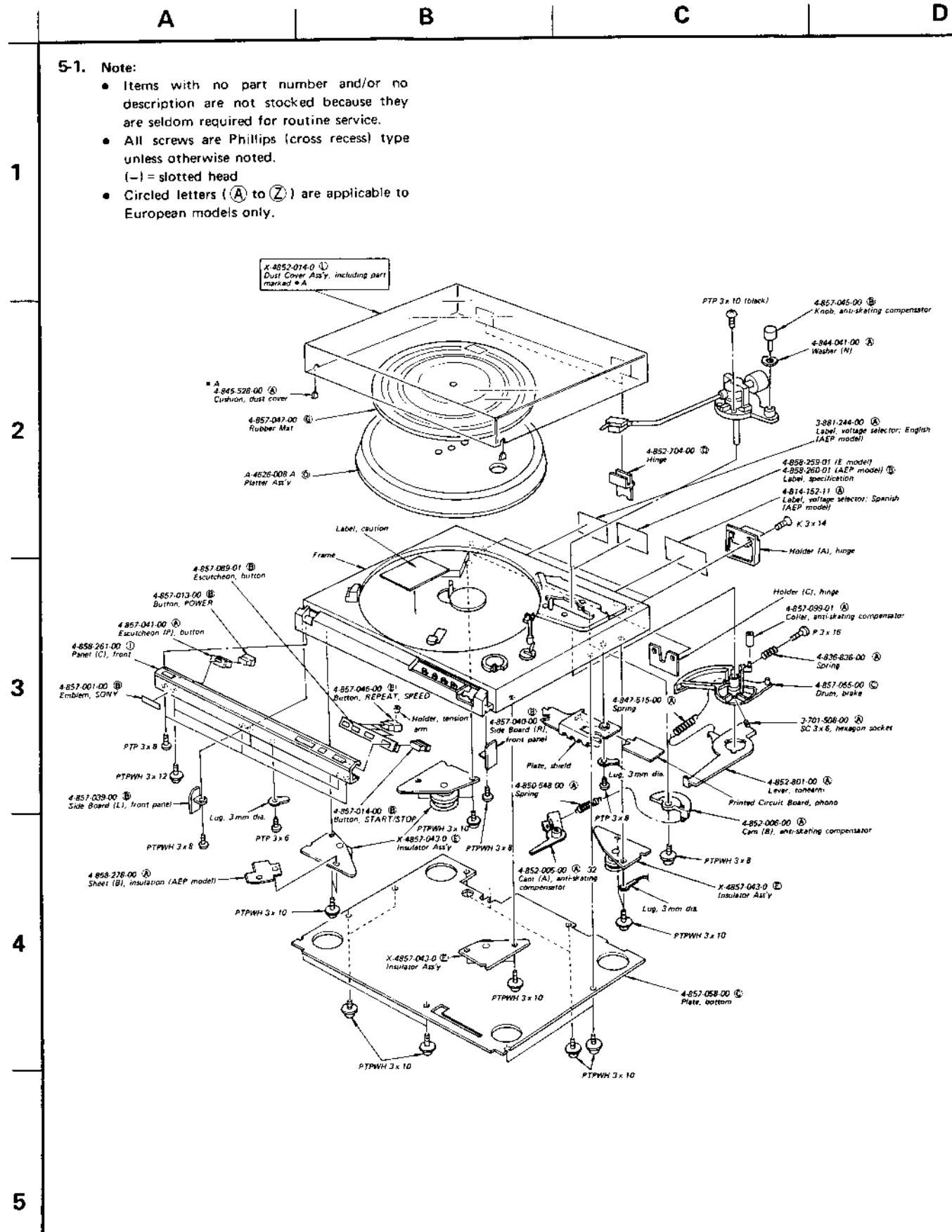

**Note: The components identified by shading and mark ⚠ are critical for safety. Replace only with part number specified.**

5-3. Note:

- Items with no part number and/or no description are not stocked because they are seldom required for routine service.
- All screws are Phillips (cross recess) type unless otherwise noted.  
(-) = slotted head
- Circled letters (A to Z) are applicable to European models only.

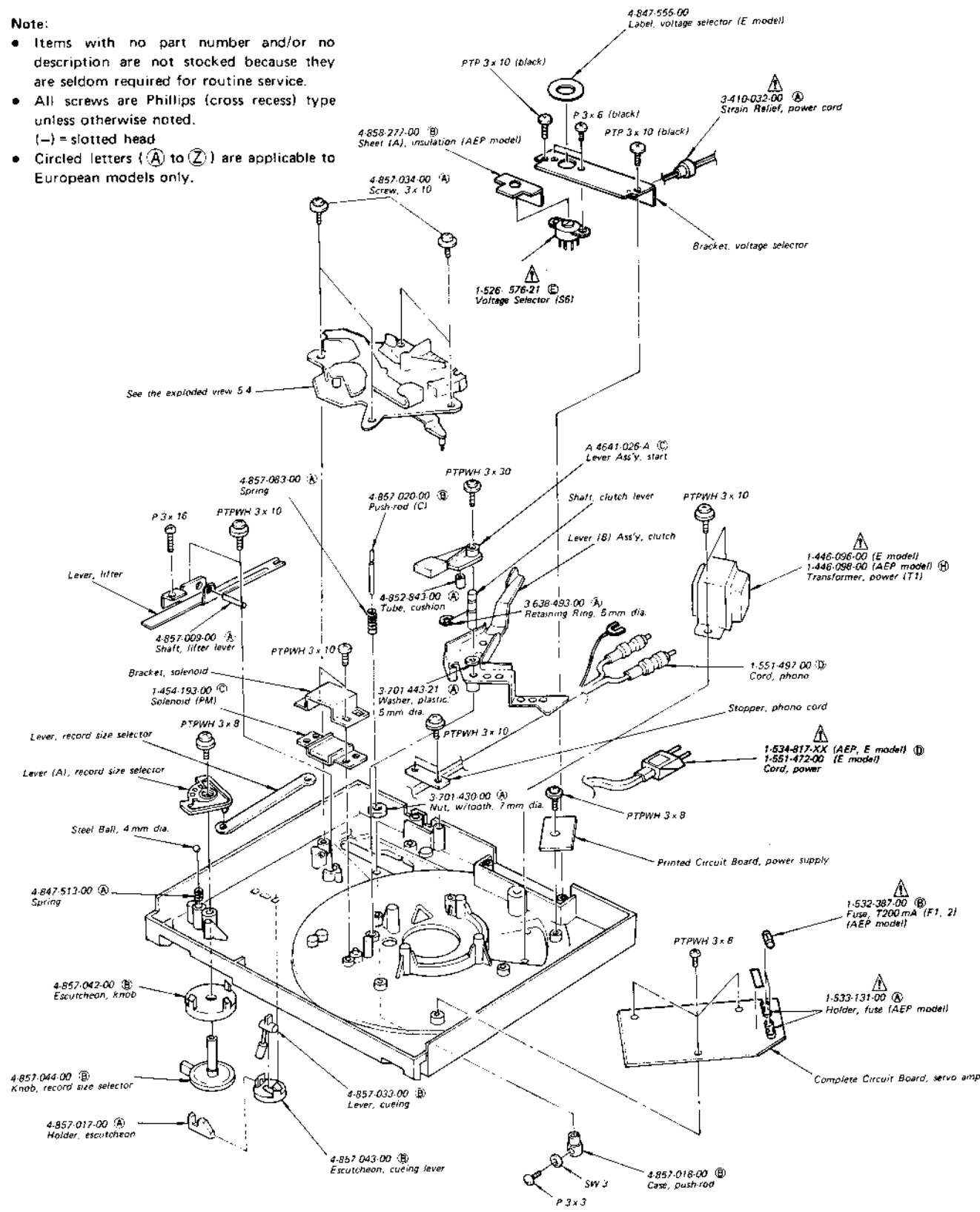

Note: The components identified by shading and mark are critical for safety. Replace only with part number specified.

5-4. Note:

- Items with no part number and/or no description are not stocked because they are seldom required for routine service.
- All screws are Phillips (cross recess) type unless otherwise noted.  
(-) = slotted head
- Circled letters (A to Z) are applicable to European models only.

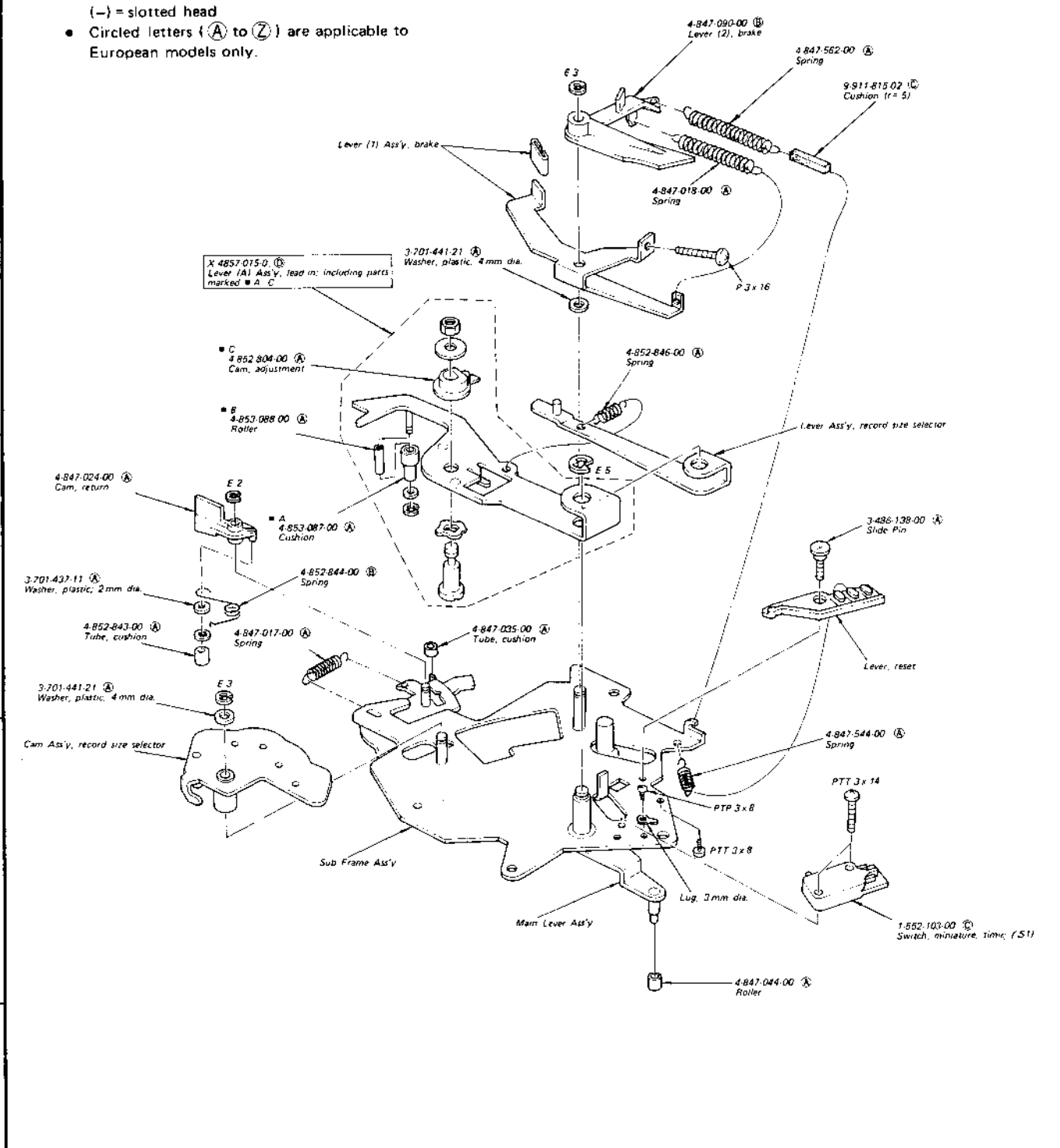

• Circled letters (A to Z) are applicable to European models only.

A B C D

5-5. Note:

- Items with no part number and/or no description are not stocked because they are seldom required for routine service.
- All screws are Phillips (cross recess) type unless otherwise noted.
- (-) = slotted head
- Circled letters (A to Z) are applicable to European models only.

1

2

3

4

5

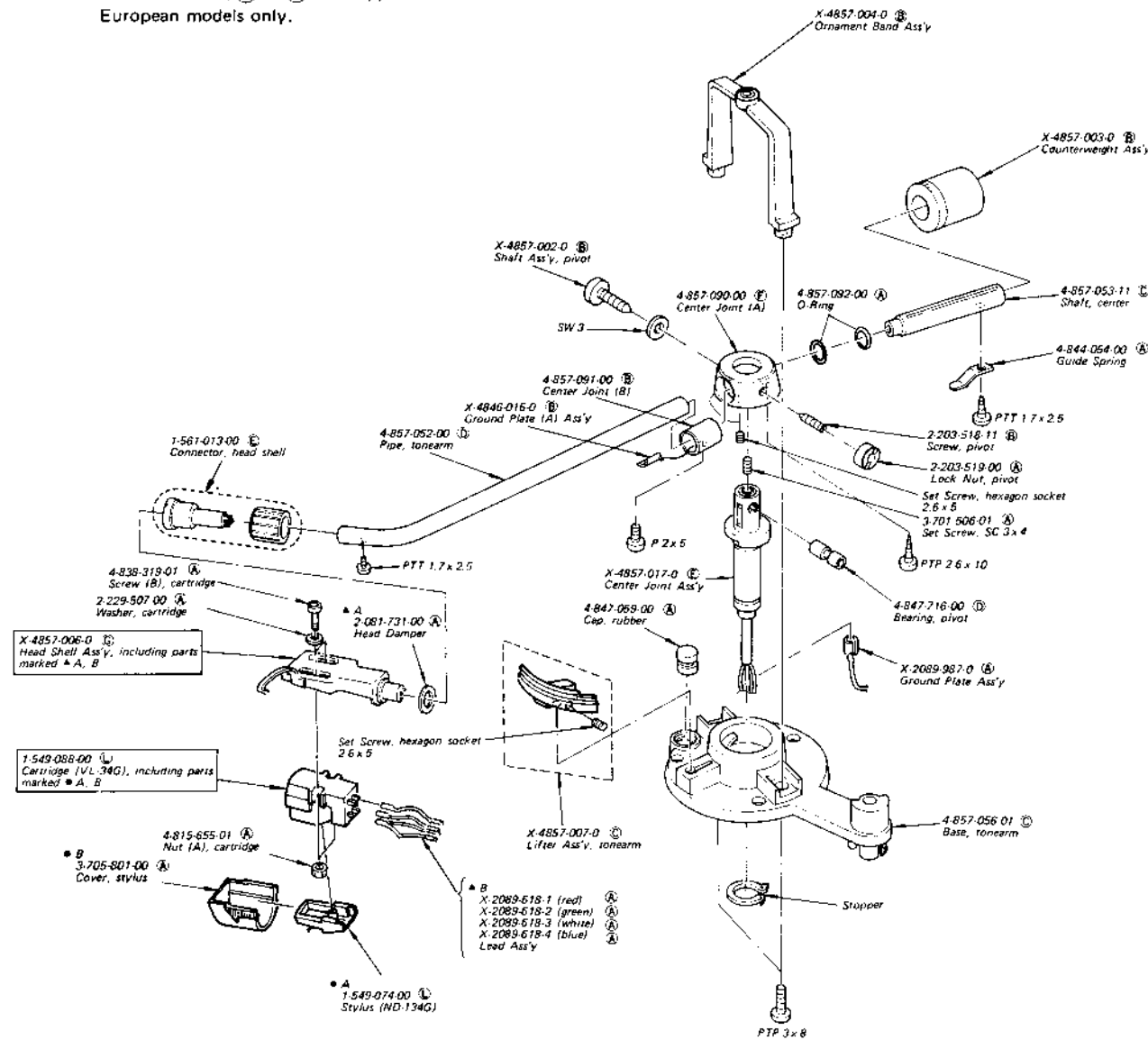

Ref. No. Part No. Description

PRINTED CIRCUIT BOARD

1-587-200-00 Ⓢ Switch (S)

SEMICONDUCTORS

Transistors

⇒ Q1-4 8-729-663-47 Ⓢ 2SC1364  
 ⇒ Q5 8-727-788-00 Ⓢ 2SA678  
 Q6 8-729-141-43 Ⓢ 2SD414  
 Q7 8-729-154-83 Ⓢ 2SB548  
 Q8 8-729-141-43 Ⓢ 2SD414  
 Q9 8-729-154-83 Ⓢ 2SB548  
 Q10 8-729-160-51 Ⓢ 2SB605  
 ⇒ Q11 8-727-788-00 Ⓢ 2SA678  
 ⇒ Q12,13 8-729-663-47 Ⓢ 2SC1364  
 ⇒ Q14 8-727-788-00 Ⓢ 2SA678  
 ⇒ Q15 8-729-663-47 Ⓢ 2SC1364

ICs

IC1,2 8-759-145-58 Ⓢ μPC4558C

Diodes

D1-3 8-719-815-55 Ⓢ 1S1555  
 D4 Ⓢ 8-719-510-10 Ⓢ 1SRB10  
 ⇒ D5,6 8-719-930-11 Ⓢ EQB01-11Z

Hall Device

⇒ H1,2 8-719-814-09 Ⓢ F1409

TRANSFORMERS

T1 Ⓢ 1-446-096-00 Power (E model)  
 Ⓢ 1-446-098-00 Power (AEP model)

Ref. No. Part No. Description

CAPACITORS

All capacitors are in μF. 50WV or less are not indicated except for electrolytics.  
 pF = μμF, elect = electrolytic

C1 1-101-006-11 Ⓢ 0.047 ceramic  
 C2 1-121-409-11 Ⓢ 47 10V elect  
 C3 1-102-114-11 Ⓢ 470p ceramic  
 C4 1-108-360-12 Ⓢ 0.039 mylar  
 C5,6 1-121-951-11 Ⓢ 0.47 50V elect  
 C7 1-121-063-11 Ⓢ 220 35V elect (AEP model)  
 1-121-936-11 220 25V elect (E model)  
 C8 1-121-951-11 Ⓢ 0.47 50V elect  
 C9 1-121-651-11 Ⓢ 10 16V elect  
 C10 1-121-410-11 Ⓢ 47 25V elect  
 C11 1-121-738-11 Ⓢ 10 50V elect  
 C12,13 1-121-940-11 Ⓢ 470 25V elect (AEP model)  
 1-121-944-11 1000 16V elect (E model)  
 C14,15 1-121-415-11 Ⓢ 100 16V elect

RESISTORS

All resistors are in ohms. Common 1/4W carbon resistors are omitted.  
 Refer to the list on the last page for their part numbers.

R1 Ⓢ 1-244-897-11 10k 1/2W carbon (E model)  
 Ⓢ 1-244-899-11 Ⓢ 12k 1/2W carbon (AEP model)  
 R42,43 Ⓢ 1-244-839-11 Ⓢ 39 1/2W carbon  
 R62 Ⓢ 1-244-847-11 82 1/2W carbon (E model)  
 Ⓢ 1-244-857-11 Ⓢ 220 1/2W carbon (AEP model)  
 R63 Ⓢ 1-244-849-11 100 1/2W carbon (E model)  
 Ⓢ 1-244-858-11 Ⓢ 240 1/2W carbon (AEP model)  
 RV1,2 1-224-647-XX Ⓢ 47 k-B, adjustable; speed  
 RV3 1-226-196-00 Ⓢ 10 k-B, variable; PITCH  
 RV4,5 1-224-644-XX Ⓢ 4.7 k-B, adjustable; offset  
 ⇒ RV6,7 1-224-644-XX Ⓢ 4.7 k-B, adjustable; gain

⇒: Due to standardization, interchangeable replacements may be substituted for parts specified in the diagrams.

Note: The components identified by shading and mark Ⓢ are critical for safety. Replace only with part number specified.

- Circled letters (A to Z) are applicable to European models only.

Ref. No.      Part No.      Description

## SWITCHES

S1	1-552-103-00	Ⓒ	Miniature, timing
S2	1-516-889-00	Ⓓ	Miniature, POWER (AEP model)
	1-552-414-00		Miniature, POWER (E model)
S3	1-552-412-00	Ⓑ	1-key, START/STOP
S4,5	1-552-519-00	Ⓓ	Pushbutton, 33/45, REPEAT
S6	1-526-576-21	Ⓔ	Voltage Selector

## MISCELLANEOUS

CP1	1-115-148-11	Ⓒ	0.01 450V oil paper (AEP model)
	1-129-718-00		0.022 630V polyethylene (E model)
F1,2	1-532-387-00	Ⓑ	Fuse, T200 mA (AEP model)
MGH	1-543-093-00	Ⓔ	Head, speed detecting
NL1	1-519-135-00	Ⓒ	Lamp, neon
PM	1-454-193-00	Ⓒ	Solenoid
	X-4857-020-0	Ⓔ	Motor Ass'y
	1-533-131-00	Ⓐ	Holder, fuse (AEP model)
	1-534-817-XX	Ⓔ	Cord, power; euro-plug
	1-549-088-00	Ⓒ	Cartridge (VL-34G) including:
	1-549-074-00	Ⓒ	Stylus (ND-134G)
	3-705-801-00	Ⓐ	Cover, stylus
	1-551-472-00		Cord, power; parallel blade plug (E model)
	1-551-497-00	Ⓓ	Cord, phono
	1-552-411-00	Ⓑ	Switch, push; lock
	1-561-013-00	Ⓔ	Connector, head shell

## ACCESSORIES &amp; PACKING MATERIALS

<u>Part No.</u>	<u>Description</u>
3-701-616-00	Ⓐ Bag, plastic
3-701-630-00	Ⓐ Bag, plastic
3-701-634-00	Ⓐ Bag, plastic
3-701-806-00	Ⓐ Adaptor (E), 45 rpm
3-770-583-11	Ⓓ Manual, instruction
3-793-395-11	Ⓑ Gauge, overhang adjustment
4-847-092-00	Ⓒ Screwdriver
4-847-314-00	Ⓒ Bag, plastic; set
4-852-078-00	Ⓑ Holder, platter
4-852-080-00	Ⓑ Cushion, upper
4-852-081-00	Ⓑ Cushion, lower
4-853-409-00	Ⓑ Cushion, tonearm
4-858-285-00	Ⓔ Carton

Note: The components identified by shading and mark **⚠** are critical for safety. Replace only with part number specified.

1/4 WATT CARBON RESISTORS <sup>(A)</sup>

Note: Circled letter <sup>(A)</sup> is applicable to European models only.

Ω	Part No.	Ω	Part No.	Ω	Part No.	Ω	Part No.	Ω	Part No.	Ω	Part No.	Ω	Part No.	Ω	Part No.
1.0	1-244-601-11	10	1-244-625-11	100	1-244-649-11	1.0k	1-244-673-11	10k	1-244-697-11	100k	1-244-721-11	1.0M	1-244-745-11		
1.1	1-244-602-11	11	1-244-626-11	110	1-244-650-11	1.1k	1-244-674-11	11k	1-244-698-11	110k	1-244-722-11	1.1M	1-244-746-11		
1.2	1-244-603-11	12	1-244-627-11	120	1-244-651-11	1.2k	1-244-675-11	12k	1-244-699-11	120k	1-244-723-11	1.2M	1-244-747-11		
1.3	1-244-604-11	13	1-244-628-11	130	1-244-652-11	1.3k	1-244-676-11	13k	1-244-700-11	130k	1-244-724-11	1.3M	1-244-748-11		
1.5	1-244-605-11	15	1-244-629-11	150	1-244-653-11	1.5k	1-244-677-11	15k	1-244-701-11	150k	1-244-725-11	1.5M	1-244-749-11		
1.6	1-244-606-11	16	1-244-630-11	160	1-244-654-11	1.6k	1-244-678-11	16k	1-244-702-11	160k	1-244-726-11	1.6M	1-244-750-11		
1.8	1-244-607-11	18	1-244-631-11	180	1-244-655-11	1.8k	1-244-679-11	18k	1-244-703-11	180k	1-244-727-11	1.8M	1-244-751-11		
2.0	1-244-608-11	20	1-244-632-11	200	1-244-656-11	2.0k	1-244-680-11	20k	1-244-704-11	200k	1-244-728-11	2.0M	1-244-752-11		
2.2	1-244-609-11	22	1-244-633-11	220	1-244-657-11	2.2k	1-244-681-11	22k	1-244-705-11	220k	1-244-729-11	2.2M	1-244-753-11		
2.4	1-244-610-11	24	1-244-634-11	240	1-244-658-11	2.4k	1-244-682-11	24k	1-244-706-11	240k	1-244-730-11	2.4M	1-244-754-11		
2.7	1-244-611-11	27	1-244-635-11	270	1-244-659-11	2.7k	1-244-683-11	27k	1-244-707-11	270k	1-244-731-11	2.7M	1-244-755-11		
3.0	1-244-612-11	30	1-244-636-11	300	1-244-660-11	3.0k	1-244-684-11	30k	1-244-708-11	300k	1-244-732-11	3.0M	1-244-756-11		
3.3	1-244-613-11	33	1-244-637-11	330	1-244-661-11	3.3k	1-244-685-11	33k	1-244-709-11	330k	1-244-733-11	3.3M	1-244-757-11		
3.6	1-244-614-11	36	1-244-638-11	360	1-244-662-11	3.6k	1-244-686-11	36k	1-244-710-11	360k	1-244-734-11	3.6M	1-244-758-11		
3.9	1-244-615-11	39	1-244-639-11	390	1-244-663-11	3.9k	1-244-687-11	39k	1-244-711-11	390k	1-244-735-11	3.9M	1-244-759-11		
4.3	1-244-616-11	43	1-244-640-11	430	1-244-664-11	4.3k	1-244-688-11	43k	1-244-712-11	430k	1-244-736-11	4.3M	1-244-760-11		
4.7	1-244-617-11	47	1-244-641-11	470	1-244-665-11	4.7k	1-244-689-11	47k	1-244-713-11	470k	1-244-737-11	4.7M	1-244-761-11		
5.1	1-244-618-11	51	1-244-642-11	510	1-244-666-11	5.1k	1-244-690-11	51k	1-244-714-11	510k	1-244-738-11	5.1M	1-244-762-11		
5.6	1-244-619-11	56	1-244-643-11	560	1-244-667-11	5.6k	1-244-691-11	56k	1-244-715-11	560k	1-244-739-11				
6.2	1-244-620-11	62	1-244-644-11	620	1-244-668-11	6.2k	1-244-692-11	62k	1-244-716-11	620k	1-244-740-11				
6.8	1-244-621-11	68	1-244-645-11	680	1-244-669-11	6.8k	1-244-693-11	68k	1-244-717-11	680k	1-244-741-11				
7.5	1-244-622-11	75	1-244-646-11	750	1-244-670-11	7.5k	1-244-694-11	75k	1-244-718-11	750k	1-244-742-11				
8.2	1-244-623-11	82	1-244-647-11	820	1-244-671-11	8.2k	1-244-695-11	82k	1-244-719-11	820k	1-244-743-11				
9.1	1-244-624-11	91	1-244-648-11	910	1-244-672-11	9.1k	1-244-696-11	91k	1-244-720-11	910k	1-244-744-11				

HARDWARE NOMENCLATURE

Screw:

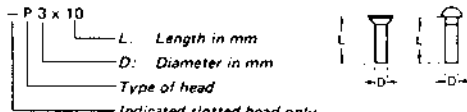

Indicated slotted-head only.  
Unless otherwise indicated, it means cross-recessed head (Phillips type).

Nut, Washer, Retaining ring:

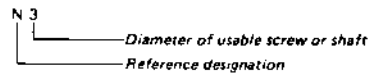

Reference Designation	Shape	Description	Remarks
<b>SCREWS</b>			
P		pan-head screw	binding-head (B) screw for replacement
PWH		pan-head screw with washer face	binding-head (B) screw and flat washer for replacement
PS PSP		pan-head screw with spring washer	binding-head (B) screw and spring washer for replacement
PSW PSPW		pan-head screw with spring and flat washers	binding-head (B) screw and spring and flat washers for replacement
R		round-head screw	binding-head (B) screw for replacement
K		flat-countersunk-head screw	
RK		oval-countersunk-head screw	
B		binding-head screw	
T		truss-head screw	binding-head (B) screw for replacement
F		flat-fillister-head screw	
RF		fillister-head screw	
BV		brazer-head screw	

Reference Designation	Shape	Description	Remarks
<b>SELF-TAPPING SCREWS</b>			
TA		self-tapping screw	ex: TA, P 3 x 10
PTP		pan-head self-tapping screw	binding-head self-tapping (TA, B) screw for replacement
PTPWH		pan-head self-tapping screw with washer face	binding-head self-tapping (TA, B) screw and flat washer for replacement
PTTWH		pan-head thread-rolling screw with washer face	binding-head (B) screw and flat washer for replacement
<b>SET SCREWS</b>			
SC		set screw	
SC		hexagon-socket set screw	ex: SC 2.6 x 4, hexagon socket
<b>NUT</b>			
N		nut	
<b>WASHERS</b>			
W		flat washer	
SW		spring washer	
LW		internal-tooth lock washer	ex: LW3, internal
LW		external-tooth lock washer	ex: LW3, external
<b>RETAINING RINGS</b>			
E		retaining ring	
G		grip-type retaining ring	

Sony Corporation

© 1978

— 32 —

# FULL AUTOMATIC STEREO TURNTABLE SYSTEM

# PS-313FA

AEP Model  
E Model

## CORRECTION

File this Correction with the Service Manual.

 : corrected portion

No. 1

March, 1979

Page 25. EXPLODED VIEW

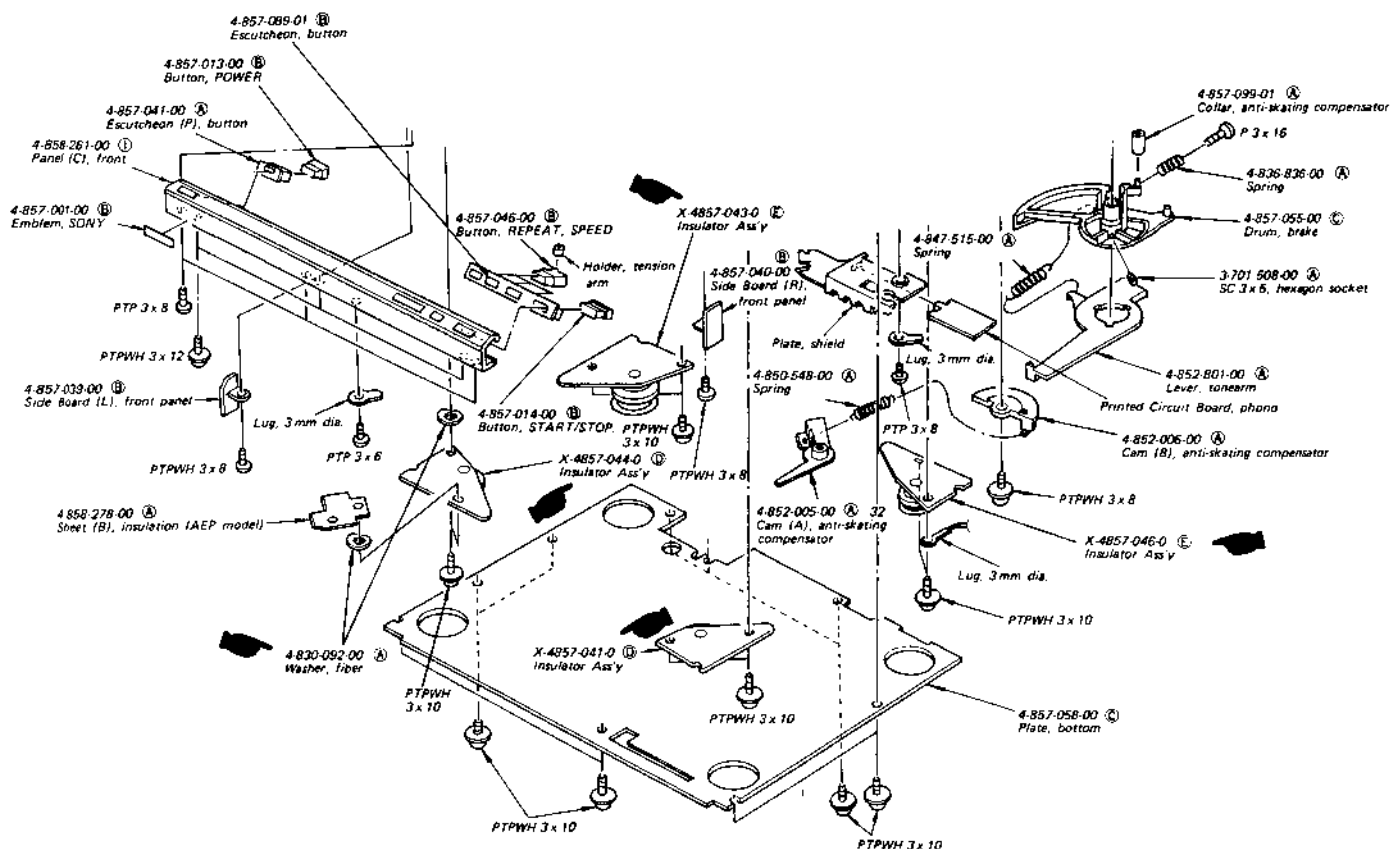

Part No.	Mark	Installing Position
X-4857-041-0	1 black line	right-front
043-0	3 black lines	left-rear
044-0	1 red line	left-front
046-0	3 red lines	right-rear

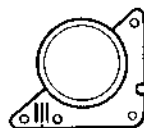

**SONY**  
SERVICE MANUAL

Page 16. SPEED DETECTION HEAD OUTPUT LEVEL ADJUSTMENT

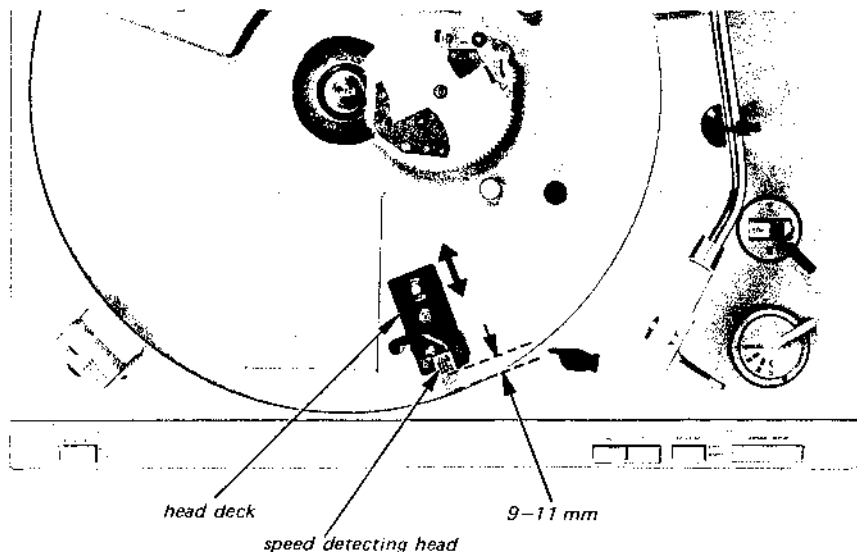

Page 21, 22. MOUNTING DIAGRAM

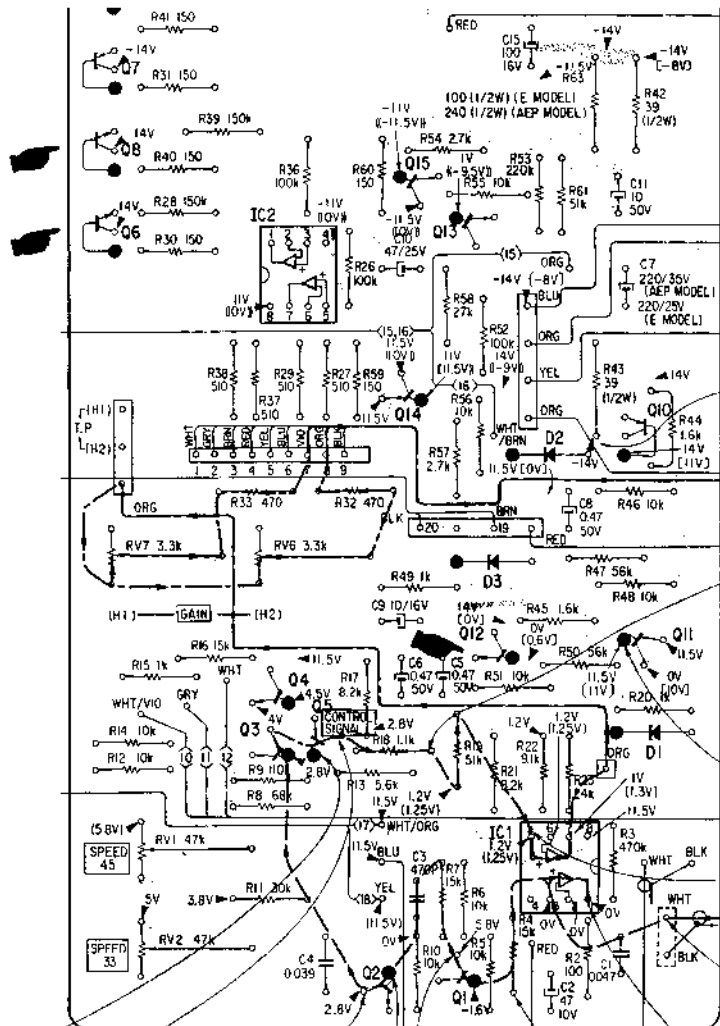

Sony Corporation

© 1979

- 2 -