

MZ-R30

SERVICE MANUAL

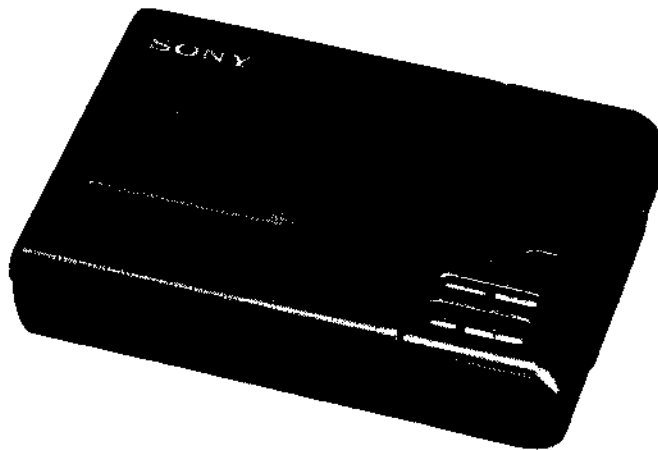

*US Model
Canadian Model
AEP Model
UK Model
E Model
Australian Model
Tourist Model*

US and foreign patents licensed from Dolby Laboratories Licensing Corporation.

Model Name Using Similar Mechanism	NEW
MD Mechanism Type	MT-MZR30-124
Optical Pick-up Type	KMS-250AJ2N

SPECIFICATIONS

System

Audio playing system
MiniDisc digital audio system
Laser diode properties
Material: GaAlAs
Wavelength: $\lambda = 780 \text{ nm}$
Emission duration: continuous
Laser output less than $44.6 \mu\text{W}$
(This output is the value measured at a distance of 200 mm from the lens surface on the optical pick-up block.)
Recording and playback time
Maximum 74 minutes (MDW-74, stereo recording)
Maximum 148 minutes (MDW-74, monaural recording)
Revolutions
400 rpm to 900 rpm (CLV)
Error correction
Advanced Cross Interleave Reed Solomon Code (ACIRC)
Sampling frequency
44.1 kHz
Sampling rate converter
Input: 33 kHz/44.1 kHz/48 kHz

Coding

Adaptive Transform Acoustic Coding (ATRAC)
Modulation system
EFM (Eight to Fourteen Modulation)
Number of channels
2 stereo channels
1 monaural channel
Frequency response
20 to 20,000 Hz $\pm 3 \text{ dB}$
Wow and Flutter
Below measurable limit
Inputs
Microphone: stereo mini-jack, 0.22 - 0.78 mV
Line in: stereo mini-jack, 69 - 194 mV
Optical (Digital) in: optical (digital) mini-jack
Outputs
Headphones: stereo mini-jack, maximum output level 5 mW + 5 mW, load impedance 16 ohm
Line out: stereo mini-jack, 194 mV, load impedance 10 kilohm

- Continued on page 2 -

PORTABLE MINIDISC RECORDER

SONY®

General

Power requirements

Sony AC power Adaptor (supplied)
connected at the DC IN 6 V jack :
120V AC, 60 Hz (US, Canadian model)
230 - 240V AC, 50/60 Hz (UK model)
240V AC, 50/60 Hz (Australian model)
220 - 230V AC, 50/60 Hz (AEP model)
100 - 240V AC, 50/60 Hz (E. Tourist model)

Lithium ion rechargeable battery LIP-12(H)
(supplied)
Two LR6 (size AA) alkaline batteries (not
supplied)

Battery operation time

See "Battery life" (page 25)

Dimensions

Approx. 116.5 x 26 x 78 mm (w/h/d)
(4⁵/₈ x 1¹/₁₆ x 3¹/₈ in.)

Mass

Approx. 220 g (7.1 oz) the recorder only
Approx. 317 g (10.2 oz) incl. a recordable
MD, remote controller, and LIP-12 lithium
ion rechargeable battery

Supplied accessories

AC power adaptor (1)
Headphones with a remote controller (1)
LIP-12 lithium ion rechargeable battery (1)
Ear pads (2)
Carrying pouch (1)
Dry battery case (1)

Design and specifications are subject to
change without notice.

For customers in Europe

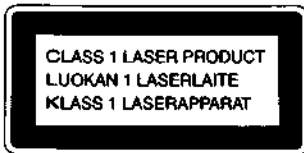

This MiniDisc Recorder is classified as a
CLASS 1 LASER product.
The CLASS 1 LASER PRODUCT label is
located on the bottom exterior.

IN NO EVENT SHALL SELLER BE
LIABLE FOR ANY DIRECT,
INCIDENTAL OR CONSEQUENTIAL
DAMAGES OF ANY NATURE, OR
LOSSES OR EXPENSES RESULTING
FROM ANY DEFECTIVE PRODUCT
OR THE USE OF ANY PRODUCT.

"MD WALKMAN" is a trademark of Sony
Corporation.

CAUTION

Use of controls or adjustments or performance of procedures other
than those specified herein may result in hazardous radiation expo-
sure.

Flexible Circuit Board Repairing

- Keep the temperature of the soldering iron around 270°C during
repairing.
- Do not touch the soldering iron on the same conductor of the cir-
cuit board (within 3 times).
- Be careful not to apply force on the conductor when soldering or
unsoldering.

Notes on chip component replacement

- Never reuse a disconnected chip component.
- Notice that the minus side of a tantalum capacitor may be dam-
aged by heat.

TABLE OF CONTENTS

Specifications	1
1. SERVICE NOTE	3
2. GENERAL	4
3. DISASSEMBLY	
3-1. Upper Panel Assy, Bottom Panel Assy Removal	20
3-2. Main Board Removal	20
3-3. Mechanism Deck Removal	21
3-4. Optical Pick-up Assy, Control Board, REC Board Removal	21
3-5. Battery Case Assy Removal	22
3-6. Switch board, Power Board Removal	22
4. TEST MODE	23
5. ELECTRICAL ADJUSTMENTS	29
6. EXPLANATION OF IC TERMINALS	33
7. DIAGRAMS	
7-1. Block Diagram	37
7-2. Circuit Boards Location	41
7-3. Printed Wiring Boards - Main Section -	42
7-4. Schematic Diagram - Main (1/3) Section -	47
7-5. Schematic Diagram - Main (2/3) Section -	51
7-6. Schematic Diagram - Main (3/3) Section -	55
7-7. Schematic Diagram - Power Section -	57
7-8. Printed Wiring Boards - Control Section -	60
7-9. Schematic Diagram - Control Section -	63
8. EXPLODED VIEWS	
8-1. Upper Panel, Bottom Panel Section	69
8-2. Chassis Section	70
8-3. Mechanism Deck Section-1	71
8-4. Mechanism Deck Section-2	72
9. ELECTRICAL PARTS LIST	73

SAFETY-RELATED COMPONENT WARNING!!

COMPONENTS IDENTIFIED BY MARK Δ OR DOTTED LINE WITH
MARK Δ ON THE SCHEMATIC DIAGRAMS AND IN THE PARTS
LIST ARE CRITICAL TO SAFE OPERATION.
REPLACE THESE COMPONENTS WITH SONY PARTS WHOSE
PART NUMBERS APPEAR AS SHOWN IN THIS MANUAL OR IN
SUPPLEMENTS PUBLISHED BY SONY.

ATTENTION AU COMPOSANT AYANT RAPPORT À LA SÉCURITÉ!

LES COMPOSANTS IDENTIFIÉS PAR UNE MARQUE Δ SUR LES
DIAGRAMMES SCHÉMATIQUES ET LA LISTE DES PIÈCES SONT
CRITIQUES POUR LA SÉCURITÉ DE FONCTIONNEMENT. NE
REPLACER CES COMPOSANTS QUE PAR DES PIÈCES SONY
DONT LES NUMÉROS SONT DONNÉS DANS CE MANUEL OU
DANS LES SUPPLÉMENTS PUBLIÉS PAR SONY.

SECTION 1 SERVICING NOTE

When repairing this device with the power on, if you remove the main board or open the upper panel assembly, this device stops working. In this case, you can work without the device stopping by fastening the hook of the Open/Close detection switch (S817) with tape.

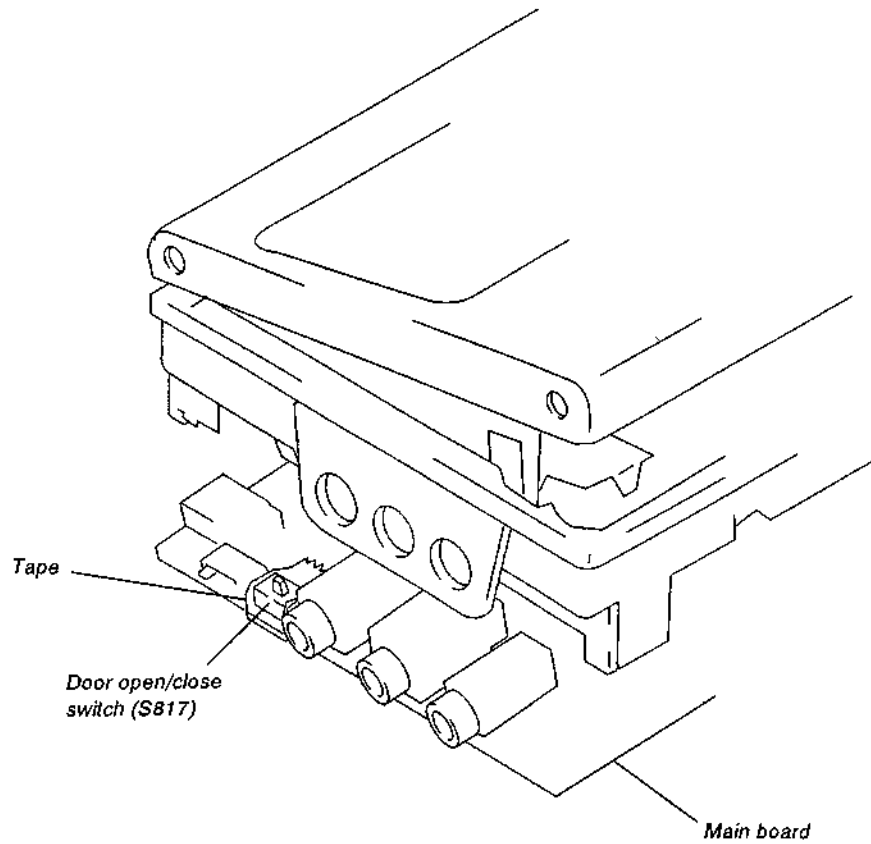

SECTION 2 GENERAL

This section is extracted from instruction manual.

Looking at the controls

See pages in () for more details.

The recorder

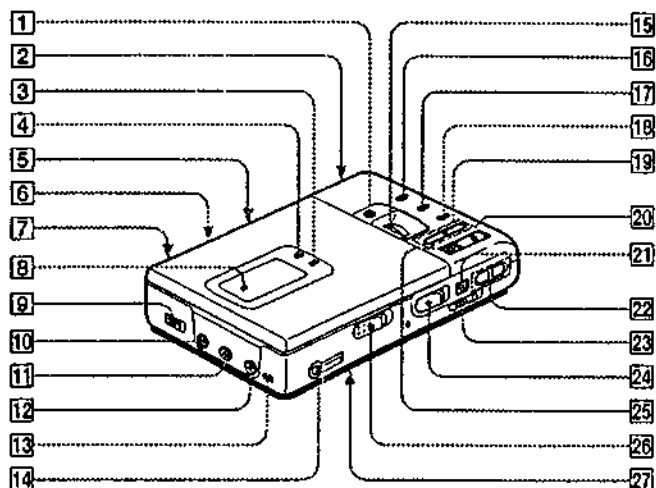

- | | |
|---|--|
| 1 TITLE/ENTER button(22) | 14 (headphones)/REMOTE jack (8) |
| 2 Battery compartment (on the bottom) (24) | 15 Vertical jog dial (16) |
| 3 MODE button (16) | 16 TRACK MARK button (21) |
| 4 DISPLAY button (14, 18) | 17 END SEARCH button (7) |
| 5 MIC SENS switch (on the bottom) (12) | 18 ERASE button (20) |
| 6 AVLS switch (on the bottom) (17) | 19 <<</>>> (search / AMS) button (7, 9) |
| 7 DC IN 6V jack (at the rear) (6) | 20 (play) button (7, 9) |
| 8 Display window (14,18) | 21 (pause) button (7, 9) |
| 9 SYNCHRO REC (synchro-recording) switch (11) | 22 VOLUME +/- button (9) |
| 10 MIC (PLUG IN POWER) jack (12) | 23 HOLD switch (18) |
| 11 LINE IN (OPTICAL) jack (6, 11) | 24 REC (record) switch (7) |
| 12 LINE OUT jack (19) | 25 (stop) button (7, 9) |
| 13 DIGITAL MEGA BASS button (17) | 26 OPEN button (6) |
| | 27 CLOCK SET button (on the bottom) (15) |

The display window

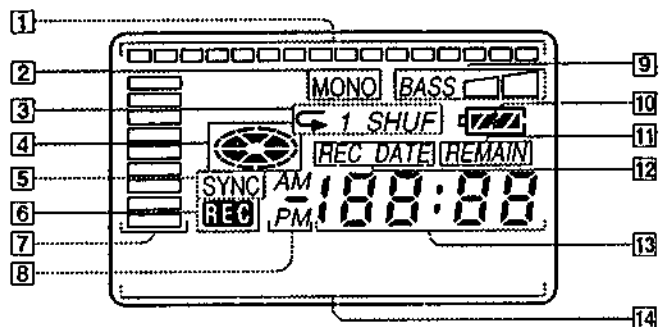

1 Position indicator (14, 18)
Shows the current location on the MD. The point under recording or playing flashes. The recorded portion lights up.

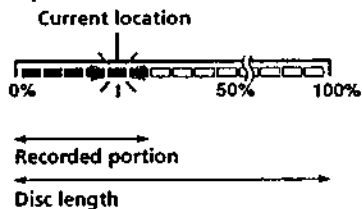

2 MONO (monaural) indication
3 Play mode indication
Shows the play mode of the MD.
4 Disc indication
Shows that the disc is rotating for recording, playing or editing an MD.
5 SYNC (synchro-recording) indication
6 REC indication (7)
Lights up while recording. When flashing, the recorder is in record standby mode.

7 Level meter
Shows the volume of the MD being played or recorded.
8 AM/PM indication (15)
Lights up along with the time indication in the 12-hour system.
9 Mega bass indication (17)
10 Battery indication (24)
Shows battery condition.
11 REMAIN (remaining time/tracks) indication (14,18)
Lights up along with the remaining time of the track, the remaining time of the MD, or the remaining number of tracks.
12 REC DATE (recorded/current date) indication
Lights up along with the date and time the MD was recorded. When only "DATE" lights up, the current date and time are displayed.
13 Time display (15)
Shows the recorded time, current time, elapsed time of the track or MD being recorded or played.
14 Character information display (14,18)
Displays the disc and track names, date, error messages, track numbers, etc.

Additional information

The headphones with a remote controller

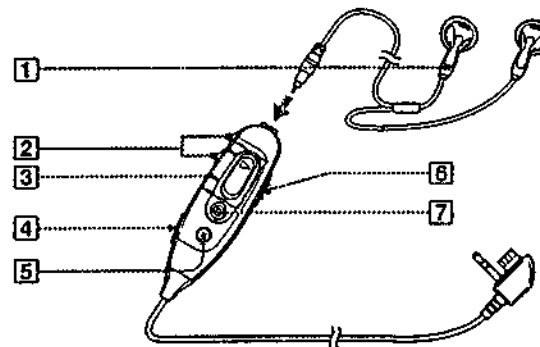

1 Headphones
Can be replaced with optional headphones.
2 VOL (volume) +/- buttons (9)
3 ▶ (play)/◀◀ (search, AMS) buttons
Press ▶ to play. While playing, press the ◀◀ side to find beginning of the current or preceding tracks or to search backward, or press the ▶▶ side to find the beginning of the succeeding tracks or to search forward.

4 TRACK MARK button (21)
5 || (pause) button (7,9)
6 HOLD switch (18)
Slide to lock the controls of the remote controller.
7 ■ (stop) button (7,9)

Recording an MD right away!

The source sound of CDs or tapes will be sent as an analog signal and recorded digitally. The recorded sound will be stereo. When you record from a digital source, see "Recording with digital input" (page 11).

1 Make connections.

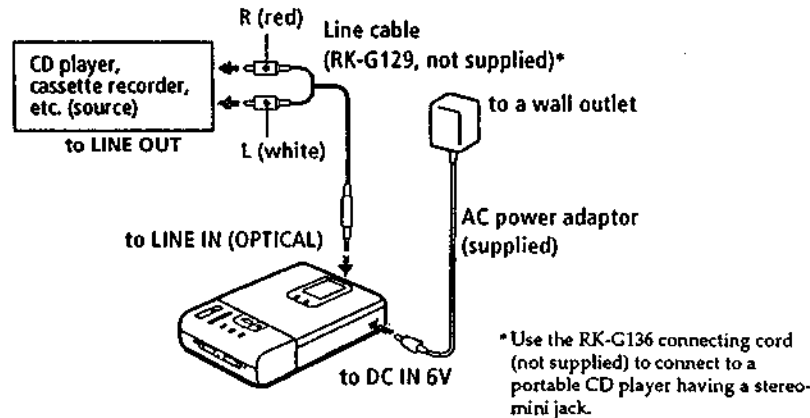

2 Insert a recordable MD.

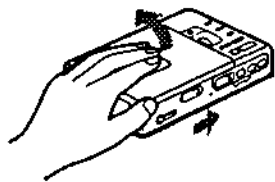

① Slide OPEN and open the lid.

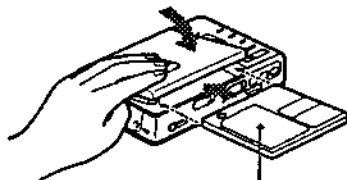

② Insert a recordable MD with the label side facing up, and press the lid down to close.

3 Record an MD.

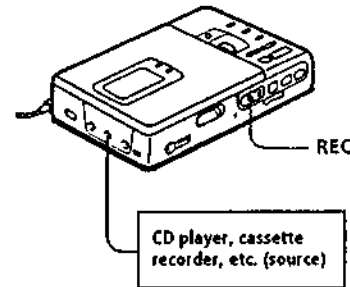

① Slide REC to the right while pressing its button. "REC" lights up and recording starts.

② Play the CD or tape you want to record.

To stop recording, press ■. "Toc Edit" flashes to record data of the recording (the track's start and end points, etc.). Do not move or jog the recorder or disconnect the power source while the indication is flashing in the display.

To	Press
Pause	¹⁾ Press again to resume recording.
Add recording to the end of the previous recording.	END SEARCH and slide REC.
Record over partway through the previous recording.	▶, ▶▶ or ◀◀ to find the start point of recording and press ■ to stop. Then slide REC.
Remove the MD.	■ and open the lid. ²⁾

¹⁾ A new track is added at the point where you pressed ||, and the recording will be marked with the new track number when you resume recording.

²⁾ Once you open the lid, the point to start recording will change to the beginning of the first track. When recording on a recorded MD, check the point to start recording on the display.

If the recording does not start

- Make sure the recorder is not locked (page 18).
- Make sure the MD is not record-protected (page 27).
- Premastered MDs cannot be recorded over.

Tips

- The level of the recorded sound is adjusted automatically.
- You can monitor the sound being recorded. Connect the supplied headphones with remote controller to ◯/REMOTE and adjust the volume by pressing VOLUME +/- (VOL +/- on the remote controller). Sound levels are copied onto the MD automatically and independently of the volume for monitoring.

Playing an MD right away!

You can also use the rechargeable battery or dry batteries (see pages 24, 25).

1 Make connections.

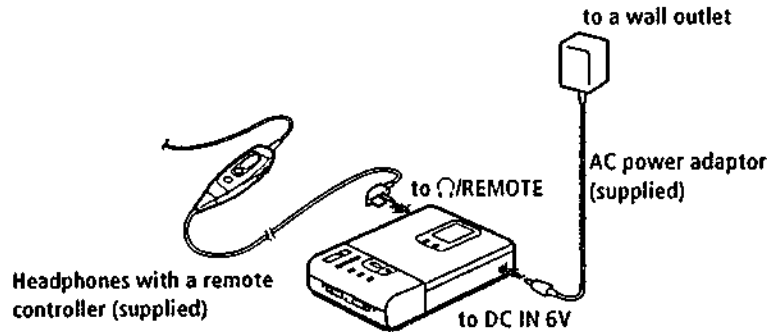

2 Insert an MD.

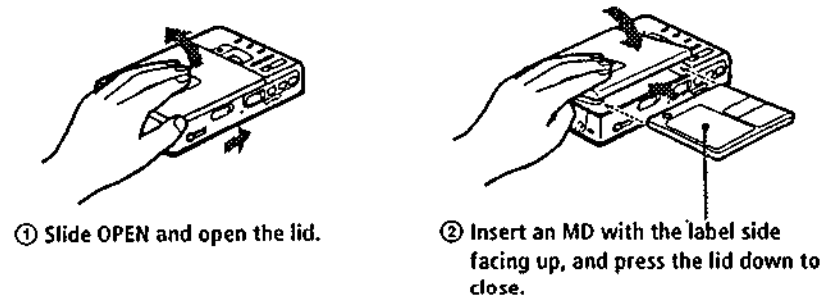

3 Play an MD.

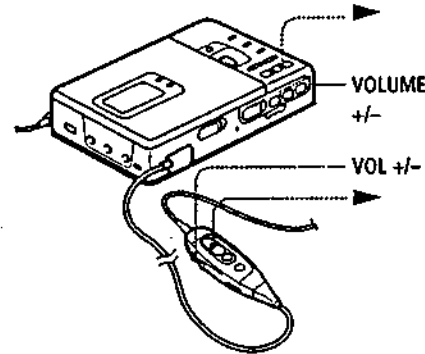

- ① Press **▶**.
A short beep sounds in the headphones.
- ② Press VOLUME +/- to adjust the volume.
You can check the volume in the display.

To stop play, press **■**.
A long beep sounds in the headphones.

To	Press (Beeps in the headphones)
Pause	 (Continuous short beeps) Press again to resume play.
Find the beginning of the current track	⏮ once (Three short beeps)
Find the beginning of the next track	⏭ once (Two short beeps)
Go backwards while playing ¹⁾	keep pressing ⏮
Go forward while playing ¹⁾	keep pressing ⏭
Remove the MD	■ and open the lid. ²⁾

¹⁾ To go backward or forward quickly without listening, press **||** and keep pressing **⏮** or **⏭**.
²⁾ Once you open the lid, the point to start play will change to the beginning of the first track.

If the play does not start
 Make sure the recorder is not locked (page 18).

Tip
 The recorder automatically switches to play the stereo or monaural sound according to the recorded sound.

Playing an MD right away!

► Various ways of recording

Two ways of connection to a sound source

The input jack of this recorder works as both digital and analog input jack. Connect the recorder to a CD player or a cassette recorder using either digital input or analog input. To record, see "Recording with digital input" (page 11) to record using digital input, and "Recording an MD right away!" (page 6) to record using analog input.

Difference between digital and analog inputs

Difference (connection)	Input	Digital input	Analog (line) input
Connectable source		Equipment with an optical digital output jack	Equipment with an analog (line) output jack
Usable cord		Digital cable (with an optical or an optical-mini plug)	Line cable (with 2 phono plugs or a stereo-mini plug)
Signal from the source		Digital	Analog Even when a digital source (such as a CD) is connected, the signal sent to the recorder is analog.
Recorded track numbers		Marked (copied) automatically • at the same positions as the source. • when the recorder is paused while recording.	Marked • after more than 2 seconds of silence. • when the recorder is paused while recording. You can erase unnecessary marks after recording ("Erasing a track mark", page 21).
Recorded sound level		Same as the source	Adjusted automatically. Can also be adjusted manually ("Adjusting the recording level", page 13).

Note

Track marks may be copied incorrectly :
 • when you record from some CD players or multi disc players using digital input.
 • when the source is in shuffle or program play mode while recording using digital input. In this case, play the source in normal play mode.

Recording with digital input

This unit has a built-in sampling rate converter so that you can record programs from digital equipment using other sampling rates, such as a BS tuner or a DAT deck.

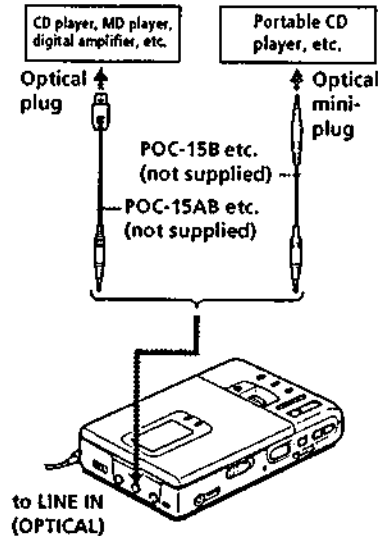

Insert a recordable MD and start recording.
 To record, see "Recording an MD right away!" (page 6). To record from a portable CD player, set the CD player to pause and then start recording.

LINE IN (OPTICAL) jack is for both digital and analog input

The recorder automatically recognizes the line cable and switches to digital or analog input.

Notes

- You can make a digital recording only from an optical type output.
- Some portable CD players with the ESP* system cannot send out digital signals when it is activated. In this case, release the ESP system.

* Electronic Shock Protection

To start/stop recording with the player (Synchro-recording)

You can easily make digital recordings of a digital source on an MD. Before synchro-recording, make connections to the digital source with a digital cable and the power source, and insert a recordable MD.

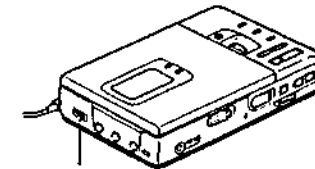

SYNCHRO REC

- 1 Slide SYNCHRO REC to ON. "SYNC" appears in the display.

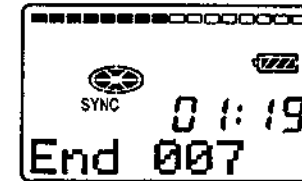

- 2 Slide REC to the right while pressing its button. The recorder stands by for recording. The recorder starts recording when you start playing the source player.

To stop synchro-recording, Press ■.

Tip

When there is no sound from the player more than 3 seconds during synchro-recording, the recorder stands by for recording automatically. When the sound comes from the player again, the recorder starts synchro-recording again.

Note

If you record in monaural, do steps 1 and 2 in "Recording in monaural for double the normal recording time of an MD" (page 12), before doing the synchro-recording steps.

Recording from a microphone

Connect a stereo microphone ECM-909A, ECM-MS907, ECM-717, etc., (not supplied) to the MIC (PLUG IN POWER) jack.

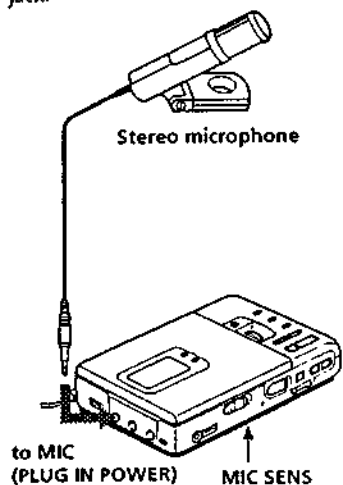

- 1 Select the input level with MIC SENS (on the bottom of the recorder). Usually, set it to HIGH. When you record loud sound such as a live concert, set it to LOW.
- 2 Insert a recordable MD and start recording. Slide REC to the right while pressing its button. "REC" lights up and recording starts. For details, see "Recording an MD right away!" (page 6).

Note
To record from a microphone, you must first disconnect any digital source. If connected, the recorder will not switch to microphone input.

Recording in monaural for double the normal recording time of an MD

For longer recordings, choose to record in monaural sound. The recording time becomes double the normal.

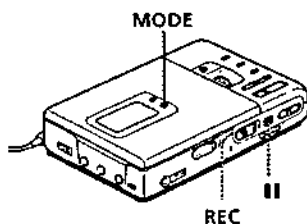

- 1 While pressing **II**, slide REC to the right. The recorder stands by for recording.
- 2 Press MODE. "Mono REC" appears in the display, and the recorder switches to monaural recording. Press MODE again to record in stereo sound.
- 3 Press **II** again to start recording.
- 4 Play the sound source.

To stop recording, press ■.
The recorder switches back to stereo recording when you record the next time.

Notes

- If you record in monaural sound from a stereo source, the sounds from left and right will be mixed.
- You cannot record in monaural, if SYNCRO REC is slide to ON.
- The MDs recorded in monaural sound can be played back only with an MD player/recorder that has the monaural playing function.

Adjusting the recording level (Manual recording)

When you record with an analog input, the sound level is adjusted automatically. If necessary, you can set the level manually.

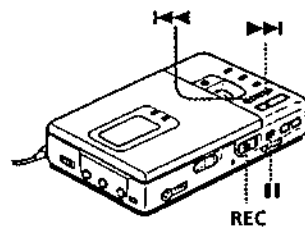

- 1 While holding down **II**, hold REC to the right for more than 2 seconds. "ManualREC" appears and the recorder stands by for recording. To return to the automatic control, while the recorder is in record pause mode, hold REC to the right for more than 2 seconds.

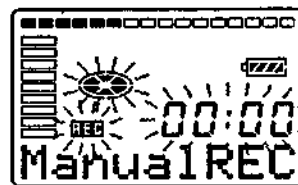

- 2 Play the source.

- 3 While observing the level meter in the display, adjust the recording level by pressing **▶▶** (+) or **◀◀** (-). Set the level so that it hits the second indicator from the top when the recorder receives the maximum sound.

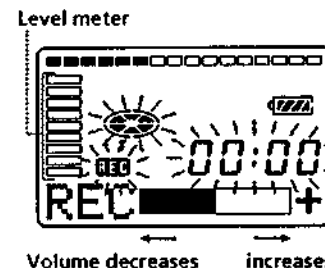

Note
The recording level should be adjusted while the recorder is in standby mode. You cannot adjust it while recording.

- 4 Press **II** again to start recording.

To stop recording, press ■.
The recording level control is switched back to automatic control.

Note
When you record with microphone input, select the input level with MIC SENS (page 12).

Various ways of recording

Checking the remaining time or the recording position

- 1 Press DISPLAY while recording or in stop mode. Each time you press the button, the display changes as follows.

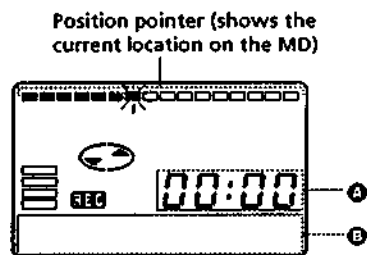
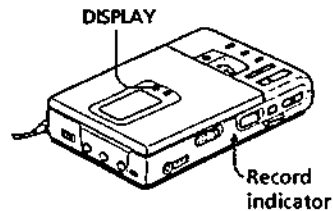

While recording

A	B
Elapsed time	Track number
Remaining time for recording	Track number
Current time ¹⁾	Current date ²⁾

¹⁾ Appears only when the clock is set.

In stop mode

A	B
Elapsed time	Track number
Remaining time for recording	Track name ¹⁾
Remaining time after the current location	Disc name ²⁾
Current time ³⁾	Current date ³⁾

¹⁾ The number of the track appears when the track has no name.

²⁾ Remaining number of tracks appears when the MD has no disc name.

³⁾ Appears only when the clock is set.

To know the recording condition

The record indicator lights up or flashes according to the recording condition.

Recording condition	Record indicator
While recording	lights up flashes according to the loudness of the source while recording with a microphone (voice mirror)
Recording standby	flashes
Less than 3 minutes' recording time available	slowly flashes

Tip

If you want to check the playing position or track name while playing, see page 18.

Setting the clock to stamp the recorded time

To stamp the date and time on the MD when you record, you first need to set the clock. When you use the recorder for the first time or after a long period of disuse, charge the built-in battery for the clock after setting the clock.

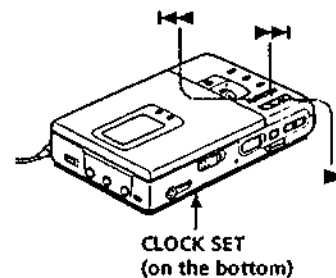

- 1 Connect the power source. Use the supplied AC power adaptor.
- 2 Press CLOCK SET at the bottom of the recorder. Use a pointed object. The digits of the year flash.

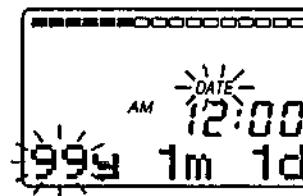

- 3 Enter the current year by pressing ◀◀ or ▶▶. To change the digits rapidly, keep pressing ◀◀ or ▶▶.

- 4 Press ▶. The digit of the month flashes.

- 5 Repeat steps 3 and 4 to enter the current month, date, hour, and minute. When you press ▶ to set the minute, the clock starts operating.

If you make a mistake while setting the clock

Press ■, and set the clock again from step 2. You can skip a step by pressing ▶.

To display the current time

When the recorder is not operating or while recording, press DISPLAY repeatedly until the current time appears in the display.

To display the time in the 24-hour system

While setting the clock, press DISPLAY. To display the time in the 12-hour system, press DISPLAY again.

Charging the built-in battery for the clock

After setting the clock, leave the recorder connected to the AC power for about 2 hours to charge the built-in battery for the clock. Once charged, the built-in battery should last about a month without connecting to any of the power sources. The recorder will automatically charge the built-in battery while connected to AC power, dry batteries or a rechargeable battery.

► Various ways of playback

Selecting the track number or track name directly

You can select the desired track directly by using the vertical jog dial.

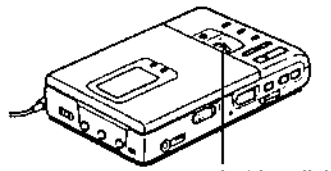

Vertical jog dial

- 1 Rotate the jog dial to select a track, and press it to play the selected track.



Rotate to select.

Press to play.

When you rotate the jog dial, the track name* appears in the display. To play the selected track, press the jog dial.

* If the track has no name, only the track number appears in the display.

Tip

If you select a track in shuffle play mode, shuffle play starts from the selected track.

Playing tracks repeatedly

You can play tracks repeatedly in three ways — all repeat, single repeat, and shuffle repeat.

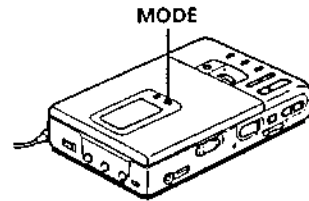

MODE

- 1 Press MODE while the recorder is playing an MD. Each time you press MODE, the play mode indication changes as follows.

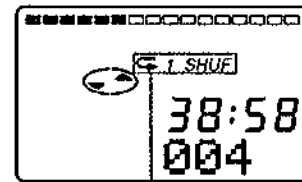

Play mode indication

Indication	Play mode
none (normal play)	All the tracks are played once.
"☐"	All the tracks are played repeatedly.
"☐ 1"	A single track is played repeatedly.
"☐ SHUF"	All the tracks are played repeatedly in random order.

Emphasizing bass (DIGITAL MEGA BASS)

Mega Bass function intensifies low frequency sound for richer quality audio reproduction. It affects only with the headphones.

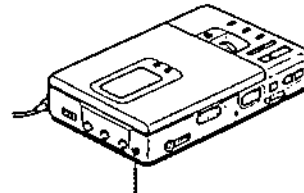

DIGITAL MEGA BASS

- 1 Press DIGITAL MEGA BASS. Each time you press DIGITAL MEGA BASS, the Mega Bass indication changes as follows.

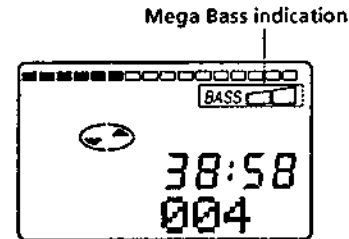

Mega Bass indication

Indication	Play mode
none	Normal play
"BASS ☐"	Mega Bass (slight effect)
"BASS ☐☐"	Mega Bass (strong effect)

Notes

- If the sound is distorted when emphasizing bass, turn down the volume.
- Mega Bass function does not affect the sound being recorded.
- Mega Bass does not function when LINE OUT jack on the recorder is connected with a line cable.

Protecting your hearing (AVLS)

The AVLS (Automatic Volume Limiter System) function keeps down the maximum volume to prevent excessive sound from harming your ears.

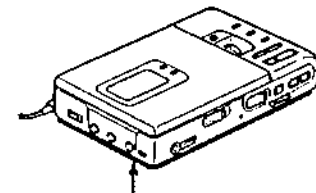

AVLS

- 1 Set AVLS at the bottom of the recorder to LIMIT. When you try to turn the volume, "AVLS" appears in the display. The volume is kept at a moderate level.

Various ways of playback

Checking the remaining time or the playing position

- 1 Press DISPLAY while playing. Each time you press DISPLAY, the display changes as follows.

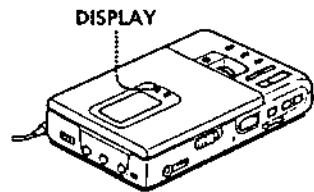

Position pointer (shows the current location on the MD)

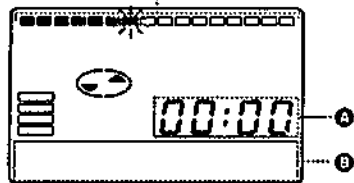

A	B
Elapsed time	Track number
Remaining time of the current track	Track name ¹⁾
Remaining time after the current location	Disc name ²⁾
Recorded time ³⁾	Recorded date ³⁾

¹⁾Track number appears when the MD has no track name.

²⁾Remaining number of the disc appears when the disc has no name.

³⁾If you record without setting the clock or play an MD that has no recorded date, "--y--m--d" and "--:--" appear.



If you want to check the remaining time or the recording position while recording or in stop mode, see page 14.

Locking the controls

To prevent the buttons from being accidentally operated when you carry the recorder, use this function.

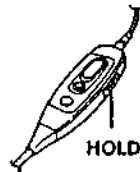
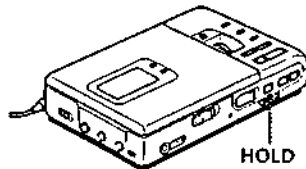

- 1 Slide HOLD in the direction of the arrow. On the recorder, slide HOLD to lock the controls of the recorder. On the remote controller, slide HOLD to lock the controls of the remote controller. Slide HOLD in the opposite direction of the arrow to unlock the controls.

Connecting to a stereo system

Connect the LINE OUT jack of the recorder to the LINE IN jacks of an amplifier or a tape player with a line cable (RK-G129 or RK-G136, not supplied). The output is analog. The recorder plays the MD digitally and sends analog signals to the connected equipment.

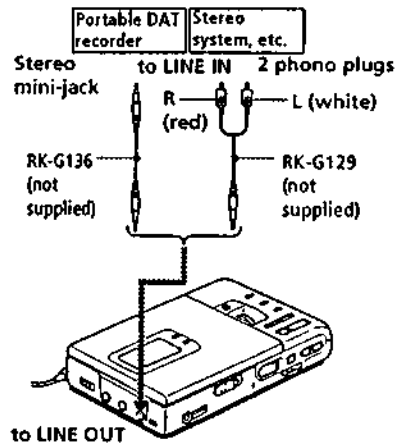

Note

The Mega Bass does not function or will be cancelled when the LINE OUT jack is connected with a line cable.

►Editing recorded tracks

You can edit your recordings by adding/erasing track marks or labeling tracks and MDs. Premastered MDs cannot be edited.

Notes on editing

- Do not move or jog the recorder while "Toc Edit" is flashing in the display.
- You cannot edit tracks on an MD that is record-protected. Before editing tracks, close the tab on the side of the MD.

Erasing tracks

To erase a track

Note that once a recording has been erased, you cannot retrieve it. Check the track number before erasing.

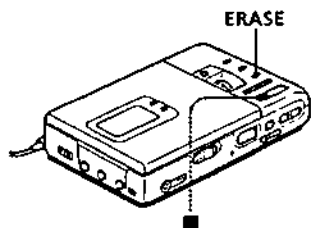

- 1 Press ERASE while playing the track you want to erase. "Erase OK?" and "Push Erase" appear in the display alternately, and the recorder plays the selected track repeatedly. To cancel erasing, press ■.
- 2 Check the track number in the display and press ERASE again. The track is erased from the MD and the remaining tracks are renumbered.

To erase a part of a track

Add track marks at the beginning and the end of the part you want to erase, then erase the part.

To erase the whole disc

You can quickly erase all the tracks and data of the MD at a time. Note that once a recording has been erased, you cannot retrieve it. Be sure to check the contents of the disc you want to erase.

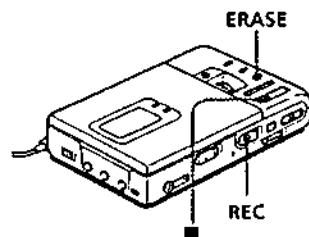

- 1 In stop mode, keep pressing ERASE and slide REC to the right. "All Erase?" and "Push Erase" appear in the display alternately. To cancel erasing, press ■.
- 2 Press ERASE again. "Toc Edit" flashes in the display. When erasing finishes, "BLANK DISC" appears.

Adding a track mark

You can add track marks so that the separated part after the track mark is as a new track. The track numbers will increase as follows.

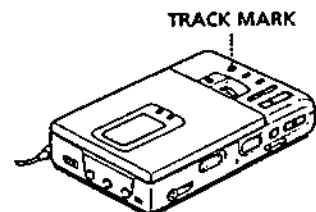
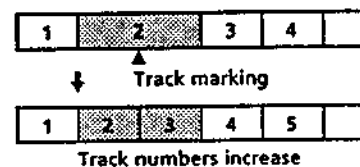

- 1 While playing or pausing an MD, press TRACK MARK on the recorder at the point you want to mark. "MARK ON" appears in the display, and a track mark is added. The track number will increase by one.

To add track marks while recording

Press TRACK MARK on the recorder or the remote commander.

Note
TRACK MARK on the remote controller does not function during playback.

Erasing a track mark

When you record with analog (line) input, unnecessary track marks may be recorded. You can erase a track mark to combine the tracks before and after the track mark. The track numbers will change as follows.

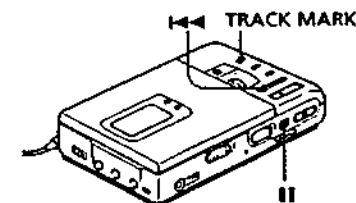
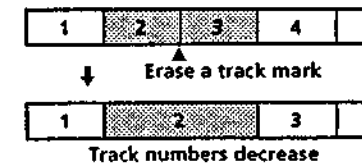

- 1 While playing the track with the track mark you want to erase, press II to pause.
- 2 Find the track mark by pressing I◀◀ slightly. For example, to erase the third track mark, find the beginning of the third track. "00:00" appears in the display.
- 3 Press TRACK MARK to erase the mark. "MARK OFF" appears in the display. The track mark is erased and the two tracks are combined.

Tip

The combined track whose mark has been erased is recorded with the date and time of the beginning of the first of the two combined tracks.

Moving recorded tracks

You can change the order of the recorded tracks.

Before moving

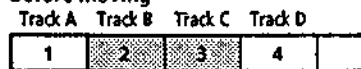

Move track C from the third to the second track.

After moving

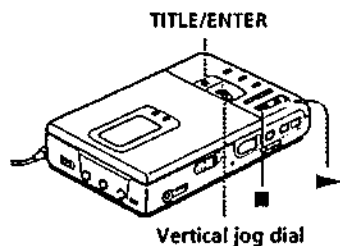

- 1 While playing, keep pressing ► and press TITLE/ENTER. The recorder plays the selected track repeatedly. For example above, "MV003→003" appears in the display.
- 2 Rotate the vertical jog dial to select the new track position. For example above, rotate the jog dial until "MV003→002" appears in the display. To cancel moving, press ■.
- 3 Press TITLE/ENTER again. Moving is completed and the recorder plays the moved track.



You can also move the track by pressing the jog dial in step 3.

Labeling recordings

You can label the MDs and tracks you recorded with letters, numbers, and marks. Each label can be made up of up to 200 characters, and each MD can hold up to 1700 characters.

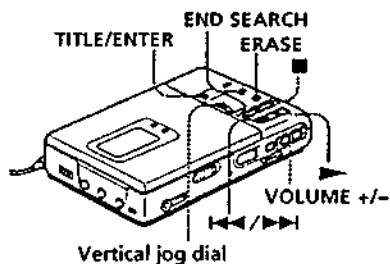

- 1 To label a track, play the track you want to label. To label an MD, insert the recordable MD you want to label. If an MD is already inserted, press ■ to stop.
- 2 Press TITLE/ENTER. If you have selected a track in step 1 above, the recorder will play that track repeatedly. A cursor flashes in the display.
- 3 Use the vertical jog dial to select and enter a character.

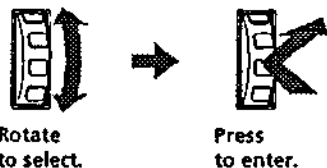

Rotate the jog dial to select a character, and press the jog dial to enter the selected character. The cursor shifts rightward and stands by for the input of the next character.

Press	To
►	Select the first of capital letters, small letters, and numbers quickly.
◀/▶	Move the cursor to the left or right.
END SEARCH	Insert a space.
ERASE	Delete a character.
■	Cancel labelling.

- 4 Repeat step 3 until you have entered all the characters for the label.
- 5 Press TITLE/ENTER. Labelling is completed.

To cancel labelling

Press ■.

Available characters

- Capital and small letters of the English alphabet
- Numbers 0 to 9
- ! " # \$ % & () * + - . ; < = > ? @ _ ` ' , / : _ (space)

To relabel recordings

Do steps 1 and 2 to display the label of the track or MD. Enter a new character over the one you want to change, then press TITLE/ENTER.

Notes

- You cannot relabel premastered MDs or label MDs that have not been recorded.
- The recorder is able to display "Kana" characters. But you cannot label with them on this recorder.

►Power sources

You can use the recorder on house current or as follows.

In the recorder ...

- a lithium ion rechargeable battery (supplied)

With supplied battery case ...

- dry batteries (not supplied)

It is preferable to use the recorder on house current when recording for a long time.

Using on a lithium ion rechargeable battery

Before using the supplied LIP-12(H) lithium ion rechargeable battery for the first time, charge it in the recorder.

- 1 Connect the supplied AC power adaptor.

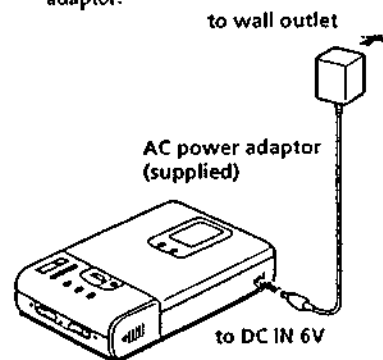

- 2 Insert the LIP-12(H) into the recorder and close the lid.

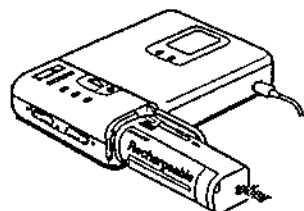

Battery indication appears in the display and charging starts. When charging is completed, battery indication disappears.

Charging time

To charge a completely discharged battery, it takes the following time.

80%	Approx. 2.5 hours
100%	Approx. 5 hours

Tip

You can use the recorder while charging.

Notes

- Be sure to use the supplied AC power adaptor.
- Charging time may vary depending on the battery condition.

Using on dry batteries

- 1 Attach the supplied battery case.

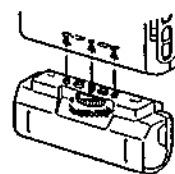

- 2 Insert two LR6 (size AA) dry batteries (not supplied).

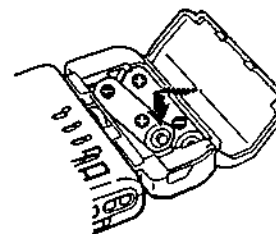

Battery life¹⁾

Batteries	Record- ing ²⁾	Playback
LIP-12(H) lithium ion rechargeable battery	Approx. 5 hours	Approx. 8 hours
Two LR6 (size AA) Sony alkaline dry batteries ³⁾	Approx. 6.5 hours
LIP-12(H) + Two LR6 (size AA) ³⁾	Approx. 15 hours

¹⁾The battery life may be shorter due to operating conditions and the temperature of the location.

²⁾When you record, use a fully charged rechargeable battery.

³⁾Recording time may differ according to the alkaline batteries.

When to replace the batteries

When the dry batteries or rechargeable battery are weak, flashing  or "LOW BATT" appear in the display. Replace the dry batteries or charge the rechargeable battery.

►Additional information

Precautions

On safety

Do not put any foreign objects in the DC IN 6 V jack.

On power sources

- Use house current, lithium ion rechargeable battery, two LR6 (size AA) batteries, or car battery.
- For use in your house: Use the AC power adaptor supplied with this recorder. Do not use any other AC power adaptor since it may cause the recorder to malfunction.

Polarity of the plug



- The recorder is not disconnected from the AC power source (mains) as long as it is connected to the wall outlet, even if the recorder itself has been turned off.
- If you are not going to use this recorder for a long time, be sure to disconnect the power supply (AC power adaptor, dry batteries, rechargeable battery, or car battery cord). To remove the AC power adaptor from the wall outlet, grasp the adaptor plug itself; never pull the cord.
- For use in the car : Use the CPA-9 car connecting pack (not supplied)

On heat build-up

Heat may build up in the recorder if it is used for an extended period of time. In this case, leave the recorder turned off until it cools down.

On installation

- Never use the recorder where it will be subjected to extremes of light, temperature, moisture or vibration.
- Never wrap the recorder in anything when it is being used with the AC power adaptor. Heat build-up in the recorder may cause malfunction or damage.

On the headphones

Road safety

Do not use headphones while driving, cycling, or operating any motorized vehicle. It may create a traffic hazard and is illegal in many areas. It can also be potentially dangerous to play your recorder at high volume while walking, especially at pedestrian crossings. You should exercise extreme caution or discontinue use in potentially hazardous situations.

Preventing hearing damage

Avoid using headphones at high volume. Hearing experts advise against continuous, loud and extended play. If you experience a ringing in your ears, reduce the volume or discontinue use.

Caring for others

Keep the volume at a moderate level. This will allow you to hear outside sounds and to be considerate of the people around you.

On the MiniDisc cartridge

- Do not break open the shutter.
- Do not place the cartridge where it will be subject to light, extreme temperatures, moisture or dust.

On cleaning

- Clean the recorder casing with a soft cloth slightly moistened with water or a mild detergent solution. Do not use any type of abrasive pad, scouring powder or solvent such as alcohol or benzene as it may mar the finish of the casing.
- Wipe the disc cartridge with a dry cloth to remove dirt.
- Dust on the lens may prevent the unit from operating properly. Be sure to close the disc compartment lid after inserting and ejecting an MD.

Notes on batteries

Incorrect battery usage may lead to leakage of battery fluid or bursting batteries. To prevent such accidents, observe the following precautions:

- Install the + and - poles of the batteries correctly.
- Do not install new and used batteries or different kinds of batteries together.
- Do not try to recharge dry batteries.
- When the recorder is not to be used for a long time, be sure to remove the batteries.
- If a battery leak should develop, carefully and thoroughly wipe away battery fluid from the battery compartment before inserting new ones.

Note on mechanical noise

The recorder produces out mechanical noise while operating, which is caused by the power-saving system of the recorder and it is not a problem.

To protect a recorded MD

To record-protect an MD, slide open the tab at the side of the MD. In this position, the MD cannot be recorded. To record again, slide the tab back so the tab is visible.

Back of the MD

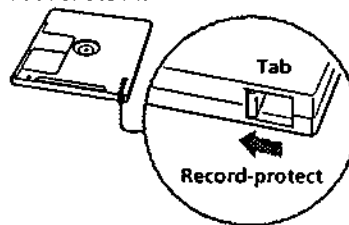

Note on digital recording

This recorder uses the Serial Copy Management System, which allows only first-generation digital copies to be made of premastered software. You can only make copies from a home-recorded MD by using the analog (line out) connections.

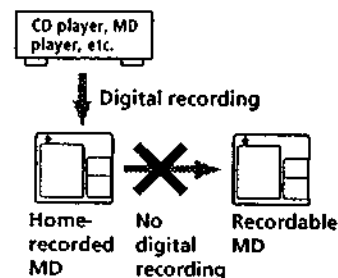

If you have any questions or problems concerning your recorder, please consult your nearest Sony dealer.

Troubleshooting

Should any problem persists after you have made these checks, consult your nearest Sony dealer.

Symptom	Cause/Solution
The recorder does not work or works poorly.	<ul style="list-style-type: none"> • Audio sources may not be securely connected. <ul style="list-style-type: none"> ➔ Disconnect the audio sources once and connect them again (pages 6,11). • Moisture has condensed inside the recorder. <ul style="list-style-type: none"> ➔ Take the MD out and leave the recorder in a warm place for several hours until the moisture evaporates. • The rechargeable battery or dry batteries are weak (☐ or "LOW BATT" flashes). <ul style="list-style-type: none"> ➔ Charge the rechargeable battery or replace the dry batteries (pages 24, 25). • The rechargeable battery or dry batteries have been installed incorrectly. <ul style="list-style-type: none"> ➔ Install the batteries correctly (page 25). • You pressed a button while the disc indication was rotating quickly. <ul style="list-style-type: none"> ➔ Wait until the indication rotates slowly. • The recording volume is too low. • The AC adaptor was unplugged during recording or a power outage occurred. • While operating, the recorder received a mechanical shock, too much static, abnormal power voltage caused by lightning, etc. <ul style="list-style-type: none"> ➔ Restart the operation as follows. <ol style="list-style-type: none"> 1 Disconnect all the power sources. 2 Leave the recorder for about 30 seconds. 3 Connect the power source.
No sound comes through the headphones.	<ul style="list-style-type: none"> • The headphones plug is not firmly connected. <ul style="list-style-type: none"> ➔ Connect the headphones with a remote controller plug firmly to ♪/REMOTE. • Volume is too low. <ul style="list-style-type: none"> ➔ Adjust the volume by pressing VOLUME +/- (VOL +/- on the remote controller). • AVLS is on. <ul style="list-style-type: none"> ➔ Side AVLS to NORMAL (page 17).
An MD is not played from the first track.	<ul style="list-style-type: none"> • Disc playing stopped before it came to the last track. <ul style="list-style-type: none"> ➔ Press ⏮ repeatedly or open and close the lid once to go back to the beginning of the disc, and restart playing after checking the track number in the display.

Symptom	Cause/Solution
Playback sound skips.	<ul style="list-style-type: none"> • The recorder is placed where it receives continuous vibration. <ul style="list-style-type: none"> ➔ Put the recorder on a stable place. • A very short track may cause sound to skip.
Sound has a lot of static.	<ul style="list-style-type: none"> • Strong magnetism from a television or such device is interfering with operation. <ul style="list-style-type: none"> ➔ Move away from the source of strong magnetism.
Cannot find the track marks.	<ul style="list-style-type: none"> • You pressed ⏸ after pressing ⏮ or ⏭. ➔ Press ⏸ before pressing ⏮ or ⏭.
Charging the rechargeable battery does not start.	<ul style="list-style-type: none"> • The rechargeable battery has been inserted incorrectly or the AC power adaptor has been connected incorrectly. <ul style="list-style-type: none"> ➔ Insert the battery correctly or connect the AC power adaptor correctly.
The clock loses time or the display flashes.	<ul style="list-style-type: none"> • The built-in battery for a clock is weak. <ul style="list-style-type: none"> ➔ Connect the AC power adaptor to DC IN 6 V on the recorder and the wall outlet to charge the built-in battery. After charging, set the clock again. Note that the clock normally loses about 2 minutes per month (page 15).
The recording date was not stamped onto the disc.	

Additional information

System limitations

The recording system in your MiniDisc recorder is radically different from those used in cassette and DAT decks and is characterized by the limitations described below. Note, however, that these limitations are due to the inherent nature of the MD recording system itself and not to mechanical causes.

Symptom	Cause
"TR FULL" appears even before the disc has reached the maximum recording time (60 or 74 minutes).	When 254 tracks have been recorded on the disc, "TR FULL" appears regardless of the total recorded time. More than 254 tracks cannot be recorded on the disc. To continue recording, erase unnecessary tracks.
"TR FULL" appears even before the disc has reached the maximum track number or recording time.	Repeating recording and erasing may cause fragmentation and scattering of data. Although those scattered data can be read, each fragment is counted as a track. In this case, the number of tracks may reach 254 and further recording is not possible. To continue recording, erase unnecessary tracks.
Track marks cannot be erased.	When the data of a track is fragmented, the track mark of a fragment under 12 seconds long cannot be erased.
The remaining recording time does not increase even after erasing numerous short tracks.	Tracks of under 12 seconds in length are not counted and so erasing them may not lead to an increase in the recording time.
The total recorded time and the remaining time on the disc may not total the maximum recording time (60 or 74 minutes).	Recording is done in minimum units of 2 seconds each, no matter how short the material. Even if the last unit of recording is less than 2 seconds, it is counted as a unit of 2 seconds. Then 2 seconds' space is put before recording starts again to prevent the last unit of the previous track from being erased. The contents recorded may thus be shorter than the maximum recording capacity.
The edited tracks may exhibit sound dropout during search operations.	The fragmentation of data may cause sound dropout while searching because the tracks are played in higher speed than normal playback.

Error messages

If the following error messages flash in the display window, check the chart below.

Error message	Meaning/Remedy
BLANKDISC	<ul style="list-style-type: none"> An MD with no recording on it is inserted. ➔ Insert a recorded MD.
DISC ERR	<ul style="list-style-type: none"> The recorder cannot read the disc (it's scratched or dirty). ➔ Reinsert or replace the disc.
DISC FULL	<ul style="list-style-type: none"> There is no more space to record on the disc (less than 12 seconds available). ➔ Replace the disc.
BUSY	<ul style="list-style-type: none"> You tried to operate the recorder while it was accessing the recorded data. ➔ Wait until the message goes out (in rare cases, it may take 2-3 minutes).
NAME FULL	<ul style="list-style-type: none"> You tried to enter more than 200 characters for a track or disc name or the total characters entered in an MD is more than 1700. ➔ Enter the characters within the limit.
Hi DC in	<ul style="list-style-type: none"> Power supply is too high (The supplied AC power adaptor or the recommended car battery cord is not used). ➔ Use the supplied AC power adaptor or the recommended car battery cord.
HOLD	<ul style="list-style-type: none"> The recorder is locked. ➔ Slide HOLD against the allow to unlock the recorder (page 18).
LOW BATT	<ul style="list-style-type: none"> Batteries are weak. ➔ Charge the rechargeable battery or replace the dry batteries (pages 24, 25).
MEM OVER	<ul style="list-style-type: none"> You tried to record when the recorder is placed where it receives continuous vibration. ➔ Put the recorder on the stable place, and start recording again.
NO COPY	<ul style="list-style-type: none"> You tried to make a copy from a disc that is protected by the Serial Copy Management System. You cannot make copies from a digitally connected source which was itself recorded using the digital connection. ➔ Use the analog connection instead (page 6).
NO DISC	<ul style="list-style-type: none"> You tried to play or record with no disc in the recorder. ➔ Insert an MD.

Error message	Meaning/Remedy
NO SIGNAL	<ul style="list-style-type: none"> The recorder could not detect digital input signals. <ul style="list-style-type: none"> Make sure that the source is connected firmly (page 11). If the error message appears while recording, press ■ to stop recording.
PB ONLY	<ul style="list-style-type: none"> You tried to record or edit on a premastered MD (PB means playback.) <ul style="list-style-type: none"> Insert a recordable MD.
PROTECTED	<ul style="list-style-type: none"> You tried to record or edit on a MD with the tab in the record-protect position. <ul style="list-style-type: none"> Slide the tab back (page 27).
SORRY	<ul style="list-style-type: none"> You tried to erase a track mark while playing the MD or at the beginning of the first track. You tried to erase a track mark to combine tracks the recorder cannot combine. (caused by system limitation)
TEMP OVER	<ul style="list-style-type: none"> Heat has built up in the recorder. <ul style="list-style-type: none"> Let the recorder cool down.
TR FULL	<ul style="list-style-type: none"> There is no more space for new data when you are editing the MD. <ul style="list-style-type: none"> Erase unnecessary tracks (page 20).
TRPROTECT	<ul style="list-style-type: none"> You tried to record or edit on a track that is protected from erasing. <ul style="list-style-type: none"> Record or edit on other tracks.

32-EN

What is MD?

How MiniDisc works

MiniDisc (MD) comes in two types: premastered (pre-recorded) and recordable (blank). Premastered MDs, recorded at music studios, can be played back almost endlessly. However, they can't be recorded on or over like cassette tapes. To record, you must use a "recordable MD".

Premastered MDs

Premastered MDs are recorded and played like regular CDs. A laser beam focuses on the pits in the surface of the MD and reflects the information back to the lens in the recorder. The recorder then decodes the signals and plays them back as music.

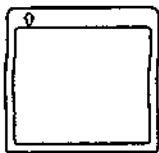

Recordable MDs

Recordable MDs, which use magneto-optical (MO) technology, can be recorded again and again. The laser inside the recorder applies heat to the MD, demagnetizing the magnetic layer of the MD. The recorder then applies a magnetic field to the layer. This magnetic field corresponds exactly to the audio signals generated by the connected source. (The north and south polarities equate to digital "1" and "0".) The demagnetized MD adopts the polarity of the magnetic field, resulting in a recorded MD.

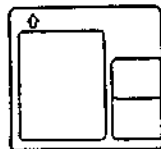

How the MiniDisc got so small

The 2.5-inch MiniDisc, encased in a plastic cartridge that looks like a 3.5-inch diskette (see illustration below), uses a new digital audio compression technology called ATRAC (Adaptive Transform Acoustic Coding). To store more sound in less space, ATRAC extracts and encodes only those frequency components actually audible to the human ear.

Quick Random Access

Like CDs, MDs offer instantaneous random access to the beginning of any music track. Premastered MDs are recorded with location addresses corresponding to each music selection. Recordable MDs are manufactured with a "User TOC Area" to contain the order of the music. The TOC system is similar to the "directory management system" of floppy disks. In other words, starting and ending addresses for all music tracks recorded on the disc are stored in this area. This lets you randomly access the beginning of any track as soon as you enter the track number (AMS), as well as label the location with a track name as you would a file on a diskette.

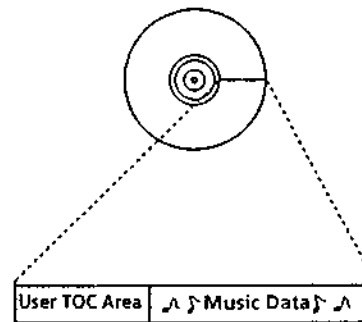

Contains the order and start/end points of the music.

Shock-Resistant Memory

One major drawback of optical read systems is that they can skip or mute when subjected to vibration. The MD system resolves this problem by using a buffer memory that stores audio data.

SECTION 3 DISASSEMBLY

- The equipment can be removed using the following procedure.

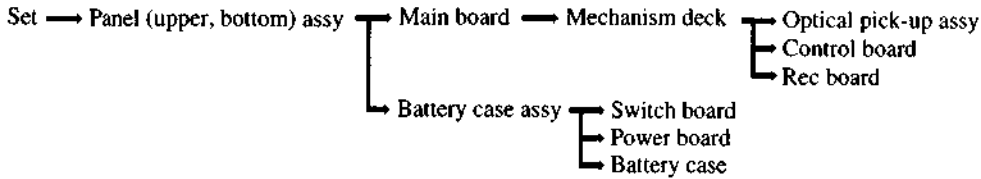

Note : Follow the disassembly procedure in the numerical order given.

3-1. UPPER PANEL ASSY, BOTTOM PANEL ASSY REMOVAL

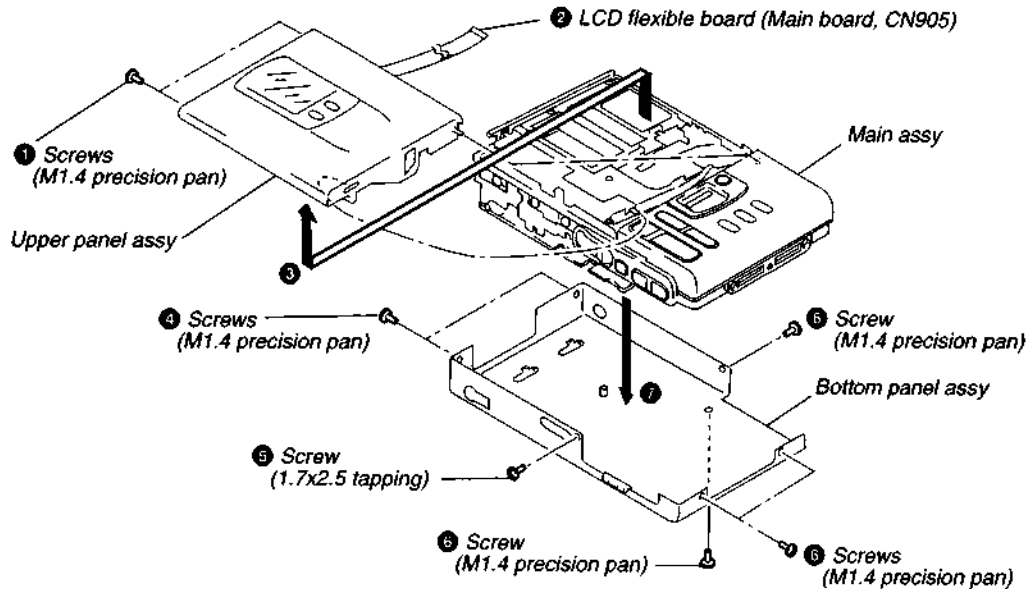

3-2. MAIN BOARD REMOVAL

* Note for installation
 Install the main board pressing the OPEN button on door open side.
 Sometime the open/close detection switch (S817) will be broken.

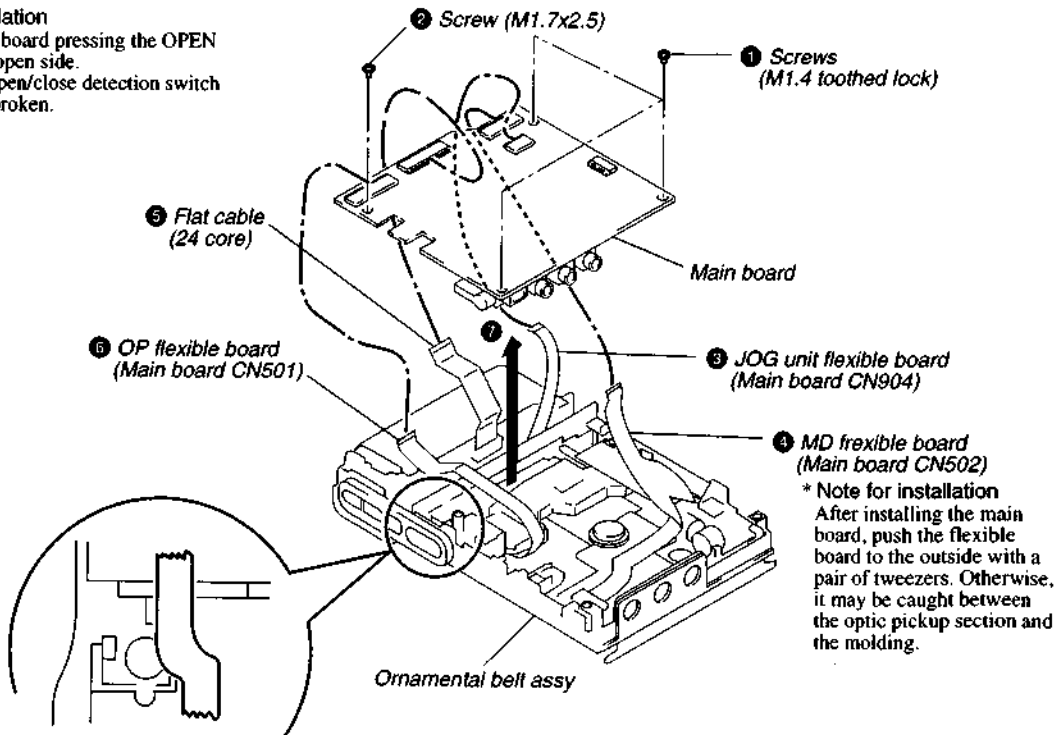

* Note for installation
 After installing the main board, make the flexible board ride on the molding. If you hold the flexible board and main board with a pair of tweezers, the board will ride correctly.

3-3. MECHANISM DECK (MT-MZR30-124) REMOVAL

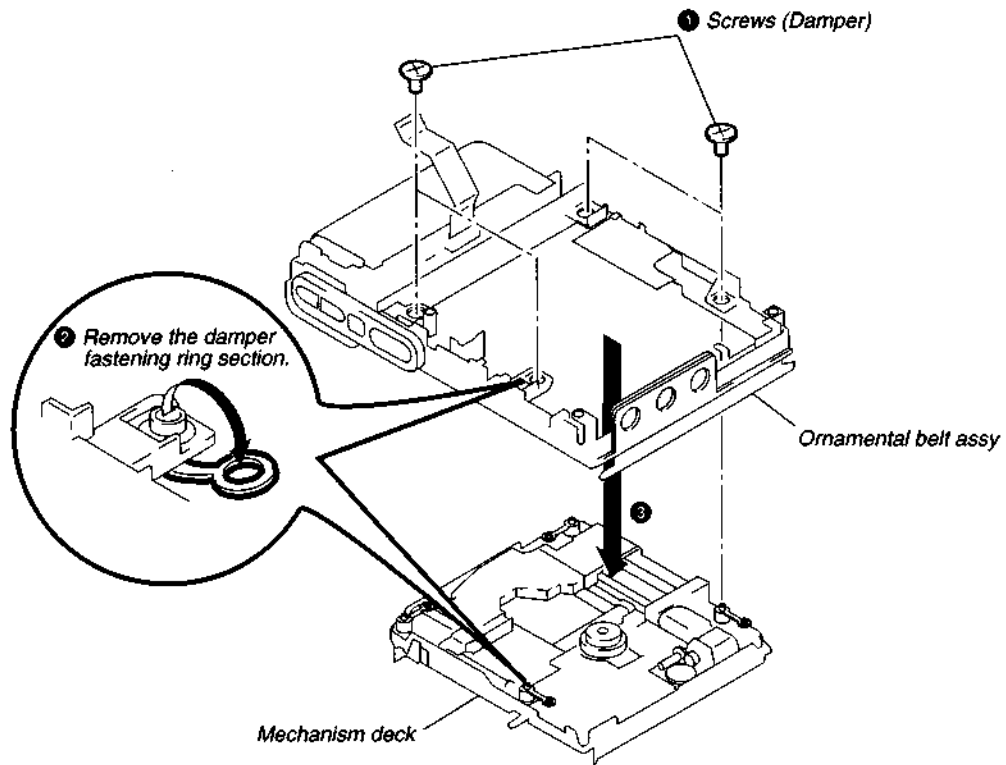

3-4. OPTICAL PICK-UP ASSY, CONTROL BOARD, REC BOARD REMOVAL

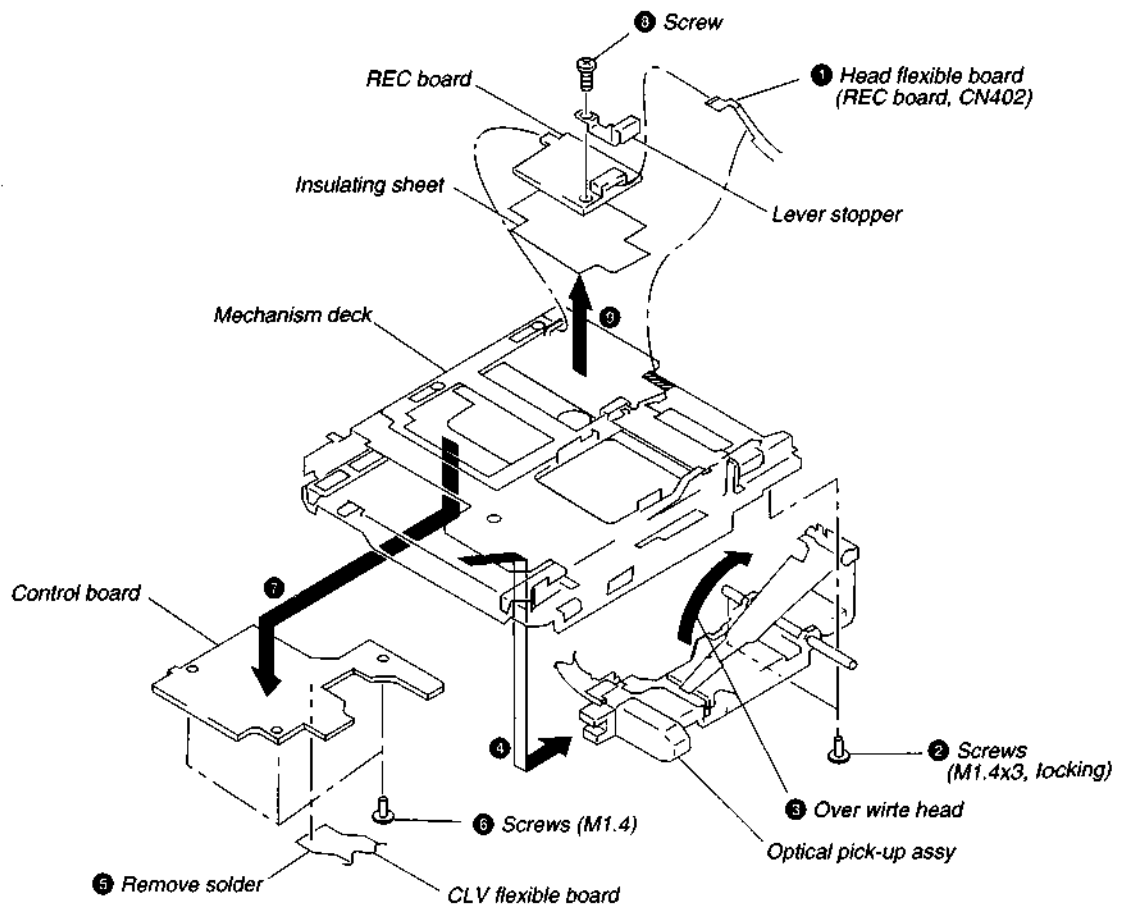

3-5. BATTERY CASE ASSY REMOVAL

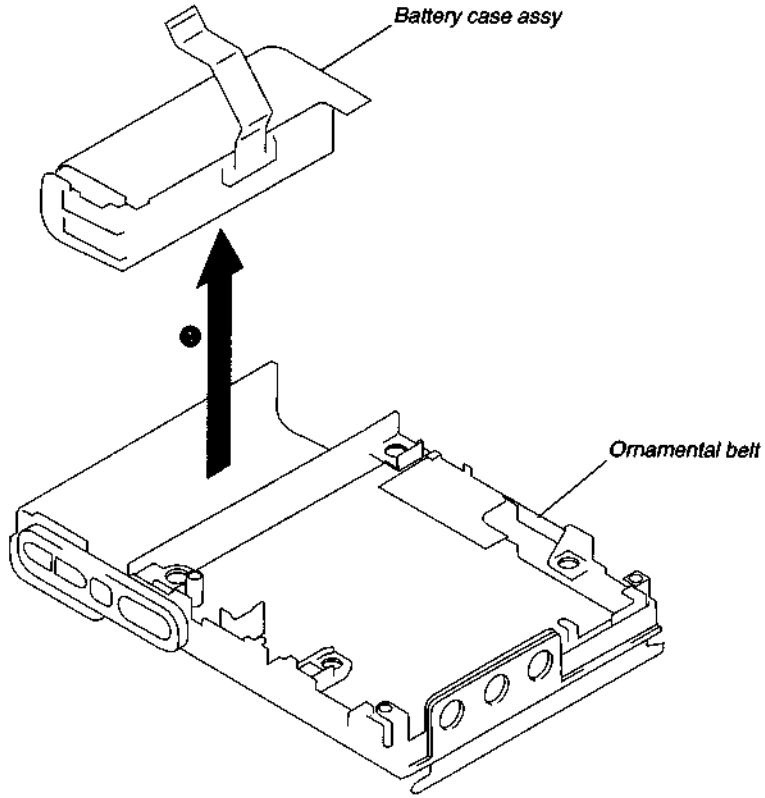

3-6. SWITCH BOARD, POWER BOARD REMOVAL

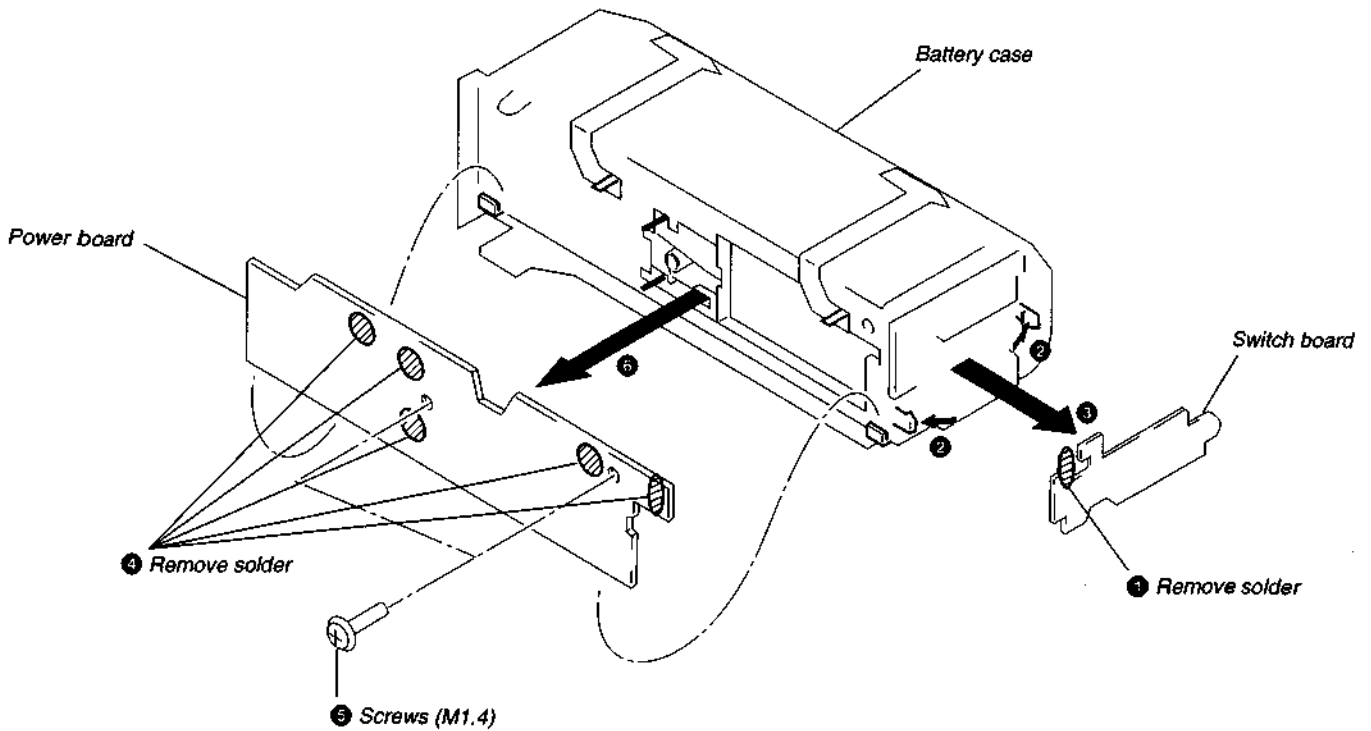

SECTION 4 TEST MODE

[Outline]

- The general adjustment mode of this unit performs CD and MO adjustments automatically when set. In this mode, the disc is determined if CD or MO and adjustments are automatically performed in order. If errors are detected, the faulty locations are displayed. The servo mode performs each adjustment automatically.

[Setting the Test Mode]

Short-circuit the soldering bridge of TAP803 (TEST) on the main board (connect Pin ② of IC801 to the GND) and turn on the power supply.

[MAIN BOARD] (SIDE A)

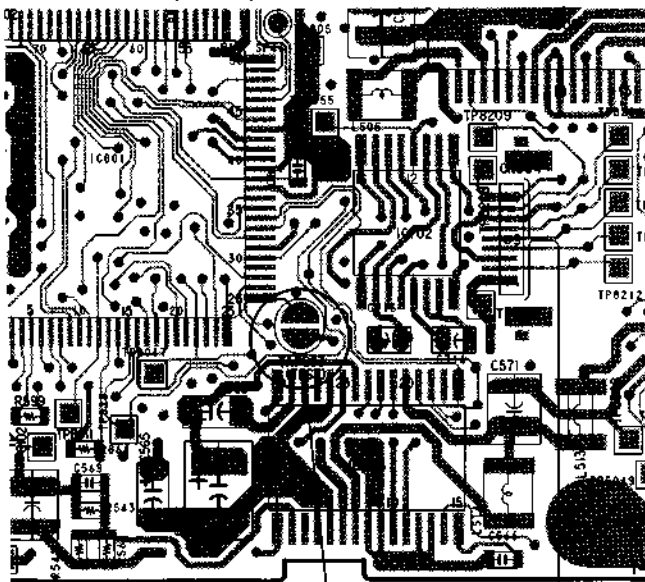

Test mode
(Short : Test mode
Open : Normal mode)

[Exiting the Test Mode]

Turn off the power supply and open the soldering bridge of TAP803 (TEST) on the main board.

[Operations When Test Mode is Set]

When the test mode is set, the LCD will display as follows.

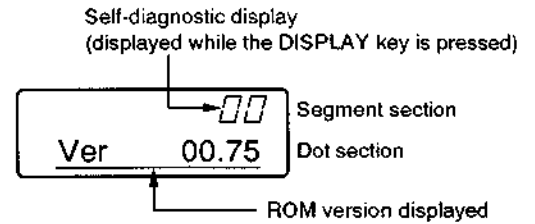

- The LCD performs the following repeatedly.
ROM version displayed → all lit → all off
- The display can be held and checked by pressing **||** key.
- The self-diagnostic display appears while the DISPLAY key is pressed.

[Structure of Test Mode]

The test mode of this unit consists of the following five modes.

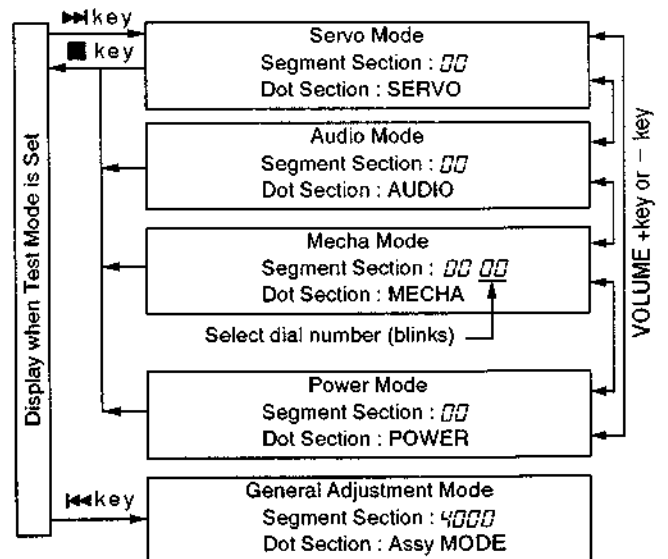

- In modes other than the general adjustment mode, the last two digits of the mode number will be displayed at the **00** section.

[Servo Mode]

- Set the test mode, press the ►► key, and set the servo mode using the VOLUME + and - keys.
- When the servo mode is set, the optical pickup will move to the outer circumference or inner circumference if the ►► key or ◄◄ key is pressed.
- To set other modes, refer to "Structure of Test Mode".

● Structure of Servo Mode

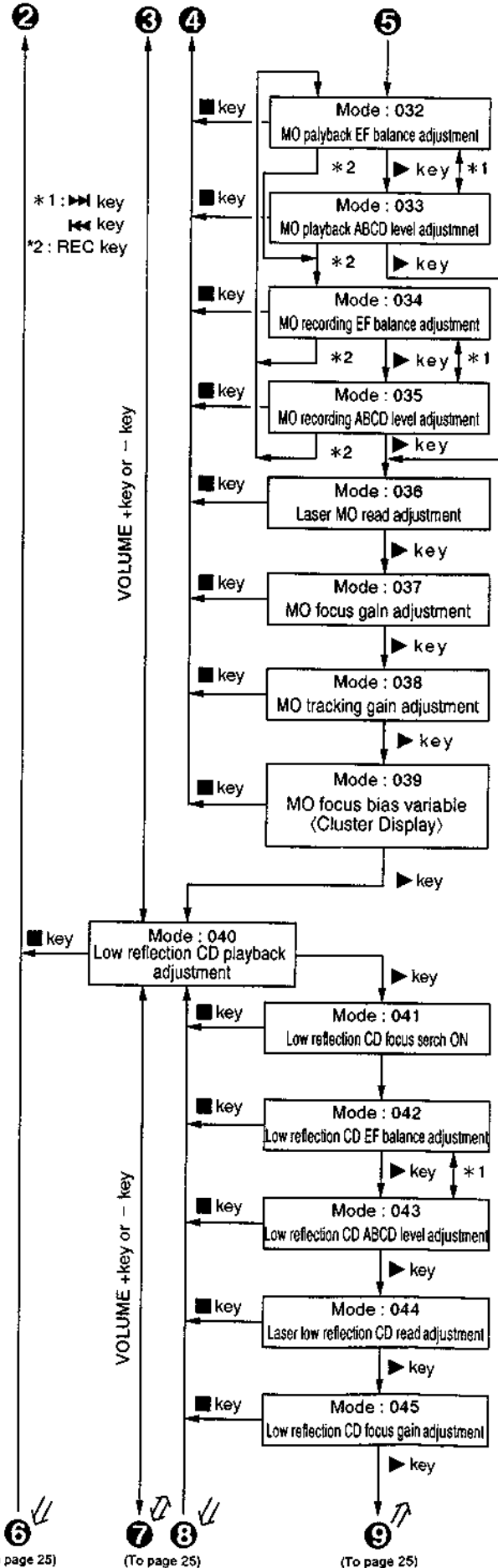
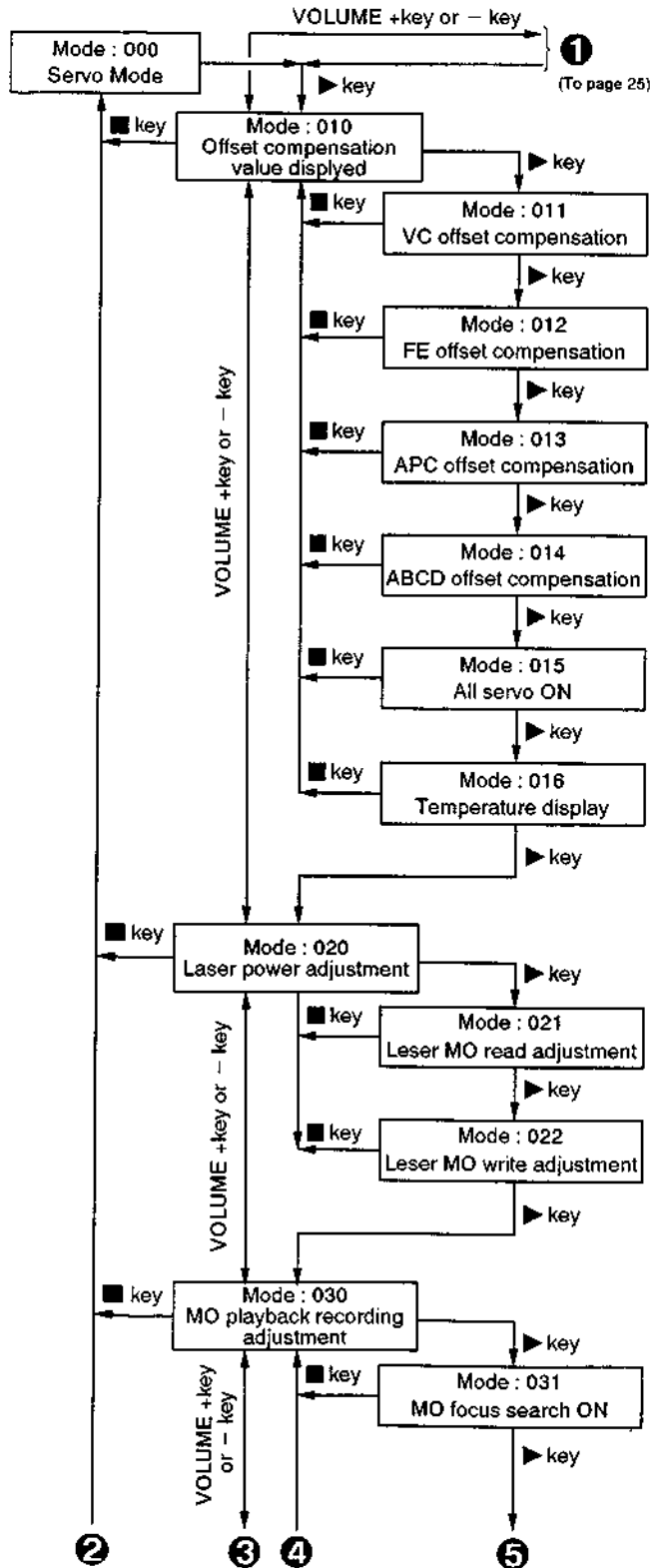

(To page 25)

(To page 25)

(To page 25)

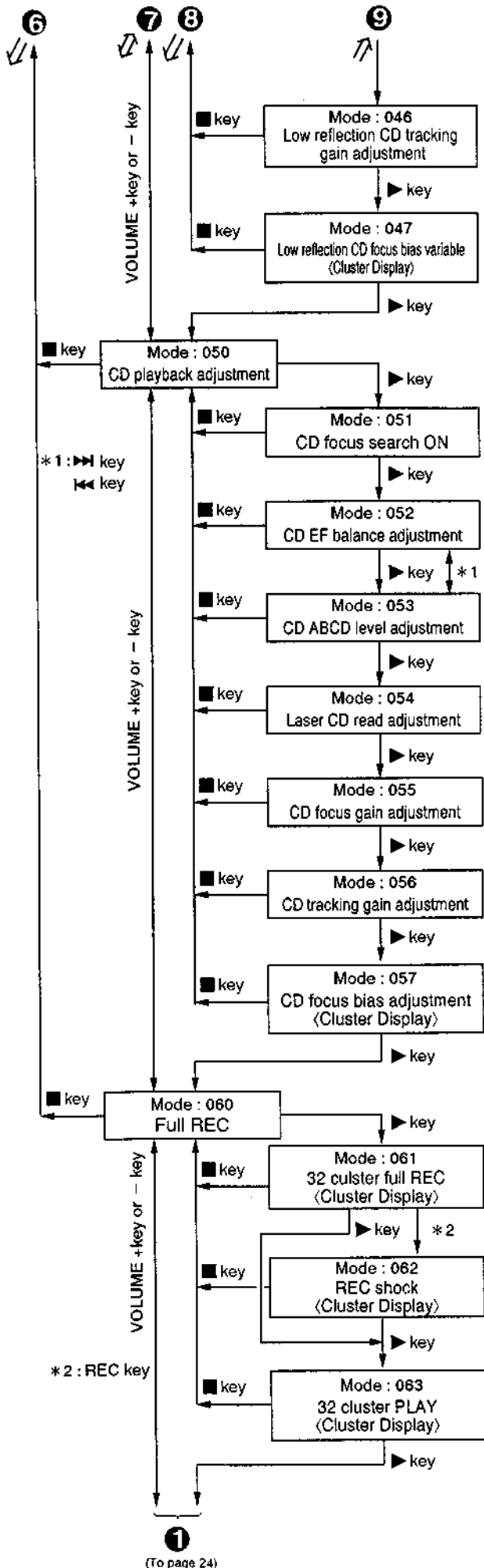

• Adjusting Method

Note : There is basically no display for individual adjustment items. Only such upper position titles as SERVO, AUDIO, etc. (100s position) are displayed.

1. When the adjustment modes are set according to "Structure of Servo Mode", the last two digits of the mode number and the adjustment value written in the EEPROM will be displayed blinking.

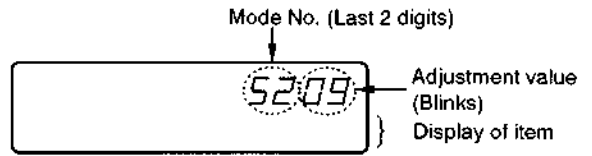

2. When the **II** key is pressed, the following will be displayed and adjustments will be performed automatically.

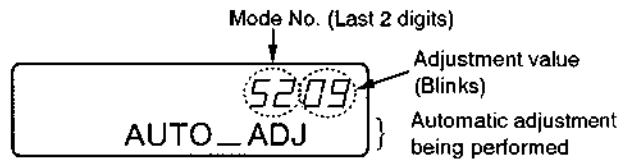

Note : The adjustment value can be changed as desired using the VOLUME + and - keys, but try to avoid this as much as possible.

3. After the adjustments are completed, the item is displayed again and the adjustment value that was blinking lights up.

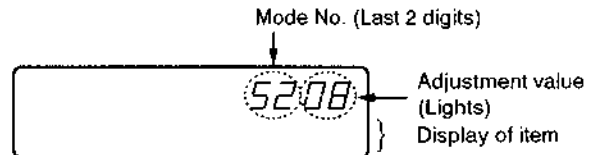

• Cluster display

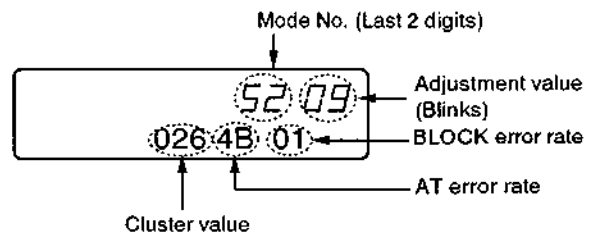

- Nothing is performed at mode numbers 070 to 073.

[Audio Mode]

- Set the test mode, press the ►key, and set the audio mode using the VOLUME + and - keys.
- To set other modes, refer to "Structure of Test Mode".

● **Structure of Audio Mode**

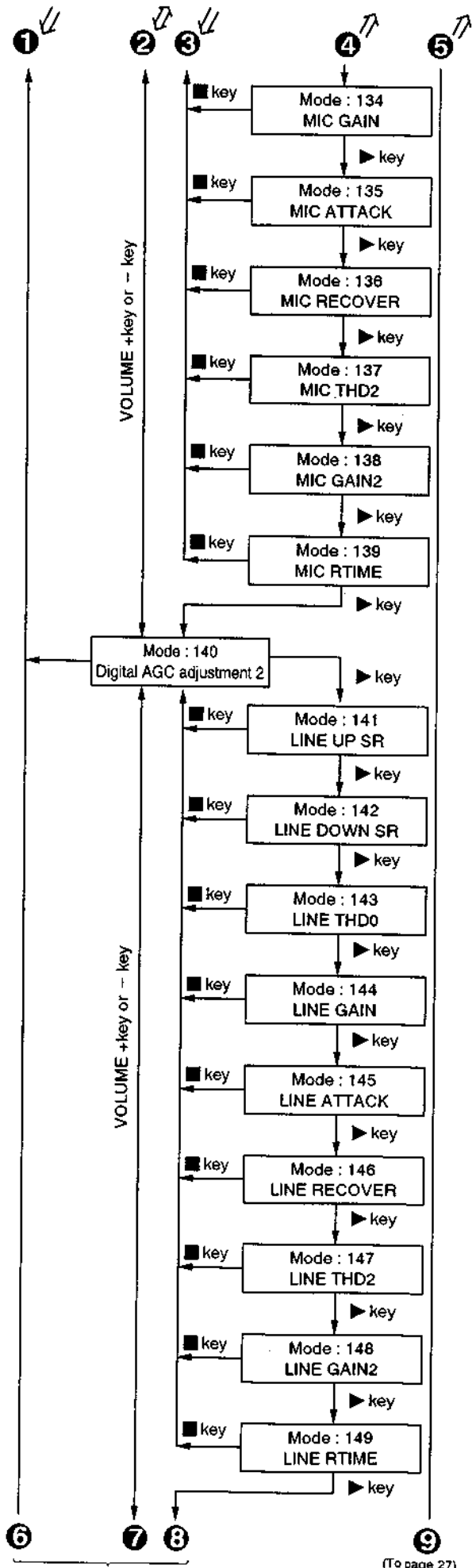
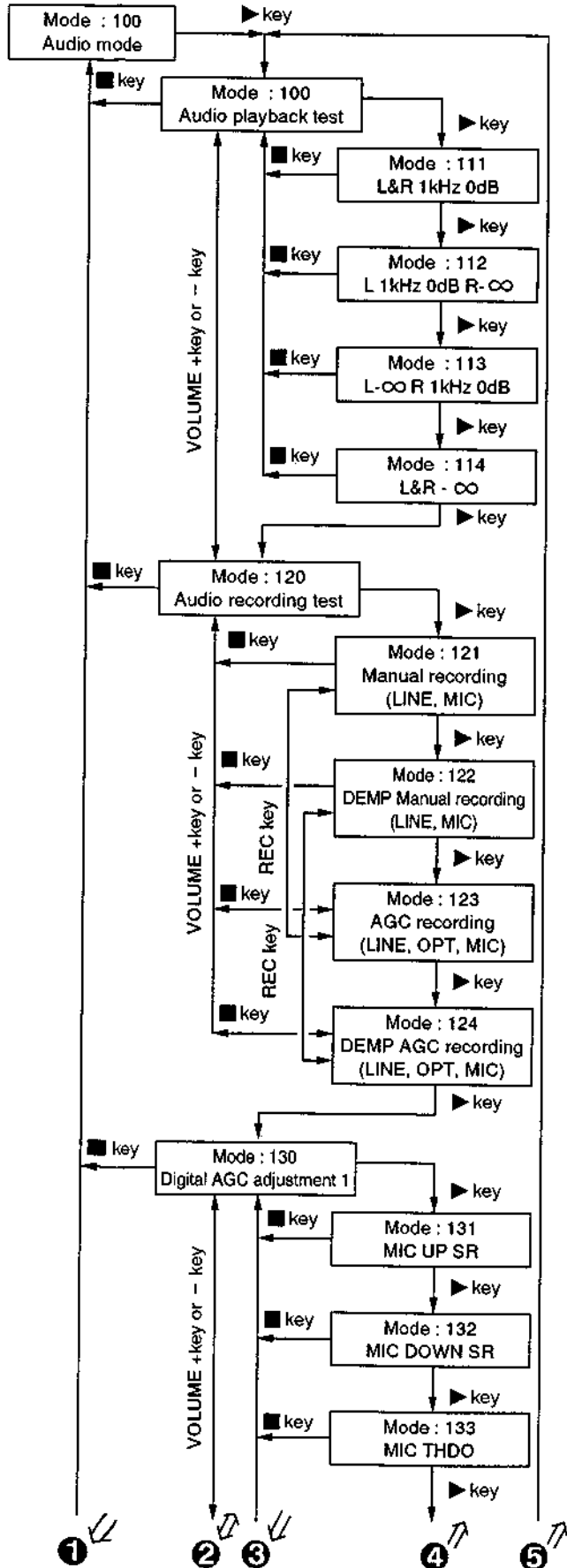

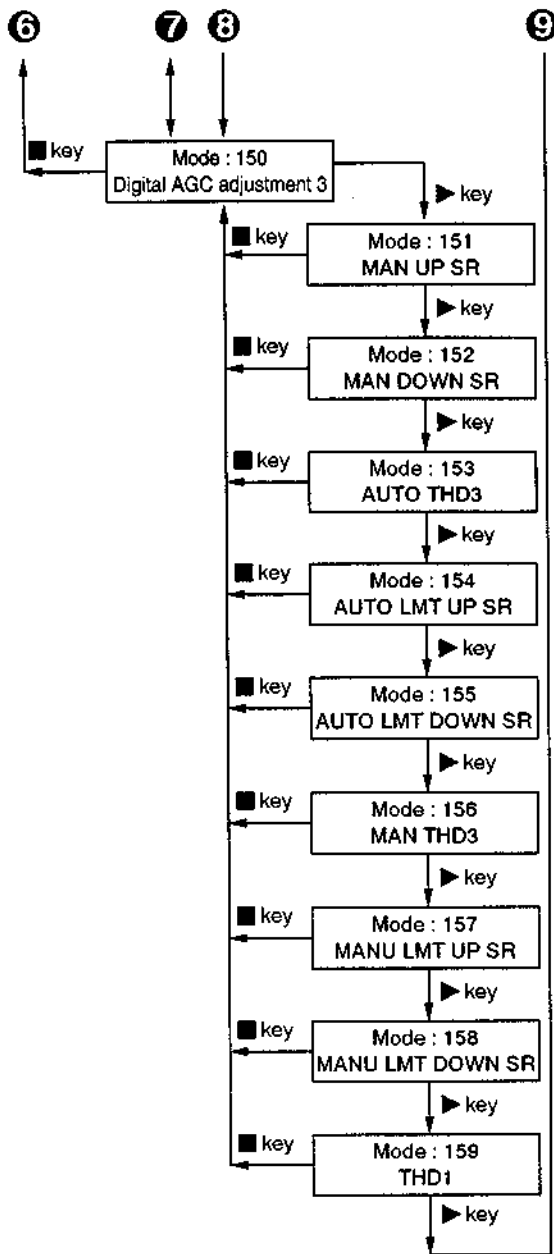

- When the **||** key is pressed at mode numbers 100, 110 to 114, the buzzer will sound.
- When the VOLUME keys + and - are pressed at mode numbers 111 to 113, 123, 124, the volume of the headphone output will increase/decrease.
When the **◀◀** key or **▶▶** key is pressed, the volume of the headphone output will become maximum/minimum.
- When the VOLUME keys + and - are pressed at mode numbers 121 or 122, the recording level will increase/decrease.
When the **◀◀** key or **▶▶** key is pressed, the recording level will become maximum/minimum.
- At mode numbers 121 to 124, the recording LED will light up.
- At mode numbers 121 to 124, the microprocessor will detect the port and automatically determine the input.

[Mecha Mode]

- Set the test mode, press the **▶▶** key, and set the mecha mode using the VOLUME + and - keys.
- To set other modes, refer to "Structure of Test Mode".

• Structure of Mecha Mode

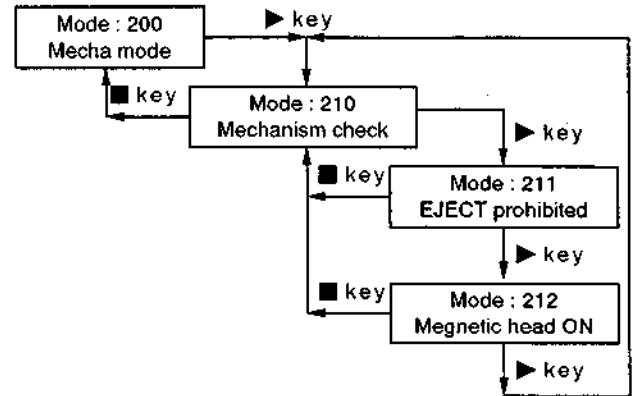

- At mode numbers 200, 210 to 212, the optical pick up can be moved to the outer circumference or inner circumference using the **◀◀** or **▶▶** key.

[Power Supply Mode]

- Set the test mode, press the **▶▶** key, and set the power supply mode using the VOLUME + and - keys.
- To set other modes, refer to "Structure of Test Mode".

• Structure of Power Supply Mode

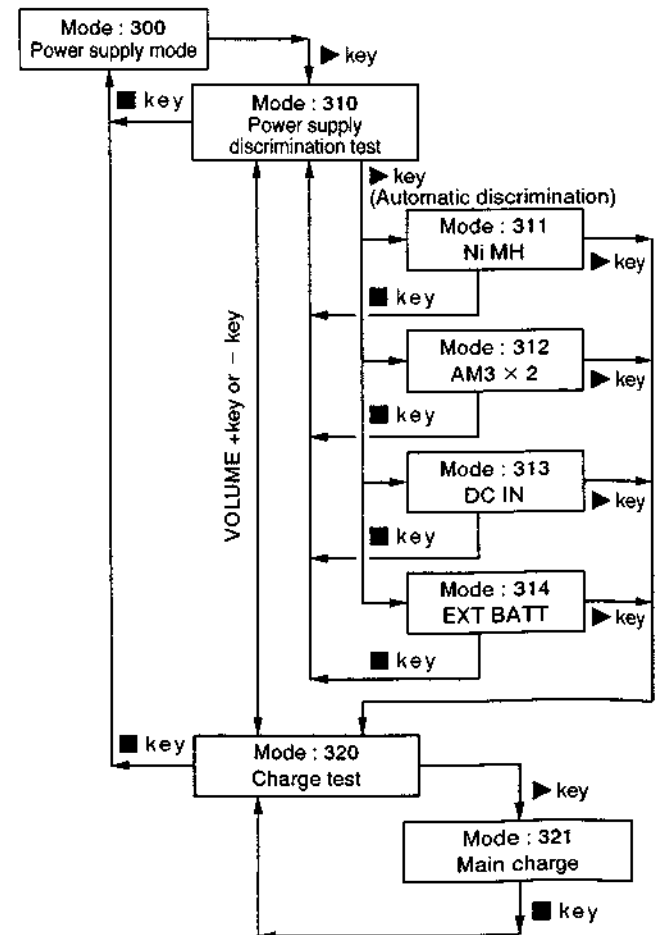

[General Adjustment Mode]

- Set the test mode, press the **⏪** key, and set the general adjustment mode.
- To set other modes, cut off the power once and power on again.
- When the general adjustment mode is set, the LCD display will be as follows.

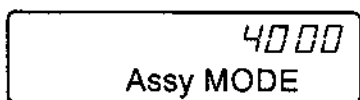

• Structure of General Adjustment Mode

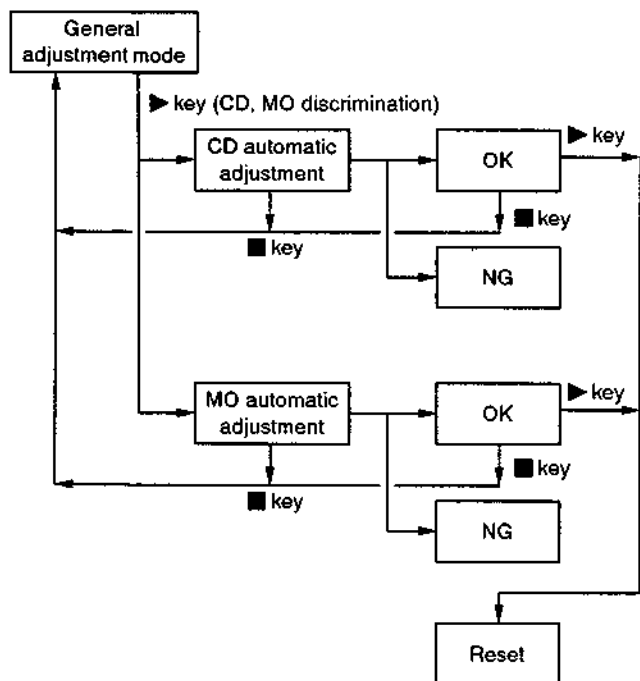

Adjusting Method :

1. Set the test mode, press the **⏪** key to set the general adjustment mode.
2. Load the CD test disc (TDYS-1) or SONY MO disc available on the market.
3. When the **▶** key is pressed, the disc is determined if CD or MO, the automatic adjustment modes are set, and adjustments are performed automatically in the following order.

• CD Automatic Adjustment

No.	Mode No.	Adjustment
1	052	CD EF balance adjustment
2	053	CD ABCD level adjustment
3	055	CD focus gain adjustment
4	056	CD tracking gain adjustment
5	057	CD focus bias adjustment

*** Display during CD automatic adjustment**

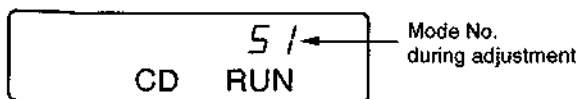

• MO Automatic Adjustment

No.	Mode No.	Adjustment
1	032	MO playback EF balance adjustment
2	033	MO playback ABCD level adjustment
3	034	MO recording EF balance adjustment
4	035	MO recording ABCD level adjustment
5	037	MO focus gain adjustment
6	038	MO tracking gain adjustment
7	061	32 cluster full REC
8	062	REC shock
9	063	32 cluster PLAY
10	039	MO focus bias adjustment
11	042	Low reflection CD EF balance adjustment
12	043	Low reflection CD ABCD level adjustment
13	045	Laser low reflection CD read adjustment
14	046	Low reflection CD tracking gain adjustment

*** Display during Mo automatic adjustment**

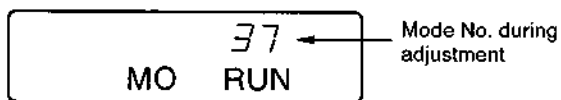

4. If the automatic adjustment results are OK, the following will be displayed.

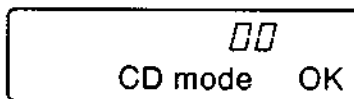

5. If the automatic adjustment results are NG, the following will be displayed.

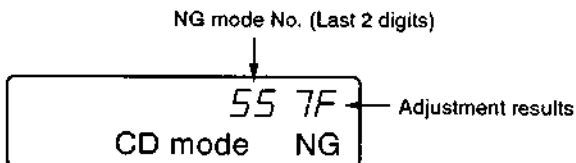

- * When the mode number is 039, 057 and the focus bias value is NG, the following will be displayed.

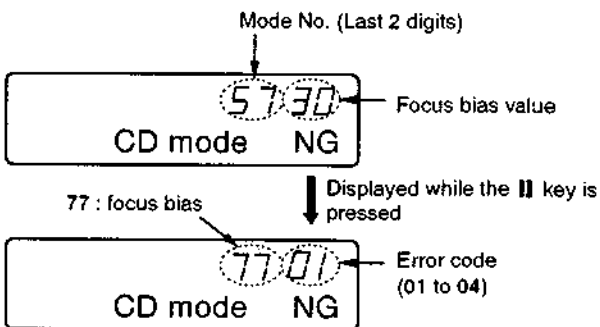

SECTION 5 ELECTRICAL ADJUSTMENTS

* When the mode number is 039, 061 and the AT error rate is NG, the following will be displayed.

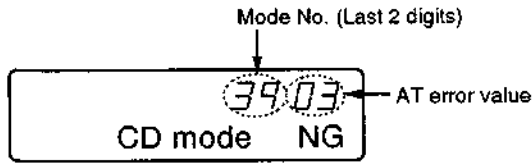

* When NG, set the servo mode and perform the automatic adjustment of the NG item. (Refer to "Servo Mode")

5-1. Precautions for Laser Diode Emission Check

When checking the emission of the laser diode during adjustments, never view directly downwards as this may lead to blindness.

5-2. Precautions for Using Optical Pickup (KMS-250A/J2N)

As the laser diode inside the optical pickup damages by static electricity easily, solder the laser tap of the flexible board when handling. Also take the necessary measures to prevent damages by static electricity. Handle the flexible board with care as it breaks easily

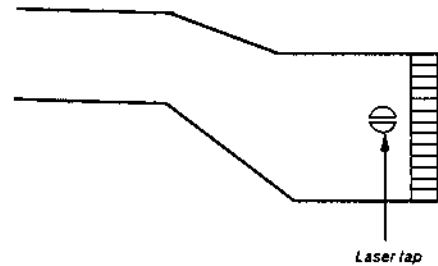

Optical pickup flexible board

5-3. Precautions for Adjustment

- 1) Perform all adjustments in the order given in the test mode. After adjusting, exit the test mode.
- 2) Use the following tools and measuring instruments.
 - CD test disc TDYS-1
(Parts Code : 4-963-646-01)
 - Recorded MO disc PTDM-1
(Parts Code : J-2501-054-A)
 - Laser power meter LPM-1
(Parts Code : J-2501-046-A)
 - Oscilloscope (Frequency band above 40MHz. Perform the calibration of probe first before measuring.)
 - Digital voltmeter
- 3) Unless specified otherwise, supply DC 6V from the DC IN 6V jack.
- 4) Switch, knob positions
 - Hold switch..... OFF
 - AVLS switch OFF

5-4. Laser Power Check

Connection :

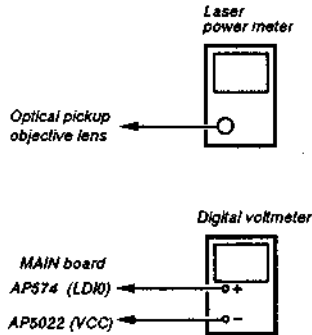

Adjusting Method :

1. Set the servo mode of the test mode (Mode : 000).
2. Press the ► key, and set the laser power adjustment mode (Mode : 020) using the volume + and - keys.
3. Press the ◀◀ key and move the optical pickup to the inner most circumference.
4. Open the cover and set the laser power meter on the objective lens of the optical pickup.
5. Press the ► key, and set the laser MO read adjustment mode (Mode : 021).
6. Check that the laser power meter reading is $0.85 \pm 0.085\text{mW}$.
7. Check that the voltage between AP574 (LDI0) and AP5022 (VCC) at this time is below 44mV.
8. Press the ► key, and set the laser MO write adjustment mode (Mode : 022).
9. Check that the laser power meter reading is $6.8 \pm 0.68\text{mW}$.
10. Press the || key to finalize the adjustment data.
11. Check that the voltage between AP574 (LDI0) and AP5022 (VCC) at this time is below 88mV.
12. Press the ■ key.
13. Exit the test mode.

5-5. MO Traverse Adjustment

Connection :

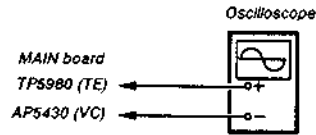

Adjusting Method :

1. Set the servo mode of the test mode (Mode : 000).
2. Press the ► key, and set the MO playback adjustment mode (Mode : 030) using the volume + and - keys.
3. Press the ◀◀ and ▶▶ keys and move the optical pickup to the center circumference.
4. Load any MO disc available on the market.
5. When the ► key is pressed, the MO playback EF balance adjustment mode (Mode : 032) will be set after focus search ON (Mode : 031).
6. Press the || key to perform automatic adjustment, and check that the traverse waveform is symmetrical at the top and bottom.
7. Slide the recording key and set the MO recording EF balance adjustment mode (Mode : 034).
8. Press the || key to perform automatic adjustment, and check that the traverse waveform is symmetrical at the top and bottom.

(Traverse Waveform)

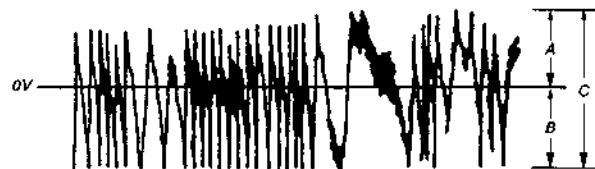

Specification : $A=B, C \geq 1.0\text{Vp-p}$

9. Check that the traverse level at this time is above 1.0Vp-p.
10. Press the ■ key.
11. Exit the test mode.

Note : Using a recorded disc in this adjustment will erase the data.

5-6. Low Reflection CD Traverse Adjustment

Connection :

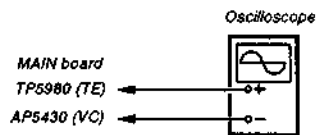

Adjusting Method :

1. Set the servo mode of the test mode (Mode : 000).
2. Press the ► key, and set the low reflection CD playback adjustment mode (Mode : 040) using the volume + and - keys.
3. Load any MO disc available on the market.
4. When the ► key is pressed, the low reflection CD playback EF balance adjustment mode (Mode : 042) will be set after low reflection CD focus search ON (Mode : 041).
5. Press the || key to perform automatic adjustment, and check that the traverse waveform is symmetrical at the top and bottom.

(Traverse Waveform)



Specification : $A=B, C \geq 0.9Vp-p$

6. Check that the traverse level at this time is above 0.9Vp-p.
7. Press the ■ key.
8. Exit the test mode.

5-7. CD Traverse Adjustment

Connection :



Adjusting Method :

1. Set the servo mode of the test mode (Mode : 000).
2. Press the ► key, and set the CD playback adjustment mode (Mode : 050) using the volume + and - keys.
3. Press the ◀◀ and ▶▶ keys and move the optical pickup to the center circumference.
4. Load a CD test disc (TDYS-1).
5. When the ► key is pressed, the CD playback EF balance adjustment mode (Mode : 052) will be set after CD focus search ON (Mode : 051).
6. Press the || key to perform automatic adjustment, and check that the traverse waveform is symmetrical at the top and bottom.

(Traverse Waveform)

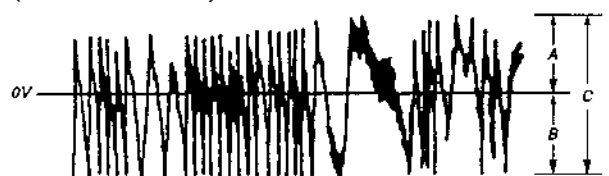

Specification : $A=B, C \geq 1.0Vp-p$

7. Check that the traverse level at this time is above 1.0Vp-p.
8. Press the ■ key.
9. Exit the test mode.

SECTION 6 EXPLANATION OF IC TERMINALS

IC503 DIGITAL SERVO, ATRAC (CXD2652R)

Pin No.	Pin name	I/O	Description
1	MNT 0	O	Traverse count signal output.
2	MNT 1	O	Track jump detect output.
3	MNT 2	-	Not used (Open).
4	MNT 3	-	Not used (Open).
5	SWDT	I	Inputs write data signal from system controller (IC801).
6	SCLK	I	Inputs serial clock signal from system controller (IC801).
7	XLAT	I	Inputs serial latch signal from system controller (IC801).
8	SRDT	O	Outputs write data signal to system controller (IC801).
9	SENS	O	Outputs internal status (SENSE) to system controller (IC801).
10	XRST	I	Inputs reset signal from system controller (IC801). Reset : L
11	SQSY	O	Output subcode Q sync (SCOR) to system controller (IC801). Outputs "L" every 13.3msec. Outputs "H" at all most mostly.
12	DQSY	O	Outputs digital-in U-bit CD format subcode Q sync (SCOR) to system controller (IC801). Outputs "L" every 13.3msec. Outputs "H" at all most mostly.
13	WRPWR	I	Inputs laser power switching signal from system controller (IC801).
14	NC	-	Not used (Open).
15	TX	I	Input of write data taransmission timing from system controller (IC801). Also used as magnetic field head ON/OFF output.
16	OSC1	O	Clock output (45MHz).
17	OSC0	I	Clock input (45MHz).
18	XTSL	-	Not used (Fixed at "L")
19	RVDD	-	Not used (Open).
20	RVSS	-	Connect to ground.
21	DIN	I	Digital audio signal input pin (For optical input).
22	NC	-	Not used (Open).
23	ADDT	I	Audio data input from A/D converter (IC303).
24	DATA	O	Monitor/decode audio data output to A/D converter (IC303).
25	ALRCK	O	L/R clock output to D/A converter (IC303).
26	ABCK	O	Bit clock signal output to A/D, D/A converter (IC303).
27	FS256	O	11.2896MHz clock output (MCLK).
28	DVDD	-	Power supply (+2.8V) for digital.
29 - 32	A03 - A00	O	Address signal output to RAM (IC509).
33	NC	-	Not used (Open).
34 - 38	A04 - A08	O	Address signal output to RAM (IC509).
39	NC	-	Not used (Open).
40	DVSS	-	Ground terminal.
41	XOE	O	Output enable contol signal output to RAM (IC509).
42	XCAS	O	Column address strobe singal output to RAM (IC509).
43	A09	O	Address signal output to RAM (IC509).
44	XRAS	O	Row address strobe signal output to RAM (IC509).
45	XWE	O	Read/write control signal output to RAM (IC509).
46 - 49	D1 - D3	I	Data signal input from RAM (IC509).
50	MVCI	-	Not used (Connect to ground).
51	ASYO	O	Playback EFM full-swing output (L : VSS, H : VDD).
52	ASYI	I	Playback EFM asymmetry comparate voltage input.

Pin No.	Pin name	I/O	Description
53	AV _{DD}	–	Power supply (+2.8V) for analog.
54	BIAS	I	Playback EFM asymmetry circuit constant current input.
55	RFI	I	Inputs playback EFM RF signal from RF amplifier (IC501).
56	AV _{SS}	–	Ground terminal.
57	PDO	–	Not used (Open).
58	PCO	O	Decoder PLL master clock PLL phase comparison output.
59	FILI	I	Decoder PLL master clock PLL filter input.
60	FILO	O	Decoder PLL master clock PLL filter output.
61	CLTV	I	Decoder PLL master clock PLL VCO control voltage input.
62	PEAK	I	Inputs peak hold signal for light amount signal from RF amplifier (IC501).
63	BOTM	I	Inputs bottom hold signal for light amount signal from RF amplifier (IC501).
64	ABCD	I	Light amount signal from RF amplifier (IC501).
65	FE	I	Input focus error signal from RF amplifier (IC501).
66	AUX1	I	Input of auxiliary signal from RF amplifier (IC501).
67	VC	I	Input of middle point voltage (+1.4V) from RF amplifier (IC501).
68	ADIO	–	Not used (Open).
69	AV _{DD}	–	Power supply (+2.8V) for analog.
70	ADRT	–	Not used (Connect to +2.8V).
71	ADRB	–	Not used (Open).
72	AV _{SS}	–	Ground terminal.
73	SE	I	Input of sled error signal from RF amplifier (IC501).
74	TE	I	Input of tracking error signal from RF amplifier (IC501).
75	AUX2	–	Not used (Open).
76	DCHG	–	Not used (Connect to +2.8V).
77	APC	–	Not used (Connect to +2.8V).
78	ADFG	I	Input of ADIP dual FM signal from RF amplifier (IC501) (22.05kHz ± 1kHz). (TTL Schmidt input)
79	FO CONT	O	Focus control output to RF amplifier (IC501).
80	XLRF	I	Latch signal input from RF amplifier (IC501).
81	CKRF	O	RFCK clock (7.35kHz) signal output.
82	DTRF	I	Serial data input from system controller (IC801).
83	APCREF	I	Laser power setting signal input.
84	LDDR	–	Not used (Open).
85	TRDR	O	Tracking servo drive signal output (–).
86	TFDR	O	Tracking servo drive signal output (+).
87	DVDD	–	Power supply (+2.8V) for digital.
88	FFDR	O	Focus servo drive signal output (+).
89	FRDR	O	Focus servo drive signal output (–).
90	FS4	O	176.4kHz clock signal output (MCLK).
91	SRDR	O	Sled servo drive signal output (–).
92	SFDR	O	Sled servo drive signal output (+).
93	SPRD	O	Spindle servo drive signal output (–).
94	SPFD	O	Spindle servo drive signal output (+).
95	FGIN	I	FG signal input from spindle motor driver (IC701).
96	TEST1	–	Not used (Connect to +2.8V).
97	TEST2	–	Not used (Connect to +2.8V).
98	TEST3	–	Not used (Connect to +2.8V).
99	DV _{SS}	–	Ground terminal.
100	EFMO	O	EFM recording signal output.

IC801 SYSTEM CONTROL (CXP81960M-632R)

Pin No.	Pin name	I/O	Description
1	CLCS	O	Chip select output to real time clock (IC804).
2	XRST	O	Reset output. L : Reset
3	WRPWR	-	Laser power switching signal output.
4	TX	O	Write data transfer timing output.
5	SENSE	I	Internal status (SENSE) input.
6	LDON	O	Laser ON signal. H : ON
7	XSHOCK	I	Track jump detection input.
8	PIT/GRV	I	COMP signal input from RF amplifier (IC501).
9	INLS	I	Detecting switch for internal circuit of sleding. Internal circuit : L
10	PROTECT	I	Disc write protect switch. H : Protect
11	DATA	O	Data output to remote control.
12	HOLD	I	Hold switch input (This unit). L : Hold
13	WP	I	Wake-up signal input from remote control key and this unit key.
14	OPEN	I	Detecting switch for opening and closing of the upper cover. Close : L
15	CLOCK	I	CLOCK SET switch input.
16	CLSDIO	I	Serial clock input.
17	SDIO2	I/O	Serial data input/output.
18	PUSH JOG	I	Push JOG switch input.
19	LCD STB	O	LCD standby output.
20	CLSCK	O	Serial clock output for real time clock (IC804).
21	SDI2	I	Serial data input.
22	SYNC. REC	I	SYNCHRO REC switch input.
23	D. B. B	I	DIGITAL MEGA BASS switch input.
24	$\overline{\text{LINEDET}}$	I	Line input detect. L : Line
25	AVLS	I	AVLS switch input. L : ON
26	TEST	I	Test mode terminal. L : Test mode
27	$\overline{\text{DCIN}}$	I	DC input detect. L : DC IN
28	KANASE L	-	Not used (Connect to ground).
29	—	--	Not used (Open).
30	$\overline{\text{PCONT}}$	O	Power control output. L : ON
31	$\overline{\text{BATTON}}$	O	Outputs L while operating with a battery.
32	RECLD	O	REC LED control. L : ON
33	MODE2	O	Head drive (IC506) control signal output.
34	MODE1	O	
35	RFSW	O	Power control output to RF amplifier (IC501).
36	$\overline{\text{LCD ON}}$	O	LCD ON/OFF control. L : ON
37	MP	-	Microprocessor mode input (Fixed at "L").
38	$\overline{\text{MRST}}$	I	Microprocessor reset input.
39	V _{ss}	-	Ground.
40	XTAL	-	System clock (12MHz).
41	EXTAL	-	System clock (12MHz).
42	CS	-	Chip Select input (Connected to +2.8V).
43	—	-	Not used (Fixed at "L").
44	LCDDATA	O	LCD data output.
45	LCDSCK	O	Serial clock output.
46	LI-MNT	I	Voltage monitor for lithium battery.
47	FDMON	I	Focus coil position monitor input.
48	HIDCMNT	I	Voltage monitor DC input.
49	KEY2	I	Remote control key input.
50	AV _{ss}	-	A/D converter ground terminal.

Pin No.	Pin name	I/O	Description
51	AVREF	I	A/D converter reference voltage input.
52	AVDD	—	A/D converter power supply terminal.
53	AM3	I	AC adaptor or EXT battery detection input. L : EXT battery
54	TEMP	I	Temp meter (IC803) input.
55	KEY3	I	PLAY Key input.
56	KEY4	I	Key input.
57	KEY0	I	Key input.
58	KEY1	I	Key input.
59	UNMNT (LI+MNT)	I	UNREG voltage monitor.
60	LIMIT (LI+MNT)	I	Voltage monitor for lithium battery.
61	FGIN	I	FG input from motor driver (IC701).
62	SLA	I	JOG dial signal input.
63	SLB	I	
64	INTSW	I	INITIAL switch input.
65	PACK IN	I	MEDIA switch input.
66	JACKDET	I	Input jack detection input.
67	OPT DET	I	Detecting input an optical input.
68	MICDET	I	MIC jack detection.
69	XLAT	O	Latch output.
70	KEYON	O	TRACK MARK jack input.
71	STISOU	O	Stepping motor signal output.
72	ST2SOU	O	
73	XAMON	O	Charge current control.
74	—	—	Not used (Open).
75	DQSY	I	Subcode Q sync (SCOR) of digital in U-bit CD format from IC503.
76	TCOUNT	I	Traverse count signal input.
77	SDI1	I	Serial data input.
78	SDO1	O	Serial data output.
79	SCK1	O	Serial clock output.
80	SQSY	I	SUB-Q/ADIP SYNC input.
81	BEEP	O	BEEP sound output control. H : BEEP sound output
82	—	—	Not used (Open).
83	REFLCT	I	CD/MO discrimination switch.
84	TEX	—	Not used (Fixed at "L")
85	XT	—	Not used (Open).
86	V _{SS}	—	Ground.
87	V _{DD}	—	Power supply pin (+2.8V).
88	NC	—	Not used (Fixed at "H")
89	\overline{CS}	I	Chip select input.
90	\overline{PD}	O	D/A converter power down detect during recording. H : Power down
91	—	—	Not used (Open).
92	—	—	Not used (Open).
93	AMUTE	O	Analog mute control. L : Mute
94	OPTCONT	O	Power supply control output for an optical input.
95	CSHP	O	Chip select output.
96	CSNV	O	
97	SCK2	O	Serial clock output.
98	XMODON	O	HF module control output.
99	SDO2	O	Serial data output.
100	LI-CHG	O	Charge control. H : Charge

SECTION 7
DIAGRAMS

7-1. BLOCK DIAGRAM

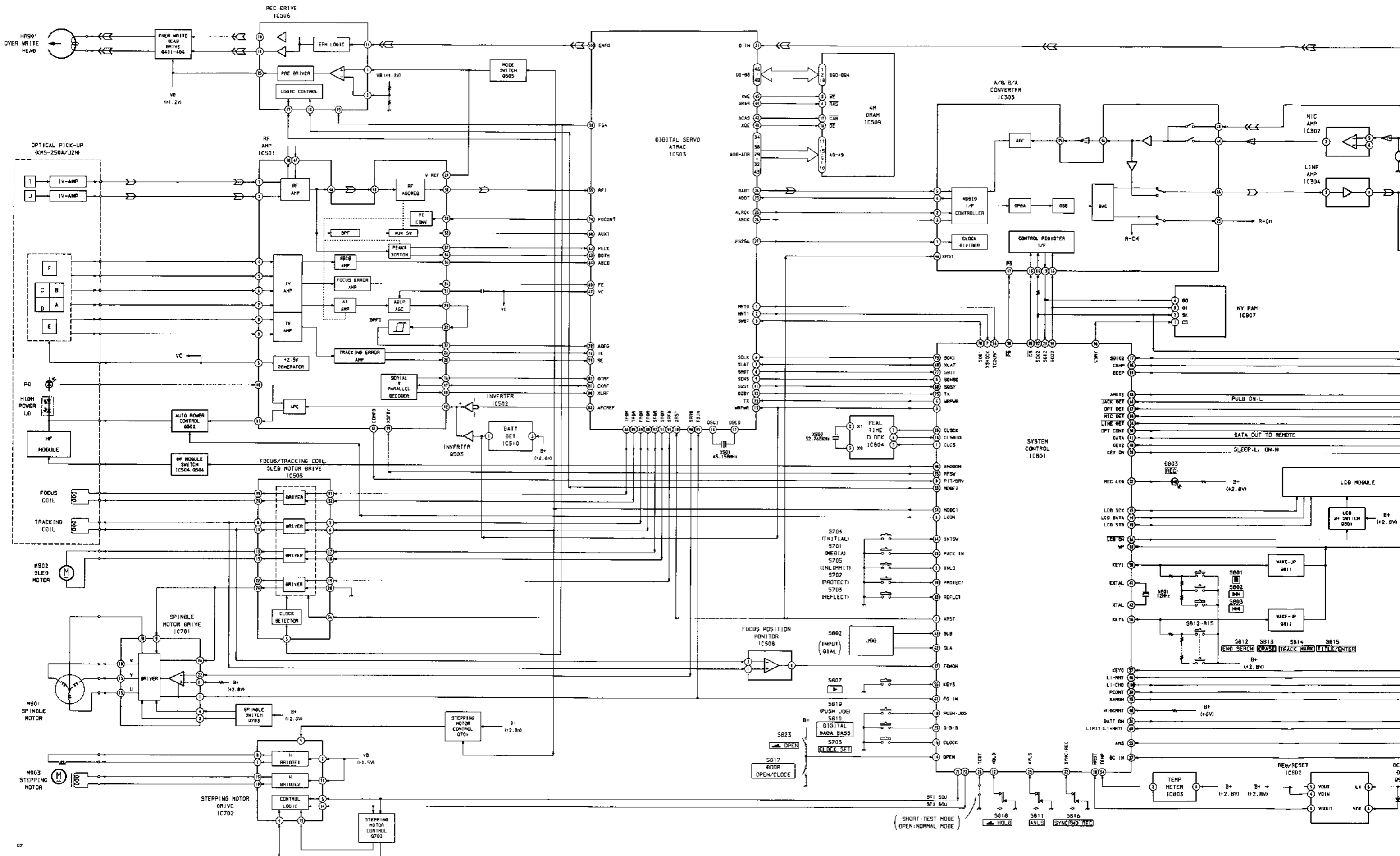

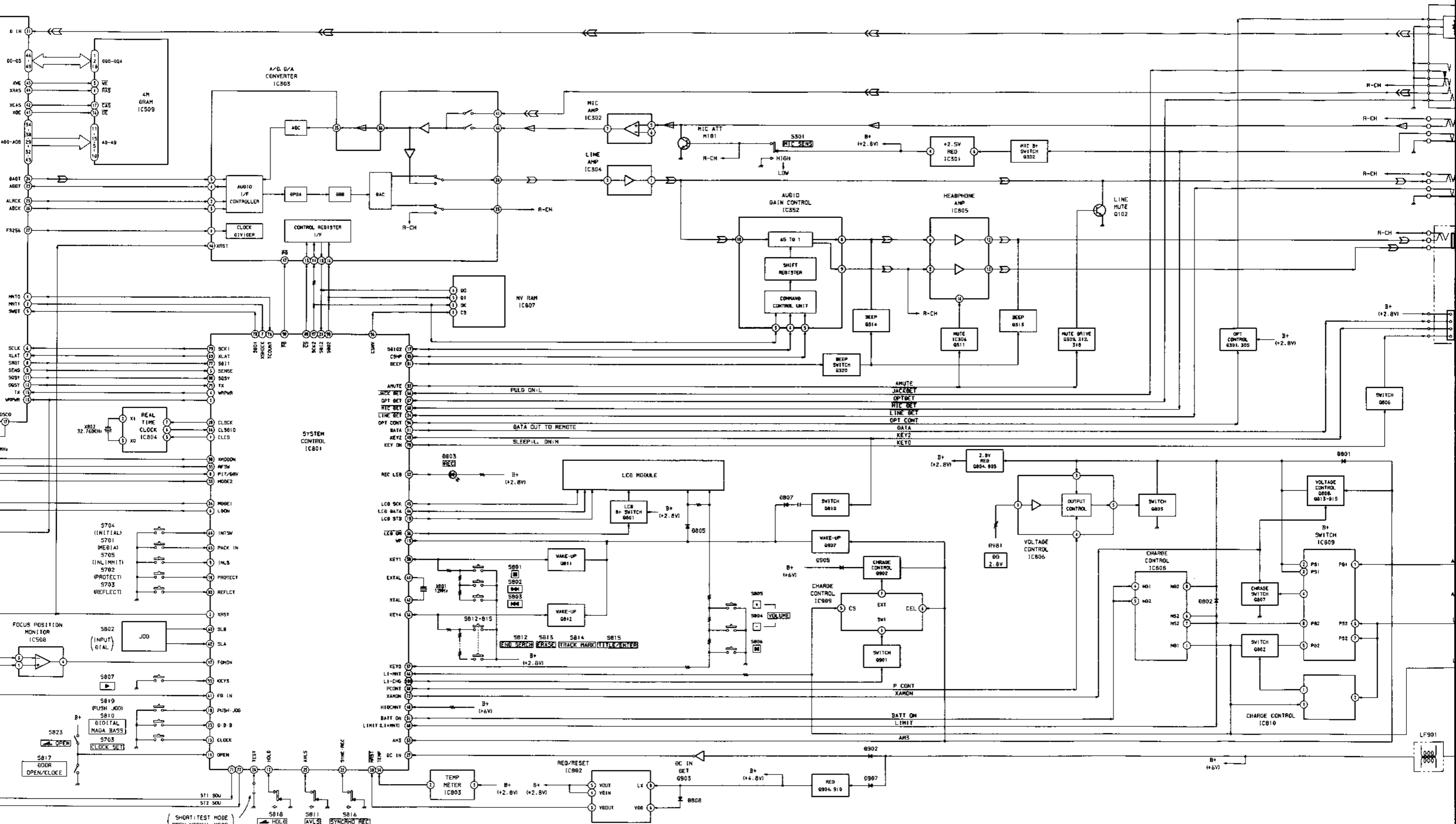

7-2. CIRCUIT BOARDS LOCATION

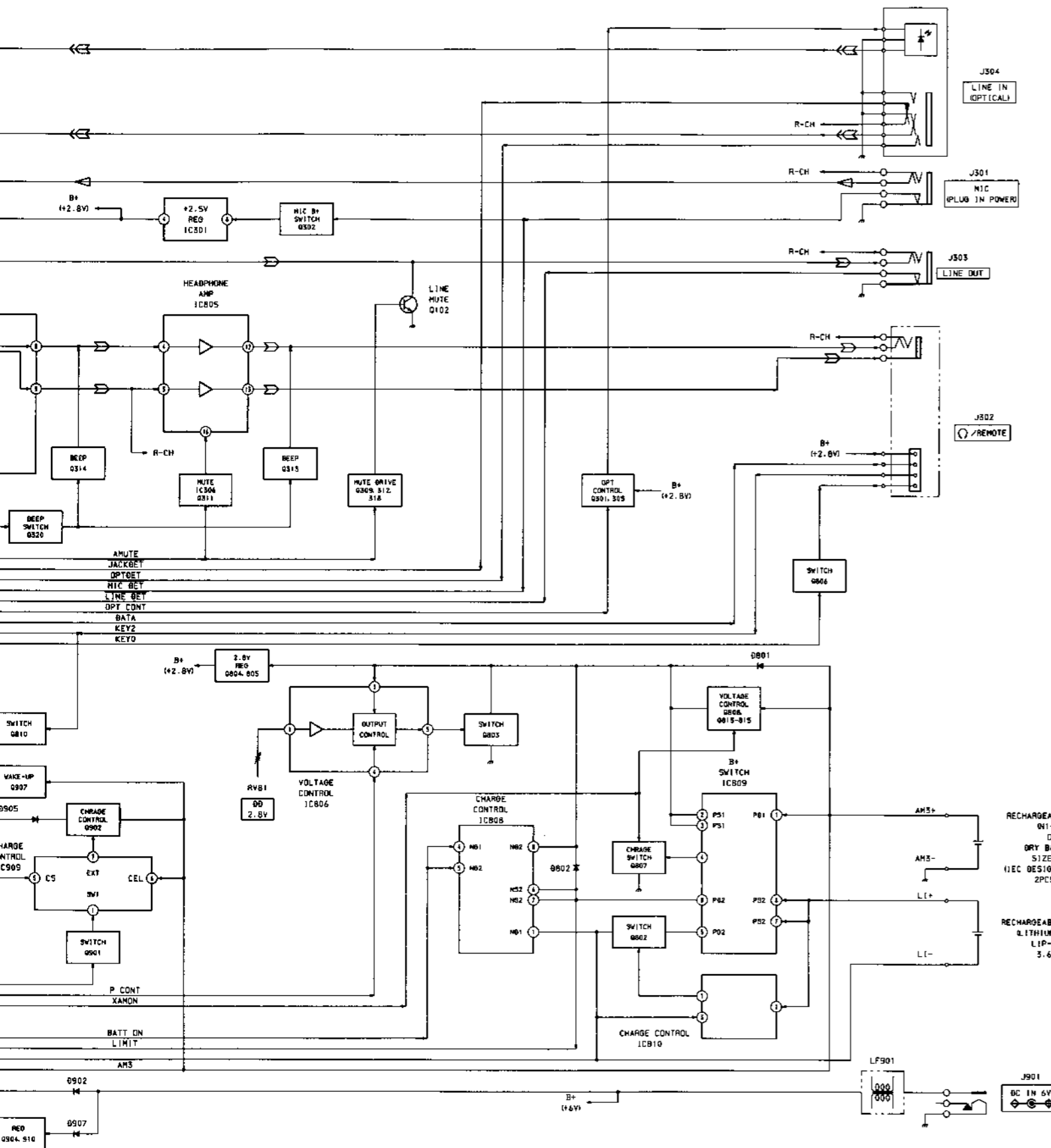
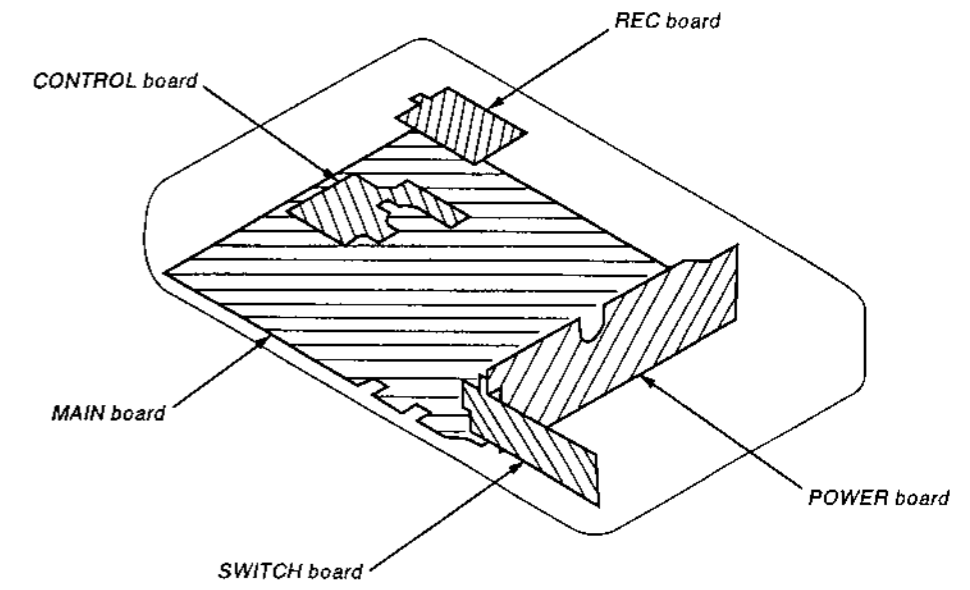

• Signal path.
 ▾ : PB
 ▽ : REC
 ▹ : MIC

7-3. PRINTED WIRING BOARDS - MAIN SECTION

• SEMICONDUCTOR LOCATION

Ref. No.	Location	Ref. No.	Location
D101	B-3	IC805	B-4
D201	B-3	IC806	B-23
D301	E-17	IC807	G-17
D303	C-4	IC808	E-23
D304	B-4	IC809	D-23
D305	C-4	IC810	B-23
D307	B-3	IC909	G-19
D308	C-17		
D310	C-3		
D501	F-14	Q101	E-4
		Q102	C-18
D502	H-15	Q201	E-4
D503	D-9	Q202	D-19
D504	D-8	Q301	D-18
D801	C-23		
D802	C-23	Q302	D-6
		Q305	D-18
D803	B-15	Q309	C-18
D804	E-16	Q311	B-17
D805	I-17	Q312	C-17
D806	H-18		
D807	B-6	Q313	B-16
		Q314	B-17
D808	H-17	Q318	C-18
D809	H-17	Q320	B-16
D810	F-26	Q502	D-13
D812	F-25		
D902	G-2	Q503	B-16
		Q504	E-15
D903	G-19	Q505	H-15
D905	F-18	Q506	C-13
D906	H-17	Q701	G-14
D907	G-19		
D3001	C-17	Q702	G-14
		Q801	H-18
IC301	E-4	Q802	B-23
IC302	E-2	Q803	B-26
IC303	E-4	Q804	G-26
IC304	D-5	Q805	F-26
IC306	C-5	Q806	C-6
		Q807	D-23
IC352	C-4	Q808	C-26
IC501	C-8	Q810	C-6
IC502	B-6		
IC503	D-14	Q811	H-13
IC504	B-13	Q812	H-13
		Q813	C-27
IC505	F-8	Q814	B-27
IC506	H-7	Q815	C-26
IC508	E-12		
IC509	D-16	Q901	G-19
IC510	B-15	Q902	G-4
		Q903	G-2
IC702	G-8	Q904	G-4
IC801	G-6	Q907	H-5
IC802	G-18		
IC803	E-7	Q910	F-3
IC804	H-18		

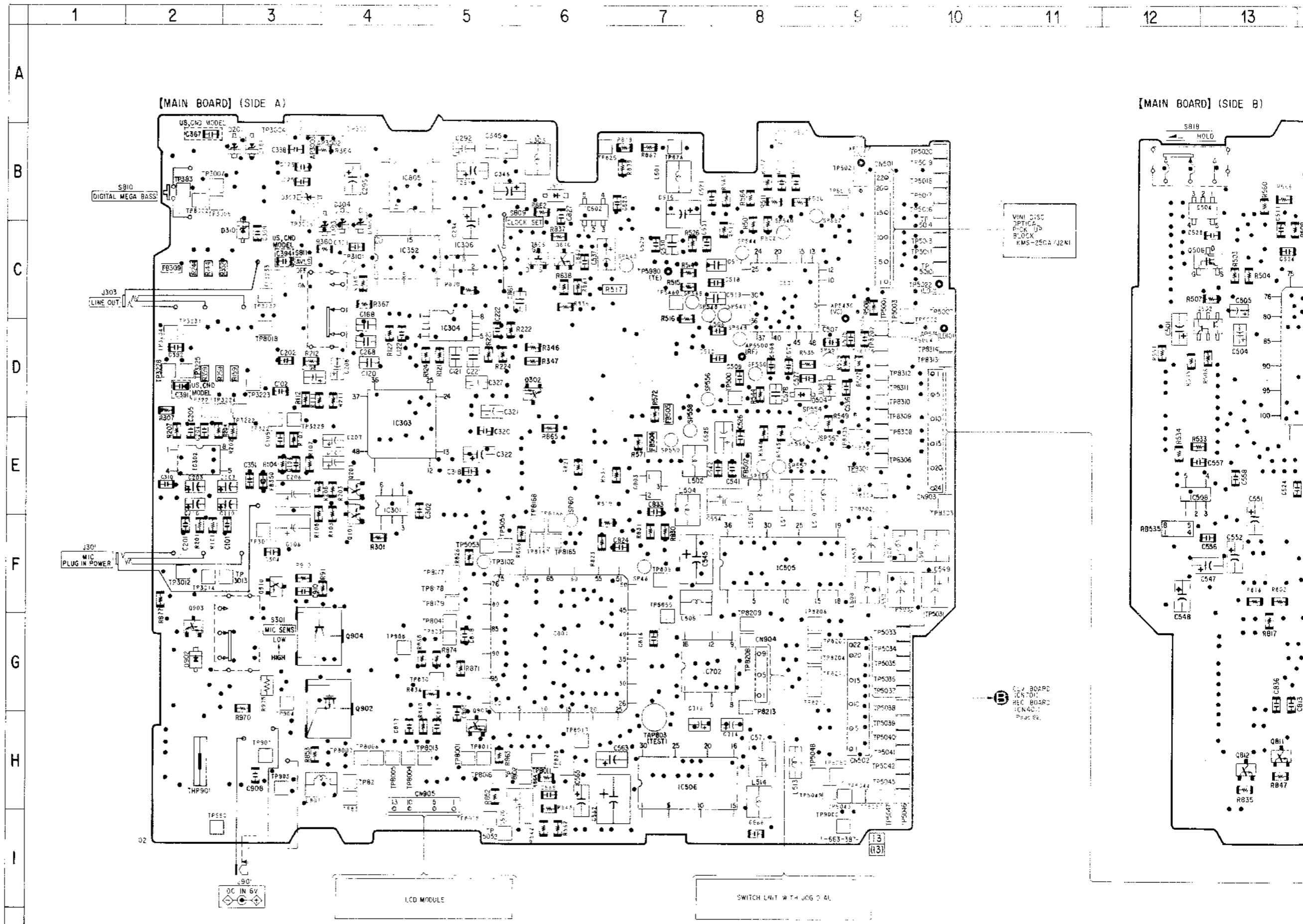

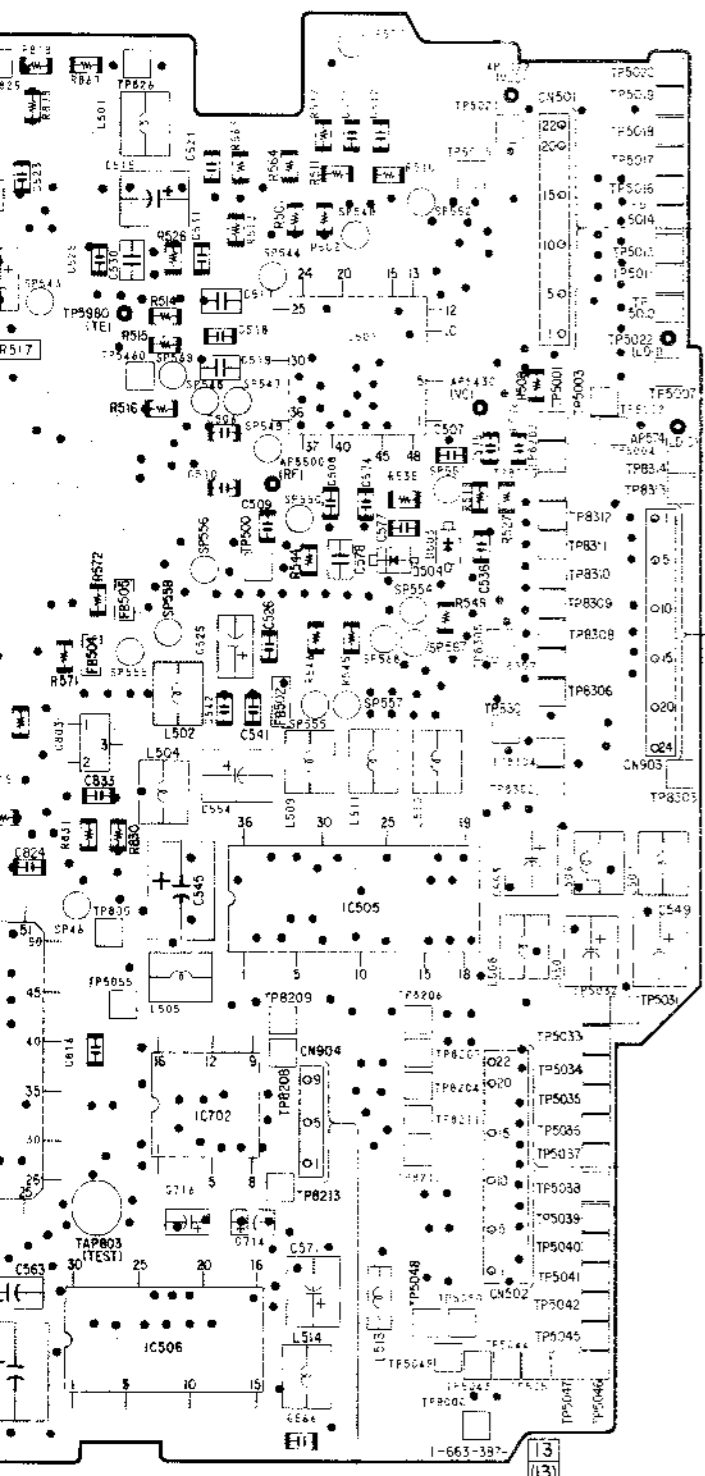

[MAIN BOARD] (SIDE B)

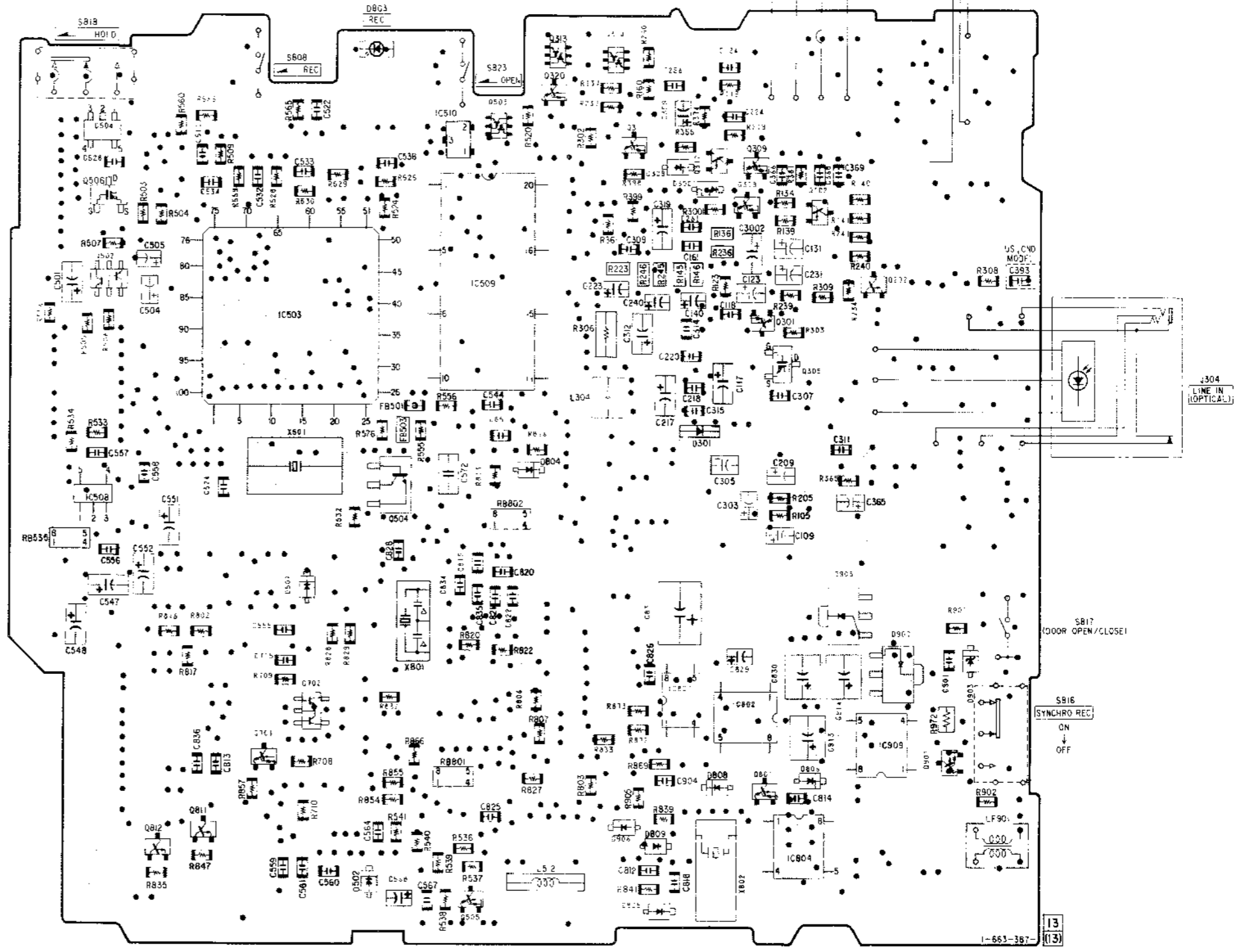

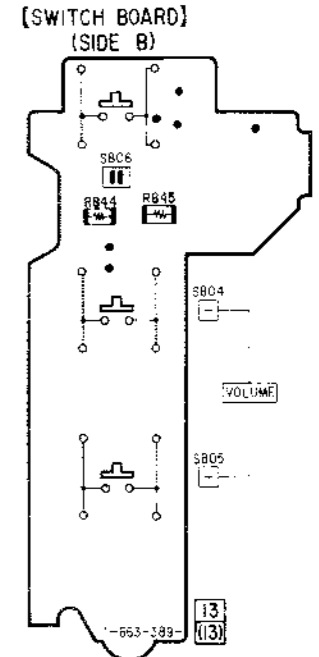
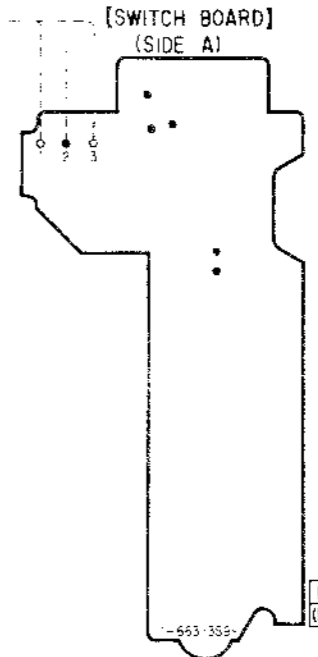
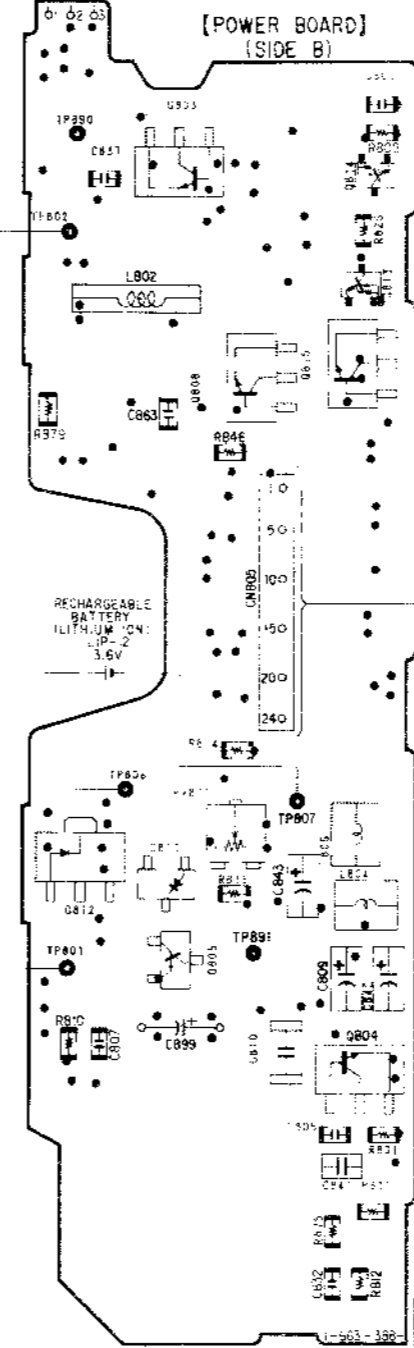
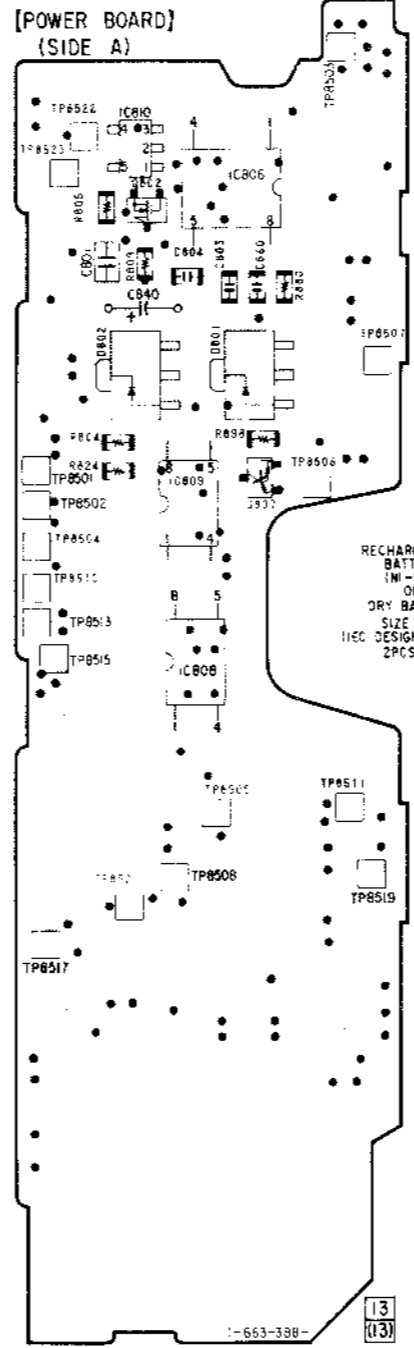
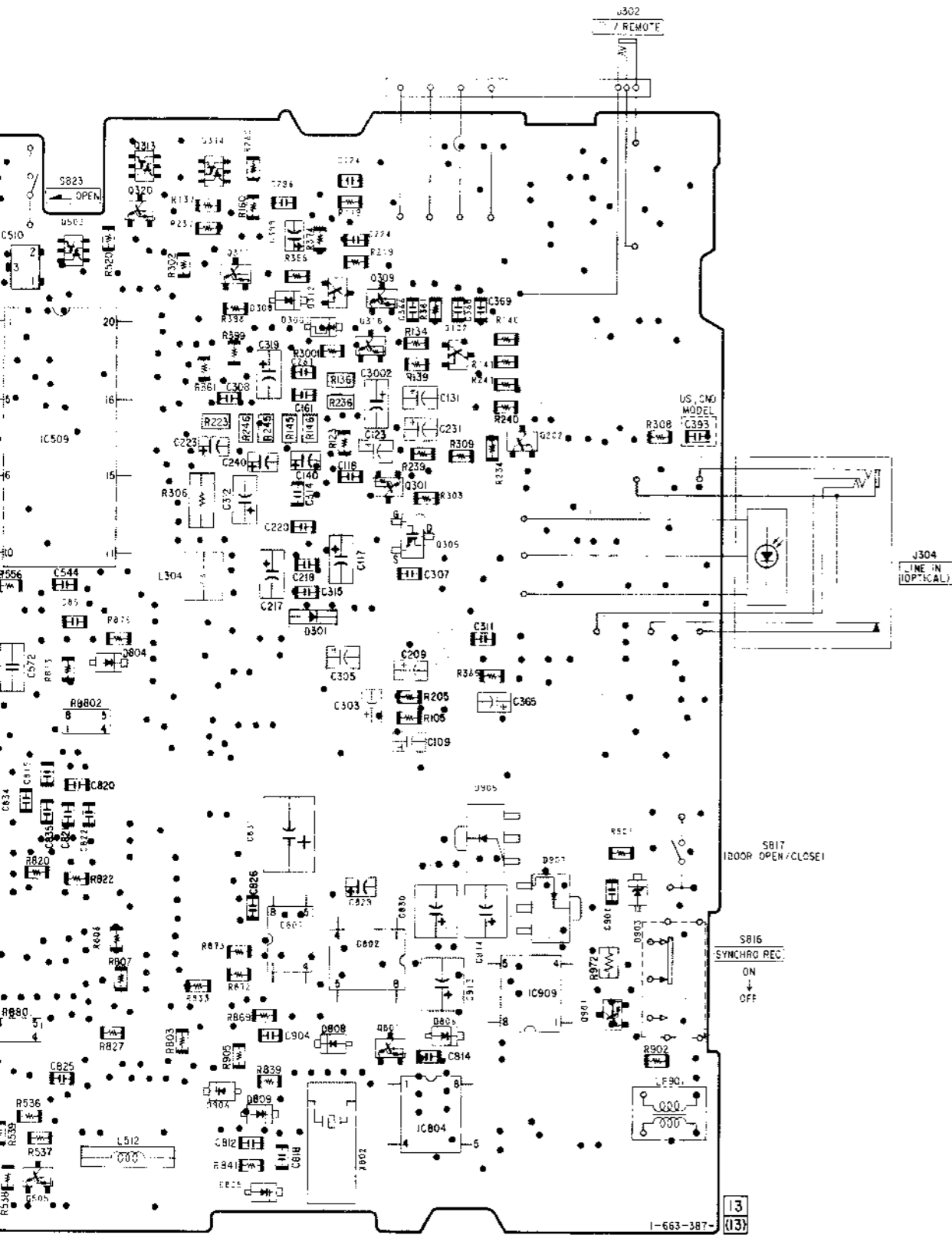

Note:

- — parts extracted from the component side.
- — through hole.
- — Pattern from the side which enables seeing. (The other layers' patterns are not indicated).

Caution:

- Pattern face side (Conductor Side) : Parts on the pattern face side seen from the pattern face are indicated.
- Parts face side (Component side) : Parts on the parts face side seen from the parts face are indicated.

• Abbreviation
 CND : Canadian
 JE : Tourist

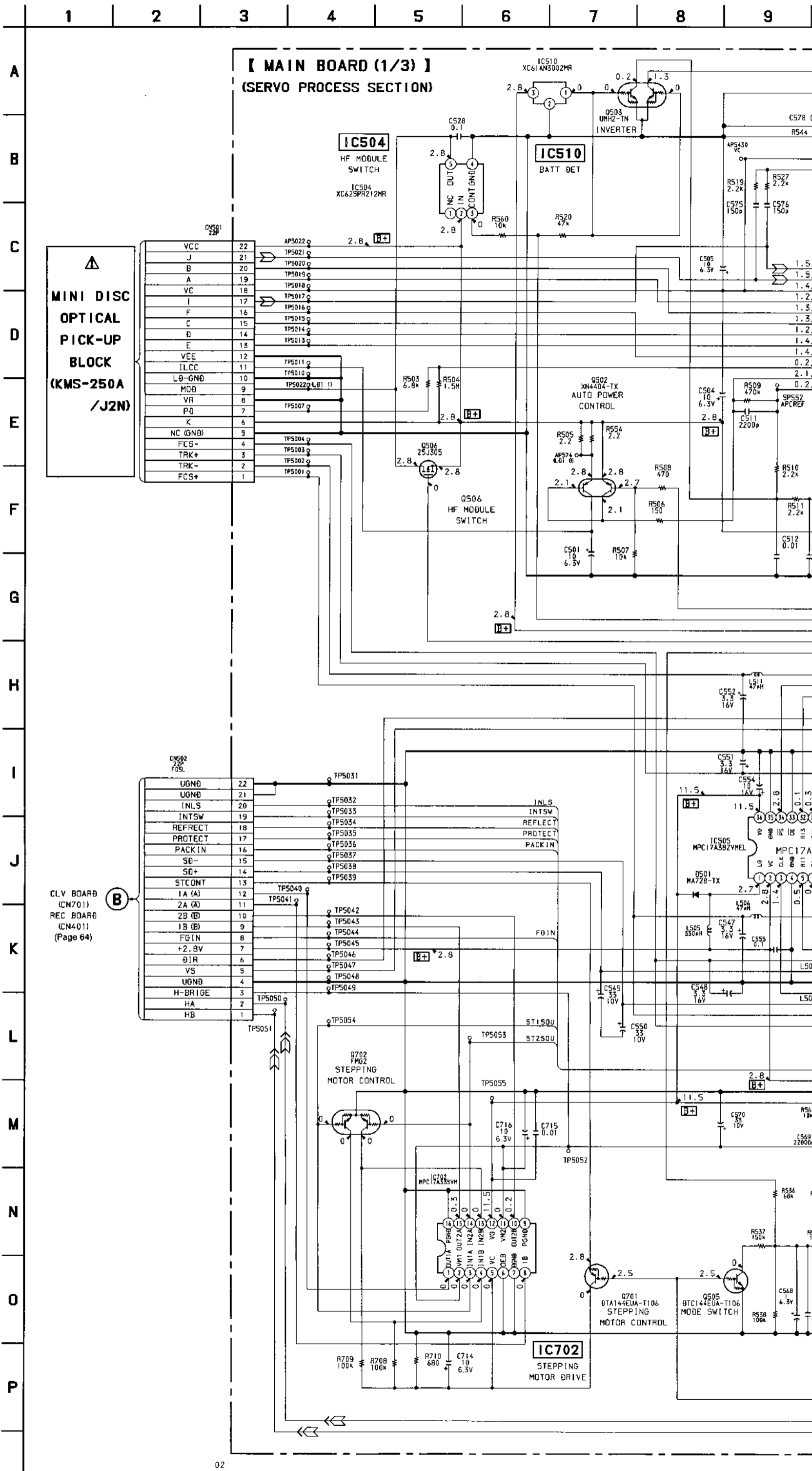

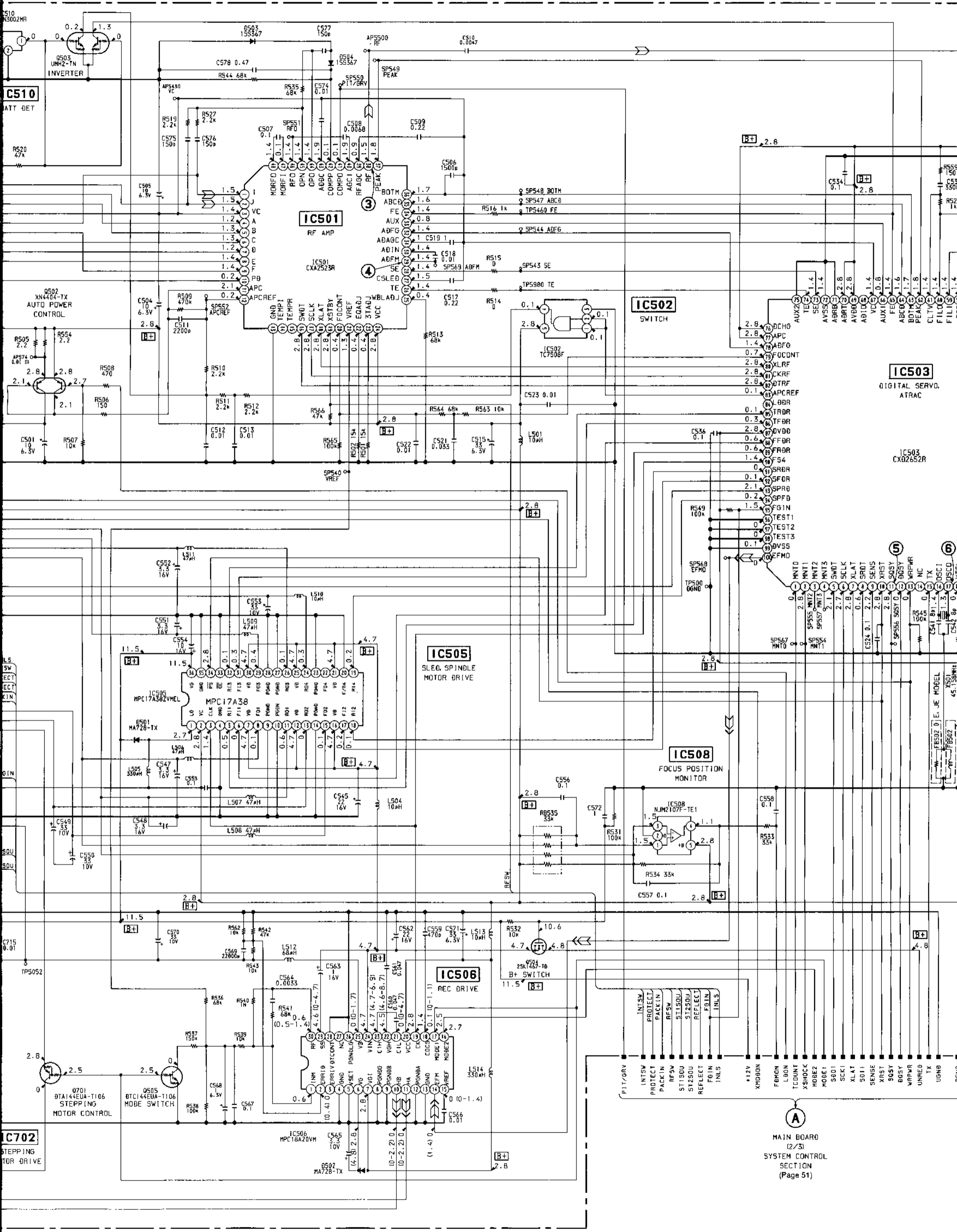

A

MAIN BOARD
(2/3)
SYSTEM CONTROL
SECTION
(Page 51)

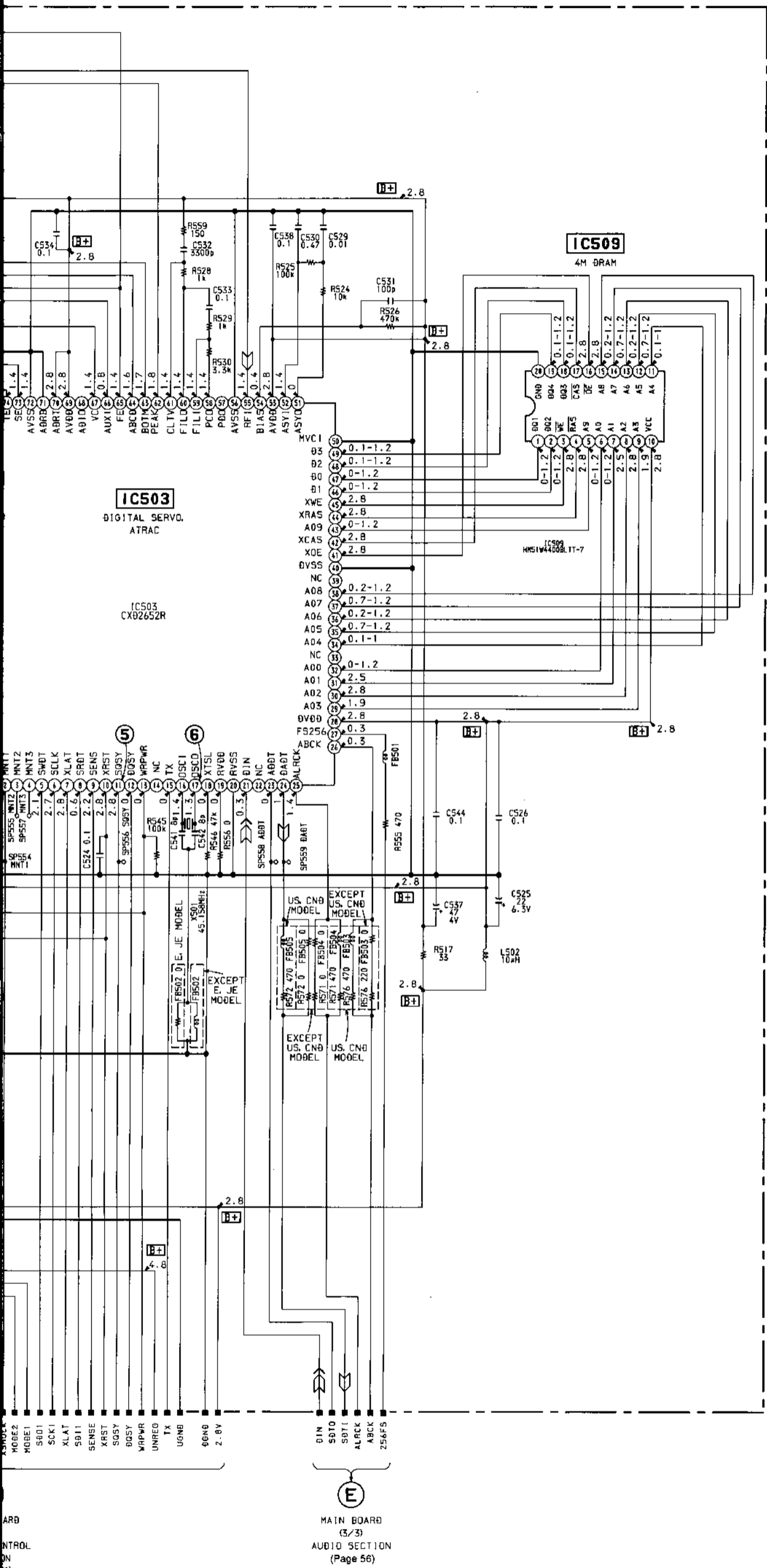

• WAVEFORMS

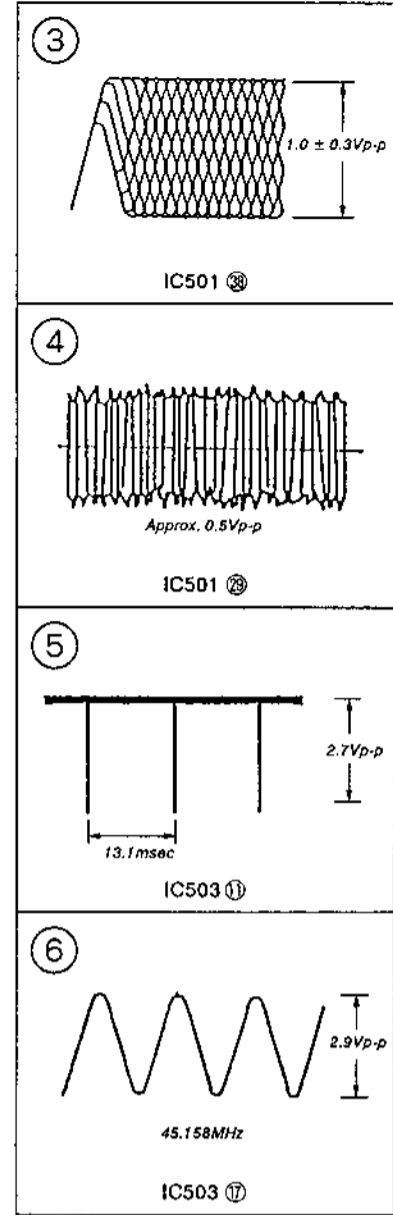

Note :

- All capacitors are in μF unless otherwise noted. pF: μF 50WV or less are not indicated except for electrolytics and tantalums.
- All resistors are in Ω and $1/4 W$ or less unless otherwise specified.
- **B+** : B+ Line
- Power voltage is dc 6V and fed with regulated dc power supply from external power voltage jack (J901).
- Voltage and waveforms are dc with respect to ground under no-signal conditions.
- no mark : PB
() : REC
- Voltages are taken with a VOM (Input impedance 10M Ω). Voltage variations may be noted due to normal production tolerances.
- Waveforms are taken with an oscilloscope. Voltage variations may be noted due to normal production tolerances.
- Circled numbers refer to waveforms.
- Signal path.
 >>> : PB
 >>>> : REC
- Abbreviation
 CND : Canadian
 JE : Tourist

• WAVEFORMS

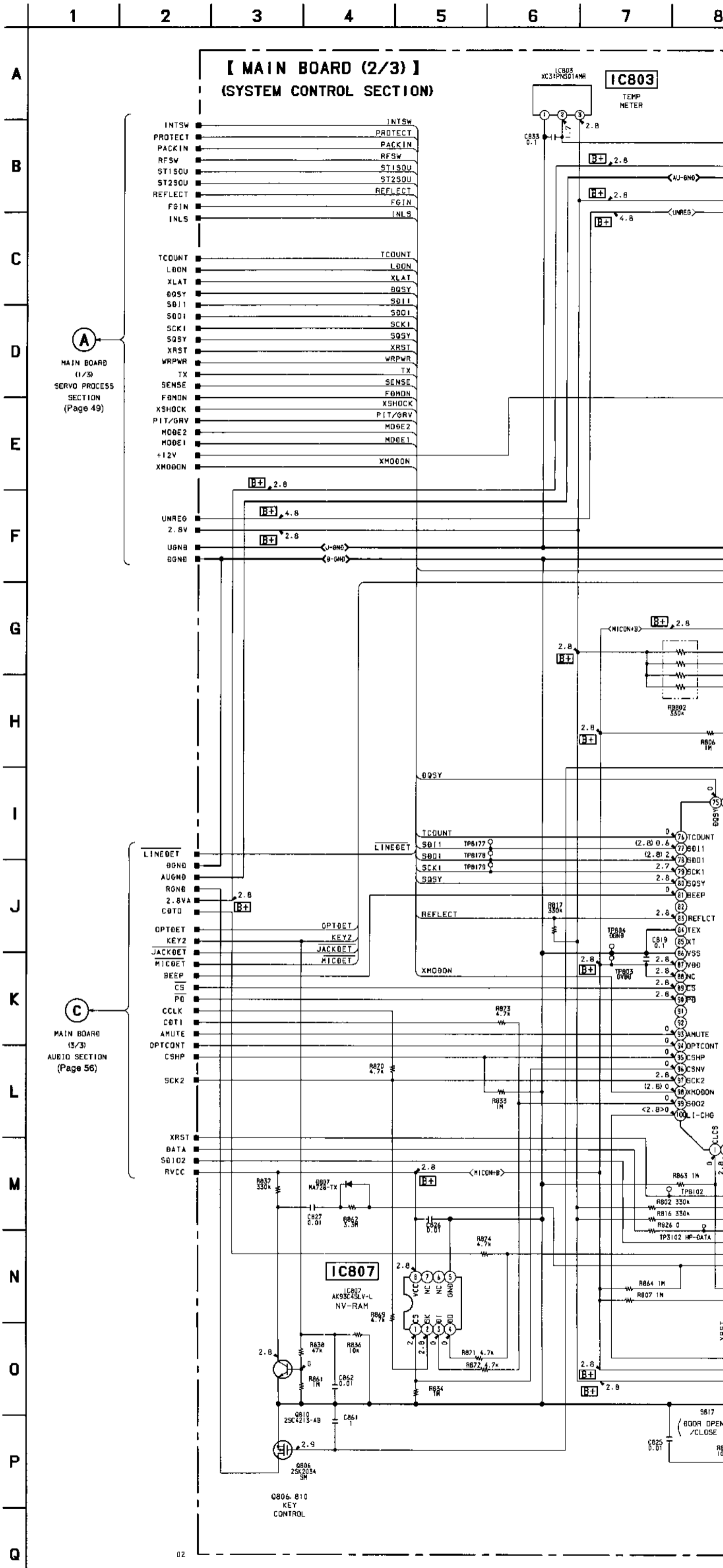
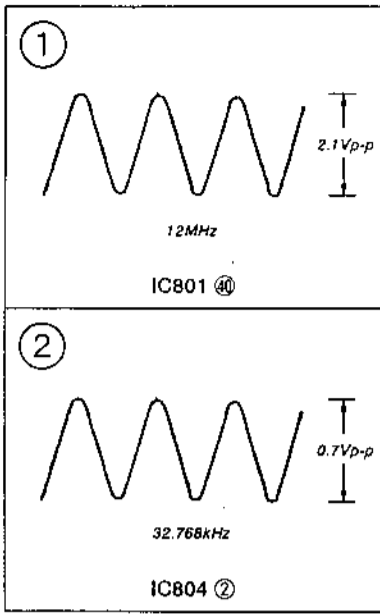

A
MAIN BOARD
(1/3)
SERVO PROCESS
SECTION
(Page 49)

C
MAIN BOARD
(5/3)
AUDIO SECTION
(Page 56)

Note :

- All capacitors are in μF unless otherwise noted. pF: μpF 50WV or less are not indicated except for electrolytics and tantalums.
- All resistors are in Ω and $\frac{1}{4}\text{W}$ or less unless otherwise specified.
- Δ : internal component.
- **B+** : B+ Line
- Power voltage is dc 6V and fed with regulated dc power supply from external power voltage jack (J901).
- Voltage and waveforms are dc with respect to ground under no-signal conditions.
no mark : PB
() : REC
< > : CHARGE
- Voltages are taken with a VOM (Input impedance 10M Ω). Voltage variations may be noted due to normal production tolerances.
- Waveforms are taken with an oscilloscope. Voltage variations may be noted due to normal production tolerances.
- Circled numbers refer to waveforms.

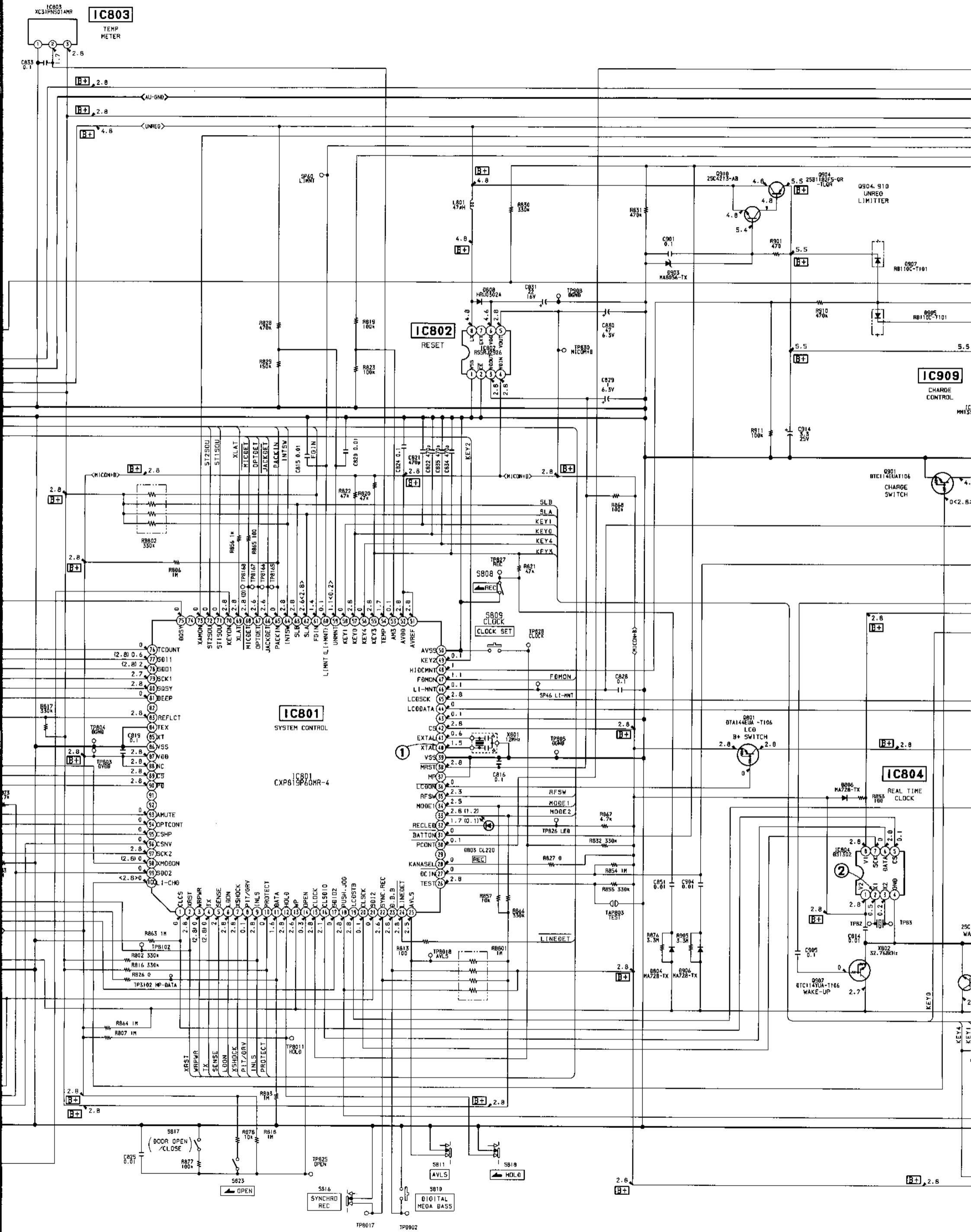

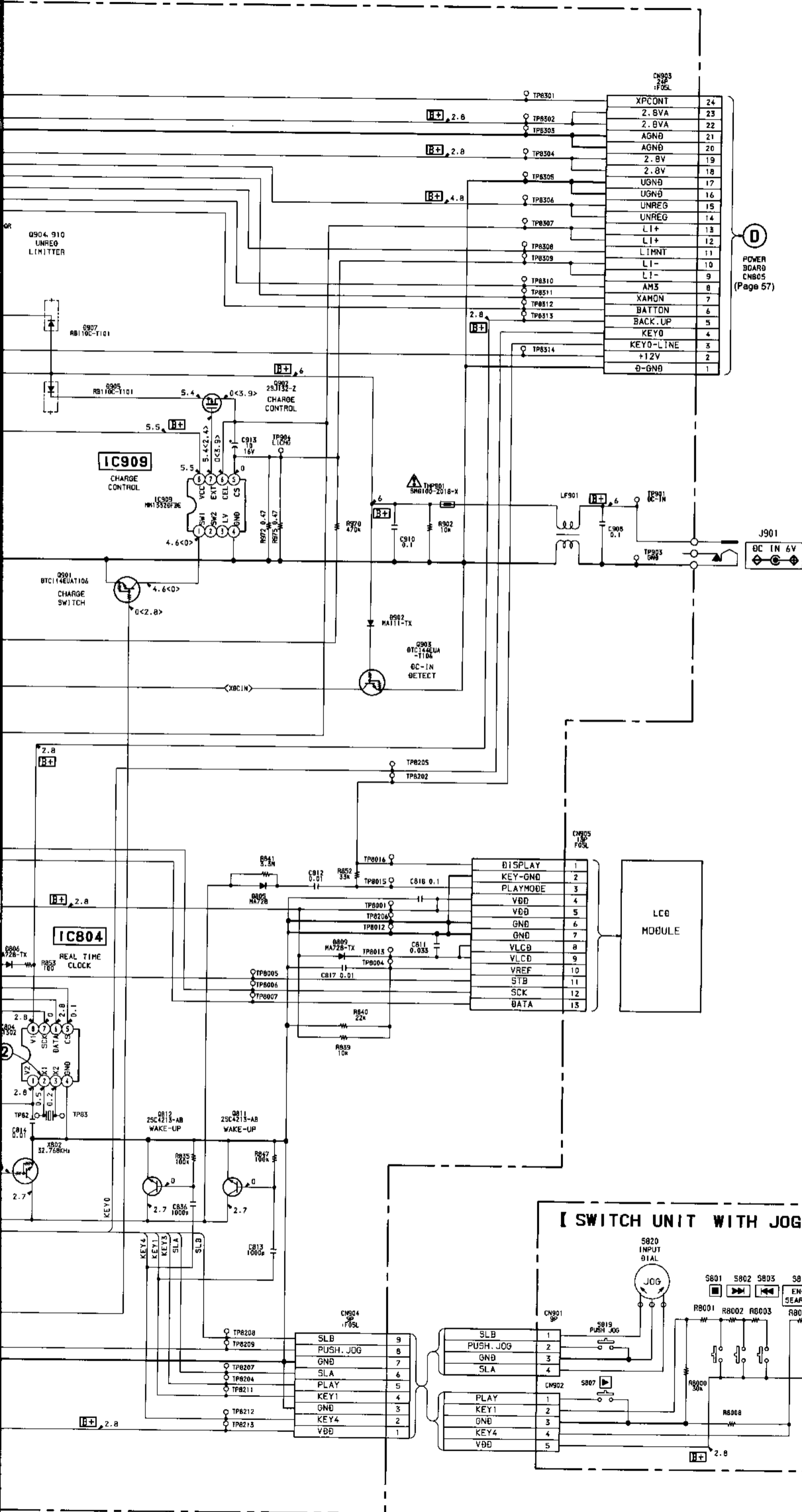

POWER BOARD CN805 (Page 57)

1 2 3 4 5 6 7 8 9 10 11 12 13 14 15 16 17 18 19

A
B
C
D
E
F
G
H
I
J
K
L

[MAIN BOARD (3/3)]
(AUDIO SECTION)

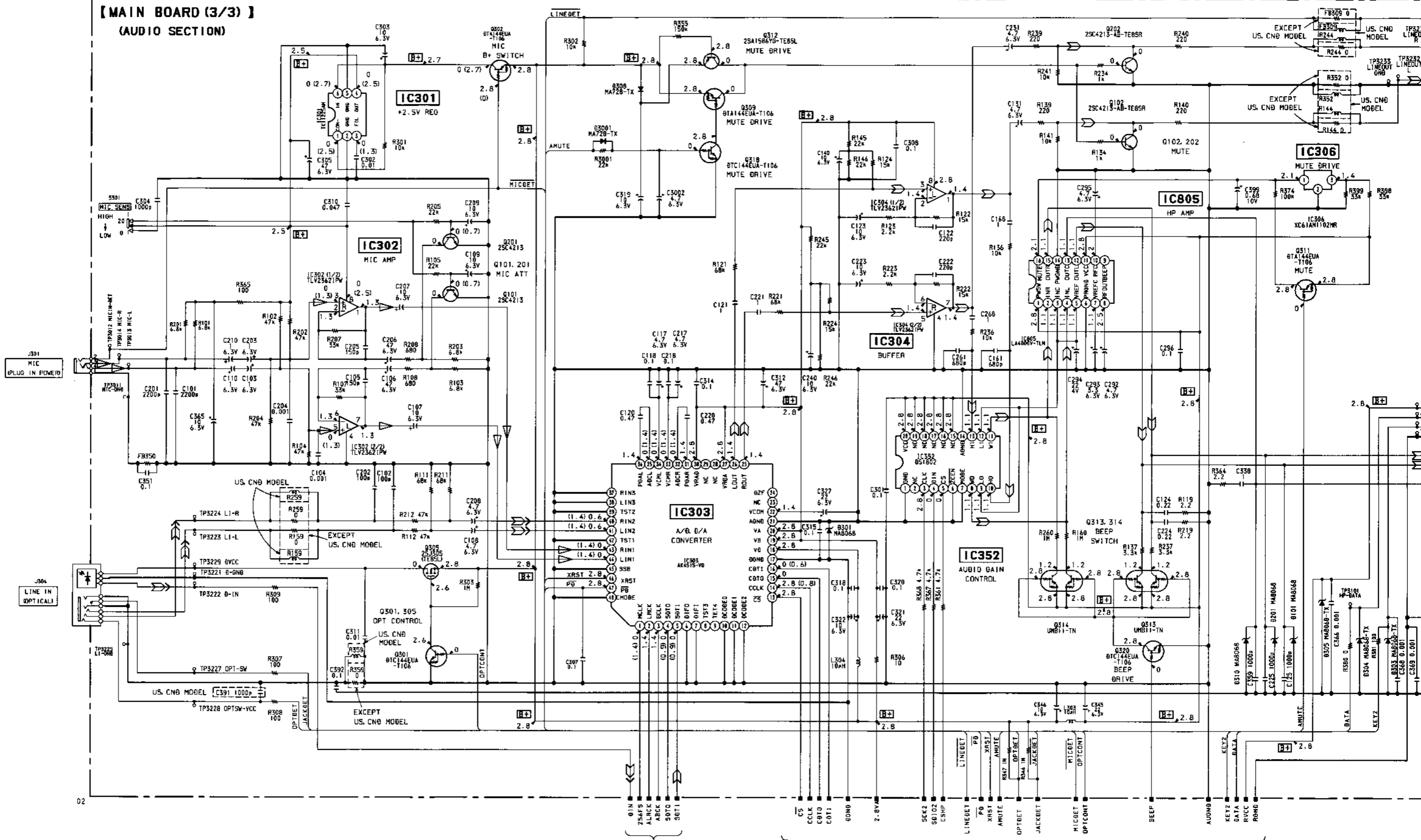

MAIN BOARD (Page 49)
(1/3)
SERVO PROCESS SECTION

MAIN BOARD (Page 51)
(2/3)
SYSTEM CONTROL SECTION

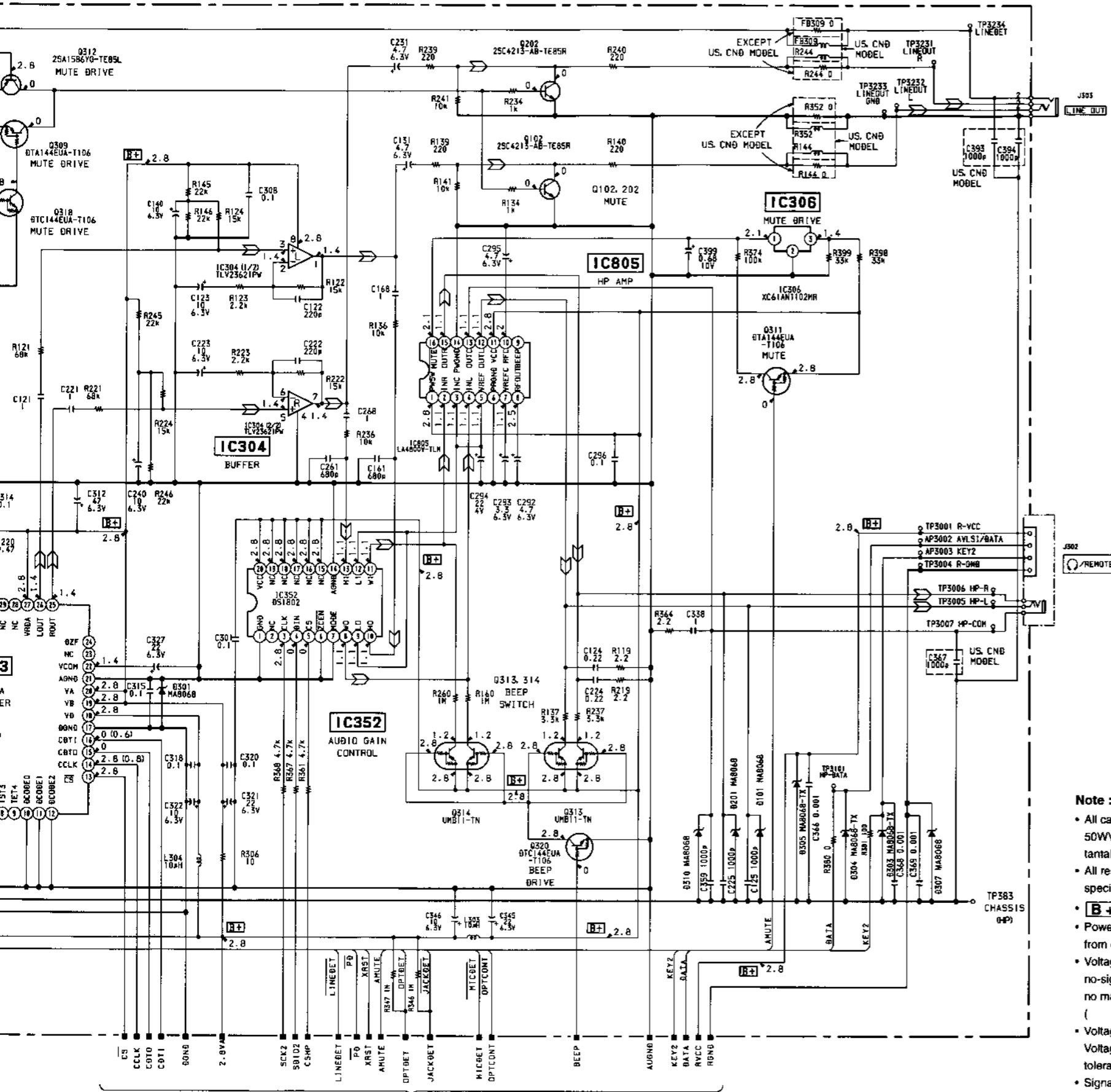

MAIN BOARD (Page 51)
(2/3)
SYSTEM CONTROL SECTION

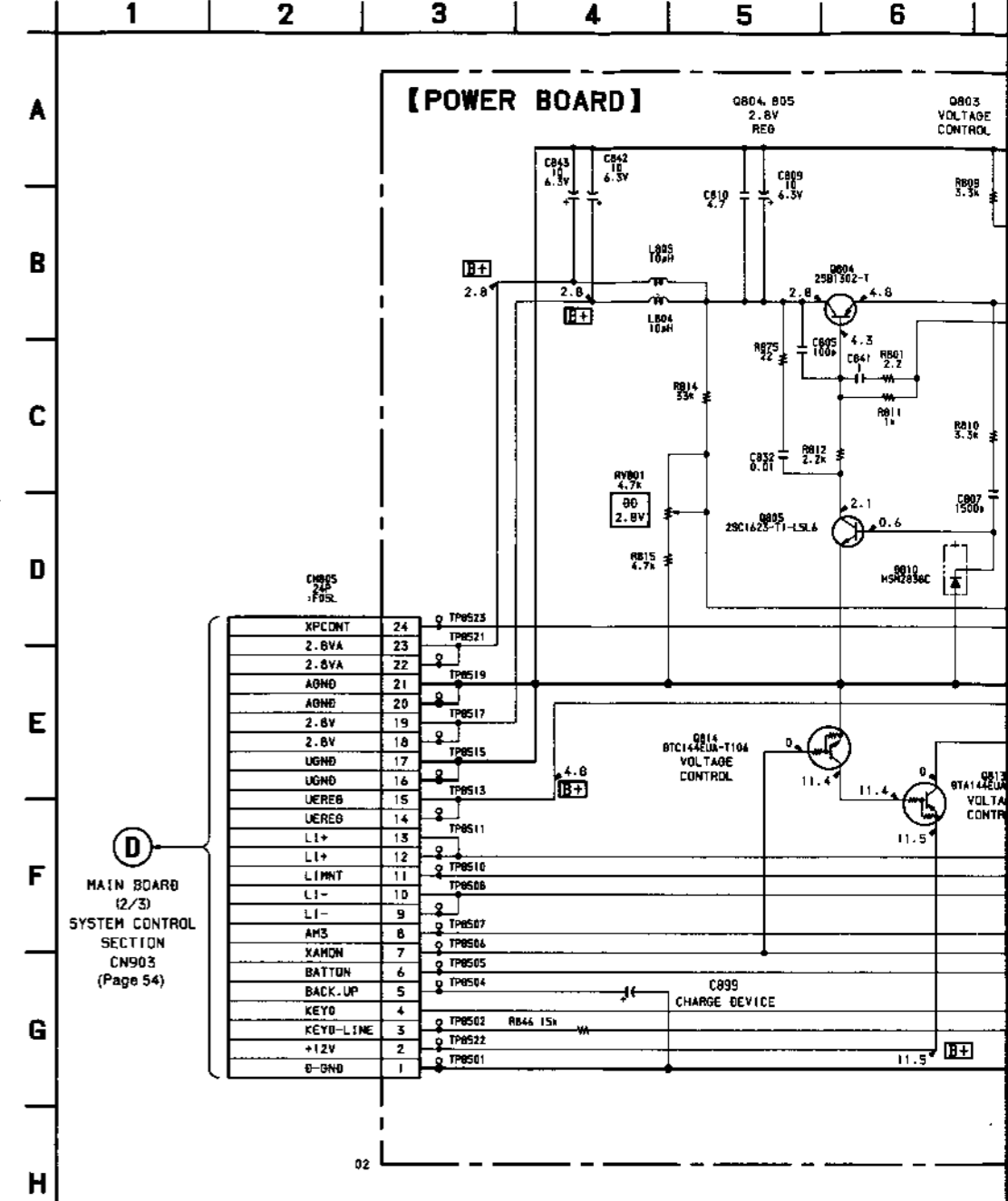

- Note :**
- All capacitors are in μF unless otherwise noted. pF : μF 50WV or less are not indicated except for electrolytics and tantalums.
 - All resistors are in Ω and $1/4\text{W}$ or less unless otherwise specified.
 - B+** : B+ Line
 - Power voltage is dc 6V and fed with regulated dc power supply from external power voltage jack (J901).
 - Voltage and waveforms are dc with respect to ground under no-signal conditions.
 - no mark : PB
 - () : REC
 - Voltages are taken with a VOM (Input impedance $10\text{M}\Omega$). Voltage variations may be noted due to normal production tolerances.
 - Signal path.
 - Σ : PB
 - ∇ : REC
 - ∇ : MIC
 - Abbreviation
 - CND : Canadian

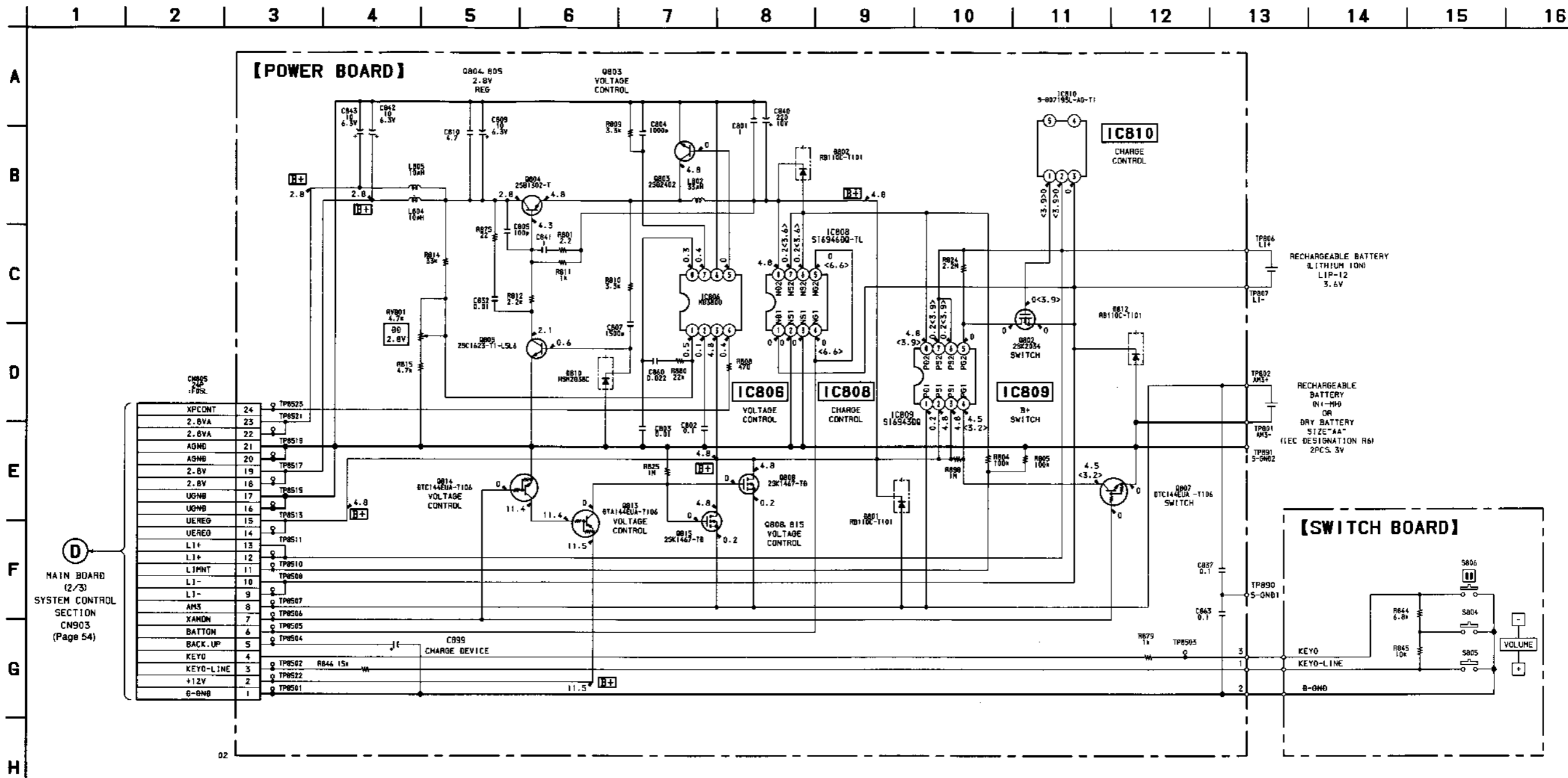

Capacitors are in μF unless otherwise noted. pF: μpF
 or less are not indicated except for electrolytics and
 resistors.
 Resistors are in Ω and $1/4\text{W}$ or less unless otherwise
 specified.

B+ Line
 Voltage is dc 6V and fed with regulated dc power supply
 from external power voltage jack (J901).
 Waveforms are dc with respect to ground under
 no-signal conditions.

Key: PB
 REC
 Measurements are taken with a VOM (Input impedance 10M Ω).
 Voltage variations may be noted due to normal production
 tolerances.

Path.
 PB
 REC
 MIC
 Location
 Canadian

Note :

- All capacitors are in μF unless otherwise noted. pF: μpF
 50WV or less are not indicated except for electrolytics and
 tantalums.
- All resistors are in Ω and $1/4\text{W}$ or less unless otherwise
 specified.
- **B+** : B+ Line
- **ADJ** : adjustment for repair.
- Power voltage is dc 6V and fed with regulated dc power supply
 from external power voltage jack (J901).
- Voltage and waveforms are dc with respect to ground under
 no-signal conditions.
- Voltages are taken with a VOM (Input impedance 10M Ω).
 Voltage variations may be noted due to normal production
 tolerances.

• SEMICONDUCTOR LOCATION

Ref. No.	Location
D401	A-11
D402	B-12
IC701	B-7
Q401	B-11
Q402	A-11
Q403	B-12
Q404	A-12
Q703	B-2

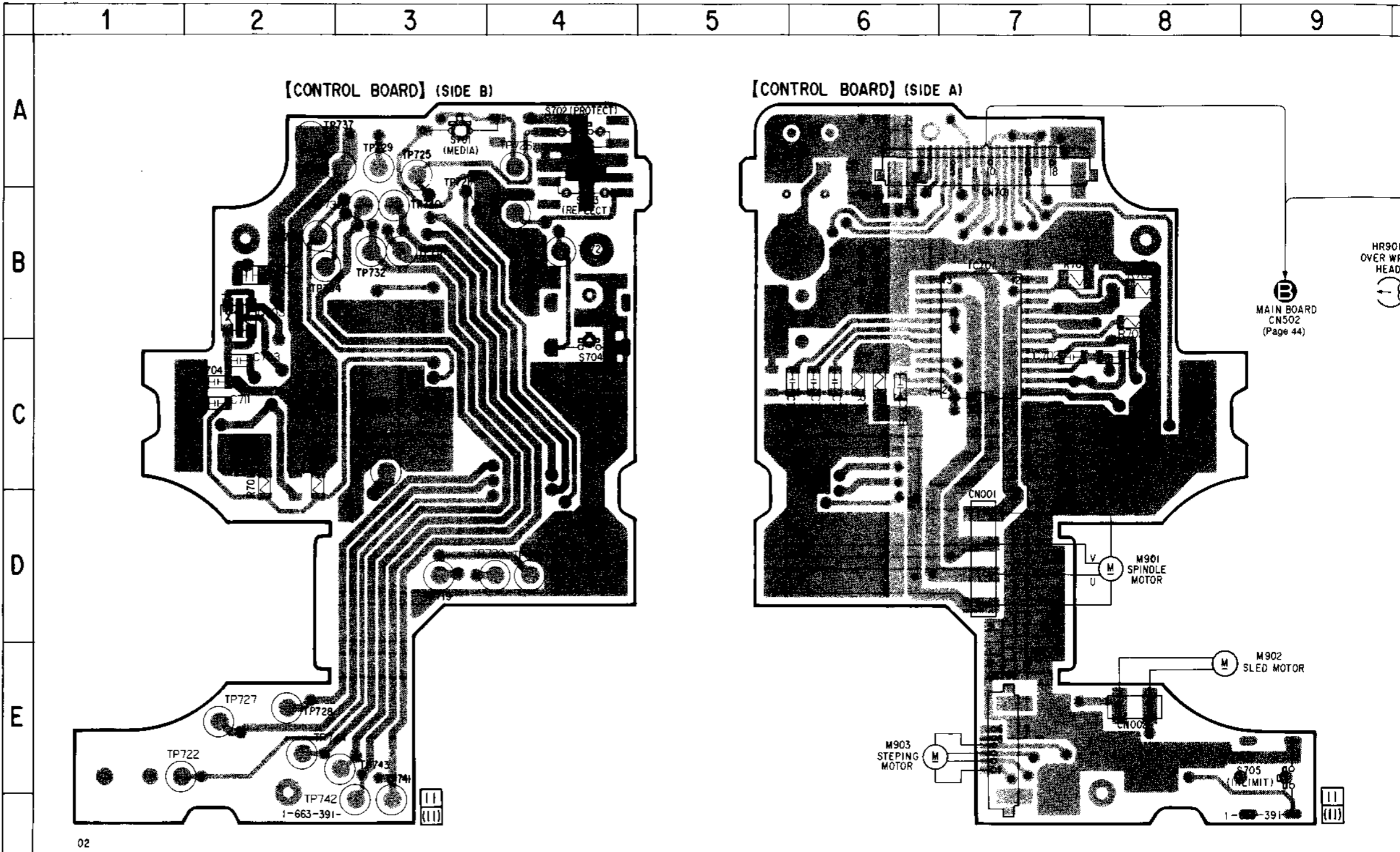

Note:

- : parts extracted from the component side.
- : Through hole.
- (with dot) : Pattern from the side which enables seeing. (The other layers' patterns are not indicated)

Caution :

Pattern face side : Parts on the pattern face side seen from (Conductor Side) the pattern face are indicated.
 Parts face side : Parts on the parts face side seen from the (Component side) parts face are indicated.

4 5 6 7 8 9 10 11 12

1 2 3

[CONTROL BOARD] (SIDE A)

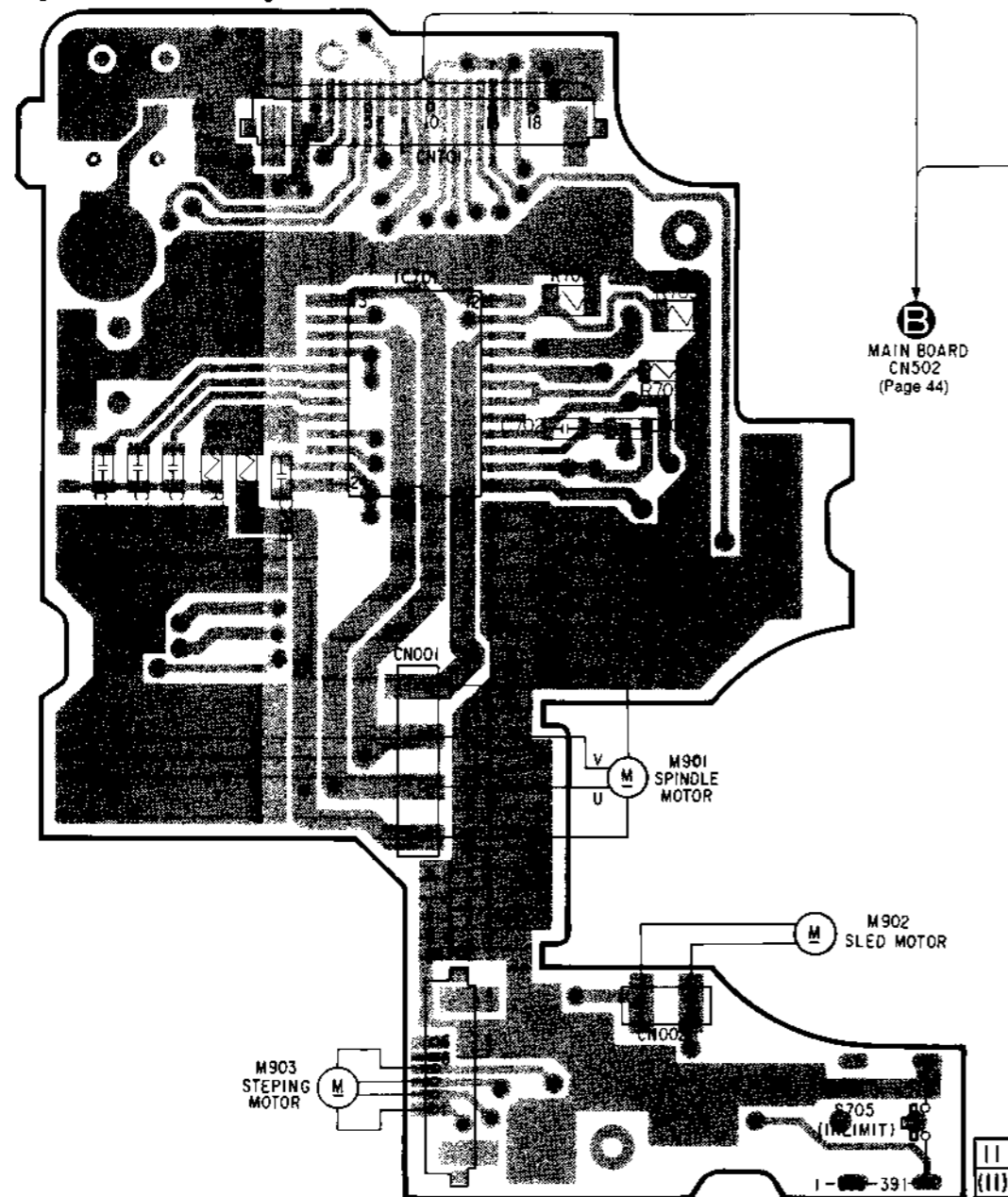

[REC BOARD] (SIDE A)

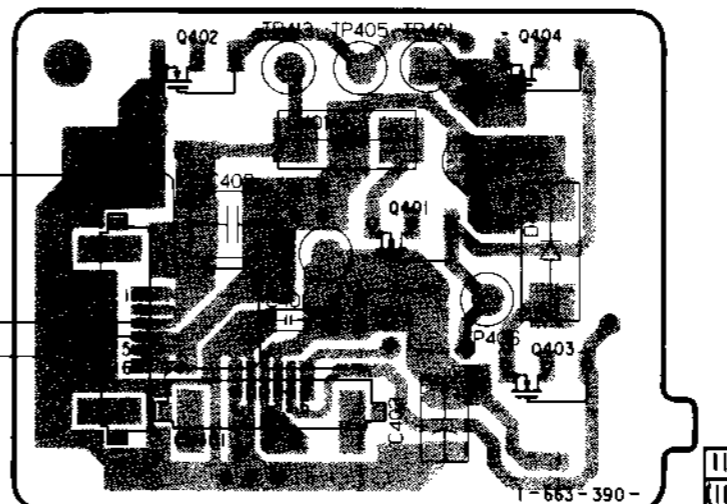

[REC BOARD] (SIDE B)

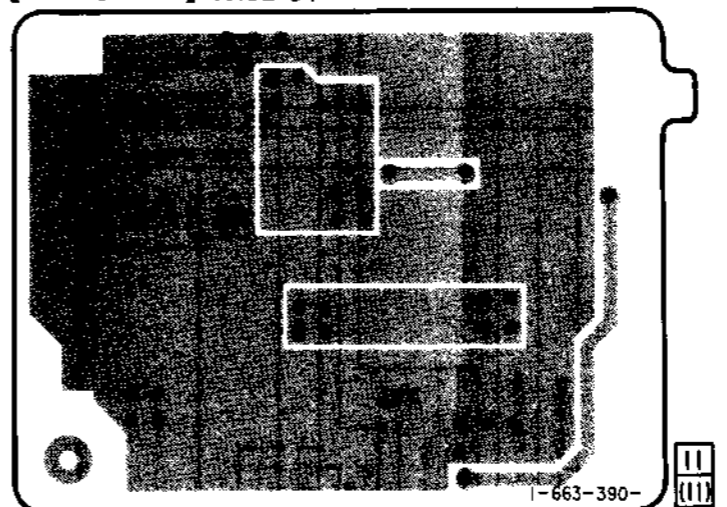

[CONTROL BOARD]

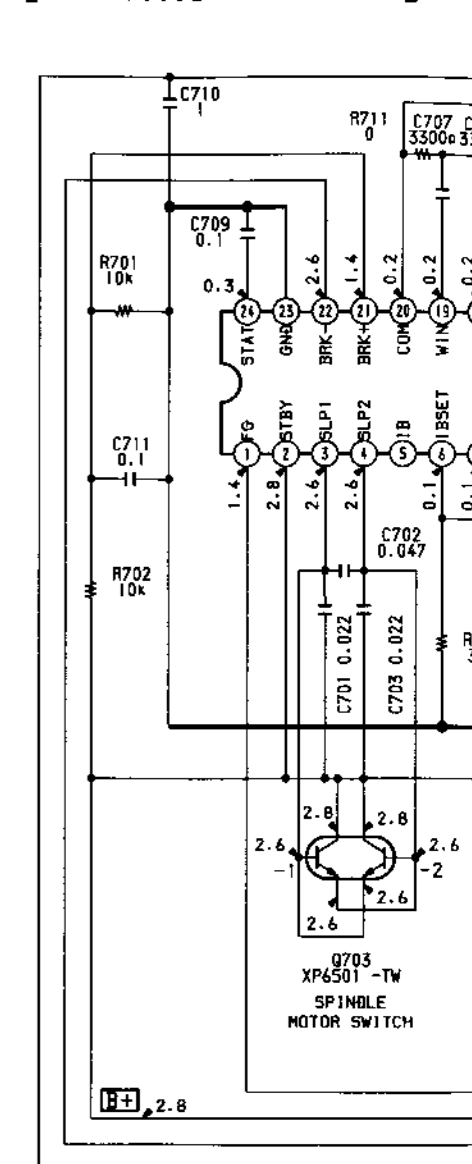

Note :

- All capacitors are in μF unless otherwise noted. pF: μpF 50WV or less are not indicated except for electrolytics and tantalums.
- All resistors are in Ω and $\frac{1}{4}\text{W}$ or less unless otherwise specified.
- **B+** : B+ Line
- Power voltage is dc 6V and fed with regulated dc power supply from external power voltage jack (J901).
- Voltage and waveforms are dc with respect to ground under no-signal conditions.
no mark : PB
() : REC
- Voltages are taken with a VOM (Input impedance 10M Ω). Voltage variations may be noted due to normal production tolerances.

11 12

1 2 3 4 5 6 7 8 9 10 11

IDE A)

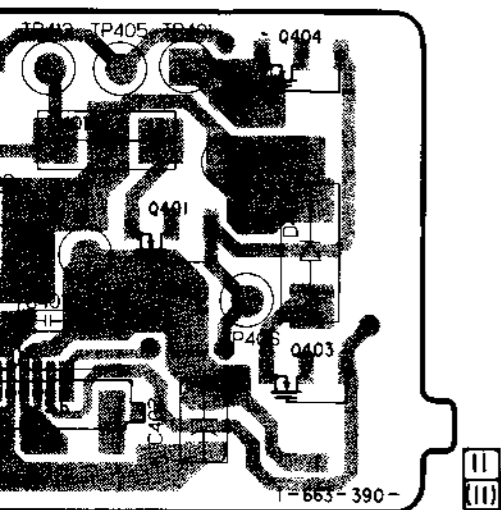

IDE B)

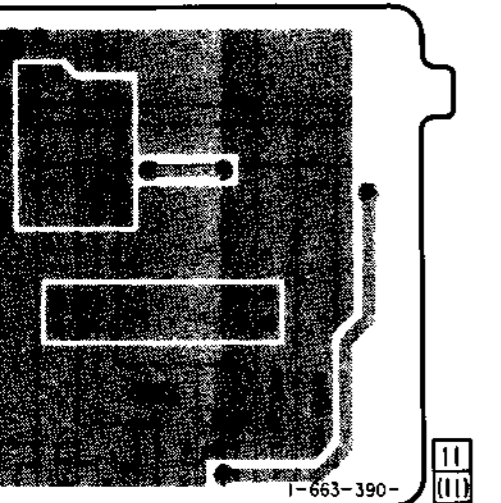

A
B
C
D
E
F
G
H
I

[CONTROL BOARD]

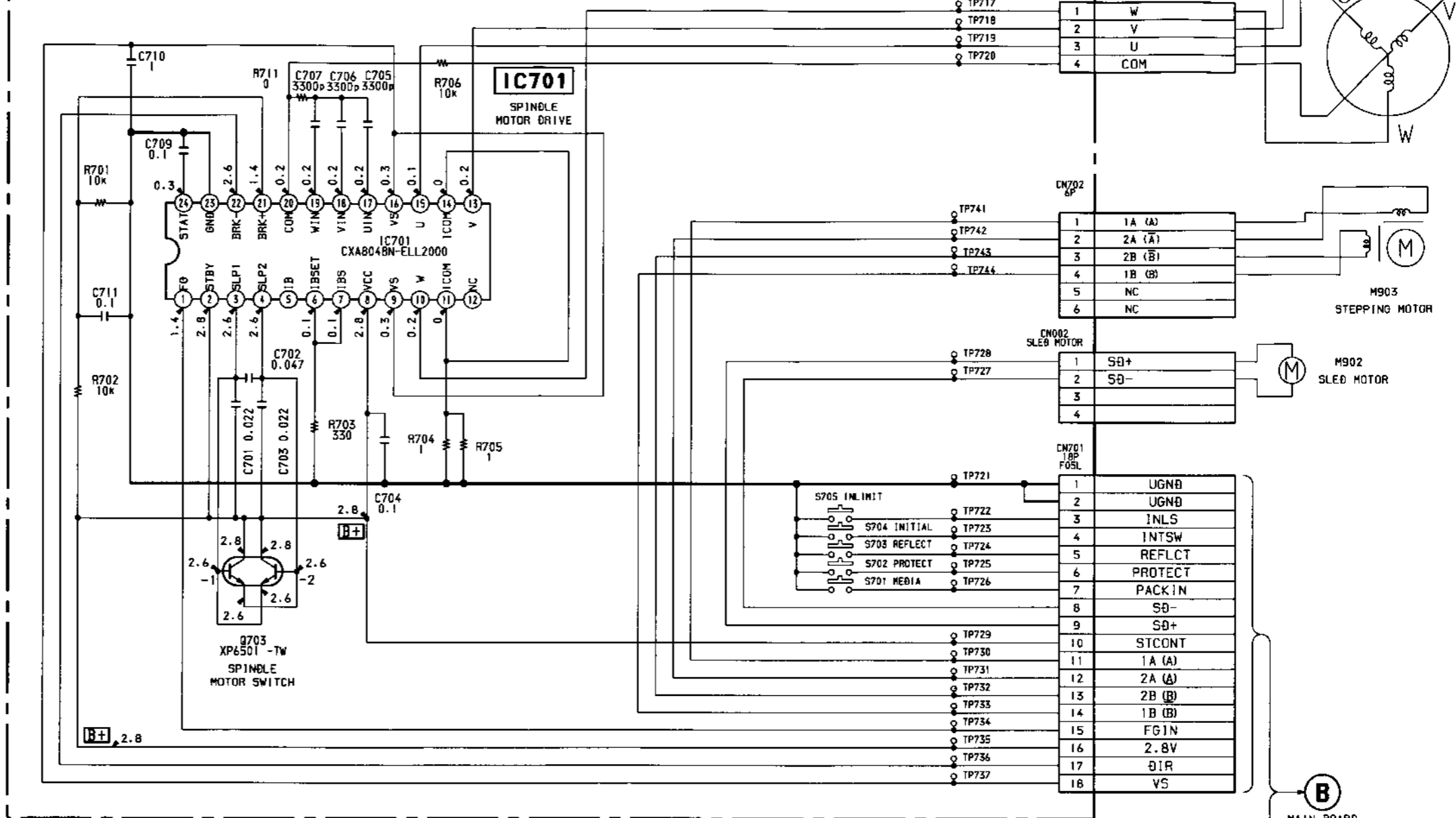

[REC BOARD]

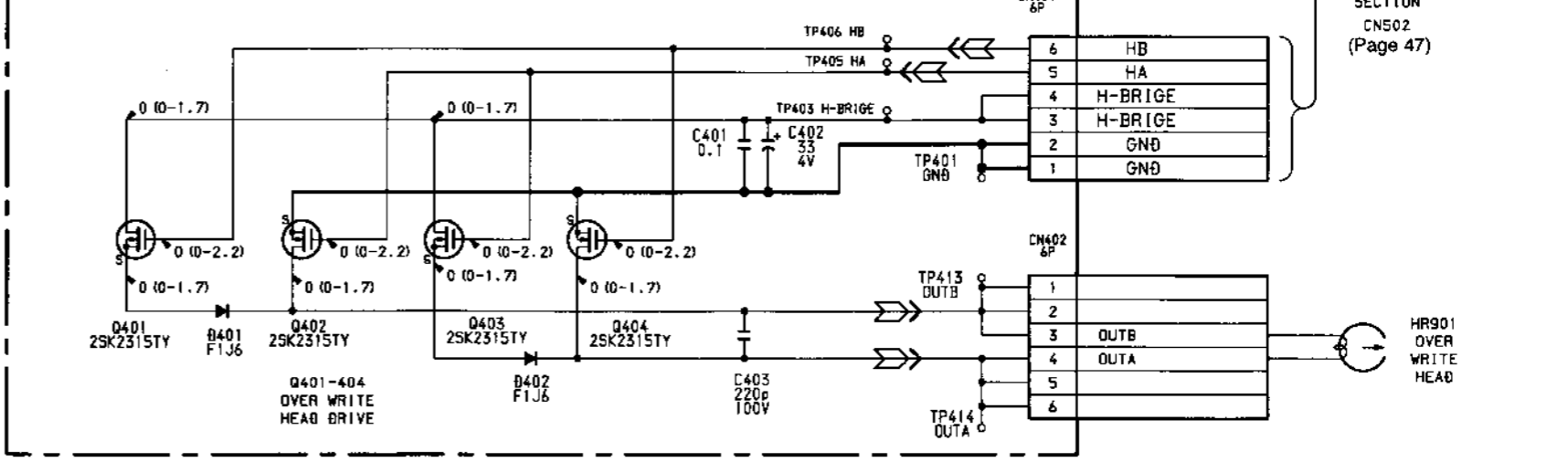

- Note :**
- All capacitors are in μF unless otherwise noted. pF: μpF 50WV or less are not indicated except for electrolytics and tantalums.
 - All resistors are in Ω and $\frac{1}{4}W$ or less unless otherwise specified.
 - B+** : B+ Line
 - Power voltage is dc 6V and fed with regulated dc power supply from external power voltage jack (J901).
 - Voltage and waveforms are dc with respect to ground under no-signal conditions.
 - no mark : PB
 - () : REC
 - Voltages are taken with a VOM (Input impedance 10M Ω). Voltage variations may be noted due to normal production tolerances.

B
MAIN BOARD
(1/3)
SERVO PROCESS
SECTION
CN502
(Page 47)

• IC BLOCK DIAGRAMS - MAIN (1/3) SECTION -

IC501 CXA2523R

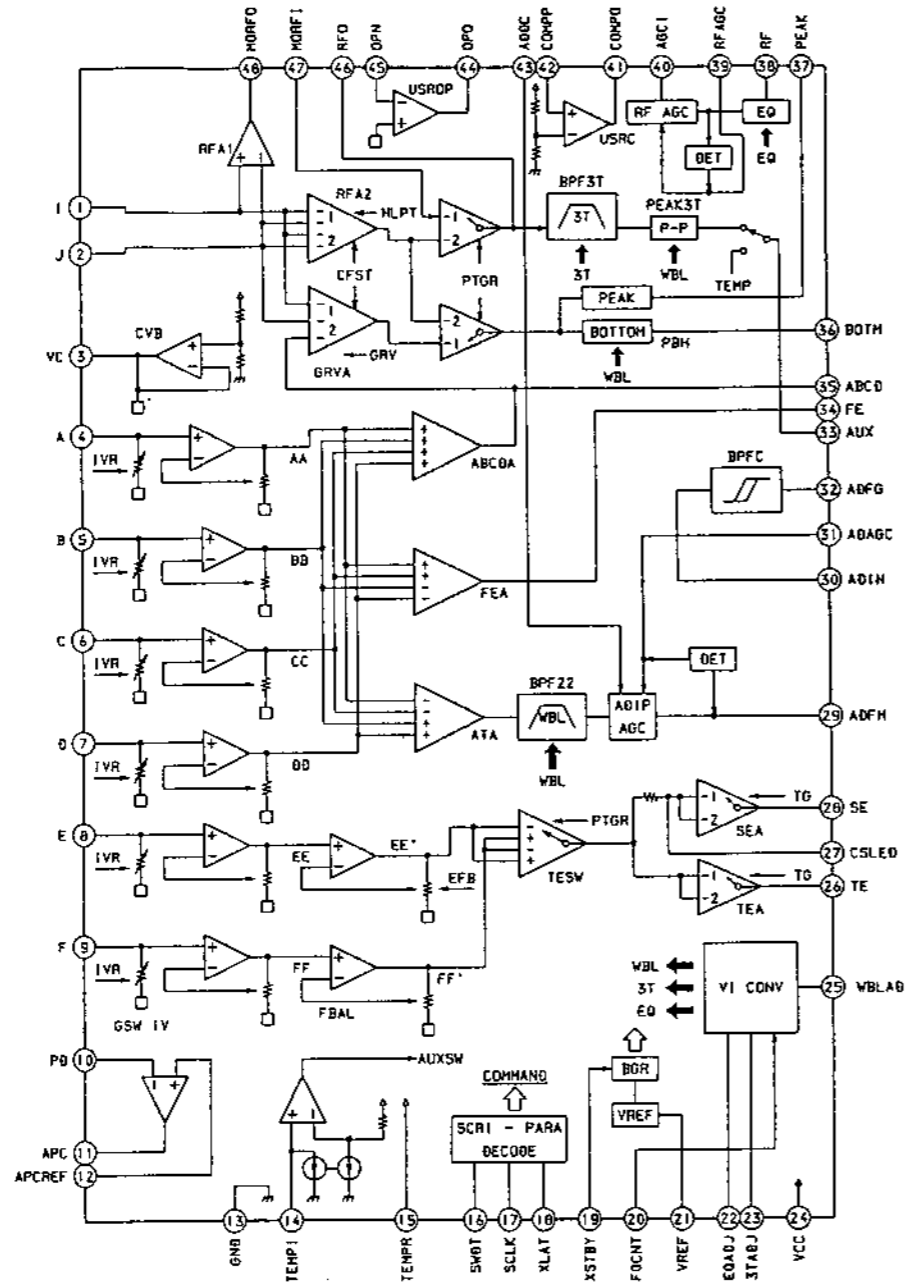

IC702 MPC17A333VMEL

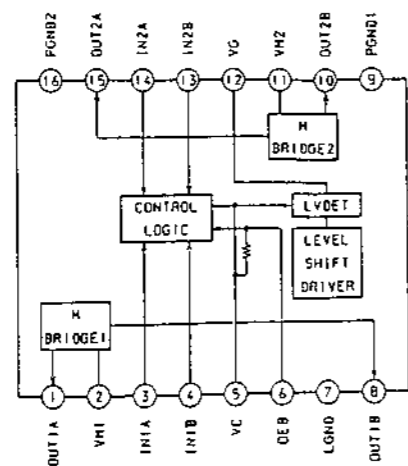

IC505 MPC17A38VMEL

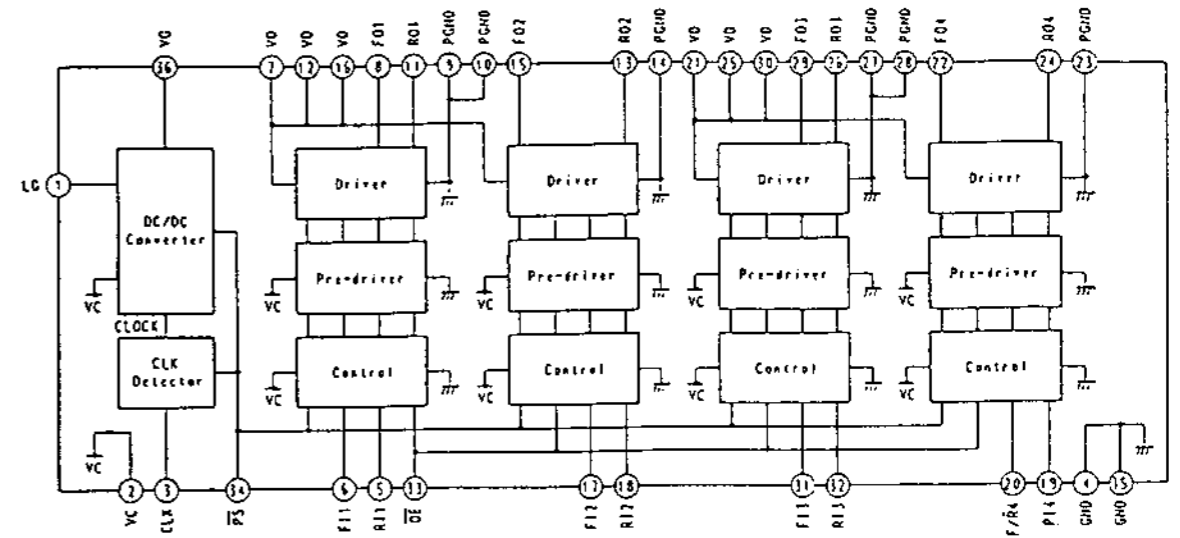

IC506 MPC18A20VMEL

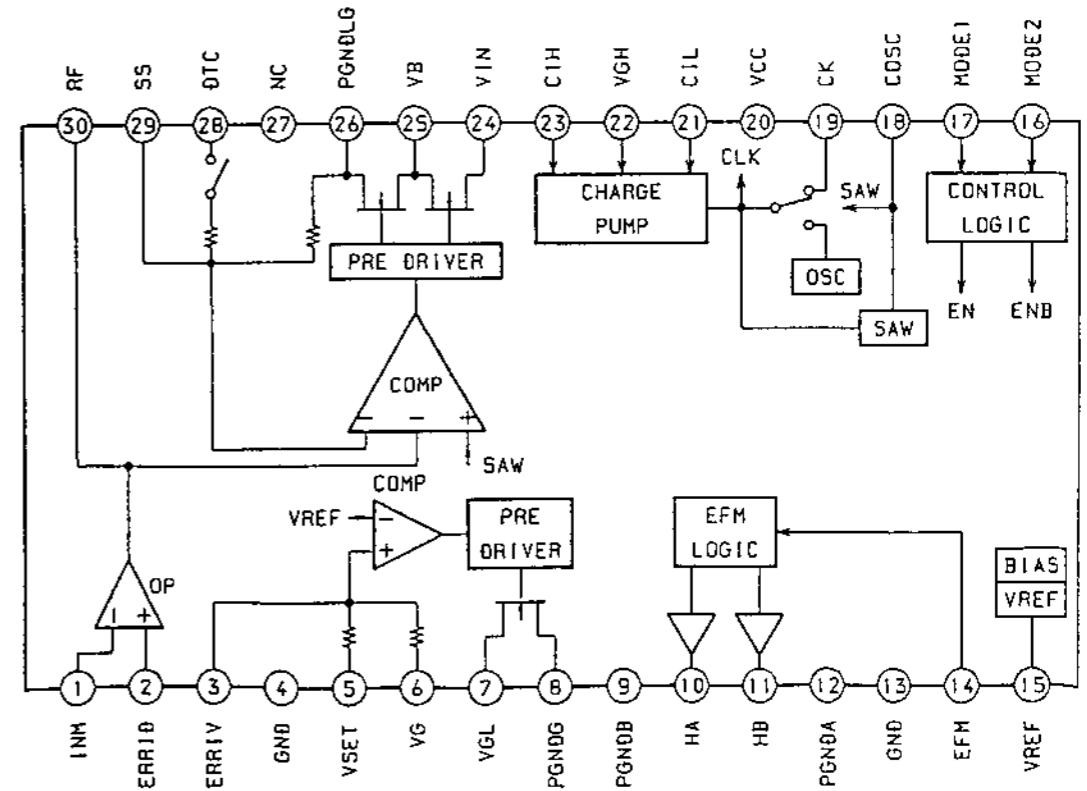

• IC BLOCK DIAGRAMS - MAIN (2/3) SECTION -
IC802 RS5RJ29261-T1

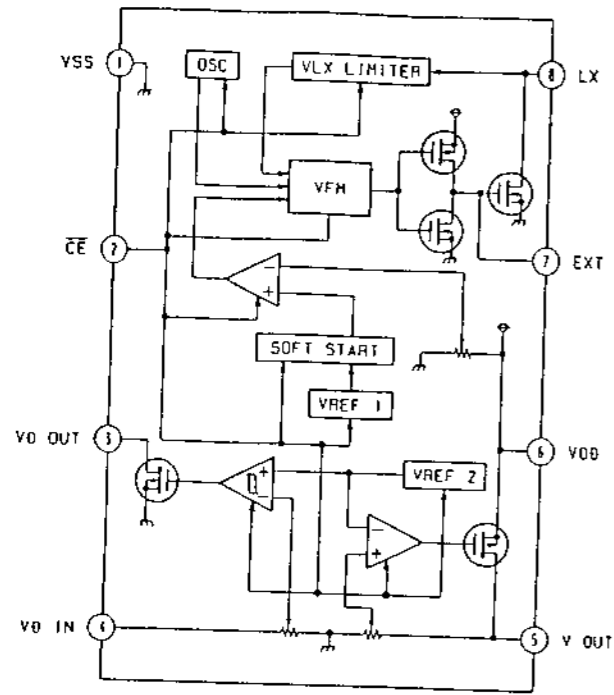

IC909 MM1332DFBE

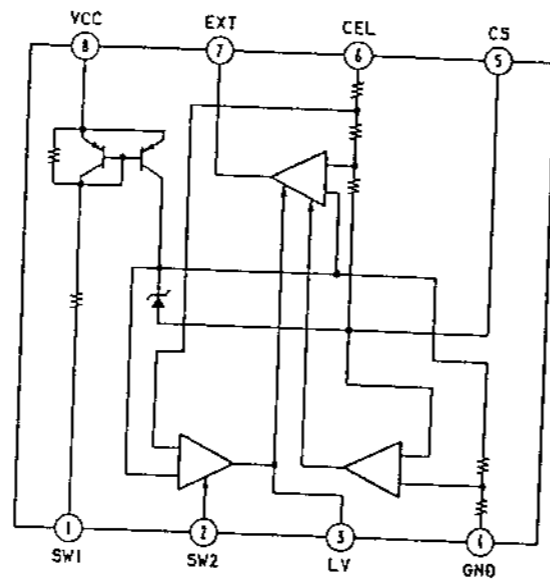

• IC BLOCK DIAGRAMS - MAIN (3/3) SECTION -
IC352 DS1802E-TE2

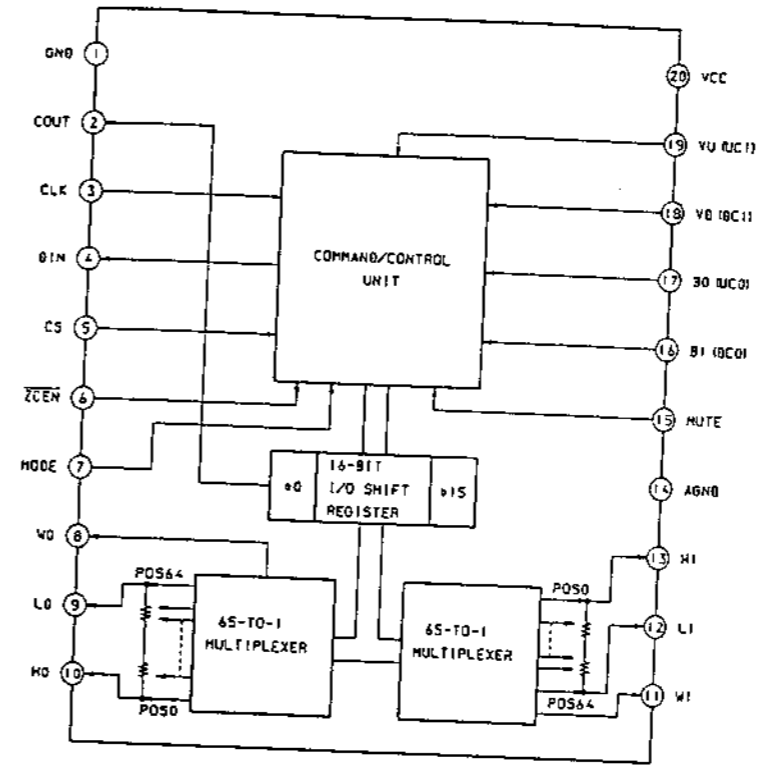

IC807 AK93C45LV-L

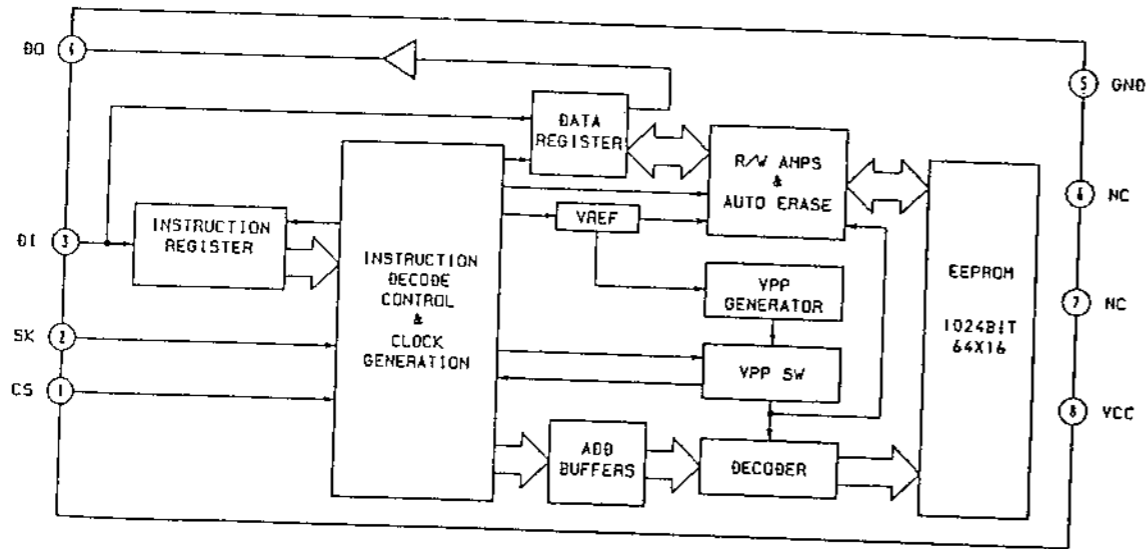

IC303 AK4515-VQ

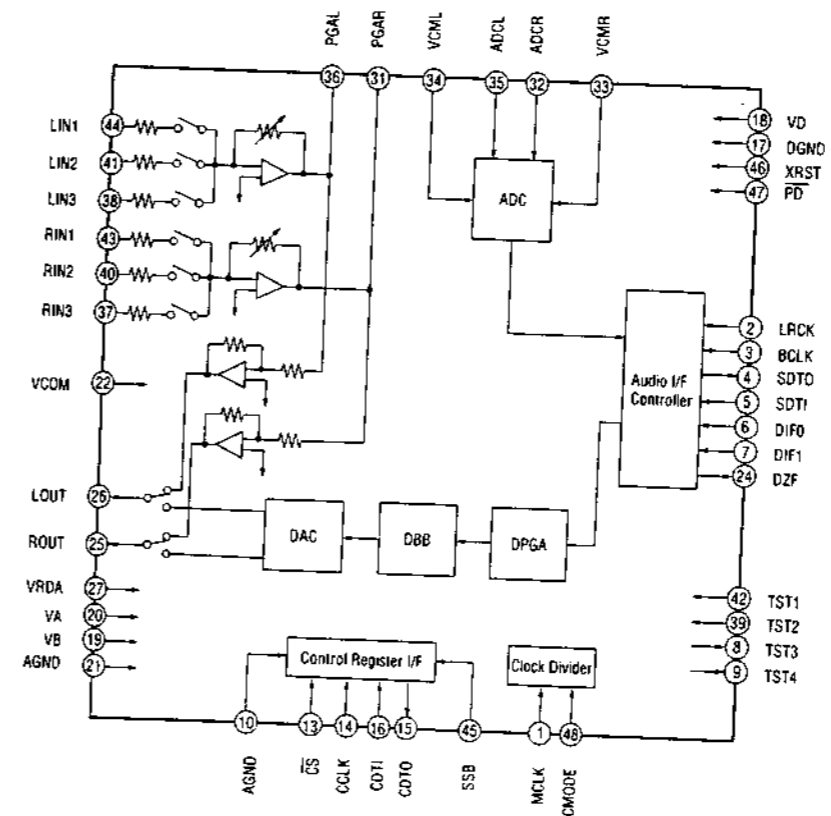

SECTION 8 EXPLODED VIEWS

NOTE :

- -XX, -X mean standardized parts, so they may have some difference from the original one.

- Color indication of Appearance Parts

Example :

KNOB, BALANCE (WHITE) ... (RED)

↑ ↑
Parts color Cabinet's color

- Items marked " * " are not stocked since they are seldom required for routine service. Some delay should be anticipated when ordering these items.

- The mechanical parts with no reference number in the exploded views are not supplied.

- Accessories and packing materials are given in the last of this parts list.

- Abbreviation

CND : Canadian

AUS : Australian

The components identified by mark Δ or dotted line with mark Δ are critical for safety.
Replace only with part number specified.

Les composants identifiés par une marque Δ sont critiques pour la sécurité. Ne les remplacer que par une pièce portant le numéro spécifié.

8-1. UPPER PANEL, BOTTOM PANEL SECTION

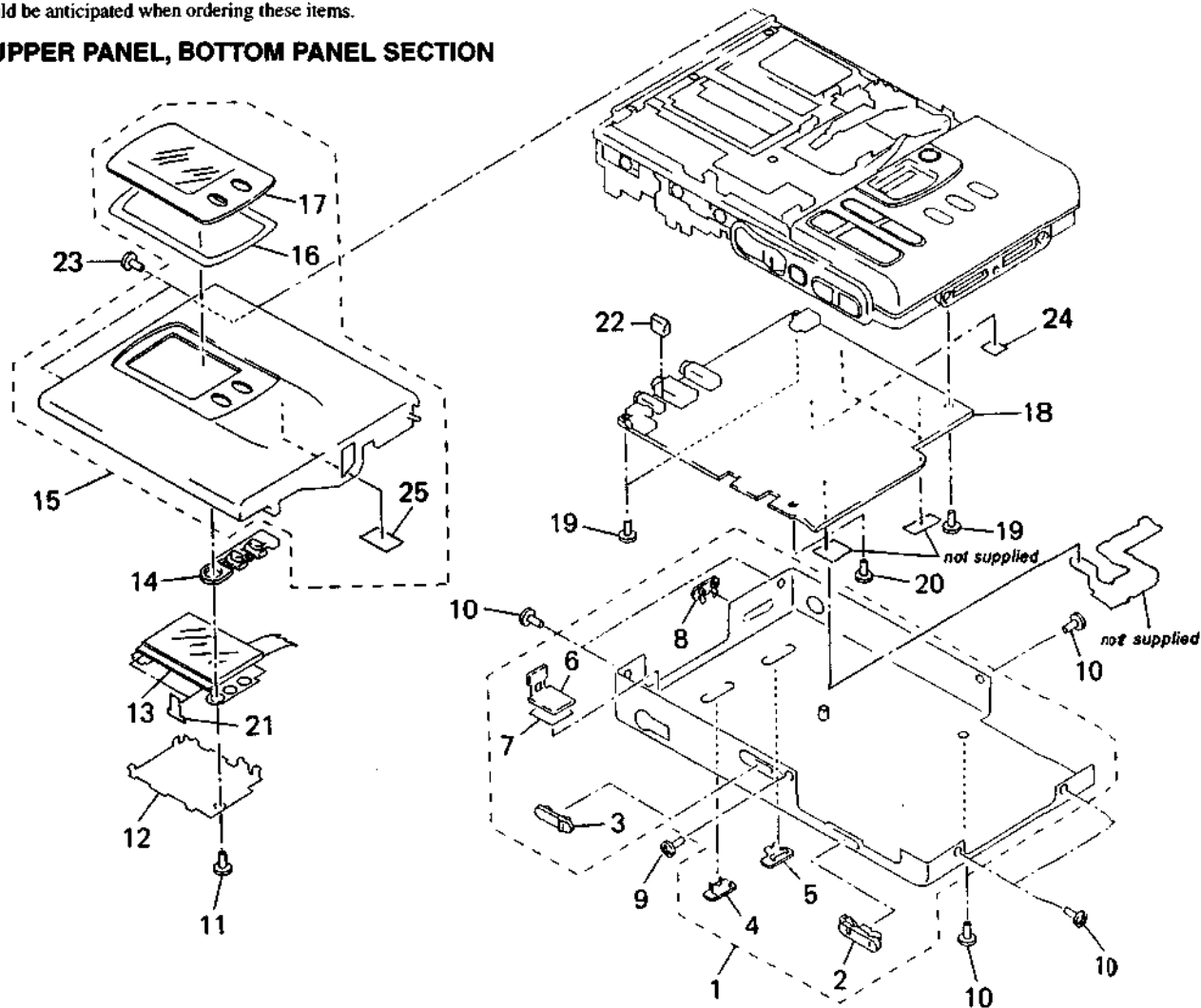

Ref. No.	Part No.	Description	Remark	Ref. No.	Part No.	Description	Remark
1	X-4947-770-1	PANEL ASSY, BOTTOM		15	X-4947-769-1	PANEL ASSY, UPPER	
2	4-986-207-01	KNOB (TUN)		16	4-986-185-01	SHEET (LCD WINDOW), ADHESIVE	
3	4-983-999-01	KNOB (OPEN)		17	4-986-184-11	WINDOW (LCD)	
4	4-972-492-11	KNOB (AVLS)		18	A-3293-312-A	MAIN BOARD, COMPLETE (E, TOURS)	
5	4-963-851-11	KNOB (AVLS)		18	A-3293-360-A	MAIN BOARD, COMPLETE (AEP, UK, AUS)	
6	4-986-204-01	BUTTON (DBB)		18	A-3293-361-A	MAIN BOARD, COMPLETE (US, CND)	
7	4-986-205-01	SHEET (DBB), ADHESIVE		19	3-335-797-91	SCREW (M1.4), TOOTHED LOCK	
8	4-984-000-01	KNOB (DBB)		20	3-375-114-21	SCREW (M1.7X2.5)	
9	4-984-017-11	SCREW (1.7X2.5), TAPPING		* 21	4-988-279-01	CUSHION (LCD)	
10	4-963-883-41	SCREW (M1.4), PRECISION PAN		* 22	4-988-280-01	CUSHION	
11	4-963-883-21	SCREW (M1.4), PRECISION PAN		23	4-963-883-21	SPACER (M1.4), PRECISION PAN... (SILVER)	
12	4-986-190-01	HOLDER (LCD)		23	4-963-883-31	SPACER (M1.4), PRECISION PAN... (BLUE)	
13	1-801-522-11	LCD MODULE		24	3-831-441-11	CUSHION (A)	
14	4-986-189-01	BUTTON (DISP)		* 25	4-988-105-01	CUSHION (HEAD)	

8-2. CHASSIS SECTION

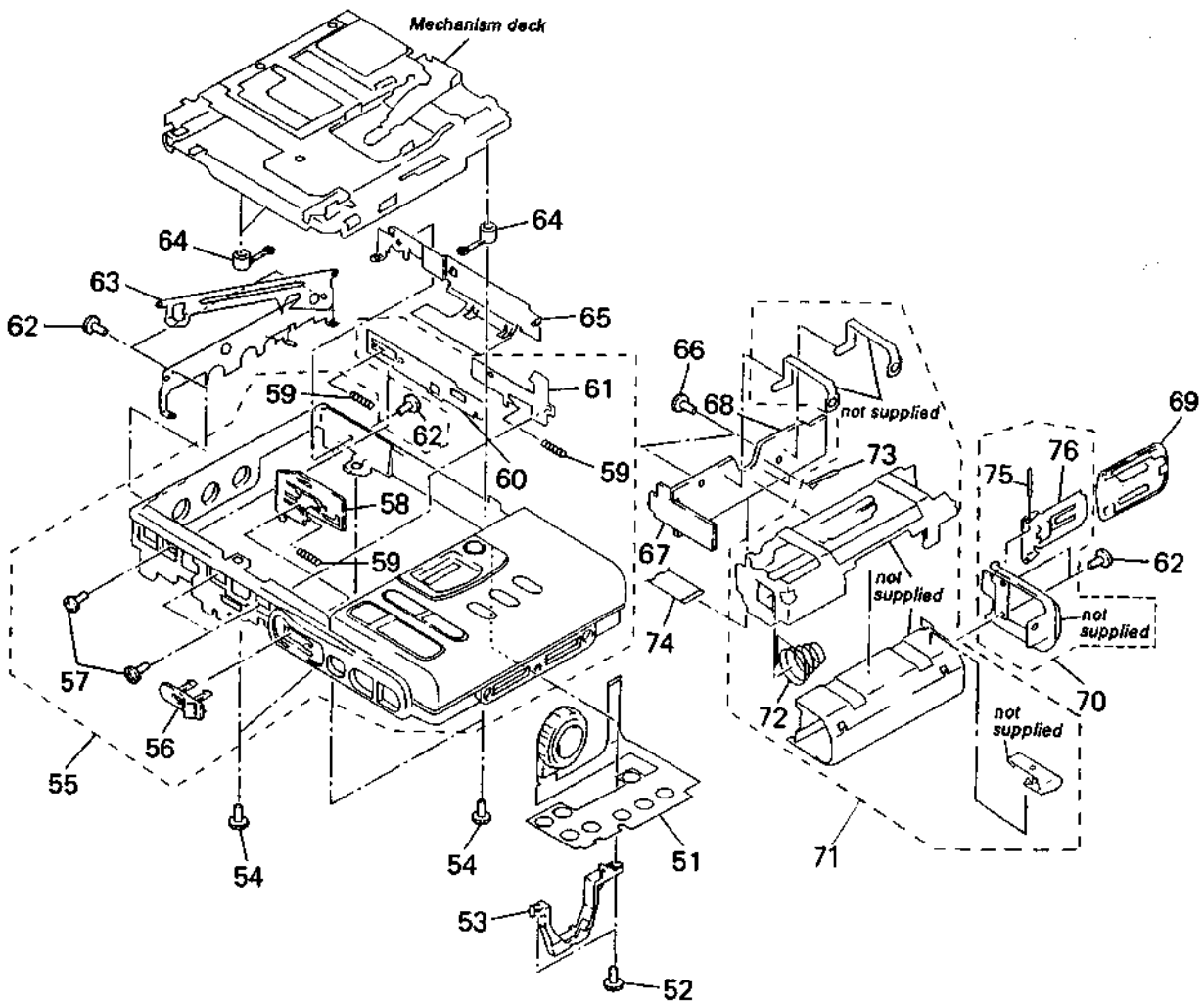

Ref. No.	Part No.	Description	Remark	Ref. No.	Part No.	Description	Remark
51	1-473-895-11	SWITCH UNIT (WITH JOG DIAL)		65	4-986-188-01	REINFORCEMENT	
52	4-984-017-11	SCREW (1.7X2.5), TAPPING		66	3-335-797-91	SCREW (M1.4), TOOTHED LOCK	
53	4-986-186-01	RETAINER (DIAL)		67	A-3306-147-A	SWITCH BOARD, COMPLETE	
54	4-963-924-01	SCREW (DAMPER)		68	A-3293-253-A	POWER BOARD, COMPLETE	
55	X-4947-771-1	BELT ASSY, ORNAMENTAL		69	4-986-183-01	LID, BATTERY CASE	
56	4-983-998-01	KNOB (REC)		70	X-4947-720-1	PLATE (BATTERY)ASSY,ORNAMENTAL ...(SILVER)	
57	4-984-006-01	SCREW, STEP		70	X-4947-842-1	PLATE (BATTERY)ASSY, (L)...(BLUE)	
58	4-983-995-01	LEVER (REC)		71	X-4947-772-1	CASE ASSY, BATTERY	
59	4-984-004-01	SPRING (LOCK), COMPRESSION		72	4-984-016-01	SPRING (POP UP), COIL	
60	4-983-993-01	LEVER (OPEN)		73	4-988-114-01	TERMINAL, BATTERY	
61	4-983-994-01	ARM, LOCK		74	1-777-761-11	WIRE (FLAT TYPE) (24 CORE)	
62	4-963-883-21	SCREW (M1.4), PRECISION PAN... (SILVER)		75	4-984-019-01	SHAFT (BATTERY CASE LID)	
62	4-963-883-31	SCREW (M1.4), PRECISION PAN... (BLUE)		76	4-984-018-01	PLATE, FULCRUM	
63	X-4947-717-1	PLATE ASSY, FULCRUM					
64	4-983-311-01	DAMPER					

**8-3. MECHANISM DECK SECTION-1
(MT-MZR30-124)**

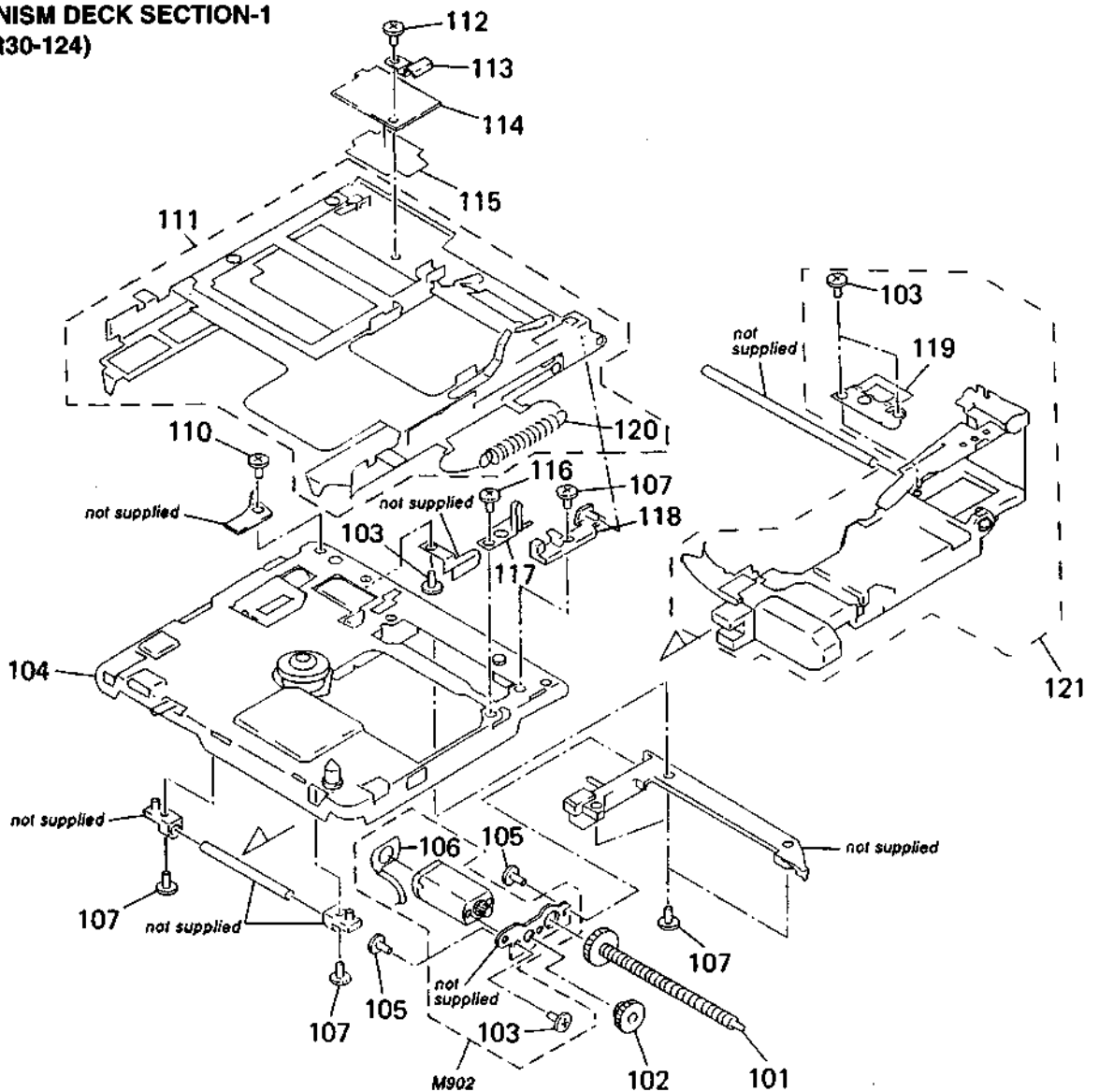

<p>The components identified by mark Δ or dotted line with mark Δ are critical for safety. Replace only with part number specified.</p>	<p>Les composants identifiés par une marque Δ sont critiques pour la sécurité. Ne les remplacer que par une pièce portant le numéro spécifié.</p>
---	---

Ref. No.	Part No.	Description	Remark	Ref. No.	Part No.	Description	Remark
101	A-3303-501-A	SCREW BLOCK ASSY, LEAD		113	4-988-174-01	STOPPER, LEVER	
102	4-972-548-01	GEAR (BH)		* 114	1-663-390-11	REC BOARD	
103	3-366-890-11	SCREW (M1.4)		115	4-984-032-01	SHEET, INSULATING	
104	X-4947-429-1	CHASSIS ASSY		116	3-348-160-01	SCREW (M1.4X1.3), PRECISION PAN	
105	4-964-537-01	SCREW (M1.4X4.5), TAPPING		117	4-983-357-01	CLAW, LOCK RELEASE	
106	1-651-018-11	SLED FLEXIBLE BOARD		* 118	4-983-356-01	GUIDE, HOLDER	
107	3-704-197-33	SCREW (M1.4X3.0), LOCKING		119	4-963-914-02	RACK (INSERTER)	
110	4-964-538-01	SCREW (M1.4X2)		120	4-983-358-01	SPRING, TENSION	
111	X-4947-887-1	HOLDER ASSY		Δ 121	X-4948-260-1	OPTICAL PICK-UP ASSY	
112	4-955-841-01	SCREW		M902	A-3303-502-A	MOTOR BLOCK ASSY (SLED)	

**8-4. MECHANISM DECK SECTION-2
(MT-MZR30-124)**

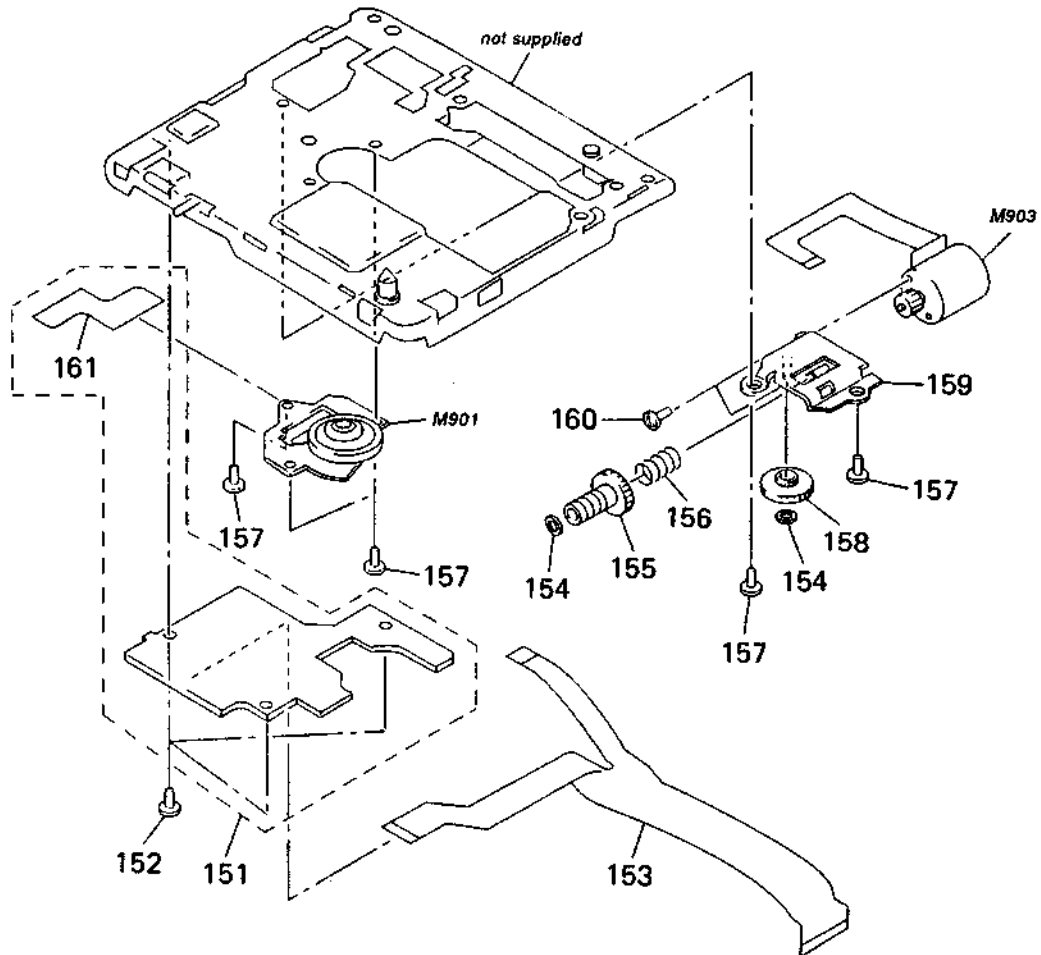

Ref. No.	Part No.	Description	Remark	Ref. No.	Part No.	Description	Remark
151	A-3293-256-A	CONTROL PC BOARD ASSY,		158	4-963-898-01	GEAR (WORM WHEEL)	
152	3-366-890-11	SCREW (M1.4)		159	X-4944-449-1	CHASSIS ASSY, GEAR	
153	1-663-392-11	MD FLEXIBLE BOARD		160	4-964-564-01	SCREW (M1.2X1.6)	
154	3-338-645-31	WASHER (0.8-2.5)		161	1-651-017-11	CLV FLEXIBLE BOARD	
155	4-963-901-01	GEAR, WORM		M901	1-698-542-11	MOTOR (SPINDLE)	
156	4-972-546-01	SPRING (WORM GEAR), COMPRESSION		M903	A-3303-499-A	STEPPER BLOCK ASSY (STEPPING)	
157	4-955-841-01	SCREW					

SECTION 9 ELECTRICAL PARTS LIST

CONTROL	MAIN
----------------	-------------

NOTE :

- Due to standardization, replacements in the parts list may be different from the parts specified in the diagrams or the components used on the set.
- -XX, -X mean standardized parts, so they may have some difference from the original one.
- RESISTORS
All resistors are in ohms
METAL : Metal-film resistor
METAL OXIDE :Metal oxide-film resistor
F : nonflammable
- Items marked " * " are not stocked since they are seldom required for routine service. Some delay should be anticipated when ordering these items.

● SEMICONDUCTORS

In each case, u : μ , for example :
 uA..... : μ A....., uPA..... : μ PA.....
 uPB..... : μ PB....., uPC..... : μ PC.....
 uPD..... : μ PD.....

● CAPACITORS

uF : μ F

● COILS

uH : μ H

● Abbreviation

CND : Canadian
 AUS : Australian
 E13 : 220-230V AC area
 E33 : 100-240V AC area

The components identified by mark Δ or dotted line with mark Δ are critical for safety.
 Replace only with part number specified.

Les composants identifiés par une marque Δ sont critiques pour la sécurité. Ne les remplacer que par une pièce portant le numéro spécifié.

When indicating parts by reference number, please include the board.

Ref. No.	Part No.	Description	Remark	Ref. No.	Part No.	Description	Remark
	A-3293-256-A	CONTROL BOARD, COMPLETE *****				< SWITCH >	
	1-651-017-11	CLV FLEXIBLE BOARD		S701	1-692-849-21	SWITCH, PUSH (1 KEY) (MEDIR)	
		< CAPACITOR >		S702	1-692-847-21	SWITCH, PUSH (1 KEY) (PROTECT)	
				S703	1-692-377-31	SWITCH, PUSH (1 KEY) (REFLECT)	
				S704	1-572-467-41	SWITCH, PUSH (1 KEY) (INITIAL)	
				S705	1-572-467-41	SWITCH, PUSH (1 KEY) (INLIMIT)	

				A-3293-312-A	MAIN BOARD, COMPLETE (E, Tourist)		
				A-3293-360-A	MAIN BOARD, COMPLETE (AEP, UK, AUS)		
				A-3293-361-A	MAIN BOARD, COMPLETE (US, CND) *****		
						< CAPACITOR >	
				C101	1-162-966-11	CERAMIC CHIP 0.0022uF 10% 50V	
				C102	1-162-927-11	CERAMIC CHIP 100PF 5% 50V	
				C103	1-135-337-11	TANTAL. CHIP 1uF 20% 6.3V	
				C104	1-162-964-11	CERAMIC CHIP 0.001uF 10% 50V	
				C105	1-164-217-11	CERAMIC CHIP 150PF 5% 50V	
				C106	1-110-975-11	TANTAL. CHIP 47uF 20% 6.3V	
				C107	1-107-813-11	TANTAL. CHIP 10uF 20% 6.3V	
				C108	1-107-812-11	TANTAL. CHIP 4.7uF 20% 6.3V	
				C109	1-107-813-11	TANTAL. CHIP 10uF 20% 6.3V	
				C110	1-135-337-11	TANTAL. CHIP 1uF 20% 6.3V	
				C117	1-135-181-21	TANTALUM CHIP 4.7uF 20% 6.3V	
				C118	1-164-156-11	CERAMIC CHIP 0.1uF 25V	
				C120	1-107-823-11	CERAMIC CHIP 0.47uF 10% 16V	
				C121	1-109-982-11	CERAMIC CHIP 1uF 10% 10V	
				C122	1-162-960-11	CERAMIC CHIP 220PF 10% 50V	
				C123	1-107-813-11	TANTAL. CHIP 10uF 20% 6.3V	
				C124	1-165-128-11	CERAMIC CHIP 0.22uF 16V	
				C125	1-162-964-11	CERAMIC CHIP 0.001uF 10% 50V	
				C131	1-107-812-11	TANTAL. CHIP 4.7uF 20% 6.3V	
				C140	1-107-813-11	TANTAL. CHIP 10uF 20% 6.3V	
				C161	1-162-963-11	CERAMIC CHIP 680PF 10% 50V	
				C168	1-109-982-11	CERAMIC CHIP 1uF 10% 10V	
				C201	1-162-966-11	CERAMIC CHIP 0.0022uF 10% 50V	
						< CONNECTOR >	
				CN701	1-691-356-21	CONNECTOR, FFC/FPC (ZIF) 18P	
				CN702	1-691-370-11	CONNECTOR, FFC/FPC 6P	
						< IC >	
				IC701	8-759-335-44	IC CXA8048N	
						< TRANSISTOR >	
				Q703	8-729-427-83	TRANSISTOR XP6501	
						< RESISTOR >	
				R701	1-218-871-11	METAL CHIP 10K 0.50% 1/16W	
				R702	1-218-871-11	METAL CHIP 10K 0.50% 1/16W	
				R703	1-216-815-11	METAL CHIP 330 5% 1/16W	
				R704	1-217-671-11	METAL CHIP 1 5% 1/10W	
				R705	1-217-671-11	METAL CHIP 1 5% 1/10W	
				R706	1-216-833-11	METAL CHIP 10K 5% 1/16W	
				R711	1-216-864-11	METAL CHIP 0 5% 1/16W	

MAIN

Ref. No.	Part No.	Description			Remark	Ref. No.	Part No.	Description			Remark
C202	1-162-927-11	CERAMIC CHIP	100PF	5%	50V	C368	1-162-964-11	CERAMIC CHIP	0.001uF	10%	50V
C203	1-135-337-11	TANTAL. CHIP	1uF	20%	6.3V	C369	1-162-964-11	CERAMIC CHIP	0.001uF	10%	50V
C204	1-162-964-11	CERAMIC CHIP	0.001uF	10%	50V	C391	1-162-964-11	CERAMIC CHIP	0.001uF	10%	50V
C205	1-164-217-11	CERAMIC CHIP	150PF	5%	50V	C392	1-164-156-11	CERAMIC CHIP	0.1uF		(US,CND) 25V
C206	1-110-975-11	TANTAL. CHIP	47uF	20%	6.3V	C393	1-162-964-11	CERAMIC CHIP	0.001uF	10%	50V
C207	1-107-813-11	TANTAL. CHIP	10uF	20%	6.3V						(US,CND)
C208	1-107-812-11	TANTAL. CHIP	4.7uF	20%	6.3V	C394	1-162-964-11	CERAMIC CHIP	0.001uF	10%	50V
C209	1-107-813-11	TANTAL. CHIP	10uF	20%	6.3V						(US,CND)
C210	1-135-337-11	TANTAL. CHIP	1uF	20%	6.3V	C399	1-107-816-11	TANTAL. CHIP	0.68uF	20%	10V
C217	1-135-181-21	TANTALUM CHIP	4.7uF	20%	6.3V	C501	1-115-169-11	TANTALUM	10uF	20%	6.3V
C218	1-164-156-11	CERAMIC CHIP	0.1uF		25V	C504	1-107-813-11	TANTAL. CHIP	10uF	20%	6.3V
C220	1-107-823-11	CERAMIC CHIP	0.47uF	10%	16V	C505	1-107-813-11	TANTAL. CHIP	10uF	20%	6.3V
C221	1-109-982-11	CERAMIC CHIP	1uF	10%	10V	C506	1-162-965-11	CERAMIC CHIP	0.0015uF	10%	50V
C222	1-162-960-11	CERAMIC CHIP	220PF	10%	50V	C507	1-107-826-11	CERAMIC CHIP	0.1uF	10%	16V
C223	1-107-813-11	TANTAL. CHIP	10uF	20%	6.3V	C508	1-162-969-11	CERAMIC CHIP	0.0068uF	10%	25V
C224	1-165-128-11	CERAMIC CHIP	0.22uF		16V	C509	1-115-467-11	CERAMIC CHIP	0.22uF	10%	10V
C225	1-162-964-11	CERAMIC CHIP	0.001uF	10%	50V	C510	1-162-968-11	CERAMIC CHIP	0.0047uF	10%	50V
C231	1-107-812-11	TANTAL. CHIP	4.7uF	20%	6.3V	C511	1-162-966-11	CERAMIC CHIP	0.0022uF	10%	50V
C240	1-107-813-11	TANTAL. CHIP	10uF	20%	6.3V	C512	1-162-970-11	CERAMIC CHIP	0.01uF	10%	25V
C261	1-162-963-11	CERAMIC CHIP	680PF	10%	50V	C513	1-162-970-11	CERAMIC CHIP	0.01uF	10%	25V
C268	1-109-982-11	CERAMIC CHIP	1uF	10%	10V	C515	1-104-752-11	TANTAL. CHIP	33uF	20%	6.3V
C292	1-107-812-11	TANTAL. CHIP	4.7uF	20%	6.3V	C517	1-164-489-11	CERAMIC CHIP	0.22uF	10%	16V
C293	1-104-912-11	TANTALUM CHIP	3.3uF	20%	6.3V	C518	1-162-970-11	CERAMIC CHIP	0.01uF	10%	25V
C294	1-104-847-11	TANTAL. CHIP	22uF	20%	4V	C519	1-109-982-11	CERAMIC CHIP	1uF	10%	10V
C295	1-135-181-21	TANTALUM CHIP	4.7uF	20%	6.3V	C521	1-164-677-11	CERAMIC CHIP	0.033uF	10%	16V
C296	1-107-826-11	CERAMIC CHIP	0.1uF	10%	16V	C522	1-162-970-11	CERAMIC CHIP	0.01uF	10%	25V
C301	1-164-156-11	CERAMIC CHIP	0.1uF		25V	C523	1-162-970-11	CERAMIC CHIP	0.01uF	10%	25V
C302	1-162-970-11	CERAMIC CHIP	0.01uF	10%	25V	C524	1-164-156-11	CERAMIC CHIP	0.1uF		25V
C303	1-107-813-11	TANTAL. CHIP	10uF	20%	6.3V	C525	1-104-929-11	TANTAL. CHIP	22uF	20%	6.3V
C304	1-162-964-11	CERAMIC CHIP	0.001uF	10%	50V	C526	1-164-156-11	CERAMIC CHIP	0.1uF		25V
C305	1-110-975-11	TANTAL. CHIP	47uF	20%	6.3V	C528	1-107-826-11	CERAMIC CHIP	0.1uF	10%	16V
C307	1-164-156-11	CERAMIC CHIP	0.1uF		25V	C529	1-162-970-11	CERAMIC CHIP	0.01uF	10%	25V
C308	1-164-156-11	CERAMIC CHIP	0.1uF		25V	C530	1-107-823-11	CERAMIC CHIP	0.47uF	10%	16V
C310	1-164-361-11	CERAMIC CHIP	0.047uF		16V	C531	1-162-927-11	CERAMIC CHIP	100PF	5%	50V
C311	1-162-970-11	CERAMIC CHIP	0.01uF	10%	25V	C532	1-162-967-11	CERAMIC CHIP	0.0033uF	10%	50V
C312	1-110-975-11	TANTAL. CHIP	47uF	20%	6.3V	C533	1-107-826-11	CERAMIC CHIP	0.1uF	10%	16V
C314	1-164-156-11	CERAMIC CHIP	0.1uF		25V	C534	1-107-826-11	CERAMIC CHIP	0.1uF	10%	16V
C315	1-164-156-11	CERAMIC CHIP	0.1uF		25V	C536	1-164-156-11	CERAMIC CHIP	0.1uF		25V
C318	1-164-156-11	CERAMIC CHIP	0.1uF		25V	C537	1-107-811-11	TANTAL. CHIP	47uF	20%	4V
C319	1-135-259-11	TANTAL. CHIP	10uF	20%	6.3V	C538	1-107-826-11	CERAMIC CHIP	0.1uF	10%	16V
C320	1-164-156-11	CERAMIC CHIP	0.1uF		25V	C541	1-162-913-11	CERAMIC CHIP	8PF	0.5PF	50V
C321	1-104-929-11	TANTAL. CHIP	22uF	20%	6.3V	C542	1-162-913-11	CERAMIC CHIP	8PF	0.5PF	50V
C322	1-135-259-11	TANTAL. CHIP	10uF	20%	6.3V	C544	1-107-826-11	CERAMIC CHIP	0.1uF	10%	16V
C327	1-104-929-11	TANTAL. CHIP	22uF	20%	6.3V	C545	1-110-574-11	TANTAL. CHIP	22uF	20%	16V
C338	1-109-982-11	CERAMIC CHIP	1uF	10%	10V	C547	1-107-765-11	TANTAL. CHIP	3.3uF	20%	16V
C345	1-104-929-11	TANTAL. CHIP	22uF	20%	6.3V	C548	1-107-765-11	TANTAL. CHIP	3.3uF	20%	16V
C346	1-135-259-11	TANTAL. CHIP	10uF	20%	6.3V	C549	1-107-814-11	TANTAL. CHIP	33uF	20%	10V
C351	1-164-156-11	CERAMIC CHIP	0.1uF		25V	C550	1-107-814-11	TANTAL. CHIP	33uF	20%	10V
C359	1-162-964-11	CERAMIC CHIP	0.001uF	10%	50V	C551	1-107-765-11	TANTAL. CHIP	3.3uF	20%	16V
C365	1-107-813-11	TANTAL. CHIP	10uF	20%	6.3V	C552	1-107-765-11	TANTAL. CHIP	3.3uF	20%	16V
C366	1-162-964-11	CERAMIC CHIP	0.001uF	10%	50V	C553	1-107-814-11	TANTAL. CHIP	33uF	20%	10V
C367	1-162-964-11	CERAMIC CHIP	0.001uF	10%	50V	C554	1-104-813-11	TANTAL. CHIP	10uF	20%	16V

(US,CND)

Ref. No.	Part No.	Description		Remark
C555	1-164-156-11	CERAMIC CHIP	0.1uF	25V
C556	1-107-826-11	CERAMIC CHIP	0.1uF	10% 16V
C557	1-107-826-11	CERAMIC CHIP	0.1uF	10% 16V
C558	1-107-826-11	CERAMIC CHIP	0.1uF	10% 16V
C559	1-162-962-11	CERAMIC CHIP	470PF	10% 50V
C560	1-165-176-11	CERAMIC CHIP	0.047uF	10% 16V
C561	1-165-176-11	CERAMIC CHIP	0.047uF	10% 16V
C562	1-110-574-11	TANTAL. CHIP	22uF	20% 16V
C563	1-135-091-00	TANTALUM CHIP	1uF	20% 16V
C564	1-162-967-11	CERAMIC CHIP	0.0033uF	10% 50V
C565	1-135-180-21	TANTALUM CHIP	3.3uF	20% 10V
C566	1-162-970-11	CERAMIC CHIP	0.01uF	10% 25V
C567	1-164-156-11	CERAMIC CHIP	0.1uF	25V
C568	1-135-337-11	TANTAL. CHIP	1uF	20% 6.3V
C569	1-164-227-11	CERAMIC CHIP	0.022uF	10% 25V
C570	1-107-814-11	TANTAL. CHIP	33uF	20% 10V
C571	1-104-630-11	TANTAL. CHIP	33uF	20% 6.3V
C572	1-107-682-11	CERAMIC CHIP	1uF	10% 16V
C574	1-162-970-11	CERAMIC CHIP	0.01uF	10% 25V
C575	1-164-217-11	CERAMIC CHIP	150PF	5% 50V
C576	1-164-217-11	CERAMIC CHIP	150PF	5% 50V
C577	1-164-217-11	CERAMIC CHIP	150PF	5% 50V
C578	1-107-823-11	CERAMIC CHIP	0.47uF	10% 16V
C714	1-107-813-11	TANTAL. CHIP	10uF	20% 6.3V
C715	1-162-970-11	CERAMIC CHIP	0.01uF	10% 25V
C716	1-107-813-11	TANTAL. CHIP	10uF	20% 6.3V
C811	1-164-677-11	CERAMIC CHIP	0.033uF	10% 16V
C812	1-162-970-11	CERAMIC CHIP	0.01uF	10% 25V
C813	1-162-964-11	CERAMIC CHIP	0.001uF	10% 50V
C814	1-162-970-11	CERAMIC CHIP	0.01uF	10% 25V
C815	1-162-970-11	CERAMIC CHIP	0.01uF	10% 25V
C816	1-164-156-11	CERAMIC CHIP	0.1uF	25V
C817	1-162-970-11	CERAMIC CHIP	0.01uF	10% 25V
C818	1-164-156-11	CERAMIC CHIP	0.1uF	25V
C819	1-164-156-11	CERAMIC CHIP	0.1uF	25V
C820	1-162-970-11	CERAMIC CHIP	0.01uF	10% 25V
C821	1-164-315-11	CERAMIC CHIP	470PF	5% 50V
C822	1-164-315-11	CERAMIC CHIP	470PF	5% 50V
C824	1-164-156-11	CERAMIC CHIP	0.1uF	25V
C825	1-162-970-11	CERAMIC CHIP	0.01uF	10% 25V
C826	1-162-970-11	CERAMIC CHIP	0.01uF	10% 25V
C827	1-162-970-11	CERAMIC CHIP	0.01uF	10% 25V
C828	1-107-826-11	CERAMIC CHIP	0.1uF	10% 16V
C829	1-135-337-11	TANTAL. CHIP	1uF	20% 6.3V
C830	1-110-569-11	TANTAL. CHIP	47uF	20% 6.3V
C831	1-110-574-11	TANTAL. CHIP	22uF	20% 16V
C833	1-164-156-11	CERAMIC CHIP	0.1uF	25V
C834	1-164-315-11	CERAMIC CHIP	470PF	5% 50V
C835	1-164-315-11	CERAMIC CHIP	470PF	5% 50V
C836	1-162-964-11	CERAMIC CHIP	0.001uF	10% 50V
C851	1-162-970-11	CERAMIC CHIP	0.01uF	10% 25V
C861	1-109-982-11	CERAMIC CHIP	1uF	10% 10V

Ref. No.	Part No.	Description		Remark
C862	1-162-970-11	CERAMIC CHIP	0.01uF	10% 25V
C901	1-107-826-11	CERAMIC CHIP	0.1uF	10% 16V
C904	1-162-970-11	CERAMIC CHIP	0.01uF	10% 25V
C905	1-107-826-11	CERAMIC CHIP	0.1uF	10% 16V
C908	1-164-156-11	CERAMIC CHIP	0.1uF	25V
C910	1-164-156-11	CERAMIC CHIP	0.1uF	25V
C913	1-104-913-11	TANTAL. CHIP	10uF	20% 16V
C914	1-135-213-21	TANTAL. CHIP	3.3uF	20% 25V
C3002	1-135-181-21	TANTALUM CHIP	4.7uF	20% 6.3V
< CONNECTOR >				
CN501	1-691-386-11	CONNECTOR, FFC/FPC 22P		
CN502	1-691-360-11	CONNECTOR, FFC/FPC (ZIF) 22P		
CN903	1-691-362-11	CONNECTOR, FFC/FPC (ZIF) 24P		
CN904	1-691-347-11	CONNECTOR, FFC/FPC (ZIF) 9P		
CN905	1-691-351-11	CONNECTOR, FFC/FPC (ZIF) 13P		
< DIODE >				
D101	8-719-017-58	DIODE MA8068		
D201	8-719-017-58	DIODE MA8068		
D301	8-719-017-58	DIODE MA8068		
D303	8-719-017-58	DIODE MA8068		
D304	8-719-017-58	DIODE MA8068		
D305	8-719-017-58	DIODE MA8068		
D307	8-719-017-58	DIODE MA8068		
D308	8-719-421-27	DIODE MA728		
D310	8-719-017-58	DIODE MA8068		
D501	8-719-421-27	DIODE MA728		
D502	8-719-421-27	DIODE MA728		
D503	8-719-049-09	DIODE 1SS367-T3SONY		
D504	8-719-049-09	DIODE 1SS367-T3SONY		
D803	8-719-052-72	LED CL-220HR-C (REC)		
D804	8-719-421-27	DIODE MA728		
D805	8-719-421-27	DIODE MA728		
D806	8-719-421-27	DIODE MA728		
D807	8-719-421-27	DIODE MA728		
D808	8-719-047-73	DIODE HRU0302A-TR		
D809	8-719-421-27	DIODE MA728		
D902	8-719-404-49	DIODE MA111		
D903	8-719-977-03	DIODE DTZ5.6B		
D905	8-719-975-33	DIODE RB110C		
D906	8-719-421-27	DIODE MA728		
D907	8-719-975-33	DIODE RB110C		
D3001	8-719-421-27	DIODE MA728		
< FERRITE BEAD >				
FB309	1-256-864-11	METAL CHIP	0	5% 1/16W (EXCEPT US, CND)
FB309	1-414-385-11	INDUCTOR, FERRITE BEAD		(US, CND)
FB350	1-414-228-11	INDUCTOR, FERRITE BEAD		
FB501	1-414-385-11	INDUCTOR, FERRITE BEAD		

MAIN

Ref. No.	Part No.	Description	Remark	Ref. No.	Part No.	Description	Remark
FB502	1-216-864-11	METAL CHIP	0 5% 1/16W (E, Tourist)	L508	1-414-402-11	INDUCTOR	47uH
FB502	1-414-385-11	INDUCTOR, FERRITE BEAD (EXCEPT E, Tourist)		L509	1-414-402-11	INDUCTOR	47uH
FB503	1-216-864-11	METAL CHIP	0 5% 1/16W (EXCEPT US, CND)	L510	1-414-410-21	INDUCTOR	10uH
FB503	1-414-385-11	INDUCTOR, FERRITE BEAD (US, CND)		L511	1-414-402-11	INDUCTOR	47uH
FB504	1-216-864-11	METAL CHIP	0 5% 1/16W (EXCEPT US, CND)	L512	1-411-322-21	COIL, CHOKE	68.0uH
FB504	1-414-385-11	INDUCTOR, FERRITE BEAD (US, CND)		L513	1-414-398-11	INDUCTOR	10uH
FB505	1-216-864-11	METAL CHIP	0 5% 1/16W (EXCEPT US, CND)	L514	1-412-034-11	INDUCTOR CHIP	330uH
FB505	1-414-385-11	INDUCTOR, FERRITE BEAD (US, CND)		L801	1-414-402-11	INDUCTOR	47uH
		< IC >				< LINE FILTER >	
IC301	8-759-337-18	IC TK11225AMTL		LF901	1-411-312-11	FILTER, COMMON MODE	
IC302	8-759-252-90	IC TLV2362IPW-ELM1500				< TRANSISTOR >	
IC303	8-759-439-74	IC AK4515-VQ		Q101	8-729-013-37	TRANSISTOR 2SC4213-AB-TE85L	
IC304	8-759-252-90	IC TLV2362IPW-ELM1500		Q102	8-729-013-37	TRANSISTOR 2SC4213-AB-TE85L	
IC306	8-759-173-00	IC XC61AN1102MR		Q201	8-729-013-37	TRANSISTOR 2SC4213-AB-TE85L	
IC352	8-759-332-22	IC DS1802E-TE2		Q202	8-729-013-37	TRANSISTOR 2SC4213-AB-TE85L	
IC501	8-752-074-77	IC CXA2523R		Q301	8-729-029-14	TRANSISTOR DTC144EUA-T106	
IC502	8-759-234-20	IC TC7S08F-TE85L		Q302	8-729-028-91	TRANSISTOR DTA144EUA-T106	
IC503	8-752-384-46	IC CXD2652R		Q305	8-729-023-89	TRANSISTOR 2SJ305(TE85L)	
IC504	8-759-432-73	IC XC62SPR212MR		Q309	8-729-028-91	TRANSISTOR DTA144EUA-T106	
IC505	8-759-442-80	IC MPC17A38ZVMEL		Q311	8-729-028-91	TRANSISTOR DTA144EUA-T106	
IC506	8-759-329-43	IC MPC18A20VMEL		Q312	8-729-230-60	TRANSISTOR 2SA1586-YG	
IC508	8-759-710-79	IC NJM2107F-TE1		Q313	8-729-929-99	TRANSISTOR UMB11-TN	
IC509	8-759-341-28	IC HM51W4400BT-7		Q314	8-729-929-99	TRANSISTOR UMB11-TN	
IC510	8-759-333-42	IC XC61AN3002MR		Q318	8-729-029-14	TRANSISTOR DTC144EUA-T106	
IC702	8-759-329-45	IC MPC17A33SVMEL		Q320	8-729-029-14	TRANSISTOR DTC144EUA-T106	
IC801	8-752-878-84	IC CXP81960M-632R		Q502	8-729-422-39	TRANSISTOR XN4404	
IC802	8-759-343-90	IC RS5RJ29261-T1		Q503	8-729-930-13	TRANSISTOR UMH2	
IC803	8-759-332-25	IC XC31PNS01AMR		Q504	8-729-019-25	TRANSISTOR 2SK1467-TD	
IC804	8-759-343-88	IC DS1302Z-TE2		Q505	8-729-029-14	TRANSISTOR DTC144EUA-T106	
IC805	8-759-458-97	IC LA4800V-TLM		Q506	8-729-023-89	TRANSISTOR 2SJ305(TE85L)	
IC807	8-759-425-16	IC AK93C45LV-L		Q701	8-729-028-91	TRANSISTOR DTA144EUA-T106	
IC909	8-759-427-91	IC MM1332DFBE		Q702	8-729-904-07	TRANSISTOR FMG2	
		< JACK >		Q801	8-729-028-91	TRANSISTOR DTA144EUA-T106	
J301	1-764-460-11	JACK (MIC, PLUG IN POWER)		Q806	8-729-031-34	TRANSISTOR 2SK2034	
J302	1-778-368-11	JACK, HEADPHONE (⊘)/REMOTE)		Q810	8-729-013-37	TRANSISTOR 2SC4213-AB-TE85L	
J303	1-764-460-21	JACK (LINE OUT)		Q811	8-729-013-37	TRANSISTOR 2SC4213-AB-TE85L	
J304	8-759-252-45	IC GP1F365R (LINE IN, OPTICAL)		Q812	8-729-013-37	TRANSISTOR 2SC4213-AB-TE85L	
J901	1-568-907-11	JACK, DC (POLARITY UNIFIED TYPE) (DC IN 6V)		Q901	8-729-907-00	TRANSISTOR DTC114EU	
		< COIL >		Q902	8-729-120-53	TRANSISTOR 2SJ132-Z	
L303	1-414-398-11	INDUCTOR	10uH	Q903	8-729-029-14	TRANSISTOR DTC144EUA-T106	
L304	1-414-410-21	INDUCTOR	10uH	Q904	8-729-921-93	TRANSISTOR 2SB1182F5-QR	
L501	1-414-398-11	INDUCTOR	10uH	Q907	8-729-028-99	TRANSISTOR DTC114YUA-T106	
L502	1-414-398-11	INDUCTOR	10uH	Q910	8-729-013-37	TRANSISTOR 2SC4213-AB-TE85L	
L504	1-414-410-21	INDUCTOR	10uH			< RESISTOR >	
L505	1-412-034-11	INDUCTOR CHIP	330uH	R101	1-218-867-11	METAL CHIP	6.8K 0.50% 1/16W
L506	1-414-402-11	INDUCTOR	47uH	R102	1-218-887-11	METAL CHIP	47K 0.50% 1/16W
L507	1-414-402-11	INDUCTOR	47uH	R103	1-218-867-11	METAL CHIP	6.8K 0.50% 1/16W
				R104	1-218-887-11	METAL CHIP	47K 0.50% 1/16W

Ref. No.	Part No.	Description	Remark	Ref. No.	Part No.	Description	Remark
R105	1-216-837-11	METAL CHIP	22K 5% 1/16W	R259	1-414-385-11	INDUCTOR, FERRITE BEAD (US, CND)	
R107	1-218-883-11	METAL CHIP	33K 0.50% 1/16W	R260	1-216-857-11	METAL CHIP	1M 5% 1/16W
R108	1-218-843-11	METAL CHIP	680 0.50% 1/16W	R301	1-216-833-11	METAL CHIP	10K 5% 1/16W
R111	1-218-891-11	METAL CHIP	68K 0.50% 1/16W	R302	1-216-833-11	METAL CHIP	10K 5% 1/16W
R112	1-218-887-11	METAL CHIP	47K 0.50% 1/16W	R303	1-216-857-11	METAL CHIP	1M 5% 1/16W
R119	1-216-789-11	METAL CHIP	2.2 5% 1/16W	R306	1-216-150-91	METAL GLAZE	10 5% 1/8W
R121	1-218-891-11	METAL CHIP	68K 0.50% 1/16W	R307	1-216-809-11	METAL CHIP	100 5% 1/16W
R122	1-218-875-11	METAL CHIP	15K 0.50% 1/16W	R308	1-216-809-11	METAL CHIP	100 5% 1/16W
R123	1-218-855-11	METAL CHIP	2.2K 0.50% 1/16W	R309	1-216-809-11	METAL CHIP	100 5% 1/16W
R124	1-218-875-11	METAL CHIP	15K 0.50% 1/16W	R346	1-216-857-11	METAL CHIP	1M 5% 1/16W
R134	1-218-847-11	METAL CHIP	1K 0.50% 1/16W	R347	1-216-857-11	METAL CHIP	1M 5% 1/16W
R136	1-218-871-11	METAL CHIP	10K 0.50% 1/16W	R352	1-216-864-11	METAL CHIP	0 5% 1/16W
R137	1-216-827-11	METAL CHIP	3.3K 5% 1/16W				(EXCEPT US, CND)
R139	1-216-813-11	METAL CHIP	220 5% 1/16W	R352	1-414-385-11	INDUCTOR, FERRITE BEAD (US, CND)	
R140	1-216-813-11	METAL CHIP	220 5% 1/16W	R355	1-216-847-11	METAL CHIP	150K 5% 1/16W
R141	1-216-833-11	METAL CHIP	10K 5% 1/16W	R359	1-216-864-11	METAL CHIP	0 5% 1/16W
R144	1-216-864-11	METAL CHIP	0 5% 1/16W				(EXCEPT US, CND)
			(EXCEPT US, CND)	R359	1-414-385-11	INDUCTOR, FERRITE BEAD (US, CND)	
R144	1-414-385-11	INDUCTOR, FERRITE BEAD (US, CND)		R361	1-216-829-11	METAL CHIP	4.7K 5% 1/16W
R145	1-218-879-11	METAL CHIP	22K 0.50% 1/16W	R364	1-216-789-11	METAL CHIP	2.2 5% 1/16W
R146	1-218-879-11	METAL CHIP	22K 0.50% 1/16W	R365	1-216-809-11	METAL CHIP	100 5% 1/16W
R159	1-216-864-11	METAL CHIP	0 5% 1/16W	R367	1-216-829-11	METAL CHIP	4.7K 5% 1/16W
			(EXCEPT US, CND)	R368	1-216-829-11	METAL CHIP	4.7K 5% 1/16W
R159	1-414-385-11	INDUCTOR, FERRITE BEAD (US, CND)		R374	1-216-845-11	METAL CHIP	100K 5% 1/16W
R160	1-216-857-11	METAL CHIP	1M 5% 1/16W	R380	1-216-864-11	METAL CHIP	0 5% 1/16W
R201	1-218-867-11	METAL CHIP	6.8K 0.50% 1/16W	R381	1-216-809-11	METAL CHIP	100 5% 1/16W
R202	1-218-887-11	METAL CHIP	47K 0.50% 1/16W	R398	1-216-839-11	METAL CHIP	33K 5% 1/16W
R203	1-218-867-11	METAL CHIP	6.8K 0.50% 1/16W	R399	1-216-839-11	METAL CHIP	33K 5% 1/16W
R204	1-218-887-11	METAL CHIP	47K 0.50% 1/16W	R501	1-216-835-11	METAL CHIP	15K 5% 1/16W
R205	1-216-837-11	METAL CHIP	22K 5% 1/16W	R502	1-216-835-11	METAL CHIP	15K 5% 1/16W
R207	1-218-883-11	METAL CHIP	33K 0.50% 1/16W	R503	1-216-831-11	METAL CHIP	6.8K 5% 1/16W
R208	1-218-843-11	METAL CHIP	680 0.50% 1/16W	R504	1-216-859-11	METAL GLAZE	1.5M 5% 1/16W
R211	1-218-891-11	METAL CHIP	68K 0.50% 1/16W	R505	1-216-789-11	METAL CHIP	2.2 5% 1/16W
R212	1-218-887-11	METAL CHIP	47K 0.50% 1/16W	R506	1-216-811-11	METAL CHIP	150 5% 1/16W
R219	1-216-789-11	METAL CHIP	2.2 5% 1/16W	R507	1-216-833-11	METAL CHIP	10K 5% 1/16W
R221	1-218-891-11	METAL CHIP	68K 0.50% 1/16W	R508	1-216-817-11	METAL CHIP	470 5% 1/16W
R222	1-218-875-11	METAL CHIP	15K 0.50% 1/16W	R509	1-216-853-11	METAL CHIP	470K 5% 1/16W
R223	1-218-855-11	METAL CHIP	2.2K 0.50% 1/16W	R510	1-216-825-11	METAL CHIP	2.2K 5% 1/16W
R224	1-218-875-11	METAL CHIP	15K 0.50% 1/16W	R511	1-216-825-11	METAL CHIP	2.2K 5% 1/16W
R234	1-218-847-11	METAL CHIP	1K 0.50% 1/16W	R512	1-216-825-11	METAL CHIP	2.2K 5% 1/16W
R236	1-218-871-11	METAL CHIP	10K 0.50% 1/16W	R513	1-216-843-11	METAL CHIP	68K 5% 1/16W
R237	1-216-827-11	METAL CHIP	3.3K 5% 1/16W	R514	1-216-864-11	METAL CHIP	0 5% 1/16W
R239	1-216-813-11	METAL CHIP	220 5% 1/16W	R515	1-216-864-11	METAL CHIP	0 5% 1/16W
R240	1-216-813-11	METAL CHIP	220 5% 1/16W	R516	1-216-821-11	METAL CHIP	1K 5% 1/16W
R241	1-216-833-11	METAL CHIP	10K 5% 1/16W	R517	1-216-162-00	METAL GLAZE	33 5% 1/8W
R244	1-216-864-11	METAL CHIP	0 5% 1/16W	R519	1-216-825-11	METAL CHIP	2.2K 5% 1/16W
			(EXCEPT US, CND)	R520	1-216-841-11	METAL CHIP	47K 5% 1/16W
R244	1-414-385-11	INDUCTOR, FERRITE BEAD (US, CND)		R524	1-216-833-11	METAL CHIP	10K 5% 1/16W
R245	1-218-879-11	METAL CHIP	22K 0.50% 1/16W	R525	1-216-845-11	METAL CHIP	100K 5% 1/16W
R246	1-218-879-11	METAL CHIP	22K 0.50% 1/16W	R526	1-216-853-11	METAL CHIP	470K 5% 1/16W
R259	1-216-864-11	METAL CHIP	0 5% 1/16W	R527	1-216-825-11	METAL CHIP	2.2K 5% 1/16W
			(EXCEPT US, CND)	R528	1-216-821-11	METAL CHIP	1K 5% 1/16W

MAIN

Ref. No.	Part No.	Description	Remark	Ref. No.	Part No.	Description	Remark
R529	1-216-821-11	METAL CHIP	1K 5% 1/16W	R820	1-218-887-11	METAL CHIP	47K 0.50% 1/16W
R530	1-216-827-11	METAL CHIP	3.3K 5% 1/16W	R821	1-218-887-11	METAL CHIP	47K 0.50% 1/16W
R531	1-216-845-11	METAL CHIP	100K 5% 1/16W	R822	1-218-887-11	METAL CHIP	47K 0.50% 1/16W
R532	1-216-833-11	METAL CHIP	10K 5% 1/16W	R823	1-218-895-11	METAL CHIP	100K 0.50% 1/16W
R533	1-216-839-11	METAL CHIP	33K 5% 1/16W	R826	1-216-864-11	METAL CHIP	0 5% 1/16W
R534	1-216-839-11	METAL CHIP	33K 5% 1/16W	R827	1-216-864-11	METAL CHIP	0 5% 1/16W
R535	1-216-843-11	METAL CHIP	68K 5% 1/16W	R828	1-216-853-11	METAL CHIP	470K 5% 1/16W
R536	1-218-891-11	METAL CHIP	68K 0.50% 1/16W	R829	1-216-847-11	METAL CHIP	150K 5% 1/16W
R537	1-218-899-11	METAL CHIP	150K 0.50% 1/16W	R830	1-216-851-11	METAL CHIP	330K 5% 1/16W
R538	1-218-895-11	METAL CHIP	100K 0.50% 1/16W	R831	1-216-853-11	METAL CHIP	470K 5% 1/16W
R539	1-216-833-11	METAL CHIP	10K 5% 1/16W	R832	1-216-851-11	METAL CHIP	330K 5% 1/16W
R540	1-216-857-11	METAL CHIP	1M 5% 1/16W	R833	1-216-857-11	METAL CHIP	1M 5% 1/16W
R541	1-216-843-11	METAL CHIP	68K 5% 1/16W	R834	1-216-857-11	METAL CHIP	1M 5% 1/16W
R542	1-218-887-11	METAL CHIP	47K 0.50% 1/16W	R835	1-216-845-11	METAL CHIP	100K 5% 1/16W
R543	1-218-871-11	METAL CHIP	10K 0.50% 1/16W	R836	1-218-871-11	METAL CHIP	10K 0.50% 1/16W
R544	1-216-843-11	METAL CHIP	68K 5% 1/16W	R837	1-216-851-11	METAL CHIP	330K 5% 1/16W
R545	1-216-845-11	METAL CHIP	100K 5% 1/16W	R838	1-218-887-11	METAL CHIP	47K 0.50% 1/16W
R546	1-216-841-11	METAL CHIP	47K 5% 1/16W	R839	1-218-871-11	METAL CHIP	10K 0.50% 1/16W
R549	1-216-845-11	METAL CHIP	100K 5% 1/16W	R840	1-218-879-11	METAL CHIP	22K 0.50% 1/16W
R554	1-216-789-11	METAL CHIP	2.2 5% 1/16W	R841	1-216-863-11	METAL GLAZE	3.3M 5% 1/16W
R555	1-216-817-11	METAL CHIP	470 5% 1/16W	R847	1-216-845-11	METAL CHIP	100K 5% 1/16W
R556	1-216-864-11	METAL CHIP	0 5% 1/16W	R852	1-218-883-11	METAL CHIP	33K 0.50% 1/16W
R559	1-216-811-11	METAL CHIP	150 5% 1/16W	R853	1-216-809-11	METAL CHIP	100 5% 1/16W
R560	1-216-833-11	METAL CHIP	10K 5% 1/16W	R854	1-216-857-11	METAL CHIP	1M 5% 1/16W
R562	1-218-871-11	METAL CHIP	10K 0.50% 1/16W	R855	1-216-851-11	METAL CHIP	330K 5% 1/16W
R563	1-216-833-11	METAL CHIP	10K 5% 1/16W	R856	1-216-821-11	METAL CHIP	1K 5% 1/16W
R564	1-216-843-11	METAL CHIP	68K 5% 1/16W	R857	1-216-833-11	METAL CHIP	10K 5% 1/16W
R565	1-216-845-11	METAL CHIP	100K 5% 1/16W	R861	1-216-857-11	METAL CHIP	1M 5% 1/16W
R566	1-216-841-11	METAL CHIP	47K 5% 1/16W	R862	1-216-863-11	METAL GLAZE	3.3M 5% 1/16W
R571	1-216-817-11	METAL CHIP	470 5% 1/16W	R863	1-216-857-11	METAL CHIP	1M 5% 1/16W
R571	1-216-864-11	METAL CHIP	0 5% 1/16W	R864	1-216-857-11	METAL CHIP	1M 5% 1/16W
R572	1-216-817-11	METAL CHIP	470 5% 1/16W	R865	1-216-809-11	METAL CHIP	100 5% 1/16W
R572	1-216-864-11	METAL CHIP	0 5% 1/16W	R866	1-216-851-11	METAL CHIP	330K 5% 1/16W
R576	1-216-813-11	METAL CHIP	220 5% 1/16W	R867	1-216-829-11	METAL CHIP	4.7K 5% 1/16W
R576	1-216-817-11	METAL CHIP	470 5% 1/16W	R868	1-216-845-11	METAL CHIP	100K 5% 1/16W
R708	1-216-845-11	METAL CHIP	100K 5% 1/16W	R869	1-216-829-11	METAL CHIP	4.7K 5% 1/16W
R709	1-216-845-11	METAL CHIP	100K 5% 1/16W	R870	1-216-829-11	METAL CHIP	4.7K 5% 1/16W
R710	1-216-819-11	METAL CHIP	680 5% 1/16W	R871	1-216-829-11	METAL CHIP	4.7K 5% 1/16W
R802	1-216-851-11	METAL CHIP	330K 5% 1/16W	R872	1-216-829-11	METAL CHIP	4.7K 5% 1/16W
R803	1-216-857-11	METAL CHIP	1M 5% 1/16W	R873	1-216-829-11	METAL CHIP	4.7K 5% 1/16W
R806	1-216-857-11	METAL CHIP	1M 5% 1/16W	R874	1-216-829-11	METAL CHIP	4.7K 5% 1/16W
R807	1-216-857-11	METAL CHIP	1M 5% 1/16W	R876	1-216-863-11	METAL GLAZE	3.3M 5% 1/16W
R813	1-216-809-11	METAL CHIP	100 5% 1/16W	R877	1-216-845-11	METAL CHIP	100K 5% 1/16W
R816	1-216-851-11	METAL CHIP	330K 5% 1/16W	R878	1-216-833-11	METAL CHIP	10K 5% 1/16W
R817	1-216-851-11	METAL CHIP	330K 5% 1/16W	R901	1-216-817-11	METAL CHIP	470 5% 1/16W
R818	1-216-857-11	METAL CHIP	1M 5% 1/16W	R902	1-216-833-11	METAL CHIP	10K 5% 1/16W
R819	1-218-895-11	METAL CHIP	100K 0.50% 1/16W	R905	1-216-863-11	METAL GLAZE	3.3M 5% 1/16W
				R910	1-216-853-11	METAL CHIP	470K 5% 1/16W
				R911	1-216-845-11	METAL CHIP	100K 5% 1/16W
				R970	1-216-853-11	METAL CHIP	470K 5% 1/16W
				R972	1-208-293-11	METAL GLAZE	0.47 10% 1/10W

Ref. No.	Part No.	Description	Remark		
R975	1-208-293-11	METAL GLAZE	0.47	10%	1/10W
R3001	1-216-837-11	METAL CHIP	22K	5%	1/16W
< COMPOSITION CIRCUIT BLOCK >					
RB535	1-239-436-11	NETWORK RESISTOR (CHIP) 33K			
RB801	1-233-703-21	NETWORK RESISTOR (CHIP) 1M			
RB802	1-239-446-11	NETWORK RESISTOR (CHIP) 330K			
< SWITCH >					
S301	1-762-078-11	SWITCH, SLIDE (MIC SENS)			
S808	1-572-467-41	SWITCH, PUSH (1 KEY) (←REC)			
S809	1-572-473-11	SWITCH, TACTIL (CLOCK SET)			
S810	1-572-499-21	SWITCH, TACTIL (DIGITAL MEGA BASS)			
S811	1-762-078-11	SWITCH, SLIDE (AVLS)			
S816	1-762-078-11	SWITCH, SLIDE (SYNCHRO REC)			
S817	1-762-805-21	SWITCH, PUSH (DOOR OPEN/CLOSE)			
S818	1-762-078-11	SWITCH, SLIDE (←HOLD)			
S823	1-572-467-41	SWITCH, PUSH (1 KEY) (←OPEN)			
< THERMISTOR >					
△ THP901	1-810-792-11	SWITCH, POLYETHYLENE			
< VIBRATOR >					
X501	1-760-173-11	VIBRATOR, CRYSTAL (45.158MHz)			
X801	1-760-174-11	VIBRATOR, CERAMIC (12MHz)			
X802	1-579-886-21	VIBRATOR, CRYSTAL (32.768kHz)			

A-3293-253-A	POWER BOARD, COMPLETE				

< CAPACITOR >					
C801	1-109-982-11	CERAMIC CHIP	1uF	10%	10V
C802	1-107-826-11	CERAMIC CHIP	0.1uF	10%	16V
C803	1-162-970-11	CERAMIC CHIP	0.01uF	10%	25V
C804	1-162-964-11	CERAMIC CHIP	0.001uF	10%	50V
C805	1-162-927-11	CERAMIC CHIP	100PF	5%	50V
C807	1-162-965-11	CERAMIC CHIP	0.0015uF	10%	50V
C809	1-115-169-11	TANTALUM	10uF	20%	6.3V
C810	1-164-506-11	CERAMIC CHIP	4.7uF		16V
C832	1-162-970-11	CERAMIC CHIP	0.01uF	10%	25V
C837	1-164-156-11	CERAMIC CHIP	0.1uF		25V
C840	1-126-923-11	ELECT	220uF	20%	10V
C841	1-109-982-11	CERAMIC CHIP	1uF	10%	10V
C842	1-135-259-11	TANTAL. CHIP	10uF	20%	6.3V
C843	1-135-259-11	TANTAL. CHIP	10uF	20%	6.3V
C860	1-164-227-11	CERAMIC CHIP	0.022uF	10%	25V
C863	1-164-156-11	CERAMIC CHIP	0.1uF		25V
C899	1-251-470-11	ELEMENT, STORAGE			
< CONNECTOR >					
CN805	1-691-362-11	CONNECTOR, FFC/FPC (ZIF) 24P			

Ref. No.	Part No.	Description	Remark		
< DIODE >					
D801	8-719-975-33	DIODE RB110C			
D802	8-719-975-33	DIODE RB110C			
D810	8-719-975-54	DIODE HSM2838C			
D812	8-719-975-33	DIODE RB110C			
< IC >					
IC806	8-759-331-73	IC MB3800PNF			
IC808	8-729-039-08	IC TRANSISTOR SI6946DQ-T1			
IC809	8-729-039-07	IC TRANSISTOR SI6943DQ-T1			
IC810	8-759-358-71	IC S-80719SL-AG-T1			
< COIL >					
L802	1-411-803-21	COIL, CHOKE	33uH		
L804	1-414-410-21	INDUCTOR	10uH		
L805	1-414-410-21	INDUCTOR	10uH		
< TRANSISTOR >					
Q802	8-729-031-34	TRANSISTOR 2SK2034			
Q803	8-729-031-31	TRANSISTOR 2SD2402			
Q804	8-729-822-62	TRANSISTOR 2SB1302-T			
Q805	8-729-120-28	TRANSISTOR 2SC1623-L5L6			
Q807	8-729-029-14	TRANSISTOR DTC144EUA-T106			
Q808	8-729-019-25	TRANSISTOR 2SK1467-TD			
Q813	8-729-028-91	TRANSISTOR DTA144EUA-T106			
Q814	8-729-029-14	TRANSISTOR DTC144EUA-T106			
Q815	8-729-019-25	TRANSISTOR 2SK1467-TD			
< RESISTOR >					
R801	1-216-789-11	METAL CHIP	2.2	5%	1/16W
R804	1-218-895-11	METAL CHIP	100K	0.5%	1/16W
R805	1-218-895-11	METAL CHIP	100K	0.5%	1/16W
R808	1-216-817-11	METAL CHIP	470	5%	1/16W
R809	1-216-827-11	METAL CHIP	3.3K	5%	1/16W
R810	1-216-827-11	METAL CHIP	3.3K	5%	1/16W
R811	1-216-821-11	METAL CHIP	1K	5%	1/16W
R812	1-216-825-11	METAL CHIP	2.2K	5%	1/16W
R814	1-218-883-11	METAL CHIP	33K	0.5%	1/16W
R815	1-218-863-11	METAL CHIP	4.7K	0.5%	1/16W
R824	1-216-861-11	METAL CHIP	2.2M	5%	1/16W
R825	1-216-857-11	METAL CHIP	1M	5%	1/16W
R846	1-218-875-11	METAL CHIP	15K	0.5%	1/16W
R875	1-216-801-11	METAL CHIP	22	5%	1/16W
R879	1-216-821-11	METAL CHIP	1K	5%	1/16W
R880	1-216-837-11	METAL CHIP	22K	5%	1/16W
R898	1-216-857-11	METAL CHIP	1M	5%	1/16W
< VARIABLE RESISTOR >					
RV801	1-238-663-11	RES. ADJ. CARBON 4.7K (2.8V ADJUST)			

<p>The components identified by mark △ or dotted line with mark △ are critical for safety. Replace only with part number specified.</p>	<p>Les composants identifiés par une marque △ sont critiques pour la sécurité. Ne les remplacer que par une pièce portant le numéro spécifié.</p>
---	---

REC SWITCH

Ref. No.	Part No.	Description	Remark
*	1-663-390-11	REC BOARD *****	
		< CAPACITOR >	
C401	1-107-826-11	CERAMIC CHIP 0.1uF 10% 16V	
C402	1-107-810-11	TANTAL. CHIP 33uF 20% 4V	
C403	1-109-814-11	MICA CHIP 220PF 5% 100V	
		< CONNECTOR >	
CN401	1-691-344-11	CONNECTOR, FFC/FPC (ZIF) 6P	
CN402	1-691-344-11	CONNECTOR, FFC/FPC (ZIF) 6P	
		< DIODE >	
D401	8-719-046-86	DIODE F1J6TP	
D402	8-719-046-86	DIODE F1J6TP	
		< TRANSISTOR >	
Q401	8-729-024-44	TRANSISTOR 2SK2315TYTR	
Q402	8-729-024-44	TRANSISTOR 2SK2315TYTR	
Q403	8-729-024-44	TRANSISTOR 2SK2315TYTR	
Q404	8-729-024-44	TRANSISTOR 2SK2315TYTR	

	A-3306-147-A	SWITCH BOARD, COMPLETE *****	
		< RESISTOR >	
R844	1-218-867-11	METAL CHIP 6.8K 0.50% 1/16W	
R845	1-218-871-11	METAL CHIP 10K 0.50% 1/16W	
		< SWITCH >	
S804	1-762-851-21	SWITCH, KEY BOARD (VOLUME -)	
S805	1-762-851-21	SWITCH, KEY BOARD (VOLUME +)	
S806	1-762-851-21	SWITCH, KEY BOARD (■)	

		MISCELLANEOUS *****	
13	1-801-522-11	LCD MODULE	
51	1-473-895-11	SWITCH UNIT (WITH JOG DIAL)	
74	1-777-761-11	WIRE (FLAT TYPE) (24 CORE)	
106	1-651-018-11	SLED FLEXIBLE BOARD	
△121	A-3311-140-A	OPTICAL PICK-UP ASSY	
153	1-663-392-11	MD FLEXIBLE BOARD	
161	1-651-017-11	CLV FLEXIBLE BOARD	
M901	1-698-542-11	MOTOR (SPINDLE)	
M902	A-3303-502-A	MOTOR BLOCK ASSY (SLED)	
M903	A-3303-499-A	STEPPER BLOCK ASSY (STEPPING)	

Ref. No.	Part No.	Description	Remark
		ACCESSORIES & PACKING MATERIALS *****	
△	1-467-510-31	ADAPTOR, AC (AC-MZ60A) (US, CND)	
△	1-467-511-31	ADAPTOR, AC (AC-MZ60A) (AEP)	
△	1-467-511-41	ADAPTOR, AC (AC-MZ60) (E13)	
△	1-467-513-21	ADAPTOR, AC (AC-MZ60) (UK, AUS)	
△	1-467-514-11	ADAPTOR, AC (AC-MZ60) (E33, Tourist)	
	1-473-109-31	REMOTE CONTROL UNIT	
	1-559-906-32	CORD, CONNECTION (AEP, UK)	
△	1-569-007-11	ADAPTOR, CONVERSION 2P (E33, Tourist)	
	1-759-277-21	CASE, BATTERY (EBP-MZR4)	
	1-779-504-11	CONNECTOR, OPTICAL (E13)	
	3-858-529-11	MANUAL, INSTRUCTION (ENGLISH, FRENCH, GERMAN, SPANISH) (CND, AEP, E33, Tourist)	
	3-858-529-21	MANUAL, INSTRUCTION (ENGLISH) (US, UK, AUS, E13)	
	3-858-529-31	MANUAL, INSTRUCTION (DUTCH, SWEDISH, ITALIAN, PORTUGUESE) (AEP)	
	3-858-529-41	MANUAL, INSTRUCTION (JAPANESE, KOREAN, CHINESE) (E13, Tourist)	
	4-973-528-01	CASE, CARRYING	
*	4-987-395-01	CASE, INDIVIDUAL (EXCEPT US)	
*	4-991-504-01	CASE, INDIVIDUAL (US)	
	8-953-091-90	HEADPHONE MDR-E838MP SET (EXCEPT US)	
	8-953-101-90	HEADPHONE MDR-24MP SET (US)	
	X-3329-657-1	ATTACHMENT ASSY (EXCEPT US)	

The components identified by mark △ or dotted line with mark △ are critical for safety. Replace only with part number specified.	Les composants identifiés par une marque △ sont critiques pour la sécurité. Ne les remplacer que par une pièce portant le numéro spécifié.
---	---