

# MZ-NF610

## SERVICE MANUAL

Ver 1.3 2004.08

US Model  
Canadian Model  
UK Model



US and foreign patents licensed from Dolby Laboratories.

- SonicStage, OpenMG and the OpenMG logo, MagicGate, Net MD and the Net MD logo are trademarks of Sony Corporation.
- Microsoft, Windows, Windows NT and Windows Media are trademarks or registered trademarks of Microsoft Corporation in the United States and /or other countries.
- IBM and PC/AT are registered trademarks of International Business Machines Corporation.
- Macintosh is a trademark of Apple Computer, Inc. in the United States and/ or other countries.
- MMX and Pentium are trademarks or registered trademarks of Intel Corporation.
- All other trademarks and registered trademarks are trademarks or registered trademarks of their respective holders.
- ™ and ® marks are omitted in this manual.

Model Name Using Similar Mechanism	MZ-R410
Mechanism Type	MT-MZN710-177
Optical Pick-up Name	LCX-5R

### SPECIFICATIONS

MD recorder

#### Audio playing system

MiniDisc digital audio system

#### Laser diode properties

Material: GaAlAs

Wavelength:  $\lambda = 790 \text{ nm}$

Emission duration: continuous

Laser output: less than  $44.6 \mu\text{W}$

(This output is the value measured at a distance of 200 mm from the lens surface on the optical pick-up block with 7 mm aperture.)

#### Recording and playback time (when using MDW-80)

Maximum 160 min. in monaural

Maximum 320 min. in LP4 stereo

#### Revolutions

380 rpm to 2,700 rpm (CLV)

#### Error correction

ACIRC (Advanced Cross Interleave Reed

Solomon Code)

#### Sampling frequency

44.1 kHz

#### Sampling rate converter

Input: 32 kHz/44.1 kHz/48 kHz

#### Coding

ATRAC (Adaptive TRansform Acoustic

Coding)

ATRAC3 — LP2/LP4

– Continued on next page –

## PORTABLE MINIDISC RECORDER

9-877-144-04

2004H16-1

© 2004.8

**Sony Corporation**

Personal Audio Company

Published by Sony Engineering Corporation

# SONY®

# MZ-NF610

## Modulation system

EFM (Eight to Fourteen Modulation)

## Frequency response

20 to 20,000 Hz  $\pm$  3 dB

## Inputs<sup>1)</sup>

Line in:

- stereo mini-jack for analog input (minimum input level 49 mV)
- optical (digital) mini-jack for optical (digital) input

## Outputs

⌚: stereo mini-jack

## Maximum output level

USA model:

5mW + 5mW; load impedance 24 $\Omega$

Canadian model:

5mW + 5mW; load impedance 16 $\Omega$

## Radio

### Frequency range

USA model:

FM: 87.5-108 MHz

AM: 530-1,710 kHz (10 kHz step)

531-1,710 kHz (9 kHz step)

TV: 2-13 CH

WEATHER: 1-7 CH

Canadian model:

FM: 87.5-108 MHz

AM: 530-1,710 kHz (10 kHz step)

531-1,710 kHz (9 kHz step)

## Antenna

FM/TV/WEATHER:

Headphones/earphones cord antenna

AM:

Built-in ferrite bar antenna

## General

### Power requirements

Sony AC Power Adaptor connected at the DC

IN 3V jack:

120 V AC, 60 Hz (Models for USA, Canada, Mexico, and Taiwan)

230 V AC, 50/60 Hz (Models for continental Europe and Chili)

240 V AC, 50 Hz (Model for Australia)

220 V AC, 50 Hz (Model for China)

230 V AC, 50 Hz (Models for U.K. and Hong Kong)

220 V AC, 60 Hz (Model for Korea)

100 - 120 V/220 - 240 V AC, 50/60 Hz (Other models)

The recorder:

Nickel metal hydride rechargeable battery

NH-7WMAA 1.2V 700 mAh (MIN) Ni-MH

LR6 (size AA) alkaline battery

## Dimensions

Approx. 81.0  $\times$  27.7  $\times$  74.4 mm (w/h/d)

(3<sup>1</sup>/<sub>4</sub>  $\times$  1<sup>1</sup>/<sub>8</sub>  $\times$  3 in.)

## Mass

Approx. 103 g (3.6 oz) the recorder only

<sup>1)</sup>The LINE IN (OPTICAL) jack is used to connect either a digital (optical) cable or a line (analog) cable.

<sup>2)</sup>The ⌚ jack connects either headphones/earphones or a line cable.

<sup>3)</sup>Measured in accordance with JEITA.

## Supplied accessories

AC power adaptor (1)

NH-7WMAA Nickel metal hydride rechargeable battery (1)

Headphones with a remote control (1)

(for USA model)

Earphones with a remote control (1)

(for Canadian model)

Dedicated USB cable (1)

Battery carrying case (1)

CD-ROM (SonicStage Ver. 1.5) (1)\*

\*Do not play a CD-ROM on an audio CD player.

US and foreign patents licensed from Dolby Laboratories.

Design and specifications are subject to change without notice.

## Battery life

The battery life may be shorter due to operating conditions, the temperature of the location, or alkaline dry battery you use.

## When recording

(Unit: approx.hours)(JEITA<sup>1)</sup>)

Batteries	SP Stereo	LP2 Stereo	LP4 Stereo
Nickel metal hydride rechargeable battery <sup>2)</sup>	5.5	8	9
LR6 Sony alkaline dry battery <sup>3)</sup>	9	12	16

<sup>1)</sup>Measured in accordance with the JEITA (Japan Electronics and Information Technology Industries Association) standard.

<sup>2)</sup>When using a 100% fully charged nickel metal hydride rechargeable battery (NH-7WMAA).

<sup>3)</sup>When using a Sony LR6 (SG) "STAMINA" alkaline dry battery (produced in Japan).

## When playing

(Unit: approx.hours)(JEITA)

Batteries	SP Stereo	LP2 Stereo	LP4 Stereo
Nickel metal hydride rechargeable battery	14.5	15.5	17.5
LR6 Sony alkaline dry battery	36	42.5	48

## When using the radio

(Unit: approx.hours)(JEITA)

Batteries	FM/AM	TV/Wb (weather) (USA model only)
Nickel metal hydride rechargeable battery	7.5	7
LR6 Sony alkaline dry battery	18.5	17

## Note

When you use the radio, it is recommended that you use a fully charged rechargeable battery or a new dry battery since more power is consumed by the radio than by MD playback.

## SAFETY-RELATED COMPONENT WARNING!!

COMPONENTS IDENTIFIED BY MARK  $\triangle$  OR DOTTED LINE WITH MARK  $\triangle$  ON THE SCHEMATIC DIAGRAMS AND IN THE PARTS LIST ARE CRITICAL TO SAFE OPERATION. REPLACE THESE COMPONENTS WITH SONY PARTS WHOSE PART NUMBERS APPEAR AS SHOWN IN THIS MANUAL OR IN SUPPLEMENTS PUBLISHED BY SONY.

## ATTENTION AU COMPOSANT AYANT RAPPORT À LA SÉCURITÉ!

LES COMPOSANTS IDENTIFIÉS PAR UNE MARQUE  $\triangle$  SUR LES DIAGRAMMES SCHÉMATIQUES ET LA LISTE DES PIÈCES SONT CRITIQUES POUR LA SÉCURITÉ DE FONCTIONNEMENT. NE REMPLACER CES COMPOSANTS QUE PAR DES PIÈCES SONY DONT LES NUMÉROS SONT DONNÉS DANS CE MANUEL OU DANS LES SUPPLÉMENTS PUBLIÉS PAR SONY.

**CAUTION**

Use of controls or adjustments or performance of procedures other than those specified herein may result in hazardous radiation exposure.

**On power sources**

- Use house current, nickel metal hydride rechargeable battery, LR6 (size AA) battery, or car battery.
- For use in your house: Do not use any other AC power adaptor since it may cause the recorder to malfunction.

**Polarity of the plug**



- Connect the AC power adaptor to an easily accessible AC outlet. Should you notice an abnormality in the AC power adaptor, disconnect it from the AC outlet immediately.
- The recorder is not disconnected from the AC power source (mains) as long as it is connected to the wall outlet, even if the recorder itself has been turned off.
- If you are not going to use this recorder for a long time, be sure to disconnect the power supply (AC power adaptor, dry battery, rechargeable battery, or car battery cord). To remove the AC power adaptor from the wall outlet, grasp the adaptor plug itself; never pull the cord.

**Notes on chip component replacement**

- Never reuse a disconnected chip component.
- Notice that the minus side of a tantalum capacitor may be damaged by heat.

**Flexible Circuit Board Repairing**

- Keep the temperature of the soldering iron around 270 °C during repairing.
- Do not touch the soldering iron on the same conductor of the circuit board (within 3 times).
- Be careful not to apply force on the conductor when soldering or unsoldering.

**UNLEADED SOLDER**

Boards requiring use of unleaded solder are printed with the lead-free mark (LF) indicating the solder contains no lead.

(Caution: Some printed circuit boards may not come printed with the lead free mark due to their particular size)



**: LEAD FREE MARK**

Unleaded solder has the following characteristics.

- Unleaded solder melts at a temperature about 40 °C higher than ordinary solder.  
Ordinary soldering irons can be used but the iron tip has to be applied to the solder joint for a slightly longer time.  
Soldering irons using a temperature regulator should be set to about 350 °C .  
Caution: The printed pattern (copper foil) may peel away if the heated tip is applied for too long, so be careful!
- Strong viscosity  
Unleaded solder is more viscous (sticky, less prone to flow) than ordinary solder so use caution not to let solder bridges occur such as on IC pins, etc.
- Usable with ordinary solder  
It is best to use only unleaded solder but unleaded solder may also be added to ordinary solder.

**TABLE OF CONTENTS**

<b>1. SERVICING NOTES</b> .....	4
<b>2. GENERAL</b> .....	5
<b>3. DISASSEMBLY</b>	
3-1. Disassembly Flow .....	6
3-2. Case (Lower) .....	7
3-3. Upper Panel Section .....	7
3-4. LCD Module, Button (Control) .....	8
3-5. MAIN Board .....	8
3-6. Mechanism Deck (MT-MZN710-177) .....	9
3-7. Set Chassis Assy .....	9
3-8. OP Service Assy (LCX-5R) .....	10
3-9. Holder Assy .....	11
3-10. DC Motor (Sled) (M602) .....	11
3-11. DC Motor (Over Write Head Up/Down) (M603), DC SSM18B Motor (Spindle) (M601) .....	12
<b>4. TEST MODE</b> .....	13
<b>5. ELECTRICAL ADJUSTMENTS</b> .....	19
<b>6. DIAGRAMS</b>	
6-1. Block Diagram .....	39
6-2. Note for Printed Wiring Board and Schematic Diagrams .....	40
6-3. Printed Wiring Board – MAIN Board (Side A) – .....	41
6-4. Printed Wiring Board – MAIN Board (Side B) – .....	42
6-5. Schematic Diagram – MAIN Board (1/4) – .....	43
6-6. Schematic Diagram – MAIN Board (2/4) – .....	44
6-7. Schematic Diagram – MAIN Board (3/4) – .....	45
6-8. Schematic Diagram – MAIN Board (4/4) – .....	46
6-9. IC Pin Function Description .....	52
<b>7. EXPLODED VIEWS</b>	
7-1. Case Section .....	58
7-2. Chassis Section .....	59
7-3. MAIN Board Section .....	60
7-4. Mechanism Deck Section-1 (MT-MZN710-177) .....	61
7-5. Mechanism Deck Section-2 (MT-MZN710-177) .....	62
<b>8. ELECTRICAL PARTS LIST</b> .....	63



## SECTION 2 GENERAL

This section is extracted from instruction manual.

### Looking at controls

#### The recorder

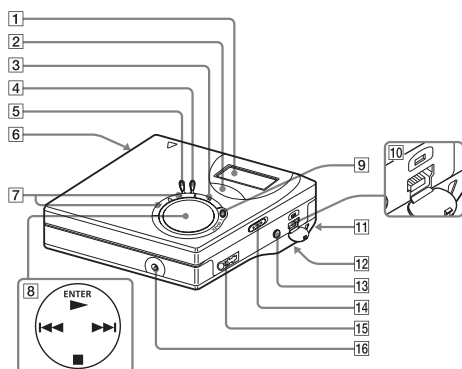

- |  |   |
|--|---|
| <p>1 Display window</p> <p>2 GROUP button</p> <p>3 <b>  </b> (pause) button</p> <p>4 END SEARCH button</p> <p>5 MENU button</p> <p>6 OPEN button</p> <p>7 VOL +, - button<br/>* VOL + has a tactile dot.</p> <p>8 4-way control key<br/>ENTER • ►*<br/>◀◀ • ►► (search/AMS)<br/>■ • CANCEL/CHG (stop/cancel/charge)<br/>* ► has a tactile dot.</p> | <p>9 REC (record) • T MARK button</p> <p>10 USB connecting jack</p> <p>11 Handstrap hole<br/>Use the hole to attach your own strap.</p> <p>12 Battery compartment (at the bottom)</p> <p>13 LINE IN (OPTICAL) jack</p> <p>14 HOLD switch<br/>To prevent the buttons from being accidentally operated when you carry the recorder, use this function.</p> <p>15  (headphones/earphones) jack</p> <p>16 DC IN 3V jack</p> |
|--|---|

14

#### The display window of the recorder

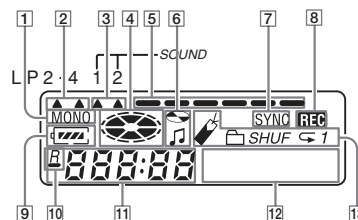

- |  |   |
|--|---|
| <p>1 MONO (monaural) indication</p> <p>2 LP mode indication</p> <p>3 Sound indications</p> <p>4 Disc indication<br/>Shows that the disc is rotating for recording or playing an MD.</p> <p>5 Level meter<br/>Shows the volume of the MD being played or recorded.</p> <p>6 Disc name/track name indication<br/>Lights up when labeling a disc or a track.</p> <p>7 SYNC (synchro-recording) indication</p> <p>8 REC indication<br/>Lights up while recording. When flashing, the recorder is in record standby mode.</p> | <p>9 Battery indication<br/>Shows approximate battery condition.</p> <p>10  : Indication for remaining playing time of the current track or of the disc<br/> : Indication for remaining recordable time of the disc</p> <p>11 Time display</p> <p>12 Character information display<br/>Displays the disc and track names, error messages, track numbers, etc.</p> <p>13 Play mode indications<br/>Shows the play mode (shuffle play, repeat play, group play, bookmark play, etc.) of the MD.</p> |
|--|---|

15

#### The headphones/earphones with a remote control

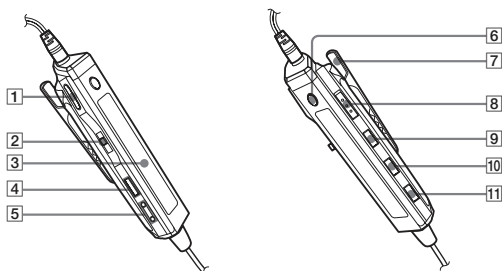

- |   |   |
|---|---|
| <p>1 VOL +, - buttons<br/>Press to adjust the volume.</p> <p>2 Jog lever (◀◀ • ►►/ENT • ►►, TUNE - • BAND • TUNE +)<br/>►►/ENT (to press): play, pause, enter<br/>◀◀ (to slide towards): REW<br/>►► (to slide towards): FF<br/>BAND (to press): select a band<br/>TUNE - (to slide towards): tune backward<br/>TUNE + (to slide towards): tune forward</p> <p>3 Display window</p> <p>4  (stop) button</p> <p>5  (group) +, - buttons</p> | <p>6 RADIO ON/OFF button<br/>Press to turn on or off the radio.</p> <p>7 Clip</p> <p>8 HOLD switch<br/>To prevent the buttons from being accidentally operated when you carry the recorder, use this function.</p> <p>9 DISPLAY button</p> <p>10 P-MODE/  button</p> <p>11 SOUND button</p> |
|---|---|

16

#### The display window of the remote control

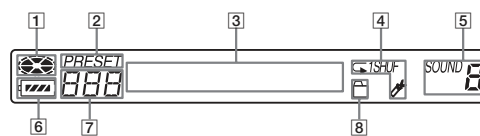

- |  |   |
|--|---|
| <p>1 Disc indication</p> <p>2 PRESET indication</p> <p>3 Character information display</p> <p>4 Play mode indication</p> <p>5 SOUND indication</p> | <p>6 Battery level indication</p> <p>7 Track number/Band/Presets number display</p> <p>8 Group indication</p> |
|--|---|

17

## SECTION 3 DISASSEMBLY

• This set can be disassembled in the order shown below.

### 3-1. Disassembly Flow

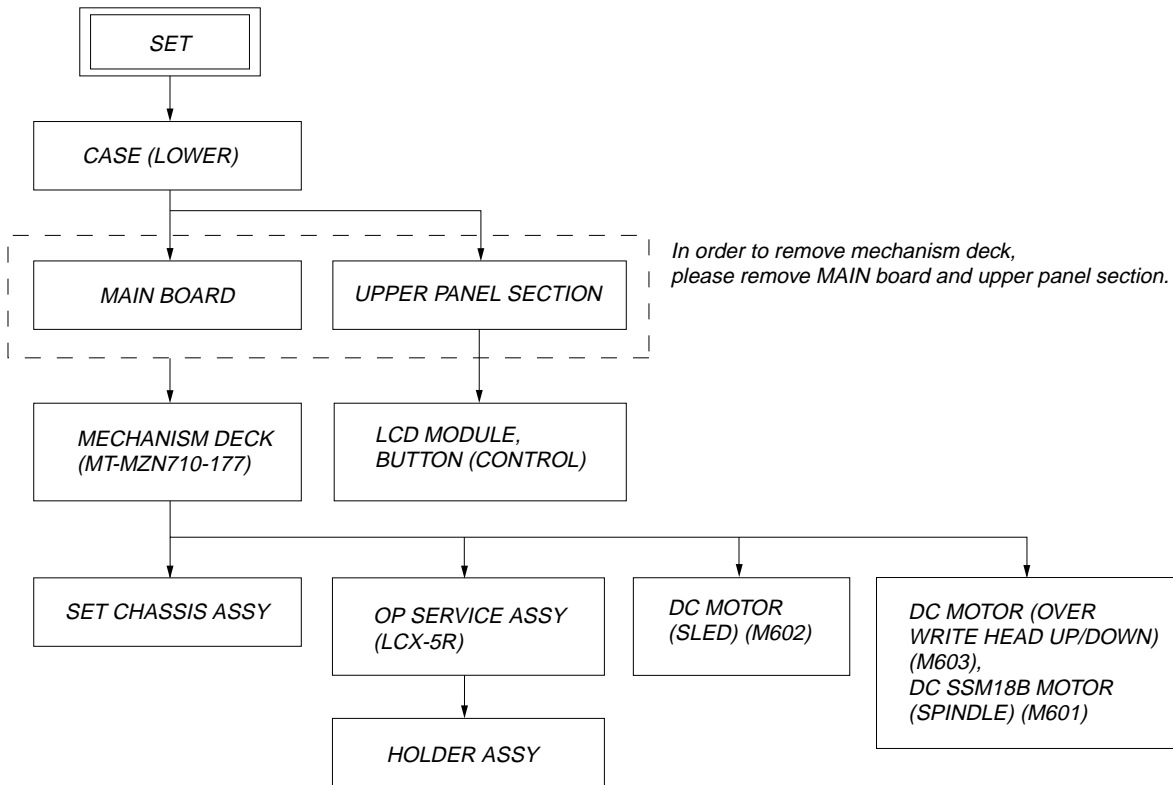

**Note:** Follow the disassembly procedure in the numerical order given.

**3-2. Case (Lower)**

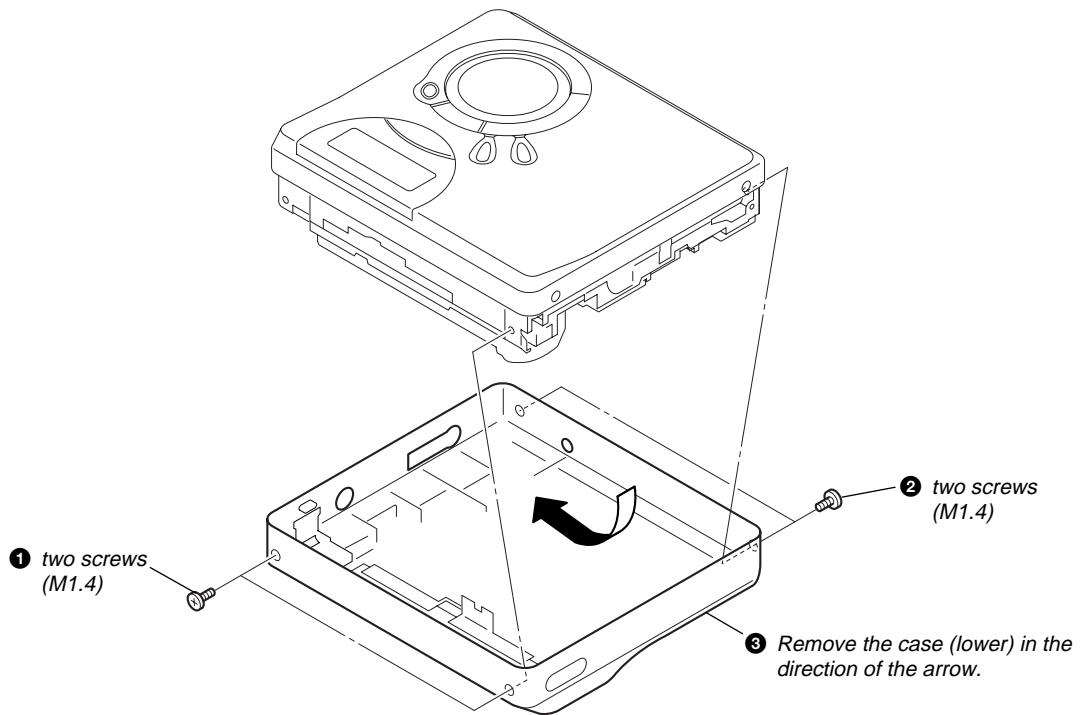

**3-3. Upper Panel Section**

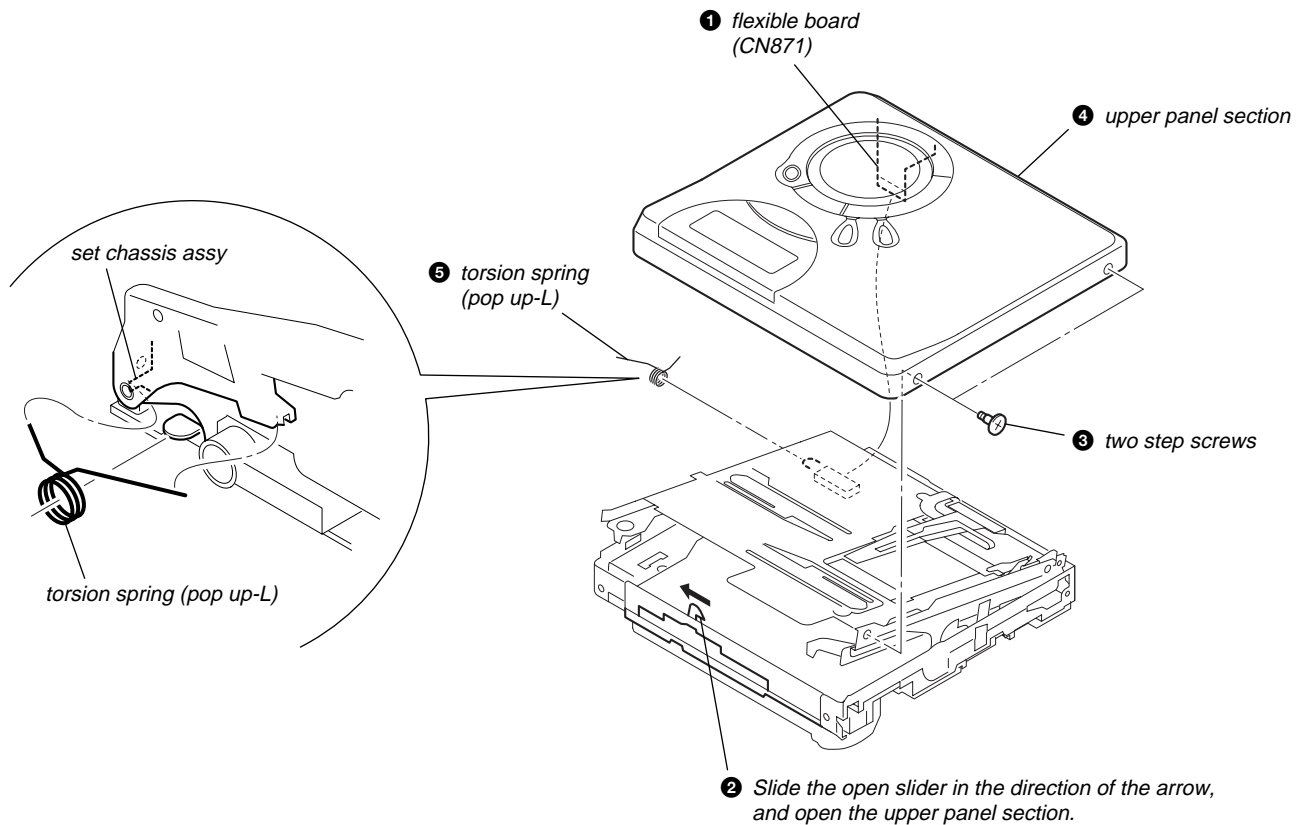

**3-4. LCD Module, Button (Control)**

*Note: On installation, adjust the position of both switch and knob (hold).*

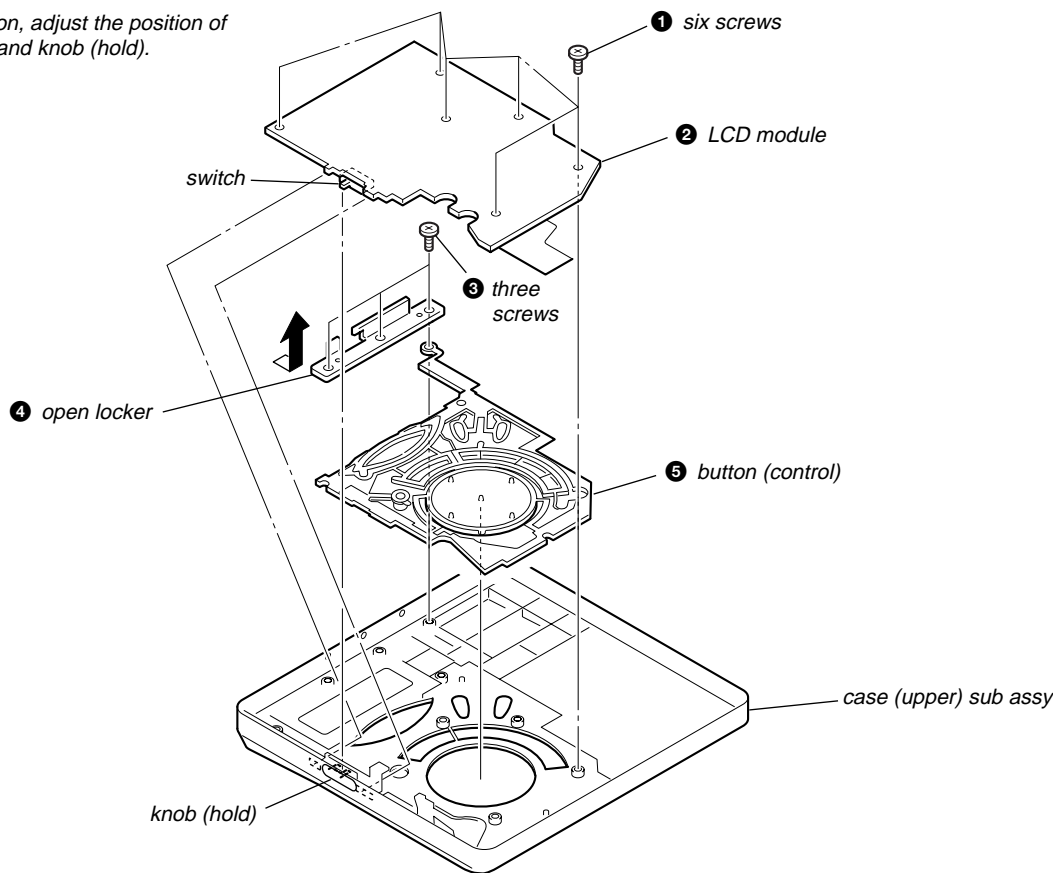

**3-5. MAIN Board**

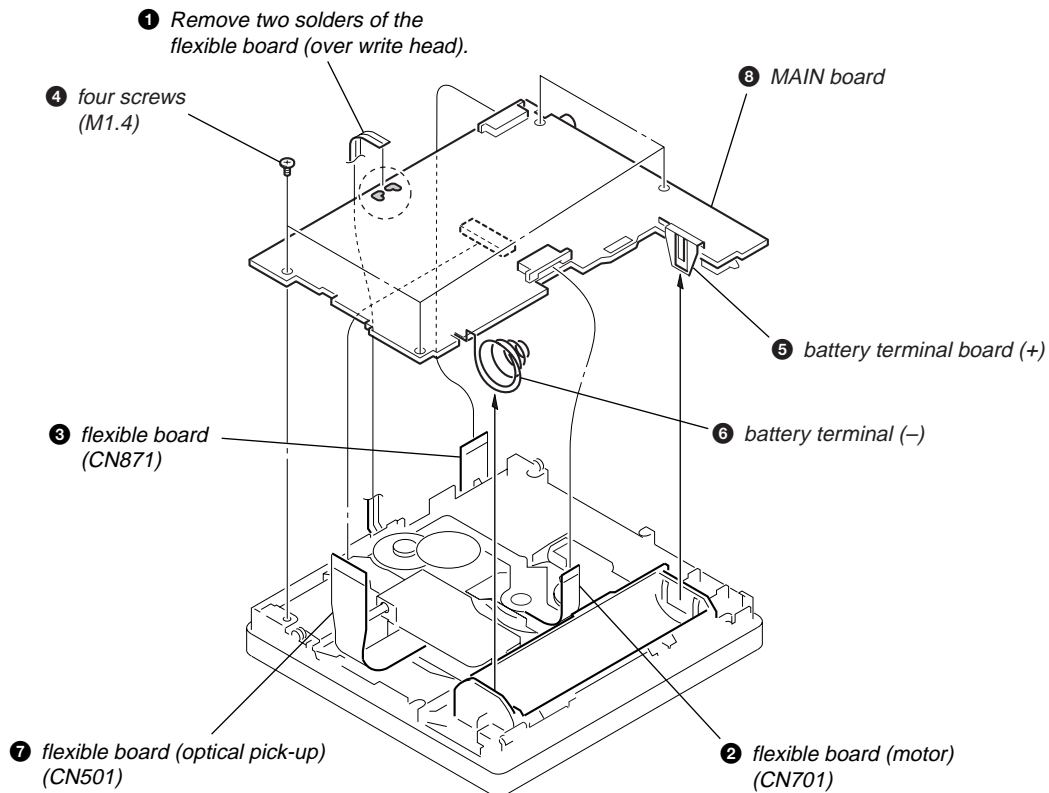



3-6. Mechanism Deck (MT-MZN710-177)

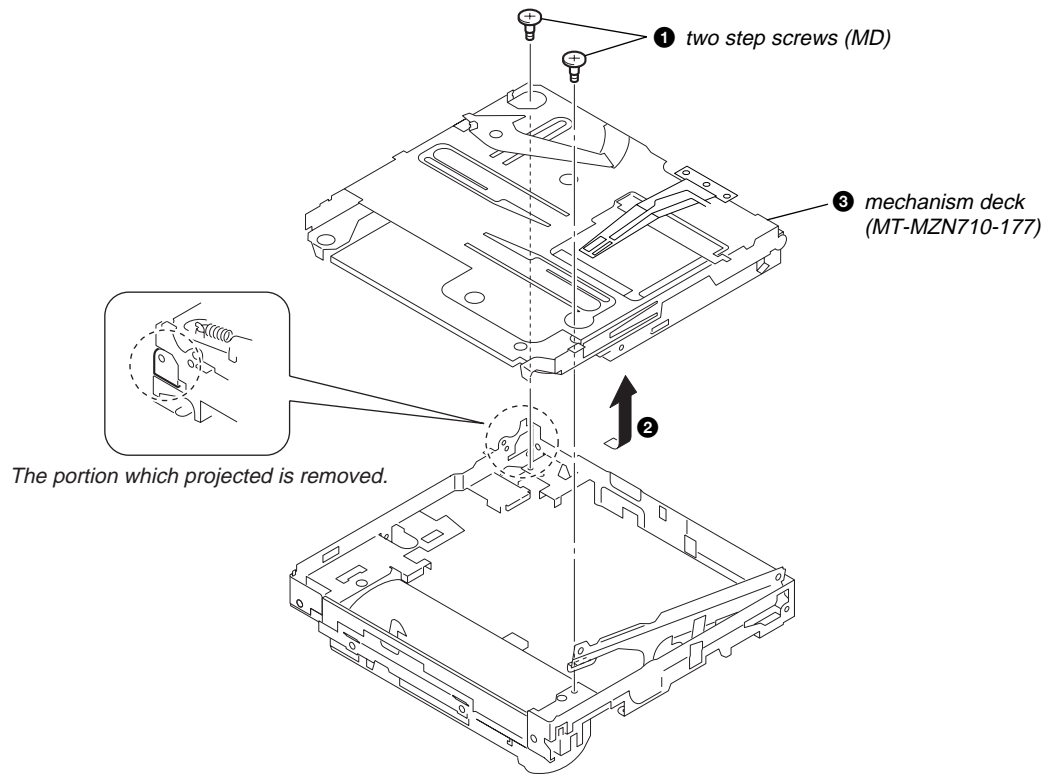

3-7. Set Chassis Assy

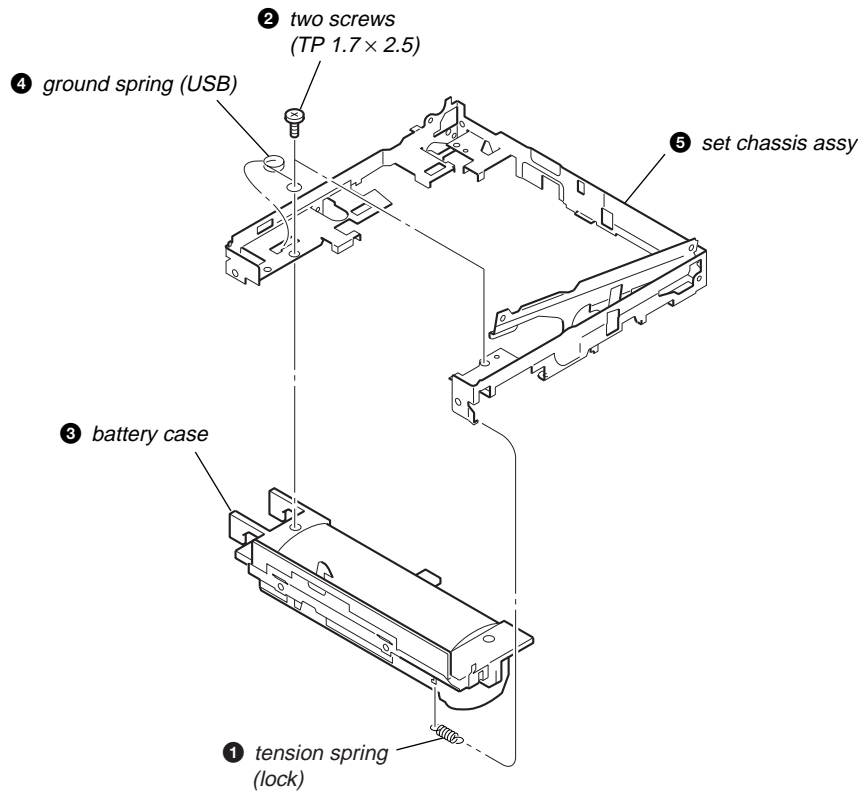

3-8. OP Service Assy (LCX-5R)

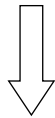
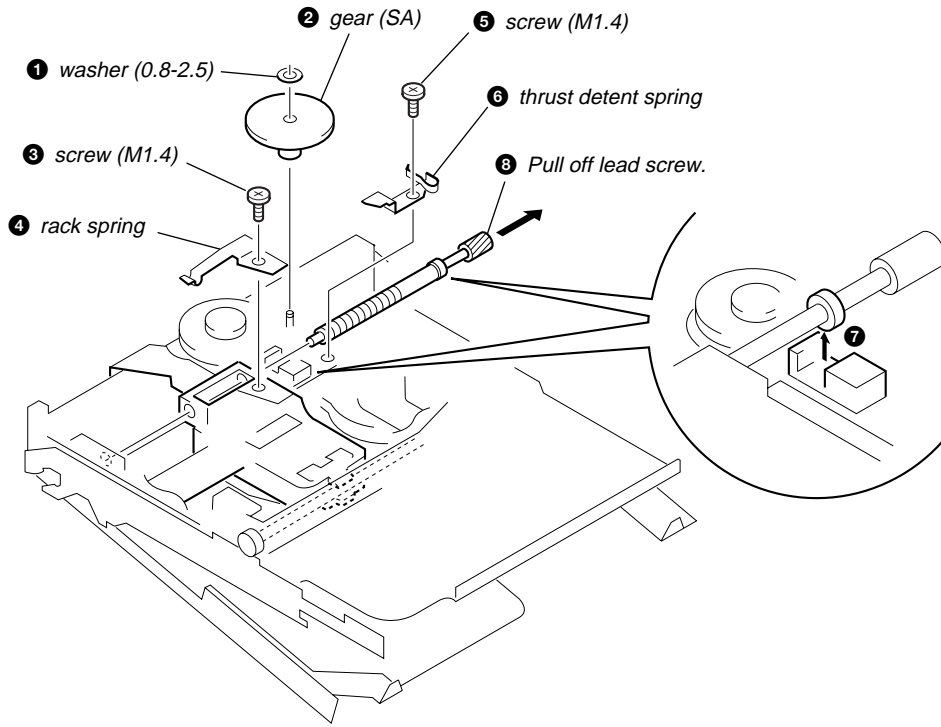

9 Opening the over write head toward the direction **A**, remove the OP service assy (LCX-5R) toward the direction **B**.

Note: Do not open the entire assy forcibly, when opening the over write head.

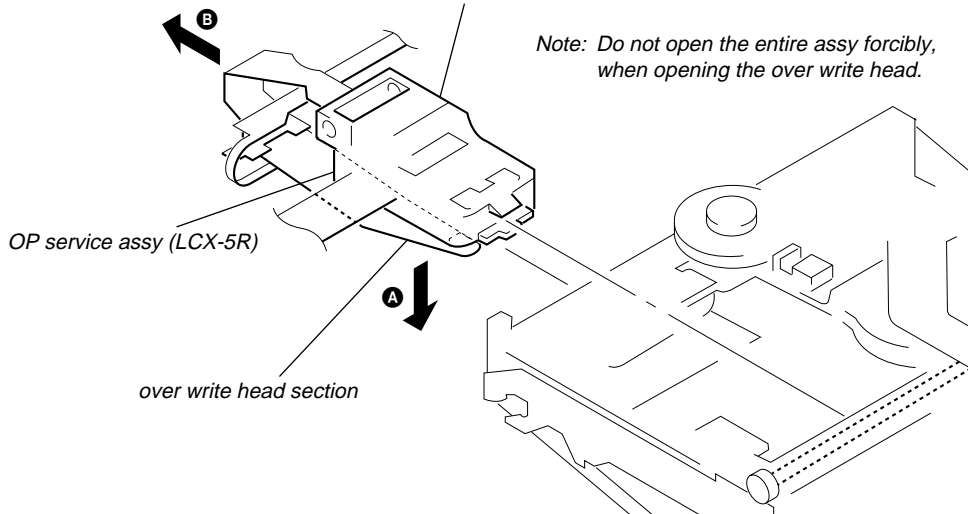

3-9. Holder Assy

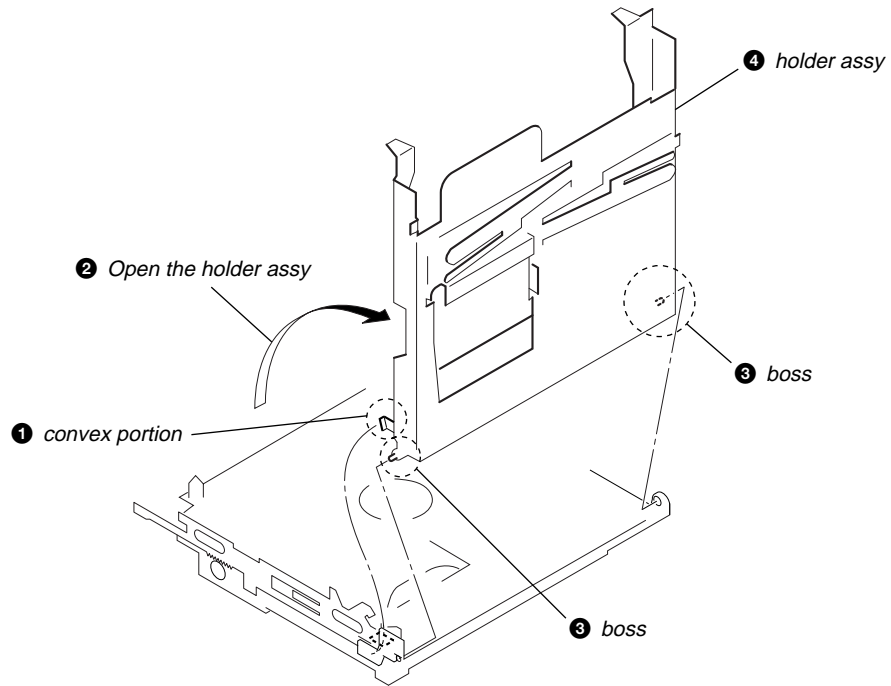

3-10. DC Motor (Sled) (M602)

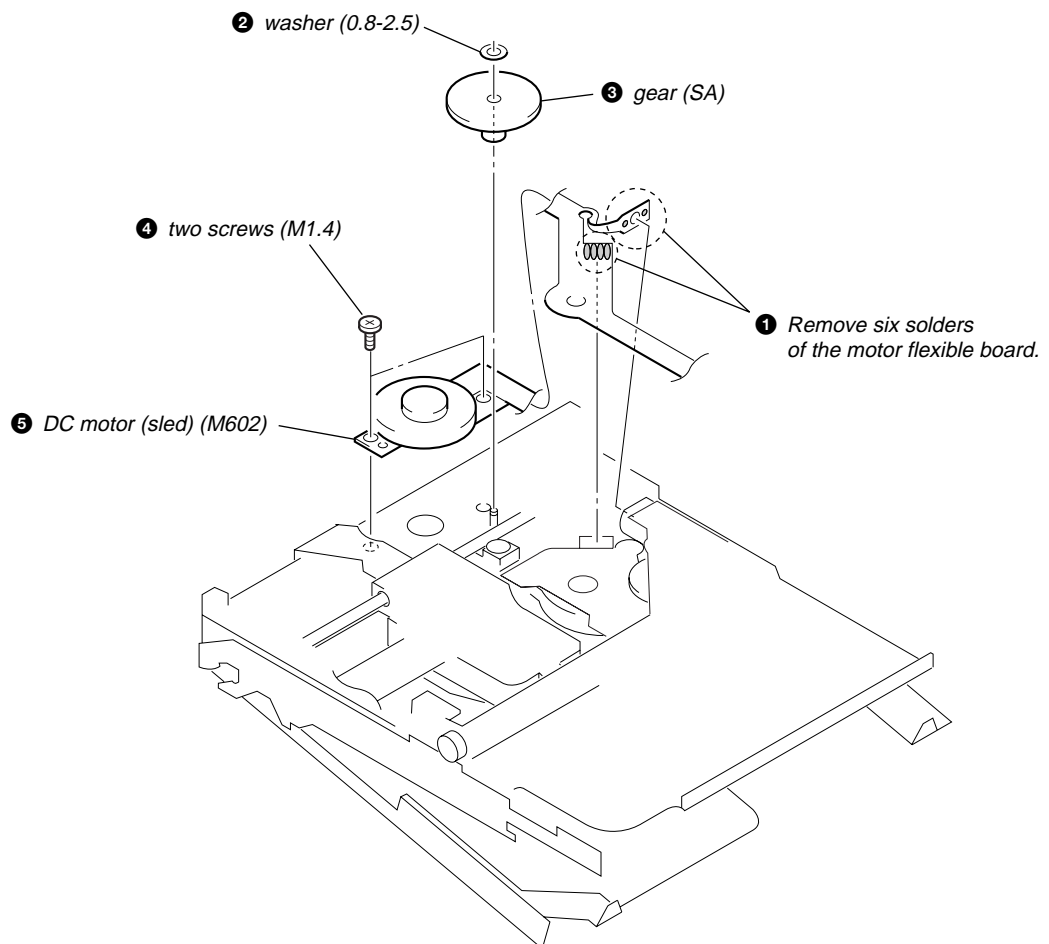

**3-11. DC Motor (Over Write Head Up/Down) (M603), DC SSM18B Motor (Spindle) (M601)**

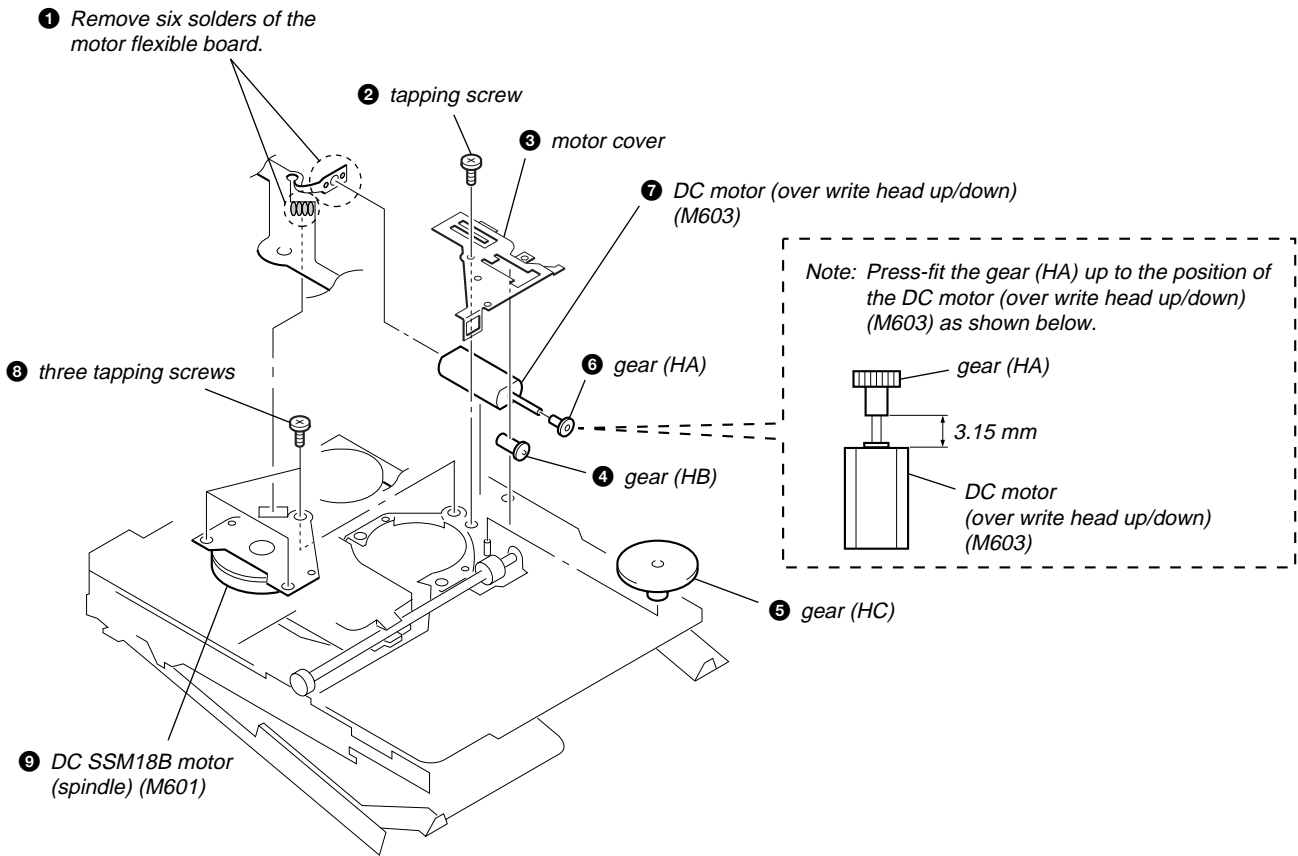

## SECTION 4 TEST MODE

### Outline

- This set provides the Overall adjustment mode that allows CD and MO discs to be automatically adjusted when in the test mode. In this overall adjustment mode, the disc is discriminated between CD and MO, and each adjustment is automatically executed in order. If a fault is found, the system displays its location. Also, the manual mode allows each individual adjustment to be automatically adjusted.
- Operation in the test mode is performed with the set. A key having no particular description in the text, indicates a set key.

### Setting Method of Test Mode

There are three different methods to set the test mode:

- ① Short SL803 (TEST) on the MAIN board with a solder bridge (connect pin ② of IC801 to the ground). Then, turn on the power.

#### – MAIN Board (Side B) –

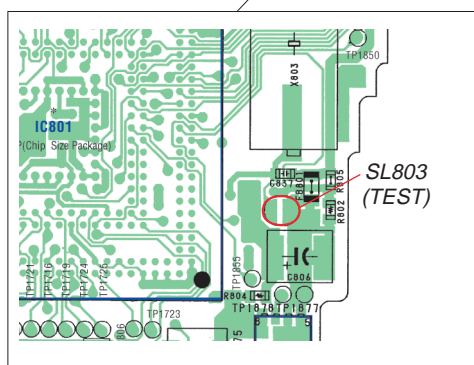
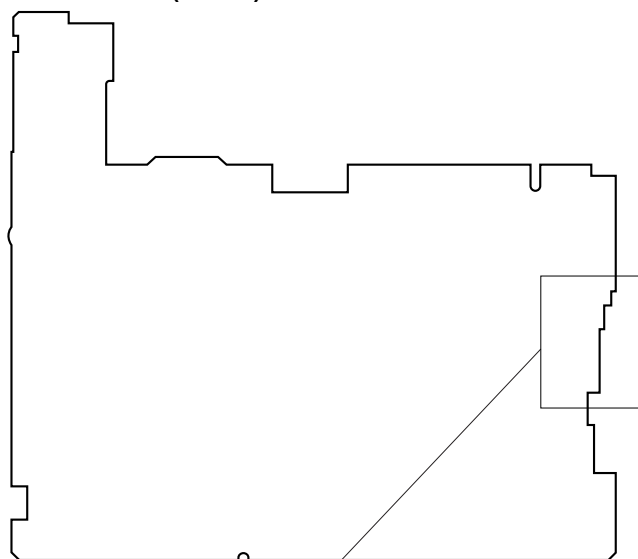

- ② In the normal mode, turn on the **[HOLD]** switch. While pressing the **[GROUP]** key press the following order:

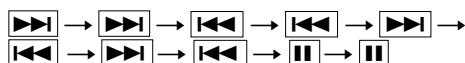

- ③ In the normal mode, turn on the **[HOLD]** switch on the set. While pressing the **[CANCEL/CHG]** key on the set, press the keys on the remote commander with the following order :

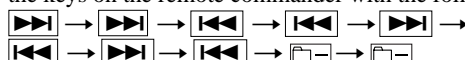

**Note:** If electrical adjustment (CD and MO overall adjustment) has not been finished completely, "ERROR" is displayed on LCD of the set.

### Operation in Setting the Test Mode

- When the test mode becomes active, first the display check mode is selected.
- Other mode can be selected from the display check mode.
- When the test mode is set, the LCD repeats the following display.

Set LCD display

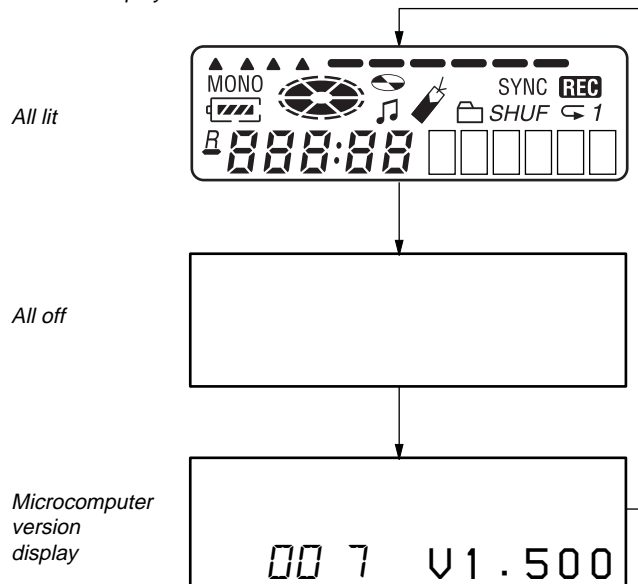

- When the **[HOLD]** key is pressed and hold down, the display at that time is held so that display can be checked.

### Releasing the Test Mode

For test mode set with the method ①:

Turn off the power and open the solder bridge on SL803 (TEST) on the MAIN board.

**Note:** Remove the solders completely. Remaining could be shorted with the chassis, etc.

For test mode set with the method ② or ③:

Turn off the power.

**Configuration of Test Mode**

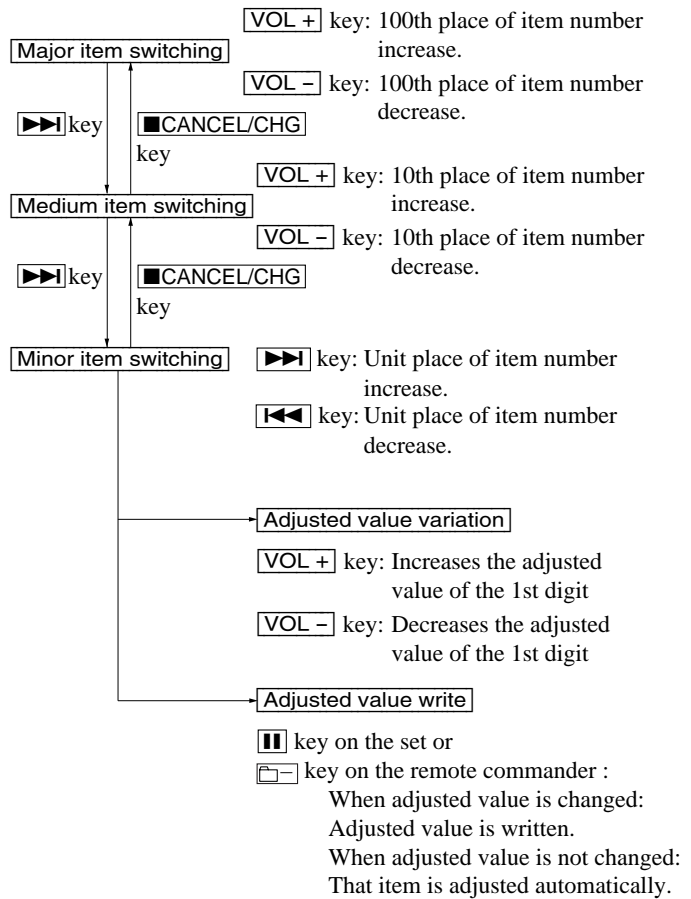
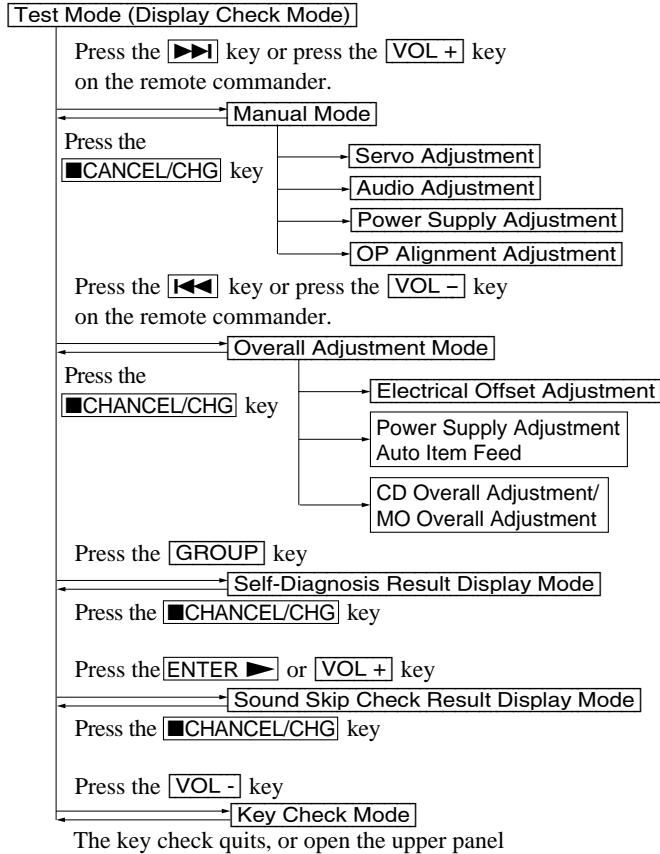

**Manual Mode**

Mode to adjust or check the operation of the set by function. Normally, the adjustment in this mode is not executed. However, the Manual mode is used to clear the memory, power supply adjustment, and laser power check before performing automatic adjustments in the Overall Adjustment mode.

**• Transition Method in Manual Mode**

1. Set the test mode (see page 13).
2. Press the **▶▶▶** or press the **VOL +** key on the remote commander activates the manual mode where the LCD display as shown below.

Set LCD display

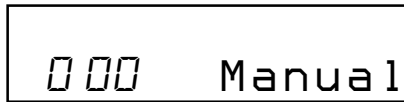

3. During each test, the optical pick-up moves outward or inward while the **▶▶▶** or **◀◀◀** key is pressed for several seconds respectively.
4. Each test item is assigned with a 3-digit item number; 100th place is a major item, 10th place is a medium item, and unit place is a minor item. The values adjusted in the test mode are written to the nonvolatile memory (for the items where adjustment was made).

5. The display changes as shown below each time the **END** **SEARCH** key is pressed.

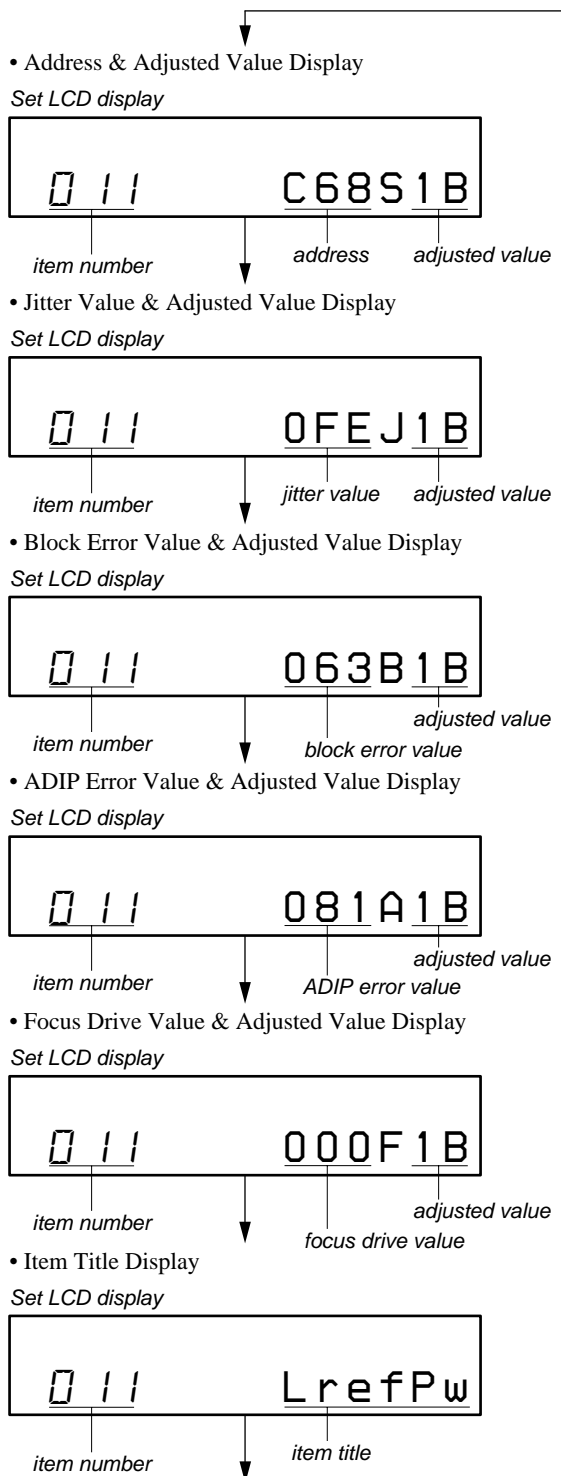

However in the power mode (item number 700's), only the item is displayed.

6. Quit the manual mode, and press the **CANCEL/CHG** key to return to the test mode (display check mode).

### Overall Adjustment Mode

Mode to adjust the servo automatically in all items. Normally, automatic adjustment is executed in this mode at the repair.

For further information, refer to "SECTION 5 ELECTRICAL ADJUSTMENTS" (see page 19).

### Self-Diagnosis Result Display Mode

This set uses the self-diagnostic function system in which if an error occurred during the recording or playing, the mechanism control block and the power supply control block in the microcomputer detect it and record its cause as history in the nonvolatile memory.

By checking this history in the test mode, you can analyze a fault and determine its location.

Total recording time is recorded as a guideline of how long the optical pick-up has been used, and by comparing it with the total recording time at the time when an error occurred in the self-diagnosis result display mode, you can determine when the error occurred.

Clear both self-diagnosis history data and total recording time, if the optical pick-up was replaced.

#### Self-Diagnosis Result Display Mode Setting Method

1. Set the test mode (see page 13).
2. In the display check mode, press the **GROUP** key activates the self-diagnosis result display mode where the LCD display as shown below.

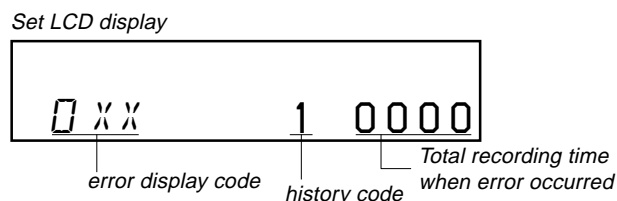

3. Then, each time the **▶▶** key is pressed, LCD display descends by one as shown below. Also, the LCD display ascends by one when the **◀◀** key is pressed.

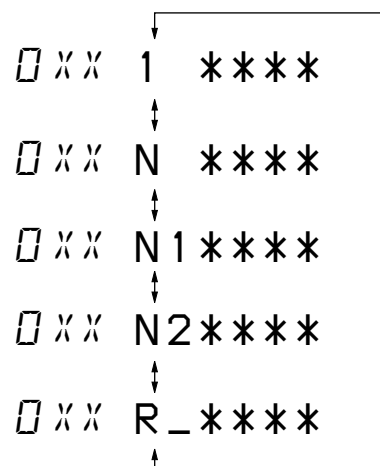

XX : Error code  
\*\*\*\* : Total recording time

If the **GROUP** key is pressed with this display, the LCD switches to the simple display mode.

4. Quit the self-diagnosis result display mode, and press the **CANCEL/CHG** key to return to the test mode (display check mode).

## • Description of Error Indication Codes

Problem	Indication code	Meaning of code	Simple display	Description
No error	00	No error	---	No error
Servo system error	01	Illegal access target address was specified	Adrs	Attempt to access an abnormal address
	02	High temperature	Temp	High temperature detected
	03	Focus error	Fcus	Disordered focus or can not read an address
	04	Spindle error	Spdl	Abnormal rotation of disc
TOC error	11	TOC error	TOC	Faulty TOC contents
	12	Data reading error	Data	data could not be read at SYNC
	13	TOC address error	Tadr	TOC address data error
Power supply system error	22	Low battery	LBat	Momentary interruption detected
Offset system error	31	Offset error	Ofst	Offset error
	32	Focus error ABCD offset error	ABCD	Focus error ABCD offset error
	33	Tracking error Offset error	TE	Tracking error Offset error
	34	X1 tracking error Offset error	X1TE	X1 tracking error Offset error
	35	MD DATA 2 disc error	MD2	MD DATA 2 disc error
	36	Mirror error	Mirr	Mirror retry over

## • Description of Indication History

History code number	Description
1	The first error
N	The last error
N1	One error before the last.
N2	Two errors before the last.
R_	Total recording time

## Reset the Error Display Code

After servicing, reset the error display code.

### • Setting Method of Reset the Error Display Code

1. Set the test mode (see page 13).
2. Press the **[GROUP]** key activates the self-diagnosis result display mode.
3. To reset the error display code, press the **[II]** key (twice) when the code is displayed (except "R\_\*\*\*").  
(All the data on the 1, N, N1, and N2 will be reset)



### Sound Skip Check Result Display Mode

This set can display the count of errors that occurred during the recording/playing for checking.

#### • Setting Method of Sound Skip Check Result Display Mode

1. Set the test mode (see page 13).
2. Press the **[ENTER▶]** key or **[VOL+]** key, and the playing or recording sound skip result display mode becomes active respectively where the LCD displays the following.

Set LCD display

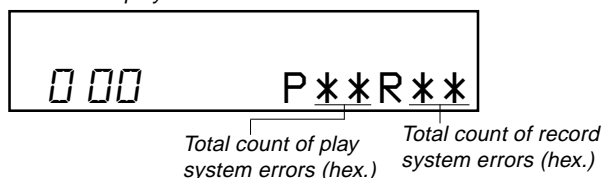

3. When the **[ENTER▶]** key is pressed, total error count is displayed on the LCD, and each time the **[▶▶]** key is pressed, the display item moves down by one as shown below. Also, if the **[◀◀]** key is pressed, the display item moves up by one, then if the **[VOL+]** key is pressed, the display in the record mode appears. When the **[VOL+]** key is pressed, total error count is displayed on the LCD, and each time the **[▶▶]** key is pressed, the display item moves down by one as shown below. Also, if the **[◀◀]** key is pressed, the display item moves up by one, then if the **[ENTER▶]** key is pressed, the display in the play mode appears.

Playing sound skip result display



Recording sound skip result display



P\*\*R\*\* : Total play/record errors (hex.)  
 \*\* : Counter of sound skip check each item (hex.)  
 ##### : 6-digit address where sound was skipped last (hex.)

#### • Cause of Sound Skip Error

	Cause of error	Description of error
Play	EIB	Sound error correction error
	Stat	Decoder status error
	Adrs	Address access error
	BEmp	Buffer is empty
Record	BOvr	Buffer is full, and sounds were dumped
	Bful	Buffer capacity becomes less, and forcible writing occurred
	Rtry	Retry times over

4. To quit the sound skip check result display mode and to return to the test mode (display check mode), press the **[CANCEL/CHG]** key.

#### • Setting Method of Key Check Mode

1. Set the test mode (see page 13).
2. Press the **[VOL-]** key activates the key check mode.

Set LCD display

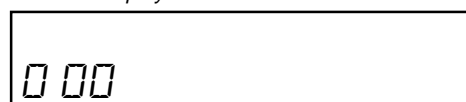

3. When each key on the set and on remote commander is pressed, its name is displayed on the set LCD. (Operated position is displayed for 4 seconds after the slide switch is operated.)

Example1: When the **[▶▶]** key on the set is pressed:

Set LCD display



Example2: When the **[▶||/ENT]** key on the remote commander is pressed:

Set LCD display

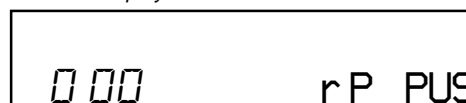

4. When all the keys on the set and on the remote commander are considered as OK, the following displays are shown.

Example1: When the keys on the set are considered as OK:

*Set LCD display*

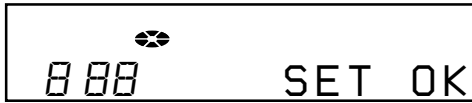

Example2: When the keys on the remote commander are considered as OK:

*Set LCD display*



5. When all keys were checked or if the upper panel is opened, the key check mode quits and the test mode (display check mode) comes back.

## SECTION 5 ELECTRICAL ADJUSTMENTS

### Outline

- In this set, automatic adjustment of CD and MO can be performed by entering the test mode. However, before starting automatic adjustment, the memory clear, power supply adjustment, and laser power check must be performed in the manual mode.
- A key having no particular description in the text, indicates a set key.

### Precautions for Adjustment

- Adjustment must be done in the test mode only. After adjusting, release the test mode.
- Use the following tools and measuring instruments.
  - Test CD disc TDYS-1 (Part No. : 4-963-646-01)
  - SONY MO disc available on the market
  - Digital voltmeter
  - Laser power meter LPM-8001 (Part No. : J-2501-046-A)
  - Thermometer (using the Temperature Correction)
  - Personal computer
  - USB cable
- Unless specified otherwise, supply DC 3V from the DC IN 3V jack (J951).
- Switch position  
HOLD switch ..... ON

### Adjustment Sequence

- NV Reset (item number: 021)  
(EEPROM clear)
  - Temperature Correction (item number: 015)
  - Power Supply Manual Adjustment
  - Laser Power Check
  - CD Overall Adjustment (item number: 031)
  - MO Overall Adjustment (item number: 034)
  - RESUME Clear (item number 043)
  - Rewriting the Patch Data  
(at replacement of the MAIN board)
  - Rewriting the NV values
- } Manual Mode  
} Overall Mode  
} Manual Mode

### NV Reset

#### • Setting Method of NV Reset

- Select the manual mode of the test mode, and set item number 021 NV Reset (see page 14).

Set LCD display

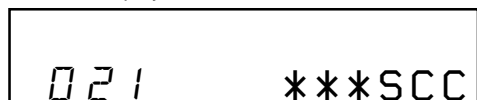

- Press the **[F]** key.

Set LCD display

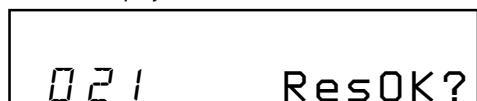

- Press the **[F]** key once more.

Set LCD display

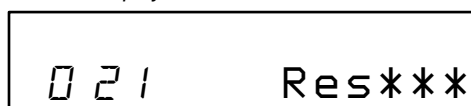

NV reset (after several seconds)

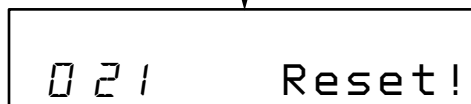

- Press the **[CANCEL/CHG]** key to quit the manual mode, and return to the test mode (display check mode).

### Temperature Correction

#### • Adjustment Method of Temperature Correction

- Select the manual mode of the test mode, and set the item number 015 (see page 14).

Set LCD display

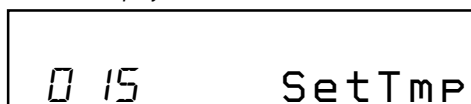

- Measure the ambient temperature.
- Adjust with **[VOL+]** or **[VOL-]** key so that the adjusted value (hexadecimal value) becomes the ambient temperature. (Initial value : 19h = 25°C, Adjusting range : 80h to 7fh (-128°C to +127°C))
- Press the **[F]** key or press the **[F]** key on the remote commander to write the adjusted value.

### Power Supply Manual Adjustment

#### • Adjustment sequence

- Adjustment must be done with the following steps.
- VC1\_LOW (PB) adjustment (item number : 741)
  - VC1\_HIGH (REC) adjustment (item number : 742)
  - VC2\_LOW adjustment (item number : 743)
  - VC2\_HIGH adjustment (item number : 744)
  - REG1 adjustment (item number : 745)
  - REG3\_LOW1 adjustment (item number : 747)
  - REG3\_LOW2 adjustment (item number : 748)
  - REG3\_HIGH adjustment (item number : 749)
  - VREC\_LOW (X2 speed) adjustment (item number : 751)
  - VREC\_MIDDLE (X4 speed) adjustment (item number : 752)
  - VREC\_HIGH (HEAD MOTOR) adjustment (item number : 753)
  - CHGV\_LOW adjustment (item number : 755)
  - CHGV\_HIGH adjustment (item number : 756)
  - CHGI\_LOW (current) adjustment (item number : 757)
  - CHGI\_HIGH (current) adjustment (item number : 758)

#### • Setting Method of Power Supply Manual Adjustment

- Make sure that the power supply voltage is 3V.
- Select the manual mode of the test mode (see page 14).
- Set item number.

**Note1:** BATT- terminal is not GND when AC adaptor is used.

**Note2:** Power supply adjustment auto item feed mode (page 25) is available to perform the temperature Correction and Power Supply Adjustment without entering the manual mode.

• **Adjustment Method of VC1\_LOW (PB)**  
(item number: 741)

Set LCD display



\*\* : Adjusted value

1. Connect a digital voltmeter to the TP1928 (VCO1) on the MAIN board, and adjust **[VOL+]** key (voltage up) or **[VOL-]** key (voltage down) so that the voltage becomes  $2.35 \pm 0.05V$ .

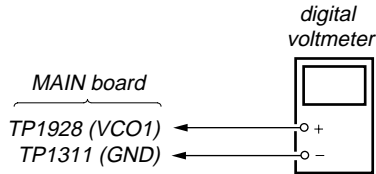

2. Press the **[M]** key on the set or the **[M]** key on the remote commander to write the adjusted value.

**Adjustment and Connection Location:** MAIN board  
(see page 24)

• **Adjustment Method of VC2\_LOW**  
(item number: 743)

Set LCD display



\*\* : Adjusted value

1. Connect a digital voltmeter to the TP1905 (VCOUT) on the MAIN board, and adjust **[VOL+]** key (voltage up) or **[VOL-]** key (voltage down) so that the voltage becomes  $2.30 \pm 0.01V$ .

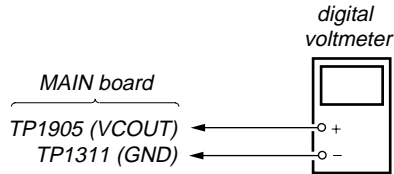

2. Press the **[M]** key on the set or the **[M]** key on the remote commander to write the adjusted value.

**Adjustment and Connection Location:** MAIN board  
(see page 24)

• **Adjustment Method of VC1\_HIGH (REC)**  
(item number: 742)

Set LCD display



\*\* : Adjusted value

1. Connect a digital voltmeter to the TP1928 (VCO1) on the MAIN board, and adjust **[VOL+]** key (voltage up) or **[VOL-]** key (voltage down) so that the voltage becomes  $2.50 \pm 0.05V$ .

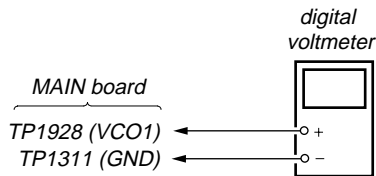

2. Press the **[M]** key on the set or the **[M]** key on the remote commander to write the adjusted value.

**Adjustment and Connection Location:** MAIN board  
(see page 24)

• **Adjustment Method of VC2\_HIGH**  
(item number: 744)

Set LCD display



\*\* : Adjusted value

1. Connect a digital voltmeter to the TP1905 (VCOUT) on the MAIN board, and adjust **[VOL+]** key (voltage up) or **[VOL-]** key (voltage down) so that the voltage becomes  $2.55 \pm 0.01V$ .

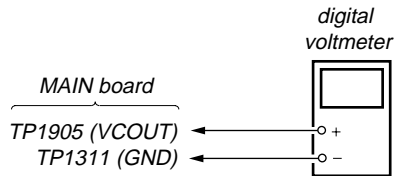

2. Press the **[M]** key on the set or the **[M]** key on the remote commander to write the adjusted value.

**Adjustment and Connection Location:** MAIN board  
(see page 24)

• **Adjustment Method of REG1**  
(item number: 745)

Set LCD display

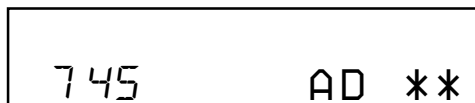

\*\* : Adjusted value

1. Connect a digital voltmeter to the TP1909 (REGO1) on the MAIN board, and adjust [VOL+] key (voltage up) or [VOL-] key (voltage down) so that the voltage becomes  $2.05 \pm 0.01V$ .

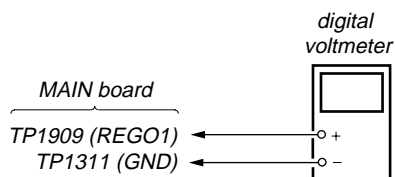

2. Press the [M] key on the set or the [M] key on the remote commander to write the adjusted value.

**Adjustment and Connection Location:** MAIN board  
(see page 24)

• **Adjustment Method of REG3\_LOW2**  
(item number: 748)

Set LCD display

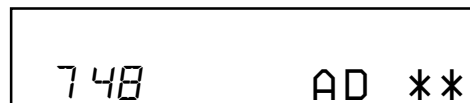

\*\* : Adjusted value

1. Connect a digital voltmeter to the TP1907 (REGO3) on the MAIN board, and adjust [VOL+] key (voltage up) or [VOL-] key (voltage down) so that the voltage becomes  $1.25 \pm 0.01V$ .

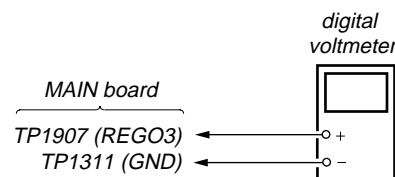

2. Press the [M] key on the set or the [M] key on the remote commander to write the adjusted value.

**Adjustment and Connection Location:** MAIN board  
(see page 24)

• **Adjustment Method of REG3\_LOW1**  
(item number: 747)

Set LCD display

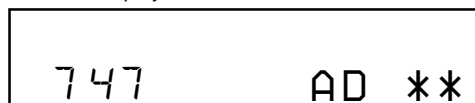

\*\* : Adjusted value

1. Connect a digital voltmeter to the TP1907 (REGO3) on the MAIN board, and adjust [VOL+] key (voltage up) or [VOL-] key (voltage down) so that the voltage becomes  $1.25 \pm 0.01V$ .

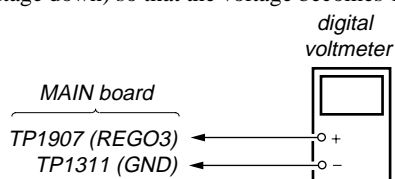

2. Press the [M] key on the set or the [M] key on the remote commander to write the adjusted value.

**Adjustment and Connection Location:** MAIN board  
(see page 24)

• **Adjustment Method of REG3\_HIGH**  
(item number: 749)

Set LCD display

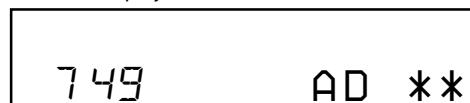

\*\* : Adjusted value

1. Connect a digital voltmeter to the TP1907 (REGO3) on the MAIN board, and adjust [VOL+] key (voltage up) or [VOL-] key (voltage down) so that the voltage becomes  $1.25 \pm 0.01V$ .

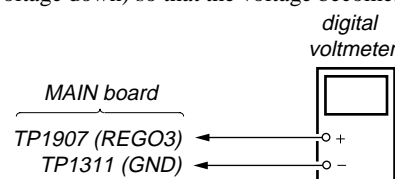

2. Press the [M] key on the set or the [M] key on the remote commander to write the adjusted value.

**Adjustment and Connection Location:** MAIN board  
(see page 24)

- **Adjustment Method of VREC\_LOW (X2 speed)**  
(item number: 751)

Set LCD display



\*\* : Adjusted value

1. Connect a digital voltmeter to the TP1620 (VREC) on the MAIN board, and adjust **[VOL +]** key (voltage up) or **[VOL -]** key (voltage down) so that the voltage becomes  $1.20 \pm 0.02V$ .

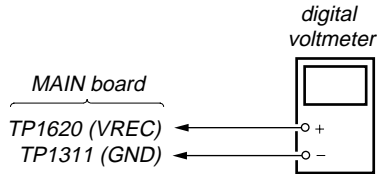

2. Press the **[M]** key on the set or the **[M]** key on the remote commander to write the adjusted value.

**Adjustment and Connection Location:** MAIN board  
(see page 24)

- **Adjustment Method of VREC\_MIDDLE (X4 speed)**  
(item number: 752)

Set LCD display



\*\* : Adjusted value

1. Connect a digital voltmeter to the TP1620 (VREC) on the MAIN board, and adjust **[VOL +]** key (voltage up) or **[VOL -]** key (voltage down) so that the voltage becomes  $1.20 \pm 0.02V$ .

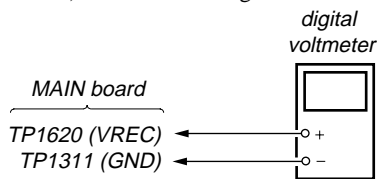

2. Press the **[M]** key on the set or the **[M]** key on the remote commander to write the adjusted value.

**Adjustment and Connection Location:** MAIN board  
(see page 24)

- **Adjustment Method of VREC\_HIGH (HEAD MOTOR)**  
(item number: 753)

Set LCD display



\*\* : Adjusted value

1. Connect a digital voltmeter to the TP1620 (VREC) on the MAIN board, and adjust **[VOL +]** key (voltage up) or **[VOL -]** key (voltage down) so that the voltage becomes between 1.65V and 1.75V.

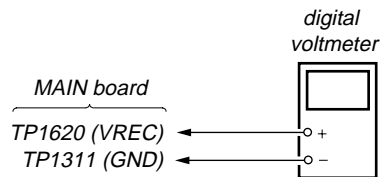

2. Press the **[M]** key on the set or the **[M]** key on the remote commander to write the adjusted value.

**Adjustment and Connection Location:** MAIN board  
(see page 24)

- **Adjustment Method of CHGV\_LOW**  
(item number: 755)

Set LCD display



\*\* : Adjusted value

**Note:** Remove the rechargeable battery.

1. Connect a digital voltmeter to the BATT+ and BATT- on the MAIN board, and adjust **[VOL +]** key (voltage up) or **[VOL -]** key (voltage down) so that the voltage becomes  $1.35 \pm 0.01V$ .

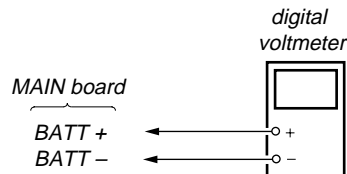

2. Press the **[M]** key on the set or the **[M]** key on the remote commander to write the adjusted value.

**Adjustment and Connection Location:** MAIN board  
(see page 24)

• **Adjustment Method of CHGV\_HIGH**  
(item number: 756)

Set LCD display

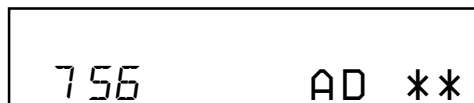

\*\* : Adjusted value

**Note:** Remove the rechargeable battery.

1. Connect a digital voltmeter to the BATT + and BATT – on the MAIN board, and adjust [VOL+] key (voltage up) or [VOL-] key (voltage down) so that the voltage becomes  $1.80 \pm 0.015V$ .

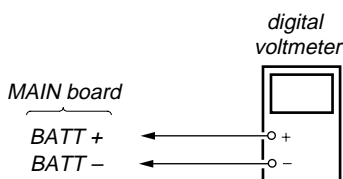

2. Press the [F1] key on the set or the [F1] key on the remote commander to write the adjusted value.

**Adjustment and Connection Location:** MAIN board  
(see page 24)

• **Adjustment Method of CHGI\_LOW (Charge current)**  
(item number: 757)

Set LCD display

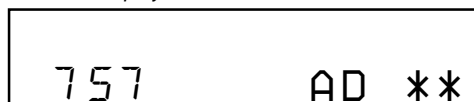

\*\* : Adjusted value

**Note:** Remove the rechargeable battery.

Connect the resistor (47 ) (0.5%) between terminals of BATT + and BATT –.

1. Connect a digital voltmeter to the BATT + and BATT – on the MAIN board, and adjust [VOL+] key (voltage up) or [VOL-] key (voltage down) so that the voltage becomes  $1.41 \pm 0.015V$ .

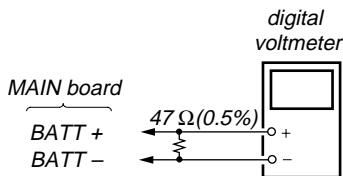

2. Press the [F1] key on the set or the [F1] key on the remote commander to write the adjusted value.

**Adjustment and Connection Location:** MAIN board  
(see page 24)

• **Adjustment Method of CHGI\_HIGH (Charge current)**  
(item number: 758)

Set LCD display

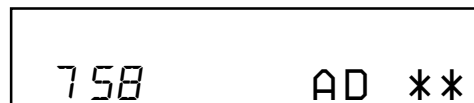

\*\* : Adjusted value

**Note:** Remove the rechargeable battery.

Connect the resistor (10 ) (0.5%) between terminals of BATT + and BATT –.

1. Connect a digital voltmeter to the BATT + and BATT – on the MAIN board, and adjust [VOL+] key (voltage up) or [VOL-] key (voltage down) so that the voltage becomes  $1.40 \pm 0.015V$ .

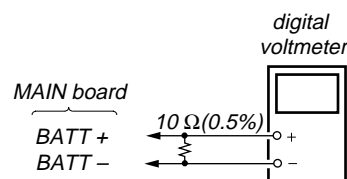

2. Press the [F1] key on the set or the [F1] key on the remote commander to write the adjusted value.

**Adjustment and Connection Location:** MAIN board  
(see page 24)

Adjustment/checking and Connection Location:

[MAIN BOARD] (SIDE B)

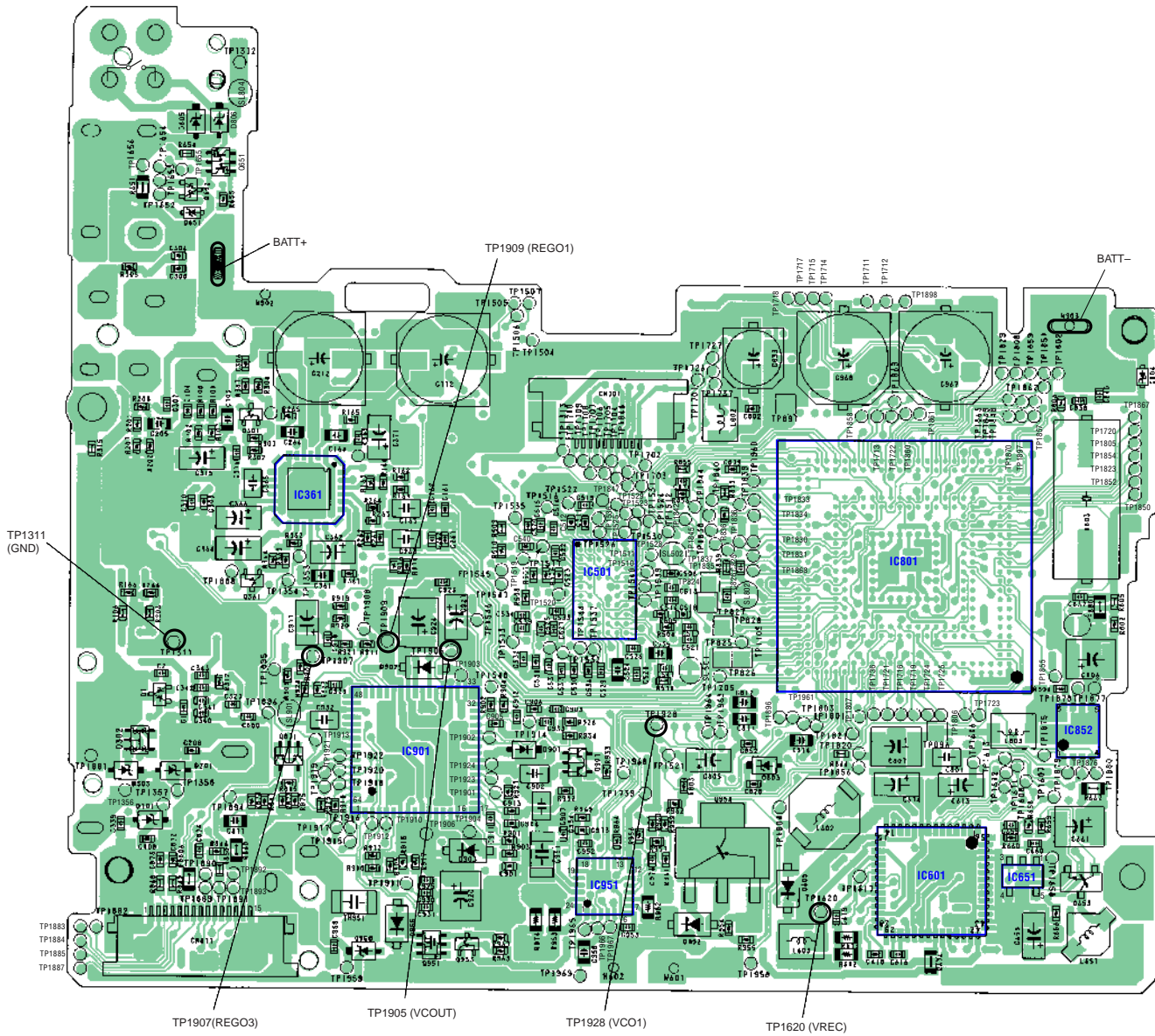



**Power Supply Adjustment Auto Item Feed**

**Note:** This mode is available to perform the temperature correction and power supply adjustment without entering the manual mode.

- Setting method of power supply adjustment auto item feed mode.
  - Set the test mode (see page 13)
  - Press the **◀◀** key or press the **[VOL-]** key on the remote commander to activate the overall adjustment mode.

Set LCD display



- Press the **[END SEARCH]** key to set the temperature correction mode.

Set LCD display

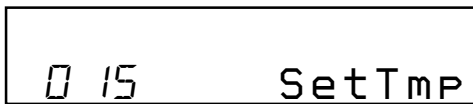

- To change the initial value (not displayed) adjust with the **[VOL+]** or **[VOL-]** key. Press the **||** key to write the adjusted value, and the item number increases automatically. When not writing the adjusted value, press the **▶▶** key to move to the next item.

Set LCD display

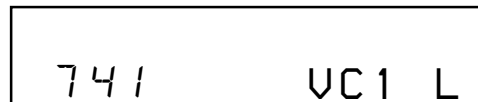

- Connect a digital voltmeter to the measuring points on the MAIN board, and adjust the voltage with the **[VOL+]** or **[VOL-]** key. (see page 19 to 23) Press the **||** key to write the adjusted value, and the item number increases automatically.
- When not writing the adjusted value, press the **▶▶** key to move to the next item. The **◀◀** key is available to back to the last item.
- The following message is displayed after all power supply adjustments finish.

Set LCD display

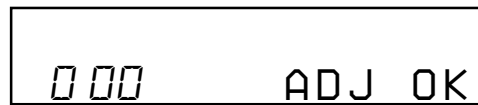

- Press the **[CANCEL/CHG]** key to return the test mode (display check mode).

**Configuration of power supply adjustment auto item feed**

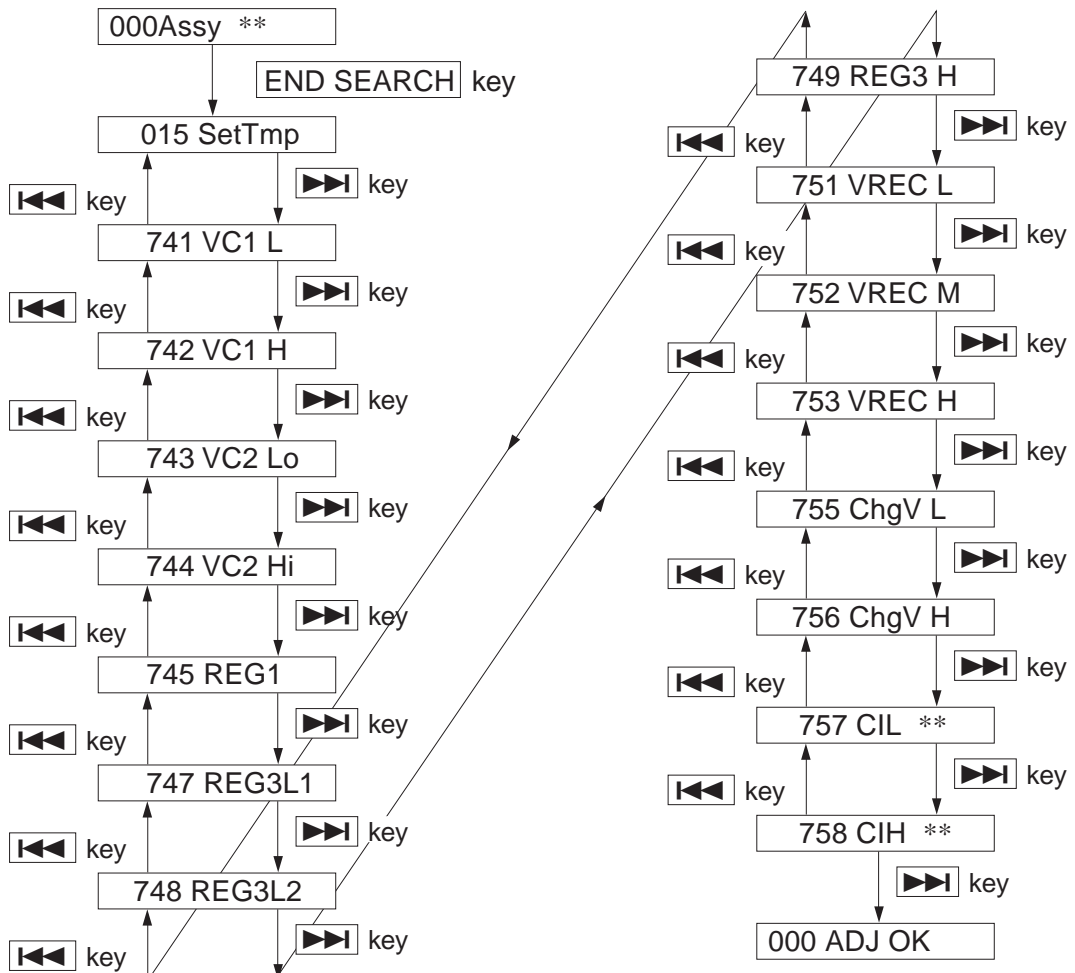

**Laser Power Check**

**Note:** If result of measurement of the laser power does not satisfy the specification, either replace the OP (optical pick-up unit) or check whether the laser circuit block is working correctly.

When the result of laser power measurement does not satisfy the specification even though the laser circuit block is confirmed to be working correctly, replace the OP (optical pick-up unit).

• **Connection**

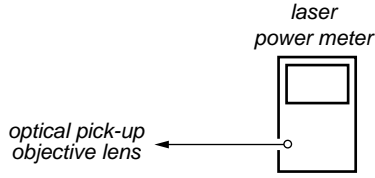

• **Checking method**

1. Select the manual mode of test mode (see page 14), and set the laser power checking mode (item number 010).

Set LCD display



2. Press the [◀◀] key continuously until the optical pick-up moves to the most inward track.
3. Open the cover and set the laser power meter on the objective lens of the optical pick-up.
4. Press the [▶▶] key, and set the laser MO read check mode (item number 011).

Set LCD display

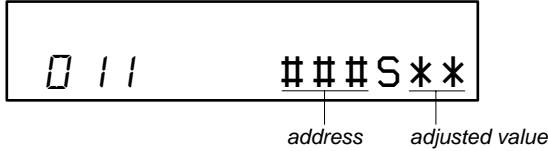

5. Check that the laser power meter reading is  $0.800 \pm 0.10$  mW.
6. Press the [▶▶] key, and set the laser CD read check mode (item number 012).

Set LCD display

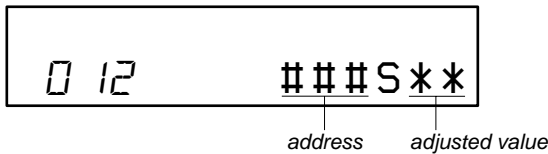

7. Check that the laser power meter reading is  $0.910 \pm 0.11$  mW.
8. Press the [▶▶] key, and set the laser MO (X2 speed) write check mode (item number 013).

Set LCD display

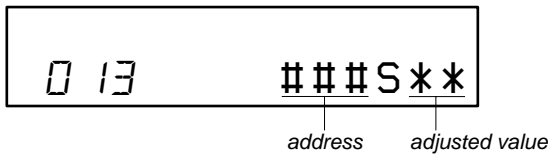

9. Check that the laser power meter reading is  $4.95 \pm 0.59$  mW.

10. Press the [▶▶] key, and set the laser MO (X4 speed) write check mode (item number 014).

Set LCD display

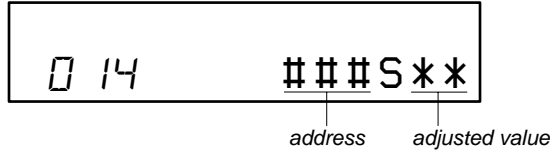

11. Check that the laser power meter reading is  $5.93 \pm 0.71$  mW.
12. Press the [■] CANCEL/CHG key to quit the manual mode, and activate the test mode (display check mode).

**Overall Adjustment Mode**

• **Configuration of Overall Adjustment Mode**

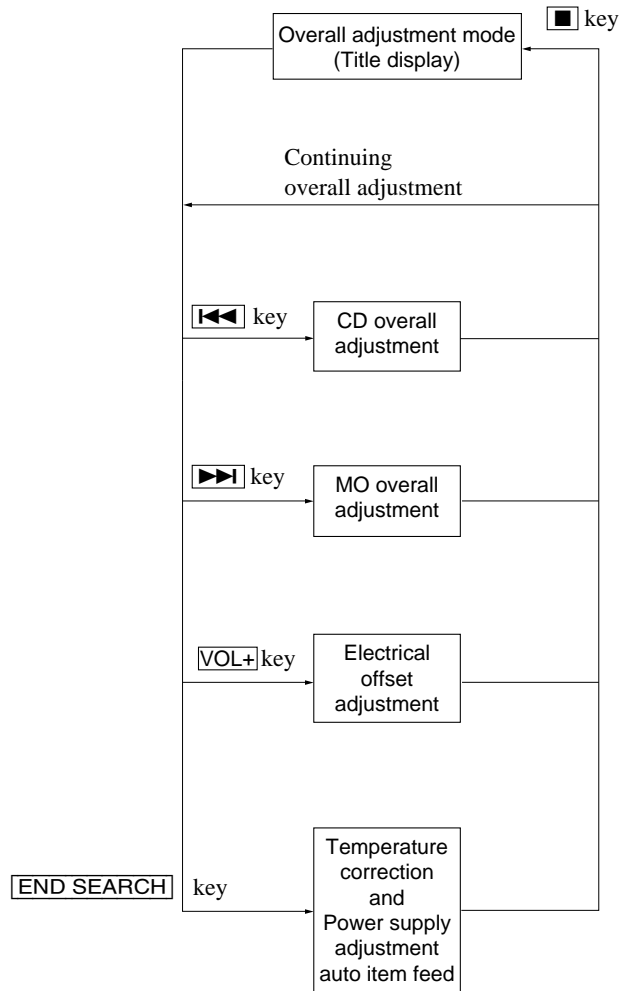

- Overall Adjustment Mode (Title Display)

Set LCD display



☉: (Disc mark) At end of power supply adjustment: Outside lit

\*\* : Left side = MO overall adjustment information

F\* : MO overall adjustment completed

1\* : Manual adjustment exists (overall adj. not completed)

0\* : Not adjusted

Right side = CD overall adjustment information

\*F : CD overall adjustment completed

\*1 : Manual adjustment exists (overall adj. not completed)

\*0 : Not adjusted

**Note:** Adjust the CD first, when performing adjustment.

• **Adjustment Method of CD and MO Overall Adjustment Mode**

1. Set the test mode (see page 13).
2. Press the **◀◀** key or press **[VOL-]** on the remote commander key to activate the overall adjustment mode.

Set LCD display



3. Insert CD disc in the set, and press the **◀◀** key to set the CD overall adjustment mode. Automatic adjustments are made.

Set LCD display



X X X : Item number for which an adjustment is being executed.

4. In case of CD overall adjustment NG, readjust from the NV reset (see page 19), The temperature correction (see page 19) may be omitted.

Set LCD display

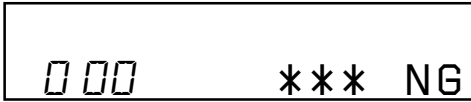

\*\* : NG item number.

5. If OK through the CD overall adjustments, then perform MO overall adjustments.

Set LCD display



6. Insert MO disc in the set, and press the **▶▶** key to set the MO overall adjustment mode. Automatic adjustments are made.

Set LCD display



X X X : Item number for which an adjustment is being executed.

7. In case of MO overall adjustment NG, readjust from the NV reset (see page 19). The temperature correction (see page 19) may be omitted.

Set LCD display

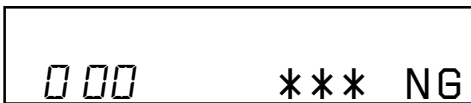

\*\* : NG item number.

8. If OK through the MO overall adjustments, press the **[CANCEL/CHG]** key to return to the test mode and terminate the overall adjustment mode.

Set LCD display



• **Overall Adjustment error message**

The following message will be displayed if adjustment procedure is mistaken in the CD and MO overall adjustment.

Message	Display timing	Description
CLOSE!	During CD/MO/DISC automatic distinction overall adjustment	DISC is not inserted.
Set CD!	During MO/DISC automatic distinction overall adjustment During offset adjustment	<ul style="list-style-type: none"> <li>• CD overall adjustment is not completed in the MO overall adjustment.</li> <li>• CD and MO overall adjustment is not completed in the offset adjustment.</li> </ul>
Set MO!	During offset adjustment	MO overall adjustment is not completed in the offset adjustment
NoTmp!	During CD/MO/DISC automatic distinction overall adjustment	Temperature correction (item number 015) is not finished.
NoChg!	During CD/MO/DISC automatic distinction overall adjustment	Charge voltage adjustments (item number 755 and 756) are not finished.

• **CD and MO Overall Adjustment Items**

1. CD overall adjustment items

Item No.	Description
761	VC,VR power supply H/L selection
300	HPIT setting . servo OFF
561	SLED inward movement
562	SLED outward movement
High reflection electrical offset adjustment	
312	Laser ON . Focus UP . vc correction
ALFA offset adjustment	
313	IJ offset adjustment
314	FE offset adjustment
HPIT adjustment	
320	Focus servo ON
324	TE offset adjustment 1
321	TE gain adjustment
328	TWPP gain adjustment
324	TE offset adjustment 1
332	TE offset adjustment 2
330	Tracking servo ON
336	ABCD gain adjustment
337	KF gain correction
338	RF gain adjustment
344	FCS gain adjustment
345	TRK gain adjustment
521	Two-axis sensitivity (inner position)

Item No.	Description
522	Two-axis sensitivity (outer position)
300	HPIT setting . servo OFF

## 2. MO overall adjustment items

Item No.	Description
716	VC,VR power supply H/L selection
100	R_GRV setting . servo OFF
Low reflection electrical offset adjustment	
112	Laser ON . Focus UP vc correction
ALFA offset adjustment	
113	IJ offset adjustment
114	FE offset adjustment
118	Wpp denominator offset adjustment
LPIT adjustment	
200	LPIT setting . servo OFF
561	SLED inward movement
220	Focus servo ON
224	TE offset adjustment 1
221	TE gain adjustment
224	TE offset adjustment 1
232	TE offset adjustment 2
230	Tracking servo ON
236	ABCD gain adjustment
237	KF gain correction
238	RF gain adjustment
244	Focus gain adjustment
245	Tracking gain adjustment
READ GRV adjustment 1	
100	R_GRV setting . servo OFF
562	SLED outward movement
120	Focus servo ON
122	TON offset adjustment
121	TE gain adjustment
122	TON offset adjustment
123	TEIN offset adjustment
124	TWPP offset adjustment 1
130	Tracking servo ON
131	TWPP offset adjustment 1
136	ABCD gain adjustment
137	KF gain correction
139	ADIP BPF f0 adjustment
144	Focus gain adjustment
145	Tracking gain adjustment
134	TWPP gain adjustment
131	TWPP offset adjustment 1
132	TWPP offset adjustment 2
149	TWPP OP offset adjustment
WRITE GRV adjustment	
410	HEAD DOWN . GRV servo ON
420	READ → WRITE selection
421	TE gain adjustment
423	TEIN offset adjustment
430	Tracking servo ON
431	TWPP offset adjustment 1
436	ABCD gain adjustment

Item No.	Description
444	Focus gain adjustment
445	Tracking gain adjustment
434	TWPP gain adjustment
431	TWPP offset adjustment 1
432	TE offset adjustment 2
449	TWPP OP offset adjustment
410	READ → WRITE selection
411	TWPP offset adjustment 1
412	TE offset adjustment 2
418	TWPP OP offset adjustment
490	HCLV LCLV selection process
450	HEAD DOWN . GRV servo ON
460	READ → WRITE selection
461	TE gain adjustment
463	TEIN offset adjustment
470	Tracking servo ON
471	TWPP offset adjustment 1
476	ABCD gain adjustment
484	Focus gain adjustment
485	Tracking gain adjustment
451	TWPP offset adjustment 1
452	TE offset adjustment 2
460	READ → WRITE selection
470	Tracking servo ON
474	TWPP gain adjustment
471	TWPP offset adjustment 1
472	TE offset adjustment 2
489	TWPP OP offset adjustment
450	WRITE → READ selection
451	TWPP offset adjustment 1
452	TE offset adjustment 2
458	TWPP OP offset adjustment
448	30 sec continuous REC
400	GRV setting . servo OFF . HEAD UP
READ GRV adjustment 2	
120	Focus servo ON
130	Tracking servo ON
138	RF gain adjustment
141	FOCUS_BIAS
035	Stray light offset measurement
100	R_GRV setting . servo OFF

## Remuse Clear

Perform the Resume clear when all adjustments completed.

### • Resume Clear Setting Method

1. Select the manual mode of the test mode, and set item number 043 (see page 14).

*Set LCD display*

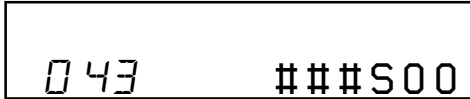

###: Address

2. Press the  key.

*Set LCD display*



*Resume clear complete*



3. Press the  key to return to the test mode (display check mode).

## Rewriting the Patch Data at Replacement of Main Board

This set requires the patch data in the nonvolatile memory (IC852) to be rewritten using the application, when the MAIN board was replaced.

**Caution:** The application that meets the microcomputer version in this set must be used when rewriting the patch data. Rewriting the patch data using the application not suitable for the microcomputer version could cause the set to malfunction.  
For a checking method of the microcomputer version, see “SECTION 4 TEST MODE” (page 13).

### • Preparation

1. USB cable (attached to the set)
2. Personal computer in which the Net MD Driver has been installed. (For further information, see “System requirements” (page 4) in “SECTION 1 SERVICING NOTES”)
3. Application “USB\_PatchWriter” for patch data rewriting

### • How to Get the Application “USB\_PatchWriter” for Patch Data Rewriting

Contact our service technical support division to get the application.

### • Pre-check

1. Check the microcomputer version in this set. (For a checking method of the microcomputer version, see “SECTION 4 TEST MODE” (page 13).)
2. Check that the Net MD Driver has been installed in the personal computer.
3. Make sure that the set is in the Normal mode.  
**Note:** Do not rewrite the patch data in the Test mode.

### • Rewriting the Patch Data

1. Connect the set to the personal computer with the USB cable.
2. Start the application “USB\_PatchWriter”.
3. Make sure that the following window opens.
4. Click the [USB CONNECT] button.

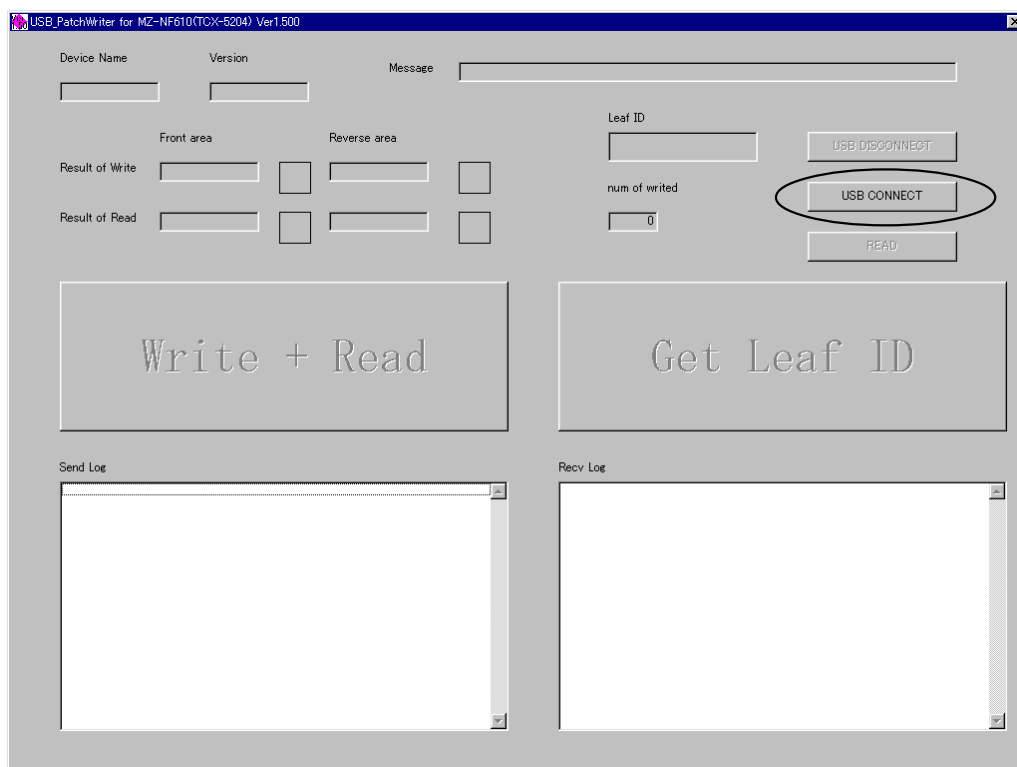

5. Confirm that the model and version indicated on the title bar coincide with the codes displayed in the Device Name block and the Version block in the window.

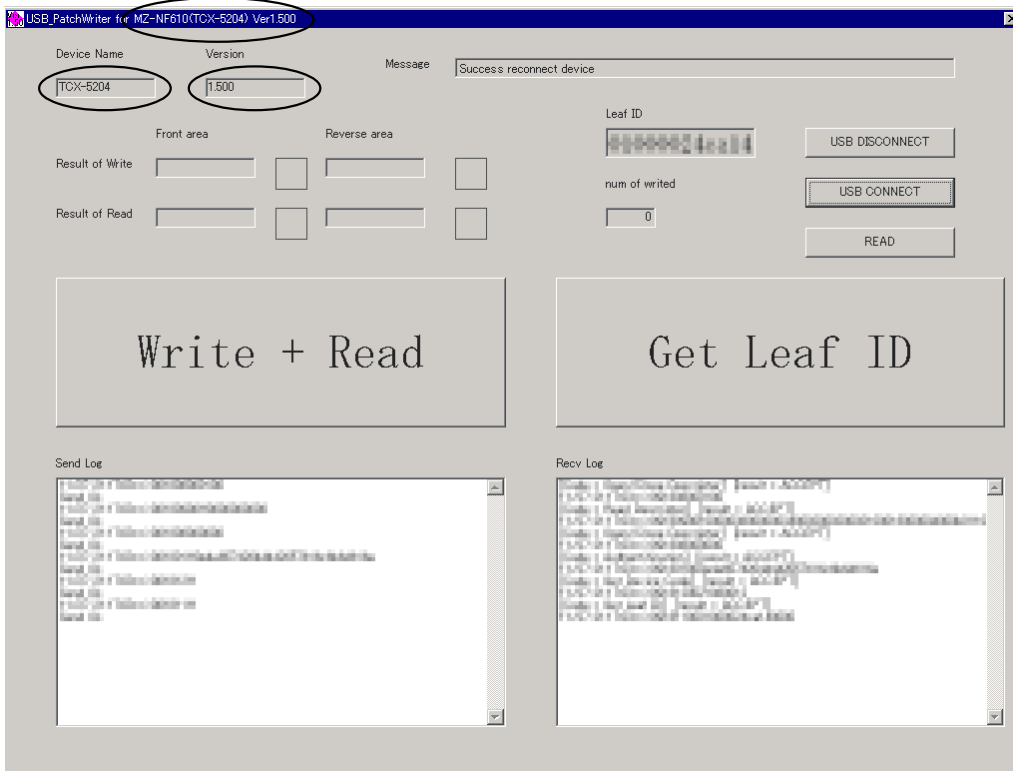

6. Click the [Write + Read] button.  
 The patch data writing and the verify processing will be executed automatically in the following order:  
 1) Writing to patch area (front area)  
 2) Writing to patch area (reverse area)  
 3) Verifying patch area (front area)  
 4) Verifying patch area (reverse area)
7. The operation will terminate with the ○ (blue) mark given to all areas.  
 If the × (red) mark is given to any area, the nonvolatile memory will be faulty.

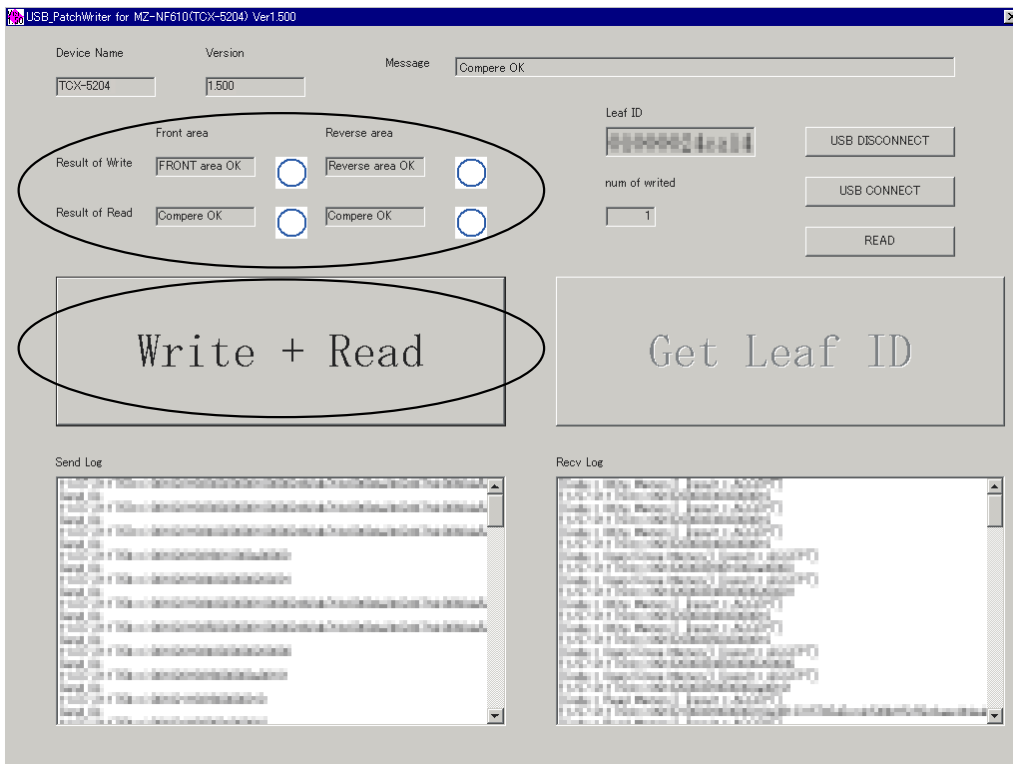



• Confirmation of contents of the patch data rewritten

1. Click the [READ] button to confirm the contents of the patch data rewritten.

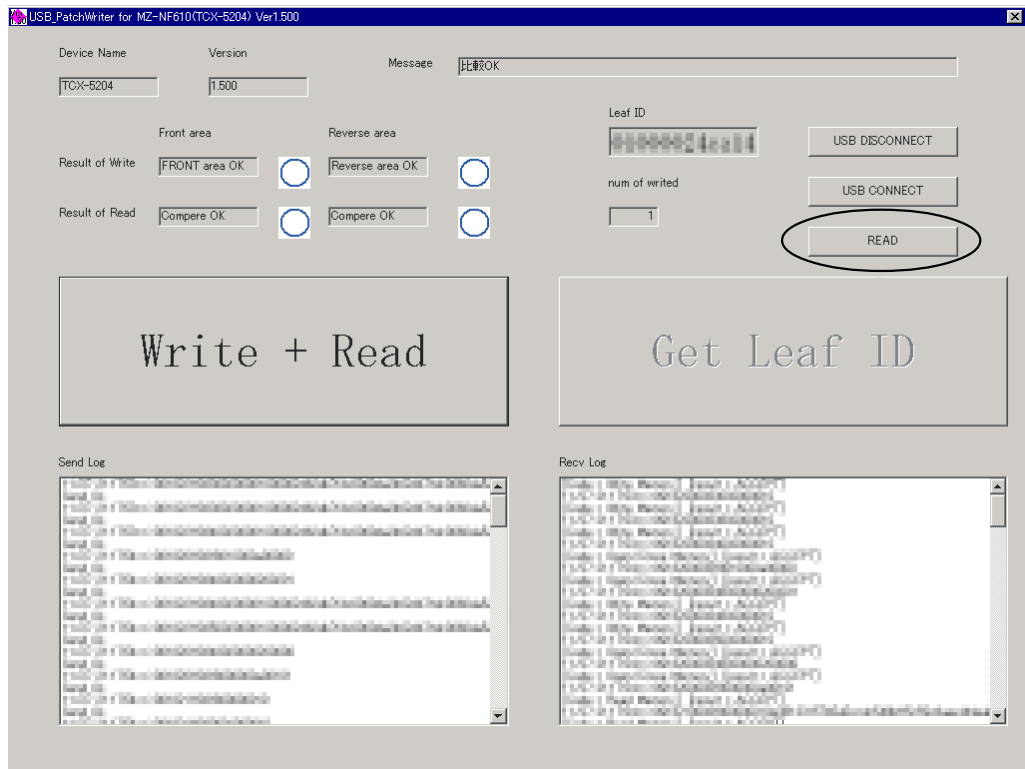

2. The application reads out the front and reverse patch areas and displays the results in the edit box. Confirm that the upper column coincides with the lower column as the following window.
3. Click the [OK] button to close the window.

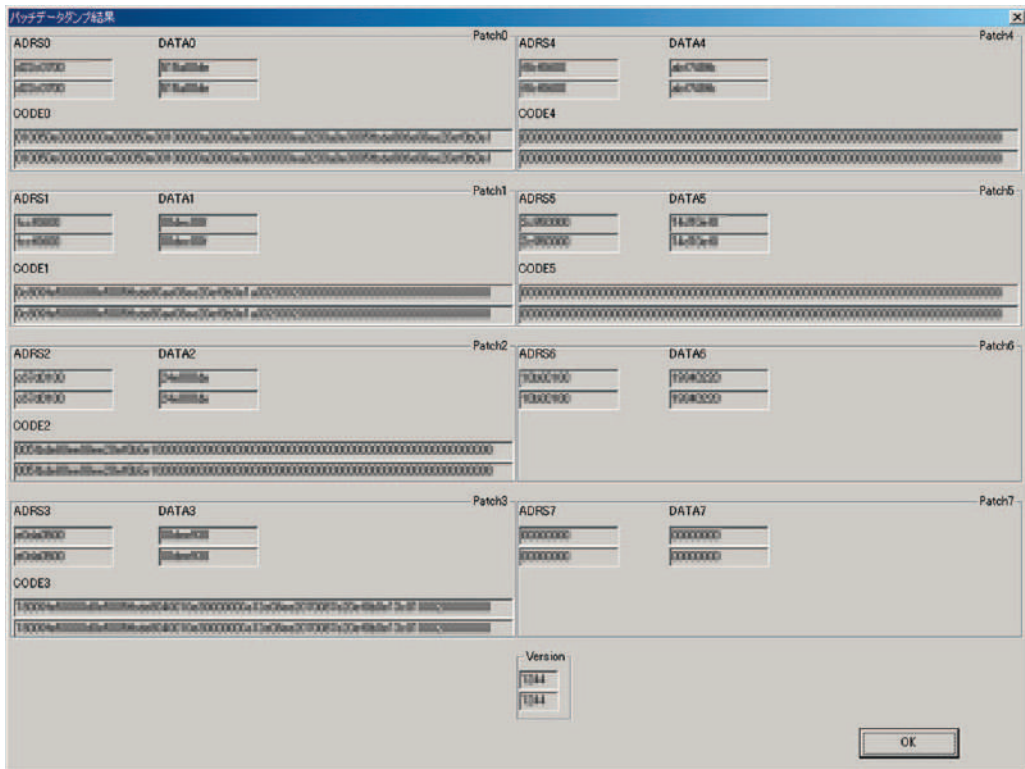

# MZ-NF610

- Disconnecting the USB cable

Disconnect the USB cable as the following procedure after rewriting the patch data and confirmation.

**Note :** When the following procedure is not completed but USB cable is extracted, the application does not recognize the set at exchanging of the set.

1. Click the [USB DISCONNECT] button.

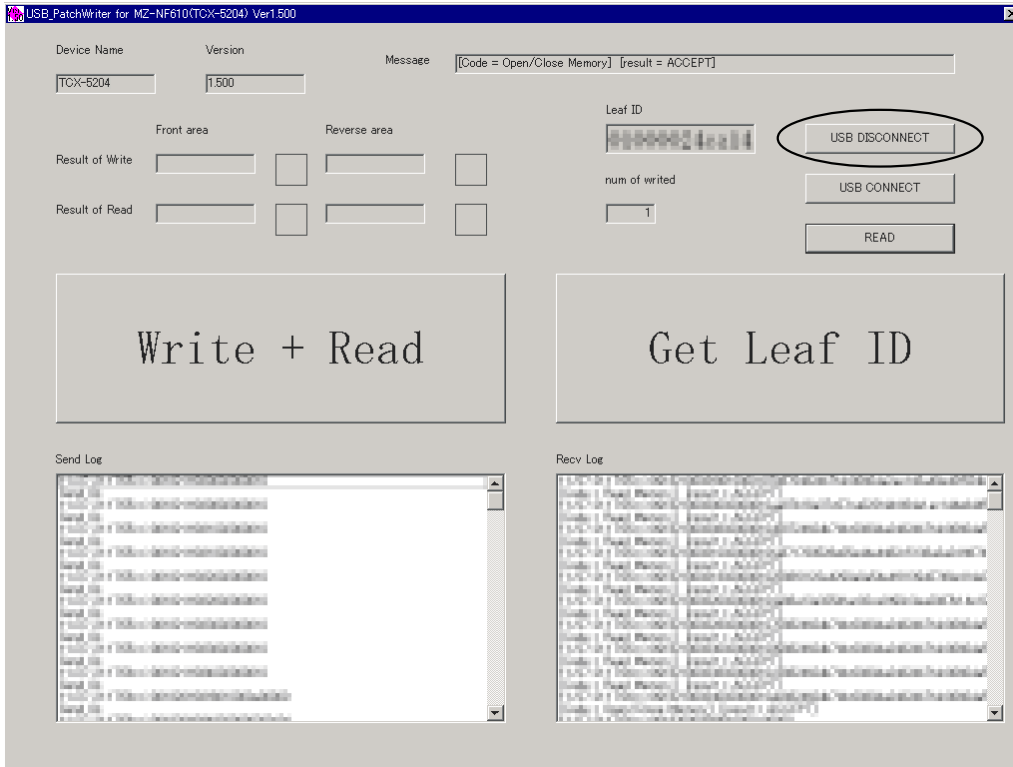

2. Confirm that "You can change another device" is displayed in the message block.

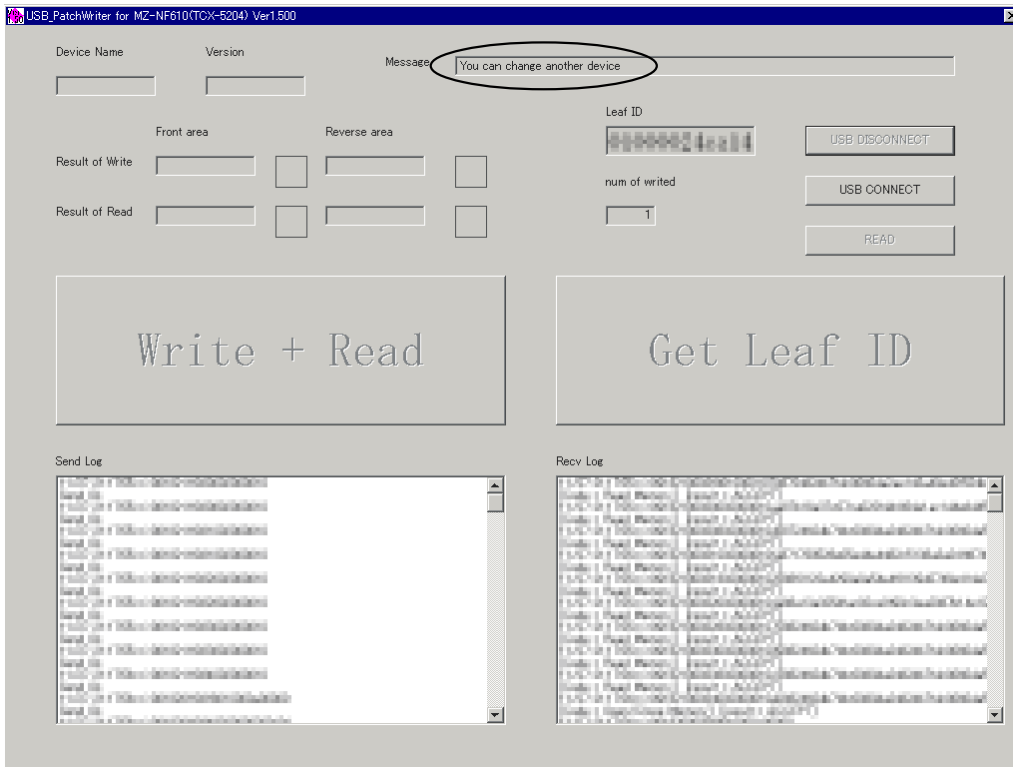

3. Disconnect the USB cable from the personal computer and the set.

## Rewriting the NV values

**Caution:** The application that meets the microcomputer version in this set must be used when rewriting the NV values. Rewriting the NV values using the application not suitable for the microcomputer version could cause the set to malfunction.  
For a checking method of the microcomputer version, see “SECTION 4 TEST MODE” (page 13).

### • Preparation

1. USB cable (attached to the set)
2. Personal computer in which the Net MD Driver has been installed. (For further information, see “System requirements” (page 4) in “SECTION 1 SERVICING NOTES”)
3. Application “NVWriter” for NV values rewriting

### • How to get the application “NVWriter” for NV values rewriting

Contact our service technical support division to get the application.

### • Pre-check

1. Check the microcomputer version in this set. (For a checking method of the microcomputer version, see “SECTION 4 TEST MODE” (page 13).)
2. Check that the Net MD Driver has been installed in the personal computer.
3. Make sure that the set is in the Normal mode.

**Note:** Do not rewrite the NV values in the Test mode.

### • Rewriting the NV values

1. Connect the set to the personal computer with the USB cable.
2. Start the application “NVWriter”.
3. Make sure that the following window opens.
4. Click the [USB CONNECT] button.

NVWriter for MZ-N610(TCX-5204) Ver1.500

Device Name	Version	Message
<input type="text"/>	<input type="text"/>	<input type="text"/>

	ADDRESS(Front)	ADDRESS(Reverse)	A write-in result
Servo1	<input type="text" value="0000038"/>	<input type="text" value="00000a0"/>	<input type="text"/>
Servo2	<input type="text" value="ffffff"/>	<input type="text" value="ffffff"/>	<input type="text"/>
Power1	<input type="text" value="0000058"/>	<input type="text" value="0000060"/>	<input type="text"/>
Power2	<input type="text" value="00000c0"/>	<input type="text" value="00000c8"/>	<input type="text"/>
System	<input type="text" value="ffffff"/>	<input type="text" value="ffffff"/>	<input type="text"/>

	DATA(Front)	DATA(Reverse)
Servo1 (Before)	<input type="text"/>	<input type="text"/>
Servo1 (After)	<input type="text"/>	<input type="text"/>
Servo2 (Before)	<input type="text"/>	<input type="text"/>
Servo2 (After)	<input type="text"/>	<input type="text"/>
Power1 (Before)	<input type="text"/>	<input type="text"/>
Power1 (After)	<input type="text"/>	<input type="text"/>
Power2 (Before)	<input type="text"/>	<input type="text"/>
Power2 (After)	<input type="text"/>	<input type="text"/>
System (Before)	<input type="text"/>	<input type="text"/>
System (After)	<input type="text"/>	<input type="text"/>

LeafID:

USB DISCONNECT

**USB CONNECT**

Write + Verify

5. Confirm that the model and version indicated on the title bar coincide with the codes displayed in the Device Name block and the Version block in the window.

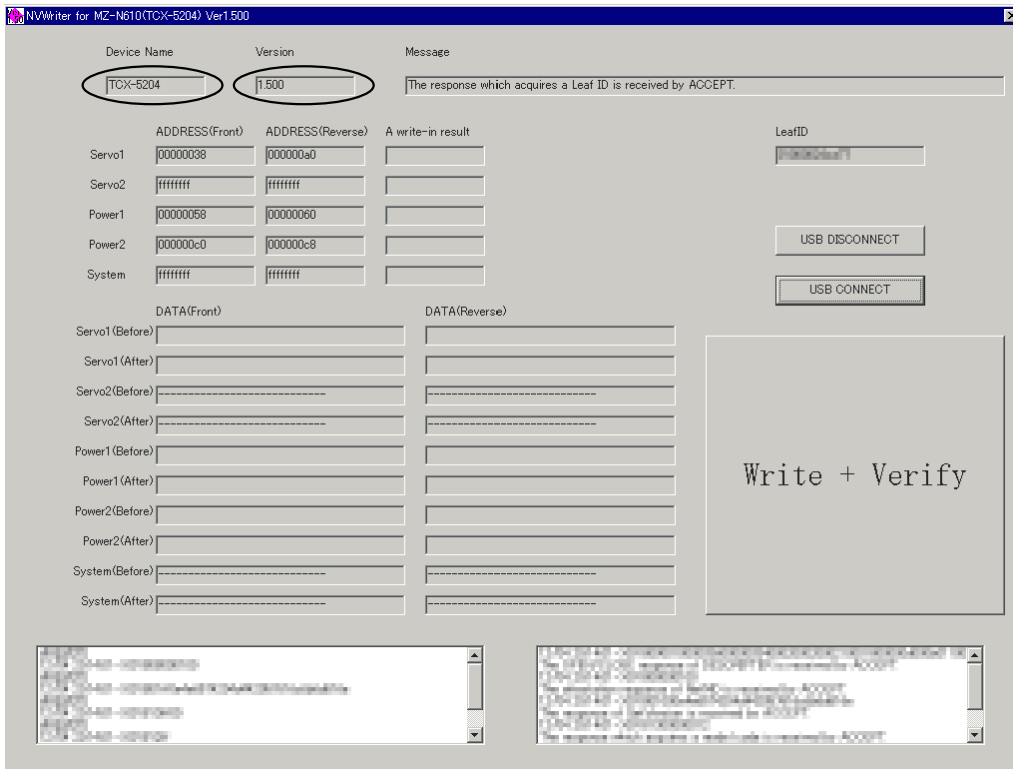

6. Click the [Write + Verify] button.

The NV values writing and the verify processing will be executed automatically in the following order:

- 1) Writing to Servo 1 area (front area)
- 2) Writing to Servo 1 area (reverse area)
- 3) Writing to Power Supply 1 area (front area)
- 4) Writing to Power Supply 1 area (reverse area)
- 5) Writing to Power Supply 2 area (front area)
- 6) Writing to Power Supply 2 area (reverse area)
- 7) Verifying to Servo 1 area (front area)
- 8) Verifying to Servo 1 area (reverse area)
- 9) Verifying to Power Supply 1 area (front area)
- 10) Verifying to Power Supply 1 area (reverse area)
- 11) Verifying to Power Supply 2 area (front area)
- 12) Verifying to Power Supply 2 area (reverse area)

- The operation will terminate with “Compere OK” given to all areas.  
If “Compere NG” is given to any area, the nonvolatile memory will be faulty.

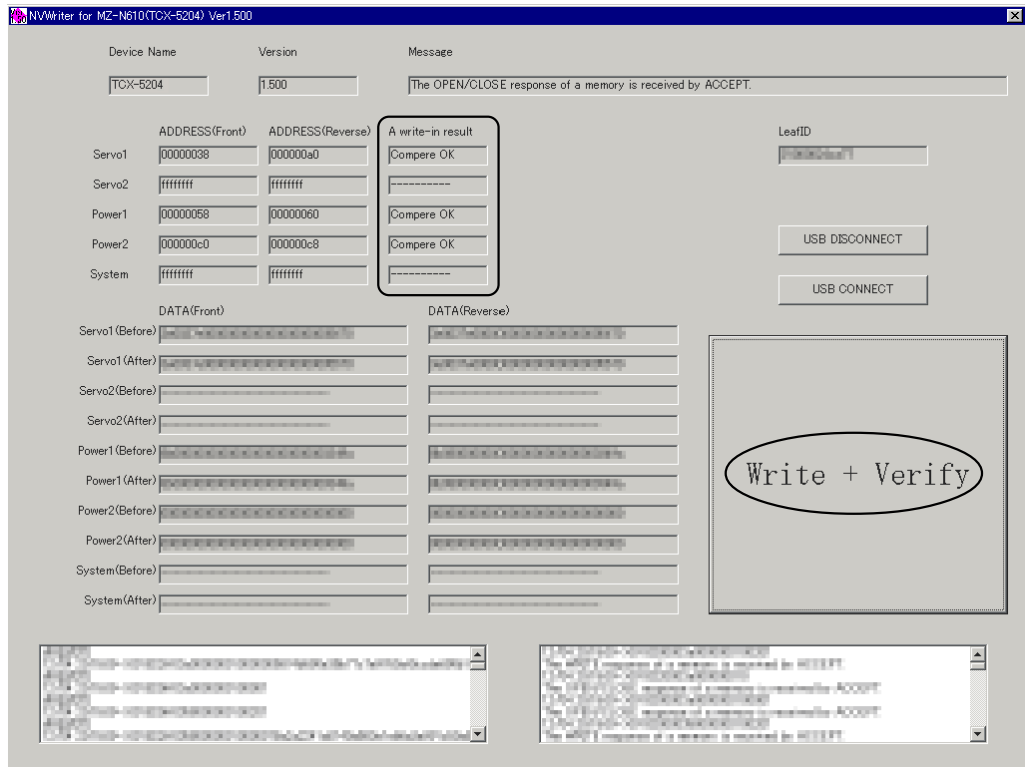

- Click the [USB DISCONNECT] button.

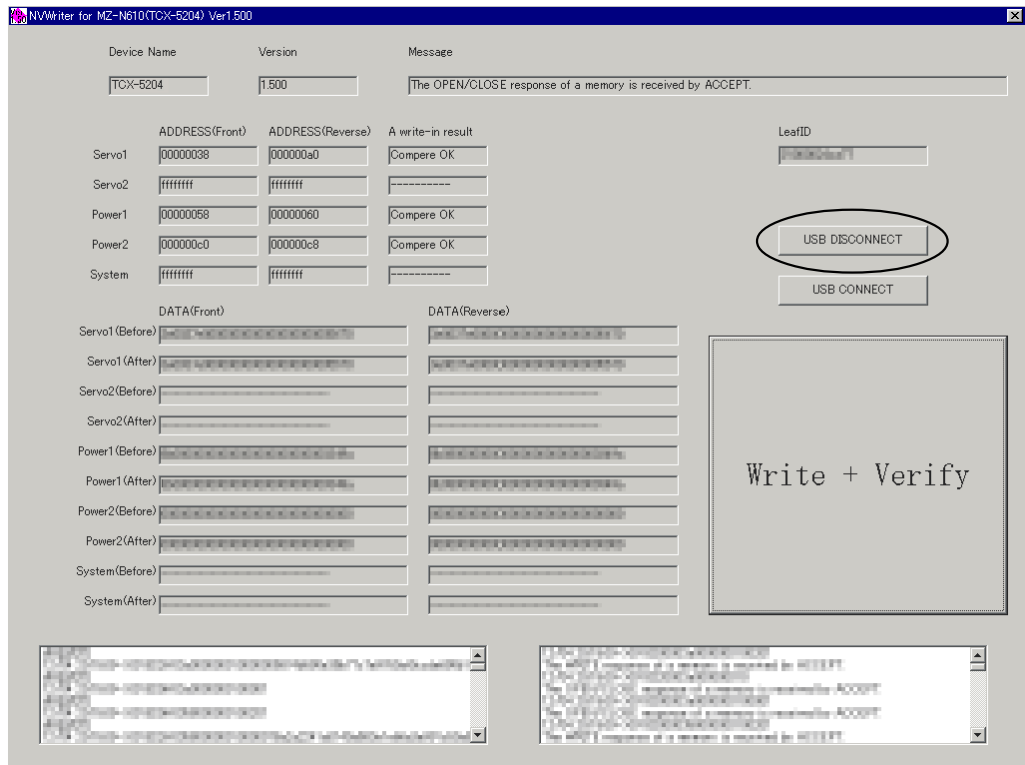

9. Confirm that the window becomes as shown below where the [Write + Verify] button is inactive.

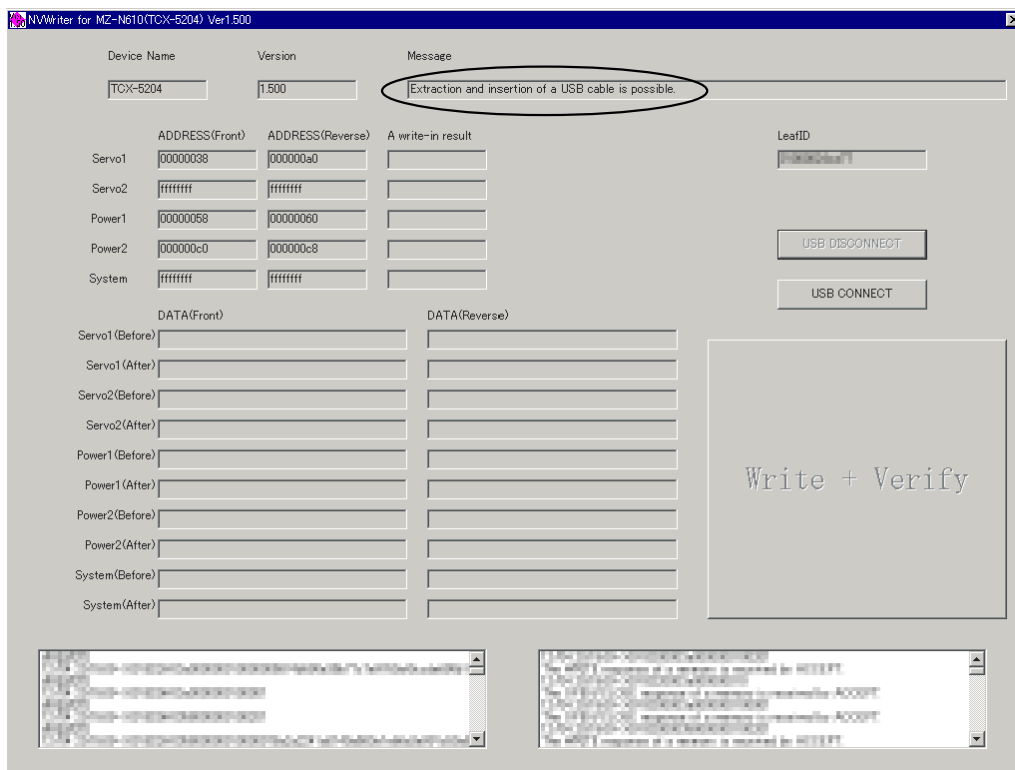

10. Disconnect the USB cable from the personal computer and the set.

# SECTION 6 DIAGRAMS

## 6-1. Block Diagram

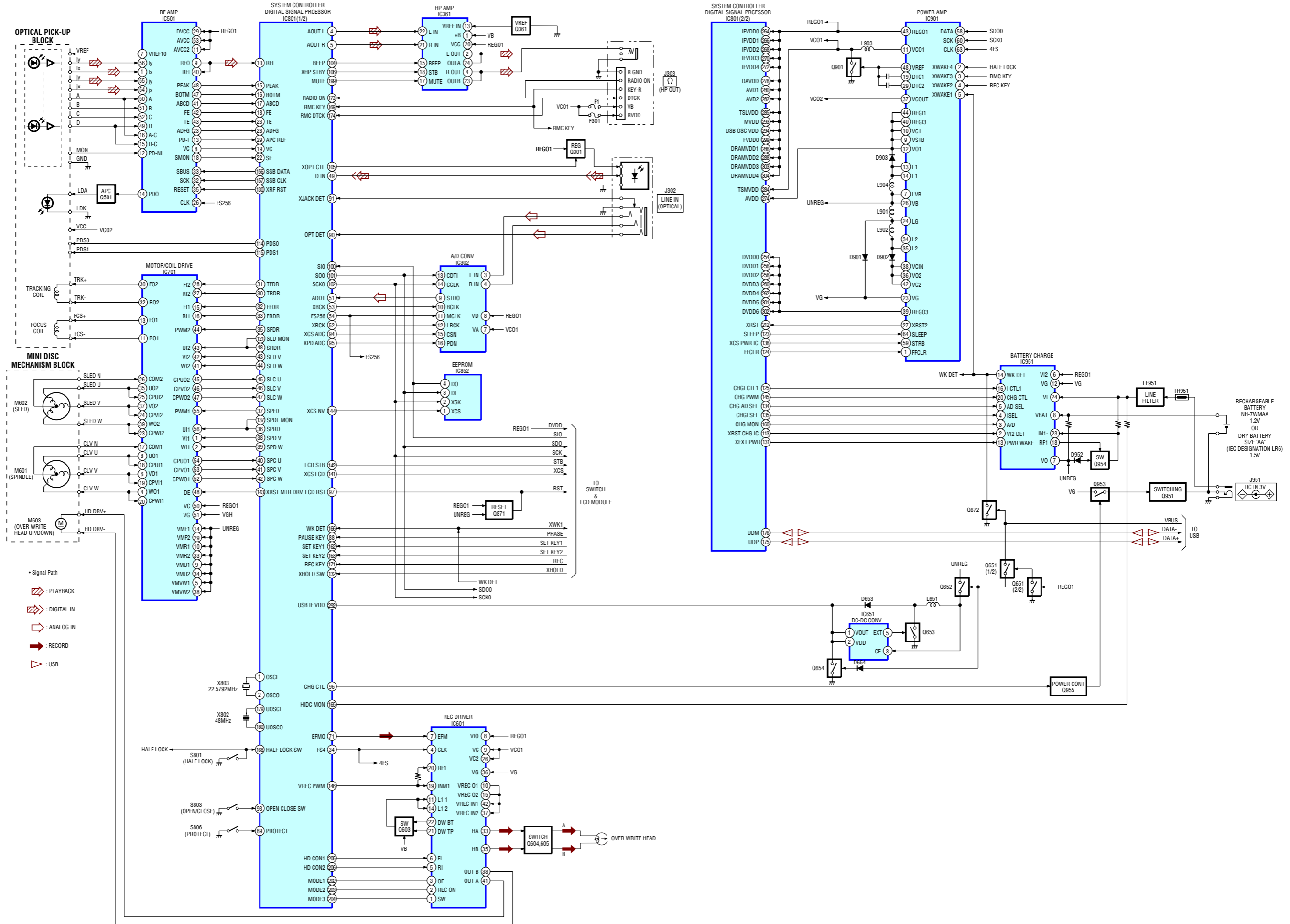

6-2. Note For Printed Wiring Board And Schematic Diagrams

Note on Printed Wiring Board:

- : parts extracted from the component side.
- : parts extracted from the conductor side.
- : Pattern from the side which enables seeing. (The other layers' patterns are not indicated.)

Caution:  
 Pattern face side: Parts on the pattern face side seen from the pattern face are indicated.  
 Parts face side: Parts on the parts face side seen from the parts face are indicated.

- MAIN board is four-layer printed board. However, the patterns of layers 2 and 3 have not been included in this diagrams.

\* Replacement of IC501, IC801 on MAIN board requires a special tool.

Lead Layouts

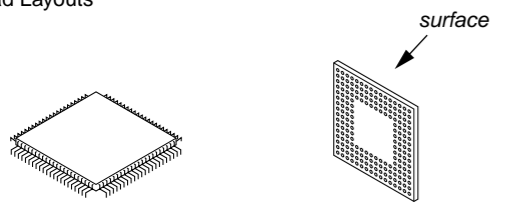

Lead layout of conventional IC      CSP (chip size package)

☆ When IC852 is damaged, replace the MAIN board.

Note on Schematic Diagram:

- All capacitors are in  $\mu\text{F}$  unless otherwise noted.  $\text{pF}$ :  $\mu\text{F}$  50 WV or less are not indicated except for electrolytics and tantalums.
- All resistors are in  $\Omega$  and  $1/4\text{ W}$  or less unless otherwise specified.
- % : indicates tolerance.
- $\Delta$  : internal component.
- : panel designation.

Note:  
 The components identified by mark  $\Delta$  or dotted line with mark  $\Delta$  are critical for safety. Replace only with part number specified.

Note:  
 Les composants identifiés par une marque  $\Delta$  sont critiques pour la sécurité. Ne les remplacer que par une pièce portant le numéro spécifié.

- : B+ Line.
- Total current is measured with MD installed.
- Power voltage is dc 3 V and fed with regulated dc power supply from DC IN 3 V jack (J951).
- Voltages and waveforms are dc with respect to ground in playback mode.
- no mark : PLAYBACK
- ( ) : REC
- \* : Impossible to measure
- Voltages are taken with a VOM (Input impedance 10 M $\Omega$ ). Voltage variations may be noted due to normal production tolerances.
- Waveforms are taken with a oscilloscope. Voltage variations may be noted due to normal production tolerances.
- Circled numbers refer to waveforms.
- Signal path.
- ⇒ : PLAYBACK
- ⇒ : DIGITAL IN
- ⇒ : ANALOG IN
- ⇒ : RECORD
- ▷ : USB
- The voltage and waveform of CSP (chip size package) cannot be measured, because its lead layout is different form that of conventional IC.

\* Replacement of IC501, IC801 on MAIN board requires a special tool.

☆ When IC852 is damaged, replace the MAIN board.

- Abbreviation
- CND : Canadian model

Waveforms

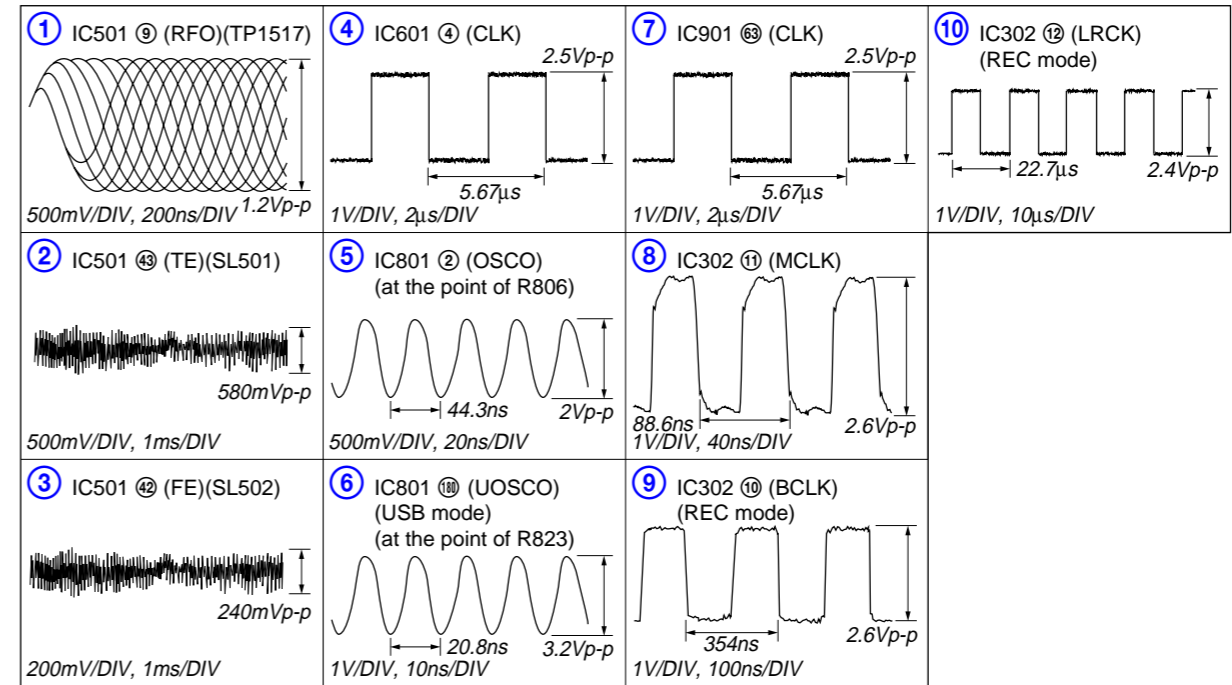



6-3. Printed Wiring Board – MAIN Board (Side A) –  :Uses unleaded solder.

• Semiconductor Location

Ref. No.	Location
D606	H-4
D607	H-3
D653	H-2
D654	H-2
D953	H-8
D958	I-8
IC302	E-9
IC701	D-5
Q501	F-7
Q603	H-4
Q604	H-4
Q605	H-3
Q652	H-2
Q654	H-3
Q672	B-9
Q955	I-7

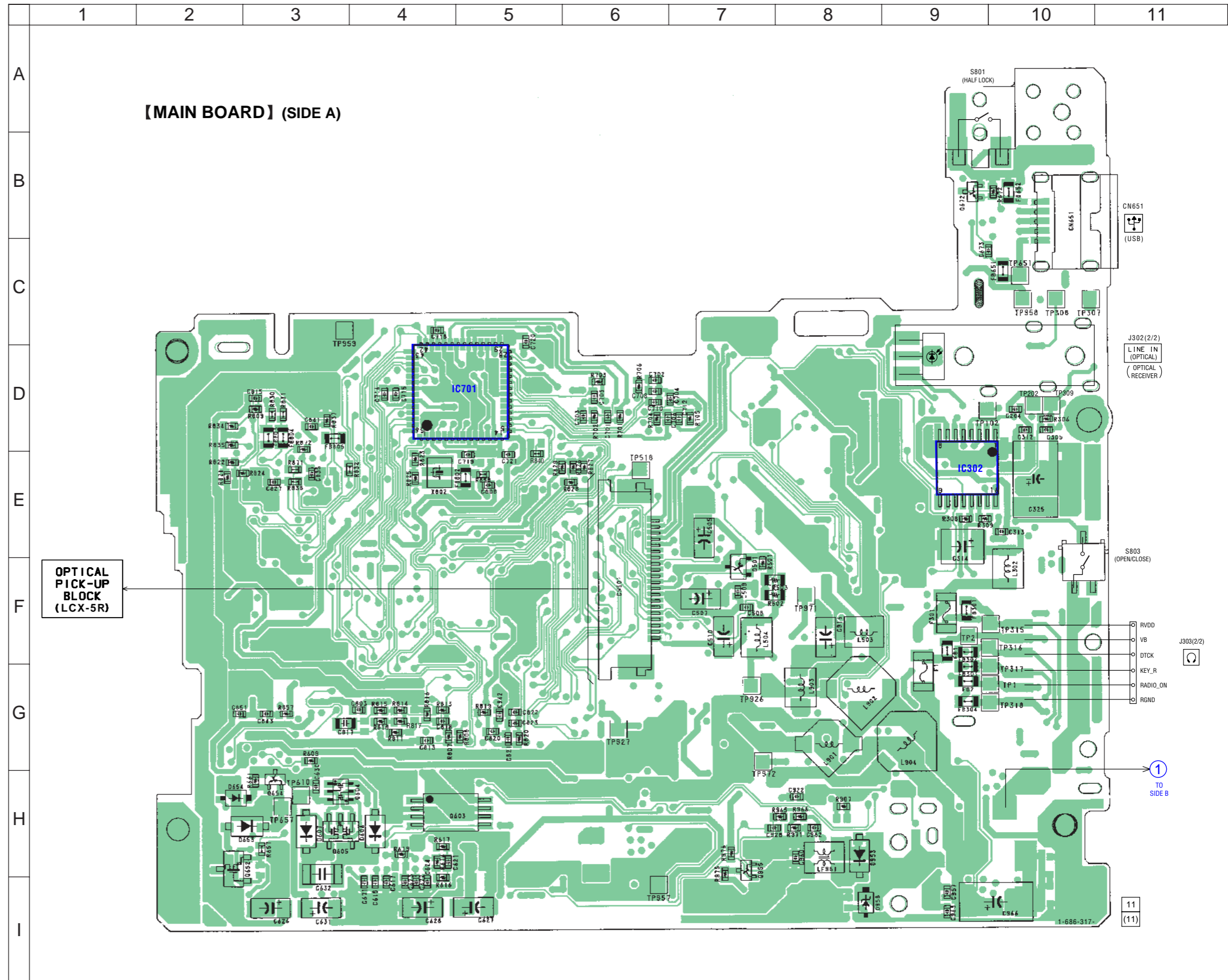

6-4. Printed Wiring Board – MAIN Board (Side B) –  :Uses unleaded solder.

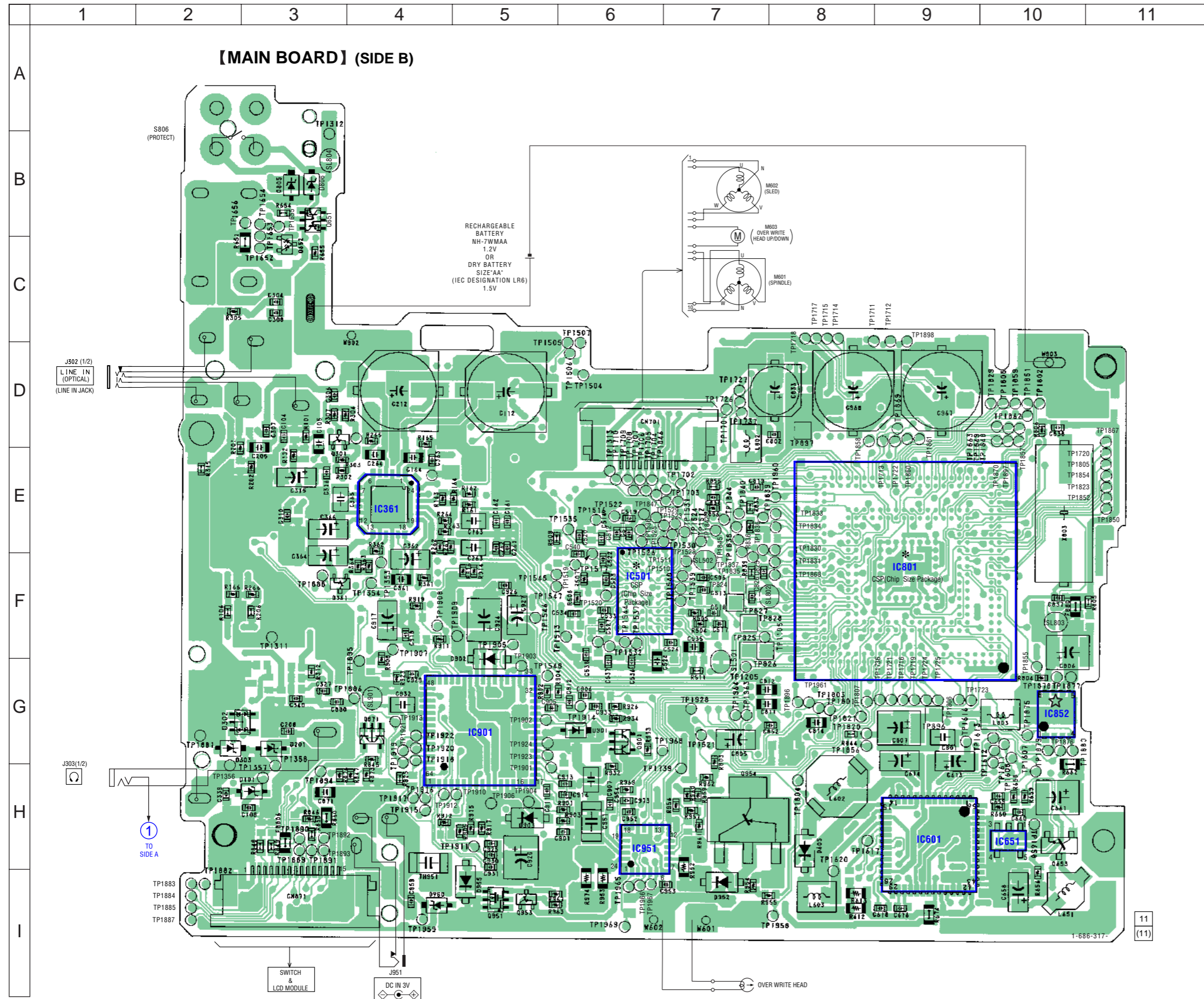

• Semiconductor Location

Ref. No.	Location
D101	H-3
D201	G-3
D302	G-2
D303	G-2
D605	H-8
D652	C-3
D901	G-6
D902	G-5
D903	H-5
D952	I-7
D955	I-5
D960	I-4
IC361	E-4
IC501	F-6
IC601	H-9
IC651	H-10
IC801	E-9
IC852	G-10
IC901	G-5
IC951	H-6
Q301	E-3
Q361	F-3
Q651	B-3
Q653	H-10
Q871	G-4
Q901	G-6
Q951	I-5
Q953	I-5
Q954	H-7



6-6. Schematic Diagram – MAIN Board (2/4) – • See page 40 for Waveform. • See page 48 and 50 for IC Block Diagrams.

1 2 3 4 5 6 7 8 9 10 11 12 13 14 15 16 17 18 19

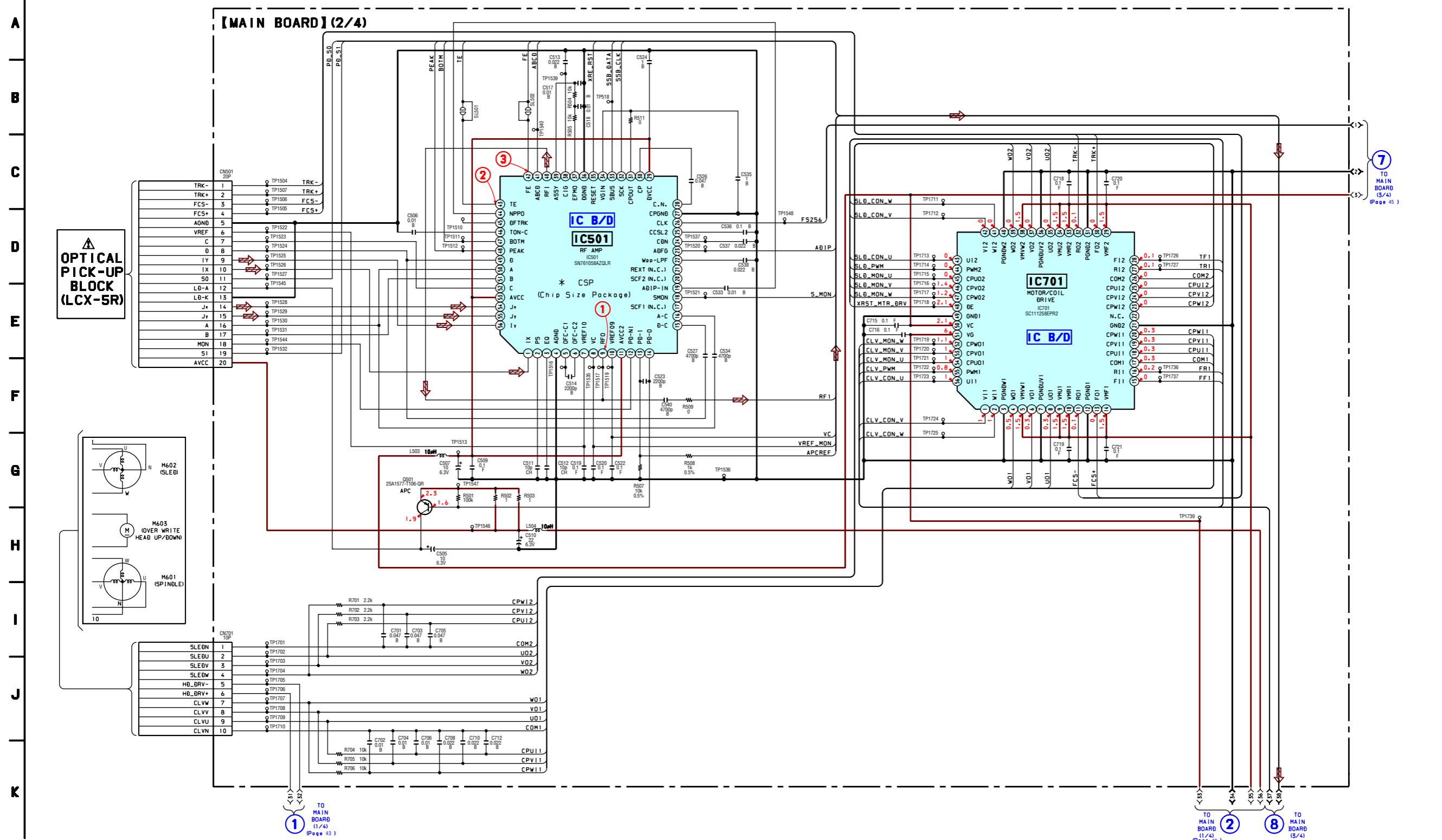



6-7. Schematic Diagram – MAIN Board (3/4) – • See page 40 for Waveforms. • See page 52 for IC Pin Function Description.

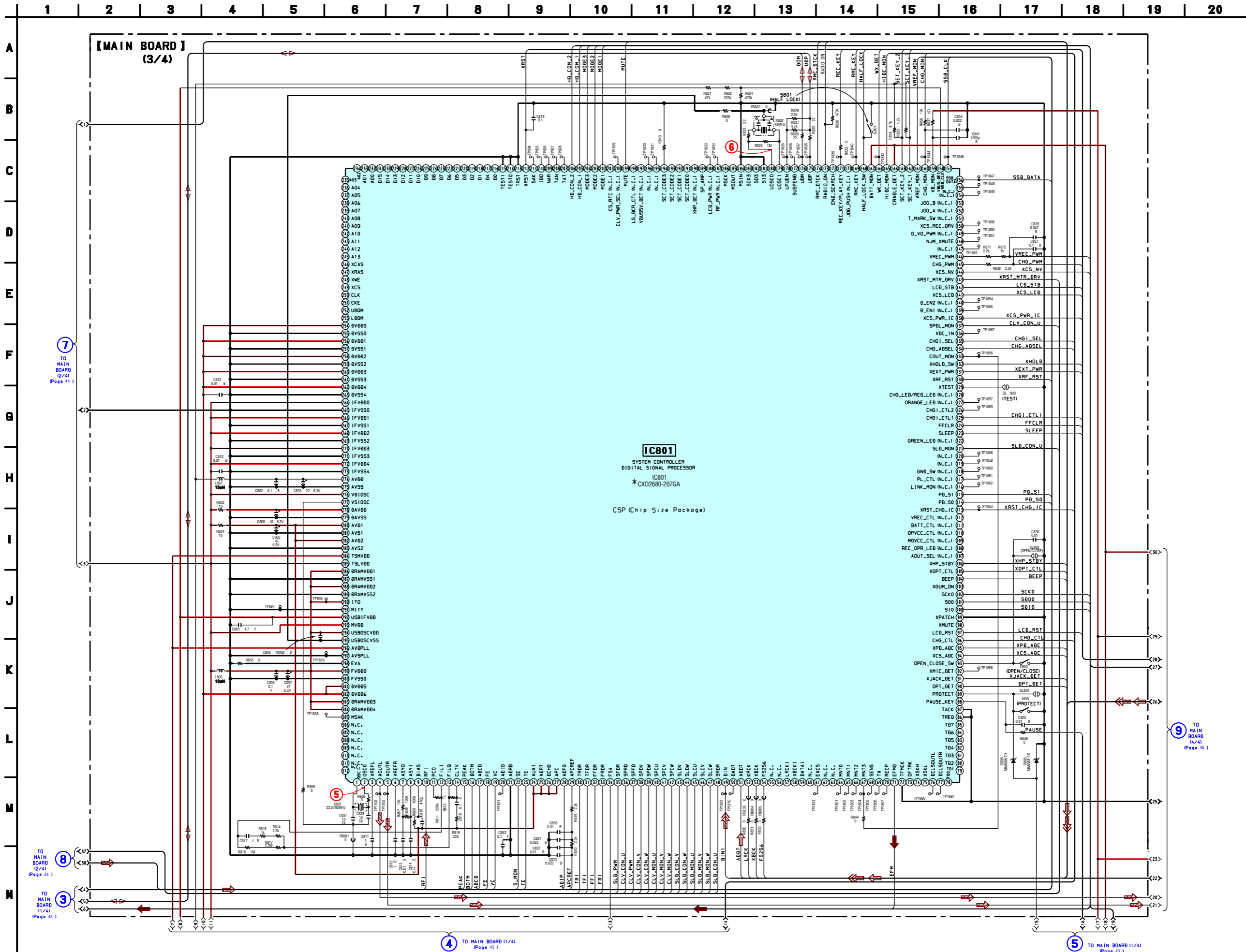

1 2 3 4 5 6 7 8 9 10 11 12 13 14 15

A B C D E F G H I J K

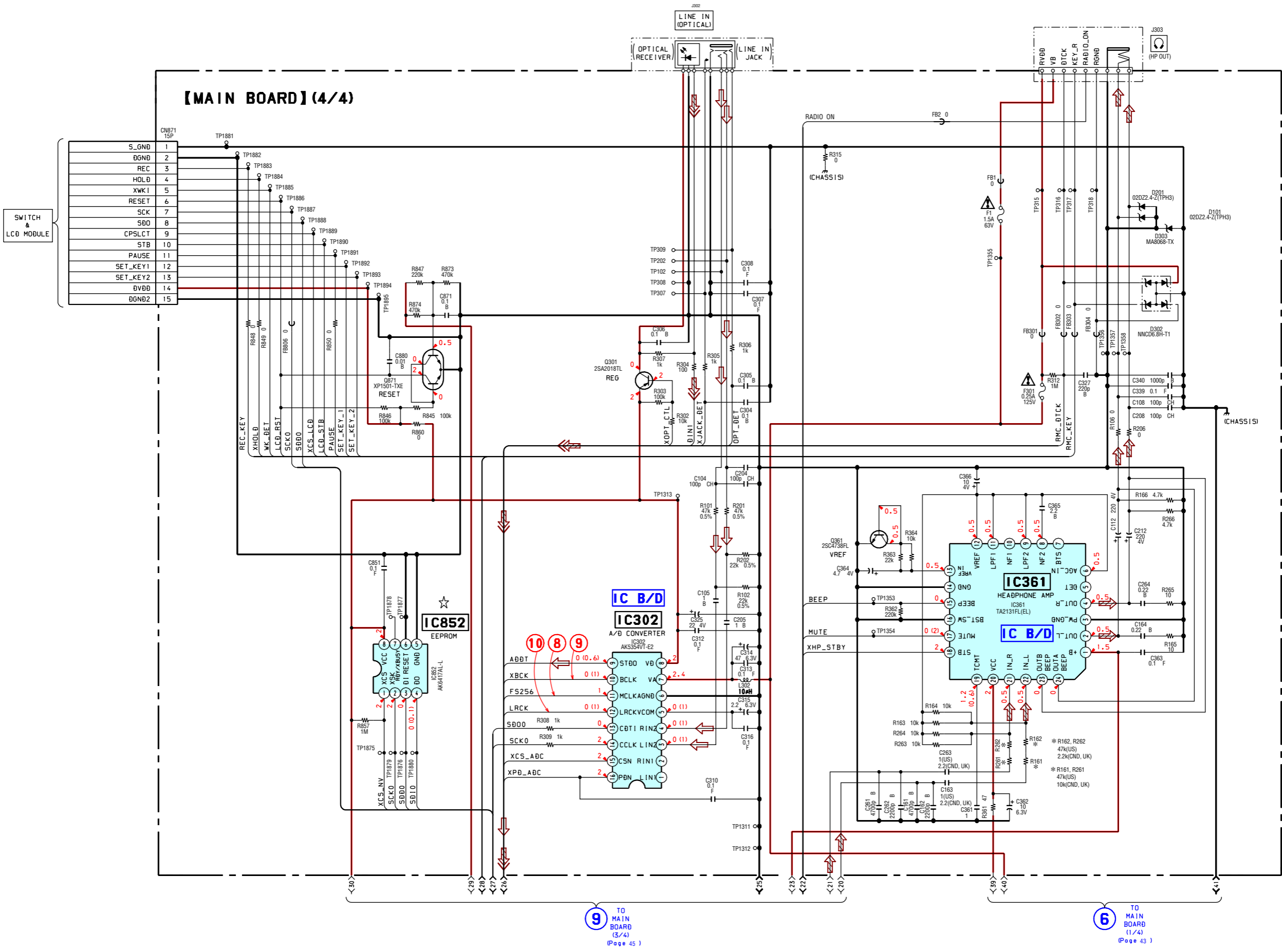

• IC Block Diagrams

IC302 AK5354VT-E2

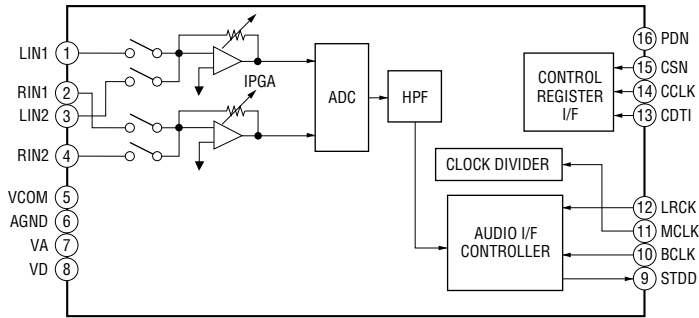

IC361 TA2131FL (EL)

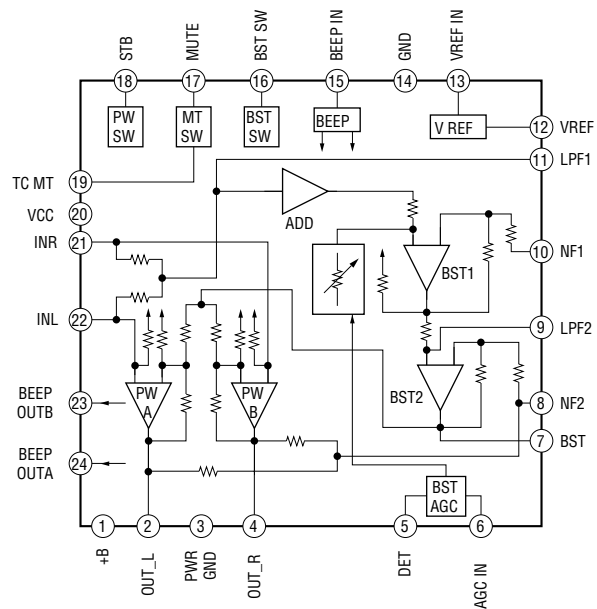

# MZ-NF610

## IC501 SN761058AZQLR

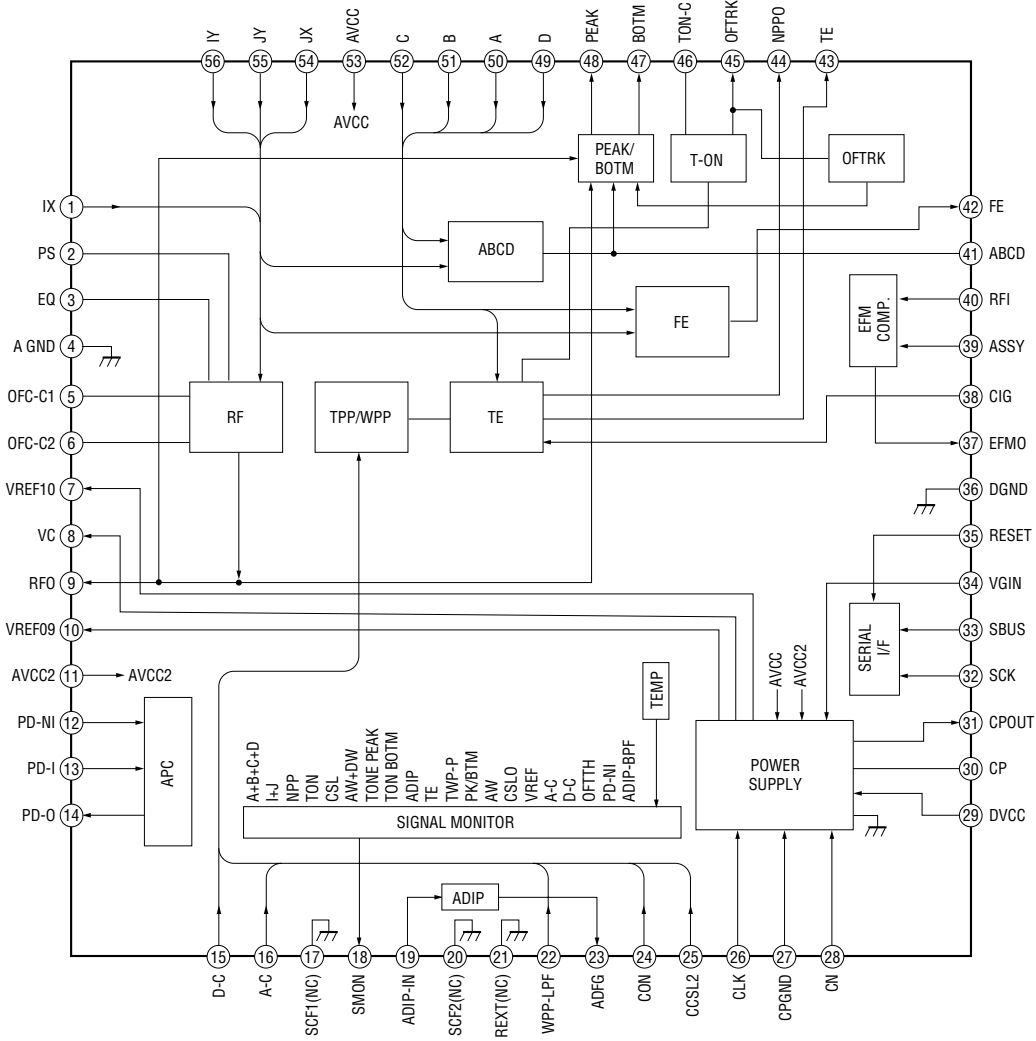



IC601 XPC18A22AEP2

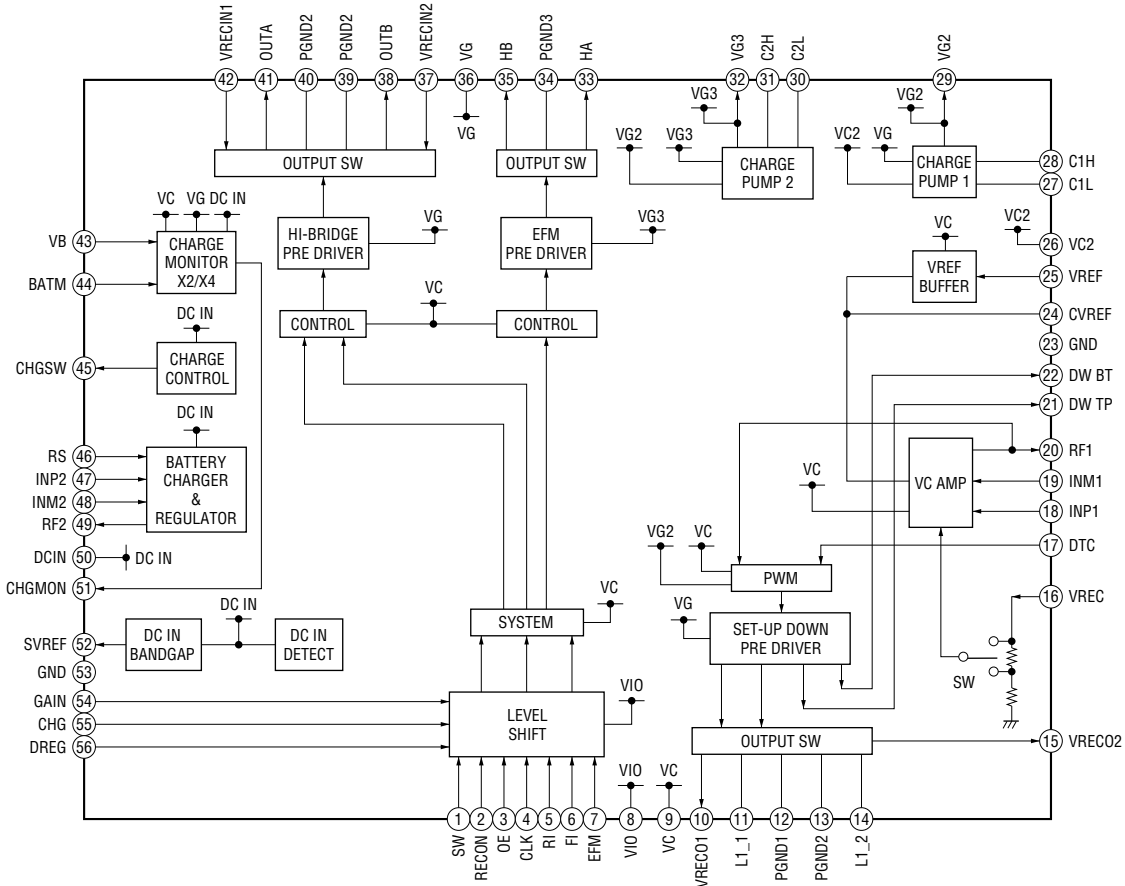

IC651 XC6367A331MR

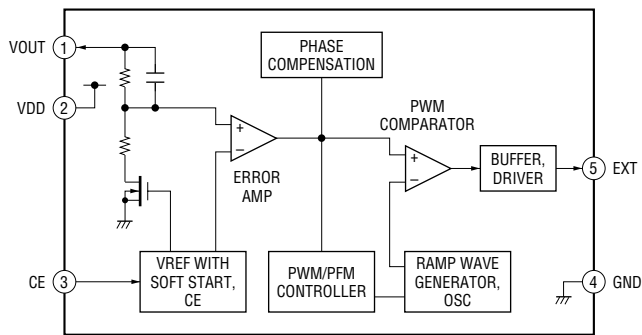

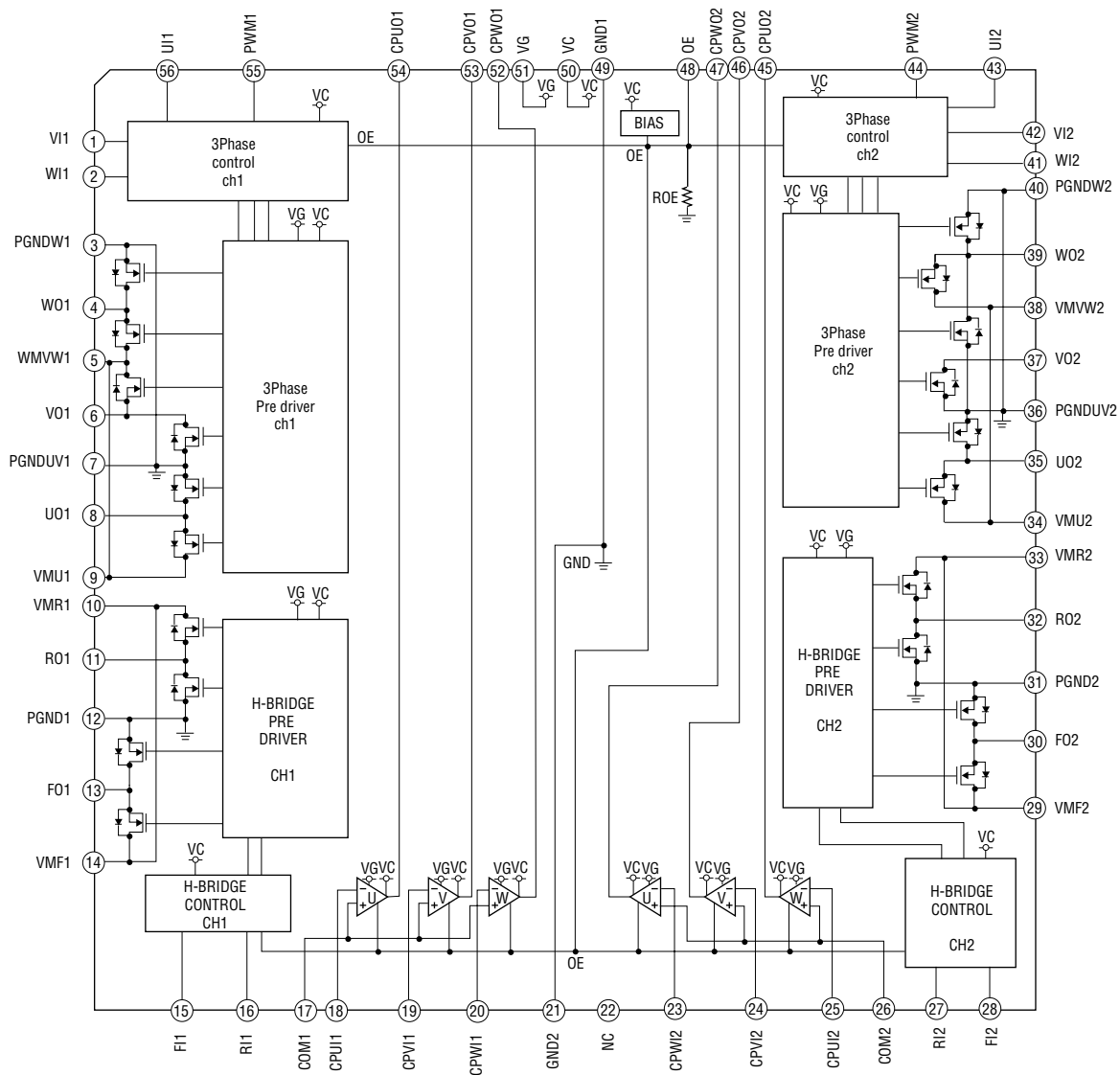

IC901 SC901580EPR2

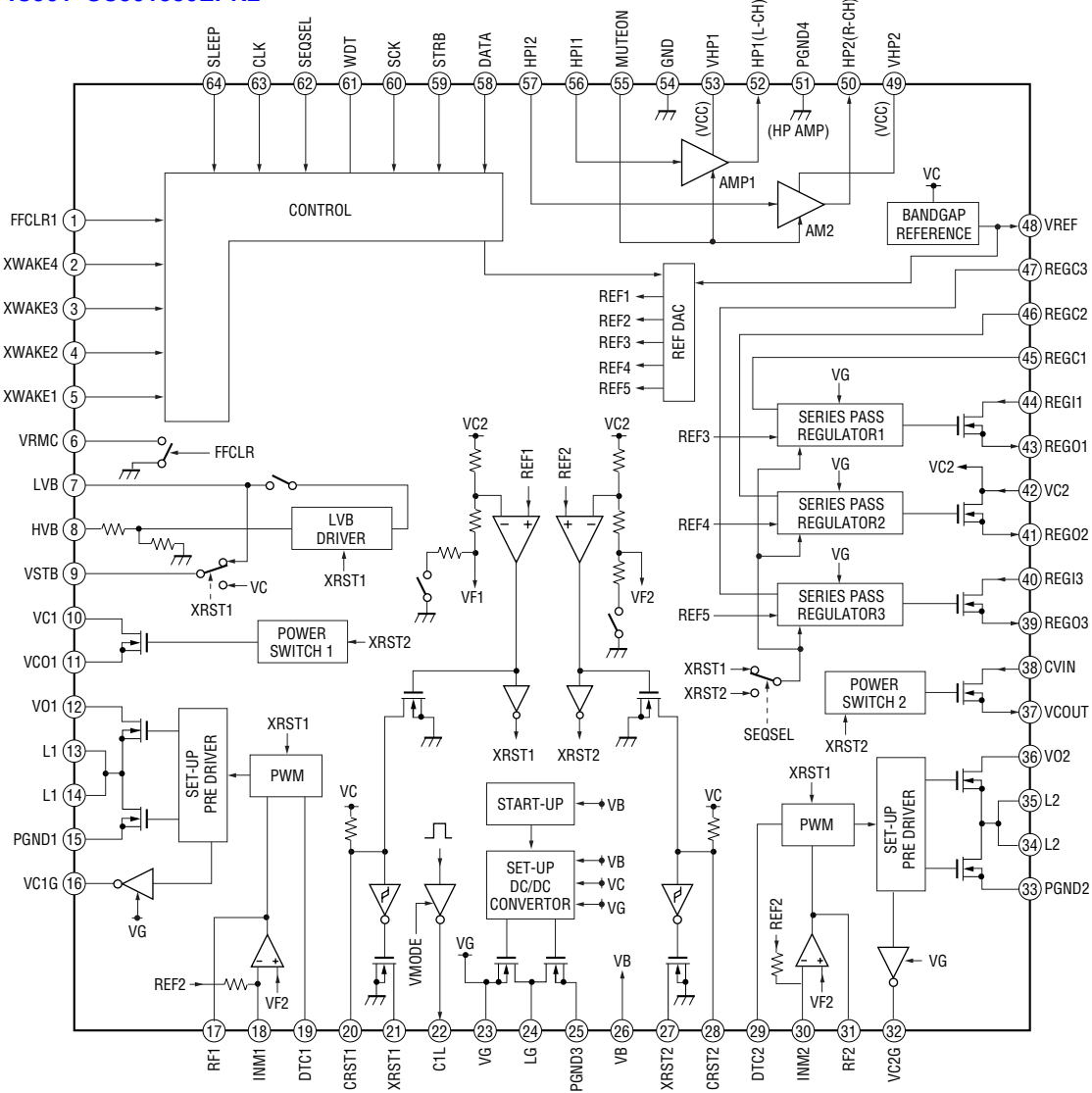

IC951 SC901582EPR2

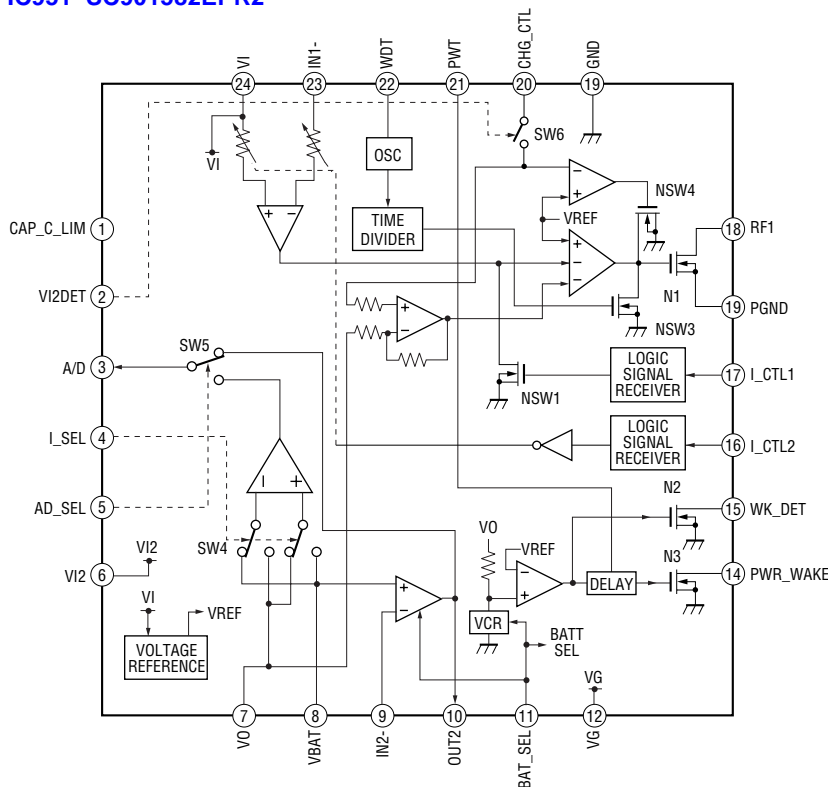

## 6-9. IC Pin Function Description

### • IC801 CXD2680-207GA (SYSTEM CONTROLLER, DIGITAL SIGNAL PROCESSOR)

Pin No.	Pin Name	I/O	Description
1	OSCI	I	Resonator connection terminal for the system clock (22.5792MHz)
2	OSCO	O	Resonator connection terminal for the system clock (22.5792MHz)
3	VREFL	O	Reference voltage terminal connected to the capacitor (for the built-in D/A converter L-CH)
4	AOUTL	O	Built-in D/A converter L-CH signal output
5	AOUTR	O	Built-in D/A converter R-CH signal output
6	VREFR	O	Reference voltage terminal connected to the capacitor (for the built-in D/A converter R-CH)
7	ASYO	O	Playback EFM duplex signal output
8	ASYI	I	Playback EFM comparator slice level input
9	BIAS	I	Bias current input terminal for the playback EFM comparator
10	RFI	I	Playback EFM RF signal input from the RF amplifier
11	PCO	O	Phase comparison output terminal for the playback EFM system master PLL
12	FILI	I	Filter input terminal for the playback EFM system master PLL
13	FILO	O	Filter output terminal for the playback EFM system master PLL
14	CLTV	I	Internal VCO control voltage input terminal for the playback EFM system master PLL
15	PEAK	I	Peak hold signal input of the light amount signal (RF/ABCD) from the RF amplifier
16	BOTM	I	Bottom hold signal input of the light amount signal (RF/ABCD) from the RF amplifier
17	ABCD	I	Light amount signal (ABCD) input from the RF amplifier
18	FE	I	Focus error signal input from the RF amplifier
19	VC	I	Middle point voltage input from the RF amplifier
20	ADIO	O	Monitor output terminal of A/D converter input signal Not used (open)
21	ADRB	I	The lower limit voltage of A/D converter input terminal (connected to the ground)
22	SE	I	Sled error signal input from the RF amplifier
23	TE	I	Tracking error signal input from the RF amplifier
24	AUX1	I	Auxiliary A/D input (fixed at H in this set)
25	ADRT	I	The upper limit voltage of A/D converter input terminal (fixed at H in this set)
26	DCHG	I	Connecting terminal with the analog power supply of low impedance (fixed at H in this set)
27	APC	I	Error signal input for the laser automatic power control (fixed at H in this set)
28	ADFG	I	ADIP duplex FM signal (22.05±1kHz) input from the RF amplifier
29	APCREF	O	Reference PWM signal output for the laser automatic power control to the RF amplifier
30	TRDR	O	Tracking servo drive PWM signal output (→) to the coil driver
31	TFDR	O	Tracking servo drive PWM signal output (+) to the coil driver
32	FFDR	O	Focus servo drive PWM signal output (+) to the coil driver
33	FRDR	O	Focus servo drive PWM signal output (→) to the coil driver
34	FS4	O	176.4kHz clock signal output
35	SFDR	O	Sled servo drive PWM signal output to the motor driver
36	SPRD	O	Spindle motor drive control signal output (U) to the motor driver
37	SPFD	O	Spindle servo drive PWM signal output to the motor driver
38	SPDV	O	Spindle motor drive control signal output (V) to the motor driver
39	SPDW	O	Spindle motor drive control signal output (W) to the motor driver
40	SPCU	I	Spindle motor drive comparison signal input (U) from the motor driver
41	SPCV	I	Spindle motor drive comparison signal input (V) from the motor driver
42	SPCW	I	Spindle motor drive comparison signal input (W) from the motor driver
43	SLDV	O	Sled motor drive control signal output (V) to the motor driver
44	SLDW	O	Sled motor drive control signal output (W) to the motor driver
45	SLCU	I	Sled motor drive comparison signal input (U) from the motor driver
46	SLCV	I	Sled motor drive comparison signal input (V) from the motor driver
47	SLCW	I	Sled motor drive comparison signal input (W) from the motor driver
48	SRDR	O	Sled motor drive control signal output (U) to the motor driver
49	DIN	I	Digital audio signal input
50	DADT	O	Audio data output terminal Not used (open)

Pin No.	Pin Name	I/O	Description
51	ADDT	I	Data input from the external A/D converter
52	KRCK	O	L/R sampling clock (44.1KHz) output to the external A/D converter
53	XBCK	O	Bit clock (2.8224MHz) output to the external A/D converter
54	FS256	O	11.2896MHz clock output
55	NC	O	Filter cutoff control signal output Not used (open)
56	NC	I	Clock input from the external VCO Not used (open)
57	LRCKI	I	Input terminal for the PCM data I/F/ ATRAC data I/F Not used (open)
58	XBCKI	I	Input terminal for the PCM data I/F/ ATRAC data I/F Not used (open)
59	DATAI	I	Input terminal for the PCM data I/F/ ATRAC data I/F Not used (open)
60	NC	—	Not used (open)
61	EXCS	O	Chip select signal output terminal for the external SDRAM Not used (open)
62, 63	NC	—	Not used (open)
64 to 66	MNT0 to 2	O	DSP monitor (0) to (2) output terminal Not used (open)
67	MNT3	O	DSP monitor (3) output terminal
68	SENS	O	DSP internal status (DSP SENS monitor) signal output terminal Not used (open)
69	TX	O	Record data output enable signal output Not used (open)
70	RECP	O	Laser power changeover signal output Not used (open)
71	EFMO	O	EFM encode data output for the record to the REC driver
72	TFMCK	I	FMCK signal input Not used (connected to the ground)
73	OFTRK	I/O	Tracking signal input/output Not used (open)
74	XSKH	O	L circuit signal output Not used (open)
75	XSKL	O	K-SHOCK circuit signal output Not used (open)
76	DCLSOUTL	O	PWM modulator signal output for the D class headphone amplifier Not used (open)
77	DCLSOUTR	O	PWM modulator signal output for the D class headphone amplifier Not used (open)
78 to 85	TD0 to 7	—	TigerI/F data 0 to 7 terminal Not used (open)
86	TREQ	—	TigerI/F REQUEST terminal Not used (connected to the ground)
87	TACK	—	TigerI/F ACK terminal Not used (connected to the ground)
88	PAUSE_KEY	I	Pause key detection input terminal from the switch & liquid crystal display module
89	PROTECT	I	Detection signal input terminal of the record check claw from the protect detection switch “H”: protect
90	OPT_DET	I	DIN plug detection signal input “H”: DIN plug detect
91	XJACK_DET	I	LINE IN plug detection signal input “L”: LINE or OPT plug detect
92	XMIC_DET	I	Microphone plug detection signal input “L”: microphone plug detect Not used (open)
93	OPEN_CLOSE_SW	I	Open/close detection switch of the upper panel input terminal “L”: when upper panel close
94	XCS_ADC	O	Chip select signal output to the A/D converter
95	XPD_ADC	O	Power supply control signal output to the A/D converter
96	CHG_CTL	O	Charge ON/OFF control signal output
97	LCD_RST	O	Reset control signal output to the liquid crystal display module
98	XMUTE	O	Analog muting control signal output to the headphone amplifier “L”: muting ON Not used (open)
99	XPATCH	I	Patch function detection terminal “L”: patch function (fixed at “L” in this set)
100	SI0	I	Serial data input from the nonvolatile memory and liquid crystal display module
101	SO0	O	Serial data output to the nonvolatile memory, A/D converter, liquid crystal display module and power control
102	SCK0	O	Serial clock output to the nonvolatile memory, A/D converter, liquid crystal display module and power control
103	XGUM_ON	I	Rechargeable battery detection switch input terminal “L”: rechargeable battery in detect Not used (open)
104	BEEP	O	Beep sound control signal output to the headphone amplifier
105	XOPT_CTL	O	Power supply ON/OFF control signal output for the DIN PD drive
106	XHP_STBY	O	Power supply control signal output to the headphone amplifier
107	AOUT_SEL	O	HP/LINE changeover signal output to the headphone amplifier Not used (open)
108	REC_OPR_LED	O	LED ON/OFF control signal output for the REC display Not used (open)
109	MDVCC_CTL	O	Power supply control signal output for the OP modulation Not used (open)
110	OPVCC_CTL	O	Power supply control signal output for the OP laser Not used (open)

Pin No.	Pin Name	I/O	Description
111	BATT_CTL	O	Control signal output for the voltage step up circuit in the external battery case Not used (open)
112	VREC_CTL	O	VREC voltage control signal output Not used (open)
113	XRST_CHG_IC	O	Reset signal output to the battery charge control IC
114, 115	PD_S0_1	O	PD IC mode changeover signal output to the optical pick up
116	LINK_MON	O	Linking area monitor signal output Not used (open)
117	PL_CTL	O	Plunger control signal output Not used (open)
118	GND_SW	O	Ground changeover switch control signal output Not used (open)
119, 120	NC	O	Not used (open)
121	SLD_MON	I	Sled servo monitor signal input
122	NC	O	Not used (open)
123	SLEEP	O	System sleep control signal output to the power control
124	FFCLR	O	Input latch output for the start switching to the power control
125	CHGI_CTL1	O	Charge current limit ON/OFF control signal output at the time of adaptor use
126	CHGI_CTL2	O	Charge current limit value changeover control signal output at the time of adaptor use Not used (open)
127	ORANGE_LED	O	Orange LED ON/OFF control signal output Not used (open)
128	CHG_LED	O	LED ON/OFF control signal output for CHG (charge display) Not used (open)
129	XTEST	I	Terminal for the test mode setting (normally open) "L": test mode
130	XRF_RST	O	Reset control signal output to the RF amplifier "L": reset
131	XEXT_PWR	I	External power supply (AC adaptor/charging stand) detection signal input
132	XHOLD_SW	I	HOLD switch input terminal "L": hold ON
133	COUT_MON	I	Traverse count measurement monitor input
134	CHG_ADSEL	O	A/D terminal of the battery charge control IC output selection signal output
135	CHGI_SEL	O	Charge/discharge changeover control signal output for the current sense amplifier
136	XDC_IN	I	DC plug detection signal input Not used (open)
137	SPDL_MON	I	Spindle servo monitor signal input
138	XCS_PWR_IC	O	Chip select signal output to the power control
139, 140	D_EN1_2	O	Control signal output for the D class headphone amplifier Not used (open)
141	XCS_LCD	O	Chip select signal output to the liquid crystal display module
142	LCD_STB	O	Strobe signal output to the liquid crystal display module
143	XRST_MTR_DRV	O	Reset control signal output to the motor driver "L": reset
144	XCS_NV	O	Chip select signal output to the nonvolatile memory
145	CHG_PWM	O	Output voltage control signal output to the battery charge control
146	VREC_PWM	O	PWM signal output for the Over write head drive power supply voltage control to the REC driver
147	NC	O	PWM signal output for the laser power supply voltage control to the power control Not used (open)
148	NJM_XMUTE	O	Muting control signal to the headphone amplifier (NJM type made by JRC) Not used (open)
149	D_VO_PWM	O	Power supply control signal output for the D class headphone amplifier Not used (open)
150	XCS_REC_DRV	O	Chip select signal output to the REC driver Not used (open)
151	T_MARK_SW	I	T MARK (track mark) switch input terminal "L": track mark detection Not used (open)
152	JOG_A	I	Jog dial pulse input from the switch & liquid crystal display module Not used (open)
153	JOG_B	I	Jog dial pulse input from the switch & liquid crystal display module Not used (open)
154, 155	NC	O	Not used (open)
156	SSB_DATA	I/O	SSB data input/output with the RF amplifier
157	SSB_CLK	O	SSB clock output to the RF amplifier
158	VBUS_DET	I	USB power supply voltage detection terminal
159	VB_MON	I	Voltage monitor input terminal (A/D input) of the UNREG power supply
160	CHG_MON	I	Decrement of voltage detection and charge/discharge current monitor input from the battery charge control
161	VREF_MON	I	Reference voltage monitor input (A/D input) from the RF amplifier
162, 163	SET_KEY_1, 2	I	Key input (A/D input) from the switch & liquid crystal display module
164	CRADLE_DET	I	USB cradle or battery case detection signal input Not used (connected to the ground)
165	HIDC_MON	I	HIGH DC voltage monitor input (A/D input)

Pin No.	Pin Name	I/O	Description
166	WK_DET	I	Set key WAKE detection signal input
167	BATT_MON	I	External battery voltage monitor input Not used (connected to the ground)
168	HALF_LOCK_SW	I	Open button detection switch input (A/D input) "L" : the open button is pressed
169	RMC_KEY	I	Key input (A/D input) from the remote commander
170	JOG_PUSH	I	Jog dial push detection signal input Not used (open)
171	REC_KEY/PLAY_KEY	I	REC key input (A/D input)
172	END_SEARCH	I	END SEARCH key input (A/D input) Not used (open)
173	RADIO_ON	I	RADIO ON detection signal input
174	RMC_DTCK	I/O	TSB master data clock input/output or SSB data input/output
175	UDP	I/O	USB data (+) input terminal
176	UDM	I/O	USB data (-) input terminal
177	SUSPEND	O	USB suspend signal output Not used (open)
178	UPUEN	O	USB pull-up resistor connection control output terminal
179	UOSCI	I	Resonator (48MHz) connection terminal for the USB oscillation circuit
180	UOSCO	O	Resonator (48MHz) connection terminal for the USB oscillation circuit
181	SI3	I	Not used (connected to the ground)
182	SO3	O	Not used (open)
183	SCK3	I/O	Not used (open)
184	MSIN	I	Not used (connected to the ground)
185	MSOUT	O	Not used (open)
186	MSCK	I/O	Not used (open)
187	RF_PWR	O	Power supply control signal output to the RF amplifier Not used (open)
188	LCD_PWR	O	Power supply control signal output to the liquid crystal display module Not used (open)
189	SP_AMP	O	Built-in speaker control signal output "H": activate Not used (open)
190	XHP_DET	I	Headphone jack detection signal input Not used (open)
191	SET_CODE0	I	Input terminal for the set (open in this set)
192	SET_CODE1	I	Input terminal for the set (open in this set)
193	SET_CODE2	I	Input terminal for the set (open in this set)
194	SET_CODE3	I	Input terminal for the set (fixed at "L" in this set)
195, 196	NC	O	Not used (open)
197	VBUS5V_DET	I	USB power supply voltage detection terminal 2 Not used (open)
198	LG_DCR_CTL	O	LG DCR control signal output Not used (open)
199	MUTE	O	Analog muting control signal output to the headphone amplifier "H": muting ON
200	CLV_PWR_SEL	O	CLV motor power supply selection control signal output Not used (open)
201	CS_RTC	O	Chip select signal output to the real time clock Not used (open)
202 to 204	MODE1 to 3	O	Power supply control signal output for the over write head to the REC driver
205, 206	HD_CON_1, 2	O	Over write head control signal output to the REC driver
207	TAT	I	Not used (open)
208	TAN	I	Not used (open)
209	NAR	I	Not used (open)
210	IOD	I	Not used (open)
211	SAK	O	Not used (open)
212	XRST	I	System reset signal input from the power control "L": reset
213	TRST	I	Terminal for the test mode setting (normally fixed at "L")
214, 215	TEST0, 1	I	Input terminal for the main test (normally fixed at "L")
216 to 231	D0 to 15	—	DRAM data0 to 15 terminal Not used (open)
232 to 245	A00 to 13	—	DRAM address0 to 13 terminal Not used (open)
246	XCAS	—	DRAM CAS terminal Not used (open)
247	XRAS	—	DRAM RAS terminal Not used (open)
248	XWE	—	DRAM write enable terminal Not used (open)

Pin No.	Pin Name	I/O	Description
249	XCS	—	DRAM chip select terminal Not used (open)
250	CLK	—	DRAM clock terminal Not used (open)
251	CKE	—	DRAM clock enable terminal Not used (open)
252	UDQM	—	DRAM byte mask terminal Not used (open)
253	LDQM	—	DRAM byte mask terminal Not used (open)
254	DVDD0	—	Power supply terminal
255	DVSS0	—	Ground terminal
256	DVDD1	—	Power supply terminal
257	DVSS1	—	Ground terminal
258	DVDD2	—	Power supply terminal
259	DVSS2	—	Ground terminal
260	DVDD3	—	Power supply terminal
261	DVSS3	—	Ground terminal
262	DVDD4	—	Power supply terminal
263	DVSS4	—	Ground terminal
264	IFVDD0	—	Power supply terminal (for the microcomputer I/F block)
265	IFVSS0	—	Ground terminal (for the microcomputer I/F block)
266	IFVDD1	—	Power supply terminal (for the microcomputer I/F block)
267	IFVSS1	—	Ground terminal (for the microcomputer I/F block)
268	IFVDD2	—	Power supply terminal (for the microcomputer I/F block)
269	IFVSS2	—	Ground terminal (for the microcomputer I/F block)
270	IFVDD3	—	Power supply terminal (for the microcomputer I/F block)
271	IFVSS3	—	Ground terminal (for the microcomputer I/F block)
272	IFVDD4	—	Power supply terminal (for the microcomputer I/F block)
273	IFVSS4	—	Ground terminal (for the microcomputer I/F block)
274	AVDD	—	Power supply terminal (for the microcomputer analog)
275	AVSS	—	Ground terminal (for the microcomputer analog)
276	VDIOSC	—	Power supply terminal (for the OSC cell)
277	VSIOSC	—	Ground terminal (for the OSC cell)
278	DAVDD	—	Power supply terminal (for the built-in D/A converter)
279	DAVSS	—	Ground terminal (for the built-in D/A converter)
280	AVD1	—	Power supply terminal (for the DSP asymmetry system analog)
281	AVS1	—	Ground terminal (for the DSP asymmetry system analog)
282	AVD2	—	Power supply terminal (for the DSP servo system analog)
283	AVS2	—	Ground terminal (for the DSP servo system analog)
284	TSMVDD	—	Power supply terminal (for the TSB master communication)
285	TSLVDD	—	Power supply terminal (for the TSB slave I/F)
286	DRAMVDD1	—	Power supply terminal (for DRAM)
287	DRAMVSS1	—	Ground terminal (for DRAM)
288	DRAMVDD2	—	Power supply terminal (for DRAM)
289	DRAMVSS2	—	Ground terminal (for DRAM)
290	ITO	—	Power supply terminal (for writing the flash memory)
291	MITY	—	Ground terminal (for writing the flash memory)
292	USBIFVDD	—	Power supply terminal (for USB I/F)
293	MVDD	—	Power supply terminal (for the microcomputer I/F block)
294	USBOSCVDD	—	Power supply terminal (for the USB oscillation circuit)
295	USBOSCVSS	—	Ground terminal (for the USB oscillation circuit)
296	AVDPLL	—	Power supply terminal (for PLL)
297	AVSPLL	—	Ground terminal (for PLL)
298	EVA	I	EVA terminal (fixed at "L" in this set)



Pin No.	Pin Name	I/O	Description
299	FVDD0	—	Power supply terminal (for the built-in flash memory)
300	FVSS0	—	Ground terminal (for the built-in flash memory)
301, 302	DVDD5, 6	—	Power supply terminal
303, 304	DRAMVDD3, 4	—	Power supply terminal (for DRAM)
305	MSAK	—	Not used (open)
306 to 312	NC	—	Not used (open)

## SECTION 7 EXPLODED VIEWS

**NOTE:**

- XX and -X mean standardized parts, so they may have some difference from the original one.

- Items marked “\*” are not stocked since they are seldom required for routine service. Some delay should be anticipated when ordering these items.
- Abbreviation  
CND : Canadian model

The components identified by mark  $\triangle$  or dotted line with mark  $\triangle$  are critical for safety. Replace only with part number specified.

Les composants identifiés par une marque  $\triangle$  sont critiques pour la sécurité. Ne les remplacer que par une pièce portant le numéro spécifié.

### 7-1. Case Section

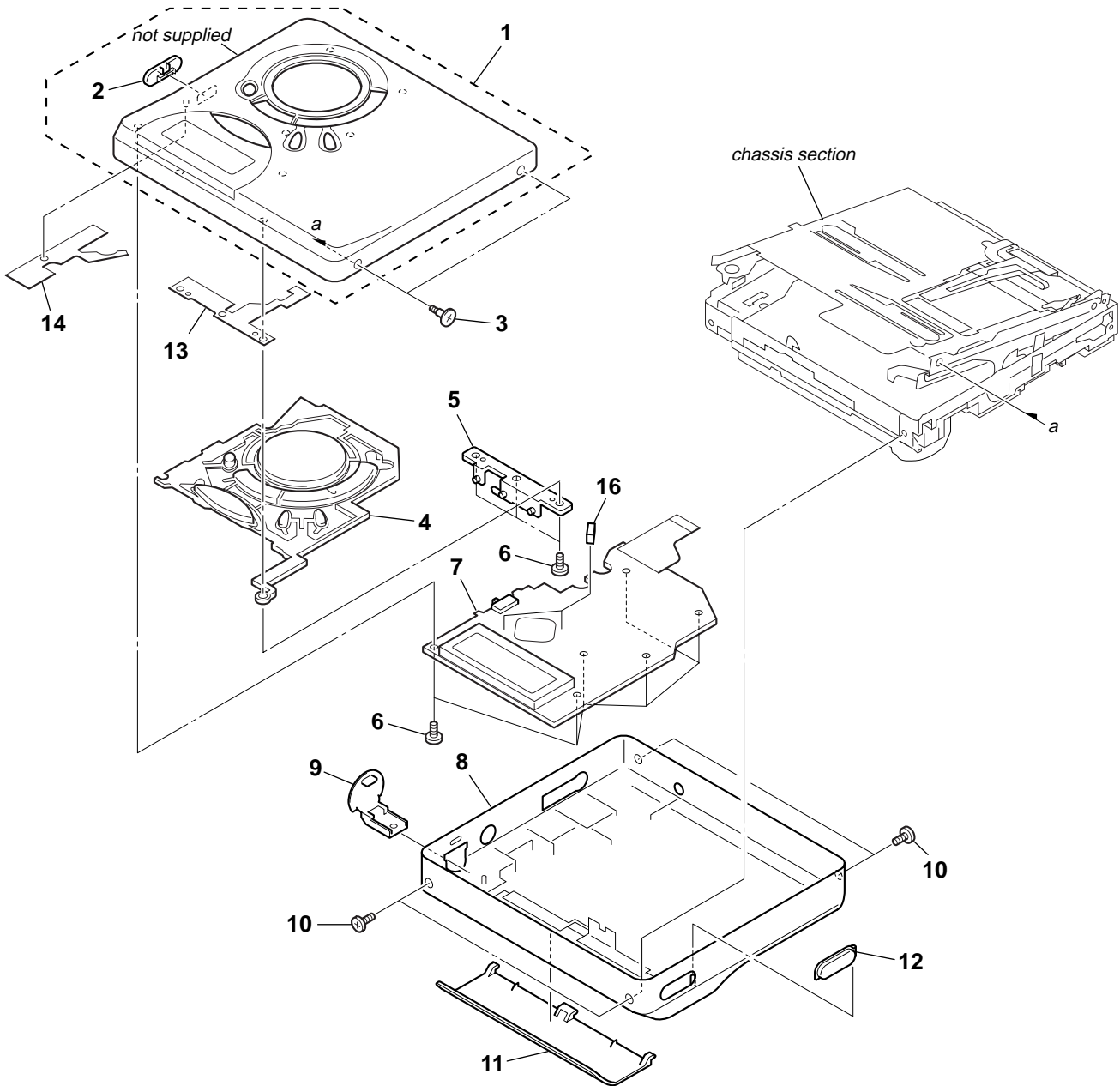

Ref. No.	Part No.	Description	Remark	Ref. No.	Part No.	Description	Remark
1	X-3383-521-1	CASE (UPPER) SUB ASSY (CND)		8	3-246-243-51	CASE (LOWER)	
1	X-3383-522-1	CASE (UPPER) SUB ASSY (US)		9	3-246-248-01	CAP (USB)	
1	X-3384-051-1	CASE (UPPER) SUB ASSY (UK)		10	3-234-449-19	SCREW (M1.4)	
2	3-249-687-31	KNOB (HOLD)		11	3-249-688-01	LID, BATTERY CASE	
3	3-241-529-01	SCREW, STEP		12	3-237-099-31	BUTTON (OPEN)	
4	3-246-238-01	BUTTON (CONTROL)		13	3-250-624-01	PAPER (O/L), GROUND	
5	3-237-097-01	LOCKER, OPEN		14	3-253-357-01	PAPER (BUTTON), GROUND	
6	3-375-114-71	SCREW		16	3-253-762-01	CUSHION (PAUSE)	
7	1-804-989-11	LCD MODULE					

7-2. Chassis Section

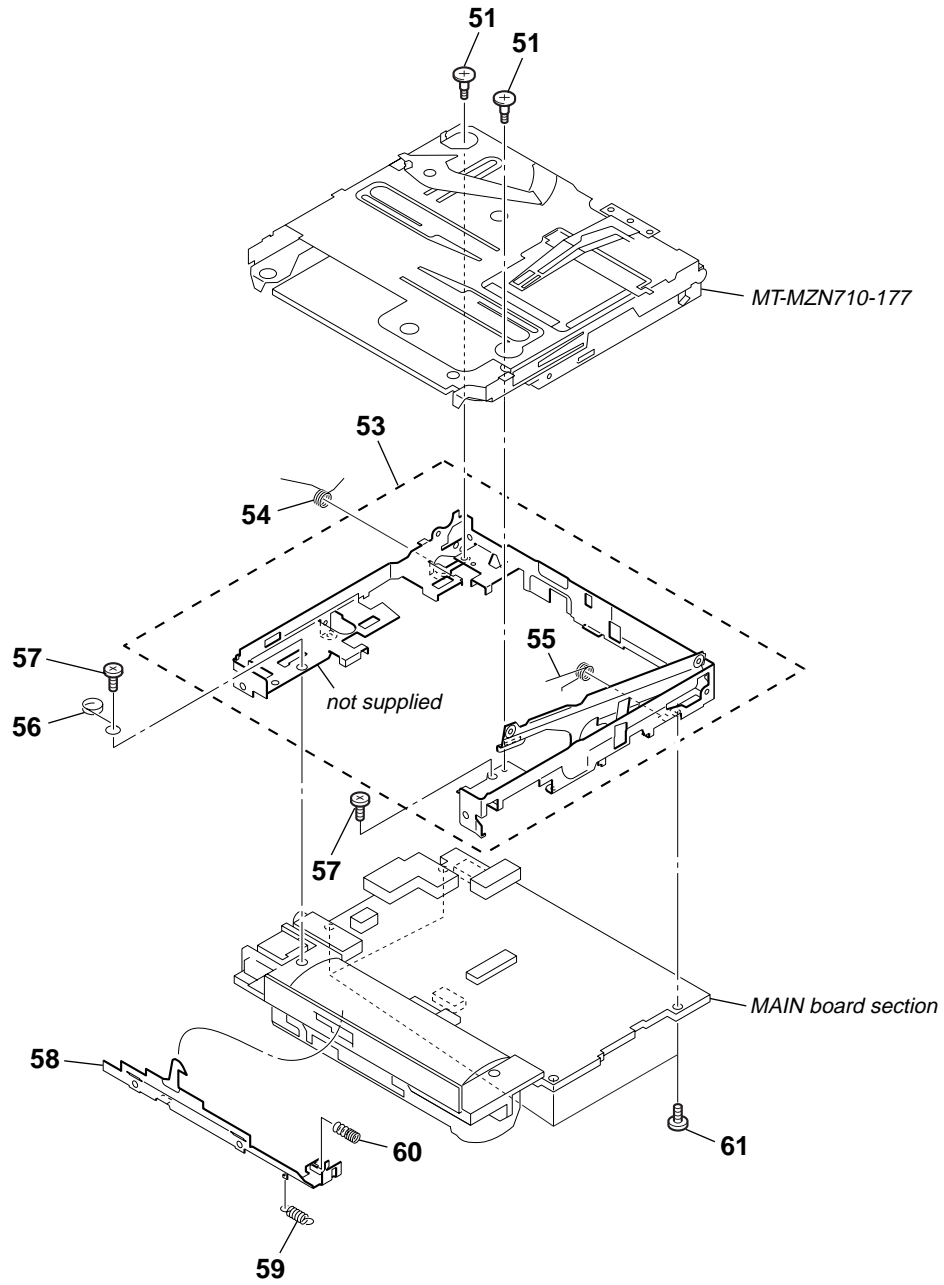

Ref. No.	Part No.	Description	Remark	Ref. No.	Part No.	Description	Remark
51	3-237-072-01	SCREW (MD), STEP		57	3-318-382-91	SCREW (1.7X2.5), TAPPING	
53	X-3382-628-1	CHASSIS ASSY, SET		58	3-246-245-01	SLIDER, OPEN	
54	3-249-532-01	SPRING (POP UP-L), TORSION		59	3-237-082-01	SPRING (LOCK), TENSION	
55	3-237-083-01	SPRING (POP UP-R), TORSION		60	3-237-081-01	SPRING (LIMITTER), COMPRESSION	
56	3-250-692-01	SPRING (USB), GROUND		61	3-225-995-91	SCREW (M1.4) (EG), TOOTHED LOCK	

**7-3. MAIN Board Section**

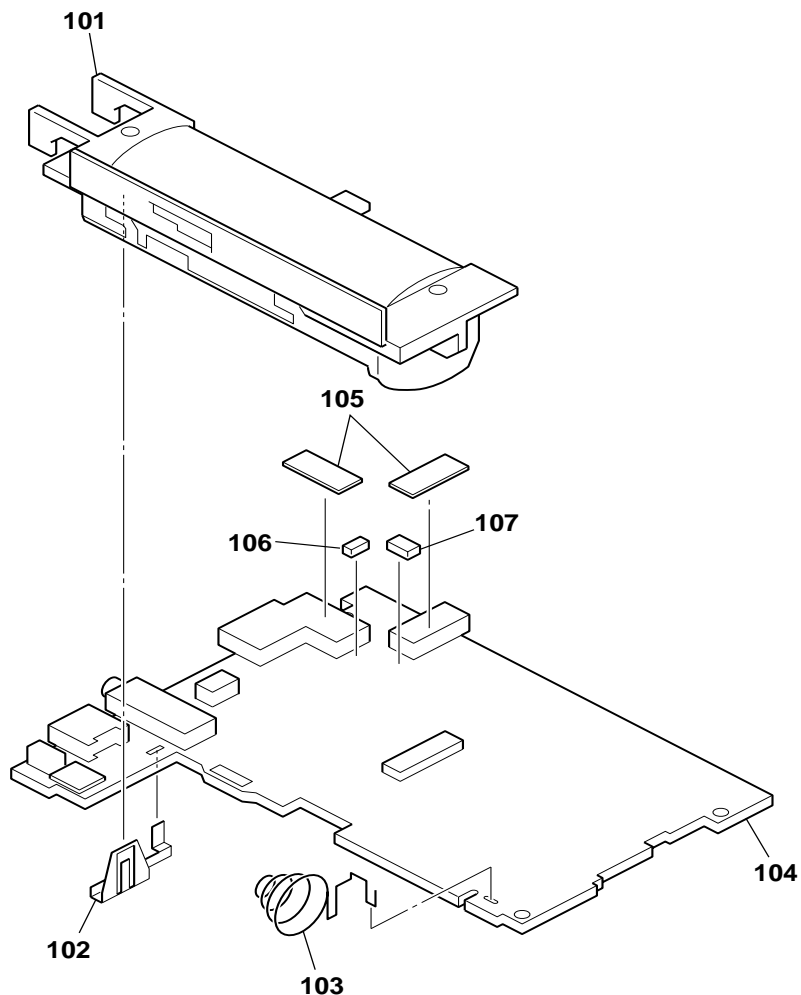

<u>Ref. No.</u>	<u>Part No.</u>	<u>Description</u>	<u>Remark</u>
101	3-246-247-01	CASE, BATTERY	
102	3-237-073-01	TERMINAL BOARD (+), BATTERY	
103	3-237-074-11	TERMINAL (-), BATTERY	
* 104	A-3683-780-B	MAIN BOARD, COMPLETE (US)	
* 104	A-3683-783-B	MAIN BOARD, COMPLETE (CND,UK)	

<u>Ref. No.</u>	<u>Part No.</u>	<u>Description</u>	<u>Remark</u>
105	3-253-535-01	SHEET (DC-IN)	
106	3-253-534-01	CUSHION (H/J)	
107	3-253-533-01	CUSHION (DC-IN)	

7-4. Mechanism Deck Section-1  
(MT-MZN710-177)

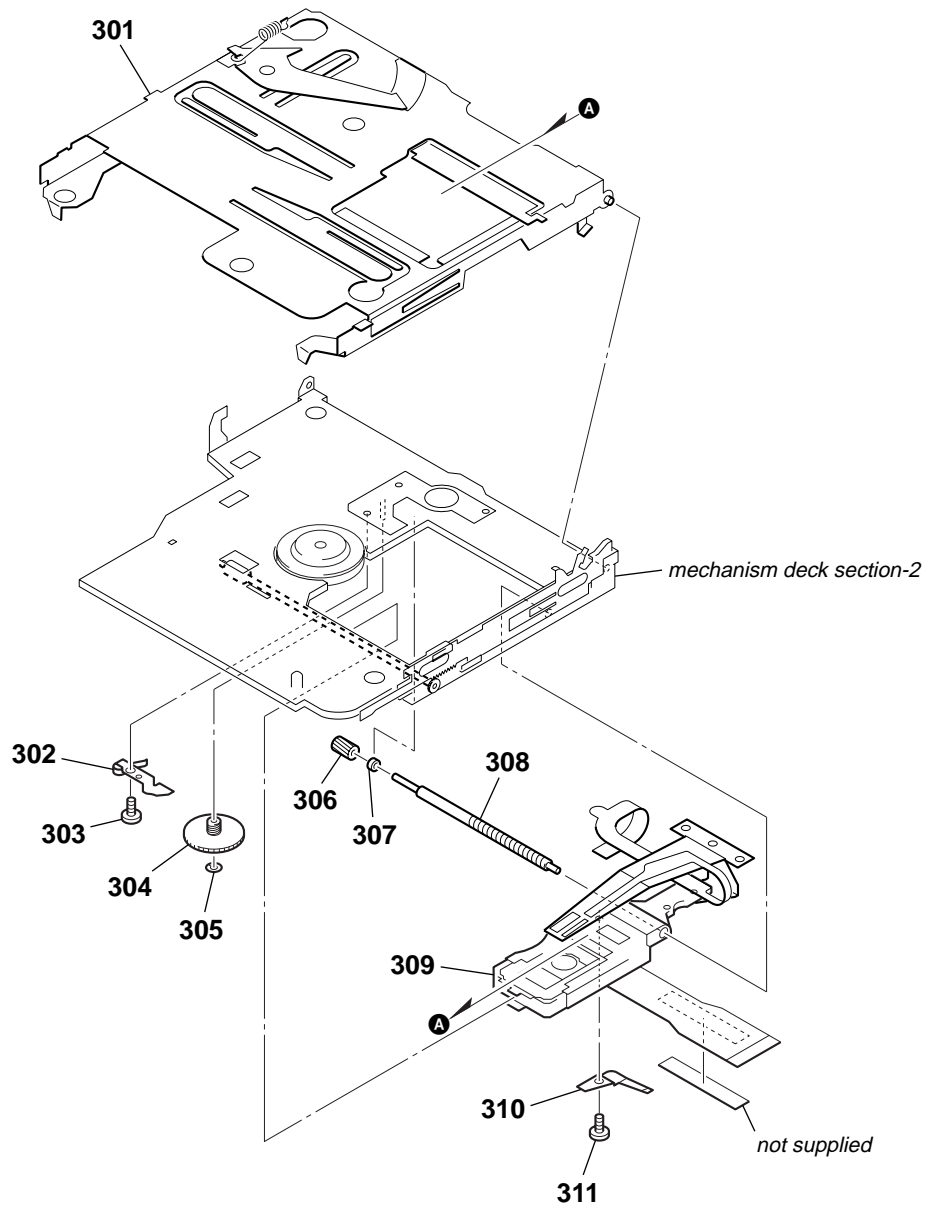

Ref. No.	Part No.	Description	Remark	Ref. No.	Part No.	Description	Remark
301	X-3381-219-1	HOLDER ASSY		307	3-043-237-02	BEARING (N)	
302	3-224-779-02	SPRING, THRUST DETENT		308	4-222-203-02	SCREW, LEAD	
303	3-225-996-01	SCREW (M1.4) (EG), PRECISION PAN		△ 309	X-3382-953-1	SERVICE ASSY, OP (LCX-5R)	
304	4-222-216-01	GEAR (SA)		310	3-049-336-03	SPRING (S), RACK	
305	3-338-645-31	WASHER (0.8-2.5)		311	3-225-996-06	SCREW (M1.4) (EG), PRECISION PAN	
306	4-222-208-01	GEAR (SB)					

<p>The components identified by mark △ or dotted line with mark △ are critical for safety. Replace only with part number specified.</p>	<p>Les composants identifiés par une marque △ sont critiques pour la sécurité. Ne les remplacer que par une pièce portant le numéro spécifié.</p>
---	---

7-5. Mechanism Deck Section-2  
(MT-MZN710-177)

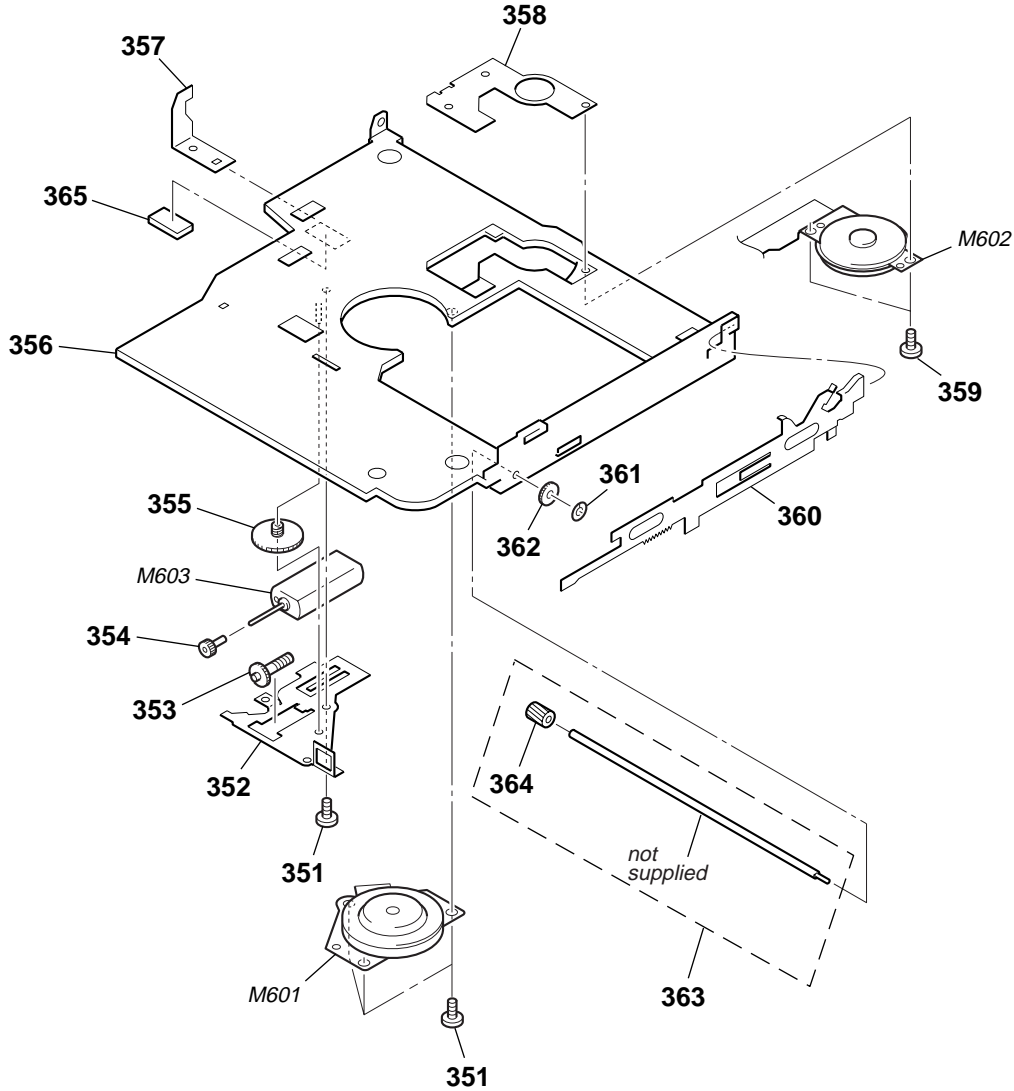

Ref. No.	Part No.	Description	Remark
351	3-225-278-12	SCREW, TAPPING	
352	3-235-838-01	COVER, MOTOR	
353	3-235-836-01	GEAR (HB)	
354	3-222-544-01	GEAR (HA)	
355	3-235-835-01	GEAR (HC)	
356	3-235-834-01	CHASSIS	
357	3-235-830-01	PLATE, RATCHET	
358	X-3379-529-4	BASE ASSY, MOTOR	
359	3-225-996-07	SCREW (M1.4) (EG), PRECISION PAN	
360	3-235-839-01	LEVER (RACK)	

Ref. No.	Part No.	Description	Remark
361	3-338-645-31	WASHER (0.8-2.5)	
362	4-222-222-01	GEAR (RACK)	
363	A-3174-089-A	SHAFT BLOCK ASSY, SUB	
364	4-222-218-02	GEAR (HD)	
365	3-253-536-01	SPACER (H/J)	
M601	8-835-744-21	MOTOR, DC SSM18B/C-NP (SPINDLE)	
M602	1-763-727-11	MOTOR, DC (SLED) (WITH GEAR)	
M603	1-763-400-21	MOTOR, DC (OVER WRITE HEAD UP/DOWN)	

## SECTION 8 ELECTRICAL PARTS LIST

MAIN

**NOTE:**

- Due to standardization, replacements in the parts list may be different from the parts specified in the diagrams or the components used on the set.
- -XX and -X mean standardized parts, so they may have some difference from the original one.
- RESISTORS  
All resistors are in ohms.  
METAL: Metal-film resistor.  
METAL OXIDE: Metal oxide-film resistor.  
F: nonflammable
- CAPACITORS  
uF:  $\mu$ F
- COILS  
uH:  $\mu$ H
- Abbreviation  
CND : Canadian model
- Items marked "\*" are not stocked since they are seldom required for routine service.  
Some delay should be anticipated when ordering these items.
- SEMICONDUCTORS  
In each case, u:  $\mu$ , for example:  
uA. . :  $\mu$ A. .      uPA. . :  $\mu$ PA. .  
uPB. . :  $\mu$ PB. .    uPC. . :  $\mu$ PC. .  
uPD. . :  $\mu$ PD. .

When indicating parts by reference number, please include the board name.

The components identified by mark  $\Delta$  or dotted line with mark  $\Delta$  are critical for safety. Replace only with part number specified.

Les composants identifiés par une marque  $\Delta$  sont critiques pour la sécurité. Ne les remplacer que par une pièce portant le numéro spécifié.

Ref. No.	Part No.	Description	Remark	Ref. No.	Part No.	Description	Remark
*	A-3683-780-B	MAIN BOARD, COMPLETE (US)		C363	1-107-820-11	CERAMIC CHIP 0.1uF	16V
*	A-3683-783-B	MAIN BOARD, COMPLETE (CND,UK)		C364	1-135-151-21	TANTALUM CHIP 4.7uF	20% 4V
		*****		C365	1-125-889-91	CERAMIC CHIP 2.2uF	10% 10V
	3-242-558-01	SPACER (LINE IN)		C366	1-135-201-11	TANTALUM CHIP 10uF	20% 4V
		< CAPACITOR >		C505	1-165-851-91	TANTAL. CHIP 10uF	20% 6.3V
C104	1-164-874-11	CERAMIC CHIP 100PF	5.00% 50V	C506	1-164-943-11	CERAMIC CHIP 0.01uF	10.00% 16V
C105	1-125-837-91	CERAMIC CHIP 1uF	10% 6.3V	C507	1-135-259-11	TANTAL. CHIP 10uF	20.00% 6.3V
C108	1-164-874-11	CERAMIC CHIP 100PF	5.00% 50V	C509	1-107-820-11	CERAMIC CHIP 0.1uF	16V
C112	1-126-246-11	ELECT CHIP 220uF	20% 4V	C510	1-119-750-11	TANTAL. CHIP 22uF	20.00% 6.3V
C161	1-164-941-11	CERAMIC CHIP 0.0047uF	10.00% 16V	C511	1-164-850-11	CERAMIC CHIP 10PF	0.50PF 50V
C162	1-164-939-11	CERAMIC CHIP 0.0022uF	10.00% 50V	C512	1-164-850-11	CERAMIC CHIP 10PF	0.50PF 50V
C163	1-109-982-11	CERAMIC CHIP 1uF	10.00% 10V (US)	C513	1-107-819-11	CERAMIC CHIP 0.022uF	10.00% 16V
C163	1-125-889-91	CERAMIC CHIP 2.2uF	10% 10V (CND,UK)	C514	1-164-939-11	CERAMIC CHIP 0.0022uF	10.00% 50V
C164	1-115-467-11	CERAMIC CHIP 0.22uF	10.00% 10V	C517	1-164-943-11	CERAMIC CHIP 0.01uF	10.00% 16V
C204	1-164-874-11	CERAMIC CHIP 100PF	5.00% 50V	C518	1-164-943-11	CERAMIC CHIP 0.01uF	10.00% 16V
C205	1-125-837-91	CERAMIC CHIP 1uF	10% 6.3V	C519	1-107-820-11	CERAMIC CHIP 0.1uF	16V
C208	1-164-874-11	CERAMIC CHIP 100PF	5.00% 50V	C520	1-107-820-11	CERAMIC CHIP 0.1uF	16V
C212	1-126-246-11	ELECT CHIP 220uF	20% 4V	C522	1-107-820-11	CERAMIC CHIP 0.1uF	16V
C261	1-164-941-11	CERAMIC CHIP 0.0047uF	10.00% 16V	C523	1-164-939-11	CERAMIC CHIP 0.0022uF	10.00% 50V
C262	1-164-939-11	CERAMIC CHIP 0.0022uF	10.00% 50V	C524	1-125-837-91	CERAMIC CHIP 1uF	10% 6.3V
C263	1-109-982-11	CERAMIC CHIP 1uF	10.00% 10V (US)	C526	1-119-923-81	CERAMIC CHIP 0.047uF	10.00% 10V
C263	1-125-889-91	CERAMIC CHIP 2.2uF	10% 10V (CND,UK)	C527	1-164-941-11	CERAMIC CHIP 0.0047uF	10.00% 16V
C264	1-115-467-11	CERAMIC CHIP 0.22uF	10.00% 10V	C533	1-164-943-11	CERAMIC CHIP 0.01uF	10.00% 16V
C304	1-125-777-11	CERAMIC CHIP 0.1uF	10.00% 10V	C534	1-164-941-11	CERAMIC CHIP 0.0047uF	10.00% 16V
C305	1-125-777-11	CERAMIC CHIP 0.1uF	10.00% 10V	C535	1-125-837-91	CERAMIC CHIP 1uF	10% 6.3V
C306	1-125-777-11	CERAMIC CHIP 0.1uF	10.00% 10V	C536	1-125-777-11	CERAMIC CHIP 0.1uF	10.00% 10V
C307	1-107-820-11	CERAMIC CHIP 0.1uF	16V	C537	1-107-819-11	CERAMIC CHIP 0.022uF	10.00% 16V
C308	1-107-820-11	CERAMIC CHIP 0.1uF	16V	C538	1-107-819-11	CERAMIC CHIP 0.022uF	10.00% 16V
C310	1-107-820-11	CERAMIC CHIP 0.1uF	16V	C540	1-164-941-11	CERAMIC CHIP 0.0047uF	10.00% 16V
C312	1-107-820-11	CERAMIC CHIP 0.1uF	16V	C613	1-135-259-11	TANTAL. CHIP 10uF	20.00% 6.3V
C313	1-107-820-11	CERAMIC CHIP 0.1uF	16V	C614	1-135-259-11	TANTAL. CHIP 10uF	20.00% 6.3V
C314	1-110-569-11	TANTAL. CHIP 47uF	20.00% 6.3V	C615	1-125-777-11	CERAMIC CHIP 0.1uF	10.00% 10V
C315	1-135-149-21	TANTALUM CHIP 2.2uF	20% 10V	C616	1-125-777-11	CERAMIC CHIP 0.1uF	10.00% 10V
C316	1-107-820-11	CERAMIC CHIP 0.1uF	16V	C617	1-125-777-11	CERAMIC CHIP 0.1uF	10.00% 10V
C325	1-128-015-11	ELECT CHIP 22uF	20.00% 4V	C618	1-125-777-11	CERAMIC CHIP 0.1uF	10.00% 10V
C327	1-164-933-11	CERAMIC CHIP 220PF	10.00% 50V	C621	1-164-943-11	CERAMIC CHIP 0.01uF	10.00% 16V
C339	1-107-820-11	CERAMIC CHIP 0.1uF	16V	C622	1-125-777-11	CERAMIC CHIP 0.1uF	10.00% 10V
C340	1-164-937-11	CERAMIC CHIP 0.001uF	10.00% 50V	C623	1-164-943-11	CERAMIC CHIP 0.01uF	10.00% 16V
C361	1-125-837-91	CERAMIC CHIP 1uF	10% 6.3V	C624	1-164-874-11	CERAMIC CHIP 100PF	5.00% 50V
C362	1-135-259-11	TANTAL. CHIP 10uF	20.00% 6.3V	C626	1-135-259-11	TANTAL. CHIP 10uF	20.00% 6.3V
				C627	1-131-862-91	TANTAL. CHIP 47uF	20% 4V
				C628	1-165-851-91	TANTAL. CHIP 10uF	20% 6.3V
				C630	1-125-777-11	CERAMIC CHIP 0.1uF	10.00% 10V
				C631	1-131-862-91	TANTAL. CHIP 47uF	20% 4V
				C632	1-137-760-91	CAP-CHIP 100PF	5% 100V





Ref. No.	Part No.	Description	Remark	Ref. No.	Part No.	Description	Remark
< FUSE >				< TRANSISTOR >			
△ F1	1-576-462-21	FUSE (SMD)	1.5A 63V	Q301	8-729-051-23	TRANSISTOR	2SA2018TL
△ F301	1-576-439-21	FUSE (SMD)	0.25A 125V	Q361	8-729-037-52	TRANSISTOR	2SC4738F-Y/GR(TPL3)
< CONDUCTOR >				Q501	8-729-922-10	TRANSISTOR	2SA1577-T106-QR
FB1	1-216-864-11	METAL CHIP	0 5% 1/10W	Q603	8-729-053-71	TRANSISTOR	TS8K1TB
FB2	1-216-864-11	METAL CHIP	0 5% 1/10W	Q604	6-550-356-01	TRANSISTOR	MCH6616-TL-E
FB301	1-216-864-11	METAL CHIP	0 5% 1/10W	Q605	6-550-357-01	TRANSISTOR	CPH5614-TL-E
FB302	1-216-864-11	METAL CHIP	0 5% 1/10W	Q651	8-729-047-48	TRANSISTOR	UMD12N-TR
FB303	1-216-864-11	METAL CHIP	0 5% 1/10W	Q652	8-729-053-03	TRANSISTOR	XP151A12A2MR
FB304	1-216-864-11	METAL CHIP	0 5% 1/10W	Q653	8-729-041-51	TRANSISTOR	FMMT617TA
FB651	1-216-864-11	METAL CHIP	0 5% 1/10W	Q654	8-729-037-63	TRANSISTOR	UN9115J-(TX).SO
FB652	1-216-864-11	METAL CHIP	0 5% 1/10W	Q672	8-729-037-71	TRANSISTOR	UN9210J-(TX).SO
FB801	1-216-864-11	METAL CHIP	0 5% 1/10W	Q871	8-729-429-44	TRANSISTOR	XP1501-TXE
FB802	1-216-864-11	METAL CHIP	0 5% 1/10W	Q901	8-729-429-44	TRANSISTOR	XP1501-TXE
FB803	1-216-864-11	METAL CHIP	0 5% 1/10W	Q951	6-550-353-01	TRANSISTOR	SI1410EDH-T1
FB804	1-216-864-11	METAL CHIP	0 5% 1/10W	Q953	8-729-037-53	TRANSISTOR	2SB1462J-QR(TX).SO
FB805	1-216-864-11	METAL CHIP	0 5% 1/10W	Q954	6-550-326-01	TRANSISTOR	FZT968TA
FB806	1-216-864-11	METAL CHIP	0 5% 1/10W	Q955	8-729-037-52	TRANSISTOR	2SC4738F-Y/GR(TPL3)
< IC >				< RESISTOR >			
IC302	8-759-694-88	IC AK5354VT-E2		R101	1-208-927-11	METAL CHIP	47K 0.5% 1/16W
IC361	8-759-598-15	IC TA2131FL(EL)		R102	1-208-715-11	METAL CHIP	22K 0.5% 1/16W
@ IC501	6-703-946-01	IC SN761058AZQLR		R106	1-218-990-11	SHORT CHIP	0
IC601	6-702-782-01	IC XPC18A22AEPR2		R161	1-218-961-11	RES-CHIP	4.7K 5% 1/16W (US)
IC651	8-759-569-80	IC XC6367A331MR		R161	1-218-965-11	RES-CHIP	10K 5% 1/16W (CND,UK)
IC701	6-702-786-01	IC SC111258EPR2		R162	1-218-957-11	RES-CHIP	2.2K 5% 1/16W (CND,UK)
@ IC801	8-753-001-00	IC CXD2680-207GA		R162	1-218-961-11	RES-CHIP	4.7K 5% 1/16W (US)
☆ IC852	-----	IC AK6417AL-L		R163	1-218-965-11	RES-CHIP	10K 5% 1/16W
IC901	6-702-865-01	IC SC901580EPR2		R164	1-218-965-11	RES-CHIP	10K 5% 1/16W
IC951	6-702-867-01	IC SC901582EPR2		R165	1-208-635-11	RES-CHIP	10 5% 1/16W
< JACK >				R166	1-218-961-11	RES-CHIP	4.7K 5% 1/16W
J302	1-815-950-12	JACK (LINE IN (OPTICAL))		R201	1-208-927-11	METAL CHIP	47K 0.5% 1/16W
J303	1-816-954-21	JACK (⊘)		R202	1-208-715-11	METAL CHIP	22K 0.5% 1/16W
J951	1-785-383-11	JACK,DC(POLARITY UNIFIED TYPE) (DC IN 3V)		R206	1-218-990-11	SHORT CHIP	0
< COIL >				R261	1-218-961-11	RES-CHIP	4.7K 5% 1/16W (US)
L302	1-414-398-11	INDUCTOR	10uH	R261	1-218-965-11	RES-CHIP	10K 5% 1/16W (CND,UK)
L503	1-414-398-11	INDUCTOR	10uH	R262	1-218-957-11	RES-CHIP	2.2K 5% 1/16W (CND,UK)
L504	1-414-398-11	INDUCTOR	10uH	R262	1-218-961-11	RES-CHIP	4.7K 5% 1/16W (US)
L602	1-400-058-21	INDUCTOR	10uH	R263	1-218-965-11	RES-CHIP	10K 5% 1/16W
L603	1-414-398-11	INDUCTOR	10uH	R264	1-218-965-11	RES-CHIP	10K 5% 1/16W
L651	1-456-218-21	COIL, CHOKE		R265	1-208-635-11	RES-CHIP	10 5% 1/16W
L802	1-414-398-11	INDUCTOR	10uH	R266	1-218-961-11	RES-CHIP	4.7K 5% 1/16W
L803	1-414-398-11	INDUCTOR	10uH	R302	1-218-965-11	RES-CHIP	10K 5% 1/16W
L901	1-456-219-21	COIL, CHOKE	220uH	R303	1-218-977-11	RES-CHIP	100K 5% 1/16W
L902	1-419-949-21	INDUCTOR	22uH	R304	1-218-941-81	RES-CHIP	100 5% 1/16W
L903	1-414-398-11	INDUCTOR	10uH	R305	1-218-953-11	RES-CHIP	1K 5% 1/16W
L904	1-419-949-21	INDUCTOR	22uH	R306	1-218-953-11	RES-CHIP	1K 5% 1/16W
< LINE FILTER >				R307	1-218-953-11	RES-CHIP	1K 5% 1/16W
LF951	1-416-405-21	FERRITE	0uH	R308	1-218-953-11	RES-CHIP	1K 5% 1/16W
				R309	1-218-953-11	RES-CHIP	1K 5% 1/16W

@ Replacement of IC501 and IC801 used in this set requires a special tool.

☆ When IC852 is damaged, replace the MAIN board.

The components identified by mark △ or dotted line with mark △ are critical for safety. Replace only with part number specified.

Les composants identifiés par une marque △ sont critiques pour la sécurité. Ne les remplacer que par une pièce portant le numéro spécifié.

# MZ-NF610

## MAIN

Ref. No.	Part No.	Description			Remark	Ref. No.	Part No.	Description			Remark
R312	1-218-989-11	RES-CHIP	1M	5%	1/16W	R825	1-218-989-11	RES-CHIP	1M	5%	1/16W
R315	1-218-990-11	SHORT CHIP	0			R826	1-218-957-11	RES-CHIP	2.2K	5%	1/16W
R361	1-218-937-11	RES-CHIP	47	5%	1/16W	R827	1-218-961-11	RES-CHIP	4.7K	5%	1/16W
R362	1-218-981-11	RES-CHIP	220K	5%	1/16W	R828	1-218-933-11	RES-CHIP	22	5%	1/16W
R363	1-218-969-11	RES-CHIP	22K	5%	1/16W	R829	1-218-933-11	RES-CHIP	22	5%	1/16W
R364	1-218-965-11	RES-CHIP	10K	5%	1/16W	R830	1-218-990-11	SHORT CHIP	0		
R501	1-218-977-11	RES-CHIP	100K	5%	1/16W	R831	1-218-990-11	SHORT CHIP	0		
R502	1-218-446-11	METAL CHIP	1	5%	1/10W	R832	1-218-990-11	SHORT CHIP	0		
R503	1-218-446-11	METAL CHIP	1	5%	1/10W	R833	1-218-990-11	SHORT CHIP	0		
R504	1-218-965-11	RES-CHIP	10K	5%	1/16W	R834	1-208-699-11	METAL CHIP	4.7K	0.5%	1/16W
R505	1-218-965-11	RES-CHIP	10K	5%	1/16W	R835	1-208-699-11	METAL CHIP	4.7K	0.5%	1/16W
R507	1-208-707-11	METAL CHIP	10K	0.5%	1/16W	R836	1-218-985-11	RES-CHIP	470K	5%	1/16W
R508	1-208-683-11	METAL CHIP	1K	0.5%	1/16W	R837	1-218-973-11	RES-CHIP	47K	5%	1/16W
R509	1-218-990-11	SHORT CHIP	0			R838	1-218-957-11	RES-CHIP	2.2K	5%	1/16W
R511	1-218-990-11	SHORT CHIP	0			R839	1-218-990-11	SHORT CHIP	0		
R609	1-218-965-11	RES-CHIP	10K	5%	1/16W	R840	1-218-990-11	SHORT CHIP	0		
R612	1-216-789-11	METAL CHIP	2.2	5%	1/10W	R844	1-218-990-11	SHORT CHIP	0		
R613	1-216-789-11	METAL CHIP	2.2	5%	1/10W	R845	1-218-977-11	RES-CHIP	100K	5%	1/16W
R614	1-218-985-11	RES-CHIP	470K	5%	1/16W	R846	1-218-977-11	RES-CHIP	100K	5%	1/16W
R616	1-218-957-11	RES-CHIP	2.2K	5%	1/16W	R847	1-218-981-11	RES-CHIP	220K	5%	1/16W
R617	1-218-965-11	RES-CHIP	10K	5%	1/16W	R848	1-218-990-11	SHORT CHIP	0		
R619	1-218-969-11	RES-CHIP	22K	5%	1/16W	R849	1-218-990-11	SHORT CHIP	0		
R651	1-216-864-11	METAL CHIP	0	5%	1/10W	R850	1-218-990-11	SHORT CHIP	0		
R654	1-218-990-11	SHORT CHIP	0			R855	1-218-990-11	SHORT CHIP	0		
R655	1-218-953-11	RES-CHIP	1K	5%	1/16W	R856	1-218-965-11	RES-CHIP	10K	5%	1/16W
R656	1-218-985-11	RES-CHIP	470K	5%	1/16W	R857	1-218-989-11	RES-CHIP	1M	5%	1/16W
R657	1-218-990-11	SHORT CHIP	0			R858	1-218-990-11	SHORT CHIP	0		
R658	1-218-961-11	RES-CHIP	4.7K	5%	1/16W	R860	1-216-864-11	METAL CHIP	0	5%	1/10W
R659	1-218-957-11	RES-CHIP	2.2K	5%	1/16W	R871	1-218-957-11	RES-CHIP	2.2K	5%	1/16W
R660	1-218-941-81	RES-CHIP	100	5%	1/16W	R872	1-218-953-11	RES-CHIP	1K	5%	1/16W
R661	1-218-973-11	RES-CHIP	47K	5%	1/16W	R873	1-218-985-11	RES-CHIP	470K	5%	1/16W
R662	1-216-864-11	METAL CHIP	0	5%	1/10W	R874	1-218-985-11	RES-CHIP	470K	5%	1/16W
R672	1-218-977-11	RES-CHIP	100K	5%	1/16W	R901	1-218-989-11	RES-CHIP	1M	5%	1/16W
R674	1-216-864-11	METAL CHIP	0	5%	1/10W	R902	1-218-989-11	RES-CHIP	1M	5%	1/16W
R701	1-218-957-11	RES-CHIP	2.2K	5%	1/16W	R903	1-218-957-11	RES-CHIP	2.2K	5%	1/16W
R702	1-218-957-11	RES-CHIP	2.2K	5%	1/16W	R904	1-218-957-11	RES-CHIP	2.2K	5%	1/16W
R703	1-218-957-11	RES-CHIP	2.2K	5%	1/16W	R905	1-208-707-11	METAL CHIP	10K	0.5%	1/16W
R704	1-218-965-11	RES-CHIP	10K	5%	1/16W	R907	1-218-985-11	RES-CHIP	470K	5%	1/16W
R705	1-218-965-11	RES-CHIP	10K	5%	1/16W	R908	1-218-969-11	RES-CHIP	22K	5%	1/16W
R706	1-218-965-11	RES-CHIP	10K	5%	1/16W	R912	1-218-977-11	RES-CHIP	100K	5%	1/16W
R803	1-208-635-11	RES-CHIP	10	5%	1/16W	R914	1-218-973-11	RES-CHIP	47K	5%	1/16W
R804	1-208-635-11	RES-CHIP	10	5%	1/16W	R915	1-218-981-11	RES-CHIP	220K	5%	1/16W
R805	1-218-990-11	SHORT CHIP	0			R917	1-218-985-11	RES-CHIP	470K	5%	1/16W
R806	1-218-990-11	SHORT CHIP	0			R919	1-218-973-11	RES-CHIP	47K	5%	1/16W
R807	1-218-965-11	RES-CHIP	10K	5%	1/16W	R923	1-218-977-11	RES-CHIP	100K	5%	1/16W
R808	1-218-977-11	RES-CHIP	100K	5%	1/16W	R925	1-218-990-11	SHORT-CHIP	0		
R809	1-218-977-11	RES-CHIP	100K	5%	1/16W	R926	1-218-969-11	RES-CHIP	22K	5%	1/16W
R811	1-218-981-11	RES-CHIP	220K	5%	1/16W	R932	1-218-985-11	RES-CHIP	470K	5%	1/16W
R813	1-218-953-11	RES-CHIP	1K	5%	1/16W	R933	1-218-981-11	RES-CHIP	220K	5%	1/16W
R814	1-218-957-11	RES-CHIP	2.2K	5%	1/16W	R934	1-218-981-11	RES-CHIP	220K	5%	1/16W
R815	1-218-953-11	RES-CHIP	1K	5%	1/16W	R952	1-245-454-21	METAL	0.022	1%	1/5W
R816	1-218-945-11	RES-CHIP	220	5%	1/16W	R953	1-245-456-21	METAL	1	1%	1/5W
R817	1-220-804-11	RES-CHIP	2.2M	5%	1/16W	R954	1-218-965-11	RES-CHIP	10K	5%	1/16W
R818	1-218-989-11	RES-CHIP	1M	5%	1/16W	R955	1-218-941-81	RES-CHIP	100	5%	1/16W
R819	1-208-691-11	METAL CHIP	2.2K	0.5%	1/16W	R956	1-208-943-11	METAL CHIP	220K	0.5%	1/16W
R820	1-208-691-11	METAL CHIP	2.2K	0.5%	1/16W	R957	1-208-927-11	METAL CHIP	47K	0.5%	1/16W
R821	1-218-973-11	RES-CHIP	47K	5%	1/16W	R959	1-208-935-11	METAL CHIP	100K	0.5%	1/16W
R822	1-218-981-11	RES-CHIP	220K	5%	1/16W	R960	1-218-985-11	METAL CHIP	470K	0.5%	1/16W
R823	1-218-933-11	RES-CHIP	22	5%	1/16W	R961	1-208-699-11	METAL CHIP	4.7K	0.5%	1/16W
R824	1-218-985-11	RES-CHIP	470K	5%	1/16W	R962	1-208-935-11	METAL CHIP	100K	0.5%	1/16W

Ref. No.	Part No.	Description	Remark
R963	1-218-973-11	RES-CHIP 47K 5%	1/16W
R965	1-218-977-11	RES-CHIP 100K 5%	1/16W
R966	1-218-965-11	RES-CHIP 10K 5%	1/16W
R967	1-218-989-11	RES-CHIP 1M 5%	1/16W
R969	1-218-957-11	RES-CHIP 2.2K 5%	1/16W
R971	1-218-961-11	RES-CHIP 4.7K 5%	1/16W
R974	1-245-455-21	METAL 0.47	1% 1/5W
R975	1-218-981-11	RES-CHIP 220K 5%	1/16W
R976	1-218-985-11	RES-CHIP 470K 5%	1/16W

< SWITCH >

S801	1-762-946-12	SWITCH, PUSH (1 KEY) (HALF LOCK)
S803	1-762-805-21	SWITCH, PUSH (1 KEY) (OPEN/CLOSE)
S806	1-786-437-11	SWITCH, PUSH (2 KEY) (PROTECT)

< THERMISTOR >

TH951	1-805-064-11	THERMISTOR, POSITIVE
-------	--------------	----------------------

< VIBRATOR >

X802	1-795-727-21	VIBRATOR, CERAMIC (48MHz)
X803	1-795-778-11	VIBRATOR, CRYSTAL (22.5792MHz)

\*\*\*\*\*

MISCELLANEOUS

\*\*\*\*\*

7	1-804-989-11	LCD MODULE
△ 309	X-3382-953-1	SERVICE ASSY, OP (LCX-5R)
M601	8-835-744-21	MOTOR, DC SSM18B/C-NP (SPINDLE)
M602	1-763-727-11	MOTOR, DC (SLED) (WITH GEAR)
M603	1-763-400-21	MOTOR, DC (OVER WRITE HEAD UP/DOWN)

\*\*\*\*\*

ACCESSORIES

\*\*\*\*\*

	1-477-530-11	REMOCON UNIT (RM-MC36LT) (CND)
	1-477-530-31	REMOCON UNIT (RM-MC36LT) (UK)
	1-477-530-51	REMOCON UNIT (WITH TUNER) (US)
△	1-477-732-11	ADAPTOR, AC (AC-ET305K) (UK)
△	1-477-737-11	ADAPTOR, AC (AC-ET305K) (US, CND)
	1-756-317-22	BATTERY, NICKEL HYDROGEN (UK)
	1-756-317-31	BATTERY, NICKEL HYDROGEN (EXCEPT UK)
	1-794-451-11	CONNECTOR, OPTICAL
	1-823-519-11	CORD, CONNECTION
	3-223-571-01	CASE, BATTERY CARRYING
	3-253-608-11	MANUAL, INSTRUCTION (HOW TO INSTALL) (ENGLISH) (US,CND)
	3-253-608-21	MANUAL, INSTRUCTION (HOW TO INSTALL) (FRENCH) (CND)
	3-255-343-11	MANUAL, INSTRUCTION (ENGLISH) (US,CND)
	3-255-343-21	MANUAL, INSTRUCTION (FRENCH) (CND)
	3-255-343-31	MANUAL, INSTRUCTION (ENGLISH) (UK)
	8-954-007-94	HEADPHONE MDR-027SP/S SET (US)
	8-954-008-90	RECEIVER, EAR MDR-E808SP/C SET (CND,UK)
	X-3383-268-1	CD-ROM (APPLICATION) ASSY (EXCEPT UK)
	X-3383-269-3	CD-ROM (APPLICATION) ASSY (UK)

The components identified by mark △ or dotted line with mark △ are critical for safety. Replace only with part number specified.

Les composants identifiés par une marque △ sont critiques pour la sécurité. Ne les remplacer que par une pièce portant le numéro spécifié.

