

MDS-JB920

SERVICE MANUAL

Self Diagnostics
Supported model

US Model
Canadian Model
AEP Model
UK Model



U.S. and foreign patents licensed form Dolby Laboratories Licensing Corporation.

Model Name Using Similar Mechanism	MDS-JE520
MD Mechanism Type	MDM-5A
Optical Pick-up Type	KMS-260A/J1N

SPECIFICATIONS

System	MiniDisc digital audio system
Disc	MiniDisc
Laser	Semiconductor laser ($\lambda=780\text{nm}$) Emission duration: continuous
Laser output	Less than $44.6 \mu\text{W}^*$ * This output is the value measured at a distance of 200 mm from the objective lens surface on the Optical Pick-up Block with 7 mm aperture.
Laser diode properties	Material: GaAlAs
Revolutions (CLV)	400 rpm to 900 rpm
Error correction	Advanced Cross Interleave Reed Solomon Code (A CIRC)
Sampling frequency	44.1 kHz
Coding	Adaptive Transform Acoustic Coding (ATRAC)
Modulation system	EFM (English-to-Fourteen Modulation)
Number fo channels	2 setero channels
Frequency response	5 to 20,000 Hz ± 0.3 dB
Signal-to-noise retio	Over 100 dB during playback
Wow and flutter	Below measureble limit

Inputs

	jack type	input impedance	Rated input	Minimum input
LINE (ANALOG) IN	phono jacks	47 kilohms	500 mVrms	125 mVrms
DIGITAL OPTICAL IN1	Square optical connector jack	Optical wave length: 660 nm	—	—
DIGITAL OPTICAL IN2	Square optical connector jack	Optical wave length: 660 nm	—	—
DIGITAL COAXIAL IN	Phono jack	75 ohms	0.5 Vp-p $\pm 20\%$	—

Outputs

	jack type	Rated output	Load impedance
PHONES	Stereo phone jack	28 mW	32 ohms
LINE (ANALOG) OUT	Phono jacks	2 Vrms (at 50 kilohms)	Over 10 kilohms
DIGIRAL OPTICAL OUT	Square optical connector jack	-18 dBm	Optical wave length: 660 nm
DIGITAL COAXIAL OUT	Phono jack	0.5 Vp-p (at 75 ohms)	75 ohms

MINI DISC DECK



SONY®

General

Power requirements

Where purchased	Power requirements
Continental Europe and UK	220 – 230 V AC, 50/60 Hz
U.S.A and Canada	120 V AC, 60 Hz

Power consumption	18 W
Dimensions (approx.) (w/h/d) incl.projecting parts and controls	430 × 107.5 × 287 mm (17 × 4 ¹ / ₄ × 11 ³ / ₈ in)
Mass (approx.)	4.8 kg (10 lb 9 oz)

Supplied accessories

Audio connecting cords (2)
Optical cable (1)
Remote commander (remote) RM-D17M (1)
R6 (size-AA) batteries (2)

Design and specifications are subject to change without notice.

SELF-DIAGNOSIS FUNCTION

The self-diagnosis function consists of error codes for customers which are displayed automatically when errors occur, and error codes which show the error history in the test mode during servicing. For details on how to view error codes for the customer, refer to the following box in the instruction manual. For details on how to check error codes during servicing, refer to the following “Procedure for using the Self-Diagnosis Function (Error History Display Mode)”.

Self-Diagnosis Function

The deck has a self-diagnosis display. This function shows a three-digit display (a combination of a letter and figures) and the corresponding message alternately, so you can check the deck's condition. If such a display appears, check the following table in order to resolve the problem. Should any problem persist, consult your nearest Sony dealer.

Self-diagnosis display



Three-digit display/Message	Cause/Remedy
C11/Protected	The inserted MD is record-protected. ➔ Take out the MD, and close the record-protect tab.
C13/REC. Error	The recording was not made properly. ➔ Set the deck in a stable place, and repeat the recording procedure. The inserted MD is dirty (with smudges, fingerprints, etc.), scratched, or not up to standards. ➔ Replace the disc, and repeat the recording procedure.
C13/Disc Error	The deck could not read the TOC of the MD properly. ➔ Take out the MD, and insert it again.
C14/Disc Error	The deck could not read the TOC of the MD properly. ➔ Insert another disc. ➔ If possible, erase all tracks on the MD using the All Erase Function.
C71/Din Unlock	A moment's lighting is due to the signals of the digital program being recorded. This does not affect the recorded material. While recording from a digital component connected through the digital input connector, the digital connecting cable was unplugged or the digital component turned off. ➔ Connect the cable or turn the digital component back on.

Procedure for using the Self-Diagnosis Function (Error History Display Mode).

Note: Perform the self-diagnosis function in the “error history display mode” in the test mode. The following describes the least required procedure. Be careful not to enter other modes by mistake. If you set other modes accidentally, press the MENU/NO button to exit the mode.

1. While pressing the [◀◀ AMS ▶▶] knob and [■] button, connect the power plug to the outlet, and release the [◀◀ AMS ▶▶] knob and [■] button.
2. Rotate the [◀◀ AMS ▶▶] knob and when “[Service]” is displayed, press the [YES] button.
3. Rotate the [◀◀ AMS ▶▶] knob and display “ERR DP MODE”.
4. Pressing the [YES] button sets the error history mode and displays “total rec”.
5. Select the contents to be displayed or executed using the [◀◀ AMS ▶▶] knob.
6. Pressing the [◀◀ AMS ▶▶] knob will display or execute the contents selected.
7. Pressing the [◀◀ AMS ▶▶] knob another time returns to step 4.
8. Pressing the [MENU/NO] button displays “ERROR DP MODE” and exits the error history mode.
9. To exit the test mode, press the [REPEAT] button. The unit sets into the STANDBY state, the disc is ejected, and the test mode ends.

Items of Error History Mode Items and Contents
Selecting the Test Mode



Display	Details of History
total rec	Displays the recording time. Displayed as "r□□□□□h". The displayed time is the total time the laser is set to the high power state. This is about 1/4 of the actual recording time. The time is displayed in decimal digits from 0h to 65535h.
total play	Displays the play time. Displayed as "p□□□□□h". The time displayed is the total actual play time. Pauses are not counted. The time is displayed in decimal digits from 0h to 65535h.
retry err	Displays the total number of retries during recording and number of retry errors during play. Displayed as "r□□ p□□". "r" indicates the retries during recording while "p" indicates the retry errors during play. The number of retries and retry errors are displayed in hexadecimal digits from 00 to FF.
total err	Displays the total number of errors. Displayed as "total □□". The number of errors is displayed in hexadecimal digits from 00 to FF.
err history	Displays the 10 latest errors. Displayed as "0□ E@@". □ indicates the history number. The smaller the number, the more recent is the error. (00 is the latest). @@ indicates the error code. Refer to the following table for the details. The error history can be switched by rotating the  knob.
er refresh	Mode which erases the "retry err", "total err", and "err history" histories. When returning the unit to the customer after completing repairs, perform this to erase the past error history. After pressing the  button and "er refresh?" is displayed, press the YES button to erase the history. "Complete!" will be displayed momentarily. Be sure to check the following when this mode has been executed. <ul style="list-style-type: none"> • The data has been erased. • The mechanism operates normally when recording and play are performed.
tm refresh	Mode which erases the "total rec" and "total play" histories. These histories serve as approximate indications of when to replace the optical pickup. If the optical pickup has been replaced, perform this operation and erase the history. After pressing the  button and "tm refresh?" is displayed, press the YES button to erase the history. "Complete!" will be displayed momentarily. Be sure to check the following when this mode has been executed. <ul style="list-style-type: none"> • The data has been erased. • The mechanism operates normally when recording and play are performed.

Table of Error Codes

Error Code	Details of Error	Error Code	Details of Error
E00	No error	E05	FOK has deviated
E01	Disc error. PTOC cannot be read (DISC ejected)	E06	Cannot focus (Servo has deviated)
		E07	Recording retry
E02	Disc error. UTOC error (DISC not ejected)	E08	Recording retry error
		E09	Playback retry error (Access error)
E03	Loading error		
E04	Address cannot be read (Servo has deviated)	E0A	Playback retry error (C2 error)

SECTION 1 SERVICING NOTES

TABLE OF CONTENTS

1. SERVICING NOTES	4
2. GENERAL	11
3. DISASSEMBLY	14
4. TEST MODE	18
5. ELECTRICAL ADJUSTMENTS	23
6. DIAGRAMS	
6-1. IC Pin Function Description	32
6-2. Block Diagram – SERVO Section –	41
6-3. Block Diagram – MAIN Section –	43
6-4. Note for Printed Wiring Boards and Schematic Diagrams	46
6-5. Printed Wiring Board – BD Section –	47
6-6. Schematic Diagram – BD Section (1/2) –	49
6-7. Schematic Diagram – BD Section (2/2)–	51
6-8. Schematic Diagram – MAIN Section (1/3)–	55
6-9. Schematic Diagram – MAIN Section (2/3)–	57
6-10. Schematic Diagram – MAIN Section (3/3)–	59
6-11. Printed Wiring Board – MAIN Board (Side A)	61
6-12. Printed Wiring Boards – MAIN Board (Side B), AC/BAT Boards	63
6-13. Printed Wiring Boards – PANEL Section –	65
6-14. Schematic Diagram – PANEL Section –	67
6-15. Schematic Diagram – BD SWITCH Section –	69
6-16. Printed Wiring Board – BD SWITCH Section –	69
7. EXPLODED VIEWS	75
8. ELECTRICAL PARTS LIST	79

SAFETY CHECK-OUT

After correcting the original service problem, perform the following safety check before releasing the set to the customer: Check the antenna terminals, metal trim, “metallized” knobs, screws, and all other exposed metal parts for AC leakage. Check leakage as described below.

LEAKAGE TEST

The AC leakage from any exposed metal part to earth ground and from all exposed metal parts to any exposed metal part having a return to chassis, must not exceed 0.5 mA (500 microamps.). Leakage current can be measured by any one of three methods.

1. A commercial leakage tester, such as the Simpson 229 or RCA WT-540A. Follow the manufacturers’ instructions to use these instruments.
2. A battery-operated AC milliammeter. The Data Precision 245 digital multimeter is suitable for this job.
3. Measuring the voltage drop across a resistor by means of a VOM or battery-operated AC voltmeter. The “limit” indication is 0.75 V, so analog meters must have an accurate low-voltage scale. The Simpson 250 and Sanwa SH-63Trd are examples of a passive VOM that is suitable. Nearly all battery operated digital multimeters that have a 2 V AC range are suitable. (See Fig. A)

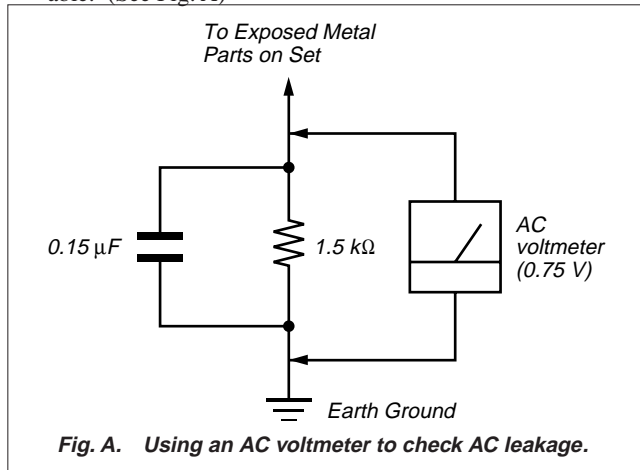

MODEL IDENTIFICATION

— BACK PANEL —

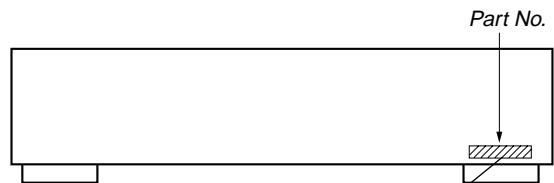

- 4-998-603-1 AEP and UK models
- 4-998-603-3 US model
- 4-998-603-4 Canadian model

CAUTION

Danger of explosion if battery is incorrectly replaced.
Replace only with the same or equivalent type recommended by the manufacturer.
Discard used batteries according to the manufacturer's instructions.

ADVARSEL!

Lithiumbatteri-Eksplosionsfare ved fejlagtig håndtering.
Udskiftning må kun ske med batteri
af samme fabrikat og type.
Levér det brugte batteri tilbage til leverandøren.

ADVARSEL

Eksplosjonsfare ved feilaktig skifte av batteri.
Benytt samme batteritype eller en tilsvarende type
anbefalt av apparatfabrikanten.
Brukte batterier kasseres i henhold til fabrikantens
instruksjoner.

WARNING

Explosionsfara vid felaktigt batteribyte.
Använd samma batterityp eller en likvärdig typ som
rekommenderas av apparattillverkaren.
Kassera använt batteri enligt gällande föreskrifter.

VAROITUS

Paristo voi räjähtää, jos se on virheellisesti asennettu.
Vaihda paristo ainoastaan laitevalmistajan suosittelemaan tyyppiin.
Hävitä käytetty paristo valmistajan ohjeiden mukaisesti.

SAFETY-RELATED COMPONENT WARNING!!

COMPONENTS IDENTIFIED BY MARK \triangle OR DOTTED LINE WITH MARK \triangle ON THE SCHEMATIC DIAGRAMS AND IN THE PARTS LIST ARE CRITICAL TO SAFE OPERATION. REPLACE THESE COMPONENTS WITH SONY PARTS WHOSE PART NUMBERS APPEAR AS SHOWN IN THIS MANUAL OR IN SUPPLEMENTS PUBLISHED BY SONY.

Laser component in this product is capable of emitting radiation exceeding the limit for Class 1.

CLASS 1 LASER PRODUCT
LUOKAN 1 LASERLAITE
KLASS 1 LASERAPPARAT

This appliance is classified as a CLASS 1 LASER product. The CLASS 1 LASER PRODUCT MARKING is located on the rear exterior.

CAUTION : INVISIBLE LASER RADIATION WHEN OPEN AND INTERLOCKS DEFEATED. AVOID EXPOSURE TO BEAM.
ADVARSEL : USYNLIG LASERSTRÅLING VED ÅBNING NÅR SIKKERHEDSafbrydere er ude af funktion. undgå udsættelse for stråling.
VORSICHT : UNSICHTBARE LASERSTRAHLUNG, WENN ABDECKUNG GEÖFFNET UND SICHERHEITSPERRUNG ÜBERBRÜCKT. NICHT DEM STRAHL AUSSETZEN.
VARO! : AVATTAESSA JA SUOJALUKITUS OHITETTAESSA OLET ALT-TIINA NÄKYMÄTTÖMÄLLE LASERSÄTEILYLLE. ÄLÄ KATSO SÄTEESEEN.
VARNING : ÖSYNLIG LASERSTRÅLING NÅR DENNA DEL ÅR ÖPPNAD OCH SPÄRREN ÅR URKOPPLAD. BETRAKTA EJ STRÅLEN.
ADVERSEL : USYNLIG LASERSTRÅLING NÅR DEKSEL ÅPNES OG SIKKERHEDSLÅS BRYTES. UNNGÅ EKSPONERING FOR STRÅLEN.
VIGYAZAT! : A BURKOLAT NYITÁSAKOR LÁTHATATLAN LÉZERSUGÁRVESZÉLY! KERÜLJE A BESUGÁRZÁST!

This caution label is located inside the unit.

CAUTION

Use of controls or adjustments or performance of procedures other than those specified herein may result in hazardous radiation exposure.

Flexible Circuit Board Repairing

- Keep the temperature of the soldering iron around 270 °C during repairing.
- Do not touch the soldering iron on the same conductor of the circuit board (within 3 times).
- Be careful not to apply force on the conductor when soldering or unsoldering.

Notes on chip component replacement

- Never reuse a disconnected chip component.
- Notice that the minus side of a tantalum capacitor may be damaged by heat.

ATTENTION AU COMPOSANT AYANT RAPPORT À LA SÉCURITÉ!

LES COMPOSANTS IDENTIFIÉS PAR UNE MARQUE \triangle SUR LES DIAGRAMMES SCHÉMATIQUES ET LA LISTE DES PIÈCES SONT CRITIQUES POUR LA SÉCURITÉ DE FONCTIONNEMENT. NE REMPLACER CES COMPOSANTS QUE PAR DES PIÈCES SONY DONT LES NUMÉROS SONT DONNÉS DANS CE MANUEL OU DANS LES SUPPLÉMENTS PUBLIÉS PAR SONY.

JIG FOR CHECKING BD BOARD WAVEFORM

The special jig (J-2501-149-A) is useful for checking the waveform of the BD board. The names of terminals and the checking items to be performed are shown as follows.

GND : Ground

I+3V : For measuring IOP (Check the deterioration of the optical pick-up laser)

IOP : For measuring IOP (Check the deterioration of the optical pick-up laser)

TE : TRK error signal (Traverse adjustment)

VC : Reference level for checking the signal

RF : RF signal (Check jitter)

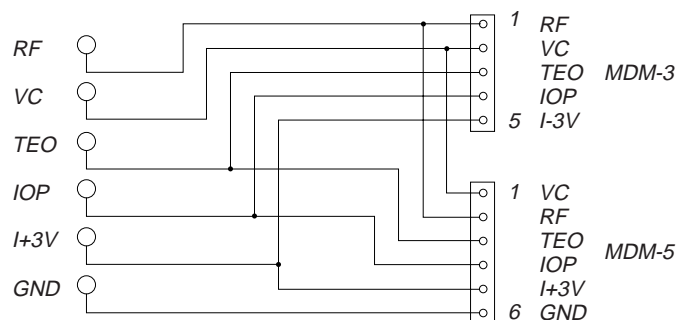
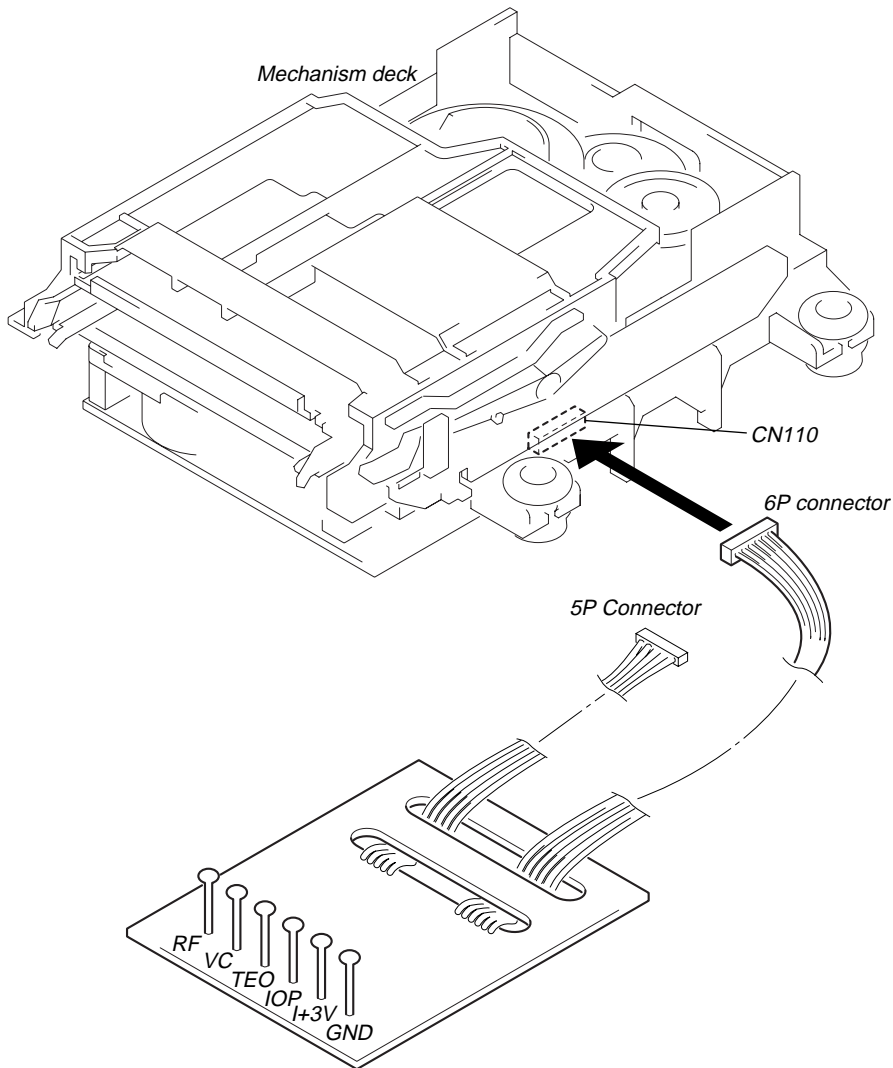

IOP Data Recording and Display When Pickup and Non-volatile Memory (IC171 of BD board) are Replaced

The IOP value labeled on the pick-up can be recorded in the non-volatile memory. By recording the value, it will eliminate the need to look at the value on the label of the optical pick-up. When replacing the pick-up or non-volatile memory (IC171 of BD board), record the IOP value on the pick-up according to the following procedure.

Record Procedure:

1. While pressing the **◀◀ AMS ▶▶** knob and **■** button, connect the power plug to the outlet, and release the **◀◀ AMS ▶▶** knob and **■** button.
2. Rotate the **◀◀ AMS ▶▶** knob to display “[Service]”, and press the **YES** button.
3. Rotate the **◀◀ AMS ▶▶** knob to display “Iop.Write” (C28), and press the **YES** button.
4. The display becomes “Ref=@@.@” (@ is an arbitrary number) and the numbers which can be changed will blink.
5. Input the IOP value written on the optical pick-up.
To select the number : Rotate the **◀◀ AMS ▶▶** knob.
To select the digit : Press the **◀◀ AMS ▶▶** knob.
6. When the **YES** button is pressed, the display becomes “Measu=@@.@” (@ is an arbitrary number).
7. As the adjustment results are recorded for the 6 value. Leave it as it is and press the **YES** button.
8. “Complete!” will be displayed momentarily. The value will be recorded in the non-volatile memory and the display will become “Iop Write”.
9. Press the **REPEAT** button to complete. “Standby” will be displayed.

Display Procedure:

1. While pressing the **◀◀ AMS ▶▶** knob and **■** button, connect the power plug to the outlet, and release the **◀◀ AMS ▶▶** knob and **■** button.
2. Rotate the **◀◀ AMS ▶▶** knob to display “[Service]”, and press the **YES** button.
3. Rotate the **◀◀ AMS ▶▶** knob to display “Iop.Read” (C27).
4. “@@.@/##.#” is displayed and the recorded contents are displayed.
@@.@ : indicates the Iop value labeled on the pick-up.
##.# : indicates the Iop value after adjustment
5. To end, press the **◀◀ AMS ▶▶** button or **MENU/NO** button to display “Iop Read”. Then press the **REPEAT** button to display “Standby”.

Checks Prior to Parts Replacement and Adjustments

Before performing repairs, perform the following checks to determine the faulty locations up to a certain extent. Details of the procedures are described in “5 Electrical Adjustments”.

	Criteria for Determination (Unsatisfactory if specified value is not satisfied)	Measure if unsatisfactory:
Laser power check (5-6-2 : See page 25)	<ul style="list-style-type: none"> 0.9 mW power Specified value : 0.84 to 0.92 mW 7.0 mW power Specified value : 6.8 to 7.2 mW 	<ul style="list-style-type: none"> Clean the optical pick-up Adjust again Replace the optical pick-up
	<ul style="list-style-type: none"> lop (at 7mW) Labeled on the optical pickup Iop value \pm 10mA 	<ul style="list-style-type: none"> Replace the optical pick-up
Traverse check (5-6-3 : See page 25)	<ul style="list-style-type: none"> Traverse waveform Specified value : Below 10% offset 	<ul style="list-style-type: none"> Replace the optical pick-up
Focus bias check (5-6-4 : See page 26)	<ul style="list-style-type: none"> Error rate check Specified value : For points a, b, and c C1 error : Below 220 AD error : Below 2 	<ul style="list-style-type: none"> Replace the optical pick-up
C PLAY check (5-6-5 : See page 26)	<ul style="list-style-type: none"> Error rate check Specified value: <ol style="list-style-type: none"> When using test disc (MDW-74/AU-1) C1 error : Below 80 AD error : Below 2 When using check disc (TDYS-1) C1 error : Below 50 	<ul style="list-style-type: none"> Replace the optical pick-up
Self-recording/playback check (REC/PLAY) (5-6-6 : See page 26)	<ul style="list-style-type: none"> CPLAY error rate check Specified value: C1 error : Below 80 AD error : Below 2 	If always unsatisfactory: <ul style="list-style-type: none"> Replace the overwrite head Check for disconnection of the circuits around the overwrite head
		If occasionally unsatisfactory: <ul style="list-style-type: none"> Check if the overwrite head is distorted Check the mechanism around the sled
TEMP check (Temperature compensation offset check) (5-6-1 : See page 25)	<ul style="list-style-type: none"> Unsatisfactory if displayed as T=@@ (##) [NG” NG (@@, ## are both arbitrary numbers) 	<ul style="list-style-type: none"> Check for disconnection of the circuits around D101 (BD board) Check the signals around IC101, IC121, CN102, CN103 (BD board)

Note:

The criteria for determination above is intended merely to determine if satisfactory or not, and does not serve as the specified value for adjustments. When performing adjustments, use the specified values for adjustments.

Forced Reset

The system microprocessor can be reset in the following procedure.

Use these procedure when the unit cannot be operated normally due to the overrunning of the microprocessor, etc.

Procedure :

Disconnect the power plug, short-circuit jumper wire of JW705 and JW706 (RESET).

[BAT BOARD] (Component Side)

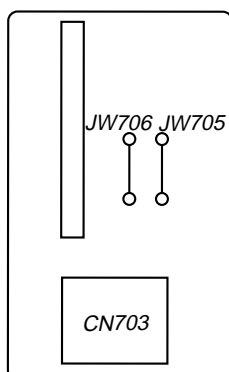

Retry Cause Display Mode

- In this test mode, the causes for retry of the unit during recording can be displayed on the fluorescent indicator tube. During playback, the “track mode” for obtaining track information will be set. This is useful for locating the faulty part of the unit.
- The following will be displayed :
 - During recording and stop: Retry cause, number of retries, and number of retry errors.
 - During playback : Information such as type of disc played, part played, copyright.
 These are displayed in hexadecimal.

Precedure:

- Load a recordable disc whose contents can be erased into the unit.
- Press the **MENU/NO** button. When “Edit/Menu” is displayed on the fluorescent display tube, rotate the **◀◀ AMS ▶▶** knob to display “All Erase?”.
- Press the **YES** button. (Or press the **◀◀ AMS ▶▶** knob)
- When “All Erase??” is displayed on the fluorescent display tube, the music calendar number blinks.
- Press the **YES** button to display “Complete!!”, and press the **■** button immediately. Wait for about 15 seconds while pressing the button. (The **◀◀ AMS ▶▶** knob can be pressed instead of the **YES** button for the same results.)
- When the “TOC” displayed on the fluorescent display tube goes off, release the **■** button.
- Press the **● REC** button to start recording. Then press the **||** button and start recording.
- To check the “track mode”, press the **▷** button to start play.
- To exit the test mode, press the **I/O** button, and turn OFF the power. When “TOC” disappears, disconnect the power plug from the outlet. If the test mode cannot be exited, refer to “Forced Reset” on page 8.

Fig. 1 Reading the Test Mode Display (During recording and stop)

RTs@@c##c**

Fluorescent display tube display

@@ : Cause of retry
 ## : Number of retries
 ** : Number of retry errors

Fig. 2 Reading the Test Mode Display (During playback)

@@####**\$\$

Fluorescent display tube display

@@ : Parts No. (name of area named on TOC)
 ## : Cluster
 ** : Sector
 \$\$: Track mode (Track information such as copyright information of each part)

Reading the Retry Cause Display

Hexadecimal	Higher Bits				Lower Bits				Hexa-decimal	Cause of Retry	Occurring conditions
	8	4	2	1	8	4	2	1			
Bit	b7	b6	b5	b4	b3	b2	b1	b0			
Binary	0	0	0	0	0	0	0	1	01	shock	When track jump (shock) is detected
	0	0	0	0	0	0	1	0	02	ader5	When ADER was counted more than five times continuously
	0	0	0	0	0	1	0	0	04	Discontinuous address	When ADIP address is not continuous
	0	0	0	0	1	0	0	0	08	DIN unlock	When DIN unlock is detected
	0	0	0	1	0	0	0	0	10	FCS incorrect	When not in focus
	0	0	1	0	0	0	0	0	20	IVR rec error	When ABCD signal level exceeds the specified range
	0	1	0	0	0	0	0	0	40	CLV unlock	When CLV is unlocked
	1	0	0	0	0	0	0	0	80	Access fault	When access operation is not performed normally

Reading the Display:

Convert the hexadecimal display into binary display. If more than two causes, they will be added.

Example

When 42 is displayed:

Higher bit: 4 = 0100 → b6

Lower bit : 2 = 0010 → b1

In this case, the retry cause is combined of “CLV unlock” and “ader5”.

When A2 is displayed:

Higher bit: A = 1010 → b7+b5

Lower bit : 2 = 0010 → b2

The retry cause in this case is combined of “access fault”, “IVR rec error”, and “ader5”.

Reading the Retry Cause Display

Hexadecimal	Higher Bits				Lower Bits				Hexa- decimal	Details	
	8	4	2	1	8	4	2	1		When 0	When 1
Bit	b7	b6	b5	b4	b3	b2	b1	b0			
Binary	0	0	0	0	0	0	0	1	01	Emphasis OFF	Emphasis ON
	0	0	0	0	0	0	1	0	02	Monaural	Stereo
	0	0	0	0	0	1	0	0	04	This is 2-bit display. Normally 01. 01:Normal audio. Others:Invalid	
	0	0	0	0	1	0	0	0	08		
	0	0	0	1	0	0	0	0	10	Audio (Normal)	Invalid
	0	0	1	0	0	0	0	0	20	Original	Digital copy
	0	1	0	0	0	0	0	0	40	Copyright	No copyright
	1	0	0	0	0	0	0	0	80	Write prohibited	Write allowed

Reading the Display:

Convert the hexadecimal display into binary display. If more than two causes, they will be added.

Example When 84 is displayed:

Higher bit : 8 = 1000 → b7

Lower bit : 4 = 0100 → b2

In this case, as b2 and b7 are 1 and others are 0, it can be determined that the retry cause is combined of “emphasis OFF”, “monaural”, “original”, “copyright exists”, and “write allowed”.

Example When 07 is displayed:

Higher bit : 0 = 1000 → All 0

Lower bit : 7 = 0111 → b0+b1+b2

In this case, as b0, b1, and b2 are 1 and others are 0, it can be determined that the retry cause is combined of “emphasis ON”, “stereo”, “original”, “copyright exists”, and “write prohibited”.

Hexadecimal → Binary Conversion Table

Hexadecimal	Binary	Hexadecimal	Binary
0	0000	8	1000
1	0001	9	1001
2	0010	A	1010
3	0011	B	1011
4	0100	C	1100
5	0101	D	1101
6	0110	E	1110
7	0111	F	1111

SECTION 2 GENERAL

LOCATION OF CONTROLS

• Front view

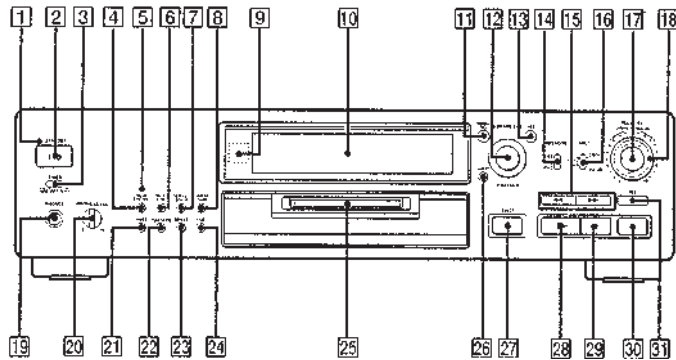

- 1 STANDBY indicator
- 2 I/⏻ (Power) button
- 3 TIMER switch
- 4 MEGA CONTROL button
- 5 MEGA CONTROL indicator
- 6 MUSIC SYNC button
- 7 SCROLL/CLOCK SET button
- 8 DISPLAY/CHAR button
- 9 Remote sensor
- 10 Fluorescent indicator tube
- 11 MENU/NO button
- 12 ⏪ AMS ⏩ knob
- 13 YES button
- 14 REC MODE switch
- 15 ⏮/⏭ button
- 16 INPUT switch
- 17 REC LEVEL knob (ANALOG)
- 18 REC LEVEL knob (DIGITAL)
- 19 PHONES jack
- 20 PHONE LEVEL knob
- 21 FADER button
- 22 PLAY MODE button
- 23 REPEAT button
- 24 TIME button
- 25 DISC slot
- 26 CLEAR button
- 27 ⏪ EJECT ⏩ button
- 28 ▷ button
- 29 || button
- 30 ■ button
- 31 ● REC button

• Rear view

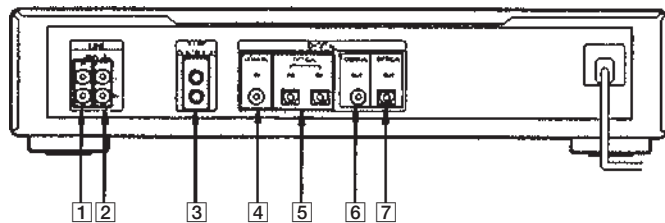

- 1 LINE (ANALOG) IN jacks
- 2 LINE (ANALOG) OUT jacks
- 3 S-LINK CONTROL A1 jacks
- 4 DIGITAL COAXIAL IN jack
- 5 DIGITAL OPTICAL IN1/IN2 connectors
- 6 DIGITAL COAXIAL OUT jack
- 7 DIGITAL OPTICAL OUT connector

Hooking Up the System

Overview

This section describes how to hook up the MD deck to an amplifier or other components such as a CD player or DAT deck. Be sure to turn off the power of each component before connection.

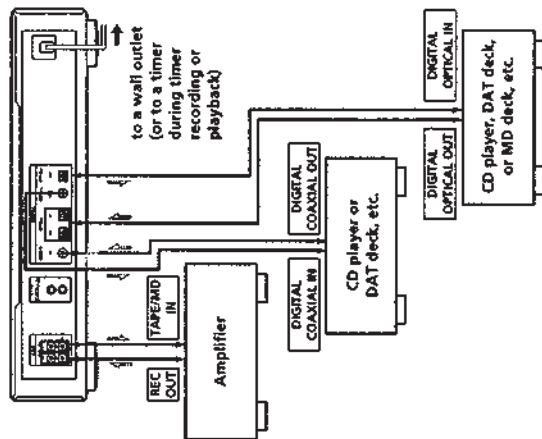

Signal flow

What cords will I need?

- Audio connecting cords (supplied) (2)
 - White (L)
 - Red (R)
- Optical cables (only one supplied) (3)
- Coaxial digital connecting cables (not supplied) (2)

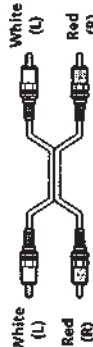

Hookups

Connecting the deck to an amplifier
Connect the amplifier to the LINE (ANALOG) IN/OUT jacks using the audio connecting cords (supplied), making sure to match the color-coded cords to the appropriate jacks on the components: red (right) to red and white (left) to white. Be sure to make connections firmly to prevent hum and noise.

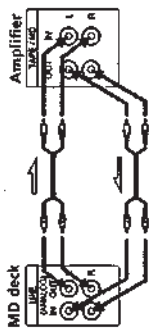

Signal flow

Connecting the deck to a digital component such as a CD player, DAT deck, digital amplifier, or another MD deck

Connect the component through the DIGITAL OPTICAL IN/OUT or DIGITAL COAXIAL IN/OUT connectors with two (or three) optical cables (only one supplied) and/or two coaxial digital connecting cables (not supplied).

When using the optical cables

Take the caps off the connectors and then insert the plugs parallelly until they click into place. Be sure not to bend or tie together the optical cables.

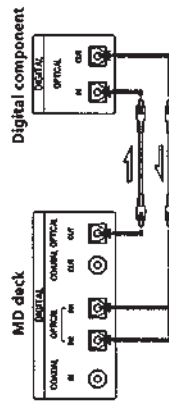

You can connect the optical cable to either OPTICAL IN1 or IN2

Signal flow

When using the coaxial digital connecting cable

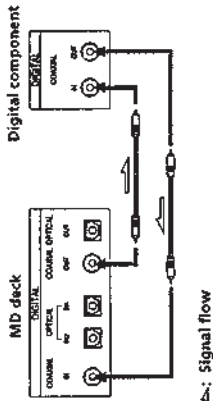

Signal flow

If "Din Unlock" and "C71" appear in the display Make sure the optical cable or the coaxial digital connecting cable is connected properly.

Automatic conversion of digital sampling rates during recording

A built-in sampling rate converter automatically converts the sampling frequency of various digital sources to the 44.1 kHz sampling rate of your MD deck. This allows you to record sources such as 32- and 48-kHz DAT or satellite broadcasts, as well as compact discs and other MDs.

Note

If "Din Unlock" alternates with "C71", or "Cannot Copy" appears in the display, recording through the digital connector is not possible. In this case, record the program source through the LINE (ANALOG) IN jacks with the INPUT switch set at ANALOG.

Connecting the AC power cord

Connect the AC power cord to a wall outlet or to the outlet of a timer.

About the CONTROL A1 Control System

This MD deck is compatible with the CONTROL A1 Control System.

The CONTROL A1 Control System was designed to simplify the operation of audio systems composed of separate Sony components. CONTROL A1 connections provide a path for the transmission of control signals which enable automatic operation and control features usually associated with integrated systems.

Currently, CONTROL A1 connections between a Sony MD deck, CD player, amplifier (receiver), and cassette deck provide automatic function selection and synchronized recording.

In the future the CONTROL A1 connection will work as a multifunction bus allowing you to control various functions for each component.

Note

The CONTROL A1 Control System is designed to maintain upward compatibility as the Control System is upgraded to handle new functions. In this case, however, older components will not be compatible with the new functions.

Compatibility with the former CONTROL A System
Although the CDP-CX153 is equipped with a CONTROL A terminal, it can be connected to CONTROL A1 components using a special connecting cable.

The CDP-CX151 however, cannot be connected to CONTROL A1.

* Use the Sony RK-G139HG (1 meter [39 1/4 in]) monoaural mini-plug stereo mini-plug connecting cable or a similar cable (less than 2 meters [78 1/2 in]) long, with no resistance.



Be sure to connect the STEREO mini-plug to the CONTROL A component and the MONO mini-plug to the CONTROL A1 component.

Connecting the CONTROL A1 Control System

- Connect the CONTROL A1 cables in series to the CONTROL A1 jacks on the back of each component. Be sure to connect a CONTROL A1 compatible amplifier (receiver) to take advantage of the automatic function selection feature.

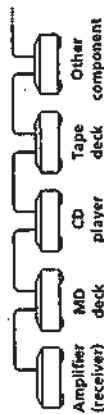

- The components can be connected in any order.
- You can connect up to ten CONTROL A1 compatible components.
- The CONTROL A1 functions will work when the component you want to operate is turned on, even if all of the connected components are not turned on.
- As a rule, the CONTROL A1 remote control system should not incorporate more than one of each type of component (i.e., 1 MD deck, 1 CD player, 1 tape deck and 1 receiver). You may, however, be able to connect more than one of certain CD players. Refer to the operating instructions supplied with the respective component for details.

About the CONTROL A1 cable

- Use a commercially available 2P (mono) mini-plug cable less than 2 meters (78 7/8 in.) long, with a maximum outer diameter no greater than 11 mm (7/8 in.), and no resistance. Some CONTROL A1 compatible components are supplied with a CONTROL A1 cable as an accessory.
- If a component has more than one CONTROL A1 jack, you can use either one, or connect a different component to each jack.

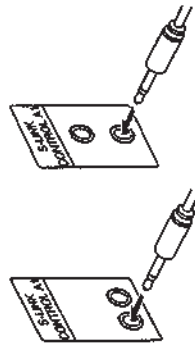

"S-LINK" is a general name for Sony's Bus System, and includes the CONTROL A1 Control System.

Setting the Clock

Once you set the MD deck's internal clock, the MD deck will automatically record the date and time of all recordings. When playing a track, you can display the date and time the track was recorded (see page 24). Time on this deck is displayed on a 12-hour clock (USA and Canadian models only) or a 24-hour clock (European model only).

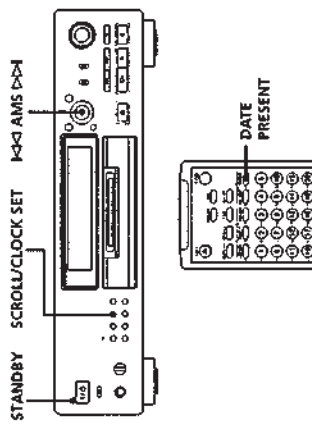

- 1 With the deck in standby status (the STANDBY indicator lights red), press SCROLL/CLOCK SET down for about 2 seconds until the month (or day) indication in the display starts flashing.

USA and Canadian models

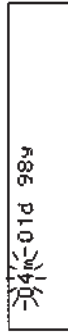

European model

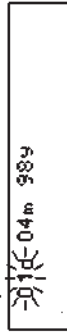

- 2 Turn AMS to enter the current month (or day), then press AMS. The month (or day) indication stops flashing, and the day (or month) indication starts flashing.

USA and Canadian models

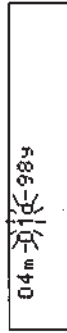

European model

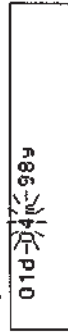

(Continued)

- 3 Repeat Step 2 to enter the month, day, year, hour, and minute.

USA and Canadian models



European model



- For precise time and date stamping of recordings. Reset the time at least once a week.

Note

If the AC power cord is disconnected for a long time, the memorized clock settings will disappear and "STANDBY" will flash in the display the next time you plug in and turn on the deck. If this happens, reset the clock.

Displaying the current date and time

You can display the current date and time any time even when the deck is in standby status.

Press DATE PRESENT.

Each press of the button changes the display as follows:



- You can display the current date and time with an on-deck button.

Press the SCROLL/CLOCK SET button. Each press of the button changes the display in the same order as the DATE PRESENT button on the remote does.

Changing the date and/or time

- 1 With the deck in standby status (the STANDBY indicator lights red), press SCROLL/CLOCK SET down for about 2 seconds until the month (or day) indication in the display starts flashing.
- 2 Press SCROLL/CLOCK SET or AMS repeatedly until the item you want to change flashes.
- 3 Turn AMS to change the contents of the selected item.
- 4 To complete the setting, press AMS repeatedly until all items stop flashing.

Deactivating the demonstration mode

If the MD deck does not contain a disc, demonstration mode is activated automatically after about ten minutes.

To deactivate the demonstration mode, press any button on the MD deck or the remote.

SECTION 3 DISASSEMBLY

- This set can be disassembled in the order shown below.

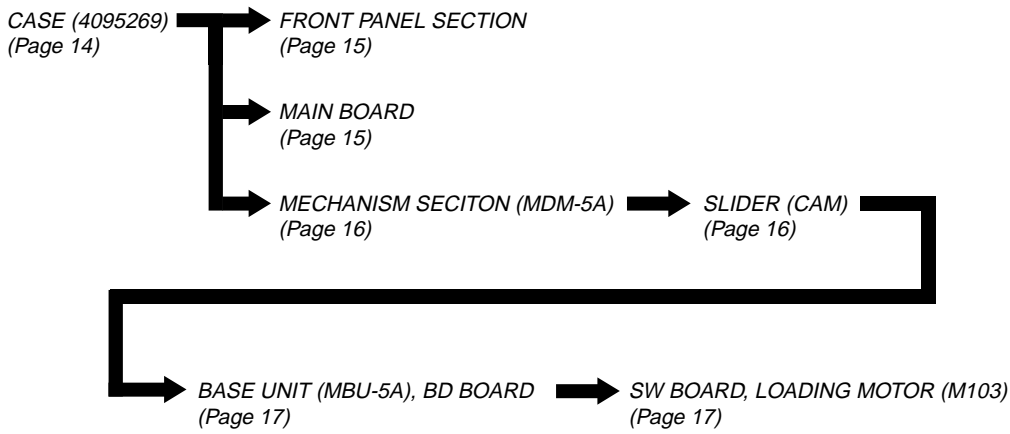

Note: Follow the disassembly procedure in the numerical order given.

CASE (4095269)

- ❶ four screws
(tapping) (SILVER)
(CASE3 TP2) (BLACK: EXCEPT UK)
(CASE) (UK)

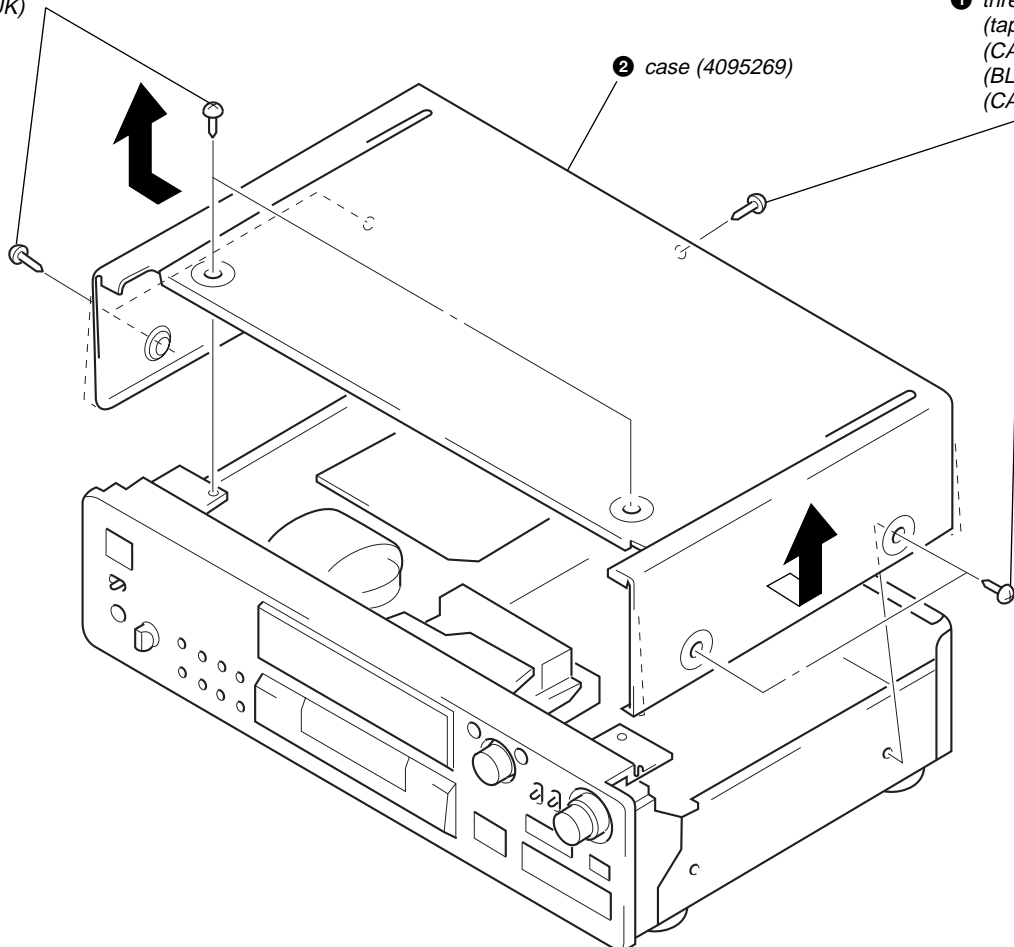

FRONT PANEL SECTION

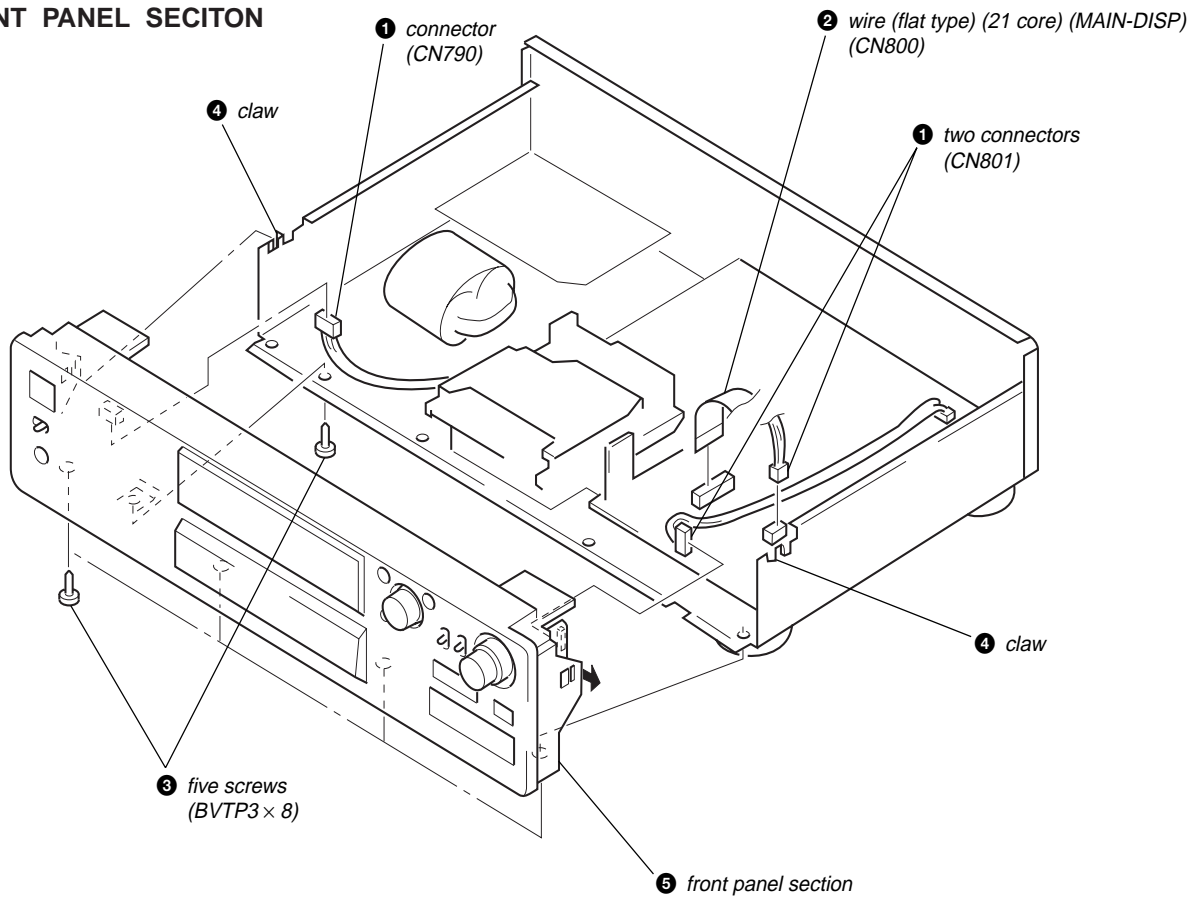

MAIN BOARD

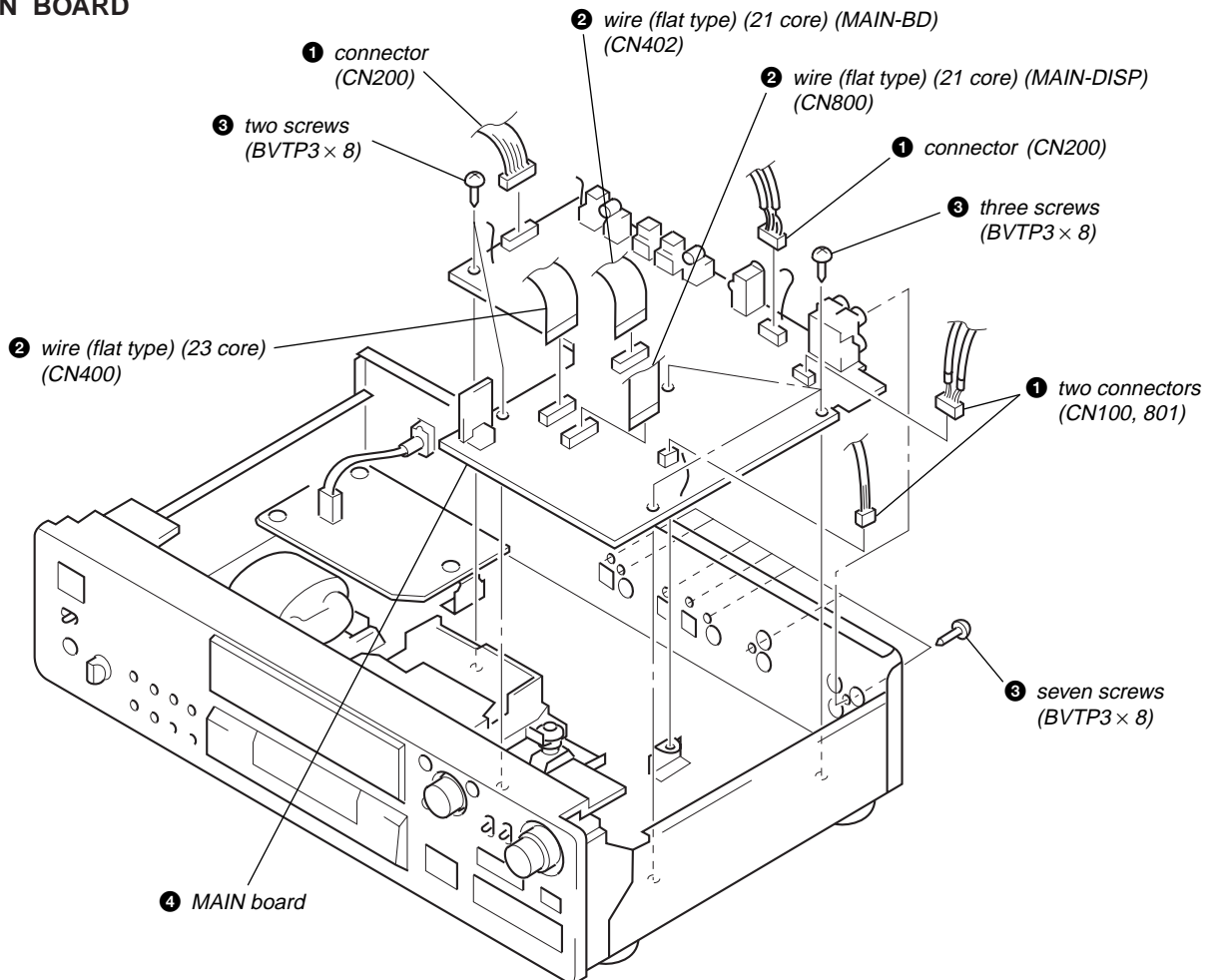

MECHANISM SECTION (MDM-5A)

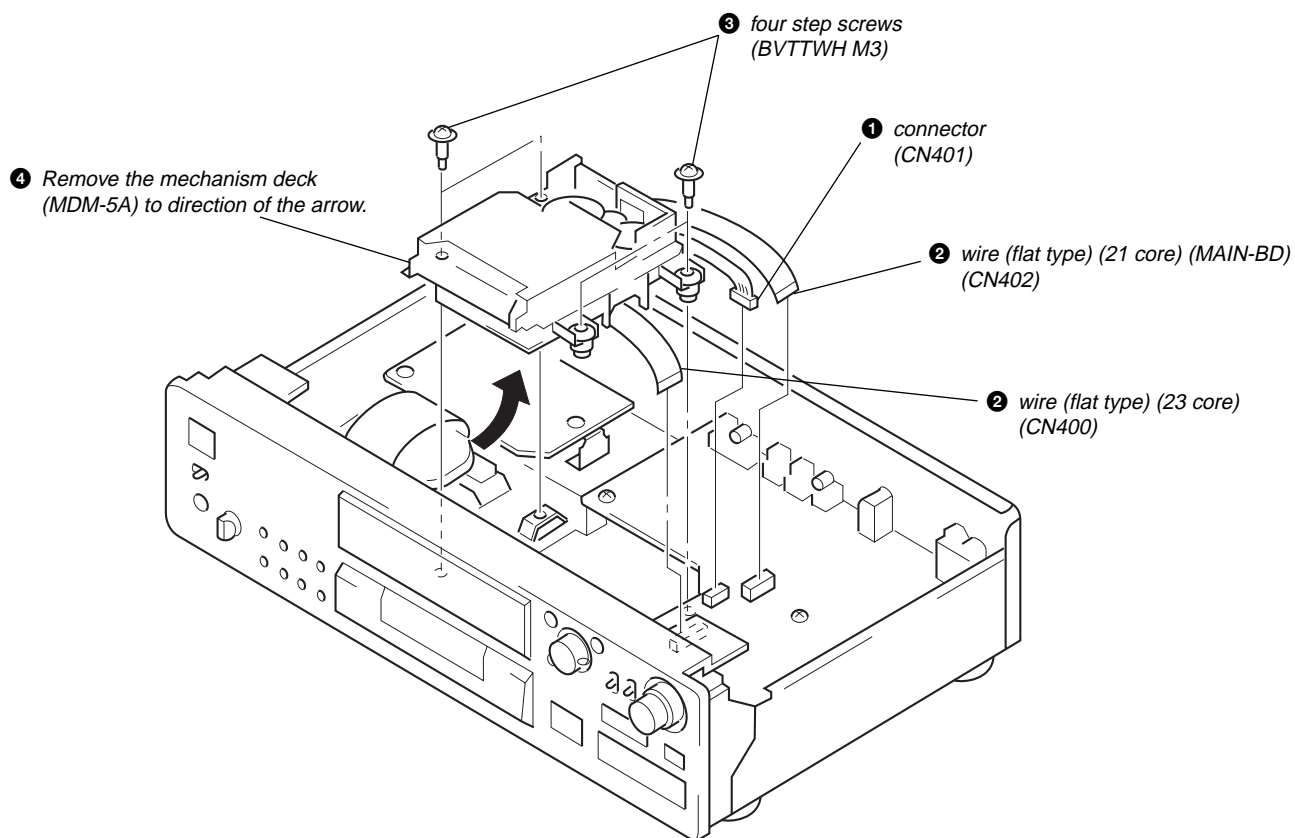

SLIDER (CAM)

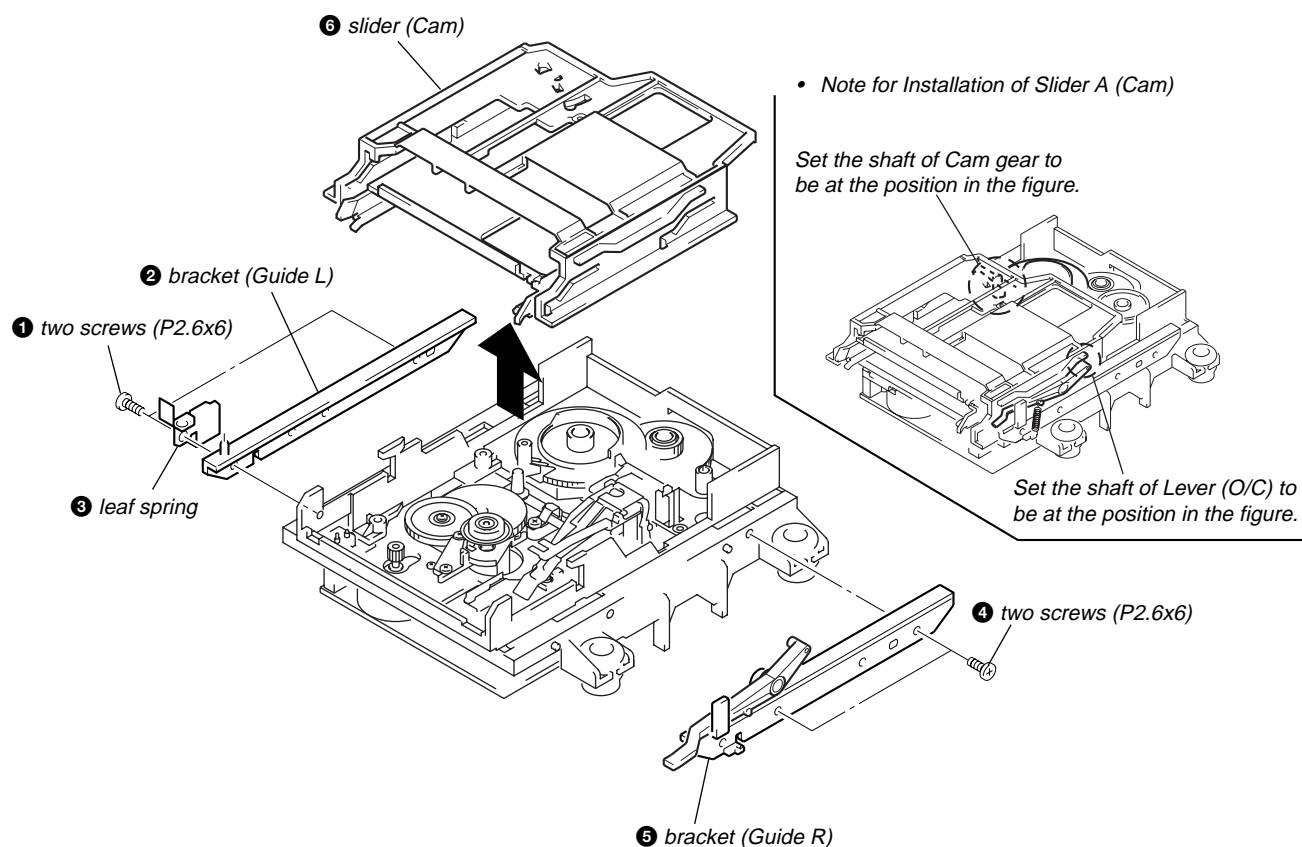

BASE UNIT (MBU-5A), BD BOARD

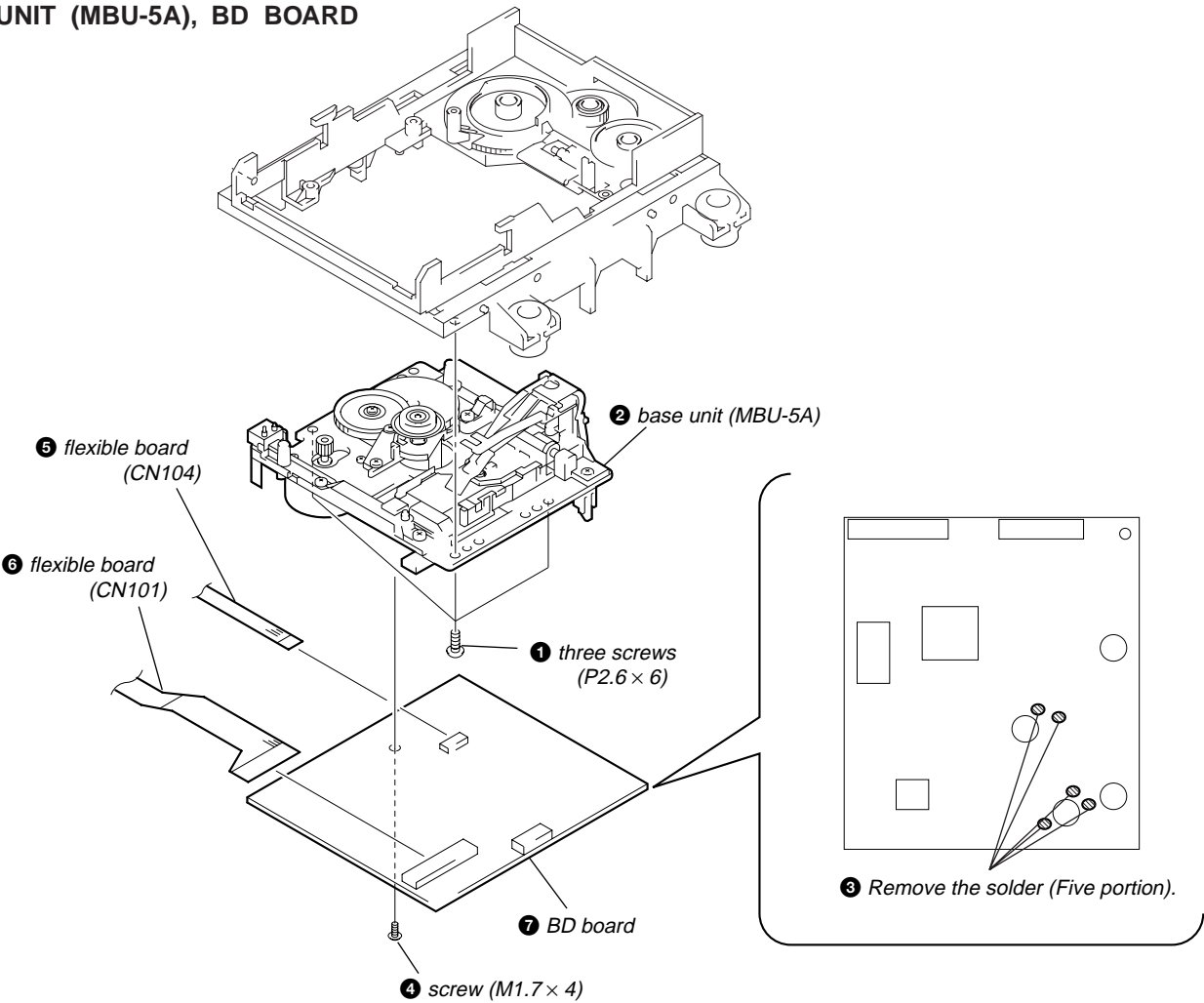

SW BOARD, LOADING MOTOR (M103)

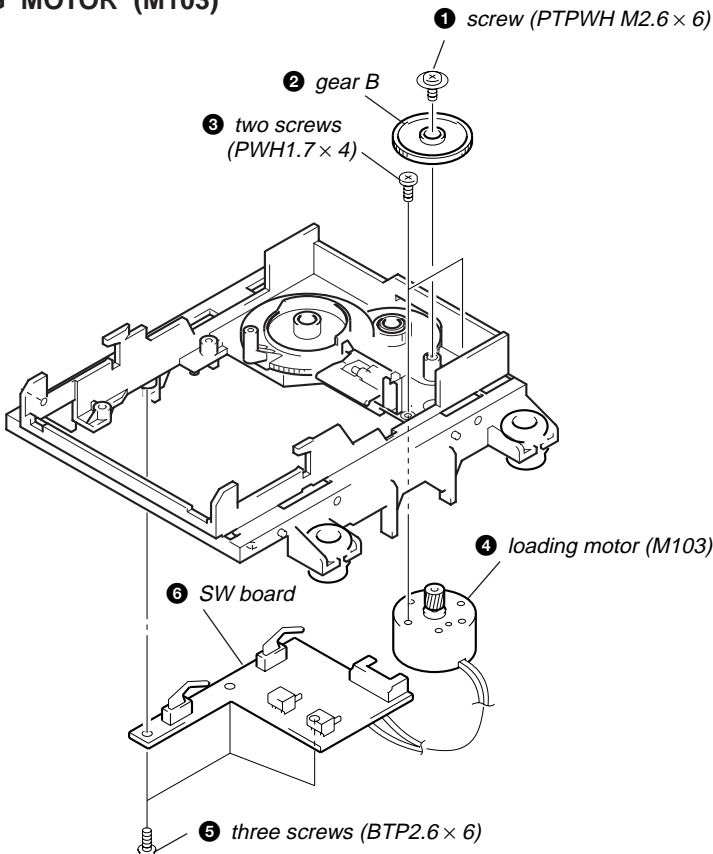

SECTION 4 TEST MODE

1. PRECAUTIONS FOR USE OF TEST MODE

- As loading related operations will be performed regardless of the test mode operations being performed, be sure to check that the disc is stopped before setting and removing it.
Even if the **EJECT** button is pressed while the disc is rotating during continuous playback, continuous recording, etc., the disc will not stop rotating.
Therefore, it will be ejected while rotating.
Be sure to press the **EJECT** button after pressing the **MENU/NO** button and the rotation of disc is stopped.

1-1. Recording laser emission mode and operating buttons

- Continuous recording mode (CREC MODE)
- Laser power check mode (LDPWR CHECK)
- Laser power adjustment mode (LDPWR ADJUST)
- Traverse (MO) check (EF MO CHECK)
- Traverse (MO) adjustment (EF MO ADJUST)
- When pressing the **REC** button.

2. SETTING THE TEST MODE

The following are two methods of entering the test mode.

Procedure 1: While pressing the **AMS** knob and **STOP** button, connect the power plug to an outlet, and release the **AMS** knob and **STOP** button.

When the test mode is set, “[Check]” will be displayed. Rotating the **AMS** knob switches between the following four groups; ... ↔ Check ↔ Adjust ↔ Service ↔ Develop ↔ ...

Procedure 2: While pressing the **AMS** knob, connect the power plug to the outlet and release the **AMS** knob. When the test mode is set, “TEMP CHECK” will be displayed. By setting the test mode using this method, only the “Check” group of method 1 can be executed.

3. EXITING THE TEST MODE

Press the **REPEAT** button. The disc is ejected when loaded, and “Standby” display blinks, and the STANDBY state is set.

4. BASIC OPERATIONS OF THE TEST MODE

All operations are performed using the **AMS** knob, **YES** button, and **MENU/NO** button.

The functions of these buttons are as follows.

Function name	Function
AMS knob	Changes parameters and modes
YES button	Proceeds onto the next step. Finalizes input.
MENU/NO button	Returns to previous step. Stops operations.

5. SELECTING THE TEST MODE

There are 31 types of test modes as shown below. The groups can be switched by rotating the $\llbracket \llcorner \text{AMS} \lrcorner \rrbracket$ knob. After selecting the group to be used, press the $\llbracket \text{YES} \rrbracket$ button. After setting a certain group, rotating the $\llbracket \llcorner \text{AMS} \lrcorner \rrbracket$ knob switches between these modes. Refer to “Group” in the table for details selected.

All items used for servicing can be treated using group S. So be carefully not to enter other groups by mistake.

Display	No.	Contents	Mark	Group (*)
TEMP CHECK	C01	Temperature compensation offset check		C S
LDPWR CHECK	C02	Laser power check		C S
EF MO CHECK	C03	Traverse (MO) check		C S
EF CD CHECK	C04	Traverse (CD) check		C S
FBIAS CHECK	C05	Focus bias check		C S
S curve CHECK	C06	S letter check	(X)	C
VERIFY MODE	C07	Non-volatile memory check	(X)	C
DETRK CHECK	C08	Detrack check	(X)	C
TEMP ADJUS	C09	Temperature compensation offset adjustment		A S
LDPWR ADJUS	C10	Laser power adjustment		A S
EF MO ADJUS	C11	Traverse (MO) adjustment		A S
EF CD ADJUS	C12	Traverse (CD) adjustment		A S
FBIAS ADJUS	C13	Focus bias adjustment		A S
EEP MODE	C14	Non-volatile memory control	(X) (!)	D
MANUAL CMD	C15	Command transmission	(X)	D
SVDATA READ	C16	Status display	(X)	D
ERR DP MODE	C17	Error history display, clear		S
SLES MOVE	C18	Sled check	(X)	D
ACCESS MODE	C19	Access check	(X)	D
0920 CHECK	C20	Outermost circumference check	(X)	D
HEAD ADJUST	C21	Head position check	(X)	D
CPLAY2 MODE	C22	Same functions as CPLAY MODE	(X)	D
CREC2 MODE	C23	Same functions as CREC MODE	(X)	D
ADJ CLEAR	C24	Initialization of non-volatile memory of adjustment value		A S
AG Set (MO)	C25	Auto gain output level adjustment (MO)		A S
AG Set (CD)	C26	Auto gain output level adjustment (CD)		A S
Iop Read	C27	IOP data display		C S
Iop Write	C28	IOP data write		A S
JB920 @.@.@	C29	Microprocessing version display		C S
CPLAY MODE	C30	Continuous play mode		C A S D
CREC MODE	C31	Continuous recording mode		C A S D

Group (*) A: Adjust
 C: Check D: Develop
 S: Service

- For details of each adjustment mode, refer to “5. Electrical Adjustments”.
 For details of “ERR DP MODE”, refer to “Self-Diagnosis Function” on page 2.
- If a different mode has been selected by mistake, press the $\llbracket \text{MENU/NO} \rrbracket$ button to exit that mode.
- Modes with (X) in the Mark column are not used for servicing and therefore are not described in detail. If these modes are set accidentally, press the $\llbracket \text{MENU/NO} \rrbracket$ button to exit the mode immediately. Be especially careful not to set the modes with (!) as they will overwrite the non-volatile memory and reset it, and as a result, the unit will not operate normally.

5-1. Operating the Continuous Playback Mode

1. Entering the continuous playback mode

- (1) Set the disc in the unit. (Whichever recordable discs or discs for playback only are available.)
- (2) Rotate the [◀◀ AMS ▶▶] knob and display “CPLAY MODE” (C30).
- (3) Press the [YES] button to change the display to “CPLAY MID”.
- (4) When access completes, the display changes to “C = [] AD = []”.

Note: The numbers “[]” displayed show you error rates and ADER.

2. Changing the parts to be played back

- (1) Press the [YES] button during continuous playback to change the display as below.



When pressed another time, the parts to be played back can be moved.

- (2) When access completes, the display changes to “C = [] AD = []”.

Note: The numbers “[]” displayed show you error rates and ADER.

3. Ending the continuous playback mode

- (1) Press the [MENU/NO] button. The display will change to “CPLAY MODE”.
- (2) Press the [EJECT] button to remove the disc.

Note: The playback start addresses for IN, MID, and OUT are as follows.

IN 40h cluster
MID 300h cluster
OUT 700h cluster

5-2. Operating the Continuous Recording Mode (Use only when performing self-recording/playback check.)

1. Entering the continuous recording mode

- (1) Set a recordable disc in the unit.
- (2) Rotate the [◀◀ AMS ▶▶] knob and display “CREC MODE”.
- (3) Press the [YES] button to change the display to “CREC MID” (C31).
- (4) When access completes, the display changes to “CREC []” and **REC** lights up.

Note: The numbers “[]” displayed shows you the recording position addresses.

2. Changing the parts to be recorded

- (1) When the [YES] button is pressed during continuous recording, the display changes as below.



When pressed another time, the parts to be recorded can be changed. **REC** goes off.

- (2) When access completes, the display changes to “CREC []” and **REC** lights up.

Note: The numbers “[]” displayed shows you the recording position addresses.

3. Ending the continuous recording mode

- (1) Press the [MENU/NO] button. The display changes to “CREC MODE” and **REC** goes off.
- (2) Press the [EJECT] button to remove the disc.

Note 1: The recording start addresses for IN, MID, and OUT are as follows.

IN 40h cluster
MID 300h cluster
OUT 700h cluster

Note 2: The [MENU/NO] button can be used to stop recording anytime.

Note 3: Do not perform continuous recording for long periods of time above 5 minutes.

Note 4: During continuous recording, be careful not to apply vibration.

5-3. Non-Volatile Memory Mode (EEP MODE)

This mode reads and writes the contents of the non-volatile memory.

It is not used in servicing. If set accidentally, press the [MENU/NO] button immediately to exit it.

6. FUNCTIONS OF OTHER BUTTONS

Function	Contents
▷	Sets continuous playback when pressed in the STOP state. When pressed during continuous playback, the tracking servo turns ON/OFF.
■	Stops continuous playback and continuous recording.
▶▶	The sled moves to the outer circumference only when this is pressed.
◀◀	The sled moves to the inner circumference only when this is pressed.
SCROLL/CLOCK SET	Switches between the pit and groove modes when pressed.
PLAY MODE	Switches the spindle servo mode (CLVS ↔ CLV A).
DISPLAY/CHAR	Switches the displayed contents each time the button is pressed
⏏ EJECT	Ejects the disc
REPEAT	Exits the test mode

7. TEST MODE DISPLAYS

Each time the [DISPLAY/CHAR] button is pressed, the display changes in the following order.

1. Mode display

Displays “TEMP ADJUST”, “CPLAYMODE”, etc.

2. Error rate display

Displays the error rate in the following way.

C = □□□□ AD = □□□□

C = Indicates the C1 error.

AD = Indicates ADER.

3. Address display

The address is displayed as follows. (MO: recordable disc, CD: playback only disc)

Pressing the [SCROLL/CLOCK SET] button switches between the group display and bit display.

h = □□□□ s = □□□□ (MO pit and CD)

h = □□□□ a = □□□□ (MO groove)

h = Indicates the header address.

s = Indicates the SUBQ address.

a = Indicates the ADIP address.

Note: “-” is displayed when servo is not imposed.

4. Auto gain display (Not used in servicing)

The auto gain is displayed as follows.

AG = □□/□□□□[□□

5. Detrack check display (Not used in servicing)

The detrack is displayed as follows.

ADR = □□□□□□□

6. IVR display (Not used in servicing)

The IVR is displayed as follows.

[□□][□□][□□

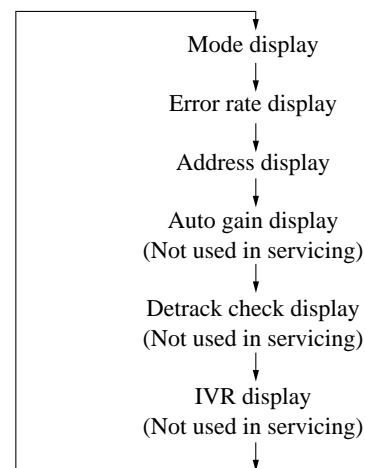

MEANINGS OF OTHER DISPLAYS

Display	Contents	
	When Lit	When Off
▷	During continuous playback (CLV: ON)	STOP (CLV: OFF)
	Tracking servo OFF	Tracking servo ON
REC	Recording mode ON	Recording mode OFF
-SYNC	CLV low speed mode	CLV normal mode
A.SPACE	ABCD adjustment completed	
OVER	Tracking offset cancel ON	Tracking offset cancel OFF
B	Tracking auto gain OK	
A-	Focus auto gain OK	
TRACK	Pit	Groove
DISC	High reflection	Low reflection
DATE	CLV-S	CLV-A
CLOCK	CLV LOCK	CLV UNLOCK

SECTION 5 ELECTRICAL ADJUSTMENTS

1. PARTS REPLACEMENT AND ADJUSTMENT

- Check and adjust the MDM and MBU as follows.
The procedure changes according to the part replaced

- Abbreviation
OP : Optical pick-up
OWH : Overwrite head

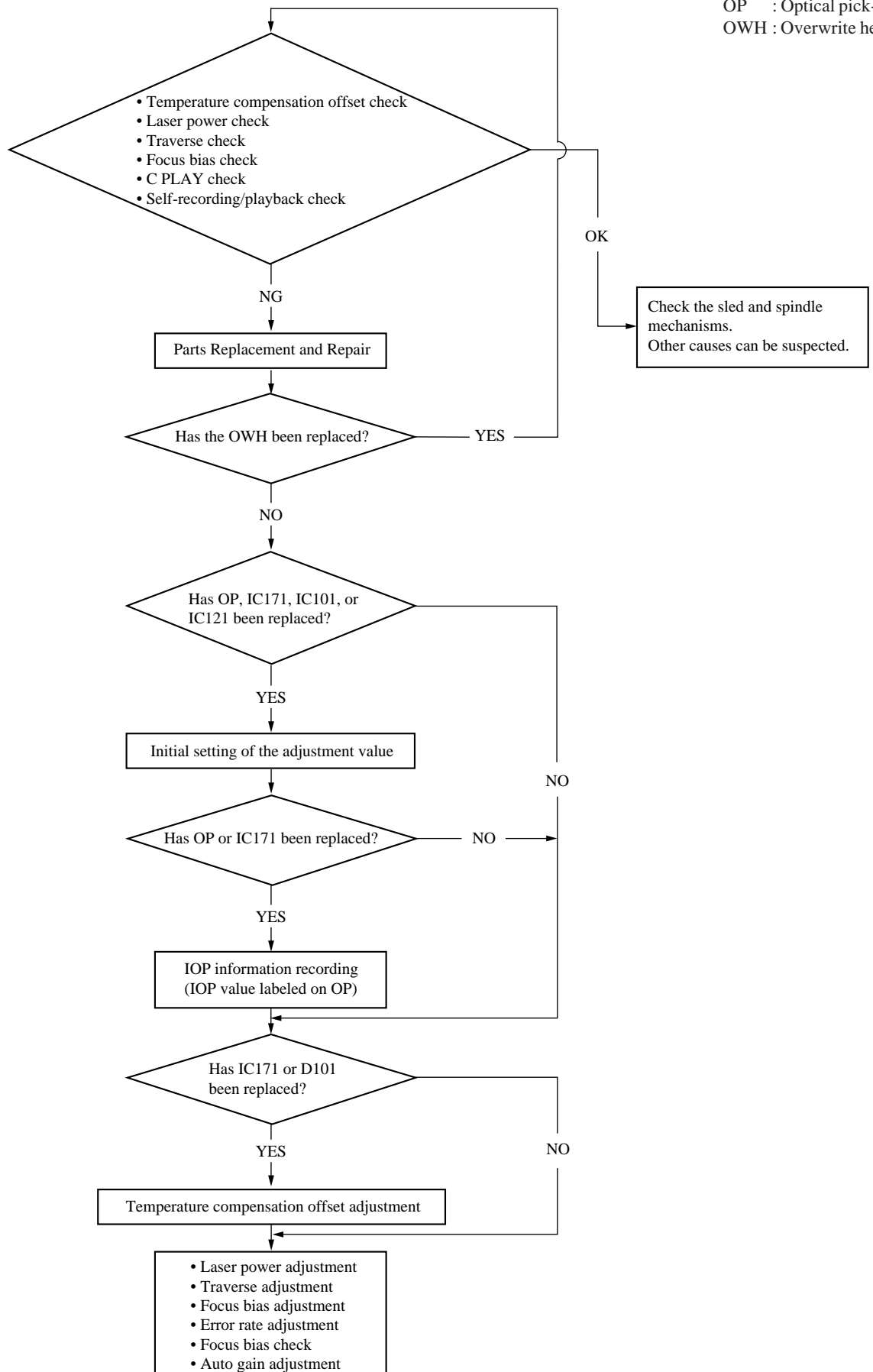

2. PRECAUTIONS FOR CHECKING LASER DIODE EMISSION

To check the emission of the laser diode during adjustments, never view directly from the top as this may lose your eye-sight.

3. PRECAUTIONS FOR USE OF OPTICAL PICK-UP (KMS-260A)

As the laser diode in the optical pick-up is easily damaged by static electricity, solder the laser tap of the flexible board when using it. Before disconnecting the connector, desolder first. Before connecting the connector, be careful not to remove the solder. Also take adequate measures to prevent damage by static electricity. Handle the flexible board with care as it breaks easily.

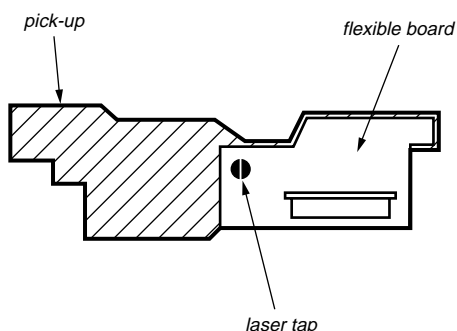

Optical pick-up flexible board

4. PRECAUTIONS FOR ADJUSTMENTS

1. When replacing the following parts, perform the adjustments and checks with **O** in the order shown in the following table.

	Optical Pick-up	BD Board			
		IC171	D101	IC101, IC121	IC192
1. Initial setting of adjustment value	O	O	X	O	X
2. Recording of IOP information (Value written in the pick-up)	O	O	X	X	X
3. Temperature compensation offset adjustment	X	O	O	X	X
4. Laser power adjustment	O	O	X	O	O
5. Traverse adjustment	O	O	X	O	X
6. Focus bias adjustment	O	O	X	O	X
7. Error rate check	O	O	X	O	X
8. Auto gain output level adjustment	O	O	X	O	X

- Set the test mode when performing adjustments. After completing the adjustments, exit the test mode. Perform the adjustments and checks in "group S" of the test mode.
- Perform the adjustments to be needed in the order shown.

- Use the following tools and measuring devices.
 - Check Disc (MD) TDYS-1 (Parts No. 4-963-646-01)
 - TEST DISK (MDW-74/AU-1) (Parts No. 8-892-341-41)
 - Laser power meter LPM-8001 (Parts No. J-2501-046-A) or MD Laser power meter 8010S (Parts No. J-2501-145-A)
 - Oscilloscope (Measure after performing CAL of prove.)
 - Digital voltmeter
 - Thermometer
 - Jig for checking BD board waveform (Parts No. : J-2501-149-A)
- When observing several signals on the oscilloscope, etc., make sure that VC and ground do not connect inside the oscilloscope. (VC and ground will become short-circuited.)
- Using the above jig enables the waveform to be checked without the need to solder. (Refer to Servicing Notes on page 6.)
- As the disc used will affect the adjustment results, make sure that no dusts nor fingerprints are attached to it.

Laser power meter

When performing laser power checks and adjustment (electrical adjustment), use of the new MD laser power meter 8010S (J-2501-145-A) instead of the conventional laser power meter is convenient.

It sharply reduces the time and trouble to set the laser power meter sensor onto the objective lens of the pick-up.

5. CREATING CONTINUOUSLY RECORDED DISC

* This disc is used in focus bias adjustment and error rate check. The following describes how to create a continuous recording disc.

- Insert a disc (blank disc) commercially available.
- Rotate the **[◀◀ AMS ▶▶]** knob and display "CREC MODE". (C31)
- Press the **[YES]** button again to display "CREC MID". Display "CREC (0300)" and start to recording.
- Complete recording within 5 minutes.
- Press the **[MENU/NO]** button and stop recording.
- Press the **[EJECT]** button and remove the disc.

The above has been how to create a continuous recorded data for the focus bias adjustment and error rate check.

Note :

- Be careful not to apply vibration during continuous recording.

6. CHECK PRIOR TO REPAIRS

These checks are performed before replacing parts according to “approximate specifications” to determine the faulty locations. For details, refer to “Checks Prior to Parts Replacement and Adjustments” (See page 8).

6-1. Temperature Compensation Offset Check

When performing adjustments, set the internal temperature and room temperature of 22 °C to 28 °C.

Checking Procedure:

1. Rotate the $\llbracket \llcorner \text{AMS} \triangleright \rrbracket$ knob to display “TEMP CHECK”.
2. Press the $\llbracket \text{YES} \rrbracket$ button.
3. “T=@(##[OK]” should be displayed. If “T=@(##[NG]” is displayed, it means that the results are bad.
(@@ indicates the current value set, and ## indicates the value written in the non-volatile memory.)

6-2. Laser Power Check

Before checking, check the IOP value of the optical pick-up.
(Refer to 5-8. Recording and Displaying IOP Information.)

Connection :

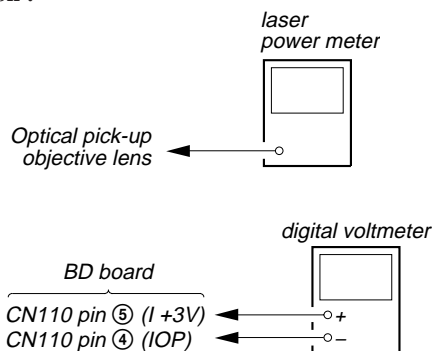

Checking Procedure:

1. Set the laser power meter on the objective lens of the optical pick-up. (When it cannot be set properly, press the \llcorner button or \triangleright button to move the optical pick-up.)
Connect the digital voltmeter to CN110 pin 5 (I+3V) and CN110 pin 4 (IOP).
2. Then, rotate the $\llbracket \llcorner \text{AMS} \triangleright \rrbracket$ knob and display “LDPWR CHECK” (C02).
3. Press the $\llbracket \text{YES} \rrbracket$ button once and display “LD 0.9 mW \$ $\llbracket \llcorner \text{ } \triangleright \rrbracket$ ”. Check that the reading of the laser power meter become 0.84 to 0.92 mW.
4. Press the $\llbracket \text{YES} \rrbracket$ button once more and display “LD 7.0 mW \$ $\llbracket \llcorner \text{ } \triangleright \rrbracket$ ”. Check that the reading the laser power meter and digital voltmeter satisfy the specified value.

Specification:

Laser power meter reading: 7.0 ± 0.2 mW

Digital voltmeter reading : Optical pick-up displayed value $\pm 10\%$

(Optical pick-up label)

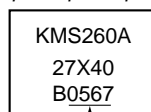

IOP=56.7 mA in this case

$IOP \text{ (mA)} = \text{Digital voltmeter reading (mV)} / 1 \text{ (}\Omega\text{)}$

5. Press the $\llbracket \text{MENU/NO} \rrbracket$ button and display “LDPWR CHECK” and stop the laser emission.
(The $\llbracket \text{MENU/NO} \rrbracket$ button is effective at all times to stop the laser emission.)

Note 1: After step 4, each time the $\llbracket \text{YES} \rrbracket$ button is pressed, the display will be switched between “LD 0.7 mW \$ $\llbracket \llcorner \text{ } \triangleright \rrbracket$ ”, “LD 6.2 mW \$ $\llbracket \llcorner \text{ } \triangleright \rrbracket$ ”, and “LD Wp ホセ イ \$ $\llbracket \llcorner \text{ } \triangleright \rrbracket$ ”. Nothing needs to be performed here.

6-3. Traverse Check

Note 1: Data will be erased during MO reading if a recorded disc is used in this adjustment.

Note 2: If the traverse waveform is not clear, connect the oscilloscope as shown in the following figure so that it can be seen more clearly.

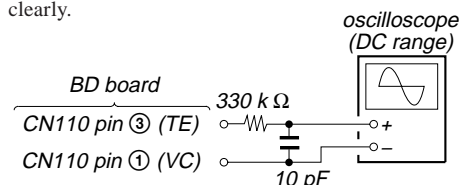

Connection :

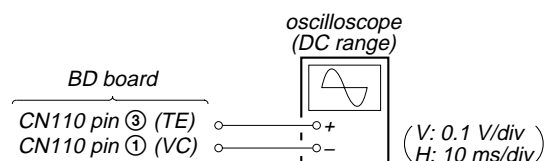

Checking Procedure:

1. Connect an oscilloscope to CN110 pin 3 (TE) and CN110 pin 1 (VC) of the BD board.
2. Load a disc (any available on the market). (Refer to Note 1.)
3. Press the $\llbracket \text{PLAY} \rrbracket$ button and move the optical pick-up outside the pit.
4. Rotate the $\llbracket \llcorner \text{AMS} \triangleright \rrbracket$ knob and display “EF MO CHECK” (C03).
5. Press the $\llbracket \text{YES} \rrbracket$ button and display “EFB = $\llbracket \llcorner \text{ } \triangleright \rrbracket$ MO-R”.
(Laser power READ power/Focus servo ON/tracking servo OFF/spindle (S) servo ON)
6. Observe the waveform of the oscilloscope, and check that the specified value is satisfied. Do not rotate the $\llbracket \llcorner \text{AMS} \triangleright \rrbracket$ knob.
(Read power traverse checking)

(Traverse Waveform)

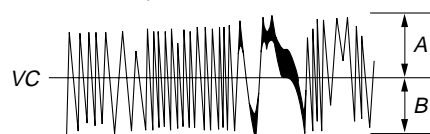

Specified value : Below 10% offset value

$$\text{Offset value (\%)} = \frac{|A - B|}{2(A + B)} \times 100$$

7. Press the $\llbracket \text{YES} \rrbracket$ button and display “EFB = $\llbracket \llcorner \text{ } \triangleright \rrbracket$ MO-W”.
8. Observe the waveform of the oscilloscope, and check that the specified value is satisfied. Do not rotate the $\llbracket \llcorner \text{AMS} \triangleright \rrbracket$ knob.
(Write power traverse checking)

(Traverse Waveform)

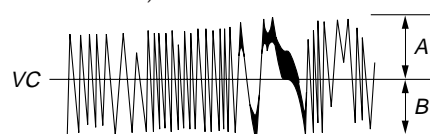

Specified value : Below 10% offset value

$$\text{Offset value (\%)} = \frac{|A - B|}{2(A + B)} \times 100$$

9. Press the **[YES]** button display “EFB = **000** MO-P”. Then, the optical pick-up moves to the pit area automatically and servo is imposed.
10. Observe the waveform of the oscilloscope, and check that the specified value is satisfied. Do not rotate the **[◀◀ AMS ▶▶]** knob.

(Traverse Waveform)

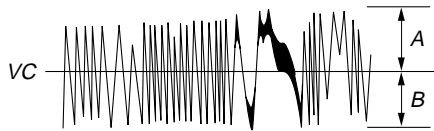

Specified value : Below 10% offset value

$$\text{Offset value (\%)} = \frac{|A - B|}{2(A + B)} \times 100$$

11. Press the **[YES]** button display “EF MO CHECK”. The disc stops rotating automatically.
12. Press the **[EJECT]** button and remove the disc.
13. Load the check disc (MD) TDYS-1.
14. Rotate the **[◀◀ AMS ▶▶]** knob and display “EF CD CHECK” (C04).
15. Press the **[YES]** button and display “EFB = **000** CD”. Servo is imposed automatically.
16. Observe the waveform of the oscilloscope, and check that the specified value is satisfied. Do not rotate the **[◀◀ AMS ▶▶]** knob.

(Traverse Waveform)

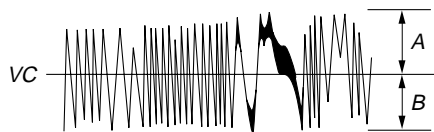

Specified value : Below 10% offset value

$$\text{Offset value (\%)} = \frac{|A - B|}{2(A + B)} \times 100$$

17. Press the **[YES]** button and display “EF CD CHECK”.
18. Press the **[EJECT]** button and remove the check disc (MD) TDYS-1.

6-4. Focus Bias Check

Change the focus bias and check the focus tolerance amount.

Checking Procedure :

1. Load a test disk (MDW-74/AU-1).
2. Rotate the **[◀◀ AMS ▶▶]** knob and display “CPLAY MODE” (C30).
3. Press the **[YES]** button twice and display “CPLAY MID”.
4. Press the **[MENU/NO]** button when “C = **0000** AD = **00**” is displayed.
5. Rotate the **[◀◀ AMS ▶▶]** knob and display “FBIAS CHECK” (C05).
6. Press the **[YES]** button and display “**0000/00** c = **00**”. The first four digits indicate the C1 error rate, the two digits after [/] indicate ADER, and the 2 digits after [c =] indicate the focus bias value. Check that the C1 error is below 220 and ADER is below 2.
7. Press the **[YES]** button and display “**0000/00** b = **00**”. Check that the C1 error is below 220 and ADER is below 2.
8. Press the **[YES]** button and display “**0000/00** a = **00**”. Check that the C1 error is below 220 and ADER is below 2.
9. Press the **[MENU/NO]** button, next press the **[EJECT]** button, and remove the test disc.

6-5. C PLAY Checking

MO Error Rate Check

Checking Procedure :

1. Load a test disk (MDW-74/AU-1).
2. Rotate the **[◀◀ AMS ▶▶]** knob and display “CPLAY MODE” (C30).
3. Press the **[YES]** button and display “CPLAY MID”.
4. The display changes to “C = **0000** AD = **00**”.
5. If the C1 error rate is below 80, check that ADER is below 2.
6. Press the **[MENU/NO]** button, stop playback, press the **[EJECT]** button, and test disc.

CD Error Rate Check

Checking Procedure :

1. Load a check disc (MD) TDYS-1.
2. Rotate the **[◀◀ AMS ▶▶]** knob and display “CPLAY MODE” (C30).
3. Press the **[YES]** button twice and display “CPLAY MID”.
4. The display changes to “C = **0000** AD = **00**”.
5. Check that the C1 error rate is below 50.
6. Press the **[MENU/NO]** button, stop playback, press the **[EJECT]** button, and the test disc.

6-6. Self-Recording/playback Check

Prepare a continuous recording disc using the unit to be repaired and check the error rate.

Checking Procedure :

1. Insert a recordable disc (blank disc) into the unit.
2. Rotate the **[◀◀ AMS ▶▶]** knob to display “CREC MODE” (C31).
3. Press the **[YES]** button to display the “CREC MID”.
4. When recording starts, “**REC**” is displayed, this becomes “CREC @@@@” (@@@@ is the address), and recording starts.
5. About 1 minute later, press the **[MENU/NO]** button to stop continuous recording.
6. Rotate the **[◀◀ AMS ▶▶]** knob to display “C PLAY MODE”(C30).
7. Press the **[YES]** button to display “C PLAY MID”.
8. “C = **0000** AD = **00**” will be displayed.
9. Check that the C1 error becomes below 80 and the AD error below 2.
10. Press the **[MENU/NO]** button to stop playback, and press the **[EJECT]** button and remove the disc.

7. INITIAL SETTING OF ADJUSTMENT VALUE

Note:

Mode which sets the adjustment results recorded in the non-volatile memory to the initial setting value. However the results of the temperature compensation offset adjustment will not change to the initial setting value.

If initial setting is performed, perform all adjustments again excluding the temperature compensation offset adjustment.

For details of the initial setting, refer to “4. Precautions on Adjustments” and execute the initial setting before the adjustment as required.







Setting Procedure :

1. Rotate the  knob to display “ADJ CLEAR (C24)”.
2. Press the **YES** button. “Complete!” will be displayed momentarily and initial setting will be executed, after which “ADJ CLEAR” will be displayed.

8. RECORDING AND DISPLAYING THE IOP INFORMATION

The IOP data can be recorded in the non-volatile memory. The IOP value on the label of the optical pickup and the IOP value after the adjustment will be recorded. Recording these data eliminates the need to read the label on the optical pick-up.

Recording Procedure :

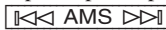
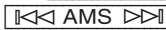
1. While pressing the  knob and  button, connect the power plug to the outlet, and release the  knob and  button.
2. Rotate the  knob to display “[Service]”, and press the **YES** button.
3. Rotate the  knob to display “Iop.Write” (C28), and press the **YES** button.
4. The display becomes Ref=@@.@ (@ is an arbitrary number) and the numbers which can be changed will blink.
5. Input the IOP value written on the optical pick-up.
To select the number : Rotate the  knob.
To select the digit : Press the  knob
6. When the **YES** button is pressed, the display becomes “Measu=@@.@” (@ is an arbitrary number).
7. As the adjustment results are recorded for the 6 value. Leave it as it is and press the **YES** button.
8. “Complete!” will be displayed momentarily. The value will be recorded in the non-volatile memory and the display will become “Iop Write”.

Display Procedure :

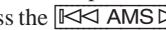
1. Rotate the  knob to display “Iop.Read”(C27).
2. “@@.@/##.#” is displayed and the recorded contents are displayed.
@@.@ indicates the Iop value labeled on the pick-up.
##.# indicates the Iop value after adjustment
3. To end, press the  button or **MENU/NO** button to display “Iop Read”.



9. TEMPERATURE COMPENSATION OFFSET ADJUSTMENT

Save the temperature data at that time in the non-volatile memory as 25 °C reference data.

Note :

1. Usually, do not perform this adjustment.
2. Perform this adjustment in an ambient temperature of 22 °C to 28 °C. Perform it immediately after the power is turned on when the internal temperature of the unit is the same as the ambient temperature of 22 °C to 28 °C.
3. When D101 has been replaced, perform this adjustment after the temperature of this part has become the ambient temperature.

Adjusting Procedure :

1. Rotate the  knob and display “TEMP ADJUS”.
2. Press the **YES** button and select the “TEMP ADJUS” mode.
3. “TEMP =  [OK” and the current temperature data will be displayed.
4. To save the data, press the **YES** button.
When not saving the data, press the **MENU/NO** button.
5. When the **YES** button is pressed, “TEMP =  SAVE” will be displayed and turned back to “TEMP ADJUS” display then.
When the **MENU/NO** button is pressed, “TEMP ADJUS” will be displayed immediately.

Specified Value :

The “TEMP = ” should be within “E0 - EF”, “F0 - FF”, “00 - 0F”, “10 - 1F” and “20 - 2F”.







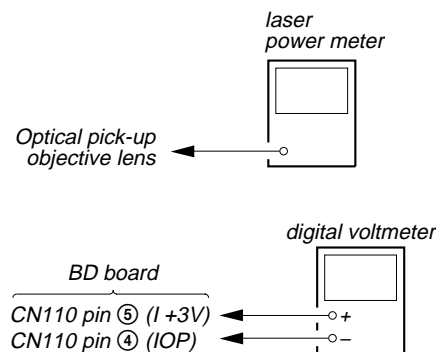

10. LASER POWER ADJUSTMENT

Check the IOP value of the optical pick-up before adjustments. (Refer to 5-8. Recording and Displaying IOP Information.)

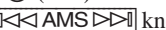
Connection :



Adjusting Procedure :

1. Set the laser power meter on the objective lens of the optical pick-up. (When it cannot be set properly, press the  button or  button to move the optical pick-up.)
Connect the digital volt meter to CN110 pin ⑤ (I+3V) and CN110 pin ④ (IOP).
2. Rotate the  knob and display “LDPWR ADJUS” (C10).
(Laser power : For adjustment)
3. Press the **YES** button once and display “LD 0.9 mW \$ .
4. Rotate the  knob so that the reading of the laser power meter becomes 0.85 to 0.91 mW. Press the **YES** button after setting the range knob of the laser power meter, and save the adjustment results. (“LD SAVE \$ ” will be displayed for a moment.)
5. Then “LD 7.0 mW \$ ” will be displayed.
6. Rotate the  knob so that the reading of the laser power meter becomes 6.9 to 7.1 mW, press the **YES** button and save it.

Note: Do not perform the emission with 7.0 mW more than 15 seconds continuously.

7. Then, rotate the $\llbracket \llcorner \text{AMS} \lrcorner \rrbracket$ knob and display "LDPWR CHECK" (C02).
8. Press the $\llbracket \text{YES} \rrbracket$ button once and display "LD 0.9 mW \$ $\square\square\square$ ". Check that the reading of the laser power meter become 0.85 to 0.91 mW.
9. Press the $\llbracket \text{YES} \rrbracket$ button once more and display "LD 7.0 mW \$ $\square\square\square$ ". Check that the reading the laser power meter and digital volt meter satisfy the specified value.
Note down the digital voltmeter reading value.

Specification:

Laser power meter reading: 7.0 ± 0.2 mW
 Digital voltmeter reading : Optical pick-up displayed value $\pm 10\%$

(Optical pick-up label)

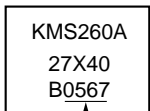

$IOP = 56.7$ mA in this case
 IOP (mA) = Digital voltmeter reading (mV)/1 (Ω)

10. Press the $\llbracket \text{MENU/NO} \rrbracket$ button and display "LDPWR CHECK" and stop the laser emission.
(The $\llbracket \text{MENU/NO} \rrbracket$ button is effective at all times to stop the laser emission.)
11. Rotate the $\llbracket \llcorner \text{AMS} \lrcorner \rrbracket$ knob to display "Iop.Write"(C28).
12. Press the $\llbracket \text{YES} \rrbracket$ button. When the display becomes Ref=@@.@ (@ is an arbitrary number), press the $\llbracket \text{YES} \rrbracket$ button to display "Measu=@@.@" (@ is an arbitrary number).
13. The numbers which can be changed will blink. Input the Iop value noted down at step 9.
To select the number : Rotate the $\llbracket \llcorner \text{AMS} \lrcorner \rrbracket$ knob.
To select the digit : Press the $\llbracket \llcorner \text{AMS} \lrcorner \rrbracket$ knob.
14. When the $\llbracket \text{YES} \rrbracket$ button is pressed, "Complete!" will be displayed momentarily. The value will be recorded in the non-volatile memory and the display will become "Iop Write".

Note 1: After step 4, each time the $\llbracket \text{YES} \rrbracket$ button is pressed, the display will be switched between "LD 0.7 mW \$ $\square\square\square$ ", "LD 6.2 mW \$ $\square\square\square$ ", and "LD Wp ホセイ \$ $\square\square\square$ ". Nothing needs to be performed here.

11. TRAVERSE ADJUSTMENT

Note 1: Data will be erased during MO reading if a recorded disc is used in this adjustment.

Note 2: If the traverse waveform is not clear, connect the oscilloscope as shown in the following figure so that it can be seen more clearly.

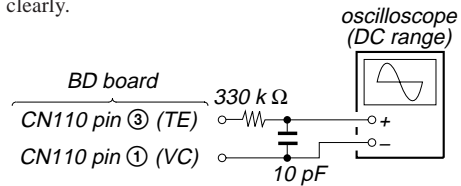

Connection :

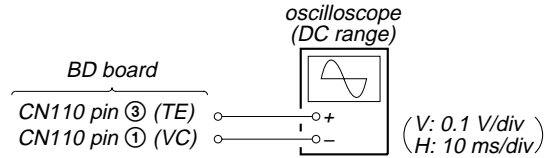

Adjusting Procedure :

1. Connect an oscilloscope to CN110 pin ③ (TE) and CN110 pin ① (VC) of the BD board.
2. Load a disc (any available on the market). (Refer to Note 1.)
3. Press the $\llbracket \blacktriangleright \blacktriangleright \rrbracket$ button and move the optical pick-up outside the pit.
4. Rotate the $\llbracket \llcorner \text{AMS} \lrcorner \rrbracket$ knob and display "EF MO ADJUS" (C10).
5. Press the $\llbracket \text{YES} \rrbracket$ button and display "EFB = $\square\square$ MO-R".
(Laser power READ power/Focus servo ON/tracking servo OFF/spindle (S) servo ON)
6. Rotate the $\llbracket \llcorner \text{AMS} \lrcorner \rrbracket$ knob so that the waveform of the oscilloscope becomes the specified value.
(When the $\llbracket \llcorner \text{AMS} \lrcorner \rrbracket$ knob is rotated, the $\square\square$ of "EFB = $\square\square$ " changes and the waveform changes.) In this adjustment, waveform varies at intervals of approx. 2%. Adjust the waveform so that the specified value is satisfied as much as possible.
(Read power traverse adjustment)

(Traverse Waveform)



Specification A = B

7. Press the $\llbracket \text{YES} \rrbracket$ button and save the result of adjustment to the non-volatile memory ("EFB = $\square\square$ SAV" will be displayed for a moment. Then "EFB = $\square\square$ MO-W" will be displayed).

- Rotate the **[◀◀ AMS ▶▶]** knob so that the waveform of the oscilloscope becomes the specified value.
(When the **[◀◀ AMS ▶▶]** knob is rotated, the **[EFB = 000 SAV]** changes and the waveform changes.) In this adjustment, waveform varies at intervals of approx. 2%. Adjust the waveform so that the specified value is satisfied as much as possible.
(Write power traverse adjustment)

(Traverse Waveform)

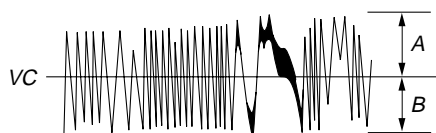

Specification A = B

- Press the **[YES]** button, and save the adjustment results in the non-volatile memory. (“EFB = 000 SAV” will be displayed for a moment.)
- “EFB = 000 MO-P” will be displayed.
The optical pick-up moves to the pit area automatically and servo is imposed.
- Rotate the **[◀◀ AMS ▶▶]** knob until the waveform of the oscilloscope moves closer to the specified value.
In this adjustment, waveform varies at intervals of approx. 2%. Adjust the waveform so that the specified value is satisfied as much as possible.

(Traverse Waveform)

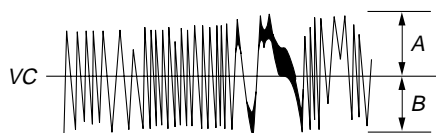

Specification A = B

- Press the **[YES]** button, and save the adjustment results in the non-volatile memory. (“EFB = 000 SAV” will be displayed for a moment.)
Next “EF MO ADJUS” is displayed. The disc stops rotating automatically.
- Press the **[EJECT]** button and remove the disc.
- Load the check disc (MD) TDYS-1.
- Rotate **[◀◀ AMS ▶▶]** knob and display “EF CD ADJUS” (C12).
- Press the **[YES]** button and display “EFB = 000 CD”. Servo is imposed automatically.
- Rotate the **[◀◀ AMS ▶▶]** knob so that the waveform of the oscilloscope moves closer to the specified value.
In this adjustment, waveform varies at intervals of approx. 2%. Adjust the waveform so that the specified value is satisfied as much as possible.

(Traverse Waveform)

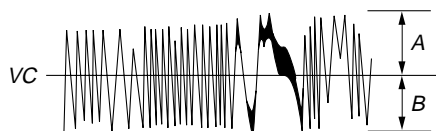

Specification A = B

- Press the **[YES]** button, display “EFB = 000 SAV” for a moment and save the adjustment results in the non-volatile memory.
Next “EF CD ADJUS” will be displayed.
- Press the **[EJECT]** button and remove the check disc (MD) TDYS-1.

12. FOCUS BIAS ADJUSTMENT

Adjusting Procedure :

- Load a test disk (MDW-74/AU-1).
- Rotate the **[◀◀ AMS ▶▶]** knob and display “CPLAY MODE” (C29).
- Press the **[YES]** button and display “CPLAY MID”.
- Press the **[MENU/NO]** button when “C = 0000 AD = 00” is displayed.
- Rotate the **[◀◀ AMS ▶▶]** knob and display “FBIAS ADJUST” (C13).
- Press the **[YES]** button and display “0000/00 a = 00”.
The first four digits indicate the C1 error rate, the two digits after [/] indicate ADER, and the 2 digits after [a =] indicate the focus bias value.
- Rotate the **[◀◀ AMS ▶▶]** knob in the clockwise direction and find the focus bias value at which the C1 error rate becomes 220 (Refer to Note 2).
- Press the **[YES]** button and display “0000/00 b = 00”.
- Rotate the **[◀◀ AMS ▶▶]** knob in the counterclockwise direction and find the focus bias value at which the C1 error rate becomes 220.
- Press the **[YES]** button and display “0000/00 c = 00”.
- Check that the C1 error rate is below 50 and ADER is 00.
Then press the **[YES]** button.
- If the “(00)” in “00 - 00 - 00 (00)” is above 20, press the **[YES]** button.
If below 20, press the **[MENU/NO]** button and repeat the adjustment from step 2.
- Press the **[EJECT]** button to remove the test disc.

Note 1: The relation between the C1 error and focus bias is as shown in the following figure. Find points a and b in the following figure using the above adjustment. The focal point position C is automatically calculated from points a and b.

Note 2: As the C1 error rate changes, perform the adjustment using the average value.

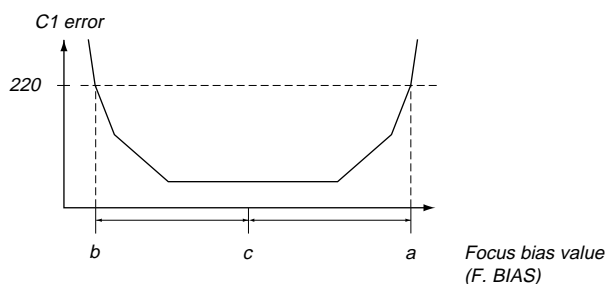

13. ERROR RATE CHECK

13-1. CD Error Rate Check

Checking Procedure :

1. Load a check disc (MD) TDYS-1.
2. Rotate the [◀◀AMS▶▶] knob and display “CPLAY MODE” (C30).
3. Press the [YES] button twice and display “CPLAY MID”.
4. The display changes to “C = [] AD = []”.
5. Check that the C1 error rate is below 20.
6. Press the [MENU/NO] button, stop playback, press the [EJECT] button, and remove the test disc.

13-2. MO Error Rate Check

Checking Procedure :

1. Load a test disc (MDW-74/AU-1).
2. Rotate the [◀◀AMS▶▶] knob and display “CPLAY MODE” (C30).
3. Press the [YES] button and display “CPLAY MID”.
4. The display changes to “C1 = [] AD = []”.
5. If the C1 error rate is below 50, check that ADER is 00.
6. Press the [MENU/NO] button, stop playback, press the [EJECT] button, and remove the test disc.

14. FOCUS BIAS CHECK

Change the focus bias and check the focus tolerance amount.

Checking Procedure :

1. Load a test disc (MDW-74/AU-1).
2. Rotate the [◀◀AMS▶▶] knob and display “CPLAY MODE” (C30).
3. Press the [YES] button twice and display “CPLAY MID”.
4. Press the [MENU/NO] button when “C = [] AD = []” is displayed.
5. Rotate the [◀◀AMS▶▶] knob and display “FBIAS CHECK” (C05).
6. Press the [YES] button and display “[]/[] c = []”.
The first four digits indicate the C1 error rate, the two digits after [/] indicate ADER, and the 2 digits after [c =] indicate the focus bias value.
Check that the C1 error is below 50 and ADER is below 2.
7. Press the [YES] button and display “[]/[] b = []”.
Check that the C1 error is below 220 and ADER is below 2.
8. Press the [YES] button and display “[]/[] a = []”.
Check that the C1 error is below 220 and ADER is below 2.
9. Press the [MENU/NO] button, next press the [EJECT] button, and remove the continuously recorded disc.

Note 1: If the C1 error and ADER are above other than the specified value at points a (step 8. in the above) or b (step 7. in the above), the focus bias adjustment may not have been carried out properly. Adjust perform the beginning again.

15. AUTO GAIN CONTROL OUTPUT LEVEL ADJUSTMENT

Be sure to perform this adjustment when the pickup is replaced. If the adjustment results becomes “Adjust NG!”, the pickup may be faulty or the servo system circuits may be abnormal.

15-1. CD Auto Gain Control Output Level Adjustment

Adjusting Procedure :

1. Insert the check disc (MD) TDYS-1.
2. Rotate the [◀◀AMS▶▶] knob to display “AG Set (CD)” (C26).
3. When the [YES] button is pressed, the adjustment will be performed automatically.
“Complete!!” will then be displayed momentarily when the value is recorded in the non-volatile memory, after which the display changes to “AG Set (CD)”.
4. Press the [EJECT] button to remove the disc.

15-2. MO Auto Gain Control Output Level Adjustment

Adjusting Procedure :

1. Insert the reference disc (MDW-74/AU-1) for recording.
2. Rotate the [◀◀AMS▶▶] knob to display “AG Set (MO)” (C25).
3. When the [YES] button is pressed, the adjustment will be performed automatically.
“Complete!!” will then be displayed momentarily when the value is recorded in the non-volatile memory, after which the display changes to “AG Set (MO)”.
4. Press the [EJECT] button to remove the disc.

16. ADJUSTING POINTS AND CONNECTING POINTS

[BD BOARD] (SIDE A)

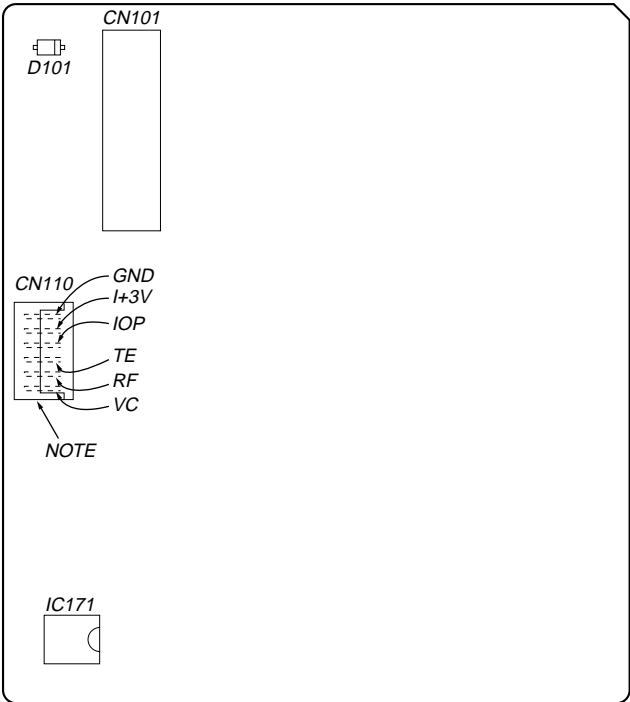

[BD BOARD] (SIDE B)

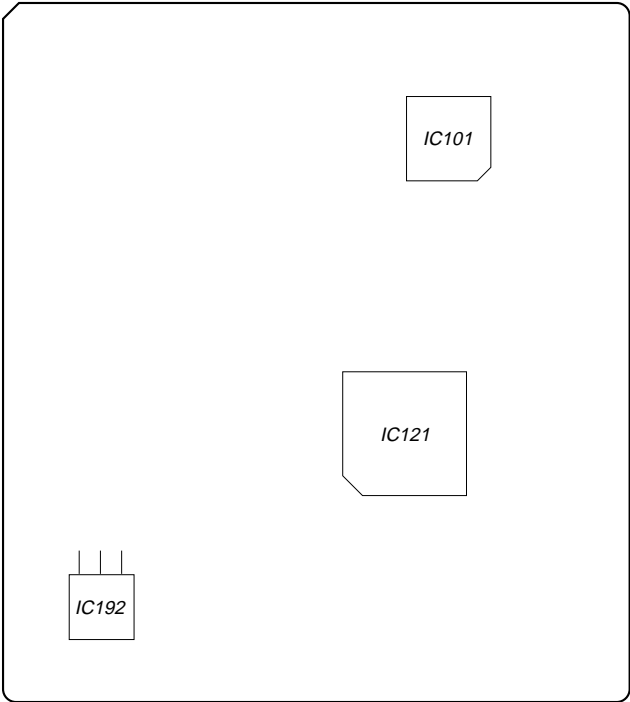

Note: It is useful to use the jig. for checking the waveform. (Refer to Servicing Notes on page 6.)

SECTION 6 DIAGRAMS

6-1. IC PIN FUNCTION DESCRIPTION

• BD BOARD IC101 CXA2523AR (RF AMP, FOCUS/TRACKING ERROR AMP)

Pin No.	Pin Name	I/O	Function
1	I	I	I-V converted RF signal I input from the optical pick-up block detector
2	J	I	I-V converted RF signal J input from the optical pick-up block detector
3	VC	O	Middle point voltage (+1.65V) generation output terminal
4 to 9	A to F	I	Signal input from the optical pick-up detector
10	PD	I	Light amount monitor input from the optical pick-up block laser diode
11	APC	O	Laser amplifier output terminal to the automatic power control circuit
12	APCREF	I	Reference voltage input terminal for setting laser power
13	GND	—	Ground terminal
14	TEMPI	I	Connected to the temperature sensor
15	TEMPR	O	Output terminal for a temperature sensor reference voltage
16	SWDT	I	Writing serial data input from the CXD2654R (IC121)
17	SCLK	I	Serial data transfer clock signal input from the CXD2654R (IC121)
18	XLAT	I	Serial data latch pulse signal input from the CXD2654R (IC121)
19	XSTBY	I	Standby signal input terminal “L”: standby (fixed at “H” in this set)
20	F0CNT	I	Center frequency control voltage input terminal of internal circuit (BPF22, BPF3T, EQ) input from the CXD2654R (IC121)
21	VREF	O	Reference voltage output terminal Not used (open)
22	EQADJ	I	Center frequency setting terminal for the internal circuit (EQ)
23	3TADJ	I	Center frequency setting terminal for the internal circuit (BPF3T)
24	VCC	—	Power supply terminal (+3.3V)
25	WBLADJ	I	Center frequency setting terminal for the internal circuit (BPF22)
26	TE	O	Tracking error signal output to the CXD2654R (IC121)
27	CSLED	I	Connected to the external capacitor for low-pass filter of the sled error signal
28	SE	O	Sled error signal output to the CXD2654R (IC121)
29	ADFM	O	FM signal output of the ADIP
30	ADIN	I	Receives a ADIP FM signal in AC coupling
31	ADAGC	I	Connected to the external capacitor for ADIP AGC
32	ADFG	O	ADIP duplex signal (22.05 kHz \pm 1 kHz) output to the CXD2654R (IC121)
33	AUX	O	Auxiliary signal (I ₃ signal/temperature signal) output to the CXD2654R (IC121)
34	FE	O	Focus error signal output to the CXD2654R (IC121)
35	ABCD	O	Light amount signal (ABCD) output to the CXD2654R (IC121)
36	BOTM	O	Light amount signal (RF/ABCD) bottom hold output to the CXD2654R (IC121)
37	PEAK	O	Light amount signal (RF/ABCD) peak hold output to the CXD2654R (IC121)
38	RF	O	Playback EFM RF signal output to the CXD2654R (IC121)
39	RFAGC	I	Connected to the external capacitor for RF auto gain control circuit
40	AGCI	I	Receives a RF signal in AC coupling
41	COMPO	O	User comparator output terminal Not used (open)
42	COMPP	I	User comparator input terminal Not used (fixed at “L”)
43	ADDC	I	Connected to the external capacitor for cutting the low band of the ADIP amplifier
44	OPO	O	User operational amplifier output terminal Not used (open)
45	OPN	I	User operational amplifier inversion input terminal Not used (fixed at “L”)
46	RFO	O	RF signal output terminal
47	MORFI	I	Receives a MO RF signal in AC coupling
48	MORFO	O	MO RF signal output terminal

• **BD BOARD IC121 CXD2654R**
(DIGITAL SIGNAL PROCESSOR, DIGITAL SERVO PROCESSOR, EFM/ACIRC ENCODER/DECODER,
SHOCK PROOF MEMORY CONTROLLER, ATRAC ENCODER/DECODER)

Pin No.	Pin Name	I/O	Function
1	MNT0 (FOK)	O	Focus OK signal output to the system controller (IC800) “H” is output when focus is on (“L”: NG)
2	MNT1 (SHOCK)	O	Track jump detection signal output to the system controller (IC800)
3	MNT2 (XBUSY)	O	Busy monitor signal output to the system controller (IC800)
4	MNT3 (SLOCK)	O	Spindle servo lock status monitor signal output to the system controller (IC800)
5	SWDT	I	Writing serial data signal input from the system controller (IC800)
6	SCLK	I (S)	Serial data transfer clock signal input from the system controller (IC800)
7	XLAT	I (S)	Serial data latch pulse signal input from the system controller (IC800)
8	SRDT	O (3)	Reading serial data signal output to the system controller (IC800)
9	SENS	O (3)	Internal status (SENSE) output to the system controller (IC800)
10	$\overline{\text{XRST}}$	I (S)	Reset signal input from the system controller (IC800) “L”: reset
11	SQSY	O	Subcode Q sync (SCOR) output to the system controller (IC800) “L” is output every 13.3 msec Almost all, “H” is output
12	DQSY	O	Digital In U-bit CD format subcode Q sync (SCOR) output to the system controller (IC800) “L” is output every 13.3 msec Almost all, “H” is output
13	RECP	I	Laser power selection signal input from the system controller (IC800) “H”: recording mode, “L”: playback mode
14	XINT	O	Interrupt status output to the system controller (IC800)
15	TX	I	Recording data output enable signal input from the system controller (IC800) Writing data transmission timing input (Also serves as the magnetic head on/off output)
16	OSCI	I	System clock signal (512Fs=22.5792 MHz) input from the D/A converter (IC200)
17	OSCO	O	System clock signal (512Fs=22.5792 MHz) output terminal Not used (open)
18	XTSL	I	Input terminal for the system clock frequency setting “L”: 45.1584 MHz, “H”: 22.5792 MHz (fixed at “H” in this set)
19	DIN0	I	Digital audio signal input terminal when recording mode (for digital optical in/digital coaxial in)
20	DIN1	I	Digital audio signal input terminal when recording mode Not used (fixed at “L”)
21	DOUT	O	Digital audio signal output terminal when playback mode (for digital optical out/digital coaxial out)
22	DATAI	I	Serial data input terminal Not used (fixed at “L”)
23	LRCKI	I	L/R sampling clock signal (44.1 kHz) input terminal Not used (fixed at “L”)
24	XBCKI	I	Bit clock signal (2.8224 MHz) input terminal Not used (fixed at “L”)
25	ADDT	I	Recording data input from the A/D converter (IC100)
26	DADT	O	Playback data output to the D/A converter (IC200)
27	LRCK	O	L/R sampling clock signal (44.1 kHz) output to the A/D converter (IC100) and D/A converter (IC200)
28	XBCK	O	Bit clock signal (2.8224 MHz) output to the A/D converter (IC100) and D/A converter (IC200)
29	FS256	O	Clock signal (11.2896 MHz) output terminal Not used (open)
30	DVDD	—	Power supply terminal (+3.3V) (digital system)
31 to 34	A03 to A00	O	Address signal output to the D-RAM (IC124)
35	A10	O	Address signal output to the external D-RAM Not used (open)
36 to 40	A04 to A08	O	Address signal output to the D-RAM (IC124)
41	A11	O	Address signal output to the external D-RAM Not used (open)
42	DVSS	—	Ground terminal (digital system)
43	$\overline{\text{XOE}}$	O	Output enable signal output to the D-RAM (IC124) “L” active
44	$\overline{\text{XCAS}}$	O	Column address strobe signal output to the D-RAM (IC124) “L” active

* I (S) stands for schmitt input, I (A) for analog input, O (3) for 3-state output, and O (A) for analog output in the column I/O.

Pin No.	Pin Name	I/O	Function
45	A09	O	Address signal output to the D-RAM (IC124)
46	<u>X</u> RAS	O	Row address strobe signal output to the D-RAM (IC124) "L" active
47	<u>X</u> WE	O	Write enable signal output to the D-RAM (IC124) "L" active
48	D1	I/O	Two-way data bus with the D-RAM (IC124)
49	D0	I/O	
50	D2	I/O	
51	D3	I/O	
52	MVCI	I (S)	Digital in PLL oscillation input from the external VCO Not used (fixed at "L")
53	ASYO	O	Playback EFM full-swing output terminal
54	ASYI	I (A)	Playback EFM asymmetry comparator voltage input terminal
55	AVDD	—	Power supply terminal (+3.3V) (analog system)
56	BIAS	I (A)	Playback EFM asymmetry circuit constant current input terminal
57	RFI	I (A)	Playback EFM RF signal input from the CXA2523AR (IC101)
58	AVSS	—	Ground terminal (analog system)
59	PCO	O (3)	Phase comparison output for master clock of the recording/playback EFM master PLL
60	FILI	I (A)	Filter input for master clock of the recording/playback master PLL
61	FILO	O (A)	Filter output for master clock of the recording/playback master PLL
62	CLTV	I (A)	Internal VCO control voltage input of the recording/playback master PLL
63	PEAK	I (A)	Light amount signal (RF/ABCD) peak hold input from the CXA2523AR (IC101)
64	BOTM	I (A)	Light amount signal (RF/ABCD) bottom hold input from the CXA2523AR (IC101)
65	ABCD	I (A)	Light amount signal (ABCD) input from the CXA2523AR (IC101)
66	FE	I (A)	Focus error signal input from the CXA2523AR (IC101)
67	AUX1	I (A)	Auxiliary signal (I ₃ signal/temperature signal) input from the CXA2523AR (IC101)
68	VC	I (A)	Middle point voltage (+1.65V) input from the CXA2523AR (IC101)
69	ADIO	O (A)	Monitor output of the A/D converter input signal Not used (open)
70	AVDD	—	Power supply terminal (+3.3V) (analog system)
71	ADRT	I (A)	A/D converter operational range upper limit voltage input terminal (fixed at "H" in this set)
72	ADRB	I (A)	A/D converter operational range lower limit voltage input terminal (fixed at "L" in this set)
73	AVSS	—	Ground terminal (analog system)
74	SE	I (A)	Sled error signal input from the CXA2523AR (IC101)
75	TE	I (A)	Tracking error signal input from the CXA2523AR (IC101)
76	DCHG	I (A)	Connected to the +3.3V power supply
77	APC	I (A)	Error signal input for the laser automatic power control Not used (fixed at "H")
78	ADFG	I (S)	ADIP duplex FM signal (22.05 kHz ± 1 kHz) input from the CXA2523AR (IC101)
79	F0CNT	O	Filter f0 control signal output to the CXA2523AR (IC101)
80	XLRF	O	Serial data latch pulse signal output to the CXA2523AR (IC101)
81	CKRF	O	Serial data transfer clock signal output to the CXA2523AR (IC101)
82	DTRF	O	Writing serial data output to the CXA2523AR (IC101)
83	APCREF	O	Control signal output to the reference voltage generator circuit for the laser automatic power control
84	LDDR	O	PWM signal output for the laser automatic power control Not used (open)
85	TRDR	O	Tracking servo drive PWM signal (-) output to the BH6511FS (IC152)
86	TFDR	O	Tracking servo drive PWM signal (+) output to the BH6511FS (IC152)
87	DVDD	—	Power supply terminal (+3.3V) (digital system)
88	FFDR	O	Focus servo drive PWM signal (+) output to the BH6511FS (IC152)
89	FRDR	O	Focus servo drive PWM signal (-) output to the BH6511FS (IC152)
90	FS4	O	Clock signal (176.4 kHz) output terminal (X'tal system) Not used (open)

* I (S) stands for schmitt input, I (A) for analog input, O (3) for 3-state output, and O (A) for analog output in the column I/O.

Pin No.	Pin Name	I/O	Function
91	SRDR	O	Sled servo drive PWM signal (–) output to the BH6511FS (IC152)
92	SFDR	O	Sled servo drive PWM signal (+) output to the BH6511FS (IC152)
93	SPRD	O	Spindle servo drive PWM signal (–) output to the BH6511FS (IC152)
94	SPFD	O	Spindle servo drive PWM signal (+) output to the BH6511FS (IC152)
95	FGIN	I (S)	Input terminal for the test (fixed at “L”)
96	TEST1	I	
97	TEST2	I	
98	TEST3	I	
99	DVSS	—	Ground terminal (digital system)
100	EFMO	O	EFM signal output terminal when recording mode

* I (S) stands for schmitt input, I (A) for analog input, O (3) for 3-state output, and O (A) for analog output in the column I/O.

• MAIN BOARD IC100 CXD8607N (A/D CONVERTER)

Pin No.	Pin Name	I/O	Function
1	INRP	I	R-ch analog signal (-) input terminal
2	INRM	I	R-ch analog signal (+) input terminal
3	REFI	I	Reference voltage (+3.3V) input terminal (for A/D converter section)
4	AVDD	—	Power supply terminal (+5V) (for A/D converter section, analog system)
5	AVSS	—	Ground terminal (for A/D converter section, analog system)
6	APD	I	Power down detection input of the A/D converter section (for analog section) “L”: power down
7	NU	—	Not used (open)
8	NU	—	Not used (open)
9	TEST1	I	Input terminal for the test (fixed at “L”)
10	LRCK1	I	L/R sampling clock signal (44.1 kHz) input from the CXD2654R (IC121) (for A/D converter section)
11	BCK1	I	Bit clock signal (2.8224 MHz) input from the CXD2654R (IC121) (for A/D converter section)
12	ADDT	O	Recording data output to the CXD2654R (IC121)
13	V35A	—	Power supply terminal (+3.3V) (for analog system)
14	VSS1	—	Ground terminal (for A/D converter section, digital system)
15	MCKI	I	Master clock (256Fs=11.2896 MHz) input of the A/D converter section
16	$\overline{\text{DPD}}$	I	Reset signal input from the system controller (IC800) Reset signal is used as a detection signal of power down to A/D converter section (digital section) “L”: reset (power down)
17	VSS2	—	Ground terminal (for D/A converter section, digital system)
18	$\overline{\text{RES}}$	I	Reset signal input terminal Reset signal is used as a initialize signal to D/A converter section “L”: reset (initialize) Not used D/A converter section in this set
19	MODE	I	Writing data input terminal Not used (fixed at “L”)
20	SHIFT	I	Serial clock signal input terminal Not used (fixed at “L”)
21	XLATCH	I	Serial data latch pulse signal input terminal Not used (fixed at “L”)
22	256CK	O	256Fs (11.2896 MHz) clock signal output terminal Not used (open)
23	V35D	—	Power supply terminal (+3.3V) (for digital system) Not used (open)
24	VSS2	—	Ground terminal (for D/A converter section, digital system)
25	512FS	O	512Fs (22.5792 MHz) clock signal output terminal Not used (pull down)
26	BCK2	I	Bit clock signal (2.8224 MHz) input terminal (for D/A converter section) Not used (fixed at “L”)
27	DADT	I	Playback data input terminal Not used (fixed at “L”)
28	LRCK2	I	L/R sampling clock signal (44.1 kHz) input terminal (for D/A converter section) Not used (fixed at “L”)
29	VDD2	—	Power supply terminal (+5V) (for D/A converter section, digital system) Not used (fixed at “L”)
30	R1	O	R-ch PLM signal 1 output terminal Not used (open)
31	AVDDR	—	Power supply terminal (+5V) (for R-ch side D/A converter section, analog system) Not used (fixed at “L”)
32	R2	O	R-ch PLM signal 2 output terminal Not used (open)
33	AVSSR	—	Ground terminal (for R-ch side D/A converter section, analog system)
34	XVDD	—	Power supply terminal (+5V) (for X’tal system) Not used (open)
35	XOUT	O	System clock output terminal (22 MHz) Not used (open)
36	XIN	I	System clock input terminal (22 MHz) Not used (fixed at “L”)
37	XVSS	—	Ground terminal (for X’tal system)
38	AVSSL	—	Ground terminal (for L-ch side D/A converter section, analog system)
39	L2	O	L-ch PLM signal 2 output terminal Not used (open)

Pin No.	Pin Name	I/O	Function
40	AVDDL	—	Power supply terminal (+5V) (for L-ch side D/A converter section, analog system) Not used (open)
41	L1	O	L-ch PLM signal 1 output terminal Not used (open)
42	VDD2	—	Power supply terminal (+5V) (for L-ch side D/A converter section, digital system) Not used (open)
43, 44	VDD1	—	Power supply terminal (+5V) (for A/D converter section, digital system)
45	VSS1	—	Ground terminal (for A/D converter section, digital system)
46	TEST2	I	Input terminal for the test (fixed at “L”)
47	TEST3	I	Input terminal for the test (fixed at “L”)
48	VSS1	—	Ground terminal (for A/D converter section, digital system)
49	NU	—	Not used (open)
50	NU	—	Not used (open)
51	AVSS	—	Ground terminal (for A/D converter section, analog system)
52	LVDD	—	Power supply terminal (+5V) (for A/D converter section, buffer system)
53	LVSS	—	Ground terminal (for A/D converter section, buffer system)
54	REFO	O	Reference voltage (+3.3V) output terminal (for A/D converter section)
55	INLM	I	L-ch analog signal (+) input terminal
56	INLP	I	L-ch analog signal (–) input terminal

• MAIN BOARD IC800 M30610MCA-264FP (SYSTEM CONTROLLER)

Pin No.	Pin Name	I/O	Function
1	JOG1	I	JOG dial pulse input from the rotary encoder (S713 ◀◀ AMS ▶▶)
2	JOG0	I	JOG dial pulse input from the rotary encoder (S713 ◀◀ AMS ▶▶)
3	C1	O	Monitor output terminal for the test C1 error rate is output when test mode
4	ADER	O	Monitor output terminal for the test ADER is output when test mode
5	SQSY	I	Subcode Q sync (SCOR) input from the CXD2654R (IC121) “L” is input every 13.3 msec Almost all, “H” is input
6	RMC	I	Remote control signal input from the remote control receiver (IC761)
7	AIN1	I	Sires remote control signal input of the S-LINK CONTROL A1
8	BYTE	I	External data bus line byte selection signal input “L”: 16 bit, “H”: 8 bit (fixed at “L”)
9	CNVSS	—	Ground terminal
10	XT-IN	I	Sub system clock input terminal (32.768 kHz)
11	XT-OUT	O	Sub system clock output terminal (32.768 kHz)
12	<u>S.RST</u>	I	System reset signal input from the LA5632 (IC700) “L”: reset For several hundreds msec. after the power supply rises, “L” is input, then it changes to “H”
13	XOUT	O	Main system clock output terminal (7 MHz)
14	GND	—	Ground terminal
15	XIN	I	Main system clock input terminal (7 MHz)
16	+3.3V	—	Power supply terminal (+3.3V)
17	NMI	I	Non-maskable interrupt input terminal (fixed at “H” in this set)
18	DQSY	I	Digital In U-bit CD format subcode Q sync (SCOR) input from the CXD2654R (IC121) “L” is input every 13.3 msec Almost all, “H” is input
19	P.DOWN	I	Power down detection signal input terminal “L”: power down, normally: “H”
20	XINT	I	Interrupt status input from the CXD2654R (IC121)
21	DVOL1	I	Digital rec level volume input terminal
22	DVOL0	I	Digital rec level volume input terminal
23 to 30	NC	I	Not used (fixed at “L”)
31	SWDT	O	Writing data output to the CXD2654R (IC121) and D/A converter (IC200)
32	SRDT	I	Reading data input from the CXD2654R (IC121)
33	SCLK	O	Serial clock signal output to the CXD2654R (IC121) and D/A converter (IC200)
34	FLCS	O	Chip select signal output to the FL/LED driver (IC771)
35	FLDATA	O	Serial data output to the FL/LED driver (IC771)
36	NC	I	Not used (fixed at “L”)
37	FLCLK	O	Serial data transfer clock signal output to the FL/LED driver (IC771)
38 to 47	NC	I	Not used (fixed at “L”)
48	CSET0	I	Destination setting terminal (US, Canadian models: fixed at “L”, AEP, UK models: fixed at “H”)
49	CSET1	I	Destination setting terminal (US, Canadian models: fixed at “H”, AEP, UK models: fixed at “L”)
50	XINSW	I	Setting terminal of the loading control system select (fixed at “H” in this set)
51	NC	I	Not used (fixed at “L”)
52	MNT2 (XBUSY)	I	Busy signal input from the CXD2654R (IC121)
53	<u>DIG-RST</u>	O	Reset signal output to the CXD2654R (IC121) and BH6511FS (IC152) “L”: reset
54	MNT1 (SHOCK)	I	Track jump detection signal input from the CXD2654R (IC121)
55	SENS	I	Internal status (SENSE) input from the CXD2654R (IC121)
56	LDON	O	Laser diode on/off control signal output to the automatic power control circuit “H”: laser on
57	REFLECT	I	Detection input from the disc reflection rate detect switch (S102) “L”: high reflection rate disc, “H”: low reflection rate disc
58	PROTECT	I	Rec-proof claw detect input from the protect detect switch (S102) “H”: write protect

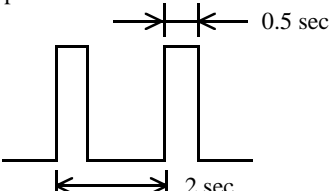
Pin No.	Pin Name	I/O	Function
59	WR-PWR	O	Laser power select signal output to the CXD2654R (IC121) and HF module switch circuit “H”: recording mode, “L”: playback mode
60	MNT3 (SLOCK)	I	Spindle servo lock status monitor signal input from the CXD2654R (IC121)
61	SDA	I/O	Two-way data bus with the EEPROM (IC171)
62	+3.3V	—	Power supply terminal (+3.3V)
63	NC	I	Not used (fixed at “L”)
64	GND	—	Ground terminal
65	SCTX	O	Recording data output enable signal output to the CXD2654R (IC121) and overwrite head driver (IC181) Writing data transmission timing output (Also serves as the magnetic head on/off output)
66	SCL	O	Clock signal output to the EEPROM (IC171)
67	MNT0 (FOK)	I	Focus OK signal input from the CXD2654R (IC121) “H” is input when focus is on (“L”: NG)
68	LIMIT-IN	I	Detection input from the sled limit-in detect switch (S101) The optical pick-up is inner position when “L”
69	MOD	O	Laser modulation select signal output to the HF module switch circuit Playback power: “H”, Stop: “L”, Recording power: 
70	XLATCH	O	Serial data latch pulse signal output to the CXD2654R (IC121)
71	NC	I	Not used (fixed at “L”)
72	REC/PB	I	Not used (fixed at “L”)
73	PACK-IN	I	Detection input from the disc detect switch Not used (fixed at “L”)
74	PB-P	I	Detection input from the playback position detect switch (S604) “L” active
75	CHACK IN	I	Detection input from the disc chucking-in detect switch (S603) “L”: chucking
76	PACK-OUT	I	Detection input from the loading-out detect switch (S602) “L” at a load-out position, others: “H”
77	REC-P	I	Detection input from the recording position detect switch (S601) “L” active
78	LDIN	O	Motor control signal output to the loading motor driver (IC400) “L” active *1
79	LDOUT	O	Motor control signal output to the loading motor driver (IC400) “L” active *1
80	LD-LOW	O	Loading motor drive voltage control signal output for the loading motor driver (IC400) “H” active
81	NC	I	Not used (fixed at “L”)
82	A1OUT	O	Sircs remote control signal output of the S-LINK CONTROL A1
83	MUTE	O	Audio line muting on/off control signal output terminal “L”: line muting on
84	STB	O	Strobe signal output to the power supply circuit “H”: power on, “L”: standby mode

Pin No.	Pin Name	I/O	Function
85	COAX/XOPT	O	Optical in 1/2 or coaxial in selection signal output to the digital input selector (IC300) “L”: OPT 1/2, “H”: COAXIAL
86	OPT2/XOPT1	O	Optical in 1 or optical in 2 selection signal output to the digital input selector (IC300) “L”: OPT 1, “H”: OPT 2
87	DALATCH	O	Serial data latch pulse signal output to the D/A converter (IC200)
88	DARST	O	Reset signal output to the A/D converter (IC100) and D/A converter (IC200) “L”: reset
89	LED0	O	LED drive signal output terminal Not used (pull down)
90	LED1	O	LED drive signal output terminal Not used (pull down)
91	TIMER	I	TIMER switch (S751) input terminal (A/D input) “L”: PLAY, “H”: REC (OFF: center voltage)
92	SOURCE	I	INPUT switch (S741) input terminal (A/D input)
93	KEY3	I	Key input terminal (A/D input) S731 to S734 (TIME, FADER, MUSIC SYNC, MEGA CONTROL keys input)
94	KEY2	I	Key input terminal (A/D input) S722 to S726 (PLAY/MODE, REPEAT, SCROLL/CLOCK SET, DISPLAY/CHAR, I/O keys input)
95	KEY1	I	Key input terminal (A/D input) S711 to S714 and S716 (MENU/NO, YES, PUSH ENTER, EJECT keys input)
96	AVSS	—	Ground terminal
97	KEY0	I	Key input terminal (A/D input) S701 to S706 (● REC, ■, ►►, ◄◄, ■■, ▷ keys input)
98	VREF	I	Reference voltage (+3.3V) input terminal (for A/D converter)
99	+3.3V	—	Power supply terminal (+3.3V) (for analog system)
100	MONO/ST	I	REC MODE switch (S746) input terminal “L”: MONO, “H”: STEREO

*1 Loading motor (M103) control

Terminal \ Mode	LOADING	EJECT	BRAKE	RUN IDLE
LDIN (pin 78)	“L”	“H”	“L”	“H”
LDOUT (pin 79)	“H”	“L”	“L”	“H”

6-2. BLOCK DIAGRAM - SERVO Section -

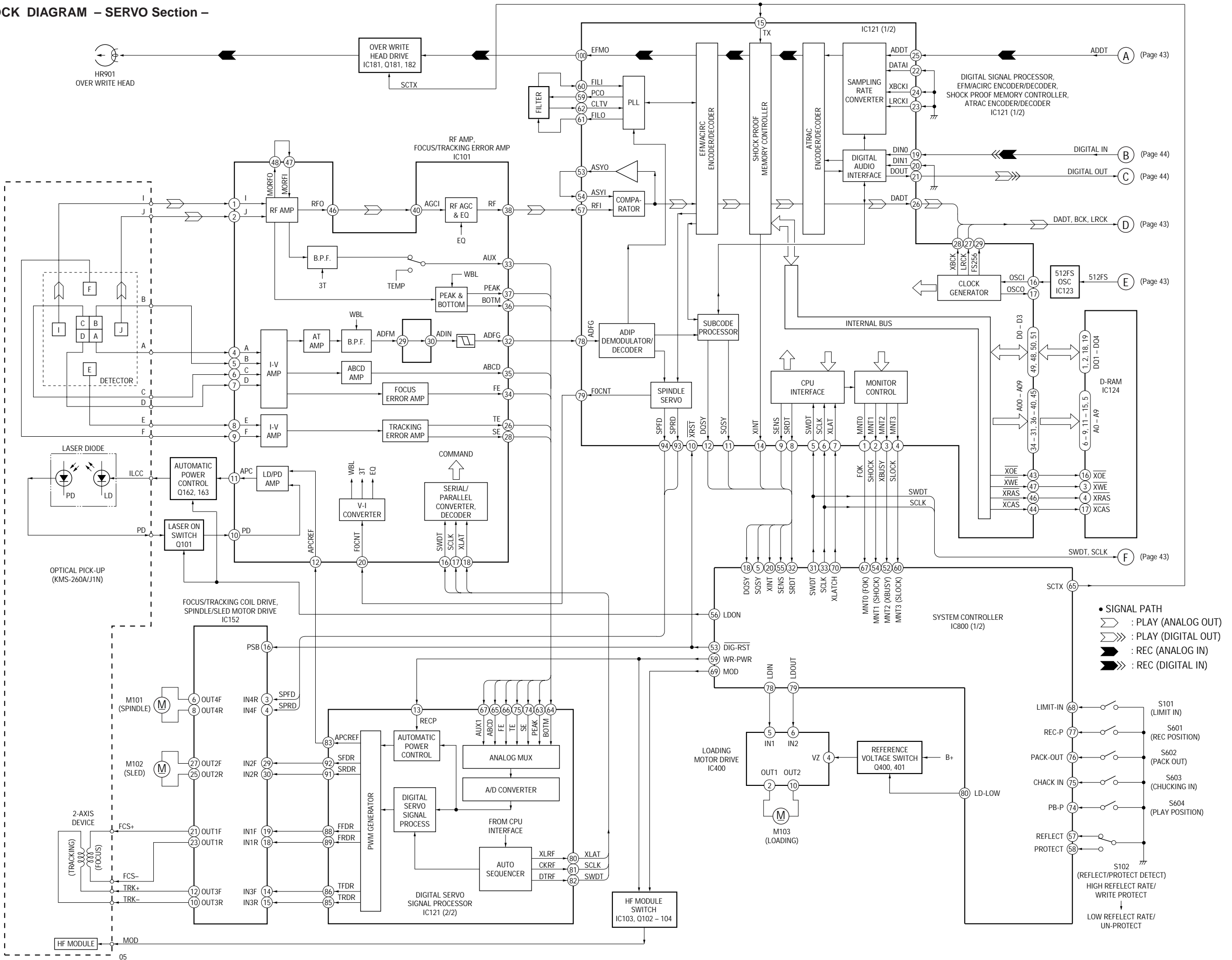

6-3. BLOCK DIAGRAM – MAIN Section –

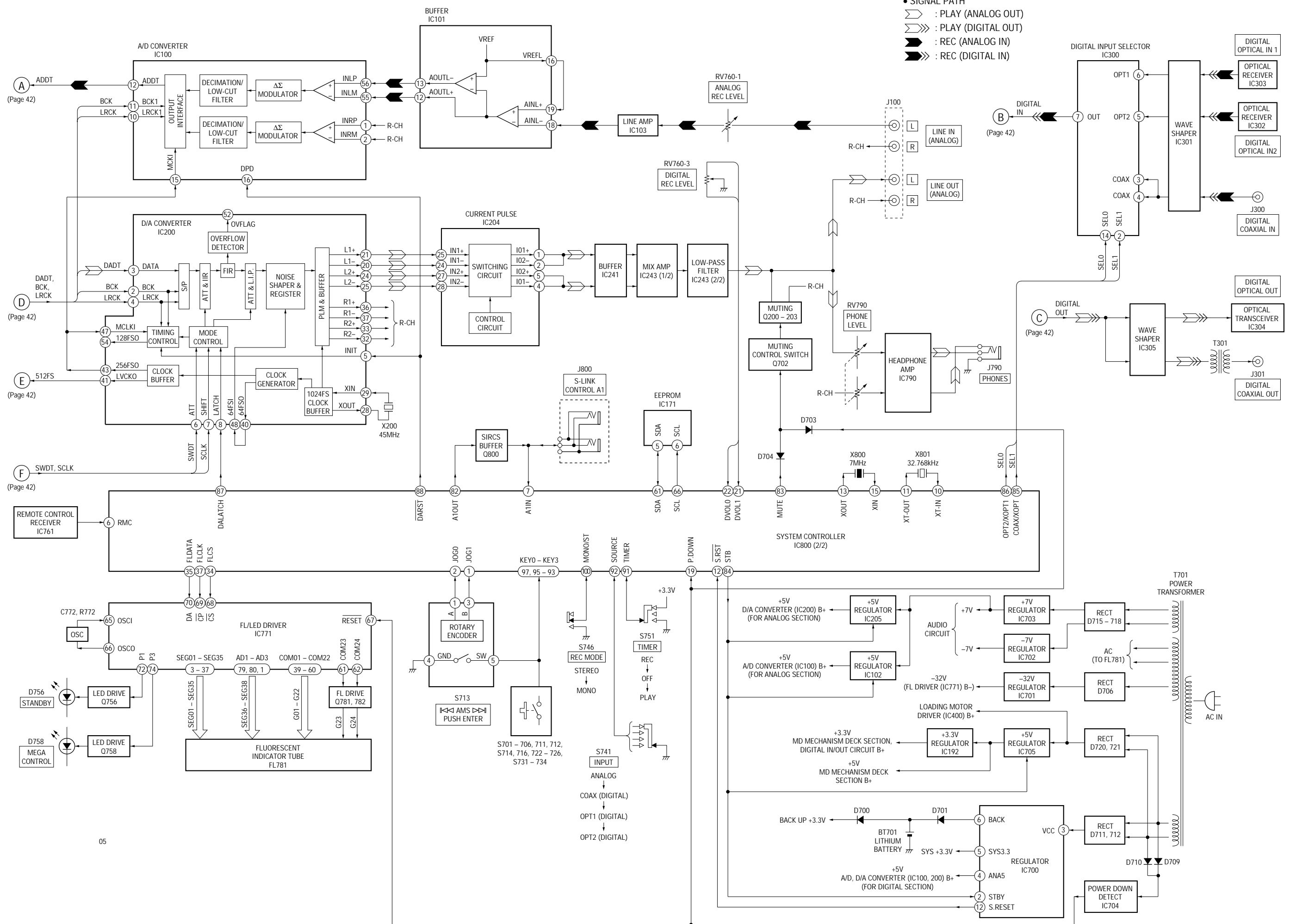

• Circuit Boards Location

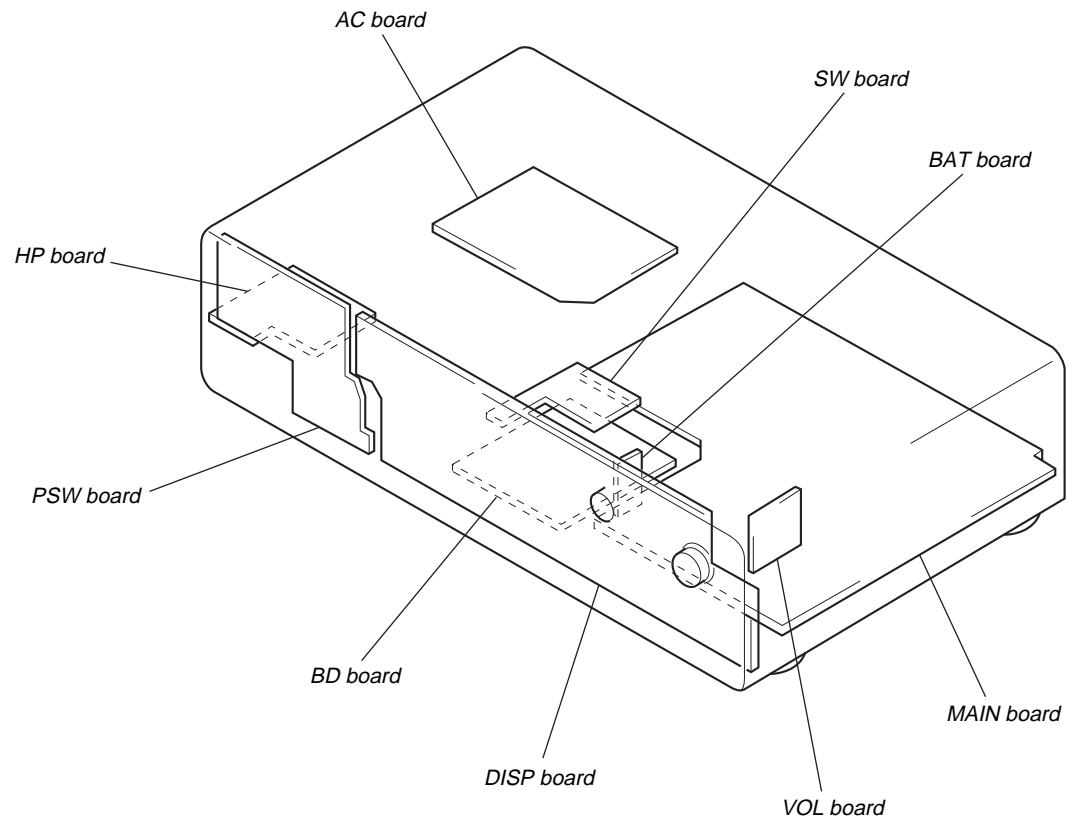

6-4. NOTE FOR PRINTED WIRING BOARDS AND SCHEMATIC DIAGRAMS

Note on Schematic Diagram:

- All capacitors are in μF unless otherwise noted. pF: μpF 50 WV or less are not indicated except for electrolytics and tantalums.
- All resistors are in Ω and $1/4\text{W}$ or less unless otherwise specified.
- % : indicates tolerance.
- Δ : internal component.
- : panel designation.

Note:

The components identified by mark Δ or dotted line with mark Δ are critical for safety. Replace only with part number specified.

Note:

Les composants identifiés par une marque Δ sont critiques pour la sécurité. Ne les remplacer que par une pièce portant le numéro spécifié.

- B+ : B+ Line.
- B- : B- Line.
- Voltages and waveforms are dc with respect to ground in playback mode.
- Voltages are taken with a VOM (Input impedance $10\text{M}\Omega$). Voltage variations may be noted due to normal production tolerances.
- Waveforms are taken with a oscilloscope. Voltage variations may be noted due to normal production tolerances.
- Circled numbers refer to waveforms.
- Signal path.
 - Σ : PB
 - \blacktriangleright : REC
 - $\Sigma \gg$: PB (Digital out)
 - $\blacktriangleright \gg$: REC (Digital in)
- Abbreviation
CND : Canadian model.

Note on Printed Wiring Boards:

- : parts extracted from the component side.
- : parts extracted from the conductor side.
- : Through hole.
- : Pattern from the side which enables seeing.

Caution:

Pattern face side: Parts on the pattern face side seen from the pattern face are indicated.
(Side B)
Parts face side: Parts on the parts face side seen from the parts face are indicated.
(Side A)

- Indication of transistor.

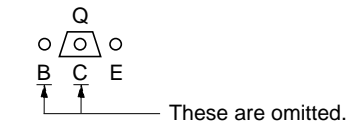
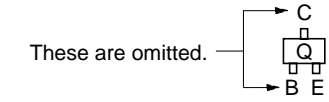

- Abbreviation
CND : Canadian model.

6-5. PRINTED WIRING BOARDS – BD Section –

• See page 45 for Circuit Boards Location.

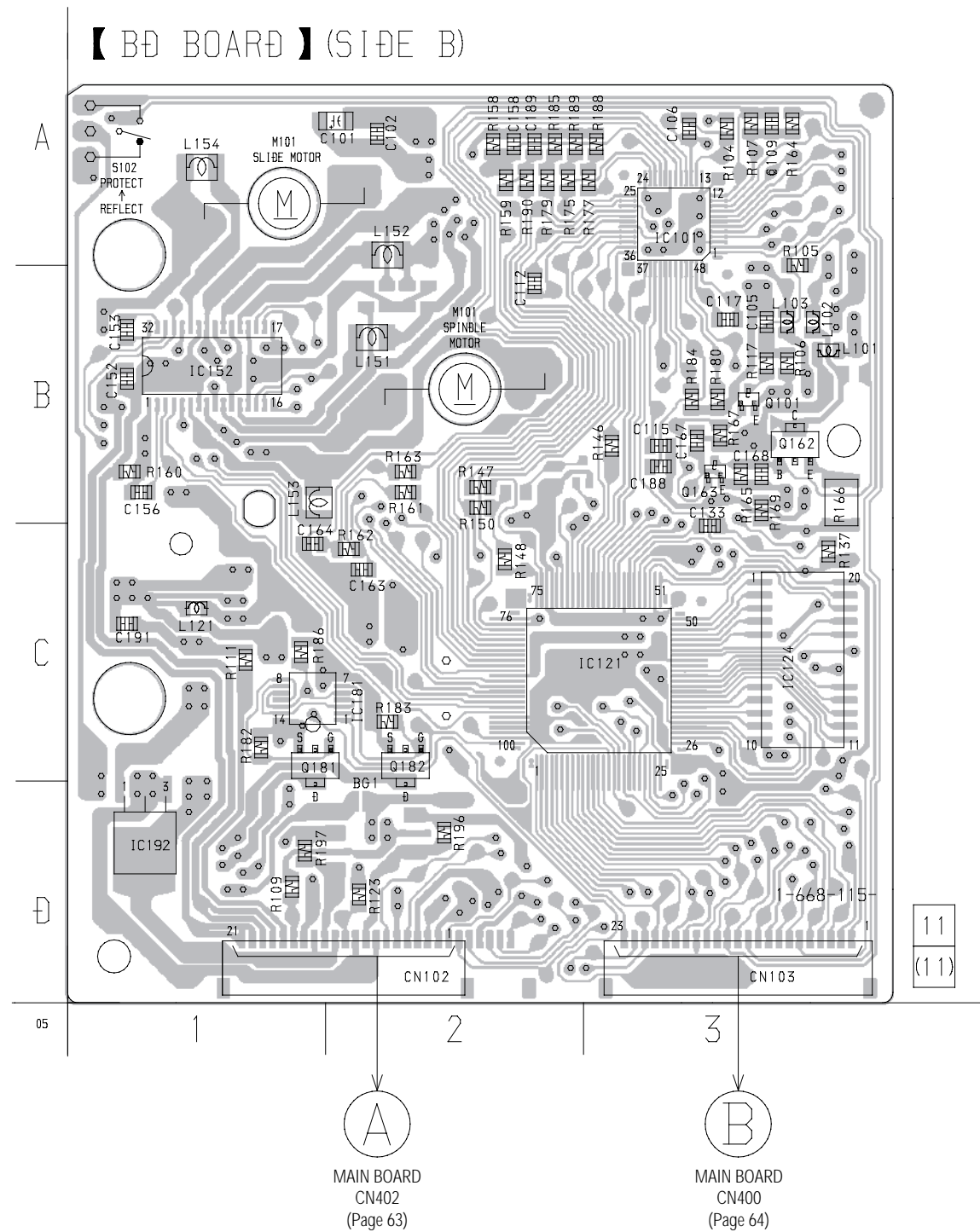
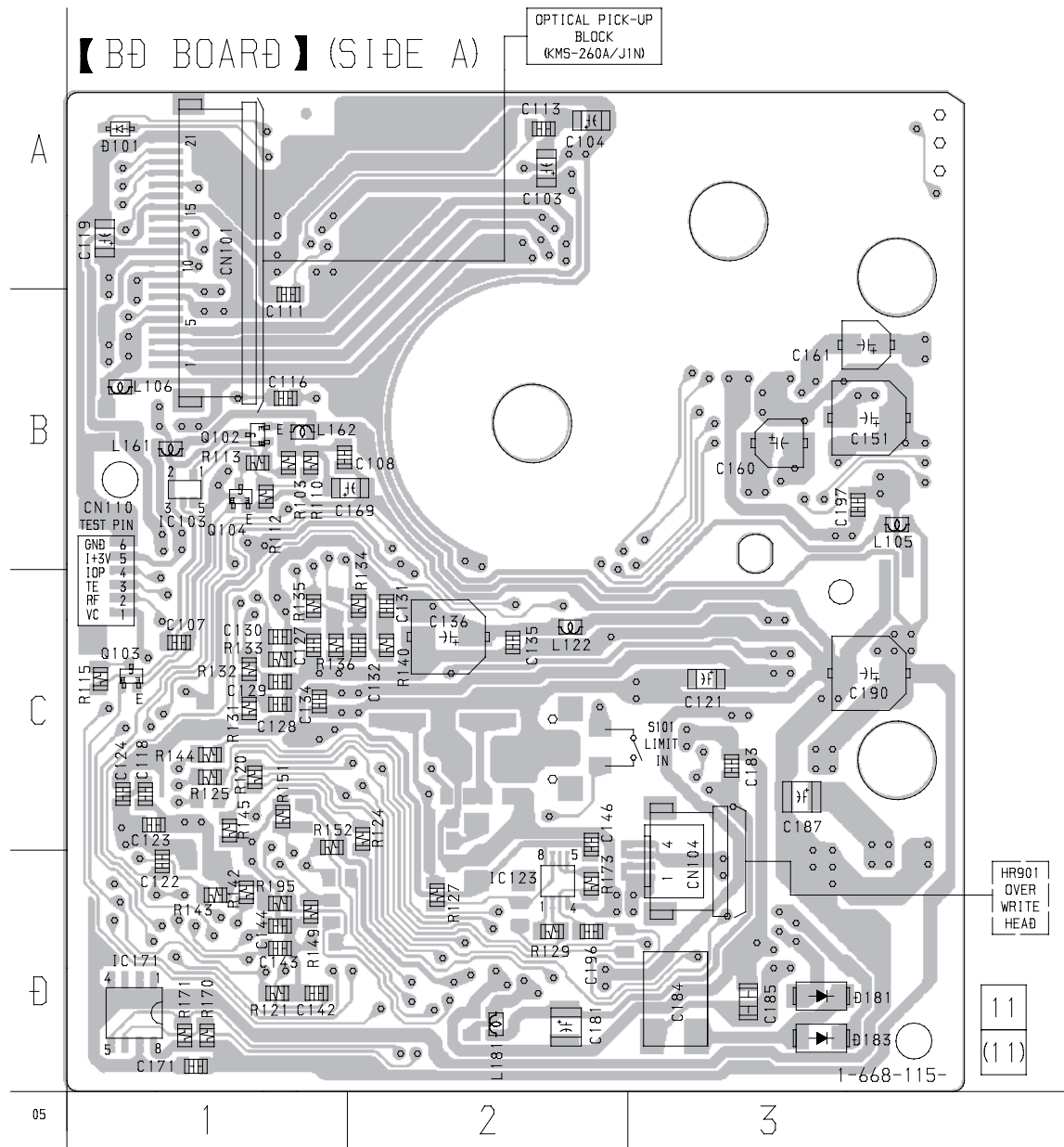

• Semiconductor Location

Ref. No.	Location
D101	A-1
D181	D-3
D183	D-3
IC103	B-1
IC171	D-1
Q102	B-1
Q103	B-1
Q104	B-1

• Semiconductor Location

Ref. No.	Location
IC101	A-3
IC121	C-3
IC123	D-2
IC124	C-3
IC152	B-1
IC181	C-1
IC192	D-1
Q101	B-3
Q162	B-3
Q163	B-3
Q181	C-1
Q182	C-2

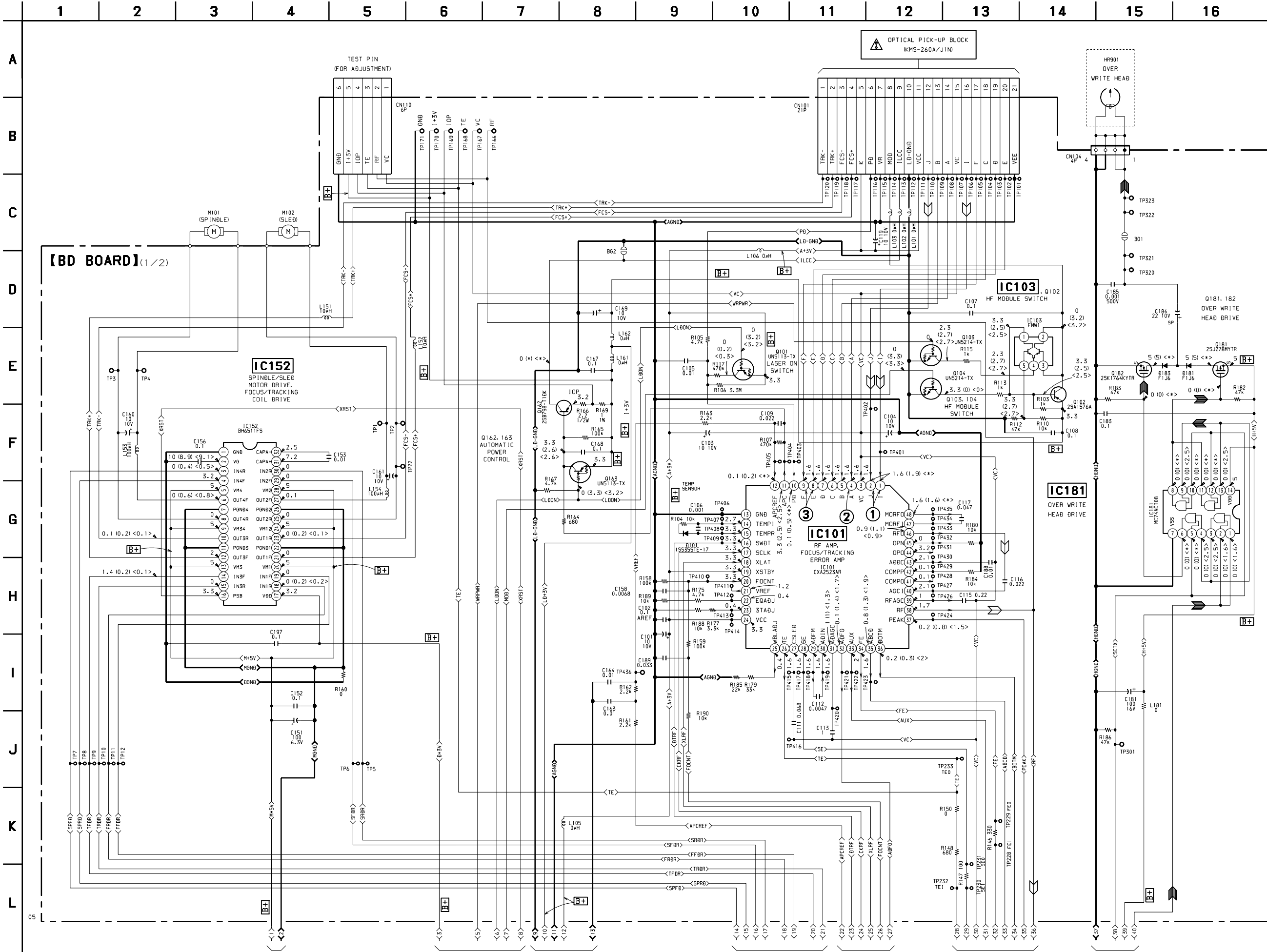

① (Page 51) ② (Page 51) ③ (Page 51) ④ (Page 52) ⑤ (Page 52) ⑥ (Page 52) ⑦ (Page 52)

6-7. SCHEMATIC DIAGRAM – BD Section (2/2) – • See page 53 for Waveforms. • See page 70 and 71 for IC Block Diagrams.

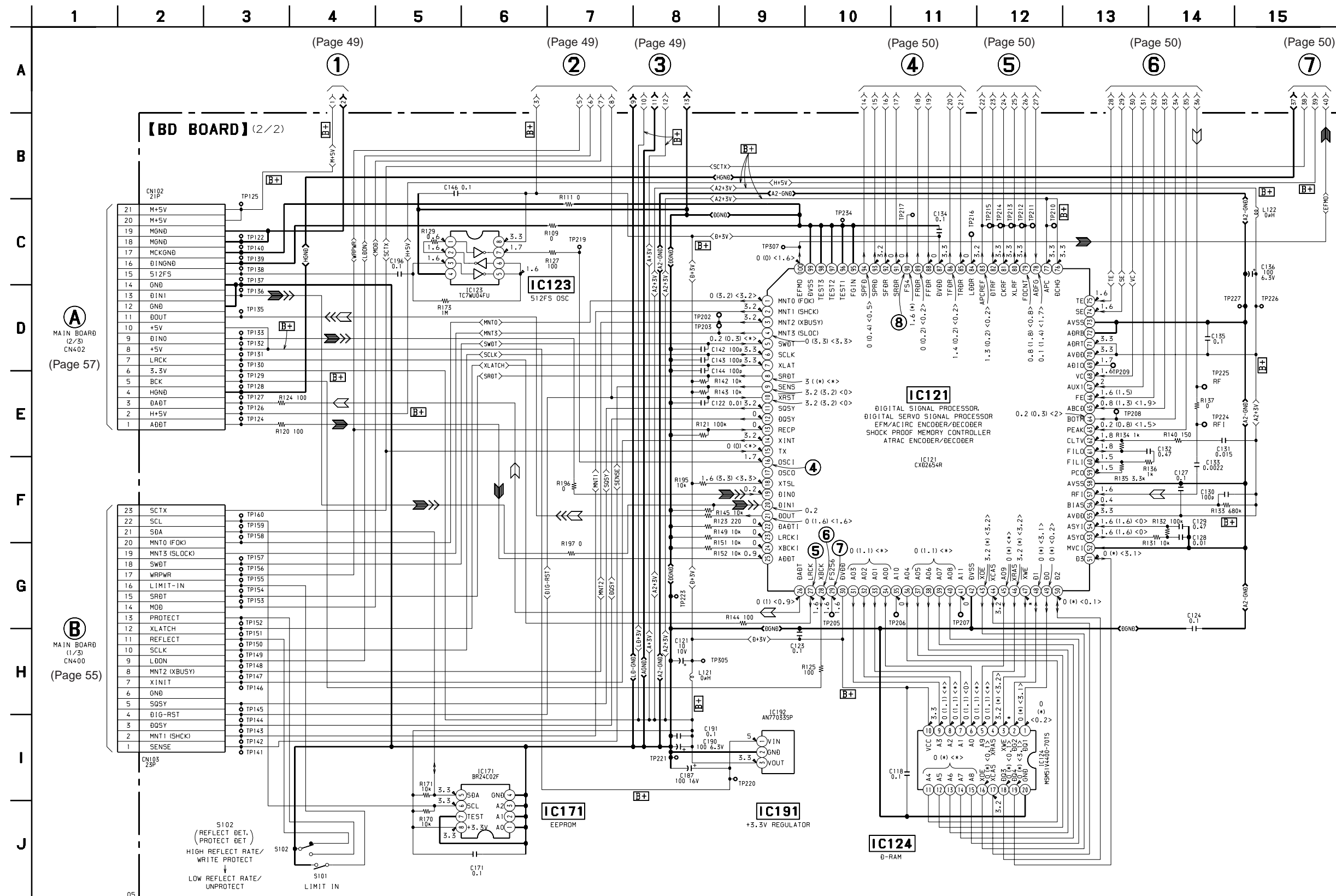

Note:

- Voltages and waveforms are dc with respect to ground in playback mode.
- no mark : Stop
- () : PB
- < > : REC
- * : Impossible to measure

The components identified by mark Δ or dotted line with mark Δ are critical for safety. Replace only with part number specified.

Les composants identifiés par une marque Δ sont critiques pour la sécurité. Ne les remplacer que par une pièce portant le numéro spécifié.

• Waveforms
– BD board –

1 IC101 ①, ② (I, J) (Play mode)

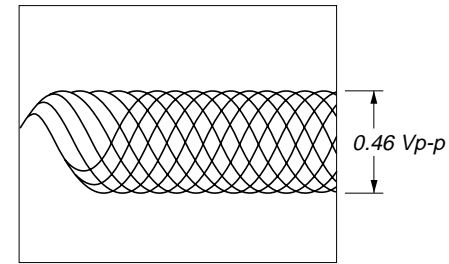

0.46 Vp-p

2 IC101 ④ (A) (Play mode)

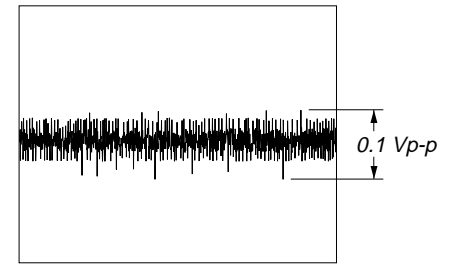

0.1 Vp-p

3 IC101 ⑧, ⑨ (E, F) (Play mode)

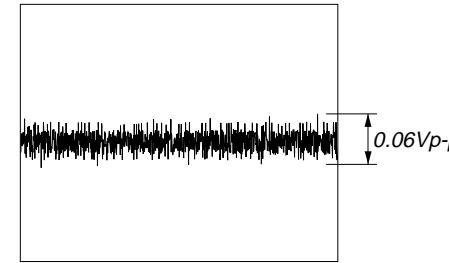

0.06 Vp-p

4 IC121 ⑱ (OSI)

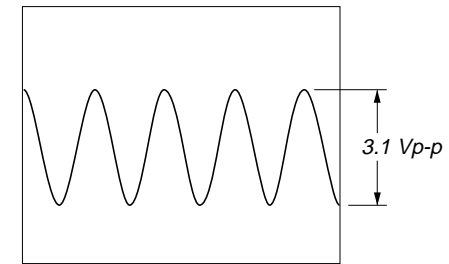

3.1 Vp-p

22.581 MHz

5 IC121 ⑳ (LRCK)

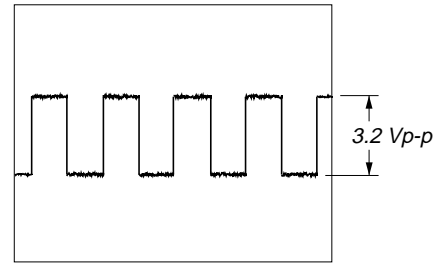

3.2 Vp-p

44.1 kHz

6 IC121 ㉔ (XBCK)

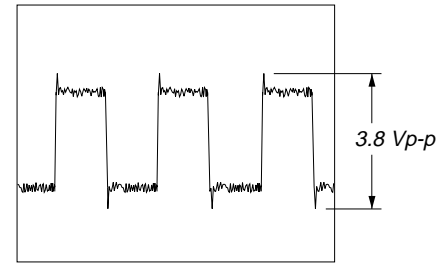

3.8 Vp-p

2.822 MHz

7 IC121 ㉙ (FS256)

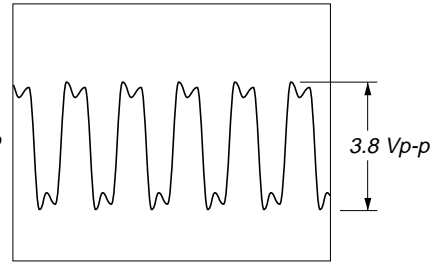

3.8 Vp-p

11.29 MHz

8 IC121 ㉚ (FS4)

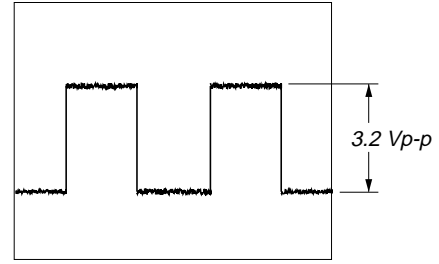

3.2 Vp-p

176.4 kHz

– MAIN board –

1 IC200 ② (BCK)

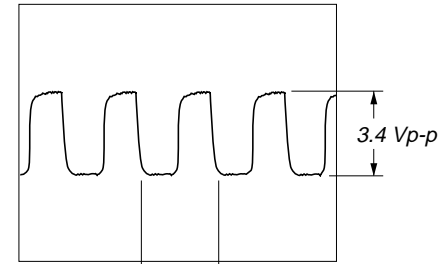

3.4 Vp-p

350 ns

2 IC200 ④ (LRCK)

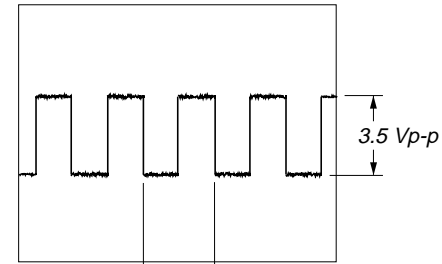

3.5 Vp-p

23 μs

3 IC200 ㉔ (XOUT)

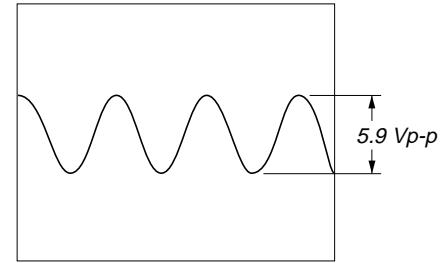

5.9 Vp-p

45 MHz

4 IC200 ㉚ (256FSO)

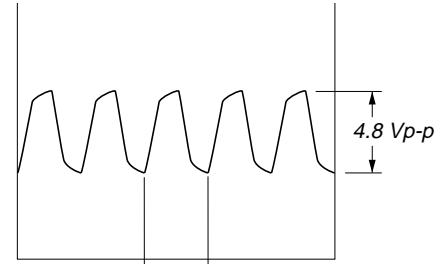

4.8 Vp-p

89 ns

5 IC200 ㉚ (64FSO)

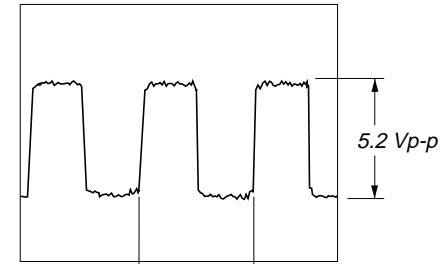

5.2 Vp-p

350 ns

6 IC100 ⑩ (LRCK1)

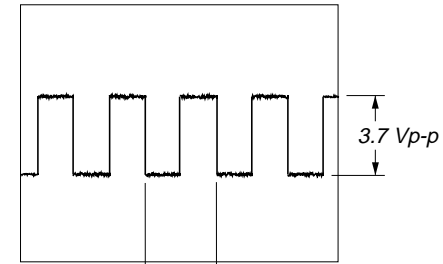

3.7 Vp-p

23 μs

7 IC100 ⑪ (BCK1)

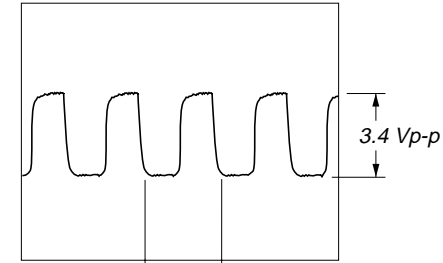

3.4 Vp-p

350 ns

8 IC800 ⑪ (XT-OUT)

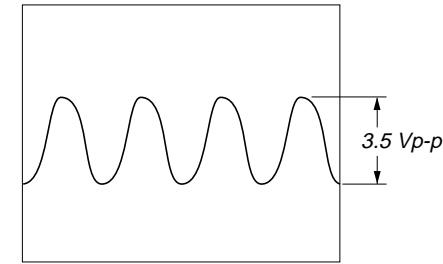

3.5 Vp-p

32.768 kHz

– DISP board –

1 IC771 ⑥⑥ (OSCO)

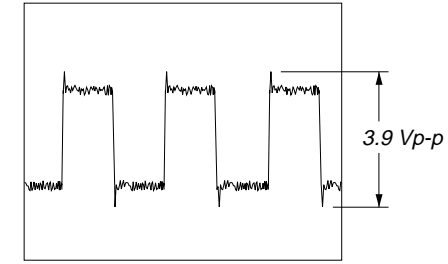

3.9 Vp-p

Approx. 2.5 MHz

2 IC771 ⑥⑤ (OSCI)

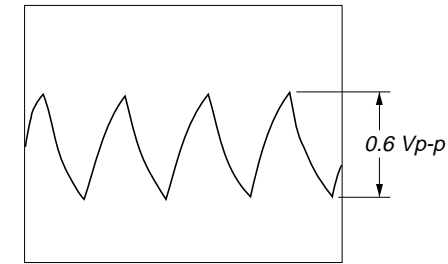

0.6 Vp-p

Approx. 2.1 MHz

6-8. SCHEMATIC DIAGRAM - MAIN Section (1/3) - • See page 54 for Waveforms. • See page 72 and 73 for IC Block Diagrams.

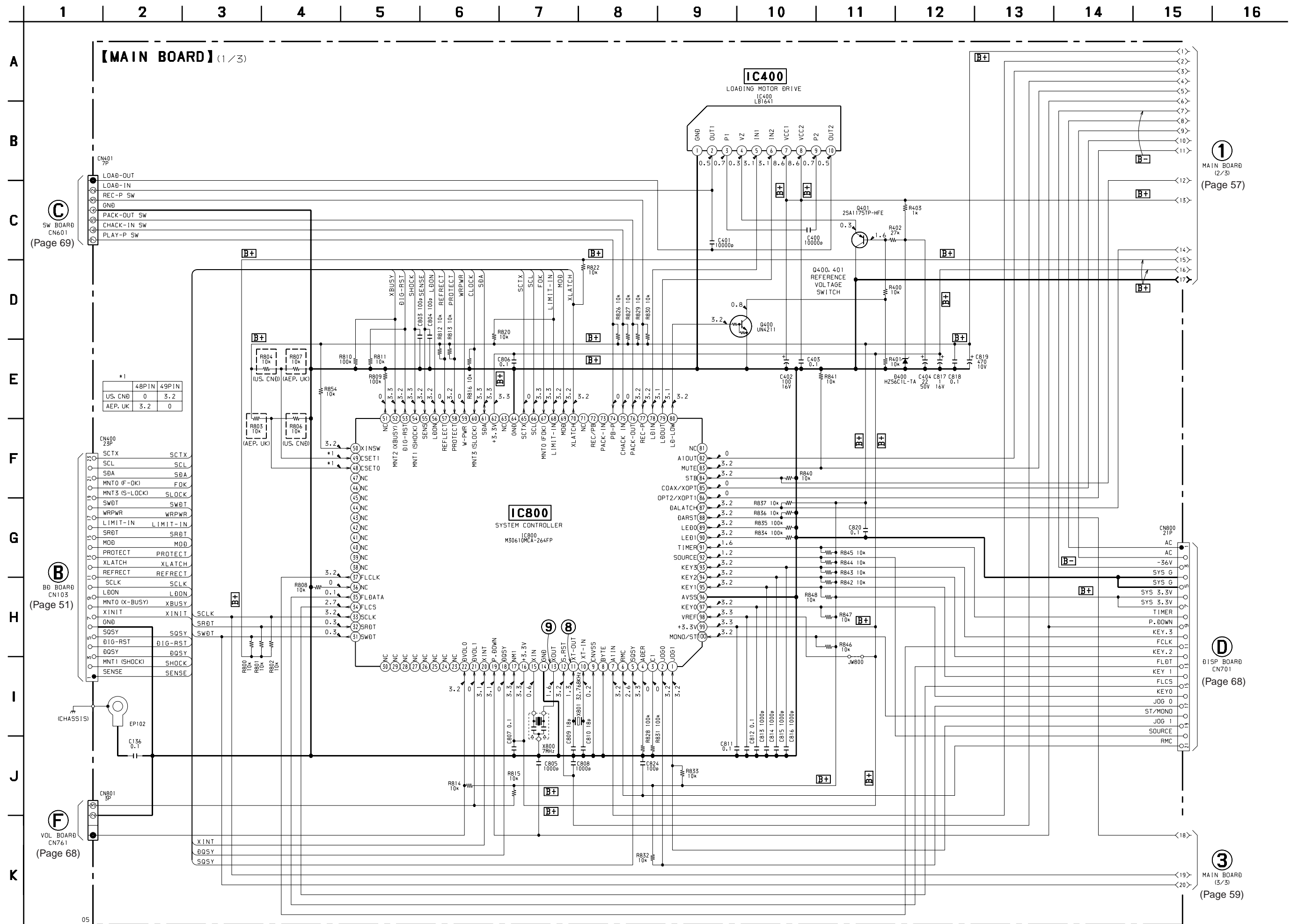

6-9. SCHEMATIC DIAGRAM – MAIN Section (2/3) – • See page 72 and 73 for IC Block Diagrams.

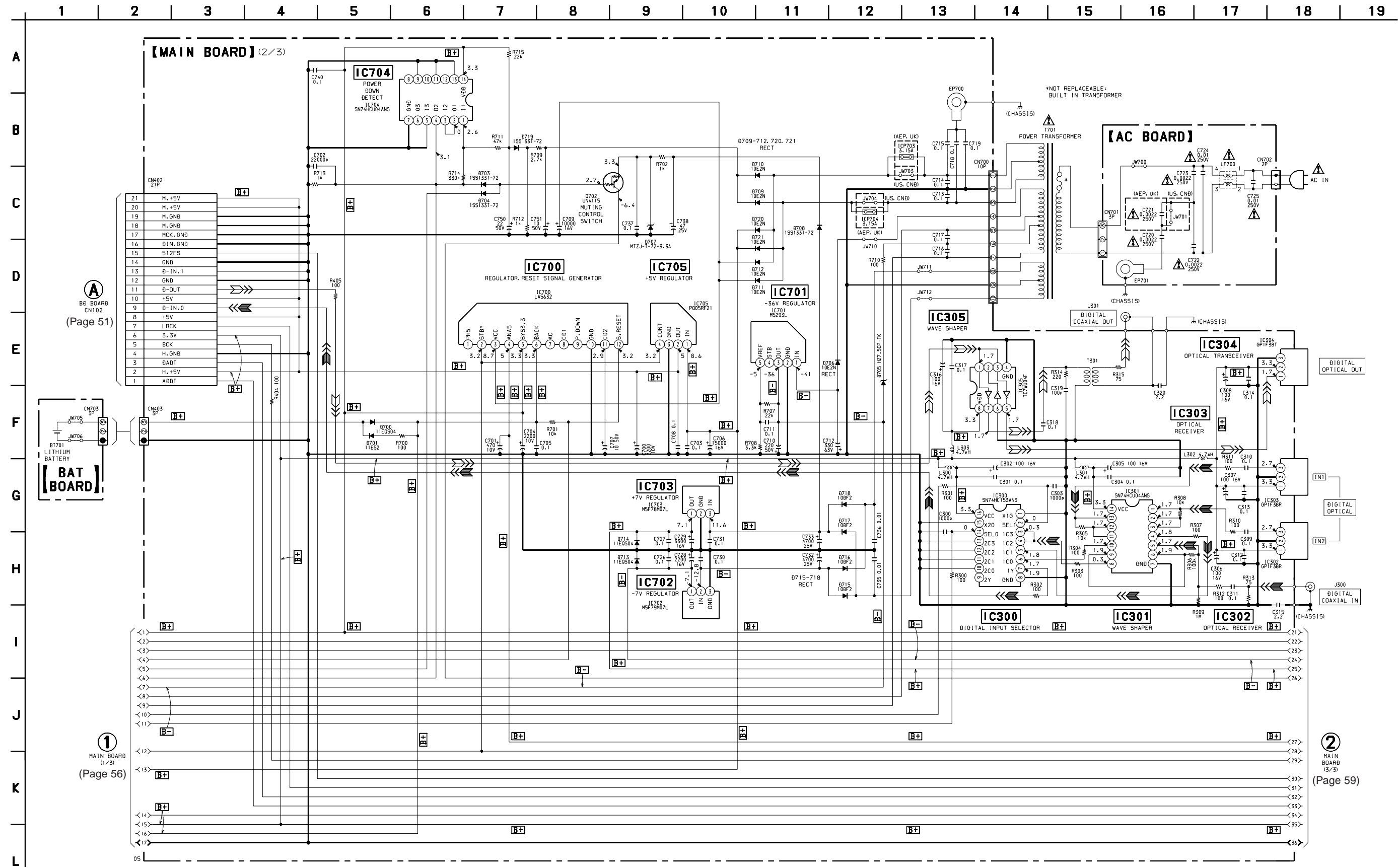

Note:
 • Voltages and waveforms are dc with respect to ground in playback mode.
 no mark : PB
 * : Impossible to measure

The components identified by mark Δ or dotted line with mark Δ are critical for safety. Replace only with part number specified.

Les composants identifiés par une marque Δ sont critiques pour la sécurité. Ne les remplacer que par une pièce portant le numéro spécifié.

6-10. SCHEMATIC DIAGRAM – MAIN Section (3/3) – • See page 53 and 54 for Waveforms. • See page 72 and 73 for IC Block Diagrams.

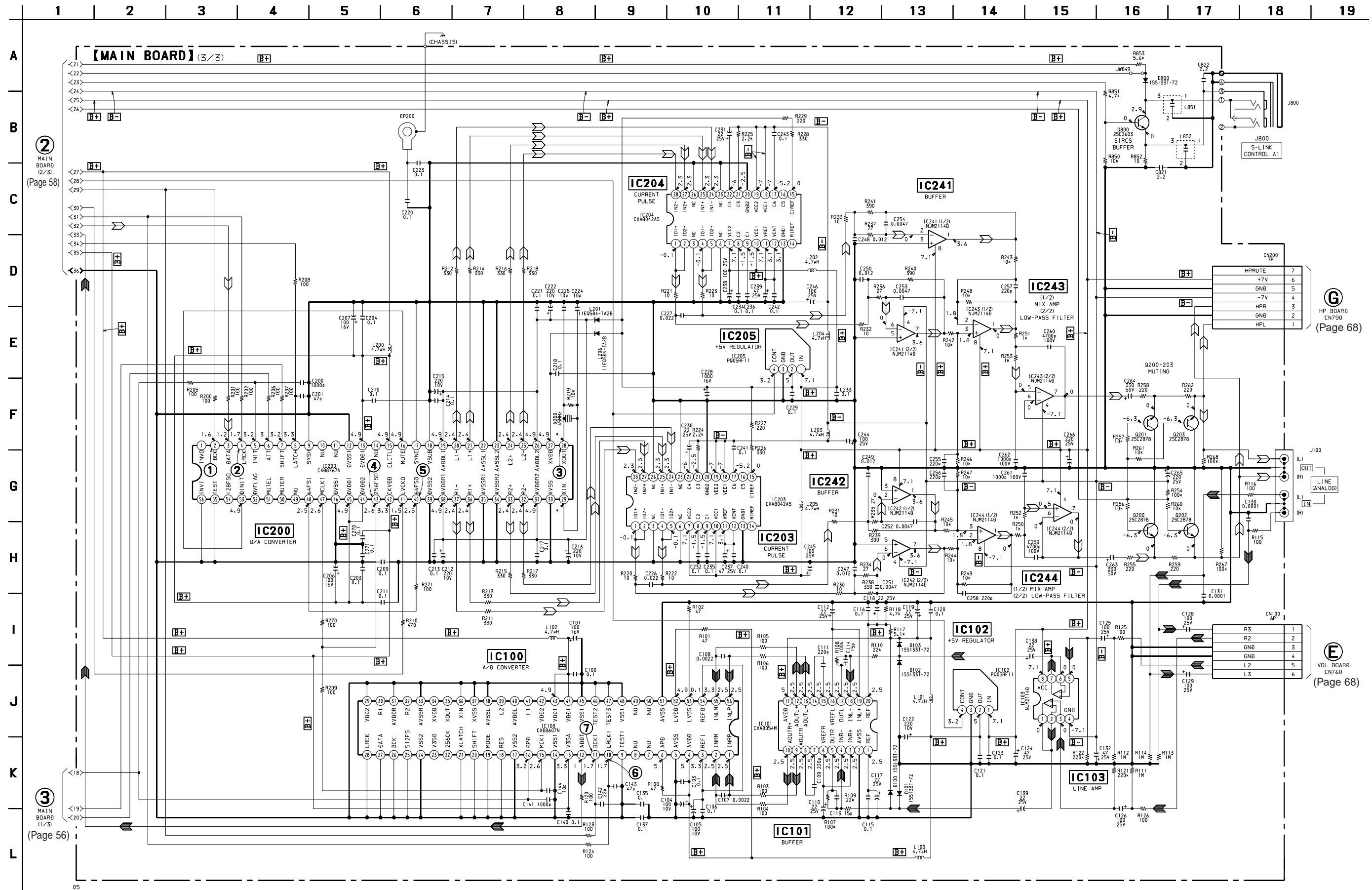

Note:
 • Voltages and waveforms are dc with respect to ground in playback mode.
 no mark : PB
 * : Impossible to measure

6-11. PRINTED WIRING BOARD – MAIN Board (side A) – • See page 45 for Circuit Boards Location.

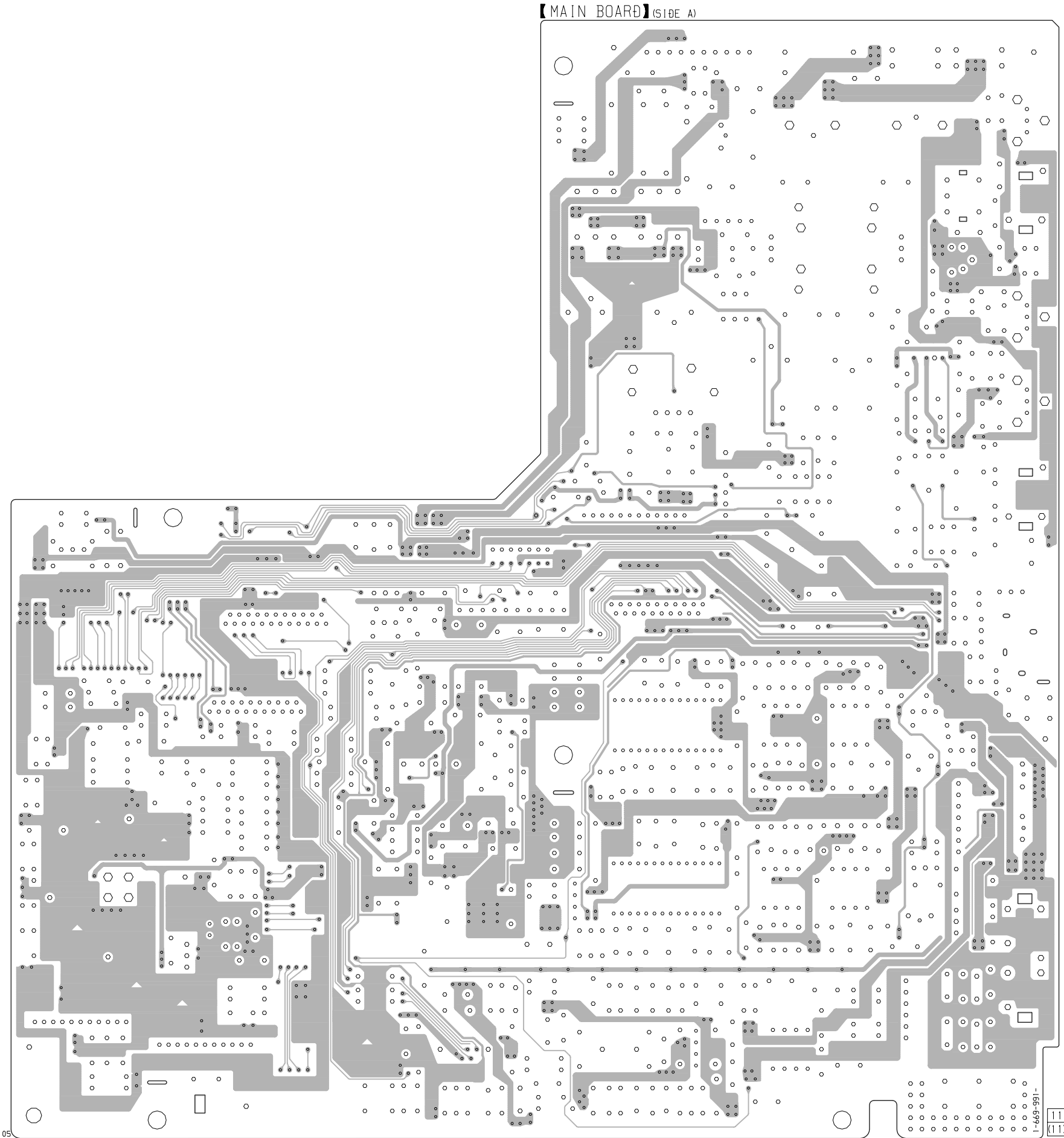

6-12. PRINTED WIRING BOARDS – MAIN Board (side B) , AC/BAT Boards – • See page 45 for Circuit Boards Location.

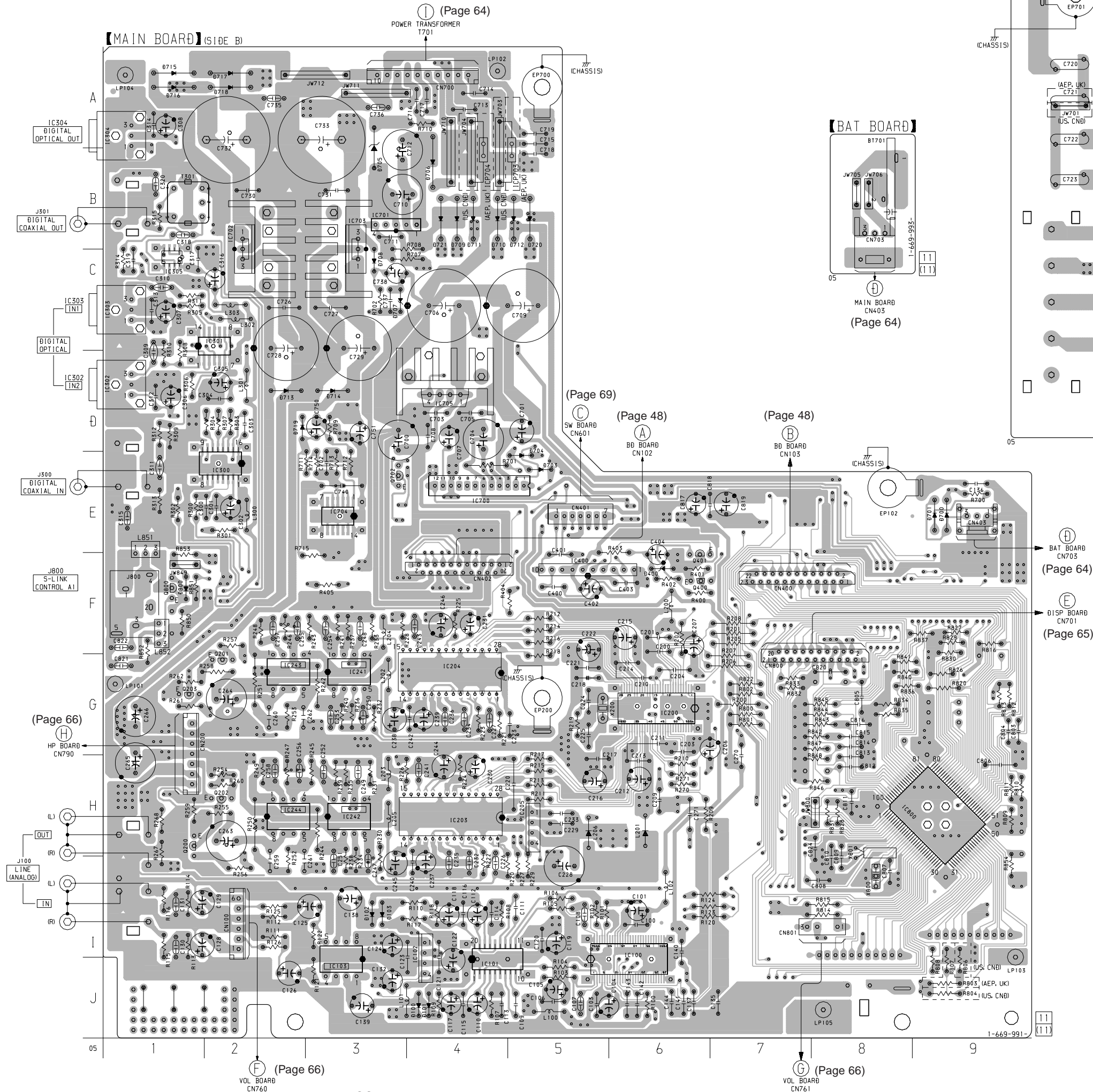

【AC BOARD】

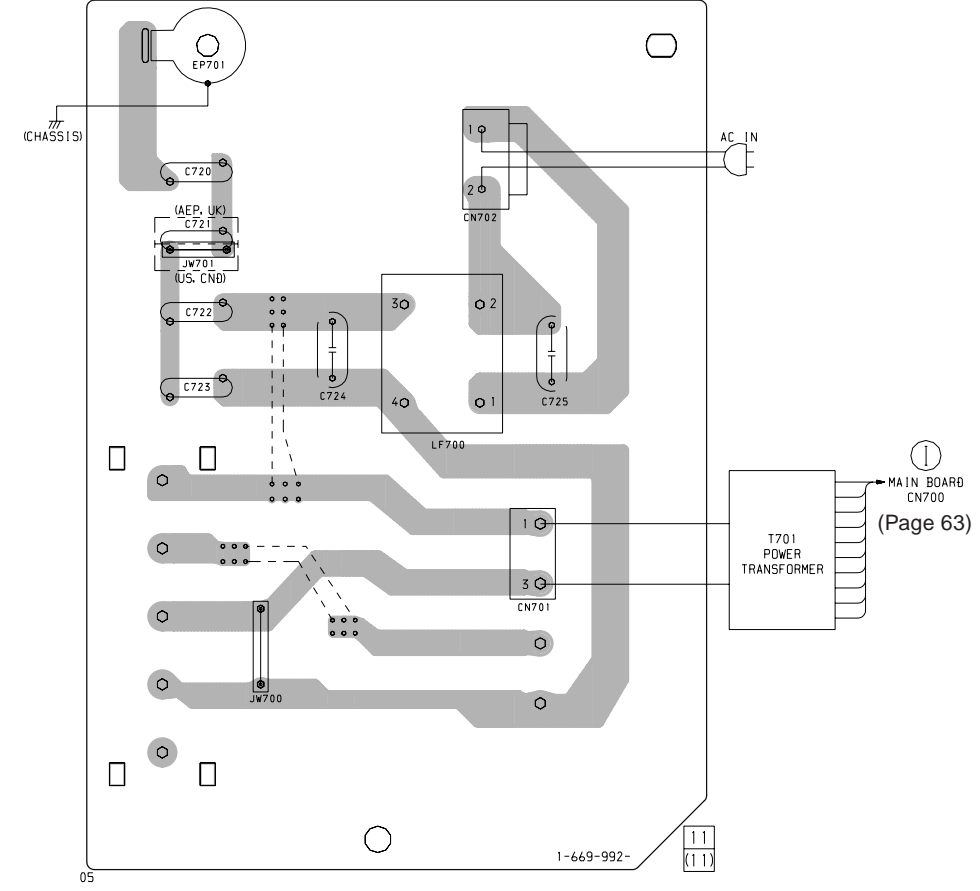

【BAT BOARD】

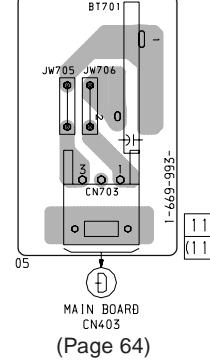

Note:
 • ○---○ : Other layers pattern (Side A).

• Semiconductor Location

Ref. No.	Location	Ref. No.	Location
D100	J-4	IC103	J-3
D101	J-4	IC200	G-6
D102	I-3	IC203	H-4
D103	I-3	IC204	G-4
D400	F-6	IC205	H-5
D700	E-9	IC241	G-3
D701	E-9	IC242	H-3
D703	E-5	IC243	G-2
D704	E-5	IC244	H-2
D705	A-3	IC300	E-2
D706	B-4	IC301	C-2
D707	C-3	IC302	D-1
D708	C-3	IC303	C-1
D709	B-4	IC304	A-1
D710	B-4	IC305	C-1
D711	B-4	IC400	F-5
D712	B-5	IC700	E-4
D713	D-2	IC701	B-3
D714	D-3	IC702	B-2
D715	A-1	IC703	B-3
D716	A-1	IC704	E-3
D717	A-2	IC705	D-4
D718	A-2	IC800	H-9
D719	D-2		
D720	B-5	Q200	H-1
D721	B-5	Q201	G-2
D800	F-1	Q202	H-2
L201	H-6	Q203	G-1
L206	H-5	Q400	F-6
		Q401	F-6
IC100	J-6	Q702	E-3
IC101	J-4	Q800	F-1
IC102	J-4		

6-13. PRINTED WIRING BOARDS – PANEL Section – • See page 45 for Circuit Boards Location.

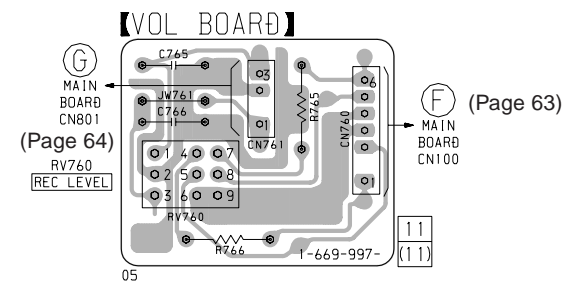
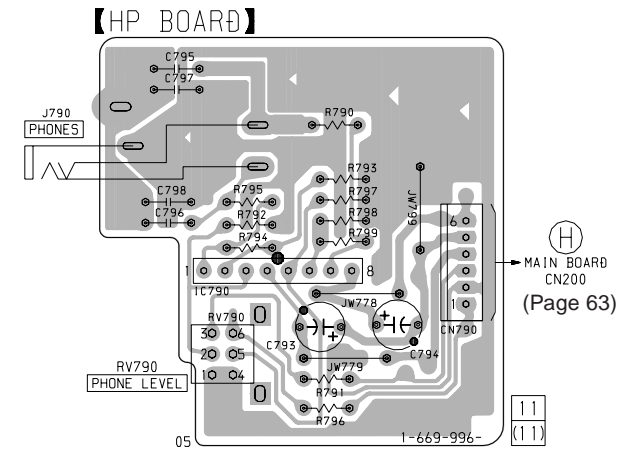
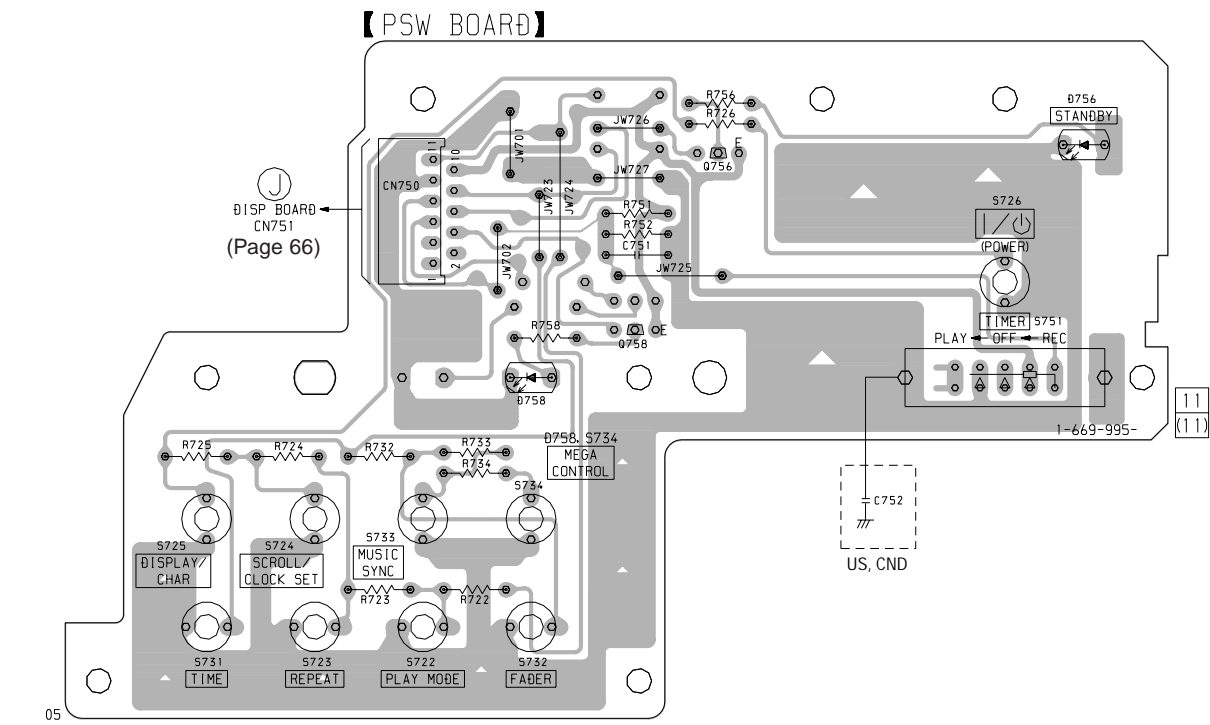
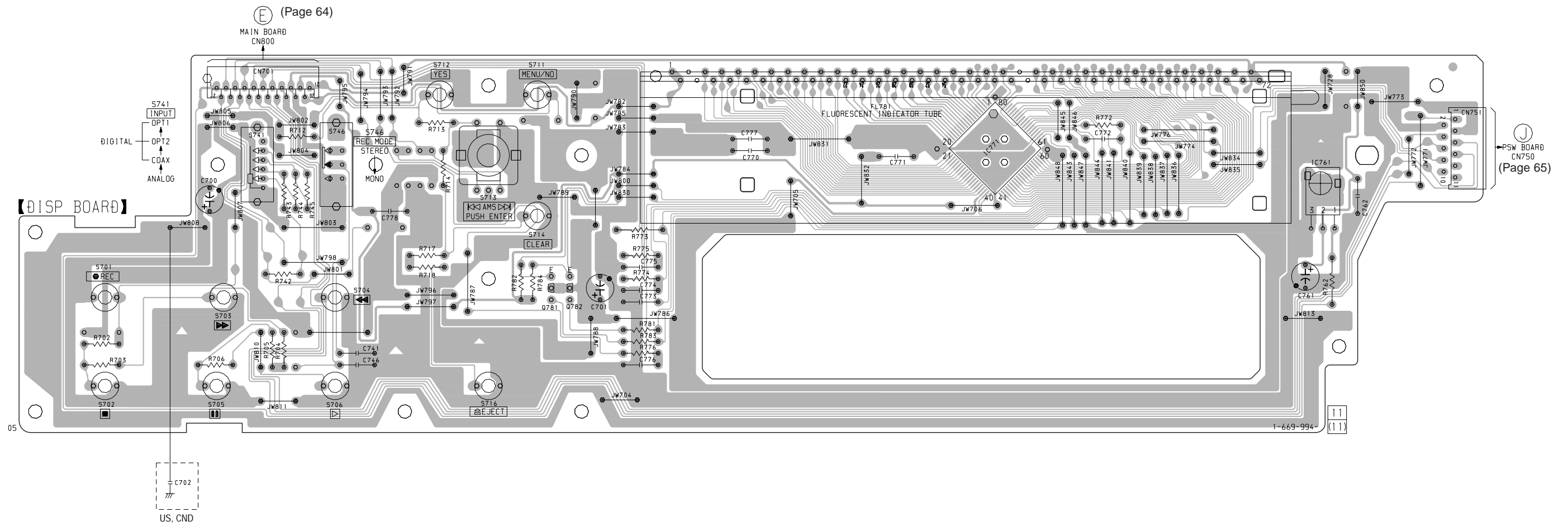

6-14. SCHEMATIC DIAGRAM – PANEL Section – • See page 54 for Waveforms.

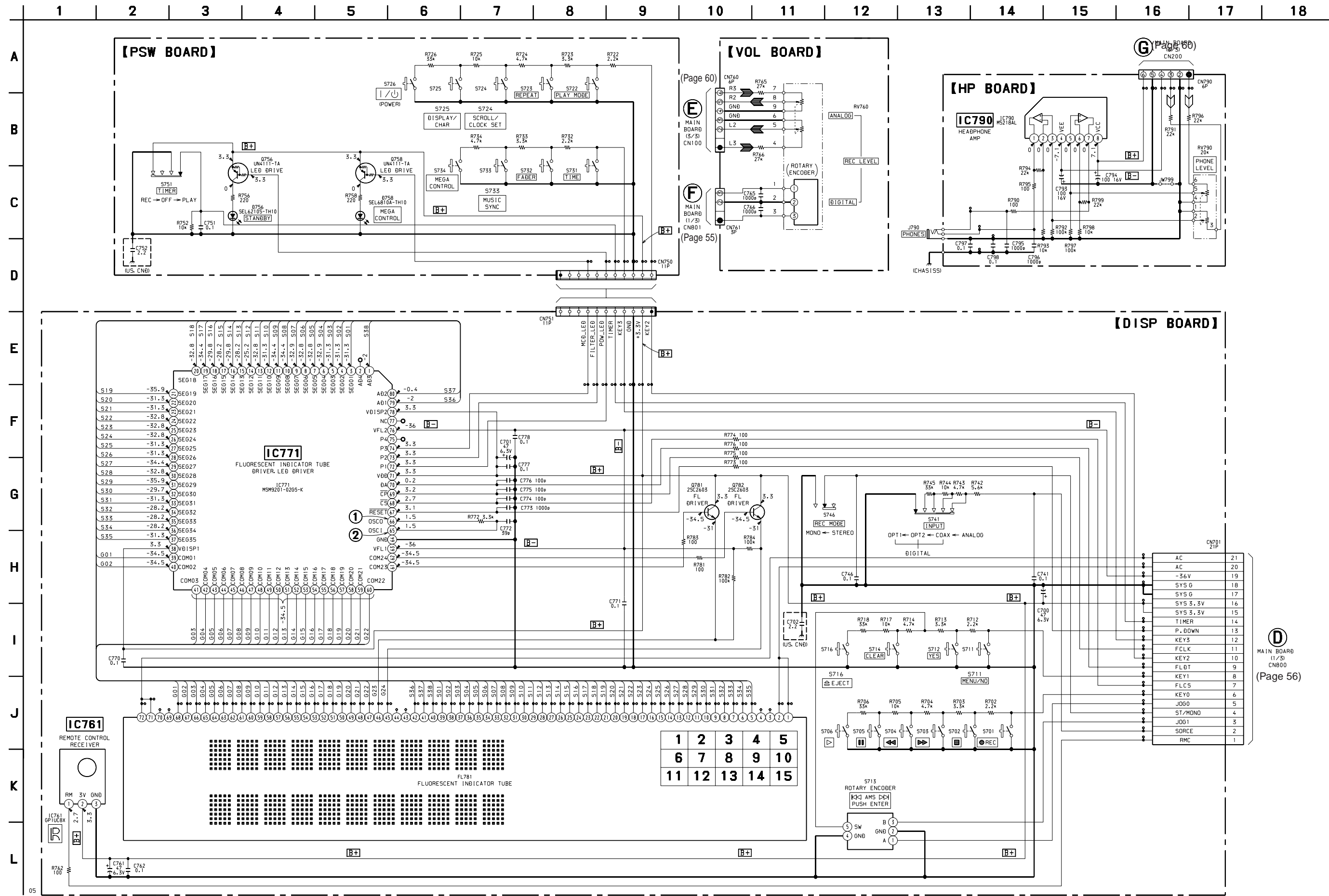

Note:
 • Voltages and waveforms are dc with respect to ground in playback mode.
 no mark : Stop

6-15. SCHEMATIC DIAGRAM – BD SWITCH Section –

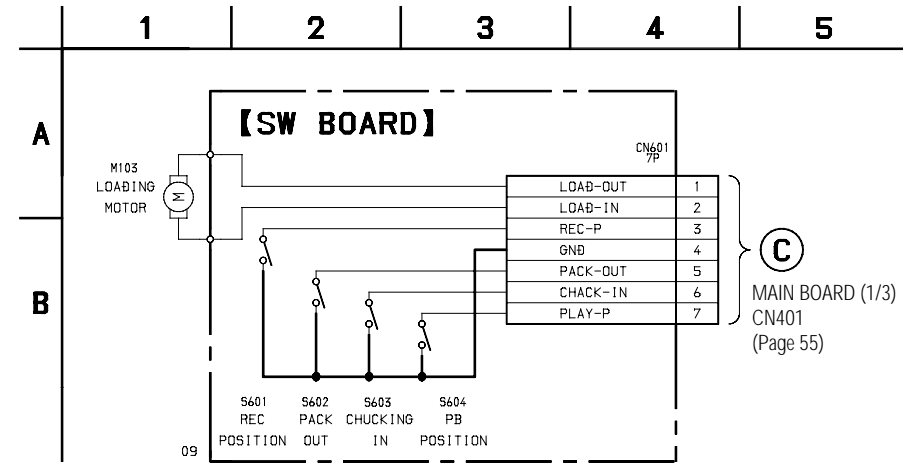

6-16. PRINTED WIRING BOARD – BD SWITCH Section –

• See page 45 for Circuit Boards Location.

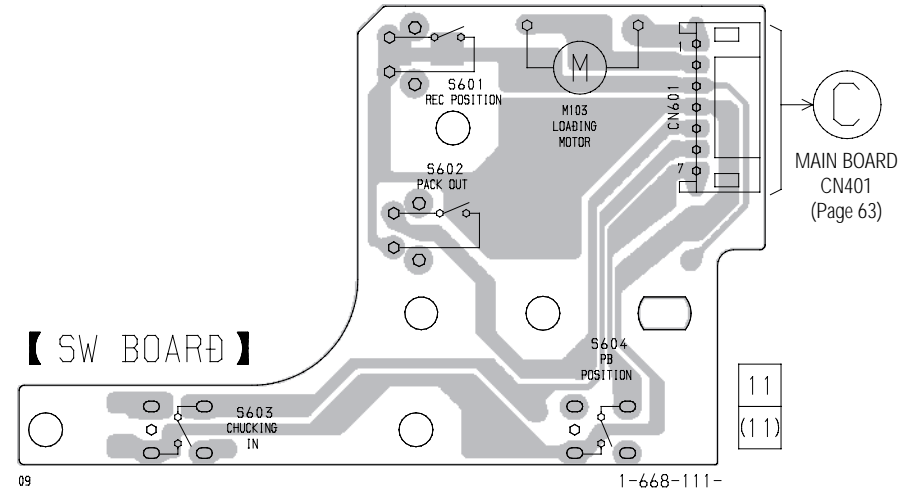

• IC Block Diagrams – BD Board –

IC101 CXA2523AR

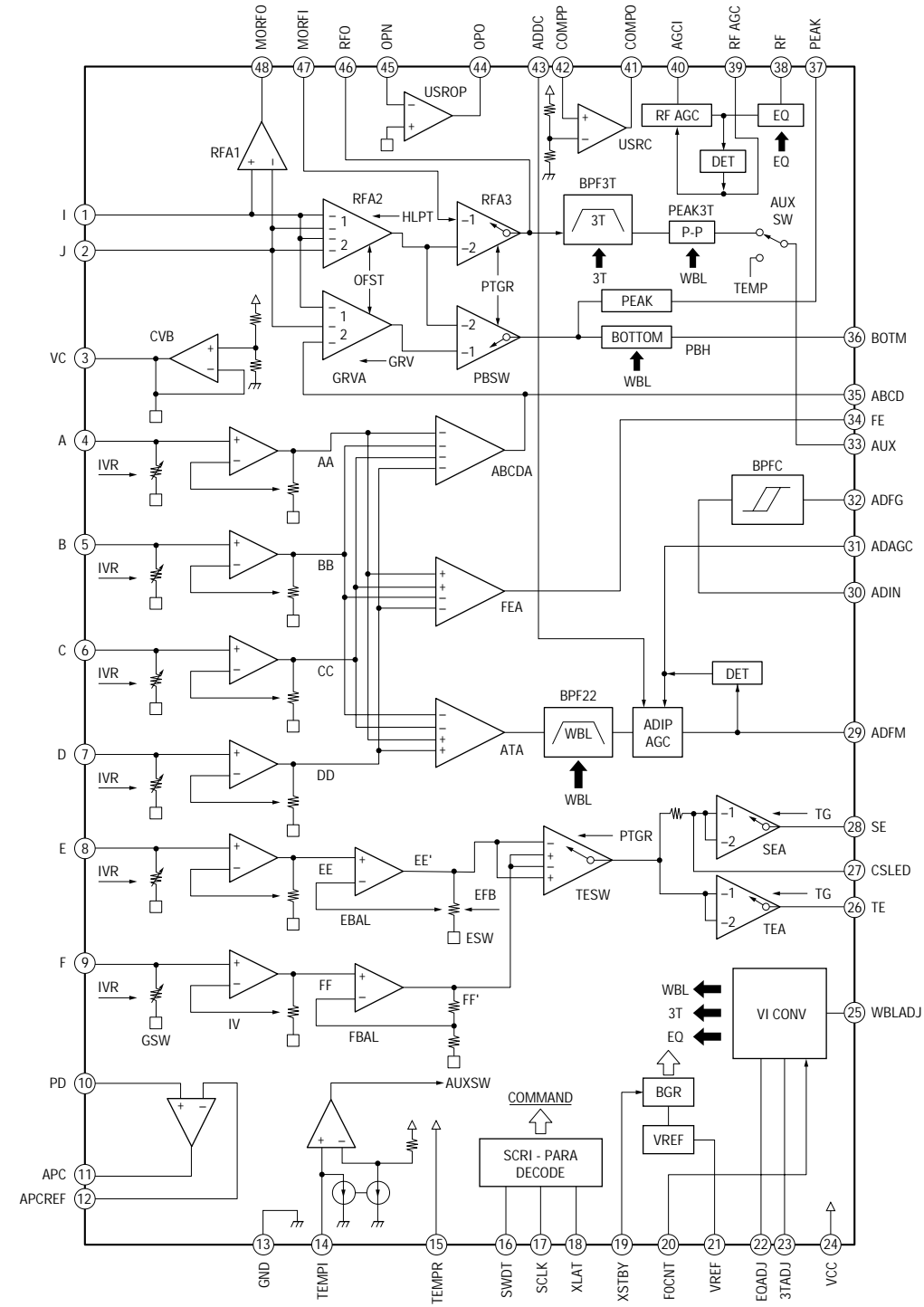

IC121 CXD2654R

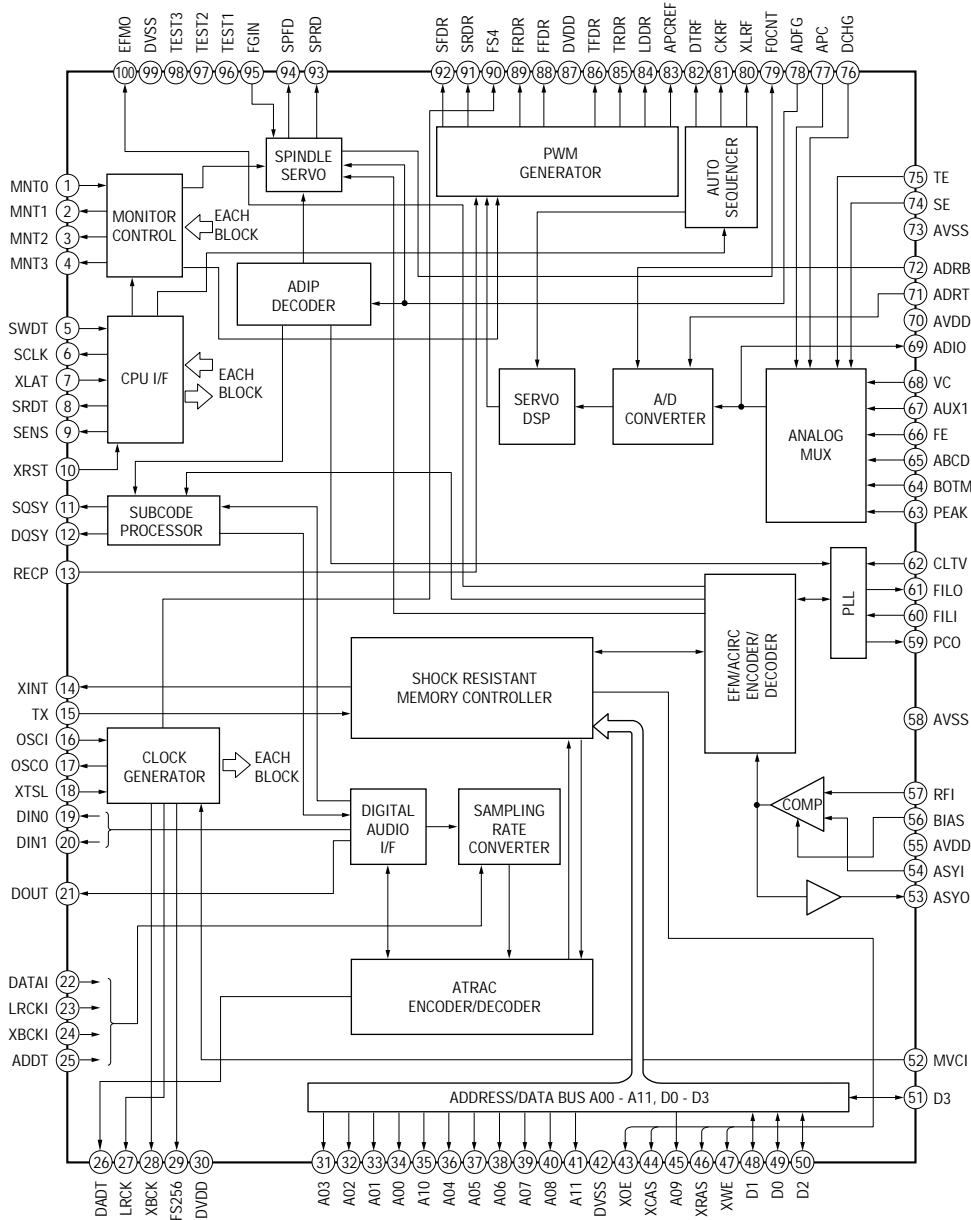

IC152 BH6511FS-E2

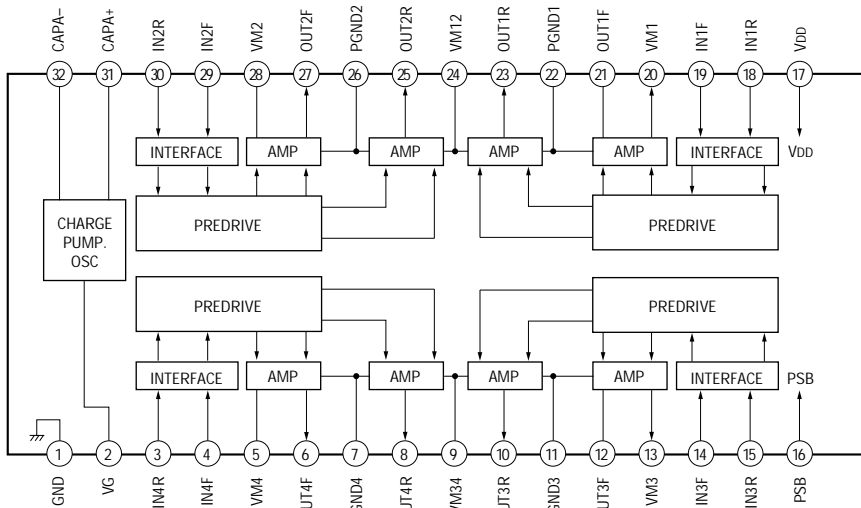

– MAIN Board –

IC100 CXD8607N

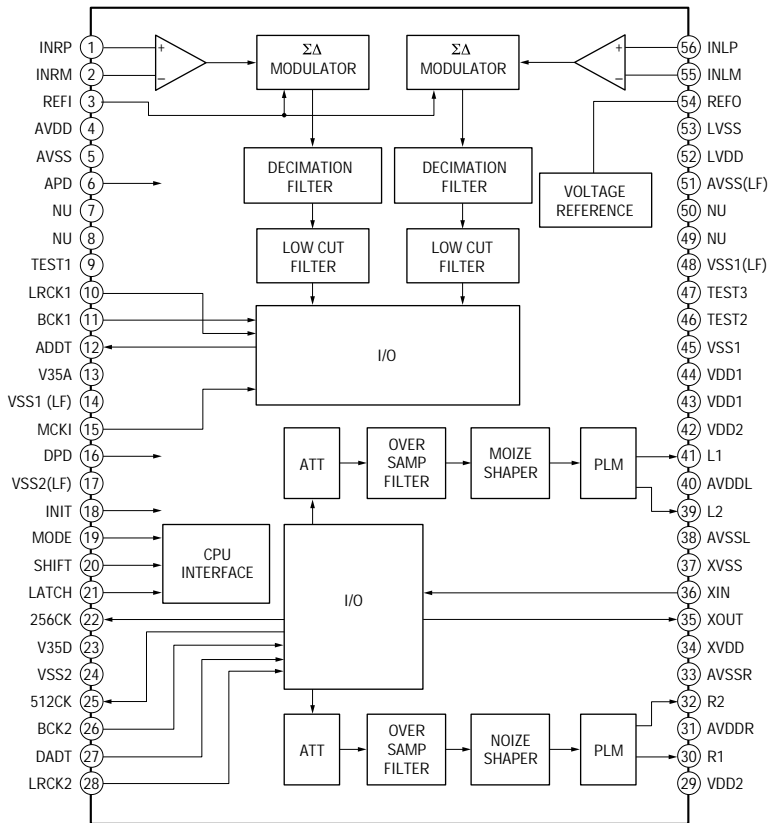

IC101 CXA8054M

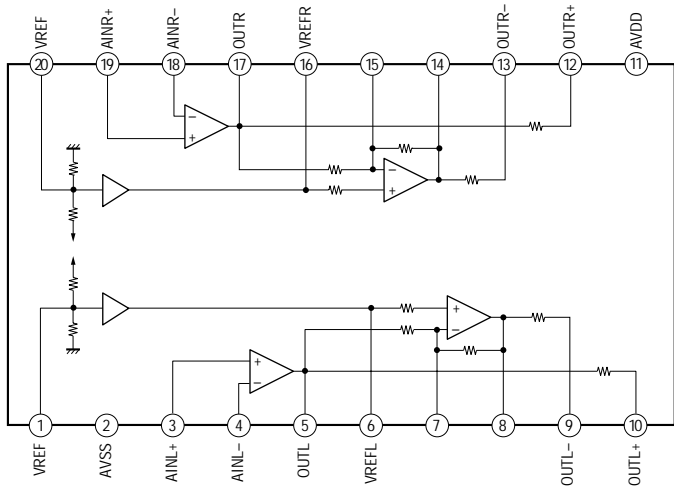

IC203, 204 CXA8042AS

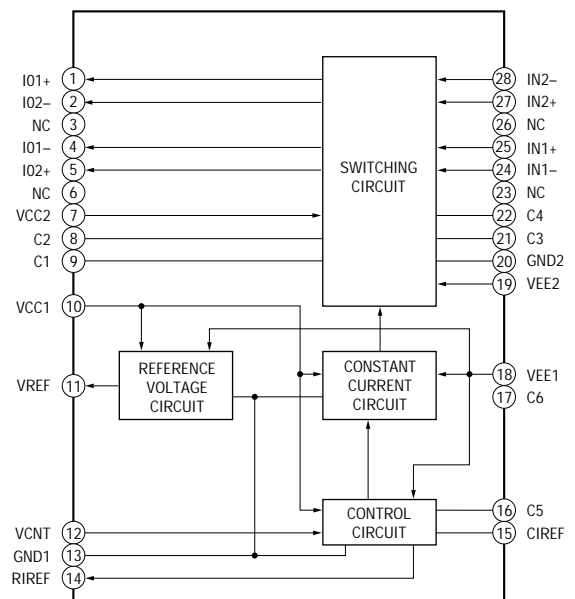

IC200 CXD8767N

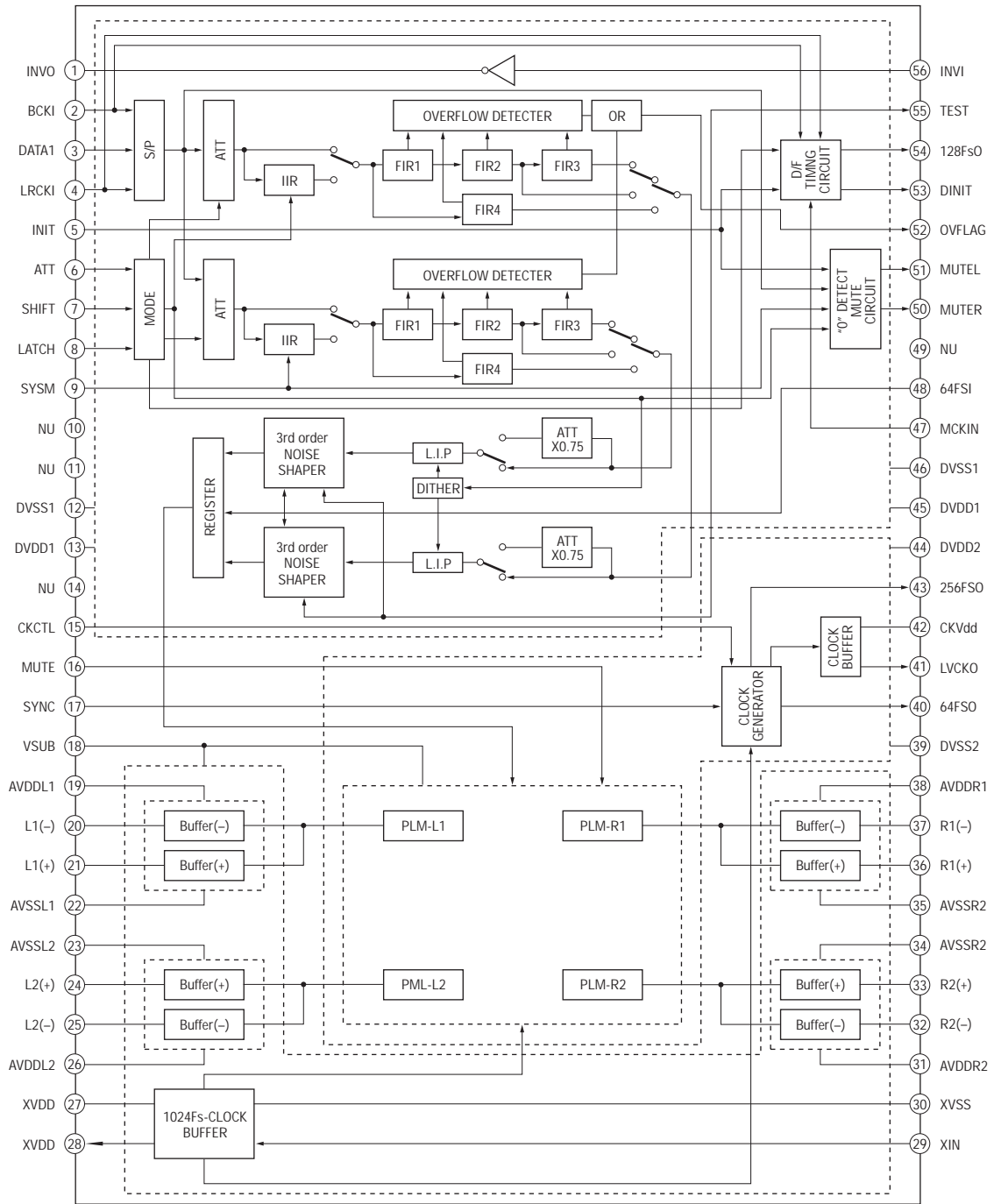

IC300 SN74HC153ANS

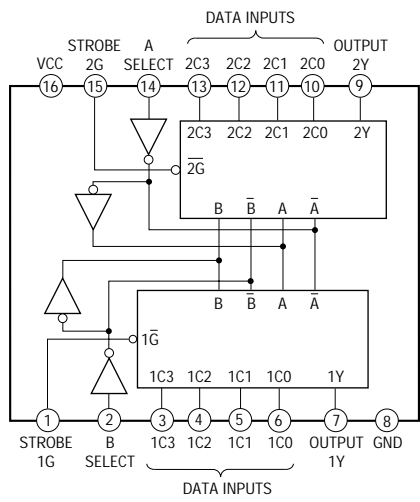

IC301, 704 SN74HCU04ANS-E20

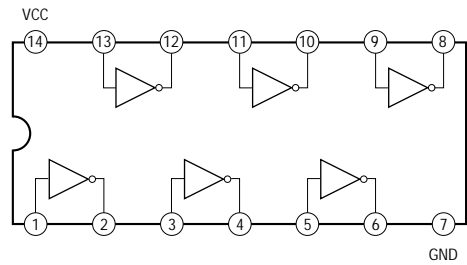

IC400 LB1641

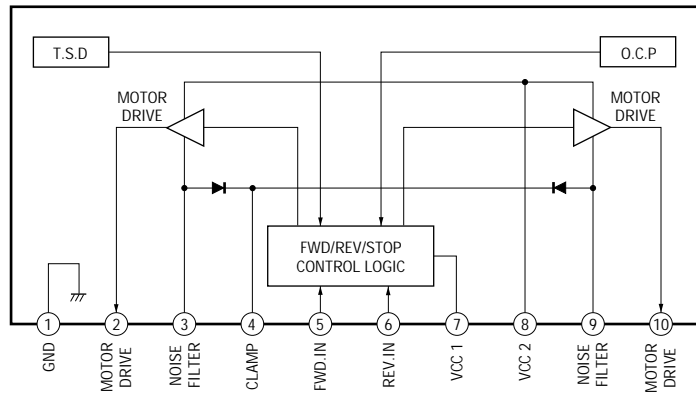

IC701 M5293L

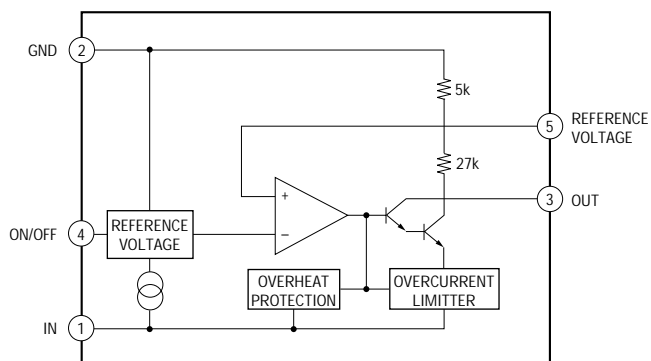

IC700 LA5632

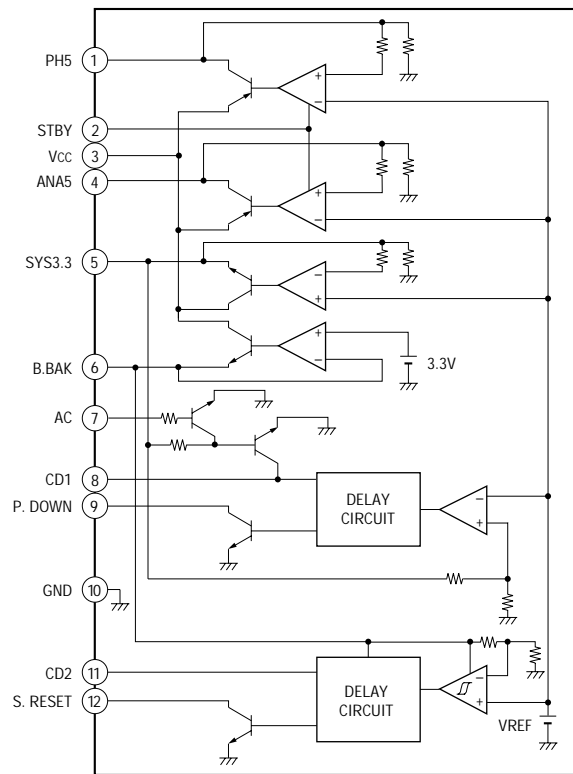

(2) FRONT PANEL SECTION

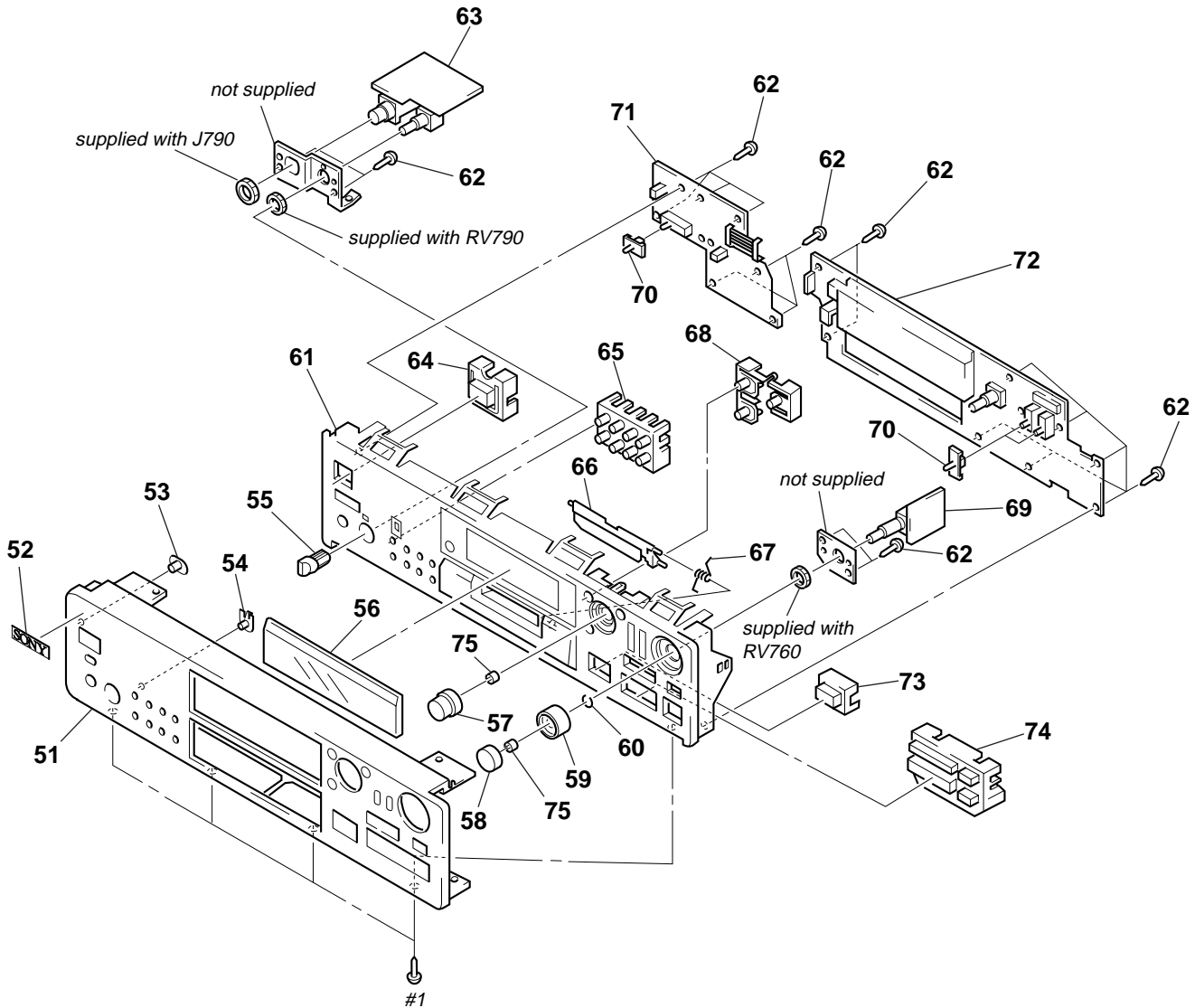

Ref. No.	Part No.	Description	Remark	Ref. No.	Part No.	Description	Remark
51	4-998-590-01	PANEL, FRONT (BLACK)		65	4-997-211-01	BUTTON (MODE) (BLACK)	
51	4-998-590-31	PANEL, FRONT (SILVER)		65	4-997-211-21	BUTTON (MODE) (SILVER)	
52	4-942-568-41	EMBLEM (NO.5), SONY		66	4-996-690-11	LID (CARTRIDGE) (SILVER)	
53	4-998-607-01	INDICATOR (POWER)		66	4-996-690-21	LID (CARTRIDGE) (BLACK)	
54	4-998-606-01	INDICATOR (MEGA)		67	4-976-593-01	SPRING (LID), TORSION	
55	4-950-189-01	KNOB (A) (VOL)		68	4-998-593-01	BUTTON (EDIT) (BLACK)	
56	4-998-598-01	WINDOW (DISPLAY)		68	4-998-593-21	BUTTON (EDIT) (SILVER)	
57	4-996-687-51	KNOB (AMS) (BLACK)		* 69	1-669-997-11	VOL BOARD	
58	4-998-597-01	KNOB (ANALOG) (BLACK)		70	4-998-595-01	KNOB (SLIDE) (BLACK)	
58	4-998-597-21	KNOB (ANALOG) (SILVER)		70	4-998-595-21	KNOB (SLIDE) (SILVER)	
59	4-998-596-01	KNOB (DIGITAL) (BLACK)		* 71	1-669-995-11	PSW BOARD	
59	4-998-596-21	KNOB (DIGITAL) (SILVER)		* 72	A-4724-044-A	DISP BOARD, COMPLETE (AEP, UK)	
60	3-382-627-11	SPRING, RING		* 72		DISP BOARD, COMPLETE (US, Canadian)	
61	X-4949-651-1	BASE ASSY, PANEL (BLACK)		73	4-998-594-01	BUTTON (EJECT) (BLACK)	
61	X-4950-253-2	BASE ASSY, PANEL (SILVER)		73	4-998-594-21	BUTTON (EJECT) (SILVER)	
62	3-704-515-21	SCREW (BV/RING)		74	4-996-689-21	BUTTON (MAIN) (BLACK)	
* 63	1-669-996-11	HP BOARD		74	4-996-689-51	BUTTON (MAIN) (SILVER)	
64	4-998-592-01	BUTTON (POWER) (BLACK)		75	3-354-981-01	SPRING (SUS), RING	
64	4-998-592-21	BUTTON (POWER) (SILVER)					

**(3) MECHANISM SECTION
(MDM-5A)**

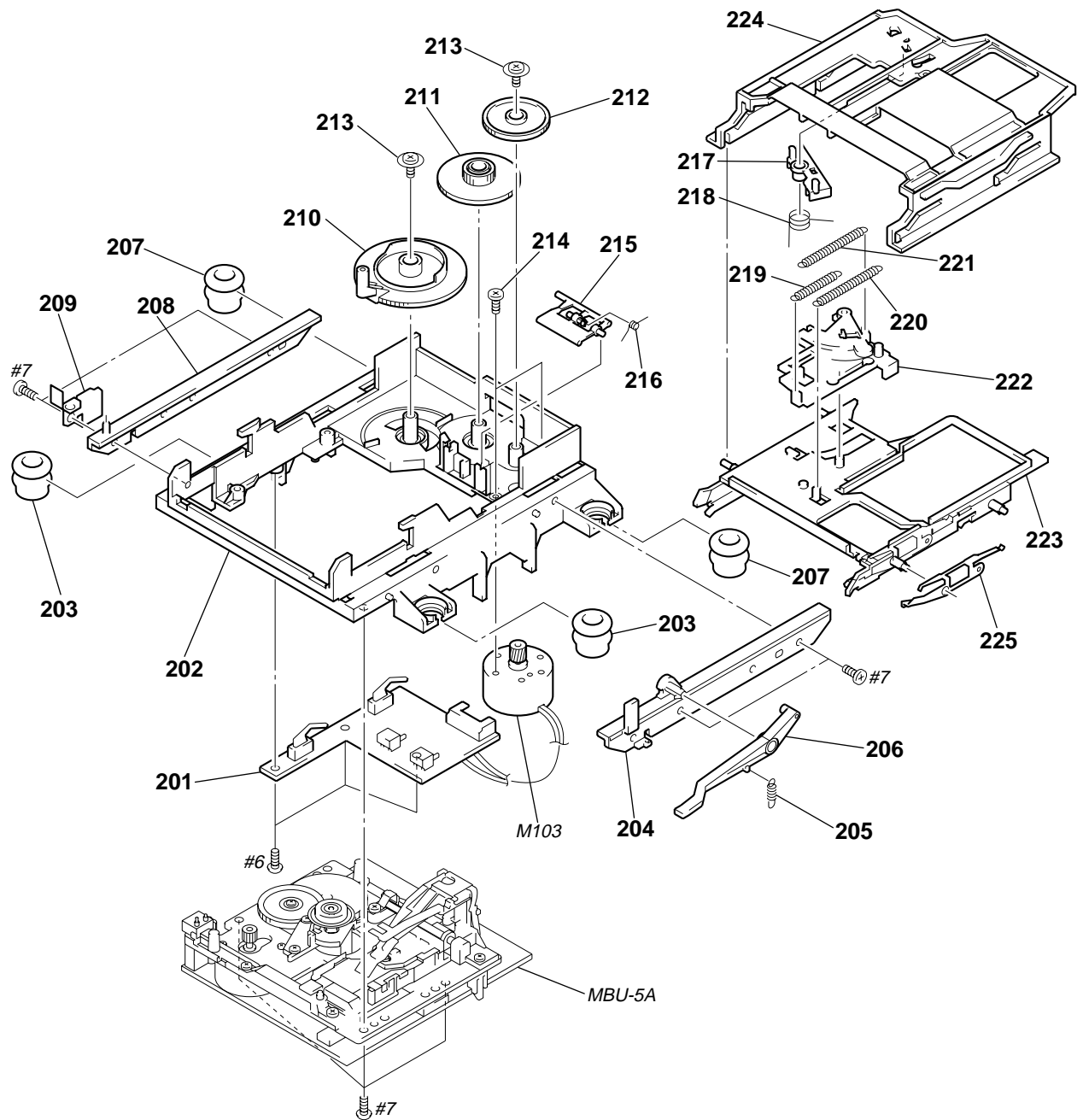

Ref. No.	Part No.	Description	Remark	Ref. No.	Part No.	Description	Remark
* 201	1-668-111-11	SW BOARD		214	4-996-224-01	SCREW (1.7X3), +PWH	
* 202	4-996-217-01	CHASSIS		215	4-996-227-01	LEVER (HEAD)	
203	4-996-223-01	INSULATOR (F) (BLACK)		216	4-996-229-01	SPRING (HEAD LEVER), TORSION	
* 204	4-996-218-01	BRACKET (GUIDE R)		217	4-996-212-01	LEVER (LIMITER)	
205	4-996-277-01	SPRING (O/C), TENSION		218	4-996-213-01	SPRING (LIMITER), TORSION	
206	4-996-226-01	LEVER (O/C)		219	4-996-214-01	SPRING (SLIDER), TENSION	
207	4-999-347-01	INSULATOR (R) (GREEN)		220	4-996-216-01	SPRING (HOLDER), TENSION	
* 208	4-996-225-01	BRACKET (GUIDE L)		221	4-210-396-01	SPRING (LOCK), TENSION	
209	4-988-466-21	SPRING (ELECTROSTATIC), LEAF		222	X-4949-246-1	SLIDER ASSY	
210	4-996-219-01	GEAR (CAM GEAR)		* 223	X-4949-245-1	HOLDER ASSY	
211	4-996-220-01	GEAR (A)		* 224	4-996-211-01	SLIDER (CAM)	
212	4-996-221-01	GEAR (B)		225	4-998-763-01	SPRING (SHUTTER), LEAF	
213	4-933-134-01	SCREW (+PTPWH M2.6X6)		M103	X-4949-264-1	MOTOR ASSY, LOADING	

**(4) BASE UNIT SECTION
(MBU-5A)**

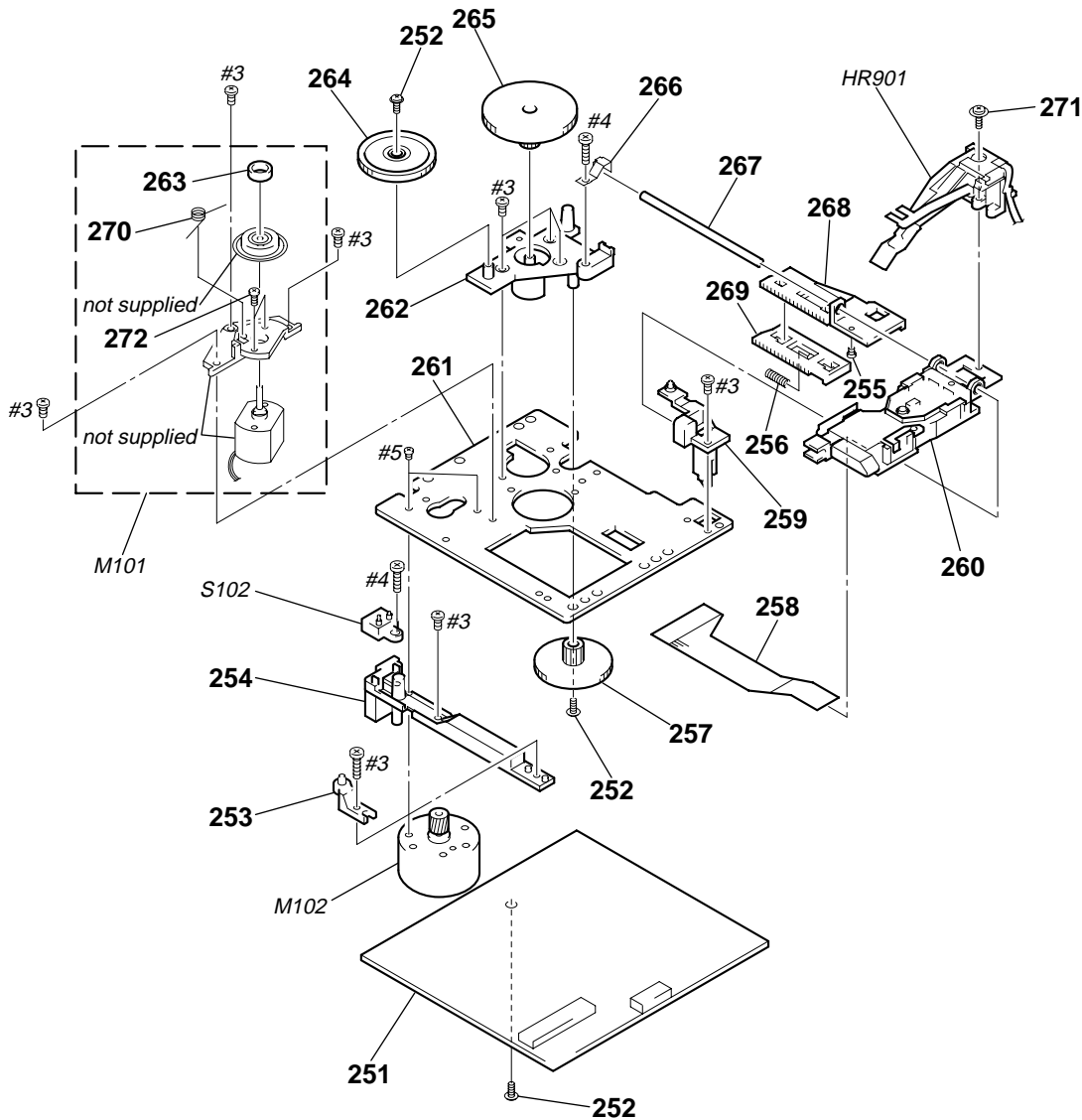

<p>The components identified by mark \triangle or dotted line with mark \triangle are critical for safety. Replace only with part number specified.</p>	<p>Les composants identifiés par une marque \triangle sont critiques pour la sécurité. Ne les remplacer que par une pièce portant le numéro spécifié.</p>
---	--

Ref. No.	Part No.	Description	Remark	Ref. No.	Part No.	Description	Remark
* 251	A-4699-893-A	BD BOARD, COMPLETE		264	4-996-260-01	GEAR (SL-A)	
252	3-372-761-01	SCREW (M1.7), TAPPING		265	4-996-261-01	GEAR (SL-B)	
* 253	4-996-267-01	BASE (BU-D)		266	4-996-264-01	SPRING (SHAFT), LEAF	
* 254	4-996-255-01	BASE (BU-C)		267	4-996-265-01	SHAFT, MAIN	
255	4-900-590-01	SCREW, PRECISION SMALL		268	4-996-256-01	SL (BASE)	
256	4-996-258-01	SPRING, COMPRESSION		269	4-996-257-01	RACK (SL)	
257	4-996-262-01	GEAR (SL-C)		270	4-996-263-01	SPRING (CLV), TORSION	
258	1-667-954-11	FLEXIBLE BOARD		271	4-988-560-01	SCREW (+P 1.7X6)	
* 259	4-996-253-01	BASE (BU-A)		272	4-211-036-01	SCREW (1.7X2.5), +PWH	
\triangle 260	8-583-028-02	OPTICAL PICK-UP KMS-260A/J1N		HR901	1-500-502-11	HEAD, OVER WRITE	
* 261	4-996-252-01	CHASSIS, BU		M101	A-4672-475-A	MOTOR ASSY, SPINDLE	
* 262	4-996-254-01	BASE (BU-B)		M102	A-4672-474-A	MOTOR ASSY, SLED	
263	4-967-688-11	MAGNET, ABSORPTION		S102	1-762-148-21	SWITCH, PUSH (2 KEY)	

(REFLECT DET, PROTECT DET)

SECTION 8 ELECTRICAL PARTS LIST

AC

BAT

BD

NOTE:

- Due to standardization, replacements in the parts list may be different from the parts specified in the diagrams or the components used on the set.
- -XX and -X mean standardized parts, so they may have some difference from the original one.
- RESISTORS
All resistors are in ohms.
METAL: Metal-film resistor.
METAL OXIDE: Metal oxide-film resistor.
F: nonflammable

- Items marked “*” are not stocked since they are seldom required for routine service. Some delay should be anticipated when ordering these items.
- SEMICONDUCTORS
In each case, u: μ , for example:
uA. . . : μ A. . . uPA. . . : μ PA. . .
uPB. . . : μ PB. . . uPC. . . : μ PC. . .
uPD. . . : μ PD. . .
- CAPACITORS
uF: μ F
- COILS
uH: μ H

The components identified by mark Δ or dotted line with mark Δ are critical for safety. Replace only with part number specified.

Les composants identifiés par une marque Δ sont critiques pour la sécurité. Ne les remplacer que par une pièce portant le numéro spécifié.

When indicating parts by reference number, please include the board.

Ref. No.	Part No.	Description	Remark	Ref. No.	Part No.	Description	Remark
*	1-669-992-11	AC BOARD *****		C105	1-164-232-11	CERAMIC CHIP 0.01uF	50V
		< CAPACITOR >		C106	1-163-275-11	CERAMIC CHIP 0.001uF	5% 50V
Δ C720	1-113-920-11	CERAMIC 0.0022uF	20% 250V	C107	1-163-038-00	CERAMIC CHIP 0.1uF	25V
Δ C721	1-113-920-11	CERAMIC 0.0022uF	20% 250V	C108	1-163-038-00	CERAMIC CHIP 0.1uF	25V
			(AEP, UK)	C109	1-163-037-11	CERAMIC CHIP 0.022uF	10% 25V
Δ C722	1-113-920-11	CERAMIC 0.0022uF	20% 250V	C111	1-164-344-11	CERAMIC CHIP 0.068uF	10% 25V
Δ C723	1-113-920-11	CERAMIC 0.0022uF	20% 250V	C112	1-163-017-00	CERAMIC CHIP 0.0047uF	5% 50V
Δ C724	1-113-925-11	CERAMIC 0.01uF	20% 250V	C113	1-109-982-11	CERAMIC CHIP 1uF	10% 10V
Δ C725	1-113-925-11	CERAMIC 0.01uF	20% 250V	C115	1-164-489-11	CERAMIC CHIP 0.22uF	10% 16V
		< CONNECTOR >		C116	1-163-037-11	CERAMIC CHIP 0.022uF	10% 25V
CN701	1-564-321-00	PIN, CONNECTOR 2P		C117	1-163-809-11	CERAMIC CHIP 0.047uF	10% 25V
CN702	1-580-230-11	PIN, CONNECTOR (PC BOARD) 2P		C118	1-163-038-00	CERAMIC CHIP 0.1uF	25V
		< GROUND PLATE >		C119	1-125-822-21	TANTALUM 10uF	20% 10V
* EP701	4-870-539-00	PLATE, GROUND		C121	1-125-822-21	TANTALUM 10uF	20% 10V
		< LINE FILTER >		C122	1-164-232-11	CERAMIC CHIP 0.01uF	50V
Δ LF700	1-424-485-11	FILTER, LINE		C123	1-163-038-00	CERAMIC CHIP 0.1uF	25V
		*****		C124	1-163-038-00	CERAMIC CHIP 0.1uF	25V
*	1-669-993-11	BAT BOARD *****		C127	1-163-038-00	CERAMIC CHIP 0.1uF	25V
		< BATTERY >		C128	1-164-232-11	CERAMIC CHIP 0.01uF	50V
BT701	1-528-887-11	BATTERY, LITHIUM SECONDARY		C129	1-107-823-11	CERAMIC CHIP 0.47uF	10% 16V
		< CONNECTOR >		C130	1-163-251-11	CERAMIC CHIP 100PF	5% 50V
* CN703	1-569-499-11	PIN, CONNECTOR 3P		C131	1-163-023-00	CERAMIC CHIP 0.015uF	5% 50V
		*****		C132	1-107-823-11	CERAMIC CHIP 0.47uF	10% 16V
		< CAPACITOR >		C133	1-164-161-11	CERAMIC CHIP 0.0022uF	10% 100V
A-4699-893-A	BD BOARD, COMPLETE	*****		C134	1-163-038-00	CERAMIC CHIP 0.1uF	25V
		< CAPACITOR >		C135	1-163-038-00	CERAMIC CHIP 0.1uF	25V
C101	1-125-822-21	TANTALUM 10uF	20% 10V	C136	1-126-206-11	ELECT CHIP 100uF	20% 6.3V
C102	1-163-038-00	CERAMIC CHIP 0.1uF	25V	C142	1-163-251-11	CERAMIC CHIP 100PF	5% 50V
C103	1-125-822-21	TANTALUM 10uF	20% 10V	C143	1-163-251-11	CERAMIC CHIP 100PF	5% 50V
C104	1-125-822-21	TANTALUM 10uF	20% 10V	C144	1-163-251-11	CERAMIC CHIP 100PF	5% 50V
				C146	1-163-038-00	CERAMIC CHIP 0.1uF	25V
				C151	1-126-206-11	ELECT CHIP 100uF	20% 6.3V
				C152	1-163-038-00	CERAMIC CHIP 0.1uF	25V
				C153	1-164-232-11	CERAMIC CHIP 0.01uF	50V
				C156	1-163-038-00	CERAMIC CHIP 0.1uF	25V
				C158	1-163-019-00	CERAMIC CHIP 0.0068uF	10% 50V
				C160	1-104-601-11	ELECT CHIP 10uF	20% 10V
				C161	1-104-601-11	ELECT CHIP 10uF	20% 10V
				C163	1-164-232-11	CERAMIC CHIP 0.01uF	50V
				C164	1-164-232-11	CERAMIC CHIP 0.01uF	50V
				C167	1-163-038-00	CERAMIC CHIP 0.1uF	25V

Ref. No.	Part No.	Description	Remark	Ref. No.	Part No.	Description	Remark	
C168	1-163-038-00	CERAMIC CHIP	0.1uF	25V	Q162	8-729-101-07	TRANSISTOR 2SB798-DL	
C169	1-125-822-21	TANTALUM	10uF	20%	10V			
C171	1-163-038-00	CERAMIC CHIP	0.1uF	25V	Q163	8-729-403-35	TRANSISTOR UN5113	
C181	1-104-913-11	TANTAL. CHIP	100uF	20%	16V	Q181	8-729-018-75	TRANSISTOR 2SJ278MY
C183	1-163-038-00	CERAMIC CHIP	0.1uF	25V	Q182	8-729-017-65	TRANSISTOR 2SK1764KY	
C184	1-117-970-11	ELECT CHIP	22uF	20%	10V		< RESISTOR >	
C185	1-164-611-11	CERAMIC CHIP	0.001uF	10%	500V	R103	1-216-049-11	RES,CHIP 1K 5% 1/10W
C187	1-104-913-11	TANTAL. CHIP	100uF	20%	16V	R104	1-216-073-00	METAL CHIP 10K 5% 1/10W
C188	1-164-232-11	CERAMIC CHIP	0.01uF	50V		R105	1-216-065-00	RES,CHIP 4.7K 5% 1/10W
C189	1-163-989-11	CERAMIC CHIP	0.033uF	10%	25V	R106	1-216-133-00	METAL CHIP 3.3M 5% 1/10W
C190	1-126-206-11	ELECT CHIP	100uF	20%	6.3V	R107	1-216-113-00	METAL CHIP 470K 5% 1/10W
C191	1-163-038-00	CERAMIC CHIP	0.1uF	25V		R109	1-216-295-00	SHORT 0
C196	1-163-038-00	CERAMIC CHIP	0.1uF	25V		R110	1-216-073-00	METAL CHIP 10K 5% 1/10W
C197	1-163-038-00	CERAMIC CHIP	0.1uF	25V		R111	1-216-295-00	SHORT 0
		< CONNECTOR >				R112	1-216-089-00	RES,CHIP 47K 5% 1/10W
CN101	1-569-479-21	CONNECTOR, FPC 21P				R113	1-216-049-11	RES,CHIP 1K 5% 1/10W
CN102	1-784-833-21	CONNECTOR (SMD) 21P				R115	1-216-049-11	RES,CHIP 1K 5% 1/10W
CN103	1-784-834-21	CONNECTOR (SMD) 23P				R117	1-216-113-00	METAL CHIP 470K 5% 1/10W
CN104	1-770-687-11	CONNECTOR, FFC/FPC 4P				R120	1-216-025-00	RES,CHIP 100 5% 1/10W
CN110	1-695-440-21	PIN, CONNECTOR (PC BOARD) 6P				R121	1-216-097-00	RES,CHIP 100K 5% 1/10W
		< DIODE >				R123	1-216-033-00	METAL CHIP 220 5% 1/10W
D101	8-719-988-62	DIODE 1SS355				R124	1-216-025-00	RES,CHIP 100 5% 1/10W
D181	8-719-046-86	DIODE F1J6TP				R125	1-216-025-00	RES,CHIP 100 5% 1/10W
D183	8-719-046-86	DIODE F1J6TP				R127	1-216-025-00	RES,CHIP 100 5% 1/10W
		< IC >				R129	1-216-295-00	SHORT 0
IC101	8-752-080-95	IC CXA2523AR				R131	1-216-073-00	METAL CHIP 10K 5% 1/10W
IC103	8-729-903-10	IC TRANSISTOR FMW1				R132	1-216-097-00	RES,CHIP 100K 5% 1/10W
IC121	8-752-389-44	IC CXD2654R				R133	1-216-117-00	METAL CHIP 680K 5% 1/10W
IC123	8-759-096-87	IC TC7WU04FU(TE12R)				R134	1-216-049-11	RES,CHIP 1K 5% 1/10W
IC124	8-759-334-38	IC MSM51V4400-70TS-K				R135	1-216-061-00	METAL CHIP 3.3K 5% 1/10W
IC152	8-759-430-25	IC BH6511FS-E2				R136	1-216-049-11	RES,CHIP 1K 5% 1/10W
IC171	8-759-487-04	IC BR24C02F-E2				R137	1-216-295-00	SHORT 0
IC181	8-759-481-17	IC MC74ACT08DTR2				R140	1-216-029-00	METAL CHIP 150 5% 1/10W
IC192	8-759-460-72	IC BA033FP-E2				R142	1-216-073-00	METAL CHIP 10K 5% 1/10W
		< COIL/SHORT >				R143	1-216-073-00	METAL CHIP 10K 5% 1/10W
L101	1-414-813-11	INDUCTOR	0uH			R144	1-216-025-00	RES,CHIP 100 5% 1/10W
L102	1-414-813-11	INDUCTOR	0uH			R145	1-216-073-00	METAL CHIP 10K 5% 1/10W
L103	1-414-813-11	INDUCTOR	0uH			R146	1-216-037-00	METAL CHIP 330 5% 1/10W
L105	1-414-813-11	INDUCTOR	0uH			R147	1-216-025-00	RES,CHIP 100 5% 1/10W
L106	1-414-813-11	INDUCTOR	0uH			R148	1-216-045-00	METAL CHIP 680 5% 1/10W
L121	1-414-813-11	INDUCTOR	0uH			R149	1-216-073-00	METAL CHIP 10K 5% 1/10W
L122	1-414-813-11	INDUCTOR	0uH			R150	1-216-295-00	SHORT 0
L151	1-412-029-11	INDUCTOR CHIP	10uH			R151	1-216-073-00	METAL CHIP 10K 5% 1/10W
L152	1-412-029-11	INDUCTOR CHIP	10uH			R152	1-216-073-00	METAL CHIP 10K 5% 1/10W
L153	1-412-032-11	INDUCTOR CHIP	100uH			R158	1-216-097-00	RES,CHIP 100K 5% 1/10W
L154	1-412-032-11	INDUCTOR CHIP	100uH			R159	1-216-097-00	RES,CHIP 100K 5% 1/10W
L161	1-414-813-11	INDUCTOR	0uH			R160	1-216-295-00	SHORT 0
L162	1-414-813-11	INDUCTOR	0uH			R161	1-216-057-00	METAL CHIP 2.2K 5% 1/10W
L181	1-216-295-91	SHORT 0				R162	1-216-057-00	METAL CHIP 2.2K 5% 1/10W
		< TRANSISTOR >				R163	1-216-057-00	METAL CHIP 2.2K 5% 1/10W
Q101	8-729-403-35	TRANSISTOR UN5113				R164	1-216-045-00	METAL CHIP 680 5% 1/10W
Q102	8-729-026-53	TRANSISTOR 2SA1576A-T106-QR				R165	1-216-097-00	RES,CHIP 100K 5% 1/10W
Q103	8-729-028-99	TRANSISTOR RN1307-TE85L				R166	1-220-149-11	REGISTER 2.2 10% 1/2W
Q104	8-729-028-99	TRANSISTOR RN1307-TE85L				R167	1-216-065-00	RES,CHIP 4.7K 5% 1/10W
						R169	1-219-724-11	METAL CHIP 1 1% 1/4W
						R170	1-216-073-00	METAL CHIP 10K 5% 1/10W
						R171	1-216-073-00	METAL CHIP 10K 5% 1/10W

Ref. No.	Part No.	Description	Remark	Ref. No.	Part No.	Description	Remark
R173	1-216-121-00	RES,CHIP	1M 5% 1/10W			< IC >	
R175	1-216-065-00	RES,CHIP	4.7K 5% 1/10W				
R177	1-216-061-00	METAL CHIP	3.3K 5% 1/10W	IC761	8-749-013-91	IC GP1UC8X	
R179	1-216-085-00	METAL CHIP	33K 5% 1/10W	IC771	8-759-525-49	IC MSM9201-02GS-K	
						< TRANSISTOR >	
R180	1-216-073-00	METAL CHIP	10K 5% 1/10W				
R182	1-216-089-00	RES,CHIP	47K 5% 1/10W	Q781	8-729-620-05	TRANSISTOR 2SC2603-EF	
R183	1-216-089-00	RES,CHIP	47K 5% 1/10W	Q782	8-729-620-05	TRANSISTOR 2SC2603-EF	
R184	1-216-073-00	METAL CHIP	10K 5% 1/10W			< RESISTOR >	
R185	1-216-081-00	METAL CHIP	22K 5% 1/10W				
R186	1-216-089-00	RES,CHIP	47K 5% 1/10W	R702	1-249-421-11	CARBON 2.2K 5% 1/4W	
R188	1-216-073-00	METAL CHIP	10K 5% 1/10W	R703	1-247-843-11	CARBON 3.3K 5% 1/4W	
R189	1-216-073-00	METAL CHIP	10K 5% 1/10W	R704	1-249-425-11	CARBON 4.7K 5% 1/4W	
R190	1-216-073-00	METAL CHIP	10K 5% 1/10W	R705	1-249-429-11	CARBON 10K 5% 1/4W	
R195	1-216-073-00	METAL CHIP	10K 5% 1/10W	R706	1-249-435-11	CARBON 33K 5% 1/4W	
R196	1-216-295-00	SHORT	0	R712	1-249-421-11	CARBON 2.2K 5% 1/4W	
R197	1-216-295-00	SHORT	0	R713	1-247-843-11	CARBON 3.3K 5% 1/4W	
		< SWITCH >		R714	1-249-425-11	CARBON 4.7K 5% 1/4W	
S101	1-762-596-21	SWITCH, PUSH (1 KEY)(LIMIT IN)		R717	1-249-429-11	CARBON 10K 5% 1/4W	
S102	1-762-148-21	SWITCH, SLIDE		R718	1-249-435-11	CARBON 33K 5% 1/4W	
		(REFLECT DET, PROTECT DET)		R742	1-249-426-11	CARBON 5.6K 5% 1/4W	
		*****		R743	1-249-425-11	CARBON 4.7K 5% 1/4W	
				R744	1-249-429-11	CARBON 10K 5% 1/4W	
*	A-4724-044-A	DISP BOARD, COMPLETE (AEP, UK)		R745	1-249-435-11	CARBON 33K 5% 1/4W	
*		DISP BOARD, COMPLETE (US, Canadian)		R762	1-247-807-31	CARBON 100 5% 1/4W	
		*****		R772	1-247-843-11	CARBON 3.3K 5% 1/4W	
	2-389-320-01	CUSHION		R773	1-247-807-31	CARBON 100 5% 1/4W	
*	4-996-686-01	HOLDER (FL)		R774	1-247-807-31	CARBON 100 5% 1/4W	
		< CAPACITOR >		R775	1-247-807-31	CARBON 100 5% 1/4W	
C700	1-126-154-11	ELECT	47uF 20% 6.3V	R776	1-247-807-31	CARBON 100 5% 1/4W	
C701	1-126-154-11	ELECT	47uF 20% 6.3V	R781	1-247-807-31	CARBON 100 5% 1/4W	
C702	1-104-464-11	CERAMIC	2.2uF 20% 50V	R782	1-249-441-11	CARBON 100K 5% 1/4W	
		(US, Canadian)		R783	1-247-807-31	CARBON 100 5% 1/4W	
C741	1-164-159-11	CERAMIC	0.1uF 50V	R784	1-249-441-11	CARBON 100K 5% 1/4W	
C746	1-164-159-11	CERAMIC	0.1uF 50V			< SWITCH >	
C761	1-126-154-11	ELECT	47uF 20% 6.3V	S701	1-762-875-21	SWITCH, KEYBOARD (● REC)	
C762	1-164-159-11	CERAMIC	0.1uF 50V	S702	1-762-875-21	SWITCH, KEYBOARD (■)	
C770	1-164-159-11	CERAMIC	0.1uF 50V	S703	1-762-875-21	SWITCH, KEYBOARD (▶▶)	
C771	1-164-159-11	CERAMIC	0.1uF 50V	S704	1-762-875-21	SWITCH, KEYBOARD (◀◀)	
C772	1-162-213-31	CERAMIC	39PF 5% 50V	S705	1-762-875-21	SWITCH, KEYBOARD ()	
C773	1-162-294-31	CERAMIC	0.001uF 10% 50V	S706	1-762-875-21	SWITCH, KEYBOARD (▷)	
C774	1-162-282-31	CERAMIC	100PF 10% 50V	S711	1-762-875-21	SWITCH, KEYBOARD (MENU/NO)	
C775	1-162-282-31	CERAMIC	100PF 10% 50V	S712	1-762-875-21	SWITCH, KEYBOARD (YES)	
C776	1-162-282-31	CERAMIC	100PF 10% 50V	S713	1-475-543-11	ENCODER, ROTARY	
C777	1-164-159-11	CERAMIC	0.1uF 50V			(◀◀ AMS ▷▷ , PUSH ENTER)	
C778	1-164-159-11	CERAMIC	0.1uF 50V	S714	1-762-875-21	SWITCH, KEYBOARD (CLEAR)	
		< CONNECTOR >		S716	1-762-875-21	SWITCH, KEYBOARD (≡ EJECT)	
CN701	1-784-335-11	CONNECTOR (FFC) 21P		S741	1-571-429-11	SWITCH, SLIDE (INPUT)	
CN751	1-784-642-11	CONNECTOR, BOARD TO BOARD 11P		S746	1-572-624-11	SWITCH, SLIDE (REC MODE)	
		< FILTER >				*****	
FL781	1-517-738-11	INDICATOR TUBE, FLUORESCENT		*	1-669-996-11	HP BOARD	

		< CAPACITOR >					
C793	1-126-933-11	ELECT	100uF 20% 16V				
C794	1-126-933-11	ELECT	100uF 20% 16V				
C795	1-162-294-31	CERAMIC	0.001uF 10% 50V				

Ref. No.	Part No.	Description	Remark			Ref. No.	Part No.	Description	Remark		
C796	1-162-294-31	CERAMIC	0.001uF	10%	50V	C123	1-164-159-11	CERAMIC	0.1uF		50V
C797	1-164-159-11	CERAMIC	0.1uF		50V	C124	1-126-022-11	ELECT	47uF	20%	25V
C798	1-164-159-11	CERAMIC	0.1uF		50V	C125	1-126-023-11	ELECT	100uF	20%	25V
		< CONNECTOR >									
* CN790	1-564-708-11	PIN, CONNECTOR (SMALL TYPE) 6P				C126	1-126-023-11	ELECT	100uF	20%	25V
		< IC >				C128	1-126-023-11	ELECT	100uF	20%	25V
IC790	8-759-634-50	IC M5218AL				C129	1-126-023-11	ELECT	100uF	20%	25V
		< JACK >				C130	1-110-335-11	MYLAR	100PF	5%	50V
J790	1-770-904-11	JACK (LARGE TYPE) (PHONES)				C131	1-110-335-11	MYLAR	100PF	5%	50V
		< RESISTOR >				C132	1-126-022-11	ELECT	47uF	20%	25V
R790	1-247-807-31	CARBON	100	5%	1/4W	C135	1-164-159-11	CERAMIC	0.1uF		50V
R791	1-249-433-11	CARBON	22K	5%	1/4W	C136	1-164-159-11	CERAMIC	0.1uF		50V
R792	1-249-441-11	CARBON	100K	5%	1/4W	C137	1-164-159-11	CERAMIC	0.1uF		50V
R793	1-249-429-11	CARBON	10K	5%	1/4W	C138	1-126-049-11	ELECT	22uF	20%	25V
R794	1-249-433-11	CARBON	22K	5%	1/4W						
R795	1-247-807-31	CARBON	100	5%	1/4W	C139	1-126-049-11	ELECT	22uF	20%	25V
R796	1-249-433-11	CARBON	22K	5%	1/4W	C140	1-164-159-11	CERAMIC	0.1uF		50V
R797	1-249-441-11	CARBON	100K	5%	1/4W	C141	1-162-294-31	CERAMIC	0.001uF	10%	50V
R798	1-249-429-11	CARBON	10K	5%	1/4W	C142	1-162-207-31	CERAMIC	22PF	5%	50V
R799	1-249-433-11	CARBON	22K	5%	1/4W	C143	1-162-215-31	CERAMIC	47PF	5%	50V
		< VARIABLE RESISTOR >				C144	1-162-199-31	CERAMIC	10PF	5%	50V
RV790	1-225-582-11	RES, VAR, CARBON 20K/20K (PHONE LEVEL)				C200	1-162-294-31	CERAMIC	0.001uF	10%	50V

*	A-4724-089-A	MAIN BOARD, COMPLETE (US, Canadian)				C203	1-164-159-11	CERAMIC	0.1uF		50V
*	A-4724-090-A	MAIN BOARD, COMPLETE (AEP, UK)				C204	1-164-159-11	CERAMIC	0.1uF		50V
		*****				C206	1-126-933-11	ELECT	100uF	20%	16V
	7-685-646-79	SCREW +BVTP 3X8 TYPE2 N-S				C207	1-126-933-11	ELECT	100uF	20%	16V
		< CAPACITOR >				C209	1-164-159-11	CERAMIC	0.1uF		50V
C100	1-164-159-11	CERAMIC	0.1uF		50V	C210	1-164-159-11	CERAMIC	0.1uF		50V
C101	1-126-933-11	ELECT	100uF	20%	16V	C211	1-164-159-11	CERAMIC	0.1uF		50V
C103	1-164-159-11	CERAMIC	0.1uF		50V	C212	1-124-995-11	ELECT	220uF	20%	10V
C104	1-124-994-11	ELECT	100uF	20%	10V						
C105	1-124-994-11	ELECT	100uF	20%	10V	C213	1-164-159-11	CERAMIC	0.1uF		50V
C106	1-164-159-11	CERAMIC	0.1uF		50V	C214	1-164-159-11	CERAMIC	0.1uF		50V
C107	1-130-475-00	MYLAR	0.0022uF	5%	50V	C215	1-124-995-11	ELECT	220uF	20%	10V
C108	1-130-475-00	MYLAR	0.0022uF	5%	50V	C216	1-124-995-11	ELECT	220uF	20%	10V
C109	1-162-286-31	CERAMIC	220PF	10%	50V	C217	1-164-159-11	CERAMIC	0.1uF		50V
C110	1-126-049-11	ELECT	22uF	20%	25V						
C111	1-162-286-31	CERAMIC	220PF	10%	50V	C218	1-164-159-11	CERAMIC	0.1uF		50V
C112	1-126-049-11	ELECT	22uF	20%	25V	C220	1-164-159-11	CERAMIC	0.1uF		50V
C113	1-162-203-31	CERAMIC	15PF	5%	50V	C221	1-164-159-11	CERAMIC	0.1uF		50V
C114	1-162-203-31	CERAMIC	15PF	5%	50V	C222	1-124-995-11	ELECT	220uF	20%	10V
C115	1-164-159-11	CERAMIC	0.1uF		50V	C223	1-164-159-11	CERAMIC	0.1uF		50V
C116	1-164-159-11	CERAMIC	0.1uF		50V						
C117	1-126-049-11	ELECT	22uF	20%	25V	C224	1-162-199-31	CERAMIC	10PF	5%	50V
C118	1-126-049-11	ELECT	22uF	20%	25V	C225	1-162-199-31	CERAMIC	10PF	5%	50V
C119	1-126-049-11	ELECT	22uF	20%	25V	C226	1-136-157-00	FILM	0.022uF	5%	50V
C120	1-164-159-11	CERAMIC	0.1uF		50V	C227	1-136-157-00	FILM	0.022uF	5%	50V
C121	1-164-159-11	CERAMIC	0.1uF		50V	C228	1-126-013-11	ELECT	1000uF	20%	16V
C122	1-124-995-11	ELECT	220uF	20%	10V						
						C229	1-164-159-11	CERAMIC	0.1uF		50V
						C230	1-126-049-11	ELECT	22uF	20%	25V
						C231	1-126-049-11	ELECT	22uF	20%	25V
						C232	1-136-165-00	FILM	0.1uF	5%	50V
						C233	1-164-159-11	CERAMIC	0.1uF		50V
						C234	1-136-165-00	FILM	0.1uF	5%	50V
						C235	1-136-165-00	FILM	0.1uF	5%	50V
						C236	1-136-165-00	FILM	0.1uF	5%	50V
						C237	1-126-022-11	ELECT	47uF	20%	25V
						C238	1-126-023-11	ELECT	100uF	20%	25V
						C239	1-126-022-11	ELECT	47uF	20%	25V
						C240	1-164-159-11	CERAMIC	0.1uF		50V
						C241	1-136-165-00	FILM	0.1uF	5%	50V
						C242	1-164-159-11	CERAMIC	0.1uF		50V
						C243	1-136-165-00	FILM	0.1uF	5%	50V

Ref. No.	Part No.	Description	Remark	Ref. No.	Part No.	Description	Remark
C244	1-126-023-11	ELECT	100uF 20% 25V	C707	1-126-964-11	ELECT	10uF 20% 50V
C245	1-126-023-11	ELECT	100uF 20% 25V	C708	1-164-159-11	CERAMIC	0.1uF 50V
C246	1-126-023-11	ELECT	100uF 20% 25V	C709	1-126-939-11	ELECT	10000uF 20% 16V
C247	1-136-154-00	FILM	0.012uF 5% 50V	C710	1-126-969-11	ELECT	220uF 20% 50V
C248	1-136-154-00	FILM	0.012uF 5% 50V	C711	1-164-159-11	CERAMIC	0.1uF 50V
C249	1-136-154-00	FILM	0.012uF 5% 50V	C712	1-128-554-11	ELECT	330uF 20% 63V
C250	1-136-154-00	FILM	0.012uF 5% 50V	C713	1-164-159-11	CERAMIC	0.1uF 50V
C251	1-130-479-00	MYLAR	0.0047uF 5% 50V	C714	1-164-159-11	CERAMIC	0.1uF 50V
C252	1-130-479-00	MYLAR	0.0047uF 5% 50V	C715	1-164-159-11	CERAMIC	0.1uF 50V
C253	1-130-479-00	MYLAR	0.0047uF 5% 50V	C716	1-164-159-11	CERAMIC	0.1uF 50V
C254	1-130-479-00	MYLAR	0.0047uF 5% 50V	C717	1-164-159-11	CERAMIC	0.1uF 50V
C255	1-110-339-11	MYLAR	220PF 5% 50V	C718	1-164-159-11	CERAMIC	0.1uF 50V
C256	1-110-339-11	MYLAR	220PF 5% 50V	C719	1-164-159-11	CERAMIC	0.1uF 50V
C257	1-110-339-11	MYLAR	220PF 5% 50V	C726	1-164-159-11	CERAMIC	0.1uF 50V
C258	1-110-339-11	MYLAR	220PF 5% 50V	C727	1-164-159-11	CERAMIC	0.1uF 50V
C259	1-136-818-11	FILM	0.0047uF 5% 100V	C728	1-126-234-11	ELECT	2200uF 20% 16V
C260	1-136-818-11	FILM	0.0047uF 5% 100V	C729	1-128-489-11	ELECT	3300uF 20% 16V
C261	1-136-814-11	FILM	0.001uF 5% 100V	C730	1-164-159-11	CERAMIC	0.1uF 50V
C262	1-136-814-11	FILM	0.001uF 5% 100V	C731	1-164-159-11	CERAMIC	0.1uF 50V
C263	1-124-700-11	ELECT	330uF 20% 25V	C732	1-115-877-11	ELECT(BLOCK)	4700uF 20% 25V
C264	1-124-700-11	ELECT	330uF 20% 25V	C733	1-115-877-11	ELECT(BLOCK)	4700uF 20% 25V
C265	1-124-699-11	ELECT	220uF 20% 25V	C735	1-136-153-00	FILM	0.01uF 5% 50V
C266	1-124-699-11	ELECT	220uF 20% 25V	C736	1-136-153-00	FILM	0.01uF 5% 50V
C270	1-164-159-11	CERAMIC	0.1uF 50V	C737	1-164-159-11	CERAMIC	0.1uF 50V
C271	1-164-159-11	CERAMIC	0.1uF 50V	C738	1-104-664-11	ELECT	47uF 20% 25V
C300	1-162-294-31	CERAMIC	0.001uF 10% 50V	C740	1-164-159-11	CERAMIC	0.1uF 50V
C301	1-164-159-11	CERAMIC	0.1uF 50V	C750	1-126-965-11	ELECT	22uF 20% 50V
C302	1-126-933-11	ELECT	100uF 20% 16V	C751	1-126-964-11	ELECT	10uF 20% 50V
C303	1-162-294-31	CERAMIC	0.001uF 10% 50V	C803	1-162-282-31	CERAMIC	100PF 10% 50V
C304	1-164-159-11	CERAMIC	0.1uF 50V	C804	1-162-282-31	CERAMIC	100PF 10% 50V
C305	1-126-933-11	ELECT	100uF 20% 16V	C805	1-162-294-31	CERAMIC	0.001uF 10% 50V
C306	1-126-933-11	ELECT	100uF 20% 16V	C806	1-164-159-11	CERAMIC	0.1uF 50V
C307	1-126-933-11	ELECT	100uF 20% 16V	C807	1-164-159-11	CERAMIC	0.1uF 50V
C308	1-126-933-11	ELECT	100uF 20% 16V	C808	1-162-294-31	CERAMIC	0.001uF 10% 50V
C309	1-136-165-00	FILM	0.1uF 5% 50V	C809	1-162-205-31	CERAMIC	18PF 5% 50V
C310	1-136-165-00	FILM	0.1uF 5% 50V	C810	1-162-205-31	CERAMIC	18PF 5% 50V
C311	1-136-165-00	FILM	0.1uF 5% 50V	C811	1-164-159-11	CERAMIC	0.1uF 50V
C312	1-164-159-11	CERAMIC	0.1uF 50V	C812	1-164-159-11	CERAMIC	0.1uF 50V
C313	1-164-159-11	CERAMIC	0.1uF 50V	C813	1-162-294-31	CERAMIC	0.001uF 10% 50V
C314	1-164-159-11	CERAMIC	0.1uF 50V	C814	1-162-294-31	CERAMIC	0.001uF 10% 50V
C315	1-104-646-11	CERAMIC	2.2uF 20% 50V	C815	1-162-294-31	CERAMIC	0.001uF 10% 50V
C316	1-126-933-11	ELECT	100uF 20% 16V	C816	1-162-294-31	CERAMIC	0.001uF 10% 50V
C317	1-164-159-11	CERAMIC	0.1uF 50V	C817	1-131-347-00	TANTALUM	1uF 10% 35V
C318	1-136-165-00	FILM	0.1uF 5% 50V	C818	1-164-159-11	CERAMIC	0.1uF 50V
C319	1-162-282-31	CERAMIC	100PF 10% 50V	C819	1-126-925-11	ELECT	470uF 20% 10V
C320	1-104-646-11	CERAMIC	2.2uF 20% 50V	C820	1-164-159-11	CERAMIC	0.1uF 50V
C400	1-162-306-11	CERAMIC	0.01uF 20% 16V	C821	1-104-646-11	CERAMIC	2.2uF 20% 50V
C401	1-162-306-11	CERAMIC	0.01uF 20% 16V	C822	1-104-646-11	CERAMIC	2.2uF 20% 50V
C402	1-126-933-11	ELECT	100uF 20% 16V	C824	1-162-282-31	CERAMIC	100PF 10% 50V
C403	1-164-159-11	CERAMIC	0.1uF 50V			< CONNECTOR >	
C404	1-126-965-11	ELECT	22uF 20% 50V	* CN100	1-564-509-11	PLUG, CONNECTOR 6P	
C700	1-126-927-11	ELECT	2200uF 20% 10V	CN200	1-564-510-11	PLUG, CONNECTOR 7P	
C701	1-126-925-11	ELECT	470uF 20% 10V	CN400	1-770-651-11	CONNECTOR, FFC/FPC 23P	
C702	1-161-494-00	CERAMIC	0.022uF 25V	* CN401	1-568-934-11	PIN, CONNECTOR 7P	
C703	1-164-159-11	CERAMIC	0.1uF 50V	CN402	1-770-649-11	CONNECTOR, FFC/FPC 21P	
C704	1-126-927-11	ELECT	2200uF 20% 10V	CN403	1-569-490-11	SOCKET, CONNECTOR 3P	
C705	1-164-159-11	CERAMIC	0.1uF 50V				
C706	1-117-850-11	ELECT	15000uF 20% 16V				

MAIN

Ref. No.	Part No.	Description	Remark	Ref. No.	Part No.	Description	Remark
CN700	1-564-513-11	PLUG, CONNECTOR 10P		IC700	8-759-525-48	IC LA5632	
CN800	1-770-649-11	CONNECTOR, FFC/FPC 21P		IC701	8-759-633-42	IC M5293L	
CN801	1-691-765-11	PLUG (MICRO CONNECTOR) 3P		IC702	8-759-604-95	IC M5F79M07L	
		< DIODE >		IC703	8-759-605-00	IC M5F78M07L	
D100	8-719-911-19	DIODE 1SS119		IC704	8-759-269-92	IC SN74HCU04ANS-E20	
D101	8-719-911-19	DIODE 1SS119		IC705	8-759-513-71	IC PQ05RF21	
D102	8-719-911-19	DIODE 1SS119		IC800	8-759-526-06	IC M30610MCA-264FP	
D103	8-719-911-19	DIODE 1SS119				< IC LINK >	
D400	8-719-933-39	DIODE HZS6C1L		ICP703	1-532-844-21	LINK, IC (AEP, UK)	
D700	8-719-210-21	DIODE 11EQS04		ICP704	1-532-844-21	LINK, IC (AEP, UK)	
D701	8-719-200-82	DIODE 11ES2				< JACK >	
D703	8-719-911-19	DIODE 1SS119		J100	1-784-430-11	JACK, PIN 4P (LINE (ANALOG) IN/OUT)	
D704	8-719-911-19	DIODE 1SS119		J300	1-784-432-11	JACK, PIN 1P (DIGITAL, COAXIAL IN)	
D705	8-719-068-31	DIODE HZ7.5CP-TK		J301	1-784-689-11	JACK, PIN 1P (DIGITAL, COAXIAL OUT)	
D706	8-719-200-77	DIODE 10E2N		J800	1-779-655-21	JACK (SMALL TYPE) (2 GANG) (S-LINK CONTROL A1)	
D707	8-719-983-62	DIODE MTZJ-T-72-3.3A				< COIL/DIODE >	
D708	8-719-911-19	DIODE 1SS119		L100	1-408-405-00	INDUCTOR 4.7uH	
D709	8-719-200-77	DIODE 10E2N		L101	1-408-405-00	INDUCTOR 4.7uH	
D710	8-719-200-77	DIODE 10E2N		L102	1-408-405-00	INDUCTOR 4.7uH	
D711	8-719-200-77	DIODE 10E2N		L200	1-408-405-00	INDUCTOR 4.7uH	
D712	8-719-200-77	DIODE 10E2N		L201	8-719-210-21	DIODE 11EQS04-TA2B	
D713	8-719-210-21	DIODE 11EQS04		L202	1-408-405-00	INDUCTOR 4.7uH	
D714	8-719-210-21	DIODE 11EQS04		L203	1-408-405-00	INDUCTOR 4.7uH	
D715	8-719-911-55	DIODE U05G		L204	1-408-405-00	INDUCTOR 4.7uH	
D716	8-719-911-55	DIODE U05G		L205	1-408-405-00	INDUCTOR 4.7uH	
D717	8-719-911-55	DIODE U05G		L206	8-719-210-21	DIODE 11EQS04-TA2B	
D718	8-719-911-55	DIODE U05G		L300	1-408-405-00	INDUCTOR 4.7uH	
D719	8-719-911-19	DIODE 1SS119		L301	1-408-405-00	INDUCTOR 4.7uH	
D720	8-719-200-77	DIODE 10E2N		L302	1-408-405-00	INDUCTOR 4.7uH	
D721	8-719-200-77	DIODE 10E2N		L303	1-408-405-00	INDUCTOR 4.7uH	
D800	8-719-911-19	DIODE 1SS119				< ENCAPSULATED COMPONENT >	
		< GROUND PLATE >		L851	1-236-164-11	ENCAPSULATED COMPONENT	
* EP102	4-870-539-00	PLATE, GROUND		L852	1-236-164-11	ENCAPSULATED COMPONENT	
* EP200	4-870-539-00	PLATE, GROUND				< TRANSISTOR >	
* EP700	4-870-539-00	PLATE, GROUND		Q200	8-729-231-55	TRANSISTOR 2SC2878-AB	
		< IC >		Q201	8-729-231-55	TRANSISTOR 2SC2878-AB	
IC100	8-759-426-99	IC CXD8607N		Q202	8-729-231-55	TRANSISTOR 2SC2878-AB	
IC101	8-759-352-59	IC CXA8054M		Q203	8-729-231-55	TRANSISTOR 2SC2878-AB	
IC102	8-759-069-28	IC PQ05RF11		Q400	8-729-900-80	TRANSISTOR DTC114ES	
IC103	8-759-712-02	IC NJM2114D		Q401	8-729-119-76	TRANSISTOR 2SA1175-HFE	
IC200	8-759-535-79	IC CXD8767N		Q702	8-729-422-61	TRANSISTOR UN4115	
IC203	8-759-371-51	IC CXA8042AS		Q800	8-729-620-05	TRANSISTOR 2SC2603-EF	
IC204	8-759-371-51	IC CXA8042AS				< RESISTOR >	
IC205	8-759-069-28	IC PQ05RF11		R100	1-259-396-11	CARBON 47 5% 1/6W	
IC241	8-759-712-02	IC NJM2114D		R101	1-259-396-11	CARBON 47 5% 1/6W	
IC242	8-759-712-02	IC NJM2114D		R102	1-259-396-11	CARBON 47 5% 1/6W	
IC243	8-759-712-02	IC NJM2114D		R103	1-259-404-11	CARBON 100 5% 1/6W	
IC244	8-759-712-02	IC NJM2114D		R104	1-259-404-11	CARBON 100 5% 1/6W	
IC300	8-759-926-17	IC SN74HC153ANS		R105	1-259-404-11	CARBON 100 5% 1/6W	
IC301	8-759-269-92	IC SN74HCU04ANS-E20		R106	1-259-404-11	CARBON 100 5% 1/6W	
IC302	8-749-012-70	IC GP1F38R (DIGITAL, OPTICAL IN2)		R107	1-259-476-11	CARBON 100K 5% 1/6W	
IC303	8-749-012-70	IC GP1F38R (DIGITAL, OPTICAL IN1)					
IC304	8-749-012-69	IC GP1F38T (DIGITAL, OPTICAL OUT)					
IC305	8-759-242-70	IC TC7WU04F					
IC400	8-759-822-09	IC LB1641					

Ref. No.	Part No.	Description	Quantity	Unit	Remark	Ref. No.	Part No.	Description	Quantity	Unit	Remark
R108	1-259-476-11	CARBON	100K	5%	1/6W	R241	1-259-418-11	CARBON	390	5%	1/6W
R109	1-259-460-11	CARBON	22K	5%	1/6W	R242	1-259-452-11	CARBON	10K	5%	1/6W
R110	1-259-460-11	CARBON	22K	5%	1/6W	R243	1-259-452-11	CARBON	10K	5%	1/6W
R111	1-259-500-11	CARBON	1M	5%	1/6W	R244	1-259-452-11	CARBON	10K	5%	1/6W
R112	1-259-500-11	CARBON	1M	5%	1/6W	R245	1-259-452-11	CARBON	10K	5%	1/6W
R113	1-259-500-11	CARBON	1M	5%	1/6W	R246	1-259-452-11	CARBON	10K	5%	1/6W
R114	1-259-500-11	CARBON	1M	5%	1/6W	R247	1-259-452-11	CARBON	10K	5%	1/6W
R115	1-259-404-11	CARBON	100	5%	1/6W	R248	1-259-452-11	CARBON	10K	5%	1/6W
R116	1-259-404-11	CARBON	100	5%	1/6W	R249	1-259-452-11	CARBON	10K	5%	1/6W
R117	1-259-445-11	CARBON	5.1K	5%	1/6W	R250	1-259-428-11	CARBON	1K	5%	1/6W
R118	1-259-444-11	CARBON	4.7K	5%	1/6W	R251	1-259-428-11	CARBON	1K	5%	1/6W
R120	1-247-807-31	CARBON	100	5%	1/4W	R252	1-259-428-11	CARBON	1K	5%	1/6W
R121	1-259-484-11	CARBON	220K	5%	1/6W	R253	1-259-428-11	CARBON	1K	5%	1/6W
R122	1-259-484-11	CARBON	220K	5%	1/6W	R254	1-259-476-11	CARBON	100K	5%	1/6W
R123	1-247-807-31	CARBON	100	5%	1/4W	R255	1-259-412-11	CARBON	220	5%	1/6W
R124	1-247-807-31	CARBON	100	5%	1/4W	R256	1-259-452-11	CARBON	10K	5%	1/6W
R125	1-259-404-11	CARBON	100	5%	1/6W	R257	1-259-452-11	CARBON	10K	5%	1/6W
R126	1-259-404-11	CARBON	100	5%	1/6W	R258	1-259-412-11	CARBON	220	5%	1/6W
R200	1-247-807-31	CARBON	100	5%	1/4W	R259	1-259-412-11	CARBON	220	5%	1/6W
R201	1-247-807-31	CARBON	100	5%	1/4W	R260	1-259-452-11	CARBON	10K	5%	1/6W
R202	1-247-807-31	CARBON	100	5%	1/4W	R261	1-259-452-11	CARBON	10K	5%	1/6W
R205	1-247-807-31	CARBON	100	5%	1/4W	R262	1-259-412-11	CARBON	220	5%	1/6W
R206	1-247-807-31	CARBON	100	5%	1/4W	R267	1-259-476-11	CARBON	100K	5%	1/6W
R207	1-247-807-31	CARBON	100	5%	1/4W	R268	1-259-476-11	CARBON	100K	5%	1/6W
R208	1-247-807-31	CARBON	100	5%	1/4W	R270	1-247-807-31	CARBON	100	5%	1/4W
R209	1-247-807-31	CARBON	100	5%	1/4W	R271	1-247-807-31	CARBON	100	5%	1/4W
R210	1-249-413-11	CARBON	470	5%	1/4W	R300	1-247-807-31	CARBON	100	5%	1/4W
R211	1-259-416-11	CARBON	330	5%	1/6W	R301	1-247-807-31	CARBON	100	5%	1/4W
R212	1-259-416-11	CARBON	330	5%	1/6W	R302	1-247-807-31	CARBON	100	5%	1/4W
R213	1-259-416-11	CARBON	330	5%	1/6W	R303	1-247-807-31	CARBON	100	5%	1/4W
R214	1-259-416-11	CARBON	330	5%	1/6W	R304	1-247-807-31	CARBON	100	5%	1/4W
R215	1-259-416-11	CARBON	330	5%	1/6W	R305	1-249-429-11	CARBON	10K	5%	1/4W
R216	1-259-416-11	CARBON	330	5%	1/6W	R306	1-249-441-11	CARBON	100K	5%	1/4W
R217	1-259-416-11	CARBON	330	5%	1/6W	R307	1-247-807-31	CARBON	100	5%	1/4W
R218	1-259-416-11	CARBON	330	5%	1/6W	R308	1-249-429-11	CARBON	10K	5%	1/4W
R219	1-259-452-11	CARBON	10K	5%	1/6W	R309	1-247-903-00	CARBON	1M	5%	1/4W
R220	1-259-380-11	CARBON	10	5%	1/6W	R310	1-247-807-31	CARBON	100	5%	1/4W
R221	1-259-380-11	CARBON	10	5%	1/6W	R311	1-247-807-31	CARBON	100	5%	1/4W
R222	1-259-380-11	CARBON	10	5%	1/6W	R312	1-247-807-31	CARBON	100	5%	1/4W
R223	1-259-380-11	CARBON	10	5%	1/6W	R313	1-247-804-11	CARBON	75	5%	1/4W
R224	1-259-436-11	CARBON	2.2K	5%	1/6W	R314	1-249-409-11	CARBON	220	5%	1/4W
R225	1-259-436-11	CARBON	2.2K	5%	1/6W	R315	1-247-804-11	CARBON	75	5%	1/4W
R226	1-259-416-11	CARBON	330	5%	1/6W	R400	1-249-429-11	CARBON	10K	5%	1/4W
R227	1-259-412-11	CARBON	220	5%	1/6W	R401	1-249-429-11	CARBON	10K	5%	1/4W
R228	1-259-416-11	CARBON	330	5%	1/6W	R402	1-249-434-11	CARBON	27K	5%	1/4W
R229	1-259-412-11	CARBON	220	5%	1/6W	R403	1-249-417-11	CARBON	1K	5%	1/4W
R230	1-259-380-11	CARBON	10	5%	1/6W	R404	1-247-807-31	CARBON	100	5%	1/4W
R231	1-259-380-11	CARBON	10	5%	1/6W	R405	1-247-807-31	CARBON	100	5%	1/4W
R232	1-259-380-11	CARBON	10	5%	1/6W	R700	1-247-807-31	CARBON	100	5%	1/4W
R233	1-259-380-11	CARBON	10	5%	1/6W	R701	1-249-429-11	CARBON	10K	5%	1/4W
R234	1-259-390-11	CARBON	27	5%	1/6W	R702	1-249-417-11	CARBON	1K	5%	1/4W
R235	1-259-390-11	CARBON	27	5%	1/6W	R707	1-249-433-11	CARBON	22K	5%	1/4W
R236	1-259-390-11	CARBON	27	5%	1/6W	R708	1-247-843-11	CARBON	3.3K	5%	1/4W
R237	1-259-390-11	CARBON	27	5%	1/6W	R709	1-249-422-11	CARBON	2.7K	5%	1/4W
R238	1-259-418-11	CARBON	390	5%	1/6W	R710	1-247-807-31	CARBON	100	5%	1/4W
R239	1-259-418-11	CARBON	390	5%	1/6W	R711	1-249-437-11	CARBON	47K	5%	1/4W
R240	1-259-418-11	CARBON	390	5%	1/6W	R712	1-249-417-11	CARBON	1K	5%	1/4W
						R713	1-249-417-11	CARBON	1K	5%	1/4W

Ref. No.	Part No.	Description	Remark
R714	1-247-891-00	CARBON 330K	5% 1/4W
R715	1-249-433-11	CARBON 22K	5% 1/4W
R800	1-249-429-11	CARBON 10K	5% 1/4W
R801	1-249-429-11	CARBON 10K	5% 1/4W
R802	1-249-429-11	CARBON 10K	5% 1/4W
R803	1-249-429-11	CARBON 10K	5% 1/4W
R804	1-249-429-11	CARBON 10K	5% 1/4W (AEP, UK) (US, Canadian)
R806	1-249-429-11	CARBON 10K	5% 1/4W (US, Canadian)
R807	1-249-429-11	CARBON 10K	5% 1/4W (AEP, UK)
R808	1-249-429-11	CARBON 10K	5% 1/4W
R809	1-249-441-11	CARBON 100K	5% 1/4W
R810	1-249-441-11	CARBON 100K	5% 1/4W
R811	1-249-429-11	CARBON 10K	5% 1/4W
R812	1-249-429-11	CARBON 10K	5% 1/4W
R813	1-249-429-11	CARBON 10K	5% 1/4W
R814	1-249-429-11	CARBON 10K	5% 1/4W
R815	1-249-429-11	CARBON 10K	5% 1/4W
R816	1-249-429-11	CARBON 10K	5% 1/4W
R820	1-249-429-11	CARBON 10K	5% 1/4W
R822	1-249-429-11	CARBON 10K	5% 1/4W
R826	1-249-429-11	CARBON 10K	5% 1/4W
R827	1-249-429-11	CARBON 10K	5% 1/4W
R828	1-249-441-11	CARBON 100K	5% 1/4W
R829	1-249-429-11	CARBON 10K	5% 1/4W
R830	1-249-429-11	CARBON 10K	5% 1/4W
R831	1-249-441-11	CARBON 100K	5% 1/4W
R832	1-249-429-11	CARBON 10K	5% 1/4W
R833	1-249-429-11	CARBON 10K	5% 1/4W
R834	1-249-441-11	CARBON 100K	5% 1/4W
R835	1-249-441-11	CARBON 100K	5% 1/4W
R836	1-249-429-11	CARBON 10K	5% 1/4W
R837	1-249-429-11	CARBON 10K	5% 1/4W
R840	1-249-429-11	CARBON 10K	5% 1/4W
R841	1-249-429-11	CARBON 10K	5% 1/4W
R842	1-249-429-11	CARBON 10K	5% 1/4W
R843	1-249-429-11	CARBON 10K	5% 1/4W
R844	1-249-429-11	CARBON 10K	5% 1/4W
R845	1-249-429-11	CARBON 10K	5% 1/4W
R846	1-249-429-11	CARBON 10K	5% 1/4W
R847	1-249-429-11	CARBON 10K	5% 1/4W
R848	1-249-429-11	CARBON 10K	5% 1/4W
R850	1-249-429-11	CARBON 10K	5% 1/4W
R851	1-249-425-11	CARBON 4.7K	5% 1/4W
R852	1-249-393-11	CARBON 10	5% 1/4W
R853	1-249-426-11	CARBON 5.6K	5% 1/4W
R854	1-249-429-11	CARBON 10K	5% 1/4W
		< COIL >	
T301	1-416-701-11	COIL (WITH CORE)	
		< VIBRATOR >	
X200	1-579-161-11	VIBRATOR, CRYSTAL (45MHz)	
X800	1-767-778-21	VIBRATOR, CERAMIC (7MHz)	

Ref. No.	Part No.	Description	Remark
X801	1-567-098-41	VIBRATOR, CRYSTAL (32.768kHz)	

*	1-669-995-11	PSW BOARD	

		< CAPACITOR >	
C751	1-164-159-11	CERAMIC 0.1uF	50V
C752	1-104-646-11	CERAMIC 2.2uF	20% 50V (US, Canadian)
		< CONNECTOR >	
CN750	1-784-641-11	CONNECTOR, BOARD TO BOARD 11P	
		< DIODE >	
D756	8-719-313-43	LED SEL6210S-TH10 (STANDBY)	
D758	8-719-313-45	LED SEL6810A-TH10 (MEGA CONTROL)	
		< TRANSISTOR >	
Q756	8-729-422-57	TRANSISTOR UN4111	
Q758	8-729-422-57	TRANSISTOR UN4111	
		< RESISTOR >	
R722	1-249-421-11	CARBON 2.2K	5% 1/4W
R723	1-247-843-11	CARBON 3.3K	5% 1/4W
R724	1-249-425-11	CARBON 4.7K	5% 1/4W
R725	1-249-429-11	CARBON 10K	5% 1/4W
R726	1-249-435-11	CARBON 33K	5% 1/4W
R732	1-249-421-11	CARBON 2.2K	5% 1/4W
R733	1-247-843-11	CARBON 3.3K	5% 1/4W
R734	1-249-425-11	CARBON 4.7K	5% 1/4W
R752	1-249-429-11	CARBON 10K	5% 1/4W
R756	1-249-409-11	CARBON 220	5% 1/4W
R758	1-249-409-11	CARBON 220	5% 1/4W
		< SWITCH >	
S722	1-762-875-21	SWITCH, KEYBOARD (PLAY MODE)	
S723	1-762-875-21	SWITCH, KEYBOARD (REPEAT)	
S724	1-762-875-21	SWITCH, KEYBOARD (SCROLL/CLOCK SET)	
S725	1-762-875-21	SWITCH, KEYBOARD (DISPLAY/CHAR)	
S726	1-762-875-21	SWITCH, KEYBOARD (I/⏻ (POWER))	
S731	1-762-875-21	SWITCH, KEYBOARD (TIME)	
S732	1-762-875-21	SWITCH, KEYBOARD (FADER)	
S733	1-762-875-21	SWITCH, KEYBOARD (MUSIC SYNC)	
S734	1-762-875-21	SWITCH, KEYBOARD (MEGA CONTROL)	
S751	1-572-625-11	SWITCH, SLIDE (TIMER)	

*	1-668-111-11	SW BOARD	

		< CONNECTOR >	
CN601	1-506-486-11	PIN, CONNECTOR 7P	
		< SWITCH >	
S601	1-572-126-11	SWITCH, PUSH (1 KEY)(REC POSITION)	
S602	1-572-126-11	SWITCH, PUSH (1 KEY)(PACK OUT)	

Ref. No.	Part No.	Description	Remark
S603	1-771-264-11	SWITCH, PUSH (CHUCKING IN)	
S604	1-771-264-11	SWITCH, PUSH (PB POSITION)	

*	1-669-997-11	VOL BOARD *****	
		< CAPACITOR >	
C765	1-162-294-31	CERAMIC 0.001uF 10% 50V	
C766	1-162-294-31	CERAMIC 0.001uF 10% 50V	
		< RESISTOR >	
R765	1-249-434-11	CARBON 27K 5% 1/4W	
R766	1-249-434-11	CARBON 27K 5% 1/4W	
		< VARIABLE RESISTOR >	
RV760	1-225-581-11	RES, VAR, CARBON 20K/20K (REC LEVEL (DIGITAL/ANALOG))	

		MISCELLANEOUS *****	
1	1-783-185-11	WIRE (FLAT TYPE) (21 CORE) (MAIN-DISP)	
8	1-783-186-11	WIRE (FLAT TYPE) (21 CORE) (MAIN-BD)	
9	1-783-187-11	WIRE (FLAT TYPE) (23 CORE)	
△ 12	1-558-568-21	CORD, POWER (AEP)	
△ 12	1-559-583-21	CORD, POWER (US, Canadian)	
△ 12	1-696-586-11	CORD, POWER (UK)	
258	1-667-954-11	FLEXIBLE BOARD	
△ 260	8-583-028-02	OPTICAL PICK-UP KMS-260A/J1N	
HR901	1-500-502-11	HEAD, OVER WRITE	
M101	A-4672-475-A	MOTOR ASSY, SPINDLE	
M102	A-4672-474-A	MOTOR ASSY, SLED	
M103	X-4949-264-1	MOTOR ASSY, LOADING	
S102	1-762-148-21	SWITCH, PUSH (2 KEY) (REFLECT DET, PROTECT DET)	
△ T701	1-431-699-11	TRANSFORMER, POWER (US, Canadian)	
△ T701	1-431-700-11	TRANSFORMER, POWER (AEP, UK)	

		***** HARDWARE LIST *****	
#1	7-685-646-79	SCREW +BVTP 3X8 TYPE2 N-S	
#2	7-685-885-09	SCREW +BVTT 4X16 (S)	
#3	7-621-772-20	SCREW +B 2X5	
#4	7-621-772-40	SCREW +B 2X8	
#5	7-627-852-08	SCREW, PRECISION +P 1.7X2.5	
#6	7-685-533-19	SCREW +BTP 2.6X6 TYPE2 N-S	
#7	7-685-133-19	SCREW +P2.6X6 TYPE2 NON-SLIT	

		ACCESSORIES & PACKING MATERIALS *****	
	1-475-580-11	REMOTE COMMANDER (RM-D17M)	
	1-574-264-11	CORD, LIGHT PLUG	
	1-590-925-31	CORD, CONNECTION	
	1-777-172-11	CORD, CONNECTION (Canadian)	
	3-864-150-11	MANUAL, INSTRUCTION (ENGLISH, FRENCH)	

Ref. No.	Part No.	Description	Remark
	3-864-150-21	MANUAL, INSTRUCTION (GERMAN, SPANISH, ITALIAN) (AEP)	
	3-864-150-31	MANUAL, INSTRUCTION (DUTCH, SWEDISH, PORTUGUESE) (AEP)	
	3-864-150-41	MANUAL, INSTRUCTION (DANISH, FINNISH) (AEP)	
	3-864-150-51	MANUAL, INSTRUCTION (ENGLISH, POLISH, RUSSIAN) (AEP)	
	4-983-537-01	COVER, BATTERY (FOR RM-D17M)	

The components identified by mark △ or dotted line with mark △ are critical for safety. Replace only with part number specified.

Les composants identifiés par une marque △ sont critiques pour la sécurité. Ne les remplacer que par une pièce portant le numéro spécifié.

