

MDS-JA3ES

SERVICE MANUAL

US Model
Canadian Model
AEP Model

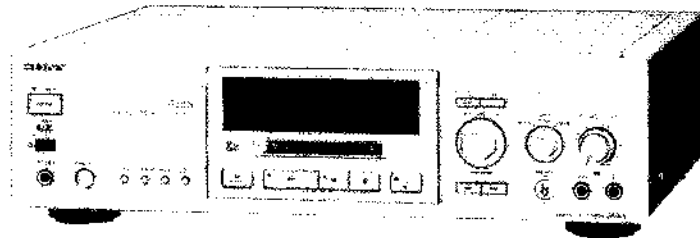

PHOTO : GOLD

Model Name Using Similar Mechanism	MDS-302
MD Mechanism Type	MDM-2C
Base Unit Type	MBU-2B
Optical Pick-up Block Type	KMS-210A/J-N

SPECIFICATIONS

MD deck section

System	MiniDisc digital audio system
Disc	MiniDisc
Laser	Semiconductor laser ($\lambda=780$ nm) Emission duration: continuous
Laser output power	Less than $44.6 \mu\text{W}^*$ * This output is the value measured at a distance of 200 mm from the objective lens surface on the optical pick-up block with 7 mm aperture.
Laser diode properties	Material: GaAlAs
Revolutions (CLV)	400 rpm to 900 rpm
Error correction	Advanced Cross Interleave Reed Solomon Code (ACIRC)
Sampling frequency	44.1 kHz
Modulation system	EFM (Eight-to-Fourteen Modulation)
Number of channels	2 stereo channels
Frequency response	5 to 20,000 Hz ± 0.5 dB
Signal-to-noise ratio	Over 102 dB (during playback)
Wow and flutter	Below measurable limit

Inputs

	Jack type	Input impedance	Rated input	Minimum input
MIC	Phono jack	600 ohms	0.8 mVrms	0.2 mVrms
LINE IN	Phono jacks	47 kilohms	500 mVrms	125 mVrms
DIGITAL IN OPTICAL	Square optical connector jack	Optical wave length 660 nm	—	—
DIGITAL IN COAXIAL	Phono jack	75 ohms	0.5 Vp-p, $\pm 20\%$	—

Outputs

	Jack type	Rated output	Load impedance
PHONES	Stereo phone jack	28 mW	32 ohms
LINE OUT	Phono jacks	2 Vrms (at 50 kilohms)	Over 10 kilohms

— Continued on next page —

MINIDISC DECK

SONY®



DIGITAL OUT	Square optical connector jack	-18 dBm	Wave length: 660 nm
----------------	--	---------	---------------------

General

Power requirements

Where purchased	Power requirements
Continental Europe	220 - 230 V AC, 50/60 Hz.
US, Canada	120 V AC, 60Hz

Power consumption 22 W

Dimensions (approx) (w/h/d)

430 x 125 x 345 mm
(17 x 5 x 13 3/4 in.) incl. projecting
parts

Mass (approx) 6.0 kg (13 lbs 4 oz)

Supplied accessories

Audio connecting cords (2 phono plugs - 2 phono plugs) (2)
Remote commander (remote) RM-D2M (1)
Sony SUM-3 (NS) batteries (2)

U.S. and foreign patents licensed from Dolby Laboratories
Licensing Corporation.

Design and specifications are subject to change without
notice.

MODEL IDENTIFICATION

— BACK PANEL —

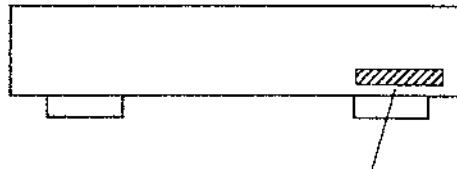

US model : 4-971-764-0□
Canadian model : 4-971-764-2□
AEP model : 4-971-764-3□

TABLE OF CONTENTS

<u>Section</u>	<u>Title</u>	<u>Page</u>	<u>Section</u>	<u>Title</u>	<u>Page</u>
SECTION 1.	GENERAL	4	SECTION 5.	DIAGRAMS	
SECTION 2.	DISASSEMBLY		5-1.	Circuit Boards Location	30
2-1.	Case and Front Panel Assembly	19	5-2.	Block Diagrams	
2-2.	MD Assembly	19	— Main Section —	31	
2-3.	Bracket (BD)	20	— Audio Section —	35	
2-4.	Slider Assembly	20	5-3.	Printed Wiring Board — RF Section —	38
2-5.	Base Unit and Loading Motor Assembly	21	5-4.	Schematic Diagram — RF Section —	41
2-6.	Slider Assembly Mounting	21	5-5.	Schematic Diagram — Digital Section —	46
SECTION 3.	TEST MODE		5-6.	Printed Wiring Board — Digital Section —	51
3-1.	Setting the Test Mode	22	5-7.	Printed Wiring Board — Audio Section —	56
3-2.	Exiting the Test Mode	22	5-8.	Schematic Diagram — Audio Section —	61
3-3.	Basic Operations of the Test Mode	22	5-9.	Printed Wiring Board — Panel Section —	65
3-4.	Selecting the Test Mode	22	5-10.	Schematic Diagram — Panel Section —	67
3-4-1.	Operating the Continuous Playback Mode	22	5-11.	IC Block Diagrams — Audio Section —	69
3-4-2.	Operating the Continuous Recording Mode	23	5-12.	IC Pin Functions	
3-4-3.	Non-Volatile Memory Mode	23	• IC101 RF Amplifier (CXA1981AR)	71	
3-5.	Functions of Other keys	23	• IC121 Digital signal processor, digital servo processor, EFM/ACIRC encoder/decoder (CXD2535AR)	72	
3-6.	Test Mode Displays	24	• IC201 System Control (M37610MD)	75	
3-7.	Meanings of Other Displays	24	• IC204 Digital Filter (CXD8512Q)	78	
3-8.	Precautions for Use of Test Mode	24	• IC205 Digital Filter (CXD8504M)	79	
SECTION 4.	ELECTRICAL ADJUSTMENTS		• IC221 Shock-Proof Memory Controller, ATRAC Encoder/ Decoder (CXD2536AR)	80	
4-1.	Precautions for Checking Laser Diode Emission	25	• IC261 Digital Audio Interface Receiver (CXD8521M)	82	
4-2.	Precautions for Use of optical pickup (KMS-210A)	25	• IC502 A/D Converter (CXD8539M)	83	
4-3.	Precautions for Adjustments	25	SECTION 6.	EXPLODED VIEWS	
4-4.	Creating MO Continuously Recorded Disc	25	6-1.	Case Section	84
4-5.	Temperature Compensation Offset Adjustment	26	6-2.	Front Panel Section	85
4-6.	Laser Power Adjustment	26	6-3.	Chassis Section	86
4-7.	Traverse Adjustment	27	6-4.	Mechanism Section (MDM-2C)	87
4-8.	Focus Bias Adjustment	28	6-5.	Base Unit Section (MBU-2B)	88
4-9.	Error Rate Check	28	SECTION 7.	ELECTRICAL PARTS LIST	89
4-9-1.	CD Error Rate Check	28			
4-9-2.	MO Error Rate Check	28			
4-10.	Focus Bias Check	28			
4-11.	Adjusting Points and Connecting Points	29			

The laser component in this product is capable of emitting radiation exceeding the limit for Class 1.

CLASS 1 LASER PRODUCT
LUOKAN 1 LASERLAITE
KLASS 1 LASERAPPARAT

This appliance is classified as a CLASS 1 LASER product. The CLASS 1 LASER PRODUCT MARKING is located on the rear exterior.

The following caution label is located inside of the recorder.

CAUTION	: INVISIBLE LASER RADIATION WHEN OPEN. AVOID EXPOSURE TO BEAM.
ADVARSEL	: USYNLIG LASERSTRÅLING VED ÅBNING NÅR SIKKERHEDSAPPARAT ER UD AF FUNKTION. UNDGÅ UDSÆTTELSE FOR STRÅLING.
VARO!	: AVATTAESSA JA SUOJALUKITUS OHITETTÄESSÄ OLET ALTTINA LASERSÄTELYLLE.
VARNING	: LASERSTRÅLING NÄR DENNA DEL ÄR ÖPPNAD OCH SPÄRREN ÄR URKÖPLAD.
ADVERSEL	: USYNLIG LASERSTRÅLING NÄR DEKSEL ÖPNES. UNNGÅ EKSPONERING FÖR STRÅLEN.

CAUTION

Use of controls or adjustments or performance of procedures other than those specified herein may result in hazardous radiation exposure.

Notes on chip component replacement

- Never reuse a disconnected chip component.
- Notice that the minus side of a tantalum capacitor may be damaged by heat.

Flexible Circuit Board Repairing

- Keep the temperature of the soldering iron around 270 °C during repairing.
- Do not touch the soldering iron on the same conductor of the circuit board (within 3 times).
- Be careful not to apply force on the conductor when soldering or unsoldering.

SAFETY-RELATED COMPONENT WARNING !!

COMPONENTS IDENTIFIED BY MARK Δ OR DOTTED LINE WITH MARK Δ ON THE SCHEMATIC DIAGRAMS AND IN THE PARTS LIST ARE CRITICAL TO SAFE OPERATION. REPLACE THESE COMPONENTS WITH SONY PARTS WHOSE PART NUMBERS APPEAR AS SHOWN IN THIS MANUAL OR IN SUPPLEMENTS PUBLISHED BY SONY.

SAFETY CHECK-OUT

After correcting the original service problem, perform the following safety checks before releasing the set to the customer:

Check the antenna terminals, metal trim, "metallized" knobs, screws, and all other exposed metal parts for AC leakage. Check leakage as described below.

LEAKAGE

The AC leakage from any exposed metal part to earth ground and from all exposed metal parts to any exposed metal part having a return to chassis, must not exceed 0.5 mA (500 microamperes). Leakage current can be measured by any one of three methods.

1. A commercial leakage tester, such as the Simpson 229 or RCA WT-540A. Follow the manufacturers' instructions to use these instruments.
2. A battery-operated AC milliammeter. The Data Precision 245 digital multimeter is suitable for this job.
3. Measuring the voltage drop across a resistor by means of a VOM or battery-operated AC voltmeter. The "limit" indication is 0.75 V, so analog meters must have an accurate low-voltage scale. The Simpson 250 and Sanwa SH-63Trd are examples of a passive VOM that is suitable. Nearly all battery operated digital multimeters that have a 2V AC range are suitable. (See Fig. A)

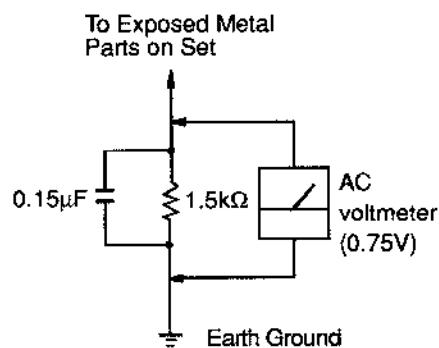

Fig. A. Using an AC voltmeter to check AC leakage.

ATTENTION AU COMPOSANT AYANT RAPPORT À LA SÉCURITÉ!!

LES COMPOSANTS IDENTIFIÉS PAR UNE MARQUE Δ SUR LES DIAGRAMMES SCHÉMATIQUES ET LA LISTE DES PIÈCES SONT CRITIQUES POUR LA SÉCURITÉ DE FONCTIONNEMENT. NE REMPLACER CES COMPOSANTS QUE PAR DES PIÈCES SONY DONT LES NUMÉROS SONT DONNÉS DANS CE MANUEL OU DANS LES SUPPLÉMENTS PUBLIÉS PAR SONY.

SECTION 1 GENERAL

FRONT PANEL

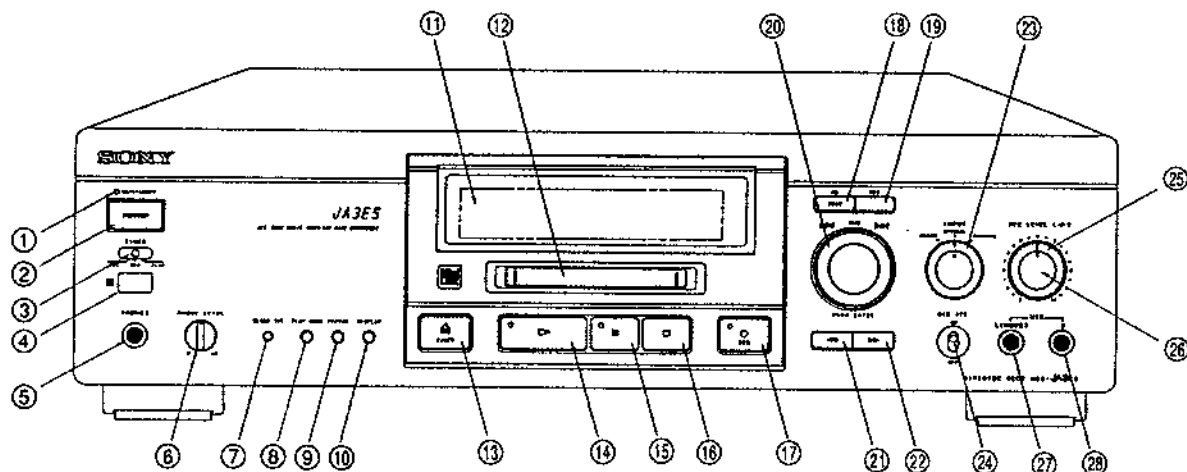

- | | |
|------------------------|-------------------------|
| ① ON/STANDBY indicator | ⑮ (pause) button |
| ② Power switch | ⑯ ■ (stop) button |
| ③ TIMER switch | ⑰ ● REC button |
| ④ Remote sensor | ⑱ EDIT/NO button |
| ⑤ PHONES jack | ⑲ YES button |
| ⑥ PHONES LEVEL control | ⑳ AMS dial |
| ⑦ CLOCK SET button | ㉑ ◀ (REW) button |
| ⑧ PLAY MODE button | ㉒ ▶ (FF) button |
| ⑨ REPEAT button | ㉓ INPUT selector switch |
| ⑩ DISPLAY button | ㉔ MIC ATT switch |
| ⑪ Display window | ㉕ REC LEVEL (L) control |
| ⑫ Disc tray | ㉖ REC LEVEL (R) control |
| ⑬ △ EJECT button | ㉗ MIC jack (L) |
| ⑭ ▷ (play) button | ㉘ MIC jack (R) |

Recording on an MD

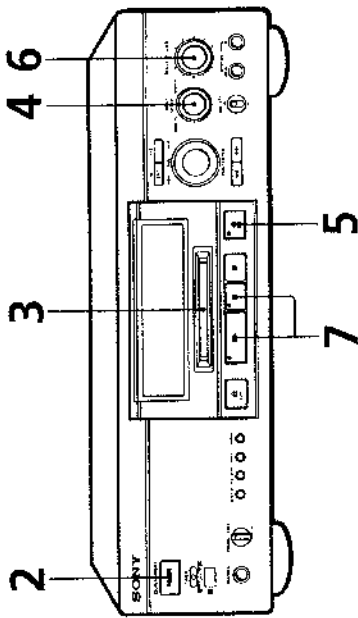

See pages 7 and 8 for hookup information.

1 Turn on the amplifier and play the program source you want to record.

2 Press POWER.

The ON/STANDBY indicator changes from red to green.

3 Insert a recordable MD.

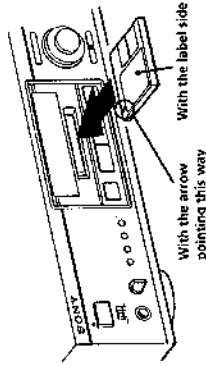

If the MD has a recorded material on it, the deck will automatically start recording from the end of the last recorded track.

4 Set INPUT to the corresponding input connector.

To record through	Set INPUT to
LINE IN or MIC L/MONO/R	ANALOG
DIGITAL IN OPTICAL	OPTICAL
DIGITAL IN COAXIAL	COAXIAL

5 Press ● REC.
The deck becomes ready to record.

When "TOC" flashes in the display
The deck is currently updating the Table Of Contents (TOC). Do not move the deck or pull out the AC power cord. Changes to an MD made through recording are saved only when you update the TOC by ejecting the MD or changing the deck to standby by pressing POWER.

6 When recording the analog input signal, adjust the recording level with REC LEVEL.

The fourth dot is satisfactory for most purposes. For details, refer to "Adjusting the Recording Level" on page 12.

7 Press ▶ or II.
Recording starts.

8 Start playing the program source.

Do not disconnect the deck from the power source immediately after recording

If you do, recorded material may not be saved to the MD. To save the material, alter recording, press EJECT to take out the MD or change the deck to standby by pressing POWER. "TOC" will flash in the display at this time. After "TOC" stops flashing and goes out, you can pull out the AC power cord.

To Stop recording ■ Press

Pause recording* II Press the button again or press ▶ to resume recording.

Take out the MD EJECT after stopping recording

* Whenever you pause recording, the track number increases by one. For example, if you paused recording while recording on track 4, the track number increases by one and recording continues on the next track when restarted.

To protect an MD against accidental erasure

To make it impossible to record on an MD, slide the tab in the direction of arrow, opening the slot. To allow recording, close the slot.

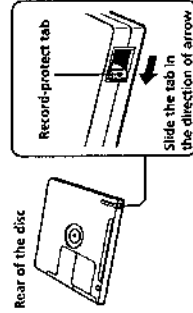

Playing an MD

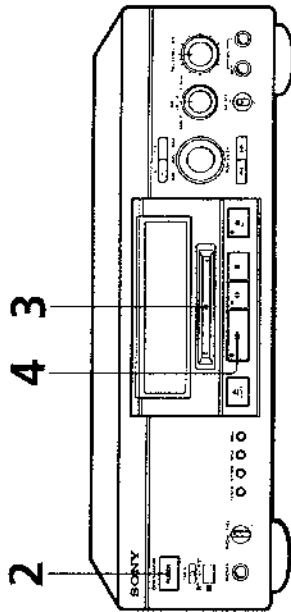

See pages 7 and 8 for hookup information.

1 Turn on the amplifier and set the source selector to the position for MD deck.

2 Press POWER.

The ON/STANDBY indicator changes from red to green.

3 Insert an MD.

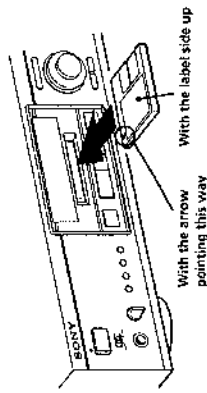

4 Press ▶.

The deck starts playing. Adjust the volume on the amplifier.

You can locate and play back a track while the deck is stopped

- 1 Turn AMS for press ◀◀◀ or ▶▶▶ until the number of the track you want to play appears.
- 2 Press AMS or ▶.

To use headphones
Connect them to PHONES jack. Use PHONE LEVEL to adjust the volume.

To

To	Do the following:
Stop playing	Press ■
Pause playing	Press II. Press the button again or press ▶ to resume playing.
Go to the next track	Turn AMS clockwise for press ▶▶▶ on the remote.
Go to the preceding track	Turn AMS counterclockwise for press ◀◀◀ on the remote.
Take out the MD	Press ◀ EJECT ▶ after stopping playing.

Getting Started

Unpacking

Check that you received the following items:

- Audio connecting cords (2)
- Remote commander (remote) (RM-F23M) (1)
- Sony SCUM-3 (NS) batteries (2)

Inserting batteries into the remote

You can control the deck using the supplied remote. Insert two Re (size-AA) batteries by matching the + and - on the batteries. When using the remote, point it at the remote sensor ◻ on the deck.

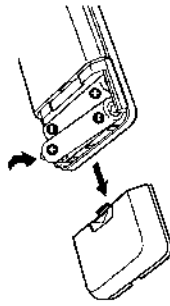

When to replace batteries

With normal use, the batteries should last for about six months. When the remote no longer operates the deck, replace all the batteries with new ones.

Notes

- Do not leave the remote near an extremely hot or humid place.
- Do not drop any foreign object into the remote casing, particularly when replacing the batteries.
- Do not expose the remote sensor to direct sunlight or lighting apparatus. Doing so may cause a malfunction.
- If you don't use the remote for an extended period of time, remove the batteries to avoid possible damage from battery leakage and corrosion.

Hooking Up the System

Overview

This section describes how to hook up the MD deck to an amplifier or other components such as a CD player or DAT deck. Be sure to turn off the power of each component before connection.

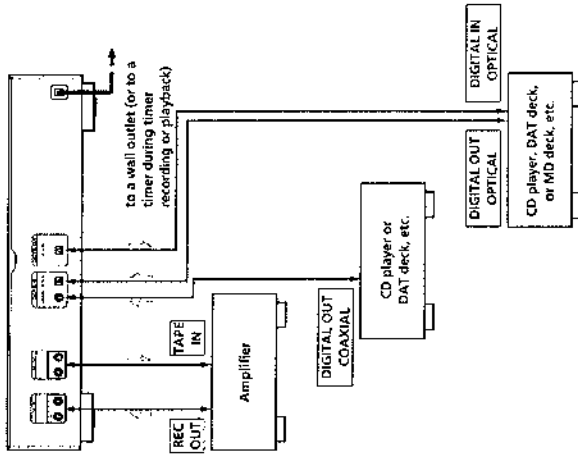

→ : Signal flow

What cords will I need?

- Audio connecting cords (supplied) (2)
- Optical cable (not supplied) (2)
- Coaxial digital connecting cable (not supplied) (1)

Hookups

Connecting the deck to an amplifier
Connect the amplifier to the LINE IN/OUT jacks using the audio connecting cords (supplied), making sure to match the color-coded cords to the appropriate jacks on the components: red (right) to red and white (left) to white. Be sure to make connections firmly to prevent hum and noise.

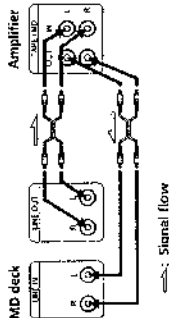

Connecting the deck to a digital component such as a CD Player, DAT deck, digital amplifier, or another MD deck
Connect the component through the DIGITAL IN/OUT connectors using optical cables or a coaxial digital connecting cable (not supplied). In the case of optical cables, take the caps off the connectors before plugging in the cables.

• **Connecting the optical cables**

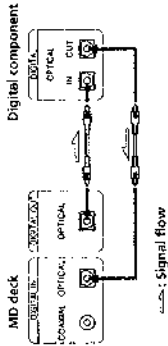

• **Connecting the coaxial digital connecting cable**

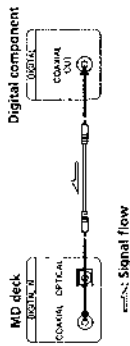

Automatic conversion of digital sampling rates during recording

A built-in 20-bit sampling rate converter automatically converts the sampling frequency of various digital sources to the 44.1 kHz sampling rate of your MD deck. This allows you to record sources such as 32- and 48-kHz DAT or analog broadcasts, as well as compact discs and other MDs.

Note
If "Dim Unlock" or "Cannot Copy" appears in the display, recording through the digital connector is not possible. In this case, record the program source through the LINE IN jacks with INPUT set to ANALOG.

Connecting the AC power cord

Connect the AC power cord to a wall outlet or to the outlet of a timer.

Note
With the exception of a timer outlet, do not connect the AC power cord to a switched outlet.

Where do I go next?

Now you're ready to use your deck. For basic operations, go to pages 4 to 6; for advanced operations, go to the sections immediately after this one.

Setting the Clock

Once you set the MD deck's internal clock, the MD deck will automatically record the date and time of all recordings. When playing a track, you can display the date and time the track was recorded (see page 18). Time on the European model is displayed in a 24-hour clock. Time on the Canadian model is displayed in a 12-hour clock.

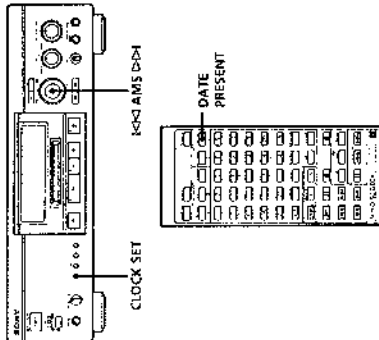

1 Press CLOCK SET down for about 2 seconds until the year indication in the display starts flashing.

European model

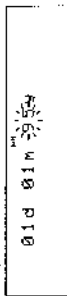

Canadian model

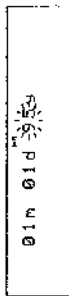

2 Turn AMS to enter the current year, then press AMS. The year indication stops flashing, and the month indication starts flashing.

European model

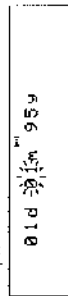

Canadian model

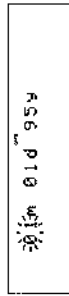

3 Repeat Step 2 to enter the month, day, hour, and minute.

European model

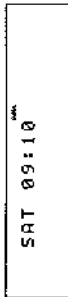

Canadian model

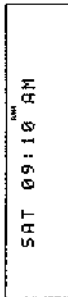

Note
For precise time and date stamping of recordings, reset the time at least once a week.

Note
If you disconnect the AC power cord for a long time, the memorized settings will disappear, and "STANDBY" will flash in the display the next time you plug in and turn on the deck. If this happens, reset the clock.

Displaying the current date and time

Press CLOCK SET on the deck. Each press of the button changes the display as follows:

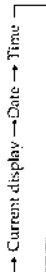

When using the remote, press DATE PRESENT. The date appears, followed by the time.

Changing the date and/or time

- Press CLOCK SET down for about 2 seconds until the year indication in the display starts flashing.
- Press AMS repeatedly until the item you want to change flashes.
- Turn AMS to change the contents of the selected item.
- To complete the setting, press AMS repeatedly until all items stop flashing.

For basic recording operations, see pages 4 and 5.

Notes on Recording

If "Protected" appears in the display, the MD is record-protected. Close the slot to record on the disc (see "To protect an MD against accidental erasure" on page 3).

If "Din Unlock" flashes in the display

- The program source is not connected to DIGITAL IN OPTICAL or COAXIAL even though you've selected DIGITAL or COAXIAL in Step 4 on page 4. To continue, connect the program source through DIGITAL IN OPTICAL or COAXIAL or set INPUT to ANALOG to record through LINE IN.

The digital signal has been interrupted (stopped) while you were recording. To continue recording, restart the digital program source. To stop recording, press **■** on the MD deck.

Depending on source being recorded, track numbers are marked in following ways:

- When recording from a CD or MD with INPUT at OPTICAL or COAXIAL and the source connected through DIGITAL IN OPTICAL or COAXIAL:
 - The deck automatically marks track numbers in the same sequence as the original. If, however, a track is repeated two or more times (e.g. by single-track repeat play) or two or more MDs or CDs are played, the track's or tracks are recorded as part of a single, continuous track with a single track number. If the source is an MD, track numbers may not be marked for tracks of less than 4 seconds.

When recording from source connected through LINE IN with INPUT at ANALOG, and "LEVEL SYNC" does not light up (see "Marking Track Numbers While Recording" on page 13) or when recording from DAT or satellite broadcasts connected through DIGITAL IN OPTICAL or COAXIAL with INPUT at OPTICAL or COAXIAL:

The source will be recorded as a single track. You can divide the track afterwards using the Divide Function (see "Dividing Recorded Tracks" on page 25) or mark track numbers during recording by using the Track Marking Function on page 13.

If "LEVEL SYNC" appears in the display, the deck automatically marks track numbers when recording analog source or digital recording of DAT or satellite broadcasts (see "Marking track numbers automatically" on page 13).

When recording from DAT or satellite broadcasts with INPUT at OPTICAL or COAXIAL, the deck automatically marks a track's number whenever the sampling frequency of the input signal changes.

When "TOC" flashes in the display

The deck is currently updating the Table Of Contents (TOC). Do not move the deck or pull out the AC power cord. Changes to an MD made through recording are saved only when you update the TOC by ejecting the MD or changing the deck to standby by pressing POWER.

The MD deck uses the SCMS (Serial Copy Management System on page 33) MDs recorded through DIGITAL IN OPTICAL or COAXIAL cannot be copied onto other MDs or DAT tapes through DIGITAL OUT OPTICAL.

When recording digital signals that have been emphasized (in the higher frequencies)

The signal is automatically de-emphasized (with attenuation proportional to the degree of emphasis) and the level of the de-emphasized signal is indicated on the peak level meters.

Sampling rate of digital signals

When the deck is recording or in recording pause, digital signals input through DIGITAL IN OPTICAL or COAXIAL are output to DIGITAL OUT OPTICAL with the same sampling rate.

To change the digital input signal to another sampling rate for output (without recording it to an MD), use input selector Function (see page 11).

Useful Tips for Recording

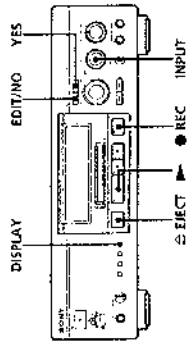

Checking the remaining recordable time on the MD

- When you press DISPLAY while recording, the remaining recordable time on the MD appears.
- When you press DISPLAY repeatedly while the deck is stopped, the display changes as follows: total recorded time, remaining recordable time on the MD, disc name (see page 17)

To turn on the Smart Space Function and Auto Cut Function again

- During recording pause, press EDIT/NO repeatedly until "S. Space" appears in the display.
- Press YES twice to display "S. Space ON".

Notes

- When you turn off the Smart Space Function, the Auto Cut Function is also turned off automatically.
- The Smart Space Function and Auto Cut Function are factory set to on.
- The Smart Space Function does not affect the order of the track numbers being recorded, even if the blank space occurs in the middle of a track.

Playing back tracks just recorded

Do this procedure to immediately playback tracks that have just been recorded.

- Press **▶** immediately after stopping recording. Playback starts from the first track of the material just recorded.

To play from the first track of the MD after recording

- Press **■** again after stopping recording.
- Press **▶** Playback starts from the first track of the MD.

Monitoring the input signal (Input Monitor)

Before starting recording, you can monitor the selected input signal through the deck's output connectors.

- Press **⊞** to remove the MD.
- Set INPUT according to the input signal you want to monitor.

When INPUT is at ANALOG

The analog signal input through LINE IN is output to DIGITAL OUT OPTICAL after A/D conversion, and then to the LINE OUT connectors and PHONES jack after D/A conversion.

When INPUT is at OPTICAL or COAXIAL

The digital signal input through DIGITAL IN OPTICAL or COAXIAL is output to DIGITAL OUT OPTICAL after passing through the sampling rate converter, and then to the LINE OUT connectors and PHONES jack after D/A conversion.

- Press **●** REC.

If the input signal is analog, "AD-DA" appears in the display.

If the input signal is digital, "DA" appears in the display.

If "Auto Cut" appears in the display (Auto Cut)

There has been no sound input for 30 seconds while INPUT is at OPTICAL or COAXIAL and the source connected through DIGITAL IN OPTICAL or COAXIAL. The 30 seconds of silence are replaced by a blank of about 3 seconds and the deck changes to recording pause.

You can turn off the Auto Cut function

For details, see "If "Smart Space" appears in the display" below.

If "Smart Space" appears in the display (Smart Space)

There has been an extended silence of 4 to 30 seconds in length when INPUT is at OPTICAL or COAXIAL and the source connected through DIGITAL IN OPTICAL or COAXIAL. The silence is replaced with a blank of about 3 seconds and the deck continues recording.

To turn off the Smart Space Function and Auto Cut Function

- During recording pause, press EDIT/NO repeatedly until "S. Space" appears in the display.
- Press YES.
- Press EDIT/NO to display "S. Space Off".

Recording Over Existing Tracks

Follow the procedure below to record over existing material just as you would on an analog cassette tape.

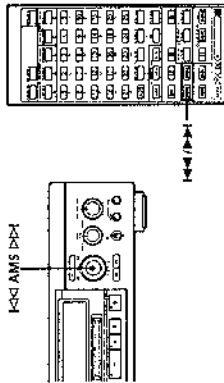

- 1 Do Steps 1 to 4 in "Recording on an MD" on page 4.
- 2 Turn AMS (or press **◀▶** or **▶▶**) until the number of the track to be recorded over appears.
- 3 To record from the start of the track, continue from Step 5 in "Recording on an MD" on page 4.

While "TRACK" flashes in the display

The deck is recording over an existing track, and stops flashing when it reaches the end of the recorded portion.

To record from the middle of the track

- 1 After Step 2 above, press **▶▶** to start playback.
- 2 Press **⏏** where you want to start recording.
- 3 Continue from Step 5 in "Recording on an MD" on page 4.

Note

You cannot record from the middle of an existing track when the "PROGRAM" or "SHUFFLE" is on.

Adjusting the Recording Level

When recording with INPUT at ANALOG and the signal input through LINE IN or MIC L/MONO/R jack(s) (see page 14), use REC LEVEL to adjust the recording level before starting recording.

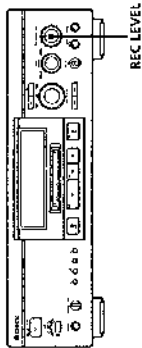

- 1 Do Steps 1 to 5 in "Recording on an MD" on page 4.
- 2 Play the portion of the program source with the strongest signal level.

- 3 While monitoring the sound, turn REC LEVEL to adjust the recording level so that the peak level meters reach their highest point without turning on the OVER indication. Occasional lighting of "OVER" is acceptable.

The outer knob controls the L (left) channel level and the inner knob the R (right) channel level. You can adjust the knobs together, or independently by turning one knob while holding the other.

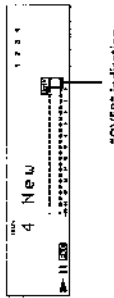

- 4 Stop playing the program source.

- 5 To start recording, do the procedure starting from Step 7 in "Recording on an MD" on page 5.

Marking Track Numbers While Recording (Track Marking)

You can mark track numbers either manually or automatically. By marking track numbers at specific points, you can quickly locate the points later using the AMS Function or Editing Functions.

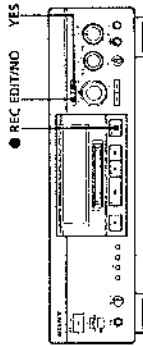

Marking track numbers manually (Manual Track Marking)

You can mark track numbers at any time while recording on an MD.

- 1 Press **REC** at the place you want to add a track mark while recording.

Marking track numbers automatically (Automatic Track Marking)

The deck adds track marks differently in the following cases:

- When recording from CDs or MDs with INPUT at OPTICAL or COAXIAL and the source connected through DIGITAL IN OPTICAL or COAXIAL: The deck marks track numbers automatically. When you record from a CD or MD, the track numbers are marked as they are found on the original.
- When recording with INPUT at ANALOG and the source connected through LINE IN, or when recording from DAT or satellite broadcasts with INPUT at OPTICAL or COAXIAL and the DAT or satellite broadcasts connected through DIGITAL IN OPTICAL or COAXIAL: The deck marks a new track number whenever the signal level drops and rises to a certain point (Automatic Track Marking). If "LEVEL SYNC" does not light up, set the LevelSync to ON as follows:

- 1 Press EDIT/NO to display "LevelSync ?" during recording or recording pause.
- 2 Press YES twice to display "LevelSync ON." "LEVEL SYNC" appears in the display.

To cancel Automatic Track Marking

- 1 Press EDIT/NO during recording or recording pause. "LevelSync ?" appears in the display.
 - 2 Press YES.
 - 3 Press EDIT/NO. "LevelSyncOFF" appears in the display.
- The signal level must remain low for 7 or more seconds before a new track number is marked.

When you want to mark track numbers after you've finished recording

Use the Divide Function (see "Dividing Recorded Tracks" on page 25).

Note

Automatic Track Marking is not possible when recording with microphones (see page 14) even if "LEVEL SYNC" appears in the display.

Starting Recording With 6 Seconds of Prestored Audio Data (Time Machine Recording)

When recording from an FM or satellite broadcast, the first few seconds of material are often lost due to the time it takes you to ascertain the contents and press the record button. To prevent the loss of this material, the Time Machine Recording Function constantly stores 6 seconds of the most recent audio data in a buffer memory so that when you begin recording the program source, the recording actually begins with the 6 seconds of audio data stored in the buffer memory in advance, as shown in the illustration below:

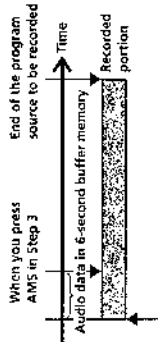

Beginning of the program source to be recorded

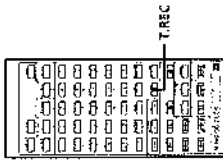

- 1 Do Steps 1 to 5 in "Recording on an MD" on page 4. The deck changes to recording pause.
- 2 Start playing the program source you want to record. The most recent 6 seconds of audio data is stored in the buffer memory.
- 3 Press **AMS** (or **T.REC**) to start Time Machine Recording. Recording of the program source starts with the 6 seconds of audio data stored in the buffer memory.

To stop Time Machine Recording
Press **■**.

Note

The deck starts storing audio data when the deck is in recording pause and you start playing the program source. With less than 6 seconds of playing of the program source and audio data stored in the buffer memory, Time Machine Recording starts with less than 6 seconds of audio data.

Recording With Microphones

You can perform stereo recording using two microphones. When you connect a single microphone to the MIC (MONO) (left/monaural) jack, the same signal is recorded to both the left and right channels for monaural recording.

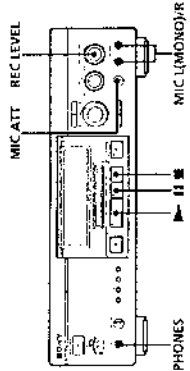

- 1 Connect the microphone(s) to the MIC (MONO)/R (or MIC (MONO)) jack(s).
- 2 Set MIC ATT to ON if necessary. When recording vocal or musical performances, the signal strength often exceeds the recommended level. If this happens, set MIC ATT to ON to lower the input level by 20 dB.
- 3 Do Steps 2 to 5 in "Recording on an MD" on page 4.
- 4 Start playing the program source and adjust the recording level with REC LEVEL (see "Adjusting the Recording Level" on page 12). By connecting headphones to the PHONES jack, you can monitor the input signal as you adjust the recording level.
- 5 Press **▶** or **■** to start recording.
- 6 Press **■** to stop recording.

Notes

- After using the microphones, be sure to disconnect them. As long as one or both microphones are connected, recording is possible only through the microphones.
- Automatic Track Marking (see page 13) is not possible when recording through microphones even if "LEVEL SYNC" appears in the display.

Synchro-Recording With a Sony CD Player (1)

By connecting your deck to a Sony CD player or Hi-Fi Component System, you can easily dub CDs onto MDs using the CD synchro buttons on the remote. If your deck is connected to a Sony CD player by the optical cable or coaxial digital connecting cable through DIGITAL OPTICAL or COAXIAL, track numbers are automatically marked as appear on the original regardless of whether "LevelSync ON" or "LevelSync OFF" is selected. If your deck is connected to a Sony CD player by audio connecting cords through LINE IN, track numbers are automatically marked when you select "LevelSync ON" (see "Marking Track Numbers While Recording" on page 13).

As the same remote controls both the CD player and the deck, you may have trouble operating both units if they are far from each other. If you do, place the CD player close to this deck.

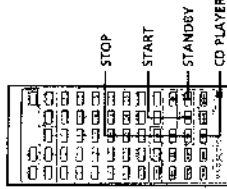

- 1 Set the source selector on the amplifier to CD.
- 2 Do Steps 2 to 4 in "Recording on an MD" on page 4 to prepare the deck for recording.
- 3 Insert a CD into the CD player.
- 4 Select the playback mode (Shuffle Play, Program Play, etc.) on the CD player.
- 5 Press STANDBY. The CD player pauses for playing and the deck pauses for recording.

- 6 Press START. The deck starts recording and the CD player starts playback. The track number and elapsed recording time of the track appear in the display.

If the CD player does not start playing. Some CD player models may not respond when you press START on the remote of the deck. Press **■** on the remote of the CD player instead.

- 7 Press STOP to stop synchro-recording.

To pause recording

Press STANDBY or CD PLAYER II. To restart recording, press START or CD PLAYER II. A new track number is marked each time you pause recording.

You can use the remote of the CD player during synchro-recording

When you press **■**, the CD player stops and the deck pauses for recording. When you press **■**, the CD player pauses and the deck pauses for recording. To restart synchro-recording, press **▶**.

You can change CDs during synchro-recording

- Do the following steps instead of Step 7 above.
- 1 Press **■** on the remote of the CD player.
 - 2 Change the CD.
 - 3 Press **▶** on the remote of the CD player. Synchro-recording restarts.

You can check the remaining recordable time on the MD

Press DISPLAY (see page 10).

Recording on an MD Using a Timer

By connecting a timer (not supplied) to the deck, you can start and stop recording operations at specified times. For further information on connecting the timer and setting the starting and ending times, refer to the instructions that came with the timer.

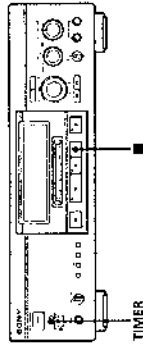

- 1 Do Steps 1 to 6 in "Recording on an MD" on pages 4 and 5.
- 2 If you want to specify the time for the start of recording, press ■.
- If you want to specify the time for the end of recording, do Steps 7 and 8 of "Recording on an MD" on page 5.
- If you want to specify the time for both start and end of recording, press ■.

3 Set TIMER on the deck to REC.

- 4 Set the timer as required.
 - When you have set the time for the start of recording, the deck turns off. When the specified time arrives, the deck turns on and starts recording.
 - When you have set the time for the end of recording, recording continues. When the specified time arrives, the deck stops recording and turns off.
- When you have set the time for both the start and end of recording, the deck turns off. When the starting time arrives, the deck turns on and starts recording. When the ending time arrives, the deck stops recording and turns off.

- 5 After you have finished using the timer, set TIMER on the deck to OFF. Then place the deck in standby status by plugging the AC power cord of the deck into a wall outlet or set the timer to continuous operation.
 - If TIMER is set at REC, the deck will automatically start recording the next time you turn the deck on.
 - If you do not change the deck to standby status for more than two or three days after timer recording has finished, the recorded contents may disappear.

Make sure to change the deck to standby status within two or three days after timer recording is completed.
The TOC on the MD is updated and recorded contents are written to the MD when you turn the deck on. If the recorded contents have disappeared, "STANDBY" shows when you turn the deck on.

Notes

- During timer recording, new material is recorded from the end of the recorded portion on the MD.
- Material recorded during timer recording will be saved to the disc the next time you turn the deck on. "TOC" will flash in the display at that time. Do not move the deck or pull out the AC power cord while "TOC" is flashing.
- Timer recording will stop if the disc becomes full.

For basic playback operations, see page 6.

Using the Display

You can use the display to check disc and track information such as the total track number, total playing time of the tracks, remaining recordable time of the disc, disc name, and recording date and time of the current track.

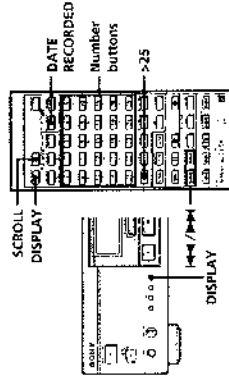

Checking the total track number, total disc playing time, remaining recordable time of the disc and the title of the disc

Each time you press DISPLAY while the deck is stopped, you can change the display as follows:

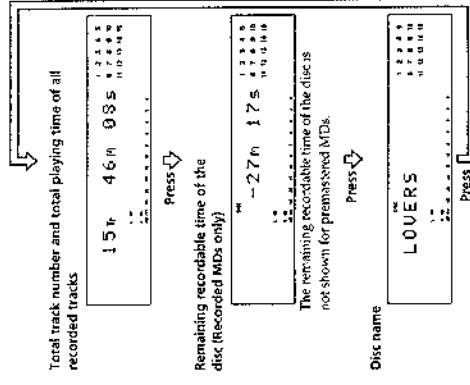

When you insert an MD, the disc name, total number of tracks, and total disc playing time appear in the display as follows:

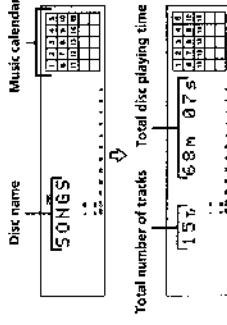

The disc name appears, followed by the total number of tracks (TP) and total disc playing time.
A music calendar showing all the track numbers appears within a grid if the MD is a premastered disc, or without a grid if the MD is a recordable disc.
If the total track number exceeds 25, ▶ appears to the right of number 25 in the music calendar.
To label a recordable disc and its tracks, see "Labeling Recordings" on page 28.

Checking remaining time and the title of a track

Each time you press DISPLAY while playing an MD, you can change the display as shown below. The track numbers in the music calendar disappear after they are played.

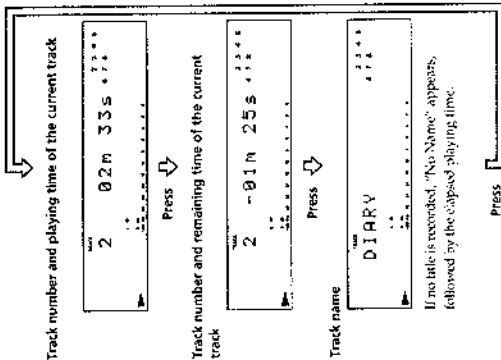

You can check the track name at any time while playing an MD by pressing SCROLL.
 Since the display shows up to 12 characters at a time, press SCROLL on the remote again to see the rest of the track title if the title has 13 characters or more. Press SCROLL again to pause scrolling, and again to continue scrolling.

Displaying the recording date

When the internal clock has been set, the deck automatically records the recording date and time of all recordings. You can then check the recording date and time of a track.

- 1 Locate the track for which you want to check the recording date and time.
 When the deck is stopped, press the number buttons playing or in play pause or number buttons.
- 2 Press DATE RECORDED.
 "No Date" appears if the internal clock has not been set or the track was recorded on another MD deck without a date and time stamp function.

Locating a Specific Track

You can quickly locate any track while playing a disc by using AMS (Automatic Music Sensor), number buttons or M-SCAN on the remote.

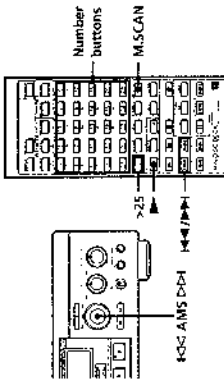

- To locate**
 The next or succeeding tracks
 During playback, turn AMS clockwise or press repeatedly until you find the track.
- The current or preceding tracks
 During playback, turn AMS counterclockwise or press repeatedly until you find the track.
- A specific track directly
 Press number buttons to enter the track number.
- By scanning each track for 6 seconds (track scan)
 1 Press M-SCAN before you start playing.
 2 When you find the track you want, press to start playing.

When you directly locate a track with a number over 25
 You must press >25 first, before entering the corresponding digits.
 Press >25 once if it is a 2-digit track number, and twice if it is a 3-digit track number.
 To enter "0," press button 10.
 Examples • To play track number 30: Press >25 once, then 3 and 0.
 • To play track number 100: Press >25 twice, then 1, 0 and 10.

You can extend the playing time during music scan
 While the deck is stopped, press M-SCAN repeatedly until the playing time you want (6, 10 or 20 seconds) appears in the display. Each press changes the time in order of 6 to 20, then from 6 again.

To pause playing at the beginning of a track
 Turn AMS or press the number buttons after pausing playback.

To go quickly to the beginning of the last track
 Turn AMS counterclockwise (or press the left arrow) while the display shows the total track number and total disc playing time. Remaining recordable time of the disc, or disc name (see page 17).

Locating a Particular Point in a Track

You can also use the left and right arrow buttons to locate a particular point in a track during playback or playback pause.

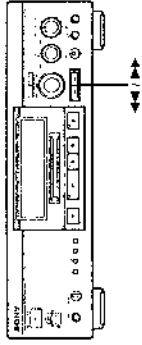

- To locate a point**
 While monitoring the sound
 Press the left arrow (backward) or the right arrow (forward) and keep pressing until you find the point.
- Quickly by observing the display during playback/pause
 Press the left arrow (backward) or the right arrow (forward) and keep pressing until you find the point. There is no sound output during this playback/pause operation.

Notes

- If the disc reaches the end while you are pressing the right arrow during playback/pause, "OVL" appears in the display. Press the left arrow (or the right arrow) or turn AMS counterclockwise to go back.
- If the disc reaches the end while you are pressing the right arrow during sound monitoring, the deck stops.
- Tracks that are only a few seconds long may be too short to scan using the search function. For such tracks, it is better to play the MD at normal speed.

Playing Tracks Repeatedly

You can play tracks repeatedly in any play mode.

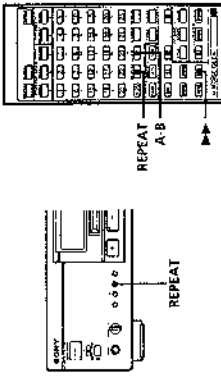

Press REPEAT. "REPEAT" appears in the display. The deck repeats the tracks as follows.

When the MD is played in	The deck repeats
Normal play (page 6)	All the tracks
Shuffle Play (page 21)	All the tracks in random order
Program Play (page 21)	This same program

To cancel repeat play

Press REPEAT several times until "REPEAT" disappears. The deck returns to the original playing mode.

Repeating the current track

While the track you want to repeat is playing in normal play, press REPEAT several times until "REPEAT 1" appears in the display.

Repeating a specific portion (A-B Repeat) [REPEAT]

You can play a specific portion of a track repeatedly. This might be useful when you want to memorize lyrics.

Note that you can only repeat a portion within the boundaries of a single track.

- 1 While playing a disc, press A-B at the starting point (point A) of the portion to be played repeatedly. "REPEAT A-" flashes in the display.
- 2 Continue playing the track or press ► until you reach the ending point (point B), then press A-B again. "REPEAT A-B" lights continuously. The deck starts to play the specified portion repeatedly.

To cancel A-B Repeat
Press REPEAT.

Setting new starting and ending points

You can repeat the portion immediately after the currently specified portion by changing the starting and ending points.

- 1 Press A-B while "REPEAT A-B" appears. The current ending point B becomes the new starting point A and "REPEAT A-" flashes in the display.
- 2 Continue playing the track or press ► until you reach the new ending point (point B), then press A-B again. "REPEAT A-B" lights continuously and the deck starts playing repeatedly the newly specified portion.

Playing in Random Order (Shuffle Play)

You can have the deck "shuffle" tracks and play them in random order.

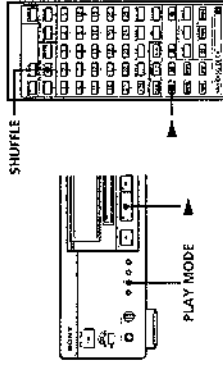

- 1 Press PLAY MODE repeatedly (or SHUFFLE once) until "SHUFFLE" appears in the display when the deck is stopped.
- 2 Press ► to start Shuffle Play. "2" appears in the display while the deck is "shuffling" the tracks.

To cancel Shuffle Play

Press PLAY MODE repeatedly (or CONTINUE once) until "SHUFFLE" disappears.

You can specify tracks during Shuffle Play

- To play the next track, turn AMS clockwise (or press ►).
- To play from the beginning of the current track again, turn AMS counterclockwise (or press ◀).
- You cannot use AMS (or ◀) to go to tracks that have already been played.

Creating Your Own Program (Program Play)

You can specify the playback order of the tracks on an MD and create your own programs containing up to 25 tracks.

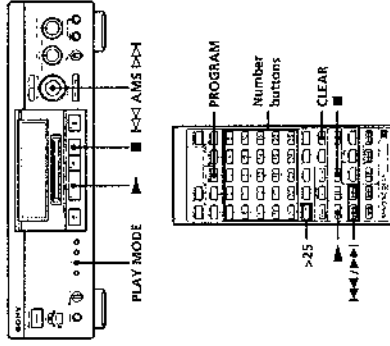

- 1 Press PLAY MODE repeatedly (or PROGRAM once) until "PROGRAM" appears in the display when the deck is stopped.
 - a) Do either a) or b):
 - i) When using the remote Press the number buttons in order the tracks you want to program in the order you want. To program a track with a number over 25, use the >25 button (see page 19).
 If you've made a mistake Press CLEAR, then press the right number button.
 - b) When using the controls on the deck
 - 1 Turn AMS until the track number you want appears in the display.
 - 2 Press AMS or PLAY MODE.
- 3 Repeat Step 2 to enter other tracks. Each time you enter a track, the total program time is added up and appears in the display.
- 4 Press ► to start Program Play.

To cancel Program Play

Press PLAY MODE repeatedly (or CONTINUE once) when the deck is stopped until "PROGRAM" disappears

You can program the same track repeatedly

While the track number appears in the display, press AMS as many times as you want.

The program remains even after Program Play ends

When you press **▶**, you can play the same program again.

Note

The display shows "1-1-5" instead of the total playing time when the total playing time of the program exceeds 100 minutes.

Checking the track order

You can check the order of tracks in your program during playback or playback pause.

Turn AMS (or press **◀▶** or **▶▶**) during playback or playback pause. The track numbers appear in the order they were programmed.

Changing the track order

You can change the order of the tracks in your program before you start playing.

To	Do the following:
Erase the last track in the program. ▶▶	Press CLEAR. Each time you press the button, the last track will be erased.
Add tracks to the end of the program.	Do Steps 2 and 3 in "Creating Your Own Program."
Change the whole program completely	1. Press ■ while the deck is stopped. 2. Do Steps 2 and 3 in "Creating Your Own Program."

Useful Tips When Recording From MDs to Tape **▶▶**

The Auto Space and Auto Pause Functions described in this section make recording from MDs to tape more easy.

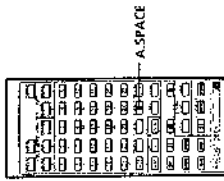

Inserting blank spaces while recording to tape (Auto Space)

The Auto Space Function inserts a 3-second blank space between each track while recording from MDs to tapes, allowing you to use the AMS function during later playback.

Press A.SPACE repeatedly until "A.SPACE" appears in the display.

To cancel Auto Space

Press A.SPACE repeatedly until "A.SPACE" disappears.

Note

If the Auto Space Function is on while recording a selection containing multiple track numbers (for example, a medley or symphony), blank spaces will be inserted within the selection whenever the track number changes.

Pausing after each track (Auto Pause)

When the Auto Pause Function is on, the deck pauses after playing each track. Auto Pause is convenient when recording single tracks or multiple, non-consecutive tracks.

Press A.SPACE repeatedly until "A.PAUSE" appears in the display.

To restart playback

Press **▶** or **▶▶**.

To cancel Auto Pause

Press A.SPACE repeatedly until "A.PAUSE" disappears.

Playing an MD Using a Timer

By connecting a timer (not supplied) to the deck, you can start and stop playback operations at specified times. For further information on connecting the timer or setting the starting and ending times, refer to the instructions that came with the timer.

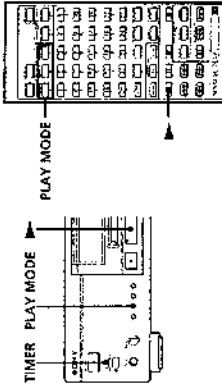

1 Do Steps 1 to 3 in "Playing an MD" on page 6.

2 Press PLAY MODE repeatedly (or one of the PLAY MODE buttons once) to select the play mode you want.

To play only specific tracks, create a program (see page 21).

3 If you want to specify the time for the start of playback, go to Step 4.

If you want to specify the time for the end of playback, press **▶▶** to start playback, then go to Step 4.

If you want to specify the time for both start and end of playback, go to Step 4.

4 Set TIMER on the deck to PLAY.

5 Set the timer as required.

- When you have set the time for the start of playback, the deck turns off. When the specified time arrives, the deck turns on and starts playing.
- When you have set the time for the end of playback, playback continues. When the specified time arrives, the deck stops playing and turns off.
- When you have set the time for both the start and end of playback, the deck turns off. When the starting time arrives, the deck turns on and starts playing. When the ending time arrives, the deck stops playing and turns off.

6 After you have finished using the timer, set TIMER on the deck to OFF.

Note

You can select Program Play in Step 2. Note, however, that programs eventually fade away when the standby status is off, and therefore if you set the time too far in the future, the program may be gone when the specified time arrives. If this has occurred, the deck enters normal play mode at the specified time and the tracks play in consecutive order.

Notes on Editing

If "Protected" appears in the display, the deck could not erase the specified track because the record-protect slot on the MD is open. Erase the track after closing the slot.

When "TOC" flashes in the display, do not move the deck or pull out the AC power cord. After editing, "TOC" lights continuously until you eject the MD or turn off the power. "TOC" flashes while the deck is updating the TOC. When the deck finishes updating the TOC, "TOC" goes off.

Erasing Recordings (Erase Function)

Do the procedures below to erase following:

- A single track
 - All tracks
 - Parts of a track
- Note, however, that once erased, MD data cannot be recovered.

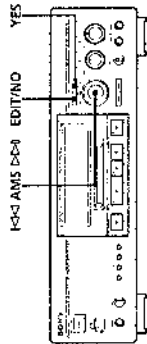

Erasing a single track

You can erase a track simply by specifying the respective track number. When you erase a track, the total number of tracks on the MD decreases by one and all tracks following the erased one are renumbered. Since erasing merely updates the TOC, there is no need to record over material.

To avoid confusion when erasing multiple tracks, you should proceed in order of high to low track number to prevent the renumbering of tracks that have not been erased yet.

Example: Erasing B

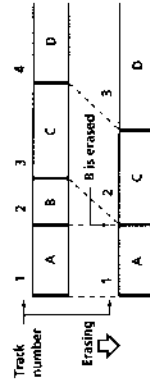

Erasing a part of a track

By using the Divide (see this page), Erase (see page 24) and Combine (see page 26) Functions, you can erase specific portions of a track.

Example: Erasing a part of track A

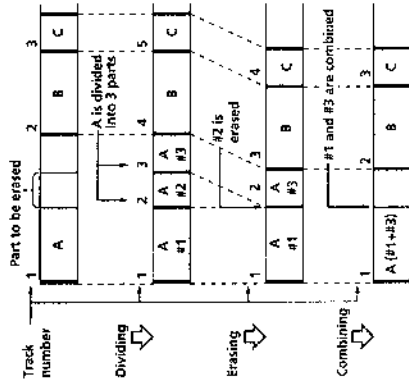

Dividing Recorded Tracks (Divide Function)

With the Divide Function you can assign a track number at places that you want to randomly access afterwards. Use this function to add tracks to MDs recorded from an analog source (and therefore contain no track numbers), or to divide an existing track into multiple portions. When you divide a track, the total number of tracks on the MD increases by one and all tracks following the divided track are renumbered.

Example: Dividing track 2 to create a new track for C

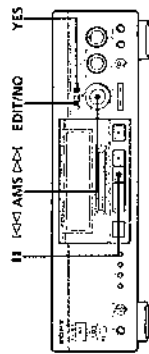
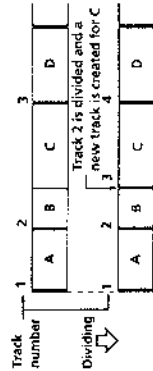

- 1 While playing the MD, press **II** at the point where you want to create a new track. The deck pauses playing.
- 2 Press **EDIT/NO** repeatedly until "Divide?" appears in the display.
- 3 Press **YES** to divide the track. "Rehearsal" alternates with "Position ok?" in the display, the track to be divided starts flashing in the music calendar, and the starting portion of the new track begins playing repeatedly.
- 4 If the starting position is incorrect, press **EDIT/NO**. (If it is correct, go to Step 7.)

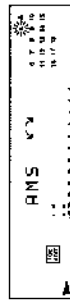

(Continued)

- While monitoring the sound, turn AMS to find the starting position of the new track. The starting portion of the new track is played back repeatedly. "Rehearsal" alternates with "Position ok?" in the display. The starting position can be moved within a maximum range of -128 to +127 steps of about 0.06 second each within a track.
- If the starting position is still incorrect, repeat Step 5 until it is correct.

- Press YES or AMS when the position is correct. When the track has been divided, "Complete" appears for a few seconds and the newly created track begins playing. The new track will have no track title even if the original track was labeled.

To cancel the Divide Function
Press ■.

You can undo a track division
Combine the tracks again (see "Combining Recorded Tracks" on this page) then redivide the tracks if necessary.

You can divide a track while recording
Use the Track Marking Function (see page 13).

Combining Recorded Tracks (Combine Function)

Use the Combine Function while the deck is stopped, playing or in pause to combine consecutive tracks on a recorded MD. This function is useful for combining several songs into a single medley, or several independently recorded portions into a single track. When you combine two tracks, the total number of tracks decreases by one and all tracks following the combined tracks are renumbered.

Example: Combining B and C

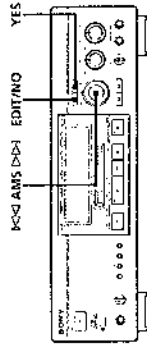
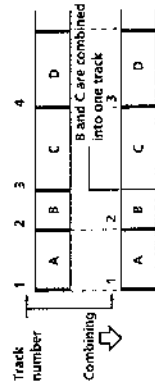

- Turn AMS until the second track of the two to be combined appears. For example, when combining tracks 3 and 4, turn AMS until 4 appears.
- Press EDIT/NO repeatedly until "Combine ?" appears in the display.
- Press YES. "Rehearsal" alternates with "Track ok?" in the display. The place where the two tracks will join (i.e., the end of the first track and the beginning of the second track) repeatedly plays back and the respective track number flashes in the music calendar.
- If the track is the wrong one, press EDIT/NO or ■, then start from Step 1 again.

- If the place is correct, press YES. When the tracks have been combined, "Complete" appears for a few seconds and the total number of tracks in the music calendar decreases by one. If both of the combined tracks have track titles, the title of the second track is erased.

To cancel the Combine Function
Press EDIT/NO or ■.

You can undo a track combination

Divide the tracks again (see "Dividing Recorded Tracks" on page 25), then repeat the combine function with the correct tracks if necessary.

Note

If "Sorry" appears in the display, the tracks cannot be combined. This sometimes happens when you've edited the same track many times, and is due to a technical limitation of the MD system, not a mechanical error.

Moving Recorded Tracks (Move Function)

Use the Move Function to change the order of any track. After you move a track, the track numbers between the new and old track positions are automatically renumbered.

Example: Moving track C to track position 2

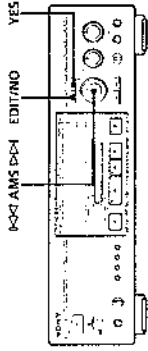
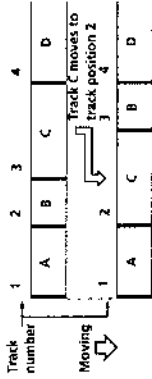

- Turn AMS until the track number you want to move appears in the display.
- Press EDIT/NO repeatedly until "Move ?" appears in the display.
- Press YES. The track number to be moved and the new track position appears.

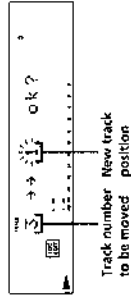

- Turn AMS until the new track position appears.



- Press YES or AMS. After you have moved the track, "Complete" appears for a few seconds and the moved track begins playing back if the deck is in play/freq mode.

To cancel the Move Function
Press EDIT/NO or ■.

Labeling Recordings (Title Function)

You can create titles for your recorded MDs and tracks. Titles — which may consist of uppercase and lowercase letters, numbers and symbols for a maximum of about 1,700 characters per disc — appear in the display during MD operation.

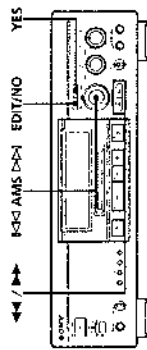

Use the following procedure to label a track or an MD. You can label a track while it is playing, pausing or recording. If the track is playing, be sure to finish labeling before the track ends. If the track ends before you've completed the labeling procedure, the characters already entered are not recorded and the track will remain unlabeled.

- 1 Press EDIT/NO repeatedly until "Name in ?" appears in the display, then do the following:

To label	Make sure that the deck is
A track	Playing, pausing, recording, the track to be labeled, or stopped after locating the track to be labeled
An MD	Stopped with no track number appearing in the display

- 2 Press YES.
A flashing cursor appears in the display.

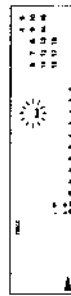

- 3 Turn AMS to select the first character.

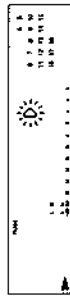

The selected character flashes. Letters, numbers, and symbols appear in sequential order as you turn AMS.

You can use the following symbols in titles:
! " # \$ % & ' () * + , - . / : ; < = > ? @ _

- 4 Press AMS to enter the selected character. The cursor shifts rightward and waits for the input of the next character.

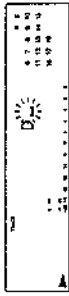

- 5 Repeat Steps 3 and 4 until you have entered the entire title.

If you entered the wrong character
Press ← or → until the character to be corrected starts flashing, and repeat Steps 3 and 4 to enter the correct character.

To erase a character
Press ← or → until the character to be erased starts flashing, then press EDIT/NO.

To enter a space
Press AMS or → while the cursor is flashing.

- 6 Press YES.
This completes the labeling procedure and the title appears on the left side of the display.

To cancel labeling
Press ■.

Note
You cannot label a track or an MD while you are recording over an existing track.

Labeling tracks and MDs with the remote [1]

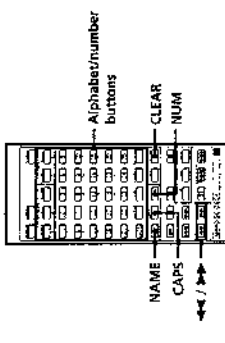

- 1 Press NAME repeatedly until a flashing cursor appears in the display, then do the following:

To label	Make sure that the deck is
A track	Playing, pausing, recording the track to be labeled, or stopped after locating the track to be labeled
An MD	Stopped with no track number appearing in the display

- 2 Select the character type as follows:

To select	Press
Lowercase letters	CAPS repeatedly until "Selected abc" appears in the display
Uppercase letters	CAPS repeatedly until "Selected ABC" appears in the display
Numbers	NUM repeatedly until "Selected 123" appears in the display

- 3 Enter one character at a time.
After you enter a character, the cursor shifts rightward and waits for the input of the next character.

- 4 Repeat Steps 2 and 3 until you have entered the entire title.

If you entered the wrong character

Press ← or → until the character to be corrected starts flashing.
Press CLEAR to erase the incorrect character, then enter the correct one.

- 5 Press NAME again.
The entered title appears on the left side of the display window after the label has been recorded.

To cancel labeling
Press ■.

Changing an existing title [1]

- 1 Press NAME, then do the following:

To change	Make sure that the deck is
A track title	Playing, pausing the track whose title is to be changed, or stopped after locating the track whose title is to be changed
A disc name	Stopped with no track number appearing in the display

- 2 Keep pressing CLEAR (or EDIT/NO on the deck) until the current title is erased.

- 3 Enter the new title.
Do Steps 3 to 5 of "Labeling Recordings," on page 28, or Steps 2 to 4 of "Labeling tracks and MDs with the remote," on this page.

- 4 Press NAME.

Erasing all titles on a disc (Name Erase Function)

Use this function to erase all titles on an MD simultaneously.

Note that once erased, titles cannot be recovered.

- 1 Keep pressing EDIT/NO while the deck is stopped until "All Erase ?" appears in the display.

- 2 Press EDIT/NO again.
"Name Erase ?" appears in the display.

- 3 Press YES.
All titles are erased.

To cancel the Name Erase Function
Press ■.

You can erase all recorded tracks and titles
See "Erasing all tracks on an MD," on page 24.

3 You can record a DAT tape or MD recorded via the DAT or MD deck's analog input jack into another DAT tape or MD deck's digital output jack. You cannot, however, make a second-generation DAT tape or MD copy via the DAT or MD deck's digital output jack.

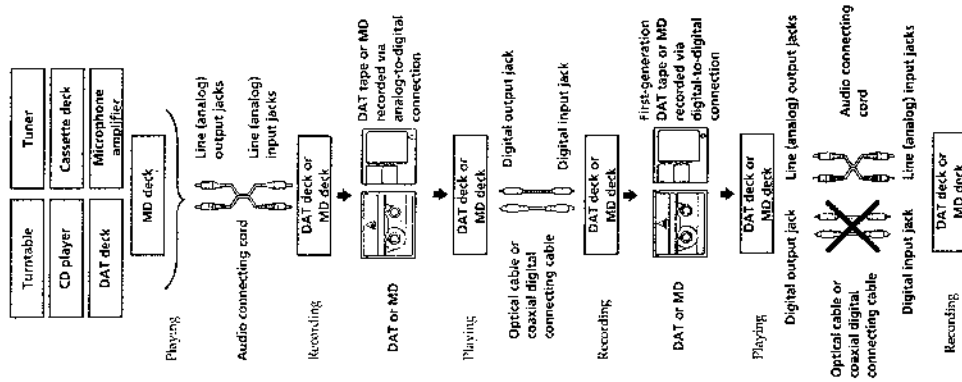

2 You can record the digital output signal of a digital satellite broadcast onto a DAT tape or recordable MD via the digital input jack on the DAT or MD deck which is capable of handling a sampling frequency of 32 kHz or 48 kHz. You can then record the contents of this recorded DAT tape or MD (first-generation) onto another DAT tape or recordable MD via digital input jack on the DAT or MD deck to create a second-generation digital copy. Subsequent recording from the second-generation copy onto another recordable DAT tape or MD is possible only through the analog input jack on the DAT or MD deck. Note, however, that on some IS tuners, second-generation digital copying may not be possible.

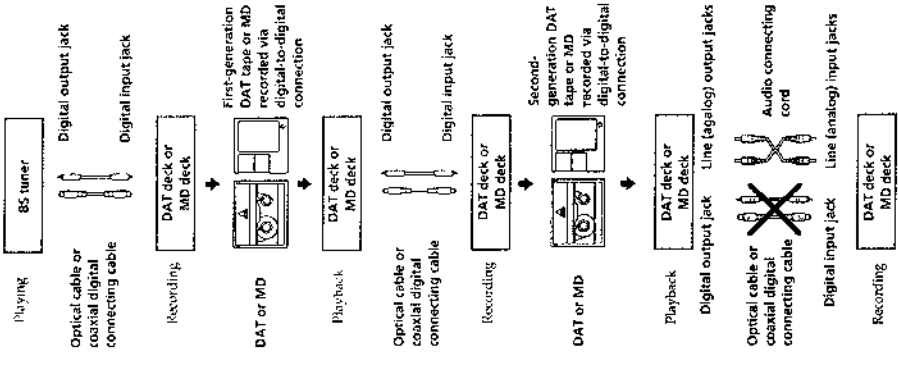

Guide to the Serial Copy Management System

This MD deck uses the Serial Copy Management System, which allows only first-generation digital copies to be made of premastered software via the deck's digital input jack. An outline of this system appears below.

1 You can record from digital program sources (CDs, DATs or premastered MDs) onto a DAT tape or recordable MD via digital input jack on the DAT or MD deck. You cannot, however, record from this recorded DAT tape or MD onto another DAT tape or recordable MD via the digital input jack on the DAT or MD deck.

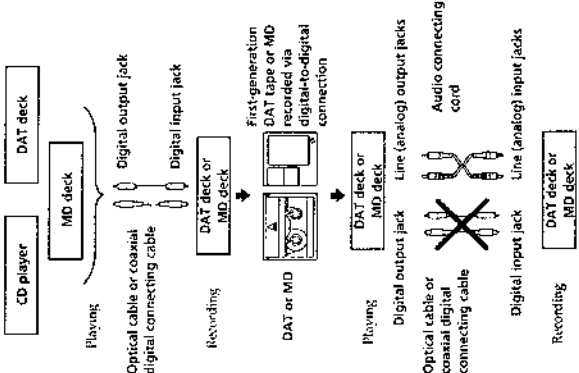

SECTION 2 DISASSEMBLY

Note : Follow the disassembly procedure in the numerical order given.

2-1. CASE AND FRONT PANEL ASSEMBLY

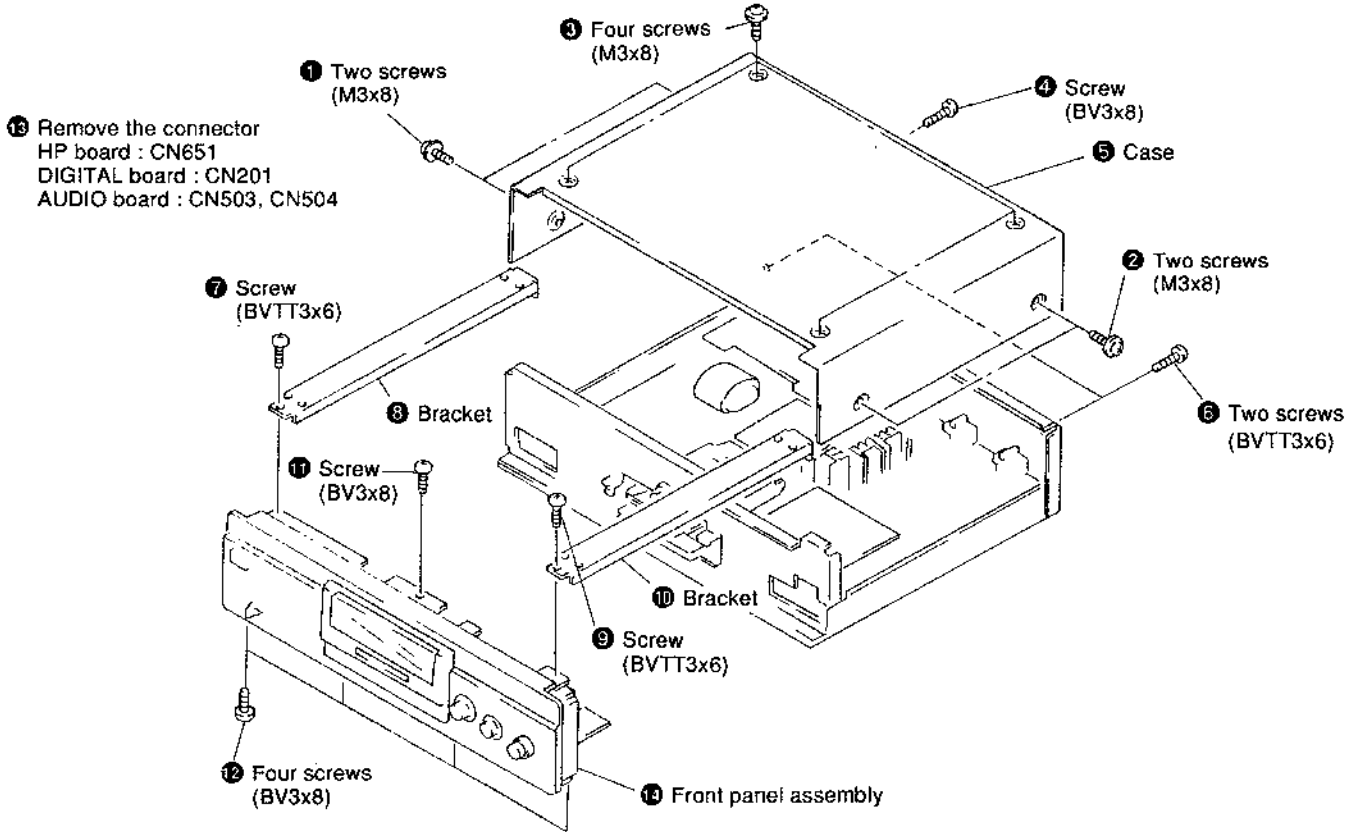

2-2. MD ASSEMBLY

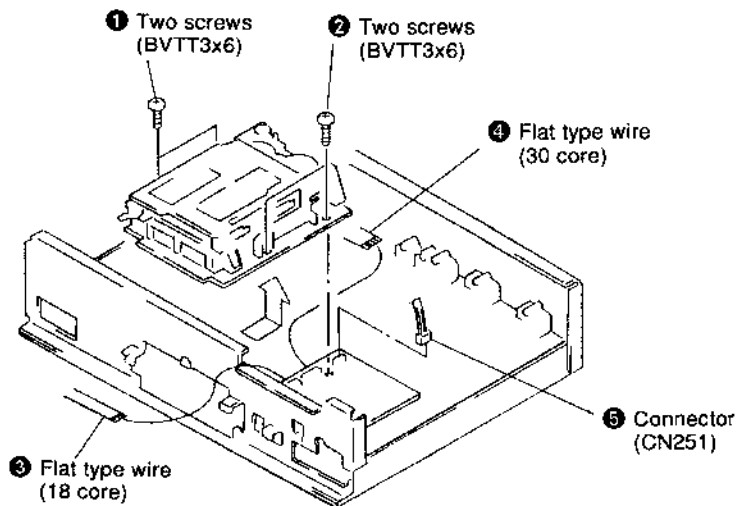

2-3. BRACKET (BD)

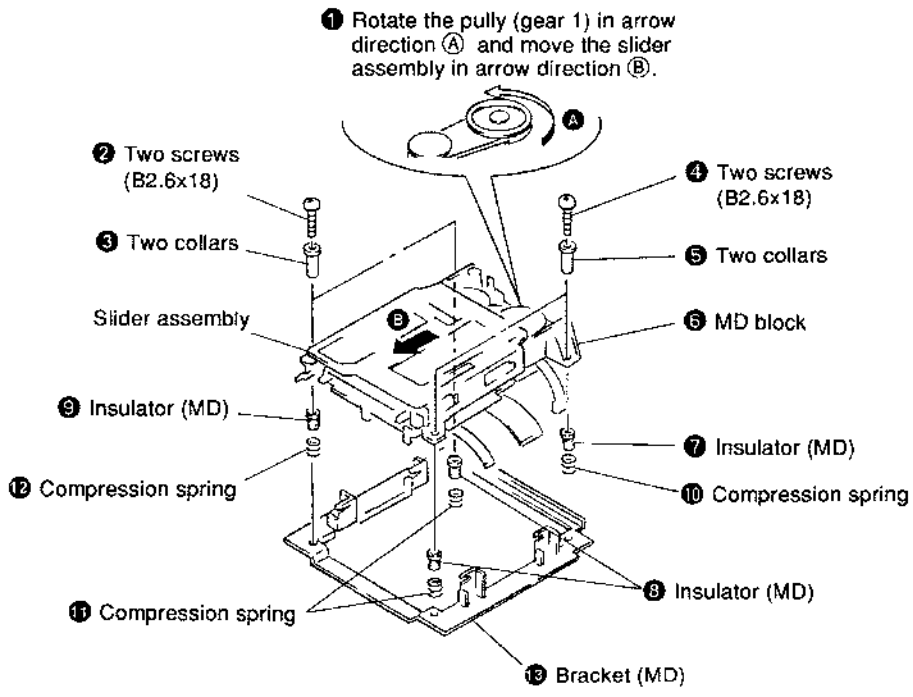

2-4. SLIDER ASSEMBLY

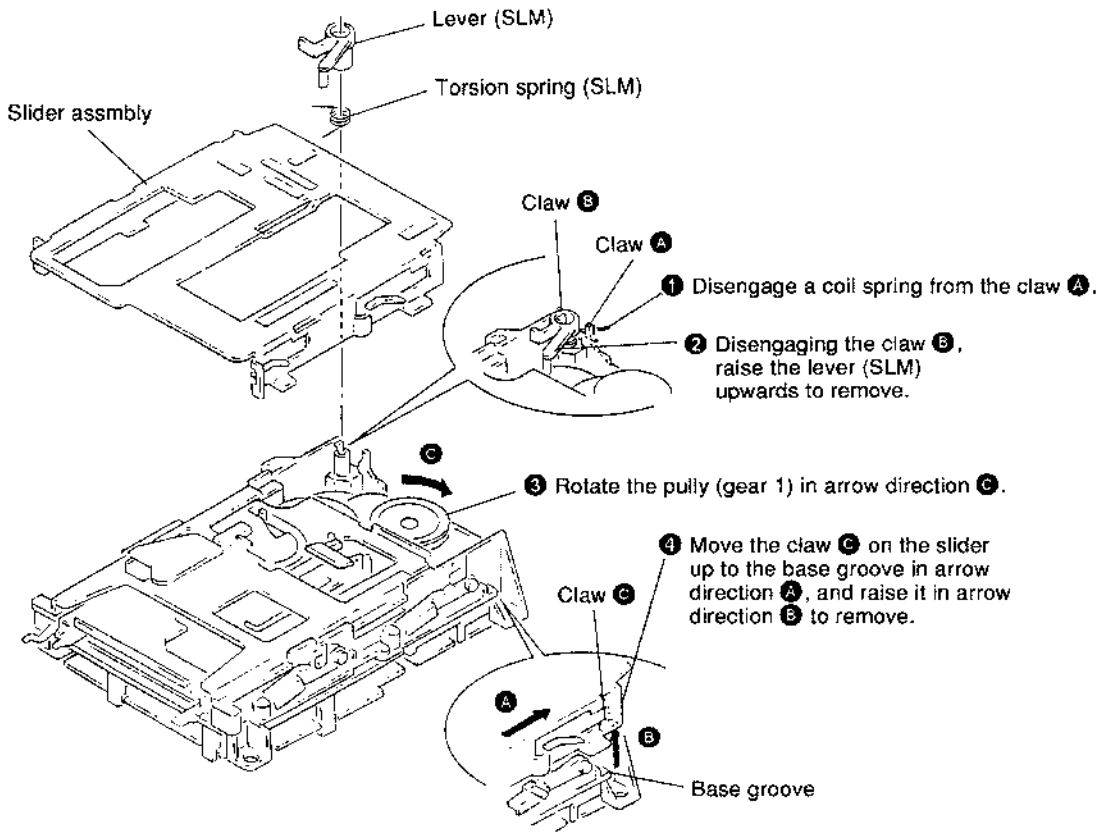

2-5. BASE UNIT AND LOADING MOTOR ASSEMBLY

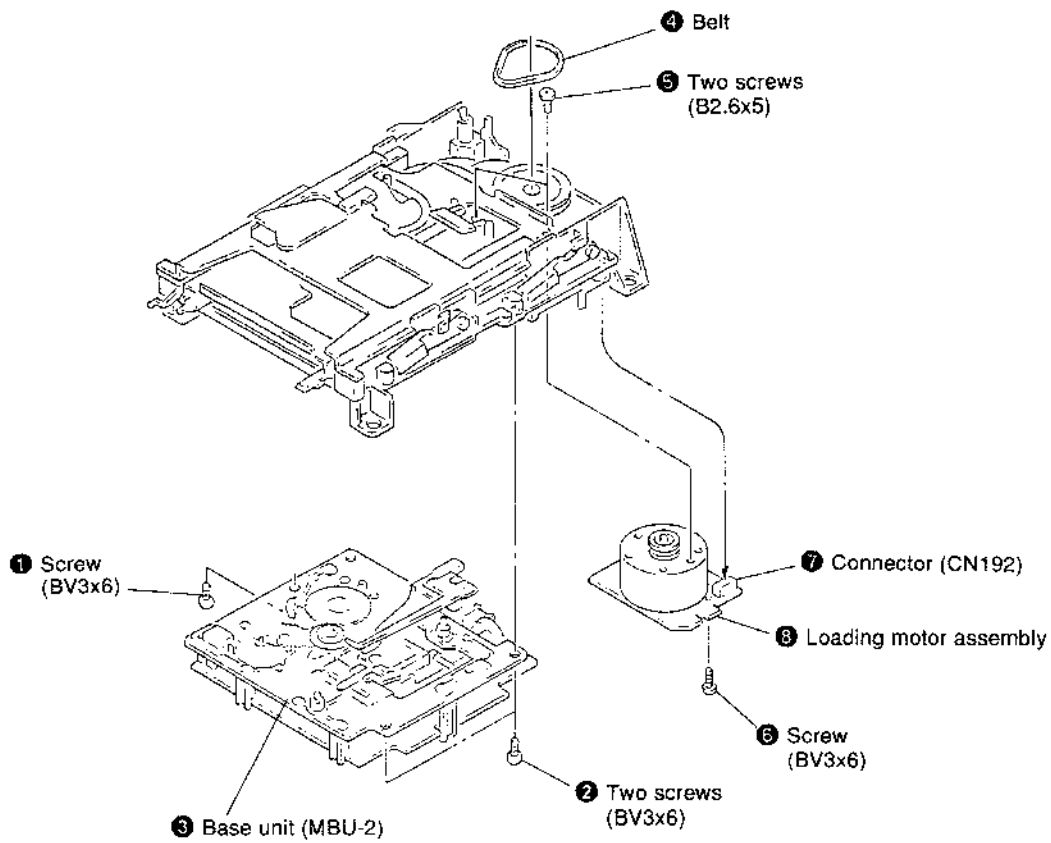

2-6. SLIDER ASSEMBLY MOUNTING

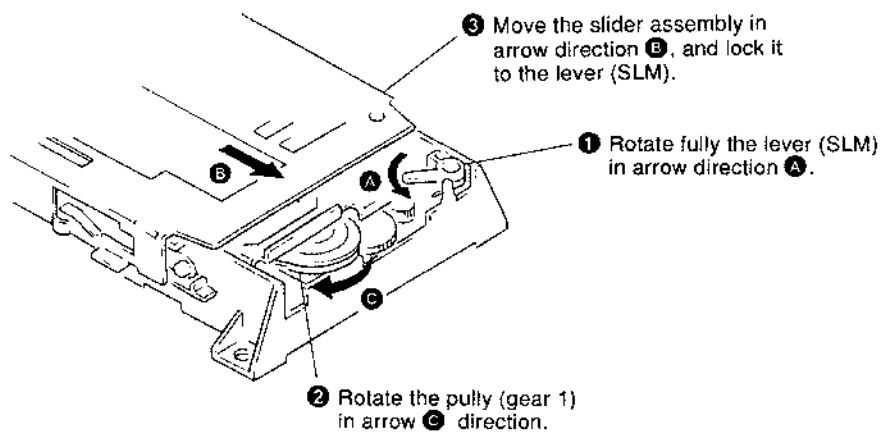

SECTION 3

TEST MODE

3-1. Setting the Test Mode

While pressing the AMS knob, insert the power plug into the power supply inlet, and release the AMS knob.

3-2. Exiting the Test Mode

Disconnect the power plug from the power supply inlet.

3-3. Basic Operations of the Test Mode

All operations are performed using the AMS knob, YES key, and NO key.

The functions of these keys are as follows.

Function	Contents
AMS knob	Changes parameters and modes
YES key	Proceeds onto the next step. Finalizes input.
NO key	Returns to previous step. Stops operations.

3-4. Selecting the Test Mode

Eight test modes are selected by turning the AMS knob.

Display	Contents
TEMP ADJUST	Temperature compensation offset adjustment
LDPWR ADJUST	Laser power adjustment
EFBAL ADJUST	Traverse adjustment
FBIAS ADJUST	Focus bias adjustment
FBIAS CHECK	Focus bias check
CPLAY MODE	Continuous playback mode
CREC MODE	Continuous recording mode
EEP MODE	Non-volatile memory mode *

For detailed description of each adjustment mode, refer to 4. Electrical Adjustments.

If a different adjustment mode has been selected by mistake, press the NO key to exit from it.

* The EEP MODE is not used in servicing. If set accidentally, press the NO key immediately to exit it.

3-4-1. Operating the Continuous Playback Mode

1. Entering the continuous playback mode
 - ① Set the disc in the unit (either MO or CD).
 - ② Rotate the AMS knob and display "CPLAY MODE".
 - ③ Press the YES key to change the display to "CPLAYIN".
 - ④ When access completes, the display changes to "C1 = [] AD = []".

Note : The "[]" displayed are arbitrary numbers.
2. Changing the parts to be played back
 - ① Press the YES key during continuous playback to change the display to "CPLY MID", "CPLAY OUT".
When pressed another time, the parts to be played back can be changed.
 - ② When access completes, the display changes to "C1 = [] AD = []".

Note : The "[]" displayed are arbitrary numbers.
3. Ending the continuous playback mode
 - ① Press the NO key. The display will change to "CPLY MODE".
 - ② Press the EJECT key and remove the disc.

Note 1 : The playback start addresses for IN, MID, and OUT are as follows.

 - IN 40h cluster
 - MID 300h cluster
 - OUT 700h cluster

3-4-2. Operating the Continuous Recording Mode

1. Entering the continuous recording mode
 - ① Set the MO disc in the unit.
 - ② Rotate the AMS knob and display "CREC MODE".
 - ③ Press the YES key to change the display to "CREC IN".
 - ④ When access completes, the display changes to "CREC (###)" and **REC** lights up.

Note : The "##" displayed are arbitrary numbers.
2. Changing the parts to be recorded
 - ① When the YES key is pressed during continuous recording, the display changes to "CREC MID", "CREC OUT" and **REC** goes off.
When pressed another time, the parts to be recorded can be changed.
 - ② When access completes, the display changes to "CREC (###)" and **REC** lights up.

Note : The "##" displayed are arbitrary numbers.
3. Ending the continuous recording mode
 - ① Press the NO key. The display changes to "CREC MODE" and **REC** goes off.
 - ② Press the EJECT key and remove the disc.

Note 1 : The recording start addresses for IN, MID, and OUT are as follows.
IN 40h cluster
MID 300h cluster
OUT 700h cluster

Note 2 : The NO key can be used to stop recording anytime.

Note 3 : During the test mode, the erasing-protection tab will not be detected. Therefore be careful not to set the continuous recording mode when a disc not to be erased is set in the unit.

Note 4 : Do not perform continuous recording for long periods of time above 5 minutes.

Note 5 : During continuous recording, be careful not to apply vibration.

3-4-3. Non-Volatile Memory Mode

This mode reads and writes the contents of the non-volatile memory.
It is not used in servicing. If set accidentally, press the NO key immediately to exit it.

3-5. Functions of Other keys

Function	Contents
▷	Sets continuous playback when pressed in the STOP state.
DD	When pressed during continuous playback, the tracking servo turns ON/OFF.
■	Stops continuous playback and continuous recording.
▶▶	The sled moves to the outer circumference only when this is pressed.
◀◀	The sled moves to the inner circumference only when this is pressed.
●	Turns recording ON/OFF when pressed during continuous playback.
SCROLL	Switches between the pit and groove modes when pressed.
PLAY MODE	Switches the spindle servo mode (CLVS and A).
DISPLAY	Switches the display when pressed. Returns to previous step. Stops operations.

Note : The erasing-protection tab is not detected during the test mode. Recording will start regardless of the position of the erasing-protection tab when the ● (REC) key is pressed.

3-6. Test Mode Displays

Each time the DISPLAY key is pressed, the display changes in the following order.

MODE display→Error rate display→Address display

1. MODE display
Displays "TEMP ADJUST", "CPLAY MODE", etc.
2. Address display
Addresses are displayed as follows.
h = [] [] [] [] s = [] [] [] [] (MO pit and CD)
h = [] [] [] [] a = [] [] [] [] (MO groove)
h = : Header address
s = : SUBQ address
a = : ADIP address
* is displayed when the address cannot be read.
3. Error rate display
Error rates are displayed as follows.
C1 = [] [] [] [] AD = [] [] [] []
C1 = : Indicates C1 error
AD = : Indicates ADER

3-7. Meanings of Other Displays

Display	Contents		
	Light	Off	Blinking
▶	During continuous playback	STOP	
∞	Tracking servo OFF	Tracking servo ON	
REC	Recording mode ON	Recording mode OFF	
CLOCK	CLV LOCK	CLV UNLOCK	
TRACK	Pit	Groove	
DISC	High reflection	Low reflection	
DATE	CLV-S	CLV-A	
A. SPACE	ABCD adjustment completed		
A - B	(Focus auto gain successful Tracking auto gain successful)		(Focus auto gain successful Tracking auto gain failed)

3-8. Precautions for Use of Test Mode

- ① As loading related operations will be performed regardless of the test mode operations being performed, be sure to check that the disc is stopped before setting and removing it.
Even if the EJECT key is pressed while the disc is rotating during continuous playback, continuous recording, etc., the disc will not stop rotating.
Therefore, it will be ejected while rotating.
Always press the NO key first before pressing the EJECT key.
- ② The erasing-protection tab is not detected in the test mode. Therefore, when modes which output the recording laser power such as continuous recording mode and traverse adjustment mode, etc. are set, the recorded contents will be erased regardless of the position of the tab. When using a disc that is not to be erased in the test mode, be careful not to enter the continuous recording mode and traverse adjustment mode.
- ③ Most keys can not be used while the error rate is displayed because of IC121 CXD2535AR bugs.

SECTION 4. ELECTRICAL ADJUSTMENTS

4-1. Precautions for Checking Laser Diode Emission

To check the emission of the laser diode during adjustments, never view directly from the top as this may lose your eye-sight.

4-2. Precautions for Use of optical pickup (KMS-210A)

As the laser diode in the optical pickup is easily damaged by static electricity, solder the laser tap of the flexible board when using it. Before disconnecting the connector, desolder first. Before connecting the connector, be careful not to remove the solder. Also take adequate measures to prevent damage by static electricity. Handle the flexible board with care as it breaks easily.

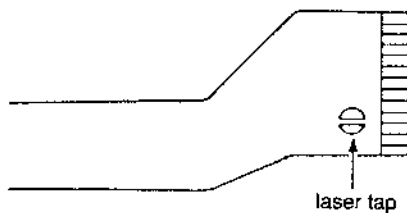

Optical pickup flexible board

4-3. Precautions for Adjustments

- 1) When replacing the following parts, perform the adjustments and checks with ○ in the order shown in the following table.

	Optical Pickup	BD Board		
		IC171	D101	IC101, IC121, IC191
1. Temperature compensation offset adjustment	X	○	○	○
2. Laser power adjustment	○	X	X	○
3. Traverse adjustment	○	○	X	○
4. Focus bias adjustment	○	○	X	○
5. Error rate check	○	○	X	○

- 2) Set the test mode when performing adjustments. After completing the adjustments, exit the test mode.
- 3) Perform the adjustments in the order shown.
- 4) Use the following tools and measuring devices.
 - MD test disc TDYS-1 (Parts No. 4-963-646-01)
 - Laser power meter LPM-8001 (Parts No. J-2501-046-A)
 - Oscilloscope
 - Digital voltmeter
 - Thermometer
- 5) When observing several signals on the oscilloscope, etc., make sure that VC and GND do not connect inside the oscilloscope. (VC and GND will become short-circuited.)
- 6) Do not move RV105 of the BD board. When replacing it, adjust to the mechanical center of the semi-fixed resistor.

4-4. Creating MO Continuously Recorded Disc

- * This disc is used in focus bias adjustment and error rate check. The following describes how to create a MO continuous recording disc.
 1. Insert a MO disc (blank disc) commercially available.
 2. Rotate the AMS knob and display "CREC MODE".
 3. Press the YES key and display "CREC IN".
 4. Press the YES key again to display "CREC MID". "CREC (0300)" is displayed for a moment and recording starts.
 5. Complete recording within 5 minutes.
 6. Press the NO key and stop recording.
 7. Press the EJECT key and remove the MO disc.

The above has been how to create a continuous recording data for the focus bias adjustment and error rate check.

Note :

- Be careful not to apply vibration during continuous recording.

4-5. Temperature Compensation Offset Adjustment

Save the temperature data at that time in the non-volatile memory as 25 °C reference data.

Note :

1. Usually, do not perform this adjustment.
2. Perform this adjustment in an ambient temperature of 22 °C to 28 °C. Perform it immediately after the power is turned on when the internal temperature of the unit is the same as the ambient temperature.
3. When D101 has been replaced, perform this adjustment after the temperature of this part has become the ambient temperature.

Adjusting Method :

1. Rotate the AMS knob and display "TEMP ADJUST".
2. Press the YES key and select the "TEMP ADJUST" mode.
3. "TEMP = 00" and the current temperature data will be displayed.
4. To save the data, press the YES key.
When not saving the data, press the NO key.
5. When the YES key is pressed, "TEMP = 00 SAVE" will be displayed for some time, followed by "TEMP ADJUST".
When the NO key is pressed, "TEMP ADJUST" will be displayed.

Specifications :

The temperature should be within "TEMP = E0" and "TEMP = 1F".

4-6. Laser Power Adjustment

Connection :

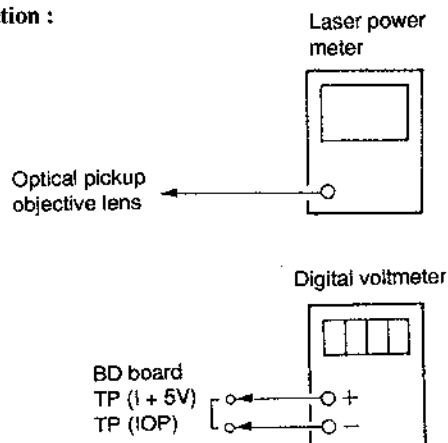

Adjusting Method :

1. Set the laser power meter on the objective lens of the optical pickup. (When it cannot be set properly, press the ◀◀ key or ▶▶ key and move the optical pickup.)
Connect the digital voltmeter to TP (IOP) and TP (I+5V).
2. Rotate the AMS knob and display "LDPWRADJUST".
(Laser power : For adjustment)
3. Press the YES key twice and display "LD \$ 4B = 3.5 mW".
4. Adjust RV102 of the BD board so that the reading of the laser power meter becomes $3.4^{+0.1}_{-0}$ mW.
5. Press the YES key and display "LD \$ 96 = 7.0 mW".
(Laser power:MO reading)
6. Check that the laser power meter and digital voltmeter readings satisfy the specified value.

Specification :

Laser power meter reading : 7.0 ± 0.3 mW

Digital voltmeter reading : Optical pickup displayed value $\pm 10\%$

(Optical pickup label)

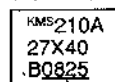

$I_{op} = 82.5$ mA in this case

I_{op} (mA) = Digital voltmeter reading (mV) / 1 (Ω)

7. Press the YES key and display "LD \$ 0F = 0.7 mW".
(Laser power:MO reading)
8. Check that the laser power meter at this time satisfies the specified value.

Specification :

Laser power meter reading : 0.70 ± 0.1 mW

9. Press the NO key and display "LDPWR ADJUST", and stop laser emission.
(The NO key is effective at all times to stop the laser emission.)

4-7. Traverse Adjustment

Connection :

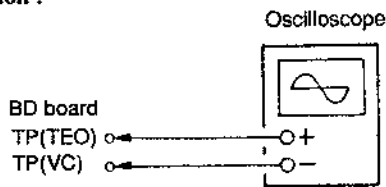

Adjusting method :

1. Connect an oscilloscope to TP (TEO) and TP (VC) of the BD board.
2. Load a MO disc (any available on the market).
3. Press the ◀ key or ▶ key and move the optical pickup outside the pit.
4. Rotate the AMS knob and display "EFBAL ADJUST".
5. Press the YES key and display "EFBAL MO-W". (Laser power WRITE power/Focus servo ON/tracking servo OFF/spindle (S) servo ON)
6. Adjust RV101 of the BD board so that the waveform of the oscilloscope becomes the specified value. (MO groove write power traverse adjustment)

(Traverse Waveform)



Specification A = B

7. Press the YES key and display "EFB = \$ ◻ MO-R". (Laser power : MO reading)
8. Rotate the AMS knob so that the waveform of the oscilloscope becomes the specified value. (When the AMS knob is rotated, the ◻ of "EFB- ◻" changes and the waveform changes.) In this adjustment, waveform varies at intervals of approx. 3%. Adjust the waveform so that the specified value is satisfied as much as possible. (MO groove read power traverse adjustment)

(Traverse Waveform)



Specification A=B

9. Press the YES key, display "EFB = \$ ◻ SAVE" for a moment and save the adjustment results in the non-volatile memory. Next "EFBAL MO-P" is displayed.
10. Press the YES key and display "EFB = \$ ◻ MO-P". The optical pickup moves to the pit area automatically and servo is imposed.

11. Rotate the AMS knob until the waveform of the oscilloscope moves closer to the specified value. In this adjustment, waveform varies at intervals of approx. 3%. Adjust the waveform so that the specified value is satisfied as much as possible.

(Traverse Waveform)



Specification A=B

12. Press the YES key, display "EFB = ◻ SAVE" for a moment and save the adjustment results in the non-volatile memory. Next "EFBAL CD" is displayed. The disc stops rotating automatically.
13. Press the EJECT key and remove the MO disc.
14. Load the test disc TDYS-1.
15. Press the YES key and display "EFB = ◻ CD". Servo is imposed automatically.
16. Rotate the AMS knob so that the waveform of the oscilloscope moves closer to the specified value. In this adjustment, waveform varies at intervals of approx. 3%. Adjust the waveform so that the specified value is satisfied as much as possible.

(Traverse Waveform)



Specification A=B

17. Press the YES key, display "EFB = \$ ◻ SAVE" for a moment and save the adjustment results in the non-volatile memory. Next "EFBAL ADJUST" is displayed.
18. Press the EJECT key and remove the test disc TDYS-1.

Note 1) Data will be erased during MO reading if a recorded disc is used in this adjustment.

Note 2) If the traverse waveform is not clear, connect the oscilloscope as shown in the following figure so that it can be seen more clearly.

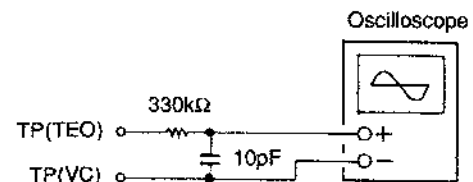

4-8. Focus Bias Adjustment

Adjusting Method :

1. Load a continuously recorded disc (Refer to "4-4. Creating MO Continuously Recorded Disc").
2. Rotate the AMS knob and display "CPLAY MODE".
3. Press the YES key twice and display "CPLAY MID".
4. Press the NO key when "C1 = [] [] AD = [] []" is displayed.
5. Rotate the AMS knob and display "FBIAS ADJUST".
6. Press the YES key and display "[] [] [] [] a = [] []".
The first four digits indicate the C1 error rate, the two digits after [] indicate ADER, and the 2 digits after [a =] indicate the focus bias value.
7. Rotate the AMS knob in the clockwise direction and find the focus bias value at which the C1 error rate becomes 220.
8. Press the YES key and display "[] [] [] [] b = [] []".
9. Rotate the AMS knob in the counterclockwise direction and find the focus bias value at which the C1 error rate becomes 220.
10. Press the YES key and display "[] [] [] [] c = [] []".
11. Check that the C1 error rate is below 50 and ADER is 00. Then press the YES key.
12. If the "[] []" in "[] [] - [] [] - [] [] [] []" is above 20, press the YES key.
If below 20, press the NO key and repeat the adjustment from step 2 again.
13. Press the NO key and press the EJECT key to remove the continuously recorded disc.

Note 1 : The relation between the C1 error and focus bias is as shown in the following figure. Find points a and b in the following figure using the above adjustment. The focal point position C is automatically calculated from points a and b.

Note 2 : As the C1 error rate changes, perform the adjustment using the average value.

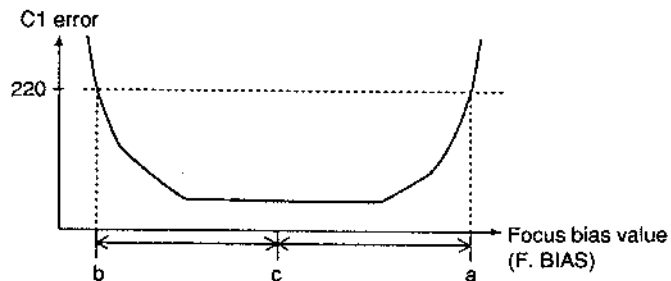

4-9. Error Rate Check

4-9-1. CD Error Rate Check

Checking Method :

1. Load a test disc TDYS-1.
2. Rotate the AMS knob and display "CPLAY MODE".
3. Press the YES key twice and display "CPLAY MID".
4. "C1 = [] [] AD = [] []" is displayed.
5. Check that the C1 error rate is below 20.
6. Press the NO key, stop playback, press the EJECT key, and remove the test disc.

4-9-2. MO Error Rate Check

Checking Method :

1. Load a continuously recorded disc (Refer to "4-4. Creating MO Continuously Recorded Disc").
2. Rotate the AMS knob and display "CPLAY MODE".
3. Press the YES key twice and display "CPLAY MID".
4. "C1 = [] [] AD = [] []" is displayed.
5. If the C1 error rate is below 50, check that ADER is 00.
6. Press the NO key, stop playback, press the EJECT key, and remove the continuously recorded disc.

4-10. Focus Bias Check

Change the focus bias and check the focus tolerance amount.

Checking Method :

1. Load a continuously recorded disc (Refer to "4-4. Creating MO Continuously Recorded Disc").
2. Rotate the AMS knob and display "CPLAY MODE".
3. Press the YES key twice and display "CPLAY MID".
4. Press the NO key when "C1 = [] [] AD = [] []" is displayed.
5. Rotate the AMS knob and display "FBIAS CHECK".
6. Press the YES key and display "[] [] [] [] c = [] []".
The first four digits indicate the C1 error rate, the two digits after [] indicate ADER, and the 2 digits after [c =] indicate the focus bias value.
Check that the C1 error is below 50 and ADER is 00.
7. Press the YES key and display "[] [] [] [] b = [] []".
Check that the C1 error is not below 220 and ADER is not above 00 every time.
8. Press the YES key and display "[] [] [] [] a = [] []".
Check that the C1 error is not below 220 and ADER is not above 00 every time.
9. Press the NO key, next press the EJECT key, and remove the continuously recorded disc.

Note 1 : If the C1 error and ADER are above 00 at points a or b, the focus bias adjustment may not have been carried out properly. Adjust perform the beginning again.

4-11. Adjusting Points and Connecting Points

[BD BOARD] (COMPONENT SIDE)

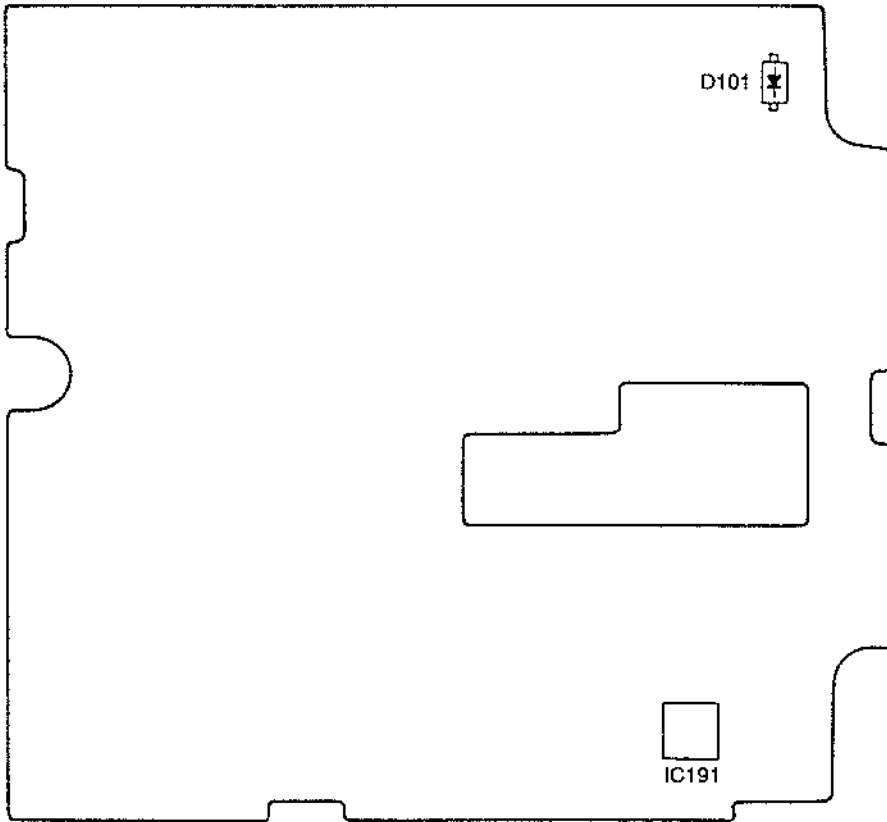

[BD BOARD] (CONDUCTOR SIDE)

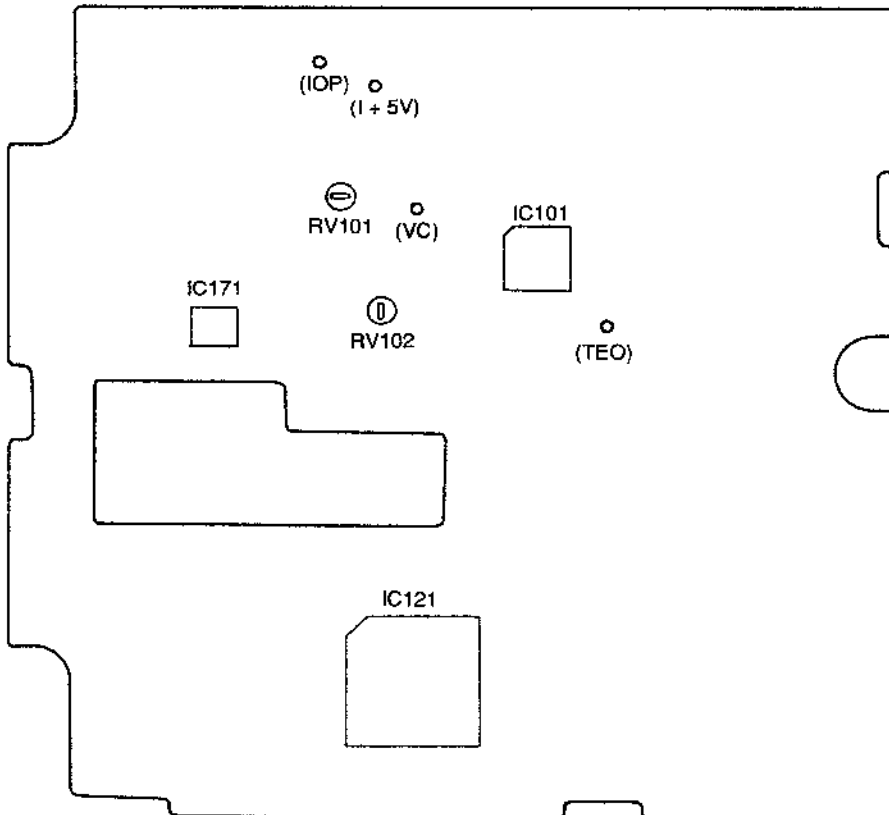

SECTION 5 DIAGRAMS

5-1. CIRCUIT BOARDS LOCATION

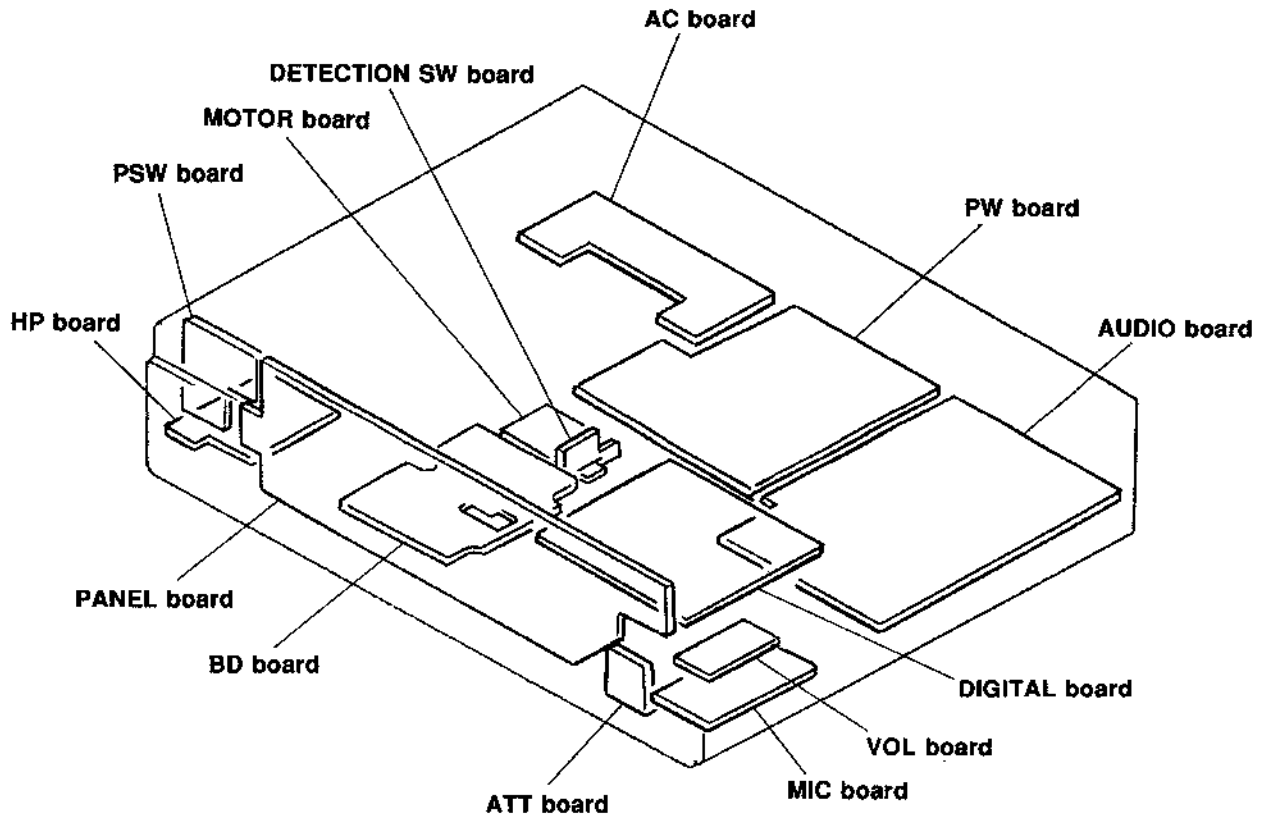

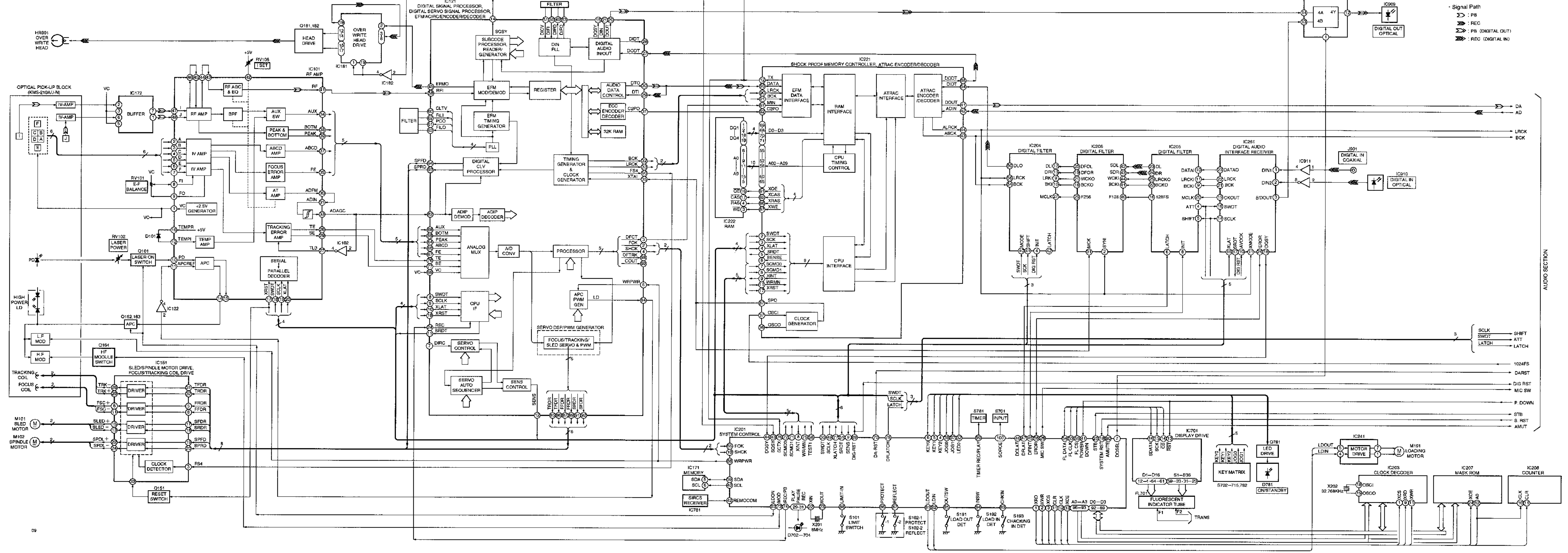

Signal Path
 >> : PB
 > : REC
 >>> : PB (DIGITAL OUT)
 >>>> : REC (DIGITAL IN)

— AUDIO SECTION —

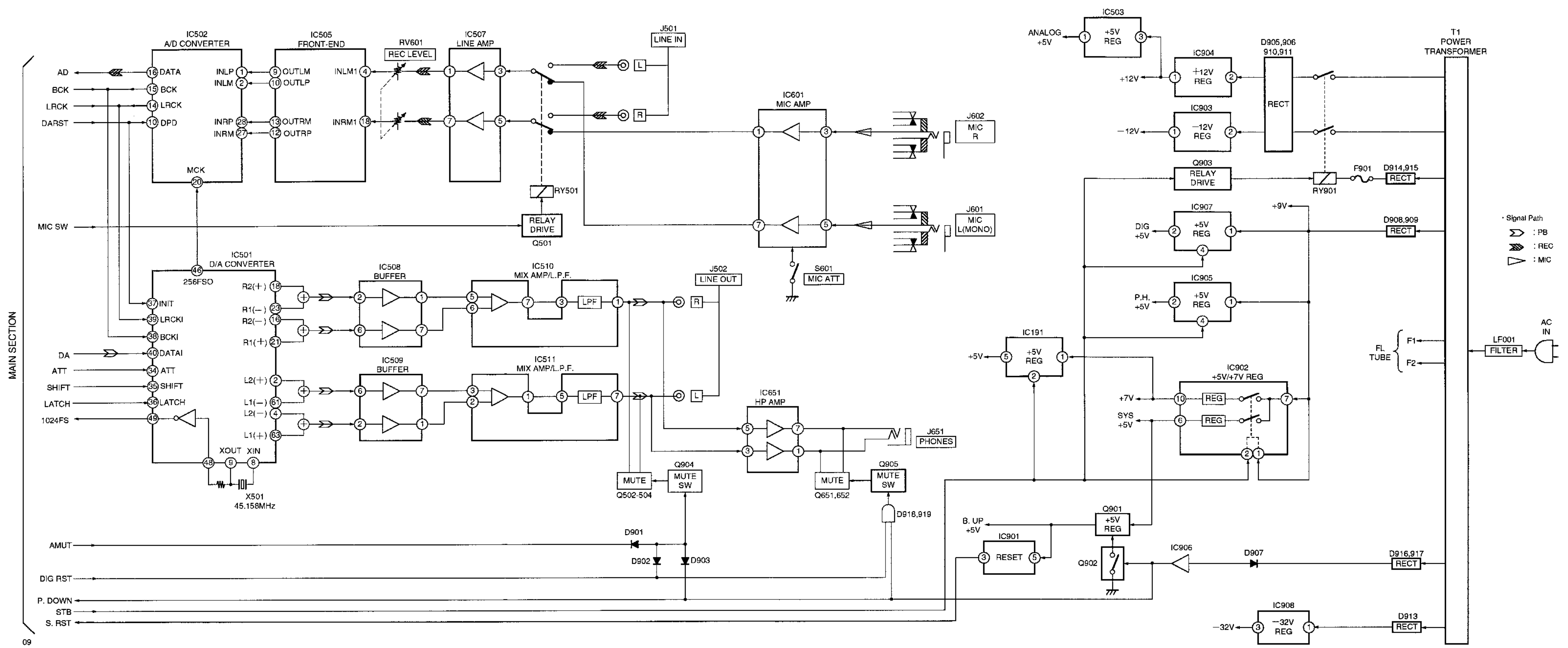

5-3. PRINTED WIRING BOARD — RF SECTION —
 • See page 30 for Circuit Boards Location.

• Semiconductor Location

Ref. No.	Location
D101	C-6
D155	F-11
D161	B-8
D181	C-2
D183	C-2
IC101	D-10
IC102	D-11
IC121	F-9
IC122	D-9
IC151	G-12
IC171	D-8
IC172	C-10
IC181	C-12
IC182	C-11
IC191	G-5
Q101	B-9
Q151	F-12
Q162	B-10
Q163	B-8
Q164	B-8
Q181	C-1
Q182	C-1

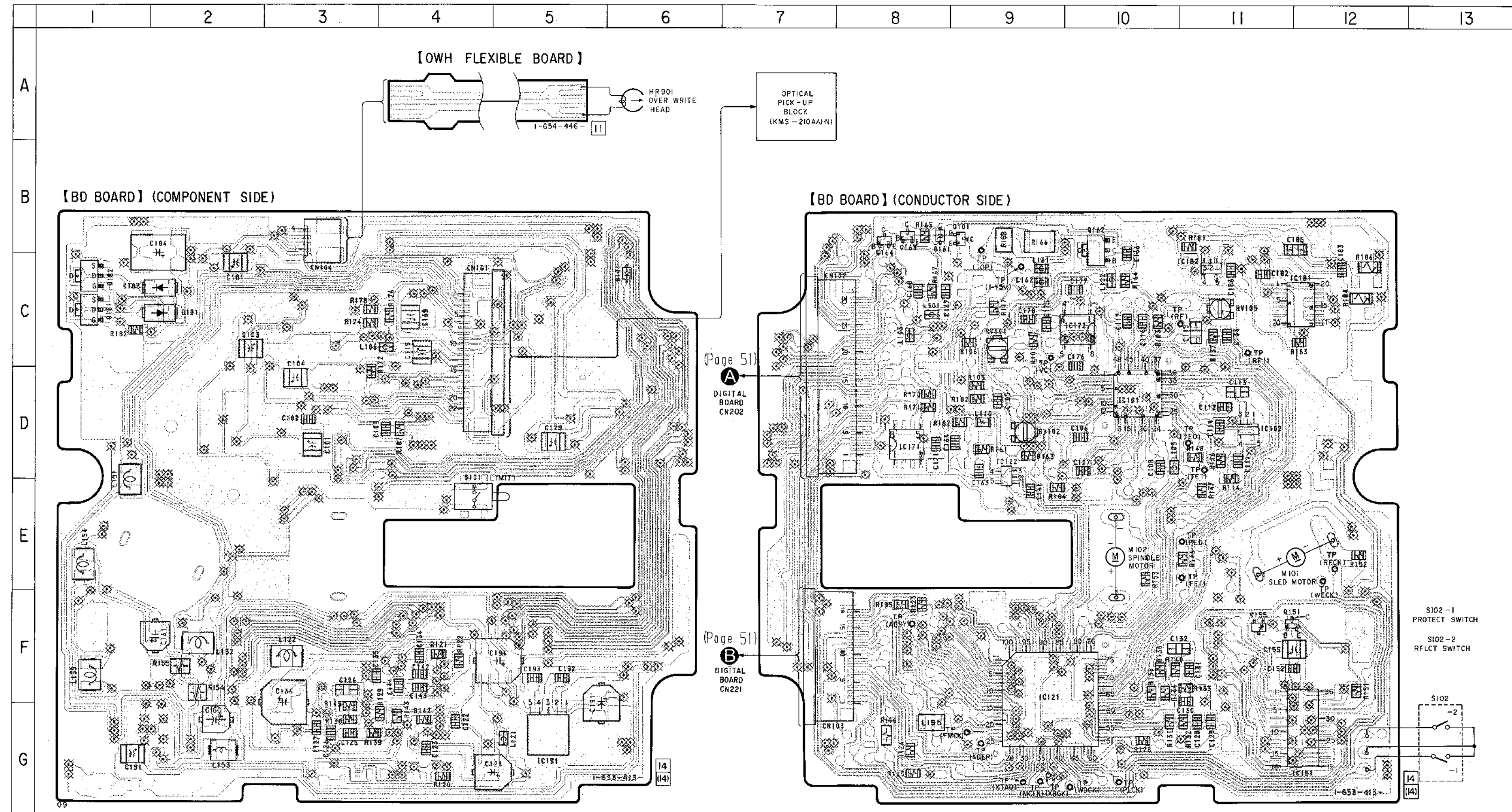

5-4. SCHEMATIC DIAGRAM — RF SECTION —
• See page 71 for IC Pin Functions. (IC101, 121)

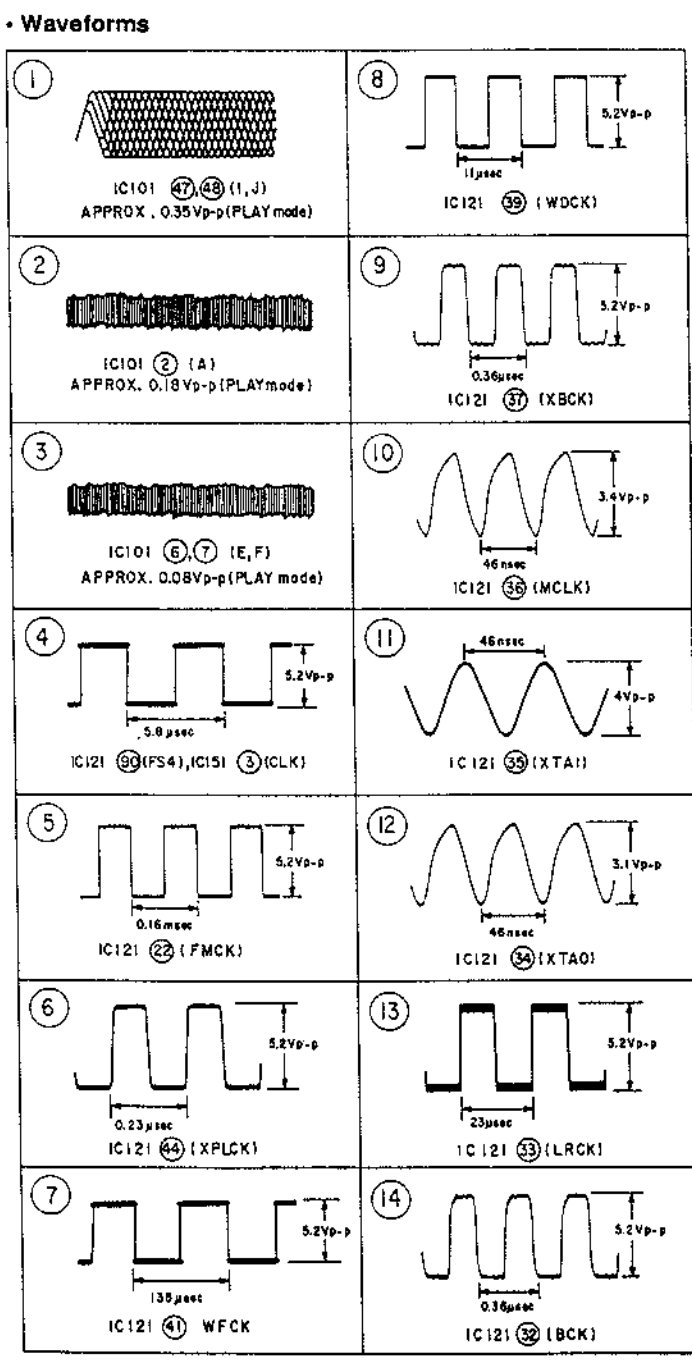
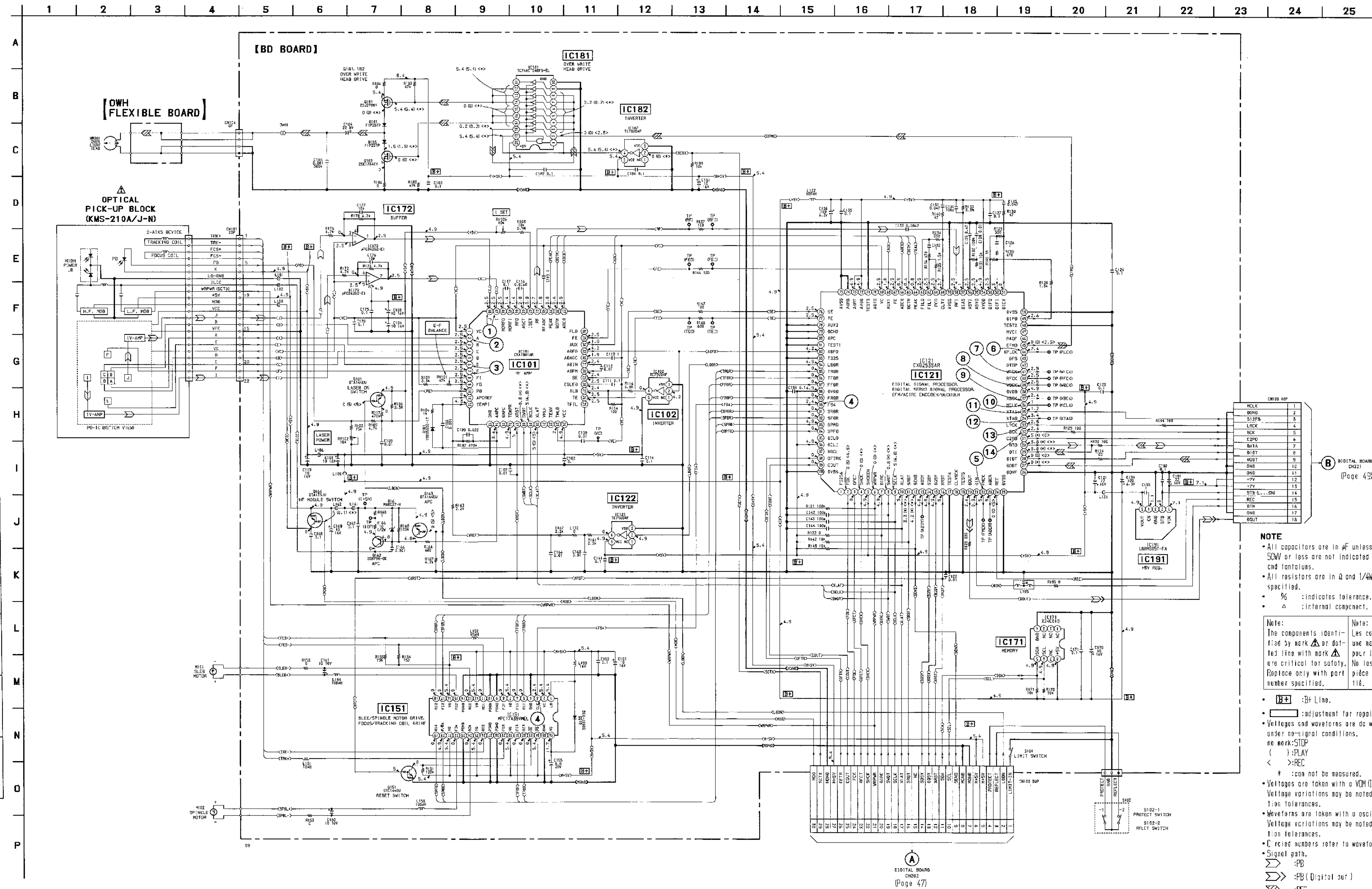

NOTE

- All capacitors are in μF unless otherwise noted, pF: pF
- 50W or less are not indicated except for electrolytics and tantalums.
- All resistors are in Ω and $1/4W$ or less unless otherwise specified.
- % : indicates tolerance.
- Δ : internal component.

Note:
The components identified by work Δ or dotted line with work Δ are critical for safety. Replace only with part number specified.

Note:
Les composants identifiés par une marque Δ sont critiques pour la sécurité. Ne les remplacer que par une pièce portant le numéro spécifié.

- \oplus : B Line.
- \square : adjustment for repair.
- Voltages and waveforms are dc with respect to ground under no-signal conditions.
- no work: STOP
- (): PLAY
- < > : REC
- * : can not be measured.
- Voltages are taken with a VOM (input impedance $10M\Omega$). Voltage variations may be noted due to normal production tolerances.
- Waveforms are taken with an oscilloscope. Voltage variations may be noted due to normal production tolerances.
- C: coded numbers refer to waveforms.
- \square : signal path.
- \square : PB
- \square : PB (Digital out)
- \square : REC
- \square : REC (Digital in)

• IC Block Diagrams

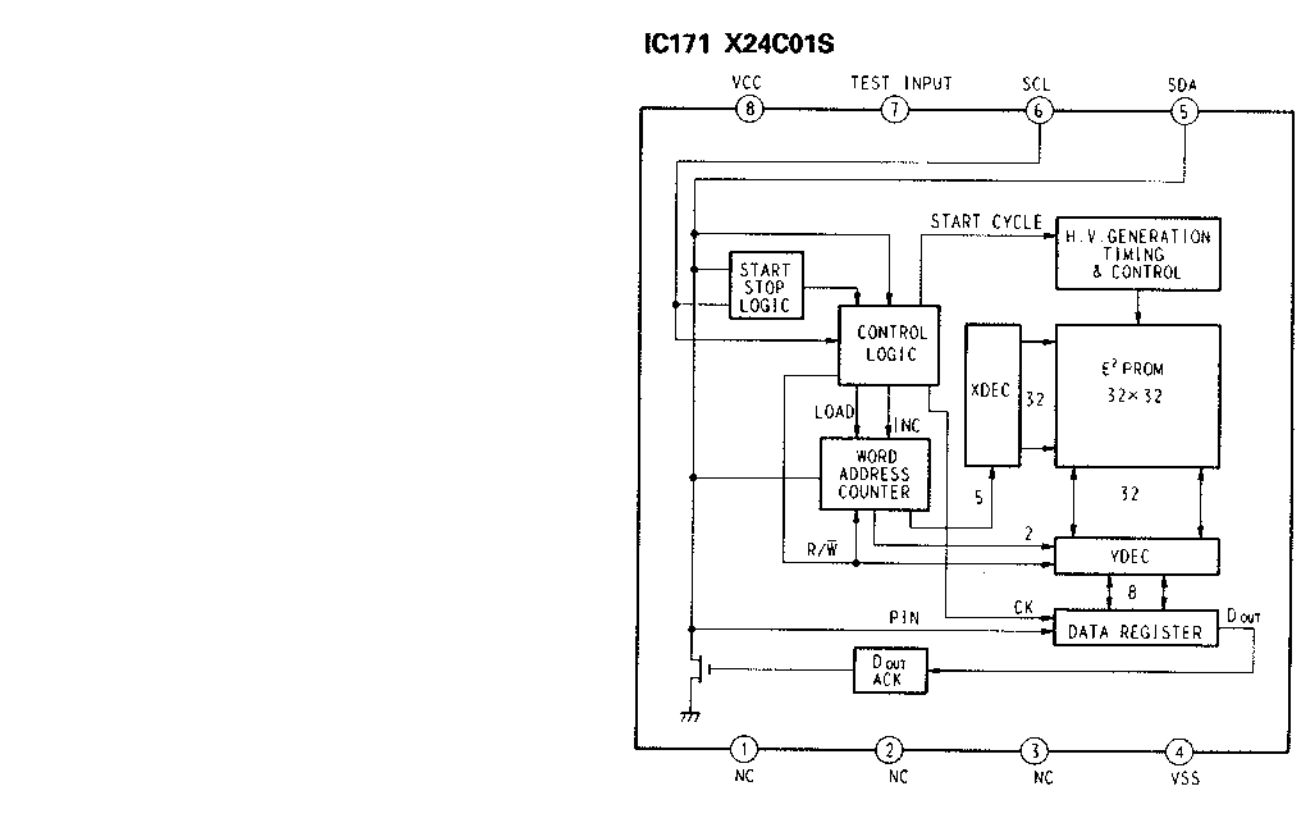
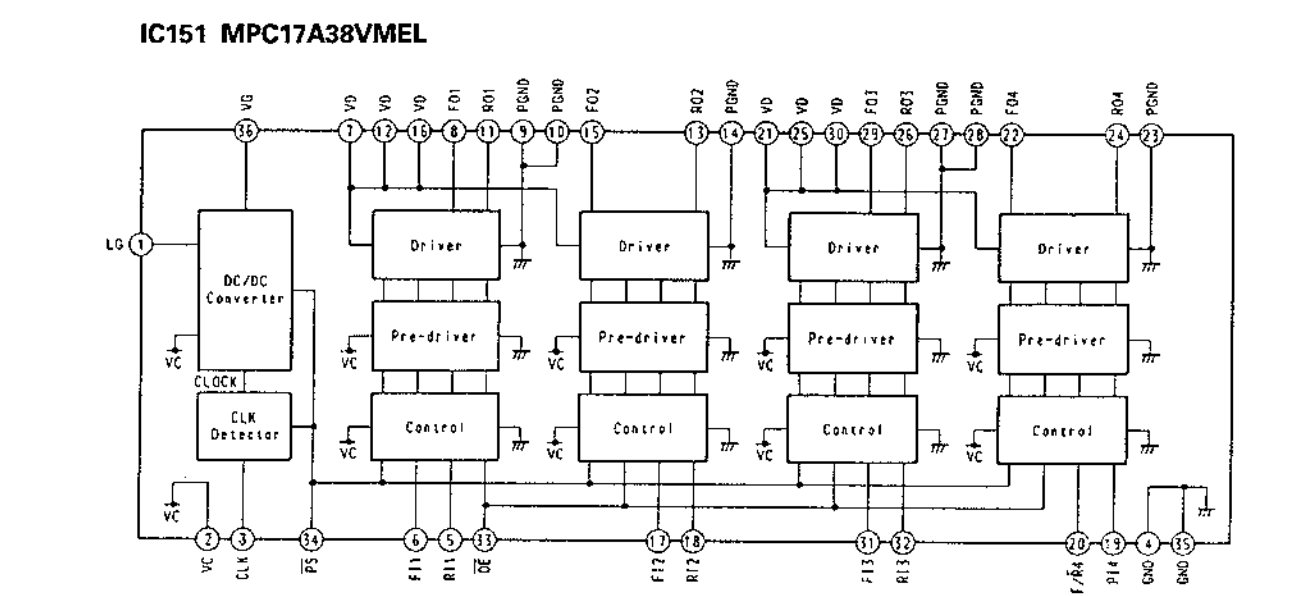
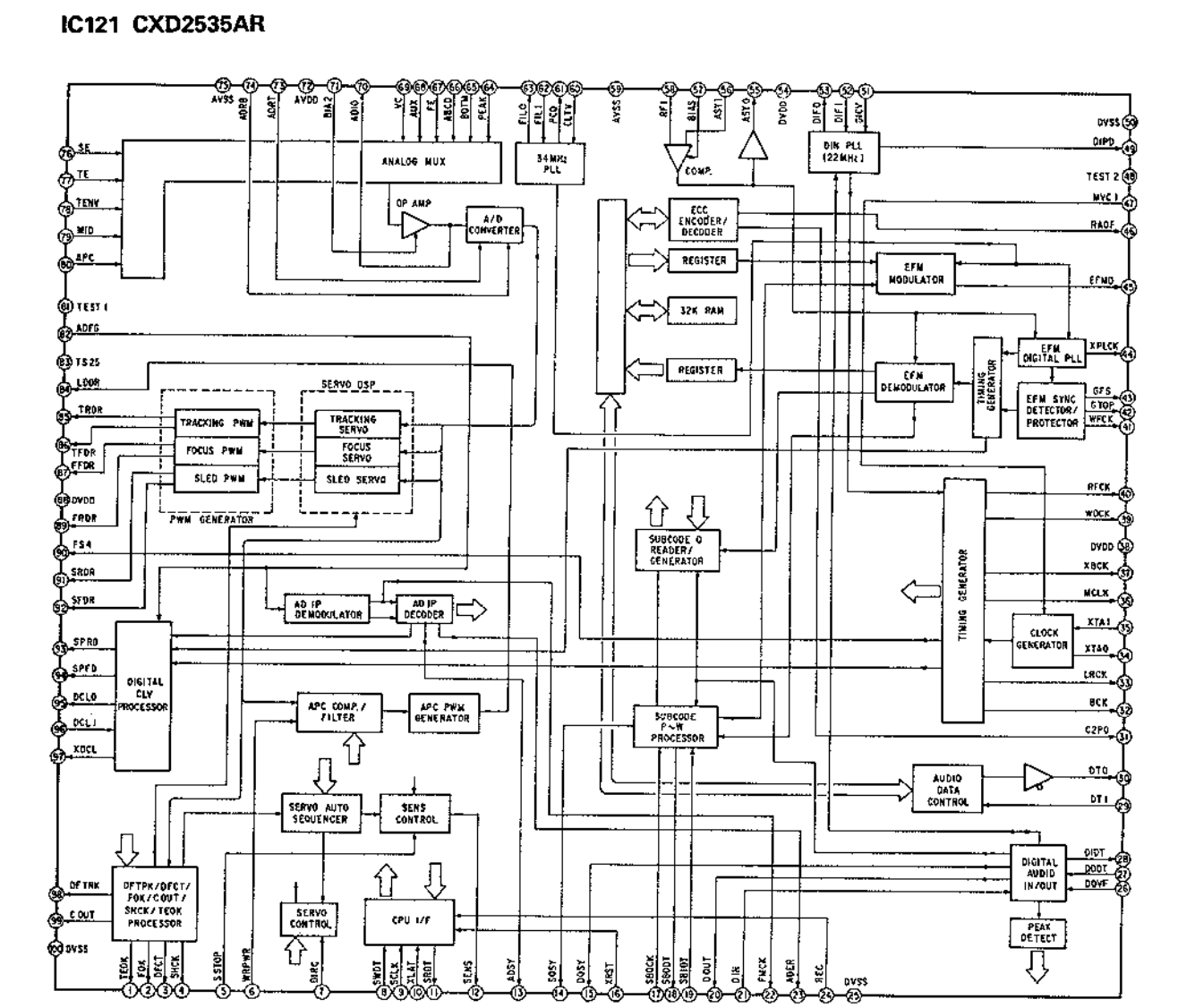

5-5. SCHEMATIC DIAGRAM — DIGITAL SECTION —
 See page 75 for IC Pin Functions. (IC201, 204, 205, 221, 261)

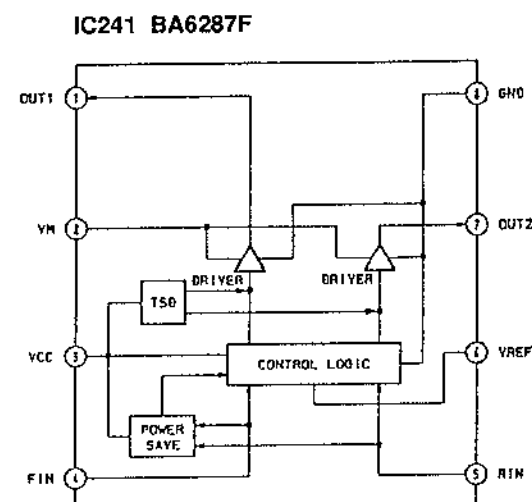
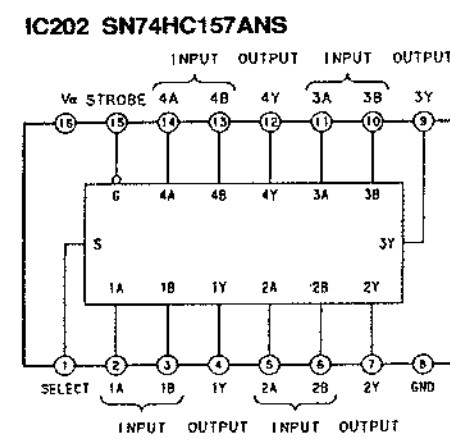

Waveforms

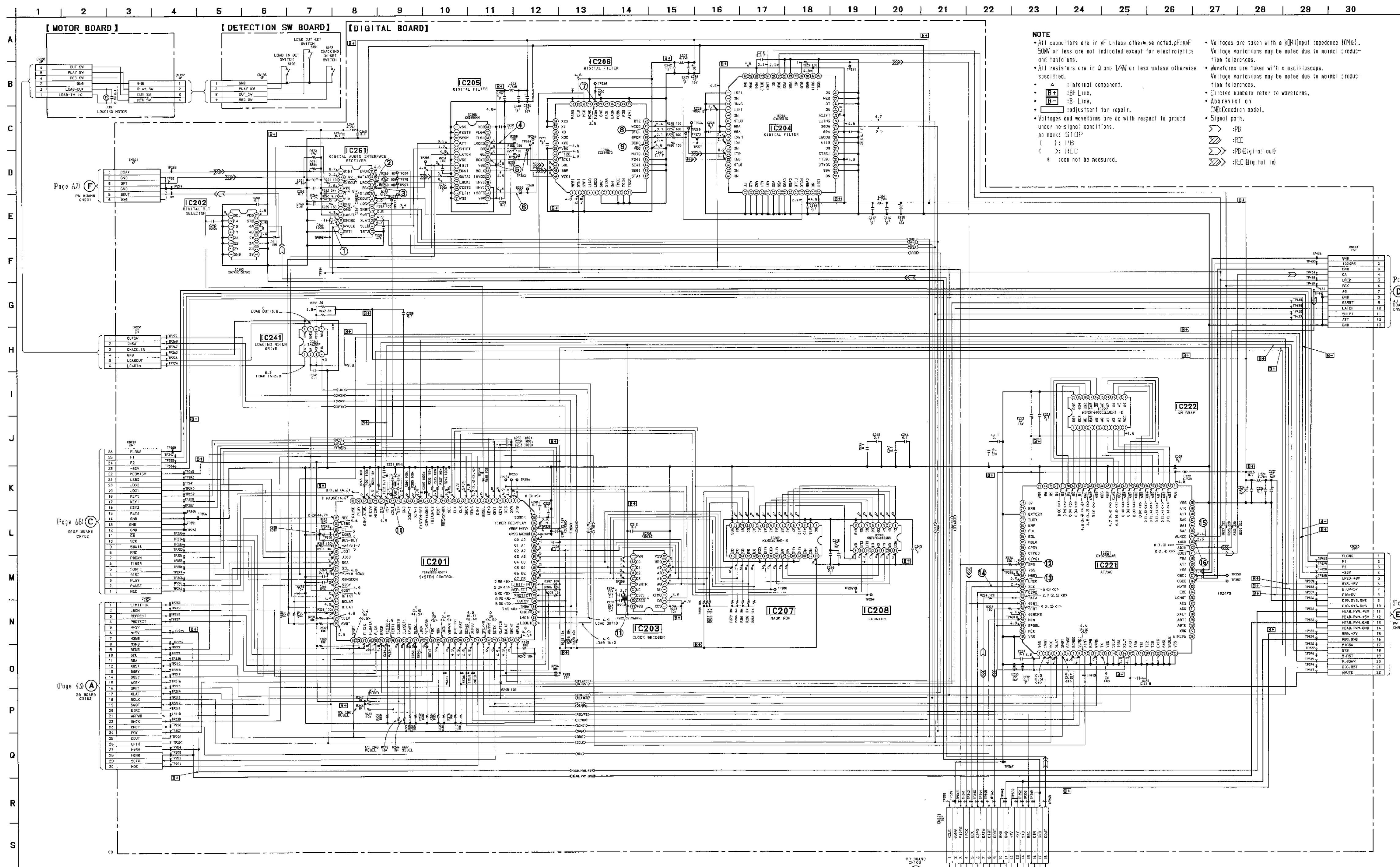
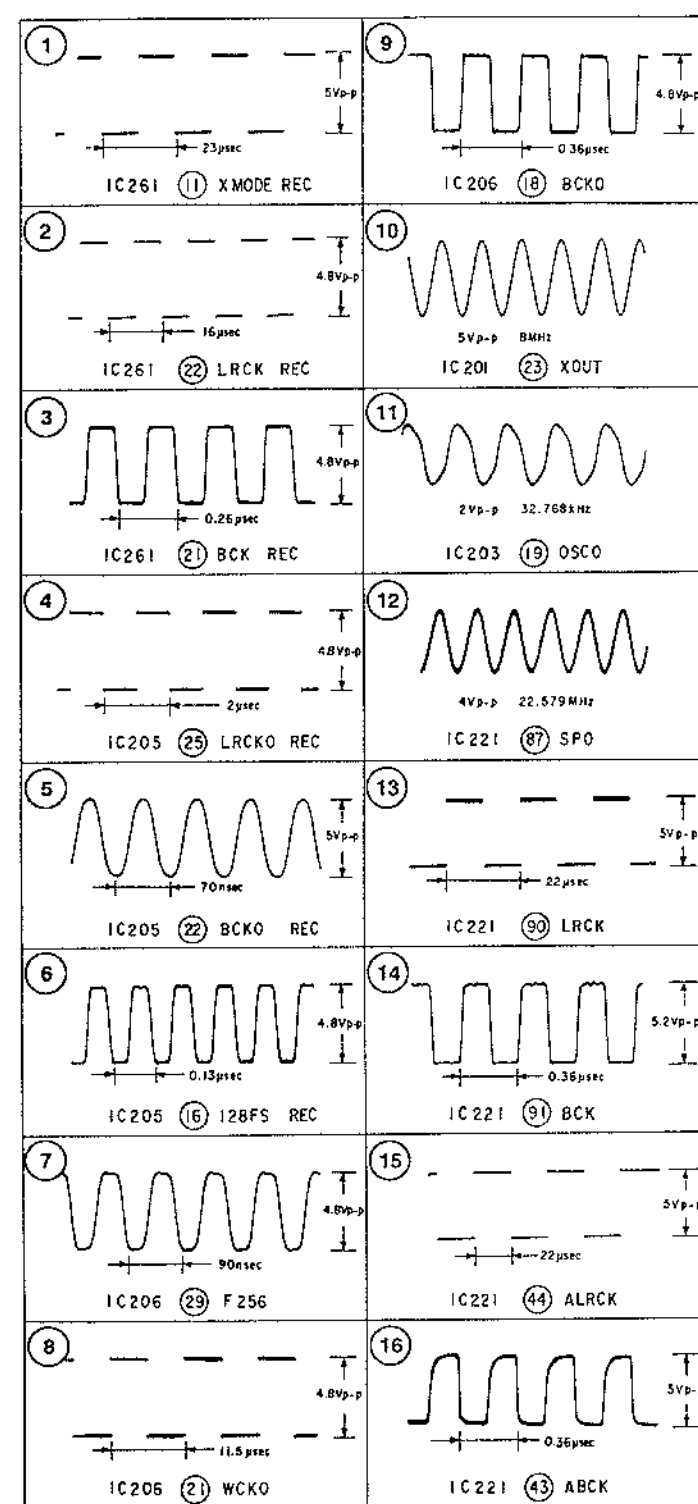

NOTE

- All capacitors are in μF unless otherwise noted. μF , μF 50W or less are not indicated except for electrolytics and tantalum.
- All resistors are in Ω and $1/\text{W}$ or less unless otherwise specified.
- ⊕ : Internal component.
- ⊖ : By Line.
- ⊙ : Line.
- ⊙ : adjustment for repair.
- Voltages and waveforms are dc with respect to ground under no signal conditions.
- no mark: STOP
- [] : PB
- < > : HCL
- * : can not be measured.

Voltages are taken with a VOM (input impedance $10\text{M}\Omega$). Voltage variations may be noted due to normal production tolerances. Waveforms are taken with an oscilloscope. Voltage variations may be noted due to normal production tolerances. * Circled numbers refer to waveforms. Abbreviat on : CND (Cetadion model). Signal path: ⊕ : PB ⊖ : HCL ⊙ : PB (digital out) ⊙ : HCL (digital in)

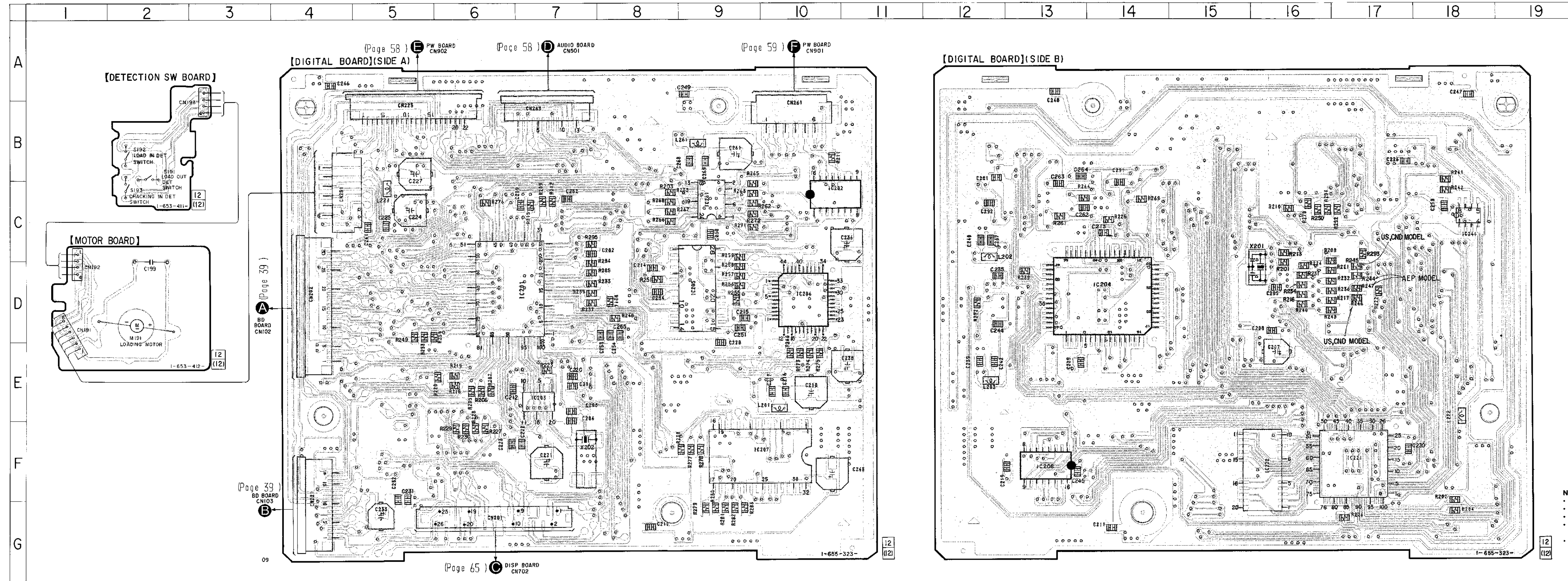

• Semiconductor Location

Ref. No.	Location
IC201	D-7
IC202	C-10
IC203	E-7
IC204	D-14
IC205	D-9
IC206	D-10
IC207	F-10
IC208	F-13
IC221	F-17
IC222	F-16
IC241	C-18
IC261	C-9

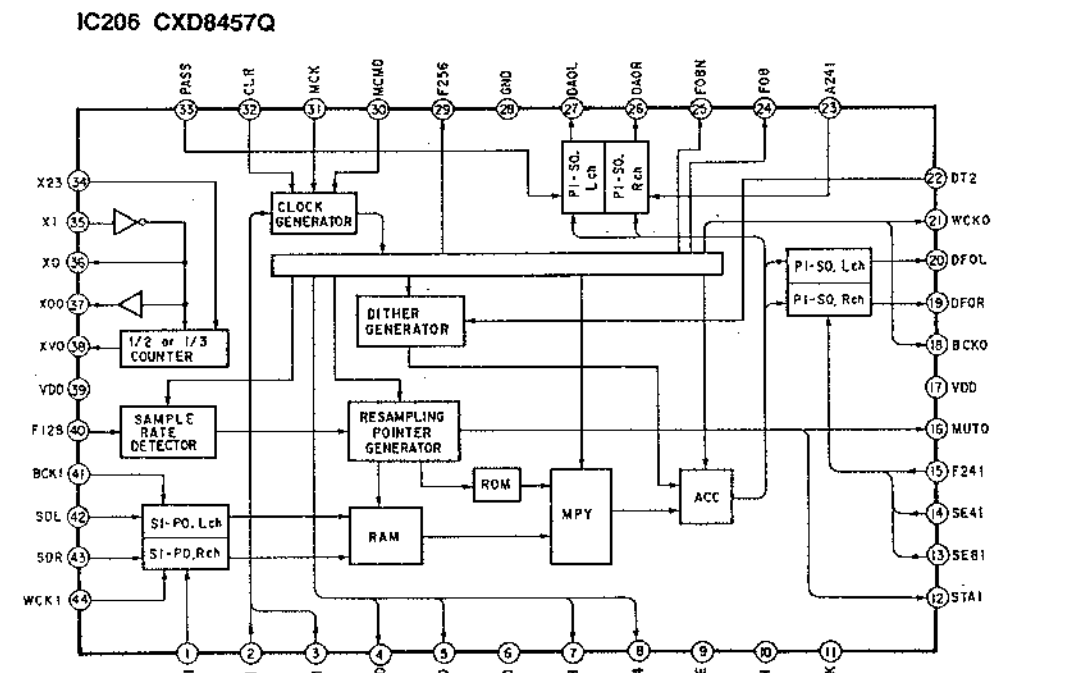
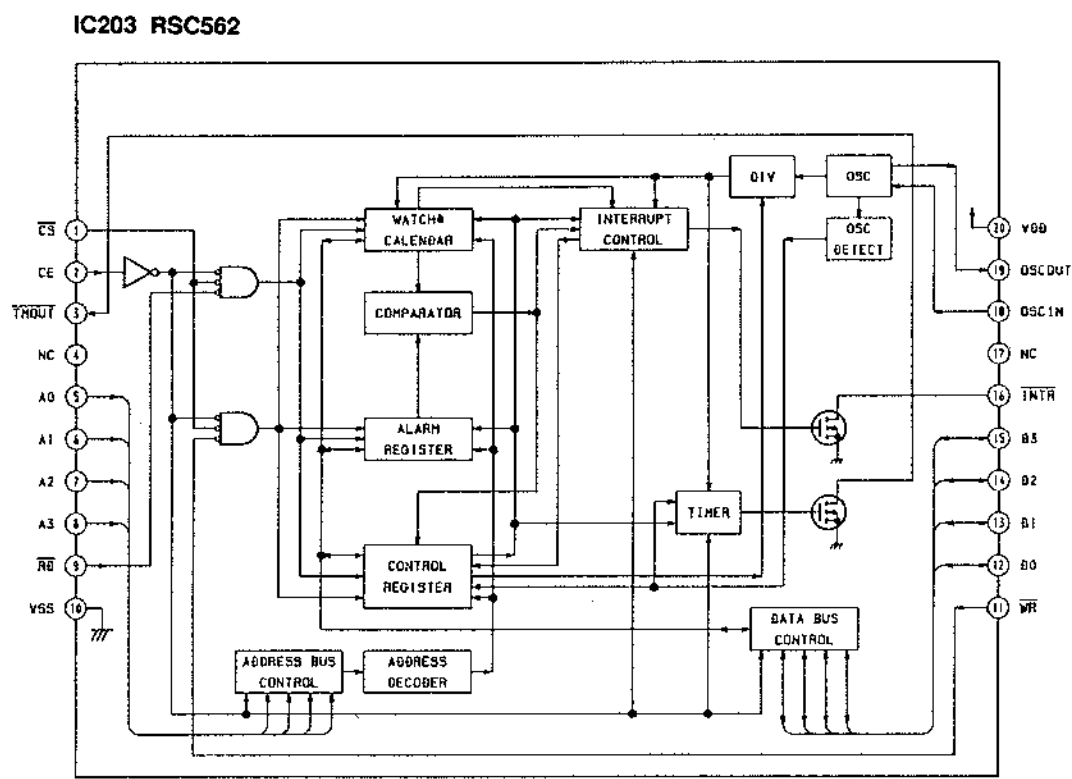

Note:

- : parts extracted from the component side.
- : Through hole.
- △ : internal component.
- : Pattern from the side which enable seeing. (The other layer's patterns are not indicated.)
- Abbreviation CND : Canadian model.

5-7. PRINTED WIRING BOARD — AUDIO SECTION —
 • See page 30 for Circuit Boards Location.

• Semiconductor Location

Ref. No.	Location
D501	C-7
D502	E-6
D503	E-6
D504	E-8
D505	D-8
D506	F-11
D507	I-11
D508	H-8
D901	G-15
D902	G-16
D903	F-15
D904	E-19
D905	B-18
D906	B-17
D907	D-18
D908	C-17
D909	C-17
D910	B-17
D911	A-18
D912	B-19
D913	E-19
D914	C-18
D915	C-18
D916	C-18
D917	C-17
D918	F-14
D919	F-14
D920	F-14
D921	E-14
D922	F-14
D923	E-14
IC501	H-10
IC502	F-7
IC503	D-8
IC505	H-7
IC507	D-7
IC508	E-9
IC509	E-11
IC510	D-9
IC511	D-11
IC601	B-4
IC651	G-3
IC901	E-14
IC902	G-18
IC903	D-15
IC904	C-15
IC905	E-16
IC906	E-18
IC907	E-17
IC908	F-19
IC909	A-16
IC910	A-15
IC911	B-15
Q501	C-8
Q502	C-11
Q503	C-9
Q504	C-11
Q505	B-9
Q651	H-3
Q652	H-3
Q901	F-15
Q902	D-14
Q903	C-18
Q904	E-15
Q905	E-14

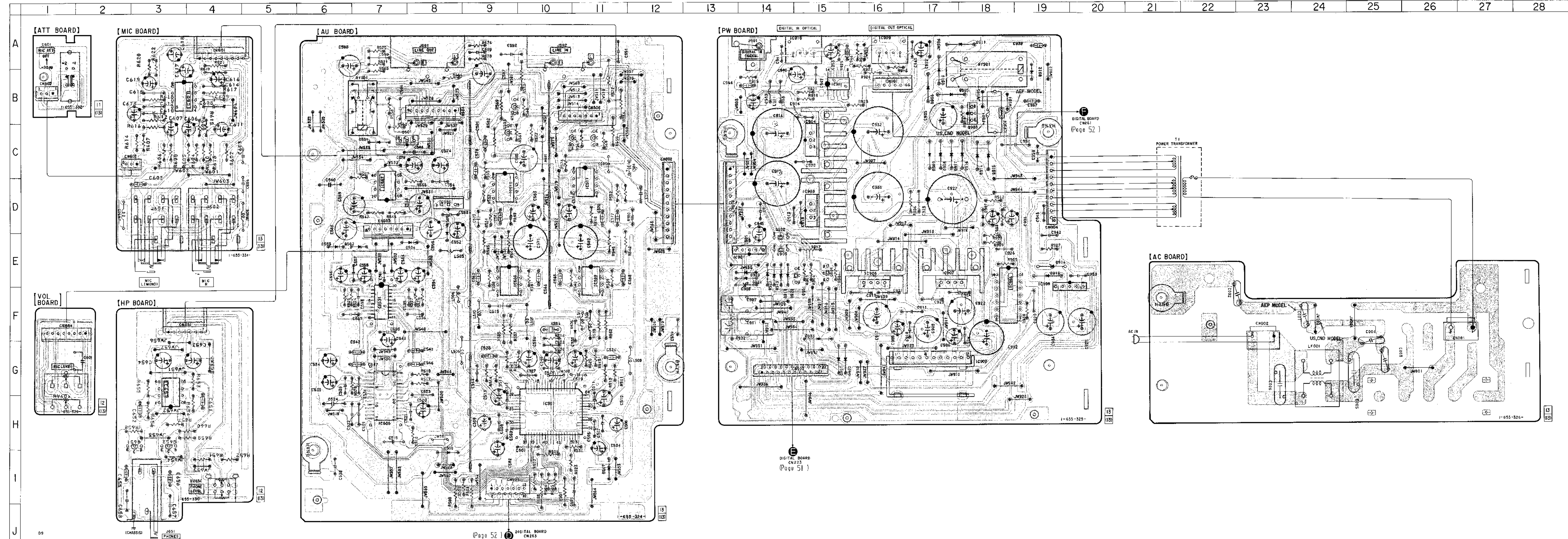

Note:
 • — : parts extracted from the component side.
 • — : parts extracted from the conductor side.
 • — : Pattern from the side which enable seeing.
 • Abbreviation
 CND : Canadian model.

5-8. SCHEMATIC DIAGRAM — AUDIO SECTION —

- See page 69 for IC Block Diagrams.
- See page 83 for IC Pin Functions. (IC502)

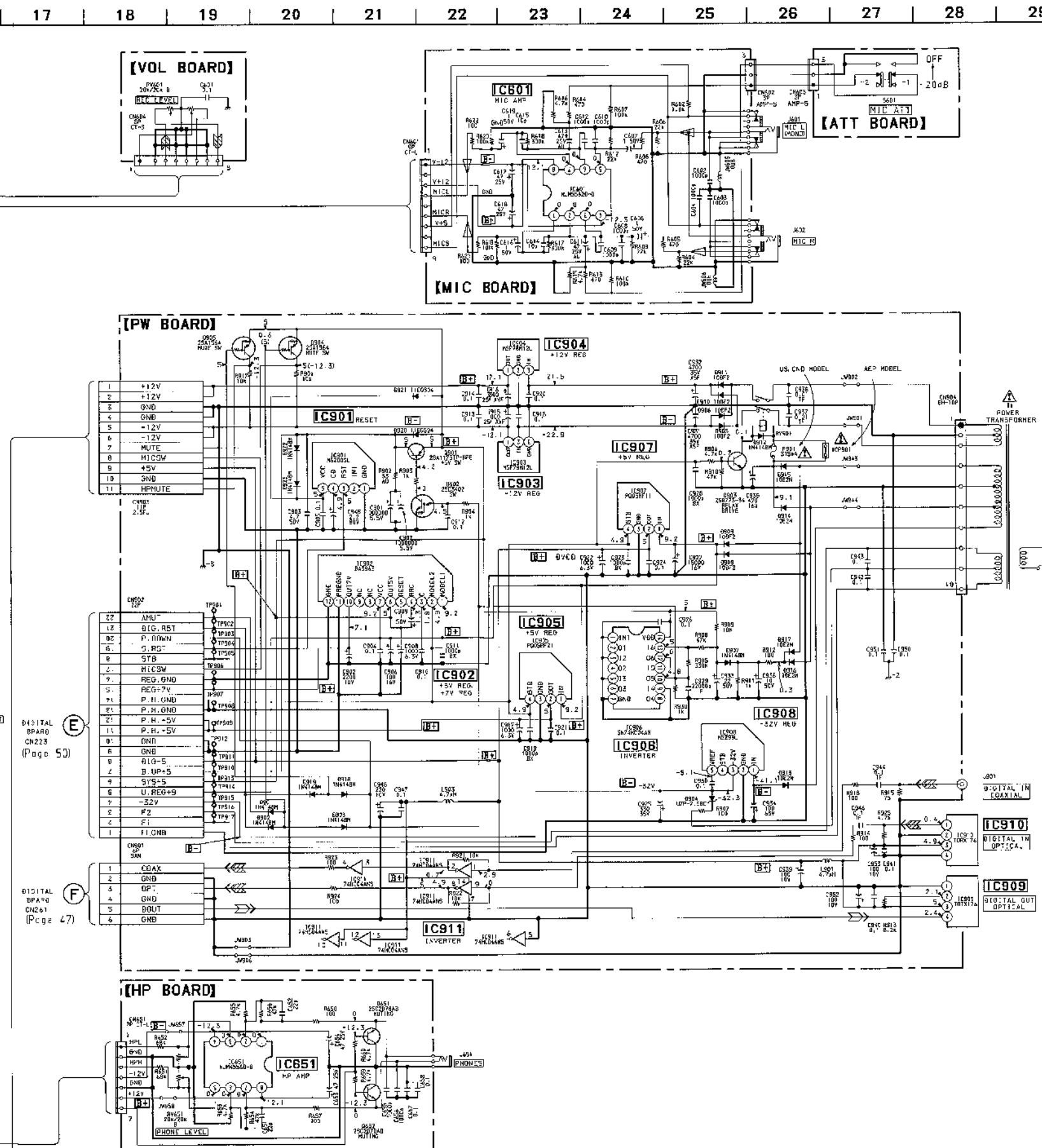
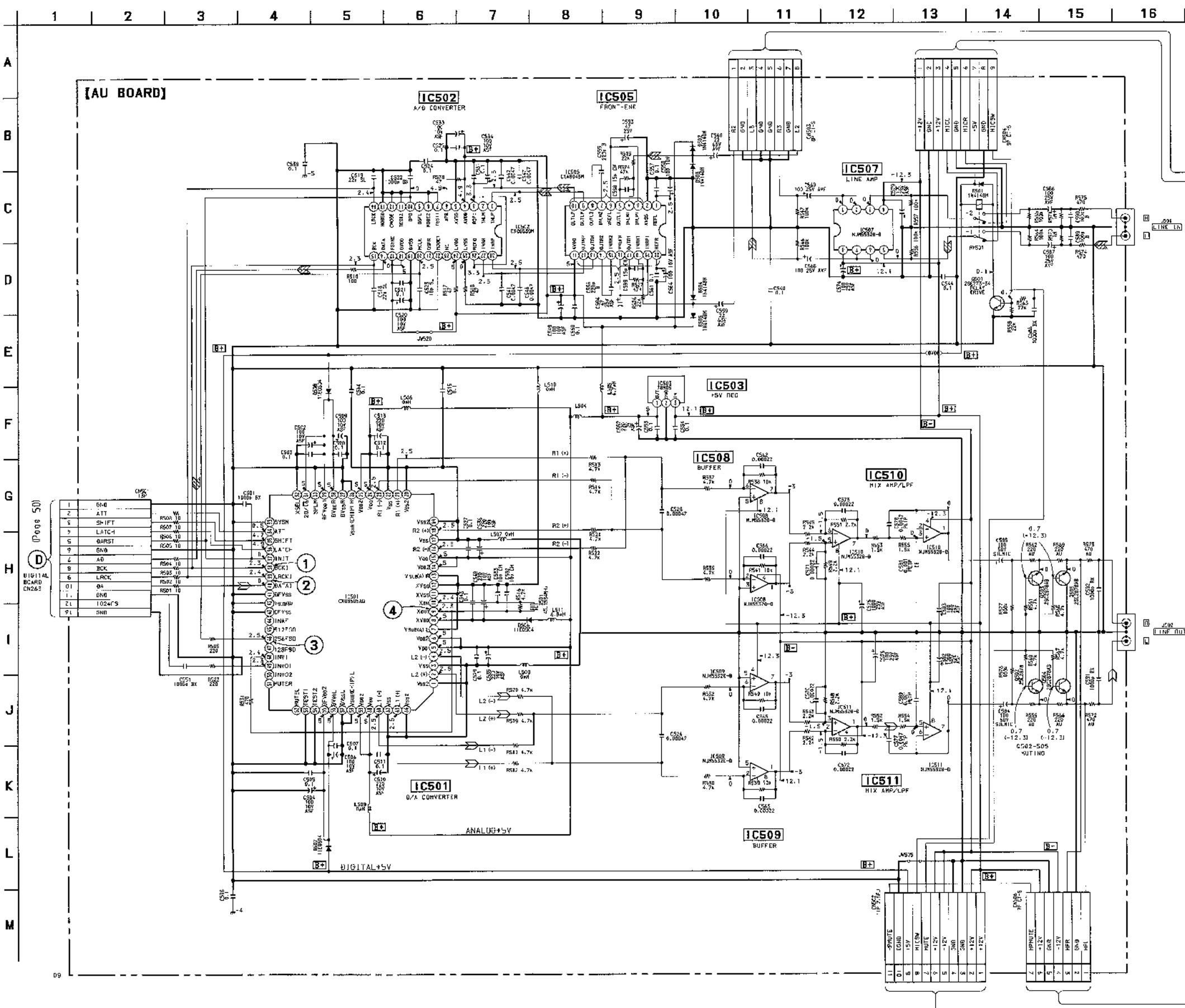

NOTE

- All capacitors are in μF unless otherwise noted; μF : μF 50WV or less are not indicated except for electrolytics and 1:2:10 u.s.
- All resistors are in Ω and 1/4W or less unless otherwise specified.
- \square : panel designation.

Note: The components identified by mark Δ or dotted line with mark Δ are critical for safety. Replace only with part number specified.

- \square : B+ :B1 Line.
- \square : B- :B- Line.
- Voltages and waveforms are dc with respect to ground under no-signal conditions.
- Voltages are taken with a VOM (input impedance 10M Ω). Voltage variations may be noted due to normal production tolerances.
- Waveforms are taken with an oscil. scope. Voltage variations may be noted due to normal production tolerances.
- Circled numbers refer to waveforms.

Abbreviation: CND: Canadian model. Signal path: Δ : P3, Δ : REC, Δ : P3 (Digital out), Δ : REC (Digital in), Δ : MIC.

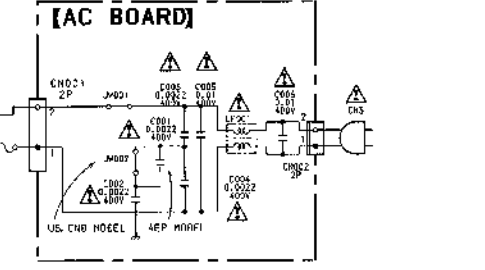

- Abbreviation: CND: Canadian model.
- Signal path: Δ : P3, Δ : REC, Δ : P3 (Digital out), Δ : REC (Digital in), Δ : MIC.

• Waveforms

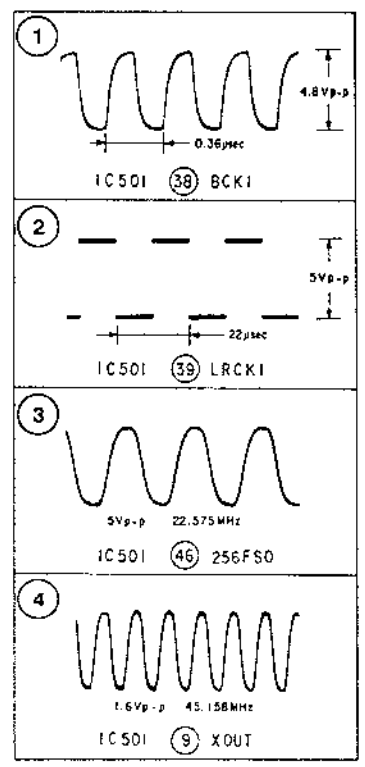

5-9. PRINTED WIRING BOARD — PANEL SECTION —
• See page 30 for Circuit Boards Location.

• Semiconductor Location

Ref. No.	Location
D702	D-11
D703	D-9
D704	D-6
D781	G-16
IC701	B-8
IC781	I-15
Q781	F-14

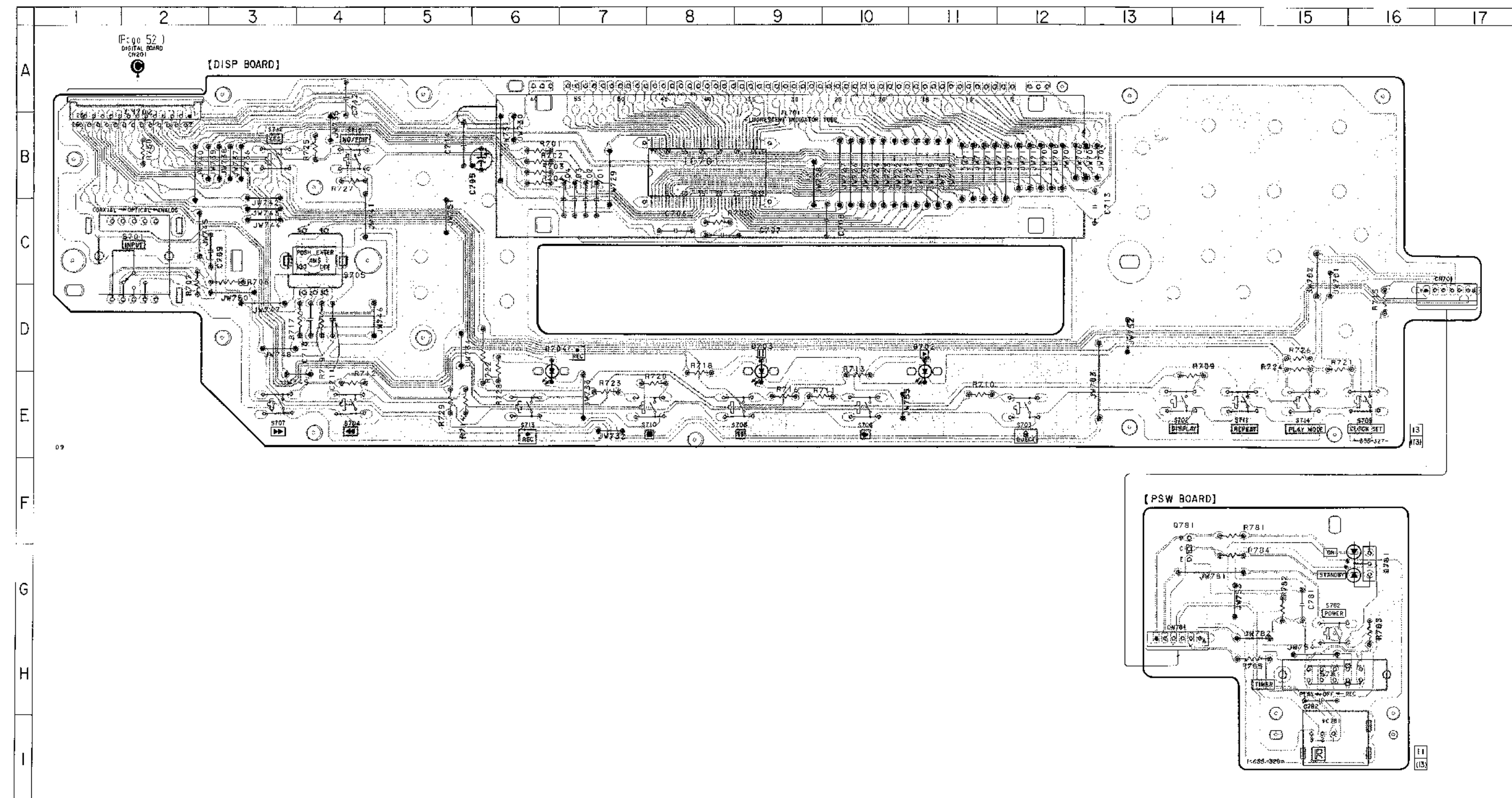

Note:
 • ○ : parts extracted from the component side.
 • □ : Pattern from the side which enable seeing.

5-10. SCHEMATIC DIAGRAM — PANEL SECTION —

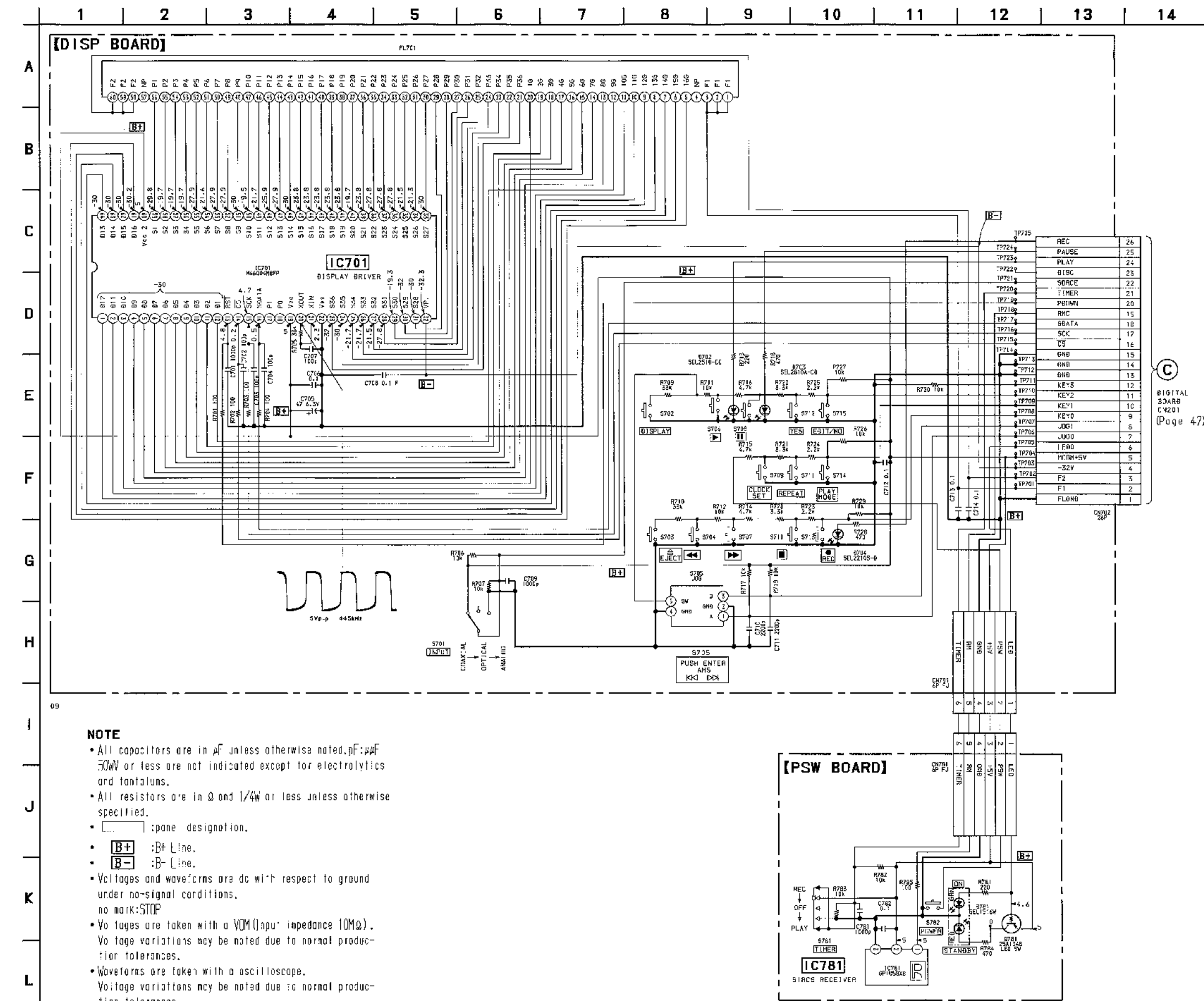

① DIGITAL BOARD C4201 (Page 47)

5-11. IC BLOCK DIAGRAMS — AUDIO SECTION —

IC501 CXD8505AQ

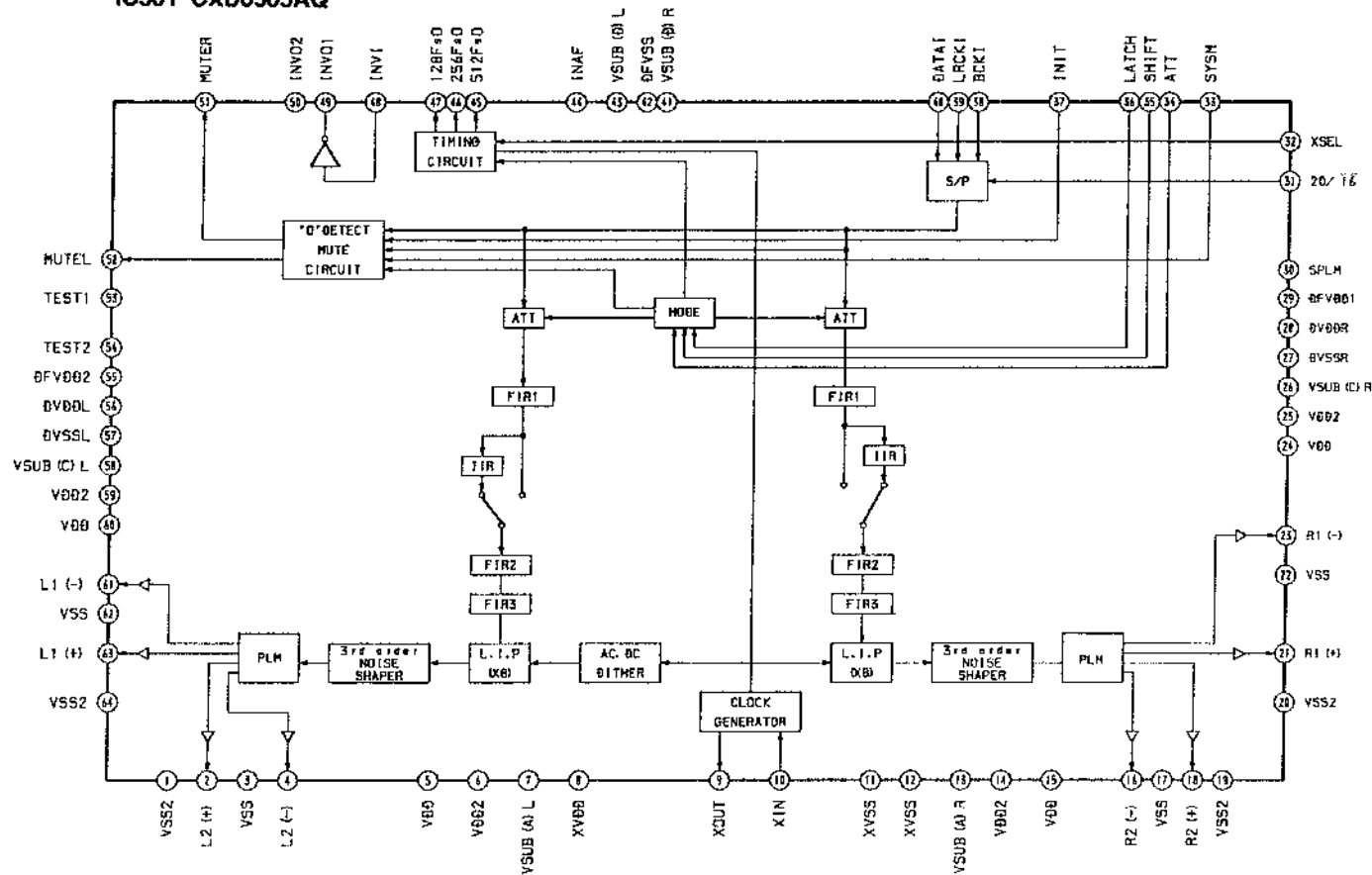

IC505 CXA8043M

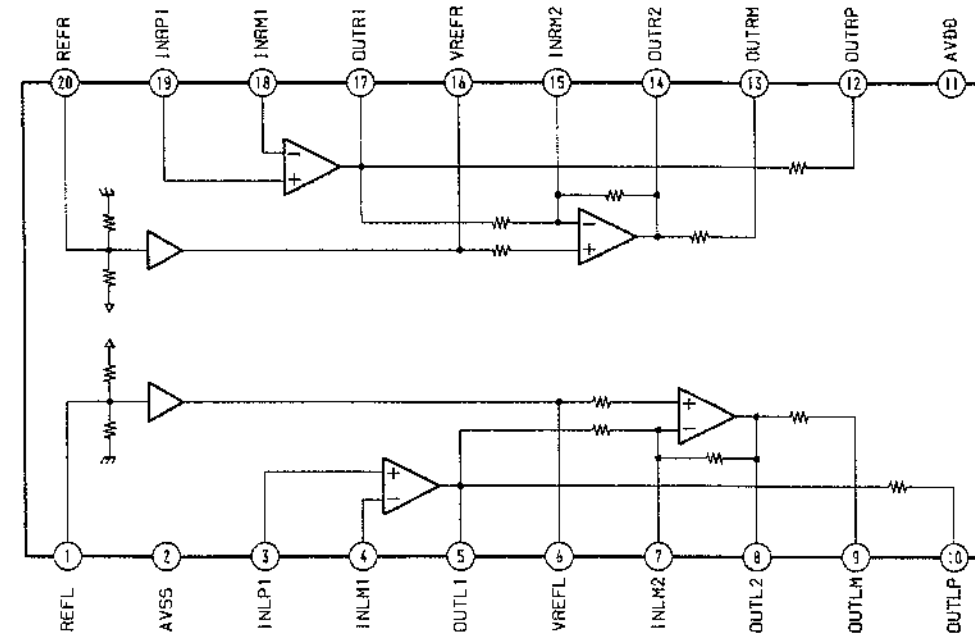

IC502 CXD8539M

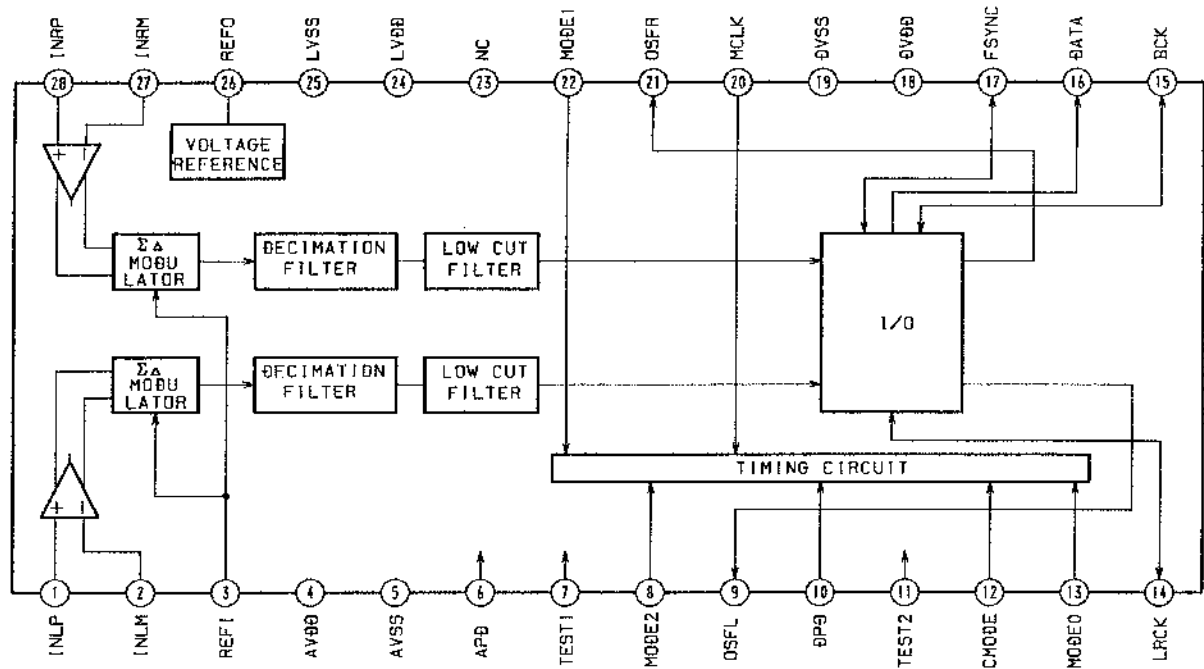

IC901 M62005L

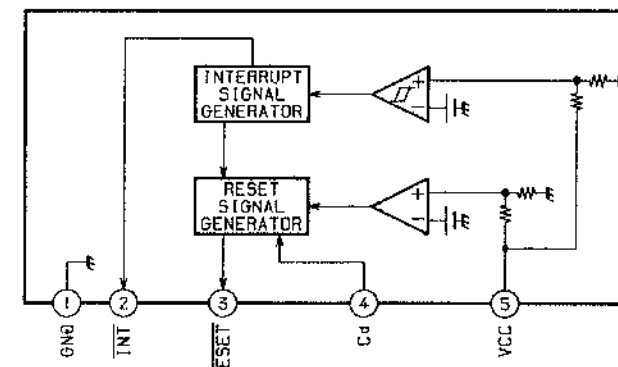

IC906 SN74HC04N

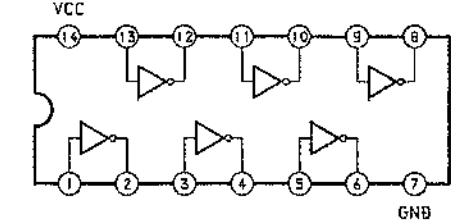

IC908 M5293L

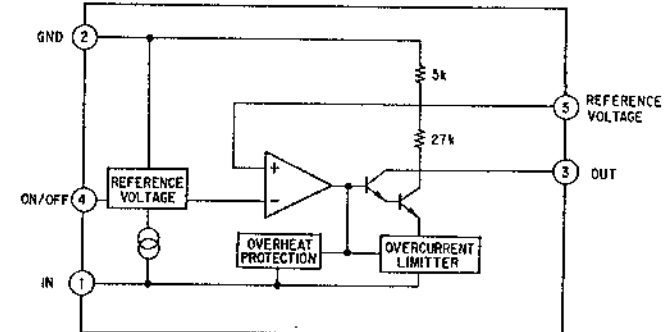

IC902 BA3963

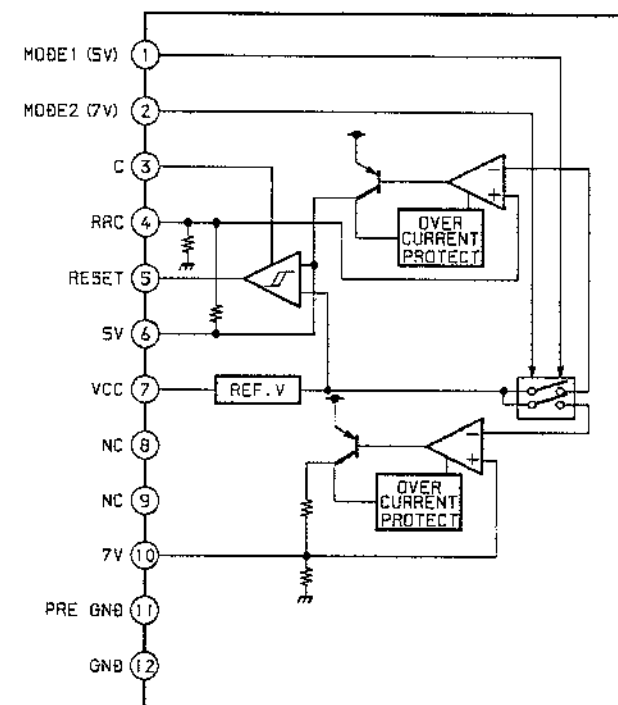

5-12. IC PIN FUNCTIONS

◆ IC101 RF Amplifier (CXA1981AR)

Pin No.	Pin Name	I/O	Function
1	VC	O	Middle point voltage (2.5V) generation output pin
2 to 7	A to F	I	Input of signal from optical block detector
8	FI	I	F operation amplifier input
9	FO	O	F operation amplifier output
10	PD	I	Front monitor. Connected to photo diode
11	APCREF	I	Input pin for setting laser power
12	TEMPI	I	Temperature sensor connection pin
13	GND	—	Ground pin
14	AAPC	O	APC LD amplifier output pin
15	DAPC	O	Not used (Opened)
16	TEMPR	O	Temperature sensor reference voltage output pin
17	XRST	I	Input of reset signal from system controller (IC201). Reset: "L"
18	SWDT	I	Input of write data signal from system controller (IC201)
19	SCLK	I	Input of clock signal from system controller (IC201)
20	XLAT	I	Input of latch signal from system controller (IC201)
21	VREF	O	Reference voltage output. Not used in this unit (Opened)
22	TENV	O	Not used (Opened)
23	THLD	I	Not used (Connected to VC)
24	VCC	—	Power supply pin (+5V)
25	TFIL	I	Not used (Opened)
26	TE	O	Output of tracking error signal to CXD2535AR (IC121)
27	TLB	I	Input pin of add signal to tracking error
28	CSLED	I	Sled error LPF pin
29	SE	O	Output of sled error signal to CXD2535AR (IC121)
30	ADFM	O	ADIP FM signal output
31	ADIN	I	Inputs ADIP FM signal by AC coupling
32	ADAGC	I	Connection pin of external capacitor for ADIP AGC
33	ADFG	O	Output of ADIP dual FM signal to CXD2535AR (IC121) (22.05 kHz ± 1 kHz)
34	AUX	O	Output of auxiliary signal to CXD2535AR (IC121)
35	FE	O	Output of focus error signal to CXD2535AR (IC121)
36	FLB	I	Not used (Opened)
37	ABCD	O	Output of light amount signal to CXD2535AR (IC121)
38	BOTM	O	Output of bottom hold signal of light amount signal to CXD2535AR (IC121)
39	PEAK	O	Output of peak hold signal of light amount signal to CXD2535AR (IC121)
40	RFAGC	I	Connection pin of RF AGC circuit external capacitor
41	RF	O	Output of playback EFM RF signal to CXD2535AR (IC121)
42	ISET	I	Internal circuit constant setting pin. 22 kHz BPF center frequency
43	AGCT	I	Inputs RF signal by AC coupling
44	RFO	O	Output pin of RF signal
45	MORFI	I	Inputs MO RF signal by AC coupling
46	MORFO	O	Output pin of MO RF signal
47, 48	I, J	I	Input of signal from optical block detector

• IC121 Digital signal processor, digital servo processor, EFM/ACIRC encoder/decoder (CXD2535AR)

Pin No.	Pin Name	I/O	Function
1	FS256	O	11.2896 MHz clock output (MCLK). Not used in this unit (Opened)
2	FOK	O	Output of FOK signal to system controller (IC201) Outputs "H" when focus is set
3	DFCT	O	Outputs defect ON/OFF switching signal to CXD2535AR (IC221)
4	SHCK	O	Outputs track jump detection signal to system controller (IC201)
5	SHCKEN	I	Track jump detection enable input. Not used in this unit. (Fixed at "H" in this unit.)
6	WRPWR	I	Inputs laser power switching signal from system controller (IC201)
7	DIRC	I	Not used in this unit. (Fixed at "H" in this unit)
8	SWDT	I	Inputs write data signal from system controller (IC201)
9	SCLK	I	Inputs serial clock signal from system controller (IC201)
10	XLAT	I	Inputs serial latch signal from system controller (IC201)
11	SRDT	O	Outputs write data signal to system controller (IC201)
12	SENS	O (3)	Outputs internal status (SENSE) to system controller (IC201)
13	ADSY	O	ADIP sync signal output. Not used in this unit (Opened)
14	SQSY	O	Output subcode Q sync (SCOR) to system controller (IC201) Outputs "L" every 13.3 msec. Outputs "H" at all most mostly
15	DQSY	O	Outputs digital-in U-bit CD format subcode Q sync (SCOR) to system controller (IC201). Outputs "L" every 13.3 msec Outputs "H" at all most mostly
16	XRST	I	Inputs reset signal from system controller (IC201). Reset: "L"
17	TEST4	I	Test input (Fixed at "L")
18	CLVSK	O	Not used in this unit (Opened)
19	TEST5	I	Test input (Fixed at "L")
20	DOUT	O	Digital audio signal output pin (For optical output)
21	DIN	I	Digital audio signal input pin (For optical input) (Opened)
22	FMCK	O	ADIP FM demodulation clock signal output
23	ADER	O	ADIP CRC flag output. "H":Error
24	REC	I	Input of recording/playback switching signal from system controller (IC201) Recording: "H". Playback: "L"
25	DVSS	-	Ground pin (Digital)
26	DOVF	I	Digital audio output validity flag input pin. Fixed at "L" in this unit
27	DODT	I	Input pin of 16bit data for digital audio output from CXD2536AR (IC221)
28	DIDT	O	Output pin of 16bit data for digital audio input to CXD2536AR (IC221)
29	DTI	I	Input pin of recording audio data signal from CXD2536AR (IC221) (Opened)
30	DTO	O (3)	Output pin of playback audio data signal to CXD2536AR (IC221)
31	C2PO	O	Outputs C2PO signal to CXD2536AR (IC221). (Output indicating data error status) Playback: C2PO ("H"). Digital recording: D.In-Vflag. Analog recording: "L"
32	BCK	O	Outputs bit clock signal (2.8224 MHz) to CXD2536AR (IC221) (MCLK)
33	LRCK	O	Outputs L/R clock signal (44.1 kHz) to CXD2536AR (IC221) (MCLK)
34	XTAO	O	System clock (512 Fs=22.5792 MHz) signal output. Not used in this unit (Opened)
35	XTAI	I	Input of system clock (512Fs=22.5792 MHz) signal input from CXD2536AR (IC221)
36	MCLK	O	MCLK clock (22.5792 MHz) signal output
37	XBCK	O	Pin 32 (BCK) inversion output
38	DVDD	-	Power supply pin (+5V) (Digital)
39	WDCK	O	WDCK clock (88.2 kHz) signal output (MCL)
40	RFCK	O	RFCK clock (7.35 kHz) signal output (MCLK)

Pin No.	Pin Name	I/O	Function
41	WFCK	O	WFCK clock (7.35 kHz) signal output (Playback: EFM decoder PLL. Recording: EFM encoder PLL)
42	GTOP	O	"H": Opens playback EFM frame sync protection window
43	GFS	O	"H": Playback EFM sync and interpolation protection timing match
44	XPLCK	O	EFM decoder PLL clock output (98 Fs=4.3218 MHz) Falling edge and EFM signal edge match
45	EFMO	O	EFM signal output (Playback)
46	RAOF	O	Internal RAM overflow detection signal output (decoder monitor output) Outputs "H" when the disc rotation exceeds $\pm 4F$ jitter margin during playback
47	MVCI	I	Digital-in PLL oscillation input. Not used in this unit (Fixed at "L" in this unit)
48	TEST2	I	Test pin (Fixed at "L" in this unit)
49	DIPD	O (3)	Digital-in PLL phase comparison output Internal VCO: (Frequency: Low \rightarrow "H"). External VCO: (Frequency: Low \rightarrow "L")
50	DVSS	-	Ground pin (Digital)
51	DICV	I (A)	Digital-in PLL internal VCO control voltage input
52	DIFI	I (A)	Filter input when digital-in PLL internal VCO is used
53	DIFO	O (A)	Filter output when digital-in PLL internal VCO is used
54	AVDD	-	Power supply pin (+5V) (Analog)
55	ASYO	O	Playback EFM full-swing output (L=VSS, H=VDD)
56	ASYI	I (A)	Playback EFM asymmetry compare voltage input
57	BIAS	I (A)	Playback EFM asymmetry circuit constant current input
58	RFI	I (A)	Inputs playback EFM RF signal from CXA1981AR (IC101)
59	AVSS	-	Ground pin (Analog)
60	CLTV	I (A)	Decoder PLL master clock PLL VCO control voltage input
61	PCO	O (3)	Decoder PLL master clock PLL phase comparison output
62	FILI	I (A)	Decoder PLL master clock PLL filter input
63	FILO	O (3)	Decoder PLL master clock PLL filter output
64	PEAK	I (A)	Inputs peak hold signal for light amount signal from CXA1981AR (IC101)
65	BOTM	I (A)	Inputs bottom hold signal for light amount signal from CXA1981AR (IC101)
66	ABCD	I (A)	Light amount signal from CXA1981AR (IC101)
67	FE	I (A)	Input of focus error signal from CXA1981AR (IC101)
68	AUX1	I (A)	Input of auxiliary signal from CXA1981AR (IC101)
69	VC	I (A)	Input of middle point voltage (+2.5V) from CXA1981AR (IC101)
70	ADIO	O (A)	A/D converter input signal monitor output
71	TEST3	I (A)	Test input (Fixed at "L")
72	AVDD	-	Power supply pin (+5V) (Analog)
73	ADRT	I (A)	A/D converter operation range upper limit voltage input (Fixed at "H" in this unit.)
74	ADRB	I (A)	A/D converter operation range lower limit voltage input (Fixed at "L" in this unit.)
75	AVSS	-	Ground pin (Analog)
76	SE	I (A)	Input of sled error signal from CXA1981AR (IC101)
77	TE	I (A)	Input of tracking error signal from CXD1981AR (IC101)
78	AUX2	I (A)	Auxiliary input pin 2. Not used in this unit. (Fixed at "L")
79	DCHG	I (A)	Connected to GND
80	APC	I (A)	Laser APC input. Not used in this unit (Fixed at "L" in this unit)

Pin No.	Pin Name	I/O	Function
81	TEST1	I	Test pin (Fixed at "L" in this unit)
82	ADFG	I	Input of ADIP dual FM signal from CXA1981AR (IC101) (22.05 kHz \pm 1 kHz) (TTL Schmidt input)
83	TS25	I	Test pin (Fixed at "L" in this unit)
84	LDDR	O	Laser APC signal output
85	TRDR	O	Tracking servo drive signal output (-)
86	TFDR	O	Tracking servo drive signal output (+)
87	FFDR	O	Focus servo drive signal output (+)
88	DVDD	-	Power supply pin (+5V) (Digital)
89	FRDR	O	Focus servo drive signal output (-)
90	FS4	O	176.4 kHz clock signal output (MCLK)
91	SRDR	O	Sled servo drive signal output (-)
92	SFDR	O	Sled servo drive signal output (+)
93	SPRD	O	Spindle servo drive signal output (-)
94	SPFD	O	Spindle servo drive signal output (+)
95	DCLO	O	Not used normally (Opened in this unit)
96	DCLI	I	Not used normally (Fixed at "H" in this unit)
97	XDCL	O	Not used normally (Opened in this unit)
98	OFTRK	O	Off track signal output
99	COUT	O	Traverse count signal output
100	DVSS	-	Ground pin (Digital)

* (3) of I/O is 3-state output, (A) is analog output.

• IC201 System Control (M37610MD)

Pin No.	Pin Name	I/O	Function
1	XRD	O	Row address strobe signal output to the clock decoder (IC203)
2	XWR	O	Read/write signal output to the clock decoder (IC203)
3	XCS	O	Chip select signal output to the clock decoder (IC203)
4 to 6	KEY 2 to KEY 0	I	Key input (A/D input)*1
7	DOSEL	O	Digital out selection
8	XINT	I	Interrupt status input from CXD2536AR (IC221)
9	SENS	I	Internal status (SENSE) input from CXD2535AR (IC121)
10	SHCK	I	Track jump signal input from CXD2535AR (IC121)
11	CLR	O	Reset signal output to the counter (IC208)
12	CLK	O	Clock signal output to the counter (IC208)
13	XOE	O	Output enable control signal output to the mask ROM (IC207)
14	REC/OTHER	O	Recording: "L", others: "H".
15	BEEP	O	Buzzer signal output
16	F. BIAS/C2	I	Fixed at "L" in this unit.
17	GND (CNVSS)	—	GND
18	SYSTEM RST	I	System reset signal input "L" is input for several hundreds msec after the power supply activation, then it is changed to "H".
19	XIN T	I	} Not used in this unit. (Fixed at "L" in this unit.)
20	XOUT T	O	
21	GND	—	GND
22	XIN	I	Clock input (8MHz)
23	XOUT	O	Clock output (8MHz)
24	+5V	—	Power supply (+5V)
25	STB	O	Strobe signal output to the power supply circuit. ON: "H", standby: "L".
26, 27	MIC SW	I	Fixed at "L" in this unit.
28	DIN/XTAL	O	Audio bus signal output
29	PLAY	O	PLAY LED (D702) drive signal output
30	PAUSE	O	PAUSE LED (D703) drive signal output
31	REC	O	REC LED (D704) drive signal output
32	LED 0	O	Drive output to POWER ON/STANDBY display LED (D781) Power ON: "H", standby: "L".
33	C1	I	} Fixed at "L" in this unit.
34	ADER	I	
35	BUS OUT	I	
36	MASTER/SLAVE	I	Master/slave switching input (Fixed at "H" in this unit.)
37, 38	JOG 1, JOG 0	I	JOG dial pulse input from the rotary encoder (S701)
39	SDA	I/O	Data signal input/output with the backup memory (IC171)
40	SCL	O	Clock signal output to the backup memory (IC171)
41	POWER DOWN	I	Power down detection input. Normally, "H" is input.
42	REMOCON	I	Remote control signal input
43	SQSY	I	ATP addressing or subcode Q sync (SCOR) input from CXD2535AR (IC121). "L" is input every 13.3 msec. Normally "H".
44	DQSY	I	Digital-in U-bit CD format subcode Q sync (SCOR) input from CXD2535AR (IC121). "L" is input every 13.3 msec. Normally "H".
45	DFINT	O	Initialization signal output to the digital filter (IC205).

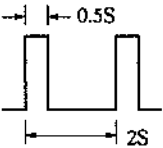
Pin No.	Pin Name	I/O	Function
46	DCLAT	O	Fixed at "H"
47	DFLAT	O	Latch signal output to the digital filter (IC205)
48	—	I	Fixed at "L" in this unit.
49	SCLK	O	Clock signal output to the serial bus
50	SWDT	O	Write data signal output to the serial bus
51	SRDT	I	Read data signal input from the serial bus
52	—	I	Connected to Pin 51.
53	FLCLK	O	Serial clock signal output to the display driver (IC701)
54	FLDATA	O	Serial data signal output to the display driver (IC701)
55	FLCS	O	Chip select signal output to the display driver (IC701)
56	EROR	I	Error signal input from the receiver (IC261)
57	TEST 0	I	Fixed at "L" in this unit.
58	TEST 1	O	Reset signal output to CXD2536AR (IC221)
59	CLKSET 0	I	Fixed at "L" for US and Canadian models, fixed at "H" for AEP model.
60	CLKSET 1	I	Fixed at "H" for US and Canadian models, fixed at "L" for AEP model.
61	AFAST	I	} Fixed at "L" in this unit.
62	SLOW	I	
63	LDON	O	Laser ON/OFF control output. "H": Laser ON.
64	PIT/GRV	I	Pit/groove detection input. "H" is input for the playback-only disc or TOC area. Not used in this unit. (Fixed at "L" in this unit.)
65	FOK	I	FOK signal input from CXD2535AR (IC121) "H" is input when focusing.
66	MON	I	Not used in this unit. (Pull down when input.)
67	LOCK	O	Not used in this unit. (Pull down when output.)
68	WRPWR	O	Laser power switching signal output to the optical block and CXD2535AR (IC121)
69	DIG RST	O	Reset signal output to CXD1981AR (IC101) and CXD2535AR (IC121) and motor driver (IC151). Reset: "L".
70	DA RST	O	Reset signal output to the D/A converter (IC501), A/D converter (IC502). Reset: "L".
71, 72	SCMD 1, SCMD 0	O	Serial command control mode output to CXD2536AR (IC221)
73	MOD	O	Laser modulation switching signal output Playback power: "L", stop: "H". Recording power: 
74	REC/PB	O	Record/playback switching signal output to CXD2535AR (IC121). Recording: "H", playback: "L".
75	WR/MN	O	Write/monitor mode switching signal output to CXD2536AR (IC221)
76	SCTX	O	Write data transfer timing output to CXD2536AR (IC221) Also serves as ON/OFF output of the magnetic head.
77	XLATCH	O	Latch signal output to the serial bus
78	DALAT	O	Latch signal output to the D/A converter (IC501).
79	SRCMT	O	Muting output. Not used in this unit. (Fixed at "L" in this unit.)
80	AMUTE	O	Line out muting output

Pin No.	Pin Name	I/O	Function
81	LDOUT	O	Loading motor (M191) control output*2
82	LDIN	O	
83	CHKIN	I	Detection input from the chucking-in switch (S193). When chucking: "L".
84	INSW	I	Detection input from the loading-in switch (S191). When the magnetic head is lowered: "L", others: "H".
85	OUTSW	I	Detection input from the loading-out switch (S192). When loaded out: "L", others: "H".
86	PROTECT	I	Recording-protect claw detection from the protect detection switch (S102-1). When protected: "H".
87	REFLECT	I	Disc reflection rate detection from the reflect detection switch (S102-2). Disc with lower reflection rate: "H".
88	LIMIT IN	I	Detection from the limit-in switch (S101). Sled limit-in: "L".
89 to 92	D3 to D0	I/O	Data signal input/output with the clock and counter
93 to 96	A3 to A0	O	Address signal output to the clock and counter
97	AVSS (AGND)	-	GND
98	VREF (+5V)	I	Reference voltage input (+5V)
99	TIMER REC/PLAY	I	Timer recording/playback/OFF switching input. Not used in this unit. (Fixed at mid-point voltage (+2.5V) in this unit: OFF condition)
100	SORCE	I	Select signal input from input signals (analog/digital input). Analog input: "L", digital input: "H".

*1 Key input

Voltage Pin	0V	0.9V	1.75V	2.5V	3.4V	4.2V	5V
KEY 0, 6 pin	S713 ●	S710 ■	/	S707 ▶▶	S704 ◀◀	S703 △	No key input
KEY 1, 5 pin	S714 PLAY MODE	S711 REPEAT	S709 CLOCK SET	/	/	/	No key input
KEY 2, 4 pin	S715 EDIT NO	S712 YES	S708 	S706 ▶	S705 ◀◀▶▶	S702 DISPLAY	No key input

*2 Loading motor control

Operation Pin	IN	OUT	BRAKE
LDIN 82 pin	"H"	"L"	"H"
LDOUT 81 pin	"L"	"H"	"H"

• IC204 Digital Filter (CXD8512Q)

Pin No.	Pin Name	I/O	Function
1	TEST	I	Test pin. Fixed at "L".
2	NC	—	Not used.
3	SYNC	I	Sync mode selection (Connected to GND.)
4	INIT	I	Initialization input
5	NC	—	Not used.
6	CFLG	O	Flag output for calibration (Not used.)
7, 8	VDD	—	Power supply (+5V)
9	LRKI	I	LRKI input (8fs/2fs/fs)
10	BK1	I	BK1 input (8fs/2fs/fs)
11	NC	—	Not used.
12	DLI	I	Lch data input (8fs/2fs/fs)
13	DRI	I	Rch data input (8fs/2fs/fs)
14	IFLG	O	Input side sync flag output (Not used.)
15, 16	NC	—	Not used.
17	TEST	I	Test pin. Fixed at "L".
18	AL2	I	Lch data input (64fs) (Connected to GND.)
19	AR2	I	Rch data input (64fs) (Connected to GND.)
20	ALI	I	Lch data input (64fs) (Connected to GND.)
21	ARI	I	Rch data input (64fs) (Connected to GND.)
22, 23	Vss	—	} Power supply (GND)
24, 25	CVss	—	
26	FCLK	O	FE clock output (128fs) (Not used.)
27	MCLK	I	Master clock input (256fs)
28	CVDD	—	Power supply (+5V)
29	NC	—	Not used.
30	IBIT	I	Data input word length selection (64fs) (Connected to GND.)
31	NC	—	Not used.
32	Vss	—	GND
33	SCALE	I	Test pin. Fixed at "L".
34	ISEL1	I	Input selection (Connected to the power supply.)
35	ISEL2	I	Input selection (Connected to GND.)
36	NC	—	Not used.
37	DITH	I	Dither (Connected to GND.)
38	BOOST	I	Boost (Connected to GND.)
39	VDD	—	Power supply (+5V)
40	MODE	I	MODE data input
41	SHIFT	I	SHIFT clock input
42	LATCH	I	Fixed at "H"
43	NC	—	Not used.
44	LC	I	Low cut (Connected to GND.)
45	TEST	I	Test pin. Fixed at "L".

Pin No.	Pin Name	I/O	Function
46	NC	—	Connected to GND.
47	TEST	I	Test pin. Fixed at "L".
48	OBIT	I	Output data word length selection (Connected to the power supply.). "H": 24 bits, "L": 16 bits.
49	DRO	O	Rch data output (Not used.)
50	DLO	O	Lch data output
51	NC	—	Not used.
52, 53	Vss	—	Power supply (GND)
54	BCK	I/O	SYNC "H": BCK output, "L": BCK input
55	NC	—	Not used.
56	LRCK	I/O	SYNC "H": LRCK output, "L": LRCK input
57	OFLG	O	Output side sync flag output (Not used.)
58	VDD	—	Power supply (+5V)
59	OVR	O	Rch overflow flag output (Not used.)
60	OVL	O	Lch overflow flag output (Not used.)

• IC205 Digital Filter (CXD8504M)

Pin No.	Pin Name	I/O	Function
1	Vss	—	Power supply (GND)
2	TEST3	I	Test pin. Normally fixed at "L".
3	SYSTEM	I	System mute input. "H": Valid. (Connected to GND.)
4	ATT	I	CTL "L": ATT data input, CTL "H": EMP input.
5	SHIFT	I	CTL "L": Shift clock input, CTL "H": FS32 input.
6	LATCH	I	CTL "L": Latch clock input, CTL "H": FS48 input.
7	Vss	—	Power supply (GND)
8	INIT	I	Re-synchronized at the rising edge of this signal.
9	BCKI	I	BCK input
10	DATAI	I	Data input
11	LRCKI	I	LRCK input
12	TEST2	—	} Test pin. Normally fixed at "L".
13	TEST1	—	
14	Vss	—	Power supply (GND)
15	VDD	—	Power supply (+5V)
16	128Fs	O	128Fs clock output
17	INVI	I	Inverter input (Connected to GND.)
18	INVO	O	Inverter output (Not used.)
19	INVO2	O	Inverter output (Not used.)
20	MCLK	I	Master clock input (f=512Fs)
21	VDD	—	Power supply (+5V)
22	BCKO	O	BCK output
23	DL	O	Lch data output
24	DR	O	Rch data output
25	LRCKO	O	LRCK output
26	FLGL	O	Rch ϕ mute flag output (Not used.)
27	FLGR	O	Lch ϕ mute flag output (Not used.)
28	VDD	—	Power supply (+5V)

• IC221 Shock-Proof Memory Controller, ATRAC Encoder/Decoder (CXD2536AR)

Pin No.	Pin Name	I/O	Function
1	VDD	–	Power supply pin (+5V)
2	SWDT	I	Input of write data signal from system controller (IC201)
3	SCK	I	Input of serial clock signal from system controller (IC201)
4	XLAT	I	Input of serial latch signal from system controller (IC201)
5	SRDT	O/Z	Output of read data signal to system controller (IC201)
6	SENSE	O/Z	Output of internal status (SENSE) to system controller (IC201) (Not used)
7	SCMD0	I	Input of serial command control mode from system controller (IC201)
8	SCMD1	I	Input of serial command control mode from system controller (IC201)
9	XINT	O	Output of interrupt status to system controller (IC201)
10	RCPB	I	Recording/playback switching input. Not used in this unit (Fixed at "L" in this unit)
11	WRMN	I	Input of write/monitor mode switching signal from system controller (IC201)
12	TX	I	Input of write data transmission timing from system controller (IC201) Also used as magnetic field head ON/OFF output
13	VSS	–	Ground pin
14	SICK	I	Chip reservation pin (Fixed at "L" in this unit)
15	IDSL	I	Chip reservation pin (Fixed at "L" in this unit)
16	XILT	I	Chip reservation pin (Fixed at "H" in this unit)
17	XRST	I	Input of reset signal from system controller (IC201). Reset: "L"
18 to 21	TS0 to TS3	I	Test pin (Fixed at "L" in this unit)
22	EXIR	I	Chip reservation pin (Fixed at "H" in this unit)
23	SASL	I	Block selection in single use. "L": ATRAC. "H": RAM controller (Fixed at "L" in this unit)
24	SNGLE	I	Normally fixed at "L". Fixed at "H" when used as ATRAC or RAM controller for single. Fixed at "L" in this unit.
25	VSS	–	Ground pin
26	AIRCPB	O	Output pin of ATRAC and external audio block recording/playback mode signal
27	XRQ	I/O	ATRAC I/F XRQ signal input/output pin
28	ADTO	I/O	ATRAC decode data signal input/output pin
29	ADTI	I/O	ATRAC encode data signal input/output
30	XALT	I/O	ATRAC I/F XALT signal input/output pin
31	ACK	I/O	ATRAC I/F ACK signal input/output pin
32	AC2	I/O	ATRAC I/F error data signal input/output pin
33	LCHST	I/O	ATRAC I/F Lch start data signal input/output pin
34	EXE	I/O	ATRAC I/F EXE signal input/output pin
35	MUTE	I/O	ATRAC I/F MUTE signal input/output pin
36	OSCO	O	Clock output (45 MHz) (Not used)
37	OSCI	I	Clock input (45 MHz)
38	VSS	–	Ground pin
39	ATT	I/O	ATRAC I/F ATT signal input/output pin
40	F86	O	ATRAC block 11.6 msec timing signal output pin
41	DOUT	O	Output of monitor/decode audio data signal to D/A converter (IC501)
42	ADIN	I	Input of recording signal from A/D converter (IC502)
43	ABCK	O	Output of bit clock signal to A/D and D/A converters (IC501, IC502)
44	ALRCK	O	Output of L/R clock to A/D and D/A converters (IC501, IC502)
45 to 47	SA2 to SA0	O	Address signal output. Not used in this unit (Opened)

Pin No.	Pin Name	I/O	Function
48, 49	A11, A10	O	Address signal output. Not used in this unit (Opened)
50	VSS	—	Ground pin
51	VDD	—	Power supply pin (+5V)
52 to 55	A03 to A00	O	Output of address signal to RAM (IC222)
56 to 60	A04 to A08	O	Output of address signal to RAM (IC222)
61	XOE	O	Output of output enable control signal to RAM (IC222)
62	XCAS	O	Output of column address strobe signal to RAM (IC222)
63	VSS	—	Ground pin
64	XCS	O	Output of chip select signal to RAM (IC222)
65	A09	O	Output of address signal to RAM (IC222)
66	XRAS	O	Output of row address strobe signal to RAM (IC222)
67	XWE	O	Output of read/write control signal to RAM (IC222)
68, 69	D1, D0	I/O	Input/output pin of data signal to/from RAM (IC222)
70, 71	D2, D3	I/O	Input/output pin of data signal to/from RAM (IC222)
72 to 74	D4 to D6	I/O	Data signal input/output pin. Not used in this unit (Opened)
75	VSS	—	Ground pin
76	D7	I/O	Data signal input/output pin. Not used in this unit (Opened)
77	ERR	I/O	Input/output pin of error (C2PO) data to external RAM. Not used in this unit (Opened)
78	EXTC2R	I	External RAM selection input for error data writing ("H": External RAM). Fixed at "L" in this unit
79	BUSY	O	RAM access BUSY signal output. Not used in this unit (Opened)
80	EMP	O	EMPTY or immediately before FULL of ATRAC data (When DSC=ASC+1: "H")
81	FUL	O	FULL or immediately before EMPTY of ATRAC data (When ASC=DSC+1: "H")
82	EQL	O	ATRAC data EMPTY (When DSC=ASC: "H")
83	MDLK	O	Indicates recording/playback data main/sub ("H": Sub, Linking: "L": Main)
84	CPSY	O	Interpolation sync signal output
85	CTMD0	O	DSC counter mode output
86	CTMD1	O	DSC counter mode output
87	SPO	O	Output of system clock (512Fs=22.5792 MHz) signal to CXD2535AR (IC121) and CXD8457Q (IC206)
88	VSS	—	Ground pin
89	MDSY	O	Main data sync detection signal output
90	LRCK	I	Input of L/R clock signal from CXD2535AR (IC121) (44.1 kHz)
91	BCK	I	Input of bit clock signal from CXD2535AR (IC121) (2.8224 MHz)
92	C2PO	I	Input of C2PO signal from CXD2535AR (IC121) (Shows data error status) Playback: C2PO ("H"). Digital recording: D.In-Vflag. Analog recording: "L"
93	DATA	I/O	Recording: Output of recording audio data signal to CXD2535AR (IC121) PPlayback: Input of playback audio data signal from CXD2535AR (IC121)
94	DIDT	I	Input of digital audio input 16-bit data from CXD2535AR (IC121)
95	DODT	O	Output of digital audio output 16-bit data to CXD2535AR (IC121)
96	DIRCPB	O	Disc drive and EFM encoder/decoder recording/playback mode output Not used in this unit (Opened)
97	MIIN	I	Input of defect ON/OFF switching signal from CXD2535AR (IC121)
98	SPOSL	I	Pin 87 (SPO) input/output switching input pin ("L": IN. "H": OUT). Fixed at "H" in this unit
99	MCKT1	O	RAM controller internal master clock output pin
100	VSS	—	Ground pin

• IC261 Digital Audio Interface Receiver (CXD8521M)

Pin No.	Pin Name	I/O	Function
1	DIN1	I	Data input pin with built-in amplifier (responding to the coaxial optical module)
2	DIN2	I	Data input (responding to the optical module)
3	E/DOUT	O	Emphasis, input bi-phase, validity flag output
4	VDD	—	Power supply (+5V)
5	R	I	VCO gain control input
6	VIN	I	VCO freerunning frequency setting input
7	VCO	O	LPF setting of PLL
8	GND	—	GND
9	CKSEL	I	System clock select input (384fs, 512fs) (Connected to the power supply.)
10	XMODE	I	Reset input
11	AVOCK	I	Clock input for preventing PLL lock failure
12	TST1	I	} Test input (Normally "L")
13	TST2	I	
14	SCLK/CL	I	Microcomputer IF clock input
15	XLAT/CE	I	Microcomputer IF latch/chip enable input
16	SWDT/DI	I	Microcomputer IF write data input
17	SRDT/DO	O	Microcomputer IF read data output
18	DQSY/LD	O	Microcomputer IF Sub-Q sync and ID sync output
19	CKOUT	O	VCO clock output (freerunning, 384fs, 512fs)
20	FS128	O	128fs clock output (Not used.)
21	BCK	O	Bit clock output
22	LRCK	O	L/R clock output
23	DATAOUT	O	Audio data output
24	ERROR	O	PLL lock error mute output

◆ IC502 A/D Converter (CXD8539M)

Pin No.	Pin Name	I/O	Function
1	INLP	I	Lch analog (+) input
2	INLM	I	Lch analog (-) input
3	REFI	I	Reference voltage input (+32V)
4	AVDD	—	Modulator analog power supply (+5V)
5	AVSS	—	Modulator analog GND
6	APD	I	Modulator power down. "H": Normal operation, "L": Power down.
7	TEST1	I	Test pin. Fixed at "L".
8	MODE2	I	Mode setting. Fixed at "L".
9	OSFL	O	Lch overflow flag output (Not used.)
10	DPD	I	Decimation filter power down. "H": Normal operation, "L": Power down/reset.
11	TEST2	I	Test pin. Fixed at "L".
12	CMODE	I	Master clock selection. "H": 384fs, "L": 256fs.
13	MODE0	I	Mode setting. Fixed at "L".
14	LRCK	I/O	Master mode: LRCK output, slave mode: LRCK input.
15	BCK	I/O	Master mode: BCK output, slave mode: BCK input.
16	DATA	O	DATA output
17	FSYNC	I/O	Master mode: FSYNC output, slave mode: FSYNC input.
18	DVDD	—	Decimation filter power supply (+5V)
19	DVSS	—	Decimation filter GND
20	MCLK	I	Master clock input (256fs)
21	OSFR	O	Rch overflow flag output (Not used.)
22	MODE1	I	Mode setting. Fixed at "L".
23	NC	—	Not used.
24	LVDD	—	Modulator logic power supply (+5V)
25	LVSS	—	Modulator logic GND
26	REFO	O	Reference voltage output
27	INRM	I	Rch analog (-) input
28	INRP	I	Rch analog (+) input

SECTION 6 EXPLODED VIEWS

NOTE:

- -XX, -X mean standardized parts, so they may have some difference from the original one.
- Items marked " * " are not stocked since they are seldom required for routine service. Some delay should be anticipated when ordering these items.
- Color Indication of Appearance Parts Example:
KNOB, BALANCE (WHITE) . . . (RED)

↑ ↑
Parts color Cabinet's color

- The mechanical parts with no reference number in the exploded views are not supplied.
- Hardware (# mark) list and accessories and packing materials are given in the last of this parts list.
- Abbreviation
CND : Canadian model
G : German model

The components identified by mark Δ or dotted line with mark Δ are critical for safety. Replace only with part number specified.

Les composants identifiés par une marque Δ sont critiques pour la sécurité. Ne les remplacer que par une pièce portant le numéro spécifié.

6-1. CASE SECTION

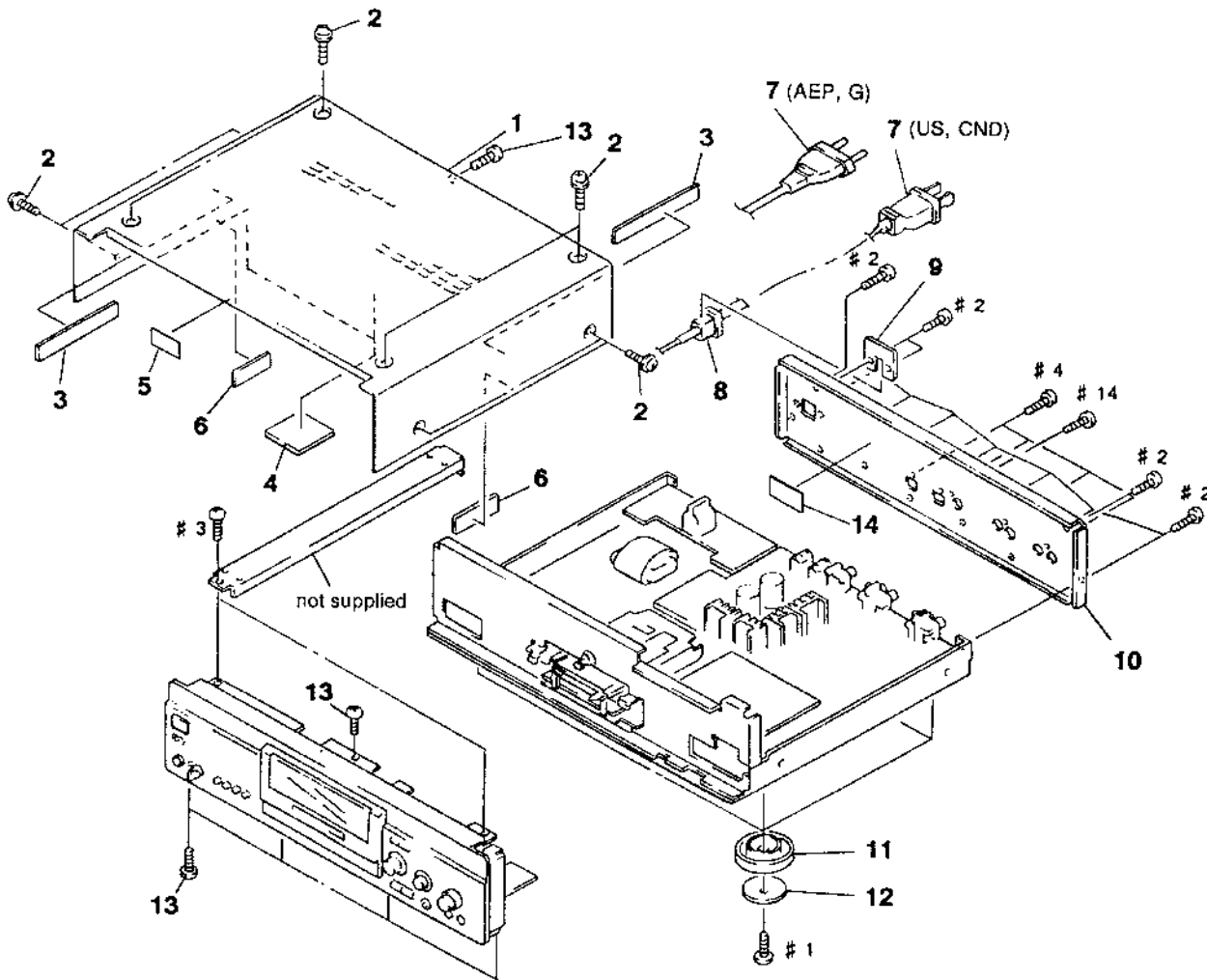

Ref. No.	Part No.	Description	Remark	Ref. No.	Part No.	Description	Remark
1	4-969-469-11	CASE (BLACK)		* 8	3-703-244-00	BUSHING (2104), CORD	
1	4-969-469-21	CASE (GOLD)		* 9	4-923-873-01	BRACKET, CORD STOPPER	
2	3-704-366-01	SCREW (CASE) (M3X8) (BLACK).. (BLACK)		* 10	4-971-764-02	PANEL, BACK (US)	
2	3-704-366-11	SCREW (CASE) (M3X8) (SILVER).. (GOLD)		* 10	4-971-764-23	PANEL, BACK (CND)	
3	4-959-077-01	DAMPER		* 10	4-971-764-32	PANEL, BACK (AEP, G)	
* 4	4-962-329-01	DAMPER		11	4-970-123-01	FOOT (F50180S)	
* 5	4-615-354-01	SPACER		12	4-970-124-01	CUSHION (F50180S)	
6	9-911-844-XX	CUSHION		13	3-703-685-21	SCREW (+BY 3X8)	
Δ 7	1-558-568-21	CORD, POWER (AEP, G)		14	3-703-044-26	LABEL, CAUTION (US, CND)	
Δ 7	1-559-583-21	CORD, POWER (US, CND)					

6-2. FRONT PANEL SECTION

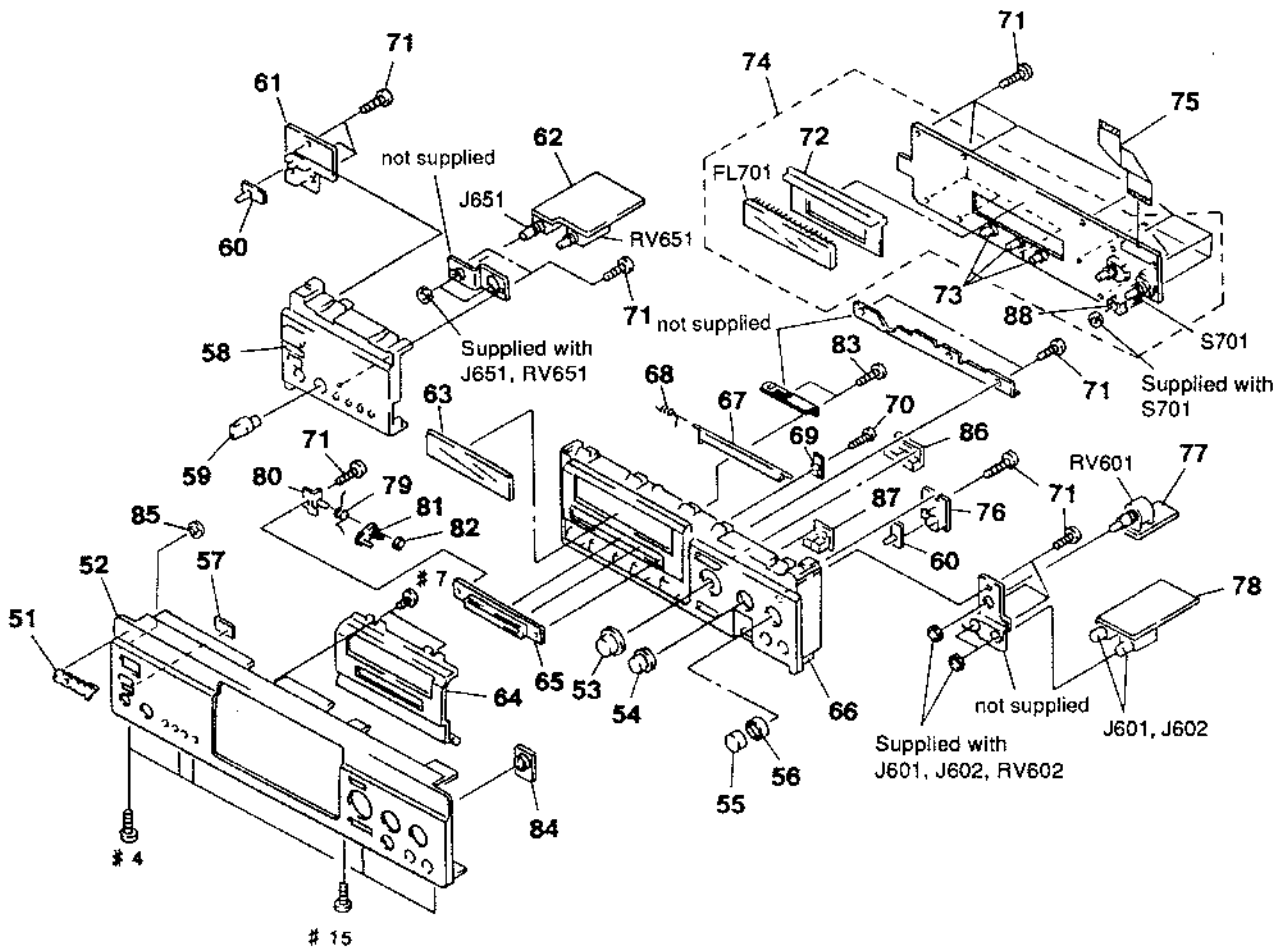

Ref. No.	Part No.	Description	Remark	Ref. No.	Part No.	Description	Remark
51	4-942-568-01	EMBLEM (NO. 5), SONY (SILVER).. (BLACK)		68	4-969-236-01	SPRING (LID), TORSION	
51	4-942-568-21	EMBLEM (NO. 5), SONY (GOLD).. (GOLD)		69	4-969-235-01	BRACKET (LID)	
52	4-971-761-01	PANEL, FRONT (BLACK) (AEP, G)		70	4-887-321-11	SCREW (BL. 7) (G), TAPPING	
52	4-971-761-11	PANEL, FRONT (GOLD)		71	4-951-620-01	SCREW (2. 6X8), +BVTP	
52	4-971-761-21	PANEL, FRONT (BLACK) (US, CND)					
53	4-971-755-01	KNOB (AMS) (BLACK)		* 72	4-971-854-01	HOLDER (FL)	
53	4-971-755-12	KNOB (AMS) (GOLD)		* 73	3-362-478-11	HOLDER (T), LED	
54	X-4945-628-1	KNOB (CONT) ASSY (BLACK)		* 74	A-4673-414-A	PANEL BOARD, COMPLETE	
54	X-4945-635-1	KNOB (CONT) ASSY (GOLD)		75	1-769-342-11	WIRE (FLAT TYPE) (26 CORE)	
55	X-4945-631-1	KNOB (A-REC) ASSY (BLACK)		* 76	1-655-332-11	ATT BOARD	
55	X-4945-638-1	KNOB (A-REC) ASSY (GOLD)		* 77	1-655-329-11	VOL BOARD	
56	4-971-775-01	KNOB (B-REC) (BLACK)		* 78	A-4673-418-A	MIC BOARD, COMPLETE	
56	4-971-775-11	KNOB (B-REC) (GOLD)		79	4-969-215-01	SPRING, TORSION	
57	4-971-773-01	WINDOW (REMOTE CONTROL)		80	X-4945-242-1	BRACKET (LEVER LID) ASSY	
58	X-4945-629-1	PANEL (L) ASSY (BLACK)		81	4-969-213-01	LEVER (LID)	
58	X-4945-636-1	PANEL (L) ASSY (GOLD)		82	3-681-678-00	WASHER, SLIT	
59	4-950-189-01	KNOB (A) (VOL) (BLACK)		83	4-908-618-21	SCREW (+BTP) (2X6)	
59	4-950-189-11	KNOB (A) (VOL) (GOLD)		84	4-971-771-01	ESCUTCHEON (BLACK)	
60	4-971-774-01	KNOB (TIMER) (BLACK)		84	4-971-771-11	ESCUTCHEON (GOLD)	
60	4-971-774-11	KNOB (TIMER) (GOLD)		85	4-971-776-01	INDICATOR	
* 61	1-655-328-11	PSW BOARD		86	4-971-751-01	BUTTON (EDIT) (BLACK)	
* 62	1-655-330-11	HP BOARD		86	4-971-751-11	BUTTON (EDIT) (GOLD)	
63	4-971-772-01	WINDOW (DISPLAY)		87	4-971-752-01	BUTTON (FF/REW) (BLACK)	
64	4-971-762-01	PLATE, ORNAMENTAL (BLACK)		87	4-971-752-11	BUTTON (FF/REW) (GOLD)	
64	4-971-762-11	PLATE, ORNAMENTAL (GOLD)		88	4-976-360-02	REINFORCEMENT (CONT)	
65	4-970-517-01	WINDOW, ORNAMENTAL (BLACK)		FL701	1-517-242-21	INDICATOR TUBE, FLUORESCENT	
65	4-970-517-11	WINDOW, ORNAMENTAL (GOLD)		J601	1-764-836-11	JACK (LARGE TYPE) (MIC L (MONO))	
66	X-4945-625-1	PANEL (R) ASSY (BLACK)		J602	1-764-836-11	JACK (LARGE TYPE) (MIC R)	
66	X-4945-632-1	PANEL (R) ASSY (GOLD)		J651	1-770-904-11	JACK (LARGE TYPE) (PHONES)	
67	4-969-226-01	LID (CARTRIDGE) (BLACK)		RV601	1-223-842-11	RES, VAR, CARBON 20K/20K (REC LEVEL)	
67	4-969-226-21	LID (CARTRIDGE) (GOLD)		RV651	1-223-843-11	RES, VAR, CARBON 20K/20K (PHONE LEVEL)	

6-3. CHASSIS SECTION

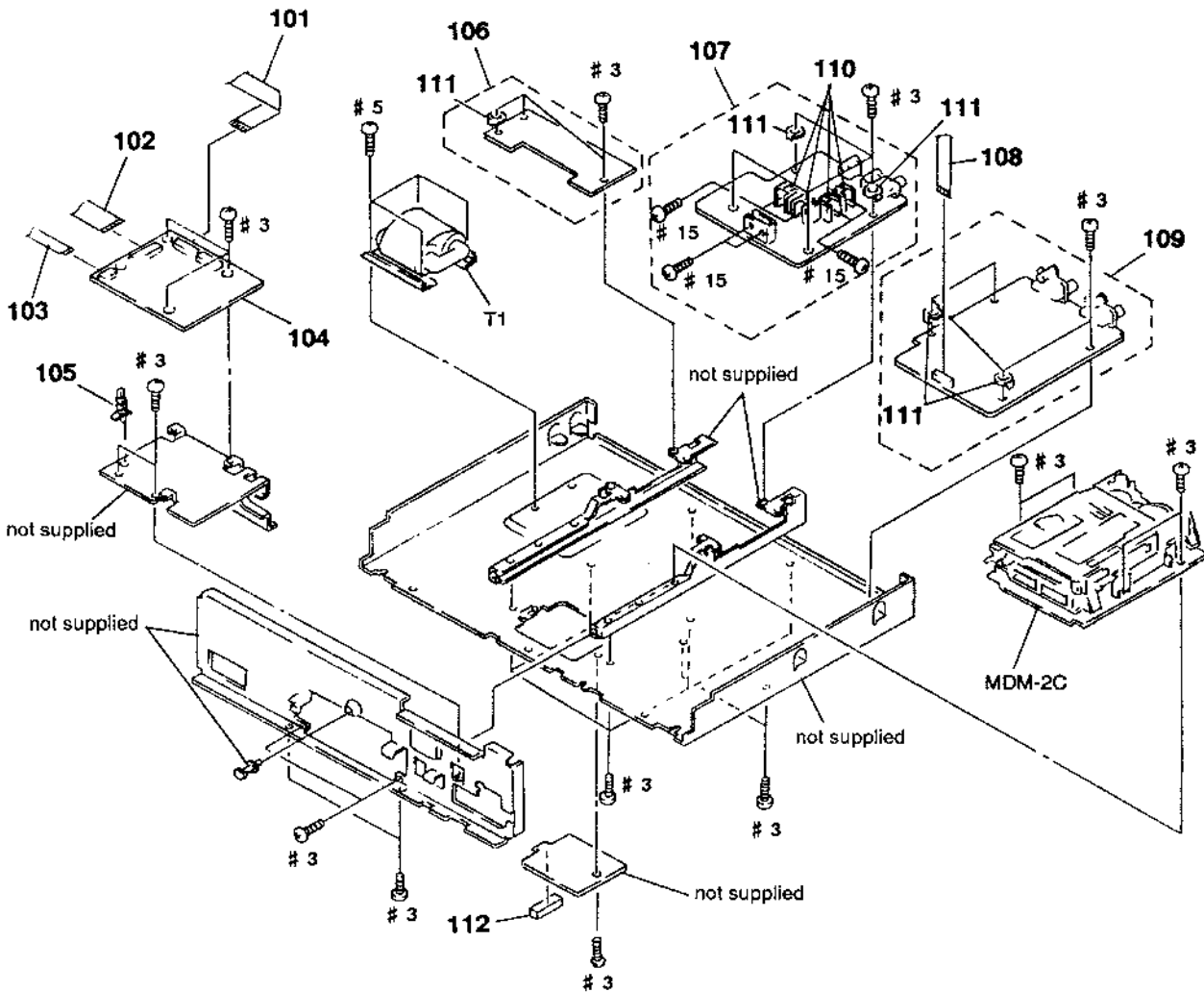

The components identified by mark Δ or dotted line with mark Δ are critical for safety. Replace only with part number specified.

Les composants identifiés par une marque Δ sont critiques pour la sécurité. Ne les remplacer que par une pièce portant le numéro spécifié.

Ref. No.	Part No.	Description	Remark	Ref. No.	Part No.	Description	Remark
101	1-769-341-11	WIRE (FLAT TYPE) (22 CORE)		108	1-769-360-11	WIRE, FLAT TYPE (13 CORE)	
102	1-775-376-11	WIRE (FLAT TYPE) (30 CORE)		* 109	A-4673-410-A	AUDIO BOARD, COMPLETE	
103	1-775-375-11	WIRE (FLAT TYPE) (18 CORE)		* 110	4-363-146-00	HEAT SINK, V. OUT	
* 104	A-4673-589-A	DIGITAL BOARD, COMPLETE (US, CND)		* 111	4-870-539-00	PLATE, GROUND	
* 104	A-4673-593-A	DIGITAL BOARD, COMPLETE (AEP, G)		112	9-911-840-XX	CUSHION, CRT	
* 105	3-703-353-02	SUPPORT, PC BOARD		Δ T1	1-427-770-11	TRANSFORMER, POWER (US, CND)	
* 106	1-655-326-11	AC BOARD		Δ T1	1-427-771-11	TRANSFORMER, POWER (AEP, G)	
* 107	A-4673-411-A	PW BOARD, COMPLETE (US, CND)					
* 107	A-4673-591-A	PW BOARD, COMPLETE (AEP, G)					

6-4. MECHANISM SECTION (MDM-2C)

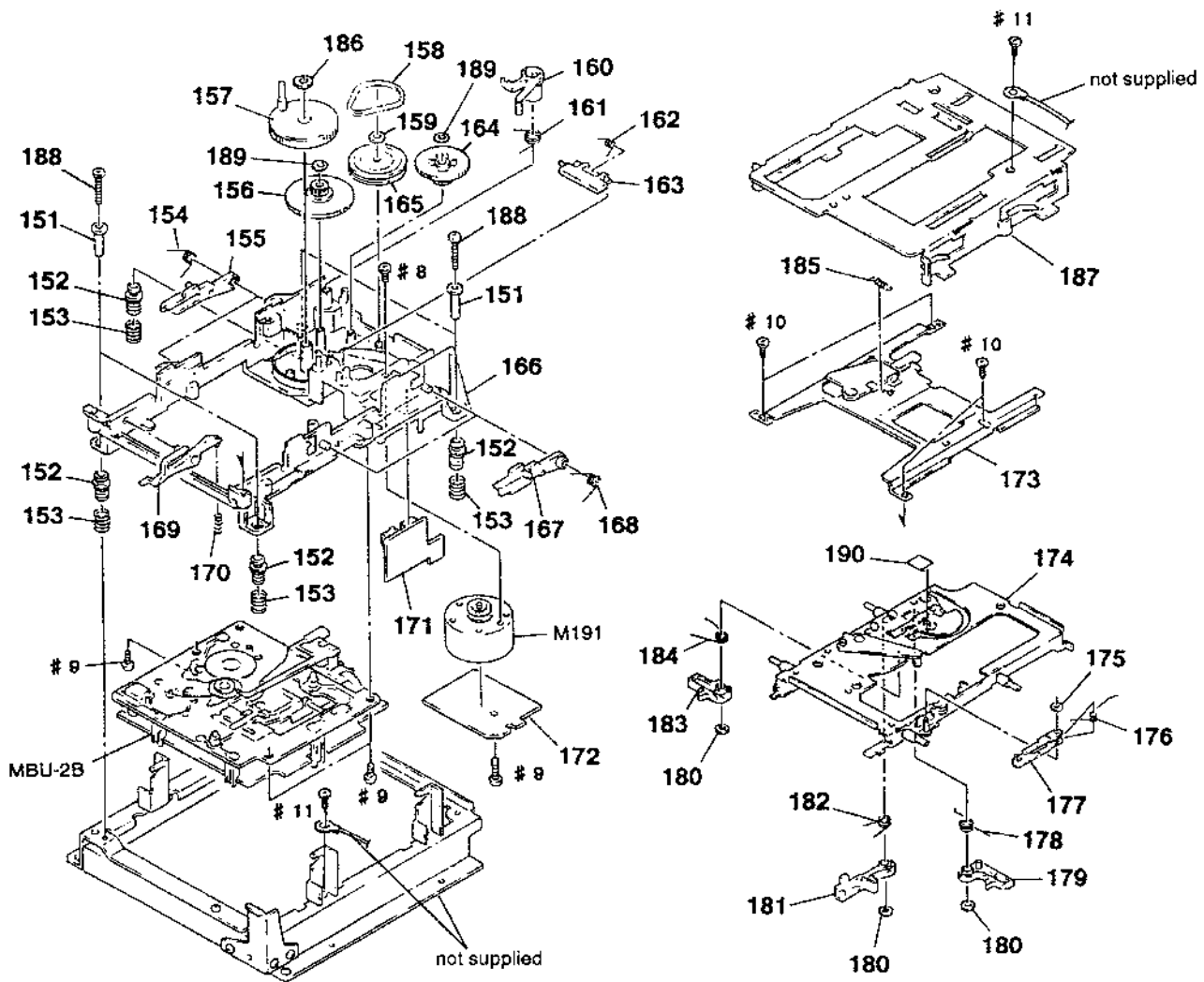

Ref. No.	Part No.	Description	Remark	Ref. No.	Part No.	Description	Remark
151	4-967-672-01	COLLAR (DAMPER)		* 172	1-653-412-11	MOTOR BOARD	
152	4-967-671-01	INSULATOR (MD)		173	A-4660-647-B	BRACKET (LVO) ASSY	
153	4-967-673-01	SPRING, COMPRESSION		* 174	X-4945-067-1	HOLDER ASSY	
154	4-967-668-01	SPRING (UDL), TORSION		175	4-968-919-11	WASHER, STOPPER	
155	4-967-667-01	LEVER (UDL)		176	4-967-646-01	SPRING (SHT), TORSION	
156	4-967-655-01	GEAR (BD-B)		177	4-967-645-01	LEVER (SHT)	
157	X-4945-069-1	CAM ASSY		178	4-967-640-01	SPRING (LM), TORSION	
158	4-967-656-01	BELT (BD)		179	4-967-639-01	LEVER (LM)	
159	4-968-919-31	WASHER, STOPPER		180	4-968-919-01	WASHER, STOPPER	
160	4-967-637-01	LEVER (SLM)		181	4-967-641-01	LEVER (L)	
161	4-967-638-01	SPRING (SLM), TORSION		182	4-967-642-01	SPRING (L), TORSION	
162	4-968-273-01	SPRING (OWH), TORSION		183	4-967-643-01	LEVER (LS)	
163	4-968-272-01	LEVER (OWH)		184	4-967-644-01	SPRING (LS), TORSION	
164	4-967-654-01	GEAR (BD-A)		185	4-971-743-02	SPRING, TENSION	
165	4-957-794-01	PULLEY (GEAR 1)		186	4-968-919-21	WASHER, STOPPER	
* 166	X-4945-068-1	BASE (BD) ASSY		* 187	X-4946-349-1	SLIDER (M) ASSY	
167	4-967-669-01	LEVER (UDR)		188	4-972-910-01	SCREW (2. 6X18), +B	
168	4-967-670-01	SPRING (UDR), TORSION		189	4-968-919-41	WASHER, STOPPER	
169	4-967-657-01	LEVER (DOOR)		190	3-561-902-00	CLOTH, RETAINING, CASSETTE	
170	4-970-710-01	SPRING, COMPRESSION		M191	A-4660-646-A	MOTOR ASSY (LOADING)	
* 171	1-653-411-11	DETECTION SW BOARD					

6-5. BASE UNIT SECTION (MBU-2B)

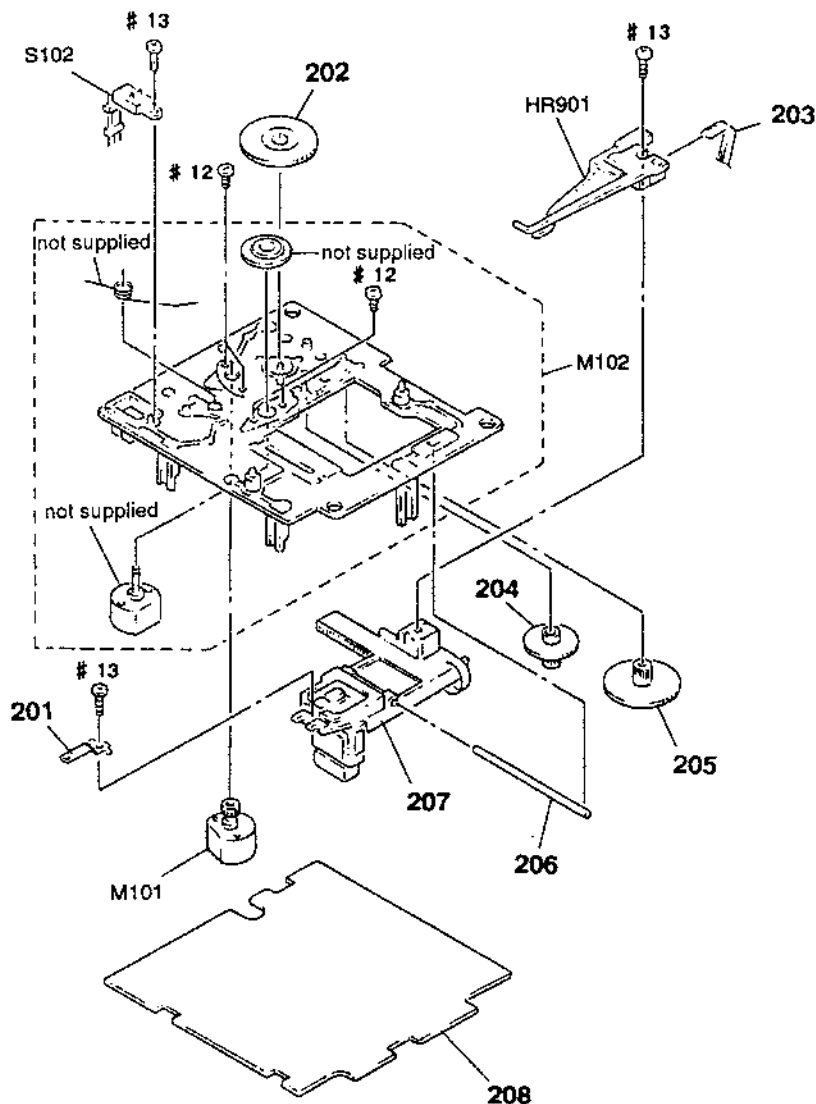

The components identified by mark ▲ or dotted line with mark △ are critical for safety. Replace only with part number specified.

Les composants identifiés par une marque ▲ sont critiques pour la sécurité. Ne les remplacer que par une pièce portant le numéro spécifié.

Ref. No.	Part No.	Description	Remark	Ref. No.	Part No.	Description	Remark
201	4-967-679-01	SPRING (OP), LEAF		▲207	8-583-009-11	OPTICAL PICK-UP BLOCK KMS-210A/J-N	
202	4-967-675-01	GEAR (SL-A)		* 208	A-4673-174-A	BD BOARD, COMPLETE	
203	1-654-446-11	FLEXIBLE BOARD (OWH)		M101	A-4660-651-A	MOTOR ASSY (SLED)	
204	4-967-676-01	GEAR (SL-B)		M102	A-4660-650-A	CHASSIS ASSY, BU (SPINDLE)	
205	4-967-677-01	GEAR (SL-C)		S102	1-762-148-11	SWITCH, PUSH (2 KEY)	
206	4-967-678-01	SHAFT (OP)		HR901	1-500-175-11	HEAD, OVER LIGHT (RF322-74A)	

SECTION 7 ELECTRICAL PARTS LIST

AC
ATT
AUDIO

NOTE:

The components identified by mark Δ or dotted line with mark Δ are critical for safety.
Replace only with part number specified.

Les composants identifiés par une marque Δ sont critiques pour la sécurité.
Ne les remplacer que par une pièce portant le numéro spécifié.

When indicating parts by reference number, please include the board name.

- Due to standardization, replacements in the parts list may be different from the parts specified in the diagrams or the components used on the set.
- -XX, -X mean standardized parts, so they may have some difference from the original one.
- Items marked "*" are not stocked since they are seldom required for routine service. Some delay should be anticipated when ordering these items.
- RESISTORS
All resistors are in ohms
METAL: Metal-film resistor
METAL OXIDE: Metal Oxide-film resistor
F: nonflammable
- SEMICONDUCTORS
In each case, u: μ , for example:
uA...: μ A..., uPA...: μ PA..., uPB...: μ PB...,
uPC...: μ PC..., uPD...: μ PD...
- CAPACITORS
uF: μ F
- COILS
uH: μ H
- Abbreviation
CND: Canadian model

Ref. No.	Part No.	Description	Remark	Ref. No.	Part No.	Description	Remark
*	1-655-326-11	AC BOARD *****		C502	1-124-994-11	ELECT	100uF 20% 10V
*	4-870-539-00	PLATE, GROUND		C503	1-164-159-11	CERAMIC	0.1uF 50V
	7-682-548-09	SCREW +BVTT 3X8 (S)		C504	1-124-994-11	ELECT	100uF 20% 10V
		< CAPACITOR >		C505	1-164-159-11	CERAMIC	0.1uF 50V
Δ C001	1-161-742-00	CERAMIC	0.0022uF 20% 400V (AEP)	C506	1-124-994-11	ELECT	100uF 20% 10V
Δ C002	1-161-742-00	CERAMIC	0.0022uF 20% 400V	C507	1-164-159-11	CERAMIC	0.1uF 50V
Δ C003	1-161-742-00	CERAMIC	0.0022uF 20% 400V	C508	1-164-159-11	CERAMIC	0.1uF 50V
Δ C004	1-161-742-00	CERAMIC	0.0022uF 20% 400V	C509	1-124-994-11	ELECT	100uF 20% 10V
Δ C005	1-161-744-51	CERAMIC	0.01uF 400V	C510	1-124-995-11	ELECT	220uF 20% 10V
Δ C006	1-161-744-51	CERAMIC	0.01uF 400V	C511	1-164-159-11	CERAMIC	0.1uF 50V
		< CONNECTOR >		C512	1-164-159-11	CERAMIC	0.1uF 50V
CN001	1-564-321-00	PIN, CONNECTOR 2P		C513	1-124-995-11	ELECT	220uF 20% 10V
CN002	1-580-230-11	PIN, CONNECTOR (PC BOARD) 2P		C514	1-164-159-11	CERAMIC	0.1uF 50V
		< LINE FILTER >		C515	1-164-159-11	CERAMIC	0.1uF 50V
Δ LF001	1-424-485-11	FILTER, LINE		C518	1-162-207-31	CERAMIC	22PF 5% 50V
*****				C519	1-162-207-31	CERAMIC	22PF 5% 50V
*	1-655-332-11	ATT BOARD *****		C520	1-124-994-11	ELECT	100uF 20% 10V
		< SWITCH >		C521	1-164-159-11	CERAMIC	0.1uF 50V
S601	1-572-624-11	SWITCH, SLIDE (MIC ATT)		C522	1-162-294-31	CERAMIC	0.001uF 10% 50V
*****				C523	1-162-199-31	CERAMIC	10PF 5% 50V
*	A-4673-410-A	AUDIO BOARD, COMPLETE *****		C524	1-164-159-11	CERAMIC	0.1uF 50V
*	4-870-539-00	PLATE, GROUND		C525	1-164-159-11	CERAMIC	0.1uF 50V
	7-682-548-09	SCREW +BVTT 3X8 (S)		C526	1-136-356-11	FILM	470PF 5% 100V
		< BUS BAR >		C527	1-164-159-11	CERAMIC	0.1uF 50V
* BB501	1-560-242-31	BUS BAR 5P		C528	1-136-356-11	FILM	470PF 5% 100V
* BB502	1-560-242-81	BUS BAR 8P		C529	1-164-159-11	CERAMIC	0.1uF 50V
		< CAPACITOR >		C530	1-124-994-11	ELECT	100uF 20% 10V
C501	1-162-294-31	CERAMIC	0.001uF 10% 50V	C531	1-164-159-11	CERAMIC	0.1uF 50V
				C532	1-162-199-31	CERAMIC	10PF 5% 50V
				C533	1-162-199-31	CERAMIC	10PF 5% 50V
				C534	1-124-994-11	ELECT	100uF 20% 10V
				C535	1-124-995-11	ELECT	220uF 20% 10V
				C536	1-124-995-11	ELECT	220uF 20% 10V
				C538	1-164-159-11	CERAMIC	0.1uF 50V
				C539	1-164-159-11	CERAMIC	0.1uF 50V
				C540	1-164-159-11	CERAMIC	0.1uF 50V
				C541	1-106-359-00	MYLAR	4700PF 5% 200V
				C542	1-106-359-00	MYLAR	4700PF 5% 200V
				C543	1-164-159-11	CERAMIC	0.1uF 50V
				C544	1-164-159-11	CERAMIC	0.1uF 50V
				C546	1-106-359-00	MYLAR	4700PF 5% 200V
				C547	1-106-359-00	MYLAR	4700PF 5% 200V

AUDIO

Ref. No.	Part No.	Description			Remark	Ref. No.	Part No.	Description	Remark
C548	1-124-995-11	ELECT	220uF	20%	10V			< CONNECTOR >	
C549	1-124-994-11	ELECT	100uF	20%	10V				
C550	1-164-159-11	CERAMIC	0.1uF		50V	CN501	1-580-465-11	SOCKET, CONNECTOR 13P	
C551	1-162-294-31	CERAMIC	0.001uF	10%	50V	CN502	1-766-201-11	SOCKET, CONNECTOR PIN 11P	
C552	1-124-995-11	ELECT	220uF	20%	10V	* CN503	1-568-935-11	PIN, CONNECTOR 8P	
C553	1-164-159-11	CERAMIC	0.1uF		50V	* CN504	1-568-936-11	PIN, CONNECTOR 9P	
C554	1-164-159-11	CERAMIC	0.1uF		50V	* CN506	1-568-934-11	PIN, CONNECTOR 7P	
								< DIODE >	
C555	1-162-286-31	CERAMIC	220PF	10%	50V	D501	8-719-987-63	DIODE 1N4148M	
C556	1-162-286-31	CERAMIC	220PF	10%	50V	D502	8-719-987-63	DIODE 1N4148M	
C557	1-164-159-11	CERAMIC	0.1uF		50V	D503	8-719-987-63	DIODE 1N4148M	
C558	1-124-994-11	ELECT	100uF	20%	10V	D504	8-719-987-63	DIODE 1N4148M	
C559	1-124-929-11	ELECT	22uF	20%	100V	D505	8-719-987-63	DIODE 1N4148M	
C560	1-124-929-11	ELECT	22uF	20%	100V	D506	8-719-210-21	DIODE 11EQS04	
C561	1-164-159-11	CERAMIC	0.1uF		50V	D507	8-719-210-21	DIODE 11EQS04	
C562	1-136-810-11	FILM	220PF	5%	100V	D508	8-719-210-21	DIODE 11EQS04	
C563	1-136-810-11	FILM	220PF	5%	100V			< IC >	
C564	1-124-994-11	ELECT	100uF	20%	10V	IC501	8-759-334-75	IC CXD8505AQ	
C565	1-136-810-11	FILM	220PF	5%	100V	IC502	8-759-326-73	IC CXD8539M	
C566	1-136-810-11	FILM	220PF	5%	100V	IC503	8-759-604-35	IC M5F78M05L	
C568	1-124-122-11	ELECT	100uF	20%	50V	IC505	8-759-326-74	IC CXA8043M	
C569	1-124-122-11	ELECT	100uF	20%	50V	IC507	8-759-982-03	IC RC5532DD	
C570	1-136-810-11	FILM	220PF	5%	100V	IC508	8-759-982-03	IC RC5532DD	
C571	1-136-810-11	FILM	220PF	5%	100V	IC509	8-759-982-03	IC RC5532DD	
C572	1-136-810-11	FILM	220PF	5%	100V	IC510	8-759-982-03	IC RC5532DD	
C573	1-136-810-11	FILM	220PF	5%	100V	IC511	8-759-982-03	IC RC5532DD	
C574	1-126-023-11	ELECT	100uF	20%	25V			< JACK >	
C575	1-126-027-11	ELECT	1000uF	20%	25V	J501	1-770-483-11	JACK, PIN (LINE IN)	
C576	1-126-023-11	ELECT	100uF	20%	25V	J502	1-770-483-11	JACK, PIN (LINE OUT)	
C577	1-106-359-00	MYLAR	4700PF	5%	200V			< COIL >	
C578	1-106-359-00	MYLAR	4700PF	5%	200V	L504	1-424-090-11	COIL, LINE FILTER	
C579	1-126-023-11	ELECT	100uF	20%	25V	L505	1-410-324-11	INDUCTOR 4.7uH	
C580	1-106-343-00	MYLAR	1000PF	5%	200V	* L506	1-410-858-21	INDUCTOR 0uH	
C581	1-106-343-00	MYLAR	1000PF	5%	200V	* L507	1-410-858-21	INDUCTOR 0uH	
C582	1-126-027-11	ELECT	1000uF	20%	25V	* L508	1-410-858-21	INDUCTOR 0uH	
C583	1-126-023-11	ELECT	100uF	20%	25V	* L509	1-410-858-21	INDUCTOR 0uH	
C584	1-124-572-11	ELECT	100uF	20%	63V	* L510	1-410-858-21	INDUCTOR 0uH	
C585	1-124-572-11	ELECT	100uF	20%	63V	L511	1-414-512-21	INDUCTOR 6.8uH	
C586	1-162-294-31	CERAMIC	0.001uF	10%	50V			< TRANSISTOR >	
C587	1-124-122-11	ELECT	100uF	20%	50V	Q501	8-729-140-98	TRANSISTOR 2SD773-34	
C588	1-124-122-11	ELECT	100uF	20%	50V	Q502	8-729-231-55	TRANSISTOR 2SC2878-AB	
C589	1-162-282-31	CERAMIC	100PF	10%	50V	Q503	8-729-231-55	TRANSISTOR 2SC2878-AB	
C590	1-162-282-31	CERAMIC	100PF	10%	50V	Q504	8-729-231-55	TRANSISTOR 2SC2878-AB	
C591	1-162-294-31	CERAMIC	0.001uF	10%	50V	Q505	8-729-231-55	TRANSISTOR 2SC2878-AB	
C592	1-162-294-31	CERAMIC	0.001uF	10%	50V				
C593	1-126-022-11	ELECT	47uF	20%	25V				
C594	1-126-022-11	ELECT	47uF	20%	25V				
C598	1-162-203-31	CERAMIC	15PF	5%	50V				
C599	1-162-203-31	CERAMIC	15PF	5%	50V				

Ref. No.	Part No.	Description	Remark	Ref. No.	Part No.	Description	Remark
< RESISTOR >							
R501	1-259-380-11	CARBON	10 5% 1/6W	R556	1-259-476-11	CARBON	100K 5% 1/6W
R502	1-259-380-11	CARBON	10 5% 1/6W	R557	1-259-476-11	CARBON	100K 5% 1/6W
R503	1-259-380-11	CARBON	10 5% 1/6W	R558	1-259-460-11	CARBON	22K 5% 1/6W
R504	1-259-380-11	CARBON	10 5% 1/6W	R559	1-247-704-11	CARBON	220 5% 1/4W F
R505	1-259-380-11	CARBON	10 5% 1/6W	R560	1-259-444-11	CARBON	4.7K 5% 1/6W
R506	1-259-380-11	CARBON	10 5% 1/6W	R561	1-259-444-11	CARBON	4.7K 5% 1/6W
R507	1-259-380-11	CARBON	10 5% 1/6W	R562	1-247-704-11	CARBON	220 5% 1/4W F
R508	1-259-380-11	CARBON	10 5% 1/6W	R563	1-259-460-11	CARBON	22K 5% 1/6W
R509	1-259-412-11	CARBON	220 5% 1/6W	R564	1-259-476-11	CARBON	100K 5% 1/6W
R510	1-259-404-11	CARBON	100 5% 1/6W	R565	1-259-476-11	CARBON	100K 5% 1/6W
R511	1-259-444-11	CARBON	4.7K 5% 1/6W	R566	1-247-704-11	CARBON	220 5% 1/4W F
R512	1-259-444-11	CARBON	4.7K 5% 1/6W	R567	1-259-444-11	CARBON	4.7K 5% 1/6W
R513	1-259-444-11	CARBON	4.7K 5% 1/6W	R568	1-259-444-11	CARBON	4.7K 5% 1/6W
R514	1-259-444-11	CARBON	4.7K 5% 1/6W	R569	1-247-704-11	CARBON	220 5% 1/4W F
R516	1-259-444-11	CARBON	4.7K 5% 1/6W	R570	1-259-500-11	CARBON	1M 5% 1/6W
R517	1-259-396-11	CARBON	47 5% 1/6W	R571	1-259-500-11	CARBON	1M 5% 1/6W
R518	1-259-396-11	CARBON	47 5% 1/6W	R572	1-247-708-11	CARBON	470 5% 1/4W F
R519	1-259-444-11	CARBON	4.7K 5% 1/6W	R573	1-247-708-11	CARBON	470 5% 1/4W F
R520	1-259-444-11	CARBON	4.7K 5% 1/6W	R574	1-259-420-11	CARBON	470 5% 1/6W
R521	1-259-444-11	CARBON	4.7K 5% 1/6W	R575	1-259-420-11	CARBON	470 5% 1/6W
R522	1-259-444-11	CARBON	4.7K 5% 1/6W	R576	1-259-476-11	CARBON	100K 5% 1/6W
R523	1-259-412-11	CARBON	220 5% 1/6W	R577	1-259-476-11	CARBON	100K 5% 1/6W
R524	1-259-468-11	CARBON	47K 5% 1/6W	R578	1-259-396-11	CARBON	47 5% 1/6W
R525	1-259-460-11	CARBON	22K 5% 1/6W	< RELAY >			
R526	1-259-460-11	CARBON	22K 5% 1/6W	RY501	1-515-725-21	RELAY	
R527	1-259-468-11	CARBON	47K 5% 1/6W	< VIBRATOR >			
R530	1-259-444-11	CARBON	4.7K 5% 1/6W	X501	1-579-161-11	VIBRATOR, CRYSTAL (45.158MHz)	
R531	1-259-420-11	CARBON	470 5% 1/6W	*****			
R532	1-259-444-11	CARBON	4.7K 5% 1/6W	*	A-4673-174-A	BD BOARD, COMPLETE	
R535	1-259-444-11	CARBON	4.7K 5% 1/6W	*****			
R537	1-259-444-11	CARBON	4.7K 5% 1/6W	< CAPACITOR >			
R538	1-259-452-11	CARBON	10K 5% 1/6W	C101	1-104-913-11	TANTAL. CHIP	10uF 20% 16V
R539	1-259-452-11	CARBON	10K 5% 1/6W	C102	1-163-038-00	CERAMIC CHIP	0.1uF 25V
R540	1-259-452-11	CARBON	10K 5% 1/6W	C103	1-104-913-11	TANTAL. CHIP	10uF 20% 16V
R541	1-259-452-11	CARBON	10K 5% 1/6W	C104	1-104-913-11	TANTAL. CHIP	10uF 20% 16V
R542	1-259-436-11	CARBON	2.2K 5% 1/6W	C105	1-164-232-11	CERAMIC CHIP	0.01uF 50V
R543	1-259-436-11	CARBON	2.2K 5% 1/6W	C106	1-163-275-11	CERAMIC CHIP	0.001uF 5% 50V
R544	1-259-436-11	CARBON	2.2K 5% 1/6W	C107	1-164-232-11	CERAMIC CHIP	0.01uF 50V
R545	1-259-436-11	CARBON	2.2K 5% 1/6W	C108	1-164-232-11	CERAMIC CHIP	0.01uF 50V
R546	1-259-476-11	CARBON	100K 5% 1/6W	C109	1-163-037-11	CERAMIC CHIP	0.022uF 10% 25V
R547	1-259-476-11	CARBON	100K 5% 1/6W	C111	1-164-004-11	CERAMIC CHIP	0.1uF 10% 25V
R548	1-259-436-11	CARBON	2.2K 5% 1/6W	C112	1-164-232-11	CERAMIC CHIP	0.01uF 50V
R549	1-259-436-11	CARBON	2.2K 5% 1/6W	C113	1-107-682-11	CERAMIC CHIP	1uF 10% 16V
R550	1-259-436-11	CARBON	2.2K 5% 1/6W	C114	1-163-038-00	CERAMIC CHIP	0.1uF 25V
R551	1-259-436-11	CARBON	2.2K 5% 1/6W	C115	1-107-682-11	CERAMIC CHIP	1uF 10% 16V
R552	1-259-432-11	CARBON	1.5K 5% 1/6W				
R553	1-259-432-11	CARBON	1.5K 5% 1/6W				
R554	1-259-432-11	CARBON	1.5K 5% 1/6W				
R555	1-259-432-11	CARBON	1.5K 5% 1/6W				

Ref. No.	Part No.	Description		Remark	Ref. No.	Part No.	Description	Remark
C116	1-163-019-00	CERAMIC CHIP	0.0068uF	10%	50V		< CONNECTOR >	
C117	1-164-004-11	CERAMIC CHIP	0.1uF	10%	25V	CN101	1-766-508-11	CONNECTOR, FFC/FPC (ZIF) 22P
C119	1-104-913-11	TANTAL. CHIP	10uF	20%	16V	CN102	1-766-510-21	CONNECTOR, FFC/FPC 30P
C121	1-126-395-11	ELECT	22uF	20%	16V	CN103	1-766-509-21	CONNECTOR, FFC/FPC 18P
C122	1-164-232-11	CERAMIC CHIP	0.01uF		50V	CN104	1-766-898-21	HOUSING, CONNECTOR (PC BOARD) 4P
C123	1-163-038-00	CERAMIC CHIP	0.1uF		25V		< DIODE >	
C124	1-163-038-00	CERAMIC CHIP	0.1uF		25V	D101	8-719-988-62	DIODE 1SS355
C125	1-104-760-11	CERAMIC CHIP	0.047uF	10%	50V	D155	8-719-031-17	DIODE 1SS322
C126	1-107-682-11	CERAMIC CHIP	1uF	10%	16V	D161	8-719-421-15	DIODE MA8027-L
C127	1-163-038-00	CERAMIC CHIP	0.1uF		25V	D181	8-719-033-60	DIODE F1P2STP
C128	1-164-232-11	CERAMIC CHIP	0.01uF		50V	D183	8-719-033-60	DIODE F1P2STP
C129	1-107-823-11	CERAMIC CHIP	0.47uF	10%	16V		< IC >	
C130	1-163-251-11	CERAMIC CHIP	100PF	5%	50V	IC101	8-752-072-68	IC CXA1981AR
C131	1-104-760-11	CERAMIC CHIP	0.047uF	10%	50V	IC102	8-759-243-19	IC TC7SU04F
C132	1-107-682-11	CERAMIC CHIP	1uF	10%	16V	IC121	8-752-375-06	IC CXD2535AR
C133	1-163-017-00	CERAMIC CHIP	0.0047uF	5%	50V	IC122	8-759-243-19	IC TC7SU04F
C134	1-163-038-00	CERAMIC CHIP	0.1uF		25V	IC151	8-759-179-60	IC MPC17A38VMEL
C135	1-163-038-00	CERAMIC CHIP	0.1uF		25V	IC171	8-759-504-12	IC X24C01S
C136	1-126-206-11	ELECT CHIP	100uF	20%	6.3V	IC172	8-759-149-73	IC uPC842G2
C141	1-163-038-00	CERAMIC CHIP	0.1uF		25V	IC181	8-759-095-65	IC TC74ACT540FS
C142	1-163-251-11	CERAMIC CHIP	100PF	5%	50V	IC182	8-759-243-19	IC TC7SU04F
C143	1-163-251-11	CERAMIC CHIP	100PF	5%	50V	IC191	8-759-822-99	IC L88MS05-FA
C144	1-163-251-11	CERAMIC CHIP	100PF	5%	50V		< COIL >	
C151	1-104-913-11	TANTAL. CHIP	10uF	20%	16V	L101	1-414-234-11	INDUCTOR, FERRITE BEAD
C152	1-163-038-00	CERAMIC CHIP	0.1uF		25V	L102	1-414-234-11	INDUCTOR, FERRITE BEAD
C155	1-104-916-11	TANTAL. CHIP	6.8uF	20%	20V	L103	1-414-234-11	INDUCTOR, FERRITE BEAD
C160	1-104-601-11	ELECT CHIP	10uF	20%	10V	L105	1-414-234-11	INDUCTOR, FERRITE BEAD
C161	1-104-601-11	ELECT CHIP	10uF	20%	10V	L106	1-414-234-11	INDUCTOR, FERRITE BEAD
C163	1-164-232-11	CERAMIC CHIP	0.01uF		50V	L110	1-216-295-00	METAL CHIP 0 5% 1/10W
C164	1-164-232-11	CERAMIC CHIP	0.01uF		50V	L121	1-414-234-11	INDUCTOR, FERRITE BEAD
C166	1-163-275-11	CERAMIC CHIP	0.001uF	5%	50V	L122	1-412-039-51	INDUCTOR CHIP 100uH
C167	1-163-038-00	CERAMIC CHIP	0.1uF		25V	L151	1-412-622-51	INDUCTOR 10uH
C168	1-163-038-00	CERAMIC CHIP	0.1uF		25V	L152	1-412-622-51	INDUCTOR 10uH
C169	1-104-913-11	TANTAL. CHIP	10uF	20%	16V	L153	1-412-039-51	INDUCTOR CHIP 100uH
C170	1-104-913-11	TANTAL. CHIP	10uF	20%	16V	L154	1-412-039-51	INDUCTOR CHIP 100uH
C171	1-163-038-00	CERAMIC CHIP	0.1uF		25V	L155	1-410-980-51	INDUCTOR CHIP 1mH
C175	1-163-038-00	CERAMIC CHIP	0.1uF		25V	L161	1-414-234-11	INDUCTOR, FERRITE BEAD
C176	1-163-227-11	CERAMIC CHIP	10PF	0.5PF	50V	L162	1-414-234-11	INDUCTOR, FERRITE BEAD
C177	1-163-227-11	CERAMIC CHIP	10PF	0.5PF	50V	L195	1-233-316-21	FILTER, CHIP EMI
C178	1-163-038-00	CERAMIC CHIP	0.1uF		25V		< TRANSISTOR >	
C181	1-104-913-11	TANTAL. CHIP	10uF	20%	16V	Q101	8-729-905-12	TRANSISTOR DTA144EU
C182	1-163-038-00	CERAMIC CHIP	0.1uF		25V	Q151	8-729-905-18	TRANSISTOR DTC144EU
C183	1-163-038-00	CERAMIC CHIP	0.1uF		25V	Q162	8-729-101-07	TRANSISTOR 2SB798-DL
C184	1-107-836-11	ELECT CHIP	22uF	20%	8V	Q163	8-729-905-12	TRANSISTOR DTA144EU
C185	1-164-611-11	CERAMIC CHIP	0.001uF	10%	500V	Q164	8-729-924-19	TRANSISTOR DTA123JU
C186	1-163-038-00	CERAMIC CHIP	0.1uF		25V	Q181	8-729-018-75	TRANSISTOR 2SJ278MY
C191	1-126-395-11	ELECT	22uF	20%	16V			
C192	1-163-038-00	CERAMIC CHIP	0.1uF		25V			
C193	1-164-346-11	CERAMIC CHIP	1uF		16V			
C194	1-126-206-11	ELECT CHIP	100uF	20%	6.3V			

BD DETECTION SW DIGITAL

Ref. No.	Part No.	Description	Remark	Ref. No.	Part No.	Description	Remark
Q182	8-729-017-65	TRANSISTOR	2SK1764KY	R168	1-218-236-11	METAL GLAZE	1 10% 1/4W
	< RESISTOR >			R170	1-216-073-00	METAL CHIP	10K 5% 1/10W
R101	1-216-061-00	METAL CHIP	3.3K 5% 1/10W	R171	1-216-073-00	METAL CHIP	10K 5% 1/10W
R102	1-216-077-00	METAL CHIP	15K 5% 1/10W	R172	1-216-065-00	METAL CHIP	4.7K 5% 1/10W
R103	1-208-806-11	METAL CHIP	10K 0.50% 1/10W	R174	1-216-065-00	METAL CHIP	4.7K 5% 1/10W
R104	1-216-049-00	METAL CHIP	1K 5% 1/10W	R176	1-216-065-00	METAL CHIP	4.7K 5% 1/10W
R105	1-216-065-00	METAL CHIP	4.7K 5% 1/10W	R178	1-216-065-00	METAL CHIP	4.7K 5% 1/10W
R106	1-216-133-00	METAL CHIP	3.3M 5% 1/10W	R181	1-216-073-00	METAL CHIP	10K 5% 1/10W
R107	1-216-113-00	METAL CHIP	470K 5% 1/10W	R182	1-216-089-91	METAL GLAZE	47K 5% 1/10W
R114	1-216-025-00	METAL CHIP	100 5% 1/10W	R183	1-216-089-91	METAL GLAZE	47K 5% 1/10W
R116	1-216-069-00	METAL CHIP	6.8K 5% 1/10W	R184	1-216-296-91	CONDUCTOR, CHIP (3216)	
R117	1-216-113-00	METAL CHIP	470K 5% 1/10W	R186	1-216-296-91	CONDUCTOR, CHIP (3216)	
R120	1-216-025-00	METAL CHIP	100 5% 1/10W	R195	1-216-295-00	METAL CHIP	0 5% 1/10W
R121	1-216-097-00	METAL CHIP	100K 5% 1/10W		< VARIABLE RESISTOR >		
R122	1-216-295-00	METAL CHIP	0 5% 1/10W	RV101	1-241-397-11	RES, ADJ, METAL GLAZE	47K
R123	1-216-037-00	METAL CHIP	330 5% 1/10W	RV102	1-241-395-11	RES, ADJ, METAL GLAZE	10K
R124	1-216-025-00	METAL CHIP	100 5% 1/10W	RV105	1-241-395-11	RES, ADJ, METAL GLAZE	10K
R125	1-216-025-00	METAL CHIP	100 5% 1/10W		< SWITCH >		
R128	1-216-053-00	METAL CHIP	1.5K 5% 1/10W	S101	1-572-467-31	SWITCH, PUSH (1 KEY) (LIMIT)	
R129	1-216-037-00	METAL CHIP	330 5% 1/10W		*****		
R130	1-216-041-00	METAL CHIP	470 5% 1/10W	* 1-653-411-11	DETECTION SW BOARD		
R131	1-216-073-00	METAL CHIP	10K 5% 1/10W		*****		
R132	1-216-097-00	METAL CHIP	100K 5% 1/10W		< CONNECTOR >		
R133	1-216-133-00	METAL CHIP	3.3M 5% 1/10W	CN193	1-770-010-21	CONNECTOR, BOARD TO BOARD	4P
R134	1-216-037-00	METAL CHIP	330 5% 1/10W		< SWITCH >		
R135	1-216-053-00	METAL CHIP	1.5K 5% 1/10W	S191	1-762-149-11	SWITCH, PUSH (1 KEY) (LOAD OUT DET)	
R136	1-216-041-00	METAL CHIP	470 5% 1/10W	S192	1-762-149-11	SWITCH, PUSH (1 KEY) (LOAD IN DET)	
R137	1-216-025-00	METAL CHIP	100 5% 1/10W	S193	1-762-149-11	SWITCH, PUSH (1 KEY) (CHACKING IN DET)	
R139	1-216-017-91	METAL GLAZE	47 5% 1/10W		*****		
R140	1-216-017-91	METAL GLAZE	47 5% 1/10W	* A-4673-589-A	DIGITAL BOARD, COMPLETE (US, CND)		
R142	1-216-073-00	METAL CHIP	10K 5% 1/10W		*****		
R143	1-216-073-00	METAL CHIP	10K 5% 1/10W	* A-4673-593-A	DIGITAL BOARD, COMPLETE (AEP)		
R144	1-216-025-00	METAL CHIP	100 5% 1/10W		*****		
R145	1-216-121-91	METAL GLAZE	1M 5% 1/10W		< CAPACITOR >		
R146	1-216-037-00	METAL CHIP	330 5% 1/10W	C201	1-163-038-00	CERAMIC CHIP	0.1uF 25V
R147	1-216-025-00	METAL CHIP	100 5% 1/10W	C202	1-163-038-00	CERAMIC CHIP	0.1uF 25V
R148	1-216-045-00	METAL CHIP	680 5% 1/10W	C203	1-163-235-11	CERAMIC CHIP	22PF 5% 50V
R151	1-216-097-00	METAL CHIP	100K 5% 1/10W	C204	1-163-235-11	CERAMIC CHIP	22PF 5% 50V
R152	1-216-295-00	METAL CHIP	0 5% 1/10W	C205	1-163-141-00	CERAMIC CHIP	0.001uF 5% 50V
R153	1-216-295-00	METAL CHIP	0 5% 1/10W	C206	1-163-038-00	CERAMIC CHIP	0.1uF 25V
R154	1-220-259-11	METAL GLAZE	150 5% 1/4W	C207	1-126-395-11	ELECT	22uF 20% 16V
R155	1-220-259-11	METAL GLAZE	150 5% 1/4W	C208	1-163-038-00	CERAMIC CHIP	0.1uF 25V
R161	1-216-057-00	METAL CHIP	2.2K 5% 1/10W				
R162	1-216-057-00	METAL CHIP	2.2K 5% 1/10W				
R163	1-216-057-00	METAL CHIP	2.2K 5% 1/10W				
R164	1-216-045-00	METAL CHIP	680 5% 1/10W				
R165	1-216-097-00	METAL CHIP	100K 5% 1/10W				
R166	1-220-250-11	METAL GLAZE	10 5% 1/2W				
R167	1-216-065-00	METAL CHIP	4.7K 5% 1/10W				

DIGITAL

Ref. No.	Part No.	Description	Remark	Ref. No.	Part No.	Description	Remark
C209	1-163-038-00	CERAMIC CHIP	0.1uF	25V	C263	1-164-232-11	CERAMIC CHIP 0.01uF 50V
C210	1-163-038-00	CERAMIC CHIP	0.1uF	25V	C264	1-163-141-00	CERAMIC CHIP 0.001uF 5% 50V
C211	1-163-038-00	CERAMIC CHIP	0.1uF	25V	C268	1-163-038-00	CERAMIC CHIP 0.1uF 25V
C212	1-163-038-00	CERAMIC CHIP	0.1uF	25V	C269	1-163-038-00	CERAMIC CHIP 0.1uF 25V
C213	1-163-038-00	CERAMIC CHIP	0.1uF	25V	C291	1-163-109-00	CERAMIC CHIP 47PF 5% 50V
C214	1-163-038-00	CERAMIC CHIP	0.1uF	25V	C292	1-163-141-00	CERAMIC CHIP 0.001uF 5% 50V
C215	1-163-038-00	CERAMIC CHIP	0.1uF	25V			
C216	1-163-038-00	CERAMIC CHIP	0.1uF	25V		< CONNECTOR >	
C217	1-163-038-00	CERAMIC CHIP	0.1uF	25V	CN201	1-770-142-11	CONNECTOR, FFC (ZIF) 26P
C218	1-126-204-11	ELECT CHIP	47uF	20% 16V	CN202	1-766-510-21	CONNECTOR, FFC/FPC 30P
C219	1-163-038-00	CERAMIC CHIP	0.1uF	25V	CN221	1-766-509-21	CONNECTOR, FFC/FPC 18P
C220	1-163-038-00	CERAMIC CHIP	0.1uF	25V	CN223	1-580-891-11	SOCKET, CONNECTOR (SMT) 22P
C221	1-126-204-11	ELECT CHIP	47uF	20% 16V	* CN251	1-770-154-11	PIN, CONNECTOR (PC BOARD) 6P
C222	1-163-038-00	CERAMIC CHIP	0.1uF	25V	* CN261	1-770-154-11	PIN, CONNECTOR (PC BOARD) 6P
C223	1-163-038-00	CERAMIC CHIP	0.1uF	25V	CN263	1-580-884-11	SOCKET, CONNECTOR (SMT) 13P
C224	1-126-204-11	ELECT CHIP	47uF	20% 16V			
C225	1-163-038-00	CERAMIC CHIP	0.1uF	25V		< IC >	
C226	1-163-038-00	CERAMIC CHIP	0.1uF	25V	IC201	8-759-328-78	IC M37610MD-057FP
C227	1-126-204-11	ELECT CHIP	47uF	20% 16V	IC202	8-759-926-18	IC SN74HC157ANS
C228	1-163-038-00	CERAMIC CHIP	0.1uF	25V	IC203	8-759-199-59	IC RS5C62-E2
C229	1-163-141-00	CERAMIC CHIP	0.001uF	5% 50V	IC204	8-759-280-17	IC CXD8512Q
C230	1-164-232-11	CERAMIC CHIP	0.01uF	50V	IC205	8-759-344-74	IC CXD8504AM
C231	1-163-038-00	CERAMIC CHIP	0.1uF	25V	IC206	8-759-249-07	IC CXD8457Q
C232	1-163-038-00	CERAMIC CHIP	0.1uF	25V	IC207	8-759-344-59	IC MX23C1010MC-15-JA3BS
C233	1-126-395-11	ELECT	22uF	20% 16V	IC208	8-759-926-98	IC SN74HC4040ANS
C234	1-163-141-00	CERAMIC CHIP	0.001uF	5% 50V	IC221	8-752-375-50	IC CXD2536AR
C235	1-163-038-00	CERAMIC CHIP	0.1uF	25V	IC222	8-759-329-31	IC MSM514400CSJADR1-K
C236	1-126-204-11	ELECT CHIP	47uF	20% 16V	IC241	8-759-040-83	IC BA6287F
C237	1-163-038-00	CERAMIC CHIP	0.1uF	25V	IC261	8-759-326-72	IC CXD8521M-TLM
C238	1-126-204-11	ELECT CHIP	47uF	20% 16V			
C239	1-163-038-00	CERAMIC CHIP	0.1uF	25V		< COIL >	
C240	1-163-038-00	CERAMIC CHIP	0.1uF	25V	L201	1-412-336-41	INDUCTOR 4.7uH
C241	1-163-038-00	CERAMIC CHIP	0.1uF	25V	L202	1-412-336-41	INDUCTOR 4.7uH
C242	1-163-038-00	CERAMIC CHIP	0.1uF	25V	L203	1-412-336-41	INDUCTOR 4.7uH
C243	1-126-204-11	ELECT CHIP	47uF	20% 16V	L221	1-412-336-41	INDUCTOR 4.7uH
C244	1-163-038-00	CERAMIC CHIP	0.1uF	25V	L222	1-412-336-41	INDUCTOR 4.7uH
C245	1-163-038-00	CERAMIC CHIP	0.1uF	25V	L261	1-412-336-41	INDUCTOR 4.7uH
C246	1-163-038-00	CERAMIC CHIP	0.1uF	25V			
C247	1-163-038-00	CERAMIC CHIP	0.1uF	25V		< RESISTOR >	
C248	1-163-038-00	CERAMIC CHIP	0.1uF	25V	R201	1-216-097-00	METAL CHIP 100K 5% 1/10W
C249	1-163-038-00	CERAMIC CHIP	0.1uF	25V	R202	1-216-025-00	METAL CHIP 100 5% 1/10W
C250	1-163-038-00	CERAMIC CHIP	0.1uF	25V	R203	1-216-025-00	METAL CHIP 100 5% 1/10W
C251	1-163-038-00	CERAMIC CHIP	0.1uF	25V	R204	1-216-025-00	METAL CHIP 100 5% 1/10W
C252	1-163-117-00	CERAMIC CHIP	100PF	5% 50V	R205	1-216-073-00	METAL CHIP 10K 5% 1/10W
C253	1-163-141-00	CERAMIC CHIP	0.001uF	5% 50V	R206	1-216-073-00	METAL CHIP 10K 5% 1/10W
C254	1-163-141-00	CERAMIC CHIP	0.001uF	5% 50V	R207	1-216-073-00	METAL CHIP 10K 5% 1/10W
C255	1-163-141-00	CERAMIC CHIP	0.001uF	5% 50V	R208	1-216-097-00	METAL CHIP 100K 5% 1/10W
C258	1-163-038-00	CERAMIC CHIP	0.1uF	25V	R209	1-216-097-00	METAL CHIP 100K 5% 1/10W
C261	1-126-204-11	ELECT CHIP	47uF	20% 16V	R210	1-216-073-00	METAL CHIP 10K 5% 1/10W
C262	1-163-038-00	CERAMIC CHIP	0.1uF	25V			

Ref. No.	Part No.	Description	Remark	Ref. No.	Part No.	Description	Remark
R211	1-216-025-00	METAL CHIP	100 5% 1/10W	R261	1-216-025-00	METAL CHIP	100 5% 1/10W
R212	1-216-097-00	METAL CHIP	100K 5% 1/10W	R262	1-216-082-00	METAL GLAZE	24K 5% 1/10W
R213	1-216-097-00	METAL CHIP	100K 5% 1/10W	R263	1-216-065-00	METAL CHIP	4.7K 5% 1/10W
R214	1-216-097-00	METAL CHIP	100K 5% 1/10W	R264	1-216-065-00	METAL CHIP	4.7K 5% 1/10W
R215	1-216-097-00	METAL CHIP	100K 5% 1/10W	R265	1-216-029-00	METAL CHIP	150 5% 1/10W
R216	1-216-073-00	METAL CHIP	10K 5% 1/10W	R266	1-216-025-00	METAL CHIP	100 5% 1/10W
R217	1-216-073-00	METAL CHIP	10K 5% 1/10W	R267	1-216-025-00	METAL CHIP	100 5% 1/10W
R218	1-216-073-00	METAL CHIP	10K 5% 1/10W	R268	1-216-025-00	METAL CHIP	100 5% 1/10W
R219	1-216-073-00	METAL CHIP	10K 5% 1/10W	R269	1-216-025-00	METAL CHIP	100 5% 1/10W
R220	1-216-073-00	METAL CHIP	10K 5% 1/10W	R270	1-216-073-00	METAL CHIP	10K 5% 1/10W
R221	1-216-097-00	METAL CHIP	100K 5% 1/10W	R271	1-216-109-00	METAL CHIP	330K 5% 1/10W
R222	1-216-073-00	METAL CHIP	10K 5% 1/10W	R272	1-216-089-91	METAL GLAZE	47K 5% 1/10W
R223	1-216-073-00	METAL CHIP	10K 5% 1/10W	R273	1-216-025-00	METAL CHIP	100 5% 1/10W
R224	1-216-097-00	METAL CHIP	100K 5% 1/10W	R274	1-216-025-00	METAL CHIP	100 5% 1/10W
R225	1-216-025-00	METAL CHIP	100 5% 1/10W	R275	1-216-025-00	METAL CHIP	100 5% 1/10W
R226	1-216-033-00	METAL CHIP	220 5% 1/10W	R276	1-216-073-00	METAL CHIP	10K 5% 1/10W
R227	1-216-033-00	METAL CHIP	220 5% 1/10W	R277	1-216-073-00	METAL CHIP	10K 5% 1/10W
R228	1-216-033-00	METAL CHIP	220 5% 1/10W	R278	1-216-073-00	METAL CHIP	10K 5% 1/10W
R229	1-216-033-00	METAL CHIP	220 5% 1/10W	R279	1-216-073-00	METAL CHIP	10K 5% 1/10W
R230	1-216-033-00	METAL CHIP	220 5% 1/10W	R280	1-216-073-00	METAL CHIP	10K 5% 1/10W
R231	1-216-097-00	METAL CHIP	100K 5% 1/10W	R281	1-216-073-00	METAL CHIP	10K 5% 1/10W
R232	1-216-097-00	METAL CHIP	100K 5% 1/10W	R282	1-216-073-00	METAL CHIP	10K 5% 1/10W
R233	1-216-097-00	METAL CHIP	100K 5% 1/10W	R283	1-216-073-00	METAL CHIP	10K 5% 1/10W
R234	1-216-097-00	METAL CHIP	100K 5% 1/10W	R284	1-216-097-00	METAL CHIP	100K 5% 1/10W
R235	1-216-097-00	METAL CHIP	100K 5% 1/10W	R285	1-216-097-00	METAL CHIP	100K 5% 1/10W
R236	1-216-097-00	METAL CHIP	100K 5% 1/10W	R291	1-216-073-00	METAL CHIP	10K 5% 1/10W
R237	1-216-097-00	METAL CHIP	100K 5% 1/10W	R292	1-216-073-00	METAL CHIP	10K 5% 1/10W
R238	1-216-073-00	METAL CHIP	10K 5% 1/10W	R293	1-216-073-00	METAL CHIP	10K 5% 1/10W
R239	1-216-025-00	METAL CHIP	100 5% 1/10W	R295	1-216-073-00	METAL CHIP	10K 5% 1/10W
R240	1-216-073-00	METAL CHIP	10K 5% 1/10W			< VIBRATOR >	
R241	1-216-021-00	METAL CHIP	68 5% 1/10W	X201	1-760-493-11	VIBRATOR, CERAMIC (CHIP TYPE) (8MHz)	
R242	1-216-021-00	METAL CHIP	68 5% 1/10W	X202	1-579-550-11	VIBRATOR, CRYSTAL (32.768kHz)	
R243	1-216-073-00	METAL CHIP	10K 5% 1/10W			*****	
R244	1-216-073-00	METAL CHIP	10K 5% 1/10W (AEP)				
R245	1-216-073-00	METAL CHIP	10K 5% 1/10W (US, CND)				
R246	1-216-073-00	METAL CHIP	10K 5% 1/10W (US, CND)	*	1-655-330-11	HP BOARD	
R247	1-216-073-00	METAL CHIP	10K 5% 1/10W (AEP)			*****	
R248	1-216-025-00	METAL CHIP	100 5% 1/10W			< CAPACITOR >	
R249	1-216-025-00	METAL CHIP	100 5% 1/10W	C651	1-164-054-11	CERAMIC	22PF 5% 50V
R250	1-216-073-00	METAL CHIP	10K 5% 1/10W	C652	1-164-054-11	CERAMIC	22PF 5% 50V
R251	1-216-025-00	METAL CHIP	100 5% 1/10W	C653	1-124-477-11	ELBCT	47uF 20% 25V
R252	1-216-025-00	METAL CHIP	100 5% 1/10W	C654	1-124-477-11	ELECT	47uF 20% 25V
R253	1-216-073-00	METAL CHIP	10K 5% 1/10W	C655	1-164-085-11	CERAMIC	0.001uF 10% 50V
R254	1-216-073-00	METAL CHIP	10K 5% 1/10W	C656	1-164-085-11	CERAMIC	0.001uF 10% 50V
R255	1-216-025-00	METAL CHIP	100 5% 1/10W	C657	1-164-159-11	CERAMIC	0.1uF 50V
R256	1-216-025-00	METAL CHIP	100 5% 1/10W	C658	1-164-159-11	CERAMIC	0.1uF 50V
R257	1-216-025-00	METAL CHIP	100 5% 1/10W			< CONNECTOR >	
R258	1-216-025-00	METAL CHIP	100 5% 1/10W	* CN651	1-568-945-11	PIN, CONNECTOR 7P	
R259	1-216-025-00	METAL CHIP	100 5% 1/10W				
R260	1-216-025-00	METAL CHIP	100 5% 1/10W				

HP MIC MOTOR

Ref. No.	Part No.	Description	Remark	Ref. No.	Part No.	Description	Remark
		< IC >				< CONNECTOR >	
IC651	8-759-711-18	IC NJM4556D-D		* CN601	1-568-947-11	PIN, CONNECTOR 9P	
		< JACK >				< IC >	
J651	1-770-904-11	JACK (LARGE TYPE) (PHONES)		IC601	8-759-982-03	IC RC5532DD	
		< TRANSISTOR >				< JACK >	
Q651	8-729-231-55	TRANSISTOR 2SC2878-AB		J601	1-764-836-11	JACK (LARGE TYPE) (MIC L (MONO))	
Q652	8-729-231-55	TRANSISTOR 2SC2878-AB		J602	1-764-836-11	JACK (LARGE TYPE) (MIC R)	
		< RESISTOR >				< INDUCTOR >	
R651	1-259-472-11	CARBON 68K 5% 1/6W		* JW605	1-410-858-21	INDUCTOR 0UH	
R652	1-259-472-11	CARBON 68K 5% 1/6W		* JW606	1-410-858-21	INDUCTOR 0UH	
R653	1-259-444-11	CARBON 4.7K 5% 1/6W				< RESISTOR >	
R654	1-259-468-11	CARBON 47K 5% 1/6W		R602	1-259-428-11	CARBON 1K 5% 1/6W	
R655	1-259-444-11	CARBON 4.7K 5% 1/6W		R604	1-259-460-11	CARBON 22K 5% 1/6W	
R656	1-259-468-11	CARBON 47K 5% 1/6W		R605	1-259-420-11	CARBON 470 5% 1/6W	
R657	1-259-404-11	CARBON 100 5% 1/6W		R606	1-259-460-11	CARBON 22K 5% 1/6W	
R658	1-259-404-11	CARBON 100 5% 1/6W		R607	1-259-476-11	CARBON 100K 5% 1/6W	
R659	1-259-444-11	CARBON 4.7K 5% 1/6W		R608	1-259-420-11	CARBON 470 5% 1/6W	
R660	1-259-444-11	CARBON 4.7K 5% 1/6W		R609	1-259-460-11	CARBON 22K 5% 1/6W	
		< VARIABLE RESISTOR >		R610	1-259-476-11	CARBON 100K 5% 1/6W	
RV651	1-223-843-11	RES, VAR, CARBON 20K/20K (PHONE LEVEL)		R612	1-259-460-11	CARBON 22K 5% 1/6W	
		*****		R613	1-259-420-11	CARBON 470 5% 1/6W	
*	A-4673-418-A	MIC BOARD, COMPLETE		R614	1-259-420-11	CARBON 470 5% 1/6W	
		*****		R615	1-259-444-11	CARBON 4.7K 5% 1/6W	
		< CAPACITOR >		R616	1-259-444-11	CARBON 4.7K 5% 1/6W	
C602	1-164-085-11	CERAMIC 0.001uF 10% 50V		R617	1-247-890-11	CARBON 300K 5% 1/6W	
C603	1-164-085-11	CERAMIC 0.001uF 10% 50V		R618	1-247-890-11	CARBON 300K 5% 1/6W	
C604	1-164-085-11	CERAMIC 0.001uF 10% 50V		R619	1-259-476-11	CARBON 100K 5% 1/6W	
C606	1-126-044-11	ELECT 1uF 20% 50V		R620	1-259-476-11	CARBON 100K 5% 1/6W	
C607	1-126-044-11	ELECT 1uF 20% 50V		R621	1-259-404-11	CARBON 100 5% 1/6W	
C608	1-162-294-31	CERAMIC 0.001uF 10% 50V		R622	1-259-404-11	CARBON 100 5% 1/6W	
C609	1-162-294-31	CERAMIC 0.001uF 10% 50V				*****	
C610	1-162-294-31	CERAMIC 0.001uF 10% 50V		*	1-653-412-11	MOTOR BOARD	
C611	1-126-022-11	ELECT 47uF 20% 25V				*****	
C612	1-162-294-31	CERAMIC 0.001uF 10% 50V				< CAPACITOR >	
C613	1-126-022-11	ELECT 47uF 20% 25V		C199	1-164-159-11	CERAMIC 0.1uF 50V	
C614	1-162-199-31	CERAMIC 10PF 5% 50V				< CONNECTOR >	
C615	1-162-199-31	CERAMIC 10PF 5% 50V		* CN191	1-568-944-11	PIN, CONNECTOR 6P	
C616	1-126-044-11	ELECT 1uF 20% 50V		CN192	1-770-011-41	CONNECTOR, BOARD TO BOARD 4P	
C617	1-124-477-11	ELECT 47uF 20% 25V				*****	
C618	1-124-477-11	ELECT 47uF 20% 25V					
C619	1-126-044-11	ELECT 1uF 20% 50V					

Ref. No.	Part No.	Description	Remark
		< IC >	
IC781	8-749-923-11	IC GPIU58XB	
		< TRANSISTOR >	
Q781	8-729-900-61	TRANSISTOR DTA114ES	
		< RESISTOR >	
R781	1-259-412-11	CARBON 220 5% 1/6W	
R782	1-259-452-11	CARBON 10K 5% 1/6W	
R783	1-259-452-11	CARBON 10K 5% 1/6W	
R784	1-259-420-11	CARBON 470 5% 1/6W	
R785	1-259-404-11	CARBON 100 5% 1/6W	
		< SWITCH >	
S781	1-572-625-11	SWITCH, SLIDE (TIMER)	
S782	1-554-303-21	SWITCH, TACTILE (POWER)	

*	A-4673-411-A	PW BOARD, COMPLETE (US, CND)	

*	A-4673-591-A	PW BOARD, COMPLETE (AEP)	

*	4-363-146-00	HEAT SINK, V. OUT	
*	4-870-539-00	PLATE, GROUND	
	7-682-548-09	SCREW +BVT 3X8 (S)	
		< CAPACITOR >	
C901	1-110-489-11	DOUBLE LAYER 1.0F 5.5V	
C902	1-126-927-11	ELECT 2200uF 20% 10V	
C903	1-126-963-11	ELECT 4.7uF 20% 50V	
C904	1-164-159-11	CERAMIC 0.1uF 50V	
C905	1-164-159-11	CERAMIC 0.1uF 50V	
C906	1-104-665-11	ELECT 100uF 20% 16V	
C907	1-110-489-11	DOUBLE LAYER 1.0F 5.5V	
C908	1-124-471-00	ELECT 1000uF 20% 6.3V	
C909	1-124-903-11	ELECT 1uF 20% 50V	
C910	1-164-159-11	CERAMIC 0.1uF 50V	
C911	1-162-294-31	CERAMIC 0.001uF 10% 50V	
C912	1-164-159-11	CERAMIC 0.1uF 50V	
C913	1-164-159-11	CERAMIC 0.1uF 50V	
C914	1-164-159-11	CERAMIC 0.1uF 50V	
C915	1-124-557-11	ELECT 1000uF 20% 25V	
C916	1-124-636-00	ELECT 3300uF 20% 25V	
C917	1-124-471-00	ELECT 1000uF 20% 6.3V	
C918	1-164-159-11	CERAMIC 0.1uF 50V	
C919	1-162-294-31	CERAMIC 0.001uF 10% 50V	
C920	1-164-159-11	CERAMIC 0.1uF 50V	
C921	1-164-159-11	CERAMIC 0.1uF 50V	

Ref. No.	Part No.	Description	Remark
C922	1-124-471-00	ELECT 1000uF 20% 6.3V	
C923	1-162-294-31	CERAMIC 0.001uF 10% 50V	
C924	1-164-159-11	CERAMIC 0.1uF 50V	
C925	1-124-485-11	ELECT 330uF 20% 35V	
C926	1-164-159-11	CERAMIC 0.1uF 50V	
C927	1-104-748-11	ELECT 15000uF 20% 16V	
C928	1-162-294-31	CERAMIC 0.001uF 10% 50V	
C929	1-161-494-00	CERAMIC 0.022uF 25V	
C930	1-164-159-11	CERAMIC 0.1uF 50V	
C931	1-104-613-21	ELECT 4700uF 20% 35V	
C932	1-104-613-21	ELECT 4700uF 20% 35V	
C933	1-124-916-11	ELECT 22uF 20% 63V	
C934	1-124-572-11	ELECT 100uF 20% 63V	
C935	1-126-941-11	ELECT 470uF 20% 16V	
C936	1-124-907-11	ELECT 10uF 20% 50V	
C937	1-136-153-00	FILM 0.01uF 5% 50V	
C938	1-136-153-00	FILM 0.01uF 5% 50V	
C939	1-124-443-00	ELECT 100uF 20% 10V	
C940	1-164-159-11	CERAMIC 0.1uF 50V	
C941	1-164-159-11	CERAMIC 0.1uF 50V	
C942	1-164-159-11	CERAMIC 0.1uF 50V	
C943	1-164-159-11	CERAMIC 0.1uF 50V	
C944	1-136-165-00	FILM 0.1uF 5% 50V	
C945	1-124-925-11	ELECT 2.2uF 20% 100V	
C946	1-136-165-00	FILM 0.1uF 5% 50V	
C947	1-164-159-11	CERAMIC 0.1uF 50V	
C948	1-104-666-11	ELECT 220uF 20% 10V	
C950	1-164-159-11	CERAMIC 0.1uF 50V	
C951	1-164-159-11	CERAMIC 0.1uF 50V	
C952	1-124-443-00	ELECT 100uF 20% 10V	
C953	1-124-443-00	ELECT 100uF 20% 10V	
		< CONNECTOR >	
* CN901	1-568-955-11	PIN, CONNECTOR 6P	
CN902	1-580-461-11	SOCKET, CONNECTOR 22P	
CN903	1-766-204-11	PLUG, CONNECTOR PIN 11P	
* CN904	1-564-513-11	PLUG, CONNECTOR 10P	
		< DIODE >	
D901	8-719-987-63	DIODE 1N4148M	
D902	8-719-987-63	DIODE 1N4148M	
D903	8-719-987-63	DIODE 1N4148M	
D904	8-719-014-96	DIODE UZP-7.5BC	
D905	8-719-911-55	DIODE U05G	
D906	8-719-911-55	DIODE U05G	
D907	8-719-987-63	DIODE 1N4148M	
D908	8-719-911-55	DIODE U05G	
D909	8-719-911-55	DIODE U05G	
D910	8-719-911-55	DIODE U05G	
D911	8-719-911-55	DIODE U05G	

Ref. No.	Part No.	Description	Remark	Ref. No.	Part No.	Description	Remark
D912	8-719-987-63	DIODE 1N4148M		R902	1-249-516-11	CARBON 33 5% 1/4W	
D913	8-719-200-77	DIODE 10E2N		R903	1-259-428-11	CARBON 1K 5% 1/6W	
D914	8-719-200-77	DIODE 10E2N		R904	1-259-428-11	CARBON 1K 5% 1/6W	
D915	8-719-200-77	DIODE 10E2N		R905	1-259-488-11	CARBON 330K 5% 1/6W	
D916	8-719-200-77	DIODE 10E2N		R906	1-259-444-11	CARBON 4.7K 5% 1/6W	
D917	8-719-200-77	DIODE 10E2N		R907	1-259-404-11	CARBON 100 5% 1/6W	
D918	8-719-987-63	DIODE 1N4148M		R908	1-259-468-11	CARBON 47K 5% 1/6W	
D919	8-719-987-63	DIODE 1N4148M		R909	1-259-452-11	CARBON 10K 5% 1/6W	
D920	8-719-210-21	DIODE 11EQS04		R910	1-259-468-11	CARBON 47K 5% 1/6W	
D921	8-719-210-21	DIODE 11EQS04		R911	1-259-428-11	CARBON 1K 5% 1/6W	
D922	8-719-987-63	DIODE 1N4148M		R912	1-259-404-11	CARBON 100 5% 1/6W	
D923	8-719-987-63	DIODE 1N4148M		R913	1-259-450-11	CARBON 8.2K 5% 1/6W	
		< FUSE >		R914	1-259-404-11	CARBON 100 5% 1/6W	
△F901	1-532-771-21	FUSE, MICRO (SECONDARY) (US, CND)		R915	1-259-401-11	CARBON 75 5% 1/6W	
		< IC >		R917	1-259-452-11	CARBON 10K 5% 1/6W	
IC901	8-759-327-15	IC M62005L		R918	1-259-404-11	CARBON 100 5% 1/6W	
IC902	8-759-274-37	IC BA3963		R921	1-259-452-11	CARBON 10K 5% 1/6W	
IC903	8-759-604-45	IC M5F79M12		R922	1-259-452-11	CARBON 10K 5% 1/6W	
IC904	8-759-604-39	IC M5F78M12		R923	1-259-404-11	CARBON 100 5% 1/6W	
IC905	8-759-513-71	IC PQ05RF21		R924	1-259-404-11	CARBON 100 5% 1/6W	
IC906	8-759-916-14	IC SN74HC04AN		R925	1-259-444-11	CARBON 4.7K 5% 1/6W	
IC907	8-759-069-28	IC PQ05RF11		R930	1-259-428-11	CARBON 1K 5% 1/6W	
IC908	8-759-633-42	IC M5293L				< RELAY >	
IC909	8-759-242-85	IC TOTX176 (DIGITAL OUT OPTICAL)		RY901	1-515-925-11	RELAY	
IC910	8-759-242-84	IC TORX176 (DIGITAL IN OPTICAL)				*****	
IC911	8-759-269-92	IC SN74HCU04ANS-E20		*	1-655-329-11	VOL BOARD	
		< IC LINK >				*****	
△ICP901	1-532-834-21	LINK, IC (AEP)				< CAPACITOR >	
		< JACK >		C601	1-164-159-11	CERAMIC 0.1uF 50V	
J901	1-568-750-21	JACK, PIN (1P SHIELD TYPE) (DIGITAL IN COAXIAL)				< CONNECTOR >	
		< COIL >		* CN604	1-568-935-11	PIN, CONNECTOR 8P	
L901	1-410-324-11	INDUCTOR 4.7uH				< VARIABLE RESISTOR >	
L903	1-410-324-11	INDUCTOR 4.7uH		RV601	1-223-842-11	RES, VAR, CARBON 20K/20K (REC LEVEL)	
		< TRANSISTOR >				*****	
Q901	8-729-119-76	TRANSISTOR 2SA1175-HFE					
Q902	8-729-900-80	TRANSISTOR DTC114ES					
Q903	8-729-140-98	TRANSISTOR 2SD773-34					
Q904	8-729-902-80	TRANSISTOR DTA114YS					
Q905	8-729-902-80	TRANSISTOR DTA114YS					
		< RESISTOR >					
R901	1-259-452-11	CARBON 10K 5% 1/6W					

The components identified by mark △ or dotted line with mark △ are critical for safety. Replace only with part number specified.	Les composants identifiés par une marque △ sont critiques pour la sécurité. Ne les remplacer que par une pièce portant le numéro spécifié.
---	---

Ref. No.	Part No.	Description	Remark	Ref. No.	Part No.	Description	Remark
		MISCELLANEOUS *****				***** HARDWARE LIST *****	
△7	1-558-568-21	CORD, POWER (AEP, G)		#1	7-682-565-04	SCREW +BVTT 4X16 (S)	
△7	1-559-583-21	CORD, POWER (US, CND)		#2	7-682-547-09	SCREW +BVTT 3X6 (S)	
75	1-769-342-11	WIRE (FLAT TYPE) (26 CORE)		#3	7-685-871-01	SCREW +BVTT 3X6 (S)	
101	1-769-341-11	WIRE (FLAT TYPE) (22 CORE)		#4	7-685-646-79	SCREW +BVTP 3X8 TYPE2 N-S	
102	1-775-376-11	WIRE (FLAT TYPE) (30 CORE)		#5	7-685-870-01	SCREW +BVTT 3X5 (S)	
103	1-775-375-11	WIRE (FLAT TYPE) (18 CORE)		#7	7-621-770-87	SCREW	
108	1-769-360-11	WIRE, FLAT TYPE (13 CORE)		#8	7-621-775-20	SCREW +B 2.6X5	
203	1-654-446-11	FLEXIBLE BOARD (QWH)		#9	7-685-645-79	SCREW +BVTP 3X6 TYPE2 N-S	
△207	8-583-009-11	OPTICAL PICK-UP BLOCK KMS-210A/J-N		#10	7-685-104-19	SCREW +P 2X6 TYPE2 NON-SLIT	
FL701	1-517-242-21	INDICATOR TUBE, FLUORESCENT		#11	7-621-773-86	SCREW +BVTT 2.6X4 (S)	
HR901	1-500-175-11	HEAD, OVER LIGHT (RF322-74A)		#12	7-627-852-08	SCREW, PRECISION +P 1.7X2.5	
J601	1-764-836-11	JACK (LARGE TYPE) (MIC L (MONO))		#13	7-685-105-19	TPG +P 2X8, TYPE 2, NON-SLIT	
J602	1-764-836-11	JACK (LARGE TYPE) (MIC R)		#14	7-682-547-04	SCREW +P 3X6	
J651	1-770-904-11	JACK (LARGE TYPE) (PHONES)		#15	7-682-548-09	SCREW +BVTT 3X8 (S)	
M101	A-4660-651-A	MOTOR ASSY (SLED)					
M102	A-4660-650-A	CHASSIS ASSY, BU (SPINDLE)					
M191	A-4660-646-A	MOTOR ASSY (LOADING)					
RV601	1-223-842-11	RES. VAR, CARBON 20K/20K (REC LEVEL)					
RV651	1-223-843-11	RES. VAR, CARBON 20K/20K (PHONE LEVEL)					
S102	1-762-148-11	SWITCH, PUSH (2 KEY)					
△T1	1-427-770-11	TRANSFORMER, POWER (US, CND)					
△T1	1-427-771-11	TRANSFORMER, POWER (AEP, G)					

		ACCESSORIES & PACKING MATERIALS *****					
	1-467-996-11	REMOTE COMMANDER (RM-D2M)					
	1-590-925-31	CORD, CONNECTION (AUDIO 100cm)					
	3-707-584-11	COVER, BATTERY (for RM-D2M)					
	3-800-104-11	MANUAL, INSTRUCTION (ENGLISH, FRENCH, SPANISH, PORTUGUESE) (CND, AEP, G)					
	3-800-104-21	MANUAL, INSTRUCTION (ENGLISH) (US)					
	3-800-104-41	MANUAL, INSTRUCTION (GERMAN, DUTCH, SWEDISH, ITALIAN) (AEP, G)					
*	4-955-666-11	CUSHION					
*	4-973-289-01	INDIVIDUAL CARTON					

The components identified by mark △ or dotted line with mark △ are critical for safety. Replace only with part number specified.	Les composants identifiés par une marque △ sont critiques pour la sécurité. Ne les remplacer que par une pièce portant le numéro spécifié.
--	--

MDS-JA3ES

SONY SERVICE MANUAL

US Model
Canadian Model
AEP Model

SUPPLEMENT-1

File this supplement with the service manual.

Subject : 1. CHANGE OF ADJUSTMENT SPECIFICATION
2. CORRECTION
3. SERVICE NOTE
4. BOARD CHANGE
5. ADDITION OF COUNTERMEASURE BOARD
6. PARTS CHANGE

(ECN-CD501076/CD501133)

1. CHANGE OF ADJUSTMENT SPECIFICATION

The specified value of the following adjustment in the service manual (9-960-228-11) issued first has been changed as shown.

4-5. Temperature Compensation Offset Adjustment

Page	CURRENT	REVISED
26	Specifications: Within "TEMP=E0" to "TEMP=1F".	Specifications: The TEMP value should be within E0 to EF, F0 to FF, 00 to 0F, 10 to 1F, and 20 to 2F.

2. CORRECTION

The service manual issued first contained the following error. Please correct as shown.

TEST MODE

Page	INCORRECT	CORRECT
23	3-5. Functions of Other keys ▷ Sets continuous playback when pressed in the STOP state. □□ When pressed during continuous playback, the tracking servo turns ON/OFF.	▷ Sets continuous playback when pressed in the STOP state. When pressed during continuous playback, the tracking servo turns ON/OFF.

ELECTRICAL PARTS LIST

Page	INCORRECT				CORRECT			
	Ref. No	Part No	Description	Remark	Ref. No	Part No	Description	Remark
97	*	A-4673-414-A	PANEL BOARD, COMPLETE *****		*	A-4673-414-A	DISP BOARD, COMPLETE *****	

3. SERVICE NOTE

• Note for replacement of IC121 and IC171 on the BD board

IC121 on the BD board of this unit has modified from CXD2535AR to CXD2535BR due to an improvement.

Some contents of nonvolatile memory in the IC171 (X24C01S) are modified according to this modification. When replacing IC171, the previous contents for IC121 (CXD2535AR) are written as an initialized value from the system control IC. (When replacing IC171, turn the power on once to write an initialized value.)

In case the IC171 on the BD board is replaced, which uses CXD2535BR to IC121, see the following procedure to rewrite the contents of nonvolatile memory. As for replacement of IC121, use CXD2535BR to rewrite the contents of IC171.

Table Comparison between CXD2535AR and CXD2535BR regarding the contents of nonvolatile memory

ADDRESS	CXD2535AR	CXD2535BR
15	90	93
2D	33	1A
2E	33	1A

How to rewrite the nonvolatile memory

- ① Plug in the power plug to an outlet pressing the AMS knob, and release the AMS knob.
- ② Turn the AMS knob to be displayed "EEP MODE".
If the YES button is pressed, the display will be changed to "EEP ** @@".
(* : Address, @@ : data)
- ③ Turn the AMS knob to be displayed "EEP 15 @@".
- ④ If the AMS knob is pressed, "EEP 15 @@ > @@" will be displayed. So turn the AMS knob to be displayed "EEP 15 @@ > 93".
- ⑤ Pressing the YES button, "Complete!" is displayed once, "EEP 15 93" is displayed, and the data is rewritten.
- ⑥ As for the address 2D and 2E, rewrite each of them to "1A" following the steps ③ to ⑤ as well.
- ⑦ After the all modification are complete, press the NO button to be displayed "EEP MODE".
- ⑧ Press the REPEAT button. In case a disc is unloaded, the display "STANDBY" will be go on and off, then unplug the power plug. In case a disc is loaded, "STANDBY" is displayed once and the disc is ejected. After that, unplug the power plug from an outlet to be out from the EEP rewriting mode. (Refer to **[How to stop test mode]** as below.)

Note : The modification in the contents of nonvolatile memory is not reflected if the power is not turned off once.

[How to stop test mode]

In the previous mentioned text regarding test mode, "Exiting the test mode" is that should be unplug the power plug from an outlet. If the test mode is released in this way, an incorrect operation will rarely occur to the set. So release the test mode according to the followings.

• Procedure

- (1) Press the **REPEAT** button.
- (2) In case a disc is unloaded, the display "STANDBY" will go on and off.
In case a disc is loaded, the "STANDBY" is displayed once and the disc is ejected.
- (3) Unplug the power plug from an outlet.

4. BOARD CHANGE

3-1. BD board change

NOTE: Many charge of mounting parts are different between boards which have a suffix No. - [15] or later and which have a suffix No. - [14]. Refer to this supplement-1 for boards which have a suffix No. - [15] or later. As for boards which have a suffix No. - [14], refer to the previous issued manual (9-960-228-11).

• Part No. Location — BD board — (Component side)

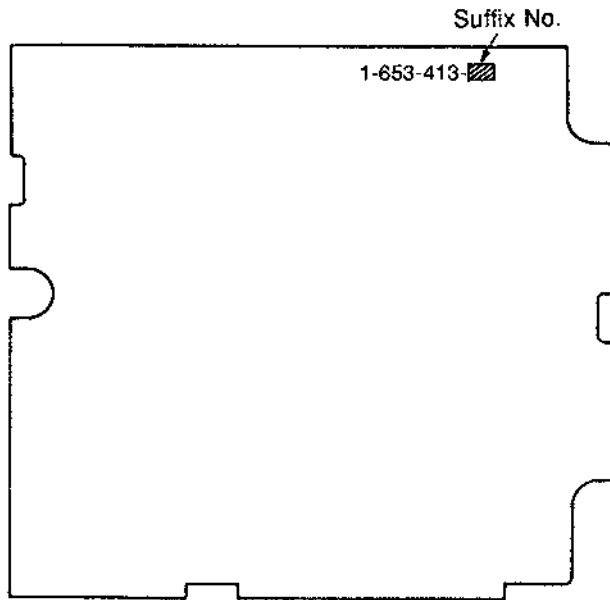

3-2. DIGITAL board change

NOTE: Many charge of mounting parts are different between boards which have a suffix No. - [13] or later and which have a suffix No. - [12]. Refer to this supplement-1 for boards which have a suffix No. - [13] or later. As for boards which have a suffix No. - [12], refer to the previous issued manual (9-960-228-11).

• Part No. Location — DIGITAL board — (Component side)

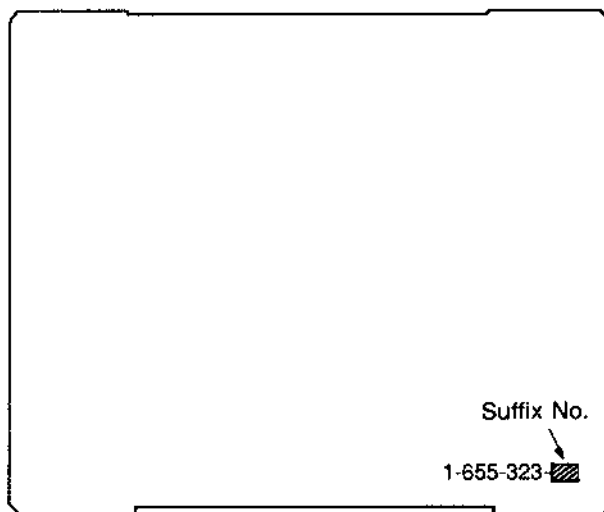

PRINTED WIRING BOARD — RF SECTION —

• Semiconductor Location

Ref. No.	Location
D101	C-6
D155	F-11
D161	B-8
D181	C-2
D183	C-2
IC101	D-10
IC102	D-11
IC121	F-9
IC122	D-9
IC151	G-12
IC171	D-8
IC172	C-10
IC181	C-12
IC182	C-11
IC191	G-5
Q101	B-9
Q151	F-12
Q162	B-10
Q163	B-8
Q164	B-8
Q181	C-1
Q182	C-1

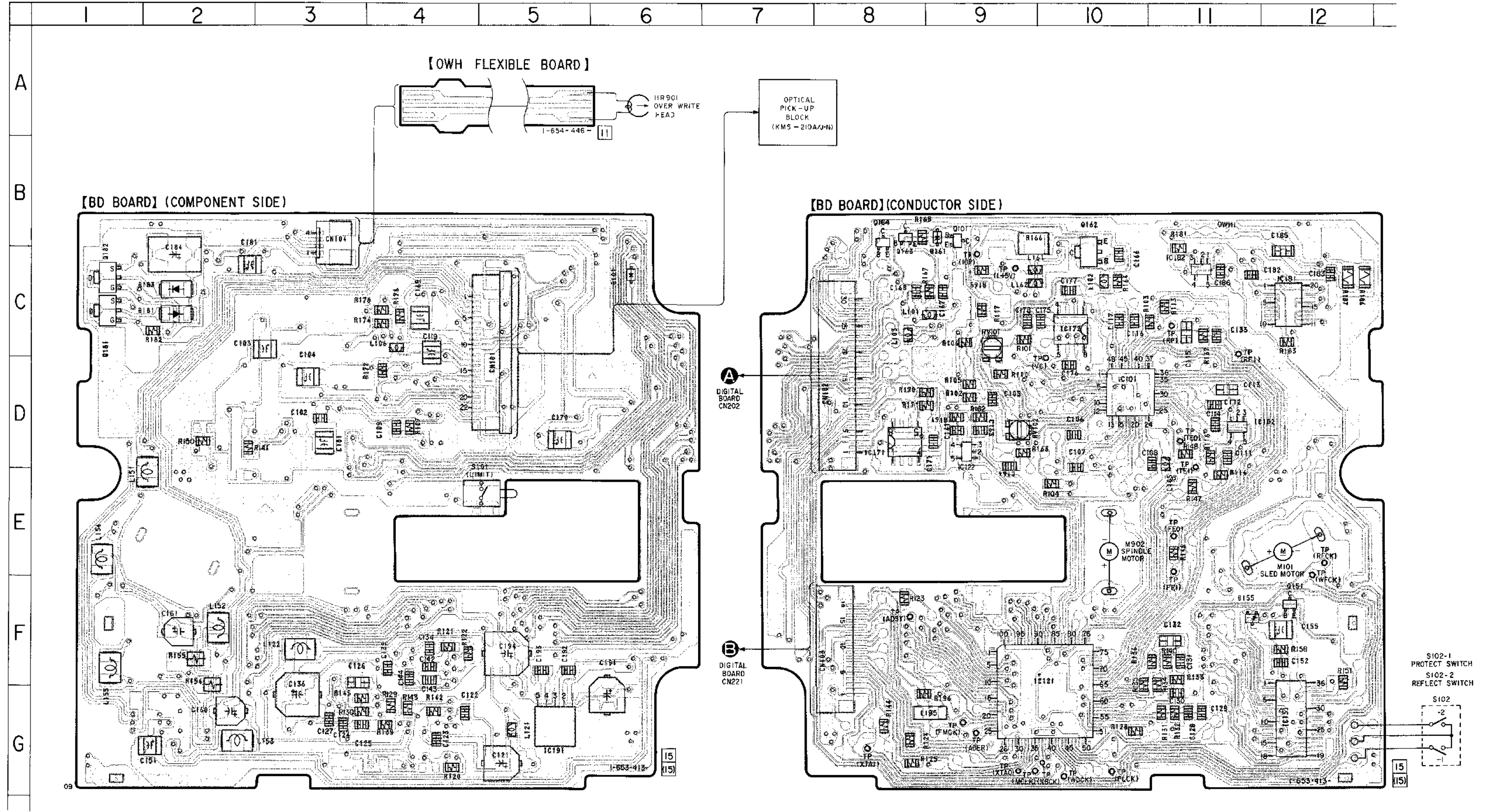

Note:

- — : parts extracted from the component side.
- — : parts extracted from the conductor side.
- : Through hole.
- ▨ : Pattern from the side which enable seeing. (The other layer's patterns are not indicated.)

SCHEMATIC DIAGRAM — RF SECTION —

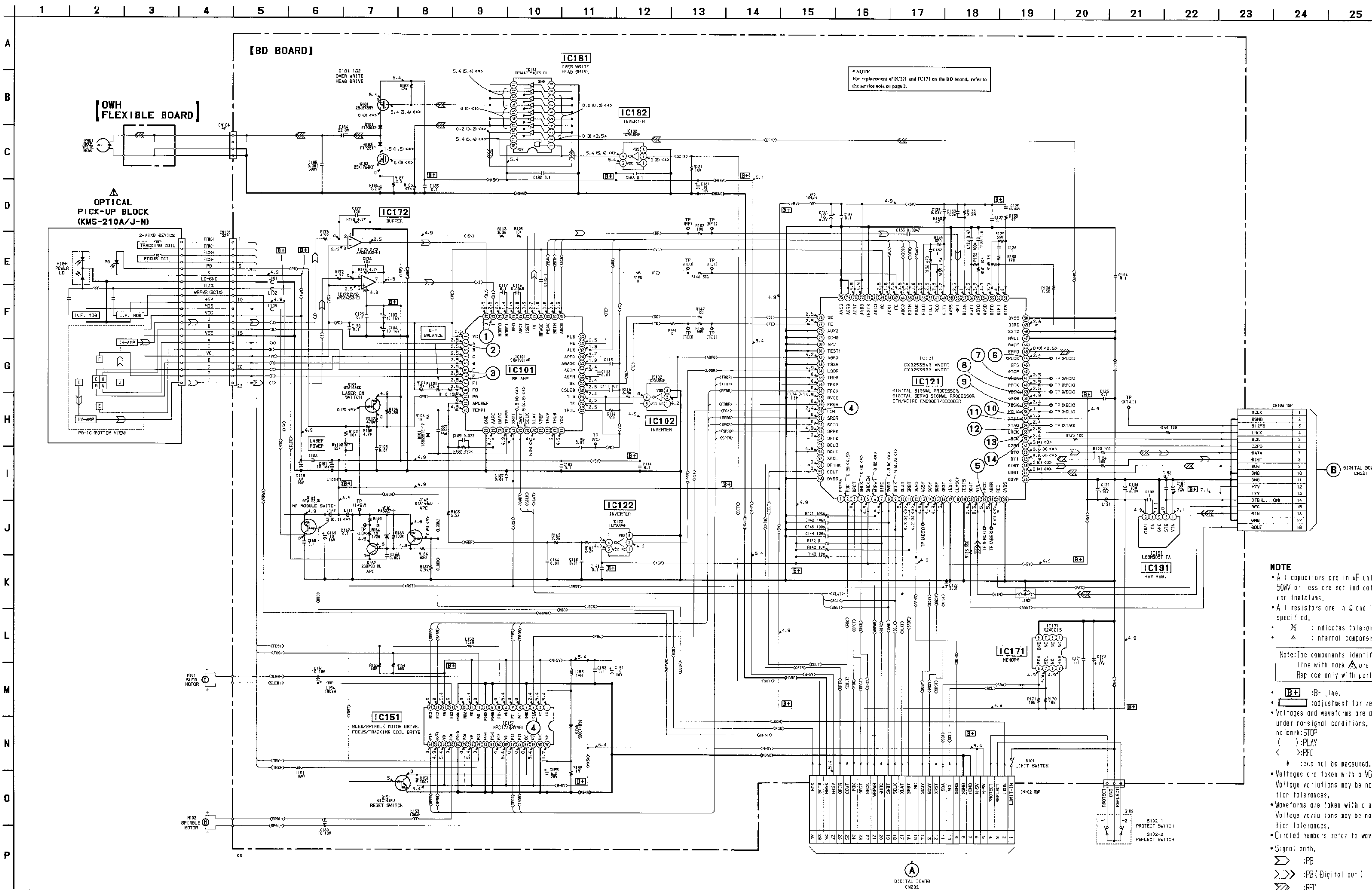

* NOTE:
For replacement of IC121 and IC171 on the BD board, refer to the service note on page 2.

NOTE

- All capacitors are in μF unless otherwise noted, μF : μF 50WV or less are not indicated except for electrolytics and tantalums.
- All resistors are in Ω and $1/4\text{W}$ or less unless otherwise specified.
- % : indicates tolerance.
- Δ : internal component.

Note: The components identified by mark Δ or dotted line with mark Δ are critical for safety. Replace only with part number specified.

- B+** :B+ Lins.
- +** :adjustment for repair.
- Voltages and waveforms are dc with respect to ground under no-signal conditions.
- no mark: STOP
- () :PLAY
- < :REC
- > :REC
- * :can not be measured.
- Voltages are taken with a VOM (input impedance 10M Ω). Voltage variations may be noted due to normal production tolerances.
- Waveforms are taken with an oscilloscope. Voltage variations may be noted due to normal production tolerances.
- Circled numbers refer to waveforms.
- Signal path:
- \Rightarrow :PB
- $\Rightarrow\Rightarrow$:PB (Digital out)
- $\Rightarrow\Rightarrow\Rightarrow$:REC
- $\Rightarrow\Rightarrow\Rightarrow\Rightarrow$:REC (Digital in)

SCHEMATIC DIAGRAM — DIGITAL SECTION —

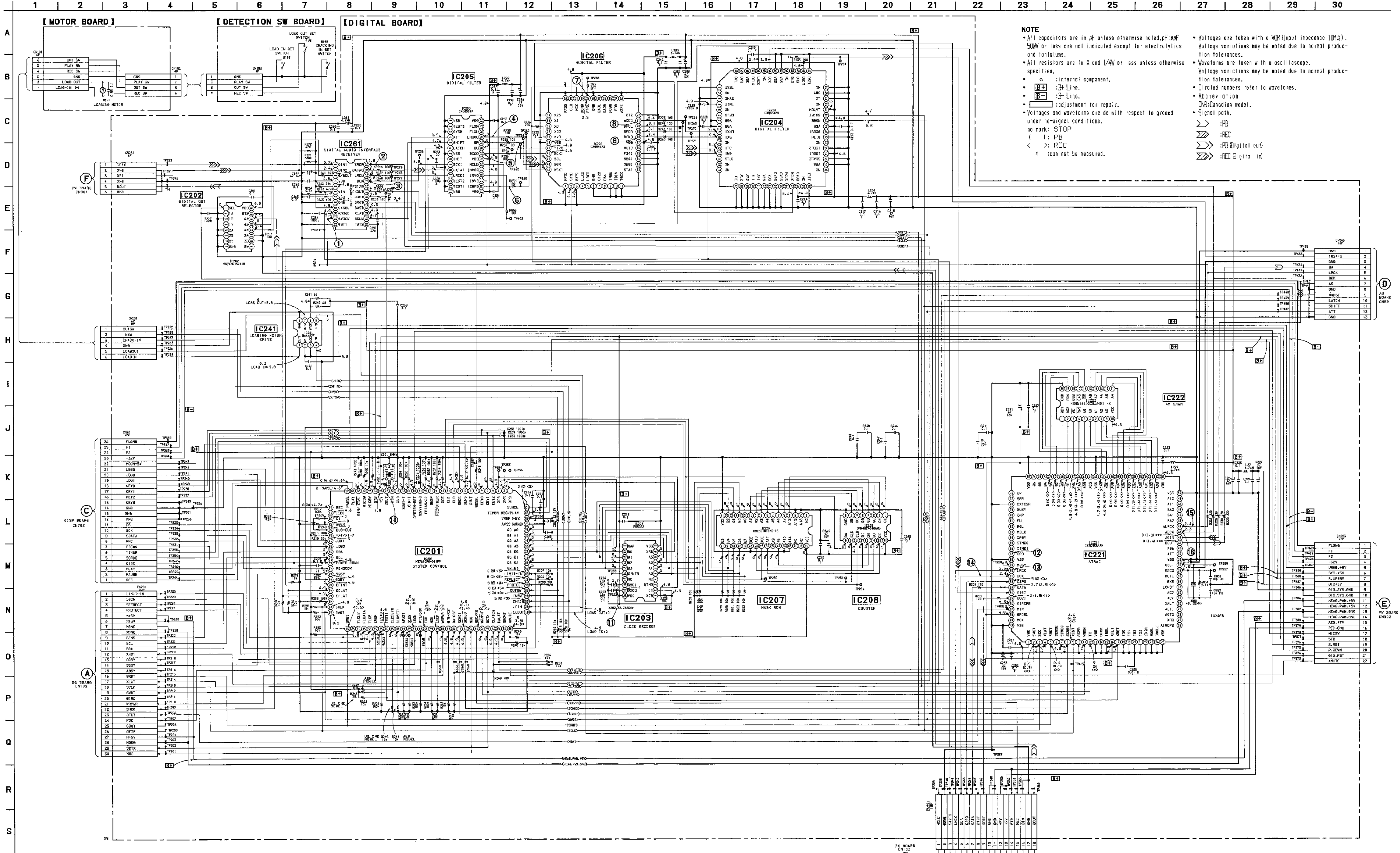

PRINTED WIRING BOARD — DIGITAL SECTION —

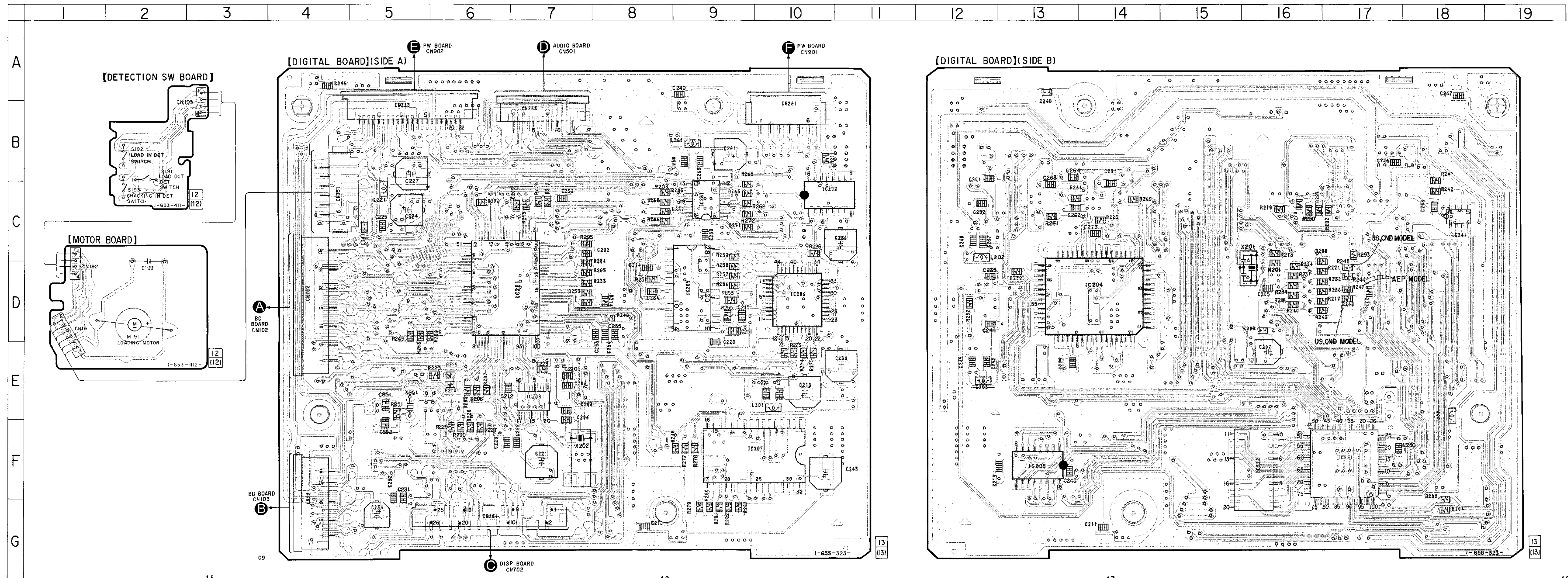

• Semiconductor Location

Ref. No.	Location
IC201	D-7
IC202	C-10
IC203	E-7
IC204	D-14
IC205	D-9
IC206	D-10
IC207	F-10
IC208	F-13
IC221	F-17
IC222	F-16
IC241	C-18
IC261	C-9

Note:
 • — : parts extracted from the component side.
 • ○ : Through hole.
 • △ : internal component.
 • — : Pattern from the side which enable seeing.
 (The other layer's patterns are not indicated.)
 • Abbreviation
 CND : Canadian model.

5. ADDITION OF COUNTERMEASURE BOARD

[Addition of countermeasure board (XTL Board, MCK Board)]

The clock circuit of the DIGITAL board IC221 (ATRAC ENCODER/DECODER) has been changed and the XTL board and MCK board have been added (these boards are not provided).

Refer to the following List of Differences for the changes.

BOARD	FORMER					NEW (Units Added with Countermeasure Board)					
	Ref.No	Part No	Description	Remark		Ref.No	Part No	Description	Remark		
AUDIO	JW901	NOT USED				JW901	NOT SUPPLIED (JUMPER, LEAD)				
	R901	NOT USED				R901	1-259-412-11	CARBON	220	5%	1/6W
	R902	NOT USED				R902	1-259-404-11	CARBON	100	5%	1/6W
DIGITAL	R226	1-216-033-00	METAL CHIP	220	5%	1/10W	R226	DELETE			
MCK	C801	NOT USED				C801	1-163-038-91	CERAMIC CHIP	0.1uF	25V	
	C802	NOT USED				C802	1-163-009-11	CERAMIC CHIP	1000PF	10%	50V
	C803	NOT USED				C803	1-163-038-91	CERAMIC CHIP	0.1uF	25V	
	JW1	NOT USED				JW1	1-216-295-00	CONDUCTOR CHIP			
	JW2	NOT USED				JW2	1-216-295-00	CONDUCTOR CHIP			
	IC801	NOT USED				IC801	8-759-925-90	IC	SN74HC74ANS		
	R801	NOT USED				R801	1-216-033-00	METAL CHIP	220	5%	1/10W
		NOT USED					4-870-539-01	PLATE, GROUND			
XTL	C851	NOT USED				C851	1-163-227-11	CERAMIC CHIP	10PF	50V	
	C852	NOT USED				C852	1-163-227-11	CERAMIC CHIP	10PF	50V	
	R851	NOT USED				R851	1-216-066-00	METAL CHIP	5.1K	5%	1/10W
	X851	NOT USED				X851	1-579-069-11	VIBRATOR CRISTAL	(49.152MHz)		

SCHEMATIC DIAGRAM — COUNTERMEASURE SECTION —

[DIGITAL BOARD]

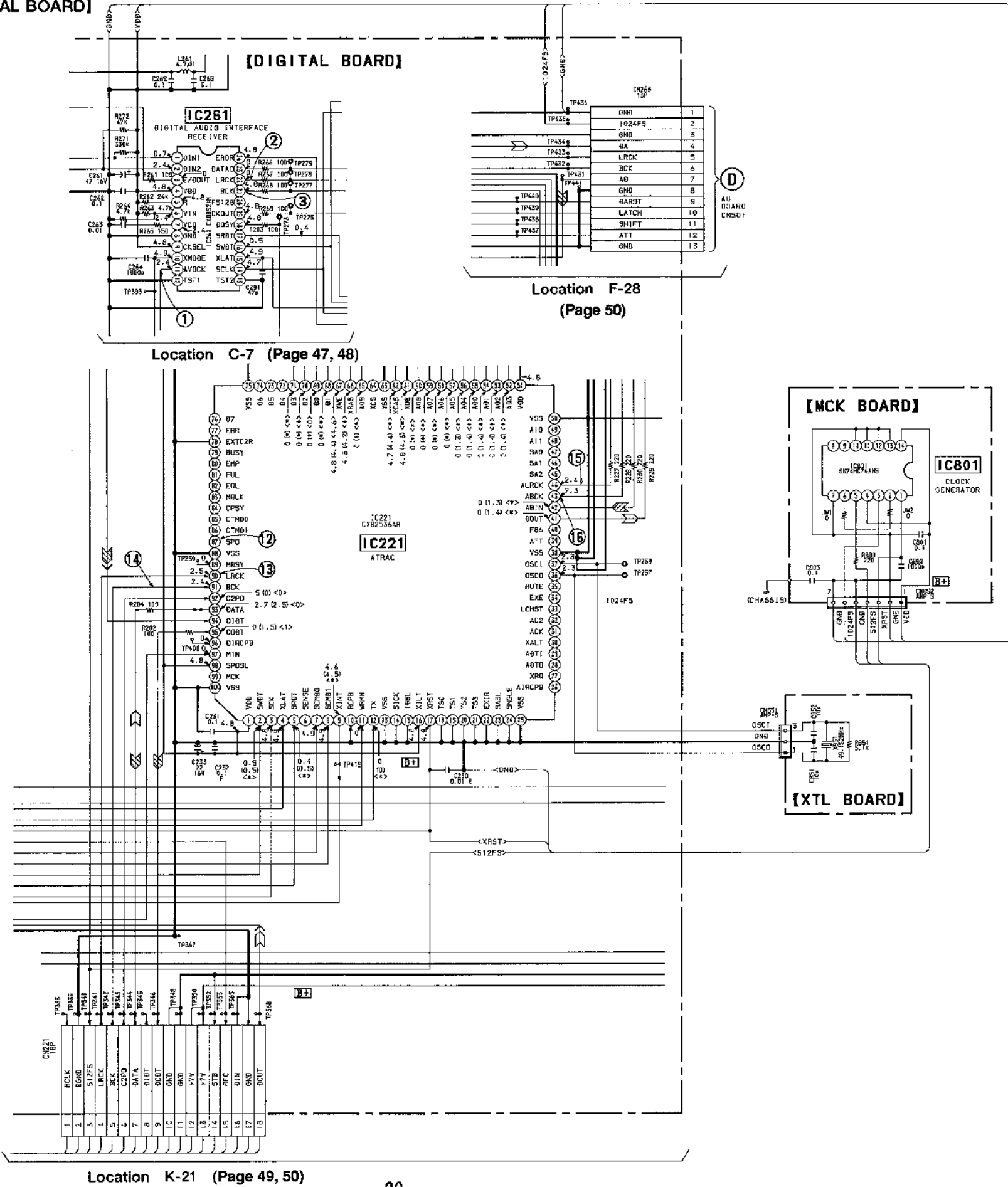

PRINTED WIRING BOARD — COUNTERMEASURE SECTION —

[DIGITAL BOARD] (SIDE A) Location E-4 (Page 51)

[XTL BOARD]

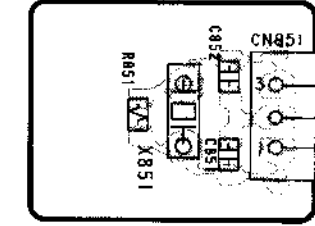

BD BOARD
CN103

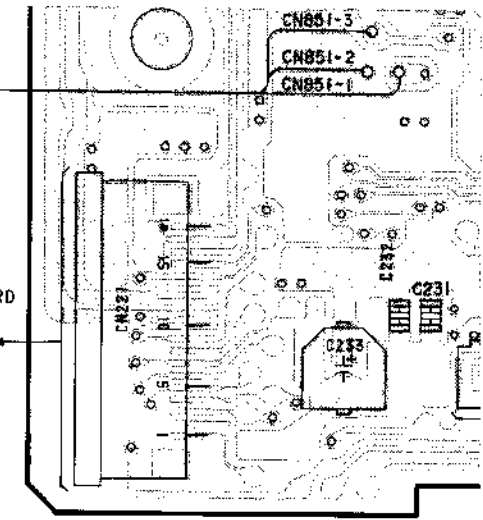

[DIGITAL BOARD] (SIDE A) Location B-6 (Page 52)

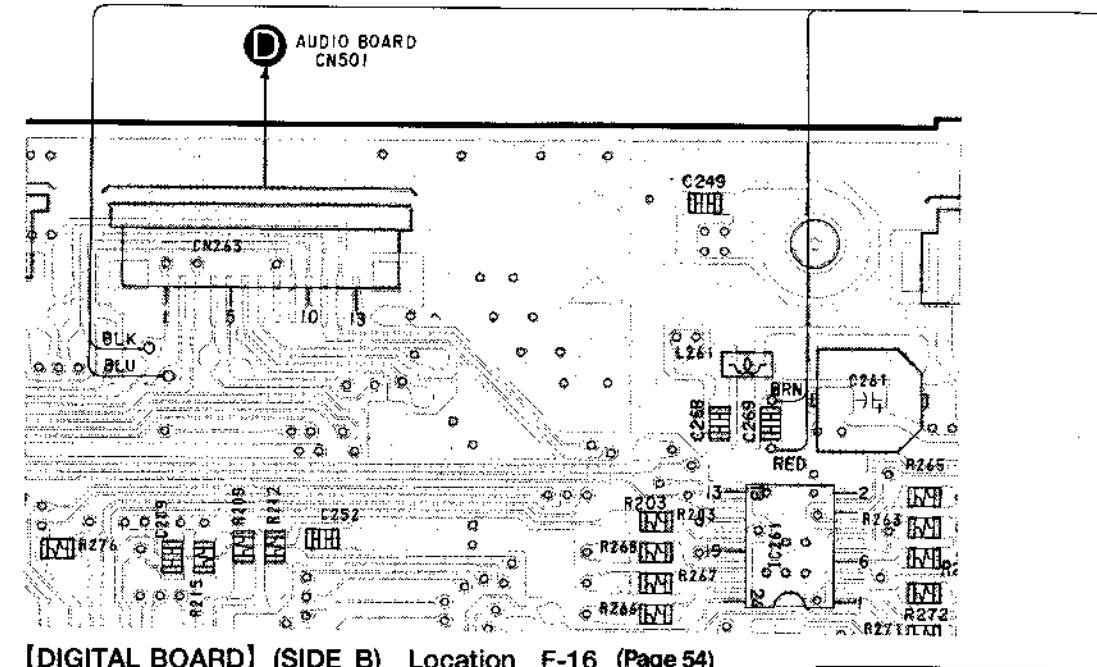

[DIGITAL BOARD] (SIDE B) Location F-16 (Page 54)

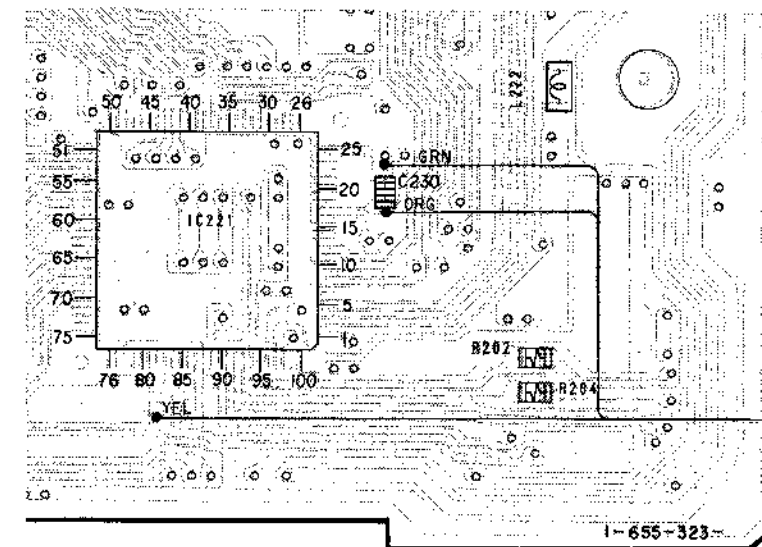

[MCK BOARD]

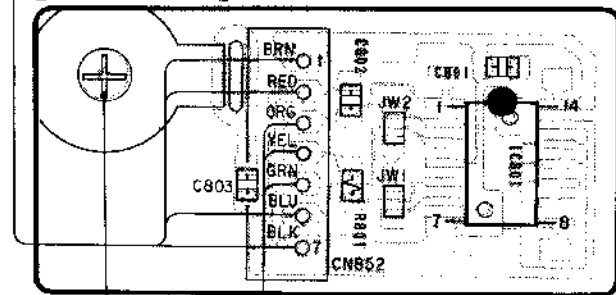

77 (CHASSIS)

11, 12
(11), (12)

6. PARTS CHANGE

Electrical Parts List

Page	FORMER						NEW					
	Ref. No	Part No	Description	Remark			Ref. No	Part No	Description	Remark		
89			** AC BOARD **						** AC BOARD **			
		7-682-548-09	+BVTT 3X8, (S)					7-685-646-79	SCREW +BVTP 3X8 TYPE 2 N-S			
			** AUDIO BOARD **						** AUDIO BOARD **			
		7-682-548-09	+BVTT 3X8, (S)					7-685-646-79	SCREW +BVTP 3X8 TYPE 2 N-S			
	C532	1-162-199-31	CERAMIC	10PF	5%	50V	C532					
90	C551	1-162-294-31	CERAMIC	0.001uF	10%	50V	C551		(JUMPER)			
	IC508	8-759-982-03	IC	RC5532DD			IC508	8-759-712-02	IC	NJM2114D		
	IC509	8-759-982-03	IC	RC5532DD			IC509	8-759-712-02	IC	NJM2114D		
	IC510	8-759-982-03	IC	RC5532DD			IC510	8-759-712-02	IC	NJM2114D		
	IC511	8-759-982-03	IC	RC5532DD			IC511	8-759-712-02	IC	NJM2114D		
91	R523	1-259-412-11	CARBON	220	5%	1/6W	R523	1-259-404-11	CARBON	100	5%	1/6W
	R531	1-259-420-11	CARBON	470	5%	1/6W	R531	1-259-402-11	CARBON	82	5%	1/6W
95			** HP BOARD **						** HP BOARD **			
	C651	1-164-054-11	CERAMIC	22PF	5%	50V	C651	1-102-959-00	CERAMIC	22PF	5%	50V
	C652	1-164-054-11	CERAMIC	22PF	5%	50V	C652	1-102-959-00	CERAMIC	22PF	5%	50V
	C655	1-164-085-11	CERAMIC	0.001uF	10%	50V	C655	1-102-074-00	CERAMIC	0.001uF	10%	50V
	C656	1-164-085-11	CERAMIC	0.001uF	10%	50V	C656	1-102-074-00	CERAMIC	0.001uF	10%	50V
96	IC651	8-759-711-18	IC	NJM4556D-D			IC651	8-759-359-60	IC	NJM4556AD-D		
			** MIC BOARD **						** MIC BOARD **			
	C602	1-164-085-11	CERAMIC	0.001uF	10%	50V	C602	1-102-074-00	CERAMIC	0.001uF	10%	50V
	C603	1-164-085-11	CERAMIC	0.001uF	10%	50V	C603	1-102-074-00	CERAMIC	0.001uF	10%	50V
	C604	1-164-085-11	CERAMIC	0.001uF	10%	50V	C604	1-102-074-00	CERAMIC	0.001uF	10%	50V
97			** DISP BOARD **						** DISP BOARD **			
		4-976-360-01	REINFORCEMENT (CONT)				*	4-955-901-01	CUSHION (FL)			
								4-976-360-02	REINFORCEMENT (CONT)			
98			** PW BOARD **						** PW BOARD **			
		7-682-548-09	+BVTT 3X8, (S)					7-685-646-79	SCREW +BVTP 3X8 TYPE 2 N-S			
	C933	1-124-916-11	ELECT	22uF	20%	63V	C933	1-126-965-11	ELECT	22uF	20%	50V
	C945	1-124-925-11	ELECT	2.2uF	20%	100V	C945	1-126-961-11	ELECT	2.2uF	20%	50V

NOTE:

The components identified by mark Δ or dotted line with mark Δ are critical for safety. Replace only with part number specified.

Les composants identifiés par une marque Δ sont critiques pour la sécurité. Ne les remplacer que par une pièce portant le numéro spécifié.

When indicating parts by reference number, please include the board name.

- Due to standardization, replacements in the parts list may be different from the parts specified in the diagrams or the components used on the set.
- Items marked "*" are not stocked since they are seldom required for routine service. Some delay should be anticipated when ordering these items.
- RESISTORS
All resistors are in ohms
METAL: Metal-film resistor
METAL OXIDE: Metal Oxide-film resistor
F: nonflammable

- SEMICONDUCTORS
In each case, u: μ , for example:
uA...: μ A..., uPA...: μ PA..., uPB...: μ PB...,
uPC...: μ PC..., uPD...: μ PD...
- CAPACITORS
uF: μ F
- COILS
uH: μ H
- Abbreviation
CND: Canadian model

* NOTE
For replacement of IC121 and IC171 on the BD board, refer to the service note on page 2.

Ref. No.	Part No.	Description	Remark	Ref. No.	Part No.	Description	Remark
*	A-4673-809-A	BD BOARD, COMPLETE *****		C155	1-104-916-11	TANTAL. CHIP 6.8uF 20%	20V
		< CAPACITOR >		C160	1-104-601-11	ELECT CHIP 10uF 20%	10V
C101	1-104-913-11	TANTAL. CHIP 10uF 20%	16V	C161	1-104-601-11	ELECT CHIP 10uF 20%	10V
C102	1-163-038-91	CERAMIC CHIP 0.1uF	25V	C163	1-164-232-11	CERAMIC CHIP 0.01uF	50V
C103	1-104-913-11	TANTAL. CHIP 10uF 20%	16V	C164	1-164-232-11	CERAMIC CHIP 0.01uF	50V
C104	1-104-913-11	TANTAL. CHIP 10uF 20%	16V	C166	1-163-275-11	CERAMIC CHIP 0.001uF 5%	50V
C105	1-164-232-11	CERAMIC CHIP 0.01uF	50V	C167	1-163-038-91	CERAMIC CHIP 0.1uF	25V
C106	1-163-275-11	CERAMIC CHIP 0.001uF 5%	50V	C168	1-163-038-91	CERAMIC CHIP 0.1uF	25V
C107	1-164-232-11	CERAMIC CHIP 0.01uF	50V	C169	1-104-913-11	TANTAL. CHIP 10uF 20%	16V
C108	1-164-232-11	CERAMIC CHIP 0.01uF	50V	C170	1-104-913-11	TANTAL. CHIP 10uF 20%	16V
C109	1-163-037-11	CERAMIC CHIP 0.022uF 10%	25V	C171	1-163-038-91	CERAMIC CHIP 0.1uF	25V
C111	1-164-004-11	CERAMIC CHIP 0.1uF 10%	25V	C175	1-163-038-91	CERAMIC CHIP 0.1uF	25V
C112	1-164-232-11	CERAMIC CHIP 0.01uF	50V	C176	1-163-227-11	CERAMIC CHIP 10PF 0.5PF	50V
C113	1-107-682-11	CERAMIC CHIP 1uF 10%	16V	C177	1-163-227-11	CERAMIC CHIP 10PF 0.5PF	50V
C114	1-163-038-91	CERAMIC CHIP 0.1uF	25V	C178	1-163-038-91	CERAMIC CHIP 0.1uF	25V
C115	1-107-682-11	CERAMIC CHIP 1uF 10%	16V	C181	1-104-913-11	TANTAL. CHIP 10uF 20%	16V
C116	1-163-019-00	CERAMIC CHIP 0.0068uF 10%	50V	C182	1-163-038-91	CERAMIC CHIP 0.1uF	25V
C117	1-164-004-11	CERAMIC CHIP 0.1uF 10%	25V	C183	1-163-038-91	CERAMIC CHIP 0.1uF	25V
C119	1-104-913-11	TANTAL. CHIP 10uF 20%	16V	C184	1-107-836-11	ELECT CHIP 22uF 20%	8V
C121	1-126-395-11	ELECT 22uF 20%	16V	C185	1-164-611-11	CERAMIC CHIP 0.001uF 10%	500V
C122	1-164-232-11	CERAMIC CHIP 0.01uF	50V	C186	1-163-038-91	CERAMIC CHIP 0.1uF	25V
C123	1-163-038-91	CERAMIC CHIP 0.1uF	25V	C191	1-126-395-11	ELECT 22uF 20%	16V
C124	1-163-038-91	CERAMIC CHIP 0.1uF	25V	C192	1-163-038-91	CERAMIC CHIP 0.1uF	25V
C125	1-104-760-11	CERAMIC CHIP 0.047uF 10%	50V	C193	1-164-346-11	CERAMIC CHIP 1uF	16V
C126	1-107-682-11	CERAMIC CHIP 1uF 10%	16V	C194	1-126-206-11	ELECT CHIP 100uF 20%	6.3V
C127	1-163-038-91	CERAMIC CHIP 0.1uF	25V			< CONNECTOR >	
C128	1-164-232-11	CERAMIC CHIP 0.01uF	50V	CN101	1-766-508-11	CONNECTOR, FFC/FPC (ZIF) 22P	
C129	1-107-823-11	CERAMIC CHIP 0.47uF 10%	16V	CN102	1-766-510-21	CONNECTOR, FFC/FPC 30P	
C130	1-163-251-11	CERAMIC CHIP 100PF 5%	50V	CN103	1-766-509-21	CONNECTOR, FFC/FPC 18P	
C131	1-104-760-11	CERAMIC CHIP 0.047uF 10%	50V	CN104	1-766-898-21	HOUSING, CONNECTOR(PC BOARD)4P	
C132	1-107-682-11	CERAMIC CHIP 1uF 10%	16V			< DIODE >	
C133	1-163-017-00	CERAMIC CHIP 0.0047uF 5%	50V	D101	8-719-988-62	DIODE 1SS355	
C134	1-163-038-91	CERAMIC CHIP 0.1uF	25V	D155	8-719-031-17	DIODE 1SS322-TE85L	
C135	1-163-038-91	CERAMIC CHIP 0.1uF	25V	D161	8-719-421-15	DIODE MA8027-L	
C136	1-126-206-11	ELECT CHIP 100uF 20%	6.3V	D181	8-719-033-60	DIODE F1P2STP	
C141	1-163-038-91	CERAMIC CHIP 0.1uF	25V	D183	8-719-033-60	DIODE F1P2STP	
C142	1-163-251-11	CERAMIC CHIP 100PF 5%	50V			< IC >	
C143	1-163-251-11	CERAMIC CHIP 100PF 5%	50V	IC101	8-752-072-68	IC CXA1981AR	
C144	1-163-251-11	CERAMIC CHIP 100PF 5%	50V	IC102	8-759-243-19	IC TC7SU04F	
C151	1-104-913-11	TANTAL. CHIP 10uF 20%	16V	IC121	8-752-375-06	IC CXD2535AR * NOTE	
C152	1-163-038-91	CERAMIC CHIP 0.1uF	25V				

Ref. No.	Part No.	Description	Remark	Ref. No.	Part No.	Description	Remark
IC121	8-752-375-36	IC CXD2535BR * NOTE		R122	1-216-295-91	CONDUCTOR, CHIP (2012)	
IC122	8-759-243-19	IC TC7SU04F		R123	1-216-037-00	METAL CHIP 330 5% 1/10W	
IC151	8-759-179-60	IC MPC17A38VMEL		R124	1-216-025-91	METAL GLAZE 100 5% 1/10W	
IC171	8-759-504-12	IC X24C01S * NOTE		R125	1-216-025-91	METAL GLAZE 100 5% 1/10W	
IC172	8-759-149-73	IC uPC842G2		R128	1-216-053-00	METAL CHIP 1.5K 5% 1/10W	
IC181	8-759-095-65	IC TC74ACT540FS		R129	1-216-037-00	METAL CHIP 330 5% 1/10W	
IC182	8-759-243-19	IC TC7SU04F		R130	1-216-041-00	METAL CHIP 470 5% 1/10W	
IC191	8-759-822-99	IC L88MS05T-FA		R131	1-216-073-00	METAL CHIP 10K 5% 1/10W	
		< COIL >		R132	1-216-097-91	METAL GLAZE 100K 5% 1/10W	
L101	1-414-234-11	INDUCTOR, FERRITE BEAD		R133	1-216-129-00	METAL CHIP 2.2M 5% 1/10W	
L102	1-414-234-11	INDUCTOR, FERRITE BEAD		R134	1-216-037-00	METAL CHIP 330 5% 1/10W	
L103	1-414-234-11	INDUCTOR, FERRITE BEAD		R135	1-216-053-00	METAL CHIP 1.5K 5% 1/10W	
L105	1-414-234-11	INDUCTOR, FERRITE BEAD		R136	1-216-041-00	METAL CHIP 470 5% 1/10W	
L106	1-414-234-11	INDUCTOR, FERRITE BEAD		R137	1-216-025-91	METAL GLAZE 100 5% 1/10W	
L121	1-414-234-11	INDUCTOR, FERRITE BEAD		R139	1-216-017-91	METAL GLAZE 47 5% 1/10W	
L122	1-412-039-51	INDUCTOR CHIP 100uH		R140	1-216-017-91	METAL GLAZE 47 5% 1/10W	
L151	1-412-622-51	INDUCTOR 10uH		R141	1-216-295-91	CONDUCTOR, CHIP (2012)	
L152	1-412-622-51	INDUCTOR 10uH		R142	1-216-073-00	METAL CHIP 10K 5% 1/10W	
L153	1-412-039-51	INDUCTOR CHIP 100uH		R143	1-216-073-00	METAL CHIP 10K 5% 1/10W	
L154	1-412-039-51	INDUCTOR CHIP 100uH		R144	1-216-025-91	METAL GLAZE 100 5% 1/10W	
L155	1-410-980-51	INDUCTOR CHIP 1mH		R145	1-216-121-91	METAL GLAZE 1M 5% 1/10W	
L161	1-414-234-11	INDUCTOR, FERRITE BEAD		R146	1-216-037-00	METAL CHIP 330 5% 1/10W	
L162	1-414-234-11	INDUCTOR, FERRITE BEAD		R147	1-216-025-91	METAL GLAZE 100 5% 1/10W	
L195	1-233-316-21	FILTER, CHIP EMI		R148	1-216-045-00	METAL CHIP 680 5% 1/10W	
		< TRANSISTOR >		R150	1-216-295-91	CONDUCTOR, CHIP (2012)	
Q101	8-729-905-12	TRANSISTOR DTA144EU		R151	1-216-097-91	METAL GLAZE 100K 5% 1/10W	
Q151	8-729-905-18	TRANSISTOR DTC144EU		R154	1-220-262-11	METAL GLAZE 680 5% 1/4W	
Q162	8-729-101-07	TRANSISTOR 2SB798-DL		R155	1-220-262-11	METAL GLAZE 680 5% 1/4W	
Q163	8-729-905-12	TRANSISTOR DTA144EU		R158	1-216-121-91	METAL GLAZE 1M 5% 1/10W	
Q164	8-729-924-19	TRANSISTOR DTA123JU		R161	1-216-057-00	METAL CHIP 2.2K 5% 1/10W	
Q181	8-729-018-75	TRANSISTOR 2SJ278MY		R162	1-216-057-00	METAL CHIP 2.2K 5% 1/10W	
Q182	8-729-017-65	TRANSISTOR 2SK1764KY		R163	1-216-057-00	METAL CHIP 2.2K 5% 1/10W	
		< RESISTOR >		R164	1-216-045-00	METAL CHIP 680 5% 1/10W	
R101	1-216-077-00	METAL CHIP 15K 5% 1/10W		R165	1-216-097-91	METAL GLAZE 100K 5% 1/10W	
R102	1-216-073-00	METAL CHIP 10K 5% 1/10W		R166	1-220-250-11	METAL GLAZE 10 5% 1/2W	
R103	1-216-073-00	METAL CHIP 10K 5% 1/10W		R167	1-216-065-00	METAL CHIP 4.7K 5% 1/10W	
R104	1-216-049-91	METAL GLAZE 1K 5% 1/10W		R169	1-219-724-11	METAL CHIP 1 1% 1/4W	
R105	1-216-065-00	METAL CHIP 4.7K 5% 1/10W		R170	1-216-073-00	METAL CHIP 10K 5% 1/10W	
R106	1-216-133-00	METAL CHIP 3.3M 5% 1/10W		R171	1-216-073-00	METAL CHIP 10K 5% 1/10W	
R107	1-216-113-00	METAL CHIP 470K 5% 1/10W		R172	1-216-065-00	METAL CHIP 4.7K 5% 1/10W	
R110	1-216-077-00	METAL CHIP 15K 5% 1/10W		R174	1-216-065-00	METAL CHIP 4.7K 5% 1/10W	
R113	1-216-061-00	METAL CHIP 3.3K 5% 1/10W		R176	1-216-065-00	METAL CHIP 4.7K 5% 1/10W	
R114	1-216-025-91	METAL GLAZE 100 5% 1/10W		R178	1-216-065-00	METAL CHIP 4.7K 5% 1/10W	
R116	1-216-069-00	METAL CHIP 6.8K 5% 1/10W		R181	1-216-073-00	METAL CHIP 10K 5% 1/10W	
R117	1-216-113-00	METAL CHIP 470K 5% 1/10W		R182	1-216-089-91	METAL GLAZE 47K 5% 1/10W	
R120	1-216-025-91	METAL GLAZE 100 5% 1/10W		R183	1-216-089-91	METAL GLAZE 47K 5% 1/10W	
R121	1-216-097-91	METAL GLAZE 100K 5% 1/10W		R186	1-216-134-00	METAL CHIP 2.2 5% 1/8W	
				R187	1-216-134-00	METAL CHIP 2.2 5% 1/8W	

* NOTE
 For replacement of IC121 and IC171 on the BD board, refer to the service note on page 2.

Ref.No.	Part No.	Description	Remark	Ref.No.	Part No.	Description	Remark
		< VARIABLE RESISTOR >					
RV101	1-241-396-11	RES, ADJ, METAL GLAZE 22K		C223	1-163-038-00	CERAMIC CHIP 0.1uF	25V
RV102	1-241-396-11	RES, ADJ, METAL GLAZE 22K		C224	1-126-204-11	ELECT CHIP 47uF	20% 16V
		< SWITCH >		C225	1-163-038-00	CERAMIC CHIP 0.1uF	25V
S101	1-572-467-31	SWITCH, PUSH (1 KEY)(LIMIT)		C226	1-163-038-00	CERAMIC CHIP 0.1uF	25V
*****				C227	1-126-204-11	ELECT CHIP 47uF	20% 16V
*	1-653-411-11	DETECTION SW BOARD		C228	1-163-038-00	CERAMIC CHIP 0.1uF	25V
		*****		C229	1-163-141-00	CERAMIC CHIP 0.001uF	5% 50V
		< CONNECTOR >		C230	1-164-232-11	CERAMIC CHIP 0.01uF	50V
CN193	1-770-010-21	CONNECTOR, BOARD TO BOARD 4P		C231	1-163-038-00	CERAMIC CHIP 0.1uF	25V
		< SWITCH >		C232	1-163-038-00	CERAMIC CHIP 0.1uF	25V
S191	1-762-149-11	SWITCH, PUSH (1 KEY)(LOAD OUT DET)		C233	1-126-395-11	ELECT 22uF	20% 16V
S192	1-762-149-11	SWITCH, PUSH (1 KEY)(LOAD IN DET)		C234	1-163-141-00	CERAMIC CHIP 0.001uF	5% 50V
S193	1-762-149-11	SWITCH, PUSH (1 KEY)(CHACKING IN DET)		C235	1-163-038-00	CERAMIC CHIP 0.1uF	25V
*****				C236	1-126-204-11	ELECT CHIP 47uF	20% 16V
*	A-4673-589-A	DIGITAL BOARD, COMPLETE (US, CND)		C237	1-163-038-00	CERAMIC CHIP 0.1uF	25V
		*****		C238	1-126-204-11	ELECT CHIP 47uF	20% 16V
*	A-4673-593-A	DIGITAL BOARD, COMPLETE (AEP)		C239	1-163-038-00	CERAMIC CHIP 0.1uF	25V
		*****		C240	1-163-038-00	CERAMIC CHIP 0.1uF	25V
		< CAPACITOR >		C241	1-163-038-00	CERAMIC CHIP 0.1uF	25V
C201	1-163-038-00	CERAMIC CHIP 0.1uF	25V	C242	1-163-038-00	CERAMIC CHIP 0.1uF	25V
C202	1-163-038-00	CERAMIC CHIP 0.1uF	25V	C243	1-126-204-11	ELECT CHIP 47uF	20% 16V
C203	1-163-235-11	CERAMIC CHIP 22PF	5% 50V	C244	1-163-038-00	CERAMIC CHIP 0.1uF	25V
C204	1-163-235-11	CERAMIC CHIP 22PF	5% 50V	C245	1-163-038-00	CERAMIC CHIP 0.1uF	25V
C205	1-163-141-00	CERAMIC CHIP 0.001uF	5% 50V	C246	1-163-038-00	CERAMIC CHIP 0.1uF	25V
C206	1-163-038-00	CERAMIC CHIP 0.1uF	25V	C247	1-163-038-00	CERAMIC CHIP 0.1uF	25V
C207	1-126-395-11	ELECT 22uF	20% 16V	C248	1-163-038-00	CERAMIC CHIP 0.1uF	25V
C208	1-163-038-00	CERAMIC CHIP 0.1uF	25V	C249	1-163-038-00	CERAMIC CHIP 0.1uF	25V
C209	1-163-038-00	CERAMIC CHIP 0.1uF	25V	C250	1-163-038-00	CERAMIC CHIP 0.1uF	25V
C210	1-163-038-00	CERAMIC CHIP 0.1uF	25V	C251	1-163-038-00	CERAMIC CHIP 0.1uF	25V
C211	1-163-038-00	CERAMIC CHIP 0.1uF	25V	C252	1-163-251-11	CERAMIC CHIP 100PF	5% 50V
C212	1-163-038-00	CERAMIC CHIP 0.1uF	25V	C253	1-163-141-00	CERAMIC CHIP 0.001uF	5% 50V
C213	1-163-038-00	CERAMIC CHIP 0.1uF	25V	C254	1-163-141-00	CERAMIC CHIP 0.001uF	5% 50V
C214	1-163-038-00	CERAMIC CHIP 0.1uF	25V	C255	1-163-141-00	CERAMIC CHIP 0.001uF	5% 50V
C215	1-163-038-00	CERAMIC CHIP 0.1uF	25V	C258	1-163-038-00	CERAMIC CHIP 0.1uF	25V
C216	1-163-038-00	CERAMIC CHIP 0.1uF	25V	C261	1-126-204-11	ELECT CHIP 47uF	20% 16V
C217	1-163-038-00	CERAMIC CHIP 0.1uF	25V	C262	1-163-038-00	CERAMIC CHIP 0.1uF	25V
C218	1-126-204-11	ELECT CHIP 47uF	20% 16V	C263	1-164-232-11	CERAMIC CHIP 0.01uF	50V
C219	1-163-038-00	CERAMIC CHIP 0.1uF	25V	C264	1-163-141-00	CERAMIC CHIP 0.001uF	5% 50V
C220	1-163-038-00	CERAMIC CHIP 0.1uF	25V	C268	1-163-038-00	CERAMIC CHIP 0.1uF	25V
C221	1-126-204-11	ELECT CHIP 47uF	20% 16V	C269	1-163-038-00	CERAMIC CHIP 0.1uF	25V
C222	1-163-038-00	CERAMIC CHIP 0.1uF	25V	C291	1-163-243-11	CERAMIC CHIP 47PF	5% 50V
		< CONNECTOR >		C292	1-163-141-00	CERAMIC CHIP 0.001uF	5% 50V
CN201	1-770-142-11	CONNECTOR, FFC (ZIF) 26P		C851	1-163-227-11	CERAMIC CHIP 10PF	0.5PF 50V
CN202	1-766-510-21	CONNECTOR, FFC/FPC 30P		C852	1-163-227-11	CERAMIC CHIP 10PF	0.5PF 50V
CN221	1-766-509-21	CONNECTOR, FFC/FPC 18P					
CN223	1-580-891-11	SOCKET, CONNECTOR (SMT) 22P					

DIGITAL

Ref. No.	Part No.	Description	Remark	Ref. No.	Part No.	Description	Remark
* CN251	1-770-154-11	PIN, CONNECTOR (PC BOARD) 6P		R223	1-216-073-00	METAL CHIP 10K 5% 1/10W	
* CN261	1-770-154-11	PIN, CONNECTOR (PC BOARD) 6P		R224	1-216-097-00	METAL CHIP 100K 5% 1/10W	
CN263	1-580-884-11	SOCKET, CONNECTOR (SMT) 13P		R226	1-216-033-00	METAL CHIP 220 5% 1/10W	
< IC >				R227	1-216-033-00	METAL CHIP 220 5% 1/10W	
IC201	8-759-366-66	IC M37610MD-061FP		R228	1-216-033-00	METAL CHIP 220 5% 1/10W	
IC202	8-759-926-18	IC SN74HC157ANS		R229	1-216-033-00	METAL CHIP 220 5% 1/10W	
IC203	8-759-199-59	IC RS5C62-E2		R230	1-216-033-00	METAL CHIP 220 5% 1/10W	
IC204	8-759-280-17	IC CXD8512Q		R231	1-216-097-00	METAL CHIP 100K 5% 1/10W	
IC205	8-759-344-74	IC CXD8504AM		R232	1-216-097-00	METAL CHIP 100K 5% 1/10W	
IC206	8-759-249-07	IC CXD8457Q		R233	1-216-097-00	METAL CHIP 100K 5% 1/10W	
IC207	8-759-344-59	IC MX23C1010MC-15-JA3ES		R234	1-216-097-00	METAL CHIP 100K 5% 1/10W	
IC208	8-759-926-98	IC SN74HC4040ANS		R235	1-216-097-00	METAL CHIP 100K 5% 1/10W	
IC221	8-752-375-50	IC CXD2536AR		R236	1-216-097-00	METAL CHIP 100K 5% 1/10W	
IC222	8-759-329-31	IC MSM514400CSJADR1-K		R237	1-216-097-00	METAL CHIP 100K 5% 1/10W	
IC241	8-759-040-83	IC BA6287F		R238	1-216-073-00	METAL CHIP 10K 5% 1/10W	
IC261	8-759-326-72	IC CXD8521M-TLM		R239	1-216-025-00	METAL CHIP 100 5% 1/10W	
< COIL >				R240	1-216-073-00	METAL CHIP 10K 5% 1/10W	
L201	1-412-336-41	INDUCTOR 4.7uH		R241	1-216-021-00	METAL CHIP 68 5% 1/10W	
L202	1-412-336-41	INDUCTOR 4.7uH		R242	1-216-021-00	METAL CHIP 68 5% 1/10W	
L203	1-412-336-41	INDUCTOR 4.7uH		R243	1-216-073-00	METAL CHIP 10K 5% 1/10W	
L221	1-412-336-41	INDUCTOR 4.7uH		R244	1-216-073-00	METAL CHIP 10K 5% 1/10W (AEP)	
L222	1-412-336-41	INDUCTOR 4.7uH		R245	1-216-073-00	METAL CHIP 10K 5% 1/10W (US, CND)	
L261	1-412-336-41	INDUCTOR 4.7uH		R246	1-216-073-00	METAL CHIP 10K 5% 1/10W (US, CND)	
< RESISTOR >				R247	1-216-073-00	METAL CHIP 10K 5% 1/10W (AEP)	
R201	1-216-097-00	METAL CHIP 100K 5% 1/10W		R248	1-216-025-00	METAL CHIP 100 5% 1/10W	
R202	1-216-025-00	METAL CHIP 100 5% 1/10W		R249	1-216-025-00	METAL CHIP 100 5% 1/10W	
R203	1-216-025-00	METAL CHIP 100 5% 1/10W		R250	1-216-073-00	METAL CHIP 10K 5% 1/10W	
R204	1-216-025-00	METAL CHIP 100 5% 1/10W		R251	1-216-025-00	METAL CHIP 100 5% 1/10W	
R205	1-216-073-00	METAL CHIP 10K 5% 1/10W		R252	1-216-025-00	METAL CHIP 100 5% 1/10W	
R206	1-216-073-00	METAL CHIP 10K 5% 1/10W		R253	1-216-073-00	METAL CHIP 10K 5% 1/10W	
R207	1-216-073-00	METAL CHIP 10K 5% 1/10W		R254	1-216-073-00	METAL CHIP 10K 5% 1/10W	
R208	1-216-097-00	METAL CHIP 100K 5% 1/10W		R255	1-216-025-00	METAL CHIP 100 5% 1/10W	
R209	1-216-097-00	METAL CHIP 100K 5% 1/10W		R256	1-216-025-00	METAL CHIP 100 5% 1/10W	
R210	1-216-073-00	METAL CHIP 10K 5% 1/10W		R257	1-216-025-00	METAL CHIP 100 5% 1/10W	
R211	1-216-025-00	METAL CHIP 100 5% 1/10W		R258	1-216-025-00	METAL CHIP 100 5% 1/10W	
R212	1-216-097-00	METAL CHIP 100K 5% 1/10W		R259	1-216-025-00	METAL CHIP 100 5% 1/10W	
R213	1-216-097-00	METAL CHIP 100K 5% 1/10W		R260	1-216-025-00	METAL CHIP 100 5% 1/10W	
R214	1-216-097-00	METAL CHIP 100K 5% 1/10W		R261	1-216-025-00	METAL CHIP 100 5% 1/10W	
R215	1-216-097-00	METAL CHIP 100K 5% 1/10W		R262	1-216-082-00	METAL GLAZE 24K 5% 1/10W	
R216	1-216-073-00	METAL CHIP 10K 5% 1/10W		R263	1-216-065-00	METAL CHIP 4.7K 5% 1/10W	
R217	1-216-073-00	METAL CHIP 10K 5% 1/10W		R264	1-216-065-00	METAL CHIP 4.7K 5% 1/10W	
R218	1-216-073-00	METAL CHIP 10K 5% 1/10W		R265	1-216-029-00	METAL CHIP 150 5% 1/10W	
R219	1-216-073-00	METAL CHIP 10K 5% 1/10W		R266	1-216-025-00	METAL CHIP 100 5% 1/10W	
R220	1-216-073-00	METAL CHIP 10K 5% 1/10W		R267	1-216-025-00	METAL CHIP 100 5% 1/10W	
R221	1-216-097-00	METAL CHIP 100K 5% 1/10W		R268	1-216-025-00	METAL CHIP 100 5% 1/10W	
R222	1-216-073-00	METAL CHIP 10K 5% 1/10W		R269	1-216-025-00	METAL CHIP 100 5% 1/10W	
				R270	1-216-073-00	METAL CHIP 10K 5% 1/10W	
				R271	1-216-109-00	METAL CHIP 330K 5% 1/10W	
				R272	1-216-089-91	METAL GLAZE 47K 5% 1/10W	
				R273	1-216-025-00	METAL CHIP 100 5% 1/10W	

Ref. No.	Part No.	Description	Remark		
R274	1-216-025-00	METAL CHIP	100	5%	1/10W
R275	1-216-025-00	METAL CHIP	100	5%	1/10W
R276	1-216-073-00	METAL CHIP	10K	5%	1/10W
R277	1-216-073-00	METAL CHIP	10K	5%	1/10W
R278	1-216-073-00	METAL CHIP	10K	5%	1/10W
R279	1-216-073-00	METAL CHIP	10K	5%	1/10W
R280	1-216-073-00	METAL CHIP	10K	5%	1/10W
R281	1-216-073-00	METAL CHIP	10K	5%	1/10W
R282	1-216-073-00	METAL CHIP	10K	5%	1/10W
R283	1-216-073-00	METAL CHIP	10K	5%	1/10W
R284	1-216-097-00	METAL CHIP	100K	5%	1/10W
R285	1-216-097-00	METAL CHIP	100K	5%	1/10W
R291	1-216-073-00	METAL CHIP	10K	5%	1/10W
R292	1-216-073-00	METAL CHIP	10K	5%	1/10W
R293	1-216-073-00	METAL CHIP	10K	5%	1/10W
R295	1-216-073-00	METAL CHIP	10K	5%	1/10W
R851	1-216-066-00	METAL CHIP	5.1K	5%	1/10W
R853	1-216-025-91	METAL CHIP	100	5%	1/10W
< VIBRATOR >					
X201	1-760-493-11	VIBRATOR, CERAMIC (CHIP TYPE) (8MHz)			
X202	1-579-550-11	VIBRATOR, CRYSTAL (32.768kHz)			
X851	1-579-069-11	VIBRATOR, CRYSTAL (49.152MHz)			

*	1-653-412-11	MOTOR BOARD			

< CAPACITOR >					
C199	1-164-159-11	CERAMIC	0.1uF		50V
< CONNECTOR >					
* CN191	1-568-944-11	PIN, CONNECTOR 6P			
CN192	1-770-011-41	CONNECTOR, BOARD TO BOARD 4P			

MISCELLANEOUS					

203	1-654-446-11	FLEXIBLE BOARD (OWH)			
△207	8-583-009-11	OPTICAL PICK-UP BLOCK KMS-210A/J-N			
HR901	1-500-175-11	HEAD, OVER LIGHT (RF322-74A)			
M101	A-4660-651-A	MOTOR ASSY (SLED)			
M102	A-4660-650-A	CHASSIS ASSY, BU (SPINDLE)			
M191	A-4660-646-A	MOTOR ASSY (LOADING)			
S102	1-762-148-11	SWITCH, PUSH (2 KEY)			

The components identified by mark △ or dotted line with mark △ are critical for safety. Replace only with part number specified.

Les composants identifiés par une marque △ sont critiques pour la sécurité. Ne les remplacer que par une pièce portant le numéro spécifié.

MDS-JA3ES

SONY SERVICE MANUAL

US Model
Canadian Model
AEP Model

SUPPLEMENT-2

File this supplement with the service manual.

- Subject : 1. CORRECTION**
2. CHANGE OF OVER WRITE HEAD
3. CHANGE OF MECHANISM DECK
4. BOARD CHANGED
5. PARTS CHANGED

(ECN-CD501853)

1. CORRECTION

As there are some mistakes in the previous service manual supplement-1, please correct the followings.

 : Corrected portion

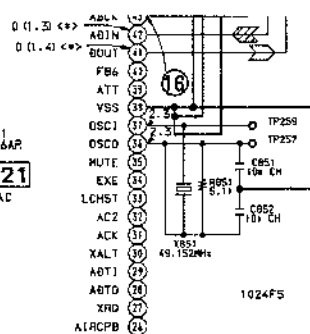
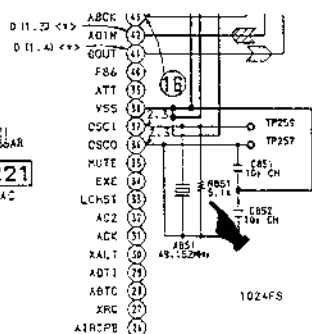
page	INCORRECT	CORRECT
14	<p>[DIGITAL BOARD] Location : M-N, 26-27</p>  <p>IC221 CX62536AP ATRAC</p>	 <p>IC221 CX62536AR ATRAC</p>

• Correct your service manual as shown below.

■ : Indicated corrected portion

(Page 87)

6-4. MECHANISM SECTION (MDM-2C)

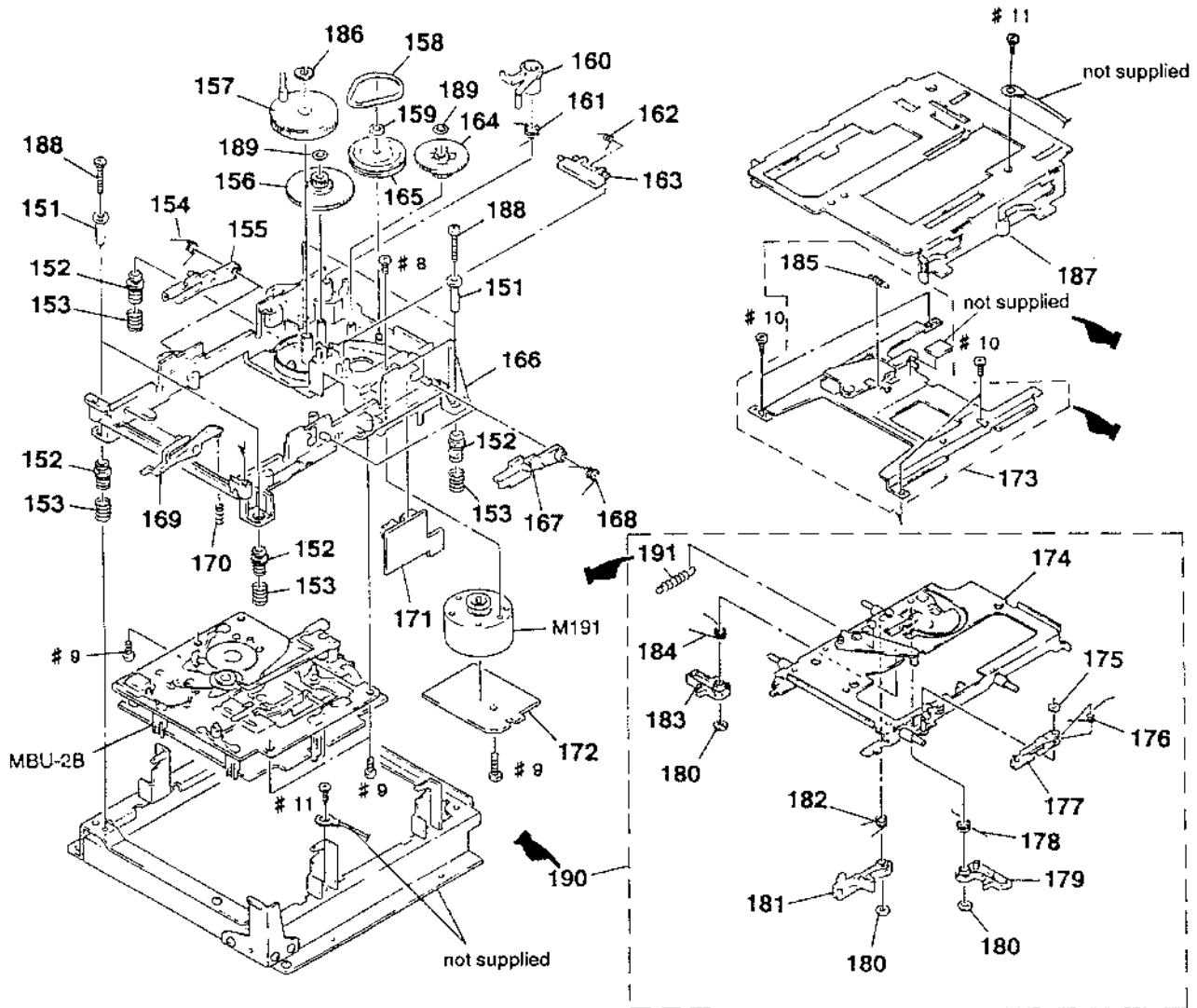

Ref. No.	Part No.	Description	Remark	Ref. No.	Part No.	Description	Remark
151	4-983-100-01	COLLAR (DAMPER)	■	* 172	1-653-412-11	MOTOR BOARD	
152	4-967-671-01	INSULATOR (MD)		173	A-4660-647-B	BRACKET (LVO) ASSY	
153	4-967-673-01	SPRING, COMPRESSION	■	* 174	X-4946-378-1	HOLDER ASSY	
154	4-967-668-01	SPRING (UDL), TORSION		175	4-968-919-11	WASHER, STOPPER	
155	4-967-667-01	LEVER (UDL)					
156	4-967-655-01	GEAR (BD-B)		176	4-967-646-01	SPRING (SHT), TORSION	
157	X-4945-069-1	CAM ASSY		177	4-967-645-01	LEVER (SHT)	
158	4-967-656-01	BELT (BD)		178	4-977-450-01	SPRING (LM), TORSION	
159	4-968-919-31	WASHER, STOPPER		179	4-967-639-01	LEVER (LM)	
160	4-967-637-01	LEVER (SLM)		180	4-968-919-01	WASHER, STOPPER	
161	4-967-638-01	SPRING (SLM), TORSION		181	4-967-641-01	LEVER (L)	
162	4-968-273-01	SPRING (OWH), TORSION		182	4-967-642-01	SPRING (L), TORSION	
163	4-968-272-01	LEVER (OWH)		183	4-967-643-01	LEVER (LS)	
164	4-967-654-01	GEAR (BD-A)	■	184	4-967-644-01	SPRING (LS), TORSION	
165	4-957-794-01	PULLEY (GEAR 1)		185	4-967-664-01	SPRING, TENSION	
* 166	X-4945-068-1	BASE (BD) ASSY		186	4-968-919-21	WASHER, STOPPER	
167	4-967-669-01	LEVER (UDR)		* 187	X-4946-349-1	SLIDER (M) ASSY	
168	4-967-670-01	SPRING (UDR), TORSION		188	4-972-910-01	SCREW (2.6X18), +B	
169	4-967-657-01	LEVER (DOOR)	■	189	4-968-919-41	WASHER, STOPPER	
170	4-970-710-01	SPRING, COMPRESSION	■	190	A-4660-953-B	HOLDER, COMPLETE ASSY	
* 171	1-653-411-11	DETECTION SW BOARD	■	191	4-971-743-02	SPRING, TENSION	
				M191	A-4660-646-A	MOTOR ASSY (LOADING)	

2. CHANGE OF OVER WRITE HEAD

The over write head has changed.

According to the change, the service form will be changed, so refer to "How to discriminate (Over write head)"

How to discriminate (Over write head)

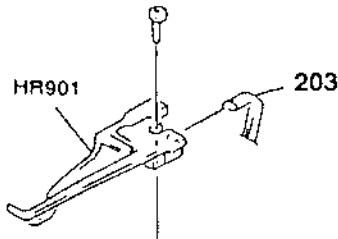
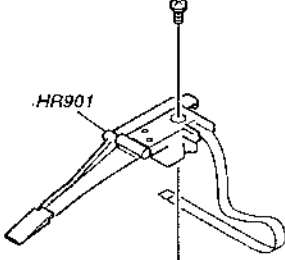
FORMER TYPE				NEW TYPE			
							
Ref.No.	Part No.	Description	Remark	Ref.No.	Part No.	Description	Remark
203	1-654-446-11	FLEXIBLE BOARD (OWH)				not used	
HR901	1-500-175-11	HEAD, OVER WRITE (RF322-74A)		HR901	1-500-304-21	HEAD, OVER WRITE	

* The new part can be used instead of the former over write head.

Difference table

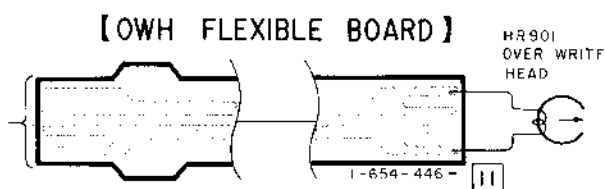
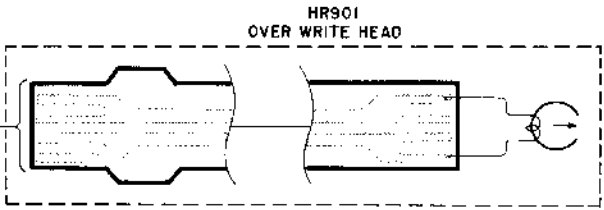
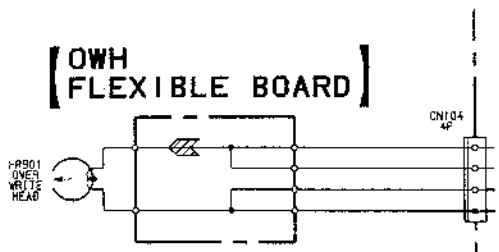
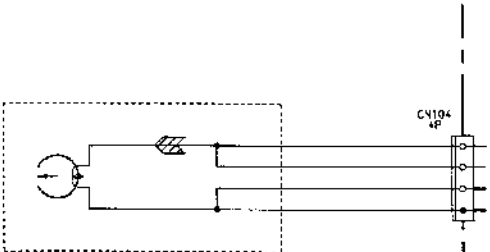
Page	FORMER	NEW
39	<p>Location: A, 4-6</p> 	<p>Location: A, 4-6</p> 
41	<p>Location: B-C, 2-4</p>  <p>OPTICAL PICK-UP BLOCK (KMS-210A/J-N)</p>	<p>Location: B-C, 2-4</p>  <p>OPTICAL PICK-UP BLOCK (KMS-210A/J-N)</p>

Page	FORMER				NEW			
	Ref.No.	Part No.	Description	Remark	Ref.No.	Part No.	Description	Remark
88	*** EXPLODED VIEWS ***				*** EXPLODED VIEWS ***			
	203	1-654-446-11	FLEXIBLE BOARD (OWH)				not used	
	HR901	1-500-175-11	HEAD, OVER WRITE (RF322-74A)		HR901	1-500-304-21	HEAD, OVER WRITE	
100	*** MISCELLANEOUS ***				*** MISCELLANEOUS ***			
	203	1-654-446-11	FLEXIBLE BOARD (OWH)				not used	
	HR901	1-500-175-11	HEAD, OVER WRITE (RF322-74A)		HR901	1-500-304-21	HEAD, OVER WRITE	

3. CHANGE OF MECHANISM DECK

The mechanism deck has been changed from MDM-2C to MDM-2CR.

Refer to "How to discriminate (Mechanism deck)" so that there is no interchangeability between MDM-2C to MDM-2CR.

How to discriminate (Mechanism deck)

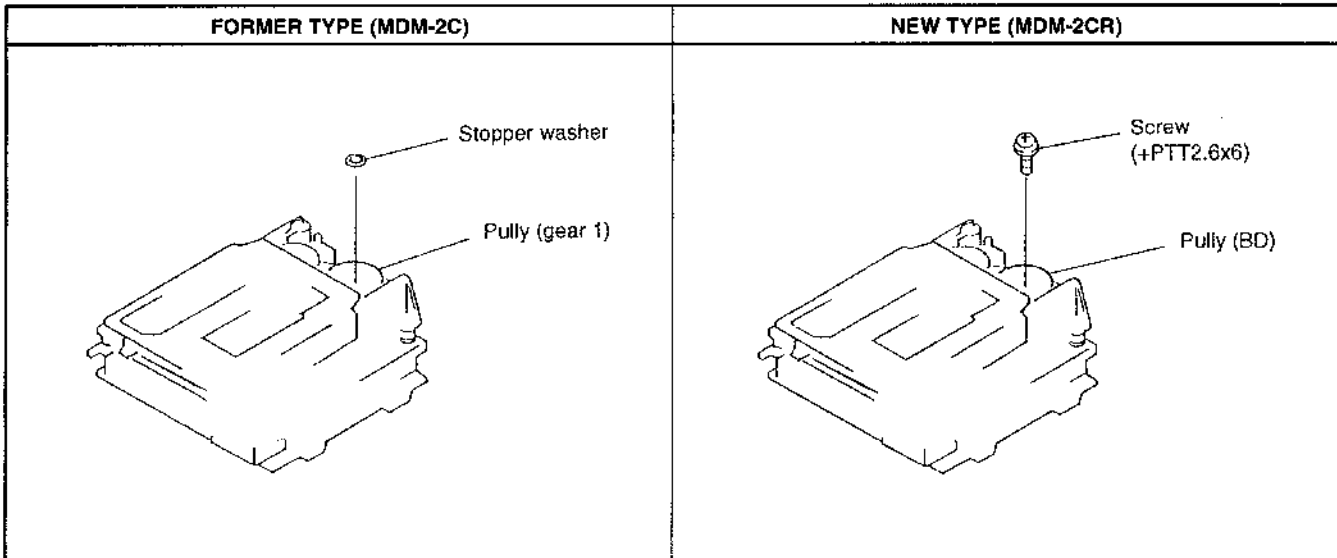

NOTE:

- Items marked " * " are not stocked since they are seldom required for routine service. Some delay should be anticipated when ordering these items.
- The mechanical parts with no reference number in the exploded views are not supplied.

MECHANISM SECTION (MDM-2CR)

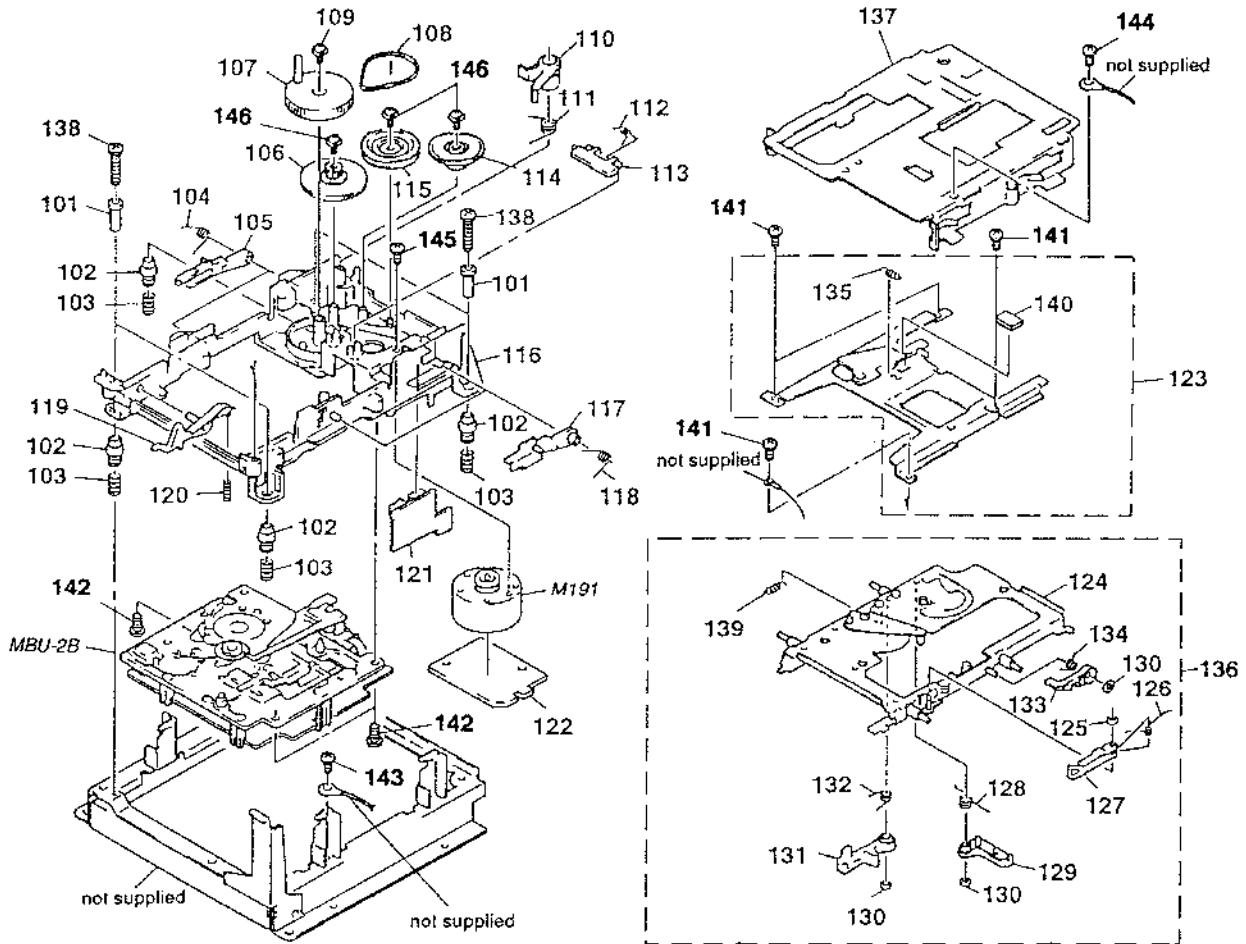

Ref. No.	Part No.	Description	Remark	Ref. No.	Part No.	Description	Remark
101	4-983-100-01	COLLAR (DAMPER)		125	4-968-919-11	WASHER, STOPPER	
102	4-967-671-01	INSULATOR (MD)		126	4-967-646-01	SPRING (SHT), TORSION	
103	4-967-673-01	SPRING, COMPRESSION		127	4-967-645-01	LEVER (SHT)	
104	4-967-668-01	SPRING (UDL), TORSION		128	4-983-106-02	SPRING (LM), TORSION	
105	4-967-667-01	LEVER (UDL)		129	4-967-639-01	LEVER (LM)	
				130	4-968-919-01	WASHER, STOPPER	
106	4-977-610-01	GEAR (BD-B)		131	4-967-641-01	LEVER (L)	
107	X-4945-069-1	CAM ASSY		132	4-967-642-01	SPRING (L), TORSION	
108	4-967-656-01	BELT (BD)		133	4-982-040-01	LEVER (LOCK)	
109	4-933-134-01	SCREW (+PTPHW M2. 6X6)		134	4-982-099-01	SPRING (LOCK), TORSION	
110	4-967-637-01	LEVER (SLM)		135	4-967-664-05	SPRING, TENSION	
				136	A-4672-071-B	HOLDER COMPLETE ASSY	
111	4-984-426-01	SPRING (SLM), TORSION		137	X-4946-349-1	SLIDER (M) ASSY	*
112	4-968-273-01	SPRING (OWH), TORSION		138	4-972-910-01	SCREW (2. 6X18), +B	
113	4-968-272-01	LEVER (OWH)		139	4-971-743-02	SPRING, TENSION	
114	4-977-609-01	GEAR (BD-A)		140	4-983-110-01	CUSHION (LVO)	
115	4-977-608-01	PULLEY (BD)		141	7-685-104-19	SCREW +P 2X6 TYPE2 NON-SLIT	
				142	7-685-645-79	SCREW +BVTP 3X6 TYPE2 N-S	
116	4-977-777-01	BASE (BD)		143	7-621-773-86	SCREW +BVTT 2. 6X4 (S)	
117	4-967-669-01	LEVER (UDR)		144	7-621-255-25	SCREW +PTT 2X4 (S)	
118	4-967-670-01	SPRING (UDR), TORSION		145	7-621-775-20	SCREW +B 2. 6X5	
119	4-979-400-01	LEVER (DOOR)		146	7-621-770-67	SCREW +PTT 2. 6X6 (S)	
120	4-970-710-01	SPRING, COMPRESSION		M191	A-4660-646-A	MOTOR (LOADING) ASSY (MD)	
* 121	1-653-411-11	DETECTION SW BOARD					
* 122	1-653-412-11	MOTOR BOARD					
123	A-4672-087-A	BRACKET (LVO) ASSY					
124	X-4947-136-2	HOLDER ASSY					

NOTE: As for the former typed mechanism deck (MDM-2C), refer to 1. CORRECTION on page 2 in this manual.

4. BOARD CHANGED



DIGITAL board change

Note : There is no interchangeability in some mounting parts of boards which have a suffix No. -**14** or later and a suffix No. -**13** or before. The differences are shown as below.

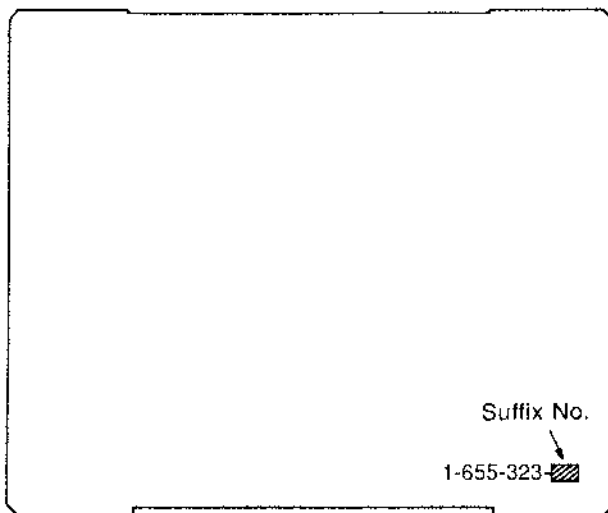
• Part No. Location —DIGITAL board —(SIDE A)



Parts change with the change of a digital board.

Ref No.	FORMER Suffix No. - 13 or before			NEW Suffix No. - 14 or later		
	Part No.	Description	Remark	Part No.	Description	Remark
C250	1-163-038-00	CERAMIC CHIP 0.1uF 25V			_____	
C251	1-163-038-00	CERAMIC CHIP 0.1uF 25V			_____	
C851	1-163-227-11	CERAMIC CHIP 10PF 0.5PF 50V		1-163-087-00	CERAMIC CHIP 47PF 0.25PF 50V	
C852	1-163-227-11	CERAMIC CHIP 10PF 0.5PF 50V		1-163-087-00	CERAMIC CHIP 47PF 0.25PF 50V	
IC205	8-759-344-74	IC CXD8504M		8-759-344-63	IC CXD8504M-T6	
R851	1-216-066-00	METAL CHIP 5.1K 5% 1/10W		1-216-063-00	METAL CHIP 3.9K 5% 1/10W	
R852		_____		1-216-033-00	METALGLAZE 220 5% 1/10W	
X851	1-579-069-11	VIBRATOR, CRYSTAL (49.152MHz)		1-579-971-11	VIBRATOR, CRYSTAL (49.152MHz)	
						
		External appearance of X851			External appearance of X851	

Note : The using parts will be changed as shown in the table above according to using X851.
Perform the replacement referring to the external appearance of X851.

■ : Changed portion

Note : The suffix No. of DIGITAL board has changed to -14, only differences compared with suffix No. -13 are mentioned in the following table.

As for the contents not mentioned here, refer to this table together with the service manual supplement-1 (9-960-228-82)

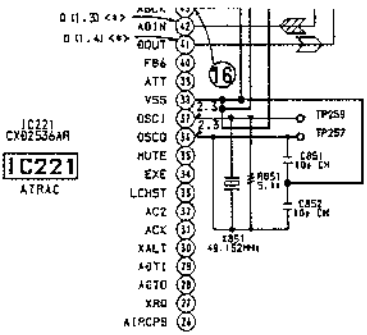
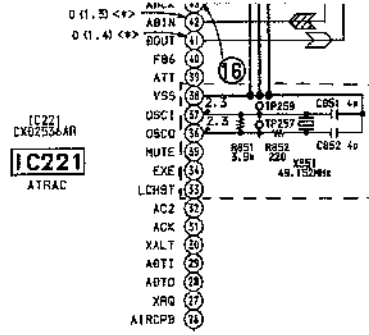
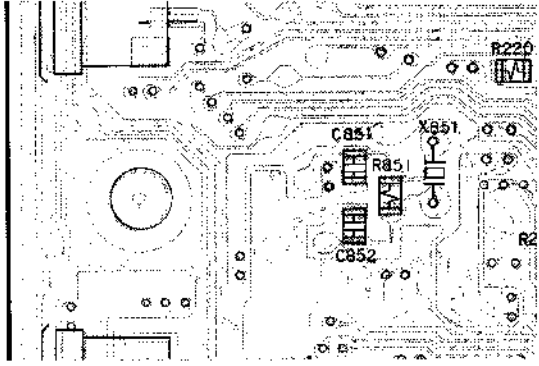
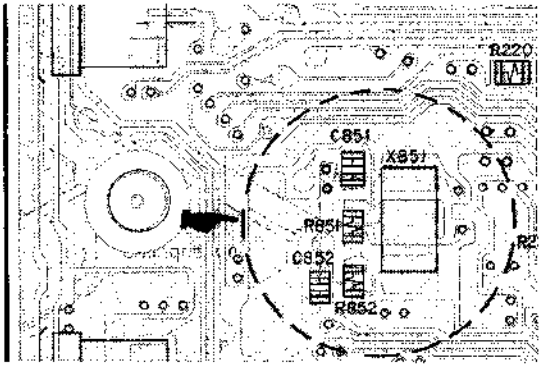
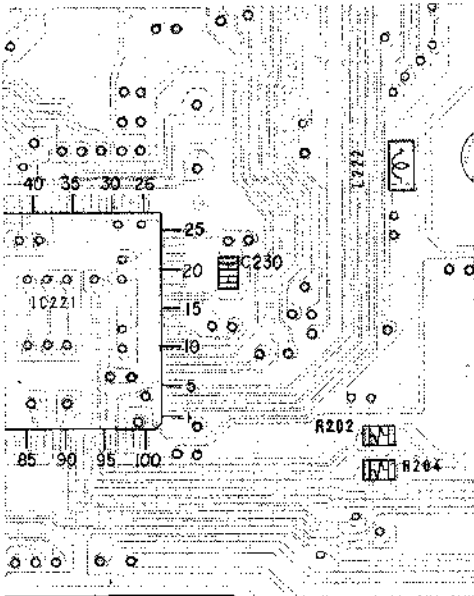
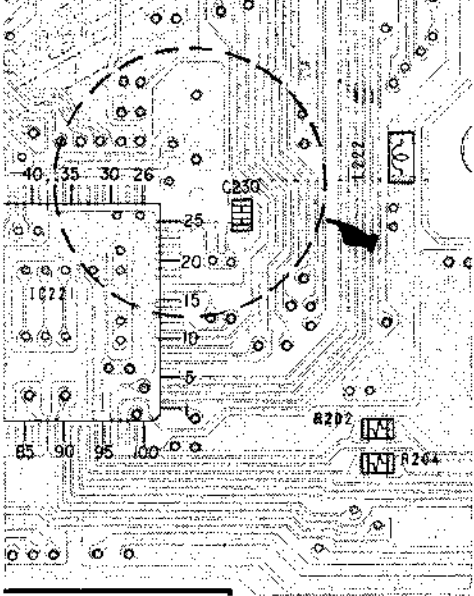
Page	FORMER Suffix No. -13 or before	NEW Suffix No. -14 or later
14	<p>[DIGITAL BOARD] Location : M-N, 26-27</p> 	
15	<p>[DIGITAL BOARD] (SIDE A) Location : E-F, 4-5</p>  <p style="text-align: right;">1-655-323-13 (13)</p>	 <p style="text-align: right;">1-655-323-14 (14)</p>
18	<p>[DIGITAL BOARD] (SIDE B) Location : E-F, 17-18</p>  <p style="text-align: right;">1-655-323-13 (13)</p>	 <p style="text-align: right;">1-655-323-14 (14)</p>

5. PARTS CHANGED

PARTS CHANGED

 : Indicated changed portion

Page	FORMER				NEW			
84	Ref.No.	Part No.	Description	Remark	Ref.No.	Part No.	Description	Remark
	*** EXPLODED VIEWS ***				*** EXPLODED VIEWS ***			
					15	3-704-515-21	SCREW (BV/RING)	

PARTS CHANGED

Page	FORMER				NEW			
85	Ref.No.	Part No.	Description	Remark	Ref.No.	Part No.	Description	Remark
	53	4-971-755-01	KNOB (AMS)(BLACK)		53	4-971-755-02	KNOB (AMS)(BLACK)	
	68	4-969-236-01	SPRING (LID), TORSION		68	4-976-593-01	SPRING (LID), TORSION	
					89	4-955-901-01	CUSHION (FL)	
					90	4-617-601-01	SCREW +B 2.6 x 4	

How to discriminate (TORSION SPRING (LID))

Ref.No.	FORMER TYPE	NEW TYPE
68		

PARTS CHANGED

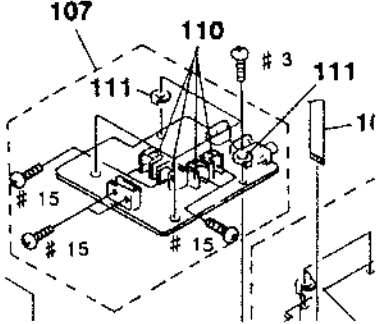
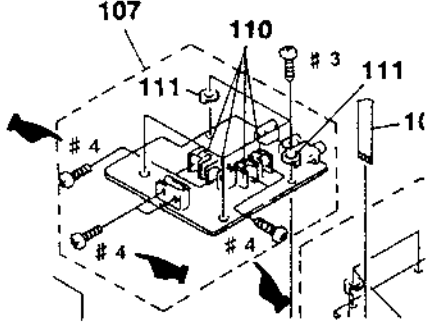
Page	FORMER				NEW			
86								
100	<u>Ref.No.</u> #7	<u>Part No.</u> 7-621-770-87	<u>Description</u> SCREW	<u>Remark</u>	<u>Ref.No.</u>	<u>Part No.</u>	<u>Description</u>	<u>Remark</u>
*** HARDWARE LIST ***				*** HARDWARE LIST ***				