

MDS-102/MD1

SERVICE MANUAL

*AEP Model
UK Model
Singapore Model
Mexican Model
Tourist Model*
MDS-102

*Canadian Model
AEP Model
Singapore Model*
MDS-MD1

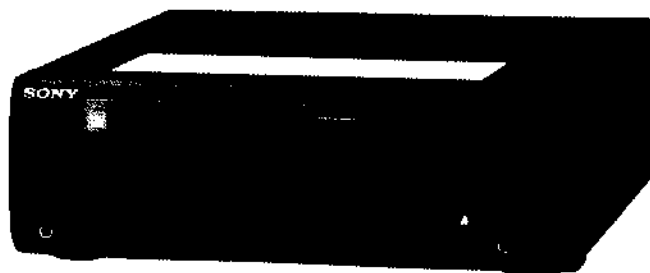

• MDS-MD1 is mini disc recorder in DHC-MD1.

U.S. and foreign patents licensed from Dolby Laboratories Licensing Corporation.

Photo: MDS-102



Model Name Using Similar Mechanism	MDS-101
Mechanism Type	MDM-1C
Base Unit Type	MBU-1
Optical Pickup Block Type	KMS-140B

SPECIFICATIONS

MD recorder section (MDS-102)

System	MiniDisc digital audio system
Disc	MiniDisc
Laser:	Semiconductor laser
Wavelength:	780 - 790nm
Laser diode properties	Material: GaAlAs Emission duration: continuous Laser output: less than 44.6 μ W (This output is the value measured at a distance of 200 mm from the lens surface on the optical pick-up block.)
Revolutions	400 rpm to 900 rpm (CLV)
Error correction	Advanced Cross Interleave Reed Solomon Code (ACIRC)
Sampling frequency	44.1 kHz
Modulation system	EFM (Eight-to-Fourteen Modulation)
Number of channels	2 stereo channels
Frequency response	5 to 20,000 Hz \pm 0.5 dB
Wow and flutter	Below measurable limit

Inputs

	Jack type	Input impedance	Rated input	Minimum input
MIC	Stereo mini-jack	600 ohms	0.8 mVrms	0.3 mVrms
LINE IN	Phono jack	More than 47 kilohms	500 mVrms	158 mVrms
DIGITAL IN	Square optical connector jack	Optical wave length 660 nm	—	—

—Continued on next page—



MiniDisc Recorder
SONY[®]

Outputs

	Jack type	Rated output	Load impedance
HEAD PHONES	Stereo mini-jack	28 mW	32 ohms
LINE OUT	Phono jack	2 Vrms at a load impedance of 50 kilohms	More than 10 kilohms
DIGITAL OUT	Square optical connector jack	-18 dBm	Optical wave length 660 nm

General

Power requirements	110 - 120/220 - 240 V AC, 50/60 Hz : Mexican, Singapore, Tourist model 220 - 230 V AC, 50/60 Hz : AEP model 240 V AC, 50 Hz : UK model
Power consumption	17 W
Dimensions	Approx 225 × 75 × 285 mm (w/h/d) (8 ⁷ / ₈ × 3 × 11 ¹ / ₄ inches) incl. projecting parts
Mass	Approx 2.8 kg (6 lb 5 oz)

Supplied accessories

- Remote commander RM-D1M (1)
- Sony SUM-3 (NS) batteries (2)
- Audio connecting cords (pin-jack × 2 ↔ pin-jack × 2) (2)
- Optical cable (1)
- Audio (AU) bus cable (1)
- Recordable MD: MDW-60 (1)
- AC plug adaptor (1)

Design and specifications are subject to change without notice.

MD Recorder section (MDS-MD1)

Recording system	Magnetic field modulation overwrite system
Playback scanning system	No-contact optical scanning (using a semiconductor laser)
Laser	Semiconductor laser (λ = 780 nm)
Sampling frequency	44.1 kHz
Coding	Adaptive Transform Acoustic Coding (ATRAC)
Frequency response	5 Hz to 20 kHz ± 0.5dB
Signal-to-noise ratio	90 dB or more (during playback)
Wow and flutter	Below measurable limit
Output jack	Square optical connector jack : -18 dBm Wavelength of emitted light: 660 nm

Supplied accessories



- AM loop antenna (1)
- Remote commander (RM-S11MD) (1)
- Sony SUM-3 (NS) batteries (2)
- FM antenna (1)
- AC power cord (1)
- Flat cord (1)
- Speaker cords (2)
- Optical transmission cable (1)

General

Power requirements	120 V AC, 60 Hz : Canadian model 220 - 230 V AC, 50/60 Hz : AEP, German, Italian model 110 - 120/220 - 240 V AC, 50/60 Hz : Singapore model
Power consumption	17 W
Dimensions	Approx 225 × 75 × 295 mm (w/h/d) (8 ⁷ / ₈ × 3 × 11 ⁵ / ₈ inches)
Mass	Approx 2.8 kg (6 lb 3 oz)

Design and specifications are subject to change without notice.

SAFETY-RELATED COMPONENT WARNING!!

COMPONENTS IDENTIFIED BY MARK  OR DOTTED LINE WITH MARK  ON THE SCHEMATIC DIAGRAMS AND IN THE PARTS LIST ARE CRITICAL TO SAFE OPERATION. REPLACE THESE COMPONENTS WITH SONY PARTS WHOSE PART NUMBERS APPEAR AS SHOWN IN THIS MANUAL OR IN SUPPLEMENTS PUBLISHED BY SONY.

ATTENTION AU COMPOSANT AYANT RAPPORT À LA SÉCURITÉ!

LES COMPOSANTS IDENTIFIÉS PAR UNE MARQUE  SUR LES DIAGRAMMES SCHÉMATIQUES ET LA LISTE DES PIÈCES SONT CRITIQUES POUR LA SÉCURITÉ DE FONCTIONNEMENT. NE REMPLACER CES COMPOSANTS QUE PAR DES PIÈCES SONY DONT LES NUMÉROS SONT DONNÉS DANS CE MANUEL OU DANS LES SUPPLÉMENTS PUBLIÉS PAR SONY.

MODEL IDENTIFICATION

— Specification Labels —

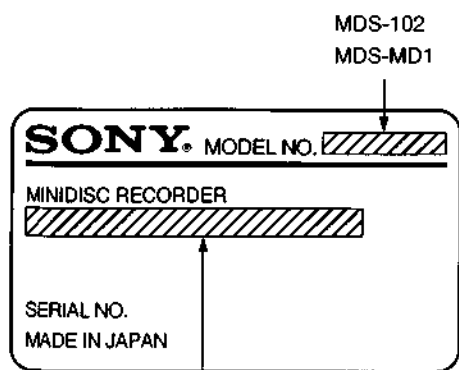

Canadian model : AC : 120V 60Hz

AEP, German, Italian model : AC : 220—230V~50/60Hz

UK model : AC : 240V~50Hz

Mexican, Singapore,

Tourist model : AC : 110—120/220—240V~50/60Hz

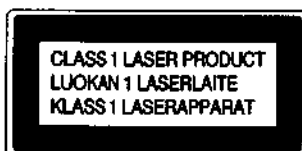

This appliance is classified as a CLASS 1 LASER product. The CLASS 1 LASER PRODUCT MARKING is located on the rear exterior.

The following caution label is located inside of the unit.

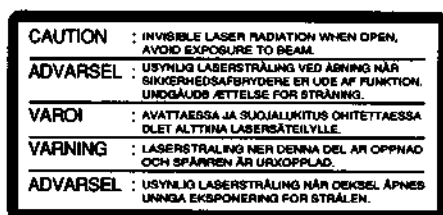
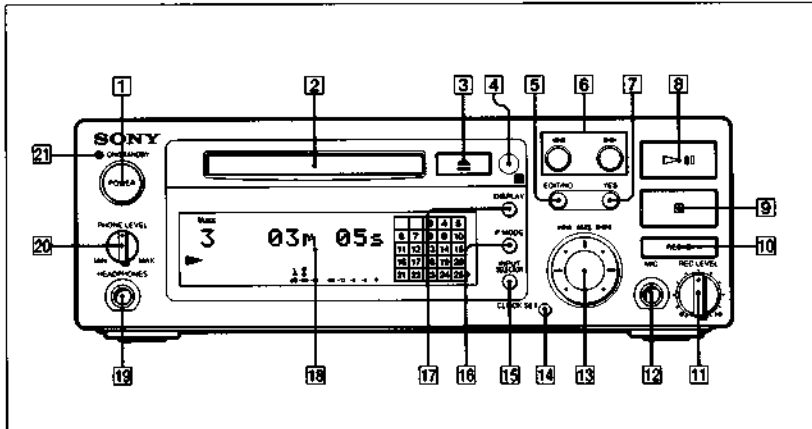

TABLE OF CONTENTS

<u>Section</u>	<u>Title</u>	<u>Page</u>
1. GENERAL		
MDS-102	4
MDS-MD1	24
2. DISASSEMBLY		
2-1.	Case, Front Panel	32
2-2.	DISP, MIC Board	33
2-3.	Power Transformer	34
2-4.	Back Panel	34
2-5.	Mechanism Deck (MDM-1C)	35
2-6.	RF/SERVO Board	35
2-7.	Base Unit (MBU-1)	36
2-8.	Loading Motor Assy	36
2-9.	Sled Motor	37
2-10.	Mini Disc Device (KMS-140B)	37
3. TEST MODE	38
4. ELECTRICAL ADJUSTMENTS	41
5. DIAGRAMS		
5-1.	IC Pin Functions	50
	IC103 EFM/ACIR Encoder/Decoder (CXD2525R)	50
	IC110 Shockproof Memory Controller (CXD2526AR)	52
	IC111 System Control (M38067M8-126FP)	54
	IC301 Function/Display Controller (M38004M8-111FP)	56
5-2.	Block Diagram	59
5-3.	Circuit Boards Location	64
5-4.	Semiconductor Lead Layouts	65
5-5.	Printed Wiring Boards—RF Section—	66
5-6.	Schematic Diagram—RF Section—	69
5-7.	Schematic Diagram—Audio Section—	73
5-8.	Printed Wiring Boards—Audio Section—	77
5-9.	Printed Wiring Boards—Digital Section—	81
5-10.	Schematic Diagram—Digital Section—	85
5-11.	Schematic Diagram—Display (MDS-102) Section—	90
5-12.	Printed Wiring Board—Display (MDS-102) Section—	93
5-13.	Printed Wiring Board—Display (MD1) Section—	96
5-14.	Schematic Diagram—Display (MD1) Section—	99
6. EXPLODED VIEWS		
6-1.	Cabinet Section	101
6-2.	Chassis Section	102
6-3.	Mechanism Deck Section-1	103
6-4.	Mechanism Deck Section-2	104
6-5.	Base Unit Section	105
7. ELECTRICAL PARTS LIST	106

Looking at the Controls

Front panel



- 1 POWER switch**
Press to turn on the unit; press again to change to stand-by.
- 2 Disc compartment**
Automatically loads an inserted disc.
- 3 (eject) button**
Press to eject the disc from the disc compartment.
- 4 Remote sensor**
Accepts commands from the remote commander.
- 5 EDIT/NO button**
Press to specify or cancel the various editing functions.
- 6 (search) buttons**
Press to find a specific point within a track.
- 7 YES button**
Press to perform editing functions (i.e., erasing, dividing, combining, and moving).
- 8 (play/pause) button**
Press to start playback or recording. Press during playback or recording to pause the MD; press again to cancel pause.
- 9 (stop) button**
Press to stop playback or recording, or to erase all programmed tracks.
- 10 REC (record) button**
Press once for recording pause. Press (play) to start recording. Use also for track marking.
- 11 REC (recording) LEVEL control**
Turn to adjust the recording level when recording from analog sources.
- 12 MIC (microphone) jack**
Connect a microphone with a stereo mini-plug here.
- 13 AMS* dial**
Turn to cue to the beginning of specific tracks, set the clock, specify the playing order of programmed tracks, edit functions, and enter text data. Press to play or pause an MD.
- 14 CLOCK SET button**
Press to set the clock.
- 15 INPUT SELECTOR button**
Press to select the input signal to be recorded. Press while the unit is stopped to select "Analog in" to record through the LINE IN (analog) jack. Press to select "Digital in" to record through the DIGITAL IN jack.
- 16 P.MODE button**
Press to select playback modes (i.e., CONTINUE, SHUFFLE, and PROGRAM).
- 17 DISPLAY button**
Press to display the title of the current track and the remaining playing time on the MD.
- 18 Display window**
Indicates the current operating status.
- 19 HEADPHONES jack**
Connect headphones with a stereo mini-plug here.
- 20 PHONE (headphones) LEVEL control**
Turn to adjust the volume of the headphones.
- 21 ON/STANDBY indicator**
Lights up when standby mode is on.

AMS: Automatic Music Sensor

Remote commander

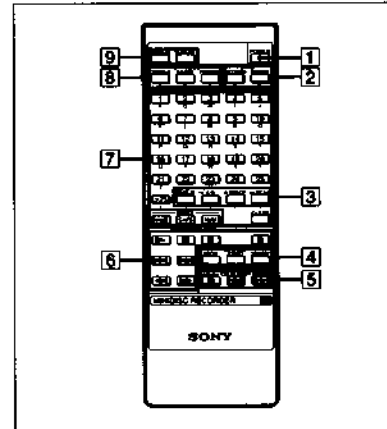

- 1 POWER switch**
Press to turn on the unit; press again to turn off (change to stand-by).
- 2 DATE buttons**
DATE RECORDED button
Press to display the recording date of a track during playback.
DATE PRESENT button
Press to display the current time and date.
- 3 REPEAT/SPACE/SCAN buttons**
REPEAT button
Press for repeated playback.
A-B button
Press for repeated playback of specific portions of a track.
A(auto).SPACE button
Press for automatic insertion of 3-second blank spaces between tracks during playback.
Misc/SCAN button
Press to scan the beginning of each track in succession.
- 4 CD-SYNC. operation buttons**
(use for synchronized recording with a Sony CD player)
STANDBY button
Press to activate recording pause prior to CD synchro recording.
START button
Press to start CD synchro recording.
STOP button
Press to stop CD synchro recording.
- 5 CD PLAYER operation buttons**
(Use to control Sony CD players)
II (pause) button
Press to pause playback; press again to resume playback.
II (AMS) buttons
Press to find the beginning of a track.
- 6 Operation buttons**
▶ (play) button
Press to start playback or recording.
II (pause) button
Press during playback or recording to pause the MD; press again to cancel pause.
■ (stop) button
Press to stop playback or recording, or to erase all programmed tracks.
● (record) button
Press once for recording pause. Press ▶ or II to start recording. Use also for track marking.
II (AMS) buttons
Press to find the beginning of a track.
◀▶ (search) buttons
Press to find a specific point within a track.
- 7 Character/Numeric buttons**
Alphabet/Numeric buttons
Use to specify tracks for immediate playback or to create programs during program play. Use also for entering disc and track titles
WRITE/CAPS, WRITE/NUM buttons
Press to select the character mode.
WRITE/NAME button
Press to apply a title
CLEAR button
Press to erase a track title, disc title or programmed track.
- 8 PLAY MODE buttons**
Press to select the playback mode (i.e., CONTINUE, SHUFFLE, or PROGRAM).
- 9 Display buttons**
DISPLAY button
Press to display the track title or the remaining playing time during MD playback.
SCROLL button
Press to scroll titles longer than 12 characters.
Press to pause scrolling.

This section is extracted from instruction manual.

Hooking Up the System

You can connect your MDS-102 to the following systems in either a digital or analog configuration:

- Sony mini Hi-Fi component systems with a digital output jack
- Sony mini Hi-Fi component systems without a digital output jack
- Other audio equipment with a digital output jack
- Other audio equipment without a digital output jack.

Illustrations of these configurations appear on pages 11 to 14.

Before you begin

- Turn off the power to all the equipment to be connected before making any connections.
- Note that the red plug of the supplied audio connecting cord is for right-channel (R) connection and the white plug for left-channel (L) connection. If another connecting cord is necessary, use the optional RK-C510HG cord.
- Insert the connecting cords fully into the jacks. A loose connection may cause hum pickup.
- Pull out the cords by grasping the plug, not the wire.

Connecting the audio connecting cords

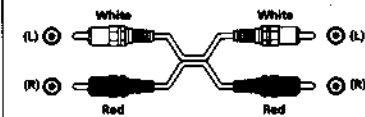

Connecting the audio bus cable



Insert the cable firmly.

The time display appears on the Mini Hi-Fi Component Systems (available at a later date) instead of the MD unit when both are connected by audio bus cable.

Notes on the optical digital input-output jacks

Use the supplied optical cable to connect digital devices with a sampling frequency of 44.1 kHz (i.e., DAT decks, amplifiers with digital inputs, DA converter units, etc.) to the optical digital input and output jacks. Recording level adjustment is not necessary when recording through the optical cable from a digital source since the output level is fixed.

Connecting the optical cable

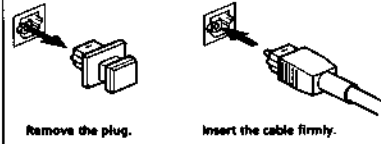

Digital sources with different sampling frequencies cannot be recorded through the digital input jack. Only CD, MD (premastered) and DAT sources with a sampling frequency of 44.1 kHz can be recorded through the digital input jack. "Din Unlock" appears in the display window when you attempt to record digital sources with a sampling frequency different from that of the MD (such as 32- or 48- kHz DAT or BS). To record these sources to an MD you must connect them through the analog LINE IN jacks.

Hooking up a Sony Mini Hi-Fi Component System

Hooking up a Sony Mini Hi-Fi Component System through the digital output jack (for digital recording)

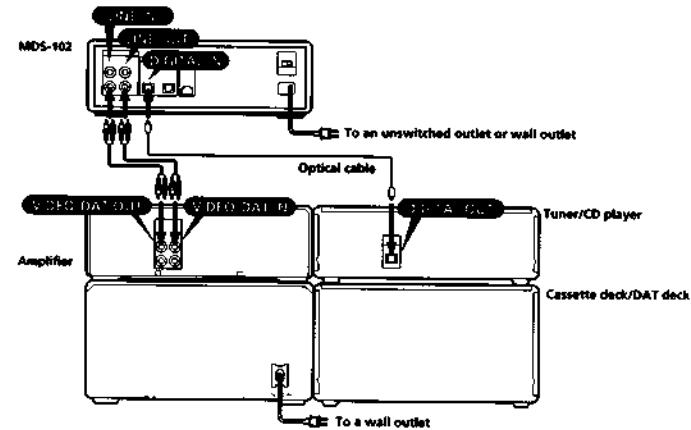

Connection to future Sony Mini Hi-Fi Component Systems with AU-bus connection capability enables the use of the automatic on/off and CD synchro recording functions.

Hooking Up the System

Hooking up a Sony Mini Hi-Fi Component System

Hooking up a Sony Mini Hi-Fi Component System without a digital output jack (for analog recording)

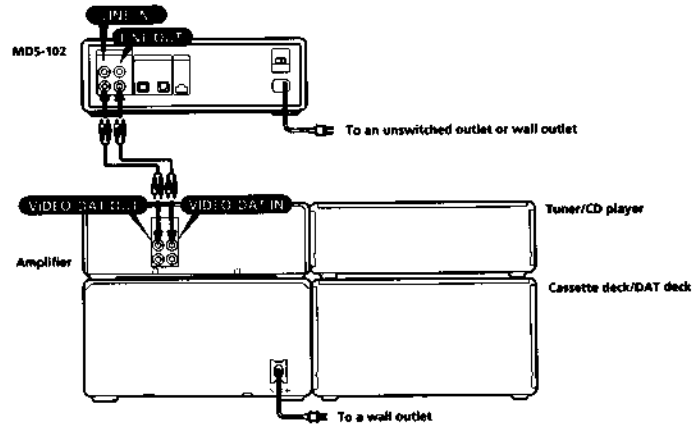

Connection to future Sony Mini Hi-Fi Component Systems with AU-bus connection capability enables the use of the automatic on/off and CD synchro recording functions.

Hooking up other audio equipment

Hooking up other audio equipment with digital output (for digital recording)

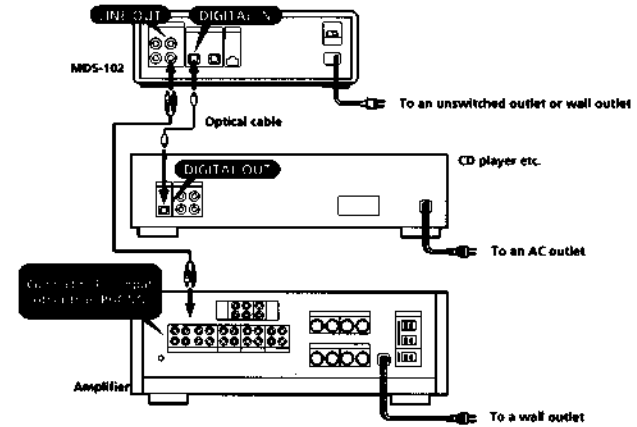

Hooking up other audio equipment without digital output (for analog recording)

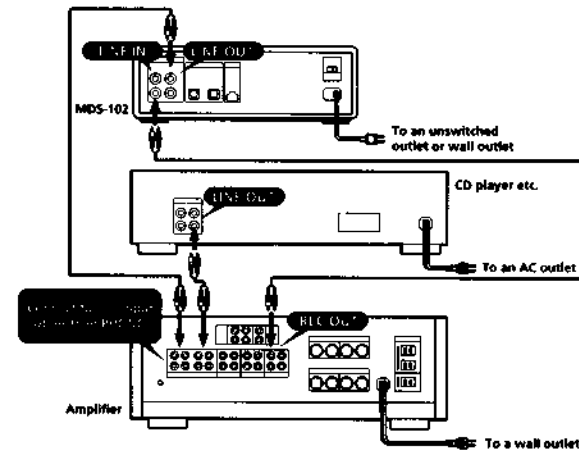

If no REC OUT selector is provided on the amplifier, connect LINE OUT of the MD recorder to the TAPE IN line input of the amplifier.

Hooking Up the System

Hooking up an amplifier with digital input, DAT deck or another MiniDisc recorder
Connect the digital input of the respective equipment to the digital output of your MD recorder.

Hooking up a microphone

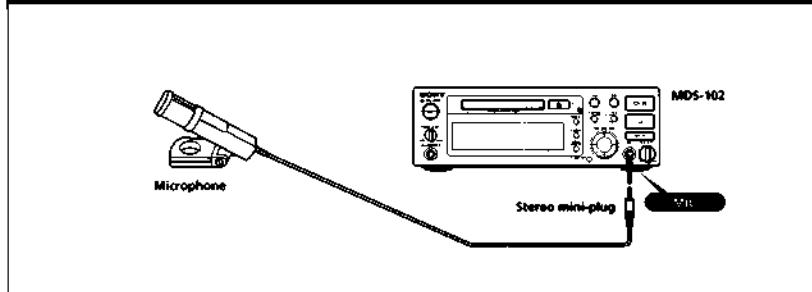

Notes

Connecting a microphone to the MIC jack disables all other source inputs. Make sure that the microphone is disconnected from the MIC jack when not in use.

Setting the Clock

By setting the clock, the time and date of all recordings will be automatically written to the MD. When you play back a recorded track, you can display the date and time of the recording in the display window. For more precise time and date stamping of recordings, we recommend that you set the clock at least once a week.

Example: Setting the clock to 9:10 AM, April 23, 1994.

1 Hold down **CLOCK SET** for about 2 seconds until the year starts to flash.

CLOCK SET

01d 01m 94y

2 Turn the **AMS dial** to enter the year, month, day, hour, and minute. Press the AMS dial after entering each item.

AMS dial

01d 03m 94y

2,3

23d 04m 94y

↓

SAT 09:10

3 After setting the minutes, press the **AMS dial** in synchronization with a time signal.

23d 04m 94y



SAT 09:10

The clock setting proceeds in order of date, then time.

Notes

To change the time and/or date

1 In step 2, press the AMS dial until the item to be changed flashes.

2 Turn the AMS dial to change the value.

3 Complete the setting by pressing **CLOCK SET** or the AMS dial until all items stop flashing.

To display the current date and time

Press **CLOCK SET** on the front panel once to display the date, then again to display the time. When using the remote commander, press **DATE PRESENT**. The date appears, followed by the time.

Changing the display mode while the recorder is off

Press **DISPLAY** to choose either no display or display of the current time.

When the power cord is unplugged for a long time

The memorized settings are lost, and "STANDBY" flashes when you plug in and turn on the recorder again. If this happens, set the clock again.

Listening to a MiniDisc (MD)

Playing an MD (Normal Play)

You can play back an MD in two ways

- Playing from the first track
- Playing from a specific track

Playing an MD from the first track

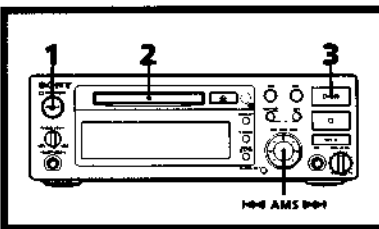

1 Press **POWER** to turn on the recorder.



2 With the label side up and the arrow pointing toward the opening, slide the MD into the disc compartment until the recorder grips it.
If you insert the MD while the recorder is off, the recorder will turn on automatically.

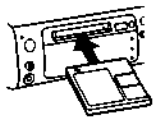

The disc name appears, followed by the total number of tracks (Tr) and total disc playing time, as shown at the top of the next column. A music calendar showing all the track numbers appears within a grid if the MD is a premastered disc, or without a grid if the MD is a recordable disc. If the total track number exceeds 25, ▶ appears to the right of number 25 in the music calendar.

3 Press **▶** (▶) or the **AMS** dial.
The MD starts playing.

The current track number, track title (if labeled), and elapsed playing time of the current track light up in the display window.

To pause playback

Press **▶** (▶) or the **AMS** dial.
To restart playback, press **▶** (▶) or the **AMS** dial again

To stop play

Press **□**.

To eject the disc

Press **▲**.

Locating a specific track

Enter the number of the track on the remote commander. The specified track will begin playing immediately.

Example: To play back the third track

Example: To play back the 26th track

Example: To play back the 100th track

Locating the beginning of a track (AMS)

The AMS function allows you to go quickly to the beginning of a track by merely specifying its number in the display window

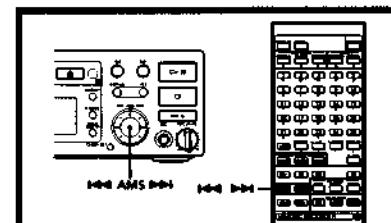

Turn the AMS dial.

This way for previous tracks.

This way for succeeding tracks.

Press **◀** or **▶**.

Press to go to previous tracks. Press to go to succeeding tracks.

Hold down each button to go to successive tracks in the respective direction.

To locate the beginning of the current track Press **◀** once.

To pause playback at the beginning of a track
Turn the AMS dial (or press **◀** or **▶**) after pausing playback

To go quickly to the beginning of the last track
Turn the AMS dial counterclockwise (or press **◀**) immediately after inserting the MD.

Playing an MD (Normal Play)

Locating a position within a track (Search)

Use the search function to quickly scan a track either forward or backward during playback to locate a specific position.

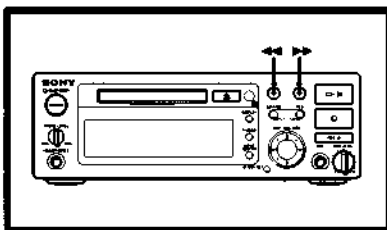

To forward scan a track
Hold down FF during playback.

To backward scan a track
Hold down RR during playback.

When you release the button, the recorder begins playing from the position located by scanning.

To go forward or backward quickly
Hold down FF or RR during playback pause. The recorder scans the disc at 160 times the normal playing speed. Since no sound is output at this time, you must keep track of the current disc location through the information that appears in the display window.

Note

Tracks that are only a few seconds in length may be too short to scan using the search function. For such tracks, it is better to play the MD back at normal speed.

Displaying the title and remaining playing time of a track

Press DISPLAY during playback to display the title and remaining playing time of the current track. "No Name" appears if a track is unlabeled. To label a recordable disc and its tracks, see "Labeling Recordings" on page 43.

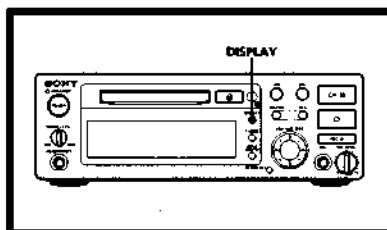

Press DISPLAY while playing back a track.

Each press of DISPLAY changes the display in the following order: remaining track playing time → track name → elapsed playing time

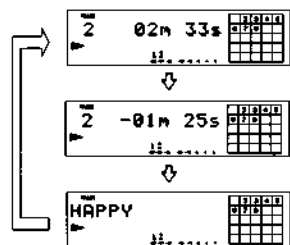

- The display window shows up to 12 characters at a time. To see a title of 13 characters or more, press SCROLL on the remote commander. Press SCROLL again to pause scrolling, and again to continue scrolling.
- If no title is recorded, "No Name" appears, followed by the elapsed playing time.
- Each press of DISPLAY while the recorder is stopped changes the display in the following order:
For premastered discs: Total disc playing time → disc name
For recorded discs: Total recorded time → remaining disc playing time → disc name

Displaying the recording date and time

Once you've set the built-in clock, the recorder will automatically record the recording date and time of all tracks. Do the following procedure to display the recording information during playback.

Remote commander operation only

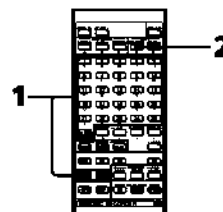

- 1 **Locate the track.**
Press FF or RR while the recorder is stopped to locate the track.



If the recorder is playing or paused, enter the track number with the numeric buttons, or keep pressing FF or RR until the number of the track appears.

- 2 **Press DATE RECORDED.**
The track number flashes.

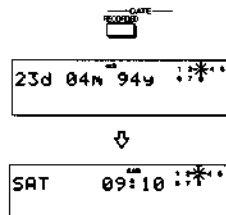

"No Date" appears if the built-in clock has not been set or the track was recorded on another unit without a date and time stamp function. The previous display reappears when you press DATE RECORDED again or after a few seconds have passed.

Playing Tracks in Random Order (SHUFFLE Play)

Use shuffle play to play back all tracks on an MD in random order.

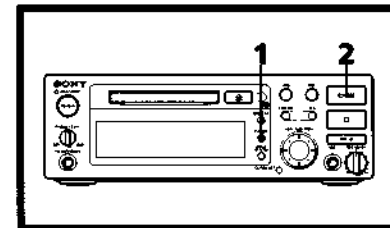

- 1 **Keep pressing P.MODE (SHUFFLE) while the recorder is stopped until "SHUFFLE" lights up.**

P.MODE

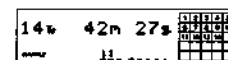

- 2 **Press D-H (▶).**
Shuffle play starts.

D-H



Specifying tracks during shuffle play

- To play the next track, turn the AMS dial clockwise (or press ▶▶).
- To play from the beginning of the current track again, turn the AMS dial counterclockwise (or press ◀◀). You cannot use the AMS dial (◀◀) to go to tracks that have already played.

To stop shuffle play

Press □.

To cancel shuffle play

Keep pressing P.MODE (CONTINUE) until "SHUFFLE" goes off.

Playing Tracks in a Specific Order (PROGRAM Play)

Program play allows you to specify the playback order of up to 25 tracks.

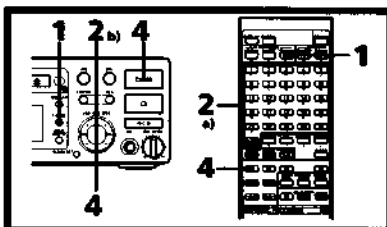

1 Keep pressing P.MODE (PROGRAM) while the recorder is stopped until "PROGRAM" lights up.

P.MODE

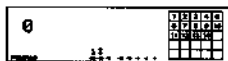

2 a) When using the remote commander:

Enter the track number with the numeric buttons.

The entered track number is programmed. In this example, "3" is pressed.



Track number

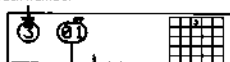

Order of the specified track

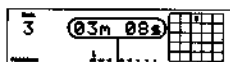

Total program play time

When programming tracks 26 to 99, press >25 once before pressing the respective numeric buttons. When programming tracks 100 and above, press >25 twice before the respective numeric buttons.

Example: To program the 26th track

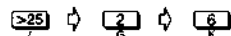

Example: To program the 100th track

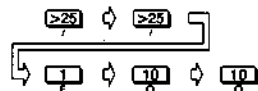

b) When using the front panel:

You can monitor the total program time as you enter each track number.

1 Turn the AMS dial until the track number to be entered lights up.

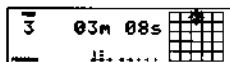

2 Press the AMS dial or P. MODE.

The selected track number is programmed.

P.MODE

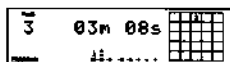

3 Repeat step 2 to enter other tracks.

Each time you enter a track, the total program time is recalculated and displayed. You can program up to 25 tracks.

4 Press >M (▶) or the AMS dial.

Program play starts from the first track of the program.

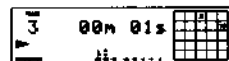

Checking the order of programmed tracks

Turn the AMS dial (or press ◀ or ▶) while the recorder is playing or paused. The track numbers appear in the order they were programmed.

To erase programmed tracks

Press CLEAR while the recorder is stopped to erase the program one track at a time starting from the end of the program.

To stop program play

Press □.

To cancel program play

Keep pressing P.MODE (CONTINUE) until "PROGRAM" disappears.

To make changes to a program

- To change a track just entered: Press CLEAR, then repeat the programming procedure from step 2 on page 20.
- To change all tracks: Press □ while the recorder is stopped, then repeat the programming procedure from step 2 on page 20.

Scanning Tracks (Music Scan)

The music scan function automatically plays back the first 6, 10 or 20 seconds of each track in succession allowing you to quickly check the contents of the disc.

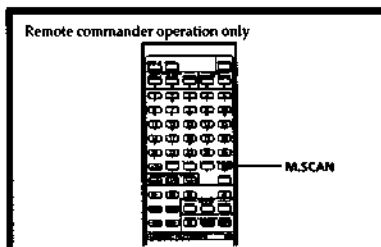

Press M.SCAN while the recorder is stopped.

M.SCAN



The scanning time appears. Press M.SCAN to select a scanning time of 6, 10, or 20 seconds.

Scanning time

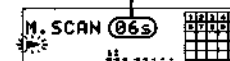

Inserting Spaces During Playback (Auto Space)

When the auto space function is on, the recorder inserts a three-second blank space after playing each track to allow use of the AMS function on tapes dubbed from the MD.

Remote commander operation only

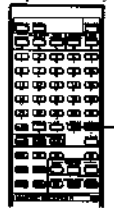

A.SPACE

Press A.SPACE once.
"A.SPACE" lights up.

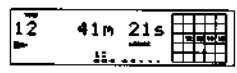
To cancel the auto space function
Press A.SPACE again to turn off "A.SPACE".

Note

Sound cut-off may occur at the start of new tracks
When a selection comprises consecutive tracks undivided by blank spaces (e.g., symphonies), the insertion of the three-second blank by the auto space function may result in some sound cut-off at the start of each track.

Playing Tracks Repeatedly

Playing tracks repeatedly

Use the repeat function for repeated playback in normal, shuffle or program play mode.

Remote commander operation only

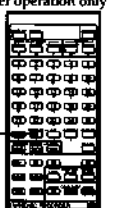

REPEAT

While the MD is playing, keep pressing REPEAT until "REPEAT" lights up.
All tracks play again.

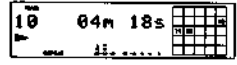
To play back the current track repeatedly, press REPEAT twice.
"REPEAT 1" lights up.

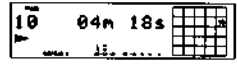

To play tracks repeatedly during shuffle or program play
Press REPEAT while in the respective playing mode.

To stop repeated playback
Press □.

To cancel the repeat function
Keep pressing REPEAT until "REPEAT" disappears.
The recorder returns to the original playing mode.

Playing a specified portion repeatedly (A-B Repeat)

By specifying starting and ending points within a track, you can play back a specified portion repeatedly.

Remote commander operation only

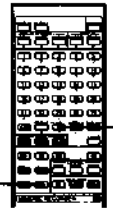

1, 2

2

1 While the MD is playing, press A-B at the starting (point A) of the portion to be repeated.
Point A is stored.



2 Continue playing the track or press ► until the end of the portion (point B), then press A-B.
Point B is stored, and the specified portion between A and B begins playing back repeatedly.

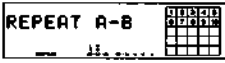

Changing the specified portion

Press A-B. Ending point B changes to starting point A.
Repeat step 2 to specify the new ending point (point B).

To cancel A-B repeat playback
Press REPEAT to turn off "REPEAT".



Before Recording

Selecting the recording mode

By selecting the recording mode, you can specify whether existing material on an MD is erased or not when you begin recording immediately after inserting an MD. The two available modes are described below:

All REC OFF — The recorder saves the contents of the MD and starts recording from the end of the existing material. This mode allows you to record from the end of existing material without searching for the ending position.

All REC ON — The recorder erases the contents of the MD and starts recording from the beginning of the MD. This mode allows you to quickly record over the entire contents of a previously recorded MD.

All REC OFF is the factory setting. To change the recording mode to All REC ON, follow the procedure below before inserting an MD into the recorder.

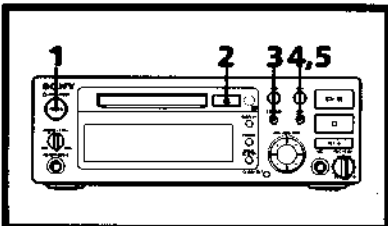

1 Press **POWER** to turn the recorder on.

2 If a disc has been loaded, press **EJECT** to eject the MD.



3 Press **EDIT/NO**.

EDIT/NO



Select REC ?

4 Press **YES**.

YES



All REC ?

5 Press **YES**.

YES



All REC ON



NO DISC

The recording mode changes to All REC ON.

Restoring the recording mode to its factory setting
Repeat the above procedure, pressing EDIT/NO in step 5 to change the recording mode to All REC OFF.

If you start recording with All REC ON mode
The recorder erases the entire contents of the MD, then begins recording from the beginning of the MD. Note, however, that even a single recording or playback operation in All REC ON mode changes the mode to All REC OFF until that MD is ejected, and any new material thereafter is recorded from the end of the existing material on the MD. When the MD is ejected, the recording mode returns to All REC ON.

To erase the entire content of an MD in All REC OFF mode (factory setting)
Use the erase function on page 36 to erase the contents of the MD before the start of recording.

Notes

- When the power cord is unplugged for a long time, All REC ON mode changes to All REC OFF (factory setting), and "STANDBY" flashes when the recorder is plugged in and turned on again. If you want to change the recording mode to All REC ON, select the recording mode again before inserting an MD into the recorder.

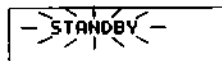

- Always eject the MD, if loaded, before changing the recording mode.

To protect a MiniDisc against accidental erasure

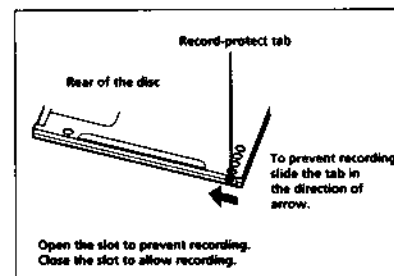

Recording

You can use your MD recorder to record in the following four ways:

- Recording from a digital source
- Recording from an analog source
- Recording from a microphone
- CD synchro recording

These recording methods are explained in the following four sections.

Notes on recording mode

- When recording from a digital, an analog source, or a microphone:
 - If the recording mode remains All REC OFF (factory setting), the recorder will record new material from the end of the existing material.*
 - If the recorder is set to All REC ON before inserting an MD, the recorder will erase the entire contents of the MD, then record the new material from the beginning of the disc.*
- During CD synchro recording:
 - The recorder stays in All REC OFF mode regardless of the recording mode setting and the recorder records new material from the end of the existing material.

* To change the recording mode, see page 24.

Recording a Digital Source

When you record from a digital source through the recorder's digital input jack, recording level adjustment is unnecessary. When you record a CD, track numbers are recorded in the same sequence as the original. When you record from a non-CD digital source, you can add track numbers either manually or automatically (see page 34)

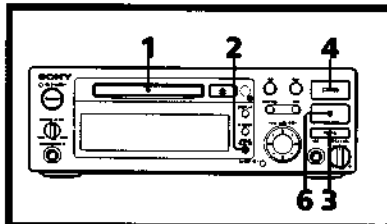

1 With the label side up and the arrow pointing toward the opening, slide the recordable MD into the disc compartment until the unit grips it.

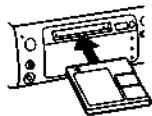

Total number of recorded tracks Total recorded time

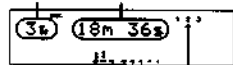

Music calendar without a grid

2 Press INPUT SELECTOR until "Digital in" lights up. The previous display appears again after a few seconds.

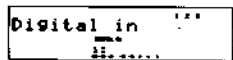

3 Press REC (●). The recorder enters recording pause.



- If the recording mode is All REC OFF (factory setting), "REC Ready" will alternate with the remaining time on the disc in the display window.

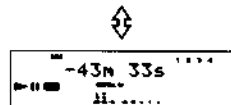
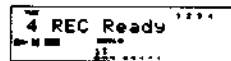

- If you changed the recording mode to All REC ON, "All REC Ready" will alternate with the remaining time on the disc in the display window.

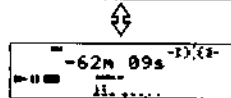
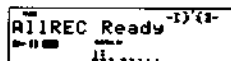

If the digital input jack is unconnected, "Din Unlock" appears in the display window.

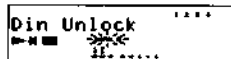

If recording pause continues for more than ten minutes, it is automatically canceled and the recorder stops.

4 Press ▷M (▶ or M). Recording pause is canceled and recording starts.



Track number being recorded Elapsed recording time

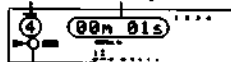

• 00m 00s

5 Play the sound source (CD player, etc.) to be recorded.

6 Press □ to stop recording. Recording stops.



To check the remaining time on the disc

Press DISPLAY.

Pressing DISPLAY while the recorder is stopped changes the display as follows: total recorded time, remaining time on the disc, disc name.

Pressing DISPLAY while the recorder is recording causes the remaining time on the disc to appear.

To pause recording

Press ▷M (▶ or M).

Press ▷M (▶ or M) again to restart recording.

Whenever recording is paused, the track number increases by one. For example, if you paused recording while recording the 4th track, recording continues on the 5th track when restarted.

To eject the disc

Press ⏏.

If there is no sound for more than 28 seconds

The recorder stops recording, keeps a 2-second blank between tracks, and erases the remaining 18 seconds of silence. During the erasure, "Auto Cut" appears in the display window.

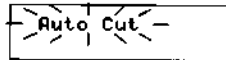

Using INPUT SELECTOR to specify track marking and signal type

- Press INPUT SELECTOR during recording or recording pause to specify manual or automatic track marking. For details, see "Writing Track Numbers While Recording (Track Marking)" on page 34.
- Press the INPUT SELECTOR button while the recorder is stopped to specify digital or analog input.

Notes

MD recording and the Serial Copy Management System
Since the MD recorder uses the SCMS (Serial Copy Management System), MDs recorded through the digital input jack cannot be used to make copies onto other MDs (see page 50).

If "Protected" appears in the display window
The disc is record-protected. Close the slot to record on the disc (see "To protect a MiniDisc against accidental erasure" on page 25).

When "TOC" flashes in the display window
Do not jog the recorder or pull out the power cord.

When recording from digital sound sources
The recorder automatically records track numbers in the same sequence as the sound source (i.e., based on changes in the sampling frequency of the input signal).

When dubbing from another MD
The recorder automatically records track numbers in the same sequence as the source disc. However, if a track is recorded more than once (i.e., due to repeated playback during program play or single-track repeat play), the same track number is recorded each time. Note also that the recorder cannot create tracks of less than 4 seconds in length.

When you're digitally recording a disc from a SONY portable MD player (or perhaps other devices), press □ (on this unit) before stopping the MD player.
If you stop playing the MD player or disconnect the optical cable from the DIGITAL IN of this unit before pressing □, the MiniDisc will not play when ▷M (▶ or M) is pressed immediately after recording. If you stop playing the MD player before you press □, please reinsert the recorded disc. Stopping play of the disc will not effect the recorded contents of the disc.

Recording From the Line (Analog) Input Jack

Analog recording

To write track numbers during analog recording, see "Writing Track Numbers While Recording (Track Marking)" on page 34.

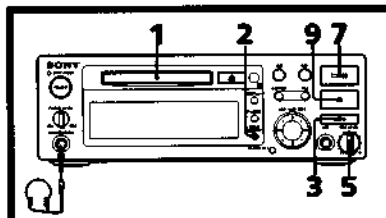

1 With the label side up and the arrow pointing toward the opening, slide the recordable MD into the disc compartment until the unit grips it.

2 Press INPUT SELECTOR until "Analog in" lights up. The previous display appears again after a few seconds.



3 Press REC (●).
The recorder enters recording pause.

4 Play the sound source (CD player, cassette deck, etc.) to be recorded.

5 While monitoring the sound through the headphones, adjust the recording level with the REC LEVEL control (see page 29). Set the REC LEVEL control to the position shown below when recording from a Sony DAT deck, CD player or cassette deck.

6 Stop the sound source to be recorded.

7 Press D-H (▶ or ||).
Recording pause is canceled and recording starts.

8 Restart the sound source to be recorded.

9 Press □ to stop recording.
Recording stops.

To check the remaining time on the disc
Press DISPLAY (see page 27).

To pause recording
Press D-H (||).
Press D-H (▶ or ||) again to restart recording. The track number increases by one each time you pause recording.

To eject a disc
Press ⏏.

Using INPUT SELECTOR to specify track marking and signal type

- Press INPUT SELECTOR during recording or recording pause to specify manual or automatic track marking. For details, see "Writing Track Numbers While Recording (Track Marking)" on page 34.
- Press the INPUT SELECTOR button while the recorder is stopped to specify digital or analog input

Notes

When "TOC" flashes in the display window
Do not jog the recorder or pull out the power cord.

If "Protected" appears in the display window
The disc is record-protected. Close the slot to record on the disc (see page 25).

Adjusting the recording level

When recording sound sources through the line (analog) input jack or microphone, use the REC LEVEL control to adjust the recording level.

1 Press REC (●) to change the recorder to recording pause.

2 Play the sound source to be recorded.

3 While monitoring the sound through the headphones, adjust the recording level with the REC LEVEL control. Adjust the recording level so that the peak level meter reaches its highest point with the least intrusion into the red (OVER) zone.

4 Press D-H (▶ or ||) to start recording.

Recording From a Microphone

By connecting a microphone with a stereo mini-plug to the MIC jack on the front panel, you can record a variety of sounds.

To write track numbers while recording from a microphone, see "Writing Track Numbers While Recording (Track Marking)" on page 34. Note that only manual track marking is possible when recording from a microphone.

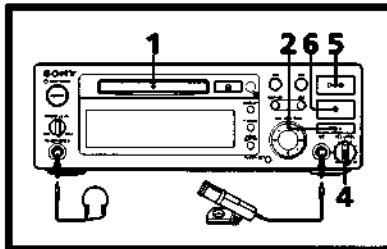

1 With the label side up and the arrow pointing toward the opening, slide the recordable MD into the disc compartment until the unit grips it.

2 Press REC (●).
The recorder enters recording pause.



- If the recording mode is All REC OFF (factory setting), "REC Ready" will alternate with the remaining time on the disc in the display window.

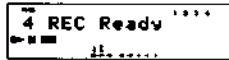

- If you changed the recording mode to All REC ON, "AllREC Ready" will alternate with the remaining time on the disc in the display window.

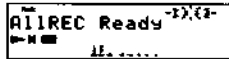

If recording pause continues for more than ten minutes, it is automatically canceled and the recorder stops.

3 Use the microphone to pick up the sound to be recorded.

4 While monitoring the sound through the headphones, adjust the recording level with the REC LEVEL control (see page 29).



5 Press ▷R (▶ or II) to cancel recording pause.
Recording starts.
The track number and elapsed recording time (in minutes and seconds) of the track being recorded appear.

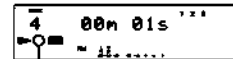

"II" goes off.

6 Press □ to stop recording.
Recording stops.



To check the remaining time on the disc
Press DISPLAY (see page 27).

To pause recording

Press ▷R (II).

Press ▷R (▶ or II) again to restart recording.

The track number increases by one each time you pause recording.

To eject a disc

Press ⏏.

Adding track numbers (track marking) while recording from the microphone

When recording from a microphone, only manual track marking is possible. Press INPUT SELECTOR during recording or recording pause to specify manual track marking (LevelSyncOFF). Automatic track marking will not occur even when "LevelSync ON" is selected. For details, see "Writing Track Numbers While Recording (Track Marking)" on page 34.

Notes

When you finish recording

Disconnect the microphone. The line input jacks on the rear of the unit will not work as long as the microphone is connected to the MIC jack.

If "Protected" appears in the display window

The disc is record-protected. Close the slot to record on the disc (see page 25).

When "TOC" flashes in the display window

Do not jog the recorder or pull out the power cord.

CD Synchro-Recording

By connecting your MiniDisc recorder to a Sony CD player or Mini Hi-Fi Component System, you can easily dub CDs onto MDs using the CD synchro buttons on the remote commander. If your recorder is connected to a Sony CD player by the optional optical cable through the digital input jack, tracks are automatically recorded in the same sequence as the original onto the MD regardless of whether "LevelSync ON" or "LevelSync OFF" is selected. During CD synchro-recording, the recording mode stays in All REC OFF mode regardless of the recording mode setting, and the recorder records new material from the end of the existing material.

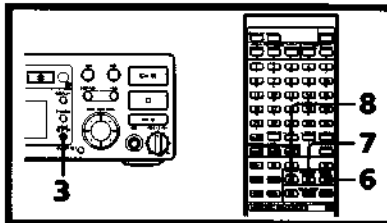

1 Set the amplifier function selector to CD.

2 With the label side up and the arrow pointing toward the opening, slide the recordable MD into the disc compartment until the unit grips it.

3 For digital recording, keep pressing INPUT SELECTOR until "Digital in" lights up.



For analog recording, keep pressing INPUT SELECTOR until "Analog in" lights up, then adjust the REC LEVEL control to the position shown below.



4 Insert a CD into the CD player.

5 Select the playback mode (shuffle play, program play, etc.) on the CD player.

6 Press STANDBY.

The CD player enters play pause, and MD recorder enters recording pause. "REC Ready" alternates with the remaining time on the disc in the display window.

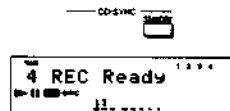

If recording pause continues for more than ten minutes, it is automatically canceled and the recorder stops.

7 Press START.

The MD recorder starts recording and the CD player starts playback. The track number and elapsed recording time of the track being recorded appear.

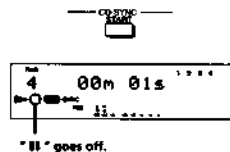

If the CD player does not start playing
Some CD player models will not start playing when you press START. Press CD PLAYER/ II instead.

8 Press STOP to stop recording.
Recording stops.

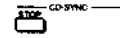

Successive CD synchro-recording of another CD
Follow the procedure below in place of step 8.

- 1 Press □ on the remote commander of the CD player.
- 2 Change the CD.
- 3 Press ► on the remote commander of the CD player. Synchro-recording restarts.

To pause recording

Press STANDBY or CD PLAYER/ II.
Press START or CD PLAYER/ II to restart recording. A new track number is created each time you pause recording.

To check the remaining time on the disc.

Press DISPLAY (see page 27).

Notes

Place the CD player close to this recorder

As the same remote commander controls both the CD player and the recorder, you may have trouble operating both units if they are far from each other.

If "Protected" appears in the display window

The disc is record-protected. Close the slot to record on the disc (see page 25).

When "TOC" flashes in the display window

Do not jog the recorder or pull out the power cord

When recording from digital sound sources

The recorder records track numbers in the same sequence as the sound source (i.e., based on changes in the emphasis data).

Playing back tracks just recorded

You can play back tracks that have just been recorded immediately.

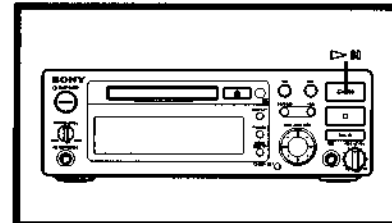

Press C-M (►) immediately after finishing recording.
Playback starts from the first track just recorded.

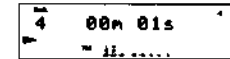

Playing back from the first track of the disc after recording

- 1 Press □ while the recorder is stopped.
 - 2 Press P-M (► or II).
- Playback starts from the first track of the disc.

Writing Track Numbers While Recording (Track Marking)

Track marking is essentially the writing of track numbers while recording. By writing track numbers at specified points, you can quickly locate those points afterwards using the AMS function. You can specify the two following methods of recording track numbers:

Automatic track marking

The recorder writes a new track number whenever the signal level drops to a certain point. When recording from a CD through the digital input jack, track numbers are automatically written, regardless of the display status ("LevelSync ON" or "LevelSync OFF"). Note that even when "LevelSync ON" is selected, you can write a new track number at any time by pressing REC ● (●).

Manual track marking

The recorder writes a new track number each time you pause recording. Note that only manual track marking is possible when recording from a microphone. The recorder also writes a new track number each time you press REC ● (●) while recording.

To add track numbers to existing recordings

Use the divide function to divide recorded tracks. A new track number is written each time you divide a track. For details, see "Dividing Recorded Tracks (Divide Function)" on page 38.

Automatic track marking

Press INPUT SELECTOR while the recorder is recording or in recording pause to display "LevelSync ON".

LevelSync ON

Manual track marking

1 Press INPUT SELECTOR while the recorder is recording or in recording pause to display "LevelSync OFF".

LevelSync OFF

2 While recording, press REC ● (●) at the point you want to add a track mark. The track number increases by one, and recording on the new track begins (the elapsed recording time restarts from zero).

4 05m 20s



5 00m 01s

Note

During automatic track marking, the signal level must remain low for 2 or more seconds before a new track number is written.

Editing a Recorded MiniDisc

Editing Functions for a Recorded MiniDisc

The editing functions allow you to erase, divide, combine and move tracks that have been recorded on an MD. A brief introduction to each function appears on this page.

Erasing recordings (Erase function) (see page 36)

The erase function allows you to erase a single track, an entire disc, or parts of a track easily and instantly. Since erasing merely updates the table of contents (TOC), there is no need to record over existing material as in the case of cassette tapes.

Example: Erasing B

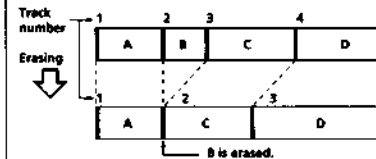

Dividing recorded tracks (Divide function) (see page 38)

The MD unit records sound sources through the LINE IN (analog) jacks or microphone as a single track on the disc. To randomly access individual tracks or portions within this track, use the divide function to create separate tracks for each song or portion. When you divide a track, the total number of tracks increments by one, and all tracks following the divided track are renumbered.

Example: Dividing track 2 to create a new track for C

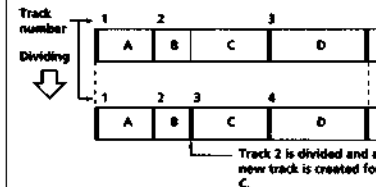

Combining recorded tracks (Combine function) (see page 40)

Use combine function to combine consecutive tracks on a recorded MD. It is useful for combining several songs into a single medley, or several independently recorded portions into a single track. When two tracks are combined, the total number of tracks decreases by one, and all tracks following the combined track are renumbered.

Example: Combining B and C

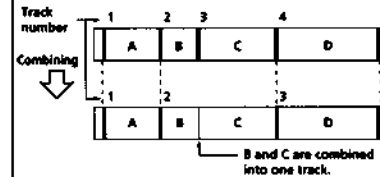

Moving recorded tracks (Move function) (see page 41)

With the move function, you can change the order of any track.

After a track is moved, the track numbers following the new position are increased by one.

Example: Moving tracks

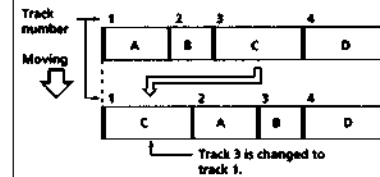

Labeling recordings (Title function) (see page 41)

Use the title function to create titles for your recorded discs and tracks. Titles — which may consist of uppercase and lowercase letters, numbers, symbols and spaces — appear in the display window during recorder operation.

Erasing Recordings (Erase Function)

You can use the erase function to do the following:

- Erase a single track
- Erase a disc
- Erase a part of a track

After you erase a specific track, the total number of tracks decreases by one, and all tracks following the erased track are renumbered.

Since tracks following an erasure are renumbered, you should erase multiple tracks in order of larger to smaller track numbers to prevent the renumbering of tracks not yet erased.

Note that once erased, a track cannot be recovered.

Erasing a single track

You can erase a track while the recorder is stopped, playing or paused simply by specifying the respective track number.

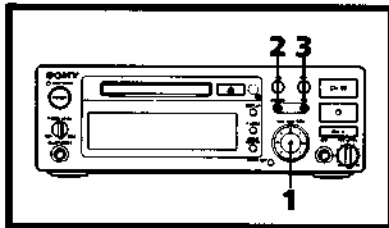

- 1 Turn the AMS dial until the number of the track to be erased lights up.



Example: Erasing track 4

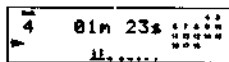

- 2 Keep pressing EDIT/NO until "Erase?" lights up.

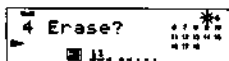

- 3 Press YES.

When the specified track has been erased, "Complete" lights up for a few seconds and the music calendar decreases by one.

YES

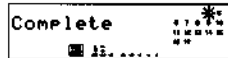

If you erase a track during playback, the following track begins playing afterwards.

- 4 Repeat steps 1 to 3 to erase additional tracks.

To cancel the erase function

Press EDIT/NO, □, or turn the AMS dial to change the track number, causing "Erase?" to disappear.

Notes

If the following indication goes on

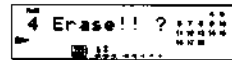

The track was recorded or edited on another unit and is record-protected. If this indication appears, press YES to erase the track.

If the "Protected" indication lights up

The recorder could not erase the specified track because the record-protect slot on the disc is open. Erase the track after closing the slot.

When "TOC" flashes in the display window

Do not jog the recorder or pull out the power cord. After the recorder updates the contents of the recording, "TOC" lights up. If you've made any changes to the MD, "TOC" lights up. If you press or POWER at this time, "TOC" flashes as the actual contents of the MD are updated.

Erasing an MD

Erasing a recordable MD deletes all recorded tracks. Note that once erased, a disc cannot be recovered.

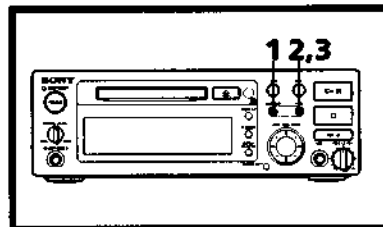

- 1 While the recorder is stopped, keep pressing EDIT/NO until "All Erase?" lights up.

EDIT/NO



- 2 Press YES.

YES

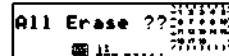

- 3 Press YES again.

When all recorded tracks have been erased, "Complete" lights up for a few seconds and the music calendar disappears.

YES



To cancel the erase function
Press EDIT/NO or □.

Erasing a part of a track

By using the dividing, erasing and combining functions, you can erase specific portions of a track.

Example: Erasing a part of selection A

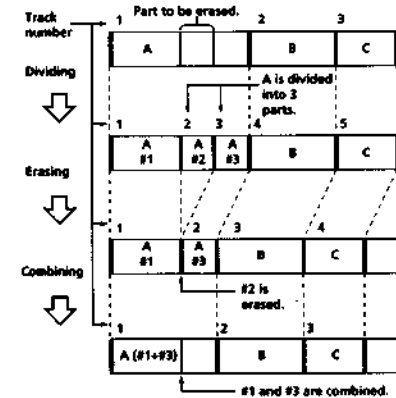

Notes

If the "Protected" indication lights up

The recorder could not edit the specified track because the record-protect slot on the disc is open. Edit the track after closing the slot.

When "TOC" flashes in the display window

Do not jog the recorder or pull out the power cord. After the recorder updates the contents of the recording, "TOC" lights up. If you've made any changes to the MD, "TOC" lights up. If you press or POWER at this time, "TOC" flashes as the actual contents of the MD are updated.

Dividing Recorded Tracks (Divide Function)

Use the divide function to create a new track number for a specific portion of an existing track during playback. By creating track numbers for specific portions, you can use the AMS function to randomly access those portions afterwards. When you divide a track, the total number of tracks increases by one, and all tracks following the divided track are renumbered. To create track numbers during recording, see "Writing Track Numbers While Recording (Track Marking)" on page 34.

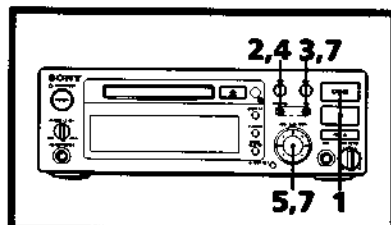

- 1** While playing the MD, press **D-II** to pause playback at the point where you want to create a new track.



- 2** Keep pressing **EDIT/NO** until "Divide ?" lights up.



Example: Dividing track 4

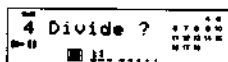

- 3** Press **YES** to divide the track. The starting portion of the new track plays back repeatedly.

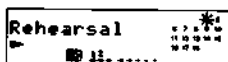

These displays alternate.

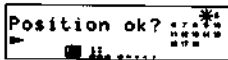

- 4** If the starting portion is incorrect, press **EDIT/NO**. (If it is okay, go to step 7.)

EDIT/NO

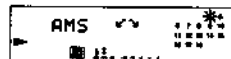

- 5** While monitoring the sound, turn the **AMS dial** to find the starting point of the new track. The starting portion of the new track is played back repeatedly.

The starting position can be moved within a range of -128 to +127 steps of about 0.06 second each.

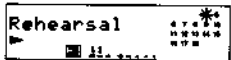
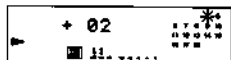

These displays alternate.

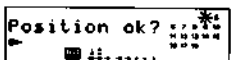

- 6** If the starting portion is still incorrect, repeat step 5 until you attain the correct portion.

- 7** Press **YES** or the **AMS dial** when the correct position is attained.

When the track has been divided, "Complete" lights up for a few seconds and the newly created track begins playing. The new track will have no track title even if the original track was labeled.

YES

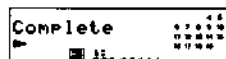

To cancel the divide function
Press **EDIT/NO** or **□**.

To undo a track division
Combine the tracks again (see "Combining Recorded Tracks" on page 40) then redivide the tracks if necessary.

Notes

If the "Protected" indication lights up
The recorder could not divide the specified track because the record-protect slot on the disc is open. Divide the track after closing the slot.

When "TOC" flashes in the display window
Do not jog the recorder or pull out the power cord. After the recorder updates the contents of the recording, "TOC" lights up. If you've made any changes to the MD, "TOC" lights up. If you press **□** or **POWER** at this time, "TOC" flashes as the actual contents of the MD are updated.

Combining Recorded Tracks (Combine Function)

The combine function allows you to combine consecutive tracks on a recorded disc while the recorder is stopped, playing or paused.

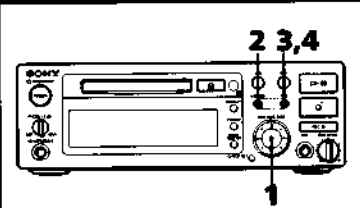

1 Turn the AMS dial until the second track of the two to be combined appears.



Example: Combining tracks 3 and 4

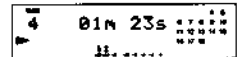

2 Keep pressing EDIT/NO until "Combine ?" lights up.

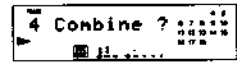

3 Press YES.

The portion where the two tracks will join (i.e., the end of the first track and the beginning of the second track) repeatedly plays back.

YES

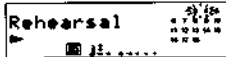

These displays alternate.

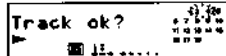

4 Verify the tracks, then press YES.

When the tracks have been combined, "Complete" lights up for a few seconds and the music calendar decreases by one.

If both of the combined tracks have track titles, the title of the second track is erased (as well as other information such as the recording date).

YES

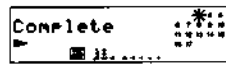

To cancel the combine function
Press EDIT/NO or □.

To undo a track combination
Divide the tracks again (see "Dividing Recorded Tracks" on page 38), then repeat the combine function with the correct tracks if necessary.

Notes

If the following indication lights up

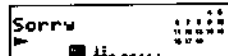

The recorder could not combine the specified tracks. Extensive editing of the same track may render it impossible to combine with another track. This is due to the technical limitation of the MD system and is not a mechanical error.

If the "Protected" indication lights up

The recorder could not combine the specified tracks because the record-protect slot on the disc is open. Combine the track after closing the slot.

When "TOC" flashes in the display window

Do not jog the recorder or pull out the power cord. After the recorder updates the contents of the recording, "TOC" lights up. If you've made any changes to the MD, "TOC" lights up. If you press Ⓚ or POWER at this time, "TOC" flashes as the actual contents of the MD are updated.

Moving Recorded Tracks (Move Function)

Use this function to change the order of specific tracks while the recorder is stopped, playing or paused.

After moving a track, track numbers following the new track position increase by one.

Example: Moving track 3 to track position 5

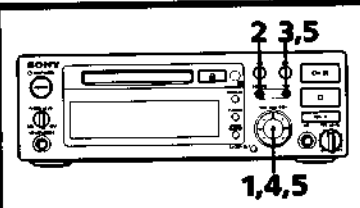

1 Turn the AMS dial until the number of the track to be moved appears.

The number of the track to be moved lights up.

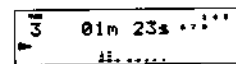
2 Keep pressing EDIT/NO until "Move ?" lights up.

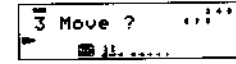

(Continued on next page)

Moving Recorded Tracks (Move Function)

(Continued from previous page)

3 Press YES.

The number of the track to be moved and the new track position light up:



4 Turn the AMS dial to specify the new track position.

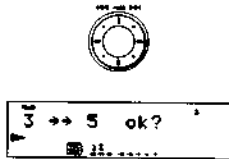

5 Press YES or the AMS dial.

When the track has been moved, "Complete" lights up for a few seconds and the moved track begins playing back if the unit is in playback mode.

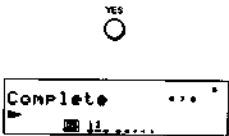

To cancel the move function

Press \square .

Notes

If the "Protected" indication lights up

The recorder could not move the specified track because the record-protect slot on the disc is open. Move the track after closing the slot

When "TOC" flashes in the display window

Do not jog the recorder or pull out the power cord. After the recorder updates the contents of the recording, "TOC" lights up. If you've made any changes to the MD, "TOC" lights up. If you press \square or POWER at this time, "TOC" flashes as the actual contents of the MD are updated.

Labeling Recordings (Title Function)

Using the front panel controls or the remote commander, you can create titles for your recorded MDs and tracks. Titles — which may consist of up to 100 uppercase and lowercase letters, numbers and symbols for a maximum of about 1,700 characters per disc — appear in the display window during MD operation. To turn off the title display, follow the procedure below.

Turning off the title display

- 1 Press Δ to eject the MD.
- 2 Press EDIT/NO to cause "Select Name ?" to light up.
- 3 Press YES to cause "Name ON ?" to light up.
- 4 Press EDIT/NO to cause "Name OFF" to light up. To turn on the title display again, repeat the above procedure, pressing YES in step 4 to cause "Name ON" to light up.

Labeling a track with the front panel controls

Use the following procedure to label a track with the front panel controls. You can label a track only while it is playing. If the track ends before you've completed the label, the characters entered to that point are not recorded and the track will remain unlabeled.

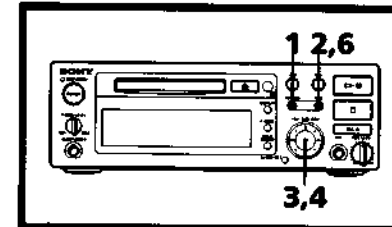

- 1 Keep pressing EDIT/NO while playing, pausing or recording the track to be labeled until "Name in ?" lights up.

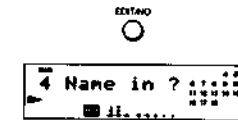

- 2 Press YES. A flashing cursor appears.

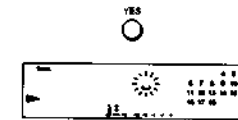

(Continued on next page)

Labeling Recordings (Title Function)

(Continued from previous page)

- 3 Turn the AMS dial to select the first character.**

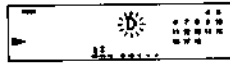

Letters, numbers, and symbols appear in sequential order as you turn the AMS dial. The following symbols can be used in titles: ! " # \$ % & ' () * + , - . / : ; < = > ? @ [\] ^ _ ` { | } ~
Note, however, that the symbols [¥] [] - may not be supported on certain MD recorder models.

- 4 Press the AMS dial to enter the selected character.**

The cursor shifts rightward and waits for input of the next character.



- 5 Repeat steps 3 and 4 until you have entered the entire title.**

If you entered the wrong character
Press ◀ or ▶ to move the flashing cursor under the character to be corrected, and repeat steps 3 and 4 to enter the correct character.

To erase a character
Press ◀ or ▶ to move the flashing cursor under the character to be erased, then press EDIT/NO.

To enter a space
Press the AMS dial or ▶.

- 6 Press YES.**
When the labeling procedure has been completed, the title appears on the left side of the display window.

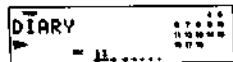

Labeling an MD with the front panel controls

After inserting the MD to be labeled, use the procedure below to label the MD with the front panel controls.

- 1 Keep pressing EDIT/NO while the recorder is stopped until "Name in ?" lights up.
- 2 Repeat steps 2 to 6 of "Labeling a track with the front panel controls" on pages 43 and 44.

To cancel the title function
Press □.

Erasing all track titles on a disc

- 1 Hold down EDIT/NO while the recorder is stopped until "All Erase ?" lights up.
- 2 Press EDIT/NO again until "Name Erase?" lights up.
- 3 Press YES.

Notes

If the "Protected" indication lights up
The recorder could not label the specified track because the record-protect slot on the disc is open. Label the track after closing the slot.

When "TOC" flashes in the display window
Do not jog the recorder or pull out the power cord. After the recorder updates the contents of the recording, "TOC" lights up. If you've made any changes to the MD, "TOC" lights up. If you press ⏻ or POWER at this time, "TOC" flashes as the actual contents of the MD are updated.

Labeling a track with the remote commander

Use the following procedure to label a track with the remote commander.

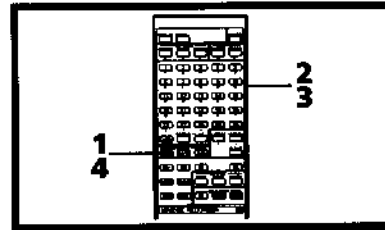

- 1 Keep pressing NAME while playing back, pausing or recording the track to be labeled.**
A flashing cursor appears.



- 2 Enter one character at a time.**



Entering the letter "D"

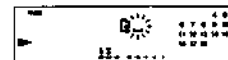

- 3 Repeat step 2 until you have entered the entire title.**

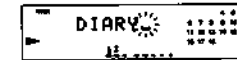

If you entered the wrong character
Press ◀ or ▶ to move the flashing cursor under the character to be corrected.
Press CLEAR to erase the incorrect character, then enter the correct letter.

- 4 Press NAME again.**
When the labeling procedure has been completed, the entered title appears on the left side of the display window.

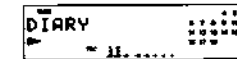

Labeling an MD with the remote commander

After inserting the MD to be labeled, follow the procedure below to label a disc with the remote commander.

- 1 Press NAME while the recorder is stopped.
- 2 Repeat steps 2 to 4 of "Labeling a track with the remote commander" on this page.

Labeling Recordings (Title Function)

Entering lowercase letters

- 1 Keep pressing CAPS until "Selected abc" lights up.
- 2 Enter the characters.

Entering uppercase letters again

- 1 Keep pressing CAPS until "Selected ABC" lights up.
- 2 Enter the characters.

Entering numbers

- 1 Keep pressing NUM until "Selected 123" lights up.
- 2 Enter the numbers.

Entering uppercase or lowercase letters again

- 1 Keep pressing CAPS or NUM until "Selected ABC" or "Selected abc" lights up.
- 2 Enter the characters.

To cancel the title function

Press \square .

Changing an existing title

- 1 To correct a track title, press NAME while playing back the respective track to cause the track name to light up. To correct a disc title, press NAME while the recorder is stopped to cause the title of the loaded MD to light up.
- 2 Hold down CLEAR until the current title is erased, then enter the new title.
- 3 Press NAME.

Notes

If the "Protected" indication lights up

The recorder could not label the disc because the record-protect slot on the disc is open. Label the disc after closing the slot.

When "TOC" flashes in the display window

Do not jog the recorder or pull out the power cord. After the recorder updates the contents of the recording, "TOC" lights up. If you've made any changes to the MD, "TOC" lights up. If you press \mathbb{A} or POWER at this time, "TOC" flashes as the actual contents of the MD are updated.

Guide to the Serial Copy Management System

Since your MD unit uses the Serial Copy Management System (SCMS), MDs recorded through the digital input jack cannot be used to make copies to other MDs through the digital output jack. The diagrams on this and the following pages show systems for making copies through the digital or analog jacks.

- 1 You can record digital sources (CD, prerecorded MD, and DAT equipment with a sampling frequency of 44.1 kHz) to a recordable MD through the digital input jack.

However, you cannot make copies of the recorded MD to other recordable MDs through the digital output jack. Subsequent copies can only be made through analog output jacks.

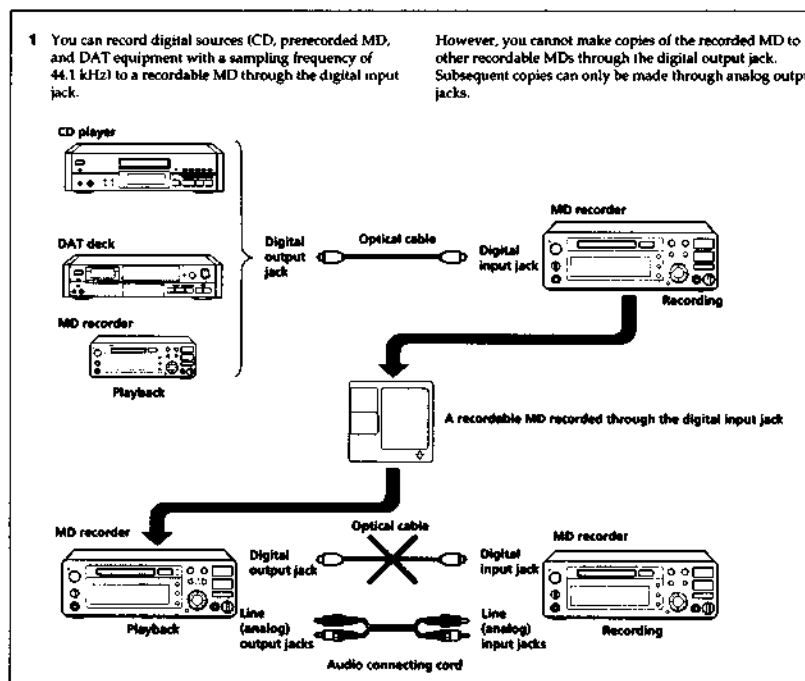

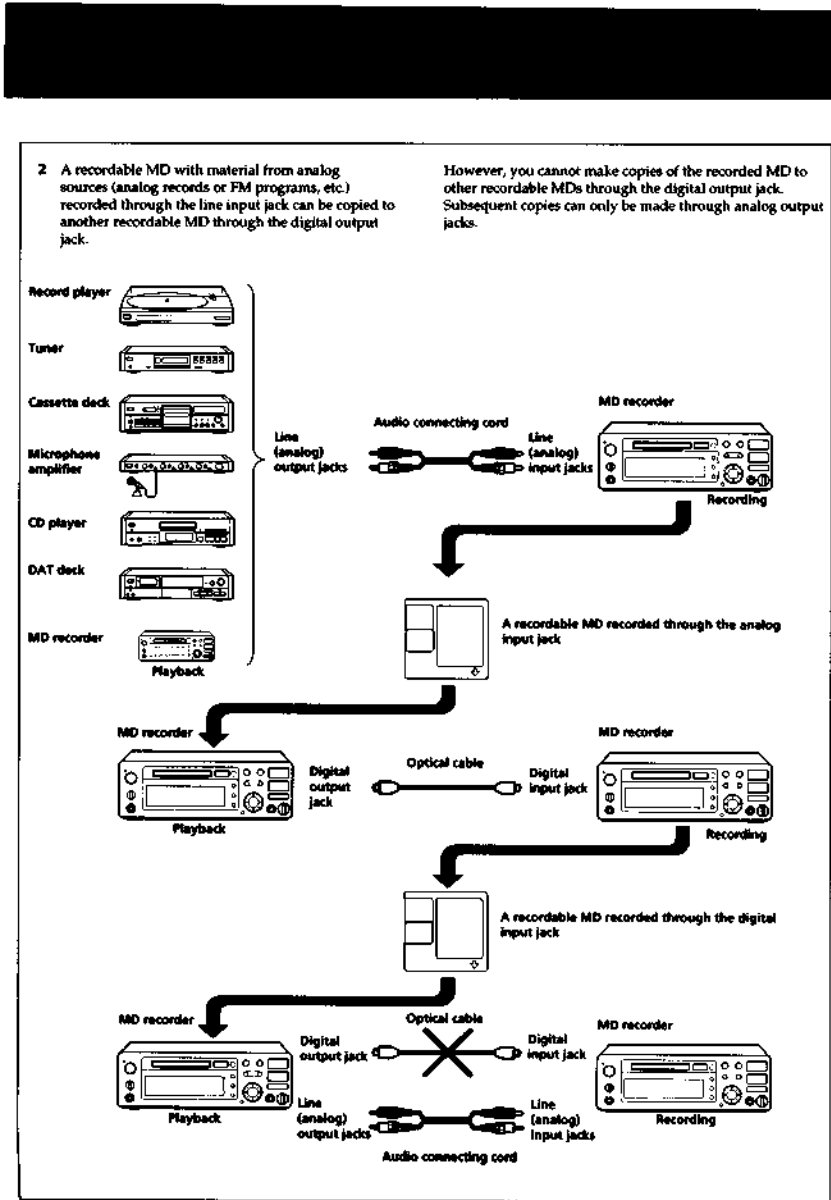

Chapter 4: the MD Recorder

Before Playing a MiniDisc

Playing a MiniDisc (normal play)

Playing Tracks in Random Order (shuffle play)

Playing Tracks in the Desired Order (program play)

Playing Tracks Repeatedly (repeat play)

Selecting the Recording Mode

Recording a CD

Recording from the Radio

Erasing Recordings (erase function)

Dividing Recorded Tracks (divide function)

Combining Recorded Tracks (combine function)

Rearranging Track Order (move function)

Labeling Recordings (title function)

Before Playing a MiniDisc

Notes on Use

Compared to an analog tape, a MiniDisc has very little background noise. Be aware that if you set the volume according to the background noise while listening to the silence at the beginning of a recording, as people do with analog tape, you may find that the volume is unexpectedly high when the music starts. Always set the volume low before the music starts, and then adjust the volume as you desire.

Handling MiniDiscs

Because the MiniDisc itself is housed in a cartridge, you can handle it normally without being concerned about dust or fingerprints; however, misoperation may result if the cartridge itself is dirty or warped. For maximum music enjoyment, be sure to observe the following points:

Do not touch the MiniDisc directly.

Do not open the shutter on the MiniDisc cartridge. Trying to force the shutter open will damage the shutter.

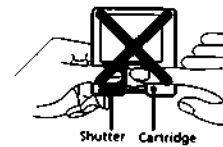

Playing a MiniDisc (normal play)

You can play back an MD in two ways

- Playing from the first track
- Playing from a specific track

Playing a MiniDisc from the First Track

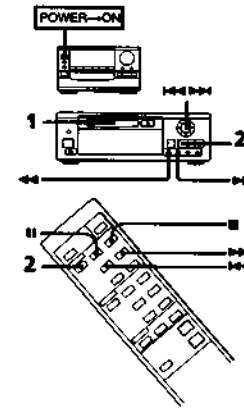

1 With the label side up and the arrow pointing toward the opening, slide the MD into the disc compartment until the recorder grips it. If you insert the MD while the recorder is off, the recorder will turn on automatically. The disc title appears, followed by the total number of tracks (Tr) and total playing time. A music calendar showing all the track numbers appears within a grid if the MD is a premastered disc, or without a grid if the MD is a recordable disc. If the disc contains more than 25 tracks, **FN** appears to the right of number 25 in the music calendar.

FN
13

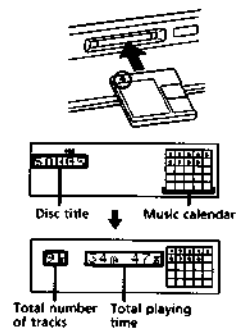

continue to next page →

→ continued

2 Press **▶** or AMS (or press **▶** on the remote commander). The MD starts playing. The current track number, track title (if labeled), and elapsed playing time of the current track light up in the display.

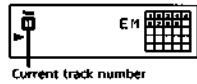

Current track number



Track title (if labeled)

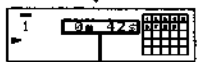

Elapsed playing time

FN

14

To	Press*
Stop play	□ (■)
Pause	⏸ or AMS (■)
Resume play	▶ or AMS (▶ or ■)
Remove the MD	⏏

* The buttons on the remote commander are indicated in parentheses.

One Touch Play feature

Press **▶** on the MD recorder (or **▶** on the remote commander) when the power is off. When an MD is in the recorder, you will be able to start listening to the MD without pressing any other buttons. If no MD is inserted, the system will just turn on.

To find the beginning of a track — Automatic Music Sensor (AMS)
You can locate the beginning of a track while the track is playing or while it's in pause mode.

To locate the beginning of the current or preceding track, turn the AMS control to the **▶** side (or press **▶** on the remote commander) until you find the track you want.

To locate the beginning of the succeeding track, turn the AMS control to the **◀** side (or press **◀** on the remote commander) until you find the track you want.

If you use the remote commander, holding down the button causes the number to change continuously. If track titles have been stored, the track titles are displayed.

To locate the beginning of a track in the pause mode

Turn the AMS control while paused. (When using the remote commander, press **▶** or **◀** while paused.)

To locate the beginning of the current track
Press **▶** on the remote commander once.

To go quickly to the beginning of the last track on the disc

Turn the AMS control counterclockwise, or press **◀** on the remote commander immediately after inserting the MD.

To find a point in a track

You can find a particular point in a track while the track is playing or while it's in pause mode.

To	Do this
Find forward quickly in a track	Hold down ▶ and release it at the desired point.
Go backwards quickly in a track	Hold down ◀ and release it at the desired point.
Search quickly without listening	Press ▶ (■) and hold down ◀ or ▶ . Press ▶ (■ or ▶) again at the desired point.

Note

If there are several tracks of only a few seconds in a row, it may not be possible to search through them normally.

Checking the Title and Remaining Time of a Track

Use the DISPLAY button on the MD recorder.

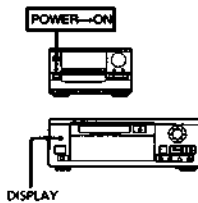

The display changes as follows:

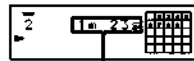

Elapsed playing time

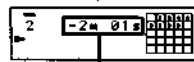

Remaining time of a track

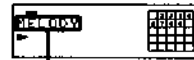

Track title

* If no title has been stored, "No Name" appears in the display momentarily then the elapsed playing time appears.

If DISPLAY is pressed while the unit is not playing, the display changes as follows:

When using a premastered MD:
Total playing time on disc → Disc title

When using a recordable MD:
Total recording time → Remaining time → Disc title

Playing Tracks in Random Order (shuffle play)

You can play all the tracks on the MD in random order. Use the buttons on the unit to do this operation.

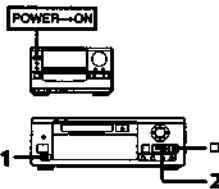

1 Press P.MODE in stop mode. "SHUFFLE" appears in the display.

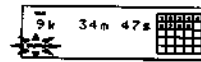

2 Press **▶** or **◀** appears and then all the tracks play in random order.

To stop playing
Press **□**.

To cancel shuffle play

Press P.MODE in stop mode repeatedly until "SHUFFLE" disappears from the display.

To play the next track during shuffle play

Turn the AMS control clockwise or press **▶** on the remote commander. To replay the current track, turn the AMS control counterclockwise or press **◀** on the remote commander. You cannot replay the previous track.

Playing Tracks in the Desired Order (program play)

You can program up to 25 tracks to play in any order you choose. You do this by designating the tracks in the order you want them to play.

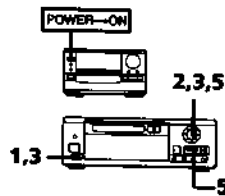

1 Press P.MODE repeatedly in stop mode until "PROGRAM" appears in the display.

2 Turn AMS to choose a track. The track number and the total playing time appears. If you want to choose this track, go to the next step. If not, turn AMS again to choose another track.



Track number Total playing time

3 Press AMS or P.MODE. The chosen track number lights up in the music calendar.

4 Repeat steps 2 and 3 to program the remaining tracks you want to play in the order you want them to play.

5 Press **▶** or AMS on the unit (or **▶** on the remote commander). All the tracks play in the order you chose.

To	Press
Stop play	□ (■)
Cancel the program	P.MODE in stop mode*
Erase the entire program	□ once in stop mode
Check the program	Turn AMS (or press ▶ or ◀) while paused

* "PROGRAM" disappears from the display.

To change the order of programmed tracks
To change the order, erase the entire program and create a new one.

Playing Tracks Repeatedly (repeat play)

You can choose between two different repeat play modes. One repeats all the tracks in the current play mode; the other repeats a single track. Use the button on the remote commander to do this operation.

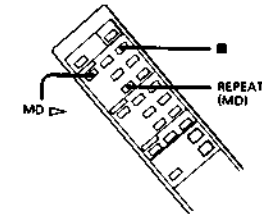

Repeating all the tracks (in any play mode)
Press REPEAT (MD) once while playing so that "REPEAT" appears in the display.

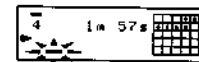

Repeating a single track (in normal play only)
Press REPEAT (MD) twice while playing the desired track so that "REPEAT 1" appears in the display.

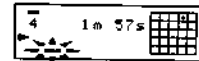

To cancel repeat play
Press REPEAT (MD) so that "REPEAT" or "REPEAT 1" disappears from the display.

Selecting the Recording Mode

By selecting the recording mode, you can specify whether existing material on an MD is erased or not when you begin recording immediately after inserting an MD. The two available modes are described below.

ALL REC OFF

The recorder saves the contents of the disc and starts recording from the end of the existing material. This mode allows you to record from the end of existing material without searching for the ending position.

ALL REC ON

The recorder erases the contents of the MD and starts recording from the beginning of the MD. This mode allows you to quickly record over the entire contents of a previously recorded MD.

continue to next page →

FN

15

→ continued

ALL REC OFF is the factory setting. To change the recording mode to ALL REC ON, follow the procedure below before inserting an MD into the recorder.

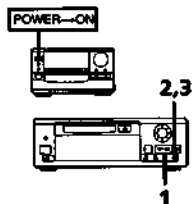

1 Eject the disc and press EDIT/NO so that "Select REC ?" appears.

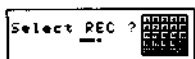

2 Press YES so that "All REC ?" appears.

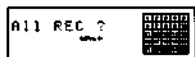

3 Press YES. After "All REC ON" appears momentarily, the display returns to the initial display. The recording mode has now been set to ALL REC ON.

To restore the recording mode to its factory setting Press EDIT/NO in step 3 so that "All REC OFF" appears in the display.

If you start recording with ALL REC ON mode

The recorder erases the entire contents of the MD. It then begins recording from the beginning of the MD. Note, however, that even a single recording or playback operation in ALL REC ON mode changes the mode to ALL REC OFF until that MD is ejected, and any new material thereafter is recorded from the end of the existing material on the MD. When the MD is ejected, the recording mode returns to ALL REC ON.

To erase the entire content of an MD in ALL REC OFF mode (factory setting)

Erase the contents of the disc as described in "Erasing all tracks on a disc" and then begin recording.

Note

If the unit is unplugged momentarily, the recording mode setting is lost and "STANDBY" appears momentarily in the display. If this happens, select the recording mode again before inserting an MD into the recorder.

To prevent accidental erasure of recordings

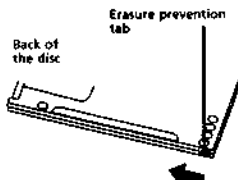

Open the slot to prevent recording. Close the slot to allow recording.

MD recording and the Serial Copy Management System Since the MD recorder uses the SCMS (Serial Copy Management System), MDs recorded through the digital input jack cannot be used to make copies onto other MDs.

Recording a CD

You can easily make digital recordings of CDs on an MD (CD Synchro recording). When recording a CD, the recording is automatically made digitally. If a microphone is connected, however, the recording is automatically made in analog. During CD synchro recording, the recorder stays in ALL REC OFF mode regardless of the recording mode setting and the recorder records new material from the end of the existing material.

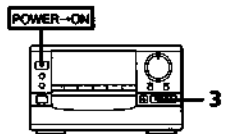

1 Insert a recordable MD into the MD recorder.

2 Press CD SYNCHRO. The display flashes between "REC Ready" (or "All REC Ready" if ALL REC OFF is not set) and the remaining time of the MD. The MD recorder goes into the recording pause mode, the CD player goes into the paused mode, and the total remaining time appears in the display. The recording pause mode is released automatically after about ten minutes.

3 Press D- (or either the CD player or the MD recorder). The CD player begins playing and the MD recorder begins recording simultaneously.

To	Press
Pause recording	D- on the CD player or the MD recorder
Stop recording	Once on the MD recorder
Eject	Once on the MD recorder

To change CDs before continuing to record

- Press D- on the CD player. The MD recorder goes into paused mode. (The MD recorder also goes into paused mode automatically if the CD finishes playing and stops.)
- Change CDs.
- Press D- on either the CD player or the MD recorder. Recording resumes.

To play back tracks just recorded Press D- while the recorder is stopped.

- To play back from the first track of the disc after recording
- Press D- while the recorder is stopped.
 - Press D- Playback starts from the first track of the disc.

To record from the middle of a track

- You can record without using the CD SYNCHRO button.
- Pause the CD at the position where you want to start recording.
 - Insert a recordable MD in the MD recorder.
 - Press REC The MD recorder stands by for recording.
 - Press D- on the MD recorder. Recording begins.
 - Begin playing the CD.

If there is no sound for more than 20 seconds The recorder stops recording, keeps a 2-second blank between tracks, and erases the remaining 18 seconds of silence. During the erasure, "Auto Cut" appears in the display.

To check the remaining time on the disc Press DISPLAY

While stopped: Each time DISPLAY is pressed, the display changes as follows: total recording time → remaining time on the disc → disc title.

During recording: When DISPLAY is pressed, the remaining time on the disc appears.

If the "Protected" indication appears The contents of the disc are protected from erasure. Slide the tab on the disc to close the slot if you want to record on the disc.

When "TOC" flashes in the display Do not jog the recorder or pull out the power cord.

Notes * A digital recording made on a MiniDisc cannot be digitally recorded onto another MiniDisc. This unit conforms with the serial copy management system. * You cannot record the sound you have adjusted.

Recording from the Radio

For details on the recording of track numbers, refer to "Writing Track Numbers While Recording (Track Marking)".

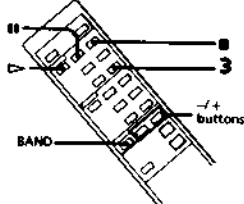
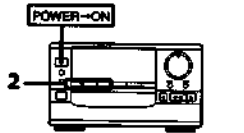
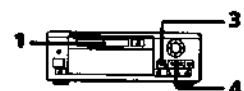

1 Insert a recordable MD.



Total recording time (minutes, seconds) Total number of tracks already recorded. No grid appears when a recordable disc is inserted.

2 Press BAND and +/- and tune in the desired station.

3 Press REC (REC on the remote commander). The MD recorder stands by for recording. (If the unit is left in the recording pause mode for about ten minutes, recording pause mode is canceled automatically.)

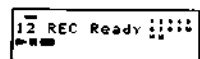

Displayed in alternation.

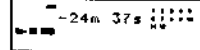

If recording mode is set to ALL REC ON, the following displays appear in alternation.

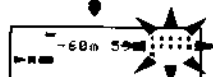

4 Press D- (D- or on the remote commander).

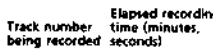

Elapsed recording time (minutes, seconds) being recorded. Track number 11 disappears.

To stop recording Press Once You can now listen to the track that you just recorded. To listen to the disc from the beginning, press Once again.

To pause while recording Press D- (on the remote commander). To resume recording, press D- (D- or on the remote commander) once again. When recording is paused, the track number changes.

If the "Protected" indication appears The contents of the disc are protected from erasure. Slide the tab on the disc to close the slot if you want to record on the disc.

When "TOC" flashes in the display Do not jog the recorder or pull out the power cord.

If you start recording The program and shuffle play modes are canceled.

Writing Track Numbers While Recording (Track Marking)

Track marking is essentially the writing of track numbers while recording. By writing track numbers at specified points, you can quickly locate those points afterwards using the AMS function. You can specify the two methods of recording track numbers: Automatic track marking and Manual track marking.

Automatic track marking The recorder writes a new track number if there is silence for about 2 seconds.

Note No track numbers are written if a microphone is plugged into the MIC jack.

Manual track marking Press REC at the point where you want to change the track number while recording. A new track number is written at the point at which you pressed REC and the track number in the display increases by one.

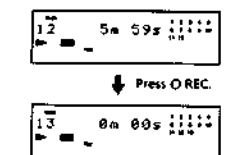

To assign track numbers after recording The track numbers increase when a track is divided by editing. For details, refer to "Dividing Recorded Tracks (divide function)".

continue to next page →

→ continued

Note

Track markings are not made if there is not a period of at least two seconds of silence between tracks.

To make digital recordings of an MD onto an MD

The track numbers are recorded automatically. However, if a given track is programmed repeatedly or a single track is repeated, the track numbers will not change

Erasing Recordings (erase function)

There are three methods for erasing a recorded disc:

- Erasing each track one at a time
- Erasing all tracks on a disc
- Erasing a portion of a track

When a track is erased, the track numbers of subsequent tracks are revised so that they remain continuous

For details on the recording of track numbers, refer to "Writing Track Numbers While Recording (Track Marking)".

Because a track cannot be restored once it is erased, always listen to the start of the track to confirm whether or not it is actually the track that you want to erase before erasing it

When erasing two or more tracks, it is best to start with the track with the highest track number so that the track numbers for the other tracks to be erased do not change.

Example: If you want to erase tracks 2 and 4, erase track 4 first, and then track 2.

This operation is not possible while SHUFFLE or PROGRAM appears.

Erasing One Track at a Time

You can erase a track completely simply by specifying the track number. This operation is possible while the unit is stopped, during playback, or while paused.

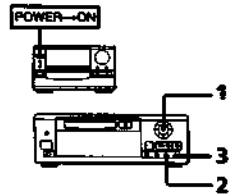

Chapter 4: the MD Recorder

1 Turn AMS so that the track number for the track to be erased appears in the display.

Example: Erasing track 13



2 Press EDIT/NO repeatedly until "Erase ?" appears in the display.



3 Press YES. If you erase a track during playback, the following track begins playback afterwards.



After appearing momentarily, this disappears; the specified track is now erased.

4 Repeat steps 1 to 3 to continue erasing more tracks.

To cancel erasing a track Press either EDIT/NO or □ so that "Erase ?" disappears from the display

What does the following display mean?



This track was recorded or edited on a different MD recorder and is protected from erasure. If you still want to erase the track, press YES while this display is on.

If the "Protected" indication appears The contents of the disc are protected from erasure, so the tracks cannot be erased. Slide the tab to close the slot before attempting to erase a track.

When "TOC" flashes in the display Do not jog the recorder or pull out the power cord. After the recorder updates the contents of the recording, "TOC" lights up. If you've made any changes to the MD, "TOC" lights up. If you press ⏻ or POWER at this time, "TOC" flashes as the actual contents of the MD are updated.

Erasing All Tracks on a Disc

You can erase all of the tracks on a disc at once. Always be sure that you want to erase every track on the disc before actually doing so, because once the tracks are erased, they cannot be restored.

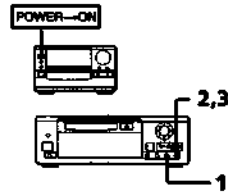

1 While the recorder is stopped, press EDIT/NO repeatedly until "All Erase ?" appears in the display.



2 Press YES so that an additional "!" appears.



3 Press YES. All tracks are erased.

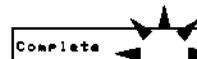

To cancel erasing the tracks Press either EDIT/NO or □ so that "All Erase ?" disappears from the display.

Erasing a Portion of a Track

By using the three functions of dividing tracks, erasing tracks, and combining tracks in combination, you can erase a portion of one track.

Example: Erasing a portion of track A

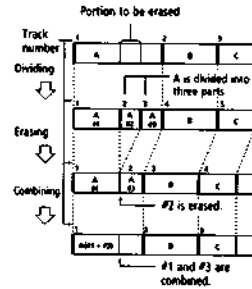

If the "Protected" indication appears The contents of the disc are protected from erasure, so the tracks cannot be edited. Slide the tab on the disc to close the slot before attempting to edit a track.

When "TOC" flashes in the display Do not jog the recorder or pull out the power cord. After the recorder updates the contents of the recording, "TOC" lights up. If you've made any changes to the MD, "TOC" lights up. If you press ⏻ or POWER at this time, "TOC" flashes as the actual contents of the MD are updated.

Dividing Recorded Tracks (divide function)

Use this function to divide one recorded track into two tracks and record a new track number for the new track. This function is used when several different tracks were recorded under one track number during an analog recording, or when you want to be able to search for a particular spot within of a track.

When a track is divided the track numbers of subsequent tracks are revised so that they remain continuous. This operation is not possible while SHUFFLE or PROGRAM appears.

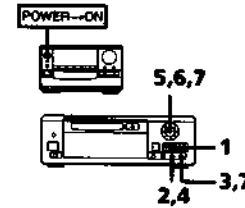

1 Press ⏻ to pause at the point in the track where you want to divide it. 2 Press EDIT/NO repeatedly until "Divide ?" appears in the display

Example: Dividing track 4

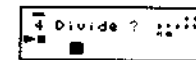

3 Press YES. The following displays appear in alternation, and the position where the division is to be made is played back repeatedly.



4 If the place being played back is not where you want to divide the track, press EDIT/NO. (If the place being played back is where you want to divide the track, skip to step 2.)



5 While monitoring the sound, turn AMS and slowly shift to the place where you want to make the division. You can shift over a range of -128 to +127 while within the same track.

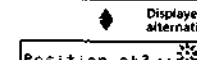
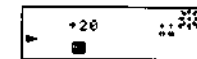

The position where the division is to be made is played back repeatedly.

6 If the place where you want to make the division is still not being played, repeat step 5.

7 If the place being played back is where you want to divide the track, press AMS or YES. After "Complete" appears in the display for a few seconds, the track is divided and playback starts from the next track following the new division. If the track that was divided had a name, the new track does not have a name.

To cancel dividing the track Press either EDIT/NO or □.

To restore a divided track to its original state Combine the two tracks by using the combine function.

To assign track numbers while recording Refer to "Writing Track Numbers While Recording (Track Marking)".

If the "Protected" indication appears The contents of the disc are protected from erasure, so the tracks cannot be divided. Slide the tab on the disc to close the slot before attempting to divide a track.

When "TOC" flashes in the display Do not jog the recorder or pull out the power cord. After the recorder updates the contents of the recording, "TOC" lights up. If you've made any changes to the MD, "TOC" lights up. If you press ⏻ or POWER at this time, "TOC" flashes as the actual contents of the MD are updated.

continue to next page →

Chapter 4: the MD Recorder

-> continued

Combining Recorded Tracks (combine function)

You can combine two tracks into one. When you combine two tracks, the track numbers of subsequent tracks are revised so that they remain continuous. This operation is not possible while SHUFFLE or PROGRAM appears. This operation is possible while the unit is stopped, during playback, or while paused.

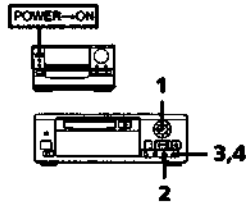

1 Display the track number of the track that you want to combine (with the track that precedes it).

Example: Combining tracks 4 and 5

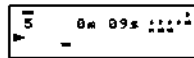

2 Press EDIT/NO repeatedly until "Combine ?" appears in the display.

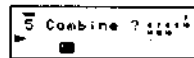

3 Press YES. The portion where the two tracks are to be combined (the end of the first track and the beginning of the second track) is played repeatedly. If the portion where the tracks are to be combined is not being played back, the combination process can be stopped by pressing EDIT/NO.

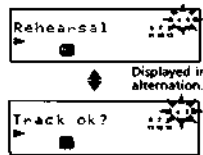

4 If the portion where the two tracks are to be combined is being played back, press YES. After "Complete" appears in the display for a few seconds, the tracks are combined and the track numbers in the music calendar decrease by one. If both of the tracks have names, the name of the second track is erased. Other information such as the recording date and time, etc., of the second track is also erased at the same time.



To cancel combining the tracks Press either EDIT/NO or □

To divide a combined track back into the original two tracks Divide the track back into two by using the divide function.

What does the following indication mean?



Those two tracks cannot be combined into one track. If editing is performed repeatedly, it may no longer be possible to combine two particular tracks. This reflects a restriction of the MiniDisc system, and is not a malfunction.

If the "Protected" indication appears The contents of the disc are protected from erasure, so the tracks cannot be combined. Slide the tab on the disc to close the slot before attempting to combine tracks.

When "TOC" flashes in the display Do not jog the recorder or pull out the power cord. After the recorder updates the contents of the recording, "TOC" lights up. If you've made any changes to the MD, "TOC" lights up. If you press @ or POWER at this time, "TOC" flashes as the actual contents of the MD are updated.

Rearranging Track Order (move function)

You can move tracks to any desired position, and change the order of the tracks. When tracks are moved, the track numbers of the other tracks are revised so that they remain continuous.

This operation is not possible while SHUFFLE or PROGRAM appears. This operation is possible while the unit is stopped, during playback, or while paused.

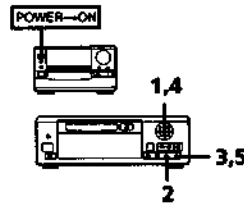

1 Turn AMS and display the track number of the track that you want to move.

Example: Moving track 3 to track 5

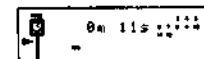

Track to be moved

2 Press EDIT/NO repeatedly until "Move ?" appears in the display.

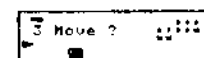

3 Press YES.



Destination track number

4 Use AMS to specify the destination.

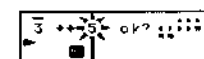

Set the destination to track 5.

5 Press YES. After "Complete" appears in the display for a few seconds, the track is moved. If performed during playback, playback of the track that was moved begins.



To cancel moving a track Press □

If the "Protected" indication appears

The contents of the disc are protected from erasure, so the tracks cannot be moved. Slide the tab on the disc to close the slot before attempting to move tracks.

When "TOC" flashes in the display

Do not jog the recorder or pull out the power cord. After the recorder updates the contents of the recording, "TOC" lights up. If you've made any changes to the MD, "TOC" lights up. If you press @ or POWER at this time, "TOC" flashes as the actual contents of the MD are updated.

Labeling Recordings (title function)

This function can be used to name tracks and discs with names consisting of up to 100 letters (upper and lower case), numbers, and symbols.

This operation is not possible while SHUFFLE or PROGRAM appears. Tracks can be named during playback, while paused, or while recording; discs can be named while the unit is stopped.

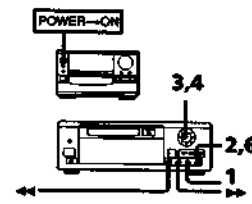

1 While in the middle of the track to be named, or with the disc inserted, press EDIT/NO repeatedly until "Name in ?" appears in the display.

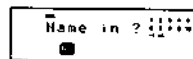

2 Press YES.

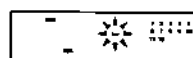

3 Turn AMS until the first letter desired appears in the display. The alphabet is followed by numbers and then symbols. The following symbols can be used: ! " # \$ % & ' () * + , - . / : ; < = > ? @ [\] ^ _ { | } ~

Note

Even if the symbols | ~ { } - are input using this recorder, they may not be displayed on other recorders.

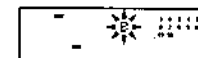

4 Press AMS and proceed to the second character.

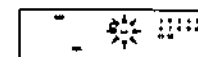

5 Repeat steps 3 and 4 until you finish inputting the desired track title.

6 Once you have input the entire track or disc title, press YES. The track or disc title appears in the display, from the beginning.



To correct mistakes

Press < or > to move the flashing cursor to the incorrect character, and then repeat steps 3 and 4.

To delete a specific character

Press < or > to move the cursor to the character to be deleted and then press EDIT/NO.

To change an entire title at once

1 Keep pressing EDIT/NO in step 3 until all of the characters are deleted, then repeat steps 3 and 4 to input the new title.

2 Press YES.

To enter a space

Either press AMS or >

To change the track title display status

When a title is assigned to a track using the Title function, the track title appears each time that track starts to play. To cancel this function, perform the following procedure and change the setting so that the track title is not displayed.

1 Press @ and exit the disc.
2 Press EDIT/NO so that "Select Name ?" appears.
3 Press YES so that "Name ON ?" appears.
4 Press EDIT/NO so that "Name OFF" appears.

To restore the original setting, press YES in step 4 above so that "Name ON ?" appears.

To cancel title function Press □.

To delete the title of the disc and the titles of all of the tracks

1 While the recorder is stopped, press EDIT/NO so that "All Erase ?" appears in the display.
2 Press EDIT/NO once again so that "Name Erase ?" appears.
3 Press YES.

If the "Protected" indication appears The contents of the disc are protected from erasure, so you cannot assign names to the tracks or the disc. Slide the tab on the disc to close the slot before attempting to name the tracks or the disc.

When "TOC" flashes in the display

Do not jog the recorder or pull out the power cord. After the recorder updates the contents of the recording, "TOC" lights up. If you've made any changes to the MD, "TOC" lights up. If you press @ or POWER at this time, "TOC" flashes as the actual contents of the MD are updated.

For Your Information

Precautions

Display Messages

System Restrictions

Troubleshooting Guide

Maintenance

Specifications

Glossary

Index to Parts and Controls

Index

Precautions

If you have any questions or problems concerning your stereo system, please consult your nearest Sony dealer.

On operating voltage

Before operating the stereo system, check that the operating voltage of your stereo system is identical with the voltage of your local power supply.

European models	220 — 230 V AC, 50/60 Hz
U.S. model	240 V AC, 50 Hz
Canadian model	120 V AC, 60 Hz

On safety

- The unit is not disconnected from the AC power source (mains) as long as it is connected to the wall outlet, even if the unit itself has been turned off.
- Unplug the system from the wall outlet (mains) if it is not to be used for an extended period of time. To disconnect the cord (mains lead), pull it out by the plug. Never pull the cord itself.
- Should any solid object or liquid fall into the component, unplug the stereo system and have the component checked by qualified personnel before operating it any further.
- AC power cord must be changed only at the qualified service shop.
- The unswitched socket outlets remain live, independently of power switch setting, at all times when the unit is connected to the AC power supply.

On installation

Place the stereo system in a location with adequate ventilation to prevent heat build-up in the stereo system.

On condensation in the CD player/MD recorder component

If the system is brought directly from a cold to a warm location, or is placed in a very damp room, moisture may condense on the lens inside the CD player and the MD recorder. Should this occur, the CD player and the MD recorder will not operate.

Remove the disc and leave the system turned on for about an hour until the moisture evaporates.

In case color irregularity is observed on nearby TV screen

With the magnetically shielded type of the speaker system, the speakers can be installed near a TV set. However, color irregularity may still be observed on the TV screen depending on the type of your TV set.

If color irregularity is observed...
Turn off the TV set once, then turn it on after 15 to 30 minutes.

If color irregularity is observed again...

Place the speakers farther away from the TV set.

Display Messages

The following table explains the various messages that appear in the display.

Message	Meaning
Blank Disc	A brand new recordable disc or one on which all tracks have been erased has been loaded.
Cannot Copy	Digital recording is not possible. (See "Serial Copy Management System".)
Cannot EDIT	An attempt was made to edit in PROGRAM or SHUFFLE play mode. Also may indicate that the disc contains Japanese ideograms.
Disc Error	A bad disc was loaded. (The disc is damaged, or does not contain a TOC.)
Disc Full	Recording is not possible because there is no time remaining on the disc. (See "System Restrictions".)
Impossible	An attempt was made to combine from the first track on a disc. The combine operation is not possible from the first track on the disc.
Name Full	There is no more space to store track titles or disc titles. Up to 1792 characters can be stored.
NO DISC	No disc is loaded.
No Track	A disc with no tracks, just a disc name, has been loaded.
Protected	The disc is protected against erasure.
Retry	The unit is redoing the recording because of vibrations or disc scratches encountered during recording.
Retry Error	Because of numerous vibrations or disc scratches, continuous attempts have been made to redo the recording but normal recording is not possible.
Sorry	An attempt was made to combine tracks that cannot be combined.

System Restrictions

The MiniDisc (MD) system is a different recording system than that used with conventional cassettes or DAT. As a result, there are several system restrictions which may manifest themselves through the following symptoms. Although these do not indicate a malfunction, you should be aware of the causes of these situations.

"Disc Full" appears, even though the maximum recording time (60 minutes, 74 minutes) has not been reached

In the MD system, when the maximum number of tracks has been recorded, the "Disc Full" message appears, regardless of the total playing time of the tracks. The maximum number of tracks that can be recorded is 255. If you want to record additional tracks, either erase unnecessary tracks or record them on a second disc.

"Disc Full" appears, even though recording time and unused tracks still remain

Fluctuations in emphasis within tracks are sometimes interpreted as track intervals, incrementing the track count and causing the "Disc Full" indication to appear.

The remaining time on the disc does not increase, even though several short tracks have been erased

Because short segments of eight seconds or less are ignored when the time remaining on a disc appears, erasing several short tracks may not always result in that amount of time being added to the time remaining.

Combining is not always possible

Sometimes it is not possible to combine an edited track.

The sum of the time recorded on a disc and the time remaining may not always equal the maximum recording time (60 minutes, 74 minutes)

Normally, the smallest unit of recording is one "cluster" (about two seconds). Even if a recorded segment is less than two seconds, two seconds worth of space is used. As a result, the amount of time that can actually be used on a disc decreases. Furthermore, if a disc has a scratch, the affected portion is automatically ignored so that the amount of available time decreases by a corresponding amount.

When searching in an edited track, the sound may occasionally be interrupted

Tracks may not be numbered accurately

When recording a CD through a digital connection, small extra tracks may be created due to the contents of the CD recording.

"TOC Reading" appears for a long time

"TOC Reading" appears for a long time when a brand new recordable disc is loaded.

Because this MD recorder is a hi-fi stereo component, it cannot use monaural format MDs

Troubleshooting Guide

If you run into any problem using the stereo, use the following check list. And first check the following points:

- The power cord is connected firmly
- The speakers are connected correctly and firmly.

Should any problem persist after you have made the checks below, consult your nearest Sony dealer.

Tuner

"TUNED" flashes in the display.
→ Adjust the antenna.

"STEREO" flashes in the display.
→ Adjust the antenna.

Severe hum or noise.

- Adjust the antenna.
- The signal strength is too weak. Connect the external antenna.
- Connect the ground wire.

A stereo FM program cannot be received in stereo.

- Press STEREO/MONO so that "STEREO" appears.

MD Recorder

The controls do not work.

- The disc is dirty or scratched. (The Disc Error message appears.) Replace the disc with a new one.

Playback is not possible.

- Moisture condensation has built up. Leave the system turned on for about an hour until the moisture evaporates.
- Nothing is recorded on the disc in the unit. (The music calendar does not appear.)

- Turn the power on.
- Insert the disc in the direction indicated by the arrow.

Recording is not possible.

- The disc is protected against erasure. (The "Protected" display appears.) Slide the tab to close the slot.
- Connect the sound source properly.
- A premastered disc is loaded in the unit. Replace the disc with a recordable disc.
- The power cord was unplugged or a power failure occurred during recording. It is possible that the information recorded up to that point will be lost. Start recording over from the beginning.
- Either replace the disc with a recordable disc that has sufficient time remaining, or else erase unneeded tracks on the current disc.
- Press O REC again.

CD Player

The CD tray does not close.

- The CD is not placed correctly.

The CD will not play.

- The CD is dirty.
- The CD is inserted label side down.
- The player is in pause mode.
- Moisture condensation has built up. Leave the system tuned on for about an hour until the moisture evaporates.

Play does not start from the first track.

- The player is in program or shuffle mode. Press P MODE repeatedly until SHUFFLE or PGM disappear.

" " " " is displayed.

- was repeatedly pressed at the end of the CD. Press or (or on the remote commander) to return to the normal display.

General

There is no sound.

- Rotate VOLUME clockwise.
- The headphones are connected. Disconnect them.

Sound comes from one channel or unbalanced left and right volume.

- Check the speaker connections of the inoperative channel.

→ continued

The left and right sound are reversed.

→ Check the speaker connection and speaker placement.

Bass is lacking or the location of the musical instruments is apparently imprecise.

→ Check the speaker connection for proper phasing.

There is severe hum or noise.

→ A TV or VCR is too close to the stereo system. Move the stereo system away from the TV or VCR.

"000" flashes in the display.

→ A power interruption occurred. Set the clock and tuner settings again.

The remote commander does not function.

→ The batteries have run down. Replace both batteries.
→ There is an obstacle between the remote commander and the system. Remove the obstacle.

Maintenance

To clean the cabinet

Use a soft cloth slightly moistened with mild detergent solution.

To clean the CD

When a CD is dirty, clean it with a cleaning cloth. Wipe the CD from the center out.

Notes on CD

• Do not use solvents such as benzene, thinner, commercially available cleaners, or anti-static spray intended for vinyl LPs.
• If there is a scratch, dirt or fingerprints on the CD, it may cause a tracking error.

Glossary

Notes on the MD recorder editing functions

The editing functions allow you to divide tracks or combine consecutive tracks on a previously recorded disc so that you can search for any desired section. It is also possible to erase tracks simply by specifying their track number, and to name discs and tracks.

Erasing tracks (Erase function)

This function allows you to easily erase recorded tracks simply by specifying the

For Your Information

corresponding track number. Unlike cassette tapes, it is not necessary to record over a previously recorded track in order to erase it.

Example: Erasing track B

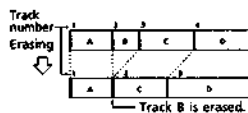

Dividing tracks (Divide function)

This function divides one track into two. When a recording was made using line input or microphone input, use this function to manually divide the tracks so that each track can be searched for separately. If a recording was made digitally, use this function so that you can easily search for your favorite parts.

Example: Dividing track 2 into tracks B and C

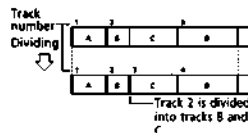

Combining tracks (Combine function)

This function combines two consecutive tracks into one track. Use this function to combine several consecutive tracks into a medley format, or to combine tracks recorded separately into a single track.

Example: Combining tracks B and C

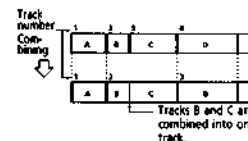

Moving tracks (Move function)

This function allows you to move tracks as you please, so that you can change the order of the tracks.

Example: Moving track C so that it is the first track

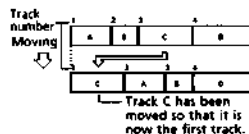

Naming tracks and discs (Title function)

This function allows you to name recorded discs and individual tracks.

About the MiniDisc

The MiniDisc is a new media developed by Sony to meet the need today for a system that allows people to enjoy high-quality music anytime, anywhere.

What is a MiniDisc?

A MiniDisc consists of a disc with a diameter of only 64 mm housed in a 66 x 72 mm pocket-sized cartridge with a thickness of 5 mm. Because the compact MiniDisc can be used to record and playback digital recordings, it is capable of high-quality sound reproduction with extremely low noise and distortion. In addition to being free from the problem of stretching or becoming tangled like ordinary cassette tapes, the MiniDisc is extremely durable and suffers from no degradation in sound quality over time. Furthermore, because the recording media is housed in a cartridge, the MiniDisc can be handled freely without concern about dust, scratches, or fingerprints.

Construction of a MiniDisc (recordable disc)

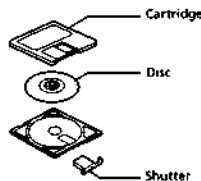

Two types of discs

There are two types of MiniDiscs: premastered (pre-recorded) MDs and recordable (blank) MDs.

Premastered MDs

This type of disc can only be played, and is used for commercial MD software. A premastered MD is an optical disc just like a compact disc, with data recorded by means of the presence or absence of pits in

the recording media. Playback is performed using an optical pickup that is also used for playing back recordable MDs.

Premastered MD



Recordable MiniDisc

This is a blank disc which you can use to record and playback any number of times. A magneto-optical disc, this disc uses a laser and magnetism to record data through the magnetic field modulation overwrite system.

Recordable MiniDisc



Compact Size Made Possible with ATRAC

While the MiniDisc is only half the size of a compact disc, it is capable of storing the same amount of music. This is made possible by a newly developed audio compression technology called ATRAC (Adaptive Transform Acoustic Coding). ATRAC compresses data by 1/3 by removing the portions of the sound that are inaudible to the human ear. Because the selection/rejection of data is based on auditory psychology, the sound quality that is heard does not suffer.

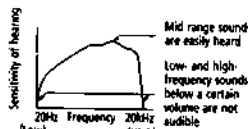

Because someone is speaking, the softer sound of a clock ticking cannot be heard (masking effect).

Immediate track selection (random access)

One of the main benefits of discs is the ease and immediacy with which any desired track can be selected. Moreover, with a MiniDisc it is not only possible to find tracks quickly but also to edit them quickly. This is because the track information (starting time, ending time, sequence, etc.) is centrally managed in an area called the User TOC (Table of Contents). Because this area is separate from the music data, editing is possible just by changing the information in the User TOC. For example, if you want to erase a track on a tape, it is necessary to record silence over the entire track from start to finish. In the case of the MiniDisc, however, a track can be erased simply by overwriting the information in the User TOC.

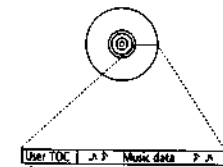

How the Shock-Resistant Memory works

The weakness of earlier optical and magneto-optical discs was the ease with which vibrations could induce skips in the sound. With the Shock-Resistant memory, a newly developed anti-vibration technology, the MiniDisc offers a dramatic improvement in vibration resistance. The main feature of the Shock-Resistant memory is that data read from the disc is not played back immediately; instead, it is stored in a semiconductor memory. Because the data that is read has been compressed (see earlier explanation), it is sent from the semiconductor memory to the ATRAC decoder for decoding. If the flow of data from the optical pickup is interrupted due to vibration, several seconds worth of compressed data is still stored in the semiconductor memory so that compressed data can be continuously sent to the ATRAC decoder without any gaps. This eliminates skips in the music as long as the optical pickup begins to read data again before all of the data in the semiconductor memory is gone.

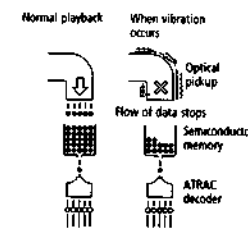

A Note on the Rules Concerning Digital Copying (Serial Copy Management System)

A disc recorded with digital input cannot be used to make another recording with digital input. As a digital audio component, this MiniDisc recorder conforms with the Serial Copy Management System standards. The Serial Copy Management System restricts copies made by recording digital signals to first-generation copies only. There are two general rules that apply to this unit.

Rule 1

Digital copies can be made onto a MD from a compact disc (CD), digital audio tape (DAT) software, or MiniDisc (MD) software.

However, it is not possible to make a copy of that MiniDisc (which was recorded through digital copying) onto another MiniDisc through digital copying.

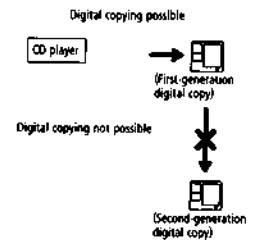

Rule 2

A MiniDisc on which an analog record, FM broadcast, or other analog source was recorded can be copied digitally onto another MiniDisc. However, it is not possible to make a copy of that second MiniDisc (which was recorded through digital copying) onto another MiniDisc through digital copying.

continue to next page →

For Your Information

→ continued



EN
32

Index to Parts and Controls

Refer to the pages indicated in parentheses for details on how to use the controls

Front Panel

HCD-MD1

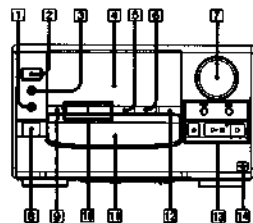

- 1 HEADPHONES jack (stereo minijack) (22, 26)
- 2 SYSTEM POWER switch (8)
- 3 Remote sensor
- 4 Display window (8)
- 5 EFFECT PRESET button (22)
- 6 EQ PRESET button (22)
- 7 VOLUME control (8, 22)
- 8 FUNCTION button (24)
- 9 BAND button (11)
- 10 +/- buttons (11)

- 11 Disc tray
- 12 P.MODE (play mode) button (9)
- 13 CD player operating buttons
 - ▶ (open/close of the disc tray) (8)
 - ⏸ (play/pause)
 - ⏹ (stop)
 - ⏮ ⏭ (AMS)*
 - ⏪ ⏩ (AMS)*
- 14 Cover open/close button

*AMS: Automatic Music Sensor

(Inside the cover)

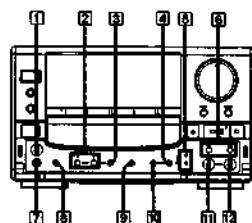

- 1 MIC LEVEL control (24)
- 2 CLOCK SET buttons (6)
 - TIMER 1 button
 - TIMER 2 button
- 3 TIMER REC button (24)
- 4 TUNING MODE button (11)
- 5 TUNING/PRESET indicators (11)
- 6 Manual search buttons (8)
- 7 MIC jack (24, 25)
- 8 KARAOKE PON button (25)
- 9 MEMORY/NEXT button (12, 23, 24)
- 10 STEREO/MONO button (11)
- 11 FREQUENCY control (22)
- 12 LEVEL control (22)

MDS-MD1

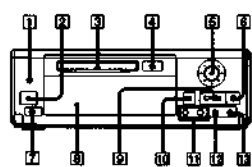

- 1 DISPLAY button (14)
- 2 CD SYNCHRO button (16)
- 3 Disc compartment
- 4 Disc button (14)
- 5 AMS* control (14)
 - ⏹ (stop) button (14)
- 6 P.MODE (play mode) button (15)
- 7 Display window (13)
- 8 (play/pause) button (14)
- 9 REC button (16, 17)
- 10 Manual search buttons (11)

- 11 EDIT/NO button (18 - 21)
- 12 YES button (18 - 21)

*AMS: Automatic Music Sensor

Display Window

HCD-MD1

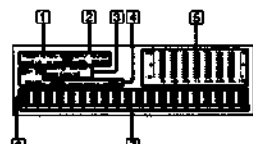

- 1 Timer indication (23, 24)
- 2 Tuner indication (11)
- 3 CD play mode indication (9, 10)
- 4 CD play status indication (8)
- 5 Spectrum analyzer (8, 11, 22)
- 6 Timer/time/function/tuner/CD indications (6, 8, 11, 23)
- 7 Music calendar (8)

MD recorder

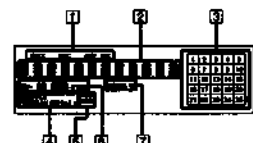

- 1 Display status indication (13)
- 2 Message/time indication (13)
- 3 Music calendar (13)
- 4 Play mode indication (15)
- 5 TOC/EDIT indication (17 - 21)
- 6 Play status indication (15)
- 7 DIGITAL IN indication

Remote commander

RM-S11MD

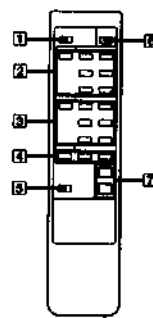

- 1 SLEEP button (23)
- 2 MD recorder operating buttons
 - ▶ (play) (14)
 - ⏸ (pause) (14)
 - ⏹ (stop) (14)
 - ⏮ ⏭ AMS* (14)
 - ⏪ ⏩ (recording) (17)
 - REPEAT button (15)
- 3 CD player operating buttons
 - ▶ (play) (8)
 - ⏸ (pause) (8)
 - ⏹ (stop) (8)
 - ⏮ ⏭ AMS* (8)
 - TIMER button (9)
 - REPEAT button (10)
- 4 BAND button (11)
- 5 PRESET +/- buttons (11)
- 6 FUNCTION button (24)
- 7 SYSTEM POWER button (6, 23)
- 8 VOL +/- buttons (22)

*AMS: Automatic Music Sensor

Index

- Adjusting the sound 22
 the volume 22
- Adjusting the sound emphasizing sound quality automatically 22
- ALL REC OFF 15
- ALL REC ON 15
- AMS 8, 14
- ATRAC 31
- CD player 8
- Clock setting 6
- Combine function 20, 30
- Combining recorded track 20, 30
- Connecting an MD recorder or DAT deck 25
 a VCR 26
 optional equipment 25
 the antennas 4
 the flat cord 4
 the optical transmission cable 4
 the power 6
 the speakers 4
 the stereo 4
- Disc-in auto power 7
- Display indications 8, 13
 messages 27
- Divide function 19, 30
- Dividing recorded track 19, 30
- Erase function 18, 30
- Erasing all tracks on a disc 18
 a portion of a track 18
 one track 18
 recordings 18, 30
- Glossary 30
- Inserting the batteries 6
- Karaoke 25
- Labeling recordings 21, 30
- Maintenance 29
- MD recorder 13
- Microphone mixing 24
- MiniDisc 13, 30
- Move function 20, 30
- Music calendar 8, 13
- Normal play 8, 13
- One touch play 7
- Parts identification 32
- Playing a CD (normal play) 8
 a MiniDisc (normal play) 13
 preset radio stations 12
 tracks in random order (shuffle play) 9, 14
 tracks repeatedly (repeat play) 10, 15
 tracks in specific order (program play) 9, 15
- Precautions 27
- Premastered MD 30
- Program play 9, 15
- Radio stations presetting 12
 tuning in 11
- Rearranging track order 20, 30
- Recordable MiniDisc 31
- Recording a CD 16
 a radio program 17
 timer recording 24
 with a microphone (mixing) 24
- Reducing the vocals 25
- Reinforcing bass 23
- Remote commander 7, 33
- Repeat play 10, 15
- Selecting the audio emphasis 22
 the recording mode 15
- Serial Copy Management System 31
- Shock-resistant memory 31
- Shuffle play 9, 14
- Simple operation 7
- Sound adjusting 22

- Speakers 4
- Specifications 29
- Supplied accessories 29
- Synchronized CD recording 10
- System restrictions 28
- Timer falling asleep to music 23
 timer recording 24
 waking up to music 23
- Title function 21, 30
- Track marking 17
- Troubleshooting guide 28
- Tuner 11
- Writing track numbers 17

EN
33

For Your Information

SECTION 2 DISASSEMBLY

NOTE: Follow the disassembly procedure in the numerical order given.

2-1. CASE, FRONT PANEL

●MDS-102

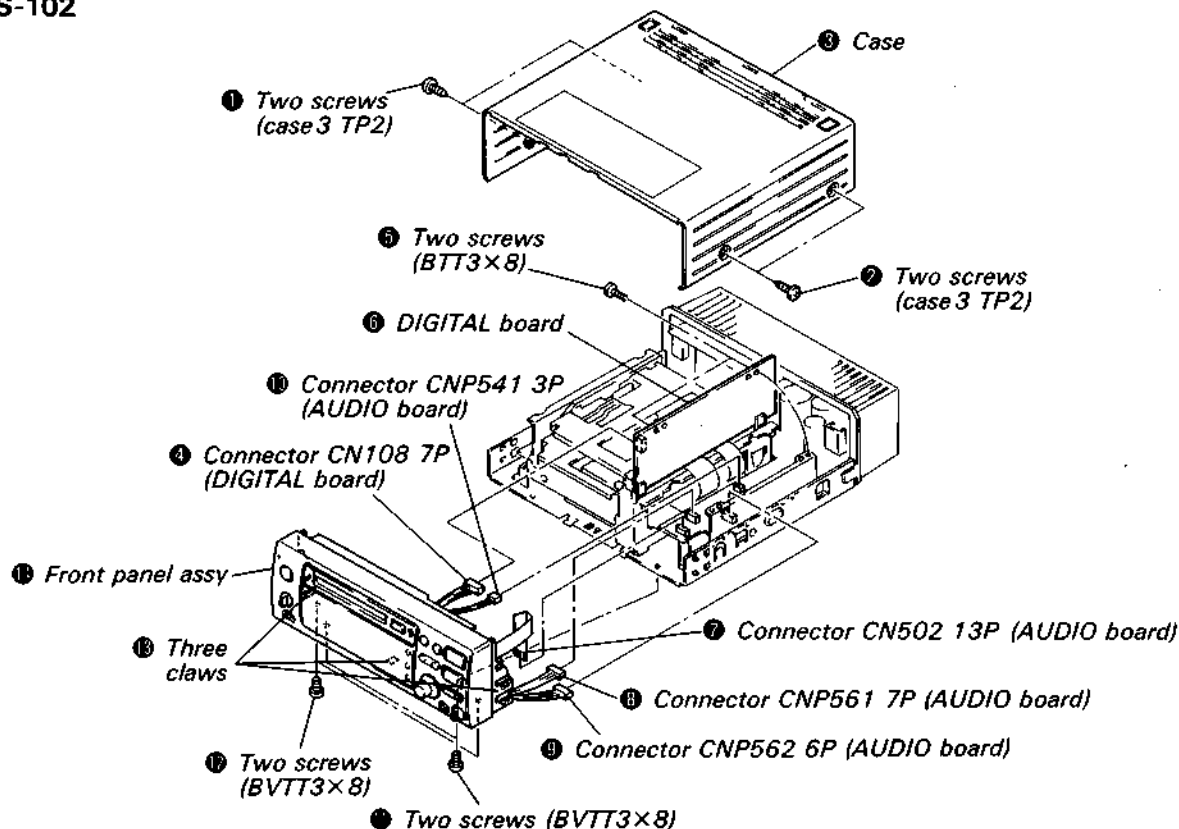

●MDS-MD1

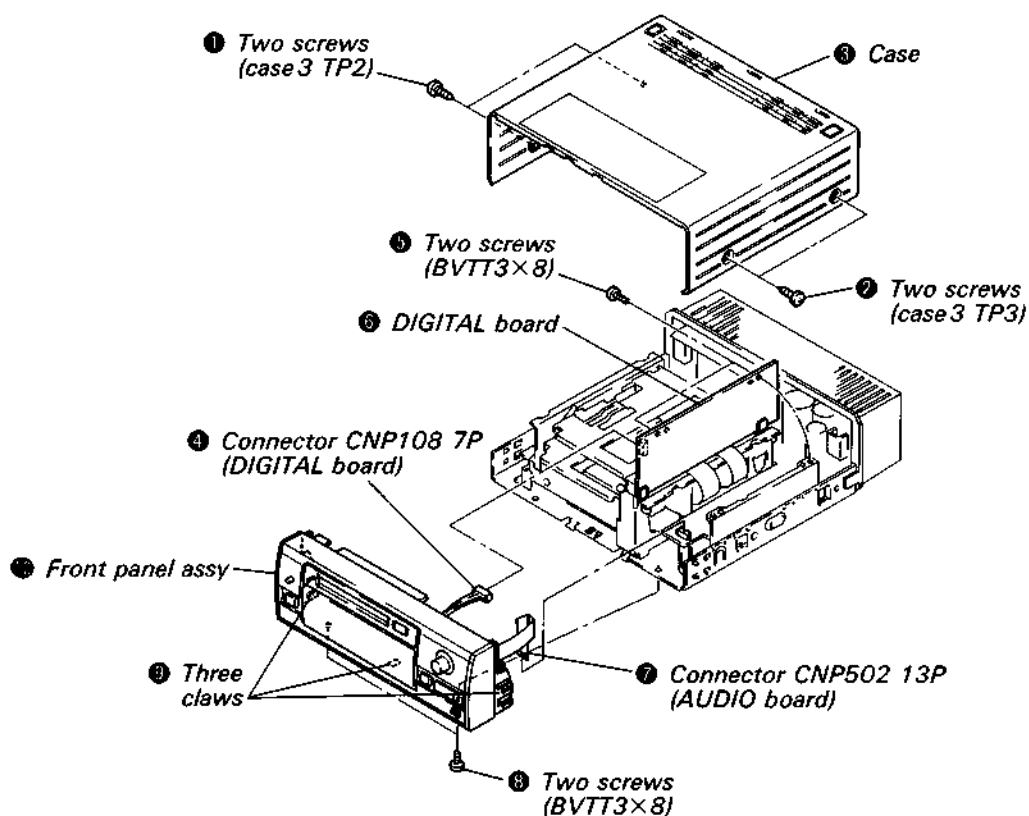

2-2. DISP, MIC BOARD

● MDS-102

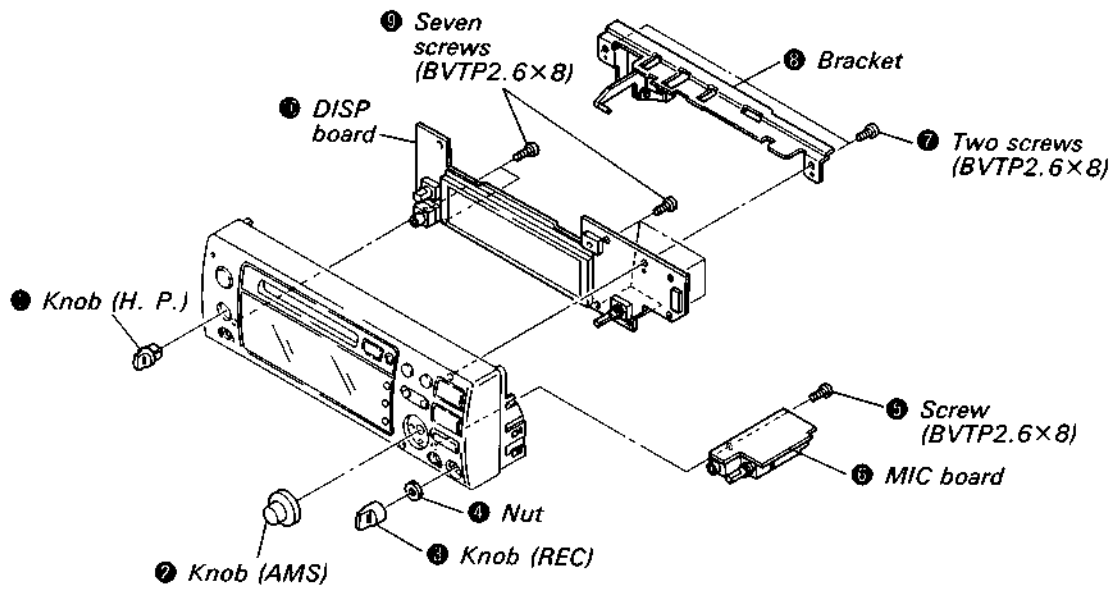

● MDS-MD1

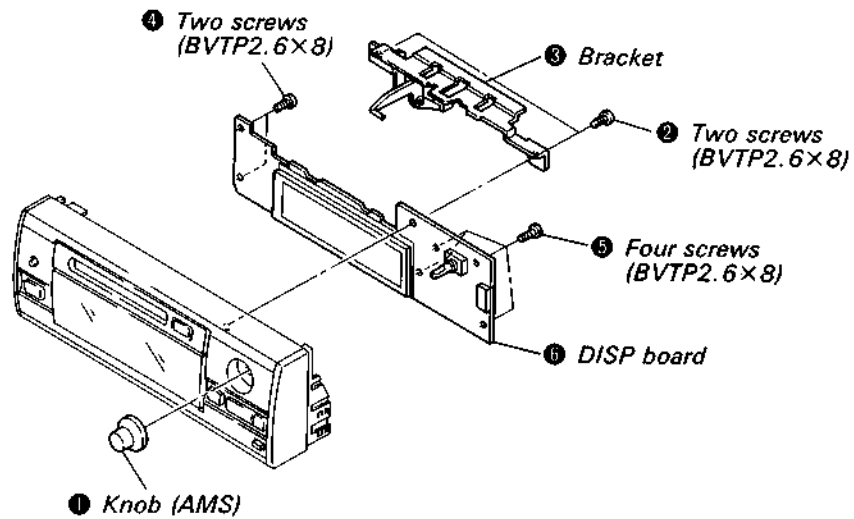

2-3. POWER TRANSFORMER

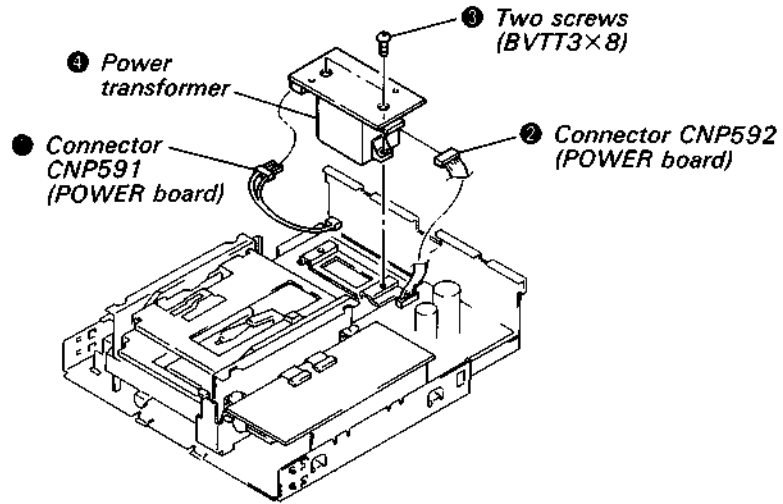

2-4. BACK PANEL

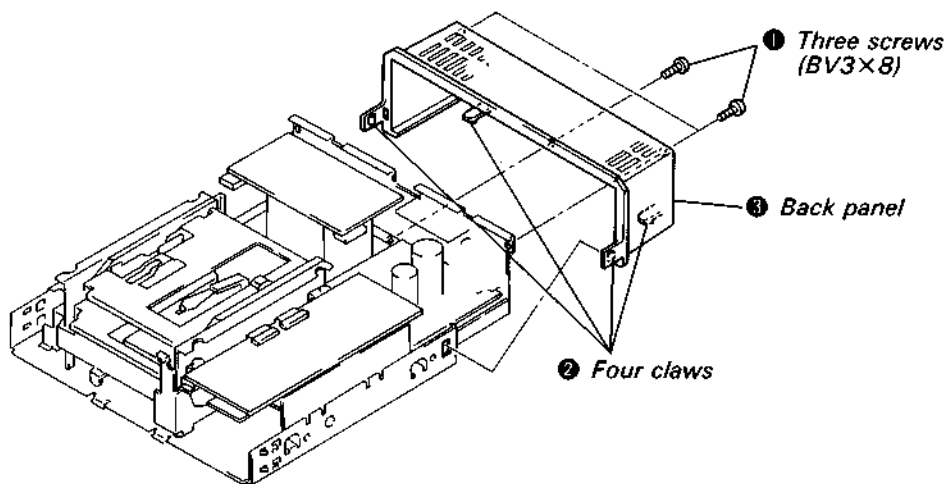

2-5. MECHANISM DECK (MDM-1C)

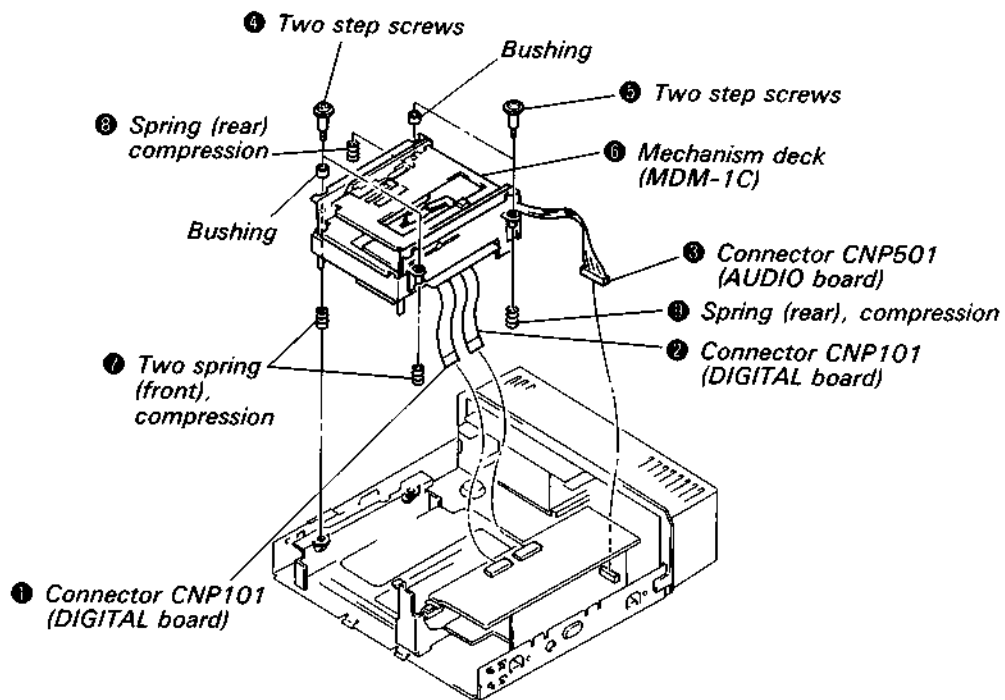

2-6. RF/SERVO BOARD

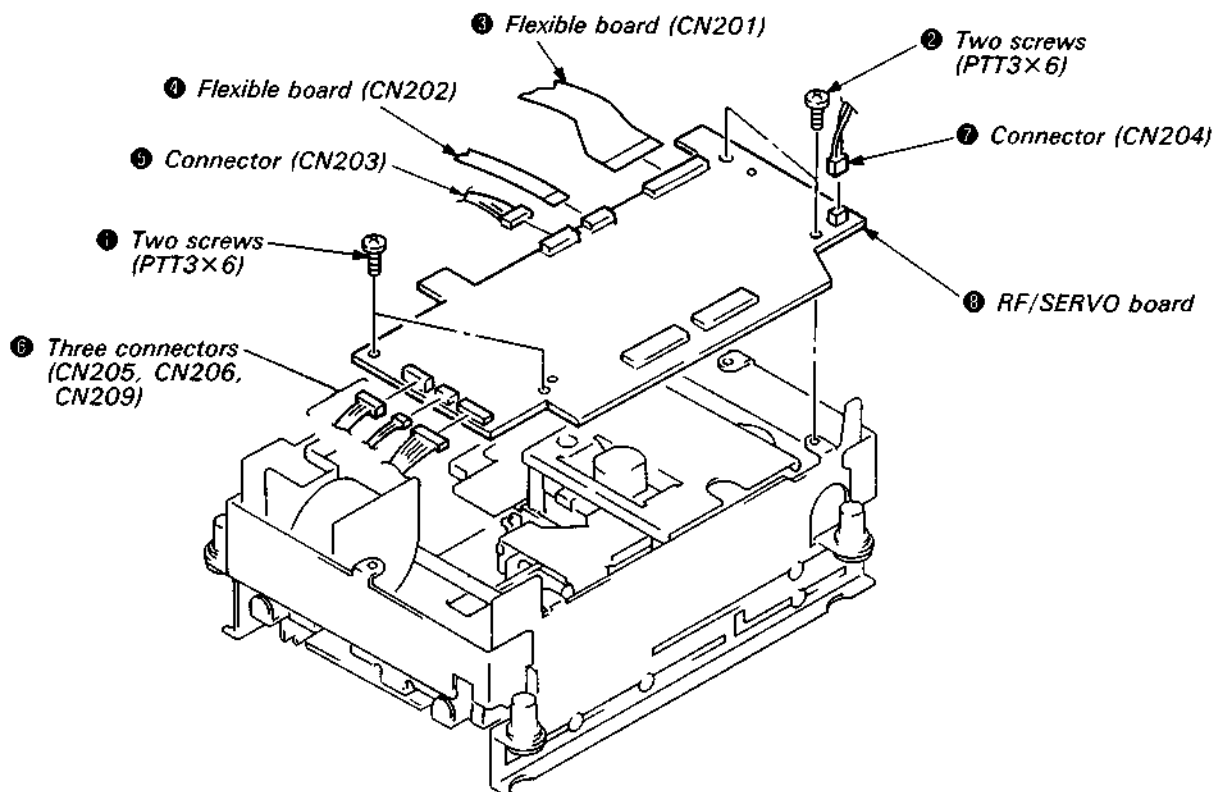

2-7. BASE UNIT (MBU-1)

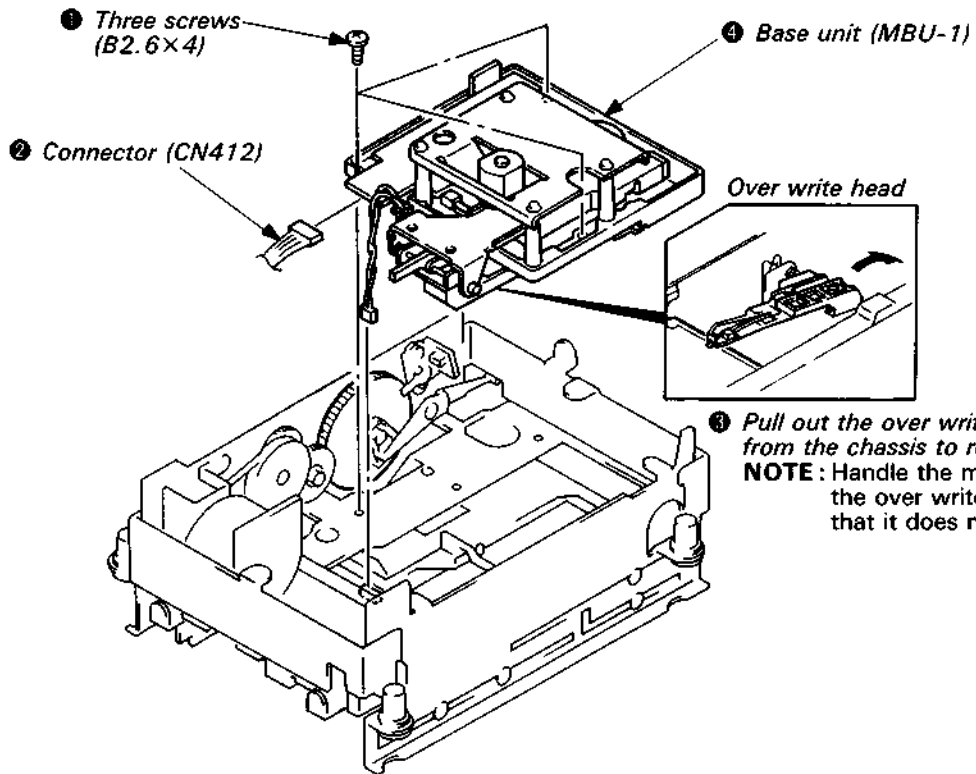

2-8. LOADING MOTOR ASSY

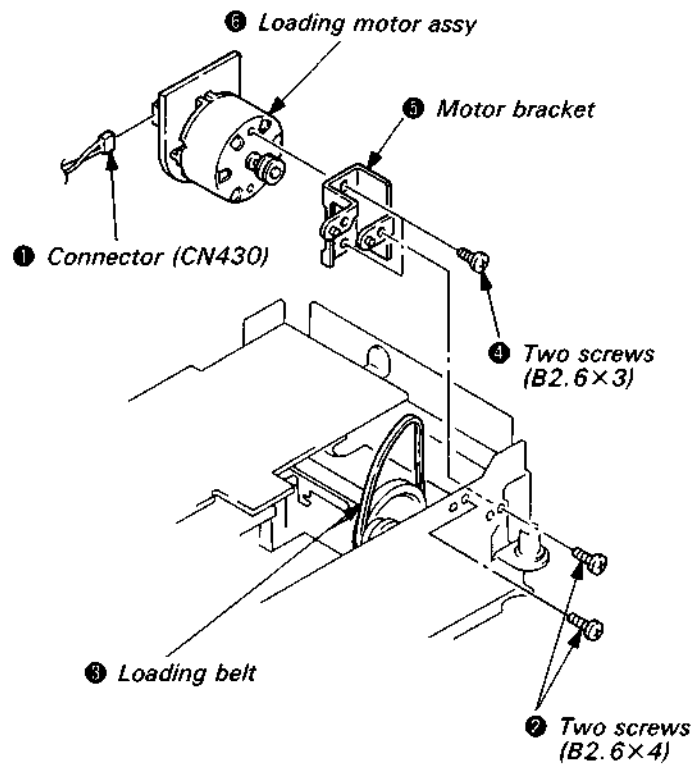

2-9. SLED MOTOR

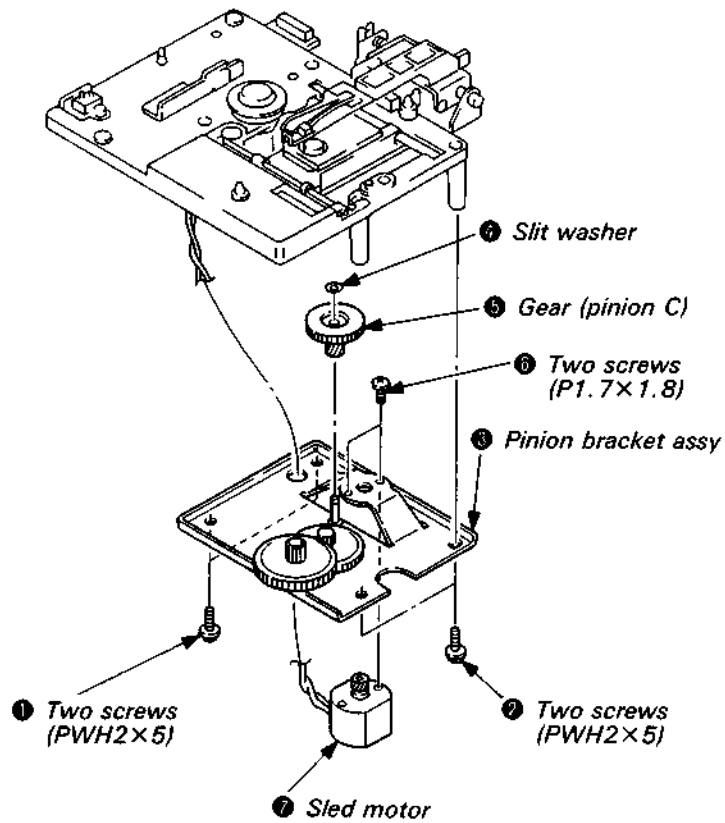

2-10. MINI DISC DEVICE (KMS-140B)

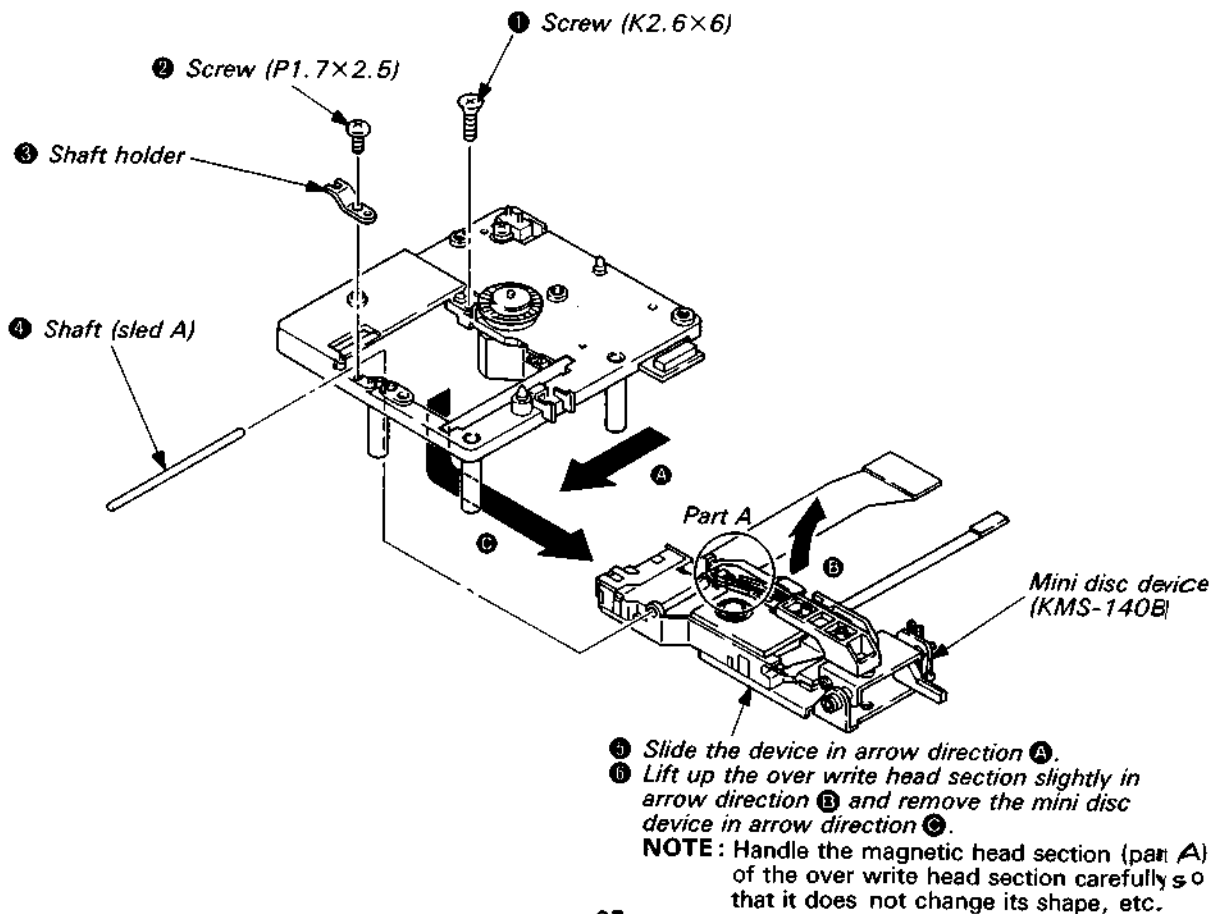

SECTION 3 TEST MODE

3-1. TEST MODE SETTING

While pressing the ►(PLAY) key, connect the power cord to the AC outlet, then release the ►(PLAY) key.

3-2. TEST MODE RELEASING

Disconnect the power cord from the AC outlet.

3-3. TEST MODE OPERATION

[] represents main operations by each key.

[MDS-102]

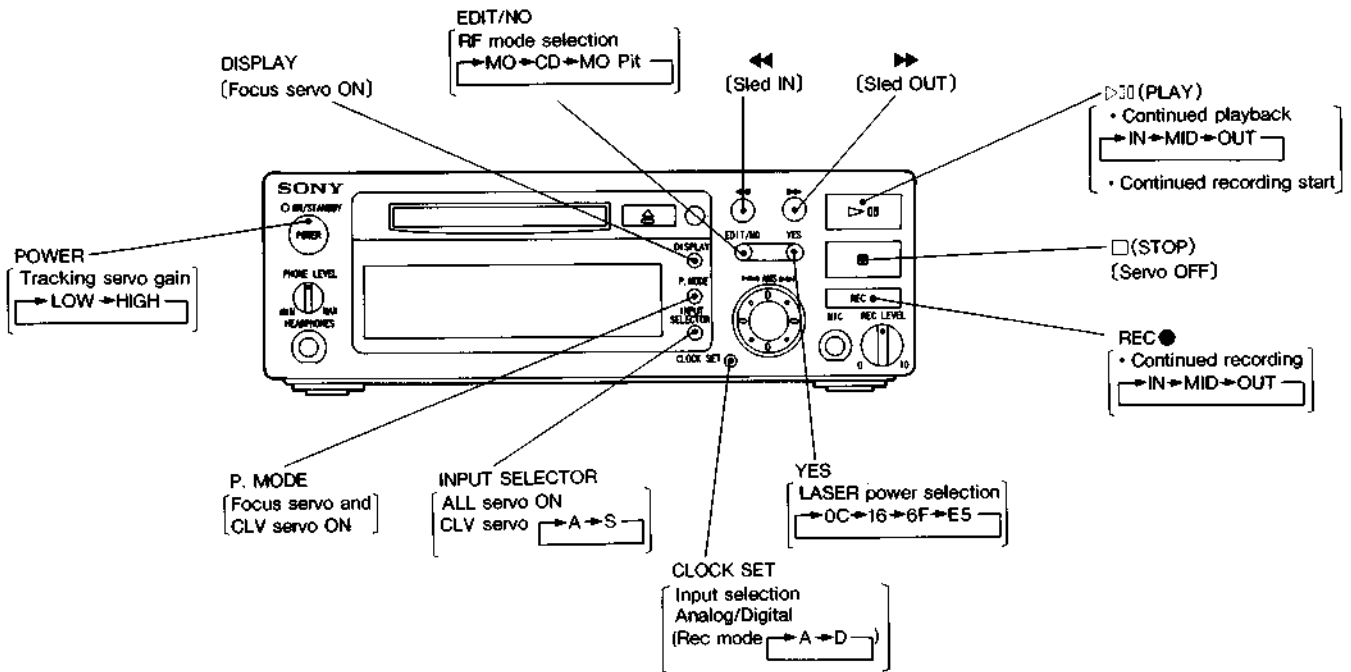

[MDS-MD1]

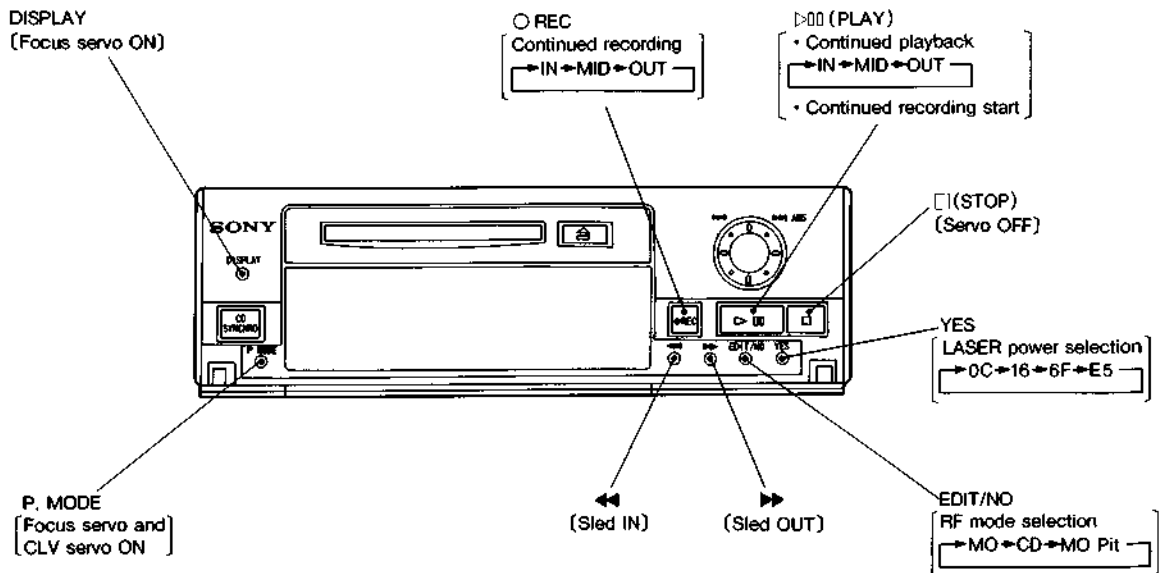

Fig. 3-1. Key arrangement

Key	Indication	Contents	Remarks	
REC	CREC-IN	Continued recording on inner circumference	<ul style="list-style-type: none"> • Indication changes as key is pressed. • After the indication shown in the left has appeared, repeated recording occurs at the indicated position by pressing ►(PLAY) key. • To stop recording, press ■(STOP) key. 	
	CREC-MIDDLE	Continued recording on middle circumference		
	CREC-OUT	Continued recording on outer circumference		
YES	Laser Power 0C	CD reading power	<ul style="list-style-type: none"> • Indication changes as key is pressed, laser power is switched and laser is emitted. • To stop the laser emission, press ■(STOP) key. 	
	Laser Power 16	MO reading power		
	Laser Power 6F	Laser power adjustment (3.5mV)		
	Laser Power E5	MO writing power (maximum generating power)		
POWER	Trk Gain Hi	Tracking servo gain UP	<ul style="list-style-type: none"> • Indication changes as key is pressed, and the tracking servo gain is selected. • Normally low. 	
	Trk Gain Low	Tracking servo gain NORMAL		
EDIT/NO	RF mod=MO	RF mode : MO groove	Adjusted on the MO disc groove.	<ul style="list-style-type: none"> • Indication changes as key is pressed, and the RF mode is selected.
	RF mod=CD	RF mode : CD	Adjusted on the CD disc.	
	RF mod=MO pit	RF mode : MO pit	Adjusted on the MO disc pit.	
EJECT	OPEN	Disc ejection		
	CLOSE	Disc loading		
CLOCK SET	Rec mode-A	Operation mode of CXD2525R : analog	PLL master mode	<ul style="list-style-type: none"> • Indication changes as key is pressed, and the input is selected. (analog/digital)
	Rec mode-D	Operation mode of CXD2525R : digital	PLL slave mode	
◀◀	sled in	Sled is moved toward inner circumference.	<ul style="list-style-type: none"> • Sled moves during key is pressed, and stops when key is released. 	
▶▶	sled out	Sled is moved toward outer circumference.		
DISPLAY	Fcs on	Focus servo on	<ul style="list-style-type: none"> • Only focus servo is on by pressing key. 	
P. MODE	Fcs ClvS on	Focus/spindle (S) servo on/tracking servo off	<ul style="list-style-type: none"> • Focus servo and spindle servo (S) are on by pressing key. 	
INPUT SELECTOR	Fcs ClvATr on	Focus / spindle (A) / tracking servo on	<ul style="list-style-type: none"> • Indication changes as key is pressed, and each servo is on. 	
	Fcs ClvSTr on	Focus / spindle (S) / tracking servo on		
▷▷ (PLAY)	C PLAY IN	Continued playback of inner circumference	<ul style="list-style-type: none"> • Indication changes as key is pressed, repeated recording occurs at the indicated position. • To stop the playback, press ■(STOP) key. 	
	C PLAY MID	Continued playback of middle circumference		
	C PLAY OUT	Continued playback of outer circumference		
■(STOP)	—	All servos off		

Table 3-1. Test mode operation

MDS-102/MD1 TEST MODE

1) Self Check at Power ON

When the power socket is connected and the POWER switch is turned on, the following message is displayed to indicate a failure, if any.

“STA” : Pin 36 is “high”. Normally it is “low”.

“STANDB” : Communication failure to mechanism controller.

2) Key & Display Test Mode

Place the pin 35 in “high” status (pull up) and connect the power socket (reset the master microcomputer if the test is executed with the board only), and the key & display test mode is activated.

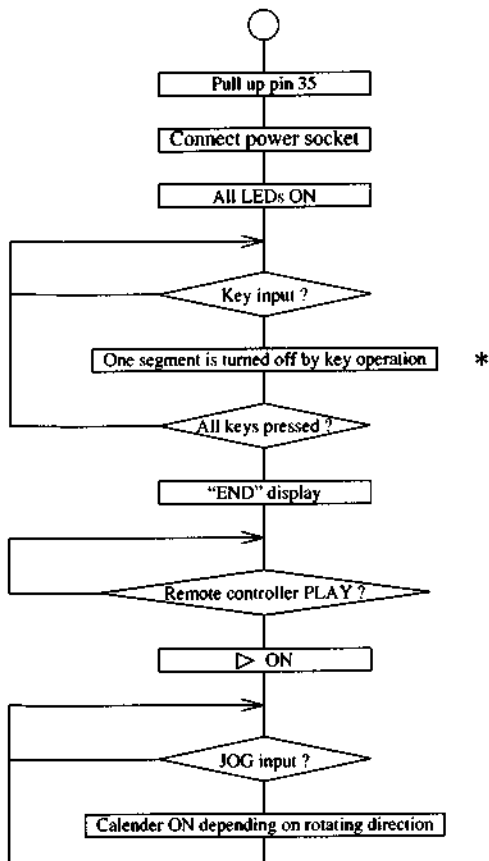

Segment turned off by key:

key	SEGMENT
POWER	TRACK
EJECT	DATE
DISPLAY	STEP
P. MODE	-SYNC
INPUTSELECT	REC
CLOCK	DISC
EDIT/NO	GUIDE
YES	PLAY MARK
FR	PAUSE MARK
FF	REC MARK
PLAY	DIGITAL IN
STOP	A. SPACE
REC	CLOCK

3) Clock IC Oscillation Adjust Mode

Connect the power socket with the pin 36 in “high” status (pull up), and 2048Hz is output from pin 8 of clock IC.

4) Test Mode for Set Checking, MO Related

Connect the power socket while pressing the PLAY key, and the following items can be checked by pressing the associated key.

Test Items	MDS-102	MD-1
C REC	REC	REC
LASER POWER	YES	YES
TRK GAIN	POWER	None
RF MODE	EDIT/NO	EDIT/NO
OPEN/CLOSE	EJECT	EJECT
REC MODE	CLOCK SET	None
SLED IN	FR	FR
SLED OUT	FF	FF
FCS ON	P. MODE	P. MODE
FCS. CLV ON	INPUT SEL	CD. SYNC
C PLAY	PLAY/PAUSE	PLAY/PAUSE
SERVO OFF	STOP	STOP

SECTION 4 ELECTRICAL ADJUSTMENTS

4-1. CAUTION ON LASER DIODE EMITTING CONFIRMATION

Never look the laser diode emission from right above when adjusting. It may cause loss of eyesight.

4-2. NOTE ON MiniDisc device (KMS-140B) HANDLING

The laser diode within the optical pickup is extremely subjected to electrostatic destruction. So, the laser tap on the flexible board should be bridge soldering when handling. Furthermore, take fully measurements against the electrostatic destruction. Take care of handling the flexible board because it can be damaged.

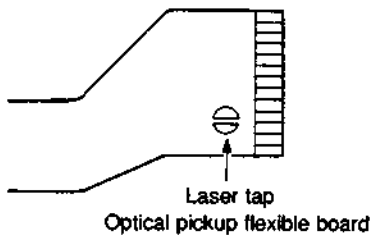

After replacing the MiniDisc device, perform adjustment and confirmation as follows.

- Temperature compensation offset adjustment
- Laser power adjustment
- MO groove traverse adjustment
- E-F balance adjustment
- MO pit traverse adjustment
- CD RF level adjustment
- CD traverse adjustment
- Error rate confirmation

4-3. NOTE ON ADJUSTMENT

- 1) Perform adjustment in the test mode.
Release the test mode after adjustment.
- 2) Adjustment should be performed in order described.
- 3) Use jigs and measurement tools described below.
 - CD test disc TGYS-1 (Part No.: 4-959-188-01)
 - Continued recorded disc PTDM-1 (Part No.: J-2501-054-A)
 - Laser power meter LPM-8001 (Part No.: J-2501-046-A)
 - Error rate counter MDPE-1 (Part No.: J-2501-047-A)
 - Oscilloscope (band more than 40 MΩ, Calibrate the probe before performing the measurement.)
 - Digital volt meter
 - Temperature meter

4-4. OFFSET ADJUSTMENT

Note: This adjustment should be performed immediately after setting the test mode. Performing other adjustments switch the operation mode, and the correct adjustment can not be performed.

1) Temperature compensation offset adjustment

Connection:

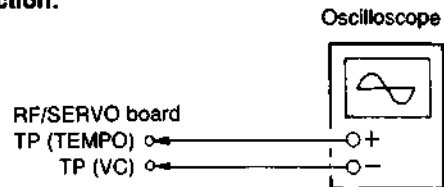

Adjustment method:

1. Connect the oscilloscope to TP (TEMPO) and TP (VC) on the RF/SERVO board.
2. Adjust RV208 on the RF/SERVO board so that the reading on the oscilloscope meets the specification.

Specification: $0 \pm 20\text{mV}$ (25°C)
 $+8.4\text{mV}/^\circ\text{C}$ (Increased by 8.4mV with every increasing temperature by 1°C)

2) Focus bias offset adjustment

Connection:

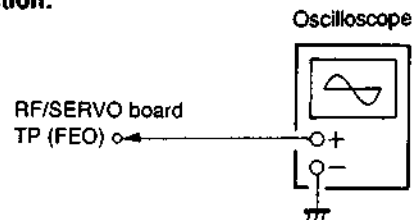

Adjustment method:

1. Connect the oscilloscope to TP (FEO) on the RF/SERVO board.
2. Adjust RV206 on the RF/SERVO board so that the reading on the oscilloscope becomes $-230 \pm 30\text{mV}$.

3) FOK offset adjustment

Connection:

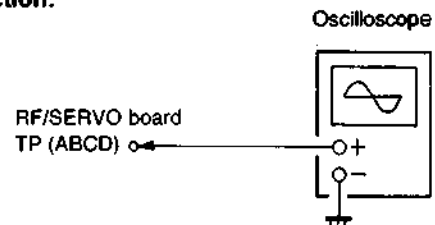

Adjustment method:

1. Connect the oscilloscope to TP (ABCD) (IC209 ③) on the RF/SERVO board.
2. Adjust RV205 on the RF/SERVO board so that the reading on the oscilloscope becomes $0 \pm 20\text{mV}$.

4-5. LASER POWER ADJUSTMENT

Connection:

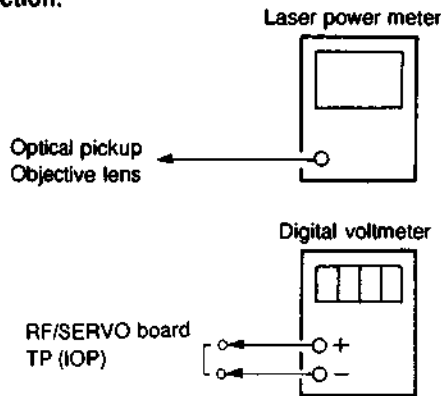

6. Press the YES key to let "Laser Power 16" appear.
(laser power : MO reading)
7. At this time, confirm that the reading on the laser power meter and digital voltmeter become the specifications shown below.

Specifications :
 Laser power meter : $0.85 \pm 0.08 \text{mW}$
 Digital voltmeter : $42 \pm 5 \text{mA}$

8. Press the ■ (STOP) key to stop the laser emitting.

Adjustment method:

1. Place the laser power meter on the objective lens of the optical pickup. (If setting can not be made correctly, move the optical pickup using the ►► or ◀◀ key.)
Connect the digital voltmeter to TP (IOP) on the RF/SERVO board.
2. Press the YES key to let "Laser Power 6F" appear.
(laser power : for adjustment)
3. Adjust RV207 on the RF/SERVO board so that the reading on the laser power meter becomes $3.4 \pm 0.1 \text{mW}$.
4. Press the YES key to let "Laser Power E5" appear.
(laser power : MO writing)
5. At this time, confirm that the reading on the laser power meter, digital voltmeter meet the specifications shown below.

Specifications:

Laser power meter : $7.0 \begin{smallmatrix} +0.2 \\ -0.4 \end{smallmatrix} \text{mW}$
 Digital voltmeter : Optical pickup reading $\pm 3 \text{mA}$

(Optical pickup level)

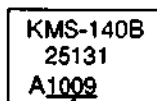

In this case : $\text{lop} = 100.9 \text{mA}$
 $\text{lop (mA)} = \text{Digital voltmeter reading (mV)} / 1(\Omega)$

4-6. MO TRAVERSE ADJUSTMENT

Connection:

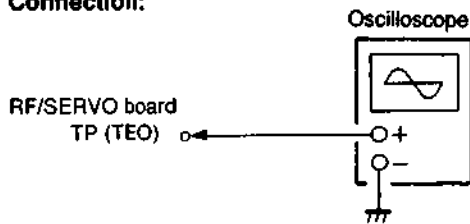

Adjustment method:

1. Connect the Oscilloscope to TP (TEO) on the RF/SERVO board.
2. Insert a MO disc (standard product).
3. Press the EDIT/NO key to let "RF mod=MO" appear.
(RF mode : MO groove)
4. Move the optical pickup from pit to outer circumference by pressing the ◀◀ or ▶▶ key.
5. Press the P. MODE key. (Focus/spindle (S) servo on, tracking servo off)
6. Adjust the RV204 on the RF/SERVO board so that the waveform of the oscilloscope meets the specification. (MO groove traverse adjustment)

(Traverse waveform)



Specification: A=B

7. Press the YES key to let "Laser Power E5" appear.
(laser power : MO writing)
8. Adjust the RV201 on the RF/SERVO board so that the waveform of the oscilloscope meets the specification.
(E-F balance adjustment)

(Traverse waveform)



Specification: A=B

9. Press the YES key to let "Laser Power 16" and "Laser Power E5" appear alternatively, and repeat adjustment until both offset values meet the specifications.
10. Press the ■ (STOP) key.
11. Move the optical pickup to the pit portion (inner most circumference) by pressing ◀◀ key.
12. Press the EDIT/NO key to let "RF mod=MOpit" appear.
(RF mode : MO Pit)
13. Press the P. MODE key. (Focus/spindle (S) servo on, tracking servo off)
14. Adjust the RV203 on the RF/SERVO board so that the waveform of the oscilloscope meets the specification. (MO pit traverse adjustment)

(Traverse waveform)



Specification: A=B

15. Press the ■ (STOP) key.
16. Press the △EJECT key to take out the MO disc.

Note 1: If a recorded disc is used for this adjustment, the data is erased when MO writing.

Note 2: If it is hard to observe the traverse waveform, connect the oscilloscope as shown below. The appearance is improved.

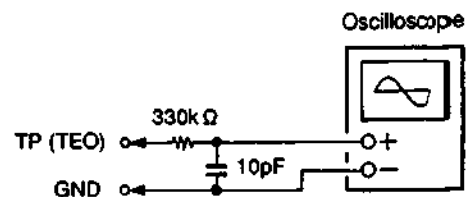

4-7. CD RF LEVEL ADJUSTMENT

Condition:

Perform adjustment in the condition where the unit is in horizontal.

Connection:

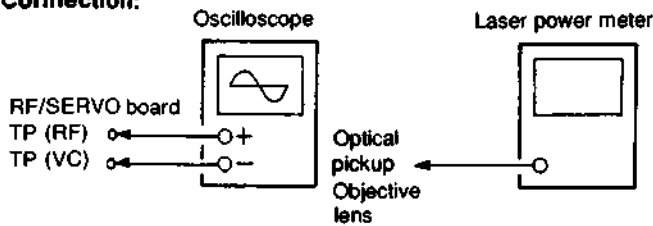

Adjustment method:

1. Connect the Oscilloscope to TP (RF) and TP (VC) on the RF/SERVO board.
2. Insert the test disc TGYS-1.
3. Press the EDIT/NO key to let "RF mod=CD" appear.
(RF mode : CD)
4. Press the >||| (PLAY) key to perform repeated playback.
5. Adjust the RV211 on the RF/SERVO board so that the RF level of the oscilloscope becomes $1.1 \pm 0.1V_{p-p}$.

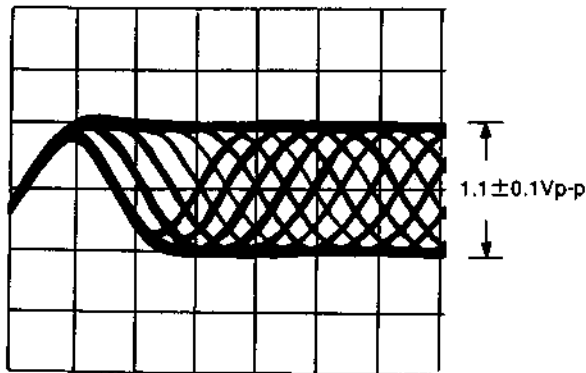

4-8. CD TRAVERSE ADJUSTMENT

Connection:

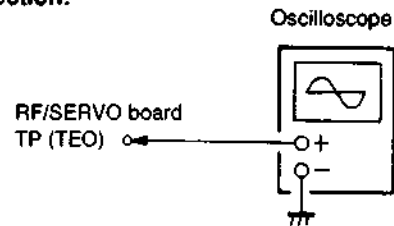

Adjustment method:

1. Connect the Oscilloscope to TP (TEO) on the RF/SERVO board.
2. Insert the test disc TGYS-1.
3. Press the EDIT/NO key to let "RF mod=CD" appear.
(RF mode : CD)
4. Press the P. MODE key. (Focus/spindle (S) servo on, tracking servo off)
5. Adjust the RV202 on the RF/SERVO board so that the reading on the oscilloscope meets the specification.

(Traverse waveform)



Specification: A=B

6. Press the ■ (STOP) key to stop playback.
7. Press the △EJECT key to take out the test disc.
8. Place the laser power meter on the objective lens of the optical pickup. (If setting can not be made correctly, move the optical pickup using >>> or <<< key.)
9. Press the YES key to let "Laser Power 0C" appear.
(laser power : CD reading)
10. Confirm that the reading of the laser power meter is $0.49 \pm 0.1mW$.
11. Press the ■ (STOP) key to stop laser diode emitting.

6. Press the ■ (STOP) key.
7. Press the △EJECT key to take out the test disc.

4-9. MO FOCUS BIAS ADJUSTMENT

Connection:

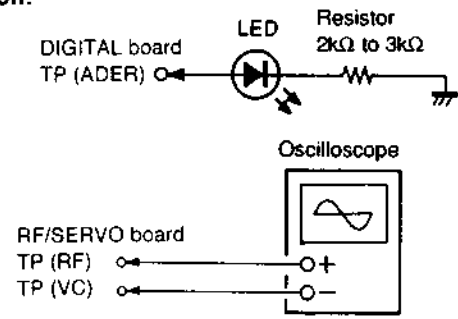

Adjustment method:

1. Connect the LED and resistor (2k to 3kΩ) to TP (ADER) on the DIGITAL board.
2. Connect the Oscilloscope to TP (RF) and TP (VC) on the RF/SERVO board.
3. Insert the continued recorded disc PTDM-1.
4. Press the EDIT/NO key to let "RF mod=MO" appear. (RF mode : MO groove)

5. Press the ▷◻◻ (PLAY) key to let "C PLAY MID" appear. (middle circumference repeated playback)
(Performing adjustment about two minutes after ▷◻◻ (PLAY) key is pressed allows more accurately adjustment since the adjustment is performed at the continued recording portion.)
6. Adjust the RV210 on the RF/SERVO board so that the eye-pattern of the oscilloscope correctly appears. (rough adjustment)
(The correct eye-pattern means that ◇ shape can be identified clearly at the center of waveform.)
7. While monitoring the LED connected to the DIGITAL board and the RF waveform of the oscilloscope, adjust the RV210 so that "AD error best point" is obtained. (fine adjustment)
(The "AD error best point" is a point where the RF waveform does not deteriorate and the LED connected to the DIGITAL board does not light up or lights up once a ten seconds by turning the RV210 from the point where the LED lights up to pass the best point a little.)
8. Press the ■ (STOP) key to stop the playback.
9. Press the △EJECT key to take out the continued recorded disc.

Normally, a relation between the RF waveform and AD error is as follows.

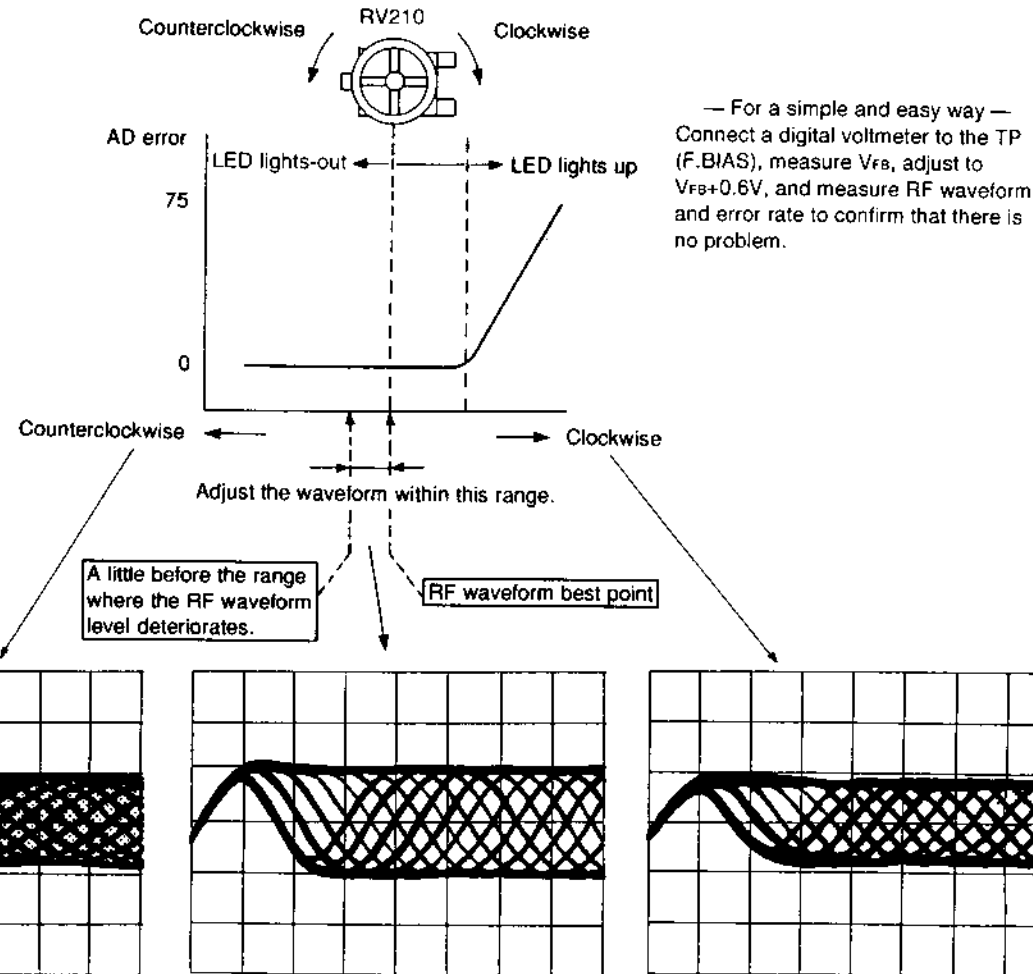

4-10. CD FOCUS BIAS ADJUSTMENT

Method requiring no error rate counter

Connection:

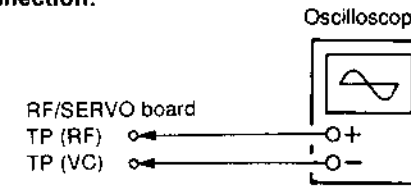

Adjustment method:

1. Connect the Oscilloscope to TP (RF) and TP (VC) on the RF/SERVO board.
2. Insert the test disc TGYS-1.
3. Press the EDIT/NO key to let "RF mod=CD" appear. (RF mode : CD)
4. Press the ▷◻◻ (PLAY) key to perform repeated playback.
5. Adjust the RV209 on the RF/SERVO board so that the eye-pattern of the oscilloscope correctly appears.
(The correct eye-pattern means that ◇ shape can be identified clearly at the center of waveform.)

An example of RF waveform

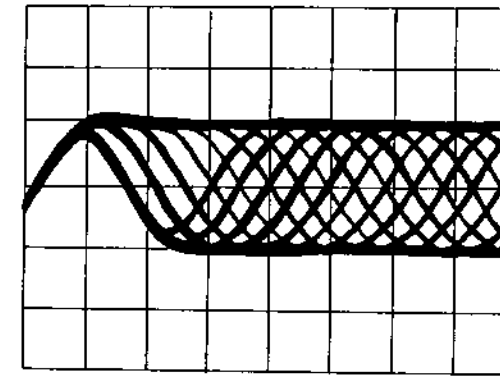

6. Press the ■ (STOP) key to stop the playback.
7. Press the △EJECT key to take out the test disc.

Method requiring error rate counter

Connection:

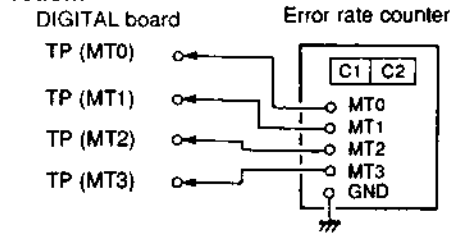

Adjustment method:

1. Connect the error rate counter to TP (MT0), TP (MT1), TP (MT2) and TP (MT3) on the DIGITAL board.
2. Insert the test disc TGYS-1.
3. Press the EDIT/NO key to let "RF mod=CD" appear. (RF mode : CD)
4. Press the ▷◻◻ (PLAY) key to let "C PLAY MID" appear. (middle circumference repeated playback)
5. Turn the RV209 on the RF/SERVO board so that the error rate (C1) of the error rate counter becomes 200 at two points. Measure these two points and adjust the RV209 to the mechanical center.

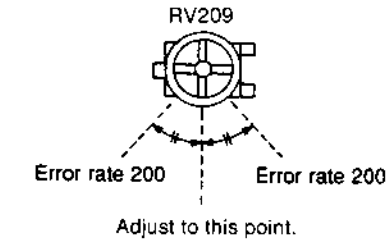

6. Press the ■ (STOP) key to stop the playback.
7. Press the △EJECT key to take out the test disc.

4-11. ERROR

Connection:

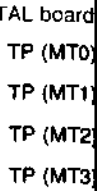

CD error rate c

1. Connect the error rate counter to TP (MT0), TP (MT1), TP (MT2) and TP (MT3) on the DIGITAL board.
2. Insert the test disc TGYS-1.
3. Press the EDIT/NO key to let "RF mod=CD" appear. (RF mode : CD)
4. Press the ▷◻◻ (PLAY) key to let "C PLAY MID" appear. (middle circumference repeated playback)
5. Confirm that the error rate (C1) of the error rate counter becomes 200 at two points. Measure these two points and adjust the RV209 to the mechanical center.
6. Press the ■ (STOP) key to stop the playback.
7. Press the △EJECT key to take out the test disc.

MO repeated re

1. Insert a standard disc.
2. Press the EDIT/NO key to let "RF mod=MO" appear. (RF mode : MO groove)
3. Press the ▷◻◻ (PLAY) key to perform repeated playback.
4. Press the POW key to let "C PLAY MID" appear. (middle circumference repeated playback)
5. Press the ▷◻◻ (PLAY) key to let "C PLAY MID" appear. (middle circumference repeated playback)
6. Press the ■ (STOP) key to stop the playback.
7. Press the △EJECT key to take out the test disc.

Performing these steps will adjust the disc for MO error.

4-10. CD FOCUS BIAS ADJUSTMENT

Method requiring no error rate counter
Connection:

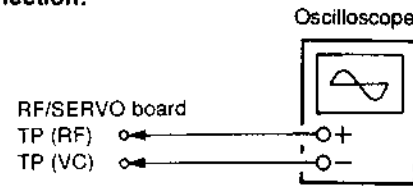

Adjustment method:

1. Connect the Oscilloscope to TP (RF) and TP (VC) on the RF/SERVO board.
2. Insert the test disc TGYS-1.
3. Press the EDIT/NO key to let "RF mod=CD" appear. (RF mode : CD)
4. Press the ▷▶▶ (PLAY) key to perform repeated playback.
5. Adjust the RV209 on the RF/SERVO board so that the eye-pattern of the oscilloscope correctly appears. (The correct eye-pattern means that ◇ shape can be identified clearly at the center of waveform.)

An example of RF waveform

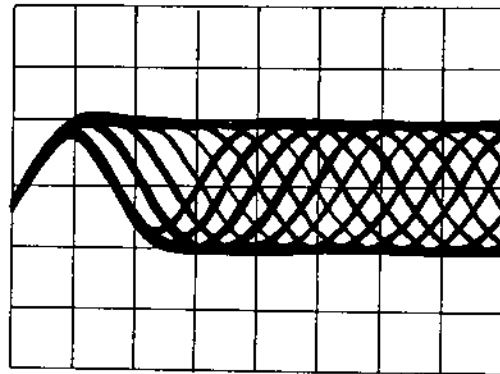

6. Press the ■ (STOP) key to stop the playback.
7. Press the △EJECT key to take out the test disc.

Method requiring error rate counter

Connection:

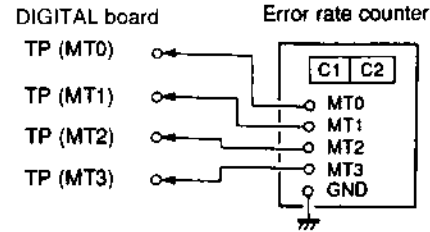

Adjustment method:

1. Connect the error rate counter to TP (MT0), TP (MT1), TP (MT2) and TP (MT3) on the DIGITAL board.
2. Insert the test disc TGYS-1.
3. Press the EDIT/NO key to let "RF mod=CD" appear. (RF mode : CD)
4. Press the ▷▶▶ (PLAY) key to let "C PLAY MID" appear. (middle circumference repeated playback)
5. Turn the RV209 on the RF/SERVO board so that the error rate (C1) of the error rate counter becomes 200 at two points. Measure these two points and adjust the RV209 to the mechanical center.

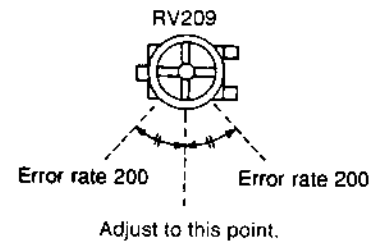

6. Press the ■ (STOP) key to stop the playback.
7. Press the △EJECT key to take out the test disc.

4-11. ERROR RATE CONFIRMATION

Connection:

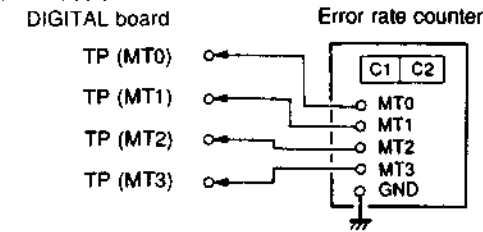

CD error rate confirmation:

1. Connect the error rate counter to TP (MT0), TP (MT1), TP (MT2) and TP (MT3) on the DIGITAL board.
2. Insert the test disc TGYS-1.
3. Press the EDIT/NO key to let "RF mod=CD" appear. (RF mode : CD)
4. Press the ▷▶▶ (PLAY) key to let "C PLAY MID" appear. (middle circumference repeated playback)
5. Confirm that the error rate (C1) of the error rate counter is less than 20.
6. Press the ■ (STOP) key to stop the playback.
7. Press the △EJECT key to take out the test disc.

MO repeated recording disc making:

1. Insert a standard product MO disc (blank disc).
2. Press the EDIT/NO key to let "RF mod=MO" appear. (RF mode : MO groove)
3. Press the ▶▶ key to move the optical pickup to outer circumference.
4. Press the POWER key to let "CREC-MIDDLE" appear. (middle circumference continued recording)
5. Press the ▷▶▶ (PLAY) key to start recording. (End the recording within one minute.)
6. Press the ■ (STOP) key to stop the recording.
7. Press the △EJECT key to take out the test disc.

Performing these steps described above permits continued recorded disc for MO error rate confirmation.

MO error rate confirmation:

Note: Be sure to use the disc (self recorded/played back) made in above steps.

1. Connect the error rate counter to TP (MT0), TP (MT1), TP (MT2) and TP (MT3) on the DIGITAL board.
2. Insert the continued recorded disc made in above steps.
3. Press the EDIT/NO key to let "RF mod=MO" appear. (RF mode : MO groove)
4. Press the ▶▶ key to move the optical pickup to outer circumference.
5. Press the ▷▶▶ (PLAY) key to let "C PLAY MID" appear. (middle circumference continued playback)
6. Confirm that the error rate (C1) of the error rate counter is less than 50.
7. Press the ■ (STOP) key to stop the playback.
8. Press the △EJECT key to take out the test disc.

[RF/SERVO BOARD](CONDUCTOR SIDE)

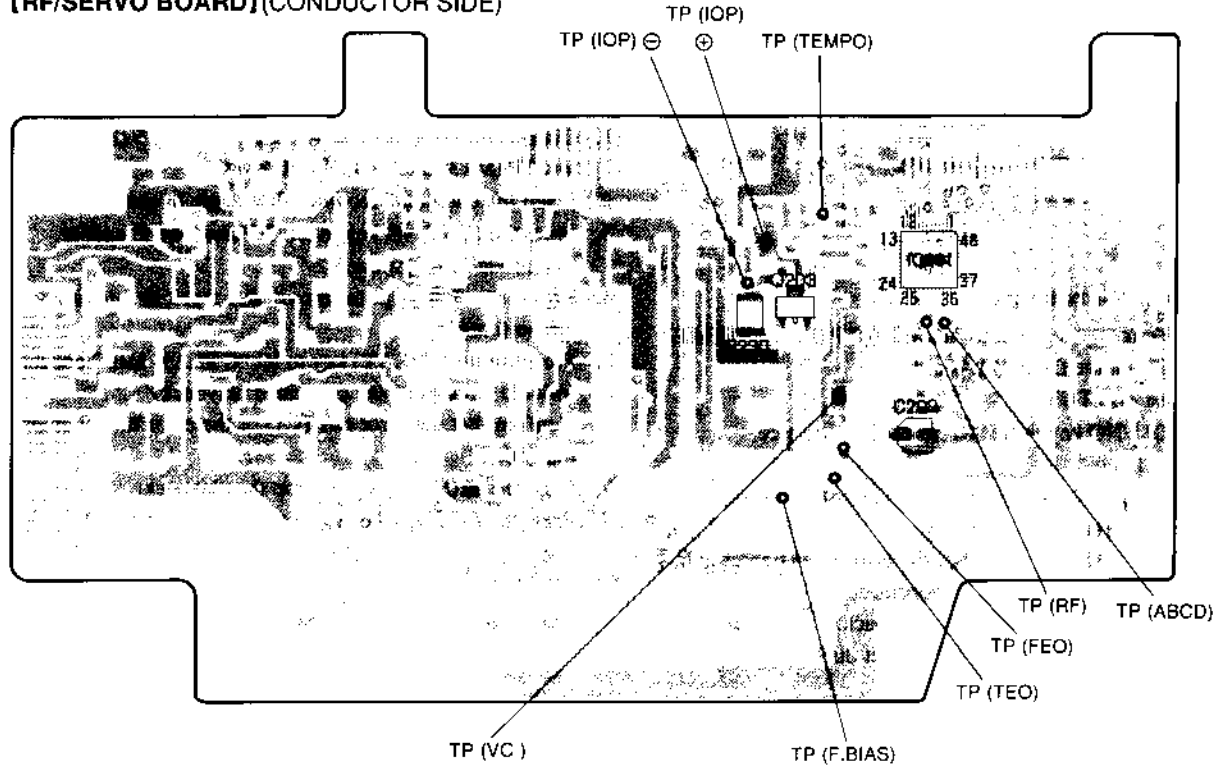

[RF/SERVO BOARD](COMPONENT SIDE)

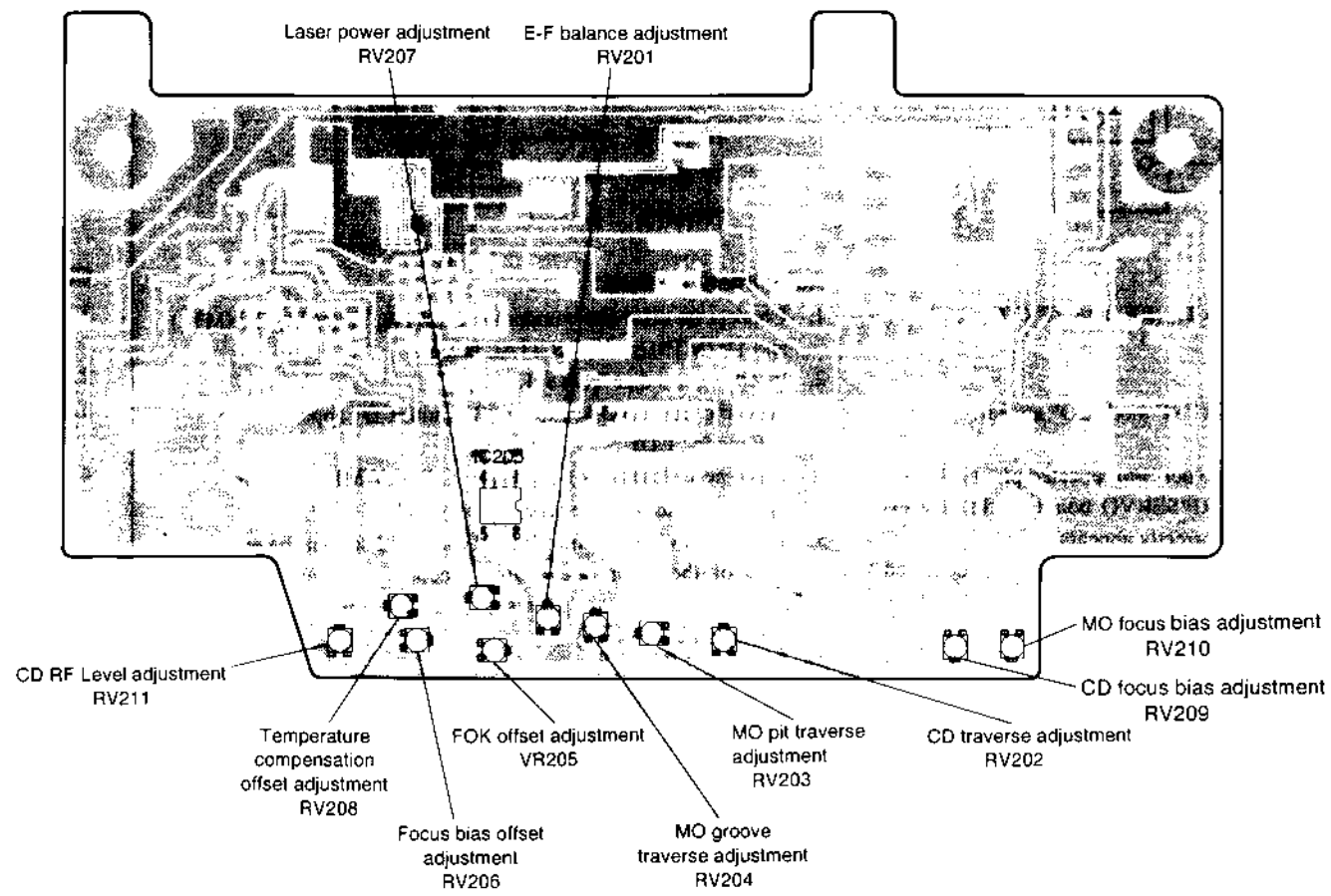

[DIGITAL BOARD](CONDUCTOR SIDE)

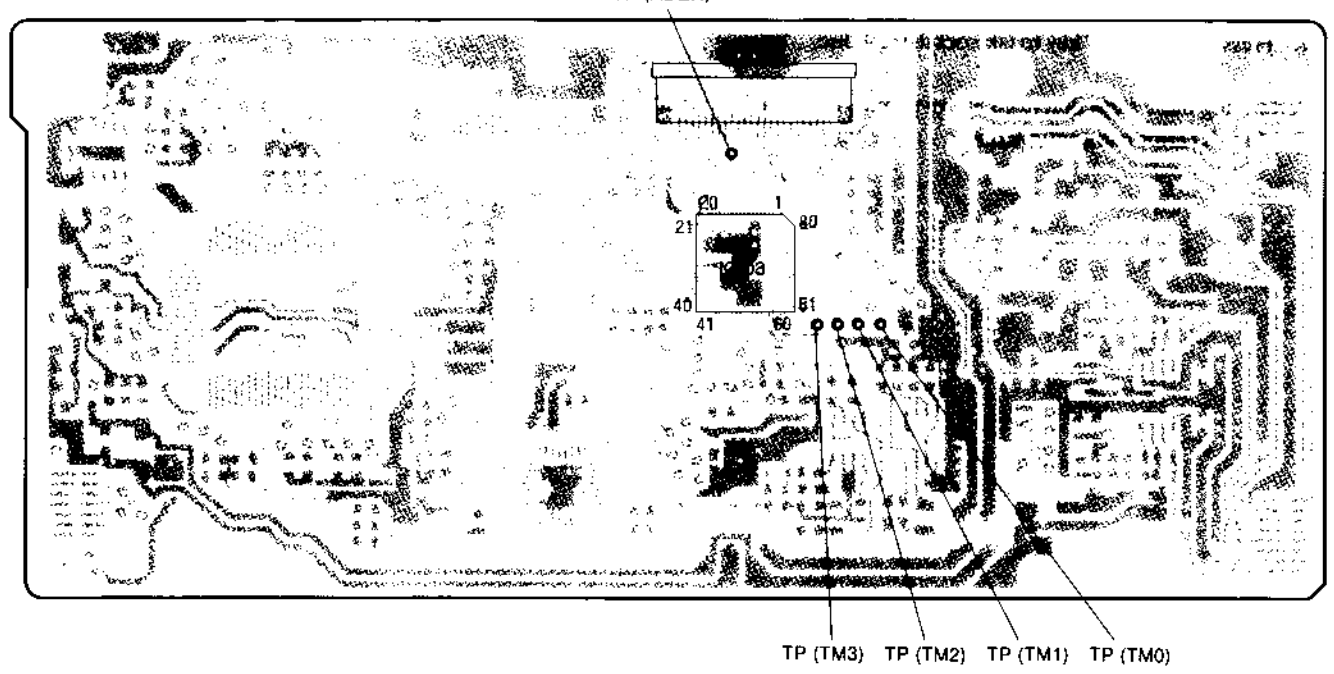

IC103 EFM/ACIR EN

Pin Name	Signal Na
1	MDP
2	MDS
3	EFMI
4	ASY
5	LOCK
6	VCOO
7	VCOI
8	TEST1
9	PDO
10	VSS
11	EFMO
12	ATER
13	CNIN
14	SENS
15	SYPL
16	FILO
17	FILI
18	PCO
19	AVSS
20	CLTV
21	AVDD
22	XRST
23	REC
24	TEST8
25	SCLK
26	XLAT
27	SWDT
28	SRDT
29	ADSY
30	SQSY
31	VDD
32	DQSY
33	TEST7
34	DTI
35	DTO
36	C2PO
37	BCK
38	XBCK
39	LRCK
40	WDCK

SECTION 5 DIAGRAMS

5-1. IC PIN FUNCTIONS

[RF/SERVO BOARD](COMPONENT SIDE)

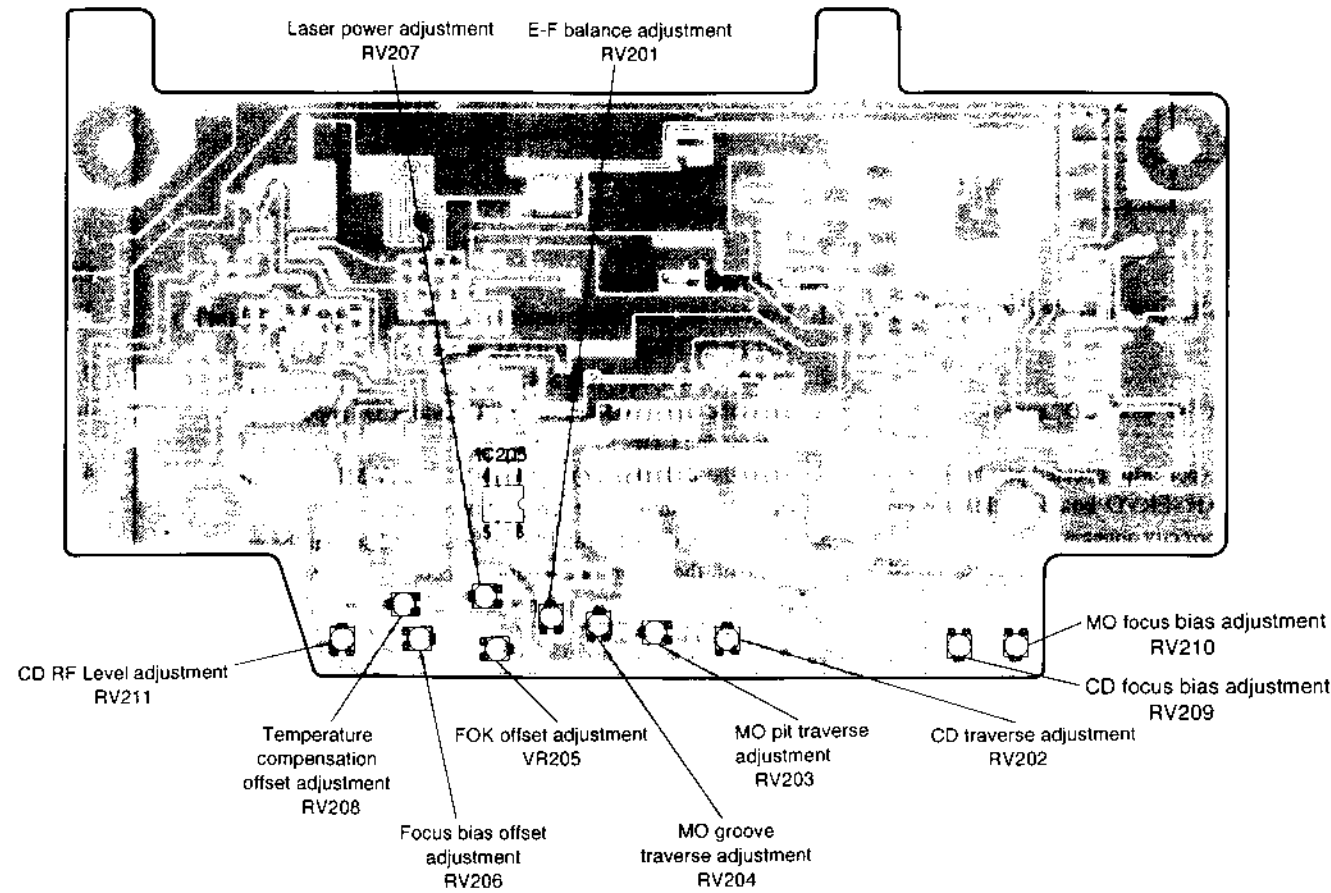

IC103 EFM/ACIR ENCODER/DECODER (CXD2525R)

* (3) of I/O is state output and (A) is analog output.

Pin Name	Signal Name	I/O	Function
1	MDP	O (3)	Spindle motor servo control
2	MDS	O (3)	Spindle motor servo control
3	EFMI	I	Playback EFM input
4	ASY	O	Playback EFM full-swing output
5	LOCK	O	Spindle servo (CLV) lock state monitor. Locks at "H".
6	VCOO	O	EFM decoder analog PLL oscillation output (196Fs=8.6436 MHz)
7	VCOI	I	EFM decoder analog PLL oscillation input (196Fs=8.6436 MHz)
8	TEST1	I	Test pin. Normally GND.
9	PDO	O (3)	EFM decoder analog PLL phase comparison output
10	VSS	-	Digital GND
11	EFMO	O	EFM output during recording
12	ATER	O	ADIP CRC flag output. "H" when error
13	CNIN	I	Track jump number count signal input
14	SENS	O (3)	Internal status output pin for the serial bus address
15	SYPL	I	SQSY, ADSY, DQSY, MQSY polarity switching input pin. Active high when "H".
16	FILO	O (A)	Digital PLL master PLL filter output
17	FILI	I	Digital PLL master PLL filter input
18	PCO	O (3)	Digital PLL master PLL phase comparison output
19	AVSS	-	Analog GND
20	CLTV	I	Digital PLL master PLL VCO control voltage input
21	AVDD	-	Analog power supply
22	XRST	I	System reset input. Active low
23	REC	I	Decoder when "L" and encoder when "H"
24	TEST8	I	Test pin. Normally GND
25	SCLK	I	Serial bus clock input
26	XLAT	I	Serial bus latch input
27	SWDT	I	Serial bus writing data input
28	SRDT	O (3)	Serial bus reading data output
29	ADSY	O	ADIP sync output
30	SQSY	O	Sub code Q sync output
31	VDD	-	Digital power supply
32	DQSY	O	Sync (SCOR) output of sub code Q of the digital in U-bit CD format
33	TEST7	O	Open
34	DTI	I	Recording audio signal input
35	DTO	O (3)	Playback audio signal output. High impedance during recording
36	C2PO	O	PLayback: C2PO. Digital REC: D. In-VFLAG. Analog REC: 0
37	BCK	O	2.8224 MHz output (MCLK system)
38	XBCK	O	BCK reverse output (MCLK system)
39	LRCK	O	44.1 kHz (=Fs) (MCLK system)
40	WDCK	O	88.2 kHz (MCLK system)

Pin Name	Signal Name	I/O	Function
41	FS4	O	176.4 kHz (MCLK system)
42	GTOP	O	Opens the sync protection window when "H" (INPUT EFM SYNC monitor output)
43	XUGFS	O	Unguarded frame sync at "L" (INPUT EFM SYNC monitor output)
44	XPLCK	O	EFM decoder PLL clock output (98Fs=4.3218MHz)
45	GFS	O	Frame sync OK at "H" (INPUT EFM SYNC monitor output)
46	EPDO	O (3)	EFM encoder external PLL phase comparison output. Freq.: low → "H"
47	RFCK	O	7.35 kHz output (MCLK system)
48	EVC1	I	EFM encoder external PLL oscillation input (196 Fs=8.6436 MHz)
49	EVCO	O	EFM encoder external PLL oscillation output (196 Fs=8.6436 MHz)
50	VSS	-	Digital GND
51	MCLK	O	22.579 MHz output. Duty will not be protected.
52	XTAI	I	Crystal oscillation input (512 Fs=22.5792 MHz)
53	XTAO	O	Crystal oscillation output (512 Fs=22.5792 MHz)
54	TEST9	I	Fixed at "L"
55	MVCI	I	Digital-in PLL oscillation input (512 Fs=22.5792 MHz)
56	MVCO	O	Digital-in PLL oscillation output (512 Fs=22.5792 MHz)
57	TEST2	O	Fixed at "Open"
58	DIPD	O (3)	Digital PLL phase comparison output. Freq.: low → "L"
59	RAOF	O	RAM overflow output (Monitor output of decoder)
60	MT3	O	Playback corrected state monitor output
61	MT2	O	Playback corrected state monitor output
62	MT1	O	Playback corrected state monitor output
63	MT0	O	Playback corrected state monitor output
64	WFCK	O	7.35 kHz output (EFM decoder PLL system during playback, EFM encoder PLL system during recording)
65	DIN	I	Digital audio input pin
66	MD2	I	Digital audio out ON/OFF pin. ON when "H"
67	DOUT	O	Digital audio output pin
68	DIDT	O	Audio data output pin of the digital audio input pin
69	DODT	I	16-bit data input pin for the digital audio output
70	DOVF	I	Validity flag input pin for the digital audio
71	VDD	-	Digital power supply
72	TEST3	I	Fixed at "L"
73	TEST4	O	Fixed at "Open"
74	TEST5	I	Fixed at "L"
75	TEST6	I	Fixed at "L"
76	FMCK	I	ADIP reading clock input (6.3 kHz) (TTL Schmidt input)
77	FMDT	I	ADIP data input (TTL Schmidt input)
78	ADFG	I	ADIP carrier signal input (20.05 kHz) (TTL Schmidt input)
79	FSW	O (3)	Spindle motor output filter switching output. "Z" when CLV-P. Others: "L"
80	NON	O	Spindle motor ON/OFF control output. ON when "H"

- Note:**
- XUGFS is a frame sync obtained from the EFM signal and is a negative pulse. Signal before sync protection.
 - PLL is made for XPLCK so that changes in the reversion and falling edge of the EFM PLL clock and the EFM signal match.
 - The GFS signal becomes "H" when the frame sync and interpolation protection timing match.
 - C2PO is a signal which shows the error state of the data.
 - RAOF is a signal generated when the 32K RAM exceeds the $\pm 4F$ jitter margin.

IC110 SHOCKPROOF MEMORY CONTROLLER (CXD2526AR)

Pin Name	Signal Name	I/O	Function
1	A16	O	When RMSL is H: SRAM address bus A16. When RMSL is L: WFOVF (Note)
2	A17	O	When RMSL is H: SRAM address bus A17. When RMSL is L: WDTM (Note)
3	A18	O	When RMSL is H: SRAM address bus A18. When RMSL is L: ZERO (Note)
4	A19	O	When RMSL is H: SRAM address bus A19. When RMSL is L: MDTSC (Note)
5	A20	O	When RMSL is H: SRAM address bus A20. When RMSL is L: CMPSY (Note)
6	LRCK	I	LRCK input from the EFM encoder/decoder
7	BCK	I	BCK input from the EFM encoder/decoder
8	C2PO	I	C2PO input from the EFM decoder
9	DATA	I/O	Input/output data from the decoder during playback and that to the encoder during recording
10	VSS	-	GND
11	TEST	I	Test pin. Normally fixed at "L"
12	XRST	I	Reset input. Resets when "L"
13	DFCT	I	DGCT Signal input
14	SRDT	(HiZ) O	Microprocessor serial data output pin "Hi-z" when the CXD2526 read register is not selected
15	SWDT	I	Microprocessor serial data input pin
16	XSLT	I	Microprocessor serial data latch signal input pin
17	SCK	I	Microprocessor serial data shift lock input pin
18	SCTX	I	Data output enable signal input pin in the recording mode
19	RCPB	I	"L": Playback mode, "H": Recording mode
20	WRMN	I	"H": Write mode, "L": Monitor mode
21	SBMN	I	"H": Records the input signal according to the SDCT. "L": Records according to the DCT
22	XINT	O	Interrupting request output pin. "L" when the interrupting status is generated
23	MDSY	O	Input data MD sync detection signal
24	MEMFUL	O	"H" when the main data area is full with data
25	MEMEMP	O	"H" when the main data area is empty
26	UNDER	O	"H" when $RMS < THUND$
27	OVER	O	"H" when $RMS \geq THOVR$
28	ERWR	O	"H" when the data which C2PO is effective is written in the RAM
29	BTOV4	O	"H" when $BCT \geq 400$ (Hex)
30	TXST	O	"H" when data is transmitted
31	VDD	-	System power supply
32	BUSY	I/O	"H" when RAM is accessed
33	ZZ2	I	Test signal. Fixed at "L"
34	ZZ1	I	Test signal. Fixed at "L"
35	ZZ0	I	Test signal. Fixed at "L"
36	XALT	O	Data ready or latch signal to CXD2527
37	ADTI	I	Pin for data input from CXD2527
38	ADTO	O	Pin for data output to CXD2527
39	ACK	O	Pin for data input/output clock output to CXD2527
40	AC2	O	Pin for output data C2PO output to CXD2527
41	XRQ	I	Pin for data request signal input from CXD2527

Pin Name	Signal Name	I/O	Function
42	SDCK	I	External sub data I/F shift clock input
43	SBDT	I/O	External sub data I/F data output pin in the playback mode and the data input pin in the recording mode
44	XWT	O	External sub data I/F wait signal. Must not transmit the clock for reading the new data at "L"
45	SRDY	O	External sub data I/F access permission signal. Ignores the clock for sub data R/W if it is transmitted at "H"
46	MCK	O	128 fs output pin
47	F256	O	256 fs output pin
48	XTLO	O	System clock output pin (22.5792 MHz)
49	XTLI	I	System clock input pin (22.5792 Mhz)
50	VSS	-	GND
51	CKSL	I	Fixed at "L"
52	RMSL	I	External RAM select pin. "H": SRAM. "L": DRAM
53	ERR	I/O	C2PO input/output pin when EXTC2R is "H"
54	D7	O	SRAM data line D7 when RMSL is "H". Test signal when "L".
55	D4	I/O	RAM data bus D4 when RMSL is "H". Test signal when "L".
56	D0	I/O	RAM data bus D0
57	D1	I/O	RAM data bus D1
58	D3	I/O	RAM data bus D3
59	D2	I/O	RAM data bus D2
60	XCAS	I/O	DRAM $\overline{\text{CAS}}$ output when RMSL is "L". Data bus D6 when "L"
61	XOE	O	RAM output enable
62	A10	O	RAM address bus A10
63	XWE	O	RAM write enable
64	XRAS	I/O	DRAM $\overline{\text{RAS}}$ output when RMSL is "L". Data bus D5 when "H"
65	A11	O	RAM address bus A11
66	A9	O	RAM address bus A9
67	A0	O	RAM address bus A0
68	A1	O	RAM address bus A1
69	A2	O	RAM address bus A2
70	A3	O	RAM address bus A3
71	VDD	O	System power
72	A8	O	RAM address bus A8
73	A7	O	RAM address bus A7
74	A6	O	RAM address bus A6
75	A5	O	RAM address bus A5
76	A4	O	RAM address bus A4
77	A12	O	RAM address bus A12 when RMSL is "H". CS output when "L"
78	A13	O	RAM address bus A13 when RMSL is "H". SYOK output when "L"
79	A12	O	RAM address bus A12 when RMSL is "H". CS output when "L"
80	A13	O	RAM address bus A13 when RMSL is "H". SYOK output when "L"

Note: WFFUL: Becomes "H" when the writing FIFO becomes full.
RFEMP: Becomes "H" when the reading FIFO becomes empty.
WFOVF: Becomes "H" when the writing FIFO becomes overflow.
WDTM: Outputs the window timing inside the D1 clock.
ZERO: Outputs "H" when BCT is 0.
MDTSC: Becomes "H" when the input data header selector is 00 to IF and "L" at other times.
CMPSY: Interpolation sync timing.

IC111 SYSTEM CONTROL (M38067M8-126FP)

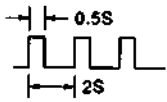
Pin Name	Signal Name	I/O	Function
1 to 3	KEY 2 to KEY 0	I	Not used
4	—	I	Not used
5	DFATT	O	Serial data to the digital filter
6	DFSHIFT	O	Serial clock to the digital filter
7	DFLATCH	O	Latch to the digital filter
8	XLAT	O	Latch to the serial bus
9	SCLK	O	Clock to the serial bus
10	SWDT	O	Data to the serial bus
11	SRDT	I	Data from the serial bus
12	APCREF	O	Reference voltage output of the laser power. Four levels: OFF, CD, MO READ, MO WRITE.
13 to 15	—	I	Not used
16	ADSY	I	ADIP sync. "L" every 13.3 ms. Almost "H".
17	SQSY	I	Sub-code Q sync. "L" every 13.3 ms. Almost "H".
18	DQSY	I	U-bit CD format sub-code Q sync of digital in. "L" every 13.3 ms. Almost "H".
19	SENS	I	Status from the serial bus.
20	MINT	O	Request for temporary interruption of communication with the master microprocessor. The master microprocessor does not send the clock during "H".
21	CLK	I	Communication clock from the master microprocessor
22	TXD	O	Serial data to the master microprocessor
23	RXD	I	Serial data from the master microprocessor
24	XINT	I	Request for interruption from the shock-proof memory controller.
25	JUMP. PULSE	I	Signal from the track-jump detection circuit. 1 pulse is output every 1 track.
26	CNVSS	—	Mode setting pin at power start-up. Always 0V.
27	RESET	I	Reset input. "H" after several hundred ms of "L" after power start-up.
28	TEST MODE SEL	I	When test mode +5V. When normal mode 0V.
29	—	I	Not used
30	XIN	I	6 MHz clock input
31	XOUT	O	6 MHz clock output
32	VSS	—	GND
33	D RESET	O	XRST control
34	A RESET	O	Reset output to the A/D D/A converter
35	—	I	Not used
36	ALLD	O	APCREF/CONSTANT selection. When CD playback power: "L". When MO playback power: "H".
37	RMS	O	Laser modulation selection. When playback power: "L". When stop: "H". When recording power: 
38	LOADIN	O	Loading control. When LOAD IN: "H"
39	LOADOUT	O	Loading control. When LOAD OUT: "H"
40	PIT/GROOVE	I	PIT/GROOVE detection input. "H": Disc for playing and TOC area
41	C. OUT	I	Track number counting signal input
42	DIRC	O	Output pin for the servo IC during 1 track jump
43	AGCTC	O	AGC time constant selection. "L": Focus searching and power selection
44	DFCTSW	O	Defect ON/OFF selection
45	FOK	I	Focus OK signal input

Pin Name	Signal Name	I/O	Function
46	CD/MO	I	CD/MO discrimination signal input
47	RFSW1	O	Disc mode selection. "H": PIT, "L": GROOVE
48	RFSW0	O	Disc mode selection. "H": High reflection rate disc. "L": Low reflection rate disc.
49	MAGUP	O	Not used
50	MGSERVO	O	Not used
51	—	I	Not used
52	CARTRIG	I	Not used
53	DSCPRO	I	REC-proof detection input. "H": Protect
54	RFLCT	I	Disc reflection rate detection input. "H": Low reflection rate disc
55	LIMITIN	I	Limit in switch input. "L": Sled limit in
56	INSW	I	Loading in switch input. "L" at the position where the head descends. Others: "H"
57	OUTSW	I	Loading out switch input. "L" at the position of load out. Others: "H".
58	SLEN	O	Sled servo ON/OFF control. Normally, the LOCK of Pin 72 is output.
59	FBC	O	Focus bias control
60	MNSB	O	Main/sub-data counter selection to the shock-proof memory controller
61	WRMN	O	Write/monitor mode selection to the shock-proof memory controller
62	INSL		Not used
63	EXEC		Not used
64	XA MUTE	O	Validity flag output pin for the digital audio
65	AMUT	O	Line out muting output
66	DIG/ANA	O	ON/OFF selection of the digital in PLL circuit
67	—	I	Not used
68	GFS	I	Guard frame sync input
69	SORS	I	Not used
70	REC	O	Encoder/decoder mode selection to the shock-proof memory controller and EPM/ACIR encoder/decoder "H": Encoder mode
71	SCTX	O	Writing data transmission timing output. Used together with the magnetic field head ON/OFF output.
72	LOCK	I	Spindle lock detection input
73	VCC	—	+5V
74	VREF	—	Maximum output voltage input pin of the 12-pin APCREF
75	AVSS	—	Analog GND
76	CHACK. IN	I	Chucking in switch input. When chucking: "L"
77	SYNC MUTE	O	Sync mute timing
78	—	I	Not used
79	ASY. DISEN	O	Asymmetry ON/OFF control. Other than disc data input: "H"
80	LDON	O	Laser ON/OFF control. When the laser is ON: "H"

IC301 FUNCTION/DISPLAY CONTROLLER (M38004M8-111FP)

Pin Name	Signal Name	I/O	Function
1	CSIN	O	Data to the clock IC
2	CSCK	O	Forward clock to the clock IC
3	S/A SW	O	Remote control input/AU BUS input selection. "H": AU BUS input
4	AUBS	O	AU BUS output
5	AUBK	I	AU BUS connection check. "H": The AU BUS is determined to have connected.
6, 7	RMC	I	Remote control, AU BUS input
8	MICSW	I	"H": Mic switch on
9	WR	O	Write signal to the clock IC
10	CS	O	Chip select signal to the clock IC
11	OUTSW	I	Slot out switch
12	MCS	O	Chip select signal to the mechanism microprocessor. "H": Mechanism microprocessor select
13	SCLK	O	Serial clock output
14	SDATA	O	Serial data output
15	SIN	I	Serial data input
16	SRST	I	BUSY signal from the mechanism microprocessor. "H": Mechanism microprocessor communication is BUSY
17	SW	I	Jog dial push sw
18	CN Vss	—	GND
19	RST IN	I	Reset input
20	CSOUT	I	Data from clock IC
21	FLCS	O	Chip select signal to the FL driver. "L": FL driver select
22	XIN	I	5 MHz clock input
23	XOUT	O	5 MHz clock output
24	Vss	—	GND
25	RST 0	O	Reset output
26	RELAY	O	Power supply control. "H": When the power is ON
27	COUNTRY 1	I	J0 U0 E1
28	COUNTRY 2	I	J0 U1 E0
29	MODEL	I	"H": MDS-102 "L": MDS-MD1
30	—		Not used
31	A	I	jog dial pulse A
32	B	I	jog dial pulse B
33	LED	O	Standby LED
34	TEST 0	I	Test mode setting pin. "H": Cancels the communication with the mechanism microprocessor
35	TEST 1	I	Test mode setting pin. "H": Key display test mode when the power is ON.
36	TEST 2	I	Test mode setting pin. "H": Clock IC test mode when the power is ON.
37	—		Not used
38	—		Not used
39	KEYS1	O	key scan digit output
40	KEYS0	O	key scan digit output
41	KEY7	I	key scan input
42	KEY6	I	key scan input
43	KEY5	I	key scan input

Pin Name	Signal Name	I/O	Function
44	KEY4	I	key scan input
45	KEY3	I	key scan input
46	KEY2	I	key scan input
47	KEY1	I	key scan input
48	KEY0	I	key scan input
49	—		Not used
50	—		Not used
51	—		Not used
52	—		Not used
53	—		Not used
54	—		Not used
55	—		Not used
56	—		Not used
57	VCC	—	5V
58	—		Not used
59	—		Not used
60	—		Not used
61	—		Not used
62	—		Not used
63	—		Not used
64	—		Not used

5-2. BLOCK DIAGRAM

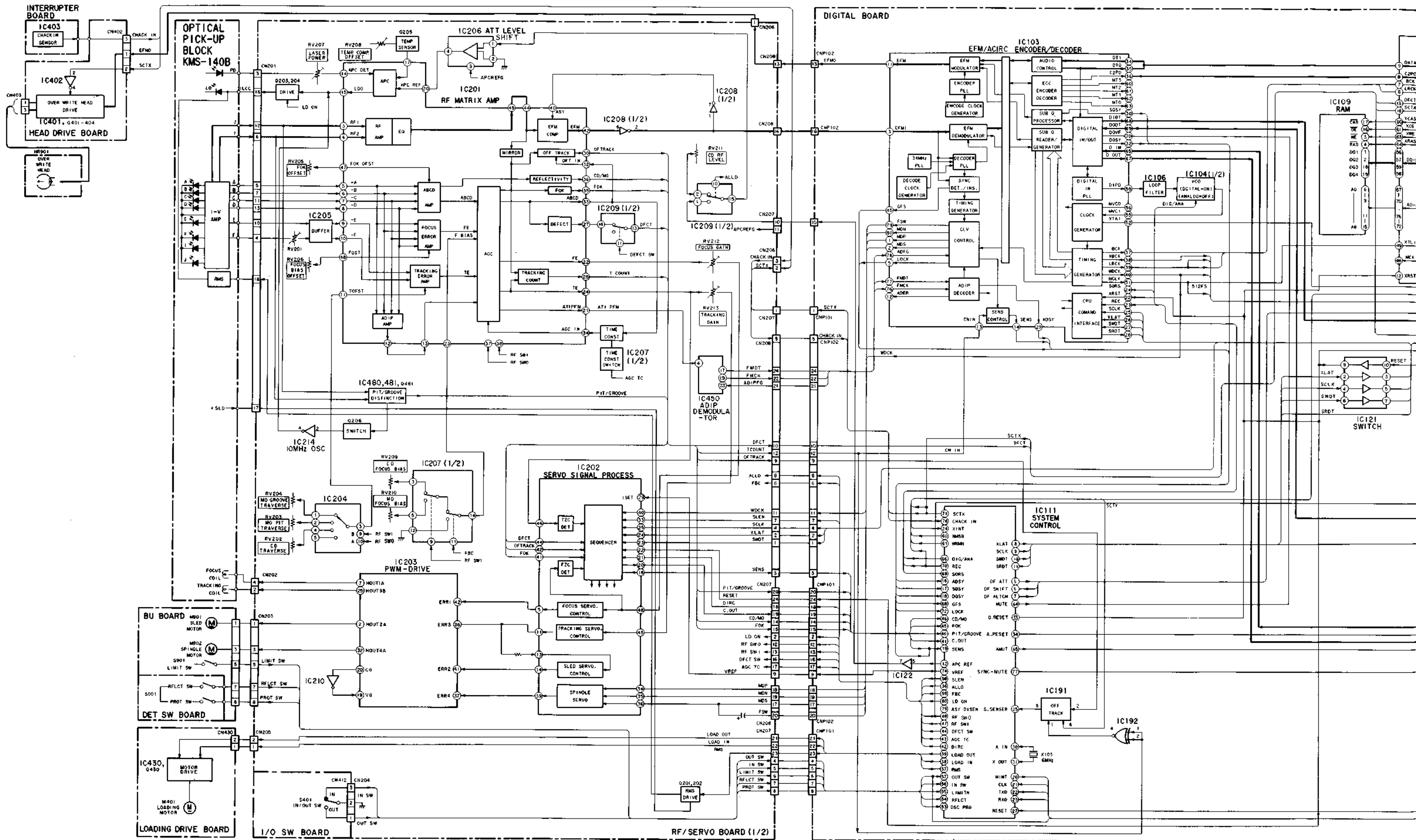

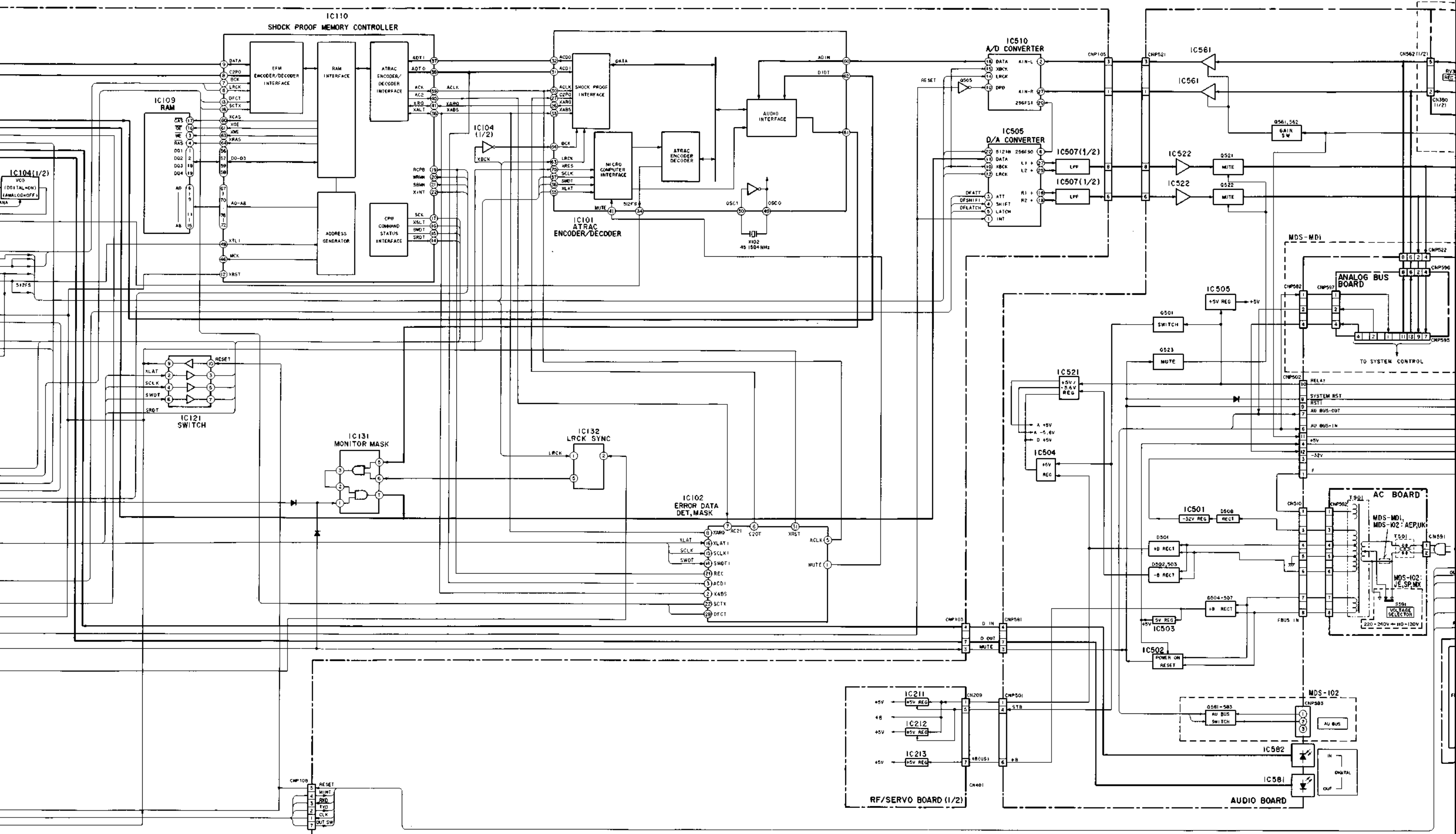

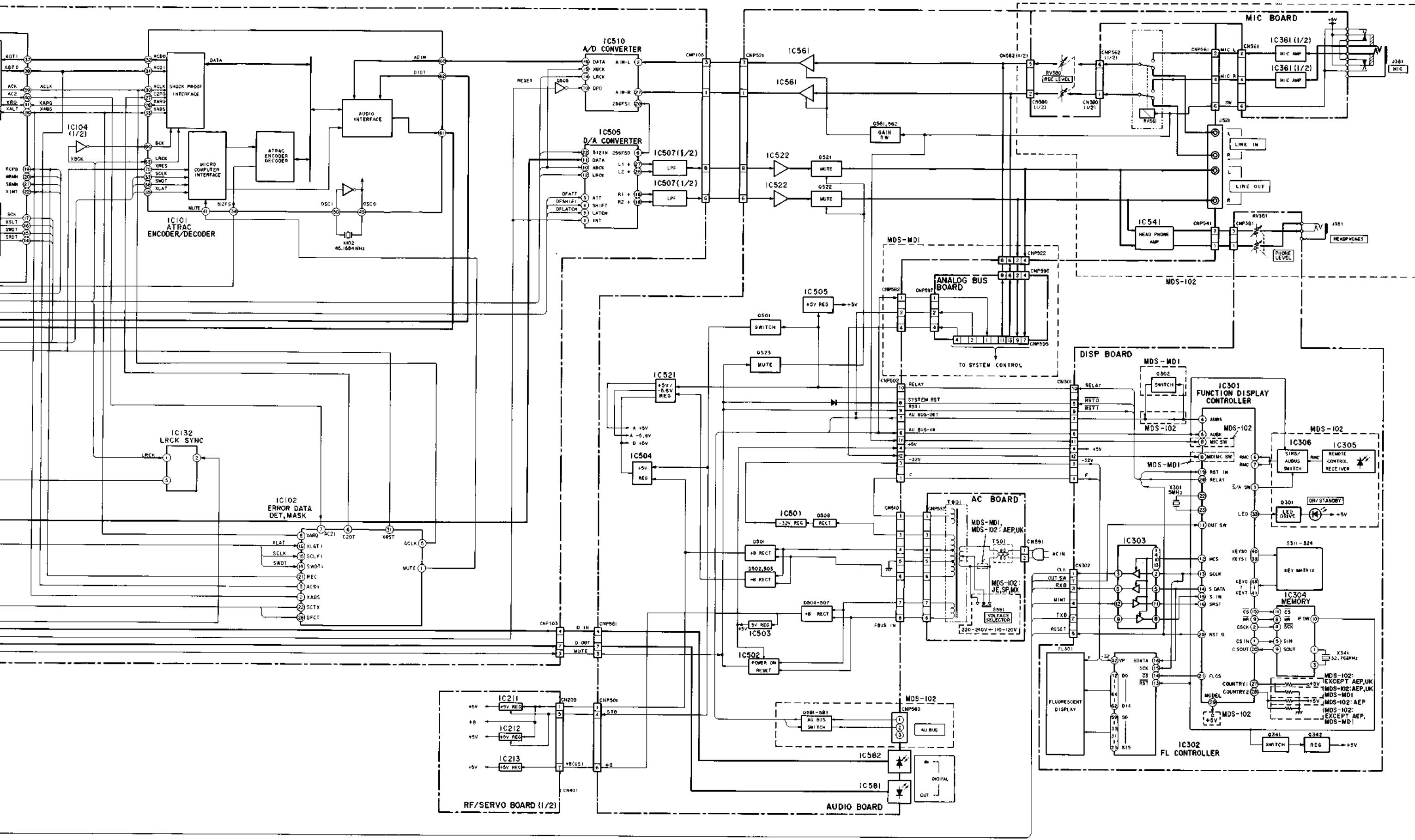

5-3. CIRCUIT BOARDS LOCATION

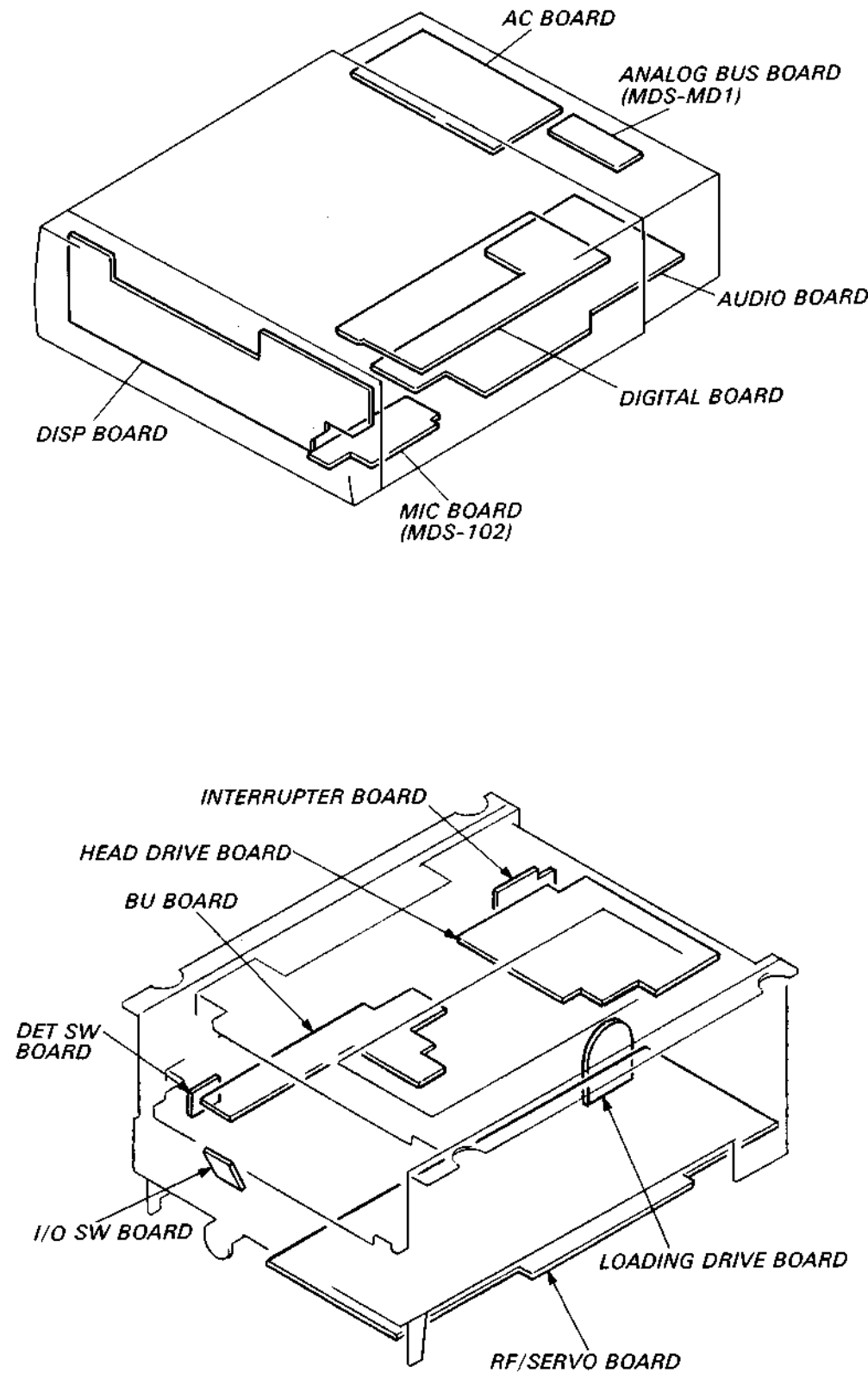

5-4. SEMICONDUCTOR LEAD LAYOUTS

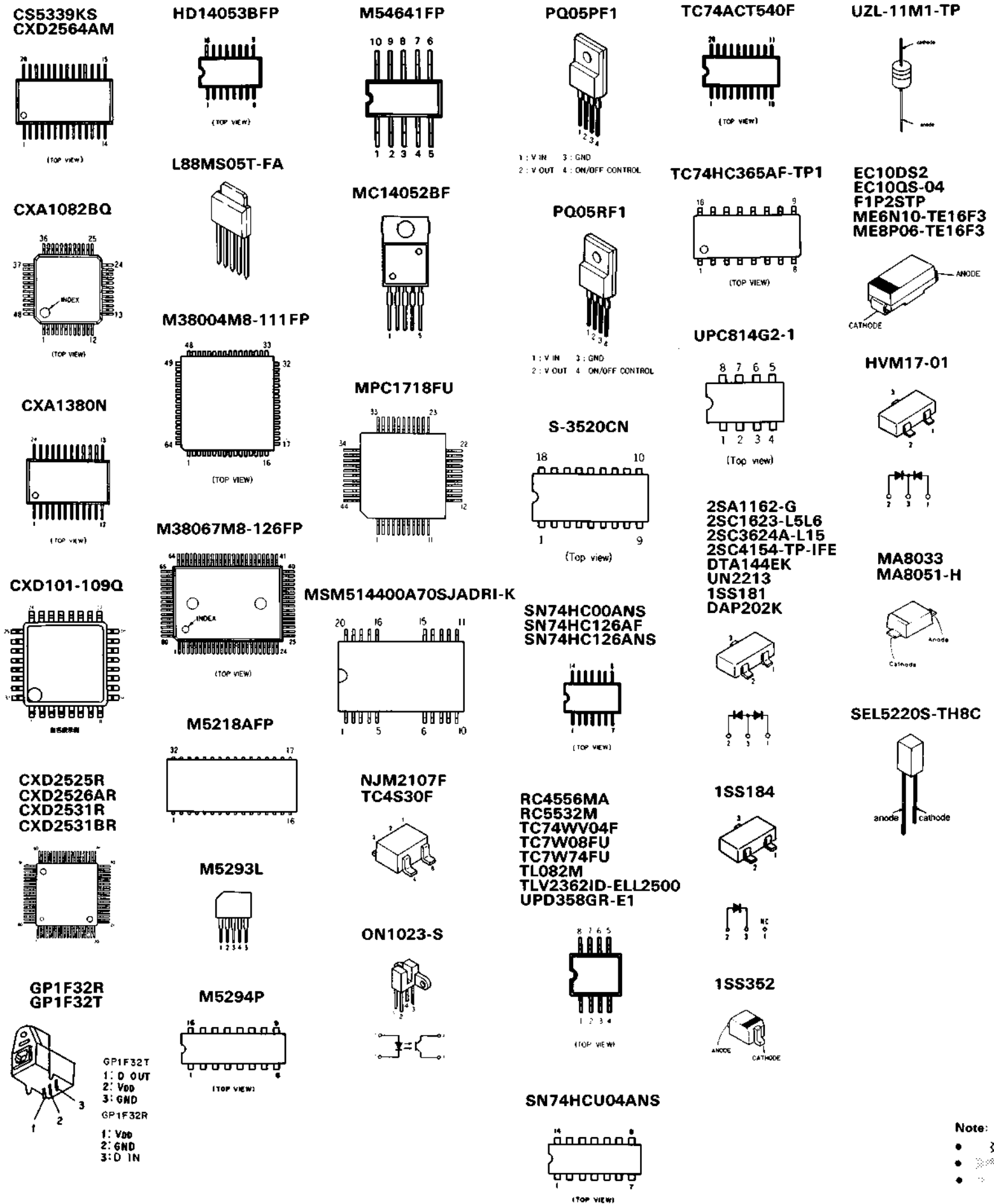

• Semiconductor Location

Ref. No.	Location
D201	G-7
D202	G-4
D203	H-17
D204	H-17
D205	H-17
D401	D-14
D402	D-13
D403	D-14
D404	D-13
D405	D-14
D406	D-13
D430	B-9
D480	H-13
IC201	G-8
IC202	H-5
IC203	G-18
IC204	I-15
IC205	J-14
IC206	H-12
IC207	I-16
IC208	I-11
IC209	I-12
IC210	H-18
IC211	H-19
IC212	H-19
IC213	I-19
IC214	G-10
IC215	G-12
IC401	C-12
IC402	C-12
IC403	D-15
IC430	B-9
IC450	I-17
IC480	I-14
IC481	I-14
Q201	H-10
Q202	H-10
Q203	H-7
Q204	G-7
Q205	I-13
Q206	G-10
Q401	D-16
Q402	D-17
Q403	D-16
Q404	D-17
Q430	B-9
Q481	I-14

Note:
 • ⊗ : Through hole.
 • ⊙ : Pattern on the side which is seen.
 • ⊙ : Pattern of the rear side

5-5. PRINTED WIRING BOARDS -RF Section-

ZL-11M1-TP

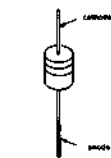

C10DS2
C10QS-04
1P2STP
IE6N10-TE16F3
IE8P06-TE16F3

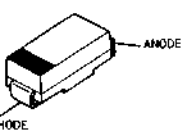

HVM17-01

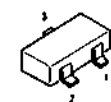

MA8033
MA8051-H

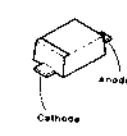

EL5220S-TH8C

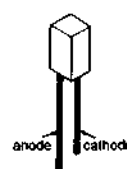

• Semiconductor Location

Ref. No.	Location
D201	G-7
D202	G-4
D203	H-17
D204	H-17
D205	H-17
D401	D-14
D402	D-13
D403	D-14
D404	D-13
D405	D-14
D406	D-13
D430	B-9
D480	H-13
IC201	G-8
IC202	H-5
IC203	G-18
IC204	I-15
IC205	J-14
IC206	H-12
IC207	I-16
IC208	I-11
IC209	I-12
IC210	H-18
IC211	H-19
IC212	H-19
IC213	I-19
IC214	G-10
IC215	G-12
IC401	C-12
IC402	C-12
IC403	D-15
IC430	B-9
IC450	I-17
IC480	I-14
IC481	I-14
Q201	H-10
Q202	H-10
Q203	H-7
Q204	G-7
Q205	I-13
Q206	G-10
Q401	D-16
Q402	D-17
Q403	D-16
Q404	D-17
Q430	B-9
Q481	I-14

Note:
 • ⊗ : Through hole.
 • ⊙ : Pattern on the side which is seen.
 • ⊖ : Pattern of the rear side.

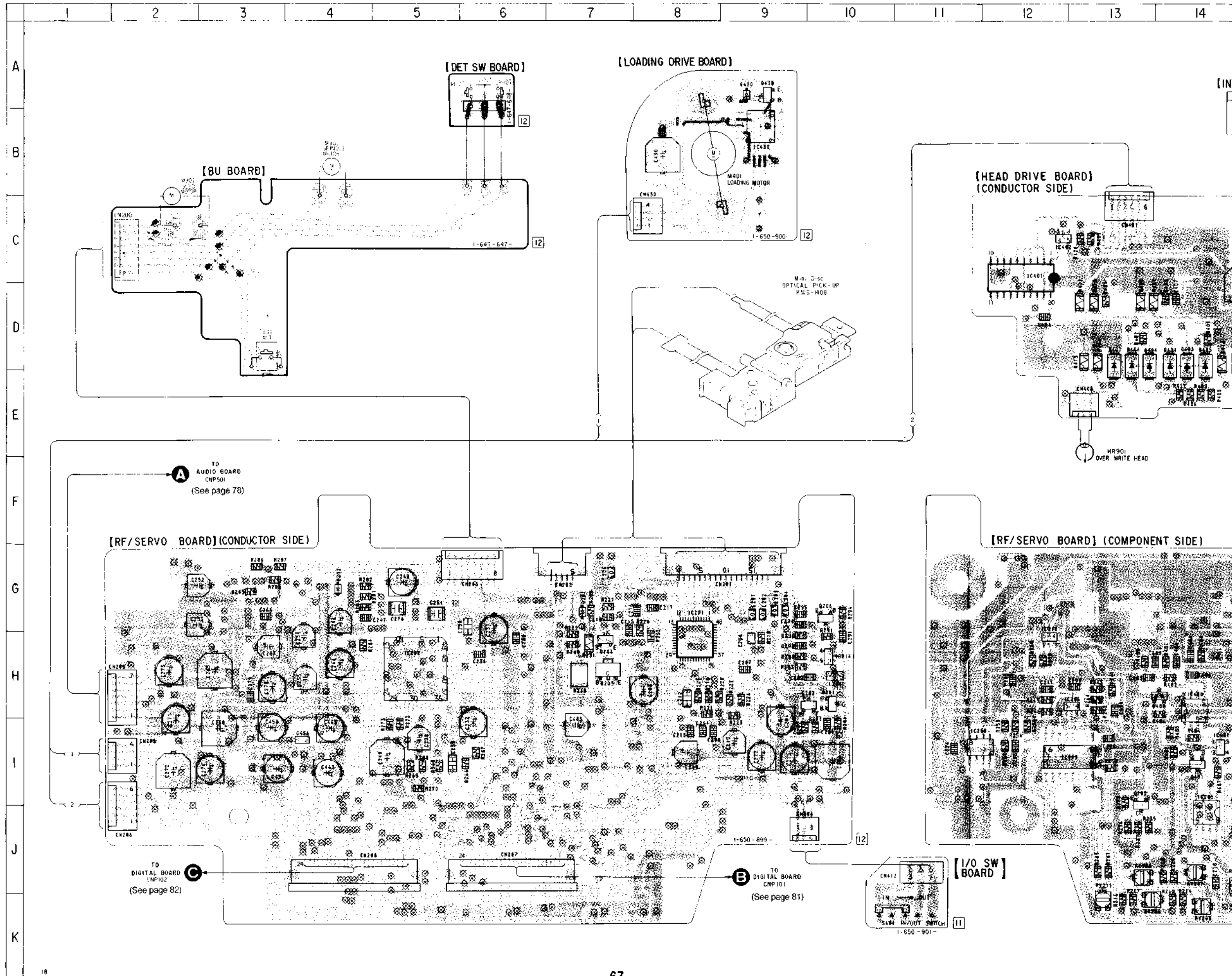

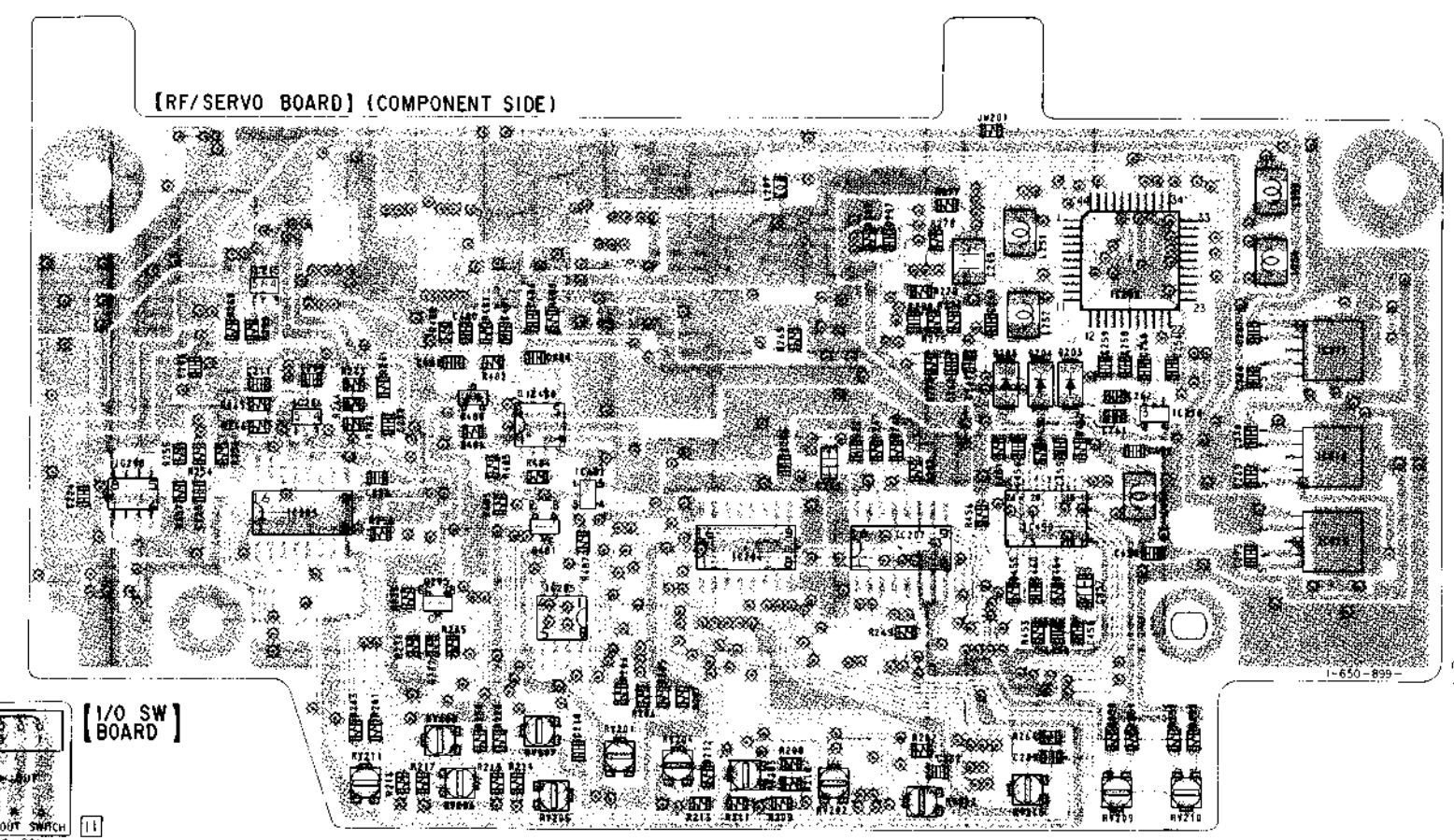
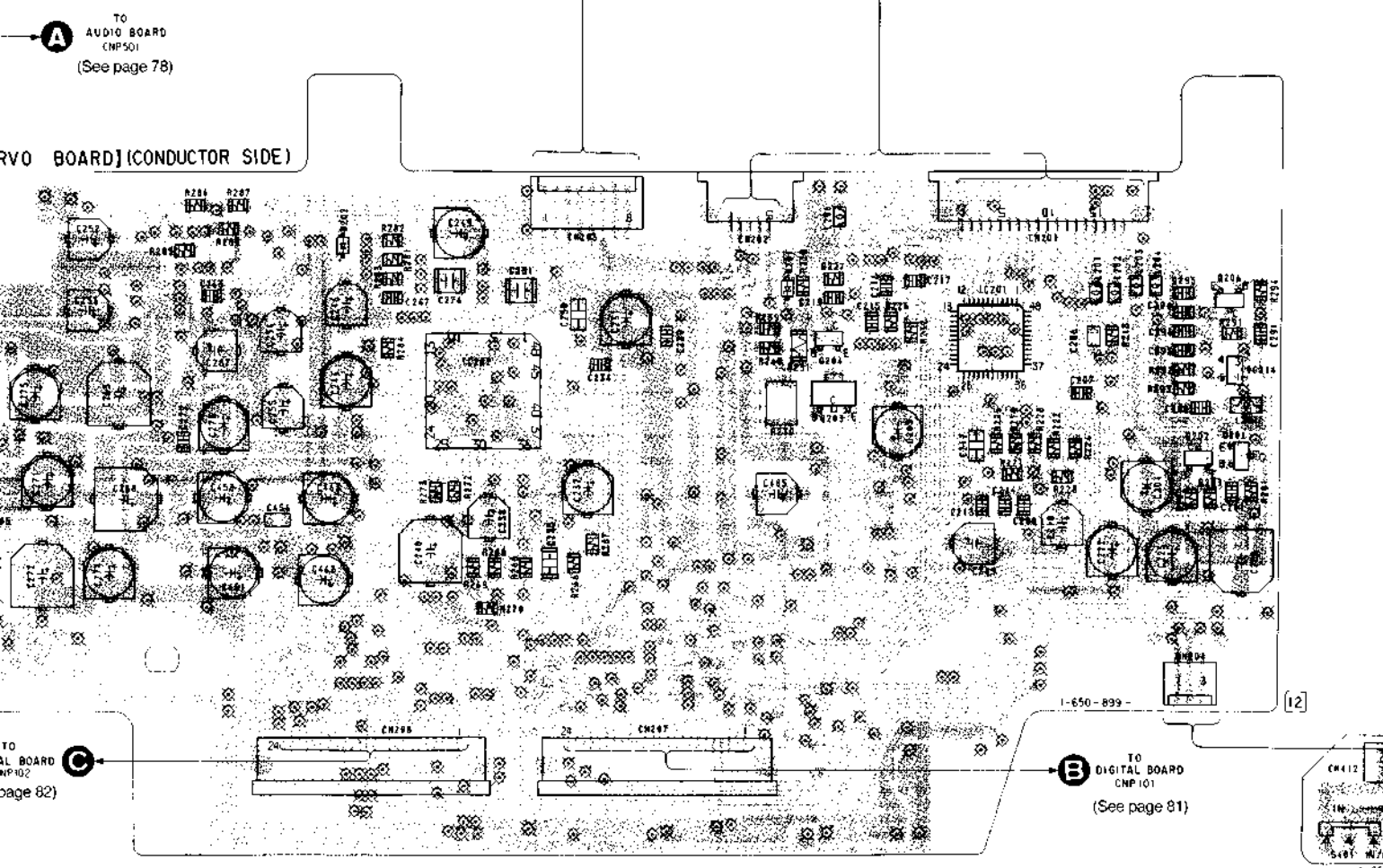
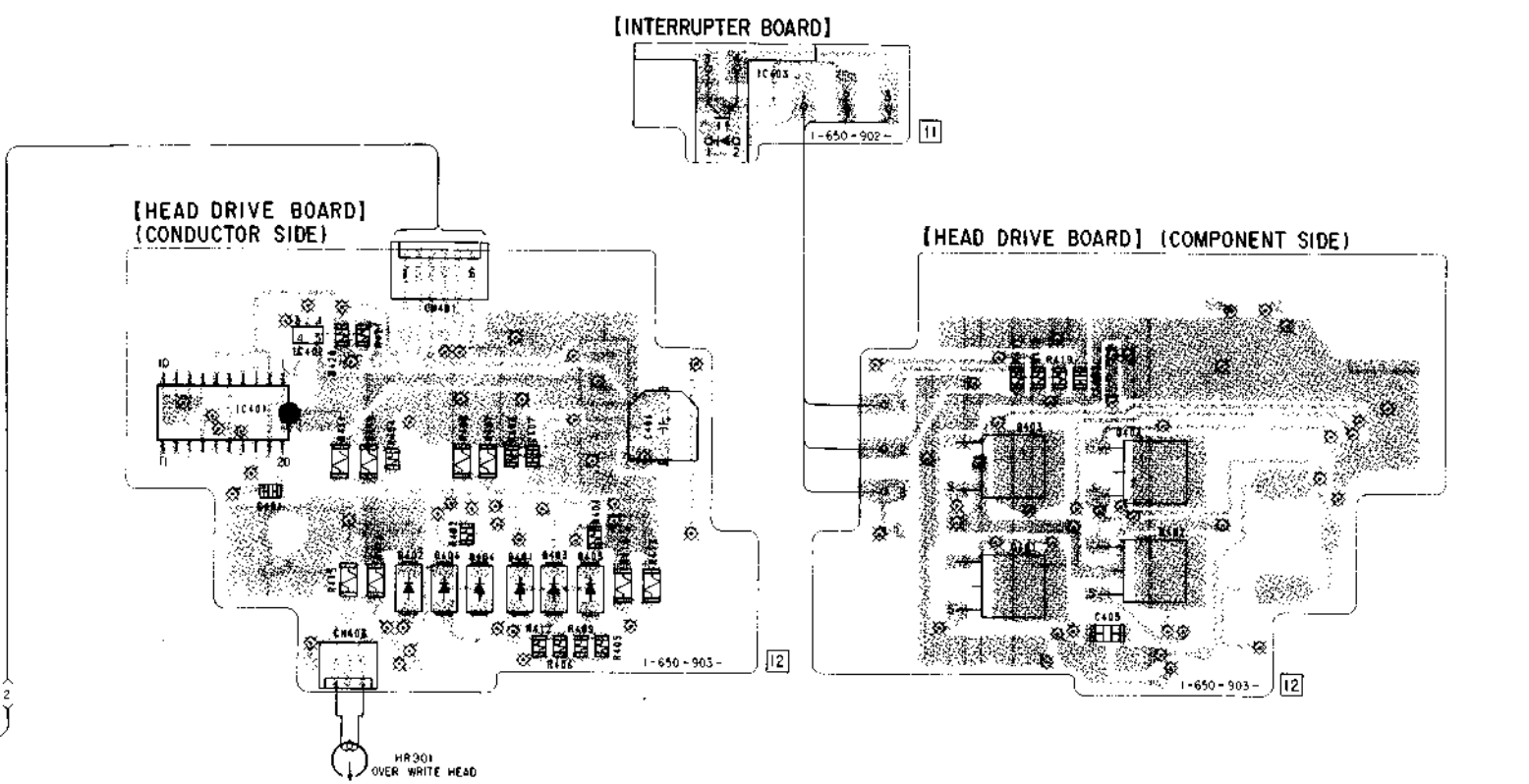
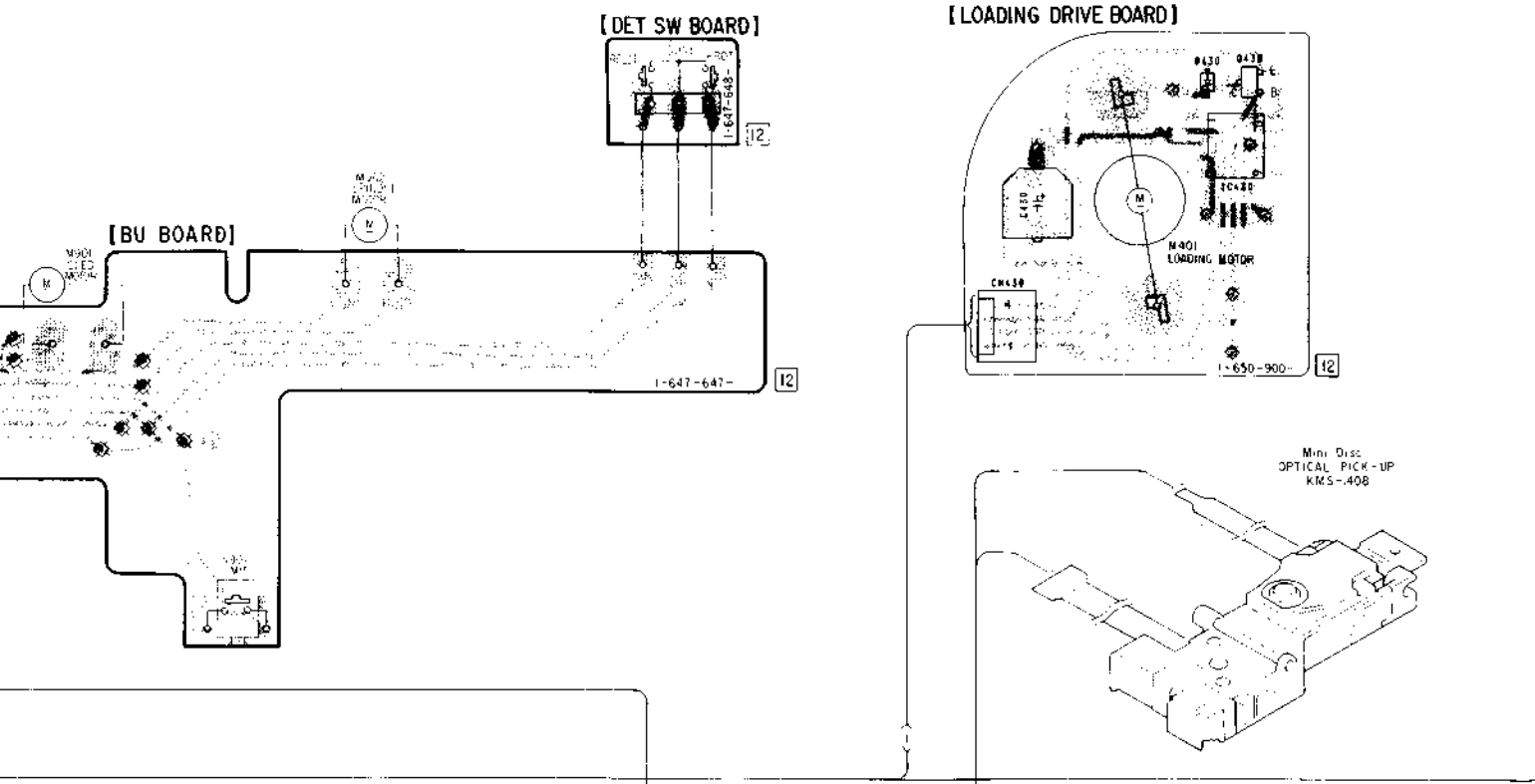

IC201 CXA1381R

IC203 MPC171

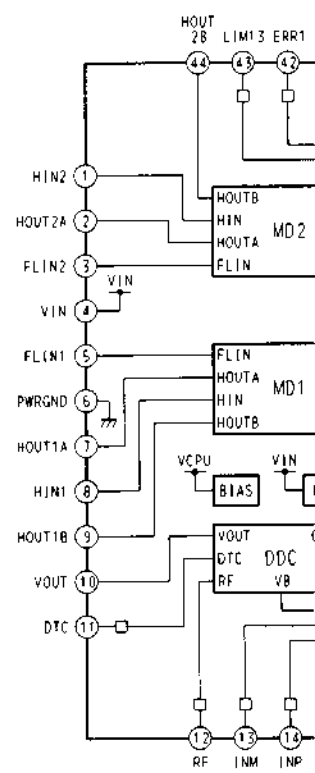
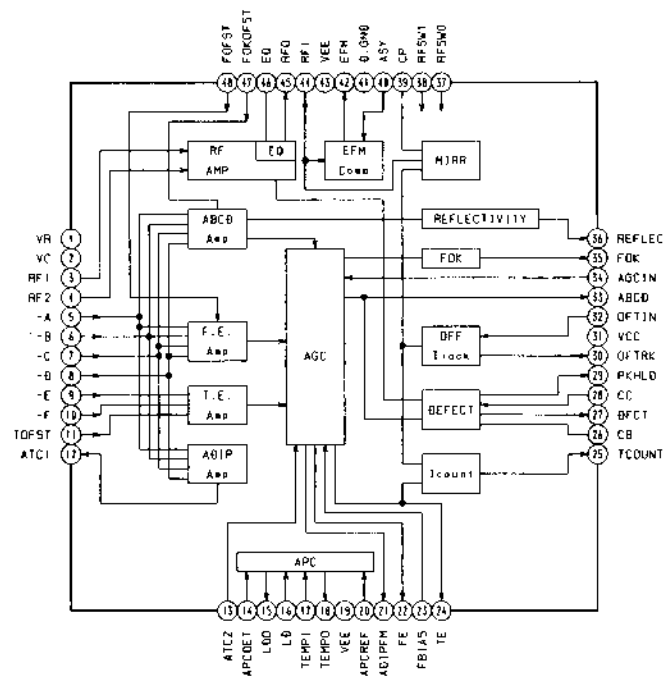

5-6. SCHEMATIC DIAGRAM -RF Section-

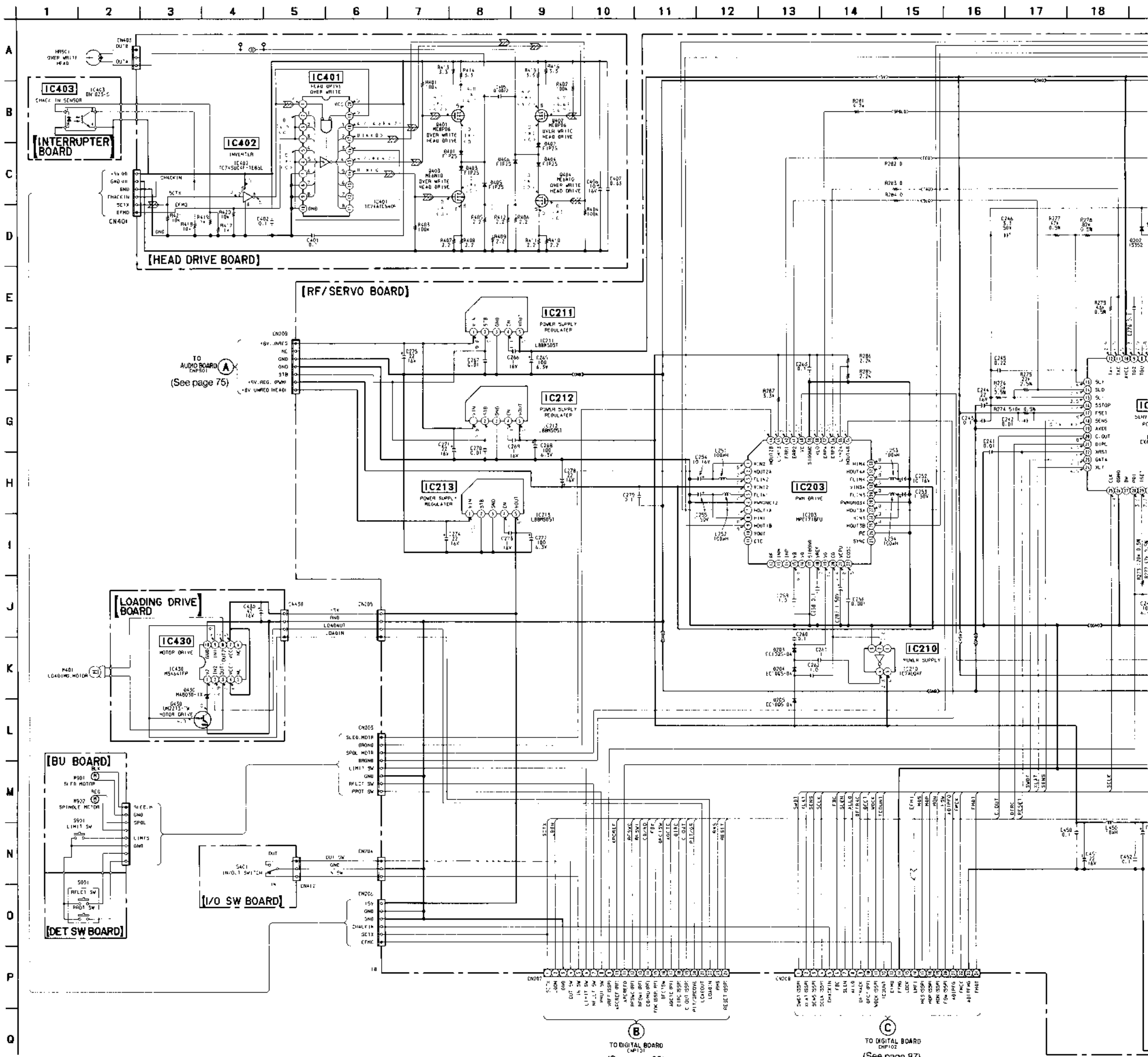

(B) TO DIGITAL BOARD (See page 85)

(C) TO DIGITAL BOARD (See page 87)

IPC1718FU

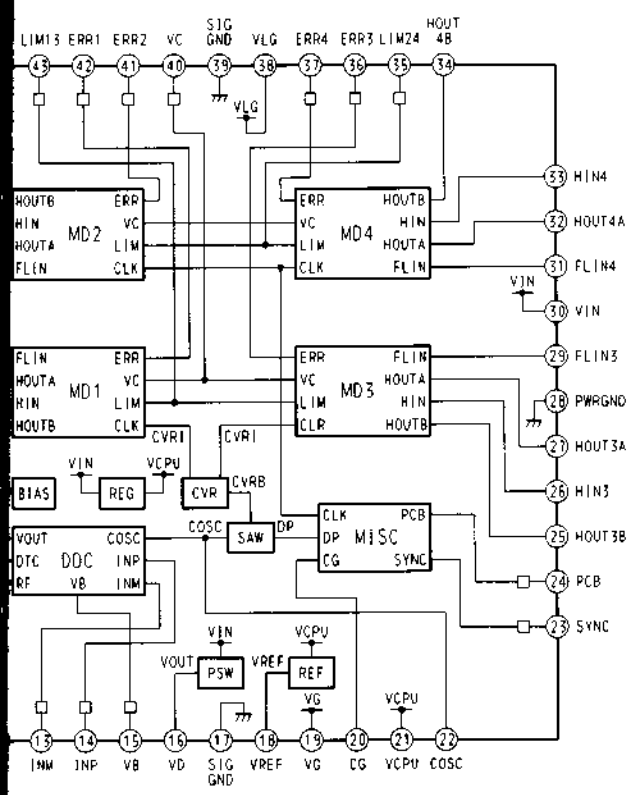

IC207, 209 MC14053BF

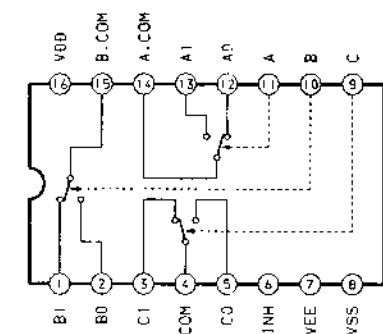

IC401 TC74ATC540F

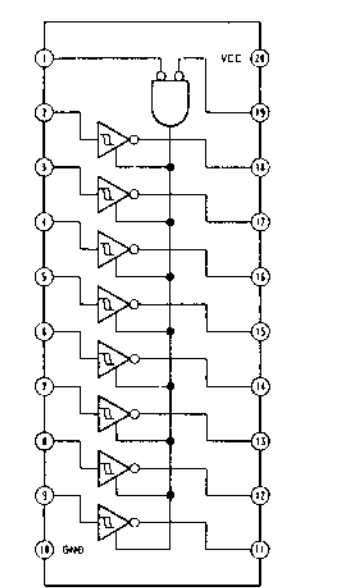

IC430 M54641FP

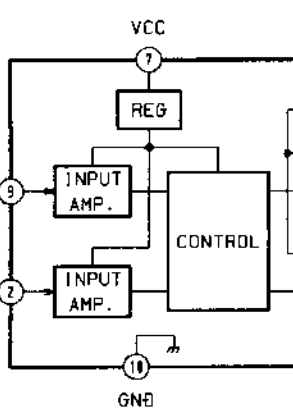

18 19 20 21 22 23 24 25 26 27 28 29 30 31 32 33 34 35 36

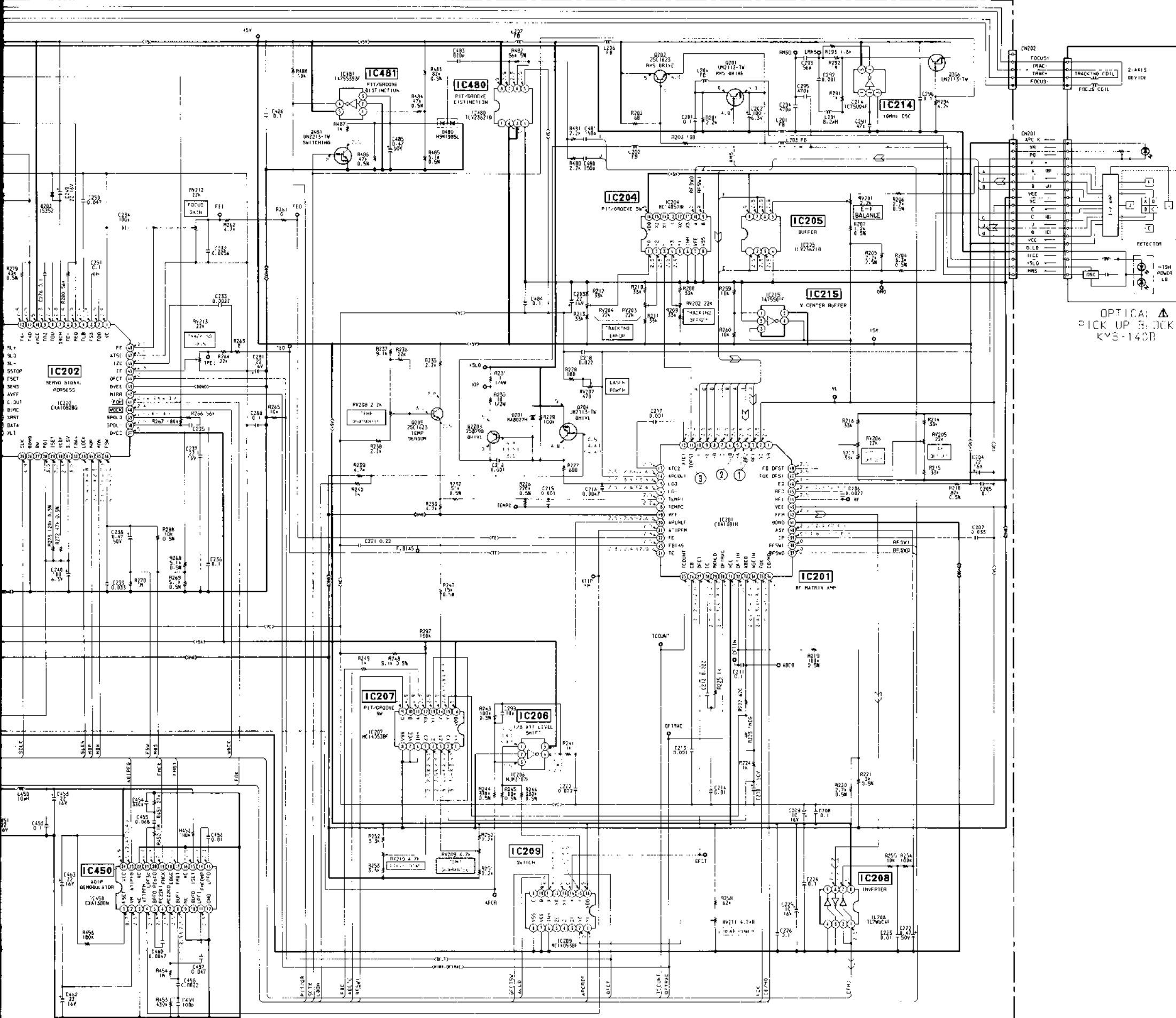

OPTICAL PICK UP BLOCK KYS-140B

01 TC74ATC540F

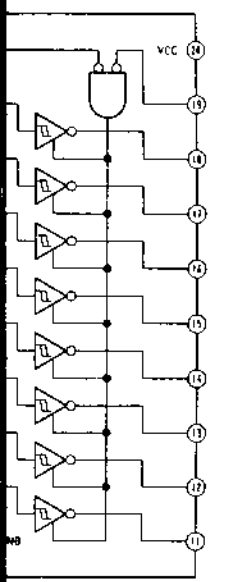

IC430 M54641FP

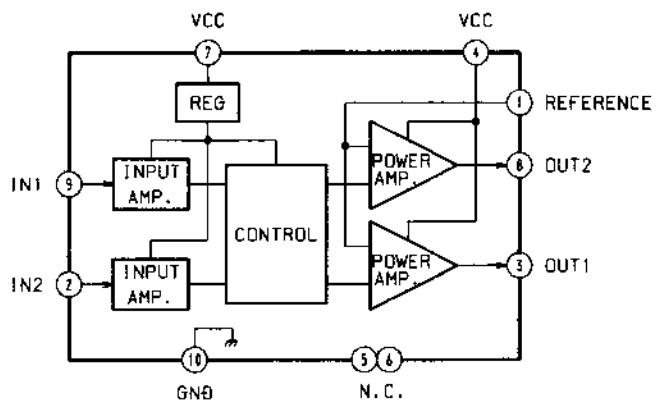

IC450 CXA1380N

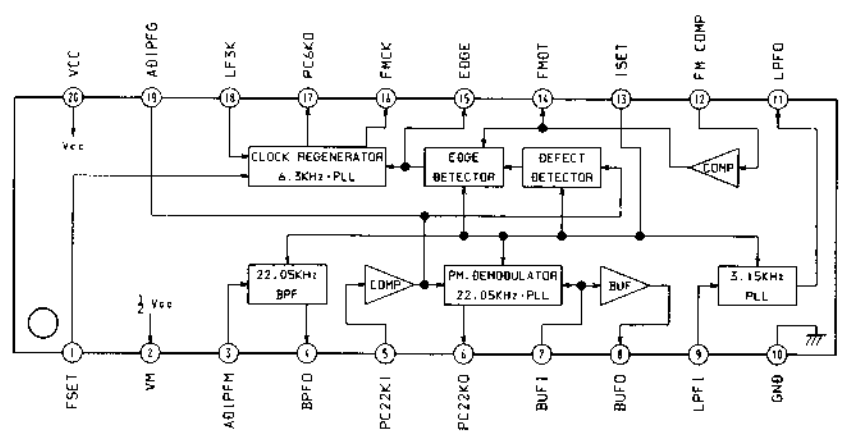

IC202 CXA1082BQ

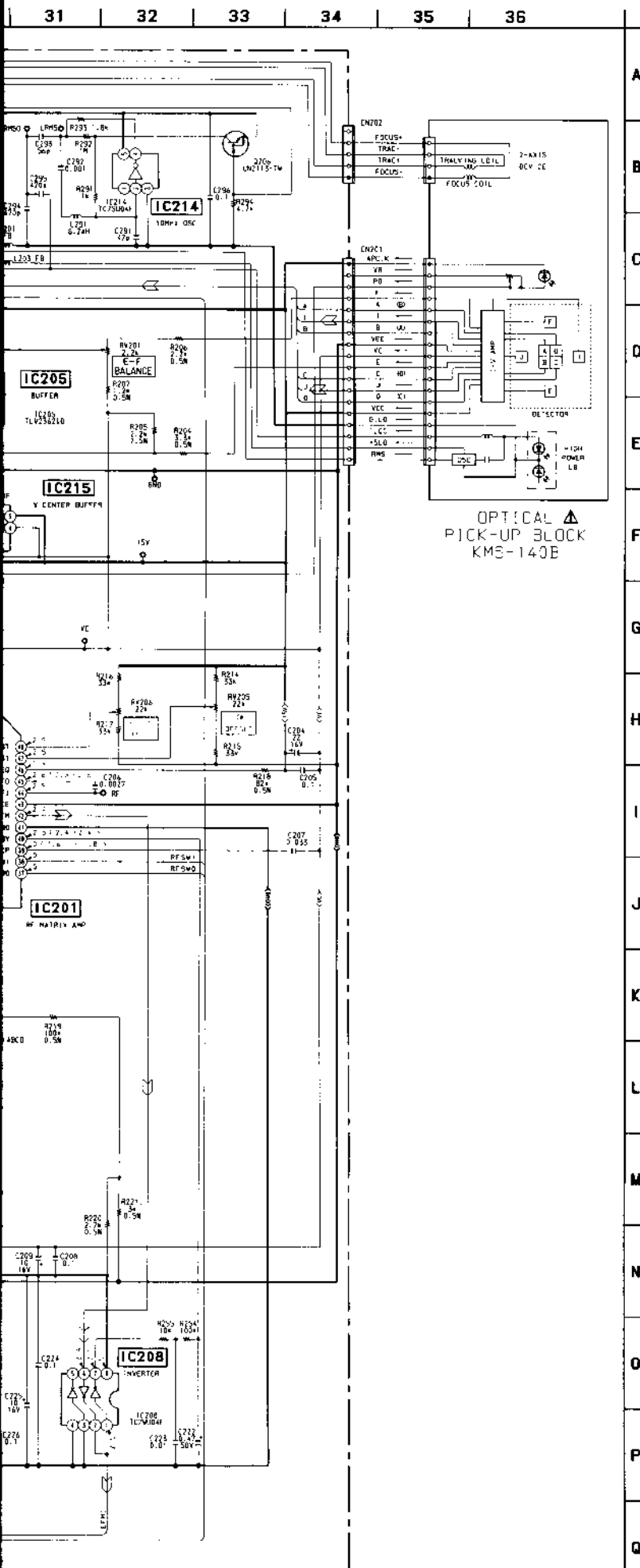
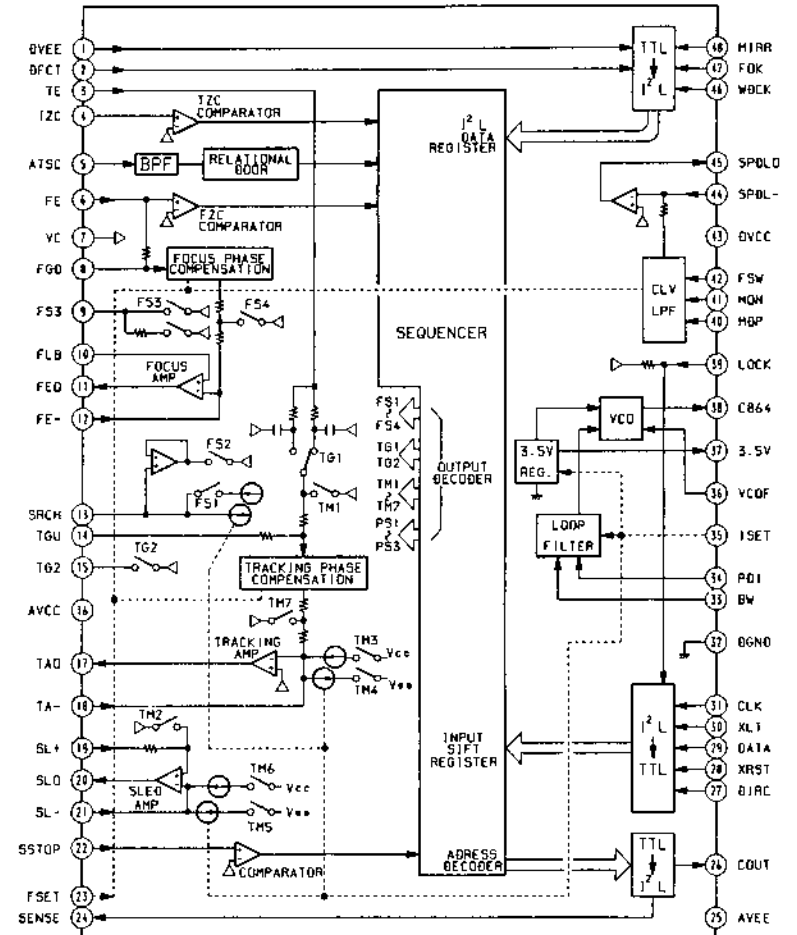

OPTICAL PICK-UP BLOCK KMS-140B

Note:

- All capacitors are in μF unless otherwise noted. pF : μF 50WV or less are not indicated except for electrolytics and tantalums.
- All resistors are in Ω and $\frac{1}{4}\text{W}$ or less unless otherwise specified.
- % : indicates tolerance.

Note: The components identified by mark Δ or dotted line with mark Δ are critical for safety. Replace only with part number specified.

Note: Les composants identifiés par une marque Δ sont critiques pour la sécurité. Ne les remplacer que par une pièce portant le numéro spécifié.

- — : B+ Line
- - - - : B- Line
- □ : adjustment for repair.
- Voltage and waveforms are dc with respect to ground under no-signal (detuned) conditions.
- no mark: STOP/PLAYBACK/RECORD
- () : RECORD
- < > : PLAYBACK
- * : impossible to measure the voltage at the marked points.
- Signal path.
- ∑ : PB (ANALOG OUTPUT) ∑ : REC (ANALOG INPUT)
- ∑∑ : PB (DIGITAL OUTPUT) ∑∑ : REC (DIGITAL INPUT)

Waveforms

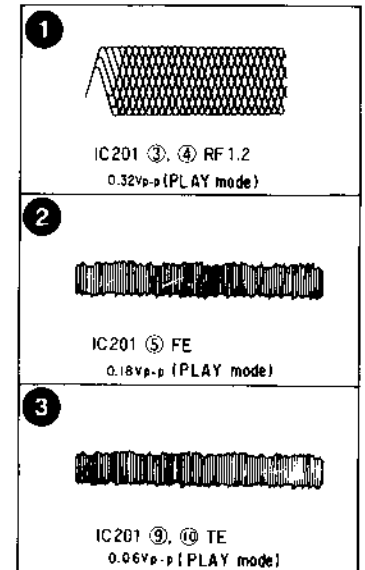

5-7. SCHEMATIC DIAGRAM -AUDIO Section-

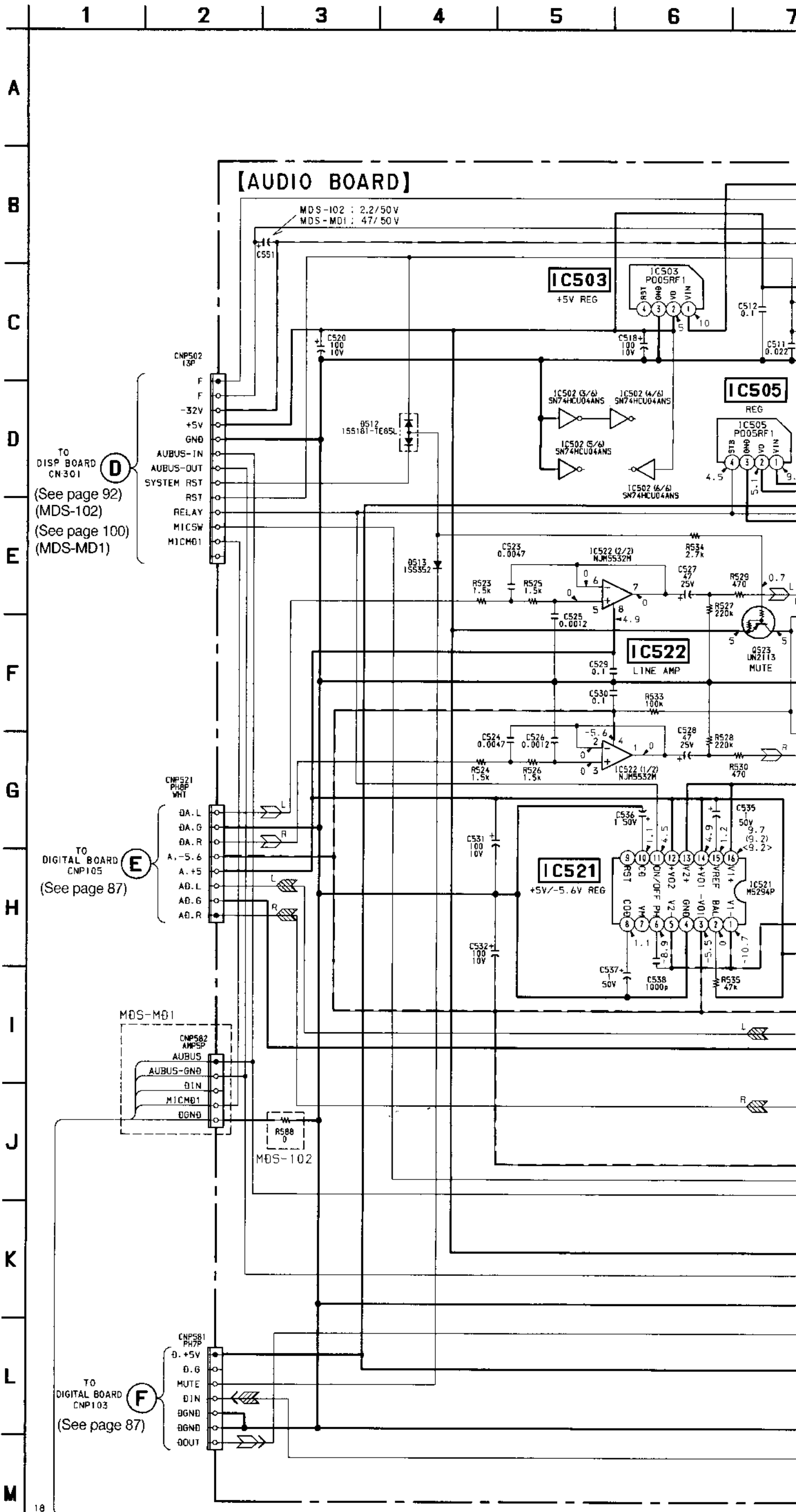

- Note:**
- All capacitors are in μF unless otherwise noted. pF: μpF 50WV or less are not indicated except for electrolytics and tantalums.
 - All resistors are in Ω and $\frac{1}{4}\text{W}$ or less unless otherwise specified.
 - % : indicates tolerance.

<p>Note: The components identified by mark Δ or dotted line with mark Δ are critical for safety. Replace only with part number specified.</p>	<p>Note: Les composants identifiés par une marque Δ sont critiques pour la sécurité. Ne les remplacer que par une pièce portant le numéro spécifié.</p>
--	--

- — : B+ Line
- - - - : B- Line
- □ : adjustment for repair.
- Voltage and waveforms are dc with respect to ground under no-signal (detuned) conditions
no mark : STOP/PLAYBACK/RECORD
() : RECORD
< > : PLAYBACK
- Signal path.
 - ▷ : PB (ANALOG OUTPUT) ▨ : REC (ANALOG INPUT)
 - ◁ : PB (DIGITAL OUTPUT) ▩ : REC (DIGITAL INPUT)
- JE : Tourist
SP : Singapore
MX : Mexican

TO RF/SERVO BOARD
CN209 (See page 69)

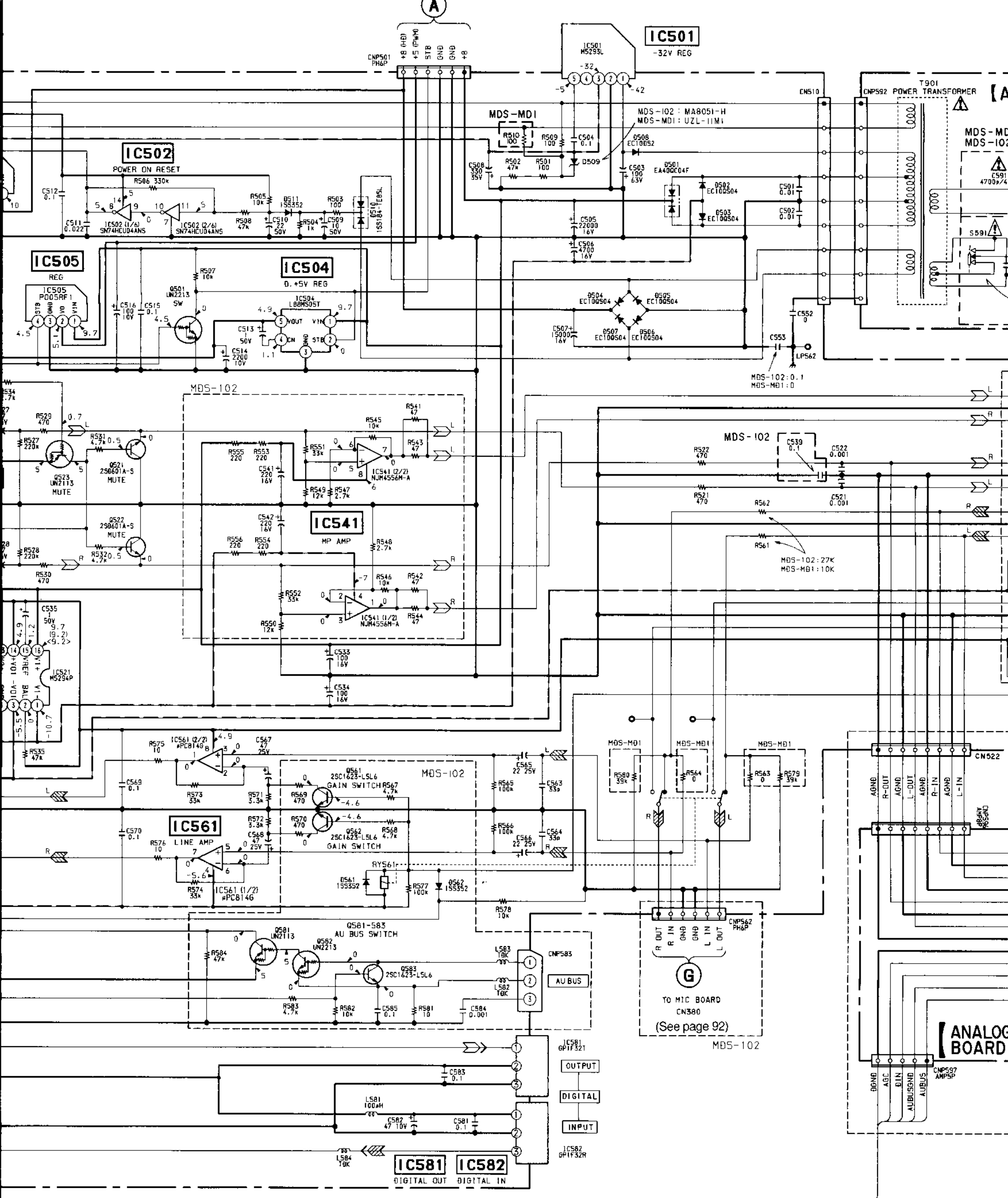

(See page 69)

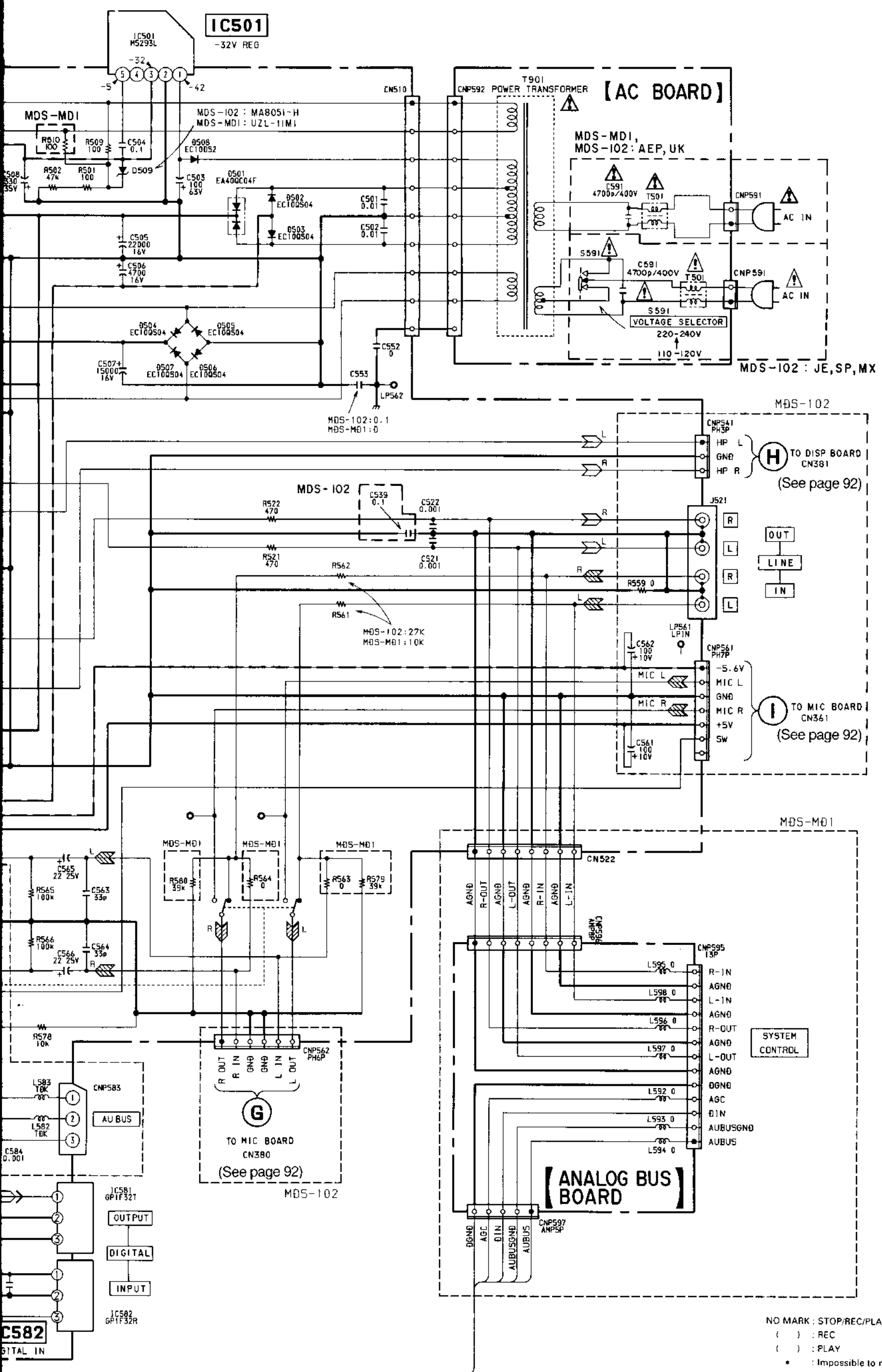

NO MARK : STOP/REC/PLAY
 () : REC
 () : PLAY
 * : Impossible to measure the voltage at the marked point

5-8. PRINTED WIRING BOARDS—AUDIO Section—

- See page 64 for Circuit Boards Location.
- See page 65,66 for Semiconductor Lead Layouts.

• Semiconductor Location

Ref. No.	Location
D501	E-4
D502	E-4
D503	E-3
D504	D-3
D505	D-3
D506	D-3
D507	D-3
D508	D-4
D509	E-5
D510	E-3
D511	G-3
D512	G-13
D513	H-10
D561	G-12
D562	G-13
IC501	E-6
IC502	F-3
IC503	G-4
IC504	F-5
IC505	G-5
IC521	G-7
IC522	G-9
IC541	H-10
IC561	F-11
IC581	E-2
IC582	F-2
Q501	F-7
Q521	H-8
Q522	H-9
Q523	H-9
Q561	G-11
Q562	G-11
Q581	D-2
Q582	D-2
Q583	C-2

Note:

- ⊕ : Through hole.
 - ◊ : Pattern on the side which is seen.
 - ◑ : Pattern of the rear side.
- JE: Tourist
 SP: Singapore
 MX: Mexican

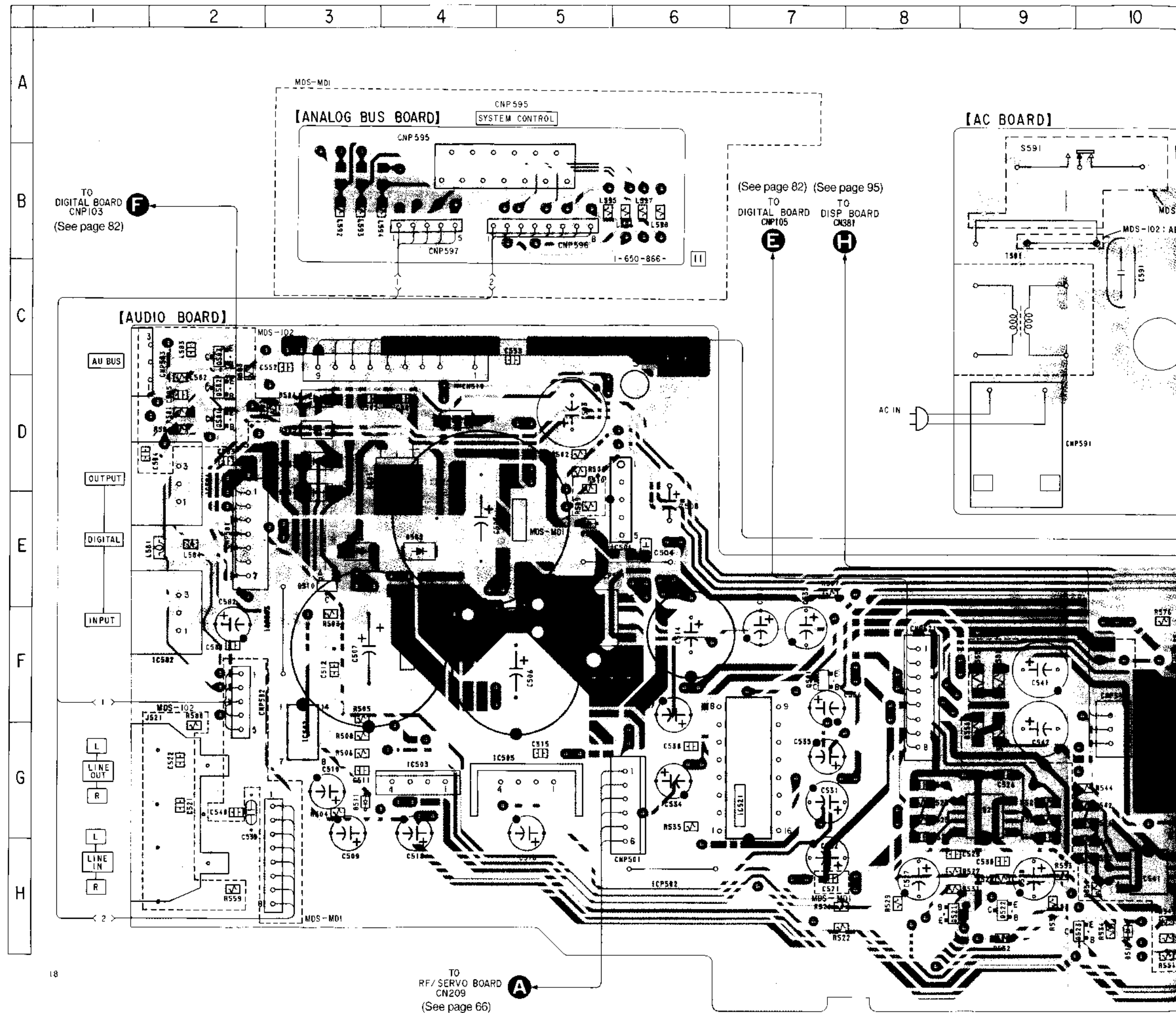

[AC BOARD]

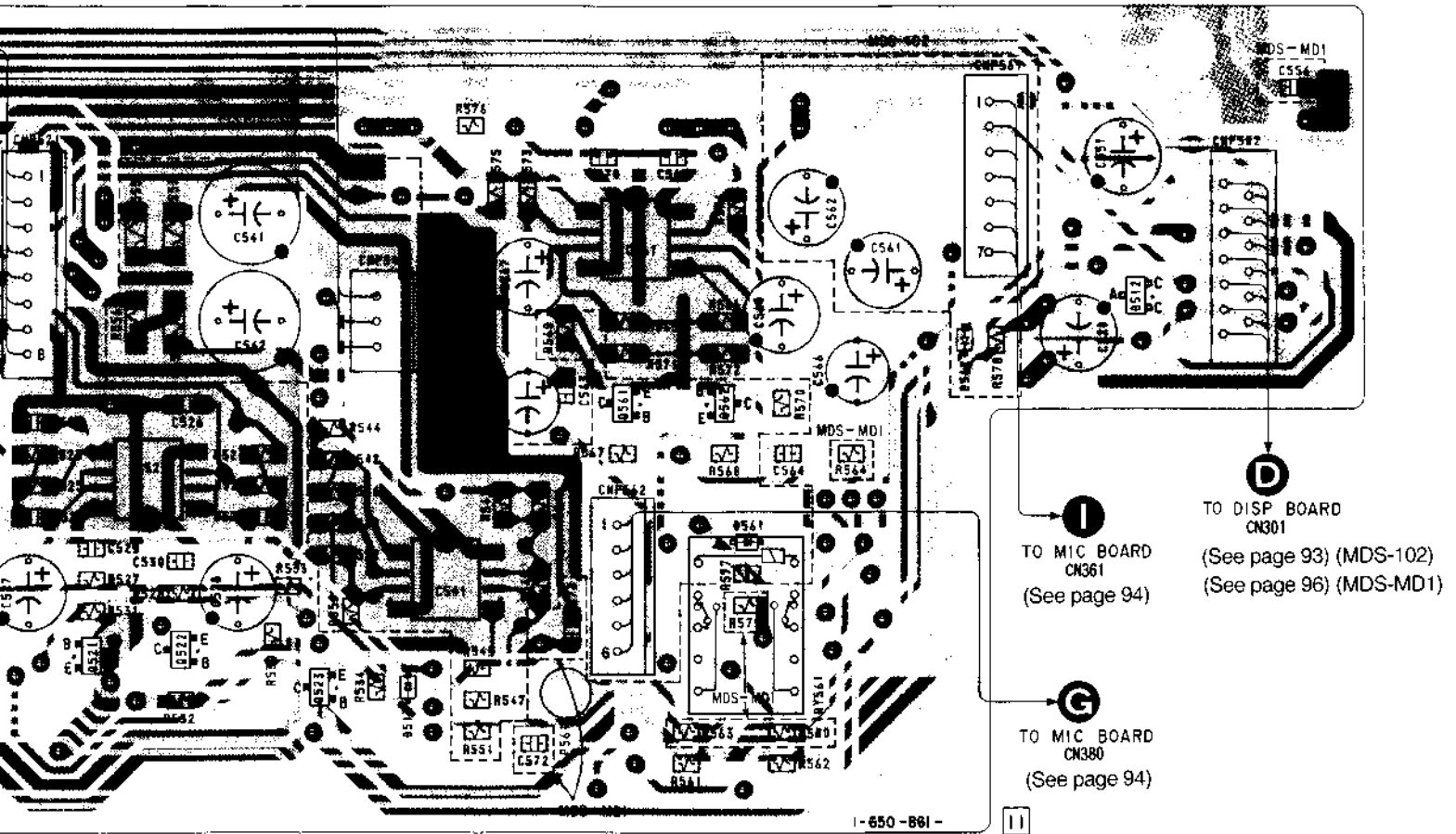
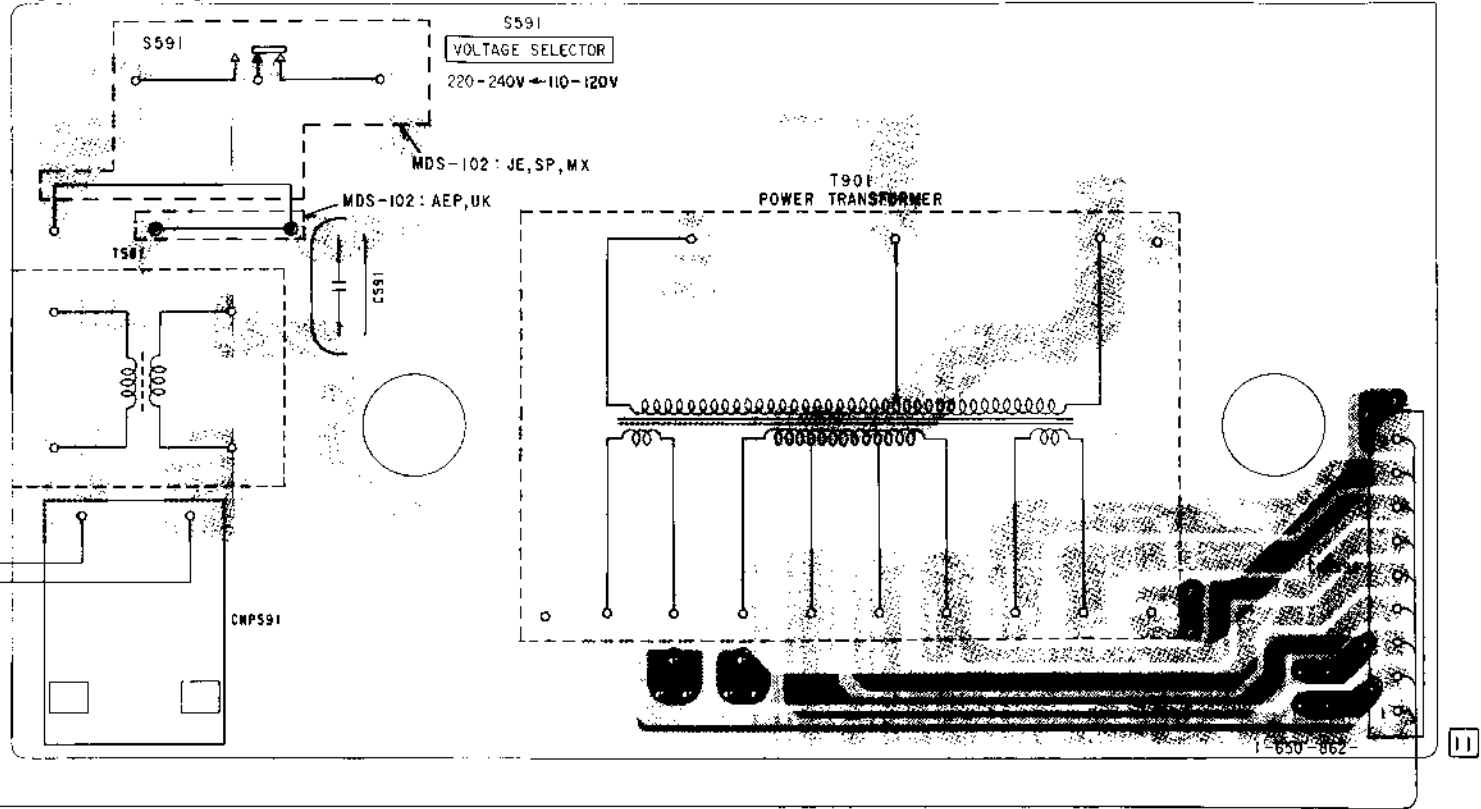

- I** TO MIC BOARD CN361 (See page 94)
- D** TO DISP BOARD CN301 (See page 93) (MDS-102) (See page 96) (MDS-MD1)
- G** TO MIC BOARD CN380 (See page 94)

5-9. PRINTED WIRING BOARDS —DIGITAL Section— ● See page 64 for Circuit Boards Location. ● See page 65,66 for Semiconductor Lead Layouts.



[DIGITAL BOARD] (COMPONENT SIDE)

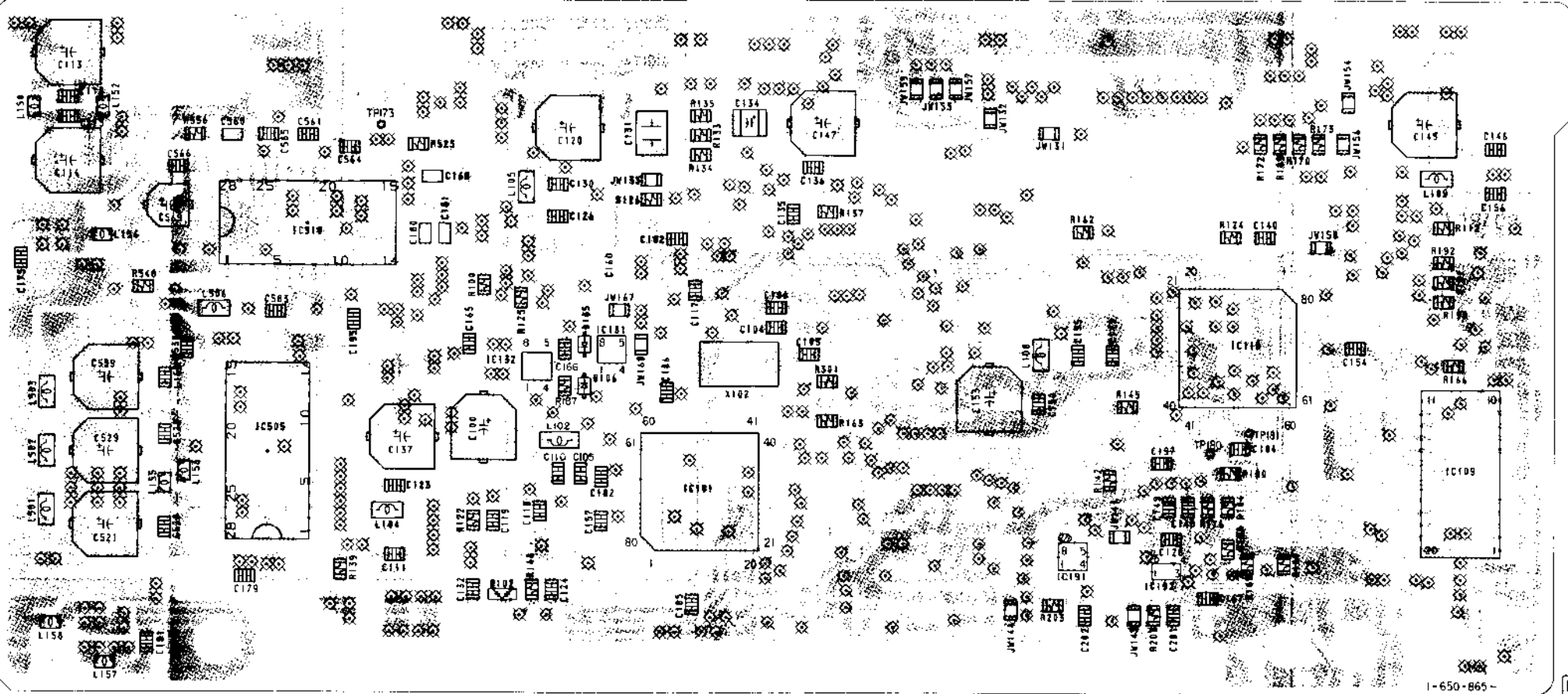

● Semiconductor Location

Ref. No.	Location
D101	F-12
D102	E-15
D103	E-7
D104	B-3
IC101	D-17
IC102	E-5
IC103	C-7
IC104	D-7
IC106	D-8
IC109	D-21
IC110	C-20
IC111	C-3
IC121	B-4
IC122	B-2
IC131	C-16
IC132	C-16
IC191	D-19
IC192	D-20
IC505	D-14
IC507	D-10
IC510	B-14
Q505	C-8

● Waveforms

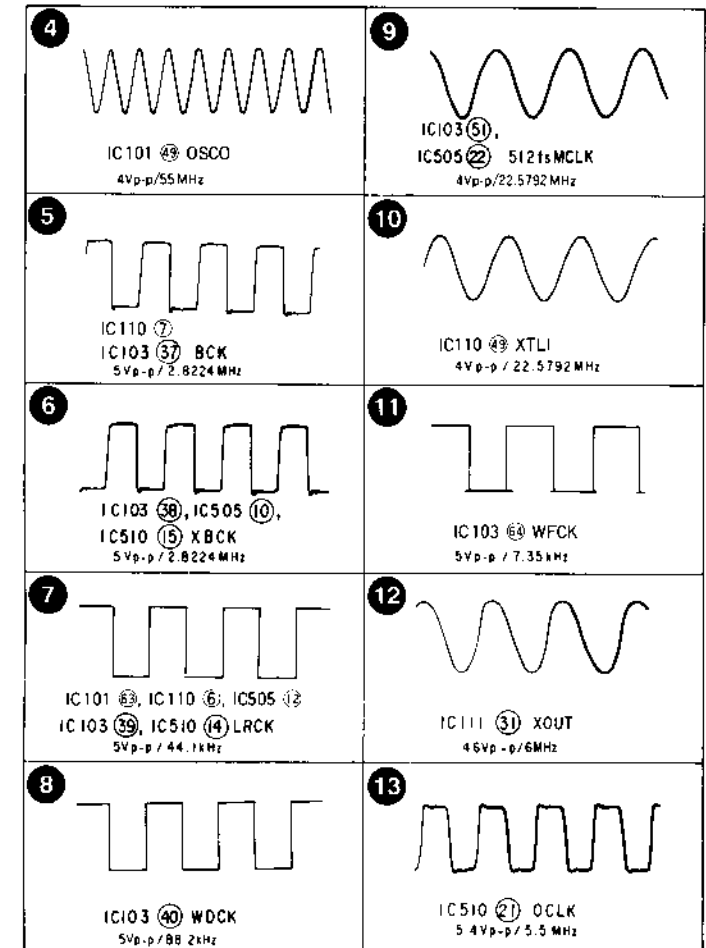

Note:

- ⊗ : Through hole.
- ○ : Pattern from the side which enables seeing.

(The other layers' patterns are not indicated.)

Caution:

Pattern face side: Parts on the pattern face side seen from (Conductor Side) the pattern face are indicated.
 Parts face side: Parts on the parts face side seen from the (Component Side) parts face are indicated.

5-10. SCHEMATIC DIAGRAM - DIGITAL Section -

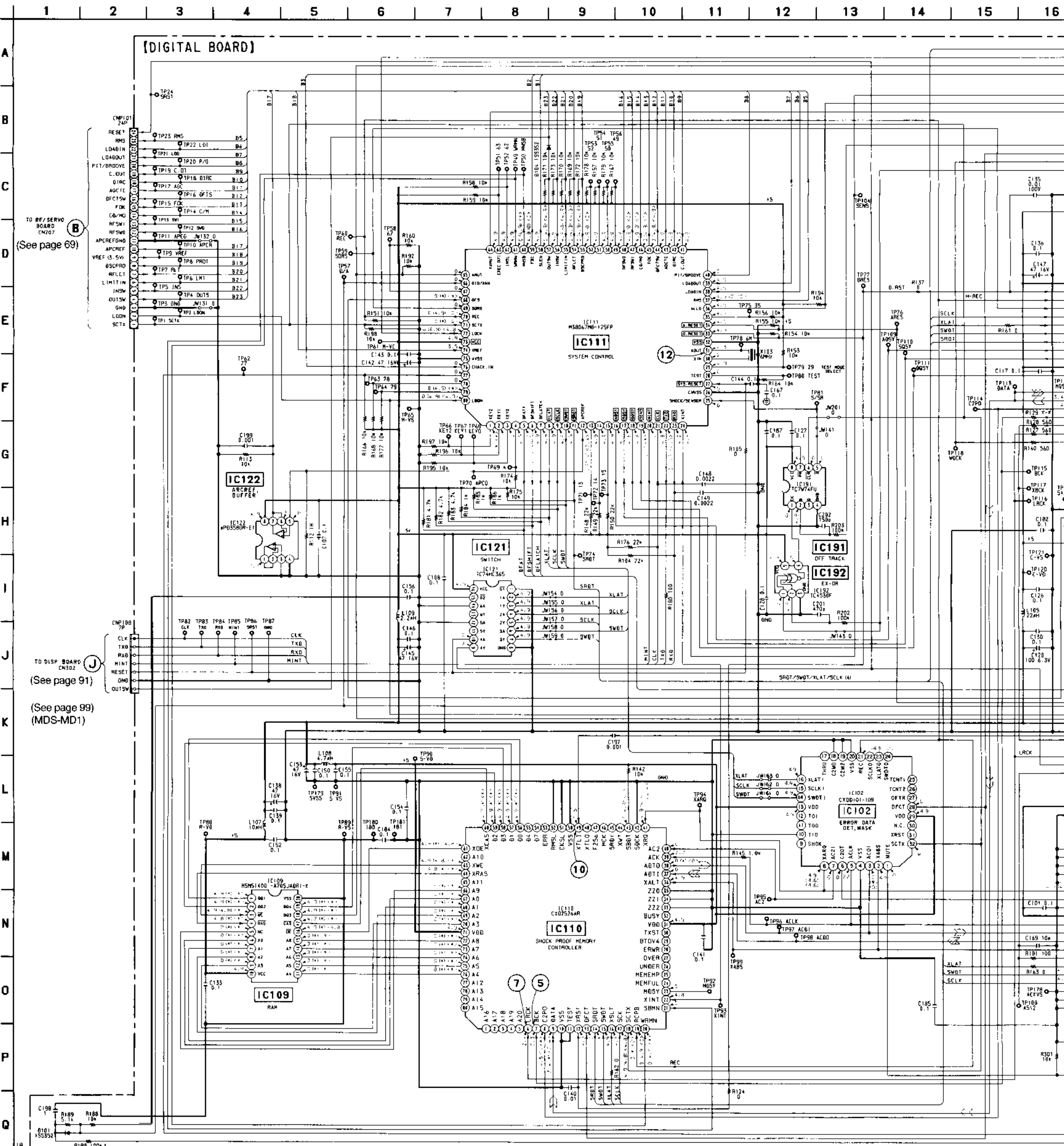

TO RF/SERVO BOARD
BOARD
CN207
(See page 69)

TO DISP BOARD
CN302
(See page 91)

(See page 99)
(MDS-MD1)

Note:

- All capacitors are in μF unless otherwise noted. μF : μF 50WV or less are not indicated except for electrolytics and tantalums.
- All resistors are in Ω and $\frac{1}{4}\text{W}$ or less unless otherwise specified.
- % : indicates tolerance.
- — : B+ Line
- - - - : B- Line
- Voltage and waveforms are dc with respect to ground under no-signal (detuned) conditions.
- no mark : STOP/PLAYBACK/RECORD
- () : RECORD
- < > : PLAYBACK
- X : Impossible to measure the voltage at the marked points.
- Signal path.
 - : PB (ANALOG OUTPUT) ➤ : REC (ANALOG INPUT)
 - : PB (DIGITAL OUTPUT) ➤➤ : REC (DIGITAL INPUT)

16 | 17 | 18 | 19 | 20 | 21 | 22 | 23 | 24 | 25 | 26 | 27 | 28 | 29 | 30 | 31

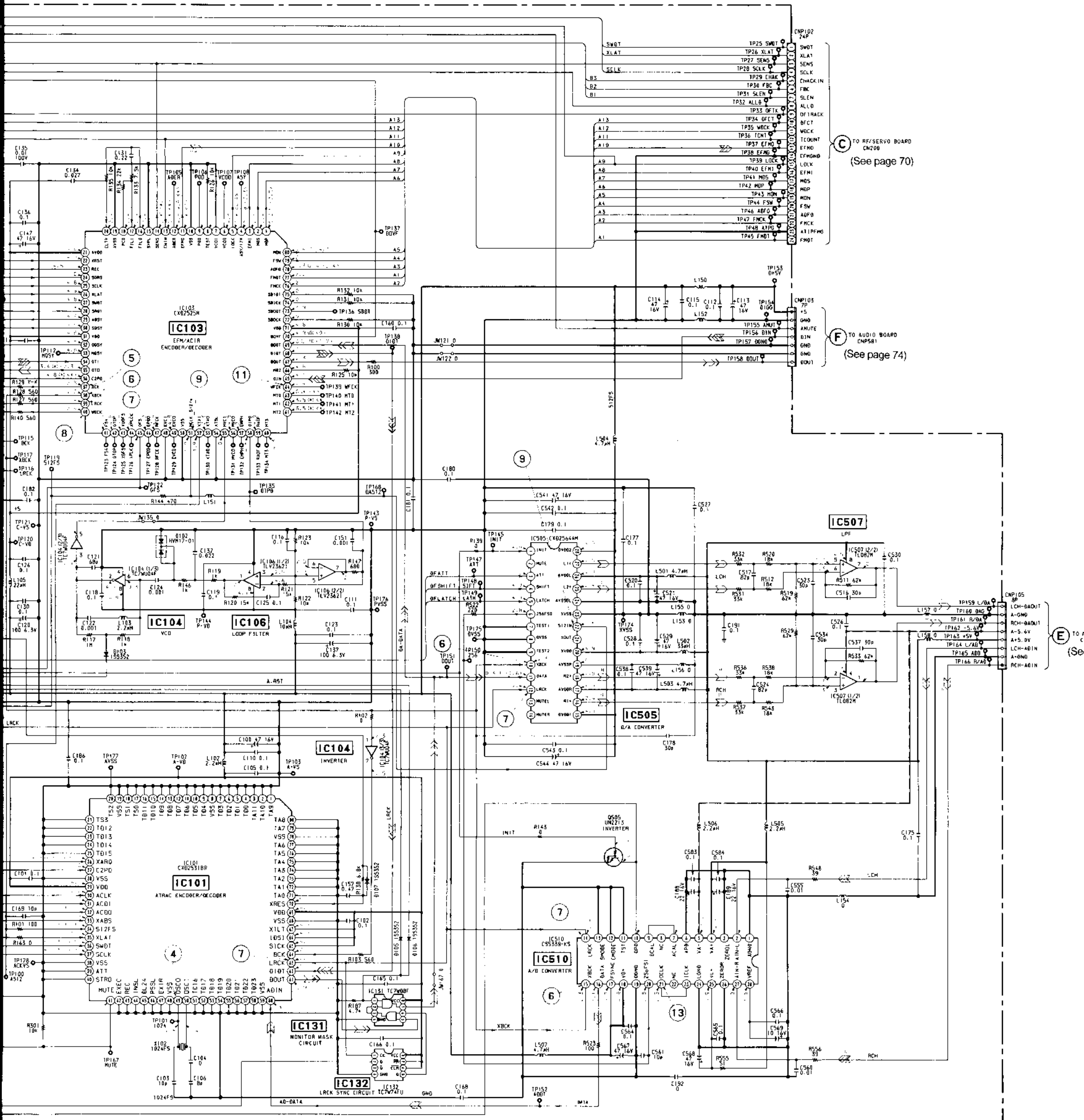

(C) TO REF/SERVO BOARD CN208 (See page 70)

(F) TO AUDIO BOARD CNP581 (See page 74)

(E) TO C (See page 74)

Note:

- All capacitors are in μF unless otherwise noted. $\text{pF} = \mu\mu\text{F}$. 50WV or less are not indicated except for electrolytics and tantalums.
- All resistors are in Ω and $1/4\text{W}$ or less unless otherwise specified.
- % : indicates tolerance.
- — : B+ Line
- - - - : B- Line
- Voltage and waveforms are dc with respect to ground under no-signal (detuned) conditions.
- no mark : STOP/PLAYBACK/RECORD
- () : RECORD
- < > : PLAYBACK
- * : Impossible to measure the voltage at the marked points.
- Signal path.
 - ▬ : PB (ANALOG OUTPUT) ▬ : REC (ANALOG INPUT)
 - ▬▬ : PB (DIGITAL OUTPUT) ▬▬ : REC (DIGITAL INPUT)

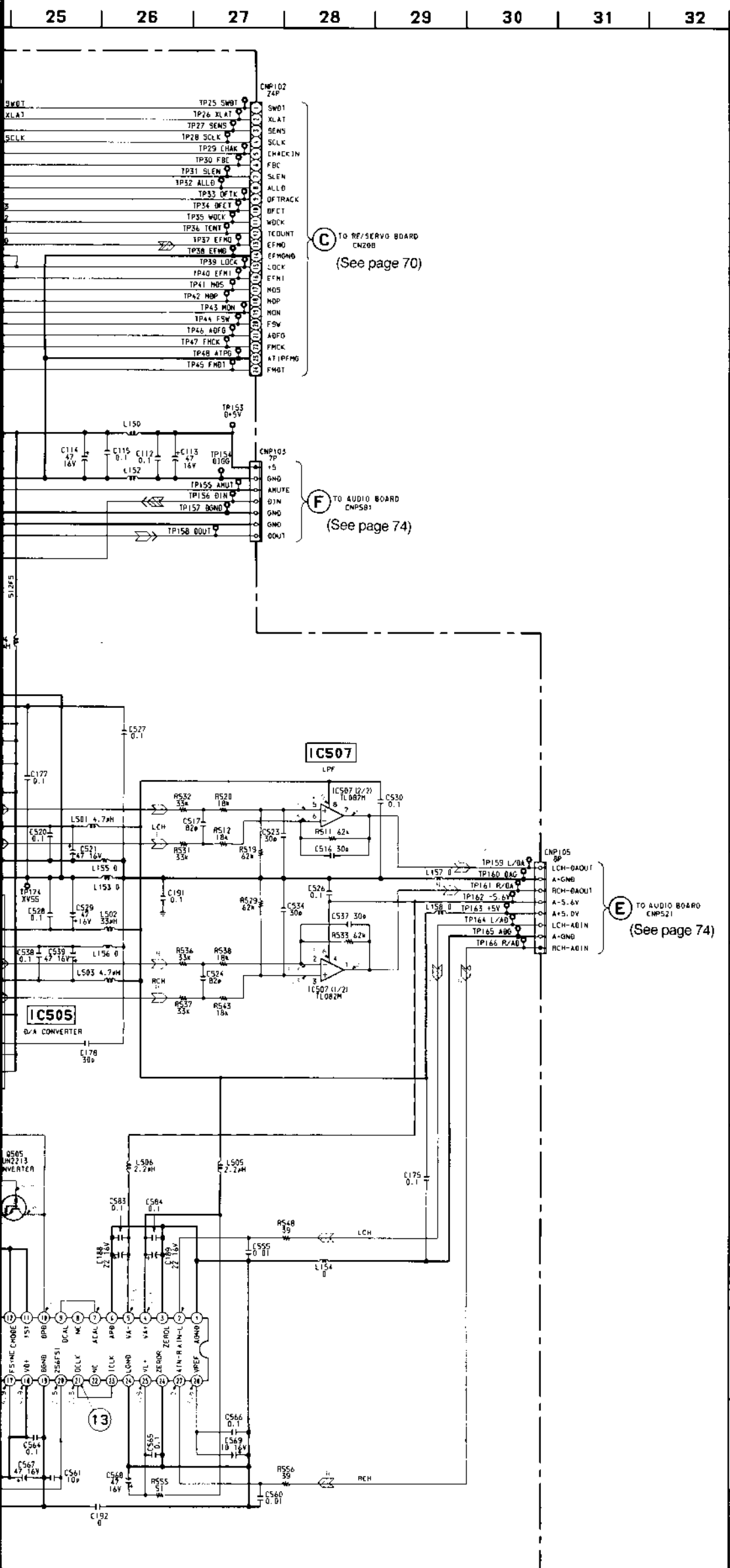

• IC Block Diagrams

IC101 CXD2531R

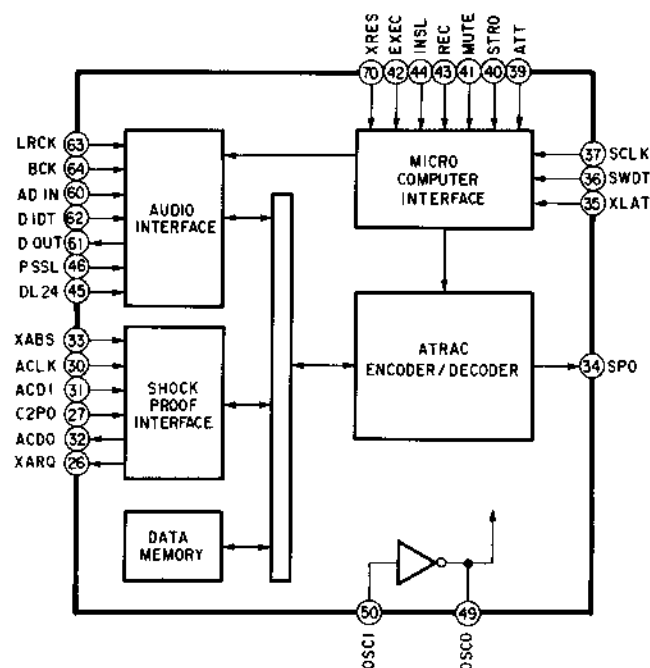

IC121 TC74HC365

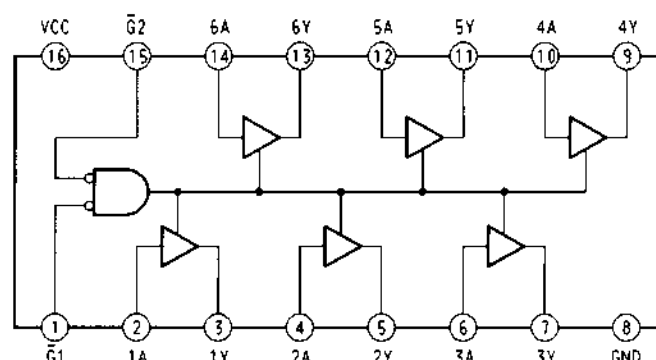

IC505 CXD2564AM

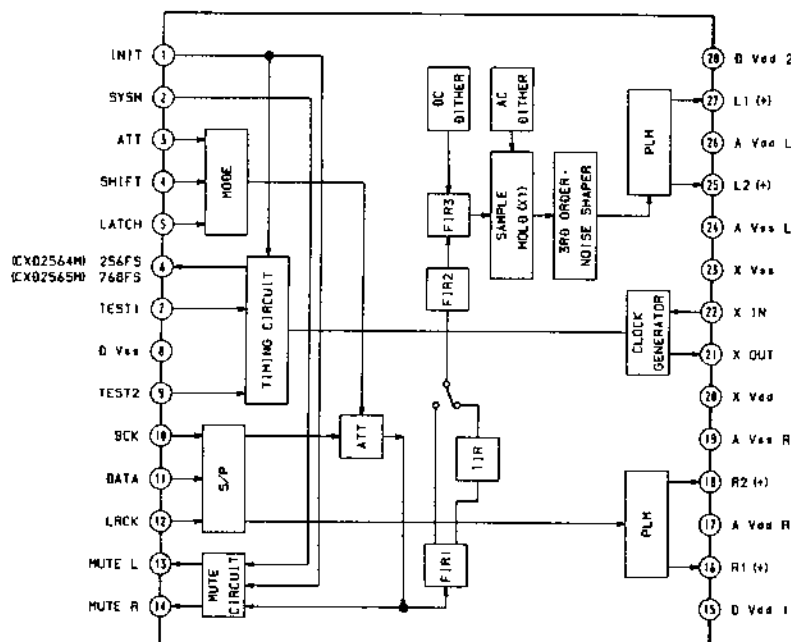

IC510 CS5339-KS

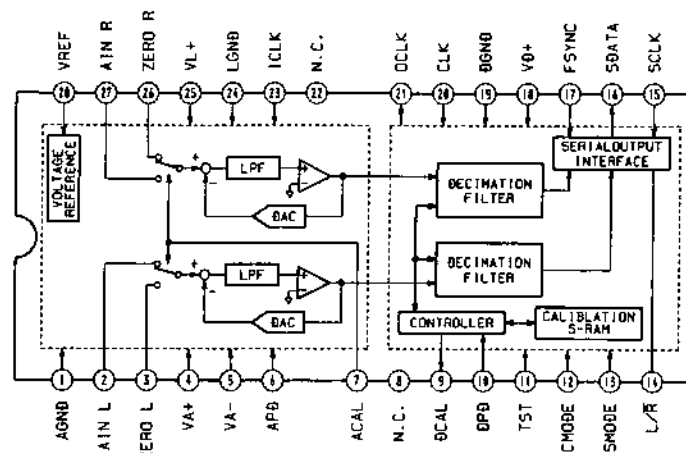

● IC Block Diagram

IC304 S-3520CF

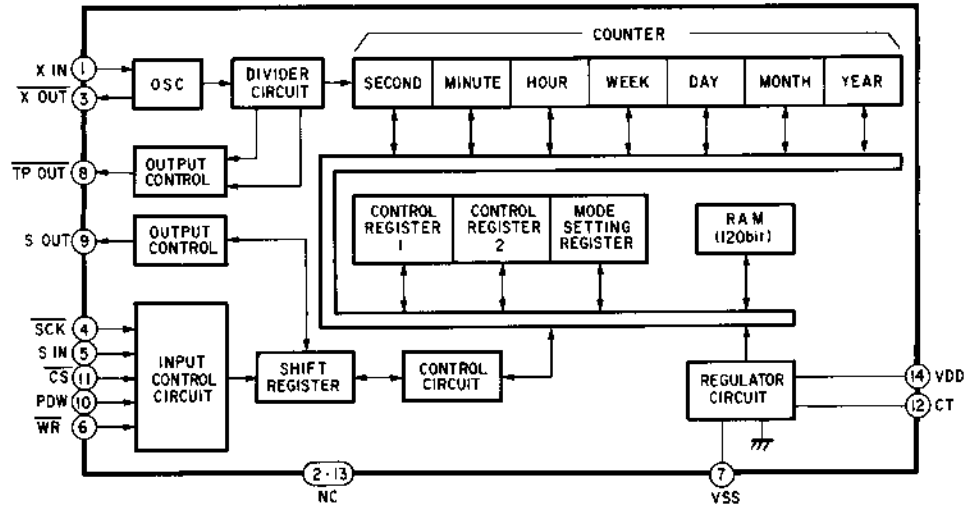

● Waveforms

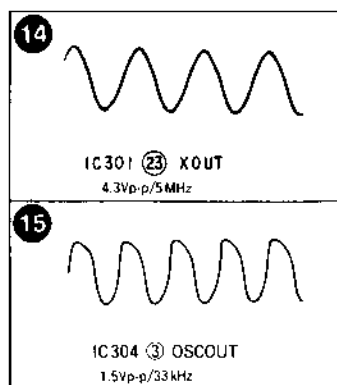

Note:

- All capacitors are in μF unless otherwise noted. pF : μF 50V or less are not indicated except for electrolytics and tantalums.
- All resistors are in Ω and $1/4\text{W}$ or less unless otherwise specified.
- % : indicates tolerance.
- — : B+ Line
- - - - : B- Line
- Voltage and waveforms are dc with respect to ground under no-signal (detuned) conditions.
no mark : STOP/PLAYBACK/RECORD
() : RECORD
< > : PLAYBACK
* : impossible to measure the voltage at the marked points.
- Signal path.

∩	: PB (ANALOG OUTPUT)	⊘	: REC (ANALOG INPUT)
∩∩	: PB (DIGITAL OUTPUT)	⊘⊘	: REC (DIGITAL INPUT)

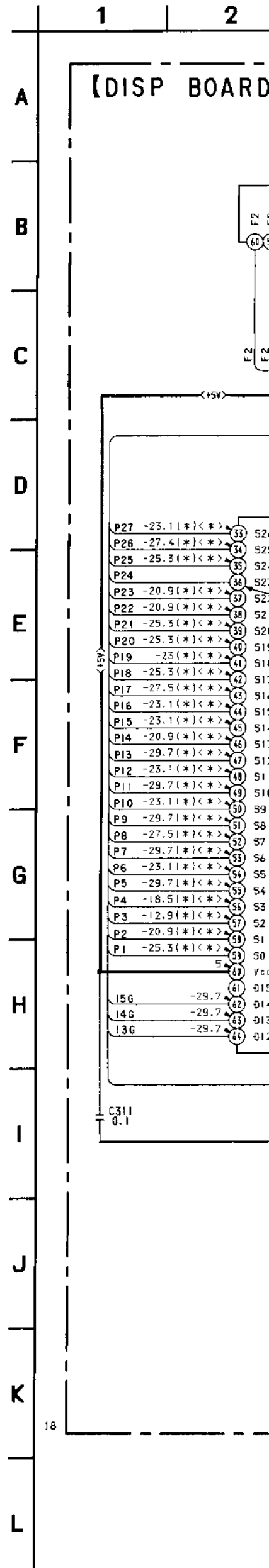

IC DIAGRAM - DISPLAY (MDS-102) Section -

2 | 3 | 4 | 5 | 6 | 7 | 8 | 9 | 10 | 11 | 12

BOARD] (MDS-102)

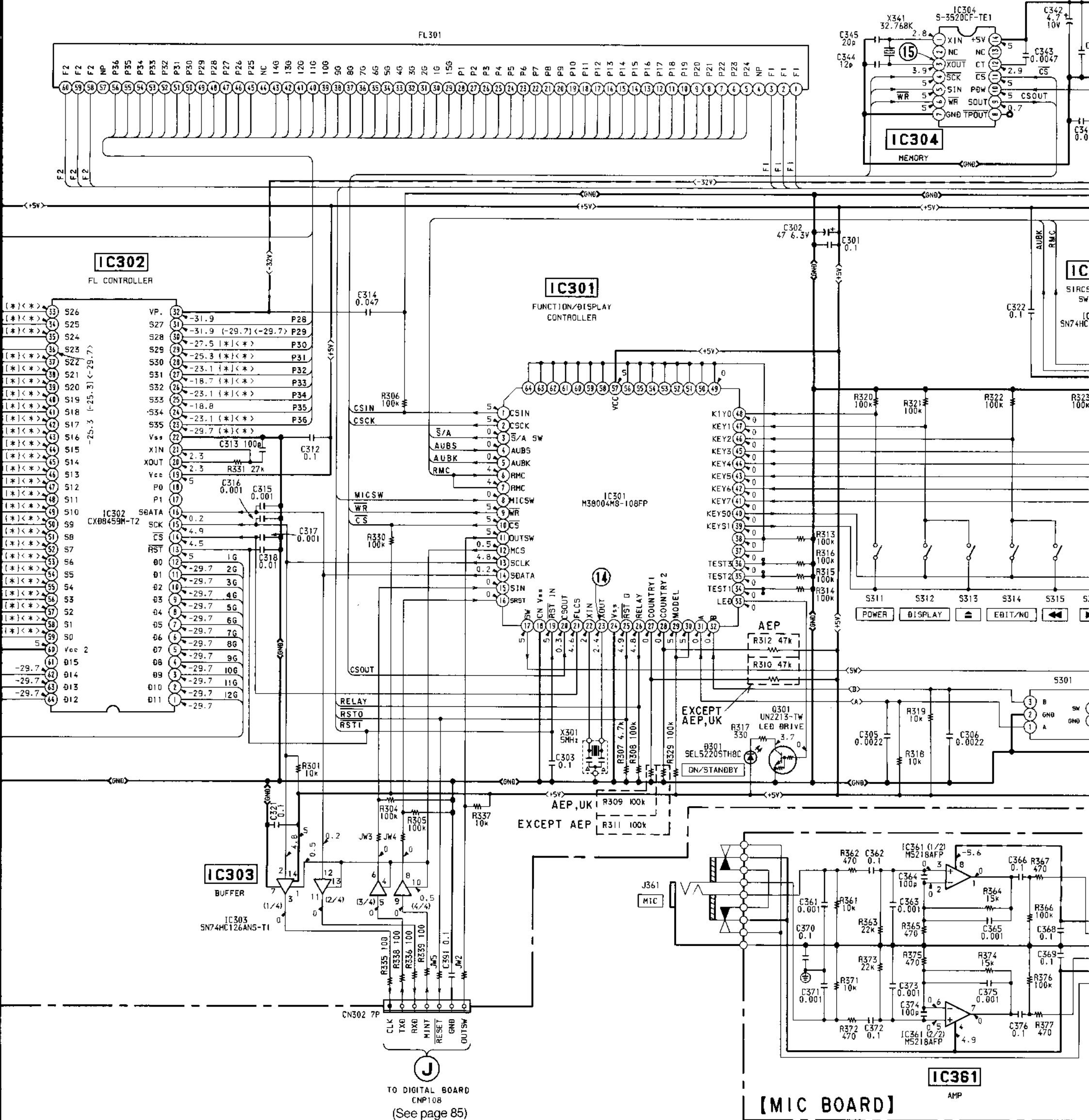

See page 64 for Circuit Boards Location. • See page 65,66 for Semiconductor Lead Layouts.

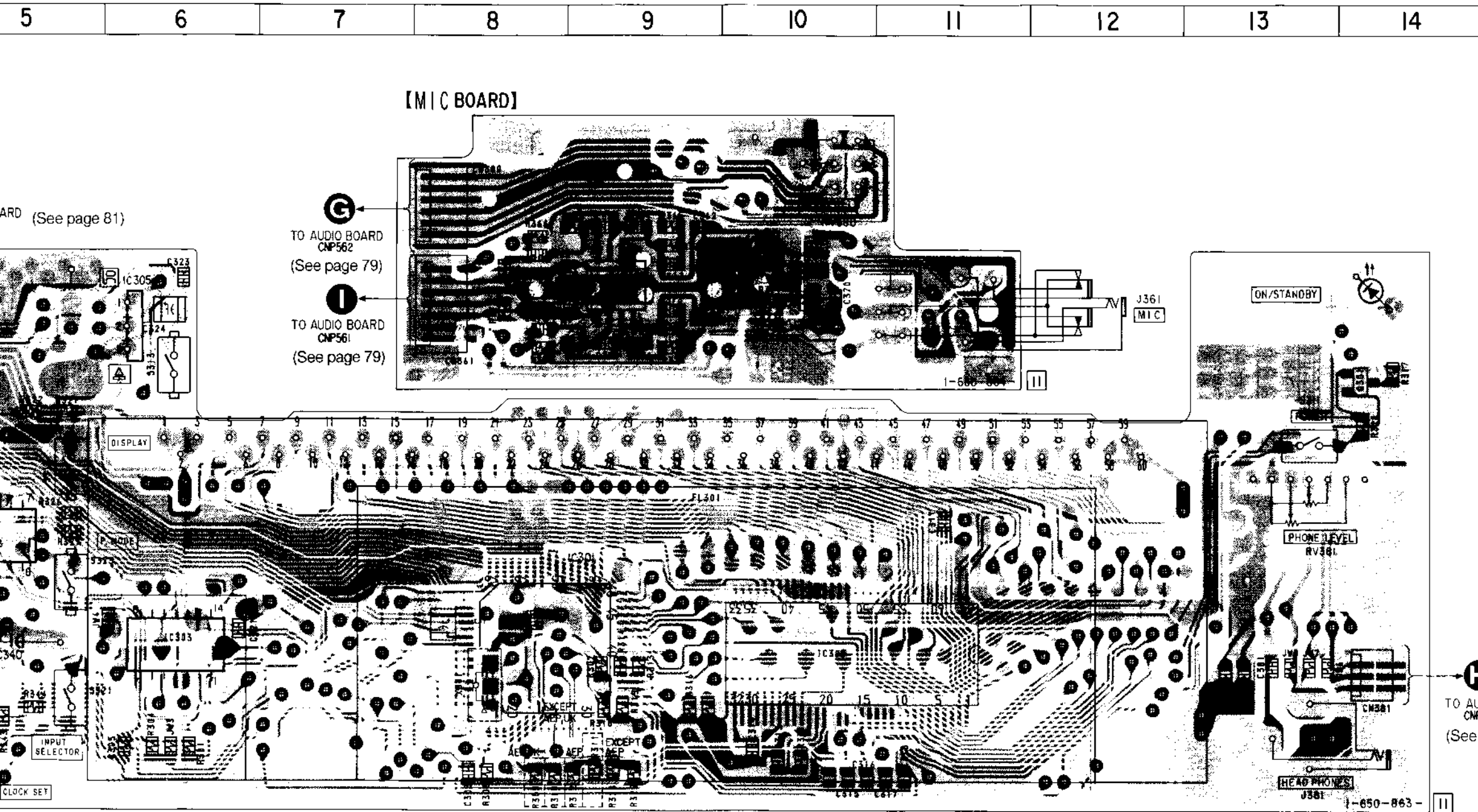

• Semiconductor Location

Ref. No.	Location
D301	B - 14
IC301	E - 8
IC302	D - 10
IC303	D - 6
IC304	D - 3
IC305	C - 5
IC306	D - 5
IC361	B - 9
Q301	B - 14
Q341	E - 5
Q342	E - 5

Note:

- ⊕ : Through hole.
- [] : Pattern on the side which is seen.
- [] : Pattern of the rear side.
- [] : Chip components extracted from the rear side.

• Semiconductor Location

Ref. No.	Location
D302	B - 3
IC301	C - 6
IC302	D - 10
IC303	C - 5
IC304	C - 3
Q302	B - 3
Q341	C - 4
Q342	B - 4

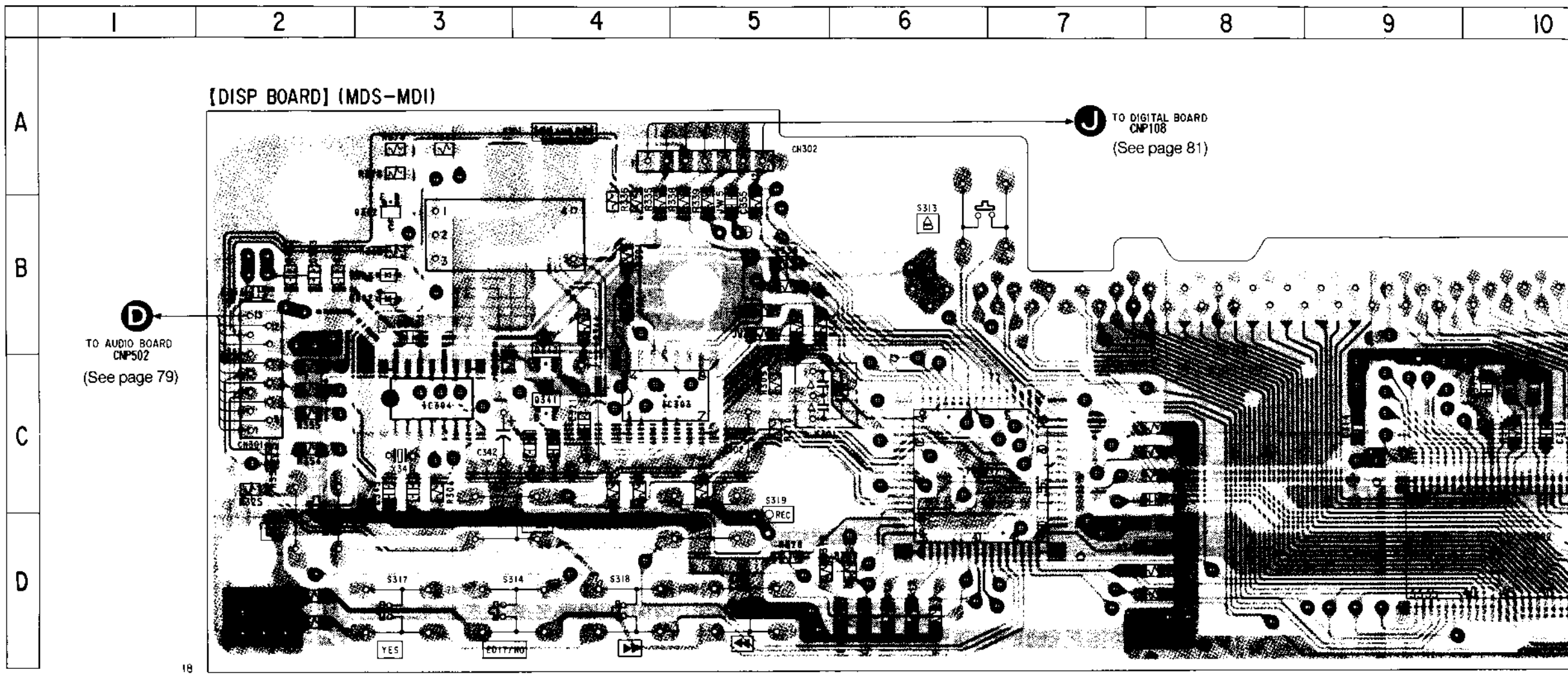

3	4	5	6	7	8	9	10	11	12	13	14
---	---	---	---	---	---	---	----	----	----	----	----

0] (MDS-MD1)

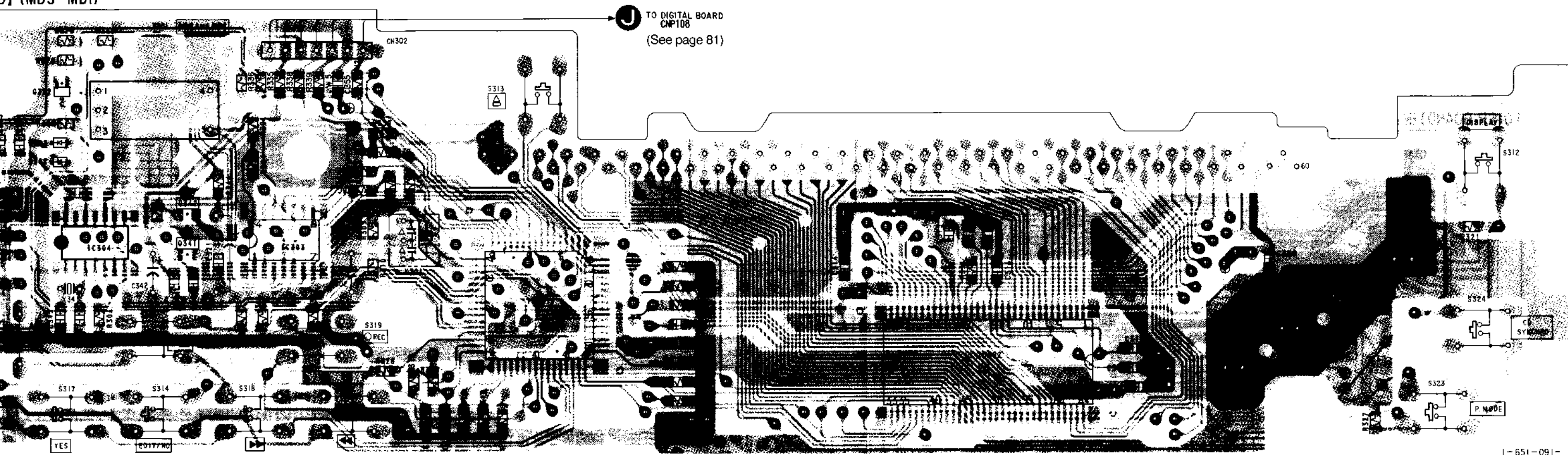

I-651-091-

II

Note:
 • ⊕ : Through hole.
 • : Pattern on the side which is seen.
 • : Pattern of the rear side.

5-14. SCHEMATIC DIAGRAM — DISPLAY (MDS-MD1) Section—

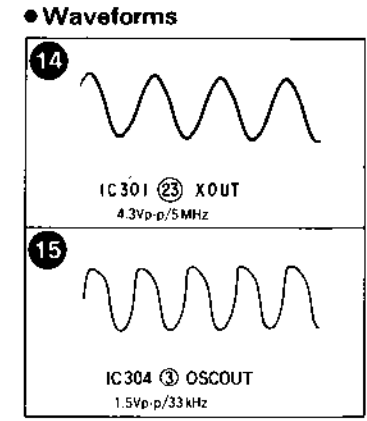
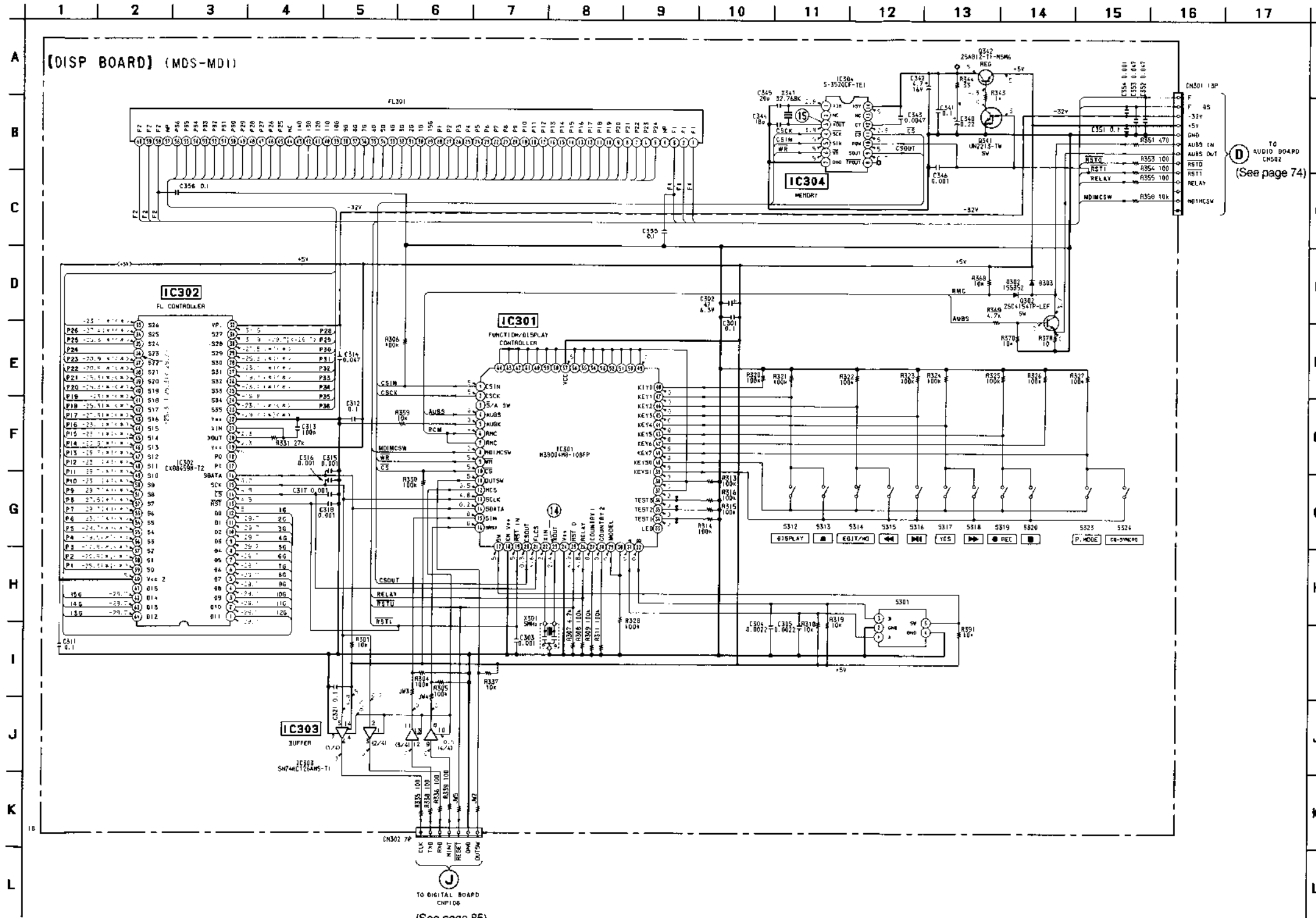

- Note:**
- All capacitors are in μF unless otherwise noted. pF : μF 50WV or less are not indicated except for electrolytics and tantalums.
 - All resistors are in Ω and $\frac{1}{4}\text{W}$ or less unless otherwise specified.
 - % : indicates tolerance.
 - — : B+ Line
 - - - - : B- Line
 - Voltage and waveforms are dc with respect to ground under no-signal (detuned) conditions.
 - no mark : STOP/PLAYBACK/RECORD
 - () : RECORD
 - < > : PLAYBACK
 - * : Impossible to measure the voltage at the marked points.
 - Signal path.
 - ▧ : PB (ANALOG OUTPUT) ▩ : REC (ANALOG INPUT)
 - ▨ : PB (DIGITAL OUTPUT) ▪ : REC (DIGITAL INPUT)

SECTION 6 EXPLODED VIEWS

NOTE:

● -xx,-x mean standardized parts, so they may have some differences from the original one.

● Color Indication of Appearance Parts

Example:

KNOB, BALANCE (WHITE)...(RED)

Parts color Cabinet's color

● Items marked "*" are not stocked since they are seldom required for routine service. Some delay should be anticipated when ordering these items.

● The mechanical parts with no reference number in the exploded views are not supplied.

● Hardware (#mark) list and accessories and packing materials are given in the last of this parts list.

● Abbreviations

CND: Canadian MX: Mexican
IT: Italian SP: Singapore
G: German JE: Tourist

102: MDS-102
MD1: MDS-MD1

The components identified by mark Δ or dotted line with mark Δ are critical for safety. Replace only with part number specified.

Les composants identifiés par une marque Δ sont critiques pour la sécurité. Ne les remplacer que par une pièce portant le numéro spécifié.

6-1. CABINET SECTION

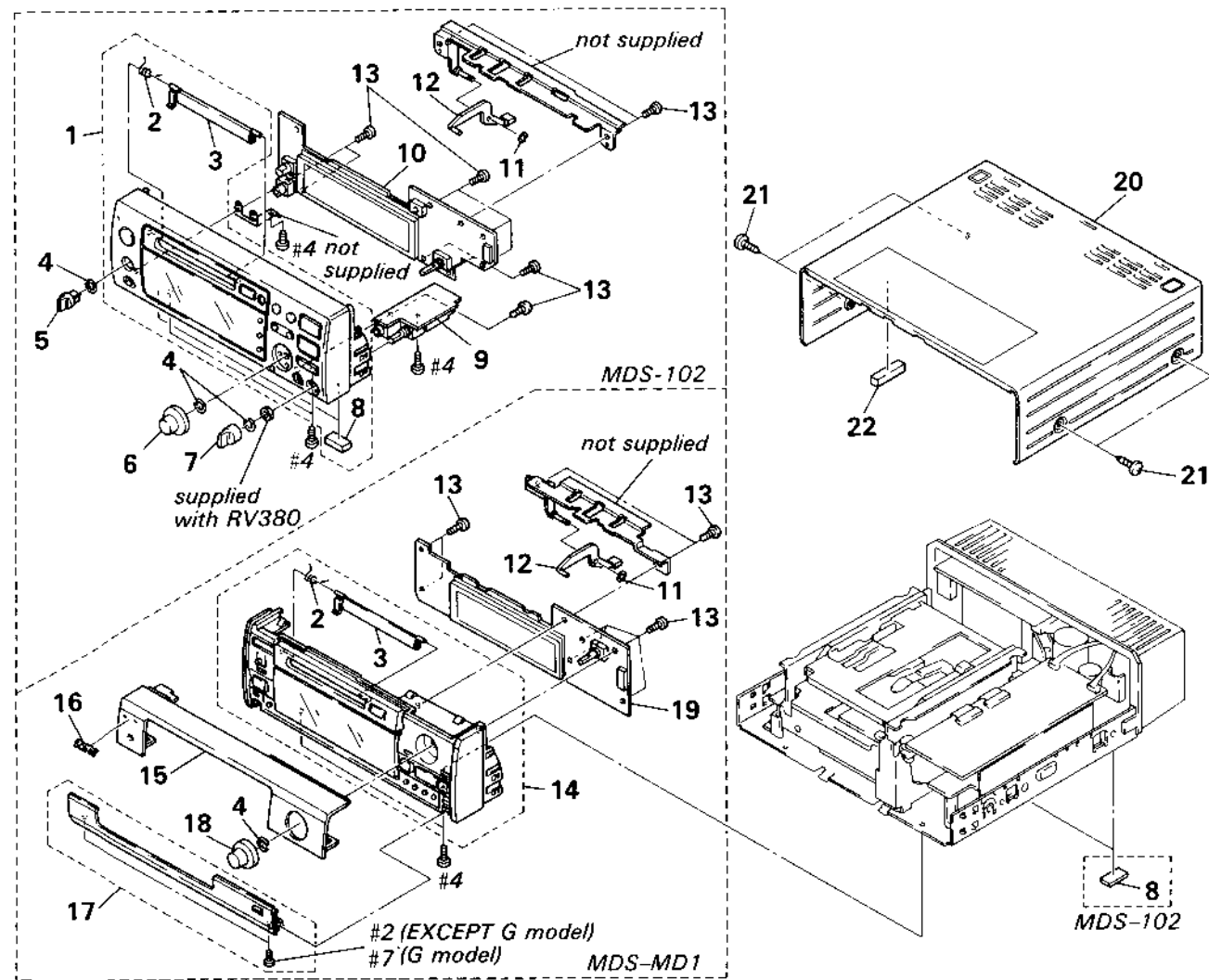

Ref.No.	Part No.	Description	Remark
1	X-4944-816-1	PANEL ASSY, FRONT (102)	
2	4-956-130-01	SPRING (LID), TORSION	
3	4-956-123-01	LID	
4	3-354-981-01	SPRING (SUS), RING	
5	4-962-168-01	KNOB (H.P.) (102)	
6	4-962-176-01	KNOB (AMS) (102)	
7	4-962-169-01	KNOB (REC) (102)	
8	4-930-336-61	FOOT (FELT) (102)	
*9	1-650-864-11	MIC BOARD (102)	
*10	A-4673-129-A	DISP BOARD, COMPLETE (102:SP, MX, JE)	
*10	A-4673-130-A	DISP BOARD, COMPLETE (102:AEP, UK)	
11	3-558-708-01	WASHER, STOPPER	
12	4-962-159-01	LEVER (LID)	

Ref.No.	Part No.	Description	Remark
13	4-951-620-01	SCREW (2.6X8), +BVTP	
14	X-4944-178-1	PANEL ASSY, FRONT (MD1)	
15	4-962-462-11	PANEL (ALUMINUM), FRONT (MD1)	
16	4-942-636-01	EMBLEM (NO.3.5), SONY (MD1)	
17	X-4944-180-1	PANEL ASSY, LID (MD1:EXCEPT G)	
17	X-4944-818-1	PANEL ASSY, LID (MD1:G)	
18	4-962-176-11	KNOB (AMS) (MD1)	
*19	A-4673-175-A	DISP BOARD, COMPLETE (MD1)	
20	4-962-937-01	CASE (102)	
20	4-962-937-21	CASE (MD1)	
21	3-363-099-01	SCREW (CASE 3 TP2)	
22	3-680-794-01	CUSHION, FRAME	

6-2. CHASSIS SECTION

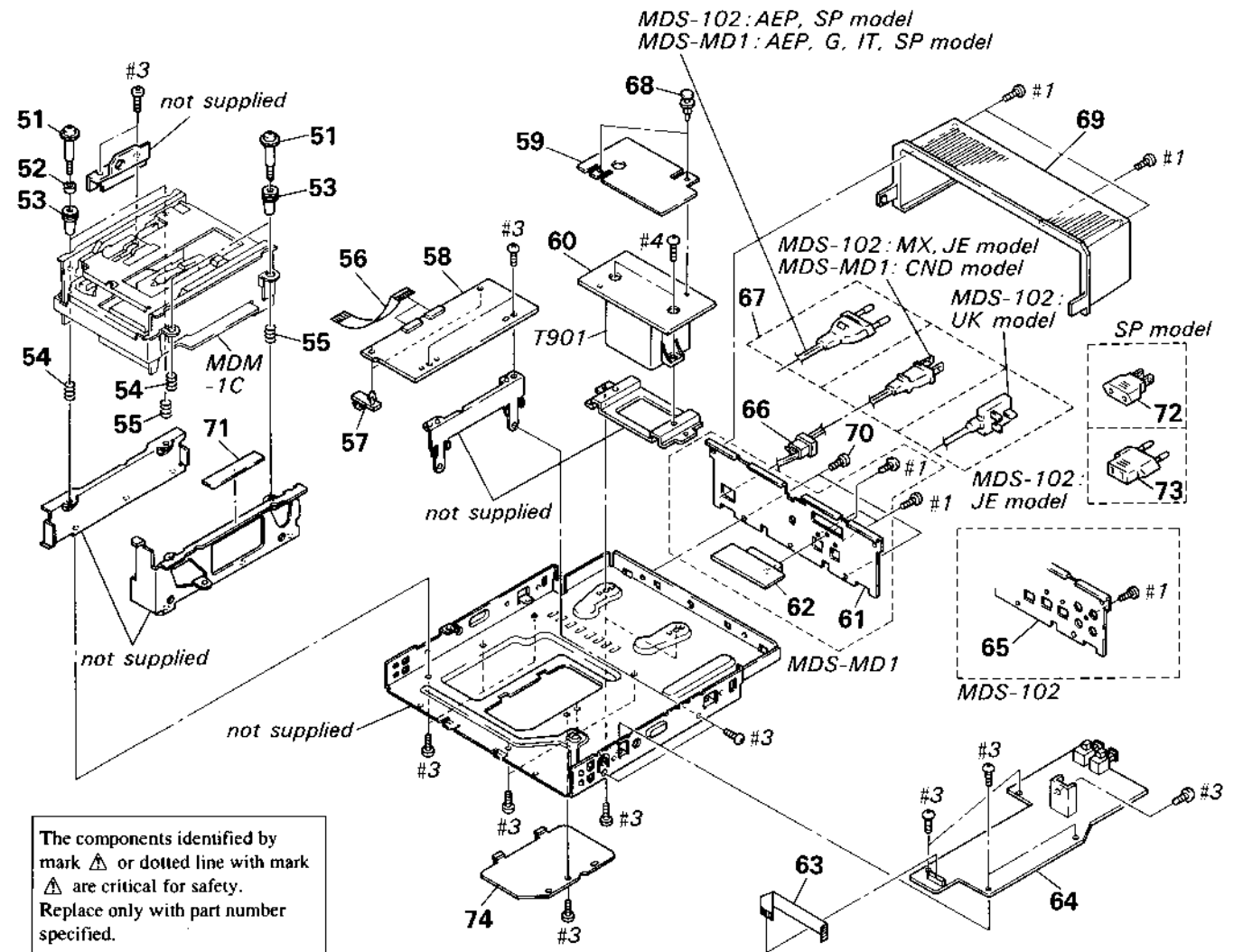

The components identified by mark Δ or dotted line with mark Δ are critical for safety. Replace only with part number specified.

Les composants identifiés par une marque Δ sont critiques pour la sécurité. Ne les remplacer que par une pièce portant le numéro spécifié.

Ref.No.	Part No.	Description	Remark
51	4-964-232-01	SCREW (M3), STEP	
52	4-958-120-01	BUSHING (DAMPER)	
53	4-957-800-11	DAMPER (MD)	
*54	4-958-087-01	SPRING (FRONT), COMPRESSION	
*55	4-958-088-01	SPRING (REAR), COMPRESSION	
56	1-751-829-11	WIRE (FLAT TYPE) (24 CORE)	
*57	3-696-448-01	HINGE, SS	
*58	A-4649-916-A	DIGITAL BOARD, COMPLETE	
*59	4-958-109-01	COVER (POWER)	
*60	1-650-862-11	AC BOARD	
*61	4-962-357-01	PLATE (MD-1), JACK (MD1)	
*62	1-650-866-11	ANALOG BUS BOARD (MD1)	
63	1-751-795-21	WIRE (FLAT TYPE) (13 CORE)	
*64	A-4649-911-A	AUDIO BOARD, COMPLETE (102)	
*64	A-4649-942-A	AUDIO BOARD, COMPLETE (MD1)	
*65	4-956-136-12	PLATE, JACK (102:SP, MX, JE)	
*65	4-956-136-21	PLATE, JACK (102:AEP, UK)	
*66	3-703-244-00	BUSHING (2104), CORD (MD1/102:AEP, UK, SP)	

Ref.No.	Part No.	Description	Remark
66	3-703-571-00	BUSHING (S) (4516), CORD (102:MX, JE)	
Δ 67	1-556-280-00	CORD, POWER (MD1:SP)	
Δ 67	1-575-131-11	CORD, POWER (MD1:AEP, G, IT)	
Δ 67	1-575-706-11	CORD, POWER (MD1:CND)	
Δ 67	1-696-027-11	CORD, POWER (102:MX, JE)	
Δ 67	1-696-586-11	CORD, POWER (102:UK)	
Δ 67	1-751-275-11	CORD, POWER (102:AEP, SP)	
68	4-812-134-00	RIVET NYLON, 3.5	
*69	4-956-138-01	PANEL, BACK	
70	3-703-685-21	SCREW (+BV 3X8)	
71	4-961-535-01	SPACER (COVER)	
Δ 72	1-569-008-11	ADAPTER, CONVERSION 2P (SP)	
Δ 73	1-569-007-11	ADAPTER, CONVERSION 2P (102:JE)	
*74	4-956-877-01	LID (CHASSIS)	
Δ T901	1-423-399-11	TRANSFORMER, POWER (MD1/102:AEP)	
Δ T901	1-423-400-11	TRANSFORMER, POWER (102:UK)	
Δ T901	1-423-401-11	TRANSFORMER, POWER (102:SP, MX, JE)	

**6-3. MECHANISM DECK SECTION-1
(MDM-1C)**

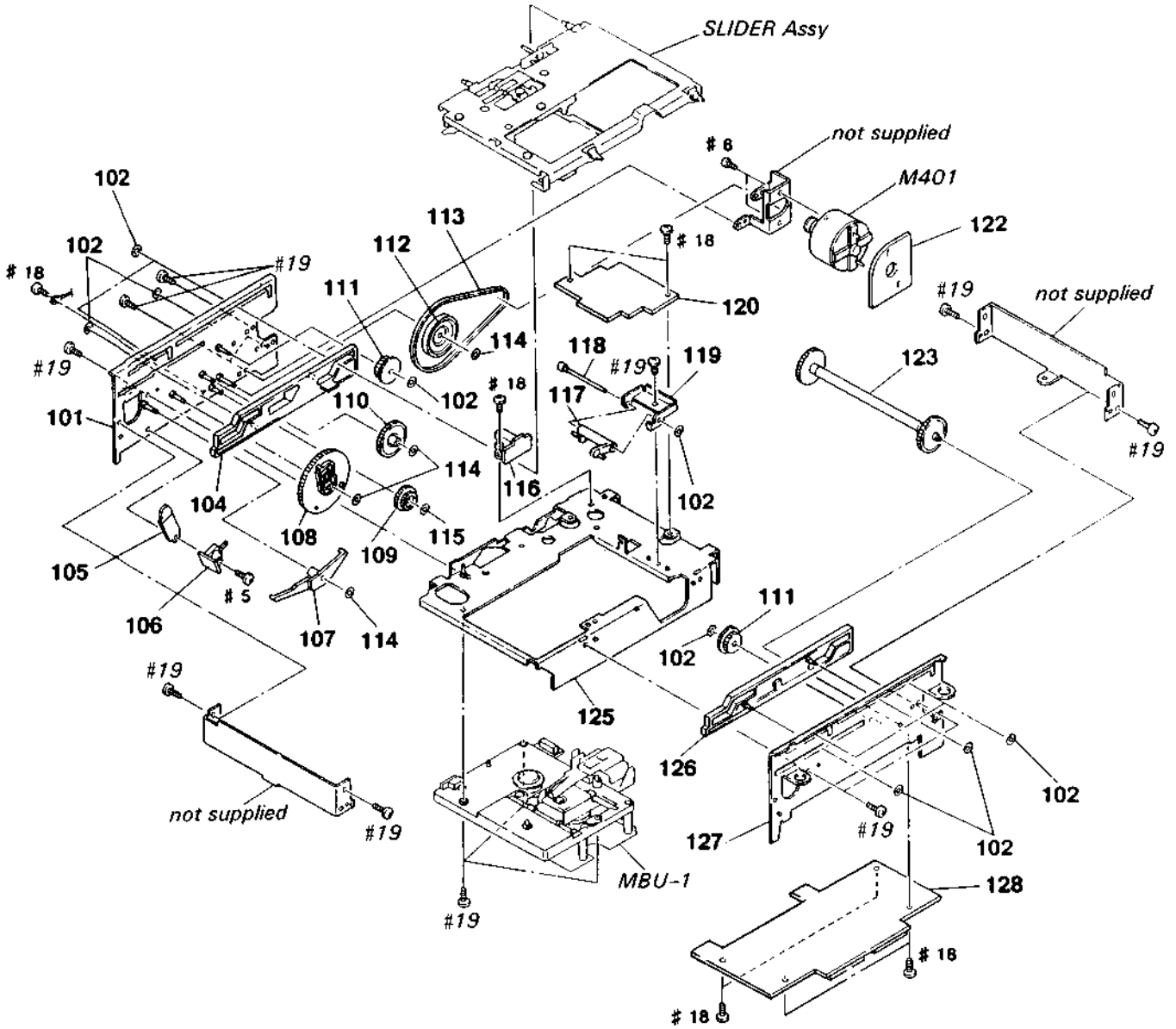

Ref.No.	Part No.	Description	Remark
*101	X-4943-546-1	BRACKET (GUIDE L) ASSY	
102	4-957-798-01	WASHER, STOPPER	
104	X-4943-553-1	RACK (PLATE CAM L) ASSY	
105	4-957-799-01	BLOCK (SW)	
*106	1-650-901-11	I/O SW BOARD	
107	4-962-171-01	LEVER (O/C)	
108	4-957-801-01	GEAR (CAM GEAR)	
109	4-957-805-01	GEAR (S)	
110	4-957-804-01	GEAR (2)	
111	4-957-795-01	GEAR (DRIVING)	
112	4-957-794-01	PULLEY (GEAR 1)	
113	4-957-797-01	BELT (LOADING)	
114	3-558-708-21	WASHER, STOPPER	

Ref.No.	Part No.	Description	Remark
115	3-558-708-01	WASHER, STOPPER	
*116	1-650-902-11	INTERRUPTER BOARD	
117	4-957-816-01	LEVER (REC LEVER)	
118	4-957-815-01	SHAFT (REC LEVER)	
*119	4-957-814-01	BRACKET (REC LEVER)	
*120	A-4649-921-A	HEAD DRIVE BOARD, COMPLETE	
*122	1-650-900-11	LOADING DRIVE BOARD	
123	A-4660-372-A	SHAFT (JOINT) ASSY	
*125	X-4943-552-1	BRACKET (BU) ASSY	
126	X-4943-551-1	RACK (PLATE CAM R) ASSY	
*127	X-4943-547-1	BRACKET (GUIDE R) ASSY	
*128	A-4649-918-A	RF/SERVO BOARD, COMPLETE	
M401	A-4660-373-A	MOTOR ASSY (LOADING)	

**6-4. MECHANISM DECK SECTION-2 (SLIDER ASSY)
(MDM-1C)**

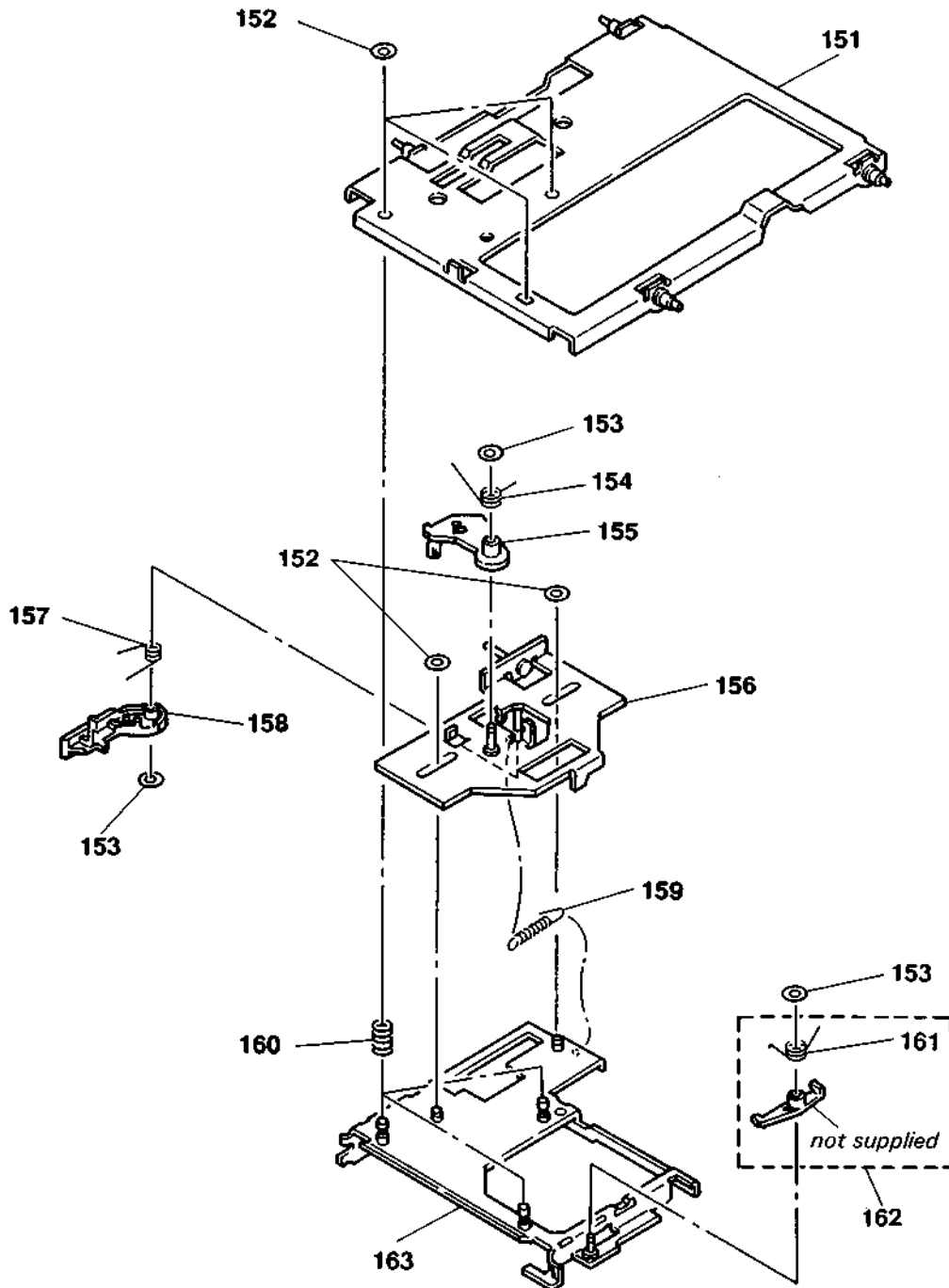

Ref.No.	Part No.	Description	Remark	Ref.No.	Part No.	Description	Remark
* 151	X-4943-549-1	SLIDER ASSY		158	4-957-803-01	LEVER (EJECT)	
152	3-558-708-01	WASHER, STOPPER		159	4-957-811-01	SPRING (EJ SLIDER), TORSION	
153	4-957-798-01	WASHER, STOPPER		160	4-957-808-01	SPRING, COMPRESSION	
154	4-957-810-01	SPRING, TORSION		161	4-957-812-01	SPRING (SHUTTER LEVER), TORSION	
155	4-957-802-01	LEVER (DETECTION)		162	X-4944-745-1	REPAIR KIT	
* 156	X-4943-550-1	SLIDER (EJECT) ASSY		* 163	X-4943-548-1	HOLDER ASSY	
157	4-957-809-01	SPRING (EJECT LEVER), TORSION					

6-5. BASE UNIT SECTION (MBU-1)

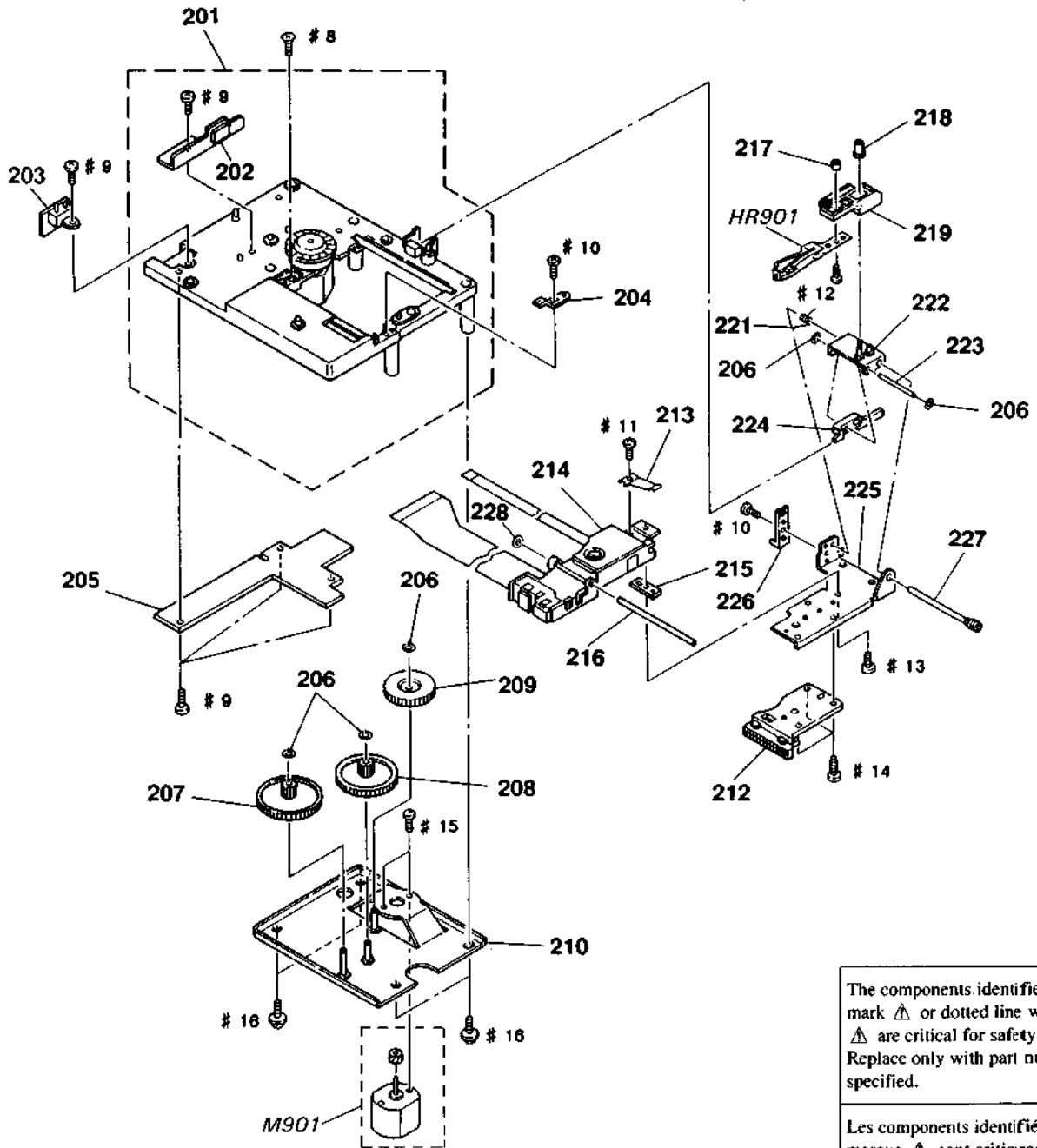

The components identified by mark Δ or dotted line with mark Δ are critical for safety. Replace only with part number specified.

Les composants identifiés par une marque Δ sont critiques pour la sécurité. Ne les remplacer que par une pièce portant le numéro spécifié.

Ref.No.	Part No.	Description	Remark
201	A-4660-222-A	CHASSIS (BU) COMPLETE ASSY BOARD, COMPLE	
202	A-4660-364-A	BRACKET (MAGNET) ASSY	
*203	1-647-648-11	DET SW BOARD	
204	4-957-047-01	HOLDER (SHAFT)	
*205	1-647-647-11	BU BOARD	
206	3-681-678-00	WASHER, SLIT	
207	4-957-057-01	GEAR (PINION A)	
208	4-957-058-01	GEAR (PINION B)	
209	4-957-059-01	GEAR (PINION C)	
*210	X-4943-431-1	BRACKET (PINION) ASSY	
212	X-4943-432-1	RACK ASSY	
213	4-957-056-01	DETENT (OPTICS BLOCK)	
Δ 214	8-583-003-21	DEVICE, MINI DISK KMS-140B	
215	4-957-048-01	SPACER	

Ref.No.	Part No.	Description	Remark
216	4-957-044-01	SHAFT (SLED A)	
217	4-957-053-01	NUT (M1.7), FITTING	
218	4-957-658-01	NUT (M2), FASTENING	
*219	4-957-054-01	HOLDER (OWH)	
221	4-957-049-01	SPRING (HOLDER), TORSION	
*222	X-4943-433-1	BRACKET (HOLDER) ASSY	
223	4-957-051-01	SHAFT (SLED D)	
*224	4-957-061-01	LEVER (OWH)	
*225	4-957-052-01	BRACKET (RACK)	
*226	4-957-055-01	HOLDER (WIRE)	
227	X-4943-434-1	SCREW ASSY, ADJUSTMENT	
228	4-958-741-01	SPACER	
HR901	1-500-006-11	HEAD, OVER LIGHT	
M901	X-4944-046-1	MOTOR ASSY (SLED)	

SECTION 7 ELECTRICAL PARTS LIST

AC
ANALOG BUS
AUDIO

NOTE:

- Due to standardization, replacements in the parts list may be different from the parts specified in the diagrams or the components used on the set.
- -XX and -X mean standardized parts, so they may have some difference from the original one.
- RESISTORS
All resistors are in ohms.
METAL: Metal-film resistor.
METAL OXIDE: Metal oxide-film resistor.
F: nonflammable

- Items marked "*" are not stocked since they are seldom required for routine service. Some delay should be anticipated when ordering these items.

● SEMICONDUCTORS

In each case, u : μ , for example:
 uA... : μ A..., uPA... : μ PA..., uPB... : μ PB...,
 uPC... : μ PC..., uPD... : μ PD...

● CAPACITORS

uF : μ F

● COILS

uH : μ H

● Abbreviations

CND : Canadian
 IT : Italian
 G : German

When indicating parts by reference number, please include the board.

The components identified by mark Δ or dotted line with mark Δ are critical for safety. Replace only with part number specified.

Les composants identifiés par une marque Δ sont critiques pour la sécurité. Ne les remplacer que par une pièce portant le numéro spécifié.

MX : Mexican 102 : MDS-102
 SP : Singapore MD1 : MDS-MD1
 JE : Tourist

Ref.No.	Part No.	Description	Remark
*	1-650-862-11	AC BOARD *****	
		< SWITCH >	
Δ S591	1-572-675-11	SWITCH, POWER VOLTAGE CHANGE (VOLTAGE SELECTOR) (102:SP, MX, JE)	
		< CAPACITOR >	
Δ C591	1-162-599-12	CERAMIC 0.0047uF 400V	
		< CONNECTOR >	
*CNP591	1-580-230-31	PIN, CONNECTOR (PC BOARD) 2P	
*CNP592	1-573-279-11	PIN, CONNECTOR 9P	
		< TRANSFORMER >	
Δ T501	1-424-485-11	FILTER, LINE *****	
*	1-650-866-11	ANALOG BUS BOARD *****	(MD1)
		< CONNECTOR >	
*CNP595	1-565-291-11	SOCKET, CONNECTOR 13P	
*CNP596	1-568-935-11	PIN, CONNECTOR 8P	
*CNP597	1-568-954-11	PIN, CONNECTOR 5P	
		< COIL >	
L592	1-216-295-00	METAL CHIP 0 5% 1/10W	
L593	1-216-295-00	METAL CHIP 0 5% 1/10W	
L594	1-216-295-00	METAL CHIP 0 5% 1/10W	
L595	1-216-295-00	METAL CHIP 0 5% 1/10W	
L596	1-216-295-00	METAL CHIP 0 5% 1/10W	
L597	1-216-295-00	METAL CHIP 0 5% 1/10W	
L598	1-216-295-00	METAL CHIP 0 5% 1/10W	

Ref.No.	Part No.	Description	Remark
*	A-4649-911-A	AUDIO BOARD, COMPLETE	(102)
*	A-4649-942-A	AUDIO BOARD, COMPLETE *****	(MD1)
		< CAPACITOR >	
	3-309-144-21	HEAT SINK	
	7-682-547-09	SCREW +BVTT 3X6 (S)	
C501	1-164-232-11	CERAMIC CHIP 0.01uF 50V	
C502	1-164-232-11	CERAMIC CHIP 0.01uF 50V	
C503	1-124-572-11	ELECT 100uF 20% 63V	
C504	1-163-038-11	CERAMIC CHIP 0.1uF 25V	
C505	1-104-773-11	ELECT 22000uF 20% 16V	
C506	1-126-937-11	ELECT 4700uF 20% 16V	
C507	1-104-748-11	ELECT 15000uF 20% 16V	
C508	1-126-950-11	ELECT 330uF 20% 35V	
C509	1-126-059-11	ELECT 10uF 20% 50V	(102)
C509	1-126-964-11	ELECT 10uF 20% 50V	(MD1)
C510	1-126-233-11	ELECT 22uF 20% 50V	
C511	1-163-037-11	CERAMIC CHIP 0.022uF 10% 25V	
C512	1-163-038-11	CERAMIC CHIP 0.1uF 25V	
C513	1-126-301-11	ELECT 1uF 20% 50V	
C514	1-126-831-71	ELECT 2200uF 20% 10V	
C515	1-163-038-11	CERAMIC CHIP 0.1uF 25V	
C516	1-124-994-11	ELECT 100uF 20% 10V	
C518	1-124-994-11	ELECT 100uF 20% 10V	
C520	1-124-994-11	ELECT 100uF 20% 10V	
C521	1-163-275-11	CERAMIC CHIP 0.001uF 5% 50V	
C522	1-163-275-11	CERAMIC CHIP 0.001uF 5% 50V	
C523	1-163-017-00	CERAMIC CHIP 0.0047uF 5% 50V	
C524	1-163-017-00	CERAMIC CHIP 0.0047uF 5% 50V	
C525	1-163-143-00	CERAMIC CHIP 0.0012uF 5% 50V	
C526	1-163-143-00	CERAMIC CHIP 0.0012uF 5% 50V	
C527	1-124-910-11	ELECT 47uF 20% 50V	
C528	1-124-910-11	ELECT 47uF 20% 50V	
C529	1-163-038-11	CERAMIC CHIP 0.1uF 25V	
C530	1-163-038-11	CERAMIC CHIP 0.1uF 25V	
C531	1-124-994-11	ELECT 100uF 20% 10V	

Ref. No.	Part No.	Description	Remark		
C532	1-124-994-11	ELECT	100uF	20%	10V
C533	1-126-023-11	ELECT	100uF	20%	16V
C534	1-126-023-11	ELECT	100uF	20%	16V
C535	1-124-903-11	ELECT	1uF	20%	50V (MD1)
C536	1-126-301-11	ELECT	1uF	20%	50V
C537	1-126-301-11	ELECT	1uF	20%	50V
C538	1-163-275-11	CERAMIC CHIP	0.001uF	5%	50V
C539	1-136-165-00	FILM	0.1uF	5%	50V (102)
C541	1-126-024-11	ELECT	220uF	20%	16V (102)
C542	1-126-024-11	ELECT	220uF	20%	16V (102)
C551	1-126-233-11	ELECT	22uF	20%	50V (102)
C551	1-124-927-11	ELECT	4.7uF	20%	100V (MD1)
C552	1-216-295-00	METAL CHIP	0	5%	1/10W
C553	1-163-038-11	CERAMIC CHIP	0.1uF		25V (102)
C553	1-216-295-00	METAL CHIP	0	5%	1/10W (MD1)
C561	1-124-994-11	ELECT	100uF	20%	10V (102)
C562	1-124-994-11	ELECT	100uF	20%	10V (102)
C563	1-163-239-11	CERAMIC CHIP	33PF	5%	50V
C564	1-163-239-11	CERAMIC CHIP	33PF	5%	50V
C565	1-126-233-11	ELECT	22uF	20%	50V
C566	1-126-233-11	ELECT	22uF	20%	50V
C567	1-124-910-11	ELECT	47uF	20%	50V
C568	1-124-910-11	ELECT	47uF	20%	50V
C569	1-163-038-11	CERAMIC CHIP	0.1uF		25V
C570	1-163-038-11	CERAMIC CHIP	0.1uF		25V
C581	1-163-038-11	CERAMIC CHIP	0.1uF		25V
C582	1-126-022-11	ELECT	47uF	20%	10V
C583	1-163-038-11	CERAMIC CHIP	0.1uF		25V
C584	1-163-275-11	CERAMIC CHIP	0.001uF	5%	50V (102)
C585	1-163-038-11	CERAMIC CHIP	0.1uF		25V (102)
< CONNECTOR >					
*CNP501	1-564-708-11	PIN, CONNECTOR (SMALL TYPE) 6P			
CNP502	1-580-465-11	SOCKET, CONNECTOR 13P			
*CNP521	1-564-710-11	PIN, CONNECTOR (SMALL TYPE) 8P			
*CNP541	1-564-705-11	PIN, CONNECTOR (SMALL TYPE) 3P (102)			
*CNP561	1-564-709-11	PIN, CONNECTOR (SMALL TYPE) 7P (102)			
*CNP562	1-564-708-11	PIN, CONNECTOR (SMALL TYPE) 6P (102)			
*CNP583	1-565-561-11	PIN, CONNECTOR 3P (102)			
*CNP581	1-564-709-11	PIN, CONNECTOR (SMALL TYPE) 7P			
< DIODE >					
D501	8-719-031-60	DIODE	EA40QC04F-TE16F2		
D502	8-719-210-39	DIODE	EC10QS-04		
D503	8-719-210-39	DIODE	EC10QS-04		
D504	8-719-210-39	DIODE	EC10QS-04		
D505	8-719-210-39	DIODE	EC10QS-04		
D506	8-719-210-39	DIODE	EC10QS-04		
D507	8-719-210-39	DIODE	EC10QS-04		

Ref. No.	Part No.	Description	Remark		
D508	8-719-210-33	DIODE	EC10DS2		
D509	8-719-422-43	DIODE	MA8051-H		(102)
D509	8-719-001-42	DIODE	UZL-11M1		(MD1)
D510	8-719-801-78	DIODE	1SS184		
D511	8-719-016-74	DIODE	1SS352		
D512	8-719-820-05	DIODE	1SS181		
D513	8-719-016-74	DIODE	1SS352		(102)
D561	8-719-016-74	DIODE	1SS352		(102)
D562	8-719-016-74	DIODE	1SS352		(102)
< IC >					
IC501	8-759-633-42	IC	M5293L		
IC502	8-759-927-29	IC	SN74HCU04ANS		
IC503	8-759-504-46	IC	PQ05RF1		
IC504	8-759-822-99	IC	L88MS05T-FA		
IC505	8-759-504-46	IC	PQ05RF1		
IC521	8-759-631-40	IC	M5294P		
IC522	8-759-982-04	IC	RC5532M		
IC541	8-759-981-86	IC	RC4556MA		(102)
IC561	8-759-114-06	IC	UPC81462-1		
IC581	8-749-921-12	IC	GP1F32T		
IC582	8-749-921-11	IC	GP1F32R		
< JACK >					
J521	1-573-520-11	JACK, PIN 4P (LINE IN/OUT)			(102)
< COIL >					
L581	1-410-393-11	INDUCTOR CHIP	100uH		
L582	1-543-962-21	BEAD, FERRITE (CHIP)			(102)
L583	1-543-962-21	BEAD, FERRITE (CHIP)			(102)
L584	1-543-962-21	BEAD, FERRITE (CHIP)			
< TRANSISTOR >					
Q501	8-729-421-19	TRANSISTOR	UN2213		
Q521	8-729-107-46	TRANSISTOR	2SC3624A-L15		
Q522	8-729-107-46	TRANSISTOR	2SC3624A-L15		
Q523	8-729-901-06	TRANSISTOR	DTA144EK		
Q561	8-729-120-28	TRANSISTOR	2SC1623-L5L6		(102)
Q562	8-729-120-28	TRANSISTOR	2SC1623-L5L6		(102)
Q581	8-729-901-06	TRANSISTOR	DTA144EK		(102)
Q582	8-729-421-19	TRANSISTOR	UN2213		(102)
Q583	8-729-120-28	TRANSISTOR	2SC1623-L5L6		(102)
< RESISTOR >					
R501	1-216-025-00	METAL CHIP	100	5%	1/10W
R502	1-216-089-00	METAL CHIP	47K	5%	1/10W
R503	1-216-025-00	METAL CHIP	100	5%	1/10W
R504	1-216-049-00	METAL CHIP	1K	5%	1/10W

AUDIO **BU** **DET SW** **DIGITAL**

Ref.No.	Part No.	Description	Remark			Ref.No.	Part No.	Description	Remark		
R505	1-216-073-00	METAL CHIP	10K	5%	1/10W	R569	1-216-041-00	METAL CHIP	470	5%	1/10W (102)
R506	1-216-109-00	METAL CHIP	330K	5%	1/10W	R570	1-216-041-00	METAL CHIP	470	5%	1/10W (102)
R507	1-216-073-00	METAL CHIP	10K	5%	1/10W	R571	1-216-061-00	METAL CHIP	3.3K	5%	1/10W
R508	1-216-089-00	METAL CHIP	47K	5%	1/10W	R572	1-216-061-00	METAL CHIP	3.3K	5%	1/10W
R509	1-216-025-00	METAL CHIP	100	5%	1/10W	R573	1-216-085-00	METAL CHIP	33K	5%	1/10W
R510	1-216-025-00	METAL CHIP	100	5%	1/10W (MD1)	R574	1-216-085-00	METAL CHIP	33K	5%	1/10W
R521	1-216-041-00	METAL CHIP	470	5%	1/10W	R575	1-216-001-00	METAL CHIP	10	5%	1/10W
R522	1-216-041-00	METAL CHIP	470	5%	1/10W	R576	1-216-001-00	METAL CHIP	10	5%	1/10W
R523	1-216-053-00	METAL CHIP	1.5K	5%	1/10W	R577	1-216-097-00	METAL CHIP	100K	5%	1/10W (102)
R524	1-216-053-00	METAL CHIP	1.5K	5%	1/10W	R578	1-216-073-00	METAL CHIP	10K	5%	1/10W
R525	1-216-053-00	METAL CHIP	1.5K	5%	1/10W	R579	1-216-689-11	METAL CHIP	39K	0.5%	1/10W (MD1)
R526	1-216-053-00	METAL CHIP	1.5K	5%	1/10W	R580	1-216-689-11	METAL CHIP	39K	0.5%	1/10W (MD1)
R527	1-216-105-00	METAL CHIP	220K	5%	1/10W	R581	1-216-001-00	METAL CHIP	10	5%	1/10W (102)
R528	1-216-105-00	METAL CHIP	220K	5%	1/10W	R582	1-216-073-00	METAL CHIP	10K	5%	1/10W (102)
R529	1-216-041-00	METAL CHIP	470	5%	1/10W	R583	1-216-065-00	METAL CHIP	4.7K	5%	1/10W (102)
R530	1-216-041-00	METAL CHIP	470	5%	1/10W	R584	1-216-089-00	METAL CHIP	47K	5%	1/10W (102)
R531	1-216-065-00	METAL CHIP	4.7K	5%	1/10W	R588	1-216-295-00	METAL CHIP	0	5%	1/10W (102)
R532	1-216-065-00	METAL CHIP	4.7K	5%	1/10W	< RELAY >					
R533	1-216-097-00	METAL CHIP	100K	5%	1/10W	RY561	1-515-719-11	RELAY	(102)		
R534	1-216-059-00	METAL CHIP	2.7K	5%	1/10W	*****					
R535	1-216-089-00	METAL CHIP	47K	5%	1/10W	* 1-647-647-11 BU BOARD					
R541	1-216-017-00	METAL CHIP	47	5%	1/10W (102)	*****					
R542	1-216-017-00	METAL CHIP	47	5%	1/10W (102)	< CONNECTOR >					
R543	1-216-017-00	METAL CHIP	47	5%	1/10W (102)	CN200	1-750-501-21	PIN, CONNECTOR (PC BOARD)	8P		
R544	1-216-017-00	METAL CHIP	47	5%	1/10W (102)	< SWITCH >					
R545	1-216-073-00	METAL CHIP	10K	5%	1/10W (102)	S901	1-572-467-21	SWITCH, PUSH (1 KEY)	(LIMIT)		
R546	1-216-073-00	METAL CHIP	10K	5%	1/10W (102)	*****					
R547	1-216-059-00	METAL CHIP	2.7K	5%	1/10W (102)	* 1-647-648-11 DET SW BOARD					
R548	1-216-059-00	METAL CHIP	2.7K	5%	1/10W (102)	*****					
R549	1-216-075-00	METAL CHIP	12K	5%	1/10W (102)	< SWITCH >					
R550	1-216-075-00	METAL CHIP	12K	5%	1/10W (102)	S001	1-692-464-11	SWITCH, PUSH (2 KEY)	(RFLCT/PROT)		
R551	1-216-085-00	METAL CHIP	33K	5%	1/10W (102)	*****					
R552	1-216-085-00	METAL CHIP	33K	5%	1/10W (102)	* A-4649-916-A DIGITAL BOARD, COMPLETE					
R553	1-216-182-91	METAL GLAZE	220	5%	1/8W (102)	*****					
R554	1-216-182-91	METAL GLAZE	220	5%	1/8W (102)	< CAPACITOR >					
R555	1-216-182-91	METAL GLAZE	220	5%	1/8W (102)	C100	1-126-204-11	ELECT CHIP	47uF	20%	16V
R556	1-216-182-91	METAL GLAZE	220	5%	1/8W (102)	C101	1-163-038-11	CERAMIC CHIP	0.1uF		25V
R559	1-216-295-00	METAL CHIP	0	5%	1/10W	C102	1-163-038-11	CERAMIC CHIP	0.1uF		25V
R561	1-216-083-00	METAL CHIP	27K	5%	1/10W (102)	C103	1-163-227-11	CERAMIC CHIP	10PF	0.5PF	50V
R561	1-216-073-00	METAL CHIP	10K	5%	1/10W (MD1)	C104	1-216-295-00	METAL CHIP	0	5%	1/10W
R562	1-216-083-00	METAL CHIP	27K	5%	1/10W (102)	C105	1-163-038-11	CERAMIC CHIP	0.1uF		25V
R562	1-216-073-00	METAL CHIP	10K	5%	1/10W (MD1)						
R563	1-216-295-00	METAL CHIP	0	5%	1/10W (MD1)						
R564	1-216-295-00	METAL CHIP	0	5%	1/10W (MD1)						
R565	1-216-097-00	METAL CHIP	100K	5%	1/10W						
R566	1-216-097-00	METAL CHIP	100K	5%	1/10W						
R567	1-216-065-00	METAL CHIP	4.7K	5%	1/10W (102)						
R568	1-216-065-00	METAL CHIP	4.7K	5%	1/10W (102)						

DIGITAL

Ref.No.	Part No.	Description	Remark	Ref.No.	Part No.	Description	Remark
C106	1-163-091-00	CERAMIC CHIP	8PF 50V	C157	1-164-005-11	CERAMIC CHIP	0.47uF 25V
C107	1-163-038-11	CERAMIC CHIP	0.1uF 25V	C160	1-163-038-11	CERAMIC CHIP	0.1uF 25V
C108	1-163-038-11	CERAMIC CHIP	0.1uF 25V	C165	1-163-038-11	CERAMIC CHIP	0.1uF 25V
C110	1-163-038-11	CERAMIC CHIP	0.1uF 25V	C166	1-163-038-11	CERAMIC CHIP	0.1uF 25V
C111	1-163-038-11	CERAMIC CHIP	0.1uF 25V	C167	1-163-038-11	CERAMIC CHIP	0.1uF 25V
C112	1-163-038-11	CERAMIC CHIP	0.1uF 25V	C168	1-163-038-11	CERAMIC CHIP	0.1uF 25V
C113	1-126-204-11	ELECT CHIP	47uF 20% 16V	C169	1-163-227-11	CERAMIC CHIP	10PF 0.5PF 50V
C114	1-126-204-11	ELECT CHIP	47uF 20% 16V	C175	1-163-038-11	CERAMIC CHIP	0.1uF 25V
C115	1-163-038-11	CERAMIC CHIP	0.1uF 25V	C177	1-163-038-11	CERAMIC CHIP	0.1uF 25V
C116	1-164-004-11	CERAMIC CHIP	0.1uF 10% 25V	C178	1-163-104-00	CERAMIC CHIP	30PF 5% 50V
C117	1-163-038-11	CERAMIC CHIP	0.1uF 25V	C179	1-163-038-11	CERAMIC CHIP	0.1uF 25V
C118	1-164-004-11	CERAMIC CHIP	0.1uF 10% 25V	C180	1-163-038-11	CERAMIC CHIP	0.1uF 25V
C119	1-164-004-11	CERAMIC CHIP	0.1uF 10% 25V	C181	1-163-038-11	CERAMIC CHIP	0.1uF 25V
C120	1-126-206-11	ELECT CHIP	100uF 20% 6.3V	C182	1-163-038-11	CERAMIC CHIP	0.1uF 25V
C121	1-163-113-00	CERAMIC CHIP	68PF 5% 50V	C184	1-163-038-11	CERAMIC CHIP	0.1uF 25V
C122	1-163-009-11	CERAMIC CHIP	0.001uF 10% 50V	C185	1-163-038-11	CERAMIC CHIP	0.1uF 25V
C123	1-164-004-11	CERAMIC CHIP	0.1uF 10% 25V	C186	1-163-038-11	CERAMIC CHIP	0.1uF 25V
C124	1-163-009-11	CERAMIC CHIP	0.001uF 10% 50V	C187	1-163-038-11	CERAMIC CHIP	0.1uF 25V
C125	1-104-563-11	FILM CHIP	0.1uF 5% 16V	C188	1-126-395-11	ELECT	22uF 20% 16V
C126	1-163-038-11	CERAMIC CHIP	0.1uF 25V	C189	1-126-395-11	ELECT	22uF 20% 16V
C127	1-163-038-11	CERAMIC CHIP	0.1uF 25V	C191	1-163-038-11	CERAMIC CHIP	0.1uF 25V
C128	1-163-038-11	CERAMIC CHIP	0.1uF 25V	C192	1-216-295-00	METAL CHIP	0 5% 1/10W
C130	1-163-038-11	CERAMIC CHIP	0.1uF 25V	C197	1-163-009-11	CERAMIC CHIP	0.001uF 10% 50V
C131	1-104-640-11	FILM CHIP	0.22uF 5% 16V	C198	1-164-346-11	CERAMIC CHIP	1uF 16V
C132	1-163-037-11	CERAMIC CHIP	0.022uF 10% 25V	C199	1-163-009-11	CERAMIC CHIP	0.001uF 10% 50V
C133	1-163-038-11	CERAMIC CHIP	0.1uF 25V	C201	1-163-133-00	CERAMIC CHIP	470PF 5% 50V
C134	1-137-299-11	FILM CHIP	0.027uF 5% 16V	C202	1-163-121-00	CERAMIC CHIP	150PF 5% 50V
C135	1-164-232-11	CERAMIC CHIP	0.01uF 50V	C516	1-163-104-00	CERAMIC CHIP	30PF 5% 50V
C136	1-163-038-11	CERAMIC CHIP	0.1uF 25V	C517	1-163-115-00	CERAMIC CHIP	82PF 5% 50V
C137	1-126-206-11	ELECT CHIP	100uF 20% 6.3V	C520	1-163-038-11	CERAMIC CHIP	0.1uF 25V
C138	1-126-204-11	ELECT CHIP	47uF 20% 16V	C521	1-126-204-11	ELECT CHIP	47uF 20% 16V
C139	1-163-038-11	CERAMIC CHIP	0.1uF 25V	C523	1-163-104-00	CERAMIC CHIP	30PF 5% 50V
C140	1-164-232-11	CERAMIC CHIP	0.01uF 50V	C524	1-163-115-00	CERAMIC CHIP	82PF 5% 50V
C141	1-163-038-11	CERAMIC CHIP	0.1uF 25V	C526	1-163-038-11	CERAMIC CHIP	0.1uF 25V
C142	1-126-204-11	ELECT CHIP	47uF 20% 16V	C527	1-163-038-11	CERAMIC CHIP	0.1uF 25V
C143	1-163-038-11	CERAMIC CHIP	0.1uF 25V	C528	1-163-038-11	CERAMIC CHIP	0.1uF 25V
C144	1-163-038-11	CERAMIC CHIP	0.1uF 25V	C529	1-126-204-11	ELECT CHIP	47uF 20% 16V
C145	1-126-204-11	ELECT CHIP	47uF 20% 16V	C530	1-163-038-11	CERAMIC CHIP	0.1uF 25V
C146	1-163-038-11	CERAMIC CHIP	0.1uF 25V	C534	1-163-104-00	CERAMIC CHIP	30PF 5% 50V
C147	1-126-204-11	ELECT CHIP	47uF 20% 16V	C537	1-163-104-00	CERAMIC CHIP	30PF 5% 50V
C148	1-164-161-11	CERAMIC CHIP	0.0022uF 10% 100V	C538	1-163-038-11	CERAMIC CHIP	0.1uF 25V
C149	1-164-161-11	CERAMIC CHIP	0.0022uF 10% 100V	C539	1-126-204-11	ELECT CHIP	47uF 20% 16V
C150	1-163-038-11	CERAMIC CHIP	0.1uF 25V	C541	1-126-204-11	ELECT CHIP	47uF 20% 16V
C151	1-163-009-11	CERAMIC CHIP	0.001uF 10% 50V	C542	1-163-038-11	CERAMIC CHIP	0.1uF 25V
C152	1-163-038-11	CERAMIC CHIP	0.1uF 25V	C543	1-163-038-11	CERAMIC CHIP	0.1uF 25V
C153	1-126-204-11	ELECT CHIP	47uF 20% 16V	C544	1-126-204-11	ELECT CHIP	47uF 20% 16V
C154	1-163-038-11	CERAMIC CHIP	0.1uF 25V	C555	1-104-551-11	FILM CHIP	0.01uF 5% 16V
C155	1-163-038-11	CERAMIC CHIP	0.1uF 25V	C560	1-104-551-11	FILM CHIP	0.01uF 5% 16V
C156	1-163-038-11	CERAMIC CHIP	0.1uF 25V	C561	1-163-093-00	CERAMIC CHIP	10PF 5% 50V

DIGITAL

Ref.No.	Part No.	Description	Remark		
C564	1-163-038-11	CERAMIC CHIP	0.1uF		25V
C565	1-164-004-11	CERAMIC CHIP	0.1uF	10%	25V
C566	1-164-004-11	CERAMIC CHIP	0.1uF	10%	25V
C567	1-126-204-11	ELECT CHIP	47uF	20%	16V
C568	1-126-204-11	ELECT CHIP	47uF	20%	16V
C569	1-124-779-00	ELECT CHIP	10uF	20%	16V
C583	1-164-004-11	CERAMIC CHIP	0.1uF	10%	25V
C584	1-164-004-11	CERAMIC CHIP	0.1uF	10%	25V

< CONNECTOR >

*CNP101	1-750-511-21	CONNECTOR, FFC/FPC 24P			
*CNP102	1-750-511-21	CONNECTOR, FFC/FPC 24P			
*CNP103	1-750-495-11	PIN, CONNECTOR (PC BOARD) 7P			
*CNP105	1-695-241-11	PIN, CONNECTOR (PC BOARD) 8P			
*CNP108	1-750-495-11	PIN, CONNECTOR (PC BOARD) 7P			

< DIODE >

D101	8-719-016-74	DIODE	1SS352		
D102	8-719-974-98	DIODE	HVM17-01		
D103	8-719-016-74	DIODE	1SS352		
D104	8-719-016-74	DIODE	1SS352		
D105	8-719-016-74	DIODE	1SS352		
D106	8-719-016-74	DIODE	1SS352		
D107	8-719-016-74	DIODE	1SS352		

< IC >

IC101	8-752-365-90	IC	CXD2531BR		
IC103	8-752-352-18	IC	CXD2525R		
IC104	8-759-242-70	IC	TC7WU04F		
IC106	8-759-177-69	IC	TLV23621D-ELL2500		
IC109	8-759-249-85	IC	MSM514400A70SJADR1-K		
IC110	8-752-363-57	IC	CXD2526AR		
IC111	8-759-269-55	IC	M38067M8-126FP		
IC121	8-759-187-04	IC	TC74HC365AF-TP1		
IC122	8-759-251-48	IC	uPD358GR-E1		
IC131	8-759-082-58	IC	TC7W08FU-TE12L		
IC132	8-759-083-94	IC	TC7W74FU		
IC191	8-759-083-94	IC	TC7W74FU		
IC192	8-759-234-13	IC	TC4S30F		
IC505	8-752-359-50	IC	CXD2564AM		
IC507	8-759-981-48	IC	TL082M		
IC510	8-759-045-15	IC	CS5339-KS		

< JUMPER RESISTOR >

JW101	1-216-295-00	METAL CHIP	0	5%	1/10W
JW121	1-216-295-00	METAL CHIP	0	5%	1/10W
JW122	1-216-295-00	METAL CHIP	0	5%	1/10W
JW131	1-216-295-00	METAL CHIP	0	5%	1/10W

Ref.No.	Part No.	Description	Remark		
JW132	1-216-295-00	METAL CHIP	0	5%	1/10W
JW133	1-216-295-00	METAL CHIP	0	5%	1/10W
JW134	1-216-295-00	METAL CHIP	0	5%	1/10W
JW135	1-216-295-00	METAL CHIP	0	5%	1/10W
JW141	1-216-295-00	METAL CHIP	0	5%	1/10W
JW143	1-216-295-00	METAL CHIP	0	5%	1/10W
JW154	1-216-295-00	METAL CHIP	0	5%	1/10W
JW155	1-216-295-00	METAL CHIP	0	5%	1/10W
JW156	1-216-295-00	METAL CHIP	0	5%	1/10W
JW157	1-216-295-00	METAL CHIP	0	5%	1/10W
JW158	1-216-295-00	METAL CHIP	0	5%	1/10W
JW159	1-216-295-00	METAL CHIP	0	5%	1/10W
JW167	1-216-295-00	METAL CHIP	0	5%	1/10W
JW201	1-216-295-00	METAL CHIP	0	5%	1/10W

< COIL >

L102	1-412-332-41	INDUCTOR	2.2uH		
L103	1-412-332-41	INDUCTOR	2.2uH		
L104	1-412-340-31	INDUCTOR	10uH		
L105	1-412-344-31	INDUCTOR	22uH		
L107	1-412-340-31	INDUCTOR	10uH		
L108	1-412-336-41	INDUCTOR	4.7uH		
L109	1-412-332-41	INDUCTOR	2.2uH		
L150	1-543-962-21	BEAD, FERRITE (CHIP)			
L151	1-550-907-21	BEAD, FERRITE (CHIP)			
L152	1-543-962-21	BEAD, FERRITE (CHIP)			
L153	1-216-295-00	METAL CHIP	0	5%	1/10W
L154	1-216-295-00	METAL CHIP	0	5%	1/10W
L155	1-216-295-00	METAL CHIP	0	5%	1/10W
L156	1-216-295-00	METAL CHIP	0	5%	1/10W
L157	1-216-295-00	METAL CHIP	0	5%	1/10W
L158	1-216-295-00	METAL CHIP	0	5%	1/10W
L501	1-412-336-41	INDUCTOR	4.7uH		
L502	1-410-387-21	INDUCTOR CHIP	33uH		
L503	1-412-336-41	INDUCTOR	4.7uH		
L504	1-412-336-41	INDUCTOR	4.7uH		
L505	1-216-296-00	METAL CHIP	0	5%	1/8W
L506	1-216-296-00	METAL CHIP	0	5%	1/8W
L507	1-412-336-41	INDUCTOR	4.7uH		

< TRANSISTOR >

Q505	8-729-421-19	TRANSISTOR	UN2213		
------	--------------	------------	--------	--	--

< RESISTOR >

R100	1-543-962-21	BEAD, FERRITE (CHIP)			
R101	1-216-025-00	METAL CHIP	100	5%	1/10W
R102	1-216-295-00	METAL CHIP	0	5%	1/10W
R103	1-216-043-00	METAL CHIP	560	5%	1/10W

DIGITAL

Ref.No.	Part No.	Description	Remark		
R104	1-216-081-00	METAL CHIP	22K	5%	1/10W
R105	1-216-295-00	METAL CHIP	0	5%	1/10W
R112	1-216-121-00	METAL CHIP	1M	5%	1/10W
R113	1-216-675-11	METAL CHIP	10K	0.5%	1/10W
R117	1-216-121-00	METAL CHIP	1M	5%	1/10W
R118	1-216-049-00	METAL CHIP	1K	5%	1/10W
R119	1-216-049-00	METAL CHIP	1K	5%	1/10W
R120	1-216-077-00	METAL CHIP	15K	5%	1/10W
R121	1-216-077-00	METAL CHIP	15K	5%	1/10W
R122	1-216-073-00	METAL CHIP	10K	5%	1/10W
R123	1-216-073-00	METAL CHIP	10K	5%	1/10W
R124	1-216-295-00	METAL CHIP	0	5%	1/10W
R125	1-216-073-00	METAL CHIP	10K	5%	1/10W
R126	1-216-073-00	METAL CHIP	10K	5%	1/10W
R127	1-216-043-00	METAL CHIP	560	5%	1/10W
R128	1-216-043-00	METAL CHIP	560	5%	1/10W
R129	1-543-963-21	BEAD, FERRITE (CHIP)			
R130	1-216-073-00	METAL CHIP	10K	5%	1/10W
R131	1-216-073-00	METAL CHIP	10K	5%	1/10W
R132	1-216-073-00	METAL CHIP	10K	5%	1/10W
R133	1-216-070-00	METAL CHIP	7.5K	5%	1/10W
R134	1-216-081-00	METAL CHIP	22K	5%	1/10W
R135	1-216-073-00	METAL CHIP	10K	5%	1/10W
R137	1-216-295-00	METAL CHIP	0	5%	1/10W
R138	1-216-069-00	METAL CHIP	6.8K	5%	1/10W
R139	1-216-295-00	METAL CHIP	0	5%	1/10W
R140	1-216-043-00	METAL CHIP	560	5%	1/10W
R142	1-216-073-00	METAL CHIP	10K	5%	1/10W
R143	1-216-295-00	METAL CHIP	0	5%	1/10W
R144	1-216-041-00	METAL CHIP	470	5%	1/10W
R145	1-216-049-00	METAL CHIP	1K	5%	1/10W
R146	1-216-049-00	METAL CHIP	1K	5%	1/10W
R147	1-216-045-00	METAL CHIP	680	5%	1/10W
R148	1-216-081-00	METAL CHIP	22K	5%	1/10W
R149	1-216-081-00	METAL CHIP	22K	5%	1/10W
R150	1-216-081-00	METAL CHIP	22K	5%	1/10W
R151	1-216-073-00	METAL CHIP	10K	5%	1/10W
R153	1-216-073-00	METAL CHIP	10K	5%	1/10W
R154	1-216-073-00	METAL CHIP	10K	5%	1/10W
R155	1-216-073-00	METAL CHIP	10K	5%	1/10W
R156	1-216-073-00	METAL CHIP	10K	5%	1/10W
R157	1-216-073-00	METAL CHIP	10K	5%	1/10W
R158	1-216-073-00	METAL CHIP	10K	5%	1/10W
R159	1-216-073-00	METAL CHIP	10K	5%	1/10W
R160	1-216-073-00	METAL CHIP	10K	5%	1/10W
R161	1-216-295-00	METAL CHIP	0	5%	1/10W
R162	1-216-295-00	METAL CHIP	0	5%	1/10W

Ref.No.	Part No.	Description	Remark		
R163	1-216-295-00	METAL CHIP	0	5%	1/10W
R164	1-216-073-00	METAL CHIP	10K	5%	1/10W
R166	1-216-073-00	METAL CHIP	10K	5%	1/10W
R167	1-216-073-00	METAL CHIP	10K	5%	1/10W
R168	1-216-073-00	METAL CHIP	10K	5%	1/10W
R169	1-216-073-00	METAL CHIP	10K	5%	1/10W
R170	1-216-073-00	METAL CHIP	10K	5%	1/10W
R171	1-216-073-00	METAL CHIP	10K	5%	1/10W
R172	1-216-073-00	METAL CHIP	10K	5%	1/10W
R173	1-216-073-00	METAL CHIP	10K	5%	1/10W
R174	1-216-073-00	METAL CHIP	10K	5%	1/10W
R175	1-216-073-00	METAL CHIP	10K	5%	1/10W
R176	1-216-081-00	METAL CHIP	22K	5%	1/10W
R177	1-216-073-00	METAL CHIP	10K	5%	1/10W
R178	1-216-073-00	METAL CHIP	10K	5%	1/10W
R179	1-216-073-00	METAL CHIP	10K	5%	1/10W
R180	1-216-025-00	METAL CHIP	100	5%	1/10W
R181	1-216-065-00	METAL CHIP	4.7K	5%	1/10W
R182	1-216-065-00	METAL CHIP	4.7K	5%	1/10W
R183	1-216-065-00	METAL CHIP	4.7K	5%	1/10W
R184	1-216-049-00	METAL CHIP	1K	5%	1/10W
R185	1-216-049-00	METAL CHIP	1K	5%	1/10W
R186	1-216-049-00	METAL CHIP	1K	5%	1/10W
R187	1-216-065-00	METAL CHIP	4.7K	5%	1/10W
R188	1-216-073-00	METAL CHIP	10K	5%	1/10W
R189	1-216-066-00	METAL CHIP	5.1K	5%	1/10W
R190	1-216-097-00	METAL CHIP	100K	5%	1/10W
R192	1-216-073-00	METAL CHIP	10K	5%	1/10W
R194	1-216-073-00	METAL CHIP	10K	5%	1/10W
R195	1-216-073-00	METAL CHIP	10K	5%	1/10W
R196	1-216-073-00	METAL CHIP	10K	5%	1/10W
R197	1-216-073-00	METAL CHIP	10K	5%	1/10W
R198	1-216-073-00	METAL CHIP	10K	5%	1/10W
R202	1-216-097-00	METAL CHIP	100K	5%	1/10W
R203	1-216-097-00	METAL CHIP	100K	5%	1/10W
R301	1-216-073-00	METAL CHIP	10K	5%	1/10W
R511	1-216-694-11	METAL CHIP	62K	0.5%	1/10W
R512	1-208-812-11	METAL CHIP	18K	0.50%	1/10W
R519	1-216-694-11	METAL CHIP	62K	0.5%	1/10W
R520	1-208-812-11	METAL CHIP	18K	0.50%	1/10W
R522	1-216-635-11	METAL CHIP	220	0.5%	1/10W
R523	1-216-627-11	METAL CHIP	100	0.5%	1/10W
R529	1-216-694-11	METAL CHIP	62K	0.5%	1/10W
R531	1-216-687-11	METAL CHIP	33K	0.5%	1/10W
R532	1-216-687-11	METAL CHIP	33K	0.5%	1/10W
R533	1-216-694-11	METAL CHIP	62K	0.5%	1/10W
R536	1-216-687-11	METAL CHIP	33K	0.5%	1/10W















DIGITAL DISP

Ref.No.	Part No.	Description	Remark		
R537	1-216-687-11	METAL CHIP	33K	0.5%	1/10W
R538	1-208-812-11	METAL CHIP	18K	0.50%	1/10W
R543	1-208-812-11	METAL CHIP	18K	0.50%	1/10W
R548	1-216-015-00	METAL CHIP	39	5%	1/10W
R555	1-216-620-11	METAL CHIP	51	0.5%	1/10W
R556	1-216-015-00	METAL CHIP	39	5%	1/10W
< VIBRATOR >					
X102	1-760-173-11	VIBRATOR, CRYSTAL (45.1584MHz)			
X103	1-579-951-11	VIBRATOR, CERAMIC (CHIP TYPE) (6MHz)			

*	A-4673-129-A	DISP BOARD, COMPLETE	(102:SP, MX, JE)		
*	A-4673-130-A	DISP BOARD, COMPLETE	(102:AEP, UK)		
*	A-4673-175-A	DISP BOARD, COMPLETE	(MD1)		

*	4-956-134-01	HOLDER (FL TUBE)			
< CAPACITOR >					
C300	1-163-038-11	CERAMIC CHIP	0.1uF		25V (102)
C301	1-163-038-11	CERAMIC CHIP	0.1uF		25V (102)
C301	1-165-319-11	CERAMIC CHIP	0.1uF		50V (MD1)
C302	1-126-205-11	ELECT CHIP	47uF	20%	6.3V
C303	1-163-038-11	CERAMIC CHIP	0.1uF		25V (102)
C303	1-165-319-11	CERAMIC CHIP	0.1uF		50V (MD1)
C304	1-164-695-11	CERAMIC CHIP	0.0022uF	5%	50V (MD1)
C305	1-164-161-11	CERAMIC CHIP	0.0022uF	10%	100V (102)
C305	1-164-695-11	CERAMIC CHIP	0.0022uF	5%	50V (MD1)
C306	1-164-161-11	CERAMIC CHIP	0.0022uF	10%	100V (102)
C311	1-163-038-11	CERAMIC CHIP	0.1uF		25V (102)
C311	1-165-319-11	CERAMIC CHIP	0.1uF		50V (MD1)
C312	1-163-038-11	CERAMIC CHIP	0.1uF		25V (102)
C312	1-165-319-11	CERAMIC CHIP	0.1uF		50V (MD1)
C313	1-163-117-00	CERAMIC CHIP	100PF	5%	50V
C314	1-163-035-00	CERAMIC CHIP	0.047uF		50V (102)
C314	1-104-760-11	CERAMIC CHIP	0.047uF	10%	50V (MD1)
C315	1-163-009-11	CERAMIC CHIP	0.001uF	10%	50V
C316	1-163-009-11	CERAMIC CHIP	0.001uF	10%	50V
C317	1-163-009-11	CERAMIC CHIP	0.001uF	10%	50V
C318	1-164-232-11	CERAMIC CHIP	0.01uF		50V (102)
C318	1-163-009-11	CERAMIC CHIP	0.001uF	10%	50V (MD1)
C321	1-163-038-11	CERAMIC CHIP	0.1uF		25V (102)
C321	1-165-319-11	CERAMIC CHIP	0.1uF		50V (MD1)
C322	1-163-038-11	CERAMIC CHIP	0.1uF		25V (102)
C323	1-163-038-11	CERAMIC CHIP	0.1uF		25V (102)
C324	1-135-155-21	TANTALUM CHIP	4.7uF	10%	16V (102)
C340	1-104-905-11	CAP, DOUBLE LAYERS	0.22F		5.5V
C341	1-163-038-11	CERAMIC CHIP	0.1uF		25V (102)
C341	1-165-319-11	CERAMIC CHIP	0.1uF		50V (MD1)

Ref.No.	Part No.	Description	Remark		
C342	1-135-155-21	TANTALUM CHIP	4.7uF	10%	16V (102)
C342	1-126-163-11	ELECT	4.7uF	20%	50V (MD1)
C343	1-163-017-00	CERAMIC CHIP	0.0047uF	5%	50V
C344	1-163-229-11	CERAMIC CHIP	12PF	5%	50V (102)
C344	1-163-099-00	CERAMIC CHIP	18PF	5%	50V (MD1)
C345	1-163-234-11	CERAMIC CHIP	20PF	5%	50V
C346	1-163-009-11	CERAMIC CHIP	0.001uF	10%	50V (MD1)
C346	1-164-232-11	CERAMIC CHIP	0.01uF		50V (102)
C351	1-165-319-11	CERAMIC CHIP	0.1uF		50V (MD1)
C351	1-163-038-11	CERAMIC CHIP	0.1uF		25V (102)
C352	1-104-760-11	CERAMIC CHIP	0.047uF	10%	50V (MD1)
C352	1-163-035-00	CERAMIC CHIP	0.047uF		50V (102)
C353	1-104-760-11	CERAMIC CHIP	0.047uF	10%	50V (MD1)
C353	1-163-035-00	CERAMIC CHIP	0.047uF		50V (102)
C354	1-165-319-11	CERAMIC CHIP	0.1uF		50V (MD1)
C355	1-165-319-11	CERAMIC CHIP	0.1uF		50V (MD1)
C356	1-165-319-11	CERAMIC CHIP	0.1uF		50V (MD1)
C381	1-163-038-11	CERAMIC CHIP	0.1uF		25V (102)
C382	1-163-141-00	CERAMIC CHIP	0.001uF	5%	50V (102)
C383	1-163-141-00	CERAMIC CHIP	0.001uF	5%	50V (102)
C391	1-163-038-11	CERAMIC CHIP	0.1uF		25V (102)
< CONNECTOR >					
CN301	1-580-477-11	SOCKET, CONNECTOR 13P	(MD1)		
CN301	1-580-867-11	SOCKET, CONNECTOR (SMT) 13P	(102)		
CN302	1-750-500-11	PIN, CONNECTOR (PC BOARDP) 7P	(102)		
CN381	1-750-491-11	PIN, CONNECTOR (PC BOARDP) 3P	(102)		
< DIODE >					
D301	8-719-038-63	LED SEL5220S-TH8C (ON/STANDBY)	(102)		
D302	8-719-016-74	DIODE 1SS352	(MD1)		
D303	8-719-016-74	DIODE 1SS352	(MD1)		
< FLUORESCENT INDICATOR TUBE >					
FL301	1-517-112-21	INDICATOR TUBE, FLUORESCENT			
< IC >					
IC301	8-759-278-72	IC M38004M8-111FP			
IC302	8-759-164-44	IC CXD8459M-T2			
IC303	8-759-926-06	IC SN74HC126ANS			
IC304	8-759-512-55	IC S-3520CF			
IC305	8-749-923-64	IC NJM32H400	(102)		
IC306	8-759-927-46	IC SN74HC00ANS	(102)		
< JACK >					
J381	1-750-925-11	JACK (SMALL TYPE) (HEADPHONE)			

Ref.No.	Part No.	Description	Remark	Ref.No.	Part No.	Description	Remark
< JUMPER RESISTOR >							
JW2	1-216-295-00	METAL CHIP	0 5% 1/10W	R329	1-216-097-00	METAL CHIP	100K 5% 1/10W (102)
JW3	1-216-295-00	METAL CHIP	0 5% 1/10W	R330	1-216-097-00	METAL CHIP	100K 5% 1/10W
JW4	1-216-295-00	METAL CHIP	0 5% 1/10W	R331	1-216-083-00	METAL CHIP	27K 5% 1/10W
JW5	1-216-295-00	METAL CHIP	0 5% 1/10W	R335	1-216-025-00	METAL CHIP	100 5% 1/10W
JW6	1-216-295-00	METAL CHIP	0 5% 1/10W (102)	R336	1-216-025-00	METAL CHIP	100 5% 1/10W
JW7	1-216-295-00	METAL CHIP	0 5% 1/10W (102)	R337	1-216-073-00	METAL CHIP	10K 5% 1/10W
JW8	1-216-295-00	METAL CHIP	0 5% 1/10W (102)	R338	1-216-025-00	METAL CHIP	100 5% 1/10W
< COIL >							
L321	1-410-393-11	INDUCTOR CHIP	100uH (102)	R339	1-216-025-00	METAL CHIP	100 5% 1/10W
< TRANSISTOR >							
Q301	8-729-421-19	TRANSISTOR	UN2213 (102)	R343	1-216-049-00	METAL CHIP	1K 5% 1/10W
Q302	8-729-602-21	TRANSISTOR	2SC4154 (MD1)	R344	1-216-013-00	METAL CHIP	33 5% 1/10W
Q341	8-729-421-19	TRANSISTOR	UN2213	R351	1-216-041-00	METAL CHIP	470 5% 1/10W
Q342	8-729-216-22	TRANSISTOR	2SA1162-G	R353	1-216-025-00	METAL CHIP	100 5% 1/10W
< RESISTOR >							
R301	1-216-073-00	METAL CHIP	10K 5% 1/10W	R352	1-216-041-00	METAL CHIP	470 5% 1/10W (102)
R304	1-216-097-00	METAL CHIP	100K 5% 1/10W	R354	1-216-025-00	METAL CHIP	100 5% 1/10W
R305	1-216-097-00	METAL CHIP	100K 5% 1/10W	R355	1-216-025-00	METAL CHIP	100 5% 1/10W
R306	1-216-097-00	METAL CHIP	100K 5% 1/10W	R356	1-216-025-00	METAL CHIP	100 5% 1/10W (102)
R307	1-216-065-00	METAL CHIP	4.7K 5% 1/10W	R358	1-216-073-00	METAL CHIP	10K 5% 1/10W (MD1)
R308	1-216-097-00	METAL CHIP	100K 5% 1/10W	R359	1-216-073-00	METAL CHIP	10K 5% 1/10W (MD1)
R309	1-216-097-00	METAL CHIP	100K 5% 1/10W (102:AEP, UK/MD1)	R368	1-216-073-00	METAL CHIP	10K 5% 1/10W (MD1)
R310	1-216-089-00	METAL CHIP	47K 5% 1/10W (102:SP, MX, JE)	R369	1-216-065-00	METAL CHIP	4.7K 5% 1/10W (MD1)
R311	1-216-097-00	METAL CHIP	100K 5% 1/10W (UK)	R370	1-216-073-00	METAL CHIP	10K 5% 1/10W (MD1)
R312	1-216-089-00	METAL CHIP	47K 5% 1/10W (MD1/102:AEP)	R378	1-216-001-00	METAL CHIP	10 5% 1/10W (MD1)
R313	1-216-097-00	METAL CHIP	100K 5% 1/10W	R391	1-216-073-00	METAL CHIP	10K 5% 1/10W
R314	1-216-097-00	METAL CHIP	100K 5% 1/10W	< VARIABLE RESISTOR >			
R315	1-216-097-00	METAL CHIP	100K 5% 1/10W	RV381	1-223-559-11	RES, VAR, CARBON 1K/1K(PHONE LEVEL)	(102)
R316	1-216-097-00	METAL CHIP	100K 5% 1/10W	< SWITCH >			
R317	1-216-037-00	METAL CHIP	330 5% 1/10W (102)	S301	1-467-490-11	ENCODER, ROTARY ( AMS )	
R318	1-216-073-00	METAL CHIP	10K 5% 1/10W	S311	1-692-481-11	SWITCH, KEY BOARD (POWER)	(102)
R319	1-216-073-00	METAL CHIP	10K 5% 1/10W	S312	1-554-303-21	SWITCH, TACTILE (DISPLAY)	(MD1)
R320	1-216-097-00	METAL CHIP	100K 5% 1/10W	S312	1-692-481-11	SWITCH, KEY BOARD (DISPLAY)	(102)
R321	1-216-097-00	METAL CHIP	100K 5% 1/10W	S313	1-554-303-21	SWITCH, TACTILE ()	(MD1)
R322	1-216-097-00	METAL CHIP	100K 5% 1/10W	S313	1-692-481-11	SWITCH, KEY BOARD ()	(102)
R323	1-216-097-00	METAL CHIP	100K 5% 1/10W	S314	1-554-303-21	SWITCH, TACTILE (EDIT/NO)	(MD1)
R324	1-216-097-00	METAL CHIP	100K 5% 1/10W	S314	1-692-481-11	SWITCH, KEY BOARD (EDIT/NO)	(102)
R325	1-216-097-00	METAL CHIP	100K 5% 1/10W	S315	1-554-303-21	SWITCH, TACTILE ()	(MD1)
R326	1-216-097-00	METAL CHIP	100K 5% 1/10W	S315	1-692-481-11	SWITCH, KEY BOARD ()	(102)
R327	1-216-097-00	METAL CHIP	100K 5% 1/10W	S316	1-554-303-21	SWITCH, TACTILE ()	(MD1)
R328	1-216-097-00	METAL CHIP	100K 5% 1/10W (MD1)	S316	1-692-481-11	SWITCH, KEY BOARD ()	(102)
				S317	1-554-303-21	SWITCH, TACTILE (YES)	(MD1)
				S317	1-692-481-11	SWITCH, KEY BOARD (YES)	(102)
				S318	1-554-303-21	SWITCH, TACTILE ()	(MD1)
				S318	1-692-481-11	SWITCH, KEY BOARD ()	(102)
				S319	1-554-303-21	SWITCH, TACTILE (REC )	(MD1)
				S319	1-692-481-11	SWITCH, KEY BOARD ()	(102)
				S320	1-554-303-21	SWITCH, TACTILE ()	(MD1)
				S320	1-692-481-11	SWITCH, KEY BOARD ()	(102)

DISP

HEAD DRIVE

INTERRUPTER

I/O SW

LOADING DRIVE

Ref.No.	Part No.	Description	Remark
S321	1-692-481-11	SWITCH, KEY BOARD (INPUT SELECTOR)	(102)
S322	1-692-481-11	SWITCH, KEY BOARD (CLOCK SET)	(102)
S323	1-554-303-21	SWITCH, TACTILE (P.MODE)	(MD1)
S323	1-692-481-11	SWITCH, KEY BOARD (P.MODE)	(102)
S324	1-554-303-21	SWITCH, TACTILE (CD SYNCHRO)	(MD1)
< VIBRATOR >			
X301	1-579-841-21	VIBRATOR, CERAMIC (CHIP TYPE) (5MHz)	(102)
X301	1-579-233-11	VIBRATOR, CERAMIC (5MHz)	(MD1)
X341	1-567-098-41	VIBRATOR, CRYSTAL (32.768Hz)	

*	A-4649-921-A	HEAD DRIVE BOARD, COMPLETE	

< CAPACITOR >			
C401	1-164-004-11	CERAMIC CHIP	0.1uF 10% 25V
C402	1-164-004-11	CERAMIC CHIP	0.1uF 10% 25V
C405	1-165-379-11	CERAMIC CHIP	0.0022uF 10% 500V
C406	1-135-159-21	TANTALUM CHIP	10uF 10% 20V
C407	1-164-336-11	CERAMIC CHIP	0.33uF 25V
< CONNECTOR >			
*CN401	1-695-123-11	PIN, CONNECTOR (PC BOARD)	6P
CN403	1-750-491-11	PIN, CONNECTOR (PC BOARD)	3P
< DIODE >			
D401	8-719-033-60	DIODE	F1P2STP
D402	8-719-033-60	DIODE	F1P2STP
D403	8-719-033-60	DIODE	F1P2STP
D404	8-719-033-60	DIODE	F1P2STP
D405	8-719-033-60	DIODE	F1P2STP
D406	8-719-033-60	DIODE	F1P2STP
< IC >			
IC401	8-759-244-73	IC	TC74ACT540F
IC402	8-759-243-19	IC	TC7SU04F
< TRANSISTOR >			
Q401	8-729-017-97	TRANSISTOR	ME8P06-TE16F3
Q402	8-729-017-97	TRANSISTOR	ME8P06-TE16F3
Q403	8-729-017-96	TRANSISTOR	ME6N10-TE16F3
Q404	8-729-017-96	TRANSISTOR	ME6N10-TE16F3
< RESISTOR >			
R401	1-216-097-00	METAL CHIP	100K 5% 1/10W
R402	1-216-097-00	METAL CHIP	100K 5% 1/10W
R403	1-216-097-00	METAL CHIP	100K 5% 1/10W
R404	1-216-097-00	METAL CHIP	100K 5% 1/10W
R405	1-216-298-00	METAL CHIP	2.2 5% 1/10W

Ref.No.	Part No.	Description	Remark
R406	1-216-298-00	METAL CHIP	2.2 5% 1/10W
R407	1-216-134-00	METAL CHIP	2.2 5% 1/8W
R408	1-216-134-00	METAL CHIP	2.2 5% 1/8W
R409	1-216-298-00	METAL CHIP	2.2 5% 1/10W
R410	1-216-134-00	METAL CHIP	2.2 5% 1/8W
R411	1-216-134-00	METAL CHIP	2.2 5% 1/8W
R412	1-216-298-00	METAL CHIP	2.2 5% 1/10W
R413	1-216-138-00	METAL CHIP	3.3 5% 1/8W
R414	1-216-138-00	METAL CHIP	3.3 5% 1/8W
R415	1-216-138-00	METAL CHIP	3.3 5% 1/8W
R416	1-216-138-00	METAL CHIP	3.3 5% 1/8W
R417	1-216-049-00	METAL CHIP	1K 5% 1/10W
R418	1-216-073-00	METAL CHIP	10K 5% 1/10W
R419	1-216-049-00	METAL CHIP	1K 5% 1/10W
R420	1-216-073-00	METAL CHIP	10K 5% 1/10W
R421	1-216-073-00	METAL CHIP	10K 5% 1/10W

*	1-650-902-11	INTERRUPTER BOARD	

< IC >			
IC403	8-759-071-52	IC	ON1023-S

*	1-650-901-11	I/O SW BOARD	

< CONNECTOR >			
CN412	1-691-992-11	PIN, CONNECTOR (PC BOARD)	3P
< SWITCH >			
S401	1-571-300-21	SWITCH, ROTARY (IN/OUT)	

*	1-650-900-11	LOADING DRIVE BOARD	

< CAPACITOR >			
C430	1-126-204-11	ELECT CHIP	47uF 20% 16V
< CONNECTOR >			
CN430	1-750-498-11	PIN, CONNECTOR (PC BOARD)	4P
< DIODE >			
D430	8-719-017-79	DIODE	MA8033

LOADING DRIVE MIC RF/SERVO

Ref.No.	Part No.	Description	Remark
		< IC >	
IC430	8-759-636-20	IC M54641FP-TP	
		< TRANSISTOR >	
Q430	8-729-421-19	TRANSISTOR UN2213	

*	1-650-864-11	MIC BOARD *****	(102)
		< CAPACITOR >	
C361	1-163-141-00	CERAMIC CHIP 0.001uF 5%	50V
C362	1-163-038-11	CERAMIC CHIP 0.1uF	25V
C363	1-163-141-00	CERAMIC CHIP 0.001uF 5%	50V
C364	1-163-117-00	CERAMIC CHIP 100PF 5%	50V
C365	1-163-141-00	CERAMIC CHIP 0.001uF 5%	50V
C366	1-163-038-11	CERAMIC CHIP 0.1uF	25V
C368	1-163-038-11	CERAMIC CHIP 0.1uF	25V
C369	1-163-038-11	CERAMIC CHIP 0.1uF	25V
C370	1-163-038-11	CERAMIC CHIP 0.1uF	25V
C371	1-163-141-00	CERAMIC CHIP 0.001uF 5%	50V
C372	1-163-038-11	CERAMIC CHIP 0.1uF	25V
C373	1-163-141-00	CERAMIC CHIP 0.001uF 5%	50V
C374	1-163-117-00	CERAMIC CHIP 100PF 5%	50V
C375	1-163-141-00	CERAMIC CHIP 0.001uF 5%	50V
C376	1-163-038-11	CERAMIC CHIP 0.1uF	25V
		< CONNECTOR >	
CN361	1-750-500-11	PIN, CONNECTOR (PC BOARDP) 7	
*CN380	1-695-123-11	PIN, CONNECTOR (PC BOARDP) 6	
		< IC >	
IC361	8-759-636-55	IC M5218AFP	
		< JACK >	
J361	1-562-837-21	JACK (MIC)	
		< RESISTOR >	
R361	1-216-073-00	METAL CHIP 10K 5%	1/10W
R362	1-216-041-00	METAL CHIP 470 5%	1/10W
R363	1-216-081-00	METAL CHIP 22K 5%	1/10W
R364	1-216-077-00	METAL CHIP 15K 5%	1/10W
R365	1-216-041-00	METAL CHIP 470 5%	1/10W
R366	1-216-097-00	METAL CHIP 100K 5%	1/10W
R367	1-216-041-00	METAL CHIP 470 5%	1/10W
R371	1-216-073-00	METAL CHIP 10K 5%	1/10W
R372	1-216-041-00	METAL CHIP 470 5%	1/10W
R373	1-216-081-00	METAL CHIP 22K 5%	1/10W

Ref.No.	Part No.	Description	Remark
R374	1-216-077-00	METAL CHIP 15K 5%	1/10W
R375	1-216-041-00	METAL CHIP 470 5%	1/10W
R376	1-216-097-00	METAL CHIP 100K 5%	1/10W
R377	1-216-041-00	METAL CHIP 470 5%	1/10W
		< VARIABLE RESISTOR >	
RV380	1-223-575-11	RES, VAR, CARBON 20K/20K (REC LEVEL)	

*	A-4649-918-A	RF/SERVO BOARD, COMPLETE *****	
		< CAPACITOR >	
C201	1-164-004-11	CERAMIC CHIP 0.1uF	10% 25V
C202	1-126-206-11	ELECT CHIP 100uF	20% 6.3V
C203	1-126-395-11	ELECT 22uF	20% 16V
C204	1-126-395-11	ELECT 22uF	20% 16V
C205	1-164-004-11	CERAMIC CHIP 0.1uF	10% 25V
C206	1-104-544-11	FILM CHIP 0.0027uF	5% 50V
C207	1-163-989-11	CERAMIC CHIP 0.033uF	10% 25V
C208	1-164-004-11	CERAMIC CHIP 0.1uF	10% 25V
C209	1-135-159-21	TANTALUM CHIP 10uF	10% 20V
C210	1-126-193-11	ELECT 1uF	20% 50V
C211	1-164-004-11	CERAMIC CHIP 0.1uF	10% 25V
C212	1-104-555-11	FILM CHIP 0.022uF	5% 16V
C213	1-163-009-11	CERAMIC CHIP 0.001uF	10% 50V
C214	1-164-232-11	CERAMIC CHIP 0.01uF	50V
C215	1-163-009-11	CERAMIC CHIP 0.001uF	10% 50V
C216	1-163-017-00	CERAMIC CHIP 0.0047uF	5% 50V
C217	1-163-009-11	CERAMIC CHIP 0.001uF	10% 50V
C218	1-163-037-11	CERAMIC CHIP 0.022uF	10% 25V
C219	1-163-009-11	CERAMIC CHIP 0.001uF	10% 50V
C220	1-163-037-11	CERAMIC CHIP 0.022uF	10% 25V
C221	1-164-489-11	CERAMIC CHIP 0.22uF	10% 16V
C222	1-126-191-11	ELECT 0.47uF	20% 50V
C223	1-164-232-11	CERAMIC CHIP 0.01uF	50V
C224	1-164-004-11	CERAMIC CHIP 0.1uF	10% 25V
C225	1-135-159-21	TANTALUM CHIP 10uF	10% 20V
C226	1-164-004-11	CERAMIC CHIP 0.1uF	10% 25V
C231	1-126-395-11	ELECT 22uF	20% 16V
C232	1-163-018-00	CERAMIC CHIP 0.0056uF	5% 50V
C233	1-104-543-11	FILM CHIP 0.0022uF	5% 50V
C234	1-163-117-00	CERAMIC CHIP 100PF	5% 50V
C235	1-135-091-00	TANTALUM CHIP 1uF	20% 16V
C236	1-164-004-11	CERAMIC CHIP 0.1uF	10% 25V
C237	1-126-395-11	ELECT 22uF	20% 16V
C238	1-126-191-11	ELECT 0.47uF	20% 50V
C239	1-104-557-11	FILM CHIP 0.033uF	5% 16V
C240	1-126-206-11	ELECT CHIP 100uF	20% 6.3V

RF/SERVO

Ref.No.	Part No.	Description	Remark			Ref.No.	Part No.	Description	Remark		
C241	1-164-232-11	CERAMIC CHIP	0.01uF		50V	C456	1-104-551-11	FILM CHIP	0.01uF	5%	16V
C242	1-164-232-11	CERAMIC CHIP	0.01uF		50V	C457	1-104-559-11	FILM CHIP	0.047uF	5%	16V
C243	1-164-004-11	CERAMIC CHIP	0.1uF	10%	25V	C458	1-164-161-11	CERAMIC CHIP	0.0022uF	10%	100V
C244	1-126-395-11	ELECT	22uF	20%	16V	C459	1-163-117-00	CERAMIC CHIP	100PF	5%	50V
C245	1-104-640-11	FILM CHIP	0.22uF	5%	16V	C460	1-163-017-00	CERAMIC CHIP	0.0047uF	5%	50V
C246	1-126-602-11	ELECT CHIP	3.3uF	20%	50V	C462	1-126-395-11	ELECT	22uF	20%	16V
C249	1-126-395-11	ELECT	22uF	20%	16V	C463	1-126-395-11	ELECT	22uF	20%	16V
C250	1-104-559-11	FILM CHIP	0.047uF	5%	16V	C480	1-163-121-00	CERAMIC CHIP	150PF	5%	50V
C251	1-104-563-11	FILM CHIP	0.1uF	5%	16V	C481	1-163-121-00	CERAMIC CHIP	150PF	5%	50V
C252	1-124-779-00	ELECT CHIP	10uF	20%	16V	C483	1-163-139-00	CERAMIC CHIP	820PF	5%	50V
C253	1-126-193-11	ELECT	1uF	20%	50V	C484	1-164-004-11	CERAMIC CHIP	0.1uF	10%	25V
C254	1-124-779-00	ELECT CHIP	10uF	20%	16V	C485	1-126-191-11	ELECT	0.47uF	20%	50V
C255	1-126-193-11	ELECT	1uF	20%	50V	C486	1-164-004-11	CERAMIC CHIP	0.1uF	10%	25V
C256	1-163-009-11	CERAMIC CHIP	0.001uF	10%	50V	< CONNECTOR >					
C258	1-164-004-11	CERAMIC CHIP	0.1uF	10%	25V	*CN201	1-695-154-11	SOCKET, CONNECTOR	18P		
C259	1-164-346-11	CERAMIC CHIP	1uF		16V	*CN202	1-750-898-11	SOCKET, CONNECTOR	5P		
C260	1-164-004-11	CERAMIC CHIP	0.1uF	10%	25V	CN203	1-750-501-21	PIN, CONNECTOR (PC BOARD)	8P		
C261	1-164-346-11	CERAMIC CHIP	1uF		16V	CN204	1-750-491-11	PIN, CONNECTOR (PC BOARD)	3P		
C262	1-164-346-11	CERAMIC CHIP	1uF		16V	CN205	1-750-498-11	PIN, CONNECTOR (PC BOARD)	4P		
C263	1-164-004-11	CERAMIC CHIP	0.1uF	10%	25V	*CN206	1-695-123-11	PIN, CONNECTOR (PC BOARD)	6P		
C265	1-126-206-11	ELECT CHIP	100uF	20%	6.3V	CN207	1-750-279-11	CONNECTOR, FFC/FPC	24P		
C266	1-164-346-11	CERAMIC CHIP	1uF		16V	CN208	1-750-279-11	CONNECTOR, FFC/FPC	24P		
C267	1-164-232-11	CERAMIC CHIP	0.01uF		50V	CN209	1-750-500-11	PIN, CONNECTOR (PC BOARD)	7P		
C268	1-126-206-11	ELECT CHIP	100uF	20%	6.3V	< DIODE >					
C269	1-164-346-11	CERAMIC CHIP	1uF		16V	D201	8-719-421-15	DIODE	MA8027-L		
C270	1-164-232-11	CERAMIC CHIP	0.01uF		50V	D202	8-719-016-74	DIODE	1SS352		
C271	1-126-395-11	ELECT	22uF	20%	16V	D203	8-719-210-39	DIODE	EC10QS-04		
C272	1-126-206-11	ELECT CHIP	100uF	20%	6.3V	D204	8-719-210-39	DIODE	EC10QS-04		
C273	1-164-346-11	CERAMIC CHIP	1uF		16V	D205	8-719-210-39	DIODE	EC10QS-04		
C274	1-126-395-11	ELECT	22uF	20%	16V	D480	8-719-029-88	DIODE	HSM198STL		
C275	1-126-395-11	ELECT	22uF	20%	16V	< IC >					
C276	1-104-563-11	FILM CHIP	0.1uF	5%	16V	IC201	8-752-064-34	IC	CXA1381R		
C278	1-126-395-11	ELECT	22uF	20%	16V	IC202	8-752-057-45	IC	CXA1082BQ		
C279	1-164-004-11	CERAMIC CHIP	0.1uF	10%	25V	IC203	8-759-084-72	IC	MPC1718FU		
C280	1-164-004-11	CERAMIC CHIP	0.1uF	10%	25V	IC204	8-759-009-06	IC	MC14052BF		
C287	1-126-193-11	ELECT	1uF	20%	50V	IC205	8-759-177-69	IC	TLV23621D-ELL2500		
C291	1-163-243-11	CERAMIC CHIP	47PF	5%	50V	IC206	8-759-710-79	IC	NJM2107F		
C292	1-163-009-11	CERAMIC CHIP	0.001uF	10%	50V	IC207	8-759-300-71	IC	HD14053BFP		
C293	1-163-245-11	CERAMIC CHIP	56PF	5%	50V	IC208	8-759-242-70	IC	TC7WU04F		
C294	1-163-133-00	CERAMIC CHIP	470PF	5%	50V	IC209	8-759-300-71	IC	HD14053BFP		
C295	1-163-133-00	CERAMIC CHIP	470PF	5%	50V	IC210	8-759-243-19	IC	TC7SU04F		
C296	1-164-004-11	CERAMIC CHIP	0.1uF	10%	25V	IC211	8-759-822-99	IC	L88MS05T-FA		
C299	1-163-227-11	CERAMIC CHIP	10PF	0.5PF	50V	IC212	8-759-822-99	IC	L88MS05T-FA		
C450	1-164-004-11	CERAMIC CHIP	0.1uF	10%	25V	IC213	8-759-822-99	IC	L88MS05T-FA		
C451	1-126-395-11	ELECT	22uF	20%	16V	IC214	8-759-243-19	IC	TC7SU04F		
C452	1-164-004-11	CERAMIC CHIP	0.1uF	10%	25V	IC215	8-759-710-79	IC	NJM2107F		
C453	1-126-395-11	ELECT	22uF	20%	16V						
C454	1-163-263-11	CERAMIC CHIP	330PF	5%	50V						
C455	1-164-344-11	CERAMIC CHIP	0.068uF	10%	25V						

Ref. No.	Part No.	Description	Remark
IC450	8-752-064-33	IC CXA1380N	
IC480	8-759-177-69	IC TLV2362ID-ELL2500	
IC481	8-759-075-70	IC TA78S393F	
< COIL >			
L201	1-216-295-00	METAL CHIP 0 5%	1/10W
L202	1-543-948-11	BEAD, FERRITE (CHIP)	
L203	1-543-948-11	BEAD, FERRITE (CHIP)	
L204	1-543-948-11	BEAD, FERRITE (CHIP)	
L205	1-410-380-31	INDUCTOR CHIP 8.2uH	
L206	1-543-948-11	BEAD, FERRITE (CHIP)	
L207	1-543-948-11	BEAD, FERRITE (CHIP)	
L251	1-412-039-51	INDUCTOR CHIP 100uH	
L252	1-412-039-51	INDUCTOR CHIP 100uH	
L253	1-412-039-51	INDUCTOR CHIP 100uH	
L254	1-412-039-51	INDUCTOR CHIP 100uH	
L450	1-412-340-31	INDUCTOR 10uH	
< TRANSISTOR >			
Q201	8-729-424-08	TRANSISTOR UN2111	
Q202	8-729-120-28	TRANSISTOR 2SC1623-L5L6	
Q203	8-729-101-07	TRANSISTOR 2SB798-DL	
Q204	8-729-901-06	TRANSISTOR DTA144EK	
Q205	8-729-120-28	TRANSISTOR 2SC1623-L5L6	
Q206	8-729-901-06	TRANSISTOR DTA144EK	
Q481	8-729-421-19	TRANSISTOR UN2213	
< RESISTOR >			
R201	1-216-057-00	METAL CHIP 2.2K 5%	1/10W
R202	1-216-021-00	METAL CHIP 68 5%	1/10W
R203	1-216-028-00	METAL CHIP 130 5%	1/10W
R204	1-216-663-11	METAL CHIP 3.3K 0.5%	1/10W
R205	1-216-659-11	METAL CHIP 2.2K 0.5%	1/10W
R206	1-216-659-11	METAL CHIP 2.2K 0.5%	1/10W
R207	1-216-653-11	METAL CHIP 1.2K 0.5%	1/10W
R208	1-216-085-00	METAL CHIP 33K 5%	1/10W
R209	1-216-085-00	METAL CHIP 33K 5%	1/10W
R210	1-216-085-00	METAL CHIP 33K 5%	1/10W
R211	1-216-085-00	METAL CHIP 33K 5%	1/10W
R212	1-216-085-00	METAL CHIP 33K 5%	1/10W
R213	1-216-085-00	METAL CHIP 33K 5%	1/10W
R214	1-216-085-00	METAL CHIP 33K 5%	1/10W
R215	1-216-085-00	METAL CHIP 33K 5%	1/10W
R216	1-216-085-00	METAL CHIP 33K 5%	1/10W
R217	1-216-085-00	METAL CHIP 33K 5%	1/10W
R218	1-216-697-91	METAL CHIP 82K 0.50%	1/10W
R219	1-216-699-11	METAL CHIP 100K 0.5%	1/10W
R220	1-216-661-11	METAL CHIP 2.7K 0.5%	1/10W

Ref. No.	Part No.	Description	Remark
R221	1-216-662-11	METAL CHIP 3K 0.5%	1/10W
R222	1-216-044-00	METAL CHIP 620 5%	1/10W
R223	1-216-121-00	METAL CHIP 1M 5%	1/10W
R224	1-216-049-00	METAL CHIP 1K 5%	1/10W
R225	1-216-049-00	METAL CHIP 1K 5%	1/10W
R226	1-218-760-11	METAL CHIP 220K 0.50%	1/10W
R227	1-216-045-00	METAL CHIP 680 5%	1/10W
R228	1-216-031-00	METAL CHIP 180 5%	1/10W
R229	1-216-097-00	METAL CHIP 100K 5%	1/10W
R230	1-220-250-11	METAL GLAZE 10 5%	1/2W
R231	1-218-236-11	METAL GLAZE 1 10%	1/4W
R232	1-216-692-11	METAL CHIP 51K 0.5%	1/10W
R233	1-216-065-00	METAL CHIP 4.7K 5%	1/10W
R235	1-216-057-00	METAL CHIP 2.2K 5%	1/10W
R236	1-216-081-00	METAL CHIP 22K 5%	1/10W
R237	1-216-072-00	METAL CHIP 9.1K 5%	1/10W
R238	1-216-057-00	METAL CHIP 2.2K 5%	1/10W
R239	1-216-667-11	METAL CHIP 4.7K 0.5%	1/10W
R240	1-216-049-00	METAL CHIP 1K 5%	1/10W
R241	1-216-049-00	METAL CHIP 1K 5%	1/10W
R243	1-216-699-11	METAL CHIP 100K 0.5%	1/10W
R244	1-218-764-11	METAL CHIP 330K 0.50%	1/10W
R245	1-216-699-11	METAL CHIP 100K 0.5%	1/10W
R246	1-218-764-11	METAL CHIP 330K 0.50%	1/10W
R247	1-216-679-11	METAL CHIP 15K 0.5%	1/10W
R248	1-216-674-11	METAL CHIP 9.1K 0.5%	1/10W
R249	1-216-049-00	METAL CHIP 1K 5%	1/10W
R250	1-216-659-11	METAL CHIP 2.2K 0.5%	1/10W
R251	1-216-659-11	METAL CHIP 2.2K 0.5%	1/10W
R252	1-216-663-11	METAL CHIP 3.3K 0.5%	1/10W
R253	1-216-663-11	METAL CHIP 3.3K 0.5%	1/10W
R254	1-216-097-00	METAL CHIP 100K 5%	1/10W
R255	1-216-073-00	METAL CHIP 10K 5%	1/10W
R258	1-216-092-00	METAL GLAZE 62K 5%	1/10W
R259	1-216-675-11	METAL CHIP 10K 0.5%	1/10W
R260	1-216-675-11	METAL CHIP 10K 0.5%	1/10W
R261	1-216-295-00	METAL CHIP 0 5%	1/10W
R262	1-216-065-00	METAL CHIP 4.7K 5%	1/10W
R263	1-216-295-00	METAL CHIP 0 5%	1/10W
R264	1-216-081-00	METAL CHIP 22K 5%	1/10W
R265	1-216-073-00	METAL CHIP 10K 5%	1/10W
R266	1-216-693-11	METAL CHIP 56K 0.5%	1/10W
R267	1-218-758-11	METAL CHIP 180K 0.50%	1/10W
R268	1-216-668-11	METAL CHIP 5.1K 0.5%	1/10W
R269	1-216-668-11	METAL CHIP 5.1K 0.5%	1/10W
R270	1-216-121-00	METAL CHIP 1M 5%	1/10W
R272	1-216-691-11	METAL CHIP 47K 0.5%	1/10W
R273	1-218-754-11	METAL CHIP 120K 0.50%	1/10W
R274	1-218-769-11	METAL CHIP 510K 0.50%	1/10W

RF/SERVO

Ref. No.	Part No.	Description	Remark		
R275	1-216-683-11	METAL CHIP	22K	0.5%	1/10W
R276	1-216-672-11	METAL CHIP	7.5K	0.5%	1/10W
R277	1-216-691-11	METAL CHIP	47K	0.5%	1/10W
R278	1-216-697-91	METAL CHIP	82K	0.50%	1/10W
R279	1-216-690-11	METAL CHIP	43K	0.5%	1/10W
R280	1-216-693-11	METAL CHIP	56K	0.5%	1/10W
R281	1-216-667-11	METAL CHIP	4.7K	0.5%	1/10W
R282	1-216-295-00	METAL CHIP	0	5%	1/10W
R283	1-216-295-00	METAL CHIP	0	5%	1/10W
R284	1-216-295-00	METAL CHIP	0	5%	1/10W
R285	1-216-057-00	METAL CHIP	2.2K	5%	1/10W
R286	1-216-057-00	METAL CHIP	2.2K	5%	1/10W
R287	1-216-061-00	METAL CHIP	3.3K	5%	1/10W
R288	1-216-675-11	METAL CHIP	10K	0.5%	1/10W
R291	1-216-049-00	METAL CHIP	1K	5%	1/10W
R292	1-216-121-00	METAL CHIP	1M	5%	1/10W
R293	1-216-055-00	METAL CHIP	1.8K	5%	1/10W
R294	1-216-667-11	METAL CHIP	4.7K	0.5%	1/10W
R297	1-216-097-00	METAL CHIP	100K	5%	1/10W
R450	1-216-121-00	METAL CHIP	1M	5%	1/10W
R451	1-216-685-11	METAL CHIP	27K	0.5%	1/10W
R452	1-218-758-11	METAL CHIP	180K	0.50%	1/10W
R453	1-216-112-00	METAL GLAZE	430K	5%	1/10W
R454	1-216-121-00	METAL CHIP	1M	5%	1/10W
R456	1-218-758-11	METAL CHIP	180K	0.50%	1/10W
R480	1-216-057-00	METAL CHIP	2.2K	5%	1/10W
R481	1-216-057-00	METAL CHIP	2.2K	5%	1/10W
R482	1-216-091-00	METAL CHIP	56K	5%	1/10W
R483	1-216-697-91	METAL CHIP	82K	0.50%	1/10W
R485	1-216-668-11	METAL CHIP	5.1K	0.5%	1/10W
R487	1-216-049-00	METAL CHIP	1K	5%	1/10W
R488	1-216-073-00	METAL CHIP	10K	5%	1/10W
< VARIABLE RESISTOR >					
RV201	1-241-393-21	RES. ADJ. METAL GLAZE	2.2K		
RV202	1-241-396-11	RES. ADJ. METAL GLAZE	22K		
RV203	1-241-396-11	RES. ADJ. METAL GLAZE	22K		
RV204	1-241-396-11	RES. ADJ. METAL GLAZE	22K		
RV205	1-241-396-11	RES. ADJ. METAL GLAZE	22K		
RV206	1-241-396-11	RES. ADJ. METAL GLAZE	22K		
RV207	1-241-391-11	RES. ADJ. METAL GLAZE	470		
RV208	1-241-393-21	RES. ADJ. METAL GLAZE	2.2K		
RV209	1-241-394-11	RES. ADJ. METAL GLAZE	4.7K		
RV210	1-241-394-11	RES. ADJ. METAL GLAZE	4.7K		
RV211	1-241-394-11	RES. ADJ. METAL GLAZE	4.7K		
RV212	1-241-396-11	RES. ADJ. METAL GLAZE	22K		
RV213	1-241-396-11	RES. ADJ. METAL GLAZE	22K		

Ref. No.	Part No.	Description	Remark
MISCELLANEOUS *****			
56	1-751-829-11	WIRE (FLAT TYPE) (24 CORE)	
63	1-751-795-21	WIRE (FLAT TYPE) (13 CORE)	
△67	1-556-280-00	CORD, POWER (MD1:SP)	
△67	1-575-131-11	CORD, POWER (MD1:AEP, G, IT)	
△67	1-575-706-11	CORD, POWER (MD1:CND)	
△67	1-696-027-11	CORD, POWER (MX, JE)	
△67	1-696-586-11	CORD, POWER (UK)	
△67	1-751-275-11	CORD, POWER (102:AEP, SP)	
△72	1-569-008-11	ADAPTER, CONVERSION 2P (SP)	
△73	1-569-007-11	ADAPTER, CONVERSION 2P (JE)	
△214	8-583-003-21	DEVICE, MINI DISK RMS-140B	
HR901	1-500-006-11	HEAD, OVER LIGHT	
M401	A-4660-373-A	MOTOR ASSY (LOADING)	
M901	X-4944-046-1	MOTOR ASSY (SLED)	
△T901	1-423-399-11	TRANSFORMER, POWER (MD1/102:AEP)	
△T901	1-423-400-11	TRANSFORMER, POWER (UK)	
△T901	1-423-401-11	TRANSFORMER, POWER (102:SP, MX, JE)	

ACCESSORIES & PACKING MATERIALS *****

1-466-914-11	COMMANDER, STANDARD (RM-D1M) (102)
1-467-613-11	REMOTE COMMANDER (RM-S11MD) (MD1)
1-501-374-11	ANTENNA, LOOP (MD1)
1-501-594-11	ANTENNA (FM) (MD1)
1-557-954-21	CORD, SPEAKER CONNECTION (MD1)
1-558-271-11	CORD, CONNECTION (102)
1-574-264-11	CORD, LIGHT PLUG (102)
1-574-264-31	CORD, LIGHT PLUG (MD1)
1-574-314-11	CORD (WITH CONNECTOR) (AU-BUS) (102)
1-765-099-11	CORD, CONNECTION 13P (MD1)
3-703-845-01	LABEL, CAUTION, NEW UL (102:UK)
3-707-584-21	COVER, BATTERY (FOR RM-D1M) (102)
3-757-559-11	MANUAL, INSTRUCTION (ENGLISH, FRENCH, SPANISH, PORTUGUESE) (102:AEP, UK)
3-757-559-41	MANUAL, INSTRUCTION (GERMAN, DUTCH, SWEDISH, ITALIAN) (102:AEP)
3-757-559-51	MANUAL, INSTRUCTION (ENGLISH, FRENCH, SPANISH, CHINESE) (102:SP, MX, JE)
3-757-678-11	MANUAL, INSTRUCTION (ENGLISH, FRENCH, SPANISH, PORTUGUESE) (MD1:CND, AEP)
3-757-678-41	MANUAL, INSTRUCTION (GERMAN, DUTCH, SWEDISH, ITALIAN) (MD1:AEP, G, IT)
3-757-678-51	MANUAL, INSTRUCTION (ENGLISH, SPANISH, CHINESE) (MD1:SP)
* 4-941-548-01	LABEL, CLASS (1)
4-941-762-21	COVER, BATTERY (FOR RM-S11MD) (MD1)

The components identified by mark △ or dotted line with mark △ are critical for safety. Replace only with part number specified.

Les composants identifiés par une marque △ sont critiques pour la sécurité. Ne les remplacer que par une pièce portant le numéro spécifié.

Ref. No.	Part No.	Description	Remark
*	4-963-767-01	CUSHION (L) (MD1)	
*	4-963-768-01	CUSHION (R) (MD1)	
*	4-964-286-01	CUSHION (FRONT) (102)	
*	4-964-287-01	CUSHION (REAR) (102)	
*	4-964-436-01	INDIVIDUAL CARTON (MD1)	
*	4-967-803-01	INDIVIDUAL CARTON (102)	

HARDWARE LIST

#1	7-685-646-79	SCREW +BVTP 3X8 TYPE2 N-S	
#2	7-685-103-19	SCREW +P 2X5 TYPE2 NON-SLIT	(MD1:EXCEPT G)
#3	7-682-547-09	SCREW +BVTT 3X6 (S)	
#4	7-682-548-09	SCREW +BVTT 3X8 (S)	
#5	7-621-770-XX	SCREW +BVTT 2.6X8 (S)	
#6	7-621-775-00	SCREW +B 2.6X3	
#7	7-685-102-19	SCREW +P 2X4 TYPE2 NON-SLIT (MD1:G)	
#8	7-621-592-00	SCREW +K 2.6X6	
#9	7-621-772-10	SCREW +B 2X4	
#10	7-627-852-08	SCREW,PRECISION +P 1.7X2.5	
#11	7-627-551-28	SCREW,PRECISION +P 1.4X2.5	
#12	7-627-552-78	SCREW,PRECISION +P 1.7X3.5	
#13	7-627-852-98	SCREW,PRECISION +P1.7X4.5TYPE3	
#14	7-627-552-48	SCREW,PRECISION +P 1.7X4	
#15	7-627-852-38	SCREW,PRECISION +P1.7X1.8TYPE3	
#16	7-621-255-35	SCREW (2MMX5), + PWH	
#18	7-621-770-67	SCREW +BVTT 2.6X6 (S)	
#19	7-621-775-10	SCREW +B 2.6X4	

MDS-102/MD1

SONY. SERVICE MANUAL

AEP Model
UK Model
Singapore Model
Mexican Model
Tourist Model
MDS-102

SUPPLEMENT-2

Revise your service manual as shown below due to parts supply classification has been changed.

Canadian Model
AEP Model
Singapore Model
MDS-MD1

 : indicates revised portion.

Page	CURRENT	REVISED									
	<p>—— not supplied ——</p> <p>—— not supplied ——</p>	<table border="1"> <thead> <tr> <th>Ref.No.</th> <th>Part No.</th> <th>Description</th> </tr> </thead> <tbody> <tr> <td>*23</td> <td>X-4944-115-1</td> <td>REINFORCEMENT (PANEL) ASSY (MDS-102)</td> </tr> <tr> <td>*24</td> <td>X-4944-431-1</td> <td>REINFORCEMENT (MD1) ASSY (MDS-MD1)</td> </tr> </tbody> </table>	Ref.No.	Part No.	Description	*23	X-4944-115-1	REINFORCEMENT (PANEL) ASSY (MDS-102)	*24	X-4944-431-1	REINFORCEMENT (MD1) ASSY (MDS-MD1)
Ref.No.	Part No.	Description									
*23	X-4944-115-1	REINFORCEMENT (PANEL) ASSY (MDS-102)									
*24	X-4944-431-1	REINFORCEMENT (MD1) ASSY (MDS-MD1)									
101	