

# MDP-450/650D

## RMT-M14

### SERVICE MANUAL

*AEP Model*  
MDP-450/650D  
*UK Model*  
*Australian Model*  
MDP-650D

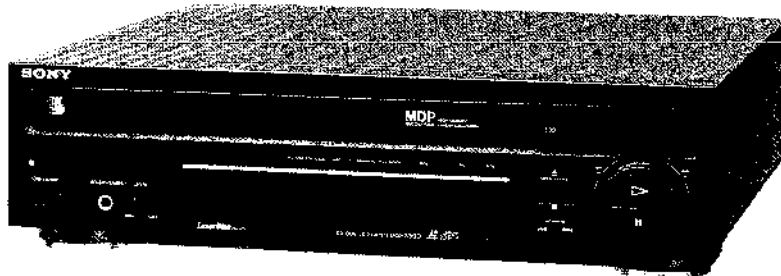

Photo: MDP-650D

#### SPECIFICATIONS

Type CD/CDV/LD Player  
Signal readout Optical (Laser beam reflection)  
Laser Semiconductor diode laser ( $\lambda = 780 \text{ nm}$ )  
Laser output  $0.3 \text{ mW} \pm 0.1 \text{ mW}$  (from objective lens)  
Signal format CCIR standard, PAL colour system  
EIA standard, NTSC colour system

Playing time

			PAL	NTSC (MDP-650D)
LD	CAV	30 cm (12 in) double-sided	72	60
		20 cm (8 in) double-sided	32	28
		20 cm (8 in) single-sided	-	14
	CLV	30 cm (12 in) double-sided	120	120
		20 cm (8 in) double-sided	40	40
		20 cm (8 in) single-sided	-	20
CDV	Audio portion	20	20	
	Video portion	6	5	
CD	12 cm (5 in) single-sided	74	74	
	8 cm (3 in) single-sided	20	20	

(minutes)

#### Digital audio specifications

Frequency response 4 Hz to 20 kHz ( $\pm 0.5 \text{ dB}$ )  
Signal-to-noise ratio More than 110 dB (EIAJ\*)  
Dynamic range More than 95 dB (EIAJ\*)  
Total harmonic distortion 0.003%  
Channel separation More than 105 dB (EIAJ\* at 1 kHz)  
Wow and flutter Below measurement limit  
( $\pm 0.001\% \text{ W.PEAK}$ ) (EIAJ\*)  
\* Measurement by under condition of standards of Electric Industries Association of JAPAN (VTC-015)  
Horizontal video resolution PAL 440 lines  
NTSC 425 lines (MDP-650D)

#### Input/output specifications

Video output 1.0 Vp-p, 75 ohms, unbalanced  
RGB output (NTSC) (MDP-650D) 0.7 Vp-p 75 ohms, unbalanced  
Audio output Stereo L, R  
Analog: 200 mVrms (1 kHz, 40% modulation)  
Digital: 200 mVrms (1 kHz, -20 dB)  
Audio digital output (optical) -18 dBm, wavelength 660 nm

- Continued on next page -



CD VIDEO CD/CDV/LD PLAYER  
**SONY**®

Headphone output  
28 mW (32 ohms), Impedance = 8 ohms  
CONTROL S IN input  
Mini jack

Power requirements  
Model for Continental Europe:  
220 – 230 V AC, 50/60 Hz  
Model for the United Kingdom  
and Austraria: (MDP-650D) 350D)  
240 V AC, 50/60 Hz

Power consumptions  
MDP-450 : 28 watts  
MDP-650D : 38 watts  
Mass  
MDP-450 : Approx. 8.3 kg  
MDP-650D : Approx. 8.5 kg  
Dimensions Approx. 430 x 115 x 410 mm (w/h/d)  
Operating temperature  
+5°C to +35°C  
Ambient humidity 5% to 90%

**Remote Commander RMT-M14**

Remote control system  
Infrared control  
Power requirements  
3 V DC, (2 IEC R6 (size AA) batteries)  
Dimensions Approx. 68 x 38 x 200 mm (w/h/d)  
Mass Approx. 175 g (including batteries)

**Supplied accessories**

Remote Commander RMT-M14 (1)  
IEC R6 (size AA) batteries (2)

Design and specifications are subject to change without notice.

**WARNING**

To prevent fire or shock hazard, do not expose the unit to rain or moisture.

To avoid electrical shock, do not open the cabinet. Refer servicing to qualified personnel only.

Laser component in this product is capable of emitting radiation exceeding the limit for Class 1.

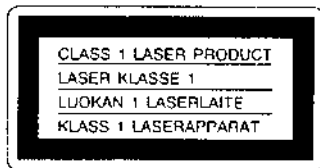

This CD CDV LD player is classified as a CLASS 1 LASER product. The CLASS 1 LASER PRODUCT label is located on the rear exterior.

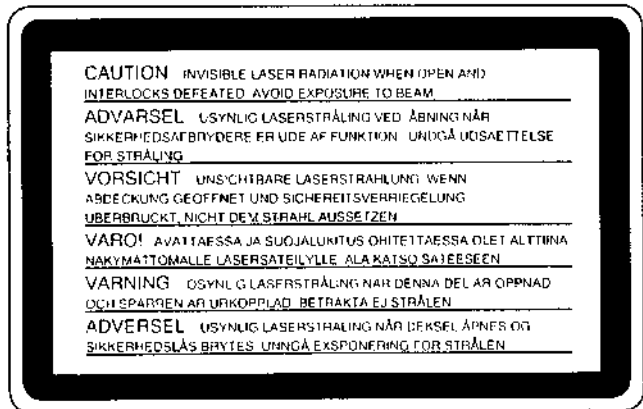

This label is located on the top cover and inside of the unit.

**SAFETY-RELATED COMPONENT WARNING!!**

COMPONENTS IDENTIFIED BY MARK OR DOTTED LINE WITH MARK ON THE SCHEMATIC DIAGRAMS AND IN THE PARTS LIST ARE CRITICAL TO SAFE OPERATION. REPLACE THESE COMPONENTS WITH SONY PARTS WHOSE PART NUMBERS APPEAR AS SHOWN IN THIS MANUAL OR IN SUPPLEMENTS PUBLISHED BY SONY.

## **SAFETY CHECK-OUT**

After correcting the original service problem, perform the following safety checks before releasing the set to the customer:

1. Check the area of your repair for unsoldered or poorly-soldered connections. Check the entire board surface for solder splashes and bridges.
2. Check the interboard wiring to ensure that no wires are "pinched" or contact high-wattage resistors.
3. Look for unauthorized replacement parts, particularly transistors, that were installed during a previous repair. Point them out to the customer and recommend their replacement.
4. Look for parts which, though functioning, show obvious signs of deterioration. Point them out to the customer and recommend their replacement.
5. Check the B+ voltage to see it is at the values specified.

## TABLE OF CONTENTS

<u>Section</u>	<u>Title</u>	<u>Page</u>	<u>Section</u>	<u>Title</u>	<u>Page</u>
1.	GENERAL		4-2.	Printed Wiring Boards and Schematic Diagrams	54
	Location and Function of Parts and Controls	5		SV-63, CK-44, FG-41, MT-28, MT-30 Boards	55
	To Connect to Audio System and to TV with Audio/Video Inputs and EURO-AV Connector	7		MP-701 (Video) Board	64
	To Connect to Audio System and TV with Audio-Video Inputs	8		RG-701 (R, G, B Separation) Board	76
	Screen Messages	8		MP-701 (System Control) Board	84
	To Play a Disc	9		MP-701, LS-704, MT-52, SW-706, SW-707 Boards	89
	To Get Sharp/Soft Image	10		MP-701 (Audio), HP-702, JC-701/703 Boards	94
	To continue Playback from the Point You Stopped at – Memory Playback (for LD only)	10		AF-701 Board	105
	To Change Playback Speed and Direction – Speed Playback (CAV) Standard-play)	11		AF-702 Board	107
	To Play Frame by Frame – Step Playback (CAV; standard-play)	11		FP-703, SW-704 Boards	111
	To Search for a Particular Scene	12		PS-701, TR-702 Boards	116
	To Play Particular Portion of a Disc	14	4-3.	Semiconductors	122
	To Search for a Particular Track	15	5.	EXPLODED VIEWS	
	To Listen Only to Particular Track(s)	15	5-1.	Cabinet, Front Panel Assemblies	124
	To Change Time Display (AV TIME)	16	5-2.	Chassis (1)	125
	Auto Program Playback	17	5-3.	Chassis (2)	126
	INTRO Scan	17	5-4.	MD Chassis	127
	Auto Pause	18	5-5.	Optical Block	128
	Shuffle Playback	18	6.	ELECTRICAL PARTS LIST	129
	Custom Index	19		Hardware List	157
2.	DISASSEMBLY		7.	ELECTRICAL ADJUSTMENTS	
2-1.	Tray Cover	20	7-1.	List of Servicing Jigs	159
2-2.	Upper Case, Front Panel Assy, Bottom Plate Assy	20	7-2.	Cautions on Adjustment	159
2-3.	MP-701, AF-701 (MDP-650D), AF-702 (MDP-450), RG-701 (MDP-650D) Boards	21	7-3.	MD Adjustment Cable (J-6082-059-B)	159
2-4.	MD Chassis, Optical Device Chassis	22	7-4.	Power Supply Check (PS-701 Board)	160
2-5.	Turntable, Spindle Motor, Skew Motor, SV-63, FG-41 Boards	22	7-5.	System Control System Adjustment	160
2-6.	Removal of the Tray	23	7-5-1.	Microprocessor Clock Adjustment (MP-701 Board)	160
2-7.	Removal of the Disc When a Problem Has Occurred with the Disc Loaded	23	7-6.	Servo System Adjustment	160
2-8.	Alignment of the Loading Gear Phase	23	7-6-1.	LD Servo System Adjustment	161
3.	DIAGRAMS		7-6-2.	CD Servo System Adjustment	165
3-1.	Circuit Boards Location	24	7-7.	Video System Adjustment	167
3-2.	Overall Block Diagram	25	7-7-1.	Video Output Level Adjustment (MP-701 Board)	167
3-3.	Servo Block Diagram	29	7-7-2.	Burst Gate Position Adjustment (MP-701 Board)	167
3-4.	System Control Microcomputer Port Functions (MP-701 Board IC612 MB89795)	31	7-7-3.	REF H Adjustment (MP-701 Board)	167
3-5.	System Control Block Diagram	33	7-7-4.	Color Framing Y Level Adjustment (MP-701 Board)	168
3-6.	Video Block Diagram	38	7-7-5.	Color Framing Chroma Level (1) Adjustment (MP-701 Board)	168
3-7.	Audio Block Diagram	43	7-7-6.	Color Framing Chroma Level (2) Adjustment (MP-701 Board)	169
3-8.	Mode Control Microcomputer Port Functions (FP-703 Board IC001 CXP50116)	45	7-7-7.	Color Framing REF H Adjustment (MP-701 Board)	169
3-9.	Mode Control Block Diagram	47	7-7-8.	APC Adjustment (RG-701 Board)	169
3-10.	Power Supply Block Diagram	49	7-7-9.	G Level Adjustment (RG-701 Board)	170
4.	PRINTED WIRING BOARDS AND SCHEMATIC DIAGRAMS		7-7-10.	R Level Adjustment (RG-701 Board)	170
4-1.	Frame Schematic Diagram	51	7-7-11.	B Level Adjustment (RG-701 Board)	170
			7-7-12.	Chroma Level Adjustment (RG-701 Board)	170
			7-7-13.	HUE Adjustment (RG-701 Board)	171
			7-8.	Audio System Adjustment	171
			7-8-1.	Analog Audio System Adjustment	171
			7-9.	Parts Arrangement Diagram for Adjustments	172

# Location and Function of Parts and Controls

Refer to the page indicated in the black circle for details.

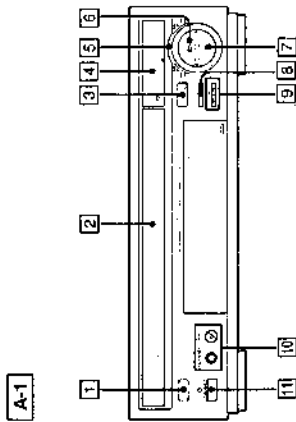

A-1

- 1 Remote control sensor
  - 2 Disc tray
  - 3 Disc tray OPEN/CLOSE button
  - 4 Display window
- Buttons on the Remote Commander have the same functions as those on the main unit.
- Point the supplied Remote Commander here.
- Press to open or close the disc tray.
- When playing back a disc, the following indications appear on the display.

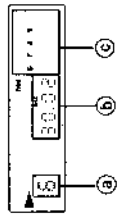

A-2

- LD Chapter number
- Time (hr./min./sec.) or frame number
- LD with TOC
- AV calendar

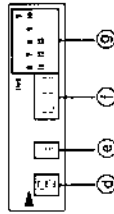

A-3

- CD/DOV
- Track number
- Index
- Elapsed time (min./sec.) for track
- AV calendar
- Shuttle ring
- Utilize for forward or reverse speed scan.
- Play button
- Pause button
- Stop button
- ACS/AMS I-1 (Automatic Chapter Select/ Music Sensor) buttons
- Use these buttons for skipping chapter/track.
- HEADPHONES jack (stereo phone type) and LEVEL control
- When listening with headphones, connect the headphones with stereo phone plug here. Adjust the volume with the LEVEL control.
- Standby button
- Press to turn on and press again to make the player on standby.

This section is extracted from instruction manual.

## SECTION 1 GENERAL

- A-4 PICTURE ENHANCE button and Indicators
  - RGB selector (NTSC only) (MDP-6500)
  - AUTO PGM button
  - PGM (program play) button
  - Disc (PAL/NTSC) indicators (MDP-6500)
  - AV TIME button
  - CLEAR button
  - NEXT button
  - BACK button
  - MEMORY PLAY button
  - Reset switch
  - SEARCH button
  - FRAME/TIME search button
  - CUSTOM INDEX button
  - FILE button
  - Number/frame search (0-9/+10/A-F) buttons
- To open the lid  
Push down the tab located on the lower right corner of the lid.
- 
- When the player is connected to the TV via the EURO-TV connector, set to ON to view an NTSC disc on PAL TV. The TV can be set to receive the RGB signal. When your TV is equipped with the RGB or composite signal selector, set on the TV to receive the RGB signal. Set to OFF when your TV is capable of receiving both PAL and NTSC.
- Use this button for Auto Program Playback.
- Use this button for program playback.
- Use this button to change time display.
- Press to cancel a wrong numerical entry or to terminate the search or other function currently in operation.
- Use this button to change numerical entries for program playback or to clear a custom index mark.
- Use this button to change numerical entries for program playback.
- Use this button for memory play.
- Reset switch see page 38.
- Use this button for frame/time search.
- Use this button for frame time search.
- Use this button for custom index search.
- Use this button for setting a custom index mark.
- These are used for entering program, chapter, track, frame, time numbers and File A/F.

### Accessories

The following accessories are included in the carton.

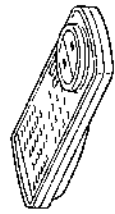

RMT-M14 Remote Commander



Two IEC R6 (size AA) batteries

# Location and Function of Parts and Controls

## Remote Commander

### Installing batteries into the Remote Commander

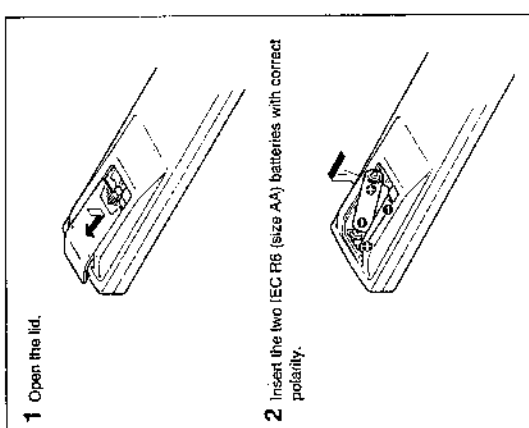

### Battery life

Batteries should last for about six months under normal operating conditions. When the operating range of the Remote Commander becomes noticeably short, replace the batteries with new ones.

### Note

When the Remote Commander is not to be used for a long period of time, remove the batteries to avoid possible damage from battery leakage.

- 18 **AUTO PAUSE button**
  - TV operation buttons (Can be used to control Sony TV sets bearing the mark.)
  - PROGR. (program) +/- buttons
  - (Volume) +/- buttons
  - button
  - Press to switch to a video equipment connected to the video/audio inputs of the TV set. (This function is available only with certain TV models.)
- 19 **INTRO (Introduction) scan button**
  - Use this button for memory playback.
- 20 **MEMORY PLAY button**
  - STOP button
- 21 **Shuttle ring**
  - Utilize for forward or reverse speed scan.
- 22 **PLAY button**
  - II PAUSE button
- 23 **ACG/AMS (Automatic Chapter Select/ Music Sensor) buttons**
  - STILL/STEP buttons
- 24 **MULTI SPEED buttons**
  - SPEED SET buttons
- 25 **ANALOG audio button**
  - Press to switch the player to analog or digital sound. (NTSC only)
- 26 **Number/file search (0-9)+ (D/A-P) buttons**
  - These are used for entering program, chapter, track, frame, time numbers and File A-F.
- 27 **CLEAR button**
  - Press to cancel a wrong numerical entry or to terminate the search or other function currently in operation. (The functions affected are marked on the Remote Commander with yellow underlines.)
- 28 **FRAME/TIME search button**
  - Disc tray OPEN/CLOSE button
  - Press to open or close the disc tray.
- 29 **PGM (program play) button**

- B-1 **Buttons on the Remote Commander have the same functions as those on the main unit.**
- 1 **DISC/TV button**
  - When the player is connected to the TV via the EURO-AV connector, press to monitor TV programmes. Press again to return to disc viewing.
- 2 **(Standby) button**
  - Press to turn on and press again to make the player on standby.
- 3 **REPEAT button**
  - Press to repeat the entire disc side, and for other repeat play.
- 4 **(Display) button**
  - Press during playback to superimpose the screen messages (see page 13) on the monitor screen. Press again to remove the message.
- 5 **1/ALL button**
  - Press to repeat the single track or chapter.
- 6 **AV TIME button**
  - Press to change time display.
- 7 **SHUFFLE button**
  - Press to play back selections on a CD, CDV, and LD with TOC in random order.
- 8 **REPEAT A → B button**
  - Press to repeat the particular portion.
- 9 **AUTO PGM button**
  - FILE button
  - Use this button for setting a custom index mark.
- 10 **BACK button**
  - CUSTOM INDEX button
  - Use this button for custom index search.
- 11 **SEARCH/NEXT button**
  - button
  - Press to manually activate the CX noise reduction system. (Not used for the MDP-450)
- 12 **AUDIO MONITOR button**
  - Press to switch the audio channels of a disc in the order of stereo, 1/L and 2/R.

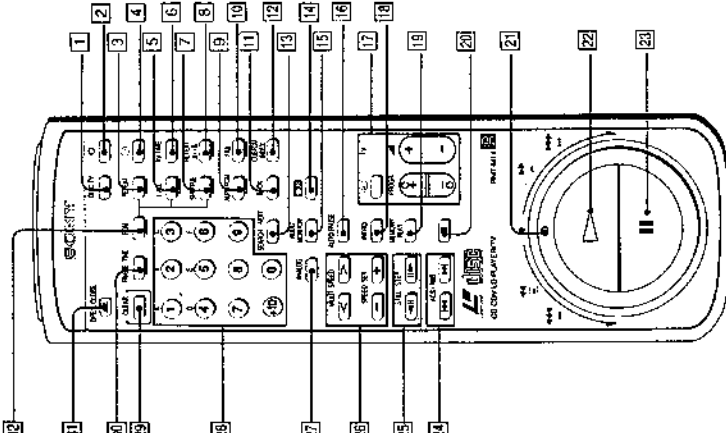

The yellow bar under a button indicates that the function of that button can be released by pressing the CLEAR button.

# To Connect to Audio System and to TV with Audio/Video Inputs and EURO-AV Connector

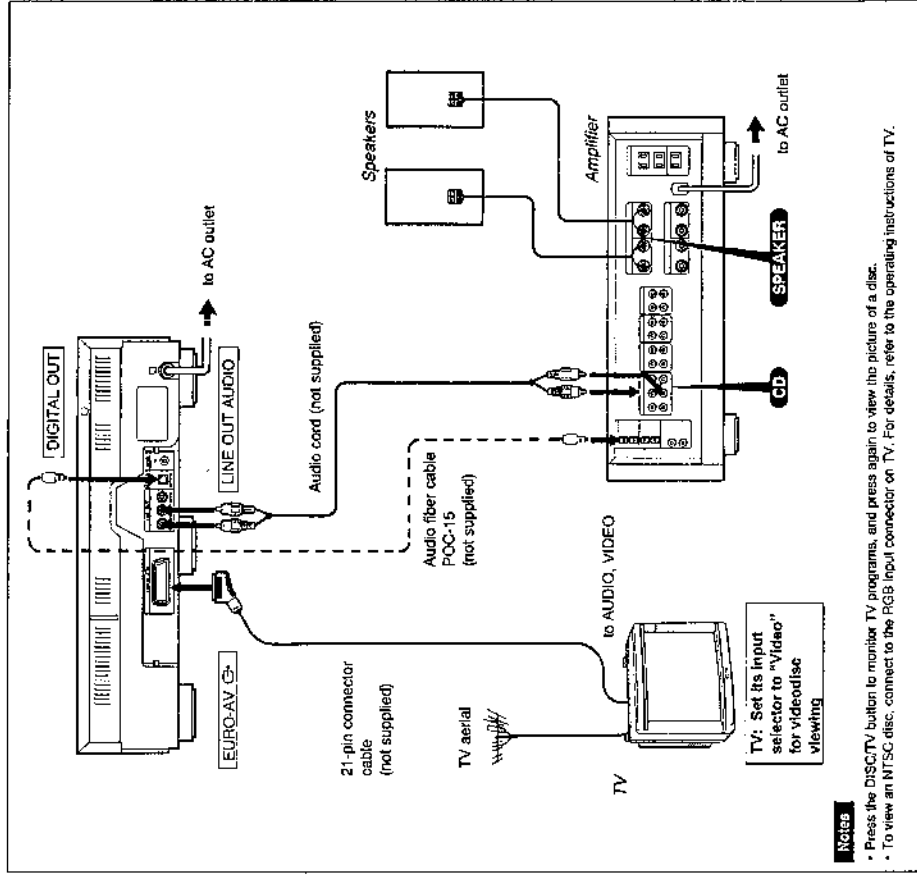

**Notes**

- Press the DISCTV button to monitor TV programs, and press again to view the picture of a disc.
- To view an NTSC disc, connect to the RGB input connector on TV. For details, refer to the operating instructions of TV.

**Connection precautions**

- Make sure that all equipment is OFF before connecting or disconnecting any cables.
  - Check the colour of the plugs: yellow indicates video; white, left audio channel; red, right audio channel.
  - Firmly insert the plugs into the jacks. A loose connection can lead to noise.
  - When unplugging a cable, grasp the plug. Never pull by the cable.
  - To prevent interference, turn off all equipment that is connected, but not currently in use.
- Connection of optical fiber cable  
Remove protective cover. Plug in connector firmly.

# Location and Function of Parts and Controls

## Rear Panel

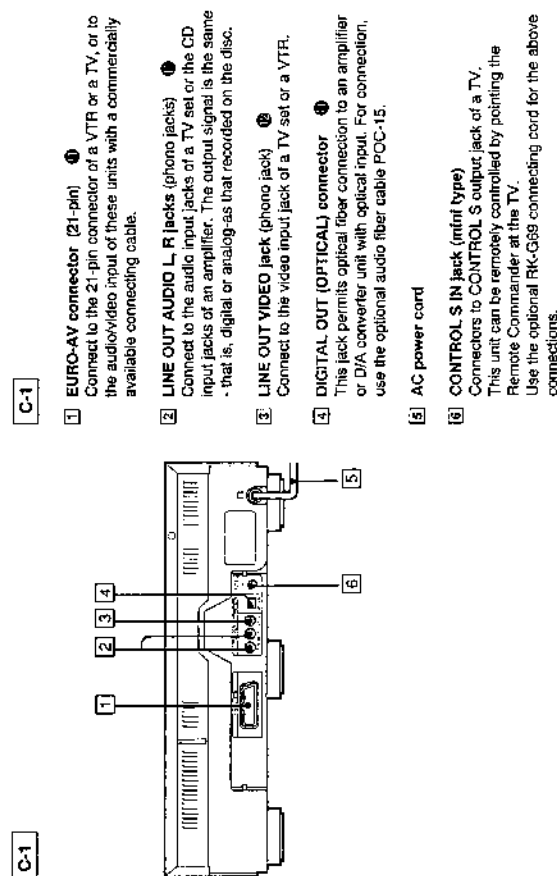

- 1 EURO-AV connector (21-pin)**  
Connect to the 21-pin connector of a VTR or a TV, or to the audio/video input of these units with a commercially available connecting cable.
- 2 LINE OUT AUDIO L, R jacks (phono jacks)**  
Connect to the audio input jacks of a TV set or the CD input jacks of an amplifier. The output signal is the same as that is, digital or analog-as that recorded on the disc.
- 3 LINE OUT VIDEO jack (phono jack)**  
Connect to the video input jack of a TV set or a VTR.
- 4 DIGITAL OUT (OPTICAL) connector**  
This jack permits optical fiber connection to an amplifier or D/A converter unit with optical input. For connection, use the optional audio fiber cable POC-15.
- 5 AC power cord**
- 6 CONTROL S IN jack (mini type)**  
Connectors to CONTROL S output jack of a TV. This unit can be remotely controlled by pointing the Remote Commander at the TV. Use the optional RC-G68 connecting cord for the above connections.

# To Connect to Audio System and TV with Audio/Video Inputs

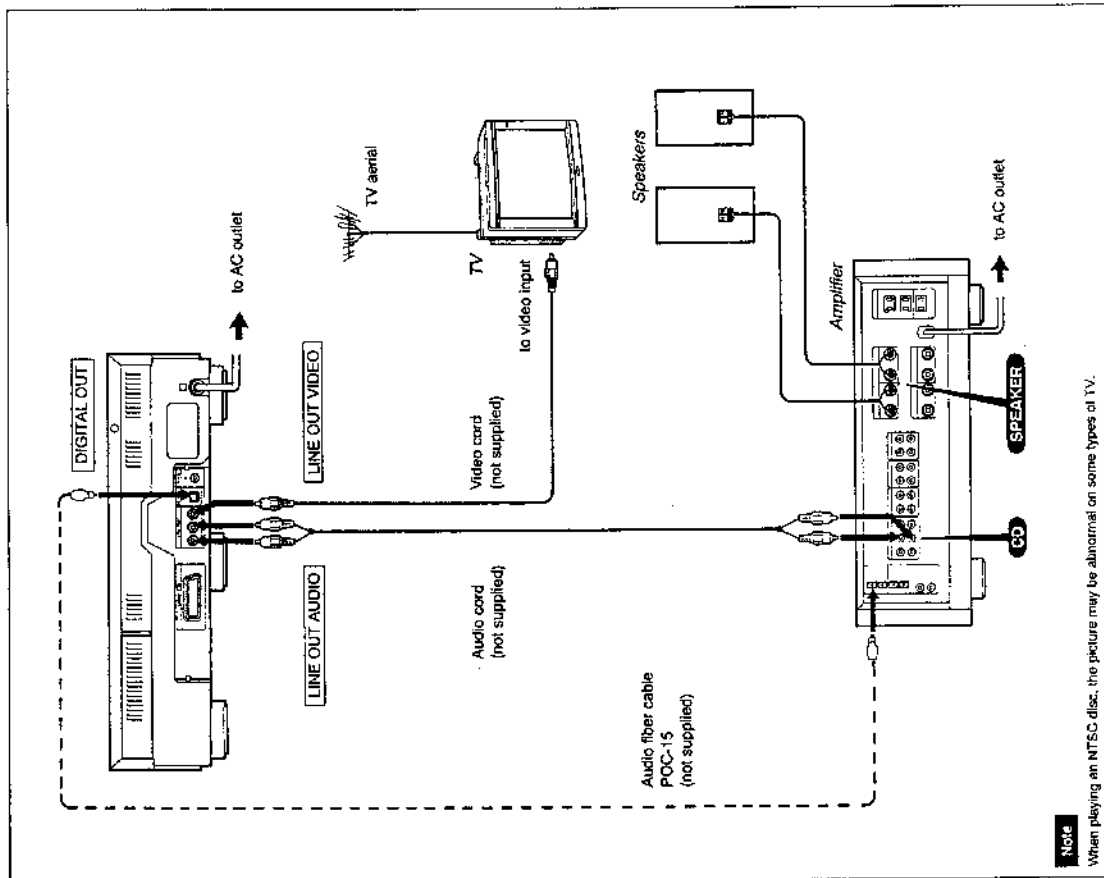

**Note:** When playing an NTSC disc, the picture may be abnormal on some types of TV.

# Screen Messages

Information on the operating condition of the unit and chapter or track numbers can be superimposed on the TV or monitor screen. While no image is displayed, such as during search, information is shown on a black background for all PAL discs and CDs. Shown on a green background for NTSC LDs and CDVs (MDP-650D).

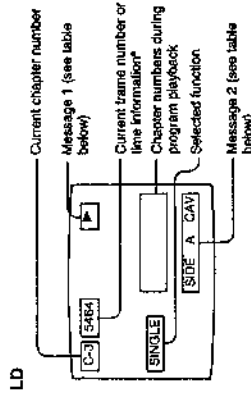

\* If seconds are not recorded on the disc, only "0:22" is shown.

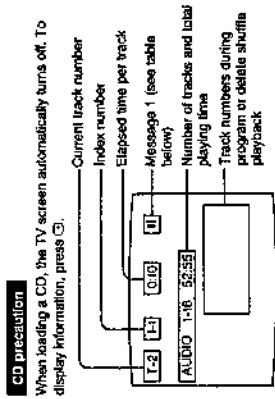
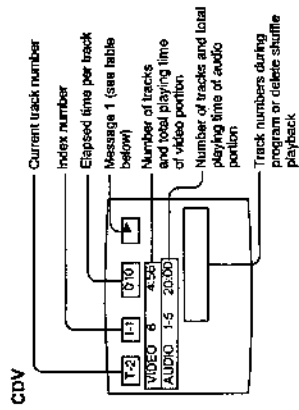

To turn on the screen message Press **Q** (Display) on the Remote Commander.



Press the button again to turn the message off.

Message 1 (Examples)

Display	Explanation
OPEN	Disc tray open
CLOSE	Disc tray close
▶	Playback
■	Stop
	Pause
⏮ / ⏪	Forward/reverse speed scan
SEARCH	Search
▶ x 1/2	1/2 speed display in forward direction

Message 2 (Examples)

Display	Explanation
SIDE A CAV	Standard-play disc side A
SIDE B CAV	Standard-play disc side B
SIDE A CLV	Extended-play disc side A
SIDE B CLV	Extended-play disc side B
1/L	Main soundtrack/left channel
2/R	Second soundtrack/right channel
J-DIGITAL	Digital sound
J-ANALOG	Analog sound

**LD precaution**

Some discs do not contain the side A or B identification code. In this case, the disc side indication may not be correct.



# To Play a Disc

## Starting Playback

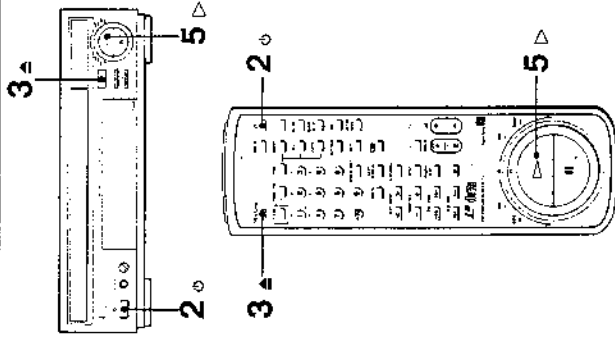

- 1 Turn on the TV and stereo system.  
TV: Select the video input. (See page 11.)  
Stereo system: Turn on the amplifier or the receiver and select the proper audio input.
- 2 Press  $\phi$  to turn on the player.
- 3 Press  $\Delta$  OPEN/CLOSE to open the disc tray.
- 4 Place a disc on the tray.  
Place a disc on the center of the tray. If the disc is not placed correctly, playback may not start.

CD/CDV

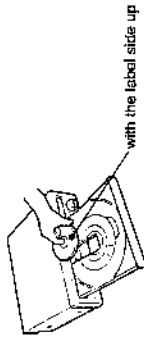

LD

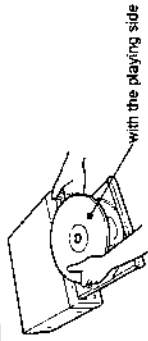

- 5 Press  $\triangleright$  (play) to start playback.  
CDV: Playback starts from the video portion.

### AV calendar

When playing a CD, CDV, or an LD containing TOC (Table of Contents) data, the AV calendar shows information on the total number of tracks or chapters. As tracks or chapters are played, the corresponding numbers on the display go out.

### Notes on disc tray

- Insert only one disc at a time.
- Make sure that the disc is placed properly in the tray. Incorrect positioning may result in permanent damage to the disc.

### Using an optional timer

When the timer supplies power at the preset time, the playback starts automatically. If there is no disc in the unit, the unit turns off.

### To pause at the beginning of a disc

Press II on the player or the Remote Commander after placing a disc on the tray. The tray closes, and the player pauses at the beginning of the disc.

## Advanced Playback

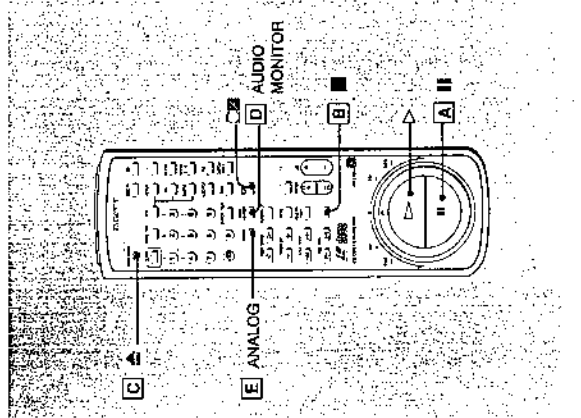

**To stop playback**  
Press  $\blacksquare$  (stop).  
To restart playback from the beginning of the disc, press  $\Delta$ .

**To stop playback and remove the disc**  
Press  $\Delta$  OPEN/CLOSE.  
Remove the disc and press  $\Delta$  OPEN/CLOSE to close the tray.

**To play a stereo or a second audio program (SAP) LD**

After playback has started, Press AUDIO MONITOR.

Press AUDIO MONITOR.

Reproduced sound	Stereo	Stereo	Left channel	Right channel
Source	SAP disc	Audio signal (1) (left channel)	Audio signal (1)	Audio signal (2)
Indicators	1A, 2R	1A	1A	2R

**To switch from digital to analog sound**  
Press the ANALOG button to switch the player to analog or digital sound. (NTSC only (MDP-650D))  
Digital affords a better quality sound reproduction. If the LD contains a digital sound signal, the player automatically sends that output to the amplifier or receiver. When you press the ANALOG button on the Remote Commander, you can switch to analog sound. With certain discs there may be a difference in volume. To return to digital sound output, press the Analog button again.

**To temporarily interrupt playback**  
Press II (pause).  
When playing CAV discs, the sound is cut off and still picture is shown.  
When playing PAL CLV discs or video part of CDV discs, the picture turns to a black screen. Playing NTSC CLV or video part of CDV discs, turns to a green screen (MDP-650D). To resume play from the same point, press  $\triangleright$ .

**Disc with CX Label (MDP-650D)**  
Discs bearing the CX label are recorded with the CX noise reduction system, which gives lower noise levels and higher dynamic range. The player detects CX discs and activates the CX noise reduction system automatically. If you press the CX button on the Remote Commander at this time, "CX ON" will appear on the TV screen for three seconds.

# To Continue Playback from the Point You Stopped at – Memory Playback (for LD only)

Even if you use the STOP (■) button to stop, you can still continue play from the point you stopped at.

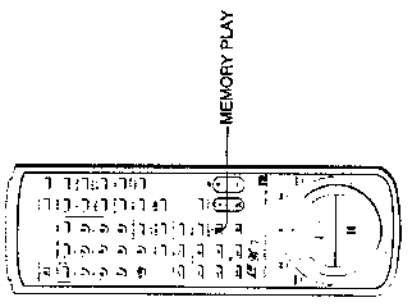

To play again from the point you stopped at

Press MEMORY PLAY while in the stop mode.

The player starts searching for the point you stopped at.

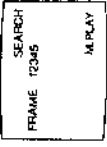

Play starts at the point you stopped.

If you have turned off the power, press MEMORY PLAY before you turn on the power. The player will turn on automatically and continue playing again from the point you stopped at. (If the power is turned on first, this function cannot be performed. The player will start playing from the very beginning of the disc.)

**Notes**

- This function can only be used for LDs.
- You cannot use this function in the shuttle, program and single repeat play. If you press >, <, <>, or <> while in the stop mode, this function is cancelled.

# To Get Sharp/Soft Image

The best picture reproduction condition for each disc can be selected.

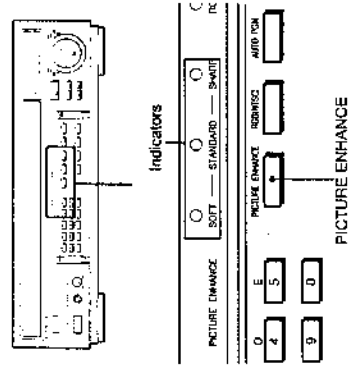

To select the picture enhance mode

Press PICTURE ENHANCE on the player to select the desired mode. The indicator of the selected mode lights up. Each time you press this button, the mode changes in the order of STANDARD, SHARP and SOFT.

SOFT	Soft picture Reduces screen noise
STANDARD	Standard picture
SHARP	Sharp picture Refines the image

Even if you turn off the player, the mode will remain stored in the player's memory. If you unplug the power cord, the mode will return to STANDARD.

## To Change Playback Speed and Direction -Speed Playback (CAV Standard-play)

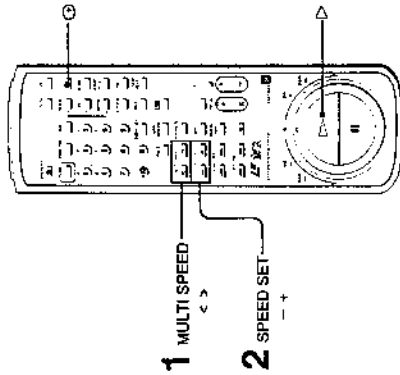

### To change the speed

- 1 Select the playback direction.  
Press > for the forward direction.  
Press < for the reverse direction.
- 2 Select the playback speed.  
Press + to increase speed.  
Press - to reduce speed.

Speed indication	Speed (approx.)
x10	10 times normal speed
x5	5 times normal speed
x3	3 times normal speed
x2	2 times normal speed
x1	Normal speed
x1/2	1/2 normal speed
x1/4	1/4 normal speed
x1/8	1/8 normal speed
x1/16	1/16 normal speed
x1/30	1/30 normal speed
x1/60	1/60 normal speed

Fast ← → Slow

Press > to resume normal playback.

### To change the direction

Press < to view the picture in reverse direction, or  
Press > to view in forward direction.  
To resume normal playback, press >.

### To display the speed and direction

Press  $\odot$ .  
The selected direction (< or >) and speed are shown.

### Sound during speed playback

The sound can be heard only during x1 (normal) speed play in the forward direction. In other speed and direction combinations, the sound is muted.

### PAL discs

The image may be in black and white during X10 (10 times) speed play in both directions.

### CLV discs

The above functions are available only with CAV discs. If they are attempted with CLV discs, a three-second warning message, SIDE A CLV or SIDE B CLV, will appear on the screen.

### Discs with automatic picture stop function

When a picture stop code is encountered during playback at the normal speed or slower than the normal speed, playback stops at that frame. Press > to resume playback or a speed play button to continue the speed play.

## To Play Frame by Frame – Step Playback (CAV standard-play)

### To view a still picture

Press II (Pause).  
The picture stops at the current frame.  
To resume normal playback, press >.

### To view one frame at a time – step playback

Press II (pause) once for freeze-frame.  
To advance the picture by one frame, press III (STEP in forward).  
To go back by one frame, press <III (STEP in reverse).  
Hold down the button for continuous frame by frame viewing.  
To resume normal playback, press >.

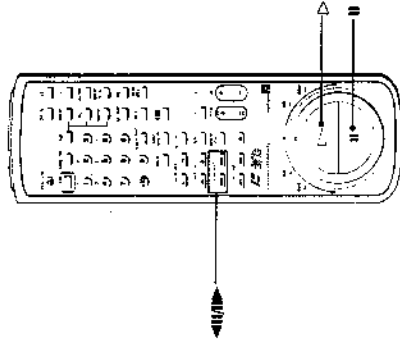

### During step playback operation

The sound is muted during step playback.

### CLV discs

The above functions are available only with CAV discs. If they are attempted with CLV discs, a three-second warning message, SIDE A CLV or SIDE B CLV, will appear on the screen.

### If you press the <III> buttons during normal playback

The frame freezes and you can achieve step playback.  
To resume normal playback, press >.

# To Search for a Particular Scene

## Dual Speed Scan

The playback speed can be changed depending on the degree the shuttle ring is turned.

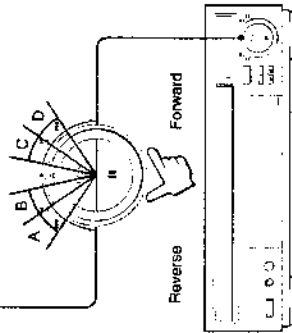
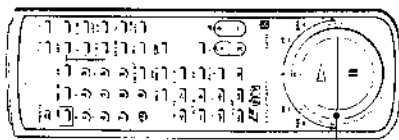

### Normal Scan

Reverse scan: Turn the shuttle ring to the B position.  
Forward scan: Turn the shuttle ring to the C position.  
Scans in the speed of approximately 10 times normal speed

### High-speed scan

Reverse scan: Turn the shuttle ring to the A position.  
Forward scan: Turn the shuttle ring to the D position.  
Scans in the speed of approximately 30 times normal speed

- To resume the normal play, release the shuttle ring

### While scanning in either direction

- The sound is muted.
- The image with a CLV disc will be in black and white with some instability.
- Scanning speed varies according to the position on the CLV disc.
- The image with a CAV discs will be in black and white on some TV.
- A certain amount of noise is inevitable with all scanning operations. Especially, the image of CAV discs may be a little noisy.

## Chapter/Track Search

### Direct chapter or track search

Enter the desired chapter or track number by pressing the number buttons. If you have pressed a wrong number, simply press the correct one. Playback automatically starts from the designated chapter or track.

### Chapter or track skip search

To advance to the beginning of successive chapters/tracks, press **▶▶** repeatedly as needed. To return to the beginning of the current chapter/track, press **◀◀** once. Press it repeatedly before the picture reappears to go to the beginning of previous chapters/tracks.

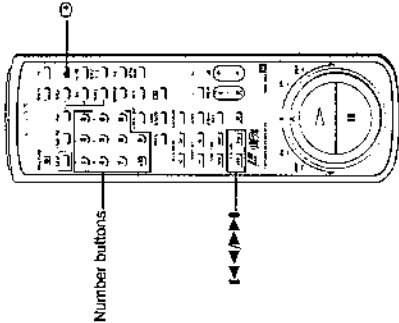

### To check the current chapter/track

The numbers are shown in the display window of the player. Press **⏏** to display them on the screen.

### To enter a number greater than 10

Use the **+10** and one of the number buttons.  
Example: To enter 14 **+10** → **4**

To enter 20 **+10** → **+10** → **0**

### If you press the +10 button by mistake

Press **+10** repeatedly until **0** is displayed, then enter the correct number.

### Notes

- The chapter search feature will not function if the disc does not include chapter numbers. In this case, the screen message will give only frame or time numbers.
- If a chapter number not contained on an LD is entered, playback stops. If the ALL repeat function is on (see page 24), playback will resume from the beginning of the disc.
- During CAV playback, the unit will not accept entry of track numbers not contained on the disc.

## To Search for a Particular Scene

### Frame Search (CAV Discs)

Each picture on a CAV (standard-play) disc is called a frame.

Example: Locate frame number 12340.

- 1 Press **FRAME/TIME**.
- 2 Press "1", "2", "3", "4", and "0" in sequence to enter the frame number. If you enter a wrong frame number, press **FRAME/TIME** once more to return the display indication to zero, and then enter the correct number.
- 3 Press **SEARCH/NEXT** (or **SEARCH** on the player). The desired frame is located, and playback automatically starts.

Search can be made in the freeze-frame, pause, repeat and speed play modes as well as the normal playback mode. When the desired frame appears after the search playback continues in the same mode.

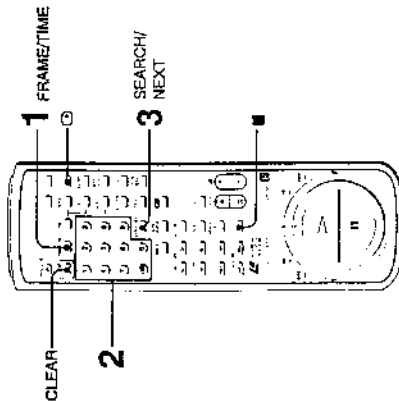

- To cancel frame search**  
 Before the **SEARCH/NEXT** button is pressed: Press **CLEAR**.  
 After the **SEARCH/NEXT** button was pressed: Press ■.
- To check the current chapter and frame numbers**  
 These numbers appear in the display window on the player. Press ■ on the Remote Commander to display them on the screen.

**Note**  
 If a frame number not contained on a disc is entered, playback stops. If the ALL-repeat function is on (see page 24), playback will resume from the beginning of the disc.

### Time Search (CLV Discs)

CLV (extended-play) discs keep track of the position as elapsed time from the beginning of the disc.

Example: Locate the 12 min 05 sec point.

- 1 Press **FRAME/TIME**.
- 2 Press "1", "2", "0", "5" in sequence. If you enter a wrong time number, press **FRAME/TIME** once more to return the display indication to zero, and then enter the correct number.
- 3 Press **SEARCH/NEXT** (or **SEARCH** on the player). The picture of the desired time number is located, and playback automatically starts.

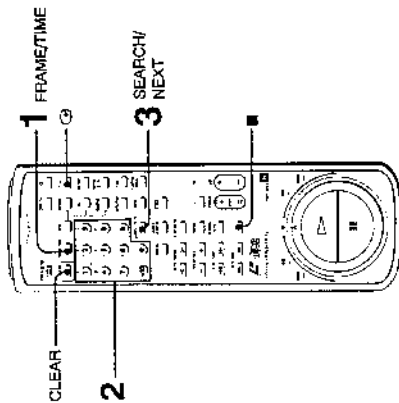

- To cancel time search**  
 Before the **SEARCH/NEXT** button is pressed: Press **CLEAR**.  
 After the **SEARCH/NEXT** button was pressed: Press ■.
- To check the current chapter and time numbers**  
 These numbers appear in the display window on the player. Press ■ on the Remote Commander to display them on the screen.

**Note**  
 If the disc does not include time data to the second, enter the time in minutes only.  
 If the selected number is greater than the total time of the disc, playback stops. If the ALL-repeat function is on (see page 24), playback will resume from the beginning of the disc.

# To Play Particular Portion of a Disc

## Repeat Playback

A single chapter or track a designated portion of a disc, or the entire side of a disc can repeatedly be played back.

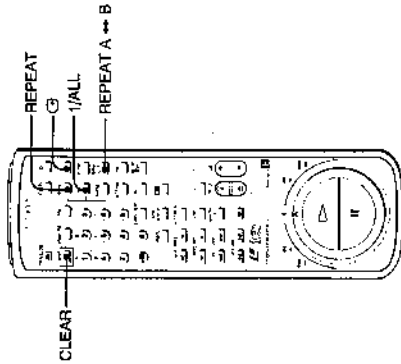

**To repeat the current chapter or track – SINGLE repeat**

- 1 Press 1/ALL.
- 2 Press REPEAT. REPEAT and 1 indications light up in the display window. When the end of the current chapter or track is reached, playback of the chapter or track is automatically repeated.

**To repeat the entire side of the disc – ALL repeat**

Press REPEAT. The REPEAT indication lights up in the display window, and the entire side of the disc is repeatedly played back.

**To repeat a designated portion of a disc – A ↔ B repeat**

- 1 During playback, press REPEAT A ↔ B at the start point (point A) of the desired portion. The REPEAT and A indication lights up, and B indication flashes in the display window.
  - 2 At the end point (point B) of the desired portion press REPEAT A ↔ B. The REPEAT A ↔ B indication lights up in the display window. The player returns to the point where REPEAT A ↔ B was first pressed, and repeat playback automatically starts.
- To check the current status**  
Check the indications in the display window or use the  $\square$  button on the Remote Commander to verify the current setting on the screen.
- To cancel A ↔ B repeat**  
Press CLEAR.
- To cancel repeat functions other than A ↔ B repeat**  
Press REPEAT again to cause the REPEAT indication in the display window to go out.

## Program Playback

Up to 20 chapters or tracks can be played back in a specified order.

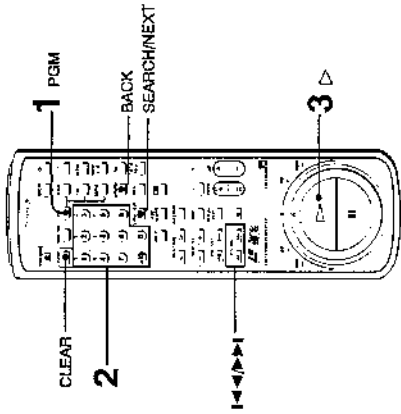

- Example: To play LD chapter 5, 4, 2, and 6 in order.
- 1 Press PGM. The PGM indication in the display window flashes. The PROGRAM! -- indications on the TV screen appear.
  - 2 Enter the chapter numbers by pressing "5", "4", "2", and "6" in sequence.
  - 3 Press  $\Delta$  (play). The first chapter is searched for, and playback starts from the beginning of chapter 5 and continues through chapter 4, 2, 6, and stops.

### NOTES

- When the shuttle ring is kept turned to the forward direction during program playback, and the playback comes to the end of the current selection, the next programmed chapter will be played back. When the shuttle ring is kept turned to the reverse direction, the unit will not go back to previous chapters. If you want to move a preceding programmed chapter, press the  $\leftarrow$  button until the desired programmed number comes up.
- If not-existing chapter numbers on a disc are entered, the program cannot be conducted.
- Programmed contents are stored until the disc is removed or the power is switched off.

**If you make a mistake in chapter number entry**

To start over, press CLEAR, and PGM again, then enter the correct numbers. To change a number, press SEARCH/NEXT (or NEXT) on the player) or BACK to advance or go back entries until the incorrect number flashes on the screen, then enter a new number.

**To release or cancel program playback**  
Press CLEAR or 1/ALL. The player reverts to normal playback.

**To repeat program playback**  
Use REPEAT to call up the REPEAT indication.

**To enter chapter numbers over 10**  
Use the +10 and one of the number buttons.

**If you press the +10 button by mistake**  
Press +10 repeatedly until 0- is displayed, then enter the correct number.

**To move to a preceding or following programmed track**  
Press the  $\leftarrow$  or  $\rightarrow$  button.

**To check the program contents**  
Press PGM. The program is displayed for about 3 seconds on the screen. The currently playing program number blinks.

## To Search for a Particular Track

The selections on CDs and CDDs are called tracks. Each track is assigned a track number which is indicated on the disc jacket or label.

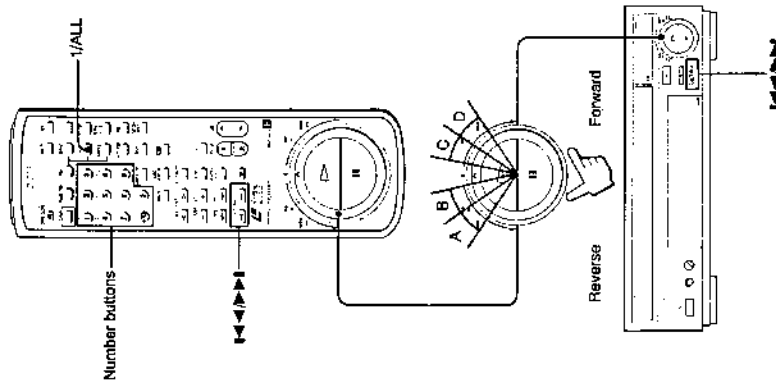

### To search by a track number

Enter the desired track number by pressing the number buttons.

### To play a single track once

Use the 1/ALL button on the Remote Commander to call up the 1 indication. Then select the track with the numerical buttons.

When the track has been played, the unit enters the stop mode. To release the sitting, press 1/ALL again.

When a wrong number was entered  
Press the button for the correct number.

### To skip tracks

To advance to the beginning of successive tracks, press **▶▶** repeatedly as needed.

To return to the beginning of the current track, press **◀◀** once. Press repeatedly to go back to the beginning of previous tracks.

### To search for a particular point

#### To scan at fast speed

Turn the shuttle ring to B position for scanning in reverse at the fast speed and C for scanning forward.

#### To scan at higher speed

Turn the shuttle ring to A position for scanning in reverse at the higher speed and D for scanning forward.

To resume normal speed, release the shuttle ring.

### To enter track numbers over 10

Use the +10 and one of the number buttons.

### If you press the +10 button by mistake

Press +10 repeatedly until 0- is displayed, then enter the correct number.

### Sound during search

When scan is started from the playback mode, the sound can be heard at a low level. When scan was started from the pause mode, the sound is muted.

## To Listen Only to Particular Track(s)

### Repeat Playback

A single track, a specified portion of a disc or all the tracks on a disc can repeatedly be played back.

### To repeat the current track - SINGLE repeat

1 Press 1/ALL.

2 Press REPEAT.

The REPEAT and 1 indications light up in the display window. When the end of the current track is reached, playback of the track is automatically repeated.

To repeat the track only once, press REPEAT to turn off the REPEAT indication.

### To repeat all tracks - ALL repeat

Press REPEAT.

The REPEAT indication lights up and the entire disc is repeatedly played back.

### To repeat a designated portion of a disc - A ↔ B repeat

1 During playback, press REPEAT A ↔ B once at the start point (point A) of the desired portion. The REPEAT and A indication lights up, and B indication flashes in the display window.

2 At the end point (point B) of the desired portion, press REPEAT A ↔ B.

The REPEAT A ↔ B indication lights up. The player returns to the point where REPEAT A ↔ B was first pressed, and repeat playback automatically starts.

To cancel A ↔ B repeat  
Press CLEAR.

To cancel repeat functions other than A ↔ B repeat

Press REPEAT again to cause the REPEAT indication in the display window to go out.

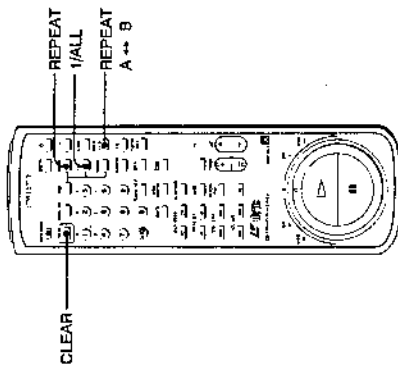

## To Listen Only to Particular Track(s)

### Program Playback

Up to 20 tracks can be played back in a specified order.

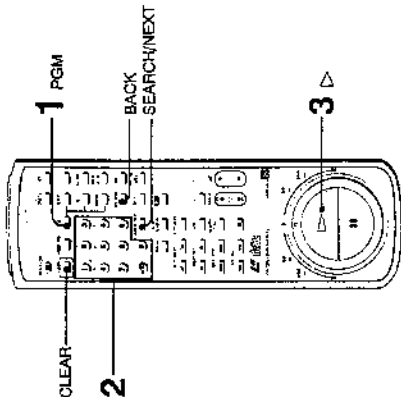

If you make a mistake in track number entry. To start over, press CLEAR, and PGM again, then enter the correct numbers.

To change a number, press SEARCH/NEXT (or NEXT on the player) or BACK to advance or go back entries until the incorrect number flashes in the display window, then enter a new number.

To enter track numbers over 10

Use the +10 and -10 buttons.  
Example: To enter 14  $\left[ \text{+10} \right] \rightarrow \left[ 4 \right]$   
To enter 20  $\left[ \text{+10} \right] \rightarrow \left[ \text{+10} \right] \rightarrow \left[ 0 \right]$

If you press the +10 button by mistake Press +10 repeatedly until 0-9 is displayed, then enter the correct number.

To release or cancel program playback Press CLEAR or HALL. The unit reverts to normal playback.

To repeat a program Press REPEAT to turn on the REPEAT indication in the display window.

To move to a preceding programmed track Press the 1-4 button.

To move to a following programmed track Press the 5-8 button.

Example: To play tracks numbered 5, 4, 2, and 6 in order.

- 1 Press PGM. The PGM indication in the display window flashes.
- 2 Enter the track numbers by pressing "5", "4", "2", and "6" in sequence.
- 3 Press  $\blacktriangleright$  (play). The first track is searched for, and playback starts from the beginning of the track 5 and continues through track 4, 2, 6 and stops.

### Notes

- When the shuttle ring is kept turned to the forward direction during program playback and the playback comes to the end of the current selection, the next programmed track will be played back. When the shuttle ring is kept turned to the reverse direction, the unit will not go back to previous tracks. If you want to move a preceding programmed track, press the 1-4 button until the desired programmed number comes up.
- If not existing track numbers on a disc are entered, the program may not be conducted.

To check time and track information on a TV or monitor screen Turn on the power of the TV or monitor connected to the player and press G. Time and track information for the CD/CDV is shown on the screen.

### During program play

The numbers on the AV calendar display go out as tracks are played. The contents of a program are stored until the disc is removed or the player is turned off.

### Program playing time

The total playing time of the program is displayed, only when tracks with numbers under 20 are programmed and the total playing time is less than 100 minutes.

## To Change Time Display (AV TIME)

To change the time display in the display window, press AV TIME. The display changes in the following sequence each time the button is pressed.

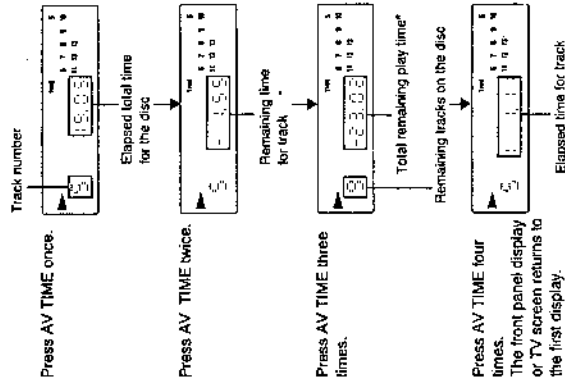

\* With a CDV disc, these figures refer only to the portion (audio/video) currently in use.

### Display on the screen

If the TV set or monitor connected to the player is on and the G button is pressed, the track number, time, and other information recorded on the CD/CDV appears on the screen.

### Note

The remaining time will not be displayed for a track number higher than 20 and playing time more than 100 minutes.

### Note on LD discs

The time display function is available only with an LD containing TOC data. First, the elapsed total time or the number of frames is displayed. Pressing the AV TIME button then changes the time display as shown above.



## Auto Program Playback

You can designate a length of time and make 2 different programs of selections filling within that period. When there is only minimal time left of the designated length of time, a selection with the longest playing time shorter than the left time will be entered. This section explains how to conduct Auto Program Playback on a CD, but the function can also be used for LDs with TOC and DVDs.

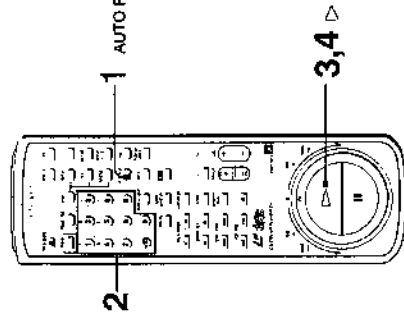

**1** Press the **AUTO PGM** button.  
PGM blinks in the player display window.

**2** Designate the time length for a single side of your tape.  
Example: For 30 minutes of playback  
Press (+10), (+10), (+10) and (0).

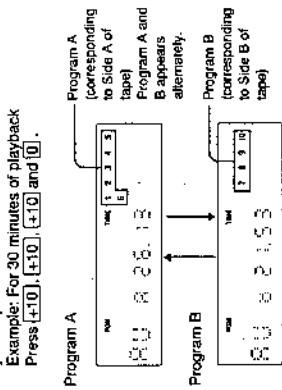

If you press the wrong number, simply press the correct one.

**3** Press the **▷** button.

The selections for Program A will be played and then the unit will pause. The number of the selection that finishes its play disappears from the AV calendar display.

**4** Press the **▷** button to play back Program B.

**To resume normal playback**

Press the **CLEAR** button or the **1/ALL** button.

**AV calendar on the screen**

The AV calendar shows information on the contents of two different programs, program A and program B, separated with a pause.

**Auto Program contents**

Program contents are stored until the disc is removed or the power is turned off.

**If your disc contains more than 20 selections**

Selection with numbers over 20 may not be programmed with the Auto Program function.

### NOTE

Auto Program will not be run if your selection is longer than the designated playing time.

## INTRO Scan

The INTRO scan plays back only the beginning (introduction) of each chapter/track on a disc for approximately 10 seconds for a PAL disc and approximately 8 seconds for an NTSC disc. The INTRO scan will also play back the scenes of the video chapter for LD and DVD.

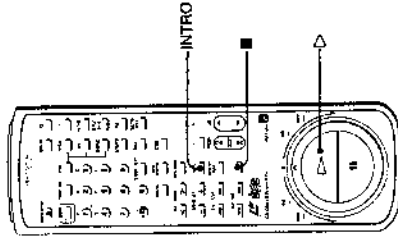

**To start INTRO scan playback**  
Press **INTRO** button.

### LD

Then the beginning portion of each chapter will be played back for a short time, about 10 seconds for a PAL disc and for about 8 seconds for an NTSC disc, in order from chapter 1.  
After the playback of the last chapter, the player will be paused.

### CD/DVD

Then the beginning portion of each track will be played back for a short time, about 10 seconds for a PAL disc and for about 8 seconds for an NTSC disc (MDF-6500), in order from track 1.

After the playback of the last track, the player will be paused.

• Playback will begin with the video portion for DVD discs.

### To resume normal playback

Press the **▷** button. During search functions, normal playback will resume from the selection to be searched when the **▷** button is pressed.

### To stop playback

Press the **■** button to stop.

## Auto Pause

After a chapter or track is played, the player enters the pause mode.

Press **AUTO PAUSE**.

To start playback of next chapter or track  
Press  $\blacktriangleright$  (play).

To return to normal playback  
Press the **AUTO PAUSE** button.

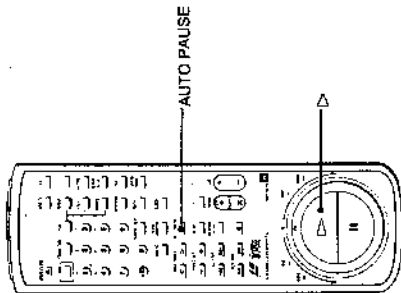

## Shuffle Playback

The chapters or tracks on the disc can be played back in random order.

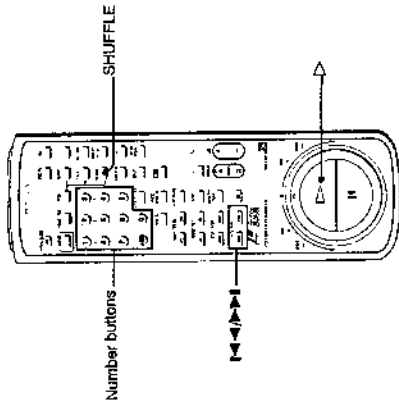

To play all tracks or chapters on a disc

To ensure correct operation, do not press **SHUFFLE** immediately after the disc tray has closed, but only after the  $\blacktriangleright$  indication in the display window has stopped flashing.

**1 Press SHUFFLE.**  
The **SHUFFLE** indication in the display window flashes. The **DELETE SHUFFLE** - indications on the TV screen appear.

**2 Press  $\blacktriangleright$  (play).**  
All chapters or tracks on the disc are played once in random order. After all chapters or tracks have been played, the unit enters the stop mode.

To play only certain chapters or tracks (delete shuffle)

**1 Press SHUFFLE.**

**2 Enter the chapter number or track number not to be played.**

On the display window, the deleted numbers in the AV callender disappear, and on the TV screen, the deleted numbers are displayed.

**3 Press  $\blacktriangleright$  (play).**  
The player automatically selects a random program excluding the deleted chapters or tracks.

If you make a mistake in entering the chapter or track number to be deleted.

Press **CLEAR**, then press **SHUFFLE** again and enter the correct number.

Or, use the **SEARCHNEXT** (or **NEXT** on the player) or **BACK** button to cause the wrong number to flash in the display window, and enter the correct number.

To skip to the next chapter or track in shuffle play  
Press the  $\blacktriangleright$  button. Returning to a previous chapter or track with the  $\blacktriangleleft$  button is not possible.

To repeat shuffle or delete shuffle play

Press **REPEAT** to turn on the **REPEAT** indication.

The player reshuffles the selections and plays them back in a different random order.

When the unit is turned off or the disc is removed, shuffle functions are cancelled.

To resume normal playback

Press **CLEAR** or **1/ALL**.

To cancel shuffle playback

Press **CLEAR** or **1/ALL**.

Normal playback resumes from the next chapter or track.

When an LD without TOC data is inserted, the indication "NO TOC" appears on the screen, and shuffle playback cannot be carried out.

Shuffle play with CDV discs

Tracks in the audio part and video part are played in random order.

# Custom Index

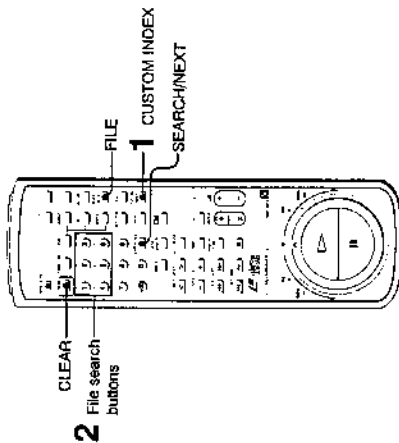

## To set a custom index mark

Press **FILE** during playback. Up to six locations (A-F) anywhere on the disc can be marked.

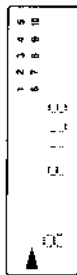

Indications A, B, C, etc. light up for each custom index mark.

## Custom index search

- 1 Press **CUSTOM INDEX**. The AV calendar goes out and the number buttons 1-6 act as file search buttons A-F.
- 2 Press the file search button for the desired location. Playback starts from the specified index point and continues until the end of the disc.

To jump to another index point Press the corresponding file search button.

To return to normal playback Press **CUSTOM INDEX** or **CLEAR**.

If you make a mistake Press **SEARCH/NEXT** (or **NEXT** on the player) until the index point appears on the display.



Press **CLEAR** and then **FILE** at the correct location.

**Custom Index**  
The Custom Index function lets you set six index marks max. at any point on the disc. Playback can then be started from an index point at the push of a button, and repeat playback between index points is also possible. This chapter explains how to set custom index marks on an LD, but the function can also be used for CDs or DVDs.

To play a section between custom index points once Press **CUSTOM INDEX**, then **FILE**, so that the 1 indication is shown in the display window. Then perform custom index search to the desired index start point. The section between this point and the next custom index point is played once.

To play a section between custom index points repeatedly Press **FILE**, so that the 1 indication is shown in the display window and press **REPEAT** to turn on the **REPEAT** indication. Then perform custom index search to the desired index start point. The section between this point and the next custom index point is continuously repeated.

**Index point rearrangement**  
The custom index points are arranged on the disc not by the order in which they were input but by their relative location from the start of the disc. If a new index mark is set before an old one, the A, B, C, ..... order is rearranged.

**Custom Index with a DVD disc**  
Although playback starts from the video position, files will be arranged from the audio portion in A, B, C, ..... order.

**How is the custom index stored?**  
The custom index data are not actually recorded on the disc but stored in the memory of the player. Therefore the custom index points set with one player cannot be used when the disc is played on another unit.

**To clear a custom index mark**  
Information on index marks is retained also when the player is switched to normal playback. To cancel a stored index mark, use the **SEARCH/NEXT** button (or **NEXT** on the player) to cause the corresponding file search indication to flash, and then press **CLEAR**.

### Note

When the disc is removed or the player is turned off, custom index memory will be erased.

## SECTION 2 DISASSEMBLY

Note: Follow the disassembly procedure in the numerical order given.

### 2-1. TRAY COVER

- 1 Turn power on, push  (OPEN/CLOSE) button and then the tray comes out.

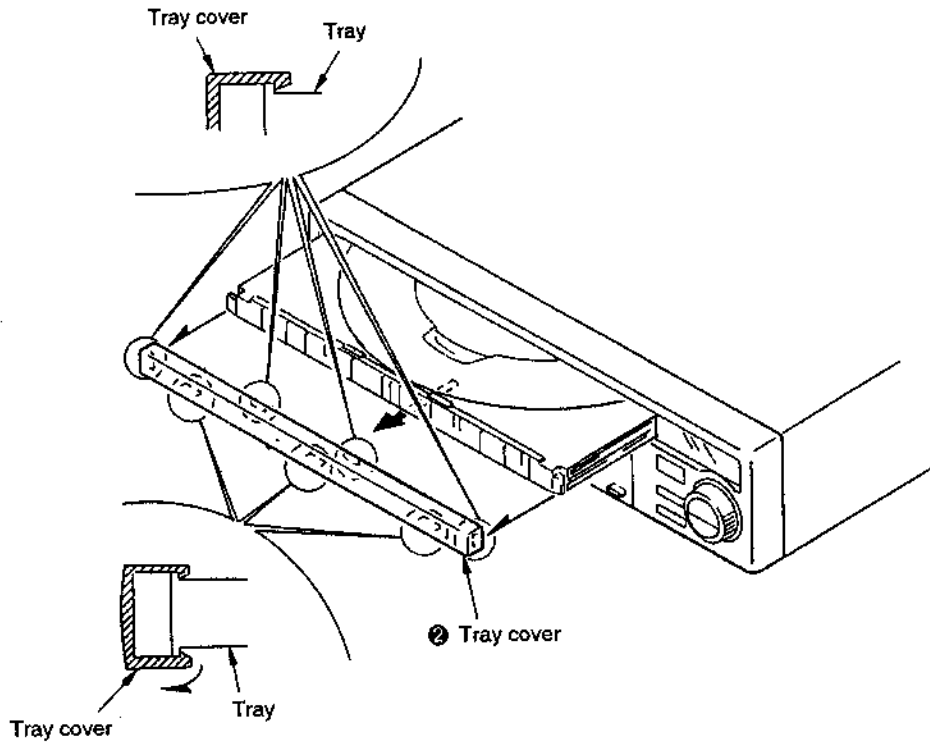

### 2-2. UPPER CASE, FRONT PANEL ASSY, BOTTOM PLATE ASSY

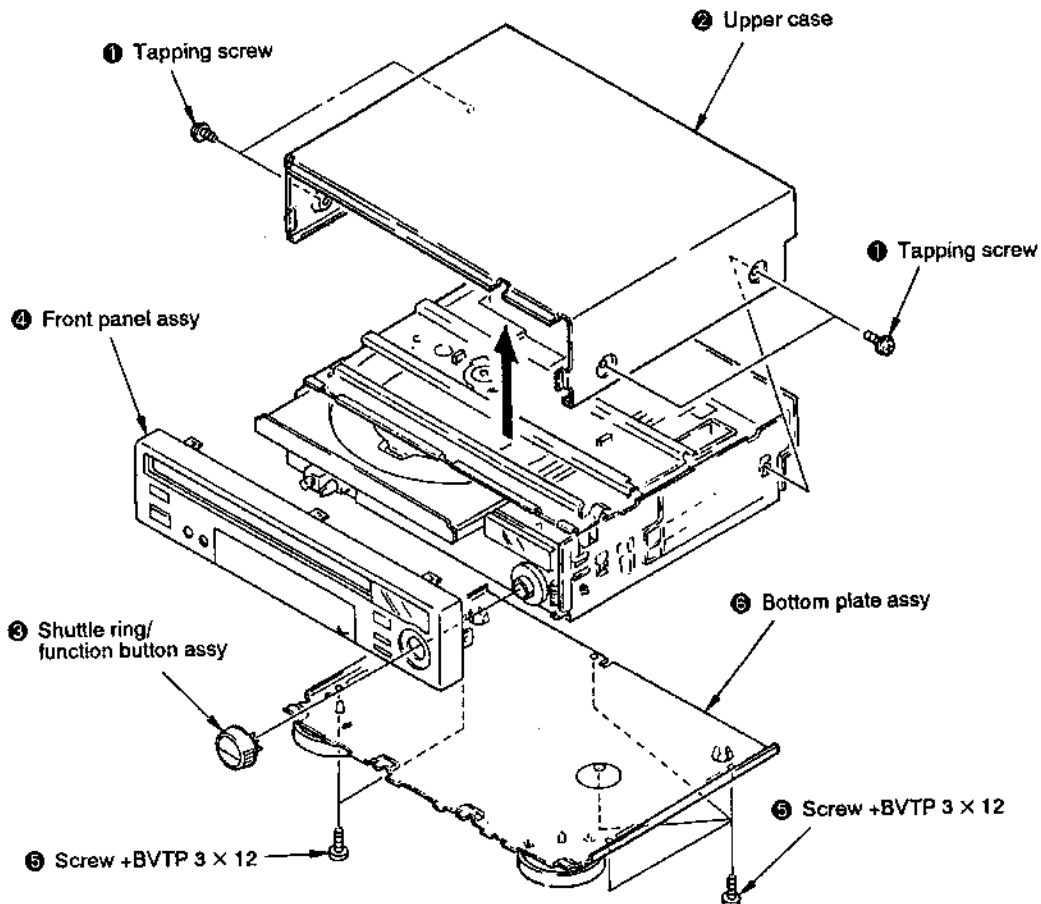

**2-3. MP-701, AF-701 (MDP-650D), AF-702 (MDP-450), RG-701 (MDP-650D) BOARD**

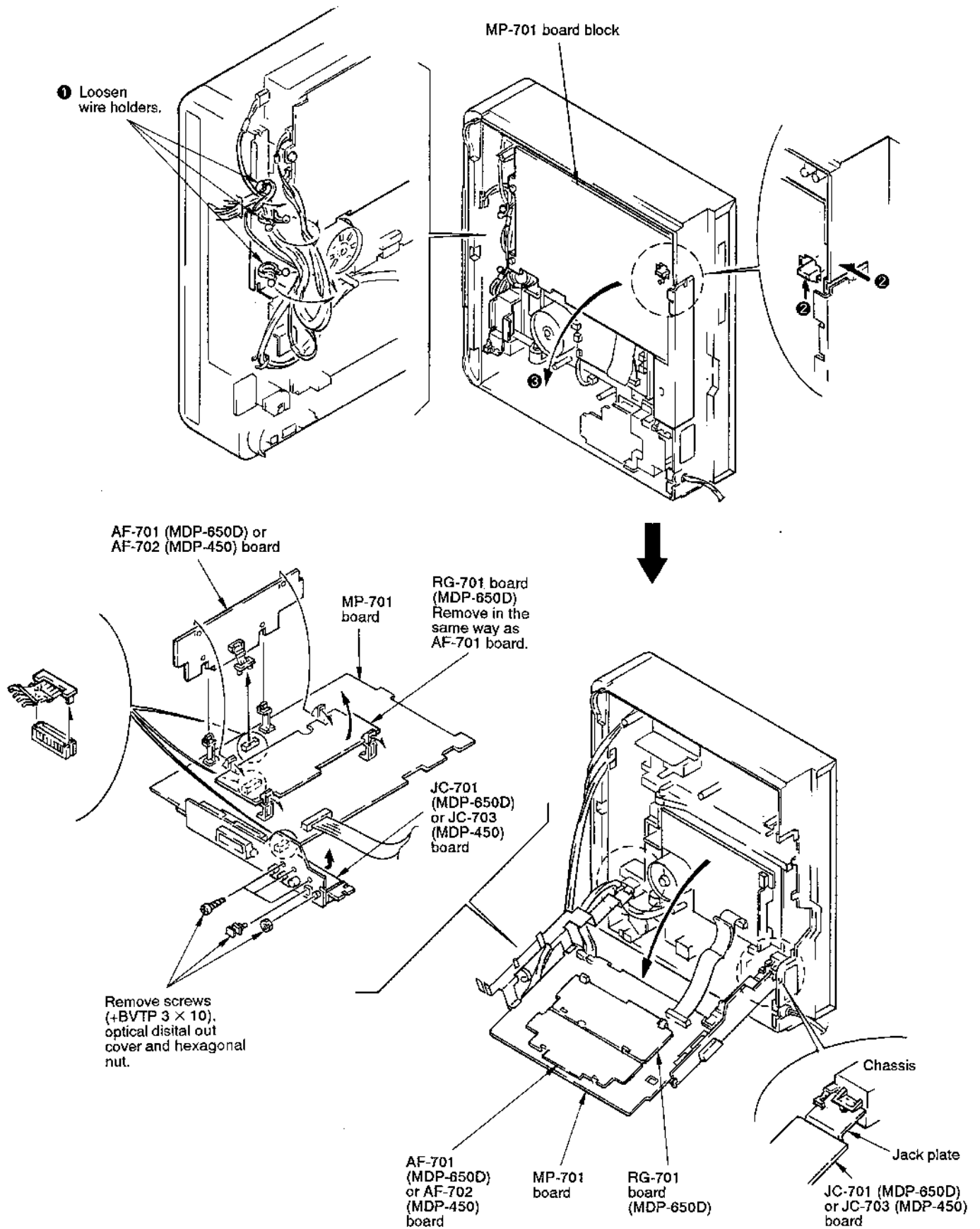

**2-4. MD CHASSIS, OPTICAL DEVICE CHASSIS**

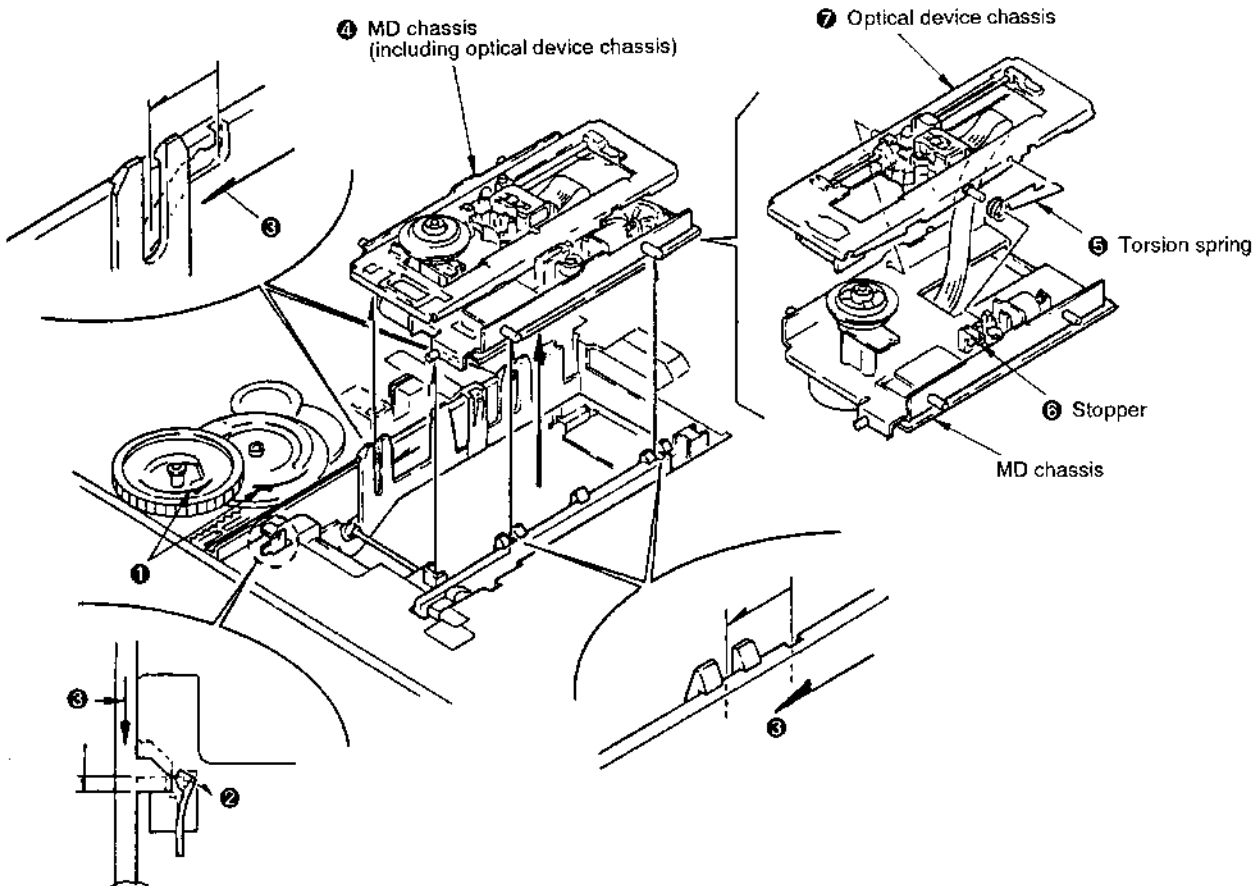

**2-5. TURNTABLE, SPINDLE MOTOR, SKEW MOTOR, SV-63, FG-41 BOARDS**

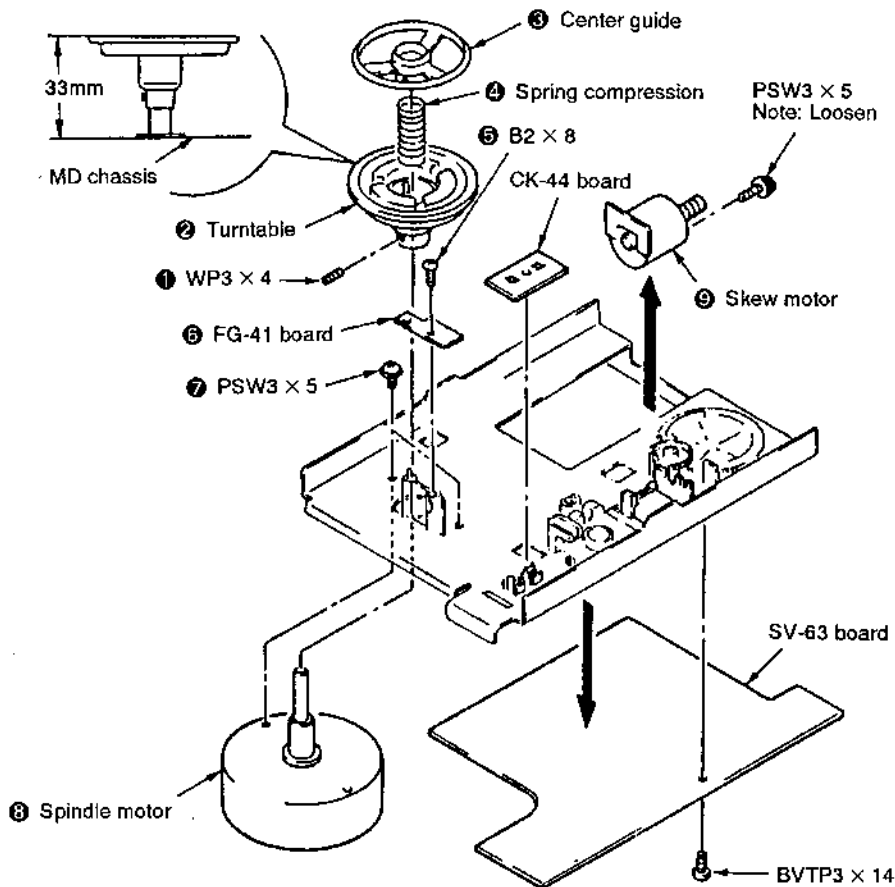

## 2-6. REMOVAL OF THE TRAY

**Note** Make sure to remove the tray after having removed the front panel and the front reinforcement plate.

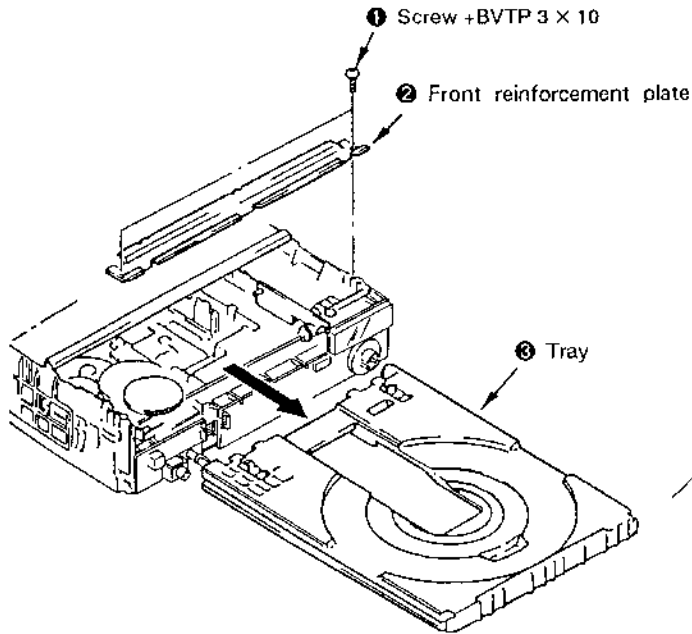

## 2-7. REMOVAL OF THE DISC WHEN A PROBLEM HAS OCCURRED WITH THE DISC LOADED.

- 1) Turn the pulley (A) in counter-clockwise direction until the tray starts moving.
- 2) Pull out the tray.

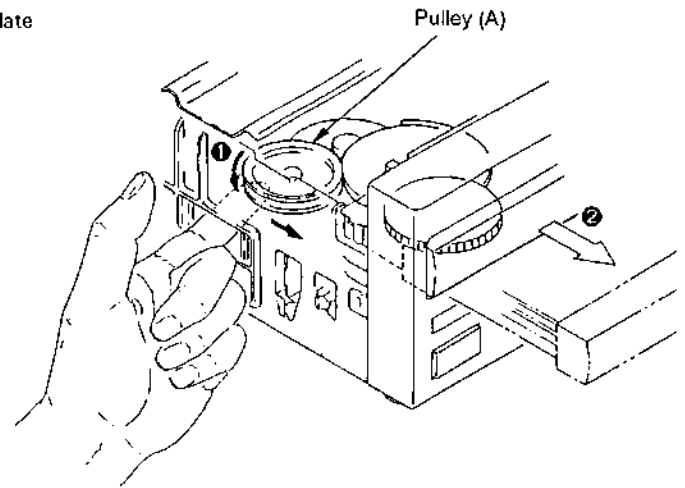

## 2-8. ALIGNMENT OF THE LOADING GEAR PHASE

- 1) Install the drive cam as shown in the illustration.  
At this time, make sure that the last tooth of gear is aligned with the line from the center of the tray gear axle and the drive gear axle.
- 2) Install the tray gear as shown in the illustration.  
At this time, make sure the flat surface of the cam is at a right angle with the drive cam.

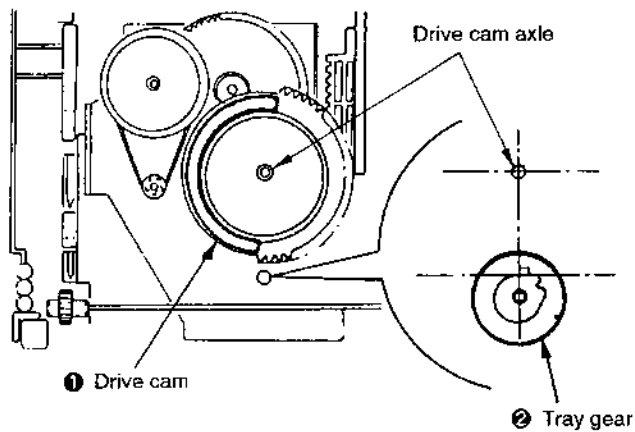

## SECTION 3 DIAGRAMS

### 3-1. CIRCUIT BOARDS LOCATION

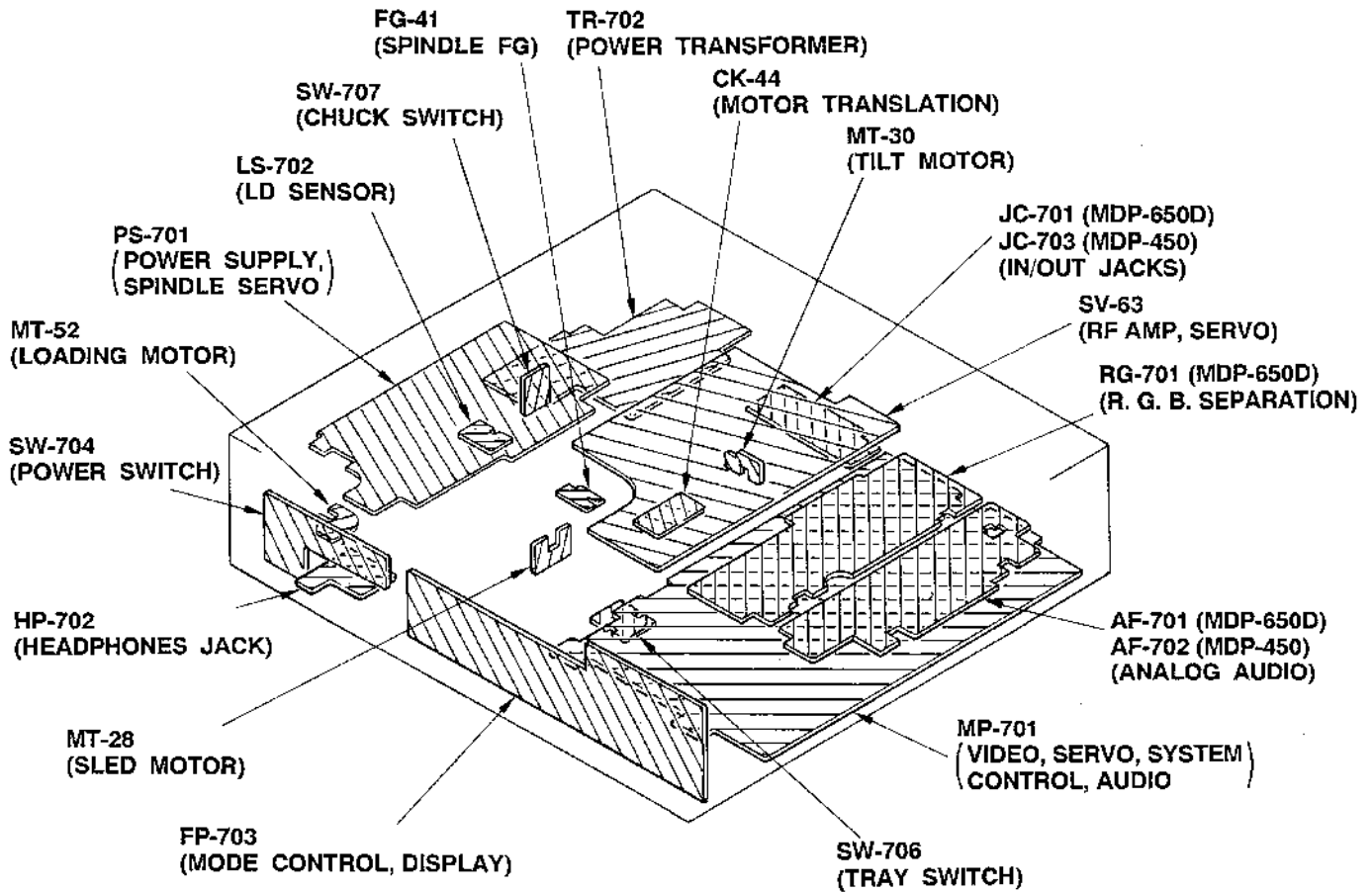

### • MAIN PARTS LOCATION

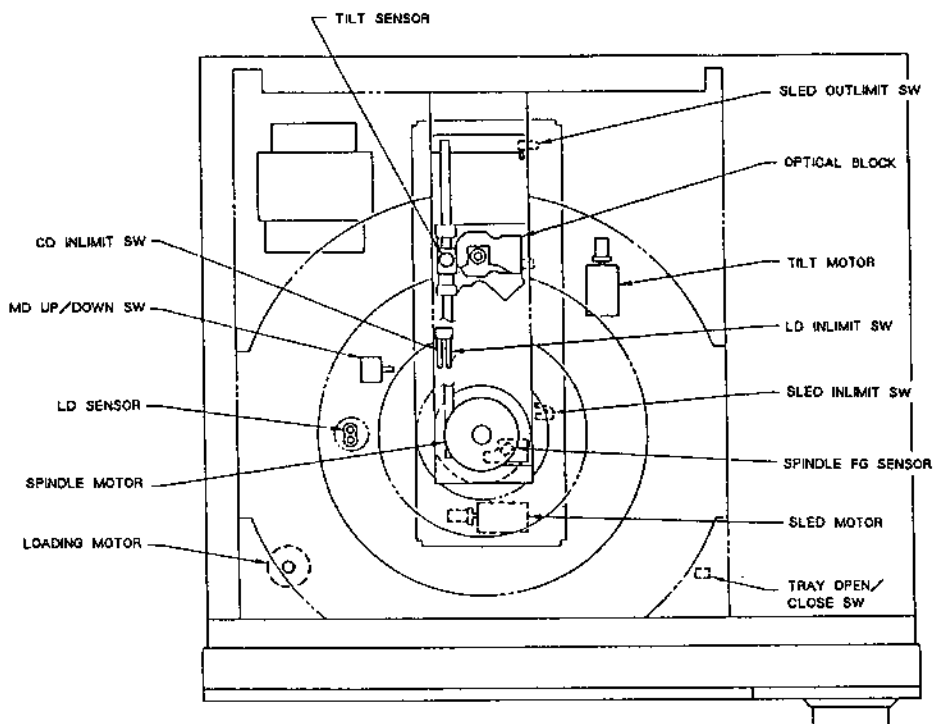



3-2. OVERALL BLOCK DIAGRAM

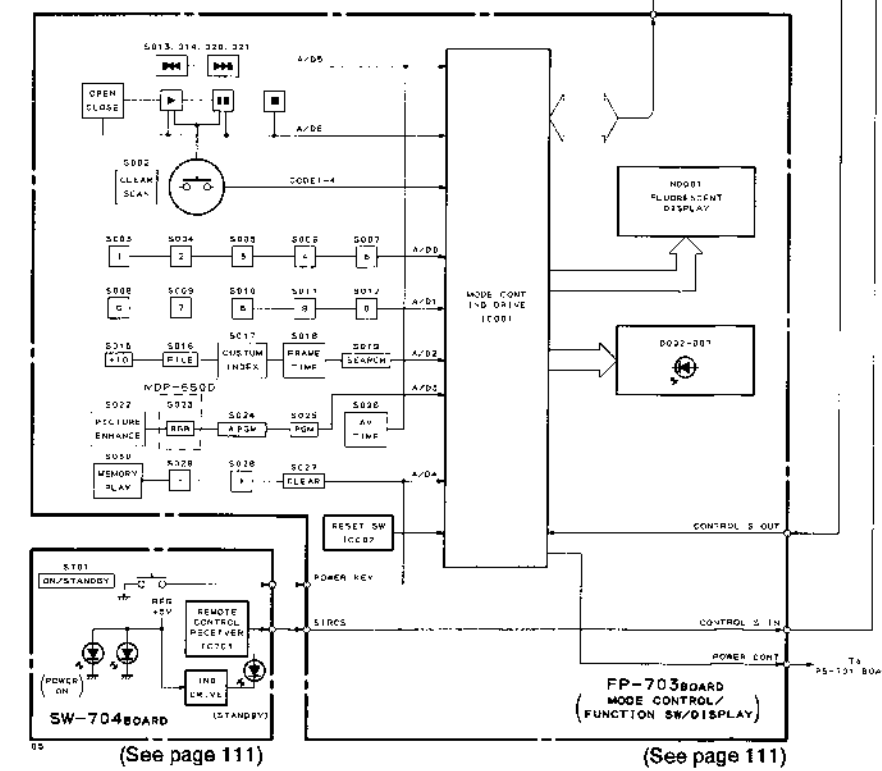
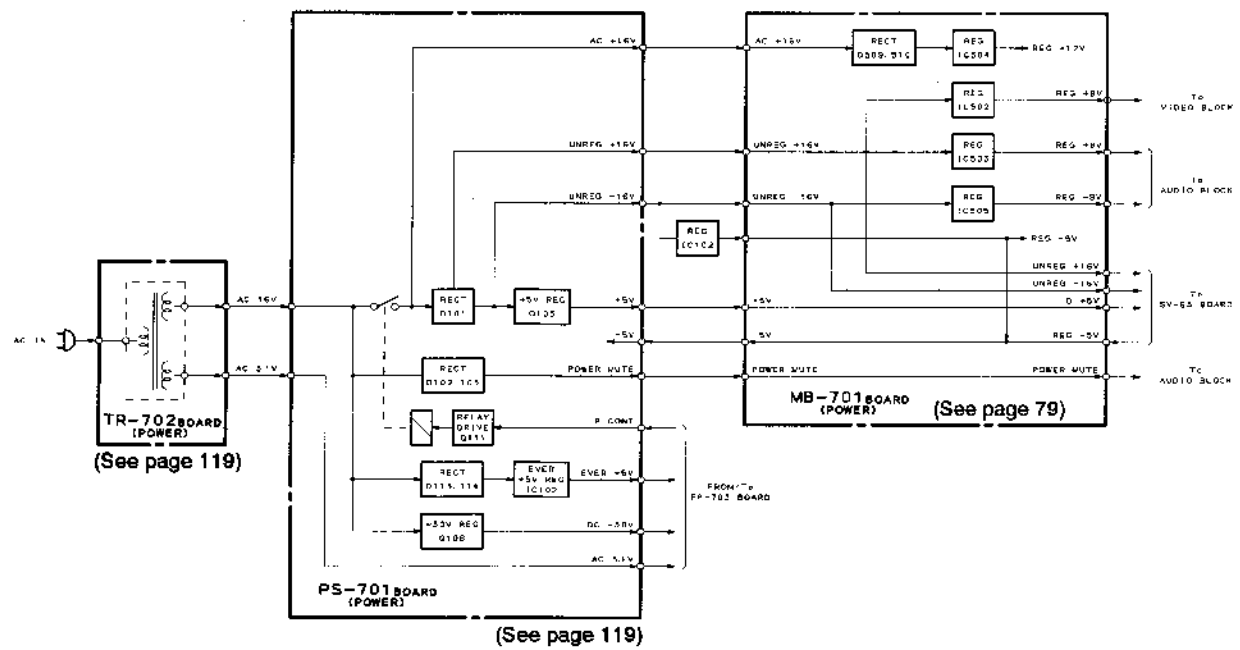
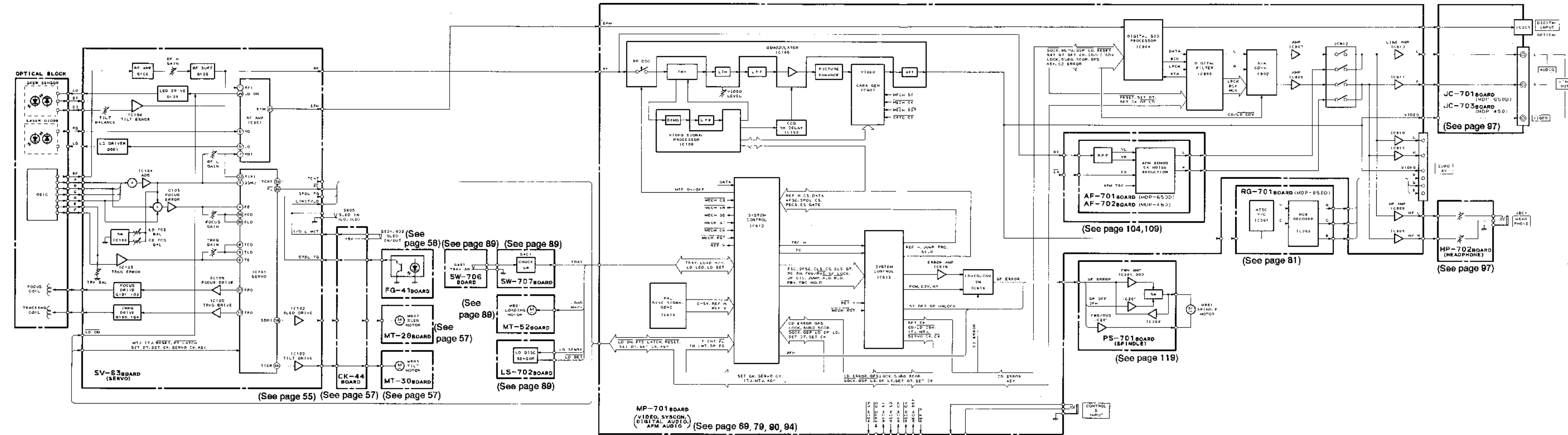

3-3. SERVO BLOCK DIAGRAM

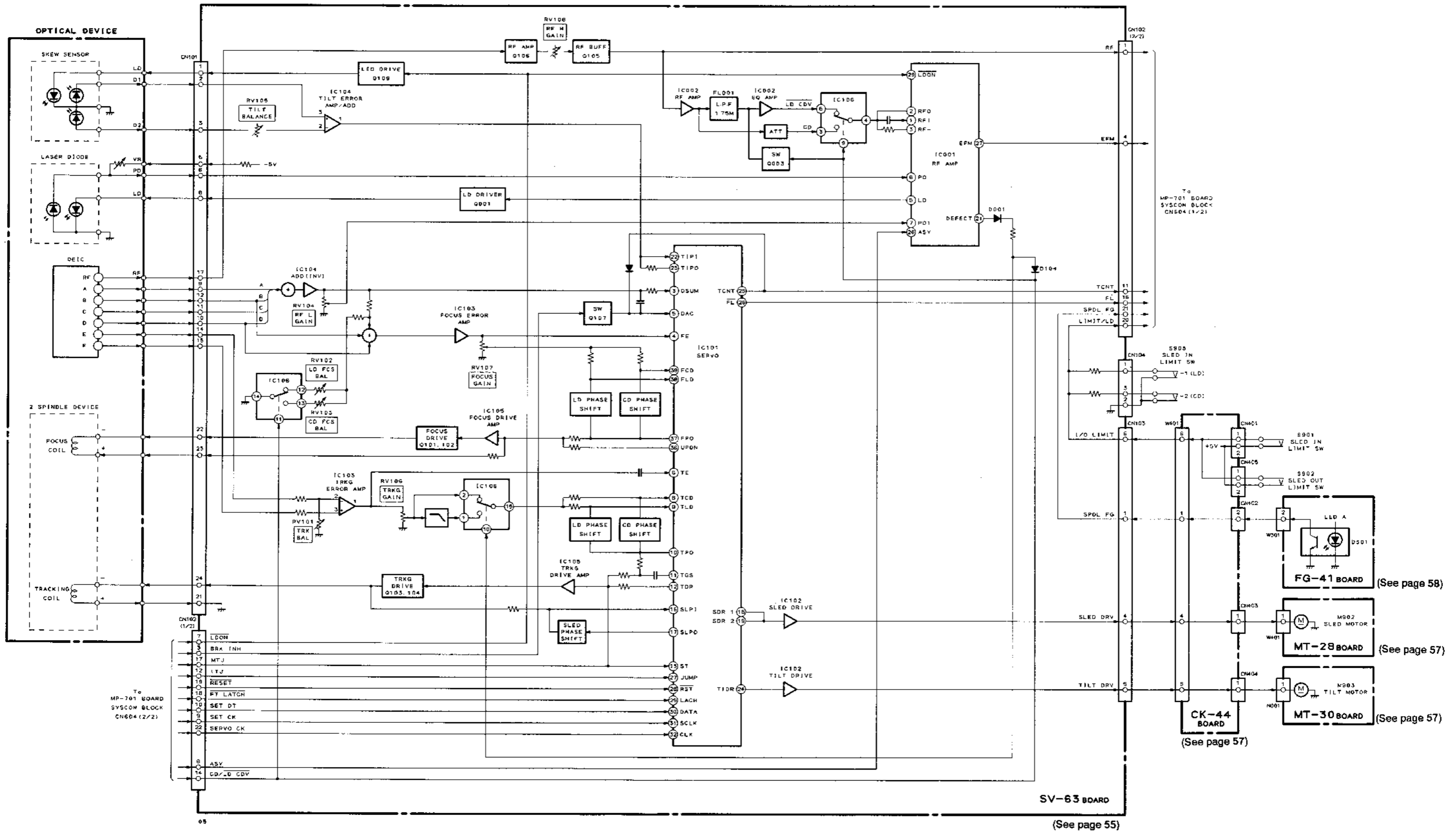

### 3-4. SYSTEM CONTROL MICROCOMPUTER PORT FUNCTIONS (MP-701 BOARD IC612 MB89795)

No.	Signal Name	I/O	Function	
1	DATA	I	Data (Philips code) input	
2	PBCS	I	Playback composite video sync. signal	
3	PC OUT	O	Playback H sync. signal output	
4	AVCC	—	A/D converter power supply	
5	AVR	—	A/D converter reference voltage	
6	AVSS	—	A/D converter ground	
7	TRAY	I	Tray loading switch voltage	
8	IN LIMIT	I	Sled position switch voltage	
9	MIRR	I	Not used	
10	LD DET	I	LD disc detection	
11	—	—	Not used	
12	MOD	I	Microcomputer internal/external ROM select	
13	XO	O	Clock output 14.31818 MHz	
14	XI	I	Clock input 14.31818 MHz	
15	VSS	—	Digital ground	
16	RST	I	Reset	
17	LOAD	O	Loading motor control (IC614)	
18	UNLOAD	O		
19	FTSLD	O	Servo IC (SV-63 board IC101) data load signal	
20	JPCTL	O	Track jump control (ITJ/MTJ)	
21	FL	I	Focus servo lock signal	
22	LD/CD CDV	O	Disc judgement signal	
23	LD ON	O	Optical pick-up laser diode emitting control	
24	—	—	Not used	
25	TBC HOLD	O	TBC HOLD control signal	
26	DUAL	I	PAL, SECAM dual/PAL only select	
27	CLS CS	O	ENABLE signal for CLS CS (IC613 Ⓢ) signal	
28	PV MUTE	O	Video mute signal for PAL "H": mute	
29	TEST	I	"L" : test mode	
30	RESET	O	Reset control	
31	ALD	O	IC613 output port (register A, B) data load signal	
32	BLD	O		
33	—	—	Not used	
34	REF H	I	Reference H sync. signal	
35	DSPLD	O	Data load signal to DSP	
36	LOCK	I	RF PLL lock signal	LOCK is made up of sampling GFS
37	GFS	I	RF PLL lock signal	
38	SP LOCK	I	Spindle servo lock signal	
39	MTF ON	O	MTF control signal	
40	CEN. C			

No.	Signal Name	I/O	Function
41	CF1	O	Color framing circuit select
42	MECH SI	I	Communicating data from mode control microcomputer (FP-703 IC001)
43	MECH SO	O	Communicating data to mode control microcomputer
44	MECH CS	I	Chip select signal from mode control microcomputer
45	MECH CK	I	Clock from mode control microcomputer
46	SUB Q	I	SUB Q data from DSP
47	—	—	Not used
48	—	—	
49	SOCK	O	Serial data clock to DSP
50	NOR/JOG	O	"L" : PAL CAV JOG mode
51	JMP	O	Track jump trigger signal
52	TCNT	I	Pulse for traverse counting
53	SP FG	I	Spindle FG pulse
54	CLS DT	I	CLV clear scan V sync. counter data
55	VCC	—	Power supply (+5 V)
56	SET DT	O	External IC communicating data
57	SET CK	O	External IC communicating clock
58	PB V IN	I	Playback V sync. signal
59	DS GT	O	Philips code reading out control signal
60	P/N IN	I	PAL/NTSC judgement signal "H" : PAL, "L" : NTSC
61	REF H	I	Reference H sync. signal
62	N REF H	O	NTSC Reference H signal
63	2FH	O	Spindle motor driver PWM carrier
64	SPDL	I	PAL spindle unlock signal "L" : unlock
65	P REF V	I	PAL Reference V signal
66	V RESET	O	V reset for PAL sync. signal IC "H" : reset
67	SCOR	I	SUB code sync. signal
68	P/N OUT	O	PAL/NTSC select signal "H" : PAL, "L" : NTSC
69	FWD/RVS	O	Multi track jump direction control
70	LD SENSE	O	LD disc sensor control pulse
71	DF LD	O	Digital filter data load signal
72	MECH EN	O	Communication control signal to mode control microcomputer (FP-703 IC001)
73	N. C	—	Not used
74	SEL H	O	H sync. signal for character generator
75	REF V	O	Reference V sync. signal
76	CF2	O	Color framing circuit select
77	2FSC	O	2fsc (7.159 MHz) output
78	DOCI	O	Not used
79	FSC	O	fsc (3.579545 MHz $\pm$ 10 MHz) output
80	TBCH	I	TBC output H sync. signal

3-5. SYSTEM CONTROL BLOCK DIAGRAM

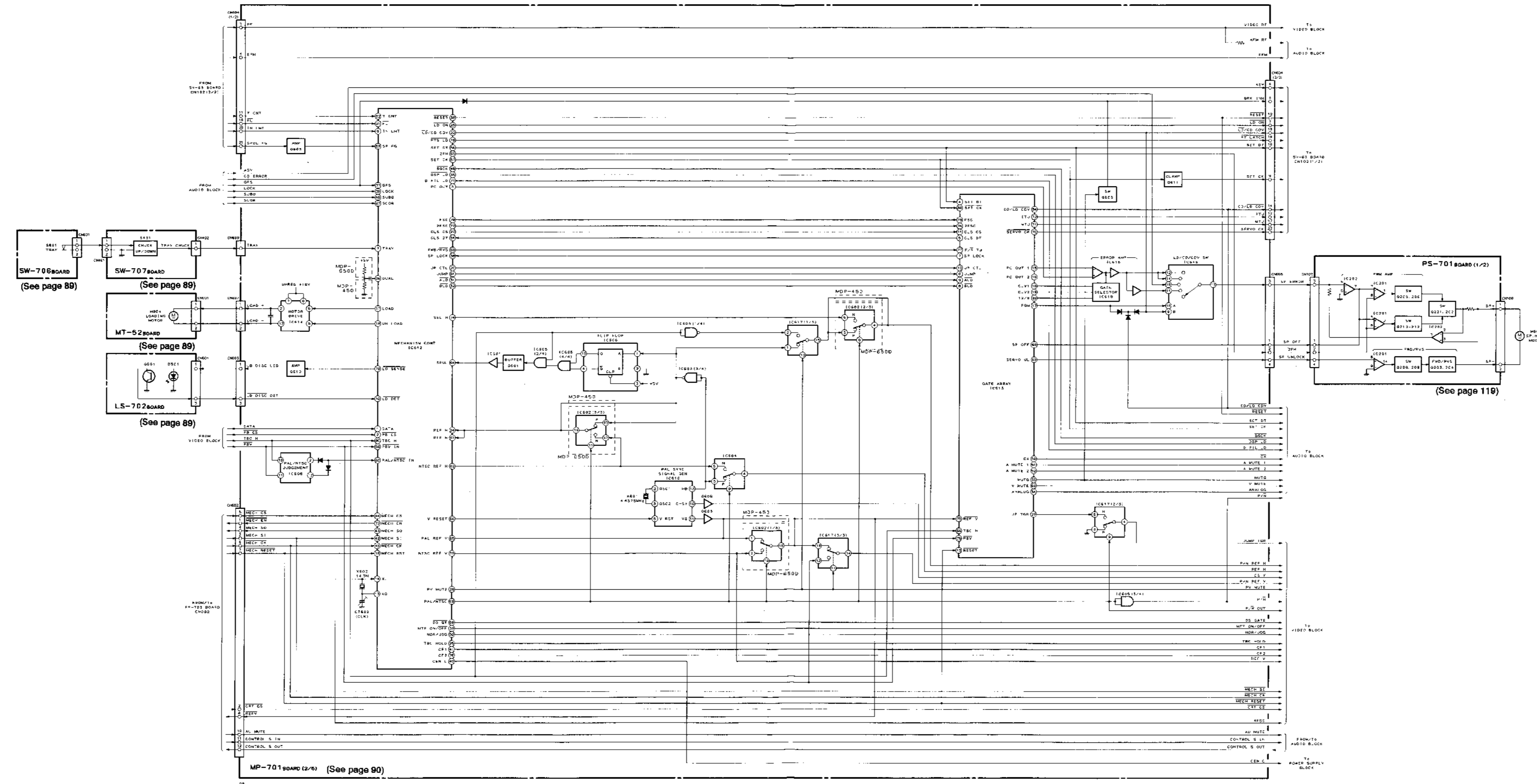

3-6. VIDEO BLOCK DIAGRAM

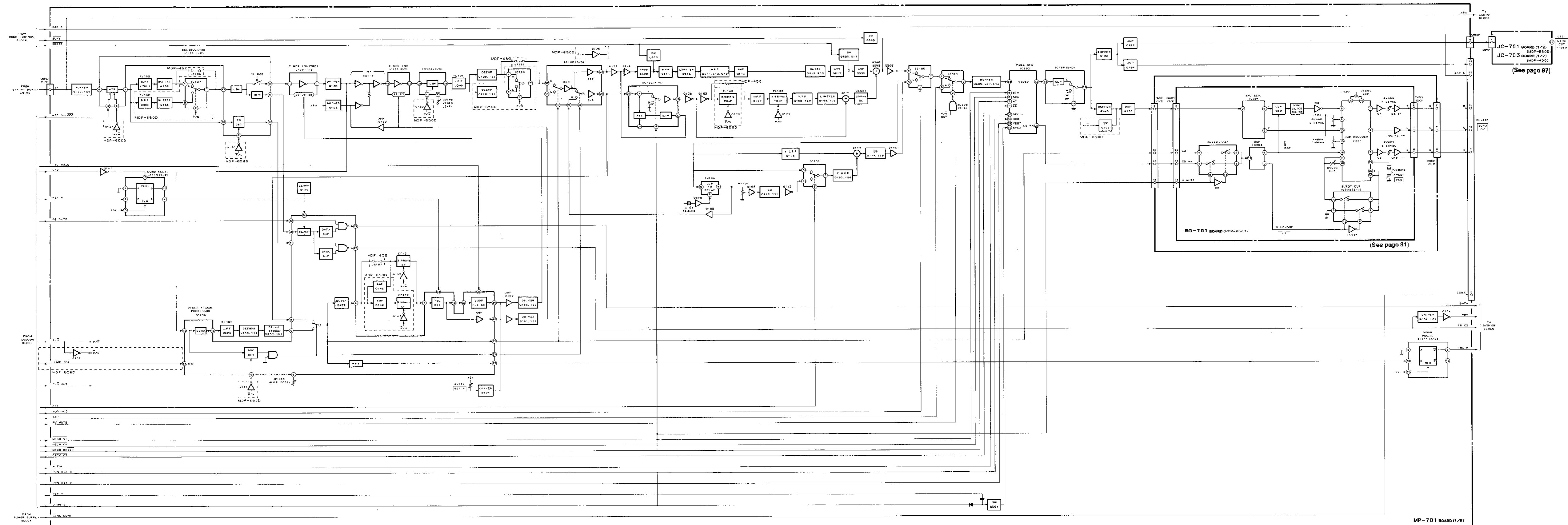

3-7. AUDIO BLOCK DIAGRAM

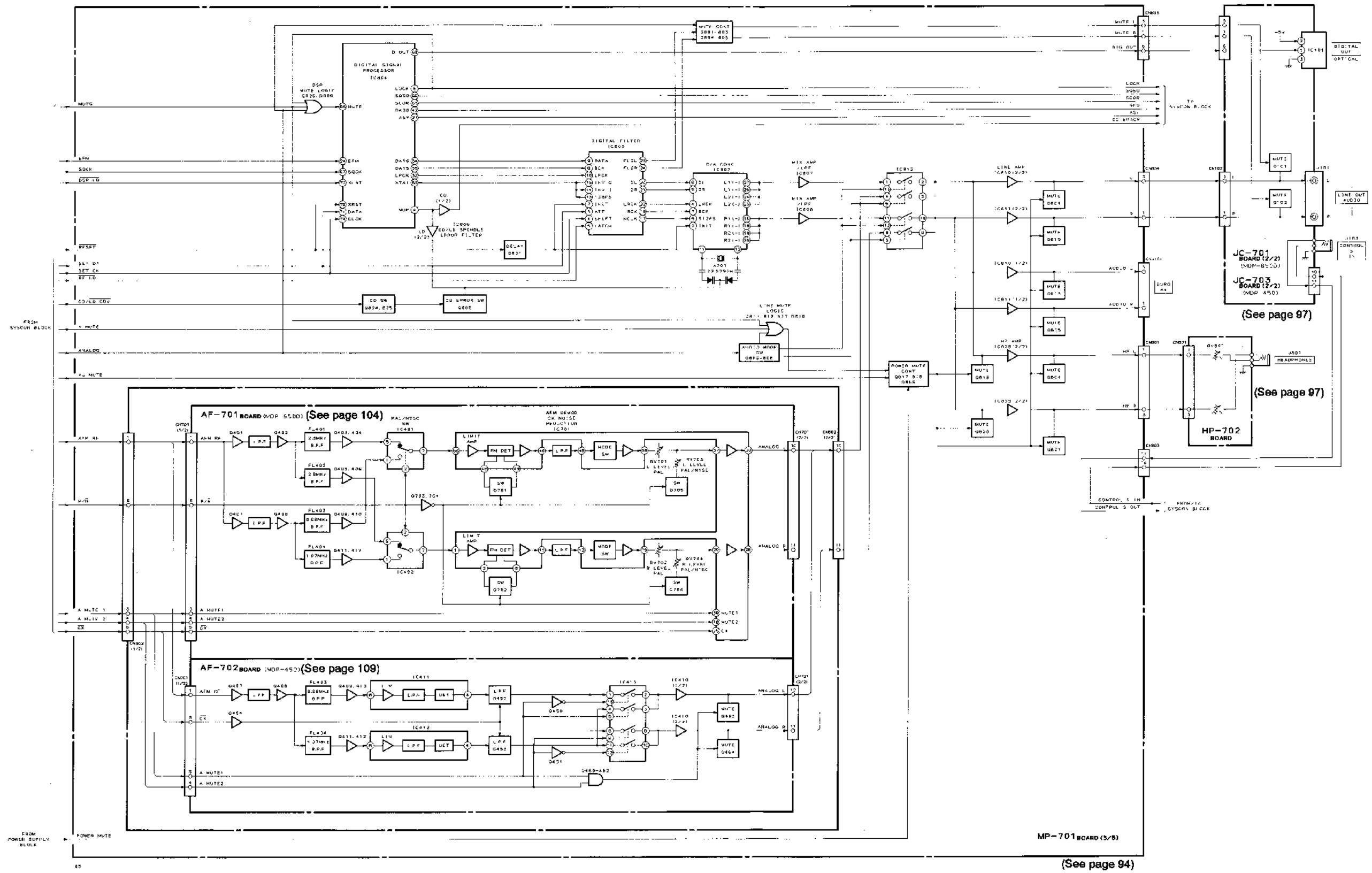

### 3-8. MODE CONTROL MICROCOMPUTER PORT FUNCTIONS (FP-703BORD IC001 CXP50116)

No.	Port Name	Signal	I/O	Function
1	S4/PG0		—	Not used
2	S5/PG1		—	
3	S6/PG2		—	
4	S7/PG3		—	
5	S8/PK0	P12	O	FDP segment output
6	S9/PK1	P11	O	
7	S10/PK2	P10	O	
8	S11/PK3	P9	O	
9	S12/PJ10	P8	O	
10	S13/PJ1	P7	O	
11	S14/PJ2	P6	O	
12	S15/PJ3	P5	O	
13	S16/T15	P4	O	
14	S17/T14	P3	O	
15	S18/T13	P2	O	
16	S19/T12	P1	O	
17	S20/T11		—	Not used
18	S21/T10		—	
19	S22/T9	10G	O	FDP timing output
20	S23/T8	9G	O	
21	T7	8G	O	
22	T6	7G	O	
23	T5	6G	O	
24	T4	5G	O	
25	T3	4G	O	
26	T2	3G	O	
27	T1	2G	O	
28	T0	1G	O	
29	INT	$\overline{\text{REF-V}}$	I	Reference V sync. signal
30	TX		O	Not used
31	TEX		I	
32	RST	$\overline{\text{RST}}$	I	Reset
33	N. C		—	Not used
34	VDD		—	VDD
35	PI0/AD0	A/D0*1	I	Key input
36	PI1/AD1	A/D1*1	I	
37	PI2/AD2	A/D2*1	I	
38	PI3/AD3	A/D3*1	I	
39	PB0/AD4	A/D4*1	I	
40	PB2/AD5	A/D5*1	I	
41	PB3/AD6	A/D6*1	I	
42	PB3/AD7	TEST	I	"L": Test mode
43	EC		—	Not used
44	PX0/SC	$\overline{\text{MECH CK}}$	O	Clock for communication to mechanism control, DSP control, character graphic IC.
45	PX1/SO	MECH SI	O	Communicating data to mechanism control, DSP control, character graphic ICs.
46	PX2/SI	MECH SO	I	Communicating data from mechanism control, DSP control, character graphic ICs.



No.	Port Name	Signal	I/O	Function
47	PA0	MECH CS	O	Chip select signal to mechanism control ICs.
48	PA1	CRTC CS	O	Chip select signal to character graphic IC.
49	PA2	MECH EN	I	Receiving completion signal from mechanism control IC.
50	PA3	MECH RST	O	Reset signal to mechanism control, DSP control ICs.
51	PF0	SOFT	O	Picture enhance LED control
52	PF1	STANDARD	O	
53	PF2	SHARP	O	
54	PF3	RGB	O	RGB LED control (MDP-650D only)
55	PE0	PAL	O	PAL LED control (MDP-650D only)
56	PE1	NTSC	O	NTSC LED control (MDP-650D only)
57	PE2	POWER CONT	O	Power supply control output
58	PE3	A MUTE	O	Audio mute output
59	PY0		O	Not used
60	PY1/PWM	CD MODE	O	REG VIDEO 5 V control
61	PY2/WP	WP	I	Wake up
62	PY3/RMC	SIRCS IN	I	SIRCS input
63	PD0		I	Not used
64	PD1		I	
65	PD2		I	
66	PD3		I	
67	PC0	CODE 4	I	Shuttle switch input
68	PC1	CODE 3	I	
69	PC2	CODE 2	I	
70	PC3	CODE 1	I	
71	VSS	GND	—	GND
72	XTAL	XTAL	O	Clock output
73	N. C		—	Not used
74	EXTAL	EXTAL	I	Clock input
75	VREF	V REF	I	Power supply
76	VFDP	VFDP	I	Power supply for FDP ( - 30 V)
77	S0/PH0		O	Not used
78	S1/PH1		O	
79	S2/PH2		O	
80	S3/PH3		O	

**\*1: Pressed keys and terminal Input voltages**

Input terminal \ Input voltage	0 V	1.1 V	2.0 V	2.9 V	3.8 V
A/D0 ㉔	5	4	3	2	1
A/D1 ㉕	0	9	8	7	6
A/D2 ㉖	SEARCH	FRAME/TIME	CUSTOM INDEX	FILE	+10
A/D3 ㉗	AV TIME	PGM	AUTO PGM	RGB	PICTURE ENHANCE
A/D4 ㉘	POWER	CLEAR	NEXT	BACK	MEMORY PLAY
A/D5 ㉙	—	◀◀	▶▶	—	—
A/D6 ㉚	▲	▶		■	—

3-9. MODE CONTROL BLOCK DIAGRAM

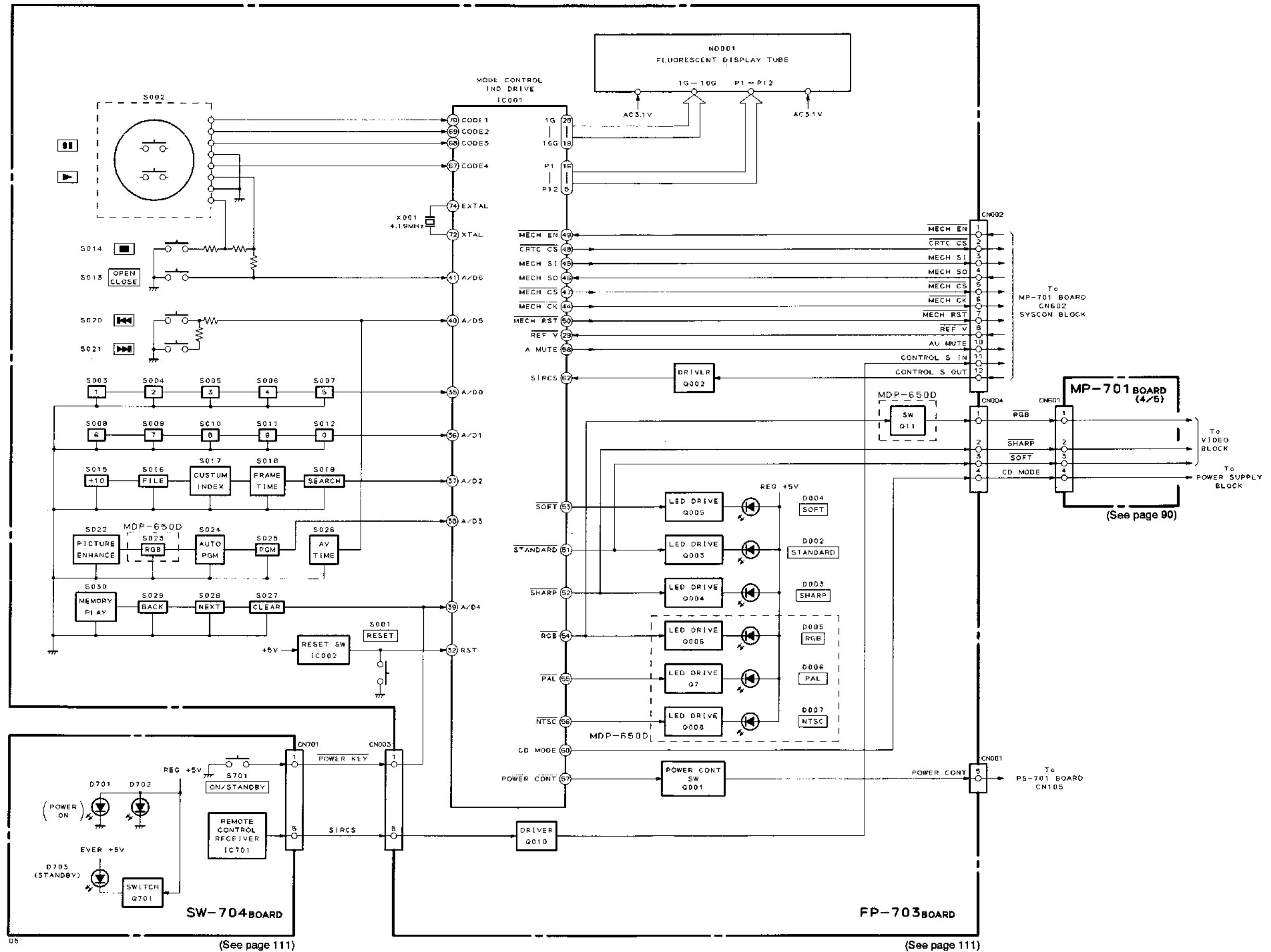

3-10. POWER SUPPLY BLOCK DIAGRAM

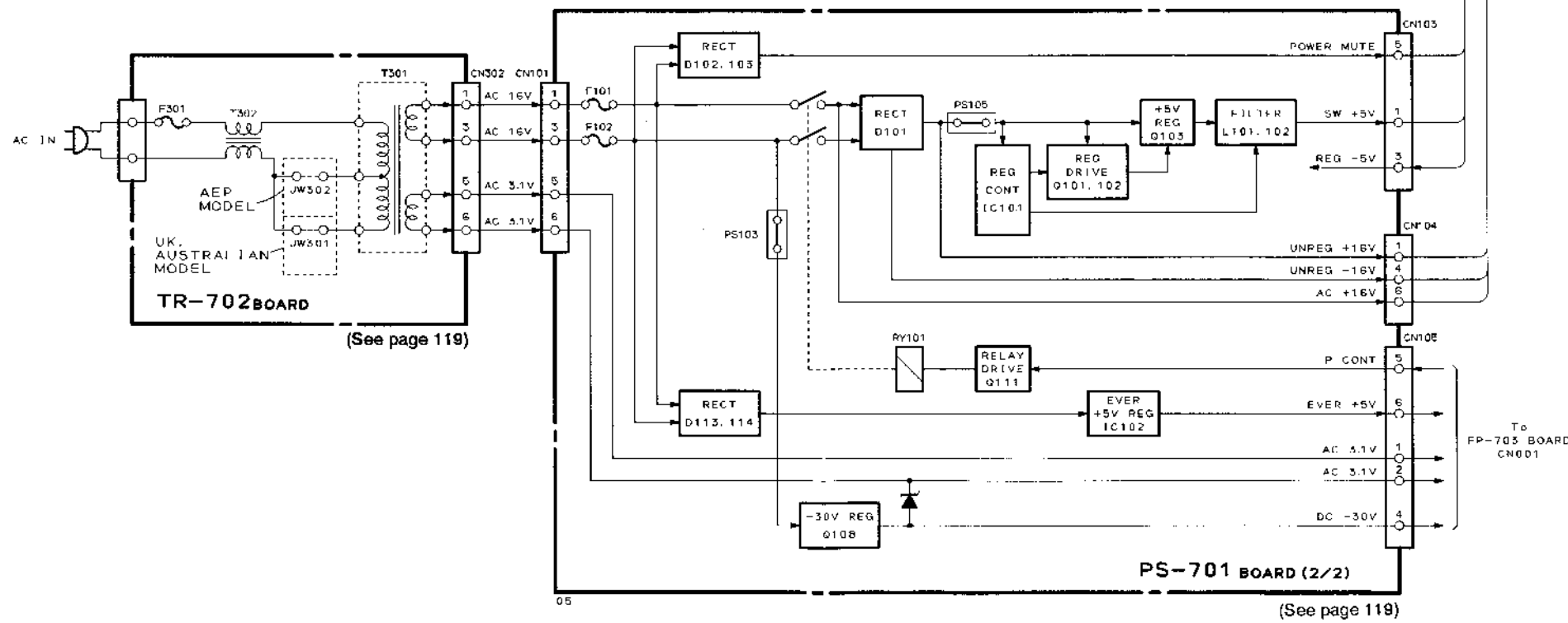
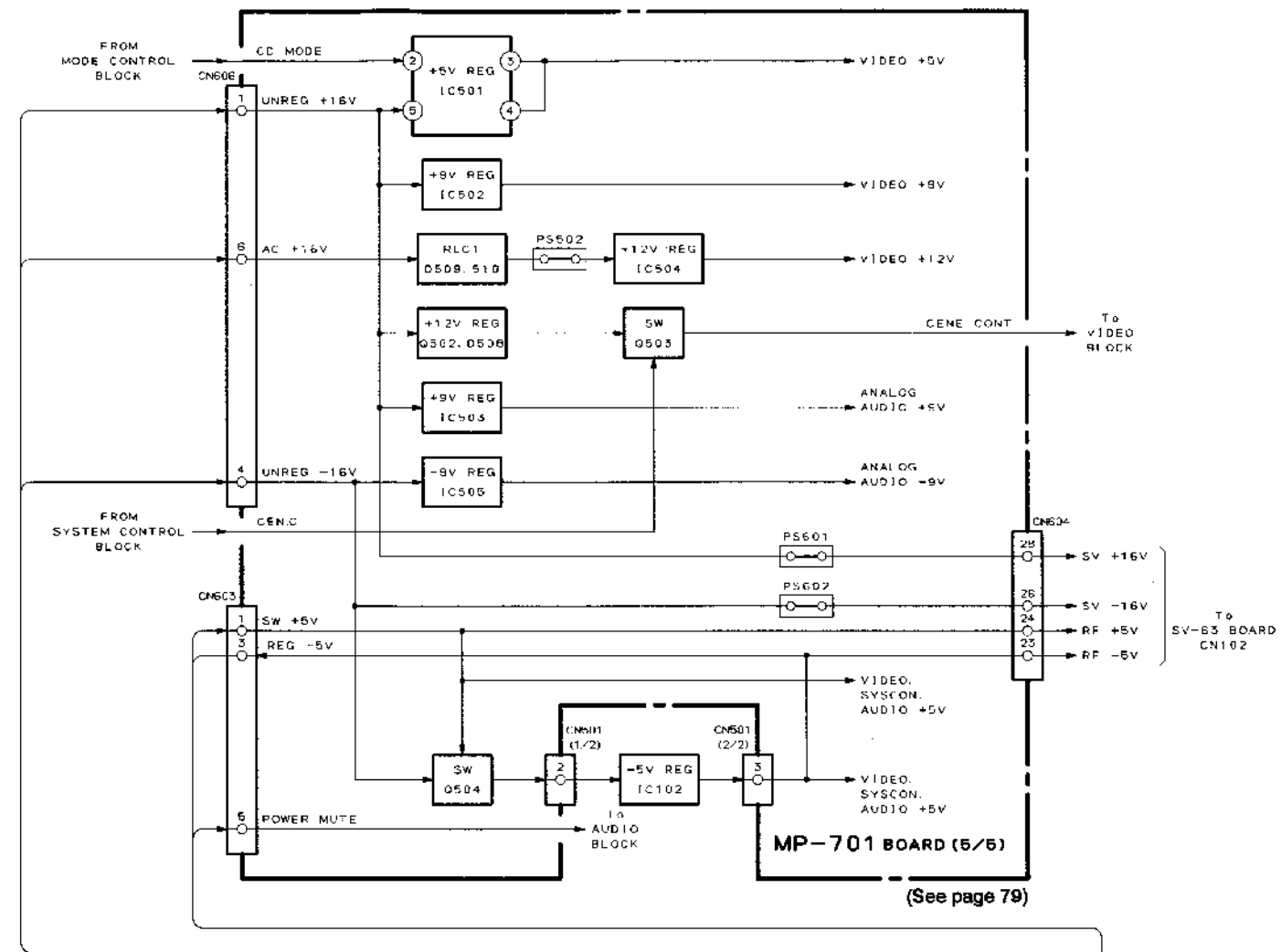

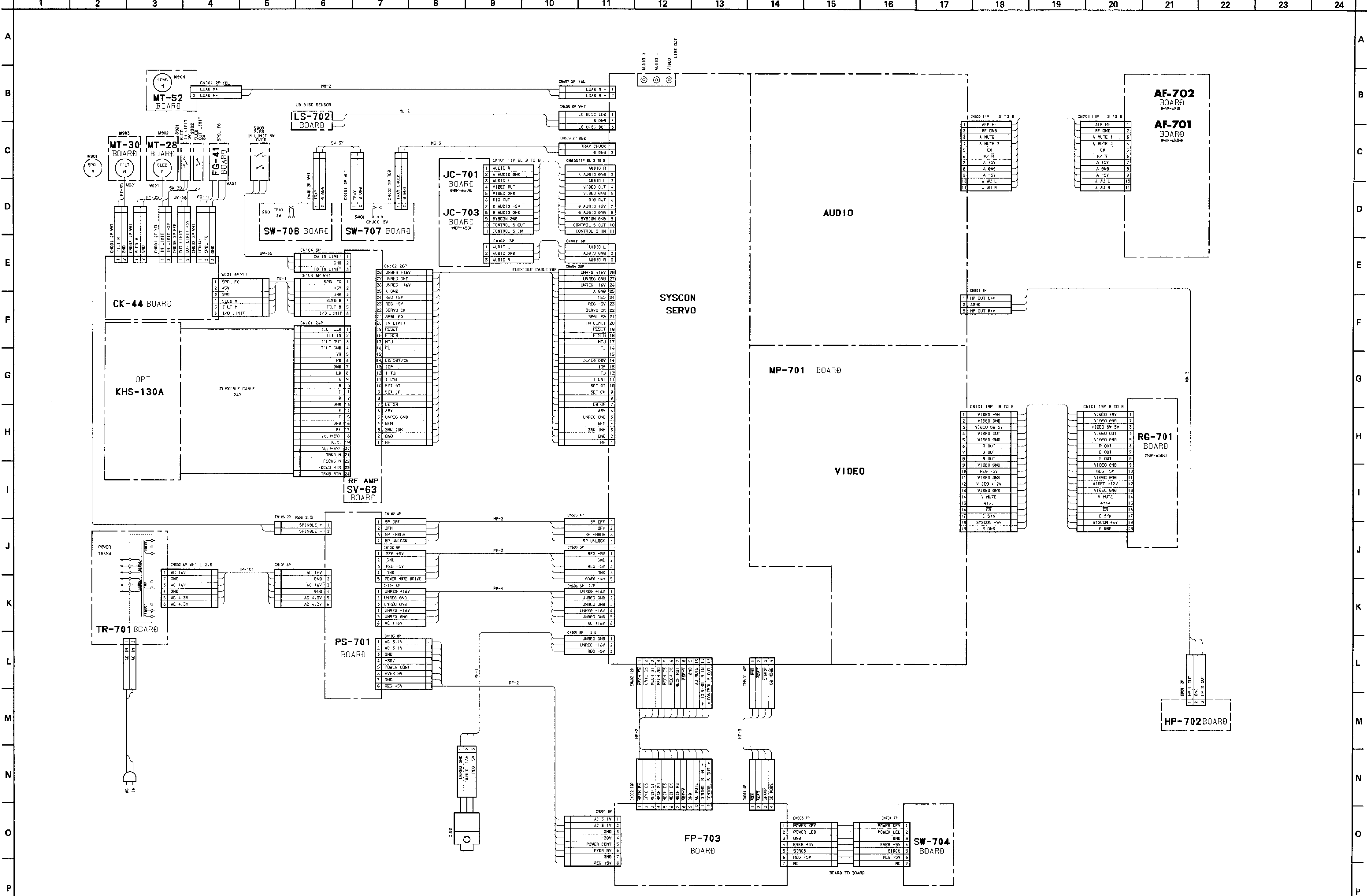

**SECTION 4  
PRINTED WIRING  
BOARDS AND  
SCHEMATIC DIAGRAM**

**4-2. PRINTED WIRING BOARDS AND  
SCHEMATIC DIAGRAMS**

**THIS NOTE IS COMMON FOR PRINTED WIRING BOARDS AND SCHEMATIC DIAGRAMS.**  
(In addition to this, the necessary note is printed in each block.)

- For printed wiring boards:**
- — indicates a lead wire mounted on the component side.
  - — indicates a lead wire mounted on the printed side.
  - — Through hole.
  - — Pattern from the side which enables seeing. (The other layers' patterns are not indicated.)

**Caution:**  
Pattern face side: Parts on the pattern face side seen from the (Conductor Side) pattern face are indicated.  
Parts face side: Parts on the parts face side seen from the (Component Side) parts face are indicated.

- \*For schematic diagram:**
- Caution when replacing chip parts.  
New parts must be attached after removal of chip. Be careful not to heat the minus side of tantalum capacitor, because it is damaged by the heat.
  - All resistors are in ohms, 1/4W (Chip resistors: 1/10W) unless otherwise noted.  
kΩ: 1000Ω, MΩ: 1000kΩ.
  - All capacitors are in μF unless otherwise noted. pF: μF/50V or less are not indicated except for electrolytics and tantalums.
  - All variable and adjustable resistors have characteristic curve B, unless otherwise noted.
  - : nonflammable resistor.
  - ▭: fusible resistor.
  - △: panel designation.
  - : internal component.
  - ▭: adjustment for repair.\*
  - B + Line.\*
  - B - Line.\*
  - Voltages are dc between measurement points and ground unless otherwise noted.\*
  - no mark: PAL
  - { } : NTSC
  - Readings are taken with a color-bar signal playback.\*
  - Readings are taken with a digital multimeter (DC10MΩ).\*
  - Voltage variations may be noted due to normal production tolerances.
  - IN/OUT direction of B line (+, -).\*
  - Circled numbers refer to waveforms.\*

When indicating parts by reference number, please include the board name.

**Note:**  
The components identified by mark △ or dotted line with mark △ are critical for safety. Replace only with part number specified.

**Note:**  
Les composants identifiés par une marque △ sont critiques pour la sécurité. Ne les remplacer que par une pièce portant le numéro spécifié.

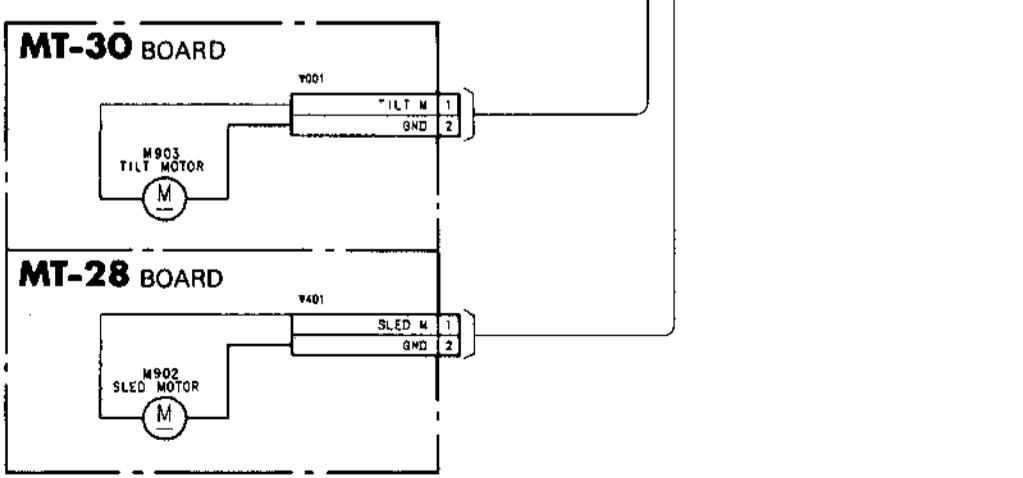
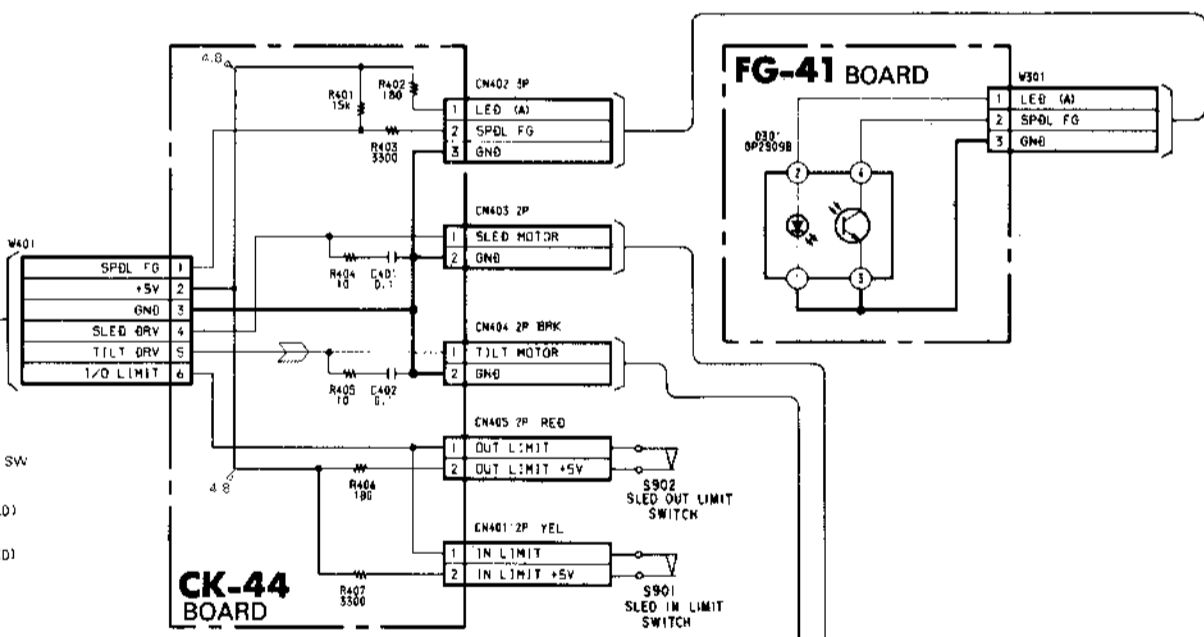
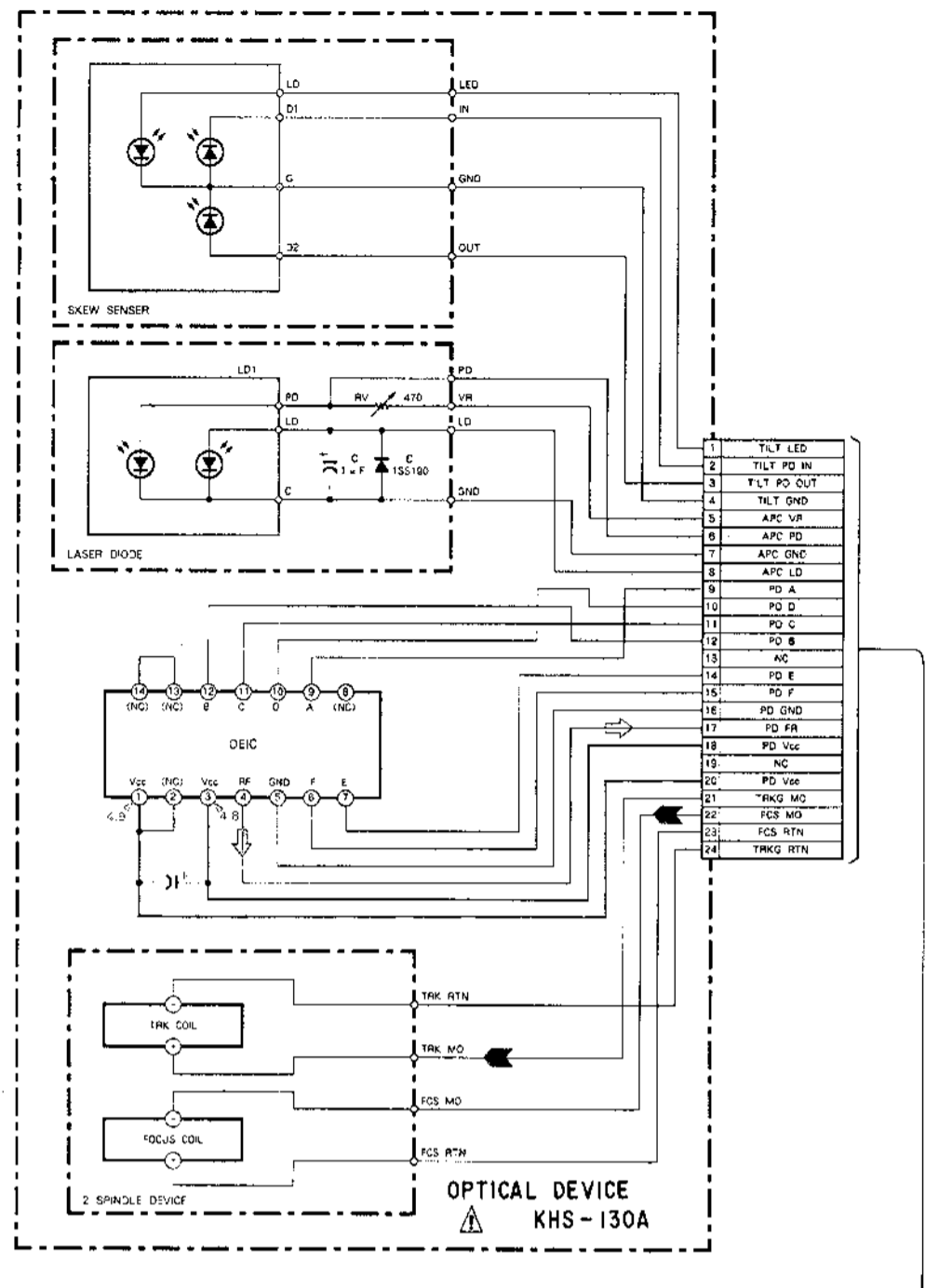
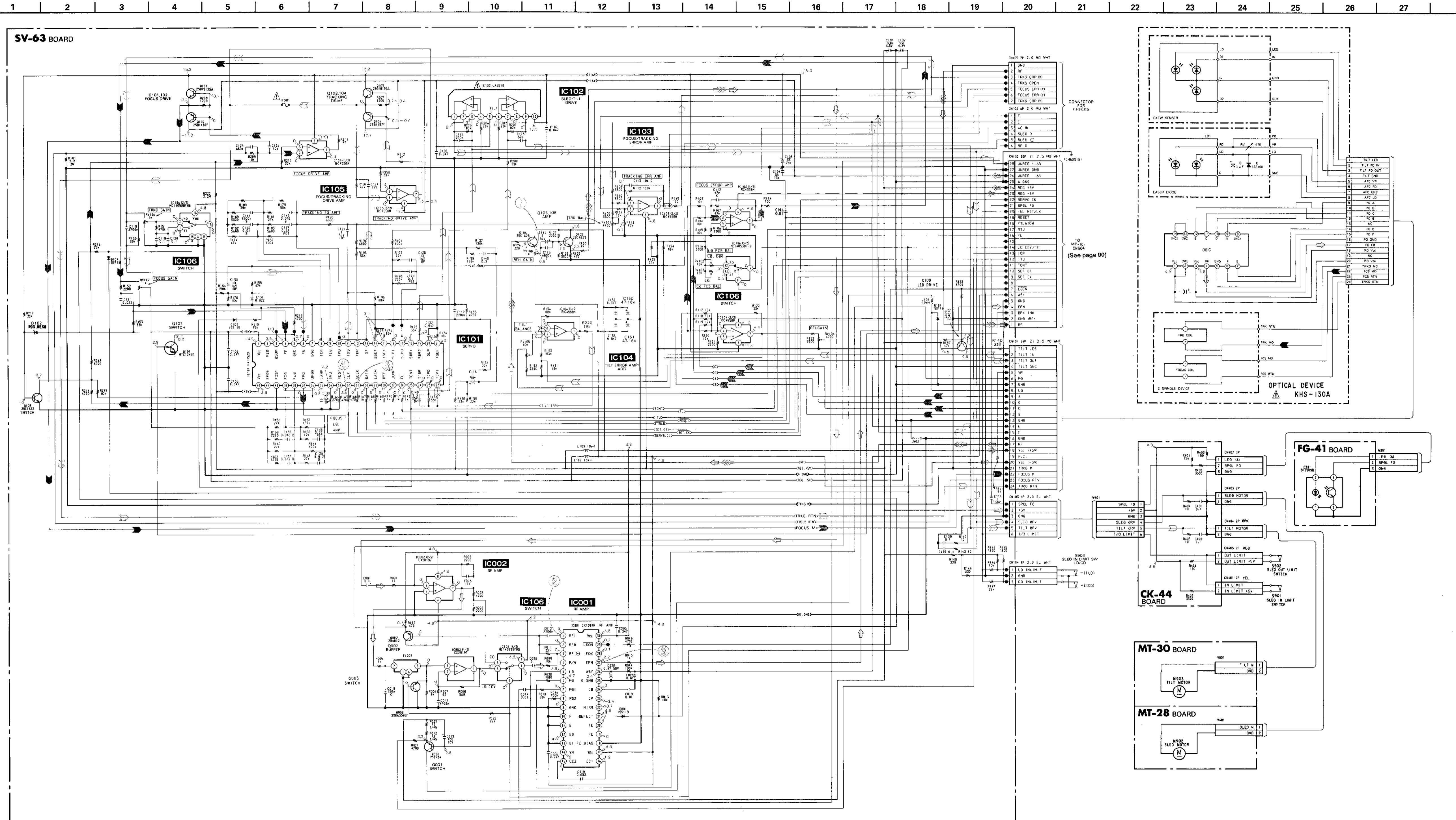

VIDEO SIGNAL	AUDIO SIGNAL		
	CHROMA	Y	Y, CHROMA
PB	↔	↔	↔

SPINDLE PHASE SERVO	↔
SPINDLE SERVO (SPEED AND PHASE)	↔
TRACKING SERVO LD/CD/CDV	↔
SLIDE SERVO LD/CD	↔
FOCUS SERVO LD/CD	↔
SKREW SERVO LD TILT	↔

- SV-63 BOARD
- D001 G-10
  - D101 C-7
  - D102 E-4
  - D103 G-7
  - D104 H-11
  - IC001 G-9
  - IC002 F-11
  - IC101 F-7
  - IC102 E-3
  - IC103 C-8
  - IC104 C-6
  - IC105 F-1
  - IC106 G-11
  - O001 E-9
  - O002 E-9
  - O003 F-11
  - O101 H-3
  - O102 H-2
  - O103 H-2
  - O104 H-1
  - O105 A-12
  - O106 B-12
  - O107 D-6
  - O108 F-4
  - O109 B-8

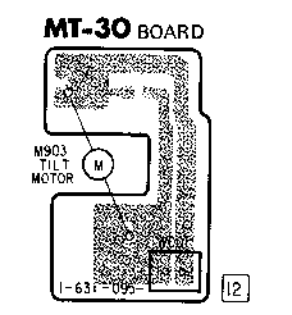
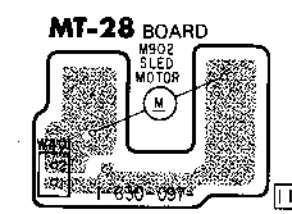
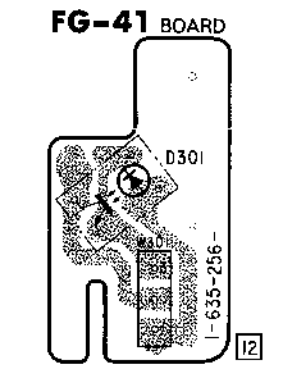
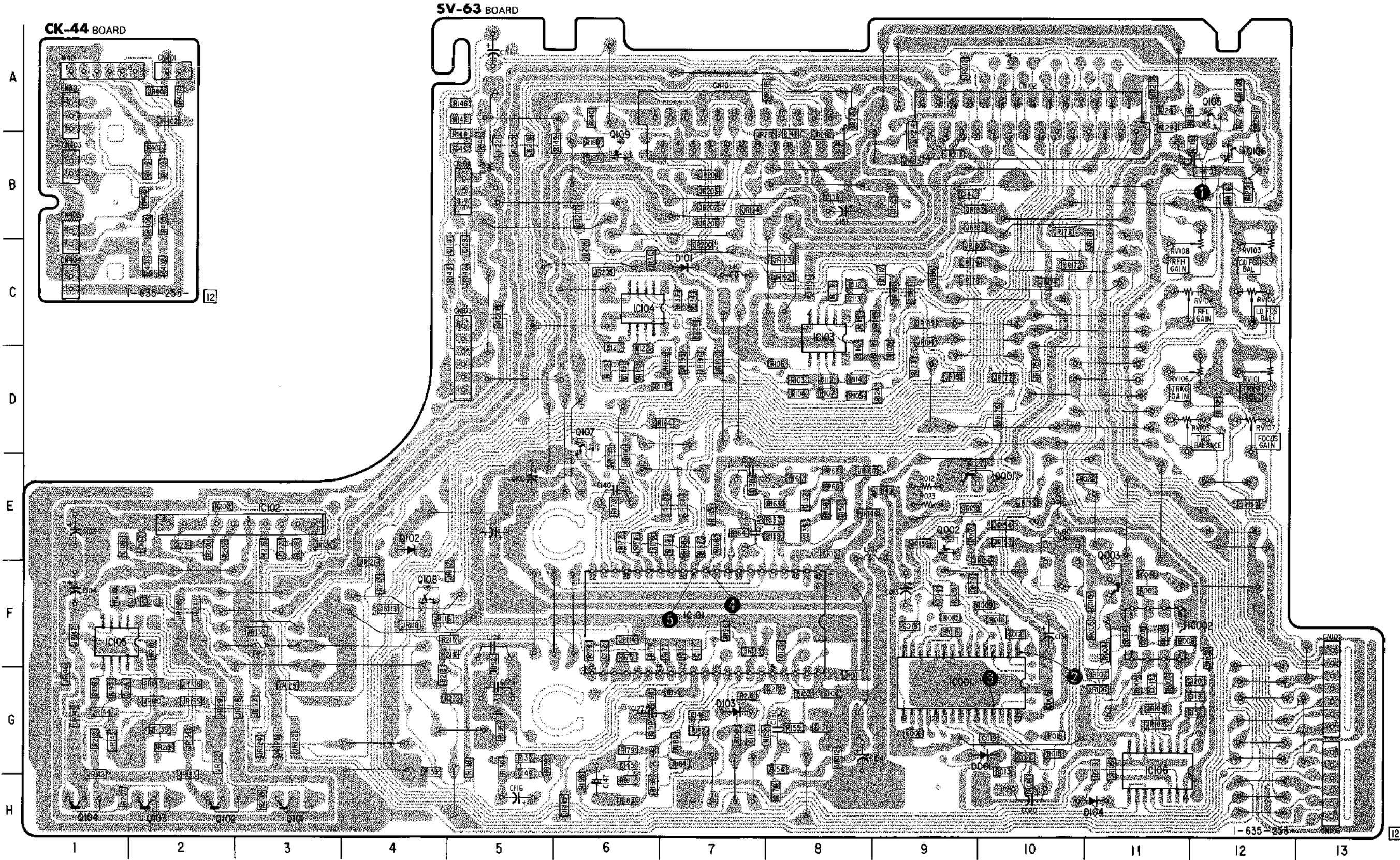

**SV-63 BOARD**

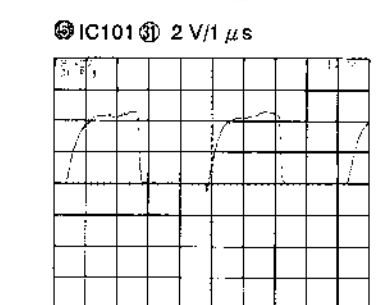
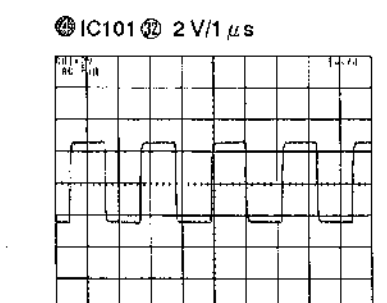
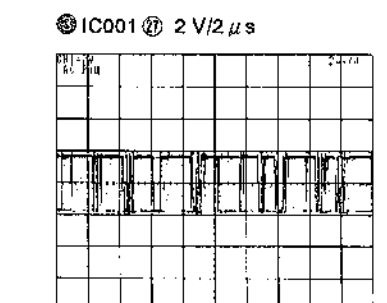
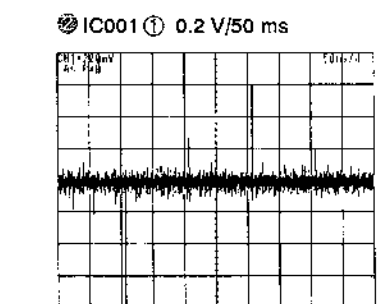
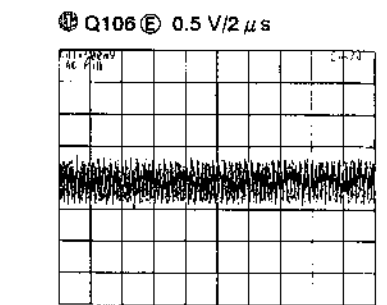

**MP-701 BOARD (SYSCON) PAL**

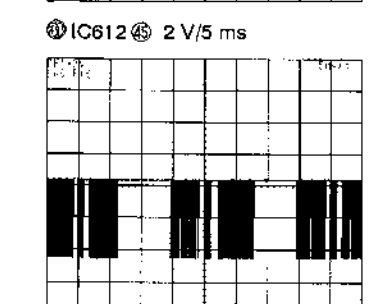
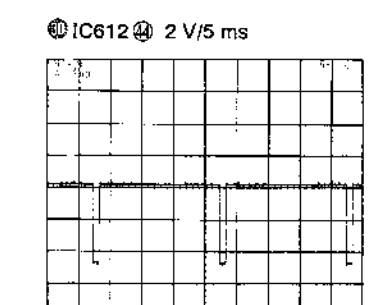
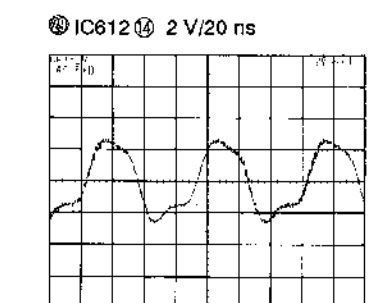
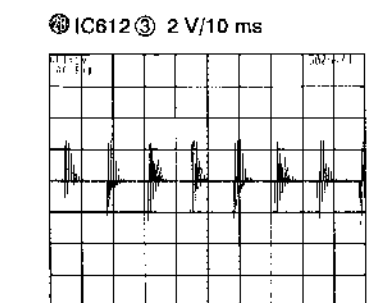
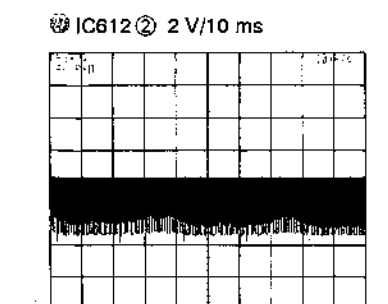
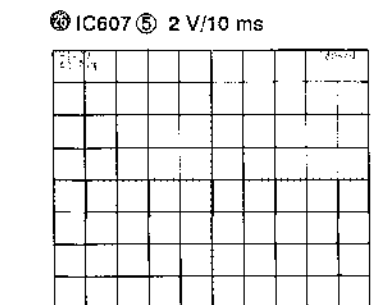

**IC612 ⑤ 2 V/500 μs**

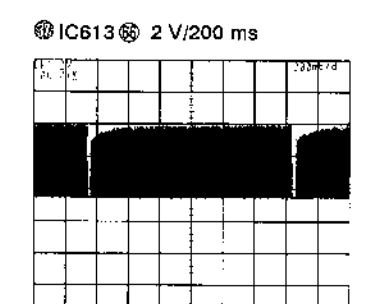
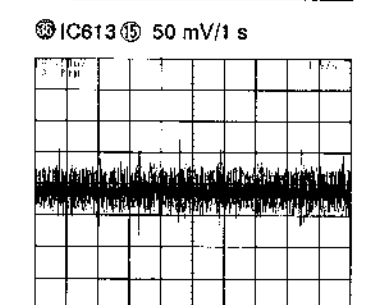
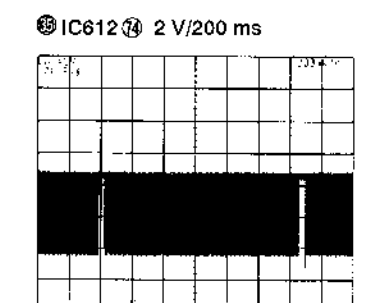
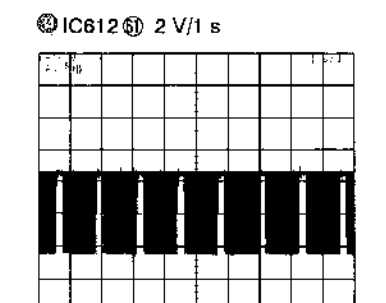
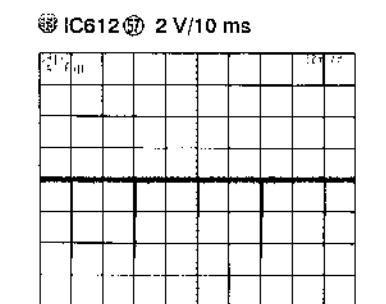
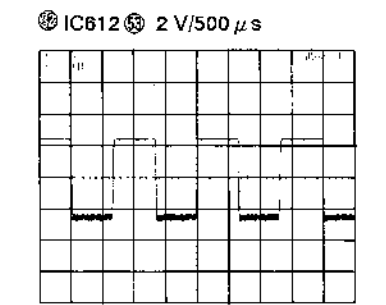

**IC610 ③ 2 V/200 ms**

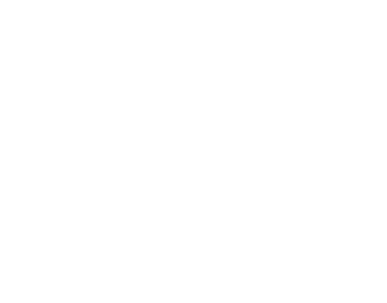
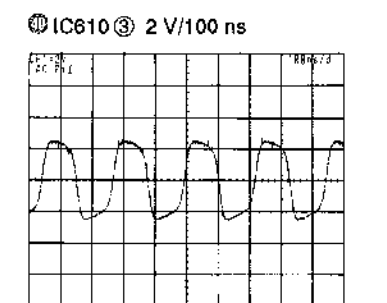
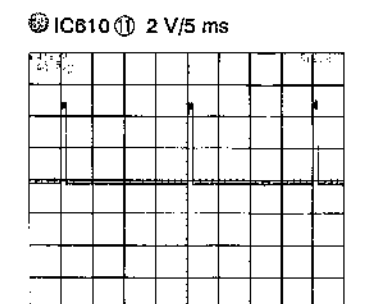
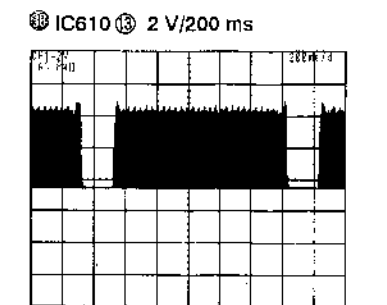

**NTSC IC607 ⑤ 2 V/20 μs**

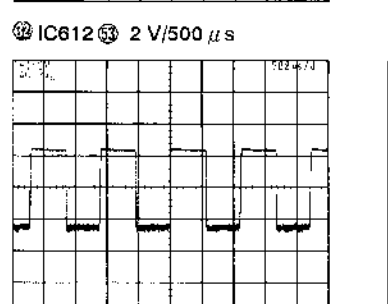
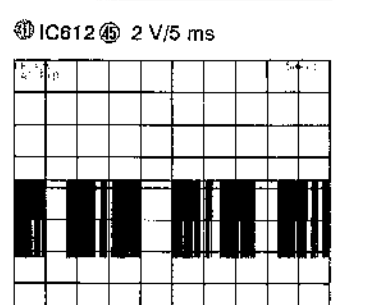
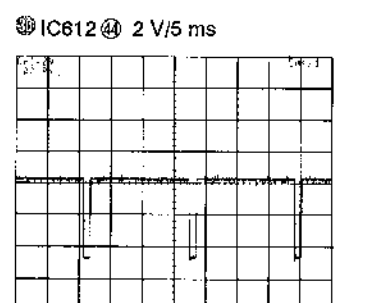
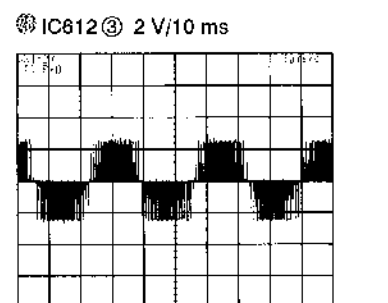
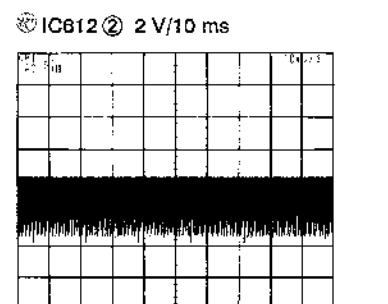
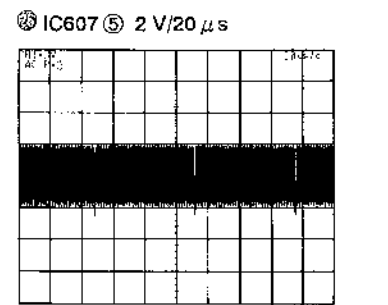

**IC612 ⑤ 2 V/10 μs**

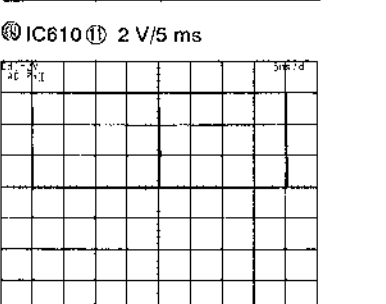
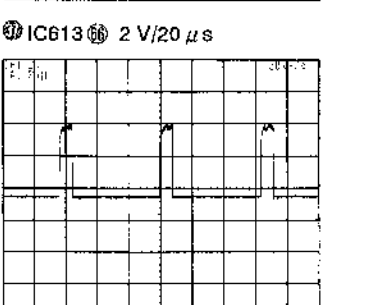
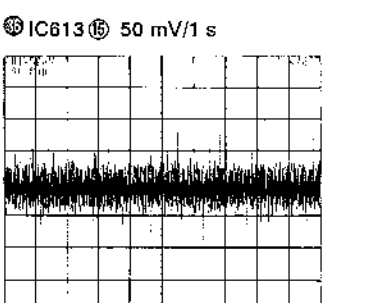
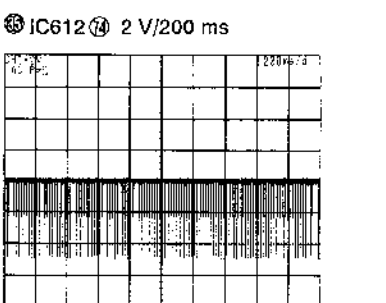
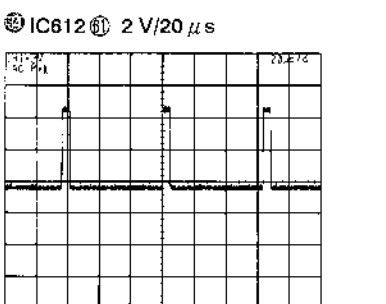
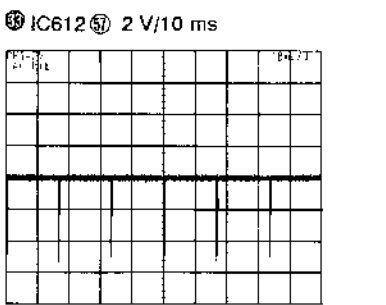

**MP-701 (VIDEO) PRINTED WIRING BOARD**

— Ref. No.: MP-701 Board; 2,000 series —

MP-701 BOARD

D102	F-6	IC804	C-5	Q164	G-25
D104	E-16	IC806	B-6	Q165	G-19
D801	D-15	IC807	B-3	Q166	G-25
D808	G-15	IC808	B-3	Q167	G-18
D809	D-12	IC809	B-2	Q168	G-9
D810	D-12	IC810	C-2	Q169	G-8
D816	F-12	IC811	C-3	Q170	G-9
D817	H-10	IC812	B-2	Q171	G-17
D818	H-10			Q172	G-8
D801	E-3	Q101	F-16	Q173	G-8
D802	E-3	Q102	G-24	Q174	G-15
D803	B-19	Q103	F-2	Q503	G-15
D804	B-19	Q104	G-24	Q504	E-15
D805	G-15	Q106	F-10	Q505	G-10
D806	D-9	Q107	F-10	Q506	G-10
D807	D-17	Q108	G-3	Q507	G-10
D808	B-17	Q109	H-8	Q508	G-16
D809	E-2	Q110	H-3	Q509	G-10
D801	C-22	Q111	H-24	Q510	H-10
D802	H-22	Q112	G-24	Q511	H-17
D803	H-22	Q113	G-23	Q512	H-17
D804	A-24	Q114	G-3	Q513	H-18
D805	A-3	Q115	G-3	Q514	H-18
D806	D-25	Q116	F-3	Q515	H-18
D807	E-1	Q117	G-24	Q516	H-9
D808	E-25	Q118	F-9	Q517	H-16
D809	A-6	Q119	G-7	Q518	H-19
D810	A-6	Q120	G-19	Q519	H-17
D816	F-12	Q121	G-7	Q520	H-16
		Q122	F-5	Q521	H-16
IC101	G-3	Q123	G-20	Q522	H-10
IC102-1	F-11	Q124	E-16	Q523	H-6
IC102-2	G-13	F-18		Q501	A-15
IC103	F-9	Q126	G-20	Q803	B-16
IC104	H-20	Q127	H-18	Q894	E-3
IC105	F-4	Q128	F-20	Q505	E-22
IC106	G-6	Q129	H-19	Q806	B-14
IC107	F-5	Q130	G-21	Q607	E-5
IC108	E-6	Q131	G-21	Q608	B-7
IC109	E-9	Q132	G-8	Q609	B-19
IC110	F-5	Q133	F-4	Q610	A-6
IC111	F-3	Q134	F-4	Q611	E-2
IC501	D-15	Q135	E-9	Q812	E-4
IC502	E-16	Q136	F-4	Q801	A-23
IC503	B-25	Q137	F-22	Q802	A-23
IC504	C-15	Q138	G-2	Q803	C-25
IC505	B-25	Q139	F-22	Q804	A-1
IC601	B-12	Q140	G-25	Q805	B-22
IC602	D-3	Q141	E-7	Q806	A-4
IC603	A-10	Q143	E-7	Q807	A-4
IC604	E-2	Q144	E-8	Q808	A-4
IC605	A-11	Q145	F-20	Q809	D-2
IC606	A-10	Q146	E-18	Q811	A-22
IC607	E-4	Q147	F-3	Q812	A-4
IC608	E-23	Q149	F-7	Q813	D-25
IC609	E-22	Q152	G-5	Q816	D-1
IC610	B-16	Q153	F-6	Q818	B-2
IC612	G-7	Q154	G-4	Q817	E-25
IC613	B-9	Q155	B-9	Q819	D-2
IC614	G-15	Q157	E-7	Q819	D-24
IC615	C-9	Q158	E-20	Q820	B-2
IC616	D-9	Q159	E-19	Q821	B-24
IC617	D-3	Q161	E-7	Q824	B-2
IC618	B-16	Q161	F-7	Q825	B-22
IC802	B-4	Q162	H-25	Q826	A-22
IC803	C-4	Q163	G-18	Q827	A-4

**MP-701 BOARD (COMPONENT SIDE)**

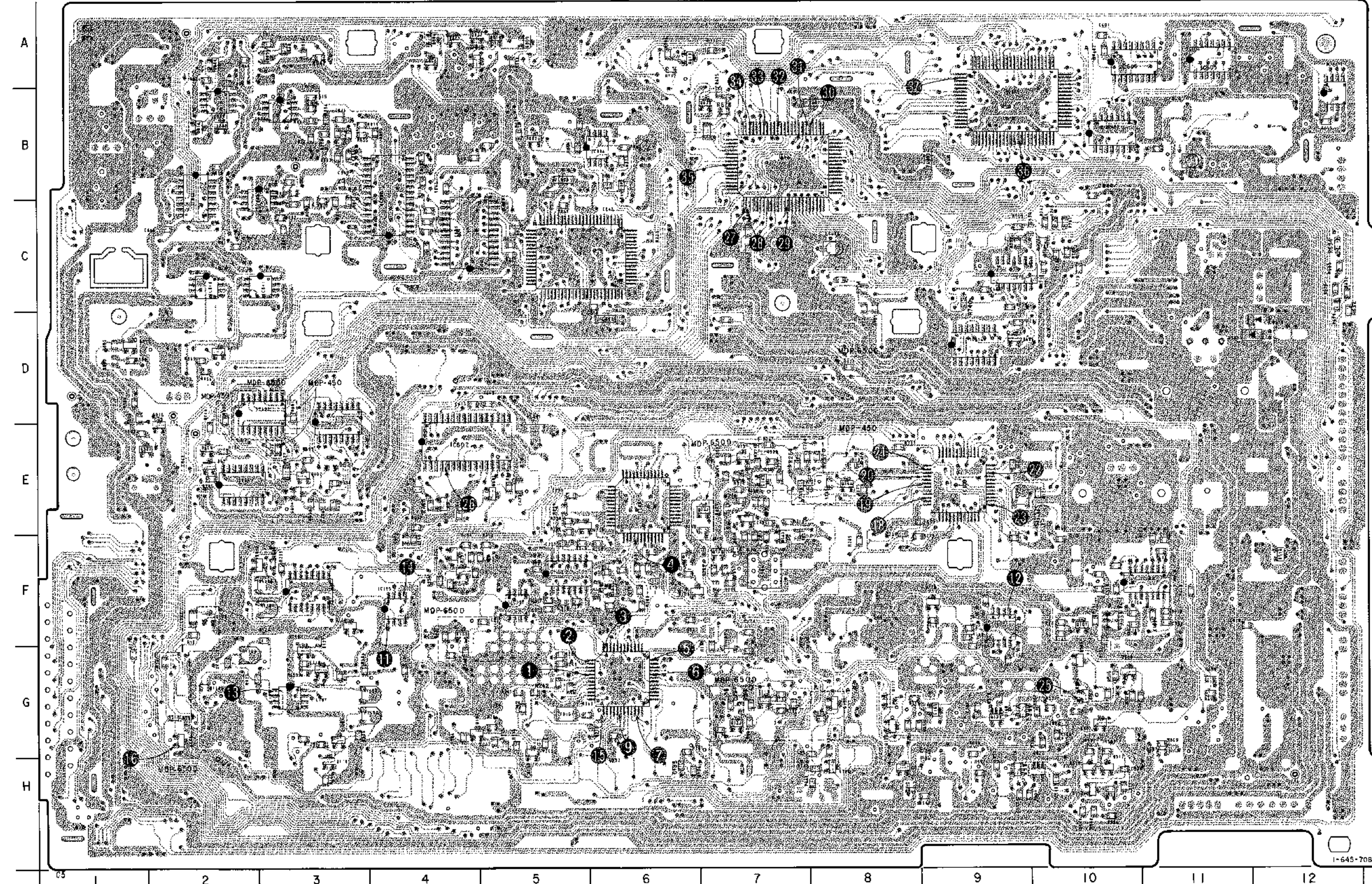

**MP-701 BOARD (CONDUCTOR SIDE)**

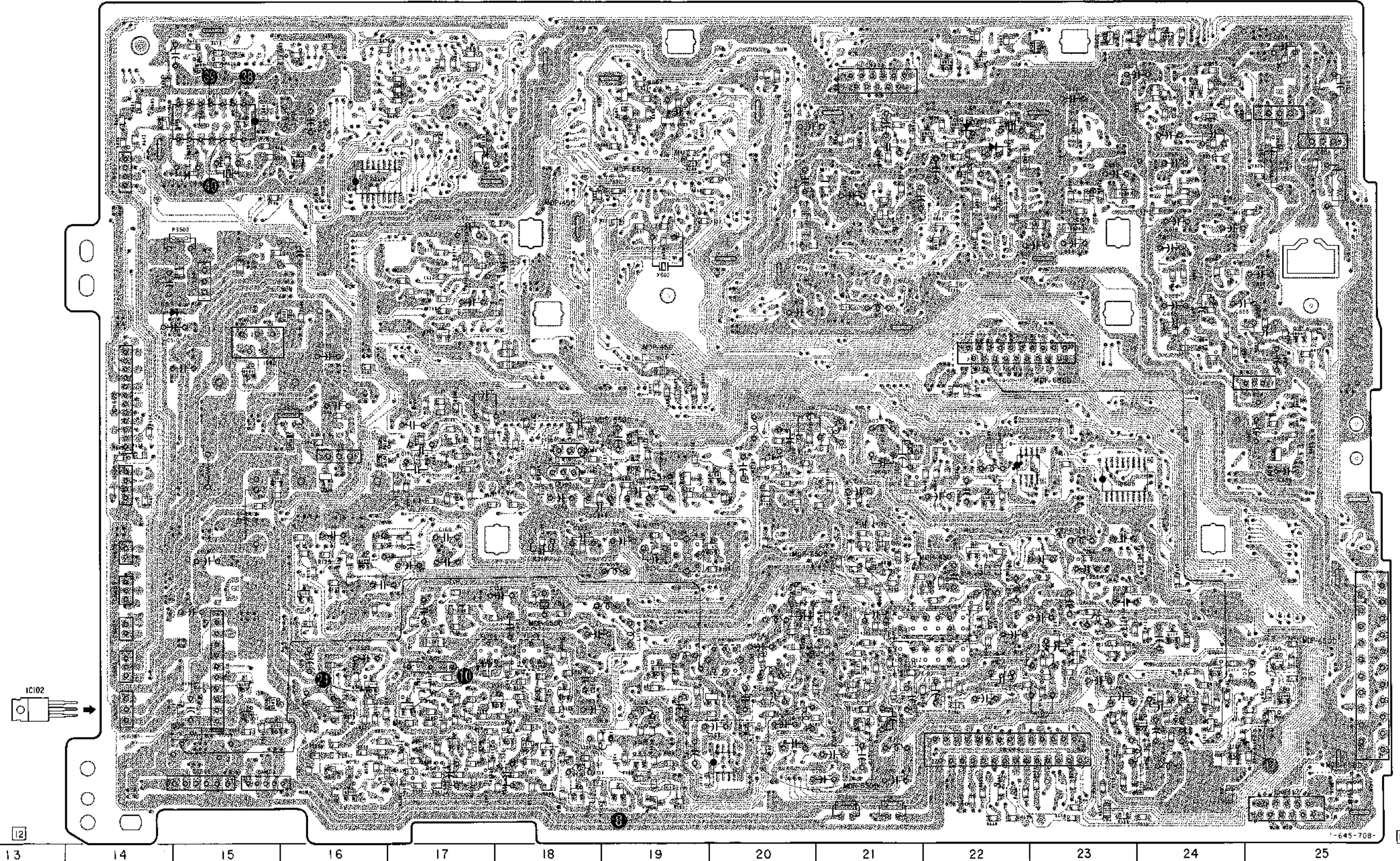

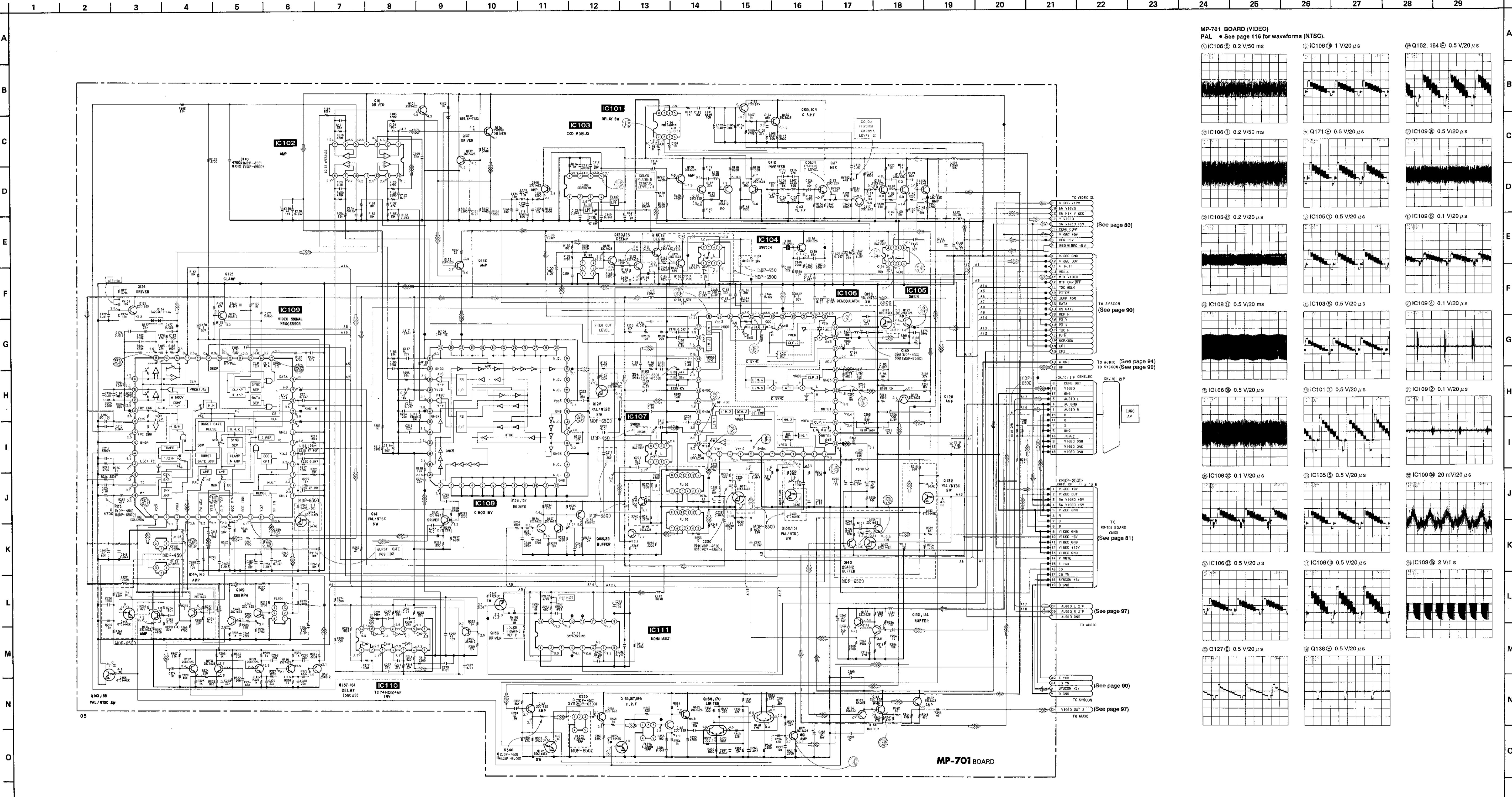

VIDEO SIGNAL			AUDIO SIGNAL
CHROMA	Y	Y/CHROMA	
PB	→	→	→
SPINDLE PHASE SERVO	→		
SPINDLE SERVO (SPEED AND PHASE)	→		
TRACKING SERVO L/D/CD/CDV	→		
SLIDE SERVO L/D/CD	→		
FOCUS SERVO L/D/CD	→		
SKREW SERVO L/D/TILT	→		

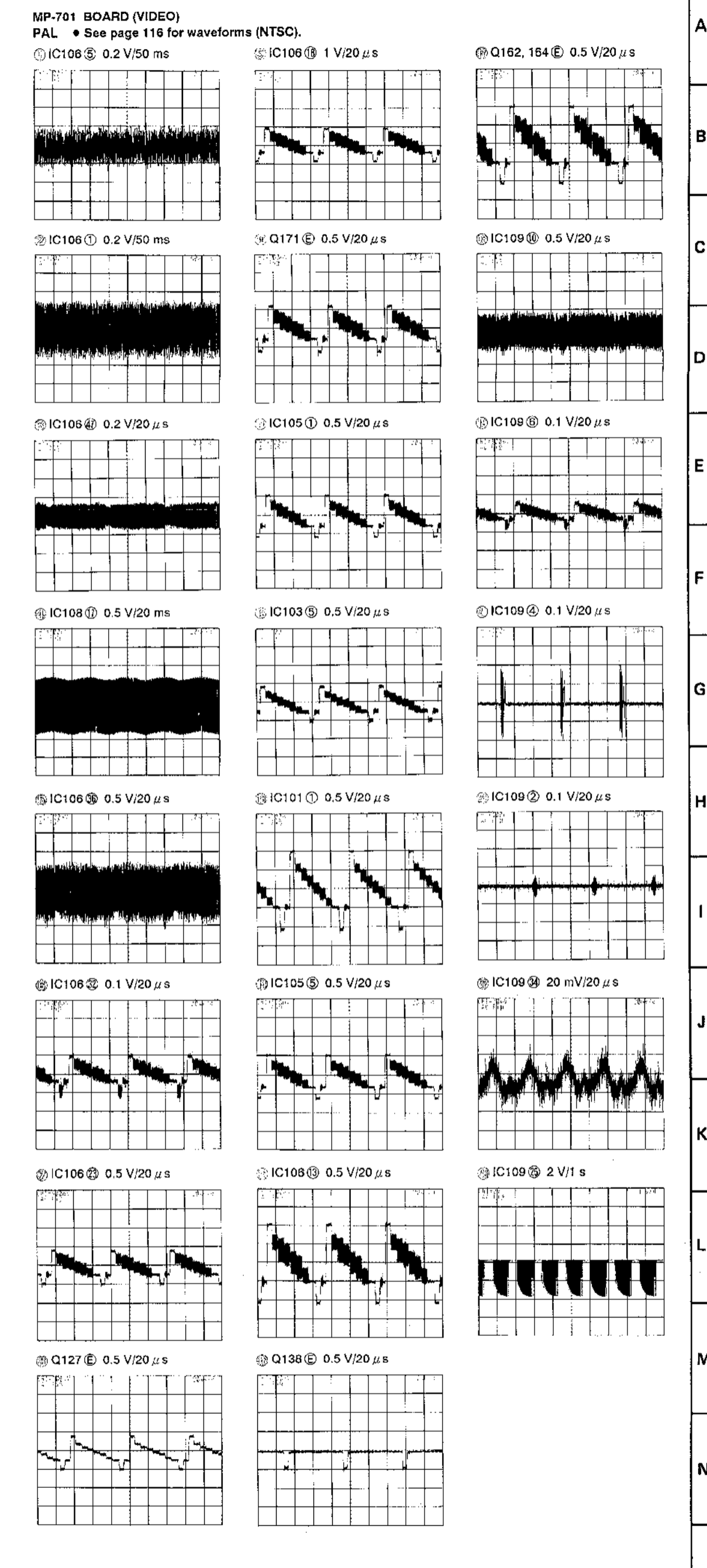



MP-701 BOARD (VIDEO)

PAL

Q508 0.5 V/20 μs

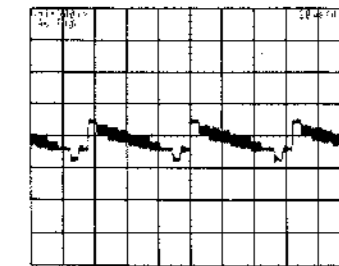

NTSC

Q508 0.5 V/20 μs

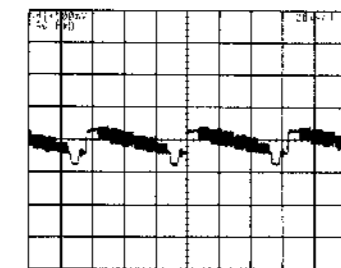

Q506 0.5 V/20 μs

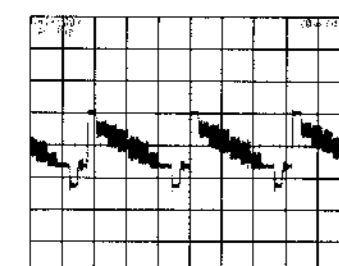

Q506 0.5 V/20 μs

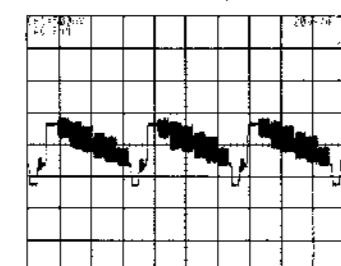

RG-701 (R. G. B. SEPARATION) PRINTED WIRING BOARDS

- Ref. No.: RG-701 Board; 2,000 series -

RG-701 BOARD

IC001 0.5 V/20 μs

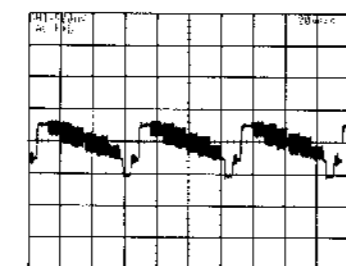

IC001 0.2 V/20 μs

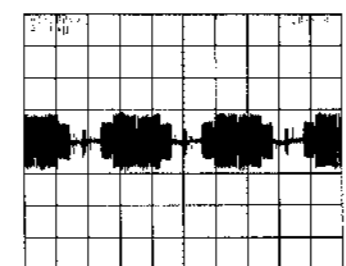

IC003 0.5 V/20 μs

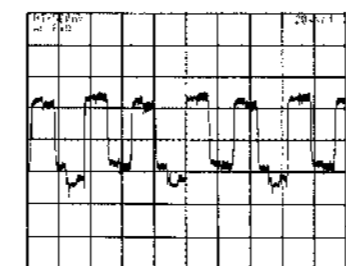

IC003 0.5 V/20 μs

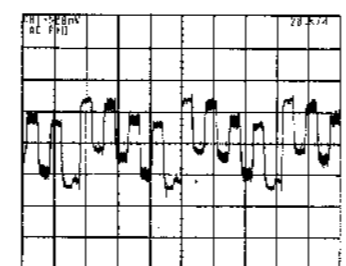

IC001 0.5 V/20 μs

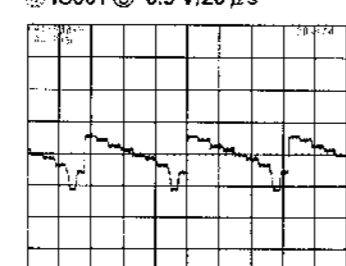

IC003 0.2 V/20 μs

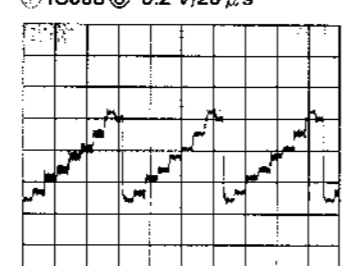

IC003 0.5 V/20 μs

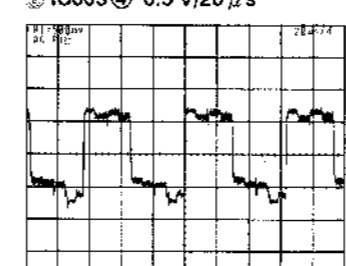

RG-701 BOARD (MOP-6500)

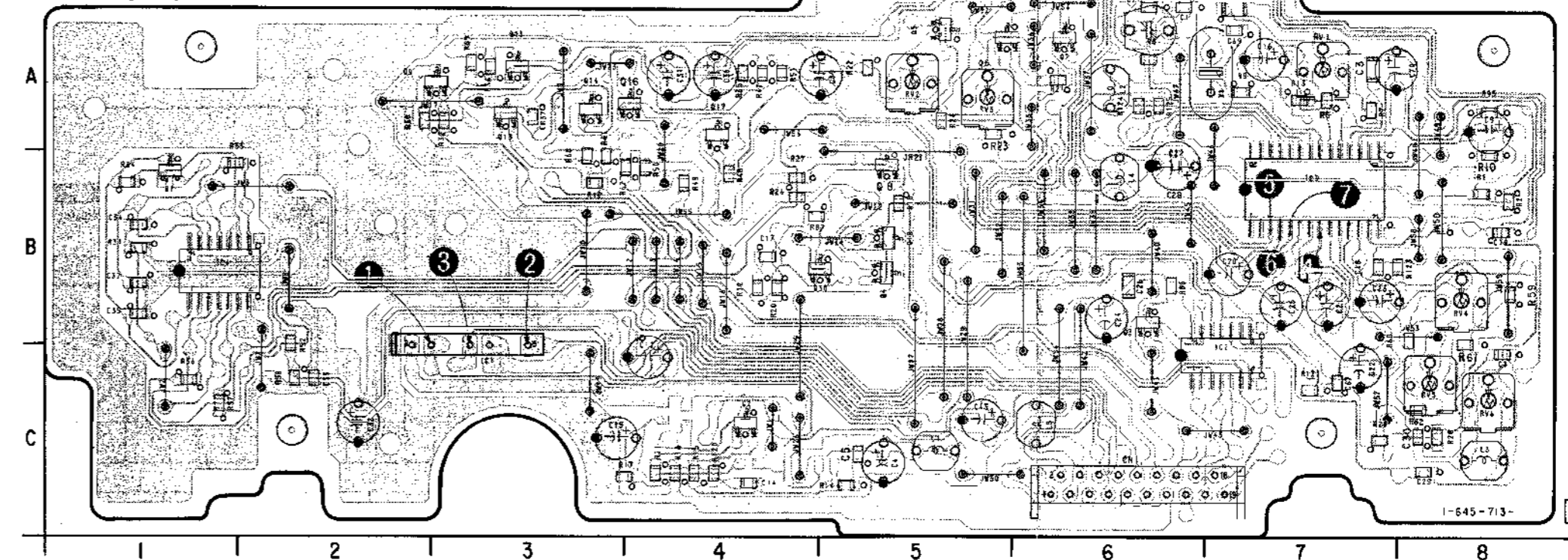

RG-701 BOARD

D001	B-1
IC001	C-3
IC002	C-7
IC003	B-7
IC004	B-1
Q002	C-4
Q003	B-4
Q004	B-5
Q005	A-5
Q006	A-5
Q007	A-6
Q008	B-5
Q009	A-2
Q011	A-3
Q013	A-3
Q014	A-3
Q018	A-4
Q017	A-4
Q018	B-6

MP-701 (VIDEO) PRINTED WIRING BOARD

- Ref. No.: MP-701 Board; 2,000 series -

MP-701 BOARD

D102	F-6	IC804	C-5	O184	G-25
D104	E-18	IC806	B-6	O185	G-18
D501	D-15	IC807	B-3	O186	G-25
D508	G-15	IC808	B-3	O187	G-18
D509	D-12	IC809	B-2	O188	G-9
D510	D-12	IC810	C-2	O189	G-9
D516	F-12	IC811	C-3	O190	G-9
D517	H-10	IC812	B-2	O191	G-17
D518	H-10			O192	G-8
D801	E-9	O101	F-16	O193	G-8
D802	E-3	O102	G-24	O502	G-15
D803	B-18	O103	F-9	O503	G-15
D804	B-18	O104	G-24	O504	B-16
D805	G-15	O105	F-10	O505	G-10
D806	D-9	O107	F-10	O506	G-10
D807	D-17	O109	H-8	O507	G-10
D808	D-17	O109	H-8	O508	G-15
D809	E-2	O110	H-3	O509	G-10
D801	C-22	O111	H-24	O510	H-10
D802	B-22	O112	G-24	O511	H-17
D803	B-22	O113	G-23	O512	H-17
D804	A-24	O114	G-3	O513	H-18
D805	A-3	O115	C-3	O514	H-18
D806	D-25	O116	F-3	O515	H-18
D807	E-1	O117	G-24	O516	H-9
D808	E-25	O118	F-0	O517	H-16
D809	A-5	O119	G-7	O518	H-19
D810	A-8	O120	G-19	O519	H-17
D516	F-12	O121	D-7	O520	H-18
		O122	F-6	O521	H-16
		O123	G-20	O522	H-10
		O124	E-16	O523	H-8
		O125	F-18	O501	A-15
		O126	G-20	O603	B-16
		O127	H-18	O604	E-3
		O128	F-20	O605	E-22
		O129	H-19	O606	B-14
		O130	G-21	O607	E-8
		O131	G-21	O608	B-7
		O132	G-8	O609	B-19
		O133	F-4	O610	A-6
		O134	F-4	O611	E-2
		O135	E-9	O612	E-4
		O136	F-4	O613	A-23
		O137	F-22	O602	A-23
		O138	G-2	O603	A-23
		O139	F-22	O604	A-1
		O140	G-25	O605	B-22
		O141	E-7	O606	A-4
		O142	G-7	O607	A-4
		O143	E-7	O608	A-4
		O144	E-8	O609	A-4
		O145	F-20	O609	D-2
		O146	F-18	O111	A-22
		O147	F-3	O812	A-4
		O148	F-7	O813	D-25
		O149	F-18	O814	B-2
		O150	F-18	O815	D-1
		O151	F-6	O816	B-2
		O152	G-4	O817	E-25
		O153	E-18	O818	B-2
		O154	G-4	O819	D-24
		O155	E-18	O820	B-2
		O156	E-7	O821	D-24
		O157	E-7	O822	B-5
		O158	B-2	O823	B-25
		O159	E-18	O824	B-25
		O160	E-7	O825	A-2
		O161	F-18	O826	B-25
		O162	H-25	O827	A-4
		O163	G-18	O827	A-4

MP-701 BOARD (COMPONENT SIDE)

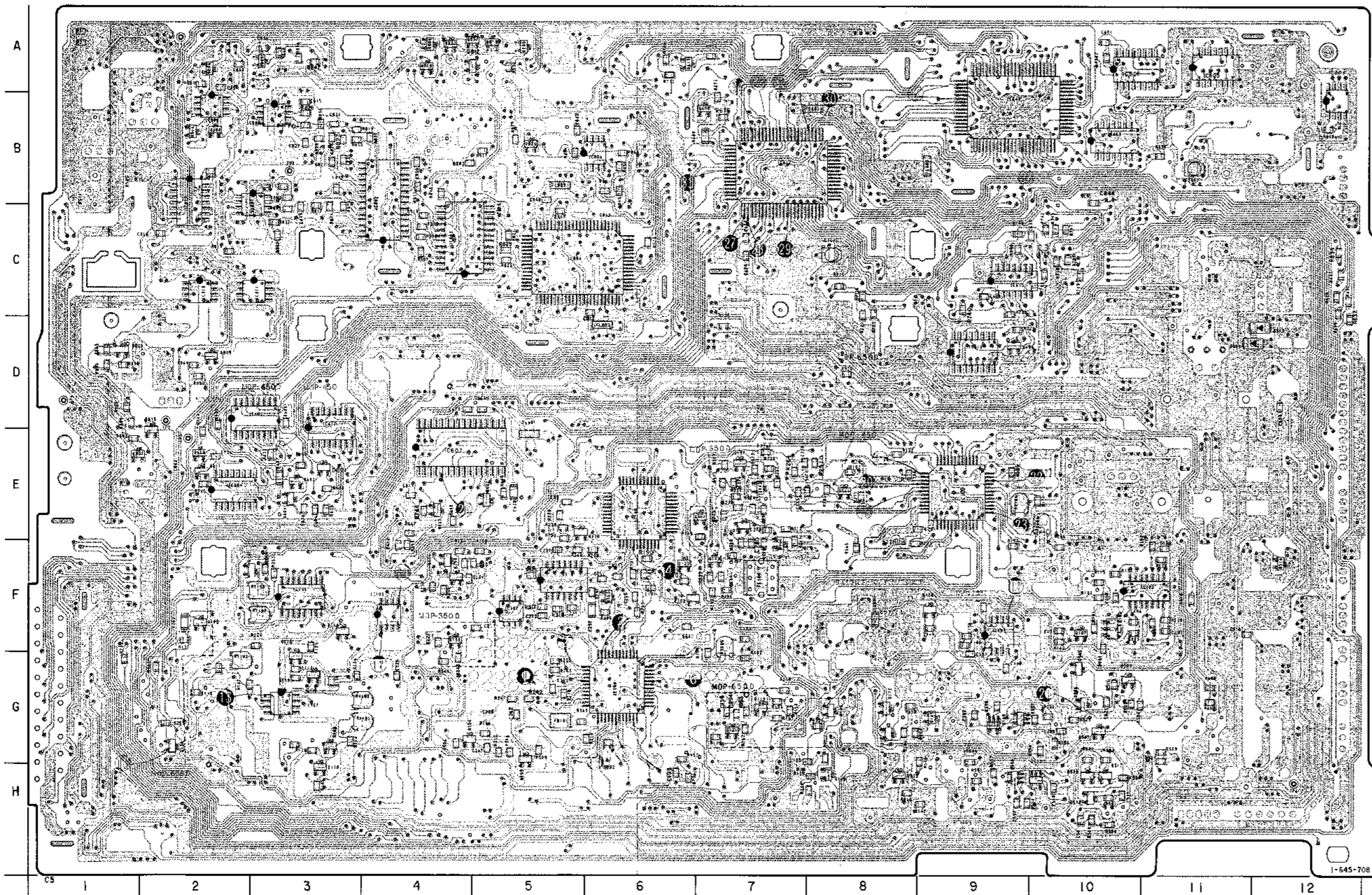

MP-701 BOARD (CONDUCTOR SIDE)

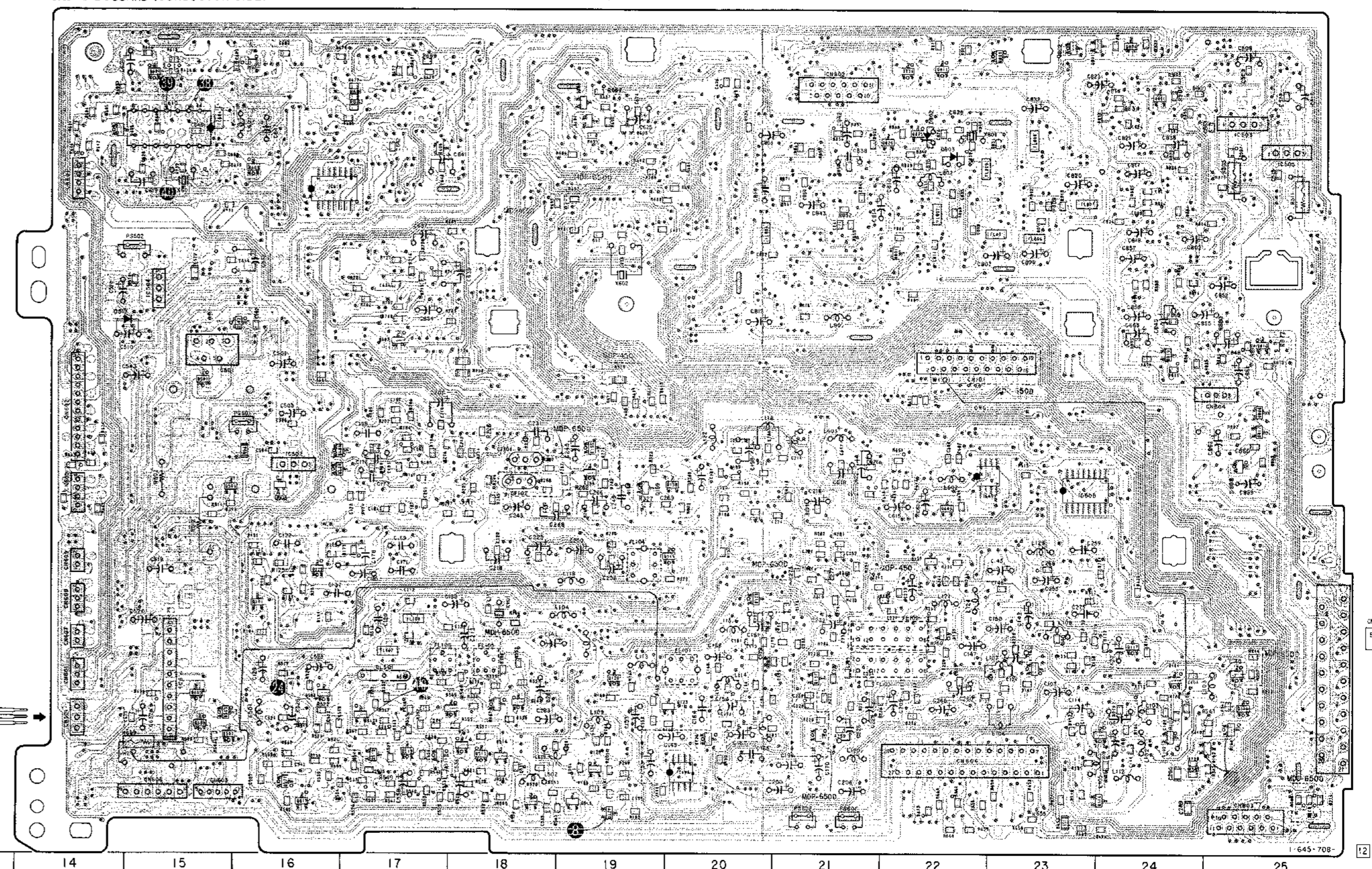

12

12

MP-701 (VIDEO 2) SCHEMATIC DIAGRAM

Ref. No.: MP-701 Board; 2,000 series

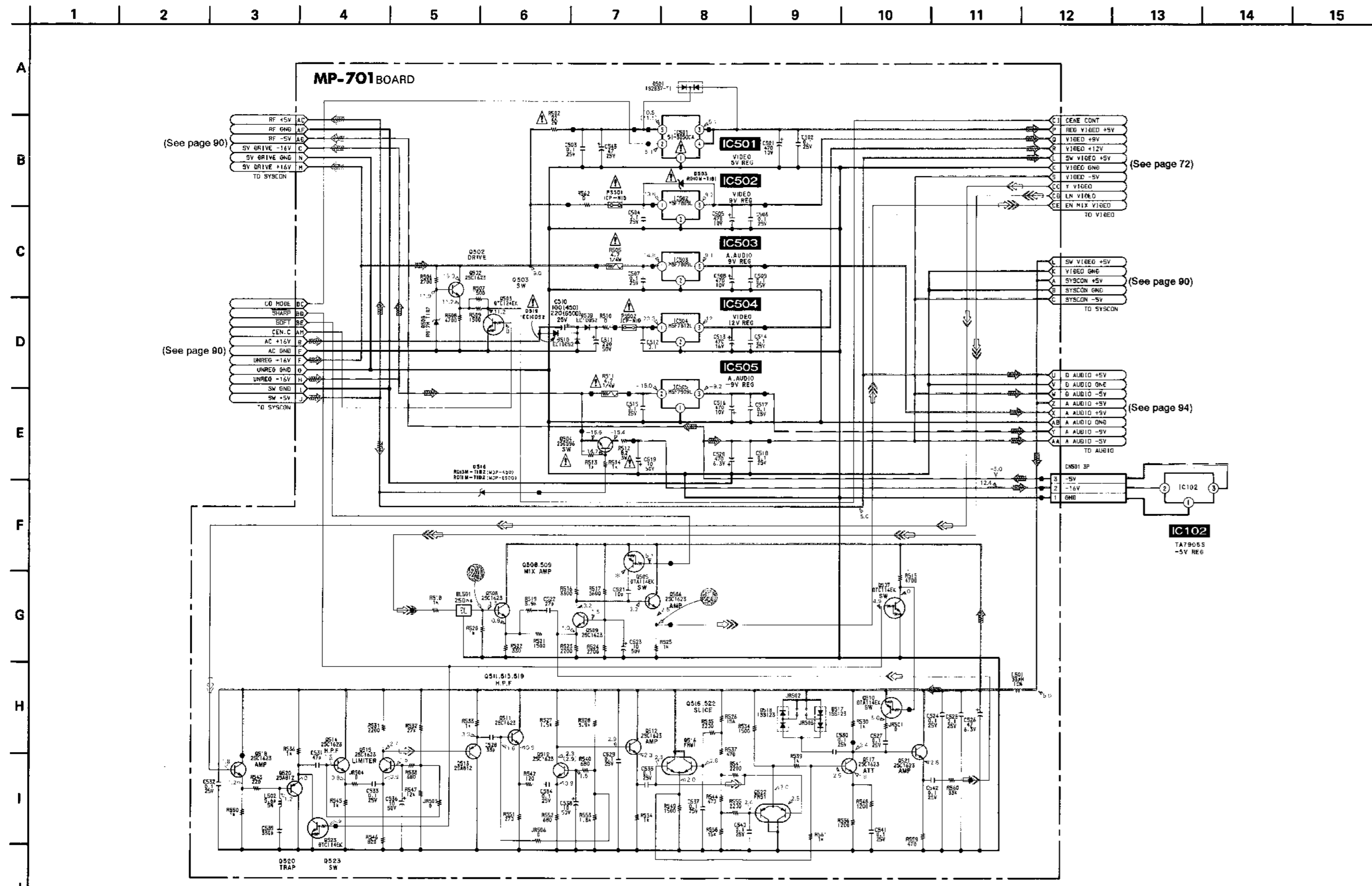

VIDEO(2) VIDEO(2)

	VIDEO SIGNAL			AUDIO SIGNAL
	CHROMA	Y	Y/CHROMA	
PB	⇨	⇨	⇨⇨	⇨

RG-701 (R. G. B. SEPARATION) SCHEMATIC DIAGRAM

Ref. No.: RG-701 Board; 2,000 series

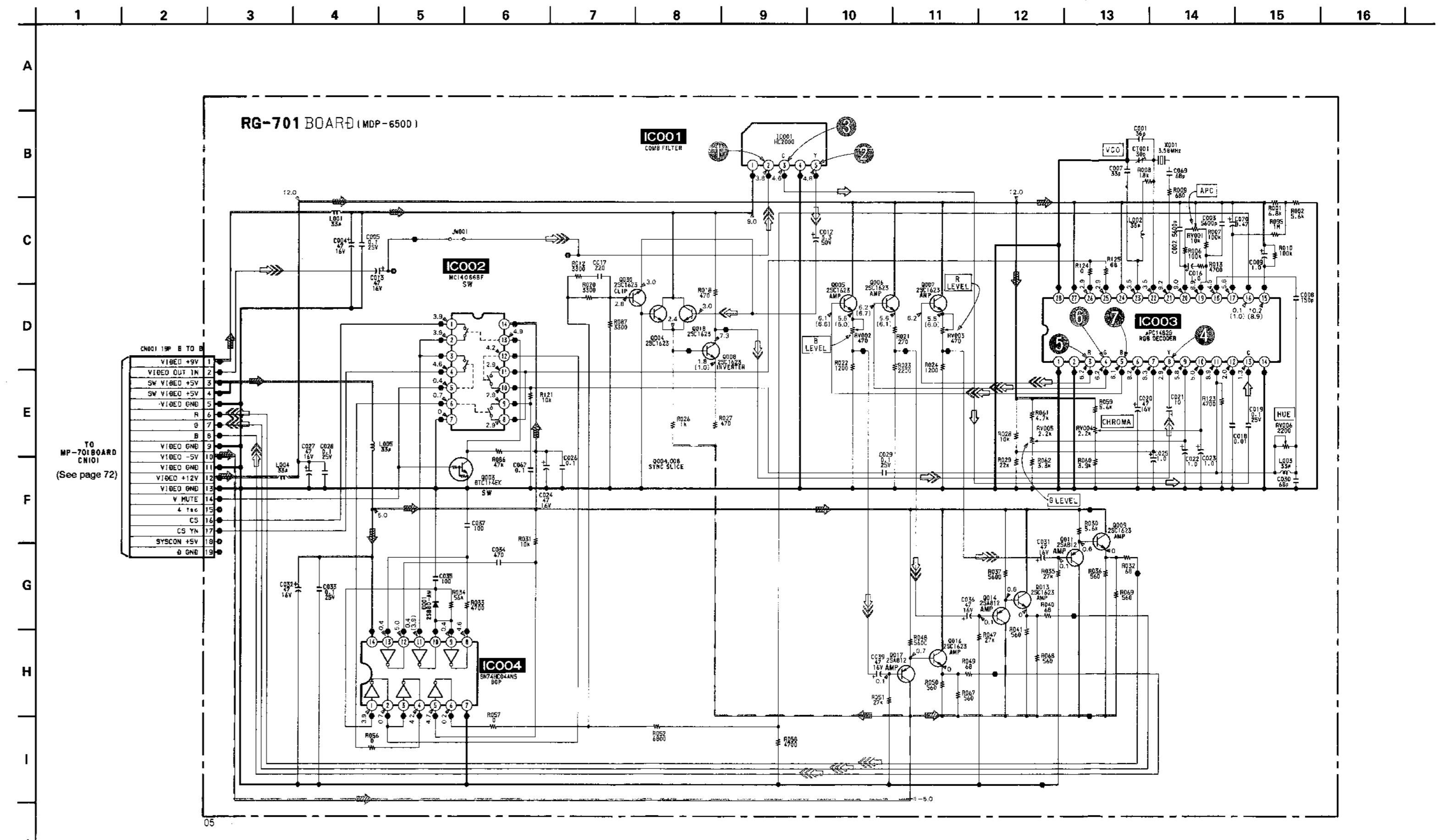

VIDEO(2) VIDEO(2)

VIDEO(2)

MP-701 (SYSTEM CONTROL) PRINTED WIRING BOARDS

— Ref. No.: MP-701 Board; 2,000 series —

MP-701 BOARD (COMPONENT SIDE)

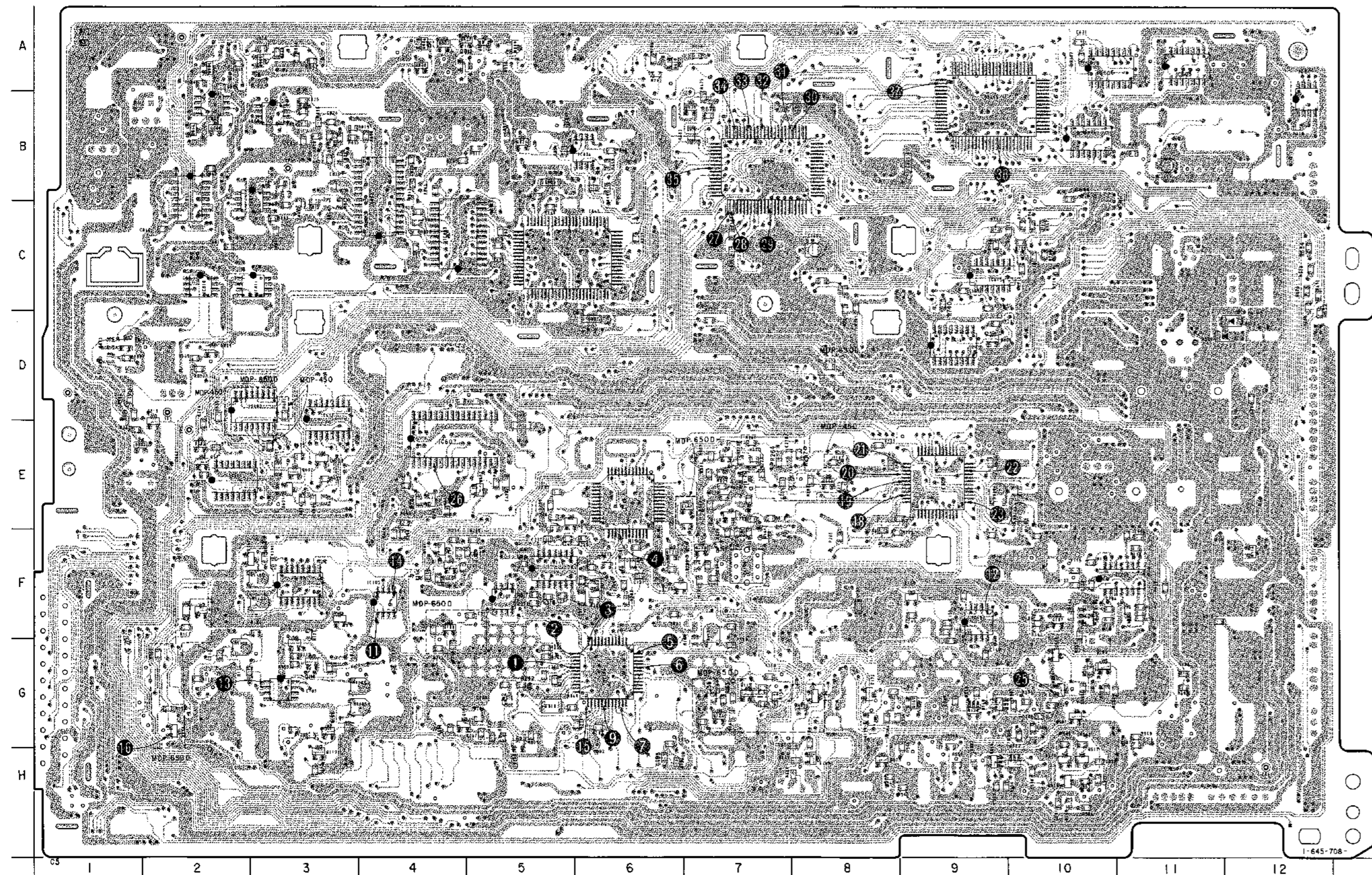

MP-701 BOARD (CONDUCTOR SIDE)

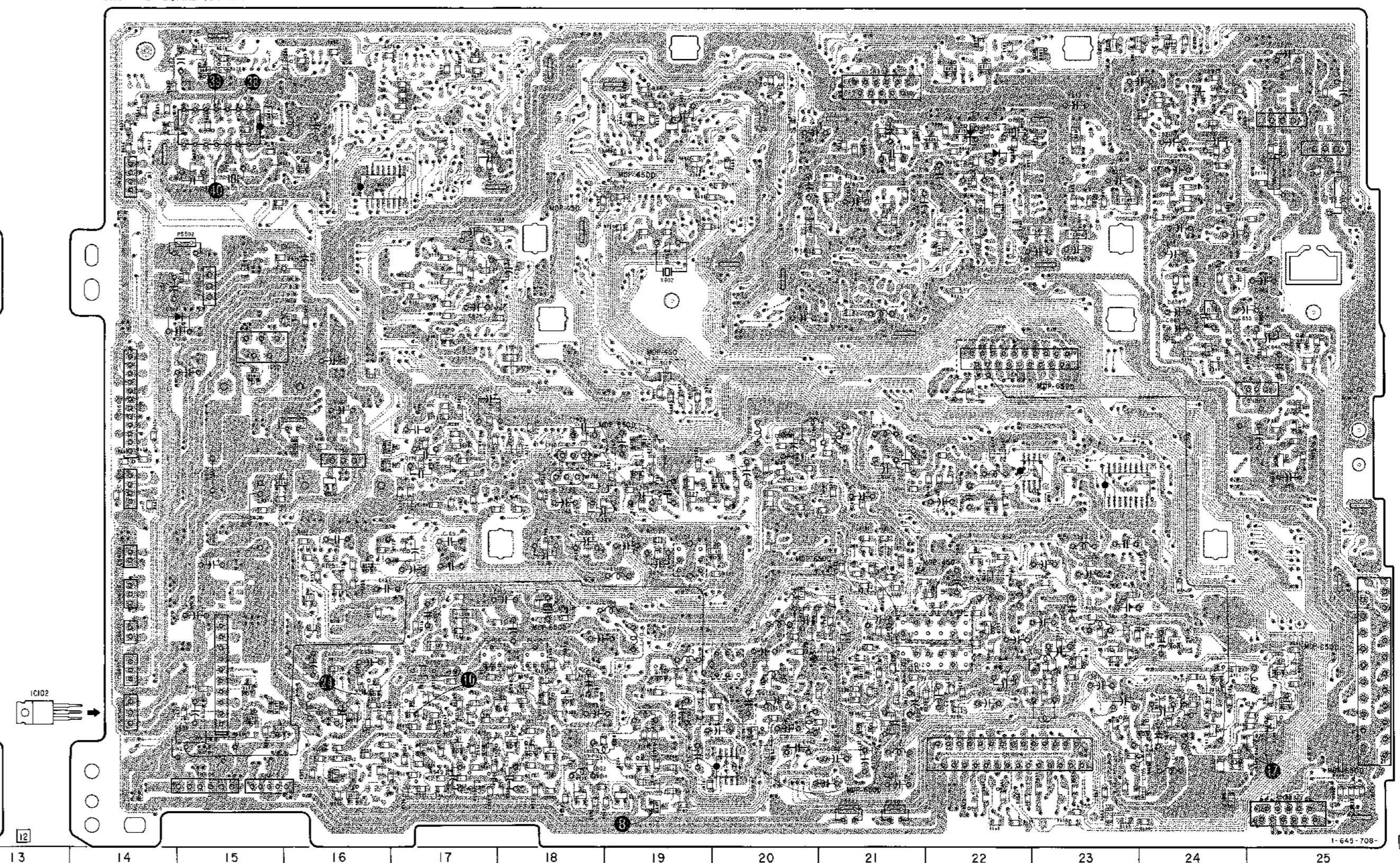

MP-701 BOARD

D102	F-6	IC804	C-5	O184	G-25
O104	E-16	IC806	B-6	O185	G-18
O301	D-15	IC807	B-3	O186	G-25
D568	G-15	IC808	B-3	O187	G-18
D569	D-12	IC809	B-2	O188	G-9
D510	D-12	IC810	C-2	O189	G-9
D511	F-12	IC811	C-3	O170	G-8
D517	H-10	IC812	B-2	O171	G-17
D518	H-10			O172	G-8
D601	E-3	O101	F-16	O173	G-8
D602	E-3	O102	G-24	O202	G-15
D603	B-19	O103	F-2	O203	G-15
D604	B-19	O104	G-24	O504	E-15
D605	G-15	O106	F-10	O505	G-10
D606	G-8	O107	F-10	O506	G-10
D607	D-17	O108	G-3	O507	G-10
D608	B-17	O109	H-8	O508	G-16
D609	E-2	O110	H-3	O509	G-10
D801	C-22	O111	H-24	O510	H-10
D802	B-22	O112	G-24	O511	H-17
O803	B-22	O113	G-23	O512	H-17
D804	A-24	O114	G-3	O513	H-18
D805	A-3	O115	G-3	O514	H-18
D806	D-25	O116	F-3	O515	H-18
D807	E-1	O117	G-24	O516	H-9
D808	E-25	O118	F-9	O517	H-16
D809	A-5	O119	G-7	O518	H-19
D810	A-5	O120	G-19	O519	H-17
D816	F-12	O121	G-7	O520	H-18
		O122	F-6	O521	H-16
IC101	G-3	O123	G-20	O522	H-10
IC102-1	F-11	O124	E-16	O523	H-6
IC102-2	G-13	O125	F-16	O501	A-15
IC103	F-9	O126	G-9	O502	B-16
IC104	H-20	O127	H-10	O504	E-3
IC105	F-4	O128	F-20	O505	E-22
IC106	G-6	O129	H-18	O506	B-14
IC107	F-5	O130	G-21	O507	E-5
IC108	E-6	O131	G-21	O508	B-7
IC109	E-9	O132	G-6	O509	B-19
IC110	F-5	O133	F-4	O510	A-6
IC111	F-3	O134	F-4	O511	E-2
IC501	D-15	O135	E-5	O512	E-4
IC502	E-18	O138	F-4	O501	A-23
IC503	B-25	O137	F-22	O502	A-23
IC504	C-15	O139	G-2	O503	A-23
IC505	B-25	O139	F-22	O504	A-1
IC801	B-12	O140	G-25	O505	B-22
IC802	D-3	O141	E-7	O506	A-4
IC803	A-10	O143	E-7	O507	A-4
IC804	E-2	O144	E-8	O508	A-4
IC805	A-11	O145	F-20	O509	D-2
IC806	A-10	O146	E-19	O510	A-22
IC807	E-4	O147	F-3	O511	A-4
IC808	E-23	O149	F-7	O513	D-25
IC809	E-22	O152	G-5	O515	D-1
IC810	B-15	O153	F-6	O516	B-2
IC812	B-7	O154	G-4	O517	E-25
IC813	B-9	O155	E-19	O518	D-24
IC614	G-15	O157	E-7	O519	D-24
IC615	C-9	O158	E-20	O520	B-2
IC616	D-9	O159	E-19	O521	B-24
IC617	D-3	O160	E-7	O522	B-5
IC618	B-15	O161	F-7	O523	B-22
IC802	B-4	O162	H-25	O524	A-22
IC803	C-4	O163	G-18	O527	A-4

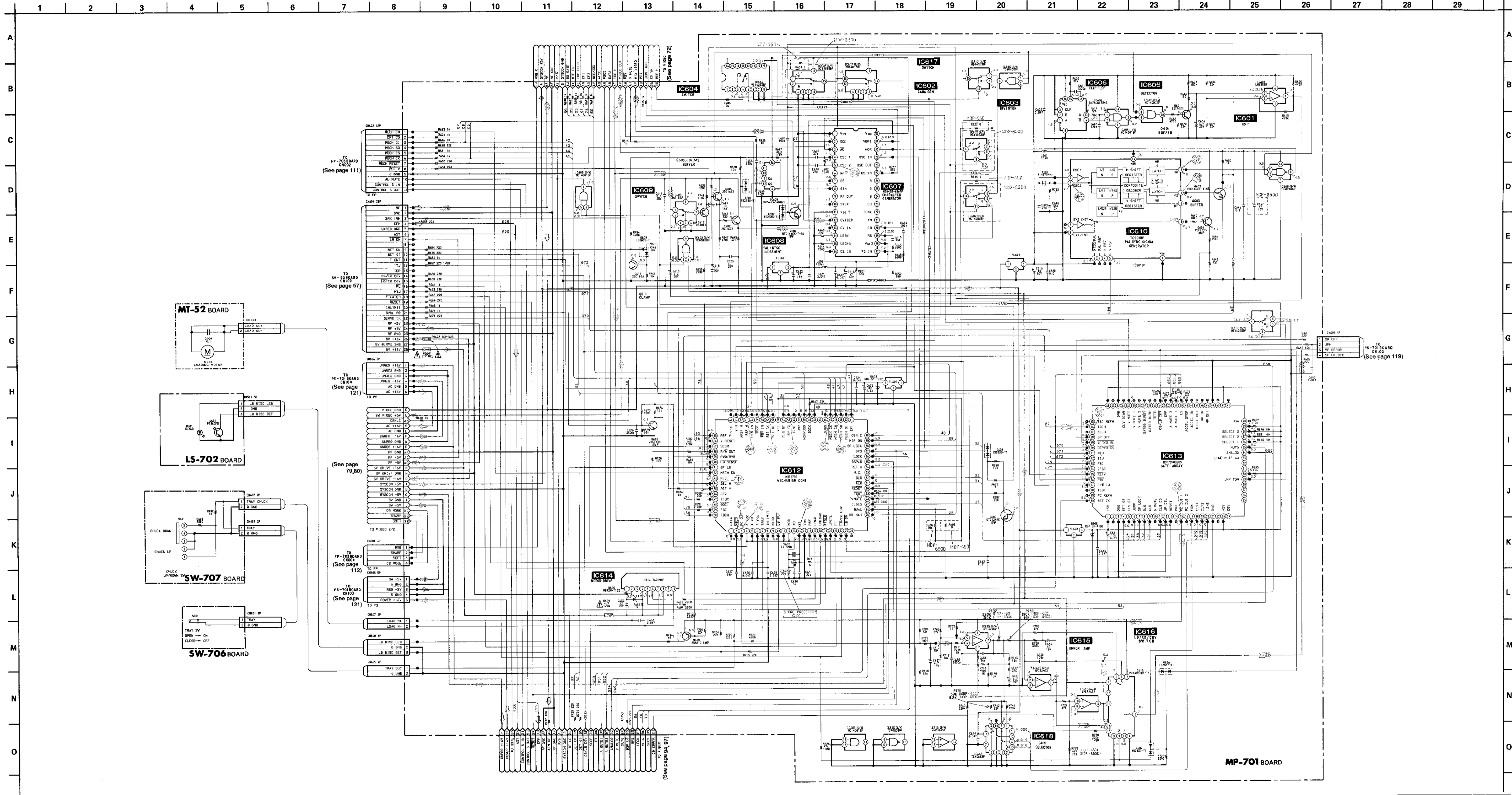

LS-702 (LD SENSOR), MT-52 (LOADING MOTOR), SW-706 (TRAY SWITCH), SW-707 (CHUCK SWITCH) PRINTED WIRING BOARDS - Ref. No.: LS-702, MT-52, SW-706, and SW-707 Boards; 3,000 series -

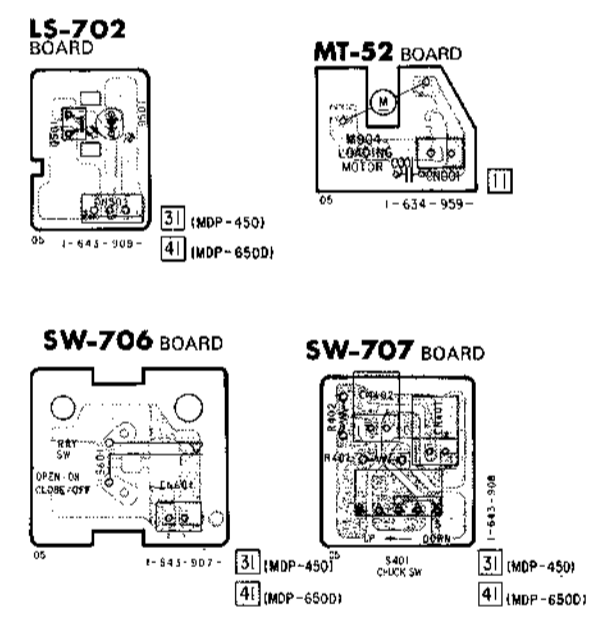

	VIDEO SIGNAL			AUDIO SIGNAL
	CHROMA	Y	Y/CHROMA	
PB	→	→	→	→
SPINDLE PHASE SERVO	↔			
SPINDLE SERVO (SPEED AND PHASE)	↔			
TRACKING SERVO LD/CDV	↔			
SLIDE SERVO LD/CD	↔			
FOCUS SERVO LD/CD	↔			
SKREW SERVO LD TILT	↔			

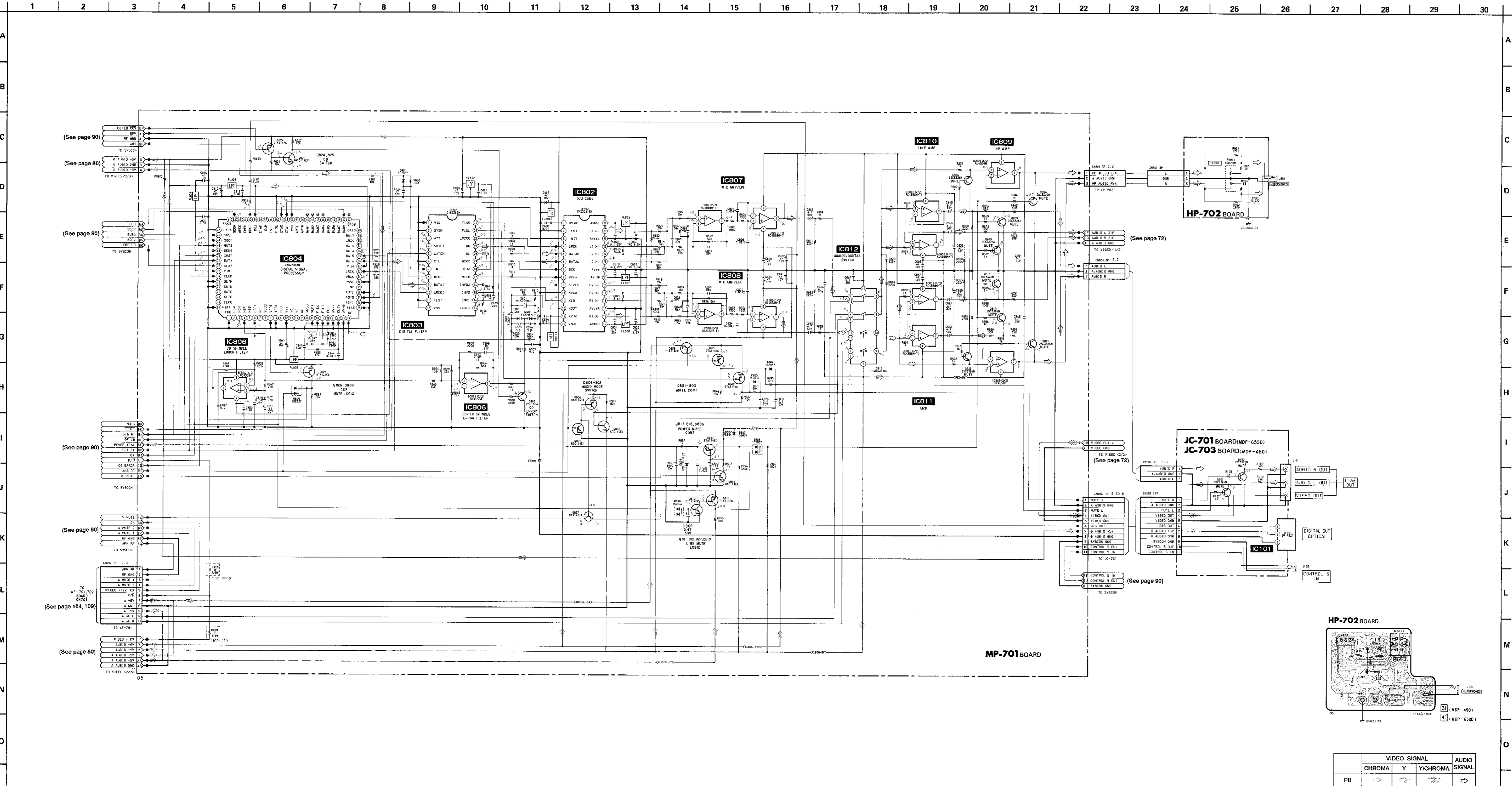

HP-702 (HEADPHONES JACK), JC-701/703 (IN/OUT JACKS), PRINTED WIRING BOARDS  
 - Ref. No.: HP-702 Board; 2000 series, JC-701 Boards; 4,000 series and JC-703 Boards; 5,000 series -

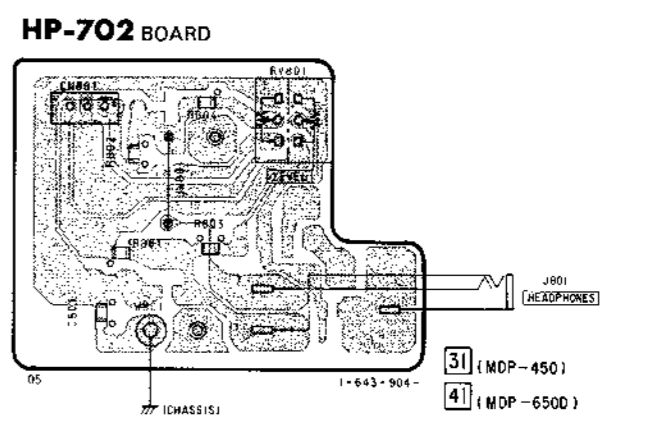
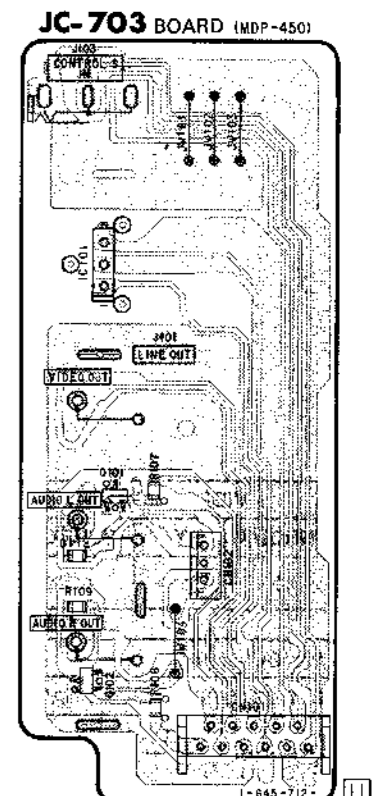
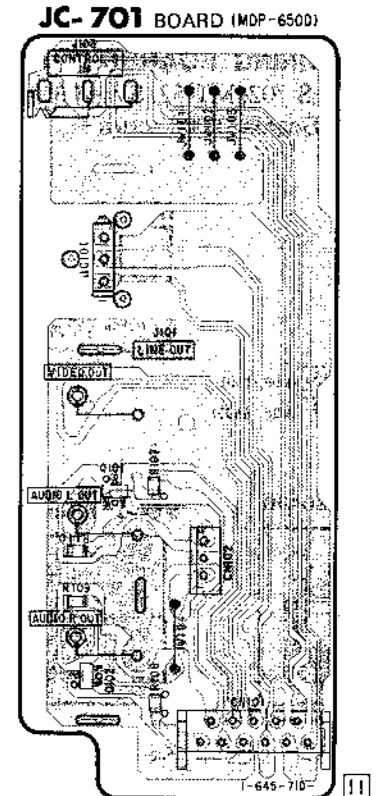

PB	VIDEO SIGNAL			AUDIO SIGNAL
	CHROMA	Y	Y/CHROMA	
→	→	→	→	→

**MP-701 (AUDIO) PRINTED WIRING BOARD**

- Ref. No.: MP-701 Boards; 2,000 series -

MP-701 BOARD

D102	F-6	IC804	C-5	Q184	G-25
D104	E-16	IC806	E-6	Q185	G-18
D501	D-15	IC807	B-3	Q186	G-25
D608	G-15	IC808	B-3	Q187	G-16
D609	D-12	IC809	B-2	Q188	G-9
D510	D-12	IC810	C-2	Q189	G-9
D516	F-12	IC811	C-3	Q190	G-9
D517	H-10	IC812	B-2	Q171	G-17
D518	H-10			Q172	G-8
D901	E-3	Q101	F-16	Q173	G-9
D605	E-3	Q102	G-24	Q502	G-15
D603	B-19	Q103	F-2	Q503	G-15
D604	B-19	Q104	G-24	Q504	E-15
D605	G-15	Q105	F-10	Q505	G-10
D606	D-9	Q107	F-10	Q506	G-10
D607	D-17	Q108	G-3	Q507	G-10
D608	B-17	Q109	H-8	Q508	G-16
D609	E-2	Q110	H-3	Q509	G-10
D601	C-22	Q111	H-24	Q510	H-10
D802	B-22	Q112	G-24	Q511	H-17
D803	B-22	Q113	G-23	Q512	H-17
D804	A-24	Q114	G-3	Q513	H-18
D805	A-3	Q115	G-3	Q514	H-18
D806	D-25	Q116	F-3	Q515	H-18
D807	E-1	Q117	G-24	Q516	H-8
D808	E-25	Q118	F-9	Q517	H-16
D809	A-5	Q119	G-7	Q518	H-19
D810	A-5	Q120	G-19	Q519	H-17
D516	F-12	Q121	G-7	Q520	H-18
		Q122	F-6	Q521	H-16
		Q123	G-20	Q522	H-10
IC101	G-3	Q124	E-16	Q523	H-9
IC102-1	F-11	Q125	F-16	Q601	A-15
IC102-2	G-13	Q126	G-20	Q603	B-16
IC103	F-9	Q127	H-19	Q604	E-3
IC104	H-20	Q128	F-20	Q605	E-22
IC105	F-4	Q129	H-19	Q606	B-14
IC106	G-6	Q130	G-21	Q607	E-5
IC107	F-5	Q131	G-21	Q608	B-7
IC108	E-6	Q132	G-8	Q609	B-19
IC109	E-8	Q133	F-4	Q610	A-6
IC110	F-5	Q134	F-4	Q611	E-2
IC111	F-3	Q135	E-5	Q612	E-4
IC501	D-15	Q136	F-4	Q601	A-23
IC502	E-16	Q137	F-22	Q602	A-23
IC503	B-25	Q138	G-2	Q603	A-23
IC504	C-15	Q139	F-22	Q604	A-1
IC505	B-25	Q140	G-25	Q605	B-22
IC601	B-12	Q141	E-7	Q606	A-4
IC602	D-3	Q142	E-7	Q607	A-4
IC603	A-10	Q143	E-7	Q608	A-4
IC604	E-2	Q144	E-8	Q609	D-2
IC605	A-11	Q145	F-20	Q610	A-22
IC606	A-10	Q146	E-19	Q611	A-22
IC607	E-4	Q147	F-3	Q612	A-4
IC608	E-23	Q149	F-7	Q613	D-25
IC609	E-22	Q152	G-5	Q615	D-1
IC610	B-15	Q153	F-5	Q616	B-2
IC512	B-7	Q154	G-4	Q617	E-25
IC513	B-9	Q155	E-19	Q618	D-2
IC614	G-15	Q157	E-7	Q619	D-24
IC616	C-9	Q158	E-20	Q620	D-2
IC618	D-8	Q159	E-19	Q621	B-24
IC617	D-3	Q160	F-7	Q624	B-7
IC618	B-18	Q161	F-7	Q625	B-22
IC602	B-4	Q162	H-25	Q626	A-22
IC603	C-4	Q163	G-18	Q627	A-4

**MP-701 BOARD (COMPONENT SIDE)**

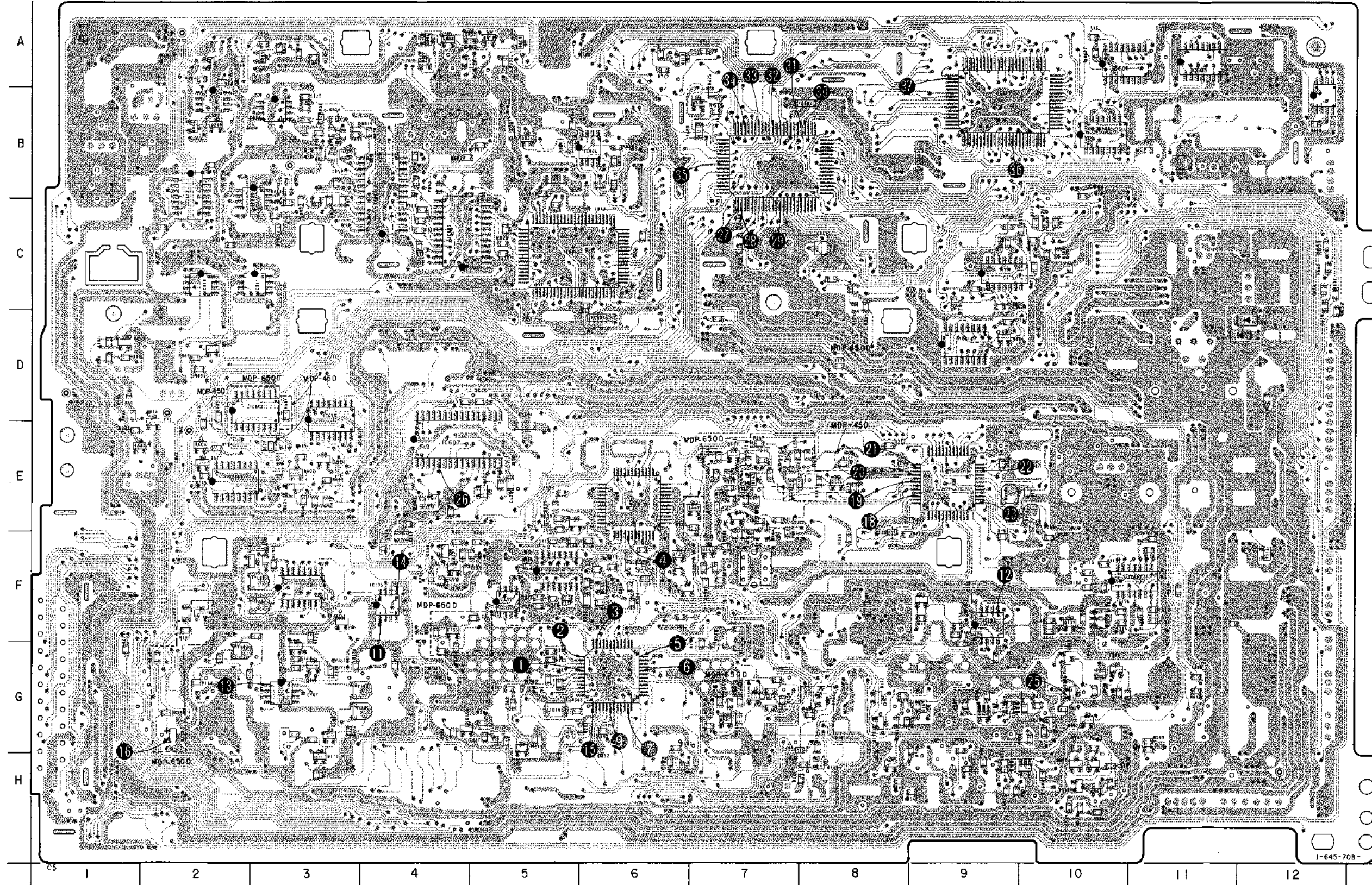

**MP-701 BOARD (CONDUCTOR SIDE)**

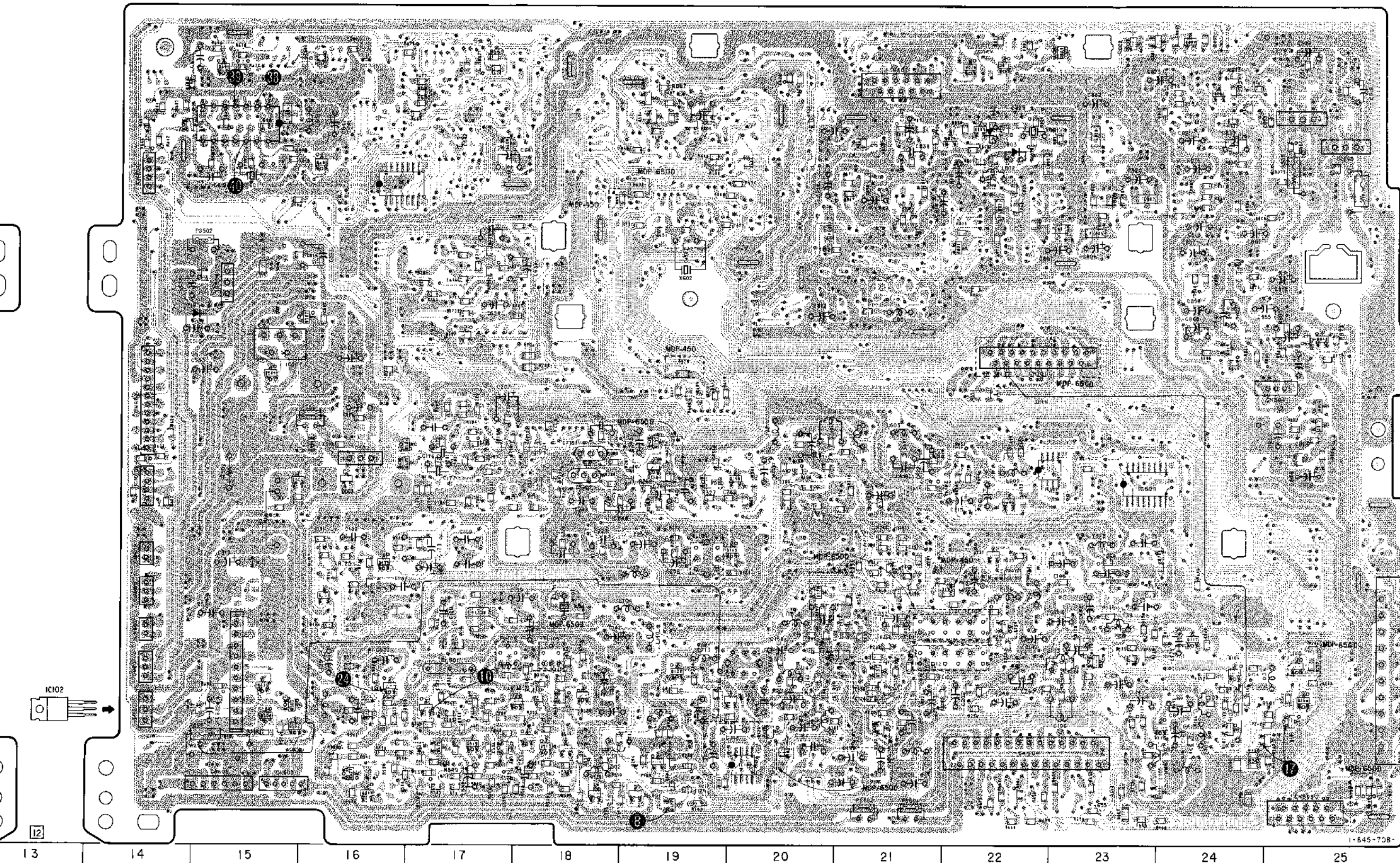

**AF-701 (ANALOG AUDIO) SCHEMATIC DIAGRAM**

— Ref. No.: AF-701 Board; 4,000 series —

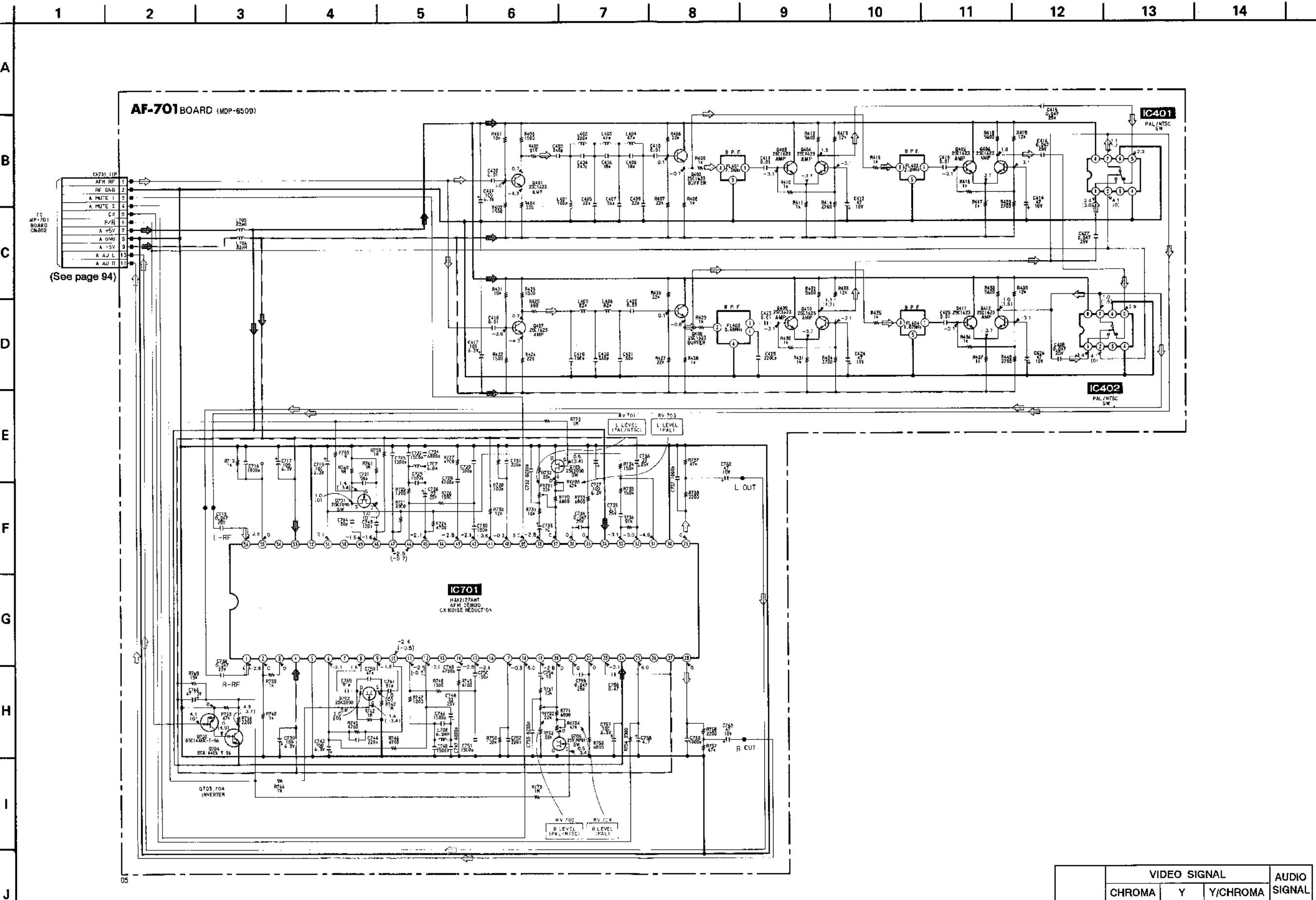

(See page 94)

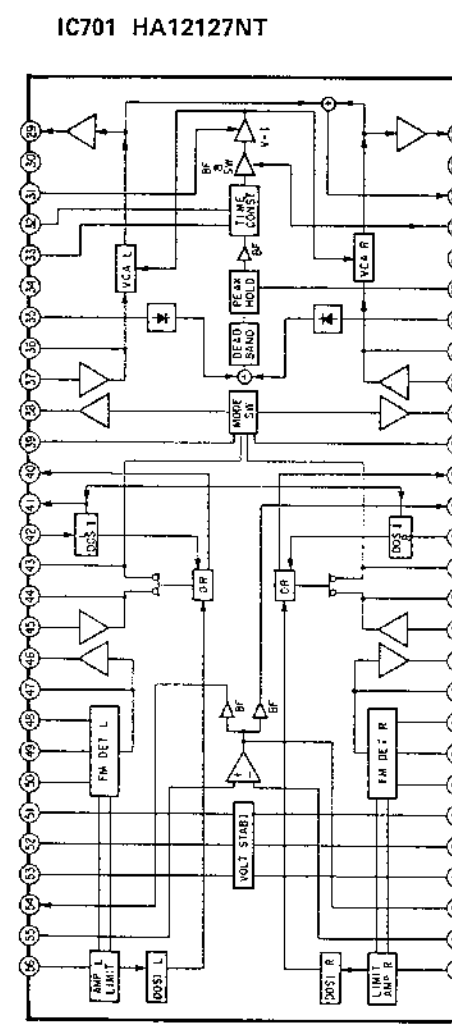

	VIDEO SIGNAL			AUDIO SIGNAL
	CHROMA	Y	Y/CHROMA	
PB	⇨	⇨⇨	⇨⇨⇨	⇨

**AF-701 (ANALOG AUDIO) PRINTED WIRING BOARD** — Ref. No.: AF-701 Board; 4,000 series —

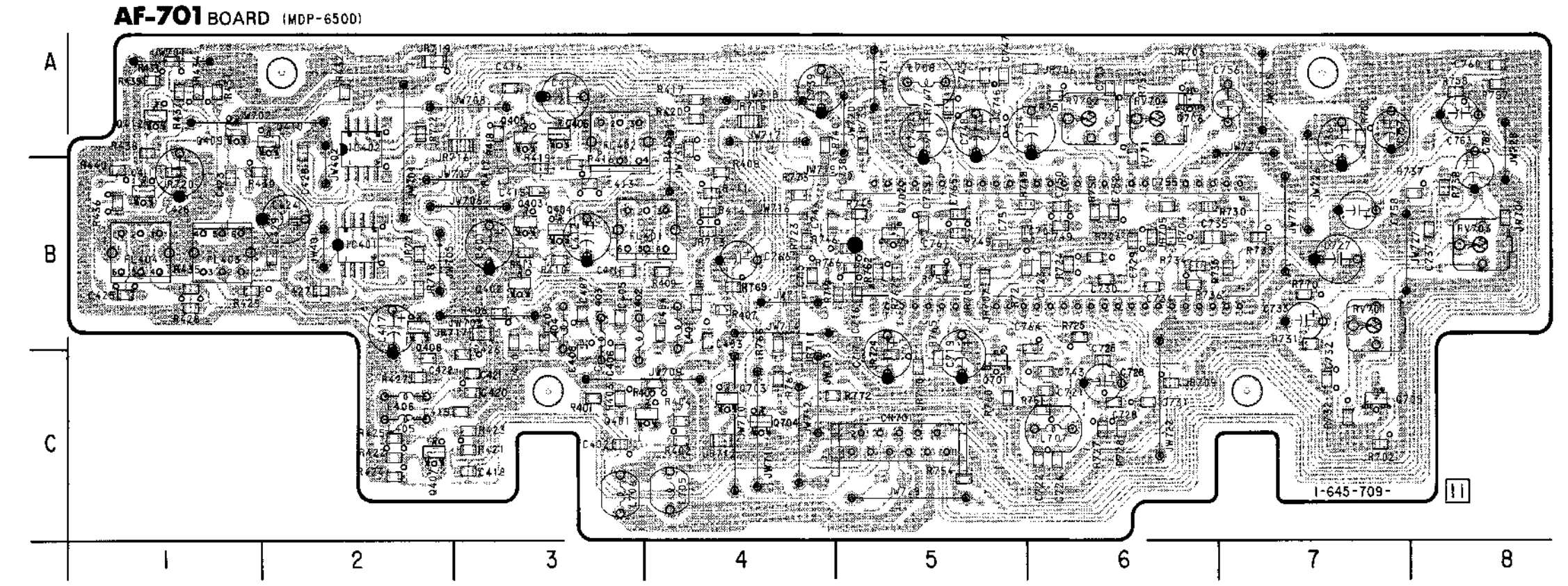

- AF-701 BOARD
- IC401 B-2
  - IC402 A-2
  - IC701 B-6
  - Q401 C-4
  - Q402 B-3
  - Q403 B-3
  - Q404 B-3
  - Q405 A-3
  - Q406 A-3
  - Q407 C-2
  - Q408 B-2
  - Q409 A-1
  - Q410 A-2
  - Q411 B-1
  - Q412 A-1
  - Q701 C-5
  - Q703 C-4
  - Q704 C-4
  - Q706 C-7
  - Q708 A-6

**AF-702 (ANALOG AUDIO) PRINTED WIRING BOARD** — Ref. No.: AF-702 Board; 5,000 series —

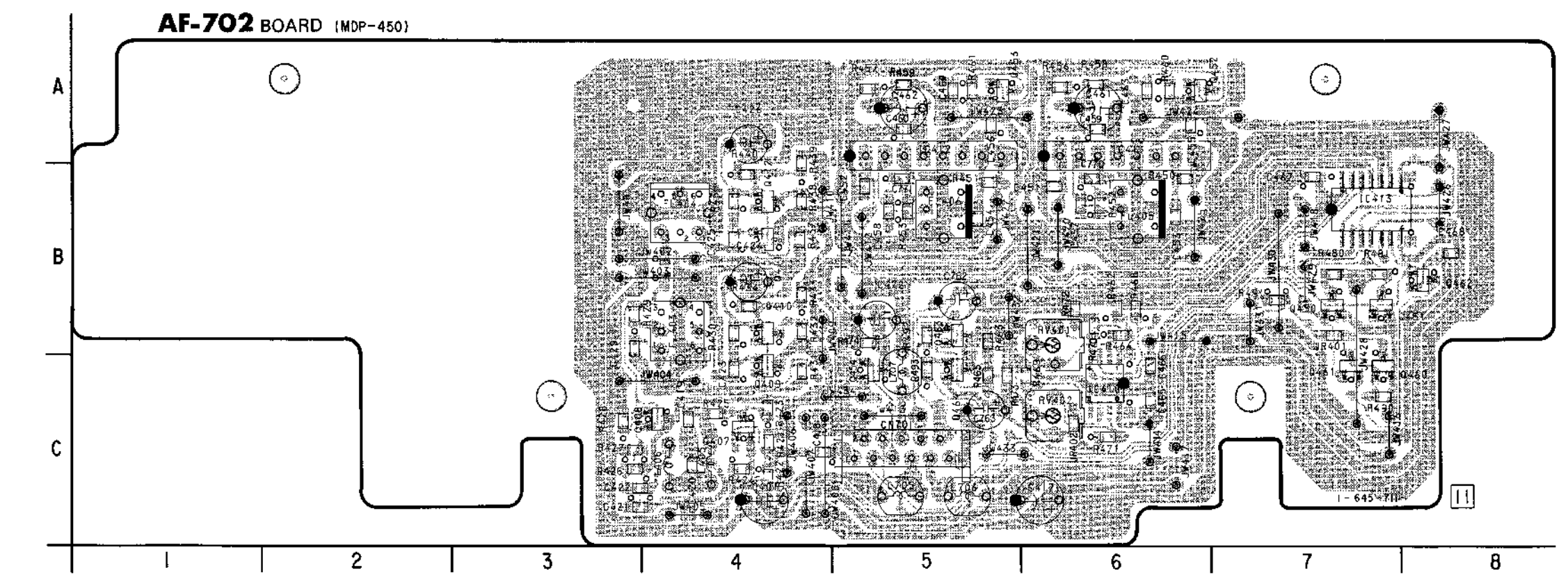

- AF-702 BOARD
- IC410 C-8
  - IC411 A-5
  - IC412 A-5
  - IC413 B-7
  - Q407 C-7
  - Q408 C-4
  - Q410 B-4
  - Q411 B-4
  - Q412 B-4
  - Q430 B-7
  - Q451 B-7
  - Q452 A-8
  - Q453 A-5
  - Q454 C-5
  - Q460 C-7
  - Q461 C-7
  - Q462 B-6
  - Q463 B-6

AF-702 (ANALOG AUDIO) SCHEMATIC DIAGRAM

- Ref. No.: AF-702 Board; 5,000 series -

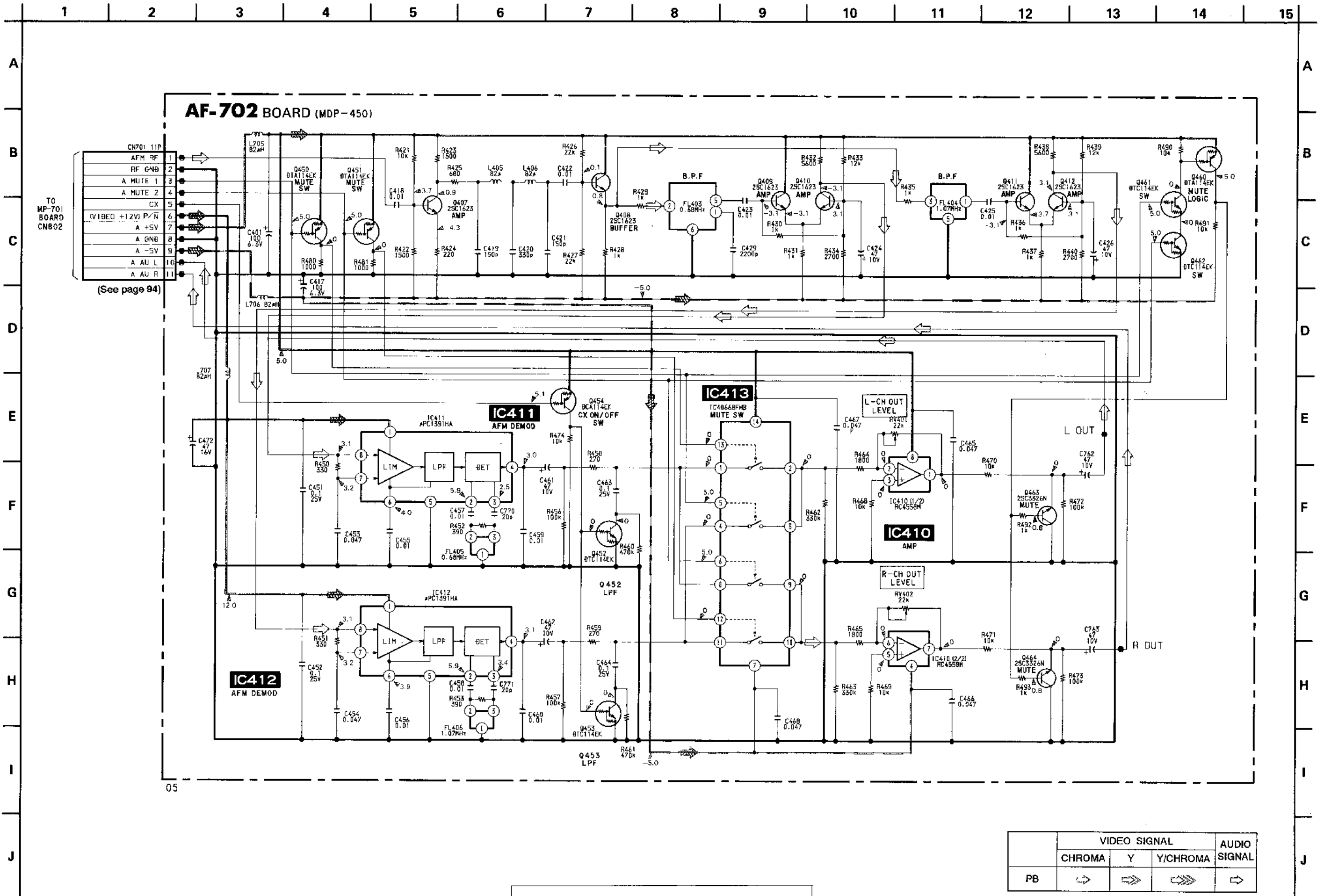

(See page 94)

PB	VIDEO SIGNAL			AUDIO SIGNAL
	CHROMA	Y	Y/CHROMA	
PB	→	⇒	⇨	⇨



**FP-703 (MODE CONTROL), SW-704 (POWER SWITCH) SCHEMATIC DIAGRAM**

— Ref. No.: FP-703, SW-704 Boards; 6,000 series —

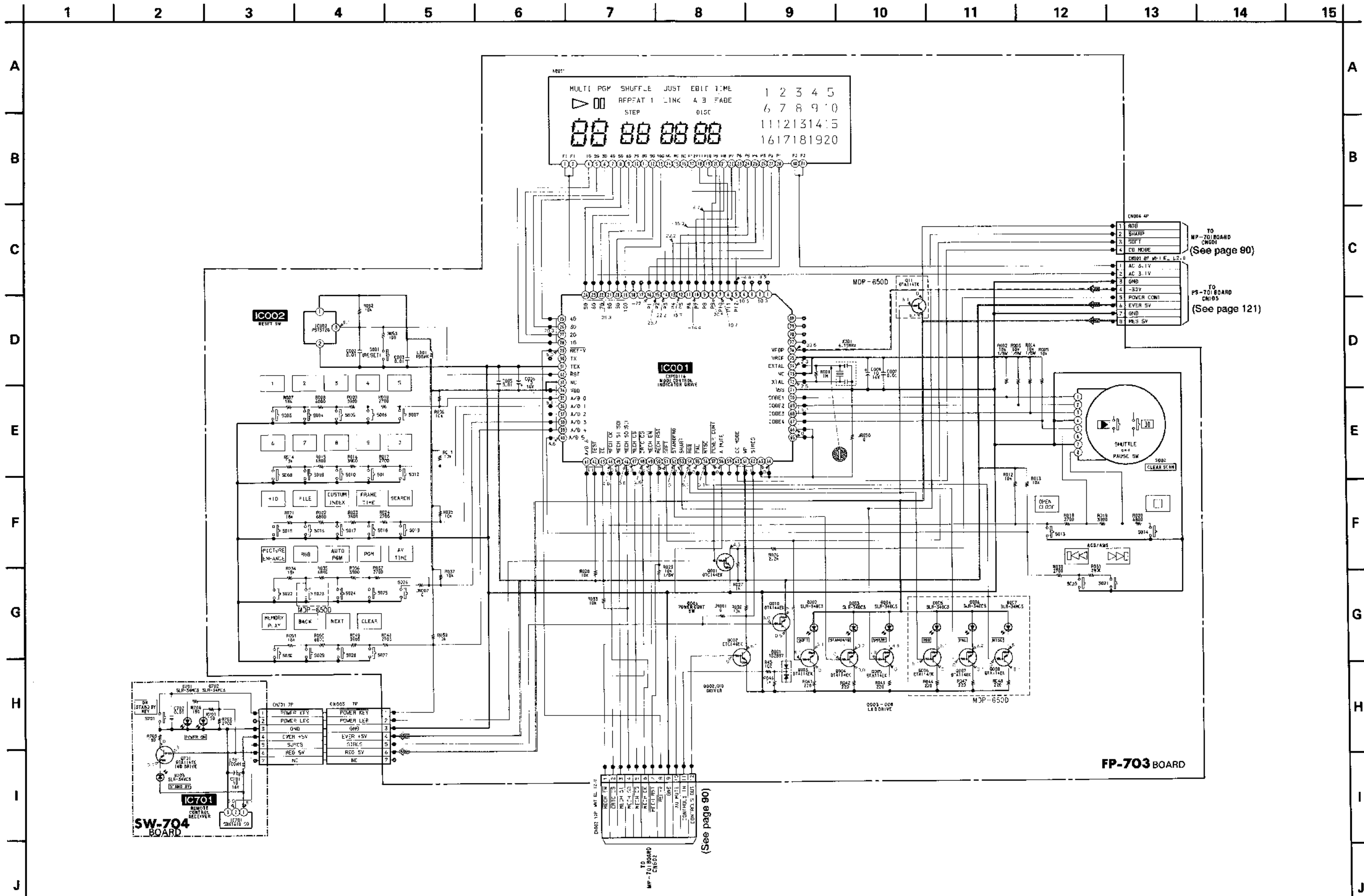

FP-703 BOARD

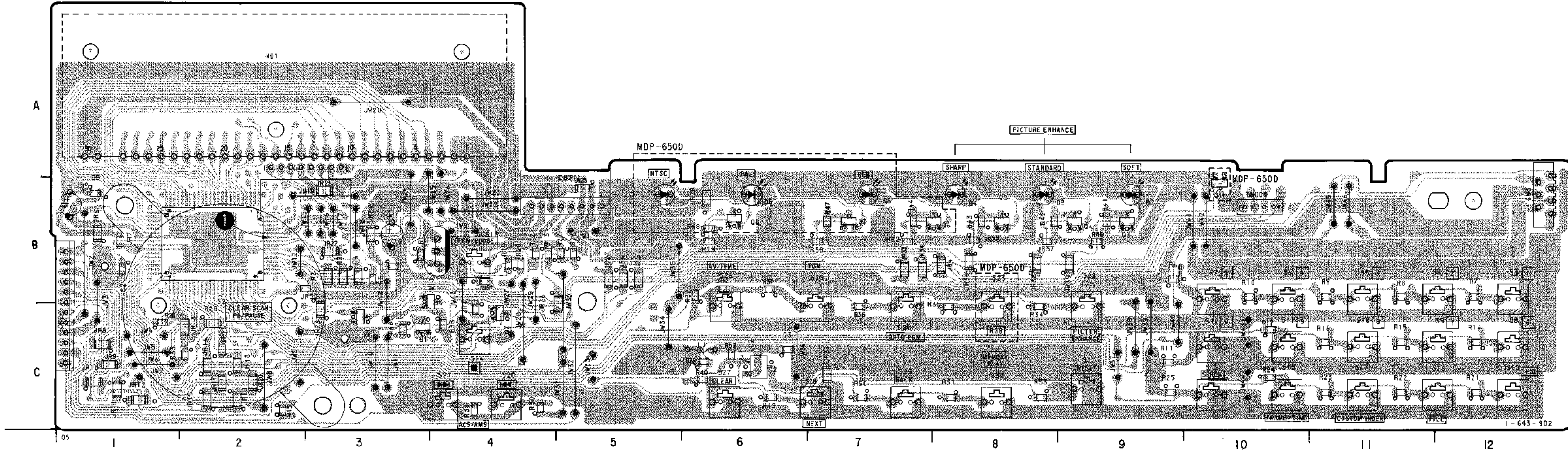

31 (MDP-450)  
 41 (MDP-650D)

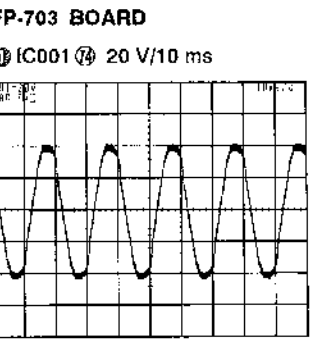

FP-703 BOARD

D001	C-3
D002	B-8
D003	B-8
D004	B-8
D005	B-7
D006	B-6
D007	B-5
IC001	B-2
IC002	C-6
Q001	C-3
Q002	C-4
Q003	B-8
Q004	B-8
Q005	B-8
Q006	B-8
Q007	B-7
Q008	B-6
Q010	B-3
Q011	B-10

SW-704 BOARD (MDP-450)

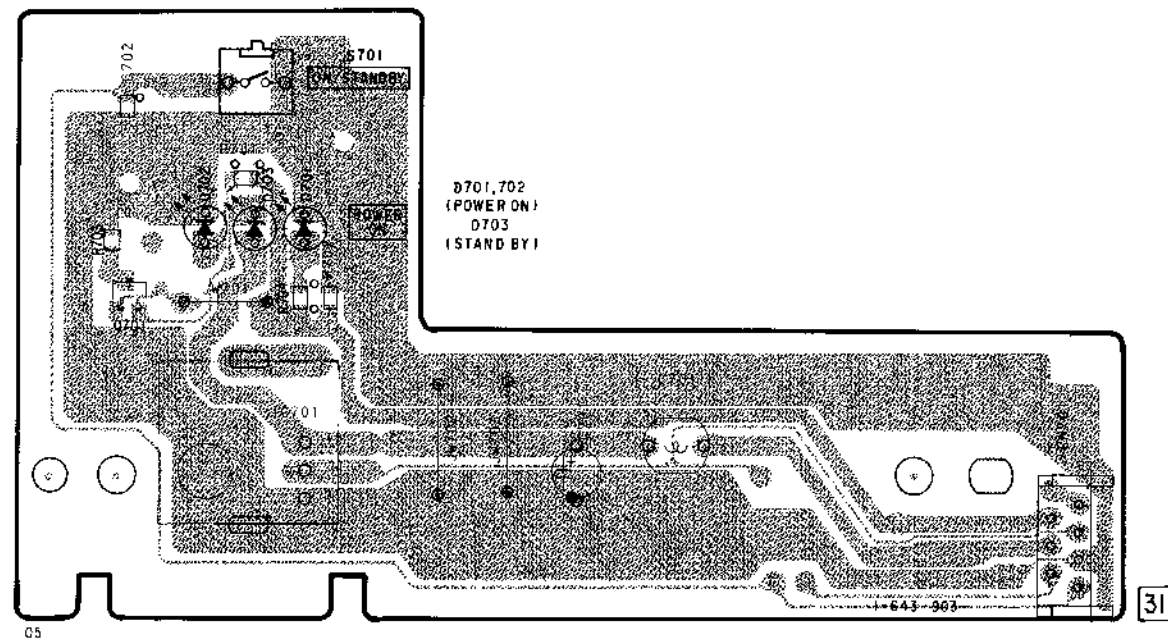

31

SW-704 BOARD (MDP-650D)

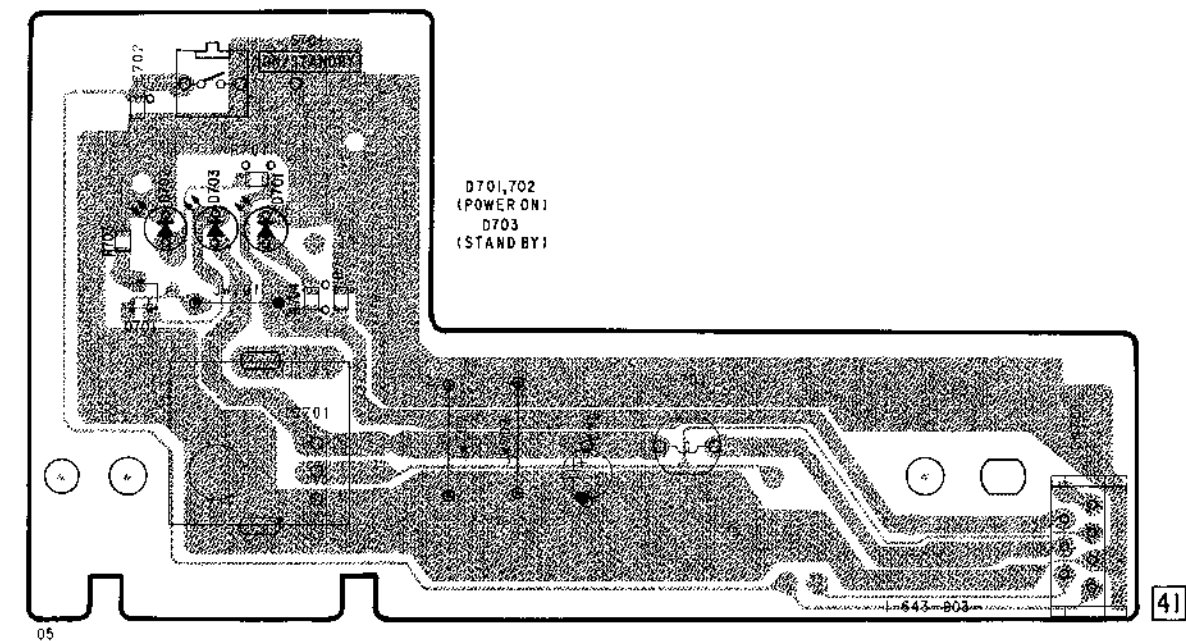

41

PS-701 (POWER SUPPLY, SPINDLE SERVO), TR-702 (POWER TRANSFORMER) PRINTED WIRING BOARDS  
 - Ref. No.: PS-701, TR-702 Boards; 7,000 series -

MP-701 BOARD (VIDEO)  
 NTSC

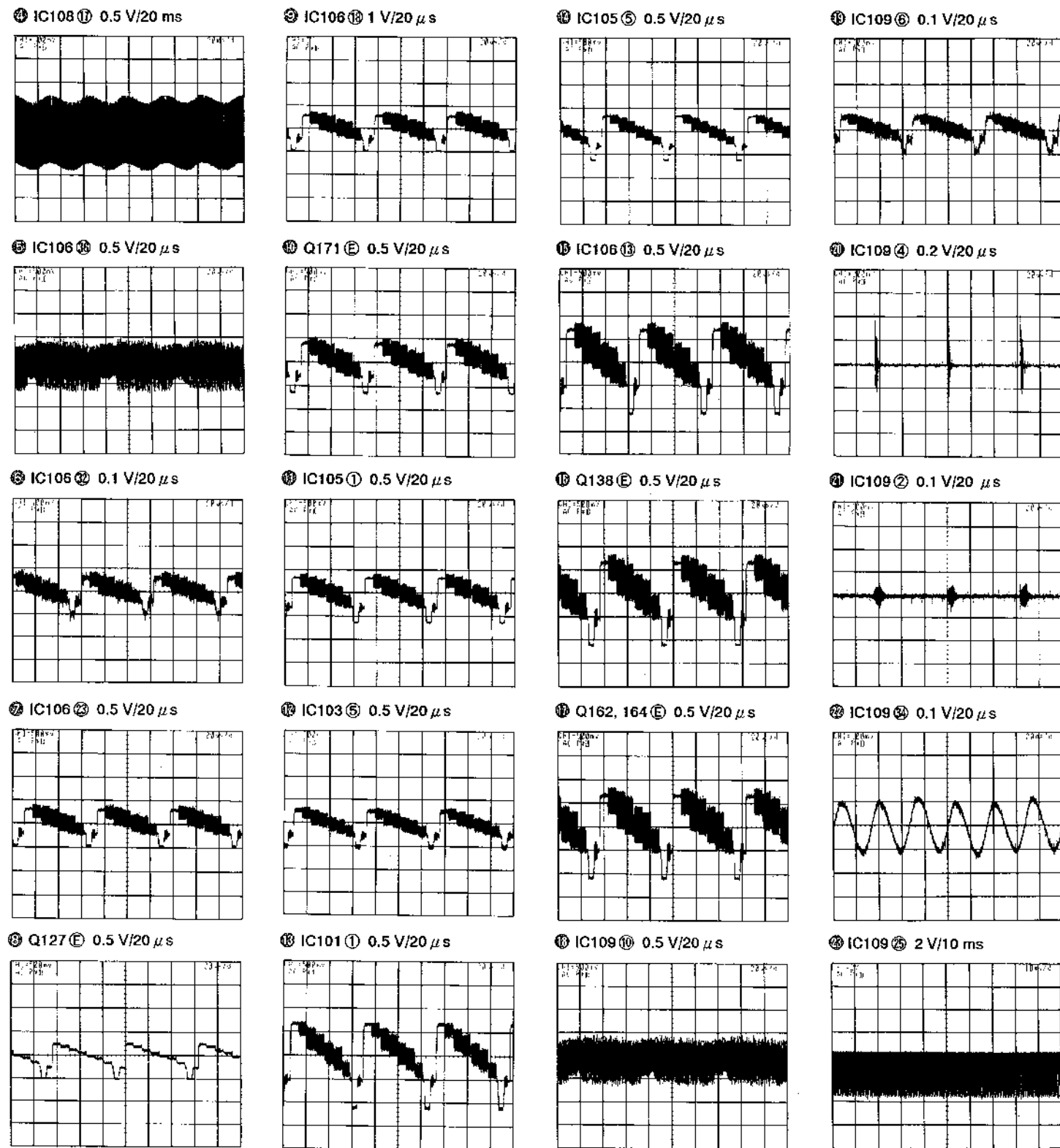

PS-701 BOARD

- |       |     |
|-------|-----|
| D101  | D-5 |
| D102  | D-5 |
| D103  | D-5 |
| D108  | B-7 |
| D109  | C-4 |
| D110  | C-4 |
| D111  | B-4 |
| D112  | B-4 |
| D113  | D-5 |
| D114  | D-5 |
| D115  | D-3 |
| D116  | C-4 |
| D117  | C-4 |
| D118  | B-3 |
| D119  | D-6 |
| D201  | B-2 |
| D202  | B-2 |
| D203  | A-2 |
| D204  | A-2 |
| D205  | B-3 |
| D206  | B-3 |
| D207  | B-2 |
| IC101 | B-6 |
| IC102 | C-6 |
| IC201 | D-1 |
| IC202 | D-2 |
| Q101  | B-7 |
| Q102  | B-7 |
| Q103  | B-7 |
| Q105  | B-8 |
| Q108  | B-4 |
| Q111  | D-3 |
| Q112  | D-6 |
| Q120  | D-7 |
| Q201  | B-1 |
| Q202  | B-2 |
| Q203  | B-2 |
| Q204  | A-3 |
| Q205  | C-2 |
| Q208  | C-1 |
| Q208  | B-2 |
| Q209  | B-2 |
| Q210  | C-2 |
| Q211  | C-2 |
| Q212  | C-2 |

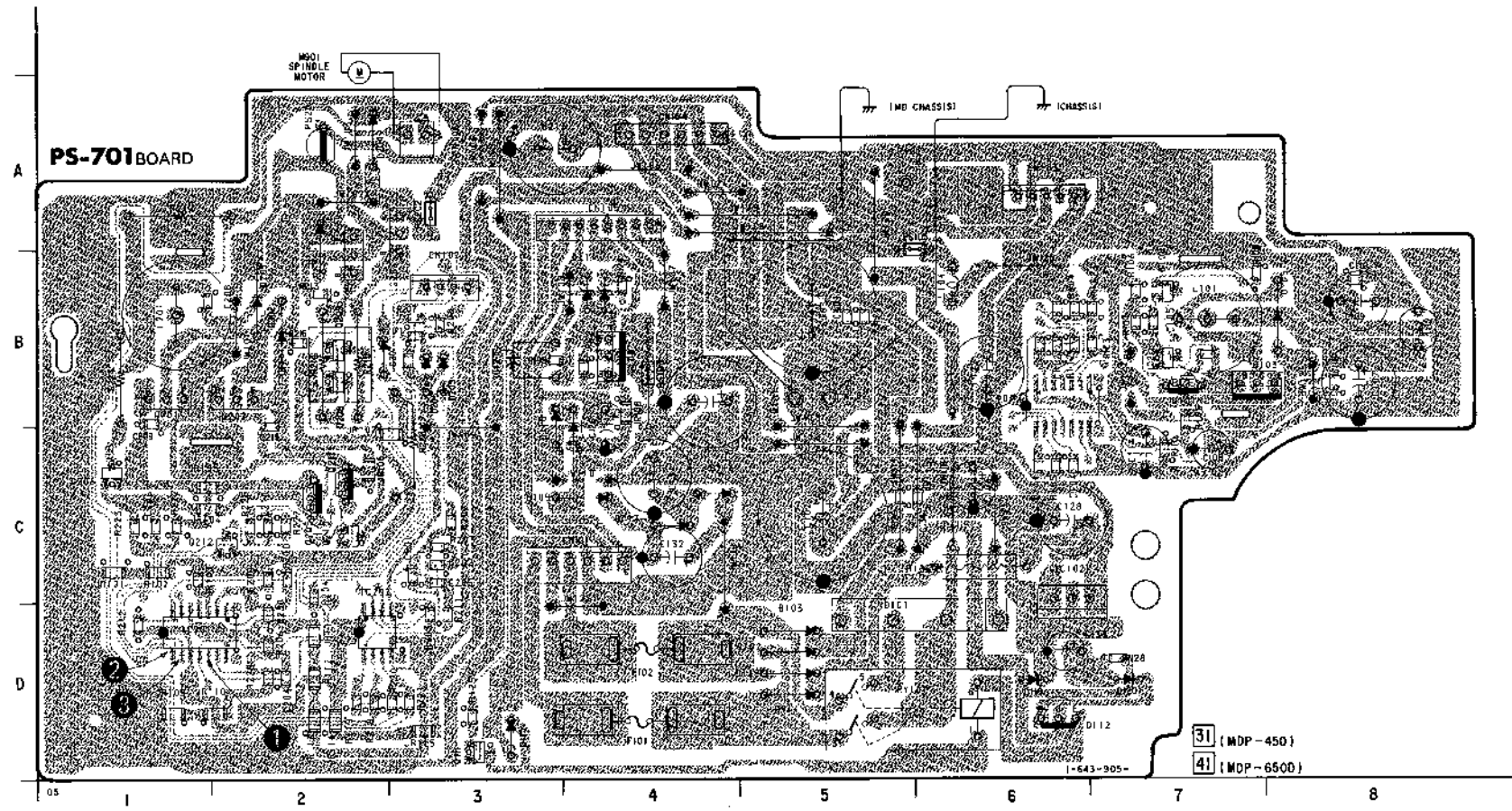

TR-702 BOARD

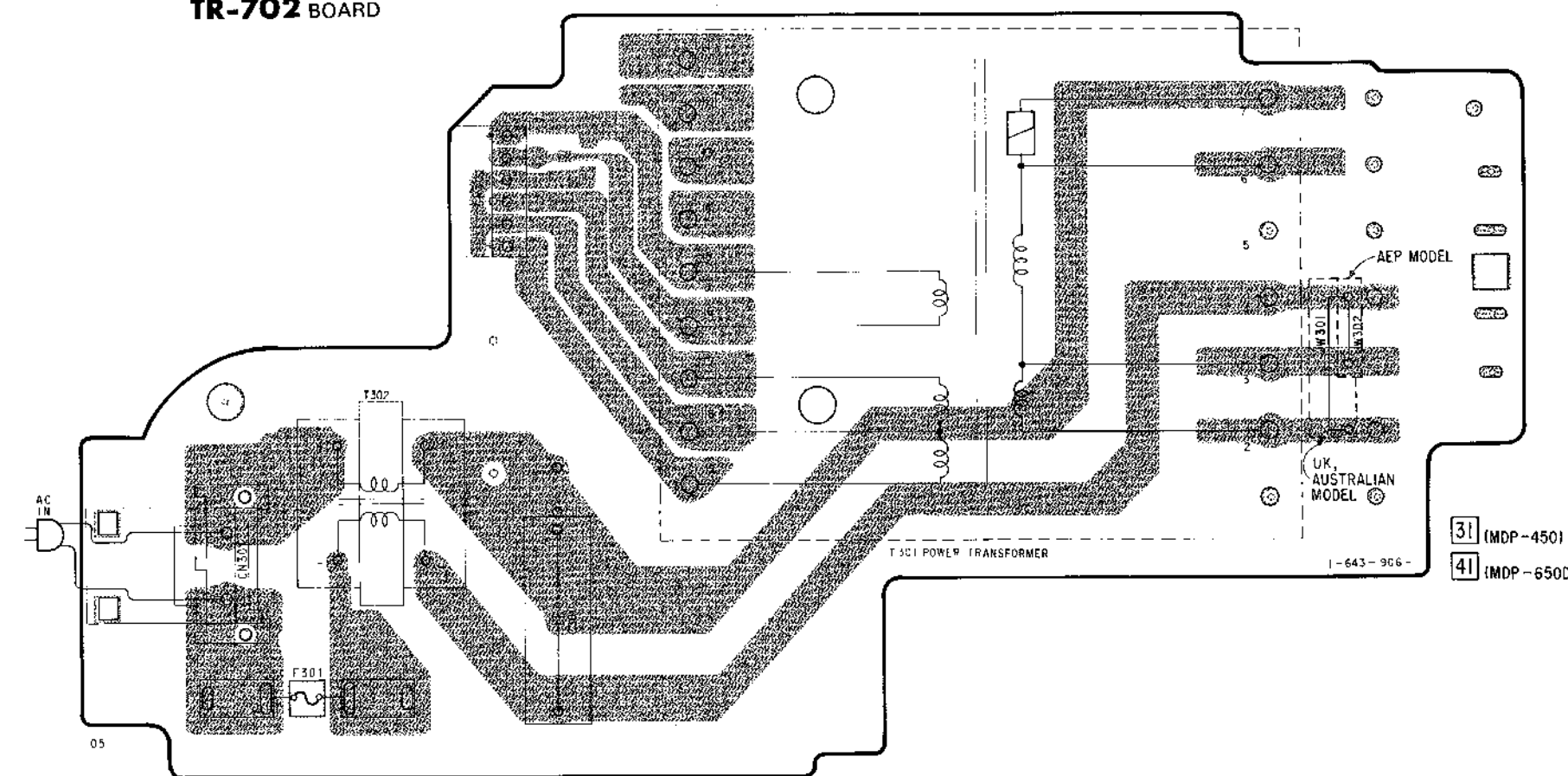

**PS-701 (POWER SUPPLY, SPINDLE SERVO), TR-702 (POWER TRANSFORMER) SCHEMATIC DIAGRAM**

- Ref. No.: PS-701, TR-702 Boards; 7,000 series -

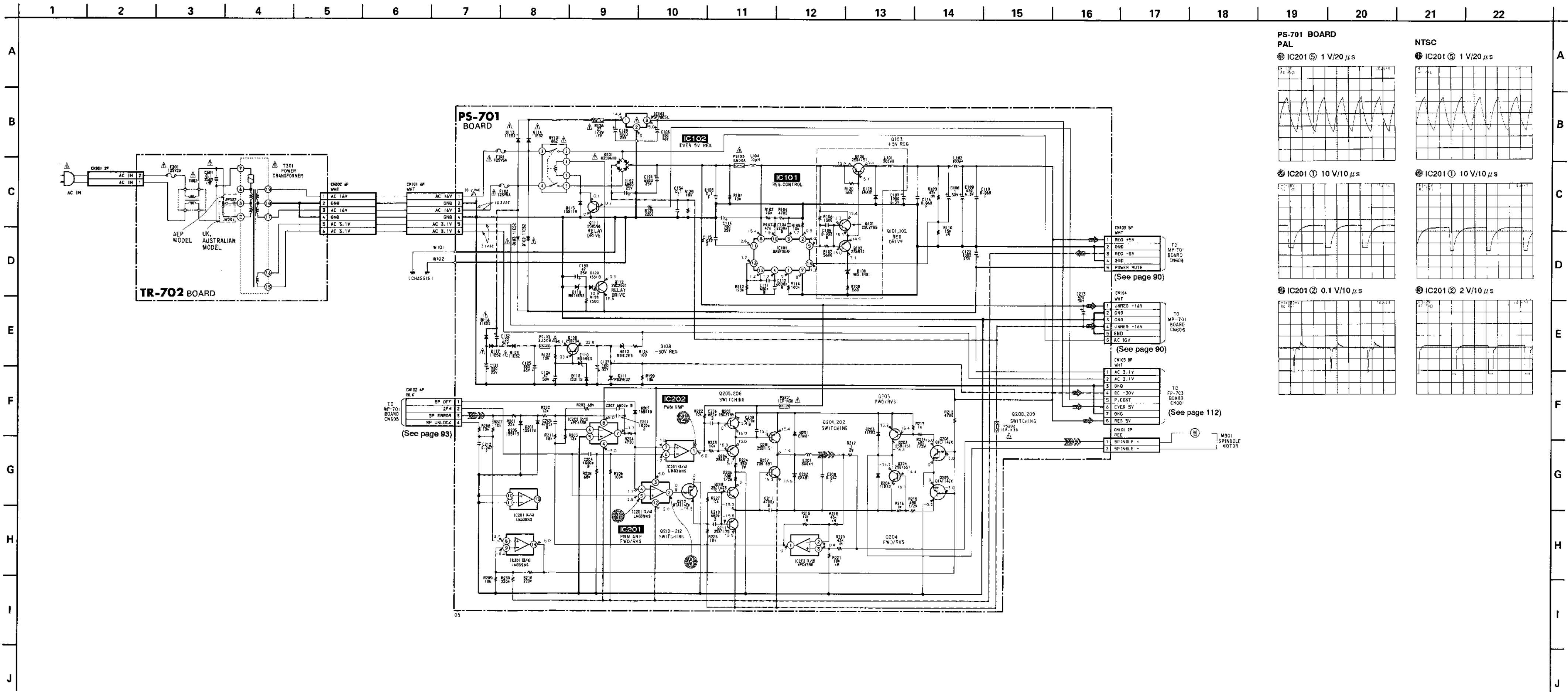

**PS-701 BOARD  
PAL**

Ⓢ IC201 Ⓢ 1 V/20 μs

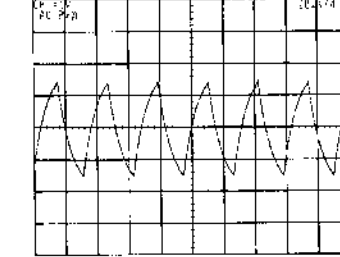

**NTSC**

Ⓢ IC201 Ⓢ 1 V/20 μs

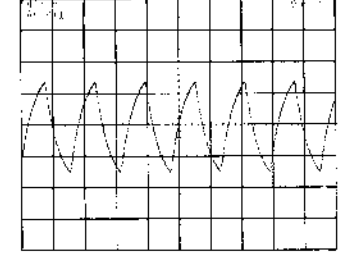

Ⓢ IC201 Ⓢ 10 V/10 μs

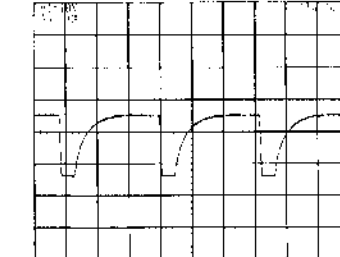

Ⓢ IC201 Ⓢ 10 V/10 μs

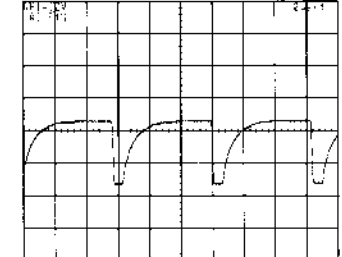

Ⓢ IC201 Ⓢ 0.1 V/10 μs

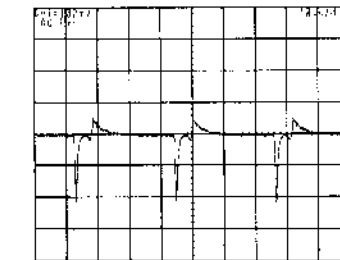

Ⓢ IC201 Ⓢ 2 V/10 μs

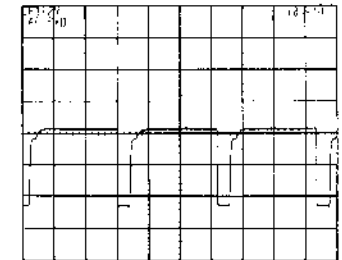

4-3. SEMICONDUCTORS

BA7131F

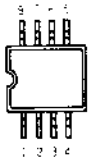

(TOP VIEW)

CXD2500AQ  
CXP50116-417Q  
MB89795

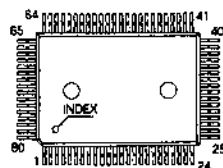

MARKING SIDE VIEW

LM324NS  
MM1148XF  
NJM2903M  
RC4558M  
PC4558G2

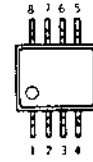

(TOP VIEW)

PC1391HA

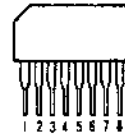

2SA1175-HFE  
2SC2785-HFE



2SB1151-L  
2SD1691-K

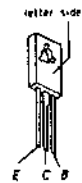

2SB1370-EF  
2SD2012

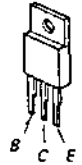

2SB733-34  
2SB734-34

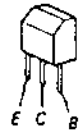

2SC2001-LK  
2SD655-E



D3SBA10



EC10DS2

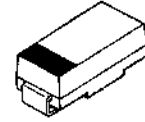

FC52M-5

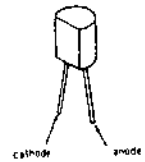

GP-2509-B

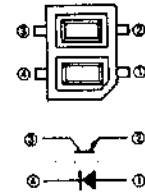

ERA81-006  
ERA83-008  
RD3.9ES-B2  
RD8.2ES-B1  
RD11ES-B2  
RD36ES-B2  
RD39ES-B2  
1SS119  
11ES2

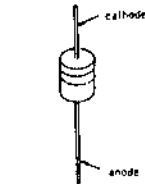

GL-360

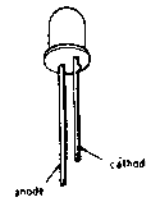

SLR34DC3  
SLR34MC3  
SLR34VC3

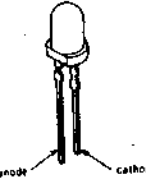

BA9700AF  
CXL5005M  
MC14066BF  
SN74H04ANS  
TC74HCU04AF  
PC324G2  
LM339NS

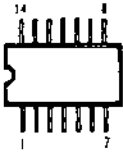

(TOP VIEW)

CX20197

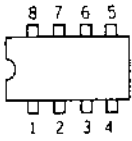

(Top view)

HD14053BFP  
MC14052BF  
MSM72H048GS-V1K  
SN74HC4040ANS  
SN74LS123NS  
SN74LS221NS

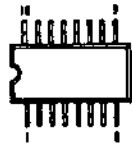

(TOP VIEW)

M5F7909L  
M5F7905L  
TA7905S

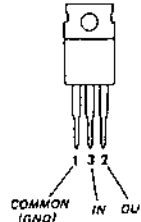

COMMON (GND) IN OUT

M50455-196FP

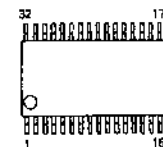

TOP VIEW

CXA1081M

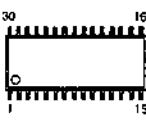

TOP VIEW

CXA1254Q  
CXA1255Q  
CXD8405Q  
CXD1152-MS

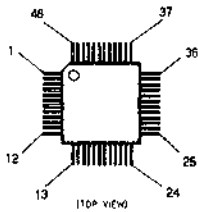

(TOP VIEW)

HA11529  
PA0034A

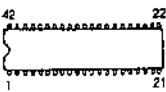

(Top view)

PST572DMT

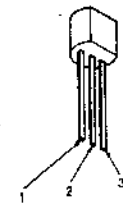

PT360FS

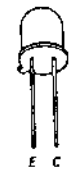

E C

CXD2560M

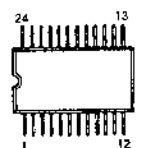

(TOP VIEW)

HA12127ANT

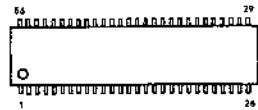

(TOP VIEW)

LA6510  
TA7291P

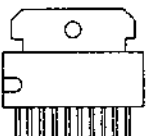

MARKING SIDE VIEW

RC7809FA  
TA7805S  
TA7812S  
PC24M09HF

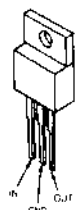

GND OUT

CXD2561BM

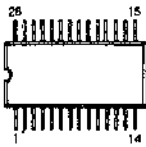

TOP VIEW

## SECTION 5 EXPLODED VIEWS

### NOTE:

- -XX and -X mean standardized parts, so they may have some difference from the original one.

- Color Indication of Appearance Parts

Example:

KNOB, BALANCE (WHITE) ... (RED)

↑                      ↑  
 Parts Color      Cabinet's Color

- Items marked "\*" are not stocked since they are seldom required for routine service. Some delay should be anticipated when ordering these items.

- The mechanical parts with no reference number in the exploded views are not supplied.

- Hardware (# mark) list is given in the last of this parts list.

The components identified by mark or dotted line with mark are critical for safety. Replace only with part number specified.

### 5-1. CABINET, FRONT PANEL ASSEMBLIES

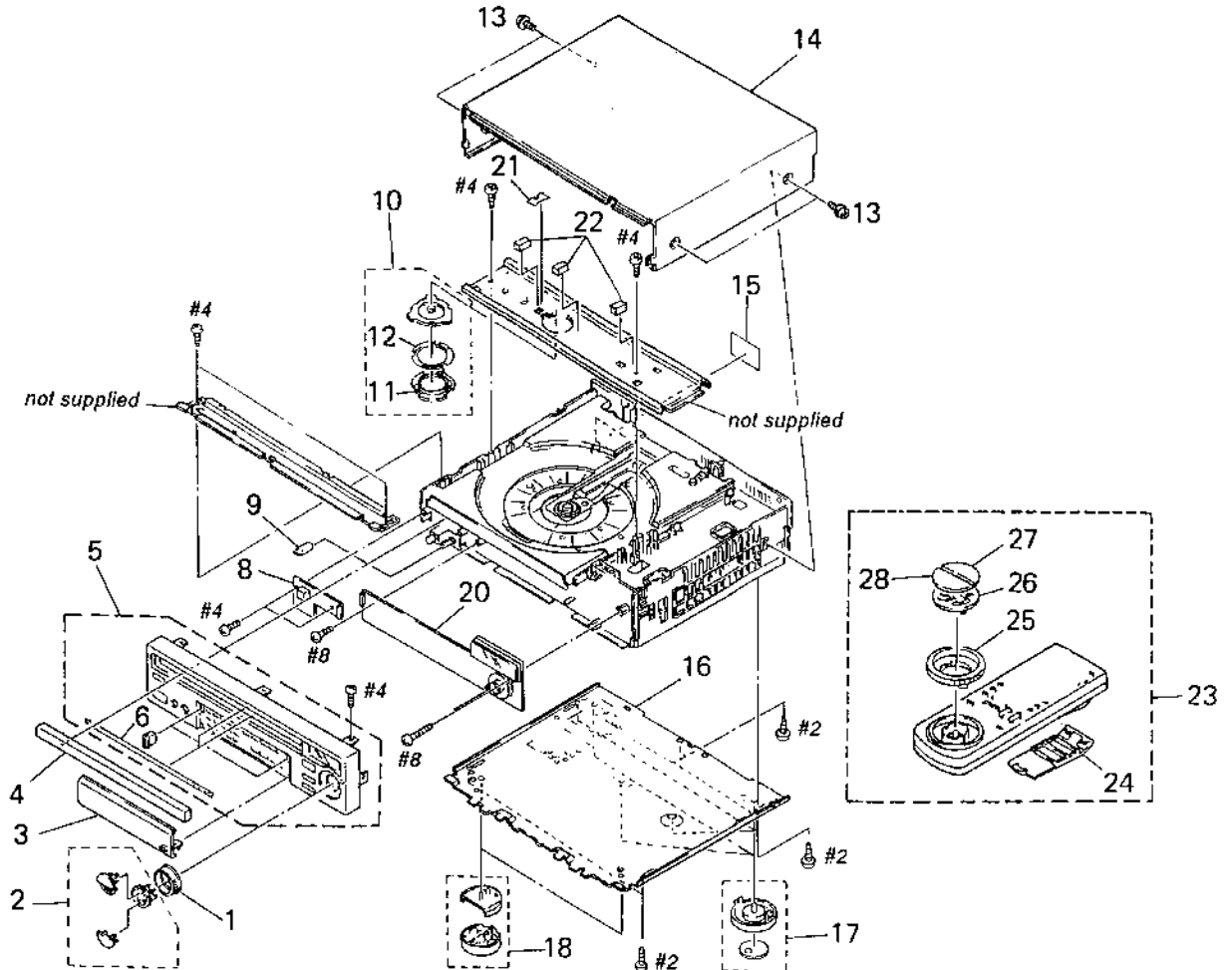

Ref. No.	Part No.	Description	Remark	Ref. No.	Part No.	Description	Remark
1	3-948-288-11	RING, SHUTTLE		* 15	3-949-814-01	LABEL, MODEL NUMBER (450)	
2	X-3941-934-2	BUTTON ASSY, FUNCTION		* 15	3-949-834-01	LABEL, MODEL NUMBER (650D: AEP)	
3	X-3942-088-1	DOOR ASSY (450)		* 15	3-951-641-01	LABEL, MODEL NUMBER (650D: UK)	
3	X-3942-092-1	DOOR ASSY (650D)		* 15	3-952-272-01	LABEL, MODEL NUMBER (650D: Australian)	
4	3 947-258-21	COVER, TRAY		* 16	X-3942-383-1	PLATE ASSY, BOTTOM	
5	X-3942-087-1	PANEL ASSY, FRONT (450)		17	X-3941-457-1	FOOT ASSY	
5	X-3942-091-1	PANEL ASSY, FRONT (650D)		18	X-3941-572-1	FOOT ASSY, FRONT	
6	3-947-248-01	SHEET (2), ACOUSTIC ISOLATION		* 20	A-6421-862-A	FP-703 BOARD, COMPLETE (650D)	
* 8	A-6426-541-A	SW-704 BOARD, COMPLETE (450)		* 20	A 6421-871-A	FP-703 BOARD, COMPLETE (450)	
* 8	A-6426-543-A	SW-704 BOARD, COMPLETE (650D)		* 21	3-737-454-01	SHEET, HOLDER	
9	A-6415-522-A	KNOB BLOCK ASSY (BR)		22	9 911-842-XX	CUSHION	
10	X-3735-006-1	PLATE ASSY, PRESS		23	1-693-095-41	REMOTE COMMANDER (HMI-M14)	
11	3-735-010-01	PLATE (1), PRESS		24	3-943-535-01	COVER, BATTERY	
12	3-735-011-01	SPRING		25	3-941-616-01	RING, SHUTTLE	
13	3-710-901-41	SCREW, TAPPING		26	3-941-619-01	HOLDER, DIAL	
* 14	3-735-065-01	CASE, UPPER		27	3-941-617-41	BUTTON, PLAYBACK	
				28	3-941-618-41	BUTTON, STOP	

## 5-2. CHASSIS (1)

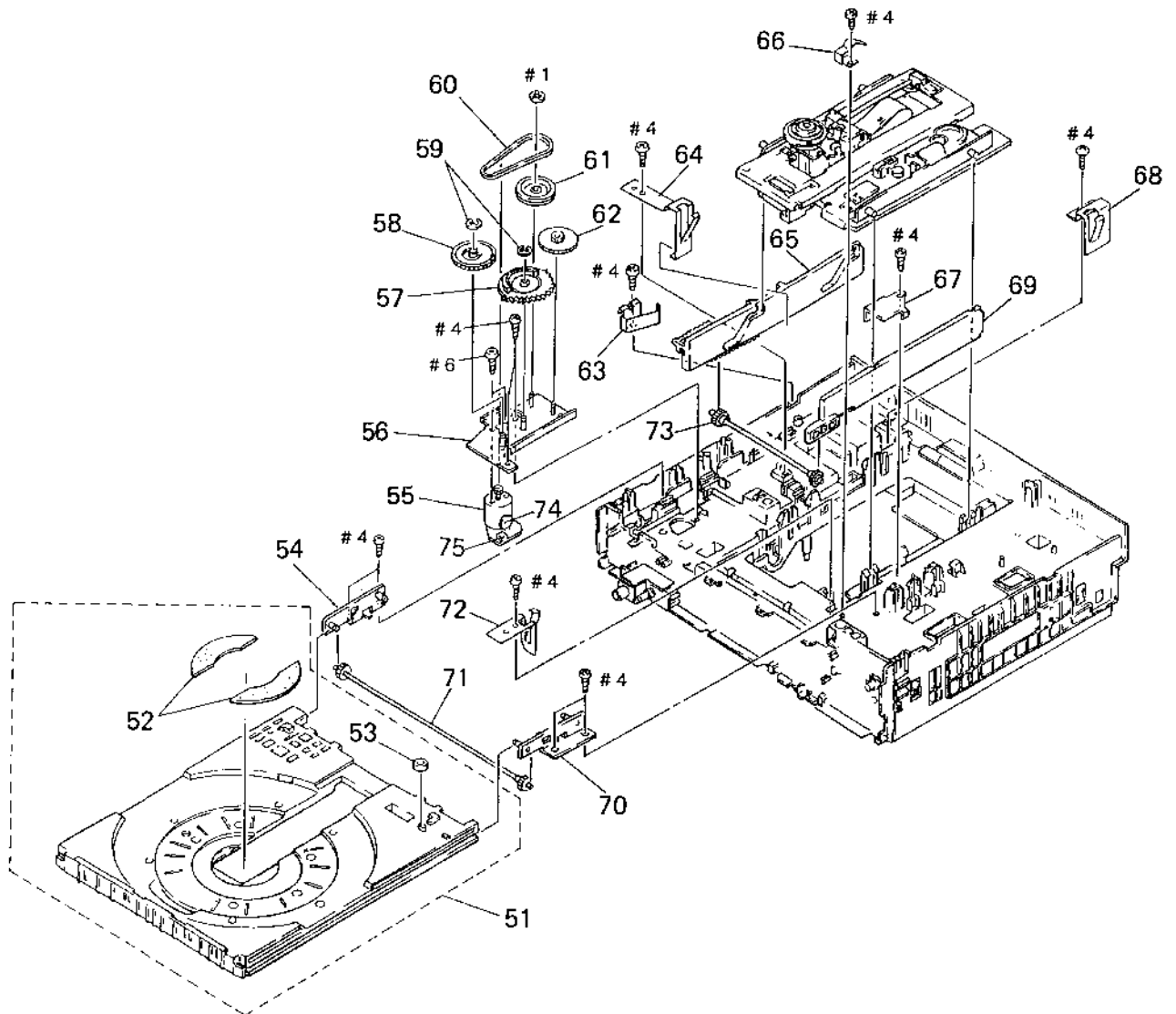

Ref. No.	Part No.	Description	Remark
51	X-3941 999 1	TRAY ASSY	
52	3-735 039 03	SHEET, CD	
* 53	4-914-248-01	STOPPER, RUBBER	
54	X-3735-071 1	GUIDE ASSY (L), TRAY	
55	A-6415-359 A	MOTOR BLOCK ASSY (X), THREADING (M904)	
56	X-3941 458 1	THREADING (BASE) ASSY (N)	
57	3-947 264 01	CAM (N), DRIVING	
58	3 735-035-01	GEAR, TRAY	
59	3-669-595-00	WASHER (2), STOPPER	
60	3-949-030-01	BELT, DRIVING	
61	3-735-036-01	PULLEY (A)	
62	3-947-262-01	GEAR (N), MIDWAY	
63	3-948-289-01	SPRING (2), TRAY	

Ref. No.	Part No.	Description	Remark
64	3-737-401-01	SPRING (1)	
65	3-735-053-01	RACK (LEFT)	
66	3 737-448-01	SPRING, LEAF	
* 67	3 749-912-01	RETAINER (B), RACK	
68	3 947-254-01	SPRING (3), MD RETAINER	
69	3-735-052-01	RACK (RIGHT)	
70	X-3735-070-1	GUIDE ASSY (R), TRAY	
71	X-3735-069-1	GEAR ASSY, PHASE	
72	3-737-402-01	SPRING (2)	
73	X-3735-008-1	GEAR ASSY, MD PHASE	
74	1-161-063-00	CERAMIC 0.1uF 10% 50V	
75	1-506-481-11	PIN, CONNECTOR 2P	

### 5-3. CHASSIS (2)

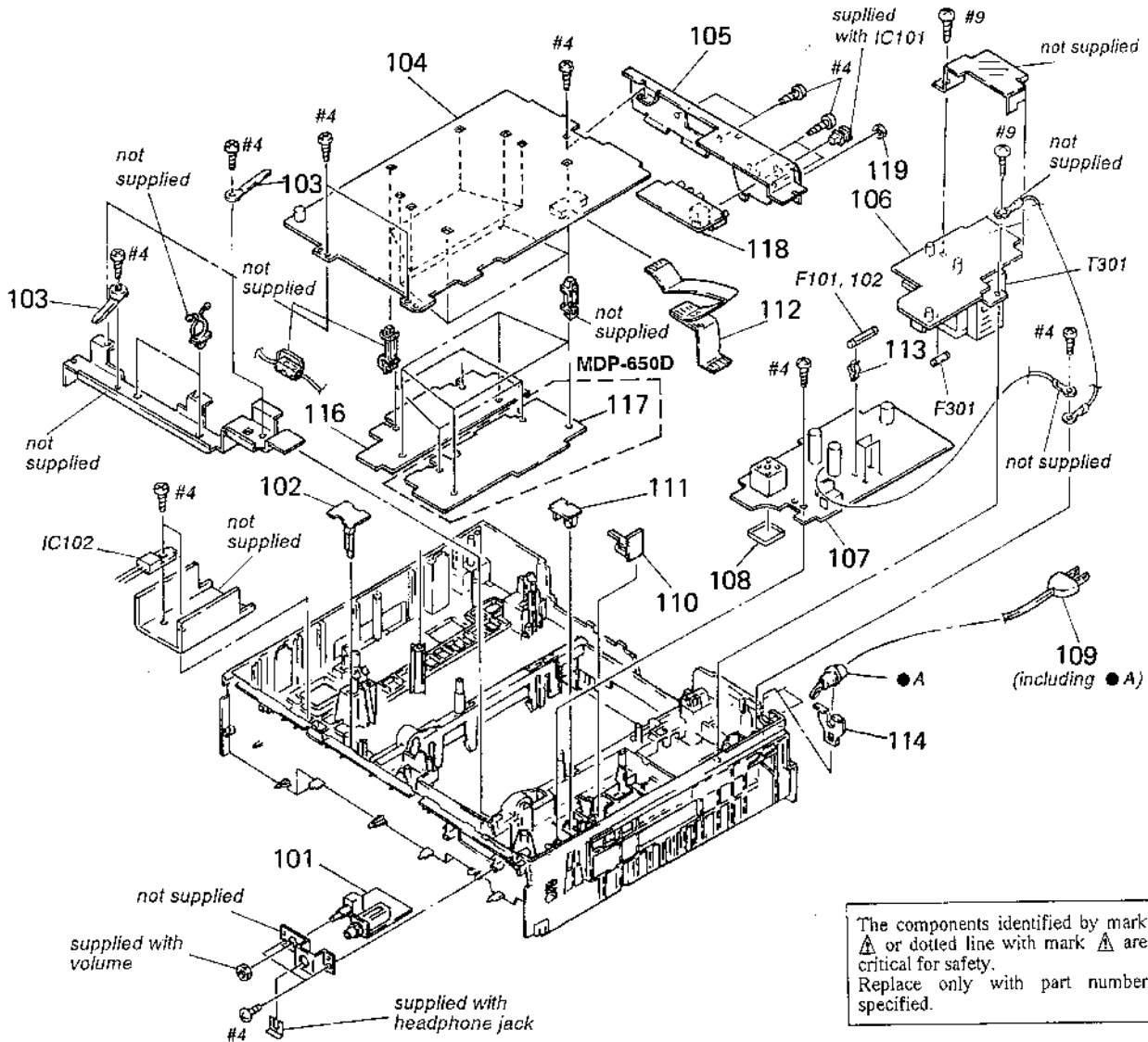

Ref.No.	Part No.	Description	Remark
* 101	A-6426-540-A	HP-702 BOARD, COMPLETE (450)	
* 101	A-6426-545-A	HP-702 BOARD, COMPLETE (650D)	
* 102	A-6421-865-A	SW-706 BOARD, COMPLETE (650D)	
* 102	A-6421-876-A	SW-706 BOARD, COMPLETE (450)	
103	3 703-150-11	STOPPER, WIRING	
* 104	A-6421-867-A	MP-701 BOARD, COMPLETE (450)	
* 104	A-6421-877-A	MP-701 BOARD, COMPLETE (650D)	
* 105	3-949-813-01	PLATE, JACK	
* 106	A-6426-542-A	TR-702 BOARD, COMPLETE (450)	
* 106	A-6426-544-A	TR-702 BOARD, COMPLETE (650D: AEP)	
* 106	A-6426-551-A	TR-702 BOARD, COMPLETE (650D: UK, Australian)	
* 107	A-6421-863-A	PS-701 BOARD, COMPLETE (650D: AEP)	
* 107	A-6421-886-A	PS-701 BOARD, COMPLETE (650D: UK, Australian)	
* 107	A-6421-874-A	PS-701 BOARD, COMPLETE (450)	
* 108	X 3940-915-1	SHIELD ASSY (2), PS LID	
⚠109	1-575-912-21	CORD, POWER (AEP)	
⚠109	1-696-690-11	CORD, POWER (Australian)	
⚠109	1-696-695-11	CORD, POWER (UK)	

Ref.No.	Part No.	Description	Remark
* 110	A-6421-866-A	SW-707 BOARD, COMPLETE (650D)	
* 110	A-6421-873-A	SW-707 BOARD, COMPLETE (450)	
* 111	A 6421-864-A	LS-702 BOARD, COMPLETE (650D)	
* 111	A 6421-875-A	LS-702 BOARD, COMPLETE (450)	
* 112	1-575-813-11	CABLE, FLAT (FLEXIBLE) (28 CORE)	
⚠113	1-533-189-11	HOLDER, FUSE	
* 114	3-737-438-01	BRACKET, AC CORD	
* 116	A 6421-868-A	AF-702 BOARD, COMPLETE (450)	
* 116	A-6421 878 A	AF-702 BOARD, COMPLETE (650D)	
* 117	A-6421-879-A	RG-701 BOARD, COMPLETE (650D)	
* 118	A-6421-872-A	JC-703 BOARD, COMPLETE (450)	
* 118	A-6421-880-A	JC-703 BOARD, COMPLETE (650D)	
119	3-724-182-01	NUT (SMALL JACK), M6	
⚠F101	1-532-237-00	FUSE, TIME-LAG (BET) (3.15A 250V)	
⚠F102	1-532-237-00	FUSE, TIME-LAG (BET) (3.15A 250V)	
⚠F301	1-532-284-00	FUSE, TIME-LAG (0.63A 250V)	
IC102	8-750-245-79	IC M5F7905	
⚠T301	1-423-319-11	TRANSFORMER, POWER	



## 5-4. MD CHASSIS

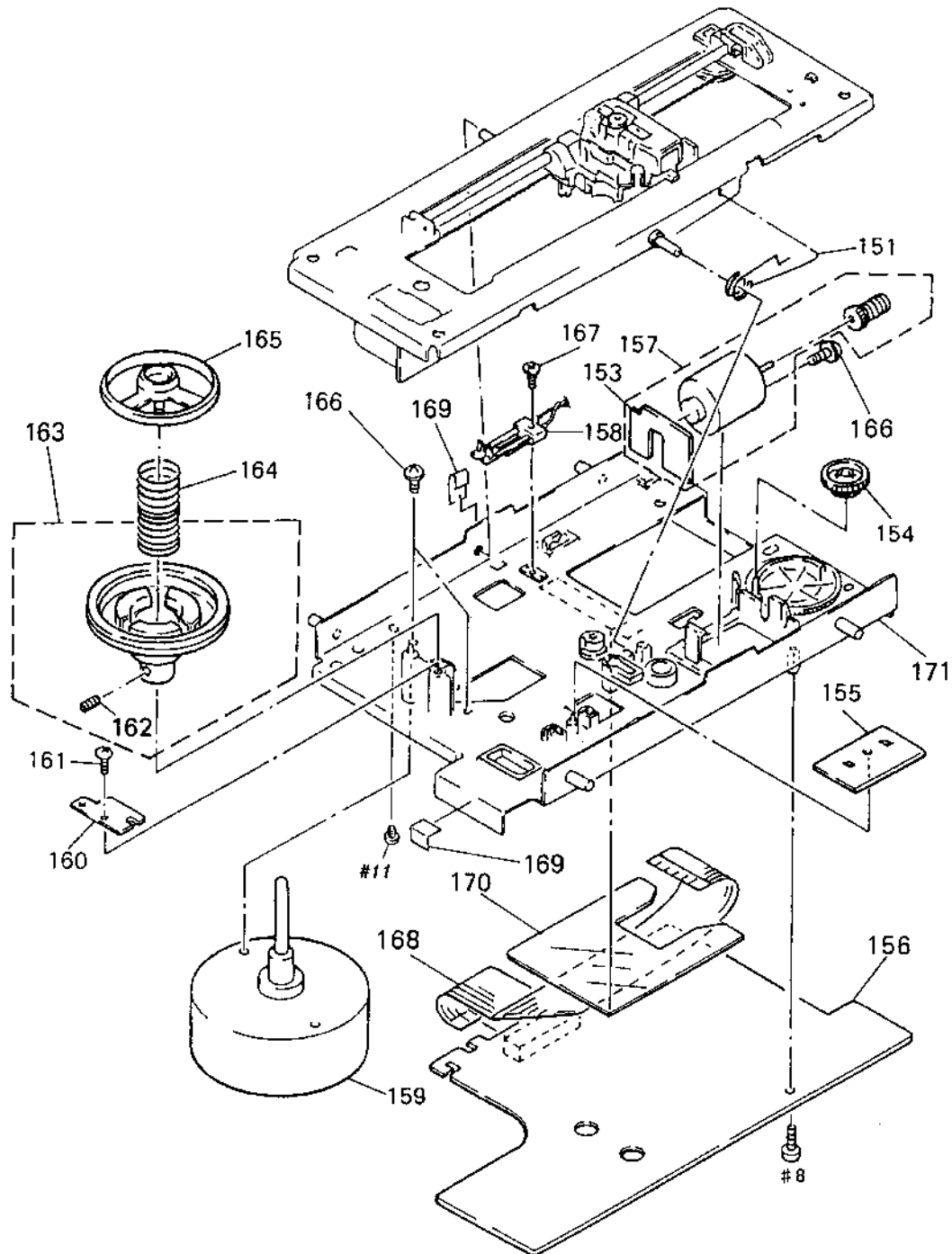

Ref. No.	Part No.	Description	Remark	Ref. No.	Part No.	Description	Remark
151	3-735-021-01	SPRING, TORSION		162	3-701-506-01	SET SCREW, DOUBLE POINT 3X4	
* 153	1-631-095-11	MT-30 BOARD		163	X-3735-003-1	TURNTABLE ASSY	
154	3-735-025-01	GEAR, SKEW		* 164	3-735-026-01	SPRING, COMPRESSION	
* 155	1-635-255-11	CK-44 BOARD		165	X-2625-077-1	GUIDE ASSY, CENTER	
156	A-6421-465-A	SV-63 BOARD, COMPLETE		166	4-606-833-01	SCREW (3X5), + PSW	
157	A-6415-290-A	MOTOR BLOCK ASSY, SKEW (M903)		167	3-899-248-01	SCREW (M3X6)	
158	1-554-468-00	SWITCH, LEAF (SLED IN LIMIT LD/CD) (S903)		168	1-574-648-11	CABLE, FLEXIBLE FLAT (24 CORE)	
159	1-541-776-21	MOTOR, LD SPINDLE (M901)		* 169	3-737-413-01	SHEET, TEFLON	
* 160	1-635-256-11	FG-41 BOARD		* 170	3-735-099-01	SHEET, FLEXIBLE RETAINER	
161	3-719-845-11	SCREW (B2X8), TAPPING		* 171	3-735-068-15	CHASSIS, MD	

### 5-5. OPTICAL BLOCK

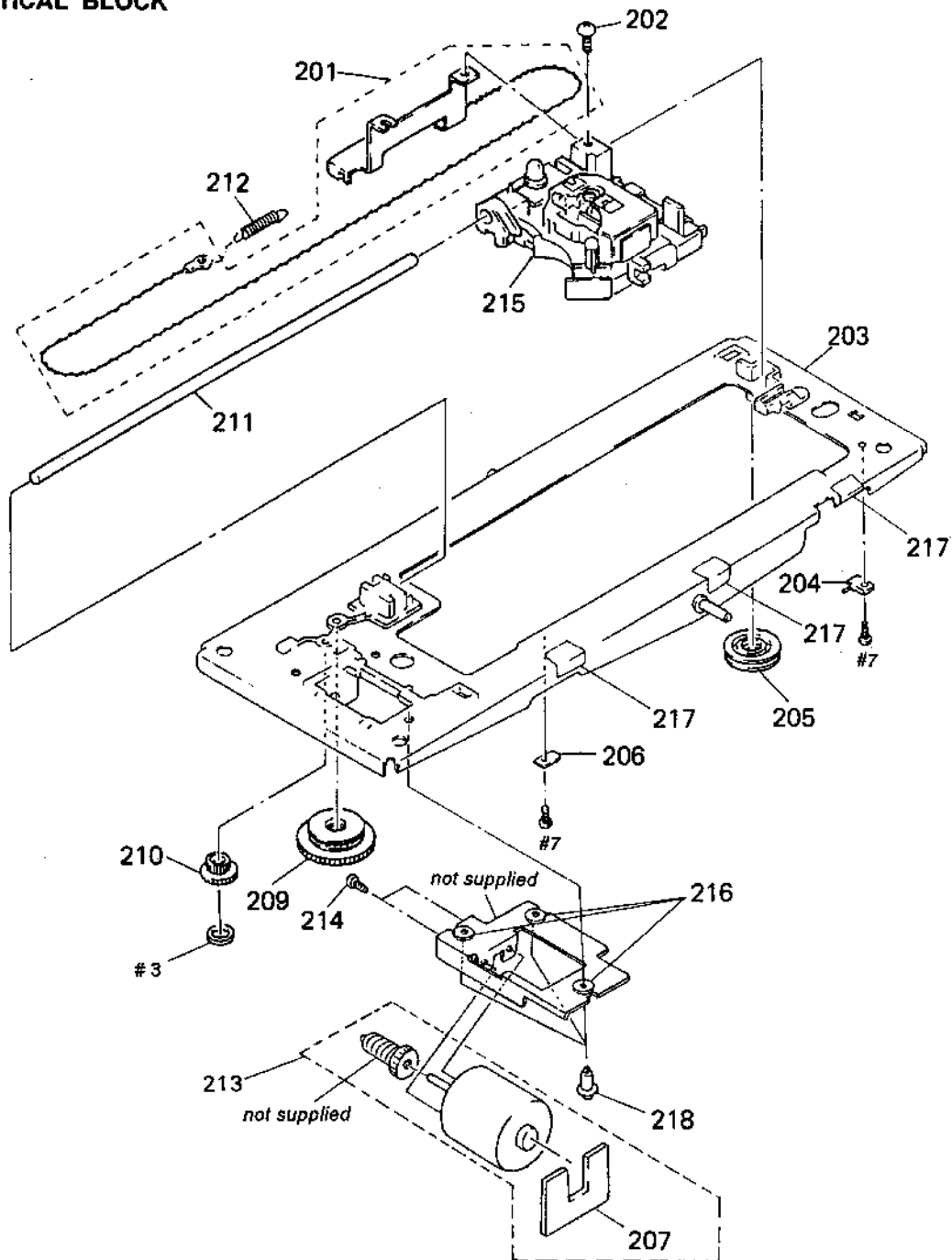

Ref. No.	Part No.	Description	Remark	Ref. No.	Part No.	Description	Remark
201	X-3735-001-1	WIRE ASSY		* 211	3-735-020-01	SHAFT, CARRIAGE	
202	3-899-248-01	SCREW (M3X6)		212	3-672-430-00	SPRING, TENSION	
* 203	X-3940-657-1	CHASSIS ASSY		213	A-6415-434-A	MOTOR BLOCK ASSY, SLED (M902)	
204	1-570-771-21	SWITCH (SLED OUT LIMIT) (S802)		214	3-949-324-01	SCREW (3X4), +PSW	
205	3-735-017-01	PULLEY, RETURN		△215	8-848-138-11	DEVICE, OPTICAL KHS-130A	
206	1-571-435-11	SWITCH (SLED IN LIMIT) (S901)		216	3-570-118-00	CUSHION, MOTOR	
* 207	1-630-097-11	MT-28 BOARD		217	3-846-312-00	SPACER	
209	3-735-016-01	PULLEY, DRIVING		218	3-570-027-00	SCREW, MOTOR	
210	3-735-015-01	GEAR, CARRIAGE					

## SECTION 6 ELECTRICAL PARTS LIST

AF-701

**NOTE:**

- Due to standardization, replacements in the parts list may be different from the parts specified in the diagrams or the components used on the set.
- -XX and -X mean standardized parts, so they may have some difference from the original one.
- RESISTORS  
All resistors are in ohms.  
METAL: Metal-film resistor.  
METAL OXIDE: Metal oxide-film resistor.  
F: nonflammable

- Items marked "\*" are not stocked since they are seldom required for routine service. Some delay should be anticipated when ordering these items.
- SEMICONDUCTORS  
In each case, u:  $\mu$ . for example:  
uA.:  $\mu$ A. uPA.:  $\mu$ PA.  
uPB.:  $\mu$ PB. uPC.:  $\mu$ PC. uPD.:  $\mu$ PD.
- CAPACITORS  
uF:  $\mu$ F
- COILS  
uH:  $\mu$ H

The components identified by mark  $\Delta$  or dotted line with mark  $\Delta$  are critical for safety. Replace only with part number specified.

When indicating parts by reference number, please include the board.

Ref. No.	Part No.	Description	Remark
*	A-6421-878-A	AF-701 BOARD, COMPLETE (650D) *****	
		< CAPACITOR >	
C401	1-126-177-11	ELECT 100uF 20%	10V
C402	1-164-232-11	CERAMIC CHIP 0.01uF	50V
C403	1-163-126-00	CERAMIC CHIP 240PF 5%	50V
C404	1-163-126-00	CERAMIC CHIP 240PF 5%	50V
C405	1-163-101-00	CERAMIC CHIP 22PF 5%	50V
C406	1-163-099-00	CERAMIC CHIP 18PF 5%	50V
C407	1-163-111-00	CERAMIC CHIP 56PF 5%	50V
C408	1-163-099-00	CERAMIC CHIP 18PF 5%	50V
C409	1-163-101-00	CERAMIC CHIP 22PF 5%	50V
C410	1-164-232-11	CERAMIC CHIP 0.01uF	50V
C411	1-164-232-11	CERAMIC CHIP 0.01uF	50V
C412	1-124-589-11	ELECT 47uF 20%	16V
C413	1-164-232-11	CERAMIC CHIP 0.01uF	50V
C414	1-124-589-11	ELECT 47uF 20%	16V
C415	1-163-809-11	CERAMIC CHIP 0.047uF 10%	25V
C416	1-163-809-11	CERAMIC CHIP 0.047uF 10%	25V
C417	1-126-177-11	ELECT 100uF 20%	10V
C418	1-164-232-11	CERAMIC CHIP 0.01uF	50V
C419	1-163-121-00	CERAMIC CHIP 150PF 5%	50V
C420	1-163-129-00	CERAMIC CHIP 330PF 5%	50V
C421	1-163-121-00	CERAMIC CHIP 150PF 5%	50V
C422	1-164-232-11	CERAMIC CHIP 0.01uF	50V
C423	1-164-232-11	CERAMIC CHIP 0.01uF	50V
C424	1-124-126-00	ELECT 47uF 20%	10V
C425	1-164-232-11	CERAMIC CHIP 0.01uF	50V
C426	1-124-126-00	ELECT 47uF 20%	10V
C427	1-163-809-11	CERAMIC CHIP 0.047uF 10%	25V
C428	1-163-809-11	CERAMIC CHIP 0.047uF 10%	25V
C429	1-164-161-11	CERAMIC CHIP 0.0022uF 10%	100V
C715	1-163-809-11	CERAMIC CHIP 0.047uF 10%	25V
C716	1-163-141-00	CERAMIC CHIP 0.001uF 5%	50V
C717	1-124-443-00	ELECT 100uF 20%	10V
C719	1-124-443-00	ELECT 100uF 20%	10V
C721	1-163-111-00	CERAMIC CHIP 56PF 5%	50V
C722	1-163-145-00	CERAMIC CHIP 0.0015uF 5%	50V

Ref. No.	Part No.	Description	Remark
C723	1-163-009-11	CERAMIC CHIP 0.001uF 10%	50V
C724	1-163-019-00	CERAMIC CHIP 0.0068uF 10%	50V
C725	1-163-145-00	CERAMIC CHIP 0.0015uF 5%	50V
C726	1-124-598-11	ELECT 22uF 20%	25V
C727	1-124-584-00	ELECT 100uF 20%	10V
C728	1-163-017-00	CERAMIC CHIP 0.0047uF 5%	50V
C729	1-163-145-00	CERAMIC CHIP 0.0015uF 5%	50V
C730	1-163-121-00	CERAMIC CHIP 150PF 5%	50V
C731	1-163-125-00	CERAMIC CHIP 220PF 5%	50V
C732	1-163-020-00	CERAMIC CHIP 0.0082uF 10%	50V
C733	1-124-261-00	ELECT 10uF 20%	50V
C734	1-163-809-11	CERAMIC CHIP 0.047uF 10%	25V
C735	1-163-077-00	CERAMIC CHIP 0.1uF 10%	25V
C736	1-124-234-00	ELECT 22uF 20%	16V
C737	1-163-141-00	CERAMIC CHIP 0.001uF 5%	50V
C738	1-163-809-11	CERAMIC CHIP 0.047uF 10%	25V
C739	1-124-584-00	ELECT 100uF 20%	10V
C742	1-124-584-00	ELECT 100uF 20%	10V
C743	1-163-119-00	CERAMIC CHIP 120PF 5%	50V
C744	1-163-125-00	CERAMIC CHIP 220PF 5%	50V
C745	1-163-145-00	CERAMIC CHIP 0.0015uF 5%	50V
C746	1-163-145-00	CERAMIC CHIP 0.0015uF 5%	50V
C747	1-163-019-00	CERAMIC CHIP 0.0068uF 10%	50V
C748	1-124-234-00	ELECT 22uF 20%	16V
C749	1-163-017-00	CERAMIC CHIP 0.0047uF 5%	50V
C750	1-163-121-00	CERAMIC CHIP 150PF 5%	50V
C751	1-163-145-00	CERAMIC CHIP 0.0015uF 5%	50V
C752	1-163-125-00	CERAMIC CHIP 220PF 5%	50V
C753	1-163-020-00	CERAMIC CHIP 0.0082uF 10%	50V
C754	1-126-096-11	ELECT 10uF 20%	35V
C755	1-163-809-11	CERAMIC CHIP 0.047uF 10%	25V
C756	1-126-529-11	ELECT 0.47uF 20%	50V
C757	1-126-177-11	ELECT 100uF 20%	10V
C758	1-126-163-11	ELECT 4.7uF 20%	50V
C759	1-163-109-00	CERAMIC CHIP 47PF 5%	50V
C760	1-163-141-00	CERAMIC CHIP 0.001uF 5%	50V
C761	1-163-116-00	CERAMIC CHIP 91PF 5%	50V
C762	1-124-589-11	ELECT 47uF 20%	16V
C763	1-124-589-11	ELECT 47uF 20%	16V
C764	1-163-119-00	CERAMIC CHIP 120PF 5%	50V

# AF-701

Ref. No.	Part No.	Description	Remark		
C765	1-163-116-00	CERAMIC CHIP	91PF	5%	50V
C766	1-124-126-00	ELECT	47uF	20%	10V
< CONNECTOR >					
CN701	1-569-340-11	CONNECTOR, BOARD TO BOARD	11P		
< FILTER >					
FL401	1-235-925-11	FILTER, BAND PASS (2.3MHz)			
FL402	1-235-926-11	FILTER, BAND PASS (2.8MHz)			
FL403	1-236-573-11	BPF (PAL LCU)			
FL404	1-236-574-11	BPF (PAL LCU)			
< IC >					
IC401	8-759-941-68	IC BA7131F			
IC402	8-759-941-68	IC BA7131F			
IC701	8-759-322-23	IC HA12127ANT			
< JUMPER RESISTOR >					
JR701	1-216-295-00	METAL CHIP	0	5%	1/10W
JR702	1-216-295-00	METAL CHIP	0	5%	1/10W
JR703	1-216-295-00	METAL CHIP	0	5%	1/10W
JR704	1-216-295-00	METAL CHIP	0	5%	1/10W
JR705	1-216-295-00	METAL CHIP	0	5%	1/10W
JR706	1-216-295-00	METAL CHIP	0	5%	1/10W
JR707	1-216-295-00	METAL CHIP	0	5%	1/10W
JR708	1-216-295-00	METAL CHIP	0	5%	1/10W
JR709	1-216-295-00	METAL CHIP	0	5%	1/10W
JR710	1-216-295-00	METAL CHIP	0	5%	1/10W
JR711	1-216-295-00	METAL CHIP	0	5%	1/10W
JR712	1-216-296-00	METAL CHIP	0	5%	1/8W
JR713	1-216-295-00	METAL CHIP	0	5%	1/10W
JR714	1-216-295-00	METAL CHIP	0	5%	1/10W
JR715	1-216-296-00	METAL CHIP	0	5%	1/8W
JR716	1-216-296-00	METAL CHIP	0	5%	1/8W
JR717	1-216-296-00	METAL CHIP	0	5%	1/8W
JR718	1-216-295-00	METAL CHIP	0	5%	1/10W
JR719	1-216-296-00	METAL CHIP	0	5%	1/8W
JR720	1-216-295-00	METAL CHIP	0	5%	1/10W
JR721	1-216-295-00	METAL CHIP	0	5%	1/10W
JR722	1-216-295-00	METAL CHIP	0	5%	1/10W
JR723	1-216-295-00	METAL CHIP	0	5%	1/10W
JR724	1-216-295-00	METAL CHIP	0	5%	1/10W
< COIL >					
L401	1-410-521-11	INDUCTOR	100uH		
L402	1-410-336-11	INDUCTOR	220uH		
L403	1-408-417-00	INDUCTOR	47uH		
L404	1-408-417-00	INDUCTOR	47uH		
L405	1-410-520-11	INDUCTOR	82uH		

Ref. No.	Part No.	Description	Remark		
L406	1-410-520-11	INDUCTOR	82uH		
L705	1-408-420-00	INDUCTOR	82uH		
L706	1-408-420-00	INDUCTOR	82uH		
L707	1-410-069-11	INDUCTOR	6.8mH		
L708	1-410-069-11	INDUCTOR	6.8mH		
< TRANSISTOR >					
Q401	8-729-120-28	TRANSISTOR	2SC1623	L5L6	
Q402	8-729-120-28	TRANSISTOR	2SC1623	L5L6	
Q403	8-729-120-28	TRANSISTOR	2SC1623	L5L6	
Q404	8-729-120-28	TRANSISTOR	2SC1623	L5L6	
Q405	8-729-120-28	TRANSISTOR	2SC1623	L5L6	
Q406	8-729-120-28	TRANSISTOR	2SC1623	L5L6	
Q407	8-729-120-28	TRANSISTOR	2SC1623	L5L6	
Q408	8-729-120-28	TRANSISTOR	2SC1623	L5L6	
Q409	8-729-120-28	TRANSISTOR	2SC1623	L5L6	
Q410	8-729-120-28	TRANSISTOR	2SC1623	L5L6	
Q411	8-729-120-28	TRANSISTOR	2SC1623	L5L6	
Q412	8-729-120-28	TRANSISTOR	2SC1623	L5L6	
Q701	8-729-220-93	TRANSISTOR	2SK209-G		
Q702	8-729-220-93	TRANSISTOR	2SK209-G		
Q703	8-729-901-01	TRANSISTOR	DTC144EK		
Q704	8-729-901-06	TRANSISTOR	DTA144EK		
Q705	8-729-220-93	TRANSISTOR	2SK209-G		
Q706	8-729-220-93	TRANSISTOR	2SK209-G		
< RESISTOR >					
R401	1-216-073-00	METAL CHIP	10K	5%	1/10W
R402	1-216-053-00	METAL CHIP	1.5K	5%	1/10W
R403	1-216-053-00	METAL CHIP	1.5K	5%	1/10W
R404	1-216-033-00	METAL CHIP	220	5%	1/10W
R405	1-216-048-00	METAL CHIP	910	5%	1/10W
R406	1-216-081-00	METAL CHIP	22K	5%	1/10W
R407	1-216-081-00	METAL CHIP	22K	5%	1/10W
R408	1-216-049-00	METAL CHIP	1K	5%	1/10W
R409	1-216-049-00	METAL CHIP	1K	5%	1/10W
R410	1-216-049-00	METAL CHIP	1K	5%	1/10W
R411	1-216-049-00	METAL CHIP	1K	5%	1/10W
R412	1-216-067-00	METAL CHIP	5.6K	5%	1/10W
R413	1-216-075-00	METAL CHIP	12K	5%	1/10W
R414	1-216-059-00	METAL CHIP	2.7K	5%	1/10W
R415	1-216-049-00	METAL CHIP	1K	5%	1/10W
R416	1-216-049-00	METAL CHIP	1K	5%	1/10W
R417	1-216-049-00	METAL CHIP	1K	5%	1/10W
R418	1-216-067-00	METAL CHIP	5.6K	5%	1/10W
R419	1-216-075-00	METAL CHIP	12K	5%	1/10W
R420	1-216-059-00	METAL CHIP	2.7K	5%	1/10W
R421	1-216-073-00	METAL CHIP	10K	5%	1/10W
R422	1-216-053-00	METAL CHIP	1.5K	5%	1/10W

Ref. No.	Part No.	Description	Remark		
R423	1-216-053-00	METAL CHIP	1.5K	5%	1/10W
R424	1-216-033-00	METAL CHIP	220	5%	1/10W
R425	1-216-045-00	METAL CHIP	680	5%	1/10W
R426	1-216-081-00	METAL CHIP	22K	5%	1/10W
R427	1-216-081-00	METAL CHIP	22K	5%	1/10W
R428	1-216-049-00	METAL CHIP	1K	5%	1/10W
R429	1-216-049-00	METAL CHIP	1K	5%	1/10W
R430	1-216-049-00	METAL CHIP	1K	5%	1/10W
R431	1-216-049-00	METAL CHIP	1K	5%	1/10W
R432	1-216-067-00	METAL CHIP	5.6K	5%	1/10W
R433	1-216-075-00	METAL CHIP	12K	5%	1/10W
R434	1-216-059-00	METAL CHIP	2.7K	5%	1/10W
R435	1-216-049-00	METAL CHIP	1K	5%	1/10W
R436	1-216-049-00	METAL CHIP	1K	5%	1/10W
R437	1-216-049-00	METAL CHIP	1K	5%	1/10W
R438	1-216-067-00	METAL CHIP	5.6K	5%	1/10W
R439	1-216-075-00	METAL CHIP	12K	5%	1/10W
R440	1-216-059-00	METAL CHIP	2.7K	5%	1/10W
R719	1-216-049-00	METAL CHIP	1K	5%	1/10W
R721	1-216-063-00	METAL CHIP	3.9K	5%	1/10W
R724	1-216-065-00	METAL CHIP	4.7K	5%	1/10W
R725	1-216-051-00	METAL CHIP	1.2K	5%	1/10W
R726	1-216-053-00	METAL CHIP	1.5K	5%	1/10W
R727	1-216-065-00	METAL CHIP	4.7K	5%	1/10W
R728	1-216-097-00	METAL CHIP	100K	5%	1/10W
R730	1-216-075-00	METAL CHIP	12K	5%	1/10W
R731	1-216-073-00	METAL CHIP	10K	5%	1/10W
R732	1-216-689-11	METAL CHIP	39K	0.5%	1/10W
R733	1-216-069-00	METAL CHIP	6.8K	5%	1/10W
R734	1-216-101-00	METAL CHIP	150K	5%	1/10W
R735	1-216-101-00	METAL CHIP	150K	5%	1/10W
R736	1-216-096-00	METAL GLAZE	91K	5%	1/10W
R737	1-216-089-00	METAL CHIP	47K	5%	1/10W
R738	1-216-057-00	METAL CHIP	2.2K	5%	1/10W
R739	1-216-049-00	METAL CHIP	1K	5%	1/10W
R740	1-216-049-00	METAL CHIP	1K	5%	1/10W
R745	1-216-065-00	METAL CHIP	4.7K	5%	1/10W
R746	1-216-065-00	METAL CHIP	4.7K	5%	1/10W
R747	1-216-051-00	METAL CHIP	1.2K	5%	1/10W
R748	1-216-053-00	METAL CHIP	1.5K	5%	1/10W
R749	1-216-065-00	METAL CHIP	4.7K	5%	1/10W
R750	1-216-097-00	METAL CHIP	100K	5%	1/10W
R751	1-216-073-00	METAL CHIP	10K	5%	1/10W
R752	1-216-689-11	METAL CHIP	39K	0.5%	1/10W
R753	1-216-069-00	METAL CHIP	6.8K	5%	1/10W
R754	1-216-063-00	METAL CHIP	3.9K	5%	1/10W
R757	1-216-089-00	METAL CHIP	47K	5%	1/10W
R758	1-216-057-00	METAL CHIP	2.2K	5%	1/10W

Ref. No.	Part No.	Description	Remark		
R759	1-216-121-00	METAL CHIP	1M	5%	1/10W
R760	1-216-121-00	METAL CHIP	1M	5%	1/10W
R761	1-216-121-00	METAL CHIP	1M	5%	1/10W
R762	1-216-121-00	METAL CHIP	1M	5%	1/10W
R763	1-216-089-00	METAL CHIP	47K	5%	1/10W
R764	1-216-057-00	METAL CHIP	2.2K	5%	1/10W
R765	1-216-121-00	METAL CHIP	1M	5%	1/10W
R766	1-216-121-00	METAL CHIP	1M	5%	1/10W
R767	1-216-121-00	METAL CHIP	1M	5%	1/10W
R769	1-216-077-00	METAL CHIP	15K	5%	1/10W
R770	1-216-069-00	METAL CHIP	6.8K	5%	1/10W
R771	1-216-069-00	METAL CHIP	6.8K	5%	1/10W
R772	1-216-121-00	METAL CHIP	1M	5%	1/10W
R773	1-216-121-00	METAL CHIP	1M	5%	1/10W

&lt; VARIABLE RESISTOR &gt;

RV701	1-228-995-00	RES, ADJ, METAL 22K
RV702	1-228-995-00	RES, ADJ, METAL 22K
RV703	1-228-996-00	RES, ADJ, METAL 47K
RV704	1-228-996-00	RES, ADJ, METAL 47K

\*\*\*\*\*

\* A-6421-868-A AF-702 BOARD, COMPLETE (450)

\*\*\*\*\*

&lt; CAPACITOR &gt;

C401	1-126-177-11	ELECT	100uF	20%	10V
C417	1-126-177-11	ELECT	100uF	20%	10V
C418	1-164-232-11	CERAMIC CHIP	0.01uF		50V
C419	1-163-121-00	CERAMIC CHIP	150PF	5%	50V
C420	1-163-129-00	CERAMIC CHIP	330PF	5%	50V
C421	1-163-121-00	CERAMIC CHIP	150PF	5%	50V
C422	1-164-232-11	CERAMIC CHIP	0.01uF		50V
C423	1-164-232-11	CERAMIC CHIP	0.01uF		50V
C424	1-124-589-11	ELECT	47uF	20%	16V
C425	1-164-232-11	CERAMIC CHIP	0.01uF		50V
C426	1-124-589-11	ELECT	47uF	20%	16V
C429	1-164-161-11	CERAMIC CHIP	0.0022uF	10%	100V
C451	1-163-038-00	CERAMIC CHIP	0.1uF		25V
C452	1-163-038-00	CERAMIC CHIP	0.1uF		25V
C453	1-163-035-00	CERAMIC CHIP	0.047uF		50V
C454	1-163-035-00	CERAMIC CHIP	0.047uF		50V
C455	1-163-031-11	CERAMIC CHIP	0.01uF		50V
C456	1-163-031-11	CERAMIC CHIP	0.01uF		50V
C457	1-164-232-11	CERAMIC CHIP	0.01uF		50V
C458	1-164-232-11	CERAMIC CHIP	0.01uF		50V
C459	1-163-031-11	CERAMIC CHIP	0.01uF		50V
C460	1-163-031-11	CERAMIC CHIP	0.01uF		50V
C461	1-124-589-11	ELECT	47uF	20%	16V
C462	1-124-589-11	ELECT	47uF	20%	16V

# AF-702

Ref. No.	Part No.	Description	Remark
C463	1-163-038-00	CERAMIC CHIP 0.1uF	25V
C464	1-163-038-00	CERAMIC CHIP 0.1uF	25V
C465	1-163-035-00	CERAMIC CHIP 0.047uF	50V
C466	1-163-035-00	CERAMIC CHIP 0.047uF	50V
C467	1-163-035-00	CERAMIC CHIP 0.047uF	50V
C468	1-163-035-00	CERAMIC CHIP 0.047uF	50V
C472	1-124-589-11	ELECT 47uF 20%	16V
C762	1-124-126-00	ELECT 47uF 20%	10V
C763	1-124-126-00	ELECT 47uF 20%	10V
C770	1-163-234-11	CERAMIC CHIP 20PF 5%	50V
C771	1-163-234-11	CERAMIC CHIP 20PF 5%	50V
< CONNECTOR >			
CN701	1-569-340-11	CONNECTOR, BOARD TO BOARD 11P	
< FILTER >			
FL403	1-236-573-11	BPF (PAL LCH)	
FL404	1-236-574-11	BPF (PAL LCH)	
FL405	1-402-734-11	COIL, DETECTOR (0.68MHz)	
FL406	1-402-735-11	COIL, DETECTOR (1.066MHz)	
< IC >			
IC410	8-759-981-92	IC RC4558M	
IC411	8-759-103-70	IC uPC1391HA	
IC412	8-759-103-70	IC uPC1391HA	
IC413	8-759-008-67	IC MC14066BF	
< JUMPER RESISTOR >			
JR401	1-216-295-00	METAL CHIP 0 5%	1/10W
JR402	1-216-295-00	METAL CHIP 0 5%	1/10W
< COIL >			
L405	1-410-520-11	INDUCTOR 82uH	
L406	1-410-520-11	INDUCTOR 82uH	
L705	1-408-420-00	INDUCTOR 82uH	
L706	1-408-420-00	INDUCTOR 82uH	
L707	1-408-420-00	INDUCTOR 82uH	
< TRANSISTOR >			
Q407	8-729-100-66	TRANSISTOR 2SC1623-L6	
Q408	8-729-100-66	TRANSISTOR 2SC1623-L6	
Q409	8-729-100-66	TRANSISTOR 2SC1623-L6	
Q410	8-729-100-66	TRANSISTOR 2SC1623-L6	
Q411	8-729-100-66	TRANSISTOR 2SC1623-L6	
Q412	8-729-100-66	TRANSISTOR 2SC1623-L6	
Q450	8-729-901-04	TRANSISTOR DTA114EK	
Q451	8-729-901-04	TRANSISTOR DTA114EK	
Q452	8-729-900-53	TRANSISTOR DTC114EK	
Q453	8-729-900-53	TRANSISTOR DTC114EK	

Ref. No.	Part No.	Description	Remark
Q454	8-729-901-04	TRANSISTOR DTA114EK	
Q460	8-729-901-04	TRANSISTOR DTA114EK	
Q461	8-729-900-53	TRANSISTOR DTC114EK	
Q462	8-729-900-53	TRANSISTOR DTC114EK	
Q463	8-729-202-38	TRANSISTOR 2SC3326N-A	
Q464	8-729-202-38	TRANSISTOR 2SC3326N-A	
< RESISTOR >			
R421	1-216-073-00	METAL CHIP 10K 5%	1/10W
R422	1-216-053-00	METAL CHIP 1.5K 5%	1/10W
R423	1-216-053-00	METAL CHIP 1.5K 5%	1/10W
R424	1-216-033-00	METAL CHIP 220 5%	1/10W
R425	1-216-045-00	METAL CHIP 680 5%	1/10W
R426	1-216-081-00	METAL CHIP 22K 5%	1/10W
R427	1-216-081-00	METAL CHIP 22K 5%	1/10W
R428	1-216-049-00	METAL CHIP 1K 5%	1/10W
R429	1-216-049-00	METAL CHIP 1K 5%	1/10W
R430	1-216-049-00	METAL CHIP 1K 5%	1/10W
R431	1-216-049-00	METAL CHIP 1K 5%	1/10W
R432	1-216-067-00	METAL CHIP 5.6K 5%	1/10W
R433	1-216-075-00	METAL CHIP 12K 5%	1/10W
R434	1-216-059-00	METAL CHIP 2.7K 5%	1/10W
R435	1-216-049-00	METAL CHIP 1K 5%	1/10W
R436	1-216-049-00	METAL CHIP 1K 5%	1/10W
R437	1-216-049-00	METAL CHIP 1K 5%	1/10W
R438	1-216-067-00	METAL CHIP 5.6K 5%	1/10W
R439	1-216-075-00	METAL CHIP 12K 5%	1/10W
R440	1-216-059-00	METAL CHIP 2.7K 5%	1/10W
R450	1-216-037-00	METAL CHIP 330 5%	1/10W
R451	1-216-037-00	METAL CHIP 330 5%	1/10W
R452	1-216-039-00	METAL CHIP 390 5%	1/10W
R453	1-216-039-00	METAL CHIP 390 5%	1/10W
R456	1-216-097-00	METAL CHIP 100K 5%	1/10W
R457	1-216-097-00	METAL CHIP 100K 5%	1/10W
R458	1-216-035-00	METAL CHIP 270 5%	1/10W
R459	1-216-035-00	METAL CHIP 270 5%	1/10W
R460	1-216-113-00	METAL CHIP 470K 5%	1/10W
R461	1-216-113-00	METAL CHIP 470K 5%	1/10W
R462	1-216-109-00	METAL CHIP 330K 5%	1/10W
R463	1-216-109-00	METAL CHIP 330K 5%	1/10W
R464	1-216-055-00	METAL CHIP 1.8K 5%	1/10W
R465	1-216-055-00	METAL CHIP 1.8K 5%	1/10W
R468	1-216-073-00	METAL CHIP 10K 5%	1/10W
R469	1-216-073-00	METAL CHIP 10K 5%	1/10W
R470	1-216-073-00	METAL CHIP 10K 5%	1/10W
R471	1-216-073-00	METAL CHIP 10K 5%	1/10W
R472	1-216-097-00	METAL CHIP 100K 5%	1/10W
R473	1-216-097-00	METAL CHIP 100K 5%	1/10W

AF-702

CK-44

FG-41

FP-703

Ref. No.	Part No.	Description	Remark		
R474	1-216-073-00	METAL CHIP	10K	5%	1/10W
R480	1-216-049-00	METAL CHIP	1K	5%	1/10W
R481	1-216-049-00	METAL CHIP	1K	5%	1/10W
R490	1-216-073-00	METAL CHIP	10K	5%	1/10W
R491	1-216-073-00	METAL CHIP	10K	5%	1/10W
R492	1-216-049-00	METAL CHIP	1K	5%	1/10W
R493	1-216-049-00	METAL CHIP	1K	5%	1/10W

< VARIABLE RESISTOR >

RV401	1-241-631-11	RES, ADJ, CARBON 22K			
RV402	1 241-631-11	RES, ADJ, CARBON 22K			

\* 1-635-256-11 CK-44 BOARD  
\*\*\*\*\*

< CAPACITOR >

C401	1-163-038-00	CERAMIC CHIP	0.1uF		25V
C402	1-163-038-00	CERAMIC CHIP	0.1uF		25V

< CONNECTOR >

CN401	1-506-467-11	PIN, CONNECTOR	2P		
CN402	1-506-468-11	PIN, CONNECTOR	3P		
CN403	1-506-467-11	PIN, CONNECTOR	2P		
CN404	1-506-467-11	PIN, CONNECTOR	2P		
CN405	1-506-467-11	PIN, CONNECTOR	2P		

< JUMPER RESISTOR >

JR401	1-216-295-00	METAL CHIP	0	5%	1/10W
JR402	1-216-296-00	METAL CHIP	0	5%	1/8W

< RESISTOR >

R401	1-216-077-00	METAL CHIP	15K	5%	1/10W
R402	1-216-031-00	METAL CHIP	180	5%	1/10W
R403	1-216-061-00	METAL CHIP	3.3K	5%	1/10W
R404	1-216-001-00	METAL CHIP	10	5%	1/10W
R405	1-216-001-00	METAL CHIP	10	5%	1/10W
R406	1-216-031-00	METAL CHIP	180	5%	1/10W
R407	1-216-061-00	METAL CHIP	3.3K	5%	1/10W

\* 1-635-256-11 FG-41 BOARD  
\*\*\*\*\*

< DIODE >

D301	8-719-939-11	DIODE GP-2S09-B			
------	--------------	-----------------	--	--	--

Ref. No.	Part No.	Description	Remark		
*	A-6421-862-A	FP-703 BOARD, COMPLETE (650D)	*****		
*	A-6421-871-A	FP-703 BOARD, COMPLETE (450)	*****		
*	3-947-249-01	HOLDER, FL			
*	3-949-760-01	SPACER (2), LCD			

< CAPACITOR >

C002	1-164-232-11	CERAMIC CHIP	0.01uF		50V
C003	1-164-232-11	CERAMIC CHIP	0.01uF		50V
C004	1-126-157-11	ELECT	10uF	20%	16V
C005	1-164-232-11	CERAMIC CHIP	0.01uF		50V
C006	1-126-157-11	ELECT	10uF	20%	16V
C007	1-164-232-11	CERAMIC CHIP	0.01uF		50V

< CONNECTOR >

CN001	1-506-487-11	PIN, CONNECTOR	8P		
CN002	1-506-477-11	PIN, CONNECTOR	12P		
CN003	1-569-336-11	CONNECTOR, BOARD TO BOARD	7P		
CN004	1-506-483-21	PIN, CONNECTOR	4P		

< DIODE >

D001	8-719-400-18	DIODE MA152WK			
D002	8-719-946-30	LED SLR34DC3 (SOFT)			
D003	8-719-946-30	LED SLR34DC3 (STANDARD)			
D004	8-719-946-30	LED SLR34DC3 (SHARP)			
D005	8-719-946-30	LED SLR34DC3 (RGB) (650D)			
D006	8-719-946-30	LED SLR34DC3 (PAL) (650D)			
D007	8-719-940-82	LED SLR34MC3 (NTSC) (650D)			

< IC >

IC001	8-752-836-08	IC CXP50116-417Q			
IC002	8-759-074-40	IC PST572DMT-T1			

< JUMPER RESISTOR >

JR002	1-216-295-00	METAL CHIP	0	5%	1/10W
JR004	1-216-296-00	METAL CHIP	0	5%	1/8W
JR005	1-216-296-00	METAL CHIP	0	5%	1/8W
JR006	1-216-296-00	METAL CHIP	0	5%	1/8W
JR007	1-216-295-00	METAL CHIP	0	5%	1/10W
JR008	1-216-296-00	METAL CHIP	0	5%	1/8W
JR009	1-216-296-00	METAL CHIP	0	5%	1/8W
JR010	1-216-296-00	METAL CHIP	0	5%	1/8W
JR011	1-216-296-00	METAL CHIP	0	5%	1/8W
JR012	1-216-296-00	METAL CHIP	0	5%	1/8W
JR013	1-216-296-00	METAL CHIP	0	5%	1/8W
JR014	1-216-296-00	METAL CHIP	0	5%	1/8W
JR015	1-216-296-00	METAL CHIP	0	5%	1/8W

**FP-703**

Ref. No.	Part No.	Description	Remark		
JR016	1-216-295-00	METAL CHIP	0	5%	1/10W
JR017	1-216-296-00	METAL CHIP	0	5%	1/8W
JR018	1-216-296-00	METAL CHIP	0	5%	1/8W
JR019	1-216-296-00	METAL CHIP	0	5%	1/8W
JR020	1-216-296-00	METAL CHIP	0	5%	1/8W
JR021	1-216-296-00	METAL CHIP	0	5%	1/8W
JR022	1-216-296-00	METAL CHIP	0	5%	1/8W
JR023	1-216-296-00	METAL CHIP	0	5%	1/8W
JR024	1-216-296-00	METAL CHIP	0	5%	1/8W
JR025	1-216-296-00	METAL CHIP	0	5%	1/8W
JR026	1-216-296-00	METAL CHIP	0	5%	1/8W
JR027	1-216-296-00	METAL CHIP	0	5%	1/8W
JR028	1-216-296-00	METAL CHIP	0	5%	1/8W
JR029	1-216-295-00	METAL CHIP	0	5%	1/10W
JR030	1-216-295-00	METAL CHIP	0	5%	1/10W
JR031	1-216-296-00	METAL CHIP	0	5%	1/8W
JR032	1-216-295-00	METAL CHIP	0	5%	1/10W
JR033	1-216-296-00	METAL CHIP	0	5%	1/8W
JR034	1-216-296-00	METAL CHIP	0	5%	1/8W
JR035	1-216-295-00	METAL CHIP	0	5%	1/10W
JR036	1-216-296-00	METAL CHIP	0	5%	1/8W
JR037	1-216-295-00	METAL CHIP	0	5%	1/10W
JR038	1-216-296-00	METAL CHIP	0	5%	1/8W
JR039	1-216-296-00	METAL CHIP	0	5%	1/8W
JR040	1-216-295-00	METAL CHIP	0	5%	1/10W
JR041	1-216-296-00	METAL CHIP	0	5%	1/8W
JR050	1-216-295-00	METAL CHIP	0	5%	1/10W
< COIL >					
L001	1-410-521-11	INDUCTOR 100uH			
< FLUORESCENT INDICATOR >					
ND001	1-519-652-11	INDICATOR TUBE, FLUORESCENT			
< TRANSISTOR >					
Q001	8-729-901-01	TRANSISTOR DTC144EK			
Q002	8-729-901-01	TRANSISTOR DTC144EK			
Q003	8-729-901-04	TRANSISTOR DTA114EK			
Q004	8-729-901-04	TRANSISTOR DTA114EK			
Q005	8-729-901-04	TRANSISTOR DTA114EK			
Q006	8-729-901-04	TRANSISTOR DTA114EK (650D)			
Q007	8-729-901-04	TRANSISTOR DTA114EK (650D)			
Q008	8-729-901-04	TRANSISTOR DTA114EK (650D)			
Q010	8-729-901-06	TRANSISTOR DTA144EK			
Q011	8-729-900-51	TRANSISTOR DTA114TK (650D)			
< RESISTOR >					
R001	1-216-121-00	METAL CHIP	1M	5%	1/10W

Ref. No.	Part No.	Description	Remark		
R002	1-216-222-00	METAL GLAZE	10K	5%	1/8W
R003	1-216-222-00	METAL GLAZE	10K	5%	1/8W
R004	1-216-222-00	METAL GLAZE	10K	5%	1/8W
R005	1-216-073-00	METAL CHIP	10K	5%	1/10W
R006	1-216-073-00	METAL CHIP	10K	5%	1/10W
R007	1-216-079-00	METAL CHIP	18K	5%	1/10W
R008	1-216-069-00	METAL CHIP	6.8K	5%	1/10W
R009	1-216-063-00	METAL CHIP	3.9K	5%	1/10W
R010	1-216-059-00	METAL CHIP	2.7K	5%	1/10W
R011	1-216-073-00	METAL CHIP	10K	5%	1/10W
R012	1-216-073-00	METAL CHIP	10K	5%	1/10W
R013	1-216-073-00	METAL CHIP	10K	5%	1/10W
R014	1-216-079-00	METAL CHIP	18K	5%	1/10W
R015	1-216-069-00	METAL CHIP	6.8K	5%	1/10W
R016	1-216-063-00	METAL CHIP	3.9K	5%	1/10W
R017	1-216-059-00	METAL CHIP	2.7K	5%	1/10W
R018	1-216-059-00	METAL CHIP	2.7K	5%	1/10W
R019	1-216-063-00	METAL CHIP	3.9K	5%	1/10W
R020	1-216-069-00	METAL CHIP	6.8K	5%	1/10W
R021	1-216-079-00	METAL CHIP	18K	5%	1/10W
R022	1-216-069-00	METAL CHIP	6.8K	5%	1/10W
R023	1-216-063-00	METAL CHIP	3.9K	5%	1/10W
R024	1-216-059-00	METAL CHIP	2.7K	5%	1/10W
R025	1-216-073-00	METAL CHIP	10K	5%	1/10W
R026	1-216-057-00	METAL CHIP	2.2K	5%	1/10W
R027	1-216-049-00	METAL CHIP	1K	5%	1/10W
R028	1-216-073-00	METAL CHIP	10K	5%	1/10W
R029	1-216-222-00	METAL GLAZE	10K	5%	1/8W
R030	1-216-059-00	METAL CHIP	2.7K	5%	1/10W
R031	1-216-063-00	METAL CHIP	3.9K	5%	1/10W
R032	1-216-073-00	METAL CHIP	10K	5%	1/10W
R033	1-216-073-00	METAL CHIP	10K	5%	1/10W
R034	1-216-079-00	METAL CHIP	18K	5%	1/10W
R035	1-216-069-00	METAL CHIP	6.8K	5%	1/10W
R036	1-216-063-00	METAL CHIP	3.9K	5%	1/10W
R037	1-216-059-00	METAL CHIP	2.7K	5%	1/10W
R038	1-216-073-00	METAL CHIP	10K	5%	1/10W
R039	1-216-073-00	METAL CHIP	10K	5%	1/10W
R040	1-216-059-00	METAL CHIP	2.7K	5%	1/10W
R041	1-216-033-00	METAL CHIP	220	5%	1/10W
R042	1-216-033-00	METAL CHIP	220	5%	1/10W
R043	1-216-033-00	METAL CHIP	220	5%	1/10W
R044	1-216-033-00	METAL CHIP	220	5%	1/10W (650D)
R045	1-216-025-00	METAL CHIP	100	5%	1/10W
R046	1-216-049-00	METAL CHIP	1K	5%	1/10W
R047	1-216-033-00	METAL CHIP	220	5%	1/10W (650D)
R048	1-216-033-00	METAL CHIP	220	5%	1/10W (650D)
R049	1-216-063-00	METAL CHIP	3.9K	5%	1/10W
R050	1-216-069-00	METAL CHIP	6.8K	5%	1/10W



**FP-703**

**HP-702**

**JC-703**

**JC-701**

Ref. No.	Part No.	Description	Remark
R051	1-216-079-00	METAL CHIP	18K 5% 1/10W
R052	1-216-073-00	METAL CHIP	10K 5% 1/10W
R053	1-216-025-00	METAL CHIP	100 5% 1/10W
< SWITCH >			
S001	1-572-946-11	SWITCH, TACTIL (RESET)	
S002	1-572-862-41	SWITCH, ROTARY (▶ / ■ /CLER SCAN)	
S003	1-572-946-11	SWITCH, TACTIL ( 1 )	
S004	1-572-946-11	SWITCH, TACTIL ( 2 )	
S005	1-572-946-11	SWITCH, TACTIL ( 3 )	
S006	1-572-946-11	SWITCH, TACTIL ( 4 )	
S007	1-572-946-11	SWITCH, TACTIL ( 5 )	
S008	1-572-946-11	SWITCH, TACTIL ( 6 )	
S009	1-572-946-11	SWITCH, TACTIL ( 7 )	
S010	1-572-946-11	SWITCH, TACTIL ( 8 )	
S011	1-572-946-11	SWITCH, TACTIL ( 9 )	
S012	1-572-946-11	SWITCH, TACTIL ( 0 )	
S013	1-572-946-11	SWITCH, TACTIL (OPEN/CLOSE)	
S014	1-572-946-11	SWITCH, TACTIL ( □ )	
S015	1-572-946-11	SWITCH, TACTIL (+10)	
S016	1-572-946-11	SWITCH, TACTIL (FILE)	
S017	1-572-946-11	SWITCH, TACTIL (CUSTOM INDEX)	
S018	1-572-946-11	SWITCH, TACTIL (FRAME TIME)	
S019	1-572-946-11	SWITCH, TACTIL (SEARCH)	
S020	1-572-946-11	SWITCH, TACTIL (ACS/AMS ◀ )	
S021	1-572-946-11	SWITCH, TACTIL (ACS/AMS ▶ )	
S022	1-572-946-11	SWITCH, TACTIL (PICTURE ENHANCE)	
S023	1-572-946-11	SWITCH, TACTIL (RGB) (650D)	
S024	1-572-946-11	SWITCH, TACTIL (AUTO PGM)	
S025	1-572-946-11	SWITCH, TACTIL (PGM)	
S026	1-572-946-11	SWITCH, TACTIL (AV TIME)	
S027	1-572-946-11	SWITCH, TACTIL (CLEAR)	
S028	1-572-946-11	SWITCH, TACTIL (NEXT)	
S029	1-572-946-11	SWITCH, TACTIL (BACK)	
S030	1-572-946-11	SWITCH, TACTIL (MEMORY)	
< VIBRATOR >			
X001	1-577-359-21	VIBRATOR, CERAMIC (4.19MHz)	

\*\*\*\*\*

Ref. No.	Part No.	Description	Remark
*	A-6426-540-A	HP-702 BOARD, COMPLETE (450)	
*****			
*	A-6426-545-A	HP-702 BOARD, COMPLETE (650D)	
*****			
< CAPACITOR >			
C801	1-163-033-00	CERAMIC CHIP	0.022uF 50V
< CONNECTOR >			
CN801	1-506-468-11	PIN, CONNECTOR	3P
< JACK >			
J801	1-507-796	71 JACK (HEAD PHONES)	
< JUMPER RESISTOR >			
JR801	1-216-295-00	METAL CHIP	0 5% 1/10W
< RESISTOR >			
R801	1-216-057-00	METAL CHIP	2.2K 5% 1/10W
R802	1-216-057-00	METAL CHIP	2.2K 5% 1/10W
R803	1-216-013-00	METAL CHIP	33 5% 1/10W
R804	1-216-013-00	METAL CHIP	33 5% 1/10W
< VARIABLE RESISTOR >			
RV801	1-241-139-11	RES, VAR, CARBON	500/500
*****			
*	A-6421-872-A	JC-703 BOARD, COMPLETE (450)	
*****			
*	A-6421-880-A	JC-701 BOARD, COMPLETE (650D)	
*****			
< CONNECTOR >			
CN101	1-569-340-11	CONNECTOR, BOARD TO BOARD	11P
CN102	1-506-468-11	PIN, CONNECTOR	3P
< IC >			
IC101	8-749-921-12	IC	6P1F32T
< JACK >			
J101	1-585-351-41	JACK, PIN	3P (LINE OUT)
J103	1-507-562-31	JACK (CONTROL S IN)	
< TRANSISTOR >			
Q101	8-729-202-38	TRANSISTOR	2SC3326N-A
Q102	8-729-202-38	TRANSISTOR	2SC3326N-A

JC-703

JC-701

LS-702

MP-701

Ref. No.	Part No.	Description	Remark
< RESISTOR >			
R107	1-216-049-00	METAL CHIP 1K 5% 1/10W	
R108	1-216-049-00	METAL CHIP 1K 5% 1/10W	
R109	1-216-627-11	METAL CHIP 100 0.5% 1/10W	
R110	1-216-627-11	METAL CHIP 100 0.5% 1/10W	
*****			
*	A-6421-864-A	LS-702 BOARD, COMPLETE (650D)	
*****			
*	A-6421-875-A	LS-702 BOARD, COMPLETE (450)	
*****			
	3-947-260-01	HOLDER, SENSOR	
< CONNECTOR >			
CN501	1-506-468-11	PIN, CONNECTOR 3P	
< DIODE >			
D501	8-719-941-81	DIODE GL360	
< TRANSISTOR >			
Q501	8-729-904-10	TRANSISTOR PT-360FS	
*****			
*	A-6421-867-A	MP-701 BOARD, COMPLETE (450)	
*****			
*	A-6421-877-A	MP-701 BOARD, COMPLETE (650D)	
*****			
< CAPACITOR >			
C101	1-163-105-00	CERAMIC CHIP 33PF 5% 50V	
C102	1-163-097-00	CERAMIC CHIP 15PF 5% 50V	
C103	1-163-113-00	CERAMIC CHIP 68PF 5% 50V	
C104	1-163-113-00	CERAMIC CHIP 68PF 5% 50V	
C105	1-163-103-00	CERAMIC CHIP 27PF 5% 50V	
C106	1-163-117-00	CERAMIC CHIP 100PF 5% 50V	
C107	1-124-261-00	ELECT 10uF 20% 50V	
C108	1-124-261-00	ELECT 10uF 20% 50V	
C109	1-163-103-00	CERAMIC CHIP 27PF 5% 50V	
C110	1-163-017-00	CERAMIC CHIP 0.0047uF 5% 50V (450)	
C110	1-163-022-00	CERAMIC CHIP 0.012uF 10% 50V (650D)	
C111	1-163-019-00	CERAMIC CHIP 0.0068uF 10% 50V	
C112	1-163-038-00	CERAMIC CHIP 0.1uF 25V	
C113	1-164-232-11	CERAMIC CHIP 0.01uF 50V	
C114	1-124-261-00	ELECT 10uF 20% 50V	
C115	1-163-095-00	CERAMIC CHIP 12PF 5% 50V	
C116	1-163-103-00	CERAMIC CHIP 27PF 5% 50V	
C117	1-163-103-00	CERAMIC CHIP 27PF 5% 50V	
C118	1-163-117-00	CERAMIC CHIP 100PF 5% 50V	
C119	1-163-115-00	CERAMIC CHIP 82PF 5% 50V	

Ref. No.	Part No.	Description	Remark
C120	1-130-495-00	MYLAR 0.1uF 5% 50V	
C121	1-164-232-11	CERAMIC CHIP 0.01uF 50V	
C122	1-130-483-00	MYLAR 0.01uF 5% 50V	
C123	1-163-101-00	CERAMIC CHIP 22PF 5% 50V	
C124	1-163-115-00	CERAMIC CHIP 82PF 5% 50V	
C125	1-163-105-00	CERAMIC CHIP 33PF 5% 50V	
C126	1-124-126-00	ELECT 47uF 20% 10V	
C127	1-124-477-11	ELECT 47uF 20% 25V	
C128	1-163-107-00	CERAMIC CHIP 39PF 5% 50V	
C129	1-124-589-11	ELECT 47uF 20% 16V	
C130	1-163-035-00	CERAMIC CHIP 0.047uF 50V	
C131	1-163-031-11	CERAMIC CHIP 0.01uF 50V	
C132	1-163-038-00	CERAMIC CHIP 0.1uF 25V	
C133	1-163-095-00	CERAMIC CHIP 12PF 5% 50V	
C134	1-163-095-00	CERAMIC CHIP 12PF 5% 50V	
C135	1-163-097-00	CERAMIC CHIP 15PF 5% 50V	
C136	1-164-182-11	CERAMIC CHIP 0.0033uF 10% 50V	
C137	1-130-489-00	MYLAR 0.033uF 5% 50V	
C138	1-163-035-00	CERAMIC CHIP 0.047uF 50V	
C139	1-124-589-11	ELECT 47uF 20% 16V	
C140	1-163-035-00	CERAMIC CHIP 0.047uF 50V	
C141	1-124-477-11	ELECT 47uF 20% 25V	
C142	1-124-903-11	ELECT 1uF 20% 50V	
C143	1-124-261-00	ELECT 10uF 20% 50V (650D)	
C144	1-163-035-00	CERAMIC CHIP 0.047uF 50V	
C145	1-124-903-11	ELECT 1uF 20% 50V	
C146	1-163-038-00	CERAMIC CHIP 0.1uF 25V	
C147	1-124-442-00	ELECT 330uF 20% 6.3V	
C148	1-126-177-11	ELECT 100uF 20% 10V	
C149	1-163-125-00	CERAMIC CHIP 220PF 5% 50V	
C150	1-163-113-00	CERAMIC CHIP 68PF 5% 50V	
C151	1-163-115-00	CERAMIC CHIP 82PF 5% 50V	
C152	1-163-129-00	CERAMIC CHIP 330PF 5% 50V	
C153	1-126-177-11	ELECT 100uF 20% 10V	
C154	1-126-301-11	ELECT 1uF 20% 50V	
C155	1-124-261-00	ELECT 10uF 20% 50V (650D)	
C156	1-163-123-00	CERAMIC CHIP 180PF 5% 50V (650D)	
C157	1-163-035-00	CERAMIC CHIP 0.047uF 50V	
C158	1-124-903-11	ELECT 1uF 20% 50V	
C159	1-163-123-00	CERAMIC CHIP 180PF 5% 50V	
C160	1-163-107-00	CERAMIC CHIP 39PF 5% 50V	
C161	1-163-035-00	CERAMIC CHIP 0.047uF 50V	
C162	1-163-101-00	CERAMIC CHIP 22PF 5% 50V	
C163	1-163-099-00	CERAMIC CHIP 18PF 5% 50V	
C164	1-108-808-11	MYLAR 0.022uF 5% 50V	
C165	1-130-483-00	MYLAR 0.01uF 5% 50V	
C166	1-163-035-00	CERAMIC CHIP 0.047uF 50V	
C167	1-131-347-00	TANTALUM 1uF 10% 35V	
C168	1-128-057-11	ELECT 330uF 20% 6.3V	

Ref. No.	Part No.	Description	Remark	Ref. No.	Part No.	Description	Remark
C169	1-130-491-00	MYLAR	0.047uF 5%	50V	C217	1-163-038-00	CERAMIC CHIP 0.1uF 25V(650D)
C170	1-126-301-11	ELECT	1uF 20%	50V	C218	1-124-126-00	ELECT 47uF 20% 10V
C171	1-130-489-00	MYLAR	0.033uF 5%	50V	C219	1-164-182-11	CERAMIC CHIP 0.0033uF 10% 50V
C172	1-163-031-11	CERAMIC CHIP	0.01uF	50V	C220	1-163-035-00	CERAMIC CHIP 0.047uF 50V
C173	1-163-103-00	CERAMIC CHIP	27PF 5%	50V(650D)	C221	1-163-038-00	CERAMIC CHIP 0.1uF 25V
C174	1-163-035-00	CERAMIC CHIP	0.047uF	50V	C222	1-163-035-00	CERAMIC CHIP 0.047uF 50V
C175	1-163-131-00	CERAMIC CHIP	390PF 5%	50V	C223	1-124-126-00	ELECT 47uF 20% 10V
C176	1-130-486-00	MYLAR	0.018uF 10%	50V	C224	1-163-101-00	CERAMIC CHIP 22PF 5% 50V
C177	1-130-489-00	MYLAR	0.033uF 5%	50V	C225	1-163-121-00	CERAMIC CHIP 150PF 5% 50V
C178	1-124-791-11	ELECT	1.0uF 20%	100V	C226	1-124-589-11	ELECT 47uF 20% 16V
C179	1-163-035-00	CERAMIC CHIP	0.047uF	50V	C227	1-163-035-00	CERAMIC CHIP 0.047uF 50V
C180	1-163-105-00	CERAMIC CHIP	33PF 5%	50V(650D)	C228	1-163-088-00	CERAMIC CHIP 5PF 50V(650D)
C180	1-163-107-00	CERAMIC CHIP	39PF 5%	50V (450)	C229	1-124-589-11	ELECT 47uF 20% 16V
C181	1-124-442-00	ELECT	330uF 20%	6.3V	C230	1-163-095-00	CERAMIC CHIP 12PF 5% 50V(650D)
C182	1-163-117-00	CERAMIC CHIP	100PF 5%	50V	C230	1-163-099-00	CERAMIC CHIP 18PF 5% 50V (450)
C183	1-163-117-00	CERAMIC CHIP	100PF 5%	50V	C231	1-130-483-00	MYLAR 0.01uF 5% 50V
C184	1-163-031-11	CERAMIC CHIP	0.01uF	50V	C232	1-124-126-00	ELECT 47uF 20% 10V
C185	1-126-387-91	ELECT	2.2uF 20%	100V	C233	1-163-035-00	CERAMIC CHIP 0.047uF 50V
C186	1-163-111-00	CERAMIC CHIP	56PF 5%	50V	C234	1-163-031-11	CERAMIC CHIP 0.01uF 50V
C187	1-163-038-00	CERAMIC CHIP	0.1uF	25V	C235	1-163-119-00	CERAMIC CHIP 120PF 5% 50V
C188	1-163-101-00	CERAMIC CHIP	22PF 5%	50V	C236	1-126-301-11	ELECT 1uF 20% 50V
C189	1-163-031-11	CERAMIC CHIP	0.01uF	50V	C237	1-163-031-11	CERAMIC CHIP 0.01uF 50V
C190	1-163-139-00	CERAMIC CHIP	820PF 5%	50V	C238	1-163-117-00	CERAMIC CHIP 100PF 5% 50V(650D)
C191	1-163-031-11	CERAMIC CHIP	0.01uF	50V	C239	1-163-031-11	CERAMIC CHIP 0.01uF 50V
C192	1-124-257-00	ELECT	2.2uF 20%	50V	C240	1-163-125-00	CERAMIC CHIP 220PF 5% 50V
C193	1-163-035-00	CERAMIC CHIP	0.047uF	50V	C241	1-163-125-00	CERAMIC CHIP 220PF 5% 50V
C194	1-163-109-00	CERAMIC CHIP	47PF 5%	50V	C242	1-163-035-00	CERAMIC CHIP 0.047uF 50V
C195	1-163-109-00	CERAMIC CHIP	47PF 5%	50V	C243	1-124-767-00	ELECT 2.2uF 20% 50V
C196	1-130-483-00	MYLAR	0.01uF 5%	50V	C244	1-163-031-11	CERAMIC CHIP 0.01uF 50V
C197	1-163-117-00	CERAMIC CHIP	100PF 5%	50V	C245	1-124-589-11	ELECT 47uF 20% 16V
C198	1-124-126-00	ELECT	47uF 20%	10V	C246	1-163-035-00	CERAMIC CHIP 0.047uF 50V
C199	1-124-442-00	ELECT	330uF 20%	6.3V	C247	1-163-035-00	CERAMIC CHIP 0.047uF 50V
C200	1-124-589-11	ELECT	47uF 20%	16V	C248	1-124-589-11	ELECT 47uF 20% 16V
C201	1-163-035-00	CERAMIC CHIP	0.047uF	50V	C249	1-130-491-00	MYLAR 0.047uF 5% 50V
C202	1-163-035-00	CERAMIC CHIP	0.047uF	50V	C250	1-124-126-00	ELECT 47uF 20% 10V
C203	1-163-038-00	CERAMIC CHIP	0.1uF	25V	C251	1-163-035-00	CERAMIC CHIP 0.047uF 50V
C204	1-163-119-00	CERAMIC CHIP	120PF 5%	50V	C252	1-163-031-11	CERAMIC CHIP 0.01uF 50V
C205	1-163-031-11	CERAMIC CHIP	0.01uF	50V	C253	1-124-443-00	ELECT 100uF 20% 10V
C206	1-128-057-11	ELECT	330uF 20%	6.3V	C254	1-163-031-11	CERAMIC CHIP 0.01uF 50V(650D)
C207	1-124-443-00	ELECT	100uF 20%	10V	C255	1-163-031-11	CERAMIC CHIP 0.01uF 50V(650D)
C208	1-163-031-11	CERAMIC CHIP	0.01uF	50V	C256	1-124-443-00	ELECT 100uF 20% 10V
C209	1-124-257-00	ELECT	2.2uF 20%	50V	C257	1-163-103-00	CERAMIC CHIP 27PF 5% 50V
C210	1-163-035-00	CERAMIC CHIP	0.047uF	50V	C258	1-163-103-00	CERAMIC CHIP 27PF 5% 50V
C211	1-163-031-11	CERAMIC CHIP	0.01uF	50V	C259	1-130-474-00	MYLAR 0.0018uF 5% 50V
C212	1-163-109-00	CERAMIC CHIP	47PF 5%	50V	C260	1-124-589-11	ELECT 47uF 20% 16V
C213	1-126-177-11	ELECT	100uF 20%	10V	C261	1-163-125-00	CERAMIC CHIP 220PF 5% 50V
C214	1-163-119-00	CERAMIC CHIP	120PF 5%	50V	C262	1-164-506-11	CERAMIC CHIP 4.7uF 16V
C215	1-163-031-11	CERAMIC CHIP	0.01uF	50V	C266	1-124-261-00	ELECT 10uF 20% 50V
C216	1-124-903-11	ELECT	1uF 20%	50V			

# MP-701

Ref. No.	Part No.	Description	Remark
C267	1-163-131-00	CERAMIC CHIP 390PF	5% 50V
C268	1-163-035-00	CERAMIC CHIP 0.047uF	50V
C269	1-163-113-00	CERAMIC CHIP 68PF	5% 50V
C270	1-163-113-00	CERAMIC CHIP 68PF	5% 50V
C271	1-163-103-00	CERAMIC CHIP 27PF	5% 50V
C272	1-163-031-11	CERAMIC CHIP 0.01uF	50V
C273	1-163-031-11	CERAMIC CHIP 0.01uF	50V
C274	1-124-907-11	ELECT 10uF	20% 50V
C275	1-130-480-00	MYLAR 0.0056uF	5% 50V
C276	1-163-113-00	CERAMIC CHIP 68PF	5% 50V
C277	1-163-103-00	CERAMIC CHIP 27PF	5% 50V
C278	1-163-101-00	CERAMIC CHIP 22PF	5% 50V
C279	1-163-101-00	CERAMIC CHIP 22PF	5% 50V
C280	1-163-101-00	CERAMIC CHIP 22PF	5% 50V
C281	1-124-589-11	ELECT 47uF	20% 16V
C282	1-163-038-00	CERAMIC CHIP 0.1uF	25V
C283	1-124-589-11	ELECT 47uF	20% 16V
C284	1-163-105-00	CERAMIC CHIP 33PF	5% 50V
C285	1-163-093-00	CERAMIC CHIP 10PF	5% 50V
C286	1-163-035-00	CERAMIC CHIP 0.047uF	50V
C287	1-163-035-00	CERAMIC CHIP 0.047uF	50V
C288	1-163-035-00	CERAMIC CHIP 0.047uF	50V
C289	1-164-506-11	CERAMIC CHIP 4.7uF	16V
C290	1-164-506-11	CERAMIC CHIP 4.7uF	16V
C291	1-163-075-00	CERAMIC CHIP 0.047uF	50V
C292	1-164-506-11	CERAMIC CHIP 4.7uF	16V
C501	1-126-373-11	ELECT 470uF	20% 10V
C502	1-163-038-00	CERAMIC CHIP 0.1uF	25V
C503	1-163-038-00	CERAMIC CHIP 0.1uF	25V
C504	1-163-038-00	CERAMIC CHIP 0.1uF	25V
C505	1-126-373-11	ELECT 470uF	20% 10V
C506	1-163-038-00	CERAMIC CHIP 0.1uF	25V
C507	1-163-038-00	CERAMIC CHIP 0.1uF	25V
C508	1-124-472-11	ELECT 470uF	20% 10V
C509	1-163-038-00	CERAMIC CHIP 0.1uF	25V
C510	1-126-336-11	ELECT 220uF	20% 25V (650D)
C510	1-126-375-11	ELECT 100uF	20% 25V (450)
C511	1-128-226-11	ELECT 220uF	25% 50V
C512	1-163-077-00	CERAMIC CHIP 0.1uF	10% 25V
C513	1-126-103-11	ELECT 470uF	20% 16V
C514	1-163-038-00	CERAMIC CHIP 0.1uF	25V
C515	1-163-038-00	CERAMIC CHIP 0.1uF	25V
C516	1-124-472-11	ELECT 470uF	20% 10V
C517	1-163-038-00	CERAMIC CHIP 0.1uF	25V
C518	1-163-038-00	CERAMIC CHIP 0.1uF	25V
C519	1-123-875-11	ELECT 10uF	20% 50V
C520	1-124-472-11	ELECT 470uF	20% 10V
C521	1-163-093-00	CERAMIC CHIP 10PF	5% 50V
C522	1-163-237-11	CERAMIC CHIP 27PF	5% 50V

Ref. No.	Part No.	Description	Remark
C523	1-124-261-00	ELECT 10uF	20% 50V
C524	1-163-038-00	CERAMIC CHIP 0.1uF	25V
C525	1-163-038-00	CERAMIC CHIP 0.1uF	25V
C526	1-126-154-11	ELECT 47uF	20% 6.3V
C527	1-163-038-00	CERAMIC CHIP 0.1uF	25V
C528	1-163-239-11	CERAMIC CHIP 33PF	5% 50V
C529	1-163-038-00	CERAMIC CHIP 0.1uF	25V
C530	1-163-038-00	CERAMIC CHIP 0.1uF	25V
C531	1-163-243-11	CERAMIC CHIP 47PF	5% 50V
C532	1-163-038-00	CERAMIC CHIP 0.1uF	25V
C533	1-163-038-00	CERAMIC CHIP 0.1uF	25V
C534	1-163-038-00	CERAMIC CHIP 0.1uF	25V
C535	1-163-038-00	CERAMIC CHIP 0.1uF	25V
C536	1-124-261-00	ELECT 10uF	20% 50V
C537	1-163-038-00	CERAMIC CHIP 0.1uF	25V
C538	1-124-261-00	ELECT 10uF	20% 50V
C539	1-163-263-11	CERAMIC CHIP 330PF	5% 50V
C540	1-163-038-00	CERAMIC CHIP 0.1uF	25V
C541	1-163-038-00	CERAMIC CHIP 0.1uF	25V
C542	1-163-038-00	CERAMIC CHIP 0.1uF	25V
C543	1-126-803-11	ELECT 47uF	20% 25V
C601	1-163-009-11	CERAMIC CHIP 0.001uF	10% 50V
C602	1-163-035-00	CERAMIC CHIP 0.047uF	50V
C603	1-163-125-00	CERAMIC CHIP 220PF	5% 50V
C604	1-126-163-11	ELECT 4.7uF	20% 50V
C605	1-163-117-00	CERAMIC CHIP 100PF	5% 50V
C606	1-163-125-00	CERAMIC CHIP 220PF	5% 50V
C607	1-163-237-11	CERAMIC CHIP 27PF	5% 50V
C608	1-163-237-11	CERAMIC CHIP 27PF	5% 50V
C609	1-163-235-11	CERAMIC CHIP 22PF	5% 50V
C610	1-163-239-11	CERAMIC CHIP 33PF	5% 50V
C611	1-163-038-00	CERAMIC CHIP 0.1uF	25V
C612	1-126-157-11	ELECT 10uF	20% 16V
C613	1-163-111-00	CERAMIC CHIP 56PF	5% 50V
C614	1-163-117-00	CERAMIC CHIP 100PF	5% 50V
C615	1-124-925-11	ELECT 2.2uF	20% 100V
C616	1-163-038-00	CERAMIC CHIP 0.1uF	25V
C617	1-163-035-00	CERAMIC CHIP 0.047uF	50V
C618	1-124-477-11	ELECT 47uF	20% 25V
C619	1-124-261-00	ELECT 10uF	20% 50V
C620	1-163-031-11	CERAMIC CHIP 0.01uF	50V
C621	1-163-035-00	CERAMIC CHIP 0.047uF	50V
C622	1-124-477-11	ELECT 47uF	20% 25V
C623	1-163-077-00	CERAMIC CHIP 0.1uF	10% 25V
C624	1-163-035-00	CERAMIC CHIP 0.047uF	50V
C625	1-124-443-00	ELECT 100uF	20% 10V
C626	1-164-182-11	CERAMIC CHIP 0.0033uF	10% 50V
C627	1-163-113-00	CERAMIC CHIP 68PF	5% 50V
C628	1-163-035-00	CERAMIC CHIP 0.047uF	50V

Ref. No.	Part No.	Description	Remark		
C629	1-163-035-00	CERAMIC CHIP	0.047uF		50V
C630	1-163-222-11	CERAMIC CHIP	5PF	0.25PF	50V
C631	1-163-235-11	CERAMIC CHIP	22PF	5%	50V
C632	1-126-233-11	ELECT	22uF	20%	50V
C633	1-163-035-00	CERAMIC CHIP	0.047uF		50V
C634	1-124-477-11	ELECT	47uF	20%	25V
C635	1-164-699-11	CERAMIC CHIP	0.0033uF	5%	50V
C636	1-163-111-00	CERAMIC CHIP	56PF	5%	50V
C637	1-126-163-11	ELECT	4.7uF	20%	50V
C638	1-163-117-00	CERAMIC CHIP	100PF	5%	50V
C639	1-126-163-11	ELECT	4.7uF	20%	50V
C640	1-163-035-00	CERAMIC CHIP	0.047uF		50V
C641	1-126-177-11	ELECT	100uF	20%	10V
C642	1-163-031-11	CERAMIC CHIP	0.01uF		50V
C644	1-163-035-00	CERAMIC CHIP	0.047uF		50V
C645	1-163-141-00	CERAMIC CHIP	0.001uF	5%	50V
C646	1-163-031-11	CERAMIC CHIP	0.01uF		50V
C647	1-124-477-11	ELECT	47uF	20%	25V (650D)
C801	1-163-017-00	CERAMIC CHIP	0.0047uF	5%	50V
C802	1-124-927-11	ELECT	4.7uF	20%	100V
C803	1-163-115-00	CERAMIC CHIP	82PF	5%	50V
C804	1-163-107-00	CERAMIC CHIP	39PF	5%	50V
C805	1-163-038-00	CERAMIC CHIP	0.1uF		25V
C806	1-124-443-00	ELECT	100uF	20%	10V
C807	1-124-126-00	ELECT	47uF	20%	10V
C808	1-163-031-11	CERAMIC CHIP	0.01uF		50V
C809	1-163-143-00	CERAMIC CHIP	0.0012uF	5%	50V
C810	1-124-589-11	ELECT	47uF	20%	16V
C811	1-163-031-11	CERAMIC CHIP	0.01uF		50V
C812	1-124-126-00	ELECT	47uF	20%	10V
C813	1-163-031-11	CERAMIC CHIP	0.01uF		50V
C814	1-124-589-11	ELECT	47uF	20%	16V
C815	1-163-107-00	CERAMIC CHIP	39PF	5%	50V
C816	1-124-126-00	ELECT	47uF	20%	10V
C817	1-124-126-00	ELECT	47uF	20%	10V
C818	1-124-126-00	ELECT	47uF	20%	10V
C819	1-163-038-00	CERAMIC CHIP	0.1uF		25V
C820	1-124-443-00	ELECT	100uF	20%	10V
C821	1-124-126-00	ELECT	47uF	20%	10V
C822	1-163-031-11	CERAMIC CHIP	0.01uF		50V
C823	1-124-126-00	ELECT	47uF	20%	10V
C824	1-163-143-00	CERAMIC CHIP	0.0012uF	5%	50V
C825	1-163-107-00	CERAMIC CHIP	39PF	5%	50V
C826	1-163-115-00	CERAMIC CHIP	82PF	5%	50V
C827	1-163-107-00	CERAMIC CHIP	39PF	5%	50V
C828	1-163-113-00	CERAMIC CHIP	68PF	5%	50V
C829	1-163-113-00	CERAMIC CHIP	68PF	5%	50V
C830	1-163-031-11	CERAMIC CHIP	0.01uF		50V
C831	1-163-038-00	CERAMIC CHIP	0.1uF		25V

Ref. No.	Part No.	Description	Remark		
C832	1-124-443-00	ELECT	100uF	20%	10V
C833	1-124-927-11	ELECT	4.7uF	20%	100V
C834	1-163-017-00	CERAMIC CHIP	0.0047uF	5%	50V
C835	1-163-102-00	CERAMIC CHIP	24PF	5%	50V
C836	1-163-038-00	CERAMIC CHIP	0.1uF		25V
C837	1-163-038-00	CERAMIC CHIP	0.1uF		25V
C838	1-126-320-11	ELECT, NONPOLAR R	10uF	20%	16V
C839	1-164-232-11	CERAMIC CHIP	0.01uF		50V
C840	1-163-031-11	CERAMIC CHIP	0.01uF		50V
C841	1-163-809-11	CERAMIC CHIP	0.047uF	10%	25V
C842	1-124-499-11	ELECT, NONPOLAR R	1uF	20%	50V
C843	1-124-126-00	ELECT	47uF	20%	10V
C844	1-163-011-11	CERAMIC CHIP	0.0015uF	10%	50V
C845	1-124-927-11	ELECT	4.7uF	20%	100V
C847	1-163-031-11	CERAMIC CHIP	0.01uF		50V
C848	1-124-927-11	ELECT	4.7uF	20%	100V
C849	1-163-809-11	CERAMIC CHIP	0.047uF	10%	25V
C850	1-163-031-11	CERAMIC CHIP	0.01uF		50V
C851	1-124-907-11	ELECT	10uF	20%	50V
C852	1-124-126-00	ELECT	47uF	20%	10V
C854	1-163-038-00	CERAMIC CHIP	0.1uF		25V
C855	1-124-126-00	ELECT	47uF	20%	10V
C857	1-124-126-00	ELECT	47uF	20%	10V
C858	1-124-126-00	ELECT	47uF	20%	10V
C860	1-163-033-00	CERAMIC CHIP	0.022uF		50V
C861	1-124-927-11	ELECT	4.7uF	20%	100V
C862	1-124-443-00	ELECT	100uF	20%	10V
C863	1-163-038-00	CERAMIC CHIP	0.1uF		25V
C865	1-124-927-11	ELECT	4.7uF	20%	100V
C866	1-163-038-00	CERAMIC CHIP	0.1uF		25V
C867	1-163-038-00	CERAMIC CHIP	0.1uF		25V
C869	1-124-465-00	ELECT	0.47uF	20%	50V
C875	1-163-092-00	CERAMIC CHIP	9PF	0.25PF	50V
C876	1-163-092-00	CERAMIC CHIP	9PF	0.25PF	50V
< FILTER >					
CF101	1-567-657-11	FILTER, CERAMIC (SFS-MC TYPE)			
CF102	1-527-831-00	FILTER, CERAMIC (650D)			
< CONNECTOR >					
CN101	1-569-338-11	CONNECTOR, BOARD TO BOARD	19P	(650D)	
* CN501	1-564-028-00	PIN, CONNECTOR	3P		
CN601	1-506-483-21	PIN, CONNECTOR	4P		
CN602	1-506-491-11	PIN, CONNECTOR	12P		
CN603	1-506-484-11	PIN, CONNECTOR	5P		
CN604	1-563-493-11	CONNECTOR, F. P. C	28P		
CN605	1-506-483-21	PIN, CONNECTOR	4P		
* CN606	1-564-031-00	PIN, CONNECTOR	6P		

# MP-701

Ref. No.	Part No.	Description	Remark
CN607	1-506-481-11	PIN, CONNECTOR 2P	
CN608	1-506-482-11	PIN, CONNECTOR 3P	
CN609	1-506-481-11	PIN, CONNECTOR 2P	
CN801	1-506-482-11	PIN, CONNECTOR 3P	
CN802	1-569-337-11	CONNECTOR, BOARD TO BOARD 11P	
CN803	1-569-337-11	CONNECTOR, BOARD TO BOARD 11P	
CN804	1-506-468-11	PIN, CONNECTOR 3P	
< JACK >			
CNJ101	1-568-016-31	SOCKET 21P	
< TRIMMER >			
CT602	1-141-322-11	CAP, VAR, TRIMMER (CHIP TYPE)	
< DIODE >			
D102	8-719-105-52	DIODE RD3. 6M-B2	
D104	8-719-800-76	DIODE 1SS226	
D501	8-719-400-18	DIODE MA152WK	
△ D503	8-719-106-52	DIODE RD10M-B1	
D508	8-719-106-71	DIODE RD12M-B2	
D509	8-719-210-33	DIODE EC10DS2	
D510	8-719-210-33	DIODE EC10DS2	
D516	8-719-106-80	DIODE RD13MB2 (450)	
D516	8-719-106-62	DIODE RD11M-B2 (650D)	
D517	8-719-800-76	DIODE 1SS226	
D518	8-719-800-76	DIODE 1SS226	
△ D519	8-719-210-33	DIODE EC10DS2	
D601	8-719-104-34	DIODE 1S2836	
D602	8-719-104-34	DIODE 1S2836	
D603	8-719-106-23	DIODE RD7. 5M-B2	
D604	8-719-104-34	DIODE 1S2836	
D605	8-719-106-71	DIODE RD12M-B2	
D606	8-719-400-18	DIODE MA152WK	
D607	8-719-400-18	DIODE MA152WK	
D608	8-719-106-23	DIODE RD7. 5M-B2	
D609	8-719-104-34	DIODE 1S2836	
D801	8-719-400-18	DIODE MA152WK	
D802	8-719-907-19	DIODE FC52M-5	
D803	8-719-907-19	DIODE FC52M-5	
D804	8-719-400-18	DIODE MA152WK	
D805	8-719-400-18	DIODE MA152WK	
D806	8-719-400-18	DIODE MA152WK	
D807	8-719-400-18	DIODE MA152WK	
D808	8-719-106-44	DIODE RDS. 1M-B2	
D809	8-719-400-18	DIODE MA152WK	
D810	8-719-400-18	DIODE MA152WK	
< DELAY LINE >			
DL501	1-415-694-11	DELAY LINE, LC	

Ref. No.	Part No.	Description	Remark
< FERRITE BEAD >			
FB101	1-543-570-11	BEAD, FERRITE (CHIP)	
< FILTER >			
FL101	1-236-580-11	FILTER, LOW PASS	
FL102	1-235-943-11	BPF (650D)	
FL103	1-236-262-11	FILTER, BAND PASS	
FL104	1-236-580-11	FILTER, LOW PASS	
FL105	1-409-431-11	COIL, TRAP (650D)	
FL106	1-409-447-11	COIL, TRAP	
FL107	1-236-744-21	FILTER, EMI	
FL108	1-236-744-21	FILTER, EMI	
FL601	1-236-744-21	FILTER, EMI	
FL602	1-236-744-21	FILTER, EMI	
FL603	1-236-744-21	FILTER, EMI	
FL604	1-236-744-21	FILTER, EMI	
FL801	1-236-744-21	FILTER, EMI	
FL802	1-236-744-21	FILTER, EMI	
FL803	1-236-744-21	FILTER, EMI	
FL804	1-236-744-21	FILTER, EMI	
FL805	1-236-744-21	FILTER, EMI	
FL806	1-236-744-21	FILTER, EMI	
FL807	1-236-744-21	FILTER, EMI	
FL808	1-236-744-21	FILTER, EMI	
FL809	1-236-744-21	FILTER, EMI	
< IC >			
IC101	8-759-048-09	IC MM1148XF	
IC102	8-759-100-95	IC uPC324G2	
IC103	8-752-322-34	IC CX15003M	
IC104	8-759-941-68	IC BA7131F (650D)	
IC105	8-759-941-68	IC BA7131F	
IC106	8-752-036-23	IC CXA1254Q	
IC107	8-759-941-68	IC BA7131F	
IC108	8-759-502-69	IC CXD1152-MS	
IC109	8-752-036-24	IC CXA1255Q	
IC110	8-759-233-64	IC TC74HCU04AF	
IC111	8-759-907-81	IC SN74LS221NS	
△ IC501	8-749-920-43	IC SI3050CA	
IC502	8-759-144-83	IC uPC24M09HF	
IC503	8-759-982-10	IC RC7809FA	
IC504	8-759-231-58	IC TA7812S	
IC505	8-759-604-49	IC M5F7909L	
IC601	8-759-700-07	IC NJM2903M	
IC602	8-759-300-71	IC HD14053BFP (650D)	
IC603	8-759-201-53	IC TC40H00F	
IC604	8-759-300-71	IC HD14053BFP	

The components identified by mark △ or dotted line with mark △ are critical for safety. Replace only with part number specified.

Ref. No.	Part No.	Description	Remark
IC605	8-759-009-19	IC MC14081BF	
IC606	8-759-902-88	IC SN74LS123NS	
IC607	8-759-634-74	IC M50455-196FP	
IC608	8-759-926-98	IC SN74HC4040ANS	
IC609	8-759-941-68	IC BA7131F	
IC610	8-759-234-43	IC TC9018P	
IC612	8-759-072-64	IC MB89795-DCX615	
IC613	8-759-074-61	IC MSM72H048GS-V1K	
IC614	8-759-231-92	IC TA7291P	
IC615	8-759-100-95	IC uPC324G2	
IC616	8-759-009-06	IC MC14052BF	
IC617	8-759-300-71	IC TC4053BF	
IC618	8-759-008-67	IC MC14066BF	
IC802	8-752-351-19	IC CXD2561BM	
IC803	8-752-342-65	IC CXD2560M	
IC804	8-752-337-26	IC CXD2500AQ	
IC806	8-759-981-92	IC RC4558M	
IC807	8-759-981-92	IC RC4558M	
IC808	8-759-981-92	IC RC4558M	
IC809	8-759-981-92	IC RC4558M	
IC810	8-759-981-92	IC RC4558M	
IC811	8-759-981-92	IC RC4558M	
IC812	8-759-008-67	IC MC14066BF	

## &lt; JUMPER RESISTOR &gt;

JR001	1-216-295-00	METAL CHIP	0	5%	1/10W (450)
JR002	1-216-295-00	METAL CHIP	0	5%	1/10W (650D)
JR101	1-216-295-00	METAL CHIP	0	5%	1/10W (450)
JR105	1-216-295-00	METAL CHIP	0	5%	1/10W (450)
JR107	1-216-295-00	METAL CHIP	0	5%	1/10W (450)
JR501	1-216-295-00	METAL CHIP	0	5%	1/10W
JR502	1-216-295-00	METAL CHIP	0	5%	1/10W
JR503	1-216-295-00	METAL CHIP	0	5%	1/10W
JR504	1-216-295-00	METAL CHIP	0	5%	1/10W
JR505	1-216-295-00	METAL CHIP	0	5%	1/10W
JR506	1-216-295-00	METAL CHIP	0	5%	1/10W

## &lt; COIL &gt;

L101	1-408-419-00	INDUCTOR 68uH	
L102	1-408-411-00	INDUCTOR 15uH	
L103	1-408-417-00	INDUCTOR 47uH	
L104	1-408-421-00	INDUCTOR 100uH	
L105	1-408-609-41	INDUCTOR 33uH	
L106	1-408-419-00	INDUCTOR 68uH	
L107	1-408-417-00	INDUCTOR 47uH	
L108	1-408-417-00	INDUCTOR 47uH	
L109	1-408-425-00	INDUCTOR 220uH	
L110	1-408-421-00	INDUCTOR 100uH	

Ref. No.	Part No.	Description	Remark
L111	1-408-417-00	INDUCTOR 47uH	
L112	1-408-421-00	INDUCTOR 100uH	
L113	1-408-421-00	INDUCTOR 100uH	
L114	1-408-417-00	INDUCTOR 47uH	
L115	1-408-421-00	INDUCTOR 100uH	
L116	1-408-609-41	INDUCTOR 33uH	
L117	1-408-421-00	INDUCTOR 100uH	
L118	1-408-424-00	INDUCTOR 180uH	
L119	1-408-421-00	INDUCTOR 100uH	
L120	1-408-421-00	INDUCTOR 100uH	
L121	1-408-421-00	INDUCTOR 100uH	
L122	1-408-421-00	INDUCTOR 100uH	
L123	1-408-421-00	INDUCTOR 100uH	
L124	1-408-409-00	INDUCTOR 10uH	
L501	1-408-609-41	INDUCTOR 33uH	
L502	1-408-406-00	INDUCTOR 5.5uH	
L601	1-408-409-00	INDUCTOR 10uH	
L602	1-408-411-00	INDUCTOR 15uH	
L603	1-408-421-00	INDUCTOR 100uH	
L801	1-408-403-00	INDUCTOR 3.3uH	
L802	1-408-403-00	INDUCTOR 3.3uH	

&lt; IC LINK &gt;

△PS501	1-532-679-00	LINK, IC
△PS502	1-532-605-00	LINK, IC 0.4A
△PS601	1-532-637-00	LINK, IC 1.0A
△PS602	1-532-637-00	LINK, IC 1.0A

## &lt; TRANSISTOR &gt;

Q101	8-729-120-28	TRANSISTOR	2SC1623-L5L6
Q102	8-729-120-28	TRANSISTOR	2SC1623-L5L6
Q103	8-729-900-53	TRANSISTOR	DTC114EK (650D)
Q104	8-729-120-28	TRANSISTOR	2SC1623-L5L6
Q106	8-729-140-75	TRANSISTOR	2SD999-CLCK
Q107	8-729-120-28	TRANSISTOR	2SC1623-L5L6
Q108	8-729-120-28	TRANSISTOR	2SC1623-L5L6
Q109	8-729-120-28	TRANSISTOR	2SC1623-L5L6
Q110	8-729-120-28	TRANSISTOR	2SC1623-L5L6
Q111	8-729-216-22	TRANSISTOR	2SA1162-G
Q112	8-729-120-28	TRANSISTOR	2SC1623-L5L6
Q113	8-729-120-28	TRANSISTOR	2SC1623-L5L6
Q114	8-729-120-28	TRANSISTOR	2SC1623-L5L6
Q115	8-729-120-28	TRANSISTOR	2SC1623-L5L6
Q116	8-729-120-28	TRANSISTOR	2SC1623-L5L6
Q117	8-729-120-28	TRANSISTOR	2SC1623-L5L6
Q118	8-729-120-28	TRANSISTOR	2SC1623-L5L6
Q119	8-729-120-28	TRANSISTOR	2SC1623-L5L6 (650D)
Q120	8-729-120-28	TRANSISTOR	2SC1623-L5L6
Q121	8-729-120-28	TRANSISTOR	2SC1623-L5L6 (650D)

The components identified by mark △ or dotted line with mark △ are critical for safety. Replace only with part number specified.

# MP-701

Ref. No.	Part No.	Description	Remark
Q122	8-729-120-28	TRANSISTOR 2SC1623-L5L6	
Q123	8-729-120-28	TRANSISTOR 2SC1623-L5L6	
Q124	8-729-120-28	TRANSISTOR 2SC1623-L5L6	
Q125	8-729-216-22	TRANSISTOR 2SA1162-G	
Q126	8-729-901-01	TRANSISTOR DTC144EK (650D)	
Q127	8-729-120-28	TRANSISTOR 2SC1623-L5L6	
Q128	8-729-901-01	TRANSISTOR DTC144EK (650D)	
Q129	8-729-120-28	TRANSISTOR 2SC1623-L5L6	
Q130	8-729-901-01	TRANSISTOR DTC144EK (650D)	
Q131	8-729-901-01	TRANSISTOR DTC144EK (650D)	
Q132	8-729-901-01	TRANSISTOR DTC144EK (650D)	
Q133	8-729-120-28	TRANSISTOR 2SC1623-L5L6 (650D)	
Q134	8-729-216-22	TRANSISTOR 2SA1162-G	
Q135	8-729-120-28	TRANSISTOR 2SC1623-L5L6	
Q136	8-729-120-28	TRANSISTOR 2SC1623-L5L6	
Q137	8-729-120-28	TRANSISTOR 2SC1623-L5L6	
Q138	8-729-120-28	TRANSISTOR 2SC1623-L5L6 (650D)	
Q139	8-729-120-28	TRANSISTOR 2SC1623-L5L6	
Q140	8-729-216-22	TRANSISTOR 2SA1162-G (650D)	
Q141	8-729-901-01	TRANSISTOR DTC144EK (650D)	
Q143	8-729-901-01	TRANSISTOR DTC144EK (650D)	
Q144	8-729-120-28	TRANSISTOR 2SC1623-L5L6 (650D)	
Q145	8-729-120-28	TRANSISTOR 2SC1623-L5L6	
Q146	8-729-120-28	TRANSISTOR 2SC1623-L5L6	
Q147	8-729-901-05	TRANSISTOR DTA124EK	
Q149	8-729-120-28	TRANSISTOR 2SC1623-L5L6	
Q152	8-729-120-28	TRANSISTOR 2SC1623-L5L6	
Q153	8-729-216-22	TRANSISTOR 2SA1162-G	
Q154	8-729-120-28	TRANSISTOR 2SC1623-L5L6	
Q155	8-729-901-01	TRANSISTOR DTC144EK	
Q157	8-729-120-28	TRANSISTOR 2SC1623-L5L6	
Q158	8-729-120-28	TRANSISTOR 2SC1623-L5L6	
Q159	8-729-120-28	TRANSISTOR 2SC1623-L5L6	
Q160	8-729-120-28	TRANSISTOR 2SC1623-L5L6	
Q161	8-729-216-22	TRANSISTOR 2SA1162-G	
Q162	8-729-120-28	TRANSISTOR 2SC1623-L5L6	
Q163	8-729-120-28	TRANSISTOR 2SC1623-L5L6	
Q164	8-729-120-28	TRANSISTOR 2SC1623-L5L6	
Q165	8-729-120-28	TRANSISTOR 2SC1623-L5L6	
Q166	8-729-216-22	TRANSISTOR 2SA1162-G	
Q167	8-729-120-28	TRANSISTOR 2SC1623-L5L6	
Q168	8-729-903-10	TRANSISTOR FMW1	
Q169	8-729-120-28	TRANSISTOR 2SC1623-L5L6	
Q170	8-729-903-10	TRANSISTOR FMW1	
Q171	8-729-120-28	TRANSISTOR 2SC1623-L5L6	
Q172	8-729-901-01	TRANSISTOR DTC144EK	
Q173	8-729-901-01	TRANSISTOR DTC144EK	
Q502	8-729-120-28	TRANSISTOR 2SC1623-L5L6	
Q503	8-729-901-00	TRANSISTOR DTC124EK	

Ref. No.	Part No.	Description	Remark
Q504	8-729-141-75	TRANSISTOR 2SD596DV345	
Q505	8-729-901-04	TRANSISTOR DTA114EK	
Q506	8-729-120-28	TRANSISTOR 2SC1623-L5L6	
Q507	8-729-900-53	TRANSISTOR DTC114EK	
Q508	8-729-120-28	TRANSISTOR 2SC1623-L5L6	
Q509	8-729-120-28	TRANSISTOR 2SC1623-L5L6	
Q510	8-729-901-04	TRANSISTOR DTA114EK	
Q511	8-729-120-28	TRANSISTOR 2SC1623-L5L6	
Q512	8-729-120-28	TRANSISTOR 2SC1623-L5L6	
Q513	8-729-216-22	TRANSISTOR 2SA1162-G	
Q514	8-729-120-28	TRANSISTOR 2SC1623-L5L6	
Q515	8-729-120-28	TRANSISTOR 2SC1623-L5L6	
Q516	8-729-903-10	TRANSISTOR FMW1	
Q517	8-729-120-28	TRANSISTOR 2SC1623-L5L6	
Q518	8-729-120-28	TRANSISTOR 2SC1623-L5L6	
Q519	8-729-120-28	TRANSISTOR 2SC1623-L5L6	
Q520	8-729-216-22	TRANSISTOR 2SA1162-G	
Q521	8-729-120-28	TRANSISTOR 2SC1623-L5L6	
Q522	8-729-902-96	TRANSISTOR FMS1	
Q523	8-729-900-53	TRANSISTOR DTC114EK	
Q601	8-729-120-28	TRANSISTOR 2SC1623-L5L6	
Q603	8-729-901-01	TRANSISTOR DTC144EK	
Q604	8-729-901-01	TRANSISTOR DTC144EK	
Q605	8-729-120-28	TRANSISTOR 2SC1623-L5L6	
Q606	8-729-120-28	TRANSISTOR 2SC1623-L5L6	
Q607	8-729-120-28	TRANSISTOR 2SC1623-L5L6	
Q608	8-729-120-28	TRANSISTOR 2SC1623-L5L6	
Q609	8-729-901-00	TRANSISTOR DTC124EK	
Q610	8-729-216-22	TRANSISTOR 2SA1162-G	
Q611	8-729-120-28	TRANSISTOR 2SC1623-L5L6	
Q612	8-729-216-22	TRANSISTOR 2SA1162-G	
Q801	8-729-901-04	TRANSISTOR DTA114EK	
Q802	8-729-901-04	TRANSISTOR DTA114EK	
Q803	8-729-901-04	TRANSISTOR DTA114EK	
Q804	8-729-202-38	TRANSISTOR 2SC3326N-A	
Q805	8-729-120-28	TRANSISTOR 2SC1623-L5L6	
Q806	8-729-901-04	TRANSISTOR DTA114EK	
Q807	8-729-900-53	TRANSISTOR DTC114EK	
Q808	8-729-900-53	TRANSISTOR DTC114EK	
Q809	8-729-202-38	TRANSISTOR 2SC3326N-A	
Q811	8-729-901-04	TRANSISTOR DTA114EK	
Q812	8-729-900-53	TRANSISTOR DTC114EK	
Q813	8-729-202-38	TRANSISTOR 2SC3326N-A	
Q815	8-729-202-38	TRANSISTOR 2SC3326N-A	
Q816	8-729-202-38	TRANSISTOR 2SC3326N-A	
Q817	8-729-901-04	TRANSISTOR DTA114EK	
Q818	8-729-900-53	TRANSISTOR DTC114EK	
Q819	8-729-202-38	TRANSISTOR 2SC3326N-A	
Q820	8-729-202-38	TRANSISTOR 2SC3326N-A	

The components identified by mark  $\Delta$  or dotted line with mark  $\Delta$  are critical for safety. Replace only with part number specified.



Ref. No.	Part No.	Description	Remark		
Q821	8-729-202-38	TRANSISTOR	2SC3326N-A		
Q824	8-729-901-04	TRANSISTOR	DTA114EK		
Q825	8-729-900-53	TRANSISTOR	DTC114EK		
Q826	8-729-901-05	TRANSISTOR	DTA124EK		
Q827	8-729-923-54	TRANSISTOR	DTA143TK		
< RESISTOR >					
R101	1-216-001-00	METAL CHIP	10	5%	1/10W(650D)
R102	1-216-049-00	METAL CHIP	1K	5%	1/10W
R103	1-216-073-00	METAL CHIP	10K	5%	1/10W
R104	1-216-097-00	METAL CHIP	100K	5%	1/10W
R105	1-216-065-00	METAL CHIP	4.7K	5%	1/10W
R106	1-216-049-00	METAL CHIP	1K	5%	1/10W
R107	1-216-049-00	METAL CHIP	1K	5%	1/10W
R108	1-216-033-00	METAL CHIP	220	5%	1/10W(650D)
R109	1-216-065-00	METAL CHIP	4.7K	5%	1/10W
R110	1-216-113-00	METAL CHIP	470K	5%	1/10W
R112	1-216-049-00	METAL CHIP	1K	5%	1/10W
R113	1-216-063-00	METAL CHIP	3.9K	5%	1/10W
R114	1-216-067-00	METAL CHIP	5.6K	5%	1/10W
R115	1-216-059-00	METAL CHIP	2.7K	5%	1/10W
R116	1-216-121-00	METAL CHIP	1M	5%	1/10W
R117	1-216-049-00	METAL CHIP	1K	5%	1/10W
R118	1-216-071-00	METAL CHIP	8.2K	5%	1/10W
R119	1-216-053-00	METAL CHIP	1.5K	5%	1/10W
R120	1-216-049-00	METAL CHIP	1K	5%	1/10W
R121	1-216-049-00	METAL CHIP	1K	5%	1/10W
R122	1-216-053-00	METAL CHIP	1.5K	5%	1/10W
R123	1-216-039-00	METAL CHIP	390	5%	1/10W
R124	1-216-037-00	METAL CHIP	330	5%	1/10W
R125	1-216-113-00	METAL CHIP	470K	5%	1/10W
R126	1-216-067-00	METAL CHIP	5.6K	5%	1/10W
R127	1-216-049-00	METAL CHIP	1K	5%	1/10W
R128	1-216-051-00	METAL CHIP	1.2K	5%	1/10W
R129	1-216-065-00	METAL CHIP	4.7K	5%	1/10W
R130	1-216-113-00	METAL CHIP	470K	5%	1/10W
R131	1-216-079-00	METAL CHIP	18K	5%	1/10W
R132	1-216-089-00	METAL CHIP	47K	5%	1/10W
R133	1-216-063-00	METAL CHIP	3.9K	5%	1/10W
R134	1-216-057-00	METAL CHIP	2.2K	5%	1/10W
R135	1-216-053-00	METAL CHIP	1.5K	5%	1/10W
R136	1-216-069-00	METAL CHIP	6.8K	5%	1/10W
R137	1-216-041-00	METAL CHIP	470	5%	1/10W
R138	1-216-073-00	METAL CHIP	10K	5%	1/10W
R139	1-216-045-00	METAL CHIP	680	5%	1/10W
R140	1-216-051-00	METAL CHIP	1.2K	5%	1/10W
R141	1-216-057-00	METAL CHIP	2.2K	5%	1/10W
R142	1-216-065-00	METAL CHIP	4.7K	5%	1/10W
R143	1-216-061-00	METAL CHIP	3.3K	5%	1/10W

Ref. No.	Part No.	Description	Remark		
R144	1-216-045-00	METAL CHIP	680	5%	1/10W
R145	1-216-049-00	METAL CHIP	1K	5%	1/10W
R146	1-216-063-00	METAL CHIP	1.5K	5%	1/10W
R147	1-216-065-00	METAL CHIP	4.7K	5%	1/10W
R148	1-216-053-00	METAL CHIP	1.5K	5%	1/10W
R149	1-216-049-00	METAL CHIP	1K	5%	1/10W
R150	1-216-049-00	METAL CHIP	1K	5%	1/10W
R151	1-216-057-00	METAL CHIP	2.2K	5%	1/10W
R152	1-216-079-00	METAL CHIP	18K	5%	1/10W
R153	1-216-077-00	METAL CHIP	15K	5%	1/10W
R154	1-216-073-00	METAL CHIP	10K	5%	1/10W
R155	1-216-059-00	METAL CHIP	2.7K	5%	1/10W
R156	1-216-025-00	METAL CHIP	100	5%	1/10W
R157	1-216-009-00	METAL CHIP	22	5%	1/10W
R158	1-216-059-00	METAL CHIP	2.7K	5%	1/10W
R159	1-216-059-00	METAL CHIP	2.7K	5%	1/10W
R160	1-216-057-00	METAL CHIP	2.2K	5%	1/10W
R161	1-216-061-00	METAL CHIP	3.3K	5%	1/10W(650D)
R162	1-216-049-00	METAL CHIP	1K	5%	1/10W(650D)
R163	1-216-045-00	METAL CHIP	680	5%	1/10W(650D)
R164	1-216-053-00	METAL CHIP	1.5K	5%	1/10W
R165	1-216-043-00	METAL CHIP	560	5%	1/10W
R166	1-216-073-00	METAL CHIP	10K	5%	1/10W
R167	1-216-073-00	METAL CHIP	10K	5%	1/10W
R168	1-216-061-00	METAL CHIP	3.3K	5%	1/10W
R169	1-216-049-00	METAL CHIP	1K	5%	1/10W
R170	1-216-049-00	METAL CHIP	1K	5%	1/10W(650D)
R171	1-216-063-00	METAL CHIP	3.9K	5%	1/10W
R172	1-216-121-00	METAL CHIP	1M	5%	1/10W
R173	1-216-089-00	METAL CHIP	47K	5%	1/10W
R174	1-216-079-00	METAL CHIP	18K	5%	1/10W
R175	1-216-077-00	METAL CHIP	15K	5%	1/10W
R176	1-216-099-00	METAL CHIP	120K	5%	1/10W(650D)
R177	1-216-083-00	METAL CHIP	27K	5%	1/10W
R178	1-216-089-00	METAL CHIP	47K	5%	1/10W
R179	1-216-081-00	METAL CHIP	22K	5%	1/10W
R180	1-216-081-00	METAL CHIP	22K	5%	1/10W
R181	1-216-049-00	METAL CHIP	1K	5%	1/10W
R182	1-216-049-00	METAL CHIP	1K	5%	1/10W
R183	1-216-049-00	METAL CHIP	1K	5%	1/10W
R184	1-216-113-00	METAL CHIP	470K	5%	1/10W
R185	1-216-083-00	METAL CHIP	27K	5%	1/10W
R186	1-216-097-00	METAL CHIP	100K	5%	1/10W
R187	1-216-065-00	METAL CHIP	4.7K	5%	1/10W
R188	1-216-073-00	METAL CHIP	10K	5%	1/10W
R189	1-216-073-00	METAL CHIP	10K	5%	1/10W
R190	1-216-059-00	METAL CHIP	2.7K	5%	1/10W
R191	1-216-039-00	METAL CHIP	390	5%	1/10W

**MP-701**

Ref. No.	Part No.	Description	Remark
R192	1-216-091-00	METAL CHIP	56K 5% 1/10W (650D)
R192	1-216-689-11	METAL CHIP	39K 0.5% 1/10W (450)
R193	1-216-117-00	METAL CHIP	680K 5% 1/10W
R194	1-216-097-00	METAL CHIP	100K 5% 1/10W
R195	1-216-689-11	METAL CHIP	39K 0.5% 1/10W
R196	1-216-079-00	METAL CHIP	18K 5% 1/10W
R197	1-216-083-00	METAL CHIP	27K 5% 1/10W
R198	1-216-073-00	METAL CHIP	10K 5% 1/10W
R199	1-216-075-00	METAL CHIP	12K 5% 1/10W
R200	1-216-057-00	METAL CHIP	2.2K 5% 1/10W
R201	1-216-073-00	METAL CHIP	10K 5% 1/10W
R202	1-216-113-00	METAL CHIP	470K 5% 1/10W
R203	1-216-043-00	METAL CHIP	560 5% 1/10W
R204	1-216-053-00	METAL CHIP	1.5K 5% 1/10W
R205	1-216-057-00	METAL CHIP	2.2K 5% 1/10W
R206	1-216-095-00	METAL CHIP	82K 5% 1/10W
R207	1-216-121-00	METAL CHIP	1M 5% 1/10W
R208	1-216-033-00	METAL CHIP	220 5% 1/10W (650D)
R209	1-216-049-00	METAL CHIP	1K 5% 1/10W
R210	1-216-115-00	METAL CHIP	560K 5% 1/10W
R211	1-216-097-00	METAL CHIP	100K 5% 1/10W
R212	1-216-053-00	METAL CHIP	3.9K 5% 1/10W
R213	1-216-097-00	METAL CHIP	100K 5% 1/10W
R214	1-216-049-00	METAL CHIP	1K 5% 1/10W
R215	1-216-047-00	METAL CHIP	820 5% 1/10W (650D)
R216	1-216-113-00	METAL CHIP	470K 5% 1/10W
R217	1-216-097-00	METAL CHIP	100K 5% 1/10W
R218	1-216-073-00	METAL CHIP	10K 5% 1/10W
R219	1-216-689-11	METAL CHIP	39K 0.5% 1/10W
R220	1-216-113-00	METAL CHIP	470K 5% 1/10W (650D)
R221	1-216-055-00	METAL CHIP	1.8K 5% 1/10W
R222	1-216-041-00	METAL CHIP	470 5% 1/10W
R223	1-216-053-00	METAL CHIP	1.5K 5% 1/10W
R224	1-216-049-00	METAL CHIP	1K 5% 1/10W
R225	1-216-689-11	METAL CHIP	39K 0.5% 1/10W
R226	1-216-109-00	METAL CHIP	330K 5% 1/10W
R227	1-216-055-00	METAL CHIP	1.8K 5% 1/10W (650D)
R228	1-216-055-00	METAL CHIP	1.8K 5% 1/10W
R229	1-216-079-00	METAL CHIP	18K 5% 1/10W
R230	1-216-073-00	METAL CHIP	10K 5% 1/10W
R231	1-216-065-00	METAL CHIP	4.7K 5% 1/10W (650D)
R231	1-216-295-00	METAL CHIP	0 5% 1/10W (450)
R232	1-216-089-00	METAL CHIP	47K 5% 1/10W
R233	1-216-097-00	METAL CHIP	100K 5% 1/10W
R234	1-216-073-00	METAL CHIP	10K 5% 1/10W
R235	1-216-073-00	METAL CHIP	10K 5% 1/10W
R236	1-216-049-00	METAL CHIP	1K 5% 1/10W
R237	1-216-109-00	METAL CHIP	330K 5% 1/10W (650D)
R238	1-216-061-00	METAL CHIP	3.3K 5% 1/10W

Ref. No.	Part No.	Description	Remark
R239	1-216-057-00	METAL CHIP	2.2K 5% 1/10W
R240	1-216-049-00	METAL CHIP	1K 5% 1/10W (650D)
R241	1-216-057-00	METAL CHIP	2.2K 5% 1/10W (650D)
R242	1-216-033-00	METAL CHIP	220 5% 1/10W
R243	1-216-049-00	METAL CHIP	1K 5% 1/10W
R244	1-216-059-00	METAL CHIP	2.7K 5% 1/10W (650D)
R245	1-216-121-00	METAL CHIP	1M 5% 1/10W
R246	1-216-121-00	METAL CHIP	1M 5% 1/10W
R247	1-216-033-00	METAL CHIP	220 5% 1/10W
R248	1-216-115-00	METAL CHIP	560K 5% 1/10W (650D)
R249	1-216-033-00	METAL CHIP	220 5% 1/10W
R250	1-216-097-00	METAL CHIP	100K 5% 1/10W
R251	1-216-097-00	METAL CHIP	100K 5% 1/10W
R252	1-216-069-00	METAL CHIP	6.8K 5% 1/10W
R253	1-216-065-00	METAL CHIP	4.7K 5% 1/10W
R254	1-216-073-00	METAL CHIP	10K 5% 1/10W
R255	1-216-295-00	METAL CHIP	0 5% 1/10W
R256	1-216-061-00	METAL CHIP	3.3K 5% 1/10W (650D)
R257	1-216-059-00	METAL CHIP	2.7K 5% 1/10W (650D)
R258	1-216-037-00	METAL CHIP	330 5% 1/10W
R259	1-216-073-00	METAL CHIP	10K 5% 1/10W
R260	1-216-057-00	METAL CHIP	2.2K 5% 1/10W
R261	1-216-059-00	METAL CHIP	2.7K 5% 1/10W
R262	1-216-295-00	METAL CHIP	0 5% 1/10W
R263	1-216-049-00	METAL CHIP	1K 5% 1/10W
R264	1-216-075-00	METAL CHIP	12K 5% 1/10W (650D)
R265	1-216-077-00	METAL CHIP	15K 5% 1/10W
R266	1-216-079-00	METAL CHIP	18K 5% 1/10W
R267	1-216-689-11	METAL CHIP	39K 0.5% 1/10W (650D)
R268	1-216-049-00	METAL CHIP	1K 5% 1/10W
R270	1-216-025-00	METAL CHIP	100 5% 1/10W
R272	1-216-059-00	METAL CHIP	2.7K 5% 1/10W
R273	1-216-059-00	METAL CHIP	2.7K 5% 1/10W
R274	1-216-061-00	METAL CHIP	3.3K 5% 1/10W
R275	1-216-295-00	METAL CHIP	0 5% 1/10W (650D)
R276	1-216-097-00	METAL CHIP	100K 5% 1/10W (650D)
R277	1-216-097-00	METAL CHIP	100K 5% 1/10W (650D)
R280	1-216-047-00	METAL CHIP	820 5% 1/10W (650D)
R281	1-216-085-00	METAL CHIP	33K 5% 1/10W
R282	1-216-085-00	METAL CHIP	33K 5% 1/10W
R283	1-216-095-00	METAL CHIP	82K 5% 1/10W (650D)
R284	1-216-045-00	METAL CHIP	680 5% 1/10W
R285	1-216-095-00	METAL CHIP	82K 5% 1/10W (650D)
R286	1-216-041-00	METAL CHIP	470 5% 1/10W
R287	1-216-065-00	METAL CHIP	4.7K 5% 1/10W (650D)
R288	1-216-065-00	METAL CHIP	4.7K 5% 1/10W (650D)
R289	1-216-043-00	METAL CHIP	560 5% 1/10W
R290	1-216-053-00	METAL CHIP	1.5K 5% 1/10W
R291	1-216-097-00	METAL CHIP	100K 5% 1/10W

Ref. No.	Part No.	Description	Remark		
R292	1-216-079-00	METAL CHIP	18K	5%	1/10W
R293	1-216-675-11	METAL CHIP	10K	0.5%	1/10W
R294	1-216-057-00	METAL CHIP	2.2K	5%	1/10W
R295	1-216-097-00	METAL CHIP	100K	5%	1/10W
R296	1-216-073-00	METAL CHIP	10K	5%	1/10W
R297	1-216-049-00	METAL CHIP	1K	5%	1/10W
R300	1-216-085-00	METAL CHIP	33K	5%	1/10W
R304	1-216-081-00	METAL CHIP	22K	5%	1/10W
R305	1-216-059-00	METAL CHIP	2.7K	5%	1/10W
R306	1-216-073-00	METAL CHIP	10K	5%	1/10W
R307	1-216-073-00	METAL CHIP	10K	5%	1/10W
R308	1-216-049-00	METAL CHIP	1K	5%	1/10W
R309	1-216-049-00	METAL CHIP	1K	5%	1/10W
R310	1-216-049-00	METAL CHIP	1K	5%	1/10W
R311	1-216-057-00	METAL CHIP	2.2K	5%	1/10W
R312	1-216-057-00	METAL CHIP	2.2K	5%	1/10W
R313	1-216-051-00	METAL CHIP	1.2K	5%	1/10W
R314	1-216-047-00	METAL CHIP	820	5%	1/10W
R315	1-216-049-00	METAL CHIP	1K	5%	1/10W
R316	1-216-041-00	METAL CHIP	470	5%	1/10W
R317	1-216-097-00	METAL CHIP	100K	5%	1/10W
R318	1-216-085-00	METAL CHIP	33K	5%	1/10W
R319	1-216-057-00	METAL CHIP	2.2K	5%	1/10W
R320	1-216-073-00	METAL CHIP	10K	5%	1/10W
R322	1-216-051-00	METAL CHIP	1.2K	5%	1/10W
R323	1-216-049-00	METAL CHIP	1K	5%	1/10W
R324	1-216-047-00	METAL CHIP	820	5%	1/10W
R325	1-216-047-00	METAL CHIP	820	5%	1/10W
R326	1-216-049-00	METAL CHIP	1K	5%	1/10W
R327	1-216-051-00	METAL CHIP	1.2K	5%	1/10W
R328	1-216-049-00	METAL CHIP	1K	5%	1/10W
R329	1-216-051-00	METAL CHIP	1.2K	5%	1/10W
R330	1-216-091-00	METAL CHIP	56K	5%	1/10W
R331	1-216-047-00	METAL CHIP	820	5%	1/10W
R332	1-216-033-00	METAL CHIP	220	5%	1/10W
R333	1-216-067-00	METAL CHIP	5.6K	5%	1/10W
R334	1-216-049-00	METAL CHIP	1K	5%	1/10W
R335	1-216-035-00	METAL CHIP	270	5%	1/10W (650D)
R335	1-216-295-00	METAL CHIP	0	5%	1/10W (450)
R336	1-216-033-00	METAL CHIP	220	5%	1/10W
R337	1-216-033-00	METAL CHIP	220	5%	1/10W
R338	1-216-081-00	METAL CHIP	22K	5%	1/10W
R339	1-216-037-00	METAL CHIP	330	5%	1/10W
R340	1-216-041-00	METAL CHIP	470	5%	1/10W
R341	1-216-041-00	METAL CHIP	470	5%	1/10W
R342	1-216-021-00	METAL CHIP	68	5%	1/10W
R343	1-216-041-00	METAL CHIP	470	5%	1/10W
R344	1-216-041-00	METAL CHIP	470	5%	1/10W

Ref. No.	Part No.	Description	Remark		
R345	1-216-021-00	METAL CHIP	68	5%	1/10W
R346	1-216-049-00	METAL CHIP	1K	5%	1/10W (650D)
R346	1-216-295-00	METAL CHIP	0	5%	1/10W (450)
R347	1-216-081-00	METAL CHIP	22K	5%	1/10W
R348	1-216-049-00	METAL CHIP	1K	5%	1/10W
R349	1-216-033-00	METAL CHIP	220	5%	1/10W
R350	1-216-061-00	METAL CHIP	3.3K	5%	1/10W
R351	1-216-089-00	METAL CHIP	47K	5%	1/10W
R352	1-216-063-00	METAL CHIP	3.9K	5%	1/10W
R353	1-216-031-00	METAL CHIP	180	5%	1/10W
R354	1-216-049-00	METAL CHIP	1K	5%	1/10W
R355	1-216-065-00	METAL CHIP	4.7K	5%	1/10W
R356	1-216-041-00	METAL CHIP	470	5%	1/10W
R357	1-216-033-00	METAL CHIP	220	5%	1/10W
R358	1-216-055-00	METAL CHIP	1.8K	5%	1/10W
R359	1-216-689 11	METAL CHIP	39K	0.5%	1/10W
R360	1-216-057-00	METAL CHIP	2.2K	5%	1/10W
R361	1-216-059-00	METAL CHIP	2.7K	5%	1/10W
R362	1-216-021-00	METAL CHIP	68	5%	1/10W (650D)
R363	1-216-001-00	METAL CHIP	10	5%	1/10W
R365	1-216-011-00	METAL CHIP	27	5%	1/10W
△R502	1-215-907-11	WIREWOUND	22	10%	2W F
△R505	1-212-849-00	FUSIBLE	4.7	5%	1/4W F
R506	1-216-059-00	METAL CHIP	2.7K	5%	1/10W
R507	1-216-053-00	METAL CHIP	1.5K	5%	1/10W
R508	1-216-065-00	METAL CHIP	4.7K	5%	1/10W
R509	1-216-053-00	METAL CHIP	1.5K	5%	1/10W
R510	1-216-295-00	METAL CHIP	0	5%	1/10W
△R511	1-212-849-00	FUSIBLE	4.7	5%	1/4W F
△R512	1-207-656-00	WIREWOUND	8.2	10%	3W F
R513	1-216-049-00	METAL CHIP	1K	5%	1/10W
R514	1-216-049-00	METAL CHIP	1K	5%	1/10W
R515	1-216-065-00	METAL CHIP	4.7K	5%	1/10W
R516	1-216-061-00	METAL CHIP	3.3K	5%	1/10W
R517	1-216-067-00	METAL CHIP	5.6K	5%	1/10W
R518	1-216-049-00	METAL CHIP	1K	5%	1/10W
R519	1-216-055-00	METAL CHIP	1.8K	5%	1/10W
R520	1-216-049-00	METAL CHIP	1K	5%	1/10W
R521	1-216-053-00	METAL CHIP	1.5K	5%	1/10W
R522	1-216-037-00	METAL CHIP	330	5%	1/10W
R523	1-216-057-00	METAL CHIP	2.2K	5%	1/10W
R524	1-216-059-00	METAL CHIP	2.7K	5%	1/10W
R525	1-216-049-00	METAL CHIP	1K	5%	1/10W
R526	1-216-077-00	METAL CHIP	15K	5%	1/10W
R527	1-216-053-00	METAL CHIP	1.5K	5%	1/10W
R528	1-216-063-00	METAL CHIP	3.9K	5%	1/10W
R530	1-216-049-00	METAL CHIP	1K	5%	1/10W
R531	1-216-057-00	METAL CHIP	2.2K	5%	1/10W
R532	1-216-083-00	METAL CHIP	27K	5%	1/10W

The components identified by mark △ or dotted line with mark △ are critical for safety. Replace only with part number specified.

**MP-701**

Ref. No.	Part No.	Description	Remark		
R533	1-216-049-00	METAL CHIP	1K	5%	1/10W
R534	1-216-053-00	METAL CHIP	1.5K	5%	1/10W
R535	1-216-057-00	METAL CHIP	2.2K	5%	1/10W
R536	1-216-049-00	METAL CHIP	1K	5%	1/10W
R537	1-216-041-00	METAL CHIP	470	5%	1/10W
R538	1-216-045-00	METAL CHIP	680	5%	1/10W
R539	1-216-049-00	METAL CHIP	1K	5%	1/10W
R540	1-216-045-00	METAL CHIP	680	5%	1/10W
R541	1-216-057-00	METAL CHIP	2.2K	5%	1/10W
R542	1-216-027-00	METAL CHIP	120	5%	1/10W
R543	1-216-033-00	METAL CHIP	220	5%	1/10W
R544	1-216-041-00	METAL CHIP	470	5%	1/10W
R545	1-216-049-00	METAL CHIP	1K	5%	1/10W
R546	1-216-047-00	METAL CHIP	820	5%	1/10W
R547	1-216-075-00	METAL CHIP	12K	5%	1/10W
R548	1-216-051-00	METAL CHIP	1.2K	5%	1/10W
R549	1-216-053-00	METAL CHIP	1.5K	5%	1/10W
R550	1-216-049-00	METAL CHIP	1K	5%	1/10W
R551	1-216-035-00	METAL CHIP	270	5%	1/10W
R552	1-216-045-00	METAL CHIP	680	5%	1/10W
R553	1-216-055-00	METAL CHIP	1.8K	5%	1/10W
R554	1-216-049-00	METAL CHIP	1K	5%	1/10W
R555	1-216-057-00	METAL CHIP	2.2K	5%	1/10W
R556	1-216-051-00	METAL CHIP	1.2K	5%	1/10W
R558	1-216-077-00	METAL CHIP	15K	5%	1/10W
R559	1-216-041-00	METAL CHIP	470	5%	1/10W
R560	1-216-077-00	METAL CHIP	15K	5%	1/10W
R561	1-216-049-00	METAL CHIP	1K	5%	1/10W
R562	1-216-296-00	METAL CHIP	0	5%	1/8W
R601	1-216-295-00	METAL CHIP	0	5%	1/10W (450)
R602	1-216-095-00	METAL CHIP	82K	5%	1/10W
R603	1-216-101-00	METAL CHIP	150K	5%	1/10W
R604	1-216-081-00	METAL CHIP	22K	5%	1/10W
R605	1-216-065-00	METAL CHIP	4.7K	5%	1/10W
R606	1-216-049-00	METAL CHIP	1K	5%	1/10W
R607	1-216-049-00	METAL CHIP	1K	5%	1/10W
R608	1-216-049-00	METAL CHIP	1K	5%	1/10W
R609	1-216-049-00	METAL CHIP	1K	5%	1/10W
R610	1-216-049-00	METAL CHIP	1K	5%	1/10W
R611	1-216-049-00	METAL CHIP	1K	5%	1/10W
R612	1-216-049-00	METAL CHIP	1K	5%	1/10W
R613	1-216-049-00	METAL CHIP	1K	5%	1/10W
R614	1-216-049-00	METAL CHIP	1K	5%	1/10W
R615	1-216-049-00	METAL CHIP	1K	5%	1/10W
R616	1-216-025-00	METAL CHIP	100	5%	1/10W
R617	1-216-081-00	METAL CHIP	22K	5%	1/10W
R618	1-216-065-00	METAL CHIP	4.7K	5%	1/10W
R619	1-216-113-00	METAL CHIP	470K	5%	1/10W
R620	1-216-081-00	METAL CHIP	22K	5%	1/10W

Ref. No.	Part No.	Description	Remark		
R621	1-216-081-00	METAL CHIP	22K	5%	1/10W
R622	1-216-295-00	METAL CHIP	0	5%	1/10W (450)
R623	1-216-049-00	METAL CHIP	1K	5%	1/10W
R624	1-216-049-00	METAL CHIP	1K	5%	1/10W
R625	1-216-049-00	METAL CHIP	1K	5%	1/10W
R626	1-216-049-00	METAL CHIP	1K	5%	1/10W
R627	1-216-246-00	METAL GLAZE	100K	5%	1/8W
R628	1-216-043-00	METAL CHIP	560	5%	1/10W
R629	1-216-033-00	METAL CHIP	220	5%	1/10W
R630	1-216-049-00	METAL CHIP	1K	5%	1/10W
R631	1-216-049-00	METAL CHIP	1K	5%	1/10W
R632	1-216-049-00	METAL CHIP	1K	5%	1/10W
R633	1-216-033-00	METAL CHIP	220	5%	1/10W
R634	1-216-033-00	METAL CHIP	220	5%	1/10W
R635	1-216-295-00	METAL CHIP	0	5%	1/10W (450)
R636	1-216-097-00	METAL CHIP	100K	5%	1/10W
R638	1-216-073-00	METAL CHIP	10K	5%	1/10W
R639	1-216-071-00	METAL CHIP	8.2K	5%	1/10W
R640	1-216-055-00	METAL CHIP	1.8K	5%	1/10W
R641	1-216-037-00	METAL CHIP	330	5%	1/10W
R642	1-216-053-00	METAL CHIP	1.5K	5%	1/10W
R643	1-216-047-00	METAL CHIP	820	5%	1/10W
R644	1-216-053-00	METAL CHIP	1.5K	5%	1/10W
R645	1-216-063-00	METAL CHIP	3.9K	5%	1/10W
R646	1-216-029-00	METAL CHIP	150	5%	1/10W
R647	1-216-113-00	METAL CHIP	470K	5%	1/10W
R648	1-216-069-00	METAL CHIP	6.8K	5%	1/10W
R649	1-216-041-00	METAL CHIP	470	5%	1/10W
R650	1-216-059-00	METAL CHIP	2.7K	5%	1/10W
R651	1-216-043-00	METAL CHIP	560	5%	1/10W
R652	1-216-045-00	METAL CHIP	680	5%	1/10W
R653	1-216-033-00	METAL CHIP	220	5%	1/10W
R654	1-216-033-00	METAL CHIP	220	5%	1/10W
R655	1-216-033-00	METAL CHIP	220	5%	1/10W
R656	1-216-049-00	METAL CHIP	1K	5%	1/10W
R657	1-216-182-00	METAL GLAZE	220	5%	1/8W
R658	1-216-033-00	METAL CHIP	220	5%	1/10W
R659	1-216-033-00	METAL CHIP	220	5%	1/10W
R660	1-216-033-00	METAL CHIP	220	5%	1/10W
R661	1-216-049-00	METAL CHIP	1K	5%	1/10W
R662	1-216-073-00	METAL CHIP	10K	5%	1/10W
R663	1-216-033-00	METAL CHIP	220	5%	1/10W
R664	1-216-033-00	METAL CHIP	220	5%	1/10W
R665	1-216-033-00	METAL CHIP	220	5%	1/10W
R666	1-216-033-00	METAL CHIP	220	5%	1/10W
R667	1-216-081-00	METAL CHIP	22K	5%	1/10W
R668	1-216-049-00	METAL CHIP	1K	5%	1/10W
R669	1-216-033-00	METAL CHIP	220	5%	1/10W
R670	1-216-033-00	METAL CHIP	220	5%	1/10W

Ref. No.	Part No.	Description	Remark
R671	1-216-033-00	METAL CHIP	220 5% 1/10W
R672	1-216-033-00	METAL CHIP	220 5% 1/10W
R673	1-216-049-00	METAL CHIP	1K 5% 1/10W
R674	1-216-033-00	METAL CHIP	220 5% 1/10W
R675	1-216-099-00	METAL CHIP	120K 5% 1/10W
R676	1-216-075-00	METAL CHIP	12K 5% 1/10W
R677	1-216-073-00	METAL CHIP	10K 5% 1/10W
R678	1-216-073-00	METAL CHIP	10K 5% 1/10W
R679	1-216-085-00	METAL CHIP	33K 5% 1/10W
R680	1-216-192-00	METAL CHIP	560 5% 1/8W
R681	1-216-073-00	METAL CHIP	10K 5% 1/10W
R682	1-216-073-00	METAL CHIP	10K 5% 1/10W
R683	1-216-073-00	METAL CHIP	10K 5% 1/10W
R684	1-216-049-00	METAL CHIP	1K 5% 1/10W
R685	1-216-073-00	METAL CHIP	10K 5% 1/10W
R686	1-216-073-00	METAL CHIP	10K 5% 1/10W
R687	1-216-081-00	METAL CHIP	22K 5% 1/10W
R688	1-216-051-00	METAL CHIP	1.2K 5% 1/10W
R689	1-216-057-00	METAL CHIP	2.2K 5% 1/10W
R690	1-216-073-00	METAL CHIP	10K 5% 1/10W
R691	1-216-051-00	METAL CHIP	1.2K 5% 1/10W
R692	1-216-073-00	METAL CHIP	10K 5% 1/10W(650D)
R693	1-216-295-00	METAL CHIP	0 5% 1/10W (450)
R694	1-216-121-00	METAL CHIP	1M 5% 1/10W
R695	1-216-049-00	METAL CHIP	1K 5% 1/10W
R696	1-216-049-00	METAL CHIP	1K 5% 1/10W
R697	1-216-057-00	METAL CHIP	2.2K 5% 1/10W
R698	1-216-057-00	METAL CHIP	2.2K 5% 1/10W
△R699	1-212-950-00	FUSIBLE	4.7 5% 1/2W F
R700	1-216-687-11	METAL CHIP	33K 0.5% 1/10W
R701	1-216-685-11	METAL CHIP	27K 0.5% 1/10W
R702	1-216-049-00	METAL CHIP	1K 5% 1/10W
R703	1-216-089-00	METAL CHIP	47K 5% 1/10W
R704	1-216-081-00	METAL CHIP	22K 5% 1/10W
R705	1-216-057-00	METAL CHIP	2.2K 5% 1/10W
R706	1-216-081-00	METAL CHIP	22K 5% 1/10W
R707	1-216-105-00	METAL CHIP	220K 5% 1/10W (450)
R707	1-216-101-00	METAL CHIP	150K 5% 1/10W (650D)
R708	1-216-111-00	METAL CHIP	390K 5% 1/10W
R709	1-216-699-11	METAL CHIP	100K 0.5% 1/10W
R710	1-216-077-00	METAL CHIP	15K 5% 1/10W
R711	1-218-165-11	METAL GLAZE	220K 1% 1/10W
R712	1-216-057-00	METAL CHIP	2.2K 5% 1/10W
R713	1-216-677-11	METAL CHIP	12K 0.5% 1/10W
R714	1-216-021-00	METAL CHIP	68 5% 1/10W
R715	1-216-081-00	METAL CHIP	22K 5% 1/10W
R716	1-216-530-00	METAL GLAZE	390K 1% 1/10W
R717	1-216-035-00	METAL CHIP	270 5% 1/10W
R718	1-216-687-11	METAL CHIP	33K 0.5% 1/10W

Ref. No.	Part No.	Description	Remark
R719	1-216-675-11	METAL CHIP	10K 0.5% 1/10W
R720	1-216-679-11	METAL CHIP	15K 0.5% 1/10W
R721	1-216-065-00	METAL CHIP	4.7K 5% 1/10W
R722	1-216-025-00	METAL CHIP	100 5% 1/10W
R723	1-216-033-00	METAL CHIP	220 5% 1/10W
R724	1-216-033-00	METAL CHIP	220 5% 1/10W
R725	1-216-033-00	METAL CHIP	220 5% 1/10W
R726	1-216-238-00	METAL GLAZE	47K 5% 1/8W
R727	1-216-089-00	METAL CHIP	47K 5% 1/10W
R728	1-216-254-00	METAL GLAZE	220K 5% 1/8W
R729	1-216-061-00	METAL CHIP	3.3K 5% 1/10W
R730	1-216-089-00	METAL CHIP	47K 5% 1/10W (450)
R730	1-216-077-00	METAL CHIP	15K 5% 1/10W (650D)
R731	1-216-295-00	METAL CHIP	0 5% 1/10W
R732	1-216-295-00	METAL CHIP	0 5% 1/10W
R734	1-216-065-00	METAL CHIP	4.7K 5% 1/10W
R737	1-216-037-00	METAL CHIP	330 5% 1/10W
R738	1-216-073-00	METAL CHIP	10K 5% 1/10W
R739	1-216-111-00	METAL CHIP	390K 5% 1/10W (450)
R739	1-216-096-00	METAL CHIP	91K 5% 1/10W (650D)
R740	1-216-105-00	METAL CHIP	220K 5% 1/10W
R741	1-216-689-11	METAL CHIP	39K 0.5% 1/10W (450)
R741	1-216-070-00	METAL CHIP	8.2K 5% 1/10W (650D)
R742	1-216-095-00	METAL CHIP	82K 5% 1/10W
R743	1-216-099-00	METAL CHIP	120K 5% 1/10W
R744	1-216-073-00	METAL CHIP	10K 5% 1/10W
R745	1-216-073-00	METAL CHIP	10K 5% 1/10W
R746	1-216-049-00	METAL CHIP	1K 5% 1/10W
R801	1-216-073-00	METAL CHIP	10K 5% 1/10W
R802	1-216-679-11	METAL CHIP	15K 0.5% 1/10W
R804	1-216-651-11	METAL CHIP	1K 0.5% 1/10W
R805	1-216-655-11	METAL CHIP	1.5K 0.5% 1/10W
R806	1-216-655-11	METAL CHIP	1.5K 0.5% 1/10W
R807	1-216-693-11	METAL CHIP	56K 0.5% 1/10W
R808	1-216-073-00	METAL CHIP	10K 5% 1/10W
R809	1-216-689-11	METAL CHIP	39K 0.5% 1/10W
R810	1-216-295-00	METAL CHIP	0 5% 1/10W
R811	1-216-105-00	METAL CHIP	220K 5% 1/10W
R812	1-216-693-11	METAL CHIP	56K 0.5% 1/10W
R813	1-216-669-11	METAL CHIP	5.6K 0.5% 1/10W
R814	1-216-689-11	METAL CHIP	39K 0.5% 1/10W
R815	1-216-679-11	METAL CHIP	15K 0.5% 1/10W
R816	1-216-049-00	METAL CHIP	1K 5% 1/10W
R817	1-216-689-11	METAL CHIP	39K 0.5% 1/10W
R818	1-216-689-11	METAL CHIP	39K 0.5% 1/10W
R819	1-216-689-11	METAL CHIP	39K 0.5% 1/10W
R820	1-216-105-00	METAL CHIP	220K 5% 1/10W
R821	1-216-025-00	METAL CHIP	100 5% 1/10W
R822	1-216-669-11	METAL CHIP	5.6K 0.5% 1/10W
R823	1-216-689-11	METAL CHIP	39K 0.5% 1/10W
R824	1-216-679-11	METAL CHIP	15K 0.5% 1/10W
R825	1-216-025-00	METAL CHIP	100 5% 1/10W

The components identified by mark △ or dotted line with mark △ are critical for safety. Replace only with part number specified.

**MP-701**

Ref. No.	Part No.	Description	Remark
R826	1-216-693-11	METAL CHIP	56K 0.5% 1/10W
R827	1-216-689-11	METAL CHIP	39K 0.5% 1/10W
R828	1-216-693-11	METAL CHIP	56K 0.5% 1/10W
R829	1-216-025-00	METAL CHIP	100 5% 1/10W
R830	1-216-669-11	METAL CHIP	5.6K 0.5% 1/10W
R831	1-216-121-00	METAL CHIP	1M 5% 1/10W
R832	1-216-669-11	METAL CHIP	5.6K 0.5% 1/10W
R833	1-216-655-11	METAL CHIP	1.5K 0.5% 1/10W
R834	1-216-655-11	METAL CHIP	1.5K 0.5% 1/10W
R835	1-216-689-11	METAL CHIP	39K 0.5% 1/10W
R836	1-216-679-11	METAL CHIP	15K 0.5% 1/10W
R838	1-216-651-11	METAL CHIP	1K 0.5% 1/10W
R839	1-216-097-00	METAL CHIP	100K 5% 1/10W
R840	1-216-097-00	METAL CHIP	100K 5% 1/10W
R841	1-216-049-00	METAL CHIP	1K 5% 1/10W
R843	1-216-049-00	METAL CHIP	1K 5% 1/10W
R845	1-216-689-11	METAL CHIP	39K 0.5% 1/10W
R846	1-216-073-00	METAL CHIP	10K 5% 1/10W
R847	1-216-073-00	METAL CHIP	10K 5% 1/10W
R848	1-216-689-11	METAL CHIP	39K 0.5% 1/10W
R849	1-216-061-00	METAL CHIP	3.3K 5% 1/10W
R850	1-216-057-00	METAL CHIP	2.2K 5% 1/10W
R851	1-216-049-00	METAL CHIP	1K 5% 1/10W
R852	1-216-061-00	METAL CHIP	3.3K 5% 1/10W
R853	1-216-073-00	METAL CHIP	10K 5% 1/10W
R854	1-216-097-00	METAL CHIP	100K 5% 1/10W
R855	1-216-081-00	METAL CHIP	22K 5% 1/10W
R856	1-216-091-00	METAL CHIP	56K 5% 1/10W
R857	1-216-049-00	METAL CHIP	1K 5% 1/10W
R858	1-216-061-00	METAL CHIP	3.3K 5% 1/10W
R859	1-216-099-00	METAL CHIP	120K 5% 1/10W
R860	1-216-078-00	METAL GLAZE	16K 5% 1/10W
R861	1-216-099-00	METAL CHIP	120K 5% 1/10W
R862	1-216-651-11	METAL CHIP	1K 0.5% 1/10W
R863	1-216-081-00	METAL CHIP	22K 5% 1/10W
R864	1-216-639-11	METAL CHIP	330 0.5% 1/10W
R865	1-216-037-00	METAL CHIP	330 5% 1/10W
R867	1-216-081-00	METAL CHIP	22K 5% 1/10W
R868	1-216-105-00	METAL CHIP	220K 5% 1/10W
R869	1-216-049-00	METAL CHIP	1K 5% 1/10W
R871	1-216-081-00	METAL CHIP	22K 5% 1/10W
R872	1-216-037-00	METAL CHIP	330 5% 1/10W
R873	1-216-037-00	METAL CHIP	330 5% 1/10W
R875	1-216-095-00	METAL CHIP	82K 5% 1/10W
R876	1-216-049-00	METAL CHIP	1K 5% 1/10W
R877	1-216-049-00	METAL CHIP	1K 5% 1/10W
R879	1-216-105-00	METAL CHIP	220K 5% 1/10W
R880	1-216-105-00	METAL CHIP	220K 5% 1/10W
R882	1-216-109-00	METAL CHIP	330K 5% 1/10W

Ref. No.	Part No.	Description	Remark
R883	1-216-105-00	METAL CHIP	220K 5% 1/10W
R884	1-216-105-00	METAL CHIP	220K 5% 1/10W
R885	1-216-049-00	METAL CHIP	1K 5% 1/10W
R887	1-216-049-00	METAL CHIP	1K 5% 1/10W
R888	1-216-049-00	METAL CHIP	1K 5% 1/10W
R889	1-216-037-00	METAL CHIP	330 5% 1/10W
R890	1-216-037-00	METAL CHIP	330 5% 1/10W
R892	1-216-049-00	METAL CHIP	1K 5% 1/10W
R894	1-216-109-00	METAL CHIP	330K 5% 1/10W
R895	1-216-105-00	METAL CHIP	220K 5% 1/10W
R896	1-216-049-00	METAL CHIP	1K 5% 1/10W
R898	1-216-639-11	METAL CHIP	330 0.5% 1/10W
R899	1-216-037-00	METAL CHIP	330 5% 1/10W
R900	1-216-049-00	METAL CHIP	1K 5% 1/10W
R901	1-216-651-11	METAL CHIP	1K 0.5% 1/10W
R902	1-216-049-00	METAL CHIP	1K 5% 1/10W
R903	1-216-095-00	METAL CHIP	82K 5% 1/10W
R904	1-216-049-00	METAL CHIP	1K 5% 1/10W
R905	1-216-049-00	METAL CHIP	1K 5% 1/10W
R906	1-216-097-00	METAL CHIP	100K 5% 1/10W
R907	1-216-049-00	METAL CHIP	1K 5% 1/10W
R908	1-216-049-00	METAL CHIP	1K 5% 1/10W
R909	1-216-049-00	METAL CHIP	1K 5% 1/10W
R910	1-216-049-00	METAL CHIP	1K 5% 1/10W
R911	1-216-049-00	METAL CHIP	1K 5% 1/10W
R912	1-216-049-00	METAL CHIP	1K 5% 1/10W
R913	1-216-049-00	METAL CHIP	1K 5% 1/10W
R926	1-216-073-00	METAL CHIP	10K 5% 1/10W
R927	1-216-073-00	METAL CHIP	10K 5% 1/10W
R928	1-216-295-00	METAL CHIP	0 5% 1/10W(650D)
R929	1-216-296-00	METAL CHIP	0 5% 1/8W (450)
R930	1-216-073-00	METAL CHIP	10K 5% 1/10W
< VARIABLE RESISTOR >			
RV101	1-230-869-11	RES. ADJ. METAL	4.7K
RV102	1-230-866-11	RES. ADJ. METAL	470
RV103	1-230-866-11	RES. ADJ. METAL	470
RV104	1-230-870-11	RES. ADJ. METAL	10K
RV105	1-230-870-11	RES. ADJ. METAL	10K
RV106	1-230-870-11	RES. ADJ. METAL	10K
RV107	1-230-869-11	RES. ADJ. METAL	4.7K
RV108	1-230-874-11	RES. ADJ. METAL	100K
< VIBRATOR >			
X101	1-567-652-11	VIBRATOR, CRYSTAL	(13.300856MHz)
X601	1-579-754-21	VIBRATOR, CRYSTAL	(4.4375MHz)
X602	1-567-900-11	OSCILLATOR, CRYSTAL	(14.31818MHz)
X801	1-579-618-11	VIBRATOR, CRYSTAL	(22.5792MHz)

\*\*\*\*\*

Ref. No.	Part No.	Description	Remark
		MT-52 BOARD *****	
		< CAPACITOR >	
C001	1-161-063-00	CERAMIC CHIP 0.01uF 10% 50V	
		< CONNECTOR >	
CN001	1-506-481-11	PIN, CONNECTOR 2P, MALE	
*****			
*	A-6421-863-A	PS-701 BOARD, COMPLETE (650D: AEP)	
*****			
*	A-6421-874-A	PS-701 BOARD, COMPLETE (450)	
*****			
*	A-6421-886-A	PS-701 BOARD, COMPLETE (650D: UK, Australian)	
*****			
	1-533-189-11	HOLDER, FUSE	
	9-910-999-33	SHEET (F), ADHESIVE	
		< CAPACITOR >	
C101	1-126-946-11	ELECT 6800uF 20% 25V	
C102	1-126-946-11	ELECT 6800uF 20% 25V	
C103	1-163-038-00	CERAMIC CHIP 0.1uF 25V	
C104	1-164-161-11	CERAMIC CHIP 0.0022uF 10% 100V	
C105	1-163-989-11	CERAMIC CHIP 0.033uF 10% 25V	
C106	1-126-101-11	ELECT 100uF 20% 16V	
C107	1-124-471-00	ELECT 1000uF 20% 6.3V	
C108	1-124-903-11	ELECT 1uF 20% 50V	
C109	1-124-472-11	ELECT 470uF 20% 10V	
C110	1-163-833-00	CERAMIC CHIP 0.068uF 25V	
C111	1-163-007-11	CERAMIC CHIP 680PF 10% 50V	
C112	1-163-019-00	CERAMIC CHIP 0.0068uF 10% 50V	
C114	1-124-478-11	ELECT 100uF 20% 25V	
C115	1-163-037-11	CERAMIC CHIP 0.022uF 10% 25V	
C116	1-163-833-00	CERAMIC CHIP 0.068uF 25V	
C122	1-124-557-11	ELECT 1000uF 20% 25V	
C125	1-124-920-11	ELECT 330uF 20% 63V	
C126	1-124-910-11	ELECT 47uF 20% 50V	
C127	1-124-122-11	ELECT 100uF 20% 50V	
C128	1-124-557-11	ELECT 1000uF 20% 25V	
C131	1-124-479-11	ELECT 330uF 20% 25V	
C132	1-124-122-11	ELECT 100uF 20% 50V	
C133	1-124-477-11	ELECT 47uF 20% 25V	
C134	1-163-038-00	CERAMIC CHIP 0.1uF 25V	
C201	1-163-009-11	CERAMIC CHIP 0.001uF 10% 50V	
C202	1-163-019-00	CERAMIC CHIP 0.0068uF 10% 50V	
C204	1-163-009-11	CERAMIC CHIP 0.001uF 10% 50V	
C205	1-163-017-00	CERAMIC CHIP 0.0047uF 5% 50V	
C206	1-163-007-11	CERAMIC CHIP 680PF 10% 50V	
C208	1-163-035-00	CERAMIC CHIP 0.047uF 50V	

Ref. No.	Part No.	Description	Remark
C209	1-163-017-00	CERAMIC CHIP 0.0047uF 5% 50V	
C210	1-163-007-11	CERAMIC CHIP 680PF 10% 50V	
C211	1-163-017-00	CERAMIC CHIP 0.0047uF 5% 50V	
C212	1-163-035-00	CERAMIC CHIP 0.047uF 50V	
C213	1-124-913-11	ELECT 470uF 20% 50V	
		< CONNECTOR >	
* CN101	1-560-894-00	PIN, CONNECTOR 6P	
CN102	1-506-469-11	PIN, CONNECTOR 4P	
CN103	1-506-470-11	PIN, CONNECTOR 5P	
* CN104	1-560-894-00	PIN, CONNECTOR 6P	
CN105	1-506-473-11	PIN, CONNECTOR 8P	
* CN106	1-560-890-00	PIN, CONNECTOR 2P	
		< DIODE >	
△D101	8-719-500-55	DIODE D3SBA10	
△D102	8-719-200-82	DIODE 11ES2	
△D103	8-719-200-82	DIODE 11ES2	
D105	8-719-980-78	DIODE ERA83-006	
D108	8-719-105-82	DIODE RD5. 1M-B2	
△D109	8-719-200-82	DIODE 11ES2	
D110	8-719-110-83	DIODE RD36ES-B2	
D111	8-719-110-88	DIODE RD39ES-B2	
D112	8-719-110-06	DIODE RD8. 2ES-B1	
△D113	8-719-200-82	DIODE 11ES2	
△D114	8-719-200-82	DIODE 11ES2	
D115	8-719-911-19	DIODE 1SS119	
△D116	8-719-200-82	DIODE 11ES2	
△D117	8-719-200-82	DIODE 11ES2	
D118	8-719-911-19	DIODE 1SS119	
D119	8-719-110-22	DIODE RD11ES-B2	
D120	8-719-911-19	DIODE 1SS119	
D201	8-719-980-78	DIODE ERA83-006	
D202	8-719-980-78	DIODE ERA83-006	
D203	8-719-200-82	DIODE 11ES2	
D204	8-719-200-82	DIODE 11ES2	
D205	8-719-911-19	DIODE 1SS119	
D206	8-719-911-19	DIODE 1SS119	
D207	8-719-911-19	DIODE 1SS119	
		< IC >	
IC101	8-759-971-39	IC BA9700AF	
IC102	8-759-231-53	IC TA7805S	
IC201	8-759-085-67	IC 1M339NS	
IC202	8-759-100-96	IC uPC4558G2	
		< JUMPER RESISTOR >	
JR101	1-216-296-00	METAL CHIP 0 5% 1/8W	
JR102	1-216-296-00	METAL CHIP 0 5% 1/8W	

The components identified by mark △ or dotted line with mark △ are critical for safety. Replace only with part number specified.

# PS-701

Ref. No.	Part No.	Description	Remark		
JR103	1-216-295-00	METAL CHIP	0	5%	1/10W
JR104	1-216-296-00	METAL CHIP	0	5%	1/8W
JR105	1-216-296-00	METAL CHIP	0	5%	1/8W
JR106	1-216-296-00	METAL CHIP	0	5%	1/8W
JR107	1-216-296-00	METAL CHIP	0	5%	1/8W
JR108	1-216-296-00	METAL CHIP	0	5%	1/8W
JR109	1-216-296-00	METAL CHIP	0	5%	1/8W
JR110	1-216-296-00	METAL CHIP	0	5%	1/8W
JR111	1-216-296-00	METAL CHIP	0	5%	1/8W
JR112	1-216-296-00	METAL CHIP	0	5%	1/8W
JR113	1-216-296-00	METAL CHIP	0	5%	1/8W
JR114	1-216-296-00	METAL CHIP	0	5%	1/8W
JR115	1-216-296-00	METAL CHIP	0	5%	1/8W

< COIL >

L101	1-424-219-11	COIL, CHOKE 300uH
L102	1-412-012-11	INDUCTOR 100uH
L104	1-410-339-11	COIL, CHOKE 10uH
L201	1-424-219-11	COIL, CHOKE 300uH

< IC LINK >

△PS103	1-532-605-00	LINK, IC 0.4A
△PS105	1-532-685-00	LINK, IC
△PS201	1-532-675-00	LINK, IC 1.5A
△PS202	1-532-675-00	LINK, IC 1.5A

< TRANSISTOR >

Q101	8-729-119-78	TRANSISTOR	2SC2785-HFE
Q102	8-729-216-22	TRANSISTOR	2SA1162-G
Q103	8-729-117-11	TRANSISTOR	2SB1151-L
Q108	8-729-140-97	TRANSISTOR	2SB734-34
Q111	8-729-141-75	TRANSISTOR	2SD596DV345
Q112	8-729-142-46	TRANSISTOR	2SC2001-LX
Q201	8-729-117-11	TRANSISTOR	2SB1151-L
Q202	8-729-143-30	TRANSISTOR	2SD1691K
Q203	8-729-117-11	TRANSISTOR	2SB1151-L
Q204	8-729-143-30	TRANSISTOR	2SD1691K
Q205	8-729-119-78	TRANSISTOR	2SC2785-HFE
Q206	8-729-216-22	TRANSISTOR	2SA1162-G
Q208	8-729-900-53	TRANSISTOR	DTC114EK
Q209	8-729-901-04	TRANSISTOR	DTA114EK
Q210	8-729-100-67	TRANSISTOR	2SC1623-L7
Q211	8-729-119-76	TRANSISTOR	2SA1175-HFE
Q212	8-729-901-04	TRANSISTOR	DTA114EK

< RESISTOR >

R101	1-216-073-00	METAL CHIP	10K	5%	1/10W
R102	1-216-073-00	METAL CHIP	10K	5%	1/10W
R103	1-216-089-00	METAL CHIP	47K	5%	1/10W

Ref. No.	Part No.	Description	Remark		
R104	1-216-065-00	METAL CHIP	4.7K	5%	1/10W
R105	1-216-073-00	METAL CHIP	10K	5%	1/10W
R106	1-216-053-00	METAL CHIP	1.5K	5%	1/10W
R107	1-216-067-00	METAL CHIP	5.6K	5%	1/10W
R108	1-216-043-00	METAL CHIP	560	5%	1/10W
R109	1-216-691-11	METAL CHIP	47K	0.5%	1/10W
R110	1-216-679-11	METAL CHIP	15K	0.5%	1/10W
R112	1-216-099-00	METAL CHIP	120K	5%	1/10W
R114	1-216-097-00	METAL CHIP	100K	5%	1/10W
R120	1-216-043-00	METAL CHIP	560	5%	1/10W
R122	1-216-073-00	METAL CHIP	10K	5%	1/10W
R124	1-216-025-00	METAL CHIP	100	5%	1/10W
R125	1-216-057-00	METAL CHIP	2.2K	5%	1/10W
△R126	1-212-867-00	FUSIBLE	27	5%	1/4W F
R128	1-216-053-00	METAL CHIP	1.5K	5%	1/10W
R129	1-216-073-00	METAL CHIP	10K	5%	1/10W
R199	1-216-079-00	METAL CHIP	18K	5%	1/10W
R201	1-216-081-00	METAL CHIP	22K	5%	1/10W
R202	1-216-075-00	METAL CHIP	12K	5%	1/10W
R203	1-216-093-00	METAL CHIP	68K	5%	1/10W
R204	1-216-065-00	METAL CHIP	4.7K	5%	1/10W
R205	1-216-075-00	METAL CHIP	12K	5%	1/10W
R206	1-216-097-00	METAL CHIP	100K	5%	1/10W
R207	1-216-073-00	METAL CHIP	10K	5%	1/10W
R208	1-216-073-00	METAL CHIP	10K	5%	1/10W
R209	1-216-073-00	METAL CHIP	10K	5%	1/10W
R210	1-216-105-00	METAL CHIP	220K	5%	1/10W
R211	1-216-073-00	METAL CHIP	10K	5%	1/10W
R212	1-216-065-00	METAL CHIP	4.7K	5%	1/10W
R213	1-216-049-00	METAL CHIP	1K	5%	1/10W
R214	1-247-750-11	CARBON	680	5%	1/2W
R215	1-247-750-11	CARBON	680	5%	1/2W
R216	1-216-049-00	METAL CHIP	1K	5%	1/10W
R217	1-216-369-00	METAL OXIDE	1	5%	2W F
R218	1-216-690-11	METAL CHIP	43K	0.5%	1/10W
R219	1-216-675-11	METAL CHIP	10K	0.5%	1/10W
R220	1-216-690-11	METAL CHIP	43K	0.5%	1/10W
R221	1-216-675-11	METAL CHIP	10K	0.5%	1/10W
R222	1-216-073-00	METAL CHIP	10K	5%	1/10W
R223	1-216-073-00	METAL CHIP	10K	5%	1/10W
R224	1-215-866-11	METAL OXIDE	330	5%	1W F
R225	1-216-073-00	METAL CHIP	10K	5%	1/10W
R226	1-247-750-11	CARBON	680	5%	1/2W
R227	1-216-073-00	METAL CHIP	10K	5%	1/10W
R228	1-216-093-00	METAL CHIP	68K	5%	1/10W
R230	1-216-105-00	METAL CHIP	220K	5%	1/10W

The components identified by mark △ or dotted line with mark △ are critical for safety. Replace only with part number specified.



Ref. No. Part No. Description Remark

< RELAY >

RY101 1-515-833-11 RELAY

\*\*\*\*\*

\* A-6421-879-A RG-701 BOARD, COMPLETE (6500)

\*\*\*\*\*

< CAPACITOR >

C001 1-163-106-00 CERAMIC CHIP 36PF 5% 50V
C002 1-164-713-11 CERAMIC CHIP 0.0056uF 5% 50V
C003 1-164-713-11 CERAMIC CHIP 0.0056uF 5% 50V
C004 1-124-477-11 ELECT 47uF 20% 16V
C005 1-163-038-00 CERAMIC CHIP 0.1uF 25V

C007 1-163-105-00 CERAMIC CHIP 33PF 5% 50V
C008 1-163-121-00 CERAMIC CHIP 150PF 5% 50V
C009 1-124-903-11 ELECT 1uF 20% 50V
C012 1-123-382-00 ELECT 3.3uF 20% 100V
C013 1-124-477-11 ELECT 47uF 20% 25V

C016 1-124-903-11 ELECT 1uF 20% 50V
C017 1-163-125-00 CERAMIC CHIP 220PF 5% 50V
C018 1-164-232-11 CERAMIC CHIP 0.01uF 50V
C019 1-163-038-00 CERAMIC CHIP 0.1uF 25V
C020 1-124-477-11 ELECT 47uF 20% 25V

C021 1-124-907-11 ELECT 10uF 20% 50V
C022 1-124-903-11 ELECT 1uF 20% 50V
C023 1-124-903-11 ELECT 1uF 20% 50V
C024 1-124-477-11 ELECT 47uF 20% 25V
C025 1-124-903-11 ELECT 1uF 20% 50V

C026 1-163-077-00 CERAMIC CHIP 0.1uF 10% 25V
C027 1-124-589-11 ELECT 47uF 20% 16V
C028 1-163-038-00 CERAMIC CHIP 0.1uF 25V
C029 1-163-038-00 CERAMIC CHIP 0.1uF 25V
C030 1-163-113-00 CERAMIC CHIP 68PF 5% 50V

C031 1-124-477-11 ELECT 47uF 20% 25V
C032 1-124-477-11 ELECT 47uF 20% 25V
C033 1-163-038-00 CERAMIC CHIP 0.1uF 25V
C034 1-163-133-00 CERAMIC CHIP 470PF 5% 50V
C035 1-163-251-11 CERAMIC CHIP 100PF 5% 50V

C036 1-124-477-11 ELECT 47uF 20% 25V
C037 1-163-251-11 CERAMIC CHIP 100PF 5% 50V
C039 1-124-477-11 ELECT 47uF 20% 25V
C067 1-163-038-00 CERAMIC CHIP 0.1uF 25V
C069 1-163-113-00 CERAMIC CHIP 68PF 5% 50V

C070 1-124-902-00 ELECT 0.47uF 20% 50V

< CONNECTOR >

CN001 1-569-341-11 CONNECTOR, BOARD TO BOARD 19P

Ref. No. Part No. Description Remark

< TRIMMER >

CT001 1-141-245-00 CAP, TRIMMER 30PF

< DIODE >

D001 8-729-104-26 TRANSISTOR 2SB804-AW

< IC >

IC001 1-466-870-11 IC FILTER BLOCK, COMB (HCF0200)
IC002 8-759-008-67 IC MC14066BF
IC003 8-759-072-63 IC uPC1482G-E1
IC004 8-759-925-74 IC SN74HC04ANS

< COIL >

L001 1-408-609-41 INDUCTOR 33uH
L002 1-408-609-41 INDUCTOR 33uH
L003 1-408-609-41 INDUCTOR 33uH
L004 1-408-609-41 INDUCTOR 33uH
L005 1-408-609-41 INDUCTOR 33uH

< TRANSISTOR >

Q003 8-729-900-53 TRANSISTOR DTC114EK
Q004 8-729-120-28 TRANSISTOR 2SC1623-L5L6
Q005 8-729-120-28 TRANSISTOR 2SC1623-L5L6
Q006 8-729-120-28 TRANSISTOR 2SC1623-L5L6
Q007 8-729-120-28 TRANSISTOR 2SC1623-L5L6

Q008 8-729-120-28 TRANSISTOR 2SC1623-L5L6
Q009 8-729-120-28 TRANSISTOR 2SC1623-L5L6
Q011 8-729-216-22 TRANSISTOR 2SA1162-G
Q013 8-729-120-28 TRANSISTOR 2SC1623-L5L6
Q014 8-729-216-22 TRANSISTOR 2SA1162-G

Q016 8-729-120-28 TRANSISTOR 2SC1623-L5L6
Q017 8-729-216-22 TRANSISTOR 2SA1162-G
Q018 8-729-120-28 TRANSISTOR 2SC1623-L5L6
Q030 8-729-120-28 TRANSISTOR 2SC1623-L5L6

< RESISTOR >

R001 1-216-069-00 METAL CHIP 6.8K 5% 1/10W
R002 1-216-067-00 METAL CHIP 5.6K 5% 1/10W
R006 1-216-097-00 METAL CHIP 100K 5% 1/10W
R007 1-216-097-00 METAL CHIP 100K 5% 1/10W
R008 1-216-055-00 METAL CHIP 1.8K 5% 1/10W

R009 1-216-045-00 METAL CHIP 680 5% 1/10W
R010 1-216-097-00 METAL CHIP 100K 5% 1/10W
R012 1-216-061-00 METAL CHIP 3.3K 5% 1/10W
R013 1-216-065-00 METAL CHIP 4.7K 5% 1/10W
R018 1-216-041-00 METAL CHIP 470 5% 1/10W

R020 1-216-061-00 METAL CHIP 3.3K 5% 1/10W
R021 1-216-035-00 METAL CHIP 270 5% 1/10W

The components identified by mark A or dotted line with mark. A are critical for safety. Replace only with part number specified.

**RG-701****SV-63**

Ref. No.	Part No.	Description	Remark		
R022	1-216-051-00	METAL CHIP	1.2K	5%	1/10W
R023	1-216-057-00	METAL CHIP	2.2K	5%	1/10W
R024	1-216-051-00	METAL CHIP	1.2K	5%	1/10W
R026	1-216-049-00	METAL CHIP	1K	5%	1/10W
R027	1-216-041-00	METAL CHIP	470	5%	1/10W
R028	1-216-073-00	METAL CHIP	10K	5%	1/10W
R029	1-216-081-00	METAL CHIP	22K	5%	1/10W
R030	1-216-067-00	METAL CHIP	5.6K	5%	1/10W
R031	1-216-073-00	METAL CHIP	10K	5%	1/10W
R032	1-216-021-00	METAL CHIP	68	5%	1/10W
R033	1-216-065-00	METAL CHIP	4.7K	5%	1/10W
R034	1-216-091-00	METAL CHIP	56K	5%	1/10W
R035	1-216-083-00	METAL CHIP	27K	5%	1/10W
R036	1-216-043-00	METAL CHIP	560	5%	1/10W
R037	1-216-067-00	METAL CHIP	5.6K	5%	1/10W
R040	1-216-021-00	METAL CHIP	68	5%	1/10W
R041	1-216-043-00	METAL CHIP	560	5%	1/10W
R047	1-216-083-00	METAL CHIP	27K	5%	1/10W
R048	1-216-067-00	METAL CHIP	5.6K	5%	1/10W
R049	1-216-021-00	METAL CHIP	68	5%	1/10W
R050	1-216-043-00	METAL CHIP	560	5%	1/10W
R051	1-216-083-00	METAL CHIP	27K	5%	1/10W
R052	1-216-069-00	METAL CHIP	6.8K	5%	1/10W
R056	1-216-295-00	METAL CHIP	0	5%	1/10W
R057	1-216-295-00	METAL CHIP	0	5%	1/10W
R058	1-216-065-00	METAL CHIP	4.7K	5%	1/10W
R059	1-216-067-00	METAL CHIP	5.6K	5%	1/10W
R060	1-216-063-00	METAL CHIP	3.9K	5%	1/10W
R061	1-216-065-00	METAL CHIP	4.7K	5%	1/10W
R062	1-216-061-00	METAL CHIP	3.3K	5%	1/10W
R067	1-216-043-00	METAL CHIP	560	5%	1/10W
R068	1-216-043-00	METAL CHIP	560	5%	1/10W
R069	1-216-043-00	METAL CHIP	560	5%	1/10W
R086	1-216-089-00	METAL CHIP	47K	5%	1/10W
R087	1-216-061-00	METAL CHIP	3.3K	5%	1/10W
R095	1-216-121-00	METAL CHIP	1M	5%	1/10W
R121	1-216-073-00	METAL CHIP	10K	5%	1/10W
R123	1-216-065-00	METAL CHIP	4.7K	5%	1/10W
R124	1-216-295-00	METAL CHIP	0	5%	1/10W
R125	1-216-021-00	METAL CHIP	68	5%	1/10W
< VARIABLE RESISTOR >					
RV001	1-241-630-11	RES, ADJ, CARBON 10K			
RV002	1-238-011-11	RES, ADJ, CARBON 470			
RV003	1-238-011-11	RES, ADJ, CARBON 470			
RV004	1-241-628-11	RES, ADJ, CARBON 2.2K			
RV005	1-241-628-11	RES, ADJ, CARBON 2.2K			
RV006	1-241-628-11	RES, ADJ, CARBON 2.2K			

Ref. No.	Part No.	Description	Remark		
< VIBRATOR >					
X001	1-567-505-11	OSCILLATOR, CRYSTAL (3.579545MHz)			
*****					
A-6421-465-A SV-63 BOARD, COMPLETE					
*****					
< CAPACITOR >					
C001	1-163-038-00	CERAMIC CHIP	0.1uF		25V
C003	1-163-093-00	CERAMIC CHIP	10PF	5%	50V
C005	1-163-035-00	CERAMIC CHIP	0.047uF		50V
C006	1-163-035-00	CERAMIC CHIP	0.047uF		50V
C009	1-163-038-00	CERAMIC CHIP	0.1uF		25V
C010	1-163-121-00	CERAMIC CHIP	150PF	5%	50V
C011	1-163-017-00	CERAMIC CHIP	0.0047uF	5%	50V
C012	1-164-161-11	CERAMIC CHIP	0.0022uF	10%	100V
C013	1-124-584-00	ELECT	100uF	20%	10V
C014	1-164-232-11	CERAMIC CHIP	0.01uF		50V
C015	1-163-989-11	CERAMIC CHIP	0.033uF	10%	25V
C019	1-164-232-11	CERAMIC CHIP	0.01uF		50V
C020	1-124-465-00	ELECT	0.47uF	20%	50V
C021	1-164-232-11	CERAMIC CHIP	0.01uF		50V
C101	1-128-057-11	ELECT	330uF	20%	6.3V
C102	1-128-057-11	ELECT	330uF	20%	6.3V
C103	1-124-242-00	ELECT	33uF	20%	25V
C104	1-124-242-00	ELECT	33uF	20%	25V
C105	1-163-035-00	CERAMIC CHIP	0.047uF		50V
C106	1-163-035-00	CERAMIC CHIP	0.047uF		50V
C107	1-163-035-00	CERAMIC CHIP	0.047uF		50V
C108	1-163-035-00	CERAMIC CHIP	0.047uF		50V
C109	1-163-038-00	CERAMIC CHIP	0.1uF		25V
C110	1-163-038-00	CERAMIC CHIP	0.1uF		25V
C111	1-126-160-11	ELECT	1uF	20%	50V
C112	1-163-109-00	CERAMIC CHIP	47PF	5%	50V
C113	1-163-093-00	CERAMIC CHIP	10PF	5%	50V
C114	1-126-160-11	ELECT	1uF	20%	50V
C115	1-163-019-00	CERAMIC CHIP	0.0068uF	10%	50V
C116	1-126-160-11	ELECT	1uF	20%	50V
C117	1-164-161-11	CERAMIC CHIP	0.0022uF	10%	100V
C118	1-163-014-00	CERAMIC CHIP	0.0027uF	10%	50V
C119	1-163-038-00	CERAMIC CHIP	0.1uF		25V
C120	1-163-038-00	CERAMIC CHIP	0.1uF		25V
C121	1-163-037-11	CERAMIC CHIP	0.022uF	10%	25V
C122	1-163-129-00	CERAMIC CHIP	330PF	5%	50V
C123	1-163-115-00	CERAMIC CHIP	82PF	5%	50V
C124	1-163-101-00	CERAMIC CHIP	22PF	5%	50V
C125	1-163-137-00	CERAMIC CHIP	680PF	5%	50V
C126	1-163-093-00	CERAMIC CHIP	10PF	5%	50V

Ref. No.	Part No.	Description	Remark
C127	1-124-499-11	ELECT, NONPOLAR R 1uF	20% 50V
C128	1-126-320-11	ELECT, NONPOLAR R 10uF	20% 16V
C129	1-136-165-00	FILM 0.1uF	5% 50V
C130	1-126-320-11	ELECT, NONPOLAR R 10uF	20% 16V
C131	1-163-037-11	CERAMIC CHIP 0.022uF	10% 25V
C132	1-163-035-00	CERAMIC CHIP 0.047uF	50V
C135	1-163-024-00	CERAMIC CHIP 0.018uF	10% 50V
C136	1-136-169-00	FILM 0.22uF	5% 50V
C137	1-163-022-00	CERAMIC CHIP 0.012uF	10% 50V
C138	1-163-022-00	CERAMIC CHIP 0.012uF	10% 50V
C139	1-124-282-00	ELECT 22uF	20% 16V
C140	1-104-485-11	ELECT 3.3uF	20% 25V
C141	1-164-232-11	CERAMIC CHIP 0.01uF	50V
C144	1-163-016-00	CERAMIC CHIP 0.0039uF	10% 50V
C145	1-163-024-00	CERAMIC CHIP 0.018uF	10% 50V
C146	1-164-232-11	CERAMIC CHIP 0.01uF	50V
C147	1-136-169-00	FILM 0.22uF	5% 50V
C149	1-164-232-11	CERAMIC CHIP 0.01uF	50V
C150	1-124-589-11	ELECT 47uF	20% 16V
C151	1-124-589-11	ELECT 47uF	20% 16V
C152	1-163-035-00	CERAMIC CHIP 0.047uF	50V
C153	1-163-035-00	CERAMIC CHIP 0.047uF	50V
< CONNECTOR >			
CN101	1-566-939-11	CONNECTOR, F. P. C 24P	
CN102	1-563-493-11	CONNECTOR, F. P. C 28P	
CN103	1-506-485-11	PIN, CONNECTOR 6P	
CN104	1-506-482-11	PIN, CONNECTOR 3P	
* CN105	1-566-969-11	HOUSING, CONNECTOR (PC BOARD) 7P	
* CN106	1-566-968-11	HOUSING, CONNECTOR (PC BOARD) 6P	
< DIODE >			
D001	8-719-911-19	DIODE 1SS119	
D101	8-719-911-19	DIODE 1SS119	
D102	8-719-109-72	DIODE RD3. 9ES-B2	
D103	8-719-911-19	DIODE 1SS119	
D104	8-719-911-19	DIODE 1SS119	
< FUSE >			
△F001	1-532-775-11	FUSE, MICRO (SECONDARY)	
< FILTER >			
F001	1-235-922-11	FILTER, LOW PASS (1.7MHz)	
< IC >			
IC001	8-752-050-19	IC CXA1081M	
IC002	8-759-603-24	IC CX20197	
IC101	8-759-321-40	IC HA11529	

Ref. No.	Part No.	Description	Remark
IC102	8-759-822-38	IC LA6510	
IC103	8-759-981-92	IC RC4558M	
IC104	8-759-981-92	IC RC4558M	
IC105	8-759-981-92	IC RC4558M	
IC106	8-759-300-71	IC HD14053BFP	
< JUMPER RESISTOR >			
JR102	1-216-295-00	METAL CHIP	0 5% 1/10W
JR103	1-216-296-00	METAL CHIP	0 5% 1/8W
JR104	1-216-296-00	METAL CHIP	0 5% 1/8W
JR105	1-216-295-00	METAL CHIP	0 5% 1/10W
JR106	1-216-296-00	METAL CHIP	0 5% 1/8W
JR107	1-216-295-00	METAL CHIP	0 5% 1/10W
JR111	1-216-296-00	METAL CHIP	0 5% 1/8W
JR112	1-216-296-00	METAL CHIP	0 5% 1/8W
JR113	1-216-296-00	METAL CHIP	0 5% 1/8W
JR114	1-216-295-00	METAL CHIP	0 5% 1/10W
JR115	1-216-296-00	METAL CHIP	0 5% 1/8W
JR116	1-216-295-00	METAL CHIP	0 5% 1/10W
JR117	1-216-295-00	METAL CHIP	0 5% 1/10W
JR118	1-216-296-00	METAL CHIP	0 5% 1/8W
JR119	1-216-296-00	METAL CHIP	0 5% 1/8W
JR121	1-216-296-00	METAL CHIP	0 5% 1/8W
JR122	1-216-296-00	METAL CHIP	0 5% 1/8W
JR123	1-216-296-00	METAL CHIP	0 5% 1/8W
JR124	1-216-296-00	METAL CHIP	0 5% 1/8W
JR125	1-216-296-00	METAL CHIP	0 5% 1/8W
JR126	1-216-296-00	METAL CHIP	0 5% 1/8W
JR127	1-216-295-00	METAL CHIP	0 5% 1/10W
JR128	1-216-296-00	METAL CHIP	0 5% 1/8W
JR129	1-216-296-00	METAL CHIP	0 5% 1/8W
JR130	1-216-296-00	METAL CHIP	0 5% 1/8W
JR132	1-216-296-00	METAL CHIP	0 5% 1/8W
JR133	1-216-296-00	METAL CHIP	0 5% 1/8W
JR134	1-216-296-00	METAL CHIP	0 5% 1/8W
JR135	1-216-296-00	METAL CHIP	0 5% 1/8W
JR136	1-216-296-00	METAL CHIP	0 5% 1/8W
JR137	1-216-296-00	METAL CHIP	0 5% 1/8W
JR138	1-216-296-00	METAL CHIP	0 5% 1/8W
JR139	1-216-296-00	METAL CHIP	0 5% 1/8W
JR140	1-216-296-00	METAL CHIP	0 5% 1/8W
JR141	1-216-296-00	METAL CHIP	0 5% 1/8W
JR142	1-216-296-00	METAL CHIP	0 5% 1/8W
JR143	1-216-296-00	METAL CHIP	0 5% 1/8W
JR144	1-216-296-00	METAL CHIP	0 5% 1/8W
JR145	1-216-296-00	METAL CHIP	0 5% 1/8W
JR146	1-216-296-00	METAL CHIP	0 5% 1/8W
JR147	1-216-296-00	METAL CHIP	0 5% 1/8W
JR148	1-216-296-00	METAL CHIP	0 5% 1/8W

The components identified by mark △ or dotted line with mark △ are critical for safety. Replace only with part number specified.

**SV-63**

Ref. No.	Part No.	Description	Remark		
JR149	1-216-296-00	METAL CHIP	0	5%	1/8W
JR150	1-216-296-00	METAL CHIP	0	5%	1/8W
JR153	1-216-296-00	METAL CHIP	0	5%	1/8W
JR154	1-216-296-00	METAL CHIP	0	5%	1/8W
JR155	1-216-296-00	METAL CHIP	0	5%	1/8W
JR156	1-216-296-00	METAL CHIP	0	5%	1/8W
JR158	1-216-295-00	METAL CHIP	0	5%	1/10W
JR159	1-216-296-00	METAL CHIP	0	5%	1/8W
JR160	1-216-296-00	METAL CHIP	0	5%	1/8W
JR161	1-216-296-00	METAL CHIP	0	5%	1/8W
JR162	1-216-296-00	METAL CHIP	0	5%	1/8W
JR164	1-216-296-00	METAL CHIP	0	5%	1/8W
JR166	1-216-295-00	METAL CHIP	0	5%	1/10W
JR170	1-216-296-00	METAL CHIP	0	5%	1/8W
JR171	1-216-295-00	METAL CHIP	0	5%	1/10W
JR172	1-216-296-00	METAL CHIP	0	5%	1/8W
JR173	1-216-296-00	METAL CHIP	0	5%	1/8W
JR174	1-216-296-00	METAL CHIP	0	5%	1/8W
JR175	1-216-295-00	METAL CHIP	0	5%	1/10W
JR176	1-216-296-00	METAL CHIP	0	5%	1/8W
JR177	1-216-296-00	METAL CHIP	0	5%	1/8W
JR178	1-216-296-00	METAL CHIP	0	5%	1/8W
JR179	1-216-296-00	METAL CHIP	0	5%	1/8W
JR180	1-216-296-00	METAL CHIP	0	5%	1/8W
JR181	1-216-296-00	METAL CHIP	0	5%	1/8W
JR182	1-216-296-00	METAL CHIP	0	5%	1/8W
JR183	1-216-295-00	METAL CHIP	0	5%	1/10W
JR184	1-216-296-00	METAL CHIP	0	5%	1/8W
JR185	1-216-296-00	METAL CHIP	0	5%	1/8W
JR186	1-216-296-00	METAL CHIP	0	5%	1/8W
JR187	1-216-296-00	METAL CHIP	0	5%	1/8W
JR188	1-216-296-00	METAL CHIP	0	5%	1/8W
JR189	1-216-295-00	METAL CHIP	0	5%	1/10W
JR191	1-216-296-00	METAL CHIP	0	5%	1/8W
JR192	1-216-296-00	METAL CHIP	0	5%	1/8W
JR193	1-216-296-00	METAL CHIP	0	5%	1/8W
JR194	1-216-296-00	METAL CHIP	0	5%	1/8W
JR195	1-216-295-00	METAL CHIP	0	5%	1/10W
JR196	1-216-296-00	METAL CHIP	0	5%	1/8W
JR197	1-216-296-00	METAL CHIP	0	5%	1/8W
JR198	1-216-296-00	METAL CHIP	0	5%	1/8W
JR199	1-216-296-00	METAL CHIP	0	5%	1/8W
JR200	1-216-296-00	METAL CHIP	0	5%	1/8W
JR201	1-216-296-00	METAL CHIP	0	5%	1/8W
JR202	1-216-296-00	METAL CHIP	0	5%	1/8W
JR203	1-216-296-00	METAL CHIP	0	5%	1/8W
JR204	1-216-296-00	METAL CHIP	0	5%	1/8W
JR205	1-216-295-00	METAL CHIP	0	5%	1/10W

Ref. No.	Part No.	Description	Remark		
JR206	1-216-295-00	METAL CHIP	0	5%	1/10W
JR207	1-216-296-00	METAL CHIP	0	5%	1/8W
JR208	1-216-296-00	METAL CHIP	0	5%	1/8W
JR209	1-216-295-00	METAL CHIP	0	5%	1/10W
JR210	1-216-295-00	METAL CHIP	0	5%	1/10W
JR211	1-216-296-00	METAL CHIP	0	5%	1/8W
JR212	1-216-296-00	METAL CHIP	0	5%	1/8W
JR213	1-216-296-00	METAL CHIP	0	5%	1/8W
JR214	1-216-296-00	METAL CHIP	0	5%	1/8W
JR215	1-216-295-00	METAL CHIP	0	5%	1/10W
JR216	1-216-295-00	METAL CHIP	0	5%	1/10W
JR217	1-216-295-00	METAL CHIP	0	5%	1/10W
JR218	1-216-296-00	METAL CHIP	0	5%	1/8W
JR219	1-216-295-00	METAL CHIP	0	5%	1/10W
JR220	1-216-296-00	METAL CHIP	0	5%	1/8W
JR221	1 216 296-00	METAL CHIP	0	5%	1/8W
< COIL >					
L101	1-410-509-11	INDUCTOR 10uH			
L102	1-410-509-11	INDUCTOR 10uH			
L103	1-410-509-11	INDUCTOR 10uH			
< TRANSISTOR >					
Q001	8-729-140-97	TRANSISTOR	2SB734-34		
Q002	8-729-216-22	TRANSISTOR	2SA1162-G		
Q003	8-729-303-37	TRANSISTOR	2SD655-E		
Q101	8-729-209-15	TRANSISTOR	2SD2012		
Q102	8-729-924-90	TRANSISTOR	2SB1370-EF		
Q103	8-729-209-15	TRANSISTOR	2SD2012		
Q104	8-729-924-90	TRANSISTOR	2SB1370-EF		
Q105	8-729-100-66	TRANSISTOR	2SC1623-L6		
Q106	8-729-100-66	TRANSISTOR	2SC1623-L6		
Q107	8-729-901-00	TRANSISTOR	DTC124EK		
Q108	8-729-100-66	TRANSISTOR	2SC1623-L6		
Q109	8-729-216-22	TRANSISTOR	2SA1162-G		
< RESISTOR >					
R001	1-216-049-00	METAL CHIP	1K	5%	1/10W
R002	1-216-057-00	METAL CHIP	2.2K	5%	1/10W
R003	1-216-065-00	METAL CHIP	4.7K	5%	1/10W
R004	1-216-057-00	METAL CHIP	2.2K	5%	1/10W
R005	1-216-049-00	METAL CHIP	1K	5%	1/10W
R006	1-216-049-00	METAL CHIP	1K	5%	1/10W
R007	1-216-023-00	METAL CHIP	82	5%	1/10W
R008	1-216-043-00	METAL CHIP	360	5%	1/10W
R009	1-216-073-00	METAL CHIP	10K	5%	1/10W
R010	1-216-095-00	METAL CHIP	82K	5%	1/10W
R011	1-216-081-00	METAL CHIP	22K	5%	1/10W

Ref. No.	Part No.	Description			Remark	Ref. No.	Part No.	Description			Remark
R012	1 249-394-11	CARBON	12	5%	1/6W F	R140	1-216-037-00	METAL CHIP	330	5%	1/10W
R013	1-216-073-00	METAL CHIP	10K	5%	1/10W	R141	1-216-024-00	METAL GLAZE	91	5%	1/10W
R014	1-216-097-00	METAL CHIP	100K	5%	1/10W	R142	1-216-001-00	METAL CHIP	10	5%	1/10W
R015	1-216-049-00	METAL CHIP	1K	5%	1/10W	R143	1-216-001-00	METAL CHIP	10	5%	1/10W
R016	1-216-101-00	METAL CHIP	150K	5%	1/10W	R144	1-216-055-00	METAL CHIP	1.8K	5%	1/10W
R017	1-216-041-00	METAL CHIP	470	5%	1/10W	R145	1-216-055-00	METAL CHIP	1.8K	5%	1/10W
R018	1-216-065-00	METAL CHIP	4.7K	5%	1/10W	R146	1-216-073-00	METAL CHIP	10K	5%	1/10W
R020	1-216-049-00	METAL CHIP	1K	5%	1/10W	R147	1-216-081-00	METAL CHIP	22K	5%	1/10W
R021	1-216-065-00	METAL CHIP	4.7K	5%	1/10W	R148	1-216-037-00	METAL CHIP	330	5%	1/10W
R022	1-216-081-00	METAL CHIP	22K	5%	1/10W	R149	1-216-033-00	METAL CHIP	220	5%	1/10W
R023	1-249-394-11	CARBON	12	5%	1/6W F	R150	1-216-085-00	METAL CHIP	33K	5%	1/10W
R101	1-216-373-11	METAL OXIDE	2.2	5%	2W F	R151	1-216-113-00	METAL CHIP	470K	5%	1/10W
R103	1-216-073-00	METAL CHIP	10K	5%	1/10W	R152	1-216-057-00	METAL CHIP	2.2K	5%	1/10W
R104	1-216-073-00	METAL CHIP	10K	5%	1/10W	R153	1-216-085-00	METAL CHIP	33K	5%	1/10W
R105	1-216-073-00	METAL CHIP	10K	5%	1/10W	R154	1-216-101-00	METAL CHIP	150K	5%	1/10W
R106	1-216-061-00	METAL CHIP	3.3K	5%	1/10W	R155	1-216-089-00	METAL CHIP	47K	5%	1/10W
R107	1-216-089-00	METAL CHIP	47K	5%	1/10W	R156	1-216-083-00	METAL CHIP	27K	5%	1/10W
R108	1-216-061-00	METAL CHIP	3.3K	5%	1/10W	R157	1-216-101-00	METAL CHIP	150K	5%	1/10W
R109	1-216-061-00	METAL CHIP	3.3K	5%	1/10W	R158	1-216-057-00	METAL CHIP	2.2K	5%	1/10W
R110	1-216-061-00	METAL CHIP	3.3K	5%	1/10W	R159	1-216-075-00	METAL CHIP	12K	5%	1/10W
R111	1-216-073-00	METAL CHIP	10K	5%	1/10W	R160	1-216-083-00	METAL CHIP	27K	5%	1/10W
R112	1-216 101-00	METAL CHIP	150K	5%	1/10W	R161	1-216-113-00	METAL CHIP	470K	5%	1/10W
R113	1-216-077-00	METAL CHIP	15K	5%	1/10W	R162	1-216-051-00	METAL CHIP	1.2K	5%	1/10W
R114	1-216-025-00	METAL CHIP	100	5%	1/10W	R163	1-216-083-00	METAL CHIP	27K	5%	1/10W
R115	1-216-025-00	METAL CHIP	100	5%	1/10W	R164	1-216-035-00	METAL CHIP	270	5%	1/10W
R116	1-216-061-00	METAL CHIP	3.3K	5%	1/10W	R165	1-216-089-00	METAL CHIP	47K	5%	1/10W
R117	1-216-073-00	METAL CHIP	10K	5%	1/10W	R166	1-216-041-00	METAL CHIP	470	5%	1/10W
R118	1-216-073-00	METAL CHIP	10K	5%	1/10W	R167	1-216-049-00	METAL CHIP	1K	5%	1/10W
R119	1-216-073-00	METAL CHIP	10K	5%	1/10W	R168	1-216-049-00	METAL CHIP	1K	5%	1/10W
R120	1-216-073-00	METAL CHIP	10K	5%	1/10W	R169	1-216-049-00	METAL CHIP	1K	5%	1/10W
R121	1-216-057-00	METAL CHIP	2.2K	5%	1/10W	R170	1-216-049-00	METAL CHIP	1K	5%	1/10W
R122	1-216-085-00	METAL CHIP	33K	5%	1/10W	R171	1-216-049-00	METAL CHIP	1K	5%	1/10W
R123	1-216-061-00	METAL CHIP	3.3K	5%	1/10W	R172	1-216-049-00	METAL CHIP	1K	5%	1/10W
R124	1-216-079-00	METAL CHIP	18K	5%	1/10W	R173	1-216-085-00	METAL CHIP	33K	5%	1/10W
R125	1-216-081-00	METAL CHIP	22K	5%	1/10W	R174	1-216 073-00	METAL CHIP	10K	5%	1/10W
R126	1-216-033-00	METAL CHIP	220	5%	1/10W	R175	1-216-085-00	METAL CHIP	33K	5%	1/10W
R127	1-216-057-00	METAL CHIP	2.2K	5%	1/10W	R176	1-216-689-11	METAL CHIP	39K	0.5%	1/10W
R128	1-216-061-00	METAL CHIP	3.3K	5%	1/10W	R177	1-216-085-00	METAL CHIP	33K	5%	1/10W
R129	1-216-041-00	METAL CHIP	470	5%	1/10W	R178	1-216-073-00	METAL CHIP	10K	5%	1/10W
R130	1-216-017-00	METAL CHIP	47	5%	1/10W	R179	1-216-101-00	METAL CHIP	150K	5%	1/10W
R131	1-216-073-00	METAL CHIP	10K	5%	1/10W	R180	1-216-689-11	METAL CHIP	39K	0.5%	1/10W
R132	1-216-057-00	METAL CHIP	2.2K	5%	1/10W	R181	1-216-083-00	METAL CHIP	27K	5%	1/10W
R133	1 216-097-00	METAL CHIP	100K	5%	1/10W	R182	1-216-067-00	METAL CHIP	5.6K	5%	1/10W
R134	1-216-097-00	METAL CHIP	100K	5%	1/10W	R183	1-216-067-00	METAL CHIP	5.6K	5%	1/10W
R135	1-216-065-00	METAL CHIP	4.7K	5%	1/10W	R184	1-216-089-00	METAL CHIP	47K	5%	1/10W
R136	1-216-081-00	METAL CHIP	22K	5%	1/10W	R186	1 216-097-00	METAL CHIP	100K	5%	1/10W
R137	1-216-099-00	METAL CHIP	120K	5%	1/10W	R187	1-216-089-00	METAL CHIP	47K	5%	1/10W
R138	1-216-081-00	METAL CHIP	22K	5%	1/10W	R188	1-216-065-00	METAL CHIP	4.7K	5%	1/10W
R139	1-216-081-00	METAL CHIP	22K	5%	1/10W	R189	1-216-061-00	METAL CHIP	3.3K	5%	1/10W

SV-63

SW-704

SW-706

Ref. No.	Part No.	Description	Remark
R190	1-216-089-00	METAL CHIP	6.8K 5% 1/10W
R191	1-216-097-00	METAL CHIP	100K 5% 1/10W
R192	1-216-081-00	METAL CHIP	22K 5% 1/10W
R193	1-216-105-00	METAL CHIP	220K 5% 1/10W
R194	1-216-069-00	METAL CHIP	6.8K 5% 1/10W
R195	1-216-085-00	METAL CHIP	33K 5% 1/10W
R196	1-216-097-00	METAL CHIP	100K 5% 1/10W
R197	1-216-089-00	METAL CHIP	47K 5% 1/10W
R198	1-216-081-00	METAL CHIP	22K 5% 1/10W
R199	1-216-099-00	METAL CHIP	120K 5% 1/10W
R200	1-216-085-00	METAL CHIP	33K 5% 1/10W
R201	1-216-095-00	METAL CHIP	82K 5% 1/10W
R202	1-216-081-00	METAL CHIP	22K 5% 1/10W
R205	1-216-097-00	METAL CHIP	100K 5% 1/10W
R206	1-216-081-00	METAL CHIP	22K 5% 1/10W
R207	1-216-051-00	METAL CHIP	1.2K 5% 1/10W
R208	1-216-051-00	METAL CHIP	1.2K 5% 1/10W
R209	1-216-073-00	METAL CHIP	10K 5% 1/10W
R210	1-216-081-00	METAL CHIP	22K 5% 1/10W
R211	1-216-017-00	METAL CHIP	47 5% 1/10W
R212	1-216-017-00	METAL CHIP	47 5% 1/10W
R213	1-216-065-00	METAL CHIP	4.7K 5% 1/10W
R214	1-216-065-00	METAL CHIP	4.7K 5% 1/10W
R215	1-216-073-00	METAL CHIP	10K 5% 1/10W
R216	1-216-081-00	METAL CHIP	22K 5% 1/10W
R217	1-216-081-00	METAL CHIP	22K 5% 1/10W
R218	1-216-077-00	METAL CHIP	15K 5% 1/10W
R219	1-216-065-00	METAL CHIP	4.7K 5% 1/10W
R220	1-216-079-00	METAL CHIP	18K 5% 1/10W
R222	1-216-129-00	METAL CHIP	2.2M 5% 1/10W
< VARIABLE RESISTOR >			
RV101	1-228-993-00	RES, ADJ, METAL	4.7K
RV102	1-228-994-00	RES, ADJ, METAL	10K
RV103	1-228-994-00	RES, ADJ, METAL	10K
RV104	1-228-993-00	RES, ADJ, METAL	4.7K
RV105	1-228-994-00	RES, ADJ, METAL	10K
RV106	1-228-990-00	RES, ADJ, METAL	1K
RV107	1-228-990-00	RES, ADJ, METAL	1K
RV108	1-228-990-00	RES, ADJ, METAL	1K

\*\*\*\*\*

Ref. No.	Part No.	Description	Remark
*	A-6426-541-A	SW-704 BOARD, COMPLETE (450)	*****
*	A-6426-543-A	SW-704 BOARD, COMPLETE (6500)	*****
< CAPACITOR >			
C701	1-126-157-11	ELECT	10uF 20% 16V
C702	1-163-031-11	CERAMIC CHIP	0.01uF 50V
< CONNECTOR >			
CN701	1-569-339-11	CONNECTOR, BOARD TO BOARD	7P
< DIODE >			
D701	8-719-940-82	LED SLR34MC3	(POWER ON)
D702	8-719-940-82	LED SLR34MC3	(POWER ON)
D703	8-719-940-99	LED SLR34VC3	(STANDBY)
< IC >			
IC701	8-741-100-48	IC SBX1610-59	
< COIL >			
L701	1-408-421-00	INDUCTOR	100uH
< TRANSISTOR >			
Q701	8-729-901-46	TRANSISTOR DTA114YK	
< RESISTOR >			
R701	1-216-029-00	METAL CHIP	150 5% 1/10W
R702	1-216-059-00	METAL CHIP	2.7K 5% 1/10W
R703	1-216-031-00	METAL CHIP	180 5% 1/10W
R704	1-216-029-00	METAL CHIP	150 5% 1/10W
< SWITCH >			
S701	1-572-946-11	SWITCH, TACTIL	(ON/STANDBY)
*****			
*	A-6421-865-A	SW-706 BOARD, COMPLETE (6500)	*****
*	A-6421-876-A	SW-706 BOARD, COMPLETE (450)	*****
< CONNECTOR >			
CN601	1-506-467-11	PIN, CONNECTOR	2P
< SWITCH >			
S601	1-554-655-00	SWITCH, LEAF	(TRAY SW)
*****			

Ref. No.	Part No.	Description	Remark
*	A-6421-866-A	SW-707 BOARD, COMPLETE (650D) *****	
*	A-6421-873-A	SW-707 BOARD, COMPLETE (450) *****	
< CONNECTOR >			
CN401	1-506-481-11	PIN, CONNECTOR 2P	
CN402	1-506-481-11	PIN, CONNECTOR 2P	
< RESISTOR >			
R401	1-249-423-11	CARBON            3.3K 5%    1/4W F	
R402	1-249-417-11	CARBON            1K    5%    1/4W F	
< SWITCH >			
S401	1-571-300-21	SWITCH, ROTARY (CHUCK SW)	
*****			
*	A-6426-542-A	TR-702 BOARD, COMPLETE (450) *****	
*	A-6426-544-A	TR-702 BOARD, COMPLETE (650D: AEP) *****	
*	A-6426-551-A	TR-702 BOARD, COMPLETE (650D: UK, Australian) *****	
	1-533-189-11	HOLDER, FUSE	
< CAPACITOR >			
△ C301	1-136-472-11	FILM            0.1uF    20%    250V	
< CONNECTOR >			
CN301	1-564-419-11	HEADER, SPRING (POWER) 2P	
* CN302	1-564-031-00	PIN, CONNECTOR 6P	
< TRANSFORMER >			
△ T302	1-424-656-11	FILTER, LINE	
*****			
MISCELLANEOUS *****			
23	1-693-095-41	REMOTE COMMANDER (RMT-M14)	
55	A-6415-359-A	MOTOR BLOCK ASSY (X), THREADING (M904)	
△ 109	1-575-912-21	CORD, POWER (AEP)	
△ 109	1-696-690-11	CORD, POWER (Australian)	
△ 109	1-696-695-11	CORD, POWER (UK)	
* 112	1-575-813-11	CABLE, FLAT (FLEXIBLE) (28 CORE)	
157	A-6415-290-A	MOTOR BLOCK ASSY, SKEW (M903)	

Ref. No.	Part No.	Description	Remark
158	1-554-468-00	SWITCH, LEAF (SLED IN LIMIT LD/CD) (S903)	
159	1-541-776-21	MOTOR, LD SPINDLE (M901)	
168	1-574-648-11	CABLE, FLEXIBLE FLAT (24 CORE)	
204	1-570-771-21	SWITCH (SLED OUT LIMIT) (S902)	
206	1-571-435-11	SWITCH (SLED IN LIMIT) (S901)	
213	A-6415-434-A	MOTOR BLOCK ASSY, SLED (M902)	
△ 215	8-848-138-11	DEVICE, OPTICAL KHS-130A	
△ F101	1-532-237-00	FUSE, TIME-LAG (BET) (3.15A 250V)	
△ F102	1-532-237-00	FUSE, TIME-LAG (BET) (3.15A 250V)	
△ F301	1-532-284-00	FUSE, TIME-LAG (0.63A 250V)	
IC102	8-759-245-79	IC MSF7905	
△ T301	1-423-319-11	TRANSFORMER, POWER	
*****			
ACCESSORIES & PACKING MATERIALS *****			
	3-755-687-11	MANUAL, INSTRUCTION (ENGLISH) (450)	
	3-755-687-41	MANUAL, INSTRUCTION (450) (FRENCH, SPANISH, GERMAN, PORTUGUESE)	
	3-755-687-51	MANUAL, INSTRUCTION (450) (DUTCH, SWEDISH, ITALIAN)	
	3-755-688-11	MANUAL, INSTRUCTION (ENGLISH) (650D)	
	3-755-688-41	MANUAL, INSTRUCTION (650: AEP) (FRENCH, SPANISH, GERMAN, PORTUGUESE)	
	3-755-688-51	MANUAL, INSTRUCTION (650D: AEP) (DUTCH, SWEDISH, ITALIAN)	
*	3-948-404-01	CUSHION (LOWER)	
*	3-948-405-01	CUSHION (UPPER)	
*	3-949-708-21	INDIVIDUAL CARTON (650D)	
*	3-949-708-31	INDIVIDUAL CARTON (450)	
*****			
***** HARDWARE LIST *****			
#1	7-624-108-04	STOP RING 4.0, TYPE -E	
#2	7-685-648-79	SCREW +BVTP 3X12 TYPE2 IT-3	
#3	7-624-100-81	STOP RING 2, TYPE-CS	
#4	7-685-647-79	SCREW +BTP 3X10 TYPE2 N-S	
#6	7-682-645-01	SCREW +PS 3X4	
#7	7-621-255-55	SCREW +P 2X8	
#8	7-685-649-79	SCREW +BVTP 3X14 TYPE2 IT-3	
#9	7-685-661-79	SCREW +BVTP 4X12 TYPE2 SLIT	
#11	7-682-545 04	SCREW (3X4) (G), TAPPING, (+) P	
*****			

The components identified by mark △ or dotted line with mark △ are critical for safety. Replace only with part number specified.

# MEMO

---

Lined area for writing the memo content.



# SECTION 7 ELECTRICAL ADJUSTMENTS

# MDP-450/650D

During these adjustment, see the parts arrangement diagram relevant to the adjustment on page from 172.

### 7-1. LIST OF SERVICING JIGS

- Oscilloscope
  - Color monitor TV
  - Digital voltmeter
  - Audio level meter
  - Frequency counter
  - Remote commander (RMT-M14)
  - LD alignment disc { \* HVL-3P (8-797-003-00) ...PAL  
\* \* HLV-8 (8-797-008-00) ...NTSC
  - CD alignment disc YEDS-18 (3-702-101-01)
  - MD adjustment cable (J-6082-059-A)
- \* : REF3P is also available.  
\* \* : REF7 is also available.

### 7-2. CAUTIONS ON ADJUSTMENT

- Disc load/unload operation must not be performed when servicing with the unit laying down sideways. (Never press the OPEN and CLOSE buttons.)
- When laying the unit down sideways, perform adjustment with the left side down and turn the power on.
- When adjusting the servo system, be sure to set up the unit horizontally.

### 7-3. MD ADJUSTMENT CABLE (J-6082-059-B)

MD adjustment cable is used to adjust the servo system with connecting to the SV-63 board. Remove it except when adjusting the servo system.

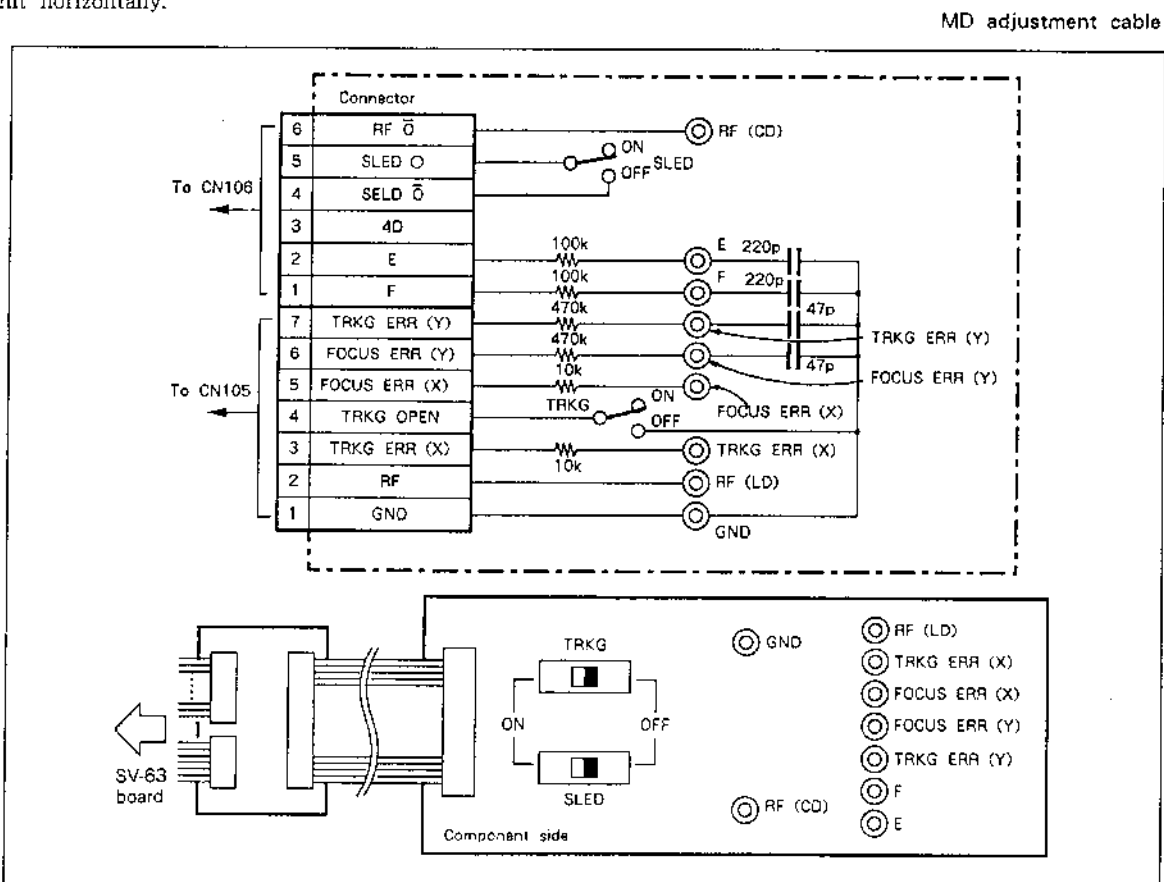

Fig. 7-1.

#### 7-4. POWER SUPPLY CHECK (PS-701 BOARD)

Mode	Stop
Measuring Equipment	Digital Voltmeter
UNREG + 16 V check	
Measurement Point	Pin ① of CN104 (Pin ②, GND)
Specified Value	+ 15.3 ± 1.0 V
UNREG - 16 V check	
Measurement Point	Pin ④ of CN104 (Pin ③, GND)
Specified Value	- 16.0 ± 1.0 V
REG + 5 V check	
Measurement Point	Pin ① of CN103 (Pin ②, GND)
Specified Value	+ 5.2 ± 0.1 V
REG - 5 V check	
Measurement Point	Pin ③ of CN103 (Pin ②, GND)
Specified Value	- 5.0 ± 0.2 V
AC 3.1 V check	
Measurement Point	Pin ①, ② of CN105
Specified Value	3.2 ± 1.0 V AC
DC - 30 V check	
Measurement Point	Pin ④ of CN105 (Pin ③, GND)
Specified Value	- 33.0 ± 2.0 V
EVER 5V Check	
Measurement Point	Pin ⑥ of CN105 (Pin ⑦, GND)
Specified Value	5.0 ± 0.2 V

- Confirm that the power supply voltages satisfy the respective specified values.

#### 7-5. SYSTEM CONTROL SYSTEM ADJUSTMENT

##### 7-5-1. Microprocessor Clock (NTSC) Adjustment (MP-701 Board)

Mode	Stop
Measurement Point	Pin ⑦ of IC612
Measuring Equipment	Frequency counter
Adjusting Element	CT602
Specified Value	3,579,545 ± 40 Hz

##### Adjustment method:

- 1) Adjust CT602 to 3,579,545 ± 10 Hz.

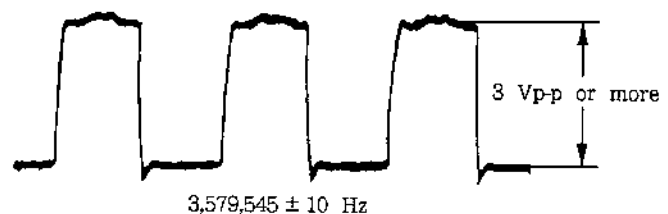

Fig. 7-2.

#### 7-6. SERVO SYSTEM ADJUSTMENT

When adjusting the servo system, look out for the following items :

- Use the MD adjustment cable (J-6082-059-B).
- Adjust the CD servo system after the digital audio system adjustment is completed.
- When setting the tracking servo to the open state, set to the STOP state once and proceed to the next step.
- When the optical block is replaced, perform the adjustment in the following order.

**Note:** Start adjustment at maximum RF H level (RV108 fully counterclockwise direction).

1. LD Tracking Balance Adjustment
  - 1) Focus balance adjustment
  - 2) Tracking balance adjustment
2. LD Focus Gain Adjustment
3. LD Cross Talk Balance Adjustment
  - 1) TAN cam adjustment
  - 2) RAD-TILT adjustment
  - 3) Focus balance adjustment
4. LD Tracking Gain Adjustment
5. RD Adjustment
6. CD Focus Balance Adjustment
7. CD RF H Level Adjustment
8. CD RF L Level Adjustment

### 7-6-1. LD Servo System Adjustment

#### 1. LD Tracking Balance Adjustment (SV-63 Board)

##### 1) Focus balance adjustment

**Note:** Perform successively 1) and 2) adjustment in this order.

Mode	Still
Signal	Frame 2201 (GRAY) (HLV-3P)
Measurement Point	MD adjustment cable (TRKG ERR (X)) (Pin ③ of CN105)
Measuring Equipment	Oscilloscope
Adjusting Element	RV102
Specified Value	Maximum amplitude

##### Adjustment method:

- 1) Select STILL (⏹) mode.
- 2) Search the frame 2201 (GRAY).
- 3) Turn the thread servo off. (MD adjustment cable SLED SW OFF)
- 4) Turn the tracking servo off. (MD adjustment cable TRKG SW OFF)
- 5) Adjust RV102 so as to maximize the signal level.

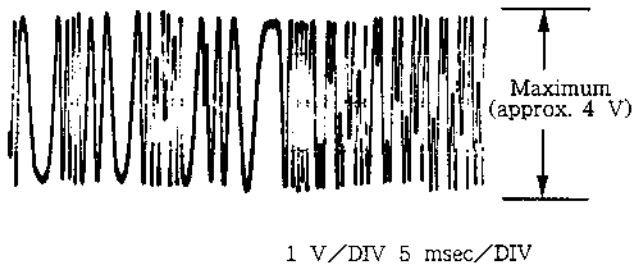

Fig. 7-3.

##### 2) Tracking balance adjustment

Mode	Still
Signal	Frame 2201 (GRAY) (HLV-3P)
Measurement Point	MD adjustment cable (TRKG ERR (X)) (Pin ③ of CN105)
Measuring Equipment	Oscilloscope
Adjusting Element	RV101
Specified Value	$A - B = 0 \pm 0.1 \text{ V}$

##### Adjustment method:

**Note:** Perform successively this adjustment after "1) Focus balance adjustment" is completed.

- 6) Adjust RV101 so that the center voltage of the tracking error signal becomes  $0 \pm 0.1 \text{ Vdc}$ .
- 7) Select STOP mode.
- 8) Turn the tracking servo on.
- 9) Turn the thread servo on.

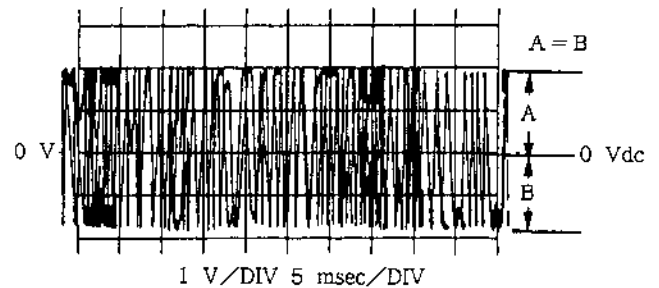
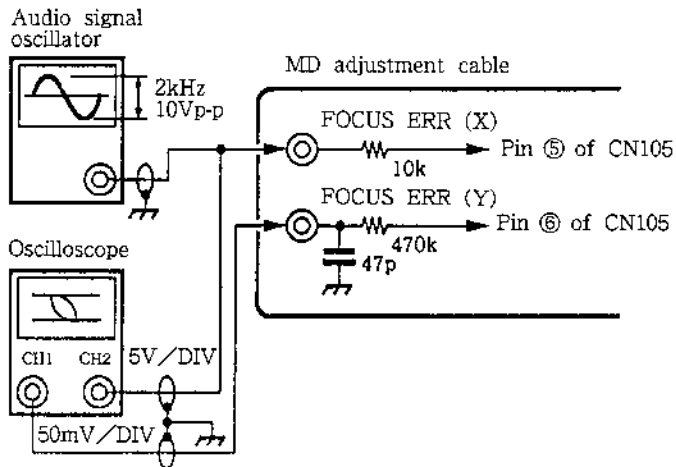

Fig. 7-4.

## 2. LD Focus Gain Adjustment (SV-63 Board)

Mode	Playback
Signal	Frame 2201 (GRAY) (HLV-3P)
Measurement Point	MD adjustment cable CH1 : [FOCUS ERR (Y)] (Pin ⑤ of CN105) CH2 : [FOCUS ERR (X)] (Pin ⑥ of CN105)
Measuring Equipment	Oscilloscope (X-Y mode)
Adjusting Element	RV107
Specified Value	See figure below

### Connections:



### Adjustment method:

- 1) Search the frame 2201.
- 2) Adjust the waveform as shown in the figure below with RV107.

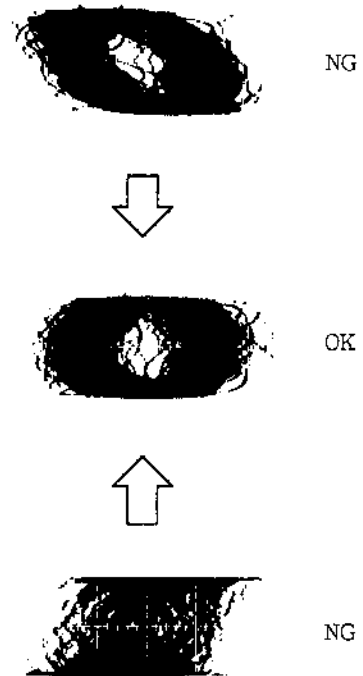

Fig. 7-5.

### 3. LD Cross Talk Balance Adjustment

#### 1) TAN cam adjustment (MD)

The cam is always set to the initial position. When replacing the optical block and so on, set the cam to the mechanical center.\*

\*Mechanical center :

Marked with the notch of the cam located at the opposite side of the optical block chassis shaft.

#### Adjustment method:

- 1) Turn the TAN cam on the bottom (See Fig. 7-6.) with a hexagonal wrench.

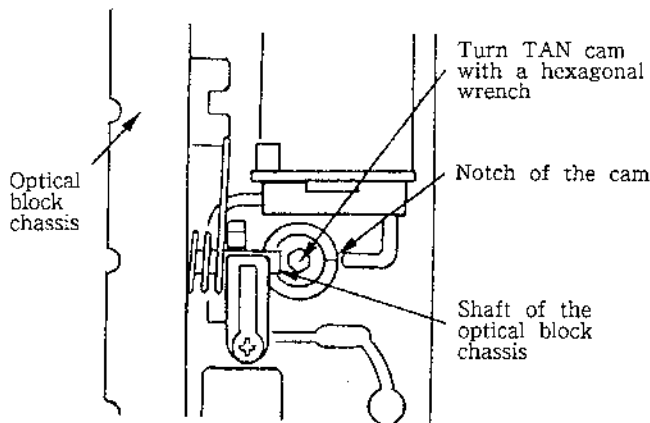

Fig. 7-6.

#### 2) RAD TILT adjustment (SV-63 board)

Mode	Still
Signal	Frame 767 (V BAR) (HLV-3P)
Measurement Point	Monitor TV
Measurement Equipment	Monitor TV
Adjusting Element	RV105
Specified Value	Cross talk (wavering) with minimum as well as the same level.

#### Adjustment method:

- 1) Select STILL (▶◀) mode.
- 2) Search the frame 767 and apply a vertical bar signal.
- 3) Adjust with RV105 so that the right and left cross talks (wavering) become minimum as well as the same level.

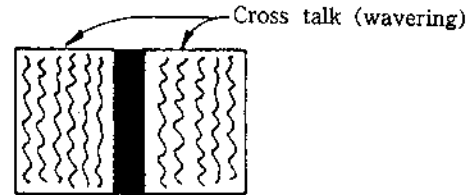

Adjust so that cross talks appeared on the both sides on the monitor display become minimum as well as the same level.

Fig. 7-7.

#### 4) Focus balance adjustment (SV-63 board)

Mode	Still
Signal	Frame 767 (V BAR) (HLV-3P)
Measurement Point	Monitor TV
Measurement Equipment	Monitor TV
Adjusting Element	RV102
Specified Value	Cross talk (wavering) with minimum as well as the same level.

#### Adjustment method:

- 1) Select STILL (▶◀) mode.
- 2) Search the frame 767 and apply a vertical bar signal.
- 3) Adjust with RV102 to minimize the right and left cross talks (wavering) level.

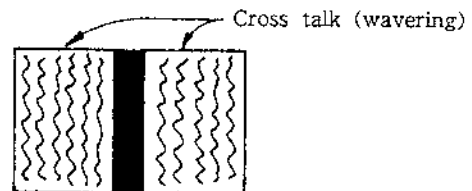
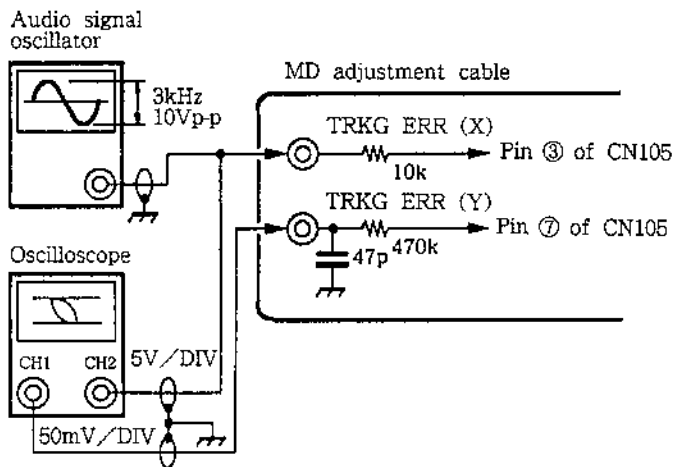

Fig. 7-8.

#### 4. LD Tracking Gain Adjustment (SV-63 Board)

Mode	Still
Signal	Frame 2201 (GRAY) (HLV-3P)
Measurement Point	MD adjustment cable CH1 : (TRKG (Y)) (Pin ⑦ of CN105) CH2 : (TRKG (X)) (Pin ③ of CN105)
Measuring Equipment	Oscilloscope (X-Y mode)
Adjusting Element	RV106 (TR GAIN)
Specified Value	See figure below

#### Connections:



#### Adjustment method:

- 1) Search the frame 2201.
- 2) Adjust the waveform as shown in the figure below with RV106.

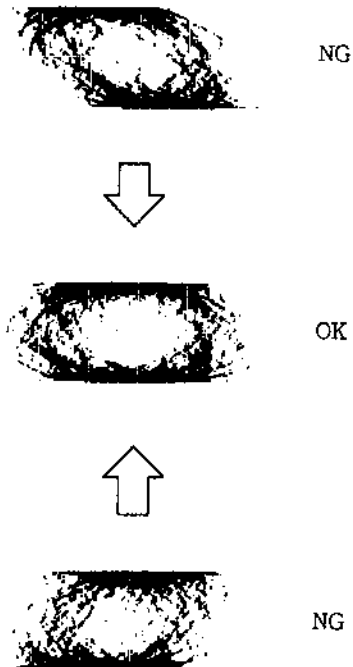

Fig. 7-9.

## 7-6-2. CD Servo System Adjustment

### 1. RD Adjustment

Mode	Pause
Signal	Track No. 1, YEDS-18
Measurement Point	MD adjustment cable CH1 : (E terminal) CH2 : (F terminal)
Measuring Equipment	Oscilloscope
Adjusting Element	RD Cam (MD)
Specified Value	A : B ≤ 10 : 1

**Note:** 1) Turn off the monitor TV switch to prevent a noise.

**Note:** 2) Long continuation of the TRKG servo off state causes the spindle motor to stop.

#### Adjustment method:

- 1) Play back the track No. 1 and select PAUSE mode.
- 2) Turn the thread servo off. (MD adjustment cable SLED SW OFF)
- 3) Turn the tracking servo off. (MD adjustment cable TRKG SW OFF)
- 4) Turn RD cam on the MD and adjust so that it becomes as a straight line as possible.

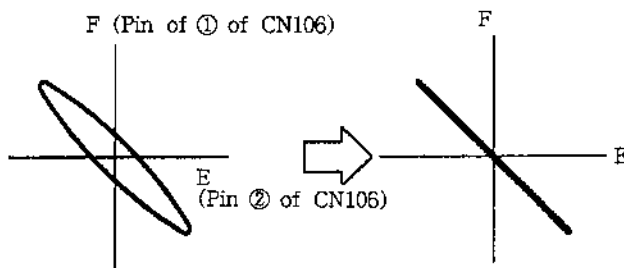

Fig. 7-10.

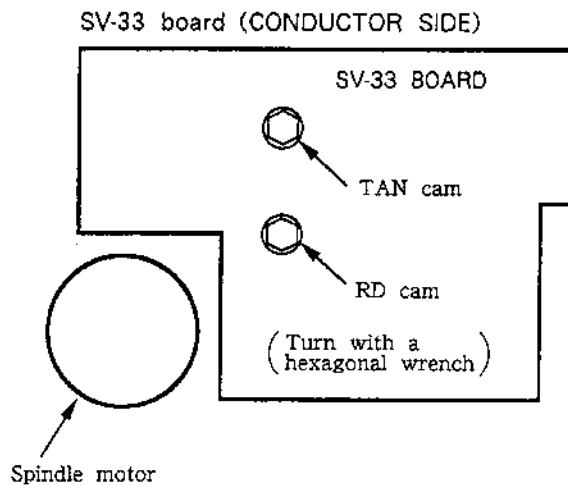

Fig. 7-11.

### 2. CD Focus Balance Adjustment (SV-63 Board)

Mode	Playback
Signal	Track No. 1, YEDS-18
Measurement Point	MD adjustment cable (RF (CD) OUT) (Pin ⑥ of CN106)
Measuring Equipment	Oscilloscope
Adjusting Element	RV103
Specified Value	Maximum amplitude

#### Adjustment method:

- 1) Play back the track No. 1.
- 2) Adjust RV103 for maximum level.

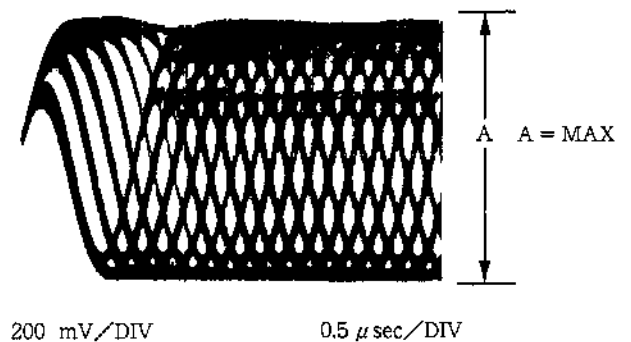

Fig. 7-12.

### 3. CD RF H Level Adjustment (SV-63 Board)

Mode	Playback
Signal	Track No. 1, YEDS-18
Measurement Point	MD adjustment cable (RF (CD) OUT) (Pin ⑥ of CN106)
Measuring Equipment	Oscilloscope
Adjusting Element	RV108
Specified Value	$1.2 \pm 0.1$ Vp-p

#### Adjustment method:

- 1) Play back the track No. 1.
- 2) Adjust RV108 for  $1.2 \pm 0.1$  Vp-p.

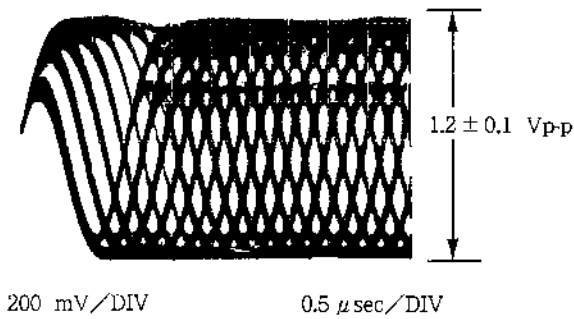

Fig. 7-13.

### 4. CD RF L Level Adjustment (SV-63 Board)

Mode	Playback
Signal	Track No. 1, YEDS-18
Measurement Point	MD adjustment cable (RF (CD) OUT) (Pin ⑥ of CN106)
Measuring Equipment	Oscilloscope
Adjusting Element	RV104
Specified Value	Clear-cut waveform

#### Adjustment method:

- 1) Play back the track No. 1.
- 2) Adjust RV104 so that the waveform of lozenge-shaped portions becomes clear-cut and the waveform slant disappear from the rising edge portion.

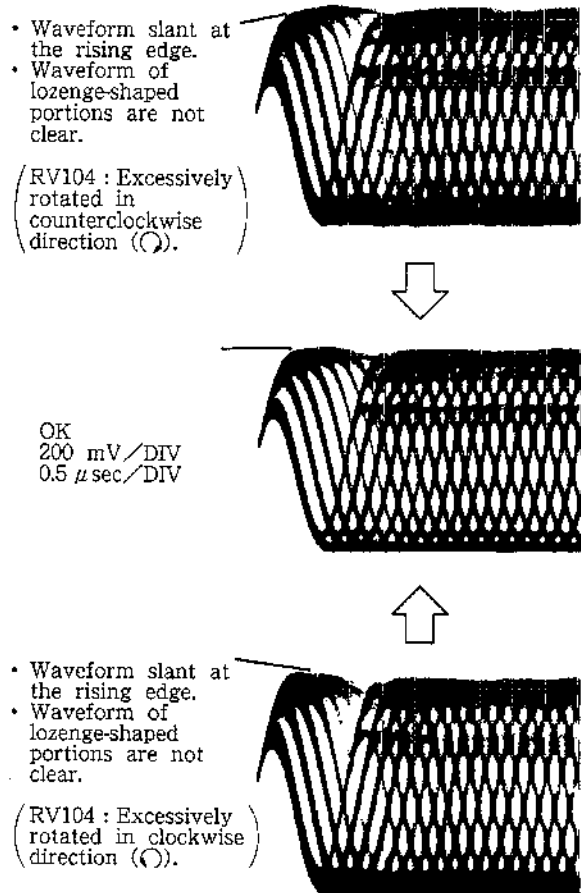

Fig. 7-14.



## 7-7. VIDEO SYSTEM ADJUSTMENT

### 7-7-1. Video Output Level Adjustment (MP-701 Board)

Mode	Still
Signal	Frame 3851 (Color bar) (HLV-3P)
Measurement Point	J101 (JC-701/703 Board) (VIDEO OUT terminal) (Terminated to 75 Ω)
Measuring Equipment	Oscilloscope
Adjusting Element	RV105
Specified Value	$1.05 \pm 0.04$ Vp-p

#### Adjustment method:

- 1) Select STILL (▶◀) mode.
- 2) Search the frame 3851 and apply a color bar signal.
- 3) Turn RV105 to fully counterclockwise direction.
- 4) Adjust RV105 to  $1.05 \pm 0.04$  Vp-p on the first adjusting point at turning clockwise direction.



Fig. 7-15.

### 7-7-2. Burst Gate Position Adjustment (MP-701 Board)

Mode	Still
Signal	Frame 3851 (Color bar) (HLV-3P)
Measurement Point	Pin ② of IC109
Adjusting Element	RV106
Specified Value	$8.2 \pm 0.1$ μsec

#### Adjustment method:

- 1) Select STILL (▶◀) mode.
- 2) Search the frame 3851.
- 3) Adjust RV106 so that  $t_w$  becomes  $8.2 \pm 0.1$  μsec.

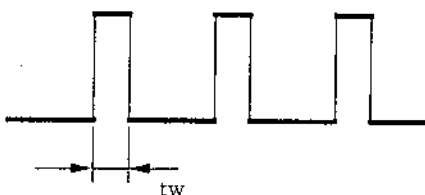

Fig. 7-16.

### 7-7-3. REF H Adjustment (MP-701 Board)

**Note:** Perform [Adjustment-1] and [Adjustment 2] in this order.

Mode	Still
Signal	Frame 3851 (Color bar) (HLV-3P)
Measurement Point	CH1: Pin ④ of IC109 External trigger: Pin ⑤ of IC109
Measuring Equipment	Oscilloscope
Adjusting Element	[Adj. 1] RV104 [Adj. 2] RV107
Specified Value	[Adj. 1] $85 \pm 1$ μsec [Adj. 2] $22 \pm 1$ μsec

#### Connection:

- Apply 5.0 Vdc to Pin ④ of IC109.

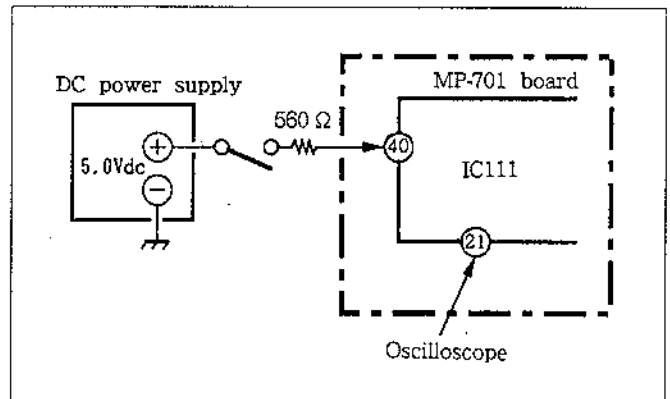

Fig. 7-17.

#### Adjustment method:

##### [Adjustment 1]

- 1) Select STILL (▶◀) mode.
- 2) Search the frame 3851.
- 3) Connect the DC Power supply (5.0 Vdc) to pin ④ of IC109.
- 4) Adjust RV104 so that rising time difference between the pulse when the power (5.0 Vdc) is on (LIM ON) and the trigger pulse (Pin ⑤ of IC109) is  $85 \pm 1$  μsec.

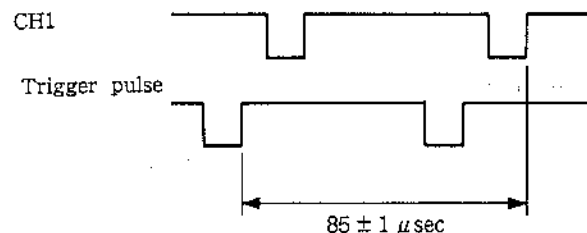

Fig. 7-18.

**(Adjustment 2)**

- 1) Select STILL (▶◀) mode.
- 2) Search the frame 3851.
- 3) Connect the DC Power supply (5.0 Vdc) to pin ④ of IC109.
- 4) Adjust with RV107 so that time difference between when the power (5.0 Vdc) is on (LIM ON) and when the power off (LIM OFF) is  $22 \pm 1 \mu\text{sec}$ .

**Note:** Since the waveform of LIM OFF is wavering, adjust at fits center position.

- Pin ② of IC109 (CH1)

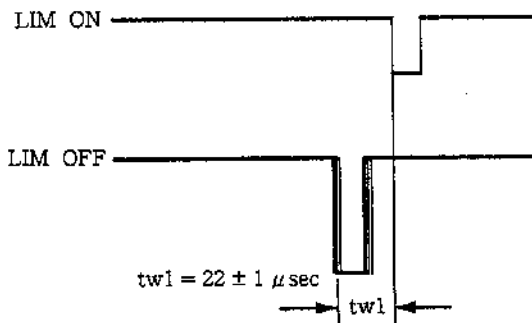

- Pin ⑤ of IC109 (Trigger pulse)



Fig. 7-19.

**7-7-4. Color Framing Y Level Adjustment (MP-701 Board)**

Mode	Play back and Still
Signal	Frame 3851 (Color bar) (HLV-3P)
Measurement Point	J101 (JC-701/703 Board) (VIDEO OUT terminal) (Terminated to 75 Ω)
Measuring Equipment	Oscilloscope
Adjusting Element	RV103
Specified Value	A = B

**Adjustment method:**

- 1) Search the frame 3851.
- 2) Equalize with RV103 Y levels on the playback mode and the still mode.

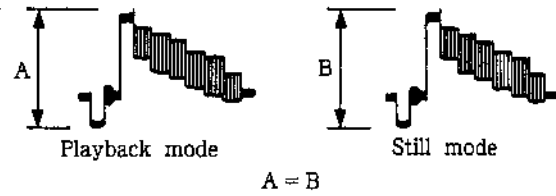

Fig. 7-20.

**7-7-5. Color Framing Chroma Level (1) Adjustment (MP-701 Board)**

Mode	Still
Signal	Frame 3851 (Color bar) (HLV-3P)
Measurement Point	J101 (JC-701/703 Board) (VIDEO OUT terminal) (Terminated to 75 Ω)
Measuring Equipment	Oscilloscope
Adjusting Element	RV101
Specified Value	Minimum

**Adjustment method:**

- 1) Select STILL (▶◀) mode.
- 2) Search the frame 3851.
- 3) Minimize with RV101 the shaking of green position.

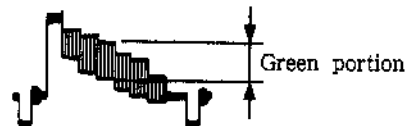

Fig. 7-21.

**7-7-6. Color Framing Chroma Level (2) Adjustment  
(MP-701 Board)**

Mode	Play back and Still
Signal	Frame 3851 (Color bar) (HLV-3P)
Measurement Point	J101 (JC-701/703 Board) (VIDEO OUT terminal) (Terminated to 75 Ω)
Measuring Equipment	Oscilloscope
Adjusting Element	RV102
Specified Value	A = B

**Adjustment method:**

- 1) Search the frame 3851.
- 2) Equalize with RV102 the green levels on the playback mode and the still mode.

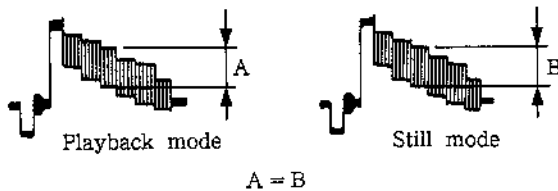

Fig. 7-22.

**7-7-7. Color Framing REF H Adjustment  
(MP-701 Board)**

Mode	Play back and Still
Signal	Frame 3851 (Color bar) (HLV-3P)
Measurement Point	Pin ④ of IC111
Measuring Equipment	Oscilloscope
Adjusting Element	RV108
Specified Value	$tw = 112 \pm 5$ msec

**Adjustment method:**

- 1) Select STILL mode.
- 2) Search the frame 3851.
- 3) Adjust with RV108 so that  $tw$  is  $112 \pm 5$  msec.

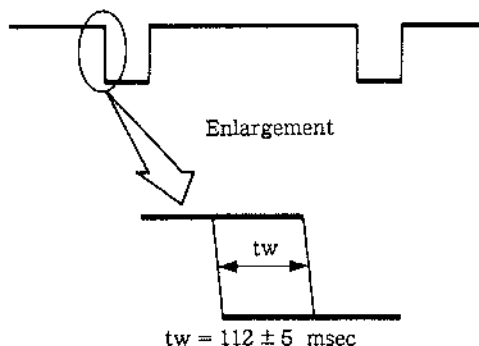

Fig. 7-23.

**7-7-8. APC Adjustment (RG-701 Board)**

Mode	Still
Signal	Frame 4100 (Color bar) (HLV-8)
Measurement Point	Pins ⑱ and ⑳ of IC13
Measuring Equipment	Digital voltmeter
Adjusting Element	[Adj. 1] CT1 [Adj. 2] RV1
Specified Value	[Adj. 1] $0 \pm 1$ mV [Adj. 2] $0 \pm 3$ mV

**Adjustment method:**

**(Adjustment 1)**

- 1) Select STILL mode.
- 2) Search the frame 4100.
- 3) Connect a digital voltmeter between Pin ⑱ (+) and Pin ⑳ (COM) of IC3.
- 4) Adjust with CT1 to  $0 \pm 1$  mV reading on digital voltmeter.

**(Adjustment 2)**

- 1) Remove JW30.
- 2) Connect IC1 side of C19 to ground.
- 3) Select STILL mode.
- 4) Search the frame 4100.
- 5) Connect a digital voltmeter between Pin ⑱ (+) and Pin ⑳ (COM) of IC3.
- 6) Adjust with RV1 to  $0 \pm 3$  mV reading on digital voltmeter.
- 7) Solder JW30.
- 8) Confirm the voltage value between Pins ⑱ and ⑳ becomes  $0 \pm 5$  mV.
- 9) When it doesn't satisfy the specified value, repeat adjustments from [Adjustment 1].

### 7-7-9. G Level Adjustment (RG-701 Board)

Mode	Still
Signal	Frame 4100 (Color bar) (HLV-8)
Measurement Point	Pin ⑦ of CN1 (Terminated to 75 Ω)
Measuring Equipment	Oscilloscope
Adjusting Element	RV5
Specified Value	$0.7 \pm 0.03$ V <sub>p-p</sub>

#### Adjustment method:

- 1) Select STILL (▶◀) mode.
- 2) Search the frame 4100.
- 3) Adjust with RV5 to  $0.7 \pm 0.03$  V<sub>p-p</sub>.



Fig. 7-24.

### 7-7-10. R Level Adjustment (RG-701 Board)

Mode	Still
Signal	Frame 4100 (Color bar) (HLV-8)
Measurement Point	Pin ⑥ of CN1 (Terminated to 75 Ω)
Measuring Equipment	Oscilloscope
Adjusting Element	RV3
Specified Value	$0.7 \pm 0.03$ V <sub>p-p</sub>

#### Adjustment method:

- 1) Select STILL (▶◀) mode.
- 2) Search the frame 4100.
- 3) Adjust with RV3 to  $0.7 \pm 0.03$  V<sub>p-p</sub>.



Fig. 7-25.

### 7-7-11. B Level Adjustment (RG-701 Board)

Mode	Still
Signal	Frame 4100 (Color bar) (HLV-8)
Measurement Point	Pin ⑧ of CN1 (Terminated to 75 Ω)
Measuring Equipment	Oscilloscope
Adjusting Element	RV2
Specified Value	$0.7 \pm 0.03$ V <sub>p-p</sub>

#### Adjustment method:

- 1) Select STILL (▶◀) mode.
- 2) Search the frame 4100.
- 3) Adjust with RV2 to  $0.7 \pm 0.03$  V<sub>p-p</sub>.



Fig. 7-26.

### 7-7-12. Chroma Level Adjustment (RG-701 Board)

Mode	Still
Signal	Frame 4100 (Color bar) (HLV-8)
Measurement Point	Pin ⑧ of CN1 (Terminated to 75 Ω)
Measuring Equipment	Oscilloscope
Adjusting Element	RV4
Specified Value	$0.53 \pm 0.03$ V <sub>p-p</sub>

#### Adjustment method:

- 1) Select STILL (▶◀) mode.
- 2) Search the frame 4100.
- 3) Adjust with RV4 to  $0.53 \pm 0.03$  V<sub>p-p</sub>. (Blue level)



Fig. 7-27.

### 7-7-13. HUE Adjustment (RG-701 Board)

Mode	Still
Signal	Frame 4100 (Color bar) (HLV-8)
Measurement Point	Pin ⑧ of CN1 (Terminated to 75 Ω)
Measuring Equipment	Oscilloscope
Adjusting Element	RV6
Specified Value	A = B = 0.53 ± 0.03 Vp-p

#### Adjustment method:

- 1) Select STILL (▶◀) mode.
- 2) Search the frame 4100.
- 3) Adjust with RV6 to 0.53 ± 0.03 Vp-p.

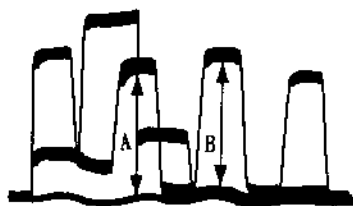

Fig. 7-28.

## 7-8. AUDIO SYSTEM ADJUSTMENT

### 7-8-1. Analog Audio System Adjustment

#### 1. MDP-650D Audio output level adjustment (AF-701 Board)

**Note:** Adjusting element of the 2/R channel is indicated in brackets ( ).

Mode	Still
Signal	Frame 4301 (RAMP/1 kHz) (HLV-3P) Frame 4301 (RAMP/1 kHz) (HLV-8)
Measurement Point	Audio output 1/L (2/R) terminal
Measuring Equipment	Audio level meter or Oscilloscope
Adjusting Element	RV701 [RV702] (NTSC) RV703 [RV704] (PAL)
Specified Value	Audio level meter : 500 ± 25 mVrms Oscilloscope : 1.4 ± 0.07 Vp-p

#### Adjustment method:

- 1) Playback the HLV-8 disc.
- 2) Search the Frame 4301 (chapter 6).

- 3) Turn off the [CX] with remote commander.  
(Confirm that the indication on the front panel of the main unit is disappeared.)
- 4) Adjust with RV701 [RV702] to 500 ± 25 mVrms or 1.4 ± 0.07 Vp-p.
- 5) Playback the HLV-3P disc.
- 6) Search the Frame 4301 (chapter 6).
- 7) Turn off the [CX] with remote commander.  
(Confirm that the indication on the front panel of the main unit is disappeared.)
- 8) Adjust with RV703 [RV704] to 500 ± 25 mVrms or 1.4 ± 0.07 Vp-p.

#### 2. MDP-450 Audio output level adjustment (AF-702 Board)

**Note:** Adjusting element of the 2/R channel is indicated in brackets ( ).

Mode	Still
Signal	Frame 4301 (RAMP/1 kHz) (HLV-3P)
Measurement Point	Audio output 1/L (2/R) terminal
Measuring Equipment	Audio level meter or Oscilloscope
Adjusting Element	RV401 (RV402)
Specified Value	Audio level meter : 500 ± 25 mVrms Oscilloscope : 1.4 ± 0.07 Vp-p

#### Adjustment method:

- 1) Playback the HLV-3P disc.
- 2) Search the Frame 4301 (chapter 6).
- 3) Turn off the [CX] with remote commander.  
(Confirm that the indication on the front panel of the main unit is disappeared.)
- 4) Adjust with RV401 [RV402] to 500 ± 25 mVrms or 1.4 ± 0.07 Vp-p.

7-9. PARTS ARRANGEMENT DIAGRAM FOR ADJUSTMENTS

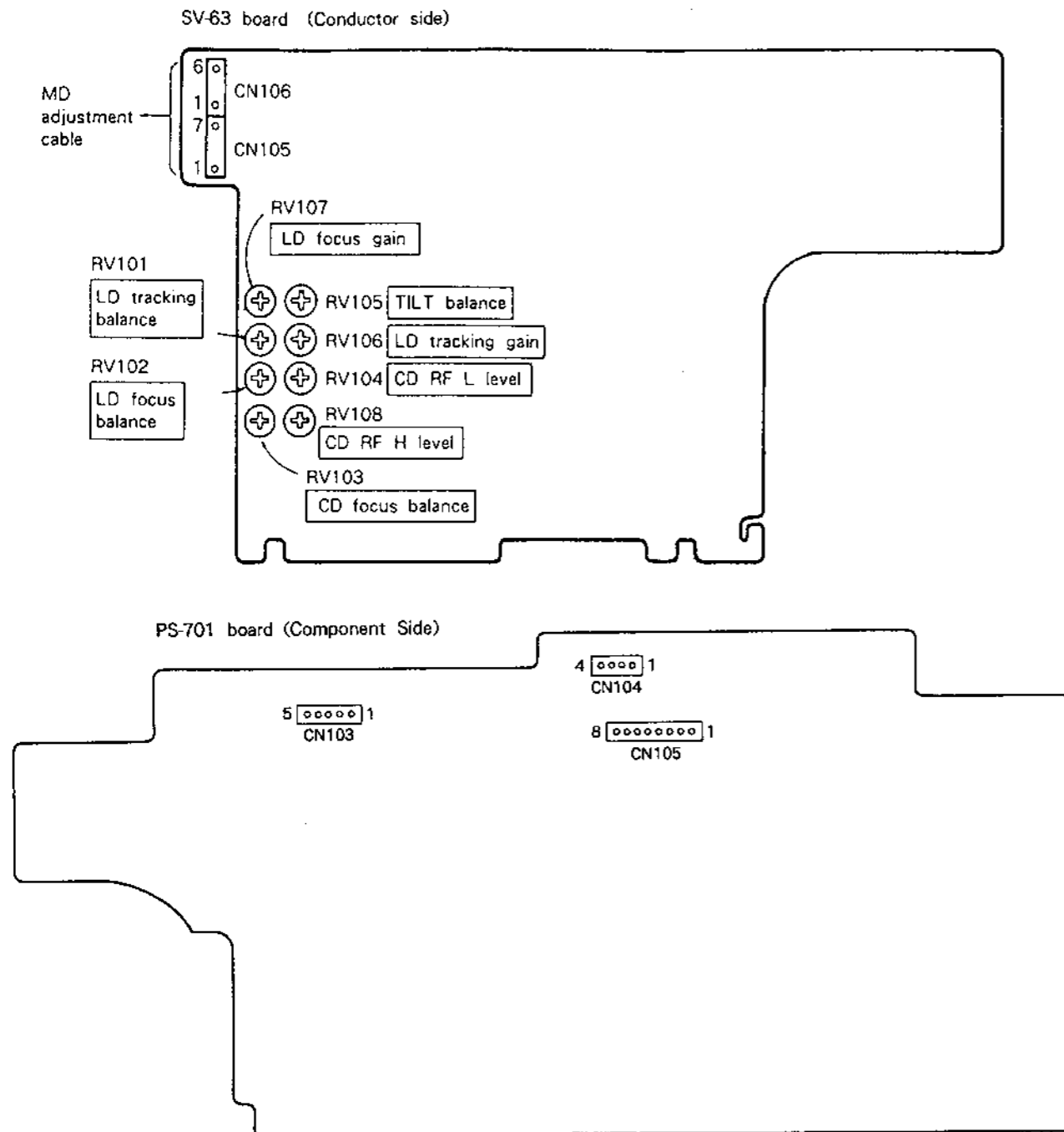

**RG-701 board (Conductor side)**  
(MDP-650D)

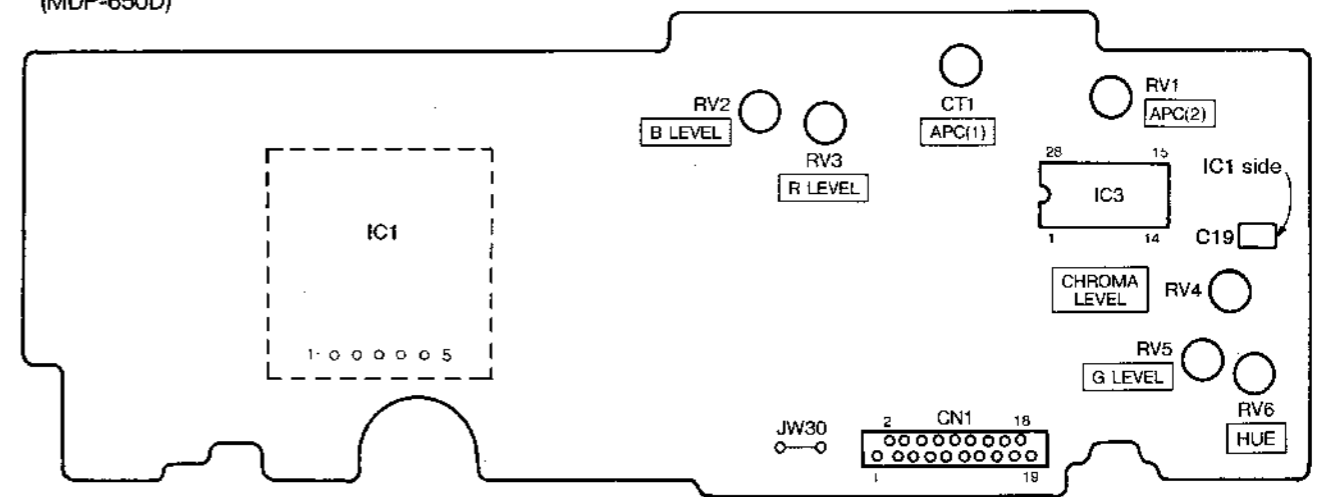

**AF-701 board (Conductor side)**  
(MDP-650D)

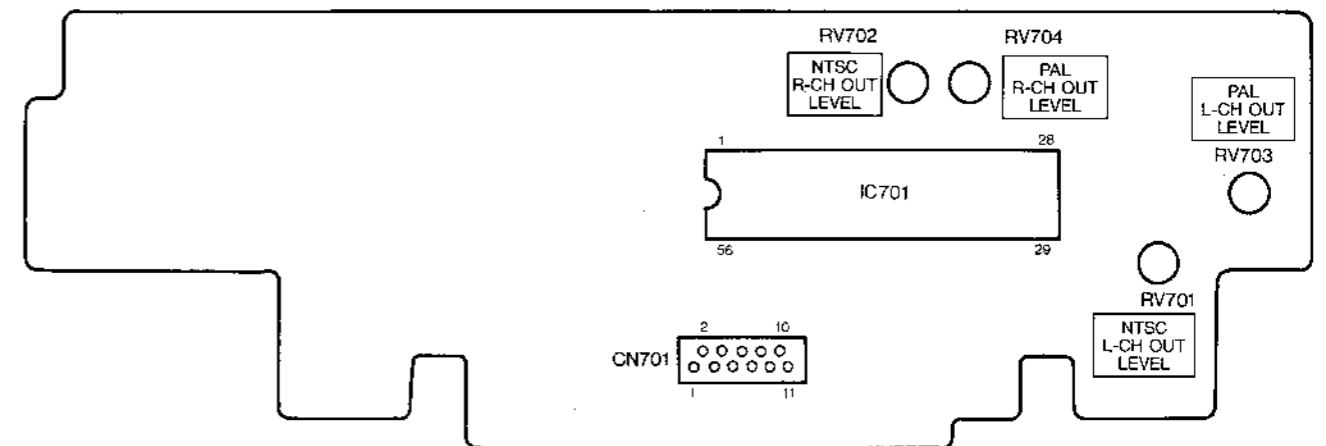

**AF-702 board (Conductor side)**  
(MDP-450)

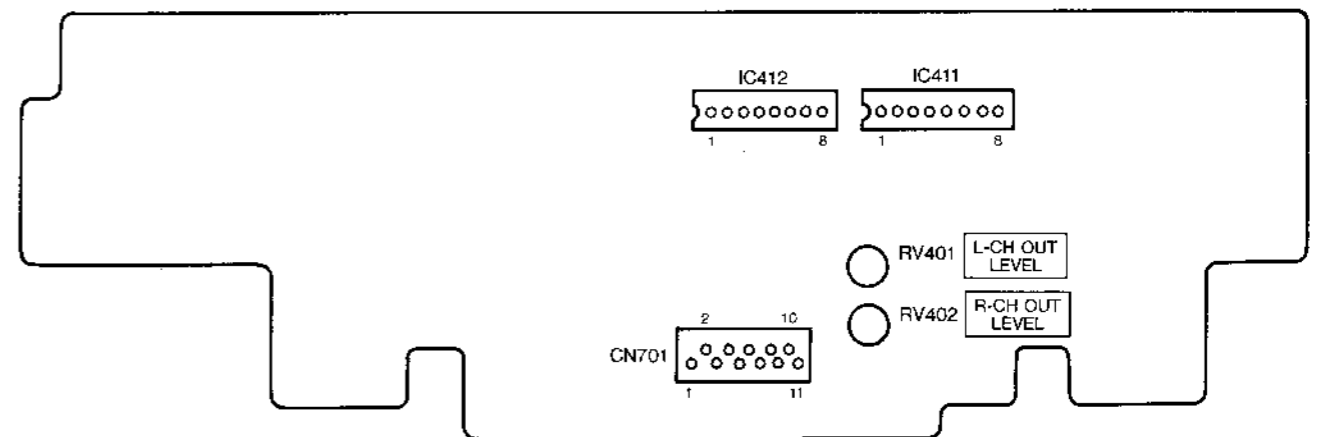

MP-701 board (Component side)

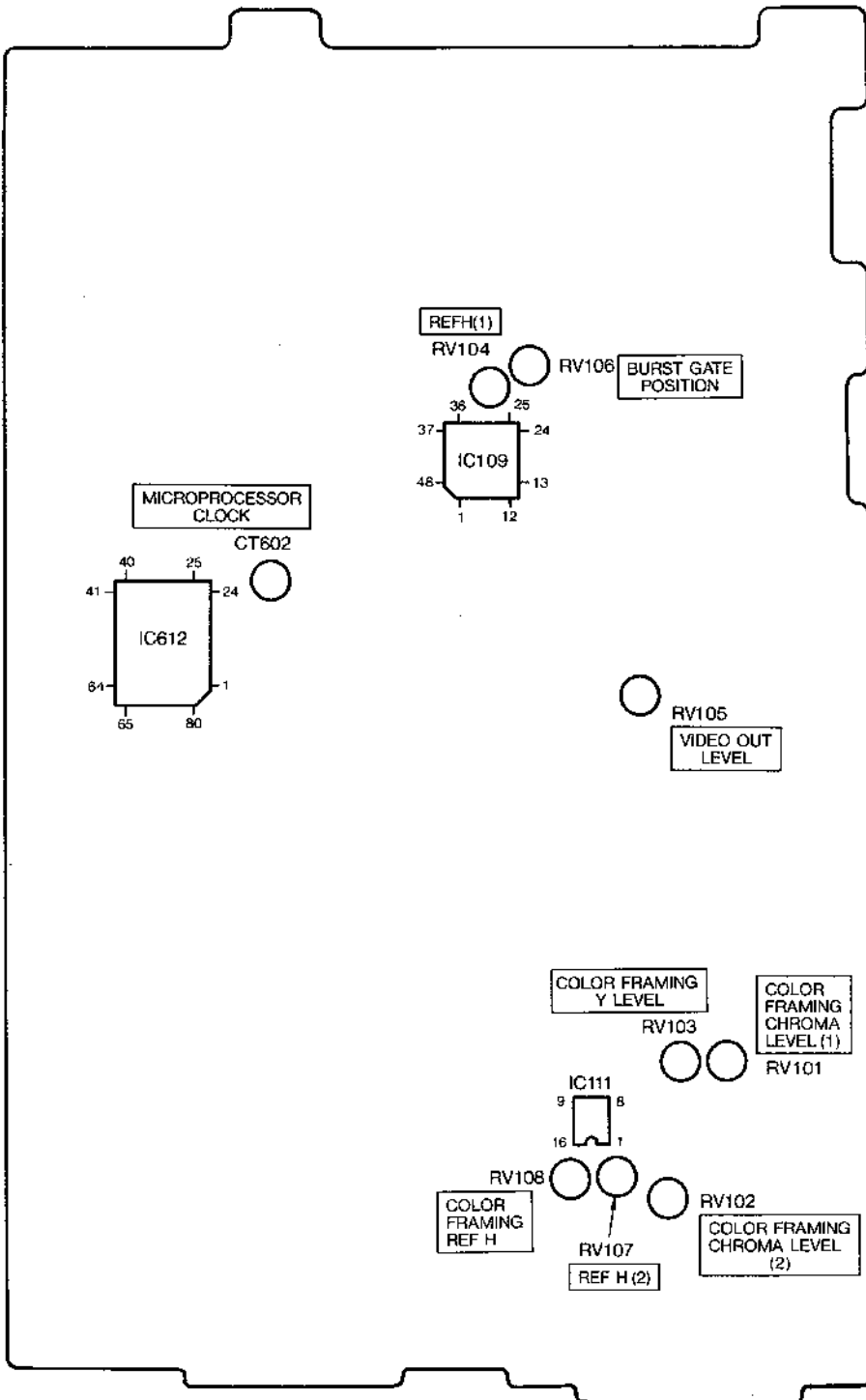











# MDP-450/650D

## RMT-M14

### SONY SERVICE MANUAL

*AEP Model*  
MDP-450/650D

*UK Model*

*Australian Model*

*Tourist Model*  
MDP-650D

## SUPPLEMENT-1

File this supplement with the Service Manual.

The tourist model has been added to the model MDP-650D.  
The specifications of the tourist model are the same as the  
AEP model.