

SERVICE MANUAL

BA-5 CHASSIS

<u>MODEL NAME</u>	<u>REMOTE COMMANDER</u>	<u>DESTINATION</u>	<u>CHASSIS NO.</u>
KV-27FV16	RM-Y171	US	SCC-S40K-A
KV-27FV16	RM-Y171	CND	SCC-S41J-A
KV-29FV16	RM-Y171	E	SCC-S38Q-A
KV-29FV16C	RM-Y171	E	SCC-S38R-A
KV-32FS12	RM-Y168	US	SCC-S40F-A
KV-32FS12	RM-Y168	CND	SCC-S41F-A
KV-32FS16	RM-Y169	US	SCC-S40G-A
KV-32FS16	RM-Y169	CND	SCC-S41G-A



KV-27FV16



RM-Y171

TRINITRON® COLOR TELEVISION

SONY®

SPECIFICATIONS

	KV-27FV16	KV-29FV16 KV-29FV16C	KV-32FS12	KV-32FS16
Power requirements	120V, 60 Hz	120-220V, 50/60Hz	120V, 60 Hz	120V, 60 Hz
Number of inputs/outputs				
Video ¹⁾	3	3	3	3
S Video ²⁾	2	2	1	1
Audio ³⁾	3	3	3	3
Audio Out ⁴⁾	1	1	1	1
Y, P _B , P _R ⁵⁾	1	1	1	1
Monitor Out	1	1	--	--
Speaker output(W)	15Wx2	15Wx2	5Wx2	5Wx2
Power Consumption(W)				
In use(Max)	220W	220W	165W	170W
In standby	1W	1W	1W	1W
Dimensions(W/H/D)				
(mm)	762 x 604 x 519 mm	762 x 604 x 519 mm	800 x 704 x 582 mm	800 x 704 x 582 mm
(in)	30 x 23 ^{7/8} x 20 ^{1/2} in.	30 x 23 ^{7/8} x 20 ^{1/2} in.	31 ^{1/2} x 27 ^{3/4} x 23 in.	31 ^{1/2} x 27 ^{3/4} x 23 in.
Mass				
(kg)	49 kg.	49 kg.	74 kg.	74 kg.
(lbs)	107 lbs. 13 oz.	107 lbs. 13 oz.	162 lbs. 13 oz.	162 lbs. 13 oz.

- 1) 1 Vp-p 75 ohms unbalanced, sync negative
- 2) Y: 1 Vp-p 75 ohms unbalanced, sync negative
C: 0.286 Vp-p (Burst signal), 75 ohms
- 3) 500mVrms (100% modulation), impedance: 47kiloohms
- 4) More than 408 mVrms at the maximum volume setting (variable)
More than 408 mVrms (fix)
- 5) Y: 1.0 Vp-p, 75 ohms, sync negative; PB: 0.7 Vp-p, 75 ohms;
PR: Vp-p, 75 ohms

Television system

American TV standard/NTSC

Channel coverage

VHF:2-13/UHF:14-69/CATV:1-125

Visible screen size

27" picture measured diagonally (KV-27FV16/29FV16/29FV16C ONLY)

32" picture measured diagonally (KV-32FS12/32FS16 ONLY)

Actual screen size

29" picture measured diagonally (KV-27FV16/29FV16/29FV16C ONLY)

34" picture measured diagonally (KV-32FS12/32FS16 ONLY)

Antenna

75 ohm external antenna terminal for VHF/UHF

Supplied accessories

- Remote Commander RM-Y168 (KV-32FS12 ONLY)
- Remote Commander RM-Y169 (KV-32FS16 ONLY)
- Remote Commander RM-Y171 (KV-27FV16/29FV16/29FV16C ONLY)
- Size AA (R6) batteries (2)

Optional accessories

- Connecting cables: VMC-810S/820S, VMC-720M,
YC-15V/30V, RK74A
- U/V mixer EAC-66
- TV Stand: SU27FD3 (KV-27FV16/32FS12/32FS16 ONLY)

Design and specifications are subject to change without notice.

(●) SRS (SOUND RETREIVAL SYSTEM)

The (●) SRS (SOUND RETREIVAL SYSTEM) is manufactured by Sony Corporation under license from SRS Labs, Inc. It is covered by U.S. Patent No. 4,748,669. Other U.S. and foreign patents pending.

The word "SRS" and the SRS symbol (●) are registered trademarks of SRS Labs, Inc.

BBE and BBE symbol are trademarks of BBE Sound, Inc. and are licensed by BBE Sound, Inc. under U.S. Patent No. 4,638,258 and 4,482,866.

TABLE OF CONTENTS

<i>Section</i>	<i>Title</i>	<i>Page</i>
	Warnings and Cautions	4
	Self-Diagnostic Function	4
	Safety Check-Out Instructions	7
1.	GENERAL	8
2.	DISASSEMBLY	
2-1.	Rear Cover Removal	14
2-2.	Chassis Assembly Removal	14
2-3.	Service Position	14
2-4.	Picture Tube Removal	15
3.	SET-UP ADJUSTMENTS	
3-1.	Beam Landing	16
3-2.	Convergence	17
3-3.	Focus	18
3-4.	Screen (G2)	19
3-5.	Method of Setting the Service Adjustment Mode	19
3-6.	White Balance Adjustments	19
4.	SAFETY RELATED ADJUSTMENTS	
4-1.	☒ R564 Confirmation Method (HV Hold-Down Confirmation and Readjustments)	20
4-2.	B+ Voltage Confirmation and Adjustment	20
5.	CIRCUIT ADJUSTMENTS	
5-1.	Setting the Service Adjustment Mode	22
5-2.	Memory Write Confirmation Method	22
5-3.	Adjustment Buttons and Indicators	22
5-4.	MA Board Adjustments	26
6.	DIAGRAMS	
6-1.	Block Diagram	31
6-2.	Circuit Board Location	35
6-3.	Printed Wiring Boards and Schematic Diagrams	35
	• A Board	36
	• MA Board	43
	• CA Board	49
	• HX Board	50
	• D Board	51
	• BC Board	53
	• HA Board	55
	• HB Board	56
	• K Board	57
	• VA Board	58
	• P Board	59
6-4.	Semiconductors	61
7.	EXPLODED VIEW	
7-1.	Chassis (KV-27V16/29FV16/29FV16C ONLY)	62
7-2.	Picture Tube (KV-27V16/29FV16/29FV16C ONLY)	63
7-3.	Chassis (KV-32FS12/32FS16 ONLY)	64
7-4.	Picture Tube (KV-32FS12/32FS16 ONLY)	65
8.	ELECTRICAL PARTS LIST	66

WARNINGS AND CAUTIONS

CAUTION

SHORT CIRCUIT THE ANODE OF THE PICTURE TUBE AND THE ANODE CAP TO THE METAL CHASSIS, CRT SHIELD, OR CARBON PAINTED ON THE CRT, AFTER REMOVING THE ANODE.

WARNING!!

AN ISOLATION TRANSFORMER SHOULD BE USED DURING ANY SERVICE TO AVOID POSSIBLE SHOCK HAZARD, BECAUSE OF LIVE CHASSIS. THE CHASSIS OF THIS RECEIVER IS DIRECTLY CONNECTED TO THE AC POWER LINE.

SAFETY-RELATED COMPONENT WARNING!!

COMPONENTS IDENTIFIED BY SHADING AND MARK \triangle ON THE SCHEMATIC DIAGRAMS, EXPLODED VIEWS, AND IN THE PARTS LIST ARE CRITICAL FOR SAFE OPERATION. REPLACE THESE COMPONENTS WITH SONY PARTS WHOSE PART NUMBERS APPEAR AS SHOWN IN THIS MANUAL OR IN SUPPLEMENTS PUBLISHED BY SONY. CIRCUIT ADJUSTMENTS THAT ARE CRITICAL FOR SAFE OPERATION ARE IDENTIFIED IN THIS MANUAL. FOLLOW THESE PROCEDURES WHENEVER CRITICAL COMPONENTS ARE REPLACED OR IMPROPER OPERATION IS SUSPECTED.

ATTENTION!!

APRES AVOIR DECONNECTE LE CAP DE L'ANODE, COURT-CIRCUITER L'ANODE DU TUBE CATHODIQUE ET CELUI DE L'ANODE DU CAP AU CHASSIS METALLIQUE DE L'APPAREIL, OU AU COUCHE DE CARBONE PEINTE SUR LE TUBE CATHODIQUE OU AU BLINDAGE DU TUBE CATHODIQUE.

ATTENTION!!

AFIN D'EVITER TOUT RESQUE D'ELECTROCUTION PROVENANT D'UN CHÂSSIS SOUS TENSION, UN TRANSFORMATEUR D'ISOLEMENT DOIT ETRE UTILISÉ LORS DE TOUT DÉPANNAGE. LE CHÂSSIS DE CE RÉCEPTEUR EST DIRECTEMENT RACCORDÉ À L'ALIMENTATION SECTEUR.

ATTENTION AUX COMPOSANTS RELATIFS A LA SECURITE!!

LES COMPOSANTS IDENTIFIES PAR UNE TRAME ET PAR UNE MARQUE \triangle SUR LES SCHEMAS DE PRINCIPE, LES VUES EXPLOSEES ET LES LISTES DE PIECES SONT D'UNE IMPORTANCE CRITIQUE POUR LA SECURITE DU FONCTIONNEMENT. NE LES REMPLACER QUE PAR DES COMPOSANTS SONY DONT LE NUMERO DE PIECE EST INDIQUE DANS LE PRESENT MANUEL OU DANS DES SUPPLEMENTS PUBLIES PAR SONY. LES REGLAGES DE CIRCUIT DONT L'IMPORTANCE EST CRITIQUE POUR LA SECURITE DU FONCTIONNEMENT SONT IDENTIFIES DANS LE PRESENT MANUEL. SUIVRE CES PROCEDURES LORS DE CHAQUE REMPLACEMENT DE COMPOSANTS CRITIQUES, OU LORSQU'UN MAUVAIS FONCTIONNEMENT SUSPECTE.

SELF-DIAGNOSTIC FUNCTION

The units in this manual contain a self-diagnostic function. If an error occurs, the STANDBY/TIMER LED will automatically begin to flash. The number of times the LED flashes translates to a probable source of the problem. A definition of the STANDBY/TIMER LED flash indicators is listed in the instruction manual for the user's knowledge and reference. If an error symptom cannot be reproduced, the Remote Commander can be used to review the failure occurrence data stored in memory to reveal past problems and how often these problems occur.

Diagnostic Test Indicators

When an error occurs, the STANDBY/TIMER LED will flash a set number of times to indicate the possible cause of the problem. If there is more than one error, the LED will identify the first of the problem areas.

Results for all of the following diagnostic items are displayed on screen. No error has occurred if the screen displays a "0".

Diagnostic Item Description	No. of Times STANDBY/TIMER LED Flashes	Self-Diagnostic Display/ Diagnostic Result	Probable Cause Location	Detected Symptoms
Power does not turn on	Does not light	—————	<ul style="list-style-type: none"> • Power cord is not plugged in. • Fuse is burned out. (F601) (A Board) 	<ul style="list-style-type: none"> • Power does not come on. • No power is supplied to the TV. • AC power supply is faulty.
+B overcurrent (OCP)*	2 times	2:0 or 2:1	<ul style="list-style-type: none"> • H.OUT (Q502) is shorted. (A Board) • IC702 is shorted. (CA Board) 	<ul style="list-style-type: none"> • Power does not come on. • Load on power line is shorted.
I-Prot	4 times	4:0 or 4:1	<ul style="list-style-type: none"> • +13V is not supplied. (A Board) • IC502 is faulty. (A Board) 	<ul style="list-style-type: none"> • Has entered standby state after horizontal raster. • Vertical deflection pulse is stopped. • Power line is shorted or power supply is stopped.
IK	5 times	5:0 or 5:1	<ul style="list-style-type: none"> • Video OUT (IC502) is faulty. (A Board) • IC301 is faulty. (MA Board) • Screen (G2) is improperly adjusted.** 	<ul style="list-style-type: none"> • No raster is generated. • CRT cathode current detection reference pulse output is small.

* If a +B overcurrent is detected, stoppage of the vertical deflection is detected simultaneously.

The symptom that is diagnosed first by the microcontroller is displayed on the screen.

** Refer to Screen (G2) Adjustments in Section 3-4 of this manual.

Display of Standby/Timer LED Flash Count

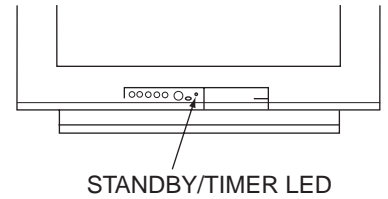
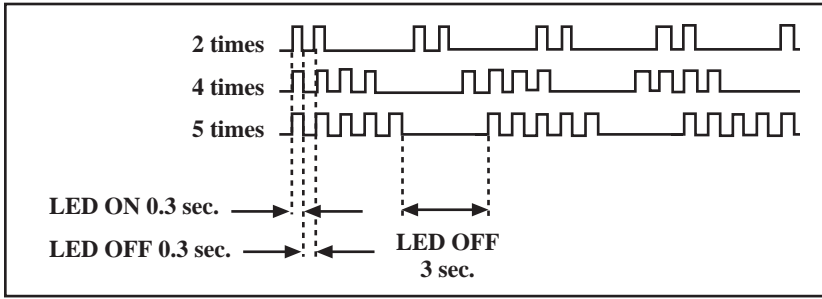

<u>Diagnostic Item</u>	<u>Flash Count*</u>
+B overcurrent	2 times
I-Prot	4 times
IK	5 times

*One flash count is not used for self-diagnostic.

Stopping the Standby/Timer LED Flash

Turn off the power switch on the TV main unit or unplug the power cord from the outlet to stop the STANDBY/TIMER LAMP from flashing.

Self-Diagnostic Screen Display

For errors with symptoms such as “power sometimes shuts off” or “screen sometimes goes out” that cannot be confirmed, it is possible to bring up past occurrences of failure on the screen for confirmation.

To Bring Up Screen Test

In standby mode, press buttons on the Remote Commander sequentially, in rapid succession, as shown below:

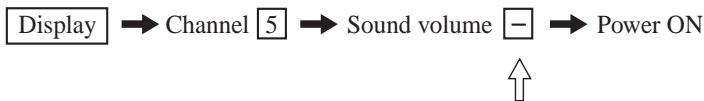

Note that this differs from entering the service mode (sound volume [+]).

Self-Diagnostic Screen Display

SELF DIAGNOSTIC			
2:		0	← Numeral “0” means that no fault was detected.
3:	N/A	0	
4:		0	
5:		1	← Numeral “1” means a fault was detected one time only.
101:	N/A	0	

Handling of Self-Diagnostic Screen Display

Since the diagnostic results displayed on the screen are not automatically cleared, always check the self-diagnostic screen during repairs. When you have completed the repairs, clear the result display to "0".

Unless the result display is cleared to "0", the self-diagnostic function will not be able to detect subsequent faults after completion of the repairs.

Clearing the Result Display

To clear the result display to "0", press buttons on the Remote Commander sequentially when the diagnostic screen is displayed, as shown below:

Channel **8** → **ENTER**

Quitting the Self-Diagnostic Screen

To quit the entire self-diagnostic screen, turn off the power switch on the Remote Commander or the main unit.

Self-Diagnostic Circuit

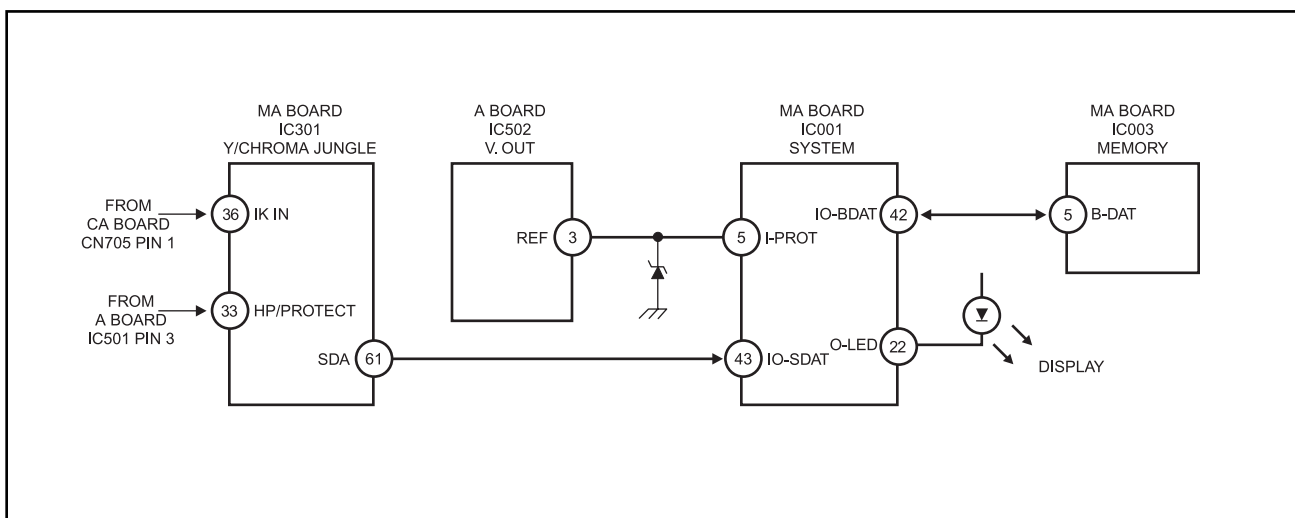

+B overcurrent (OCP)

Occurs when an overcurrent on the +B (135V) line is detected by pin 33 of IC301 (MA Board). If the voltage of pin 33 of IC301 (MA Board) is less than 1V when V.SYNC is more than seven verticals in a period, the unit will automatically turn off.

I-Prot

Occurs when an absence of the vertical deflection pulse is detected by pin 5 of IC001 (MA Board). Power supply will shut down when waveform interval exceeds 2 seconds.

IK

If the RGB levels* do not balance within 2 seconds after the power is turned on, this error will be detected by IC301 (MA Board). TV will stay on, but there will be no picture.

*(Refers to the RGB levels of the AKB detection Ref pulse that detects 1K).

SAFETY CHECK-OUT

After correcting the original service problem, perform the following safety checks before releasing the set to the customer:

1. Check the area of your repair for unsoldered or poorly soldered connections. Check the entire board surface for solder splashes and bridges.
2. Check the interboard wiring to ensure that no wires are "pinched" or touching high-wattage resistors.
3. Check that all control knobs, shields, covers, ground straps, and mounting hardware have been replaced. Be absolutely certain that you have replaced all the insulators.
4. Look for unauthorized replacement parts, particularly transistors, that were installed during a previous repair. Point them out to the customer and recommend their replacement.
5. Look for parts which, though functioning, show obvious signs of deterioration. Point them out to the customer and recommend their replacement.
6. Check the line cords for cracks and abrasion. Recommend the replacement of any such line cord to the customer.
7. Check the B+ and HV to see if they are specified values. Make sure your instruments are accurate; be suspicious of your HV meter if sets always have low HV.
8. Check the antenna terminals, metal trim, "metallized" knobs, screws, and all other exposed metal parts for AC leakage. Check leakage as described below.

Leakage Test

The AC leakage from any exposed metal part to earth ground and from all exposed metal parts to any exposed metal part having a return to chassis, must not exceed 0.5 mA (500 microamperes). Leakage current can be measured by any one of three methods.

1. A commercial leakage tester, such as the Simpson 229 or RCA WT-540A. Follow the manufacturers' instructions to use these instruments.
2. A battery-operated AC milliammeter. The Data Precision 245 digital multimeter is suitable for this job.
3. Measuring the voltage drop across a resistor by means of a VOM or battery-operated AC voltmeter. The "limit" indication is 0.75 V, so analog meters must have an accurate low voltage scale. The Simpson's 250 and Sanwa SH-63TRD are examples of passive VOMs that are suitable. Nearly all battery-operated digital multimeters that have a 2 VAC range are suitable (see Figure A).

How to Find a Good Earth Ground

A cold-water pipe is a guaranteed earth ground; the cover-plate retaining screw on most AC outlet boxes is also at earth ground. If the retaining screw is to be used as your earth ground, verify that it is at ground by measuring the resistance between it and a cold-water pipe with an ohmmeter. The reading should be zero ohms. If a cold-water pipe is not accessible, connect a 60- to 100-watt trouble- light (not a neon lamp) between the hot side of the receptacle and the retaining screw. Try both slots, if necessary, to locate the hot side on the line; the lamp should light at normal brilliance if the screw is at ground potential (see Figure B).

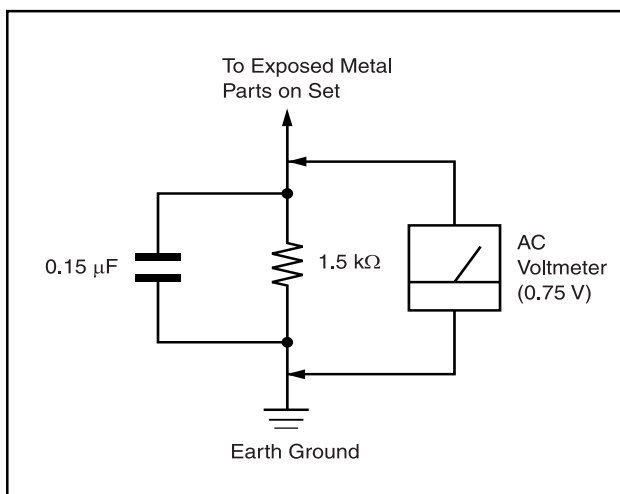

Figure A. Using an AC voltmeter to check AC leakage.

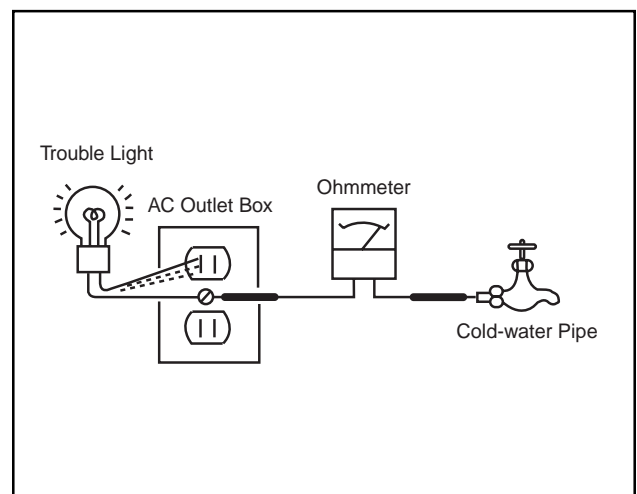

Figure B. Checking for earth ground.

The instructions mentioned here are partial abstracts from the Operating Instruction Manual. The page numbers shown reflect those of the Operating Instruction Manual.

Connecting Your TV

Read this chapter before setting up your TV for the first time. This section covers basic connections in addition to any optional equipment you may be connecting.

Basic Connections

TV with indoor or outdoor antenna, or CATV cable

Depending on the cable available in your home, choose one of the connections below:

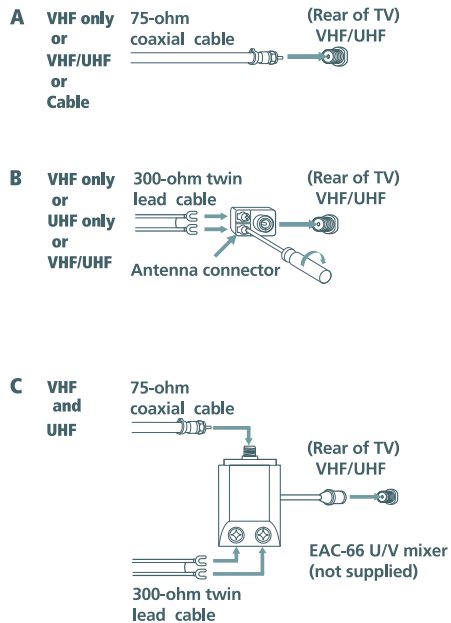

If you are connecting to an indoor or outdoor antenna, you may need to adjust the orientation of the antenna for best reception.

3

Operating Instructions

Cable Box Connections

Some pay cable TV systems use scrambled or encoded signals that require a cable box to view all channels.

Cable Box

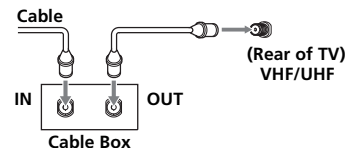

- 1 Connect the coaxial cable from your cable service to the IN jack on your cable box.
- 2 Connect a coaxial cable (not supplied) from the OUT jack on your cable box to the VHF/UHF jack on your TV.

If you will be controlling all channel selection through your cable box, you should consider using the Channel Fix feature, (see page 26).

Cable Box and Cable

For this set up, you can switch between scramble channels (through your cable box), and normal (CATV) channels by using the **ANT** button.

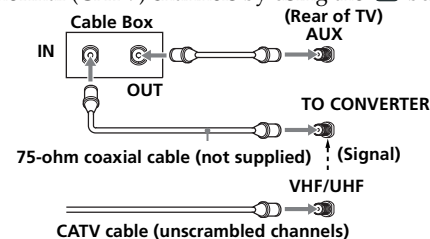

If you are connecting a cable box through the AUX input and would like to switch between the AUX and normal (CATV) input, you should consider using the Channel Fix feature, (see page 26).

Your Sony remote control can be programmed to operate your cable box, (see page 36).

When using PIP, you cannot view the AUX input in the window picture.

4

Connecting Additional Equipment

TV and VCR

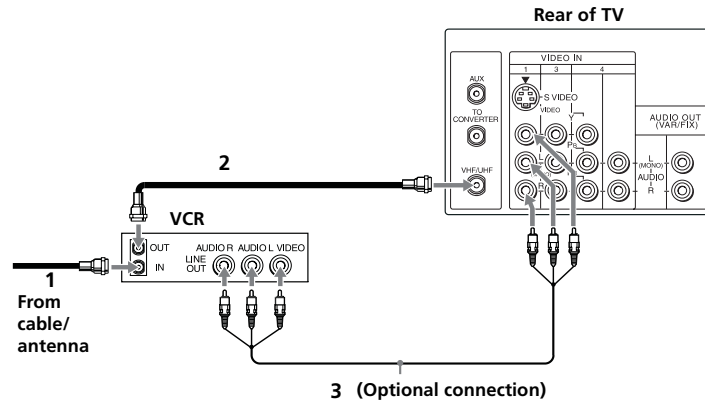

- 1** Connect the coaxial cable from your TV antenna or cable service to the IN jack on your VCR.
- 2** Connect a coaxial cable (not supplied) from the OUT jack on your VCR to the VHF/UHF jack on the TV.

To watch video programs from your VCR, tune your TV to channel 3 or 4 (as set on the rear of your VCR).

(Optional connection)

- 3** If your VCR is equipped with video outputs, you can get better picture quality by connecting A/V cables (not supplied) from AUDIO and VIDEO OUT on your VCR to AUDIO/VIDEO IN on your TV.

For optimum picture quality, use S VIDEO instead of the yellow AV cable. S VIDEO does not provide sound, the audio cables must still be connected.

You can use the button to switch between the VHF/UHF and VIDEO inputs.

TV and Cable Box

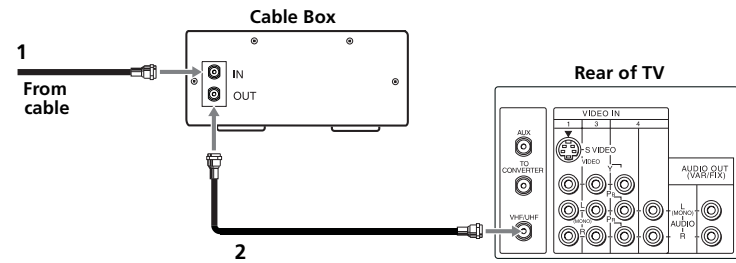

- 1** Connect the coaxial cable from your cable service to the IN jack on your cable box.
- 2** Connect a coaxial cable (not supplied) from the OUT jack on your cable box to the VHF/UHF jack on the TV.

To view channels from your cable box, tune your TV to channel 3 or 4 (as set on the rear panel of your cable box) and use the cable box's remote control to change channels.

If you will be controlling all channel selection through your cable box, you should consider using the Channel Fix feature, (see page 26).

Connecting Your TV

TV, Cable box, and Cable

KV-27FS16, KV-27FV16, KV-32FS16, KV-29FV16 only

For this set up, you can switch between scrambled channels (through your cable box) and normal (CATV) channels by pressing .

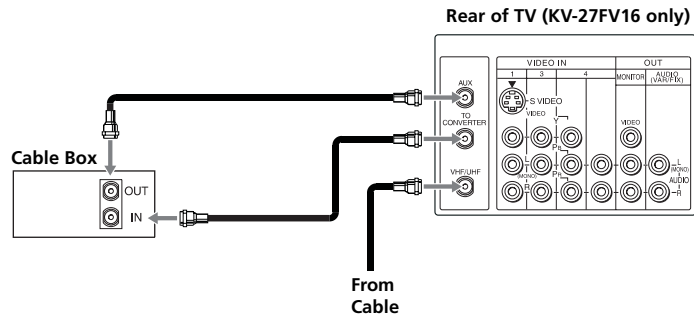

 When using PIP, the AUX input cannot be viewed in the window picture.

7

Operating Instructions

TV, VCR, and Cable box

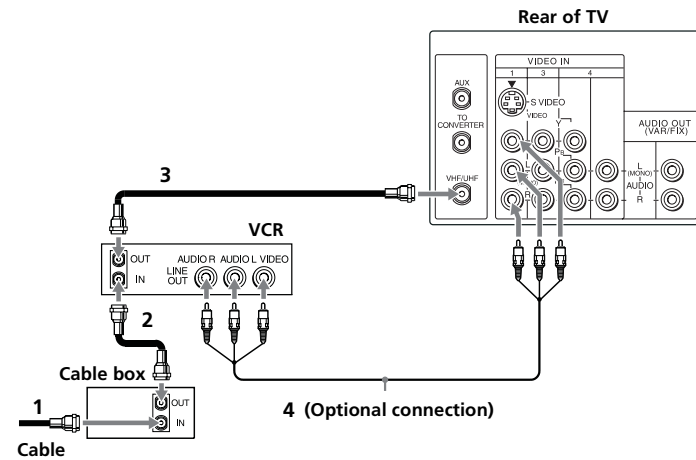



- 1** Connect the coaxial cable from your cable service to the IN jack on your cable box.
- 2** Connect a coaxial cable (not supplied) from the OUT jack on your cable box to the IN jack on your VCR.
- 3** Connect a coaxial cable (not supplied) from the OUT jack on your VCR to the VHF/UHF jack on the TV.

 If you will be controlling all channel selection through your cable box, you should consider using the Channel Fix feature, (see page 26).

(Optional connection)

- 4** If your VCR is equipped with video outputs, you can get better picture quality by connecting A/V cables (not supplied) from AUDIO and VIDEO OUT on your VCR to AUDIO/VIDEO IN on your TV.

 For optimum picture quality, use S VIDEO instead of the yellow A/V cable. S VIDEO does not provide sound, the audio cables must still be connected.

 You can use the  button to switch between the VHF/UHF and VIDEO inputs.

8

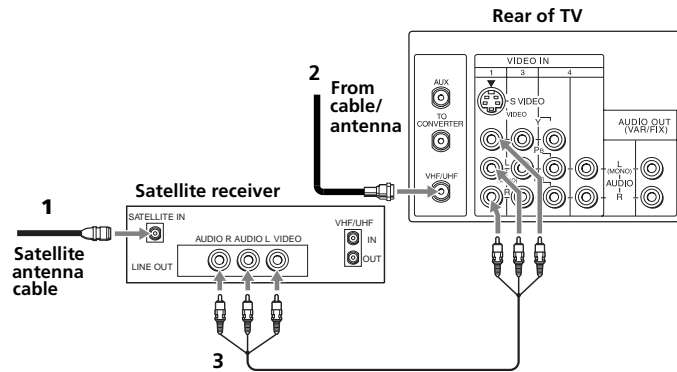

Connecting Your TV

TV and Satellite Receiver



- 1** Connect the cable from your satellite antenna to SATELLITE IN on your satellite receiver.
- 2** Connect the coaxial cable from your cable or antenna to the VHF/UHF jack on your TV.
- 3** Using A/V cables, connect AUDIO and VIDEO OUT on your satellite receiver to AUDIO and VIDEO IN on your TV.

 For optimum picture quality, use S VIDEO instead of the yellow A/V cable. S VIDEO does not provide sound, the audio cables must still be connected.



 You can use the  button to switch between the VHF/UHF and satellite receiver inputs.

Operating Instructions

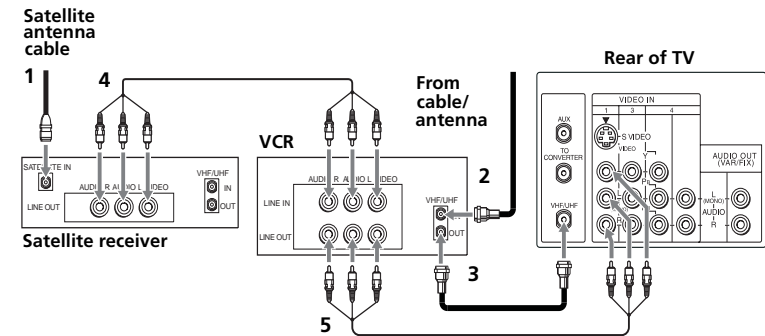
TV, Satellite Receiver, and VCR



- 1** Connect the cable from your satellite antenna to SATELLITE IN on your satellite receiver.
- 2** Connect the coaxial cable from your cable or antenna to the IN jack on your VCR.
- 3** Using a coaxial cable, connect the OUT jack on your VCR to the VHF/UHF jack on your TV.
- 4** Using A/V cables, connect AUDIO and VIDEO OUT on your satellite receiver to AUDIO and VIDEO IN on your VCR.
- 5** Using A/V cables, connect AUDIO and VIDEO OUT on your VCR to AUDIO and VIDEO IN on your TV.

 To view from the satellite receiver or VCR, select the video input to which your satellite receiver or VCR is connected by pressing  on the remote control.

Using the Remote Control and Basic Functions

This section shows you how to use the more advanced buttons on the remote control and how to use the on-screen menus.

Using the Remote Control

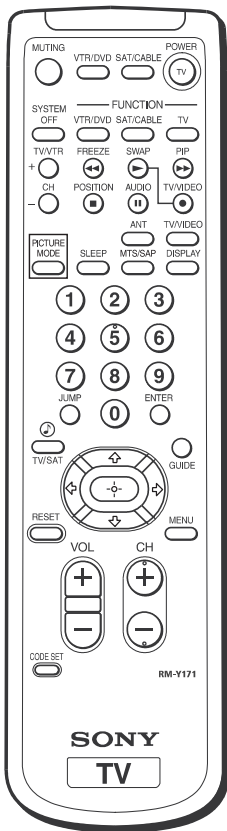

Button	Description
POWER	Press when you want to turn connected equipment on and off.
FUNCTION	Press when you want to control connected equipment with your remote control.
MUTING	Instantly turns off the sound. Press again or press to restore sound.
SYSTEM OFF	Powers off all Sony equipment at once, (may not work with older equipment).
TV/VIDEO	Cycles through available video inputs.
ANT	Press to change the VHF/UHF input to the AUX input (KV-27FS16, KV-27FV16, KV-32FS16 only).
TV/VTR	Press when you are finished using a VCR and you want to switch to the TV input. Your VCR power will remain on.
	Moves the cursor in the on-screen menus. Press the arrow buttons to move the cursor. Press the center button to select or access an option.
PICTURE MODE	Cycles through the available Video Mode settings.

The remote control shown (RM-Y171) is for KV-27FV16. Your remote control may not look like the one illustrated.

Using the Remote Control and Basic Functions

SLEEP	Turns the TV off automatically in approximately 15, 30, 45, 60, 90, or 120 minutes. Cancel by pressing until SLEEP OFF appears.
MTS/SAP	Cycles through the Multi-channel TV Sound (MTS) options: Stereo, Mono, and Auto-SAP (Second Audio Programming).
DISPLAY	Press once to show current time, (if set) and channel number.
JUMP	Cycles through available Steady Sound settings, (see page 23). Alternates between the last two channels selected with the buttons.
GUIDE	Brings up the custom guide of your satellite receiver.
MENU	Displays the on-screen menu. Press again to exit the menu at any time.
RESET	Press to return to factory settings while in an on-screen menu.
CODE SET	Use to program your remote control to operate connected video equipment, (see page 36).













For information on Picture in Picture (PIP) operation buttons, see page 17.

If you lost your remote control, see page 40.

Troubleshooting

If you are having a problem with your TV, try the suggestions below. If the problem persists, contact your nearest Sony dealer.

No picture, no sound	<ul style="list-style-type: none"> <input type="checkbox"/> Make sure the power cord is plugged in. <input type="checkbox"/> If red light is flashing on the front of your TV for more than a few minutes, disconnect and reconnect the power cord to restore the TV. If the problem continues, call your local service center. <input type="checkbox"/> Check the TV/VIDEO settings: when watching TV, set to TV; when watching video equipment, set to VIDEO (page 14). <input type="checkbox"/> Make sure the batteries have been inserted correctly into the remote control (page 2). <input type="checkbox"/> Try another channel, it could be station trouble.
Poor or no picture, good sound	<ul style="list-style-type: none"> <input type="checkbox"/> Adjust Picture in the Video menu (page 22). <input type="checkbox"/> Adjust Brightness in the Video menu (page 22). <input type="checkbox"/> Check the antenna and/or cable connections (page 3).
Good picture, no sound	<ul style="list-style-type: none"> <input type="checkbox"/> Press  so that MUTING disappears from the screen (page 14). <input type="checkbox"/> Check your Audio settings. Your TV may be set to Auto-SAP (page 24).
No color	<ul style="list-style-type: none"> <input type="checkbox"/> Adjust Color in the Video menu (page 22).
No signal	<ul style="list-style-type: none"> <input type="checkbox"/> Check the Cable setting in the Channel Setup menu (page 25). <input type="checkbox"/> Check the antenna and/or cable connections (page 3). <input type="checkbox"/> Make sure the channel selected is currently broadcasting.
Dotted lines or stripes	<ul style="list-style-type: none"> <input type="checkbox"/> Adjust the antenna. <input type="checkbox"/> Move the TV away from other electronic equipment. Some electronic equipment can create electrical noise, which can interfere with TV reception.
Double images or ghosts	<ul style="list-style-type: none"> <input type="checkbox"/> Check your outdoor antenna or call your cable service.

Cannot receive higher number channels (UHF) when using an antenna	<ul style="list-style-type: none"> <input type="checkbox"/> Make sure Cable is set to OFF in the Channel Setup menu (page 25). <input type="checkbox"/> Perform Auto Program to add channels that are not presently in the memory (page 16).
Cable stations don't seem to work	<ul style="list-style-type: none"> <input type="checkbox"/> Make sure Cable is set to ON in the Channel Setup menu (page 25). <input type="checkbox"/> Perform Auto Program to add channels that are not presently in the memory (page 16).
Remote control does not operate	<ul style="list-style-type: none"> <input type="checkbox"/> Batteries could be weak. Replace them (page 2). <input type="checkbox"/> Move the TV 3-4 feet away from fluorescent lights.
The TV needs to be cleaned	<ul style="list-style-type: none"> <input type="checkbox"/> Clean the TV with a soft dry cloth. Never use strong solvents such as thinner or benzine, which might damage the finish of the cabinet.
Lost password for Parental Control	<ul style="list-style-type: none"> <input type="checkbox"/> In the password screen, enter the following master password: 4357. After using the master password, you must create a new password, it cannot be used to unlock currently blocked channels.
You lost your remote control	<ul style="list-style-type: none"> <input type="checkbox"/> You can use the front A/V panel controls to access the menu. Press  to open the menu. Use the  or  buttons on the front A/V panel instead of the  or  buttons on the remote control. Use the  button on the front A/V panel instead of the , , and  buttons on the remote control. Press  again when the setting or adjustment is complete. Contact your nearest Sony dealer to order a replacement.
Cannot access other menus when using the Basic Menu	<ul style="list-style-type: none"> <input type="checkbox"/> If you use the  button to close the Basic menu, only the Basic menu appears when you press  again. To have access to the other menus, use the  button to select Advance Menu (page 35).

If, after reading these Operating Instructions, you have additional questions related to the use of your Sony television, please call our Direct Response Center at 1-800-222-SONY (7669) (U.S. residents only) or (416) 499-SONY (7669) (Canadian residents only).

SECTION 2 DISASSEMBLY

2-1. REAR COVER REMOVAL

KV-27FV16/29FV16/29FV16C ONLY

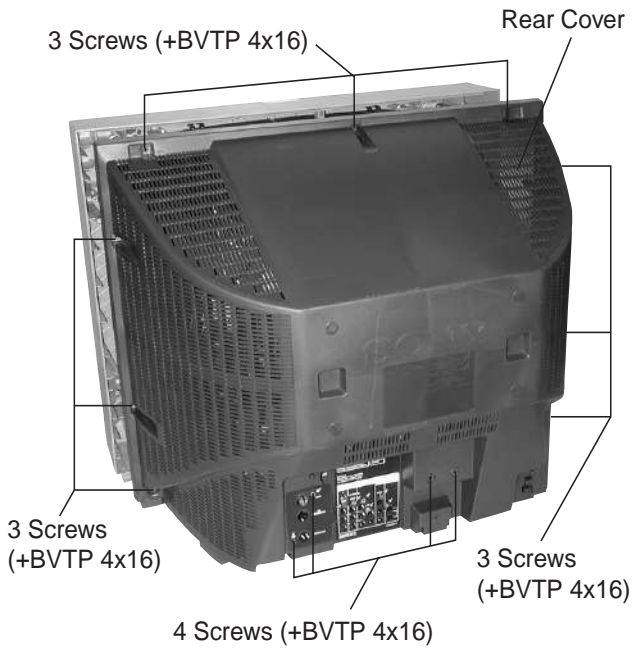

KV-32FS12/32FS16 ONLY

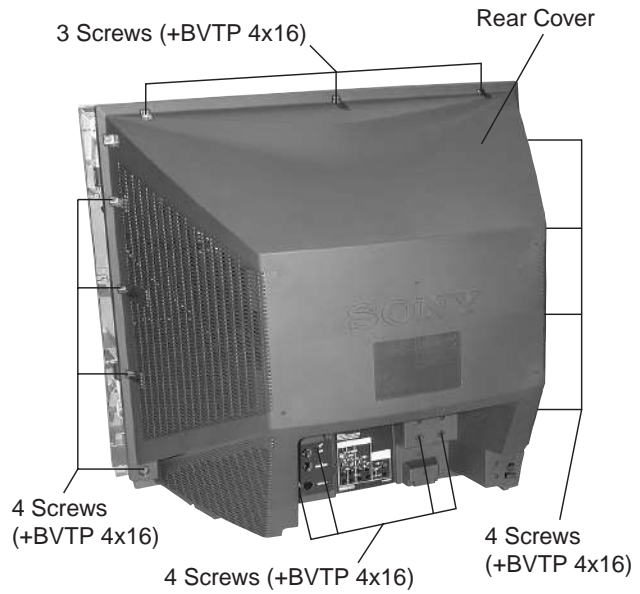

2-2. CHASSIS ASSEMBLY REMOVAL

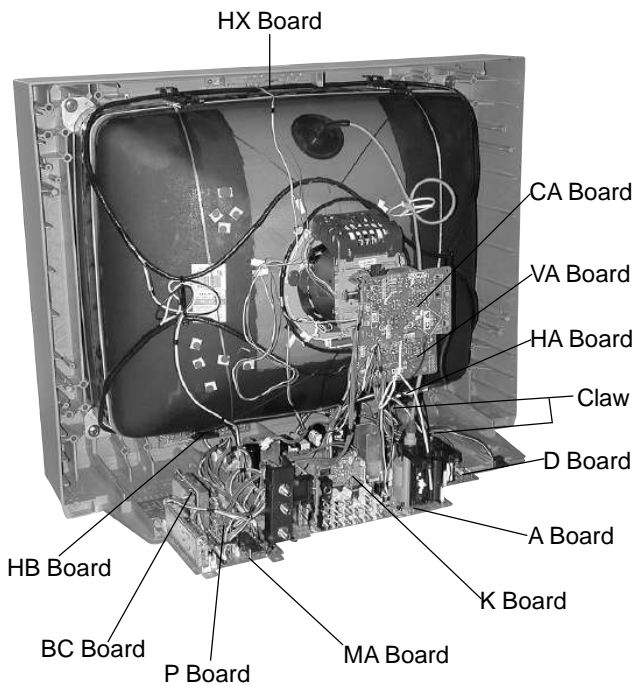

2-3. SERVICE POSITION

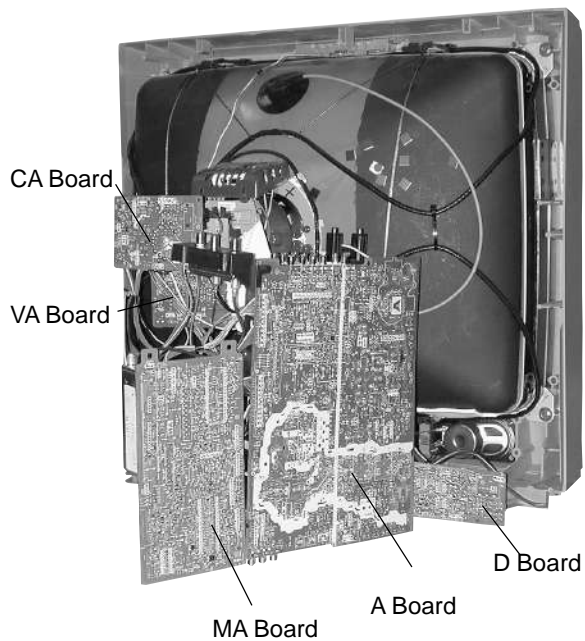

2-4. PICTURE TUBE REMOVAL

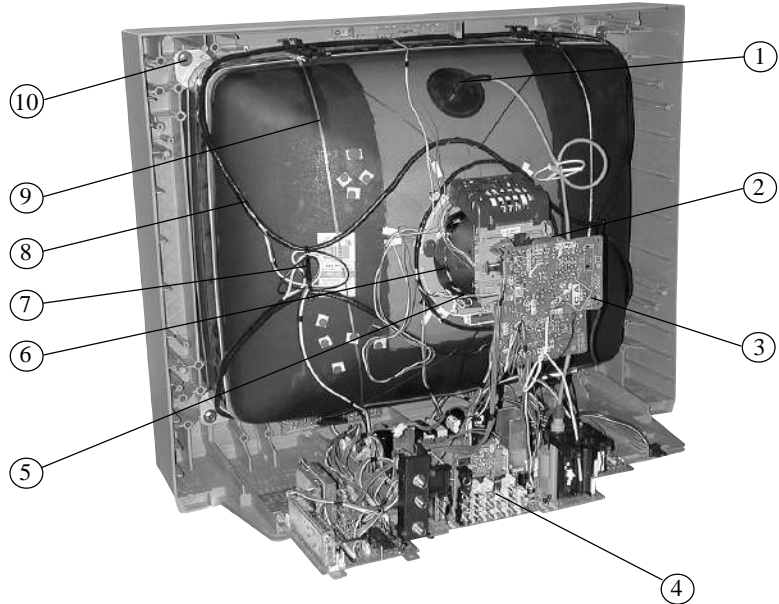
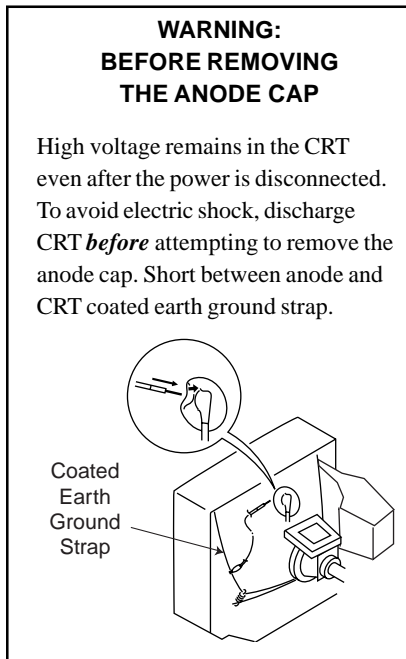

1. Discharge the anode of the CRT and remove the anode cap.
2. Unplug all interconnecting leads from the deflection yoke, neck assembly, degaussing coils and CRT grounding strap.
3. Remove the CA Board from the CRT.
4. Remove the chassis assembly.
5. Loosen the neck assembly fixing screw and remove.
6. Loosen the deflection yoke fixing screw and remove.
7. Place the set with the CRT face down on a cushion and remove the degaussing coil holders.
8. Remove the degaussing coils.
9. Remove the CRT grounding strap and spring tension devices.
10. Unscrew the four CRT fixing screws [located on each CRT corner] and remove the CRT [Take care not to handle the CRT by the neck].

ANODE CAP REMOVAL

WARNING: High voltage remains in the CRT even after the power is disconnected. To avoid electrical shock, discharge the CRT *before* attempting to remove the anode cap. Short between anode and coated earth ground strap of CRT.

NOTE: After removing the anode, short circuit the anode of the picture tube and the anode cap to either the metal chassis, CRT shield, or carbon painted on the CRT.

REMOVAL PROCEDURES

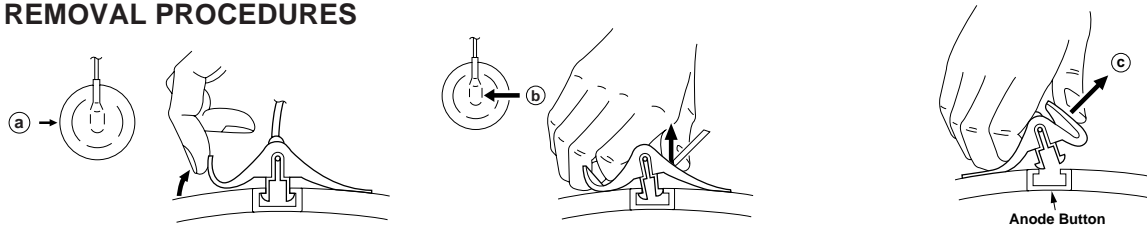

- ① Turn up one side of the rubber cap in the direction indicated by arrow (a).
- ② Use your thumb to pull the rubber cap firmly in the direction indicated by arrow (b).
- ③ When one side of the rubber cap separates from the anode button, the anode cap can be removed by turning the rubber cap and pulling it in the direction of arrow (c).

HOW TO HANDLE AN ANODE CAP

- ① Do not use sharp objects which may cause damage to the surface of the anode cap.
- ② To avoid damaging the anode cap, do not squeeze the rubber covering too hard. A material fitting called a shatter-hook terminal is built into the rubber.
- ③ Do not force turn the foot of the rubber cover. This may cause the shatter-hook terminal to protrude and damage the rubber.

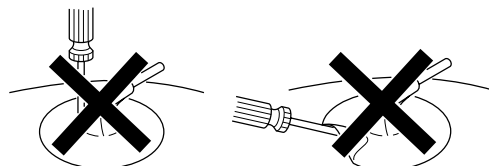

SECTION 3 SET-UP ADJUSTMENTS

The following adjustments should be made when a complete realignment is required or when a new picture tube is installed.

These adjustments should be performed with rated power supply voltage unless otherwise noted.

Set the controls as follows unless otherwise noted:

VIDEO MODE: STANDARD

PICTURE control: Normal

BRIGHTNESS control: Normal

Perform the adjustments in order as follows:

1. Beam Landing
2. Convergence
3. Focus
4. Screen (G2)
5. White Balance

Note: Test equipment required:

- Color Bar Pattern Generator
- Degausser
- DC Power Supply
- Digital Multimeter

3-1. BEAM LANDING

Before beginning adjustment procedure:

1. Degauss the entire screen.
2. Feed in the white pattern signal.

Adjustment Procedure

1. Input a raster signal with the pattern generator.
2. Loosen the deflection yoke mounting screw and set the purity control to the center as shown below.

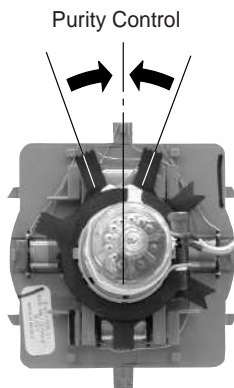

3. Turn the raster signal of the pattern generator to green.
4. Move the deflection yoke backward and adjust the purity control so that green is in the center and red and blue are at the sides evenly.

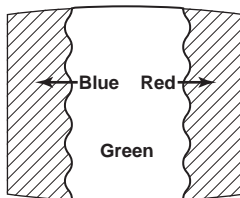

5. Move the deflection yoke forward and adjust so that the entire screen becomes green.

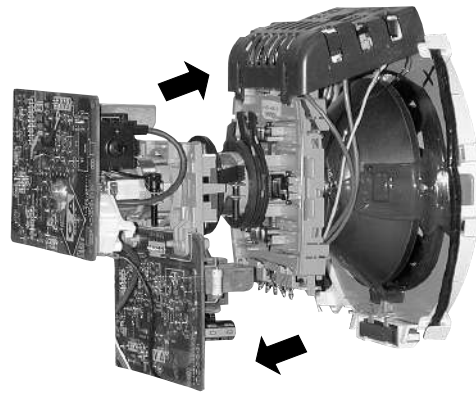

6. Switch over the raster signal to red and blue and confirm the condition.
7. When the position of the deflection yoke is determined, tighten it with the deflection yoke mounting screw.
8. If landing at the corner is not right, adjust by using the disk magnets.

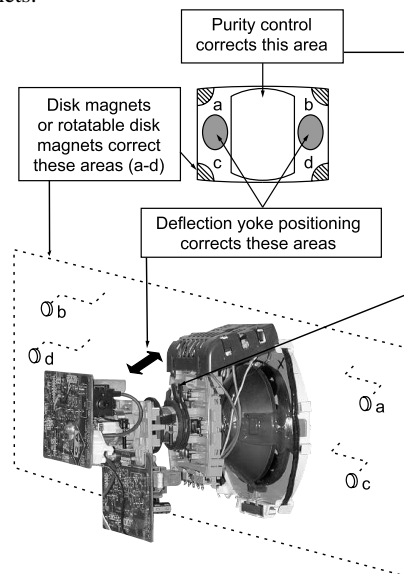

3-2. CONVERGENCE

Before starting convergence adjustments:

1. Perform FOCUS, V.LIN AND V.SIZE adjustments.
2. Set BRIGHTNESS control to minimum.
3. Feed in dot pattern.

Vertical Static Convergence

1. Adjust V.STAT magnet to converge red, green and blue dots in the center of the screen (Vertical movement adjust V.STAT RV 701 to converge).

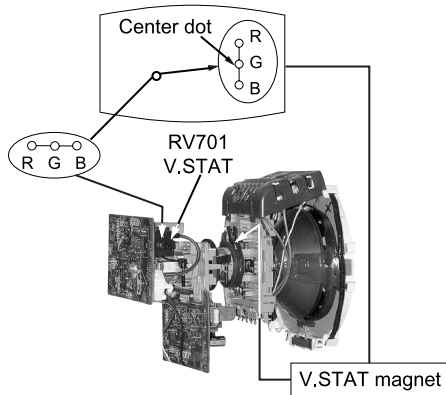

2. Tilt the V.STAT magnet and adjust static convergence to open or close the V.STAT magnet.

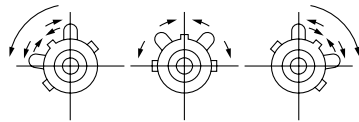

When the V.STAT magnet is moved in the direction of arrows a and b, red, green, and blue dots move as shown below:

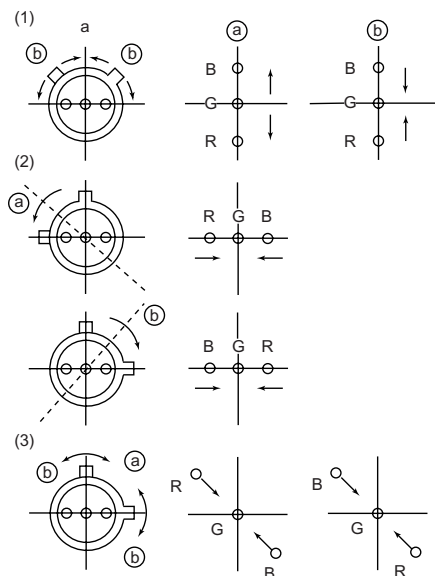

Horizontal Static Convergence

If the blue dot does not converge with the red and green dots, perform the following:

1. Move BMC magnet (a) to correct insufficient H. Static convergence.
2. Rotate BMC magnet (b) to correct insufficient V. Static convergence.
3. After adjusting the BMC magnet, repeat Beam Landing Adjustment.

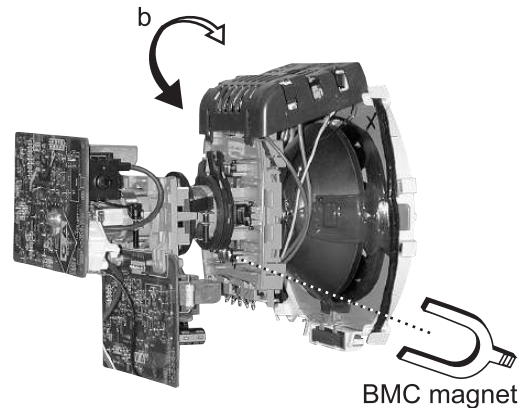
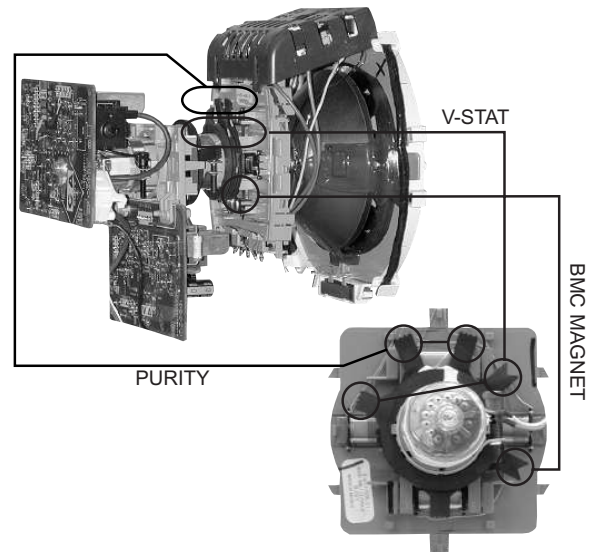

Dynamic Convergence Adjustment

Before performing this adjustment, perform Horizontal and Vertical Static Convergence Adjustment.

1. Slightly loosen deflection yoke screw.
2. Remove deflection yoke spacers.
3. Move the deflection yoke for best convergence as shown on the following page.

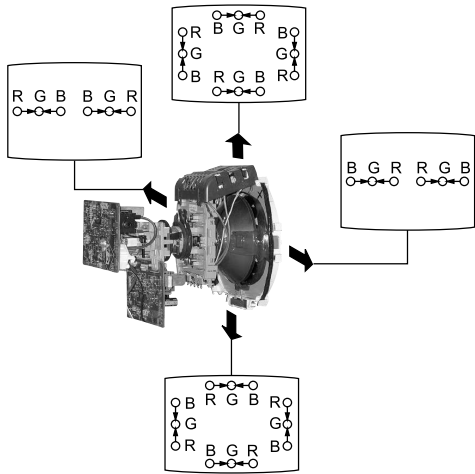

4. Tighten the deflection yoke screw.
5. Install the deflection yoke spacers.

TLH Plate Adjustment

1. Input crosshatch pattern.
2. Adjust PICTURE QUALITY to standard, PICTURE and BRIGHTNESS to 50%, and OTHER to standard.
3. Adjust the Horizontal Convergence of red and blue dots by tilting the TLH plate on the deflection yoke.

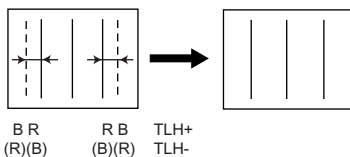
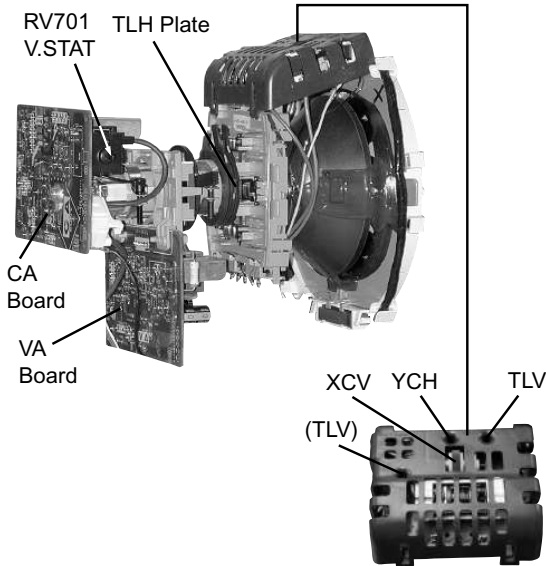

4. Adjust XCV core to balance X axis.
 5. Adjust YCH VR to balance Y axis.
 6. Adjust vertical red and blue convergence with V.TILT (TLV VR).
- Perform adjustments while tracking items 1 and 2.

Screen-Corner Convergence

1. Affix a permalloy assembly corresponding to the misconverged areas.

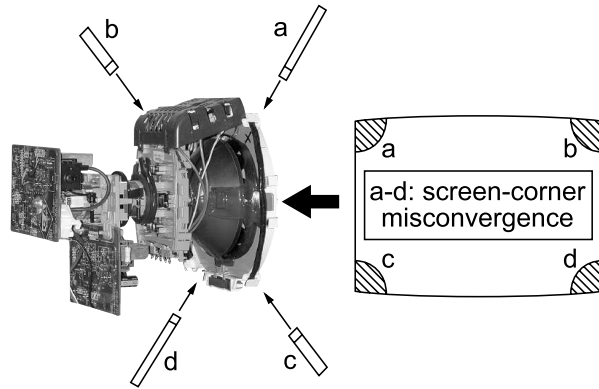

3-3. FOCUS

1. Adjust FOCUS control for best picture.

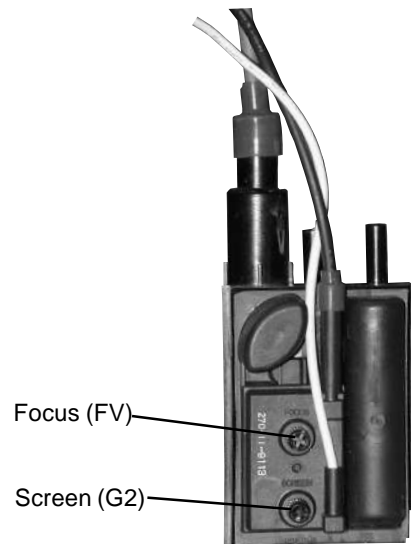

3-4. SCREEN (G2)

1. Input a dots pattern.
2. Set the PICTURE and BRIGHTNESS controls at minimum and COLOR control at normal.
3. Adjust SBRT, GCUT, BCUT in service mode with an oscilloscope as shown below so that voltages on the red, green, and blue cathodes are 170 ± 2.0 VDC.

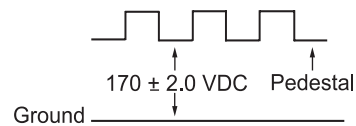

4. Observe the screen and adjust SCREEN (G2) VR in FBT to obtain the faintly visible background of dot signal.

3-5. METHOD OF SETTING THE SERVICE ADJUSTMENT MODE

Service Mode Procedure

1. Standby mode (power off).
2. **Display** → Channel **5** → Sound volume **+** → Power on the Remote Commander (press each button within a second).

Service Adjustment Mode In

1. The CRT displays the item being adjusted.

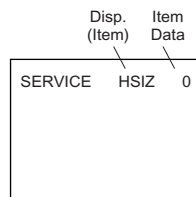

2. Press **1** or **4** on the Remote Commander to select the item.
3. Press **3** or **6** on the Remote Commander to change the data.
4. Press **MUTING** then **ENTER** to save into the memory.

Service Adjustment Mode Memory

Turn set off then on to exit service adjustment mode.

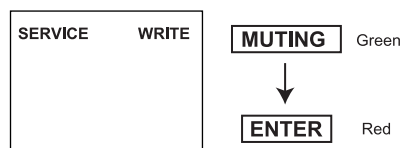

3-6. WHITE BALANCE ADJUSTMENTS

1. Input an entire white signal with burst.
2. Set to Service Adjustment Mode.
3. Set the PICTURE and BRIGHTNESS to minimum.
4. Adjust with SBRT if necessary.
5. Select GCUT and BCUT with **1** and **4**.
6. Adjust with **3** and **6** for the best white balance.
7. Set PICTURE and BRIGHTNESS to maximum.
8. Select GDRV and BDRV with **1** and **4**.
9. Adjust with **3** and **6** for the best white balance.
10. To write into memory, press **MUTING** then **ENTER**.

SECTION 4 SAFETY RELATED ADJUSTMENTS

4-1. ▣ R564 CONFIRMATION METHOD (HV HOLD-DOWN CONFIRMATION) AND READJUSTMENTS

The following adjustments should always be performed when replacing the following components which are marked with ▣ on the schematic diagram:

Part Replaced (▣)	Adjustment (▣)
DY, T505, CRT, IC501, C507, C520, C505, C509, C515, T504, T503, C551, L510, C546, C537, C547, D517, D518, D519, R560, R561, R562, R563, R565, R566, R567, R525 A Board	HV HOLD-DOWN R564
IC301 MA Board	

Preparation Before Confirmation

- Using a Variac, apply AC input voltage: 120 ± 2 VAC.
- Turn the POWER switch ON.
- Input a white signal and set the PICTURE and BRIGHTNESS controls to maximum.
- Confirm that the voltage between C546 (+) or TP503 and ground is more than 21.0 VDC (KV-27FV16/29FV16/29FV16C ONLY), 23.0 VDC (KV-32FS12/32FS16 ONLY).

Hold-Down Operation Confirmation

- Connect the current meter between Pin 11 of the FBT (T505) and the PWB land where Pin 11 would normally attach. (See Figure 1 on the next page.)
- Input a dot signal and set PICTURE and BRIGHTNESS to minimum: IABL = 1730 ± 100 μ A (KV-27FV16/29FV16/29FV16C ONLY), IABL = $2175 + 100/- 325$ μ A (KV-32FS12/32FS16 ONLY).
- Confirm the voltage of A Board TP-600 is 135 ± 1.5 VDC.
- Connect the digital voltmeter and the DC power supply via diode 1SS119 to C546 (+) and ground. (See Figure 1 on the next page.)
- Increase the DC power voltage gradually until the picture blanks out.
- Turn DC power source off immediately.
- Read the digital voltmeter indication (standard < $24.78 + 0.0/- 0.1$ VDC - KV-27FV16/29FV16/29FV16C ONLY) (standard < $27.24 + 0.0/- 0.1$ VDC - KV-32FS12/32FS16 ONLY).
- Input a white signal and set PICTURE and BRIGHTNESS to maximum: IABL = 1730 ± 100 μ A (KV-27FV16/29FV16/29FV16C ONLY), IABL = $2175 + 100/- 325$ μ A (KV-32FS12/32FS16 ONLY).
- Repeat steps 4 to 7.

Hold-Down Readjustment

If the setting indicated in step 2 of Hold-Down Operation Confirmation cannot be met, readjustment should be performed by altering the resistance value of R564 component marked with ▣.

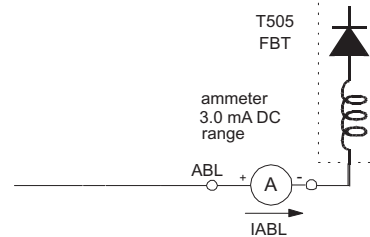

4-2. B+ VOLTAGE CONFIRMATION AND ADJUSTMENT

Note: The following adjustments should always be performed when replacing the following components, which are marked with ▣ on the schematic diagram on the A Board.

A BOARD: IC601, PH601

- Using a Variac, apply AC input voltage: $130 + 2.0/- 0.0$ VAC.
- Input a monoscope pattern.
- Set the PICTURE and BRIGHTNESS controls to minimum.
- Confirm that the voltage of A Board TP-600 is < 136.5 VDC.
- If step 3 is not satisfied, replace the components listed above, then repeat steps 1–3.

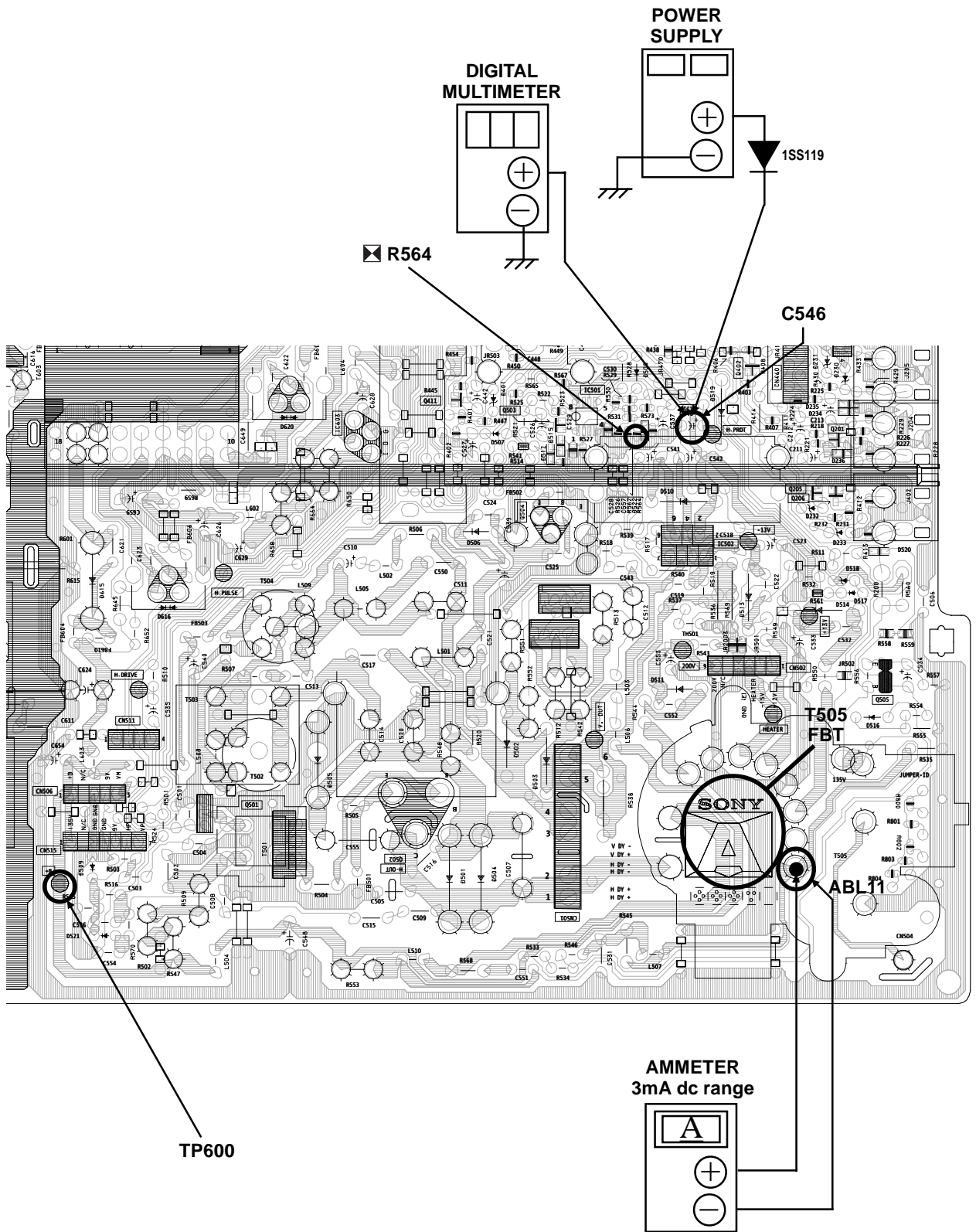

Figure 1

SECTION 5 CIRCUIT ADJUSTMENTS

ELECTRICAL ADJUSTMENTS BY REMOTE COMMANDER

Use the Remote Commander (RM-Y168, RM-Y169 or RM-Y171) to perform the circuit adjustments in this section.

NOTE: Test Equipment Required:

- Pattern generator
- Frequency counter
- Digital multimeter
- Audio oscillator

5-1. SETTING THE SERVICE ADJUSTMENT MODE

1. Standby mode (power off).
2. **Display** → Channel **5** → Sound volume **+** → Power on the Remote Commander (press each button within a second).

Service Adjustment Mode On

1. The CRT displays the item being adjusted.

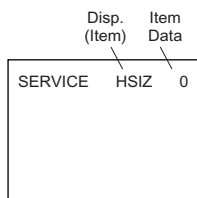

2. Press **1** or **4** on the Remote Commander to select an item.
3. Press **3** or **6** on the Remote Commander to change the data.
4. Press **MUTING** then **ENTER** to save into the memory.

Service Adjustment Mode Memory

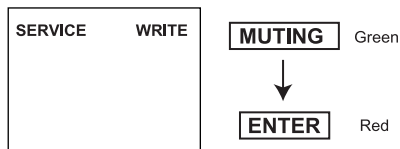

1. Press **8** then **ENTER** on the Remote Commander to initialize.

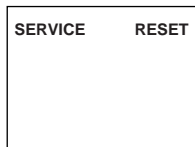

Carry out step 1 when adjusting IDs 0–4 and when replacing and adjusting IC003.

2. Turn set off then on to exit service adjustment mode.

5-2. MEMORY WRITE CONFIRMATION METHOD

1. After adjustment, remove the power plug from the AC outlet, then plug it in again.
2. Turn the power switch ON and set to service mode.
3. Call the adjusted items again to confirm they were adjusted.

5-3. ADJUSTMENT BUTTONS AND INDICATORS

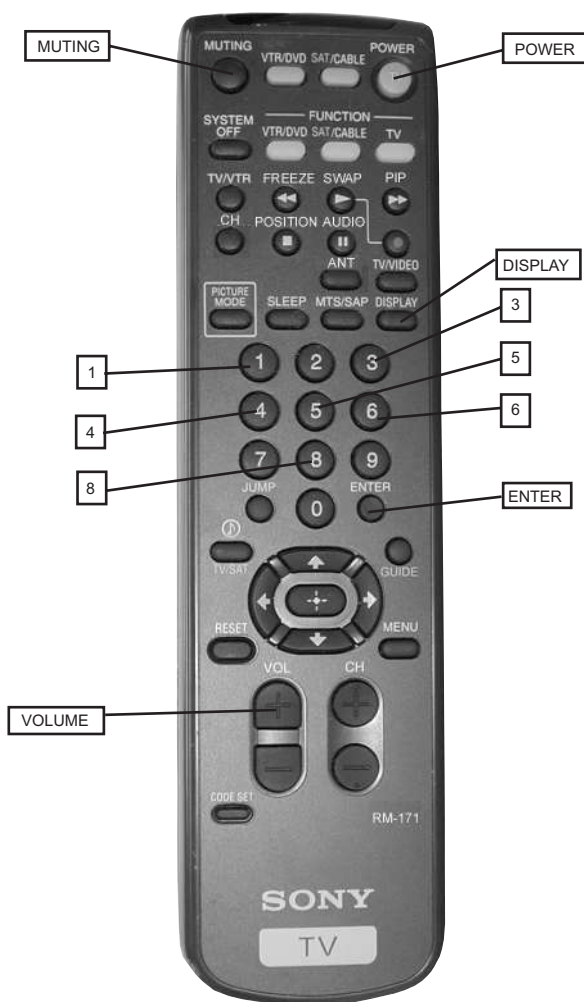

RM-Y171

Adjustment Items

Reg #	ITEM	FUNCTION	RANGE	FIX DATA	NTSC 27	PAL M	PAL N	VIDEO	NTSC 32	RF	AVERAGE DATA 27FV	AVERAGE DATA 32FS
1	HSIZ	Horizontal Size Adjustment	0-63		15	12	7		18		11	22
2	HPOS	Horizontal Position Adjustment	0-63		13	8	9		13		20	22
3	VBOW	Vertical Line Bowing Adj.	0-15		9	10	8		9		7	9
4	VANG	Vertical Line Bowing Slant Adj.	0-15		8	10	9		3		9	7
5	VTRP	TRAPEZIUM	0-31		19	14	14		18		21	17
6	HTRP	Horiz. Trapezoid	0-15		6	7	5		6		0	2
7	TROT	Tilt Correction	0-63		31	31	31		31		31	31
8	PAMP	Horizontal PIN distortion Adj.	0-63		19	19	21		27		20	27
9	UPIN	Upper PIN Distortion Adj.	0-63		34	33	36		41		37	38
10	LPIN	Lower PIN Distortion Adj.	0-63		32	34	40		39		33	35
11	VSIZ	Vertical Size Adjustment	0-63		32	43	29		51		33	51
12	VPOS	Vertical Position Adj.	0-63		30	30	32		42		36	39
13	VLIN	Vertical lineality Adj.	0-15		3	6	10		5		3	4
14	SCOR	Vertical "S" Correction Adjustment	0-15		6	8	10		8		8	8
15	VZOM	16:9 CRT Z Mode on/off	0-1	0							0	0
16	EHT	Vertical High-Voltage Compensation	0-15	5							5	5
17	ASP	Aspect Ratio control	0-63	47							47	47
18	SCRL	16:9 CRT Z Mode Trans. Scroll	0-63	31							31	31
19	HBLK	Horizontal Blanking on/off	0-1	1							1	1
20	LBLK	Left Blanking Adjustment	0-15	13							13	13
21	RBLK	Right Blanking Adjustment	0-15	8							7	8
22	HDW	Horizontal Drive Pulse Width		1							1	1
23	EWDC	"Parabola" EW, D.C. Adjustment	0-1	0							0	0
24	LVLN	Lower Screen BTM Vertical Line Adj.	0-15	0							0	0
25	UVLN	Upper Screen BTM Vertical Line Adj.	0-15	0							0	0
26	INTL	INTERLACE	0-3	0							0	0
27	G2SW		0-1	0							0	0
28	G2LV		0-7	0							0	0
29	HOSC	Horizontal VCO Oscillation Freq.	0-15	7							7	7
30	VSS	Vertical Sync Slice Level	0-3	0							0	0
31	HSS	Horizontal Sync Slice Level	0-1	0							0	0
32	HMSK	For Macro Vision	0-1	0							0	0
33	VTMS	Select Signal VTIM Pin	0-3	0							0	0
34	CDMD	Vertical Count Down Mode Switching	0-3		*	*	*	3			3	3
35	AFC	AFC Loop Gain Switching	0-3	0							0	0
36	FIFR	Field Frequency	0-3	**							3	3
37	VBLK	VBLKW	0-3	0							0	0
38	REFP	REFP	0-1	0							0	0
39	JPSW	JUMPSW	0-1	MENU							0	0
40	RDRV	R Output Drive control	0-63	***							31	40
41	GDRV	G Output Drive control	0-63	25							22	42
42	BDRV	B Output Drive control	0-63	25							21	31
43	RCUT	R Output Cutoff control	0-63	31							31	31
44	GCUT	G Output Cutoff control	0-63	15							13	12
45	BCUT	B Output Cutoff control	0-63	12							14	15
46	SCON	SUB CONT	0-15	8							11	11
47	SHUE	Sub HUE adjustment	0-15	16							17	16
48	SCOL	Sub COLOR adjustment	0-15		16	16	16				17	18
49	SBRT	Sub BRIGHTNESS adjustment	0-31	16							15	16
50	CHUE	SUB COLOR (RF)	0-31	7							6	6
51	CCOL	SUB COLOR (RF)	0-31		7	7	7				7	4
52	UOFS	YUV U OFFSET	0-15	7							7	7
53	VOFS	YUV V OFFSET	0-15	7							7	7
54	RON	R Output on/off	0-1	1							1	1
55	GON	G Output on/off	0-1	1							1	1
56	BON	B Output on/off	0-1	1							1	1
57	AXPL	Axis PAL	0-1	0							0	0
58	AXNT	Axis NTSC	0-1	1							1	1
59	CBPF	Chroma BPF on/off	0-1	1							1	1
60	CTRP	Y TRAP FILTER on/off	0-1	1							1	1
61	COFF	Color On/off	0-1	0							0	0
62	KOFF	Set Color Killer	0-1	0							0	0
63	SSHP	Sub SHARPNESS	0-15	5							5	5
64	SHPF	SHARPNESS Circuit Fo	0-3	Palette							2	2
65	PREL	Pre-Shoot/ Over-Shoot	0-1	1							0	0
66	Y-DC	DC transmission Ratio Switching	0-3	Palette							2	2
67	GAMM	Gamma Correction	0-3	Palette							2	2
68	ABLM	ABL Mode Switch	0-1	1							1	1
69	VTH	ABL CD VHT Switching	0-1	1							1	1
70	YDEL	Y Delay Time Control	0-15	7							7	7
71	NCOL	No Color ID	0-1	1							1	1
72	FSC	FSC Out on/off	0-1	1							1	1
73	K-ID	Killer ID Control on/off	0-1	0							0	0
74	GDOF		0-31	3							3	3
75	BDOF		0-31	16							16	16
76	GCOF		0-31	16							16	16
77	BCOF		0-31	7							7	7
78	SYSC	Color System	0-7	4							4	4
79	VENH	Vertical Enhancement	0-7	Palette							5	3

KV-27FV16/29FV16/29FV16C/32FS12/32FS16

Reg #	ITEM	FUNCTION	RANGE	FIX DATA	NTSC 27	PAL M	PAL N	VIDEO	NTSC 32	RF	AVERAGE DATA 27FV	AVERAGE DATA 32FS
80	PDSO	PDS OFF	0-1	0							0	0
81	CK	CK	0-1	0							0	0
82	VNL	VNL	0-15	3							3	3
83	HPK	HPK	0-1	0							0	0
84	HPKO	HPK OFF	0-1	Palette							0	0
85	CORE	CORE	0-3	2							1	1
86	TRAP	TRAP	0-1	1							1	1
87	CHTR	CH TRAP	0-1	0							0	0
88	CBPF	CBPF	0-1	1							1	1
89	ENHO	ENHOFF	0-1	0							0	0
90	NMRD	NMRD	0-3	0							0	0
91	YAPS	YAPS	0-3	3							3	3
92	CLKS	CLKS	0-3	0							0	0
93	NSTD	NSTDS	0-3	0							0	0
94	MSS	MSS	0-3	0							0	0
95	KILS	KILS	0-3	1							1	1
96	ADIN	ADIN	0-1	0							0	0
97	EXCS	EXCSS	0-3	1							1	1
98	CPP	CPP	0-3	2							2	2
99	HDP	HDP	0-7	4							4	4
100	CDL	CDL	0-7	4							4	4
101	DYCR	DYCOR	0-15	2							2	2
102	DYGN	DYGAIN	0-15	10							10	10
103	DCCR	DCCOR	0-15	3							3	3
104	DCGN	DCGAIN	0-15	6							6	6
105	YNRL	YNRLIM	0-3	1							1	1
106	CNRL	CNRLIM	0-3	1							1	1
107	WSC	WSC	0-3	1							1	1
108	VTRH	VTRH	0-3	1							1	1
109	VTRR	VTRR	0-3	1							1	1
110	LDSR	LDSR	0-3	2							2	2
111	VAPG	VAPGAIN	0-7	3							3	3
112	VAPI	VAPINV	0-31	6							6	6
113	TEST	TEST	0-1	0							0	0
114	YPFT	YPFT	0-3	3							3	3
115	YPFG	YPFG	0-15	7							7	7
116	CC3N	CC3N	0-1	0							0	0
117	SELD		0-1	1							1	1
118	D2GN	D2GAIN	0-7	4							5	5
119	YHCR	YHCOR	0-3	0							0	0
120	YPFC	YPFCOR	0-1	0							0	0
121	SHT	SHT	0-3	0							0	0
122	MVT	MVT	0-1	0							0	0
123	OTT	OTT	0-1	0							0	0
124	CL2D	CL2D	0-1	1							1	1
125	CLKG	CLKGGT	0-1	0							0	0
126	HPLL	HPLLFS	0-1	1							1	1
127	BPLL	BPLLFS	0-1	0							0	0
128	FSCF	FSCFG	0-1	0							0	0
129	PLLS	PLLS	0-1	1							1	1
130	KILR	KILR	0-15	3							3	3
131	HSSL	HSSL	0-15	12							12	12
132	VSSL	VSSL	0-15	8							8	8
133	BGPS	BGPS	0-15	4							4	4
134	BGPW	BGPW	0-15	10							10	10
135	ADCK	ADCLKS	0-3	3							3	3
136	NDSW	NDSW	0-1	1							1	1
137	PFRN	FREE_RUN	0-1	0							0	0
138	PRVS	RVS	0-1	0							0	0
139	PCON	CONTRAST	0-127	45							45	45
140	PUCO	U-DAC	0-127	16							16	16
141	PVCO	V-DAC	0-127	24							24	24
142	PHUE		0-31	15							15	15
143	PKIL	KILLER	1	0							0	0
144	PSEP	EXT_SC_SEL	0-3	2							2	2
145	PHIM		0-1	0							0	0
146	PSUB		0-1	0							0	0
147	PBGS	BG_START	0-63	14							14	14
148	PDL0		0-15	6							6	6
149	PDL1		0-15	13							13	13
150	PBRT	Y_OFFSET	0-31	25							25	25
151	PVP1			0							0	0
152	PUP1			0							0	0
153	PVP2			0							0	0
154	PUP2			0							0	0
155	PVP3			0							0	0
156	PUP3			0							0	0
157	PACS	SET_ACC	0-1	1							1	1
158	PSDL	SYNC_DELAY	0-3	0							0	0

Reg #	ITEM	FUNCTION	RANGE	FIX DATA	NTSC 27	PAL M	PAL N	VIDEO	NTSC 32	RF	AVERAGE DATA 27FV	AVERAGE DATA 32FS
159	PDCO		0-3	0							0	0
160	PCGA	C_GAIN	0-1	1							1	1
161	PAAF		0-1	0							0	0
162	PSU2		0-1	0							0	0
163	PCVF		0-1	0							0	0
164	PBIT	BITSEL	0-1	0							0	0
165	PAFC	AFCBITSEL	0-1	0							0	0
166	PACC	ACC_LEVEL	0-63	22							22	22
167	PBUR	BURST_CLK	0-1	0							0	0
168	PEVE	EVENUPRA	0-1	0							0	0
169	PINW	INV_WFF	0-1	0							0	0
170	PINR	INV_REF	0-1	0							0	0
171	PREF	RFF_FIX	0-1	0							0	0
172	PARE	AUTO_REF	0-1	1							1	1
173	PAVE	AVERAGE	0-1	0							0	0
174	PFRA	FREE_RUN_ADJ	0-15	0							0	0
175	PPAL	SUB_PALM_JUDGE	0-255	0							0	0
176	PHPO		0-31	6							7	6
177	PVPO		0-31	22							22	22
178	PHTI	HT	0-15	7							9	9
179	PHAJ	ADJ	0-15	1							1	1
180	PBGY	BGY	0-15	0							0	0
181	PCRO	CROSS_SEL	0-1	0							0	0
182	PPAR	PALRY	0-63	2							2	2
183	PHPF	HPFOFF	0-1	0							0	0
184	PFSC	FSC_OUTPUT	0-1	0							0	0
185	PVCH	SET_VCHIP	0-1	0							0	0
186	PVON	VCHIP_ONLY	0-1	1							1	1
187	PVLN	LINE_NUM	0-31	17							17	17
188	PVSB	STB_DLY	0-255	64							64	64
189	PVLV	L_LEVEL	0-255	130							130	130
190	SBAL	Sub Balance	0-7	5							5	5
191	SBAS	Sub Bass	0-7	0							0	0
192	STRE	Sub Treble	0-7	3							3	3
193	BBEL	BBE Low	0-15	0	****						0	0
194	BBEH	BBE High	0-15	0	*****						0	0
195	BBE	BBE	0-1	0	*****						0	0
196	AUX	SRS, Simulated	0-3	0	0						0	0
197	DISP	O.S.D Display position	0-127	20							32	34
198	HCLW	Horizontal Count lower limit	0-255	16				16			16	16
199	HCHG	Horizontal Count High limit	0-255	64				64			64	64
200	ID0		0-255	89							See ID Map	
201	ID1		0-255	31							See ID Map	
202	ID2		0-255	79							See ID Map	
203	ID3		0-255	146							See ID Map	
204	ID4		0-255	137							See ID Map	
205	ID5		0-255	19							See ID Map	
206	ID6		0-255	0							See ID Map	

* CDMD = 3 for US & CND, CDMD = 0 for Other

** FIFR = 3 for NTSC models, FIFR = 1 for Trinorma models

*** 41 for 27FS/32FS families, 31 for 27FV family

**** BBEL = 5 for 27FV family; 6 for 29FV family and 0 for 32FS family

***** BBEH = 5 for 27FV family; 7 for 29FV family and 0 for 32FS family

***** BBE = 1 for 27FV/29FV families and 0 for 32FS family

SERVICE	ID0	25
---------	-----	----

Notes:

No. 1–206 show the order that each adjustment mode may be selected while in service mode. Data Range shows the range of possible settings for each adjustment mode. Initial Data shows the standard settings for each adjustment mode.

Feature ID Map

Model	Destination	ID-0	ID-1	ID-2	ID-3	ID-4	ID-5	ID-6
KV-27FV16	US	89	63	239	146	133	19	7
KV-27FV16	CND	89	63	239	178	133	19	7
KV-29FV16	E	17	63	255	130	229	19	7
KV-29FV16C	E	17	63	255	130	229	19	7
KV-32FS12	US	89	31	79	146	137	19	0
KV-32FS12	CND	89	31	79	178	137	19	0
KV-32FS16	US	89	31	79	146	137	19	7
KV-32FS16	CND	89	31	79	178	137	19	7

5-4. MA BOARD ADJUSTMENTS

H. Frequency (Free Run) Check

1. Input a TV mode (RF) with no signal.
2. Connect a frequency counter to base of Q501 (TP-500 H. DRIVE) on the A Board.
3. Check H. Frequency for 15735 ± 200 Hz

V. Frequency (Free Run) Check

1. Select video 1 with no signal input.
2. Set the conditions for a standard setting.
3. Connect the frequency counter to TP-508 (V OUT) or CN501 pin ⑥ (V DY+) and ground on the A Board .
4. Check that V. Frequency shows 60 ± 4 Hz.

Drive (RDRV)

1. Input a color-bar signal and set the level to 75%.
2. In Standard mode, set PICTURE to maximum and COLOR to minimum.
3. Activate the Service Adjustment Mode.
4. Set both GON and BON items. Using [3] and [6]; set each to the following values. Leave RON set to "1".

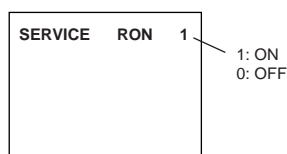

R ON: ON (1)
G ON: OFF (0)
B ON: OFF (0)

5. Connect an oscilloscope probe to CA Board, J701 Pin 12 (KR) (Red Out) .
6. Select RDRV with [1] and [4] .
7. Adjust the value of RDRV with [3] and [6] for 92.5 ± 3 VDC.

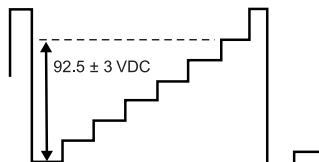

8. Reset GON and BON values to "1".

R ON: ON (1)
G ON: ON (1)
B ON: ON (1)

9. Reset Picture and Color to normal values:

PICTURE: MAX
COLOR: CENTER

10. Press [MUTING] then [ENTER] to save into the memory.

Display Position Adjustment (DISP)

1. Input a color-bar signal.
2. Set to Service Adjustment Mode.
3. Select DISP with [1] and [4] .
4. Adjust values of DISP with [3] and [6] to adjust characters to the center.
5. Write to memory by pressing [MUTING] then [ENTER] .
6. Check to see if the text is displayed on the screen.

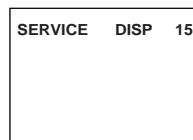

Sub Bright Adjustment (SBRT)

1. Input a monoscope signal.
2. Activate the Service Adjustment Mode.
3. Set the PICTURE and BRIGHTNESS to minimum.
4. Select the SBRT item with [1] and [4] .
5. Adjust the values of SBRT with [3] and [6] to obtain a faintly visible crosshatch.
6. Press [MUTING] then [ENTER] to save into the memory.

Sub Hue, Sub Color Adjustment (CHUE, CCOL)

1. Input a color-bar signal and set level to 75%.
2. Activate the Service Adjustment Mode.
3. Connect an oscilloscope probe to CA Board, CN705 Pin ④.
4. Select the CHUE and CCOL item with [1] and [4] .
5. While showing the CHUE item, adjust the waveform with [3] and [6] until the second and third bars show the same level ($V2 = V3 < 0.1$ Vp-p).
6. While showing the CCOL item, adjust the waveform with [3] and [6] until the first and fourth bars show the same level ($V1 = V4 < 0.1$ Vp-p).

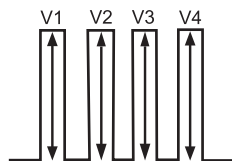

7. Press [MUTING] then [ENTER] to save into the memory.

V. Size Adjustment (VSIZ)

1. Input a crosshatch signal.
2. Activate the Service Adjustment Mode.
3. Select the VSIZ item with [1] and [4] .
4. Adjust value of VPOS with [3] and [6] for the best vertical center.
5. Press [MUTING] then [ENTER] to save into the memory.

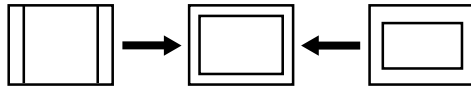

V. Center Adjustment (VPOS)

Perform this adjustment after performing H. Frequency (Free Run) Check.

1. Input a crosshatch signal.
2. Activate the Service Adjustment Mode.
3. Select the VPOS item with **[1]** and **[4]**.
4. Adjust value of VPOS with **[3]** and **[6]** for the best vertical center.
5. Press **[MUTING]** then **[ENTER]** to save into the memory.

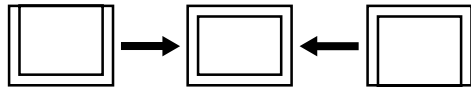

H. Center Adjustment (HPOS)

Perform this adjustment after performing H. Frequency (Free Run) Check.

1. Input a crosshatch signal.
2. Activate the Service Adjustment Mode.
3. Select the HPOS item with **[1]** and **[4]**.
4. Adjust the value of HPOS with **[3]** and **[6]** for the best horizontal center.
5. Press **[MUTING]** then **[ENTER]** to save into the memory.

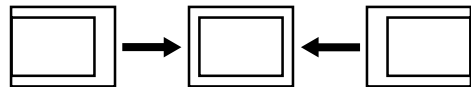

H. Size Adjustment (HSIZ)

1. Input a monoscope signal.
2. Activate the Service Adjustment Mode.
3. Select HSIZ with **[1]** and **[4]**.
4. Adjust with **[3]** and **[6]** for the best horizontal size.
5. Press **[MUTING]** then **[ENTER]** to save into the memory.

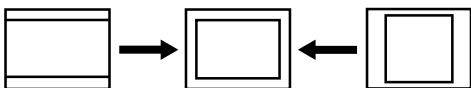

V. Linearity (VLIN), V. Correction (VSCO), Pin Amp (PAMP), and Horizontal Trapezoid (TRAP) Adjustments

1. Input a crosshatch signal.
2. Activate the Service Adjustment Mode.
3. Select VLIN, VSCO, PAMP, and PPHA with with **[1]** and **[4]**.
4. Adjust with **[3]** and **[6]** for the best horizontal size.
5. Press **[MUTING]** then **[ENTER]** to save into the memory.

V LINEARITY (VLIN)

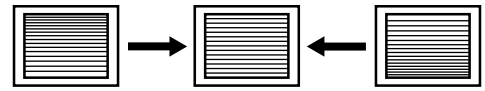

V CORRECTION (VSCO)

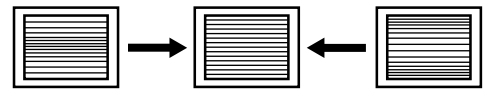

PIN AMP (PAMP)

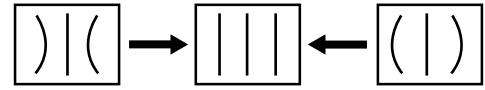

HORIZONTAL TRAPEZOID (TRAP)

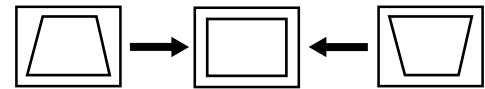

V. Angle (VANG), V. Bow (VBOW), Upper pin (UPIN) and Low Pin (LPIN) Adjustments

1. Input a crosshatch signal.
2. Activate the Service Adjustment Mode.
3. Select VANG, VBOW, UPIN, and LPIN with **[1]** and **[4]**.
4. Adjust with **[3]** and **[6]** for the best picture.
5. Press **[MUTING]** then **[ENTER]** to save into the memory.

V ANGLE (VANG)

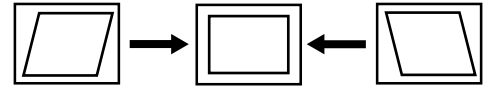

V BOW (VBOW)

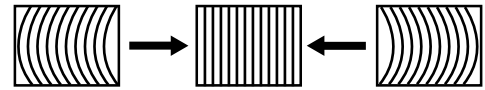

UPPER PIN (UPIN)

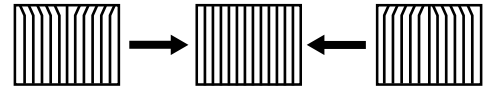

LOW PIN (LPIN)

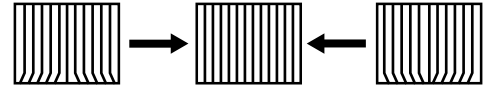

Service Adjustment Mode Memory

1. Change the value of the DCOL item to "1".
2. After completing all adjustments, press **[0]** then **[ENTER]**.

Read From Memory

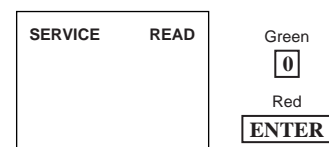

NOTES:

Lined area for notes

SECTION 6
DIAGRAMS

6.1 BLOCK DIAGRAM

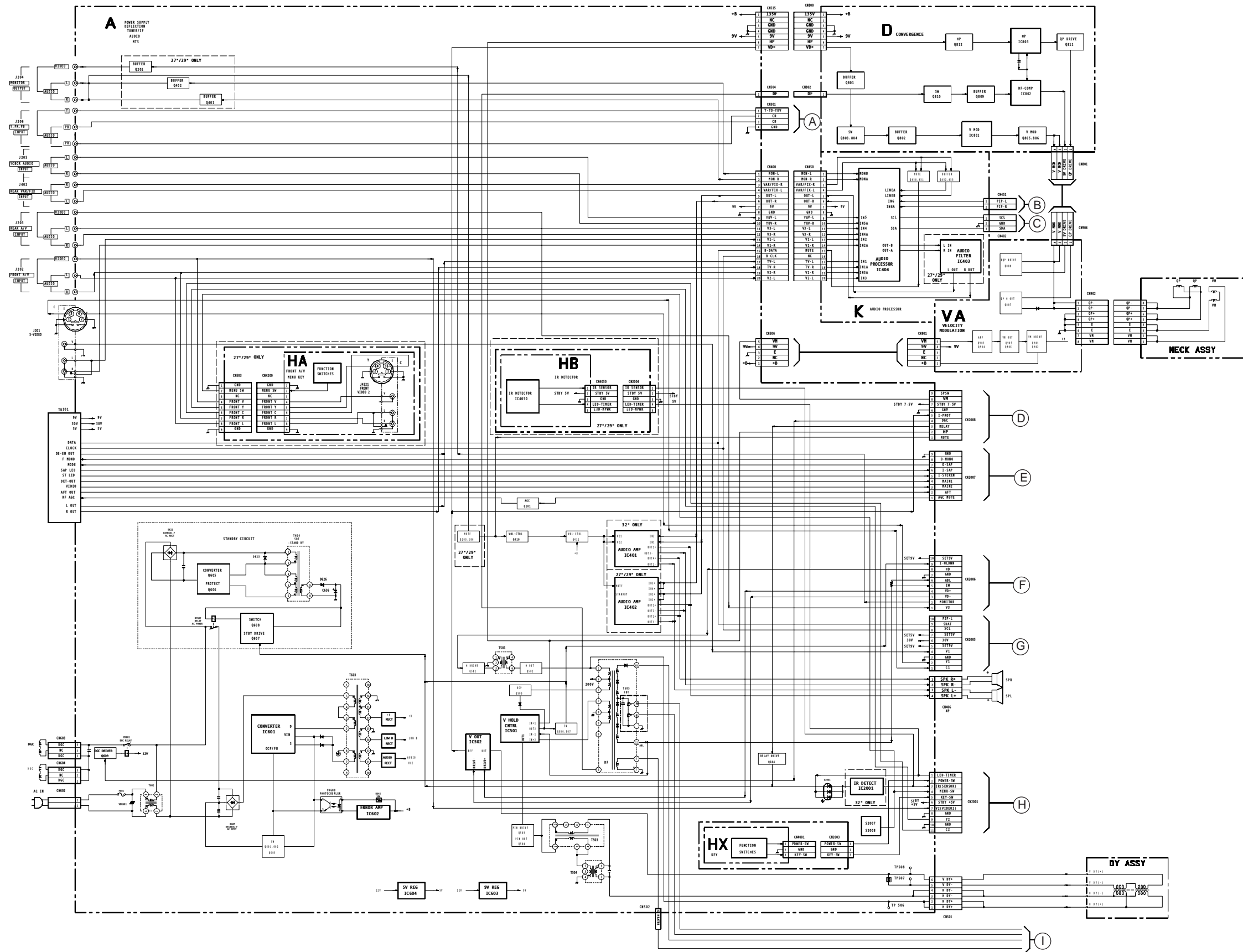

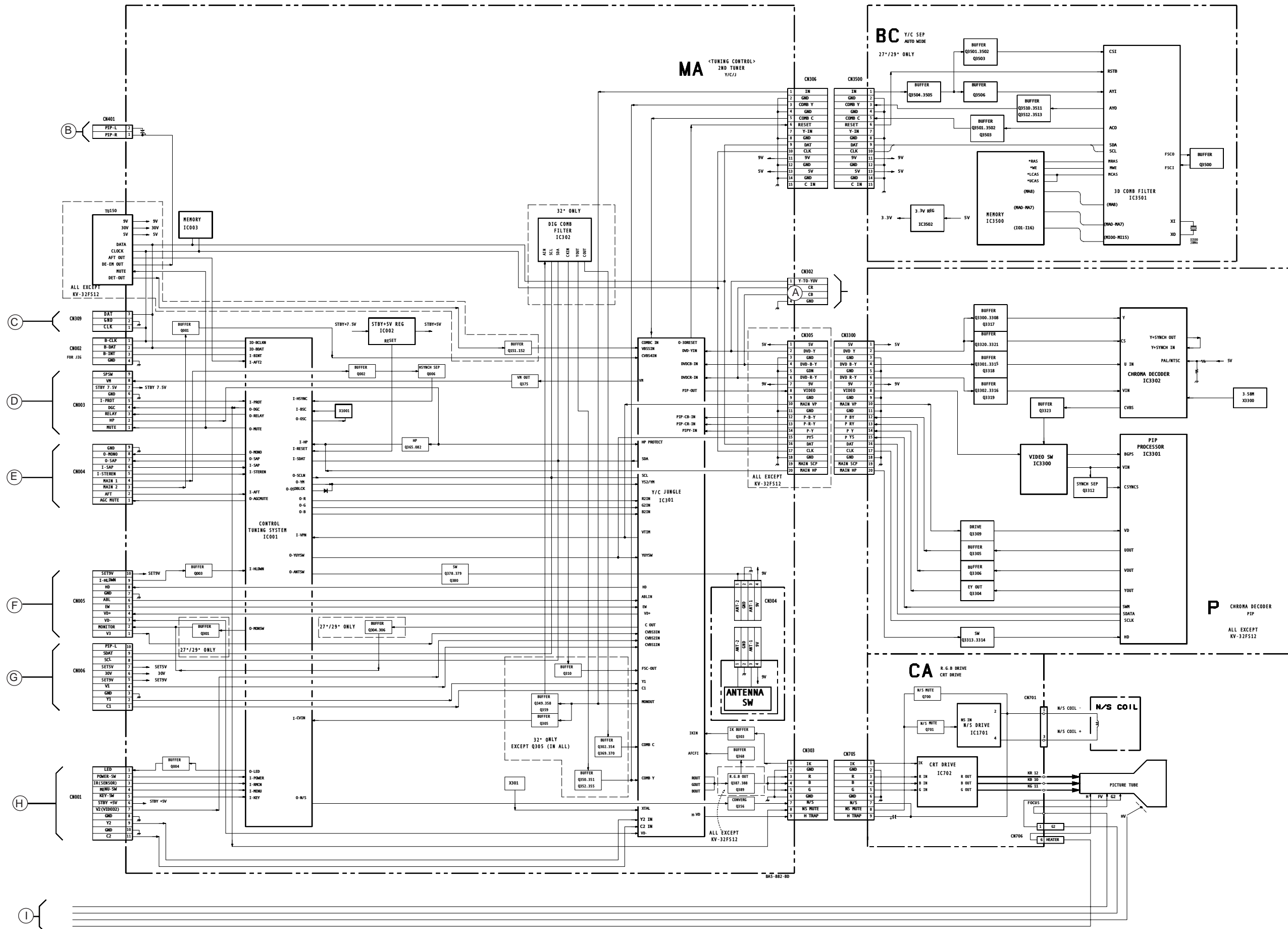

6.2 CIRCUIT BOARD LOCATIONS

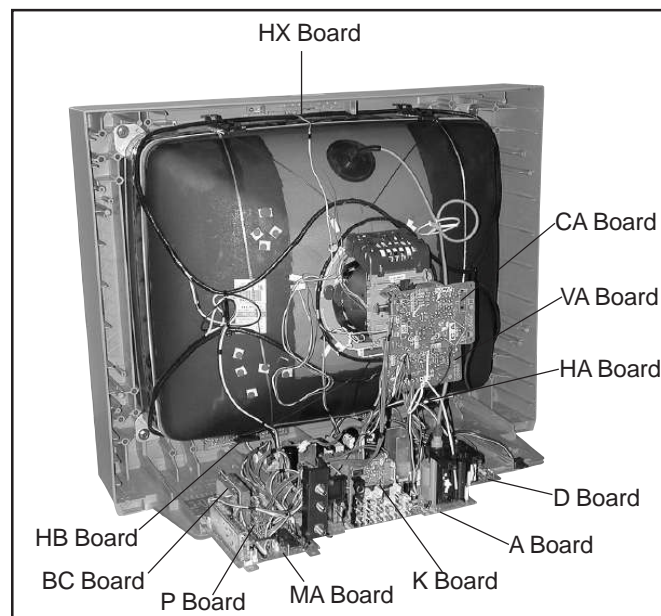

6-3. PRINTED WIRING BOARDS AND SCHEMATIC DIAGRAMS

- All capacitors are in μF unless otherwise noted. pF: μF 50 WV or less are not indicated except for electrolytic and tantalums.
- All electrolytics are 50V unless otherwise specified.
- Indication of resistance, which does not have one for rating electrical power, is as follows:
Pitch: 5mm
Rating electrical power 1/4W (CHIP: 1/10W)
- All resistors are in ohms.
 $\text{K}\Omega = 1000\Omega$ $\text{M}\Omega = 1000\text{K}\Omega$
- : nonflammable resistor
- : fusible resistor
- : internal component
- : panel designation and adjustment for repair
- : earth-ground
- : earth-chassis
- All variable and adjustable resistors have characteristic curve B, unless otherwise noted.
- The components identified by in this manual have been carefully factory-selected for each set in order to satisfy regulations regarding X-ray radiation. Should replacement be required, replace only with the value originally used.
- When replacing components identified by make the necessary adjustments indicated. If results do not meet the specified value, change the component identified by and repeat the adjustment until the specified value is achieved (refer to Safety Related Adjustments on page 20).
- When replacing parts shown in the table below, be sure to perform the related adjustments.

Part Replaced ()	Adjustment ()
DY, T505, CRT, IC501, C507, C520, C505, C509, C515, T504, T503, C551, L510, C546, C537, C547, D517, D518, D519, R560, R561, R562, R563, R565, R566, R567, R525.....A Board	HV HOLD-DOWN (R564)
IC301.....MA Board	
IC601, PH601.....A Board	B+ VOLTAGE CONFIRMATION

- All voltages are in Volts
- Voltage is DC with respect to ground unless otherwise noted.
- Readings are taken with a 10M Ω digital multimeter.
- Readings are taken with a color-bar signal input.
- Voltage variations may be noted due to normal production tolerance.
- Circled numbers are waveform references.
- * : cannot be measured
- : B + Line
- : B - Line
- : Signal path

Reference Information

RESISTOR	: RN	METAL FILM
	: RC	SOLID
	: FPRD	NON FLAMMABLE CARBON
	: FUSE	NON FLAMMABLE FUSIBLE
	: RW	NON FLAMMABLE WIREWOUND
	: RS	NON FLAMMABLE METAL OXIDE
	: RB	NON FLAMMABLE CEMENT
	:	ADJUSTMENT RESISTOR
COIL	: LF-8L	MICRO INDUCTOR
CAPACITOR	: TA	TANTALUM
	: PS	STYROL
	: PP	POLYPROPYLENE
	: PT	MYLAR
	: MPS	METALIZED POLYESTER
	: MPP	METALIZED POLYPROPYLENE
	: ALB	BIPOLAR
	: ALT	HIGH TEMPERATURE
	: ALR	HIGH RIPPLE

Note:

The components identified by shading and mark are critical for safety. Replace only with the part number specified. The symbol (displayed on component side of the circuit board) indicates fast operating fuse. Replace only with fuse of the same rating as marked.

Les composants identifiés per un tramé et une marque sont critiques pour la sécurité. Ne les remplacer que par une pièce portant le numéro spécifié. Le symbole indique une fusible a action rapide. Doit être remplacée par une fusible de même valeur, comme marqué.

A BOARD IC BLOCK DIAGRAMS

A BOARD: IC401 TDA7057AQ/2 (KV-32FS12/32FS16 ONLY)

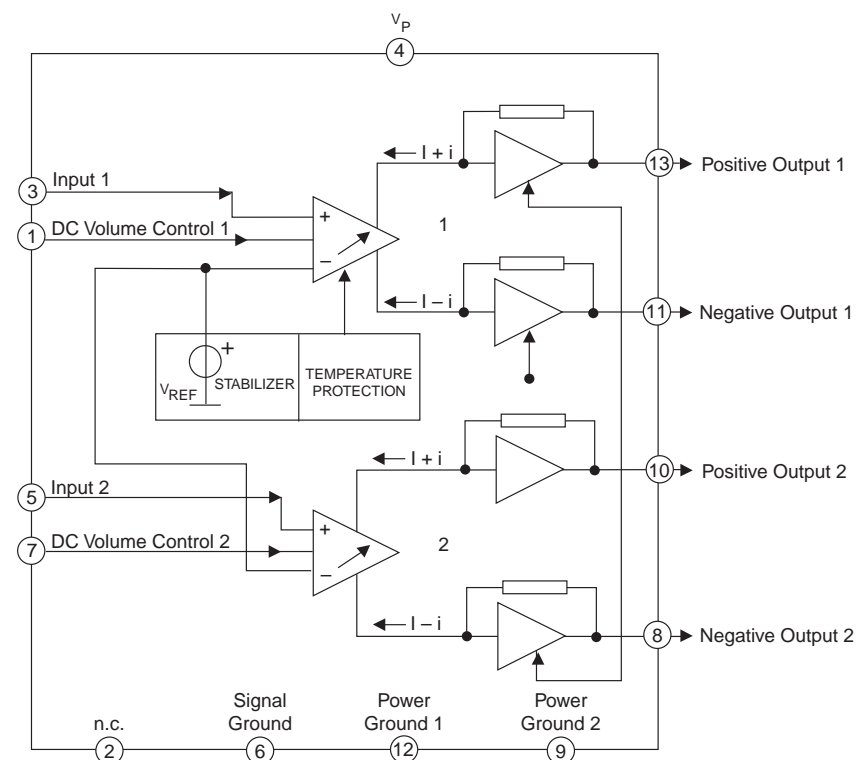

A BOARD: IC402 TDA8580Q/N1 (ALL EXCEPT 32FS12/32FS16)

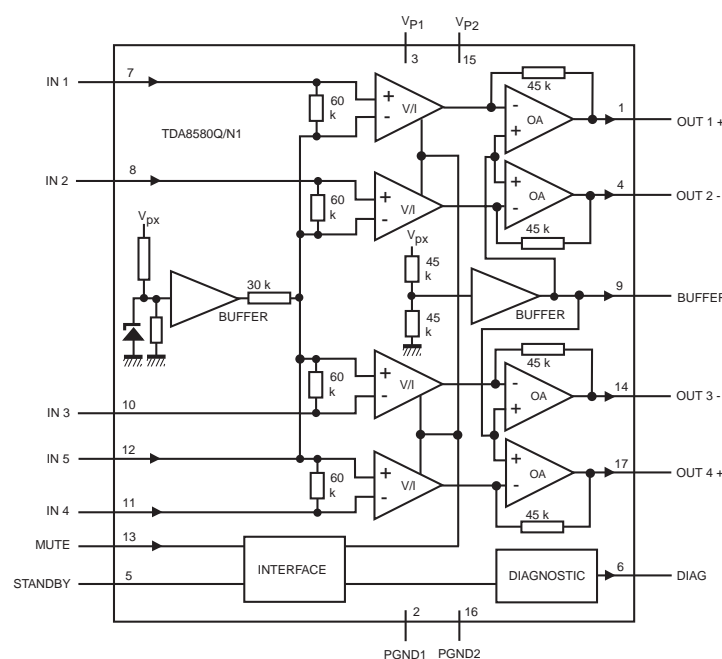

A BOARD: IC502 TDA8172 (ALL EXCEPT 32FS12/32FS16)

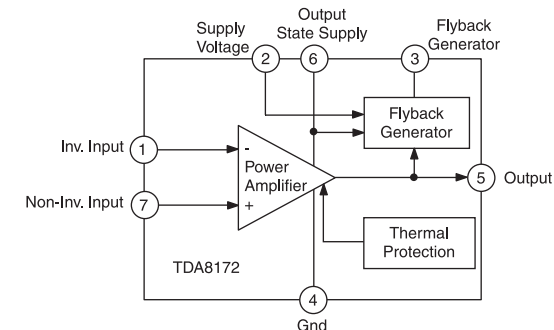

A BOARD: IC502 STV9379 (KV-32FS12/32FS16 ONLY)

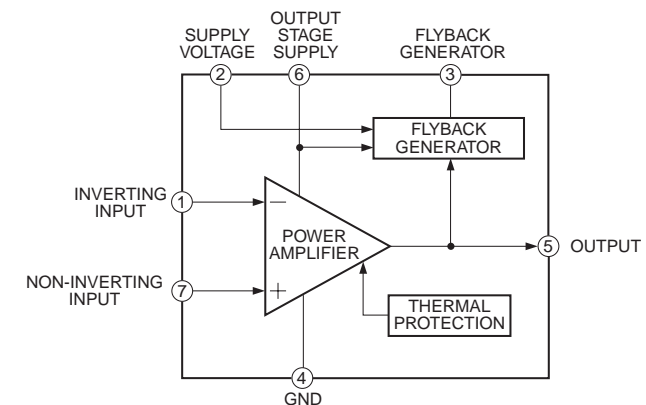

A

[POWER SUPPLY, DEFLECTION, TUNER/IF, AUDIO, MTS]

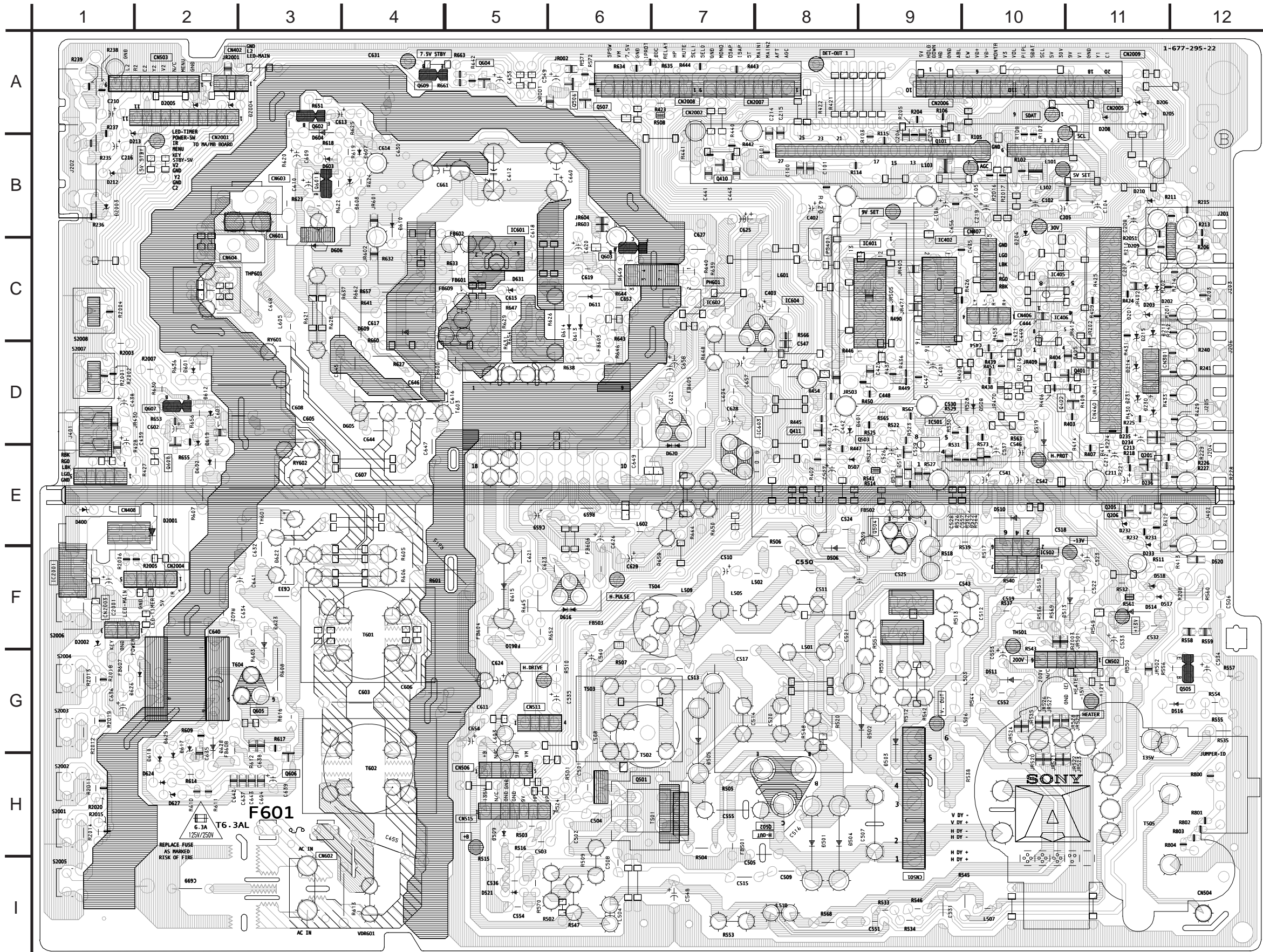

A BOARD LOCATOR LIST

DIODE	D602	E-2	Q402	C-11	
D201	C-11	D603	B-3	Q410	B-7
D202	C-11	D604	B-3	Q411	D-8
D203	C-11	D605	D-4	Q501	H-7
D204	B-10	D606	C-3	Q502	H-7
D205	A-11	D607	B-4	Q503	D-9
D206	A-11	D608	B-3	Q504	E-9
D208	A-11	D609	C-4	Q505	G-12
D209	C-11	D610	B-4	Q506	A-6
D210	B-11	D611	C-6	Q507	A-6
D211	C-11	D612	D-2	Q601	B-3
D212	B-1	D613	C-6	Q602	A-3
D213	B-1	D614	C-6	Q603	C-6
D214	D-11	D615	F-5	Q604	A-5
D215	C-11	D616	F-6	Q605	G-3
D216	C-10	D617	H-2	Q606	H-3
D230	D-11	D618	H-2	Q607	D-2
D231	D-11	D619	D-2	Q608	D-2
D232	E-11	D620	D-7	Q609	A-4
D233	E-11	D622	F-3		
D234	D-11	D623	G-2		
D235	D-11	D624	G-5		
D236	E-11	D625	H-2		
D401	D-8	D626	G-1		
D501	H-8	D627	H-2		
D502	G-9	D628	H-2		
D503	G-9	D2001	E-2		
D504	H-8	D2002	F-1		
D505	G-7	D2003	B-1		
D506	F-8	D2004	A-2		
D507	E-8	D2005	A2		
D508	D-9		IC		
D509	H-5	IC401	C-9		
D510	E-10	IC402	B-9		
D511	G-10	IC501	D-9		
D512	E-9	IC502	F-10		
D513	F-10	IC601	B-5		
D514	F-11	IC602	C-7		
D515	E-9	IC603	D-7		
D516	G-11	IC604	C-8		
D517	F-11	IC2001	E-1		
D518	F-11		TRANSISTOR		
D519	D-10	Q101	A-9		
D520	F-12	Q201	D-11		
D521	I-5	Q205	E-11		
D522	E-9	Q206	E-11		
D601	D-2	Q401	C-11		

A BOARD SCHEMATIC DIAGRAM

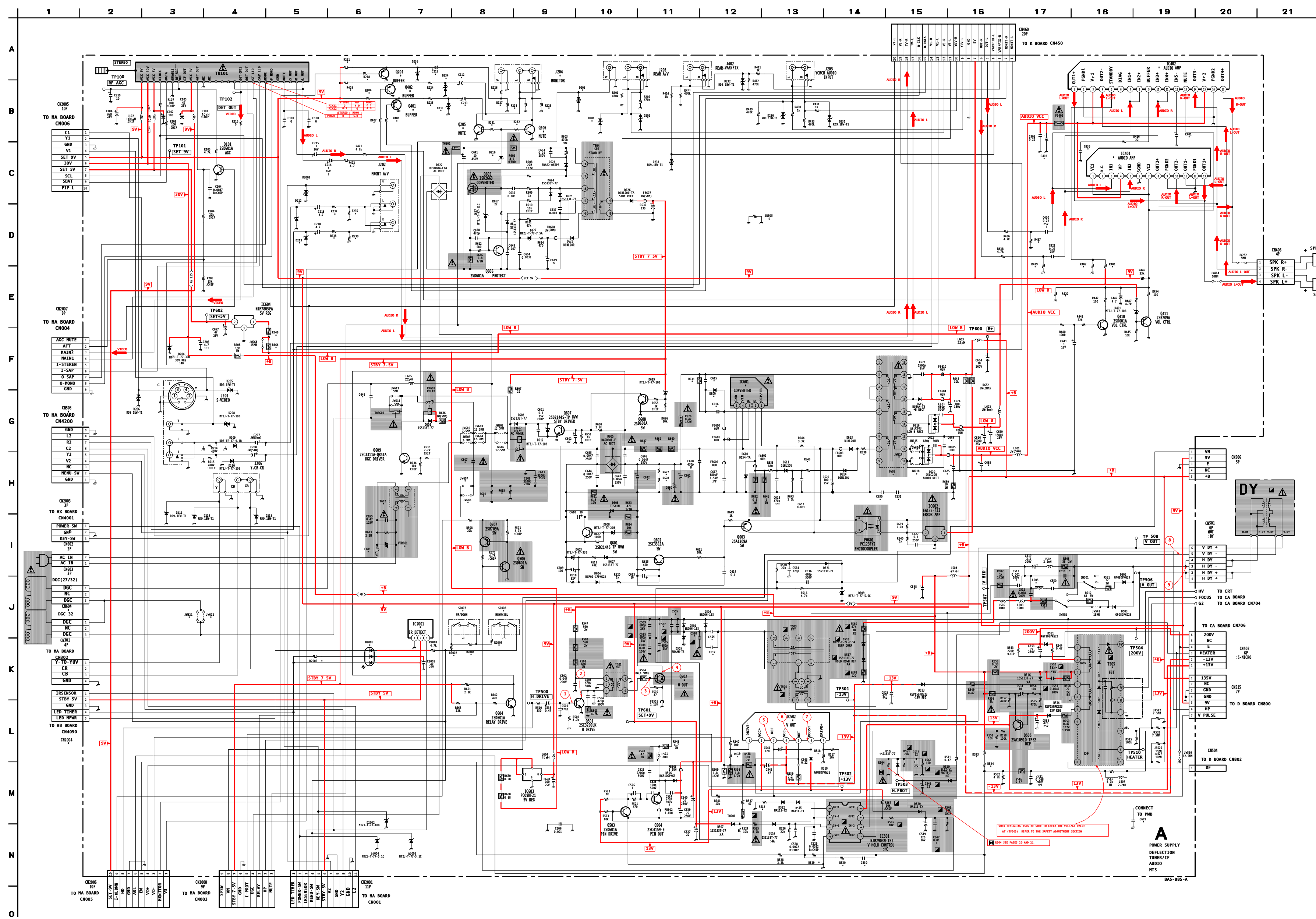

A BOARD MARK (*) LIST

REF NO.	LOC.	KV-27FV16	KV-29FV16	KV-32FS12	KV-32FS16	REF NO.	LOC.	KV-27FV16	KV-29FV16	KV-32FS12	KV-32FS16
C211	A-7	470 16V	470	#	#	Q205	B-8	2SD601A-QRS-TX	2SD601A-QRS-TX	#	#
C212	A-8	#	#	#	#	Q206	B-9	2SD601A-QRS-TX	2SD601A-QRS-TX	#	#
C213	B-8	4.7	4.7	#	#	Q401	B-7	2SB709A-QRS-TX	2SB709A-QRS-TX	#	#
C401	B-19	100	100	#	#	Q402	B-6	2SB709A-QRS-TX	2SB709A-QRS-TX	#	#
C402	B-17	1000	1000	2200 25V	Q502	K-11	2SD2578-YB	2SD2578-YB	2SD2580-YB	#	#
C435	C-18	#	#	#	#	R218	A-6	#	#	100	#
C507	K-1	17000PF 1.2KV	17000PF 1.2KV	22000PF 1.2KV	R221	A-6	220	#	#	#	#
C511	I-17	1 250V	1 250V	82 250V	R224	B-7	4.7K	4.7K	#	#	#
C514	K-11	.68 250V	.68 250V	82 250V	R225	B-7	4.7K	4.7K	#	#	#
C517	K-11	#	#	0.1	R226	B-8	75	75	#	#	#
C520	K-11	.047 630V	.047 630V	.051 400V	R227	B-8	470K	470K	#	#	#
C530	N-14	0.0022	0.0022	0.001	R228	B-8	470K	470K	#	#	#
C548	J-15	22 160V	22 160V	100 160V	R229	B-9	470K	470K	#	#	#
C550	J-17	.1 250V	.1 250V	.47 250V	R231	B-8	6.8K	6.8K	#	#	#
C555	K-11	2700PF 1.2KV	2700PF 1.2KV	4700PF 1.2KV	R232	B-8	6.8K	6.8K	#	#	#
C607	H-11	.47 125V	.47 300V	.47 125V	R235	D-6	#	#	470K	#	#
C612	H-17	820 250V	#	820 250V	R237	C-6	#	#	220	#	#
C615	F-12	#	0.022	#	R238	D-6	#	#	220	#	#
C616	F-12	#	220PF	#	R239	D-6	#	#	470K	#	#
C625	H-16	1000	1000	#	R401	D-18	20K	20K	#	#	#
C631	H-15	.0047 250V	#	.0047 250V	R402	D-18	10K	10K	#	#	#
C631	H-15	.0047 250V	#	.0047 250V	R403	B-6	4.7K	4.7K	#	#	#
C648	G-6	.22 125V	22 300V	22 125V	R404	B-6	4.7K	4.7K	#	#	#
C649	H-15	.0047 500V	0.0047	#	R407	B-6	100	100	#	#	#
C658	H-16	1000	1000	1000 25V	R408	B-6	100	100	#	#	#
C660	H-11	#	330 400V	#	R420	F-17	#	#	3.9K	#	#
C661	H-11	#	330 400V	#	R437	E-17	10K	10K	4.7K	#	#
C699	N-19	.0047 250V	#	.0047 250V	R439	E-17	10K	10K	4.7K	#	#
CN503	G-1	9P	9P	#	R518	L-13	6.8K	6.8K	5.6K	#	#
CN604	J-1	#	#	3P	R519	L-12	6.8K	6.8K	5.6K	#	#
CN2001	N-5	11P	11P	8P	R513	J-17	22 3W	22 3W	10 3W	#	#
CN2004	K-1	5P	5P	#	R514	M-12	22K	22K	8.2K	#	#
D201	C-10	RD9.1EW-T1	RD9.1EW-T1	#	R529	N-14	330K	330K	270K	#	#
D203	C-10	RD9.1EW-T1	RD9.1EW-T1	#	R530	N-14	15K	15K	18K	#	#
D212	D-5	#	#	MTZJ-T7710B	R534	M-16	36K	36K	33K	#	#
D213	D-5	#	#	MTZJ-T7710B	R564	M-14	180K	180K	56K	#	#
D216	C-8	100	100	#	R601	H-8	4.7M 1/2W	#	4.7M 1/2W	#	#
D234	B-7	UDZ-TE-17-9.1B	UDZ-TE-17-9.1B	#	R615	I-8	#	8.2M 1W	#	#	#
D235	B-7	UDZ-TE-17-9.1B	UDZ-TE-17-9.1B	#	R627	H-11	390K	270K	390K	#	#
D236	B-7	UDZ-TE-17-9.1B	UDZ-TE-17-9.1B	#	R628	H-11	#	270K	270K	#	#
D609	G-12	#	RJ-1P	#	R631	F-12	#	100K 3W	#	#	#
D2001	K-6	#	#	LNK0120022G	R637	H-11	#	5.6K 3W	#	#	#
D2003	C-5	#	#	RD9.1EW-T1	R638	H-14	33	56	33	#	#
F601	I-6	6.3A/125V	6.3A/250V	#	R646	H-13	1.5K	1.2K	1.5K	#	#
IC401	B-18	#	#	TDA7057AQ/N2	R648	E-4	4.7 3W	4.7 3W	33 3W	#	#
IC402	A-17	TDA8580Q/N1	TDA8580Q/N1	#	R650	H-11	15K 3W	5.6K 3W	15K 3W	#	#
IC502	L-12	TDA8172	TDA8172	ST91879	R662	H-11	#	#	#	#	#
IC601	G-12	STR-F6626	STR-F6656	STR-F6626	R664	F-4	4.7 3W	4.7 3W	#	#	#
IC2001	J-7	#	#	SBX3081-71	R2001	K-8	#	#	2.2K	#	#
J202	C-6	#	#	3P	R2002	K-8	#	#	1.5K	#	#
J204	A-8	3P	3P	#	R2004	J-8	#	#	6.8K	#	#
JW615	G-15	#	#	5MM	R2005	K-5	#	#	0	#	#
JW616	G-15	#	#	5MM	S2007	J-7	#	#	1-762-816-11	#	#
JW617	G-15	#	#	5MM	S2008	J-8	#	#	1-762-816-11	#	#
JW618	G-15	#	#	5MM	T504	L-13	1-431-693-11	1-431-693-11	1-435-098-11	#	#
JW621	J-3	7.5MM	7.5MM	#	T505	K-18	8-598-834-20	8-598-834-20	8-598-824-10	#	#
JW622	J-3	7.5MM	7.5MM	#	T602	H-6	1-435-617-11	1-435-617-11	1-435-617-11	#	#
L505	J17	150UH	150UH	68UH	T603	F-14	1-435-403-11	1-435-402-11	1-435-403-11	#	#
PS401	B-17	1-532-686-21	1-532-686-21	1-576-336-21	VDR601	I-6	1-803-585-11	1-803-585-11	1-803-585-11	#	#
Q201	A-6	2SB709A-QRS-TX	2SB709A-QRS-TX	#	#	#	#	#	#	#	#

A BOARD IC VOLTAGE LIST

IC401	12	0.0	10	4.1	4	GND	7	2.1	IC603	IC2001	7	5.5	20	5.0					
pin	volt		pin	volt	pin	volt	pin	volt	pin	volt	pin	volt	pin	volt					
1	0.6	IC402	11	4.1	5	9.5	IC601	pin	volt	pin	volt	8	2.1	21	0.3				
2	0.0	pin	volt	13	5.2	7	0.1	1	-31.8	2	8.9	2	5	10	4.1	23	0.0		
3	2.4	1	6.8	14	6.8	8	14.0	2	-32.7	3	GND	3	GND	11	0.0	24	0.0		
4	14.3	2	GND	15	14.1	IC502	3	53.2	4	13.3	TU101	12	N/C	25	0.0				
5	2.4	3	14.1	16	GND	pin	volt	4	-23.8	IC604	pin	volt	13	N/C	26	4.5			
6	0.0	4	6.8	17	6.8	1	2.1	5	-32.7	pin	volt	1	8.6	14	N/C	27	4.5		
7	0.6	5	4.3	IC501	2	14.0	IC602	1	13.3	2	30.7	15	N/C						
8	6.9	6	NC	pin	volt	3	-12.6	pin	volt	2	5.0	3	5.1	16	N/C				
9	0.0	7	4.1	1	0.2	4	-13.9	1	135.9	3	GND	4	4.9	17	4.7				
10	6.9	8	4.1	2	3.7	5	0.2	2	123.4	4	5.9	18	4.4						
11	6.9	9	6.8	3	2.5	6	14.3	3	GND	6	GND	19	5.0						

A BOARD TRANSISTOR VOLTAGE LIST

Q605	pin	volt
	D	-35.6
	G	40.8
	S	36.8

All voltages are in V

A BOARD TRANSISTOR VOLTAGE LIST

Q101	Q401	Q501	Q505	Q602	Q607						
pin	volt	pin	volt	pin	volt	pin	volt	pin	volt	pin	volt
B	0.0	B	4.5	B	0.0	B	134.9	B	-32.8	B	0.7
C	5.6	C	GND	C	93.3	C	1.8	C	-23.6	C	0.1
E	GND	E	0.1	E	GND	E	135.5	E	-32.9	E	GND

A BOARD WAVEFORMS

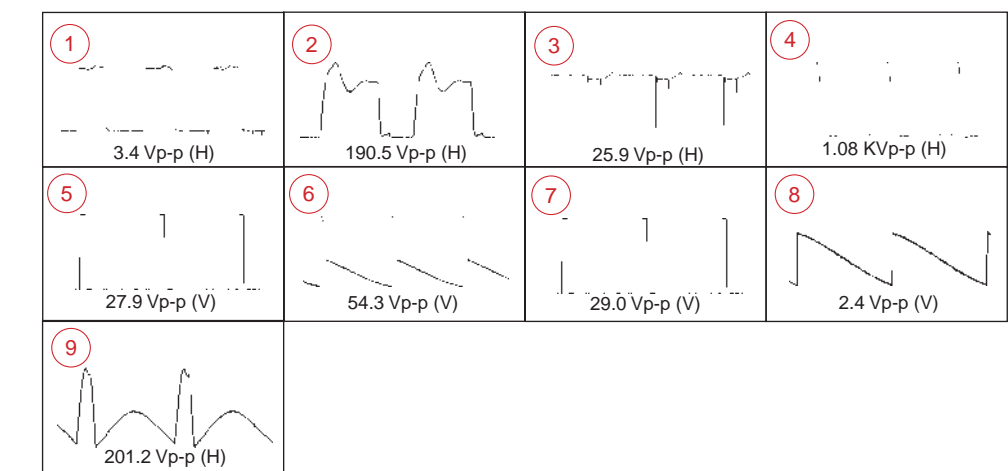

MA BOARD SCHEMATIC DIAGRAM

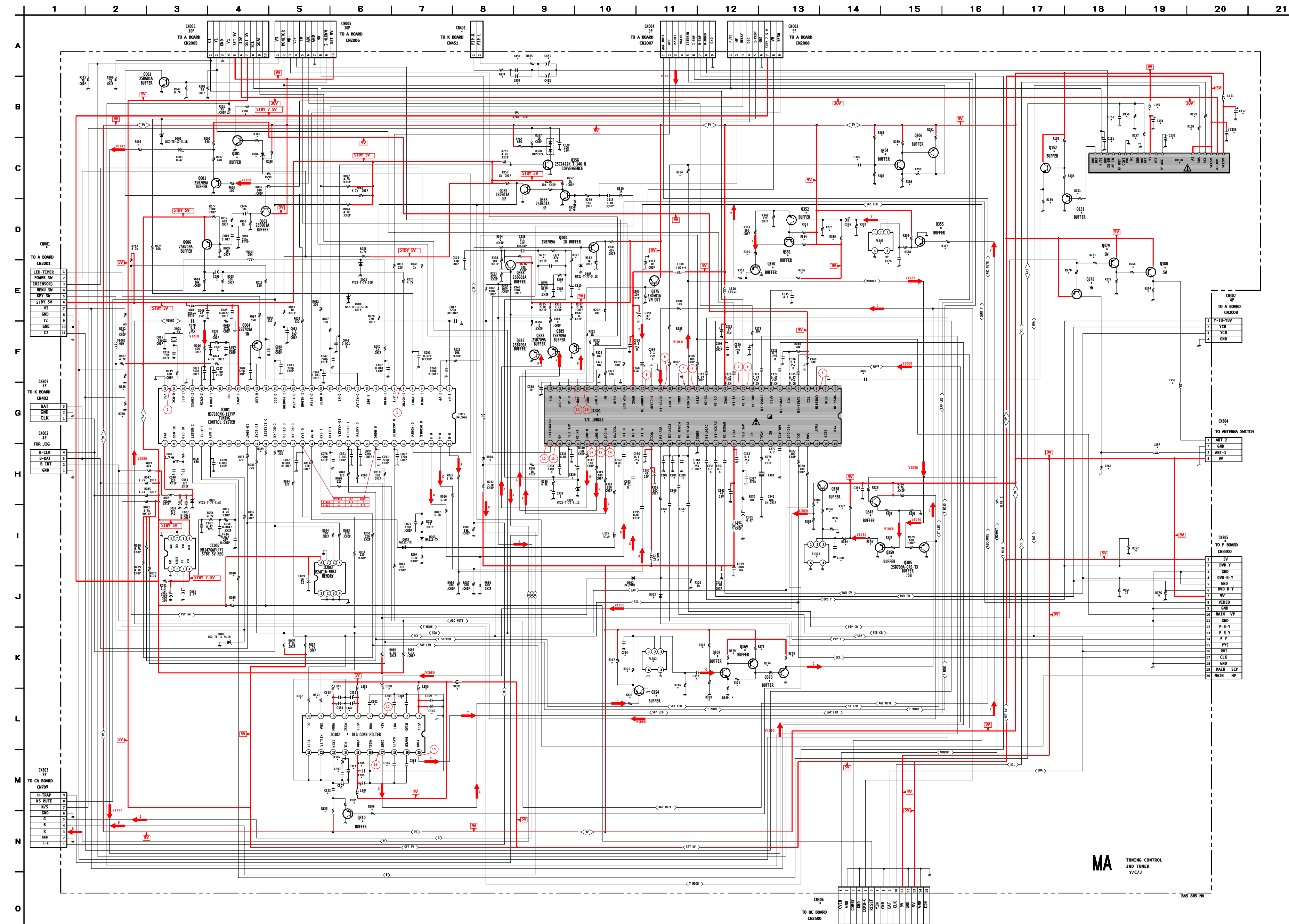

MA BOARD MARK (*) LIST

REF NO.	LOC.	KV-27FV16 KV-29FV16C	KV-32FS12	KV-32FS16	REF NO.	LOC.	KV-27FV16 KV-29FV16C	KV-32FS12	KV-32FS16
C305	E-14	#	#	47 25V	Q378	E-13	#	#	2SB709A-QRS-TX
C151	C-18	#	#	#	Q380	E-19	#	#	2SB709A-QRS-TX
C153	B-18	0.0047	#	#	R048	J-3	#	#	100
C154	B-19	47	#	47	R069	H-6	220	#	220
C155	C-19	10	#	10	R085	J-3	4.7K	#	#
C156	C-20	47 25V	#	47 25V	R089	H-4	220	#	#
C157	B-20	100	#	100	R150	D-17	1.5K	#	1.5K
C302	L-6	#	0.01	0.01	R151	D-18	100	#	100
C303	L-6	#	0.01	0.01	R154	D-17	560	#	560
C304	L-6	#	0.01	0.01	R155	C-17	560	#	560
C305	L-7	#	100 16V	100 16V	R156	B-17	33K	#	33K
C306	C-14	1 16V	#	#	R157	C-19	22K	#	22K
C307	M-5	#	10PF	10PF	R158	C-20	100	#	100
C308	M-6	#	0.01	0.01	R159	B-20	100	#	100
C309	M-6	#	100 16V	100 16V	R264	C-19	22K	#	22K
C311	M-6	#	180PF	180PF	R265	H-18	22K	#	22K
C314	K-10	#	15PF	15PF	R270	E-18	22K	#	22K
C317	K-11	#	0.01	0.01	R271	E-18	22K	#	22K
C324	F-15	#	15PF	15PF	R272	E-18	22K	#	22K
C332	M-5	#	0.0012	0.0012	R275	D-14	#	22K	22K
C336	D-14	#	47 25V	47 25V	R277	E-9	2.2M	#	3.3M
C345	I-11	0.01	#	100 16V	R284	C-15	1.5K	#	#
C346	I-11	0.01	#	0.01	R285	F-11	1K	#	#
C347	I-11	0.01	#	0.01	R286	C-14	47K	#	#
C348	I-11	0.01	#	0.01	R287	C-14	100K	#	#
C350	L-6	#	0.47	0.47	R288	C-15	470	#	#
C351	L-6	#	0.01	0.01	R289	C-15	1K	#	#
C354	L-6	#	100 16V	100 16V	R290	C-15	560	#	#
C359	A-9	#	0.01	0.01	R291	C-15	1.5K	#	#
C366	H-10	#	0.01	0.01	R298	C-4	4.7K	#	#
C368	M-7	#	0.01	0.01	R299	C-4	220	#	#
C369	L-7	#	0.01	0.01	R300	H-13	#	0	0
C380	I-11	#	0.01	0.01	R302	F-11	5MM	#	#
C381	I-11	#	0.01	0.01	R305	N-6	#	0	0
C382	I-11	#	0.01	0.01	R307	D-10	8.2K	#	#
C389	A-9	0.033	#	0.047	R311	G-2	#	100	100
C390	I-14	#	15PF	15PF	R314	E-19	22K	#	22K
C391	H-14	#	100 16V	100 16V	R316	K-11	#	5.6K	5.6K
C397	M-6	#	0.01	0.01	R317	D-15	#	100	100
C451	A-9	1 16V	#	1 16V	R318	K-12	#	56K	56K
C452	A-9	1 16V	#	1 16V	R319	K-12	#	22K	22K
C453	A-9	1 16V	#	1 16V	R320	K-11	#	100	100
C454	A-9	1 16V	#	1 16V	R321	K-11	#	560	560
CN001	E-1	11P	#	8P	R328	I-14	#	100	100
CN304	G-20	4P	#	4P	R331	D-13	#	1K	1K
CN305	J-20	20P	#	20P	R333	D-14	#	5.6K	5.6K
CN306	O-14	15P	#	#	R334	I-14	#	100	100
CN401	A-8	2P	#	2P	R339	D-13	#	56K	56K
D303	J-11	1SS1331-77	#	1SS1331-77	R348	F-2	75	#	#
D304	C-4	MT2J1-T77-3.3	#	#	R350	G-2	75	#	#
FB301	L-7	#	0UH	0UH	R351	I-14	#	470	470
FL301	I-13	#	1-239-847-11	1-239-847-11	R352	L-5	#	100	100
FL302	K-11	#	1-239-847-11	1-239-847-11	R353	L-8	#	100	100
FL303	D-14	#	1-239-847-11	1-239-847-11	R354	I-14	#	100	100
IC301	G-9	8-752-094-86	8-752-094-86	8-752-094-86	R355	N-6	#	1.5K	1.5K
IC302	L-5	#	TC90A49P	TC90A49P	R359	D-14	#	2.2K	2.2K
L150	B-19	10UH	#	10UH	R364	K-13	#	100	100
L151	B-20	100UH	#	100UH	R365	E-12	#	100	100
L303	L-5	#	10UH	10UH	R366	E-12	#	1.5K	1.5K
L304	M-6	#	10UH	10UH	R367	K-11	#	2.2K	2.2K
L350	L-7	#	10UH	10UH	R368	D-14	#	560	560
L351	L-6	#	10UH	10UH	R369	K-12	#	220	220
L356	G-19	0	#	0	R372	K-12	#	560	560
L357	H-19	0	#	0	R373	K-12	#	100	100
Q151	C-18	2SB709A-QRS-TX	#	2SB709A-QRS-TX	R374	K-13	#	100	100
Q152	C-17	2SD601A-QRS-TX	#	2SD601A-QRS-TX	R375	K-13	#	1.5K	1.5K
Q301	B-4	2SD601A-QRS-TX	#	#	R377	H-13	#	2.2K	2.2K
Q302	K-12	#	2SD601A-QRS-TX	2SD601A-QRS-TX	R378	I-14	#	0	0
Q304	C-15	2SD601A-QRS-TX	#	#	R379	K-12	#	1K	1K
Q306	C-15	2SD601A-QRS-TX	#	#	R380	B-4	#	#	#
Q310	H-6	#	2SB709A-QRS-TX	2SB709A-QRS-TX	R381	C-4	6.8K	#	#
Q349	I-14	#	2SD601A-QRS-TX	2SD601A-QRS-TX	R386	M-6	#	820	820
Q350	E-12	#	2SB709A-QRS-TX	2SB709A-QRS-TX	R389	I-13	#	1K	1K
Q351	D-13	#	2SB709A-QRS-TX	2SB709A-QRS-TX	R392	I-14	#	5.6K	5.6K
Q352	D-13	#	2SD601A-QRS-TX	2SD601A-QRS-TX	R394	I-14	#	560	560
Q354	K-11	#	2SB709A-QRS-TX	2SB709A-QRS-TX	R395	I-15	#	560	560
Q355	D-14	#	2SB709A-QRS-TX	2SB709A-QRS-TX	R396	N-6	#	100	100
Q358	H-13	#	2SD601A-QRS-TX	2SD601A-QRS-TX	R398	E-9	56K	330K	330K
Q359	I-14	#	2SB709A-QRS-TX	2SB709A-QRS-TX	R399	E-9	330K	39K	39K
Q369	K-12	#	2SB709A-QRS-TX	2SB709A-QRS-TX	R434	A-8	4.7K	#	4.7K
Q370	K-13	#	2SB709A-QRS-TX	2SB709A-QRS-TX	R435	A-9	4.7K	#	4.7K
Q378	E-18	2SB709A-QRS-TX	#	2SB709A-QRS-TX	TU150	C-18	FSS BTF-FA402	#	FSS BTF-FA402

MA BOARD WAVEFORMS

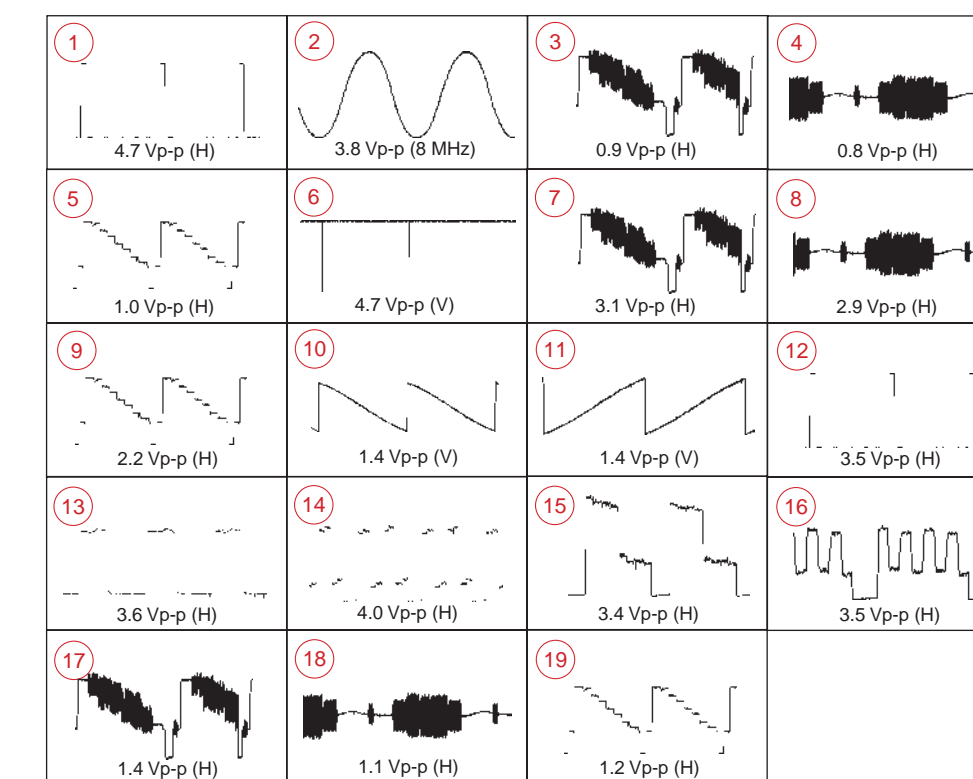



[TUNING CONTROL, 2ND TUNER, Y/C/J]

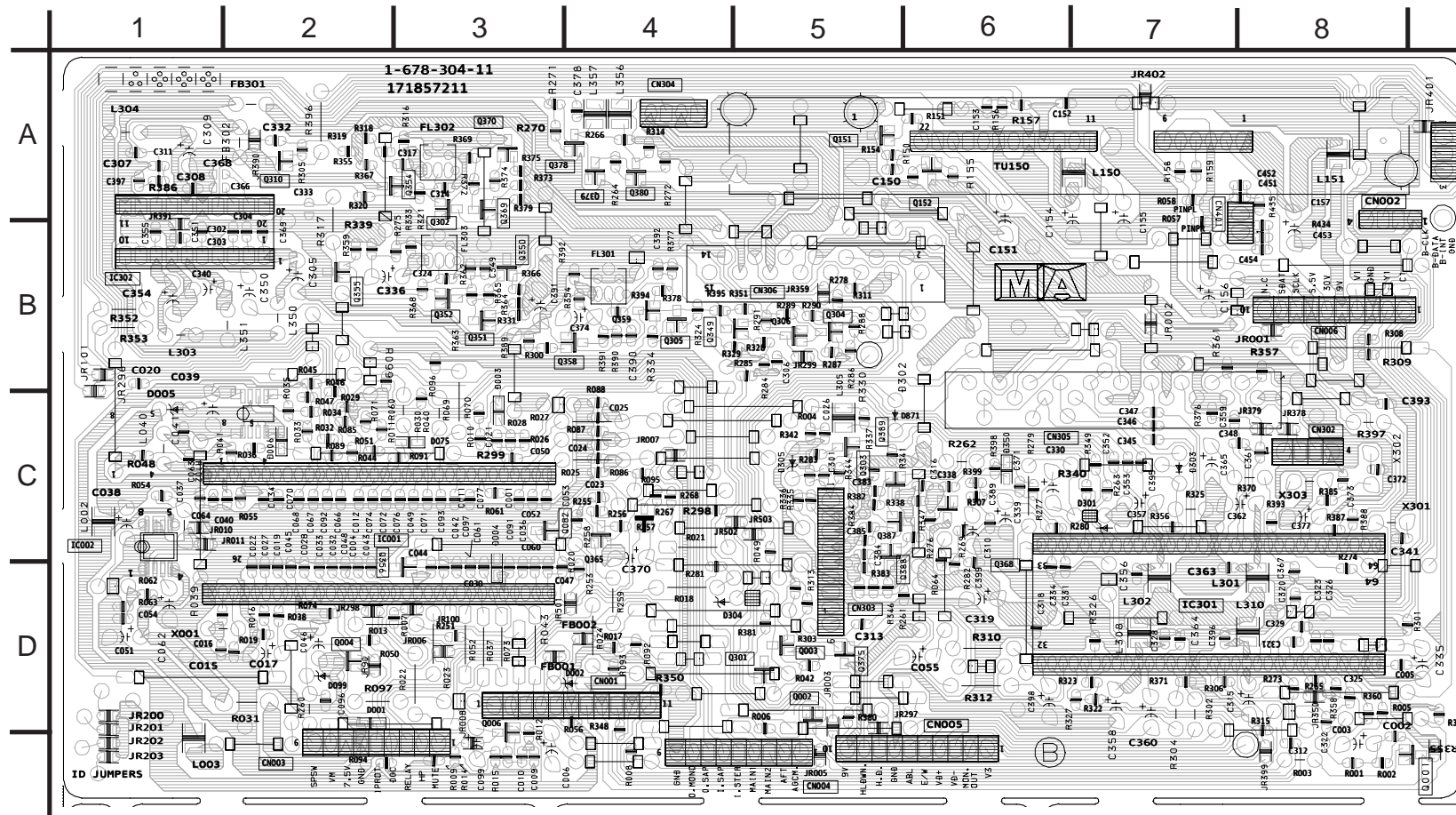

MA BOARD TRANSISTOR VOLTAGE LIST

Q001		Q151		Q305		Q352		Q365		Q379	
pin	volt	pin	volt	pin	volt	pin	volt	pin	volt	pin	volt
B	5.0	B	4.0	B	4.4	B	2.5	B	0.5	B	4.4
C	GND	C	GND	C	GND	C	7.8	C	3.8	C	5.1
E	5.6	E	4.6	E	5.0	E	1.9	E	0.0	E	5.1
Q002		Q152		Q306		Q354		Q368		Q380	
pin	volt	pin	volt	pin	volt	pin	volt	pin	volt	pin	volt
B	4.4	B	6.8	B	9.0	B	2.5	B	2.4	B	5.1
C	9.0	C	9.0	C	8.8	C	GND	C	9.0	C	0.0
E	3.8	E	6.2	E	9.0	E	3.2	E	2.4	E	5.1
Q003		Q301		Q310		Q355		Q369		Q387	
pin	volt	pin	volt	pin	volt	pin	volt	pin	volt	pin	volt
B	0.6	B	0.7	B	4.8	B	0.0	B	7.6	B	1.9
C	0.0	C	0.0	C	GND	C	GND	C	5.8	C	GND
E	GND	E	GND	E	5.4	E	3.0	E	8.3	E	2.5
Q004		Q302		Q349		Q356		Q370		Q388	
pin	volt	pin	volt	pin	volt	pin	volt	pin	volt	pin	volt
B	4.9	B	2.5	B	4.4	B	0.5	B	5.8	B	1.9
C	GND	C	7.6	C	9.0	C	1.3	C	GND	C	GND
E	3.9	E	1.9	E	3.8	E	GND	E	6.4	E	2.5
Q006		Q303		Q350		Q358		Q375		Q389	
pin	volt	pin	volt	pin	volt	pin	volt	pin	volt	pin	volt
B	5.2	B	3.6	B	4.0	B	2.4	B	5.0	B	2.0
C	0.7	C	0.1	C	GND	C	8.9	C	9.0	C	GND
E	5.0	E	3.5	E	4.7	E	1.8	E	4.4	E	2.6
Q082		Q304		Q351		Q359		Q378		All voltages are in V	
pin	volt	pin	volt	pin	volt	pin	volt	pin	volt		
B	0.6	B	8.9	B	7.8	B	2.1	B	4.3		
C	0.5	C	9.0	C	4.0	C	GND	C	4.9		
E	GND	E	8.8	E	8.4	E	2.7	E	5.1		

MA BOARD IC VOLTAGE LIST

IC001		IC002		IC301		IC302		TU150	
pin	volt	pin	volt	pin	volt	pin	volt	pin	volt
19	4.3	39	NC	59	NC	3	GND	13	8.9
20	0.1	40	NC	60	NC	4	GND	14	NC
21	NC	41	NC	61	0.1	5	4.8	15	NC
22	5.0	42	4.8	62	0.1	6	4.8	16	4.8
23	NC	43	4.8	63	0.1	7	GND	17	4.4
24	5.0	44	NC	64	0.1	8	5.0	18	GND
25	2.1	45	4.8	65	0.1	9	5.0	19	7.2
26	NC	46	NC	66	0.1	10	5.0	20	2.5
27	0.3	47	4.8	67	0.1	11	5.0	21	11
28	2.2	48	0.1	68	0.1	12	5.0	22	0
29	GND	49	0.1	69	0.1	13	5.0	23	11
30	2.2	50	5.0	70	0.1	14	5.0	24	13
31	2.3	51	5.0	71	0.1	15	5.0	25	13
32	GND	52	NC	72	0.1	16	5.0	26	13
33	5.0	53	1.0	73	0.1	17	5.0	27	13
34	2.5	54	0.1	74	0.1	18	5.0	28	13
35	2.5	55	NC	75	0.1	19	5.0	29	13
36	5.0	56	1.0	76	0.1	20	5.0	30	13
37	3.1	57	NC	77	0.1	21	5.0	31	13
38	5.0	58	0.1	78	0.1	22	5.0	32	13

MA BOARD LOCATOR LIST

DIODE	D006	C-2	D305	B-5	IC301	D-7	Q004	D-2	Q302	A-3	Q349	C-4	Q356	D-3	Q370	A-3	Q388	B-5	
D001	D-2	D075	C-3	D360	B-4	IC302	B-1	Q006	D-3	Q303	C-5	Q350	B-3	Q358	B-4	Q375	B-5	Q389	C-5
D002	D-4	D301	C-7	IC	TRANSISTOR	Q082	B-3	Q304	B-5	Q351	B-3	Q359	B-4	Q378	A-3	CRYSTAL			
D003	C-3	D302	C-5	IC001	C-2	Q001	D-8	Q151	A-5	Q305	B-4	Q352	B-3	Q365	C-4	Q379	A-4	X001	D-1
D004	D-3	D303	C-7	IC002	C-1	Q002	D-5	Q152	A-6	Q306	B-5	Q354	A-3	Q368	C-6	Q380	A-4	X301	C-8
D005	C-1	D304	D-4	IC003	C-2	Q003	D-5	Q301	D-4	Q310	B-3	Q355	B-2	Q369	B-3	Q387	C-5		

MA BOARD IC BLOCK DIAGRAMS

MA BOARD: IC301 CXA2154S

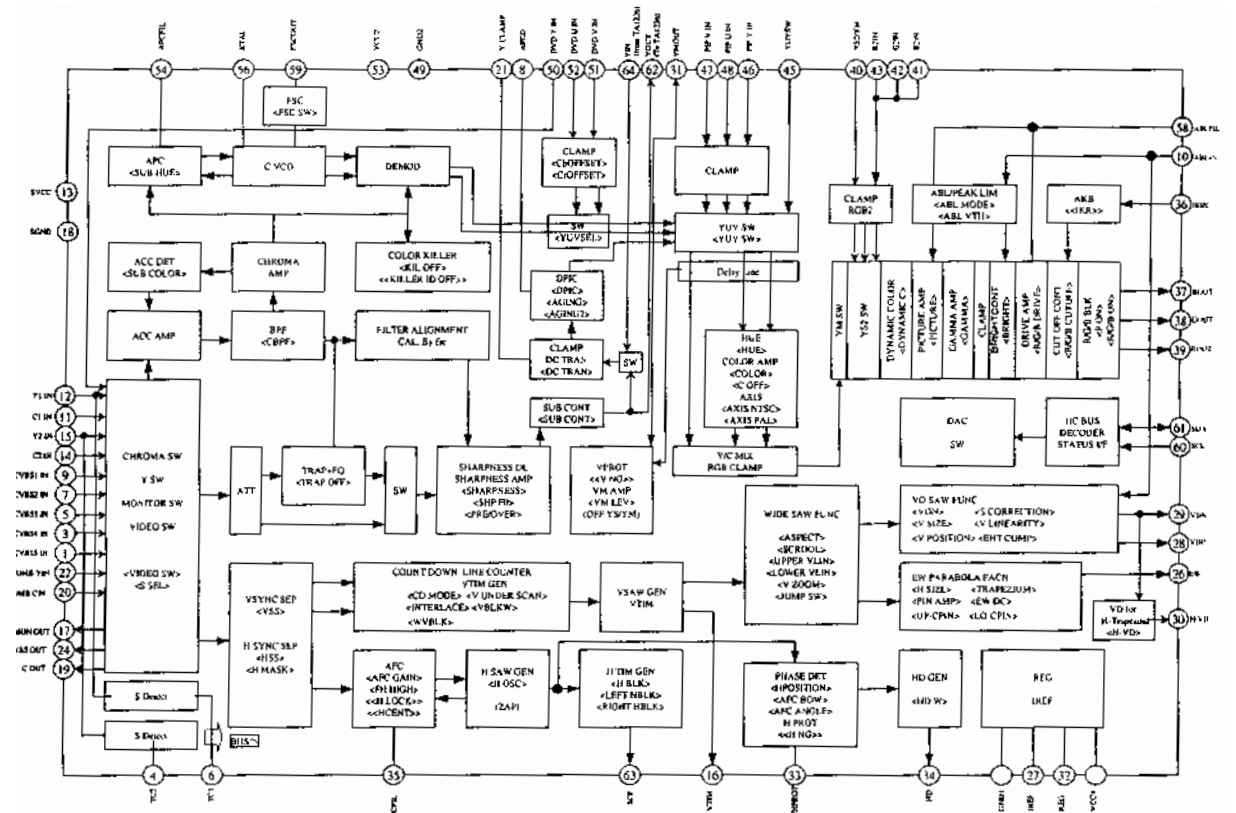

CA BOARD SCHEMATIC DIAGRAM

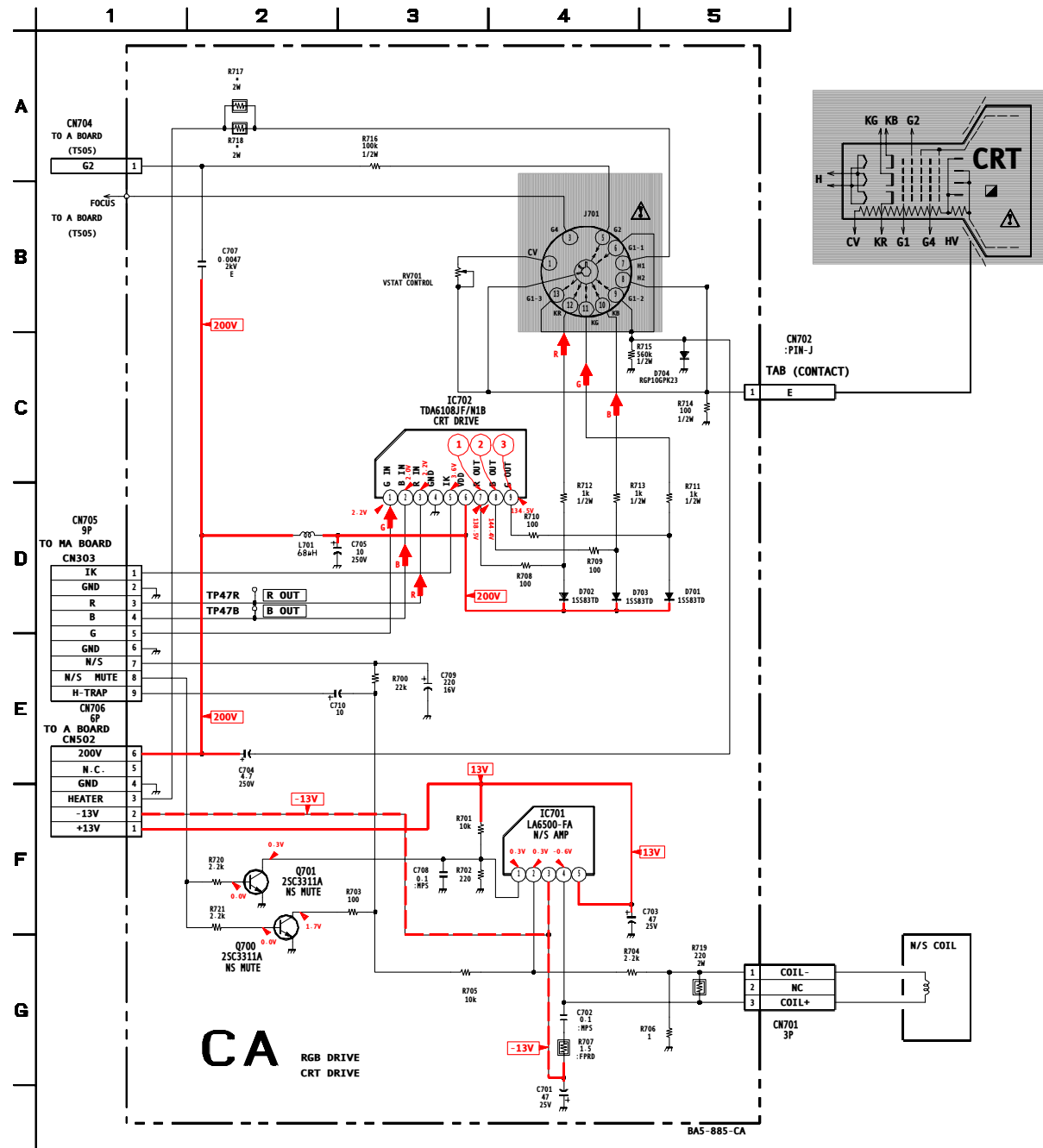

CA [RGB DRIVE, CRT DRIVE]

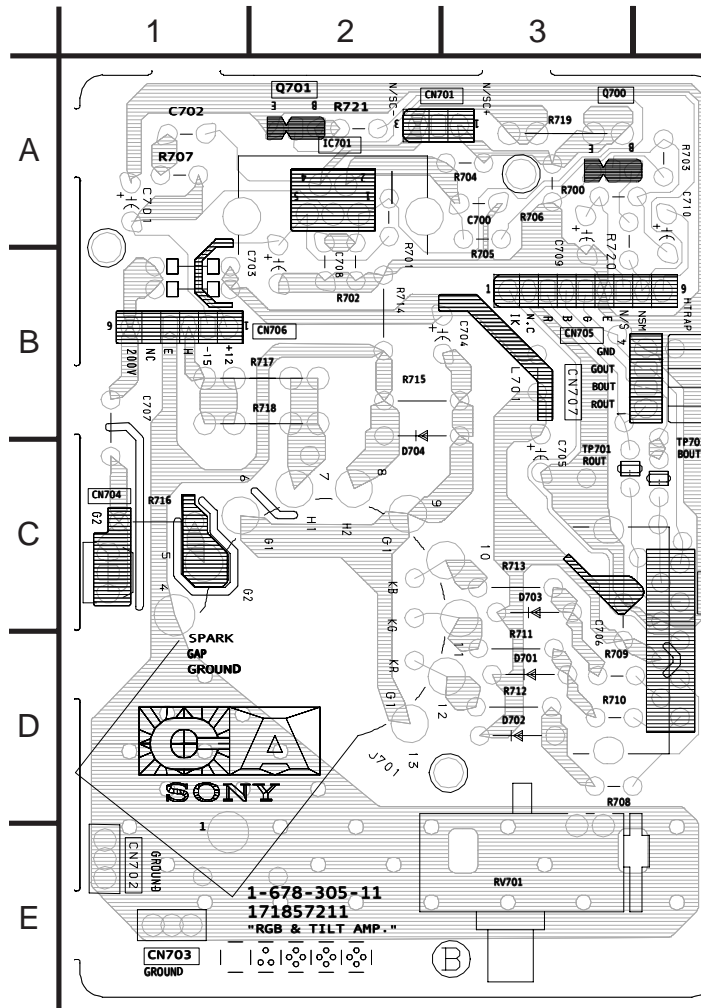

CA BOARD WAVEFORMS

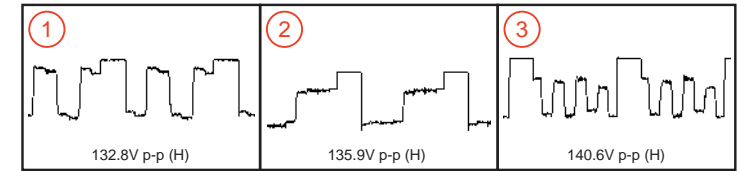

CA BOARD MARK (*) LIST

REF NO.	LOC.	KV-27FV16 KV-29FV16 KV-29FV16C	KV-32FS12 KV-32FS16
R717	A-2	2.2 2W	#
R718	A-2	#	3.3 2W

#: Not Mounted

HX BOARD SCHEMATIC DIAGRAM

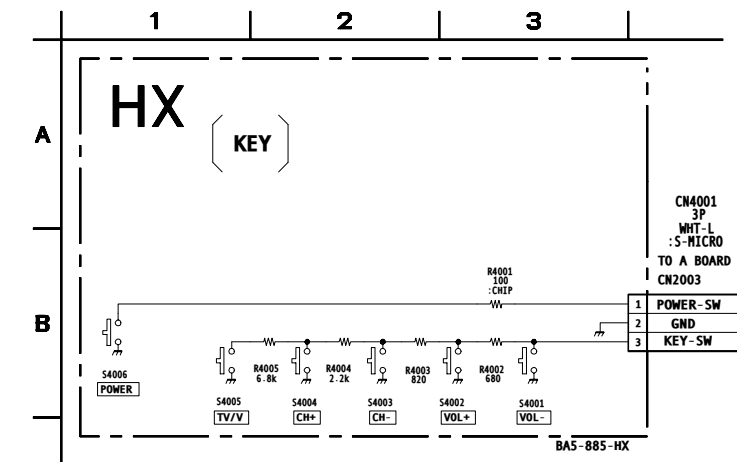

HX [KEY]

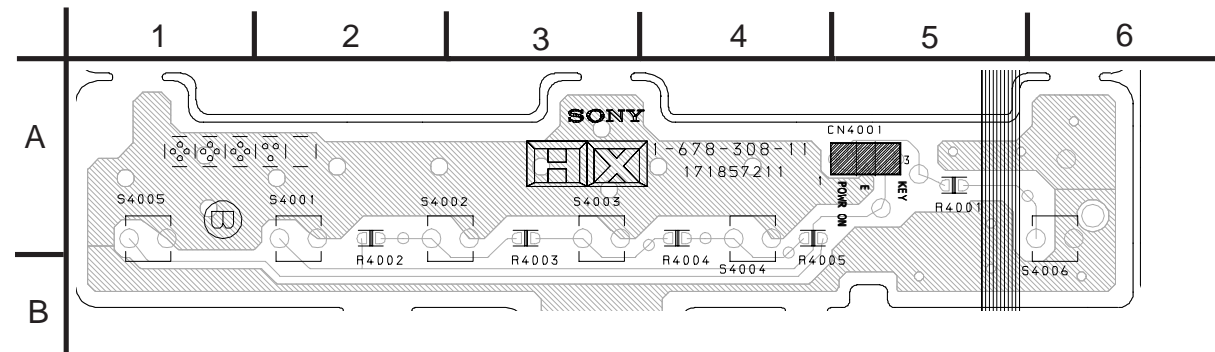

D BOARD SCHEMATIC DIAGRAM

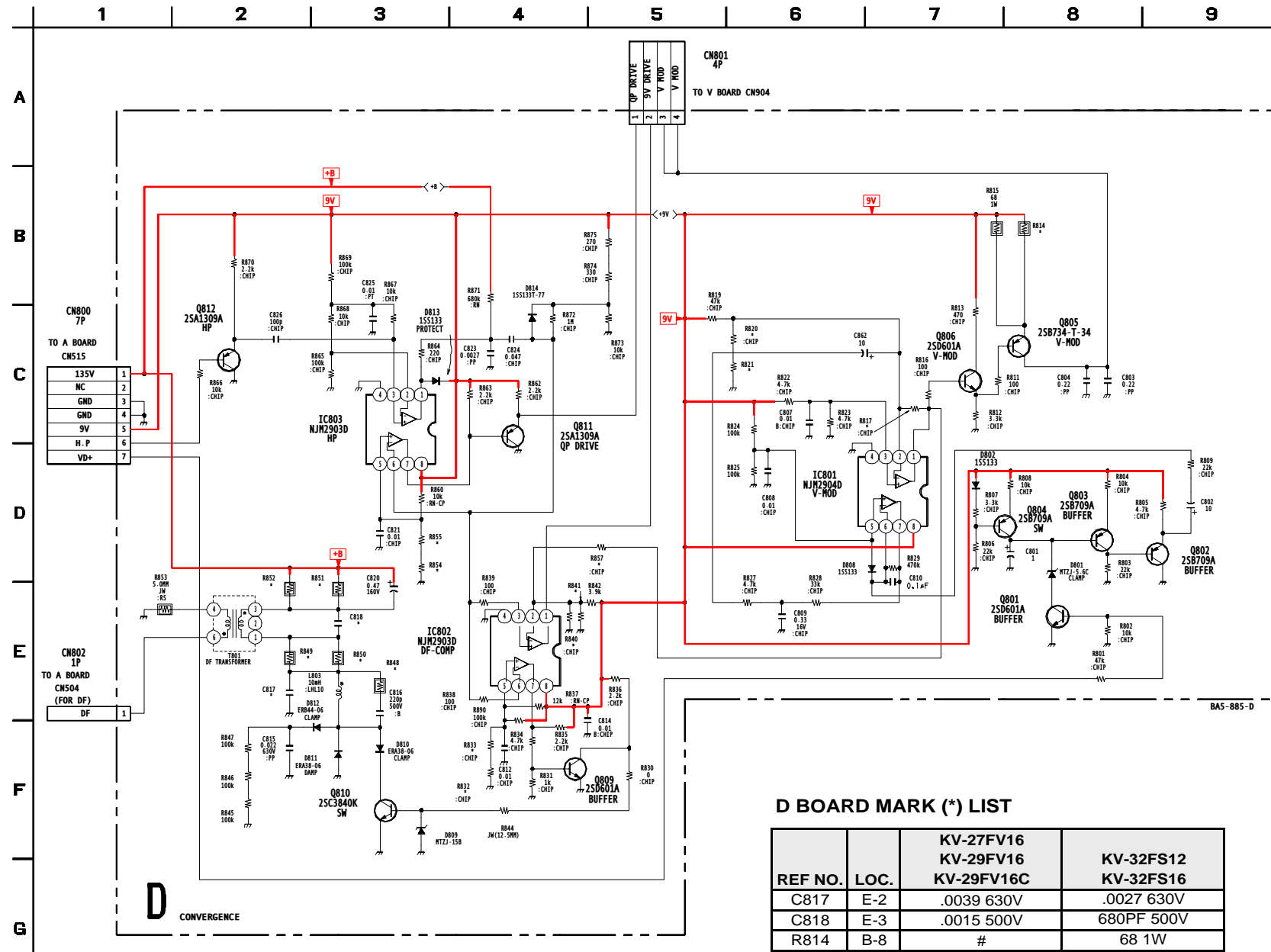

D BOARD MARK (*) LIST

REF NO.	LOC.	KV-27FV16 KV-29FV16 KV-29FV16C	KV-32FS12 KV-32FS16
C817	E-2	.0039 630V	.0027 630V
C818	E-3	.0015 500V	680PF 500V
R814	B-8	#	68 1W
R817	C-7	56K	47K
R820	C-6	22K	33K
R821	C-5	15K	3.3K
R832	F-4	5.6K	3.3K
R833	F-4	33K	39K
R840	E-4	68K	#
R841	E-4	6.8K	10K
R848	E-3	15K 1W	2.2K 2W
R849	E-3	3.3K 3W	8.2K 3W
R850	E-3	#	8.2K 3W
R851	E-3	2.2K 2W	6.8K 3W
R852	E-2	#	6.8K 3W
R854	D-3	6.8K	5.6K
R855	D-3	47K	56K
R857	D-4	#	33K

#: Not Mounted

D [CONVERGENCE]

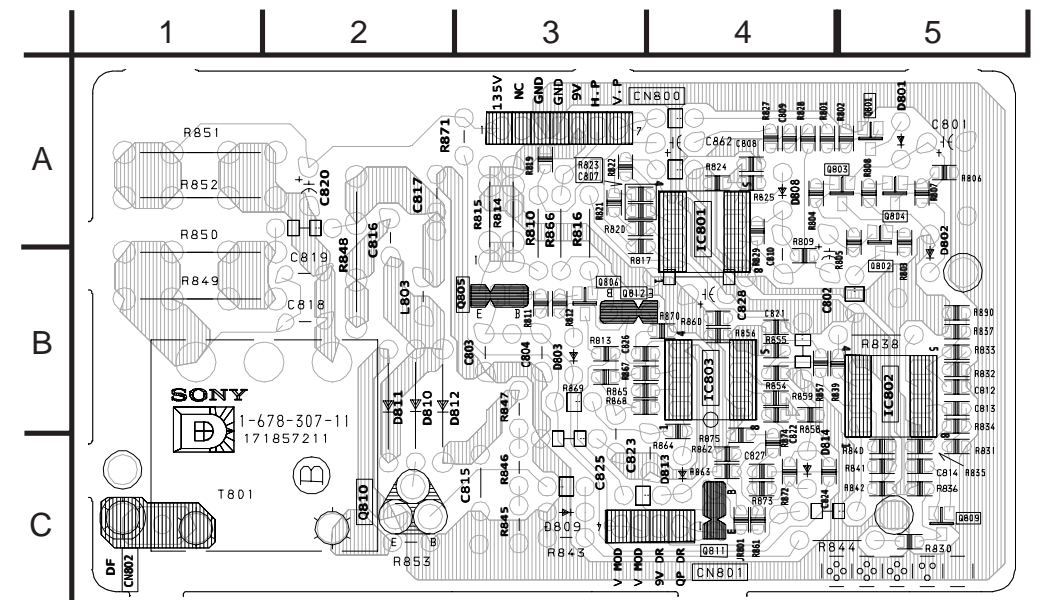

D BOARD TRANSISTOR VOLTAGE LIST

Q801		Q806	
pin	volt	pin	volt
B	-2.2	B	7.3
C	3.4	C	8.1
E	GND	E	6.7
Q802		Q809	
pin	volt	pin	volt
B	4.3	B	0.3
C	GND	C	0.3
E	4.9	E	GND
Q803		Q810	
pin	volt	pin	volt
B	6.4	B	0.3
C	4.3	C	1.2
E	7.0	E	GND
Q804		Q811	
pin	volt	pin	volt
B	7.4	B	6.3
C	6.4	C	GND
E	7.9	E	6.4
Q805		Q812	
pin	volt	pin	volt
B	6.7	B	0.0
C	0.6	C	GND
E	7.3	E	0.6

All voltages are in V

D BOARD IC VOLTAGE LIST

IC801		IC803	
pin	volt	pin	volt
1	7.3	1	2.3
2	4.4	2	4.3
3	4.5	3	4.7
4	GND	4	GND
5	4.5	5	7.6
6	4.5	6	6.7
7	4.5	7	6.0
8	9.0	8	9.0
IC802		IC803	
pin	volt	pin	volt
1	6.8		
2	5.7		
3	0.0		
4	GND		
5	6.8		
6	6.7		
7	3.2		
8	9.0		

All voltages are in V

BC BOARD SCHEMATIC DIAGRAM

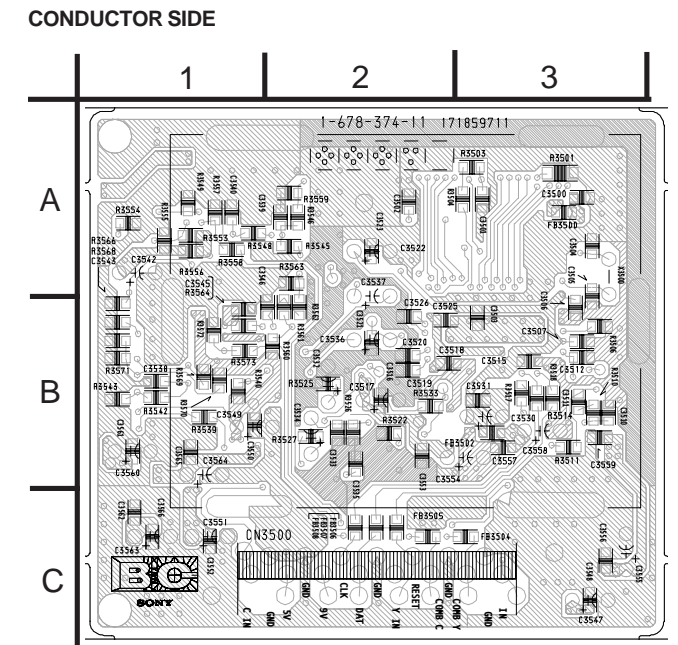
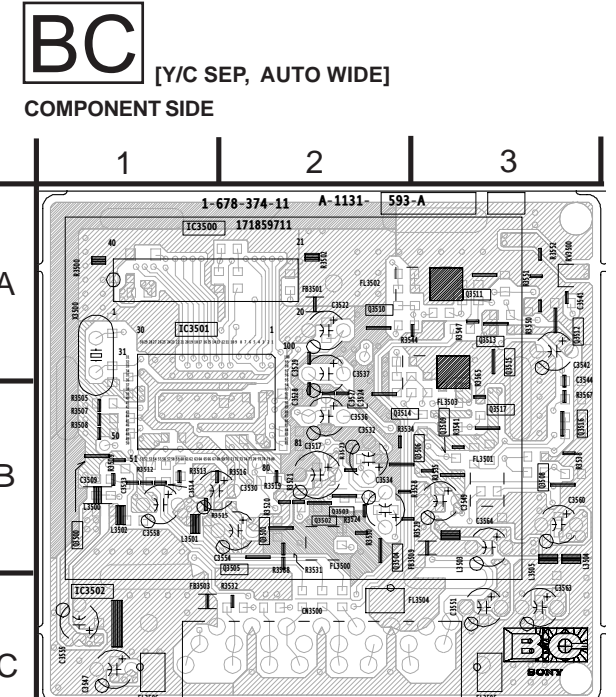
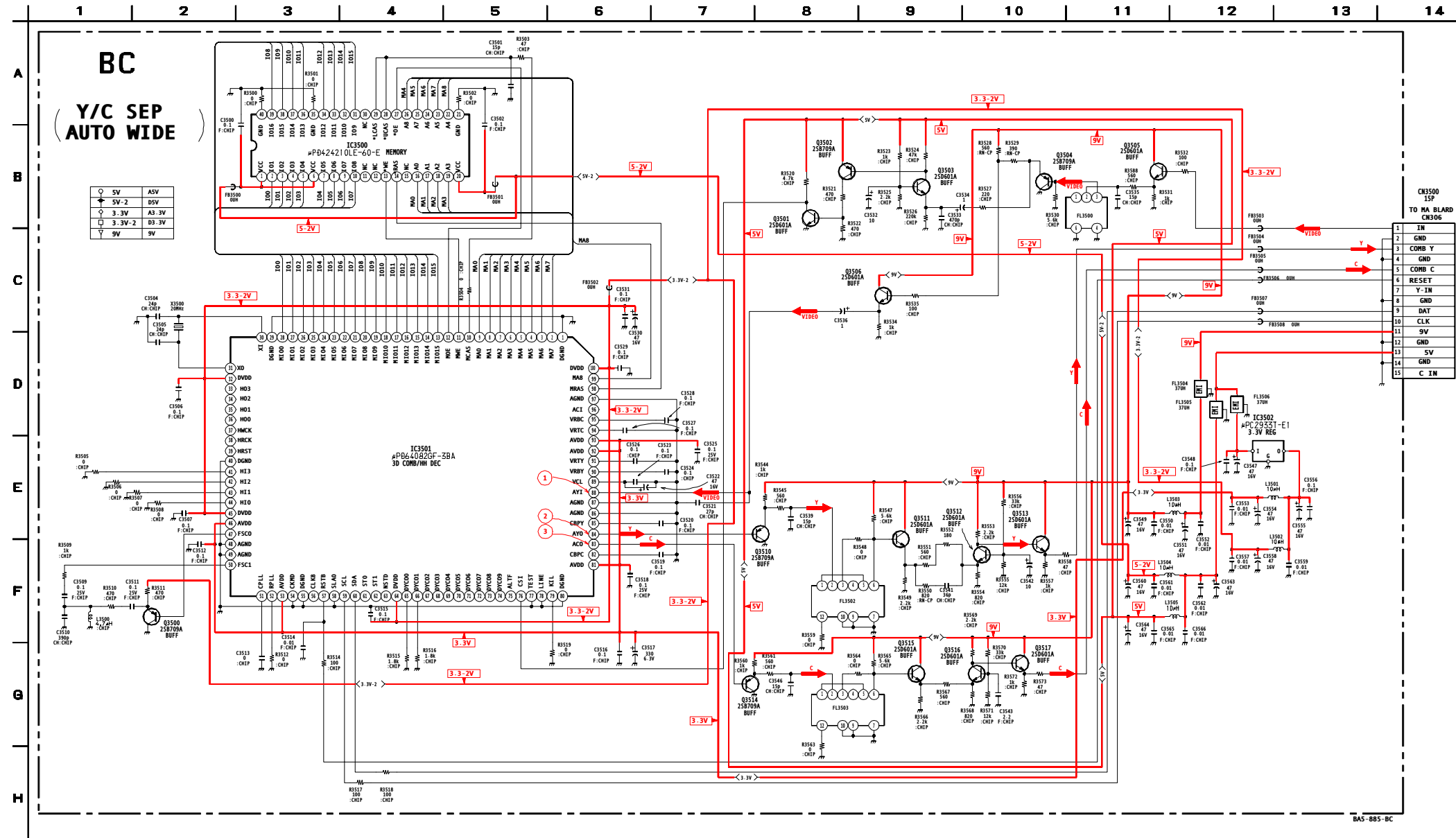

BC BOARD IC VOLTAGE LIST

IC3500																	IC3501			
pin	volt	16	1.5	33	1.1	8	1.5	25	0.9	42	0.0	59	4.8	76	3.3	93	3.3	pin	volt	
1	5.0	18	1.5	35	GND	10	1.0	27	0.9	44	0.0	61	NC	78	GND	95	2.0	16	1.1	
2	0.8	19	1.5	36	1.1	11	2.9	28	0.8	45	3.3	62	NC	79	0.0	96	NC	17	1.1	
3	0.9	20	5.0	37	1.1	12	2.4	29	GND	46	3.3	63	NC	80	GND	97	0.0	18	1.1	
4	0.9	21	GND	38	1.0	13	0.3	30	1.5	47	1.8	64	3.3	81	3.3	98	0.5	19	1.0	
5	0.9	22	1.6	39	0.1	14	1.1	31	1.6	48	GND	65	0.7	82	1.1	99	1.6	20	0.1	
6	5.0	23	1.5	40	GND	15	1.1	32	3.3	49	GND	66	1.5	83	1.7	100	3.3	21	1.1	
7	0.8	24	1.5	IC3501		16	1.1	33	NC	50	1.5	67	NC	84	1.4	IC3501		22	1.4	
8	0.7	25	1.5	pin	volt	17	1.1	34	NC	51	0.0	68	NC	85	1.1	pin	volt	23	0.7	
9	1.4	26	1.5	1	GND	18	1.1	35	NC	52	0.0	69	NC	86	0.0	G	GND	24	0.8	
10	1.1	27	2.4	2	1.5	19	1.0	36	NC	53	3.3	70	NC	87	0.0	I	5.0	25	1.5	
11	NC	28	1.1	3	1.5	20	0.1	37	NC	54	GND	71	NC	88	0.9	O	3.3	26	1.5	
12	NC	29	1.1	4	1.5	21	1.1	38	NC	55	GND	72	NC	89	0.9				27	0.9
13	2.9	30	0.0	5	1.5	22	1.4	39	NC	56	NC	73	NC	90	1.0				28	0.8
14	0.5	31	0.3	6	1.5	23	0.7	40	GND	57	3.3	74	NC	91	1.6				29	GND
15	NC	32	1.1	7	1.5	24	0.8	41	0.0	58	GND	75	NC	92	3.3				30	0.9

All voltages are in V

BC BOARD TRANSISTOR VOLTAGE LIST

Q3500		Q3504		Q3511		Q3515	
pin	volt	pin	volt	pin	volt	pin	volt
B	1.8	B	3.9	B	3.0	B	3.0
C	0.0	C	GND	C	8.9	C	8.9
E	2.4	E	4.5	E	2.4	E	2.3
Q3501		Q3505		Q3512		Q3516	
pin	volt	pin	volt	pin	volt	pin	volt
B	0.2	B	5.0	B	2.3	B	2.4
C	3.3	C	8.9	C	5.5	C	6.5
E	GND	E	4.3	E	1.7	E	1.7
Q3502		Q3506		Q3513		Q3517	
pin	volt	pin	volt	pin	volt	pin	volt
B	4.7	B	6.3	B	5.5	B	6.5
C	0.8	C	8.9	C	8.9	C	8.9
E	5.0	E	5.7	E	4.9	E	5.8
Q3503		Q3510		Q3514			
pin	volt	pin	volt	pin	volt		
B	3.5	B	1.4	B	1.7		
C	4.7	C	GND	C	0.0		
E	3.7	E	2.1	E	2.4		

All voltages are in V

BC BOARD WAVEFORMS

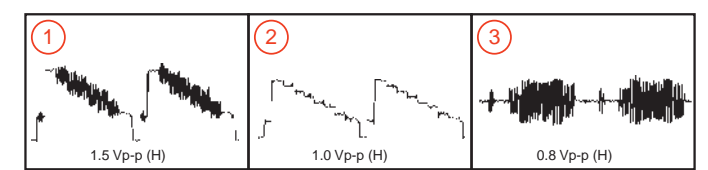

HA [FRONT A/V, MENU KEY]

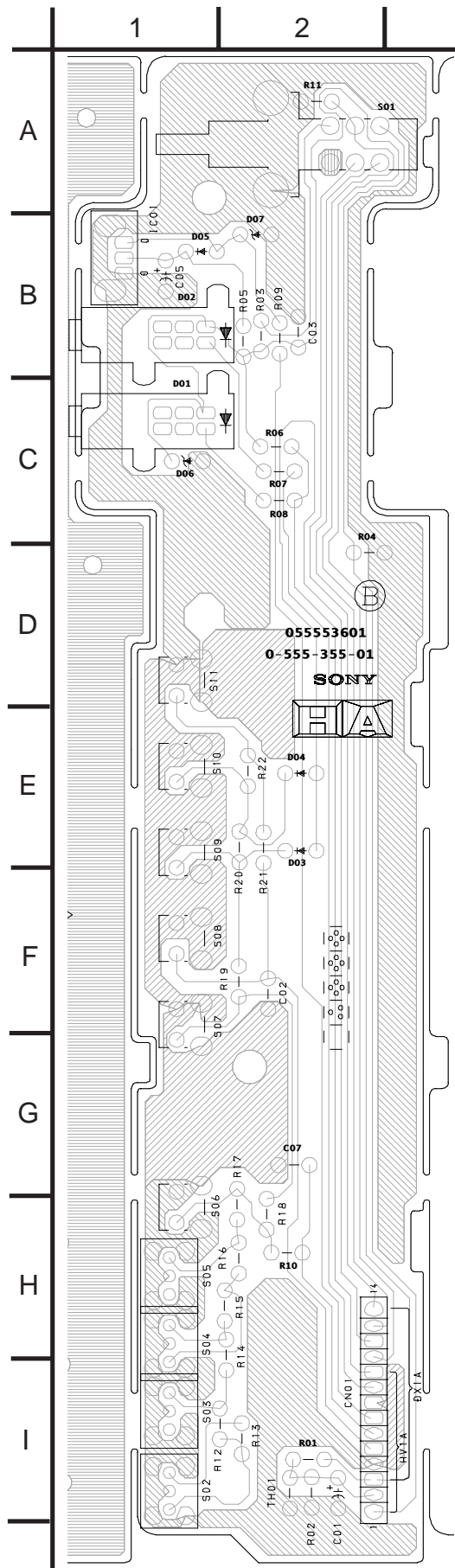

HA BOARD SCHEMATIC DIAGRAM

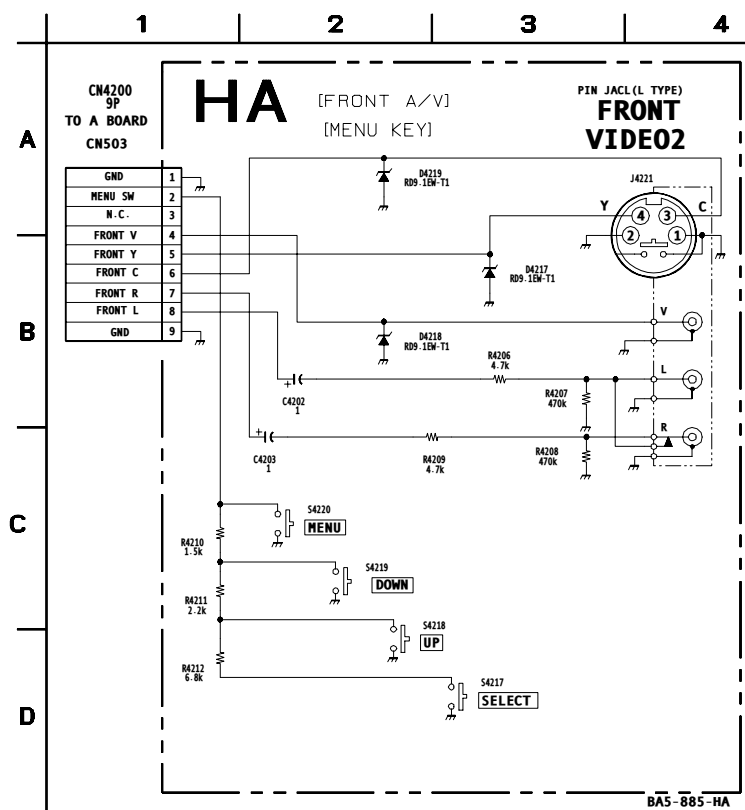

HB BOARD SCHEMATIC DIAGRAM

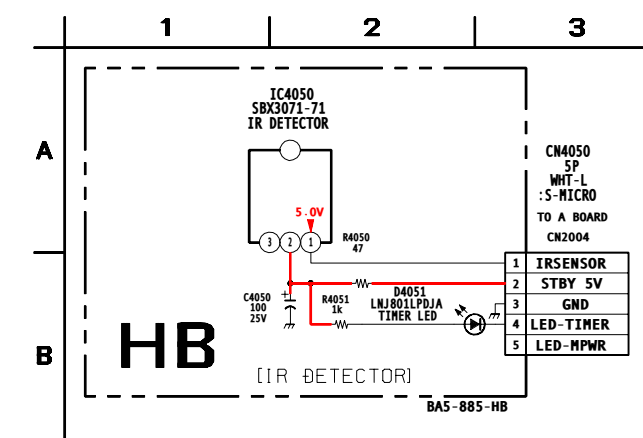

HB [IR DETECTOR]

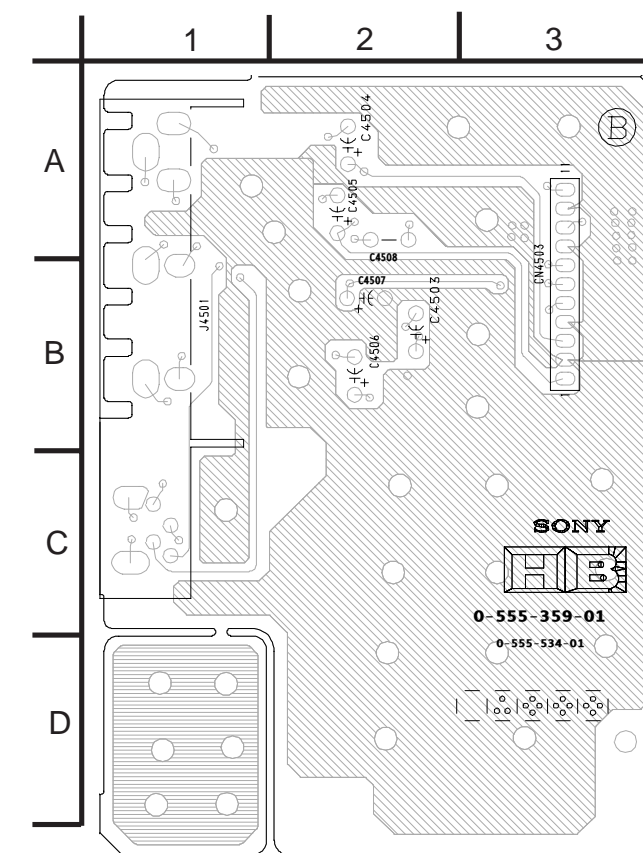

K BOARD SCHEMATIC DIAGRAM

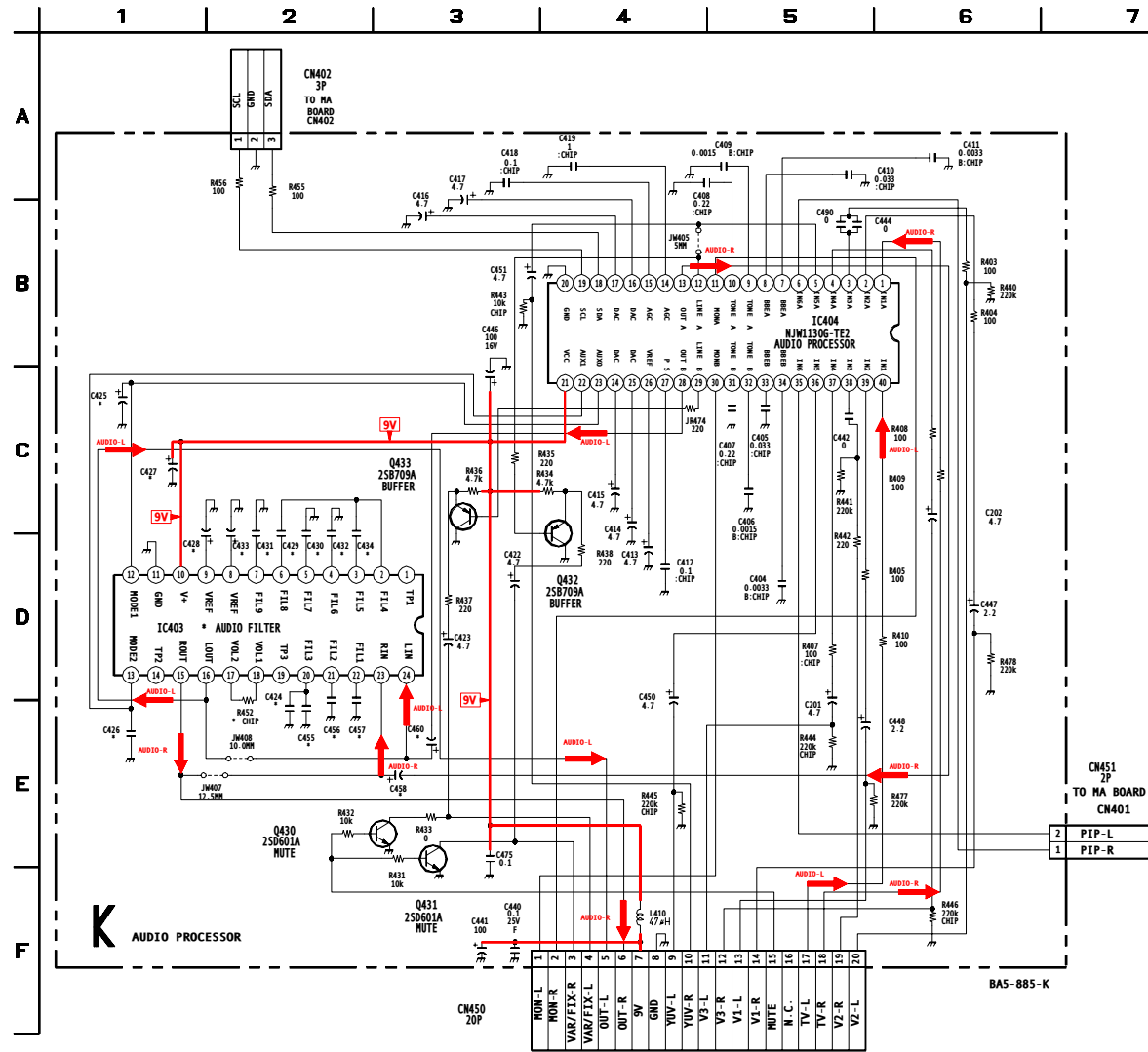

K [AUDIO PROCESSOR]

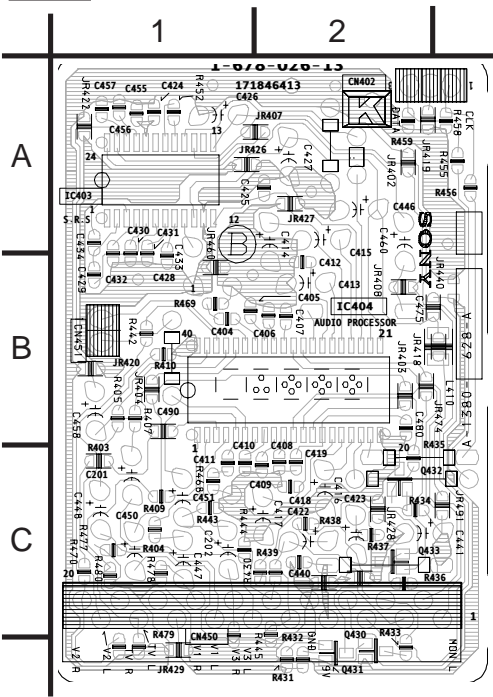

K BOARD TRANSISTOR VOLTAGE LIST

Q430		Q431		Q432		Q433	
pin	volt	pin	volt	pin	volt	pin	volt
B	0.3	B	0.3	B	4.5	B	4.5
C	0.0	C	0.0	C	GND	C	GND
E	GND	E	GND	E	5.1	E	5.2

VA [VELOCITY MODULATOR]

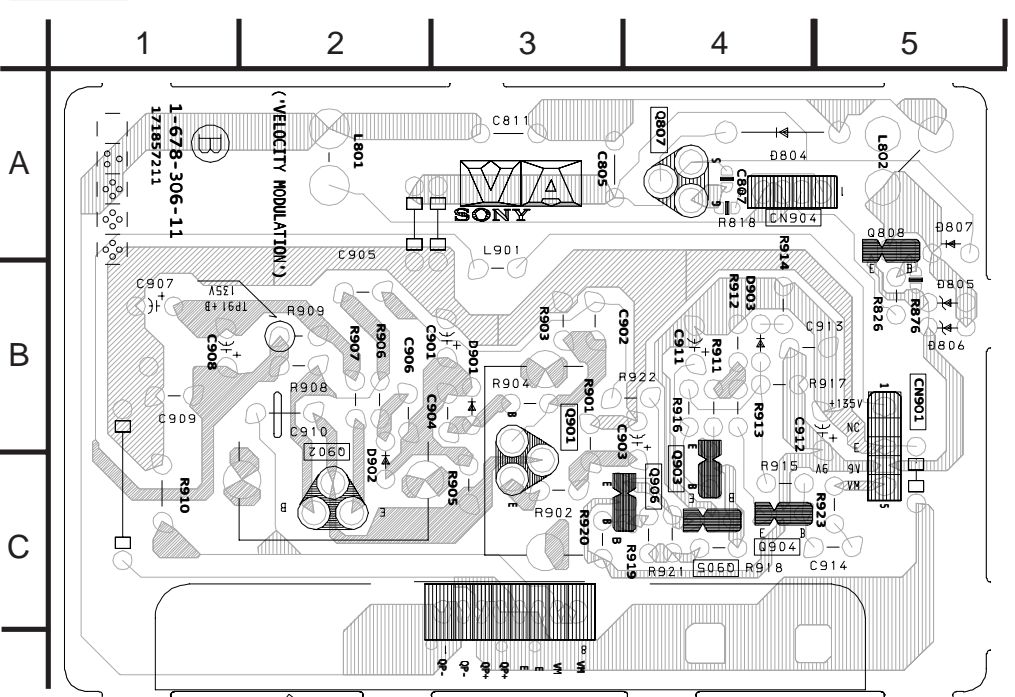

VA BOARD MARK(*) LIST

REF NO.	LOC.	KV-27FV16 KV-29FV16 KV-29FV16C	KV-32FS12 KV-32FS16
C805	B-6	.033UF 200V	.01UF 630V
C811	A-6	.047UF 200V	.082UF 200V

#: Not Mounted

VA BOARD SCHEMATIC DIAGRAM

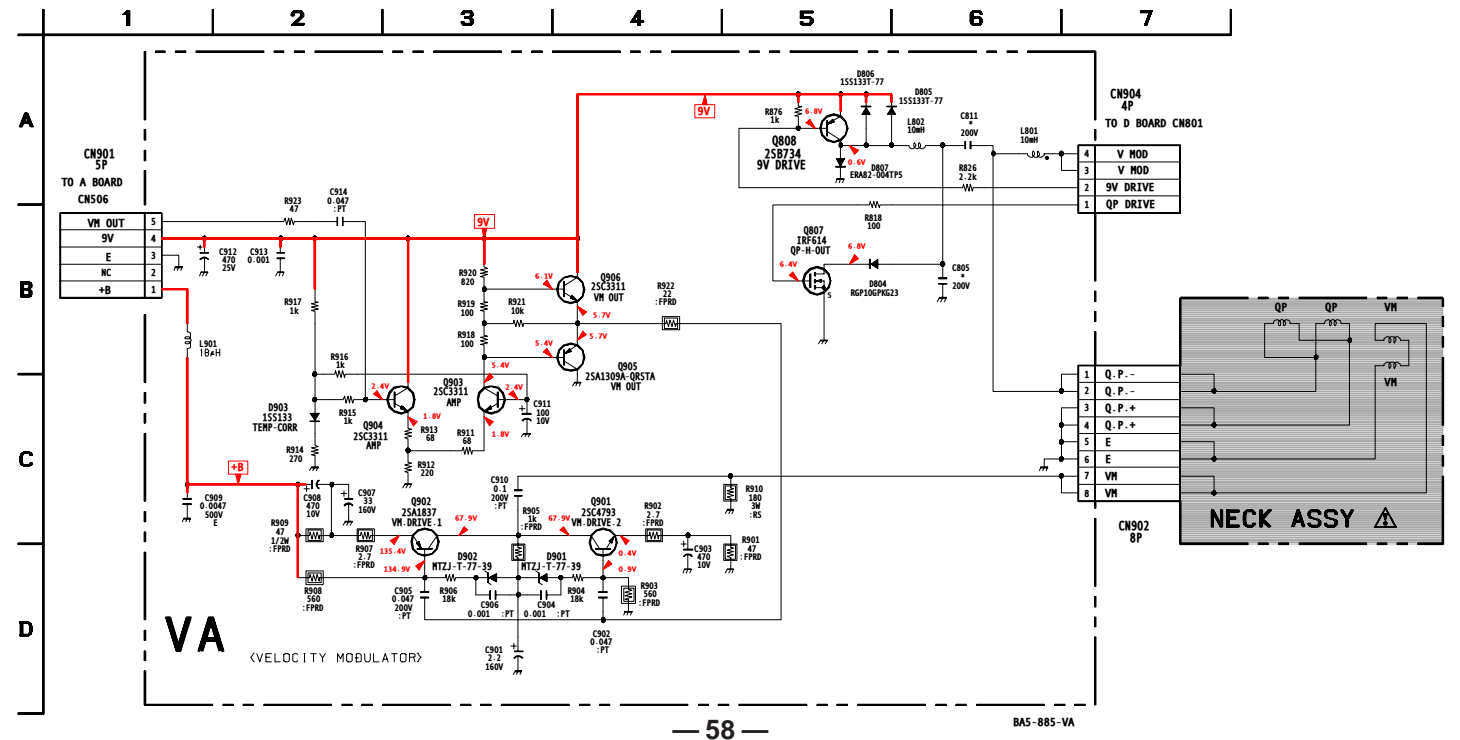

K BOARD IC VOLTAGE LIST

IC403		16	4.5	7	4.7	24	1.3
pin	volt	17	4.5	8	4.5	25	1.3
1	NC	18	4.5	9	4.5	26	4.4
2	4.5	19	NC	10	4.5	27	3.9
3	4.5	20	4.5	11	NC	28	4.5
4	4.5	21	4.5	12	4.5	29	4.5
5	4.5	22	4.5	13	4.5	30	NC
6	4.5	23	4.5	14	1.0	31	4.5
7	4.5	24	4.5	15	4.5	32	4.5
8	4.5	IC404		16	0.9	33	4.5
9	4.5	pin	volt	17	0.9	34	4.5
10	9.0	1	4.5	18	4.8	35	NC
11	GND	2	4.5	19	4.9	36	4.5
12	0	3	4.5	20	GND	37	4.5
13	0	4	4.5	21	8.9	38	4.5
14	NC	5	4.5	22	NC	39	4.5
15	4.5	6	NC	23	NC	40	4.5

All voltages are in V

K BOARD MARK(*) LIST

REF NO.	LOC.	KV-27FV16 KV-29FV16 KV-29FV16C	KV-32FS12 KV-32FS16
C424	E-2	.47 25V	#
C425	C-1	1 16V	#
C426	E-2	1	#
C427	C-1	100	#
C428	D-2	100	#
C429	D-2	0.0047	#
C430	D-2	.22 25V	#
C431	D-2	.1 25V	#
C432	D-2	0.01	#
C433	D-2	1 16V	#
C434	D-2	.1 25V	#
C455	E-2	.4725V	#
C456	E-2	0.01	#
C457	E-2	0.033	#
C458	E-3	4.7	#
C460	E-3	4.7	#
IC403	D-1	NJM2198-TE2	#
R452	E-2	10K	#

#: Not Mounted

P BOARD SCHEMATIC DIAGRAM

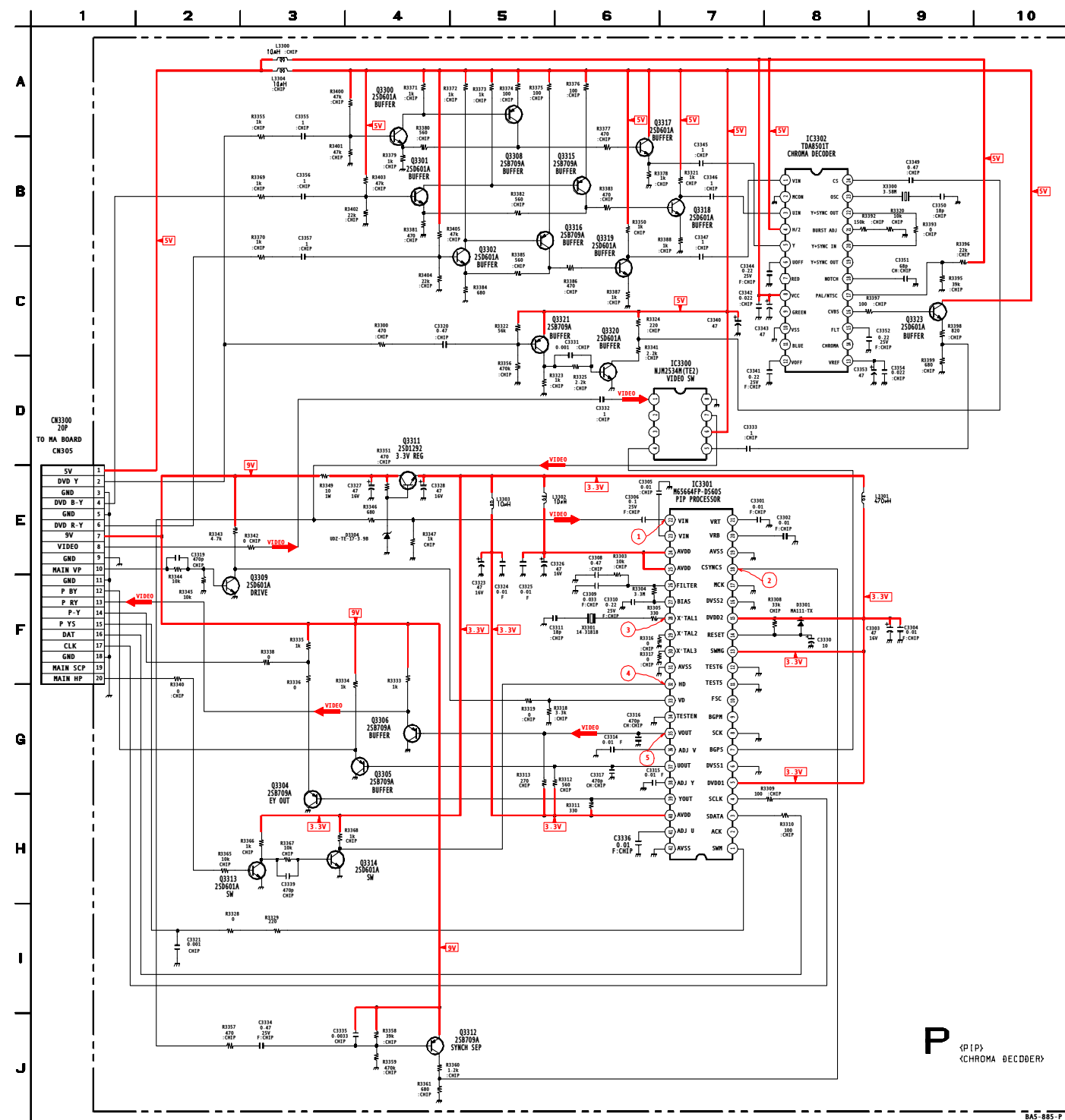

P [PIP, CHROMA DECODER]

COMPONENT SIDE

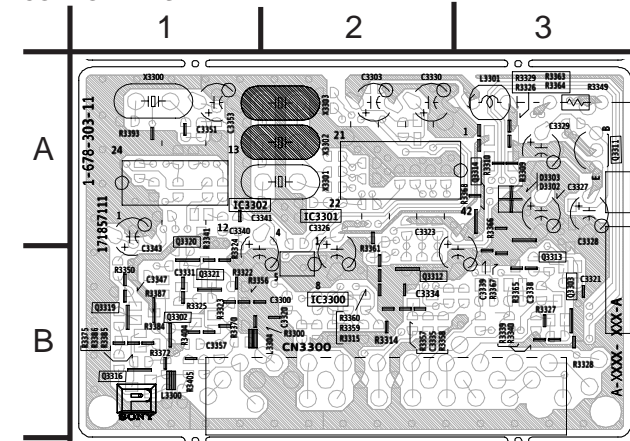

CONDUCTOR SIDE

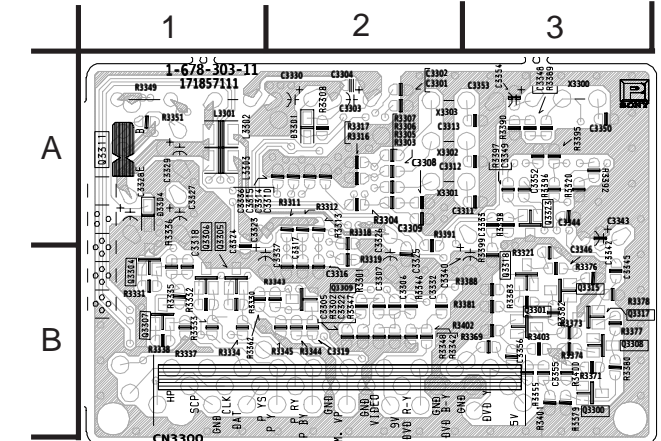

P BOARD IC VOLTAGE LIST

IC3300		29	0.0
pin	volt	30	0.0
1	2.6	31	0.0
2	NC	32	0.5
3	NC	33	0.0
4	0.0	34	GND
5	2.6	35	3.1
6	5.0	36	1.1
7	1.8	37	3.0
8	GND	38	1.2
IC3301		39	2.6
pin	volt	40	3.5
1	0.2	41	1.0
2	GND	42	GND
3	4.7	IC3302	
4	4.8	pin	volt
5	3.2	1	0.0
6	GND	2	GND
7	0.0	3	0.0
8	GND	4	5.0
9	NC	5	0.3
10	NC	6	2.0
11	GND	7	NC
12	GND	8	5.1
13	3.2	9	NC
14	3.2	10	GND
15	3.2	11	NC
16	GND	12	2.0
17	GND	13	2.5
18	0.3	14	NC
19	GND	15	0.8
20	0.5	16	1.7
21	1.6	17	3.3
22	1.0	18	1.7
23	0.6	19	NC
24	3.4	20	1.7
25	3.4	21	2.5
26	1.4	22	1.7
27	1.7	23	1.3
28	2.0	24	1.9

All voltages are in V

P BOARD TRANSISTOR VOLTAGE LIST

Q3300		Q3305		Q3311		Q3315		Q3319	
pin	volt	pin	volt	pin	volt	pin	volt	pin	volt
B	2.4	B	3.0	B	4.1	B	4.2	B	1.9
C	4.2	C	GND	C	7.7	C	2.4	C	3.8
E	1.8	E	3.7	E	3.5	E	4.8	E	1.3
Q3301		Q3306		Q3312		Q3316		Q3320	
pin	volt	pin	volt	pin	volt	pin	volt	pin	volt
B	1.6	B	3.1	B	8.8	B	0.0	B	0.0
C	4.2	C	GND	C	0.7	C	1.9	C	5.0
E	1.0	E	3.8	E	9.0	E	4.9	E	GND
Q3302		Q3308		Q3313		Q3317		Q3321	
pin	volt	pin	volt	pin	volt	pin	volt	pin	volt
B	1.6	B	4.2	B	0.2	B	2.9	B	4.7
C	4.3	C	2.9	C	2.7	C	5.0	C	0.0
E	1.0	E	4.9	E	GND	E	2.3	E	5.0
Q3304		Q3309		Q3314		Q3318		Q3323	
pin	volt	pin	volt	pin	volt	pin	volt	pin	volt
B	2.6	B	0.7	B	0.5	B	2.4	B	1.8
C	GND	C	0.0	C	0.6	C	3.3	C	5.0
E	3.3	E	GND	E	GND	E	1.8	E	1.1

All voltages are in V

P BOARD WAVEFORMS

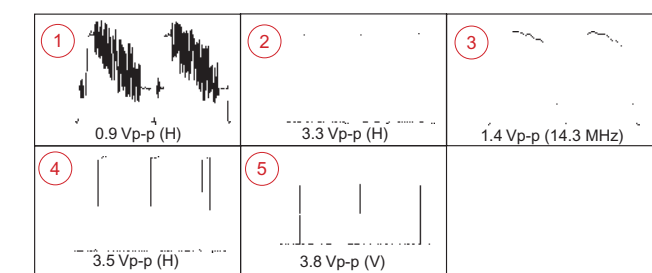

6-4. SEMICONDUCTORS

2SA1037AK-7146-QR
2SB709A-QRS-TX
2SD601A-QRS-TX
2SC2412K-T-146-QR

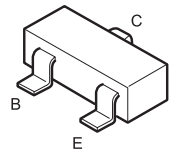

2SB734-7-34
2SC3209LK-TP

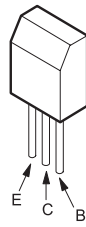

2SC1740S-QRT

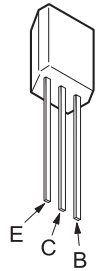

2SA1309A-QRSTA
2SC3311A-QRSTA
2SD2144S-TP-UVW

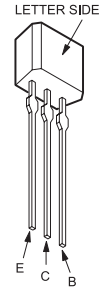

2SC3840K

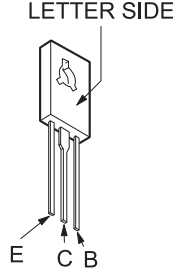

2SA1837
2SC4159-E

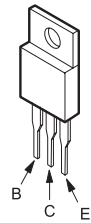

2SA1091O-TPE2
2SA993AS-QRT

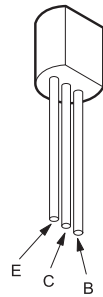

2SK2845-LB102

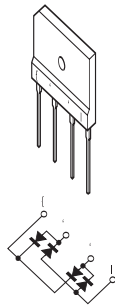

TF541M

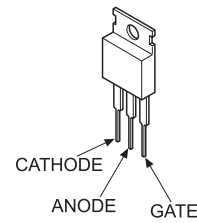

IRF614



ERA38-06TP1
ERA82-004TP5
1SS133T-77
D1N2OR-TA
D1NS4-TA
MTZJ-T-7712C
MTZJ-T-77-33B
MTZJ-T-77-39

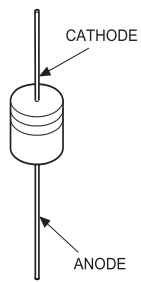

RU-1P
ERC06-15S
MTZJ-T-77-5.1C
MTZJ-T-775.6C
MTZJ-T-77-7.5A
MTZJ-T-77-10B
MTZJ-T-7730D
RD10ES-T1B
RGP10-GPKG3
RGP02-17PKG23

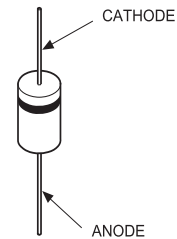

ERB44-06TP1
1SS83TD
D1NL2OU-TA
EL1Z-V1
ERA22-08TP3
GP08DPKG23
RGP10GPKG23
RU4AM-T3

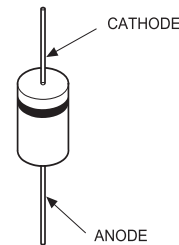

RD9.1EW-T1

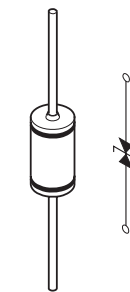

MA111-TX

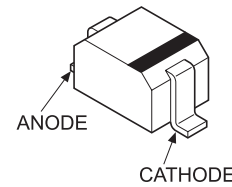

D2SB60A-F04

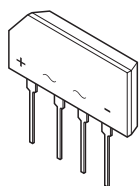

DAP202K-T-146

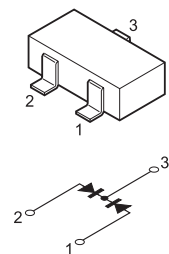

D4SB60L-F

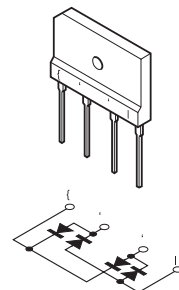

D5LC20U

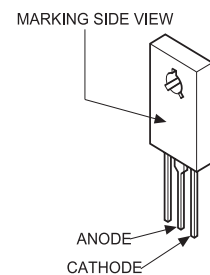

SECTION 7
EXPLODED VIEW

- Items with no part number and no description are not stocked because they are seldom required for routine service.
- The component parts of an assembly are indicated by the reference numbers in the remarks column.
- Items marked * are not stocked since they are seldom required for routine service. Some delay should be anticipated when ordering these items.

Note:

The components identified by shading and mark are critical for safety. Replace only with part number specified.

Note:

Les composants identifiés par un trame et une marque sont critiques pour la sécurité. Ne les remplacer que par une pièce portant le numéro spécifié.

7-1. CHASSIS (KV-27FV16/29FV16/29FV16 ONLY)

- 7-685-648-79 SCREW +BVTP 3X12
- 7-685-663-79 SCREW +BVTP 4X16

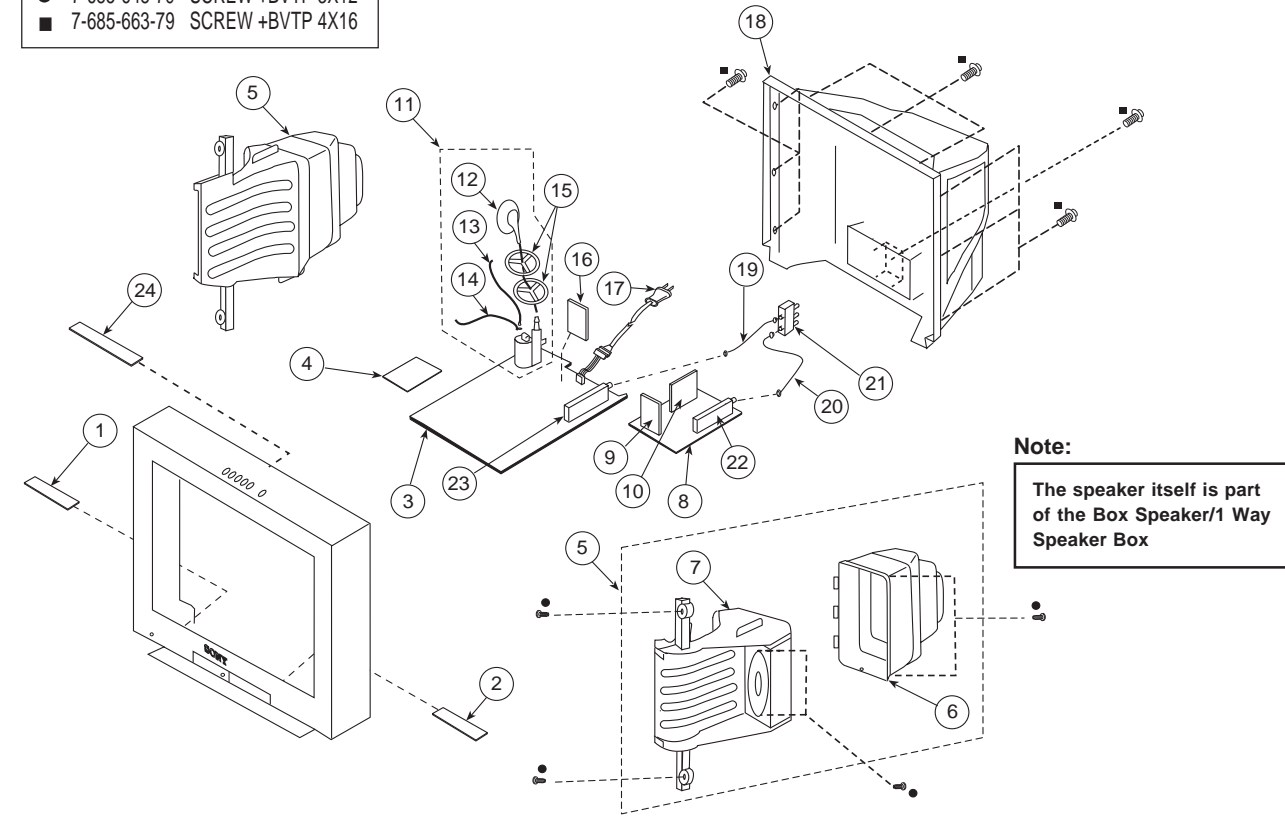

Note:

The speaker itself is part of the Box Speaker/1 Way Speaker Box

REF. NO.	PART NO.	DESCRIPTION	REMARK	REF. NO.	PART NO.	DESCRIPTION	REMARK
1	*	A-1372-825-A	HA MOUNTED PC BOARD	11	1-453-310-11	FBT ASSY NX-4521//X4J4	12-14
2	*	A-1372-826-A	HB (VAR) MOUNTED PC BOARD	12	1-251-374-13	HV CAP ASSY	
3	*	A-1299-244-A	A COMPLETE PC BOARD (KV-29FV16/29FV16C ONLY)	13	1-900-800-82	FOCUS LEAD	
3	*	A-1299-243-A	A COMPLETE PC BOARD (KV-27FV16 ONLY)	14	1-900-803-22	G2 LEAD	
		The high-voltage leads associated with the FBT on this board are not included and must be ordered separately. (See 12-14)		15	3-704-372-71	HOLDER, HV CABLE	
4	*	A-1343-875-A	D (VAR) MOUNTED PC BOARD	16	*	A-1380-633-A	K (VAR) MOUNTED PC BOARD
5	*	1-529-336-11	BOX, 1 WAY SPEAKER (10CM) (KV-29FV16/29FV26C ONLY)	17	1-792-874-11	CORD, AC POWER(WITH CONNECTOR) (KV-27FV16 ONLY)	
5	*	1-529-358-11	SPEAKER, BOX (5,10CM) (KV-27FV16 ONLY)	17	1-790-316-21	CORD, AC POWER(WITH CONNECTOR) (KV-29FV16 ONLY)	
6	*	4-068-987-01	COVER, SPEAKER	17	1-769-796-31	CORD, POWER (WITH CONNECTOR) (KV-29FV16C ONLY)	
7		4-068-988-01	BAFFLE, SPEAKER	18	4-076-875-01	COVER, REAR	
8	*	A-1304-202-A	MA (VAR) MOUNTED PC BOARD	19	*	1-557-056-31	CABLE, P-P
9	*	A-1190-367-A	P MOUNTED PC BOARD	20	*	1-783-800-11	CABLE, PIN
10	*	A-1131-593-A	BC MOUNTED PC BOARD	21	8-598-414-20	CHANGER, ANTENNA AS-2F	
				22	8-598-501-00	TUNER, FSS BTF-FA402	
				23	8-598-431-30	TUNER, FSS BTF-WA411	
				24	*	A-1372-817-A	HX MOUNTED PC BOARD

Note:

The components identified by shading and mark ▲ are critical for safety. Replace only with part number specified.

Note:

Les composants identifiés par un trame et une marque ▲ sont critiques pour la sécurité. Ne les remplacer que par une pièce portant le numéro spécifié.

7-2. PICTURE TUBE (KV-27FV16/29FV16/29FV16 ONLY)

▲ 4-046-765-12 SCREW (7) TAPPING

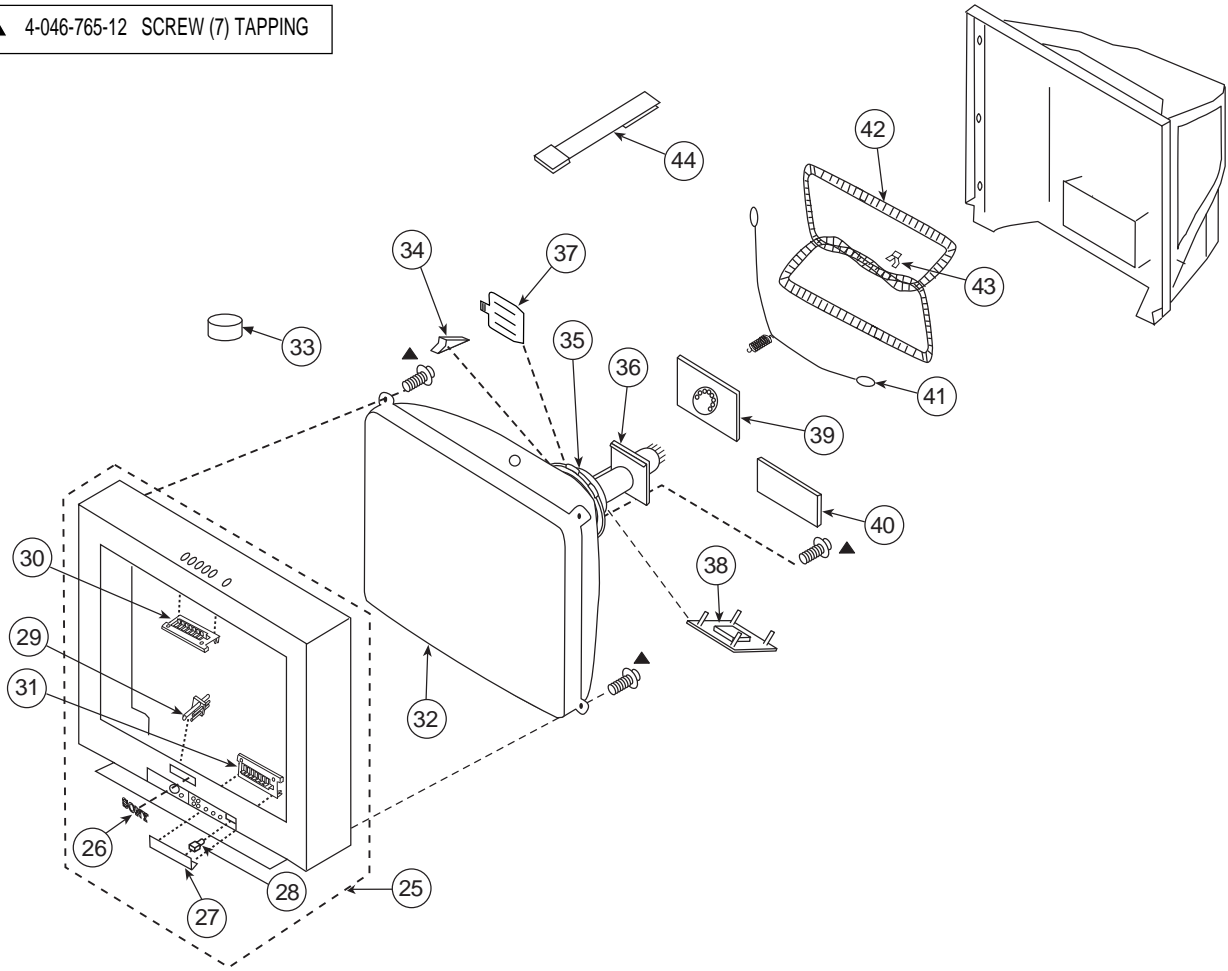

REF.NO.	PART.NO.	DESCRIPTION	REMARK	REF.NO.	PART.NO.	DESCRIPTION	REMARK
25	X-4037-842-1	BEZNET ASSY	26-28	37	2-163-920-01	PLATE, TLH CORRECTION	
26	3-704-179-31	EMBLEM (NO.9), SONY		38	1-452-896-11	COIL, NA ROTATION (RT200)	
27	4-068-985-04	DOOR		39	* A-1332-063-A	CA (VAR) MOUNTED PC BOARD	
28	3-703-574-00	RETAINER, DOOR		40	* A-1342-550-A	VA (VAR) MOUNTED PC BOARD	
29	4-068-986-11	GUIDE, LED		41	4-036-329-01	SPRING (B), TENSION	
30	4-068-982-02	MULTI-BUTTON (TOP)		42	▲ 1-419-156-11	COIL, DEGAUSSING (KV-27FV16 ONLY)	
31	4-068-984-01	MULTI-BUTTON (BOTTOM)		42	▲ 1-419-523-21	COIL, DEGAUSSING (KV-29FV16/29FV16C ONLY)	
32	▲ 8-735-041-05	CRT 29RSN (KV-27FV16/29FV16 ONLY)		43	* 4-062-970-01	CLIP (29RSN), DGC	
32	▲ 8-735-052-05	CRT 29RSN(FOR EQUATORIAL AREA) (KV-29FV16C ONLY)		44	4-062-047-01	PIECE A(110), CONV CORRECT	
33	1-452-032-00	MAGNET,DISC					
34	4-053-005-01	SPACER, DY					
35	▲ 8-451-494-31	DY Y29RSA-S					
36	▲ 8-453-011-11	NA299-M					

Note:

The components identified by shading and mark \triangle are critical for safety. Replace only with part number specified.

Note:

Les composants identifiés par un trame et une marque \triangle sont critiques pour la sécurité. Ne les remplacer que par une pièce portant le numéro spécifié.

7-3. CHASSIS (KV-32FS12/32FS16 ONLY)

- 7-685-648-79 SCREW +BVTP 3X12
- 7-685-663-79 SCREW +BVTP 4X16

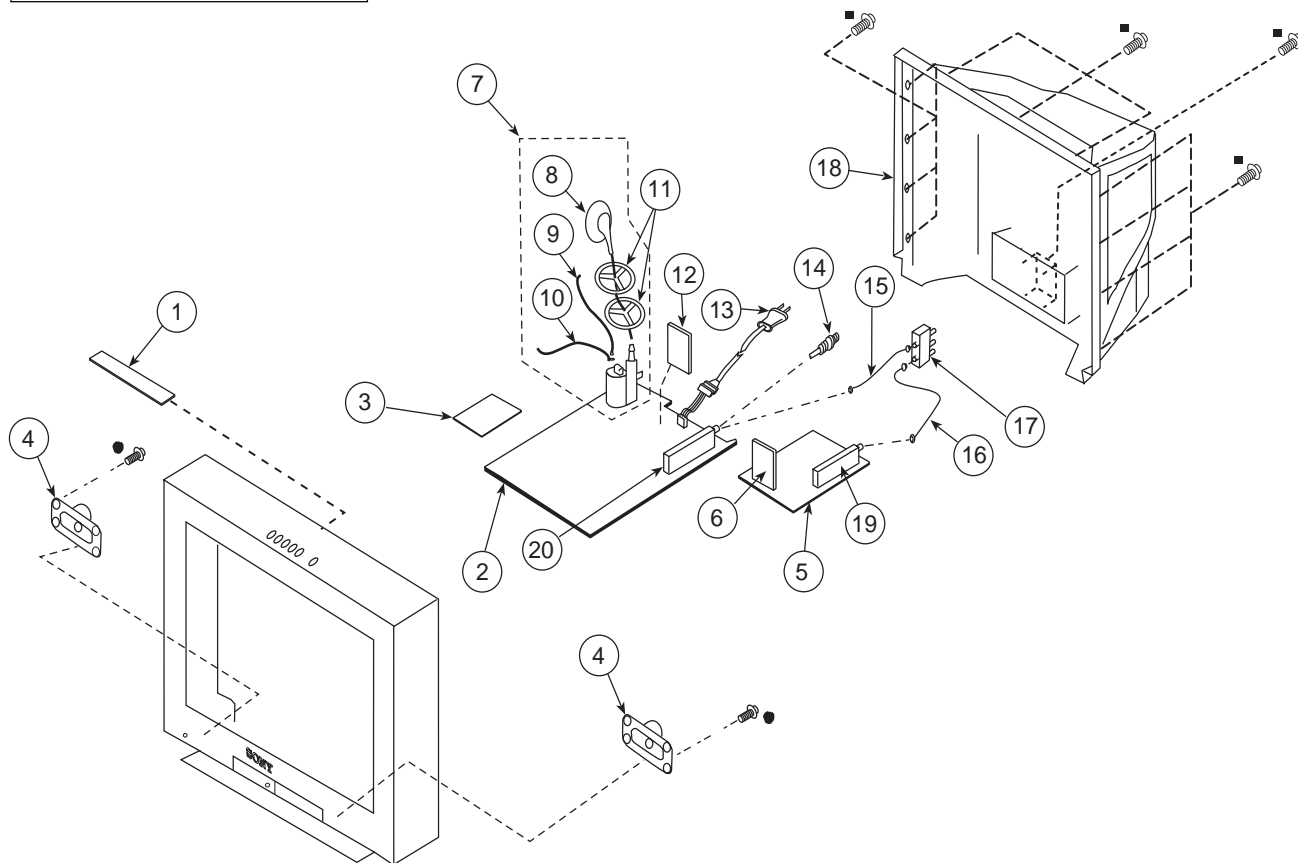

REF. NO.	PART NO.	DESCRIPTION	REMARK	REF. NO.	PART NO.	DESCRIPTION	REMARK
1	* A-1372-817-A	HX MOUNTED PC BOARD		11	3-704-372-71	HOLDER, HV CABLE	
2	* A-1299-218-A	A COMPLETE PC BOARD	The high-voltage leads associated with the FBT on this board are not included and must be ordered separately. (See 8-10)	12	* A-1380-632-A	K (VAR) MOUNTED PC BOARD	
3	* A-1343-874-A	D (VAR) MOUNTED PC BOARD		13	\triangle 1-792-874-11	CORD, AC POWER(WITH CONNECTOR)	
4	1-529-498-11	SPEAKER (13.1X6.2CM)		14	1-766-374-11	PLUG, F-PIN (KV-32FS12 ONLY)	
5	* A-1304-203-A	MA (VAR) MOUNTED PC BOARD (KV-32FS12 ONLY)		15	* 1-557-056-31	CABLE, P-P (KV-32FS16 ONLY)	
5	* A-1304-196-A	MA (VAR) MOUNTED PC BOARD (KV-32FS16 ONLY)		16	* 1-783-800-11	CABLE, PIN (KV-32FS16 ONLY)	
6	* A-1190-367-A	P MOUNTED PC BOARD (KV-32FS16 ONLY)		17	8-598-414-20	CHANGER, ANTENNA AS-2F (KV-32FS16 ONLY)	
7	\triangle 1-453-338-11	FBT ASSY NX-4600//X4J4	8-10	18	4-075-654-11	COVER, REAR	
8	1-251-374-13	HV CAP ASSY		19	\triangle 8-598-501-00	TUNER, FSS BTF-FA402 (KV-32FS16 ONLY)	
9	1-900-800-82	FOCUS LEAD		20	\triangle 8-598-431-30	TUNER, FSS BTF-WA411	
10	1-900-803-50	G2 LEAD					

Note:

The components identified by shading and mark  are critical for safety. Replace only with part number specified.





Note:

Les composants identifiés par un triangle et une marque  sont critiques pour la sécurité. Ne les remplacer que par une pièce portant le numéro spécifié.

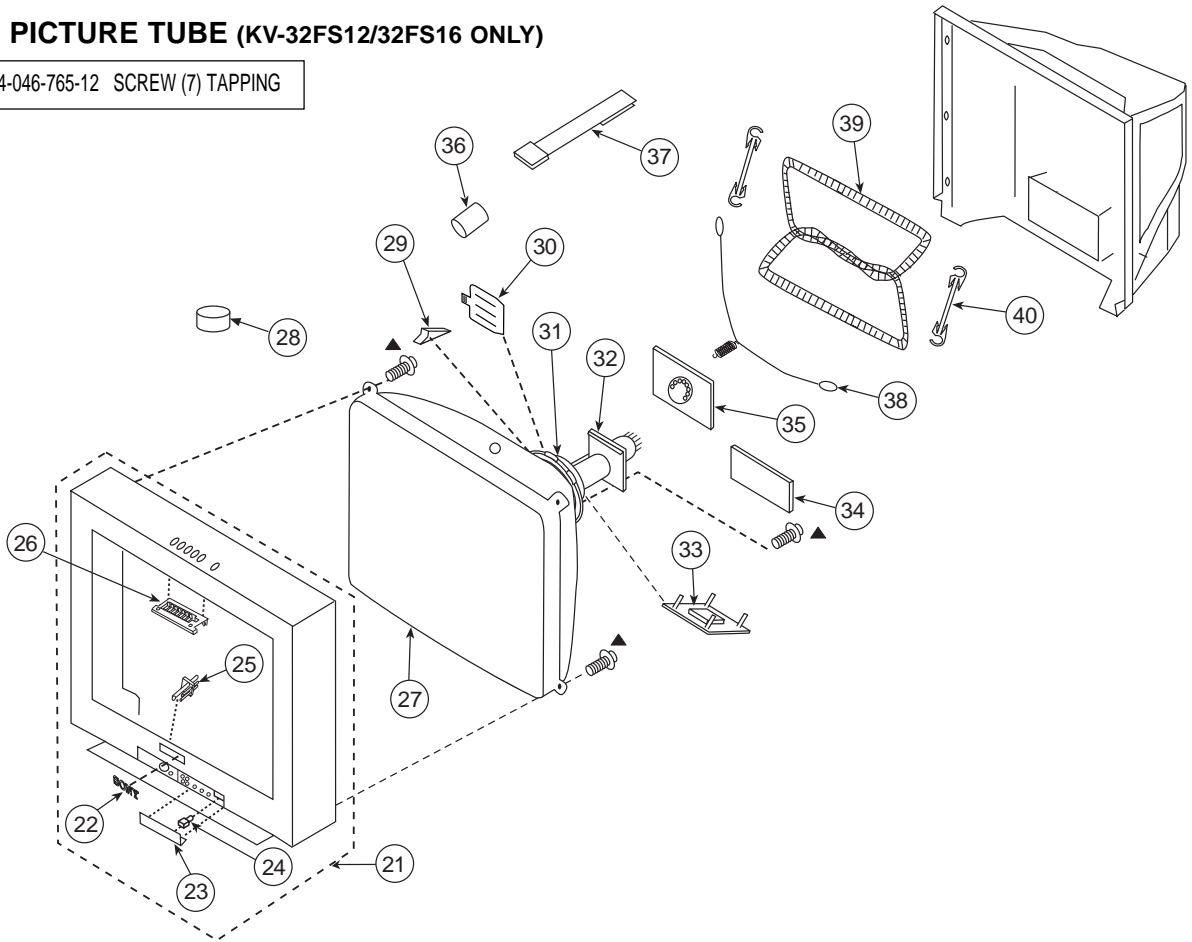
7-4. PICTURE TUBE (KV-32FS12/32FS16 ONLY)

▲ 4-046-765-12 SCREW (7) TAPPING



REF.NO.	PART NO.	DESCRIPTION	REMARK
21	X-4037-664-1	BEZNET ASSY	22-25
22	3-704-179-31	EMBLEM (NO.9), SONY	
23	4-075-658-01	DOOR	
24	4-047-464-01	CATCHER, PUSH	
25	4-075-657-01	GUIDE, LED	
26	4-068-982-02	MULTI-BUTTON (TOP)	
27	 8-735-066-05	CRT 34RSN(SDP)	
28	1-452-032-00	MAGNET,DISC	
29	4-053-005-01	SPACER, DY	
30	2-163-920-01	PLATE, TLH CORRECTION	
31	 8-451-499-21	DY Y34RSA-X	
32	 8-453-007-41	NA324-M4	
33	1-452-896-11	COIL, NA ROTATION (RT200)	
34	* A-1342-549-A	VA (VAR) MOUNTED PC BOARD	
35	* A-1332-061-A	CA (VAR) MOUNTED PC BOARD	
36	1-500-586-11	FILTER, CLAMP (FERRITE CORE)	
37	4-062-047-01	PIECE A(110), CONV CORRECT	
38	4-036-329-01	SPRING (B), TENSION	
39	 1-416-827-21	COIL, DEGAUSSING	
40	4-065-895-03	HOLDER, DGC	

SECTION 8 ELECTRICAL PARTS LIST

A

Note:

The components identified by shading and mark \triangle are critical for safety. Replace only with part number specified.

The components identified by \triangle in this manual have been carefully factory-selected for each set in order to satisfy regulations regarding X-ray radiation. Should replacement be required, replace only with the value originally used.

Note:

Les composants identifiés par un trame et une marque \triangle sont critiques pour la sécurité. Ne les remplacer que par une pièce portant le numéro spécifié.

- Items marked * are not stocked since they are seldom required for routine service. Some delay should be anticipated when ordering these items.
- All variable and adjustable resistors have characteristic curve B, unless otherwise noted.

RESISTORS

- All resistors are in ohms
- F : nonflammable

When indicating parts by reference number, please include the board name.

REF. NO.	PART NO.	DESCRIPTION	REMARK	REF. NO.	PART NO.	DESCRIPTION	REMARK				
<div style="border: 1px solid black; padding: 5px; display: inline-block; font-size: 2em; font-weight: bold;">A</div>				C215	1-164-346-11	CERAMIC CHIP	1 μ F 16V				
				C216	1-126-963-11	ELECT	4.7 μ F 20% 50V				
				C219	1-126-964-11	ELECT	10 μ F 20% 50V				
				C401	1-126-968-11	ELECT	100 μ F 20% 50V				
				C402	1-126-972-11	ELECT	1000 μ F 20% 50V (KV-27FV16/29FV16/29FV16C ONLY)				
				C402	1-126-943-11	ELECT	2200 μ F 20% 25V (KV-32FS12/32FS16 ONLY)				
				C403	1-126-957-11	ELECT	0.22 μ F 20% 50V				
				C420	1-164-222-11	CERAMIC CHIP	0.22 μ F 25V				
				C421	1-164-222-11	CERAMIC CHIP	0.22 μ F 25V				
				C435	1-164-222-11	CERAMIC CHIP	0.22 μ F 25V (KV-27FV16/29FV16/29FV16C ONLY)				
				C441	1-164-346-11	CERAMIC CHIP	1 μ F 16V				
				C442	1-126-963-11	ELECT	4.7 μ F 20% 50V				
				C501	1-102-114-00	CERAMIC	470PF 10% 50V				
				C502	1-106-383-00	MYLAR	0.047 μ F 10% 200V				
				C503	1-102-228-00	CERAMIC	470PF 10% 500V				
				C504	1-102-228-00	CERAMIC	470PF 10% 500V				
				C505 \triangle	1-162-116-00	CERAMIC	680PF 10% 2KV				
				C506	1-162-318-11	CERAMIC	0.001 μ F 10% 500V				
				C507 \triangle	1-117-717-11	FILM	17000PF 3% 1.2KV (KV-27FV16/29FV16/29FV16C ONLY)				
				C507 \triangle	1-117-652-11	FILM	22000PF 3% 1.2KV (KV-32FS12/32FS16 ONLY)				
				C508 \triangle	1-137-150-11	MYLAR	0.01 μ F 10% 100V				
				C509 \triangle	1-162-116-00	CERAMIC	680PF 10% 2KV				
				C510	1-107-649-11	ELECT	2.2 μ F 20% 250V				
				C511 \triangle	1-115-522-11	FILM	1 μ F 5% 250V (KV-27FV16/29FV16/29FV16C ONLY)				
				C511 \triangle	1-115-521-11	FILM	0.82 μ F 5% 250V (KV-32FS12/32FS16 ONLY)				
				C512 \triangle	1-106-387-00	MYLAR	0.068 μ F 10% 200V				
				C513	1-104-987-11	MYLAR	0.001 μ F 10% 100V				
				C514	1-109-844-11	FILM	0.68 μ F 5% 250V (KV-27FV16/29FV16/29FV16C ONLY)				
				C514	1-115-521-11	FILM	0.82 μ F 5% 250V (KV-32FS12/32FS16 ONLY)				
				C515 \triangle	1-162-116-00	CERAMIC	680PF 10% 2KV				
								C100	1-216-295-91	SHORT	
C101	1-216-295-91	SHORT									
C102	1-126-933-11	ELECT	100 μ F 20% 16V								
C104	1-126-941-11	ELECT	470 μ F 20% 25V								
C105	1-104-664-11	ELECT	47 μ F 20% 25V								
C204	1-163-017-00	CERAMIC CHIP	0.0047 μ F 10% 50V								
C205	1-126-963-11	ELECT	4.7 μ F 20% 50V								
C210	1-126-963-11	ELECT	4.7 μ F 20% 50V								
C211	1-126-935-11	ELECT	470 μ F 20% 16V (KV-27FV16/29FV16/29FV16C ONLY)								
C212	1-126-963-11	ELECT	4.7 μ F 20% 50V (KV-27FV16/29FV16/29FV16C ONLY)								
C213	1-126-963-11	ELECT	4.7 μ F 20% 50V (KV-27FV16/29FV16/29FV16C ONLY)								
C214	1-164-346-11	CERAMIC CHIP	1 μ F 16V								
								CAPACITOR			
								C100	1-216-295-91	SHORT	
				C101	1-216-295-91	SHORT					
				C102	1-126-933-11	ELECT	100 μ F 20% 16V				
				C104	1-126-941-11	ELECT	470 μ F 20% 25V				
				C105	1-104-664-11	ELECT	47 μ F 20% 25V				
				C204	1-163-017-00	CERAMIC CHIP	0.0047 μ F 10% 50V				
				C205	1-126-963-11	ELECT	4.7 μ F 20% 50V				
				C210	1-126-963-11	ELECT	4.7 μ F 20% 50V				
				C211	1-126-935-11	ELECT	470 μ F 20% 16V (KV-27FV16/29FV16/29FV16C ONLY)				

Note:

The components identified by shading and mark Δ are critical for safety. Replace only with part number specified.

Note:

Les composants identifiés par un trame et une marque Δ sont critiques pour la sécurité. Ne les remplacer que par une pièce portant le numéro spécifié.

A

REF.NO.	PARTNO.	DESCRIPTION	REMARK	REF.NO.	PARTNO.	DESCRIPTION	REMARK
C517	1-107-846-11	FILM (KV-32FS12/32FS16 ONLY)	0.1 μ F 5% 250V	C607	Δ 1-136-311-11	MYLAR (KV-29FV16/29FV16C ONLY)	0.47 μ F 20% 300V
C520	Δ 1-129-722-00	FILM (KV-27FV16/29FV16/29FV16C ONLY)	0.047 μ F 5% 630V	C607	Δ 1-136-311-11	MYLAR (ALL EXCEPT 29FV16/29FV16C)	0.47 μ F 20% 125V
C520	Δ 1-130-118-91	FILM (KV-32FS12/32FS16 ONLY)	0.051 μ F 5% 400V	C609	1-126-968-11	ELECT	100 μ F 20% 50V
C521	1-164-646-11	CERAMIC	2200PF 10% 500V	C610	1-126-964-11	ELECT	10 μ F 20% 50V
C523	1-126-941-11	ELECT	470 μ F 20% 25V	C611	Δ 1-127-795-51	CERAMIC	3300PF 20% 250V
C524	1-102-244-00	CERAMIC	220PF 10% 500V	C612	Δ 1-113-611-11	ELECT(BLOCK) (ALL EXCEPT KV-29FV16/29FV16C)	820 μ F 20% 250V
C525	1-107-612-11	CERAMIC	100PF 5% 500V	C613	1-126-964-11	ELECT	10 μ F 20% 50V
C526	1-126-960-11	ELECT	1 μ F 20% 50V	C614	1-130-495-00	MYLAR	0.1 μ F 5% 50V
C527	1-126-965-11	ELECT	22 μ F 20% 50V	C615	1-130-202-00	FILM (KV-29FV16/29FV16C ONLY)	0.022 μ F 10% 400V
C528	1-164-161-11	CERAMIC CHIP	0.0022 μ F 10% 50V	C616	1-107-824-11	CERAMIC (KV-29FV16/29FV16C ONLY)	220PF 5% 1KV
C529	1-164-161-11	CERAMIC CHIP	0.0022 μ F 10% 50V	C617	1-125-893-11	FILM	680PF 3% 1.5KV
C530	1-164-161-11	CERAMIC CHIP (KV-27FV16/29FV16/29FV16C ONLY)	0.0022 μ F 10% 50V	C618	1-164-081-11	CERAMIC	470PF 10% 50V
C530	1-163-009-11	CERAMIC CHIP (KV-32FS12/32FS16 ONLY)	0.001 μ F 10% 50V	C619	1-136-356-11	MYLAR	470PF 5% 50V
C531	1-106-387-00	MYLAR	0.068 μ F 10% 200V	C620	1-104-665-11	ELECT	100 μ F 20% 25V
C533	1-126-941-11	ELECT	470 μ F 20% 25V	C621	1-125-772-91	CERAMIC	1500PF 10% 2KV
C534	Δ 1-126-964-11	ELECT	10 μ F 20% 50V	C622	1-164-625-11	CERAMIC	680PF 10% 500V
C535	1-126-959-11	ELECT	0.47 μ F 20% 50V	C623	1-164-625-11	CERAMIC	680PF 10% 500V
C536	1-102-228-00	CERAMIC	470PF 10% 500V	C624	1-131-867-51	ELECT	100 μ F 160V
C537	Δ 1-126-965-11	ELECT	22 μ F 20% 50V	C625	1-135-572-51	ELECT (KV-27FV16/29FV16/29FV16C ONLY)	1000 μ F 20% 50V
C539	1-107-662-11	ELECT	22 μ F 20% 250V	C625	1-135-412-51	ELECT (KV-32FS12/32FS16 ONLY)	1000 μ F 20% 25V
C540	1-107-645-11	ELECT	22 μ F 20% 160V	C626	1-135-573-51	ELECT	15000 μ F 20% 25V
C541	1-126-969-11	ELECT	220 μ F 20% 50V	C627	1-136-189-00	MYLAR	0.1 μ F 10% 250V
C542	1-126-967-11	ELECT	47 μ F 20% 50V	C628	1-104-665-11	ELECT	100 μ F 20% 25V
C543	1-136-169-00	MYLAR	0.22 μ F 5% 50V	C630	1-113-924-11	CERAMIC (ALL EXCEPT KV-29FV16/29FV16C)	0.0047 μ F 20% 250V
C546	Δ 1-126-965-11	ELECT	22 μ F 20% 50V	C631	1-113-924-11	CERAMIC (ALL EXCEPT KV-29FV16/29FV16C)	0.0047 μ F 20% 250V
C547	Δ 1-163-031-11	CERAMIC CHIP	0.01 μ F 50V	C634	1-137-605-11	MYLAR	0.01 μ F 10% 250V
C548	1-104-710-11	ELECT (KV-27FV16/29FV16/29FV16C ONLY)	22 μ F 160V	C635	1-163-009-11	CERAMIC CHIP	0.001 μ F 10% 50V
C548	1-107-995-11	ELECT (KV-32FS12/32FS16 ONLY)	100 μ F 160V	C636	1-126-970-11	ELECT	330 μ F 20% 50V
C549	1-126-934-11	ELECT	220 μ F 20% 16V	C637	1-163-009-11	CERAMIC CHIP	0.001 μ F 10% 50V
C550	1-107-846-11	FILM (KV-27FV16/29FV16/29FV16C ONLY)	0.1 μ F 5% 250V	C638	1-163-005-11	CERAMIC CHIP	470PF 10% 50V
C550	1-117-667-11	FILM (KV-32FS12/32FS16 ONLY)	0.47 μ F 5% 250V	C639	1-126-965-11	ELECT	22 μ F 20% 50V
C551	Δ 1-137-417-11	MYLAR	0.0047 μ F 10% 200V	C641	1-107-679-91	ELECT	10 μ F 20% 450V
C553	1-107-662-11	ELECT	22 μ F 20% 250V	C643	1-104-760-11	CERAMIC CHIP	0.047 μ F 10% 50V
C554	1-102-110-00	CERAMIC	220PF 10% 50V	C644	1-161-964-91	CERAMIC	0.0047 μ F 250V
C555	Δ 1-117-629-11	FILM (KV-27FV16/29FV16/29FV16C ONLY)	2700PF 3% 1.2KV	C645	1-161-964-91	CERAMIC	0.0047 μ F 250V
C555	1-117-635-11	FILM (KV-32FS12/32FS16 ONLY)	4700PF 3% 1.2KV	C646	1-161-964-91	CERAMIC	0.0047 μ F 250V
C601	1-164-004-11	CERAMIC CHIP	0.1 μ F 10% 25V	C647	1-161-964-91	CERAMIC	0.0047 μ F 250V
C602	1-126-967-11	ELECT	47 μ F 20% 50V	C648	1-136-346-21	MYLAR (KV-29FV16/29FV16C ONLY)	0.22 μ F 20% 300V
C604	1-164-182-11	CERAMIC CHIP	0.0033 μ F 10% 50V	C648	1-136-346-21	MYLAR (ALL EXCEPT 29FV16/29FV16C)	0.22 μ F 20% 125V
C606	Δ 1-127-795-51	CERAMIC	3300PF 20% 250V				

A

Note:

The components identified by shading and mark \triangle are critical for safety. Replace only with part number specified.

Note:

Les composants identifiés par un trame et une marque \triangle sont critiques pour la sécurité. Ne les remplacer que par une pièce portant le numéro spécifié.

REF.NO.	PART NO.	DESCRIPTION	REMARK	REF.NO.	PART NO.	DESCRIPTION	REMARK
C649	1-161-830-00	CERAMIC (KV-27FV16/29FV16/29FV16C ONLY)	0.0047 μ F 20% 500V	D203	8-719-108-12	DIODE RD9.1EW-T1 (KV-27FV16/29FV16/29FV16C ONLY)	
C652	1-130-471-00	MYLAR	0.001 μ F 5% 50V	D204	8-719-982-22	DIODE MTZJ-T-77-30D	
C654	1-107-636-11	ELECT	10 μ F 20% 160V	D205	8-719-108-12	DIODE RD9.1EW-T1	
C655	\triangle 1-136-311-11	MYLAR	0.47 μ F 20% 125V	D206	8-719-108-12	DIODE RD9.1EW-T1	
C657	1-104-664-11	ELECT	47 μ F 20% 25V	D208	8-719-110-17	DIODE MTZJ-T-77-10B	
C658	1-135-572-51	ELECT (KV-27FV16/29FV16/29FV16C ONLY)	1000 μ F 20% 50V	D209	8-719-977-22	DIODE UDZ-TE-17-9.1B	
C658	1-135-412-51	ELECT (KV-32FS12/32FS16 ONLY)	1000 μ F 20% 25V	D210	8-719-110-17	DIODE MTZJ-T-77-10B	
C659	1-135-573-51	ELECT	15000 μ F 20% 25V	D211	8-719-108-12	DIODE RD9.1EW-T1	
C660	\triangle 1-128-714-11	ELECT (KV-29FV16/29FV16C ONLY)	330 μ F 20% 400V	D212	8-719-110-17	DIODE MTZJ-T-77-10B (KV-32FS12/32FS16 ONLY)	
C661	\triangle 1-128-714-11	ELECT (KV-29FV16/29FV16C ONLY)	330 μ F 20% 400V	D213	8-719-110-17	DIODE MTZJ-T-77-10B (KV-32FS12/32FS16 ONLY)	
C699	1-117-703-11	CERAMIC (ALL EXCEPT KV-29FV16/29FV16C)	0.0047 μ F 20% 250V	D214	8-719-108-12	DIODE RD9.1EW-T1	
C2001	1-104-664-11	ELECT	47 μ F 20% 25V	D215	8-719-108-12	DIODE RD9.1EW-T1	
				D216	1-216-025-91	RES-CHIP 100 5% 1/10W (KV-27FV16/29FV16/29FV16C ONLY)	
				D230	8-719-108-12	DIODE RD9.1EW-T1	
				D231	8-719-108-12	DIODE RD9.1EW-T1	
				D232	8-719-108-12	DIODE RD9.1EW-T1	
				D233	8-719-108-12	DIODE RD9.1EW-T1	
				D234	8-719-977-22	DIODE UDZ-TE-17-9.1B (KV-27FV16/29FV16/29FV16C ONLY)	
				D235	8-719-977-22	DIODE UDZ-TE-17-9.1B (KV-27FV16/29FV16/29FV16C ONLY)	
				D236	8-719-977-22	DIODE UDZ-TE-17-9.1B (KV-27FV16/29FV16/29FV16C ONLY)	
				D401	8-719-110-17	DIODE MTZJ-T-77-10B	
				D501	8-719-945-80	DIODE ERC06-15S	
				D502	8-719-908-03	DIODE GP08DPKG23	
				D503	8-719-908-03	DIODE GP08DPKG23	
				D504	8-719-945-80	DIODE ERC06-15S	
				D505	8-719-312-10	DIODE RU4AM-T3	
				D506	8-719-302-43	DIODE RGP10GPKG3	
				D507	8-719-991-33	DIODE 1SS133T-77	
				D508	8-719-991-33	DIODE 1SS133T-77	
				D509	8-719-109-89	DIODE MTZJ-T-77-5.6C	
				D510	8-719-908-03	DIODE GP08DPKG23	
				D511	8-719-302-43	DIODE RGP10GPKG23	
				D512	8-719-073-01	DIODE MA111-TX	
				D513	8-719-979-85	DIODE RGP15GPKG23	
				D514	8-719-979-85	DIODE RGP15GPKG23	
				D515	8-719-073-01	DIODE MA111-TX	
				D516	\triangle 8-719-991-33	DIODE 1SS133T-77	
				D517	\triangle 8-719-991-33	DIODE 1SS133T-77	
				D518	\triangle 8-719-921-63	DIODE MTZJ-T-77-7.5X	
				D519	\triangle 8-719-302-43	DIODE EL1Z-V1	
				D520	\triangle 8-719-073-01	DIODE MA111-TX	
D201	8-719-108-12	DIODE RD9.1EW-T1 (KV-27FV16/29FV16/29FV16C ONLY)		D521	8-719-991-33	DIODE 1SS133T-77	
D202	8-719-108-12	DIODE RD9.1EW-T1 (KV-27FV16/29FV16/29FV16C ONLY)		D522	8-719-991-33	DIODE 1SS133T-77	

CONNECTOR**DIODE**

Note:

The components identified by shading and mark \triangle are critical for safety. Replace only with part number specified.

Note:

Les composants identifiés par un trame et une marque \triangle sont critiques pour la sécurité. Ne les remplacer que par une pièce portant le numéro spécifié.

A

REF.NO.	PART NO.	DESCRIPTION	REMARK	REF.NO.	PART NO.	DESCRIPTION	REMARK
D601	8-719-991-33	DIODE 1SS133T-77		FB603	1-412-911-11	FERRITE	0 μ H
D602	8-719-991-33	DIODE 1SS133T-77		FB604	1-412-911-11	FERRITE	0 μ H
D603	8-719-982-26	DIODE MTZJ-T-77-33B		FB605	1-412-911-11	FERRITE	0 μ H
D604	8-719-028-72	DIODE RGP02-17PKG23		FB606	1-412-911-11	FERRITE	0 μ H
D605	\triangle 8-719-510-53	DIODE D4SB60L-F		FB609	1-412-911-11	FERRITE	0 μ H
D606	\triangle 8-719-108-18	DIODE TF541M		FB610	1-412-911-11	FERRITE	0 μ H
D607	8-719-991-33	DIODE 1SS133T-77		IC			
D608	8-719-110-53	DIODE MTZJ-T-77-20B		IC401	8-759-490-17	IC TDA7057AQ/N2 (KV-32FS12/32FS16 ONLY)	
D609	8-719-311-31	DIODE RU-1P (KV-29FV16/29FV16C ONLY)		IC402	8-759-573-40	IC TDA8580Q/N1 (KV-27FV16/29FV16/29FV16C ONLY)	
D610	8-719-510-02	DIODE D1NS4-TA		IC501	\triangle 8-759-700-07	IC NJM2903M-TE2	
D611	8-719-063-70	DIODE D1NL20U-TA		IC502	8-759-980-58	IC TDA8172 (KV-27FV16/29FV16/29FV16C ONLY)	
D612	8-719-110-17	DIODE MTZJ-T-77-10B		IC502	8-759-192-71	IC STV9379 (KV-32FS12/32FS16 ONLY)	
D613	8-719-063-70	DIODE D1NL20U-TA		IC601	\triangle 8-749-014-48	IC STR-F6656 (KV-29FV16/29FV16C ONLY)	
D614	8-719-063-70	DIODE D1NL20U-TA		IC601	\triangle 8-749-015-61	IC STR-F6626 (ALL EXCEPT KV-29FV16/29FV16C)	
D615	8-719-312-10	DIODE RU4AM-T3		IC602	\triangle 8-749-016-47	IC EA135-F12	
D616	8-719-510-37	DIODE D5LC20U		IC603	8-759-198-03	IC PQ09RF21	
D617	8-719-110-31	DIODE MTZJ-T-77-12C		IC604	8-759-701-75	IC NJM7805FA	
D618	8-719-991-33	DIODE 1SS133T-77		IC2001	8-742-212-20	HYB IC SBX3081-71 (KV-32FS12/32FS16 ONLY)	
D619	8-719-110-17	DIODE MTZJ-T-77-10B		JACK			
D620	8-719-510-37	DIODE D5LC20U		J201	1-794-119-11	TERMINAL BLOCK, S 4P	
D622	8-719-077-76	DIODE D2SB60A-F04		J202	1-794-267-11	JACK, PIN 3P (KV-32FS12/32FS16 ONLY)	
D623	8-719-948-45	DIODE ERA22-08TP3		J203	1-794-118-11	JACK BLOCK, PIN 3P	
D624	8-719-991-33	DIODE 1SS133T-77		J204	1-794-118-11	JACK BLOCK, PIN 3P (KV-27FV16/29FV16/29FV16C ONLY)	
D625	8-719-991-33	DIODE 1SS133T-77		J205	1-794-116-11	JACK BLOCK, PIN 2P	
D626	8-719-063-70	DIODE D1NL20U-TA		J206	1-794-117-11	JACK BLOCK, PIN 3P	
D627	8-719-110-03	DIODE MTZJ-T-77-7.5A		J402	1-794-116-11	JACK BLOCK, PIN 2P	
D628	8-719-510-48	DIODE D1N20R-TA		CHIP CONDUCTOR			
D2001	8-719-070-80	DIODE LNK0120022G (KV-32FS12/32FS16 ONLY)		JR001	1-216-295-91	SHORT	
D2002	8-719-110-17	DIODE MTZJ-T-77-10B		JR002	1-216-295-91	SHORT	
D2003	8-719-108-12	DIODE RD9.1EW-T1 (KV-32FS12/32FS16 ONLY)		JR402	1-216-295-91	SHORT	
D2004	8-719-921-44	DIODE MTZJ-T-77-5.1C		JR403	1-216-295-91	SHORT	
D2005	8-719-921-44	DIODE MTZJ-T-77-5.1C		JR405	1-216-295-91	SHORT (KV-27FV16/29FV16/29FV16C ONLY)	
FUSE							
F601	\triangle 1-532-506-51	FUSE 6.3A/250V (KV-29FV16/29FV16C ONLY)		JR411	1-216-295-91	SHORT	
F601	\triangle 1-576-193-11	FUSE 6.3A/125V (ALL EXCEPT KV-29FV16/29FV16C)		JR471	1-216-295-91	SHORT (KV-27FV16/29FV16/29FV16C ONLY)	
FERRITE BEAD							
FB501	1-410-397-21	FERRITE	1.1 μ H	JR502	1-216-295-91	SHORT	
FB502	1-410-397-21	FERRITE	1.1 μ H	JR503	1-216-295-91	SHORT	
FB503	1-410-397-21	FERRITE	1.1 μ H				
FB600	1-412-911-11	FERRITE	0 μ H				
FB601	1-412-911-11	FERRITE	0 μ H				
FB602	1-412-911-11	FERRITE	0 μ H				

A**Note:**

The components identified by shading and mark \triangle are critical for safety. Replace only with part number specified.

Note:

Les composants identifiés par un trame et une marque \triangle sont critiques pour la sécurité. Ne les remplacer que par une pièce portant le numéro spécifié.

REF.NO.	PART NO.	DESCRIPTION	REMARK	REF.NO.	PART NO.	DESCRIPTION	REMARK
JR505	1-216-295-91	SHORT		Q411	8-729-216-22	TRANSISTOR 2SB709A-QRS-TX	
JR522	1-216-295-91	SHORT		Q501	8-729-140-50	TRANSISTOR 2SC3209LK-TP	
JR523	1-216-295-91	SHORT		Q502 \triangle	8-729-046-07	TRANSISTOR 2SD2578-YB (KV-27FV16/29FV16/29FV16C ONLY)	
JR526	1-216-295-91	SHORT		Q502 \triangle	8-729-045-26	TRANSISTOR 2SD2580-YB (KV-32FS12/32FS16 ONLY)	
JR527	1-216-295-91	SHORT		Q503	8-729-422-27	TRANSISTOR 2SD601A-QRS-TX	
COIL				Q504	8-729-809-29	TRANSISTOR 2SC4159-E	
L101	1-412-029-11	INDUCTOR CHIP	10 μ H	Q505 \triangle	8-729-200-17	TRANSISTOR 2SA1091O-TPE2	
L102	1-412-032-11	INDUCTOR CHIP	100 μ H	Q506 \triangle	8-729-422-27	TRANSISTOR 2SD601A-QRS-TX	
L103	1-412-029-11	INDUCTOR CHIP	10 μ H	Q507 \triangle	8-729-216-22	TRANSISTOR 2SB709A-QRS-TX	
L503	1-406-677-11	INDUCTOR	10mH	Q601	8-729-922-37	TRANSISTOR 2SD2144S-TP-UVW	
L506	1-406-677-11	INDUCTOR	10mH	Q602	8-729-423-33	TRANSISTOR 2SC3311A-QRSTA	
L604	1-412-525-31	INDUCTOR	10 μ H	Q603	8-729-119-76	TRANSISTOR 2SA1309A-QRSTA	
L505	1-406-978-11	INDUCTOR	150 μ H (KV-27FV16/29FV16/29FV16C ONLY)	Q604	8-729-422-27	TRANSISTOR 2SD601A-QRS-TX	
L505	1-406-976-11	INDUCTOR	68 μ H (KV-32FS12/32FS16 ONLY)	Q605 \triangle	8-729-046-40	TRANSISTOR 2SK2663	
L510 \triangle	1-412-528-11	INDUCTOR	18 μ H	Q606	8-729-422-27	TRANSISTOR 2SD601A-QRS-TX	
L502	1-412-552-11	INDUCTOR	2.2mH	Q607	8-729-922-37	TRANSISTOR 2SD2144S-TP-UVW	
L507	1-412-552-11	INDUCTOR	2.2mH	Q608	8-729-422-27	TRANSISTOR 2SD601A-QRS-TX	
L603	1-412-529-11	INDUCTOR	22 μ H	Q609	8-729-423-33	TRANSISTOR 2SC3311A-QRSTA	
L605	1-412-529-11	INDUCTOR	22 μ H	RESISTOR			
L504	1-412-533-21	INDUCTOR	47 μ H	R105	1-216-065-91	RES-CHIP	4.7K 5% 1/10W
L501	1-409-955-11	INDUCTOR	8mH	R107	1-216-025-91	RES-CHIP	100 5% 1/10W
PHOTO COUPLER				R108	1-216-025-91	RES-CHIP	100 5% 1/10W
PH601 \triangle	8-749-010-64	PHOTO COUPLER PC123FY2		R115	1-216-295-91	SHORT	
IC LINK				R201	1-216-113-00	RES-CHIP	470K 5% 1/10W
PS401 \triangle	1-532-686-21	LINK, IC 2.7A/150V (KV-27FV16/29FV16/29FV16C ONLY)		R202	1-216-113-00	RES-CHIP	470K 5% 1/10W
PS401 \triangle	1-576-336-21	LINK, IC (KV-32FS12/32FS16 ONLY)		R204	1-216-081-00	RES-CHIP	22K 5% 1/10W
TRANSISTOR				R205	1-216-085-00	RES-CHIP	33K 5% 1/10W
Q101	8-729-422-27	TRANSISTOR 2SD601A-QRS-TX		R208	1-215-924-00	METAL OXIDE	15K 5% 3W
Q201	8-729-216-22	TRANSISTOR 2SB709A-QRS-TX (KV-27FV16/29FV16/29FV16C ONLY)		R214	1-216-113-00	RES-CHIP	470K 5% 1/10W
Q205	8-729-422-27	TRANSISTOR 2SD601A-QRS-TX (KV-27FV16/29FV16/29FV16C ONLY)		R215	1-216-113-00	RES-CHIP	470K 5% 1/10W
Q206	8-729-422-27	TRANSISTOR 2SD601A-QRS-TX (KV-27FV16/29FV16/29FV16C ONLY)		R218	1-216-025-91	RES-CHIP	100 5% 1/10W (KV-27FV16/29FV16/29FV16C ONLY)
Q401	8-729-216-22	TRANSISTOR 2SB709A-QRS-TX (KV-27FV16/29FV16/29FV16C ONLY)		R221	1-216-033-00	RES-CHIP	220 5% 1/10W (KV-27FV16/29FV16/29FV16C ONLY)
Q402	8-729-216-22	TRANSISTOR 2SB709A-QRS-TX (KV-27FV16/29FV16/29FV16C ONLY)		R224	1-216-065-91	RES-CHIP	4.7K 5% 1/10W (KV-27FV16/29FV16/29FV16C ONLY)
Q410	8-729-422-27	TRANSISTOR 2SD601A-QRS-TX		R225	1-216-065-91	RES-CHIP	4.7K 5% 1/10W (KV-27FV16/29FV16/29FV16C ONLY)
				R226	1-216-022-00	RES-CHIP	75 5% 1/10W (KV-27FV16/29FV16/29FV16C ONLY)
				R227	1-216-113-00	RES-CHIP	470K 5% 1/10W (KV-27FV16/29FV16/29FV16C ONLY)
				R228	1-216-113-00	RES-CHIP	470K 5% 1/10W (KV-27FV16/29FV16/29FV16C ONLY)
				R229	1-216-113-00	RES-CHIP	470K 5% 1/10W (KV-27FV16/29FV16/29FV16C ONLY)

Note:

The components identified by shading and mark \triangle are critical for safety. Replace only with part number specified.

Note:

Les composants identifiés par un trame et une marque \triangle sont critiques pour la sécurité. Ne les remplacer que par une pièce portant le numéro spécifié.

A

REF.NO.	PART NO.	DESCRIPTION	REMARK	REF.NO.	PART NO.	DESCRIPTION	REMARK
R231	1-216-069-00	RES-CHIP (KV-27FV16/29FV16/29FV16C ONLY)	6.8K 5% 1/10W	R447	1-216-065-91	RES-CHIP	4.7K 5% 1/10W
R232	1-216-069-00	RES-CHIP (KV-27FV16/29FV16/29FV16C ONLY)	6.8K 5% 1/10W	R454	1-216-025-91	RES-CHIP	100 5% 1/10W
R235	1-216-113-00	RES-CHIP (KV-32FS12/32FS16 ONLY)	470K 5% 1/10W	R501	1-249-425-11	CARBON	4.7K 5% 1/4W
R237	1-216-033-00	RES-CHIP (KV-32FS12/32FS16 ONLY)	220 5% 1/10W	R502 \triangle	1-216-455-21	METAL OXIDE	560 5% 2W
R238	1-216-033-00	RES-CHIP (KV-32FS12/32FS16 ONLY)	220 5% 1/10W	R503 \triangle	1-249-425-11	CARBON	4.7K 5% 1/4W
R239	1-216-113-00	RES-CHIP (KV-32FS12/32FS16 ONLY)	470K 5% 1/10W	R505	1-249-401-11	CARBON	47 5% 1/4W
R401	1-216-080-00	RES-CHIP (KV-27FV16/29FV16/29FV16C ONLY)	20K 5% 1/10W	R506 \triangle	1-215-883-11	METAL OXIDE	33 5% 2W
R402	1-216-073-00	RES-CHIP (KV-27FV16/29FV16/29FV16C ONLY)	10K 5% 1/10W	R507 \triangle	1-260-328-11	CARBON	1K 5% 1/2W
R403	1-216-065-91	RES-CHIP (KV-27FV16/29FV16/29FV16C ONLY)	4.7K 5% 1/10W	R508	1-247-863-91	CARBON	22K 5% 1/4W
R404	1-216-065-91	RES-CHIP (KV-27FV16/29FV16/29FV16C ONLY)	4.7K 5% 1/10W	R509 \triangle	1-215-891-11	METAL OXIDE	680 5% 2W
R407	1-216-025-91	RES-CHIP (KV-27FV16/29FV16/29FV16C ONLY)	100 5% 1/10W	R510	1-249-411-11	CARBON	330 5% 1/4W
R408	1-216-025-91	RES-CHIP (KV-27FV16/29FV16/29FV16C ONLY)	100 5% 1/10W	R511	1-249-377-11	CARBON	0.47 5% 1/4W
R411	1-249-417-11	CARBON	1K 5% 1/4W	R512	1-215-910-00	METAL OXIDE	68 5% 3W
R412	1-216-113-00	RES-CHIP	470K 5% 1/10W	R513 \triangle	1-215-907-11	METAL OXIDE (KV-27FV16/29FV16/29FV16C ONLY)	22 5% 3W
R413	1-216-113-00	RES-CHIP	470K 5% 1/10W	R513 \triangle	1-215-905-11	METAL OXIDE (KV-32FS12/32FS16 ONLY)	10 5% 3W
R414	1-249-417-11	CARBON	1K 5% 1/4W	R514	1-216-683-11	METAL CHIP (KV-27FV16/29FV16/29FV16C ONLY)	22K 0.50% 1/10W
R421	1-249-425-11	CARBON	4.7K 5% 1/4W	R514	1-216-071-00	RES-CHIP (KV-32FS12/32FS16 ONLY)	8.2K 5% 1/10W
R420	1-208-796-11	METAL CHIP (KV-32FS12/32FS16 ONLY)	3.9K 0.50% 1/10W	R516	1-249-425-11	CARBON	4.7K 5% 1/4W
R422	1-249-389-11	CARBON	4.7 5% 1/4W	R517	1-215-445-00	METAL	10K 1% 1/4W
R426	1-216-009-91	RES-CHIP	22 5% 1/10W	R518	1-249-427-11	CARBON (KV-27FV16 ONLY)	6.8K 5% 1/4W
R429	1-216-113-00	RES-CHIP	470K 5% 1/10W	R518	1-215-439-00	METAL (ALL EXCEPT KV-27FV16)	5.6K 1% 1/4W
R430	1-216-049-91	RES-CHIP	1K 5% 1/10W	R519	1-249-427-11	CARBON (KV-27FV16/29FV16/29FV16C ONLY)	6.8K 5% 1/4W
R431	1-216-049-91	RES-CHIP	1K 5% 1/10W	R519	1-215-439-00	METAL (KV-32FS12/32FS16 ONLY)	5.6K 1% 1/4W
R433	1-216-113-00	RES-CHIP	470K 5% 1/10W	R520 \triangle	1-215-884-11	METAL OXIDE	47 5% 2W
R436	1-216-065-91	RES-CHIP	4.7K 5% 1/10W	R521	1-249-413-11	CARBON	470 5% 1/4W
R437	1-216-073-00	RES-CHIP (KV-27FV16/29FV16/29FV16C ONLY)	10K 5% 1/10W	R522	1-249-417-11	CARBON	1K 5% 1/4W
R437	1-216-065-91	RES-CHIP (KV-32FS12/32FS16 ONLY)	4.7K 5% 1/10W	R523	1-216-073-00	RES-CHIP	10K 5% 1/10W
R438	1-216-065-91	RES-CHIP	4.7K 5% 1/10W	R524	1-249-429-11	CARBON	10K 5% 1/4W
R439	1-216-073-00	RES-CHIP (KV-27FV16/29FV16/29FV16C ONLY)	10K 5% 1/10W	R525 \triangle	1-208-804-11	METAL CHIP	8.2K 0.50% 1/10W
R439	1-216-065-91	RES-CHIP (KV-32FS12/32FS16 ONLY)	4.7K 5% 1/10W	R526	1-208-814-91	METAL CHIP	22K 0.50% 1/10W
R440	1-216-097-91	RES-CHIP	100K 5% 1/10W	R528	1-215-429-00	METAL	2.2K 1% 1/4W
R441	1-216-081-00	RES-CHIP	22K 5% 1/10W	R529	1-216-109-00	RES-CHIP (KV-27FV16/29FV16/29FV16C ONLY)	330K 5% 1/10W
R442	1-216-025-91	RES-CHIP	100 5% 1/10W	R529	1-216-107-00	RES-CHIP (KV-32FS12/32FS16 ONLY)	270K 5% 1/10W
R445	1-216-073-00	RES-CHIP	10K 5% 1/10W	R530	1-216-077-91	RES-CHIP (KV-27FV16/29FV16/29FV16C ONLY)	15K 5% 1/10W
R446	1-215-457-00	METAL	33K 1% 1/4W	R530	1-208-812-11	METAL CHIP (KV-32FS12/32FS16 ONLY)	18K 0.50% 1/10W
				R532	1-215-437-00	METAL	4.7K 1% 1/4W
				R533	1-215-457-00	METAL (KV-27FV16/29FV16/29FV16C ONLY)	33K 1% 1/4W

KV-27FV16/29FV16/29FV16C/32FS12/32FS16



Note:

The components identified by shading and mark **△** are critical for safety. Replace only with part number specified.

Note:

The components identified by **☒** in this manual have been carefully factory-selected for each set in order to satisfy regulations regarding x-ray radiation. Should replacement be required, replace only with the value originally used.

REF.NO.	PART NO.	DESCRIPTION	REMARK	REF.NO.	PART NO.	DESCRIPTION	REMARK
R533	1-215-453-00	METAL (KV-32FS12/32FS16 ONLY)	22K 1% 1/4W	R608	1-240-205-11	CARBON	22M 5% 1/2W
R534	1-215-458-00	METAL (KV-27FV16/29FV16/29FV16C ONLY)	36K 1% 1/4W	R609	1-216-049-91	RES-CHIP	1K 5% 1/10W
R534	1-215-457-00	METAL (KV-32FS12/32FS16 ONLY)	33K 1% 1/4W	R610	1-216-073-00	RES-CHIP	10K 5% 1/10W
R535	1-249-441-11	CARBON	100K 5% 1/4W	R611	1-216-089-91	RES-CHIP	47K 5% 1/10W
R536	△ 1-214-798-21	METAL	1.8 1% 1/2W	R612	1-216-045-00	RES-CHIP	680 5% 1/10W
R537	1-249-401-11	CARBON	47 5% 1/4W	R613	△ 1-219-512-11	CARBON	2.2M 5% 1/2W
R538	△ 1-215-889-00	METAL OXIDE	330 5% 2W	R614	1-249-413-11	CARBON	470 5% 1/4W
R539	1-249-385-11	CARBON	2.2 5% 1/4W	R615	△ 1-218-265-11	METAL (KV-29FV16/29FV16C ONLY)	8.2M 5% 1W
R540	1-215-445-00	METAL	10K 1% 1/4W	R616	△ 1-260-302-51	CARBON	6.8 5% 1/2W
R541	1-249-429-11	CARBON	10K 5% 1/4W	R617	1-216-009-91	RES-CHIP	22 5% 1/10W
R543	1-247-887-00	CARBON	220K 5% 1/4W	R618	1-249-440-11	CARBON	82K 5% 1/4W
R544	1-249-377-11	CARBON	0.47 5% 1/4W	R619	1-249-437-11	CARBON	47K 5% 1/4W
R545	1-215-873-00	METAL OXIDE	4.7K 5% 1W	R620	1-249-417-11	CARBON	1K 5% 1/4W
R546	△ 1-249-377-11	CARBON	0.47 5% 1/4W	R621	△ 1-240-251-11	CEMENTED	6.8 5% 10W
R547	1-216-455-21	METAL OXIDE	560 5% 2W	R622	1-249-441-11	CARBON	100K 5% 1/4W
R548	1-216-377-11	METAL OXIDE	4.7 5% 2W	R623	△ 1-260-324-11	CARBON	470 5% 1/2W
R549	△ 1-260-288-11	CARBON	0.47 5% 1/2W	R624	△ 1-249-429-11	CARBON	10K 5% 1/4W
R550	△ 1-260-288-11	CARBON	0.47 5% 1/2W	R625	1-249-437-11	CARBON	47K 5% 1/4W
R551	1-215-907-11	METAL OXIDE	22 5% 3W	R626	△ 1-220-926-11	FUSIBLE	0.47 10% 1/2W
R553	△ 1-216-363-00	METAL OXIDE	0.33 5% 2W	R627	1-215-479-00	METAL (KV-29FV16/29FV16C ONLY)	270K 1% 1/4W
R554	△ 1-249-429-11	CARBON	10K 5% 1/4W	R627	1-215-483-00	METAL (ALL EXCEPT KV-29FV16/29FV16C)	390K 1% 1/4W
R555	△ 1-247-895-91	CARBON	470K 5% 1/4W	R628	1-215-479-00	METAL (ALL EXCEPT KV-27FV16)	270K 1% 1/4W
R556	△ 1-249-417-11	CARBON	1K 5% 1/4W	R630	1-249-421-11	CARBON	2.2K 5% 1/4W
R557	△ 1-247-895-91	CARBON	470K 5% 1/4W	R631	1-215-929-11	METAL OXIDE (KV-29FV16/29FV16C ONLY)	100K 5% 3W
R558	△ 1-216-097-91	RES-CHIP	100K 5% 1/10W	R632	△ 1-217-611-00	METAL	0.1 10% 2W
R559	△ 1-216-073-00	RES-CHIP	10K 5% 1/10W	R633	1-249-415-11	CARBON	680 5% 1/4W
R560	△ 1-215-902-11	METAL OXIDE	47K 5% 1W	R634	1-216-073-00	RES-CHIP	10K 5% 1/10W
R561	△ 1-249-406-11	CARBON	120 5% 1/4W	R635	1-216-057-00	RES-CHIP	2.2K 5% 1/10W
R562	△ 1-208-808-11	METAL CHIP	12K 0.50% 1/10W	R637	△ 1-216-485-11	METAL OXIDE (KV-29FV16/29FV16C ONLY)	5.6K 5% 3W
R563	△ 1-247-863-91	CARBON	22K 5% 1/4W	R638	1-249-402-11	CARBON (KV-29FV16/29FV16C ONLY)	56 5% 1/4W
☒ R564	△ 1-208-836-11	METAL CHIP (KV-27FV16/29FV16/29FV16C ONLY)	180K 0.50% 1/10W	R638	1-249-399-11	CARBON (ALL EXCEPT KV-29FV16/29FV16C)	33 5% 1/4W
☒ R564	△ 1-208-824-11	METAL CHIP (KV-32FS12/32FS16 ONLY)	56K 0.50% 1/10W	R639	1-249-421-11	CARBON	2.2K 5% 1/4W
R565	△ 1-249-429-11	CARBON	10K 5% 1/4W	R640	1-249-417-11	CARBON	1K 5% 1/4W
R566	△ 1-216-073-00	RES-CHIP	10K 5% 1/10W	R641	△ 1-216-369-00	METAL OXIDE	1 5% 2W
R567	△ 1-216-073-00	RES-CHIP	10K 5% 1/10W	R642	1-216-089-91	RES-CHIP	47K 5% 1/10W
R568	△ 1-215-882-00	METAL OXIDE	22 5% 2W	R643	1-249-419-11	CARBON	1.5K 5% 1/4W
R569	1-214-798-21	METAL	1.8 1% 1/2W	R644	1-247-843-11	CARBON	3.3K 5% 1/4W
R570	1-247-863-91	CARBON	22K 5% 1/4W	R645	1-215-898-11	METAL OXIDE	10K 5% 2W
R571	1-216-065-91	RES-CHIP	4.7K 5% 1/10W	R646	1-249-418-11	CARBON (KV-29FV16/29FV16C ONLY)	1.2K 5% 1/4W
R572	1-216-065-91	RES-CHIP	4.7K 5% 1/10W	R646	1-249-419-11	CARBON (ALL EXCEPT KV-29FV16/29FV16C)	1.5K 5% 1/4W
R601	△ 1-219-513-11	CARBON (ALL EXCEPT KV-29FV16/29FV16C)	4.7M 5% 1/2W				
R602	△ 1-249-389-11	CARBON	4.7 5% 1/4W				
R603	1-215-485-00	METAL	470K 1% 1/4W				
R607	1-215-859-00	METAL OXIDE	22 5% 1W				

Note:

The components identified by shading and mark \triangle are critical for safety. Replace only with part number specified.

Note:

Les composants identifiés par un trame et une marque \triangle sont critiques pour la sécurité. Ne les remplacer que par une pièce portant le numéro spécifié.



REF.NO.	PART NO.	DESCRIPTION	REMARK	REF.NO.	PART NO.	DESCRIPTION	REMARK	
R648	1-216-397-11	METAL OXIDE (KV-27FV16/29FV16/29FV16C ONLY)	4.7 5% 3W	T503	\triangle 1-426-981-11	TRANSFORMER, FERRITE (PMT)		
R648	1-215-908-00	METAL OXIDE (KV-32FS12/32FS16 ONLY)	33 5% 3W	T504	\triangle 1-431-693-11	TRANSFORMER, HORIZONTAL LINEAR (KV-27FV16/29FV16/29FV16C ONLY)		
R649	1-249-417-11	CARBON	1K 5% 1/4W	T504	\triangle 1-435-098-11	TRANSFORMER, HORIZONTAL LINEAR (KV-32FS12/32FS16 ONLY)		
R650	1-216-387-11	METAL OXIDE	0.68 5% 3W	T505	\triangle 1-453-310-11	FBT ASSY NX-4521//X4J4 (KV-27FV16/29FV16/29FV16C ONLY)		
R651	1-249-429-11	CARBON	10K 5% 1/4W	T505	\triangle 1-453-338-11	FBT ASSY, NX-4600//X4J4 (KV-32FS12/32FS16 ONLY)		
R653	1-216-049-91	RES-CHIP	1K 5% 1/10W	T602	\triangle 1-426-717-11	TRANSFORMER, LINE FILTER (LFT) (KV-29FV16/29FV16C ONLY)		
R655	1-216-049-91	RES-CHIP	1K 5% 1/10W	T602	\triangle 1-435-617-11	TRANSFORMER, LINE FILTER (ALL EXCEPT KV-29FV16/29FV16C)		
R656	1-249-429-11	CARBON	10K 5% 1/4W	T603	\triangle 1-435-402-11	TRANSFORMER, CONVERTER (SRT) (KV-29FV16/29FV16C ONLY)		
R658	1-216-387-11	METAL OXIDE	0.68 5% 3W	T603	\triangle 1-435-403-11	TRANSFORMER, CONVERTER (S.R.T) (ALL EXCEPT KV-29FV16/29FV16C)		
R659	1-215-857-11	METAL OXIDE	10 5% 1W	T604	\triangle 1-431-852-11	TRANSFORMER, CONVERTER (SRT)		
R660	\triangle 1-216-485-11	METAL OXIDE (KV-29FV16/29FV16C ONLY)	5.6K 5% 3W	THERMISTOR				
R660	\triangle 1-215-924-00	METAL OXIDE (ALL EXCEPT KV-29FV16/29FV16C)	15K 5% 3W	TH501	1-800-193-00	THERMISTOR		
R661	1-216-057-00	RES-CHIP	2.2K 5% 1/10W	TH601	\triangle 1-803-586-11	THERMISTOR, NTC		
R662	\triangle 1-216-485-11	METAL OXIDE (KV-29FV16/29FV16C ONLY)	5.6K 5% 3W	THERMISTOR				
R663	1-216-081-00	RES-CHIP	22K 5% 1/10W	THP601	\triangle 1-803-540-11	THERMISTOR		
R664	1-216-397-11	METAL OXIDE (KV-27FV16/29FV16/29FV16C ONLY)	4.7 5% 3W	TUNER				
R2001	1-216-057-00	RES-CHIP (KV-32FS12/32FS16 ONLY)	2.2K 5% 1/10W	TU101	\triangle 8-598-431-30	TUNER, FSS BTF-WA411		
R2002	1-216-053-00	RES-CHIP (KV-32FS12/32FS16 ONLY)	1.5K 5% 1/10W	VARISTOR				
R2003	1-249-425-11	CARBON	4.7K 5% 1/4W	VDR601	\triangle 1-803-967-11	VARISTOR (ENE621D-14A) (KV-29FV16/29FV16C ONLY)		
R2004	1-216-069-00	RES-CHIP (KV-32FS12/32FS16 ONLY)	6.8K 5% 1/10W	VDR601	\triangle 1-803-585-11	VARISTOR ENE271D-10A (ALL EXCEPT KV-29FV16/29FV16C)		
R2005	1-216-295-91	SHORT (KV-32FS12/32FS16 ONLY)		BC				
RELAY				* A-1131-593-A BC MOUNTED PC BOARD (ALL EXCEPT KV-32FS12/32FS16)				
RY601	\triangle 1-755-198-11	RELAY		CAPACITOR				
RY602	\triangle 1-755-266-11	RELAY, AC POWER		C3500	1-165-319-11	CERAMIC CHIP	0.1 μ F	50V
SWITCH				C3501	1-163-231-11	CERAMIC CHIP	15PF	5% 50V
S2007	1-762-816-11	SWITCH, TACTILE (KV-32FS12/32FS16 ONLY)		C3502	1-165-319-11	CERAMIC CHIP	0.1 μ F	50V
S2008	1-762-816-11	SWITCH, TACTILE (KV-32FS12/32FS16 ONLY)		TRANSFORMER				
SWITCH				T501	\triangle 1-437-195-11	TRANSFORMER, HORIZONTAL DRIVE		
SW501	1-572-707-11	SWITCH, LEVER						
SW502	1-572-707-11	SWITCH, LEVER						



Note:

The components identified by shading and mark △ are critical for safety. Replace only with part number specified.

Note:

Les composants identifies per un trame et une marque △ sont critiques pour la securite. Ne les remplacer que par une piece portant le numero specifie.

REF.NO.	PART NO.	DESCRIPTION	REMARK	REF.NO.	PART NO.	DESCRIPTION	REMARK
C3504	1-163-102-00	CERAMIC CHIP	24PF 5% 50V	C3559	1-163-031-11	CERAMIC CHIP	0.01µF 50V
C3505	1-163-102-00	CERAMIC CHIP	24PF 5% 50V	C3560	1-104-664-11	ELECT	47µF 20% 16V
C3506	1-165-319-11	CERAMIC CHIP	0.1µF 50V	C3561	1-163-031-11	CERAMIC CHIP	0.01µF 50V
C3507	1-165-319-11	CERAMIC CHIP	0.1µF 50V	C3562	1-163-031-11	CERAMIC CHIP	0.01µF 50V
C3509	1-163-038-91	CERAMIC CHIP	0.1µF 25V	C3563	1-104-664-11	ELECT	47µF 20% 16V
C3510	1-163-131-00	CERAMIC CHIP	390PF 5% 50V	C3564	1-104-664-11	ELECT	47µF 20% 16V
C3511	1-163-038-91	CERAMIC CHIP	0.1µF 25V	C3565	1-163-031-11	CERAMIC CHIP	0.01µF 50V
C3512	1-165-319-11	CERAMIC CHIP	0.1µF 50V	C3566	1-163-031-11	CERAMIC CHIP	0.01µF 50V
C3513	1-216-295-91	SHORT		CONNECTOR			
C3514	1-163-031-11	CERAMIC CHIP	0.01µF 50V	CN3500*	1-691-632-21	CONNECTOR, BOARD TO BOARD	15P
C3515	1-165-319-11	CERAMIC CHIP	0.1µF 50V	FERRITE BEAD			
C3516	1-165-319-11	CERAMIC CHIP	0.1µF 50V	FB3500	1-414-234-22	INDUCTOR CHIP	0µH
C3517	1-126-924-11	ELECT	330µF 20% 6.3V	FB3501	1-414-234-22	INDUCTOR CHIP	0µH
C3518	1-163-038-91	CERAMIC CHIP	0.1µF 25V	FB3502	1-414-234-22	INDUCTOR CHIP	0µH
C3519	1-165-319-11	CERAMIC CHIP	0.1µF 50V	FB3503	1-414-234-22	INDUCTOR CHIP	0µH
C3520	1-165-319-11	CERAMIC CHIP	0.1µF 50V	FB3504	1-414-234-22	INDUCTOR CHIP	0µH
C3521	1-163-237-11	CERAMIC CHIP	27PF 5% 50V	FB3505	1-414-234-22	INDUCTOR CHIP	0µH
C3522	1-104-664-11	ELECT	47µF 20% 16V	FB3506	1-414-234-22	INDUCTOR CHIP	0µH
C3523	1-165-319-11	CERAMIC CHIP	0.1µF 50V	FB3507	1-414-234-22	INDUCTOR CHIP	0µH
C3524	1-165-319-11	CERAMIC CHIP	0.1µF 50V	FB3508	1-414-234-22	INDUCTOR CHIP	0µH
C3525	1-163-038-91	CERAMIC CHIP	0.1µF 25V	FILTER			
C3526	1-165-319-11	CERAMIC CHIP	0.1µF 50V	FL3500	1-239-848-21	FILTER, LOW PASS	
C3527	1-165-319-11	CERAMIC CHIP	0.1µF 50V	FL3502	1-239-848-21	FILTER, LOW PASS	
C3528	1-165-319-11	CERAMIC CHIP	0.1µF 50V	FL3503	1-239-848-21	FILTER, LOW PASS	
C3529	1-165-319-11	CERAMIC CHIP	0.1µF 50V	FL3504	1-233-512-21	FERRITE	37µH
C3530	1-104-664-11	ELECT	47µF 20% 16V	FL3505	1-233-512-21	FERRITE	37µH
C3531	1-165-319-11	CERAMIC CHIP	0.1µF 50V	FL3506	1-233-512-21	FERRITE	37µH
C3532	1-126-964-11	ELECT	10µF 20% 50V	IC			
C3533	1-163-133-00	CERAMIC CHIP	470PF 5% 50V	IC3500	8-759-568-27	IC UPD424210LE-60-E2	
C3534	1-126-960-11	ELECT	1µF 20% 50V	IC3501	8-759-594-44	IC UPD64082GF-3BA	
C3535	1-163-231-11	CERAMIC CHIP	15PF 5% 50V	IC3502	8-759-583-47	IC UPC2933T-E1	
C3536	1-126-960-11	ELECT	1µF 20% 50V	COIL			
C3539	1-163-231-11	CERAMIC CHIP	15PF 5% 50V	L3500	1-412-028-11	INDUCTOR CHIP	4.7µH
C3541	1-163-106-00	CERAMIC CHIP	36PF 5% 50V	L3501	1-414-267-11	INDUCTOR	10µH
C3542	1-126-964-11	ELECT	10µF 20% 50V	L3502	1-414-267-11	INDUCTOR	10µH
C3543	1-164-505-11	CERAMIC CHIP	2.2µF 16V	L3503	1-414-267-11	INDUCTOR	10µH
C3546	1-163-231-11	CERAMIC CHIP	15PF 5% 50V	L3504	1-414-267-11	INDUCTOR	10µH
C3547	1-104-664-11	ELECT	47µF 20% 16V	L3505	1-414-267-11	INDUCTOR	10µH
C3548	1-165-319-11	CERAMIC CHIP	0.1µF 50V	COIL			
C3549	1-104-664-11	ELECT	47µF 20% 16V	L3500	1-412-028-11	INDUCTOR CHIP	4.7µH
C3550	1-163-031-11	CERAMIC CHIP	0.01µF 50V	L3501	1-414-267-11	INDUCTOR	10µH
C3551	1-104-664-11	ELECT	47µF 20% 16V	L3502	1-414-267-11	INDUCTOR	10µH
C3552	1-163-031-11	CERAMIC CHIP	0.01µF 50V	L3503	1-414-267-11	INDUCTOR	10µH
C3553	1-163-031-11	CERAMIC CHIP	0.01µF 50V	L3504	1-414-267-11	INDUCTOR	10µH
C3554	1-104-664-11	ELECT	47µF 20% 16V	L3505	1-414-267-11	INDUCTOR	10µH
C3555	1-104-664-11	ELECT	47µF 20% 16V	L3505	1-414-267-11	INDUCTOR	10µH
C3556	1-165-319-11	CERAMIC CHIP	0.1µF 50V	COIL			
C3557	1-163-031-11	CERAMIC CHIP	0.01µF 50V	L3500	1-412-028-11	INDUCTOR CHIP	4.7µH
C3558	1-104-664-11	ELECT	47µF 20% 16V	L3501	1-414-267-11	INDUCTOR	10µH

Note:

The components identified by shading and mark \triangle are critical for safety. Replace only with part number specified.

Note:

Les composants identifiés par un trame et une marque \triangle sont critiques pour la sécurité. Ne les remplacer que par une pièce portant le numéro spécifié.



REF.NO.	PART NO.	DESCRIPTION	REMARK	REF.NO.	PART NO.	DESCRIPTION	REMARK
TRANSISTOR				R3531	1-216-049-91	RES-CHIP	1K 5% 1/10W
Q3500	8-729-216-22	TRANSISTOR 2SB709A-QRS-TX		R3532	1-216-025-91	RES-CHIP	100 5% 1/10W
Q3501	8-729-422-27	TRANSISTOR 2SD601A-QRS-TX		R3534	1-216-049-91	RES-CHIP	1K 5% 1/10W
Q3502	8-729-216-22	TRANSISTOR 2SB709A-QRS-TX		R3535	1-216-025-91	RES-CHIP	100 5% 1/10W
Q3503	8-729-422-27	TRANSISTOR 2SD601A-QRS-TX		R3544	1-216-049-91	RES-CHIP	1K 5% 1/10W
Q3504	8-729-216-22	TRANSISTOR 2SB709A-QRS-TX		R3545	1-216-043-91	RES-CHIP	560 5% 1/10W
				R3547	1-216-067-00	RES-CHIP	5.6K 5% 1/10W
Q3505	8-729-422-27	TRANSISTOR 2SD601A-QRS-TX		R3548	1-216-295-91	SHORT	
Q3506	8-729-422-27	TRANSISTOR 2SD601A-QRS-TX		R3549	1-216-057-00	RES-CHIP	2.2K 5% 1/10W
Q3510	8-729-216-22	TRANSISTOR 2SB709A-QRS-TX		R3550	1-216-649-11	METAL CHIP	820 0.50% 1/10W
Q3511	8-729-422-27	TRANSISTOR 2SD601A-QRS-TX		R3551	1-208-776-11	METAL CHIP	560 0.50% 1/10W
Q3512	8-729-422-27	TRANSISTOR 2SD601A-QRS-TX		R3552	1-208-764-11	METAL CHIP	180 0.50% 1/10W
Q3513	8-729-422-27	TRANSISTOR 2SD601A-QRS-TX		R3553	1-216-057-00	RES-CHIP	2.2K 5% 1/10W
Q3514	8-729-216-22	TRANSISTOR 2SB709A-QRS-TX		R3554	1-216-047-91	RES-CHIP	820 5% 1/10W
Q3515	8-729-422-27	TRANSISTOR 2SD601A-QRS-TX		R3555	1-216-075-00	RES-CHIP	12K 5% 1/10W
Q3516	8-729-422-27	TRANSISTOR 2SD601A-QRS-TX		R3556	1-216-085-00	RES-CHIP	33K 5% 1/10W
Q3517	8-729-422-27	TRANSISTOR 2SD601A-QRS-TX		R3557	1-216-049-91	RES-CHIP	1K 5% 1/10W
RESISTOR				R3558	1-216-017-91	RES-CHIP	47 5% 1/10W
R3500	1-216-296-91	SHORT		R3559	1-216-295-91	SHORT	
R3501	1-216-296-91	SHORT		R3560	1-216-049-91	RES-CHIP	1K 5% 1/10W
R3502	1-216-296-91	SHORT		R3561	1-216-043-91	RES-CHIP	560 5% 1/10W
R3503	1-216-017-91	RES-CHIP	47 5% 1/10W	R3563	1-216-295-91	SHORT	
R3504	1-216-295-91	SHORT		R3564	1-216-295-91	SHORT	
R3505	1-216-295-91	SHORT		R3565	1-216-067-00	RES-CHIP	5.6K 5% 1/10W
R3506	1-216-295-91	SHORT		R3566	1-216-057-00	RES-CHIP	2.2K 5% 1/10W
R3507	1-216-295-91	SHORT		R3567	1-216-043-91	RES-CHIP	560 5% 1/10W
R3508	1-216-295-91	SHORT		R3568	1-216-047-91	RES-CHIP	820 5% 1/10W
R3509	1-216-049-91	RES-CHIP	1K 5% 1/10W	R3569	1-216-057-00	RES-CHIP	2.2K 5% 1/10W
R3510	1-216-041-00	RES-CHIP	470 5% 1/10W	R3570	1-216-085-00	RES-CHIP	33K 5% 1/10W
R3511	1-216-041-00	RES-CHIP	470 5% 1/10W	R3571	1-216-075-00	RES-CHIP	12K 5% 1/10W
R3512	1-216-295-91	SHORT		R3572	1-216-049-91	RES-CHIP	1K 5% 1/10W
R3514	1-216-025-91	RES-CHIP	100 5% 1/10W	R3573	1-216-017-91	RES-CHIP	47 5% 1/10W
R3515	1-216-055-00	RES-CHIP	1.8K 5% 1/10W	R3588	1-216-043-91	RES-CHIP	560 5% 1/10W
R3516	1-216-055-00	RES-CHIP	1.8K 5% 1/10W	CRYSTAL			
R3517	1-216-025-91	RES-CHIP	100 5% 1/10W	X3500	1-767-606-11	VIBRATOR, CRYSTAL	
R3518	1-216-025-91	RES-CHIP	100 5% 1/10W				
R3519	1-216-295-91	SHORT					
R3520	1-216-065-91	RES-CHIP	4.7K 5% 1/10W				
R3521	1-216-041-00	RES-CHIP	470 5% 1/10W				
R3522	1-216-041-00	RES-CHIP	470 5% 1/10W				
R3523	1-216-049-91	RES-CHIP	1K 5% 1/10W				
R3524	1-216-089-91	RES-CHIP	47K 5% 1/10W				
R3525	1-216-057-00	RES-CHIP	2.2K 5% 1/10W				
R3526	1-216-105-91	RES-CHIP	220K 5% 1/10W				
R3527	1-216-033-00	RES-CHIP	220 5% 1/10W				
R3528	1-216-645-11	METAL CHIP	560 0.50% 1/10W				
R3529	1-216-641-11	METAL CHIP	390 0.50% 1/10W				
R3530	1-216-067-00	RES-CHIP	5.6K 5% 1/10W				

CA D**Note:**

The components identified by shading and mark \triangle are critical for safety. Replace only with part number specified.

Note:

Les composants identifiés par un trame et une marque \triangle sont critiques pour la sécurité. Ne les remplacer que par une pièce portant le numéro spécifié.

REF.NO.	PART NO.	DESCRIPTION	REMARK	REF.NO.	PART NO.	DESCRIPTION	REMARK
				TRANSISTOR			
				Q700	8-729-423-33	TRANSISTOR 2SC3311A-QRSTA	
				Q701	8-729-423-33	TRANSISTOR 2SC3311A-QRSTA	
				RESISTOR			
				R706	1-249-381-11	CARBON	1 5% 1/4W
				R707	1-249-383-11	CARBON	1.5 5% 1/4W
				R703	1-247-807-31	CARBON	100 5% 1/4W
				R708	1-247-807-31	CARBON	100 5% 1/4W
				R709	1-247-807-31	CARBON	100 5% 1/4W
				R710	1-247-807-31	CARBON	100 5% 1/4W
				R714	1-260-087-11	CARBON	100 5% 1/2W
				R702	1-247-815-91	CARBON	220 5% 1/4W
				R716	1-260-123-11	CARBON	100K 5% 1/2W
				R701	1-249-429-11	CARBON	10K 5% 1/4W
				R705	1-249-429-11	CARBON	10K 5% 1/4W
				R711	1-260-099-11	CARBON	1K 5% 1/2W
				R712	1-260-099-11	CARBON	1K 5% 1/2W
				R713	1-260-099-11	CARBON	1K 5% 1/2W
				R704	1-249-421-11	CARBON	2.2K 5% 1/4W
				R720	1-249-421-11	CARBON	2.2K 5% 1/4W
				R721	1-249-421-11	CARBON	2.2K 5% 1/4W
				R700	1-247-863-91	CARBON	22K 5% 1/4W
				R715	1-260-132-11	CARBON	560K 5% 1/2W
				R717	1-216-373-11	METAL OXIDE	2.2 5% 2W
						(KV-27FV16/29FV16/29FV16C ONLY)	
				R718	1-216-375-00	METAL OXIDE	3.3 5% 2W
						(KV-32FS12/32FS16 ONLY)	
				R719	1-215-888-00	METAL OXIDE	220 5% 2W
				VARIABLE RESISTOR			
				RV701	1-241-656-11	RES, ADJ, METAL FILM 110M	
				CAPACITOR			
				C801	1-126-960-11	ELECT	1 μ F 20% 50V
				C802	1-126-964-11	ELECT	10 μ F 20% 50V
				C803	1-136-191-11	MYLAR	0.22 μ F 5% 63V
				C804	1-136-191-11	MYLAR	0.22 μ F 5% 63V
CA				D			
* A-1332-063-A	CA (VAR) MOUNTED PC BOARD			* A-1343-875-A	D (VAR) MOUNTED PC BOARD		
	(KV-27FV16/29FV16/29FV16C ONLY)				(KV-27FV16/29FV16/29FV16C ONLY)		
* A-1332-061-A	CA (VAR) MOUNTED PC BOARD			* A-1343-874-A	D (VAR) MOUNTED PC BOARD		
	(KV-32FS12/32FS16 ONLY)				(KV-32FS12/32FS16 ONLY)		
4-382-854-11	SCREW (M3X10), P, SW (+)						
CAPACITOR							
C701	1-104-664-11	ELECT	47 μ F 20% 25V				
C702	1-136-165-00	MYLAR	0.1 μ F 5% 50V				
C703	1-104-664-11	ELECT	47 μ F 20% 25V				
C704	1-107-651-11	ELECT	4.7 μ F 20% 250V				
C705	1-107-652-11	ELECT	10 μ F 20% 250V				
C707	1-162-114-00	CERAMIC	0.0047 μ F 2K				
C708	1-136-165-00	MYLAR	0.1 μ F 5% 50V				
C709	1-126-934-11	ELECT	220 μ F 20% 16V				
C710	1-126-964-11	ELECT	10 μ F 20% 50V				
CONNECTOR							
CN701 *	1-564-506-11	PLUG, CONNECTOR 3P					
CN702	1-695-915-11	TAB (CONTACT)					
CN704	1-784-281-11	HOUSING, CONNECTOR 1P					
CN706 *	1-564-509-11	PLUG, CONNECTOR 6P					
DIODE							
D701	8-719-901-83	DIODE 1SS83TD					
D702	8-719-901-83	DIODE 1SS83TD					
D703	8-719-901-83	DIODE 1SS83TD					
D704	8-719-302-43	DIODE RGP10GPKG23					
IC							
IC701	8-759-803-42	IC LA6500-FA					
IC702	8-759-562-43	IC TDA6108JF/N1B					
JACK							
J701	1-451-470-21	SOCKET, CRT					
COIL							
L701	1-408-613-31	INDUCTOR	68 μ H				

Note:

The components identified by shading and mark \triangle are critical for safety. Replace only with part number specified.

Note:

Les composants identifiés par un trame et une marque \triangle sont critiques pour la sécurité. Ne les remplacer que par une pièce portant le numéro spécifié.

D

REF.NO.	PART NO.	DESCRIPTION	REMARK	REF.NO.	PART NO.	DESCRIPTION	REMARK
C807	1-163-021-91	CERAMIC CHIP	0.01 μ F 10%				
C808	1-163-021-91	CERAMIC CHIP	0.01 μ F 10%				
C809	1-110-501-11	CERAMIC CHIP	0.33 μ F 10%				
C810	1-130-495-00	MYLAR	0.1 μ F 5%				
C812	1-163-021-91	CERAMIC CHIP	0.01 μ F 10%				
C814	1-163-021-91	CERAMIC CHIP	0.01 μ F 10%				
C815	1-129-718-00	FILM	0.022 μ F 5%				
C816	1-102-244-00	CERAMIC	220PF 10%				
C817	1-136-558-11	FILM	0.0039 μ F 5%				
		(KV-27FV16/29FV16/29FV16C ONLY)					
C817	1-129-928-00	FILM	0.0027 μ F 10%				
		(KV-32FS12/32FS16 ONLY)					
C818	1-164-735-51	CERAMIC	0.0015 μ F 10%				
		(KV-27FV16/29FV16/29FV16C ONLY)					
C818	1-164-625-11	CERAMIC	680PF 10%				
		(KV-32FS12/32FS16 ONLY)					
C820	1-109-954-11	ELECT	0.47 μ F 20%				
C821	1-163-021-91	CERAMIC CHIP	0.01 μ F 10%				
C823	1-130-967-00	FILM	0.0027 μ F 5%				
C824	1-104-760-11	CERAMIC CHIP	0.047 μ F 10%				
C825	1-137-150-11	MYLAR	0.01 μ F 5%				
C826	1-163-251-11	CERAMIC CHIP	100PF 5%				
C862	1-126-964-11	ELECT	10 μ F 20%				
CONNECTOR							
CN800 *	1-564-510-11	PLUG, CONNECTOR 7P					
CN801 *	1-564-507-11	PLUG, CONNECTOR 4P					
CN802 *	1-508-784-21	PIN, CONNECTOR (5MM PITCH) 1P					
DIODE							
D801	8-719-109-89	DIODE MTZJ-T-77-5.6C					
D802	8-719-991-33	DIODE 1SS133T-77					
D808	8-719-991-33	DIODE 1SS133T-77					
D809	8-719-110-41	DIODE MTZJ-T-77-15B					
D810	8-719-970-87	DIODE ERA38-06TP1					
D811	8-719-970-87	DIODE ERA38-06TP1					
D812	8-719-300-33	DIODE ERB44-06TP1					
D813	8-719-991-33	DIODE 1SS133T-77					
D814	8-719-991-33	DIODE 1SS133T-77					
IC							
IC801	8-759-700-42	IC NJM2904D					
IC802	8-759-659-67	IC NJM2903D					
IC803	8-759-659-67	IC NJM2903D					
COIL							
L803	1-406-677-11	INDUCTOR	10mH				
TRANSISTOR							
Q801	8-729-422-27	TRANSISTOR 2SD601A-QRS-TX					
Q802	8-729-216-22	TRANSISTOR 2SB709A-QRS-TX					
Q803	8-729-216-22	TRANSISTOR 2SB709A-QRS-TX					
Q804	8-729-216-22	TRANSISTOR 2SB709A-QRS-TX					
Q805	8-729-140-97	TRANSISTOR 2SB734-T-34					
Q806	8-729-422-27	TRANSISTOR 2SD601A-QRS-TX					
Q809	8-729-422-27	TRANSISTOR 2SD601A-QRS-TX					
Q810	8-729-043-95	TRANSISTOR 2SC3840K					
Q811	8-729-119-76	TRANSISTOR 2SA1309A-QRSTA					
Q812	8-729-119-76	TRANSISTOR 2SA1309A-QRSTA					
RESISTOR							
R801	1-216-089-91	RES-CHIP	47K 5%				1/10W
R802	1-216-073-00	RES-CHIP	10K 5%				1/10W
R803	1-216-081-00	RES-CHIP	22K 5%				1/10W
R804	1-216-073-00	RES-CHIP	10K 5%				1/10W
R805	1-216-065-91	RES-CHIP	4.7K 5%				1/10W
R806	1-216-081-00	RES-CHIP	22K 5%				1/10W
R807	1-216-061-00	RES-CHIP	3.3K 5%				1/10W
R808	1-216-073-00	RES-CHIP	10K 5%				1/10W
R809	1-216-081-00	RES-CHIP	22K 5%				1/10W
R811	1-216-025-91	RES-CHIP	100 5%				1/10W
R812	1-216-061-00	RES-CHIP	3.3K 5%				1/10W
R813	1-216-041-00	RES-CHIP	470 5%				1/10W
R814	1-215-862-11	METAL OXIDE	68 5%				1W
		(KV-32FS12/32FS16 ONLY)					
R815	1-215-862-11	METAL OXIDE	68 5%				1W
R816	1-247-807-31	CARBON	100 5%				1/4W
R817	1-216-091-00	RES-CHIP	56K 5%				1/10W
		(KV-27FV16/29FV16/29FV16C ONLY)					
R817	1-208-822-11	METAL CHIP	47K 0.50%				1/10W
		(KV-32FS12/32FS16 ONLY)					
R819	1-216-089-91	RES-CHIP	47K 5%				1/10W
R820	1-216-683-11	METAL CHIP	22K 0.50%				1/10W
		(KV-27FV16/29FV16/29FV16C ONLY)					
R820	1-208-818-11	METAL CHIP	33K 0.50%				1/10W
		(KV-32FS12/32FS16 ONLY)					
R821	1-216-077-91	RES-CHIP	15K 5%				1/10W
		(KV-27FV16/29FV16/29FV16C ONLY)					
R821	1-216-061-00	RES-CHIP	3.3K 5%				1/10W
		(KV-32FS12/32FS16 ONLY)					
R822	1-216-065-91	RES-CHIP	4.7K 5%				1/10W
R823	1-216-065-91	RES-CHIP	4.7K 5%				1/10W
R824	1-208-830-11	METAL CHIP	100K 0.50%				1/10W
R825	1-208-830-11	METAL CHIP	100K 0.50%				1/10W
R827	1-216-065-91	RES-CHIP	4.7K 5%				1/10W
R828	1-216-085-00	RES-CHIP	33K 5%				1/10W
R829	1-208-846-11	METAL CHIP	470K 0.50%				1/10W
R830	1-216-295-91	SHORT					

**Note:**

The components identified by shading and mark \triangle are critical for safety. Replace only with part number specified.

Note:

Les composants identifiés par un trame et une marque \triangle sont critiques pour la sécurité. Ne les remplacer que par une pièce portant le numéro spécifié.

REF.NO.	PART NO.	DESCRIPTION	REMARK	REF.NO.	PART NO.	DESCRIPTION	REMARK
R831	1-216-049-91	RES-CHIP	1K 5% 1/10W	R863	1-216-057-00	RES-CHIP	2.2K 5% 1/10W
R832	1-216-067-00	RES-CHIP	5.6K 5% 1/10W	R864	1-216-033-00	RES-CHIP	220 5% 1/10W
		(KV-27FV16/29FV16/29FV16C ONLY)		R865	1-216-097-91	RES-CHIP	100K 5% 1/10W
R832	1-216-061-00	RES-CHIP	3.3K 5% 1/10W	R866	1-249-429-11	CARBON	10K 5% 1/4W
		(KV-32FS12/32FS16 ONLY)		R867	1-216-073-00	RES-CHIP	10K 5% 1/10W
R833	1-216-687-11	METAL CHIP	33K 0.50% 1/10W	R868	1-216-073-00	RES-CHIP	10K 5% 1/10W
		(KV-27FV16/29FV16/29FV16C ONLY)		R869	1-216-097-91	RES-CHIP	100K 5% 1/10W
R833	1-216-689-11	RES-CHIP	39K 5% 1/10W	R870	1-216-057-00	RES-CHIP	2.2K 5% 1/10W
		(KV-32FS12/32FS16 ONLY)		R871	1-215-489-00	METAL	680K 1% 1/4W
R834	1-216-065-91	RES-CHIP	4.7K 5% 1/10W	R872	1-216-121-91	RES-CHIP	1M 5% 1/10W
R835	1-216-057-00	RES-CHIP	2.2K 5% 1/10W	R873	1-216-073-00	RES-CHIP	10K 5% 1/10W
R836	1-216-057-00	RES-CHIP	2.2K 5% 1/10W	R874	1-216-037-00	RES-CHIP	330 5% 1/10W
R837	1-208-808-11	METAL CHIP	12K 0.50% 1/10W	R875	1-216-035-00	RES-CHIP	270 5% 1/10W
R838	1-247-807-31	CARBON	100 5% 1/4W	R890	1-216-097-91	RES-CHIP	100K 5% 1/10W
R839	1-216-025-91	RES-CHIP	100 5% 1/10W	TRANSFORMER			
R840	1-216-093-91	RES-CHIP	68K 5% 1/10W	T801	1-424-584-11	TRANSFORMER, DYNAMIC FOCUS	
		(KV-27FV16/29FV16/29FV16C ONLY)		HA			
R841	1-208-802-11	METAL CHIP	6.8K 0.50% 1/10W	* A-1372-825-A HA MOUNTED PC BOARD (ALL EXCEPT KV-32FS12/32FS16)			
		(KV-27FV16/29FV16/29FV16C ONLY)		CAPACITOR			
R841	1-208-806-11	METAL OXIDE	10K 0.50% 1/10W	C4202	1-117-534-91	ELECT	1 μ F 20% 100V
		(KV-32FS12/32FS16 ONLY)		C4203	1-117-534-91	ELECT	1 μ F 20% 100V
R842	1-208-796-11	METAL CHIP	3.9K 0.50% 1/10W	CONNECTOR			
R845	1-249-441-11	CARBON	100K 5% 1/4W	CN4200*	1-564-512-11	PLUG, CONNECTOR 9P	
R846	1-249-441-11	CARBON	100K 5% 1/4W	DIODE			
R847	1-249-441-11	CARBON	100K 5% 1/4W	D4217	8-719-108-12	DIODE RD9.1EW-T1	
R848	1-215-876-00	METAL OXIDE	15K 5% 1W	D4218	8-719-108-12	DIODE RD9.1EW-T1	
		(KV-27FV16/29FV16/29FV16C ONLY)		D4219	8-719-108-12	DIODE RD9.1EW-T1	
R848	1-215-894-11	METAL OXIDE	2.2K 5% 2W	JACK			
		(KV-32FS12/32FS16 ONLY)		J4221	1-770-361-11	TERMINAL BLOCK, S	
R849	1-215-920-11	METAL OXIDE	3.3K 5% 3W	RESISTOR			
		(KV-27FV16/29FV16/29FV16C ONLY)		R4206	1-249-425-11	CARBON	4.7K 5% 1/4W
R849	1-216-486-21	METAL OXIDE	8.2K 5% 3W	R4207	1-247-895-91	CARBON	470K 5% 1/4W
		(KV-32FS12/32FS16 ONLY)					
R850	1-216-486-21	METAL OXIDE	8.2K 5% 3W				
		(KV-32FS12/32FS16 ONLY)					
R851	1-215-894-11	METAL OXIDE	2.2K 5% 2W				
		(KV-27FV16/29FV16/29FV16C ONLY)					
R851	1-215-922-11	METAL OXIDE	6.8K 5% 3W				
		(KV-32FS12/32FS16 ONLY)					
R852	1-215-922-11	METAL OXIDE	6.8K 5% 3W				
		(KV-32FS12/32FS16 ONLY)					
R854	1-216-069-00	RES-CHIP	6.8K 5% 1/10W				
		(KV-27FV16/29FV16/29FV16C ONLY)					
R854	1-216-067-00	RES-CHIP	5.6K 5% 1/10W				
		(KV-32FS12/32FS16 ONLY)					
R855	1-216-089-91	RES-CHIP	47K 5% 1/10W				
		(KV-27FV16/29FV16/29FV16C ONLY)					
R855	1-216-091-00	RES-CHIP	56K 5% 1/10W				
		(KV-32FS12/32FS16 ONLY)					
R857	1-208-818-11	METAL CHIP	33K 0.50% 1/10W				
		(KV-32FS12/32FS16 ONLY)					
R860	1-208-806-11	METAL CHIP	10K 0.50% 1/10W				
R862	1-216-057-00	RES-CHIP	2.2K 5% 1/10W				

Note:

The components identified by shading and mark Δ are critical for safety. Replace only with part number specified.

Note:

Les composants identifiés par un trame et une marque Δ sont critiques pour la sécurité. Ne les remplacer que par une pièce portant le numéro spécifié.



REF.NO.	PART NO.	DESCRIPTION	REMARK	REF.NO.	PART NO.	DESCRIPTION	REMARK
R4208	1-247-895-91	CARBON	470K 5% 1/4W	RESISTOR			
R4209	1-249-425-11	CARBON	4.7K 5% 1/4W	R4001	1-216-025-91	RES-CHIP	100 5% 1/10W
R4210	1-249-419-11	CARBON	1.5K 5% 1/4W	R4002	1-216-045-00	RES-CHIP	680 5% 1/10W
R4211	1-249-421-11	CARBON	2.2K 5% 1/4W	R4003	1-216-047-91	RES-CHIP	820 5% 1/10W
R4212	1-249-427-11	CARBON	6.8K 5% 1/4W	R4004	1-216-057-00	RES-CHIP	2.2K 5% 1/10W
				R4005	1-216-069-00	RES-CHIP	6.8K 5% 1/10W
				SWITCH			
SWITCH				S4001	1-762-196-21	SWITCH, TACTILE	
S4217	1-762-196-21	SWITCH, TACTILE		S4002	1-762-196-21	SWITCH, TACTILE	
S4218	1-762-196-21	SWITCH, TACTILE		S4003	1-762-196-21	SWITCH, TACTILE	
S4219	1-762-196-21	SWITCH, TACTILE		S4004	1-762-196-21	SWITCH, TACTILE	
S4220	1-762-196-21	SWITCH, TACTILE		S4005	1-762-196-21	SWITCH, TACTILE	
				S4006	1-762-196-21	SWITCH, TACTILE	
HB				K			
* A-1372-826-A	HB (VAR) MOUNTED PC BOARD	(ALL EXCEPT KV-32FS12/32FS16)		* A-1380-633-A	K (VAR) MOUNTED PC BOARD	(KV-27FV16/29FV16/29FV16C ONLY)	
				* A-1380-632-A	K (VAR) MOUNTED PC BOARD	(KV-32FS12/32FS16 ONLY)	
CAPACITOR				CAPACITOR			
C4050	1-104-665-11	ELECT	100μF 20% 25V	C201	1-126-963-11	ELECT	4.7μF 20% 50V
				C202	1-126-963-11	ELECT	4.7μF 20% 50V
				C404	1-164-182-11	CERAMIC CHIP	0.0033μF 10% 50V
				C405	1-163-034-00	CERAMIC CHIP	0.033μF 50V
				C406	1-163-011-11	CERAMIC CHIP	0.0015μF 10% 50V
				C407	1-164-222-11	CERAMIC CHIP	0.22μF 25V
				C408	1-164-222-11	CERAMIC CHIP	0.22μF 25V
				C409	1-163-011-11	CERAMIC CHIP	0.0015μF 10% 50V
				C410	1-163-034-00	CERAMIC CHIP	0.033μF 50V
				C411	1-164-182-11	CERAMIC CHIP	0.0033μF 10% 50V
CONNECTOR				C412	1-163-038-91	CERAMIC CHIP	0.1μF 25V
CN4050*	1-564-520-11	PLUG, CONNECTOR 5P		C413	1-126-963-11	ELECT	4.7μF 20% 50V
				C414	1-126-963-11	ELECT	4.7μF 20% 50V
DIODE				C415	1-126-963-11	ELECT	4.7μF 20% 50V
D4051	8-719-057-09	DIODE LNJ801LPDJA		C416	1-126-963-11	ELECT	4.7μF 20% 50V
IC				C417	1-126-963-11	ELECT	4.7μF 20% 50V
IC4050	8-742-211-20	HYB IC SBX3071-71		C418	1-163-038-91	CERAMIC CHIP	0.1μF 25V
				C419	1-164-346-11	CERAMIC CHIP	1μF 16V
RESISTOR				C422	1-126-963-11	ELECT	4.7μF 20% 50V
R4050	1-249-401-11	CARBON	47 5% 1/4W	C423	1-126-963-11	ELECT	4.7μF 20% 50V
R4051	1-249-417-11	CARBON	1K 5% 1/4W	C424	1-164-005-11	CERAMIC CHIP	0.47μF 25V
							(KV-27FV16/29FV16/29FV16C ONLY)
				C425	1-164-346-11	CERAMIC CHIP	1μF 16V
							(KV-27FV16/29FV16/29FV16C ONLY)
HX							
* A-1372-817-A	HX MOUNTED PC BOARD						
CONNECTOR							
CN4001	1-564-518-11	PLUG, CONNECTOR 3P					

**Note:**

The components identified by shading and mark \triangle are critical for safety. Replace only with part number specified.

Note:

Les composants identifies per un trame et une marque \triangle sont critiques pour la securite. Ne les remplacer que par une piece portant le numero specifiee.

REF.NO.	PART NO.	DESCRIPTION	REMARK	REF.NO.	PART NO.	DESCRIPTION	REMARK
C426	1-126-960-11	ELECT	1 μ F 20% 50V (KV-27FV16/29FV16/29FV16C ONLY)				
C427	1-126-968-11	ELECT	100 μ F 20% 50V (KV-27FV16/29FV16/29FV16C ONLY)				
C428	1-126-968-11	ELECT	100 μ F 20% 50V (KV-27FV16/29FV16/29FV16C ONLY)				
C429	1-163-017-00	CERAMIC CHIP	0.0047 μ F 10% 50V (KV-27FV16/29FV16/29FV16C ONLY)				
C430	1-164-222-11	CERAMIC CHIP	0.22 μ F 25V (KV-27FV16/29FV16/29FV16C ONLY)				
C431	1-163-038-91	CERAMIC CHIP	0.1 μ F 25V (KV-27FV16/29FV16/29FV16C ONLY)				
C432	1-163-021-91	CERAMIC CHIP	0.01 μ F 10% 50V (KV-27FV16/29FV16/29FV16C ONLY)				
C433	1-164-346-11	CERAMIC CHIP	1 μ F 16V (KV-27FV16/29FV16/29FV16C ONLY)				
C434	1-163-038-91	CERAMIC CHIP	0.1 μ F 25V (KV-27FV16/29FV16/29FV16C ONLY)				
C440	1-163-038-91	CERAMIC CHIP	0.1 μ F 25V				
C441	1-126-968-11	ELECT	100 μ F 20% 50V				
C442	1-216-295-91	SHORT					
C444	1-216-295-91	SHORT					
C446	1-126-933-11	ELECT	100 μ F 20% 16V				
C447	1-126-961-11	ELECT	2.2 μ F 20% 50V				
C448	1-126-961-11	ELECT	2.2 μ F 20% 50V				
C450	1-126-963-11	ELECT	4.7 μ F 20% 50V				
C451	1-126-963-11	ELECT	4.7 μ F 20% 50V				
C455	1-164-005-11	CERAMIC CHIP	0.47 μ F 25V (KV-27FV16/29FV16/29FV16C ONLY)				
C456	1-163-021-91	CERAMIC CHIP	0.01 μ F 10% 50V (KV-27FV16/29FV16/29FV16C ONLY)				
C457	1-163-034-00	CERAMIC CHIP	0.033 μ F 50V (KV-27FV16/29FV16/29FV16C ONLY)				
C458	1-126-963-11	ELECT	4.7 μ F 20% 50V (KV-27FV16/29FV16/29FV16C ONLY)				
C460	1-126-963-11	ELECT	4.7 μ F 20% 50V (KV-27FV16/29FV16/29FV16C ONLY)				
C475	1-163-038-91	CERAMIC CHIP	0.1 μ F 25V				
C490	1-216-295-91	SHORT					
CONNECTOR							
CN402 *	1-564-506-11	PLUG, CONNECTOR 3P					
CN450	1-573-301-21	CONNECTOR, BOARD TO BOARD 20P					
IC							
IC403	8-759-658-19	IC NJM2198-TE2 (KV-27FV16/29FV16/29FV16C ONLY)					
IC404	8-759-658-01	IC NJW1130G-TE2					
				CHIP CONDUCTOR			
				JR403	1-216-295-91	SHORT	
				JR404	1-216-295-91	SHORT	
				JR420	1-216-295-91	SHORT	
				JR421	1-216-295-91	SHORT	
				JR422	1-216-295-91	SHORT	
				JR423	1-216-295-91	SHORT	
				JR425	1-216-295-91	SHORT	
				JR426	1-216-295-91	SHORT	
				JR427	1-216-295-91	SHORT	
				JR428	1-216-295-91	SHORT	
				JR429	1-216-295-91	SHORT	
				JR452	1-216-295-91	SHORT	
				JR474	1-216-295-91	SHORT	
				JR477	1-216-295-91	SHORT	
				JR491	1-216-295-91	SHORT	
				COIL			
				L410	1-414-271-11	INDUCTOR	47 μ H
				TRANSISTOR			
				Q430	8-729-422-27	TRANSISTOR 2SD601A-QRS-TX	
				Q431	8-729-422-27	TRANSISTOR 2SD601A-QRS-TX	
				Q432	8-729-216-22	TRANSISTOR 2SB709A-QRS-TX	
				Q433	8-729-216-22	TRANSISTOR 2SB709A-QRS-TX	
				RESISTOR			
				R403	1-216-025-91	RES-CHIP	100 5% 1/10W
				R404	1-216-025-91	RES-CHIP	100 5% 1/10W
				R405	1-216-025-91	RES-CHIP	100 5% 1/10W
				R407	1-216-025-91	RES-CHIP	100 5% 1/10W
				R408	1-216-025-91	RES-CHIP	100 5% 1/10W
				R409	1-216-025-91	RES-CHIP	100 5% 1/10W
				R410	1-216-025-91	RES-CHIP	100 5% 1/10W
				R431	1-216-073-00	RES-CHIP	10K 5% 1/10W
				R432	1-216-073-00	RES-CHIP	10K 5% 1/10W
				R433	1-216-073-00	RES-CHIP	10K 5% 1/10W
				R434	1-216-065-91	RES-CHIP	4.7K 5% 1/10W
				R435	1-216-033-00	RES-CHIP	220 5% 1/10W
				R436	1-216-065-91	RES-CHIP	4.7K 5% 1/10W
				R437	1-216-033-00	RES-CHIP	220 5% 1/10W
				R438	1-216-033-00	RES-CHIP	220 5% 1/10W
				R440	1-216-105-91	RES-CHIP	220K 5% 1/10W
				R441	1-216-105-91	RES-CHIP	220K 5% 1/10W
				R442	1-216-033-00	RES-CHIP	220 5% 1/10W
				R443	1-216-105-91	RES-CHIP	220K 5% 1/10W
				R444	1-216-105-91	RES-CHIP	220K 5% 1/10W

Note:

The components identified by shading and mark \triangle are critical for safety. Replace only with part number specified.

Note:

Les composants identifiés par un trame et une marque \triangle sont critiques pour la sécurité. Ne les remplacer que par une pièce portant le numéro spécifié.



REF.NO.	PART NO.	DESCRIPTION	REMARK	REF.NO.	PART NO.	DESCRIPTION	REMARK
R445	1-216-105-91	RES-CHIP	220K 5% 1/10W	C045	1-164-161-11	CERAMIC CHIP	0.0022μF 10% 50V
R446	1-216-105-91	RES-CHIP	220K 5% 1/10W	C046	1-104-664-11	ELECT	47μF 20% 25V
R452	1-216-073-00	RES-CHIP (KV-27FV16/29FV16/29FV16C ONLY)	10K 5% 1/10W	C047	1-163-259-91	CERAMIC CHIP	220PF 5% 50V
R455	1-216-025-91	RES-CHIP	100 5% 1/10W	C048	1-163-259-91	CERAMIC CHIP	220PF 5% 50V
R456	1-216-025-91	RES-CHIP	100 5% 1/10W	C051	1-126-935-11	ELECT	470μF 20% 16V
R477	1-216-105-91	RES-CHIP	220K 5% 1/10W	C060	1-163-005-11	CERAMIC CHIP	470PF 10% 50V
R478	1-216-105-91	RES-CHIP	220K 5% 1/10W	C062	1-126-959-11	ELECT	0.47μF 20% 50V
				C063	1-137-194-81	MYLAR	0.47μF 5% 50V
				C064	1-163-017-00	CERAMIC CHIP	0.0047μF 10% 50V
				C070	1-163-009-11	CERAMIC CHIP	0.001μF 10% 50V
				C071	1-163-009-11	CERAMIC CHIP	0.001μF 10% 50V
				C076	1-163-259-91	CERAMIC CHIP	220PF 5% 50V
				C077	1-163-259-91	CERAMIC CHIP	220PF 5% 50V
				C091	1-163-037-11	CERAMIC CHIP	0.022μF 10% 50V
				C093	1-163-259-91	CERAMIC CHIP	220PF 5% 50V
				C097	1-163-009-11	CERAMIC CHIP	0.001μF 10% 50V
				C099	1-126-960-11	ELECT	1μF 20% 50V
				C151	1-126-960-11	ELECT	1μF 20% 50V
						(ALL EXCEPT KV-32FS12)	
				C153	1-163-017-00	CERAMIC CHIP	0.0047μF 10% 50V
						(ALL EXCEPT KV-32FS12)	
				C154	1-126-967-11	ELECT	47μF 20% 50V
						(ALL EXCEPT KV-32FS12)	
				C155	1-126-964-11	ELECT	10μF 20% 50V
						(ALL EXCEPT KV-32FS12)	
				C156	1-104-664-11	ELECT	47μF 20% 25V
						(ALL EXCEPT KV-32FS12)	
				C157	1-126-968-11	ELECT	100μF 20% 50V
						(ALL EXCEPT KV-32FS12)	
				C302	1-163-021-91	CERAMIC CHIP	0.01μF 10% 50V
						(KV-32FS12/32FS16 ONLY)	
				C303	1-163-021-91	CERAMIC CHIP	0.01μF 10% 50V
						(KV-32FS12/32FS16 ONLY)	
				C304	1-163-021-91	CERAMIC CHIP	0.01μF 10% 50V
						(KV-32FS12/32FS16 ONLY)	
				C305	1-126-933-11	ELECT	100μF 20% 16V
						(KV-32FS12/32FS16 ONLY)	
				C306	1-164-346-11	CERAMIC CHIP	1μF 16V
						(KV-27FV16/29FV16/29FV16C ONLY)	
				C307	1-163-227-11	CERAMIC CHIP	10PF 0.50PF 50V
						(KV-32FS12/32FS16 ONLY)	
				C308	1-163-021-91	CERAMIC CHIP	0.01μF 10% 50V
						(KV-32FS12/32FS16 ONLY)	
				C309	1-126-933-11	ELECT	100μF 20% 16V
						(KV-32FS12/32FS16 ONLY)	
				C310	1-126-960-11	ELECT	1μF 20% 50V
				C311	1-163-123-00	CERAMIC CHIP	180PF 5% 50V
						(KV-32FS12/32FS16 ONLY)	
				C312	1-164-005-11	CERAMIC CHIP	0.47μF 25V
				C313	1-163-021-91	CERAMIC CHIP	0.01μF 10% 50V
				C314	1-163-231-11	CERAMIC CHIP	15PF 5% 50V
						(KV-32FS12/32FS16 ONLY)	

MA

- * A-1304-202-A MA (VAR) MOUNTED PC BOARD
(KV-27FV16/29FV16/29FV16C ONLY)
- * A-1304-203-A MA (VAR) MOUNTED PC BOARD
(KV-32FS12 ONLY)
- * A-1304-196-A MA (VAR) MOUNTED PC BOARD
(KV-32FS16 ONLY)

CAPACITOR

C003	1-126-959-11	ELECT	0.47μF	20%	50V
C005	1-164-005-11	CERAMIC CHIP	0.47μF		25V
					(ALL EXCEPT KV-32FS12)
C006	1-126-964-11	ELECT	10μF	20%	50V
C009	1-163-259-91	CERAMIC CHIP	220PF	5%	50V
C010	1-163-035-00	CERAMIC CHIP	0.047μF		50V
C011	1-163-259-91	CERAMIC CHIP	220PF	5%	50V
C012	1-163-009-11	CERAMIC CHIP	0.001μF	10%	50V
C015	1-163-231-11	CERAMIC CHIP	15PF	5%	50V
C016	1-163-231-11	CERAMIC CHIP	15PF	5%	50V
C017	1-126-960-11	ELECT	1μF	20%	50V
C019	1-163-259-91	CERAMIC CHIP	220PF	5%	50V
C020	1-163-038-91	CERAMIC CHIP	0.1μF		25V
C021	1-163-259-91	CERAMIC CHIP	220PF	5%	50V
C022	1-163-135-00	CERAMIC CHIP	560PF	5%	50V
C027	1-163-009-11	CERAMIC CHIP	0.001μF	10%	50V
C028	1-163-259-91	CERAMIC CHIP	220PF	5%	50V
C032	1-164-004-11	CERAMIC CHIP	0.1μF	10%	25V
C033	1-163-259-91	CERAMIC CHIP	220PF	5%	50V
C034	1-163-037-11	CERAMIC CHIP	0.022μF	10%	50V
C037	1-164-161-11	CERAMIC CHIP	0.0022μF	10%	50V
C038	1-126-935-11	ELECT	470μF	20%	16V
C039	1-126-964-11	ELECT	10μF	20%	50V
C040	1-163-229-11	CERAMIC CHIP	12PF	5%	50V
C041	1-163-229-11	CERAMIC CHIP	12PF	5%	50V
C042	1-163-259-91	CERAMIC CHIP	220PF	5%	50V
C043	1-163-009-11	CERAMIC CHIP	0.001μF	10%	50V
C044	1-163-009-11	CERAMIC CHIP	0.001μF	10%	50V

**Note:**

The components identified by shading and mark \triangle are critical for safety. Replace only with part number specified.

Note:

Les composants identifiés par un trame et une marque \triangle sont critiques pour la sécurité. Ne les remplacer que par une pièce portant le numéro spécifié.

REF.NO.	PART NO.	DESCRIPTION	REMARK	REF.NO.	PART NO.	DESCRIPTION	REMARK
C315	1-104-664-11	ELECT	47 μ F 20% 25V	C360	1-126-959-11	ELECT	0.47 μ F 20% 50V
C316	1-163-243-11	CERAMIC CHIP	47PF 5% 50V	C361	1-163-038-91	CERAMIC CHIP	0.1 μ F 25V
C317	1-163-021-91	CERAMIC CHIP	0.01 μ F 10% 50V	C362	1-104-664-11	ELECT	47 μ F 20% 25V
		(KV-32FS12/32FS16 ONLY)		C363	1-163-038-91	CERAMIC CHIP	0.1 μ F 25V
C318	1-163-021-91	CERAMIC CHIP	0.01 μ F 10% 50V	C364	1-164-004-11	CERAMIC CHIP	0.1 μ F 10% 25V
C319	1-126-767-11	ELECT	1000 μ F 20% 16V				
				C365	1-137-194-81	MYLAR	0.47 μ F 5% 50V
C320	1-164-005-11	CERAMIC CHIP	0.47 μ F 25V	C366	1-163-021-91	CERAMIC CHIP	0.01 μ F 10% 50V
C321	1-164-005-11	CERAMIC CHIP	0.47 μ F 25V			(KV-32FS12/32FS16 ONLY)	
C322	1-164-005-11	CERAMIC CHIP	0.47 μ F 25V	C367	1-163-005-11	CERAMIC CHIP	470PF 10% 50V
C323	1-164-004-11	CERAMIC CHIP	0.1 μ F 10% 25V	C368	1-163-021-91	CERAMIC CHIP	0.01 μ F 10% 50V
C324	1-163-231-11	CERAMIC CHIP	15PF 5% 50V			(KV-32FS12/32FS16 ONLY)	
		(KV-32FS12/32FS16 ONLY)		C369	1-163-021-91	CERAMIC CHIP	0.01 μ F 10% 50V
						(KV-32FS12/32FS16 ONLY)	
C325	1-164-005-11	CERAMIC CHIP	0.47 μ F 25V				
C326	1-164-004-11	CERAMIC CHIP	0.1 μ F 10% 25V	C370	1-126-933-11	ELECT	100 μ F 20% 16V
C328	1-164-004-11	CERAMIC CHIP	0.1 μ F 10% 25V	C371	1-163-243-11	CERAMIC CHIP	47PF 5% 50V
C329	1-164-004-11	CERAMIC CHIP	0.1 μ F 10% 25V	C377	1-126-963-11	ELECT	4.7 μ F 20% 50V
C330	1-126-960-11	ELECT	1 μ F 20% 50V	C380	1-163-021-91	CERAMIC CHIP	0.01UF 10% 50V
						(KV-32FS12 ONLY)	
C331	1-163-021-91	CERAMIC CHIP	0.01 μ F 10% 50V	C381	1-163-021-91	CERAMIC CHIP	0.01UF 10% 50V
C332	1-163-010-11	CERAMIC CHIP	0.0012 μ F 10% 50V			(KV-32FS12 ONLY)	
		(KV-32FS12/32FS16 ONLY)		C382	1-163-021-91	CERAMIC CHIP	0.01UF 10% 50V
C334	1-163-003-11	CERAMIC CHIP	330PF 10% 50V			(KV-32FS12 ONLY)	
C335	1-126-963-11	ELECT	4.7 μ F 20% 50V	C389	1-115-185-11	CERAMIC CHIP	0.033 μ F 10% 50V
C336	1-104-664-11	ELECT	47 μ F 20% 25V			(KV-27FV16/29FV16/29FV16C ONLY)	
		(KV-32FS12/32FS16 ONLY)		C389	1-104-760-11	CERAMIC CHIP	0.047UF 10% 50V
						(KV-32FS12/32FS16 ONLY)	
C338	1-164-004-11	CERAMIC CHIP	0.1 μ F 10% 25V	C390	1-163-231-11	CERAMIC CHIP	15PF 5% 50V
C339	1-126-960-11	ELECT	1 μ F 20% 50V			(KV-32FS12/32FS16 ONLY)	
				C391	1-126-933-11	ELECT	100 μ F 20% 16V
C340	1-126-933-11	ELECT	100 μ F 20% 16V			(KV-32FS12/32FS16 ONLY)	
		(KV-32FS12/32FS16 ONLY)		C341	1-163-233-11	CERAMIC CHIP	18PF 5% 50V
C341	1-163-233-11	CERAMIC CHIP	18PF 5% 50V	C345	1-163-021-91	CERAMIC CHIP	0.01 μ F 10% 50V
C345	1-163-021-91	CERAMIC CHIP	0.01 μ F 10% 50V			(ALL EXCEPT KV-32FS12)	
		(ALL EXCEPT KV-32FS12)		C346	1-163-021-91	CERAMIC CHIP	0.01 μ F 10% 50V
						(ALL EXCEPT KV-32FS12)	
C347	1-163-021-91	CERAMIC CHIP	0.01 μ F 10% 50V			(ALL EXCEPT KV-32FS12)	
C348	1-164-005-11	CERAMIC CHIP	0.47 μ F 25V	C348	1-164-005-11	CERAMIC CHIP	0.47 μ F 25V
C350	1-126-959-11	ELECT	0.47 μ F 20% 50V	C350	1-126-959-11	ELECT	0.47 μ F 20% 50V
		(KV-32FS12/32FS16 ONLY)				(KV-32FS12/32FS16 ONLY)	
C351	1-163-021-91	CERAMIC	0.01 μ F 10% 50V	C351	1-163-021-91	CERAMIC	0.01 μ F 10% 50V
		(KV-32FS12/32FS16 ONLY)				(KV-32FS12/32FS16 ONLY)	
C352	1-163-021-91	CERAMIC CHIP	0.01 μ F 10% 50V	C352	1-163-021-91	CERAMIC CHIP	0.01 μ F 10% 50V
C353	1-163-021-91	CERAMIC CHIP	0.01 μ F 10% 50V	C353	1-163-021-91	CERAMIC CHIP	0.01 μ F 10% 50V
C354	1-126-933-11	ELECT	100 μ F 20% 16V	C354	1-126-933-11	ELECT	100 μ F 20% 16V
		(KV-32FS12/32FS16 ONLY)				(KV-32FS12/32FS16 ONLY)	
C355	1-163-021-91	CERAMIC CHIP	0.01 μ F 10% 50V	C355	1-163-021-91	CERAMIC CHIP	0.01 μ F 10% 50V
		(KV-32FS12/32FS16 ONLY)				(KV-32FS12/32FS16 ONLY)	
C356	1-164-004-11	CERAMIC CHIP	0.1 μ F 10% 25V	C356	1-164-004-11	CERAMIC CHIP	0.1 μ F 10% 25V
C357	1-104-664-11	ELECT	47 μ F 20% 25V	C357	1-104-664-11	ELECT	47 μ F 20% 25V
C358	1-104-664-11	ELECT	47 μ F 20% 25V	C358	1-104-664-11	ELECT	47 μ F 20% 25V
C359	1-163-038-91	CERAMIC CHIP	0.1 μ F 25V	C359	1-163-038-91	CERAMIC CHIP	0.1 μ F 25V
				CONNECTOR			
				CN001	1-764-334-11	PLUG, CONNECTOR 11P	(KV-27FV16/29FV16/29FV16C ONLY)
				CN001 *	1-564-511-11	PLUG, CONNECTOR 8P	(KV-32FS12/32FS16 ONLY)
				CN002 *	1-560-124-00	PLUG, CONNECTOR (2.5MM) 4P	
				CN003 *	1-564-512-11	PLUG, CONNECTOR 9P	

Note:

The components identified by shading and mark \triangle are critical for safety. Replace only with part number specified.

Note:

Les composants identifiés par un trame et une marque \triangle sont critiques pour la sécurité. Ne les remplacer que par une pièce portant le numéro spécifié.



REF.NO.	PART NO.	DESCRIPTION	REMARK	REF.NO.	PART NO.	DESCRIPTION	REMARK
CN004 *	1-564-512-11	PLUG, CONNECTOR 9P		IC301 \triangle	8-752-098-86	IC CXA2154S	
CN005 *	1-764-333-11	PLUG, CONNECTOR 10P				(ALL EXCEPT KV-32FS12)	
CN006 *	1-764-333-11	PLUG, CONNECTOR 10P		IC301 \triangle	8-752-094-98	IC CXA2154S	
CN302 *	1-564-507-11	PLUG, CONNECTOR 4P				(KV-32FS12 ONLY)	
CN304 *	1-564-507-11	PLUG, CONNECTOR 4P (ALL EXCEPT KV-32FS12)		IC302	8-759-655-75	IC TC90A49P	
						(KV-32FS12/32FS16 ONLY)	
CN305	1-573-298-21	CONNECTOR, BOARD TO BOARD 20P (ALL EXCEPT KV-32FS12)		CHIP CONDUCTOR			
CN306 *	1-691-616-21	CONNECTOR, BOARD TO BOARD 15P (KV-27FV16/29FV16/29FV16C ONLY)		JR001	1-216-295-91	SHORT	
CN309 *	1-564-506-11	PLUG, CONNECTOR 3P		JR002	1-216-295-91	SHORT	
CN401 *	1-564-505-11	PLUG, CONNECTOR 2P (ALL EXCEPT KV-32FS12)		JR003	1-216-295-91	SHORT	
				JR005	1-216-295-91	SHORT	
				JR006	1-216-295-91	SHORT	
				JR007	1-216-295-91	SHORT	
				JR008	1-216-295-91	SHORT	
				JR010	1-216-295-91	SHORT	
				JR011	1-216-295-91	SHORT	
				JR090	1-216-295-91	SHORT	
				JR100	1-216-295-91	SHORT	
				JR101	1-216-295-91	SHORT	
				JR296	1-216-295-91	SHORT	
				JR297	1-216-295-91	SHORT	
				JR298	1-216-295-91	SHORT	
				JR350	1-216-295-91	SHORT	
				JR378	1-216-295-91	SHORT	
				JR379	1-216-295-91	SHORT	
				JR399	1-216-295-91	SHORT	
				JR401	1-216-295-91	SHORT	
				COIL			
				L002	1-414-273-11	INDUCTOR	100 μ H
				L003	1-414-273-11	INDUCTOR	100 μ H
				L040	1-408-963-11	INDUCTOR	2.7 μ H
				L150	1-414-267-11	INDUCTOR	10 μ H
						(ALL EXCEPT KV-32FS12)	
				L151	1-414-273-11	INDUCTOR	100 μ H
						(ALL EXCEPT KV-32FS12)	
				L301	1-414-267-11	INDUCTOR	10 μ H
				L302	1-414-271-11	INDUCTOR	47 μ H
				L303	1-414-856-11	INDUCTOR	10 μ H
						(KV-32FS12/32FS16 ONLY)	
				L304	1-414-856-11	INDUCTOR	10 μ H
						(KV-32FS12/32FS16 ONLY)	
				L305	1-414-267-11	INDUCTOR	10 μ H
				L308	1-414-273-11	INDUCTOR	100 μ H
				L310	1-414-273-11	INDUCTOR	100 μ H
				L350	1-414-856-11	INDUCTOR	10 μ H
						(KV-32FS12/32FS16 ONLY)	
				L351	1-414-856-11	INDUCTOR	10 μ H
						(KV-32FS12/32FS16 ONLY)	
DIODE							
D001	8-719-976-99	DIODE UDZ-TE-17-5.1B					
D002	8-719-110-17	DIODE MTZJ-T-77-10B					
D003	8-719-073-01	DIODE MA111-TX					
D004	8-719-976-99	DIODE UDZ-TE-17-5.1B					
D005	8-719-109-89	DIODE MTZJ-T-77-5.6C					
D006	8-719-977-22	DIODE UDZ-TE-17-9.1B					
D075	8-719-073-01	DIODE MA111-TX					
D301	8-719-921-44	DIODE MTZJ-T-77-5.1C					
D303	8-719-991-33	DIODE 1SS133T-77 (ALL EXCEPT KV-32FS12)					
D304	8-719-981-99	DIODE MTZJ-T-77-3.3 (KV-27FV16/29FV16/29FV16C ONLY)					
D305	8-719-921-44	DIODE MTZJ-T-77-5.1C					
D360	8-719-914-44	DIODE DAP202K-T-146					
FERRITE BEAD							
FB001	1-414-234-22	INDUCTOR CHIP	0 μ H				
FB002	1-414-234-22	INDUCTOR CHIP	0 μ H				
FB301	1-412-911-11	FERRITE (KV-32FS12/32FS16 ONLY)	0 μ H				
FILTER							
FL301	1-239-847-11	FILTER, LOW PASS (KV-32FS12/32FS16 ONLY)					
FL302	1-239-847-11	FILTER, LOW PASS (KV-32FS12/32FS16 ONLY)					
FL303	1-239-847-11	FILTER, LOW PASS (KV-32FS12/32FS16 ONLY)					
IC							
IC001	8-759-680-52	IC M37280MK-111SP					
IC002	8-759-663-29	IC MM1476AF(TP)					
IC003	8-759-527-77	IC M24C16-MN6T					



Note:

The components identified by shading and mark \triangle are critical for safety. Replace only with part number specified.

Note:

Les composants identifiés par un trame et une marque \triangle sont critiques pour la sécurité. Ne les remplacer que par une pièce portant le numéro spécifié.

REF.NO.	PART NO.	DESCRIPTION	REMARK	REF.NO.	PART NO.	DESCRIPTION	REMARK
L356	1-216-296-91	SHORT (ALL EXCEPT KV-32FS12)		Q375	8-729-422-27	TRANSISTOR 2SD601A-QRS-TX	
L357	1-216-296-91	SHORT (ALL EXCEPT KV-32FS12)		Q378	8-729-216-22	TRANSISTOR 2SB709A-QRS-TX (ALL EXCEPT KV-32FS12)	
TRANSISTOR				Q379	8-729-216-22	TRANSISTOR 2SB709A-QRS-TX (KV-27FV16/29FV16/29FV16C ONLY)	
Q001	8-729-216-22	TRANSISTOR 2SB709A-QRS-TX		Q380	8-729-216-22	TRANSISTOR 2SB709A-QRS-TX (KV-27FV16/29FV16/29FV16C ONLY)	
Q002	8-729-422-27	TRANSISTOR 2SD601A-QRS-TX		Q387	8-729-216-22	TRANSISTOR 2SB709A-QRS-TX	
Q003	8-729-422-27	TRANSISTOR 2SD601A-QRS-TX		Q388	8-729-216-22	TRANSISTOR 2SB709A-QRS-TX	
Q004	8-729-216-22	TRANSISTOR 2SB709A-QRS-TX		Q389	8-729-216-22	TRANSISTOR 2SB709A-QRS-TX	
Q006	8-729-216-22	TRANSISTOR 2SB709A-QRS-TX		RESISTOR			
Q082	8-729-422-27	TRANSISTOR 2SD601A-QRS-TX		R001	1-216-043-91	RES-CHIP	560 5% 1/10W
Q151	8-729-216-22	TRANSISTOR 2SB709A-QRS-TX (ALL EXCEPT KV-32FS12)		R002	1-216-041-00	RES-CHIP	470 5% 1/10W
Q152	8-729-422-27	TRANSISTOR 2SD601A-QRS-TX (ALL EXCEPT KV-32FS12)		R003	1-247-807-31	CARBON	100 5% 1/4W
Q301	8-729-422-27	TRANSISTOR 2SD601A-QRS-TX (KV-27FV16/29FV16/29FV16C ONLY)		R004	1-216-061-00	RES-CHIP	3.3K 5% 1/10W
Q302	8-729-422-27	TRANSISTOR 2SD601A-QRS-TX (KV-32FS12/32FS16 ONLY)		R005	1-216-295-91	SHORT	
Q303	8-729-216-22	TRANSISTOR 2SB709A-QRS-TX		R006	1-216-025-91	RES-CHIP	100 5% 1/10W
Q304	8-729-422-27	TRANSISTOR 2SD601A-QRS-TX (KV-27FV16/29FV16/29FV16C ONLY)		R007	1-216-025-91	RES-CHIP	100 5% 1/10W
Q305	8-729-216-22	TRANSISTOR 2SB709A-QRS-TX		R008	1-216-049-91	RES-CHIP	1K 5% 1/10W
Q306	8-729-216-22	TRANSISTOR 2SB709A-QRS-TX (KV-27FV16/29FV16/29FV16C ONLY)		R009	1-216-121-91	RES-CHIP	1M 5% 1/10W
Q310	8-729-216-22	TRANSISTOR 2SB709A-QRS-TX (KV-32FS12/32FS16 ONLY)		R010	1-216-033-00	RES-CHIP	220 5% 1/10W
Q349	8-729-422-27	TRANSISTOR 2SD601A-QRS-TX (KV-32FS12/32FS16 ONLY)		R011	1-216-033-00	RES-CHIP	220 5% 1/10W
Q350	8-729-216-22	TRANSISTOR 2SB709A-QRS-TX (KV-32FS12/32FS16 ONLY)		R012	1-216-045-00	RES-CHIP	680 5% 1/10W
Q351	8-729-216-22	TRANSISTOR 2SB709A-QRS-TX (KV-32FS12/32FS16 ONLY)		R013	1-249-417-11	CARBON	1K 5% 1/4W
Q352	8-729-422-27	TRANSISTOR 2SD601A-QRS-TX (KV-32FS12/32FS16 ONLY)		R014	1-216-073-00	RES-CHIP	10K 5% 1/10W
Q354	8-729-216-22	TRANSISTOR 2SB709A-QRS-TX (KV-32FS12/32FS16 ONLY)		R015	1-216-073-00	RES-CHIP	10K 5% 1/10W
Q355	8-729-216-22	TRANSISTOR 2SB709A-QRS-TX (KV-32FS12/32FS16 ONLY)		R016	1-216-041-00	RES-CHIP	470 5% 1/10W
Q356	8-729-422-27	TRANSISTOR 2SD601A-QRS-TX		R017	1-208-798-11	METAL CHIP	4.7K 0.50% 1/10W
Q358	8-729-422-27	TRANSISTOR 2SD601A-QRS-TX (KV-32FS12/32FS16 ONLY)		R018	1-247-815-91	CARBON	220 5% 1/4W
Q359	8-729-216-22	TRANSISTOR 2SB709A-QRS-TX (KV-32FS12/32FS16 ONLY)		R019	1-216-113-00	RES-CHIP	470K 5% 1/10W
Q365	8-729-422-27	TRANSISTOR 2SD601A-QRS-TX		R020	1-216-033-00	RES-CHIP	220 5% 1/10W
Q369	8-729-216-22	TRANSISTOR 2SB709A-QRS-TX (KV-32FS12/32FS16 ONLY)		R021	1-249-429-11	CARBON	10K 5% 1/4W
Q368	8-729-422-27	TRANSISTOR 2SD601A-QRS-TX		R022	1-247-815-91	CARBON	220 5% 1/4W
Q370	8-729-216-22	TRANSISTOR 2SB709A-QRS-TX (KV-32FS12/32FS16 ONLY)		R023	1-249-429-11	CARBON	10K 5% 1/4W
				R024	1-247-815-91	CARBON	220 5% 1/4W
				R025	1-249-426-11	CARBON	5.6K 5% 1/4W
				R026	1-249-426-11	CARBON	5.6K 5% 1/4W
				R027	1-249-426-11	CARBON	5.6K 5% 1/4W
				R028	1-216-049-91	RES-CHIP	1K 5% 1/10W
				R029	1-216-065-91	RES-CHIP	4.7K 5% 1/10W
				R030	1-216-065-91	RES-CHIP	4.7K 5% 1/10W
				R031	1-216-355-11	METAL OXIDE	3.3 5% 1W
				R032	1-216-033-00	RES-CHIP	220 5% 1/10W
				R033	1-216-033-00	RES-CHIP	220 5% 1/10W
				R034	1-216-033-00	RES-CHIP	220 5% 1/10W
				R035	1-216-033-00	RES-CHIP	220 5% 1/10W
				R036	1-216-049-91	RES-CHIP	1K 5% 1/10W
				R037	1-247-815-91	CARBON	220 5% 1/4W
				R038	1-216-049-91	RES-CHIP	1K 5% 1/10W

Note:

The components identified by shading and mark \triangle are critical for safety. Replace only with part number specified.

Note:

Les composants identifiés par un trame et une marque \triangle sont critiques pour la sécurité. Ne les remplacer que par une pièce portant le numéro spécifié.



REF.NO.	PART NO.	DESCRIPTION	REMARK	REF.NO.	PART NO.	DESCRIPTION	REMARK
R039	1-216-045-00	RES-CHIP	680 5% 1/10W	R155	1-216-043-91	RES-CHIP 560 5% 1/10W	
R040	1-247-815-91	CARBON	220 5% 1/4W			(ALL EXCEPT KV-32FS12)	
R041	1-216-045-00	RES-CHIP	680 5% 1/10W	R156	1-216-085-00	RES-CHIP 33K 5% 1/10W	
R042	1-216-071-00	RES-CHIP	8.2K 5% 1/10W			(ALL EXCEPT KV-32FS12)	
R043	1-249-417-11	CARBON	1K 5% 1/4W	R157	1-216-081-00	RES-CHIP 22K 5% 1/10W	
						(ALL EXCEPT KV-32FS12)	
R044	1-216-033-00	RES-CHIP	220 5% 1/10W	R158	1-216-025-91	RES-CHIP 100 5% 1/10W	
R045	1-216-065-91	RES-CHIP	4.7K 5% 1/10W			(ALL EXCEPT KV-32FS12)	
R046	1-216-033-00	RES-CHIP	220 5% 1/10W	R159	1-216-025-91	RES-CHIP 100 5% 1/10W	
R047	1-216-065-91	RES-CHIP	4.7K 5% 1/10W			(ALL EXCEPT KV-32FS12)	
R048	1-216-025-91	RES-CHIP	100 5% 1/10W				
		(ALL EXCEPT KV-32FS12)		R251	1-216-065-91	RES-CHIP 4.7K 5% 1/10W	
R050	1-216-033-00	RES-CHIP	220 5% 1/10W	R253	1-216-049-91	RES-CHIP 1K 5% 1/10W	
R051	1-216-033-00	RES-CHIP	220 5% 1/10W	R256	1-216-073-00	RES-CHIP 10K 5% 1/10W	
R052	1-249-417-11	CARBON	1K 5% 1/4W	R257	1-216-049-91	RES-CHIP 1K 5% 1/10W	
R054	1-216-065-91	RES-CHIP	4.7K 5% 1/10W	R258	1-216-065-91	RES-CHIP 4.7K 5% 1/10W	
R055	1-216-065-91	RES-CHIP	4.7K 5% 1/10W				
R056	1-208-798-11	METAL CHIP	4.7K 0.50% 1/10W	R259	1-249-429-11	CARBON 10K 5% 1/4W	
R057	1-216-065-91	RES-CHIP	4.7K 5% 1/10W	R260	1-247-815-91	CARBON 220 5% 1/4W	
R058	1-216-065-91	RES-CHIP	4.7K 5% 1/10W	R261	1-216-113-00	RES-CHIP 470K 5% 1/10W	
R060	1-247-815-91	CARBON	220 5% 1/4W	R262	1-247-807-31	CARBON 100 5% 1/4W	
R061	1-216-033-00	RES-CHIP	220 5% 1/10W	R263	1-216-025-91	RES-CHIP 100 5% 1/10W	
R064	1-216-295-91	SHORT		R264	1-216-081-00	RES-CHIP 22K 5% 1/10W	
R069	1-247-815-91	CARBON	220 5% 1/4W			(ALL EXCEPT KV-32FS12)	
		(ALL EXCEPT KV-32FS12)		R266	1-216-081-00	RES-CHIP 22K 5% 1/10W	
R070	1-216-065-91	RES-CHIP	4.7K 5% 1/10W			(ALL EXCEPT KV-32FS12)	
R071	1-216-065-91	RES-CHIP	4.7K 5% 1/10W	R267	1-216-049-91	RES-CHIP 1K 5% 1/10W	
R073	1-249-425-11	CARBON	4.7K 5% 1/4W	R268	1-216-045-00	RES-CHIP 680 5% 1/10W	
				R269	1-216-049-91	RES-CHIP 1K 5% 1/10W	
R074	1-216-065-91	RES-CHIP	4.7K 5% 1/10W				
R077	1-216-097-91	RES-CHIP	100K 5% 1/10W	R270	1-216-081-00	RES-CHIP 22K 5% 1/10W	
R085	1-216-065-91	RES-CHIP	4.7K 5% 1/10W			(ALL EXCEPT KV-32FS12)	
		(KV-27FV16/29FV16/29FV16C ONLY)		R272	1-216-081-00	RES-CHIP 22K 5% 1/10W	
R086	1-216-045-00	RES-CHIP	680 5% 1/10W			(ALL EXCEPT KV-32FS12)	
R087	1-216-045-00	RES-CHIP	680 5% 1/10W	R273	1-216-073-00	RES-CHIP 10K 5% 1/10W	
				R274	1-216-295-91	SHORT	
R088	1-216-045-00	RES-CHIP	680 5% 1/10W				
R089	1-216-033-00	RES-CHIP	220 5% 1/10W	R275	1-216-081-00	RES-CHIP 22K 5% 1/10W	
		(KV-27FV16/29FV16/29FV16C ONLY)				(KV-32FS12/32FS16 ONLY)	
R091	1-216-073-00	RES-CHIP	10K 5% 1/10W	R276	1-216-085-00	RES-CHIP 33K 5% 1/10W	
R092	1-208-798-11	METAL CHIP	4.7K 0.50% 1/10W	R277	1-216-129-00	RES-CHIP 2.2M 5% 1/10W	
R093	1-216-065-91	RES-CHIP	4.7K 5% 1/10W			(KV-27FV16/29FV16/29FV16C ONLY)	
				R277	1-216-133-00	RES-CHIP 3.3M 5% 1/10W	
R094	1-216-065-91	RES-CHIP	4.7K 5% 1/10W			(KV-32FS12/32FS16 ONLY)	
R095	1-216-065-91	RES-CHIP	4.7K 5% 1/10W	R278	1-216-295-91	SHORT	
R096	1-216-065-91	RES-CHIP	4.7K 5% 1/10W				
R097	1-249-414-11	CARBON	560 5% 1/4W	R279	1-247-807-31	CARBON 100 5% 1/4W	
R099	1-216-089-91	RES-CHIP	47K 5% 1/10W	R280	1-216-069-00	RES-CHIP 6.8K 5% 1/10W	
				R281	1-208-798-11	METAL CHIP 4.7K 0.50% 1/10W	
R150	1-216-053-00	RES-CHIP	1.5K 5% 1/10W	R282	1-208-790-11	METAL CHIP 2.2K 0.50% 1/10W	
		(ALL EXCEPT KV-32FS12)		R283	1-216-689-11	RES-CHIP 39K 5% 1/10W	
R151	1-216-025-91	RES-CHIP	100 5% 1/10W	R284	1-216-049-91	RES-CHIP 1K 5% 1/10W	
		(ALL EXCEPT KV-32FS12)				(KV-27FV16/29FV16/29FV16C ONLY)	
R154	1-216-043-91	RES-CHIP	560 5% 1/10W	R285	1-216-049-91	RES-CHIP 1K 5% 1/10W	
		(ALL EXCEPT KV-32FS12)				(KV-27FV16/29FV16/29FV16C ONLY)	



Note:

The components identified by shading and mark \triangle are critical for safety. Replace only with part number specified.

Note:

Les composants identifiés par un trame et une marque \triangle sont critiques pour la sécurité. Ne les remplacer que par une pièce portant le numéro spécifié.

REF.NO.	PART NO.	DESCRIPTION	REMARK	REF.NO.	PART NO.	DESCRIPTION	REMARK
R286	1-216-089-91	RES-CHIP (KV-27FV16/29FV16/29FV16C ONLY)	47K 5% 1/10W	R326	1-208-806-11	METAL CHIP	10K 0.50% 1/10W
R287	1-216-097-91	RES-CHIP (KV-27FV16/29FV16/29FV16C ONLY)	100K 5% 1/10W	R327	1-216-025-91	RES-CHIP	100 5% 1/10W
R288	1-216-041-00	RES-CHIP (KV-27FV16/29FV16/29FV16C ONLY)	470 5% 1/10W	R328	1-216-025-91	RES-CHIP (KV-32FS12/32FS16 ONLY)	100 5% 1/10W
R289	1-216-049-91	RES-CHIP (KV-27FV16/29FV16/29FV16C ONLY)	1K 5% 1/10W	R329	1-216-025-91	RES-CHIP	100 5% 1/10W
R290	1-216-043-91	RES-CHIP (KV-27FV16/29FV16/29FV16C ONLY)	560 5% 1/10W	R331	1-216-049-91	RES-CHIP (KV-32FS12/32FS16 ONLY)	1K 5% 1/10W
R291	1-216-053-00	RES-CHIP (KV-27FV16/29FV16/29FV16C ONLY)	1.5K 5% 1/10W	R332	1-216-022-00	RES-CHIP	75 5% 1/10W
R298	1-216-065-91	RES-CHIP (KV-27FV16/29FV16/29FV16C ONLY)	4.7K 5% 1/10W	R333	1-216-067-00	RES-CHIP (KV-32FS12/32FS16 ONLY)	5.6K 5% 1/10W
R299	1-216-033-00	RES-CHIP (KV-27FV16/29FV16/29FV16C ONLY)	220 5% 1/10W	R334	1-216-025-91	RES-CHIP (KV-32FS12/32FS16 ONLY)	100 5% 1/10W
R300	1-216-295-91	SHORT (KV-32FS12/32FS16 ONLY)		R335	1-216-057-00	RES-CHIP	2.2K 5% 1/10W
R301	1-216-022-00	RES-CHIP	75 5% 1/10W	R336	1-216-057-00	RES-CHIP	2.2K 5% 1/10W
R303	1-216-073-00	RES-CHIP	10K 5% 1/10W	R337	1-216-057-00	RES-CHIP	2.2K 5% 1/10W
R304	1-247-807-31	CARBON	100 5% 1/4W	R338	1-216-073-00	RES-CHIP	10K 5% 1/10W
R305	1-216-295-91	SHORT (KV-32FS12/32FS16 ONLY)		R339	1-216-091-00	RES-CHIP (KV-32FS12/32FS16 ONLY)	56K 5% 1/10W
R306	1-216-025-91	RES-CHIP	100 5% 1/10W	R340	1-216-025-91	RES-CHIP	100 5% 1/10W
R307	1-216-071-00	RES-CHIP (KV-27FV16/29FV16/29FV16C ONLY)	8.2K 5% 1/10W	R341	1-216-089-91	RES-CHIP	47K 5% 1/10W
R308	1-216-022-00	RES-CHIP	75 5% 1/10W	R342	1-216-049-91	RES-CHIP	1K 5% 1/10W
R309	1-216-022-00	RES-CHIP	75 5% 1/10W	R343	1-216-097-91	RES-CHIP	100K 5% 1/10W
R310	1-249-417-11	CARBON	1K 5% 1/4W	R344	1-216-295-91	SHORT	
R311	1-216-025-91	RES-CHIP (KV-32FS12/32FS16 ONLY)	100 5% 1/10W	R345	1-216-097-91	RES-CHIP	100K 5% 1/10W
R312	1-249-417-11	CARBON	1K 5% 1/4W	R346	1-216-097-91	RES-CHIP	100K 5% 1/10W
R313	1-216-049-91	RES-CHIP	1K 5% 1/10W	R347	1-216-025-91	RES-CHIP	100 5% 1/10W
R314	1-216-081-00	RES-CHIP (ALL EXCEPT KV-32FS12)	22K 5% 1/10W	R348	1-216-022-00	RES-CHIP (KV-27FV16/29FV16/29FV16C ONLY)	75 5% 1/10W
R315	1-216-022-00	RES-CHIP	75 5% 1/10W	R349	1-216-025-91	RES-CHIP	100 5% 1/10W
R316	1-216-067-00	RES-CHIP (KV-32FS12/32FS16 ONLY)	5.6K 5% 1/10W	R350	1-216-022-00	RES-CHIP (KV-27FV16/29FV16/29FV16C ONLY)	75 5% 1/10W
R317	1-247-807-31	CARBON (KV-32FS12/32FS16 ONLY)	100 5% 1/4W	R351	1-216-041-00	RES-CHIP (KV-32FS12/32FS16 ONLY)	470 5% 1/10W
R318	1-216-091-00	RES-CHIP (KV-32FS12/32FS16 ONLY)	56K 5% 1/10W	R352	1-247-807-31	CARBON (KV-32FS12/32FS16 ONLY)	100 5% 1/4W
R319	1-216-081-00	RES-CHIP (KV-32FS12/32FS16 ONLY)	22K 5% 1/10W	R353	1-247-807-31	CARBON (KV-32FS12/32FS16 ONLY)	100 5% 1/4W
R320	1-216-025-91	RES-CHIP (KV-32FS12/32FS16 ONLY)	100 5% 1/10W	R354	1-216-025-91	RES-CHIP (KV-32FS12/32FS16 ONLY)	100 5% 1/10W
R321	1-216-043-91	RES-CHIP (KV-32FS12/32FS16 ONLY)	560 5% 1/10W	R355	1-216-053-00	RES-CHIP (KV-32FS12/32FS16 ONLY)	1.5K 5% 1/10W
R322	1-216-025-91	RES-CHIP	100 5% 1/10W	R356	1-216-025-91	RES-CHIP	100 5% 1/10W
R323	1-216-025-91	RES-CHIP	100 5% 1/10W	R357	1-216-022-00	RES-CHIP	75 5% 1/10W
R324	1-216-065-91	RES-CHIP	4.7K 5% 1/10W	R358	1-216-093-91	RES-CHIP	68K 5% 1/10W
R325	1-249-417-11	CARBON	1K 5% 1/4W	R359	1-216-057-00	RES-CHIP (KV-32FS12/32FS16 ONLY)	2.2K 5% 1/10W
				R360	1-216-093-91	RES-CHIP	68K 5% 1/10W
				R361	1-216-022-00	RES-CHIP	75 5% 1/10W
				R362	1-216-035-00	RES-CHIP	270 5% 1/10W
				R363	1-216-039-00	RES-CHIP	390 5% 1/10W

Note:

The components identified by shading and mark \triangle are critical for safety. Replace only with part number specified.

Note:

Les composants identifiés par un trame et une marque \triangle sont critiques pour la sécurité. Ne les remplacer que par une pièce portant le numéro spécifié.



REF.NO.	PART NO.	DESCRIPTION	REMARK	REF.NO.	PART NO.	DESCRIPTION	REMARK
R364	1-216-025-91	RES-CHIP 100 (KV-32FS12/32FS16 ONLY)	5% 1/10W	R398	1-216-109-00	RES-CHIP 330K (KV-32FS12/32FS16 ONLY)	5% 1/10W
R365	1-216-025-91	RES-CHIP 100 (KV-32FS12/32FS16 ONLY)	5% 1/10W	R399	1-216-109-00	RES-CHIP 330K (KV-27FV16/29FV16/29FV16C ONLY)	5% 1/10W
R366	1-216-053-00	RES-CHIP 1.5K (KV-32FS12/32FS16 ONLY)	5% 1/10W	R399	1-216-689-11	RES-CHIP 39K (KV-32FS12/32FS16 ONLY)	5% 1/10W
R367	1-216-057-00	RES-CHIP 2.2K (KV-32FS12/32FS16 ONLY)	5% 1/10W	R434	1-216-065-91	RES-CHIP 4.7K (ALL EXCEPT KV-32FS12)	5% 1/10W
R368	1-216-043-91	RES-CHIP 560 (KV-32FS12/32FS16 ONLY)	5% 1/10W	R435	1-216-065-91	RES-CHIP 4.7K (ALL EXCEPT KV-32FS12)	5% 1/10W
R369	1-216-033-00	RES-CHIP 220 (KV-32FS12/32FS16 ONLY)	5% 1/10W	TUNER			
R370	1-249-429-11	CARBON 10K	5% 1/4W	TU150 \triangle	8-598-501-00	TUNER, FSS BTF-FA402 (ALL EXCEPT KV-32FS12)	
R372	1-216-043-91	RES-CHIP 560 (KV-32FS12/32FS16 ONLY)	5% 1/10W	CRYSTAL			
R373	1-216-025-91	RES-CHIP 100 (KV-32FS12/32FS16 ONLY)	5% 1/10W	X001	1-767-487-11	VIBRATOR, CRYSTAL	
R374	1-216-025-91	RES-CHIP 100 (KV-32FS12/32FS16 ONLY)	5% 1/10W	X301	1-567-505-11	OSCILLATOR, CRYSTAL	
R375	1-216-053-00	RES-CHIP 1.5K (KV-32FS12/32FS16 ONLY)	5% 1/10W	P			
R376	1-216-022-00	RES-CHIP 75	5% 1/10W	* A-1190-367-A P MOUNTED PC BOARD (ALL EXCEPT KV-32FS12)			
R377	1-216-057-00	RES-CHIP 2.2K (KV-32FS12/32FS16 ONLY)	5% 1/10W	CAPACITOR			
R378	1-216-295-91	SHORT (KV-32FS12/32FS16 ONLY)		C3301	1-163-031-11	CERAMIC CHIP 0.01 μ F	50V
R379	1-216-049-91	RES-CHIP 1K (KV-32FS12/32FS16 ONLY)	5% 1/10W	C3302	1-163-031-11	CERAMIC CHIP 0.01 μ F	50V
R380	1-216-295-91	SHORT (KV-27FV16/29FV16/29FV16C ONLY)		C3303	1-104-664-11	ELECT 47 μ F	20% 16V
R381	1-216-069-00	RES-CHIP 6.8K (KV-27FV16/29FV16/29FV16C ONLY)	5% 1/10W	C3304	1-163-031-11	CERAMIC CHIP 0.01 μ F	50V
R382	1-216-295-91	SHORT		C3305	1-163-031-11	CERAMIC CHIP 0.01 μ F	50V
R383	1-216-295-91	SHORT		C3306	1-163-038-91	CERAMIC CHIP 0.1 μ F	25V
R384	1-216-295-91	SHORT		C3308	1-164-005-11	CERAMIC CHIP 0.47 μ F	25V
R387	1-216-025-91	RES-CHIP 100	5% 1/10W	C3309	1-163-034-00	CERAMIC CHIP 0.033 μ F	50V
R386	1-216-047-91	RES-CHIP 820 (KV-32FS12/32FS16 ONLY)	5% 1/10W	C3310	1-164-222-11	CERAMIC CHIP 0.22 μ F	25V
R388	1-216-025-91	RES-CHIP 100	5% 1/10W	C3311	1-163-233-11	CERAMIC CHIP 18PF	5% 50V
R389	1-216-049-91	RES-CHIP 1K (KV-32FS12/32FS16 ONLY)	5% 1/10W	C3314	1-163-031-11	CERAMIC CHIP 0.01 μ F	50V
R392	1-216-067-00	RES-CHIP 5.6K (KV-32FS12/32FS16 ONLY)	5% 1/10W	C3315	1-163-031-11	CERAMIC CHIP 0.01 μ F	50V
R394	1-216-043-91	RES-CHIP 560 (KV-32FS12/32FS16 ONLY)	5% 1/10W	C3316	1-163-133-00	CERAMIC CHIP 470PF	5% 50V
R395	1-216-043-91	RES-CHIP 560 (KV-32FS12/32FS16 ONLY)	5% 1/10W	C3317	1-163-133-00	CERAMIC CHIP 470PF	5% 50V
R396	1-247-807-31	CARBON 100 (KV-32FS12/32FS16 ONLY)	5% 1/4W	C3319	1-163-133-00	CERAMIC CHIP 470PF	5% 50V
R398	1-216-091-00	RES-CHIP 56K (KV-27FV16/29FV16/29FV16C ONLY)	5% 1/10W	C3320	1-164-005-11	CERAMIC CHIP 0.47 μ F	25V
				C3321	1-163-009-11	CERAMIC CHIP 0.001 μ F	10% 50V
				C3323	1-104-664-11	ELECT 47 μ F	20% 16V
				C3324	1-163-031-11	CERAMIC CHIP 0.01 μ F	50V
				C3325	1-163-031-11	CERAMIC CHIP 0.01 μ F	50V
				C3326	1-104-664-11	ELECT 47 μ F	20% 16V

**Note:**

The components identified by shading and mark \triangle are critical for safety. Replace only with part number specified.

Note:

Les composants identifiés par un trame et une marque \triangle sont critiques pour la sécurité. Ne les remplacer que par une pièce portant le numéro spécifié.

REF.NO.	PART NO.	DESCRIPTION	REMARK	REF.NO.	PART NO.	DESCRIPTION	REMARK
C3327	1-104-664-11	ELECT	47 μ F 20% 16V				
C3328	1-104-664-11	ELECT	47 μ F 20% 16V				
C3330	1-126-964-11	ELECT	10 μ F 20% 50V				
C3331	1-163-009-11	CERAMIC CHIP	0.001 μ F 10% 50V				
C3332	1-164-346-11	CERAMIC CHIP	1 μ F 16V				
C3333	1-164-346-11	CERAMIC CHIP	1 μ F 16V				
C3334	1-164-005-11	CERAMIC CHIP	0.47 μ F 25V				
C3335	1-164-182-11	CERAMIC CHIP	0.0033 μ F 10% 50V				
C3336	1-163-031-11	CERAMIC CHIP	0.01 μ F 50V				
C3339	1-163-005-11	CERAMIC CHIP	470PF 10% 50V				
C3340	1-126-967-11	ELECT	47 μ F 20% 50V				
C3341	1-164-222-11	CERAMIC CHIP	0.22 μ F 25V				
C3342	1-163-037-11	CERAMIC CHIP	0.022 μ F 10% 50V				
C3343	1-126-967-11	ELECT	47 μ F 20% 50V				
C3344	1-164-222-11	CERAMIC CHIP	0.22 μ F 25V				
C3345	1-164-346-11	CERAMIC CHIP	1 μ F 16V				
C3346	1-164-346-11	CERAMIC CHIP	1 μ F 16V				
C3347	1-164-346-11	CERAMIC CHIP	1 μ F 16V				
C3349	1-164-005-11	CERAMIC CHIP	0.47 μ F 25V				
C3350	1-163-233-11	CERAMIC CHIP	18PF 5% 50V				
C3351	1-163-113-00	CERAMIC CHIP	68PF 5% 50V				
C3352	1-164-222-11	CERAMIC CHIP	0.22 μ F 25V				
C3353	1-126-967-11	ELECT	47 μ F 20% 50V				
C3354	1-163-037-11	CERAMIC CHIP	0.022 μ F 10% 50V				
C3355	1-164-346-11	CERAMIC CHIP	1 μ F 16V				
C3356	1-164-346-11	CERAMIC CHIP	1 μ F 16V				
C3357	1-164-346-11	CERAMIC CHIP	1 μ F 16V				
CONNECTOR							
CN3300	1-573-301-21	CONNECTOR, BOARD TO BOARD 20P					
DIODE							
D3301	8-719-073-01	DIODE MA111-TX					
D3304	8-719-422-12	DIODE UDZ-TE-17-3.9B					
IC							
IC3300	8-759-353-00	IC NJM2534M(TE2)					
IC3301	8-759-660-74	IC M65664FP-DS60S					
IC3302	8-759-458-18	IC TDA8501T					
COIL							
L3300	1-414-267-11	INDUCTOR	10 μ H				
L3301	1-410-682-31	INDUCTOR	470 μ H				
L3302	1-414-267-11	INDUCTOR	10 μ H				
L3303	1-414-267-11	INDUCTOR	10 μ H				
L3304	1-414-267-11	INDUCTOR	10 μ H				
				TRANSISTOR			
				Q3300	8-729-422-27	TRANSISTOR 2SD601A-QRS-TX	
				Q3301	8-729-422-27	TRANSISTOR 2SD601A-QRS-TX	
				Q3302	8-729-422-27	TRANSISTOR 2SD601A-QRS-TX	
				Q3304	8-729-216-22	TRANSISTOR 2SB709A-QRS-TX	
				Q3305	8-729-216-22	TRANSISTOR 2SB709A-QRS-TX	
				Q3306	8-729-216-22	TRANSISTOR 2SB709A-QRS-TX	
				Q3308	8-729-216-22	TRANSISTOR 2SB709A-QRS-TX	
				Q3309	8-729-422-27	TRANSISTOR 2SD601A-QRS-TX	
				Q3311	8-729-111-55	TRANSISTOR 2SD1292	
				Q3312	8-729-216-22	TRANSISTOR 2SB709A-QRS-TX	
				Q3313	8-729-422-27	TRANSISTOR 2SD601A-QRS-TX	
				Q3314	8-729-422-27	TRANSISTOR 2SD601A-QRS-TX	
				Q3315	8-729-216-22	TRANSISTOR 2SB709A-QRS-TX	
				Q3316	8-729-216-22	TRANSISTOR 2SB709A-QRS-TX	
				Q3317	8-729-422-27	TRANSISTOR 2SD601A-QRS-TX	
				Q3318	8-729-422-27	TRANSISTOR 2SD601A-QRS-TX	
				Q3319	8-729-422-27	TRANSISTOR 2SD601A-QRS-TX	
				Q3320	8-729-422-27	TRANSISTOR 2SD601A-QRS-TX	
				Q3321	8-729-216-22	TRANSISTOR 2SB709A-QRS-TX	
				Q3323	8-729-422-27	TRANSISTOR 2SD601A-QRS-TX	
				RESISTOR			
				R3300	1-216-041-00	RES-CHIP 470 5% 1/10W	
				R3303	1-216-073-00	RES-CHIP 10K 5% 1/10W	
				R3304	1-216-133-00	RES-CHIP 3.3M 5% 1/10W	
				R3305	1-216-037-00	RES-CHIP 330 5% 1/10W	
				R3308	1-216-085-00	RES-CHIP 33K 5% 1/10W	
				R3309	1-216-025-91	RES-CHIP 100 5% 1/10W	
				R3310	1-216-025-91	RES-CHIP 100 5% 1/10W	
				R3311	1-216-037-00	RES-CHIP 330 5% 1/10W	
				R3312	1-216-043-91	RES-CHIP 560 5% 1/10W	
				R3313	1-216-035-00	RES-CHIP 270 5% 1/10W	
				R3316	1-216-295-91	SHORT	
				R3317	1-216-295-91	SHORT	
				R3318	1-216-061-00	RES-CHIP 3.3K 5% 1/10W	
				R3319	1-216-295-91	SHORT	
				R3320	1-216-073-00	RES-CHIP 10K 5% 1/10W	
				R3321	1-216-049-91	RES-CHIP 1K 5% 1/10W	
				R3322	1-216-091-00	RES-CHIP 56K 5% 1/10W	
				R3323	1-216-049-91	RES-CHIP 1K 5% 1/10W	
				R3324	1-216-033-00	RES-CHIP 220 5% 1/10W	
				R3325	1-216-057-00	RES-CHIP 2.2K 5% 1/10W	
				R3328	1-216-295-91	SHORT	
				R3329	1-216-033-00	RES-CHIP 220 5% 1/10W	
				R3333	1-216-049-91	RES-CHIP 1K 5% 1/10W	
				R3334	1-216-049-91	RES-CHIP 1K 5% 1/10W	
				R3335	1-216-049-91	RES-CHIP 1K 5% 1/10W	

**Note:**

The components identified by shading and mark \triangle are critical for safety. Replace only with part number specified.

Note:

Les composants identifiés par un trame et une marque \triangle sont critiques pour la sécurité. Ne les remplacer que par une pièce portant le numéro spécifié.

REF.NO.	PART NO.	DESCRIPTION	REMARK	REF.NO.	PART NO.	DESCRIPTION	REMARK
CONNECTOR				R915	1-249-417-11	CARBON	1K 5% 1/4W
CN901 *	1-564-508-11	PLUG, CONNECTOR 5P		R916	1-249-417-11	CARBON	1K 5% 1/4W
CN902 *	1-770-723-11	CONNECTOR, BOARD TO BOARD 8P		R917	1-249-417-11	CARBON	1K 5% 1/4W
CN904 *	1-564-507-11	PLUG, CONNECTOR 4P		R918	1-247-807-31	CARBON	100 5% 1/4W
				R919	1-247-807-31	CARBON	100 5% 1/4W
DIODE				R920	1-249-416-11	CARBON	820 5% 1/4W
D804	8-719-302-43	DIODE RGP10GPKG23		R921	1-249-429-11	CARBON	10K 5% 1/4W
D805	8-719-991-33	DIODE 1SS133T-77		R922	1-249-397-11	CARBON	22 5% 1/4W
D806	8-719-991-33	DIODE 1SS133T-77		R923	1-249-401-11	CARBON	47 5% 1/4W
D807	8-719-210-21	DIODE ERA82-004TP5		ACCESSORIES AND PACKAGING			
D901	8-719-110-88	DIODE MTZJ-T-77-39		* 4-041-259-01	BAG, PROTECTION		
D902	8-719-110-88	DIODE MTZJ-T-77-39			(KV-32FS12/32FS16 ONLY)		
D903	8-719-991-33	DIODE 1SS133T-77		* 4-041-255-01	BAG, PROTECTION		
					(KV-27FV16/29FV16/29FV16C ONLY)		
				* 4-073-714-01	CARTON, INDIVIDUAL		
					(KV-32FS12/32FS16 ONLY)		
				* 4-075-524-01	CARTON, INDIVIDUAL		
					(KV-29FV16/29FV16C ONLY)		
				* 4-075-517-01	CARTON, INDIVIDUAL		
					(KV-27FV16 ONLY)		
				* 4-075-515-01	CUSHION ASSY, UPPER		
					(KV-27FV16/29FV16/29FV16C ONLY)		
				* 4-075-516-01	CUSHION ASSY, LOWER		
					(KV-27FV16/29FV16/29FV16C ONLY)		
				* 4-073-715-01	CUSHION ASSY, UPPER		
					(KV-32FS12/32FS16 ONLY)		
				* 4-073-716-01	CUSHION ASSY, LOWER		
					(KV-32FS12/32FS16 ONLY)		
				4-075-499-41	MANUAL, INSTRUCTION		
					(KV-29FV16/29FV16C ONLY)		
				4-075-499-21	MANUAL, INSTRUCTION		
					(KV-27FV16/32FS12/32FS16 ONLY)		
				REMOTE COMMANDER			
R818	1-216-025-91	RES-CHIP	100 5% 1/10W	1-418-496-11	REMOTE COMMANDER (RM-Y171)		
R826	1-249-421-11	CARBON	2.2K 5% 1/4W		(KV-27FV16/29FV16/29FV16C ONLY)		
R876	1-216-049-91	RES-CHIP	1K 5% 1/10W	1-418-387-11	REMOTE COMMANDER (RM-Y168)		
R901	1-249-401-11	CARBON	47 5% 1/4W		(KV-32FS12 ONLY)		
R902	1-249-386-11	CARBON	2.7 5% 1/4W	1-418-384-11	REMOTE COMMANDER (RM-Y169)		
					(KV-32FS16 ONLY)		
R903	1-249-414-11	CARBON	560 5% 1/4W	4-978-977-01	BATTERY COVER		
R904	1-249-432-11	CARBON	18K 5% 1/4W		(FOR RM-Y168/RM-Y169/RM-Y171)		
R905	1-249-417-11	CARBON	1K 5% 1/4W				
R906	1-249-432-11	CARBON	18K 5% 1/4W				
R907	1-249-386-11	CARBON	2.7 5% 1/4W				
R908	1-249-414-11	CARBON	560 5% 1/4W				
R909	1-260-312-11	CARBON	47 5% 1/2W				
R910	1-216-476-11	METAL OXIDE	180 5% 3V				
R911	1-249-403-11	CARBON	68 5% 1/4W				
R912	1-247-815-91	CARBON	220 5% 1/4W				
R913	1-249-403-11	CARBON	68 5% 1/4W				
R914	1-249-410-11	CARBON	270 5% 1/4W				

HISTORY INFORMATION FOR THE FOLLOWING MANUAL:

SERVICE MANUAL

BA-5 CHASSIS

<u>MODEL NAME</u>	<u>REMOTE COMMANDER</u>	<u>DESTINATION</u>	<u>CHASSIS NO.</u>
KV-27FV16	RM-Y171	US	SCC-S40K-A
KV-27FV16	RM-Y171	CND	SCC-S41J-A
KV-29FV16	RM-Y171	E	SCC-S38Q-A
KV-29FV16C	RM-Y171	E	SCC-S38R-A
KV-32FS12	RM-Y168	US	SCC-S40F-A
KV-32FS12	RM-Y168	CND	SCC-S41F-A
KV-32FS16	RM-Y169	US	SCC-S40G-A
KV-32FS16	RM-Y169	CND	SCC-S41G-A

ORIGINAL MANUAL ISSUE DATE: 5/2000

ALL REVISIONS AND UPDATES TO THE ORIGINAL MANUAL ARE APPENDED TO THE END OF THE PDF FILE.

<u>REVISION DATE</u>	<u>REVISION TYPE</u>	<u>SUBJECT</u>
5/2000	No revisions or updates are applicable at this time.	
6/2000	CORRECTION-1	New Block Diagram
10/2002	CORRECTION-2	New 2 Pin THP601

TRINITRON® COLOR TELEVISION
SONY®

<u>MODEL</u>	<u>COMMANDER</u>	<u>DEST</u>	<u>CHASSIS NO.</u>
KV-27FV16	RM-Y171	US	SCC-S40K-A
KV-27FV16	RM-Y171	CND	SCC-S41J-A
KV-29FV16	RM-Y171	E	SCC-S38Q-A
KV-29FV16C	RM-Y171	E	SCC-S38R-A
KV-32FS12	RM-Y168	US	SCC-S40F-A
KV-32FS12	RM-Y168	CND	SCC-S41F-A
KV-32FS16	RM-Y169	US	SCC-S40G-A
KV-32FS16	RM-Y169	CND	SCC-S41G-A

CORRECTION-1

Subject: New Block Diagrams

**Correct the service manual as shown below.
File this correction with the service manual.**

**Section 6: Block Diagrams (Page 31-34)
Size of Block Diagrams increased and replaced.**

SECTION 6
DIAGRAMS

6.1 BLOCK DIAGRAM (1/2)

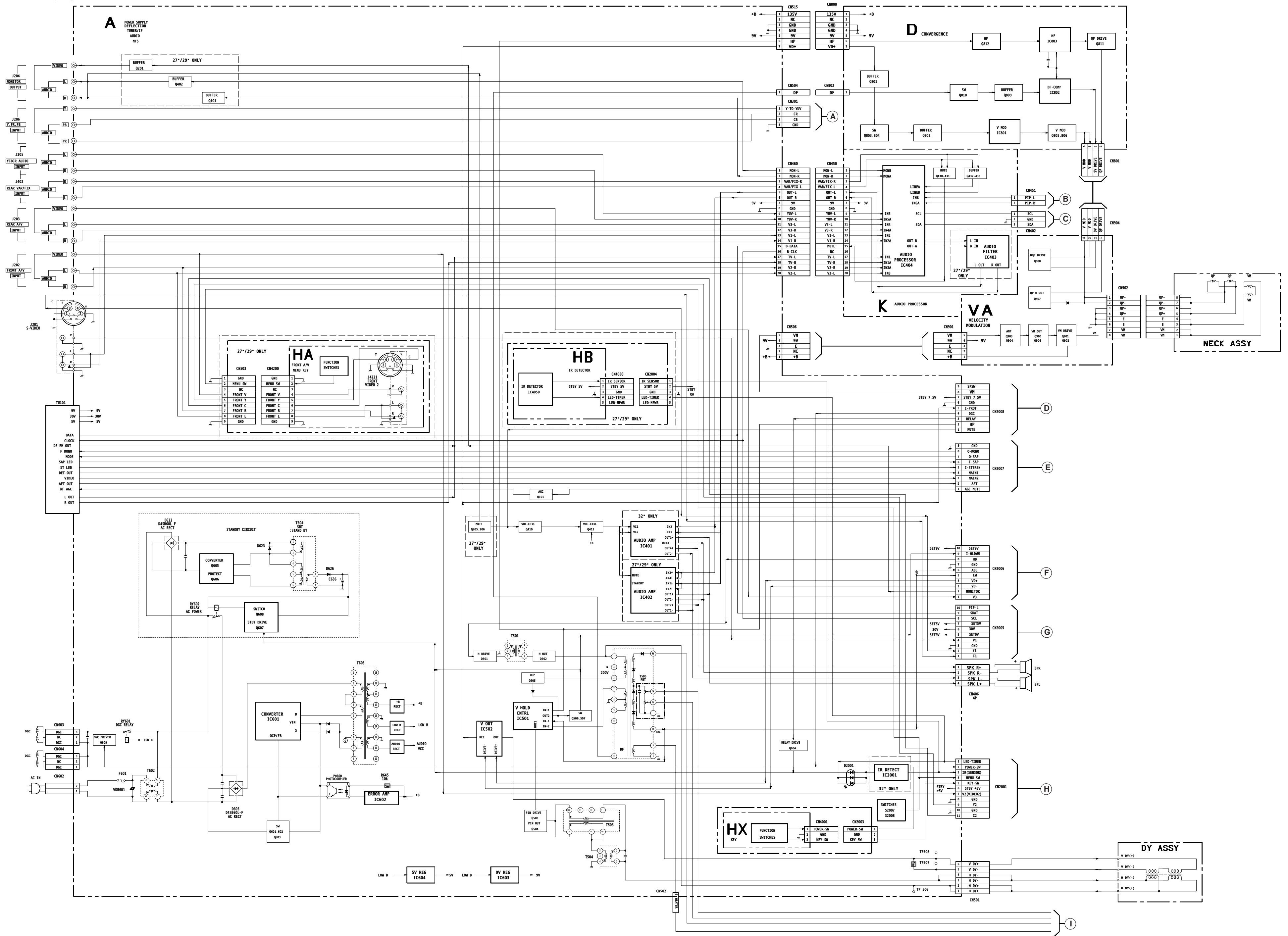

6.1 BLOCK DIAGRAM (2/2)

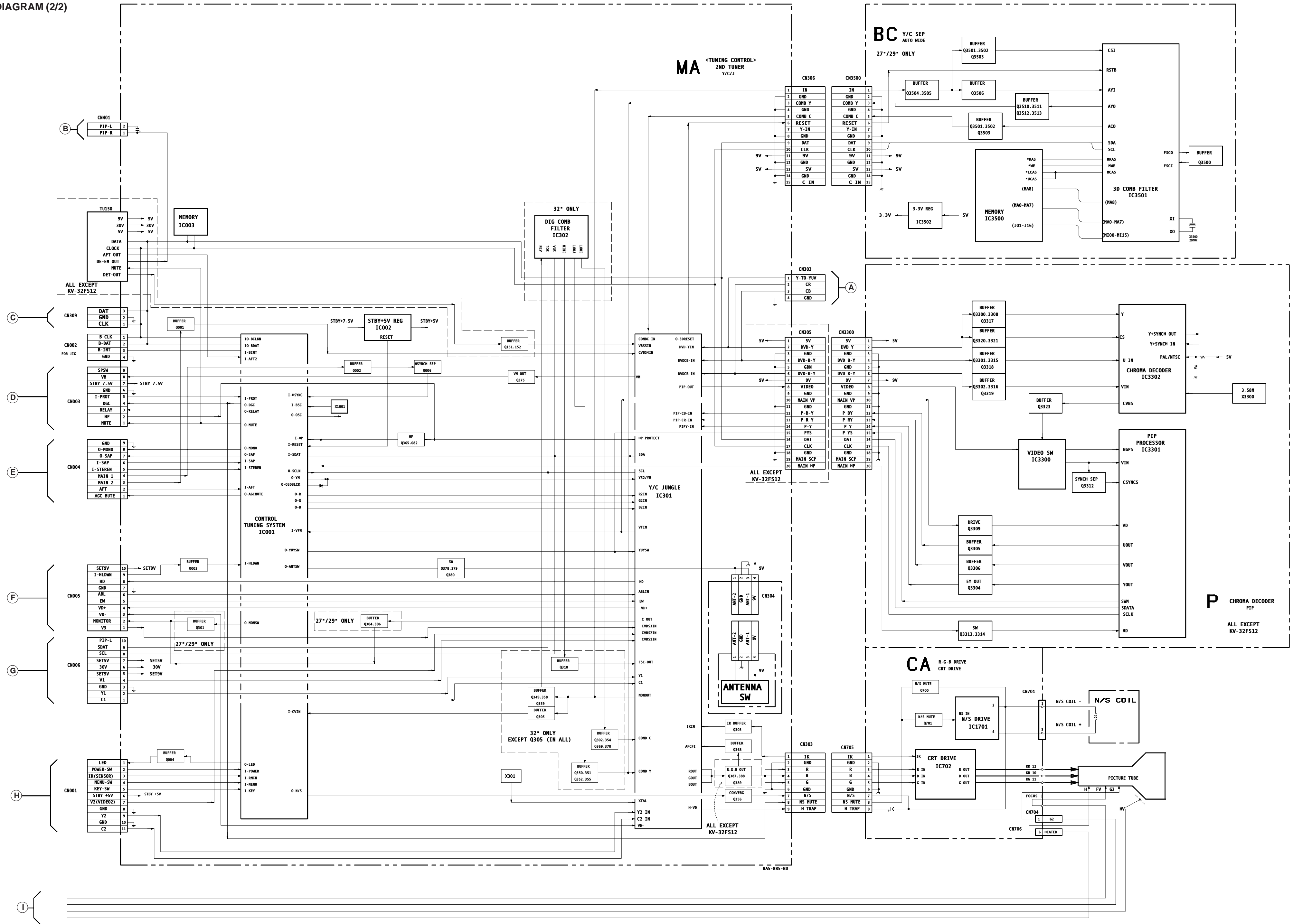

SERVICE MANUAL

BA-5 CHASSIS

<u>MODEL NAME</u>	<u>REMOTE COMMANDER</u>	<u>DESTINATION</u>	<u>CHASSIS NO.</u>
KV-27FV16	RM-Y171	US	SCC-S40K-A
KV-27FV16	RM-Y171	CND	SCC-S41J-A
KV-29FV16	RM-Y171	E	SCC-S38Q-A
KV-29FV16C	RM-Y171	E	SCC-S38R-A
KV-32FS12	RM-Y168	US	SCC-S40F-A
KV-32FS12	RM-Y168	CND	SCC-S41F-A
KV-32FS16	RM-Y169	US	SCC-S40G-A
KV-32FS16	RM-Y169	CND	SCC-S41G-A

CORRECTION - 2

SUBJECT: NEW 2 PIN THP601

Correct the service manual as shown.
File this Correction with the service manual.

SECTION 6: DIAGRAMS

6-3. A Board Schematic Diagram (Page 39)

SECTION 8: ELECTRICAL PARTS LIST (Page 73)

TRINITRON® COLOR TELEVISION

SONY®

 : Corrected Item

SECTION 6: DIAGRAMS

6-3.A Board Schematic Diagram (Page 39)

If a set requires a 3 pin (THP601) thermistor it may still be ordered using the existing part number. If a set requires a 2 pin (THP601) thermistor the new part number must be used.

For 3 Pin Configuration

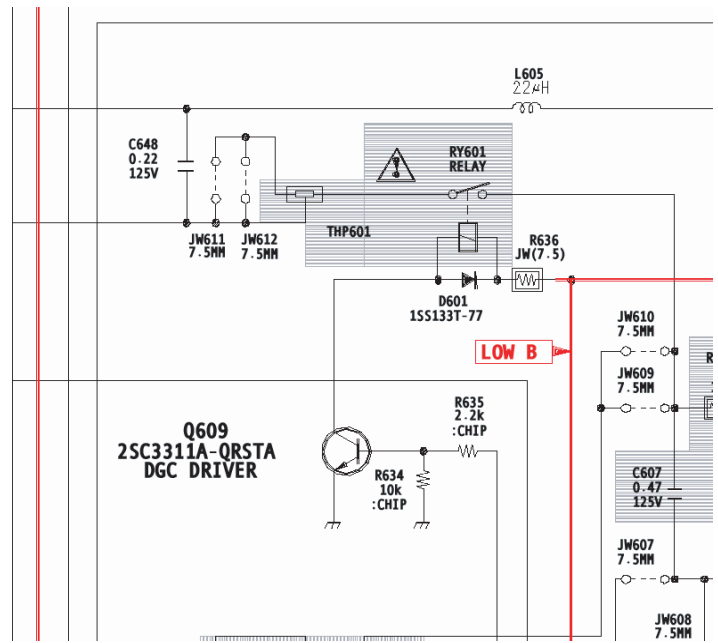
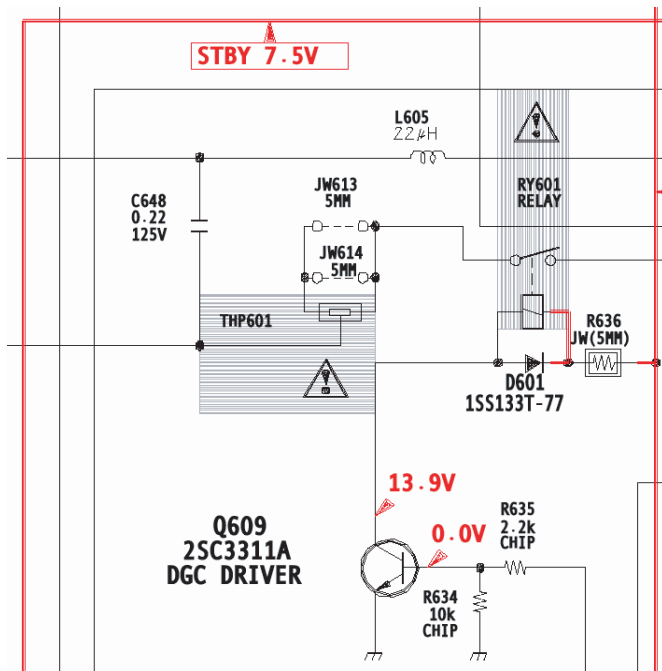

For 2 Pin Configuration



SECTION 8: ELECTRICAL PARTS LIST (Page 73)

OLD

NEW

REF. NO.	PART NO.	DESCRIPTION	REF. NO.	PART NO.	DESCRIPTION
 THP601	1-803-540-11	THERMISTOR	 THP601	1-803-540-11	THERMISTOR (3 PIN)
			 THP601	1-804-313-11	THERMISTOR (2 PIN)