

# SERVICE MANUAL

# BA-5 CHASSIS

<u>MODEL NAME</u>	<u>REMOTE COMMANDER</u>	<u>DESTINATION</u>	<u>CHASSIS NO.</u>
<b>KV-13FM13</b>	RM-Y172	Canada	SCC-S41N-A
<b>KV-13FM14</b>	RM-Y172	Canada	SCC-S41P-A



KV-13FM13



RM-Y172

TRINITRON® COLOR TELEVISION

# SONY®

# TABLE OF CONTENTS

SECTION TITLE	PAGE
Specifications.....	3
Warnings and Cautions.....	4
Safety Check-out.....	5
Self-Diagnostic Function.....	6
<b>1. Disassembly</b>	
1-1. Rear Cover Removal.....	9
1-2. Chassis Assembly Removal.....	9
1-3. Service Position.....	9
1-4. Picture Tube Removal.....	10
Anode Cap Removal Procedure.....	10
<b>2. Set-up Adjustments</b>	
2-1. Beam Landing.....	11
2-2. Convergence.....	12
2-3. Focus.....	13
2-4. Screen (G2).....	14
2-5. Method of Setting the Service Adjustment Mode.....	14
2-6. White Balance Adjustments.....	14
<b>3. Safety Related Adjustments</b>	
3-1. Hold Down Confirmation and Readjustments.....	15
3-2. B+ Voltage Confirmation and Adjustment.....	15
<b>4. Circuit Adjustments</b>	
4-1. Setting the Service Adjustment Mode.....	17
4-2. Memory Write Confirmation Method.....	17
4-3. Remote Adjustment Buttons and Indicators.....	17
4-4. MB Board Adjustments Lists.....	20
<b>5. Diagrams</b>	
5-1. Circuit Board Location.....	22
5-2. Printed Wiring Boards and Schematic Diagrams.....	22
5-3. Block Diagram.....	23
A Board.....	28
MB Board.....	29
CB Board.....	33
HC Board.....	35
HD Board.....	36
5-4. Semiconductors.....	37
<b>6. Exploded Views</b>	
6-1. Chassis.....	38
<b>7. Electrical Parts List.....</b>	<b>39</b>

## SPECIFICATIONS

### Power Requirements

120V, 60Hz

### Number of Inputs/Outputs

Video <sup>1)</sup>	2
Audio <sup>2)</sup>	2
Headphone Out	1
Speaker Output	3W

<sup>1)</sup> (1 Vp-p 75 ohms unbalanced, sync negative)

<sup>2)</sup> (500 Vrms (100% modulation), Impedance: 47 kilohms)

### Power Consumption

In Use (Max)	80W
In Standby	1W

### Dimensions (W x H x D)

450 x 338 x 438 mm  
 17 <sup>3/4</sup> x 13 <sup>3/8</sup> x 17 <sup>1/4</sup> in

### Mass

12 kg  
 26 lbs 7 oz.

### Television system

American TV standard, NTSC

### Channel coverage

VHF: 2-13/ VHF: 14-69/ CATV: 1-125

### Picture tube

Trinitron<sup>®</sup> tube

### Visible screen size

13" inch picture measured diagonally

### Actual screen size

14" inch measured diagonally

### Antenna

75 ohm external terminal for VHF/UHF

### Supplied Accessories

Remote Commander RM-Y172  
 Size AA (R6) batteries (2)

Design and specifications are subject to change without notice.

## WARNINGS AND CAUTIONS

### CAUTION

Short circuit the anode of the picture tube and the anode cap to the metal chassis, crt shield, or carbon painted on the crt, after removing the anode.

### WARNING!!

An isolation transformer should be used during any service to avoid possible shock hazard, because of live chassis. The chassis of this receiver is directly connected to the ac power line.

### SAFETY-RELATED COMPONENT WARNING!!

Components identified by shading and  mark on the schematic diagrams, exploded views, and in the parts list are critical for safe operation. Replace these components with sony parts whose part numbers appear as shown in this manual or in supplements published by sony. Circuit adjustments that are critical for safe operation are identified in this manual. Follow these procedures whenever critical components are replaced or improper operation is suspected.

---

### ATTENTION!!

Après avoir déconnecté le cap de l'anode, court-circuiter l'anode du tube cathodique et celui de l'anode du cap au châssis métallique de l'appareil, ou la couche de carbone peinte sur le tube cathodique ou au blindage du tube cathodique.

Afin d'éviter tout risque d'électrocution provenant d'un châssis sous tension, un transformateur d'isolement doit être utilisé lors de tout dépannage. Le châssis de ce récepteur est directement raccordé à l'alimentation du secteur.

### ATTENTION AUX COMPOSANTS RELATIFS A LA SECURITE!!

Les composants identifiés par une trame et par une marque  sur les schémas de principe, les vues explosées et les listes de pièces sont d'une importance critique pour la sécurité du fonctionnement. Ne les remplacer que par des composants sony dont le numéro de pièce est indiqué dans le présent manuel ou dans des suppléments publiés par sony. Les réglages de circuit dont l'importance est critique pour la sécurité du fonctionnement sont identifiés dans le présent manuel. Suivre ces procédures lors de chaque remplacement de composants critiques, ou lorsqu'un mauvais fonctionnement suspecte.

## SAFETY CHECK-OUT

After correcting the original service problem, perform the following safety checks before releasing the set to the customer:

1. Check the area of your repair for unsoldered or poorly soldered connections. Check the entire board surface for solder splashes and bridges.
2. Check the interboard wiring to ensure that no wires are "pinched" or touching high-wattage resistors.
3. Check that all control knobs, shields, covers, ground straps, and mounting hardware have been replaced. Be absolutely certain that you have replaced all the insulators.
4. Look for unauthorized replacement parts, particularly transistors, that were installed during a previous repair. Point them out to the customer and recommend their replacement.
5. Look for parts which, though functioning, show obvious signs of deterioration. Point them out to the customer and recommend their replacement.
6. Check the line cords for cracks and abrasion. Recommend the replacement of any such line cord to the customer.
7. Check the B+ and HV to see if they are specified values. Make sure your instruments are accurate; be suspicious of your HV meter if sets almost always have low HV.
8. Check the antenna terminals, metal trim, "metallized" knobs, screws, and all other exposed metal parts for AC leakage. Check leakage as described below.

### Leakage Test

The AC leakage from any exposed metal part to earth ground and from all exposed metal parts to any exposed metal part having a return to chassis, must not exceed 0.5 mA (500 microamperes). Leakage current can be measured by any one of three methods.

1. A commercial leakage tester, such as the Simpson 229 or RCA WT-540A. Follow the manufacturers' instructions to use these instructions.
2. A battery-operated AC milliammeter. The Data Precision 245 digital multimeter is suitable for this job.
3. Measuring the voltage drop across a resistor by means of a VOM or battery-operated AC voltmeter. The "limit" indication is 0.75 V, so analog meters must have an accurate low voltage scale. The Simpson's 250 and Sanwa SH-63TRD are examples of passive VOMs that are suitable. Nearly all battery-operated digital multimeters that have a 2 VAC range are suitable (see Figure A).

### How to Find a Good Earth Ground

A cold-water pipe is a guaranteed earth ground; the cover-plate retaining screw on most AC outlet boxes is also at earth ground. If the retaining screw is to be used as your earth ground, verify that it is at ground by measuring the resistance between it and a cold-water pipe with an ohmmeter. The reading should be zero ohms.

If a cold-water pipe is not accessible, connect a 60- to 100-watt trouble-light (not a neon lamp) between the hot side of the receptacle and the retaining screw. Try both slots, if necessary, to locate the hot side on the line; the lamp should light at normal brilliance if the screw is at ground potential (see Figure B).

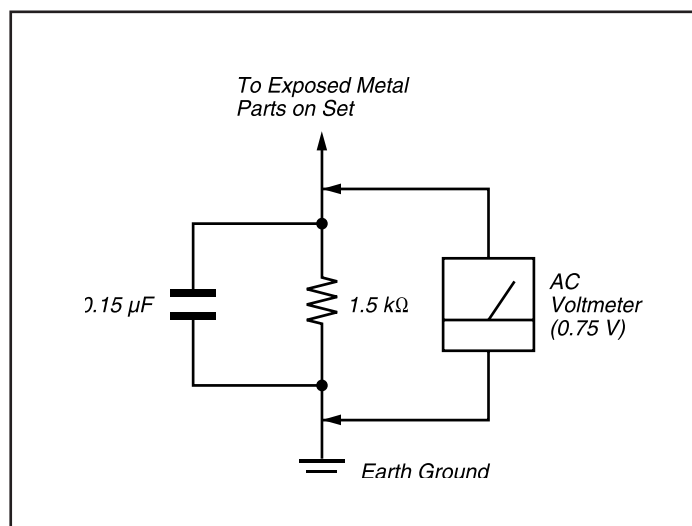

Figure A. Using an AC voltmeter to check AC leakage.

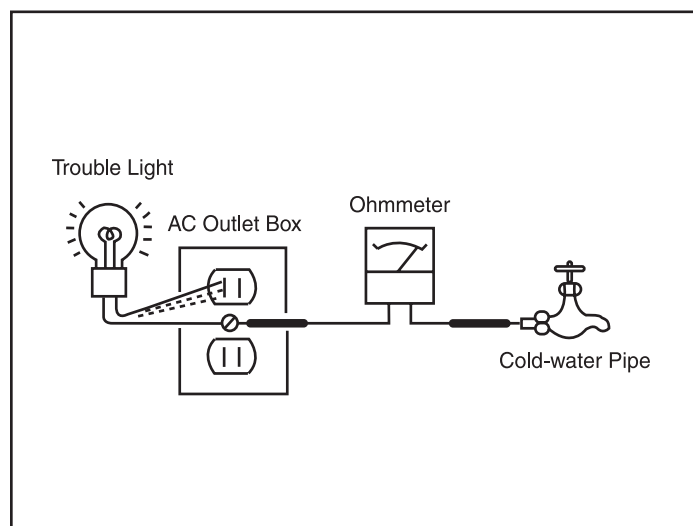

Figure B. Checking for earth ground.

## SELF-DIAGNOSTIC FUNCTION



The units in this manual contain a self-diagnostic function. If an error occurs, the STANDBY/TIMER LED will automatically begin to flash. The number of times the LED flashes translates to a probable source of the problem. A definition of the STANDBY/TIMER LED flash indicators is listed in the instruction manual for the user's knowledge and reference. If an error symptom cannot be reproduced, the Remote Commander can be used to review the failure occurrence data stored in memory to reveal past problems and how often these problems occur.

### Diagnostic Test Indicators

When an error occurs, the STANDBY/TIMER LED will flash a set number of times to indicate the possible cause of the problem. If there is more than one error, the LED will identify the first of the problem areas.

Results for all of the following diagnostic items are displayed on screen. If the screen displays a "0", no error has occurred.

Diagnostic Item	No. of times STANDBY/TIMER lamp flashes	Display Result	Probable Cause Location	Detected Symptoms
Power does not turn on	Does not light	_____	<ul style="list-style-type: none"> <li>Power cord is not plugged in.</li> <li>Fuse is burned out (F601) (A Board)</li> </ul>	<ul style="list-style-type: none"> <li>Power does not come on.</li> <li>No Power is supplied to the TV.</li> <li>AC power supply is faulty.</li> </ul>
+B overcurrent (OCP)*	2 times	2:0 or 2:1	<ul style="list-style-type: none"> <li>H.OUT (Q502) is shorted (A Board)</li> <li>IC702 is shorted. (CB Board)</li> </ul>	<ul style="list-style-type: none"> <li>Power does not come on.</li> <li>Load on power line is shorted.</li> </ul>
I-Prot*	4 times	4:0 or 4:1	<ul style="list-style-type: none"> <li>+13V is not supplied. (A Board)</li> <li>IC502 is faulty. (A Board)</li> </ul>	<ul style="list-style-type: none"> <li>Has entered standby state after horizontal raster.</li> <li>Vertical deflection pulse is stopped.</li> <li>Power line is shorted or power supply is stopped.</li> </ul>
IK	5 times	5:0 or 5:1	<ul style="list-style-type: none"> <li>Video OUT (IC502) is faulty. (A Board)</li> <li>IC1301 is faulty. (MB Board)</li> <li>Screen (G2) is improperly adjusted. **</li> </ul>	<ul style="list-style-type: none"> <li>No raster is generated.</li> <li>CRT cathode current detection reference pulse output is small.</li> </ul>

\* If a +B overcurrent is detected, stoppage of the vertical deflection is detected simultaneously. The symptom that is diagnosed first by the microcontroller is displayed on the screen.

\*\* Refer to Screen (G2) Adjustments in Section 3-4 of this manual.

### Display of Standby/Timer LED Flash Count

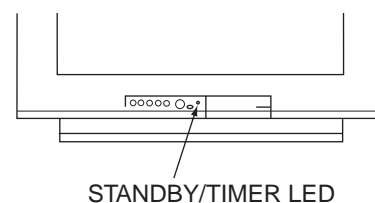
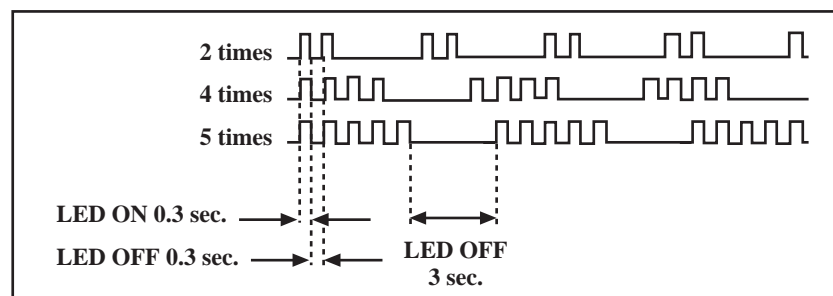

Diagnostic Item	Flash Count*
+B overcurrent	2 times
I-Prot	4 times
IK	5 times

\*One flash count is not used for self-diagnostic.

### Stopping the Standby/Timer LED Flash

Turn off the power switch on the TV main unit or unplug the power cord from the outlet to stop the STANDBY/TIMER LAMP from flashing.

### Self-Diagnostic Screen Display

For errors with symptoms such as "power sometimes shuts off" or "screen sometimes goes out" that cannot be confirmed, it is possible to bring up past occurrences of failure on the screen for confirmation.

#### To Bring Up Screen Test

In standby mode, press buttons on the Remote Commander sequentially, in rapid succession, as shown below:

Display → Channel 5 → Sound Volume\* → Power ON

\*Note that this differs from entering the service mode (sound volume +)

### Self-Diagnostic Screen Display

SELF DIAGNOSIS	
2: +B OCP	N/A
3: +B OVP	N/A
4: VSTOP	0
5: AKB	1
101: WDT	24

Numeral "0" means that no fault was detected.

Numeral "1" means a fault was detected one time only.

#### Handling of Self-Diagnostic Screen Display

Since the diagnostic results displayed on the screen are not automatically cleared, always check the self-diagnostic screen during repairs. When you have completed the repairs, clear the result display to "0".

Unless the result display is cleared to "0", the self-diagnostic function will not be able to detect subsequent faults after completion of the repairs.

#### Clearing the Result Display

To clear the result display to "0", press buttons on the Remote Commander sequentially when the diagnostic screen is displayed, as shown below:

Channel 8 → ENTER

#### Quitting the Self-Diagnostic Screen

To quit the entire self-diagnostic screen, turn off the power switch on the Remote Commander or the main unit.

## Self-Diagnostic Circuit

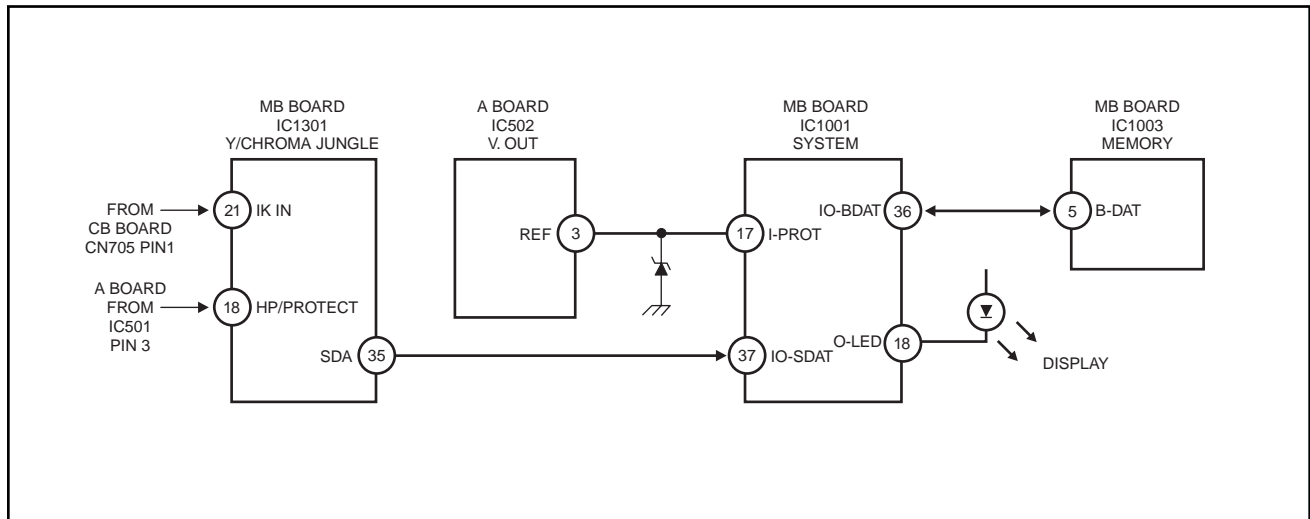

### +B overcurrent (OCP)

Occurs when an overcurrent on the +B (135V) line is detected by pin 18 of IC1301 (MB Board). If the voltage of pin 18 of IC1301 (MB Board) is less than 1V when V.SYNC is more than seven verticals in a period, the unit will automatically turn off.

### I-Prot

Occurs when an absence of the vertical deflection pulse is detected by pin 17 of IC1001 (MB Board). Power supply will shut down when waveform interval exceeds 2 seconds.

### IK

If the RGB levels\* do not balance within 2 seconds after the power is turned on, this error will be detected by IC1301 (MB Board). TV will stay on, but there will be no picture.

\*(Refers to the RGB levels of the AKB detection Ref pulse that detects 1K).



## SECTION 1: DISASSEMBLY

### 1-1. REAR COVER REMOVAL



### 1-2. CHASSIS ASSEMBLY REMOVAL

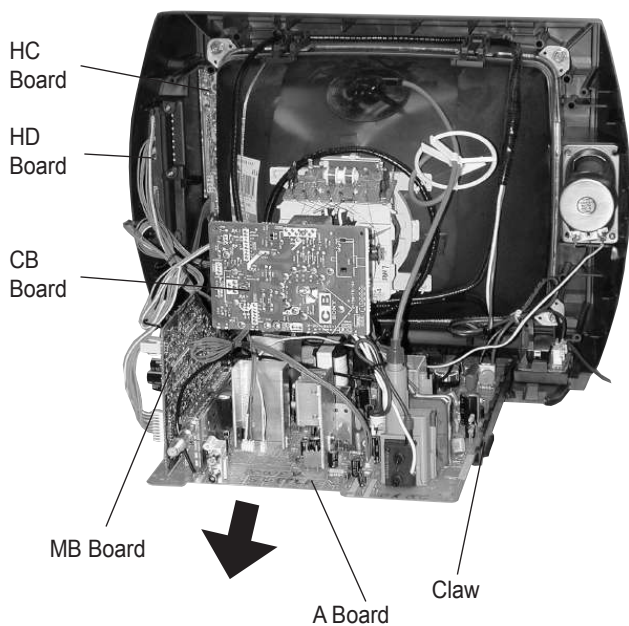

### 1-3. SERVICE POSITION

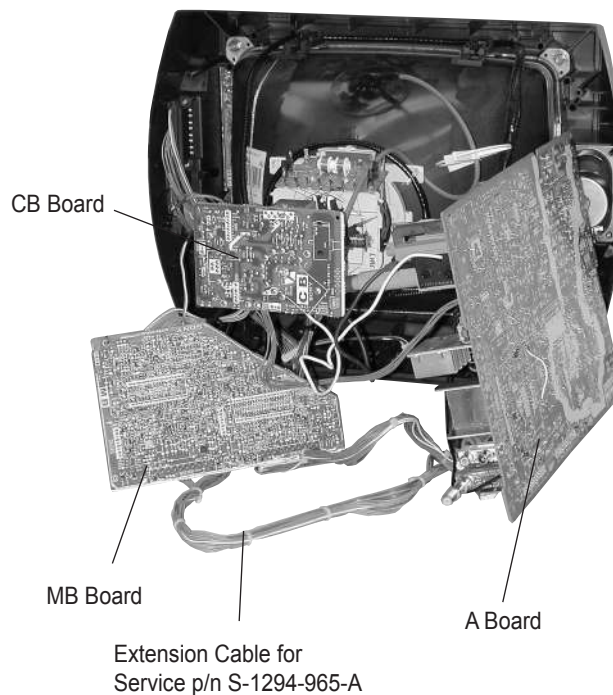

## 1-4. PICTURE TUBE REMOVAL

### WARNING: BEFORE REMOVING THE ANODE CAP

High voltage remains in the CRT even after the power is disconnected. To avoid electric shock, discharge CRT before attempting to remove the anode cap. Short between anode and CRT coated earth ground strap.

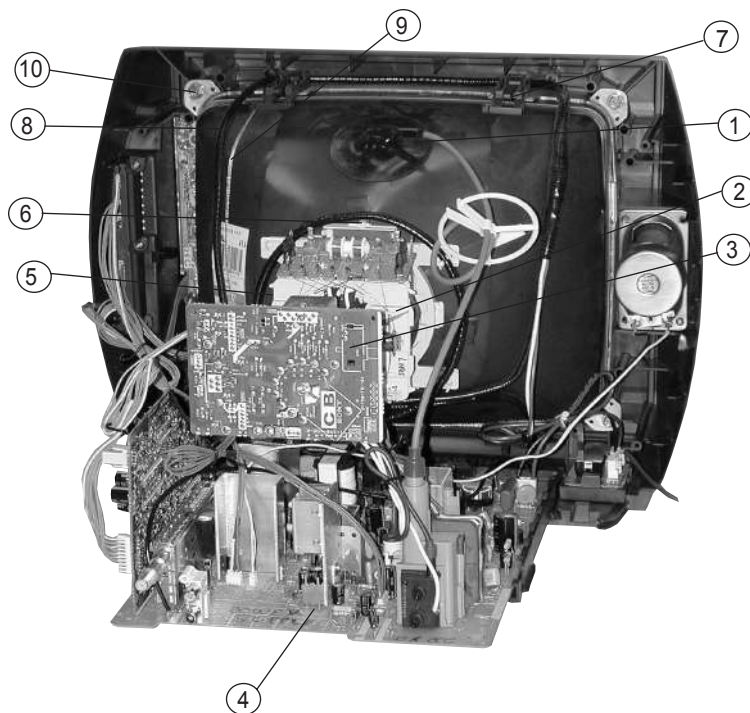
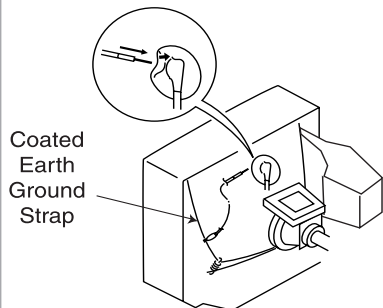

1. Discharge the anode of the CRT and remove the anode cap.
2. Unplug all interconnecting leads from the deflection yoke, neck assembly, degaussing coils and CRT grounding strap.
3. Remove the CB Board from the CRT.
4. Remove the chassis assembly.
5. Loosen the neck assembly fixing screw and remove.
6. Loosen the deflection yoke fixing screw and remove.
7. Place the set with the CRT face down on a cushion and remove the degaussing coil holders.
8. Remove the degaussing coils.
9. Remove the CRT grounding strap and spring tension devices.
10. Unscrew the four CRT fixing screws [located on each CRT corner] and remove the CRT [Take care not to handle the CRT by the neck].

## ANODE CAP REMOVAL PROCEDURE

WARNING: High voltage remains in the CRT even after the power is disconnected. To avoid electric shock, discharge CRT before attempting to remove the anode cap. After removing the anode cap, short circuit to either the metal chassis, CRT shield, or carbon painted on the CRT.

### REMOVAL PROCEDURES

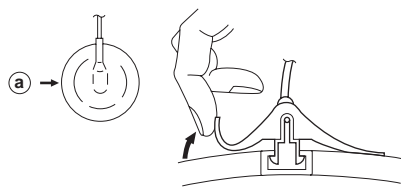

Turn up one side of the rubber cap in the direction indicated by arrow a .

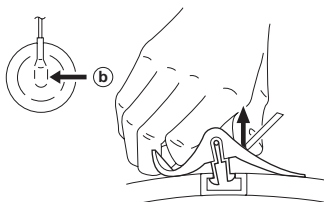

Use your thumb to pull the rubber cap firmly in the direction indicated by arrow b .

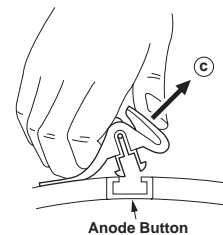

When one side of the rubber cap separates from the anode button, the anode cap can be removed by turning the rubber cap and pulling it in the direction of arrow c .

### HOW TO HANDLE AN ANODE CAP

1. Do not use sharp objects which may cause damage to the surface of the anode cap.
2. To avoid damaging the anode cap, do not squeeze the rubber covering too hard. A material fitting called a shatter-hook terminal is built into the rubber.
3. Do not force turn the foot of the rubber cover. This may cause the shatter-hook terminal to protrude and damage the rubber.



## SECTION 2: SET-UP ADJUSTMENTS

The following adjustments should be made when a complete realignment is required or a new picture tube is installed. These adjustments should be performed with rated power supply voltage unless otherwise noted.

The controls and switch should be set as follows unless otherwise noted:

PICTURE CONTROL: normal  
BRIGHTNESS CONTROL: normal

Perform the adjustments in order as follows:

1. Beam Landing
2. Convergence
3. Focus
4. Screen (G2)/White Balance

Test Equipment Required:

1. Color Bar Pattern Generator
2. Degausser
3. DC Power Supply
4. Digital Multimeter

### 2-1. BEAM LANDING

#### Preparation:

- Degauss the entire screen.
- Feed in the white pattern signal.

#### Adjustment Procedure

1. Input a raster signal with the pattern generator.
2. Loosen the deflection yoke mounting screw, and set the purity control to the center as shown below:

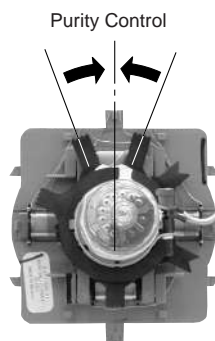

3. Turn the raster signal of the pattern generator to green.
4. Move the deflection yoke backward, and adjust with the purity control so that green is in the center and red and blue are even on both sides.

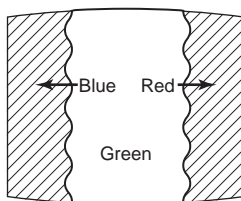

5. Move the deflection yoke forward, and adjust so that the entire screen becomes green.

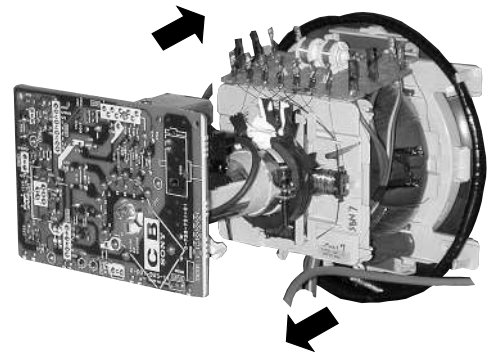

6. Switch over the raster signal to red and blue and confirm the condition.
7. When the position of the deflection yoke is determined, tighten it with the deflection yoke mounting screw.
8. When landing at the corner is not right, adjust by using the disk magnets.

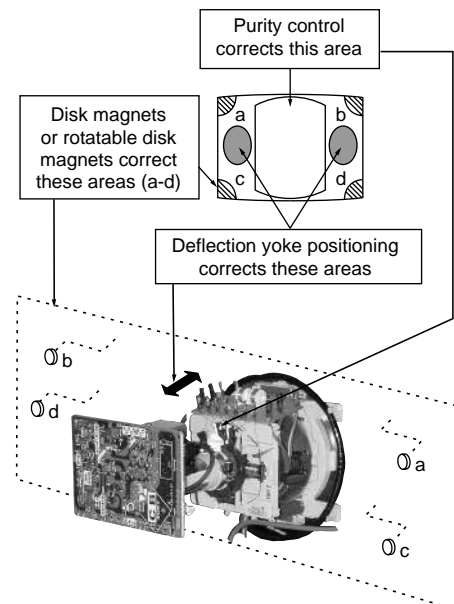

## 2-2. CONVERGENCE

### Preparation:

- Perform FOCUS, V. LIN and V. SIZE adjustments.
- Set BRIGHTNESS control to minimum.
- Input dot pattern.

### VERTICAL STATIC CONVERGENCE

1. Adjust V. STAT magnet to converge red, green and blue dots in the center of the screen (Vertical movement).

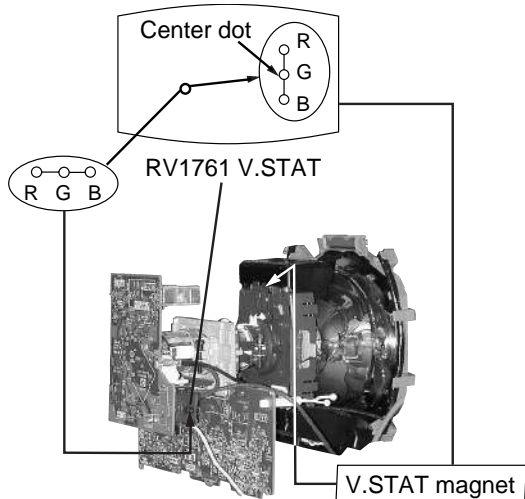

Tilt the V. STAT magnet and adjust static convergence to open or close the V. STAT magnet.

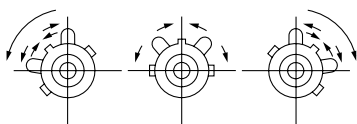

2. When the V. STAT magnet is moved in the direction of arrow a and b, red, green, and blue dots move as shown below:

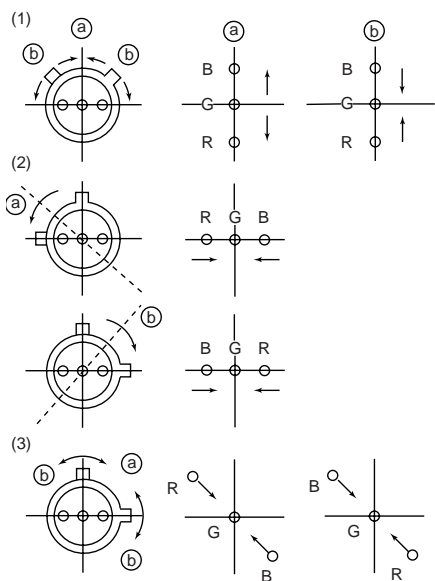

### HORIZONTAL STATIC CONVERGENCE

If the blue dot does not converge with the red and green dots, perform the following:

1. Move BMC magnet (a) to correct insufficient H. Static convergence.
2. Rotate BMC magnet (b) to correct insufficient V. Static convergence.
3. After adjusting the BMC magnet, repeat Beam Landing Adjustment.

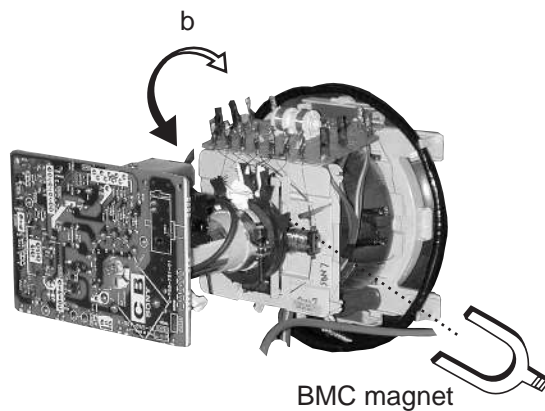
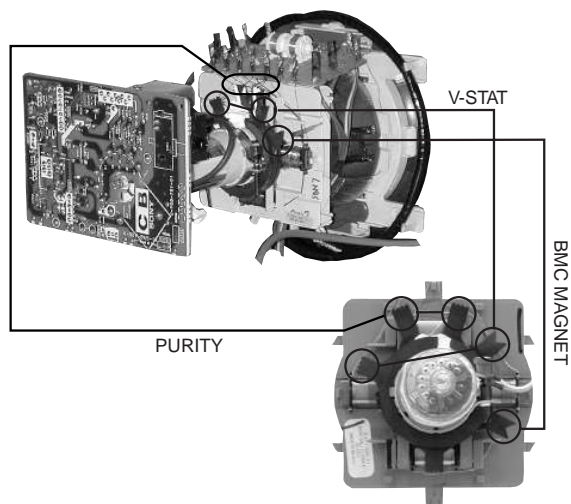

## DYNAMIC CONVERGENCE ADJUSTMENT

Before starting, perform Vertical and Horizontal Static Convergence Adjustment.

1. Slightly loosen deflection yoke screw.
2. Remove deflection yoke spacers.
3. Move the deflection yoke for best convergence as shown below:

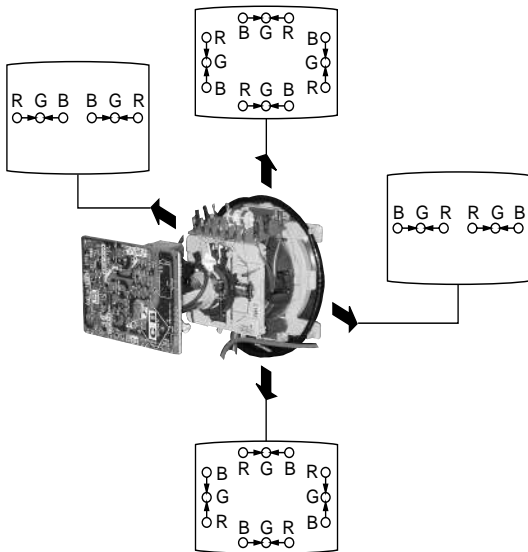

4. Tighten the deflection yoke screw.
5. Install the deflection yoke spacers.

## TLH PLATE ADJUSTMENT

1. Input crosshatch pattern.
2. Adjust PICTURE QUALITY to standard, PICTURE and BRIGHTNESS to 50%, and OTHER to standard.
3. Adjust the Horizontal Convergence of red and blue dots by tilting the TLH plate on the deflection yoke.

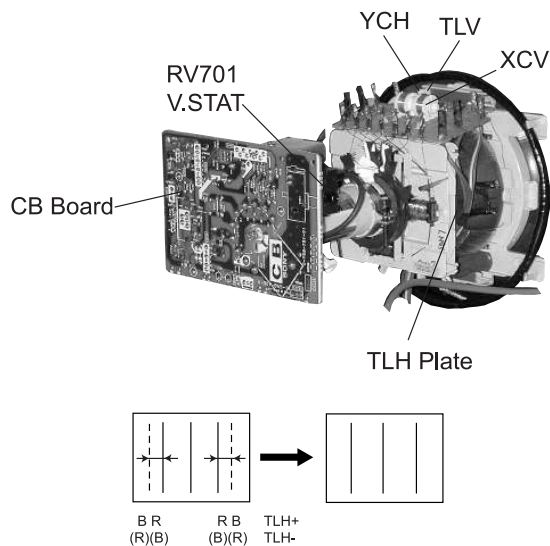

4. Adjust XCV core to balance X axis.

5. Adjust YCH VR to balance Y axis.
6. Adjust vertical red and blue convergence with V.TILT (TLV VR). Perform adjustments while tracking items 1 and 2.

## SCREEN-CORNER CONVERGENCE

1. Affix a permalloy assembly corresponding to the misconverged areas.

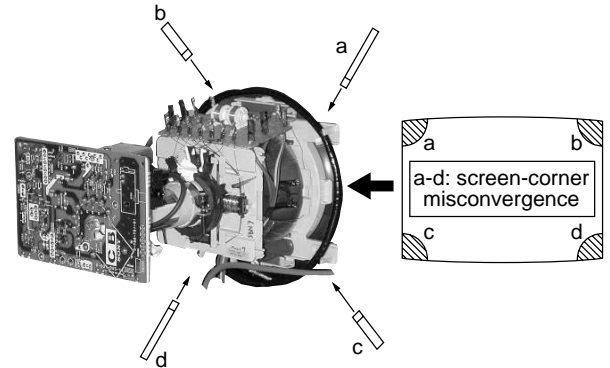

## 2-3. FOCUS

1. Adjust FOCUS control for best picture.

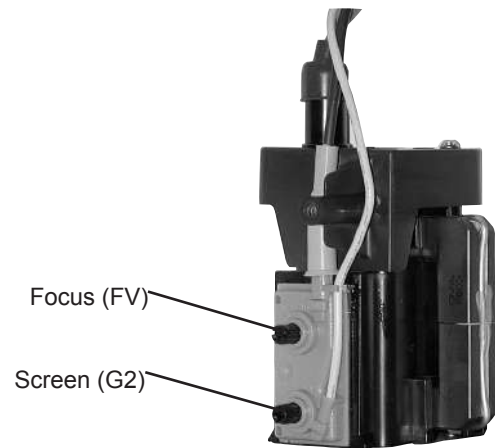

## 2-4. SCREEN (G2)

1. Input a dot pattern.
2. Set the PICTURE and BRIGHTNESS controls at minimum and COLOR control at normal.
3. Adjust SBRT, GCUT, BCUT in service mode with an oscilloscope as shown below so that voltages on the red, green, and blue cathodes are  $170 \pm 2$  VDC.

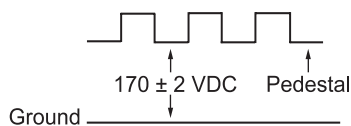

4. Observe the screen and adjust SCREEN (G2) VR in FBT to obtain the faintly visible background of dot signal.

## 2-5. METHOD OF SETTING THE SERVICE ADJUSTMENT MODE

### Service Mode Procedure

1. Standby mode (power off).
2. On the remote commander, press:

**Display** → **Channel 5** → **Sound Volume +** → **Power**

(press each button within a second).

### Service Adjustment Mode In

1. The CRT displays the item being adjusted.

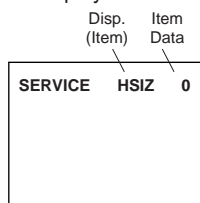

2. Press **1** or **4** on the Remote Commander to select the item.
3. Press **3** or **6** on the Remote Commander to change the data.
4. Press MUTING then ENTER to save into the memory.

### Service Adjustment Mode Memory

Turn set off then on to exit service adjustment mode.

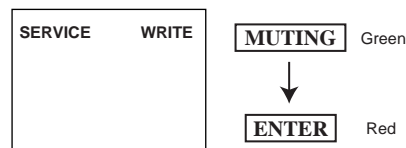



## 2-6. WHITE BALANCE ADJUSTMENTS

1. Input an entire white signal with burst.
2. Set to Service Adjustment Mode.
3. Set DCOL to "0".
4. Set the PICTURE and BRIGHTNESS to minimum.
5. Adjust with SBRT if necessary.
6. Select GCUT and BCUT with **1** and **4**.
7. Adjust with **3** and **6** for the best white balance.
8. Set PICTURE and BRIGHTNESS to maximum.
9. Select GDRV and BDRV with **1** and **4**.
10. Adjust with **3** and **6** for the best white balance.
11. Reset DCOL to "1".
12. To write into memory, press MUTING then ENTER.

## SECTION 3: SAFETY RELATED ADJUSTMENTS

### 3-1. R564 CONFIRMATION METHOD (HV HOLD-DOWN CONFIRMATION AND READJUSTMENTS)

The following adjustments should always be performed when replacing the following components which are marked with  on the schematic diagram:

Part Replaced (  )	Adjustment (  )
DY, T505, CRT, IC501, C507, C520, C505, C509, C515, L509, L508, C551, L510, C546, C537, C547, D517, D518, D519, R560, R561, R562, R563, R565, R566, R567, R525.....A Board	HV HOLD-DOWN R564
IC1301.....MB Board	

#### Preparation Before Confirmation

- Using a Variac, apply AC input voltage:  $120 \pm 2$  VAC.
- Turn the POWER switch ON.
- Input a white signal and set the PICTURE and BRIGHTNESS controls to maximum.
- Confirm that the voltage between C546 (+) or TP503 and ground is more than 100 VDC.

#### Hold-Down Operation Confirmation

- Connect the current meter between Pin 11 of the FBT (T505) and the PWB land where Pin 11 would normally attach. (See Figure 1 on the next page.)
- Input a dot signal and set PICTURE and BRIGHTNESS to minimum: IABL =  $100 \pm 100$   $\mu$ A.
- Confirm the voltage of A Board TP600 is  $135 \pm 1$  VDC.
- Connect the digital voltmeter and the DC power supply via diode 1SS119 to C546 (+) and ground. (See Figure 1 on the next page.)
- Increase the DC power voltage gradually until the picture blanks out.
- Turn DC power source off immediately.
- Read the digital voltmeter indication (standard <  $120 \pm 0.3$  VDC).
- Input a white signal and set PICTURE and BRIGHTNESS to maximum: IABL =  $820 \pm 100$   $\mu$ A.
- Repeat steps 4 to 7.

#### Hold-Down Readjustment

If the setting indicated in step 2 of Hold-Down Operation Confirmation cannot be met, readjustment should be performed by altering the resistance value of R564 component marked with .

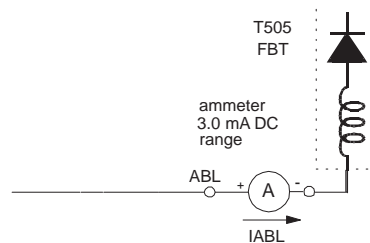

### 3-2. B+ VOLTAGE CONFIRMATION AND ADJUSTMENT

Note: The following adjustments should always be performed when replacing the following components, which are marked with  on the schematic diagram on the A Board.

<b>A BOARD:</b>	IC601, PH601
-----------------	--------------

- Using a Variac, apply AC input voltage:  $130 + 2.0/-0.0$  VAC.
- Input a dot signal.
- Set the PICTURE and BRIGHTNESS controls to minimum.
- Confirm that the voltage of A Board TP600 is <136 VDC.
- If step 4 is not satisfied, replace the components listed above, then repeat steps 1–3.

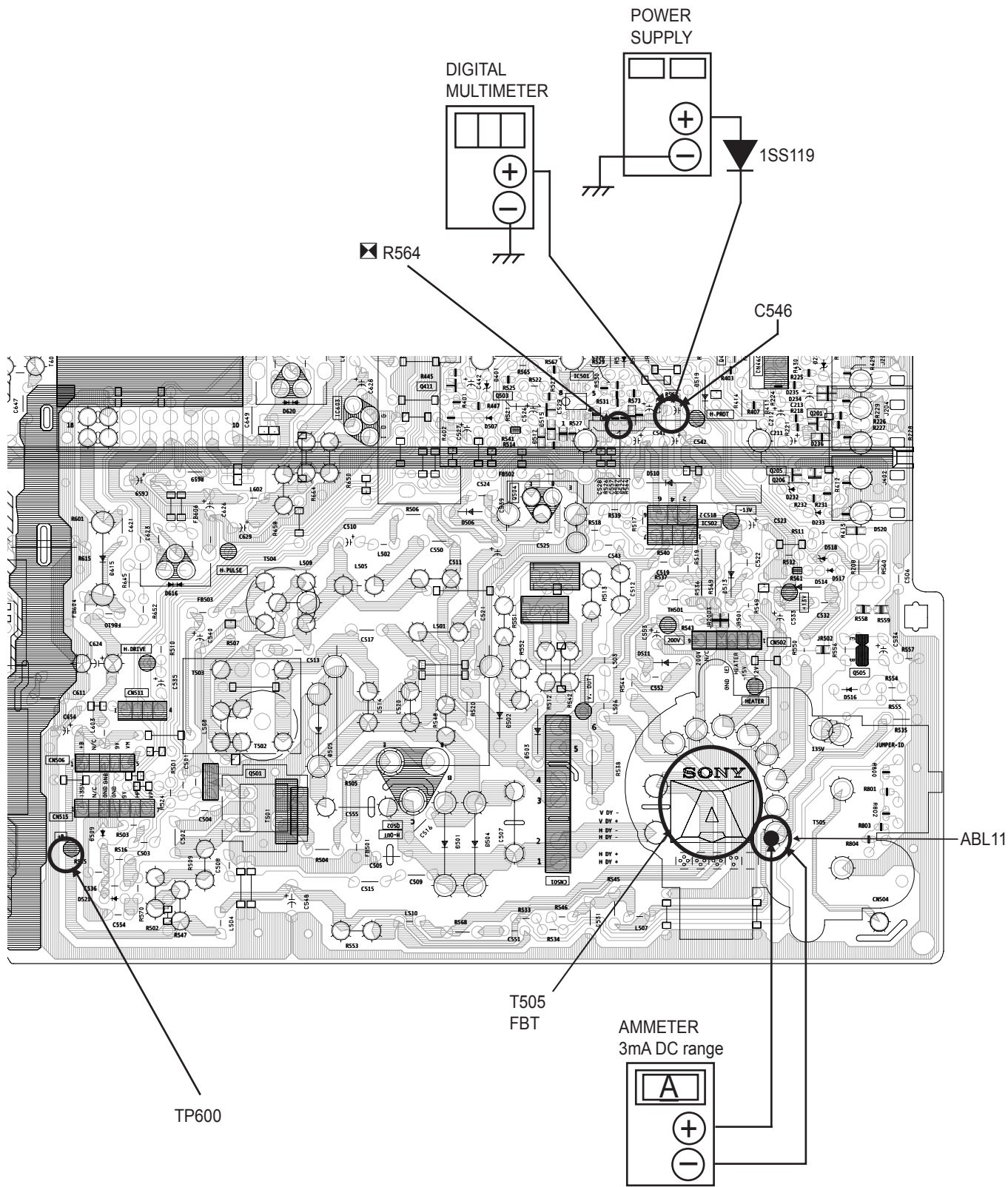

Figure 1



## SECTION 4: CIRCUIT ADJUSTMENTS

### ELECTRICAL ADJUSTMENTS BY REMOTE COMMANDER

Use the Remote Commander (RM-Y172) to perform the circuit adjustments in this section.

**Test Equipment Required:** 1. Pattern generator 2. Frequency counter 3. Digital multimeter 4. Audio oscillator

#### 4-1. SETTING THE SERVICE ADJUSTMENT MODE

- Standby mode (power off).
- On the remote commander, press the following within one second of each other:

Display → Channel 5 → Sound Volume + → Power

#### Service Adjustment Mode On

- The CRT displays the item being adjusted.

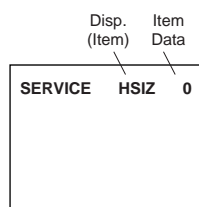

- Press 1 or 4 on the Remote Commander to select an item.
- Press 3 or 6 on the Remote Commander to change the data.
- Press MUTING then ENTER to save into the memory.

#### Service Adjustment Mode Memory

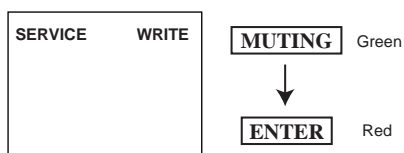

- Press 8 then ENTER on the Remote Commander to initialize.

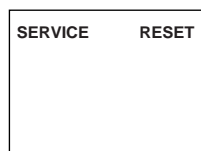

Carry out step 1 when adjusting IDs 0-4 and when replacing and adjusting IC1003.

- Turn set off then on to exit service adjustment mode.

#### 4-2. MEMORY WRITE CONFIRMATION METHOD

- After adjustment, remove the power plug from the AC outlet, then plug it in again.
- Turn the power switch ON and set to service mode.
- Call the adjusted items again to confirm they were adjusted.

#### 4-3. ADJUSTMENT BUTTONS AND INDICATORS

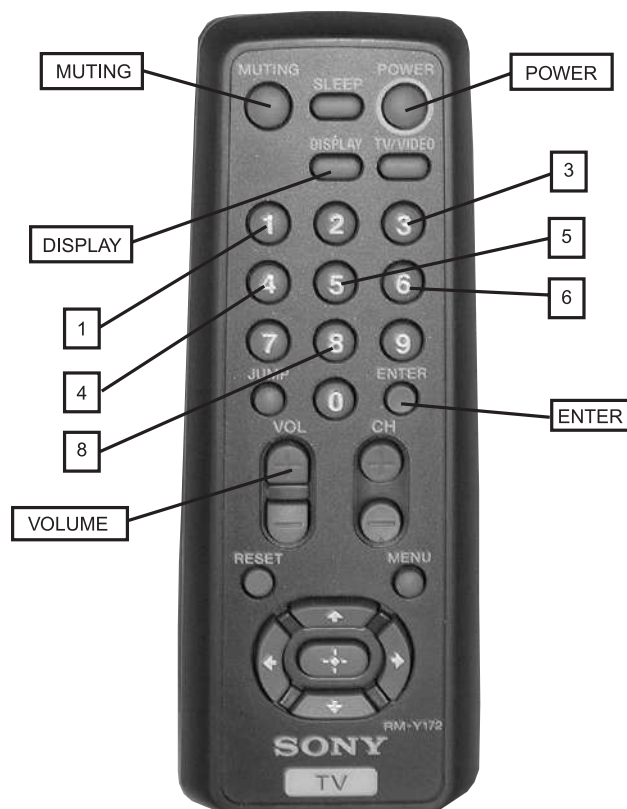

RM-Y172

## ADJUSTMENT ITEMS (1 OF 2)

Reg #	ITEM	FUNCTION	RANGE	FIX DATA	NTSC	PAL M	PAL N	VIDEO	RF	AVERAGE DATA		
1	HSIZ	Horizontal Size Adjustment	0-63	35	35	35	35			31		
2	HPOS	Horizontal Position Adjustment	0-63	20	33	33	33			17		
3	VBOW	Vertical Line Bowing Adj.	0-15	7	5	5	5			7		
4	VANG	Vertical Line Bowing Slant Adj.	0-15	7	7	7	7			8		
5	TRAP	Horizontal Trapezoid Adj.	0-15	7	7	7	7			6		
6	PAMP	Horizontal PIN distortion Adj.	0-63	20	7	7	7			15		
7	UPIN	Upper PIN Distortion Adj.	0-63	31	36	36	36			28		
8	LPIN	Lower PIN Distortion Adj.	0-63	31	36	36	36			34		
9	VM	Velocity Modulation on/off	0,1	Palette mode controls this register								0
10	BLKO	Vertical Blanking on/ff	0,1	0						0		
11	VMLV	Velocity Modulation Level	0-3	Palette mode controls this register								0
12	AGN2	Aging 2	0,1	0						0		
13	REFP	Reference Pulse position	0,1	0						0		
14	VBLK	Vertical Blanking on/off	0,3	0						0		
15	JPSW		0,1	0						0		
16	VSIZ	Vertical Size Adjustment	0-63	31	47	47	47			23		
17	VPOS	Vertical Position Adj.	0-63	31	32	32	32			32		
18	VLIN	Vertical linearity Adj.	0-15	7						5		
19	SCOR	Vertical "S" Correction Adjustment	0-15	6						4		
20	VZOM	16:9 CRT Z Mode on/off	0,1	0						0		
21	EHT	Vertical High-Voltage Compensation	0-15	8						10		
22	ASP	Aspect Ratio control	0-63	47						47		
23	SCRL	16:9 CRT Z Mode Trans. Scroll	0-63	31						31		
24	HBLK	Horizontal Blanking on/off	0,1	1						1		
25	LBLK	Left Blanking Adjustment	0-15	11						11		
26	RBLK	Right Blanking Adjustment	0-15	8						8		
27	VUSN	V Saw Waveform Compress	0,1	0						0		
28	HDW	Horizontal Drive Pulse Width	0,1	1						1		
29	EWDC	"Parabola" EW, D.C. Adjustment	0,1	0						0		
30	LVLN	Lower Screen BTM Vertical Line Adj.	0-15	0						0		
31	UVLN	Upper Screen BTM Vertical Line Adj.	0-15	0						0		
32	HTRP	Horiz. Trapezoid	0-1	0						0		
33	RDRV	R Output Drive control	0-63	31						21		
34	GDRV	G Output Drive control	0-63	21						14		
35	BDRV	B Output Drive control	0-63	21						14		
36	RCUT	R Output Cutoff control	0-15	10						10		
37	GCUT	G Output Cutoff control	0-15	6						7		
38	BCUT	B Output Cutoff control	0-15	6						7		
39	DCOL	Dynamic Color on/off	0,1	0						1		
40	SHUE	Sub HUE adjustment	0-31	12						14		
41	SCOL	Sub COLOR adjustment	0-31		14	14	14			14		
42	SBRT	Sub BRIGHTNESS adjustment	0-31	13						13		
43	RON	R Output on/off	0,1	1						1		
44	GON	G Output on/off	0,1	1						1		
45	BON	B Output on/off	0,1	1						1		
46	AXPL	Axis PAL	0,1	0						0		
47	AXNT	Axis NTSC	0,1	0						1		
48	CBPF	Chroma BPF on/off	0,1	1						1		
49	CTRP	Y TRAP FILTER on/off	0,1	1						1		
50	COFF	Color On/off	0,1	0						0		
51	KOFF	Set Color Killer	0,1	0						0		
52	SSH P	Sub SHARPNESS	0-15	5						5		
53	SHPF	SHARPNESS Circuit Focus	0,1	Palette mode controls this register								1
54	PREL	Pre-Shoot/ Over-Shoot	0,1	1						1		
55	Y-DC	DC Transmission Ratio Switching	0,1	Palette mode controls this register								1
56	GAMM	Gamma Correction	0-3	Palette mode controls this register								1
57	ABLM	ABL Mode Switch	0,1	1						1		
58	VTH	ABL CD VHT Switching	0,1	1						1		
59	YDEL	Y Delay Time Control	0-15	7						7		
60	NCOL	No Color ID	0,1	1						1		
61	FSC	FSC Out on/off	0,1	1						1		
62	K-ID	Killer ID Control on/off	0,1	0						0		
63	HOSC	Horizontal VCO Oscillation Freq.	0-15	10						7		

## ADJUSTMENT ITEMS (2 OF 2)

Reg #	ITEM	FUNCTION	RANGE	FIX DATA	NTSC	PAL M	PAL N	VIDEO	AVERAGE DATA
64	VSS	Vertical Sync Slice Level	0,1	1					0
65	HSS	Horizontal Sync Slice Level	0,1	0					0
66	HMSK	For Macro Vision	0,1	0					0
67	VTMS	Select Signal VTIM Pin	0-3	0					0
68	CDMD	Vertical Count Down Mode Switching	0-3	3				3	
69	AFC	AFC Loop Gain Switching	0-3	0				0	0
70	FIFR	Field Frequency	0-3		3	1	1		3
71	SBAL	Sub Balance	0-15	5					7
72	SBAS	Sub Bass	0-7	0					9
73	STRE	Sub Treble	0-7	3					9
74	BBEH	BBE High	0-15	6					
75	BBEL	BBE Low	0-15	8					12
76	SRND	Surround	0,1	0					13
77	AUX	SRS, Simulated	0,3	0					
78	DISP	O.S.D Display position	0-130	26					15
79	TROT	Tilt Correction	0-63	31					31
80	HCLW	Horizontal Count lower limit	0-255	16					16
81	HCHG	Horizontal Count High limit	0-255	64					64
106	SYSC	Color System	0-7	4					6
107	VENH	Vertical Enhancement	0-7	Palette mode controls this register					4
108	PDSO		0,1	0					
109	CK		0,1	0					
110	VNL		0,15	3					3
111	HPK		0,1	0					0
112	HPK0		0,1	Palette mode controls this register					
113	CORE		0,3	1					1
114	TRAP		0,1	1					1
115	CHTR		0,1	0					0
116	CHPF		0,1	1					1
117	ENHO		0,1	0					0
118	ID0		0,255						89
119	ID1		0,255						3
120	ID2		0,255						72
121	ID3		0,255						16
122	ID4		0,255						137
123	ID5		0,255						1
124	ID6		0,255						0

## Notes:

No. 1–100 show the order that each adjustment mode may be selected while in service mode.

Data Range shows the range of possible settings for each adjustment mode.

Initial Data shows the standard settings for each adjustment mode.

SERVICE	ID0	25
---------	-----	----

## 4-4. MB BOARD ADJUSTMENTS

### H. FREQUENCY (FREE RUN) CHECK

1. Input a TV mode (RF) with no signal.
2. Connect a frequency counter to base of Q501 (TP500 H. DRIVE).
3. Check H. Frequency for  $15735 \pm 200$  Hz for NTSC.

### V. FREQUENCY (FREE RUN) CHECK

1. Select video 1 with no signal input.
2. Set the conditions for a standard setting.
3. Connect the frequency counter on the A Board to TP508 (V OUT) or CN501 pin 6 (V DY+) and ground.
4. Check that V. Frequency shows  $60 \pm 4$  Hz for NTSC.

### DRIVE (RDRV)

1. Input a color-bar signal and set the level to 75%.
2. In Standard mode, set PICTURE to maximum and COLOR to minimum.
3. Activate the Service Adjustment Mode.
4. Set both GON and BON items. Using **3** and **6**; set each to the following values. Leave RON set to "1".

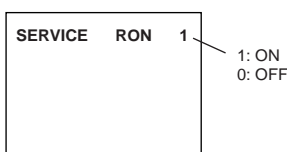

R ON: ON (1)  
G ON: OFF (0)  
B ON: OFF (0)

5. Select the DCOL item and set it to "0".
6. Connect an oscilloscope probe to CB board, J701 pin 11, KR (RED OUT).
7. Select RDRV with **1** and **4**.
8. Adjust the value of RDRV with **3** and **6** for  $70 \pm 3$  VDC.

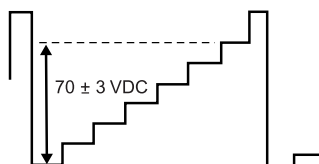

9. Reset the item DCOL to "1".
10. Reset GON and BON values to "1".

R ON: ON (1)  
G ON: ON (1)  
B ON: ON (1)

11. Reset Picture and Color to normal values:

PICTURE: MAX  
COLOR: CENTER

12. Press MUTING, then ENTER to save into the memory.

### DISPLAY POSITION ADJUSTMENT (DISP)

1. Input a color-bar signal.
2. Set to Service Adjustment Mode.
3. Select DISP with **1** and **4**.
4. Adjust values of DISP with **3** and **6** to adjust characters to the center.
5. Write to memory by pressing MUTING, then ENTER.
6. Check to see if the text is displayed on the screen.

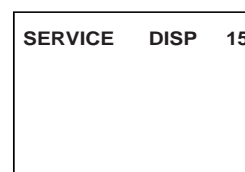

### SUB BRIGHT ADJUSTMENT (SBRT)

1. Input a monoscope signal.
2. Activate the Service Adjustment Mode.
3. Set the PICTURE and BRIGHTNESS to minimum.
4. Select the SBRT item with **1** and **4**.
5. Adjust the values of SBRT with **3** and **6** to obtain a faintly visible crosshatch.
6. Press MUTING then ENTER to save into the memory.

### SUB HUE, SUB COLOR ADJUSTMENT (SHUE, SCOL)

1. Input a color-bar signal.
2. Activate the Service Adjustment Mode.
3. Select the DCOL item and set the value to "0".
4. Connect an oscilloscope probe to CB board, CN705 Pin 4 (Blue Out).
5. Select the SHUE and SCOL item with **1** and **4**.
6. While showing the SHUE item, adjust the waveform with **3** and **6** until the second and third bars show the same level ( $V2 = V3 < 0.1$  Vp-p).
7. While showing the SCOL item, adjust the waveform with **3** and **6** until the first and fourth bars show the same level ( $V1 = V4 < 0.1$  Vp-p).

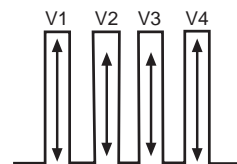

8. Select the DCOL item and reset to 1.
9. Press MUTING and ENTER to save into the memory.

### V. SIZE ADJUSTMENT (VSIZ)

1. Input a crosshatch signal.
2. Activate the Service Adjustment Mode.
3. Select the VSIZ item with **1** and **4**.
4. Adjust value of VPOS with **3** and **6** for the best vertical center.

- Press MUTING then ENTER to save into the memory.

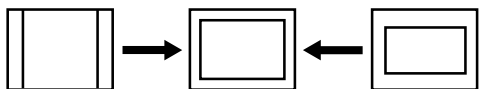

## V. CENTER ADJUSTMENT (VPOS)

Perform this adjustment after performing H. Frequency (Free Run) Check.

- Input a crosshatch signal.
- Activate the Service Adjustment Mode.
- Select the VPOS item with **1** and **4**.
- Adjust value of VPOS with **3** and **6** for the best vertical center.
- Press MUTING then ENTER to save into the memory.

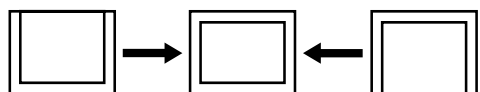

## H. CENTER ADJUSTMENT (HPOS)

Perform this adjustment after performing H. Frequency (Free Run) Check.

- Input a crosshatch signal.
- Activate the Service Adjustment Mode.
- Select the HPOS item with **1** and **4**.
- Adjust the value of HPOS with **3** and **6** for the best horizontal center.
- Press MUTING and ENTER to save into the memory.

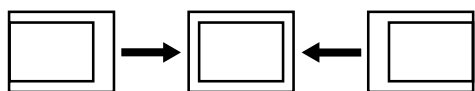

## H. SIZE ADJUSTMENT (HSIZ)

- Input a monoscope signal.
- Activate the Service Adjustment Mode.
- Select HSIZ with **1** and **4**.
- Adjust with **3** and **6** for the best horizontal size.
- Press MUTING and ENTER to save into the memory.

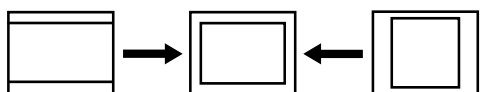

## V. LINEARITY (VLIN), V. CORRECTION (VSCO), PIN AMP (PAMP), AND HORIZONTAL TRAPEZOID (TRAP) ADJUSTMENTS

- Input a crosshatch signal.
- Activate the Service Adjustment Mode.
- Select VLIN, VSCO, PAMP, and PPHA with **1** and **4**.
- Adjust with **3** and **6** for the best horizontal size.

- Press MUTING then ENTER to save into the memory.

### V LINEARITY (VLIN)

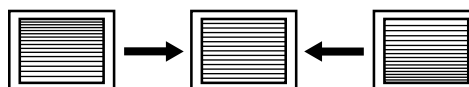

### V CORRECTION (VSCO)

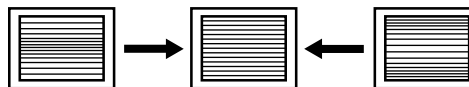

### PIN AMP (PAMP)

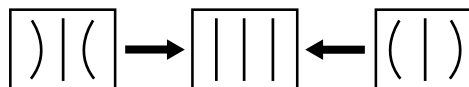

### HORIZONTAL TRAPEZOID (TRAP)

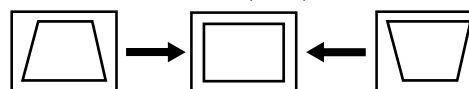

## V. ANGLE (VANG), V. BOW (VBOW), UPPER PIN (UPIN) AND LOW PIN (LPIN) ADJUSTMENTS

- Input a crosshatch signal.
- Activate the Service Adjustment Mode.
- Select VANG, VBOW, UPIN, and LPIN with **1** and **4**.
- Adjust with **3** and **6** for the best picture.
- Press MUTING and ENTER to save into the memory.

### V ANGLE (VANG)

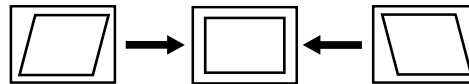

### V BOW (VBOW)

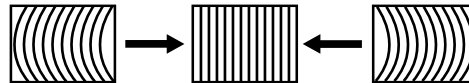

### UPPER PIN (UPIN)

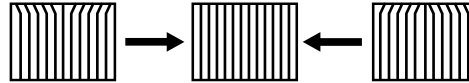

### LOW PIN (LPIN)

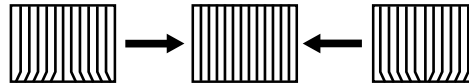

## SERVICE ADJUSTMENT MODE MEMORY

- Change the value of the DCOL item to "1".
- After completing all adjustments, press **0** then ENTER.

Read From Memory

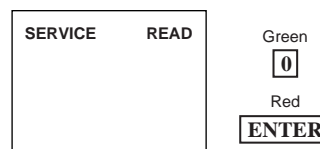

## SECTION 5: DIAGRAMS

### 5-1. CIRCUIT BOARDS LOCATION

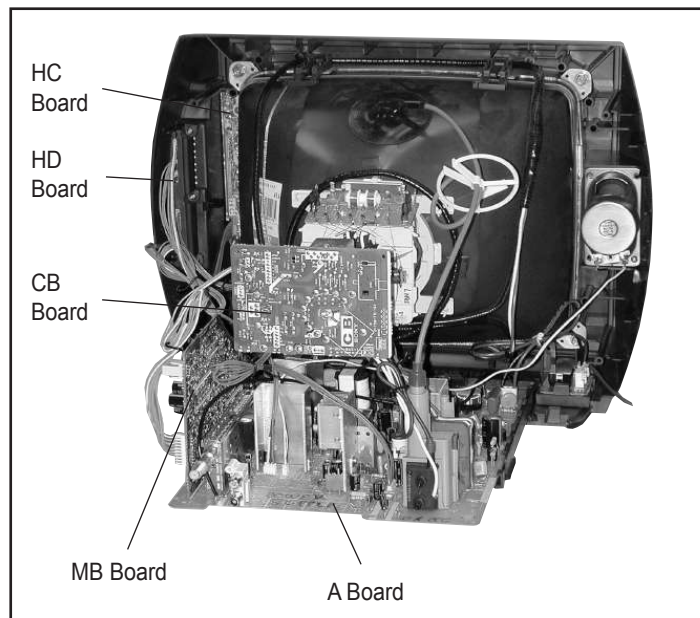

### 5-2. PRINTED WIRING BOARDS AND SCHEMATIC DIAGRAMS INFORMATION

All capacitors are in  $\mu\text{F}$  unless otherwise noted.  $\text{pF}$  :  $\mu\text{F}$  50WV or less are not indicated except for electrolytics and tantalums.

All electrolytics are in 50V unless otherwise specified.

All resistors are in ohms.  $\text{K}\Omega=1000\Omega$ ,  $\text{M}\Omega=1000\text{k}\Omega$

Indication of resistance, which does not have one for rating electrical power, is as follows: Pitch : 5mm

Rating electrical power :  $\frac{1}{4}$  W

$\frac{1}{4}$  W in resistance,  $\frac{1}{10}$  W and  $\frac{1}{8}$  W in chip resistance.

: nonflammable resistor.

: fusible resistor.

$\Delta$  : internal component.

: panel designation and adjustment for repair.

All variable and adjustable resistors have characteristic curve B, unless otherwise noted.

Readings are taken with a color-bar signal input.

Readings are taken with a 10M $\Omega$  digital multimeter.

Voltages are DC with respect to ground unless otherwise noted.

Voltage variations may be noted due to normal production tolerances.

All voltages are in V.

S : Measurement impossibility.

: B+line.

: B-line. (Actual measured value may be different).

: signal path. (RF)

Circled numbers are waveform references.

The components identified by shading and  $\Delta$  symbol are critical for safety. Replace only with part number specified.

The symbol indicates a fast operating fuse and is displayed on the component side of the board. Replace only with fuse of the same rating as marked.

Les composants identifiés par un trame et une marque  $\Delta$  sont critiques pour la sécurité. Ne les remplacer que par une pièce portant le numéro spécifié.

Le symbole indique une fusible à action rapide. Doit être remplacé par une fusible de même valeur, comme marqué.

The components identified by in this basic schematic diagram have been carefully factory-selected for each set in order to satisfy regulations regarding X-ray radiation. Should replacement be necessary, replace only with the value originally used.

When replacing components identified by , make the necessary adjustments as indicated. If the results do not meet the specified value, change the component identified by and repeat the adjustment until the specified value is achieved.

(Refer to R564 Adjustment on page 15.)

When replacing the parts listed in the table below, it is important to perform the related adjustments.

Part Replaced ()	Adjustment ()
DY, T505, CRT, IC501, C507, C520, C505, C509, C515, L509, L508, C551, L510, C546, C537, C547, D517, D518, D519, R560, R561, R562, R563, R565, R566, R567, R525.....A Board	HV HOLD-DOWN R564
IC1301.....MB Board	

### REFERENCE INFORMATION

#### RESISTOR

: RN METAL FILM  
: RC SOLID  
: FPRD NONFLAMMABLE CARBON  
: FUSE NONFLAMMABLE FUSIBLE  
: RW NONFLAMMABLE WIREWOUND  
: RS NONFLAMMABLE METAL OXIDE  
: RB NONFLAMMABLE CEMENT  
: ADJUSTMENT RESISTOR

#### COIL

: LF-8L MICRO INDUCTOR  
CAPACITOR  
: TA TANTALUM  
: PS STYROL  
: PP POLYPROPYLENE  
: PT MYLAR  
: MPS METALIZED POLYESTER  
: MPP METALIZED POLYPROPYLENE  
: ALB BIPOLAR  
: ALT HIGH TEMPERATURE  
: ALR HIGH RIPPLE

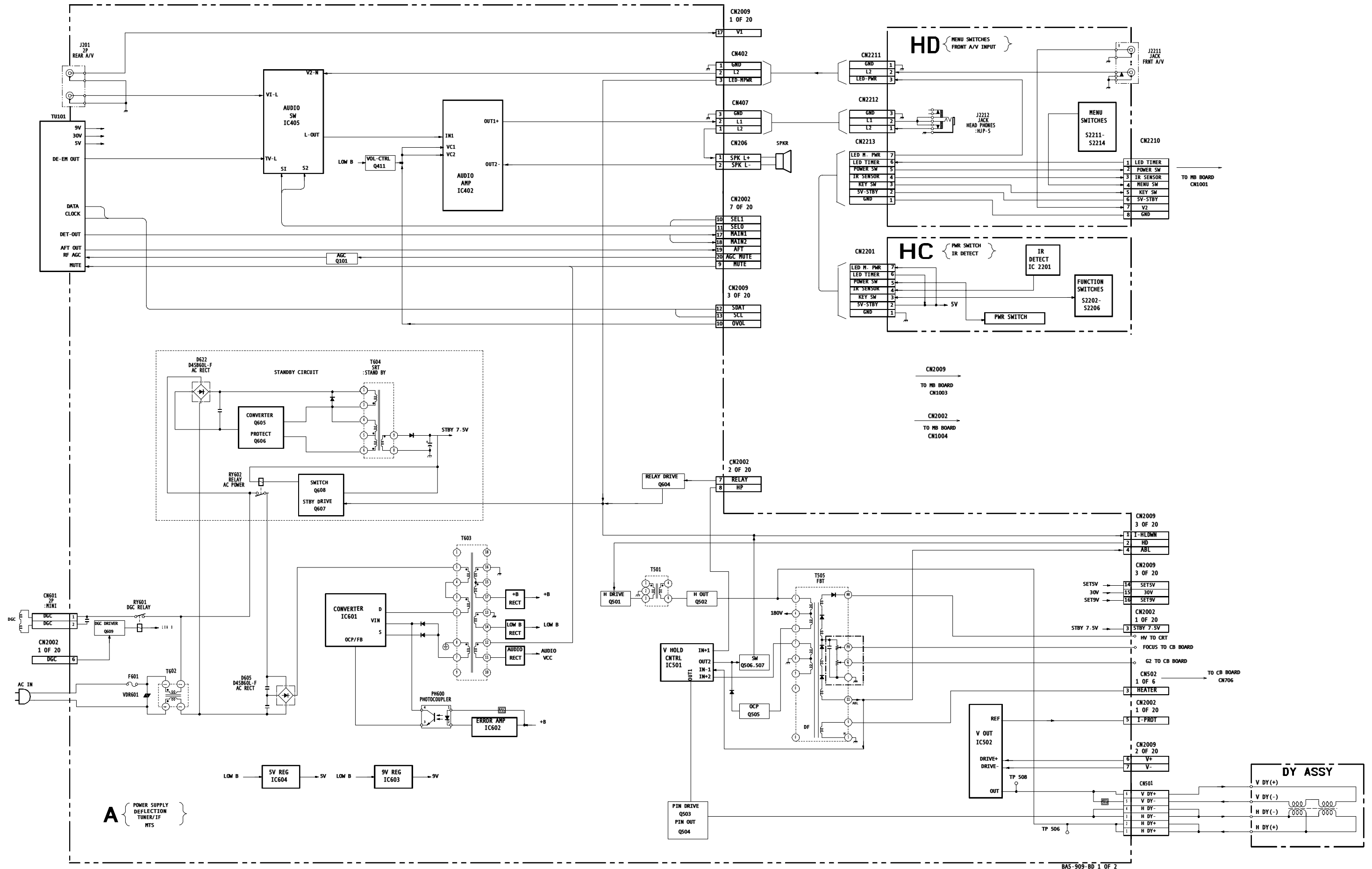

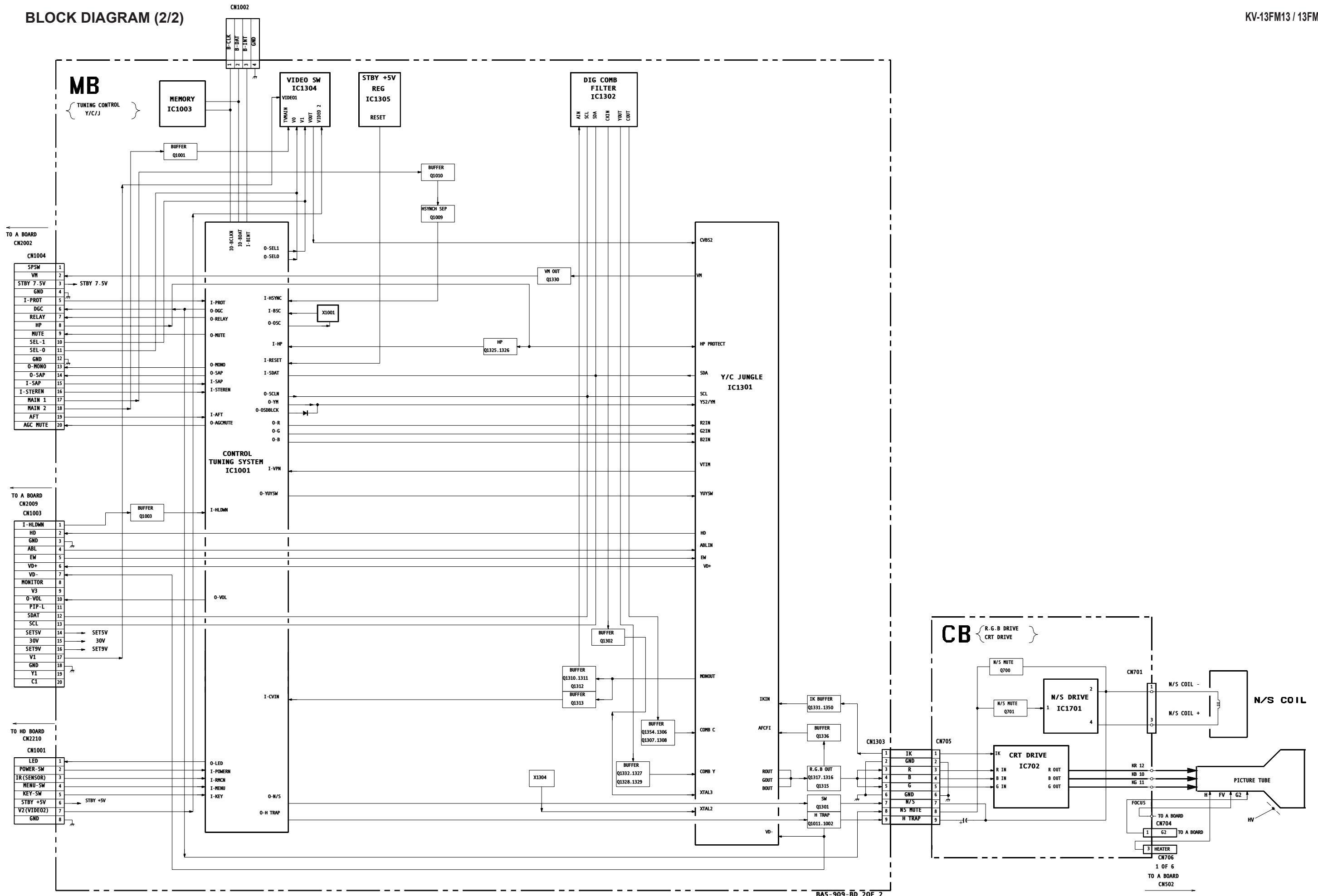

BA5-909-BD 20F 2



**A** [POWER SUPPLY, DEFLECTION, TUNER/IF, AUDIO, MTS]

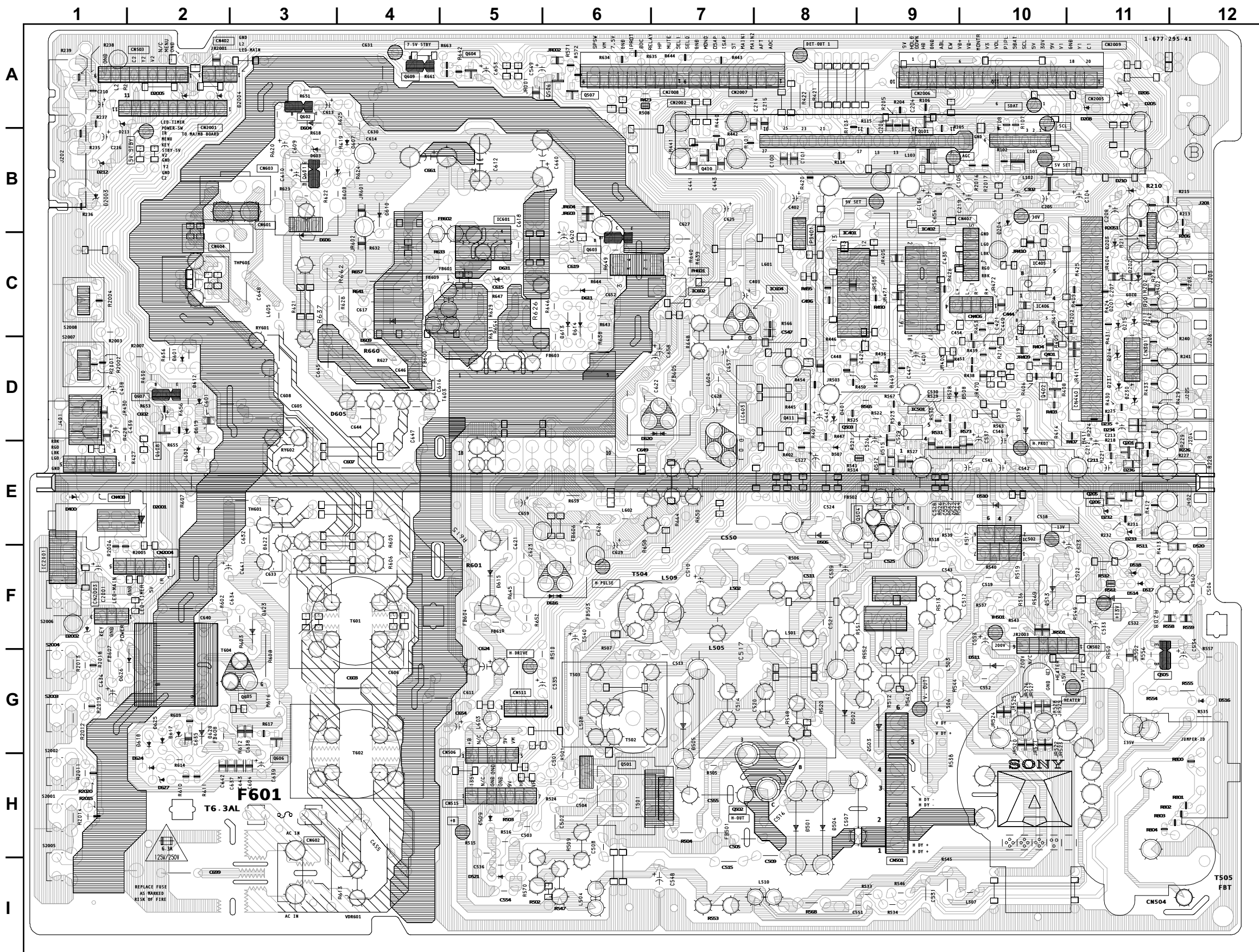

**A BOARD LOCATOR LIST**

DIODE	D620	E-7	
D204	C-10	D622	F-3
D208	B-11	D623	F-3
D209	B-11	D624	H-2
D210	B-11	D625	G-2
D400	E-1	D626	G-2
D401	E-8	D627	H-2
D502	G-9	D628	G-2
D503	G-9	D2002	F-1
D504	H-9	D2004	A-3
D505	G-7	D2005	A-2
D506	E-8		IC
D507	E-8	IC401	C-9
D508	E-10	IC405	C-10
D509	H-5	IC501	D-9
D510	E-10	IC502	F-10
D511	G-10	IC601	B-5
D513	F-10	IC602	C-7
D514	F-11	IC603	E-7
D516	G-12	IC604	C-8
D517	F-11	TRANSISTOR	
D518	F-11	Q101	B-9
D519	E-10	Q411	D-8
D520	F-12	Q501	H-6
D601	D-2	Q502	H-7
D602	E-2	Q503	D-8
D605	D-4	Q504	E-9
D610	C-4	Q505	G-11
D611	C-6	Q506	A-6
D612	C-2	Q507	A-6
D613	D-6	Q604	A-5
D614	D-6	Q605	G-3
D615	F-5	Q606	G-3
D616	F-6	Q607	D-2
D617	G-2	Q608	E-2
D618	G-2	Q609	A-4
D619	D-2		

## A BOARD IC BLOCK DIAGRAMS

## A BOARD: IC401 TDA7057AQ/N2

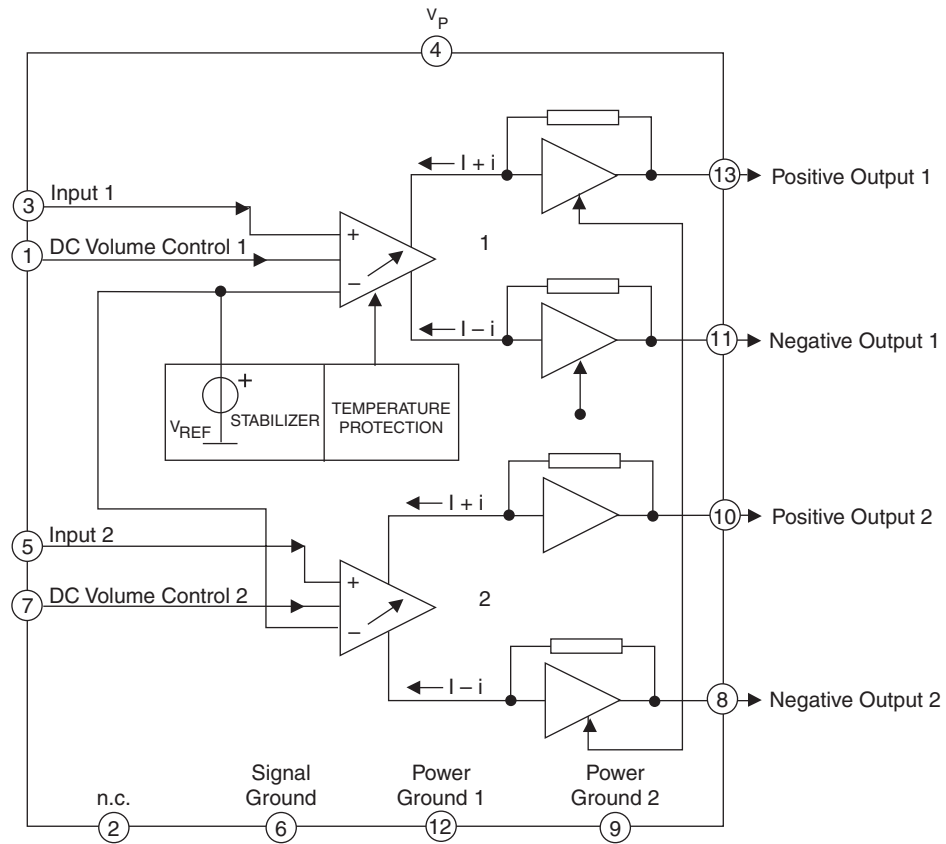

## A BOARD: IC502 TDA8172

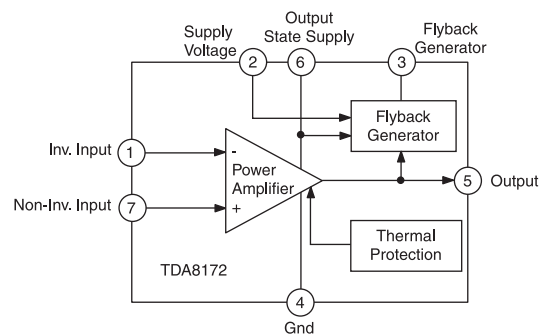

**A BOARD IC VOLTAGE LIST**

IC401		9	0.0	4	0.1	4	GND	4	-13.9	5	-32.7	3	GND
pin	volt	10	6.9	5	6.1	5	9.5	5	0.2	IC602		4	13.3
1	0.6	11	6.9	6	9.0	6	10.1	6	14.3	pin	volt	IC604	
2	0.0	12	0.0	7	5.3	7	0.1	7	2.1	1	135.9	pin	volt
3	2.4	13	6.9	8	GND	8	14.0	IC601		2	123.4	1	13.3
4	14.3	IC405		IC501		IC502		pin	volt	3	GND	2	5.0
5	2.4	pin	volt	pin	volt	pin	volt	1	-31.8	IC603		3	GND
6	0.0	1	6.0	1	0.2	1	2.1	2	-32.7	pin	volt		
7	0.6	2	0.1	2	3.7	2	14.0	3	53.2	1	13.3		
8	6.9	3	6.1	3	2.5	3	-12.6	4	-23.8	2	8.9		

TU101		4	4.9	9	9.0	14	N/C
pin	volt	5	4.9	10	3.9	15	N/C
1	8.8	6	GND	11	GND	16	0.1
2	30.5	7	3.5	12	N/C	17	0.1
3	5.0	8	0	13	N/C	18	3.1

All voltages are in V

**A BOARD TRANSISTOR VOLTAGE LIST**

Q101		Q502		Q505		Q604		Q608	
pin	volt	pin	volt	pin	volt	pin	volt	pin	volt
B	0.0	B	-0.1	B	134.9	B	0.1	B	0.0
C	5.6	C	133	C	1.8	C	4.1	C	0.7
E	GND	E	GND	E	135.5	E	GND	E	GND
Q411		Q503		Q506		Q606		Q609	
pin	volt	pin	volt	pin	volt	pin	volt	pin	volt
B	5.3	B	0.2	B	0.0	B	-36.1	B	0.0
C	GND	C	3.8	C	0.0	C	-35.3	C	13.9
E	5.2	E	0.0	E	GND	E	-36.3	E	GND
Q501		Q504		Q507		Q607		All voltages are in V	
pin	volt	pin	volt	pin	volt	pin	volt		
B	0.0	B	0.1	B	0.0	B	0.7		
C	93.3	C	-6.5	C	0.0	C	0.1		
E	GND	E	0.0	E	0.0	E	GND		

**A BOARD TRANSISTOR VOLTAGE LIST**

Q605	
pin	volt
D	-35.6
G	40.8
S	36.8

All voltages are in V

A BOARD SCHEMATIC DIAGRAM

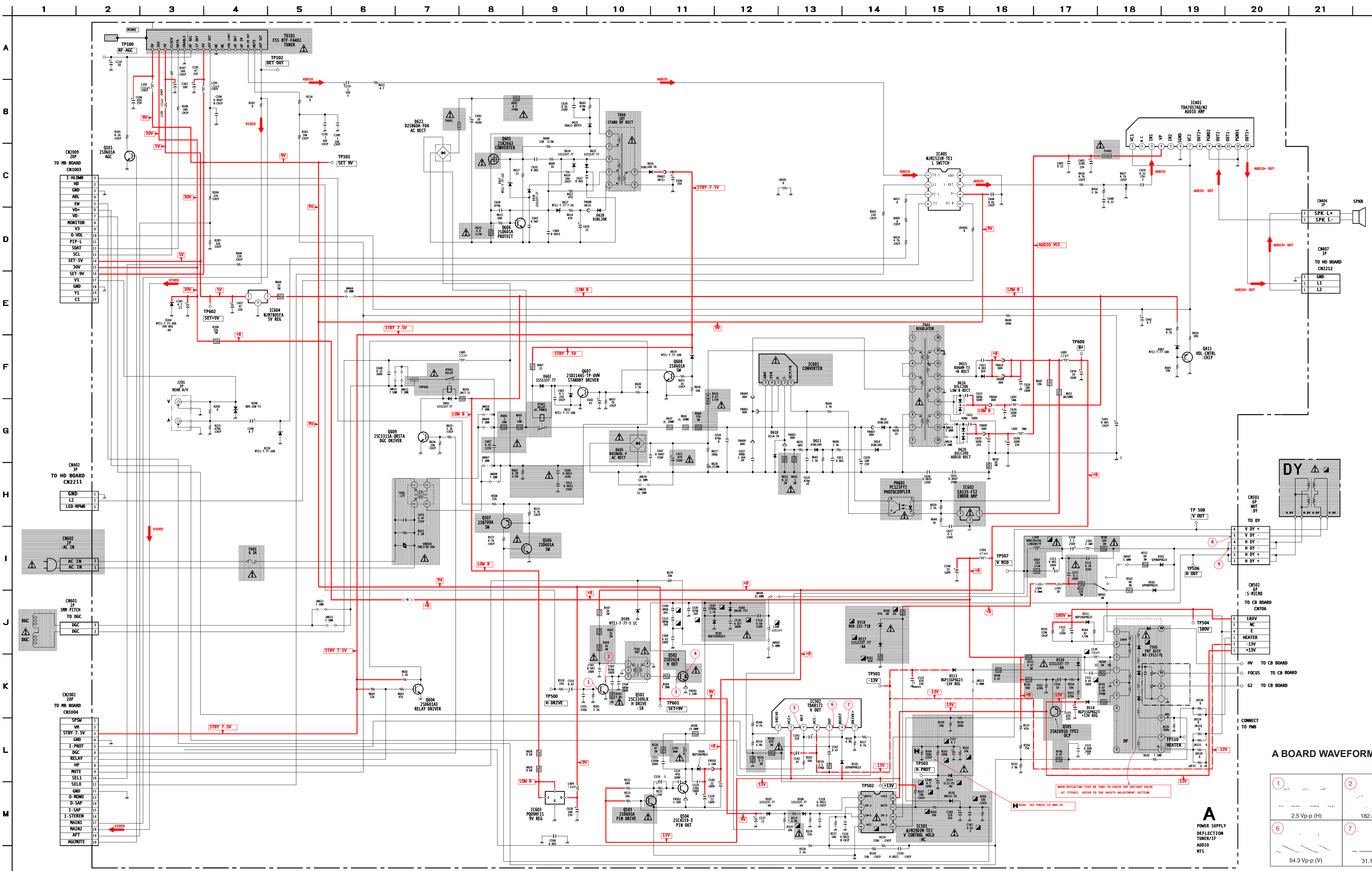

A BOARD WAVEFORMS

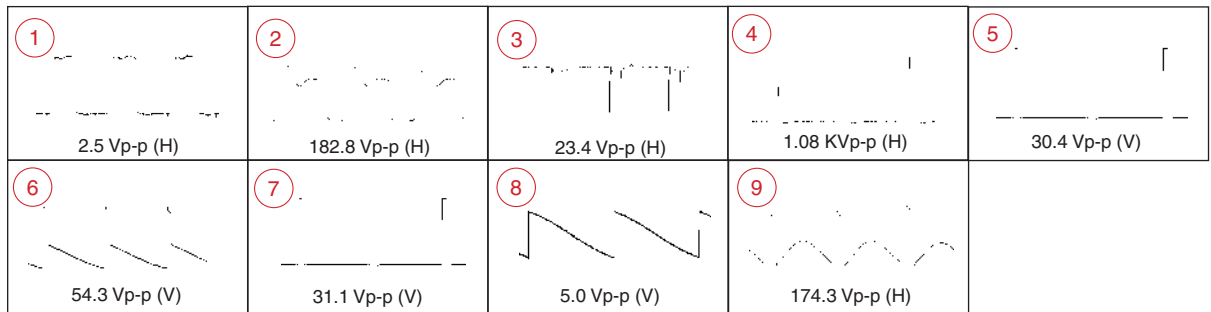

**A**  
POWER SUPPLY  
DEFLECTION  
TUNER/IF  
AUDIO  
RTS

BAS-909-A

MB BOARD SCHEMATIC DIAGRAM

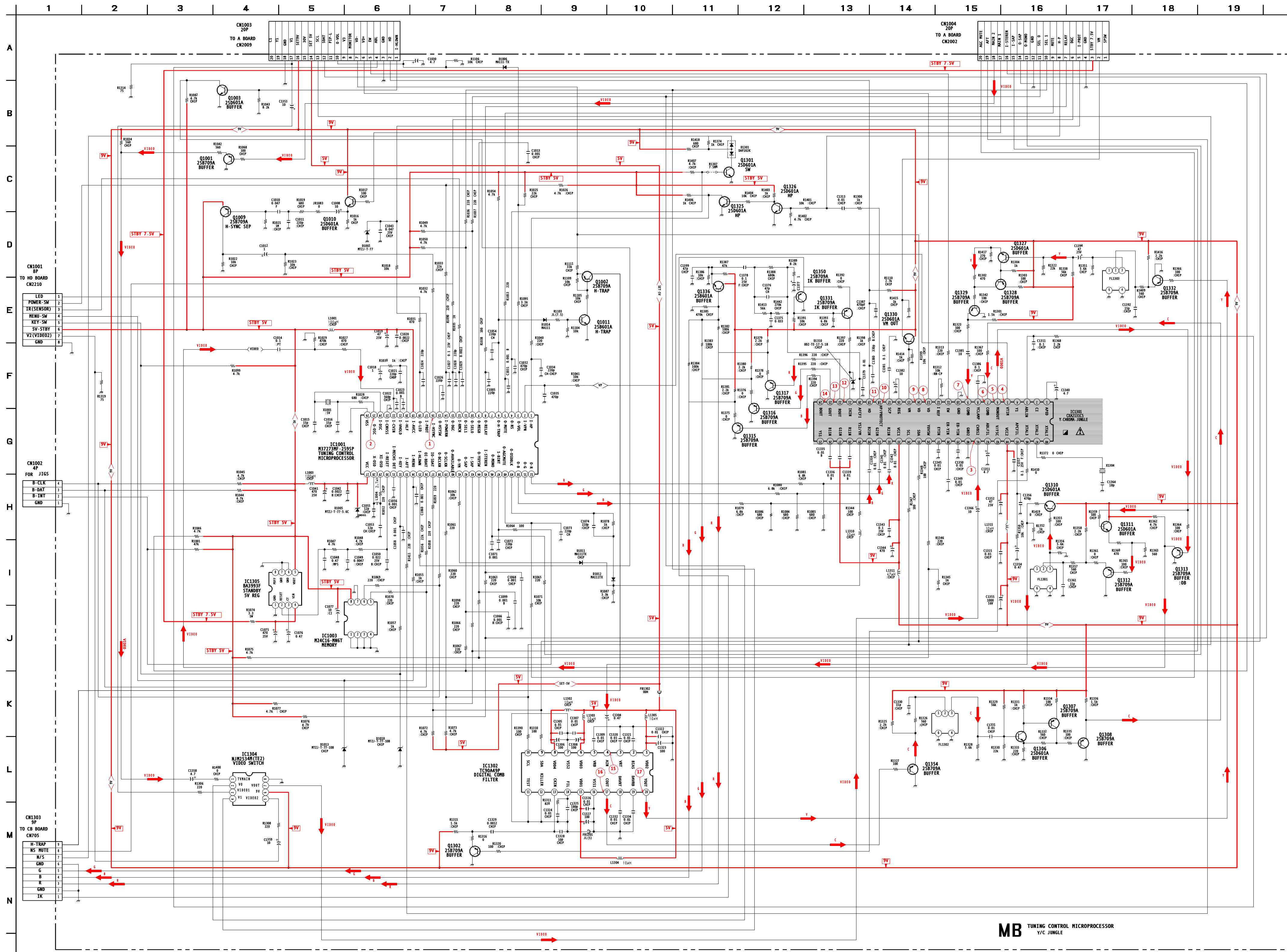

MB BOARD WAVEFORMS

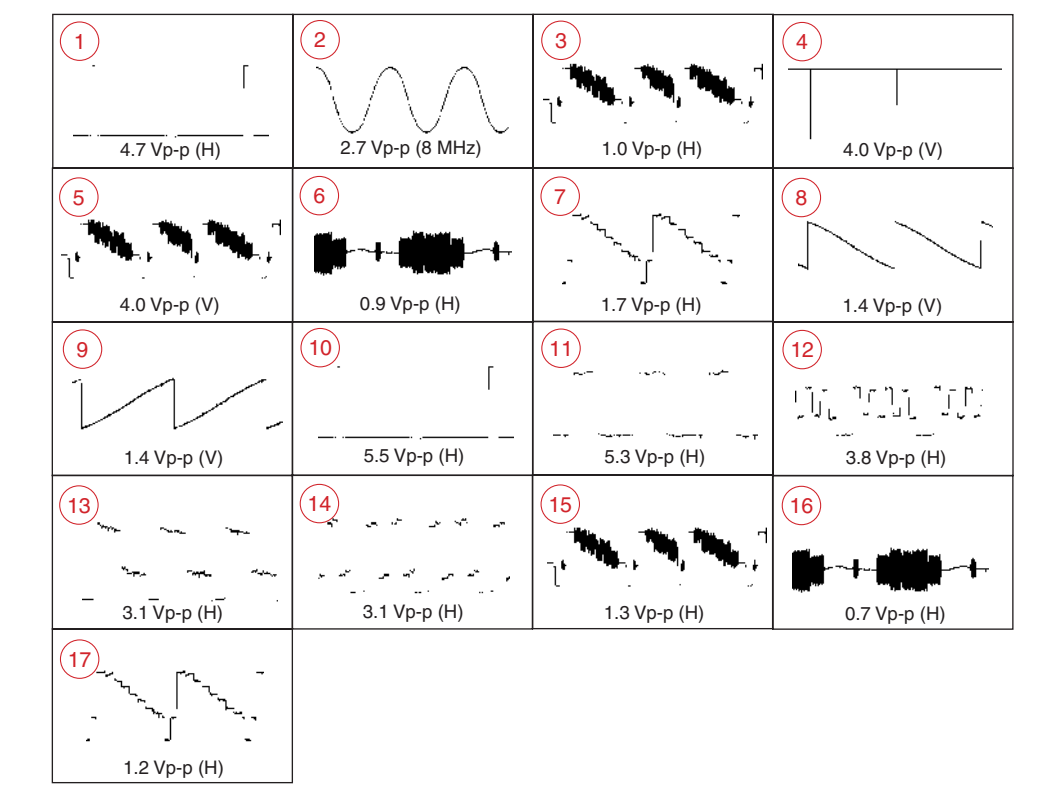

MB TUNING CONTROL MICROPROCESSOR Y/C JUNGLE

## MB BOARD IC VOLTAGE

IC1001		IC1003		43	5.1
pin	volt	pin	volt	44	8.7
1	1.7	1	GND	45	5.2
2	4.8	2	GND	46	4.6
3	0.0	3	GND	47	1.7
4	0.4	4	GND	48	0.2
5	0.0	5	4.8	IC1302	
6	0.1	6	4.8	pin	volt
7	NC	7	GND	1	5.0
8	0.0	8	5.0	2	1.4
9	0.0	IC1301		3	3.2
10	0.1	pin	volt	4	2.4
11	0.1	1	3.3	5	1.9
12	5.0	2	5.1	6	5.0
13	0.0	3	1.3	7	0.0
14	4.3	4	5.1	8	5.0
15	4.9	5	4.8	9	4.9
16	0.0	6	4.3	10	4.9
17	-0.2	7	6.3	11	0.0
18	4.9	8	5.0	12	0.0
19	5.0	9	5.1	13	2.5
20	2.1	10	GND	14	2.1
21	0.2	11	4.1	15	5.0
22	2.3	12	2.4	16	0.0
23	GND	13	3.5	17	2.5
24	2.2	14	3.5	18	3.2
25	2.3	15	5.4	19	1.9
26	0.0	16	7.7	20	2.4
27	4.9	17	1.6	IC1304	
28	2.2	18	3.5	pin	volt
29	2.3	19	2.3	1	4.6
30	5.0	20	2.6	2	0.1
31	0.0	21	1.5	3	4.6
32	5.0	22	1.5	4	0.1
33	2.4	23	1.6	5	4.6
34	4.4	24	1.4	6	8.9
35	5.0	25	NC	7	3.8
36	4.8	26	4.6	8	GND
37	4.8	27	4.6	IC1305	
38	4.8	28	4.6	pin	volt
39	4.8	29	0.0	1	GND
40	NC	30	4.5	2	5.0
41	0.0	31	4.5	3	1.6
42	0.1	32	4.5	4	7.4
43	5.0	33	8.7	5	5.0
44	0.1	34	4.9	6	GND
45	5.0	35	4.8	7	GND
46	0.0	36	0.2	8	NC
47	5.0	37	4.6	All voltages are in V	
48	0.0	38	5.3		
49	0.0	39	5.3		
50	0.0	40	GND		
51	0.0	41	5.1		
52	0.0	42	6.2		

## MB BOARD TRANSISTOR VOLTAGE

Q1001		Q1011		Q1308		Q1315		Q1327		Q1332	
pin	volt	pin	volt	pin	volt	pin	volt	pin	volt	pin	volt
B	4.8	B	0.0	B	5.7	B	1.4	B	2.4	B	2.4
C	GND	C	3.5	C	GND	C	GND	C	7.6	C	GND
E	5.4	E	GND	E	6.3	E	2.0	E	1.8	E	3.0
Q1002		Q1301		Q1310		Q1316		Q1328		Q1336	
pin	volt	pin	volt	pin	volt	pin	volt	pin	volt	pin	volt
B	3.5	B	0.4	B	2.4	B	1.6	B	7.6	B	2.0
C	3.5	C	2.3	C	8.7	C	GND	C	4.5	C	8.9
E	3.5	E	GND	E	1.8	E	2.2	E	8.3	E	1.7
Q1003		Q1302		Q1311		Q1317		Q1329		Q1350	
pin	volt	pin	volt	pin	volt	pin	volt	pin	volt	pin	volt
B	0.0	B	4.6	B	0.0	B	1.5	B	4.5	B	3.6
C	5.0	C	GND	C	8.9	C	GND	C	GND	C	GND
E	GND	E	5.2	E	3.7	E	2.2	E	5.1	E	3.6
Q1009		Q1306		Q1312		Q1325		Q1330		Q1354	
pin	volt	pin	volt	pin	volt	pin	volt	pin	volt	pin	volt
B	5.2	B	2.4	B	2.0	B	0.6	B	4.9	B	0.0
C	0.8	C	7.5	C	GND	C	0.7	C	8.9	C	GND
E	5.0	E	1.8	E	0.0	E	GND	E	4.3	E	3.2
Q1010		Q1307		Q1313		Q1326		Q1331		All voltages are in V	
pin	volt	pin	volt	pin	volt	pin	volt	pin	volt		
B	4.5	B	0.0	B	4.3	B	0.0	B	3.6		
C	8.7	C	5.7	C	GND	C	3.8	C	1.6		
E	3.8	E	8.2	E	5.0	E	GND	E	3.6		

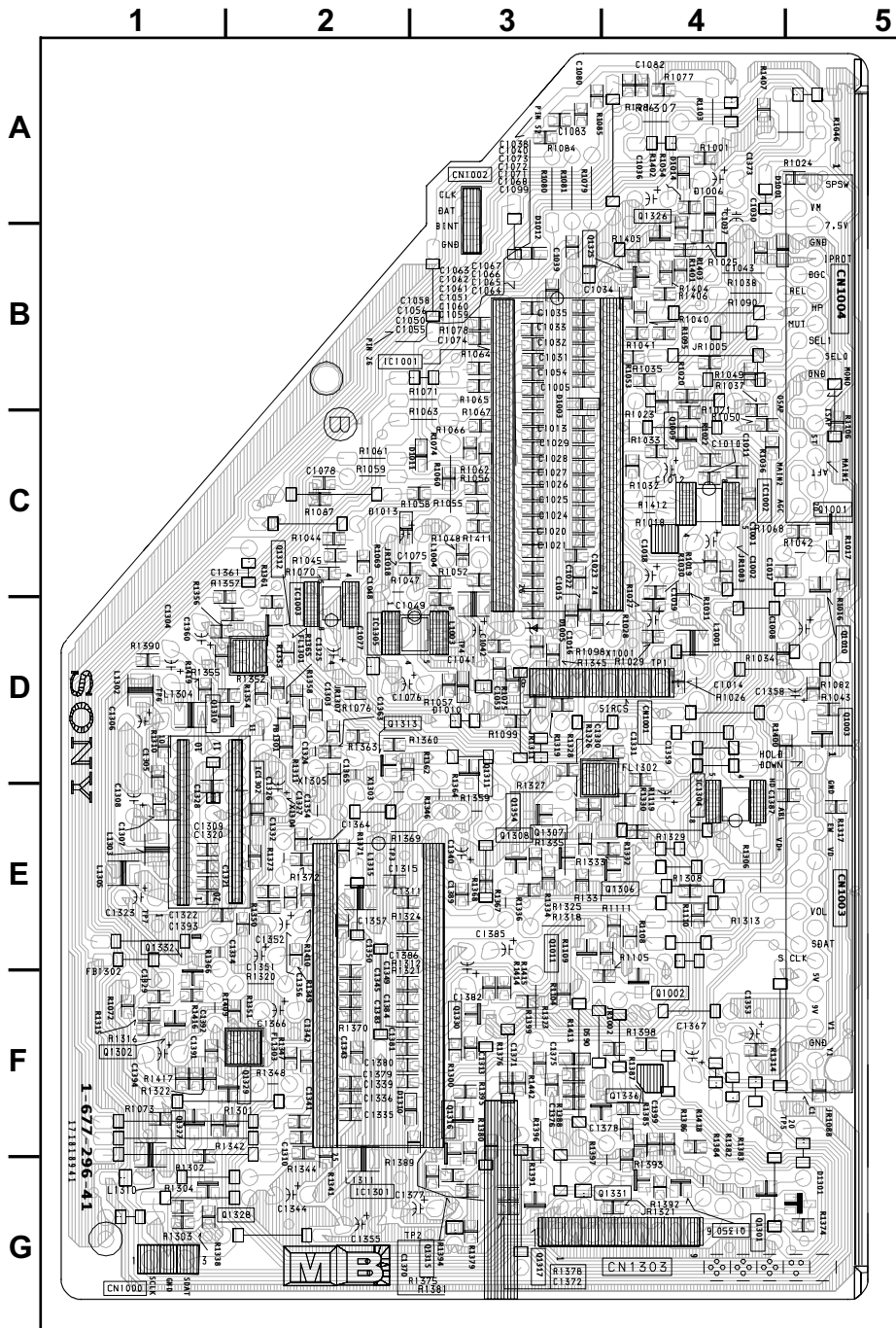

**MB BOARD LOCATOR LIST**

DIODE	D1013	C-2	IC1302	E-1	Q1010	C-5	Q1311	E-3	Q1327	F-2	Q1354	D-3
D1001	B-5	D1014	A-4	IC1304	E-4	Q1011	E-3	Q1312	D-2	Q1328	G-1	CRYSTAL
D1003	C-3	D1301	G-5	IC1305	D-3	Q1301	G-5	Q1313	D-2	Q1329	F-2	X1001
D1005	D-3	D1310	F-3	TRANSISTOR	Q1302	F-1	Q1315	G-3	Q1330	F-3	X1303	E-2
D1006	D-3	IC	Q1001	C-5	Q1306	E-4	Q1316	F-3	Q1331	G-4	X1304	E-2
D1010	D-3	IC1001	C-3	Q1002	F-4	Q1307	E-3	Q1317	G-3	Q1332	F-1	X1305
D1011	C-3	IC1003	D-2	Q1003	D-5	Q1308	E-3	Q1325	B-4	Q1336	F-4	
D1012	B-3	IC1301	F-2	Q1009	C-4	Q1310	D-2	Q1326	B-4	Q1350	G-4	

MB BOARD IC BLOCK DIAGRAMS

MB BOARD: IC1301 CXA2131AS

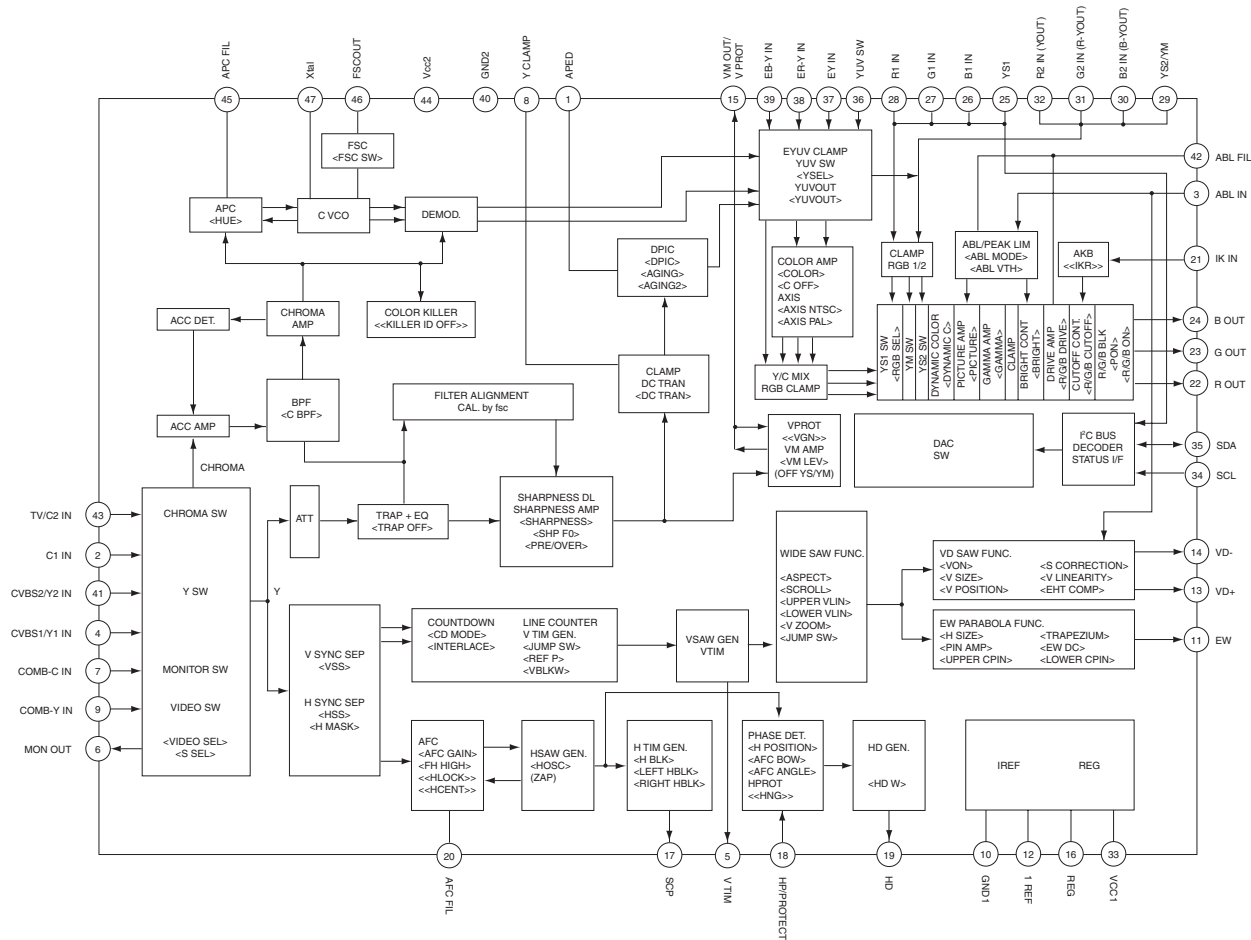

MB BOARD: IC1301 CXA2135S

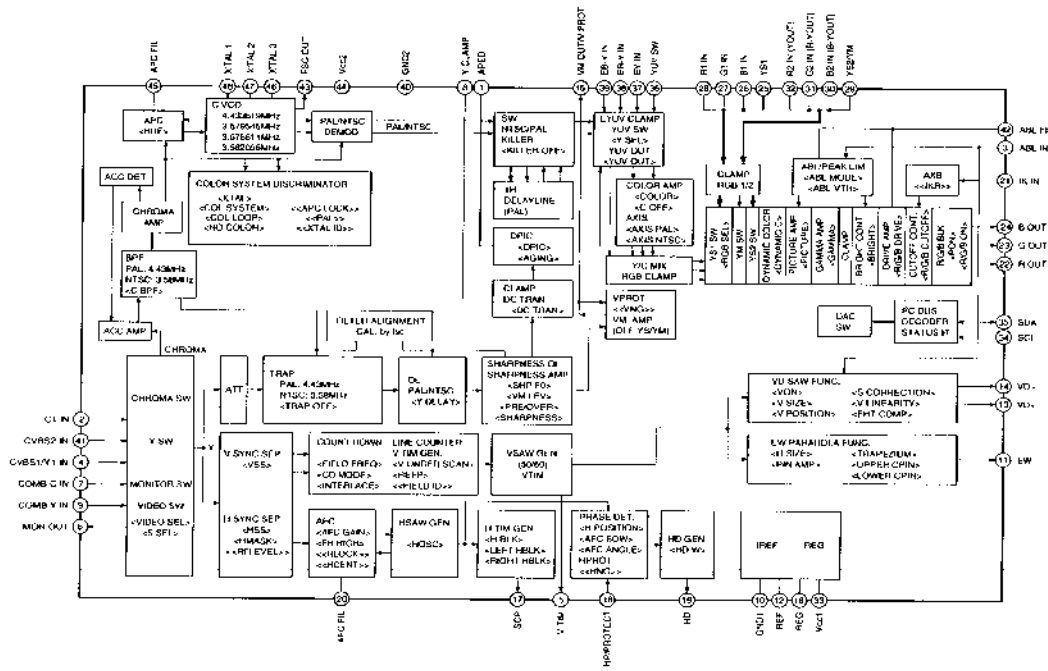



# CB BOARD SCHEMATIC DIAGRAM

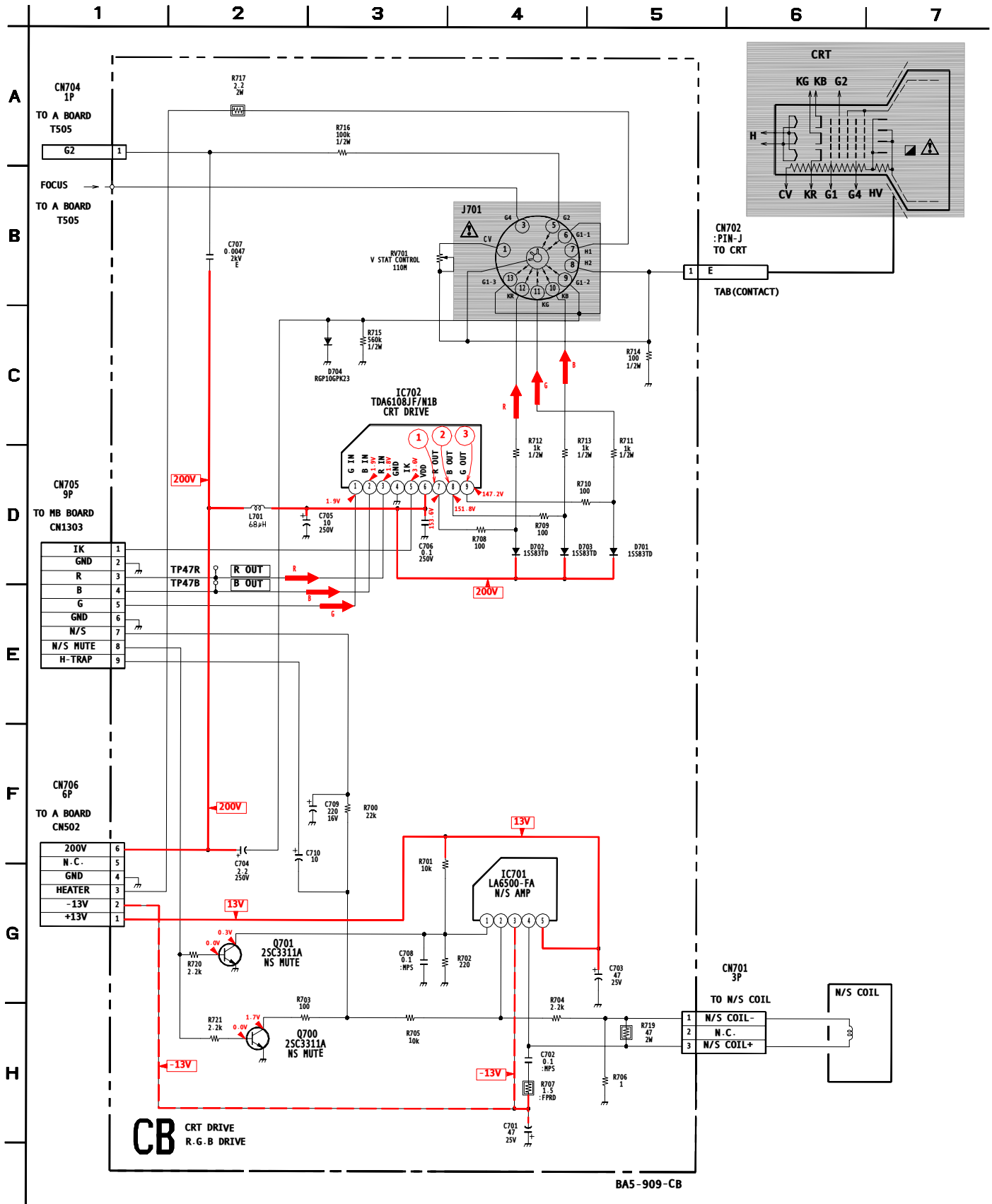

**CB** [CRT DRIVE, RGB DRIVE]

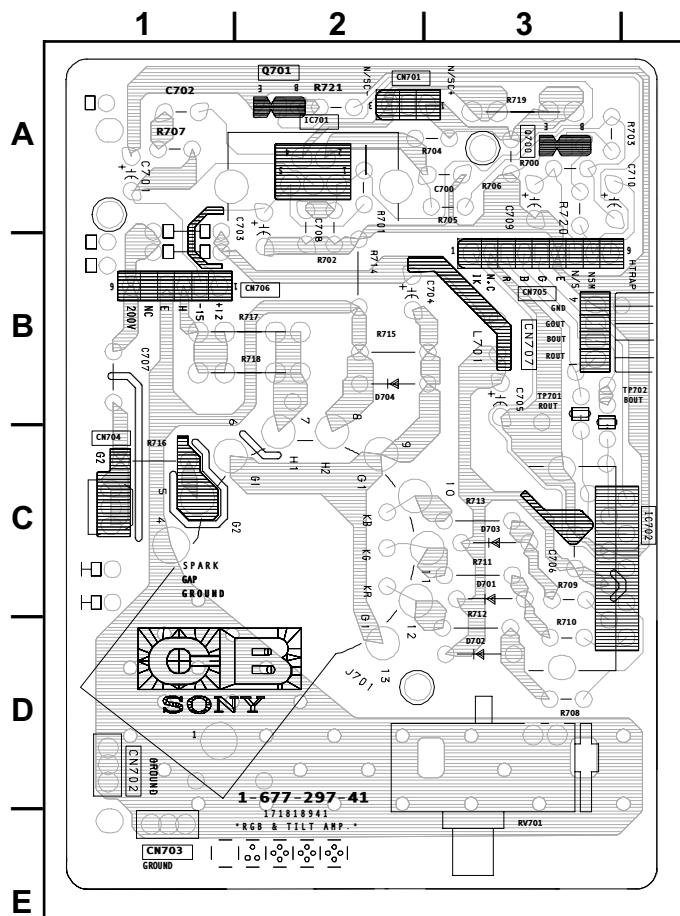

**CB BOARD WAVEFORMS**

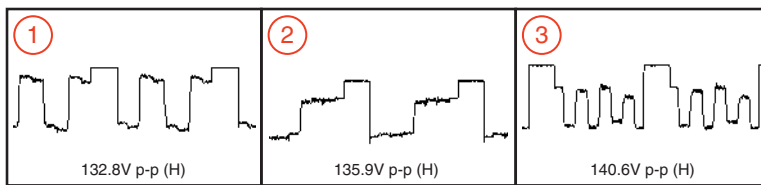

### HC BOARD SCHEMATIC DIAGRAM

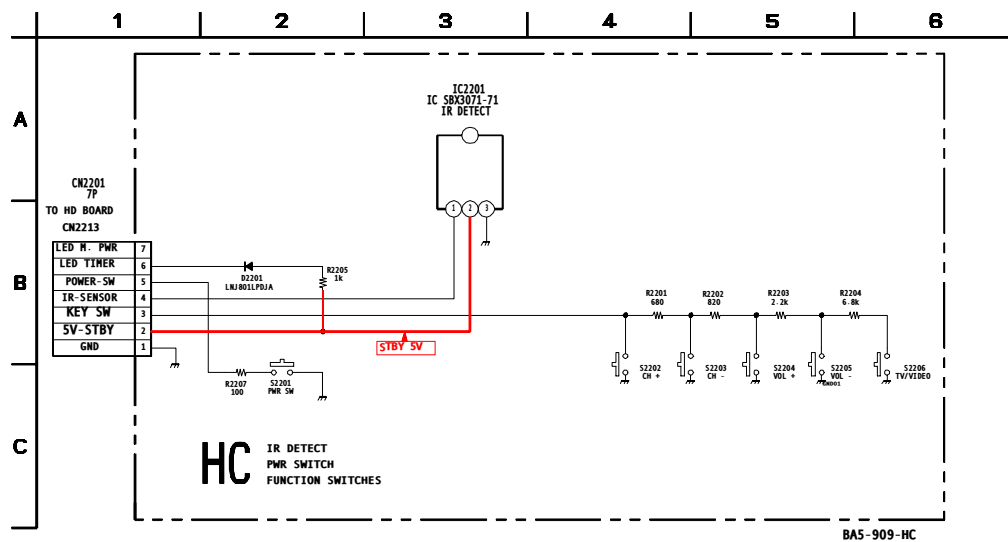

### HC [IR-DETECT/POWER SWITCH FUNCTION SWITCHES]

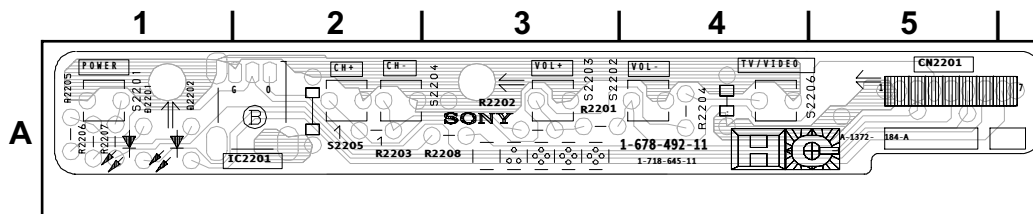

# HD BOARD SCHEMATIC DIAGRAM

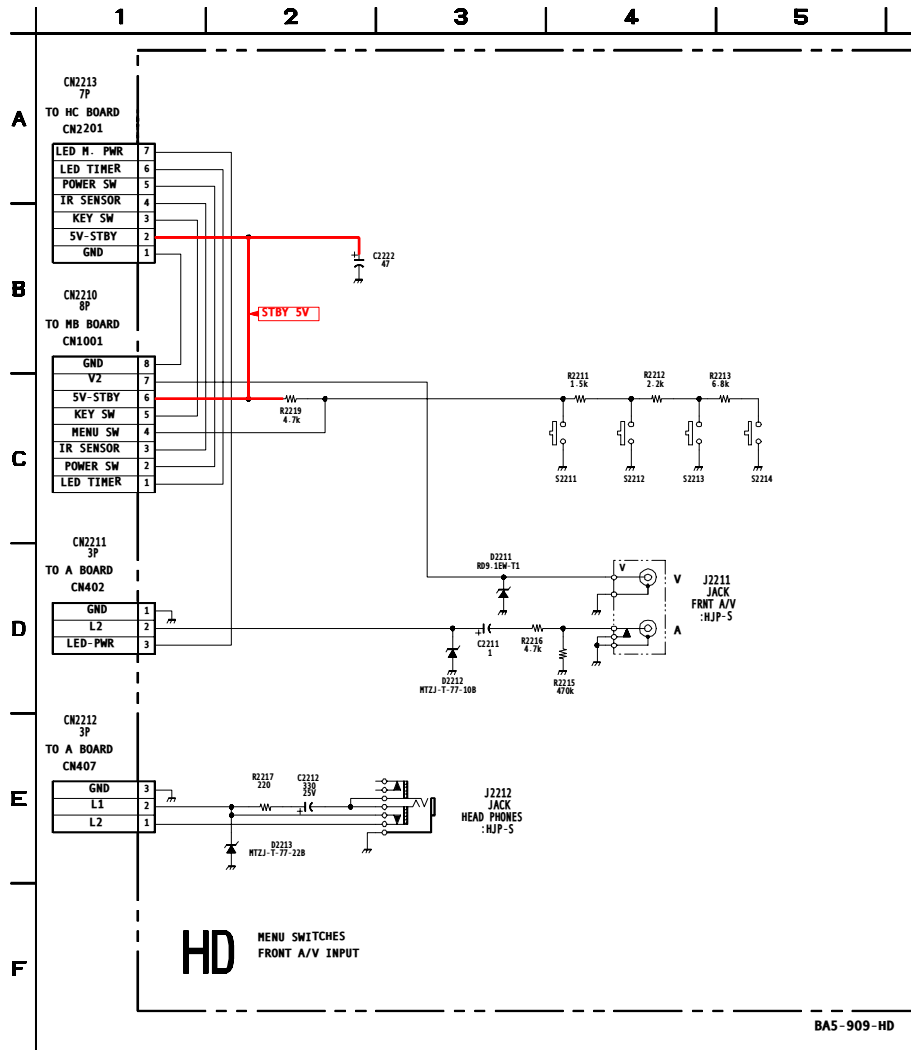

## HD [MENU SWITCHES, FRONT A/V INPUT]

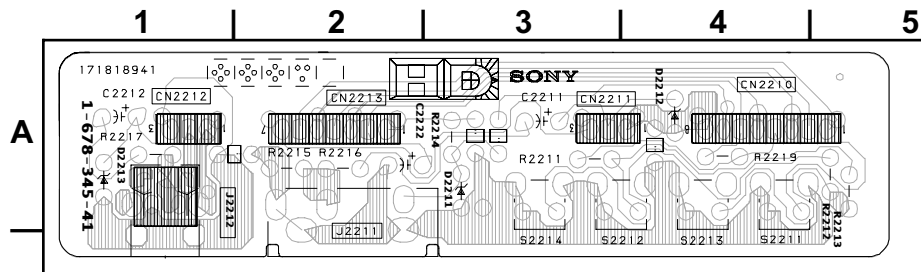

5-4. SEMICONDUCTORS

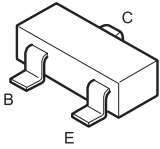
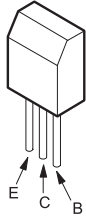
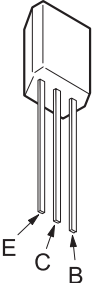
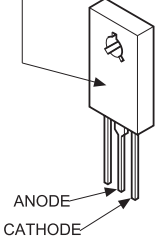
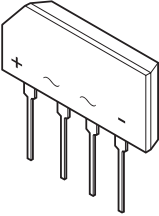
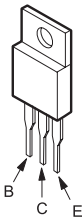
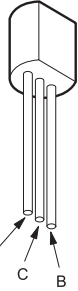
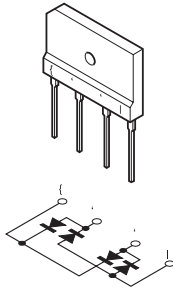
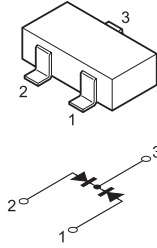
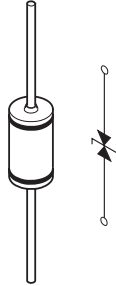
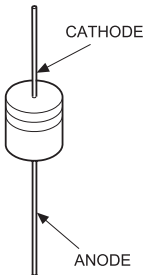
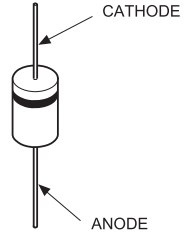
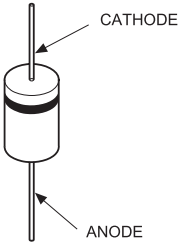
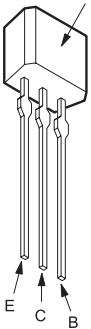
<p>2SB709A-QRS-TX 2SD601A-QRS-TX 2SC2412K-T-146-QR</p> 	<p>2SC3209LK-TP</p> 	<p>2SC331740S-QRT</p> 	<p>D5LC20U</p> <p>MARKING SIDE VIEW</p> 	<p>D2SB60A-F04</p> 
<p>2SA1837 2SC4159-E</p> 	<p>2SA1091Q-TPE2 2SA993SA-QRT</p> 	<p>2SK2845-LB102 D4SB60L-F</p> 	<p>DAP202K-T-146</p> 	<p>RD9.1EW-T1</p> 
<p>1SS133T-77 D1N20R-TA D1NS4-TA MTZJ-T-7712C MTZJ-T-77-39 RD8.2ES-T1B</p> 	<p>ERC06-15S MTZJ-T-77-5.1C MTZJ-T-775.6C MTZJ-T-77-7.5A MTZJ-T-77-8.2B MTZJ-T-77-10B MTZJ-T-7730D RD10ES-T1B</p> 	<p>1SS83TD D1NL20R-TA EL1Z-V1 ERA22-08TP3 GP08DPKG23 RGP10GPKG23 RU4AM-T3</p> 	<p>2SA1309A-QRT 2SC3311A-QRSTA 2SD2144S-TP-UVW</p> <p>LETTER SIDE</p> 	

## SECTION 6: EXPLODED VIEWS

Components not identified by a part number or description are not stocked because they are seldom required for routine service.

The component parts of an assembly are indicated by the reference numbers in the far right column of the parts list and within the dotted lines of the diagram.

\* Items marked with an asterisk are not stocked since they are seldom required for routine service. Expect some delay when ordering these components.









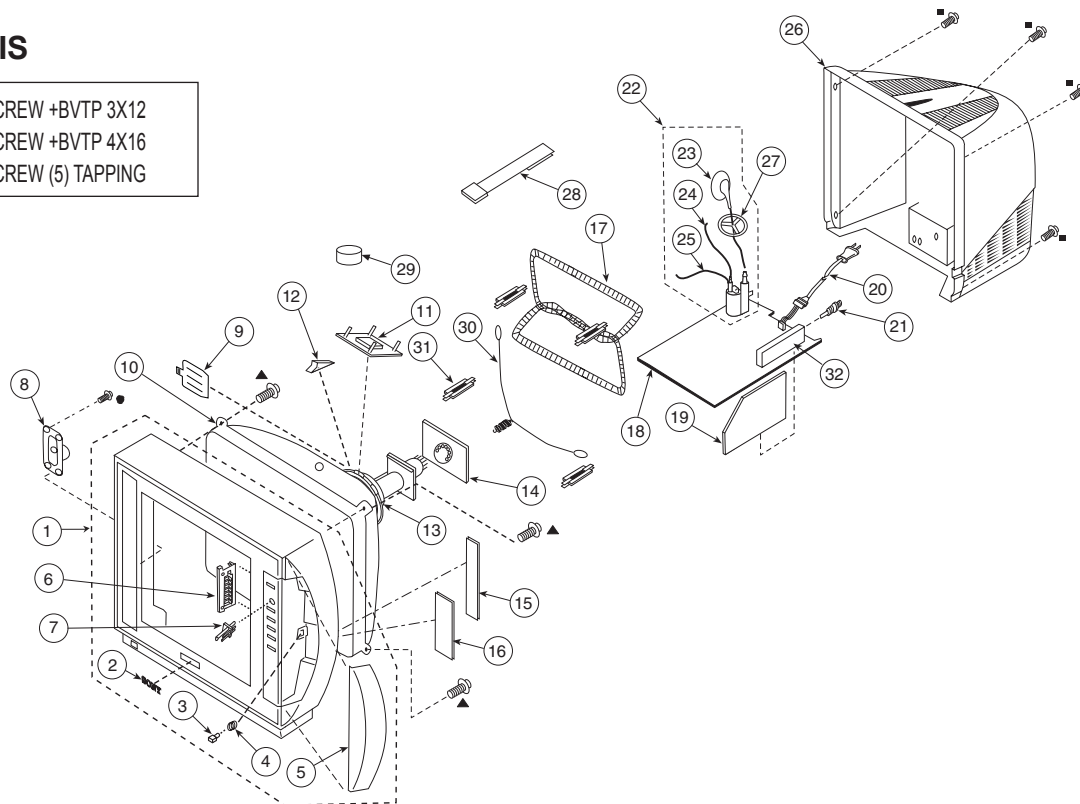

NOTE: The components identified by shading and  mark are critical for safety. Replace only with part number specified.

NOTE: Les composants identifiés par un trame et une marque  sont critiques pour la sécurité. Ne les remplacer que par une pièce portant le numéro spécifié.

## 6-1. CHASSIS

- 7-685-648-71 SCREW +BVTP 3X12
- 7-685-663-71 SCREW +BVTP 4X16
- ▲ 4-365-808-01 SCREW (5) TAPPING



REF.NO.	PART NO.	DESCRIPTION	[Assembly Includes]	REF.NO.	PART NO.	DESCRIPTION	[Assembly Includes]
1	X-4037-635-2	BEZNET ASSY (KV-13FM13 only)	2-5	18	* A-1299-219-A	A BOARD, COMPLETE	
1	X-4037-632-2	BEZNET ASSY (KV-13FM14 only)	2-5			The high-voltage leads associated with the FBT on this board are not included and must be ordered separately. (See 23-25)	
2	3-704-176-61	EMBLEM (NO.6), SONY		19	* A-1304-197-A	MB (VAR) BOARD, MOUNTED	
3	4-392-036-01	CATCHER, PUSH		20	 1-791-935-11	CORD, AC POWER(WITH CONNECTOR)(KV-13FM14 only)	
4	4-076-248-01	SPRING, DOOR		20	 1-790-316-31	CORD, AC POWER(WITH CONNECTOR)(KV-13FM13 only)	
5	4-075-399-21	DOOR (KV-13FM14 only)		21	1-766-374-11	PLUG, F-PIN	
5	4-075-399-41	DOOR (KV-13FM13 only)		22	 1-453-339-11	FBT ASSY NX-1912/M3E4	23-25
6	4-075-400-01	BUTTON, MULTI		23	 1-473-159-11	HV CAP ASSY	
7	4-075-401-01	GUIDE, LED		24	 1-900-800-65	FOCUS LEAD	
8	1-529-613-11	SPEAKER (9X5CM)		25	 1-900-803-22	G2 LEAD	
9	2-163-920-01	PLATE, TLH CORRECTION		26	4-076-249-11	COVER, REAR (KV-13FM13 only)	
10	 8-735-570-05	CRT 14RSN (A34LRG70X)		26	4-076-249-21	COVER, REAR (KV-13FM14 only)	
11	1-452-728-61	COIL, NA ROTATION		27	3-704-372-71	HOLDER, HV CABLE	
12	4-053-005-01	SPACER, DY		28	4-051-735-42	PIECE A(75), CONV. CORRECT	
13	 8-451-401-11	DY Y14RSA-S		29	1-452-032-00	MAGNET,DISC	
14	* A-1332-062-A	CB (VAR) BOARD, MOUNTED		30	4-375-394-01	SPRING, TENSION	
15	* A-1372-814-A	HC (VAR) BOARD, MOUNTED		31	4-069-972-01	CLIP (14RSN), DGC	
16	* A-1372-816-A	HD (COM) BOARD, MOUNTED		32	 8-598-501-30	TUNER, FSS BTF-FA402	
17	 1-419-559-21	COIL, DEGAUSSING					

## SECTION 7: ELECTRICAL PARTS LIST

NOTE: The components identified by shading and  mark are critical for safety. Replace only with part number specified.

NOTE: Les composants identifiés par un trame et une marque  sont critiques pour la sécurité. Ne les remplacer que par une pièce portant le numéro spécifié.

The components in this manual identified by the following symbol:  indicate parts that have been carefully factory-selected to satisfy regulations regarding X-ray radiation for each set.

Should replacement be required for one of these components, replace only with the value originally used.











\* Items marked with an asterisk are not stocked since they are seldom required for routine service. Expect some delay when ordering these components.

## RESISTORS

- All resistors are in ohms
- F : nonflammable
- All variable and adjustable resistors have characteristic curve B, unless otherwise noted.



When ordering parts by reference number, please include the board name.

REF.NO.	PART NO.	DESCRIPTION	VALUES	REF.NO.	PART NO.	DESCRIPTION	VALUES
							
*	<b>A-1299-219-A</b>	<b>A BOARD, COMPLETE</b>					
*	1-508-784-21	PIN,CONNECTOR (5MM PITCH)	1P				
	1-533-223-11	HOLDER, FUSE					
*	4-374-846-11	COVER, CAPACITOR, CAP TYPE					
	4-382-854-11	SCREW (M3X10), P, SW (+)					
		The high-voltage leads associated with the FBT on this board are not included and must be ordered separately. Order the following leads when requesting this A Board:					
	1-473-159-11	HV CAP ASSY					
	1-900-800-65	FOCUS LEAD					
	1-900-803-22	G2 LEAD					
		<b>CAPACITOR</b>					
C100	1-164-346-11	CERAMIC CHIP	1μF 16V				
C101	1-164-346-11	CERAMIC CHIP	1μF 16V				
C102	1-126-933-11	ELECT	100μF 20% 16V				
C104	1-126-941-11	ELECT	470μF 20% 25V				
C105	1-104-664-11	ELECT	47μF 20% 25V				
C204	1-163-017-00	CERAMIC CHIP	.0047μF 10% 50V				
C205	1-126-963-11	ELECT	4.7μF 20% 50V				
C208	1-126-963-11	ELECT	4.7μF 20% 50V				
C214	1-164-346-11	CERAMIC CHIP	1μF 16V				
C219	1-126-964-11	ELECT	10μF 20% 50V				
C402	1-126-943-11	ELECT	2200μF 20% 25V				
C403	1-126-957-11	ELECT	0.22μF 20% 50V				
C420	1-164-222-11	CERAMIC CHIP	0.22μF 25V				
C442	1-126-963-11	ELECT	4.7μF 20% 50V				
C443	1-163-009-11	CERAMIC CHIP	0.001μF 10% 50V				
C444	1-163-021-91	CERAMIC CHIP	0.01μF 10% 50V				
C448	1-164-222-11	CERAMIC CHIP	0.22μF 25V				
C501	1-102-112-00	CERAMIC	330pF 10% 50V				
C502	1-106-383-00	MYLAR	0.047μF 10% 200V				
C503	1-102-212-00	CERAMIC	820pF 10% 500V				
				C504	1-102-002-00	CERAMIC	680pF 10% 500V
				C505	1-162-134-11	CERAMIC	470pF 10% 2KV
				C506	1-162-318-11	CERAMIC	0.001μF 10% 500V
				 C507	1-117-638-11	FILM	5700pF 3% 1.2KV
				C508	1-137-150-11	MYLAR	0.01μF 10% 100V
				C509	1-162-116-00	CERAMIC	680pF 10% 2KV
				C510	1-107-649-11	ELECT	2.2μF 20% 250V
				 C511	1-117-666-11	FILM	0.39μF 5% 250V
				 C512	1-104-999-11	MYLAR	0.1μF 10% 200V
				C513	1-104-987-11	MYLAR	0.001μF 10% 100V
				 C514	1-109-844-11	FILM	0.68μF 5% 250V
				C515	1-162-116-00	CERAMIC	680pF 10% 2KV
				 C520	1-129-719-00	FILM	0.027μF 5% 400V
				C521	1-164-646-11	CERAMIC	2200pF 10% 500V
				C523	1-126-941-11	ELECT	470μF 20% 25V
				C524	1-102-244-00	CERAMIC	220pF 10% 500V
				C525	1-162-815-11	CERAMIC	47pF 5% 500V
				C526	1-126-960-11	ELECT	1μF 20% 50V
				C527	1-126-965-11	ELECT	22μF 20% 50V
				C528	1-164-161-11	CERAMIC CHIP	0.0022μF 10% 50V
				C529	1-164-161-11	CERAMIC CHIP	0.0022μF 10% 50V
				C530	1-164-161-11	CERAMIC CHIP	0.0022μF 10% 50V
				C531	1-106-387-00	MYLAR	0.068μF 10% 200V
				C533	1-126-941-11	ELECT	470μF 20% 25V
				 C534	1-126-964-11	ELECT	10μF 20% 50V
				C535	1-126-959-11	ELECT	0.47μF 20% 50V
				 C537	1-126-963-11	ELECT	4.7μF 20% 50V
				C539	1-107-645-11	ELECT	22μF 20% 160V
				C540	1-107-645-11	ELECT	22μF 20% 160V
				C541	1-126-969-11	ELECT	220μF 20% 50V
				C542	1-126-967-11	ELECT	47μF 20% 50V
				C543	1-137-194-81	FILM	0.47μF 5% 50V
				 C546	1-107-635-11	ELECT	4.7μF 20% 160V
				 C547	1-163-031-11	CERAMIC CHIP	0.01μF 50V
				C548	1-123-024-21	ELECT	33μF 160V

NOTE: The components identified by shading and  $\triangle$  mark are critical for safety. Replace only with part number specified.

NOTE: Les composants identifiés par un trame et une marque  $\triangle$  sont critiques pour la sécurité. Ne les remplacer que par une pièce portant le numéro spécifique.

















REF.NO.	PART NO.	DESCRIPTION	VALUES			REF.NO.	PART NO.	DESCRIPTION	VALUES
$\triangle$ C549	1-126-934-11	ELECT	220 $\mu$ F	20%	16V	*	CN601	1-508-786-00	PIN,CONNECTOR (5MM PITCH) 2P
C551	1-107-364-11	MYLAR	0.01 $\mu$ F	10%	200V		CN602	1-580-843-11	PIN,CONNECTOR (POWER)
C553	1-107-662-11	ELECT	22 $\mu$ F	20%	250V		CN2002	1-573-298-21	CONNECTOR, BOARD TO BOARD 20P
C601	1-164-004-11	CERAMIC CHIP	0.1 $\mu$ F	10%	25V		CN2009	1-573-298-21	CONNECTOR, BOARD TO BOARD 20P
C602	1-126-967-11	ELECT	47 $\mu$ F	20%	50V				
C604	1-164-182-11	CERAMIC CHIP	0.0033 $\mu$ F	10%	50V				<b>DIODE</b>
$\triangle$ C606	1-113-920-11	CERAMIC	0.0022 $\mu$ F	20%	250V		D204	8-719-982-22	DIODE MTZJ-T-77-30D
$\triangle$ C607	1-136-311-11	MYLAR	0.47 $\mu$ F	20%	125V		D208	8-719-108-12	DIODE RD9.1EW-T1
$\triangle$ C611	1-113-920-11	CERAMIC	0.0022 $\mu$ F	20%	250V		D210	8-719-110-17	DIODE MTZJ-T-77-10B
$\triangle$ C612	1-117-893-11	ELECT	470 $\mu$ F	20%	250V		D401	8-719-110-17	DIODE MTZJ-T-77-10B
C617	1-125-893-11	FILM	680pF	3%	1.5KV		D502	8-719-908-03	DIODE GP08DPKG23
C618	1-164-081-11	CERAMIC	470pF	10%	50V		D503	8-719-908-03	DIODE GP08DPKG23
C619	1-136-356-11	MYLAR	470pF	5%	50V	$\triangle$	D504	8-719-945-80	DIODE ERC06-15S
C620	1-104-665-11	ELECT	100 $\mu$ F	20%	25V	$\triangle$	D505	8-719-979-85	DIODE RGP15GPKG23
C621	1-117-214-11	CERAMIC	0.001 $\mu$ F	10%	2KV		D506	8-719-302-43	DIODE RGP10GPKG3
C622	1-164-625-11	CERAMIC	680pF	10%	500V		D507	8-719-991-33	DIODE 1SS133T-77
C623	1-164-625-11	CERAMIC	680pF	10%	500V		D508	8-719-991-33	DIODE 1SS133T-77
C624	1-131-867-51	ELECT	100 $\mu$ F	160V			D509	8-719-921-44	DIODE MTZJ-T-77-5.1C
C625	1-135-412-51	ELECT	1000 $\mu$ F	20%	25V		D510	8-719-908-03	DIODE GP08DPKG23
C626	1-135-412-51	ELECT	1000 $\mu$ F	20%	25V		D511	8-719-302-43	DIODE RGP10GPKG23
C627	1-136-189-00	MYLAR	0.1 $\mu$ F	10%	250V		D513	8-719-979-85	DIODE RGP15GPKG23
C628	1-104-665-11	ELECT	100 $\mu$ F	20%	25V		D514	8-719-979-85	DIODE RGP15GPKG23
C630	1-113-923-11	CERAMIC	0.0033 $\mu$ F	20%	250V	$\triangle$	D516	8-719-991-33	DIODE 1SS133T-77
C631	1-113-924-11	CERAMIC	.0047 $\mu$ F	20%	250V	$\triangle$	D517	8-719-991-33	DIODE 1SS133T-77
C634	1-137-605-11	MYLAR	0.01 $\mu$ F	10%	250V	$\triangle$	D518	8-719-110-08	DIODE MTZJ-T-77-8.2B
C635	1-163-009-11	CERAMIC CHIP	0.001 $\mu$ F	10%	50V	$\triangle$	D519	8-719-979-84	DIODE EGP20DPKG23
C636	1-126-970-11	ELECT	330 $\mu$ F	20%	50V	$\triangle$	D520	8-719-073-01	DIODE MA111-TX
C637	1-163-009-11	CERAMIC CHIP	0.001 $\mu$ F	10%	50V		D601	8-719-991-33	DIODE 1SS133T-77
C638	1-163-005-11	CERAMIC CHIP	470pF	10%	50V		D602	8-719-991-33	DIODE 1SS133T-77
C639	1-126-965-11	ELECT	22 $\mu$ F	20%	50V	$\triangle$	D605	8-719-510-53	DIODE D4SB60L-F
C641	1-107-679-91	ELECT	10 $\mu$ F	20%	450V		D610	8-719-210-21	DIODE 11EQS04-NTA1B
C643	1-104-760-11	CERAMIC CHIP	0.047 $\mu$ F	10%	50V		D611	8-719-046-74	DIODE 10ELS2N-TA1B2
C647	1-161-964-91	CERAMIC	.0047 $\mu$ F	250V			D612	8-719-110-17	DIODE MTZJ-T-77-10B
C648	1-136-346-21	MYLAR	0.22 $\mu$ F	20%	125V		D613	8-719-046-74	DIODE 10ELS2N-TA1B2
C652	1-130-471-00	MYLAR	0.001 $\mu$ F	5%	50V		D614	8-719-046-74	DIODE 10ELS2N-TA1B2
C654	1-107-636-11	ELECT	10 $\mu$ F	20%	160V		D615	8-719-312-10	DIODE RU4AM-T3
$\triangle$ C655	1-136-311-11	MYLAR	0.47 $\mu$ F	20%	125V		D616	8-719-510-37	DIODE D5LC20U
C657	1-104-664-11	ELECT	47 $\mu$ F	20%	25V		D617	8-719-110-31	DIODE MTZJ-T-77-12C
C658	1-135-412-51	ELECT	1000 $\mu$ F	20%	25V		D618	8-719-991-33	DIODE 1SS133T-77
		<b>CONNECTOR</b>					D619	8-719-110-17	DIODE MTZJ-T-77-10B
*	CN402	1-564-506-11	PLUG,CONNECTOR	3P			D620	8-719-510-37	DIODE D5LC20U
	CN406	1-564-505-11	PLUG,CONNECTOR	2P			D622	8-719-077-76	DIODE D2SB60A-F04
*	CN407	1-564-506-11	PLUG,CONNECTOR	3P			D623	8-719-081-70	DIODE BA159DGPKG3
*	CN501	1-580-798-11	CONNECTOR PIN (DY)	6P			D624	8-719-991-33	DIODE 1SS133T-77
	CN502	1-564-509-11	PLUG,CONNECTOR	6P			D625	8-719-991-33	DIODE 1SS133T-77
							D626	8-719-046-74	DIODE 10ELS2N-TA1B2





**NOTE:** The components identified by shading and  mark are critical for safety. Replace only with part number specified.

**NOTE:** Les composants identifiés par un trame et une marque  sont critiques pour la sécurité. Ne les remplacer que par une pièce portant le numéro spécifique.





































REF.NO.	PART NO.	DESCRIPTION	VALUES	REF.NO.	PART NO.	DESCRIPTION	VALUES
D627	8-719-110-03	DIODE MTZJ-T-77-7.5A		JR2001	1-216-295-11	SHORT	
D628	8-719-510-48	DIODE D1N20R-TA		JR2003	1-216-295-11	SHORT	
<b>FUSE</b>				<b>COIL</b>			
	F601	1-576-193-11	FUSE 6.3A/125V	L101	1-412-029-11	INDUCTOR	10µH
<b>FERRITE BEAD</b>				L102	1-412-032-11	INDUCTOR	100µH
FB501	1-410-397-21	FERRITE	1.1µH	L103	1-412-029-11	INDUCTOR	10µH
FB502	1-410-397-21	FERRITE	1.1µH		L501	1-409-955-11	INDUCTOR 8MH
FB503	1-410-397-21	FERRITE	1.1µH	L502	1-412-552-11	INDUCTOR	2.2MH
FB600	1-412-911-11	FERRITE	0µH	L503	1-406-677-11	INDUCTOR	10MH
FB601	1-412-911-11	FERRITE	0µH	L504	1-412-533-21	INDUCTOR	47µH
FB602	1-412-911-11	FERRITE	0µH	L508	1-406-982-41	INDUCTOR	680µH
FB603	1-412-911-11	FERRITE	0µH		L509	1-419-488-11	COIL, HORIZONTAL LINEARITY
FB604	1-412-911-11	FERRITE	0µH	L510	1-412-528-11	INDUCTOR	18µH
FB605	1-412-911-11	FERRITE	0µH	L603	1-412-529-11	INDUCTOR	22µH
FB606	1-412-911-11	FERRITE	0µH	L604	1-412-525-31	INDUCTOR	10µH
FB609	1-412-911-11	FERRITE	0µH	L605	1-412-529-11	INDUCTOR	22µH
FB610	1-412-911-11	FERRITE	0µH	<b>PHOTO COUPLER</b>			
<b>IC</b>					PH601	8-749-010-64	PHOTO COUPLER PC123FY2
IC401	8-759-490-17	IC TDA7057AQ/N2		<b>IC LINK</b>			
IC405	8-759-450-93	IC NJM2521M-TE1			PS401	1-576-413-21	LINK, IC
	IC501	8-759-700-07	IC NJM2903M-TE2	<b>TRANSISTOR</b>			
IC502	8-759-980-58	IC TDA8172		Q101	8-729-422-27	TRANSISTOR 2SD601A-QRS-TX	
	IC601	8-749-018-45	IC STR-F6424	Q411	8-729-216-22	TRANSISTOR 2SB709A-QRS-TX	
	IC602	8-749-016-47	IC EA135-F12	Q501	8-729-140-50	TRANSISTOR 2SC3209LK-TP	
IC603	8-759-653-07	IC PQ09RD21			Q502	8-729-051-69	TRANSISTOR 2SD2624
IC604	8-759-714-26	IC LM7805CT			Q503	8-729-422-27	TRANSISTOR 2SD601A-QRS-TX
<b>JACK</b>				Q504	8-729-053-87	TRANSISTOR KTC4370A	
J201	1-794-115-11	JACK BLOCK, PIN 2P			Q505	8-729-200-17	TRANSISTOR 2SA1091O-TPE2
<b>CHIP CONDUCTOR</b>					Q506	8-729-422-27	TRANSISTOR 2SD601A-QRS-TX
JR001	1-216-295-11	SHORT			Q507	8-729-216-22	TRANSISTOR 2SB709A-QRS-TX
JR002	1-216-295-11	SHORT		Q604	8-729-422-27	TRANSISTOR 2SD601A-QRS-TX	
JR403	1-216-295-11	SHORT			Q605	8-729-046-40	TRANSISTOR 2SK2663
JR501	1-216-295-11	SHORT		Q606	8-729-422-27	TRANSISTOR 2SD601A-QRS-TX	
JR502	1-216-295-11	SHORT		Q607	8-729-922-37	TRANSISTOR 2SD2144S-TP-UVV	
JR503	1-216-295-11	SHORT		Q608	8-729-422-27	TRANSISTOR 2SD601A-QRS-TX	
JR505	1-216-295-11	SHORT		Q609	8-729-423-33	TRANSISTOR 2SC3311A-QRSTA	
JR520	1-216-295-11	SHORT		<b>RESISTOR</b>			
JR521	1-216-295-11	SHORT		R101	1-216-073-00	RES-CHIP	10K 5% 1/10W
JR524	1-216-295-11	SHORT		R103	1-216-295-11	SHORT	
JR525	1-216-295-11	SHORT		R105	1-216-071-00	RES-CHIP	8.2K 5% 1/10W
JR528	1-216-295-11	SHORT		R107	1-216-025-11	RES-CHIP	100 5% 1/10W
JR529	1-216-295-11	SHORT		R108	1-216-025-11	RES-CHIP	100 5% 1/10W

NOTE: The components identified by shading and  mark are critical for safety. Replace only with part number specified.

A component identified by this  symbol indicates that it has been carefully factory-selected to satisfy regulations regarding X-ray radiation. Should replacement be required, replace only with the value originally used.



REF.NO.	PART NO.	DESCRIPTION	VALUES			REF.NO.	PART NO.	DESCRIPTION	VALUES			
R114	1-216-295-11	SHORT					R536	1-216-355-11	METAL OXIDE	3.3	5%	1W
R204	1-216-081-00	RES-CHIP	22K	5%	1/10W		R538	1-215-890-11	METAL OXIDE	470	5%	2W
R205	1-216-085-00	RES-CHIP	33K	5%	1/10W		R539	1-249-385-11	CARBON	2.2	5%	1/4W
R206	1-216-295-11	SHORT					R540	1-249-425-11	CARBON	4.7K	5%	1/4W
R208	1-215-924-00	METAL OXIDE	15K	5%	3W		R541	1-249-429-11	CARBON	10K	5%	1/4W
R215	1-216-113-00	RES-CHIP	470K	5%	1/10W		R542	1-215-910-00	METAL OXIDE	68	5%	3W
R409	1-216-295-11	SHORT					R543	1-247-887-00	CARBON	220K	5%	1/4W
R422	1-249-389-11	CARBON	4.7	5%	1/4W		R544	1-260-312-11	CARBON	47	5%	1/2W
R424	1-216-065-91	RES-CHIP	4.7K	5%	1/10W		R546	1-249-377-11	CARBON	0.47	5%	1/4W
R425	1-216-295-11	SHORT					R547	1-215-892-11	METAL OXIDE	1K	5%	2W
R436	1-216-065-91	RES-CHIP	4.7K	5%	1/10W		R549	1-260-288-11	CARBON	0.47	5%	1/2W
R437	1-216-065-91	RES-CHIP	4.7K	5%	1/10W		R550	1-260-288-11	CARBON	0.47	5%	1/2W
R440	1-216-097-11	RES-CHIP	100K	5%	1/10W		R552	1-215-910-00	METAL OXIDE	68	5%	3W
R443	1-216-033-00	RES-CHIP	220	5%	1/10W		R553	1-216-365-00	METAL OXIDE	0.47	5%	2W
R444	1-216-033-00	RES-CHIP	220	5%	1/10W		R554	1-249-429-11	CARBON	10K	5%	1/4W
R445	1-216-073-00	RES-CHIP	10K	5%	1/10W		R555	1-247-895-91	CARBON	470K	5%	1/4W
R447	1-216-065-91	RES-CHIP	4.7K	5%	1/10W		R556	1-249-414-11	CARBON	560	5%	1/4W
R450	1-216-061-00	RES-CHIP	3.3K	5%	1/10W		R557	1-247-895-91	CARBON	470K	5%	1/4W
R454	1-216-025-11	RES-CHIP	100	5%	1/10W		R558	1-216-097-11	RES-CHIP	100K	5%	1/10W
R501	1-247-843-11	CARBON	3.3K	5%	1/4W		R559	1-216-073-00	RES-CHIP	10K	5%	1/10W
 R502	1-215-892-11	METAL OXIDE	1K	5%	2W		R560	1-215-879-11	METAL OXIDE	47K	5%	1W
 R503	1-249-426-11	CARBON	5.6K	5%	1/4W		R561	1-215-416-00	METAL	620	1%	1/4W
 R506	1-215-886-11	METAL OXIDE	100	5%	2W		R562	1-208-806-11	METAL CHIP	10K	0.50%	1/10W
 R507	1-260-320-11	CARBON	220	5%	1/2W		R563	1-215-469-00	METAL	100K	1%	1/4W
R508	1-249-433-11	CARBON	22K	5%	1/4W		 R564	1-216-111-00	RES-CHIP	390K	5%	1/10W
 R509	1-215-892-11	METAL OXIDE	1K	5%	2W		R565	1-249-429-11	CARBON	10K	5%	1/4W
R510	1-249-411-11	CARBON	330	5%	1/4W		R566	1-216-073-00	RES-CHIP	10K	5%	1/10W
 R513	1-215-913-11	METAL OXIDE	220	5%	3W		R567	1-216-073-00	RES-CHIP	10K	5%	1/10W
R516	1-249-429-11	CARBON	10K	5%	1/4W		R568	1-215-882-00	METAL OXIDE	22	5%	2W
R517	1-249-425-11	CARBON	4.7K	5%	1/4W		R571	1-216-065-91	RES-CHIP	4.7K	5%	1/10W
R518	1-249-427-11	CARBON	6.8K	5%	1/4W		R572	1-216-065-91	RES-CHIP	4.7K	5%	1/10W
R519	1-249-427-11	CARBON	6.8K	5%	1/4W		R601	1-219-513-11	CARBON	4.7M	5%	1/2W
 R520	1-215-861-00	METAL OXIDE	47	5%	1W		R602	1-249-389-11	CARBON	4.7	5%	1/4W
R521	1-249-411-11	CARBON	330	5%	1/4W		R603	1-215-485-00	METAL	470K	1%	1/4W
R522	1-249-415-11	CARBON	680	5%	1/4W		R605	1-205-998-11	CEMENTED	1	5%	10W
R523	1-216-073-00	RES-CHIP	10K	5%	1/10W		R606	1-205-998-11	CEMENTED	1	5%	10W
R524	1-249-429-11	CARBON	10K	5%	1/4W		R607	1-215-859-00	METAL OXIDE	22	5%	1W
 R525	1-208-802-11	METAL CHIP	6.8K	0.50%	1/10W		R608	1-240-205-11	CARBON	22M	5%	1/2W
R526	1-208-814-91	METAL CHIP	22K	0.50%	1/10W		R609	1-216-049-11	RES-CHIP	1K	5%	1/10W
R527	1-216-079-00	RES-CHIP	18K	5%	1/10W		R610	1-216-073-00	RES-CHIP	10K	5%	1/10W
R528	1-249-421-11	CARBON	2.2K	5%	1/4W		R611	1-216-089-11	RES-CHIP	47K	5%	1/10W
R529	1-216-101-00	RES-CHIP	150K	5%	1/10W		R612	1-216-045-00	RES-CHIP	680	5%	1/10W
R530	1-216-091-00	RES-CHIP	56K	5%	1/10W		R613	1-219-512-11	CARBON	2.2M	5%	1/2W
R532	1-215-435-00	METAL	3.9K	1%	1/4W		R614	1-249-413-11	CARBON	470	5%	1/4W
R533	1-215-461-00	METAL	47K	1%	1/4W							
R534	1-215-466-00	METAL	75K	1%	1/4W							
R535	1-249-441-11	CARBON	100K	5%	1/4W							



NOTE: The components identified by shading and  $\triangle$  mark are critical for safety. Replace only with part number specified.

NOTE: Les composants identifiés par un trame et une marque  $\triangle$  sont critiques pour la sécurité. Ne les remplacer que par une pièce portant le numéro spécifique.

REF.NO.	PART NO.	DESCRIPTION	VALUES			REF.NO.	PART NO.	DESCRIPTION	VALUES		
$\triangle$ R616	1-260-302-51	CARBON	6.8	5%	1/2W	<b>THERMISTOR</b>					
R617	1-216-009-91	RES-CHIP	22	5%	1/10W	$\triangle$ THP601	1-809-539-11	THERMISTOR, POSITIVE			
$\triangle$ R626	1-220-926-11	FUSIBLE	0.47	10%	1/2W	<b>TUNER</b>					
R627	1-215-483-00	METAL	390K	1%	1/4W	$\triangle$ TU101	8-598-501-30	TUNER, FSS BTF-FA402			
R630	1-249-421-11	CARBON	2.2K	5%	1/4W	<b>VARISTOR</b>					
$\triangle$ R632	1-216-361-00	METAL OXIDE	0.22	5%	2W	$\triangle$ VDR601	1-803-585-11	VARISTOR ENE271D-10A			
R633	1-249-415-11	CARBON	680	5%	1/4W	<b>MB</b>					
R634	1-216-073-00	RES-CHIP	10K	5%	1/10W	*	A-1304-197-A	MB (VAR) BOARD, MOUNTED			
R635	1-216-057-00	RES-CHIP	2.2K	5%	1/10W	<b>CAPACITOR</b>					
R638	1-249-399-11	CARBON	33	5%	1/4W	C1005	1-163-259-91	CERAMIC CHIP	220pF	5%	50V
R639	1-249-421-11	CARBON	2.2K	5%	1/4W	C1008	1-126-964-11	ELECT	10 $\mu$ F	20%	50V
R640	1-249-417-11	CARBON	1K	5%	1/4W	C1010	1-163-035-00	CERAMIC CHIP	0.047 $\mu$ F		50V
$\triangle$ R641	1-216-369-00	METAL OXIDE	1	5%	2W	C1011	1-163-259-91	CERAMIC CHIP	220pF	5%	50V
R642	1-216-089-11	RES-CHIP	47K	5%	1/10W	C1012	1-126-960-11	ELECT	1 $\mu$ F	20%	50V
R643	1-249-419-11	CARBON	1.5K	5%	1/4W	C1013	1-163-009-11	CERAMIC CHIP	0.001 $\mu$ F	10%	50V
R644	1-247-843-11	CARBON	3.3K	5%	1/4W	C1014	1-130-495-00	MYLAR	0.1 $\mu$ F	5%	50V
R645	1-215-898-11	METAL OXIDE	10K	5%	2W	C1015	1-163-231-11	CERAMIC CHIP	15pF	5%	50V
R646	1-249-419-11	CARBON	1.5K	5%	1/4W	C1016	1-163-231-11	CERAMIC CHIP	15pF	5%	50V
R648	1-215-908-00	METAL OXIDE	33	5%	3W	C1018	1-126-960-11	ELECT	1 $\mu$ F	20%	50V
R650	1-216-387-11	METAL OXIDE	0.68	5%	3W	C1019	1-104-664-11	ELECT	47 $\mu$ F	20%	25V
R653	1-216-049-11	RES-CHIP	1K	5%	1/10W	C1020	1-164-161-11	CERAMIC CHIP	0.0022 $\mu$ F	10%	50V
R655	1-216-049-11	RES-CHIP	1K	5%	1/10W	C1021	1-163-259-91	CERAMIC CHIP	220pF	5%	50V
R656	1-249-429-11	CARBON	10K	5%	1/4W	C1022	1-163-135-00	CERAMIC CHIP	560pF	5%	50V
R658	1-216-387-11	METAL OXIDE	0.68	5%	3W	C1023	1-163-009-11	CERAMIC CHIP	0.001 $\mu$ F	10%	50V
R659	1-215-857-11	METAL OXIDE	10	5%	1W	C1024	1-163-259-91	CERAMIC CHIP	220pF	5%	50V
$\triangle$ R660	1-215-924-00	METAL OXIDE	15K	5%	3W	C1026	1-163-259-91	CERAMIC CHIP	220pF	5%	50V
R661	1-216-057-00	RES-CHIP	2.2K	5%	1/10W	C1027	1-163-038-11	CERAMIC CHIP	0.1 $\mu$ F		25V
R663	1-216-081-00	RES-CHIP	22K	5%	1/10W	C1028	1-163-259-91	CERAMIC CHIP	220pF	5%	50V
<b>RELAY</b>						C1029	1-164-161-11	CERAMIC CHIP	0.0022 $\mu$ F	10%	50V
$\triangle$ RY601	1-755-198-11	RELAY				C1030	1-126-963-11	ELECT	4.7 $\mu$ F	20%	50V
$\triangle$ RY602	1-755-266-11	RELAY, AC POWER				C1031	1-163-009-11	CERAMIC CHIP	0.001 $\mu$ F	10%	50V
<b>SWITCH</b>						C1032	1-163-133-00	CERAMIC CHIP	470pF	5%	50V
SW502	1-572-707-11	SWITCH LEVER				C1034	1-163-259-91	CERAMIC CHIP	220pF	5%	50V
<b>TRANSFORMER</b>						C1035	1-163-133-00	CERAMIC CHIP	470pF	5%	50V
$\triangle$ T501	1-435-374-11	TRANSFORMER, FERRITE (HDT)				C1041	1-126-941-11	ELECT	470 $\mu$ F	20%	25V
$\triangle$ T505	1-453-339-11	FBT ASSY NX-1912//M3E4				C1042	1-164-161-11	CERAMIC CHIP	0.0022 $\mu$ F	10%	50V
$\triangle$ T602	1-431-419-11	TRANSFORMER, LINE FILTER				C1043	1-163-809-11	CERAMIC CHIP	0.047 $\mu$ F	10%	25V
$\triangle$ T603	1-433-806-11	TRANSFORMER, REGULAT				C1048	1-137-194-81	FILM	0.47 $\mu$ F	5%	50V
$\triangle$ T604	1-431-852-11	TRANSFORMER, CONVERTER (SRT)				C1049	1-163-017-00	CERAMIC CHIP	.0047 $\mu$ F	10%	50V
<b>THERMISTOR</b>						C1050	1-163-037-11	CERAMIC CHIP	0.022 $\mu$ F	10%	50V
$\triangle$ TH601	1-803-586-11	THERMISTOR, NTC				C1053	1-163-229-11	CERAMIC CHIP	12pF	5%	50V
						C1054	1-163-259-91	CERAMIC CHIP	220pF	5%	50V



REF.NO.	PART NO.	DESCRIPTION	VALUES			REF.NO.	PART NO.	DESCRIPTION	VALUES		
C1055	1-163-229-11	CERAMIC CHIP	12pF	5%	50V	C1349	1-163-021-91	CERAMIC CHIP	0.01μF	10%	50V
C1056	1-163-009-11	CERAMIC CHIP	0.001μF	10%	50V	C1350	1-163-021-91	CERAMIC CHIP	0.01μF	10%	50V
C1058	1-163-009-11	CERAMIC CHIP	0.001μF	10%	50V	C1351	1-126-963-11	ELECT	4.7μF	20%	50V
C1060	1-163-009-11	CERAMIC CHIP	0.001μF	10%	50V	C1352	1-104-664-11	ELECT	47μF	20%	25V
C1066	1-163-009-11	CERAMIC CHIP	0.001μF	10%	50V	C1353	1-126-964-11	ELECT	10μF	20%	50V
C1068	1-163-009-11	CERAMIC CHIP	0.001μF	10%	50V	C1354	1-137-194-81	FILM	0.47μF	5%	50V
C1071	1-163-009-11	CERAMIC CHIP	0.001μF	10%	50V	C1355	1-126-767-11	ELECT	1000μF	20%	16V
C1072	1-163-259-91	CERAMIC CHIP	220pF	5%	50V	C1356	1-163-133-00	CERAMIC CHIP	470pF	5%	50V
C1073	1-163-259-91	CERAMIC CHIP	220pF	5%	50V	C1357	1-163-038-11	CERAMIC CHIP	0.1μF		25V
C1074	1-163-259-91	CERAMIC CHIP	220pF	5%	50V	C1358	1-126-963-11	ELECT	4.7μF	20%	50V
C1075	1-126-941-11	ELECT	470μF	20%	25V	C1359	1-126-964-11	ELECT	10μF	20%	50V
C1076	1-126-959-11	ELECT	0.47μF	20%	50V	C1361	1-163-231-11	CERAMIC CHIP	15pF	5%	50V
C1077	1-126-964-11	ELECT	10μF	20%	50V	C1364	1-163-233-11	CERAMIC CHIP	18pF	5%	50V
C1099	1-163-009-11	CERAMIC CHIP	0.001μF	10%	50V	C1366	1-126-964-11	ELECT	10μF	20%	50V
C1304	1-126-959-11	ELECT	0.47μF	20%	50V	C1375	1-163-034-00	CERAMIC CHIP	0.033μF		50V
C1305	1-163-021-91	CERAMIC CHIP	0.01μF	10%	50V	C1376	1-163-243-11	CERAMIC CHIP	47pF	5%	50V
C1306	1-126-933-11	ELECT	100μF	20%	16V	C1377	1-126-960-11	ELECT	1μF	20%	50V
C1307	1-163-021-91	CERAMIC CHIP	0.01μF	10%	50V	C1378	1-163-038-11	CERAMIC CHIP	0.1μF		25V
C1308	1-126-933-11	ELECT	100μF	20%	16V	C1379	1-163-021-91	CERAMIC CHIP	0.01μF	10%	50V
C1309	1-163-021-91	CERAMIC CHIP	0.01μF	10%	50V	C1380	1-163-003-11	CERAMIC CHIP	330pF	10%	50V
C1310	1-163-021-91	CERAMIC CHIP	0.01μF	10%	50V	C1381	1-163-038-11	CERAMIC CHIP	0.1μF		25V
C1311	1-163-038-11	CERAMIC CHIP	0.1μF		25V	C1382	1-126-964-11	ELECT	10μF	20%	50V
C1313	1-163-021-91	CERAMIC CHIP	0.01μF	10%	50V	C1385	1-126-964-11	ELECT	10μF	20%	50V
C1315	1-163-021-91	CERAMIC CHIP	0.01μF	10%	50V	C1386	1-163-038-11	CERAMIC CHIP	0.1μF		25V
C1320	1-163-021-91	CERAMIC CHIP	0.01μF	10%	50V	C1387	1-163-133-00	CERAMIC CHIP	470pF	5%	50V
C1321	1-163-021-91	CERAMIC CHIP	0.01μF	10%	50V	C1392	1-163-231-11	CERAMIC CHIP	15pF	5%	50V
C1322	1-163-021-91	CERAMIC CHIP	0.01μF	10%	50V	C1394	1-104-664-11	ELECT	47μF	20%	25V
C1323	1-126-933-11	ELECT	100μF	20%	16V	C1399	1-163-243-11	CERAMIC CHIP	47pF	5%	50V
C1324	1-163-021-91	CERAMIC CHIP	0.01μF	10%	50V						
C1325	1-163-123-00	CERAMIC CHIP	180pF	5%	50V			<b>CONNECTOR</b>			
C1326	1-163-021-91	CERAMIC CHIP	0.01μF	10%	50V	* CN1001	1-564-511-11	PLUG,CONNECTOR			8P
C1327	1-126-933-11	ELECT	100μF	20%	16V	* CN1002	1-560-124-00	PLUG,CONNECTOR (2.5MM)			4P
C1328	1-163-227-11	CERAMIC CHIP	10pF	0.50pF	50V	CN1003	1-573-301-21	CONNECTOR, BOARD TO BOARD			20P
C1329	1-163-010-11	CERAMIC CHIP	0.0012μF	10%	50V	CN1004	1-573-301-21	CONNECTOR, BOARD TO BOARD			20P
C1330	1-163-231-11	CERAMIC CHIP	15pF	5%	50V	CN1303	1-900-805-12	CONNECTOR ASSY 9P BOARD			
C1331	1-163-021-91	CERAMIC CHIP	0.01μF	10%	50V			<b>DIODE</b>			
C1332	1-163-021-91	CERAMIC CHIP	0.01μF	10%	50V	D1001	8-719-069-54	DIODE UDZSTE-175.1B			
C1334	1-163-021-91	CERAMIC CHIP	0.01μF	10%	50V	D1005	8-719-109-89	DIODE MTZJ-T-77-5.6C			
C1335	1-163-021-91	CERAMIC CHIP	0.01μF	10%	50V	D1006	8-719-073-01	DIODE MA111-TX			
C1336	1-163-021-91	CERAMIC CHIP	0.01μF	10%	50V	D1010	8-719-069-60	DIODE UDZSTE-179.1B			
C1339	1-163-021-91	CERAMIC CHIP	0.01μF	10%	50V	D1011	8-719-073-01	DIODE MA111-TX			
C1340	1-126-963-11	ELECT	4.7μF	20%	50V	D1012	8-719-073-01	DIODE MA111-TX			
C1341	1-163-021-91	CERAMIC CHIP	0.01μF	10%	50V	D1013	8-719-069-60	DIODE UDZSTE-179.1B			
C1342	1-163-021-91	CERAMIC CHIP	0.01μF	10%	50V	D1014	8-719-073-01	DIODE MA111-TX			
C1343	1-163-038-11	CERAMIC CHIP	0.1μF		25V	D1301	8-719-914-44	DIODE DAP202K-T-146			
C1344	1-126-941-11	ELECT	470μF	20%	25V	D1310	8-719-069-54	DIODE UDZSTE-175.1B			
C1345	1-163-021-91	CERAMIC CHIP	0.01μF	10%	50V						



NOTE: The components identified by shading and  $\triangle$  mark are critical for safety. Replace only with part number specified.

NOTE: Les composants identifiés par un trame et une marque  $\triangle$  sont critiques pour la sécurité. Ne les remplacer que par une pièce portant le numéro spécifique.

REF.NO.	PART NO.	DESCRIPTION	VALUES	REF.NO.	PART NO.	DESCRIPTION	VALUES
<b>FERRITE BEAD</b>							
FB1302	1-412-911-11	FERRITE	0 $\mu$ H	Q1308	8-729-216-22	TRANSISTOR 2SB709A-QRS-TX	
<b>FILTER</b>				Q1310	8-729-422-27	TRANSISTOR 2SD601A-QRS-TX	
FL1301	1-239-847-11	FILTER, LOW PASS		Q1311	8-729-422-27	TRANSISTOR 2SD601A-QRS-TX	
FL1302	1-239-847-11	FILTER, LOW PASS		Q1312	8-729-216-22	TRANSISTOR 2SB709A-QRS-TX	
FL1303	1-239-847-11	FILTER, LOW PASS		Q1313	8-729-216-22	TRANSISTOR 2SB709A-QRS-TX	
<b>IC</b>				Q1315	8-729-216-22	TRANSISTOR 2SB709A-QRS-TX	
IC1001	8-759-824-80	IC M37273 $\mu$ F-306SP		Q1316	8-729-216-22	TRANSISTOR 2SB709A-QRS-TX	
IC1003	8-759-699-33	IC M24C16-MN6T(A)		Q1317	8-729-216-22	TRANSISTOR 2SB709A-QRS-TX	
$\triangle$ IC1301	8-752-098-79	IC CXA2131CS		Q1325	8-729-422-27	TRANSISTOR 2SD601A-QRS-TX	
IC1302	8-759-655-75	IC TC90A49P		Q1326	8-729-422-27	TRANSISTOR 2SD601A-QRS-TX	
IC1304	8-759-353-00	IC NJM2534M(TE2)		Q1327	8-729-422-27	TRANSISTOR 2SD601A-QRS-TX	
IC1305	8-759-658-02	IC BA3993F		Q1328	8-729-216-22	TRANSISTOR 2SB709A-QRS-TX	
<b>CHIP CONDUCTOR</b>				Q1329	8-729-216-22	TRANSISTOR 2SB709A-QRS-TX	
JR1002	1-216-295-11	SHORT		Q1330	8-729-422-27	TRANSISTOR 2SD601A-QRS-TX	
JR1005	1-216-295-11	SHORT		Q1331	8-729-216-22	TRANSISTOR 2SB709A-QRS-TX	
JR1018	1-216-295-11	SHORT		Q1332	8-729-216-22	TRANSISTOR 2SB709A-QRS-TX	
JR1083	1-216-295-11	SHORT		Q1336	8-729-422-27	TRANSISTOR 2SD601A-QRS-TX	
JR1088	1-216-295-11	SHORT		Q1350	8-729-216-22	TRANSISTOR 2SB709A-QRS-TX	
JR1307	1-216-295-11	SHORT		Q1354	8-729-216-22	TRANSISTOR 2SB709A-QRS-TX	
JR1321	1-216-295-11	SHORT		<b>RESISTOR</b>			
<b>COIL</b>				R1001	1-216-089-11	RES-CHIP	47K 5% 1/10W
L1001	1-412-032-11	INDUCTOR	100 $\mu$ H	R1016	1-216-049-11	RES-CHIP	1K 5% 1/10W
L1003	1-412-032-11	INDUCTOR	100 $\mu$ H	R1017	1-216-025-11	RES-CHIP	100 5% 1/10W
L1004	1-408-963-11	INDUCTOR	2.7 $\mu$ H	R1018	1-249-429-11	CARBON	10K 5% 1/4W
L1302	1-412-029-11	INDUCTOR	10 $\mu$ H	R1019	1-216-045-00	RES-CHIP	680 5% 1/10W
L1303	1-412-029-11	INDUCTOR	10 $\mu$ H	R1021	1-216-121-11	RES-CHIP	1M 5% 1/10W
L1304	1-412-029-11	INDUCTOR	10 $\mu$ H	R1022	1-216-073-00	RES-CHIP	10K 5% 1/10W
L1305	1-412-029-11	INDUCTOR	10 $\mu$ H	R1023	1-216-073-00	RES-CHIP	10K 5% 1/10W
L1310	1-412-029-11	INDUCTOR	10 $\mu$ H	R1025	1-208-814-91	METAL CHIP	22K 0.50% 1/10W
L1311	1-412-031-11	INDUCTOR	47 $\mu$ H	R1026	1-216-065-91	RES-CHIP	4.7K 5% 1/10W
L1315	1-412-029-11	INDUCTOR	10 $\mu$ H	R1027	1-216-041-00	RES-CHIP	470 5% 1/10W
<b>TRANSISTOR</b>				R1028	1-216-045-00	RES-CHIP	680 5% 1/10W
Q1001	8-729-216-22	TRANSISTOR 2SB709A-QRS-TX		R1029	1-216-113-00	RES-CHIP	470K 5% 1/10W
Q1002	8-729-216-22	TRANSISTOR 2SB709A-QRS-TX		R1030	1-216-049-11	RES-CHIP	1K 5% 1/10W
Q1003	8-729-422-27	TRANSISTOR 2SD601A-QRS-TX		R1031	1-216-041-00	RES-CHIP	470 5% 1/10W
Q1009	8-729-216-22	TRANSISTOR 2SB709A-QRS-TX		R1032	1-216-065-91	RES-CHIP	4.7K 5% 1/10W
Q1010	8-729-422-27	TRANSISTOR 2SD601A-QRS-TX		R1033	1-216-081-00	RES-CHIP	22K 5% 1/10W
Q1011	8-729-422-27	TRANSISTOR 2SD601A-QRS-TX		R1034	1-216-043-91	RES-CHIP	560 5% 1/10W
Q1301	8-729-422-27	TRANSISTOR 2SD601A-QRS-TX		R1035	1-216-049-11	RES-CHIP	1K 5% 1/10W
Q1302	8-729-216-22	TRANSISTOR 2SB709A-QRS-TX		R1036	1-216-033-00	RES-CHIP	220 5% 1/10W
Q1306	8-729-422-27	TRANSISTOR 2SD601A-QRS-TX		R1037	1-216-033-00	RES-CHIP	220 5% 1/10W
Q1307	8-729-216-22	TRANSISTOR 2SB709A-QRS-TX		R1038	1-247-807-31	CARBON	100 5% 1/4W
				R1040	1-216-033-00	RES-CHIP	220 5% 1/10W
				R1041	1-216-073-00	RES-CHIP	10K 5% 1/10W
				R1042	1-249-414-11	CARBON	560 5% 1/4W
				R1043	1-216-071-00	RES-CHIP	8.2K 5% 1/10W
				R1044	1-216-065-91	RES-CHIP	4.7K 5% 1/10W



REF.NO.	PART NO.	DESCRIPTION	VALUES			REF.NO.	PART NO.	DESCRIPTION	VALUES		
R1045	1-216-065-91	RES-CHIP	4.7K	5%	1/10W	R1106	1-216-073-00	RES-CHIP	10K	5%	1/10W
R1046	1-249-425-11	CARBON	4.7K	5%	1/4W	R1109	1-216-073-00	RES-CHIP	10K	5%	1/10W
R1047	1-216-065-91	RES-CHIP	4.7K	5%	1/10W	R1110	1-216-059-00	RES-CHIP	2.7K	5%	1/10W
R1048	1-216-065-91	RES-CHIP	4.7K	5%	1/10W	R1111	1-216-085-00	RES-CHIP	33K	5%	1/10W
R1049	1-216-065-91	RES-CHIP	4.7K	5%	1/10W	R1300	1-216-049-11	RES-CHIP	1K	5%	1/10W
R1050	1-216-065-91	RES-CHIP	4.7K	5%	1/10W	R1301	1-216-053-00	RES-CHIP	1.5K	5%	1/10W
R1052	1-216-033-00	RES-CHIP	220	5%	1/10W	R1302	1-216-041-00	RES-CHIP	470	5%	1/10W
R1053	1-216-033-00	RES-CHIP	220	5%	1/10W	R1303	1-216-025-11	RES-CHIP	100	5%	1/10W
R1054	1-216-065-91	RES-CHIP	4.7K	5%	1/10W	R1304	1-216-049-11	RES-CHIP	1K	5%	1/10W
R1055	1-216-049-11	RES-CHIP	1K	5%	1/10W	R1306	1-249-409-11	CARBON	220	5%	1/4W
R1056	1-216-081-00	RES-CHIP	22K	5%	1/10W	R1308	1-216-033-00	RES-CHIP	220	5%	1/10W
R1057	1-216-049-11	RES-CHIP	1K	5%	1/10W	R1310	1-216-025-11	RES-CHIP	100	5%	1/10W
R1058	1-216-635-11	METAL CHIP	220	0.50%	1/10W	R1311	1-216-047-91	RES-CHIP	820	5%	1/10W
R1059	1-249-409-11	CARBON	220	5%	1/4W	R1312	1-208-806-11	METAL CHIP	10K	0.50%	1/10W
R1060	1-216-635-11	METAL CHIP	220	0.50%	1/10W	R1313	1-249-409-11	CARBON	220	5%	1/4W
R1061	1-249-409-11	CARBON	220	5%	1/4W	R1314	1-216-022-00	RES-CHIP	75	5%	1/10W
R1062	1-216-073-00	RES-CHIP	10K	5%	1/10W	R1315	1-216-053-00	RES-CHIP	1.5K	5%	1/10W
R1063	1-249-409-11	CARBON	220	5%	1/4W	R1316	1-216-295-11	SHORT			
R1064	1-216-025-11	RES-CHIP	100	5%	1/10W	R1319	1-216-022-00	RES-CHIP	75	5%	1/10W
R1065	1-216-033-00	RES-CHIP	220	5%	1/10W	R1320	1-247-807-31	CARBON	100	5%	1/4W
R1066	1-216-033-00	RES-CHIP	220	5%	1/10W	R1322	1-216-081-00	RES-CHIP	22K	5%	1/10W
R1067	1-216-033-00	RES-CHIP	220	5%	1/10W	R1323	1-247-807-31	CARBON	100	5%	1/4W
R1068	1-216-025-11	RES-CHIP	100	5%	1/10W	R1325	1-249-421-11	CARBON	2.2K	5%	1/4W
R1069	1-216-033-00	RES-CHIP	220	5%	1/10W	R1326	1-216-043-91	RES-CHIP	560	5%	1/10W
R1070	1-216-033-00	RES-CHIP	220	5%	1/10W	R1327	1-247-807-31	CARBON	100	5%	1/4W
R1071	1-249-429-11	CARBON	10K	5%	1/4W	R1328	1-216-067-00	RES-CHIP	5.6K	5%	1/10W
R1072	1-216-065-91	RES-CHIP	4.7K	5%	1/10W	R1329	1-216-091-00	RES-CHIP	56K	5%	1/10W
R1073	1-216-065-91	RES-CHIP	4.7K	5%	1/10W	R1330	1-216-081-00	RES-CHIP	22K	5%	1/10W
R1074	1-216-355-11	METAL OXIDE	3.3	5%	1W	R1331	1-216-049-11	RES-CHIP	1K	5%	1/10W
R1075	1-216-065-91	RES-CHIP	4.7K	5%	1/10W	R1332	1-216-043-91	RES-CHIP	560	5%	1/10W
R1076	1-216-065-91	RES-CHIP	4.7K	5%	1/10W	R1333	1-216-033-00	RES-CHIP	220	5%	1/10W
R1077	1-216-065-91	RES-CHIP	4.7K	5%	1/10W	R1334	1-216-025-11	RES-CHIP	100	5%	1/10W
R1078	1-216-049-11	RES-CHIP	1K	5%	1/10W	R1335	1-216-025-11	RES-CHIP	100	5%	1/10W
R1079	1-249-427-11	CARBON	6.8K	5%	1/4W	R1336	1-216-053-00	RES-CHIP	1.5K	5%	1/10W
R1080	1-249-427-11	CARBON	6.8K	5%	1/4W	R1338	1-216-091-00	RES-CHIP	56K	5%	1/10W
R1081	1-249-427-11	CARBON	6.8K	5%	1/4W	R1342	1-216-025-11	RES-CHIP	100	5%	1/10W
R1082	1-216-065-91	RES-CHIP	4.7K	5%	1/10W	R1344	1-216-025-11	RES-CHIP	100	5%	1/10W
R1084	1-216-045-00	RES-CHIP	680	5%	1/10W	R1345	1-216-049-11	RES-CHIP	1K	5%	1/10W
R1085	1-216-045-00	RES-CHIP	680	5%	1/10W	R1346	1-249-409-11	CARBON	220	5%	1/4W
R1086	1-216-045-00	RES-CHIP	680	5%	1/10W	R1347	1-216-025-11	RES-CHIP	100	5%	1/10W
R1087	1-216-061-00	RES-CHIP	3.3K	5%	1/10W	R1348	1-247-807-31	CARBON	100	5%	1/4W
R1090	1-249-409-11	CARBON	220	5%	1/4W	R1350	1-216-073-00	RES-CHIP	10K	5%	1/10W
R1095	1-216-061-00	RES-CHIP	3.3K	5%	1/10W	R1351	1-216-067-00	RES-CHIP	5.6K	5%	1/10W
R1098	1-216-033-00	RES-CHIP	220	5%	1/10W	R1352	1-216-049-11	RES-CHIP	1K	5%	1/10W
R1099	1-208-798-11	METAL CHIP	4.7K	0.50%	1/10W	R1355	1-216-025-11	RES-CHIP	100	5%	1/10W
R1104	1-216-073-00	RES-CHIP	10K	5%	1/10W	R1356	1-216-067-00	RES-CHIP	5.6K	5%	1/10W
R1105	1-216-073-00	RES-CHIP	10K	5%	1/10W	R1357	1-216-043-91	RES-CHIP	560	5%	1/10W





REF.NO.	PART NO.	DESCRIPTION	VALUES	REF.NO.	PART NO.	DESCRIPTION	VALUES
<b>COIL</b>				<b>RESISTOR</b>			
L701	1-408-613-31	INDUCTOR	68μH	R2201	1-249-415-11	CARBON	680 5% 1/4W
<b>TRANSISTOR</b>				R2202	1-249-416-11	CARBON	820 5% 1/4W
Q700	8-729-423-33	TRANSISTOR 2SC3311A-QRSTA		R2203	1-249-421-11	CARBON	2.2K 5% 1/4W
Q701	8-729-423-33	TRANSISTOR 2SC3311A-QRSTA		R2204	1-249-427-11	CARBON	6.8K 5% 1/4W
<b>RESISTOR</b>				R2205	1-249-417-11	CARBON	1K 5% 1/4W
R700	1-249-433-11	CARBON	22K 5% 1/4W	R2207	1-247-807-31	CARBON	100 5% 1/4W
R701	1-249-429-11	CARBON	10K 5% 1/4W	<b>SWITCH</b>			
R702	1-249-409-11	CARBON	220 5% 1/4W	S2201	1-762-196-21	SWITCH, TACTILE	
R703	1-247-807-31	CARBON	100 5% 1/4W	S2202	1-762-196-21	SWITCH, TACTILE	
R704	1-249-421-11	CARBON	2.2K 5% 1/4W	S2203	1-762-196-21	SWITCH, TACTILE	
R705	1-249-429-11	CARBON	10K 5% 1/4W	S2204	1-762-196-21	SWITCH, TACTILE	
R706	1-249-381-11	CARBON	1 5% 1/4W	S2205	1-762-196-21	SWITCH, TACTILE	
R707	1-249-383-11	CARBON	1.5 5% 1/4W	S2206	1-762-196-21	SWITCH, TACTILE	
R708	1-247-807-31	CARBON	100 5% 1/4W	<b>HD</b>			
R709	1-247-807-31	CARBON	100 5% 1/4W	*	A-1372-816-A	HD (COM) BOARD, MOUNTED	
R710	1-247-807-31	CARBON	100 5% 1/4W	<b>CAPACITOR</b>			
R711	1-260-328-11	CARBON	1K 5% 1/2W	C2211	1-126-960-11	ELECT	1μF 20% 50V
R712	1-260-328-11	CARBON	1K 5% 1/2W	C2212	1-126-940-11	ELECT	330μF 20% 25V
R713	1-260-328-11	CARBON	1K 5% 1/2W	C2222	1-104-664-11	ELECT	47μF 20% 25V
R714	1-260-087-11	CARBON	100 5% 1/2W	<b>CONNECTOR</b>			
R715	1-260-132-11	CARBON	560K 5% 1/2W	* CN2210	1-564-523-11	PLUG,CONNECTOR	8P
R716	1-260-123-11	CARBON	100K 5% 1/2W	* CN2211	1-564-518-11	PLUG,CONNECTOR	3P
R717	1-216-373-11	METAL OXIDE	2.2 5% 2W	* CN2212	1-564-518-11	PLUG,CONNECTOR	3P
R719	1-215-884-11	METAL OXIDE	47 5% 2W	* CN2213	1-564-522-11	PLUG,CONNECTOR	7P
R720	1-249-421-11	CARBON	2.2K 5% 1/4W	<b>DIODE</b>			
R721	1-249-421-11	CARBON	2.2K 5% 1/4W	D2211	8-719-108-12	DIODE RD9.1EW-T1	
<b>VARIABLE RESISTOR</b>				D2212	8-719-110-17	DIODE MTZJ-T-77-10B	
RV701	1-241-656-11	RES, ADJ, METAL FILM	110M	D2213	8-719-924-13	DIODE MTZJ-T-77-22B	
<b>HC</b>				<b>JACK</b>			
*	A-1372-814-A	HC (VAR) BOARD, MOUNTED		J2211	1-794-266-21	JACK, PIN 2P	
<b>CONNECTOR</b>				J2212	1-568-267-21	JACK	
* CN2201	1-564-522-11	PLUG,CONNECTOR	7P	<b>RESISTOR</b>			
<b>DIODE</b>				R2211	1-249-419-11	CARBON	1.5K 5% 1/4W
D2201	8-719-057-09	DIODE LNJ801LPDJA		R2212	1-249-421-11	CARBON	2.2K 5% 1/4W
<b>IC</b>				R2213	1-249-427-11	CARBON	6.8K 5% 1/4W
IC2201	8-742-211-20	HYB IC SBX3071-71		R2215	1-247-895-91	CARBON	470K 5% 1/4W
				R2216	1-249-425-11	CARBON	4.7K 5% 1/4W
				R2217	1-249-409-11	CARBON	220 5% 1/4W
				R2219	1-249-425-11	CARBON	4.7K 5% 1/4W



REF.NO.	PART NO.	DESCRIPTION	VALUES	REF.NO.	PART NO.	DESCRIPTION	VALUES
<b><u>SWITCH</u></b>							
S2211	1-692-431-21	SWITCH, TACTILE					
S2212	1-692-431-21	SWITCH, TACTILE					
S2213	1-692-431-21	SWITCH, TACTILE					
S2214	1-692-431-21	SWITCH, TACTILE					
<b><u>ACCESSORIES AND PACKING MATERIAL</u></b>							
*	4-041-254-01	BAG, PROTECTION					
*	4-075-175-03	CUSHION ASSY, LOWER					
*	4-075-174-04	CUSHION ASSY, UPPER					
*	4-075-183-04	CARTON, INDIVIDUAL					
	4-075-509-21	MANUAL, INSTRUCTION(English)					
	4-075-509-31	MANUAL, INSTRUCTION(French)					
<b><u>REMOTE COMMANDER</u></b>							
	1-418-854-11	REMOTE COMMANDER (RM-Y172) (KV-13FM13 only)					
	1-476-231-11	REMOTE COMMANDER (RM-Y172) (KV-13FM14 only)					
	3-709-322-11	COVER, BATTERY (KV-13FM14 only)					
	3-709-322-21	COVER, BATTERY (KV-13FM13 only)					

# A BOARD SCHEMATIC DIAGRAM

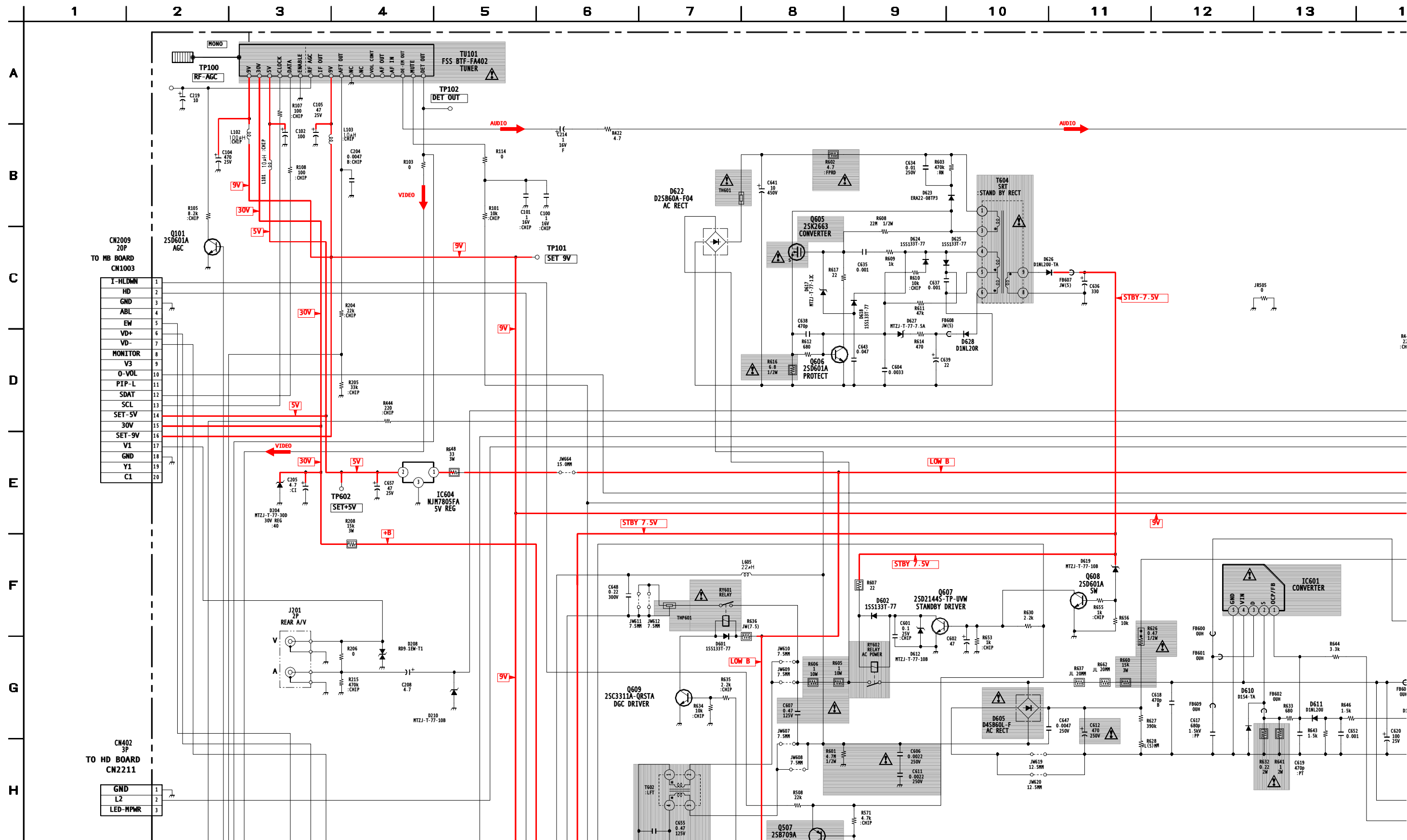

14 15 16 17 18 19 20 21

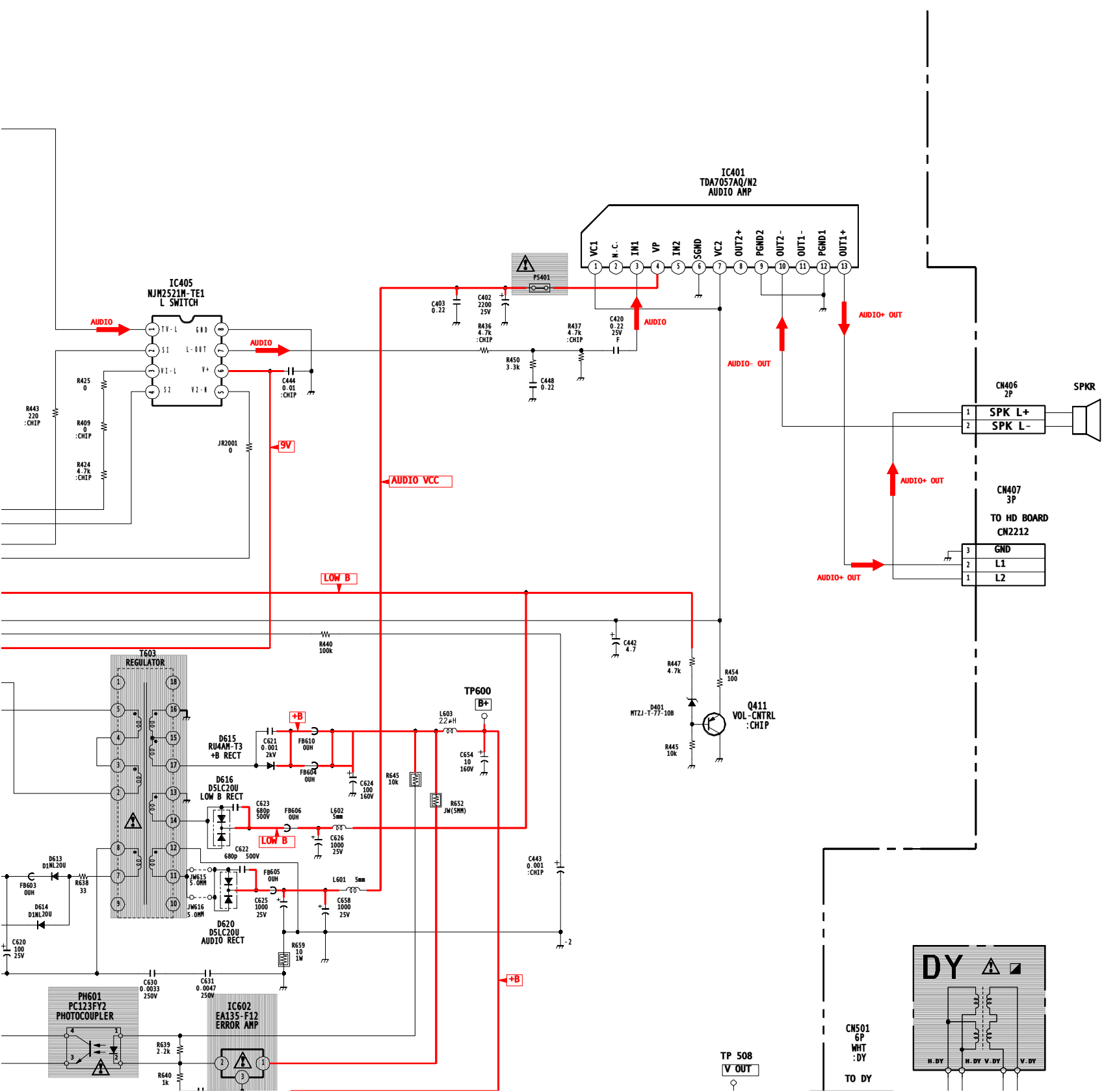

I  
J  
K  
L  
M  
N

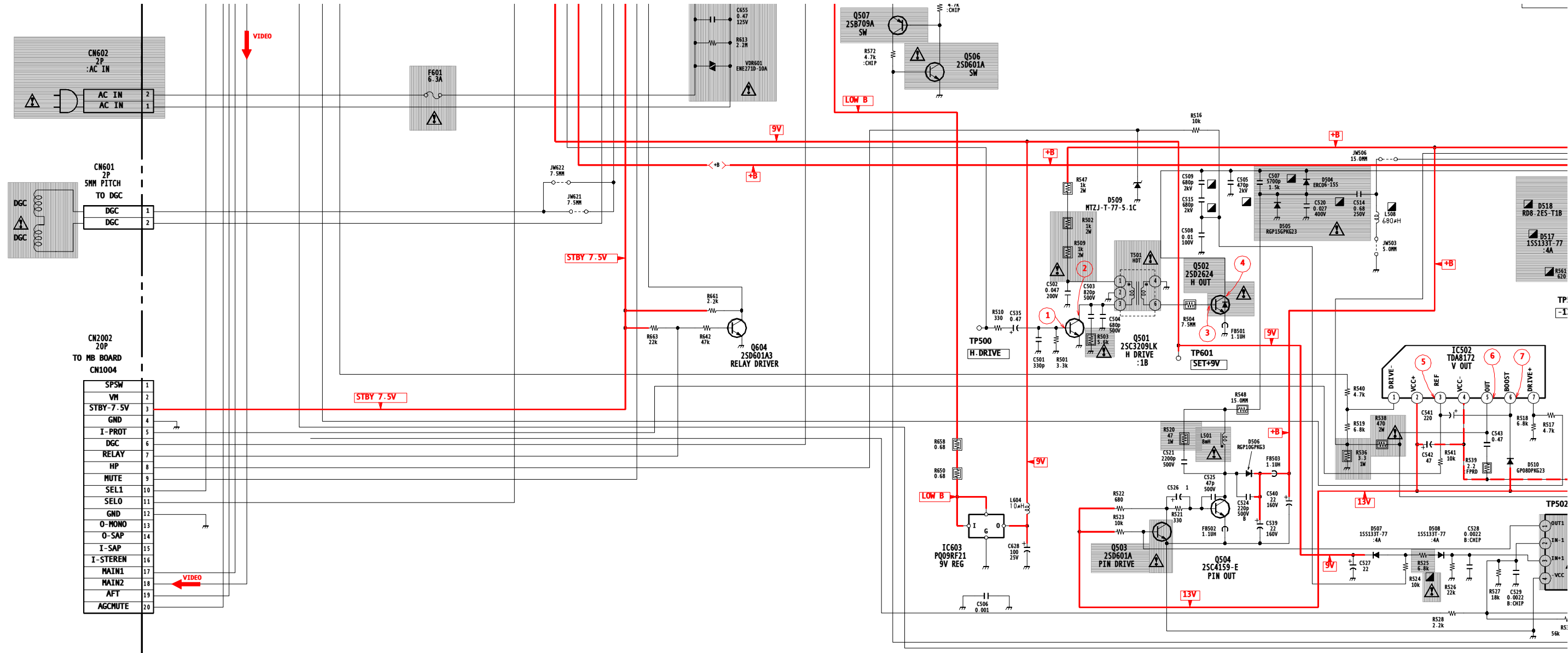

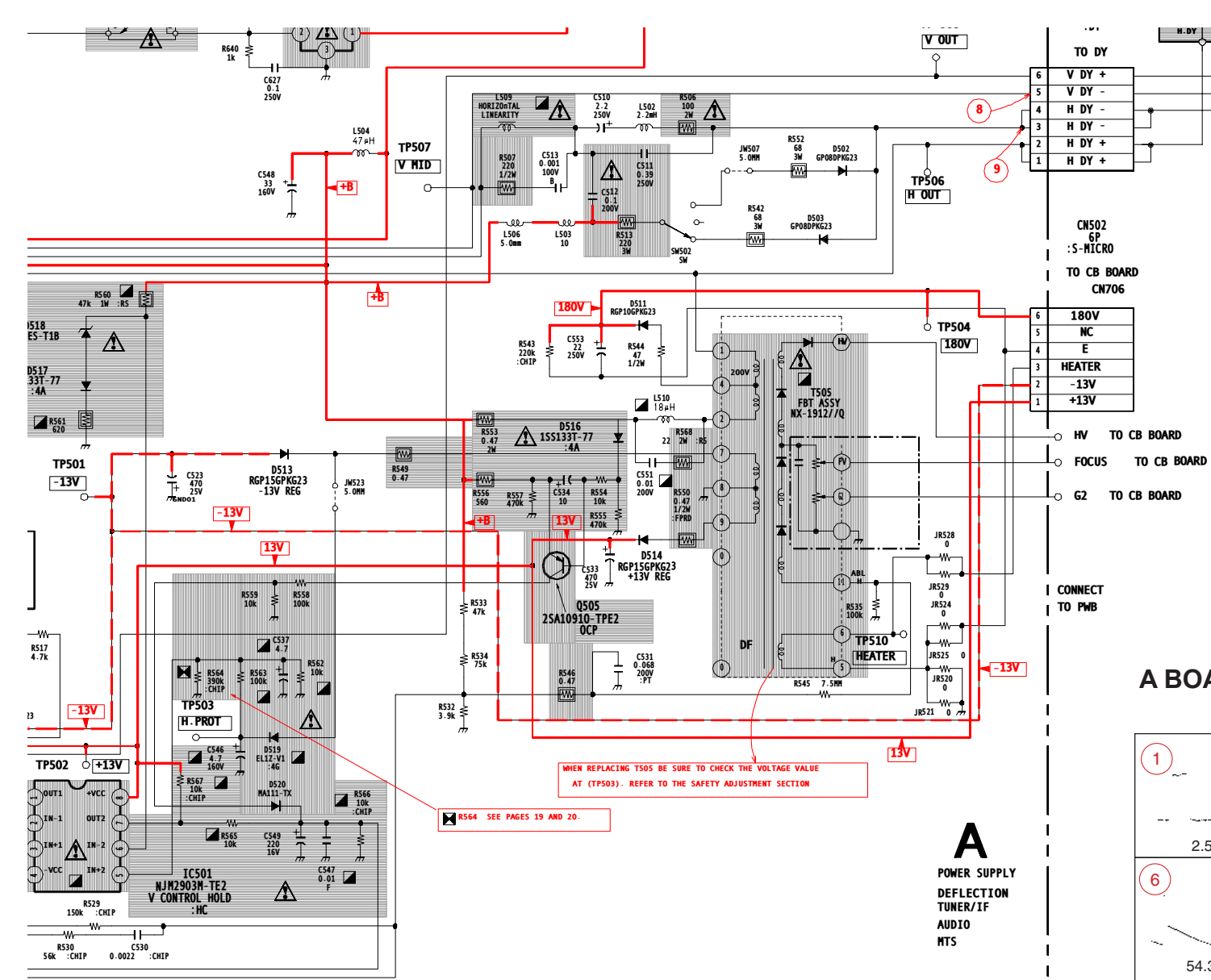

### A BOARD WAVEFORMS

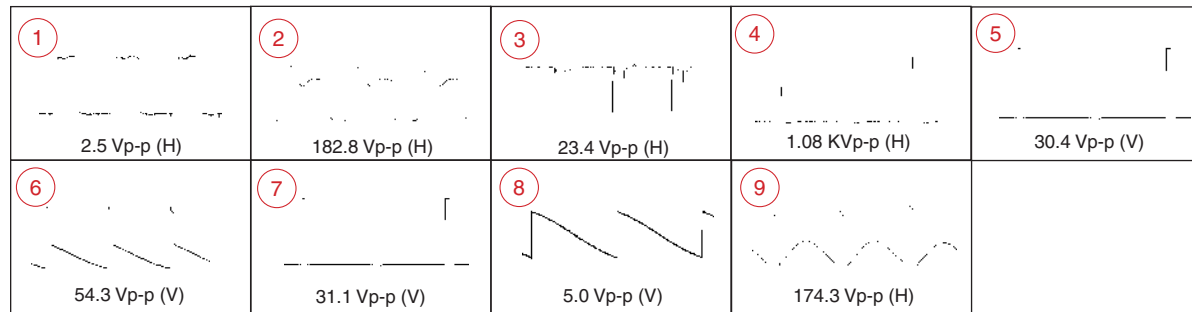

# MB BOARD SCHEMATIC DIAGRAM

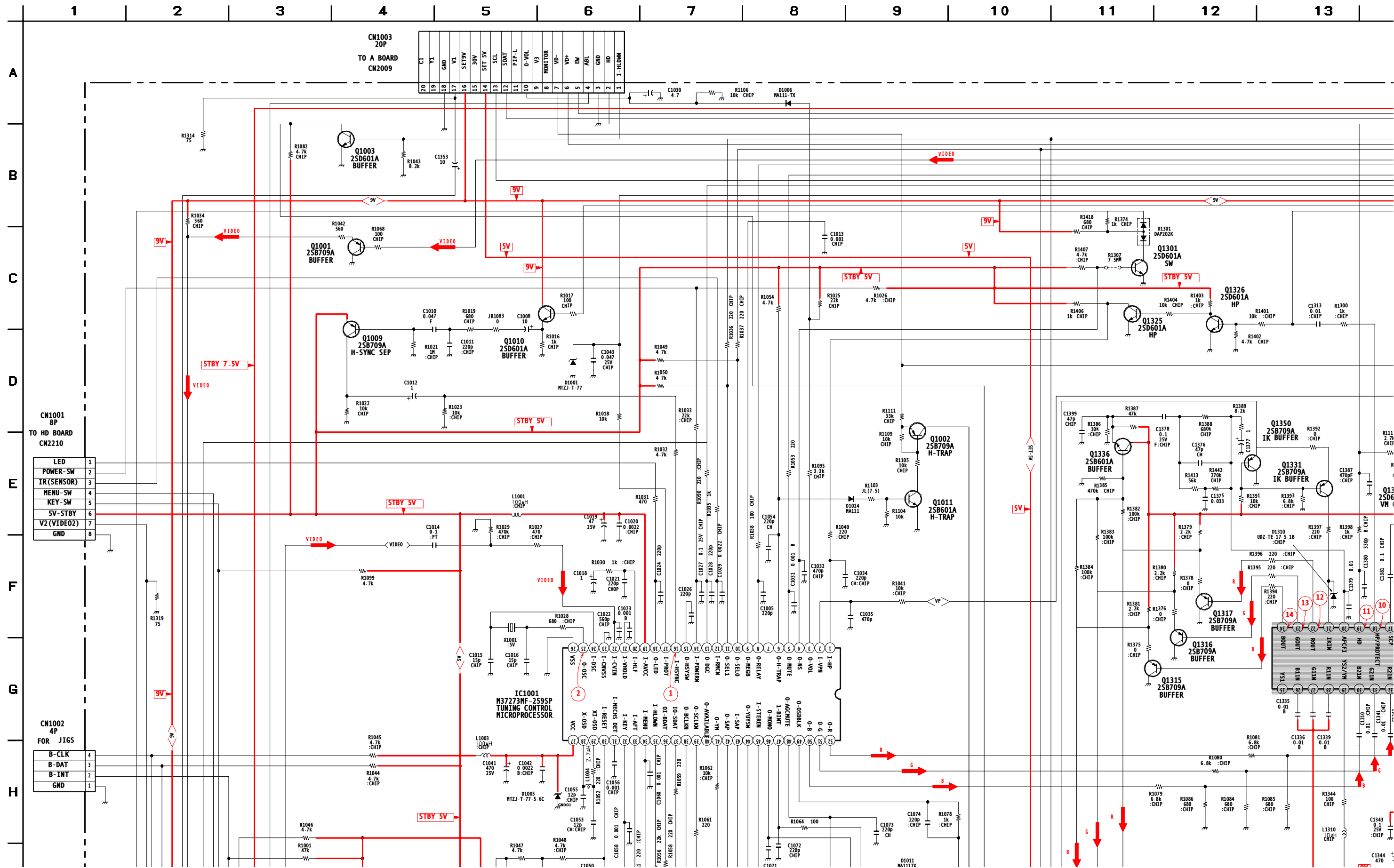

14 | 15 | 16 | 17 | 18 | 19

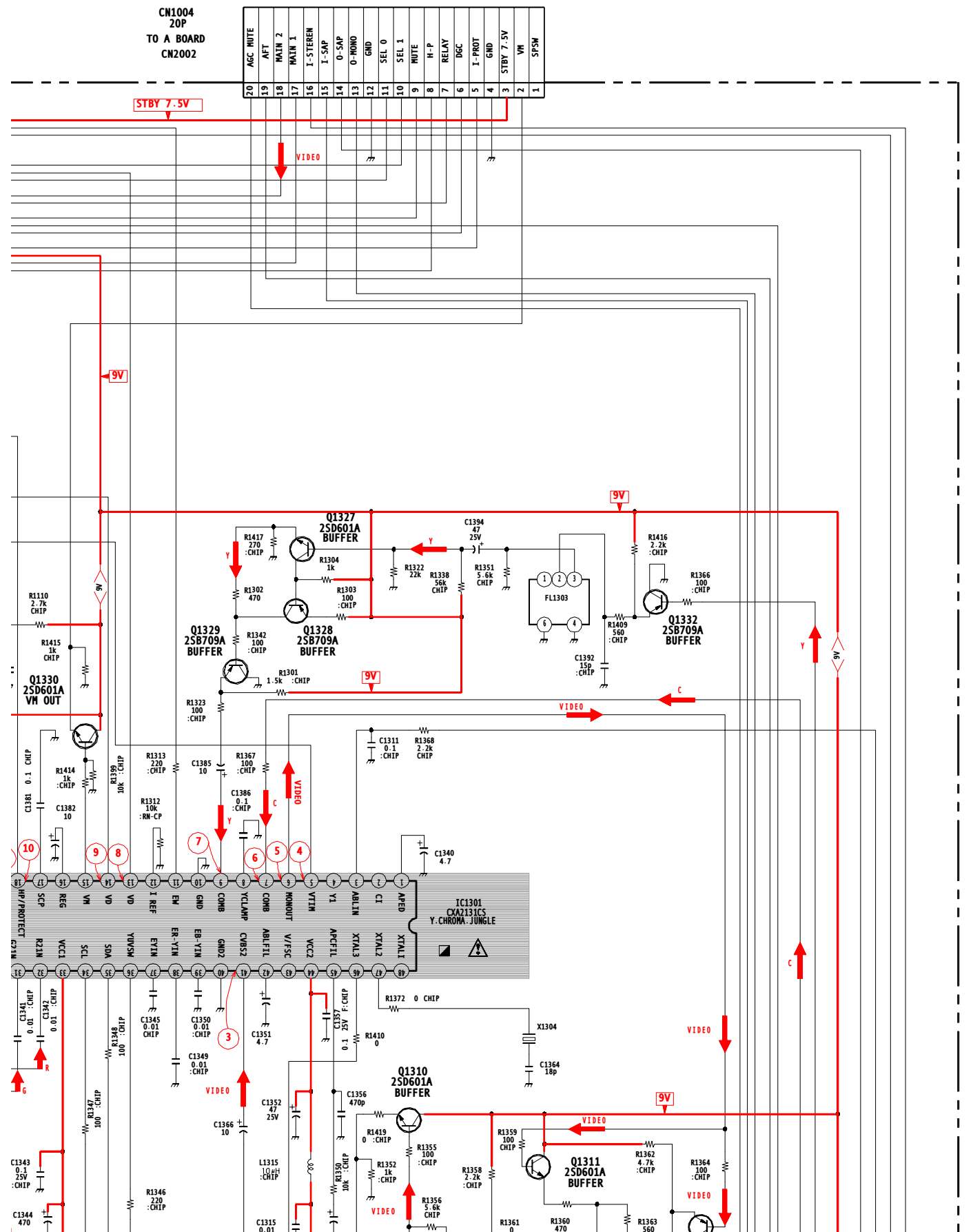

**MB BOARD WAVEFORMS**

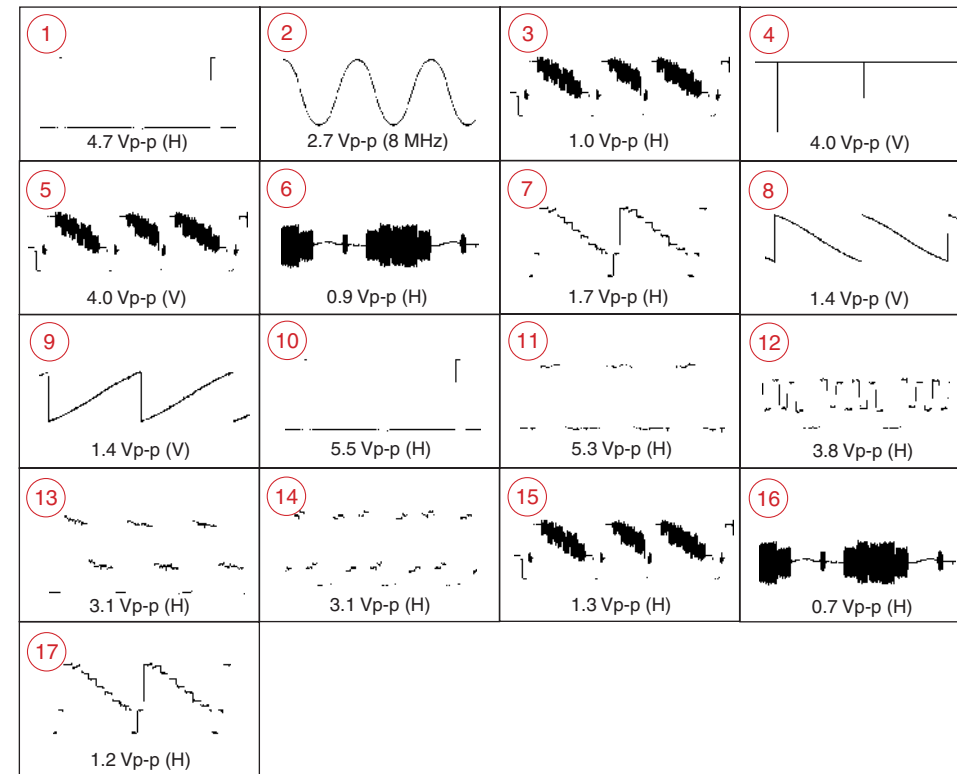

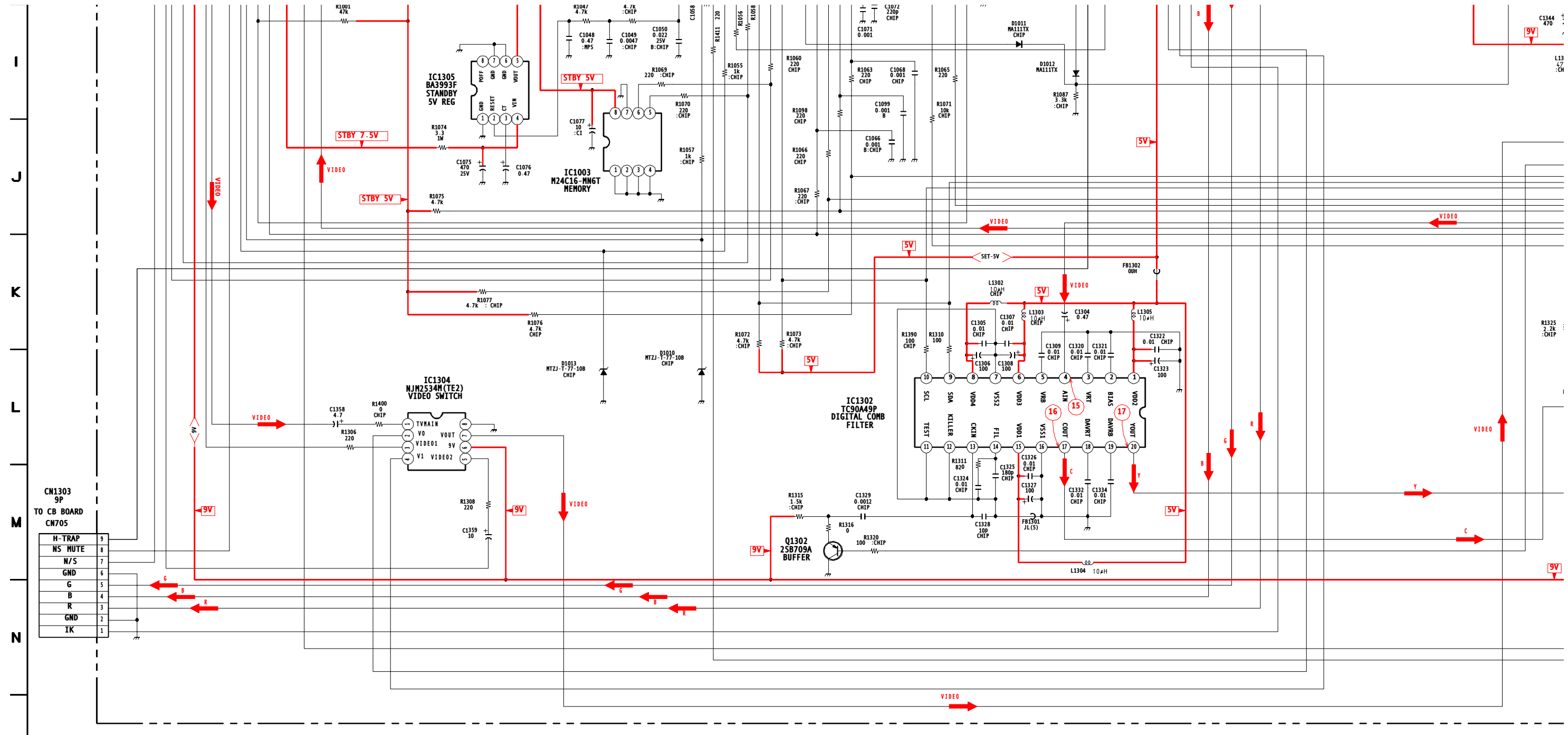



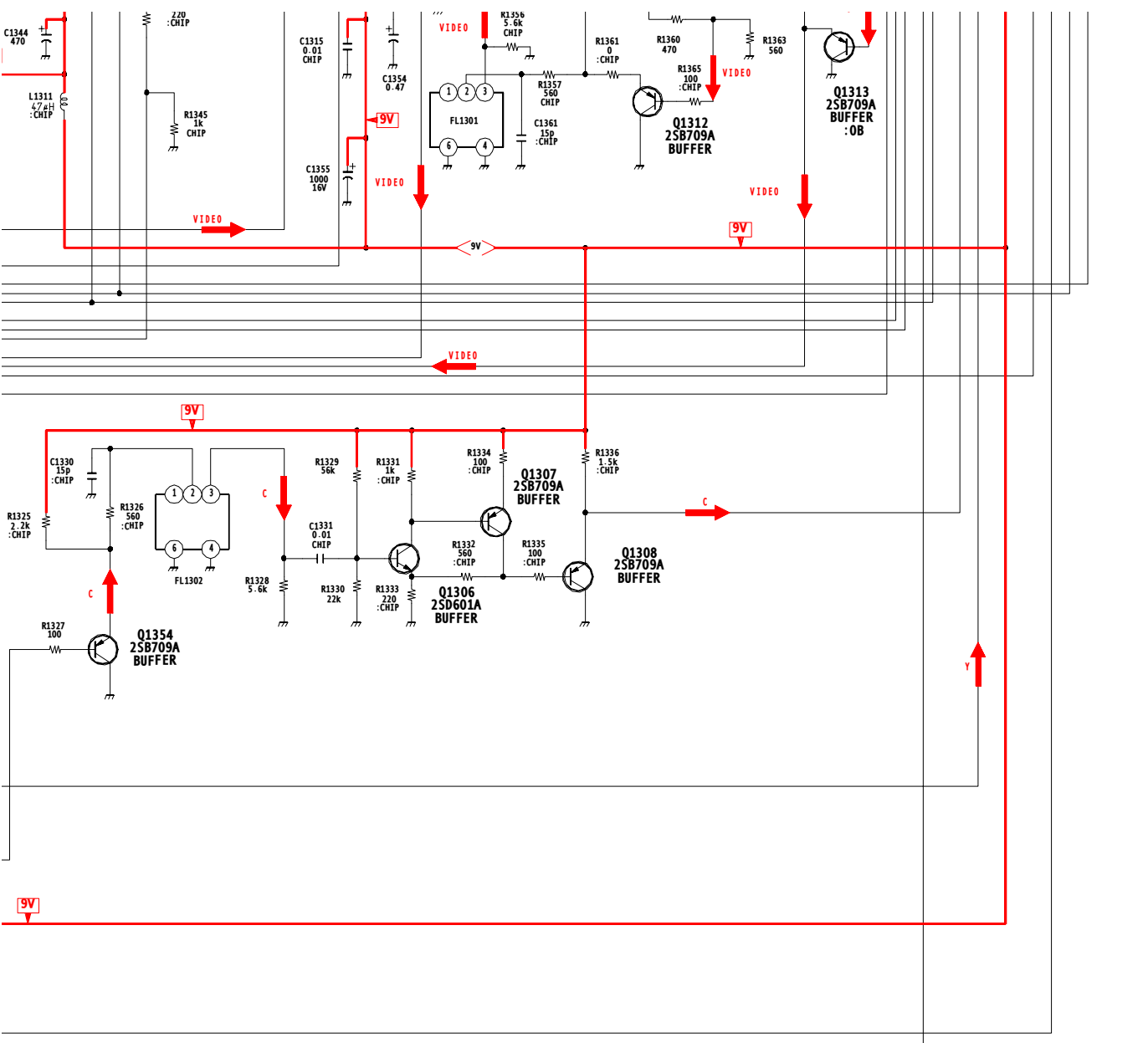

**MB** TUNING CONTROL MICROPROCESSOR  
Y/C JUNGLE



FD Trinitron  
**WEGA**

---

***Trinitron® Color TV***

Operating Instructions

*KV-13FM12*  
*KV-13FM13*  
*KV-13FM14*  
*KV-20FS12*



# WARNING

To reduce the risk of fire or electric shock, do not expose the TV to rain or moisture.

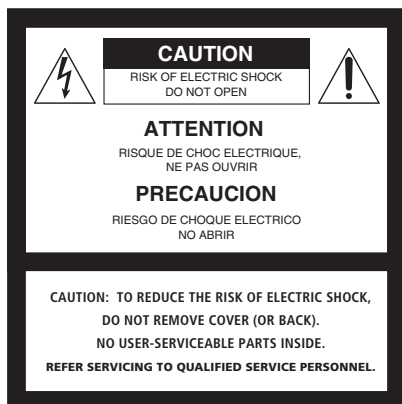

This symbol is intended to alert the user to the presence of uninsulated “dangerous voltage” within the product’s enclosure that may be of sufficient magnitude to constitute a risk of electric shock to persons.



This symbol is intended to alert the user to the presence of important operating and maintenance (servicing) instructions in the literature accompanying the appliance.

## Note to the CATV Installer

This reminder is provided to call the CATV system installer’s attention to Article 820-40 of the NEC that provides guidelines for proper grounding and, in particular, specifies that the cable ground shall be connected to the grounding system of the building as close to the point of cable entry as practical.

## SAFETY PRECAUTIONS

- Operate the TV only on 120 V AC.
- One blade of the power plug is wider than the other for safety purposes and will fit into the power outlet only one way. If you are unable to insert the plug fully into the outlet, contact your dealer.
- If any liquid or solid object falls into the TV, unplug it and have it checked by qualified personnel before operating it further.

## CAUTION

When using TV games, computers, and similar products with your TV, keep the brightness and contrast functions at low settings. If a fixed (non-moving) pattern is left on the screen for long periods of time at a high brightness or contrast setting, the image can be permanently imprinted onto the screen. Continuously watching the same channel can cause the imprint of station logos onto the TV screen. These types of imprints are not covered by your warranty because they are the results of misuse.



**To reduce the risk of electric shock, do not use this polarized plug with an extension cord, receptacle, or other outlet unless the blades can be fully inserted to prevent blade exposure.**

 You are cautioned that any changes or modifications not expressly approved in this manual could void your authority to operate this equipment.

## NOTIFICATION

This equipment has been tested and found to comply with the limits for a Class B digital device pursuant to Part 15 of the FCC Rules. These limits are designed to provide reasonable protection against harmful interference in a residential installation. This equipment generates, uses, and can radiate radio frequency energy and, if not installed and used in accordance with the instructions, may cause harmful interference with radio communications. However, there is no guarantee that interference will not occur in a particular installation. If this equipment does cause harmful interference to radio or television reception, which can be determined by turning the equipment off and on, the user is encouraged to try to correct the interference by one or more of the following measures:

- Reorient or relocate the receiving antennas.
- Increase the separation between the equipment and receiver.
- Connect the equipment into an outlet on a circuit different from that to which the receiver is connected.
- Consult the dealer or an experienced radio/TV technician for help.

## Protecting the TV

- To prevent internal heat build-up, do not block the ventilation openings.
- Do not install the TV in a hot or humid place, or in a place subject to excessive dust or mechanical vibration.

## Note on Caption Vision

This television receiver provides display of television closed captioning in accordance with § 15.119 of the FCC rules.

Use of this television for other than private viewing of programs broadcast on UHF or VHF or transmitted by cable companies for the use of the general public may require authorization from the broadcaster-cable company and/or program owner.

## Owner's Record

The model and serial numbers are located on the front cover of this manual and the rear of your TV.

## Trademarks and Copyrights

ENERGY STAR® is a registered mark.



As an ENERGY STAR® Partner, Sony has determined that this product or product model meets the ENERGY STAR® guidelines for energy efficiency.

# Important Safeguards

For your protection, please read these instructions completely, and keep this manual for future reference. Carefully observe and comply with all warnings, cautions and instructions placed on the set, or described in the operating instructions or service manual.

## WARNING

To guard against injury, the following basic safety precautions should be observed in the installation, use, and servicing of the set.

## Use

### Power Sources

This set should be operated only from the type of power source indicated on the serial/model plate. If you are not sure of the type of electrical power supplied to your home, consult your dealer or local power company. For those sets designed to operate from battery power, refer to the operating instructions.



### Grounding or Polarization

This set is equipped with a polarized AC power cord plug (a plug having one blade wider than the other), or with a three-wire grounding type plug (a plug having a third pin for grounding).

Follow the instructions below:

### For the set with a polarized AC power cord plug

This plug will fit into the power outlet only one way. This is a safety feature. If you are unable to insert the plug fully into the outlet, try reversing the plug. If the plug should still fail to fit, contact your electrician to have a suitable outlet installed. Do not defeat the safety purpose of the polarized plug by forcing it in.



### Alternate Warning For the set with a three-wire grounding type AC plug

This plug will only fit into a grounding-type power outlet. This is a safety feature. If you are unable to insert the plug into the outlet, contact your electrician to have a suitable outlet installed. Do not defeat the safety purpose of the grounding plug.

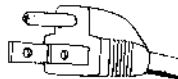

## Overloading

Do not overload wall outlets, extension cords or convenience receptacles beyond their capacity, since this can result in fire or electric shock. Always turn the set off when it is not to be used. When the set is left unattended and unused for long periods of time, unplug it from the wall outlet as a precaution against the possibility of an internal malfunction that could create a fire hazard.



## Object and Liquid Entry

Never push objects of any kind into the set through the cabinet slots as they may touch dangerous voltage points or short out parts that could result in a fire or electric shock. Never spill liquid of any kind on the set.



## Attachments

Do not use attachments not recommended by the manufacturer, as they may cause hazards.

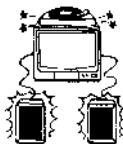

## Cleaning

Unplug the set from the wall outlet before cleaning or polishing it. Do not use liquid cleaners or aerosol cleaners. Use a cloth lightly dampened with water for cleaning the exterior of the set.



If a snapping or popping sound from a TV set is continuous or frequent while the TV is operating, unplug the TV and consult your dealer or service technician. It is normal for some TV sets to make occasional snapping or popping sounds, particularly when being turned on or off.



## Installation

### Water and Moisture

Do not use power-line operated sets near water — for example, near a bathtub, washbowl, kitchen sink, or laundry tub, in a wet basement, or near a swimming pool, etc.



## Accessories

Do not place the set on an unstable cart, stand, tripod, bracket, table, or shelf. The set may fall, causing serious injury to a child or an adult, and serious damage to the set. Use only a cart or stand recommended by the manufacturer for the specific model of TV. Any mounting of the product should follow the manufacturer's instructions, and should use a mounting accessory recommended by the manufacturer. An appliance and cart combination should be moved with care. Quick stops, excessive force, and uneven surfaces may cause the appliance and cart combination to overturn.



## Ventilation

The slots and openings in the cabinet and in the back or bottom are provided for necessary ventilation. To ensure reliable operation of the set, and to protect it from overheating, these slots and openings must never be blocked or covered.

- **Never cover the slots and openings with a cloth or other materials.**



- **Never block the slots and openings by placing the set on a bed, sofa, rug or other similar surface.**



- **Never place the set in a confined space, such as a bookcase, or built-in cabinet, unless proper ventilation is provided.**



- **Do not place the set near or over a radiator or heat register, or where it is exposed to direct sunlight.**



## Power-Cord Protection

Do not allow anything to rest on or roll over the power cord, and do not place the set where the power cord is subject to wear or abuse.





## Grounding or Polarization

This set may be equipped with a polarized alternating current line plug (a plug having one blade wider than other). This plug will fit into the power outlet only one way. This is a safety feature. If you are unable to insert the plug fully into the outlet, try reversing the plug. If the plug should still fail to fit, contact you electrician to replace your obsolete outlet. Do not defeat the safety purpose of the polarized plug

## Antennas

### Outdoor Antenna Grounding

If an outdoor antenna is installed, follow the precautions below. An outdoor antenna system should not be located in the vicinity of overhead power lines or other electric light or power circuits, or where it can come in contact with such power lines or circuits.

WHEN INSTALLING AN OUTDOOR ANTENNA SYSTEM, EXTREME CARE SHOULD BE TAKEN TO KEEP FROM CONTACTING SUCH POWER LINES OR CIRCUITS AS CONTACT WITH THEM IS ALMOST INVARIABLY FATAL.

Be sure the antenna system is grounded so as to provide some protection against voltage surges and built-up static charges. Section 810 of the National Electrical Code (NEC) in USA and Section 54 of the Canadian Electrical Code in Canada provides information with respect to proper grounding of the mast and supporting structure, grounding of the lead-in wire to an antenna discharge unit, size of grounding conductors, location of antenna discharge unit, connection to grounding electrodes, and requirements for the grounding electrode.

### Antenna Grounding According to the NEC

Refer to section 54-300 of Canadian Electrical Code for Antenna Grounding.

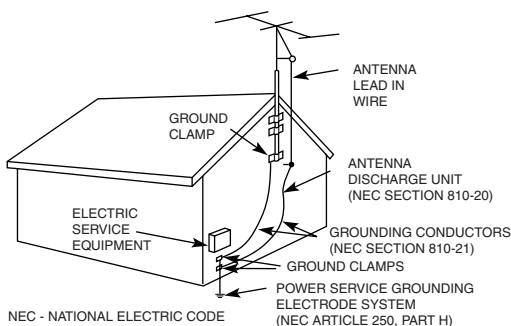

## Lightning

For added protection for this television receiver during a lightning storm, or when it is left unattended and unused for long periods of time, unplug it from the wall outlet and disconnect the antenna. This will prevent damage to the receiver due to lightning and power-line surges.

## Service

### Damage Requiring Service

Unplug the set from the wall outlet and refer servicing to qualified service personnel under the following conditions:

- When the power cord or plug is damaged or frayed.

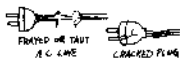

- If liquid has been spilled into the set or objects have fallen into the product.



- If the set has been exposed to rain or water.



- If the set has been subject to excessive shock by being dropped, or the cabinet has been damaged.



- If the set does not operate normally when following the operating instructions. Adjust only those controls that are specified in the operating instructions. Improper adjustment of other controls may result in damage and will often require extensive work by a qualified technician to restore the set to normal operation.



- When the set exhibits a distinct change in performance — this indicates a need for service.

### Servicing

Do not attempt to service the set yourself since opening the cabinet may expose you to dangerous voltage or other hazards. Refer all servicing to qualified service personnel.

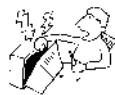

### Replacement Parts

When replacement parts are required, be sure the service technician certifies in writing that he has used replacement parts specified by the manufacturer that have the same characteristics as the original parts. Unauthorized substitutions may result in fire, electric shock, or other hazards.



### Safety Check

Upon completion of any service or repairs to the set, ask the service technician to perform routine safety checks (as specified by the manufacturer) to determine that the set is in safe operating condition, and to so certify. When the set reaches the end of its useful life, improper disposal could result in a picture tube implosion. Ask a qualified service technician to dispose of the set.





# Contents

## Introduction

Trinitron® Color TV Features .....	1
Batteries for the Remote Control.....	2
About this Manual .....	2





## Connecting Your TV

Basic Connections.....	3
Connecting Additional Equipment .....	4

## Using the Remote Control and Basic Functions

Using the Remote Control.....	11
Setting Up the TV Automatically.....	13
Quick Start to the Menus.....	14

## Using the Menus

Using the Video  Menu .....	17
Using the Audio  Menu (KV-20FS12 only).....	18
Using the Channel Setup  Menu.....	19
Parental Control.....	20
Using the Parental Control  Menu .....	23
Using the Timer  Menu .....	26
Using the Setup  Menu.....	27
Options Menu .....	28

## Other Information

Troubleshooting .....	29
Specifications.....	31

<b>Index</b> .....	32
--------------------	----



# Introduction

Congratulations on your purchase of the Sony Trinitron® Color TV. Before you begin using this manual, please check the model number located on the rear of your TV or on the front cover of this manual.

## Trinitron® Color TV Features

Some of the features you will enjoy include:

- ❑ **FLAT CRT** — New technologically advanced screen for optimal picture quality.
- ❑ **Parental Control** — A tool for parents to help monitor what their children watch on TV by establishing rating limits.
- ❑ **Favorite Channel** — Instant access to your favorite channels with the touch of a button.
- ❑ **Energy Star®** — A recognized symbol of energy efficiency.
- ❑ **Direct MTS** — Allows direct access to changing your Multi-Channel TV Sound: Stereo, Mono, or Auto-SAP (Second Audio Program), with the touch of a button (KV-20FS12 only).
- ❑ **Trilingual Menus** — Choose between English, French, or Spanish menus.
- ❑ **Front Panel Controls** — Allows access to the on-screen menus without the use of a remote control.
- ❑ **Front A/V inputs** — A quick connection for video games, camcorders stereo/mono equipment, or headphones.





In this manual, references to the KV-13FM12 include the KV-13FM12, KV-13FM13, and KV-13FM14 models.

## Batteries for the Remote Control

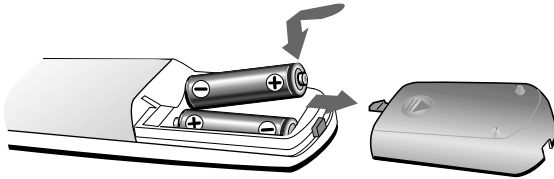
Insert two AA (R6) batteries (supplied) into the remote control using the following illustration as a guide.



 Under normal conditions, batteries will last up to six months. If the remote control does not operate properly, the batteries might be worn out.

 If you will not be using the remote control for an extended period of time, remove the batteries to avoid possible damage from battery leakage.

## About this Manual

This manual provides instructions to help you enjoy your new TV. It shows you how to connect to an antenna or cable, cable box, VCR, DVD, satellite receiver, or camcorder. Once you are connected, follow the instructions and use the remote control to access the on-screen menus.

 The TV front and rear panels illustrated in this manual are for KV-20FS12. The front and rear panels on your TV may not look exactly like those illustrated.

# Connecting Your TV

Read this section before setting up your TV for the first time. This section covers basic connections in addition to any optional equipment you may be connecting.

## Basic Connections

### TV with indoor or outdoor antenna, or CATV cable

Depending on the cable available in your home, choose one of the connections below:

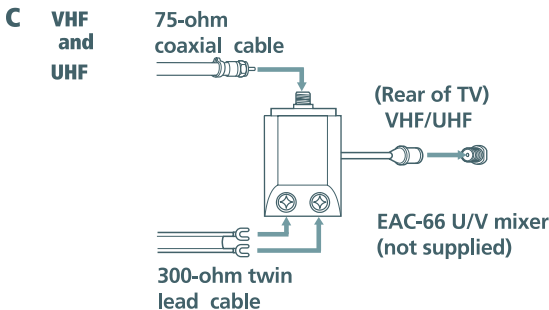
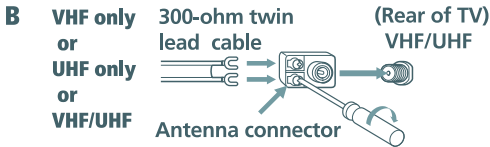
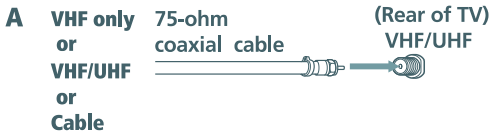

 If you are connecting to an indoor or outdoor antenna, you may need to adjust the orientation of the antenna for best reception.



# Connecting Additional Equipment

## TV and VCR

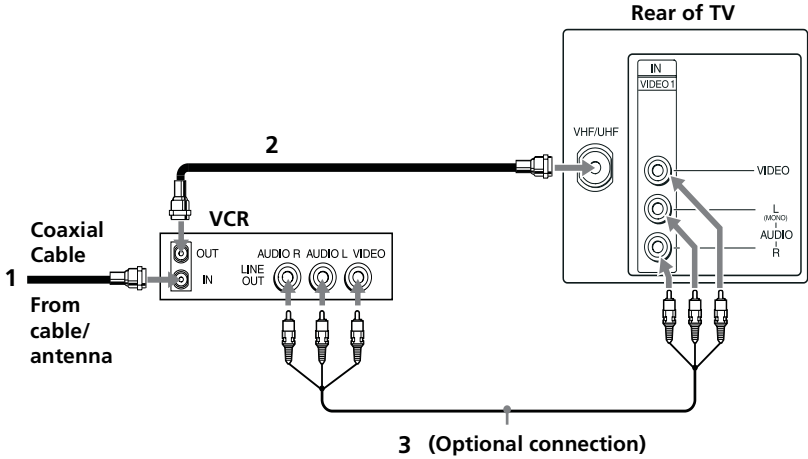

- 1 Connect the coaxial cable from your TV antenna or cable service to the IN jack on your VCR.
- 2 Connect a coaxial cable (not supplied) from the OUT jack on your VCR to the VHF/UHF jack on the TV.

To watch video programs from your VCR, tune your TV to channel 3 or 4 (as set on the rear of your VCR).

### (Optional connection)

- 3 If your VCR is equipped with video outputs, you can get better picture quality by connecting A/V cables (not supplied) from AUDIO and VIDEO OUT on your VCR to AUDIO/VIDEO IN on your TV.

You can use the button to switch between the VHF/UHF and VIDEO inputs.

## TV and Cable Box

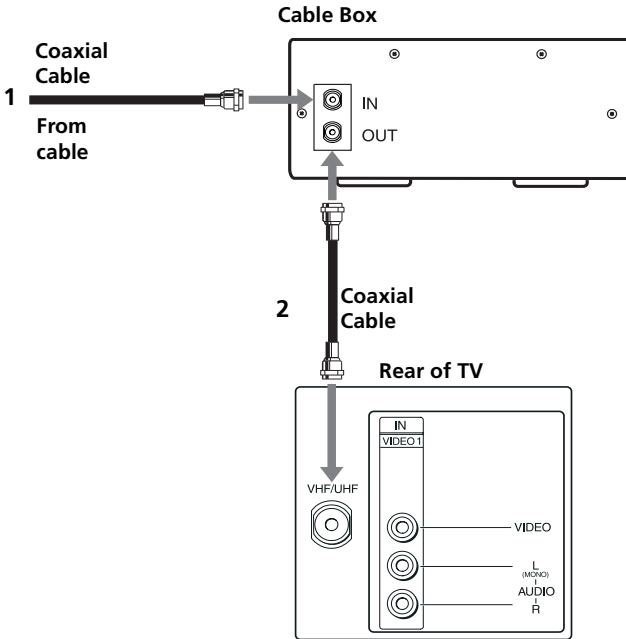

- 1** Connect the coaxial cable from your cable service to the IN jack on your cable box.
- 2** Connect a coaxial cable (not supplied) from the OUT jack on your cable box to the VHF/UHF jack on the TV.

 To view channels from your cable box, tune your TV to channel 3 or 4 (as set on the rear panel of your cable box) and use the cable box's remote control to change channels.

 If you will be controlling all channel selection through your cable box, you should consider using the Channel Fix feature, (see page 19).

## TV, VCR, and Cable box

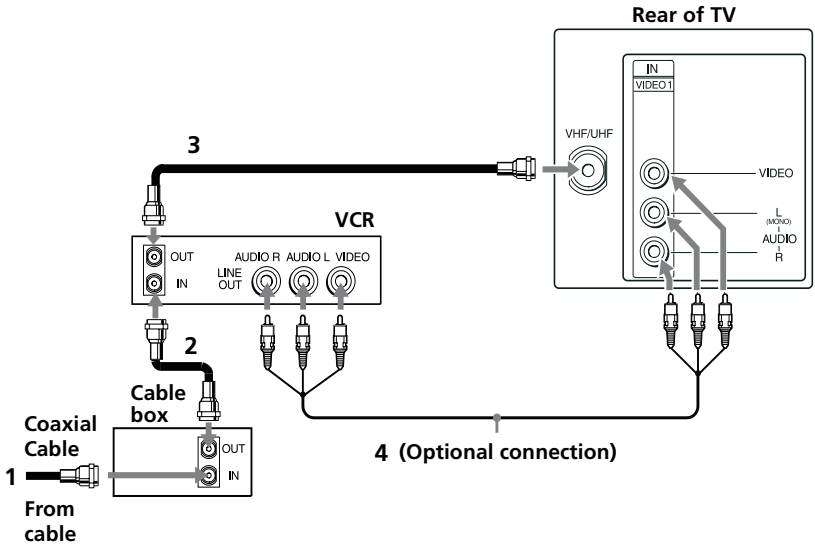

- 1 Connect the coaxial cable from your cable service to the IN jack on your cable box.
- 2 Connect a coaxial cable (not supplied) from the OUT jack on your cable box to the IN jack on your VCR.
- 3 Connect a coaxial cable (not supplied) from the OUT jack on your VCR to the VHF/UHF jack on the TV.

If you will be controlling all channel selection through your cable box, you should consider using the Channel Fix feature, (see page 19).

### (Optional connection)



- 4 If your VCR is equipped with video outputs, you can get better picture quality by connecting A/V cables (not supplied) from AUDIO and VIDEO OUT on your VCR to AUDIO/VIDEO IN on your TV.

You can use the button to switch between the VHF/UHF and VIDEO inputs.

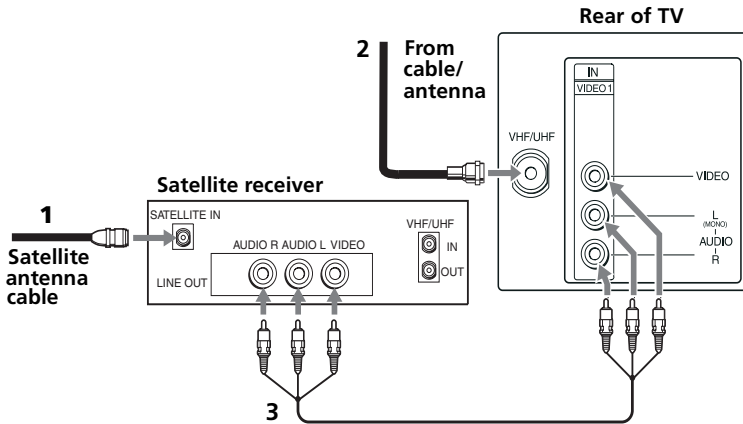
## TV and Satellite Receiver





- 1** Connect the cable from your satellite antenna to SATELLITE IN on your satellite receiver.
- 2** Connect the coaxial cable from your cable service or antenna to the VHF/UHF jack on your TV.
- 3** Using A/V cables, connect AUDIO and VIDEO OUT on your satellite receiver to AUDIO and VIDEO IN on your TV.

 You can use the  button to switch between the VHF/UHF and VIDEO inputs.

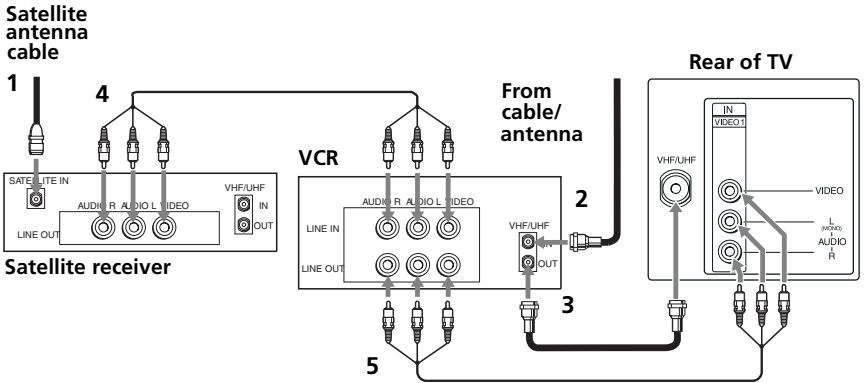
## TV, Satellite Receiver, and VCR



- 1** Connect the cable from your satellite antenna to SATELLITE IN on your satellite receiver.
- 2** Connect the coaxial cable from your cable service or antenna to the IN jack on your VCR.
- 3** Using a coaxial cable, connect the OUT jack on your VCR to the VHF/UHF jack on your TV.
- 4** Using A/V cables, connect AUDIO and VIDEO OUT on your satellite receiver to AUDIO and VIDEO IN on your VCR.
- 5** Using A/V cables, connect AUDIO and VIDEO OUT on your VCR to AUDIO and VIDEO IN on your TV.

 To view from the satellite receiver or VCR, select the video input to which your satellite receiver or VCR is connected by pressing  on the remote control.

## Connecting a Camcorder

Using A/V cables, connect AUDIO and VIDEO OUT on your camcorder to AUDIO and VIDEO IN on your TV.

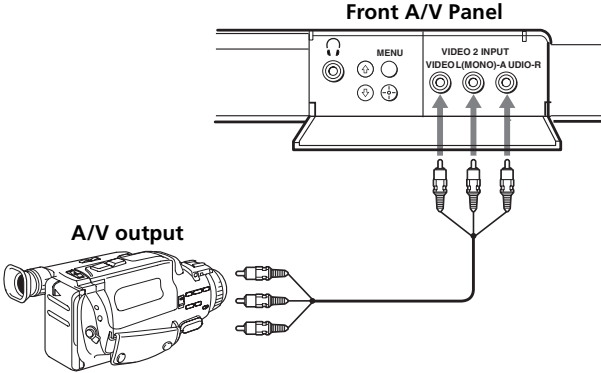

## Connecting a DVD Player

Using A/V cables, connect AUDIO and VIDEO OUT on your DVD player to AUDIO and VIDEO IN on your TV.

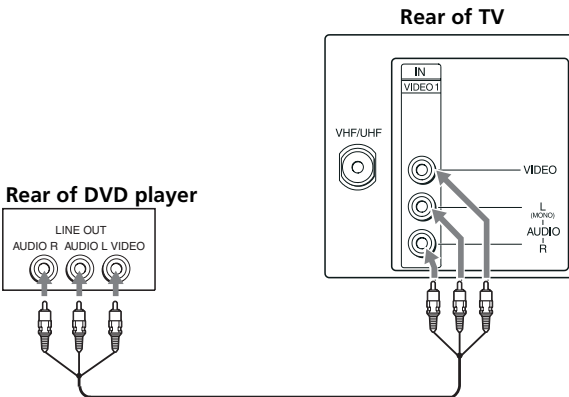

## Connecting Headphones

Connect your headphones to the  jack on the front of your TV.

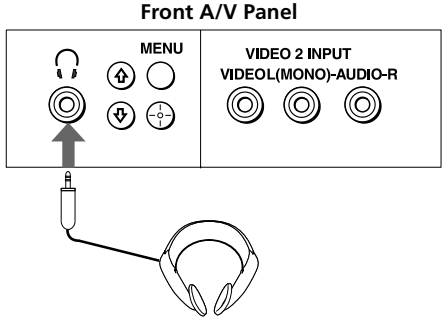



# Using the Remote Control and Basic Functions

This section shows you how to use the more advanced buttons on the remote control and how to use the on-screen menus.

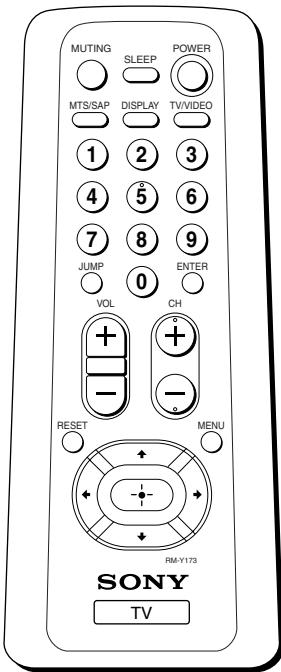
## Using the Remote Control

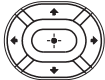

Button	Description
<b>POWER</b>	Press when you want to turn the TV on and off.
<b>MUTING</b>	Instantly turns off the sound. Press again or press  to restore sound.
<b>TV/VIDEO</b>	Cycles through available video inputs.
	Moves the cursor in the on-screen menus. Press the arrow buttons to move the cursor. Press the center button to select or access an option.
<b>SLEEP</b>	Turns the TV off automatically in approximately 15, 30, 45, 60, or 90 minutes. Cancel by pressing until SLEEP OFF appears.
<b>MTS/SAP</b>	Cycles through the Multi-channel TV Sound (MTS) options: Stereo, Mono, and Auto-SAP (Second Audio Programming) (KV-20FS12 only).
<b>DISPLAY</b>	Press to display the current time, (if set) and channel number.
<b>JUMP</b>	Alternates between the last two channels selected with the  buttons.

 The remote control shown (RM-Y173) is for KV-20FS12. For KV-13FM12 models, your remote control does not have the MTS/SAP button.

(continued)



<b>MENU</b>	Displays the on-screen menu. Press again to exit the menu at any time.
<b>RESET</b>	Press to return to factory settings while in an on-screen menu.

 If you lost your remote control, see page 30.

## Setting Up the TV Automatically





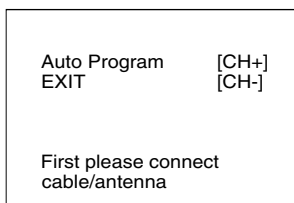











After you have finished connecting your TV, you can perform Auto Program to set up your channels.

- 1 Press  to turn on the TV. The Initial Setup screen appears.



- 2 Press  on the remote control or in the TV front panel to perform Auto Program.





### To perform Auto Program again

- 1 Press .
- 2 Press  to highlight Setup (.
- 3 Press  to highlight Options. Press  or  to select.
- 4 Press  to select Cable. Press  or  to select.
- 5 Press  or  to select ON or OFF according to how you connected your TV. Press  or .
- 6 Press  to highlight Auto Program. Press  or  to search for channels.

 The Initial Setup screen appears each time you turn on the TV until you perform Auto Program.

# Quick Start to the Menus

The following settings are available in your on-screen menus:

Menu	Allows you to
 Video Picture Brightness Color Hue Sharpness VM: Low Move (←→↑↓) Select (+) End MENU	Make adjustments to your picture settings.
 Audio MTS: Stereo Move (←→↑↓) Select (+) End MENU	Change your Multi-channel TV Sound settings (KV-20FS12 only).
 Channel Setup Favorite Channel Channel Fix: OFF Channel Skip/Add Channel Label Move (←→↑↓) Select (+) End MENU	Customize your channel settings.
 Parental Control Password: ____ Move (←→↑↓) Select (+) End MENU	Set rating limits on your TV based on a program's rating or content.

 The menus shown in this manual are for KV-20FS12. Your menus may not look like those illustrated.

**Menu**

**Allows you to**

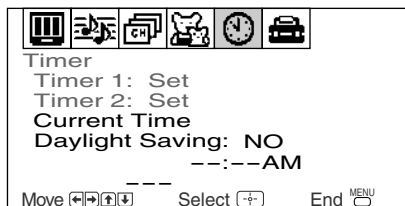

Set the clock on your TV and program scheduled viewing using Timer 1 and Timer 2.

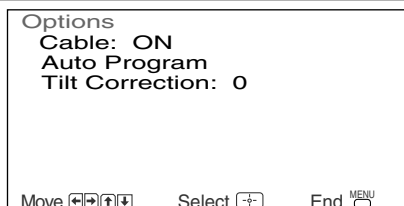
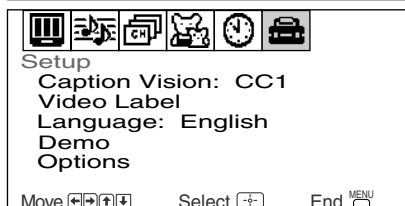

Program your channels, label video inputs, select menu languages, or run a demo of the menus.











The Options menu offers other setup options.



# Using the Menus

This section shows the options available for setting up and adjusting your TV.





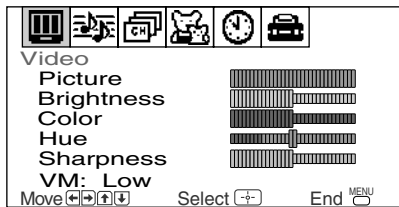

## To access a menu

- 1 Press .
- 2 Use the  or  buttons to move through the menus.
- 3 Use the  or  buttons to highlight an option.
- 4 Press  or  to select or access an option.
- 5 After adjusting or selecting an option, press  or  to complete the adjustment.
- 6 Press  to go to the previous menu, or press  to close the menu.

## Using the Video Menu

To access the Video menu, see “To access a menu” above.



Item	Press  or  to	Press  or  to
<b>Picture</b>	Decrease picture contrast	Increase picture contrast
<b>Brightness</b>	Darken the picture	Brighten the picture
<b>Color</b>	Decrease color saturation	Increase color saturation
<b>Hue</b>	Increase the red tones	Increase the green tones
<b>Sharpness</b>	Softens the picture	Sharpen the picture
<b>VM</b> <i>Velocity</i> <i>Modulation</i>	Sharpens picture definition to give objects a sharp, clean edge. Use the  or  buttons to select from one of the following options: <b>OFF, High, Low</b> (KV-20FS12 only).	



## Using the Audio Menu (KV-20FS12 only)

To access the Audio menu, see “To access a menu” on page 17.



### MTS

*Multi-Channel  
Sound*



Press  or  to select one of the following options:

**Stereo:** Select when viewing a broadcast in stereo.

**Mono:** Select to reduce noise in areas of poor reception.

**Auto-SAP:** Select to have the TV automatically switch to a Second Audio Program (SAP) when a signal is received.

 If your TV is set to Auto-SAP, some programs may be muted or distorted. If your TV does not output sound, change your Audio settings to Stereo or Mono.

 Press  for direct MTS settings (Stereo, Mono, Auto-SAP).

## Using the Channel Setup Menu

To access the Channel Setup menu, see “To access a menu” on page 17.



### Favorite Channel

*Quick access to favorite channels*

With the Favorite Channel menu open:

- 1 Press  $\leftarrow$  or  $\rightarrow$  to select.
- 2 Use the  $\uparrow$  or  $\downarrow$  buttons to select Auto or Manual (selecting Auto will display in gray the last five channels accessed by the  $\text{0-9}$  buttons).
- 3 When in Manual, press  $\leftarrow$  then  $\downarrow$  to select the position (1-5) where you want to set a favorite channel. Then press  $\rightarrow$  or  $\rightarrow$ .
- 4 Using the  $\uparrow$  or  $\downarrow$  buttons, select the desired channel.
- 5 Press  $\rightarrow$  then  $\text{MENU}$ , the TV will change to the channel entered.



To use Favorite Channel: Exit all menus and press  $\rightarrow$ . Press  $\downarrow$  or  $\uparrow$  to move the cursor to the desired channel number and press  $\rightarrow$ .

### Channel Fix

**2-6:** Select when you want to control all channel selection through a cable box or VCR. Select the appropriate channel (usually 3 or 4) and use the cable box's or VCR's remote control for channel selection.

**Video:** Select from available video inputs when you have connected video equipment (e.g. satellite receiver) and you want your TV fixed to it.

**OFF:** Channel Fix is not set.

### Channel Skip/Add

Use this feature after you run Auto Program to skip unwanted channels or add new ones.

- 1 Use the  $\text{0-9}$  buttons or the [CH+/-] buttons to select the channel, then press  $\rightarrow$ .
- 2 Press  $\rightarrow$  to Skip or Add (only one option will be available).

### Channel Label

*Label up to 40 channels with their call letters*

With the Channel Label window open:

- 1 Press  $\rightarrow$ , then press  $\uparrow$  or  $\downarrow$  until you reach the desired channel number.
- 2 Press  $\rightarrow$  to activate the channel.
- 3 Press  $\uparrow$  or  $\downarrow$  to display the first call letter or number of the caption and press  $\rightarrow$  to select it. When finished, press  $\rightarrow$  or  $\rightarrow$  to activate.



Favorite Channel, Channel Skip/Add, and Channel Label cannot be used when Channel Fix is set.



# Parental Control

The Parental Control feature is designed to help parents monitor what their children watch on television. This section shows you the different rating systems available and how to set your TV's rating limit.

## Overview of the Ratings

Once you have become familiar with these rating systems, you should be ready to set your TV's rating limit.

## TV Ratings

The TV ratings are divided into two groups: age-based and content-based.

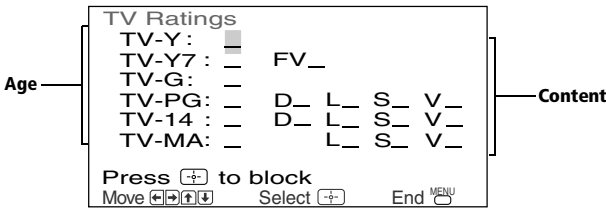

Age	Defined as
<b>TV-Y</b>	All children
<b>TV-Y7</b>	Directed to older children
<b>TV-G</b>	General audience
<b>TV-PG</b>	Parental Guidance suggested
<b>TV-14</b>	Parents Strongly cautioned
<b>TV-MA</b>	Mature Audience only

Contents	Defined as
<b>FV</b>	Fantasy Violence
<b>D</b>	Suggestive dialogue
<b>L</b>	Strong language
<b>S</b>	Sexual situations
<b>V</b>	Violence

The content ratings will increase depending on the level of the age-based rating. For example, a program with a TV-PG V (Violence) rating may contain moderate violence, while a TV-14 V (Violence) rating may contain intense violence.

## Movie Ratings

### (U.S. models only)

This system defines the rating levels of movies shown in theaters and on prime cable channels.

Rating	Defined as
<b>G</b>	General audience
<b>PG</b>	Parental Guidance suggested
<b>PG-13</b>	Parents strongly cautioned
<b>R</b>	Restricted
<b>NC-17</b>	No one 17 and under admitted
<b>X</b>	No one 17 and under admitted

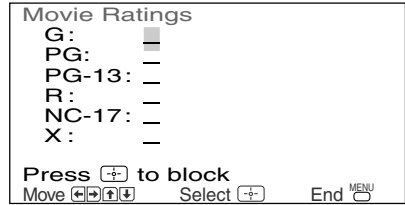

## Unrated

### (U.S. models only)

You have the option of blocking TV programs or movies that are not rated.

<b>View All</b>	Allows all unrated programs
<b>Block All</b>	Blocks all unrated programming
<b>Block TV</b>	Blocks all unrated TV programs
<b>Block Movies</b>	Blocks all unrated movies

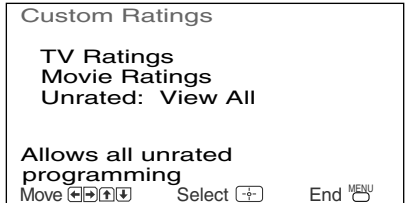

If you choose to block unrated TV programs, please be aware that the following programs may be blocked: emergency broadcasts, political programs, sports, news, public service announcements, religious programs and weather.

## English Ratings

### (Canadian models only)

These ratings are for Canadian programs that are broadcast in English.

Rating	Defined as
<b>C</b>	Children
<b>C8+</b>	Children 8 years and older
<b>G</b>	General programming
<b>PG</b>	Parental Guidance
<b>14+</b>	Viewers 14 and older
<b>18+</b>	Adult programming

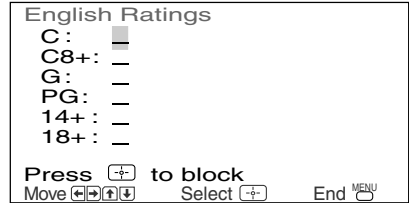

## French Ratings

### (Canadian models only)

These ratings are for Canadian programs that are broadcast in French.

Rating	Defined as
<b>G</b>	General
<b>8 ans+</b>	Not recommended for younger children
<b>13 ans+</b>	Not recommended for children under age 13
<b>16 ans+</b>	Not recommended for ages under 16
<b>18 ans+</b>	This program is restricted to adults

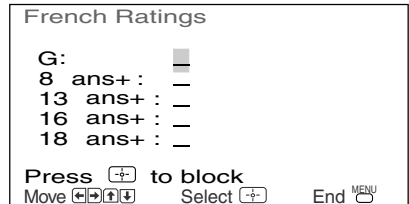

## U.S.A. Ratings

### (Canadian models only)

For programs from the United States, see “TV Ratings” on page 20.

## Using the Parental Control Menu

To access the Parental Control menu, see “To access a menu” on page 17.



In the Parental Control  menu, you will be asked to set a 4-digit password for any further access into Parental Control.

- 1 Press  or , then use the - buttons to enter a 4-digit password.

 Keep this manual in a safe place. If you forget your password, see page 30.

- 2 Confirm your password by entering it again.

Once your password is set correctly, the next Parental Control menu appears.

## Setting the rating

You can change the Rating by selecting one of the Lock options.



**1** Move the cursor to Lock and press  $\rightarrow$  or  $\leftarrow$ .

If you are not familiar with the Parental Guidelines rating system, use one of the following preselected categories to simplify the rating selections: OFF, Child, Youth, Young Adult, or Custom.

**2** Use the  $\uparrow$  or  $\downarrow$  buttons to select the desired rating and press  $\rightarrow$  or  $\leftarrow$ .



Rating	TV will allow a maximum rating of:
Child	TV-Y, TV-G, G (U.S. models only), G (Canadian models only)
Youth	TV-PG, PG (U.S. models only), PG (Canadian models only)
Young Adult	TV-14, PG-13 (U.S. models only), 14+ (Canadian models only)
Custom	Select to set more restrictive ratings, (see next section)
OFF	No rating limit

## Using the Custom Menu

Before setting Custom ratings, see pages 20-22, “Overview of the Ratings,” for a description of the available rating systems.

Follow the instructions on the screen to make your custom settings. See page 21 for U.S. models and page 22 for Canadian models for more information.

 Once you have blocked a rating or content, all higher ratings or content will be automatically blocked.

## Changing your password

- 1 Use the  $\uparrow$  or  $\downarrow$  buttons to move the cursor to Change Password and press  $\rightarrow$  or  $\leftarrow$ .
- 2 Follow steps 2 and 3 of “Using the Parental Control Menu” on page 23.

## Information for Parents

### To view a program that exceeds the TV rating

- Press , then use the  $\text{0}$ - $\text{9}$  buttons to enter your password.

 Entering your password to view a blocked program will temporarily turn Lock to OFF. To reactivate your Lock settings, turn the TV off then back on. The TV will return to the settings that you have selected.

## Using the Timer Menu

To access the Timer menu, see “To access a menu” on page 17.

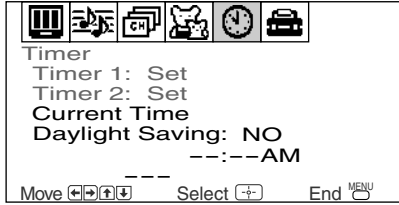



### Timer 1 and Timer 2

*Scheduled  
viewing*

With the menu open, highlight Timer 1 or Timer 2:

- 1 Press  $\leftarrow$  or  $\rightarrow$ , then press  $\uparrow$  or  $\downarrow$  again.
- 2 Press  $\uparrow$  or  $\downarrow$  until the desired day or range of days is displayed, then press  $\leftarrow$  or  $\rightarrow$ .
- 3 Press  $\uparrow$  or  $\downarrow$  to select the hour you want the TV to turn on, then press  $\leftarrow$  or  $\rightarrow$ .
- 4 Press  $\uparrow$  or  $\downarrow$  to select the minute you want the TV to turn on, then press  $\leftarrow$  or  $\rightarrow$ .
- 5 Press  $\uparrow$  or  $\downarrow$  to set the duration, up to 6 hours, then press  $\leftarrow$  or  $\rightarrow$ .
- 6 Press  $\uparrow$  or  $\downarrow$  to set the channel and press  $\leftarrow$  or  $\rightarrow$ .

 You must set the Current Time before you can use Timer 1 and Timer 2.

 You can set the Timer to ON, Set, or OFF. Once the timer is set, you can turn it on or off without having to go through the settings.

### Current Time

With the menu open:

- 1 Press  $\leftarrow$  or  $\rightarrow$ .
- 2 Press  $\uparrow$  or  $\downarrow$  to select the day and press  $\leftarrow$  or  $\rightarrow$ .
- 3 Press  $\uparrow$  or  $\downarrow$  until the current hour is displayed, then press  $\leftarrow$  or  $\rightarrow$ .
- 4 Press  $\uparrow$  or  $\downarrow$  until the current minute is displayed, then press  $\leftarrow$  or  $\rightarrow$ .

### Daylight Saving

**YES:** Select in spring to compensate for Daylight Saving.  
**NO:** Select in fall at the end of Daylight Saving.

 When you perform Auto Program, all Timer 1 and Timer 2 settings will be cleared.

 Any loss of power will cause Timer 1 and Timer 2 settings to be cleared.

## Using the Setup Menu

To access the Setup menu, see “To access a menu” on page 17.



<b>Caption Vision</b> <i>Closed-Captioning</i>	Press $\uparrow$ or $\downarrow$ to select one of the following options: <b>CC1, 2, 3, 4:</b> Displays printed dialogue and sound effects of a program. <b>TEXT1, 2, 3, 4:</b> Displays network/station information. <b>XDS</b> (Extended Data Services): Displays information about the network and current program, if available. <b>OFF:</b> Caption Vision is not activated.
<b>Video Label</b> <i>Label connected equipment</i>	With the Video Label window open: <b>1</b> Press $\uparrow$ or $\downarrow$ to access the input you want to label and press $\rightarrow$ or $\rightarrow$ . <b>2</b> Press $\uparrow$ or $\downarrow$ to choose a label and press $\rightarrow$ or $\rightarrow$ .
<b>Language</b>	Display all menus in your language of choice. Use the $\uparrow$ or $\downarrow$ buttons to select the desired language and press $\rightarrow$ or $\rightarrow$ .
<b>Demo</b>	Press $\rightarrow$ or $\rightarrow$ to run a demonstration of the on-screen menus.



## Options Menu

To access the Options menu, see “To access a menu” on page 17.

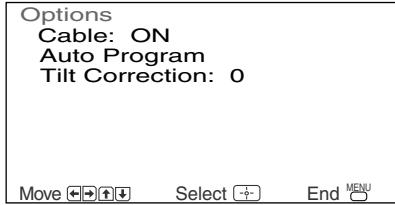

- 
- Cable**      **ON:** Select if you are receiving cable channels with a CATV cable.  
**OFF:** Select if you are using a TV antenna.

 After changing your cable settings, you will need to perform Auto Program.

- 
- Auto Program**    Perform Auto Program whenever setting up your TV. It will cycle through all available channels and program any receivable channels.

- 
- Tilt Correction**    Press  $\updownarrow$  to correct any tilt of the picture from -5 to +5, then press  $\leftrightarrow$  or  $\ominus$  to activate.
-

# Other Information











## Troubleshooting

If you are having a problem with your TV, try the suggestions below. If the problem persists, contact your nearest Sony dealer.

---

<b>No picture, no sound</b>	<ul style="list-style-type: none"><li><input type="checkbox"/> Make sure the power cord is plugged in.</li><li><input type="checkbox"/> If a red light is flashing on the front of your TV for more than a few minutes, disconnect and reconnect the power cord to restore the TV. If the problem continues, call your local service center.</li><li><input type="checkbox"/> Check the TV/VIDEO settings: when watching TV, set to TV; when watching video equipment, set to VIDEO (page 11).</li><li><input type="checkbox"/> Make sure the batteries have been inserted correctly into the remote control (page 2).</li><li><input type="checkbox"/> Try another channel, it could be station trouble.</li></ul>
<b>Poor or no picture, good sound</b>	<ul style="list-style-type: none"><li><input type="checkbox"/> Adjust Picture in the Video menu (page 17).</li><li><input type="checkbox"/> Adjust Brightness in the Video menu (page 17).</li><li><input type="checkbox"/> Check the antenna and/or cable connections (page 3).</li></ul>
<b>Good picture, no sound</b>	<ul style="list-style-type: none"><li><input type="checkbox"/> Press  so that MUTING disappears from the screen (page 11).</li><li><input type="checkbox"/> Check your Audio settings (KV-20FS12 only). Your TV may be set to Auto-SAP (page 18).</li></ul>
<b>No color</b>	<ul style="list-style-type: none"><li><input type="checkbox"/> Adjust Color in the Video menu (page 17).</li></ul>
<b>No signal</b>	<ul style="list-style-type: none"><li><input type="checkbox"/> Check the Cable setting in the Options menu under Setup (page 28).</li><li><input type="checkbox"/> Check the antenna and/or cable connections (page 3).</li><li><input type="checkbox"/> Make sure the channel selected is currently broadcasting.</li></ul>
<b>Dotted lines or stripes</b>	<ul style="list-style-type: none"><li><input type="checkbox"/> Adjust the antenna.</li><li><input type="checkbox"/> Move the TV away from other electronic equipment. Some electronic equipment can create electrical noise, which can interfere with TV reception.</li></ul>
<b>Double images or ghosts</b>	<ul style="list-style-type: none"><li><input type="checkbox"/> Check your outdoor antenna or call your cable service.</li></ul>

---

<b>Cannot receive higher number channels (UHF) when using an antenna</b>	<ul style="list-style-type: none"><li>❑ Make sure Cable is set to OFF in the Options menu under Setup (page 28).</li><li>❑ Perform Auto Program to add channels that are not presently in the memory (page 13).</li></ul>
<b>Cable stations don't seem to work</b>	<ul style="list-style-type: none"><li>❑ Make sure Cable is set to ON in the Options menu under Setup (page 28).</li><li>❑ Perform Auto Program to add channels that are not presently in the memory (page 13).</li></ul>
<b>Remote control does not operate</b>	<ul style="list-style-type: none"><li>❑ Batteries could be weak. Replace them (page 2).</li><li>❑ Move the TV 3-4 feet away from fluorescent lights.</li></ul>
<b>The TV needs to be cleaned</b>	<ul style="list-style-type: none"><li>❑ Clean the TV with a soft dry cloth. Never use strong solvents such as thinner or benzine, which might damage the finish of the cabinet.</li></ul>
<b>Lost password for Parental Control</b>	<ul style="list-style-type: none"><li>❑ In the password screen, enter the following master password: 4357. After using the master password, you must create a new password, it cannot be used to unlock currently blocked channels.</li></ul>
<b>You lost your remote control</b>	<ul style="list-style-type: none"><li>❑ You can use the front A/V panel controls to access the menu. Press  to open the menu. Use the  or  buttons on the front A/V panel instead of the  or  buttons on the remote control. Use the  button on the front A/V panel instead of the , , and  buttons on the remote control. Press  again when the setting or adjustment is complete. Contact your nearest Sony dealer to order a replacement.</li></ul>

*If, after reading these Operating Instructions, you have additional questions related to the use of your Sony television, please call our Direct Response Center at 1-800-222-SONY (7669) (U.S. residents only) or (416) 499-SONY (7669) (Canadian residents only).*

## Specifications

### For all models (except as noted)

Television system	American TV standard/NTSC
Channel coverage	VHF: 2-13/UHF: 14-69/CATV: 1-125
Antenna	75-ohm external antenna terminal for VHF/UHF
Picture tube	FD Trinitron® tube
Power requirements	120V, 60 Hz
Supplied Accessories	Size AA (R6) batteries (2) Remote Control RM-Y172 (1) (KV-13FM12, KV-13FM13, KV-13FM14) RM-Y173 (1) (KV-20FS12)
Optional Accessories	Connecting cables VMC-810S/820S, VMC-720M, YC-YC-15V/30V, RK74A EAC-66 U/V mixer

### **KV-13FM12, KV-13FM13, KV-13FM14**

Screen size	Visible screen size: 13 inches (330 mm) measured diagonally Actual screen size: 14 inches (356 mm) measured diagonally
Inputs/outputs	2 video, 2 audio 1 headphone jack
Speaker output	3 W x 1
Power Consumption	80 W in use 1 W in standby
Dimensions (W/H/D)	450 x 338 x 438 mm (17 <sup>3</sup> / <sub>4</sub> x 13 <sup>3</sup> / <sub>8</sub> x 17 <sup>1</sup> / <sub>4</sub> in.)
Mass	12 kg (26 lbs. 7 oz.)

### **KV-20FS12**

Screen size	Visible screen size: 20 inches (508 mm) measured diagonally Actual screen size: 21 inches (533 mm) measured diagonally
Inputs/outputs	2 video, 2 audio 1 headphone jack
Speaker output	3 W x 2
Power Consumption	115 W in use 1 W in standby
Dimensions (W/H/D)	512 x 475 x 493 mm (20 <sup>1</sup> / <sub>4</sub> x 18 <sup>3</sup> / <sub>4</sub> x 19 <sup>1</sup> / <sub>2</sub> in.)
Mass	24 kg (52 lbs. 15oz.)

Design and specifications are subject to change without notice.

# Index

## A

- Audio  menu 18
- Auto Program 13, 28
- Auto-SAP 18

## B

- Battery Installation 2
- Brightness 17

## C

- Cable 28
- Caption Vision 27
- Channel Fix 19
- Channel Label 19
- Channel Setup  menu 19
- Color 17
- Connections
  - Cable and antenna 3
  - Connecting a Camcorder 9
  - Connecting a DVD player 9
  - Connecting Headphones 10
  - TV and Cable Box 5
  - TV and Satellite Receiver 7
  - TV and VCR 4
  - TV, Satellite Receiver, and VCR 8
  - TV, VCR, and Cable box 6
- Current Time 26

## D

- Daylight Saving 26
- Demo 27

## F

- Favorite Channel 19







## H

- Hue 17

## L

- Language 27

## M

- Menus
  - Audio  18
  - Channel Setup  19
  - Parental Control  23
  - Setup  27
  - Timer  26
  - Video  17
- Mono 18
- MTS 18
  - Auto-SAP 18
  - Mono 18
  - Stereo 18

## O

- Options menu 28
- Overview of the Ratings 20

## P

- Parental Control 20
- Parental Control  menu 23
- Picture 17

## R

- Ratings 20
  - English Ratings 22
  - French Ratings 22
  - Movie Rating 21
  - TV Ratings 20
  - Unrated 21
  - U.S.A. Ratings 22
- Remote Control 11

## S

- Setup  menu 27
- Sharpness 17
- Specifications 31
- Stereo 18

## T

- Tilt Correction 28
- Timer  menu 26
- Timer 1 and Timer 2 26
- Troubleshooting 29
- TV Features 1

## V

- Video  menu 17
- Video Label 27
- VM 17











# PRINTING THE SERVICE MANUAL

The PDF of this service manual is not designed to be printed from cover to cover. The pages vary in size, and must therefore be printed in sections based on page dimensions.

## NON-SCHEMATIC PAGES

Data that does NOT INCLUDE schematic diagrams are formatted to 8.5 x 11 inches and can be printed on standard letter-size and/or A4-sized paper.

## SCHEMATIC DIAGRAMS

The schematic diagram pages are provided in two ways, full size and tiled. The full-sized schematic diagrams are formatted on paper sizes between 8.5" x 11" and 18" x 30" depending upon each individual diagram size. Those diagrams that are LARGER than 11" x 17" in full-size mode have been tiled for your convenience and can be printed on standard 11" x 17" (tabloid-size) paper, and reassembled.

### TO PRINT FULL SIZE SCHEMATIC DIAGRAMS

---

If you have access to a large paper plotter or printer capable of outputting the full-sized diagrams, output as follows:

- 1) Note the page size(s) of the schematics you want to output as indicated in the middle window at the bottom of the viewing screen.
- 2) Go to the File menu and select Print Set-up. Choose the printer name and driver for your large format printer. Confirm that the printer settings are set to output the indicated page size or larger.
- 3) Close the Print Set Up screen and return to the File menu. Select "Print..." Input the page number of the schematic(s) you want to print in the print range window. Choose OK.

### TO PRINT TILED VERSION OF SCHEMATICS

---

Schematic pages that are larger than 11" x 17" full-size are provided in a 11" x 17" printable tiled format near the end of the document. These can be printed to tabloid-sized paper and assembled to full-size for easy viewing.



If you have access to a printer capable of outputting the tabloid size (11" x 17") paper, then output the tiled version of the diagram as follows:

- 1) Note the page number(s) of the schematics you want to output as indicated in the middle window at the bottom of the viewing screen.
- 2) Go to the File menu and select Print Set-up. Choose the printer name and driver for your printer. Confirm that the plotter settings are set to output 11" x 17", or tabloid size paper in landscape (  ) mode.
- 3) Close the Print Set Up screen and return to the File menu. Select "Print..." Input the page number of the schematic(s) you want to print in the print range window. Choose OK.

### TO PRINT SPECIFIC SECTIONS OF A SCHEMATIC

---

To print just a particular section of a PDF, rather than a full page, access the Graphics Select tool in the Acrobat Reader tool bar.

- 1) To view the Graphics Select Tool, press and HOLD the mouse button over the Text Select Tool which looks like: . This tool will expand to reveal to additional tools. Choose the Graphics Select tool by placing the cursor over the button on of the far right that looks like: 
- 2) After selecting the Graphics Select Tool, place your cursor in the document window and the cursor will change to a plus (+) symbol. Click and drag the cursor over the area you want to print. When you release the mouse button, a marquee (or dotted lined box) will be displayed outlining the area you selected.
- 3) With the marquee in place, go to the file menu and select the "Print..." option. When the print window appears, choose the option under the section called "Print Range" which says "Selected Graphic".

Select OK and the output will print only the area that you outlined with the marquee. 

(continued >)

## ON-SCREEN SEARCH OPTION

All of the text within the service manual PDF is content searchable. This means that you can enter any text, word, phrase or reference number that appears in the manual, and the PDF software will search, find and move the cursor to the location where you requested text first appears. This feature can be particularly useful in locating components on a specific schematic or printed wire circuit board (PWB) diagrams.

Follow these steps to effectively locate a component on a schematic diagram:

- 1) Locate the schematic you want to search by clicking on the corresponding bookmark on the left side of the screen. The view on the right of the screen will then jump to the desired schematic page.
- 2) Magnify the diagram to at least 400% before conducting a component search. This will enable you to easily view the reference number when it is highlighted on screen. To do this, click on the magnifying glass button on the tool bar at the top of the screen. Move the cursor over the diagram and RIGHT click you mouse. Select the 400% magnification option on the pop-up menu. Click on the button with the icon of the open hand to deactivate the magnification tool
- 3) Search the diagram (or the entire manual) by clicking on the binocular button tool at the top of the screen. The "Find" window will appear and allow you to type in your desired text. Type in a reference designator, such as R502, and click on the "Find" button. If the component is not on the diagram, but is listed anywhere else in the manual, the cursor will jump to the first location the text is found in the file. To find another instance of that same text, click on the binocular button again and select "Find Again."