

ICF-SW100E/SW100S

AN-100

SERVICE MANUAL

Ver. 1.1 2005.11

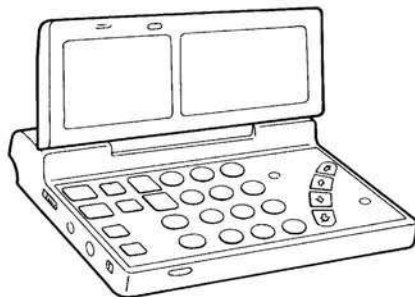

US Model
Canadian Model
Tourist Model
ICF-SW100S
AEP Model
E Model
ICF-SW100E/SW100S
UK Model
Australian Model
ICF-SW100E

• The ICF-SW100S and ICF-SW100E differ only in supplied accessories.

SPECIFICATIONS

Circuit system	FM: Superheterodyne SW/MW/LW: Dual conversion superheterodyne																				
Frequency range	<table border="1"><thead><tr><th>Band</th><th>Italy model</th><th>Saudi Arabia model</th><th>Other models</th></tr></thead><tbody><tr><td>FM</td><td>87.5–108.0 MHz</td><td>87.5–108.0 MHz</td><td>76.0–108.0 MHz</td></tr><tr><td>SW</td><td>3850–26100 kHz</td><td>1621–26100 kHz</td><td>1621–29999 kHz</td></tr><tr><td>MW</td><td>530–1620 kHz</td><td>530–1620 kHz</td><td>530–1620 kHz</td></tr><tr><td>LW</td><td>150–285 kHz</td><td>150–285 kHz</td><td>150–529 kHz</td></tr></tbody></table>	Band	Italy model	Saudi Arabia model	Other models	FM	87.5–108.0 MHz	87.5–108.0 MHz	76.0–108.0 MHz	SW	3850–26100 kHz	1621–26100 kHz	1621–29999 kHz	MW	530–1620 kHz	530–1620 kHz	530–1620 kHz	LW	150–285 kHz	150–285 kHz	150–529 kHz
Band	Italy model	Saudi Arabia model	Other models																		
FM	87.5–108.0 MHz	87.5–108.0 MHz	76.0–108.0 MHz																		
SW	3850–26100 kHz	1621–26100 kHz	1621–29999 kHz																		
MW	530–1620 kHz	530–1620 kHz	530–1620 kHz																		
LW	150–285 kHz	150–285 kHz	150–529 kHz																		
Intermediate frequency	FM: 10.7 MHz SW/MW/LW: 55.845 MHz (first), 455 kHz (second)																				
Speaker	Approx. 40 mm (1 7/8 inches) dia, 8 ohms																				
Power output	250 mW (at 10 % harmonic distortion)																				
Outputs	Recording output jack (stereo minijack) output level 245 mV (–10 dBs) output impedance 10 kilohm or less Headphones jack (stereo minijack) 16 ohms																				
Power requirements	3 V DC Two R6 (size AA) batteries AC power adaptor AC-E312: 120 V, 60 Hz (for USA model) AC-E314: 100–240 V, 50/60 Hz (for Canada model) AC-E311/E313: 100–240 V, 50/60 Hz (for other models) Optional DCC-E130L car battery																				
Battery life	Using Sony SUM-3 (NS) batteries: FM: approx. 12 hours, AM: approx. 9 hours Using Sony AM-3 (N) alkaline batteries: FM: approx. 23 hours, AM: approx. 18 hours (When listening for four hours a day at normal volume)																				

Dimensions	Approx. 110.6 × 23.5 × 72.6 mm (w/h/d) (4 3/8 × 15/16 × 2 7/8 inches) including projecting parts and controls
Mass	Approx. 220 g (7.8 oz) including batteries
Accessories supplied	ICF-SW100S: Stereo headphones (1) AC power adaptor (1) AC plug adaptor (1) Active antenna (1) Suction cup (1) Carrying case (1) Wave handbook (1) ICF-SW100E: Stereo headphones (1) Compact antenna (1) Carrying case (1) Wave handbook (1)

Note

This appliance conforms with EEC Directive 87/308/EEC regarding interference suppression.

Design and specifications subject to change without notice.

**FM STEREO/SW/MW/LW
PLL SYNTHESIZED RECEIVER**

FEATURES

- An FM stereo/SW/MW/LW receiver with worldwide band coverage.
- Quartz controlled PLL (Phase Locked Loop) synthesizer system using a microcomputer for easy pinpoint tuning. The tuned frequency is digitally displayed.
- FM stereo reception for headphones.

Worldtime clock	Finding out the time anywhere in the world by selecting only the city name.
Preset tuning	Tuning in a preset station by selecting the name of the station. Up to 5 stations in every 10 paged memories can be preset for button-touch tuning.
Direct tuning	Tuning in the station by inputting the frequency of the station directly
Manual tuning	Even if you don't know the frequency of the station, you can tune in the station precisely.
Scan tuning	Automatic searching of a station
Editable label	Naming preset stations and one time zone with 6 characters.
Timer standby	Receiving a desired station at the desired time.
Sleep timer	Turning the radio off automatically in 60 minutes.
Power sources	Three different power sources: internal batteries, house current, car batteries.

The ICF-SW100S and ICF-SW100E differ only in supplied accessories. Sold type might be different from country to country.

The ICF-SW100S system includes the following components.

- FM stereo/SW/MW/LW PLL synthesized receiver ICF-SW100
- AC power adaptor: AC-E311 for the Saudi Arabia model, AC-E313 for the other models
- AC plug adaptor
- Active antenna AN-100
- Stereo headphones
- Carrying case

The ICF-SW100E system includes the following components.

- FM stereo/SW/MW/LW PLL synthesized receiver ICF-SW100
- Compact antenna AN-71 (supplied only for the Saudi Arabia model)
- Stereo headphones
- Carrying case

TABLE OF CONTENTS

<u>Section</u>	<u>Title</u>	<u>Page</u>
1. GENERAL		
	Location and Function of Controls	3
	Power Sources	4
	Setting the Clock	4
	Tuning in by Selecting a Preset Station Name	5
	Direct Tuning	6
	Manual Tuning	6
	Scan Tuning	7
	Prestting a Station	7
	Editing Labels	8
	Using the Standby Function	8
	Using the Sleep Timer	9
	For Better SW/MW/LW Reception	9
	Recording Radio Programs	10
2. DISASSEMBLY		
2-1.	Chassis	11
2-2.	Cabinet (Rear) (Lid)	11
3. ELECTRICAL ADJUSTMENTS		12
4. DIAGRAMS		
4-1.	IC Pin Functions	
	• IC102 μ PD1724GB-599-1A7 (PLL SYNTHESIZER CONTROL)	15
	• IC603 MSM64164C-029 (MAIN SYSTEM CONTROL)	16
	• IC604 MSM64164C-030 (SUB SYSTEM CONTROL)	17
4-2.	Block Diagram	18
4-3.	Semiconductor Lead Layouts	21
4-4.	Schematic Diagram	
	— ACTIVE Antenna (AN-100) Section —	23
4-5.	Printed Wiring Board	
	— ACTIVE Antenna (AN-100) Section —	25
4-6.	Printed Wiring Board — Tuner Section —	28
4-7.	Schematic Diagram — Tuner Section	31
4-8.	Schematic Diagram — Control Section —	34
4-9.	Printed Wiring Board — Control Section —	37
5. EXPLODED VIEWS		
5-1.	MAIN Section	39
5-2.	Active Antenna (AN-100) Section	40
6. ELECTRICAL PARTS LIST		41

Location and Function of Controls

Refer to the pages indicated () in for details

Front

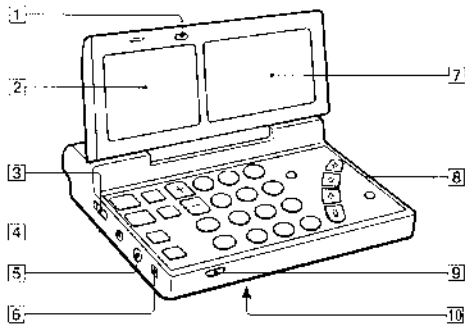

- 1 LIGHT button
Press this button to illuminate the display window for about 15 seconds
- 2 Speaker
- 3 MAIN POWER ON/OFF switch
Set this switch to ON when using this radio. Set the switch to OFF when carrying the radio to prevent draining the power on accidentally
- 4 DC IN 3V (external power input) jack (49)
- 5 ACTIVE ANT jack (49)
- 6 SENS DX/LOCAL (FM/AM sensitivity) selector (56)
- 7 Display
- 8 Control panel
- 9 PUSH OPEN button
It is a tapped hole on the bottom. Fasten or unfasten the screw at the carrying case with a coin.

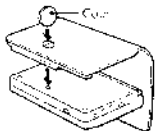

Rear

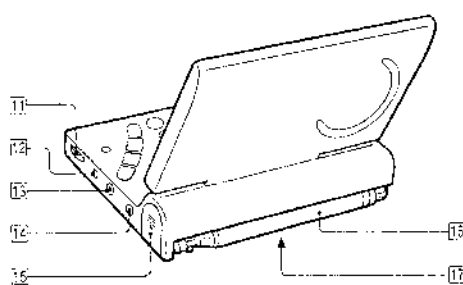

- 11 VOL (volume) control
- 12 AM TONE/FM MODE switch
In AM band, works as a tone selector
In FM band, works as a mono/stereo selector
- 13 LINE OUT (recording output) jack (72)
- 14 (headphones) jack
When the stereo headphones are plugged in, no signal comes from the speaker. You can listen FM stereo
- 15 Battery compartment (48)
- 16 Telescopic antenna (55)
- 17 RESET button
There is a button in the small hole. Press this button with a pointed object when the unit functions incorrectly because of an electric discharge caused by static electricity, etc. When this button is pressed, the preset stations are permanently retained.

Location and Function of Controls

Control panel

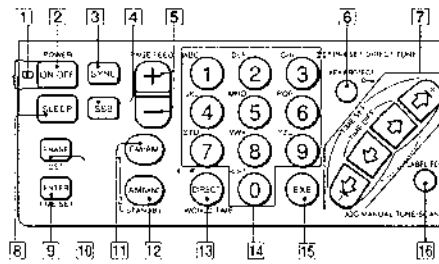

- 1 Main power indicator
- 2 POWER ON/OFF button
- 3 SYNC button
- 4 SSB button (not applied for the Saudi Arabia model)
- 5 PAGE FEED +/- buttons
- 6 KEY PROTECT button
- 7 JOG/MANUAL TUNE/SCAN buttons
- 8 SLEEP button
- 9 ENTER/TIME SET button
- 10 ERASE/DST button
- 11 FM/AM/STANDBY 1 button
- 12 AM BAND/STANDBY 2 button
- 13 DIRECT/WORLD TIME button
- 14 PRESET/DIRECT TUNE buttons
- 15 EXE (execute) button
- 16 LABEL EDIT button

Display

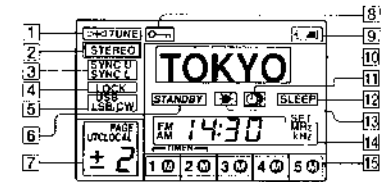

- 1 Tuning indicator
Appears when a station is tuned in
- 2 STEREO indicator
Appears when a stereo program is tuned in
- 3 SYNC U/L (SYNC mode) indicators
- 4 LOCK (SYNC lock) indicator
Appears when the synchronous detection is performed
- 5 USB/LSB/CW (SSB mode) indicators (not applied for the Saudi Arabia model)
- 6 STANDBY indicator
Appears when the standby timer is reserved
- 7 Memory page/time difference display
- 8 Key protect indicator
While this indicator appears, all the functions of the buttons are locked
- 9 Battery empty indicator
- 10 Label display
Names of the preset stations, cities, broadcast bands, or meter bands are displayed
* When the name of a preset station is displayed, frequency is displayed when the name is not preset.
* When the meter band descriptor is displayed
- 11 World time indicator
Appears when a world time is displayed
- 12 SLEEP indicator
Appears when the sleep timer is operating
- 13 DST indicator
Appears when the daylight saving time (summer time) is specified
- 14 Time/frequency display
- 15 Preset memory indicators

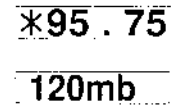

Power Sources

Installing Batteries

Install two R6 (size AA) batteries with correct polarity.

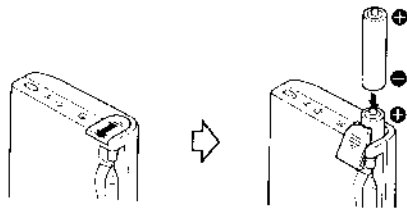

House Current

Use the AC-E311/E313 AC power adaptor (supplied only for the ICJ-SIV1005).

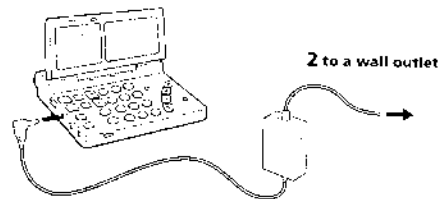

1 to DC IN 3V jack

2 to a wall outlet

12V Car Battery

For use on 12 V car battery, connect the Sony DCC FE30 car battery cord (optional) to the DC IN 3V jack.

Note on the lid of the battery compartment
Do not open the lid for a long time. It cannot be fully opened as illustrated.

Note
When the batteries are removed for a long time, the clock and timer settings will be erased. In this case, set them again.

Battery replacement

When the batteries are exhausted, the sound becomes weak or distorted and the LCD indication flashes in the display. To place all the batteries with new ones, when the batteries run down completely, the power is turned off and the LCD indication flashes.

- When removing the batteries, the LCD indication starts flashing. Replace the batteries within ten minutes.
- Otherwise, the current time and the timer settings will be erased. However, the present status will not be erased.
- For battery life, see "Specifications".

Notes

- The AC power plug cannot be inserted in the wall outlet, use the supplied AC plug adaptor.
- The internal batteries are automatically disconnected when the AC power adaptor and/or car battery cord is connected to the DC IN 3V jack.
- After using the AC power adaptor or the car battery cord, disconnect the DC IN 3V jack first. When the cord is connected to the DC IN 3V jack, the radio does not operate by the internal batteries.
- Keep the battery essential for the built-in computer backup and you can use the external power sources. However, replace the battery once a year because they are discharging gradually.

Use only the resin model AC power adaptor or car battery cord manufactured by Sony. The polarity of the plug of other model adaptor may be different.

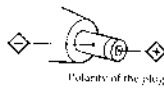

Polarity of the plug

Setting the Clock

Set the time when the radio is turned off.

Local time means the time in your area and world time means the time in a certain place in the world.

Setting the Local Current Time

The current time is set for the local time.

Before setting the clock, check the time difference between the local time in your area and the UTC (Universal Time Coordinated) time by referring to the table on page 52. Major city names and their time difference from the UTC are already memorized at the factory.

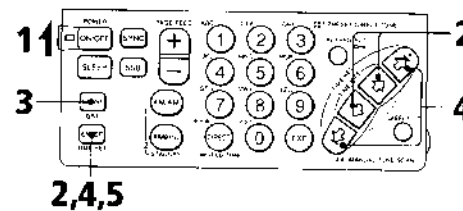

1 Set MAIN POWER ON/OFF to ON.

When you first install batteries or reset the clock, "0.00" flashes in the display. Press TIME SET.

2 While holding down TIME SET, press inner buttons of JOG/MANUAL TUNE/SCAN until your city name or the time difference between your local time and the UTC time appears in the display.



When even the world time indicator is displayed, the local time is specified by pressing TIME SET.

3 When daylight saving time (summer time) is not used in your area or DST is already displayed, skip this step.

Press DST if your area is now under daylight saving time. DST appears in the display.

4 While holding down TIME SET, press outer buttons of JOG/MANUAL TUNE/SCAN to adjust the clock to the current local time. Every pressing JOG/MANUAL TUNE/SCAN changes the time setting by one minute. To advance the three digits rapidly, keep JOG/MANUAL TUNE/SCAN pressed.

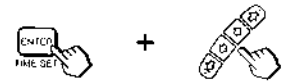

5 Release TIME SET

The " " indication starts flashing, and the clock begins to operate.

While listening to the radio
You cannot set the clock when you are listening to the radio. To set the clock, press POWER ON/OFF to turn the radio off and then set the clock.

The display when MAIN POWER ON/OFF is OFF
The screen here is displayed.

Zero second adjustment

If you want to adjust the time exactly to the second with a telephone time signal, proceed as in the following example.

Example: To set to 19:15

- Adjust the time indication to "9:15" in step 4 above, and stop TIME SET.
- Release TIME SET simultaneously with the telephone time signal. The clock will operate showing the present time.

For Areas Where Daylight Saving Time (Summer Time) Is Used

Press DST during the summer time period. DST appears in the display. Press DST again at the end of the summer time. The time indication will be changed automatically. When the clock has been set during the standard time period, press DST at the beginning of the daylight saving time. The time indication will change to the daylight saving time indicator.

Setting the Clock

Time Difference Between Local Time and UTC (Universal Time Coordinated)

The table shows the difference between the local time and the UTC time in each area. The differences marked with a plus sign (+) indicate the number of hours ahead of the UTC. The differences marked with a minus sign (-) indicate the number of hours behind the UTC.

To see the time difference during the period for daylight saving time (summer time) if necessary, add one hour to the difference indicated in the table.

Time difference	Label/Preset	City or area	Other cities in the area	kHz auto scan step
± 0	LONDON CELEST	London	Lisbon	9 kHz
+ 1	CELEST	Central Europe	Amsterdam, Berlin, Brussels, Madrid, Paris, Rome, Stockholm, Vienna, Zurich	
+ 2	CAIRO	Cairo	Algiers, Istanbul	
+ 3	JERUSALEM	Jerusalem	Nairobi, Riyadh, Moscow	
+ 4	DUBAI	Dubai		
+ 5	REKACTI	Rangoon		
+ 6	INDIA-A	Dhaka/Thailand		
+ 7	BANGKOK	Bangkok	Tokyo, Beijing, Hongkong	
+ 8	SINGAPORE	Singapore	Seoul	
+ 9	TOKYO	Tokyo	Guang	
+ 10	SYDNEY	Sydney		10 kHz
+ 11	SUN MON	Solomon	Niue	
+ 12	AUCKLAND	Auckland		
+ 13	SAMOA	Samoa		
+ 14	HAWAII	Hawaii	Honolulu, Tahiti	
+ 15	ANANTING	Ananting		
+ 16	L.A.	Los Angeles	San Francisco, Vancouver	
+ 17	DENVER	Denver	Calgary	
+ 18	DALLAS	Dallas	Mexico	
+ 19	N.Y.	New York	Lima, Panama, Toronto	
+ 20	SARAGO	Sarago		9 kHz
+ 21	RIO	Rio de Janeiro	Buenos Aires, Sao Paulo	
+ 22	ENISE	Enise		
+ 23	AZORES	Azores Island		

* Max. 8 characters

Finding Out the Current Time in Some Place in the World

When the radio is off, you can find out the time in some other place in the world.

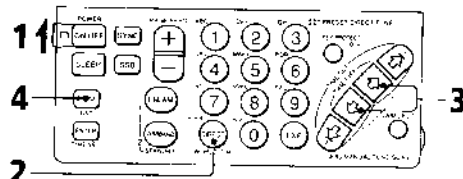

- 1 Set the MAIN POWER ON/OFF to ON.
- 2 When the LOCAL time indication is displayed, Press WORLD TIME to display the world time indication.
- 3 Press the inner buttons of JOG/MANUAL TUNE/SCAN until the desired city name or the time difference between desired place and the UTC appears.
- 4 When daylight saving time (summer time) is not used in the desired place or DST is already displayed, skip this step. Press DST if the desired place is now under daylight saving time. DST appears in the display.

Tuning in by Selecting a Preset Station Name

Once the frequencies of the stations are preset, you can tune in the station easily just by selecting the memory page and pressing the desired preset button.

Up to 50 stations of either FM or AM, 5 stations for every 10 pages, can be preset. Some stations are already preset in this unit at the factory. Let's try to receive some of the preset stations.

To preset the stations, go on to the next section to learn how to tune in a station by direct, manual or scan tuning and read the "Presetting a Station (page 62)" and "Editing Labels (page 64)".

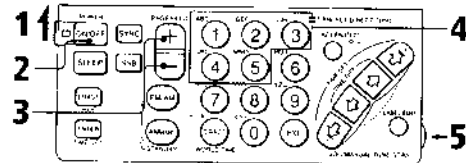

- 1 Set MAIN POWER ON/OFF to ON.
- 2 Press POWER ON/OFF.
- 3 Select the desired memory page by pressing PAGE FEED +/- . When you select memory page 1, beeps sound.
- 4 Press the desired PRESET/DIRECT TUNE button 1 to 5. The station preset on that button will be tuned in.
- 5 Adjust VOL (volume).
To turn off the radio, press POWER ON/OFF.

Ex. When selecting AM 5975 kHz on button 1 of page 0



The illustration does not necessarily show the preset memory or station.

To check your presetting

Turn it on and use a preset station. The preset label and frequency of the preset station is displayed. You can also edit the preset label of the preset stations. (See page 64.)

To Improve Reception

For MW/LW reception

Retract the telescopic antenna. The built-in ferrite bar antenna activates. Since this antenna is directional, rotate the unit horizontally for optimum direction.



For SW reception

Pull out the telescopic antenna to its full length and set it vertically.

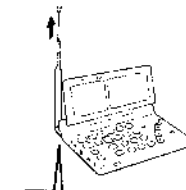

For FM reception

pull out the telescopic antenna to expose its swivel base and adjust its length, angle and direction.

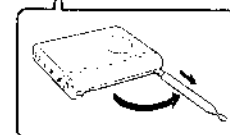
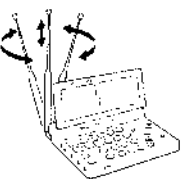

Direct Tuning

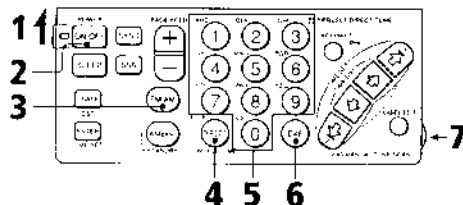

Examples

FM 97.5 MHz

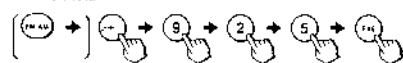

AM 1242 kHz

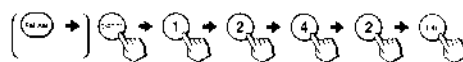

AM 1000 kHz



AM 2100 kHz

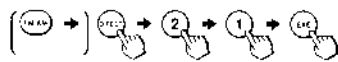

Note

After pressing a button, press the next button within 10 seconds. If you do not, the display will return to the previously received station.

If you input a wrong frequency

Press **DIRECT** to cancel the entry, and perform the above procedure from step 4 with the correct frequency.

When the sound is distorted

Normally, set **SENSE** to **DX**. However, when the sound is distorted, set it to **TX AT**.

On AM TONE selector

Set **AM TONE** to **NEWS** when you tune in a station clearly. When you are listening to music, set **AM TONE** to **TX AT** for better sound work in FM band.

On FM MODE selector (only for listening through stereo headphones)

For FM reception, the way to set **FM MODE** to **STEREO**. When it is set to **MONO** (automatically), the reception will be better than when set to **STEREO**. However, when you listen to music, set it to **MONO** (automatically). The reception will be better than when set to **STEREO**. In this mode, there is no stereo effect.

To Prevent Accidental Change of the Received Station

Press **STATION LOCK** (LOCK) to lock the frequency in the display window and to prevent accidental change of the received station.
To release the key-locked function, press **KEY PROMPT** (PROM) again.

Manual Tuning

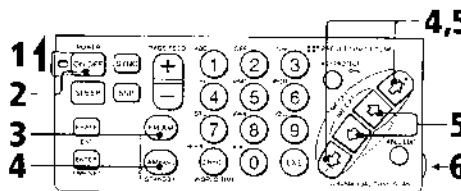

- 1 Set **MAIN POWER ON/OFF** to **ON**.
- 2 Press **POWER ON/OFF**. The radio is turned on.
- 3 Press **FM/AM** to select the band (FM or AM).
- 4 If you select the FM band, skip this step. **While pressing the AM BAND, press the outer buttons of JOG/MANUAL TUNE/SCAN repeatedly** to select the desired band or meter band.

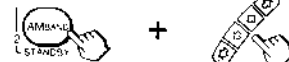

The minimum frequency in the band or meter band is received.

- 5 Press an **outer or inner button of JOG/MANUAL TUNE/SCAN** to search for a desired station. Pressing the outer or inner buttons changes the frequency in the following frequency step.

Band	Outer buttons	Inner buttons
FM	50 kHz	50 kHz
SW	3 kHz	1 kHz
MW	9/10 kHz	1 kHz
LW	3 kHz	1 kHz
SSB/AM	1 kHz	0.1 kHz

When the station is tuned in, the tuning indicator appears in the display.

- 6 Adjust **VOL**(volume).

To turn off the radio, press **POWER ON/OFF**.

What is a meter band?

SW is divided into 13 bands by the wave length (meter). Each band is called a meter band. (See the table on page 63.)

Frequency band does not change

If you keep pressing **JOG/MANUAL TUNE/SCAN**, the frequency will repeat in the following ranges.

Band	Inner buttons	Outer buttons
FM	87.5 ~ 107.9 MHz	87.5 ~ 108 MHz
AM	150 kHz ~ 2999.9 kHz	150 kHz ~ 2999.9 kHz

** See tuning mode.

** All frequencies are for the Saudi Arabia model.

** For the Saudi Arabia model.

To Receive the SSB (Single Side Band) (not available for the Saudi Arabia model)

Press **SSB** repeatedly while the radio is on.

Every press changes the display as follows.

(Normal) → USB → LSB → CW

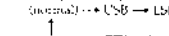

What is SSB?

SSB is very popular among ham and business radio users, and will be found on all of the station bands because of its signal intelligibility. In general, SSB transmissions employ USB modulation, and for amateur bands lower than 13.6 MHz, LSB is often used.

What is CW (Continuous Wave)?

CW is also popular among ham and business radio users. In CW transmission, the amplitude of a carrier is not modulated, while that of other systems is modulated. CW conveys information by interrupting a carrier using Morse code. It can be heard as a beat sound only with the unit equipped with the BFO circuit. To understand the information transmitted by CW, you need to learn the Morse code.

To Receive the SYNC (Synchronous Detection)

Press **SYNC** repeatedly while the radio is on.

Every press changes the display as follows.

(Normal) → SYNC L → SYNC R



When the synchronous detection is locked, "LOCK" and station appears in the display.

What is synchronous detection?

There are two big problems in AM reception: distortion due to fading and interference from adjacent stations. The synchronous detection is effective in solving these problems. Distortion due to fading is caused by over-modulation, which occurs when a carrier component of the received signal is attenuated or the wave. In this receiver, a pure carrier frequency with the level variation perfectly synchronized with the original carrier is generated in the synchronous detector circuit and is mixed with the received signal to compensate the attenuated carrier component. In this way, if station is remarkably received. On the other hand, AM (SW, MW, and LW) broadcasting generally uses double-sideband transmission, in which modulated signals are transmitted using both the upper and lower sidebands (USB and LSB). In most cases, one sideband is affected by interference from adjacent stations (station). In the synchronous detector circuit, one of LSB and USB can be received. Thus, the clear reception without interference from adjacent stations.

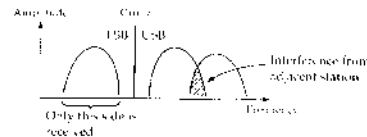

Scan Tuning

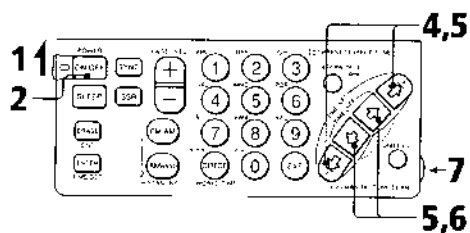

- 1 Set **MAIN POWER ON/OFF** to **ON**.
- 2 Press **POWER ON/OFF**.
- 3 Receive a **broadcast band** by way of direct tuning or manual tuning. (Refer to the table on page 61 for the frequency range of each broadcast band.)
- 4 Keep pressing one of outer buttons of **JOG/MANUAL TUNE/SCAN** for about 2 seconds. "SCAN" will appear in the label display and scan tuning will begin within the frequency range of the table on page 61. When a station is received, the scanning will stop automatically for about 2 seconds and the tuning indicator appears in the display.
- 5 Press one of **JOG/MANUAL TUNE/SCAN** again to listen to the station being received. The scan tuning stops and the station being received is tuned in.
- 6 Tune in the station more precisely by inner buttons of **JOG/MANUAL TUNE/SCAN**.
- 7 Adjust **VOL (volume)**.

To turn off the radio, press **POWER ON/OFF**.

The Frequency Range of the Auto Scan for Each Broadcast Band

Broadcast band	Frequency range	SW meter band
LW	150 kHz - 624 kHz ¹⁾	—
	576 kHz - 1620 kHz	—
MW	531 kHz (step) ²⁾	—
	531 kHz - 1620 kHz	—
AM	2250 kHz - 2580 kHz	12 meter band
	3150 kHz - 3480 kHz	90 meter band
	3850 kHz - 4050 kHz	75 meter band
	4700 kHz - 5100 kHz	60 meter band
	5900 kHz - 6250 kHz	48 meter band
	7100 kHz - 7400 kHz	41 meter band
	9400 kHz - 10900 kHz	31 meter band
	11500 kHz - 12150 kHz	25 meter band
	13500 kHz - 15900 kHz	22 meter band
	15000 kHz - 15700 kHz	19 meter band
SW	17450 kHz - 18000 kHz	16 meter band
	21400 kHz - 21950 kHz	13 meter band
	25600 kHz - 26100 kHz	11 meter band
	—	—
FM	76.00 MHz - 108.00 MHz ³⁾	—

- 1) 150 - 285 kHz for the Saudi Arabia model
- 2) The frequency range is different according to the channel step which is linked to the Local Time
- 3) 87.50 - 108.00 MHz for the Saudi Arabia model

Presetting a Station

Once the frequencies of the stations are preset, you can tune in the station easily just by selecting the memory page and pressing the desired preset button (page 54).
Some stations are already preset in this unit at the factory.

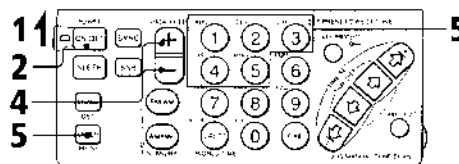

Ex. To preset FM 95.75 MHz on button 1 of page 3

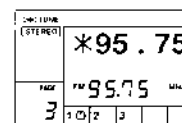

- 1 Set **MAIN POWER ON/OFF** to **ON**.
- 2 Press **POWER ON/OFF**.
- 3 Tune in a **desired station** by way of direct tuning (see page 56), manual tuning (see page 58) or scan tuning (see page 60).
- 4 Press **PAGE FEED +/-** to display a **desired memory page** from 0 to 9. When you select memory page 1, beeps sound.
- 5 While keeping **ENTER** pressed, press one of the **PRESET/DIRECT TUNE** buttons 1 to 5.
The desired station is preset on that button. The preset number and O^* mark appears in the display and the frequency with an asterisk "*" is displayed as the label.

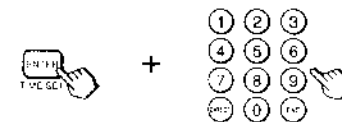

The number of stations you can preset
Up to 50 stations of each FM or AM. 5 stations for every 10 pages can be preset in PRESET/DIRECT TUNE button 1 to 5.

To check your presetting
Tune in a desired preset station (see page 54). The preset label and frequency of the preset station is displayed. You can also see the preset label or the preset station (see page 64).

To change the preset station
Press a button to the desired PRESET/DIRECT TUNE button 1 to 5 of the desired memory page. The station preset on that button is erased.

To erase the preset station
1 Select the desired memory page by pressing **PAGE FEED +/-**.
2 While pressing **FRAME**, press a desired **PRESET/DIRECT TUNE** button 1 to 5 which you want to erase. The preset number and O^* mark on the preset memory display are disappearing. The station preset to that button is erased. The label displayed is restored and you can change the preset once restored.

The frequency allocation (channel step)
LW: 3 kHz
MW: 9 kHz (10 kHz)
SW: 5 kHz
FM: 50 kHz

When scan tuning stops too often
SENSITIVITY LOCAL

Frequency band does not change
If you don't stop scanning, the scanning will repeat in the range of the broadcast band or meter band (see the above table).

Editing Labels

You can edit the label (up to 6 characters) of the preset stations or one of the time difference.

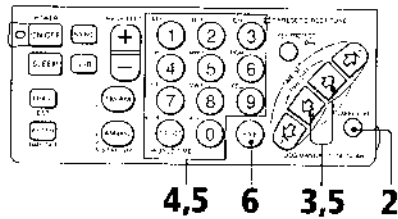

- 1 Display the label you want to edit** by way of the preset tuning (see page 54) or the world-time clock (see page 53).
- 2 Press LABEL EDIT**. The first character of the label flashes.
- 3 Press the inner buttons of JOG/MANUAL TUNE/SCAN** to move the cursor to the character which you want to edit.
- 4 Press the desired PRESET/DIRECT TUNE button to enter the character**. The characters appear left of each PRESET/DIRECT TUNE button shows the character which is entered by pressing the button. Every press of the button changes the character as follows. Ex: Pressing the PRESET/DIRECT TUNE 1

A	B	C
←	→	→

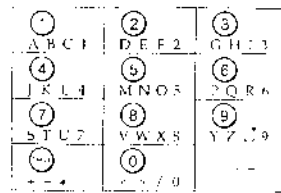

- 5 Fix all characters** of the label which you want to edit. During editing characters, you should press a button within 15 seconds after pressing the precedent button.
- 6 Press EXE**. Beep sounds and the displayed characters are preset as the label.

When the flashing of the character stops
This occurs when you have not pressed any button within 15 seconds during editing characters. Press LABEL EDIT again.

To interrupt the editing
Press LABEL EDIT.

To preset a station with the label
When a mark is displayed at the preset memory display, you can preset a file (the site) by page 53.
You can also press LABEL EDIT together with the frequency when presetting a station within the following procedure.
1 Time-out as described on page 53 (see page 54 for manual tuning, see page 54 for scan tuning, see page 54).

2 Enter the file by the above step 1 and 2.
3 Preset the station by the step 1 and 2 in the "Presetting a station" page 53. The label displayed will be stored in memory by the world time frequency.

When you edit a label of time difference
1 You can edit the label of the time difference and return to the normal label.

Using The Standby Function

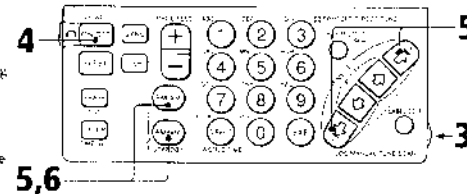

- 1 Preset the station which you want to listen to at the desired time to the PRESET/DIRECT TUNE 1 or 2 of page 0**. The station preset to preset 1 is for standby 1 and preset 2 for standby 2.

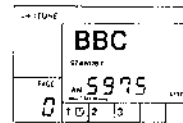

- 2 Tune in the desired preset station which is preset in the step 1.**
- 3 Adjust VOL (volume).**
- 4 Press POWER ON/OFF**. The radio will be turned on.

- 5 Set the time by pressing outer buttons of JOG/MANUAL TUNE/SCAN while keeping STANDBY 1 or STANDBY 2 pressed**. The STANDBY indicator and "SET" flash in the display while pressing STANDBY 1 or STANDBY 2.

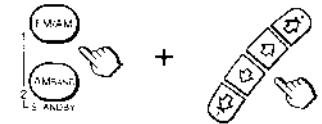

Ex: Setting 7:15 to STANDBY 1

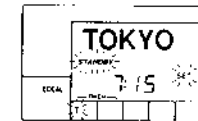

When the world time is displayed, the time display automatically changes to the local time. If you keep a JOG/MANUAL TUNE/SCAN pressed, the time will change continuously.

6 Stop pressing STANDBY 1 or STANDBY 2. The current time appears in the display, and the STANDBY indicator will continue to be displayed.

When you set the standby time
Preset station in the radio. You can also set the standby time with a time difference to the radio.

To cancel the standby mode
When you press STANDBY 1 or STANDBY 2, you can cancel the standby mode. Press the JOG/MANUAL TUNE/SCAN button.

When you are listening to the radio at the preset time
The frequency will change to the preset time by the world time frequency.

When the radio is turned on at the standby time
The radio will be turned on automatically at the preset time.

When no frequency is preset to the appropriate preset button
When the preset time has not been preset, the time will not be preset. The time will be preset to the preset time.

Once you preset the standby time
The radio will be turned on at the preset time.

You can set both the standby 1 and 2 at a time
When the standby time is set, during the other standby works, the time standby will work with the appropriate frequency.

If you set standby 1 and 2 to a same desired time
Only the standby 1 will work.

When you use the standby function abroad
Since the standby time is set at the local time, set the place you stay as the local area before pressing the standby time.

To check the preset standby time
Press STANDBY 1 or 2. When you have the radio on, standby 1 or 2 press STANDBY 1 or 2 again to display the preset standby time.

To change the preset standby time
Set the desired standby time and the time previously set is erased.

Using the Sleep Timer

Before using the sleep timer, set the clock (see page 50).

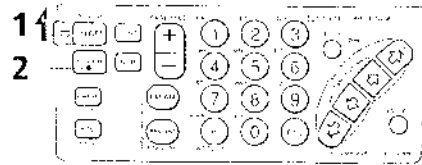

- 1 Set **MAIN POWER ON/OFF** to **ON**.
- 2 Press **SLEEP**.
The function is turned on. The **SLEEP** function appears on the display.
- 3 Tune in the desired station and adjust the volume.
The radio will be turned off automatically after a set amount of time.

For Better SW/MW/LW Reception

Using the Active Antenna AN-100 (supplied for ICF-SW100S)

When using the active antenna, collapse the telescopic antenna.

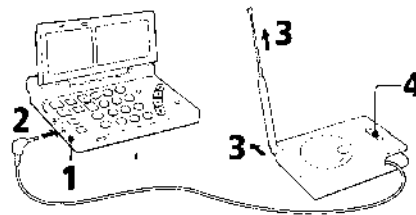

- 1 Set **SENS** of the radio to **DX**.
- 2 Pull out the output cable from the active antenna and plug it into the **ACTIVE ANT** jack.
- 3 Extend the telescopic antenna of the active antenna.
- 4 Set **AM BPF FREQ** to **WIDE**. When the sound is distorted, set it to a suitable frequency range.
- 5 Turn on the radio and tune in the desired station.

It is also possible to set the antenna module on the floor.

For Better SW/MW/LW Reception

Using the SW Compact Antenna AN-71 (supplied only for the Saudi Arabia model ICF-SW100E)

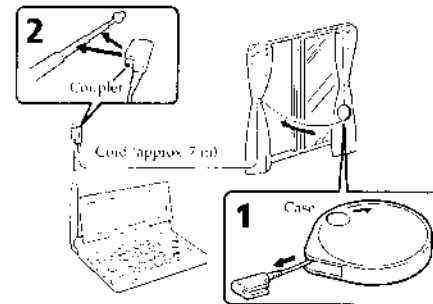

- 1 Fully pull out the cord from the case.
- 2 Attach the coupler to the telescopic antenna.
- 3 When the window can be opened: Extend the cord and the case out through the window, after making sure there is no danger.
When the window cannot be opened: Fully extend the cord along the frame of the window.

Using the Wide Range Antenna (not supplied)

Use the wide range antenna AN-1 or AN-102 (not supplied). There are following two methods.

Method A (for SW reception)

With a connecting cord, connect the **OUTPUT** jack of the antenna controller (supplied with the AN-1 or AN-102) and the **ACTIVE ANT** jack of the ICF-SW100.

Method B (for MW/LW reception only)

- 1 With the connecting cord, connect the **OUTPUT** jack of the antenna controller and the **INPUT** jack of the antenna coupler (supplied with the AN-1 or AN-102).
- 2 Put the antenna coupler near the ICF-SW100.

Example: When the AN-1 is used.

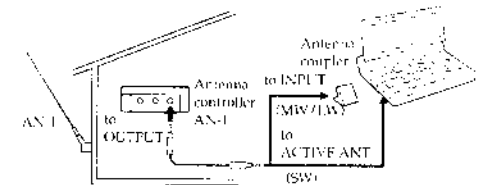

To turn off the radio before the sleep time:
Press **POWER ON/OFF**.

When you press **SLEEP** while listening to the radio:
The radio will be turned on again with the same station and volume.

To prolong the listening time:
To extend the listening time, set the alarm at a later time.

If you press **SLEEP** after the radio is turned off:
To extend the listening time, set the alarm at a later time.

Note
Connect only the antenna recommended in the manual to the **ACTIVE ANT** jack. Do not connect any other type, since power (DC, SW) is supplied to this jack for the special antennas.

After use
1 Collapse the telescopic antenna.
2 Roll up the output cable.

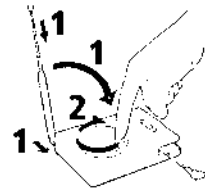

After use



Notes

- When receiving MW or LW broadcasts in urban areas, be sure to disconnect a SW external antenna (when using a car antenna) to avoid the possibility of a radio fire or antenna damage.
- Do not plug the antenna into the wire of an external antenna and connect to AC power adapter to connect to the radio.

- When using a switch antenna, connect the telescopic antenna.
- Use the antenna antenna as far away from the street as possible.
- For details about the antenna, refer to the instruction manual.

Recording Radio Programs

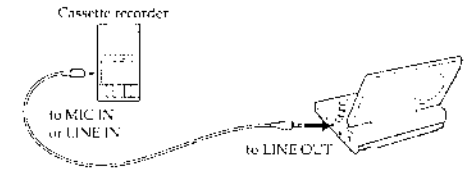

Cassette recorder		
Type	Jack	Connecting cable
Monoaural	MIC IN (4mm jack)	RK-G135
	MIC IN (6mm jack)	RK-G134
Stereo	LINE IN (6mm jack)	RK-G136
	LINE IN (4mm jack)	RK-G129

Turn to a desired radio program and set the cassette recorder to the record mode.

Note
The VOLUME control setting on the radio has no effect on the recording.

Stereo recording
When connected with a stereo cassette, FM stereo programs are recorded in stereo and AM programs are recorded monoaurally in both channels.



SECTION 2 DISASSEMBLY

NOTE: Follow the disassembly procedure in the numerical order given.

2-1. CABINET (REAR) (LID)

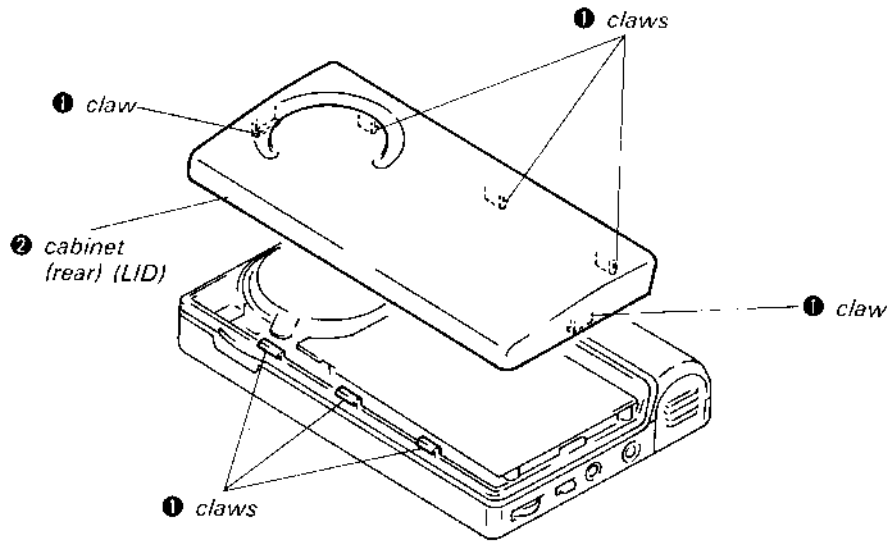

2-2. CHASSIS

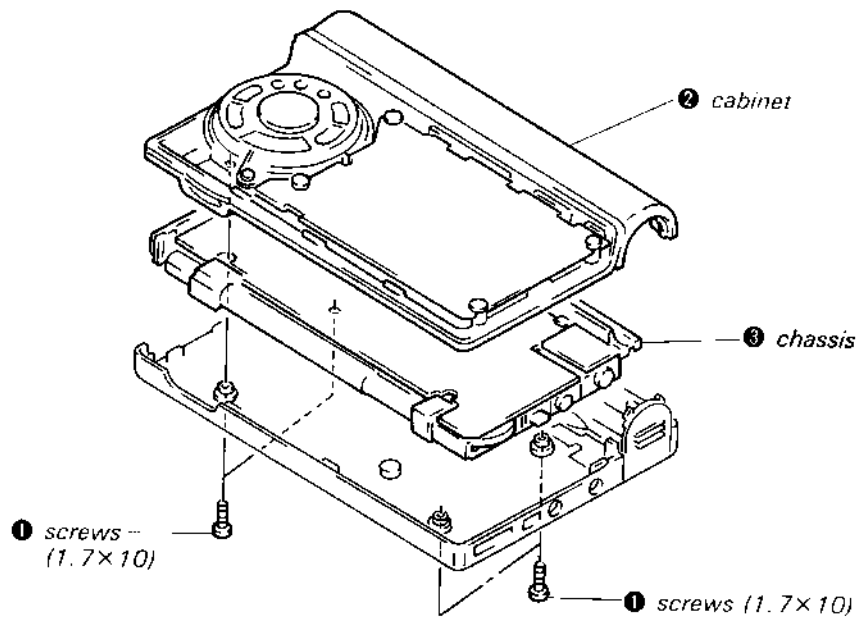

SECTION 3 ELECTRICAL ADJUSTMENTS

- Parts location diagram relevant to the adjustment

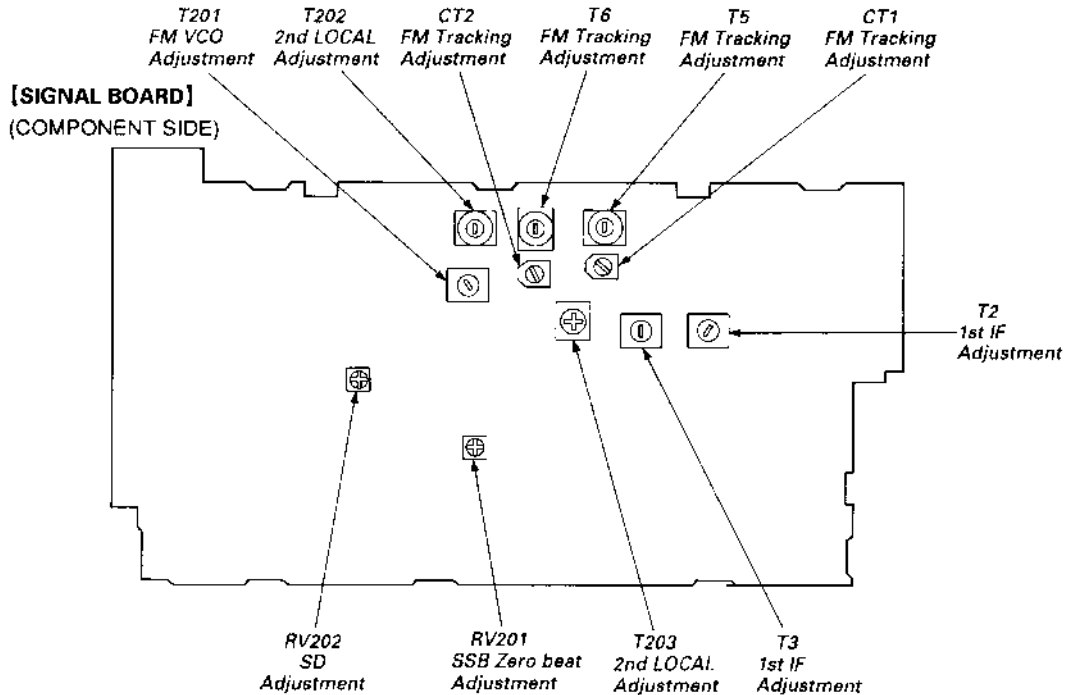

• AM SECTION 2nd LOCAL ADJUSTMENT

Setup:

VOLUME control: as required

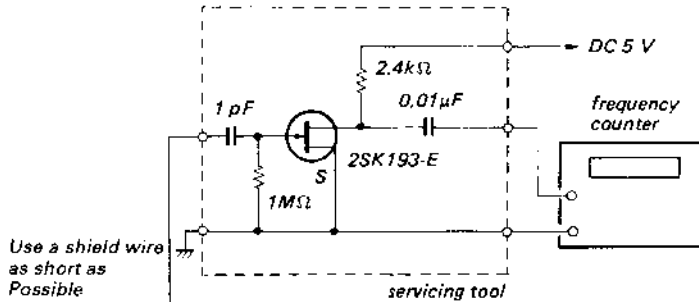

[SIGNAL BOARD] (CONDUCTOR SIDE)

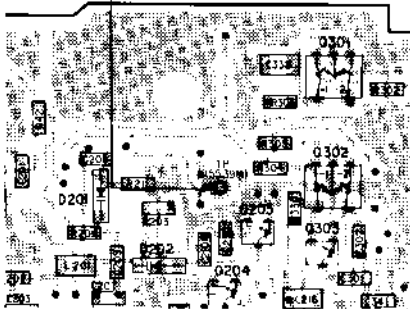

Procedure:

1. Tune the set to AM 150 kHz.
2. Press the [SSB] key, and confirm that [USB] is displayed.
3. Press the [↕] key (outside).
4. Adjust T202 (Pink) to obtain a 55.38997 – 55.39003 MHz on the frequency counter.
5. Press the [↕] key (inside) only once. (Return to 2 if wrong)
6. Adjust T203 (Yellow) to obtain a 55.38907 – 55.38913 MHz on the frequency counter.

1st IF ADJUSTMENT

Setup:

VOLUME control: as required

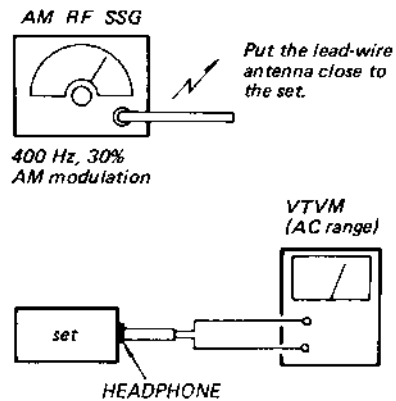

Procedure:

1. Set the frequencies of the AM RF SSG and the frequency display of the set to 150 kHz.
2. Adjust T2 and T3 to obtain a maximum reading on the VTVM.

● FM SECTION

FM FREQUENCY COVERAGE (VCO VOLTAGE) ADJUSTMENT

Setup:

VOLUME control: as required

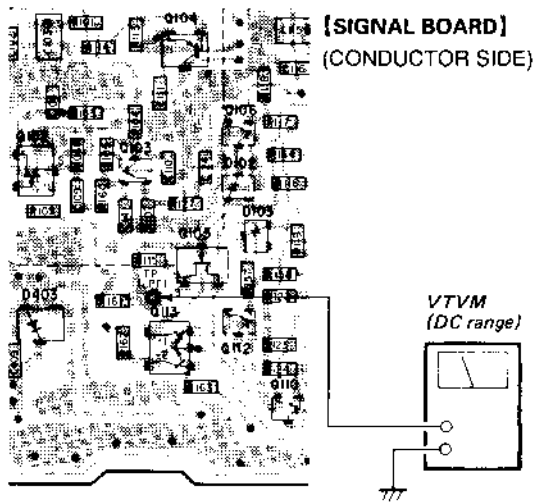

Procedure:

1. Tune the set to 76 MHz.
2. Adjust T201 to obtain a 1.75 – 1.85 V on the VTVM.
3. Tune the set to 108 MHz.
4. Make sure that the VTVM reading is below 11V.

FM STEREO ADJUSTMENT

Setup:

VOLUME control: as required

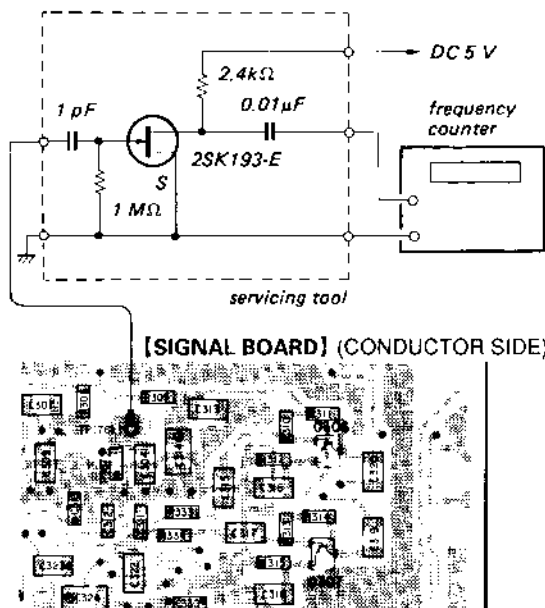

Procedure:

1. Adjust RV301 to obtain a 75.7 – 76.3 kHz on the frequency counter.

FM TRACKING ADJUSTMENT

NOTE: This adjustment should be performed after the remove Rod-Antenna (ANT1).

This adjustment should be performed after the FM FREQUENCY-COVERAGE ADJUSTMENT.

Setup:

VOLUME control: as required

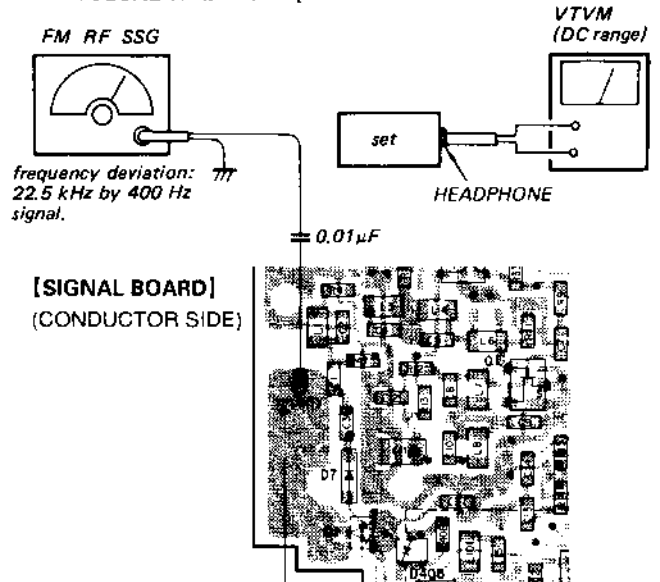

Procedure:

1. Set the frequencies of the FM RF SSG and the frequency display of the set to 76 MHz.
2. Adjust T5 and T6 to obtain a maximum reading on the VTVM.
3. Set the frequencies of the FM RF SSG and the frequency display of the set to 108 MHz.
4. Adjust CT1 and CT2 to obtain a maximum reading on the VTVM.
5. Repeat the above steps several times, and finish the adjustment with the trimmers CT1 and CT2.

SD ADJUSTMENT

Setup:

VOLUME control: as required

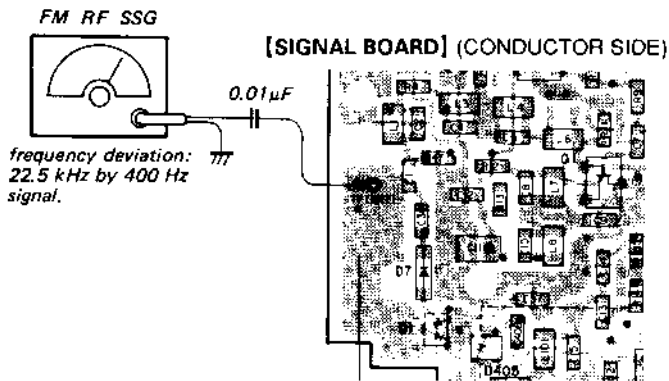

SSB ZERO BEAT ADJUSTMENT

Setup:

BAND select switch: AM
MODE: SSB (USB or LSB/CW)

Procedure:

1. Tune to the strong and stable AM station nearby.
2. Adjust the RV201 to attain zero beat (no beat sound heard).
3. Change the mode to the alternative band (LSB/CW if USB), and check if the zero beat is retained.
If not, readjust.

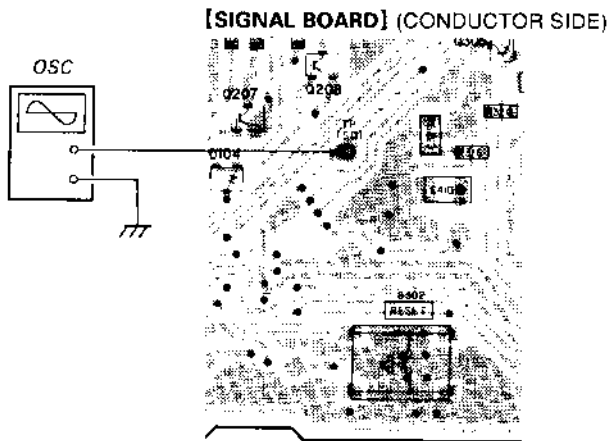

Procedure:

1. Set the frequencies of the FM RF SSG and the frequency display of the set to 93 MHz.
2. Adjust the RV202 so that a waveform on oscilloscope is as shown below.

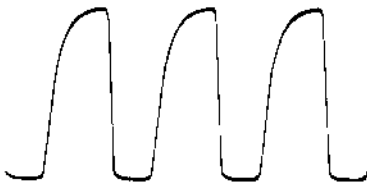

SECTION 4 DIAGRAMS

4-1. IC PIN FUNCTIONS

•IC102 μ PD1724GB-599-1A7 (PLL SYNTHESIZER CONTROL)

Pin No.	Pin Name	I/O	Description
1 — 10	LCD10 — LCD1	O	Not used this set.
11	N. C	—	No connection.
12 — 14	COM3 — COM1	O	Not used this set.
15	VSS3	—	Not used this set.
16	CAP2	—	
17	CAP1	—	
18	VSS2	—	
19	N. C	O	Not used this set.
20	BEEP	O	Beep signal (1kHz/3kHz) output terminal.
21	N. C	—	No connection.
22	VDD	—	Power supply terminal.
23	VCOH	I	FM local oscillation input terminal.
24	VCOM	I	AM local oscillation input terminal. (PLL local oscillation frequency input at direct frequency division.)
25	VCOL	I	Not used this set.
26	VSS1	—	Ground terminal.
27	EO1	O	Not used this set.
28	EO2	O	PLL error output terminal.
29	CE	I	Chip enable input terminal. (Device select signal input. "H": Normal operation.)
30	XO	O	75kHz clock oscillation output terminal.
31	XI	I	75kHz clock oscillation input terminal.
32	VSS4	—	Not used this set.
33	BAR/ROD	O	BAR/ROD select. "H": BAR "L": ROD
34	AM/FM	O	AM/FM select. "H": AM "L": FM
35	W/N	O	Not used this set.
36	IF POWER	O	Power supply control terminal.
37	D/A	O	A/D conversion to get the voltage for the 2nd local shift.
38			
39			
40			
41	SSB/SYNC	O	SSB/SYNC select. "H": SSB "L": SYNC
42	ENV/PSN	O	ENV/PSN select. "H": ENV "L": PSN
43	USB/LSB	O	USB/LSB select. "H": USB "L": LSB
44	READY	O	Ready signal output to SUB system control (IC604).
45	DATA	I	Data signal input from SUB system control (IC604).
46	CLK	I	Clock signal input from SUB system control (IC604).
47	REQ	I	Request signal input from SUB system control (IC604).
48	UNLOCK	I	PLL UNLOCK detection.
49, 50	N. C	—	No connection.
51 — 56	S16 — S11	O	Not used this set.

•IC603 MSM64164C-029 (MAIN SYSTEM CONTROL)

Pin No.	Pin Name	I/O	Description
1 — 15	MS20 — MS6	O	Segment signal output to LCD (LCD601).
16	VDET2	I	Battery voltage detection input terminal.
17	VDET1	I	Battery voltage detection input terminal.
18	MAIN POWER	I	Tuner power control signal input from S701 (MAIN POWER switch).
19	SCK IN	I	Clock signal input from SUB system control (IC604).
20	INT	I	Interrupt signal input from SUB system control (IC604).
21 — 24	KR4 — KR1	I	Key Return terminal.
25 — 27	KS7 — KS5	O	Key Source terminal.
28	BD	—	Not used this set.
29	VEE		Minus power supply terminal for inner logic.
30	VDD	—	Power supply terminal.
31 — 39	N. C	—	Not used this set.
40	VSS1	—	LCD driving bias output terminal.
41	VSS	—	Ground terminal.
42	VSS2	—	LCD driving bias output terminal.
43	VSS3	—	LCD driving bias output terminal.
44	C1	—	Capacitor connection terminal for LCD driving bias generator.
45	C2	—	Capacitor connection terminal for LCD driving bias generator.
46 — 49	MC1 — MC4	O	Common signal output to LCD (LCD601).
50 — 54	MS1 — MS5	O	Segment signal output to LCD (LCD601).
55 — 58	KS4 — KS1	O	Key source terminal.
59	DO	O	Data signal output to EEP ROM (IC606).
60	SK	O	Clock signal output to EEP ROM (IC606).
61	CS	O	Chip select signal output to EEP ROM (IC606).
62	N. C	—	Not used this set.
63	OSC2	O	High speed clock oscillation terminal.
64	OSC1	I	High speed clock oscillation terminal.
65	VDD	—	Not used this set.
66	XTO	O	32.768kHz clock oscillation output terminal.
67	XTI	I	32.768kHz clock oscillation input terminal.
68	RST	I	System reset input terminal.
69, 70	N. C	—	Not used this set.
71	MUTE	O	Mute signal output terminal.
72	SOUT	O	Data signal output to SUB system control (IC604).
73	START	O	Start signal output to SUB system control (IC604).
74	SCK OUT	O	Clock signal output to SUB system control (IC604).
75, 76	KR5, KR6	I	Key Return terminal.
77	SIN	I	Data signal input from SUB system control (IC604).
78	EDI	I	Data signal input from EEP ROM (IC606).
79, 80	MS22, MS21	O	Segment signal output to LCD (LCD601).

4-2. BLOCK DIAGRAM

•IC604 MSM64164C-030 (SUB SYSTEM CONTROL)

Pin No.	Pin Name	I/O	Description
1—15	SS28—SS14	O	Segment signal output to LCD (LCD601).
16	SD	I	SD signal input from IC201. (Active "L")
17	TUNE	I	TUNE signal input from IC201. (Active "L")
18	STEREO	I	STEREO/MONO select signal input terminal. "L": STEREO
19	EDI	—	Not used this set.
20	EDO	—	Not used this set.
21	SCK IN	I	Clock signal input from MAIN system control (IC603).
22	POWER	O	Power control signal output to PLL synthesizer control (IC102).
23	REQ	O	Request signal output to PLL synthesizer control (IC102).
24	READY	I	Ready signal input from PLL synthesizer control (IC102).
25	DATA	O	Data signal output to PLL synthesizer control (IC102).
26	CLK	O	Clock signal output to PLL synthesizer control (IC102).
27	LIGHT	O	Not used this set.
28	N.C	—	Not used this set.
29	VEE	—	Minus power supply terminal for inner logic.
30	VDD	—	Power supply terminal.
31—39	N.C	—	Not used this set.
40	VSS1	—	LCD driving bias output terminal.
41	VSS	—	Ground terminal.
42	VSS2	—	LCD driving bias output terminal.
43	VSS3	—	LCD driving bias output terminal.
44	C1	—	Capacitor connection terminal for LCD driving bias generator.
45	C2	—	Capacitor connection terminal for LCD driving bias generator.
46—49	SC1—SC4	O	Common signal output to LCD (LCD601).
50—62	SS1—SS13	O	Segment signal output to LCD (LCD601).
63	OSC2	O	High speed clock oscillation terminal.
64	OSC1	I	High speed clock oscillation terminal.
65	VDD	—	Power supply terminal.
66	XTO	O	Not used this set.
67	XTI	I	32,768kHz clock oscillation input terminal.
68	RST	I	System reset input terminal.
69, 70	N.C	—	Not used this set.
71	N.C	—	No connection.
72	SOUT	O	Data signal output to MAIN system control (IC603).
73	SCK OUT	O	Clock signal output to MAIN system control (IC603).
74	START	O	Start signal output to MAIN system control (IC603).
75	N.C	—	No connection.
76	INT	I	Interrupt signal input from MAIN system control (IC603).
77	SIN	I	Data signal input from MAIN system control (IC603).
78	N.C	—	No connection.
79, 80	SS30, SS29	O	Segment signal output to LCD (LCD601).

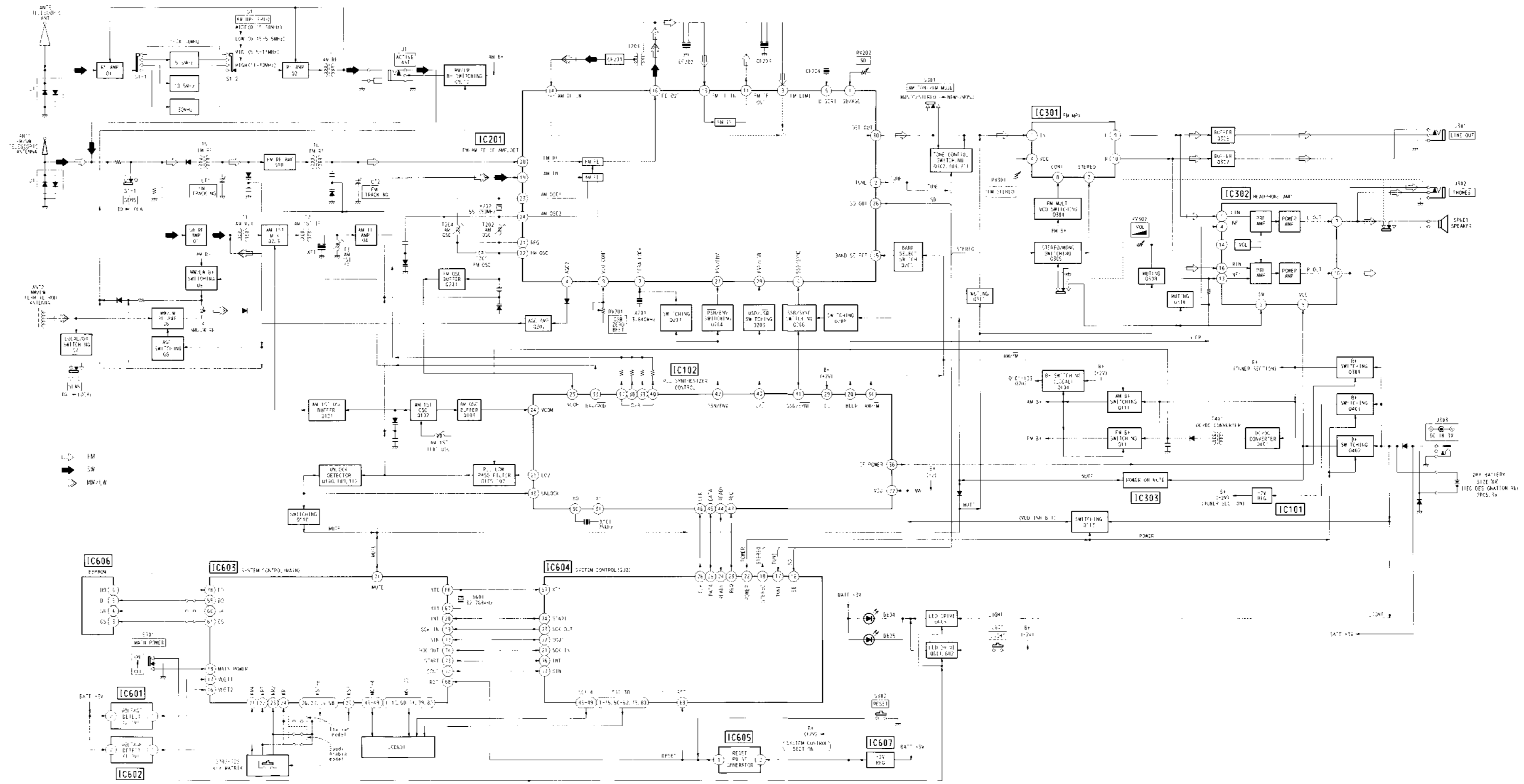

4-3. SEMICONDUCTOR LEAD LAYOUTS

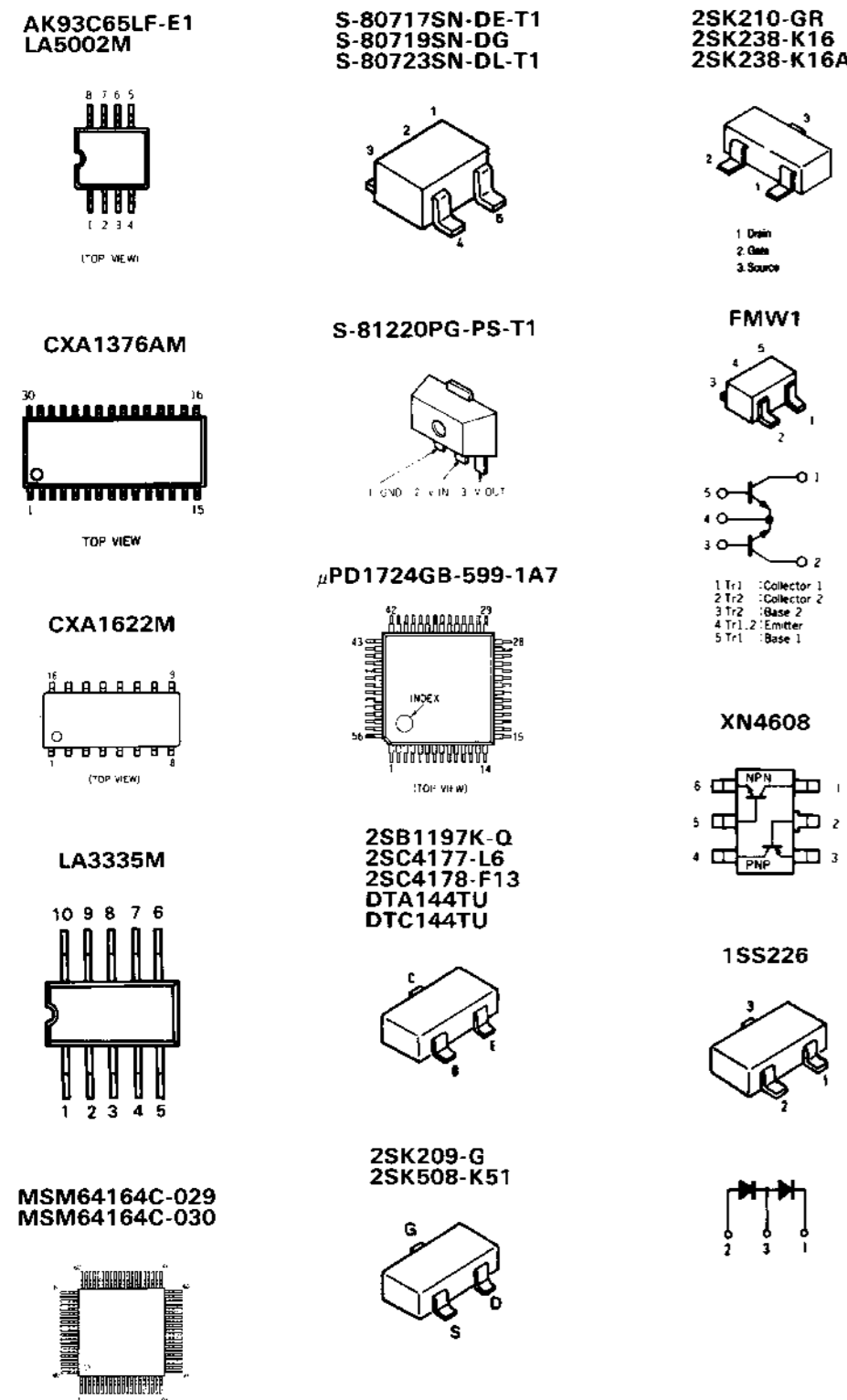

4-4. SCHEMATIC DIAGRAM —ACTIVE ANTENNA (AN-100) Section—

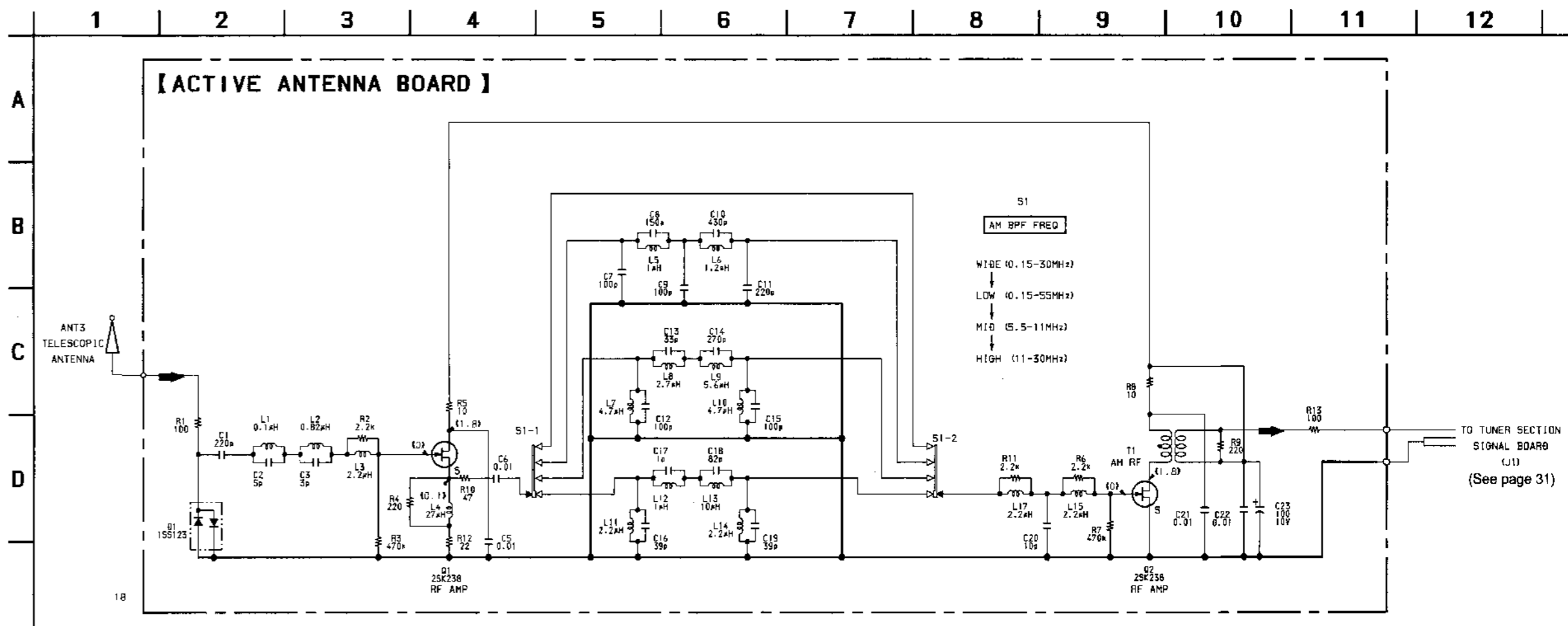

- Note:**
- All capacitors are in μF unless otherwise noted. pF : μpF 50WV or less are not indicated except for electrolytics and tantalums.
 - All resistors are in Ω and $\frac{1}{4}\text{W}$ or less unless otherwise specified.
 - Power voltage is supplied through miniplug connected to the active antenna jack.
 - Voltage and waveforms are dc with respect to ground under detuned conditions.
 - Voltages are taken with a VOM (Input Impedance 10M Ω). Voltage variations may be noted due to normal production tolerances.
 - Signal path.

4-5. PRINTED WIRING BOARD —ACTIVE ANTENNA (AN-100) Section—

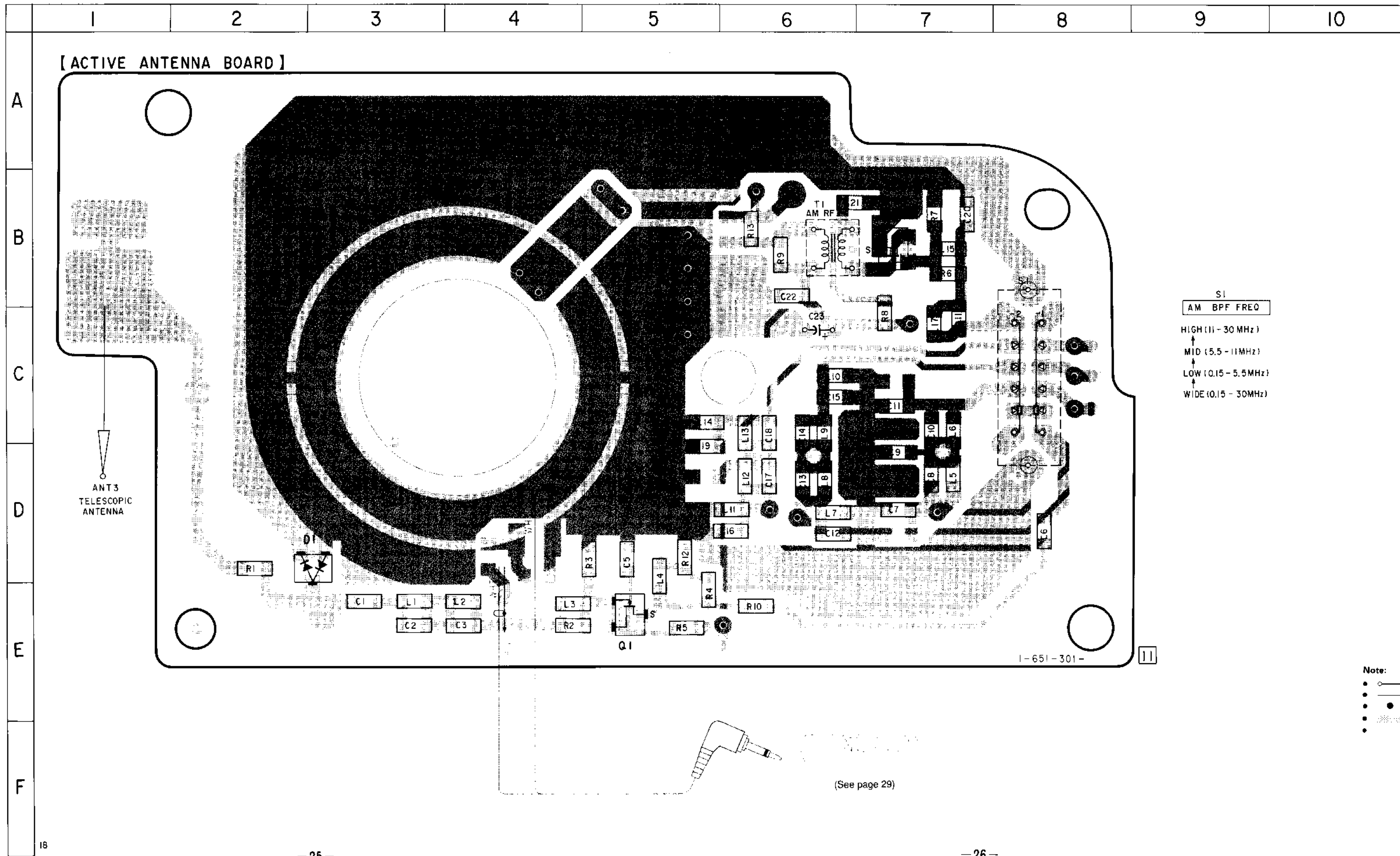

• Semiconductor Location

Ref. No.	Location
D1	D-2
Q1	E-5
Q2	B-7

S1
 AM BPF FREQ
 HIGH (11 - 30 MHz)
 MID (5.5 - 11MHz)
 LOW (0.15 - 5.5MHz)
 WIDE (0.15 - 30MHz)

Note:
 • ○ : parts extracted from the component side.
 • — : parts extracted from the conductor side.
 • ● : Through hole.
 • [Pattern] : Pattern on the side which is seen.
 • [Pattern] : Pattern of the rear side.

(See page 29)

4-6. PRINTED WIRING BOARD -TUNER Section-

• Semiconductor Location

Ref. No.	Location	Ref. No.	Location
D1	D-13	Q12	B-10
D2	C-15	Q101	D-14
D3	B-15	Q102	E-15
D4	B-11	Q103	E-15
D5	B-17	Q104	D-15
D6	B-18	Q105	E-16
D7	C-13	Q106	D-16
D101	E-14	Q107	D-16
D102	E-16	Q108	E-16
D103	E-16	Q109	F-16
D104	E-19	Q110	F-16
D201	B-19	Q111	D-10
D202	C-19	Q112	F-16
D203	D-18	Q113	F-15
D401	B-4	Q201	D-18
D402	B-3	Q202	D-17
D403	F-15	Q203	C-20
D405	D-14	Q204	C-19
		Q205	D-18
IC101	D-9	Q206	D-19
IC102	E-8	Q207	E-19
IC201	D-6	Q208	D-19
IC301	C-4	Q301	B-20
IC302	D-4	Q302	B-20
IC303	F-7	Q303	C-20
		Q304	D-20
Q1	C-14	Q305	D-20
Q2	C-15	Q306	C-22
Q3	C-15	Q307	D-22
Q4	C-16	Q308	B-23
Q5	C-15	Q309	F-10
Q6	B-15	Q310	E-22
Q7	B-16	Q311	B-23
Q8	C-16	Q401	B-4
Q9	B-2	Q402	F-4
Q10	B-17	Q403	E-10
Q11	B-17	Q404	F-4

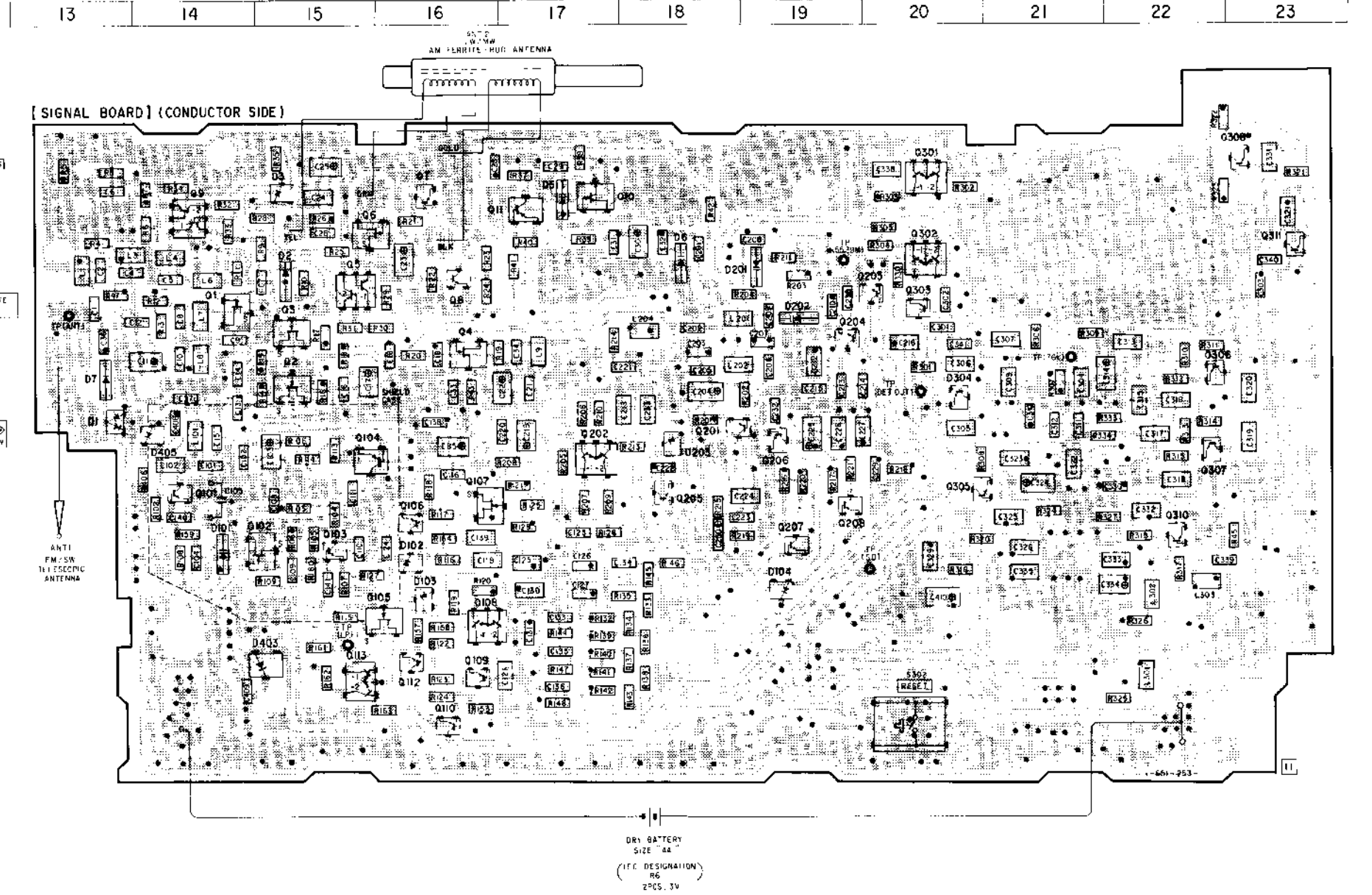
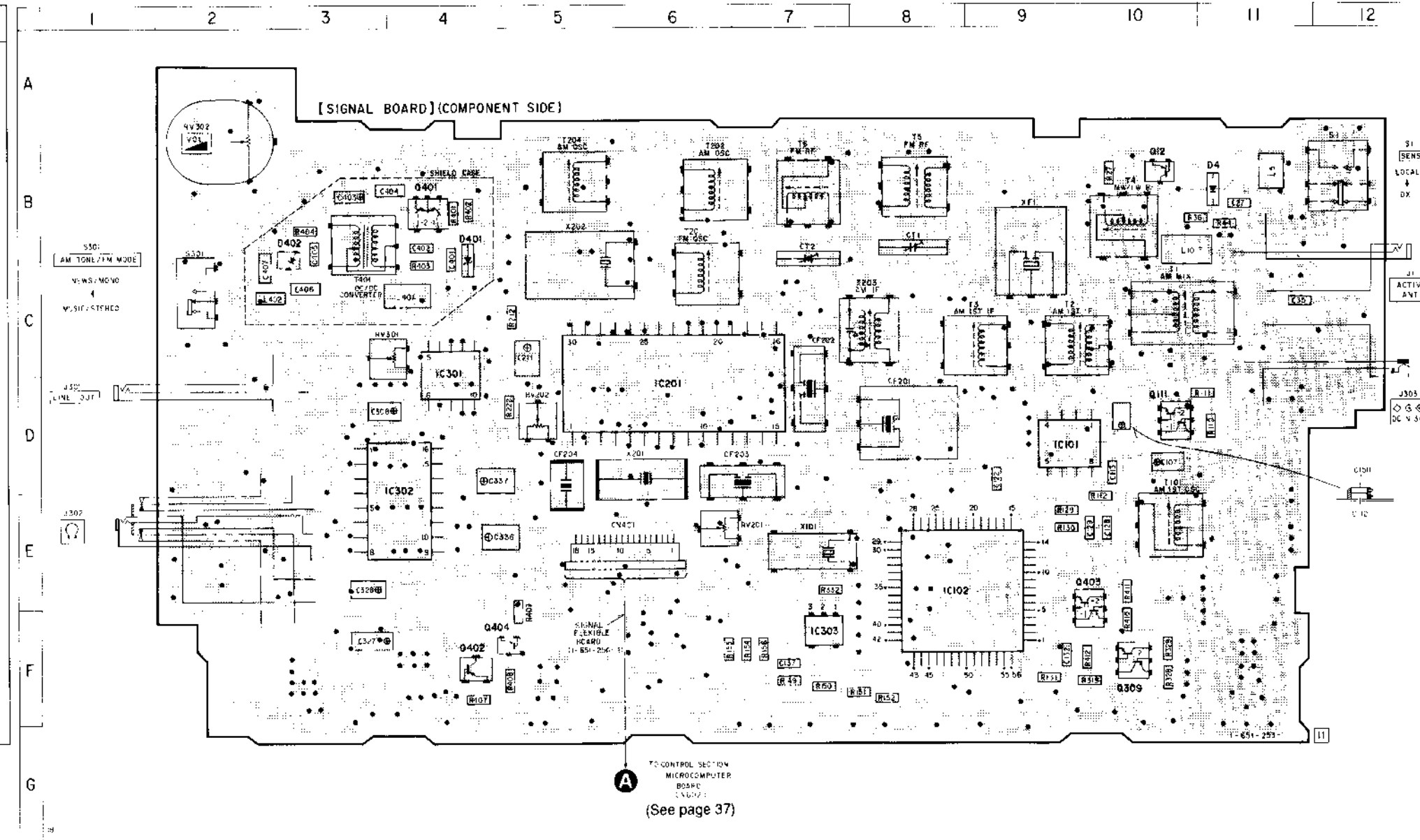

Note:

- : parts extracted from the component side
- : parts extracted from the conductor side.
- : Through hole.
- : Pattern from the side which enables seeing.

(The other layers' patterns are not indicated.)

Caution:

Pattern face side: Parts on the pattern face side seen from (Conductor Side) the pattern face are indicated.

Parts face side: Parts on the parts face side seen from the (Component Side) parts face are indicated.

Note:

- All capacitors are in μF unless otherwise noted. pF : μF 50WV or less are not indicated except for electrolytics and tantalums.
- All resistors are in Ω and $1/4\text{W}$ or less unless otherwise specified.
- --- : B+ Line
- --- : adjustment for repair.
- Power voltage is dc 3 V and fed with regulated dc power supply from external power voltage jack.
- Voltage and waveforms are dc with respect to ground under detuned conditions
- no mark: FM
- I : LW/MW
- \llcorner : SW
- Voltages are taken with a VOM (Input Impedance $10\text{M}\Omega$). Voltage variations may be noted due to normal production tolerances.
- Waveforms are taken with an oscilloscope. Voltage variations may be noted due to normal production tolerances.
- Circled numbers refer to waveforms.
- Signal path:
 --- : FM
 --- : LW/MW
 --- : SW

IC101 LA5002M

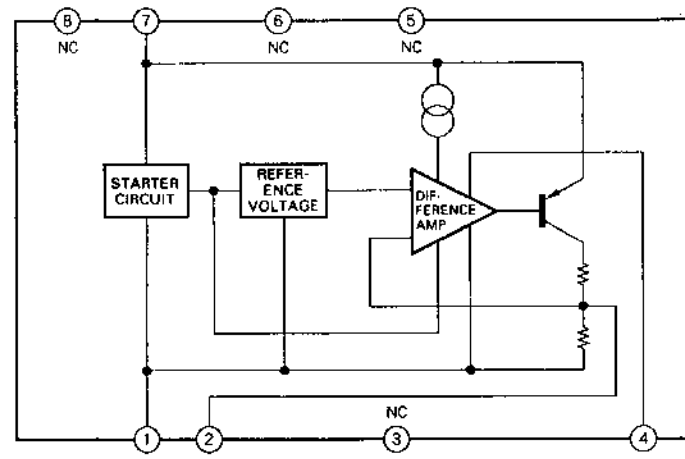

IC301 LA3335M

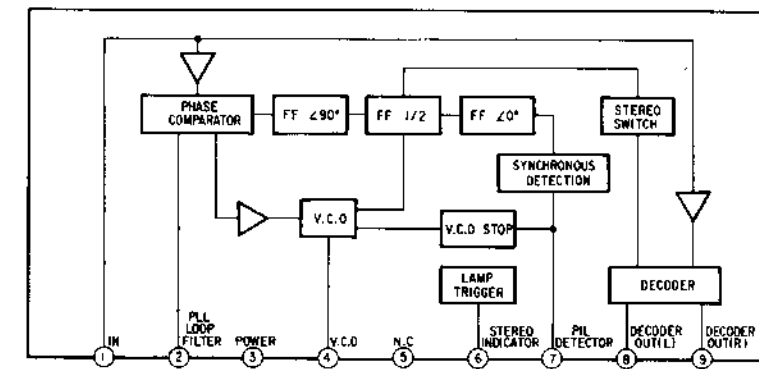

IC302 CXA1622M

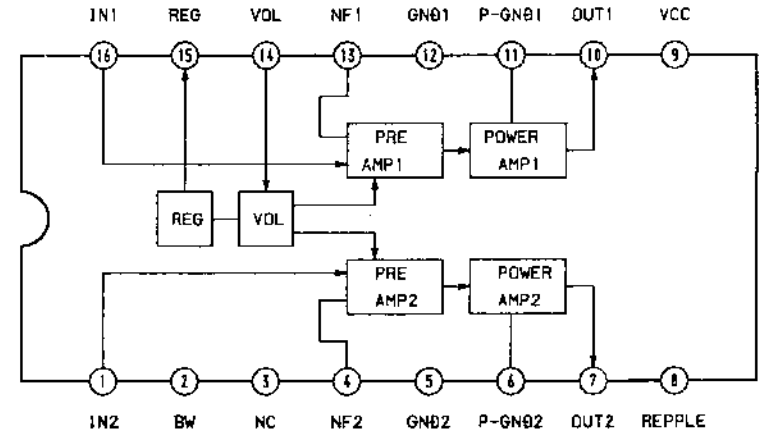

IC201 CXA1376AM

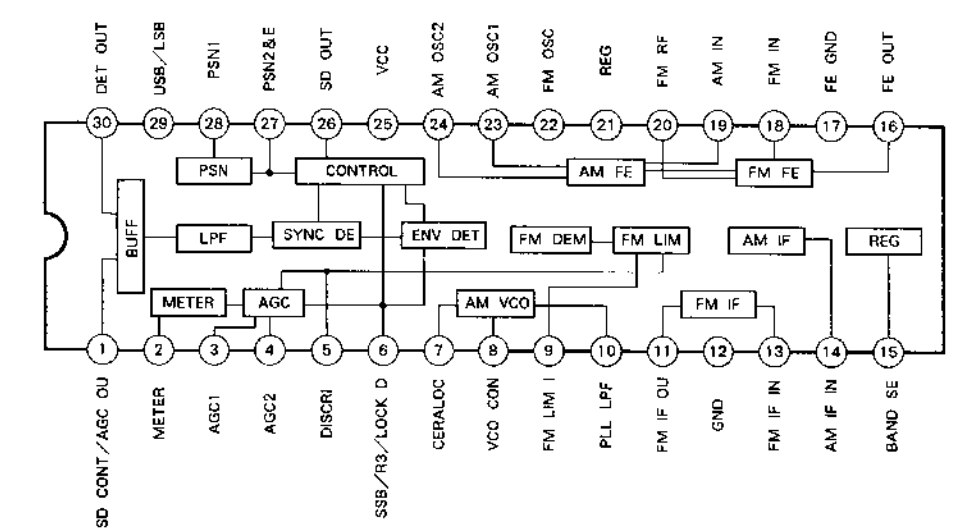

4-7 SCHEMATIC DIAGRAM -TUNER Section-

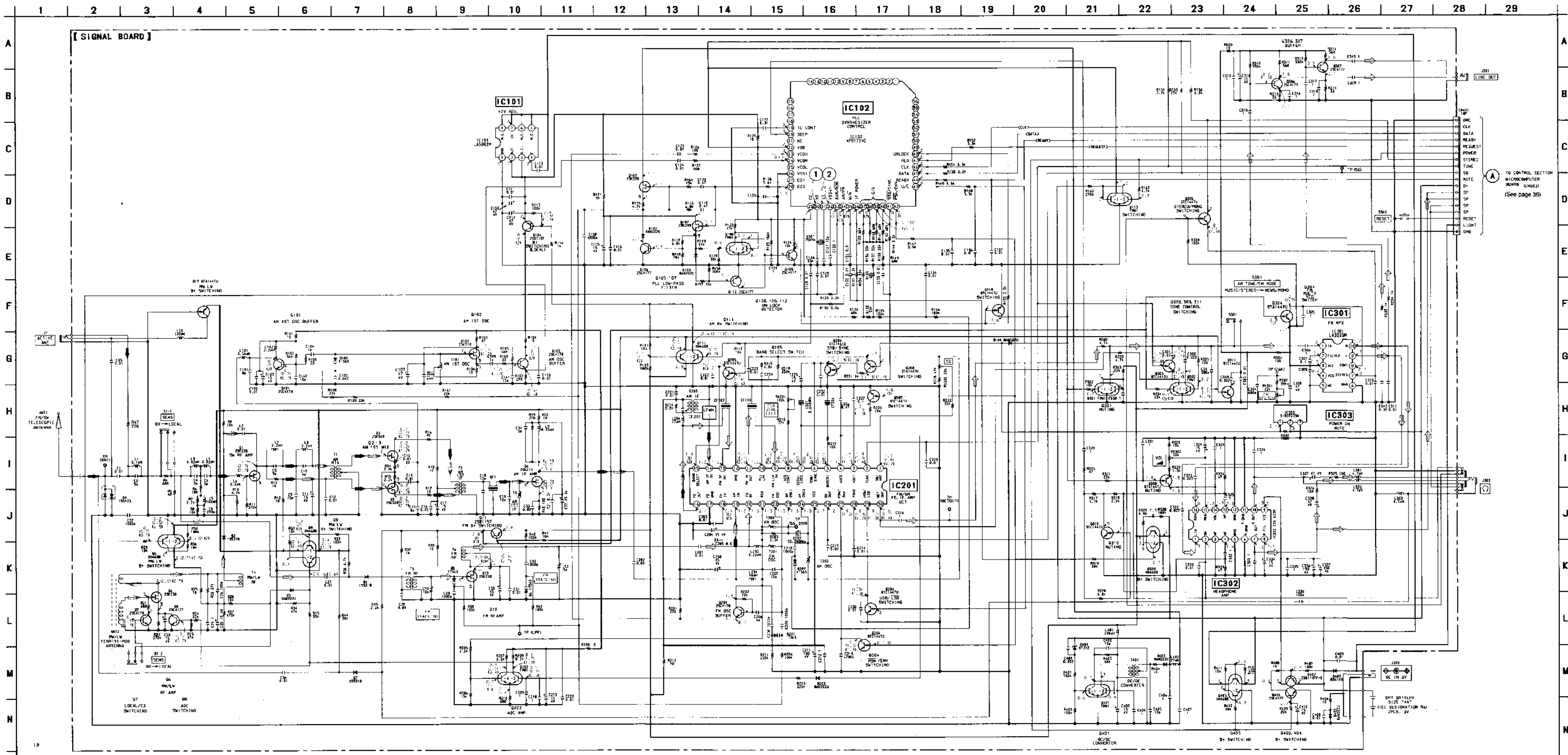

• Waveforms

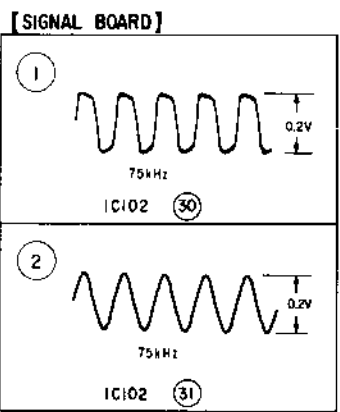

IC606 AK93C65LF-E1

- Note:**
- All capacitors are in μF unless otherwise noted. pF: μF 50WV or less are not indicated except for electrolytics and tantalums.
 - All resistors are in Ω and $\frac{1}{2}\text{W}$ or less unless otherwise specified.
 - --- : B+ Line
 - --- : adjustment for repair.
 - Power voltage is dc 3 V and fed with regulated dc power supply from external power voltage jack.
 - Voltage and waveforms are dc with respect to ground under detuned conditions.
 - no mark : FM
 - () : LW/MW
 - () : SW
 - Voltages are taken with a VOM (Input Impedance 10M Ω). Voltage variations may be noted due to normal production tolerances.
 - Waveforms are taken with an oscilloscope. Voltage variations may be noted due to normal production tolerances.
 - Circled numbers refer to waveforms.
 - Signal path
 - \Rightarrow : FM

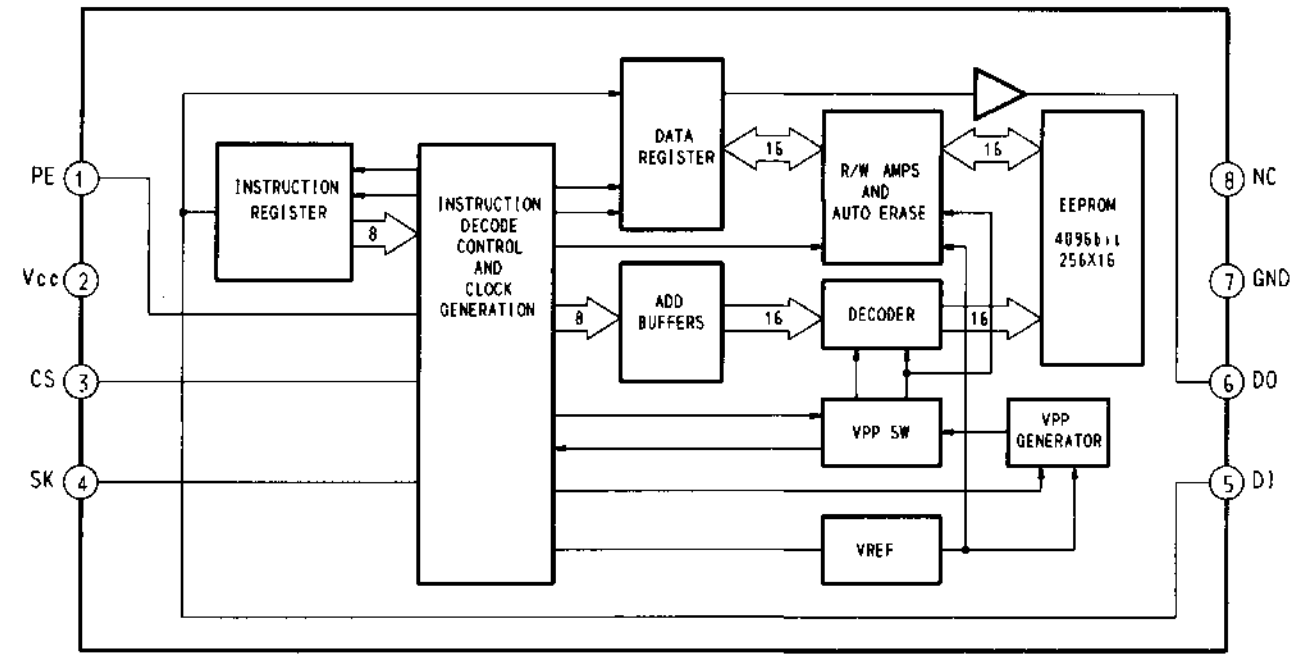

4-8. SCHEMATIC DIAGRAM - CONTROL Section-

• Waveforms

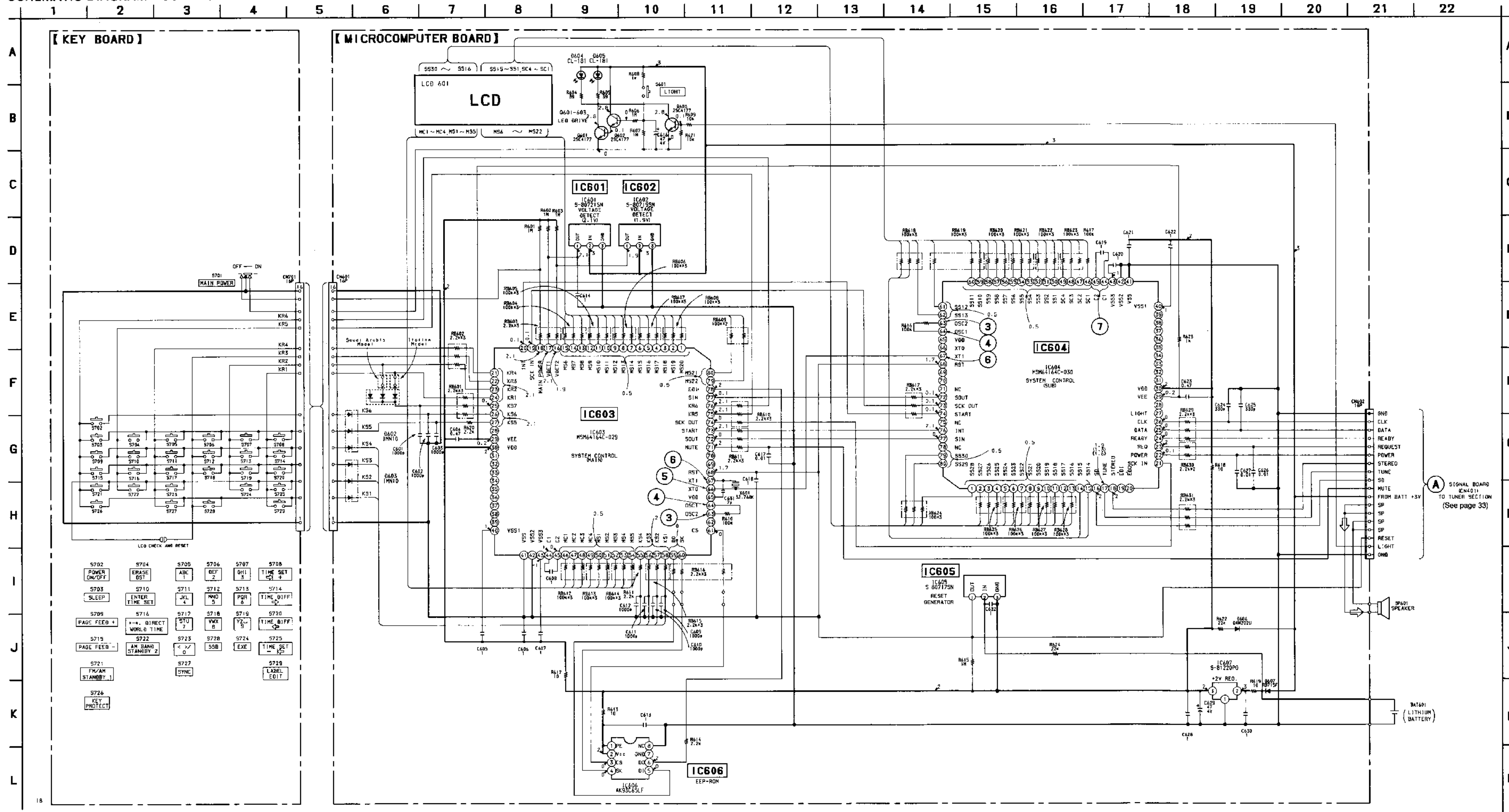
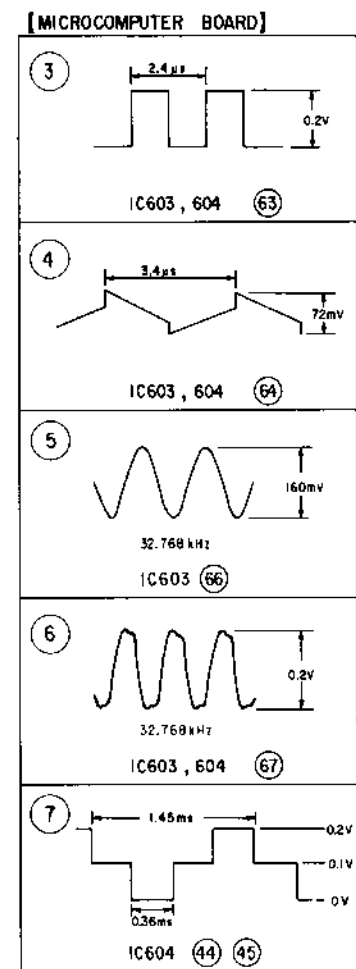

① SIGNAL BOARD TO TUNER SECTION (See page 33)

4-9. PRINTED WIRING BOARD – CONTROL Section –

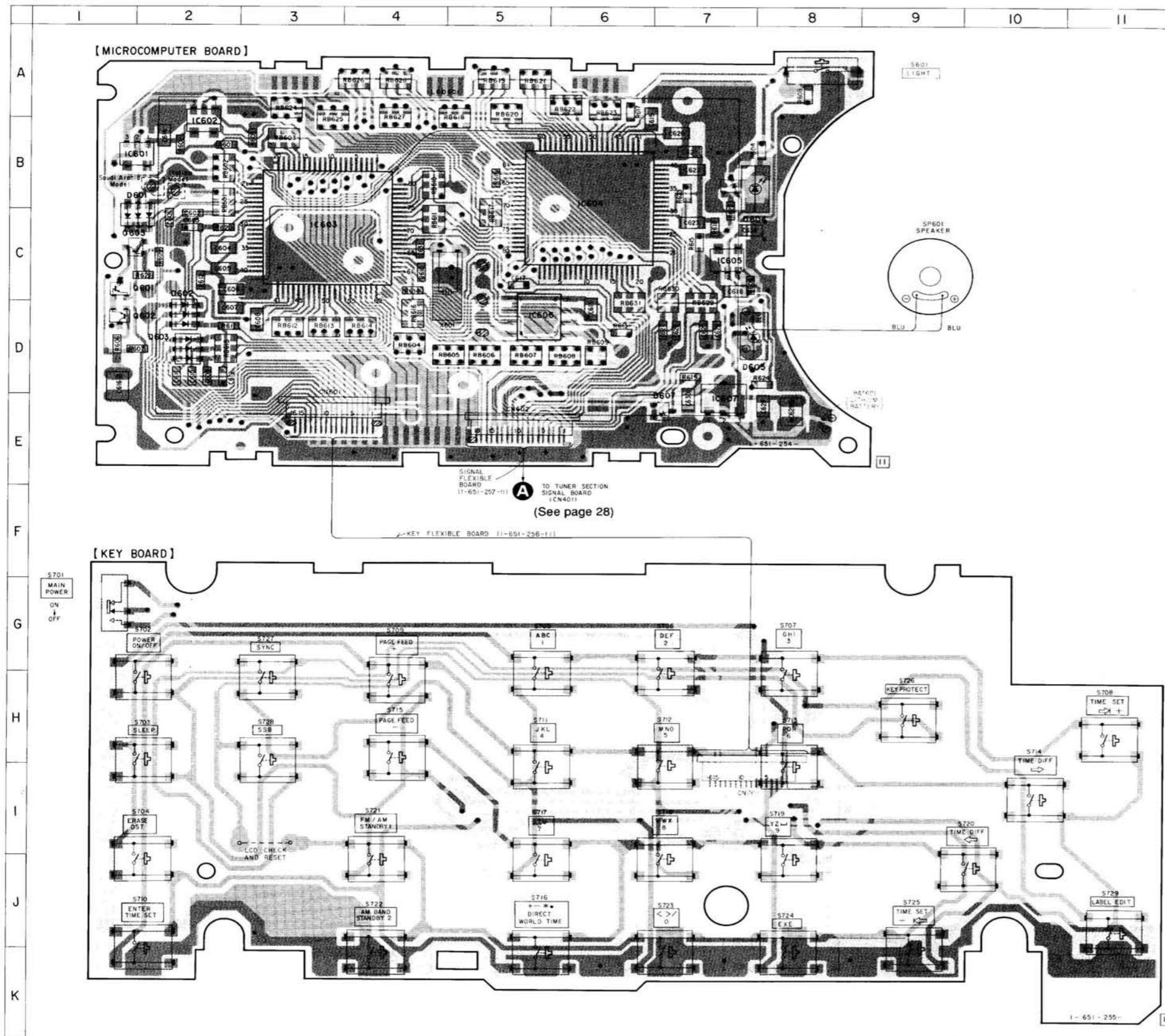

● Semiconductor Location

Ref. No.	Location
D601	C-1
D602	D-2
D603	D-2
D604	B-7
D605	D-7
D606	B-7
D607	E-7
IC601	B-1
IC602	B-2
IC603	C-3
IC604	B-6
IC605	C-7
IC606	D-5
IC607	E-7
Q601	C-2
Q602	D-2
Q603	C-1

Note:

- : parts extracted from the component side.
- : parts extracted from the conductor side.
- : Through hole.
- : Pattern on the side which is seen.
- : Pattern of the rear side.
- : Chip components extracted from the rear side.

SECTION 5
EXPLODED VIEWS

NOTE:

- XX and -X mean standardized parts, so they may have some difference from the original one.
- Abbreviation
EA: Saudi Arabia

- Items marked "*" are not stocked since they are seldom required for routine service. Some delay should be anticipated when ordering these items.
- The mechanical parts with no reference number in the exploded views are not supplied.

5-1. MAIN SECTION

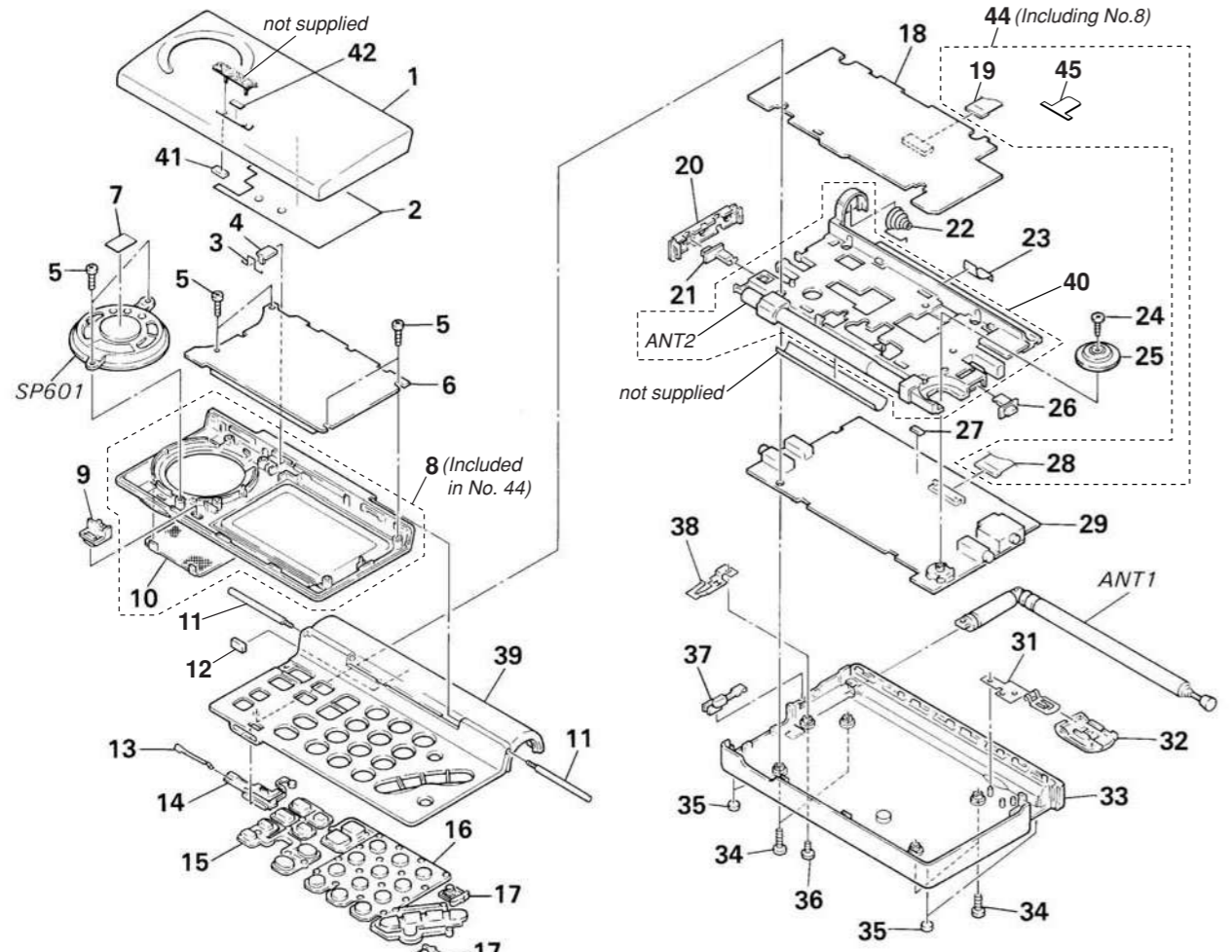

Ref. No.	Part No.	Description	Remark	Ref. No.	Part No.	Description	Remark
1	3-909-832-01	CABINET (REAR) (LID)		25	3-909-836-01	KNOB (VOL)	
2	3-911-703-01	COPPER LEAF		26	3-909-835-01	KNOB (TONE)	
3	3-913-417-01	SPRING		* 27	3-355-447-01	SPACER (OPEN)	
4	3-911-702-01	PLATE, CLICK		28	1-651-257-12	PC BOARD, FLEXIBLE (SIGNAL)	
5	3-384-797-01	SCREW		* 29	A-3679-561-A	SIGNAL BOARD, COMPLETE	
* 6	A-3661-961-A	MICROCOMPUTER BOARD, COMPLETE		* 31	A-3638-005-A	TERMINAL (+) ASSY, BATTERY	
7	3-565-241-01	CLOTH (B) 1 UNWEAVED		32	3-909-841-01	LID, BATTERY CASE	
8	X-3371-472-2	CABINET (FRONT) (LID) ASSY (included in No.44)		33	3-909-831-01	CABINET (REAR) (MAIN)	
9	3-909-839-01	BUTTON (LIGHT)		34	3-910-063-01	SCREW (1.7X10)	
10	3-909-851-01	GRILLE, SP		35	3-910-062-01	FOOT, RUBBER	
11	3-909-857-02	SCREW, SHAFT		36	3-719-381-01	SCREW (M2X4)	
12	3-913-419-01	CUSHION		37	3-909-834-01	KNOB (POWER)	
13	3-911-701-01	SPRING (B), LEAF		38	3-909-492-01	PLATE (ANT), CONTACT	
14	3-909-842-01	CLAW (LOCK)		39	X-3368-534-2	CABINET (FRONT) (MAIN) ASSY (EXCEPT EA)	
15	3-909-838-01	BUTTON (MEMORY)		39	X-3368-535-2	CABINET (FRONT) (MAIN) ASSY (EA)	
16	3-909-837-01	BUTTON (10 KEY)		40	X-3368-536-2	CHASSIS ASSY	
17	3-909-840-01	BUTTON (KEY PROTECT)		* 41	4-023-575-01	CUSHION, LID	
* 18	A-3661-960-A	KEY BOARD, COMPLETE		42	3-355-482-11	SHEET (KT), ADHESIVE	
19	1-651-256-12	PC BOARD, FLEXIBLE (KEY)		44	X-3372-340-4	CHASSIS ASSY, FLEXIBLE (including No.8)	
20	3-909-847-01	PANEL, SIDE		45	3-019-248-01	PLATE, BLIND	
21	3-909-846-01	KNOB (SENS)		ANT1	1-501-658-21	ANTENNA, TELESCOPIC	
22	3-909-853-01	SPRING, BATTERY COIL		ANT2	1-501-657-31	ANTENNA, FERRITE-ROD (LW.MW)	
23	4-017-441-01	CUSHION (B)		SP601	1-505-165-12	SPEAKER (4cm)	
24	3-892-318-00	SCREW, SMALL					

5-2. ACTIVE ANTENNA (AN-100) SECTION
(ICF-SW100S)

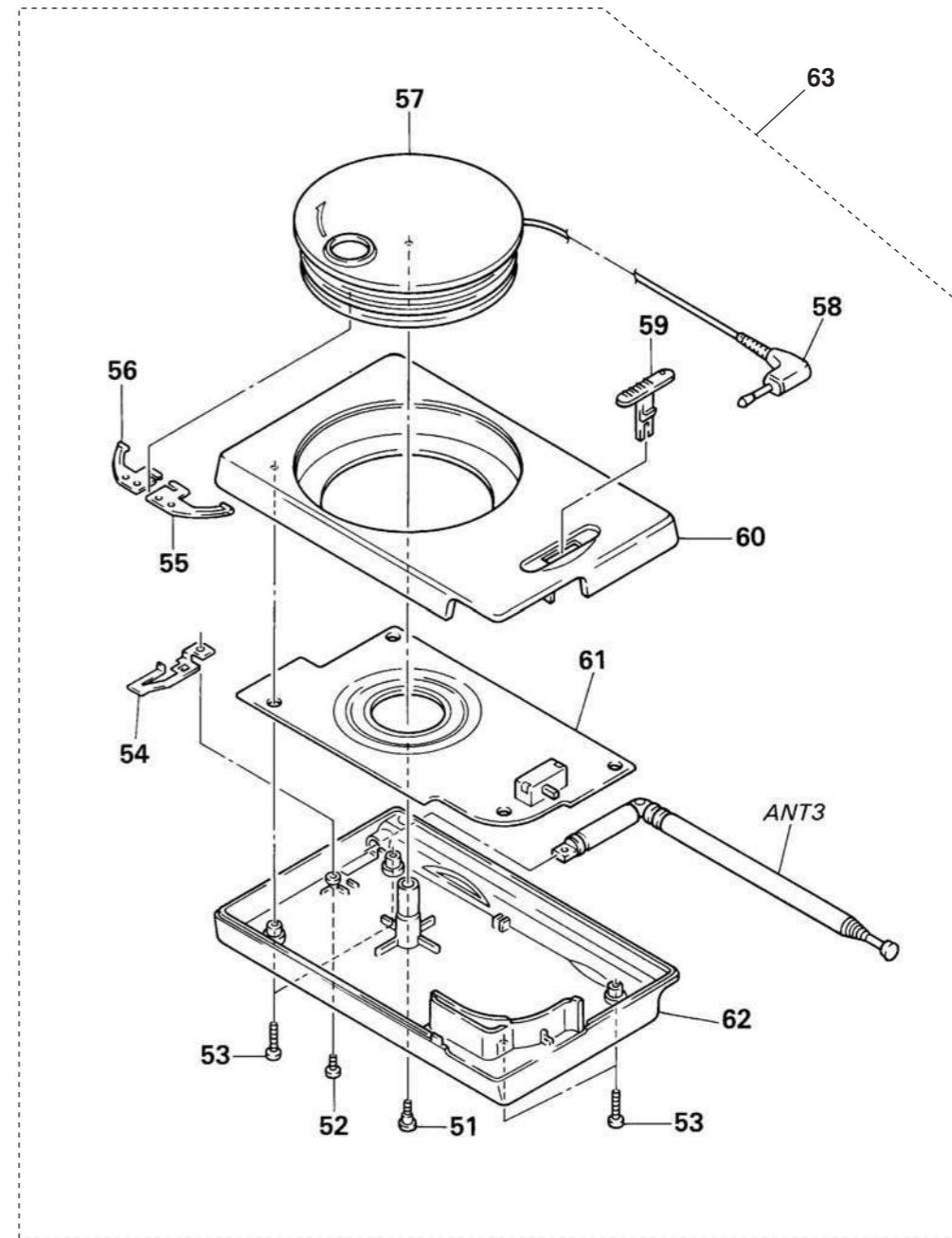

Ref. No.	Part No.	Description	Remark	Ref. No.	Part No.	Description	Remark
51	3-895-517-11	SCREW (2), TAPPING, STEP		58	1-559-706-11	CORD (WITH PLUG)	
52	3-719-381-01	SCREW (M2X4)		59	3-909-489-01	KNOB (ANTENNA)	
53	3-910-063-01	SCREW (1.7X10)		60	3-909-486-02	CASE (UPPER)	
54	3-909-492-01	PLATE (ANT), CONTACT		* 61	A-3661-962-A	ACTIVE ANTENNA BOARD, COMPLETE	
55	3-909-491-01	PLATE (B), CONTACT		62	3-909-487-01	CASE (LOWER)	
56	3-909-490-01	PLATE (A), CONTACT		* 63	A-3638-008-A	ANTENNA ASSY, ACTIVE	
57	3-909-488-01	REEL		ANT3	1-501-658-21	ANTENNA, TELESCOPIC	

SECTION 6 ELECTRICAL PARTS LIST

Ver. 1.1

ACTIVE ANTENNA

NOTE:

- Due to standardization, replacements in the parts list may be different from the parts specified in the diagrams or the components used on the set.
- -XX and -X mean standardized parts, so they may have some difference from the original one.
- RESISTORS
All resistors are in ohms.
METAL: Metal-film resistor.
METAL OXIDE: Metal oxide-film resistor.
F: nonflammable
- Abbreviation
AUS : Australian mode IT : Italian model
CND : Canadian model JE : Tourist model
EA : Saudi Arabia model
- Items marked "*" are not stocked since they are seldom required for routine service. Some delay should be anticipated when ordering these items.
- SEMICONDUCTORS
In each case, u: μ , for example:
uA... : μ A... uPA... : μ PA...
uPB... : μ PB... uPC... : μ PC...
uPD... : μ PD...
- CAPACITORS
uF: μ F
- COILS
uH: μ H

The components identified by mark Δ or dotted line with mark Δ are critical for safety.
Replace only with part number specified.

Les composants identifiés par une marque Δ sont critiques pour la sécurité. Ne les remplacer que par une pièce portant le numéro spécifié.

When indicating parts by reference number, please include the board.

Ref. No.	Part No.	Description	Remarks	Ref. No.	Part No.	Description	Remarks
*	A-3661-962-A	ACTIVE ANTENNA BOARD. COMPLETE (ICF-SW100S) *****		L9	1-412-003-41	INDUCTOR CHIP 5.6uH	
		< CAPACITOR >		L10	1-412-002-31	INDUCTOR CHIP 4.7uH	
C1	1-163-125-00	CERAMIC CHIP 220PF 5% 50V		L11	1-410-997-31	INDUCTOR CHIP 2.2uH	
C2	1-163-088-00	CERAMIC CHIP 5PF 50V		L12	1-410-993-11	INDUCTOR CHIP 1uH	
C3	1-163-086-00	CERAMIC CHIP 3PF 50V		L13	1-412-006-31	INDUCTOR CHIP 10uH	
C5	1-164-232-11	CERAMIC CHIP 0.01uF 50V		L14	1-410-997-31	INDUCTOR CHIP 2.2uH	
C6	1-164-232-11	CERAMIC CHIP 0.01uF 50V		L15	1-410-997-31	INDUCTOR CHIP 2.2uH	
C7	1-163-117-00	CERAMIC CHIP 100PF 5% 50V		L17	1-410-997-31	INDUCTOR CHIP 2.2uH	
C8	1-163-121-00	CERAMIC CHIP 150PF 5% 50V				< TRANSISTOR >	
C9	1-163-117-00	CERAMIC CHIP 100PF 5% 50V		Q1	8-729-105-89	TRANSISTOR 2SK238-K16A	
C10	1-163-132-00	CERAMIC CHIP 430PF 5% 50V		Q2	8-729-105-89	TRANSISTOR 2SK238-K16A	
C11	1-163-125-00	CERAMIC CHIP 220PF 5% 50V				< RESISTOR >	
C12	1-163-117-00	CERAMIC CHIP 100PF 5% 50V		R1	1-216-025-00	METAL CHIP 100 5% 1/10W	
C13	1-163-105-00	CERAMIC CHIP 33PF 5% 50V		R2	1-216-057-00	METAL CHIP 2.2K 5% 1/10W	
C14	1-163-127-00	CERAMIC CHIP 270PF 5% 50V		R3	1-216-113-00	METAL CHIP 470K 5% 1/10W	
C15	1-163-117-00	CERAMIC CHIP 100PF 5% 50V		R4	1-216-033-00	METAL CHIP 220 5% 1/10W	
C16	1-163-107-00	CERAMIC CHIP 39PF 5% 50V		R5	1-216-001-00	METAL CHIP 10 5% 1/10W	
C17	1-163-083-00	CERAMIC CHIP 1PF 50V		R6	1-216-057-00	METAL CHIP 2.2K 5% 1/10W	
C18	1-163-115-00	CERAMIC CHIP 82PF 5% 50V		R7	1-216-113-00	METAL CHIP 470K 5% 1/10W	
C19	1-163-107-00	CERAMIC CHIP 39PF 5% 50V		R8	1-216-001-00	METAL CHIP 10 5% 1/10W	
C20	1-163-093-00	CERAMIC CHIP 10PF 5% 50V		R9	1-216-033-00	METAL CHIP 220 5% 1/10W	
C21	1-164-232-11	CERAMIC CHIP 0.01uF 50V		R10	1-216-017-00	METAL CHIP 47 5% 1/10W	
C22	1-164-232-11	CERAMIC CHIP 0.01uF 50V		R11	1-216-057-00	METAL CHIP 2.2K 5% 1/10W	
C23	1-124-584-00	ELECT 100uF 20% 10V		R12	1-216-009-00	METAL CHIP 22 5% 1/10W	
		< DIODE >		R13	1-216-025-00	METAL CHIP 100 5% 1/10W	
D1	8-719-800-76	DIODE 1SS226				< SWITCH >	
		< COIL >		S1	1-571-717-21	SWITCH, SLIDE (AM BPF FREQ WIDE/LOW/MID/HIGH)	
L1	1-410-981-31	INDUCTOR CHIP 0.1uH				< TRANSFORMER >	
L2	1-410-992-11	INDUCTOR CHIP 0.82uH		T1	1-426-357-11	TRANSFORMER, AM RF	
L3	1-410-997-31	INDUCTOR CHIP 2.2uH				*****	
L4	1-412-011-31	INDUCTOR CHIP 27uH					
L5	1-410-993-11	INDUCTOR CHIP 1uH					
L6	1-410-994-11	INDUCTOR CHIP 1.2uH					
L7	1-412-002-31	INDUCTOR CHIP 4.7uH					
L8	1-410-998-31	INDUCTOR CHIP 2.7uH					

KEY MICROCOMPUTER

Ref.No.	Part No.	Description	Remark
*	A-3661-960-A	KEY BOARD, COMPLETE *****	
		< CONNECTOR >	
CN701	1-764-370-11	HOUSING, FPC CONNECTOR(ZIF)16P	
		< SWITCH >	
S701	1-571-275-11	SWITCH, SLIDE (MAIN POWER)	
S702	1-572-938-21	SWITCH, TACTIL (POWER ON/OFF)	
S703	1-572-938-21	SWITCH, TACTIL (SLEEP)	
S704	1-572-938-21	SWITCH, TACTIL (ERASE DSF)	
S705	1-572-938-21	SWITCH, TACTIL (ABC 1)	
S706	1-572-938-21	SWITCH, TACTIL (DEF 2)	
S707	1-572-938-21	SWITCH, TACTIL (GHI 3)	
S708	1-572-938-21	SWITCH, TACTIL (TIME SET ⇨ +)	
S709	1-572-938-21	SWITCH, TACTIL (PAGE FEED +)	
S710	1-572-938-21	SWITCH, TACTIL (ENTER TIME SET)	
S711	1-572-938-21	SWITCH, TACTIL (JKL 4)	
S712	1-572-938-21	SWITCH, TACTIL (MNO 5)	
S713	1-572-938-21	SWITCH, TACTIL (PQR 6)	
S714	1-572-938-21	SWITCH, TACTIL (TIME DIFF ⇨)	
S715	1-572-938-21	SWITCH, TACTIL (PAGE FEED -)	
S716	1-572-938-21	SWITCH, TACTIL (+ - * DIRECT WORLD TIME)	
S717	1-572-938-21	SWITCH, TACTIL (STU 7)	
S718	1-572-938-21	SWITCH, TACTIL (VWX 8)	
S719	1-572-938-21	SWITCH, TACTIL (YZ 9)	
S720	1-572-938-21	SWITCH, TACTIL (TIME DIFF ⇨)	
S721	1-572-938-21	SWITCH, TACTIL (FM/AM STANDBY 1)	
S722	1-572-938-21	SWITCH, TACTIL (AM BAND STANDBY 2)	
S723	1-572-938-21	SWITCH, TACTIL (< > / 0)	
S724	1-572-938-21	SWITCH, TACTIL (EXE)	
S725	1-572-938-21	SWITCH, TACTIL (TIME SET - ⇨)	
S726	1-572-938-21	SWITCH, TACTIL (KEY PROTECT)	
S727	1-572-938-21	SWITCH, TACTIL (SYNC)	
S728	1-572-938-21	SWITCH, TACTIL (SSB)	
S729	1-572-938-21	SWITCH, TACTIL (LABEL EDIT)	

*	A-3661-961-A	MICROCOMPUTER BOARD, COMPLETE *****	
	1-537-683-11	CONDUCTIVE BOARD, CONNECTION	
	3-909-845-01	PLATE, LIGHT GUIDE	
	3-909-849-01	SHIELD (LCD)	
		< BATTERY >	
BAT601	1-528-412-11	BATTERY, PAS SECONDARY	

Ref.No.	Part No.	Description	Remark
		< CAPACITOR >	
C601	1-162-964-11	CERAMIC CHIP	0.001uF 10% 50V
C602	1-162-964-11	CERAMIC CHIP	0.001uF 10% 50V
C603	1-162-964-11	CERAMIC CHIP	0.001uF 10% 50V
C604	1-164-005-11	CERAMIC CHIP	0.47uF 25V
C605	1-164-346-11	CERAMIC CHIP	1uF 16V
C606	1-164-346-11	CERAMIC CHIP	1uF 16V
C607	1-164-346-11	CERAMIC CHIP	1uF 16V
C608	1-164-346-11	CERAMIC CHIP	1uF 16V
C609	1-162-964-11	CERAMIC CHIP	0.001uF 10% 50V
C610	1-162-964-11	CERAMIC CHIP	0.001uF 10% 50V
C611	1-162-964-11	CERAMIC CHIP	0.001uF 10% 50V
C612	1-162-964-11	CERAMIC CHIP	0.001uF 10% 50V
C613	1-164-346-11	CERAMIC CHIP	1uF 16V
C614	1-164-346-11	CERAMIC CHIP	1uF 16V
C615	1-135-254-11	TANTAL. CHIP	47uF 20% 4V
C617	1-162-970-11	CERAMIC CHIP	0.01uF 10% 25V
C618	1-164-346-11	CERAMIC CHIP	1uF 16V
C619	1-164-346-11	CERAMIC CHIP	1uF 16V
C620	1-164-346-11	CERAMIC CHIP	1uF 16V
C621	1-164-346-11	CERAMIC CHIP	1uF 16V
C622	1-164-346-11	CERAMIC CHIP	1uF 16V
C623	1-164-005-11	CERAMIC CHIP	0.47uF 25V
C624	1-162-961-11	CERAMIC CHIP	330PF 10% 50V
C625	1-162-961-11	CERAMIC CHIP	330PF 10% 50V
C626	1-162-970-11	CERAMIC CHIP	0.01uF 10% 25V
C627	1-162-970-11	CERAMIC CHIP	0.01uF 10% 25V
C628	1-164-346-11	CERAMIC CHIP	1uF 16V
C629	1-135-254-11	TANTAL. CHIP	47uF 20% 4V
C630	1-164-346-11	CERAMIC CHIP	1uF 16V
C631	1-162-938-11	CERAMIC CHIP	7PF 0.5PF 50V
C632	1-164-346-11	CERAMIC CHIP	1uF 16V
		< CONNECTOR >	

CN601	1-764-370-11	HOUSING, FPC CONNECTOR(ZIF)16P	
CN602	1-764-368-11	HOUSING, FPC CONNECTOR(ZIF)18P	
		< DIODE >	
D601	8-719-951-22	DIODE	1MN10
D602	8-719-951-22	DIODE	1MN10
D603	8-719-951-22	DIODE	1MN10
D604	8-719-037-7	LED	CL-181G-C
D605	8-719-037-7	LED	CL-181G-C
D606	8-719-941-86	DIODE	DAN202U
D607	8-719-988-82	DIODE	RB715F

Ref.No.	Part No.	Description	Remark
< IC >			
IC601	8-759-249-34	IC S-807195N-DG	
IC602	8-759-255-02	IC S-80723SN-DL-T1	
IC603	8-759-254-75	IC MSM64164C-029	
IC604	8-759-254-74	IC MSM64164C-030	
IC605	8-759-255-03	IC S-807175N-DE-T1	
IC606	8-759-255-05	IC AK93C65LF-E1	
IC607	8-759-255-04	IC S-81220PG-PS-T1	
< LIQUID CRYSTAL DISPLAY >			
LCD601	1-810-427-11	DISPLAY PANEL, LIQUID CRYSTAL	
< TRANSISTOR >			
Q601	8-729-117-32	TRANSISTOR 2SC4177-L6	
Q602	8-729-117-32	TRANSISTOR 2SC4177-L6	
Q603	8-729-117-32	TRANSISTOR 2SC4177 L6	
< RESISTOR >			
R601	1-216-857-11	METAL CHIP 1M 5% 1/16W	
R602	1-216-857-11	METAL CHIP 1M 5% 1/16W	
R603	1-216-857-11	METAL CHIP 1M 5% 1/16W	
R604	1-216-804-11	METAL CHIP 39 5% 1/16W	
R605	1-216-804-11	METAL CHIP 39 5% 1/16W	
R606	1-216-857-11	METAL CHIP 1M 5% 1/16W	
R607	1-216-857-11	METAL CHIP 1M 5% 1/16W	
R608	1-216-821-11	METAL CHIP 1K 5% 1/16W	
R609	1-216-833-11	METAL CHIP 10K 5% 1/16W	
R610	1-216-845-11	METAL CHIP 100K 5% 1/16W	
R611	1-216-825-11	METAL CHIP 2.2K 5% 1/16W	
R612	1-216-797-11	METAL CHIP 10 5% 1/16W	
R613	1-216-797-11	METAL CHIP 10 5% 1/16W	
R614	1-216-825-11	METAL CHIP 2.2K 5% 1/16W	
R615	1-216-857-11	METAL CHIP 1M 5% 1/16W	
R616	1-216-845-11	METAL CHIP 100K 5% 1/16W	
R617	1-216-845-11	METAL CHIP 100K 5% 1/16W	
R618	1-216-797-11	METAL CHIP 10 5% 1/16W	
R619	1-216-797-11	METAL CHIP 10 5% 1/16W	
R620	1-216-825-11	METAL CHIP 2.2K 5% 1/16W	
R621	1-216-833-11	METAL CHIP 10K 5% 1/16W	
R622	1-216-837-11	METAL CHIP 22K 5% 1/16W	
R623	1-216-821-11	METAL CHIP 1K 5% 1/16W	
R624	1-216-837-11	METAL CHIP 22K 5% 1/16W	
< RESISTOR BLOCK >			
RB601	1-236-631-11	RES, NETWORK	
RB602	1-236-631-11	RES, NETWORK	
RB603	1-236-631-11	RES, NETWORK	
RB604	1-236-502-11	RES, NETWORK	

Ref.No.	Part No.	Description	Remark
RB605	1-236-502-11	RES, NETWORK	
RB606	1-236-502-11	RES, NETWORK	
RB607	1-236-502-11	RES, NETWORK	
RB608	1-236-502-11	RES, NETWORK	
RB609	1-236-875-11	RES, NETWORK	
RB610	1-236-631-11	RES, NETWORK	
RB611	1-236-631-11	RES, NETWORK	
RB612	1-236-502-11	RES, NETWORK	
RB613	1-236-502-11	RES, NETWORK	
RB614	1-236-502-11	RES, NETWORK	
RB615	1-236-631-11	RES, NETWORK	
RB616	1-236-631-11	RES, NETWORK	
RB617	1-236-631-11	RES, NETWORK	
RB618	1-236-502-11	RES, NETWORK	
RB619	1-236-502-11	RES, NETWORK	
RB620	1-236-502-11	RES, NETWORK	
RB621	1-236-502-11	RES, NETWORK	
RB622	1-236-502-11	RES, NETWORK	
RB623	1-236-502-11	RES, NETWORK	
RB624	1-236-502-11	RES, NETWORK	
RB625	1-236-502-11	RES, NETWORK	
RB626	1-236-502-11	RES, NETWORK	
RB627	1-236-502-11	RES, NETWORK	
RB628	1-236-502-11	RES, NETWORK	
RB629	1-236-631-11	RES, NETWORK	
RB630	1-236-855-11	RES, NETWORK	
RB631	1-236-631-11	RES, NETWORK	
< SWITCH >			
S601	1-572-473-11	SWITCH, TACTIL (LIGHT)	
< VIBRATOR >			
X601	1-760-201-11	VIBRATOR, CRYSTAL (32.768 kHz)	

*	A-3679-561-A	SIGNAL BOARD, COMPLETE	

*	3-909-850-01	SHIELD (DDCON)	
*	3-909-856-01	PLATE (BATTERY), CONTACT	
*	3-909-858-01	SHIELD (VCO)	
< CAPACITOR >			
C1	1-162-970-11	CERAMIC CHIP 0.01uF 10% 25V	
C2	1-162-936-11	CERAMIC CHIP 5PF 0.25PF 50V	
C4	1-162-934-11	CERAMIC CHIP 3PF 0.25PF 50V	
C5	1-162-936-11	CERAMIC CHIP 5PF 0.25PF 50V	
C6	1-162-958-11	CERAMIC CHIP 270PF 5% 50V	

SIGNAL

Ref.No.	Part No.	Description	Remark
C7	1-162-970-11	CERAMIC CHIP	0.01uF 10% 25V
C8	1-162-940-11	CERAMIC CHIP	9PF 0.5PF 50V
C9	1-162-943-11	CERAMIC CHIP	15PF 5% 50V
C10	1-162-935-11	CERAMIC CHIP	4PF 0.25PF 50V
C11	1-135-235-11	TANTAL. CHIP	15uF 20% 4V
C12	1-162-970-11	CERAMIC CHIP	0.01uF 10% 25V
C13	1-162-970-11	CERAMIC CHIP	0.01uF 10% 25V
C14	1-162-970-11	CERAMIC CHIP	0.01uF 10% 25V
C15	1-162-939-11	CERAMIC CHIP	8PF 0.5PF 50V
C16	1-162-970-11	CERAMIC CHIP	0.01uF 10% 25V
C17	1-135-235-11	TANTAL. CHIP	15uF 20% 4V
C18	1-162-942-11	CERAMIC CHIP	12PF 5% 50V
C19	1-162-942-11	CERAMIC CHIP	12PF 5% 50V
C21	1-162-970-11	CERAMIC CHIP	0.01uF 10% 25V
C22	1-135-235-11	TANTAL. CHIP	15uF 20% 4V
C23	1-135-235-11	TANTAL. CHIP	15uF 20% 4V
C24	1-164-346-11	CERAMIC CHIP	1uF 16V
C25	1-135-235-11	TANTAL. CHIP	15uF 20% 4V
C26	1-162-953-11	CERAMIC CHIP	100PF 5% 50V
C27	1-162-970-11	CERAMIC CHIP	0.01uF 10% 25V
C28	1-162-970-11	CERAMIC CHIP	0.01uF 10% 25V
C29	1-162-964-11	CERAMIC CHIP	0.001uF 10% 50V
C30	1-135-235-11	TANTAL. CHIP	15uF 20% 4V
C31	1-162-970-11	CERAMIC CHIP	0.01uF 10% 25V
C32	1-162-964-11	CERAMIC CHIP	0.001uF 10% 50V
C33	1-162-970-11	CERAMIC CHIP	0.01uF 10% 25V
C34	1-162-943-11	CERAMIC CHIP	15PF 5% 50V
C35	1-162-970-11	CERAMIC CHIP	0.01uF 10% 25V
C36	1-162-970-11	CERAMIC CHIP	0.01uF 10% 25V
C37	1-162-964-11	CERAMIC CHIP	0.001uF 10% 50V
C101	1-162-939-11	CERAMIC CHIP	8PF 0.5PF 50V
C102	1-162-970-11	CERAMIC CHIP	0.01uF 10% 25V
C103	1-135-235-11	TANTAL. CHIP	15uF 20% 4V
C104	1-162-930-11	CERAMIC CHIP	1PF 0.25PF 50V
C105	1-161-021-11	CERAMIC	0.047uF 10% 25V
C107	1-135-254-11	TANTAL. CHIP	47uF 20% 4V
C108	1-162-970-11	CERAMIC CHIP	0.01uF 10% 25V
C109	1-162-930-11	CERAMIC CHIP	1PF 0.25PF 50V
C110	1-162-970-11	CERAMIC CHIP	0.01uF 10% 25V
C111	1-162-970-11	CERAMIC CHIP	0.01uF 10% 25V
C112	1-135-254-11	TANTAL. CHIP	47uF 20% 4V
C113	1-162-970-11	CERAMIC CHIP	0.01uF 10% 25V
C115	1-135-235-11	TANTAL. CHIP	15uF 20% 4V
C116	1-162-970-11	CERAMIC CHIP	0.01uF 10% 25V
C118	1-107-823-11	CERAMIC CHIP	0.47uF 10% 16V
C121	1-164-346-11	CERAMIC CHIP	1uF 16V
C122	1-162-970-11	CERAMIC CHIP	0.01uF 10% 25V
C123	1-162-970-11	CERAMIC CHIP	0.01uF 10% 25V
C124	1-162-970-11	CERAMIC CHIP	0.01uF 10% 25V

Ref.No.	Part No.	Description	Remark
C125	1-164-346-11	CERAMIC CHIP	1uF 16V
C126	1-162-947-11	CERAMIC CHIP	33PF 5% 50V
C127	1-164-185-11	CERAMIC CHIP	13PF 5% 50V
C128	1-162-970-11	CERAMIC CHIP	0.01uF 10% 25V
C129	1-162-970-11	CERAMIC CHIP	0.01uF 10% 25V
C130	1-164-346-11	CERAMIC CHIP	1uF 16V
C131	1-162-970-11	CERAMIC CHIP	0.01uF 10% 25V
C132	1-162-970-11	CERAMIC CHIP	0.01uF 10% 25V
C133	1-162-970-11	CERAMIC CHIP	0.01uF 10% 25V
C134	1-162-970-11	CERAMIC CHIP	0.01uF 10% 25V
C135	1-162-970-11	CERAMIC CHIP	0.01uF 10% 25V
C136	1-162-970-11	CERAMIC CHIP	0.01uF 10% 25V
C137	1-162-970-11	CERAMIC CHIP	0.01uF 10% 25V
C138	1-162-969-11	CERAMIC CHIP	0.0068uF 10% 25V
C139	1-107-823-11	CERAMIC CHIP	0.47uF 10% 16V
C140	1-162-943-11	CERAMIC CHIP	15PF 5% 50V
C141	1-162-943-11	CERAMIC CHIP	15PF 5% 50V
C150	1-135-254-11	TANTAL. CHIP	47uF 20% 4V
C201	1-162-970-11	CERAMIC CHIP	0.01uF 10% 25V
C202	1-162-970-11	CERAMIC CHIP	0.01uF 10% 25V
C203	1-162-970-11	CERAMIC CHIP	0.01uF 10% 25V
C204	1-135-235-11	TANTAL. CHIP	15uF 20% 4V
C205	1-162-970-11	CERAMIC CHIP	0.01uF 10% 25V
C206	1-162-935-11	CERAMIC CHIP	4PF 0.25PF 50V
C207	1-162-941-11	CERAMIC CHIP	10PF 0.5PF 50V
C208	1-162-964-11	CERAMIC CHIP	0.001uF 10% 50V
C209	1-162-964-11	CERAMIC CHIP	0.001uF 10% 50V
C210	1-162-964-11	CERAMIC CHIP	0.001uF 10% 50V
C211	1-135-339-11	TANTAL. CHIP	150uF 20% 4V
C212	1-164-346-11	CERAMIC CHIP	1uF 16V
C213	1-162-966-11	CERAMIC CHIP	0.0022uF 10% 50V
C214	1-162-970-11	CERAMIC CHIP	0.01uF 10% 25V
C215	1-162-970-11	CERAMIC CHIP	0.01uF 10% 25V
C216	1-164-346-11	CERAMIC CHIP	1uF 16V
C218	1-164-346-11	CERAMIC CHIP	1uF 16V
C219	1-135-235-11	TANTAL. CHIP	15uF 20% 4V
C220	1-162-970-11	CERAMIC CHIP	0.01uF 10% 25V
C221	1-162-970-11	CERAMIC CHIP	0.01uF 10% 25V
C222	1-162-970-11	CERAMIC CHIP	0.01uF 10% 25V
C223	1-162-970-11	CERAMIC CHIP	0.01uF 10% 25V
C224	1-164-346-11	CERAMIC CHIP	1uF 16V
C225	1-135-235-11	TANTAL. CHIP	15uF 20% 4V
C226	1-107-823-11	CERAMIC CHIP	0.47uF 10% 16V
C227	1-163-038-00	CERAMIC CHIP	0.1uF 25V
C229	1-162-970-11	CERAMIC CHIP	0.01uF 10% 25V
C230	1-162-970-11	CERAMIC CHIP	0.01uF 10% 25V
C232	1-162-970-11	CERAMIC CHIP	0.01uF 10% 25V
C233	1-164-346-11	CERAMIC CHIP	1uF 16V

Ref.No.	Part No.	Description		Remark
C250	1-135-235-11	TANTAL. CHIP	15uF	20% 4V
C301	1-162-970-11	CERAMIC CHIP	0.01uF	10% 25V
C302	1-164-227-11	CERAMIC CHIP	0.022uF	10% 25V
C303	1-162-970-11	CERAMIC CHIP	0.01uF	10% 25V
C304	1-163-137-00	CERAMIC CHIP	680PF	5% 50V
C305	1-164-346-11	CERAMIC CHIP	1uF	16V
C306	1-164-346-11	CERAMIC CHIP	1uF	16V
C307	1-163-038-00	CERAMIC CHIP	0.1uF	25V
C308	1-135-254-11	TANTAL. CHIP	47uF	20% 4V
C309	1-164-346-11	CERAMIC CHIP	1uF	16V
C310	1-162-970-11	CERAMIC CHIP	0.01uF	10% 25V
C311	1-162-970-11	CERAMIC CHIP	0.01uF	10% 25V
C312	1-162-970-11	CERAMIC CHIP	0.01uF	10% 25V
C313	1-164-346-11	CERAMIC CHIP	1uF	16V
C314	1-135-235-11	TANTAL. CHIP	15uF	20% 4V
C315	1-164-346-11	CERAMIC CHIP	1uF	16V
C316	1-164-346-11	CERAMIC CHIP	1uF	16V
C317	1-164-346-11	CERAMIC CHIP	1uF	16V
C318	1-164-346-11	CERAMIC CHIP	1uF	16V
C319	1-164-346-11	CERAMIC CHIP	1uF	16V
C320	1-164-346-11	CERAMIC CHIP	1uF	16V
C321	1-164-346-11	CERAMIC CHIP	1uF	16V
C322	1-163-986-00	CERAMIC CHIP	0.027uF	10% 25V
C323	1-163-986-00	CERAMIC CHIP	0.027uF	10% 25V
C324	1-135-235-11	TANTAL. CHIP	15uF	20% 4V
C325	1-164-346-11	CERAMIC CHIP	1uF	16V
C326	1-164-346-11	CERAMIC CHIP	1uF	16V
C327	1-135-254-11	TANTAL. CHIP	47uF	20% 4V
C328	1-135-254-11	TANTAL. CHIP	47uF	20% 4V
C329	1-164-346-11	CERAMIC CHIP	1uF	16V
C330	1-162-970-11	CERAMIC CHIP	0.01uF	10% 25V
C331	1-164-346-11	CERAMIC CHIP	1uF	16V
C332	1-164-346-11	CERAMIC CHIP	1uF	16V
C333	1-164-346-11	CERAMIC CHIP	1uF	16V
C334	1-135-235-11	TANTAL. CHIP	15uF	20% 4V
C335	1-164-346-11	CERAMIC CHIP	1uF	16V
C336	1-135-339-11	TANTAL. CHIP	150uF	20% 4V
C337	1-135-339-11	TANTAL. CHIP	150uF	20% 4V
C338	1-164-346-11	CERAMIC CHIP	1uF	16V
C339	1-162-953-11	CERAMIC CHIP	100PF	5% 50V
C340	1-164-227-11	CERAMIC CHIP	0.022uF	10% 25V
C341	1-164-145-11	CERAMIC CHIP	390PF	5% 50V
C401	1-164-227-11	CERAMIC CHIP	0.022uF	10% 25V
C402	1-162-941-11	CERAMIC CHIP	10PF	0.5PF 50V
C403	1-135-235-11	TANTAL. CHIP	15uF	20% 4V
C404	1-164-346-11	CERAMIC CHIP	1uF	16V
C405	1-162-941-11	CERAMIC CHIP	10PF	0.5PF 50V
C406	1-164-346-11	CERAMIC CHIP	1uF	16V
C407	1-164-346-11	CERAMIC CHIP	1uF	16V

Ref.No.	Part No.	Description		Remark
C408	1-162-970-11	CERAMIC CHIP	0.01uF	10% 25V
C409	1-162-970-11	CERAMIC CHIP	0.01uF	10% 25V
C410	1-135-235-11	TANTAL. CHIP	15uF	20% 4V
< FILTER >				
CF201	1-760-199-11	FILTER, CERAMIC		
CF202	1-579-974-11	FILTER, CERAMIC		
CF203	1-579-974-11	FILTER, CERAMIC		
CF204	1-577-312-91	FILTER, CERAMIC (BEFORE BOARD SUFFIX-16)		
< CONNECTOR >				
CN401	1-764-369-11	CONNECTOR, FFC/FPC (ZIF) 18P		
< TRIMMER >				
CT1	1-141-327-11	CAP, VAR, TRIMMER (CHIP TYPE)		
CT2	1-141-325-11	CAP, VAR, TRIMMER (CHIP TYPE)		
< DIODE >				
D1	8-719-800-76	DIODE 1SS226		
D2	8-719-971-18	DIODE 1SS318		
D3	8-719-941-86	DIODE DAN202U		
D4	8-719-971-18	DIODE 1SS318		
D5	8-719-002-81	DIODE 1T363		
D6	8-719-002-81	DIODE 1T363		
D7	8-719-971-18	DIODE 1SS318		
D101	8-719-002-81	DIODE 1T363		
D102	8-719-941-86	DIODE DAN202U		
D103	8-719-941-86	DIODE DAN202U		
D104	8-719-941-86	DIODE DAN202U		
D201	8-719-002-81	DIODE 1T363		
D202	8-719-002-81	DIODE 1T363		
D203	8-719-941-86	DIODE DAN202U		
D401	8-719-977-34	DIODE DTZ12		
D402	8-719-941-86	DIODE DAN202U		
D403	8-719-975-40	DIODE RB411D		
D405	8-719-941-86	DIODE DAN202U		
< IC >				
IC101	8-759-804-76	IC LA5002M		
IC102	8-759-254-73	IC uPD1724GB-599-1A7 (BEFORE BOARD SUFFIX-16)		
IC201	8-752-064-32	IC CXA1376AM		
IC301	8-759-804-98	IC LA3335M		
IC302	8-752-058-42	IC CXA1622M		
IC303	8-759-255-02	IC S-80723SN-DL-T1		
< JACK >				
J1	1-764-624-11	JACK (ACTIVE ANT)		
J301	1-764-624-11	JACK (LINE OUT)		

SIGNAL

Ref.No.	Part No.	Description	Remark
J302	1-764-625-11	JACK (Ω)	
J303	1-764-628-21	JACK, DC (POLARITY UNIFIED TYPE) (DC IN 3V)	
< COIL >			
L1	1-410-981-31	INDUCTOR CHIP	0.1uH
L3	1-410-992-11	INDUCTOR CHIP	0.82uH
L4	1-410-992-11	INDUCTOR CHIP	0.82uH
L5	1-410-216-31	INDUCTOR CHIP	100uH
L6	1-410-997-31	INDUCTOR CHIP	2.2uH
L7	1-410-997-31	INDUCTOR CHIP	2.2uH
L8	1-410-997-31	INDUCTOR CHIP	2.2uH
L9	1-410-987-11	INDUCTOR CHIP	0.33uH
L10	1-410-216-31	INDUCTOR CHIP	100uH
L101	1-410-990-31	INDUCTOR CHIP	0.56uH
L102	1-410-997-31	INDUCTOR CHIP	2.2uH
L201	1-412-006-31	INDUCTOR CHIP	10uH
L202	1-410-985-11	INDUCTOR CHIP	0.22uH
L204	1-412-011-31	INDUCTOR CHIP	27uH
L301	1-412-002-31	INDUCTOR CHIP	4.7uH
L302	1-412-002-31	INDUCTOR CHIP	4.7uH
L303	1-412-002-31	INDUCTOR CHIP	4.7uH
L401	1-410-220-31	INDUCTOR CHIP	220uH
L402	1-412-011-31	INDUCTOR CHIP	27uH
< TRANSISTOR >			
Q1	8-729-123-86	TRANSISTOR	2SK238-K16
Q2	8-729-116-64	TRANSISTOR	2SK508-K51
Q3	8-729-116-64	TRANSISTOR	2SK508-K51
Q4	8-729-208-47	TRANSISTOR	2SK210-GR
Q5	8-729-402-16	TRANSISTOR	XN4608
Q6	8-729-123-86	TRANSISTOR	2SK238-K16
Q7	8-729-117-72	TRANSISTOR	2SC4178-F13
Q8	8-729-117-32	TRANSISTOR	2SC4177-L6
Q9	8-729-402-16	TRANSISTOR	XN4608
Q10	8-729-123-86	TRANSISTOR	2SK238-K16
Q11	8-729-904-86	TRANSISTOR	2SB1197K-Q
Q12	8-729-921-58	TRANSISTOR	DTA144TU
Q101	8-729-117-72	TRANSISTOR	2SC4178-F13
Q102	8-729-208-47	TRANSISTOR	2SK210-GR
Q103	8-729-117-72	TRANSISTOR	2SC4178-F13
Q104	8-729-904-86	TRANSISTOR	2SB1197K-Q
Q105	8-729-220-93	TRANSISTOR	2SK209-G
Q106	8-729-117-32	TRANSISTOR	2SC4177-L6
Q107	8-729-220-93	TRANSISTOR	2SK209-G
Q108	8-729-903-10	TRANSISTOR	FMW1
Q109	8-729-117-32	TRANSISTOR	2SC4177-L6
Q110	8-729-921-08	TRANSISTOR	DTC144TU
Q111	8-729-402-16	TRANSISTOR	XN4608
Q112	8-729-117-32	TRANSISTOR	2SC4177-L6

Ref.No.	Part No.	Description	Remark
Q113	8-729-903-10	TRANSISTOR	FMW1
Q201	8-729-117-72	TRANSISTOR	2SC4178-F13
Q202	8-729-903-10	TRANSISTOR	FMW1
Q203	8-729-921-08	TRANSISTOR	DTC144TU
Q204	8-729-921-08	TRANSISTOR	DTC144TU
Q205	8-729-921-08	TRANSISTOR	DTC144TU
Q206	8-729-921-08	TRANSISTOR	DTC144TU
Q207	8-729-921-08	TRANSISTOR	DTC144TU
Q208	8-729-921-58	TRANSISTOR	DTA144TU
Q301	8-729-903-10	TRANSISTOR	FMW1
Q302	8-729-903-10	TRANSISTOR	FMW1
Q303	8-729-921-08	TRANSISTOR	DTC144TU
Q304	8-729-921-58	TRANSISTOR	DTA144TU
Q305	8-729-921-08	TRANSISTOR	DTC144TU
Q306	8-729-117-32	TRANSISTOR	2SC4177-L6
Q307	8-729-117-32	TRANSISTOR	2SC4177-L6
Q308	8-729-921-58	TRANSISTOR	DTA144TU
Q309	8-729-402-16	TRANSISTOR	XN4608
Q310	8-729-921-08	TRANSISTOR	DTC144TU
Q311	8-729-921-08	TRANSISTOR	DTC144TU
Q401	8-729-903-10	TRANSISTOR	FMW1
Q402	8-729-904-86	TRANSISTOR	2SB1197K-Q
Q403	8-729-402-16	TRANSISTOR	XN4608
Q404	8-729-117-32	TRANSISTOR	2SC4177-L6
< RESISTOR >			
R4	1-216-819-11	METAL CHIP	680 5% 1/16W
R5	1-216-807-11	METAL CHIP	68 5% 1/16W
R6	1-216-809-11	METAL CHIP	100 5% 1/16W
R7	1-216-825-11	METAL CHIP	2.2K 5% 1/16W
R8	1-216-833-11	METAL CHIP	10K 5% 1/16W
R9	1-216-833-11	METAL CHIP	10K 5% 1/16W
R10	1-216-829-11	METAL CHIP	4.7K 5% 1/16W
R11	1-216-850-11	METAL CHIP	270K 5% 1/16W
R12	1-216-821-11	METAL CHIP	1K 5% 1/16W
R13	1-216-797-11	METAL CHIP	10 5% 1/16W
R14	1-216-825-11	METAL CHIP	2.2K 5% 1/16W
R15	1-216-825-11	METAL CHIP	2.2K 5% 1/16W
R16	1-216-797-11	METAL CHIP	10 5% 1/16W
R17	1-216-797-11	METAL CHIP	10 5% 1/16W
R18	1-216-797-11	METAL CHIP	10 5% 1/16W
R19	1-216-814-11	METAL CHIP	270 5% 1/16W
R20	1-216-797-11	METAL CHIP	10 5% 1/16W
R21	1-216-819-11	METAL CHIP	680 5% 1/16W
R22	1-216-850-11	METAL CHIP	270K 5% 1/16W
R23	1-216-841-11	METAL CHIP	47K 5% 1/16W
R24	1-216-837-11	METAL CHIP	22K 5% 1/16W
R25	1-216-797-11	METAL CHIP	10 5% 1/16W

Ref.No.	Part No.	Description	Remark		
R26	1-216-838-11	METAL CHIP	27K	5%	1/16W
R27	1-216-853-11	METAL CHIP	470K	5%	1/16W
R28	1-216-833-11	METAL CHIP	10K	5%	1/16W
R29	1-216-833-11	METAL CHIP	10K	5%	1/16W
R30	1-216-833-11	METAL CHIP	10K	5%	1/16W
R31	1-216-845-11	METAL CHIP	100K	5%	1/16W
R32	1-216-833-11	METAL CHIP	10K	5%	1/16W
R33	1-216-845-11	METAL CHIP	100K	5%	1/16W
R34	1-216-841-11	METAL CHIP	47K	5%	1/16W
R35	1-216-840-11	METAL CHIP	39K	5%	1/16W
R36	1-216-829-11	METAL CHIP	4.7K	5%	1/16W
R37	1-216-821-11	METAL CHIP	1K	5%	1/16W
R38	1-216-845-11	METAL CHIP	100K	5%	1/16W
R39	1-216-797-11	METAL CHIP	10	5%	1/16W
R40	1-216-845-11	METAL CHIP	100K	5%	1/16W
R41	1-216-833-11	METAL CHIP	10K	5%	1/16W
R42	1-216-845-11	METAL CHIP	100K	5%	1/16W
R43	1-216-809-11	METAL CHIP	100	5%	1/16W
R44	1-216-829-11	METAL CHIP	4.7K	5%	1/16W
R45	1-216-825-11	METAL CHIP	2.2K	5%	1/16W
R47	1-216-813-11	METAL CHIP	220	5%	1/16W
R101	1-216-797-11	METAL CHIP	10	5%	1/16W
R102	1-216-842-11	METAL CHIP	56K	5%	1/16W
R103	1-216-805-11	METAL CHIP	47	5%	1/16W
R104	1-216-797-11	METAL CHIP	10	5%	1/16W
R105	1-216-842-11	METAL CHIP	56K	5%	1/16W
R106	1-216-797-11	METAL CHIP	10	5%	1/16W
R107	1-216-814-11	METAL CHIP	270	5%	1/16W
R108	1-216-837-11	METAL CHIP	22K	5%	1/16W
R109	1-216-837-11	METAL CHIP	22K	5%	1/16W
R110	1-216-845-11	METAL CHIP	100K	5%	1/16W
R111	1-216-833-11	METAL CHIP	10K	5%	1/16W
R112	1-216-833-11	METAL CHIP	10K	5%	1/16W
R113	1-216-845-11	METAL CHIP	100K	5%	1/16W
R114	1-216-821-11	METAL CHIP	1K	5%	1/16W
R115	1-216-829-11	METAL CHIP	4.7K	5%	1/16W
R116	1-216-831-11	METAL CHIP	6.8K	5%	1/16W
R117	1-216-831-11	METAL CHIP	6.8K	5%	1/16W
R118	1-216-833-11	METAL CHIP	10K	5%	1/16W
R119	1-218-293-11	METAL CHIP	24K	5%	1/16W
R120	1-216-840-11	METAL CHIP	39K	5%	1/16W
R121	1-216-797-11	METAL CHIP	10	5%	1/16W
R122	1-216-841-11	METAL CHIP	47K	5%	1/16W
R123	1-216-845-11	METAL CHIP	100K	5%	1/16W
R124	1-216-833-11	METAL CHIP	10K	5%	1/16W
R125	1-216-797-11	METAL CHIP	10	5%	1/16W
R126	1-216-809-11	METAL CHIP	100	5%	1/16W
R127	1-216-809-11	METAL CHIP	100	5%	1/16W

Ref.No.	Part No.	Description	Remark		
R128	1-216-830-11	METAL CHIP	5.6K	5%	1/16W
R129	1-216-827-11	METAL CHIP	3.3K	5%	1/16W
R130	1-216-827-11	METAL CHIP	3.3K	5%	1/16W
R131	1-216-827-11	METAL CHIP	3.3K	5%	1/16W
R132	1-216-843-11	METAL CHIP	68K	5%	1/16W
R133	1-216-839-11	METAL CHIP	33K	5%	1/16W
R134	1-216-839-11	METAL CHIP	33K	5%	1/16W
R135	1-216-843-11	METAL CHIP	68K	5%	1/16W
R136	1-216-839-11	METAL CHIP	33K	5%	1/16W
R137	1-216-839-11	METAL CHIP	33K	5%	1/16W
R138	1-216-839-11	METAL CHIP	33K	5%	1/16W
R139	1-216-843-11	METAL CHIP	68K	5%	1/16W
R140	1-216-843-11	METAL CHIP	68K	5%	1/16W
R141	1-216-843-11	METAL CHIP	68K	5%	1/16W
R142	1-216-843-11	METAL CHIP	68K	5%	1/16W
R143	1-216-843-11	METAL CHIP	68K	5%	1/16W
R144	1-216-827-11	METAL CHIP	3.3K	5%	1/16W
R145	1-216-845-11	METAL CHIP	100K	5%	1/16W
R146	1-216-845-11	METAL CHIP	100K	5%	1/16W
R147	1-216-827-11	METAL CHIP	3.3K	5%	1/16W
R148	1-216-827-11	METAL CHIP	3.3K	5%	1/16W
R149	1-216-827-11	METAL CHIP	3.3K	5%	1/16W
R150	1-216-827-11	METAL CHIP	3.3K	5%	1/16W
R151	1-216-827-11	METAL CHIP	3.3K	5%	1/16W
R152	1-216-827-11	METAL CHIP	3.3K	5%	1/16W
R153	1-216-827-11	METAL CHIP	3.3K	5%	1/16W
R154	1-216-825-11	METAL CHIP	2.2K	5%	1/16W
R155	1-216-838-11	METAL CHIP	27K	5%	1/16W
R156	1-216-831-11	METAL CHIP	6.8K	5%	1/16W
R157	1-216-839-11	METAL CHIP	33K	5%	1/16W
R158	1-216-845-11	METAL CHIP	100K	5%	1/16W
R159	1-216-803-11	METAL CHIP	33	5%	1/16W
R160	1-216-803-11	METAL CHIP	33	5%	1/16W
R161	1-216-837-11	METAL CHIP	22K	5%	1/16W
R162	1-216-850-11	METAL CHIP	270K	5%	1/16W
R163	1-216-829-11	METAL CHIP	4.7K	5%	1/16W
R164	1-216-835-11	METAL CHIP	15K	5%	1/16W
R201	1-216-814-11	METAL CHIP	270	5%	1/16W
R202	1-216-837-11	METAL CHIP	22K	5%	1/16W
R203	1-216-825-11	METAL CHIP	2.2K	5%	1/16W
R204	1-216-845-11	METAL CHIP	100K	5%	1/16W
R205	1-216-825-11	METAL CHIP	2.2K	5%	1/16W
R206	1-216-833-11	METAL CHIP	10K	5%	1/16W
R207	1-216-827-11	METAL CHIP	3.3K	5%	1/16W
R208	1-216-797-11	METAL CHIP	10	5%	1/16W
R209	1-216-832-11	METAL CHIP	8.2K	5%	1/16W
R210	1-216-819-11	METAL CHIP	680	5%	1/16W
R211	1-216-849-11	METAL CHIP	220K	5%	1/16W
R212	1-216-797-11	METAL CHIP	10	5%	1/16W

SIGNAL

Ref.No.	Part No.	Description	Remark		
R213	1-216-849-11	METAL CHIP	220K	5%	1/16W
R214	1-216-825-11	METAL CHIP	2.2K	5%	1/16W
R215	1-216-831-11	METAL CHIP	6.8K	5%	1/16W
R216	1-216-838-11	METAL CHIP	27K	5%	1/16W
R217	1-216-809-11	METAL CHIP	100	5%	1/16W
R218	1-216-841-11	METAL CHIP	47K	5%	1/16W
R219	1-216-851-11	METAL CHIP	330K	5%	1/16W
R220	1-216-833-11	METAL CHIP	10K	5%	1/16W
R221	1-216-821-11	METAL CHIP	1K	5%	1/16W
R222	1-216-839-11	METAL CHIP	33K	5%	1/16W
R301	1-216-829-11	METAL CHIP	4.7K	5%	1/16W
R302	1-216-833-11	METAL CHIP	10K	5%	1/16W
R303	1-216-837-11	METAL CHIP	22K	5%	1/16W
R304	1-216-833-11	METAL CHIP	10K	5%	1/16W
R305	1-216-833-11	METAL CHIP	10K	5%	1/16W
R306	1-216-809-11	METAL CHIP	100	5%	1/16W
R307	1-216-840-11	METAL CHIP	39K	5%	1/16W
R308	1-216-845-11	METAL CHIP	100K	5%	1/16W
R309	1-216-797-11	METAL CHIP	10	5%	1/16W
R310	1-216-851-11	METAL CHIP	330K	5%	1/16W
R311	1-216-818-11	METAL CHIP	560	5%	1/16W
R312	1-216-803-11	METAL CHIP	33	5%	1/16W
R313	1-216-851-11	METAL CHIP	330K	5%	1/16W
R314	1-216-818-11	METAL CHIP	560	5%	1/16W
R315	1-216-803-11	METAL CHIP	33	5%	1/16W
R316	1-216-805-11	METAL CHIP	47	5%	1/16W
R317	1-216-829-11	METAL CHIP	4.7K	5%	1/16W
R318	1-216-825-11	METAL CHIP	2.2K	5%	1/16W
R319	1-216-833-11	METAL CHIP	10K	5%	1/16W
R320	1-216-831-11	METAL CHIP	6.8K	5%	1/16W
R321	1-216-837-11	METAL CHIP	22K	5%	1/16W
R322	1-216-823-11	METAL CHIP	1.5K	5%	1/16W
R323	1-216-833-11	METAL CHIP	10K	5%	1/16W
R324	1-216-805-11	METAL CHIP	47	5%	1/16W
R325	1-216-809-11	METAL CHIP	100	5%	1/16W
R326	1-216-809-11	METAL CHIP	100	5%	1/16W
R327	1-216-805-11	METAL CHIP	47	5%	1/16W
R328	1-216-845-11	METAL CHIP	100K	5%	1/16W
R329	1-216-831-11	METAL CHIP	6.8K	5%	1/16W
R330	1-216-829-11	METAL CHIP	4.7K	5%	1/16W
R332	1-216-845-11	METAL CHIP	100K	5%	1/16W
R333	1-216-821-11	METAL CHIP	1K	5%	1/16W
R334	1-216-821-11	METAL CHIP	1K	5%	1/16W
R401	1-216-845-11	METAL CHIP	100K	5%	1/16W
R402	1-216-845-11	METAL CHIP	100K	5%	1/16W
R403	1-216-843-11	METAL CHIP	68K	5%	1/16W
R404	1-216-821-11	METAL CHIP	1K	5%	1/16W
R406	1-216-797-11	METAL CHIP	10	5%	1/16W

Ref.No.	Part No.	Description	Remark		
R407	1-216-845-11	METAL CHIP	100K	5%	1/16W
R408	1-216-821-11	METAL CHIP	1K	5%	1/16W
R409	1-216-840-11	METAL CHIP	39K	5%	1/16W
R410	1-216-845-11	METAL CHIP	100K	5%	1/16W
R411	1-216-833-11	METAL CHIP	10K	5%	1/16W
R412	1-216-833-11	METAL CHIP	10K	5%	1/16W
< VARIABLE RESISTOR >					
RV201	1-241-597-11	RES, ADJ, CARBON 100K			
RV202	1-223-587-11	RES, ADJ, CARBON 22K			
RV301	1-223-587-11	RES, ADJ, CARBON 22K			
RV302	1-223-573-11	RES, VAR, CARBON 50K (VOL ↘)			
< SWITCH >					
S1	1-571-674-11	SWITCH, SLIDE (SENS DX/LOCAL)			
S301	1-571-275-11	SWITCH, SLIDE (AM TONE/FM MODE)			
S302	1-572-938-21	SWITCH, TACTIL (RESET)			
< TRANSFORMER >					
T1	1-423-981-11	TRANSFORMER, HIGH FREQUENCY (AM MIX)			
T2	1-403-633-11	TRANSFORMER, IF (AM 1ST IF)			
T3	1-403-634-11	TRANSFORMER, IF (AM 1ST IF)			
T4	1-423-983-11	TRANSFORMER, HIGH FREQUENCY (MW/LW RF)			
T5	1-403-636-11	COIL (WITH CORE) (FM RF)			
T6	1-403-637-11	COIL (WITH CORE) (FM RF)			
T101	1-403-629-11	COIL (WITH CORE) (AM 1ST OSC)			
T201	1-403-638-11	COIL (WITH CORE) (FM OSC)			
T202	1-403-632-11	COIL (WITH CORE) (AM OSC)			
T203	1-403-631-11	TRANSFORMER, IF (AM IF)			
T204	1-403-630-11	COIL (WITH CORE) (AM OSC)			
T401	1-449-021-21	COIL, DC/DC/ CONVERTER			
< VIBRATOR >					
X101	1-579-744-21	VIBRATOR, CRYSTAL (75kHz)			
X201	1-760-200-11	VIBRATOR, CERAMIC (3.640 MHz)			
X202	1-760-197-11	VIBRATOR, CRYSTAL (55.390 MHz)			
< FILTER >					
XF1	1-760-198-11	FILTER, CRYSTAL			

Ref. No.	Part No.	Description	Remarks
		MISCELLANEOUS *****	
19	1-651-256-12	PC BOARD, FLEXIBLE (KEY)	
28	1-651-257-12	PC BOARD, FLEXIBLE (SIGNAL)	
58	1-559-706-11	CORD (WITH PLUG)	
ANT1	1-501-658-21	ANTENNA, TELESCOPIC	
ANT2	1-501-657-31	ANTENNA, FERRITE-ROD (LW.MW)	
ANT3	1-501-658-21	ANTENNA, TELESCOPIC	
SP601	1-505-165-12	SPEAKER (4cm)	

		ACCESSORIES *****	
△	1-467-543-41	ADAPTOR, AC (AC-E314) (CND)	
△	1-476-124-11	ADAPTOR, AC (AC-E321) (SW100S: EA)	
△	1-476-124-12	ADAPTOR, AC (AC-E321) (SW100S: AEP, IT, E)	
△	1-476-125-13	ADAPTOR, AC (AC-E322) (US)	
△	1-476-126-13	ADAPTOR, AC (AC-E323) (JE)	
△	1-569-007-11	ADAPTOR, CONVERSION 2P (JE)	
△	1-569-008-12	ADAPTOR, CONVERSION 2P (SW100S: AEP, IT, E)	
△	1-569-008-21	ADAPTOR, CONVERSION 2P (SW100S: EA)	
△	1-573-856-11	ADAPTOR, CHANGE (CND)	
	X-3329-657-1	ATTACHMENT	
	3-757-853-08	MANUAL, INSTRUCTION (ENGLISH, ARABIC, KORIAN, JAPANESE) (EA, JE)	
	3-757-853-22	MANUAL, INSTRUCTION (ENGLISH, FRENCH, SPANISH, PORTUGUESE, SWEDISH) (AEP, E, US)	
	3-757-853-32	MANUAL, INSTRUCTION (ENGLISH, FRENCH, GERMAN, ITALIAN, DUTCH) (SW100E: AEP/SW100S: AEP, IT)	
	3-757-853-58	MANUAL, INSTRUCTION (ENGLISH, FRENCH, GERMAN, ITALIAN, DUTCH) (SW100S: CND/SW100E: UK, IT, AUS)	
	3-893-802-18	BOOK, GUIDE, WAVE (SW100E: IT/SW100S: CND, JE)	
	3-893-802-32	BOOK, GUIDE, WAVE (SW100E: AEP, E/SW100S: AEP, IT, E, US)	
	3-899-567-02	PLATE (ASSY), ABSORPTION	
	3-910-057-03	CASE, CARRYING	
	3-912-505-01	LIST, FREQUENCY	
	8-954-008-93	RECEIVER, EAR MDR-E808LP/C1 SET	
*	A-3638-036-A	AN-71.2 (SW100E)	

The components identified by mark △ or dotted line with mark △ are critical for safety.
Replace only with part number specified.

Les composants identifiés par une marque △ sont critiques pour la sécurité.
Ne les remplacer que par une pièce portant le numéro spécifié.

MEMO

ICF-SW100E/SW100S

AN-100

SONY®

SERVICE MANUAL

Ver. 1.1

US Model
Canadian Model
Tourist Model
ICF-SW100S
AEP Model
E Model
ICF-SW100E/SW100S
UK Model
Australian Model
ICF-SW100E

SUPPLEMENT - 4

Subject :

- SUFFIX CHANGE OF KEY, MICROCOMPUTER AND SIGNAL BOARD.
- CHANGE OF THE MICROCOMPUTER (IC102).

• CHANGE OF BOARD SUFFIX

The KEY board, MICROCOMPUTER board and SIGNAL board changed to new type.

The schematic diagram, the printed wiring board and the electrical parts list of a new type are described in this SUPPLEMENT-4.

Refer to original service manual (9-959-320-12) for other informations.

< NEW TYPE IDENTIFICATION >

[KEY BOARD]

[KEY BOARD] (SIDE A)

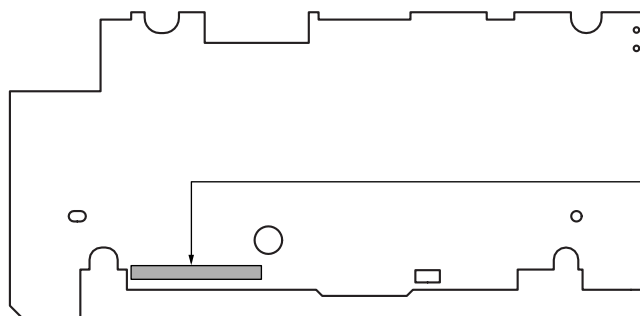

before 1-651-255-12 : former type
after 1-651-255-13 : new type

ICF-SW100E/SW100S

[MICROCOMPUTER BOARD]

[MICROCOMPUTER BOARD] (SIDE A)

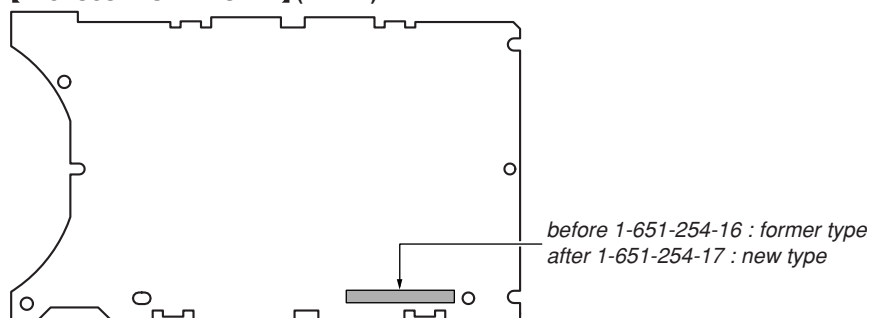

[SIGNAL BOARD]

[SIGNAL BOARD] (SIDE A)

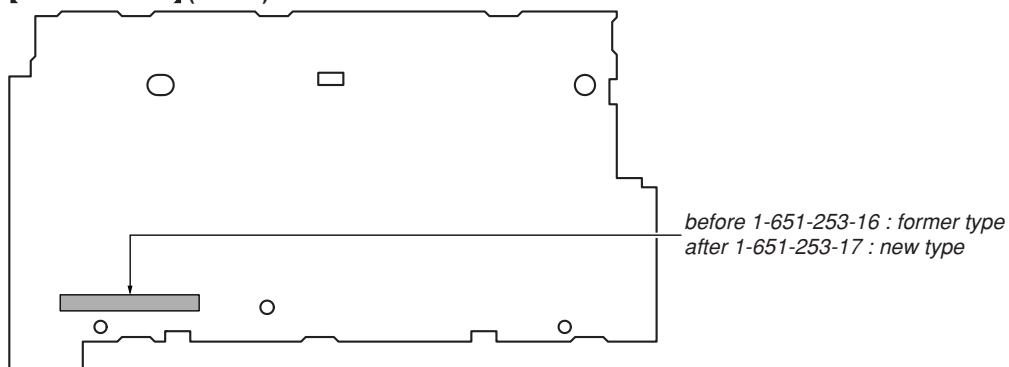

• CHANGE OF THE MICROCOMPUTER (IC102)

At the same time as changing the board, a microcomputer (SIGNAL board IC102) and a ceramic filter (SIGNAL board CF204) were changed. Therefore, please synchronize the exchange of these parts with the board suffix.

	BEFOR BOARD SUFFIX-16	AFTER BOARD SUFFIX-17
CF204	1-577-065-31 FILTER, CERAMIC	1-767-414-71 FILTER, CERAMIC
IC102	8-759-254-73 uPD1724GB-599-1A7	8-806-218-01 uPD17072GB-575-1A7-A

IC606 AK93C65LF-E1

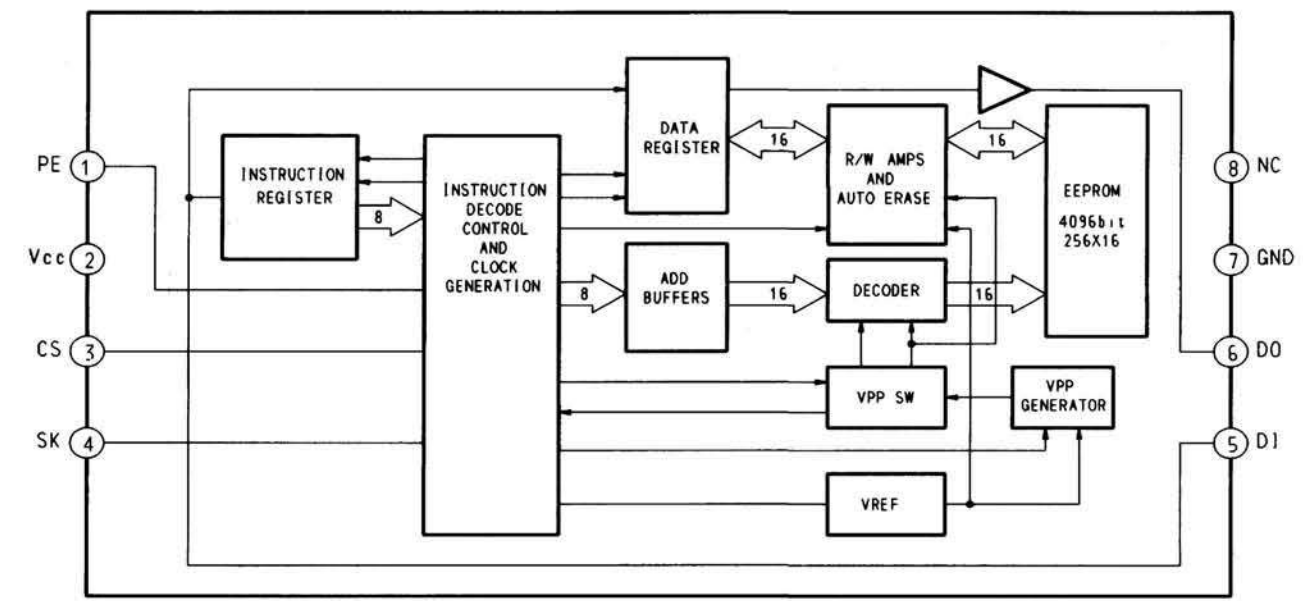

- Note:**
- All capacitors are in μF unless otherwise noted. pF: μF 50WV or less are not indicated except for electrolytics and tantalums.
 - All resistors are in Ω and $1/4\text{W}$ or less unless otherwise specified.
 - --- : B+ Line
 - --- : adjustment for repair.
 - Power voltage is dc 3 V and fed with regulated dc power supply from external power voltage jack.
 - Voltage and waveforms are dc with respect to ground under detuned conditions.
 - no mark: FM
 - (): LW/MW
 - \llcorner : SW
 - Voltages are taken with a VOM (Input Impedance $10\text{M}\Omega$). Voltage variations may be noted due to normal production tolerances.
 - Waveforms are taken with an oscilloscope. Voltage variations may be noted due to normal production tolerances.
 - Circled numbers refer to waveforms.
 - Signal path.
 - \curvearrowright : FM

1-2. SCHEMATIC DIAGRAM - CONTROL Section -

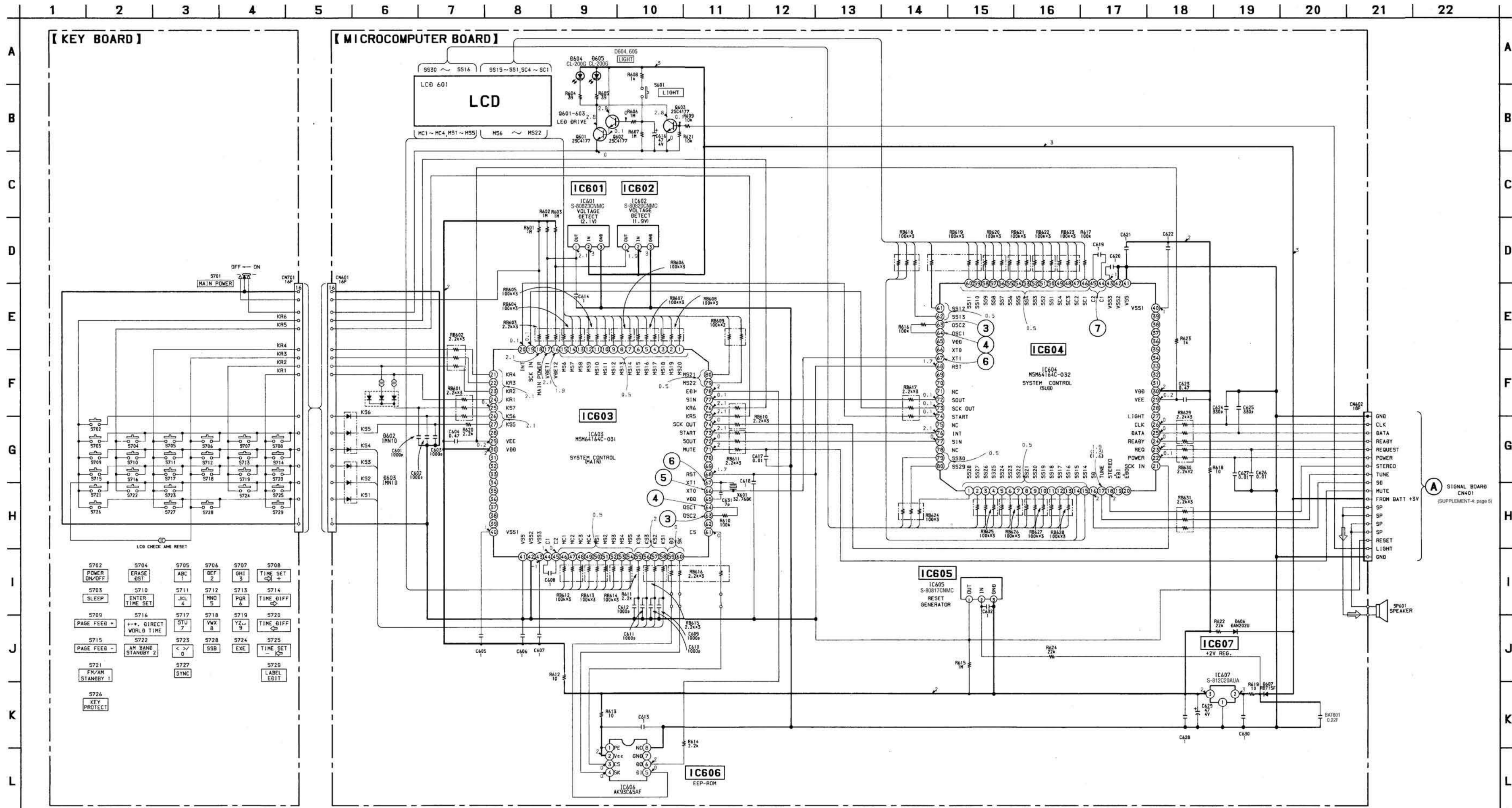
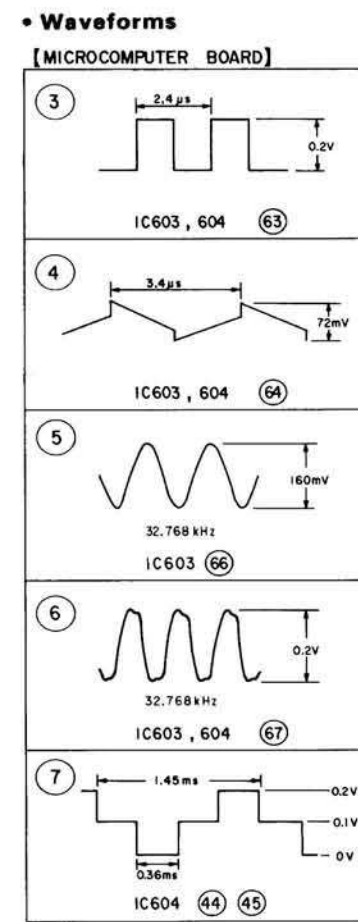

1-3. PRINTED WIRING BOARD – SIGNAL BOARD (SIDE A) –

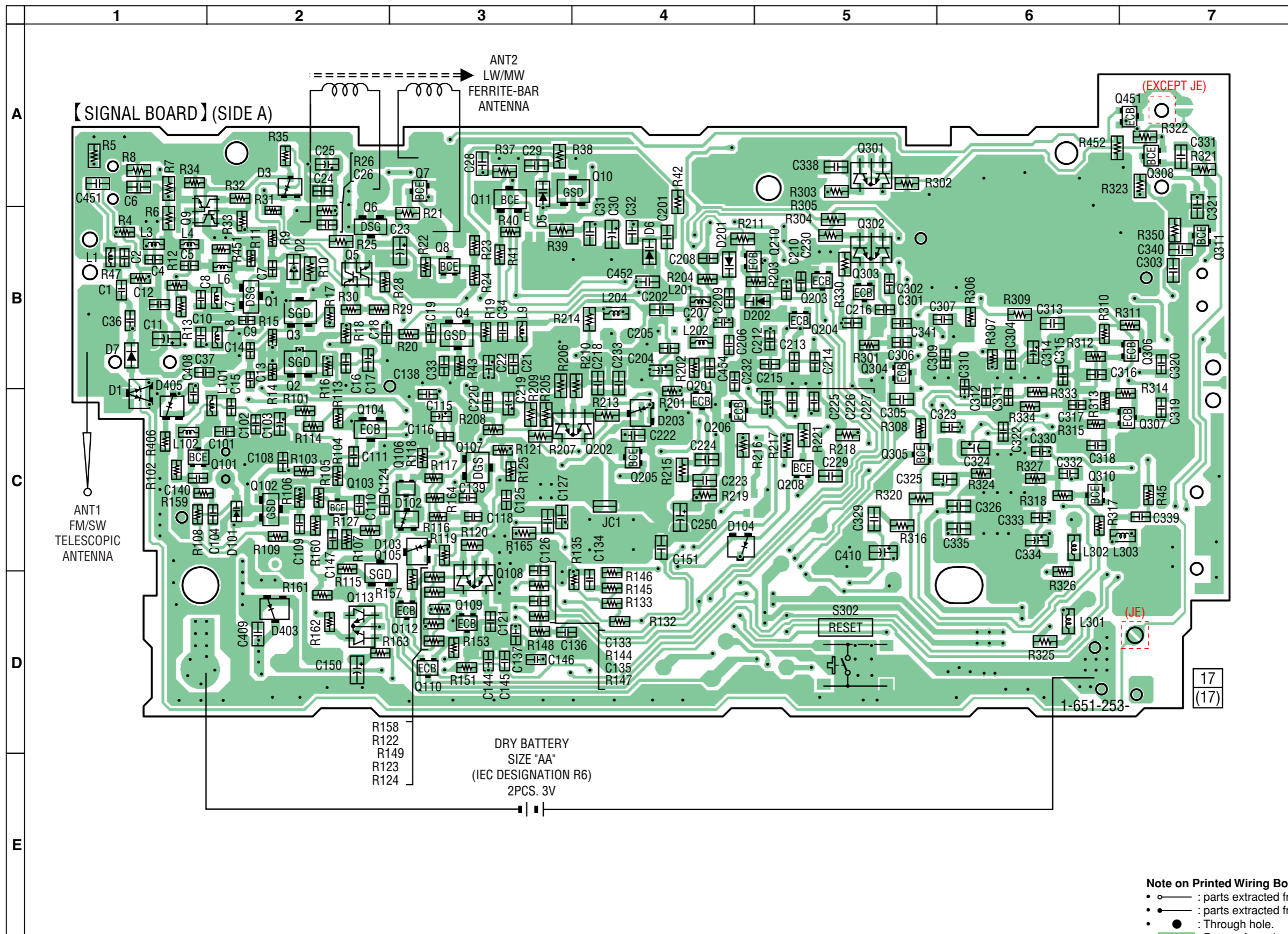

• Semiconductor Location

Ref. No.	Location
D1	C-1
D2	B-2
D3	A-2
D5	A-3
D6	B-4
D7	B-1
D101	C-2
D102	C-3
D103	C-3
D104	C-4
D201	B-4
D202	B-5
D203	C-4
D403	D-2
D405	C-1
Q1	B-2
Q2	B-2
Q3	B-2
Q4	B-3
Q5	B-2
Q6	B-2
Q7	A-3
Q8	B-3
Q9	B-1
Q10	A-4
Q11	A-3
Q101	C-1
Q102	C-2
Q103	C-2
Q104	C-2
Q105	D-2
Q106	C-3
Q107	C-3
Q108	D-3
Q109	D-3
Q110	D-3
Q112	D-3
Q113	D-2
Q201	C-4
Q202	C-4
Q203	B-5
Q204	B-5
Q205	C-4
Q206	C-4
Q208	C-5
Q210	B-5
Q301	A-5
Q302	B-5
Q303	B-5
Q304	B-5
Q305	C-5
Q306	B-7
Q307	C-7
Q308	A-7
Q310	C-6
Q311	B-7
Q451	A-7

Note on Printed Wiring Boards:
 • — : parts extracted from the component side.
 • — : parts extracted from the conductor side.
 • ● : Through hole.
 • ■ : Pattern from the side which enables seeing.
 (The other layers' Patterns are not indicated.)

Caution:
 Pattern face side: Parts on the pattern face side seen from the pattern face are indicated.
 Parts face side: Parts on the parts face side seen from the parts face are indicated.

• Abbreviation
 JE: Tourist model

1-4. PRINTED WIRING BOARD – SIGNAL BOARD (SIDE B) –

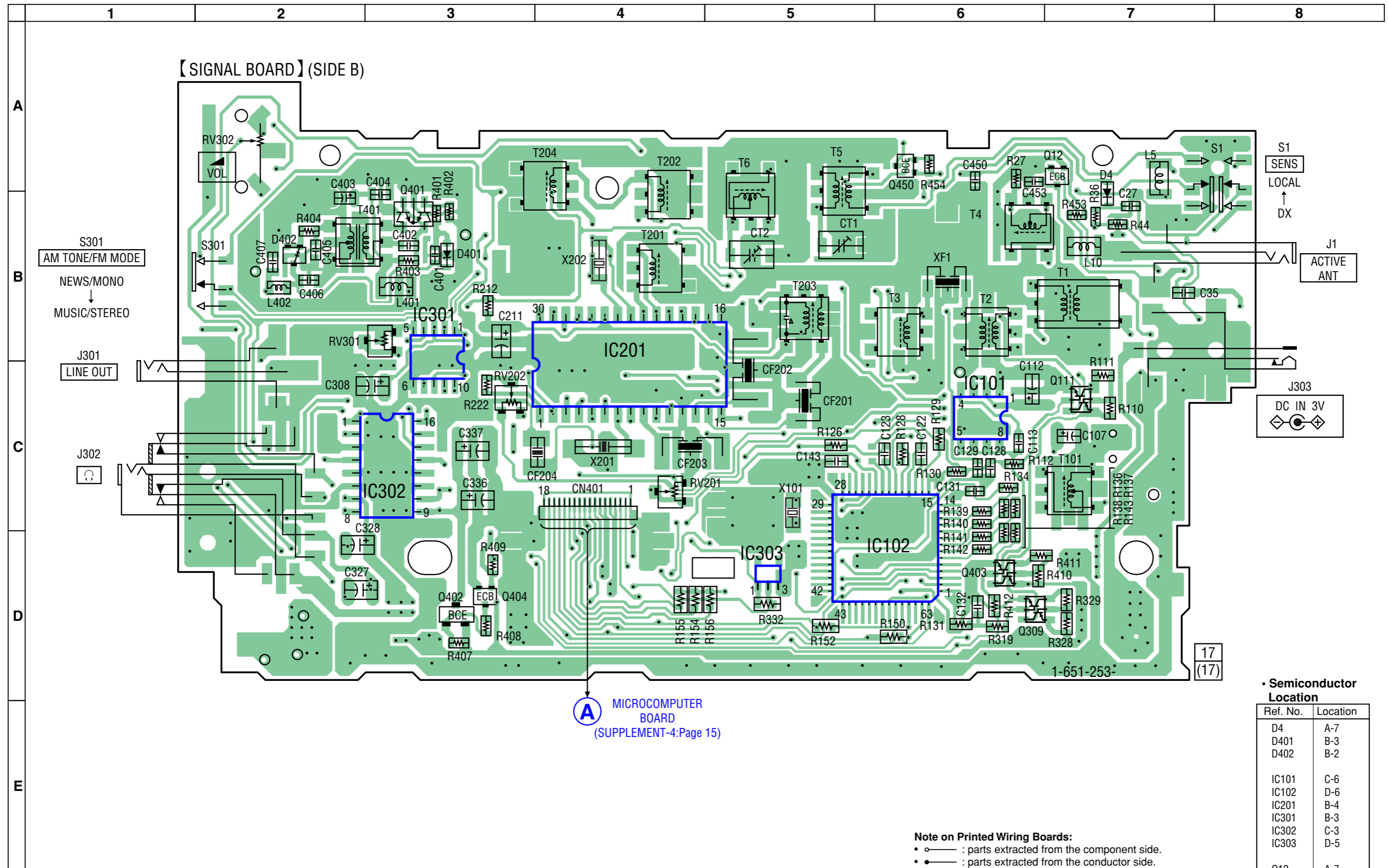

• Semiconductor Location

Ref. No.	Location
D4	A-7
D401	B-3
D402	B-2
IC101	C-6
IC102	D-6
IC201	B-4
IC301	B-3
IC302	C-3
IC303	D-5
Q12	A-7
Q111	C-7
Q309	D-6
Q401	B-3
Q402	D-3
Q403	D-6
Q404	D-3
Q450	A-6

Note on Printed Wiring Boards:

- : parts extracted from the component side.
- : parts extracted from the conductor side.
- : Through hole.
- : Pattern from the side which enables seeing. (The other layers' Patterns are not indicated.)

Caution:
 Pattern face side: Parts on the pattern face side seen from the pattern face are indicated.
 Parts face side: Parts on the parts face side seen from the parts face are indicated.

1-5. PRINTED WIRING BOARD – MICROCOMPUTER BOARD (SIDE A) –

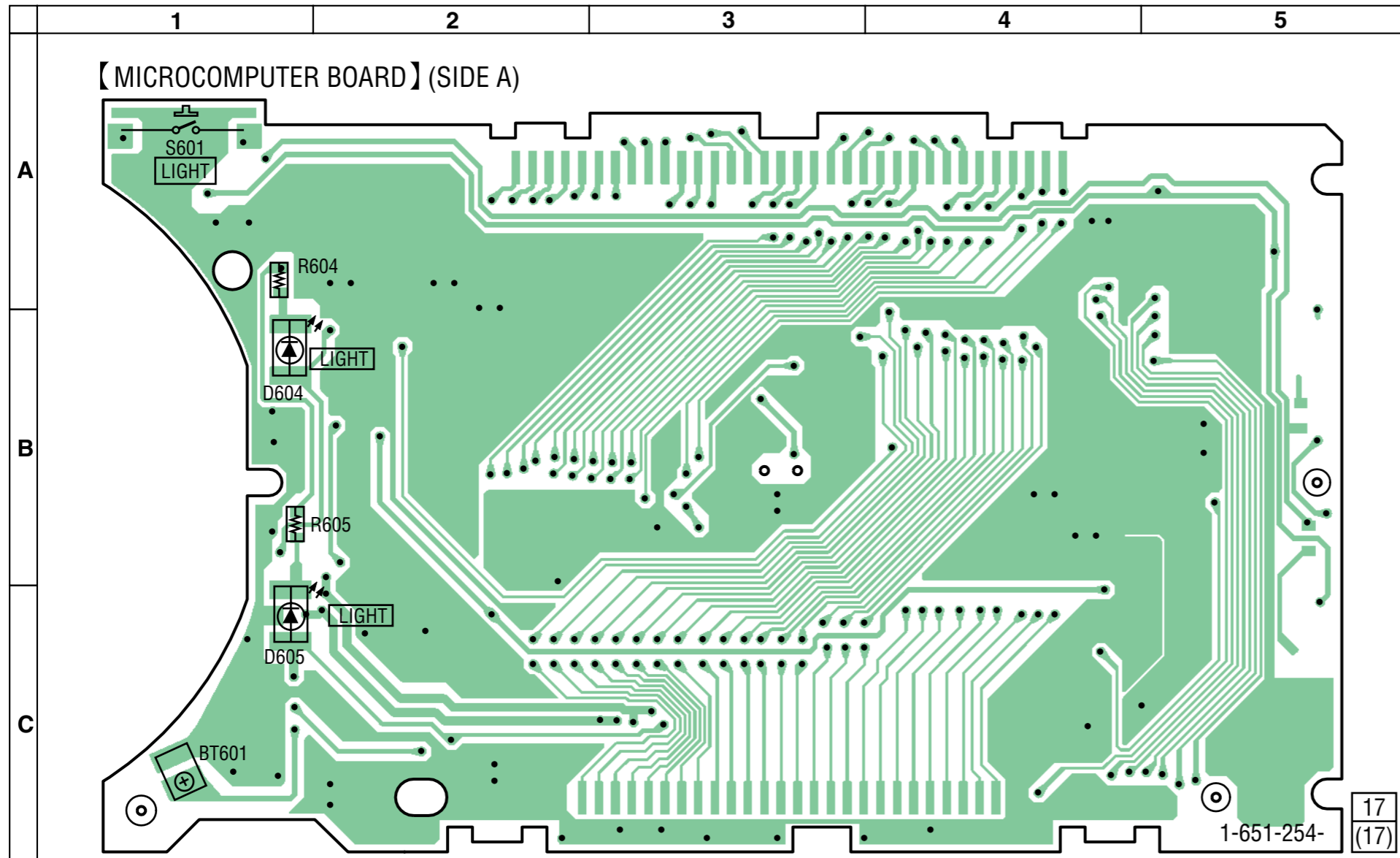

• Semiconductor Location

Ref. No.	Location
D604	B-1
D605	C-1

Note on Printed Wiring Boards:

- : parts extracted from the component side.
- : parts extracted from the conductor side.
- : Through hole.
- : Pattern from the side which enables seeing.
(The other layers' Patterns are not indicated.)

Caution:
 Pattern face side: Parts on the pattern face side seen from the pattern face are indicated.
 (Side A)
 Parts face side: Parts on the parts face side seen from the parts face are indicated.
 (Side B)

1-6. PRINTED WIRING BOARD – MICROCOMPUTER BOARD (SIDE B) –

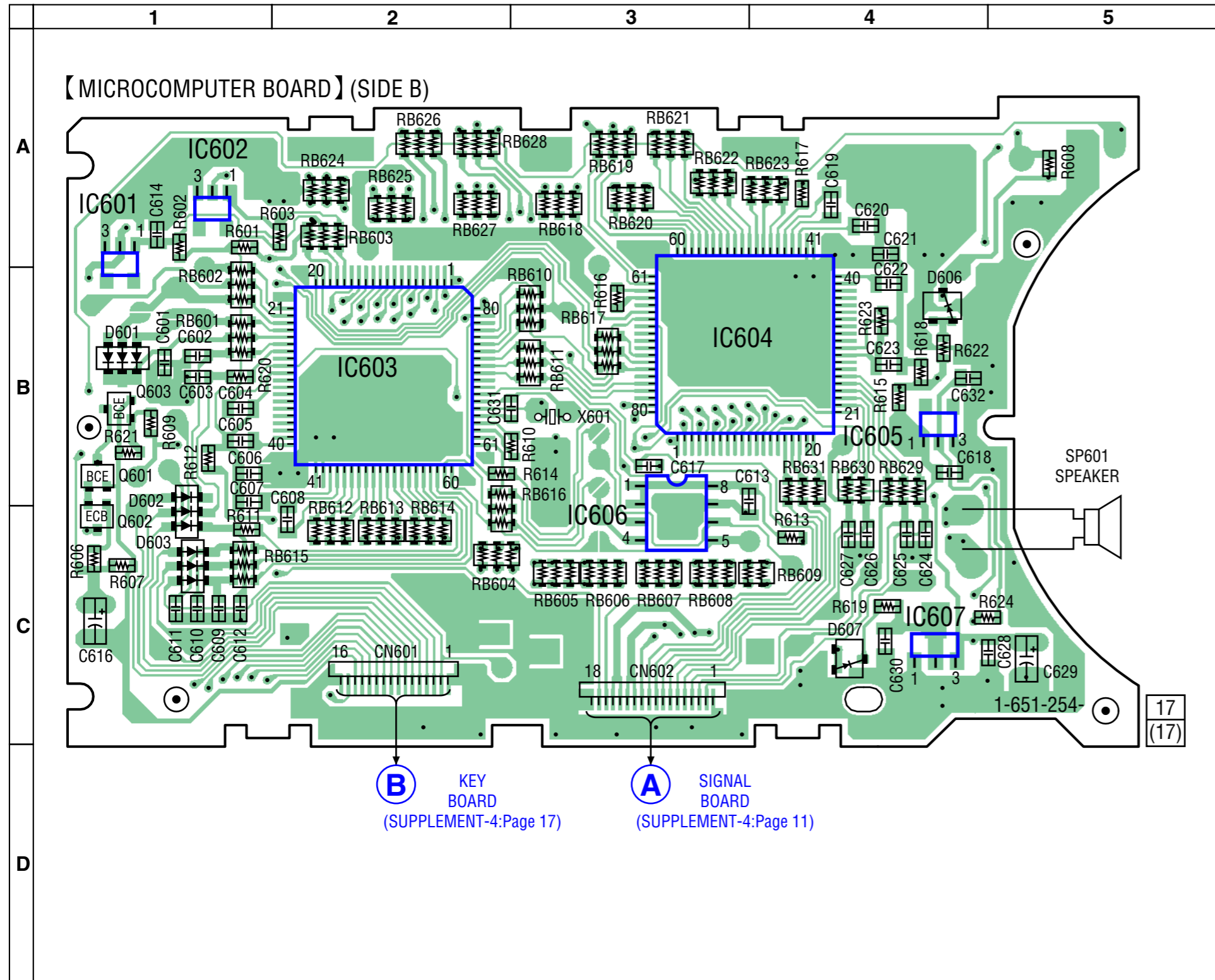

• Semiconductor Location

Ref. No.	Location
D601	B-1
D602	C-1
D603	C-1
D606	B-4
D607	C-4
IC601	A-1
IC602	A-1
IC603	B-2
IC604	B-3
IC605	B-4
IC606	C-3
IC607	C-4
Q601	B-1
Q602	C-1
Q603	B-1

Note on Printed Wiring Boards:

- : parts extracted from the component side.
- : parts extracted from the conductor side.
- : Through hole.
- : Pattern from the side which enables seeing.
(The other layers' Patterns are not indicated.)

Caution:
 Pattern face side: Parts on the pattern face side seen from the pattern face are indicated.
 Parts face side: Parts on the parts face side seen from the parts face are indicated.

1-7. PRINTED WIRING BOARD – KEY BOARD (SIDE A) –

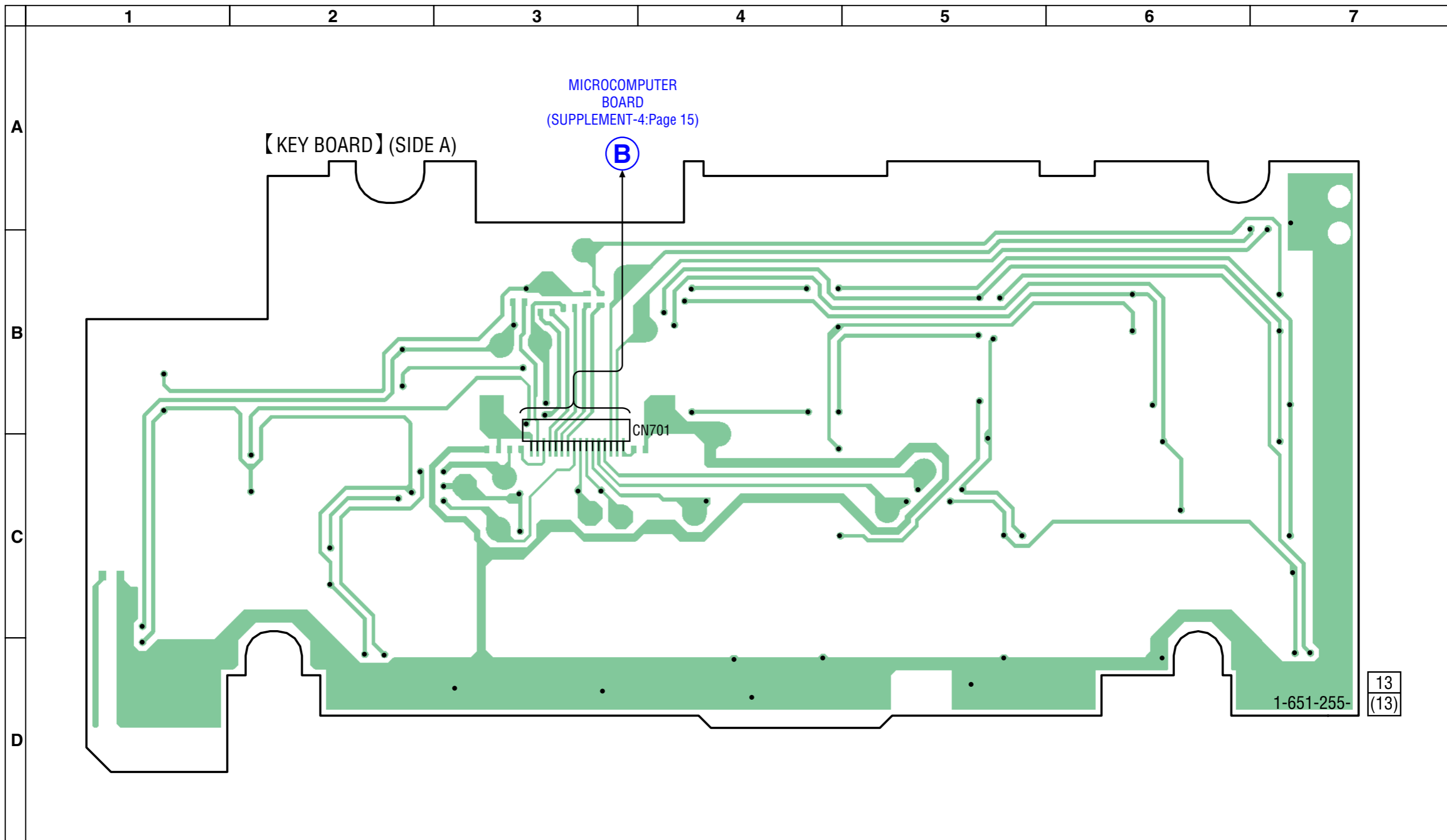

Note on Printed Wiring Boards:

- ○ — : parts extracted from the component side.
- ● — : parts extracted from the conductor side.
- ● : Through hole.
- ■ : Pattern from the side which enables seeing.
(The other layers' Patterns are not indicated.)

Caution:
 Pattern face side: Parts on the pattern face side seen from the pattern face are indicated.
 Parts face side: Parts on the parts face side seen from the parts face are indicated.

1-8. PRINTED WIRING BOARD – KEY BOARD (SIDE B) –

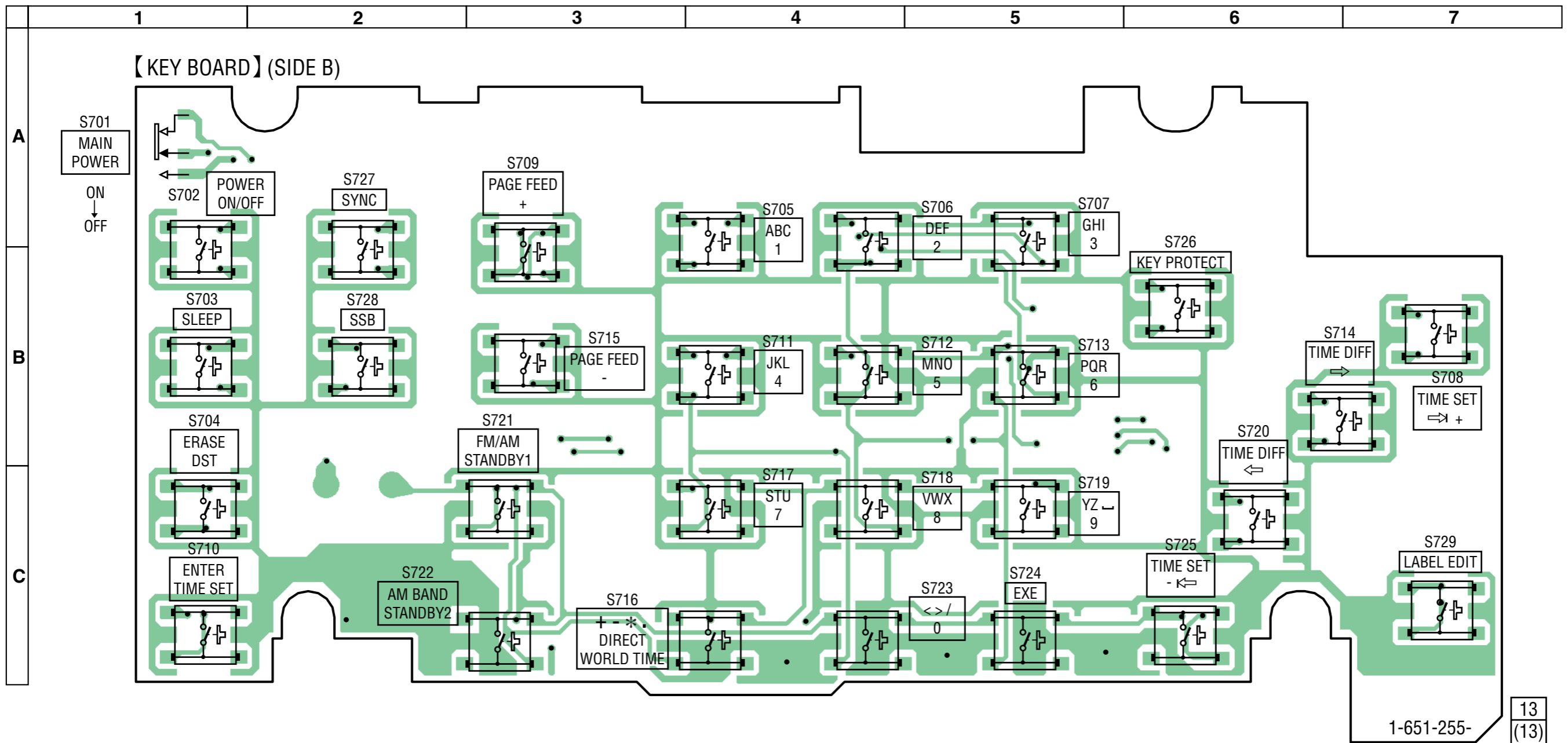

Note on Printed Wiring Boards:

- : parts extracted from the component side.
- : parts extracted from the conductor side.
- : Through hole.
- : Pattern from the side which enables seeing.
(The other layers' Patterns are not indicated.)

Caution:

Pattern face side: Parts on the pattern face side seen from the (Side A) pattern face are indicated.
Parts face side: Parts on the parts face side seen from the (Side B) parts face are indicated.

SECTION 2
ELECTRICAL PARTS LIST

KEY MICROCOMPUTER

NOTE:

- Due to standardization, replacements in the parts list may be different from the parts specified in the diagrams or the components used on the set.
- -XX and -X mean standardized parts, so they may have some difference from the original one.
- RESISTORS
All resistors are in ohms.
METAL: Metal-film resistor.
METAL OXIDE: Metal oxide-film resistor.
F: nonflammable

- Items marked “*” are not stocked since they are seldom required for routine service. Some delay should be anticipated when ordering these items.
- SEMICONDUCTORS
In each case, u: μ , for example:
uA... : μ A... uPA... : μ PA...
uPB... : μ PB... uPC... : μ PC...
uPD... : μ PD...
• CAPACITORS
uF: μ F
• COILS
uH: μ H

When indicating parts by reference number, please include the board.

Ref. No.	Part No.	Description	Remark	Ref. No.	Part No.	Description	Remark
*	A-3661-960-A	KEY BOARD, COMPLETE *****				< CAPACITOR >	
		< CONNECTOR >		BAT601	1-100-984-11	DOUBLE LAYER 0.22F	3.3V
CN701	1-764-370-11	HOUSING, FPC CONNECTOR (ZIF) 16P				< CAPACITOR >	
		< SWITCH >		C601	1-162-964-11	CERAMIC CHIP 0.001uF	10% 50V
S701	1-572-922-11	SWITCH, SLIDE (MAIN POWER)		C602	1-162-964-11	CERAMIC CHIP 0.001uF	10% 50V
S702	1-572-938-21	SWITCH, TACTIL (POWER ON/OFF)		C603	1-162-964-11	CERAMIC CHIP 0.001uF	10% 50V
S703	1-572-938-21	SWITCH, TACTIL (SLEEP)		C604	1-164-005-11	CERAMIC CHIP 0.47uF	25V
S704	1-572-938-21	SWITCH, TACTIL (ERASE DST)		C605	1-164-346-11	CERAMIC CHIP 1uF	16V
S705	1-572-938-21	SWITCH, TACTIL (ABC 1)		C606	1-164-346-11	CERAMIC CHIP 1uF	16V
S706	1-572-938-21	SWITCH, TACTIL (DEF 2)		C607	1-164-346-11	CERAMIC CHIP 1uF	16V
S707	1-572-938-21	SWITCH, TACTIL (GHI 3)		C608	1-164-346-11	CERAMIC CHIP 1uF	16V
S708	1-572-938-21	SWITCH, TACTIL (TIME SET \Rightarrow +))		C609	1-162-964-11	CERAMIC CHIP 0.001uF	10% 50V
S709	1-572-938-21	SWITCH, TACTIL (PAGE FEED +)		C610	1-162-964-11	CERAMIC CHIP 0.001uF	10% 50V
S710	1-572-938-21	SWITCH, TACTIL (ENTER TIME SET)		C611	1-162-964-11	CERAMIC CHIP 0.001uF	10% 50V
S711	1-572-938-21	SWITCH, TACTIL (JKL 4)		C612	1-162-964-11	CERAMIC CHIP 0.001uF	10% 50V
S712	1-572-938-21	SWITCH, TACTIL (MNO 5)		C613	1-164-346-11	CERAMIC CHIP 1uF	16V
S713	1-572-938-21	SWITCH, TACTIL (PQR 6)		C614	1-164-346-11	CERAMIC CHIP 1uF	16V
S714	1-572-938-21	SWITCH, TACTIL (TIME DIFF \Rightarrow)		C616	1-135-254-11	TANTAL. CHIP 47uF	20% 4V
S715	1-572-938-21	SWITCH, TACTIL (PAGE FEED -)		C617	1-162-970-11	CERAMIC CHIP 0.01uF	10% 25V
S716	1-572-938-21	SWITCH, TACTIL (+ - *. DIRECT WORLD TIME)		C618	1-164-346-11	CERAMIC CHIP 1uF	16V
S717	1-572-938-21	SWITCH, TACTIL (STU 7)		C619	1-164-346-11	CERAMIC CHIP 1uF	16V
S718	1-572-938-21	SWITCH, TACTIL (VWX 8)		C620	1-164-346-11	CERAMIC CHIP 1uF	16V
S719	1-572-938-21	SWITCH, TACTIL (YZ 9)		C621	1-164-346-11	CERAMIC CHIP 1uF	16V
S720	1-572-938-21	SWITCH, TACTIL (TIME DIFF \Leftarrow)		C622	1-164-346-11	CERAMIC CHIP 1uF	16V
S721	1-572-938-21	SWITCH, TACTIL (FM/AM STANDBY 1)		C623	1-164-005-11	CERAMIC CHIP 0.47uF	25V
S722	1-572-938-21	SWITCH, TACTIL (AM BAND STANDBY 2)		C624	1-162-961-11	CERAMIC CHIP 330PF	10% 50V
S723	1-572-938-21	SWITCH, TACTIL (< >/ 0)		C625	1-162-961-11	CERAMIC CHIP 330PF	10% 50V
S724	1-572-938-21	SWITCH, TACTIL (EXE)		C626	1-162-970-11	CERAMIC CHIP 0.01uF	10% 25V
S725	1-572-938-21	SWITCH, TACTIL (TIME SET - \Leftarrow)		C627	1-162-970-11	CERAMIC CHIP 0.01uF	10% 25V
S726	1-572-938-21	SWITCH, TACTIL (KEY PROTECT)		C628	1-164-346-11	CERAMIC CHIP 1uF	16V
S727	1-572-938-21	SWITCH, TACTIL (SYNC)		C629	1-135-254-11	TANTAL. CHIP 47uF	20% 4V
S728	1-572-938-21	SWITCH, TACTIL (SSB)		C630	1-164-346-11	CERAMIC CHIP 1uF	16V
S729	1-572-938-21	SWITCH, TACTIL (LABEL EDIT)		C631	1-162-912-11	CERAMIC CHIP 7PF	0.5PF 50V
*****				C632	1-164-346-11	CERAMIC CHIP 1uF	16V
		< CONNECTOR >				< DIODE >	
*	A-3661-961-A	MICROCOMPUTER BOARD, COMPLETE *****		CN601	1-764-370-11	HOUSING, FPC CONNECTOR (ZIF) 16P	
		1-537-683-21 CONDUCTIVE BOARD, CONNECTION		CN602	1-764-368-11	HOUSING, FPC CONNECTOR (ZIF) 18P	
		3-909-845-05 PLATE, LIGHT GUIDE				< DIODE >	
		3-909-849-01 CASE (LCD), SHIELD		D601	8-719-951-22	DIODE 1M10	

ICF-SW100E/SW100S

MICROCOMPUTER

SIGNAL

Ref. No.	Part No.	Description	Remark	Ref. No.	Part No.	Description	Remark
D602	8-719-951-22	DIODE IMN10		RB607	1-236-502-11	RES, NETWORK	
D603	8-719-951-22	DIODE IMN10		RB608	1-236-502-11	RES, NETWORK	
D604	8-719-049-21	DIODE CL-200G-C-TS (LIGHT)		RB609	1-236-875-11	RES, NETWORK	
D605	8-719-049-21	DIODE CL-200G-C-TS (LIGHT)		RB610	1-236-631-11	RES, NETWORK	
D606	8-719-941-86	DIODE DAN202U		RB611	1-236-631-11	RES, NETWORK	
D607	8-719-988-82	DIODE RB715F		RB612	1-236-502-11	RES, NETWORK	
		< IC >		RB613	1-236-502-11	RES, NETWORK	
IC601	6-703-918-01	IC S-80823CNMC-B8IT2G		RB614	1-236-502-11	RES, NETWORK	
IC602	6-705-592-01	IC S-80820CNMC-B8FT2G		RB615	1-236-631-11	RES, NETWORK	
IC603	8-759-267-81	IC MSM64164C-031TS-K		RB616	1-236-631-11	RES, NETWORK	
IC604	8-759-267-82	IC MSM64164C-032TS-K		RB617	1-236-631-11	RES, NETWORK	
IC605	6-705-594-01	IC S-80817CNMC-B8CT2G		RB618	1-236-502-11	RES, NETWORK	
IC606	8-759-481-53	IC AK93C65AF-E1		RB619	1-236-502-11	RES, NETWORK	
IC607	6-705-460-01	IC S-812C20AUA-C2AT2G		RB620	1-236-502-11	RES, NETWORK	
		< LIQUID CRYSTAL DISPLAY PANEL >		RB621	1-236-502-11	RES, NETWORK	
LCD601	1-810-427-11	DISPLAY PANEL, LIQUID CRYSTAL		RB622	1-236-502-11	RES, NETWORK	
		< TRANSISTOR >		RB623	1-236-502-11	RES, NETWORK	
Q601	8-729-117-32	TRANSISTOR 2SC4177-L6		RB624	1-236-502-11	RES, NETWORK	
Q602	8-729-117-32	TRANSISTOR 2SC4177-L6		RB625	1-236-502-11	RES, NETWORK	
Q603	8-729-117-32	TRANSISTOR 2SC4177-L6		RB626	1-236-502-11	RES, NETWORK	
		< RESISTOR >		RB627	1-236-502-11	RES, NETWORK	
R601	1-216-857-11	METAL CHIP 1M 5% 1/10W		RB628	1-236-502-11	RES, NETWORK	
R602	1-216-857-11	METAL CHIP 1M 5% 1/10W		RB629	1-236-631-11	RES, NETWORK	
R603	1-216-857-11	METAL CHIP 1M 5% 1/10W		RB630	1-236-855-11	RES, NETWORK	
R604	1-216-804-11	METAL CHIP 39 5% 1/10W		RB631	1-236-631-11	RES, NETWORK	
R605	1-216-804-11	METAL CHIP 39 5% 1/10W				< SWITCH >	
R606	1-216-857-11	METAL CHIP 1M 5% 1/10W		S601	1-572-473-11	SWITCH, TACTILE (LIGHT)	
R607	1-216-857-11	METAL CHIP 1M 5% 1/10W				< VIBRATOR >	
R608	1-216-821-11	METAL CHIP 1K 5% 1/10W		X601	1-760-201-11	VIBRATOR, CRYSTAL (32.768kHz)	
R609	1-216-833-11	METAL CHIP 10K 5% 1/10W		*****			
R610	1-216-845-11	METAL CHIP 100K 5% 1/10W		*	A-3679-561-A	SIGNAL BOARD, COMPLETE	
R611	1-216-825-11	METAL CHIP 2.2K 5% 1/10W		*****			
R612	1-216-797-11	METAL CHIP 10 5% 1/10W		*	3-831-441-99	SHEET (1)	
R613	1-216-797-11	METAL CHIP 10 5% 1/10W		*	3-909-850-01	CASE (DDCON), SHIELD	
R614	1-216-825-11	METAL CHIP 2.2K 5% 1/10W		*	3-909-856-01	PLATE (BATTERY), CONTACT	
R615	1-216-857-11	METAL CHIP 1M 5% 1/10W		*	3-909-858-01	SHIELD (VCO)	
R616	1-216-845-11	METAL CHIP 100K 5% 1/10W				< CAPACITOR >	
R617	1-216-845-11	METAL CHIP 100K 5% 1/10W		C1	1-162-970-11	CERAMIC CHIP 0.01uF 10% 25V	
R618	1-216-797-11	METAL CHIP 10 5% 1/10W		C2	1-162-910-11	CERAMIC CHIP 5PF 0.25PF 50V	
R619	1-216-797-11	METAL CHIP 10 5% 1/10W		C4	1-162-908-11	CERAMIC CHIP 3PF 0.25PF 50V	
R620	1-216-825-11	METAL CHIP 2.2K 5% 1/10W		C5	1-162-910-11	CERAMIC CHIP 5PF 0.25PF 50V	
R621	1-216-833-11	METAL CHIP 10K 5% 1/10W		C6	1-162-958-11	CERAMIC CHIP 270PF 5% 50V	
R622	1-216-837-11	METAL CHIP 22K 5% 1/10W		C7	1-162-970-11	CERAMIC CHIP 0.01uF 10% 25V	
R623	1-216-821-11	METAL CHIP 1K 5% 1/10W		C8	1-162-914-11	CERAMIC CHIP 9PF 0.5PF 50V	
R624	1-216-837-11	METAL CHIP 22K 5% 1/10W		C9	1-162-917-11	CERAMIC CHIP 15PF 5% 50V	
		< COMPOSITION CIRCUIT BLOCK >		C10	1-162-909-11	CERAMIC CHIP 4PF 0.25PF 50V	
RB601	1-236-631-11	RES, NETWORK		C11	1-107-685-11	TANTAL. CHIP 15uF 20% 6.3V	
RB602	1-236-631-11	RES, NETWORK		C12	1-162-970-11	CERAMIC CHIP 0.01uF 10% 25V	
RB603	1-236-631-11	RES, NETWORK		C13	1-162-970-11	CERAMIC CHIP 0.01uF 10% 25V	
RB604	1-236-502-11	RES, NETWORK		C14	1-162-970-11	CERAMIC CHIP 0.01uF 10% 25V	
RB605	1-236-502-11	RES, NETWORK		C15	1-162-913-11	CERAMIC CHIP 8PF 0.5PF 50V	
RB606	1-236-502-11	RES, NETWORK		C16	1-162-970-11	CERAMIC CHIP 0.01uF 10% 25V	
				C17	1-107-685-11	TANTAL. CHIP 15uF 20% 6.3V	

Ref. No.	Part No.	Description			Remark	Ref. No.	Part No.	Description			Remark
C18	1-162-916-11	CERAMIC CHIP	12PF	5%	50V	C151	1-164-346-11	CERAMIC CHIP	1uF		16V
C19	1-162-916-11	CERAMIC CHIP	12PF	5%	50V	C201	1-162-970-11	CERAMIC CHIP	0.01uF	10%	25V
C21	1-162-970-11	CERAMIC CHIP	0.01uF	10%	25V	C202	1-162-970-11	CERAMIC CHIP	0.01uF	10%	25V
C22	1-107-685-11	TANTAL. CHIP	15uF	20%	6.3V	C204	1-107-685-11	TANTAL. CHIP	15uF	20%	6.3V
C23	1-107-685-11	TANTAL. CHIP	15uF	20%	6.3V	C205	1-162-970-11	CERAMIC CHIP	0.01uF	10%	25V
C24	1-164-346-11	CERAMIC CHIP	1uF		16V	C206	1-162-909-11	CERAMIC CHIP	4PF	0.25PF	50V
C25	1-107-685-11	TANTAL. CHIP	15uF	20%	6.3V	C207	1-162-915-11	CERAMIC CHIP	10PF	0.5PF	50V
C26	1-162-927-11	CERAMIC CHIP	100PF	5%	50V	C208	1-162-964-11	CERAMIC CHIP	0.001uF	10%	50V
C27	1-162-970-11	CERAMIC CHIP	0.01uF	10%	25V	C209	1-162-964-11	CERAMIC CHIP	0.001uF	10%	50V
C28	1-162-970-11	CERAMIC CHIP	0.01uF	10%	25V	C210	1-162-964-11	CERAMIC CHIP	0.001uF	10%	50V
C29	1-162-964-11	CERAMIC CHIP	0.001uF	10%	50V	C211	1-135-339-11	TANTAL. CHIP	150uF	20%	4V
C30	1-107-685-11	TANTAL. CHIP	15uF	20%	6.3V	C212	1-164-346-11	CERAMIC CHIP	1uF		16V
C31	1-162-970-11	CERAMIC CHIP	0.01uF	10%	25V	C213	1-162-966-11	CERAMIC CHIP	0.0022uF	10%	50V
C32	1-162-964-11	CERAMIC CHIP	0.001uF	10%	50V	C214	1-162-970-11	CERAMIC CHIP	0.01uF	10%	25V
C33	1-162-970-11	CERAMIC CHIP	0.01uF	10%	25V	C215	1-162-970-11	CERAMIC CHIP	0.01uF	10%	25V
C34	1-162-917-11	CERAMIC CHIP	15PF	5%	50V	C216	1-164-346-11	CERAMIC CHIP	1uF		16V
C35	1-162-970-11	CERAMIC CHIP	0.01uF	10%	25V	C218	1-164-346-11	CERAMIC CHIP	1uF		16V
C36	1-162-970-11	CERAMIC CHIP	0.01uF	10%	25V	C219	1-107-685-11	TANTAL. CHIP	15uF	20%	6.3V
C37	1-162-964-11	CERAMIC CHIP	0.001uF	10%	50V	C220	1-162-970-11	CERAMIC CHIP	0.01uF	10%	25V
C101	1-162-913-11	CERAMIC CHIP	8PF	0.5PF	50V	C222	1-162-970-11	CERAMIC CHIP	0.01uF	10%	25V
C102	1-162-970-11	CERAMIC CHIP	0.01uF	10%	25V	C223	1-162-970-11	CERAMIC CHIP	0.01uF	10%	25V
C103	1-107-685-11	TANTAL. CHIP	15uF	20%	6.3V	C224	1-164-346-11	CERAMIC CHIP	1uF		16V
C104	1-162-905-11	CERAMIC CHIP	1PF	0.25PF	50V	C225	1-107-685-11	TANTAL. CHIP	15uF	20%	6.3V
C105	1-161-021-11	CERAMIC	0.047uF	10%	25V	C226	1-164-346-11	CERAMIC CHIP	1uF		16V
C107	1-135-254-11	TANTAL. CHIP	47uF	20%	4V	C227	1-164-346-11	CERAMIC CHIP	1uF		16V
C108	1-162-970-11	CERAMIC CHIP	0.01uF	10%	25V	C229	1-162-970-11	CERAMIC CHIP	0.01uF	10%	25V
C109	1-162-905-11	CERAMIC CHIP	1PF	0.25PF	50V	C230	1-162-970-11	CERAMIC CHIP	0.01uF	10%	25V
C110	1-162-970-11	CERAMIC CHIP	0.01uF	10%	25V	C232	1-162-970-11	CERAMIC CHIP	0.01uF	10%	25V
C111	1-162-970-11	CERAMIC CHIP	0.01uF	10%	25V	C233	1-164-346-11	CERAMIC CHIP	1uF		16V
C112	1-135-339-11	TANTAL. CHIP	150uF	20%	4V	C250	1-107-685-11	TANTAL. CHIP	15uF	20%	6.3V
C113	1-162-970-11	CERAMIC CHIP	0.01uF	10%	25V	C301	1-162-970-11	CERAMIC CHIP	0.01uF	10%	25V
C115	1-107-685-11	TANTAL. CHIP	15uF	20%	6.3V	C302	1-164-227-11	CERAMIC CHIP	0.022uF	10%	25V
C116	1-162-970-11	CERAMIC CHIP	0.01uF	10%	25V	C303	1-162-970-11	CERAMIC CHIP	0.01uF	10%	25V
C118	1-107-823-11	CERAMIC CHIP	0.47uF	10%	16V	C304	1-163-137-00	CERAMIC CHIP	680PF	5%	50V
C121	1-164-346-11	CERAMIC CHIP	1uF		16V	C305	1-164-346-11	CERAMIC CHIP	1uF		16V
C122	1-162-970-11	CERAMIC CHIP	0.01uF	10%	25V	C306	1-164-346-11	CERAMIC CHIP	1uF		16V
C123	1-162-970-11	CERAMIC CHIP	0.01uF	10%	25V	C307	1-163-038-91	CERAMIC CHIP	0.1uF		25V
C124	1-162-970-11	CERAMIC CHIP	0.01uF	10%	25V	C308	1-135-254-11	TANTAL. CHIP	47uF	20%	4V
C125	1-164-346-11	CERAMIC CHIP	1uF		16V	C309	1-164-346-11	CERAMIC CHIP	1uF		16V
C126	1-162-919-11	CERAMIC CHIP	22PF	5%	50V	C310	1-162-970-11	CERAMIC CHIP	0.01uF	10%	25V
C127	1-164-185-11	CERAMIC CHIP	13PF	5%	50V	C311	1-162-970-11	CERAMIC CHIP	0.01uF	10%	25V
C128	1-162-970-11	CERAMIC CHIP	0.01uF	10%	25V	C312	1-162-970-11	CERAMIC CHIP	0.01uF	10%	25V
C129	1-162-970-11	CERAMIC CHIP	0.01uF	10%	25V	C313	1-164-346-11	CERAMIC CHIP	1uF		16V
C131	1-162-970-11	CERAMIC CHIP	0.01uF	10%	25V	C314	1-107-685-11	TANTAL. CHIP	15uF	20%	6.3V
C132	1-162-970-11	CERAMIC CHIP	0.01uF	10%	25V	C315	1-164-346-11	CERAMIC CHIP	1uF		16V
C133	1-162-970-11	CERAMIC CHIP	0.01uF	10%	25V	C316	1-164-346-11	CERAMIC CHIP	1uF		16V
C134	1-162-970-11	CERAMIC CHIP	0.01uF	10%	25V	C317	1-164-346-11	CERAMIC CHIP	1uF		16V
C135	1-162-970-11	CERAMIC CHIP	0.01uF	10%	25V	C318	1-164-346-11	CERAMIC CHIP	1uF		16V
C136	1-162-970-11	CERAMIC CHIP	0.01uF	10%	25V	C319	1-164-346-11	CERAMIC CHIP	1uF		16V
C137	1-162-970-11	CERAMIC CHIP	0.01uF	10%	25V	C320	1-164-346-11	CERAMIC CHIP	1uF		16V
C138	1-162-969-11	CERAMIC CHIP	0.0068uF	10%	25V	C321	1-164-346-11	CERAMIC CHIP	1uF		16V
C139	1-107-823-11	CERAMIC CHIP	0.47uF	10%	16V	C322	1-163-986-00	CERAMIC CHIP	0.027uF	10%	25V
C140	1-162-917-11	CERAMIC CHIP	15PF	5%	50V	C323	1-163-986-00	CERAMIC CHIP	0.027uF	10%	25V
C141	1-162-917-11	CERAMIC CHIP	15PF	5%	50V	C324	1-107-685-11	TANTAL. CHIP	15uF	20%	6.3V
C144	1-162-927-11	CERAMIC CHIP	100PF	5%	50V	C325	1-164-346-11	CERAMIC CHIP	1uF		16V
C145	1-162-927-11	CERAMIC CHIP	100PF	5%	50V	C326	1-164-346-11	CERAMIC CHIP	1uF		16V
C146	1-162-927-11	CERAMIC CHIP	100PF	5%	50V	C327	1-135-254-11	TANTAL. CHIP	47uF	20%	4V
C150	1-107-685-11	TANTAL. CHIP	15uF	20%	6.3V						

ICF-SW100E/SW100S

SIGNAL

Ref. No.	Part No.	Description	Remark	Ref. No.	Part No.	Description	Remark
C328	1-135-254-11	TANTAL. CHIP	47uF 20%	4V	D202	8-719-083-90	DIODE HVU363ATRU
C329	1-164-346-11	CERAMIC CHIP	1uF	16V	D203	8-719-941-86	DIODE DAN202U
C330	1-162-970-11	CERAMIC CHIP	0.01uF 10%	25V	D401	8-719-083-82	DIODE UDZS-TE17-12B
C331	1-164-346-11	CERAMIC CHIP	1uF	16V			
C332	1-164-346-11	CERAMIC CHIP	1uF	16V	D402	8-719-941-86	DIODE DAN202U
C333	1-164-346-11	CERAMIC CHIP	1uF	16V	D403	8-719-975-40	DIODE RB411D
C334	1-107-685-11	TANTAL. CHIP	15uF 20%	6.3V	D405	8-719-941-86	DIODE DAN202U
C335	1-164-346-11	CERAMIC CHIP	1uF	16V			< IC >
C336	1-135-339-11	TANTAL. CHIP	150uF 20%	4V	IC101	6-700-361-01	IC LA5002M-TE-L
C337	1-135-339-11	TANTAL. CHIP	150uF 20%	4V	IC102	6-806-218-01	IC uPD17072GB-575-1A7-A (AFTER BOARD SUFFIX -17)
C338	1-164-346-11	CERAMIC CHIP	1uF	16V	IC201	8-752-064-32	IC CXA1376AM
C339	1-162-927-11	CERAMIC CHIP	100PF 5%	50V	IC301	6-700-363-01	IC LA3335M-TLM-E
C340	1-164-227-11	CERAMIC CHIP	0.022uF 10%	25V	IC302	8-752-058-42	IC CXA1622M
C341	1-164-145-11	CERAMIC CHIP	390PF 5%	50V	IC303	6-703-918-01	IC S-80823CNMC-B8IT2G
C401	1-164-227-11	CERAMIC CHIP	0.022uF 10%	25V			< JACK >
C402	1-162-915-11	CERAMIC CHIP	10PF 0.5PF	50V	J1	1-764-624-11	JACK (ACTIVE ANT)
C403	1-107-685-11	TANTAL. CHIP	15uF 20%	6.3V	J301	1-764-624-11	JACK (LINE OUT)
C404	1-164-346-11	CERAMIC CHIP	1uF	16V	J302	1-764-625-11	JACK (⊕)
C405	1-162-915-11	CERAMIC CHIP	10PF 0.5PF	50V	J303	1-764-628-21	JACK, DC (POLARITY UNIFIED TYPE) (DC IN 3V)
C406	1-164-346-11	CERAMIC CHIP	1uF	16V			< JUMPER RESISTOR >
C407	1-164-346-11	CERAMIC CHIP	1uF	16V	JC1	1-216-864-11	SHORT CHIP 0
C408	1-162-970-11	CERAMIC CHIP	0.01uF 10%	25V			< COIL >
C409	1-162-970-11	CERAMIC CHIP	0.01uF 10%	25V	L1	1-410-981-42	INDUCTOR 0.1uH
C410	1-107-685-11	TANTAL. CHIP	15uF 20%	6.3V	L3	1-410-992-11	INDUCTOR 0.82uH
C450	1-162-970-11	CERAMIC CHIP	0.01uF 10%	25V	L4	1-410-992-11	INDUCTOR 0.82uH
C451	1-162-970-11	CERAMIC CHIP	0.01uF 10%	25V	L5	1-412-064-11	INDUCTOR 100uH
C452	1-162-964-11	CERAMIC CHIP	0.001uF 10%	50V	L6	1-410-997-42	INDUCTOR 2.2uH
C453	1-115-156-11	CERAMIC CHIP	1uF	10V	L7	1-410-997-42	INDUCTOR 2.2uH
C454	1-162-964-11	CERAMIC CHIP	0.001uF 10%	50V	L8	1-410-997-42	INDUCTOR 2.2uH
		< FILTER >			L9	1-410-987-42	INDUCTOR 0.33uH
CF201	1-760-199-11	FILTER, CERAMIC			L10	1-412-064-11	INDUCTOR 100uH
CF202	1-767-313-11	FILTER, CERAMIC			L101	1-410-990-41	INDUCTOR 0.56uH
CF203	1-767-313-11	FILTER, CERAMIC			L102	1-410-997-42	INDUCTOR 2.2uH
CF204	1-767-414-71	FILTER, CERAMIC (AFTER BOARD SUFFIX -17)			L201	1-412-006-31	INDUCTOR 10uH
		< CONNECTOR >			L202	1-410-985-42	INDUCTOR 0.22uH
CN401	1-764-369-11	CONNECTOR, FFC/FPC (ZIF) 18P			L204	1-412-004-31	INDUCTOR 6.8uH
		< TRIMMER >			L301	1-412-002-31	INDUCTOR 4.7uH
CT1	1-141-327-11	CAP, CHIP TYPE TRIMMER	10PF (FM TRACKING)		L302	1-412-002-31	INDUCTOR 4.7uH
CT2	1-141-325-11	CAP, CHIP TYPE TRIMMER	5PF (FM TRACKING)		L303	1-412-002-31	INDUCTOR 4.7uH
		< DIODE >			L401	1-412-066-21	INDUCTOR 220uH
D1	8-719-062-51	DIODE 1PS226-115			L402	1-412-011-31	INDUCTOR 27uH
D2	8-719-044-76	DIODE 1SS356-TW11					< TRANSISTOR >
D3	8-719-941-86	DIODE DAN202U			Q1	8-729-123-86	TRANSISTOR 2SK238-K16
D4	8-719-044-76	DIODE 1SS356-TW11			Q2	8-729-116-64	TRANSISTOR 2SK508-T1K52
D5	8-719-083-90	DIODE HVU363ATRU			Q3	8-729-116-64	TRANSISTOR 2SK508-T1K52
D6	8-719-083-90	DIODE HVU363ATRU			Q4	8-729-208-47	TRANSISTOR 2SK210GR-TE85L
D7	8-719-044-76	DIODE 1SS356-TW11			Q5	8-729-402-16	TRANSISTOR XN4608
D101	8-719-083-90	DIODE HVU363ATRU			Q6	8-729-123-86	TRANSISTOR 2SK238-K16
D102	8-719-941-86	DIODE DAN202U			Q7	8-729-117-72	TRANSISTOR 2SC4178-F13
D103	8-719-941-86	DIODE DAN202U			Q8	8-729-117-32	TRANSISTOR 2SC4177-L6
D104	8-719-941-86	DIODE DAN202U			Q9	8-729-402-16	TRANSISTOR XN4608
D201	8-719-083-90	DIODE HVU363ATRU			Q10	8-729-123-86	TRANSISTOR 2SK238-K16

Ref. No.	Part No.	Description	Remark	Ref. No.	Part No.	Description	Remark
Q11	8-729-904-86	TRANSISTOR	2SB1197K-Q	R20	1-216-797-11	METAL CHIP	10 5% 1/10W
Q12	8-729-028-74	TRANSISTOR	DTA114TUA-T106	R21	1-216-819-11	METAL CHIP	680 5% 1/10W
Q101	8-729-117-72	TRANSISTOR	2SC4178-F13	R22	1-216-850-11	METAL CHIP	270K 5% 1/10W
Q102	8-729-208-47	TRANSISTOR	2SK210GR-TE85L	R23	1-216-841-11	METAL CHIP	47K 5% 1/10W
Q103	8-729-117-72	TRANSISTOR	2SC4178-F13				
Q104	8-729-904-86	TRANSISTOR	2SB1197K-Q	R24	1-216-837-11	METAL CHIP	22K 5% 1/10W
Q105	8-729-220-93	TRANSISTOR	2SK209-G	R25	1-216-797-11	METAL CHIP	10 5% 1/10W
Q106	8-729-117-32	TRANSISTOR	2SC4177-L6	R26	1-216-838-11	METAL CHIP	27K 5% 1/10W
Q107	8-729-220-93	TRANSISTOR	2SK209-G	R27	1-216-853-11	METAL CHIP	470K 5% 1/10W
Q108	8-729-903-10	TRANSISTOR	FMW1	R28	1-216-833-11	METAL CHIP	10K 5% 1/10W
Q109	8-729-117-32	TRANSISTOR	2SC4177-L6	R29	1-216-833-11	METAL CHIP	10K 5% 1/10W
Q110	8-729-029-15	TRANSISTOR	DTC144TUA-T106	R30	1-216-845-11	METAL CHIP	100K 5% 1/10W
Q111	8-729-402-16	TRANSISTOR	XN4608	R31	1-216-833-11	METAL CHIP	10K 5% 1/10W
Q112	8-729-117-32	TRANSISTOR	2SC4177-L6	R32	1-216-833-11	METAL CHIP	10K 5% 1/10W
Q113	8-729-903-10	TRANSISTOR	FMW1	R33	1-216-845-11	METAL CHIP	100K 5% 1/10W
Q201	8-729-117-72	TRANSISTOR	2SC4178-F13	R34	1-216-841-11	METAL CHIP	47K 5% 1/10W
Q202	8-729-402-13	TRANSISTOR	XN1501	R35	1-216-840-11	METAL CHIP	39K 5% 1/10W
Q203	8-729-029-15	TRANSISTOR	DTC144TUA-T106	R36	1-216-829-11	METAL CHIP	4.7K 5% 1/10W
Q204	8-729-029-15	TRANSISTOR	DTC144TUA-T106	R37	1-216-821-11	METAL CHIP	1K 5% 1/10W
Q205	8-729-029-15	TRANSISTOR	DTC144TUA-T106	R38	1-216-845-11	METAL CHIP	100K 5% 1/10W
Q206	8-729-029-15	TRANSISTOR	DTC144TUA-T106	R39	1-216-797-11	METAL CHIP	10 5% 1/10W
Q208	8-729-921-58	TRANSISTOR	DTA144TU	R40	1-216-845-11	METAL CHIP	100K 5% 1/10W
Q210	8-729-921-58	TRANSISTOR	DTA144TU	R41	1-216-833-11	METAL CHIP	10K 5% 1/10W
Q301	8-729-903-10	TRANSISTOR	FMW1	R42	1-216-845-11	METAL CHIP	100K 5% 1/10W
Q302	8-729-903-10	TRANSISTOR	FMW1	R43	1-216-809-11	METAL CHIP	100 5% 1/10W
Q303	8-729-029-15	TRANSISTOR	DTC144TUA-T106	R44	1-216-829-11	METAL CHIP	4.7K 5% 1/10W
Q304	8-729-921-58	TRANSISTOR	DTA144TU	R45	1-216-825-11	METAL CHIP	2.2K 5% 1/10W
Q305	8-729-029-15	TRANSISTOR	DTC144TUA-T106	R47	1-216-813-11	METAL CHIP	220 5% 1/10W
Q306	8-729-117-32	TRANSISTOR	2SC4177-L6	R101	1-216-797-11	METAL CHIP	10 5% 1/10W
Q307	8-729-117-32	TRANSISTOR	2SC4177-L6	R102	1-216-842-11	METAL CHIP	56K 5% 1/10W
Q308	8-729-921-58	TRANSISTOR	DTA144TU	R103	1-216-805-11	METAL CHIP	47 5% 1/10W
Q309	8-729-402-16	TRANSISTOR	XN4608	R104	1-216-797-11	METAL CHIP	10 5% 1/10W
Q310	8-729-029-15	TRANSISTOR	DTC144TUA-T106	R105	1-216-842-11	METAL CHIP	56K 5% 1/10W
Q311	8-729-029-15	TRANSISTOR	DTC144TUA-T106	R106	1-216-797-11	METAL CHIP	10 5% 1/10W
Q401	8-729-402-13	TRANSISTOR	XN1501	R107	1-216-814-11	METAL CHIP	270 5% 1/10W
Q402	8-729-904-86	TRANSISTOR	2SB1197K-Q	R108	1-216-837-11	METAL CHIP	22K 5% 1/10W
Q403	8-729-402-16	TRANSISTOR	XN4608	R109	1-216-837-11	METAL CHIP	22K 5% 1/10W
Q404	8-729-117-32	TRANSISTOR	2SC4177-L6	R110	1-216-845-11	METAL CHIP	100K 5% 1/10W
Q450	8-729-921-58	TRANSISTOR	DTA144TU	R111	1-216-833-11	METAL CHIP	10K 5% 1/10W
Q451	8-729-029-15	TRANSISTOR	DTC144TUA-T106	R112	1-216-833-11	METAL CHIP	10K 5% 1/10W
		< RESISTOR >		R113	1-216-845-11	METAL CHIP	100K 5% 1/10W
R4	1-216-819-11	METAL CHIP	680 5% 1/10W	R114	1-216-821-11	METAL CHIP	1K 5% 1/10W
R5	1-216-807-11	METAL CHIP	68 5% 1/10W	R115	1-216-829-11	METAL CHIP	4.7K 5% 1/10W
R6	1-216-809-11	METAL CHIP	100 5% 1/10W	R116	1-218-867-11	METAL CHIP	6.8K 0.5% 1/10W
R7	1-216-825-11	METAL CHIP	2.2K 5% 1/10W	R117	1-218-867-11	METAL CHIP	6.8K 0.5% 1/10W
R8	1-216-833-11	METAL CHIP	10K 5% 1/10W	R118	1-216-833-11	METAL CHIP	10K 5% 1/10W
R9	1-216-833-11	METAL CHIP	10K 5% 1/10W	R119	1-218-725-11	METAL CHIP	24K 0.5% 1/10W
R10	1-216-829-11	METAL CHIP	4.7K 5% 1/10W	R120	1-216-840-11	METAL CHIP	39K 5% 1/10W
R11	1-216-850-11	METAL CHIP	270K 5% 1/10W	R121	1-216-797-11	METAL CHIP	10 5% 1/10W
R12	1-216-821-11	METAL CHIP	1K 5% 1/10W	R122	1-216-843-11	METAL CHIP	68K 5% 1/10W
R13	1-216-797-11	METAL CHIP	10 5% 1/10W	R123	1-216-845-11	METAL CHIP	100K 5% 1/10W
R14	1-216-825-11	METAL CHIP	2.2K 5% 1/10W	R124	1-216-833-11	METAL CHIP	10K 5% 1/10W
R15	1-216-825-11	METAL CHIP	2.2K 5% 1/10W	R125	1-216-797-11	METAL CHIP	10 5% 1/10W
R16	1-216-797-11	METAL CHIP	10 5% 1/10W	R126	1-216-809-11	METAL CHIP	100 5% 1/10W
R17	1-216-797-11	METAL CHIP	10 5% 1/10W	R127	1-216-809-11	METAL CHIP	100 5% 1/10W
R18	1-216-797-11	METAL CHIP	10 5% 1/10W	R128	1-216-830-11	METAL CHIP	5.6K 5% 1/10W
R19	1-216-814-11	METAL CHIP	270 5% 1/10W	R129	1-216-827-11	METAL CHIP	3.3K 5% 1/10W
				R130	1-216-827-11	METAL CHIP	3.3K 5% 1/10W
				R131	1-216-827-11	METAL CHIP	3.3K 5% 1/10W

ICF-SW100E/SW100S

SIGNAL

Ref. No.	Part No.	Description	Remark	Ref. No.	Part No.	Description	Remark
R132	1-216-843-11	METAL CHIP	68K 5%	1/10W	R303	1-216-837-11	METAL CHIP 22K 5% 1/10W
R133	1-216-839-11	METAL CHIP	33K 5%	1/10W	R304	1-216-833-11	METAL CHIP 10K 5% 1/10W
R134	1-216-839-11	METAL CHIP	33K 5%	1/10W	R305	1-216-833-11	METAL CHIP 10K 5% 1/10W
R135	1-216-843-11	METAL CHIP	68K 5%	1/10W	R306	1-216-809-11	METAL CHIP 100 5% 1/10W
R136	1-216-839-11	METAL CHIP	33K 5%	1/10W	R307	1-216-840-11	METAL CHIP 39K 5% 1/10W
R137	1-216-839-11	METAL CHIP	33K 5%	1/10W	R308	1-216-845-11	METAL CHIP 100K 5% 1/10W
R138	1-216-839-11	METAL CHIP	33K 5%	1/10W	R309	1-216-797-11	METAL CHIP 10 5% 1/10W
R139	1-216-843-11	METAL CHIP	68K 5%	1/10W	R310	1-216-851-11	METAL CHIP 330K 5% 1/10W
R140	1-216-843-11	METAL CHIP	68K 5%	1/10W	R311	1-216-818-11	METAL CHIP 560 5% 1/10W
R141	1-216-843-11	METAL CHIP	68K 5%	1/10W	R312	1-216-803-11	METAL CHIP 33 5% 1/10W
R142	1-216-843-11	METAL CHIP	68K 5%	1/10W	R313	1-216-851-11	METAL CHIP 330K 5% 1/10W
R143	1-216-843-11	METAL CHIP	68K 5%	1/10W	R314	1-216-818-11	METAL CHIP 560 5% 1/10W
R144	1-216-827-11	METAL CHIP	3.3K 5%	1/10W	R315	1-216-803-11	METAL CHIP 33 5% 1/10W
R145	1-216-845-11	METAL CHIP	100K 5%	1/10W	R316	1-216-805-11	METAL CHIP 47 5% 1/10W
R146	1-216-845-11	METAL CHIP	100K 5%	1/10W	R317	1-216-829-11	METAL CHIP 4.7K 5% 1/10W
R147	1-216-827-11	METAL CHIP	3.3K 5%	1/10W	R318	1-216-825-11	METAL CHIP 2.2K 5% 1/10W
R148	1-216-827-11	METAL CHIP	3.3K 5%	1/10W	R319	1-216-833-11	METAL CHIP 10K 5% 1/10W
R149	1-216-827-11	METAL CHIP	3.3K 5%	1/10W	R320	1-218-867-11	METAL CHIP 6.8K 0.5% 1/10W
R150	1-216-827-11	METAL CHIP	3.3K 5%	1/10W	R321	1-216-837-11	METAL CHIP 22K 5% 1/10W
R151	1-216-827-11	METAL CHIP	3.3K 5%	1/10W	R322	1-216-823-11	METAL CHIP 1.5K 5% 1/10W
R152	1-216-827-11	METAL CHIP	3.3K 5%	1/10W	R323	1-216-833-11	METAL CHIP 10K 5% 1/10W
R153	1-216-827-11	METAL CHIP	3.3K 5%	1/10W	R324	1-216-805-11	METAL CHIP 47 5% 1/10W
R154	1-216-825-11	METAL CHIP	2.2K 5%	1/10W	R325	1-216-809-11	METAL CHIP 100 5% 1/10W
R155	1-216-838-11	METAL CHIP	27K 5%	1/10W	R326	1-216-809-11	METAL CHIP 100 5% 1/10W
R156	1-218-867-11	METAL CHIP	6.8K 0.5%	1/10W	R327	1-216-805-11	METAL CHIP 47 5% 1/10W
R157	1-216-839-11	METAL CHIP	33K 5%	1/10W	R328	1-216-845-11	METAL CHIP 100K 5% 1/10W
R158	1-216-845-11	METAL CHIP	100K 5%	1/10W	R329	1-218-867-11	METAL CHIP 6.8K 0.5% 1/10W
R159	1-216-803-11	METAL CHIP	33 5%	1/10W	R330	1-218-867-11	METAL CHIP 6.8K 0.5% 1/10W
R160	1-216-803-11	METAL CHIP	33 5%	1/10W	R332	1-216-845-11	METAL CHIP 100K 5% 1/10W
R161	1-216-837-11	METAL CHIP	22K 5%	1/10W	R333	1-216-821-11	METAL CHIP 1K 5% 1/10W
R162	1-216-850-11	METAL CHIP	270K 5%	1/10W	R334	1-216-821-11	METAL CHIP 1K 5% 1/10W
R163	1-216-845-11	METAL CHIP	100K 5%	1/10W	R350	1-216-841-11	METAL CHIP 47K 5% 1/10W
R164	1-216-835-11	METAL CHIP	15K 5%	1/10W	R401	1-216-845-11	METAL CHIP 100K 5% 1/10W
R165	1-216-849-11	METAL CHIP	220K 5%	1/10W	R402	1-216-845-11	METAL CHIP 100K 5% 1/10W
R201	1-216-814-11	METAL CHIP	270 5%	1/10W	R403	1-216-843-11	METAL CHIP 68K 5% 1/10W
R202	1-216-837-11	METAL CHIP	22K 5%	1/10W	R404	1-216-821-11	METAL CHIP 1K 5% 1/10W
R203	1-216-825-11	METAL CHIP	2.2K 5%	1/10W	R406	1-216-797-11	METAL CHIP 10 5% 1/10W
R204	1-216-845-11	METAL CHIP	100K 5%	1/10W	R407	1-216-845-11	METAL CHIP 100K 5% 1/10W
R205	1-216-825-11	METAL CHIP	2.2K 5%	1/10W	R408	1-216-821-11	METAL CHIP 1K 5% 1/10W
R206	1-216-833-11	METAL CHIP	10K 5%	1/10W	R409	1-216-840-11	METAL CHIP 39K 5% 1/10W
R207	1-216-827-11	METAL CHIP	3.3K 5%	1/10W	R410	1-216-845-11	METAL CHIP 100K 5% 1/10W
R208	1-216-797-11	METAL CHIP	10 5%	1/10W	R411	1-216-833-11	METAL CHIP 10K 5% 1/10W
R209	1-216-832-11	METAL CHIP	8.2K 5%	1/10W	R412	1-216-833-11	METAL CHIP 10K 5% 1/10W
R210	1-216-819-11	METAL CHIP	680 5%	1/10W	R451	1-216-821-11	METAL CHIP 1K 5% 1/10W
R211	1-216-849-11	METAL CHIP	220K 5%	1/10W	R452	1-216-853-11	METAL CHIP 470K 5% 1/10W
R212	1-216-797-11	METAL CHIP	10 5%	1/10W	R453	1-216-845-11	METAL CHIP 100K 5% 1/10W
R213	1-216-849-11	METAL CHIP	220K 5%	1/10W	R454	1-216-853-11	METAL CHIP 470K 5% 1/10W
R214	1-216-825-11	METAL CHIP	2.2K 5%	1/10W			< VARIABLE RESISTOR >
R215	1-216-835-11	METAL CHIP	15K 5%	1/10W	RV201	1-223-589-11	RES, ADJ, CARBON 100K (SSB ZERO BEAT)
R216	1-216-838-11	METAL CHIP	27K 5%	1/10W	RV202	1-223-587-11	RES, ADJ, CARBON 22K (SD)
R217	1-216-809-11	METAL CHIP	100 5%	1/10W	RV301	1-223-587-11	RES, ADJ, CARBON 22K (FM STEREO)
R218	1-216-829-11	METAL CHIP	4.7K 5%	1/10W	RV302	1-223-573-11	RES, VAR, CARBON 50K (VOL ◀)
R219	1-216-851-11	METAL CHIP	330K 5%	1/10W			< SWITCH >
R221	1-216-821-11	METAL CHIP	1K 5%	1/10W	S1	1-571-674-11	SWITCH, SLIDE (SENS DX/LOCAL)
R222	1-216-839-11	METAL CHIP	33K 5%	1/10W	S301	1-572-922-11	SWITCH, SLIDE (AM TONE/FM MODE)
R301	1-216-828-11	METAL CHIP	3.9K 5%	1/10W			
R302	1-216-833-11	METAL CHIP	10K 5%	1/10W			

<u>Ref. No.</u>	<u>Part No.</u>	<u>Description</u>	<u>Remark</u>
S302	1-572-938-21	SWITCH, TACTIL (RESET)	
		< TRANSFORMER >	
T1	1-423-981-11	TRANSFORMER, HIGH FREQUENCY (AM MIX)	
T2	1-403-633-11	TRANSFORMER, IF (AM 1ST IF)	
T3	1-403-634-11	TRANSFORMER, IF (AM 1ST IF)	
T4	1-423-983-11	TRANSFORMER, HIGH FREQUENCY (MW/LW RF)	
T5	1-403-636-11	COIL (WITH CORE) (FM TRACKING)	
T6	1-403-637-11	COIL (WITH CORE) (FM TRACKING)	
T101	1-403-629-11	COIL (WITH CORE) (OSC) (AM 1ST OSC)	
T201	1-403-638-11	COIL (WITH CORE) (OSC) (FM VCO)	
T202	1-403-632-22	COIL (WITH CORE) (2ND LOCAL))	
T203	1-403-631-11	TRANSFORMER, IF (2ND LOCAL)	
T204	1-403-630-11	COIL (WITH CORE) (OSC) (AM OSC)	
T401	1-449-021-21	COIL, DC/DC CONVERTER	
		< VIBRATOR >	
X101	1-579-744-21	VIBRATOR, CRYSTAL (75kHz)	
X201	1-760-200-11	VIBRATOR, CERAMIC (3.640MHz)	
X202	1-760-197-11	VIBRATOR, CRYSTAL (55.390MHz)	
		< FILTER >	
XF1	1-760-198-11	FILTER, CRYSTAL	

