

ICF-C20RDS

SERVICE MANUAL

AEP Model
UK Model

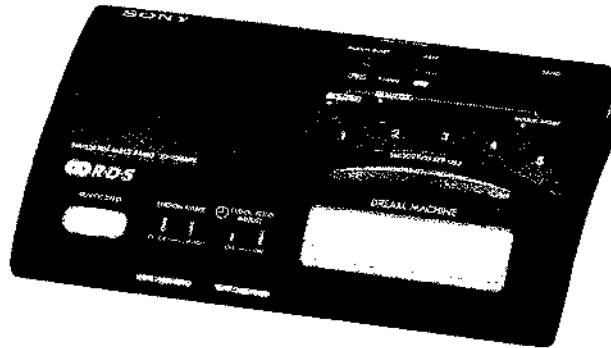

SPECIFICATIONS

Time display:

UK: 12-hour system
Other countries: 24-hour system

Frequency range:

Band	Frequency range	Channel step
FM	87.5-108 MHz	0.05* MHz(fixed)
AM (MW)	531-1,602 kHz	9 kHz(fixed)
LW	153-279 kHz	9 kHz(fixed)

* The frequency display is raised or lowered by a step of 0.1 MHz. (Example: Frequency 88.05 MHz is displayed as "88.0 MHz".)

Intermediate frequency:

FM: 10.7 MHz, AM (MW): 450 kHz

Speaker:

Approx. 6.6 cm (2 5/8 inches) dia., 8Ω

Power output:

250 mW (at 10 % harmonic distortion)

Power requirements:

UK: 240V AC, 50 Hz
Other countries: 220-230V AC, 50 Hz

Dimensions:

Approx. 201 × 68.2 × 147 mm (w/h/d)
(8 × 2 3/4 × 5 7/8 inches) incl. projecting parts
and controls

Mass:

Approx. 690 g (1 lb 8 oz)

Accessory supplied:

FM antenna coupler (1, Models for
Netherlands, Belgium, Switzerland and
Scandinavia only)

Design and specifications subject to change
without notice.

Note

This appliance conforms with EEC Directive 87/
308/EEC regarding interference suppression.

FM/AM RDS CLOCK RADIO
FM/MW/LW 3BAND RDS CLOCK RADIO
SONY®

SECTION 1

SERVICING NOTE

CORD DRESSING (POWER, ANTENNA, SPEAKER)

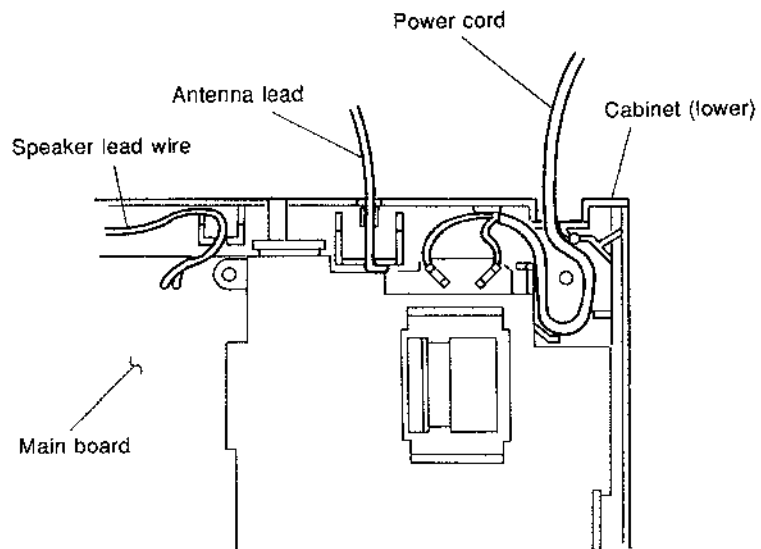

Notes on chip component replacement

- Never reuse a disconnected chip component.
- Notice that the minus side of a tantalum capacitor may be damaged by heat.

SAFETY-RELATED COMPONENT WARNING !!

COMPONENTS IDENTIFIED BY MARK Δ OR DOTTED LINE WITH MARK Δ ON THE SCHEMATIC DIAGRAMS AND IN THE PARTS LIST ARE CRITICAL TO SAFE OPERATION. REPLACE THESE COMPONENTS WITH SONY PARTS WHOSE PART NUMBERS APPEAR AS SHOWN IN THIS MANUAL OR IN SUPPLEMENTS PUBLISHED BY SONY.

SECTION 2 GENERAL

This section is extracted from instruction manual.

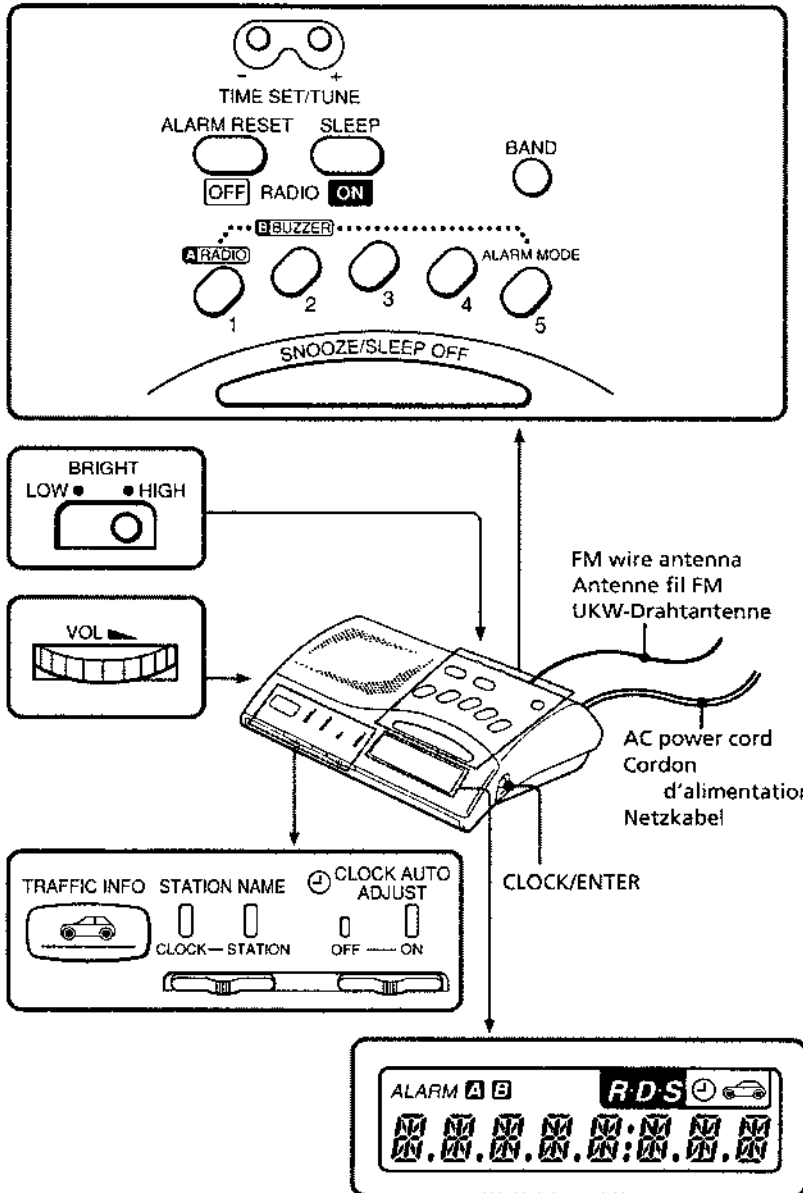

Setting the Alarm

You can set the radio and buzzer alarms.

1. Turn off the radio.
2. While holding down **A RADIO** or **B BUZZER**, press either **TIME SET/TUNE -** or **+** till the desired time appears in the display window. "**ALARM A**" or "**ALARM B**" flashes while these buttons are being held down.

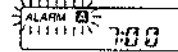

3. When you release **A RADIO** or **B BUZZER**, the alarm time is set. The indication shows the current time.
4. Press **ALARM MODE** till the alarm you want to set appears in the display. Every push changes the alarm indication as follows.

No alarm → ALARM **A** → ALARM **B**
 ↕ ALARM **A B** ↙

When you want to set both **A RADIO** and **B BUZZER** alarm, set both **A RADIO** and **B BUZZER** alarm time by performing steps 2 and 3 above.

The radio or buzzer will automatically sound at the preset time, and automatically turn itself off after 60 minutes, unless it is turned off manually.

- To shut off the alarm manually, press **RADIO OFF/ALARM RESET**. The alarm will come on at the preset time the next day.
- To cancel the alarm before the alarm time, press **ALARM MODE** till the appropriate alarm indication disappears.
- To check the preset time, press **A RADIO** or **B BUZZER**.

Notes

- When the radio alarm comes on, "**ALARM A**" indication flashes. If you want to keep on listening to radio and stop flashing, press the **RADIO ON/SLEEP**.
- The buzzer sound level is fixed, and independent of the VOL.
- If you set **A RADIO** and **B BUZZER** to the same desired time, only **A RADIO** will work.

To Doze for a Few More Minutes

1. Press **SNOOZE/SLEEP OFF**.

The radio or buzzer will shut off but will automatically come on again after about 8 minutes.

You can repeat this process within 1 hour.

- When the snooze alarm function is operating, the alarm indication flashes.

SECTION 3 ELECTRICAL ADJUSTMENTS

• MW/LW Section

Setting :

BAND switch : MW/LW

AM RF signal generator

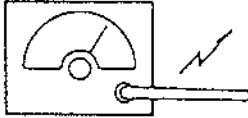

Put the lead-wire antenna close to the set.

30% amplitude modulation
by 400Hz signal
output level : as low as possible

• FM Section

Setting :

BAND switch : FM

FM RF signal generator

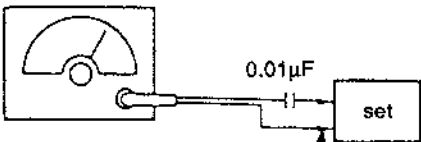

22.5kHz frequency deviation by 400Hz signal
output level : as low as possible

lead antenna terminal

VTVM
(range : 0.5 – 5V ac)

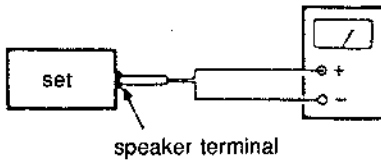

- Repeat the procedures in each adjustment several times, and the frequency coverage and the tracking adjustments should be finally done by the trimmer capacitors.

MW IF ADJUSTMENT

Adjust for a maximum reading on VTVM.

L7

450kHz

MW VCO VOLTAGE ADJUSTMENT

Adjustment Part	Frequency Display	Reading on Digital voltmeter
L6	531kHz	2.7V ± 0.1V
(confirmation)	1,602kHz	8.6V ± 0.1V (check)

Note : Not use the AM RF signal generator in this adjustment.

MW TRACKING ADJUSTMENT

Adjust for a maximum reading on VTVM.

L1

CT1

621kHz

1,404kHz

LW VCO VOLTAGE ADJUSTMENT

Adjustment Part	Frequency Display	Reading on Digital voltmeter
CT4	153kHz	2.2V ± 0.1V
(confirmation)	297kHz	8.6V ± 1.0V (check)

Note : Not use the AM RF signal generator in this adjustment.

LW TRACKING ADJUSTMENT

Adjust for a maximum reading on VTVM.

L1

CT2

162kHz

243kHz

FM VCO VOLTAGE CHECK

Adjustment Part	Frequency Display	Reading on Digital voltmeter
(confirmation)	108.0MHz	9.0V ± 1.5V (check)
(confirmation)	87.5MHz	2.0V ± 0.3V (check)

Note : Not use the FM RF signal generator in this adjustment.

FM TRACKING ADJUSTMENT

Adjust for a maximum reading on VTVM.

L4

CT3

87.5MHz

108MHz

Adjustment Location : MAIN board (Conductor Side)

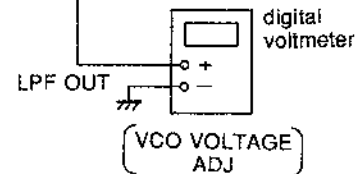
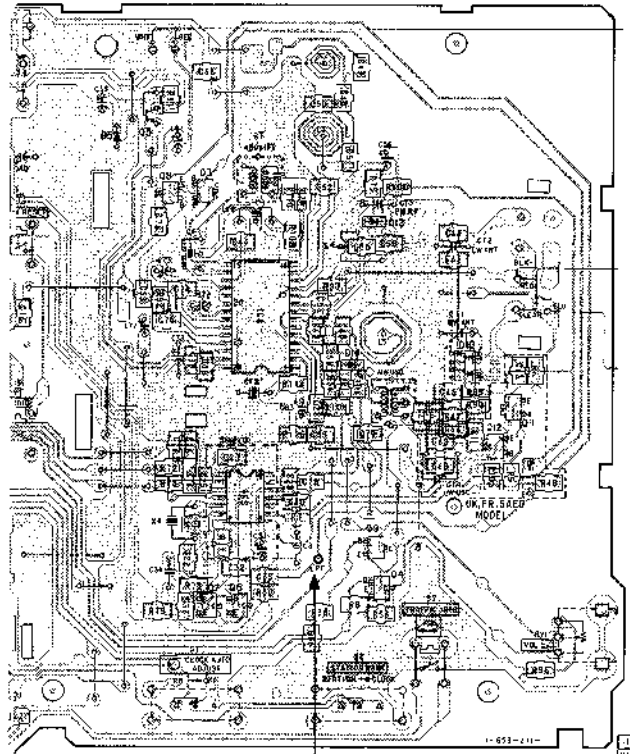

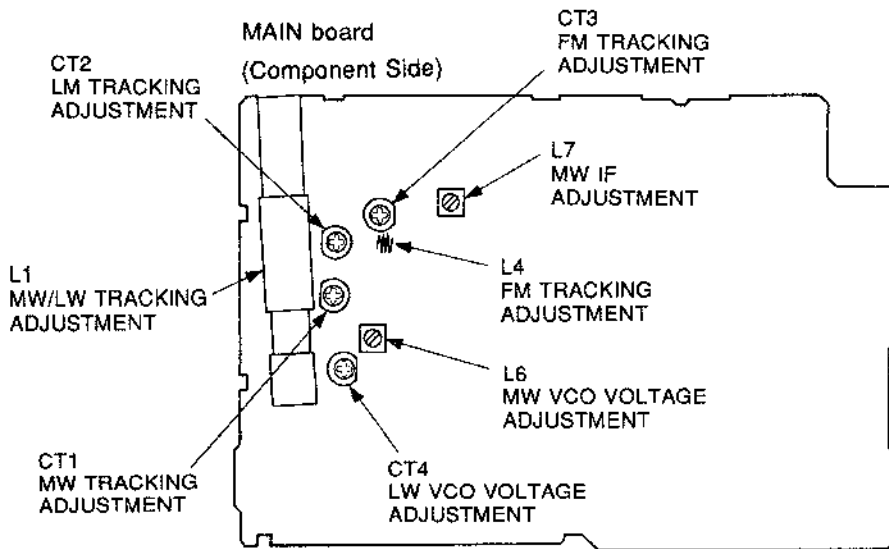

SECTION 4 DIAGRAMS

4-1. SEMICONDUCTOR LEAD LAYOUTS

CXA1019M

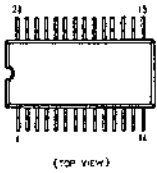

μPD75308-SR7190

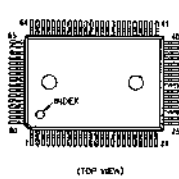

KV1560

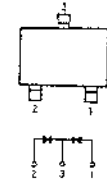

SLZ-235C-15

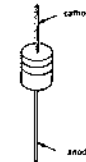

CXD1118M

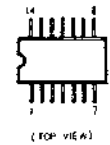

**DTA144EK
2SA1162G
2SC2712-YG
2SC2714-Y**

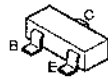

KV1563M-3

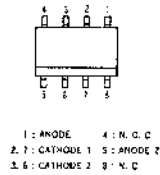

1S2836

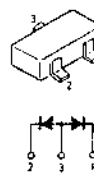

SAA6579T

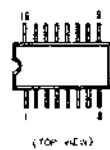

2SC2001TP-K1K2



SB007-03CP

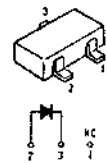

10E2

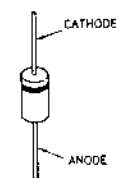

S-80728AN-DR

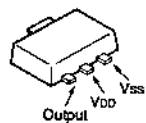

**DTZ5.1C
1T362**

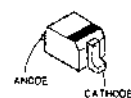

4-2. PRINTED WIRING BOARD

• See page 6 for Semiconductor Lead Layouts.

• Semiconductor Location

Ref. No.	Location
D1	F-2
D2	E-2
D3	B-4
D4	B-5
D5	B-6
D6	D-3
D7	G-4
D8	G-3
D9	G-2
D10	D-9
D11	G-4
D12	C-4
D13	C-8
D14	D-8
IC1	F-4
IC2	D-5
IC3	F-2
IC4	D-7
IC5	E-7
Q1	D-4
Q2	E-4
Q3	C-7
Q4	F-8
Q5	B-6
Q6	F-7
Q7	F-7
Q8	C-7
Q9	F-8
Q11	E-10
Q12	E-10

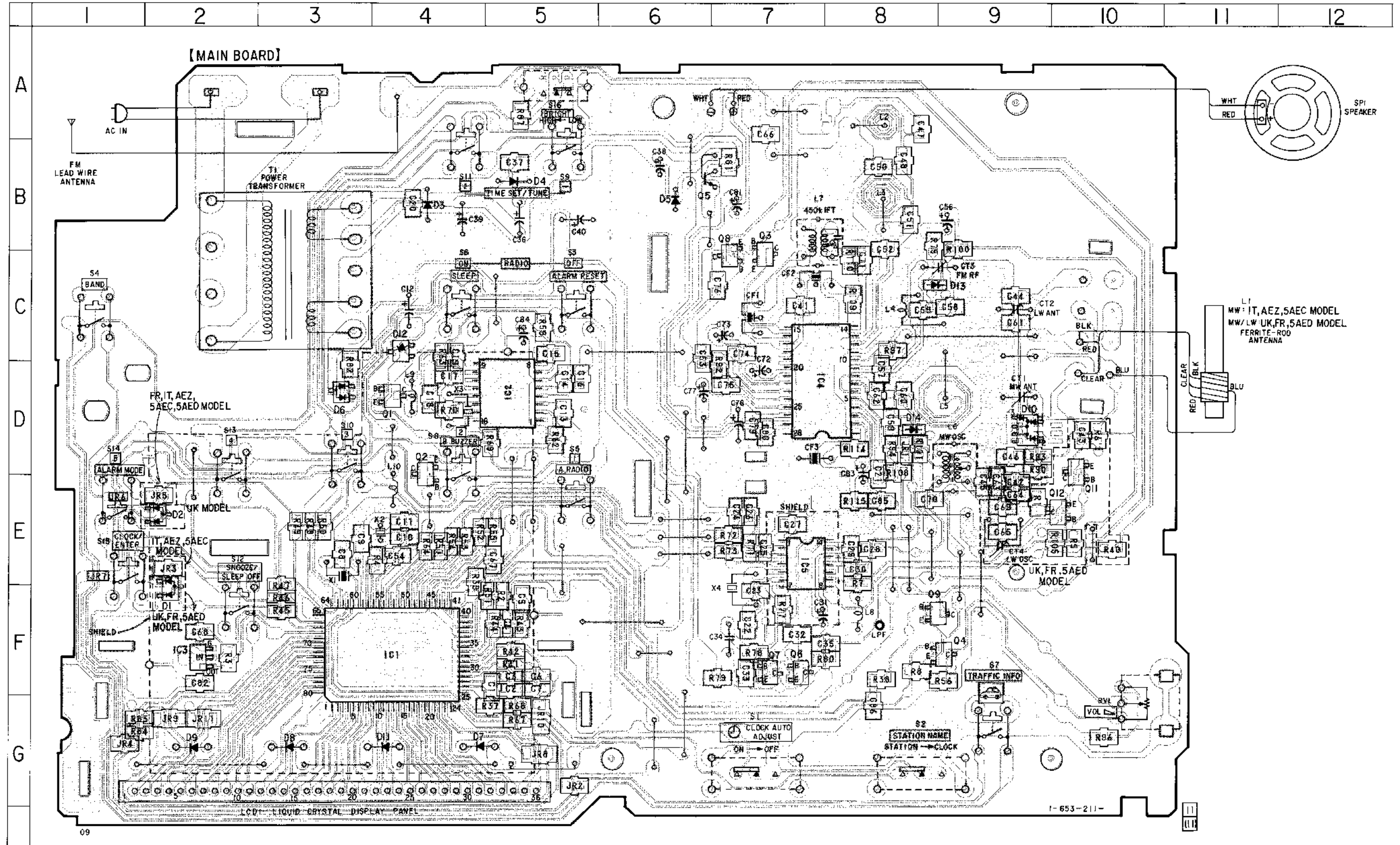

Note:

- — : parts extracted from the component side.
- Δ : internal component.
- [] : Pattern from the side which enable seeing.

4-3. SCHEMATIC DIAGRAM

- See page 12 for IC Block Diagrams.
- See page 13 for IC Pin Functions. (IC1)

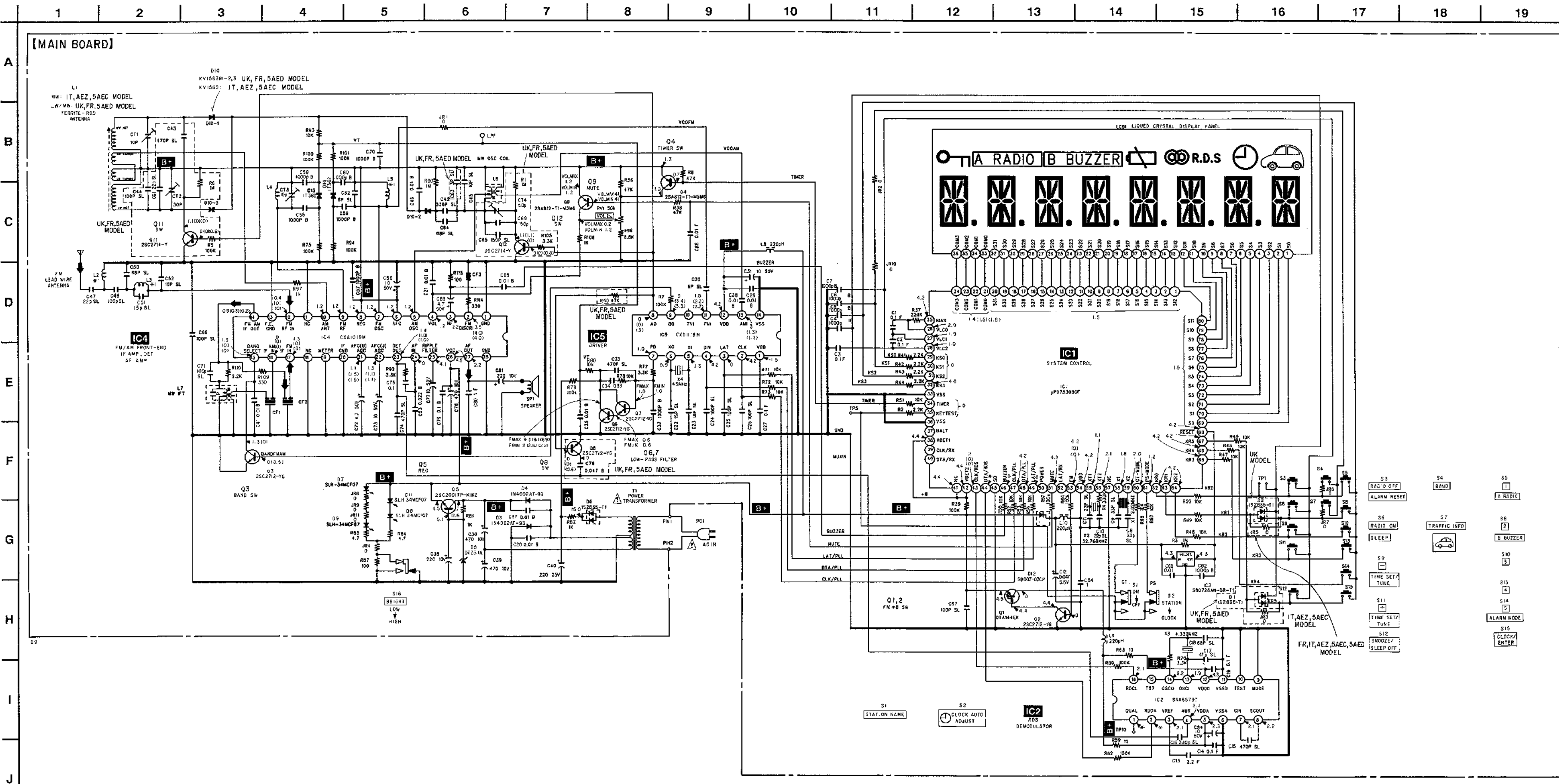

- Note:**
- All capacitors are in μF unless otherwise noted. pF : μF
 - All resistors are in Ω and $1/4\text{W}$ or less unless otherwise specified.
 - Δ : internal component.
 - \square : panel designation.
- Note:** The components identified by mark Δ or dotted line with mark Δ are critical for safety. Replace only with part number specified.
- **B+**: B+ Line
 - \square : adjustment for repair.
 - Voltage and waveforms are dc with respect to ground under no-signal (detuned) conditions.
 - no mark : FM
 - () : MW
 - < > : LW
 - * : can not be measured.
 - Voltages are taken with a VOM (Input impedance $10\text{M}\Omega$). Voltage variations may be noted due to normal production tolerances.
 - *1 : Printed pattern functions as a kind of coil.
 - Signal path.
 - ➔ : FM

4-4. IC BLOCK DIAGRAMS

IC2 SAA6579T

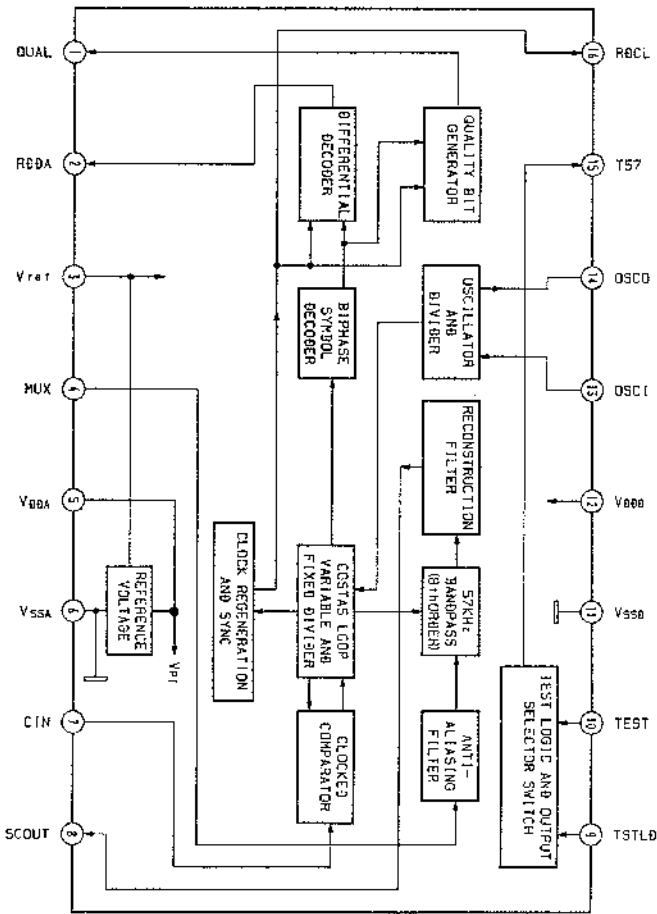

IC5 CXD1118M

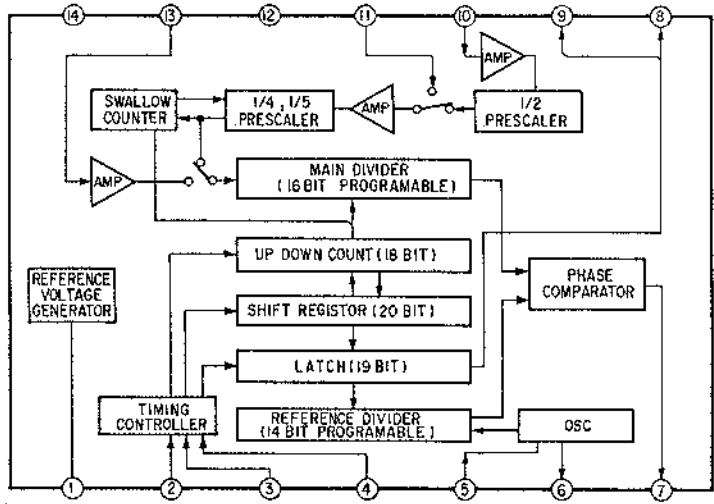

IC4 CXA1019M

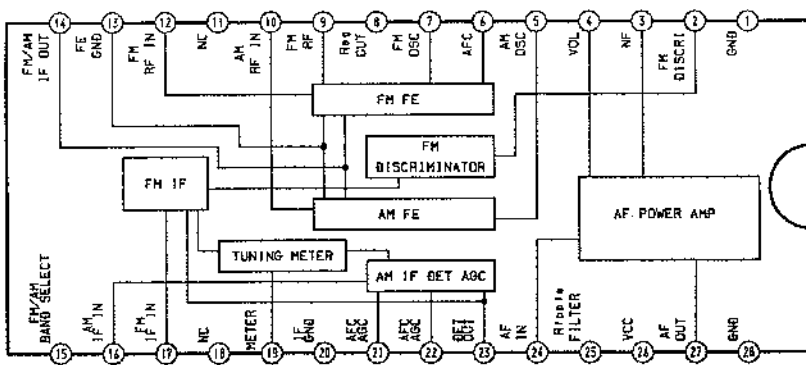

4-5. IC PIN FUNCTIONS

• μ PD75308GF-R90-3B9 (IC1)

Pin No.	Pin Name	I/O	Function
1 to 20	S12 to S20	O	LCD indication segment.
21 to 24	COM0 to COM3	O	LCD indication common.
25	BIAS	O	Bias output.
26 to 28	VLC0 to VLC2	-	Power supply of LCD DRIVER.
29 to 32	KS0 to KS3	O	Key source.
33	VSS	-	GND
34	TIMER	O	TIMER. (H: Alarm operation at radio, turn up the volume slightly when a traffic information is received)
35	KEYTEST	O	L: Under the key test.
36	VSS	-	GND
37	HALT	O	H: When HALT operating. (Not used)
38	VDET1	I	Reduced voltage detection 1. (L: Reduced voltage)
39	CLK/RX	O	Receiving level output clock. (Not used)
40	DTA/RX	O	Receiving level output data. (Not used)
41	NC	-	Not used.
42	VDET2	I	Reduced voltage detection 2. (L: Reduced voltage)
43	CLK/RDS	I	RDS clock.
44	DTA/RDS	I	RDS data.
45	SD	I	Station signal. (L: A broadcasting station is existed)
46	BUZZER	O	Buzzer output.
47	CLK/PLL	O	PLL clock.
48	DTA/PLL	O	PLL data.
49	LAT/PLL	O	PLL latch.
50	POWER	O	Power supply of radio. (H: Power on)
51	MUTE	O	Mute. (L: Mute on)
52	LAT/RX	O	Receiving level output latch. (Not used)
53	FM	O	FM output. (H: When FM receiving)
54	VDD	-	Power supply. (+5V)
55	XT1	O	} Crystal oscillation. (32.768 Hz)
56	XT2	I	
57	NC	-	Not used.
58	X1	O	} Ceramic oscillation. (2.62 MHz)
59	X2	I	
60	CT-MODE	I	CT mode switching switch. (L: Automatic time setting, H: Non)
61	PS-MODE	I	PS indication switching switch. (L: Frequency/station name indication, H: Present time indication)
62 to 67	KR0 to KR5	I	Key return.
68	RESET	I	Reset.
69 to 80	S0 to S11	O	LCD indication segment.

SECTION 5 EXPLODED VIEWS

NOTE:

- Items marked " * " are not stocked since they are seldom required for routine service. Some delay should be anticipated when ordering these items.
- -XX, -X mean standardized parts, so they may have some difference from the original one.
- The mechanical parts with no reference number in the exploded views are not supplied.

- Abbreviation
 IT : Italian model
 FR : French model
 SAED : Swiss and Belgian model
 SAEC : Netherlands, Norwegian and Austrian model
 AEZ : German, Spanish and Portuguese model

The components identified by mark or dotted line with mark are critical for safety. Replace only with part number specified.

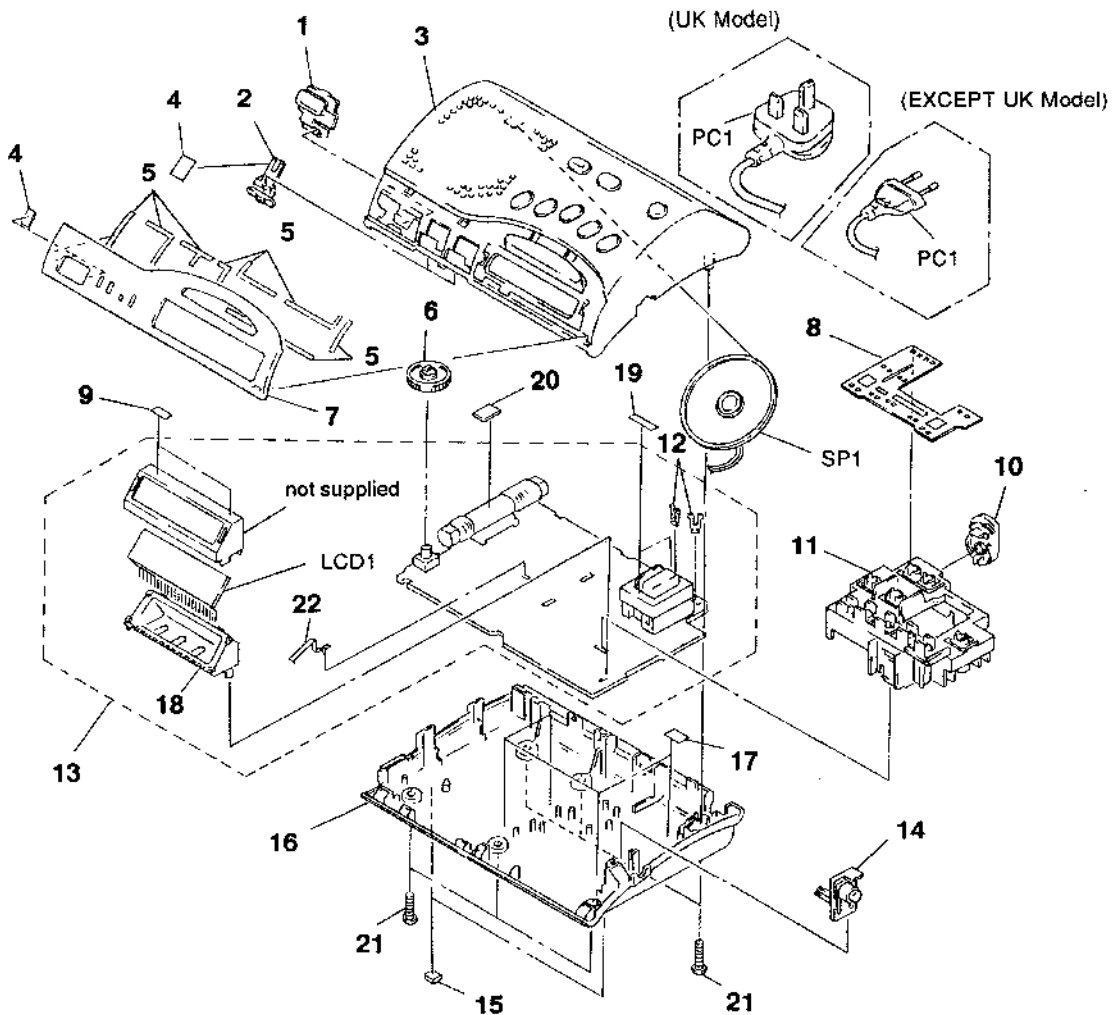

Ref. No.	Part No.	Description	Remark	Ref. No.	Part No.	Description	Remark
1	3-914-196-01	BUTTON (RDS)		* 13	A-3662-068-A	MAIN BOARD, COMPLETE (UK)	
2	3-914-197-01	KNOB (RDS)		14	3-377-647-21	BUTTON (MODE)	
3	X-3369-588-1	CABINET (UPPER) ASSY (IT, AEZ, 5AEC)		15	3-368-852-01	FOOT	
3	X-3369-588-2	CABINET (UPPER) ASSY (UK, FR, 5AED)		16	3-377-653-41	CABINET (LOWER) (UK, FR, 5AED)	
4	3-831-441-XX	CUSHION		16	3-377-653-71	CABINET (LOWER) (IT, AEZ, 5AEC)	
* 5	3-915-385-01	SHEET (A), ADHESIVE		17	9-911-840-XX	CUSHION	
6	3-368-840-21	KNOB (VOL.)		18	3-914-547-01	REFLECTOR	
7	3-914-193-01	PANEL, TRANSPARENT		19	3-919-378-01	CUSHION (TRANS)	
8	3-919-466-01	SHEET (BUTTON)		20	3-919-377-01	CUSHION (ANT)	
9	9-911-838-XX	SHEET, RUBBER		21	7-685-649-79	SCREW +P 3X14 TYPE2 NON-SLIT	
10	3-914-198-01	KNOB (BRIGHT)		22	3-918-998-01	PLATE (X'TAL), CONTACT	
* 11	3-914-195-01	BUTTON, MIDDLE		LCD1	1-810-640-11	DISPLAY PANEL, LIQUID CRYSTAL	
* 12	1-535-771-11	TERMINAL		PC1	1-555-795-00	COAD, POWER (EXCEPT UK)	
* 13	A-3662-062-A	MAIN BOARD, COMPLETE (FR, 5AED)		PC1	1-696-572-21	COAD, POWER (UK)	
* 13	A-3662-065-A	MAIN BOARD, COMPLETE (IT, AEZ, 5AEC)		SP1	1-503-082-00	SPEAKER (6.6CM)	

SECTION 6

ELECTRICAL PARTS LIST

MAIN

NOTE:

The components identified by mark Δ or dotted line with mark Δ are critical for safety. Replace only with part number specified.

When indicating parts by reference number, please include the board name.

- Due to standardization, replacements in the parts list may be different from the parts specified in the diagrams or the components used on the set.
- Items marked "*" are not stocked since they are seldom required for routine service. Some delay should be anticipated when ordering these items.
- -XX, -X mean standardized parts, so they may have some difference from the original one.
- Abbreviation
 IT : Italian model
 FR : French model
 5AED : Swiss and Belgian model
 5AEC : Netherlands, Norwegian and Austrian model
 AEZ : German, Spanish and Portuguese model
- RESISTORS
 All resistors are in ohms
 METAL: Metal-film resistor
 METAL OXIDE: Metal Oxide-film resistor
 F : nonflammable
- SEMICONDUCTORS
 In each case, u: μ . for example:
 uA...: μ A..., uPA...: μ PA..., uPB...: μ PB...,
 uPC...: μ PC..., uPD...: μ PD...
- CAPACITORS
 uF : μ F
- COILS
 uH : μ H

Ref. No.	Part No.	Description	Remark	Ref. No.	Part No.	Description	Remark
*	A-3662-062-A	MAIN BOARD, COMPLETE (FR, 5AED)		C31	1-124-907-11	ELECT	10uF 20% 50V
		*****		C32	1-163-009-11	CERAMIC CHIP	0.001uF 10% 50V
*	A-3662-065-A	MAIN BOARD, COMPLETE (IT, AEZ, 5AEC)		C33	1-163-133-00	CERAMIC CHIP	470PF 5% 50V
		*****		C34	1-136-171-00	FILM	0.33uF 5% 50V
				C35	1-164-232-11	CERAMIC CHIP	0.01uF 50V
*	A-3662-068-A	MAIN BOARD, COMPLETE (UK)		C36	1-124-472-11	ELECT	470uF 20% 10V
		*****		C37	1-164-232-11	CERAMIC CHIP	0.01uF 50V
*	1-535-771-11	TERMINAL		C38	1-126-176-11	ELECT	220uF 20% 10V
	3-914-547-01	REFLECTOR		C39	1-124-472-11	ELECT	470uF 20% 10V
		< CAPACITOR >		C40	1-124-120-11	ELECT	220uF 20% 25V
C1	1-163-038-00	CERAMIC CHIP	0.1uF 25V	C41	1-164-232-11	CERAMIC CHIP	0.01uF 50V
C2	1-163-038-00	CERAMIC CHIP	0.1uF 25V	C42	1-163-129-00	CERAMIC CHIP	330PF 5% 50V
C3	1-163-038-00	CERAMIC CHIP	0.1uF 25V	C43	1-163-133-00	CERAMIC CHIP	470PF 5% 50V
C4	1-163-009-11	CERAMIC CHIP	0.001uF 10% 50V	C44	1-163-117-00	CERAMIC CHIP	100PF 5% 50V
C5	1-163-009-11	CERAMIC CHIP	0.001uF 10% 50V	C45	1-163-093-00	CERAMIC CHIP	10PF 5% 50V
C6	1-163-009-11	CERAMIC CHIP	0.001uF 10% 50V	C46	1-164-232-11	CERAMIC CHIP	0.01uF 50V
C7	1-163-009-11	CERAMIC CHIP	0.001uF 10% 50V	C47	1-163-101-00	CERAMIC CHIP	22PF 5% 50V
C8	1-163-105-00	CERAMIC CHIP	33PF 5% 50V	C48	1-163-117-00	CERAMIC CHIP	100PF 5% 50V
C9	1-163-105-00	CERAMIC CHIP	33PF 5% 50V	C50	1-163-113-00	CERAMIC CHIP	68PF 5% 50V
C10	1-163-101-00	CERAMIC CHIP	22PF 5% 50V	C51	1-163-097-00	CERAMIC CHIP	15PF 5% 50V
C11	1-163-101-00	CERAMIC CHIP	22PF 5% 50V	C52	1-163-093-00	CERAMIC CHIP	10PF 5% 50V
C12	1-125-701-11	DOUBLE LAYER	0.047F 5.5V	C53	1-163-037-11	CERAMIC CHIP	0.022uF 10% 25V
C13	1-164-505-11	CERAMIC CHIP	2.2uF 16V	C54	1-164-346-11	CERAMIC CHIP	1uF 16V
C14	1-163-038-00	CERAMIC CHIP	0.1uF 25V	C55	1-163-009-11	CERAMIC CHIP	0.001uF 10% 50V
C15	1-163-133-00	CERAMIC CHIP	470PF 5% 50V	C56	1-124-907-11	ELECT	10uF 20% 50V
C16	1-163-129-00	CERAMIC CHIP	330PF 5% 50V	C57	1-163-009-11	CERAMIC CHIP	0.001uF 10% 50V
C17	1-163-109-00	CERAMIC CHIP	47PF 5% 50V	C58	1-163-009-11	CERAMIC CHIP	0.001uF 10% 50V
C18	1-163-113-00	CERAMIC CHIP	68PF 5% 50V	C59	1-163-009-11	CERAMIC CHIP	0.001uF 10% 50V
C19	1-163-038-00	CERAMIC CHIP	0.1uF 25V	C60	1-163-009-11	CERAMIC CHIP	0.001uF 10% 50V
C20	1-164-232-11	CERAMIC CHIP	0.01uF 50V	C61	1-163-101-00	CERAMIC CHIP	22PF 5% 50V
C21	1-164-232-11	CERAMIC CHIP	0.01uF 50V				(UK, FR, 5AED)
C22	1-163-097-00	CERAMIC CHIP	15PF 5% 50V	C62	1-163-089-00	CERAMIC CHIP	6PF 50V
C23	1-163-093-00	CERAMIC CHIP	10PF 5% 50V	C63	1-163-086-00	CERAMIC CHIP	3PF 50V
C24	1-163-117-00	CERAMIC CHIP	100PF 5% 50V				(UK, FR, 5AED)
C25	1-163-117-00	CERAMIC CHIP	100PF 5% 50V	C64	1-163-113-00	CERAMIC CHIP	68PF 5% 50V
C26	1-163-117-00	CERAMIC CHIP	100PF 5% 50V	C65	1-163-121-00	CERAMIC CHIP	150PF 5% 50V
C27	1-163-038-00	CERAMIC CHIP	0.1uF 25V				(UK, FR, 5AED)
C28	1-164-232-11	CERAMIC CHIP	0.01uF 50V	C66	1-163-117-00	CERAMIC CHIP	100PF 5% 50V
C29	1-164-232-11	CERAMIC CHIP	0.01uF 50V	C67	1-163-117-00	CERAMIC CHIP	100PF 5% 50V
C30	1-163-089-00	CERAMIC CHIP	6PF 50V	C68	1-163-031-11	CERAMIC CHIP	0.01uF 50V

MAIN

Ref. No.	Part No.	Description	Remark	Ref. No.	Part No.	Description	Remark
C69	1-163-121-00	CERAMIC CHIP	150PF 5% 50V (UK, FR, 5AED)			< IC >	
C70	1-163-009-11	CERAMIC CHIP	0.001uF 10% 50V	IC1	8-759-278-22	IC uPD75308GF-R90-3B9	
C71	1-163-117-00	CERAMIC CHIP	100PF 5% 50V	IC2	8-759-065-98	IC SAA6579T	
C72	1-124-927-11	ELECT	4.7uF 20% 100V	IC3	8-759-096-23	IC S-80728AN-DR	
C73	1-124-907-11	ELECT	10uF 20% 50V	IC4	8-752-050-16	IC CXA1019M	
C74	1-163-133-00	CERAMIC CHIP	470PF 5% 50V	IC5	8-752-323-84	IC CXD1118M	
C75	1-163-038-00	CERAMIC CHIP	0.1uF 25V			< JUMPER RESISTOR >	
C76	1-163-809-11	CERAMIC CHIP	0.047uF 10% 25V (UK, FR, 5AED)	JR1	1-216-295-91	METAL GLAZE 0 5% 1/10W	
C77	1-124-907-11	ELECT	10uF 20% 50V	JR2	1-216-295-91	METAL GLAZE 0 5% 1/10W	
C78	1-124-472-11	ELECT	470uF 20% 10V	JR3	1-216-295-91	METAL GLAZE 0 5% 1/10W (IT, AEZ, 5AEC)	
C79	1-164-004-11	CERAMIC CHIP	0.1uF 10% 25V	JR4	1-216-295-91	METAL GLAZE 0 5% 1/10W	
C80	1-164-346-11	CERAMIC CHIP	1uF 16V	JR5	1-216-295-91	METAL GLAZE 0 5% 1/10W (FR, IT, AEZ, 5AEC, 5AED)	
C81	1-126-176-11	ELECT	220uF 20% 10V	JR6	1-216-295-91	METAL GLAZE 0 5% 1/10W	
C82	1-163-009-11	CERAMIC CHIP	0.001uF 10% 50V	JR7	1-216-296-91	METAL GLAZE 0 5% 1/8W	
C83	1-124-927-11	ELECT	4.7uF 20% 100V	JR8	1-216-296-91	METAL GLAZE 0 5% 1/8W	
C84	1-124-907-11	ELECT	10uF 20% 50V	JR9	1-216-296-91	METAL GLAZE 0 5% 1/8W	
C85	1-164-232-11	CERAMIC CHIP	0.01uF 50V	JR10	1-216-296-91	METAL GLAZE 0 5% 1/8W	
C86	1-163-031-11	CERAMIC CHIP	0.01uF 50V	JR11	1-216-296-91	METAL GLAZE 0 5% 1/8W	
		< FILTER >				< COIL >	
CF1	1-577-072-21	FILTER, CERAMIC	(IT, AEZ, 5AEC)	L1	1-402-616-11	ANTENNA, FERRITE-ROD (MW) (IT, AEZ, 5AEC)	
CF1	1-578-677-21	FILTER, CRYSTAL	(UK, FR, 5AED)	L1	1-501-715-11	ANTENNA, FERRITE-ROD (LW/MW) (UK, FR, 5AED)	
CF2	1-579-632-11	FILTER, CERAMIC		L4	1-406-545-11	COIL, AIR-CORE	
CF3	1-579-632-11	FILTER, CERAMIC		L6	1-406-485-11	COIL (OSC)	
		< TRIMMER >		L7	1-404-341-00	TRANSFORMER, IF (IT, AEZ, 5AEC)	
CT1	1-141-304-21	CAP, TRIMMER	10PF	L7	1-404-902-21	TRANSFORMER, IF (UK, FR, 5AED)	
CT2	1-141-443-11	TRIMMER, CERAMIC	30PF (UK, FR, 5AED)	L8	1-410-336-11	INDUCTOR 220uH	
CT3	1-141-304-21	CAP, TRIMMER	10PF	L9	1-410-336-11	INDUCTOR 220uH	
CT4	1-141-444-11	TRIMMER, CERAMIC	50PF (UK, FR, 5AED)	L10	1-410-336-11	INDUCTOR 220uH	
		< DIODE >				< LIQUID CRYSTAL DISPLAY >	
D1	8-719-104-34	DIODE	1S2836 (UK, FR, 5AED)	LCD1	1-810-640-11	DISPLAY PANEL, LIQUID CRYSTAL	
D2	8-719-104-34	DIODE	1S2836 (UK)			< POWER CORD >	
D3	8-719-200-02	DIODE	10E2	PC1	1-555-795-00	CORD, POWER (FR, IT, AEZ, 5AEC, 5AED)	
D4	8-719-200-02	DIODE	10E2	PC1	1-696-572-21	CORD, POWER (UK)	
D5	8-719-977-00	DIODE	DT25. 1C			< TRANSISTOR >	
D6	8-719-104-34	DIODE	1S2836	Q1	8-729-901-06	TRANSISTOR DTA144EK	
D7	8-719-042-10	DIODE	SLZ-235C-15	Q2	8-729-230-49	TRANSISTOR 2SC2712-YG	
D8	8-719-042-10	DIODE	SLZ-235C-15	Q3	8-729-230-49	TRANSISTOR 2SC2712-YG	
D9	8-719-042-10	DIODE	SLZ-235C-15	Q4	8-729-216-22	TRANSISTOR 2SA1162-G	
D10	8-719-023-XX	DIODE	KV1563MIL-3 (UK, FR, 5AED)	Q5	8-729-011-92	TRANSISTOR 2SC2001TP-K1K2	
D10	8-719-951-05	DIODE	KV1560 (IT, AEZ, 5AEC)	Q6	8-729-230-49	TRANSISTOR 2SC2712-YG	
D11	8-719-042-10	DIODE	SLZ-235C-15	Q7	8-729-230-49	TRANSISTOR 2SC2712-YG	
D12	8-719-941-04	DIODE	SB007-03CP	Q8	8-729-230-49	TRANSISTOR 2SC2712-YG (UK, FR, 5AED)	
D13	8-713-100-11	DIODE	1T362	Q9	8-729-216-22	TRANSISTOR 2SA1162-G	
D14	8-713-100-11	DIODE	1T362				

Ref. No.	Part No.	Description	Remark	Ref. No.	Part No.	Description	Remark
Q11	8-729-200-87	TRANSISTOR 2SC2714-Y (UK, FR, 5AED)		R78	1-216-073-00	METAL CHIP 10K 5% 1/10W	
Q12	8-729-200-87	TRANSISTOR 2SC2714-Y (UK, FR, 5AED)		R79	1-216-097-00	METAL CHIP 100K 5% 1/10W	
		< RESISTOR >		R80	1-216-073-00	METAL CHIP 10K 5% 1/10W	
R1	1-216-121-00	METAL CHIP 1M 5% 1/10W	(UK, FR, 5AED)	R81	1-216-049-00	METAL CHIP 1K 5% 1/10W	
R2	1-216-057-00	METAL CHIP 2.2K 5% 1/10W		R82	1-216-049-00	METAL CHIP 1K 5% 1/10W	
R3	1-216-121-00	METAL CHIP 1M 5% 1/10W		R84	1-216-308-00	METAL CHIP 4.7 5% 1/10W	
R4	1-216-109-00	METAL CHIP 330K 5% 1/10W		R85	1-216-308-00	METAL CHIP 4.7 5% 1/10W	
R5	1-216-097-00	METAL CHIP 100K 5% 1/10W	(UK, FR, 5AED)	R87	1-216-025-00	METAL CHIP 100 5% 1/10W	
R6	1-216-121-00	METAL CHIP 1M 5% 1/10W	(UK, FR, 5AED)	R90	1-216-121-00	METAL CHIP 1M 5% 1/10W	
R7	1-216-097-00	METAL CHIP 100K 5% 1/10W		R92	1-216-061-00	METAL CHIP 3.3K 5% 1/10W	
R8	1-216-089-91	METAL GLAZE 47K 5% 1/10W		R93	1-216-073-00	METAL CHIP 10K 5% 1/10W	
R37	1-216-105-00	METAL CHIP 220K 5% 1/10W		R94	1-216-097-00	METAL CHIP 100K 5% 1/10W	
R38	1-216-089-91	METAL GLAZE 47K 5% 1/10W		R96	1-216-069-00	METAL CHIP 6.8K 5% 1/10W	
R39	1-216-097-00	METAL CHIP 100K 5% 1/10W		R97	1-216-049-00	METAL CHIP 1K 5% 1/10W	
R40	1-216-089-91	METAL GLAZE 47K 5% 1/10W	(UK, FR, 5AED)	R100	1-216-097-00	METAL CHIP 100K 5% 1/10W	
R41	1-216-057-00	METAL CHIP 2.2K 5% 1/10W		R101	1-216-097-00	METAL CHIP 100K 5% 1/10W	
R42	1-216-057-00	METAL CHIP 2.2K 5% 1/10W		R105	1-216-061-00	METAL CHIP 3.3K 5% 1/10W	(UK, FR, 5AED)
R43	1-216-057-00	METAL CHIP 2.2K 5% 1/10W		R108	1-216-049-00	METAL CHIP 1K 5% 1/10W	
R44	1-216-057-00	METAL CHIP 2.2K 5% 1/10W		R109	1-216-037-00	METAL CHIP 330 5% 1/10W	
R45	1-216-073-00	METAL CHIP 10K 5% 1/10W		R110	1-216-057-00	METAL CHIP 2.2K 5% 1/10W	
R46	1-216-073-00	METAL CHIP 10K 5% 1/10W		R114	1-216-037-00	METAL CHIP 330 5% 1/10W	
R47	1-216-073-00	METAL CHIP 10K 5% 1/10W		R115	1-216-025-00	METAL CHIP 100 5% 1/10W	
R48	1-216-073-00	METAL CHIP 10K 5% 1/10W				< VARIABLE RESISTOR >	
R49	1-216-073-00	METAL CHIP 10K 5% 1/10W		RV1	1-241-586-11	RES. VAR, CARBON 50K (VOL ∇)	
R50	1-216-073-00	METAL CHIP 10K 5% 1/10W				< SWITCH >	
R51	1-216-073-00	METAL CHIP 10K 5% 1/10W		S1	1-552-370-00	SWITCH, SLIDE (STATION NAME)	
R52	1-216-073-00	METAL CHIP 10K 5% 1/10W		S2	1-552-370-00	SWITCH, SLIDE (CLOCK AUTO ADJUST)	
R53	1-216-073-00	METAL CHIP 10K 5% 1/10W		S3	1-554-937-11	SWITCH, KEY BOARD (RADIO OFF/ALARM RESET)	
R54	1-216-073-00	METAL CHIP 10K 5% 1/10W		S4	1-554-937-11	SWITCH, KEY BOARD (BAND)	
R55	1-216-073-00	METAL CHIP 10K 5% 1/10W		S5	1-554-937-11	SWITCH, KEY BOARD (1/A RADIO)	
R56	1-216-089-91	METAL GLAZE 47K 5% 1/10W		S6	1-554-937-11	SWITCH, KEY BOARD (RADIO ON/SLEEP)	
R57	1-216-097-00	METAL CHIP 100K 5% 1/10W		S7	1-554-937-11	SWITCH, KEY BOARD (TRAFFIC INFO)	
R59	1-216-001-00	METAL CHIP 10 5% 1/10W		S8	1-554-937-11	SWITCH, KEY BOARD (2/B BUZZER)	
R62	1-216-097-00	METAL CHIP 100K 5% 1/10W		S9	1-554-937-11	SWITCH, KEY BOARD (TIMESSET/TUNE/-)	
R63	1-216-001-00	METAL CHIP 10 5% 1/10W		S10	1-554-937-11	SWITCH, KEY BOARD (3)	
R64	1-216-097-00	METAL CHIP 100K 5% 1/10W		S11	1-554-937-11	SWITCH, KEY BOARD (TIMESSET/TUNE/+)	
R67	1-216-073-00	METAL CHIP 10K 5% 1/10W		S12	1-554-937-11	SWITCH, KEY BOARD (SNOOZE/SLEEP OFF)	
R68	1-216-073-00	METAL CHIP 10K 5% 1/10W		S13	1-554-937-11	SWITCH, KEY BOARD (4)	
R69	1-216-097-00	METAL CHIP 100K 5% 1/10W		S14	1-554-937-11	SWITCH, KEY BOARD (5/ALARM MODE)	
R70	1-216-061-00	METAL CHIP 3.3K 5% 1/10W		S15	1-554-937-11	SWITCH, KEY BOARD (CLOCK/ENTER)	
R71	1-216-073-00	METAL CHIP 10K 5% 1/10W		S16	1-571-478-11	SWITCH, SLIDE (BRIGHT)	
R72	1-216-073-00	METAL CHIP 10K 5% 1/10W				< TRANSFORMER >	
R73	1-216-073-00	METAL CHIP 10K 5% 1/10W		△T1	1-450-923-11	TRANSFORMER, POWER	
R75	1-216-097-00	METAL CHIP 100K 5% 1/10W					
R77	1-216-061-00	METAL CHIP 3.3K 5% 1/10W					

The components identified by mark Δ or dotted line with mark Δ are critical for safety. Replace only with part number specified.

MAIN

<u>Ref.No.</u>	<u>Part No.</u>	<u>Description</u>	<u>Remark</u>
< VIBRATOR >			
X1	1-579-825-11	VIBRATOR, CERAMIC (2.62MHz)	
X2	1-567-098-41	VIBRATOR, CRYSTAL (32.768kHz)	
X3	1-579-900-21	VIBRATOR, CRYSTAL (4.332MHz)	
X4	1-578-785-11	VIBRATOR, CRYSTAL (4.5MHz)	

MISCELLANEOUS			

* 12	1-535-771-11	TERMINAL	
LCD1	1-810-640-11	DISPLAY PANEL, LIQUID CRYSTAL	
△PC1	1-555-795-00	COAD, POWER (EXCEPT UK)	
△PC1	1-696-572-21	COAD, POWER (UK)	
SP1	1-503-082-00	SPEAKER (6.6CM)	

ACCESSORIES & PACKING MATERIALS			

	1-501-499-11	COUPLER, ANTENNA (5AED)	
	3-759-163-11	MANUAL, INSTRUCTION (ENGLISH, FRENCH, GERMAN) (UK, FR, AEZ, 5AEC, 5AED)	
	3-759-163-41	MANUAL, INSTRUCTION (DUTCH, SWEDISH, ITALIAN) (IT, 5AEC, 5AED)	
	3-759-163-51	MANUAL, INSTRUCTION (SPANISH, PORTUGUESE) (AEZ)	
*	3-916-741-01	INDIVIDUAL CARTON (FR, 5AED)	
*	3-916-743-01	INDIVIDUAL CARTON (UK, IT, AEZ, 5AEC)	

The components identified by mark
△ or dotted line with mark △ are
critical for safety.
Replace only with part number
specified.