

# ICF-9740W

US Model  
Canadian Model



## FM/AM 2-BAND RADIO

### SPECIFICATIONS

<b>Frequency range:</b>	FM 87.5—108 MHz (3.43—2.78m) AM 530—1,605 kHz (566—187m)
<b>Antennas:</b>	FM: AC power cord antenna External antenna terminals (75 ohms) AM: Built-in ferrite bar antenna
<b>Speaker:</b>	Approx. 16cm (6 <sup>3</sup> / <sub>8</sub> inches) dia.
<b>Power output:</b>	2W (at 10% harmonic distortion)
<b>Power requirements:</b>	120V ac, 60 Hz
<b>Dimensions:</b>	Approx. 330x232x136mm (w/h/d) (13x9 <sup>1</sup> / <sub>4</sub> x5 <sup>3</sup> / <sub>8</sub> inches)
<b>Weight:</b>	Incl. projecting parts and controls Approx. 2.2kg (4 lb 13 oz)

### ATTENTION AU COMPOSANT AYANT RAPPORT À LA SÉCURITÉ!

LES COMPOSANTS IDENTIFIÉS PAR UNE TRAME ET UNE MARQUE  SUR LES DIAGRAMMES SCHEMATIQUES, LES VUES EXPLOSÉES ET LA LISTE DES PIÈCES SONT CRITIQUES POUR LA SÉCURITÉ DE FONCTIONNEMENT. NE REMPLACER CES COMPOSANTS QUE PAR DES PIÈCES SONY DONT LES NUMÉROS SONT DONNÉS DANS CE MANUEL OU DANS LES SUPPLÉMENTS PUBLIÉS PAR SONY.

### SAFETY-RELATED COMPONENT WARNING!!

COMPONENTS IDENTIFIED BY SHADING AND MARK  ON THE SCHEMATIC DIAGRAMS, EXPLODED VIEWS AND IN THE PARTS LIST ARE CRITICAL TO SAFE OPERATION. REPLACE THESE COMPONENTS WITH SONY PARTS WHOSE PART NUMBERS APPEAR AS SHOWN IN THIS MANUAL OR IN SUPPLEMENTS PUBLISHED BY SONY.



MICROFILM

# SONY<sup>®</sup>

---

## SERVICE MANUAL

## SECTION 1 OUTLINE

### 1-1. BLOCK DIAGRAM

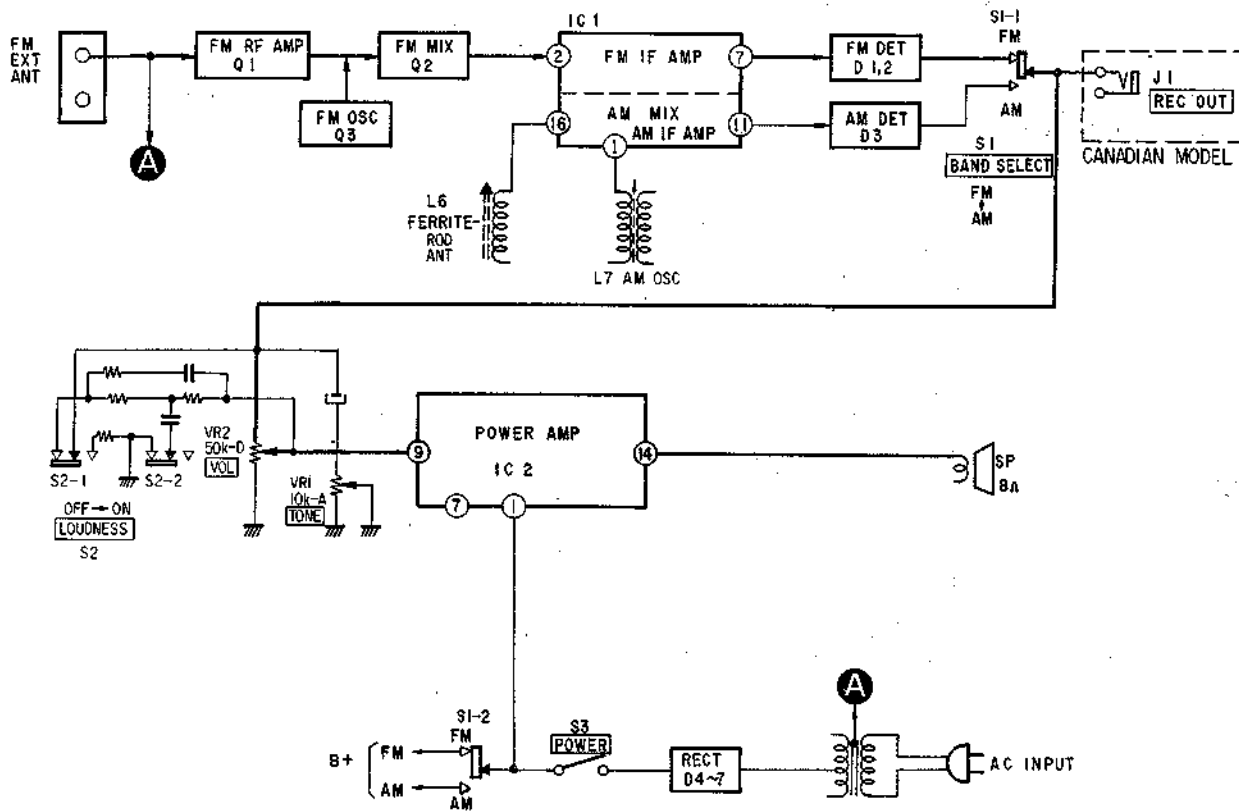

## SECTION 2 DISASSEMBLY

- Follow the disassembly procedure in the numerical order given.

### 2-1. REMOVAL

#### REAR PANEL

Remove the three screws (TA, BTP3 x 20).

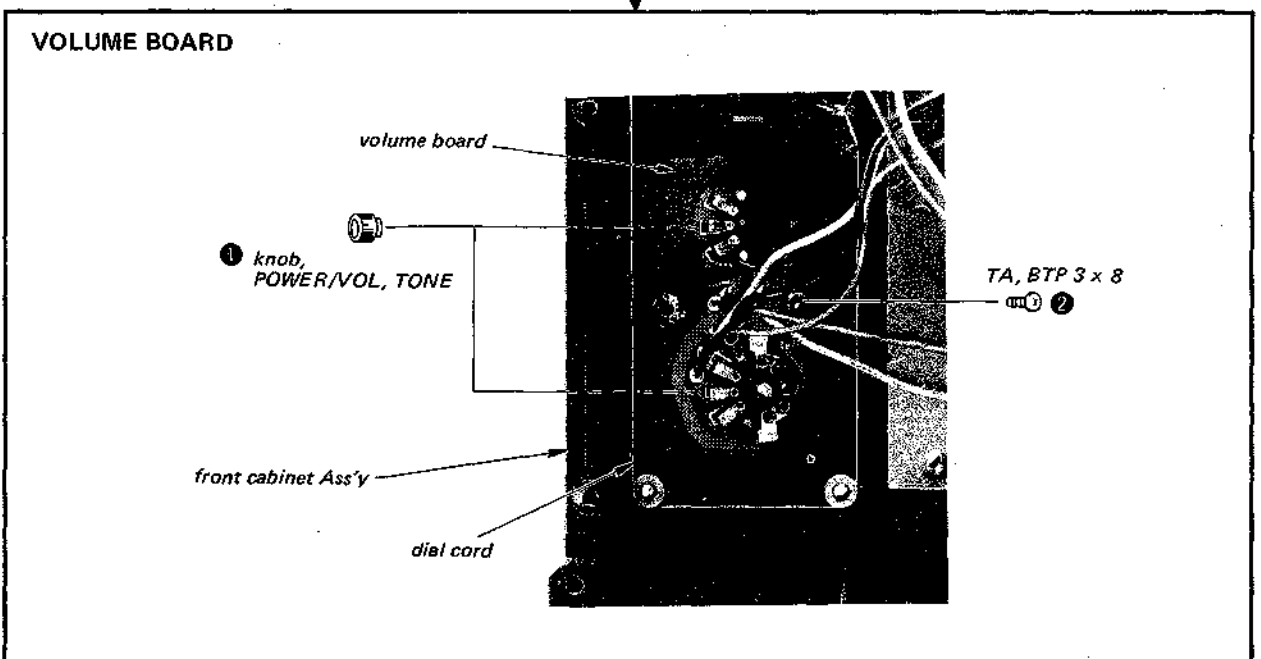
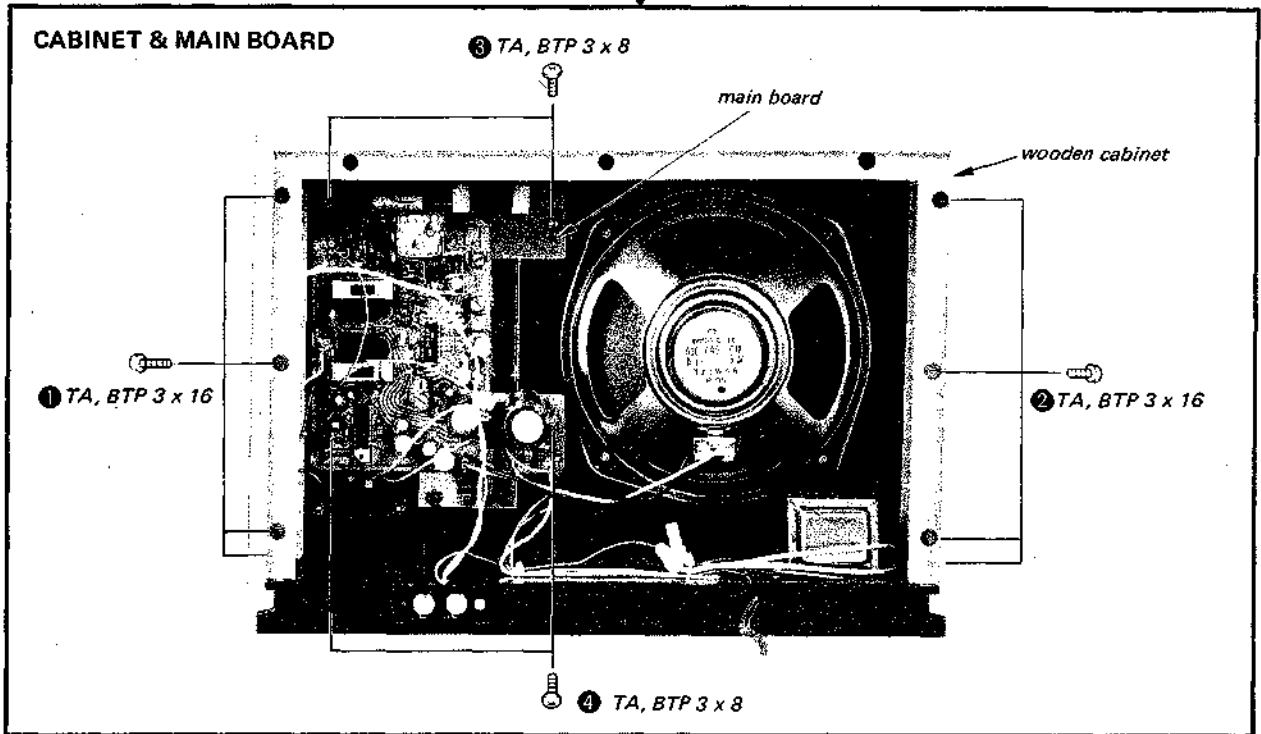

## 2-2. DIAL CORD STRINGING

### (1) Dial Cord Length

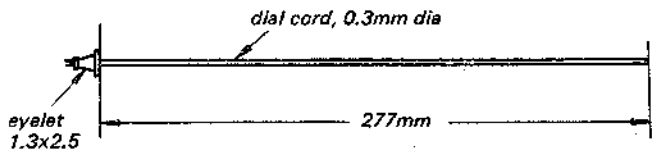

### (2) Dial Cord Stringing

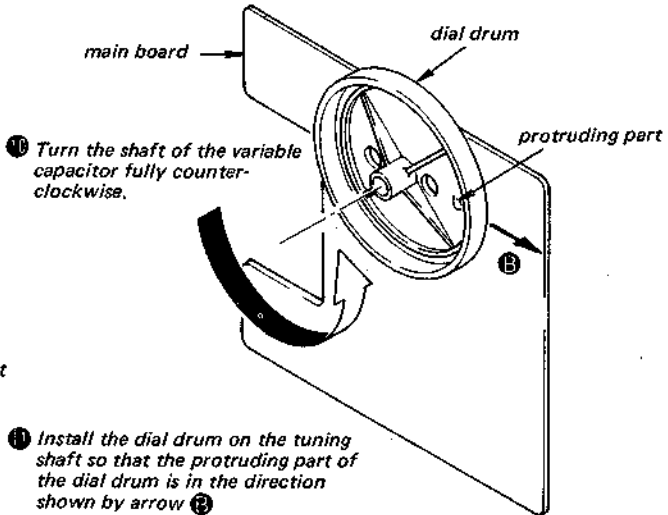
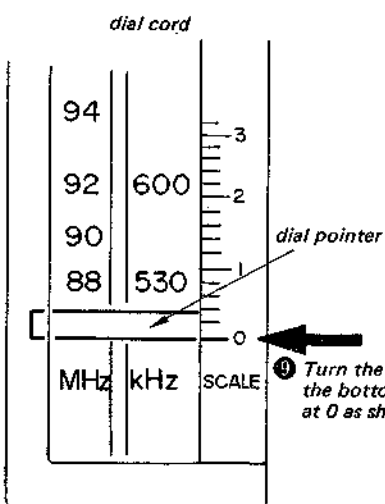
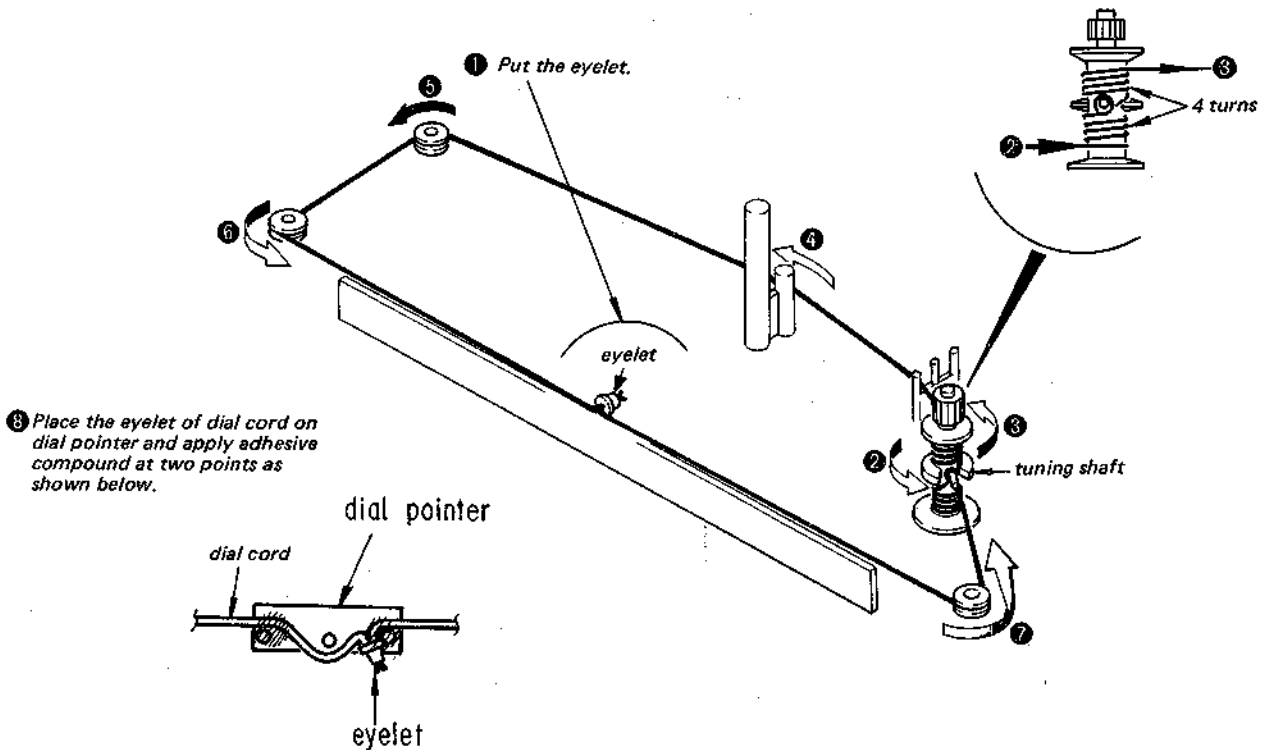

SECTION 3  
ADJUSTMENTS

AM

Setting:

FUNCTION switch: AM

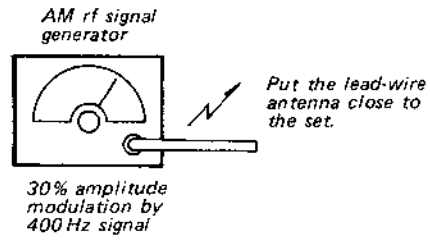

FM

Setting:

FUNCTION switch: FM

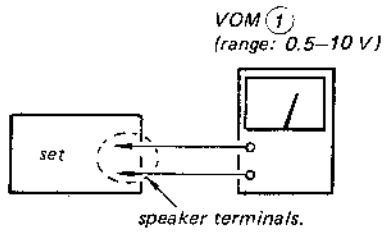
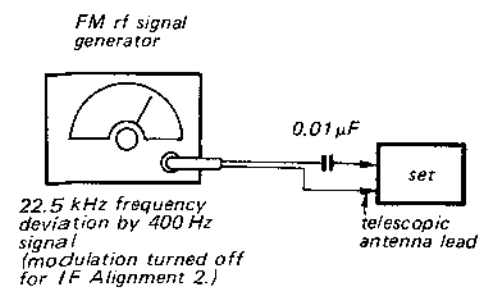

- Repeat the procedures in each adjustment several times, and the frequency coverage and tracking adjustments should be finally done by the trimmer capacitors.

FM TRACKING ADJUSTMENT	
Adjust for a maximum reading on VOM ①.	
108.5 MHz	CT-1
87.1 MHz	L2,3

FM FREQUENCY COVERAGE ADJUSTMENT	
Adjust for a maximum reading on VOM ①.	
108.5 MHz	CT-2
87.1 MHz	L5

FM IF ALIGNMENT 1 (10.7 MHz with modulation)	
Adjust for maximum reading on VOM ①.	
IFT 1	
IFT 2	
IFT 3	

AM TRACKING ADJUSTMENT	
Adjust for a maximum reading on VOM ①.	
620 kHz	1,400 kHz
L6	CT-3

AM FREQUENCY COVERAGE ADJUSTMENT	
Adjust for a maximum reading on VOM ①.	
CT-4	1,680 kHz
L7	520 kHz

AM IF ALIGNMENT	
Adjust for a maximum reading on VOM ①.	
IFT 4	455 kHz
IFT 5	
IFT 6	

IFT 3	
Adjust for 0V reading on VOM ②.	
FM IF ALIGNMENT 2 (10.7 MHz with no modulation)	

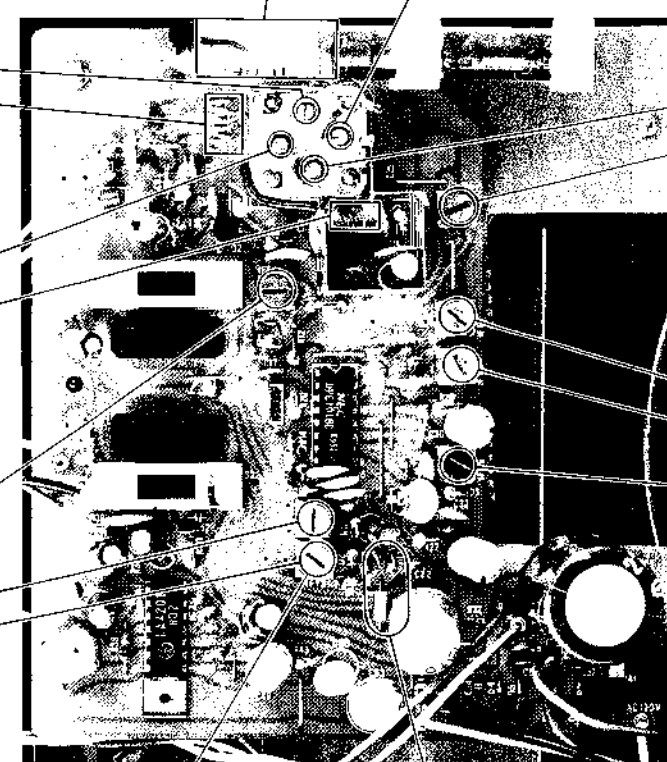
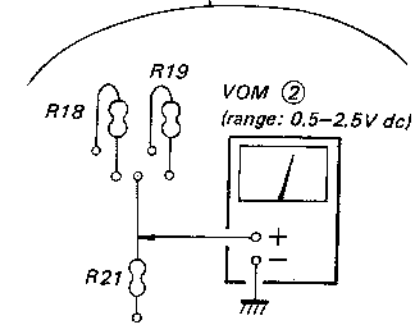

SECTION 4  
DIAGRAMS

4-1. MOUNTING DIAGRAM

SEMICONDUCTOR LEAD LAYOUTS

LA4201

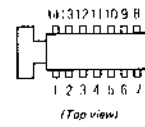

2SC1674  
2SC1674K  
2SC1675  
2SC1675K

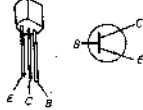

μPC1018C

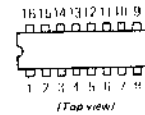

IT22AM  
IT23A  
IT261  
IN4002

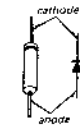

2SC710-13

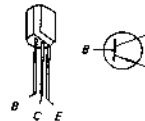

1  
2  
3  
4  
5

D	Q, IC
	IC2
	1
	2
	IC1
2, 1	3
3	
4	
5	
6	
7	
D	Q, IC

[MAIN BOARD]

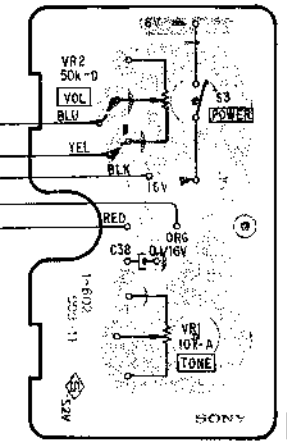
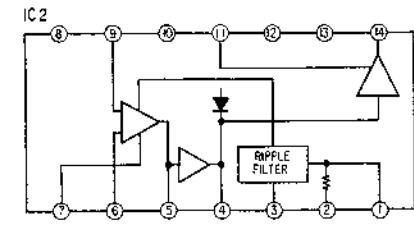
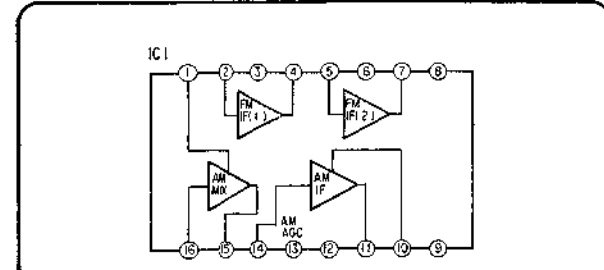
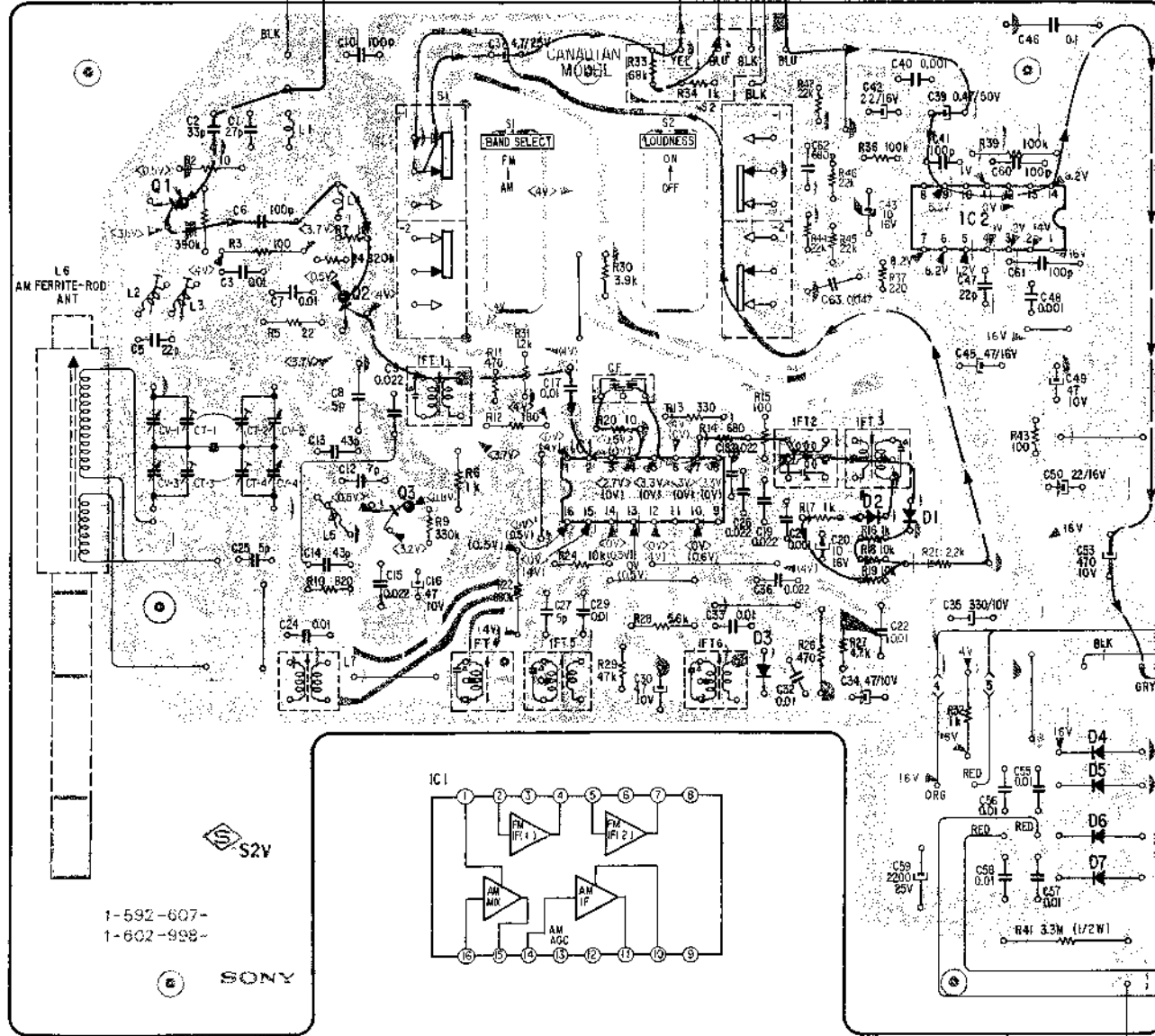

[VOLUME BOARD]

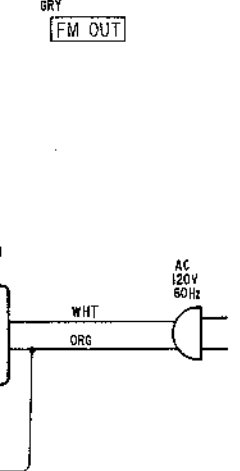
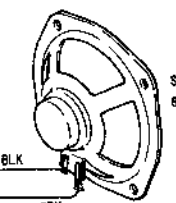

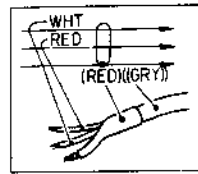

Note:  
• Color code of sleeving over the end of the jacket.



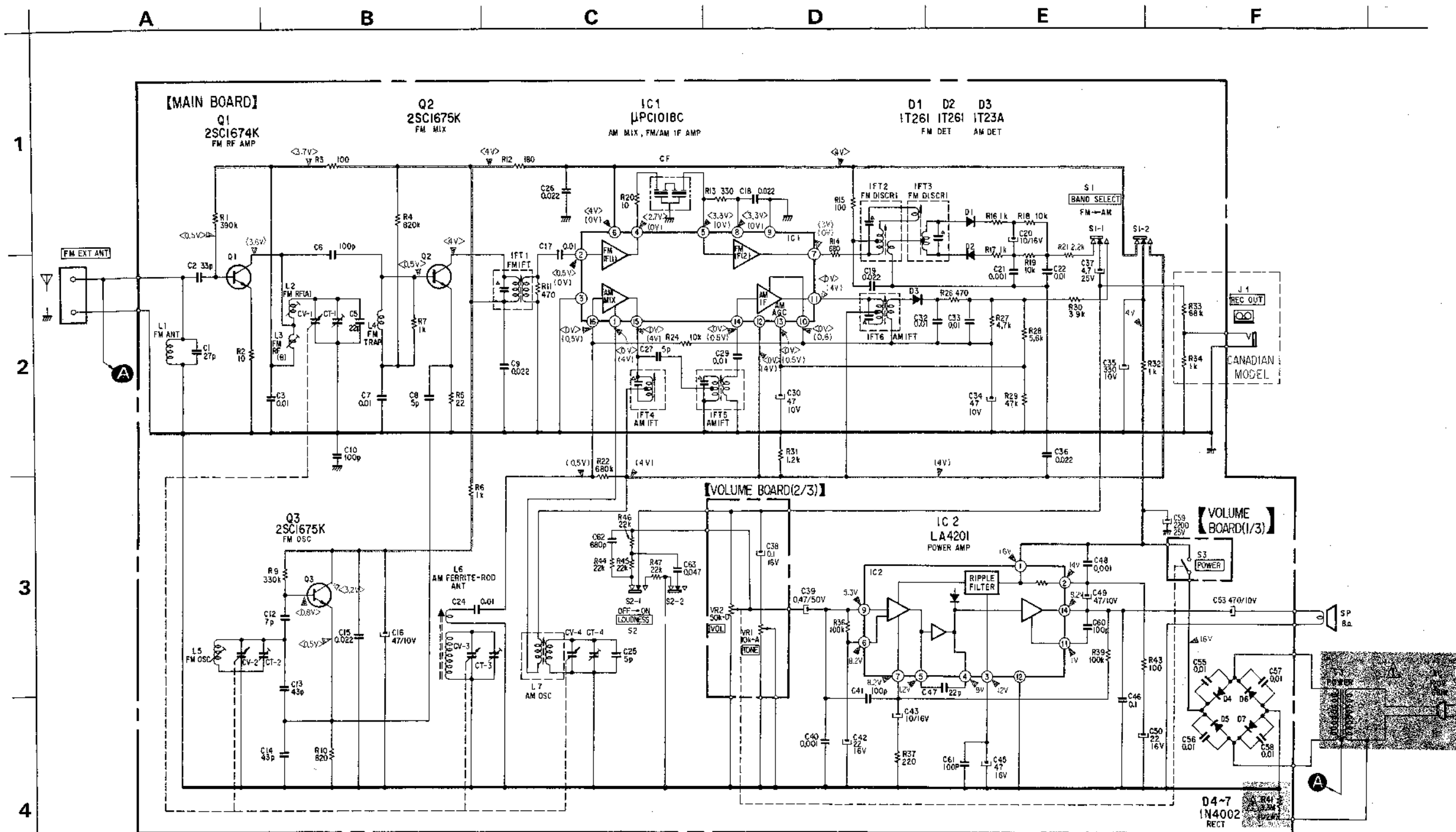

• B+ pattern  
• signal path

# ICF-9740W ICF-9740W



**Note:** The components identified by shading and mark  are critical for safety. Replace only with part number specified.

**Note:** Les composants identifiés par une trame et une marque  sont critiques pour la sécurité. Ne les remplacer que par une pièce portant le numéro spécifié.

- Note:**
- All capacitors are in  $\mu\text{F}$  unless otherwise noted,  $\text{pF} : \mu\text{F}$  50WV or less are not indicated except for electrolytics and tantalums.
  - All resistors are in ohms,  $\frac{1}{4}\text{W}$  unless otherwise noted.  $\text{k}\Omega : 1000\Omega$ ,  $\text{M}\Omega : 1000\text{k}\Omega$
  -  : B+ bus.
  -  : panel designation.
  - Readings are taken under no-signal (detuned) conditions with a VOM (20k $\Omega$ /V).
  - ( ) : AM ; ( ) : FM
  - Voltage variations may be noted due to normal production tolerances.

SECTION 5  
EXPLODED VIEW

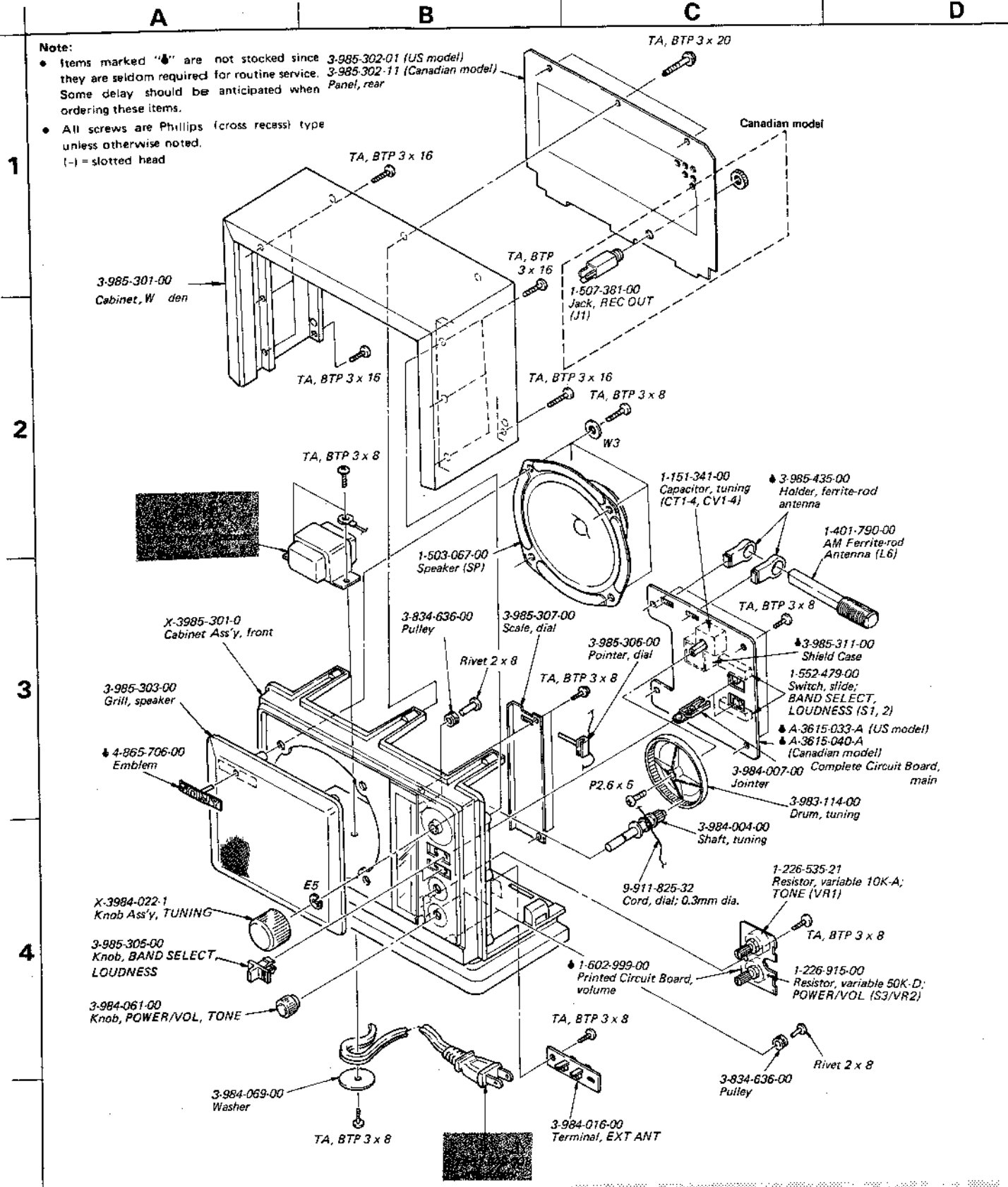

SECTION 6  
ELECTRICAL PARTS LIST

Ref. No.	Part No.	Description	Ref. No.	Part No.	Description
<b>SEMICONDUCTORS</b>					
<b>Transistors</b>					
Q1	8-729-167-42	2SC1674	C27	1-102-945-00	5P
Q2, 3	8-729-671-13	2SC710-13	C29	1-101-923-00	0.01
<b>ICs</b>					
IC1	8-759-110-15	μPC1018C	C30	1-123-306-00	47 10V elect
IC2	1-800-661-11	LA4201	C32, 33	1-161-032-00	0.01 (semiconductor)
<b>Diodes</b>					
D1, 2	8-719-026-11	IT261	C34	1-123-306-00	47 10V elect
D3	8-719-422-21	IT22AM	C35	1-123-309-00	330 10V elect
D4-7	8-719-200-02	10E2	C36	1-161-034-00	0.022 (semiconductor)
<b>CAPACITORS</b>					
All capacitors are in μF and ceramic unless otherwise noted. 50WV or less are not indicated except for electrolytics. elect: electrolytics					
C1	1-102-968-00	27P	C37	1-123-328-00	4.7 25V elect
C2	1-102-969-00	33P	C38	1-127-019-00	0.1 16V solid aluminum
C3	1-101-923-00	0.01	C39	1-123-351-00	0.47 50V elect
C5	1-102-967-00	22P	C40	1-161-026-00	0.001 (semiconductor)
C6	1-102-975-00	100P	C41	1-102-975-00	100P
C7	1-101-923-00	0.01	C42	1-123-317-00	22 16V elect
C8	1-102-942-00	5P	C43	1-123-316-00	10 16V elect
C9	1-101-924-00	0.022	C45	1-123-319-00	47 16V elect
C10	1-102-975-00	100P	C46	1-130-528-00	0.1 film
C12	1-102-944-00	7P	C47	1-102-967-00	22P
C13, 14	1-102-521-00	43P	C48	1-161-026-00	0.001 (semiconductor)
C15	1-101-924-00	0.022	C49	1-123-306-00	47 10V elect
C16	1-123-306-00	47 10V elect	C50	1-123-317-00	22 16V elect
C17	1-101-923-00	0.01	C53	1-123-310-00	470 10V elect
C18, 19	1-101-924-00	0.022	C55-58	1-101-923-00	0.01
C20	1-123-316-00	10 16V elect	C59	1-123-338-00	2200 25V elect
C21	1-161-026-00	0.001 (semiconductor)	C60, 61	1-102-975-00	100P
C22	1-161-032-00	0.01 (semiconductor)	C62	1-102-116-00	680P
C24	1-101-923-00	0.01	C63	1-101-006-00	0.047
C25	1-102-942-00	5P	CT1-4		
C26	1-161-034-00	0.022	CV1-4	1-151-341-00	Tuning
<b>RESISTORS</b>					
Common 1/4W carbon resistor are omitted. Refer to the list on page 14 for their part numbers.					
R41	1-202-725-00	3.3MΩ 1/4W, composition			
VR1	1-226-535-21	10kΩ-A, variable; TONE			
VR2	1-226-915-00	50kΩ-D, variable; VOLUME (including S3; power)			
<b>MISCELLANEOUS</b>					
CF	1-527-795-71	Ceramic Filter, 10.7 MHz			

Note: The components identified by shading and mark are critical for safety. Replace only with part number specified.

Note: Les composants identifiés par une trame et une marque sont critiques pour la sécurité. Ne les remplacer que par une pièce portant le numéro spécifié.

Note: The components identified by shading and mark are critical for safety. Replace only with part number specified.

Note: Les composants identifiés par une trame et une marque sont critiques pour la sécurité. Ne les remplacer que par une pièce portant le numéro spécifié.



<u>Ref. No.</u>	<u>Part No.</u>	<u>Description</u>
IFT 1	1-403-872-00	FM IFT
IFT 2	1-403-959-00	FM DISCRI
IFT 3	1-403-953-00	FM DSCRI
IFT 4	1-404-288-00	AM IFT
IFT 5	1-404-288-00	AM IFT
IFT 6	1-403-929-00	AM IFT
J1	1-507-381-00	Jack, REC OUT (Canadian model)
L1	♣ 1-401-228-00	Coil, FM ANT
L2	1-420-956-00	Coil, FM RF (A)
L3	1-420-957-00	Coil, FM RF (B)
L4	1-409-293-00	Coil, FM TRAP
L5	1-420-962-00	Coil, FM OSC
L6	1-401-790-00	AM Ferrite-rod Antenna
L7	1-405-685-00	Coil, AM OSC
S1, 2	1-552-479-00	Switch, slide; BAND SELECT/ LOUDNESS
S3	—————	Switch, Power: included in VR2
SP	1-503-067-00	Speaker
T1	⚠ 1-446-089-00	Transformer, Power
	⚠ 1-551-949-00	Cord, power

<b>ACCESSORIES &amp; PACKING MATERIALS</b>	
<u>Part No.</u>	<u>Description</u>
3-701-636-00	Bag, polyethylene
3-703-390-01	Instruction (US model)
3-903-184-01	Label, indicating; material (US model)
3-985-312-00	Carton, individual (US model)
3-985-312-11	Carton, individual (Canadian model)
3-985-314-00	Cushion
3-993-230-31	Instruction, French (Canadian model)
3-995-884-21	Manual, instruction

### PRINTED CIRCUIT BOARD

♣ 1-602-999-00 Volume

### COMPLETE CIRCUIT BOARD

♣ A-3615-033-A Main (US model)  
 ♣ A-3615-040-A Main (Canadian model)

## 1/4 WATT CARBON RESISTORS

Ω	Part No.	Ω	Part No.	Ω	Part No.	Ω	Part No.	Ω	Part No.	Ω	Part No.	Ω	Part No.
1.0	1-246-401-00	10	1-246-425-00	100	1-246-449-00	1.0k	1-246-473-00	10k	1-246-497-00	100k	1-246-521-00	1.0M	1-246-545-00
1.1	1-246-402-00	11	1-246-426-00	110	1-246-450-00	1.1k	1-246-474-00	11k	1-246-498-00	110k	1-246-522-00	1.1M	1-210-814-00
1.2	1-246-403-00	12	1-246-427-00	120	1-246-451-00	1.2k	1-246-475-00	12k	1-246-499-00	120k	1-246-523-00	1.2M	1-210-815-00
1.3	1-246-404-00	13	1-246-428-00	130	1-246-452-00	1.3k	1-246-476-00	13k	1-246-500-00	130k	1-246-524-00	1.3M	1-210-816-00
1.5	1-246-405-00	15	1-246-429-00	150	1-246-453-00	1.5k	1-246-477-00	15k	1-246-501-00	150k	1-246-525-00	1.5M	1-210-817-00
1.6	1-246-406-00	16	1-246-430-00	160	1-246-454-00	1.6k	1-246-478-00	16k	1-246-502-00	160k	1-246-526-00	1.6M	1-210-818-00
1.8	1-246-407-00	18	1-246-431-00	180	1-246-455-00	1.8k	1-246-479-00	18k	1-246-503-00	180k	1-246-527-00	1.8M	1-210-819-00
2.0	1-246-408-00	20	1-246-432-00	200	1-246-456-00	2.0k	1-246-480-00	20k	1-246-504-00	200k	1-246-528-00	2.0M	1-210-820-00
2.2	1-246-409-00	22	1-246-433-00	220	1-246-457-00	2.2k	1-246-481-00	22k	1-246-505-00	220k	1-246-529-00	2.2M	1-210-821-00
2.4	1-246-410-00	24	1-246-434-00	240	1-246-458-00	2.4k	1-246-482-00	24k	1-246-506-00	240k	1-246-530-00	2.4M	1-244-754-00
2.7	1-246-411-00	27	1-246-435-00	270	1-246-459-00	2.7k	1-246-483-00	27k	1-246-507-00	270k	1-246-531-00	2.7M	1-244-755-00
3.0	1-246-412-00	30	1-246-436-00	300	1-246-460-00	3.0k	1-246-484-00	30k	1-246-508-00	300k	1-246-532-00	3.0M	1-244-756-00
3.3	1-246-413-00	33	1-246-437-00	330	1-246-461-00	3.3k	1-246-485-00	33k	1-246-509-00	330k	1-246-533-00	3.3M	1-244-757-00
3.6	1-246-414-00	36	1-246-438-00	360	1-246-462-00	3.6k	1-246-486-00	36k	1-246-510-00	360k	1-246-534-00	3.6M	1-244-758-00
3.9	1-246-415-00	39	1-246-439-00	390	1-246-463-00	3.9k	1-246-487-00	39k	1-246-511-00	390k	1-246-535-00	3.9M	1-244-759-00
4.3	1-246-416-00	43	1-246-440-00	430	1-246-464-00	4.3k	1-246-488-00	43k	1-246-512-00	430k	1-246-536-00	4.3M	1-244-760-00
4.7	1-246-417-00	47	1-246-441-00	470	1-246-465-00	4.7k	1-246-489-00	47k	1-246-513-00	470k	1-246-537-00	4.7M	1-244-761-00
5.1	1-246-418-00	51	1-246-442-00	510	1-246-466-00	5.1k	1-246-490-00	51k	1-246-514-00	510k	1-246-538-00	5.1M	1-244-762-00
5.6	1-246-419-00	56	1-246-443-00	560	1-246-467-00	5.6k	1-246-491-00	56k	1-246-515-00	560k	1-246-539-00		
6.2	1-246-420-00	62	1-246-444-00	620	1-246-468-00	6.2k	1-246-492-00	62k	1-246-516-00	620k	1-246-540-00		
6.8	1-246-421-00	68	1-246-445-00	680	1-246-469-00	6.8k	1-246-493-00	68k	1-246-517-00	680k	1-246-541-00		
7.5	1-246-422-00	75	1-246-446-00	750	1-246-470-00	7.5k	1-246-494-00	75k	1-246-518-00	750k	1-246-542-00		
8.2	1-246-423-00	82	1-246-447-00	820	1-246-471-00	8.2k	1-246-495-00	82k	1-246-519-00	820k	1-246-543-00		
9.1	1-246-424-00	91	1-246-448-00	910	1-246-472-00	9.1k	1-246-496-00	91k	1-246-520-00	910k	1-246-544-00		

## HARDWARE NOMENCLATURE

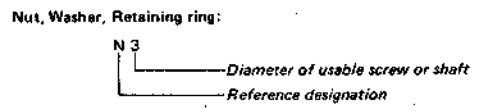
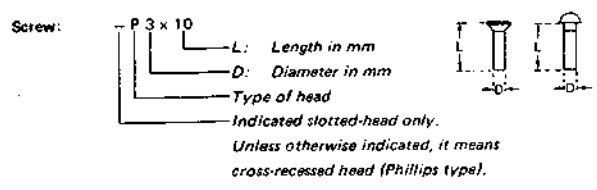

Reference Designation	Shape	Description	Remarks
SCREWS			
P		pan-head screw	binding-head (B) screw for replacement
PWH		pan-head screw with washer face	binding-head (B) screw and flat washer for replacement
PS PSP		pan-head screw with spring washer	binding-head (B) screw and spring washer for replacement
PSW PSPW		pan-head screw with spring and flat washers	binding-head (B) screw and spring and flat washers for replacement
R		round-head screw	binding-head (B) screw for replacement
K		flat-countersunk-head screw	
RK		oval-countersunk-head screw	
B		binding-head screw	
T		truss-head screw	binding-head (B) screw for replacement
F		flat-fillister-head screw	
RF		fillister-head screw	
BV		brazer-head screw	

Reference Designation	Shape	Description	Remarks
SELF-TAPPING SCREWS			
TA		self-tapping screw	ex: TA, P 3 x 10
PTP		pan-head self-tapping screw	binding-head self-tapping (TA, B) screw for replacement
PTPWH		pan-head self-tapping screw with washer face	binding-head self-tapping (TA, B) screw and flat washer for replacement
PTTWH		pan-head thread-rolling screw with washer face	binding-head (B) screw and flat washer for replacement
SET SCREWS			
SC		set screw	
SC		hexagon-socket set screw	ex: SC 2.6 x 4, hexagon socket
NUT			
N		nut	
WASHERS			
W		flat washer	
SW		spring washer	
LW		internal-tooth lock washer	ex: LW3, internal
LW		external-tooth lock washer	ex: LW3, external
RETAINING RINGS			
E		retaining ring	
G		grip-type retaining ring	

Sony Corporation

© 1981

# ICF-9740W

US Model

No. 1  
March, 1983

## SUPPLEMENT

File this supplement with the service manual.

### SAFETY CHECK-OUT (US Model)

After correcting the original service problem, perform the following safety check before releasing the set to the customer:

Check the antenna terminals, metal trim, "metallized" knobs, screws, and all other exposed metal parts for AC leakage. Check leakage as described below.

#### LEAKAGE TEST

The AC leakage from any exposed metal part to earth ground and from all exposed metal parts to any exposed metal part having a return to chassis, must not exceed 0.5 mA (500 microamperes). Leakage current can be measured by any one of three methods.

1. A commercial leakage tester, such as the Simpson 229 or RCA WT-540A. Follow the manufacturers' instructions to use these instruments.
2. A battery-operated AC milliammeter. The Data Precision 245 digital multimeter is suitable for this job.
3. Measuring the voltage drop across a resistor by means of a VOM or battery-operated AC voltmeter. The "limit" indication is 0.75 V, so analog meters must have an accurate low-voltage scale. The Simpson 250 and Sanwa SH-63Trd are examples of a passive VOM that is suitable. Nearly all battery operated digital multimeters that have a 2V AC range are suitable. (See Fig. A)

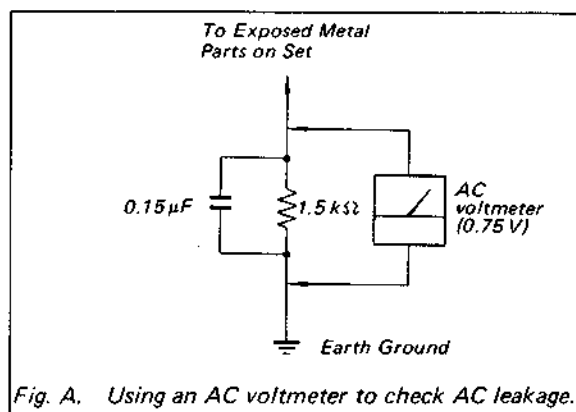

Fig. A. Using an AC voltmeter to check AC leakage.

**SONY**  
SERVICE MANUAL

Sony Corporation  
Consumer Products Group  
Technical Support Dept.