

# ICF-4920/5100

## SERVICE MANUAL

*US Model*

*ICF-4920*

*AEP Model*

*UK Model*

*E Model*

*ICF-5100*

- Refer to ICF-4900/4910 Service Manual previously issued for the information except for schematic and mounting diagrams of ICF-4920/5100.

(ICF-4920 is based on ICF-4910.)  
(ICF-5100 is based on ICF-4900.)

+ 2821

- Refer to ICF-4900/4910 Supplement No. 1 for schematic and mounting diagrams of ICF-4920/5100.
- Parts on next page differ from those in ICF-4900/4910.



FM/MW/SW 9BAND RECEIVER  
**SONY**®

2823 TR

# ICF-4920/5100

• Following parts differ from those in ICF-4900/4910.

## GENERAL SECTION

No.	Part No.	Description
1	3-891-813-11	STRAP, HAND
8	3-893-902-11	BUTTON (L), SELECTION
9	3-893-903-11	BUTTON (S), SELECTION
11	3-893-907-11	DRUM, INDICATE
15	3-893-912-11	SCALE (B), DIAL
18	*3-893-975-01	(4920)...LABEL, MODEL NUMBER
	*3-893-980-01	(5100)...LABEL, MODEL NUMBER
20	3-893-920-21	DIAL (A), SCALE
39	X-3893-911-1	(5100:AEP).....CABINET (FRONT) ASSY
	X-3893-912-1	(5100:G-AEP,UK,E)...CABINET (FRONT) ASSY
	X-3893-913-1	(4920).....CABINET (FRONT) ASSY

## ELECTRICAL PARTS

Ref.No.	Part No.	Description			
504	A-3660-525-A	(EXCEPT FOR G-AEP)...MOUNTED PCB, MAIN			
	A-3660-555-A	(5100:G-AEP).....MOUNTED PCB, MAIN			
C1	1-163-021-00	CERAMIC CHIP 0.01MF	10%	50V	
C2	1-163-021-00	CERAMIC CHIP 0.01MF	10%	50V	
C3	1-163-021-00	CERAMIC CHIP 0.01MF	10%	50V	
C5	1-163-021-00	CERAMIC CHIP 0.01MF	10%	50V	
C7	1-163-086-00	CERAMIC CHIP 3PF	0.25PF	50V	
C9	1-163-021-00	CERAMIC CHIP 0.01MF	10%	50V	
C10	1-163-059-00	CERAMIC CHIP 0.01MF	10%	50V	
C11	1-163-021-00	CERAMIC CHIP 0.01MF	10%	50V	
C15	1-163-125-00	CERAMIC CHIP 220PF	10%	50V	
C18	1-163-111-00	CERAMIC CHIP 56PF	5%	50V	
C22	1-163-111-00	CERAMIC CHIP 56PF	5%	50V	
C32	1-163-090-00	CERAMIC CHIP 7PF	0.25PF	50V	
C37	1-163-117-00	CERAMIC CHIP 100PF	5%	50V	
C38	1-163-021-00	CERAMIC CHIP 0.01MF	10%	50V	
C39	1-163-021-00	CERAMIC CHIP 0.01MF	10%	50V	
C43	1-163-033-00	CERAMIC CHIP 0.022MF		50V	
C53	1-163-021-00	CERAMIC CHIP 0.01MF	10%	50V	
C56	1-163-021-00	CERAMIC CHIP 0.01MF	10%	50V	
C59	1-163-084-00	CERAMIC CHIP 1.5PF	0.25PF	50V	
C61	1-163-021-00	CERAMIC CHIP 0.01MF	10%	50V	
C66	1-163-085-00	(5100:G-AEP) ...CERAMIC CHIP	2PF	0.25PF 50V	
C101	1-163-081-00	CERAMIC CHIP 0.22MF		25V	
C102	1-163-141-00	CERAMIC CHIP 0.001MF	10%	50V	
C103	1-163-141-00	CERAMIC CHIP 0.001MF	10%	50V	
C104	1-163-141-00	CERAMIC CHIP 0.001MF	10%	50V	
C105	1-163-141-00	CERAMIC CHIP 0.001MF	10%	50V	
C106	1-163-141-00	CERAMIC CHIP 0.001MF	10%	50V	
C107	1-163-141-00	CERAMIC CHIP 0.001MF	10%	50V	
R3	1-216-043-00	METAL CHIP	560	5%	1/10W
R4	1-216-057-00	METAL CHIP	2.2K	5%	1/10W
R8	1-216-041-00	METAL CHIP	470	5%	1/10W
R9	1-216-041-00	METAL CHIP	470	5%	1/10W
R11	1-216-075-00	METAL CHIP	12K	5%	1/10W
R12	1-216-025-00	METAL CHIP	100	5%	1/10W
R14	1-216-073-00	METAL CHIP	10K	5%	1/10W
R15	1-216-045-00	METAL CHIP	680	5%	1/10W
R16	1-216-198-00	METAL CHIP	1K	5%	1/8W
R17	1-216-083-00	METAL CHIP	27K	5%	1/10W
R18	1-216-065-00	METAL CHIP	4.7K	5%	1/10W
R19	1-216-065-00	METAL CHIP	4.7K	5%	1/10W

## ACCESSORY & PACKING MATERIAL

No.	Part No.	Description
55	3-893-972-01	(4920)...INDIVIDUAL CARTON
	3-893-977-01	(5100)...INDIVIDUAL CARTON
56	3-893-940-01	(5100:E).....GUIDE, SHORT WAVE
	3-893-940-11	(5100:AEP,UK)...GUIDE, SHORT WAVE
62	3-764-464-01	(5100:G-AEP)...INSTRUCTION
65	*3-893-984-01	SHEET, INSULATING

## ELECTRICAL PARTS

Ref.No.	Part No.	Description			
R20	1-216-049-00	METAL CHIP	1K	5%	1/10W
R21	1-216-091-00	METAL CHIP	56K	5%	1/10W
R22	1-216-041-00	METAL CHIP	470	5%	1/10W
R23	1-216-057-00	METAL CHIP	2.2K	5%	1/10W
R25	1-216-049-00	METAL CHIP	1K	5%	1/10W
R26	1-216-049-00	METAL CHIP	1K	5%	1/10W
R27	1-216-009-00	METAL CHIP	22	5%	1/10W
R29	1-216-029-00	METAL CHIP	150	5%	1/10W
R36	1-216-069-00	METAL CHIP	6.8K	5%	1/10W
R37	1-216-069-00	METAL CHIP	6.8K	5%	1/10W
R40	1-216-057-00	METAL CHIP	2.2K	5%	1/10W
R41	1-216-049-00	METAL CHIP	1K	5%	1/10W
R42	1-216-061-00	METAL CHIP	3.3K	5%	1/10W
R48	1-216-053-00	METAL CHIP	1.5K	5%	1/10W
R101	1-216-296-00	METAL CHIP	0	5%	1/8W
R102	1-216-296-00	METAL CHIP	0	5%	1/8W
R103	1-216-168-00	METAL CHIP	56	5%	1/8W
R104	1-216-295-00	METAL CHIP	0	5%	1/10W
R105	1-216-242-00	METAL CHIP	68K	5%	1/8W
R106	1-216-081-00	METAL CHIP	22K	5%	1/10W
R107	1-216-192-00	METAL CHIP	560	5%	1/8W
R108	1-216-192-00	METAL CHIP	560	5%	1/8W
R109	1-216-055-00	METAL CHIP	1.8K	5%	1/10W
R110	1-216-093-00	METAL CHIP	68K	5%	1/10W
R111	1-216-097-00	METAL CHIP	100K	5%	1/10W
R112	1-216-295-00	METAL CHIP	0	5%	1/10W
R113	1-216-097-00	METAL CHIP	100K	5%	1/10W
R114	1-216-295-00	METAL CHIP	0	5%	1/10W
R115	1-216-097-00	METAL CHIP	100K	5%	1/10W
R116	1-216-097-00	METAL CHIP	100K	5%	1/10W
R117	1-216-296-00	METAL CHIP	0	5%	1/8W
R118	1-216-296-00	METAL CHIP	0	5%	1/8W
R119	1-216-296-00	METAL CHIP	0	5%	1/8W
R120	1-216-097-00	METAL CHIP	100K	5%	1/10W
R121	1-216-097-00	METAL CHIP	100K	5%	1/10W
R122	1-216-296-00	METAL CHIP	0	5%	1/8W
R123	1-216-296-00	METAL CHIP	0	5%	1/8W
R124	1-216-295-00	METAL CHIP	0	5%	1/10W

Sony Corporation  
Audio Group

9-952-837-11

English  
87G0494-1  
Printed in Japan  
© 1987. 7

# ICF-4900 / 4910

## SERVICE MANUAL

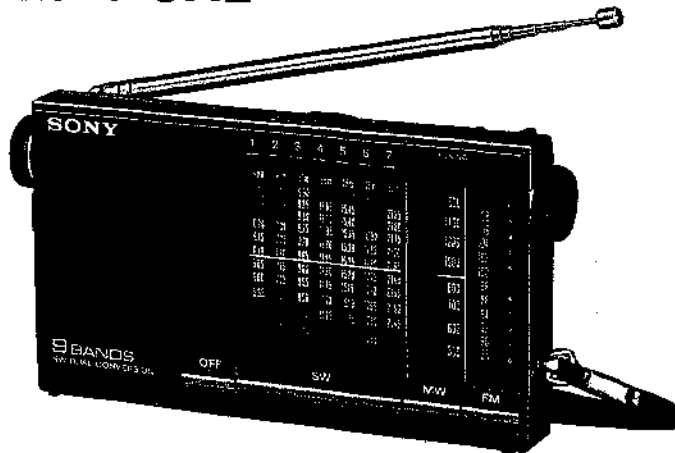

ICF-4900  
AEP Model  
E Model  
UK Model

ICF-4910  
US Model  
Canadian Model

### SPECIFICATIONS

Frequency range	FM 87.6 - 108 MHz SW <sub>1</sub> 5.85 - 6.35 MHz (49 m) SW <sub>2</sub> 6.95 - 7.45 MHz (41 m) SW <sub>3</sub> 9.4 - 9.9 MHz (31 m) SW <sub>4</sub> 11.6 - 12.1 MHz (25 m) SW <sub>5</sub> 15.0 - 15.5 MHz (19 m) SW <sub>6</sub> 17.55 - 18.05 MHz (16 m) SW <sub>7</sub> 21.4 - 21.9 MHz (13 m) MW 530 - 1,605 kHz
Antennas	FM/SW: Telescopic antenna MW: Built-in ferrite bar antenna
Speaker	Approx. 5 cm (3 inches) dia.
Power output	100 mW (at 10% harmonic distortion) at dc operation
Output	Earphone jack (minijack)
Power requirements	3 V dc two size AA batteries (IEC designation R6) DC IN 3 V jack accepts: optional Sony AC-37 ac power adaptor for use on 220 V ac, 60 Hz . . . (ICF-4900; AEP model) optional Sony AC-38 ac power adaptor for use on 110-120 V, 220-240 V ac, 50/60 Hz . . . (ICF-4900; E model) optional Sony AC-39 ac power adaptor for use on 120 V ac, 60 Hz . . . (ICF-4910) optional Sony DCC-70 car battery cord for use with 12 V car battery
Battery life	Approx. 22 hours with Sony SUM-3 (NS) New Super batteries or Eveready No. 1215 Heavy Duty batteries
Dimensions	Approx. 144 × 76 × 24.5 mm (w/h/d) (5 <sup>3</sup> / <sub>4</sub> × 3 × 3 <sup>1</sup> / <sub>2</sub> inches) incl. projecting parts and controls
Weight	Approx. 245 g (8.6 oz) incl. batteries

FM/MW/SW 9 BAND RECEIVER  
**SONY**



## FEATURES

- Handy FM/MW/SW1-7 9 band receiver with high sensitivity and high selectivity.
- Band spread system enables you to easily tune in SW stations.
- Dual conversion circuit effectively reduces interference from other SW stations.

## LOCATION AND FUNCTION OF CONTROLS

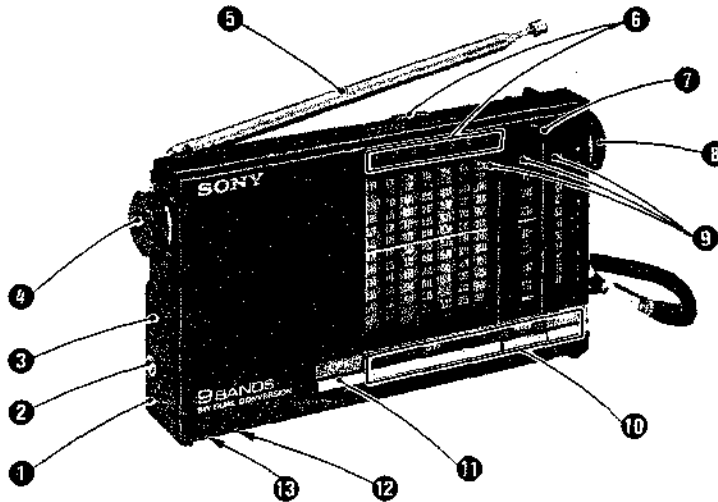

- ① DC IN 3V (external power input) jack
- ② ③ Earphone jack
- ③ TONE control
- ④ VOLUME control
- ⑤ Telescopic antenna
- ⑥ SW band selector and indicators
- ⑦ TUNING indicator
- ⑧ TUNING knob
- ⑨ Dial scales
- ⑩ Band select buttons and indicators
- ⑪ OFF button
- ⑫ SAFETY switch (bottom)
- ⑬ Battery compartment (rear)

### Note on Ceramic Filter Replacement

FM IF ceramic filters (CF1, CFF1) are color-painted on their bodies. The color of CF1 and CFF1 should be the same, respectively. CF1 and CFF1 are supplied in pairs. These must be replaced in pairs when used in this set.

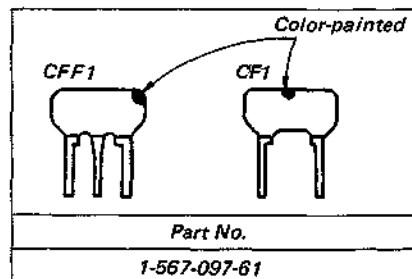

**Replacing chip components**

All chip components should be connected and disconnected, using a tapered soldering iron [temperature of the iron tip: less than 280°C (536°F)], a pair of tweezers and braided wire.

**Precautions for replacement**

1. Do not disconnect the chip component forcefully. Otherwise, the pattern may peel off.
2. Never re-use a disconnected chip component. Dispose of all old chip components.
3. To protect the chip component, heating time for attaching the component should be within 3 seconds.

○ **Removing chip components**

(1) **Removing solder at electrode**

Remove the solder at the electrode, using a thin braided wire. Do not remove the solder of the part (chip component) attached adjacent to the electrode.

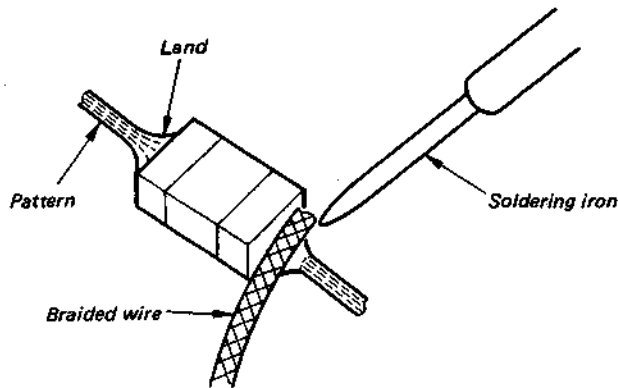

(2) **Disconnecting chip components**

Turn the tweezers with the soldering iron alternately applied to both electrodes, and the chip component will be disconnected. Take careful precautions while disconnecting, because if the chip component is forcefully removed the land may peel off. Never re-use a disconnected chip component.

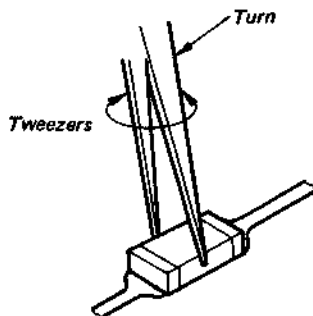

(3) **Smoothing the soldered surface**

After disconnecting the chip component, remove the solder by using a braided wire to smooth the land surface.

○ **Connecting chip components**

The value of chip components is not displayed on the main body. Take due precautions to avoid mixing new chip components with other ones.

(1) **Applying solder to land on one side**

Apply a thin layer of solder to the land on one side where the chip component is to be connected. Too much solder may cause bridging.



(2) **Speedy soldering**

Hold the chip component at the desired position, using tweezers, and apply the soldering iron in the arrow-marked direction. To protect the chip component, heating time should be within 3 seconds.

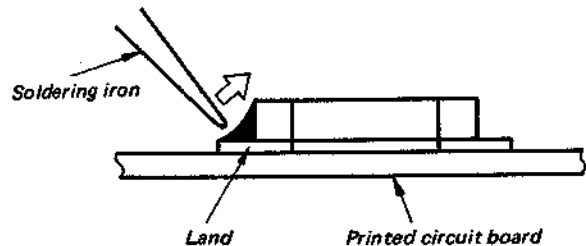

(3) **Speedy soldering of electrode on the other side**

Solder the electrode on the other side in the same way as in (2) above.

## MELF (Metal Electrodes Face-Bonding) Components (AEP, UK, E Model)

### Warning

If MELF components are forcibly removed from the printed circuit board with pincers or pliers, the circuit board pattern is likely to peel away. Always remove MELF components according to the procedure described on the next page.

MELF components are soldered directly to the surface of the printed circuit board.

MELF resistors and capacitors have the same dimensions and are distinguished by their background colors: light brown for resistors, and pink or light green for capacitors.

The MELF resistor color coding is the same as for conventional resistors, and MELF capacitor color coding is the same as for tube-type ceramic capacitors.

Components larger than resistors and without a color code are cross conductors, which are used instead of jumper wires.

### 1. Structure

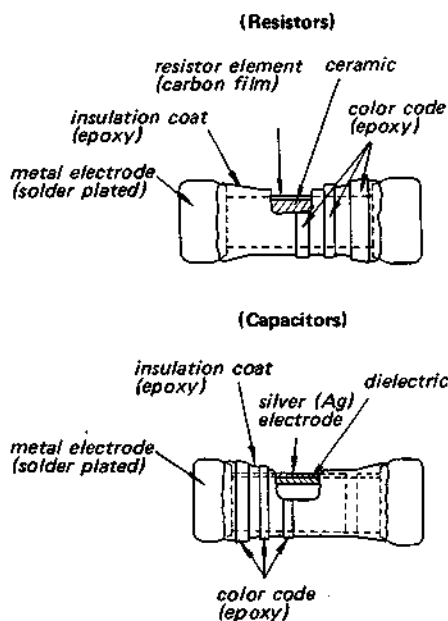
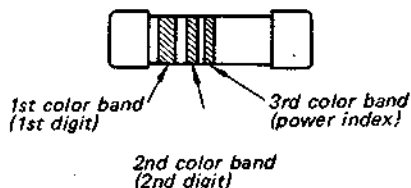
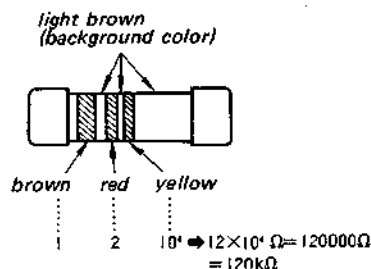

Fig. 1

### 2. Color Code Reading



#### (Example of Resistor)



#### (Example of Capacitor)

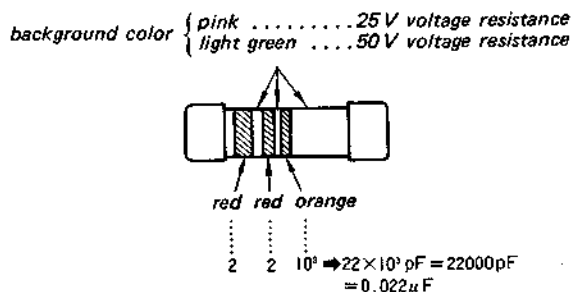

Fig. 2

**3. How to Remove MELF Components**

Use a soldering iron of at least 40W with an iron tip 4 mm in diameter and file the tip down to the angle shown in the diagram.

1. Bring the flat surface of the soldering iron in equal contact with both soldered ends of the component.
2. The solder should melt in about 4 seconds. (The solder will melt more readily if a small amount of solder is attached to the iron tip and the iron tip is placed against the component.)
3. Once the solder has melted, tap the component aside with the tip of the soldering iron, and remove it from the board.

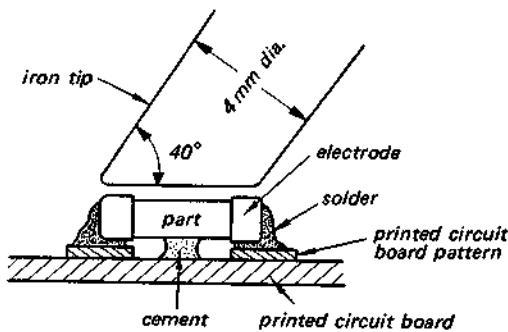

Fig. 3

**4. Connecting MELF components**

The value of MELF components is not displayed on the main body. Take due precautions to avoid mixing new MELF components with other ones.

**1. Applying solder to land on one side**

Apply a thin layer of solder to the land on one side where the MELF component is to be connected. Too much solder may cause bridging.



Fig. 4

**2. Speedy soldering**

Hold the MELF component at the desired position, using tweezers, and apply the soldering iron in the arrow-marked direction. To protect the MELF component, heating time should be within 3 seconds.

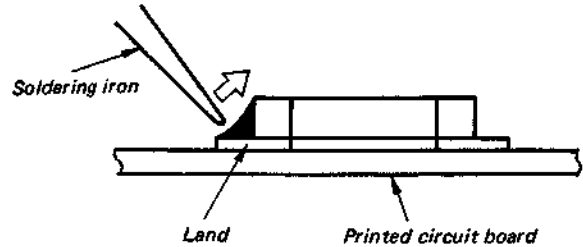

Fig. 5

**3. Speedy soldering of electrode on the other side**

Solder the electrode on the other side in the same way as in 2. above.

**Note:** In this model, MELF components are supplied for following parts.

1Ω	1-249-001-00
3.3pF	1-162-327-00
5.6pF	1-162-330-00
6.8pF	1-162-331-00

Use lead type resistors or 3216 type chip components in place of the mounted MELF components.

Lead type resistors may be mounted with leads cut short (see Fig. 6).

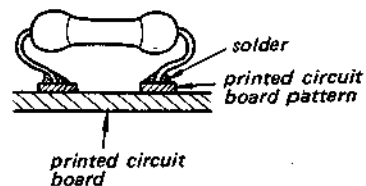
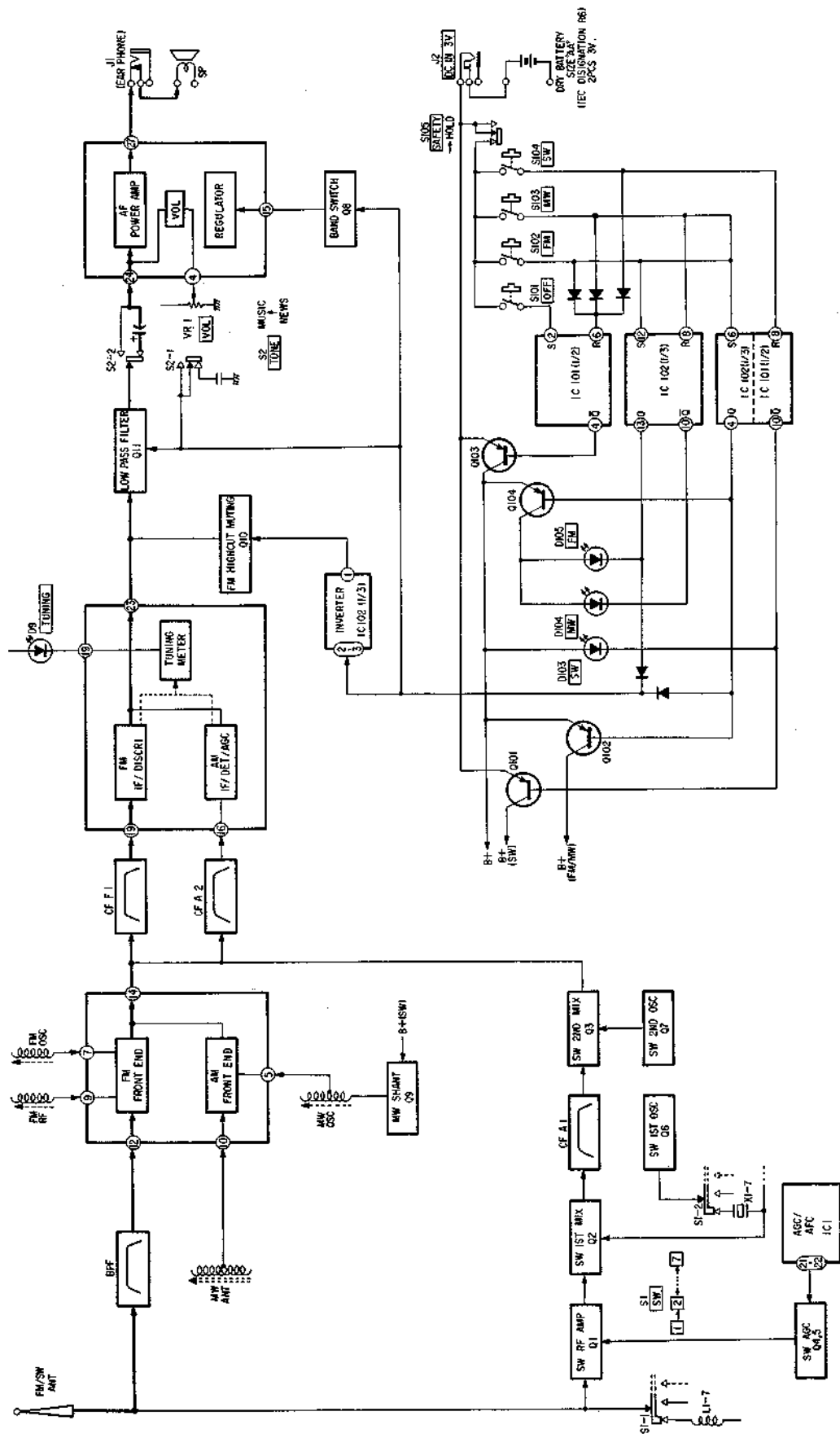

Fig. 6

See page 3 for mounting of chip components.

SECTION 1  
OUTLINE

1-1. BLOCK DIAGRAM





SECTION 2  
DISASSEMBLY

• Follow the disassembly procedure in the numerical order given.

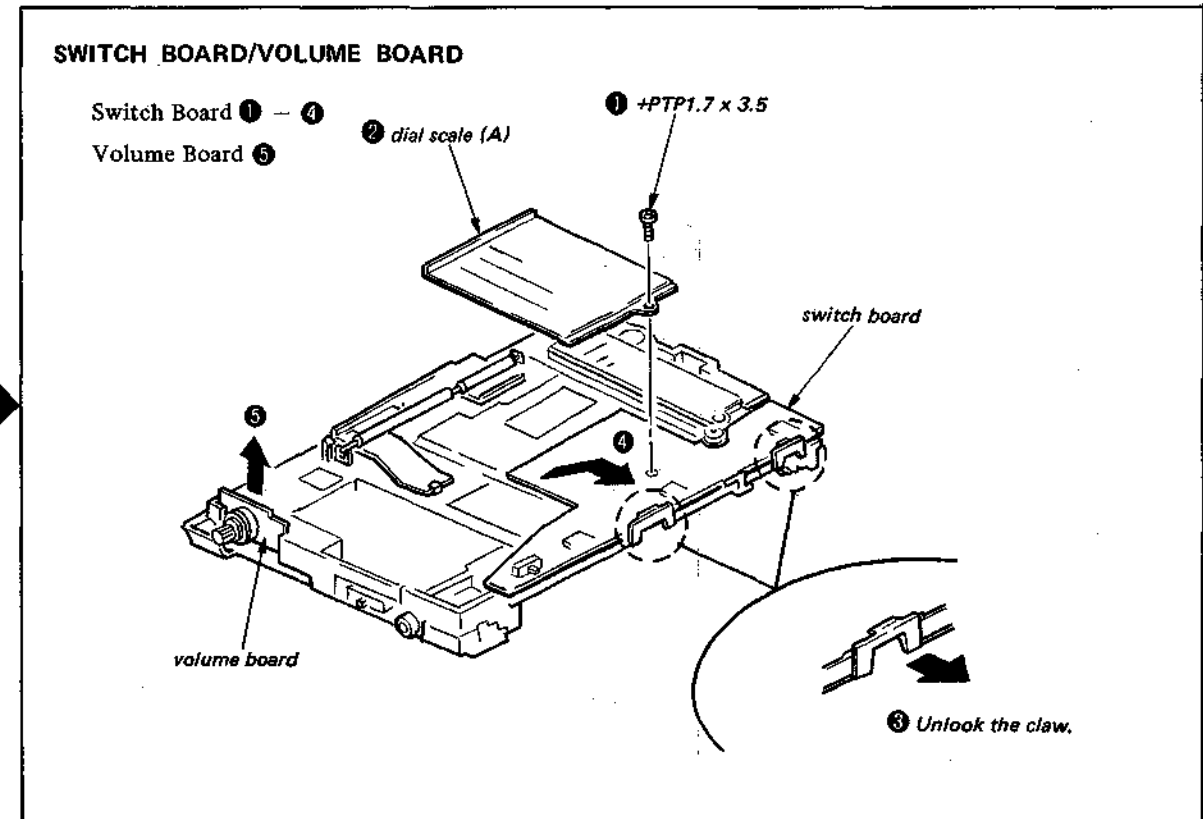
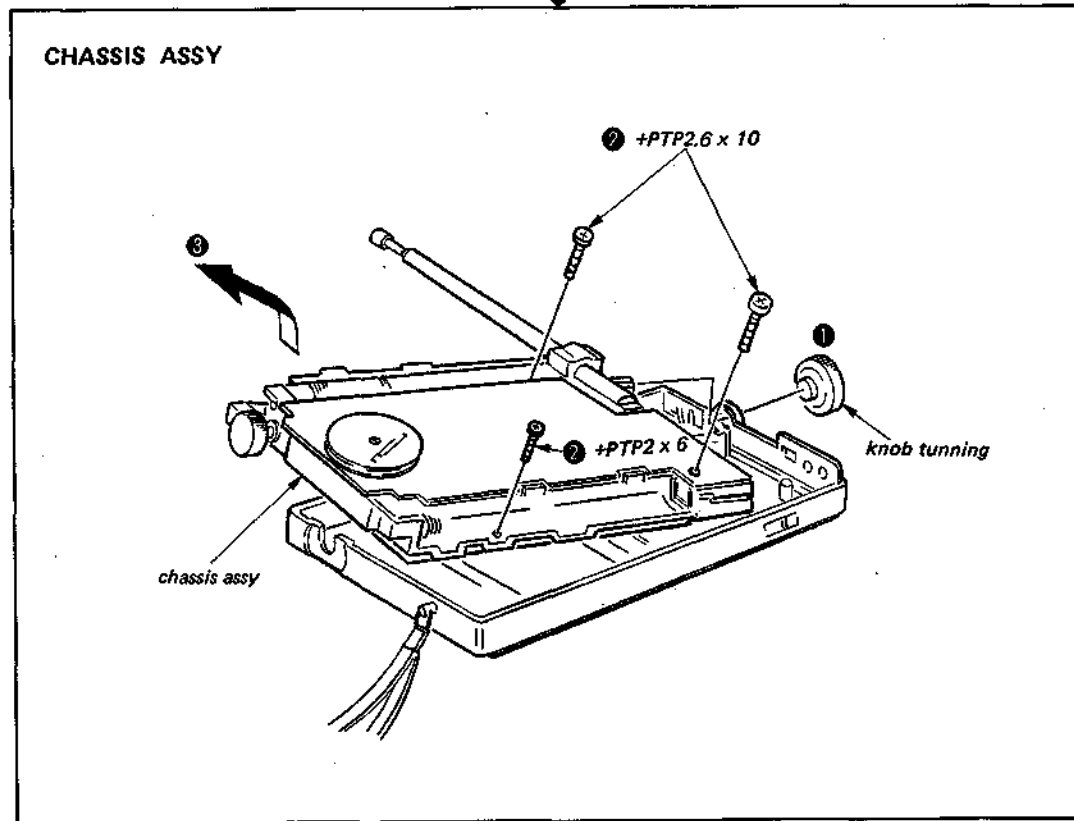
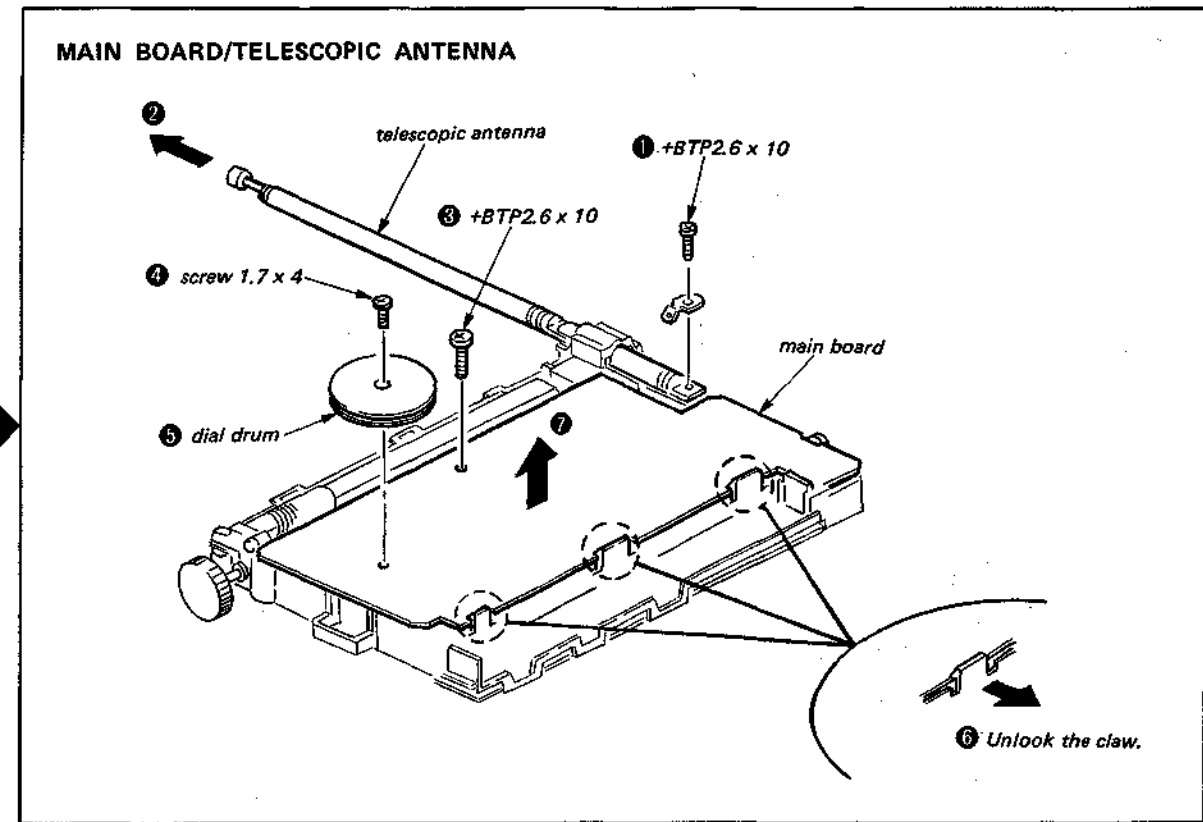
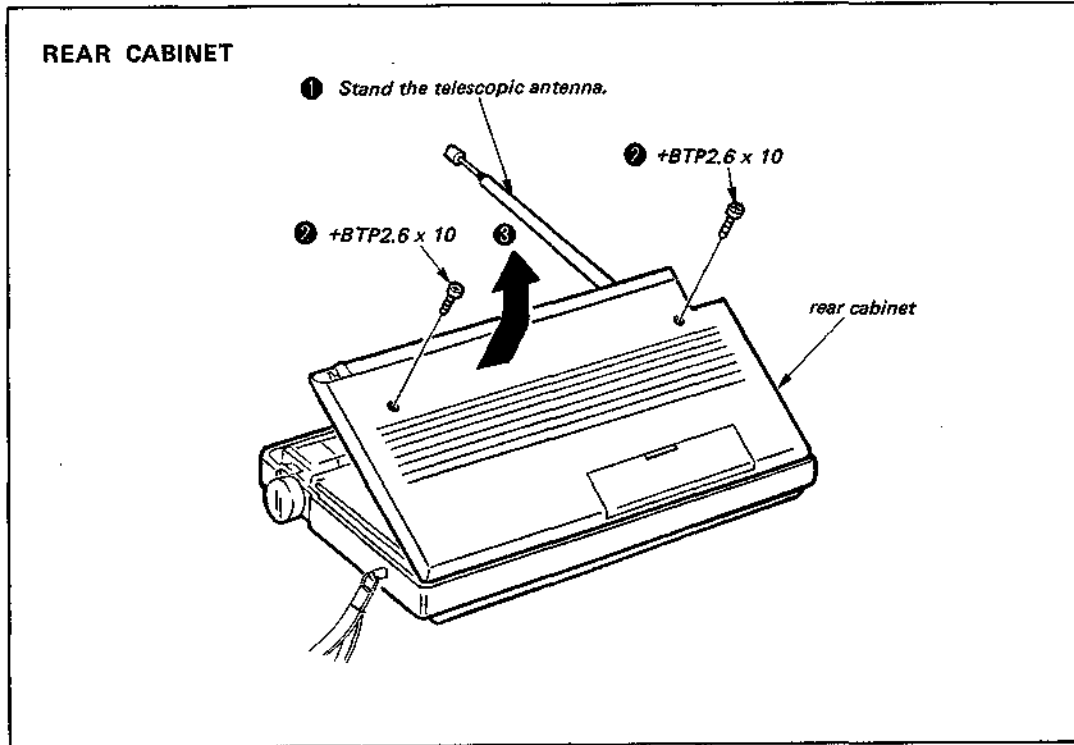

SECTION 3  
ADJUSTMENTS

DIAL CORD STRINGING

1. Preparation

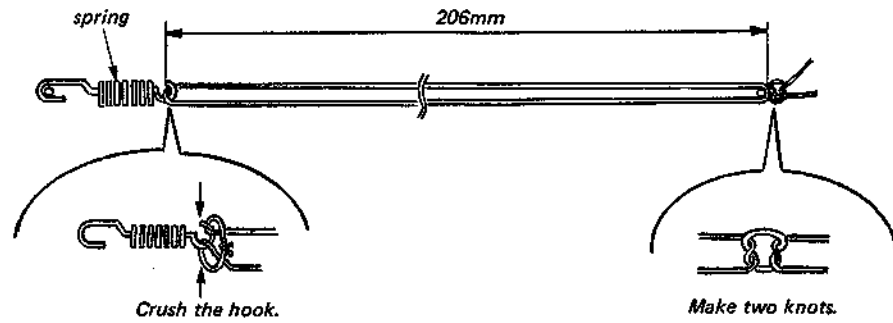

2. Stringing

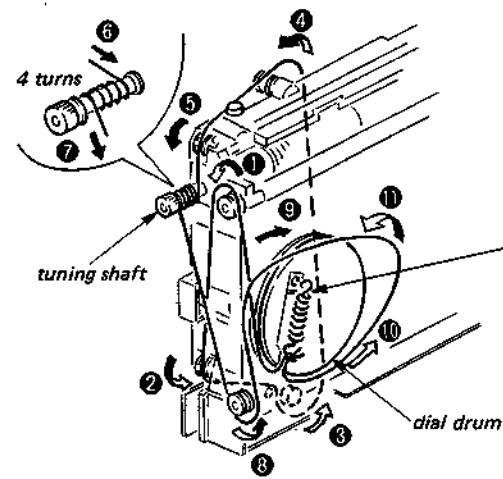

1. Turn the dial drum fully clockwise.
2. String the dial cord in the numerical order (1 - 10).

3. Pointer Installation

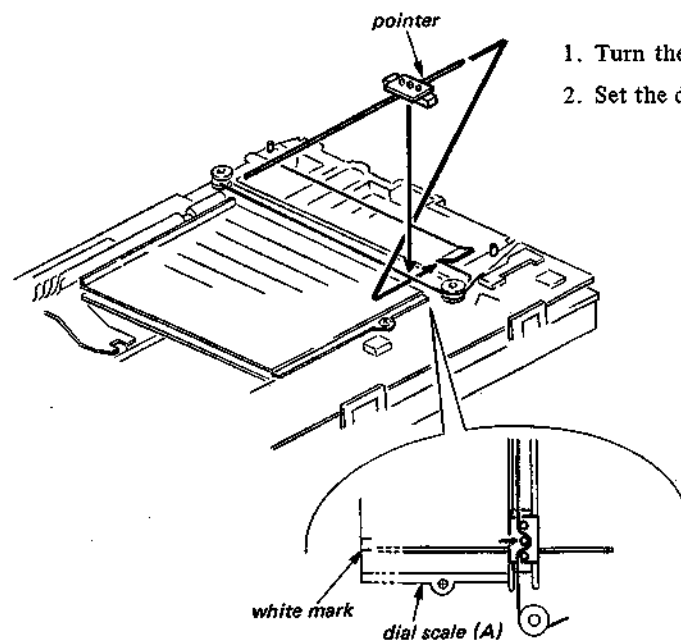

1. Turn the tuning knob fully counterclockwise.
2. Set the dial pointer as illustrated.

3-1. MW SECTION

AM RF SG



30% amplitude modulation by 400 Hz signal

Put the lead-wire antenna close to the set.

VTVM (0.5 - 5V AC range)

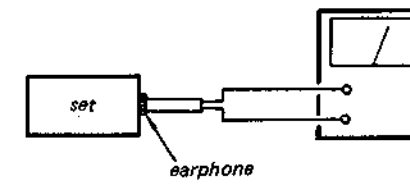

- Repeat the procedures in each adjustment several times, and the frequency coverage and tracking adjustments should be finally done by the trimmer capacitors.

MW IF ALIGNMENT	
Adjust for a maximum reading on VTVM.	
455kHz	
T3	

MW TRACKING ADJUSTMENT	
Adjust for a maximum reading on VTVM.	
620kHz	1400kHz
L12	CT2

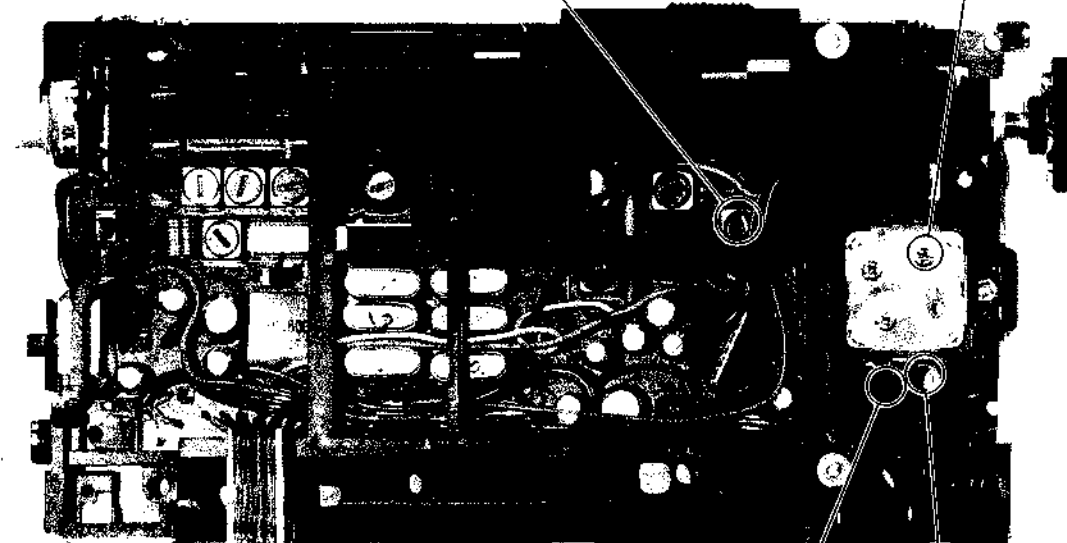

L15	CT5
520kHz	1650kHz
Adjust for a maximum reading on VTVM.	
MW FREQUENCY COVERAGE ADJUSTMENT	

3-2. SW SECTION

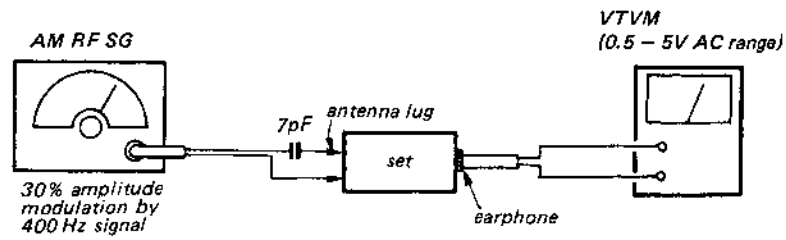

- Repeat the procedures in each adjustment several times, and the frequency coverage and tracking adjustments should be finally done by the trimmer capacitors.

SW1-7 TRACKING ADJUSTMENT							
Adjust for a maximum reading on VTVM.							
6.1MHz	7.2MHz	9.65MHz	11.85MHz	15.25MHz	17.8MHz	21.65MHz	
T1	L1	L2	L3	L4	L5	L6	L7

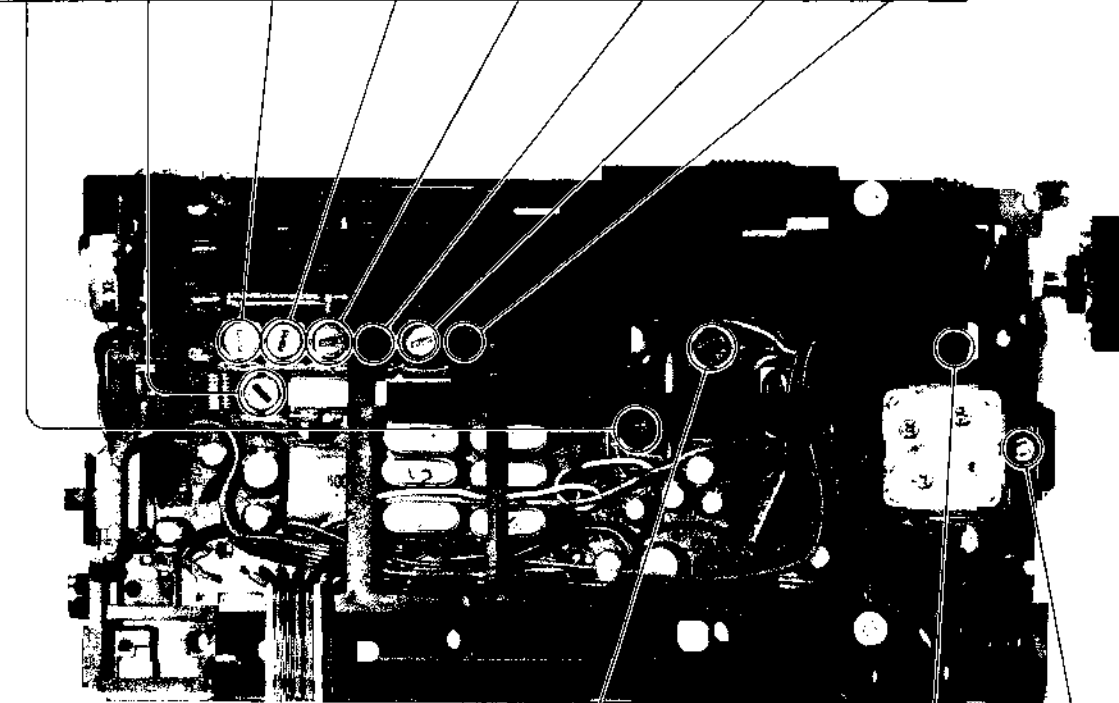

T2
455kHz
Adjust for a maximum reading on VTVM.
SW IF ALIGNMENT

T4	CT1
10.875MHz	11.435MHz
Adjust for a maximum reading on VTVM.	
SW FREQUENCY COVERAGE ADJUSTMENT	

3-3. FM SECTION

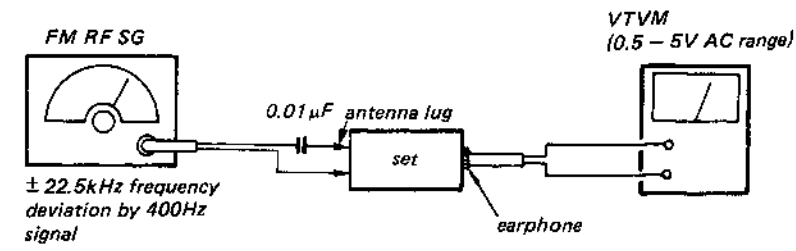

- Repeat the procedures in each adjustment several times, and the frequency coverage and tracking adjustments should be finally done by the trimmer capacitors.

FM TRACKING ADJUSTMENT	
Adjust for a maximum reading on VTVM.	
86.5MHz	109.5MHz
L13	CT3

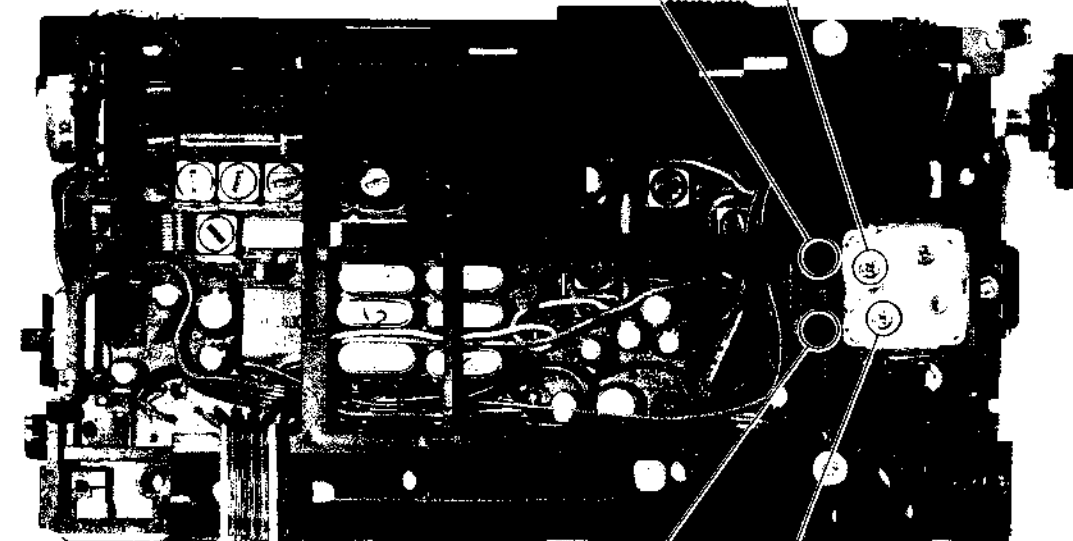

L14	CT4
86.5MHz	109.5MHz
Adjust for a maximum reading on VTVM.	
FM FREQUENCY COVERAGE ADJUSTMENT	



# ICF-4900/4910 ICF-4900/4910

## 4-2. SCHEMATIC DIAGRAM

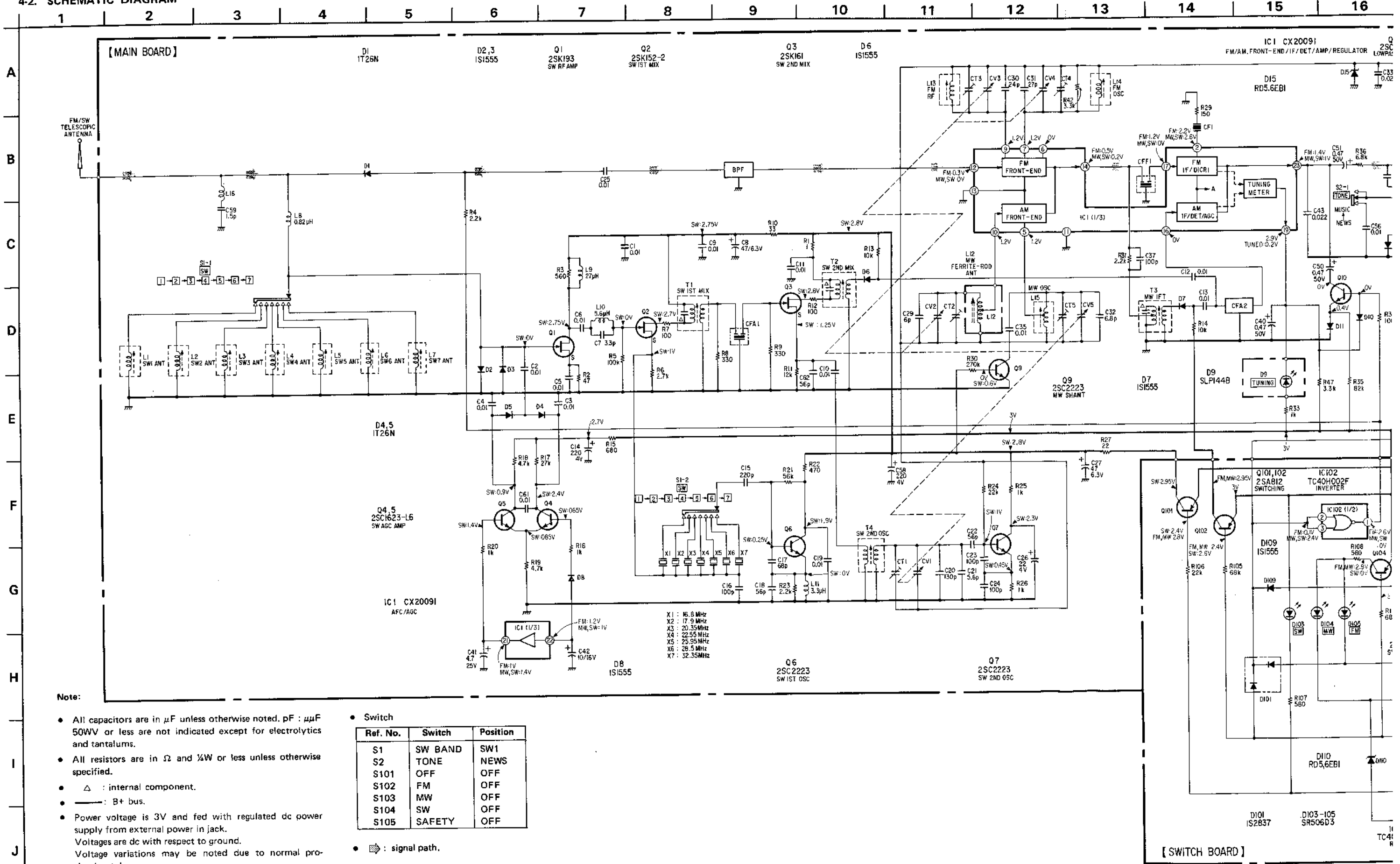

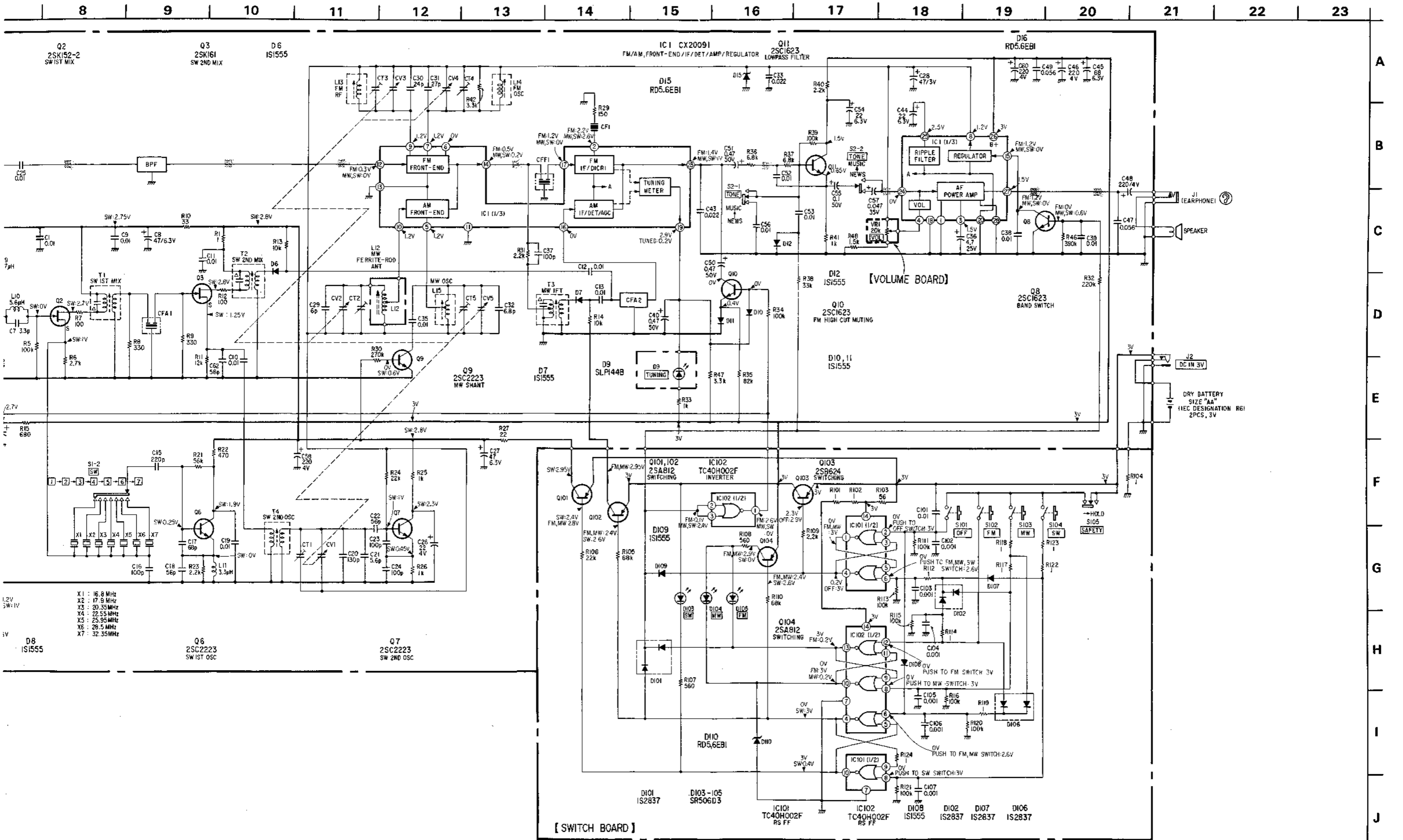

SECTION 5  
EXPLODED VIEW AND PARTS LIST

Semiconductor Lead Layouts

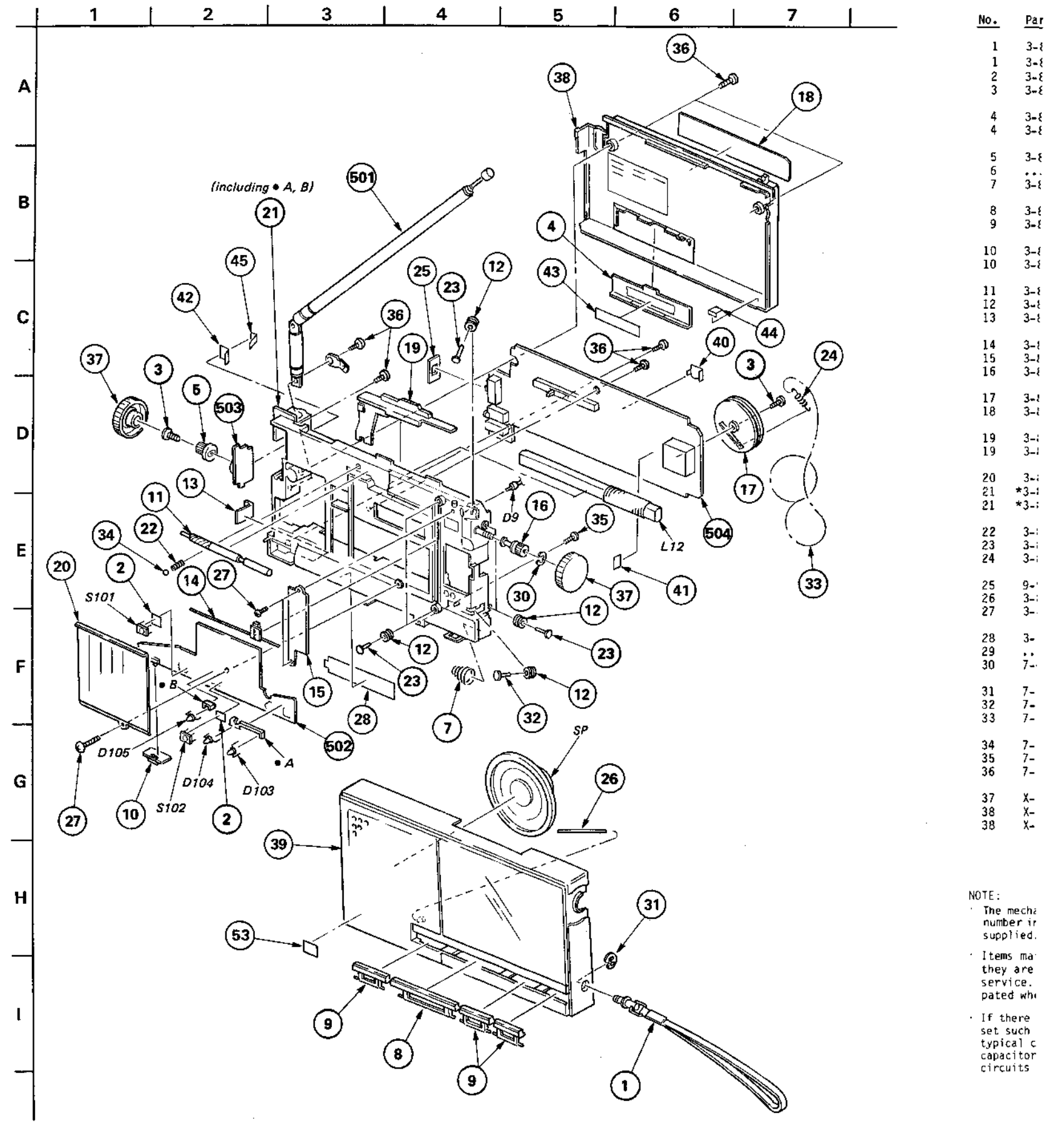
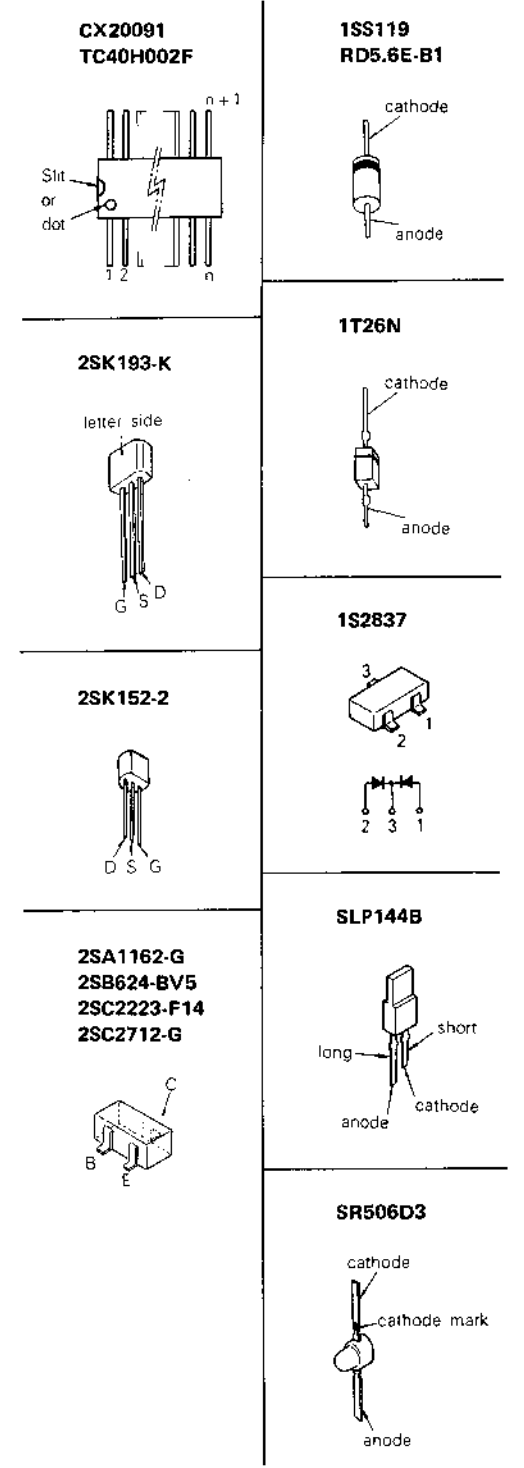

NOTE:  
The mech number is supplied.  
Items marked with an asterisk are service parts.  
If there is a set such as typical capacitor circuits

SECTION 5  
EXPLODED VIEW AND PARTS LIST

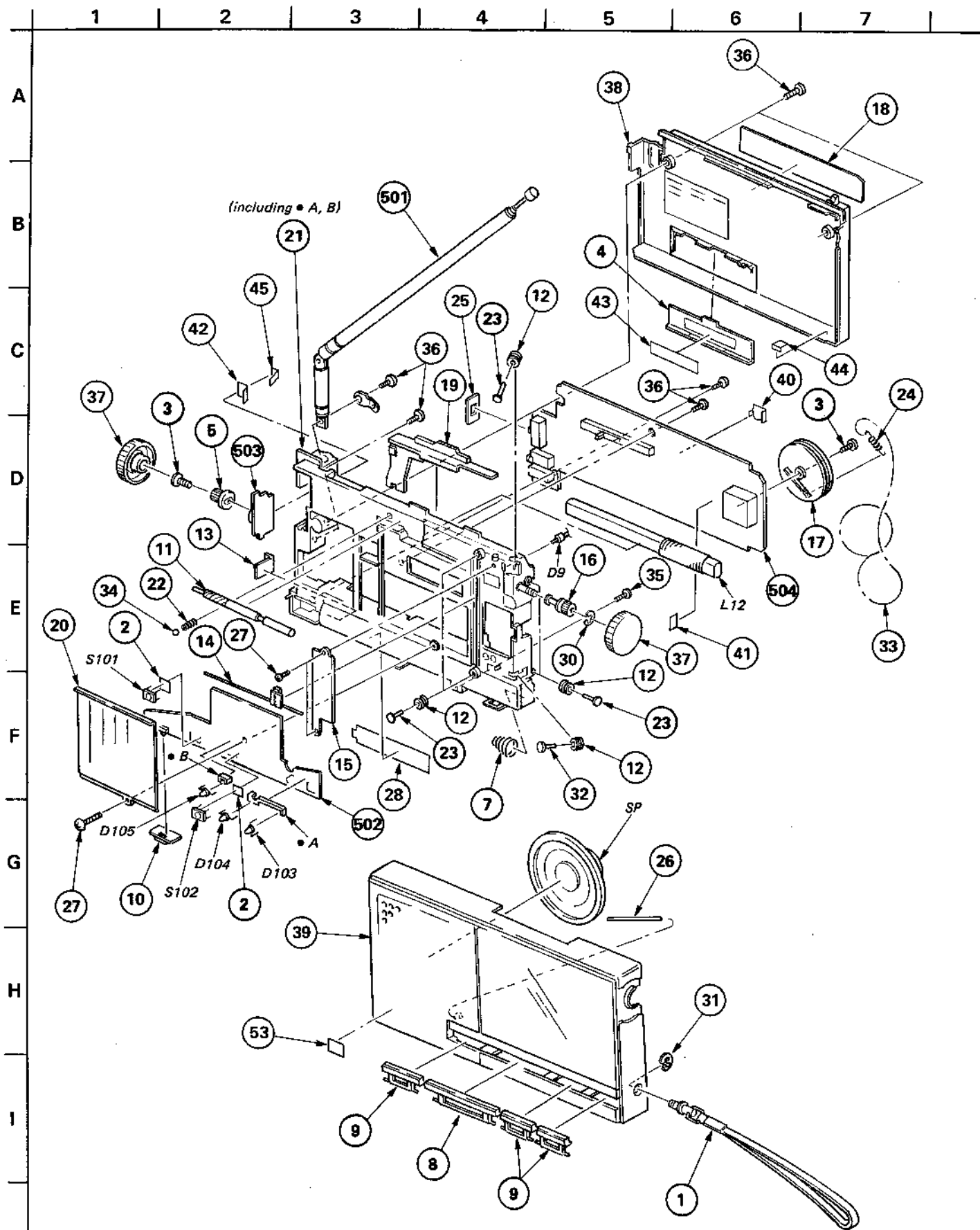

GENERAL SECTION		
No.	Part No.	Description
1	3-881-938-00	(BLACK)...STRAP, HAND
1	3-881-938-11	(SILVER)...STRAP, HAND
2	3-885-031-01	SPACER (A)
3	3-888-156-00	SCREW (1.7X4)
4	3-889-802-00	(BLACK)...LID, BATTERY CASE
4	3-889-802-51	(SILVER)...LID, BATTERY CASE
5	3-889-808-00	SHAFT, CONTROL
6	.....	.....
7	3-889-819-00	SPRING
8	3-893-902-01	BUTTON (L), SELECTION
9	3-893-903-01	BUTTON (S), SELECTION
10	3-893-905-01	(BLACK)...KNOB, HOLD
10	3-893-905-11	(SILVER)...KNOB, HOLD
11	3-893-907-01	DRUM, INDICATE
12	3-893-908-01	PULLEY (DIA.4)
13	3-893-910-01	PLATE, POLE, BATTERY
14	3-893-911-01	POINTER
15	3-893-912-01	SCALE (B), DIAL
16	3-893-913-01	SHAFT, TUNING
17	3-893-914-01	DRUM, DIAL
18	3-893-917-01	(4910)...LABEL, MODEL NUMBER
19	3-893-919-01	(BLACK)...KNOB, SUB BAND
19	3-893-919-11	(SILVER)...KNOB, SUB BAND
20	3-893-920-01	SCALE (A), DIAL
21	*3-893-923-01	(BLACK)...CHASSIS
21	*3-893-923-11	(SILVER)...CHASSIS
22	3-893-926-01	SPRING, COMPRESSION
23	3-893-927-01	RIVET
24	3-893-928-01	SPRING
25	9-911-838-XX	SHEET, BLIND
26	3-893-933-01	SPRING
27	3-893-942-01	SCREW (1.7X4), TAPPING (B)
28	3-893-944-01	SHEET INDICATION, POLARITY
29	.....	.....
30	7-624-103-01	RETAINING, RING E-1.9
31	7-624-104-04	STOP RING 2.0, TYPE -E
32	7-625-702-80	RIVET
33	7-633-120-52	STRING, DIAL
34	7-671-113-02	STEEL BOLL 3.0
35	7-685-104-14	SCREW +P 2X6 TYPE2 SLIT
36	7-685-135-14	SCREW +P 2.6X10 TYPE2 NON-SLIT
37	X-3889-802-1	TUNING KNOB ASSY
38	X-3893-901-1	(BLACK)...CABINET (REAR) ASSY
38	X-3893-902-1	(SILVER)...CABINET (REAR) ASSY

GENERAL SECTION		
No.	Part No.	Description
39	X-3893-903-1	(4900;BLACK)...CABINET (FRONT) ASSY
39	X-3893-904-1	(4900;SILVER)...CABINET (FRONT) ASSY
39	X-3893-905-1	(4910;BLACK)...CABINET (FRONT) ASSY
39	X-3893-906-1	(4910;SILVER)...CABINET (FRONT) ASSY
40	*3-893-947-01	FOIL (B), COPPER
41	*3-893-948-01	FOIL (C), COPPER
42	*3-893-949-01	FOIL (D), COPPER
43	3-831-441-XX	CUSHION (B)
44	*3-893-952-01	FOIL (E), COPPER
45	*3-893-953-01	FOIL (F), COPPER

ACCESSORY & PACKING MATERIAL		
No.	Part No.	Description
51	1-504-059-11	MAGNETIC EARPHONE (ME-20H)
52	3-570-631-01	BAG, POLYETHYLENE
53	3-703-710-01	STICKER, SONY SYMBOL (12)
54	3-893-934-01	CASE, CARRYING
55	3-893-936-01	(4900)...INDIVIDUAL CARTON
55	3-893-939-01	(4910)...INDIVIDUAL CARTON
56	3-893-940-01	(4900)...GUIDE, SHORT WAVE
56	3-893-940-11	(4910)...GUIDE, SHORT WAVE
57	3-893-938-01	CUSHION
58	3-893-950-01	SHEET
59	3-990-005-11	(4900)...MANUAL, INSTRUCTION
60	3-990-005-21	(4910)...MANUAL, INSTRUCTION
61	3-990-005-31	(4910;Canadian)...MANUAL, INSTRUCTION
62	3-993-321-11	INSTRUCTION
63	7-703-895-01	(BLACK)...LABEL (L), COLOR
63	7-703-906-01	(SILVER)...LABEL (L), COLOR
64	7-703-910-01	(BLACK)...LABEL (S), COLOR
64	7-703-921-01	(SILVER)...LABEL (S), COLOR

NOTE:

The mechanical parts with no reference number in the exploded views are not supplied.

Items marked "\*" are not stocked since they are seldom required for routine service. Some delay should be anticipated when ordering these items.

If there are two or more same circuits in a set such as a stereophonic machine, only typical circuit parts may be indicated and capacitors and resistors in other same circuits may be omitted.

CAPACITORS:

All capacitors are in  $\mu\text{F}$ . Common capacitors are omitted. Refer to the following lists for their part numbers.  
MF:  $\mu\text{F}$ , PF:  $\mu\text{pF}$ .

COILS

MMH : mH, UH :  $\mu\text{H}$

SEMICONDUCTORS

In each case, U :  $\mu$ , for example:  
UA...:  $\mu\text{A}$ ..., UPA...:  $\mu\text{PA}$ ..., UPC...:  $\mu\text{PC}$ ...,  
UPD...:  $\mu\text{PD}$ ...



## ELECTRICAL PARTS

Ref.No.	Part No.	Description			
501	1-501-323-11	ANTENNA, TELESCOPIC			
502	*1-613-378-11	PC BOARD, SWITCH			
503	*1-613-379-11	PC BOARD, VOLUME			
504	*A-3660-525-A	MOUNTED PCB, MAIN			
BPF	1-235-171-00	FILTER, BAND PASS			
C1	1-163-059-00	CERAMIC CHIP 0.01MF	10%	50V	
C2	1-163-059-00	CERAMIC CHIP 0.01MF	10%	50V	
C3	1-163-059-00	CERAMIC CHIP 0.01MF	10%	50V	
C4	1-162-306-31	CERAMIC 0.01MF	10%	50V	
C5	1-163-059-00	CERAMIC CHIP 0.01MF	10%	50V	
C6	1-163-059-00	CERAMIC CHIP 0.01MF	10%	50V	
C7	1-162-327-00	CERAMIC MELF 3.3PF	10%	50V	
C8	1-123-647-00	ELECT 47MF	20%	6.3V	
C9	1-163-059-00	CERAMIC CHIP 0.01MF	10%	50V	
C10	1-163-059-00	CERAMIC CHIP 0.01MF	10%	50V	
C11	1-163-059-00	CERAMIC CHIP 0.01MF	10%	50V	
C12	1-163-059-00	CERAMIC CHIP 0.01MF	10%	50V	
C13	1-163-059-00	CERAMIC CHIP 0.01MF	10%	50V	
C14	1-124-434-00	ELECT 220MF	20%	4V	
C15	1-163-189-00	CERAMIC CHIP 220PF	5%	50V	
C16	1-102-973-00	CERAMIC 100PF	5%	50V	
C17	1-101-888-00	CERAMIC 68PF	5%	50V	
C18	1-101-884-00	CERAMIC 56PF	5%	50V	
C19	1-161-013-00	CERAMIC 0.01MF	10%	25V	
C20	1-102-914-00	CERAMIC 130PF	5%	50V	
C21	1-162-330-00	CERAMIC MELF 5.6PF	10%	50V	
C22	1-101-884-00	CERAMIC 56PF	5%	50V	
C23	1-102-529-00	CERAMIC 100PF	10%	50V	
C24	1-102-529-00	CERAMIC 100PF	10%	50V	
C25	1-162-306-31	CERAMIC 0.01MF	10%	50V	
C26	1-124-430-00	ELECT 22MF	20%		
C27	1-131-387-00	TANTAL 47MF	20%	6.3V	
C28	1-131-393-00	TANTAL 47MF	20%	3.15V	
C29	1-102-942-00	CERAMIC 5PF	0.5PF	50V	
C30	1-102-960-00	CERAMIC 24PF	5%	50V	
C31	1-102-883-00	CERAMIC 27PF	5%	50V	
C32	1-162-331-00	CERAMIC MELF 6.8PF	10%	50V	
C33	1-163-073-00	CERAMIC CHIP 0.022MF		50V	
C35	1-163-059-00	CERAMIC 0.01MF	10%	50V	
C36	1-123-616-00	ELECT 4.7MF	20%	25V	
C37	1-163-181-00	CERAMIC CHIP 100PF	10%	50V	
C38	1-163-059-00	CERAMIC CHIP 0.01MF	10%	50V	
C39	1-163-059-00	CERAMIC CHIP 0.01MF	10%	50V	
C40	1-123-610-00	ELECT 0.47MF	20%	50V	
C41	1-123-616-00	ELECT 4.7MF	20%	25V	

## ELECTRICAL PARTS

Ref.No.	Part No.	Description			
C42	1-123-617-00	ELECT 10MF	20%	16V	
C43	1-163-073-00	CERAMIC CHIP 0.022MF		50V	
C44	1-123-618-00	ELECT 22MF	20%	6.3V	
C45	1-131-388-00	TANTAL 68MF	20%	6.3V	
C46	1-124-413-00	ELECT 220MF	20%	4V	
C47	1-163-828-00	CERAMIC CHIP 0.056MF	10%	50V	
C48	1-124-434-00	ELECT 220MF	20%	4V	
C49	1-163-828-00	CERAMIC CHIP 0.056MF	10%	50V	
C50	1-123-610-00	ELECT 0.47MF	20%	50V	
C51	1-123-610-00	ELECT 0.47MF	20%	50V	
C52	1-161-013-00	CERAMIC 0.01MF	10%	25V	
C53	1-161-013-00	CERAMIC 0.01MF	10%	25V	
C54	1-123-618-00	ELECT 22MF	20%	6.3V	
C55	1-123-607-00	ELECT 0.1MF	20%	50V	
C56	1-163-059-00	CERAMIC CHIP 0.01MF	10%	50V	
C57	1-131-479-00	TANTAL 0.047MF	20%	16	
C58	1-124-413-00	ELECT 220MF	20%	4V	
C59	1-163-148-00	CERAMIC CHIP 1.5PF	20%	50V	
C60	1-124-413-00	ELECT 220MF	20%	4V	
C61	1-163-059-00	CERAMIC CHIP 0.01MF	10%	50V	
C62	1-101-884-00	CERAMIC 56PF	5%	50V	
C101	1-163-059-00	CERAMIC CHIP 0.01MF	5%	50V	
C102	1-163-205-00	CERAMIC CHIP 0.001MF	5%	50V	
C103	1-163-205-00	CERAMIC CHIP 0.001MF	5%	50V	
C104	1-163-205-00	CERAMIC CHIP 0.001MF	5%	50V	
C105	1-163-205-00	CERAMIC CHIP 0.001MF	5%	50V	
C106	1-163-205-00	CERAMIC CHIP 0.001MF	5%	50V	
C107	1-163-205-00	CERAMIC CHIP 0.001MF	5%	50V	
CF1	1-567-097-61	FILTER, CERAMIC			
CFA1	1-567-312-11	FILTER, CERAMIC			
CFA2	1-527-982-00	FILTER, CERAMIC			
CFF1	1-567-097-61	FILTER, CERAMIC			
CT1	1-141-311-11	CAP, VAR, TRIMMER			
CT5	1-141-290-00	CAP, FILM TRIMMER			
CV1-5	1-151-480-11	CAP, TUNING, POLYETHYLEN			
CT2-4	1-151-480-11	CAP, TUNING, POLYETHYLEN			
D1	8-719-104-15	DIODE 1T26N			
D2	8-719-911-19	DIODE 1SS119			
D3	8-719-911-19	DIODE 1SS119			
D4	8-719-104-15	DIODE 1T26N			
D5	8-719-104-15	DIODE 1T26N			
D6	8-719-911-19	DIODE 1SS119			
D7	8-719-911-19	DIODE 1SS119			
D8	8-719-911-19	DIODE 1SS119			
D9	8-719-901-44	DIODE SLP1448			

### NOTE:

- The mechanical parts with no reference number in the exploded views are not supplied.
- Items marked " \* " are not stocked since they are seldom required for routine service. Some delay should be anticipated when ordering these items.
- If there are two or more same circuits in a set such as a stereophonic machine, only typical circuit parts may be indicated and capacitors and resistors in other same circuits may be omitted.

### CAPACITORS:

All capacitors are in  $\mu\text{F}$ . Common capacitors are omitted. Refer to the following lists for their part numbers.  
MF:  $\mu\text{F}$ , PF:  $\mu\text{PF}$ .

### COILS

MMH : mH, UH :  $\mu\text{H}$

### SEMICONDUCTORS

In each case, U :  $\mu$ , for example:  
UA... :  $\mu\text{A}$ ..., UPA... :  $\mu\text{PA}$ ..., UPC... :  $\mu\text{PC}$ ,  
UPD... :  $\mu\text{PD}$ ...

## ELECTRICAL PARTS

Ref.No.	Part No.	Description
D10	8-719-911-19	DIODE 1SS119
D11	8-719-911-19	DIODE 1SS119
D12	8-719-911-19	DIODE 1SS119
D15	8-719-100-34	DIODE RD5.6EB1
D101	8-719-100-05	DIODE 1S2837
D102	8-719-100-05	DIODE 1S2837
D103	8-719-104-37	DIODE SR506D3
D104	8-719-104-37	DIODE SR506D3
D105	8-719-104-37	DIODE SR506D3
D106	8-719-100-05	DIODE 1S2837
D107	8-719-100-05	DIODE 1S2837
D108	8-719-911-19	DIODE 1SS119
D109	8-719-911-19	DIODE 1SS119
D110	8-719-100-34	DIODE RD5.6EB1
IC1	8-752-009-10	IC CX20091
IC101	8-759-201-60	IC TC40H002F
IC102	8-759-201-60	IC TC40H002F
J1	1-507-921-00	JACK
J2	1-507-850-00	JACK, EXTENTION POWER
L1	1-402-127-11	COIL (ANT)
L2	1-402-126-11	COIL (ANT)
L3	1-406-053-00	COIL (OSC)
L4	1-402-125-11	COIL (ANT)
L5	1-406-082-11	COIL, OSCILLATION
L6	1-402-025-00	COIL (ANT)
L7	1-402-124-00	COIL (ANT)
L8	1-410-008-00	MICRO INDUCTOR 0.82UH
L9	1-410-026-00	MICRO INDUCTOR 27UH
L10	1-410-018-00	MICRO INDUCTOR 5.6UH
L11	1-410-015-00	MICRO INDUCTOR 3.3UH
L12	1-402-122-11	ANTENNA, FERRITE-ROD (MM)
L13	1-459-435-00	COIL (WITH CORE)
L14	1-459-418-00	COIL (WITH CORE)
L15	1-405-989-00	COIL, OSC
L16	1-425-607-00	COIL, AIR-CORE QF TYPE
Q1	8-729-119-35	TRANSISTOR 2SK193-K
Q2	8-769-162-00	TRANSISTOR 2SK152-2
Q3	8-729-119-35	TRANSISTOR 2SK193-K
Q4	8-729-100-66	TRANSISTOR 2SC1623
Q5	8-729-100-66	TRANSISTOR 2SC1623
Q6	8-729-102-08	TRANSISTOR 2SC2223-F14
Q7	8-729-102-08	TRANSISTOR 2SC2223-F14
Q8	8-729-271-22	TRANSISTOR 2SC2712-G
Q9	8-729-102-08	TRANSISTOR 2SC2223-F14

## ELECTRICAL PARTS

Ref.No.	Part No.	Description
Q10	8-729-100-66	TRANSISTOR 2SC1623
Q11	8-729-100-66	TRANSISTOR 2SC1623
Q101	8-729-216-22	TRANSISTOR 2SA1162-G
Q102	8-729-216-22	TRANSISTOR 2SA1162-G
Q103	8-729-162-45	TRANSISTOR 2SB624-BV5
Q104	8-729-216-22	TRANSISTOR 2SA1162-G
R1	1-249-001-00	CARBON MELF 1 5% 1/6W
R2	1-247-799-00	CARBON 47 5% 1/6W
R3	1-247-825-00	CARBON 560 5% 1/6W
R4	1-247-839-00	CARBON 2.2K 5% 1/6W
R5	1-247-879-00	CARBON 100K 5% 1/6W
R6	1-247-841-00	CARBON 2.7K 5% 1/6W
R7	1-247-807-00	CARBON 100 5% 1/6W
R8	1-247-819-00	CARBON 330 5% 1/6W
R9	1-247-819-00	CARBON 330 5% 1/6W
R10	1-247-795-00	CARBON 33 5% 1/6W
R11	1-247-857-00	CARBON 12K 5% 1/6W
R12	1-247-807-00	CARBON 100 5% 1/6W
R13	1-247-855-00	CARBON 10K 5% 1/6W
R14	1-247-855-00	CARBON 10K 5% 1/6W
R15	1-247-827-00	CARBON 680 5% 1/6W
R16	1-247-831-00	CARBON 1K 5% 1/6W
R17	1-247-865-00	CARBON 27K 5% 1/6W
R18	1-247-847-00	CARBON 4.7K 5% 1/6W
R19	1-247-847-00	CARBON 4.7K 5% 1/6W
R20	1-247-831-00	CARBON 1K 5% 1/6W
R21	1-247-873-00	CARBON 56K 5% 1/6W
R22	1-247-823-00	CARBON 470 5% 1/6W
R23	1-247-839-00	CARBON 2.2K 5% 1/6W
R24	1-247-863-00	CARBON 22K 5% 1/6W
R25	1-247-831-00	CARBON 1K 5% 1/6W
R26	1-247-831-00	CARBON 1K 5% 1/6W
R27	1-247-791-00	CARBON 22 5% 1/6W
R29	1-247-811-00	CARBON 150 5% 1/6W
R30	1-247-889-00	CARBON 270K 5% 1/6W
R31	1-247-839-00	CARBON 2.2K 5% 1/6W
R32	1-247-887-00	CARBON 220K 5% 1/6W
R33	1-247-831-00	CARBON 1K 5% 1/6W
R34	1-247-879-00	CARBON 100K 5% 1/6W
R35	1-247-877-00	CARBON 82K 5% 1/6W
R36	1-247-851-00	CARBON 6.8K 5% 1/6W
R37	1-247-851-00	CARBON 6.8K 5% 1/6W
R38	1-247-867-00	CARBON 33K 5% 1/6W
R39	1-247-879-00	CARBON 100K 5% 1/6W
R40	1-247-839-00	CARBON 2.2K 5% 1/6W

### NOTE:

- The mechanical parts with no reference number in the exploded views are not supplied.
- Items marked " \* " are not stocked since they are seldom required for routine service. Some delay should be anticipated when ordering these items.
- If there are two or more same circuits in a set such as a stereophonic machine, only typical circuit parts may be indicated and capacitors and resistors in other same circuits may be omitted.

### CAPACITORS:

All capacitors are in  $\mu\text{F}$ . Common capacitors are omitted. Refer to the following lists for their part numbers.  
MF:  $\mu\text{F}$ , PF:  $\mu\text{pF}$ .

### COILS

MMH: mH, UH:  $\mu\text{H}$

### SEMICONDUCTORS

In each case, U:  $\mu$ , for example:  
UA:  $\mu\text{A}$ , UPA:  $\mu\text{PA}$ , UPC:  $\mu\text{PC}$ ,  
UPD:  $\mu\text{PD}$

ELECTRICAL PARTS

Ref.No.	Part No.	Description			
R41	1-247-831-00	CARBON	1K	5%	1/6W
R42	1-247-843-00	CARBON	3.3K	5%	1/6W
R46	1-247-893-00	CARBON	390K	5%	1/6W
R47	1-247-843-00	CARBON	3.3K	5%	1/6W
R48	1-247-835-00	CARBON	1.5K	5%	1/6W
R101	1-249-001-00	CARBON MELF	1	5%	1/5W
R102	1-249-001-00	CARBON MELF	1	5%	1/5W
R103	1-247-801-00	CARBON	56	5%	1/6W
R104	1-249-001-00	CARBON MELF	1	5%	1/5W
R105	1-247-875-00	CARBON	68K	5%	1/6W
R106	1-247-863-00	CARBON	22K	5%	1/6W
R107	1-247-825-00	CARBON	560	5%	1/6W
R108	1-247-825-00	CARBON	560	5%	1/6W
R109	1-247-839-00	CARBON	2.2K	5%	1/6W
R110	1-247-875-00	CARBON	68K	5%	1/6W
R111	1-247-879-00	CARBON	100K	5%	1/6W
R112	1-249-001-00	CARBON MELF	1	5%	1/5W
R113	1-247-879-00	CARBON	100K	5%	1/6W
R114	1-249-001-00	CARBON MELF	1	5%	1/5W
R115	1-247-879-00	CARBON	100K	5%	1/6W
R116	1-247-879-00	CARBON	100K	5%	1/6W
R117	1-249-001-00	CARBON MELF	1	5%	1/5W
R118	1-249-001-00	CARBON MELF	1	5%	1/5W
R119	1-249-001-00	CARBON MELF	1	5%	1/5W
R120	1-247-879-00	CARBON	100K	5%	1/6W
R121	1-247-879-00	CARBON	100K	5%	1/6W
R122	1-249-001-00	CARBON MELF	1	5%	1/5W
R123	1-249-001-00	CARBON MELF	1	5%	1/5W
R124	1-249-001-00	CARBON MELF	1	5%	1/5W
S1	1-554-979-11	SWITCH, SLIDE (SW BAND)			
S2	1-554-123-00	SWITCH, SLIDE (TONE)			
S101	1-554-978-11	SWITCH, KEY BOARD (OFF)			
S102	1-554-978-11	SWITCH, KEY BOARD (FM)			
S103	1-554-978-11	SWITCH, KEY BOARD (MW)			
S104	1-554-978-11	SWITCH, KEY BOARD (SW)			
S105	1-553-510-00	SWITCH, SLIDE (SAFETY)			
SP	1-503-397-11	SPEAKER			

ELECTRICAL PARTS

Ref.No.	Part No.	Description
T1	1-404-578-11	TRANSFORMER, IFT
T2	1-404-362-00	TRANSFORMER, IF
T3	1-404-362-00	TRANSFORMER, IF
T4	1-405-992-00	COIL, OSC
VR1	1-230-071-00	RES, VAR, CARBON 20K
X1	1-567-314-11	VIBRATOR, CRYSTAL
X2	1-567-315-11	VIBRATOR, CRYSTAL
X3	1-567-316-11	VIBRATOR, CRYSTAL
X4	1-567-317-11	VIBRATOR, CRYSTAL
X5	1-567-318-11	VIBRATOR, CRYSTAL
X6	1-567-319-11	VIBRATOR, CRYSTAL
X7	1-567-320-11	VIBRATOR, CRYSTAL

NOTE:

- The mechanical parts with no reference number in the exploded views are not supplied.
- Items marked " \* " are not stocked since they are seldom required for routine service. Some delay should be anticipated when ordering these items.
- If there are two or more same circuits in a set such as a stereophonic machine, only typical circuit parts may be indicated and capacitors and resistors in other same circuits may be omitted.

CAPACITORS:

- All capacitors are in  $\mu\text{F}$ . Common capacitors are omitted. Refer to the following lists for their part numbers.
- MF:  $\mu\text{F}$ , PF:  $\mu\text{F}$ .

COILS

- MMH : mH, UH :  $\mu\text{H}$

SEMICONDUCTORS

- In each case, U :  $\mu$ , for example:
- UA... :  $\mu\text{A}$ ..., UPA... :  $\mu\text{PA}$ ..., UPC... :  $\mu\text{PC}$ ,
- UPD... :  $\mu\text{PD}$ ...



ICF-4900/4910

ICF-4900/4910

# SERVICE MANUAL

## SUPPLEMENT

File this supplement with the Service Manual.

Subject: Circuit Change

- Schematic and mounting diagrams have been changed.
- Applicable Serial No.

US, Canadian Model: 205,251 and later  
AEP Model: 209,351 and later  
G-AEP Model: 194,251 and later  
UK Model: 194,851 and later  
E Model: 198,451 and later

*AEP Model*  
*UK Model*  
*E Model*

*ICF-4900*

*US Model*  
*Canadian Model*

*ICF-4910*

No. 1

FM/MW/SW 9BAND RECEIVER  
**SONY**<sup>®</sup>

TR

# ICF-4900/4910 ICF-4900/4910

## 1. MOUNTING DIAGRAM

### • Semiconductor Location

Ref. No.	Location
D1	A-9
D2	B-6
D3	B-6
D4	C-8
D5	C-8
D6	B-4
D7	B-4
D8	D-8
D9	E-7
D10	C-5
D11	C-5
D12	C-10
D15	C-3
D101	G-4
D102	F-4
D103	H-1
D104	H-2
D105	H-4
D106	F-3
D107	F-5
D108	G-6
D109	G-6
D110	G-3
IC1	D-3
IC101	F-5
IC102	F-4
Q1	B-6
Q2	B-5
Q3	B-5
Q4	C-8
Q5	C-8
Q6	C-6
Q7	B-2
Q8	C-4
Q9	D-2
Q10	C-5
Q11	C-9
Q101	G-5
Q102	G-5
Q103	G-6
Q104	G-3

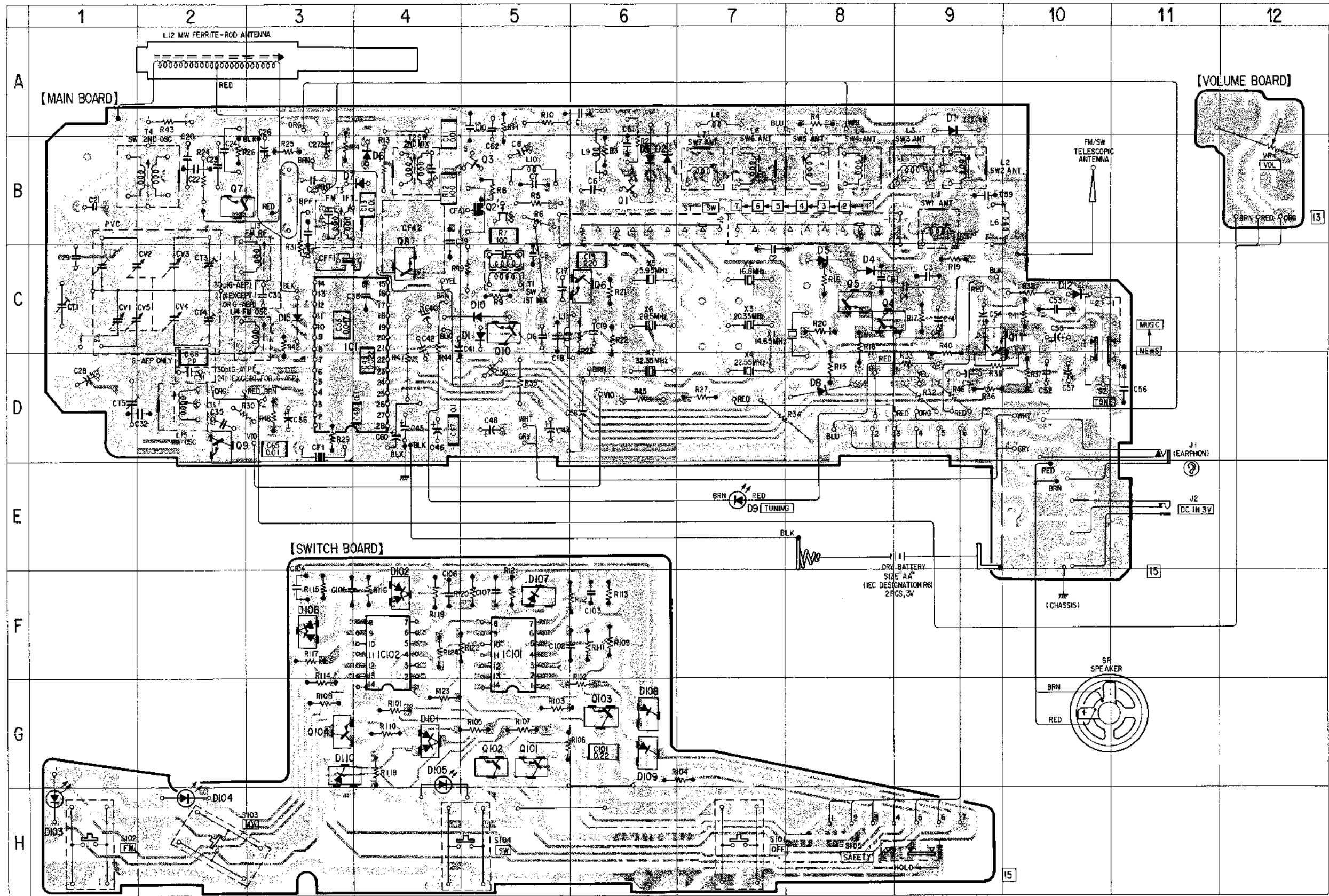

# ICF-4900/4910 ICF-4900/4910

## 2. SCHEMATIC DIAGRAM

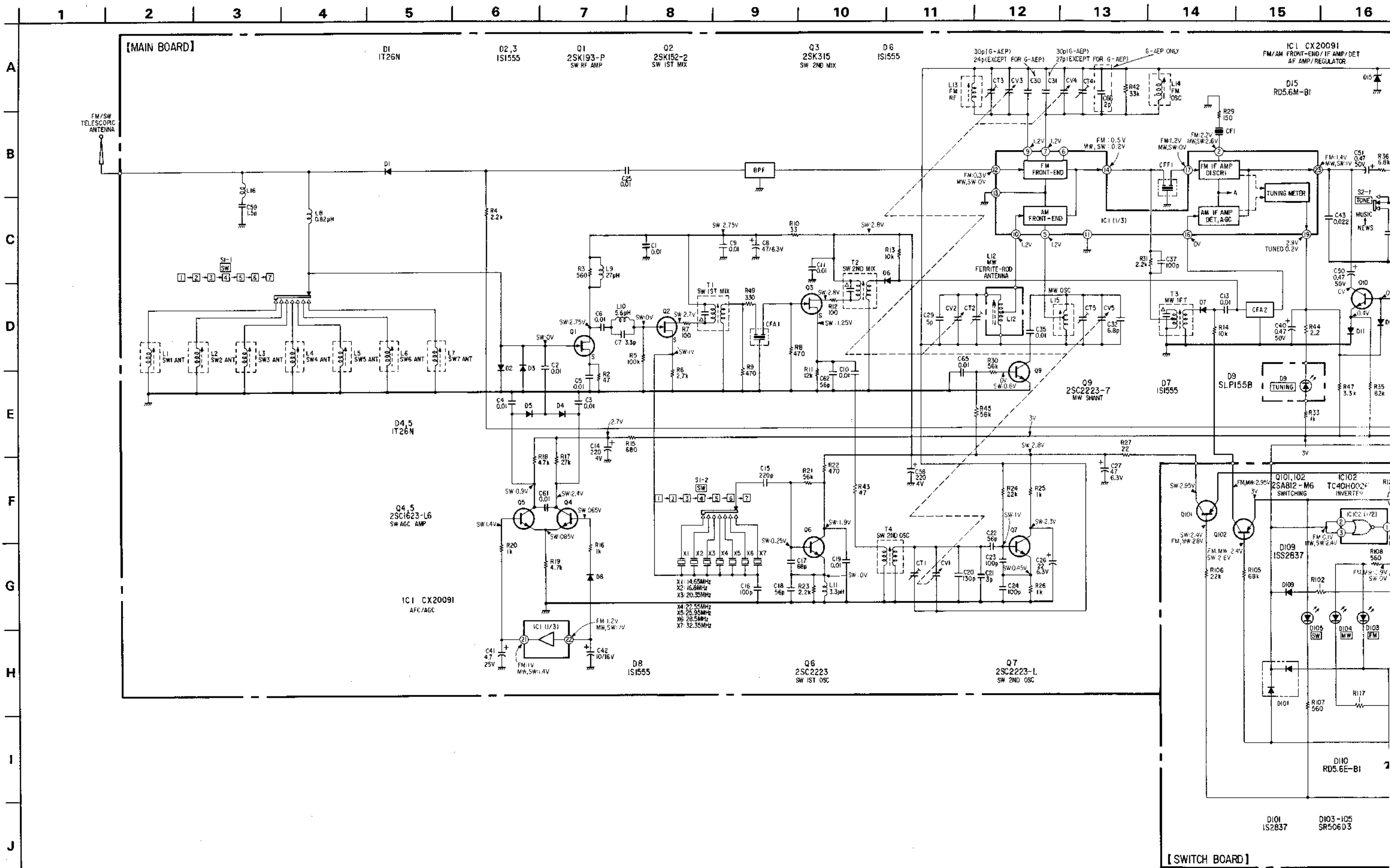

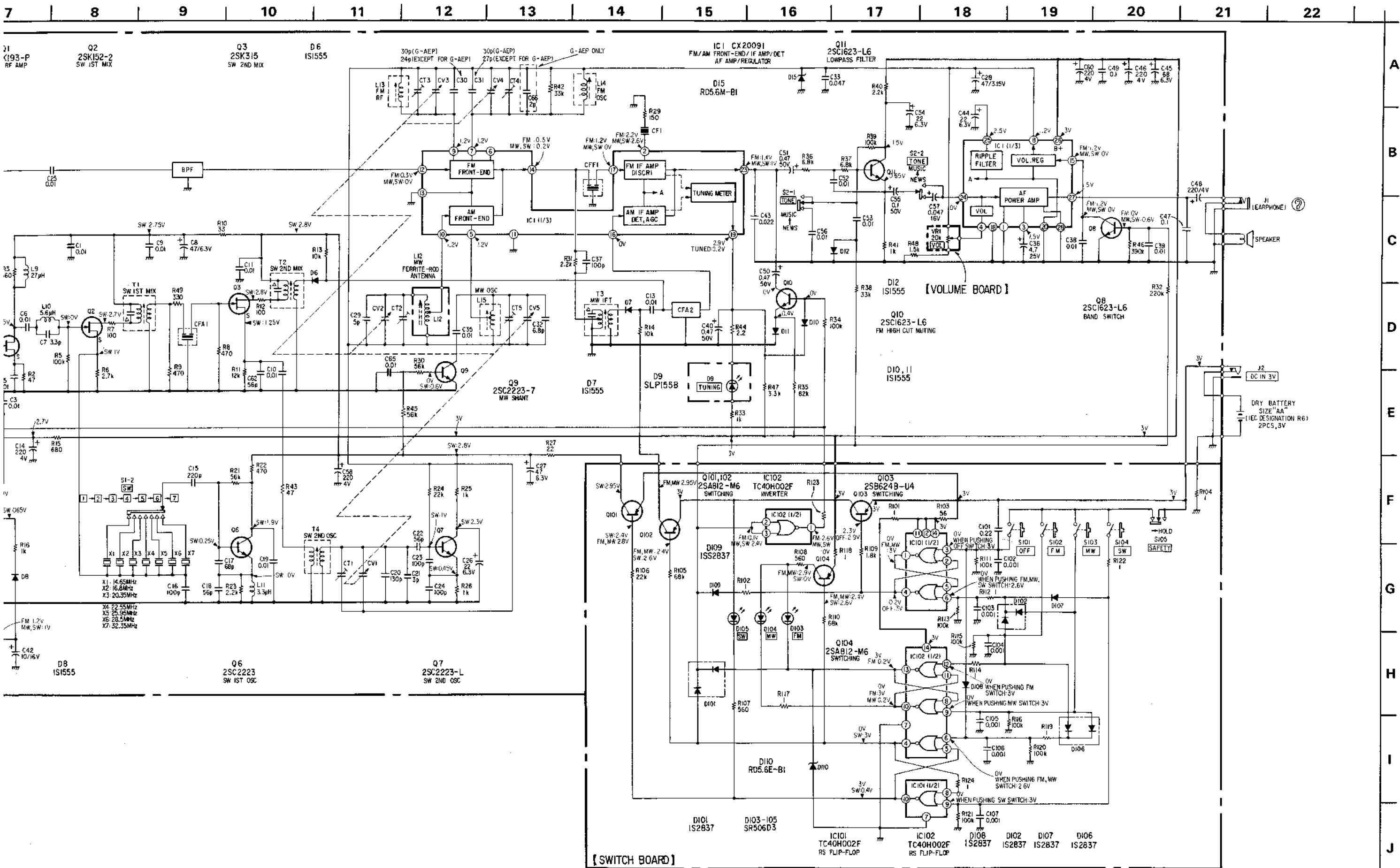



3. ELECTRICAL PARTS LIST

NOTE:

Items marked " \* " are not stocked since they are seldom required for routine service. Some delay should be anticipated when ordering these items.  
If there are two or more same circuits in a set such as a stereophonic machine, only typical circuit parts may be indicated and capacitors and resistors in other same circuits may be omitted.

CAPACITORS:

MF:µF, PF:µµF.

RESISTORS

All resistors are in ohms.  
F : nonflammable

COILS

MMH : mH, UH : µH

SEMICONDUCTORS

In each case, U : V, for example:  
UA...: µA..., UPA...: µPA..., UPC...: µPC,  
UPD...: µPD...

ELECTRICAL PARTS		
Ref.No.	Part No.	Description
501	1-501-323-11	ANTENNA, TELESCOPIC
502	*1-613-378-15	PC BOARD, SWITCH
503	*1-613-379-11	PC BOARD, VOL
504	*A-3660-525-A	(EXCEPT FOR G-AEP)...MOUNTED PCB, MAIN
	*A-3660-555-A	(G-AEP)...MOUNTED PCB, MAIN
BPF	1-235-171-00	FILTER, BAND PASS
C1	1-163-059-00	CERAMIC MELF 0.01MF 30% 16V
C2	1-163-059-00	CERAMIC MELF 0.01MF 30% 16V
C3	1-163-059-00	CERAMIC MELF 0.01MF 30% 16V
C4	1-161-379-00	CERAMIC 0.01MF 30% 16V
C5	1-163-059-00	CERAMIC MELF 0.01MF 30% 16V
C6	1-151-013-00	CERAMIC 0.01MF 10% 25V
C7	1-162-327-00	CERAMIC MELF 3.3PF 10% 50V
C8	1-131-387-00	TANTALUM 47MF 10% 6.3V
C9	1-163-059-00	CERAMIC MELF 0.01MF 30% 16V
C10	1-163-059-00	CERAMIC MELF 0.01MF 30% 16V
C11	1-163-059-00	CERAMIC CHIP 0.01MF 10% 50V
C13	1-163-021-00	CERAMIC CHIP 0.01MF 10% 50V
C14	1-124-434-00	ELECT 220MF 20% 4V
C15	1-163-189-00	CERAMIC CHIP 220PF 5% 50V
C16	1-102-973-00	CERAMIC 100PF 5% 50V
C17	1-101-888-00	CERAMIC 68PF 5% 50V
C18	1-163-175-00	CERAMIC MELF 56PF 5% 50V
C19	1-161-013-00	CERAMIC 0.01MF 10% 25V
C20	1-102-914-00	CERAMIC 130PF 5% 50V
C21	1-102-936-00	CERAMIC 3PF 0.5PF 50V
C22	1-163-175-00	CERAMIC MELF 56PF 5% 50V
C23	1-102-529-00	CERAMIC 100PF 5% 50V
C24	1-102-529-00	CERAMIC 100PF 5% 50V
C25	1-161-013-00	CERAMIC 0.01MF 10% 25V
C26	1-124-638-11	ELECT 22MF 20% 6.3V
C27	1-131-387-00	TANTALUM 47MF 10% 6.3V
C28	1-131-393-00	TANTALUM 47MF 10% 3.15V
C29	1-102-942-00	CERAMIC 5PF 0.5PF 50V
C30	1-102-960-00	(EXCEPT FOR G-AEP)...CERAMIC 24PF 5% 50V
C30	1-102-962-00	(G-AEP)...CERAMIC 30PF 5% 50V
C31	1-102-961-00	(EXCEPT FOR G-AEP)...CERAMIC 27PF 5% 50V
C31	1-102-673-00	(G-AEP)...CERAMIC 30PF 5% 50V
C32	1-162-331-00	CERAMIC MELF 6.8PF 10% 50V
C33	1-163-035-00	CERAMIC CHIP 0.047MF 10% 25V
C35	1-161-013-00	CERAMIC 0.01MF 10% 25V
C36	1-124-245-00	ELECT 4.7MF 20% 25V
C37	1-163-181-00	CERAMIC MELF 100PF 10% 50V
C38	1-163-059-00	CERAMIC MELF 0.01MF 30% 16V
C39	1-163-059-00	CERAMIC MELF 0.01MF 30% 16V

ELECTRICAL PART		
Ref.No.	Part No.	Description
C40	1-124-465-00	ELECT 0.47MF 20% 50V
C41	1-124-245-00	ELECT 4.7MF 20% 25V
C42	1-123-617-00	ELECT 10MF 20% 16V
C43	1-163-063-00	CERAMIC CHIP 0.022MF 50V
C44	1-124-638-11	ELECT 22MF 20% 6.3V
C45	1-131-388-00	TANTALUM 68MF 10% 6.3V
C46	1-124-434-00	ELECT 220MF 20% 4V
C47	1-163-077-00	CERAMIC CHIP 0.1MF 10% 25V
C48	1-124-434-00	ELECT 220MF 20% 4V
C49	1-163-077-00	CERAMIC CHIP 0.1MF 10% 25V
C50	1-124-465-00	ELECT 0.47MF 20% 50V
C51	1-124-465-00	ELECT 0.47MF 20% 50V
C52	1-161-013-00	CERAMIC 0.01MF 10% 25V
C53	1-163-059-00	CERAMIC MELF 0.01MF 30% 16V
C54	1-124-638-11	ELECT 22MF 20% 6.3V
C55	1-124-463-00	ELECT 0.1MF 20% 50V
C56	1-163-059-00	CERAMIC MELF 0.01MF 30% 16V
C57	1-131-479-00	TANTALUM 0.047MF 20% 16V
C58	1-124-413-00	ELECT 220MF 20% 4V
C59	1-163-148-00	CERAMIC MELF 1.5PF 20% 50V
C60	1-124-413-00	ELECT 220MF 20% 4V
C61	1-163-059-00	CERAMIC MELF 0.01MF 30% 16V
C62	1-101-884-00	CERAMIC 56PF 5% 50V
C65	1-163-021-00	CERAMIC CHIP 0.01MF 10% 50V
C66	1-163-149-00	(G-AEP)...CERAMIC CHIP 2PF 0.25PF 50V
C101	1-163-081-00	CERAMIC CHIP 0.22MF 25V
C102	1-163-205-00	CERAMIC MELF 0.001MF 10% 50V
C103	1-163-205-00	CERAMIC MELF 0.001MF 10% 50V
C104	1-163-205-00	CERAMIC MELF 0.001MF 10% 50V
C105	1-163-205-00	CERAMIC MELF 0.001MF 10% 50V
C106	1-163-205-00	CERAMIC MELF 0.001MF 10% 50V
C107	1-163-205-00	CERAMIC MELF 0.001MF 10% 50V
CF1	1-567-097-61	FILTER, CERAMIC
CFA1	1-567-561-11	FILTER, CERAMIC
CFA2	1-527-982-00	FILTER, CERAMIC
CFF1	1-567-097-61	FILTER, CERAMIC
CT1	1-141-311-11	CAP, VAR, TRIMMER
CT5	1-141-290-11	CAP, VAR FILM TRIMMER
CT2-4	1-151-480-11	CAP, TUNING, POLYETHYLEN
CV1-5	1-151-480-11	CAP, TUNING, POLYETHYLEN
D1	8-719-104-15	DIODE 1T26N
D2	8-719-815-55	DIODE 1S1555
D3	8-719-815-55	DIODE 1S1555
D4	8-719-104-15	DIODE 1T26N

ELECTRICAL PART		
Ref.No.	Part No.	Description
D5	8-719-104-15	DIODE 1T26N
D6	8-719-911-19	DIODE 1SS119
D7	8-719-911-19	DIODE 1SS119
D8	8-719-815-55	DIODE 1S1555
D9	8-719-901-44	DIODE SLP144B
D10	8-719-911-19	DIODE 1SS119
D11	8-719-911-19	DIODE 1SS119
D12	8-719-911-19	DIODE 1SS119
D15	8-719-109-88	DIODE RD5.6ES-B1
D101	8-719-100-05	DIODE 1S2837
D102	8-719-100-05	DIODE 1S2837
D103	8-719-104-37	DIODE SR506D3
D104	8-719-104-37	DIODE SR506D3
D105	8-719-104-37	DIODE SR506D3
D106	8-719-100-05	DIODE 1S2837
D107	8-719-100-05	DIODE 1S2837
D108	8-719-100-05	DIODE 1S2837
D109	8-719-100-05	DIODE 1S2837
D110	8-719-105-91	DIODE RD5.6M-B2
IC1	8-752-009-10	IC CX20091
IC101	8-759-201-60	IC TC40H002F
IC102	8-759-201-60	IC TC40H002F
J1	1-507-921-00	JACK
J2	1-507-850-00	JACK, EXTENTION POWER
L1	1-402-127-11	COIL (ANT)
L2	1-402-126-11	COIL (ANT)
L3	1-406-053-00	COIL (OSC)
L4	1-402-125-11	COIL (ANT)
L5	1-406-082-11	COIL, OSCILLATION
L6	1-402-025-00	COIL (ANT)
L7	1-402-124-11	COIL (ANT)
L8	1-410-360-11	MICRO INDUCTOR 0.82UH
L9	1-410-363-11	MICRO INDUCTOR 27UH
L10	1-410-325-11	MICRO INDUCTOR 5.6UH
L11	1-410-322-11	MICRO INDUCTOR 3.3UH
L12	1-402-122-11	ANTENNA, FERRITE-ROD (MM)
L13	1-459-435-00	COIL (WITH CORE)
L14	1-459-418-00	COIL (WITH CORE)
L15	1-405-989-00	COIL, OSC
L16	*1-425-607-00	COIL, AIR-CORE QF TYPE
Q1	8-729-119-35	TRANSISTOR 2SK193-K
Q2	8-769-162-00	TRANSISTOR 2SK152-2
Q3	8-729-802-66	TRANSISTOR 2SK315-F
Q4	8-729-100-66	TRANSISTOR 2SC1623
Q5	8-729-100-66	TRANSISTOR 2SC1623
Q6	8-729-102-06	TRANSISTOR 2SC2223

ELECTRICAL PART		
Ref.No.	Part No.	Description
Q7	8-729-102-06	TRANSISTOR 2SC2223
Q8	8-729-271-22	TRANSISTOR 2SC2712-G
Q9	8-729-102-06	TRANSISTOR 2SC2223
Q10	8-729-100-66	TRANSISTOR 2SC1623
Q11	8-729-100-66	TRANSISTOR 2SC1623
Q101	8-729-100-76	TRANSISTOR 2SA812
Q102	8-729-100-76	TRANSISTOR 2SA812
Q103	8-729-162-44	TRANSISTOR 2SB624-BV4
Q104	8-729-100-76	TRANSISTOR 2SA812
R2	1-249-401-11	CARBON 47 5% 1/6W
R3	1-249-414-11	CARBON MELF 560 5% 1/5W
R4	1-249-421-11	CARBON MELF 2.2K 5% 1/5W
R5	1-249-441-11	CARBON 100K 5% 1/6W
R6	1-249-422-11	CARBON 2.7K 5% 1/6W
R7	1-216-025-00	METAL CHIP 100 5% 1/10W
R8	1-249-413-11	CARBON MELF 470 5% 1/5W
R9	1-249-413-11	CARBON MELF 470 5% 1/5W
R10	1-249-399-11	CARBON 33 5% 1/6W
R11	1-249-430-11	CARBON MELF 12K 5% 1/5W
R12	1-216-174-00	METAL CHIP 100 5% 1/8W
R13	1-249-429-11	CARBON 10K 5% 1/6W
R14	1-249-429-11	CARBON MELF 10K 5% 1/5W
R15	1-249-035-00	CARBON MELF 680 5% 1/5W
R16	1-249-417-11	CARBON MELF 1K 5% 1/5W
R17	1-249-434-11	CARBON MELF 27K 5% 1/5W
R18	1-249-425-11	CARBON MELF 4.7K 5% 1/5W
R19	1-249-425-11	CARBON MELF 4.7K 5% 1/5W
R20	1-249-417-11	CARBON MELF 1K 5% 1/5W
R21	1-249-438-11	CARBON MELF 56K 5% 1/5W
R22	1-249-413-11	CARBON MELF 470 5% 1/5W
R23	1-249-421-11	CARBON MELF 2.2K 5% 1/5W
R24	1-249-433-11	CARBON 22K 5% 1/6W
R25	1-249-417-11	CARBON MELF 1K 5% 1/5W
R26	1-249-417-11	CARBON MELF 1K 5% 1/5W
R27	1-249-397-11	CARBON MELF 22 5% 1/5W
R29	1-249-407-11	CARBON MELF 150 5% 1/5W
R30	1-249-438-11	CARBON 56K 5% 1/6W
R31	1-249-421-11	CARBON 2.2K 5% 1/6W
R32	1-247-887-00	CARBON 220K 5% 1/6W
R33	1-249-417-11	CARBON 1K 5% 1/6W
R34	1-249-441-11	CARBON 100K 5% 1/6W
R35	1-249-440-11	CARBON 82K 5% 1/6W
R36	1-249-427-11	CARBON MELF 6.8K 5% 1/5W
R37	1-249-427-11	CARBON MELF 6.8K 5% 1/5W
R38	1-249-435-11	CARBON 33K 5% 1/6W

ELECTRICAL PART

Ref.No.	Part No.	Description
D5	8-719-104-15	DIODE 1T26N
D6	8-719-911-19	DIODE 1SS119
D7	8-719-911-19	DIODE 1SS119
D8	8-719-815-55	DIODE 1S1555
D9	8-719-901-44	DIODE SLP144B
D10	8-719-911-19	DIODE 1SS119
D11	8-719-911-19	DIODE 1SS119
D12	8-719-911-19	DIODE 1SS119
D15	8-719-109-88	DIODE RD5.6ES-B1
D101	8-719-100-05	DIODE 1S2837
D102	8-719-100-05	DIODE 1S2837
D103	8-719-104-37	DIODE SR50603
D104	8-719-104-37	DIODE SR50603
D105	8-719-104-37	DIODE SR50603
D106	8-719-100-05	DIODE 1S2837
D107	8-719-100-05	DIODE 1S2837
D108	8-719-100-05	DIODE 1S2837
D109	8-719-100-05	DIODE 1S2837
D110	8-719-105-91	DIODE RD5.6M-B2
IC1	8-752-009-10	IC CX20091
IC101	8-759-201-60	IC TC40H002F
IC102	8-759-201-60	IC TC40H002F
J1	1-507-921-00	JACK
J2	1-507-850-00	JACK, EXTENTION POWER
L1	1-402-127-11	COIL (ANT)
L2	1-402-126-11	COIL (ANT)
L3	1-406-053-00	COIL (OSC)
L4	1-402-125-11	COIL (ANT)
L5	1-406-082-11	COIL, OSCILLATION
L6	1-402-025-00	COIL (ANT)
L7	1-402-124-11	COIL (ANT)
L8	1-410-360-11	MICRO INDUCTOR 0.82UH
L9	1-410-363-11	MICRO INDUCTOR 27UH
L10	1-410-325-11	MICRO INDUCTOR 5.6UH
L11	1-410-322-11	MICRO INDUCTOR 3.3UH
L12	1-402-122-11	ANTENNA, FERRITE-ROD (MW)
L13	1-459-435-00	COIL (WITH CORE)
L14	1-459-418-00	COIL (WITH CORE)
L15	1-405-989-00	COIL, OSC
L16	*1-425-607-00	COIL, AIR-CORE QF TYPE
Q1	8-729-119-35	TRANSISTOR 2SK193-K
Q2	8-769-162-00	TRANSISTOR 2SK152-2
Q3	8-729-802-66	TRANSISTOR 2SK315-F
Q4	8-729-100-66	TRANSISTOR 2SC1623
Q5	8-729-100-66	TRANSISTOR 2SC1623
Q6	8-729-102-06	TRANSISTOR 2SC2223

ELECTRICAL PART

Ref.No.	Part No.	Description
Q7	8-729-102-06	TRANSISTOR 2SC2223
Q8	8-729-271-22	TRANSISTOR 2SC2712-G
Q9	8-729-102-06	TRANSISTOR 2SC2223
Q10	8-729-100-66	TRANSISTOR 2SC1623
Q11	8-729-100-66	TRANSISTOR 2SC1623
Q101	8-729-100-76	TRANSISTOR 2SA812
Q102	8-729-100-76	TRANSISTOR 2SA812
Q103	8-729-162-44	TRANSISTOR 2SB624-BV4
Q104	8-729-100-76	TRANSISTOR 2SA812
R2	1-249-401-11	CARBON 47 5% 1/6W
R3	1-249-414-11	CARBON MELF 560 5% 1/5W
R4	1-249-421-11	CARBON MELF 2.2K 5% 1/5W
R5	1-249-441-11	CARBON 100K 5% 1/6W
R6	1-249-422-11	CARBON 2.7K 5% 1/6W
R7	1-216-025-00	METAL CHIP 100 5% 1/10W
R8	1-249-413-11	CARBON MELF 470 5% 1/5W
R9	1-249-413-11	CARBON MELF 470 5% 1/5W
R10	1-249-399-11	CARBON 33 5% 1/6W
R11	1-249-430-11	CARBON MELF 12K 5% 1/5W
R12	1-216-174-00	METAL CHIP 100 5% 1/8W
R13	1-249-429-11	CARBON 10K 5% 1/6W
R14	1-249-429-11	CARBON MELF 10K 5% 1/5W
R15	1-249-035-00	CARBON MELF 680 5% 1/5W
R16	1-249-417-11	CARBON MELF 1K 5% 1/5W
R17	1-249-434-11	CARBON MELF 27K 5% 1/5W
R18	1-249-425-11	CARBON MELF 4.7K 5% 1/5W
R19	1-249-425-11	CARBON MELF 4.7K 5% 1/5W
R20	1-249-417-11	CARBON MELF 1K 5% 1/5W
R21	1-249-438-11	CARBON MELF 56K 5% 1/5W
R22	1-249-413-11	CARBON MELF 470 5% 1/5W
R23	1-249-421-11	CARBON MELF 2.2K 5% 1/5W
R24	1-249-433-11	CARBON 22K 5% 1/6W
R25	1-249-417-11	CARBON MELF 1K 5% 1/5W
R26	1-249-417-11	CARBON MELF 1K 5% 1/5W
R27	1-249-397-11	CARBON MELF 22 5% 1/5W
R29	1-249-407-11	CARBON MELF 150 5% 1/5W
R30	1-249-438-11	CARBON 56K 5% 1/6W
R31	1-249-421-11	CARBON 2.2K 5% 1/6W
R32	1-247-887-00	CARBON 220K 5% 1/6W
R33	1-249-417-11	CARBON 1K 5% 1/6W
R34	1-249-441-11	CARBON 100K 5% 1/6W
R35	1-249-440-11	CARBON 82K 5% 1/6W
R36	1-249-427-11	CARBON MELF 6.8K 5% 1/5W
R37	1-249-427-11	CARBON MELF 6.8K 5% 1/5W
R38	1-249-435-11	CARBON 33K 5% 1/6W

ELECTRICAL PART

Ref.No.	Part No.	Description
R39	1-249-441-11	CARBON 100K 5% 1/6W
R40	1-249-421-11	CARBON MELF 2.2K 5% 1/5W
R41	1-249-417-11	CARBON MELF 1K 5% 1/5W
R42	1-249-423-11	CARBON MELF 3.3K 5% 1/5W
R43	1-249-401-11	CARBON 47 5% 1/6W
R44	1-249-385-11	CARBON 2.2 5% 1/6W
R45	1-247-873-00	CARBON 56K 5% 1/6W
R46	1-215-483-00	CARBON 390K 5% 1/6W
R47	1-249-423-11	CARBON 3.3K 5% 1/6W
R48	1-249-419-11	CARBON MELF 1.5K 5% 1/5W
R49	1-249-411-11	CARBON 330 5% 1/6W
R101	1-249-001-00	CARBON MELF 1 5% 1/5W
R102	1-249-001-00	CARBON MELF 1 5% 1/5W
R103	1-249-402-11	CARBON MELF 56 5% 1/5W
R104	1-249-001-00	CARBON MELF 1 5% 1/5W
R105	1-249-439-11	CARBON MELF 68K 5% 1/5W
R106	1-249-433-11	CARBON MELF 22K 5% 1/5W
R107	1-249-414-11	CARBON MELF 560 5% 1/5W
R108	1-249-414-11	CARBON MELF 560 5% 1/5W
R109	1-249-420-11	CARBON MELF 1.8K 5% 1/5W
R110	1-249-439-11	CARBON MELF 68K 5% 1/5W
R111	1-249-441-11	CARBON MELF 100K 5% 1/5W
R112	1-249-001-00	CARBON MELF 1 5% 1/5W
R113	1-249-441-11	CARBON MELF 100K 5% 1/5W
R114	1-249-001-00	CARBON MELF 1 5% 1/5W
R115	1-249-441-11	CARBON MELF 100K 5% 1/5W
R116	1-249-441-11	CARBON MELF 100K 5% 1/5W
R117	1-249-001-00	CARBON MELF 1 5% 1/5W
R118	1-249-001-00	CARBON MELF 1 5% 1/5W
R119	1-249-001-00	CARBON MELF 1 5% 1/5W
R120	1-249-441-11	CARBON MELF 100K 5% 1/5W
R121	1-249-441-11	CARBON MELF 100K 5% 1/5W
R122	1-249-001-00	CARBON MELF 1 5% 1/5W
R123	1-249-001-00	CARBON MELF 1 5% 1/5W
R124	1-249-001-00	CARBON MELF 1 5% 1/5W

ELECTRICAL PART

Ref.No.	Part No.	Description
S1	1-554-979-11	SWITCH, SLIDE (SW BAND)
S2	1-554-123-00	SWITCH, SLIDE (TONE)
S101	1-554-978-11	SWITCH, KEY BOARD (OFF)
S102	1-554-978-11	SWITCH, KEY BOARD (FM)
S103	1-554-978-11	SWITCH, KEY BOARD (MW)
S104	1-554-978-11	SWITCH, KEY BOARD (SW)
S105	1-553-510-00	SWITCH, SLIDE (SAFETY)
SP	1-503-282-00	SPEAKER
T1	1-404-578-11	TRANSFORMER, IFT
T2	1-404-362-41	TRANSFORMER, IF
T3	1-404-362-41	TRANSFORMER, IF
T4	1-405-992-00	COIL, OSC
VR1	1-230-071-00	RES, VAR, CARBON 20K
X1	1-567-314-11	VIBRATOR, CRYSTAL
X2	1-567-315-11	VIBRATOR, CRYSTAL
X3	1-567-316-11	VIBRATOR, CRYSTAL
X4	1-567-317-11	VIBRATOR, CRYSTAL
X5	1-567-318-11	VIBRATOR, CRYSTAL
X6	1-567-319-11	VIBRATOR, CRYSTAL
X7	1-567-320-11	VIBRATOR, CRYSTAL