

GV-D200/D200E/D800/D800E

SERVICE MANUAL

Self Diagnosis
Supported model

Ver 1.0 2000.09

Digital 8

InfoLITHIUM™
SERIES

VIDEO
WALKMAN



Photo : GV-D800E

US Model
Canadian Model
GV-D200/D800
AEP Model
UK Model
E Model
GV-D200E/D800E

B MECHANISM

NTSC MODEL : GV-D200/D800
PAL MODEL : GV-D200E/D800E
Function difference table

Model Function	GV-D200/200E	GV-D800/D800E
LCD	—	4.0 inches

For MECHANISM ADJUSTMENT, refer to the "8mm Video MECHANICAL ADJUSTMENT MANUAL VII" (9-973-801-11).

SPECIFICATIONS

VCR

System

Video recording system
2 rotary heads
Helical scanning system
Audio recording system
Rotary heads, PCM system
Quantization: 12 bits (Fs 32 kHz, stereo 1, stereo 2), 16 bits (Fs 48 kHz, stereo)
Video signal
GV-D200/D800:
NTSC color, EIA standards
GV-D200E/D800E:
PAL colour, CCIR standards
Recommended cassette
Hi8 Hi8i/Digital8 video cassette
Recording/playback time
(GV-D200/D800: using
120 min. Hi8 video cassette)
(GV-D200E/D800E: using
90 min. Hi8 (PAL) video cassette)
SP mode: 1 hour
LP mode: 1 hour and 30 minutes
Fastforward/rewind time
(GV-D200/D800: using
120 min. Hi8 video cassette)
(GV-D200E/D800E: using
90 min. Hi8 (PAL) video cassette)
Approx. 5 minutes and 15 seconds

Input/output connectors

S video input
4-pin mini DIN
Luminance signal: 1 Vp-p, 75 ohms, unbalanced
GV-D200/D800:
Chrominance signal: 0.286 Vp-p
GV-D200E/D800E:
Chrominance signal: 0.3 Vp-p, 75 ohms, unbalanced
S video output
4-pin mini DIN
Luminance signal: 1 Vp-p, 75 ohms, unbalanced
GV-D200/D800:
Chrominance signal: 0.286 Vp-p
GV-D200E/D800E:
Chrominance signal: 0.3 Vp-p, 75 ohms, unbalanced
Audio/Video input
AV MINIJACK
Video: 1 Vp-p, 75 ohms, unbalanced, sync negative
Audio: 327 mV, input impedance more than 47 kilohms
Video output
Phono jack, 1 Vp-p, 75 ohms, unbalanced, sync negative
Audio output
Phono jacks (2) 327 mV, output impedance less than 1 kilohm
RFU DC OUT
Special minijack DC 5 V

DV input/output
4-pin connector
Headphone jack
Stereo minijack (ø 3.5 mm)
LANC jack
Stereo mini-minijack (ø 2.5 mm)

LCD screen (GV-D800/D800E)

Picture
4.0 type
80.6 × 60.5 mm (3 1/4 × 2 1/2 in.)
Total dot number
123,200 (560 × 220)

General

Power requirements
7.2 V (battery pack)
8.4 V (AC power adaptor)
Average power consumption (when using the battery pack)
GV-D800/D800E only
During playback using LCD
4.9 W
During playing back when you close the LCD panel
3.0 W
Operating temperature
0 °C to 40 °C (32 °F to 104 °F)
Storage temperature
-20 °C to +60 °C (-4 °F to +140 °F)

Dimensions (Approx.)
GV-D200/D200E:
148 × 50 × 135 mm
(5 7/8 × 2 × 5 3/8 in.)
GV-D800/D800E:
148 × 65 × 135 mm
(5 7/8 × 2 5/8 × 5 3/8 in.) (w/h/d)
Mass (approx.)
GV-D200/D200E:
660 g (1 lb 7 oz)
GV-D800/D800E:
930 g (2 lb)
excluding the battery pack and cassette
Supplied accessories
See page 2.

AC power adaptor

Power requirements
100 - 240 V AC, 50/60 Hz
Power consumption
23 W
Output voltage
DC OUT: 8.4 V, 1.5 A in the operating mode
Operating temperature
0 °C to 40 °C (32 °F to 104 °F)
Storage temperature
-20 °C to +60 °C (-4 °F to +140 °F)

— Continued on next page —

DIGITAL VIDEO CASSETTE RECORDER

SONY®

Dimensions (approx.)

125 × 39 × 62 mm
 (5 × 1 9/16 × 2 1/2 in.) (w/h/d)
 excluding projecting parts

Mass (approx.)

280 g (9.8 oz) excluding power cord

Cord length (approx.)

Power cord: 2 m (6.6 feet)
 Connecting cord: 1.6 m (5.2 feet)

Design and specifications are subject
 to change without notice.

• SUPPLIED ACCESSORIES

Make sure that the following accessories are supplied with your VCR.

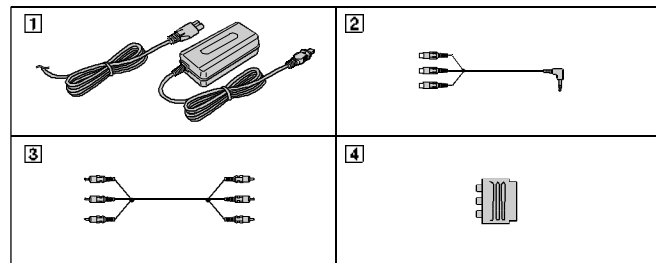

1 AC-L10A/L10B/L10C AC power adaptor (1),
 Mains lead (1)

3 A/V connecting cable (1)

2 A/V converting cable (1)

4 21-pin adaptor (1)
 GV-D200E/D800E only

SAFETY-RELATED COMPONENT WARNING!!

COMPONENTS IDENTIFIED BY MARK \triangle OR DOTTED LINE WITH MARK \triangle ON THE SCHEMATIC DIAGRAMS AND IN THE PARTS LIST ARE CRITICAL TO SAFE OPERATION. REPLACE THESE COMPONENTS WITH SONY PARTS WHOSE PART NUMBERS APPEAR AS SHOWN IN THIS MANUAL OR IN SUPPLEMENTS PUBLISHED BY SONY.

ATTENTION AU COMPOSANT AYANT RAPPORT À LA SÉCURITÉ!

LES COMPOSANTS IDENTIFIÉS PAR UNE MARQUE \triangle SUR LES DIAGRAMMES SCHÉMATIQUES ET LA LISTE DES PIÈCES SONT CRITIQUES POUR LA SÉCURITÉ DE FONCTIONNEMENT. NE REMPLACER CES COMPOSANTS QUE PAR DES PIÈCES SONY DONT LES NUMÉROS SONT DONNÉS DANS CE MANUEL OU DANS LES SUPPLÉMENTS PUBLIÉS PAR SONY.

SAFETY CHECK-OUT

After correcting the original service problem, perform the following safety checks before releasing the set to the customer.

1. Check the area of your repair for unsoldered or poorly-soldered connections. Check the entire board surface for solder splashes and bridges.
2. Check the interboard wiring to ensure that no wires are "pinched" or contact high-wattage resistors.
3. Look for unauthorized replacement parts, particularly transistors, that were installed during a previous repair. Point them out to the customer and recommend their replacement.
4. Look for parts which, through functioning, show obvious signs of deterioration. Point them out to the customer and recommend their replacement.
5. Check the B+ voltage to see it is at the values specified.
6. Flexible Circuit Board Repairing
 - Keep the temperature of the soldering iron around 270°C during repairing.
 - Do not touch the soldering iron on the same conductor of the circuit board (within 3 times).
 - Be careful not to apply force on the conductor when soldering or unsoldering.

TABLE OF CONTENTS

SERVICE NOTE

1. POWER SUPPLY DURING REPAIRS	6
2. TO TAKE OUT A CASSETTE WHEN NOT EJECT (FORCE EJECT) (1)	6
3. TO TAKE OUT A CASSETTE WHEN NOT EJECT (FORCE EJECT) (2) (TO TAKE OUT A CASSETTE WITHOUT HURTING THE TAPE)	7

SELF-DIAGNOSIS FUNCTION

1. SELF-DIAGNOSIS FUNCTION	8
2. SELF-DIAGNOSIS DISPLAY	8
3. SERVICE MODE DISPLAY	8
3-1. Display Method	8
3-2. Switching of Backup No.	8
3-3. End of Display	8
4. SELF-DIAGNOSIS CODE TABLE	9

1. GENERAL

Getting started	
Using this manual	1-1
Checking supplied accessories	1-1
Step 1 Preparing the power supply	1-1
Connecting to the mains	1-1
Using with a battery pack (not supplied)	1-2
Step 2 Inserting a cassette	1-2
Basic operations	
Playing back a tape	1-3
Viewing the recording on TV	1-4
Recording from the other VCR or TV	1-5
Advanced operations	
Enlarging playback images – PB ZOOM	1-6
Watching a tape with special effects – Picture effect	1-7
Watching a tape with special performances – Digital effect ..	1-7
Quickly locating a scene – Zero set memory	1-8
Searching with recording date – Date search	1-8
Searching for a photo – Photo search/Photo scan	1-9
Displaying recording data and screen indicators	
– Data code function	1-9
Superimposing a title	1-10
Making your own titles	1-10
Editing	
Dubbing a tape	1-11
Dubbing only desired scenes – Digital program editing	1-12
Using with an analogue video unit and a personal computer	
– Signal convert function	1-15
Inserting a scene from the other (playback) VCR	
– Insert Editing	1-15
Customizing your VCR	
Changing the menu settings	1-16
Resetting the date and time	1-17
Additional information	
Digital8 F system, recording, and playback	1-18
About i.LINK	1-19
Troubleshooting	1-19
Self-diagnosis display	1-20
Warning indicators and messages	1-20
Using your VCR abroad	1-21
Maintenance information and precautions	1-21
Quick reference	
Identifying the parts and controls	1-22

2. DISASSEMBLY

2-1. CASSETTE LID ASSEMBLY	2-2
2-2. BOTTOM CABINET ASSEMBLY, FP-571 FLEXIBLE BOARD (LITHIUM BATTERY)	2-2
2-3. LCD CABINET ASSEMBLY (D800, D800E MODEL) ..	2-3

2-4. PD-130, LS-56 BOARDS (D800, D800E MODEL)	2-4
2-5. LCD WINDOW CABINET ASSEMBLY (SP-901, 902) (D800, D800E MODEL)	2-5
2-6. BATTERY PANEL ASSEMBLY, BATTERY TERMINAL BOARD, DC-IN CONNECTOR	2-6
2-7. VC-250, FU-145 BOARDS	2-6
2-8. CONTROL SWITCH BLOCK (FK-78), LOADING LID ..	2-7
2-9. MECHANISM DECK, MAIN FRAME ASSEMBLY ..	2-7
2-10. CABINET (R) BLOCK ASSEMBLY, JACK FRAME (IO-68, IR-38 BOARDS)	2-8
2-11. EX-36 BOARD, FP-570 FLEXIBLE BOARD	2-9
2-12. UPPER CABINET ASSEMBLY, LCD BLOCK ASSEMBLY (D800, D800E MODEL)	2-9
2-13. HINGE UNIT, FP-569 FLEXIBLE BOARD (D800, D800E MODEL)	2-10
2-14. CIRCUIT BOARDS LOCATION	2-12
2-15. FLEXIBLE BOARDS LOCATION	2-13

3. BLOCK DIAGRAMS

3-1. OVERALL BLOCK DIAGRAM (1/4)	3-1
3-2. OVERALL BLOCK DIAGRAM (2/4)	3-3
3-3. OVERALL BLOCK DIAGRAM (3/4)	3-5
3-4. OVERALL BLOCK DIAGRAM (4/4)	3-7
3-5. POWER BLOCK DIAGRAM (1/2)	3-9
3-6. POWER BLOCK DIAGRAM (2/2)	3-11

4. PRINTED WIRING BOARDS AND SCHEMATIC DIAGRAMS

4-1. FRAME SCHEMATIC DIAGRAM (1/2)	4-1
FRAME SCHEMATIC DIAGRAM (2/2)	4-3
4-2. PRINTED WIRING BOARDS AND SCHEMATIC DIAGRAMS	4-5
• VC-250 (REC/PB AMP, DAC, DV INTERFACE, AD CONVERTER, Y/C PROCESSOR, LINE A/D, LINE I/O, IR, AUDIO I/O, DRUM/CAPSTAN MOTOR DRIVE, MECHA CONTROL, HI CONTROL, DC/DC CONVERTER, CONNECTION) PRINTED WIRING BOARD	4-7
• VC-250 (REC/PB AMP)(1/16) SCHEMATIC DIAGRAM	4-11
• VC-250 (PB AMP, DAC)(2/16) SCHEMATIC DIAGRAM	4-13
• VC-250 (DV INTERFACE)(3/16) SCHEMATIC DIAGRAM	4-15
• VC-250 (DV INTERFACE)(4/16) SCHEMATIC DIAGRAM	4-17
• VC-250 (AD CONVERTER)(5/16) SCHEMATIC DIAGRAM	4-19
• VC-250 (Y/C PROCESSOR)(6/16) SCHEMATIC DIAGRAM	4-21
• VC-250 (LINE A/D)(7/16) SCHEMATIC DIAGRAM	4-23
• VC-250 (LINE IN/OUT)(8/16) SCHEMATIC DIAGRAM	4-25
• VC-250 (IR)(9/16) SCHEMATIC DIAGRAM	4-27
• VC-250 (MECHANISM CONTROL)(10/16) SCHEMATIC DIAGRAM	4-29
• VC-250 (AUDIO I/O)(11/16) SCHEMATIC DIAGRAM	4-31
• VC-250 (DRUM/CAPSTAN MOTOR DRIVE)(12/16) SCHEMATIC DIAGRAM	4-33
• VC-250 (MECHA CONTROL)(13/16) SCHEMATIC DIAGRAM	4-35
• VC-250 (HI CONTROL)(14/16) SCHEMATIC DIAGRAM	4-37

• VC-250 (DC/DC CONVERTER)(15/16)	
SCHEMATIC DIAGRAM	4-39
• VC-250 (CONNECTION)(16/16)	
SCHEMATIC DIAGRAM	4-41
• FP-575 (LANC), IO-68 (AV IN/OUT)	
PRINTED WIRING BOARDS	4-43
• IO-68 (AV IN/OUT)	
SCHEMATIC DIAGRAM	4-45
• FU-145 (DC/DC CONVERTER)	
PRINTED WIRING BOARD	4-47
• FU-145 (DC/DC CONVERTER)	
SCHEMATIC DIAGRAM	4-49
• PD-130 (LCD DRIVER, BACK-LIGHT)	
PRINTED WIRING BOARD	4-51
• LS-56 (LCD SWITCH)	
PRINTED WIRING BOARD	4-54
• PD-130 (LCD DRIVER, BACK-LIGHT)(1/2)	
SCHEMATIC DIAGRAM	4-55
• PD-130 (BACK-LIGHT)(2/2)	
SCHEMATIC DIAGRAM	4-57
• IR-38 (IR TRANSMITTER),	
CONTROL SWITCH BLOCK (FK-78)	
PRINTED WIRING BOARDS	4-59
• CONTROL SWITCH BLOCK (FK-78)	
SCHEMATIC DIAGRAM	4-61
• EX-36 (MULTI CONNECTOR)	
PRINTED WIRING BOARD	4-63
• EX-36 (MULTI CONNECTOR)	
SCHEMATIC DIAGRAM	4-65
• FP-571 (BATTERY), FP-249 (S/T REEL)	
PRINTED WIRING BOARDS	4-67
4-3. WAVEFORMS	4-68
4-4. MOUNTED PARTS LOCATION	4-70

5. ADJUSTMENTS

1. Before starting adjustment	5-1
1-1. Adjusting items when replacing main parts and boards	5-2
5-1. ADJUSTMENT PREPARATIONS	5-3
1-1. PREPARATIONS BEFORE ADJUSTMENT	5-3
1-1-1. List of Service Tools	5-3
5-2. MECHANISM SECTION ADJUSTMENT	5-4
2-1. Hi8/STANDARD8 MODE	5-4
2-1-1. OPERATING WITHOUT CASSETTE	5-4
2-1-2. TAPE PATH ADJUSTMENT	5-4
1. Preparations for Adjustment	5-4
2-2. DIGITAL8 MODE	5-5
2-2-1. HOW TO ENTER RECORD MODE WITHOUT CASSETTE	5-5
2-2-2. HOW TO ENTER PLAYBACK MODE WITHOUT CASSETTE	5-5
2-2-3. OVERALL TAPE PATH CHECK	5-5
1. Recording of the tape path check signal	5-5
2. Tape path check	5-5
5-3. ELECTRICAL ADJUSTMENT	5-6
3-1. PREPARATIONS BEFORE ADJUSTMENTS	5-6
3-1-1. Equipment to Required	5-6
3-1-2. Precautions on Adjusting	5-7
3-1-3. Adjusting Connectors	5-7
3-1-4. Connecting the Equipment	5-8
3-1-5. Alignment Tape	5-9
3-1-6. Input/output Level and Impedance	5-10
3-2. INITIALIZATION OF C, D, E, F, 7, 8 PAGE DATA	5-11
3-2-1. INITIALIZATION OF C, D, 8 PAGE DATA	5-11
1. Initializing the C, D, 8 Page Data	5-11
2. Modification of C, D, 8 Page Data	5-11
3. C Page Table	5-11
4. D Page Table	5-12
5. 8 Page Table	5-13
3-2-2. INITIALIZATION OF E, F, 7 PAGE DATA	5-14
1. Initializing the E, F, 7 Page Data	5-14
2. Modification of E, F, 7 Page Data	5-14
3. F Page Table	5-14
4. E Page Table	5-15
5. 7 Page Table	5-16
3-3. SYSTEM CONTROL SYSTEM ADJUSTMENT	5-17
1. Serial No. Input	5-17
1-1. Company ID Input	5-17
1-2. Serial No. Input	5-17
2. Battery End Adjustment	5-19
3-4. SERVO AND RF SYSTEM ADJUSTMENT	5-20
1. REEL FG Adjustment (VC-250 Board)	5-20
2. PLL fo & LPF fo Pre-Adjustment (VC-250 Board)	5-20
3. Switching Position Adjustment (VC-250 Board)	5-21
4. AGC Center Level and APC & AEQ Adjustment	5-21
4-1. Preparations before adjustments	5-21
4-2. AGC Center Level Adjustment (VC-250 Board)	5-21
4-3. APC & AEQ Adjustment (VC-250 Board)	5-22
4-4. Processing after Completing Adjustments	5-22
5. PLL fo & LPF fo Final Adjustment (VC-250 Board)	5-23
6. Hi8/Standard8 Switching Position Adjustment (VC-250 Board)	5-23
7. CAP FG Offset Adjustment (VC-250 board)	5-24
3-5. VIDEO SYSTEM ADJUSTMENTS	5-25
1. 27MHz Origin Oscillation Adjustment (VC-250 board)	5-25
2. Chroma BPF fo Adjustment (VC-250 Board)	5-25
3. S VIDEO OUT Y Level Adjustment (VC-250 Board)	5-26
4. S VIDEO OUT Chroma Level Adjustment (VC-250 Board)	5-26
5. VIDEO OUT Y, Chroma Level Check (VC-250 Board)	5-27
6. Hi8/Standard8 Y/C Output Level Setting (VC-250 Board)	5-27
7. Hi8/standard 8mm AFC fo Adjustment (VC-250 board)	5-28
3-6. IR TRANSMITTER ADJUSTMENTS	5-29
1. IR Video Carrier Frequency Adjustment (VC-250 board)	5-29
2. IR Video Deviation Adjustment (VC-250 board)	5-29
3. IR Audio Deviation Adjustment (VC-250 board)	5-30
3-7. AUDIO SYSTEM ADJUSTMENTS	5-31
1. Hi8/Standard8 AFM BPF fo Adjustment (VC-250 board)	5-31
2. Hi8/Standard8 AFM 1.5 MHz Deviation Adjustment (VC-250 board)	5-32
3. Hi8/Standard8 AFM 1.7 MHz Deviation Adjustment (VC-250 board)	5-32
4. Digital8 Playback Level Check	5-32
5. Overall Level Characteristics Check	5-32
6. Overall Distortion Check	5-32
7. Overall Noise Level Check	5-33
8. Overall Separation Check	5-33
3-8. LCD SYSTEM ADJUSTMENT (GV-D800/D800E)	5-34
1. LCD Initial Data Input (1)	5-34
2. LCD Initial Data Input (2)	5-35
3. VCO Adjustment (PD-130 board)	5-35
4. RGB AMP Adjustment (PD-130 board)	5-36
5. Contrast Adjustment (PD-130 board)	5-36
6. COM AMP Adjustment (PD-130 board)	5-37
7. V-COM Adjustment (PD-130 board)	5-37
8. White Balance Adjustment (PD-130 board)	5-38
5-4. SERVICE MODE	5-39
4-1. ADJUSTMENT REMOTE COMMANDER	5-39
1. Using the Adjustment Remote Commander	5-39
2. Precautions Upon Using the Adjustment Remote Commander	5-39
4-2. DATA PROCESS	5-40
4-3. SERVICE MODE	5-41
1. Setting the Test Mode	5-41
2. Emergence Memory Address	5-41

2-1.	C Page Emergence Memory Address	5-41
2-2.	F Page Emergence Memory Address	5-42
2-3.	EMG Code (Emergency Code)	5-42
2-4.	MSW Code	5-43
3.	Bit Value Discrimination	5-44
4.	Switch check (1)	5-44
5.	Switch check (2)	5-44
6.	Switch check (3)	5-44
7.	Switch check (4)	5-45
8.	Record of Use check	5-45
9.	Record of Self-diagnosis check	5-46

6. REPAIR PARTS LIST

6-1.	EXPLODED VIEWS	6-1
6-1-1.	OVERALL SECTION-1	6-1
6-1-2.	OVERALL SECTION-2	6-2
6-1-3.	LCD SECTION (D800/D800E MODEL)	6-3
6-1-4.	MECHANISM SECTION	6-4
6-1-5.	CASSETTE COMPARTMENT ASSEMBLY	6-5
6-1-6.	LS CHASSIS ASSEMBLY	6-6
6-1-7.	MECHANISM CHASSIS ASSEMBLY	6-7
6-2.	ELECTRICAL PARTS LIST	6-8

SERVICE NOTE

1. POWER SUPPLY DURING REPAIRS

In this unit, about 10 seconds after power is supplied (8.4V) to the battery terminal using the service power code (J-6082-223-A), the power is shut off so that the unit cannot operate.

These following two methods are available to prevent this. Take note of which to use during repairs.

Method 1:

Connect the adjustment remote commander RM-95 (J-6082-053-B) to the LANC jack, and set the HOLD switch to the "ADJ" side.

Method 2:

Use the DC IN terminal. (Use the AC power adaptor. (AC-L10, AC-VQ800 etc.))

2. TO TAKE OUT A CASSETTE WHEN NOT EJECT (FORCE EJECT) (1)

- ① Remove the power supply (Battery or AC power adaptor).
- ② Push the EJECT switch and open the cassette lid.
- ③ Refer to 2-2. to remove the cabinet (lid) assembly.
- ④ Refer to 2-2. to remove the cabinet (bottom) assembly.
- ⑤ Add 5V from the regulated power supply between Pin ⑤, ⑥ of CN4401 (ULD5V +) and Pin ⑦, ⑧ of CN4401 (ULD5V -), and unload the cassette.

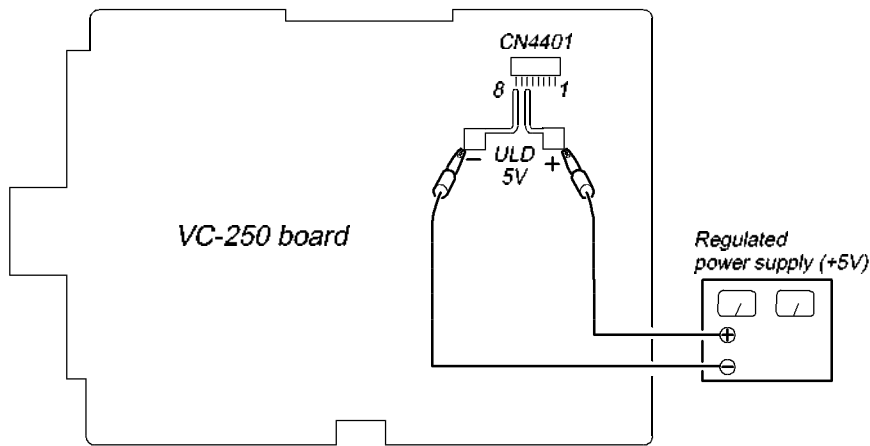

3. TO TAKE OUT A CASSETTE WHEN NOT EJECT (FORCE EJECT) (2) (TO TAKE OUT A CASSETTE WITHOUT HURTING THE TAPE)

- ① Disconnect the power supply (Battery or AC adaptor)
- ② Refer to 2-2. to remove the cabinet (lid) assembly.
- ③ Refer to 2-2. to remove the cabinet (bottom) assembly.
- ④ Refer to 2-1. to remove the Cassette (lid) assembly.
- ⑤ Refer to 2-6 to 2-8. to remove the LCD block (GV-D800/D800E only) and the cabinet (upper) assembly.
- ⑥ Remove the FU-145 board.
- ⑦ Refer to 2-9. to remove the lid frame assembly.
- ⑧ Add +5V from the regulated power supply and unload with a pressing the cassette lid.

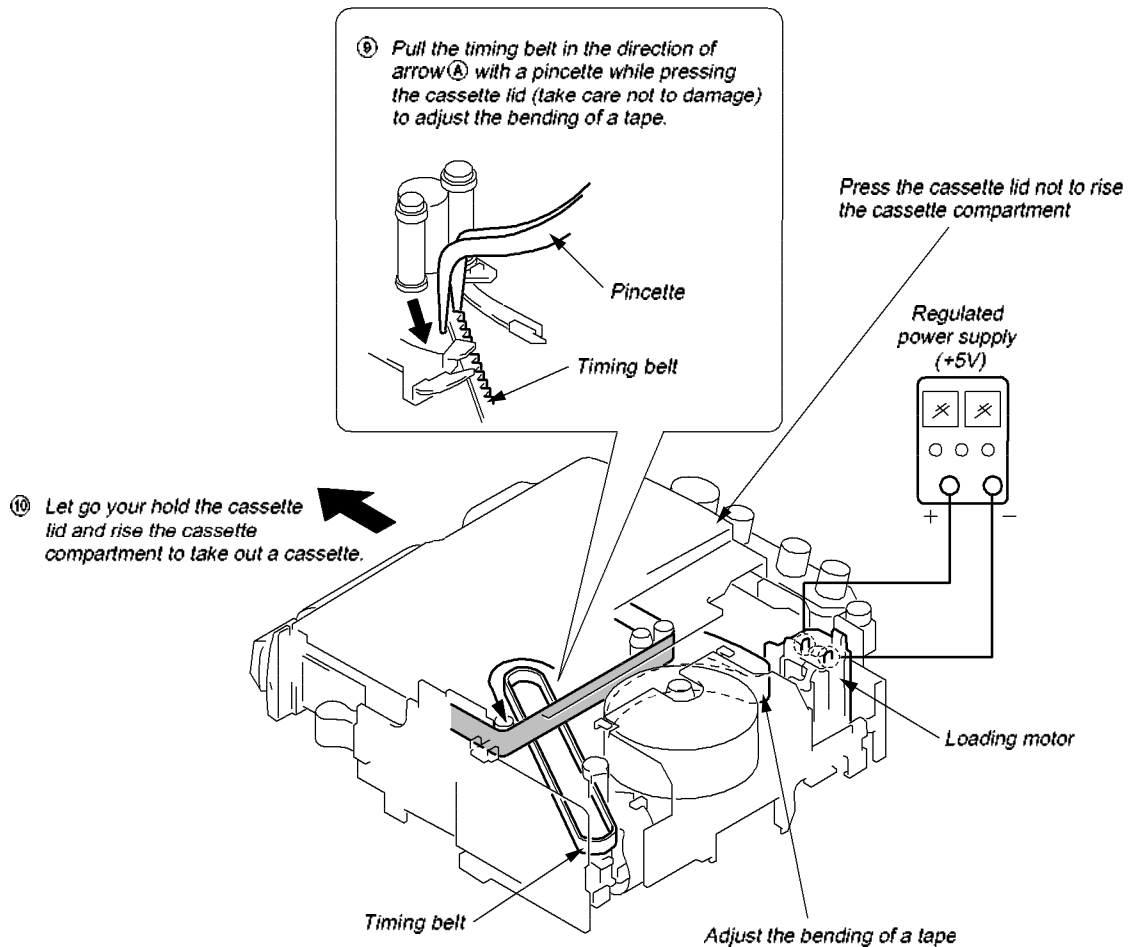

SELF-DIAGNOSIS FUNCTION

1. SELF-DIAGNOSIS FUNCTION

When problems occur while the unit is operating, the self-diagnosis function starts working, and displays on the LCD screen or monitor TV (Note) what to do. This function consists of two display; self-diagnosis display and service mode display.

Details of the self-diagnosis functions are provided in the Instruction manual.

LCD screen or monitor TV

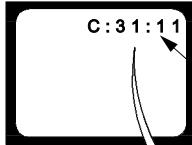

Blinks at 3.2Hz

C : 3 1 : 1 1

Repaired by:

Block

Detailed Code

C : Corrected by customer
H : Corrected by dealer
E : Corrected by service engineer

Indicates the appropriate step to be taken.
E.g.
31Reload the tape.
32Turn on power again.

Refer to page 9.
Self-diagnosis Code Table.

2. SELF-DIAGNOSIS DISPLAY

When problems occur while the unit is operating, the counter of the viewfinder shows a 4-digit display consisting of an alphabet and numbers, which blinks at 3.2 Hz. This 5-character display indicates the “repaired by:”, “block” in which the problem occurred, and “detailed code” of the problem.

Note: Set the DISPLAY in the menu system to V-OUT/LCD only for the model with LCD screen, and press the DISPLAY button.

3. SERVICE MODE DISPLAY

The service mode display shows up to six self-diagnosis codes shown in the past.

3-1. Display Method

While pressing the “STOP” key, set the POWER switch from OFF to ON, and continue pressing the “STOP” key for 10 seconds continuously. The service mode will be displayed, and the counter will show the backup No. and the 5-character self-diagnosis codes.

LCD screen or monitor TV



Lights up

[3]

C : 3 1 : 1 1

Backup No.

self-diagnosis codes

Order of previous errors

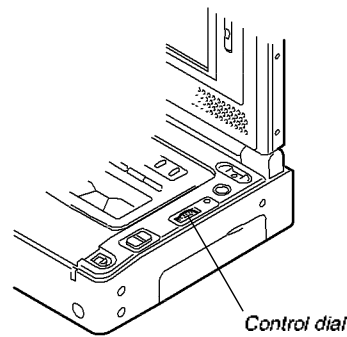

Control dial

3-2. Switching of Backup No.

By rotating the control dial, past self-diagnosis codes will be shown in order. The backup No. in the [] indicates the order in which the problem occurred. (If the number of problems which occurred is less than 6, only the number of problems which occurred will be shown.)

[1] : Occurred first time [4] : Occurred fourth time
[2] : Occurred second time [5] : Occurred fifth time
[3] : Occurred third time [6] : Occurred the last time

3-3. End of Display

Turning OFF the power supply will end the service mode display.

Note: The “self-diagnosis display” data will be backed up by the coin-type lithium battery of FP-571 flexible board. When this coin-type lithium battery is removed, the “self-diagnosis display” data will be lost by initialization.

4. SELF-DIAGNOSIS CODE TABLE

Self-diagnosis Code			Symptom/State	Correction
Repaired by:	Block Function	Detailed Code		
C	0 4	0 0	Non-standard battery is used.	Use the info LITHIUM battery.
C	2 1	0 0	Condensation.	Remove the cassette, and insert it again after one hour.
C	2 2	0 0	Video head is dirty.	Clean with the optional cleaning cassette.
C	3 1	1 0	LOAD direction. Loading does not complete within specified time	Load the tape again, and perform operations from the beginning.
C	3 1	1 1	UNLOAD direction. Loading does not complete within specified time	Load the tape again, and perform operations from the beginning.
C	3 1	2 0	T reel side tape slacking when unloading.	Load the tape again, and perform operations from the beginning.
C	3 1	2 1	Winding S reel fault when counting the rest of tape.	Load the tape again, and perform operations from the beginning.
C	3 1	2 2	T reel fault.	Load the tape again, and perform operations from the beginning.
C	3 1	2 3	S reel fault.	Load the tape again, and perform operations from the beginning.
C	3 1	2 4	T reel fault.	Load the tape again, and perform operations from the beginning.
C	3 1	3 0	FG fault when starting capstan.	Load the tape again, and perform operations from the beginning.
C	3 1	4 0	FG fault when starting drum.	Load the tape again, and perform operations from the beginning.
C	3 1	4 2	FG fault during normal drum operations.	Load the tape again, and perform operations from the beginning.
C	3 1	1 0	LOAD direction loading motor time-out.	Remove the battery or power cable, connect, and perform operations from the beginning.
C	3 1	1 1	UNLOAD direction loading motor time-out.	Remove the battery or power cable, connect, and perform operations from the beginning.
C	3 2	2 0	T reel side tape slacking when unloading.	Remove the battery or power cable, connect, and perform operations from the beginning.
C	3 2	2 1	Winding S reel fault when counting the rest of tape.	Remove the battery or power cable, connect, and perform operations from the beginning.
C	3 2	2 2	T reel fault.	Remove the battery or power cable, connect, and perform operations from the beginning.
C	3 2	2 3	S reel fault.	Remove the battery or power cable, connect, and perform operations from the beginning.
C	3 2	2 4	T reel fault.	Remove the battery or power cable, connect, and perform operations from the beginning.
C	3 2	3 0	FG fault when starting capstan.	Remove the battery or power cable, connect, and perform operations from the beginning.
C	3 2	4 0	FG fault when starting drum	Remove the battery or power cable, connect, and perform operations from the beginning.
C	3 2	4 2	FG fault during normal drum operations	Remove the battery or power cable, connect, and perform operations from the beginning.

SECTION 1
GENERAL

This section is extracted from instruction manual. (GV-D800E model)

— Getting started —
Using this manual

As you read through this manual, buttons and settings on your VCR are shown in capital letters, e.g. Set the POWER switch to ON.
When you carry out an operation, you can hear a beep sound to indicate that the operation is being carried out.

Before using your VCR

With your VCR, you can use Hi8 Hi8V Digital Hi-Fi video cassettes. Your VCR records and plays back pictures in the Digital Hi-Fi system. Also, your VCR plays back tapes recorded in the Hi8 Hi-Fi standard Hi-Fi analog system. However, you cannot use the functions in "Advanced Operations" on page 27 to 48 for playback in the Hi8 Hi-Fi standard Hi-Fi system. To enable smooth transition, we recommend that you do not mix pictures recorded in Hi8 Hi-Fi standard Hi-Fi with the Digital Hi-Fi system on a tape.

Note on TV colour systems

TV colour systems differ from country to country. To view your recordings on a TV, you need a PAL system-based TV.

Copyright precautions

Because programmes, films, video tapes, and other materials may be copyrighted, unauthorized recording of such materials may be contrary to the provision of the copyright laws.

— Подготовка к эксплуатации —
Использование данного руководства

При чтении данного руководства учитывайте, что кнопки и установки на видеомагнитофоне показаны заглавными буквами. Например: Установить переключатель POWER в положение ON.
При выполнении операции вы можете услышать звуковой сигнал, подтверждающий выполнение операции.

Перед первым использованием видеомагнитофона

Этот видеомагнитофон используется в видеокассетами Hi8 Hi8V Digital Hi-Fi. Он выполняет запись и воспроизведение изображений в системе Digital Hi-Fi. Кроме того, видеомагнитофон может воспроизводить кассеты, записанные в (аналоговой) системе Hi8 Hi-Fi standard Hi-Fi. Однако функции, описанные в разделе "Усовершенствованные операции" на стр. с. 27 по 48, нельзя использовать для воспроизведения в системе Hi8 Hi-Fi standard Hi-Fi. Для обеспечения плавного перевода на одной кассете рекомендуется не записывать изображения в различных системах. Не Hi8 Hi-Fi standard Hi-Fi и Digital Hi-Fi.

Системы цветного телевидения

Системы цветного телевидения различаются в зависимости от страны. Для просмотра записей на экране телевизора необходимо использовать телевизор на базе системы PAL.

Предостережение об авторском праве

Телепрограммы, программы, кинофильмы, видеокассеты и другие материалы могут быть защищены авторскими правами. Несанкционированная запись таких материалов может противоречить положениям закона об авторском праве.

Using this manual

Precautions on VCR care

- The LCD screen is manufactured using high-precision technology. However, there may be some tiny black points and/or bright points (red, blue, green or white) that constantly appear on the LCD screen. These points occur normally in the manufacturing process and do not affect the recorded picture in any way. Effective ratio of pixels and/or screen are 99.99% or more.
- Do not let your VCR get wet. Keep your VCR away from rain and sea water. Letting your VCR get wet may cause your VCR to malfunction. Sometimes this malfunction cannot be repaired [a].
- Never leave your VCR exposed to temperatures above 60°C (140°F), such as in a car parked in the sun or under direct sunlight [b].
- Do not place your VCR so as to point the LCD screen toward the sun. The inside of the LCD screen may be damaged [c].

Использование данного руководства

Меры предосторожности при уходе за видеомагнитофоном

- Экран ЖКД изготовлен с помощью высокоточной технологии. Однако на экране ЖКД могут постоянно появляться черные или белые точки (красные, синие, желтые или белые). Появление этих точек обычно связано с производственным процессом, и они абсолютно не влияют на записываемое изображение. Сильнее 99,99% экранов предназначено для эффективного использования.
- Не допускайте, чтобы видеомагнитофон стал влажным. Избегайте попадания на видеомагнитофон дождя и морской воды. Если Вы намоете видеомагнитофон, то это может привести к неисправности аппарата. Иногда неисправность устранить невозможно [а].
- Нельзя допускать, чтобы видеомагнитофон подвергался воздействию высоких температур, например, в автомобиле, паркованном в солнечном месте, или под лучами солнечного света [б].
- Не допускайте попадания прямых солнечных лучей на экран ЖКД. Иначе могут возникнуть повреждения изображения устройства экрана ЖКД [в].

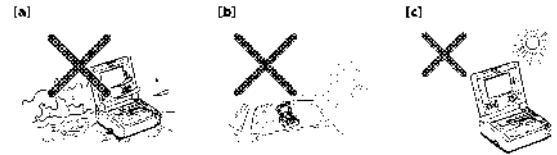

Contents of the recording cannot be compensated if recording or playback is not made due to a malfunction of the VCR, video tapes, etc.

Содержимое записываемой или воспроизводимой копии не может быть компенсировано, если запись или воспроизведение не получено из-за неисправности видеомагнитофона, видеокассеты и т.д.

5 6

Checking supplied accessories

Make sure that the following accessories are supplied with your VCR.

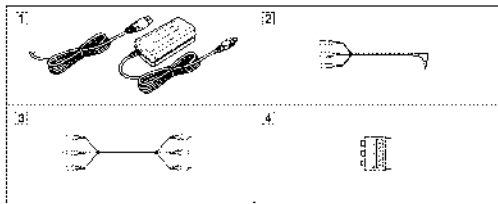

1 AC-L10A/L10B/L10C AC power adaptor (1). Mains lead (1) (стр. 8, 10)

2 A/V converting cable (1) (стр. 23, 62)

3 A/V connecting cable (1) (стр. 19, 23, 48, 62)

4 21-pin adaptor (1) (стр. 20)

Проверка прилагаемых принадлежностей

Убедитесь, что следующие принадлежности входят в комплект этого видеомагнитофона.

1 Сетевой адаптер переменного тока AC-L10A/L10B/L10C (1), провод электропитания (1) (стр. 8, 10)

2 Преобразовательный кабель аудио/видео (1) (стр. 23, 62)

3 Соединительный кабель аудио/видео (1) (стр. 19, 23, 48, 62)

4 21-штырьковый адаптер (1) (стр. 20)

Step 1 Preparing the power supply

Connecting to the mains

When you use your VCR for an extended period, we recommend that you power it from the mains using the AC power adaptor.

- Open the DC IN jack cover and connect the AC power adaptor to the DC IN jack of your VCR with the plug's ▲ mark facing left.
- Connect the mains lead to the AC power adaptor.
- Connect the mains lead to the mains.

Пункт 1 Подготовка источника питания

Подключение к сетевой розетке

При длительной эксплуатации видеомагнитофона рекомендуется использовать питание от электрической сети с помощью сетевого адаптера переменного тока.

- Откройте крышку гнезда DC IN и подсоедините сетевой адаптер переменного тока к гнезду DC IN, так чтобы метка ▲ на штекере была направлена влево.
- Подсоедините сетевой адаптер переменного тока к адаптеру переменного тока.
- Подсоедините сетевой шнур к электросети.

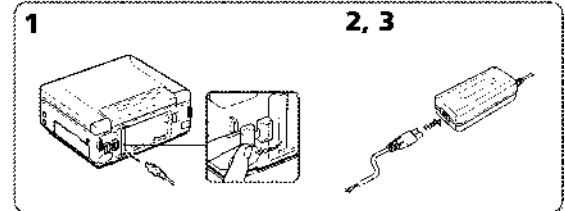

PRECAUTION
The set is not disconnected from the AC power source (the mains) as long as it is connected to the mains, even if the set itself has been turned off.

- Notes**
- The AC power adaptor can supply power even if the battery pack (not supplied) is attached to your VCR.
 - The DC IN jack has "Source symbols". This means that the battery pack can supply direct current supply power if the mains lead is connected to the DC IN jack, even when the mains lead is not plugged into the mains.
 - Keep the AC power adaptor away from your VCR if the picture is disturbed.

When you use your VCR outdoors
Use the battery pack (not supplied) (стр. 20)

Using a car battery
Use the Auto DC Adaptor/Charger (not supplied).

ПРЕДОСТЕРЕЖЕНИЕ
Аппарат не отключается от источника питания переменного тока, пока он подсоединен к электрической сети, даже если сам аппарат выключен.

- Примечания**
- Питание от сетевого адаптера переменного тока может подаваться даже в случае, если батарейный блок (не входит в комплект) прикреплен к Вашему видеомагнитофону.
 - Гнездо DC IN снабжено "признаками источника". Это означает, что питание от батарейного блока (не входит в комплект) не подается, пока провод электропитания подсоединен к гнезду DC IN, даже если провод электропитания не вставлен в сетевую розетку.
 - Если изображение искажается, отодвиньте сетевой адаптер переменного тока подальше от видеомагнитофона.

При использовании видеомагнитофона вне помещения
Используйте батарейный блок (не входит в комплект) (стр. 20)

Использование автомобильного аккумулятора
Используйте адаптер/зарядное устройство постоянного тока. Шнур не входит в комплект.

7 8

Step 1 Preparing the power supply

Using with a battery pack (not supplied)

Install the battery pack to use your VCR outdoors. Your VCR operates only with the "IntellITHIUM" battery pack (1 series).

Installing the battery pack

Press and slide the battery pack in the direction of the arrow.

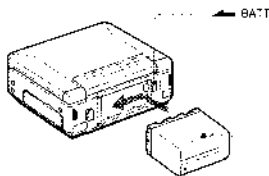

Battery Pack (not supplied)
Батарейный блок (не входит в комплект)

To remove the battery pack

While pressing **BATT**, slide the battery pack left.

After installing the battery pack

Do not carry your VCR by holding the battery pack. If you do so, the battery pack may slide off and cause damage to your VCR.

Remaining battery time indicator

When you use an "IntellITHIUM" battery pack, the remaining battery time is displayed on the LCD screen. It may not be displayed properly, however, depending on the conditions and circumstances of use. The message appears when the battery is low. When you lose the VCR panel and open it again, it does not estimate for a correct remaining battery time to be displayed.

Пункт 1 Подготовка источника питания

Использование батарейного блока (не входит в комплект)

Установите батарейный блок, чтобы использовать видеоминифон вне помещений. Ваш видеоминифон работает только с батарейным блоком "IntellITHIUM" (серия 1).

Установка батарейного блока

Нажмите на батарейный блок и сдвиньте его в направлении стрелки.

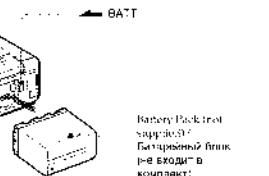

Батарейный блок (не входит в комплект)

Для снятия батарейного блока

Нажмите на кнопку **BATT**, сдвиньте батарейный блок влево.

После установки батарейного блока

Не переносите свой видеоминифон, держа его за батарейный блок. В противном случае, батарейный блок может соскользнуть с того видеоминифона, что может привести к его повреждению.

Индикатор оставшегося времени работы батареи

При использовании батарейного блока Инф. "IntellITHIUM" остается время работы батареи отображается на экране ЖКД. Это может отображаться не совсем точно, в зависимости от условий и обстоятельств, в которых используется аппаратура. Когда батарея разряжена, отображается контрольное сообщение. Если вы откроете панель ЖКД и откроете ее снова, то придет около 1 минуты прежде, чем на дисплее появится правильное время оставшегося заряда батарейного блока.

Step 1 Preparing the power supply

Charging time/Время зарядки

Battery pack/ Батарейный блок	Full charge (Normal charge)/ Полная зарядка (нормальная зарядка)
NP-F30	130 (140)
NP-F50/F50	210 (230)
NP-F70/F70	300 (320)
NP-F30/F50	290 (320)
NP-F60	420 (450)

Approximate number of minutes for battery supply battery pack. / Приблизительное время в минутах для зарядки полностью разряженного батарейного блока

Playing time/Время воспроизведения

Battery pack/ Батарейный блок	Playing time on LCD screen/ Время воспроизведения на экране ЖКД	Playing time with LCD closed/ Время воспроизведения при закрытом ЖКД
NP-F30	63 (55)	105 (95)
NP-F50	100 (90)	175 (160)
NP-F50	130 (115)	210 (190)
NP-F70	225 (205)	365 (325)
NP-F70	265 (235)	445 (395)
NP-F60	360 (325)	575 (520)
NP-F60	405 (360)	675 (610)
NP-F60	475 (440)	795 (710)

Approximate number of minutes when you use a fully charged battery pack. / Приблизительное время в минутах при использовании полностью заряженного батарейного блока

Numbers in parentheses "()" indicate the time used at normally charged battery pack. The battery life will be shorter if you use your VCR in a cold environment.

You can charge the battery pack abroad. For details, refer to page 94.

If the power goes off even though the battery remaining indicator shows that the battery pack has enough power to operate. Charge the battery pack fully again so that the battery remaining indicator is correct.

What is "IntellITHIUM"?

The "IntellITHIUM" is a lithium ion battery pack which can exchange data with a battery communication with compatible external equipment. This VCR is compatible with the "IntellITHIUM" battery pack (1 series). Your VCR operates only with the "IntellITHIUM" battery pack. The "IntellITHIUM" battery pack has the **IntellITHIUM** mark.

"IntellITHIUM" is a trademark of Sony Corporation.

Пункт 1 Подготовка источника питания

Зарядка батареи

Батарейный блок	Полная зарядка (нормальная зарядка)
NP-F30	130 (140)
NP-F50/F50	210 (230)
NP-F70/F70	300 (320)
NP-F30/F50	290 (320)
NP-F60	420 (450)

Приблизительное время в минутах при использовании полностью заряженного батарейного блока

Время воспроизведения

Батарейный блок	Время воспроизведения на экране ЖКД	Время воспроизведения при закрытом ЖКД
NP-F30	63 (55)	105 (95)
NP-F50	100 (90)	175 (160)
NP-F50	130 (115)	210 (190)
NP-F70	225 (205)	365 (325)
NP-F70	265 (235)	445 (395)
NP-F60	360 (325)	575 (520)
NP-F60	405 (360)	675 (610)
NP-F60	475 (440)	795 (710)

Приблизительное время в минутах при использовании полностью заряженного батарейного блока

Цифры в скобках "()" указывают время при использовании батарейного блока с нормальной зарядкой. При использовании в холодных условиях срок службы батарейного блока сокращается.

Вы можете заряжать батарею за рубежом. Для подробной информации см. стр. 94.

Если питание отключится, хотя индикатор оставшегося времени работы батареи показывает достаточный для работы заряд. Зарядите полностью снова батарейный блок, чтобы индикатор правильно показывал оставшийся время работы батареи.

Что такое "IntellITHIUM"?
"IntellITHIUM" представляет собой ионнолитиевый батарейный блок, который может обмениваться данными с совместимым внешним оборудованием. Этот видеоминифон совместим с батарейным блоком "IntellITHIUM" (серия 1). Ваш видеоминифон работает только с батарейным блоком "IntellITHIUM". Не заряжайте блок "IntellITHIUM" никаким другим способом.
"IntellITHIUM" является торговой маркой корпорации Sony.

Step 1 Preparing the power supply

Charging the battery pack

Use the battery pack after charging it for your VCR. You can charge the battery with your VCR.

- 1) Insert the battery pack.
- 2) Open the DC IN jack cover and connect the AC power adaptor (supplied with your VCR) to the DC IN jack with the plug's **▲** mark facing right.
- 3) Connect the power lead to the AC power adaptor.
- 4) Connect the power lead to the mains.
- 5) Set the POWER switch to OFF. When charging begins, the POWER ON/CHARGE lamp lights up orange.

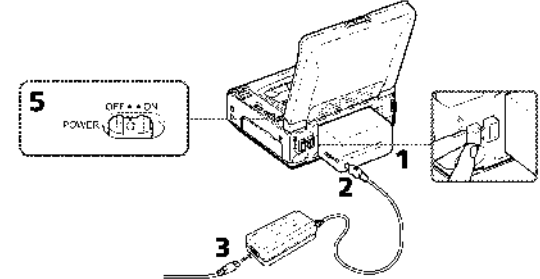

After charging the battery pack

Disconnect the AC power adaptor from the DC IN jack on your VCR.

Notes

- Prevent metallic objects from coming into contact with the metal parts of the DC IN plug of the AC power adaptor. Otherwise, a short circuit may occur and damage the AC power adaptor.
- Keep the battery pack dry.
- The battery pack is not to be used for an extended period, charge the battery pack once fully, and then use it until fully discharged again. Keep the battery pack in a cool place.

When the battery pack is charged fully the POWER ON/CHARGE lamp goes off.

Пункт 1 Подготовка источника питания

Зарядка батарейного блока

Используйте батарейный блок для этого видеоминифона после его зарядки. Батарейный блок можно зарядить на своем видеоминифоне.

- 1) Установите батарейный блок.
- 2) Откройте крышку порта DC IN и подсоедините сетевой адаптер переменного тока (прилагается к видеоминифону) к порту DC IN так, чтобы метка **▲** на адаптере была направлена вправо.
- 3) Подсоедините провод электросети к адаптеру переменного тока.
- 4) Подсоедините сетевой шнур к электросетевой сети.
- 5) Установите переключатель POWER в положение OFF. Когда зарядка начинается, лампочка POWER ON/CHARGE загорается оранжевым цветом.

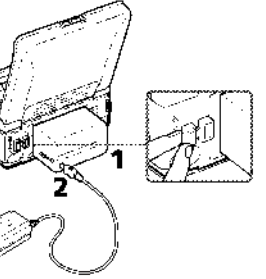

После зарядки батарейного блока

Отсоедините сетевой адаптер переменного тока от порта DC IN на видеоминифоне.

Примечания

- Не допускайте контакта металлических предметов с металлическими частями штекера постоянного тока сетевого адаптера. Иначе может произойти короткое замыкание и повреждение Вашего видеоминифона.
- Всегда удаляйте влагу с батарейного блока.
- Если батарейный блок не будет использоваться в течение длительного промежутка времени, полностью зарядите его, а затем используйте, пока он не разрядится окончательно. Храните батарейный блок в прохладном месте.

Когда батарейный блок заряжен полностью лампочка POWER ON/CHARGE не горит.

Step 2 Inserting a cassette

We recommend using Hi8 Hi8 Digital Hi8 video cassettes.

- 1) Prepare the power supply (p. 8-11).
- 2) While pressing **POWER OPEN**, open the LCD panel.
- 3) While pressing the small blue button, slide **EJECT** in the direction of the arrow. The cassette compartment automatically opens and opens.
- 4) Insert a cassette with the window facing up.
- 5) Close the cassette compartment by pressing the **REW** mark on the cassette compartment.

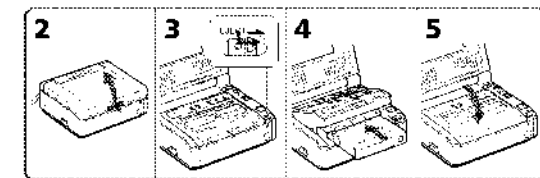

To eject a cassette

Follow the procedure above, and ejet the cassette in step 4.

Notes

- Do not touch your fingers or hands inside the cassette compartment with your fingers or hands when it is in the same state. VCR is malfunction.
- Your VCR records pictures in the Date/Time mode.
- The recording time when you use your VCR is 70 for Hi8 and 60 for Hi8 Digital Hi8.
- In case of the Hi8 mode, the picture is always taken at time of Hi8 Hi8 Digital Hi8.
- If you use standard **▶** tape, be sure to place back the protection cap.
- Music pattern noise may appear when you play back standard Hi8 tape on the VCR.

To prevent accidental erasure

Slide the write-protect tab on the cassette to expose the red mark.

Пункт 2 Установка кассеты

Рекомендуется использовать кассеты Hi8 Hi8 Digital Hi8.

- 1) Подготовьте источник питания (стр. 8-11).
- 2) Нажав кнопку **POWER OPEN**, откройте панель ЖКД.
- 3) Нажав небольшую синюю кнопку, передвиньте переключатель **EJECT** в направлении стрелки. Кассетный отсек автоматически откроется и откроется.
- 4) Вставьте кассету так, чтобы окошко было обращено вверх.
- 5) Закройте кассетный отсек, нажав на иконку кнопки **▶**.

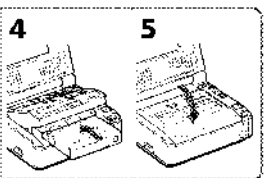

Для извлечения кассеты

Выполните указанную выше процедуру и выньте кассету в пункте 4.

Примечания

- Когда окладчатый диск открыт, не прикасайтесь пальцами или другими частями. Это может повредить или испортить видеоминифон.
- Ваш видеоминифон записывает изображения в режиме Date/Time.
- Время записи при использовании Вашего видеоминифона составляет 70 времени, если используется кассета Hi8 Hi8 Digital Hi8. При использовании кассеты Hi8 Hi8 Digital Hi8.
- Если использовать кассету Hi8 Digital Hi8, не следует открывать на этом же видеоминифоне. При использовании кассеты Hi8 Digital Hi8 на других видеоминифонах могут появиться музыкальные помехи.

Для предотвращения случайного стирания

Передвиньте лепесток защиты записи на кассете, так чтобы появилась красная метка.

— Basic Operations —

Playing back a tape

- 1) Prepare the power supply and insert a cassette to play back (p. 87).
- 2) While pressing the small green button on the POWER switch, set it to ON. The POWER ON/CHARGE lamp (green) on the front lights up.
- 3) Press **▶▶** to start playback.
- 4) Adjust the brightness using **LCD BRIGHT**.
- 5) Adjust the volume using **VOLUME**.

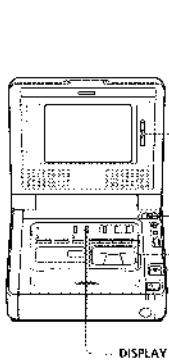

To stop playback
Press **■**

Note on the DISPLAY button
Press **DISPLAY** to display the zone indicators. To make the indicators disappear, press it again.

— Основные операции —

Воспроизведение ленты

- 1) Подготовьте источник питания и вставьте кассету для воспроизведения (стр. 87).
- 2) Нажав на маленькую зеленую кнопку на переключателе POWER, установите его в положение ON. Загорится зеленый диодик POWER ON/CHARGE, расположенный на передней панели.
- 3) Нажмите кнопку **▶▶** для начала воспроизведения.
- 4) Отрегулируйте яркость с помощью кнопки **LCD BRIGHT**.
- 5) Отрегулируйте громкость с помощью кнопки **VOLUME**.

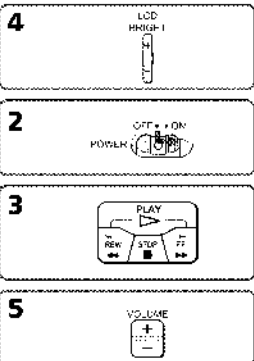

Для остановки воспроизведения
Нажмите кнопку **■**

Примечания относительно кнопки DISPLAY
Нажмите кнопку **DISPLAY** для отображения зонных индикаторов. Нажмите ее еще раз, чтобы индикаторы исчезли.

Basic Operations Основные операции

Playing back a tape

In these various playback modes
• Noise may appear when your VCR plays back tapes recorded in the Hi-Fi standard B system. • Sound is muted.
• The previous recording may appear as a music image when playing back in Digital B system.
• The VCR does not automatically detect Digital Hi-Fi or Hi-Fi standard B systems in the various playback mode.

Notes on the playback pause mode
• When playback pause mode lasts for 3 minutes, your VCR automatically enters the stop mode. To resume playback, press **▶▶**.
• The previous rewinding may appear.

Slow playback for tapes recorded in the Digital Hi-Fi system
Slow playback mode can be performed separately on your VCR; however, this function does not work for an output signal from the **DV IN / OUT** jack.

When you play back a tape in reverse
Horizontal noise may appear at the corner of top and bottom of the screen. This is not a malfunction.

Using headphones
Connect headphones (not supplied) to the **Headphones** by using the **VOLUME** button. When you connect headphones, the sound does not output from the speakers.

Замедленное воспроизведение кассет, записанных в системе Digital Hi-Fi
Режим замедленного воспроизведения может использоваться на Полумесяце надписи на экране, однако эта функция не работает, когда выходящий сигнал выдается через гнездо **DV IN/OUT**.

При воспроизведении ленты в обратном направлении
В центре или сверху и снизу экрана могут появиться горизонтальные помехи. Однако это не является неисправностью.

Использование головных телефонов
Подсоедините «слезные» телефоны (не входит в комплект) к гнезду **Headphones**. Громкость в системе Headphones может отрегулировать с помощью кнопки **VOLUME**. При использовании головных телефонов звук из динамиков не выводится.

Воспроизведение ленты

Для просмотра воспроизведения изображения на удвоенной скорости
Во время воспроизведения нажмите кнопку **⏏**. Для возобновления на удвоенной скорости в обратном направлении во время обратного воспроизведения нажмите кнопку **⏏** **◀**, затем нажмите кнопку **▶**. Для возобновления обычного воспроизведения нажмите кнопку **▶▶**.

Для кадрового просмотра воспроизведения изображения
Нажмите кнопку **▶▶** **FRAMES** (1) в режиме паузы воспроизведения. Для кадрового просмотра воспроизведения в обратном направлении нажмите кнопку **⏏** **◀** **FRAMES** (1) в режиме паузы воспроизведения. Для возобновления обычного воспроизведения нажмите кнопку **▶▶**.

При работе в различных режимах воспроизведения
• При воспроизведении на экран выводится только кадр, записанный в системе Hi-Fi standard B. • Пользователь может выбрать режим.
• Звук будет приглушен.
• При воспроизведении в системе Digital Hi-Fi предыдущая запись может отображаться как музыкальное изображение.
• При работе в различных режимах воспроизведения видеомонитор не распознает систему Digital Hi-Fi или Hi-Fi standard B автоматически.

Примечания относительно режима паузы воспроизведения
• Если звуковой сигнал на экране в режиме паузы воспроизведения 3 минуты, он автоматически перейдет в режим остановки. Для возобновления обычного воспроизведения нажмите кнопку **▶▶**.
• Может появиться предыдущая запись.

Замедленное воспроизведение кассет, записанных в системе Digital Hi-Fi
Режим замедленного воспроизведения может использоваться на Полумесяце надписи на экране, однако эта функция не работает, когда выходящий сигнал выдается через гнездо **DV IN/OUT**.

При воспроизведении ленты в обратном направлении
В центре или сверху и снизу экрана могут появиться горизонтальные помехи. Однако это не является неисправностью.

Использование головных телефонов
Подсоедините «слезные» телефоны (не входит в комплект) к гнезду **Headphones**. Громкость в системе Headphones может отрегулировать с помощью кнопки **VOLUME**. При использовании головных телефонов звук из динамиков не выводится.

Basic Operations Основные операции

Playing back a tape

Various playback modes

To operate the video control buttons, set the POWER switch to ON.

To view a still image (playback pause)
Press **■** during playback. The **PAUSE** lamp (orange) lights up. To resume playback, press **▶▶** or **▶▶**.

To advance the tape
Press **▶▶** in stop mode. To resume normal playback, press **▶▶**.

To rewind the tape
Press **◀◀** in stop mode. To resume normal playback, press **▶▶**.

To change the playback direction
Press **◀◀** or **▶▶** during playback to reverse the play back direction. To resume normal playback, press **▶▶**.

To locate a scene while searching the picture (picture search)
Keep pressing **◀◀** or **▶▶** during playback. To resume normal playback, release the button.

To monitor the high-speed playback at high speed while advancing or rewinding the tape (skip scan)
Keep pressing **◀◀** while rewinding or **▶▶** while advancing the tape. To resume rewinding or advancing, release the button.

To view the picture at slow speed (slow playback)
Press **▶▶** during playback. For slow playback in the reverse direction, press **◀◀** or **▶▶** during playback, then press **▶▶**. To resume normal playback, press **▶▶**.

To view the picture at double speed
Press **▶▶** during playback. For double speed playback in the reverse direction, press **◀◀** or **▶▶** during playback, then press **▶▶**. To resume normal playback, press **▶▶**.

To view the picture frame-by-frame
Press **▶▶** **FRAMES** (1) in playback pause mode. For frame-by-frame playback in the reverse direction, press **◀◀** **FRAMES** (1) in playback pause mode. To resume normal playback, press **▶▶**.

Воспроизведение ленты

Различные режимы воспроизведения

Для использования кнопки управления видеовоспроизведением переключатель POWER в положение ON.

Для просмотра неподвижного изображения (пауза воспроизведения)
Во время воспроизведения нажмите кнопку **■** (Закроет лампочка PAUSE (оранжевый свет)). Для возобновления обычного воспроизведения нажмите кнопку **▶▶** или **▶▶**.

Для ускоренной перемотки ленты вперед
В режиме остановки нажмите кнопку **▶▶**. Для возобновления обычного воспроизведения нажмите кнопку **▶▶**.

Для ускоренной перемотки ленты назад
Нажмите в режиме остановки кнопку **◀◀**. Для возобновления обычного воспроизведения нажмите кнопку **▶▶**.

Для изменения направления воспроизведения
Во время воспроизведения нажмите кнопку **◀◀** или **▶▶** для изменения направления воспроизведения. Для возобновления обычного воспроизведения нажмите кнопку **▶▶**.

Для отыскания эпизода во время поиска изображения (поиск изображения)
Держите нажатой кнопку **◀◀** или **▶▶** во время воспроизведения. Для возобновления обычного воспроизведения нажмите кнопку **▶▶**.

Для контроля изображения на высокой скорости во время перемотки ленты вперед или назад (поиск методом прогона)
Держите нажатой кнопку **◀◀** во время перемотки ленты назад или кнопку **▶▶** во время перемотки ленты вперед. Для возобновления перемотки ленты вперед или назад отпустите кнопку.

Для просмотра воспроизведения изображения на замедленной скорости (замедленное воспроизведение)
Во время воспроизведения нажмите кнопку **▶▶**. Для замедленного воспроизведения в обратном направлении нажмите кнопку **◀◀** или **▶▶** во время воспроизведения, затем нажмите кнопку **▶▶**. Для возобновления обычного воспроизведения нажмите кнопку **▶▶**.

Playing back a tape

Playing back a dual soundtrack tape

When you play back a dual soundtrack tape, select the desired sound in the menu settings.

- 1) Press **MENU** to display the menu settings.
- 2) Turn the **SEL./PUSH EXEC.** dial to select the desired menu item.
- 3) Turn the **SEL./PUSH EXEC.** dial to select **HiFi SOUND**, then press the dial.
- 4) Turn the **SEL./PUSH EXEC.** dial to select the desired sound, then press the dial. For details about the sound mode, refer to page 65.
- 5) Press **MENU** to make the menu disappear.



Воспроизведение ленты

Воспроизведение ленты с двойной звуковой дорожкой

При воспроизведении ленты с двойной звуковой дорожкой выберите нужный звук в меню.

- 1) Нажмите кнопку **MENU** для отображения экрана меню.
- 2) Поверните диск **SEL./PUSH EXEC.** для выбора желаемого меню.
- 3) Поверните диск **SEL./PUSH EXEC.** для выбора **HiFi SOUND**, а затем нажмите на диск.
- 4) Поверните диск **SEL./PUSH EXEC.** для выбора нужного звука, а затем нажмите на диск. Подробные сведения о звуковых режимах см. на обратной стороне справочника (стр. 67).
- 5) Нажмите кнопку **MENU** для того, чтобы убрать меню.

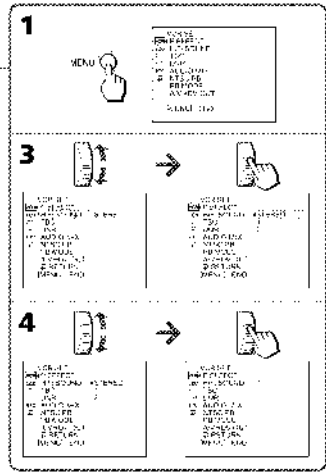

Playing back a tape

Using a Remote Commander

You can operate your VCR using the Remote Commander supplied with a Sony product. Set COMMANDER in the menu settings, according to the remote control code of the Sony product.

Code	Sony product
VTR 1	VCR/VCR
VTR 2	Mini video camera recorder
VTR 3	Digital video camera recorder
VTR 4	VHS VCR
VTR 5	Digital VCR
VTR 6	Digital VCR

Note
You cannot set the POWER switch to ON or OFF, or reset the cassette with the Remote Commander.

Воспроизведение ленты

Использование пульта дистанционного управления

Используя Ваш пульт дистанционного управления, можно управлять функциями видеомонитора. Установите для параметра COMMANDER в установках меню соответствующий код пульта дистанционного управления аппарата Sony.

Код	Аппаратура Sony
VTR 1	Видеомагнитофон Betamax
VTR 2	Видеокамера стандарта 8 мм
VTR 3	Видеомагнитофон стандарта VHS
VTR 4	Цифровая видеомагнитофон
VTR 5 и 6	Цифровая видеомагнитофон

Примечание
С помощью пульта дистанционного управления нельзя установить переключатель POWER в положение ON или OFF или изменить канал.

Basic Operations Основные операции

Playing back a tape

Wide mode playback and recording

Pictures recorded with a Sony digital video camera recorder that have an aspect ratio of 16:9 on your VCR can be played back. For details, refer to the operating instructions of your TV. Back bands appear on the LCD screen during playback in 16:9 WIDE mode [a]. The picture during playback on a normal TV [b] or a wide-screen TV [c] are compressed in the vertical direction. If you set screen mode of the 16:9 wide-screen TV to the full mode, you can see normal images [d].

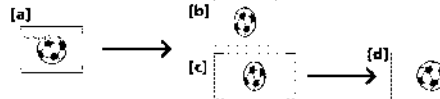

When recording a 16:9 screen
Your VCR automatically detects the wide-mode signals and records in wide mode.

Воспроизведение ленты

Воспроизведение и запись в широкоэкранном режиме

На Вашем видеомониторе можно воспроизводить изображения, записанные с помощью цифровой видеокамеры Sony и имеющие формат изображения 16:9. Подробные сведения см. в инструкции по эксплуатации Вашего телевизора. Во время воспроизведения в режиме 16:9 WIDE [a] на экране ЖКД появляются черные полосы. Изображение во время воспроизведения на обычном телевизоре [b] или на широкоэкранным телевизоре [c] будет сжато по ширине. Если установить формат экрана в режиме широкоэкранным телевизора с форматом 16:9 изображения будут иметь обычный размер [d].

При записи изображения формата 16:9
Ваш видеомонитор автоматически распознает сигналы широкоформатного режима и записывает в этом режиме.

Viewing the recording on TV

Connect your VCR to your TV or to the other VCR with the A/V connecting cable supplied with your VCR to watch the playback picture on the TV screen. Connect the plugs to the jacks in the same order as your VCR and the TV or the other VCR. Refer to the operating instructions of your TV or the other VCR. The playback procedure is the same as when playing back on the LCD screen. Turn down the volume of your VCR.

Open the jack cover. Connect your VCR to the TV using the A/V connecting cable. Then, set the TV/VCR selector on the TV to VCR.

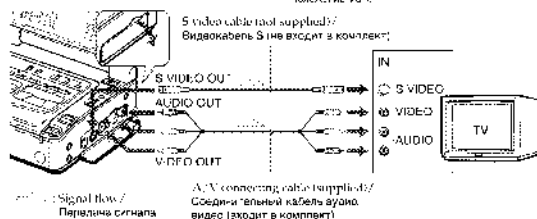

If your TV is already connected to the other VCR

Connect your VCR to the LINE IN input on the other VCR with the A/V connecting cable (supplied). Set the input selector on the VCR to LINE.

If your TV or the other VCR is a monaural type

Connect the yellow plug of the A/V connecting cable to the video input jack and the white plug to the audio input jack on the other VCR or the TV. You do not connect the red plug. With this connection, the sound is monaural even in stereo mode.

Просмотр записи на экране телевизора

Для просмотра записанного изображения на экране телевизора подсоедините видеомонитор к телевизору или другому видеомонитору с помощью прилагаемого кабеля аудиовидео. Кабели вставьте в соответствующие гнезда видеомонитора. Подключите аппаратуру к тем же гнездам видеомонитора или телевизора или другого видеомонитора. См. инструкции по эксплуатации Вашего телевизора или другого видеомонитора. Процедура воспроизведения аналогична той, что используется при воспроизведении на экране ЖКД. Уменьшите громкость на видеомониторе.

Откройте крышку гнезд. Подключите видеомонитор к телевизору с помощью прилагаемого кабеля аудиовидео. Затем установите переключатель TV/VCR на телевизоре в положение VCR.

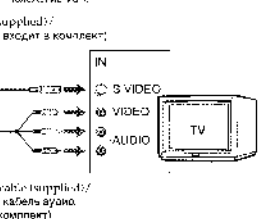

Если телевизор уже подсоединен к другому видеомонитору

Подсоедините видеомонитор к входному гнезду LINE IN на другом видеомониторе с помощью соединительного кабеля аудиовидео (входит в комплект). Установите селектор входного сигнала на видеомониторе в положение LINE.

Если Ваш телевизор или другой видеомонитор монофонического типа

Подсоедините желтый штекер соединительного кабеля аудиовидео к входному гнезду видеосигнала, а белый штекер - к входному гнезду аудиосигнала на другом видеомониторе или телевизоре. Не подсоединяйте красный штекер. При этом видеосигналом будет монофоническим, даже если Вы в режиме стерео.

17 18

Basic Operations Основные операции

Viewing the recording on TV

To connect to a TV or the other VCR without video/audio input jacks

Use a PAL system RFU adaptor (not supplied). Refer to the operating instructions of your TV or the other VCR and the RFU adaptor. With an RFU adaptor the sound is monaural even on stereo models.

If your TV or the other VCR has a 21-pin connector (EUROCONNECTOR)

Use the 21-pin adaptor supplied with your VCR.

Просмотр записи на экране телевизора

Для подключения к телевизору или другому видеомонитору, не оснащенному входными гнездами видеоаудио

Используйте адаптер RFU системы PAL (не входит в комплект). См. инструкции по эксплуатации Вашего телевизора или другого видеомонитора и адаптера RFU. При подсоединении адаптера RFU звук будет монофоническим, даже если подключение модели является устройством с функцией стерео.

Если на телевизоре или другом видеомониторе имеется 21-штырьковый разъем (EUROCONNECTOR)

Используйте 21-штырьковый адаптер, прилагаемый к Вашему видеомонитору.



If your TV or the other VCR has an S video jack
Connect using an S video cable (not supplied) to obtain high quality pictures. With this connection, you do not need to connect the yellow video plug of the A/V connecting cable.
Connect an S video cable (not supplied) to the S VIDEO OUT jack on your VCR and the S video jack on the TV or the other VCR.

Если на телевизоре или другом видеомониторе имеется видеогнездо S
Получите четкие и качественные изображения S-Video сигнала с помощью видеокабеля S-Video (не входит в комплект) для получения высококачественного изображения. При таком соединении не надо будет подсоединять желтый и белый (аудио) соединительные кабели аудиовидео. Подключите видеокабель S-Video (не входит в комплект) к гнезду S VIDEO OUT на этом видеомониторе и к видеогнезду S на телевизоре или другом видеомониторе.

19 20

Viewing the recording on TV

Using the AV cordless IR receiver

Once you connect the AV cordless IR receiver (not supplied) to your TV or the other VCR, you can easily view the picture on your TV. For details, refer to the operating instructions of the AV cordless IR receiver.

SUPER LASER LINK

infrared rays emitter/
Излучатель
инфракрасных лучей

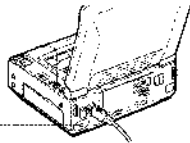

- After connecting your TV and the AV cordless IR receiver, set the POWER switch on the AV cordless IR receiver to ON.
- Turn the TV on and set the TV/VCR selector on the TV to VCR.
- Set the POWER switch on your VCR to ON.
- Press SUPER LASER LINK. The lamp on the SUPER LASER LINK button lights up.
- Press Play on your VCR to start playback.
- Point your VCR at the AV cordless IR receiver. Adjust the position of your VCR and the AV cordless IR receiver to obtain clear playback pictures.

Просмотр записи на экране телевизора

Использование беспроводного ИК аудиовидеоприемника

После подсоединения беспроводного ИК аудиовидеоприемника (не входит в комплект) к вашему телевизору или другому видеомонитору можно просматривать изображение на экране телевизора. Подробные сведения см. в инструкциях по эксплуатации беспроводного ИК аудиовидеоприемника.

- После подсоединения беспроводного ИК аудиовидеоприемника к заднему телевизору установите переключатель POWER на беспроводном ИК аудиовидеоприемнике в положение ON.
- Включите телевизор и установите селектор TV/VCR на телевизоре в положение VCR.
- Установите переключатель POWER на видеомониторе в положение ON.
- Нажмите кнопку SUPER LASER LINK. Загорится лампочка SUPER LASER LINK.
- Нажмите кнопку Play на видеомагнитофоне для начала воспроизведения.
- Направьте видеомагнитофон на беспроводный ИК аудиовидеоприемник. Отрегулируйте положение видеомагнитофона и беспроводного ИК аудиовидеоприемника для получения четкого воспроизводимого изображения.

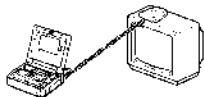

To cancel the super laser link function

Press SUPER LASER LINK. The lamp on the SUPER LASER LINK button goes off.

Для отмены функции лазерного суперканала передачи сигналов нажмите кнопку SUPER LASER LINK. Лампочка SUPER LASER LINK погаснет.

Viewing the recording on TV

If you turn the power off, the super laser link function turns off automatically.

When super laser link function is activated (the SUPER LASER LINK button is lit) Your VCR consumes power. Press SUPER LASER LINK to turn off the super laser link function when it is not needed.

is a trademark of Sony Corporation

Просмотр записи на экране телевизора

При выключении питания функция лазерного суперканала передачи сигналов автоматически выключается.

При включенном лазерном суперканале передачи сигнала (при этом подсвечивается кнопка SUPER LASER LINK) Видеомагнитофон потребляет энергию. Нажмите кнопку SUPER LASER LINK, чтобы отключить функцию лазерного суперканала передачи сигнала, если она не требуется.

is a trademark of Sony Corporation

Recording from the other VCR or TV

Using the AV connecting cable You can record a tape from the other VCR or a TV programme that has audio/video outputs. Use your VCR as a recorder.

- Insert a blank tape (or a tape you want to record over) into your recording VCR. If you are recording a tape from the other (playback) VCR, insert a recorded tape into the other (playback) VCR.
- Set the POWER switch to ON.
- Press REC and the button on the right simultaneously on your recording VCR. From immediately press Play on your recording VCR. The RED (red) and PAUSE (orange) lamps light up.
- Press Play on the other (playback) VCR to start playback if you are recording a tape from the other (playback) VCR. Select a TV programme if you are recording from TV. The picture from a TV or the other VCR appears on the LCD screen of your recording VCR.
- Press Play on your (recording) VCR on the screen where you want to start recording from. The REC lamp turns on and the lamp on the PAUSE button goes off.

Запись с другого видеомонитора или телевизора

Использование соединительного кабеля аудио/видео Можно выполнить запись на кассету с другого видеомонитора или воспроизведения с телевизора, который имеет выходы аудио/видео. Для этого в видеомониторе и качестве запись записывающего устройства.

- Вставьте чистую кассету или кассету, на которую вы хотите выполнить запись, в свой видеомониторный видеомагнитофон. При записи с другого видеомонитора, вставьте кассету, с которой будет воспроизводиться запись, в другой (воспроизводящий) видеомониторный видеомагнитофон.
- Установите переключатель POWER в положение ON.
- Одновременно нажмите кнопку REC и кнопку справа от нее (записывающему) видеомонитору, затем сразу нажмите кнопку Play на записывающем видеомониторе. Загорятся две лампочки: REC (красная) и PAUSE (оранжевая).
- Если запись выполняется с другого (воспроизводящего) видеомонитора, нажмите на нем кнопку Play для начала воспроизведения. Выберите телевизионную программу, если запись выполняется с телевизора. Изображение с телевизора или другого видеомонитора появляется на экране ЖКД этого (записывающего) видеомонитора.
- Нажмите кнопку Play на Вашем видеомониторе/видеомагнитофоне в том месте, где хотите начать запись. Лампочка REC продолжает гореть, а лампочка над кнопкой PAUSE погаснет.

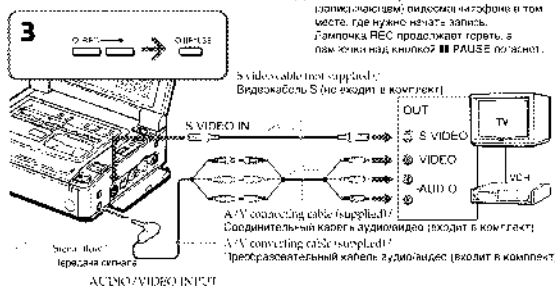

Recording from the other VCR or TV

When you have finished recording a tape Press Stop (or back) your (recording) VCR and the other (playback) VCR.

- Notes
- To enable smooth transition, we recommend that you do not mix pictures recorded in the Hi8/Hi8mm format with the Digital Hi8 system on a tape.
 - If you use fast-forward or slow-playback mode on the other (playback) VCR, the image being recorded may fluctuate. When you return from the other (playback) VCR, restore to play back the original tape at normal speed.
 - You can record a picture from another VCR or TV of PAL system only, not from the VCR or TV of SECAM system.

If the other (playback) VCR or TV is a manual type Connect the yellow plug of the AV connecting cable to the video output jack and the white plug to the audio output jack on the VCR or the TV. Do not connect the red plug. The sound is monoaural.

If your TV or the other (playback) VCR has an S video jack Connect using an S video cable (not supplied) to obtain high-quality pictures. With this connection, you do not need to connect the yellow video plug of the AV connecting cable. Connect an S video cable (not supplied) to the S video jacks of both your (recording) VCR and the TV or the other (playback) VCR.

Запись с другого видеомонитора или телевизора

После завершения записи кассеты Нажмите кнопку Stop (или назад) на вашем (записывающем) и другом (воспроизводящем) видеомониторе.

- Примечания
- Для обеспечения плавного перепада на одной кассете рекомендуется не записывать изображения в различных системах - Hi8, standard 8 и Digital Hi8.
 - Во время быстрого перемотки вперед или в режиме замедленного воспроизведения на другом (воспроизводящем) видеомониторе запись с кассеты воспроизводится. При записи с другого (воспроизводящего) видеомонитора воспроизводите кассету оригинала на обычной скорости.
 - Вы можете записывать изображения только с другого видеомонитора или телевизора системы PAL. Запись изображения с другого видеомонитора или телевизора системы SECAM невозможна.

Если другой (воспроизводящий) видеомониторный или телевизор монофонического типа Подключите желтый штекер соединительного кабеля видеомонитора к видеому выводу видеомонитора, а белый штекер к аудиому выводу видеомонитора на видеомониторе или телевизоре. Не подключайте красный штекер. Звук будет монофоническим.

Если на телевизоре или другом (воспроизводящем) видеомониторе имеется видеовход S-Video Выполните соединение с помощью видеокабеля S-Video (входит в комплект) для получения высококачественных изображений. При такой соединении не требуется подключать желтый штекер (плоский) соединительного кабеля аудио/видео. Подсоедините видеокабель S-Video (входит в комплект) к видеому выводу S на Вашем (записывающем) видеомониторе и видеому выводу или аудиому выводу (циркуляющему) видеомонитора или телевизора.

Recording from the other VCR or TV

Using the i.LINK cable (DV connecting cable)

Simply connect the i.LINK cable (DV connecting cable) (not supplied) to the DV IN/OUT or DV IN/OUT jacks on the DV product. With digital (digital) connection, video and audio signals are transferred in digital form for high-quality editing.

- Insert a blank tape for a tape you want to record onto into your recording VCR, and insert the recorded tape into the other (playback) VCR.
- Set the POWER switch to ON.
- Press REC and the button of single start/advance on your recording VCR. Then, immediately press **II** on your (recording) VCR. The REC (red) and PAUSE (orange) lamps light up.
- Press **II** on the other (playback) VCR to start playback. The picture from a TV or the other (playback) VCR appears on the LCD screen of your (recording) VCR.
- Press **II** on your (recording) VCR at the scene you want to start recording from. The REC lamp remains on and the PAUSE lamp goes off.

Запись с другого видеомаягнитофона или телевизора

Использование кабеля i.LINK (соединительный кабель DV)

Просто подсоедините кабель i.LINK (соединительный кабель DV) (не входит в комплект) к гнездам DV IN/OUT или к гнезду DV IN/OUT аппаратов DV. При использовании цифрового соединения видео и аудиосигналы передаются в цифровом виде для высококачественного монтажа.

- Вставьте чистую кассету (или кассету, на которую Вы хотите выполнить запись) в свой (записывающий) видеомаягнитофон и вставьте записанную кассету в другой (воспроизводящий) видеомаягнитофон. Закрыйте две лампочки REC (красная) и PAUSE (оранжевая).
- Нажмите кнопку POWER и положение ON.
- Содержимое кассеты нажмите кнопку REC и кнопку **II** на Вашем (записывающем) видеомаягнитофоне. Лампочка REC (красная) и лампочка PAUSE (оранжевая) загорятся.
- Нажмите кнопку **II** на другом (воспроизводящем) видеомаягнитофоне для начала воспроизведения. Изображение с титров (звездочка) или другого (воспроизводящего) видеомаягнитофона появится на экране ЖКД этого (записывающего) видеомаягнитофона.
- Нажмите кнопку **II** на Вашем (записывающем) видеомаягнитофоне в том месте, где нужно начать запись. Лампочка REC продолжает гореть, а лампочка PAUSE погаснет.

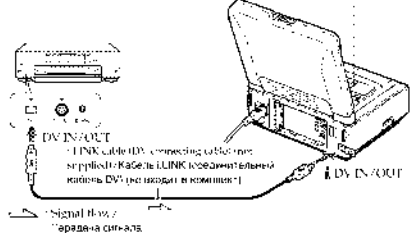

Basic Operations - Основные операции

Recording from the other VCR or TV

When you have finished recording a tape

Press **II** on both your (recording) VCR and the other (playback) VCR.

Note
If the connected equipment has a different kind of i.LINK system, it is not compatible with your VCR.

You can connect one VCR only using the i.LINK cable (DV connecting cable).

During digital editing
The color of the display may be unvaca. However, this does not affect the dubbed picture.

If you record a playback pause picture with the DV IN/OUT jack
The recorded picture becomes rough, and when you play back the picture using your VCR, the picture may jitter.

Before recording
Make sure that the DV IN indicator appears on the LCD screen by pressing the DISPLAY button. The DV IN indicator may appear on both screens.

Запись с другого видеомаягнитофона или телевизора

После завершения записи кассеты

Нажмите кнопку **II** на этом (записывающем) и другом (воспроизводящем) видеомаягнитофоне.

Примечание
Если подключаемая аппаратура использует другой тип системы i.LINK, она не совместима с этим видеомаягнитофоном.

Вы можете подсоединить только один видеомаягнитофон с помощью кабеля i.LINK (соединительный кабель DV).

Во время цифрового монтажа
Цвет изображения может быть неравномерным. Однако, это не влияет на переключенное изображение.

При записи неподвижного изображения с помощью гнезда DV IN/OUT
Записанное изображение становится шероховатым. При воспроизведении изображения на данном видеомаягнитофоне могут возникнуть дрожания.

Перед записью
Убедитесь, что три лампы на кнопке DISPLAY на экране ЖКД отображаются. Индикатор DV IN индикатор DV IN может появиться на обоих экранах.

Advanced Operations - Усовершенствованные операции

Enlarging playback images - PB ZOOM

You can enlarge moving and still images played back on tape.

- Press PB ZOOM on your VCR while you are playing back. The image is enlarged and **+** appears on the LCD screen.
- Turn the SEL/PUSH EJECT dial to move the enlarged image. Then press the dial. The image moves downwards.
- Turn the SEL/PUSH EJECT dial to move the enlarged image. Then press the dial. The image moves rightward. Then the dial downwards. The image moves leftward. (Turn the dial upwards.)

Усовершенствованные операции - Увеличение воспроизводимых изображений - PB ZOOM

Можно увеличивать подвижные и неподвижные изображения, воспроизводимые на кассетах.

- Во время просмотра нажмите кнопку PB ZOOM на Вашем видеомаягнитофоне. Изображение будет увеличено, а на экране ЖКД появится **+**.
- Поверните диск SEL/PUSH EJECT для перемещения увеличенного изображения. Затем нажмите на диск. Изображение переместится вниз.
- Поверните диск SEL/PUSH EJECT для перемещения увеличенного изображения. Затем нажмите на диск. Изображение сместится вправо. (Поверните диск вниз.) Изображение переместится влево. (Поверните диск вверх.)

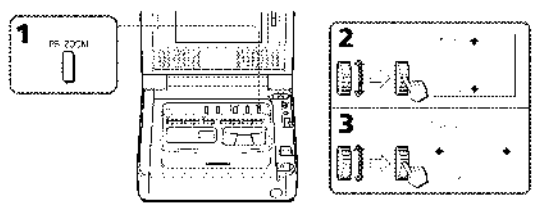

Advanced Operations - Усовершенствованные операции

Enlarging playback images - PB ZOOM

To cancel the PB ZOOM function

Press PB ZOOM again.

- Notes**
- The PB ZOOM function works only for tapes recorded in the Digital Hi system.
 - You cannot process externally input scenes using the PB ZOOM function.
 - You cannot record pictures that you have processed using the PB ZOOM function with your VCR. To record pictures that you have processed using the PB ZOOM function, record the pictures on the other VCR using your VCR as a player.

Pictures processed by the PB ZOOM function
Pictures processed by the PB ZOOM function are not input through the DV IN/OUT jack.

When you set the POWER switch to OFF or stop playback
The PB ZOOM function is automatically cancelled.

Увеличение воспроизводимых изображений - PB ZOOM

Для выключения функции PB ZOOM

Нажмите кнопку PB ZOOM еще раз.

- Примечания**
- Функция PB ZOOM работает только для кассет, записанных в системе Digital Hi.
 - Вы не можете обрабатывать внешние кадры с помощью функции PB ZOOM изображения, полученные от внешнего источника.
 - Вы не можете записывать изображения, которые были видоизменены с помощью функции PB ZOOM этого видеомаягнитофона. Для записи изображений, которые были видоизменены с помощью функции PB ZOOM, запишите изображения на другой видеомаягнитофон, используя свой видеомаягнитофон в качестве плеера.

Изображения, видоизмененные с помощью функции PB ZOOM
Изображения, видоизмененные с помощью функции PB ZOOM, не передаются через гнездо DV IN/OUT.

При установке переключателя POWER в положение OFF или остановке воспроизведения
Функция PB ZOOM автоматически отключится.

Watching a tape with special effects - Picture effect

You can digitally process playback images to obtain special effects like those in films or on TV.

- NEG. ART [a]** - The colors and brightness of the image are reversed.
SEPIA - The image is monochrome (black and white).
SOLARIZE [b] - The light intensity is clearer and the image looks like an illustration.



- Press MENU during playback.
- Turn the SEL/PUSH EXEC dial to select **PICTURE EFFECT**, then press the dial.
- Turn the SEL/PUSH EXEC dial to select **PICTURE EFFECT**, then press the dial.
- Turn the SEL/PUSH EXEC dial to select the desired picture effect mode, then press the dial. The indicator changes as follows: NEG. ART → SEPIA → B&W → SOLARIZE.
- Press MENU to make the menu settings disappear.

Просмотр кассет со специальными эффектами - Эффект изображения

Можно выполнить цифровую обработку воспроизводимых изображений для получения специальных эффектов, как в кинофильмах или на телевидении.

- NEG. ART [a]** - Установка цвета и яркости изображений соотносятся.
SEPIA - Изображение будет иметь серый цвет.
B&W - Изображение будет монохромным (чёрно-белым).
SOLARIZE [b] - Интенсивность света будет увеличена, а изображение будет выглядеть как рисунок.

- Нажмите кнопку MENU во время воспроизведения.
- Поверните диск SEL/PUSH EXEC для выбора установки P.EFFECT, а затем нажмите на диск.
- Поверните диск SEL/PUSH EXEC для выбора P.EFFECT, а затем нажмите на диск.
- Поверните диск SEL/PUSH EXEC для выбора нужного режима эффекта изображения, а затем нажмите на диск. Индикатор будет изменяться следующим образом: NEG. ART → SEPIA → B&W → SOLARIZE.
- Нажмите кнопку MENU, чтобы исчезли установки меню.

Адвентур Оперейшнс Удовлетворительные операции

Watching a tape with special effects - Picture effect

- Notes**
- The picture effect function works only for tapes recorded in the Digital Hi system.
 - You cannot process externally input sources using the picture effect function.
 - You cannot record pictures that you have processed using the picture effect function, record the pictures on the other VCR using your VCR as a player.

Pictures processed by the picture effect function
 Pictures processed by the picture effect function are not output through the DVD IN/OUT jack.

When you set the POWER switch to OFF or stop playback, the picture effect function is automatically cancelled.

Просмотр кассет со специальными эффектами - Эффект изображения

- ПРИМЕЧАНИЯ**
- Функция эффекта изображения работает только для кассет, записанных в системе Digital Hi.
 - Вы не можете воспроизводить изображения, введенные из внешнего источника, с помощью функции эффектов изображения.
 - Вы не можете записывать изображения, которые были видоизменены с помощью функции эффекта изображения, используя это изображение ни на чем. Для снятия изображений, которые были видоизменены с помощью функции эффектов изображения, запишите изображения на другой видеонаборный формат, используя этот видеонаборный формат в качестве плеера.

Изображения, видоизмененные с помощью функции эффектов изображения, воспроизводятся с помощью функции эффектов изображения, не передаются через гнездо DVD IN/OUT.

При установке переключателя POWER в положение OFF или остановке воспроизведения функция эффектов изображения автоматически отключается.

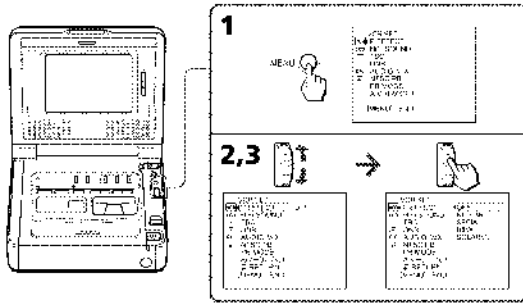

29 30

Watching a tape with special performances - Digital effect

You can add special effects to playback images using the various digital functions.

- STILL** - You can play back a still image so that it is superimposed on a moving image.
FLASH (FLASH MOTION) - You can mask a higher area in a still image with a moving image.
LUMI. (LUMINANCEKEY) - You can mask a higher area in a still image with a moving image.

TRAIL - You can play back the images so that an incidental trailing image is left.

Просмотр кассет со специальными эффектами - Цифровой эффект

Вы можете добавлять специальные эффекты к воспроизводимому изображению с помощью различных цифровых функций.

- STILL** - Можно воспроизводить неподвижное изображение и накладывать его на подвижное изображение.
FLASH (FLASH MOTION) - Можно маскировать неподвижное изображение с помощью подвижного изображения через постоянные интервалы.
LUMI. (LUMINANCEKEY) - Вы можете изменить яркие места на неподвижном изображении на подвижное изображение.
TRAIL - Вы можете воспроизводить изображения с эффектом задерживания.

Адвентур Оперейшнс Удовлетворительные операции

Watching a tape with special performances - Digital effect

- Press DIGITAL EFFECT during playback. The digital effect indicator appears.
- Turn the SEL/PUSH EXEC dial to select the desired digital effect mode. The indicator changes as follows: STILL → FLASH → LUMI. → TRAIL.
- Press the SEL/PUSH EXEC dial. The indicator lights up and the bars appear in the STILL and LUMI modes. The still image is stored in memory.
- Turn the SEL/PUSH EXEC dial to adjust the effect as follows:

- STILL** - The rate at the still image you want to superimpose on the moving image.
FLASH - The interval of flash motion.
LUMI. - The extent of the area in the still image which is to be masked with a moving image.
TRAIL - The vanishing time of the incidental image.

When the number of bars on the LCD screen is getting bigger, the digital effect will be getting bigger.

Просмотр кассет со специальными эффектами - Цифровой эффект

- Нажмите кнопку DIGITAL EFFECT во время воспроизведения. Появится индикатор цифровых эффектов.
- Поверните диск SEL/PUSH EXEC для выбора режима нужного цифрового эффекта. Индикатор будет изменяться следующим образом: STILL → FLASH → LUMI. → TRAIL.
- Нажмите на диск SEL/PUSH EXEC. Высветятся индикатор и появятся полосы. В режимах STILL и LUMI неподвижное изображение будет сохранено в памяти.
- Поверните диск SEL/PUSH EXEC для регулировки изображения следующим образом:

- STILL** - Интенсивность неподвижного изображения, которое нужно наложить на подвижное изображение.
FLASH - Интервал прерывистого движения.
LUMI. - Цветовая гамма области неподвижного изображения, которую нужно замаскировать подвижным изображением.
TRAIL - Время исчезновения побочного изображения.

При увеличении числа полос на экране ЖКД цифровой эффект усиливается.

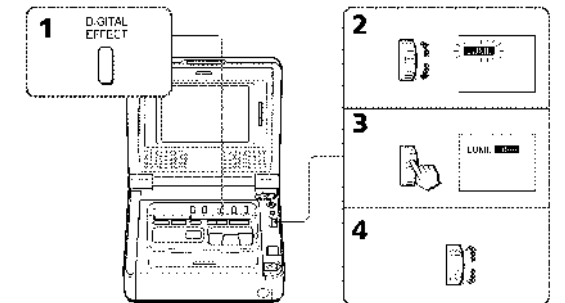
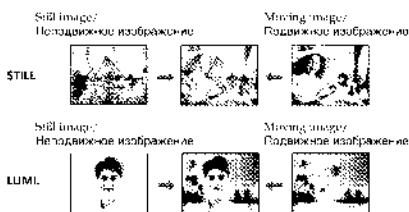

To cancel the digital effect function
 Press DIGITAL EFFECT again.

Для отмены функции цифровых эффектов
 Нажмите кнопку DIGITAL EFFECT еще раз.

31 32

Watching a tape with special performances – Digital effect

Notes

- The digital effect function works only for tapes recorded in the Digital Hi-Fi system.
- You cannot process externally input scenes using the digital effect function.
- You cannot record images that you have processed using the digital effect function with your VCR. To record images that you have processed using the digital effect function, record the images on the other VCR using your VCR as a player.

Pictures processed by the digital effect function

Pictures processed by the digital effect function are not output through the VIDEO OUTPUT jack.

When you set the POWER switch to OFF or stop playback the digital effect function is automatically cancelled.

Просмотр кассет со специальными эффектами – Цифровой эффект

Примечания

- Функция цифрового эффекта работает только для кассет, записанных в системе Digital Hi-Fi.
- Вы не можете видеозаписать изображения, выделенные из записанных источников, с помощью функции цифровых эффектов.
- Вы не можете записывать изображения, которые были выделены с помощью функции цифрового эфира с помощью видеоматричного. Для записи изображений, которые были выделены с помощью функции цифровых эффектов, записать изображения на другой видеоматричный, используя этот видеоматричный в качестве плеера.

Изображения, выделенные с помощью функций цифровых эффектов

Изображения, выделенные с помощью функций цифровых эффектов, не выводятся через разъем VIDEO INPUT.

При установке переключателя POWER в положение OFF или остановке воспроизведения

Функция цифровых эффектов автоматически отменяется.

Quickly locating a scene – Zero set memory

Your VCR goes forward or backward to stop automatically at a desired scene having a counter value of "00:00". Use the Remote Command supplied with a Sony digital video camera recorder for this operation. For details, refer to the operating instructions of the digital video camera recorder. Use this function, for example, to view a JESSED scene later on during playback.

- Press DISPLAY during playback.
- Press ZERO SET MEMORY on the Remote Command at the point you want to locate later. The counter shows "00:00" and the ZERO SET MEMORY indicator flashes.
- Press \blacktriangleleft when you want to stop playback.
- Press \blacktriangleleft to rewind the tape to the counter's zero point. The tape stops automatically when the counter reaches approximately zero. The ZERO SET MEMORY indicator disappears and the time code appears.
- Press \blacktriangleright . Playback starts from the counter's zero point.

Быстрый поиск эпизода – Память нулевой отметки

Видеокассета выполняет перемещение вперед или назад с автоматическим остановкой на нужном эпизоде, где показана отметка "00:00". Для этой операции используйте пульт дистанционного управления, поставляемый с цифровой видеокассетой Sony. Подробные сведения см. в инструкции по эксплуатации цифровой видеокассеты. Используйте эту функцию, например, для просмотра фильма эпизодом позже во время воспроизведения.

- Нажмите кнопку DISPLAY во время воспроизведения.
- Нажмите кнопку ZERO SET MEMORY на пульте дистанционного управления в том месте, куда вы хотите перейти позже. Показание счетчика изменится на "00:00", и начнет мигать индикатор ZERO SET MEMORY.
- Нажмите кнопку \blacktriangleleft , когда необходимо остановить воспроизведение.
- Нажмите кнопку \blacktriangleleft , чтобы перемотать ленту назад к нулевой точке счетчика ленты. Лента остановится автоматически, если счетчик достигнет приблизительно нулевой отметки. Индикатор ZERO SET MEMORY исчезнет и появится код времени.
- Нажмите кнопку \blacktriangleright . Воспроизведение начнется с нулевой отметки счетчика.

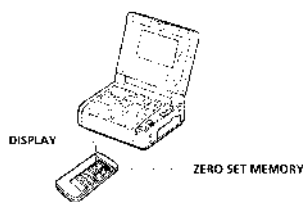

Quickly locating a scene – Zero set memory

Notes

- The zero set memory function works only for tapes recorded in the Digital Hi-Fi system.
- When you press ZERO SET MEMORY again before rewinding the tape, the zero set memory function is cancelled.
- There may be a discrepancy of several seconds from the time code.

If a tape has a blank portion between recorded portions the zero set memory function may not work correctly.

Быстрый поиск эпизода – Память нулевой отметки

Примечания

- Функция памяти нулевой отметки работает только для кассет, записанных в системе Digital Hi-Fi.
- Если вы еще раз нажмете кнопку ZERO SET MEMORY до начала перемотки ленты назад, то функция памяти нулевой отметки будет отменена.
- Между кодом времени и действительным временем может быть расхождение в несколько секунд.

Если на записанной ленте имеются незаписанные участки функция памяти нулевой отметки может работать неправильно.

Searching with recording date – Date search

You can automatically search for the point where the recording date changes and start playback from that point (Date search). Use the Remote Command supplied with a Sony digital video camera recorder for this operation. For details, refer to the operating instructions of the digital video camera recorder. Use this function to check where recording date changes or to edit the time at which recording date

Поиск по дате записи – Поиск даты

Можно автоматически выполнить поиск места, где изменилась дата записи, и начинать воспроизведение с этого места (поиск даты). Для этой операции используйте пульт дистанционного управления, поставляемый с цифровой видеокассетой Sony. Подробные сведения см. в инструкции по эксплуатации цифровой видеокассеты. Анализируйте эту функцию для проверки, где изменилась дата записи, или выделенных моментов ленты по дате записи.

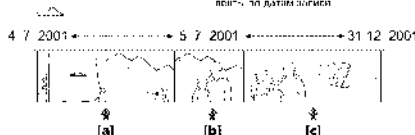

- Press SEARCH MODE on the Remote Command repeatedly, until the date search indicator appears. The indicator changes as follows: DATE SEARCH → PHOTO SEARCH → PHOTO SCAN.
- When the current position is (b), press \blacktriangleleft to search backwards (a) or press \blacktriangleright to search forwards (c). Your VCR automatically starts playback at the point where the date changes. To return you press \blacktriangleleft or \blacktriangleright , the VCR searches for the previous or next date.

- Нажмите кнопку SEARCH MODE на пульте дистанционного управления, пока не появится индикатор поиска даты. Индикатор будет изменяться следующим образом: DATE SEARCH → PHOTO SEARCH → PHOTO SCAN.
- Если лента находится в положении (b), нажмите кнопку \blacktriangleleft для поиска в направлении в заданном (a) или кнопку \blacktriangleright для поиска в направлении в заданном (c). Видеокассета автоматически начнет воспроизведение в том месте, где дата изменится. При каждом нажатии кнопки \blacktriangleleft или \blacktriangleright видеокассета выполнит поиск предыдущей или следующей даты.

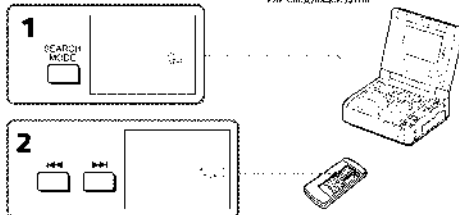

To stop searching Press \blacksquare .

Для остановки поиска Нажмите кнопку \blacksquare .

Searching with recording date - Date search

Notes

- The date search works only for tapes recorded in the Digital II system.
- The date search works only for tapes recorded with the date and time set.
- If time/day recording is less than two minutes, your VCR may not accurately find the point where the recording date changes.

If a tape has a blank portion between recorded portions

The date search function may not work correctly.

Поиск по дате записи - Поиск даты

Примечания

- Поиск по дате работает только для кассет, записанных в системе Digital II.
- Поиск по дате работает только для кассет, записанных с установкой даты и времени.
- Если продолжительность записи одного дня менее двух минут, видеомаястра может не точно найти место, где изменился дата записи.

Если на записанной ленте имеются независимые участки

Функция поиска даты может работать неправильно.

Searching for a photo - Photo search/Photo scan

You can search for the still images recorded on a tape with a Sony digital video camera recorder (photo search). You can also search for still images one after another and display each image for five seconds automatically (photo scan). Use the Remote Commander supplied with a Sony digital video camera recorder for these operations. For details, refer to the operating instructions of a Sony digital video camera recorder. Use these functions to check the still images of to edit only still images.

Searching for a photo

- Press SEARCH MODE on the Remote Commander repeatedly, until the photo search indicator appears. The indicator changes as follows: DATE SEARCH → PHOTO SEARCH → PHOTO SCAN.
- Press **⏪** or **⏩** to scroll the photo for playback. Each time you press **⏪** or **⏩**, your VCR searches for the previous or next photo. Your VCR automatically starts playback from the photo.

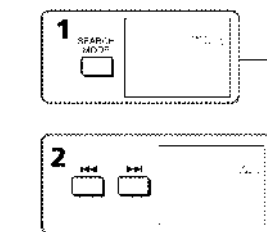

To stop searching
Press **■**

Поиск фото - Фотопоиск/Фотосканирование

Можно просмотреть, классифицировать и редактировать, записанные на кассете с помощью цифровой видеокамеры Sony (фотопоиск). Можно также выводить поиск неподвижных изображений поочередно и автоматически (фотосканирование). Для этих операций используйте пульт дистанционного управления, поставляемый с цифровой видеокамерой Sony. Подробные сведения см. в инструкции по эксплуатации цифровой видеокамеры Sony. Эти функции используются для проверки или редактирования только неподвижных изображений.

Поиск фото

- Нажмите кнопку SEARCH MODE на пульте дистанционного управления, пока не появится индикатор поиска фото. Индикатор будет изменяться следующим образом: DATE SEARCH → PHOTO SEARCH → PHOTO SCAN.
- Нажмите кнопку **⏪** или **⏩**, чтобы выбрать фото для воспроизведения. При каждом нажатии кнопки **⏪** или **⏩** видеомаястра выполняет поиск предыдущего или следующего фото. Видеомаястра автоматически начнет воспроизведение с этого фото.

Для остановки поиска
Нажмите кнопку **■**

Searching for a photo - Photo search/Photo scan

Scanning photo

- Press SEARCH MODE on the Remote Commander repeatedly, until the photo scan indicator appears. The indicator changes as follows: DATE SEARCH → PHOTO SEARCH → PHOTO SCAN.
- Press **⏪** or **⏩**. Each photo is played back for about 5 seconds automatically.

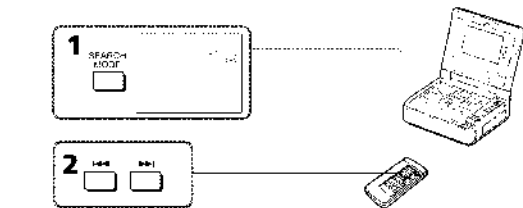

To stop scanning
Press **■**

Note

The photo search and photo scan functions work only for tapes recorded in the Digital II system.

If a tape has a blank portion between recorded portions

The photo search and photo scan functions may not work correctly.

Поиск фото - Фотопоиск/Фотосканирование

Сканирование фото

- Нажмите кнопку SEARCH MODE на пульте дистанционного управления, пока не появится индикатор поиска фотосканирования. Индикатор будет изменяться следующим образом: DATE SEARCH → PHOTO SEARCH → PHOTO SCAN.
- Нажмите кнопку **⏪** или **⏩**. Каждое фото будет автоматически отображаться примерно 5 секунд.

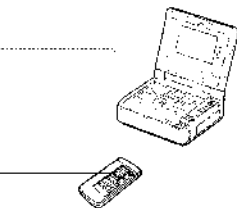

Для остановки сканирования
Нажмите кнопку **■**

Примечание

Функции фотопоиска и фотосканирования работают только для кассет, записанных в системе Digital II.

Если на записанной ленте имеются независимые участки

Функции фотопоиска и фотосканирования могут работать неправильно.

Displaying recording data - Data code function

When you play back tapes recorded by your VCR, you can check the recording date/time. Also, when you playback tapes recorded by a Digital II system video camera recorder with the data code function, you can check the recording date/time and various settings when you have recorded.

Using the data code function

Your VCR automatically stores the date/time and the recording data used during the recording in the memory of the tape.

DATA CODE



Press DATA CODE on your VCR.

The display changes as follows: date/time → various settings (steady shot, exposure AUTO/MANUAL, white balance, gain, shift speed, aperture value) → standby.

Date/time дата/время

12:00
12:00

- (a) SteadyShot OFF indicator
- (b) Exposure mode indicator
- (c) White balance indicator
- (d) Gain indicator
- (e) Shutter speed indicator
- (f) Aperture value

To not display various settings
Set DATA CODE to DATE in the menu settings (p. 63).

The display changes as follows: date/time → no indicator

Отображение данных записи и экранных индикаторов - Функция кода данных

При воспроизведении кассет, записанных с помощью цифровой видеокамеры, можно просмотреть дату и время записи. Кроме того, при воспроизведении кассет, записанных с помощью видеокамеры системы Digital II с функцией кода данных, можно просмотреть дату и время записи, а также другие различные параметры.

Использование функции кода данных

Ваш видеомаястра автоматически сохраняет дату и время, а также все другие данные, использованные во время записи, в память кассеты.

Нажмите кнопку DATA CODE на видеомаястре.

Индикатор будет изменяться следующим образом: дата/время → различные установки (устойчивый кадр, эксп. АВТО/МАНУАЛ, баланс белого, усиление, скорость затвора, величина диафрагмы) → без индикации.

Various settings Разные установки

(a) SteadyShot OFF indicator
(b) Exposure mode indicator
(c) White balance indicator
(d) Gain indicator
(e) Shutter speed indicator
(f) Aperture value

(a) Индикатор выключенной устойчивой съемки OFF

- (b) Индикатор режима экспозиции
- (c) Индикатор баланса белого
- (d) Индикатор усиления
- (e) Индикатор скорости затвора
- (f) Величина диафрагмы

Для отмены отображения разных установок
Установите индикатор DATA CODE в положение DATE в установках меню (стр. 67).

Индикатор будет изменяться следующим образом: дата/время → без индикации

Displaying recording data and screen indicators - Data code function

Note on the data code function

The data code function works only for tapes recorded in the Digital Hi-Fi system.

Recording data

Recording data is the information on your VCR's camcorder when you have recorded.

When you use the data code function, bars (— — — — —) appear if

— A blank sector on the tape is being played back.

— The tape is unreadable due to tape damage or noise.

— The tape was recorded by a camcorder or your VCR without the date and time settings.

Data code

When you connect your VCR to the TV, the data code appears on the TV screen.

Отображение данных записи и экранных индикаторов - Функция кода данных

Применения относительно функции кода данных

Функция кода данных работает только для кассет, записанных в системе Digital Hi-Fi.

Записанные данные

Записанные данные - это информация о том, когда была выполнена запись видеоматериалом или видеозаписью.

При использовании функции кода данных появляются полосы (— — — — —), если

— Воспроизводится незаписанный участок на ленте.

— Лента не годится для считывания из-за повреждений или шума.

— Запись на ленту была выполнена, когда в видеорежиссер или видеоматрирование не были установлены дата и время.

Код данных

Когда видеоматрирование подключено и телекабель, код данных также будет отображаться на экране телевизора.

Advanced Operations, Управляющие операции

Superimposing a title

You can select one of eight preset titles and two custom titles (1-4). You can also select the language, colour, size, and position of titles.

Наложение титра

Вы можете выбрать один из восьми предустановленных и двух собственных титров (стр. 44). Можно также выбрать язык, цвет, размер и положение титров.

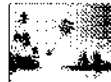

- Press TITLE to display the title menu.
- Turn the SEL/PUSH EXEC dial to select TITLE , then press the dial.
- Turn the SEL/PUSH EXEC dial to select the desired title, then press the dial. The titles are displayed in the language you selected.
- Change the colour, size, or position, if necessary.
 - Turn the SEL/PUSH EXEC dial to select the colour, size, or position, then press the dial. The item appears.
 - Turn the SEL/PUSH EXEC dial to select the desired item, then press the dial.
 - Repeat steps ① and ② until the title is laid out as desired.
- Turn the SEL/PUSH EXEC dial to select TITLE, then press the SEL/PUSH EXEC dial again to complete the setting.
- Press REC to start recording.
- When you want to stop recording the title, press TITLE.

- Нажмите кнопку TITLE для отображения меню титров.
- Поверните диск SEL/PUSH EXEC для выбора и нажмите TITLE в меню титров на диск.
- Поверните диск SEL/PUSH EXEC для выбора нужного титра, затем нажмите на диск. Титры отображаются на выбранном языке.
- Измените цвет, размер или положение титра, если нужно.
 - Поверните диск SEL/PUSH EXEC для выбора цвета, размера или положения титра нажмите на диск. Появится элемент.
 - Поверните диск SEL/PUSH EXEC для выбора нужного элемента, затем нажмите на диск.
 - Повторите пункты ① и ② до тех пор, пока титр не будет расположен надлежащим образом.
- Поверните диск SEL/PUSH EXEC для выбора TITLE, затем снова нажмите на диск SEL/PUSH EXEC для завершения установки.
- Нажмите кнопку REC для начала записи.
- Когда потребуется остановить запись титра, нажмите кнопку TITLE.

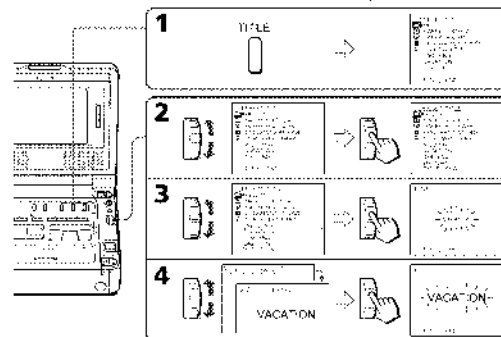

41

42

Superimposing a title

To superimpose the title while you are recording

Press TITLE while you are recording, select TITLE on steps 2 to 3. When you press the SEL/PUSH EXEC dial in step 3, the title is recorded.

To select the language of a preset title

If you want to change the language, select LANG before step 2. Then select the desired language and return to step 2.

To use the custom title

If you want to use the custom title, select CUSTOM in step 2.

Title setting

The title colour changes as follows:

WHITE \leftrightarrow YELLOW \leftrightarrow VIOLET \leftrightarrow RED \leftrightarrow CYAN \leftrightarrow GREEN \leftrightarrow BLUE

The title size changes as follows:

SMALL \leftrightarrow LARGE

You cannot input more than 12 characters in LARGE size.

The title position changes as follows:

1 \leftrightarrow 2 \leftrightarrow 3 \leftrightarrow 4 \leftrightarrow 5 \leftrightarrow 6 \leftrightarrow 7 \leftrightarrow 8 \leftrightarrow 9

When the number of the title position getting large, the title is positioned in getting lower on the LCD screen.

When you select the title size as LARGE, you cannot choose position 9.

When you are selecting and setting the title

You cannot record the title displayed on the screen.

When you are playing back

You can superimpose a title. However, the title is not recorded on the tape.

You can record a title when you dub a tape by connecting your VCR to the other VCR with the A/V connecting cable. If you use the LINK cable (A/V connecting cable) (not supplied).

Instead of the A/V connecting cable, you cannot record the title.

Наложение титра

Чтобы наложить титр во время записи

Нажмите кнопку TITLE во время записи и выберите пункты 2 до 3. После нажатия на диск SEL/PUSH EXEC в пункте 3 титр будет записан на диск.

Чтобы выбрать язык предустановленного титра

Если необходимо изменить язык, выберите LANG перед выполнением пункта 2. Затем выберите необходимый язык и вернитесь к пункту 2.

Для использования собственного титра

Если нужно использовать собственный титр выберите CUSTOM в пункте 2.

Установка титра

Цвет титра изменяется следующим образом:

WHITE (БЕЛЫЙ) \leftrightarrow YELLOW (ЖЕЛТЫЙ) \leftrightarrow VIOLET (ФИОЛЕТОВЫЙ) \leftrightarrow RED (КРАСНЫЙ) \leftrightarrow CYAN (ГОЛУБОВЫЙ) \leftrightarrow GREEN (ЗЕЛЕНЫЙ) \leftrightarrow BLUE (СИНИЙ)

Размер титра изменяется следующим образом:

SMALL (МАЛЕНЬКИЙ) \leftrightarrow LARGE (БОЛЬШОЙ)

При LARGE размере нельзя ввести более 12 символов.

Позиция титра изменяется следующим образом:

1 \leftrightarrow 2 \leftrightarrow 3 \leftrightarrow 4 \leftrightarrow 5 \leftrightarrow 6 \leftrightarrow 7 \leftrightarrow 8 \leftrightarrow 9

При увеличении номера позиции титра он будет располагаться ниже на экране ЖКД.

Если выбран размер титра LARGE (большой), нельзя выбрать положение 9.

При выборе и установке титра

Запись титра, отображаемого на экране невозможна.

Во время воспроизведения

Можно наложить титр. Однако титр не записывается на ленту.

Титр можно записать во время перемотки кассеты, подключив видеоматрирование к другому видеорежиссеру с помощью соединительного кабеля аудиовидео.

Если вместо соединительного кабеля аудиовидео используется кабель LINK (соединительный кабель) (не входит в комплект), запись титра невозможна.

Advanced Operations, Управляющие операции

Making your own titles

You can make up to two titles, and store them in your VCR. Each title can have up to 20 characters.

- Press TITLE.
- Turn the SEL/PUSH EXEC dial to select CUSTOM , then press the dial.
- Turn the SEL/PUSH EXEC dial to select the first line (CUSTOM1) or second line (CUSTOM2), then press the dial.
- Turn the SEL/PUSH EXEC dial to select the column of the desired character, then press the dial.
- Turn the SEL/PUSH EXEC dial to select the desired character, then press the dial.
- Repeat steps 4 and 5 until you have selected all characters and completed the title.
- To finish making your own titles, turn the SEL/PUSH EXEC dial to select TITLE , then press the dial. The title is stored in memory.
- Press TITLE to make the title menu disappear.

Создание собственных титров

Можно создать не более двух титров и сохранить их в видеоматрирование. Каждый титр может содержать не более 20 символов.

- Нажмите кнопку TITLE.
- Поверните диск SEL/PUSH EXEC для выбора установки CUSTOM , а затем нажмите на диск.
- Поверните диск SEL/PUSH EXEC для выбора первой строки (CUSTOM1) или второй строки (CUSTOM2), затем нажмите на диск.
- Поверните диск SEL/PUSH EXEC для выбора колонки нужного символа, затем нажмите на диск.
- Поверните диск SEL/PUSH EXEC для выбора нужного символа, затем нажмите на диск.
- Повторите пункты 4 и 5 до тех пор, пока не будут выбраны все символы, и полностью создан титр.
- Для завершения создания собственного титра поверните диск SEL/PUSH EXEC для выбора TITLE, затем нажмите на диск. Титр будет сохранен в памяти.
- Нажмите кнопку TITLE, чтобы исчезло меню титров.

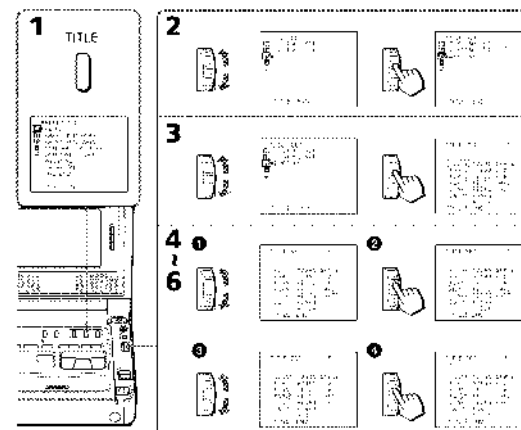

43

44

Dubbing a tape

Note on tapes that are not recorded in the Digital Hi system
The picture may fluctuate. This is not a malfunction.

During playback of tapes recorded in the Hi/standard 8 system
Digital signals are output as the image signals from the DV IN/OUT jack.

You can connect one VCR only using the i.LINK cable (DV connecting cable).

If you record a playback pause picture with the DV IN/OUT jack
The recorded picture becomes rough. Also, when you play back the recorded pictures on other video equipment, the picture may jitter.

Перезапись кассеты

Примечание относительно кассет, которые записаны не в системе Digital Hi
Изображение может быть неуравновешено. Однако это не является неисправностью.

При воспроизведении кассет, записанных в системе Hi/standard 8
Цифровые сигналы выводятся как сигналы изображения, через гнездо DV IN/OUT.

Вы можете подсоединить только один видеомонитор с помощью кабеля i.LINK (соединительный кабель DV).

При записи неподвижного изображения через гнездо DV IN/OUT
Записываемое изображение становится неровным. Кроме того, при воспроизведении записанного изображения на другое видеоаппаратуру оно может дрожать.

Dubbing only desired scenes - Digital program editing

You can duplicate selected scenes (program) for editing onto a tape without operating the other recording VCR.



Before operating the Digital program editing

- 1 Connecting the other (recording) VCR (p. 30).
- 2 Setting the other (recording) VCR for operation (p. 31).
- 3 Adjusting the synchronicity of the other (recording) VCR (p. 32).

When you dub using the same (recording) VCR data, you can skip steps 2 and 3.

Using the Digital program editing function

- 1 Making the programme (p. 29).
- 2 Performing a Digital program editing (dubbing a tape) (p. 31)

Notes

- The Digital program editing works only for tapes recorded in the Digital Hi system.
- You cannot dub the display indicators.
- When you edit a digital video, the operation signals cannot be sent with i.LINK.
- When you confirm the setup screen, connect your (playing) VCR to a TV, or a monitor using the super-laser link function.

Step 1: Connecting the other (recording) VCR

You can connect either the A/V connecting cable or the i.LINK cable (DV connecting cable). When you use the A/V connecting cable, connect the devices as illustrated on page 49. When you use the i.LINK cable (DV connecting cable), connect the devices as illustrated on page 48.

Перезапись только нужных эпизодов - Цифровой монтаж по программе

Можно дублировать на кассете выбранные для монтажа эпизоды (программы) без помощи другого (записывающего) видеомонитора.

Эпизоды можно выбирать по кадрам.

Перед началом цифрового монтажа по программе

- 1 Подключение другого (записывающего) видеомонитора (стр. 30).
- 2 Настройка другого (записывающего) видеомонитора для работы (стр. 31).
- 3 Регулировка синхронности другого (записывающего) видеомонитора (стр. 32).

Если вы дублируете с помощью той же записывающей видеомонитора, шаги 2 и 3 можно пропустить.

Использование функции цифрового монтажа по программе

- 1 Создание программы (стр. 29).
- 2 Выполнение цифрового монтажа по программе (дублирование кассеты) (стр. 31).

Примечания

- Эта функция работает только в программе редактирования для систем Hi/standard 8.
- Индикаторы не дублируются.
- При монтаже цифрового видео сигналы управления не передаются через кабель i.LINK.
- При подтверждении экрана меню настроек, подключите ваш (воспроизводящий) видеомонитор к телевизору или монитору с помощью функции суперлазерной связи.

Шаг 1: Подключение другого (записывающего) видеомонитора

Можно подключить соединительный кабель A/V или кабель i.LINK (соединительный кабель DV). При использовании соединительного кабеля A/V подключение устройств показано на странице 49. При использовании кабеля i.LINK (соединительный кабель DV) устройства должны быть подключены к телевизору или монитору (стр. 48).

Dubbing only desired scenes - Digital program editing

Step 2: Setting the other (recording) VCR for operation - Using the A/V connecting cable

To dub using the other (recording) VCR, send the control signal by entered key to the remote control of the other (recording) VCR. When you connect using the A/V connecting cable, follow the procedures below.

- 1 Set the POWER switch to ON on your (playing) VCR.
- 2 Turn the power of the other (recording) VCR on, then set the input selector to i.LINK.
- 3 When you confirm a digital video camera record, set the POWER switch to VCR/VTR.
- 4 Press MENU to display the menu settings.
- 5 Turn the SEL/PUSH EXEC dial to select EDIT SET, then press the dial.
- 6 Turn the SEL/PUSH EXEC dial to select CONTROL, then press the dial.
- 7 Turn the SEL/PUSH EXEC dial to select IR, then press the dial.
- 8 Turn the SEL/PUSH EXEC dial to select IR SETUP, then press the dial.
- 9 Turn the SEL/PUSH EXEC dial to select the IR SETUP code of the other (recording) VCR (p. 52), then press the dial.

Перезапись только нужных эпизодов - Цифровой монтаж по программе

Шаг 2: Настройка другого (записывающего) видеомонитора для работы - Использование соединительного кабеля аудио/видео

Для дублирования материала с воспроизводящего другого (записывающего) видеомонитора можно передать ИК-сигналы управления на его датчик дистанционного управления. Если подключение производится с помощью соединительного аудио/видео кабеля, выполните процедуры, указанные ниже.

- 1 Убедитесь, что переключатель POWER в положении ON на воспроизводящем видеомониторе.
- 2 Включите питание другого (записывающего) видеомонитора и установите селектор видеовхода сигнала в положение i.LINK.
- 3 При подтверждении экрана видеомонитора установите его переключатель POWER в положение VCR/VTR.
- 4 Нажмите кнопку MENU для отображения меню настроек.
- 5 Поверните диск SEL/PUSH EXEC для выбора EDIT SET, а затем нажмите на диск.
- 6 Поверните диск SEL/PUSH EXEC для выбора CONTROL, а затем нажмите на диск.
- 7 Поверните диск SEL/PUSH EXEC для выбора IR, а затем нажмите на диск.
- 8 Поверните диск SEL/PUSH EXEC для выбора IR SETUP, а затем нажмите на диск.
- 9 Поверните диск SEL/PUSH EXEC для выбора кода IR SETUP другого (записывающего) видеомонитора (стр. 52), а затем нажмите на диск.

Dubbing only desired scenes - Digital program editing

About the IR SETUP code
The IR SETUP code is stored in the memory of your VCR. Be sure to set the correct code, depending on the other (recording) VCR. The default setting is code number 3.

Brand Фирма-производитель	IR SETUP code Код IR SETUP
Sony	1, 2, 3, 4, 5, 6
Avia	47, 53, 54
Asa	62, 50, 59
Alba	73
Arcton	84
Bird	36, 30
Blaupunkt	83, 78
Burb	74
Canon	97
CCM	47, 83, 78
Clatronic	73
Daewon	26
Edison	76
Eisher	73
Funai	80
Gold-star	47
Grundig	76, 84
Gruenig	83, 4
Hilachi	42, 76
HT/Neos Instant	36
JVC	12, 11, 15, 11, 21
Kenaco	47
Kenwood	16, 47, 84
Laxar	89
Mira	26
Mitsubi	47, 60, 58
Mitsubishi	26, 30

Перезапись только нужных эпизодов - Цифровой монтаж по программе

Информация о коде IR SETUP
Код IR SETUP сохраняется в памяти видеомонитора. Установите правильный код, исходя из кода другого (записывающего) видеомонитора. По умолчанию устанавливается код 3.

Brand Фирма-производитель	IR SETUP code Код IR SETUP
Nakai	89, 30
Nakai Dynamic	26
Nordmende	76
Osaka	60, 52, 53
Orion	70, 58
Panasonic	16, 28, 56
Philips	83, 84, 56
Phonola	83, 44
Recofan	47
SDA	76, 21
Samsung	43, 84, 52, 27
Sanyo	36
Schneider	84, 16
SEC	73
Selec	47, 74
Sharp	89, 58
Siemens	10, 30
Tanling	26
Tecoflexon	83, 92
Tosai	73
Technico	26, 100
Thera	36, 47
Toshiba	40
Ukrainian	92, 30, 47
W.M. House	47
Watsen	83, 58

* TV/VCR component/компонент "телевизор/видеомонитор"

Note on the IR SETUP code
The Digital program editing does not work if the VCR is not corresponded to IR SETUP codes.

Примечание относительно кода IR SETUP
Функция цифрового монтажа по программе не работает, если видеомонитор не соответствует кодам IR SETUP.

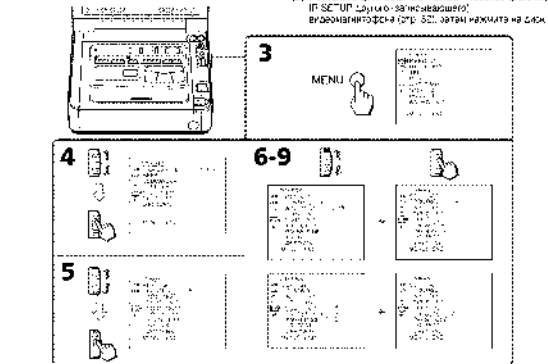

Editing Montage

Editing Montage

Dubbing only desired scenes – Digital program editing

Setting the modes to cancel the recording pause on the other (recording) VCR

- Turn the SEL/PUSH EXEC dial to select PAUSE MODE, then press the dial.
- Turn the SEL/PUSH EXEC dial to select the mode to cancel recording pause on the other (recording) VCR, then press the dial. The correct button depends on the other (recording) VCR. Refer to the operating instructions on the other (recording) VCR.

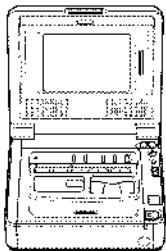

Перезапись только нужных эпизодов – Цифровой монтаж по программе

Установка режимов для отмены паузы при записи на другом (записывающем) видеомаягнитофоне

- Поверните диск SEL/PUSH EXEC для выбора PAUSE MODE, а затем нажмите на диск.
- Поверните диск SEL/PUSH EXEC, чтобы выбрать режим для отмены паузы при записи на другом (записывающем) видеомаягнитофоне, а затем нажмите на диск. Выбор правильной кнопки зависит от другого (записывающего) видеомаягнитофона. Обратитесь к инструкциям по эксплуатации другого (записывающего) видеомаягнитофона.

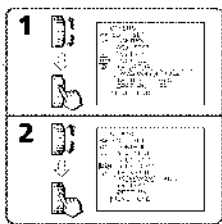

The buttons to cancel recording pause on the other (recording) VCR

Select the buttons when you cancel recording pause on the other (recording) VCR, and start recording.

- The buttons vary depending on the other (recording) VCR. To cancel recording pause:
- Select PAUSE if the button to cancel recording pause is II
 - Select REW if the button to cancel recording pause is ●
 - Select FFB if the button to cancel recording pause is ►

Кнопки для отмены паузы при записи на другом (записывающем) видеомаягнитофоне

Выберите эти кнопки при отмене паузы при записи на другом (записывающем) видеомаягнитофоне и начните запись.

- Кнопки могут быть разными в зависимости от модели (записывающего) видеомаягнитофона. Для отмены паузы при записи:
- Выберите PAUSE, если кнопка для отмены паузы при записи - II
 - Выберите FFB, если кнопка для отмены паузы записи - ●
 - Выберите FFB, если кнопка для отмены паузы записи - ►

Editing Montage

53

Dubbing only desired scenes – Digital program editing

Setting your (playback) VCR and the other (recording) VCR to face each other

Locate the infrared rays emitter of your (playback) VCR to face it towards the remote sensor of the other (recording) VCR. Set the devices more than 30 cm (12 in.) apart, and remove any obstacles between the devices.

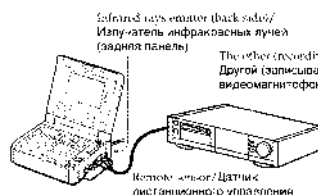

Перезапись только нужных эпизодов – Цифровой монтаж по программе

Установите этот (воспроизводящий) и другой (записывающий) видеомаягнитофон так, чтобы они находились друг против друга

Инфракрасный излучатель этого (воспроизводящего) видеомаягнитофона необходимо направить на датчик дистанционного управления другого (записывающего) видеомаягнитофона. Установите устройства на расстоянии более 30 см друг от друга и устраните любые препятствия между ними.

Step 2: Setting the other (recording) VCR for operation - Using the i.LINK cable (DV connecting cable)

When you connect using the i.LINK cable (DV connecting cable) (not supplied), follow the procedures below.

- Set the POWER switch to ON on your (playback) VCR.
- Turn the power of the other (recording) VCR on, then set the input selector to DV input. When you connect a digital video camera recorder, set it to POWER switch to VCR/AVR.
- Press MENU to display the menu screen.
- Turn the SEL/PUSH EXEC dial to select: EPI, then press the dial.
- Turn the SEL/PUSH EXEC dial to select: EDIT SET, then press the dial.
- Turn the SEL/PUSH EXEC dial to select: CONTROL, then press the dial.
- Turn the SEL/PUSH EXEC dial to select: i.LINK, then press the dial.

Перезапись только нужных эпизодов – Цифровой монтаж по программе

Шаг 2: Настройка другого (записывающего) видеомаягнитофона для работы - Использование кабеля i.LINK (соединительный кабель DV)

При выполнении соединения с помощью кабеля i.LINK (соединительный кабель DV) (не входит в комплект) выполните процедуры, указанные ниже.

- Включите переключатель POWER в положение ON на VCR (воспроизводящий видеомаягнитофон).
- Включите питание другого (записывающего) видеомаягнитофона и установите селектор входного сигнала в положение DV. При подключении цифровой видеокамеры установите переключатель POWER в положение VCR/AVR.
- Нажмите кнопку MENU для отображения экрана меню.
- Поверните диск SEL/PUSH EXEC для выбора элемента EPI, а затем нажмите на диск.
- Поверните диск SEL/PUSH EXEC для выбора EDIT SET, а затем нажмите на диск.
- Поверните диск SEL/PUSH EXEC для выбора CONTROL, а затем нажмите на диск.
- Поверните диск SEL/PUSH EXEC для выбора i.LINK, а затем нажмите на диск.

Dubbing only desired scenes – Digital program editing

Confirming the other (recording) VCR operation

- Insert a recordable tape into the other (recording) VCR, then set to recording pause TEST. Then press the dial.
- Turn the SEL/PUSH EXEC dial to select: EXECUTE, then press the dial. If the other (recording) VCR starts recording, the setting is correct. When finished, the indicator changes to COMPLETE.

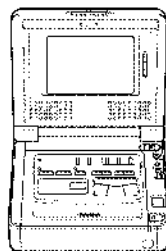

Перезапись только нужных эпизодов – Цифровой монтаж по программе

Проверка работы другого (записывающего) видеомаягнитофона

- Вставьте кассету для записи в другой (записывающий) видеомаягнитофон, затем установите режим паузы записи.
- Поверните диск SEL/PUSH EXEC для выбора EPI, а затем нажмите на диск.
- Поверните диск SEL/PUSH EXEC для выбора элемента EXECUTE, затем нажмите на диск. Если другой (записывающий) видеомаягнитофон начнет запись, это означает правильную настройку. По окончании индикатор изменится на COMPLETE.

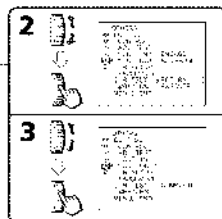

If the other (recording) VCR operates correctly

Skip to step 3 on page 57.

If the other (recording) VCR does not operate correctly

- Set the IR SETUP mode, or select the button to cancel the recording pause on the other (recording) VCR.
- Place some 40cm (16 in.) VCR (at least 40 cm (12 in.) away from the other (recording) VCR.
- Refer to the operating instructions of the other (recording) VCR.

Если другой (записывающий) видеомаягнитофон работает правильно

Перейдите к шагу 3 на стр. 57.

Если другой (записывающий) видеомаягнитофон работает неправильно

- Установите код IR SETUP, или выберите кнопку для отмены паузы при записи на другом (записывающем) видеомаягнитофоне.
- Установите (воспроизводящий) видеомаягнитофон на расстоянии не менее 40 см от другого (записывающего) видеомаягнитофона.
- Обратитесь к инструкциям по эксплуатации другого (записывающего) видеомаягнитофона.

Editing Montage

55

If you connect using the i.LINK cable (DV connecting cable)

With digital-to-digital connection, video and audio signals are transmitted in digital form for high-quality editing.

Если подключение производится с помощью кабеля i.LINK (соединительный кабель DV) при использовании цифрового соединения видео- и аудиосигналы передаются в цифровом виде для высококачественного редактирования монтажа.

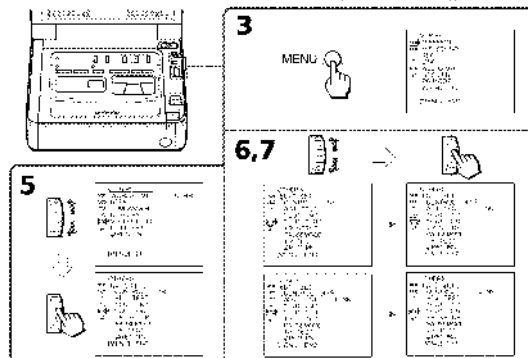

55

56

Dubbing only desired scenes – Digital program editing

Step 3: Adjusting the synchronicity of the other (recording) VCR

You can adjust the synchronicity of your playback VCR and the other (recording) VCR. First, eject the tape from your (playback) VCR. Have a pen and paper ready for notes.

- Insert a blank tape for a tape you want to record over into the other (recording) VCR, then set to recording pause.
- When you select **LINK** in **CONTROL**, the above procedure is not necessary.
- Turn the **SEL/PUSH EXEC** dial to select **ADJ TEST**, then press the dial.
- Turn the **SEL/PUSH EXEC** dial to select **EXECUTE**. Then press the dial.
- IN** and **OUT** are recorded on the image for the times each to calculate the numerical values for adjusting the synchronicity. The **EXECUTING** indicator flashes on the LCD screen. When finished, the indicator changes to **COMPLETE**.
- Rewind the tape in the other (recording) VCR, then start slow playback. Take a note of the opening numerical value of each **IN**, and the closing numerical value of each **OUT**.
- Calculate the average of all the opening numerical values in each **IN**, and the average of all the closing numerical values of each **OUT**.
- Turn the **SEL/PUSH EXEC** dial to select **“CUT-N”**, then press the dial.
- Turn the **SEL/PUSH EXEC** dial to select the average numerical value of **IN**, then press the dial. The calculated start position for recording is set.
- Turn the **SEL/PUSH EXEC** dial to select **“CUT-OUT”**, then press the dial. The calculated end position for recording is set.
- Turn the **SEL/PUSH EXEC** dial to select **RETURN**, then press the dial.

Перезапись только нужных эпизодов – Цифровой монтаж по программе

Шаг 3: Регулировка синхронности другого (записывающего) видеомагнитофона

Можно отрегулировать синхронность эонов (воспроизведения) и другого (записывающего) видеомагнитофона. Сначала извлеките кассету из своего (воспроизводящего) видеомагнитофона. Приготовьте ручку и бумагу для записей.

- Вставьте кассету в кассету (или кассету, на которую нужно записать запись) в другой (записывающий) видеомагнитофон, затем установите режим паузы. Запись.
- После выбора **LINK** в первоначальном **CONTROL** опишите выше процедуру вылетов нежелательных ямок.
- Поверните диск **SEL/PUSH EXEC** для выбора **ADJ TEST**, а затем нажмите на диск.
- Поверните диск **SEL/PUSH EXEC** для выбора установленного выше процедура вылетов нежелательных ямок.
- На изображение залитой по пять меток **IN** и **OUT**, чтобы можно было рассчитать числовые значения для регулировки синхронности. На экране ЖКД мигает индикатор **EXECUTING**. По окончании индикатор изменится на **COMPLETE**.
- Перемотайте кассету в другом (записывающем) видеомагнитофоне на начало, затем включите замедленное воспроизведение. Обратите внимание на начальное числовое значение в каждой метке **IN** и конечное числовое значение каждой метки **OUT**.
- Рассчитайте среднее значение всех начальных числовых значений на каждой метке **IN**, а также среднее значение всех конечных числовых значений каждой метки **OUT**.
- Поверните диск **SEL/PUSH EXEC** для выбора **“CUT-N”**, а затем нажмите на диск.
- Поверните диск **SEL/PUSH EXEC** для выбора среднего числового значения **IN**, затем нажмите на диск.
- Поверните диск **SEL/PUSH EXEC** для выбора среднего числового значения **OUT**, затем нажмите на диск.
- Рассчитанное начальное положение для записи установлено.
- Поверните диск **SEL/PUSH EXEC** для выбора **“CUT-OUT”**, а затем нажмите на диск.
- Поверните диск **SEL/PUSH EXEC** для выбора среднего числового значения **OUT**, затем нажмите на диск.
- Рассчитанное конечное положение для записи установлено.
- Поверните диск **SEL/PUSH EXEC** для выбора **RETURN**, а затем нажмите на диск.

Видео Монтаж

Dubbing only desired scenes – Digital program editing

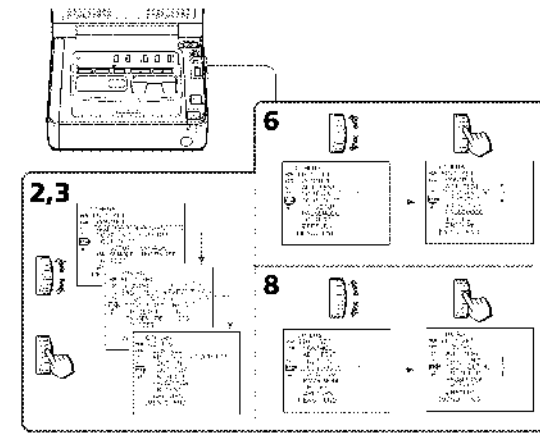

- Notes**
- If you start recording from the very beginning of the tape, the first few seconds of the tape may not be recorded properly. Be sure to allow about 10 seconds' lead before starting the recording.
 - When you complete step 3, the image to adjust the synchronicity is recorded for about 30 seconds.

Перезапись только нужных эпизодов – Цифровой монтаж по программе

Шаг 3: Регулировка синхронности другого (записывающего) видеомагнитофона

Можно отрегулировать синхронность эонов (воспроизведения) и другого (записывающего) видеомагнитофона. Сначала извлеките кассету из своего (воспроизводящего) видеомагнитофона. Приготовьте ручку и бумагу для записей.

- Вставьте кассету в кассету (или кассету, на которую нужно записать запись) в другой (записывающий) видеомагнитофон, затем установите режим паузы. Запись.
- После выбора **LINK** в первоначальном **CONTROL** опишите выше процедуру вылетов нежелательных ямок.
- Поверните диск **SEL/PUSH EXEC** для выбора **ADJ TEST**, а затем нажмите на диск.
- Поверните диск **SEL/PUSH EXEC** для выбора установленного выше процедура вылетов нежелательных ямок.
- На изображение залитой по пять меток **IN** и **OUT**, чтобы можно было рассчитать числовые значения для регулировки синхронности. На экране ЖКД мигает индикатор **EXECUTING**. По окончании индикатор изменится на **COMPLETE**.
- Перемотайте кассету в другом (записывающем) видеомагнитофоне на начало, затем включите замедленное воспроизведение. Обратите внимание на начальное числовое значение в каждой метке **IN** и конечное числовое значение каждой метки **OUT**.
- Рассчитайте среднее значение всех начальных числовых значений на каждой метке **IN**, а также среднее значение всех конечных числовых значений каждой метки **OUT**.
- Поверните диск **SEL/PUSH EXEC** для выбора **“CUT-N”**, а затем нажмите на диск.
- Поверните диск **SEL/PUSH EXEC** для выбора среднего числового значения **IN**, затем нажмите на диск.
- Поверните диск **SEL/PUSH EXEC** для выбора среднего числового значения **OUT**, затем нажмите на диск.
- Рассчитанное начальное положение для записи установлено.
- Поверните диск **SEL/PUSH EXEC** для выбора **“CUT-OUT”**, а затем нажмите на диск.
- Поверните диск **SEL/PUSH EXEC** для выбора среднего числового значения **OUT**, затем нажмите на диск.
- Рассчитанное конечное положение для записи установлено.
- Поверните диск **SEL/PUSH EXEC** для выбора **RETURN**, а затем нажмите на диск.

- Примечания:**
- Если запись начинается с самого начала кассеты, то первые несколько секунд на ленте может записываться изображение нечетко сфокусированной картинки. Прежде чем начать запись, необходимо пропустить приблизительно 10 секунд на ленте.
 - По завершении шага 3 изображение для регулировки синхронности записывается в течение 30 секунд.

When you connect with the iLINK cable (DV connecting cable)
You may not be able to operate the dubbing function correctly depending on the other VCR. Keep the iLINK connection, and follow the procedure from step 2 on page 71.

При подключении с помощью кабеля iLINK (соединительный кабель DV)
Функция дублирования может работать неправильно в зависимости от другого видеомагнитофона. Не отключая соединения с помощью кабеля iLINK, выполните процедуру из пункта 2 на стр. 71.

Dubbing only desired scenes – Digital program editing

Operation 1: Making the programme

- Eject the tape for playback, and insert a tape for recording into the other (recording) VCR.
- Press **MENU** to display the menu settings.
- Turn the **SEL/PUSH EXEC** dial to select **MENU**, then press the dial.
- Turn the **SEL/PUSH EXEC** dial to select **VIDEO EDIT**, then press the dial.
- Search for the beginning of the first scene you want to insert using the video operation buttons, then press **II** to stop the playback momentarily (p. 14).
- Press the **SEL/PUSH EXEC** dial. The **IN** point of the first programme is set, and the top part of the programme mark changes to light blue.
- Search for the end of the first scene you want to insert using the video operation buttons, then press **II** to suspend playback momentarily.
- Press the **SEL/PUSH EXEC** dial. The **OUT** point of the first programme is set, and the bottom part of the programme mark changes to light blue.
- Repeat steps 5 to 8 to set programme. When the programme is set, the programme mark changes to light blue. You can set a maximum of 20 programmes.

Перезапись только нужных эпизодов – Цифровой монтаж по программе

Операция 1: Создание программы

- Извлеките кассету, с которой необходимо сделать запись, и вставьте (записывающий) видеомагнитофон в кассету для записи и в другой (записывающий) видеомагнитофон.
- Нажмите кнопку **MENU** для отображения меню настроек.
- Поверните диск **SEL/PUSH EXEC** для выбора **MENU**, затем нажмите на диск.
- Поверните диск **SEL/PUSH EXEC** для выбора **VIDEO EDIT**, затем нажмите на диск.
- С помощью кнопок управления видео найдите начало первого эпизода, который вы хотите вставить, и нажмите кнопку **II** чтобы временно остановить воспроизведение (стр. 14).
- Нажмите на диск **SEL/PUSH EXEC**. Место начала **IN** первого запрограммированного эпизода установлено, и цвет верхнего индикатора метки программы изменится на светло-голубой.
- С помощью кнопок управления видео найдите конец первого эпизода, который вы хотите вставить, и нажмите кнопку **II** чтобы временно остановить воспроизведение.
- Нажмите на диск **SEL/PUSH EXEC**. Место окончания **OUT** первого запрограммированного эпизода установлено, и цвет нижнего индикатора метки программы изменится на светло-голубой.
- Повторите пункты 5 и 8, затем запишите запрограммированные эпизоды. Когда запись будет завершена, программа изменится на светло-голубую. Можно составить не более 20 программ.

Видео Монтаж

Dubbing only desired scenes – Digital program editing

Erasing the programme you have set

- Press **OL** first and then **IN**. Into the last programme.
- Turn the **SEL/PUSH EXEC** dial to select **UNDO**, then press the dial.
 - Turn the **SEL/PUSH EXEC** dial to select **EXECUTE**, then press the dial. The last set programme mark flashes, then the setting is cancelled.

To cancel erasing
Select **RETURN** in step 2, then press the dial.

- Erasing all programmes**
- Select **VIDEO EDIT** in **MENU** in the menu settings.
 - Turn the **SEL/PUSH EXEC** dial to select **ERASE ALL**, then press the dial.
 - Turn the **SEL/PUSH EXEC** dial to select **EXECUTE**, then press the dial. All the programme marks flash, then the settings are cancelled.

To cancel erasing all programmes
Select **RETURN** in step 3, then press the dial.

To cancel a programme you have set
Press **MENU**. The programme is stored in memory until the tape is ejected.

- You cannot set IN and OUT when**
- You use a tape that is recorded in other than Digital **II** system.
 - The tape has a blank portion.

The total time code may not be displayed correctly when

- You use a tape that is recorded in other than Digital **II** system.
- There is a blank portion between **IN** and **OUT** on the tape.

When you select **PB MODE to **HiFi** in the menu settings**
You cannot operate the Digital program editing.

Перезапись только нужных эпизодов – Цифровой монтаж по программе

Удаление заданной программы

- Сначала удалите метку **OUT**, а затем метку **IN** последнего запрограммированного эпизода.
- Поверните диск **SEL/PUSH EXEC** для выбора **UNDO**, а затем нажмите на диск.
 - Поверните диск **SEL/PUSH EXEC** для выбора установленного **EXECUTE**, а затем нажмите на диск. Последняя установленная метка программы для этого эпизода загорится.

Для отмены удаления
Выберите **RETURN** в пункте 2, затем нажмите на диск.

- Удаление из программы всех запрограммированных эпизодов**
- Выберите **VIDEO EDIT** в **MENU** в установках меню.
 - Поверните диск **SEL/PUSH EXEC** для выбора **ERASE ALL**, а затем нажмите на диск.
 - Поверните диск **SEL/PUSH EXEC** для выбора установленного **EXECUTE**, а затем нажмите на диск. Все индикаторы запрограммированных эпизодов начнут мигать, и установки для этих эпизодов будут отменены.

Для отмены удаления всех запрограммированных эпизодов
Выберите **RETURN** в пункте 3, затем нажмите на диск.

Для отмены программы
Нажмите кнопку **MENU**. Программа хранится в памяти до момента извлечения кассеты.

- Невозможно установить метки IN и OUT, если**
- Используется кассета с записью, выполненной не в системе Digital **II**.
 - На ленте имеется незаписанный участок.

Код общего времени может отображаться неправильно, если

- Используется кассета с записью, выполненной не в системе Digital **II**.
- На кассете есть незаписанный участок между метками **IN** и **OUT**.

При выборе значения **HiFi для **PB MODE** в установках меню**
Невозможно выполнять цифровой монтаж по программе.

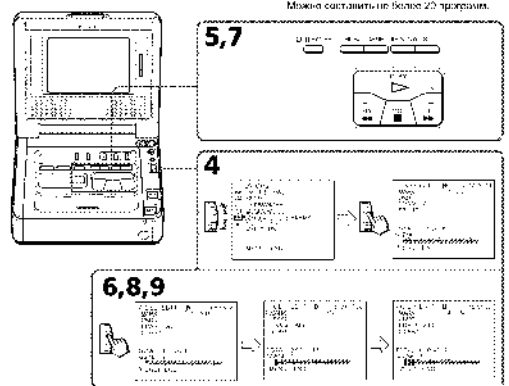

Dubbing only desired scenes – Digital program editing

Operation 2: Performing a Digital program editing (dubbing a tape)

Make sure both your (playback) VCR and the other (recording) VCR are connected, and that the other (recording) VCR is set to recording mode. When you use the LINK cable (DV connecting cable) the following procedure is not necessary.

When you use a digital video camera transfer, set the POWER switch to VCR/VTR.

- (1) Select VIDEO EDIT in **EDIT** in the menu settings.
- (2) Turn the SEL./PUSH EXEC. dial to select START, then press the dial.
- (3) Turn the SEL./PUSH EXEC. dial to select EXECUTE, then press the dial. Search for the beginning of the first programme. Then start dubbing. The programme mark flashes. The SEARCH indicator appears during search on the LCD screen. The programme indicator changes to light blue after the dubbing is complete.

When the dubbing ends, both your (playback) VCR and the other (recording) VCR automatically stop.

To stop dubbing
Press **STOP** using the video operation buttons.

To end the Digital program editing function
Your (playback) VCR stops when the dubbing is complete. Then the display returns to VIDEO EDIT in the menu settings. Press MENU to end the Digital program editing function.

- You cannot record on the other VCR when**
- The cassette is not inserted.
 - The tape has run out.
 - The write-protect tab is set to expose the red mark.
 - The IR-REPEAT mode is not correct. (When IR is selected.)
 - The button to control recording pause is not correct. (When IR is selected.)
 - The programmes to operate the Digital program editing have not been made.
 - LINK cable is selected but the LINK cable (DV connecting cable) is not connected.
 - The power of the other (recording) VCR is not turned on.

Using with an analogue video unit and a personal computer – Signal convert function

- Notes**
- You need to install software which can exchange video signals.
 - Depending on the condition of the analogue video signals, the personal computer may not be able to capture the image correctly when you send it analogue video signals from digital video signals via your VCR. Depending on the analogue video unit, the image may contain noise or incorrect colours.
 - You cannot record or capture the video output via your VCR when the video includes copyright protected signals.

If the other VCR has an S video jack
Connect using an S video cable (not supplied) to obtain high quality pictures. With this connection, you do not need to connect the yellow (video) plug of the A/V connecting cable. Connect an S video cable (not supplied) to the S video jacks of both VCRs.

Перезапись только нужных эпизодов – цифровой монтаж по программе

Операция 2: Выполнение цифрового монтажа по программе (перезапись кассеты)

Убедитесь, что этот видеорекассидер и другой (записывающий) видеорекассидер, подключены друг к другу, и другой видеорекассидер находится в режиме записи. При использовании кабеля LINK (соединительный кабель DV), установка ниже процедуры является необязательной. При выборе на цифровую видеокамеру режима передачи изображения POWER в панели VCR/VTR.

- (1) Выберите VIDEO EDIT в **EDIT** в установочном меню.
- (2) Выберите диск SEL./PUSH EXEC для выбора START, и затем нажмите на диск.
- (3) Выберите диск SEL./PUSH EXEC для выбора установки EXECUTE, затем нажмите на диск. Поиск начала первого запрограммированного эпизода и начало перезаписи. Во время поиска на экране ЖКД отображается значок SEARCH. После завершения перезаписи свет индикатора программы мигает на светлом фоне.

По окончании перезаписи этот видеорекассидер и другой (записывающий) видеорекассидер автоматически останавливаются.

Для остановки перезаписи
Нажмите **STOP** с помощью кнопки управления видео.

Чтобы отключить функцию цифрового монтажа программы
Эта функция деактивируется, когда вы используете панель управления видео. Затем на дисплее снова появится команда VIDEO EDIT в установочном меню. Нажмите кнопку MENU, для отключения функции монтажа программы.

- На другом видеорекассидере не удастся произвести запись, если**
- В него вставлена кассета.
 - Закончился лент.
 - Защита от записи установлена так, что видна красная метка.
 - Неправильный код IR SETUP. (Когда выбран IR.)
 - Кнопка для остановки ленты при записи является некорректной. (Когда выбран IR (стр. 53).)
 - Не создана программа управления функцией цифрового монтажа по программе.
 - Выбрана установка LINK, но кабель LINK (соединительный кабель DV) не подключен.
 - Другой (записывающий) видеорекассидер не включен.

Using with an analogue video unit and a personal computer – Signal convert function

You can convert analogue video signals into digital video signals via your VCR connected to a personal computer and analog video unit.

Capturing images and sound from an analogue video unit

Analogue video signals → Digital video signals

- (1) Set the POWER switch to ON.
 - (2) Set A/V → DV OUT to ON in the video settings (p. 57).
 - (3) Set playback on the analogue video unit.
 - (4) Start capturing procedures on your personal computer.
- The operation procedures depend on your personal computer and the software which you use. For details on how to capture images, refer to the instruction manuals of your personal computer and software.

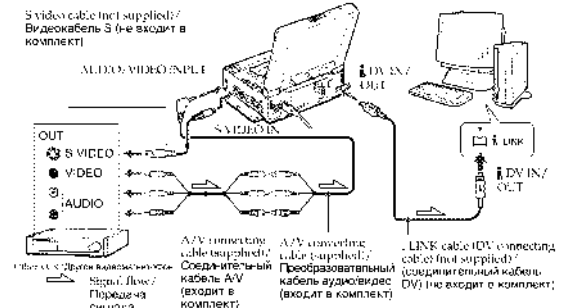

After capturing images and sound
After capturing procedures on your personal computer, and stop the playback on the analogue video unit.

Использование с аналоговым видеоборудованием и персональным компьютером – Функция преобразования сигнала

Можно проводить преобразование аналоговых видеосигналов в цифровые видеосигналы путем подключения Вашого видеорекассидера к персональному компьютеру и аналоговому видеоборудованию.

Перенос изображения и звука с аналогового видеоборудования

Аналоговые видеосигналы → Цифровые видеосигналы

- (1) Установите переключатель POWER в положение ON.
- (2) Установите команду A/V → DV OUT в положение ON в 7-ой в установочном меню (стр. 57).
- (3) На экране ЖКД появится "AV → DV".
- (4) Запустите режим воспроизведения на аналоговом видеоборудовании.
- (5) Начните процесс на персональном компьютере. Порядок действий при этом зависит от используемого программного обеспечения компьютера и программного обеспечения видео. Подробности относительно процедуры переноса изображения см. в инструкции по эксплуатации персонального компьютера и программного обеспечения.

После переноса изображения и звука продолжите процедуру переноса на персональном компьютере и остановите воспроизведение на аналоговом видеоборудовании.

Inserting a scene from the other (playback) VCR – Insert Editing

- Set the POWER switch to ON.
- On the other (playback) VCR, locate the insert start point [a], then press PAUSE to set the other (playback) VCR to the playback pause mode.
- On your (recording) VCR, locate the insert end point [b] by pressing ◀▶ or ▶▶. Then press II to set your (recording) VCR to the playback pause mode.
- Press ZERO SET MEMORY on the Remote Commander. The ZERO SET MEMORY indicator flashes and the end point of the insert is stored in memory. The counter shows "00:00".
- On your (recording) VCR, locate the insert start point [a] by pressing ◀▶, then press REC and the button with its light simultaneously to start your (recording) VCR to the recording pause mode.
- First press PAUSE on the other (playback) VCR, and after a few seconds press II on your (recording) VCR to start inserting the new scene. Inserting automatically stops near the zero point of the counter. Your (recording) VCR automatically stops. The end point [c] of the insert stored in memory is cancelled.

Вставка эпизода с другого (воспроизводящего) видеомagnetифона – Монтаж вставки

- Установите переключатель POWER в положение ON.
- На другом (воспроизводящем) видеомagnetифоне найдите место, где будет вставлен эпизод [a], затем нажмите кнопку PAUSE для остановки другого (воспроизводящего) видеомagnetифона в режиме паузы (остановки).
- На главном магнетифоне найдите конец вставляемого эпизода [b], нажмите кнопку ◀▶ или ▶▶. Затем нажмите кнопку II для установки этого видеомagnetифона в режим паузы (остановки).
- Нажмите кнопку ZERO SET MEMORY на пульте дистанционного управления. Индикатор ZERO SET MEMORY начнет мигать в месте окончания вставки и будет обозначен в памяти. Показание счетчика станет равным "00:00".
- На этом (записывающем) видеомagnetифоне найдите место начала вставляемого эпизода [a], нажмите кнопку ◀▶, затем одновременно нажмите кнопки REC и кнопку с лампочкой для установки этого эпизода в режим паузы (остановки).
- Сначала нажмите кнопку PAUSE на другом (воспроизводящем) видеомagnetифоне и, спустя несколько секунд, кнопку II на этом (записывающем) видеомagnetифоне для начала вставки нового эпизода. Вставка автоматически прекратится в месте нулевой отметки счетчика. Этот (записывающий) видеомagnetифон автоматически остановится. Место окончания вставки [c], сохраненное в памяти, будет удалено.

Editing Montage

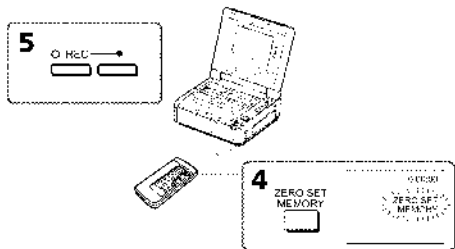

To change the insert end point
Press ZERO SET MEMORY again after step 3 to erase the ZERO SET MEMORY indicator and begin from step 3.

Для изменения места окончания вставки
Снова нажмите кнопку ZERO SET MEMORY после пункта 3 для удаления индикатора ZERO SET MEMORY и начните с пункта 3.

65 66

— Customizing Your VCR — Changing the menu settings

To change the menu settings in the menu settings, select the menu items with the SEL/PUSH EXEC dial. The default settings can be partially changed. First, select the icon, then the menu item, and then the mode.

- Press MENU to display the main settings.
- Turn the SEL/PUSH EXEC dial to select the desired icon, then press the dial to set.
- Turn the SEL/PUSH EXEC dial to select the desired item, then press the dial to set.
- Turn the SEL/PUSH EXEC dial to select the desired mode, and press the dial to set.
- If you want to change other items, select RETURN and press the dial, then repeat steps from 2 to 4.

For details, refer to "Selecting the mode setting of each item" (p. 66).

— Выполнение индивидуальных настроек видеомagnetифона — Изменение установок меню

Для изменения установок меню в установках меню выберите элементы меню с помощью диска SEL/PUSH EXEC. Элементы установки меню частично можно изменить. Сначала выберите значок, затем элемент меню, а затем режим.

- Нажмите кнопку MENU для отображения установок меню.
- Поверните диск SEL/PUSH EXEC для выбора нужного значка, а затем нажмите диск для выполнения установки.
- Поверните диск SEL/PUSH EXEC для выбора нужного элемента, затем для установки нажмите на диск.
- Поверните диск SEL/PUSH EXEC для выбора нужного режима, а затем нажмите диск для выполнения установки.
- Если нужно изменить другие элементы, выберите кнопку RETURN, а затем нажмите на диск, после чего повторите пункты от 2 до 4.

Порядок в соединении цифровых и разделов "Выбор установок" рожины каждого элемента (стр. 72).

Customizing Your VCR – Выполнение индивидуальных настроек видеомagnetифона

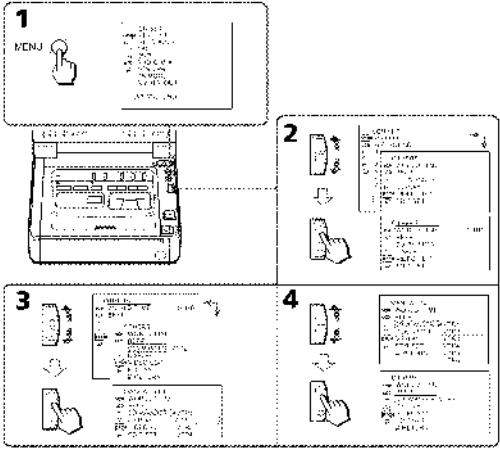

To make the menu display disappear
Press MENU again.

Для того чтобы скрыть индикацию меню
Нажмите кнопку MENU еще раз.

67 68

Inserting a scene from the other (playback) VCR – Insert Editing

- Notes**
- The erased memory function works only for tapes recorded in the Digital Hi-Fi system.
 - The picture and sound recorded on the system between the insert start and end points will be erased when you insert the new scene.

When the inserted picture is played back
The picture may be distorted at the end of the inserted section. This is not a malfunction.

To insert a scene without setting the insert end point
Skip step 3 and 4. Press II when you want to stop inserting.

Вставка эпизода с другого (воспроизводящего) видеомagnetифона – Монтаж вставки

- Примечания**
- Функция ПАВЕТИ нугеветы отметки работавт только для магнетов, записанных в системе Digital Hi-Fi.
 - Изображение и звук, записанные на ленте между местами начала и окончания вставки будут стерты при вставке нового эпизода.

При воспроизведении вставленного изображения
В конце вставленного эпизода изображение может искажаться. Это не является неисправностью.

Для вставки эпизода без указания места окончания вставки
Пропустите пункты 3 и 4. Нажмите кнопку II, когда вы хотите остановить вставку.

Changing the menu settings

- Menu items are displayed as the following icons:
- VCR SET
 - LCD SET
 - TAPE SET
 - SETUP MENU
 - OTHERS

Изменение установок меню

- Элементы меню отображаются в виде следующих значков:
- VCR SET
 - LCD SET
 - TAPE SET
 - SETUP MENU
 - OTHERS

English

Selecting the mode setting of each item ● is the default setting.
The LCD screen shows only the items you can operate at the moment.

Icon/Item	Mode	Meaning
VCR P EFFECT	● OFF	No special effects are obtained for images.
	NRG ART	The colors and brightness of the image are reversed.
	SEPIA	The image is sepia.
	SKW	The image's perspective (black-trace effect).
	SOLARIZE	The light intensity is cleared, and the image looks like an illustration.
HIFI SOUND	● STEREO	To play back a stereo tape or dual sound track tape with main and sub sound (p. 66).
	1	To play back a stereo tape with the left sound or a dual sound track tape with main sound.
TBC*	1	To play back a stereo tape with the right sound or a dual sound track tape with sub sound.
	● ON	To correct jitter.
TBC stands for "Time Base Correction."	OFF	To not correct jitter. Set TBC to OFF when playing back a tape with red and blue dotted cover and recorded the signals of a TV game console machine.
	● ON	To reduce picture noise.
DNR**	● ON	To reduce picture noise.
	OFF	To reduce a noisy picture after freeze when the picture has a dot movement.

* When you play back tapes recorded in the Hi-Fi standard Hi-Fi system only.

Note on P EFFECT
The picture effect function works only for tapes recorded in the Digital Hi-Fi system.

Changing the menu settings

Icon/item	Mode	Meaning
AUDIO MIX	---	To adjust the balance between the stereo 1 and stereo 2.
PB MODE	● AUTO	To automatically select the system (HLS/standard 8 or Digital) that was used to record on the tape, and play back the tape.
	● HLB/H	To play back a tape that was recorded in the HLB standard system to your VCR, but not automatically distinguish the recording system.
A/V → DV OUT	● OFF	To convert digital video signals into analogue video signals via your VCR.
	ON	To convert analogue video signals into digital video signals on your VCR.
NTSC PB	● ON/PAL TV	To play back a tape recorded in the NTSC colour system on a PAL system TV.
	NTSC/L	To play back a tape recorded in the NTSC colour system on a TV with the NTSC-L mode.
LCD B.L.	● SHUT NORMAL	To set the brightness on the LCD screen normal.
LCD COLOUR	● BK/IT	To brighten the LCD screen.
	---	To adjust the colour on the LCD screen.

Notes on AUDIO MIX

- You can adjust the balance only for tapes recorded in the Digital system.
- When playing back a tape recorded in the Hi-bit mode, you cannot adjust the balance.

Note on PB MODE

The mode will return to the default setting when you remove the battery pack or power source, or you turn the POWER switch to OFF.

Note on NTSC PB

When you play back a tape on a Multi System TV, select the best mode with existing the picture on TV.

Note on LCD B.L.

When you select STILL, battery life is reduced by about 50 percent during recording.

Changing the menu settings

Icon/item	Mode	Meaning
REC MODE	● SP*	To record in the SP (Standard Play) mode.
	LP*	To increase the recording time to 1.5 times the SP mode.
AUDIO MODE*	● LHBT	To record or play back in the LH-bit mode (two stereo sounds).
	LHBT	To record or play back in the LH-bit mode (like one stereo sound with high quality).
REC REMAIN	● M/30	To display the remaining tape time. • For about 30 seconds after your VCR is turned on and calculates the remaining amount of tape. • For about 3 seconds after 25% is pressed. • For about 3 seconds after the DISPLAY button is pressed during tape rewinding, forwarding, or picture search.
	ON	To always display the remaining tape time.
	● DATE/TIME	To display date, time, and recording data during playback.
	DATE	To display date and time during playback.

* To dub a tape to the other VCR

You cannot select AUDIO MODE for tapes recorded in the Digital system. However, you can select AUDIO MODE for tapes recorded in the HLB standard system to the other VCR using the i.LINK cable (DV connecting cable).

Note on REC MODE

When you record on the standard 8 tape, your VCR records in the SP mode even if you select the LP mode in the menu settings. In this case, the indicator "STAN. IAPL → SP REC, HLB TAPE → LP/SP REC" appears on the LCD screen. Use HLB/H tapes for the LP mode.

Notes on the LP mode

- When you record a tape in the LP mode on your VCR, you cannot play the tape on your VCR.
- When you play back the tape on other VCRs or camcorders, noise may occur in images or sound.
- When you record in the SP and LP modes on one tape or you record some scenes in the LP mode, the playback image may be distorted in the time code tray or be written properly between scenes.

(Continued on the following page) 69 70

Changing the menu settings

Icon/item	Mode	Meaning
CLOCK SET	---	To reset the clock to time 12:00.
LTR SIZE	● NORMAL	To display selected menu items in normal size.
	2x	To display selected menu items at twice the normal size.
DEMO MODE	● OFF	To cancel the demonstration mode.
	ON	To make the demonstration appear.
WORLD TIME	---	To set the clock to the local time. From the SEL/PUSH EXEC dial to set a time zone difference. The clock changes by the time difference you set here. If you set the time difference to 0, the clock returns to the originally set time.
	---	To set the melody when you set the BATTERY switch to ON, change the menu settings, or when an unusual condition occurs on your VCR.
BEEP	● MUTE	To output the beep sound instead of the melody.
	NORMAL	To output the beep sound instead of the melody.
	OFF	To cancel all sound.
COMMANDER	● VTR2	To activate your VCR with a Remote Commander supplied with a Sony video camera recorder.
	VTR1-6	To activate your VCR with a Remote Commander supplied with a Sony product. For details, refer to "Playing back a tape" (p. 17).
	OFF	To deactivate the Remote Commander to avoid remote control operation caused by other VCR's remote control.
DISPLAY	● LCD	To show the display on the LCD screen.
	V CRT/LCD	To show the display on the TV screen and LCD screen.
VIDEO EDIT	---	To make a programme and perform video editing (p. 70).
EDIT SET	---	To adjust and set the system on your VCR and the other VCR for dubbing in edit mode.

Note on DEMO MODE

You cannot select DEMO MODE when a cassette is inserted in your VCR.

Note

The display does not appear when you connect and output through the i.LINK cable (DV connecting cable).

In more than 5 minutes after removing the power source

The AUDIO MIX and BATTERY MODE items are returned to their default settings. The other menu items are held in memory even when the battery is reinserted.

Resetting the date and time

The default clock setting is set to London time for United Kingdom and Paris time for the other European Countries.

If you do not use your VCR for about six months, the date and time settings may be deleted.

Because the standard lithium battery installed on your VCR will have been discharged, charge the battery. Before you reset the date and time.

First, set the year, then the month, the day, the hour and then the minute.

- (1) Press MENU to display the menu settings.
- (2) Turn the SEL/PUSH EXEC dial to select [C], then press the dial.
- (3) Turn the SEL/PUSH EXEC dial to select [C] (CLOCK SET), then press the dial.
- (4) Turn the SEL/PUSH EXEC dial to adjust the desired year, then press the dial.
- (5) Set the month, day, and hour by turning the SEL/PUSH EXEC dial and pressing the dial.
- (6) Set the minute by turning the SEL/PUSH EXEC dial and pressing the dial by the time signal. The clock starts to run.
- (7) Press MENU to make the menu settings disappear.

Переустановка даты и времени

По умолчанию часы установлены на лондонское время для моделей европейского и Великобритании, и на парижское время для других европейских моделей.

Если вы не использовали видеорекодер в течение около шести месяцев, установка даты и времени могут удалиться, поскольку стандартная литиевая батарея разрядится.

Зарядите батарею, прежде чем установить дату и время.

Сначала установите год, затем месяц, день, час и минуту.

- (1) Нажмите кнопку MENU для отображения меню настроек.
- (2) Поверните диск SEL/PUSH EXEC для выбора установки [C], а затем нажмите на диск.
- (3) Поверните диск SEL/PUSH EXEC для выбора [C] (CLOCK SET), затем нажмите на диск.
- (4) Поверните диск SEL/PUSH EXEC для выбора нужного года, а затем нажмите на диск.
- (5) Установите месяц, день и час путем вращения диска SEL/PUSH EXEC и нажатия на диск.
- (6) Установите минуты путем вращения диска SEL/PUSH EXEC и нажатия на диск по сигналу точного времени. Часы начнут работать.
- (7) Нажмите кнопку MENU, чтобы исчезли установки меню.

Resetting the date and time

Перустановка даты и времени

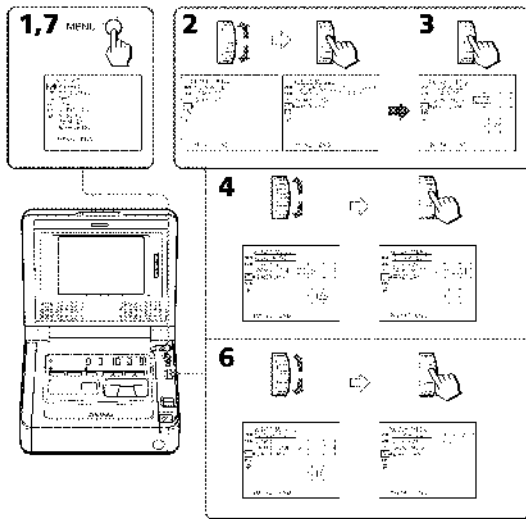

The year changes as follows:

Год будет изменяться следующим образом:

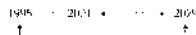

If you do not set the date and time, "1999" is recorded in the data field of the tape.

Если Вы не установите дату и время на кассете в поле даты будет записана индикация "1999".

Note on the time indicator
The internal clock of your VCR operates on a 24-hour code.

Примечание относительно индикатора времени
Внутренние часы видеочипа работают в 24-часовом режиме.

Additional Information: Воспроизведение информации, записанной на видеокассете

Additional Information

Digital Hi-Fi system, recording, and playback

What is the "Digital Hi-Fi system"?
This video system has been developed for ensuring digital recording to Hi-Fi Hi-Fi/Digital Hi-Fi video cassette.

Usable cassette tapes
We recommend using Hi-Fi Hi-Fi/Digital Hi-Fi video cassettes.

The recording time when you use your Digital Hi-Fi system VCR on Hi-Fi Hi-Fi/standard Hi-Fi tape is 72 minutes; the recording time of the conventional Hi-Fi Hi-Fi/standard Hi-Fi system VCR (90 minutes) or recording time becomes 90 minutes in the SP mode.

* If you use standard Hi-Fi tape to see to playback the tape on your VCR (the CV-DB005), Matrix pattern noise may appear when you playback standard Hi-Fi tape on other VCRs (including another CV-DB005).

Notes

- Tapes recorded on the Digital Hi-Fi system cannot be played back on a Hi-Fi Hi-Fi/standard Hi-Fi (analog) system medium.
- RL time code and data code recorded on Hi-Fi Hi-Fi/standard Hi-Fi (analog) system cannot be displayed on the monitor screen.
- PCM sound recorded on Hi-Fi Hi-Fi/standard Hi-Fi (analog) system cannot be played back with your VCR.

is a trademark.
 is a trademark.
 is a trademark.

Additional Information

Система Digital Hi-Fi, запись и воспроизведение

Что такое система "Digital Hi-Fi"?
Эта система разработана для обеспечения цифрового записи на видеокассету Hi-Fi Hi-Fi/Digital Hi-Fi.

Используемые кассеты
Рекомендуется использовать кассеты Hi-Fi Hi-Fi/Digital Hi-Fi.

Время записи при использовании видеочипа системы Digital Hi-Fi на кассете Hi-Fi Hi-Fi/standard Hi-Fi составляет 72 минуты; время записи выполняемой на обычном видеочипа системы Hi-Fi Hi-Fi/standard Hi-Fi (90 минут) или время записи становится 90 минутами в режиме SP.

* Если вы используете кассету standard Hi-Fi, эту кассету следует воспроизводить на этом же видеочипе (шум матрицы). Шум матрицы (CV-DB005) при воспроизведении кассеты standard Hi-Fi на других видеочипах (включая CV-DB005), могут появиться косые помехи.

Примечания

- Кассеты, записанные в системе Digital Hi-Fi, нельзя воспроизводить на аналоговой аппаратуре системы Hi-Fi Hi-Fi/standard Hi-Fi.
- Коды времени и данные видеочипа системы записанные в (аналоговых) системах Hi-Fi Hi-Fi/standard Hi-Fi, не отображаются на экране монитора.
- Звук PCM, записанный в аналоговой системе Hi-Fi Hi-Fi/standard Hi-Fi, не воспроизводится на Вашем видеочипах.

- торговая марка.
 - торговая марка.
 - торговая марка.

Digital Hi-Fi system, recording, and playback

Система Digital Hi-Fi, запись и воспроизведение

Playback system

The Digital Hi-Fi system or Hi-Fi Hi-Fi/standard Hi-Fi system is automatically detected before the tape is played back.

During playback of tapes recorded in the Hi-Fi Hi-Fi/standard Hi-Fi system, digital signals are output as the image and sound signals from the DV IN/OUT jack.

Display during automatic detection of system
The Digital Hi-Fi system or Hi-Fi Hi-Fi/standard Hi-Fi system is automatically detected and the playback system is automatically switched to. During switching of systems, the screen turns blue, and the following displays appear. A hissing noise also sometimes can be heard.

→ : During switching from Digital Hi-Fi to Hi-Fi Hi-Fi/standard Hi-Fi.
 → : During switching from Hi-Fi Hi-Fi/standard Hi-Fi to Digital Hi-Fi.

When you play back

Playing back an NTSC-recorded tape
You can play back tapes recorded in the NTSC video system on the LCD screen if the tape is recorded in the SP mode.

Copyright signal

When you play back
Using any other VCR, you cannot record on a parental lock or record copyright control signals for overlight protection of software which is played back on your VCR.

When you record
You cannot record software on your VCR that contains copyright control signals for copyright protection of software.

CV-DB005 appears on the LCD screen of TV when it can be recorded on software. Your VCR does not record copyright control signals on the tape when it records.

Система воспроизведения

Система Digital Hi-Fi или Hi-Fi Hi-Fi/standard Hi-Fi автоматически распознается перед началом воспроизведения кассеты.

Во время воспроизведения кассет, записанных в системе Hi-Fi Hi-Fi/standard Hi-Fi, цифровые сигналы выдвоятся, как оптические изображения и звука, через разъем DV IN/OUT.

Индикация на дисплее во время автоматического распознавания системы. Система Digital Hi-Fi или Hi-Fi Hi-Fi/standard Hi-Fi распознается автоматически, после чего воспроизведение переключается в нужную систему. Во время переключения системы экран становится голубым и появляются следующие индикации. Иногда также может быть слышен шум.

→ : Во время переключения с Digital Hi-Fi на Hi-Fi Hi-Fi/standard Hi-Fi.
 → : Во время переключения с Hi-Fi Hi-Fi/standard Hi-Fi на Digital Hi-Fi.

При воспроизведении

Воспроизведение кассеты, записанной в системе NTSC
Если кассета записана в режиме SP, можно использовать кассету, записанную в видеосистеме NTSC, на экране ЖКД.

Сигнал авторского права

При воспроизведении
Используя любой другой видеочипах, Вы не сможете выполнить запись на ленту, на которой записаны сигналы авторского права для защиты авторских прав программ, воспроизводимых на Вашем видеочипах.

При записи

Нельзя записывать данные программы, которая содержит сигналы авторского права для защиты авторских прав программ, на эту видеочипах. CV-DB005 на ЖКД телевизора появляется индикация CV-DB005, если запись этой видеочипах не выполняется сигналы авторского права на ленту.

77

78

Digital Hi-Fi system, recording, and playback

Система Digital Hi-Fi, запись и воспроизведение

When you play back a dual sound track tape

When you use tapes recorded in the Digital Hi-Fi system

When you play back a Digital Hi-Fi system tape which is dubbed from a dual sound track tape recorded in the DV system, set Hi-Fi SOUND to the desired mode in the menu settings (p. 67).

Hi-Fi Sound Mode	Playing back a stereo tape	Playing back a dual sound track tape
STEREO	Stereo	Main sound and Sub-sound
1	Left	Main sound
2	Right	Sub-sound

When you use a tape recorded in the Hi-Fi/standard Hi-Fi system

When you play back a dual sound track tape recorded in an AFM Hi-Fi system, set Hi-Fi SOUND to the desired mode in the menu settings (p. 67).

Hi-Fi Sound Mode	Playing back a stereo tape	Playing back a dual sound track tape
STEREO	Stereo	Main sound and sub-sound
1	Monaural	Main sound
2	Unaural Stereo	Sub-sound

You cannot record dual sound programs on your VCR.

При воспроизведении ленты с двойной звуковой дорожкой

При использовании кассет, записанных в системе Digital Hi-Fi

При воспроизведении кассеты, записанной в системе Digital Hi-Fi из кассеты с двойной звуковой дорожкой в системе DV, установить требуемый режим для команды Hi-Fi SOUND в установках меню (стр. 67).

Hi-Fi Sound Mode	Воспроизведение стереофонической ленты	Воспроизведение ленты с двойной звуковой дорожкой
STEREO	Стерео	Основной и дополнительный звук
1	ЛЕВ. КАН.	Основной звук
2	ПРАВ. КАН.	Дополнительный звук

При использовании кассет, записанных в системе Hi-Fi/standard Hi-Fi

При воспроизведении кассеты с двойной звуковой дорожкой в системе AFM, установить требуемый режим для команды Hi-Fi SOUND в установках меню (стр. 67).

Hi-Fi Sound Mode	Воспроизведение стереофонической ленты	Воспроизведение ленты с двойной звуковой дорожкой
STEREO	Стерео	Основной и дополнительный звук
1	Монофонический	Основной звук
2	Нестереофонический	Дополнительный звук

На этом видеочипах невозможно записывать программы с двойной звуковой дорожкой.

79

80

About i.LINK

The DV jack on this unit is an i.LINK-compatible DV iX/40L1 jack. This section describes the i.LINK standard and its features.

What is "i.LINK"?

i.LINK is a digital serial interface for handling digital video, digital audio and stereo data in two directions between equipment having the i.LINK jack, and the controlling other equipment.

i.LINK-compatible equipment can be connected by a single i.LINK cable. Possible applications are operations and data transactions with various digital AV equipment.

When two or more i.LINK-compatible equipment are connected to this unit in a daisy chain, operations and data transactions are possible with not only the equipment that this unit is connected to but also with other devices via the daisy chain (connected) equipment.

Note, however, that the method of operation and specifications of the equipment to be connected, and that operations and data transactions are sometimes not possible on some connected equipment.

Note

Naturally, only one piece of equipment can be connected to this unit by the i.LINK cable/DV connecting cable. When connecting this unit to i.LINK-compatible equipment having two or more i.LINK jacks/DV jacks, refer to the instruction manual of the equipment to be connected.

О кабеле i.LINK

Где-то DV на данном аппарате является i.LINK совместимым гнездом DV iX/40L1. В данном разделе описывается стандарт i.LINK и его особенности.

Что такое "i.LINK"?

i.LINK - это цифровой последовательный интерфейс для передачи цифрового видео- и аудиосигнала, а также других данных между оборудованием, имеющим гнездо i.LINK, в двух направлениях, а также для подключения друг к другу оборудования.

i.LINK-совместимое оборудование должно подключаться с помощью одного кабеля i.LINK. Может использоваться с различным цифровым аудио- и видео-оборудованием для передачи данных.

Когда одно или несколько i.LINK совместимых устройств подключены к данному аппарату по последовательной схеме приема, управление и передача данных возможны не только для устройства, к которому подключен данный аппарат, но также и для других устройств через оборудование, подключенное к нему. Однако, иметь в виду, что метод управления иногда меняется в соответствии с характеристиками и спецификацией подключаемого оборудования. Кроме этого, управление и передача данных иногда возможны на некотором подключаемом устройстве.

Примечание

Обычно, с помощью кабеля i.LINK (соединительный кабель DV) к данному аппарату можно подключить только одно устройство. При подключении данного аппарата к i.LINK-совместимому устройству, имеющему два или более гнезд i.LINK (гнезд DV), обратитесь к инструкции по эксплуатации подключаемого оборудования.

About i.LINK

About the Name "i.LINK"

i.LINK is a more familiar term for IEEE 1394 data transfer has proposed by SONY, and is a trademark supported by many corporations. IEEE 1394 is an international standard standardized by the Institute of Electrical and Electronic Engineers.

i.LINK Baud rate

i.LINK's maximum baud rate varies according to the equipment. Then maximum baud rates are defined as:

500 (approx. 10Mbps)
520 (approx. 20Mbps)
540 (approx. 40Mbps)

The baud rate is listed under "Specifications" in the instruction manual of each equipment. It is also indicated near the i.LINK jack on some equipment.

The maximum baud rate of equipment on which it is not indicated on the specification is "510". When units are connected to equipment having a different maximum baud rate, the baud rate sometimes differs from the indicated baud rate.

* What is "Mbps"?

Mbps stands for megabits per second, or the amount of data that can be sent or received in one second. For example, a baud rate of 10Mbps means that 10⁷ bytes of data can be sent in one second.

О кабеле i.LINK

О названии "i.LINK"

i.LINK является более знакомым термином для шины передачи данных стандарта IEEE 1394, придуманным корпорацией SONY. LINK является торговой маркой, признанной многими корпорациями. IEEE 1394 - это международный стандарт приняты институтом инженеров по электротехнике и радиоэлектронике.

Скорость передачи в бодах по кабелю i.LINK

Максимальная скорость передачи в бодах по кабелю i.LINK изменяется в зависимости от оборудования. Определяются три максимальных скорости передачи в бодах.

5100 (прибл. 100 Мбит/с)
5200 (прибл. 200 Мбит/с)
5400 (прибл. 400 Мбит/с)

Скорость передачи в бодах указывается в разделе "Характеристики" инструкции по эксплуатации каждого устройства. На некоторых устройствах она также указывается рядом с гнездом i.LINK.

Максимальная скорость передачи в бодах для устройства, на котором она не указана, например, для данного аппарата, равна "510". Если подключаемый данному аппарату устройству, имеющему другую максимальную скорость передачи в бодах, эта скорость иногда отличается от указанной.

* Что такое "Мбит/с"?

Мбит/с означает число мегабайт в секунду или объем данных, которые можно передать или передать за одну секунду. Например, скорость передачи в бодах, равная 100 Мбит/с, означает, что за одну секунду можно передать 100 мегабайт данных.

81 82

About i.LINK

i.LINK Functions on this unit

For details on how to dub when this unit is connected to other video equipments having DV jacks, refer to "Dubbing a tape" (p. 46).

This unit can also be connected to other i.LINK (DV) compatible equipments made by SONY (e.g. VADO series personal computer) other than video equipment.

Before connecting this unit to a personal computer, make sure the application software supported by this unit is already installed on the personal computer.

For details on precautions when connecting this unit, also refer to the instruction manual for the equipment to be connected.

Required i.LINK Cable

Use the Sony i.LINK 4-pin to 4-pin cable during DV dubbing.

i.LINK and  are trademarks.

О кабеле i.LINK

Функции i.LINK на данном аппарате

Более подробную информацию о передаче, когда этот аппарат подключен к другому видеоборудованию, имеющему гнездо DV, см. в разделе "Передача кассеты" (стр. 46). Данный аппарат также можно подключить к другому i.LINK (DV) совместимому оборудованию фирмы SONY (например, персональный компьютер серии VADO), не являющемуся видеооборудованием.

Перед подключением этого аппарата к персональному компьютеру обязательно установить на компьютере программное обеспечение, прилагаемое к данному аппарату. Более подробную информацию о мерах предосторожности при подключении данного аппарата к видеокамере найти в инструкции по эксплуатации подключаемого оборудования.

Требуемый кабель i.LINK

Используйте кабель Sony i.LINK 4 на 4 штырька (во время переписки цифрового видео).

i.LINK и  - торговые марки.

English Troubleshooting

If you run into any problem using your VCR, use the following table to troubleshoot the problem. If the problem persists, disconnect the power source and contact your Sony dealer or a local authorized Sony service facility. If "SERVICE" appears on the LCD screen, use self diagnosis display function (see manual). Refer to "Self diagnosis display" (p. 82).

Symptom	Cause and/or Corrective Actions
The power does not turn on.	<ul style="list-style-type: none"> The AC power adapter is not connected to the main. Connect the AC power adaptor to the mains (p. 8). The battery pack is not installed, or is dead or nearly dead. Install a charged battery pack (p. 9-11).
You cannot playback.	<ul style="list-style-type: none"> The VCR/VR switch is not set to ON. Set VCR/ON (p. 13). The tape has run out. Rewind the tape (p. 14).
There are horizontal lines over the picture or the picture picture is not seen or shows no picture.	<ul style="list-style-type: none"> The video head may be dirty. Clean the heads using a Sony V6-25/CD cleaning cassette (not supplied) (p. 95). The volume is turned to minimum. Press VCI LME - (p. 13, 102). The slow tape is played back with Fast Forward (set to 2 in the menu settings). Set it as STILL/O (p. 67). AUDIO MIX is set to STP (side in the menu settings). Adjust AUDIO MIX (p. 67).
The date search does not work correctly.	<ul style="list-style-type: none"> The tape has a blank portion between recorded portions (p. 37).
The picture which is recorded in the Playback system is not seen on VCR. The tape which is recorded in the Playback system is not played back correctly.	<ul style="list-style-type: none"> PH MODE is set to PH/BI in the menu settings. Set it as PH/BI (p. 67). Set PH MODE to PH/BI in the menu settings (p. 67).
You cannot record.	<ul style="list-style-type: none"> The VCR/VR switch is not set to ON. Set it as ON (p. 13). The tape has run out. Rewind the tape or insert a new one (p. 12, 14). The write-protect tab is set to expose the red mark. Use a new tape or slide the tab (p. 12). The tape is stuck to the drum (drum time condensation). Remove the cassette and leave your VCR for at least 1 hour as acclimatization (p. 95).
You cannot record on the LP mode.	<ul style="list-style-type: none"> The tape is the standard 8 tape. Use HS PH/BI (p. 67) or LP (p. 39).
The cassette cannot be removed from the holder.	<ul style="list-style-type: none"> The power source is disconnected. Contact a Sony (p. 8). The battery is dead. Use a charged battery pack (p. 9-11).
The PH and BI status lights do not function except for a cassette system work.	<ul style="list-style-type: none"> Moisture condensation has occurred. Remove the cassette and leave your VCR for at least 1 hour as acclimatization (p. 95).

83 84

Troubleshooting

Symptom	Cause and/or Corrective Actions
Nonrecording works even though the power is on.	<ul style="list-style-type: none"> Disconnect the main lead of the AC power adapter or remove the battery, then reconnect it after about one minute. Turn the power on. If the functions still do not work, press the RESET button on the back side of your (recording) VCR using a sharp pointed object. (If you press the RESET button, all the settings, including the date and time, return to the default.)
The battery pack weakly discharges.	<ul style="list-style-type: none"> The operating temperature is too low. The battery pack is not fully charged. Charge the battery pack fully again (p. 10). The battery pack is completely dead, and cannot be recharged. Replace with a new battery pack (p. 75).
You cannot charge the battery pack.	<ul style="list-style-type: none"> The POWER/CHARGE switch is not set to OFF. Set it to OFF.
While charging the battery pack, the POWER/CHARGE lamp flashes.	<ul style="list-style-type: none"> Something is wrong with the battery pack. Contact your Sony dealer or a local authorized Sony service facility.
The audio or video signals in 3 seconds.	<ul style="list-style-type: none"> Moisture condensation has occurred. Remove the cassette and leave your (recording) VCR for at least 1 hour to acclimatize (p. 95). Some trouble has occurred in your (recording) VCR. Remove the cassette and insert it again, then operate your (recording) VCR.
While editing using the LINK cable (EW connecting cable), the recording picture cannot be recorded.	<ul style="list-style-type: none"> Remove the LINK cable (EW connecting cable), and connect it again.
Digital program editing does not function.	<ul style="list-style-type: none"> The input selector on the other (play back) VCR is not set correctly. Check the connection and set the input selector on the other (play back) VCR again (p. 46, 48). Your (recording) VCR is connected to an Sony (25) equipment using the LINK cable (EW connecting cable). Keep the connection and follow the procedure on page 51 to 53. Setting a program on a blank portion of the tape is attempted. Set the program again on a recorded portion (p. 59). Your (recording) VCR and the other (play back) VCR are not synchronized. Adjust the synchronicity (p. 53).
The Remote commander supplied with a Sony digital video camera recorder does not work.	<ul style="list-style-type: none"> The remote control code is not set correctly. Set COMMANDER in the menu settings (p. 17, 67). Something is blocking the infrared rays. Remove the obstacle. The batteries are inserted in the battery holder with the + and - polarities incorrectly matching the + and - marks. Insert the batteries with the correct polarity. The batteries are dead. Insert new ones.

Additional information: Remote commander setup manual

85

86

English

Self-diagnosis display

Your VCR has a self-diagnosis display function. For function display, the current condition of your VCR as a 5-digit code (a combination of letters and figures) on the LCD screen. If a 5-digit code is displayed, check the following code chart. The last two digits and color by LED will differ depending on the state of your VCR.

LCD screen

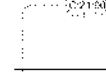

Self-diagnosis display

* 000000
 You can service your VCR yourself.
 * E00000
 Contact your Sony dealer or a local authorized Sony service facility.

Five-digit display	Cause and/or Corrective Actions
C01000	<ul style="list-style-type: none"> You are using a battery pack that is not an "InfoLITHIUM" battery pack. Use an "InfoLITHIUM" battery pack (p. 5, 71).
C01001	<ul style="list-style-type: none"> Moisture condensation has occurred. Remove the cassette and leave your VCR for at least 1 hour to acclimatize (p. 95).
C02000	<ul style="list-style-type: none"> The video heads are dirty. Clean the heads using a Sony V8 250 D cleaning cassette (not supplied) (p. 96).
C03000	<ul style="list-style-type: none"> A malfunction, other than the above, that you can service has occurred. Remove the cassette and insert it again, then operate your VCR. Disconnect the power cord of the AC power adapter or remove the battery pack. After returning the power source, operate your VCR.
E00000	<ul style="list-style-type: none"> A malfunction that you cannot service has occurred. Contact your Sony dealer or a local authorized Sony service facility and inform them of the 5-digit code (example: E00100).

If you are unable to rectify the problem even if you try corrective actions a few times, contact your Sony dealer or a local authorized Sony service facility.

English

Warning indicators and messages

If the CAUTION lamp and the indicators on the LCD screen flash, check the following. If the CAUTION lamp flashes, but no indicators appear on the LCD screen, contact your Sony dealer or a local authorized Sony facility.

- You can hear the beep sound when BEEP is set to MELODY/NOISY in the menu settings.
- The POWER/CHARGE lamp flashes green.
- The CAUTION lamp flashes yellow.

 Slow flashing: The battery is weak. Fast flashing: The battery is empty or dead (p. 75). Depending on conditions, the LED indicator may flash, even if there are 1 to 200 minutes remaining.	 Tape end.
 No tape has been inserted.	 The write protect tab on the tape is set (red).
 The clock is not set.	 Moisture condensation may have occurred (p. 95).
 The video heads may be dirty.	 Some other trouble has occurred.
 The battery is not the "InfoLITHIUM" type.	 You cannot record in the LP mode.
 You cannot dub the recordings.	 You tried to record a picture that has a copyright-protected signal (p. 79).

Additional information: Remote commander setup manual

- The battery is weak or dead.**
Slow flashing: The battery is weak.
Fast flashing: The battery is empty or dead (p. 75).
Depending on conditions, the LED indicator may flash, even if there are 1 to 200 minutes remaining.
- The tape is near the end.**
The flashing is slow, and the REC lamp flashes.
- The tape has run out.**
The flashing becomes rapid.
When you press the REC button, the indicators appear.
- No tape has been inserted.**
When you press the REC button, the indicators appear.
- The write protect tab on the tape is set (red).**
When you press the REC button, the indicators appear.

87

88

Warning indicators and messages

- Moisture condensation may have occurred (p. 95).**
- The video heads may be contaminated (p. 96).**
- The clock is not set.**
When this message appears even though you set the date and time, the Canadian-lithium battery is discharged. Charge the Canadian-lithium battery (p. 97).
- Some other trouble has occurred.**
Disconnect the power source and contact your Sony dealer or a local authorized facility.
- The battery is not the "InfoLITHIUM" type.**
- You cannot dub the recordings.**
You tried to record a picture that has a copyright-protected signal (p. 79).
- You cannot record in the LP mode.**
Use the **HIB** (Digital Hi) option when you record in the LP mode (p. 70).

Using your VCR abroad

Using your VCR abroad

You can use your VCR in many countries at once with the supplied AC power adapter with your VCR within 100 V to 230 V AC, 50/60 Hz.

Your VCR is a PAL system based VCR. If you want to view the playback picture on your TV, it must be a PAL system based TV with a AUDIO/VIDEO input jack. The following shows TV colour systems used overseas.

PAL system

Australia, Austria, Belgium, China, Czech Republic, Denmark, Finland, Germany, Great Britain, Holland, Hong Kong, Italy, Kuwait, Malaysia, New Zealand, Norway, Portugal, Singapore, Slovak Republic, Spain, Sweden, Switzerland, Thailand, etc.

PAL-M system

Brazil

PAL-N system

Argentina, Paraguay, Uruguay

NTSC system

Bahama Islands, Bolivia, Canada, Central America, Chile, Colombia, Ecuador, Guatemala, Japan, Korea, Mexico, Peru, Sarawak, Taiwan, the Philippines, the U.S.A., Venezuela, etc.

SECAM system

Romania, France, Guyana, Hungary, Iraq, Iraq, Madagascar, Poland, Russia, Ukraine, etc.

Simple setting of clock by time difference

You can easily set the clock to the local time by setting a time difference. Select WORLD TIME for the menu setting (p. 67). See page 71 for more information.

Использование видеомагнитофона за границей

Использование видеомагнитофона за границей

Вы можете использовать свой видеомагнитофон в любой стране или области благодаря прилагаемому к нему адаптеру питания переменного тока, который можно подключить к сети с напряжением от 100 до 240 В переменного тока и частотой 50/60 Гц.

В этом видеомагнитофоне используется система PAL. Если Вы хотите просматривать воспроизводимое изображение на телевизоре, то это должен быть телевизор, работающий в системе PAL и оснащенный входными гнездами AUDIO/VIDEO.

Ниже приведены системы штепсельных телевидения, используемые за рубежом.

Система PAL

Австралия, Австрия, Бельгия, Китай, Финляндия, Республика Дания, Фиджи, Германия, Великобритания, Голландия, Гонконг, Италия, Кувейт, Малайзия, Новая Зеландия, Норвегия, Португалия, Сингапур, Словацкая Республика, Испания, Швеция, Тайвань, Таиланд и т.д.

Система PAL-M

Бразилия

Система PAL-N

Аргентина, Парагвай, Уругвай

Система NTSC

Багамские острова, Боливия, Канада, Центральная Америка, Чили, Колумбия, Эквадор, Гватемала, Япония, Корея, Мексика, Перу, Саравак, Тайвань, Филиппины, Венесуэла и т.д.

Система SECAM

Болгария, Франция, Гвинея, Венгрия, Ирак, Иран, Ионские острова, Польша, Румыния, Украина и т.д.

Простая установка разницы во времени на часах

Можно легко установить местное время на часах путем установки разницы во времени. Выберите команду WORLD TIME в установочном меню (стр. 67). Подсбные сведения см. на стр. 75.

Maintenance information and precautions

Moisture condensation

If your VCR is brought directly from a cold place to a warm place, moisture may condense inside your VCR or on the surface of the tape. In this condition, the tape may stick to the head drum and be damaged or your VCR may not operate correctly. If there is moisture inside your VCR, the loop sounds and the **RE** indicator flashes. If the **RE** indicator flashes at the same time a cassette is inserted in your VCR.

If moisture condensation occurs

None of the functions except cassette ejection will be found to work. Expect the cassette, turn off your VCR and leave it for about 1 hour with the cassette compartment open. Your VCR can be used again if the **RE** indicator does not appear when the power is turned on again.

Note on moisture condensation

Moisture may condense when you bring your VCR from a cold place into a warm place, for example, or when you use your VCR in a hot place as follows.

You bring your VCR from a shop straight into a place warmed up by a heating device.

You bring your VCR from an air-conditioned car or room into a hot place outside.

You use your VCR after a shower or a shower.

You use your VCR in a high temperature and humid place.

How to prevent moisture condensation

When you bring your VCR from a cold place into a warm place, put your VCR in a plastic bag and tightly seal it. Remove the bag when the air temperature inside the plastic bag has reached the surrounding temperature. Wait about 1 hour.

Информация по уходу за аппаратом и меры предосторожности

Конденсация влаги

Если видеомагнитофон привнесен из холодного места в теплое помещение, то внутри видеомагнитофона или на поверхности ленты может произойти конденсация влаги. В таком состоянии лента может прилипнуть к барабану головки и повредиться или видеомагнитофон не сможет работать надолго. Если одновременно с появлением звуковых сигналов индикатор **RE** мигает, это означает, что в видеомагнитофоне образовалась конденсация влаги.

Если произошла конденсация влаги

Ничего из функций, кроме функции извлечения кассеты, не будет работать. Выньте кассету из видеомагнитофона и оставьте его примерно на 1 час с открытым отсеком для кассеты. Видеомагнитофон снова можно использовать, если индикатор **RE** не появляется при повторном включении питания.

Примечание относительно конденсации влаги

Влага может конденсироваться, если Вы привнесете видеомагнитофон из холодного места в теплое место, например, или когда Вы используете видеомагнитофон в жарком месте в следующих случаях.

— Вы принесли видеомагнитофон с магазина прямо в помещение, где работает обогреватель.

— Вы принесли видеомагнитофон из автомобиля или из кондиционированного помещения.

— Вы используете Ваш видеомагнитофон после душа или дождя.

— Вы используете видеомагнитофон в месте с повышенной температурой воздуха и повышенной влажностью.

Как предотвратить конденсацию влаги

Если видеомагнитофон привнесен из холодного места в теплое место, положите его в полиэтиленовый пакет и плотно закройте его. Выньте видеомагнитофон из пакета, когда температура воздуха внутри пакета достигнет температуры окружающей воздуха (приблизительно через 1 час).

Maintenance information and precautions

Maintenance information

Cleaning the LCD screen

If fingerprints or dust make the LCD screen dirty, wipe it clean using a LCD cleaning kit (not supplied) to clean the LCD screen.

Cleaning the video head

To ensure normal recording and clear pictures, clean the video heads.

When you playback/record in the Digital B system

The video head may be dirty if a noise pattern noise appears on the playback picture.

- playback pictures do not move,
- playback pictures are hardly visible,
- playback pictures do not appear,
- the **CLEANING** and **CLEANING CASSETTE** message appear alternately on the LCD screen.



не/или



When you play back in the Hi8/standard 8 (analogue) system

The video head may be dirty if playback pictures are hardly visible, playback pictures do not appear.



не/или



If the above problem occurs, clean the video heads with a Sony VHS-CLD cleaning cassette (not supplied). Check the picture and if the above problem persists, repeat cleaning.

Информация по уходу за аппаратом и меры предосторожности

Информация по уходу за аппаратом

Чистка экрана ЖКД

Если на экране ЖКД появляются отпечатки пальцев или пыль, рекомендуется воспользоваться очистительным набором для ЖКД (не входит в комплект) для чистки ЖКД.

Чистка видеоголовки

Для обеспечения нормальной записи и четкого изображения следует периодически чистить видеоголовку.

При воспроизведении/записи в системе Digital B

Видеоголовки, возможно, загрязнены, если:

- на изображении видны изображения помех/шума;
- воспроизводимое изображение практически невидимо;
- изображение отсутствует.



При воспроизведении в (аналоговой) Hi8/standard 8

Видеоголовки, возможно, загрязнены, если:

- на изображении видны изображения помех/шума;
- воспроизводимое изображение почти невидимо;
- изображение отсутствует.



При возникновении перечисленных выше проблем, очистите видеоголовку с помощью чистящей кассеты Sony VHS-CLD (не входит в комплект). Проверьте качество изображения и если проблеме устранить не удалось, повторите чистку.

Maintenance information and precautions

Charging the vanadium-lithium battery in your VCR

Your VCR comes with a vanadium-lithium battery installed so as to retain the date and time, etc., regardless of the setting of the POWER switch. The vanadium-lithium battery is always charged as long as you are using your VCR. The battery, however, will become discharged gradually if you do not use your VCR. It will be completely discharged in about six months if you do not use your VCR at all. Even if the vanadium-lithium battery is not charged, it will not affect the VCR operation. To retain the date and time, etc., charge the battery if the battery is discharged.

Charging the vanadium-lithium battery:

Connect your VCR to the mains using the AC power adaptor supplied with your VCR, or connect your VCR to a charged battery and leave your VCR switched off for more than 24 hours.

Информация по уходу за аппаратом и меры предосторожности

Зарядка ванадиево-литиевой батареи в видеомагнитофоне

В Вашем видеомагнитофоне установлена ванадиево-литиевая батарея, которая сохраняет в памяти дату и время и т.д., независимо от положения переключателя POWER. Ванадиево-литиевая батарея всегда заряжается, пока Вы используете видеомагнитофон. Однако, если видеомагнитофон не используется, батарея будет постепенно разряжаться. Если видеомагнитофон совсем не используется, зарядка полностью разрядится примерно через шесть месяцев. Даже если видеомагнитофон не используется, это никак не повлияет на работу видеомагнитофона. Если батарея разряжена, то для восстановления даты, времени и т.д. необходимо зарядить батарею.

Зарядка ванадиево-литиевой батареи:

Подсоедините видеомагнитофон к электрической сети с помощью прилагаемого к нему сетевого адаптера переменного тока или к зарядке от другой батареи или к заряженной ванадиево-литиевой батарее с включенным питанием более чем на 24 часа.

Maintenance information and precautions

Precautions

VCR operation

- Operate your VCR on 7.2 V (battery pack) or 8.4 V (AC power adaptor).
- For DC or AC operation, use the accessories recommended in this operating instructions.
- If any solid object or liquid gets inside the casing, stopping your VCR and then it is packed by a Sony dealer before operating it any further.
- Handle your VCR rightly, and do not give a mechanical shock.
- Keep the POWER switch set to OFF when you are not using your VCR.
- Do not wrap your VCR with a towel, for example, and operate it. Doing so might cause heat to build up inside.
- Keep your VCR away from strong magnetic fields or mechanical vibration. Noise may appear on the image.
- Do not touch the LCD screen with your fingers or a sharp-pointed object.
- If your VCR is used in a cold place, a residual image may appear on the LCD screen. This is not a malfunction.
- When using your VCR, the fan for the LCD screen may heat up. This is not a malfunction.

On handling tapes

Do not insert anything into the small holes on the rear of the cassette. These holes are used to sense the type and thickness of the tape and if the recording tab is inserted.

VCR care

- Remove the tape, and periodically turn on the power and play back a tape for about 30 minutes when your VCR is not to be used for a long time.
- Clean the VCR body with a dry soft cloth, or a soft cloth lightly moistened with a mild detergent solution. Do not use any type of solvent which may damage the finish.
- Do not let sand get into your VCR. When you use your VCR in a sandy beach or a dusty place, protect it from the sand or dust. Sand or dust may cause your VCR to malfunction, and sometimes this malfunction cannot be repaired.

Maintenance information and precautions

Battery pack

- Use only the specified charger or video equipment with the charging function.
- To prevent an accidental short circuit, do not allow metal objects to come into contact with the battery terminals.
- Keep the battery pack away from fire.
- Never expose the battery pack to temperatures above 60°C (140°F), such as in a car parked in the sun or under direct sunlight.
- Keep the battery pack dry.
- Do not remove the battery pack to any mechanical shock.
- Do not allow someone to modify the battery pack.
- Attach the battery pack to the video equipment securely.
- Charging while some capacity remains does not affect the original battery capacity.

Информация по уходу за аппаратом и меры предосторожности

Меры предосторожности

Работа видеомagnetofона

- Видеомagnetofон должен работать от назначенной 7.2 В (батарейный блок) или 8.4 В (сетевой адаптер переменного тока).
- Для работы видеомagnetofона от источника постоянного или переменного тока, рекомендуем использовать принадлежность, рекомендованную в инструкции по эксплуатации.
- Если внутрь корпуса попал какой-либо твердый предмет или жидкость, выключите видеомagnetofон и порадуйте дальнейшую эксплуатацию проверьте это у дилера Sony.
- Обращайтесь с видеомagnetofоном аккуратно и не подвергайте его сильному механическому воздействию.
- Если видеомagnetofон не используется, производите переключатель POWER в положение OFF.
- Не загромождайте видеомagnetofон, например, не накрывайте его тканью, и не используйте его в таком состоянии. В этом случае может появиться изображение на экране ЖКД.
- Не подвергайте видеомagnetofон воздействию сильных магнитных полей или механической вибрации. На изображении могут возникнуть помехи.
- Не прикасайтесь к экрану ЖКД, пленке или острым предметам.
- Если видеомagnetofон не используется на долгое время, экран ЖКД может пожелтеть от остаточного изображения. Однако это не является неисправностью.
- Во время эксплуатации видеомagnetofона будьте осторожны с песком, жидкостью, пылью и другими предметами, а также для определения наличия посторонней защиты от записи.

Обращение с кассетами

- Не вставляйте никакие предметы в маленькие отверстия с задней стороны кассеты. Эти отверстия используются для определения типа и толщины ленты, а также для определения наличия посторонней защиты от записи.
- Когда видеомagnetofон в течение длительного времени не используется, вынимайте кассету, а также периодически включайте питание в источнике записи кассеты (триммер на три минуты).
- Чистите корпус видеомagnetofона с помощью сухой мягкой ткани или мягкой ткани, слегка смоченной в слабом растворе мыльного средства. Не пользуйтесь растворителями, которые могут повредить пластик.
- Не допускайте попадания песка в видеомagnetofон. Если вы используете видеомagnetofон на песчаном пляже или в пыльном месте, предохраняйте аппарат от попадания пыли. Песок и пыль могут вызвать помехи на изображении видеомagnetofона, которые не всегда можно устранить.

Информация по уходу за аппаратом и меры предосторожности

Батарейный блок

- Используйте только указанное зарядное устройство или зарядное устройство с функцией зарядки.
- Для предотвращения случайного короткого замыкания не допускайте контакта металлических предметов с полюсами батарейного блока.
- Не держите батарейный блок близко к пламени, никогда не подвергайте батарейный блок воздействию температуры выше 80°C (140°F), например, не оставляйте его в автомобиле, припаркованном в солнечном месте, или под прямыми солнечными лучами.
- Всегда удаляйте влагу с батарейного блока.
- Не позволяйте батарейному блоку находиться в механических ударах.
- Не разбирайте и не изменяйте батарейный блок.
- Надежно прикрывайте батарейный блок к видеомagnetofону.
- Зарядка не полностью заряженного батареи не влияет на первоначальную емкость.

Maintenance information and precautions

Connection to your personal computer

- When recording with the iLINK cable the image processed or sent by your personal computer, use a new Hi8 Hi8i Digital Hi8 tape.
- When you capture the pictures recorded in the Hi8 Hi8i standard Hi8 system to a personal computer, do the recording to the Digital Hi8 or DV system first, then capture them to the personal computer.

When inputting the image recorded by Hi8/standard 8 system into a Sony VAIO

The Programme Capture function of iDVgate motion doesn't work. To use this function, dub the image into a Digital Hi8 or DV tape first, and then input it into a Sony VAIO.

AC power adaptor

- Do not operate the unit with the mains when you do not intend to use the unit for a long time. To disconnect the mains lead, pull it out by the plug. Never pull the mains lead itself.
- Do not let the unit be damaged or damaged.
- Do not touch the mains lead directly, or place a sharp object on it. This will damage the cord and may cause fire or electrical shock.
- Prevent metallic objects from coming into contact with the metal parts of the plug or cord. If this happens, a short circuit occurs and the unit may be damaged.
- Always keep mains cord in a safe place.
- Do not disconnect the unit.
- Do not apply mechanical shock or drop the unit.
- While the unit is in use, particularly during charging, keep it away from AM receivers and video equipment, digital AM receiver and video operation.
- The unit becomes warm during use. This is not a malfunction.
- Do not place the unit in locations that are extremely hot or cold.
- Dusty or dirty.
- Very humid.
- Vibrating.

Информация по уходу за аппаратом и меры предосторожности

Подключение к персональному компьютеру

- При записи с помощью кабеля iLINK изображений, обработанных или измененных на ПК, используйте новую кассету Hi8 Hi8i Digital Hi8.
- При передаче изображений, записанных в системе Hi8 Hi8i standard 8, на персональный компьютер сначала перепишите запись на систему Digital Hi8 или DV, затем передайте ее на ПК.

При передаче изображения, записанного в системе Hi8/standard 8, на персональный компьютер Sony VAIO

Функция Program Capture системы iDVgate motion не работает. Для использования этой функции сначала перепишите изображение на кассету Digital Hi8 или DV, а затем передайте его на персональный компьютер Sony VAIO.

Сетевой адаптер переменного тока

- Отсоедините аппарат от электрической сети, если вы не собираетесь его использовать, длительное время. Для отсоединения от сети электрического питания, выньте вилку из розетки. Никогда не тяните за шнур.
- Не эксплуатировать аппарат, когда поврежден шнур питания, или если аппарат упал или поврежден.
- Шнур не свисайте сетевой провод и не ставьте на него тяжелые предметы. Это вызовет повреждение провода и может привести к пожару или повреждению электрического тока.
- Никакие металлические предметы не должны соприкасаться с металлическими частями вилки или гнезда.
- Всегда держите в чистоте металлические контакты.
- Не разбирайте аппарат.
- Не подвергайте аппарат механическим воздействиям и не роняйте его.
- При использовании в жарком, особенно во время зарядки, держите его подальше от AM-радиоприемника и видеомagnetofона.
- Радиоприемник и видеомagnetofон могут нагреваться.
- Однако это не является неисправностью.
- Не размещайте аппарат в месте:
 - Чрезмерно жарком или холодном.
 - Пыльном или грязном.
 - Очень влажном.
- Подверженном вибрации.

Additional Information: Дополнительная информация

— Quick Reference —

Identifying the parts and controls

VCR

1. LCD screen
2. VOLUME +/- buttons (p. 13)
3. EJECT knob (p. 12)
4. Cassette compartment (p. 12)
5. POWER ON/CHARGE lamp (p. 13)
6. Remote sensor
Aim a Remote Commander (not supplied) here for remote control.
7. RESET button (bottom) (p. 85)
8. SEL/PUSH EXEC dial (p. 16, 67)
9. LCD BRIGHT buttons (p. 13)
10. MENU button (p. 67)
11. POWER switch (p. 13)
12. SUPER LASER LINK button (p. 21)
13. LANC jack
LANC stands for Local Application Command for System. The LANC control jack is used for controlling the tape transport of video equipment and peripherals connected to it. This jack has the same function as the jack on a video control unit or REMOTE.
14. Jack cover (p. 19)
15. AUDIO/VIDEO INPUT jack (p. 23, 62)

Видеомagnetofон

- 
1. Экран ЖКД
 2. Кнопки VOLUME +/- (стр. 13)
 3. Кнопка EJECT (стр. 12)
 4. Комpartимент кассеты (стр. 12)
 5. Лампочка POWER ON/CHARGE (стр. 13)
 6. Датчик дистанционного управления
Направьте на него пульт дистанционного управления (не входит в комплект) для удаленного управления аппаратом.
 7. Кнопка RESET (снизу) (стр. 85)
 8. Диск SEL/PUSH EXEC (стр. 16, 67)
 9. Кнопки LCD BRIGHT (стр. 13)
 10. Кнопка MENU (стр. 67)
 11. Переключатель POWER (стр. 13)
 12. Кнопка SUPER LASER LINK (стр. 21)
 13. Гнездо LANC
 - LANC означает систему локального управления. Пульт управления LANC используется для контроля за перемещением изображения видеомagnetofона и подключенными к ней периферийными устройствами. Данное гнездо имеет такую же функцию, как и гнездо управления, обозначенные как L или REMOTE.
 14. Крышка гнезда (стр. 19)
 15. Входное гнездо AUDIO/VIDEO INPUT (стр. 23, 62)

This mark indicates that this product is a genuine accessory for Sony video products. When purchasing Sony video products, Sony recommends that you purchase accessories with this GENUINE VIDEO ACCESSORIES mark.

Данный знак означает, что это изделие является подлинной принадлежностью для видеомagnetofона Sony. При покупке видеомagnetofона Sony рекомендуется приобретать для нее принадлежности со знаком GENUINE VIDEO ACCESSORIES.

Identifying the parts and controls

Обозначение деталей и органов управления

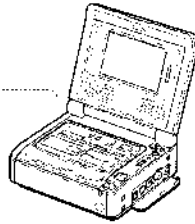
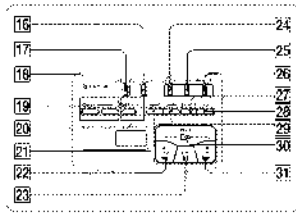

- 16 DISPLAY button (p. 13)
- 17 DATA CODE button (p. 40)
- 18 CAUTION lamp (p. 87)
- 19 REC (recording) buttons and lamp (p. 23)
- 20 PAUSE (pause) button and lamp (p. 23)
- 21 II- (FRAME -) button (p. 14)
- 22 REW (rewind) button (p. 14)
- 23 STOP (stop) button (p. 13)
- 24 DIGITAL EFFECT button (p. 32)
- 25 TITLE button (p. 42, 44)
- 26 PB (playback) ZOOM button (p. 27)
- 27 SLOW button (p. 14)
- 28 x2 button (p. 14)
- 29 II+ (FRAME +) button (p. 14)
- 30 PLAY (playback) button (p. 13, 14)
- 31 FF (fastforward) button (p. 14)

- 16 Кнопка DISPLAY (стр. 13)
- 17 Кнопка DATA CODE (стр. 40)
- 18 Лампочка CAUTION (стр. 87)
- 19 Кнопки и лампочка REC (запись) (стр. 23)
- 20 Кнопка и лампочка PAUSE (пауза) (стр. 23)
- 21 Кнопка II- (FRAME -) (стр. 14)
- 22 Кнопка REW (ускоренная перемотка назад) (стр. 14)
- 23 Кнопка STOP (стоп) (стр. 13)
- 24 Кнопка DIGITAL EFFECT (стр. 32)
- 25 Кнопка TITLE (стр. 42, 44)
- 26 Кнопка PB (воспроизведение) ZOOM (стр. 27)
- 27 Кнопка II- SLOW (стр. 14)
- 28 Кнопка x2 (стр. 14)
- 29 Кнопка II+ (FRAME +) (стр. 14)
- 30 Кнопка G- PLAY (воспроизведение) (стр. 13, 14)
- 31 Кнопка FF (ускоренная перемотка вперед) (стр. 14)

Identifying the parts and controls

Обозначение деталей и органов управления

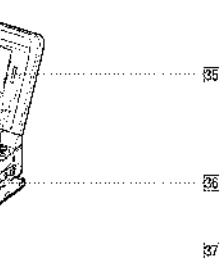
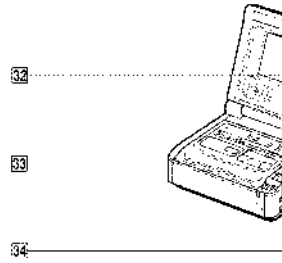

- 32 Speaker
- 33 (headphones) jack (p. 15)
- 34 S VIDEO IN jack (p. 23, 62)
- 35 VIDEO/AUDIO L/R OUT jacks (p. 19, 23, 46, 62)
- 36 RFU DC OUT jack (p. 20)
- 37 S VIDEO OUT jack (p. 19, 46)

- 32 Динамик
- 33 Гнездо (головные телефоны) (стр. 15)
- 34 Гнездо S VIDEO IN (стр. 23, 62)
- 35 Гнезда VIDEO/AUDIO L/R OUT (стр. 19, 23, 46, 62)
- 36 Гнездо RFU DC OUT (стр. 20)
- 37 Гнездо S VIDEO OUT (стр. 19, 46)

Одича Радивоича, Катяна Справичкич

Identifying the parts and controls

Обозначение деталей и органов управления

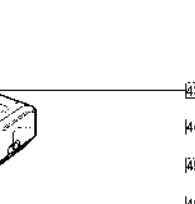
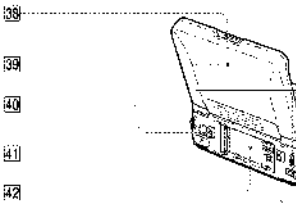

- 38 PUSH OPEN button (p. 12)
- 39 LCD panel
- 40 DC IN jack (p. 8, 10)
- 41 Infrared rays emitter (p. 21, 54)
- 42 Battery mounting surface (p. 9)
- 43 Hooks for shoulder strap
- 44 RELEASE knob
- 45 DV IN/OUT jack (p. 25, 48, 62)
The DV IN/OUT jack is i.LINK compatible.
- 46 BATT release lever (p. 9)

- 38 Кнопка PUSH OPEN (стр. 12)
- 39 Панель ЖКД
- 40 Гнездо DC IN (стр. 8, 10)
- 41 Инфракрасный излучатель (стр. 21, 54)
- 42 Поверхность для установки батареи (стр. 9)
- 43 Крючки для плечевого ремня
- 44 Кнопка RELEASE
- 45 Гнездо DV IN/OUT (стр. 25, 48, 62)
Гнездо DV IN/OUT поддерживает передачу сигнала по стандарту i.LINK.
- 46 Рычажок освобождения BATT (стр. 9)

Note on Release knob
When you release the terminal cover, open the LCD panel first.

Примечания для кнопки Release
При открытии крышки терминала сначала откройте панель ЖКД.

Identifying the parts and controls

Обозначение деталей и органов управления

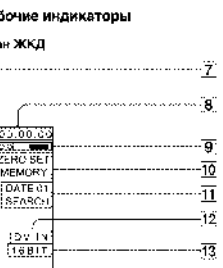
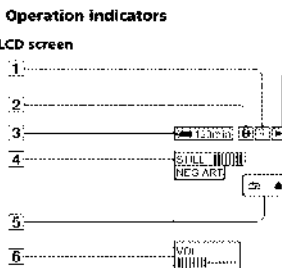

- 1 Recording mode indicator (p. 70)
- 2 Format indicator (p. 79)
[H] [M] or [S] indicator appears
- 3 Remaining battery time indicator
- 4 Picture effect indicator (p. 29)/Digital effect indicator (p. 32)
- 5 Warning indicators (p. 87)
- 6 LCD bright indicator (p. 13)/Volume indicator/Data code indicator (p. 40)
- 7 Video control mode indicator (p. 14)
- 8 Tape counter indicator (p. 34)/Time code indicator/Self-diagnosis display (p. 86)
- 9 Remaining tape indicator
- 10 ZERO SET MEMORY indicator (p. 34, 65)
- 11 Search mode indicator (p. 36, 38, 39)
- 12 DV IN indicator (p. 26)/A/V → DV indicator (p. 62)
- 13 Audio mode indicator (p. 70)

- 7 Индикатор режима записи (стр. 74)
- 8 Индикатор формата (стр. 79)
Появится индикатор [H] [M] [S] или [S]
- 9 Индикатор оставшегося времени работы батареи
- 4 Индикатор эффекта изображения (стр. 29)/Индикатор цифровых эффектов (стр. 32)
- 5 Предупреждающие индикаторы (стр. 87)
- 6 Индикатор яркости ЖКД (стр. 13)/Индикатор яркости/Индикатор кода данных (стр. 40)
- 7 Индикатор режима видеоконтроля (стр. 14)
- 8 Индикатор счетчика ленты (стр. 34)/Индикатор кода времени/Индикатор диагностики (стр. 86)
- 9 Индикатор оставшейся ленты
- 10 Индикатор ZERO SET MEMORY (стр. 34, 65)
- 11 Индикатор режима поиска (стр. 36, 38, 39)
- 12 Индикатор DV IN (стр. 26)/Индикатор A/V → DV (стр. 62)
- 13 Индикатор аудиорежима (стр. 74)

About the time code
A time code is recorded on the tape to search for scenes easily. Your VCR records the time code during recording. Time-DISPLAY lets you see the time code. Hour, minutes, seconds, and frames appear on the LCD screen on the TV screen. "00:00:00" is recorded at the beginning of the tape. If there is a blank portion on the tape, however, "00:00:00" is recorded after the blank portion. You cannot rewrite the time code later. The time code of your VCR is a drop frame system. It may skip some frames to adjust the time code.

Код времени
На ленту записывается код времени, позволяющий быстро найти нужный эпизод. Видеокамера записывает код времени на время записи. Нажимая кнопку DISPLAY, вы увидите код времени. На экране ЖКД или телевизора появятся часы, минуты, секунды и кадры. В начале ленты записывается "00:00:00". Однако если на ленте имеется свободная часть, "00:00:00" записывается после свободной части. Записать код времени нельзя переписать. Для кода времени в ленте видеокамеры используется система пропусков кадров. Она может пропускать некоторые кадры для коррекции кода времени.

Одича Радивоича, Катяна Справичкич

SECTION 2 DISASSEMBLY

The following flow chart shows the disassembly procedure.

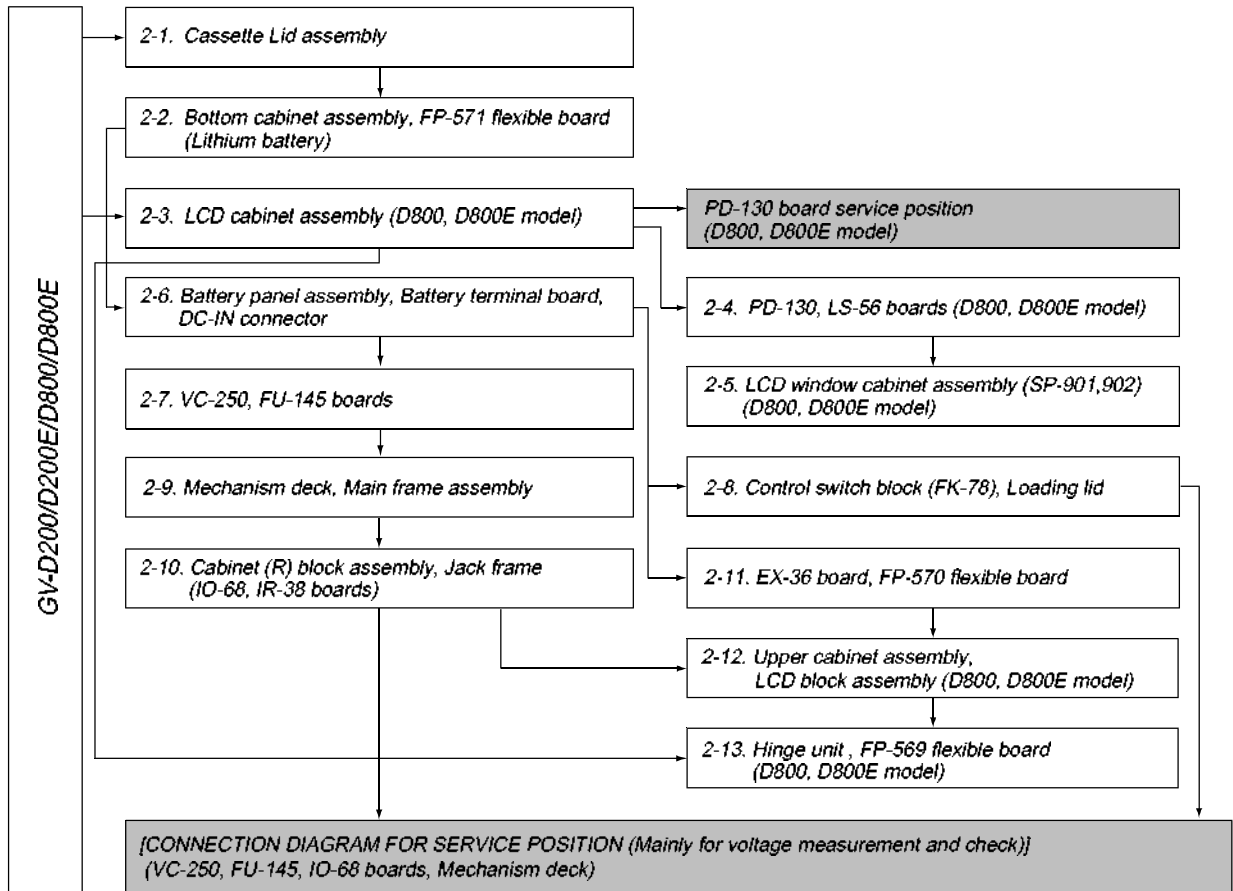

NOTE: Follow the disassembly procedure in the numerical order given.

2-1. CASSETTE LID ASSEMBLY

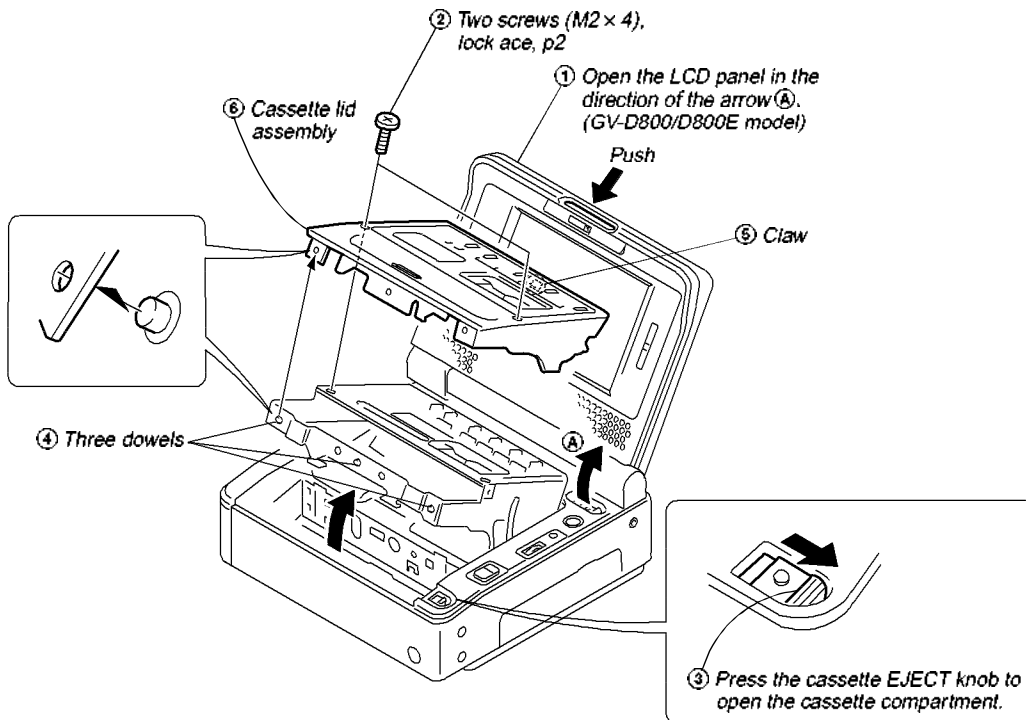

2-2. BOTTOM CABINET ASSEMBLY, FP-571 FLEXIBLE BOARD (LITHIUM BATTERY)

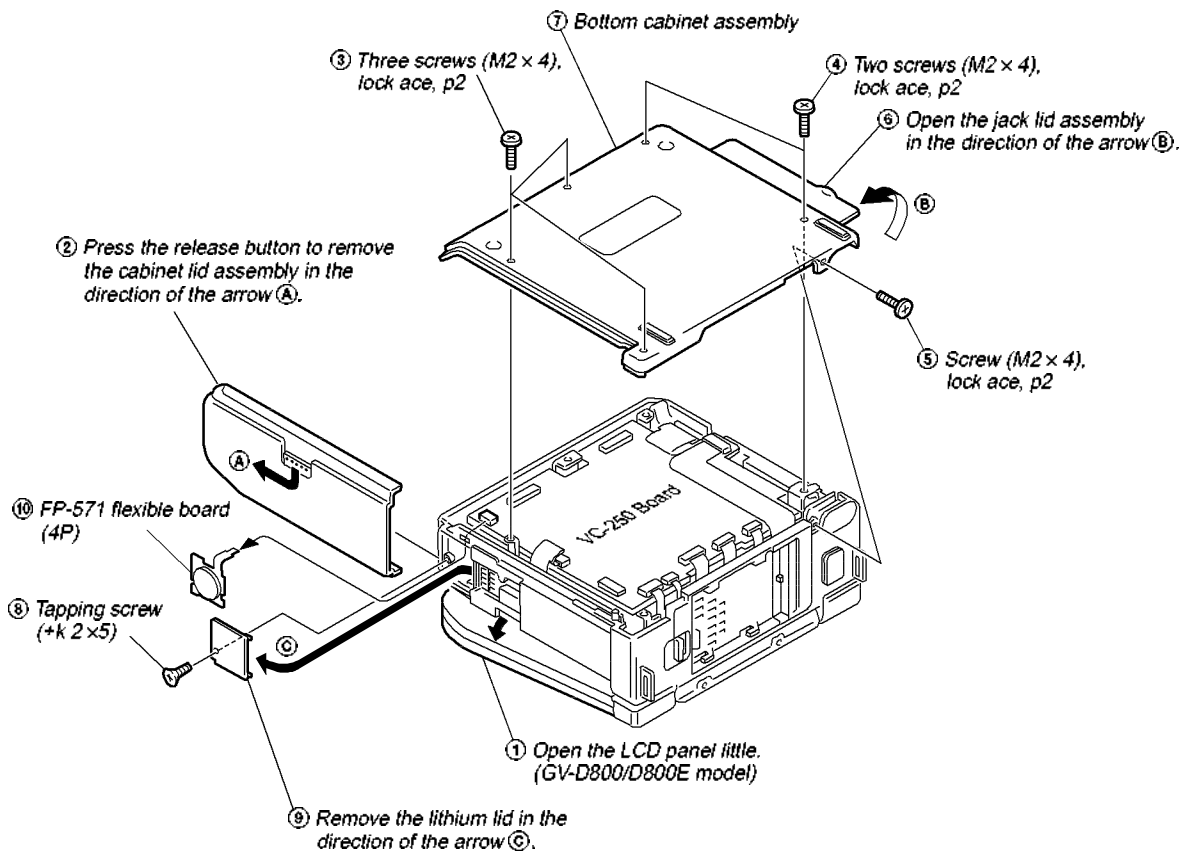

2-3. LCD CABINET ASSEMBLY (D800, D800E MODEL)

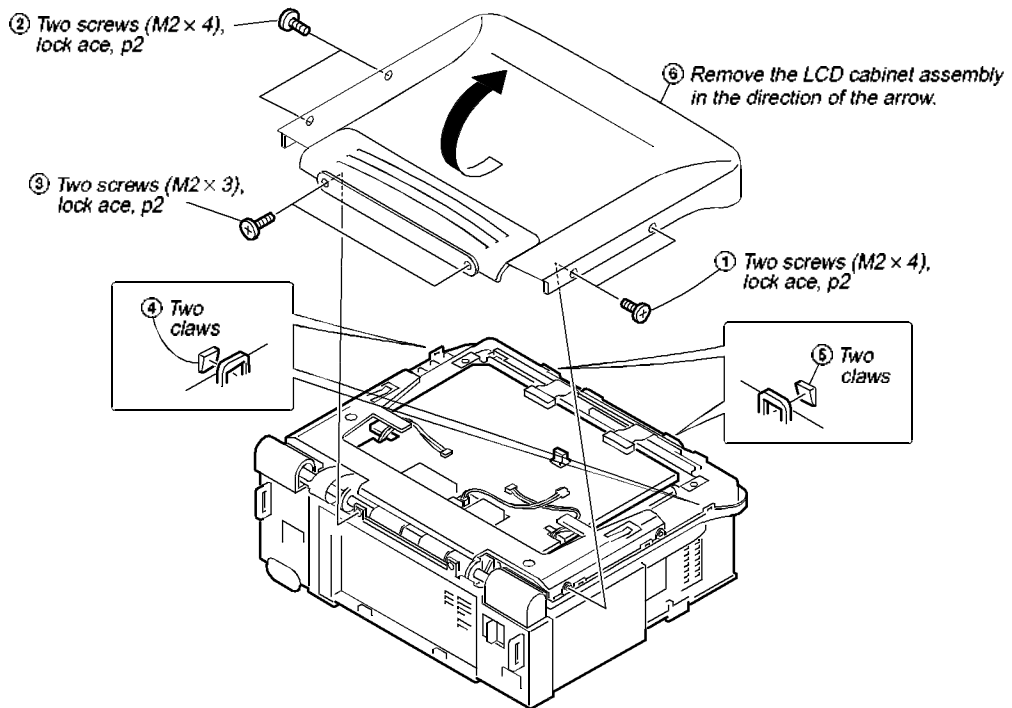

[PD-130 BOARD SERVICE POSITION] (D800, D800E MODEL)

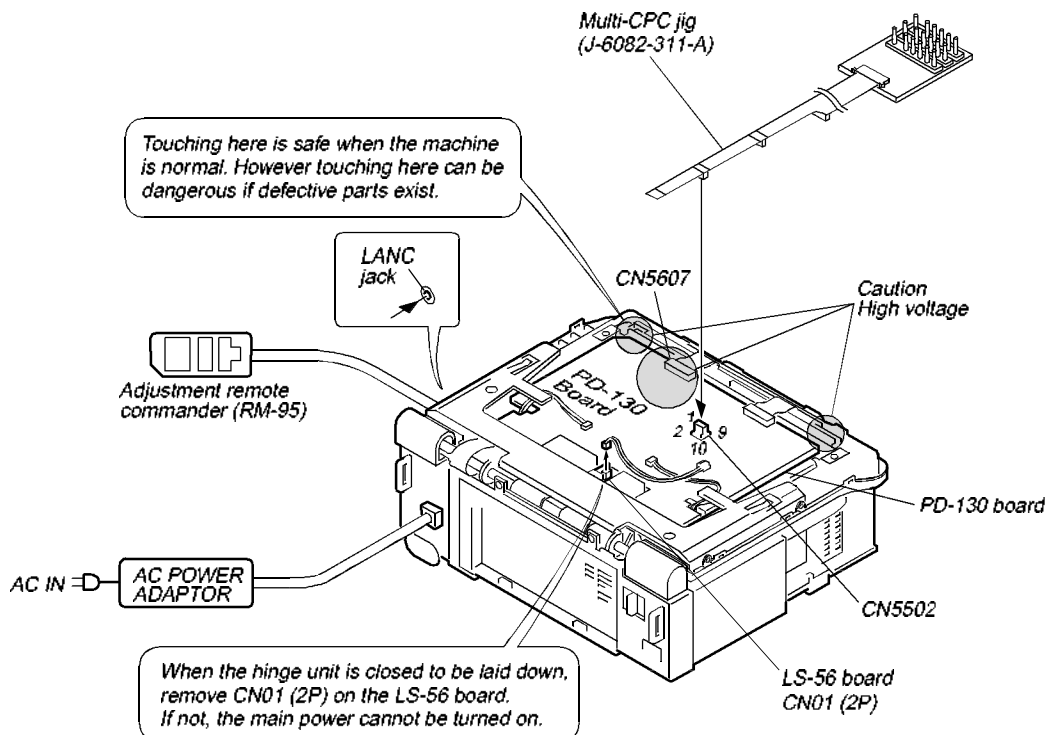

2-4. PD-130, LS-56 BOARDS (D800, D800E MODEL)

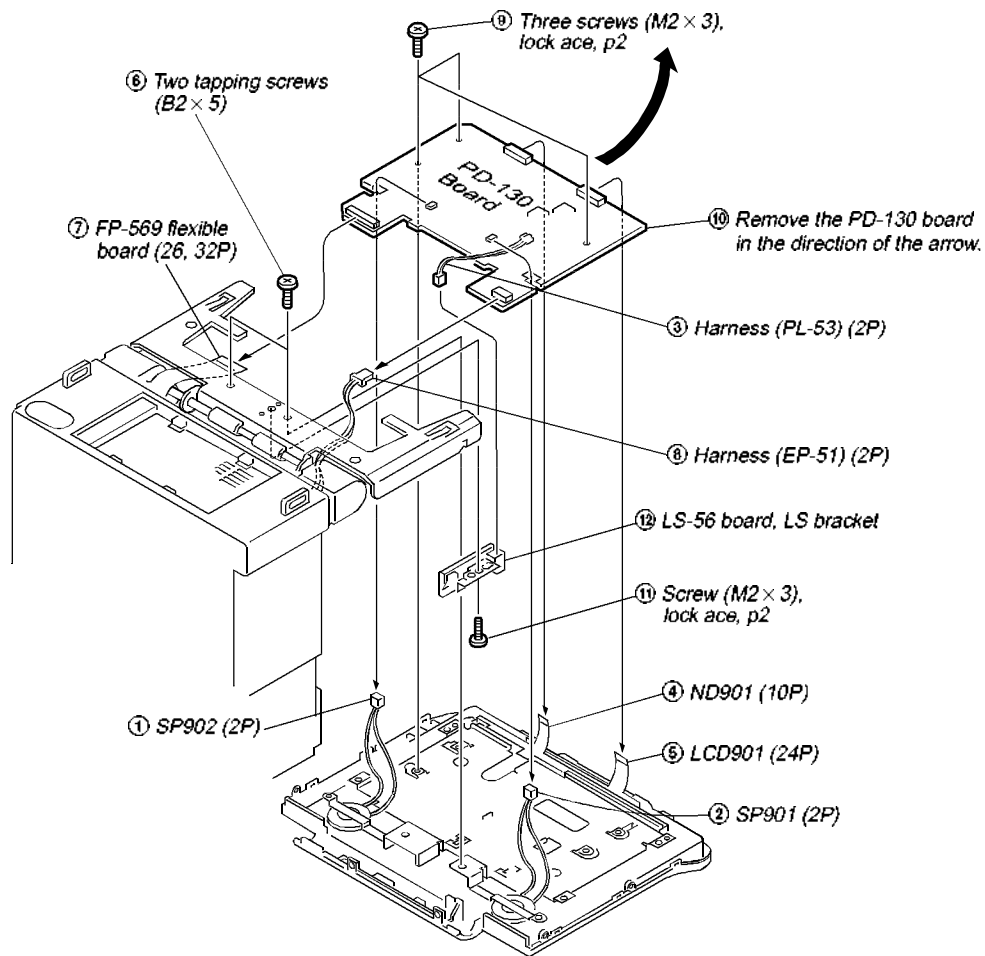

2-5. LCD WINDOW CABINET ASSEMBLY (SP-901, 902)(D800, D800E MODEL)

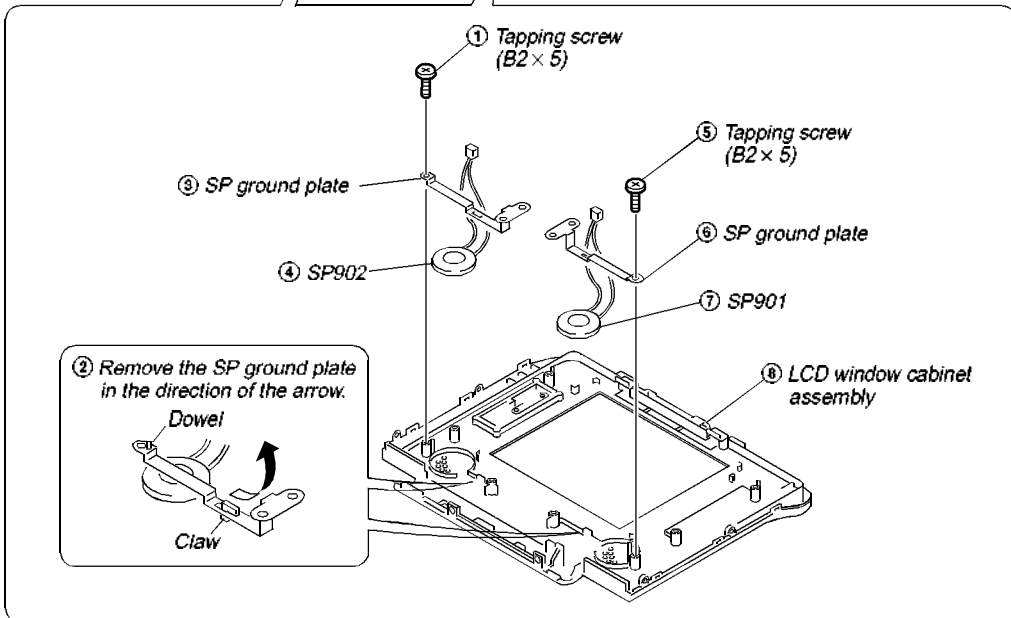
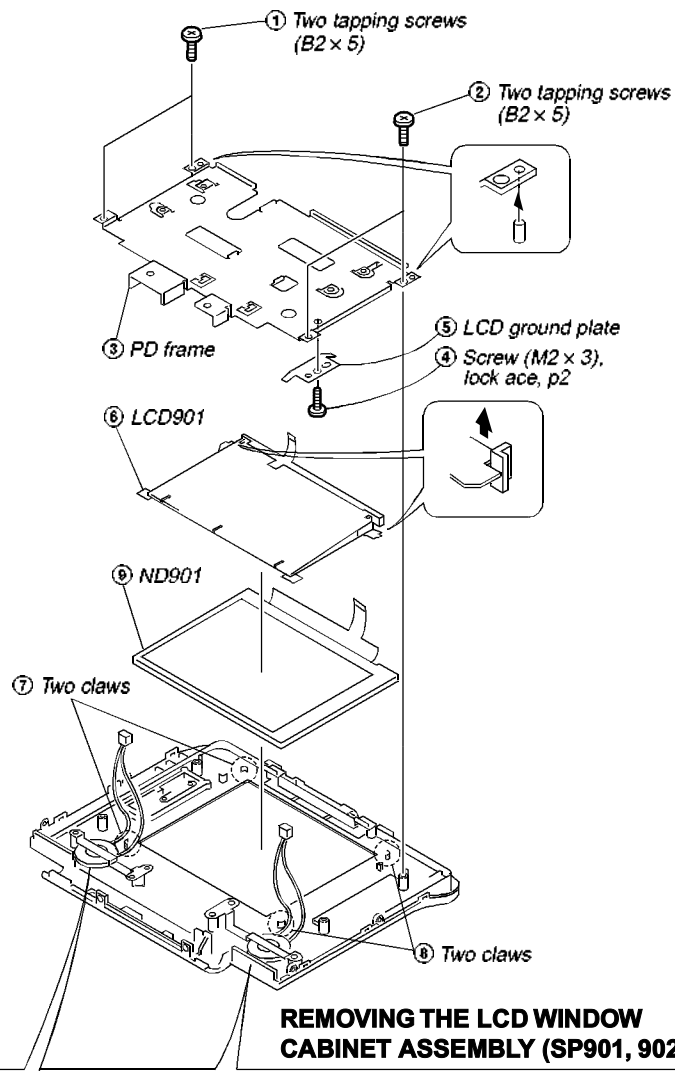

2-6. BATTERY PANEL ASSEMBLY, BATTERY TERMINAL BOARD, DC-IN CONNECTOR

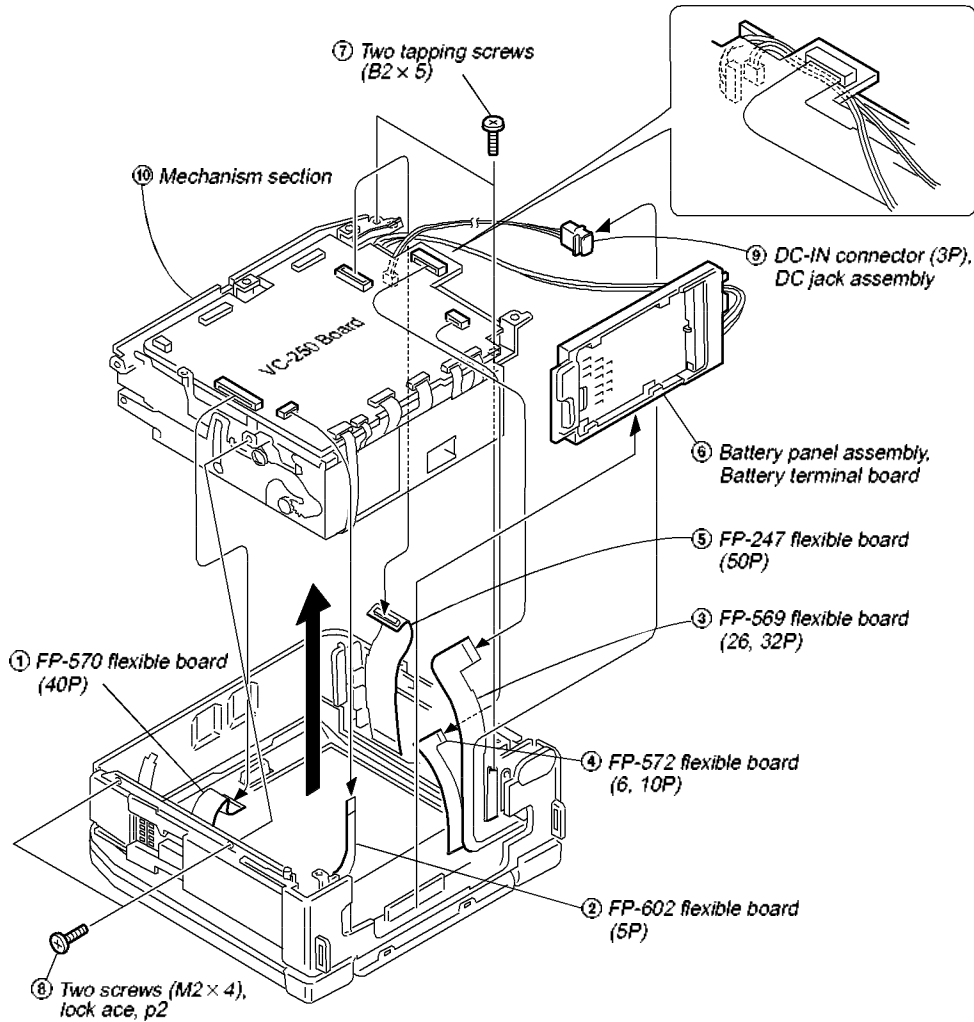

2-7. VC-250, FU-145 BOARDS

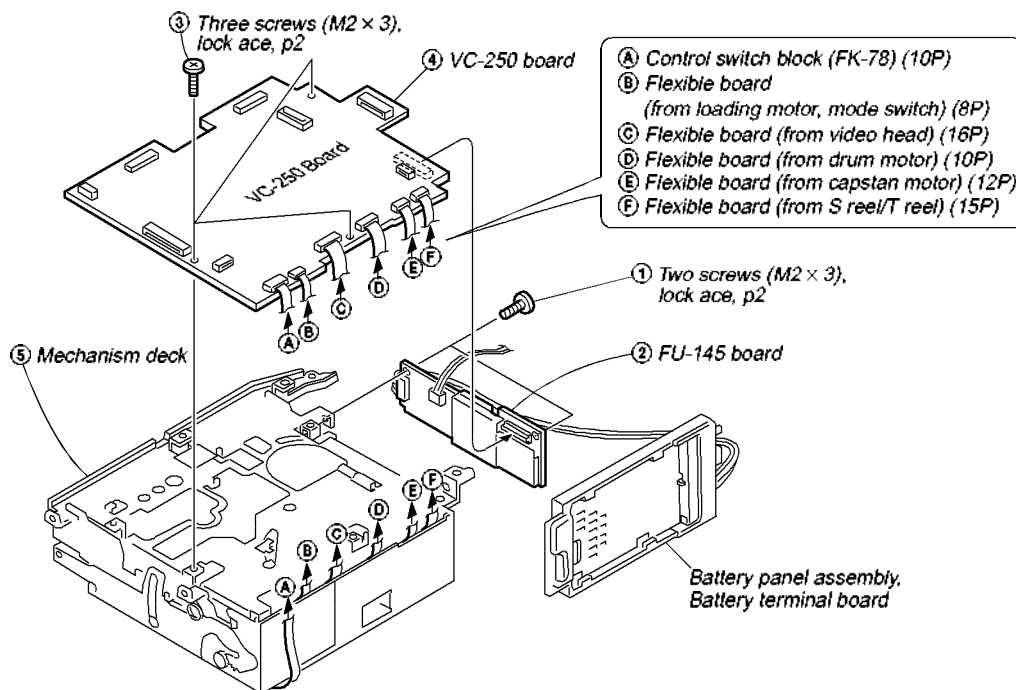

2-8. CONTROL SWITCH BLOCK (FK-78), LOADING LID

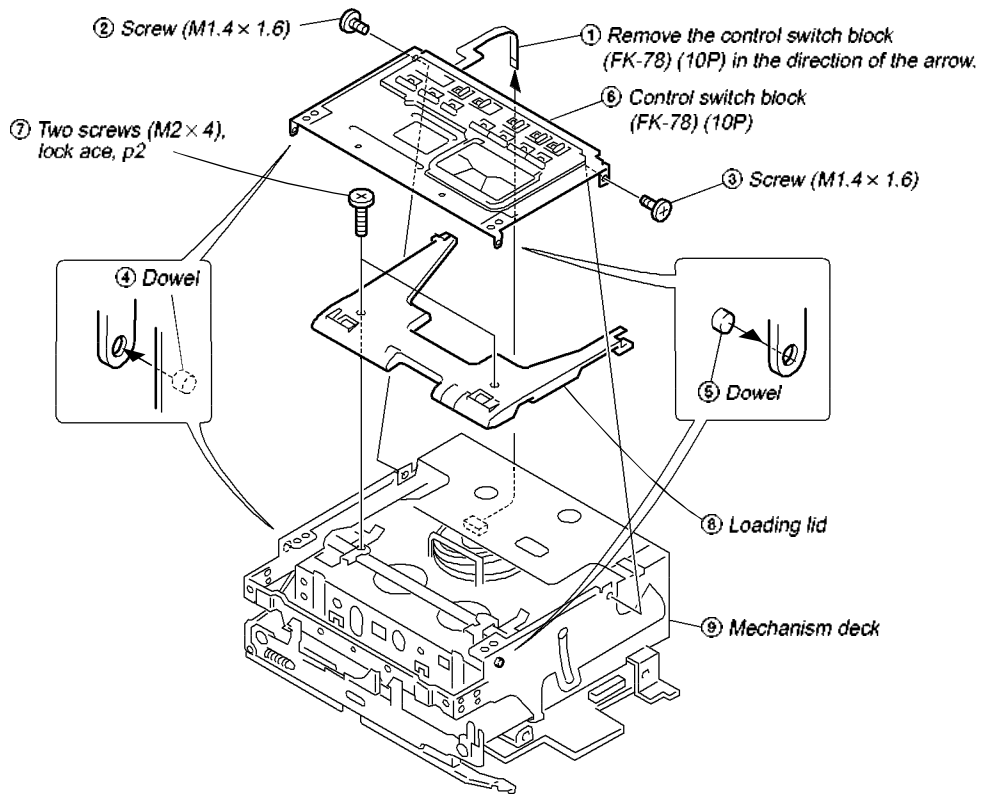

2-9. MECHANISM DECK, MAIN FRAME ASSEMBLY

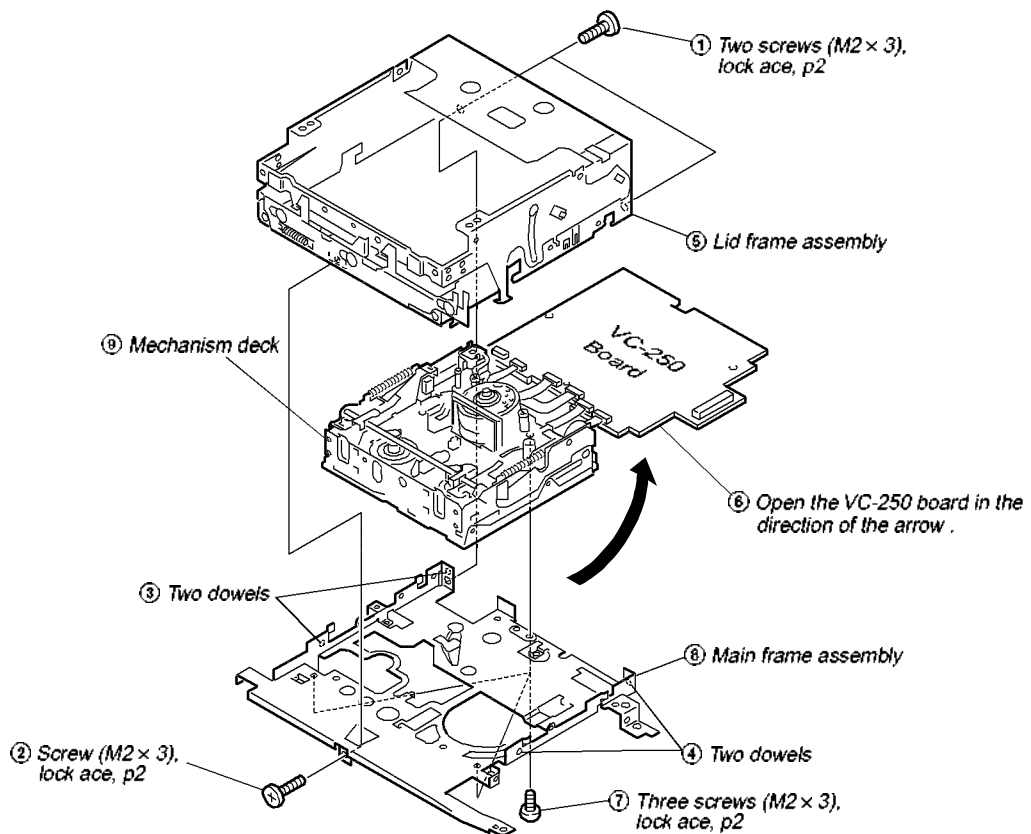

2-10. CABINET (R) BLOCK ASSEMBLY, JACK FRAME (IO-68, IR-38 BOARDS)

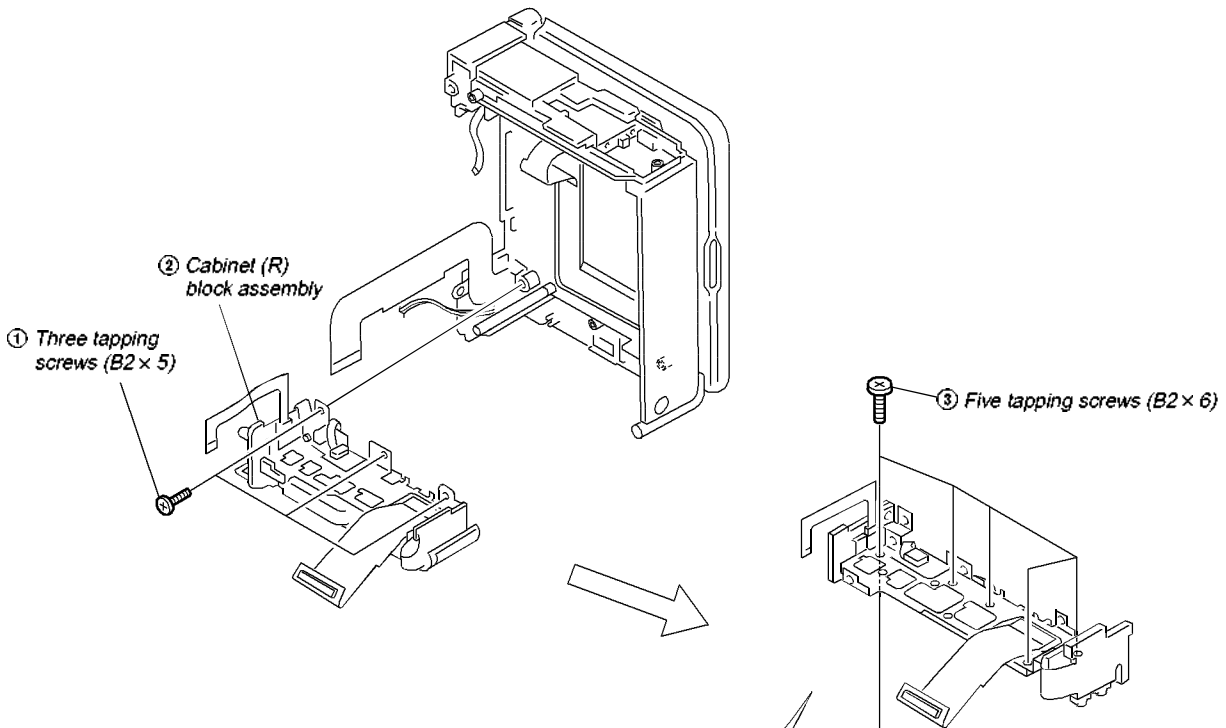

REMOVING THE JACK FRAME

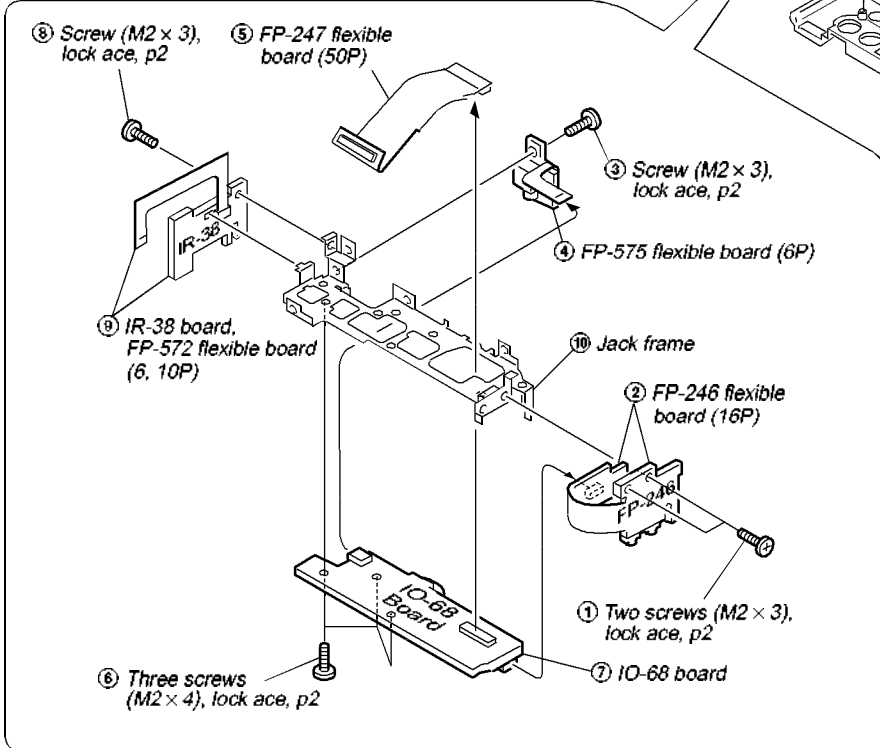

2-11. EX-36 BOARD, FP-570 FLEXIBLE BOARD

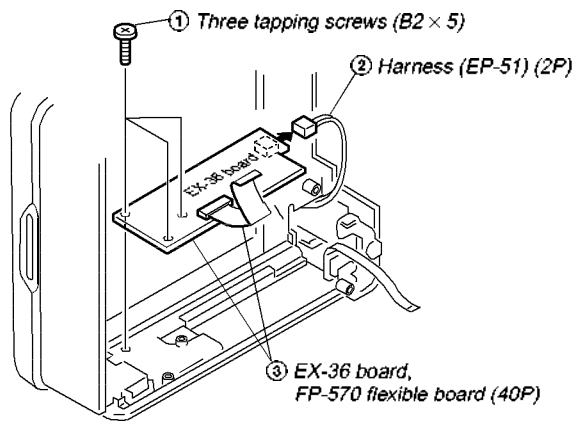

2-12. UPPER CABINET ASSEMBLY, LCD BLOCK ASSEMBLY (D800, D800E MODEL)

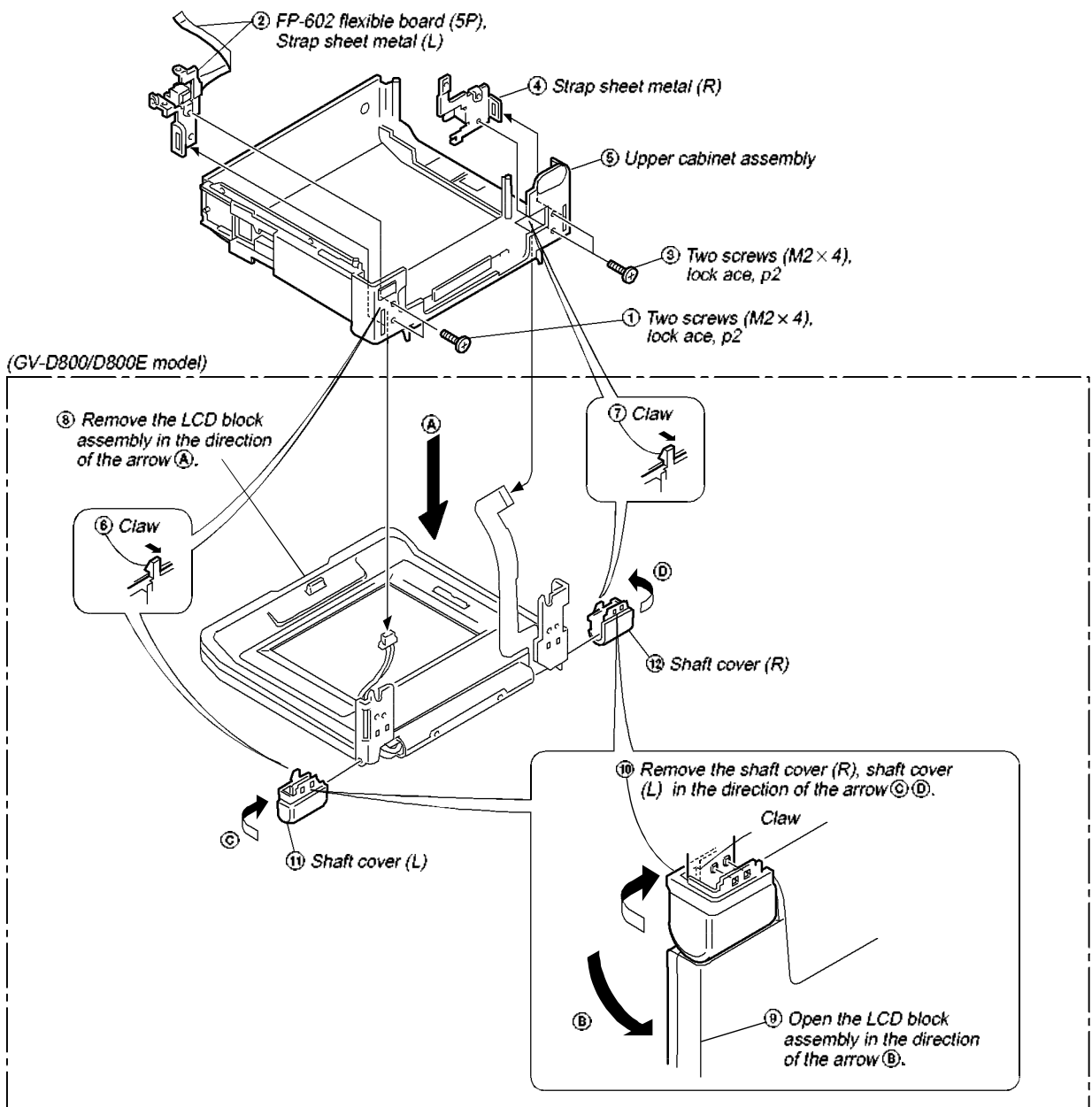

2-13. HINGE UNIT, FP-569 FLEXIBLE BOARD (D800, D800E MODEL)

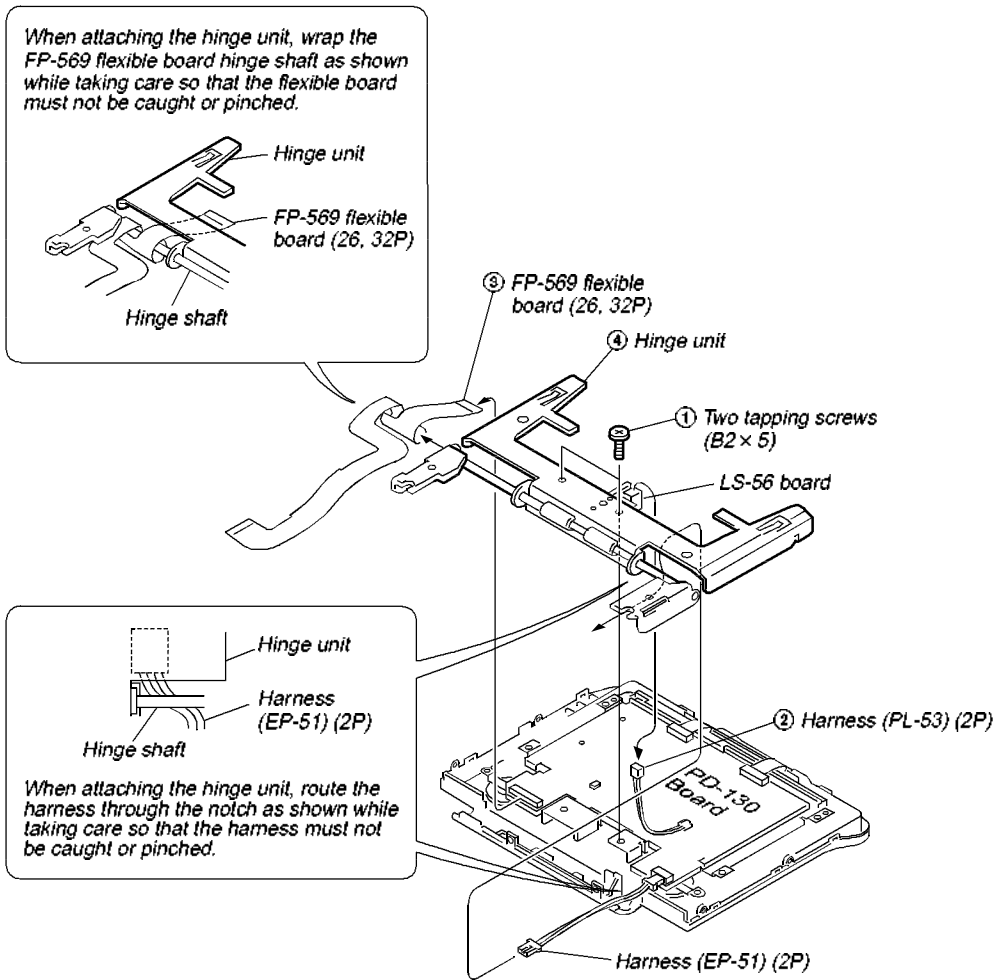

**[CONNECTION DIAGRAM FOR SERVICE POSITION (Mainly for voltage measurement and check)]
 (VC-250, FU-145, IO-68 BOARDS, MECHANISM DECK)**

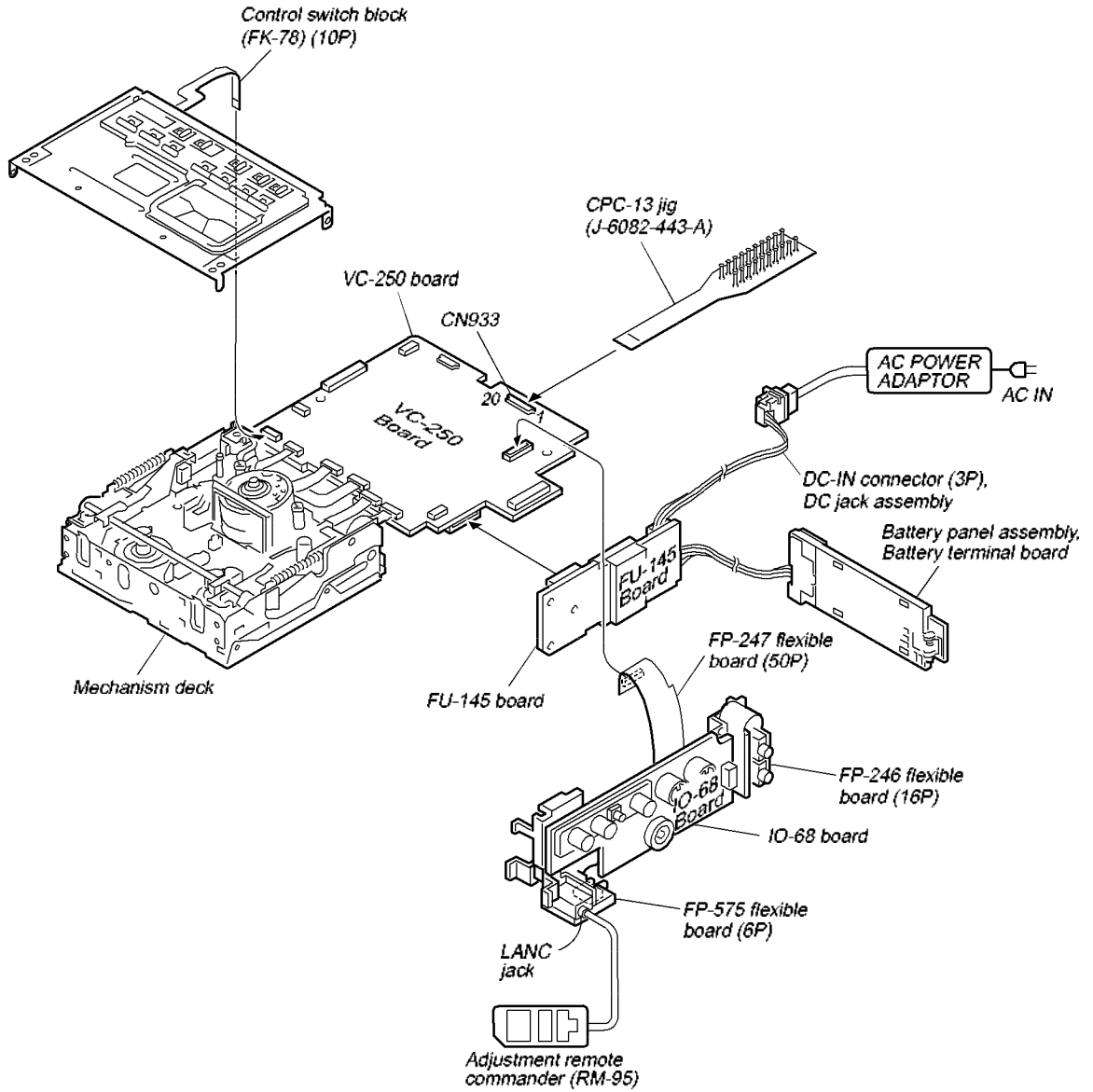

2-14. CIRCUIT BOARDS LOCATION

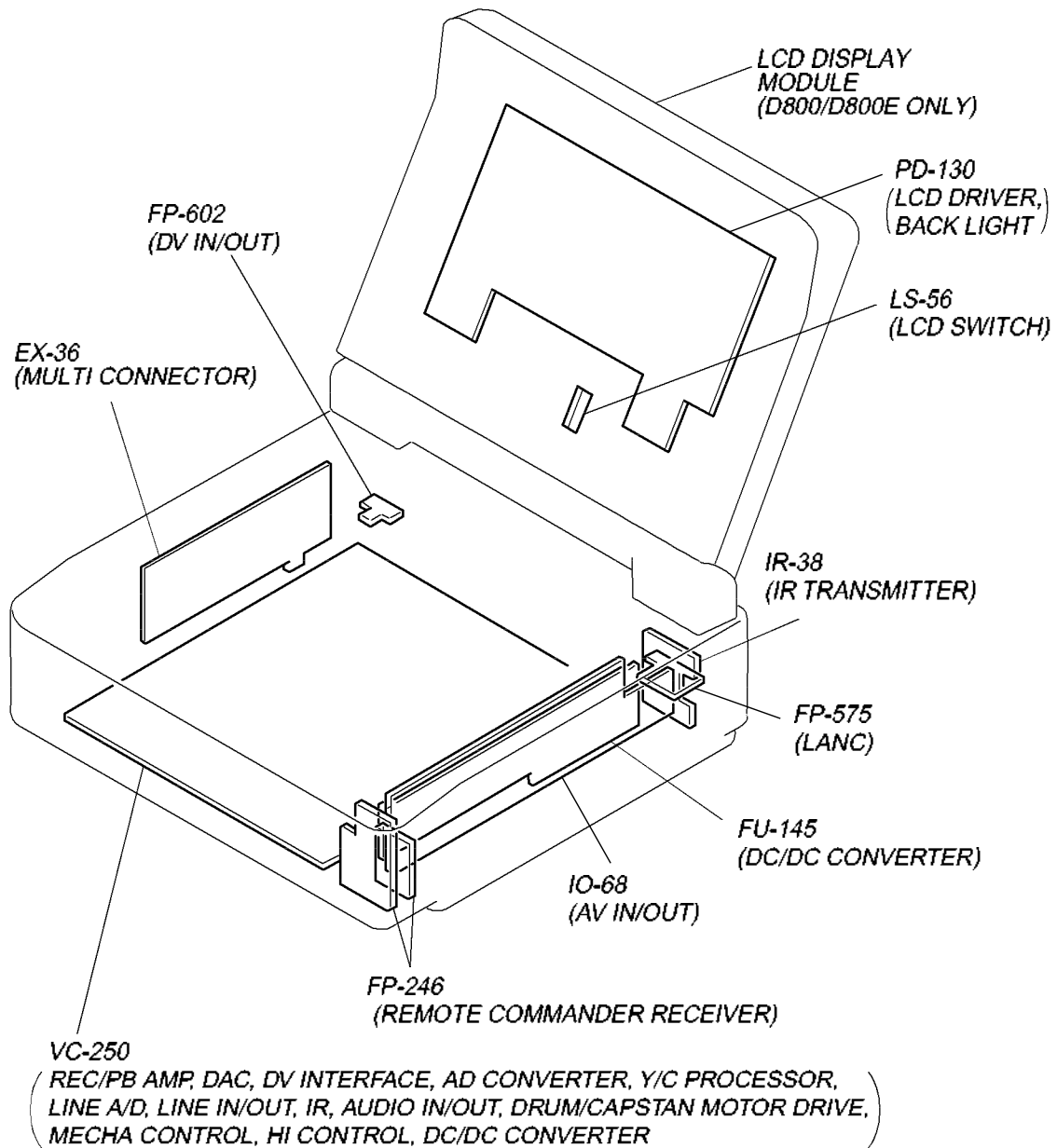

2-15. FLEXIBLE BOARDS LOCATION

The flexible boards contained in the mechanism deck are not shown.

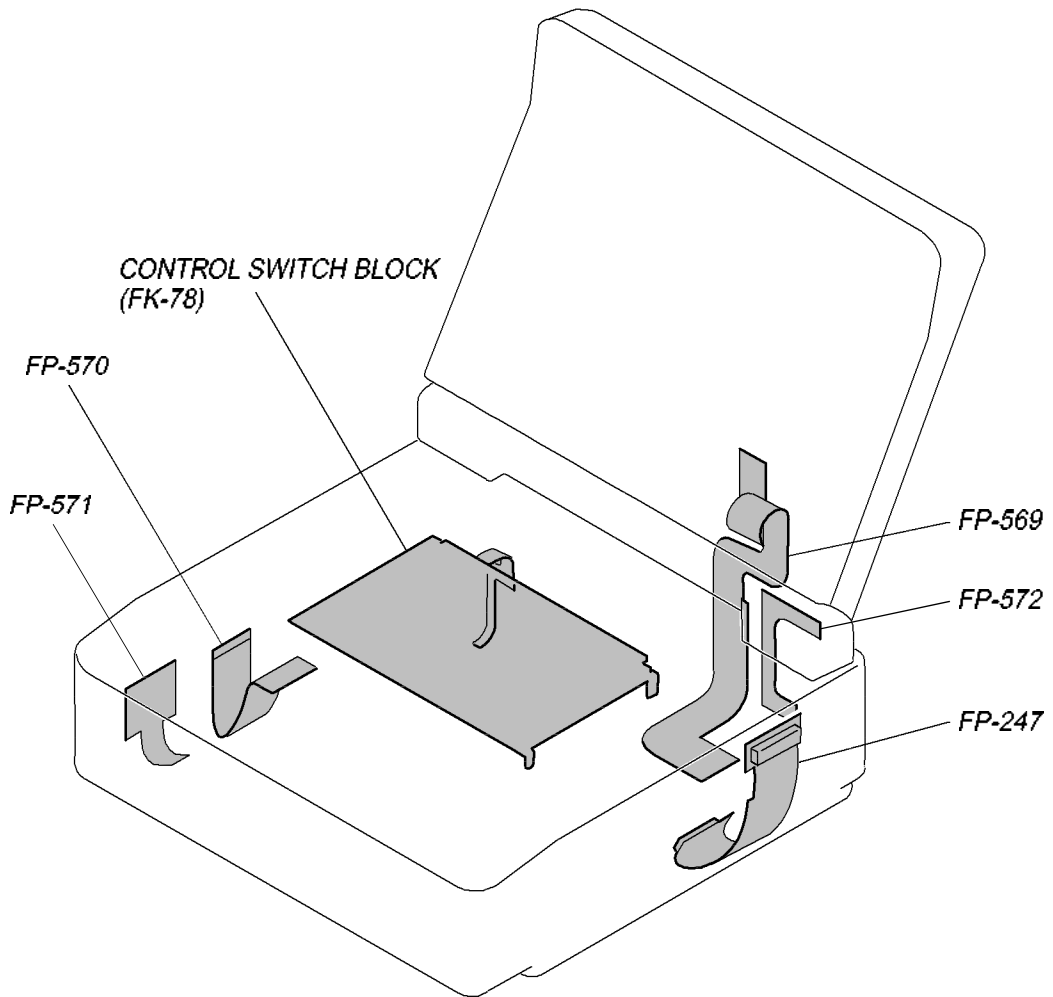

**SECTION 3
BLOCK DIAGRAMS**

3-1. OVERALL BLOCK DIAGRAM (1/4) (): Page No. shown in () indicates the page to refer on the schematic diagram.

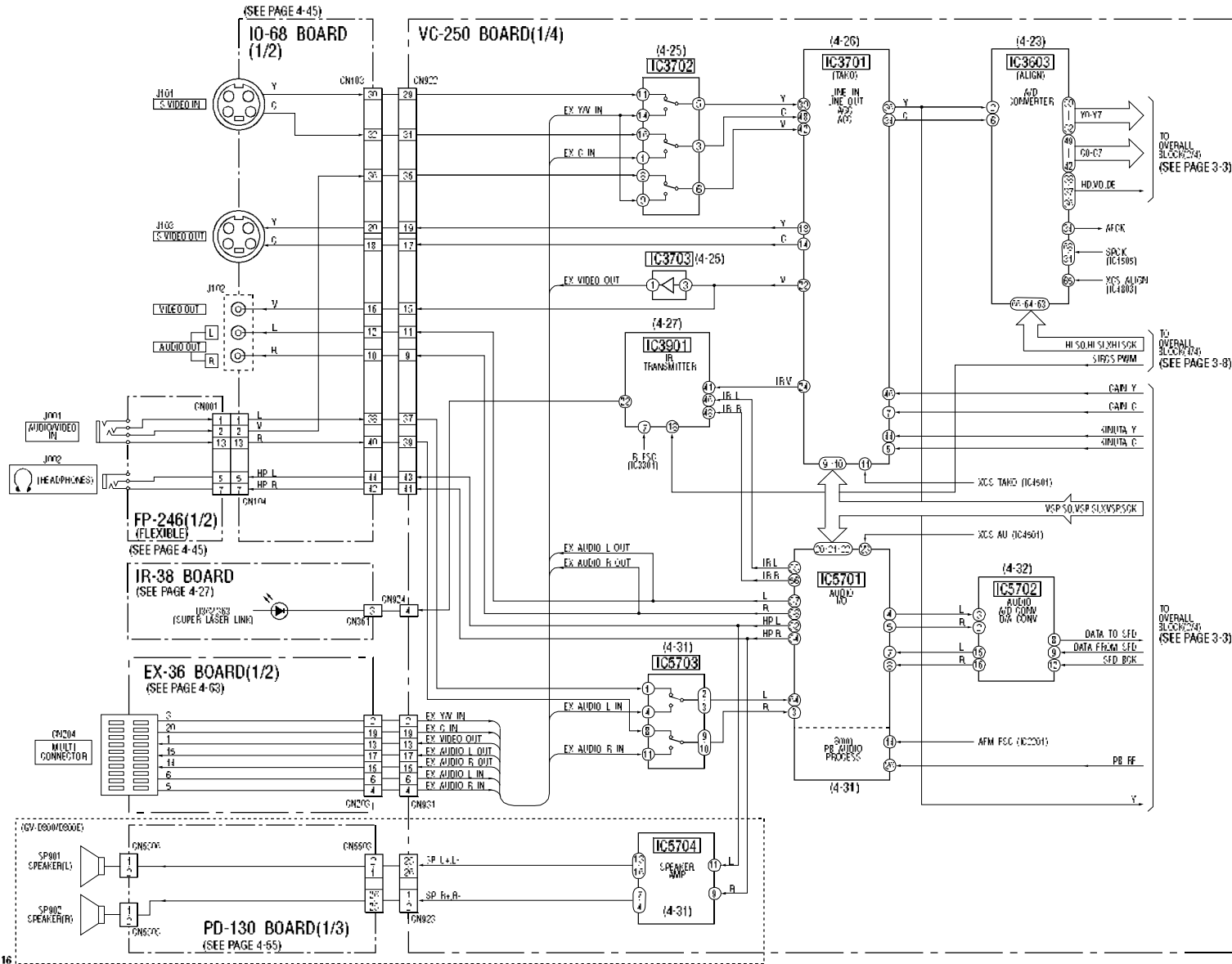

3-2. OVERALL BLOCK DIAGRAM (2/4) (): Page No. shown in () indicates the page to refer on the schematic diagram.

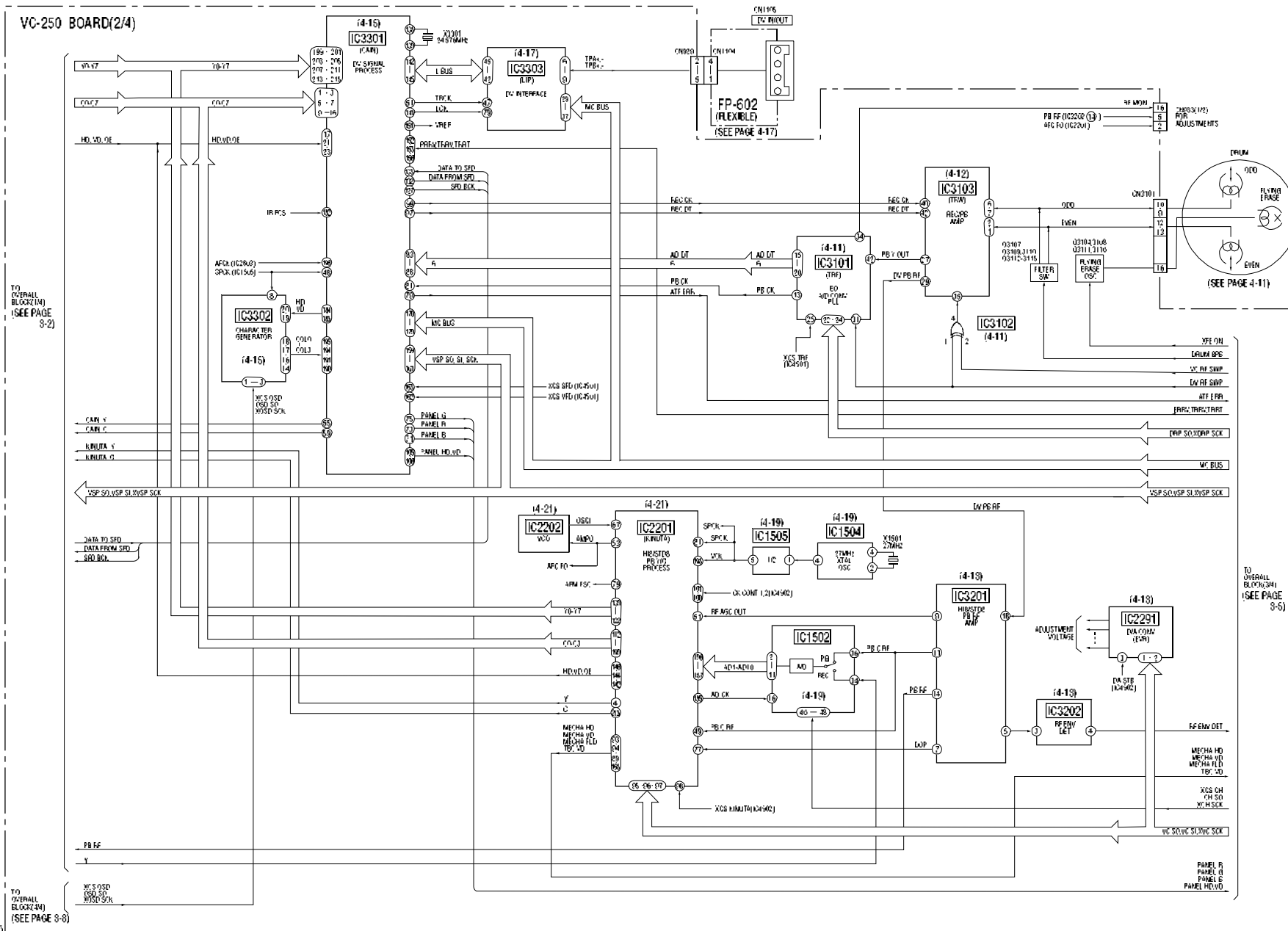

TO OVERALL BLOCK (3/4) (SEE PAGE 3-3)

TO OVERALL BLOCK (3/4) (SEE PAGE 3-5)

3-3. OVERALL BLOCK DIAGRAM (3/4) (): Page No. shown in () indicates the page to refer on the schematic diagram.

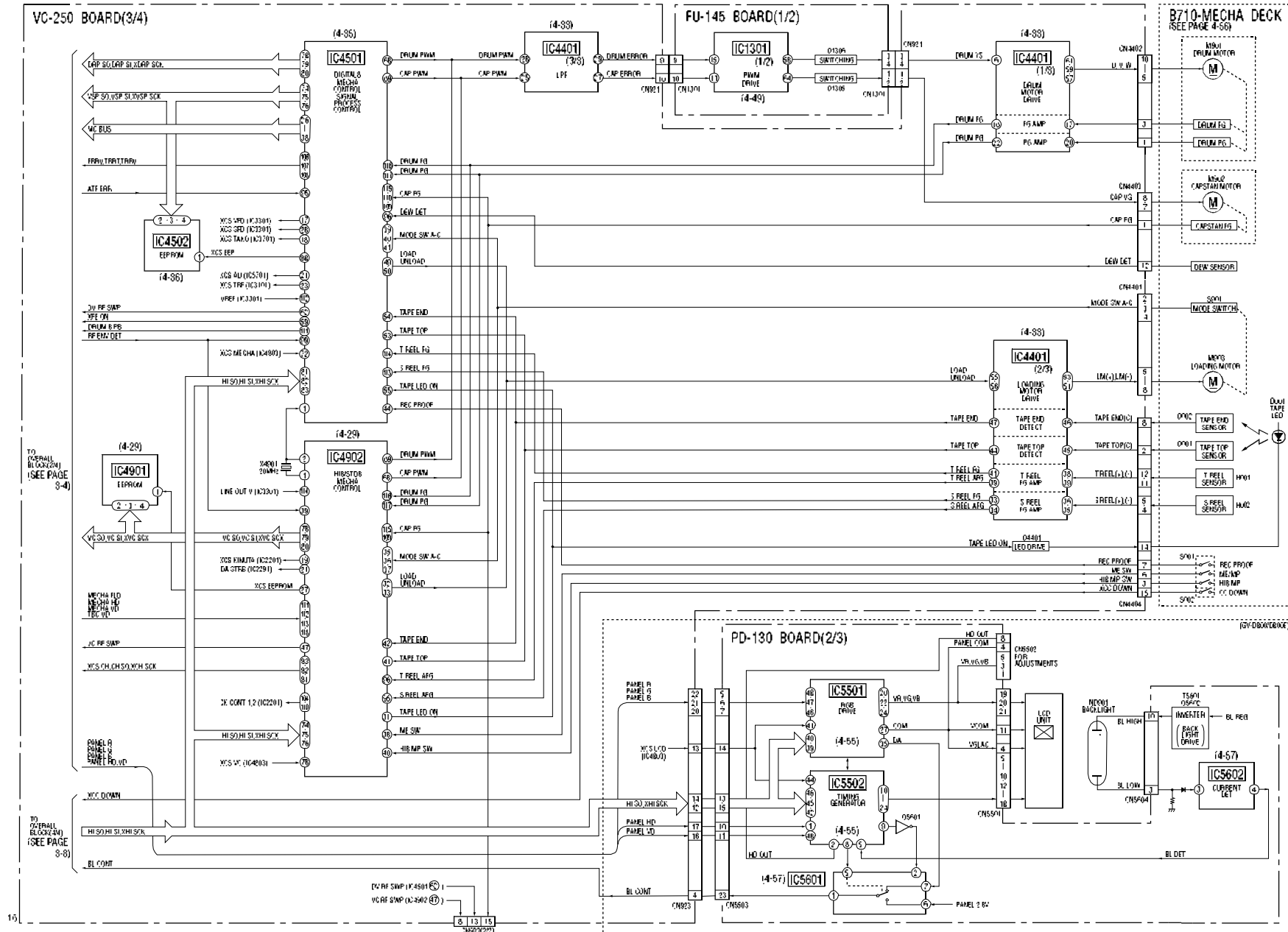

3-4. OVERALL BLOCK DIAGRAM (4/4) (): Page No. shown in () indicates the page to refer on the schematic diagram.

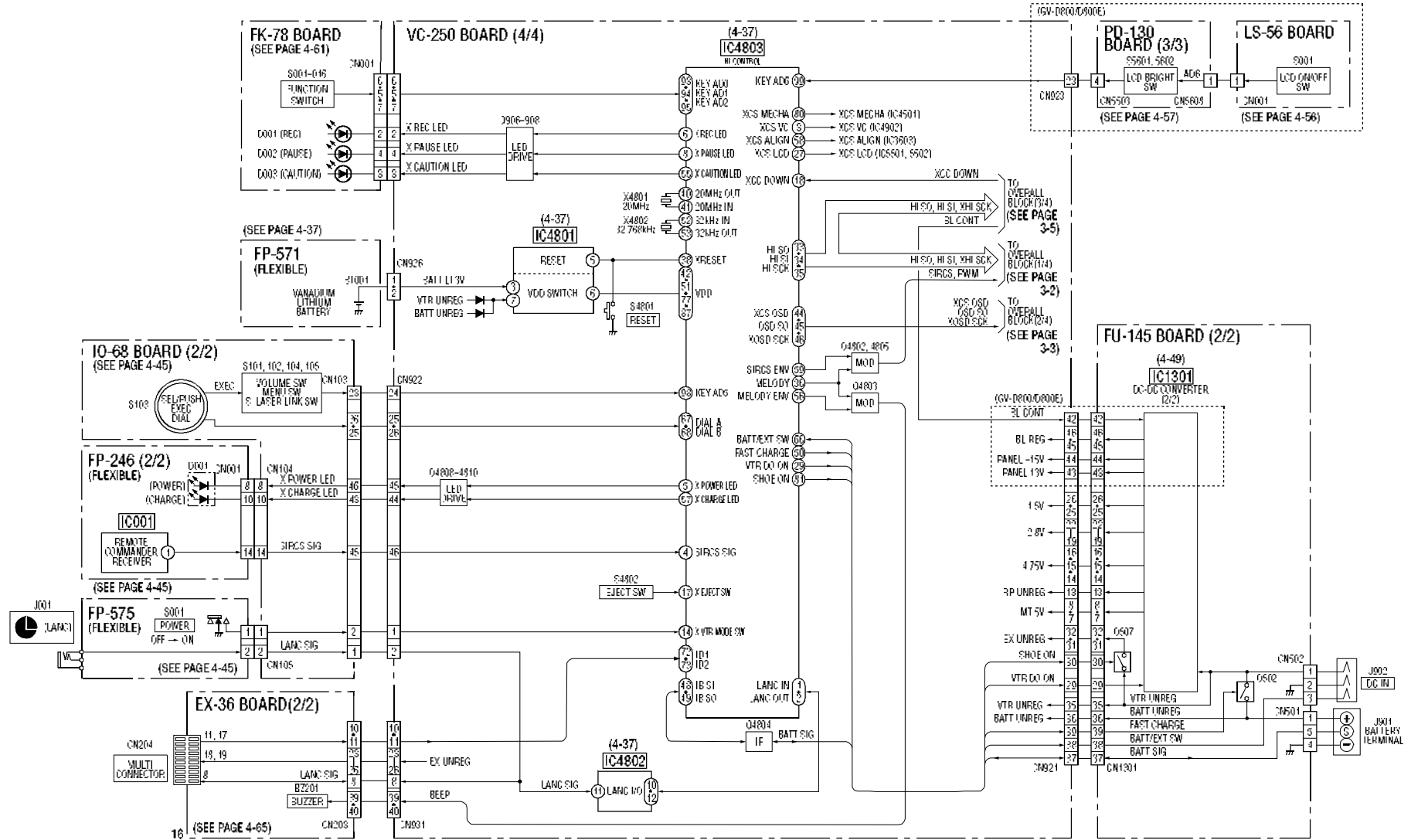

3-5. POWER BLOCK DIAGRAM (1/2) (): Page No. shown in () indicates the page to refer on the schematic diagram.

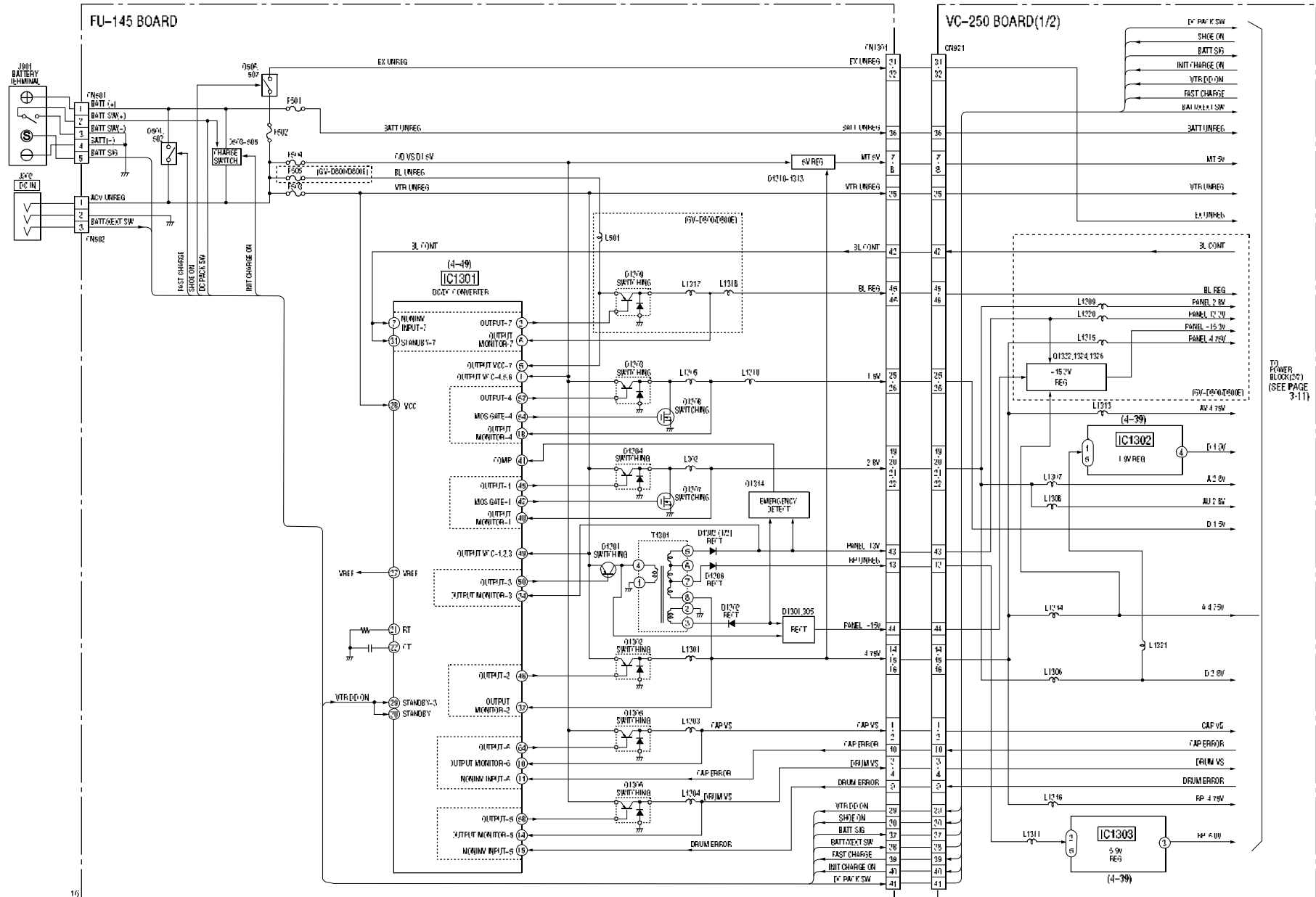

TO POWER BLOCK(2) (SEE PAGE 3-11)

3-6. POWER BLOCK DIAGRAM (2/2) (): Page No. shown in () indicates the page to refer on the schematic diagram.

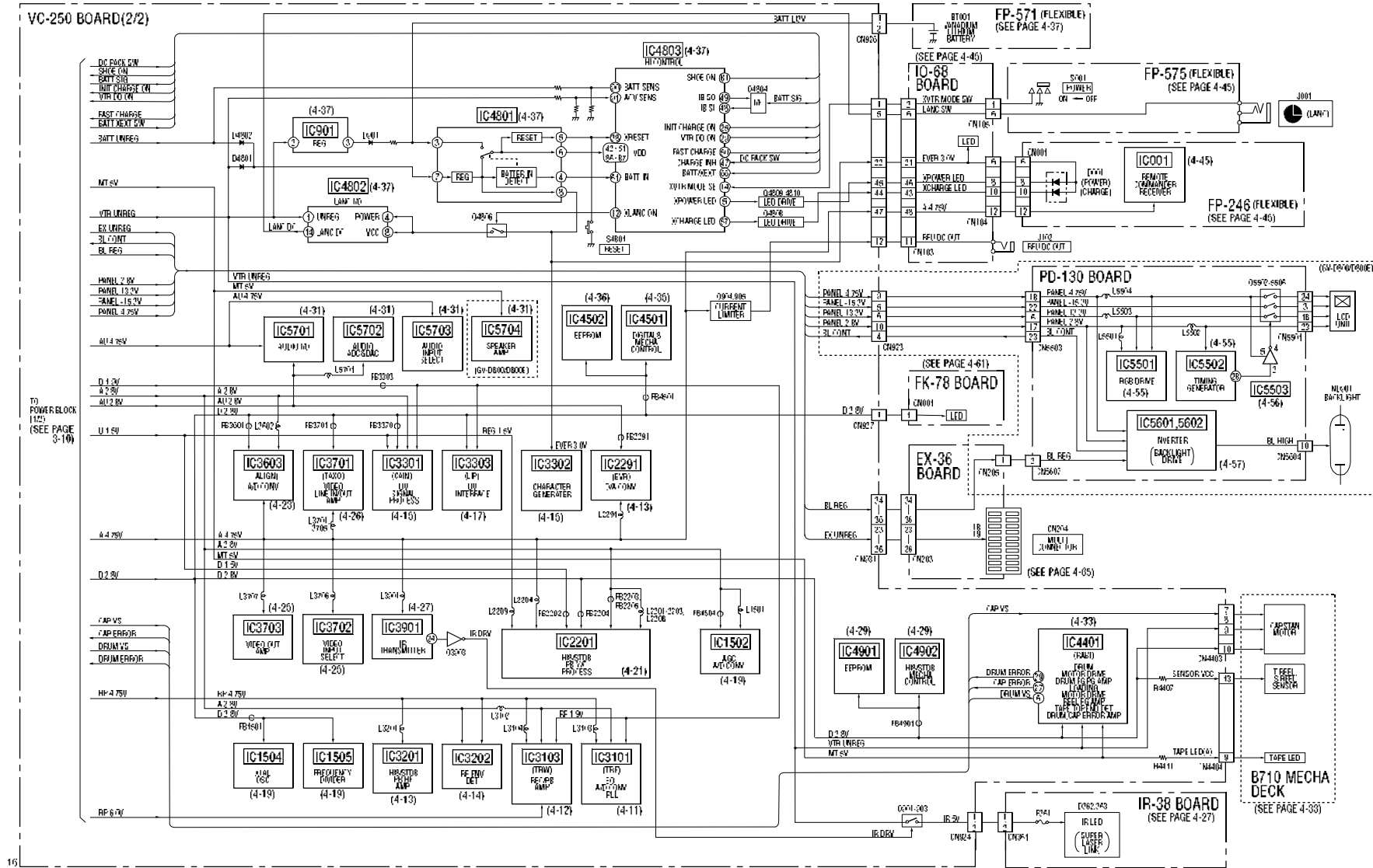

SECTION 4
PRINTED WIRING BOARDS AND SCHEMATIC DIAGRAMS

4-1. FRAME SCHEMATIC DIAGRAM (1/2)

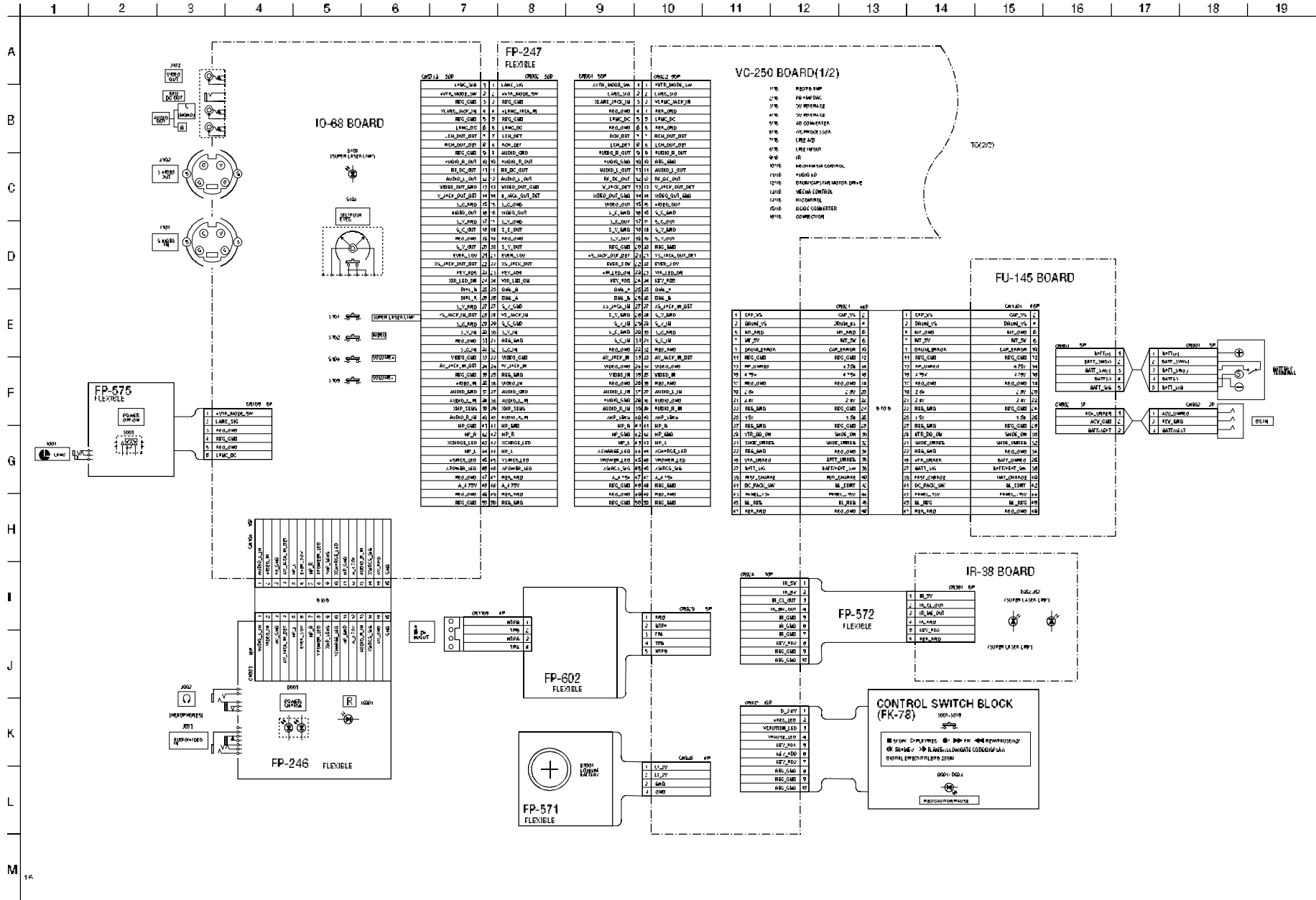

FRAME SCHEMATIC DIAGRAM (2/2)

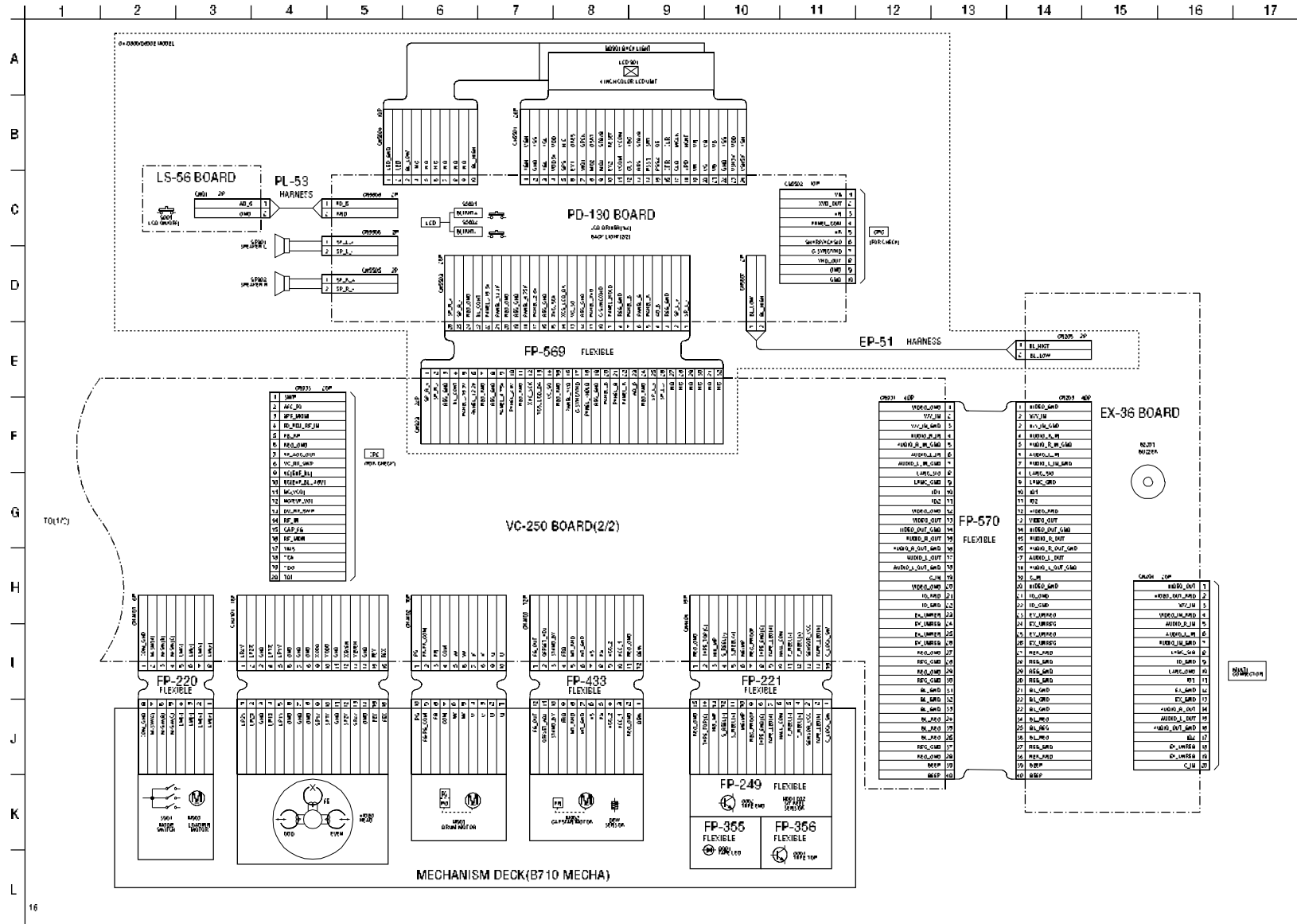

4-2. PRINTED WIRING BOARDS AND SCHEMATIC DIAGRAMS

THIS NOTE IS COMMON FOR WIRING BOARDS AND SCHEMATIC DIAGRAMS
 (In addition to this, the necessary note is printed in each block)

(For printed wiring boards)

-  Pattern from the side which enables seeing. (The other layers' patterns are not indicated.)
- Through hole is omitted.
- Circled numbers refer to waveforms.
- There are few cases that the part printed on diagram isn't mounted in this model.
- Chip parts.

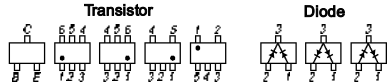

(Measuring conditions voltage and waveform)





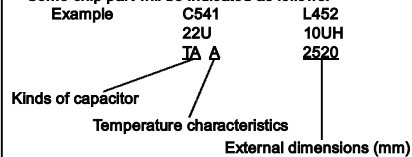

- Voltages and waveforms are measured between the measurement points and ground when composite video signal is REC or PB. They are reference values and reference waveforms. *
- (VOM of DC 10 MΩ input impedance is used.)
- Voltage values change depending upon input impedance of VOM used.)

When indicating parts by reference number, please include the board name.

(For schematic diagrams)

- All capacitors are in μF unless otherwise noted. pF : μ. μF. 50V or less are not indicated except for electrolytics and tantalums.
- Chip resistors are 1/10W unless otherwise noted. KΩ=1000Ω, MΩ=1000KΩ.
- Caution when replacing chip parts. New parts must be attached after removal of chip. Be careful not to heat the minus side of tantalum capacitor, Because it is damaged by the heat.
- Some chip part will be indicated as follows.



- Constants of resistors, capacitors, ICs and etc with XX indicate that they are not used. In such cases, the unused circuits may be indicated.
- Parts with * differ according to the model/destination. Refer to the mount table for each function.
- All variable and adjustable resistors have characteristic curve B, unless otherwise noted.
- Signal name
 XEDIT → EDIT PB/XREC → PB/REC
- : non flammable resistor
- : fusible resistor
- : panel designation
- : B+ Line *
- : B- Line *
- : IN/OUT direction of (+,-) B LINE. *
- : adjustment for repair. *
- Circled numbers refer to waveforms. *
- Indicated by the color red.

<p>Note : The components identified by mark Δ or dotted line with mark Δ are critical for safety. Replace only with part number specified.</p>	<p>Note : Les composants identifiés par une marque Δ sont critiques pour la sécurité. Ne les remplacer que par une pièce portant le numéro spécifié.</p>
--	--

VC-250 (REC/PB AMP, DAC, DV INTERFACE, AD CONVERTER, Y/C PROCESSOR, LINE A/D, LINE I/O, IR, AUDIO I/O, DRUM/CAPSTAN MOTOR DRIVE, MECHA CONTROL, HI CONTROL, DC/DC CONVERTER, CONNECTION) PRINTED WIRING BOARD

— Ref. No. VC-250 Board; 30,000 Series —

VC-250 BOARD (SIDE A)

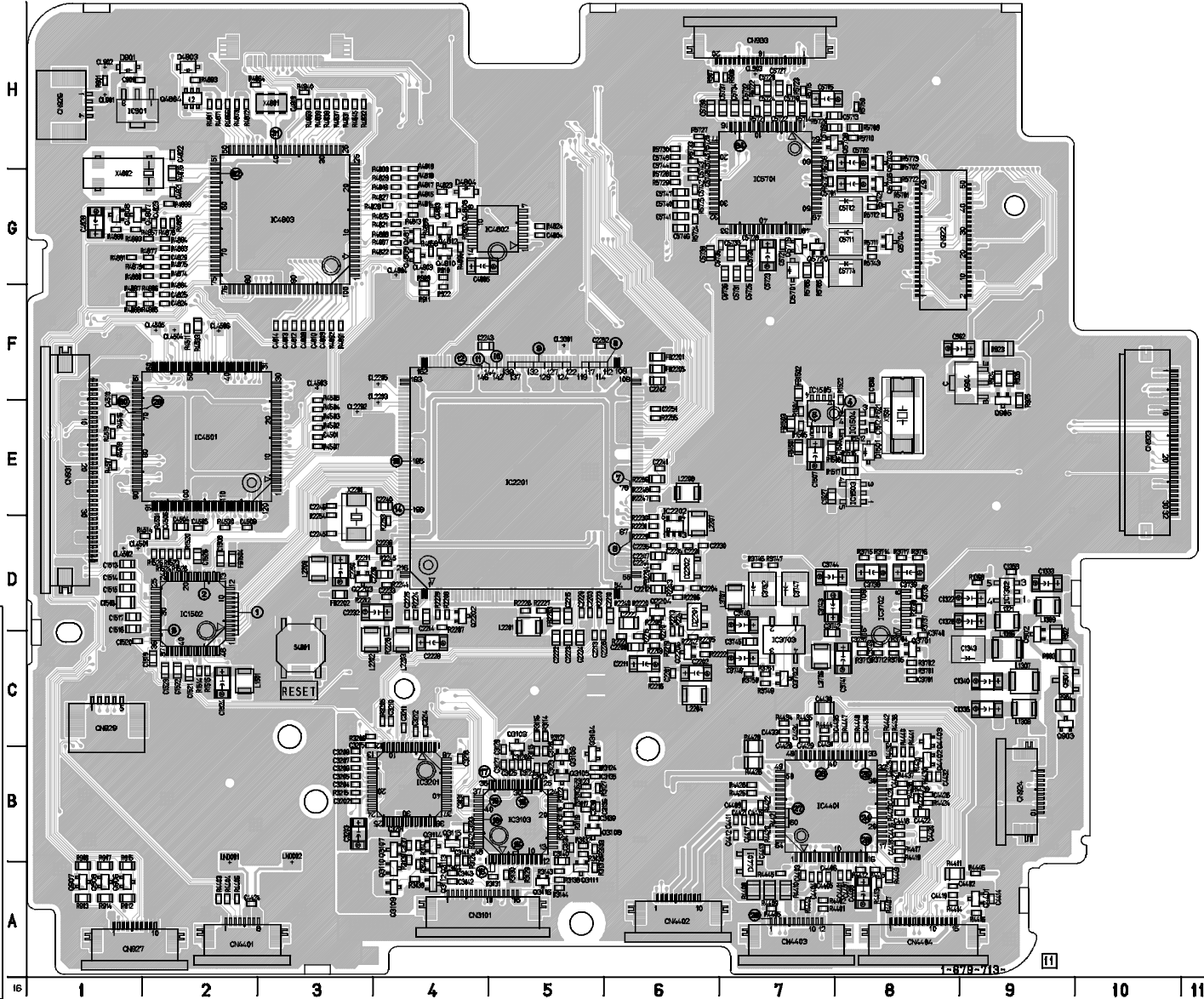

For printed wiring board

- Refer to pages 4-70, 71 for parts location.
- VC-250 board consists of multiple layers. However, only the sides (layers) A and B are shown.
- Chip parts



There are few cases that the part printed on this diagram isn't mounted in this model.

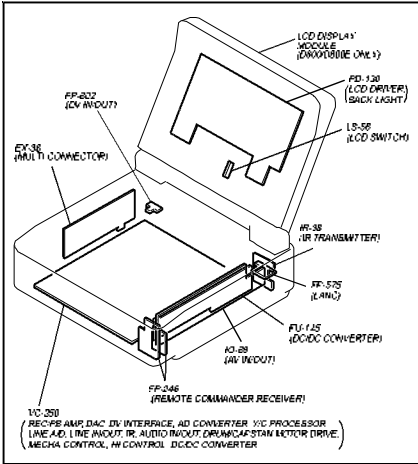

VC-250 BOARD(SIDE B)

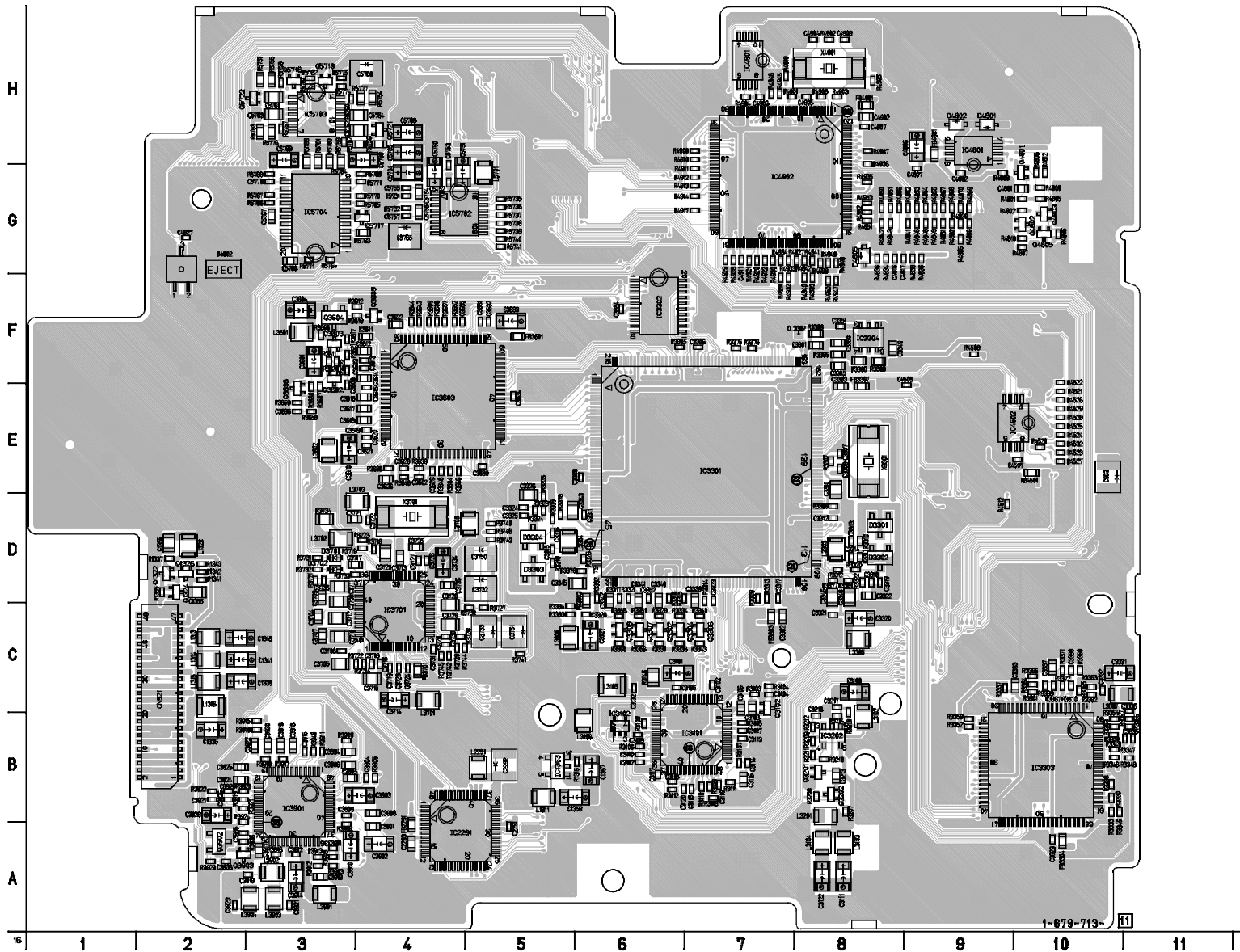

For Schematic Diagram

- Refer to page 4-7 for printed wiring board.
- Refer to page 4-68 for waveforms.

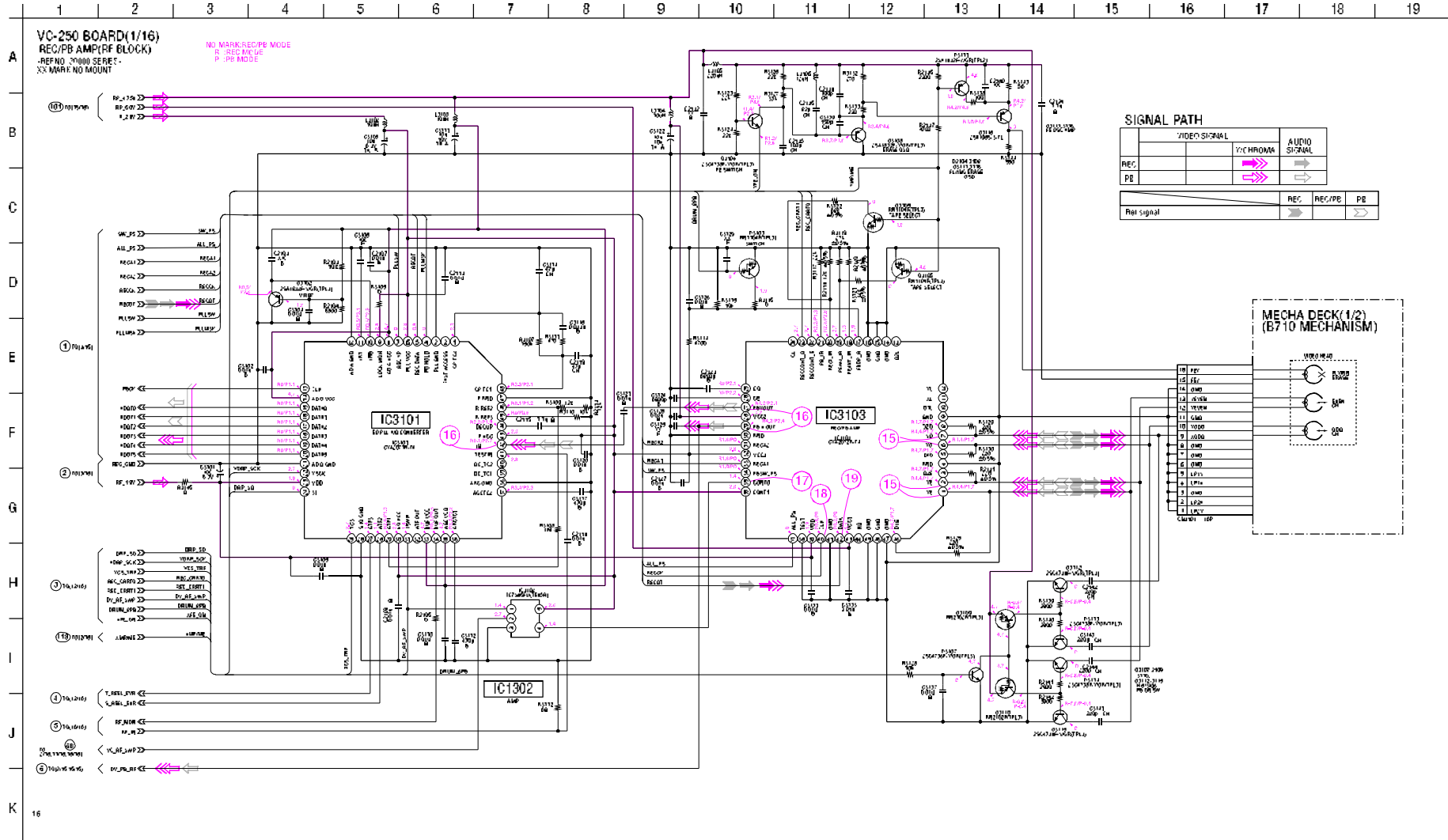

For Schematic Diagram
 • Refer to page 4-7 for printed wiring board.

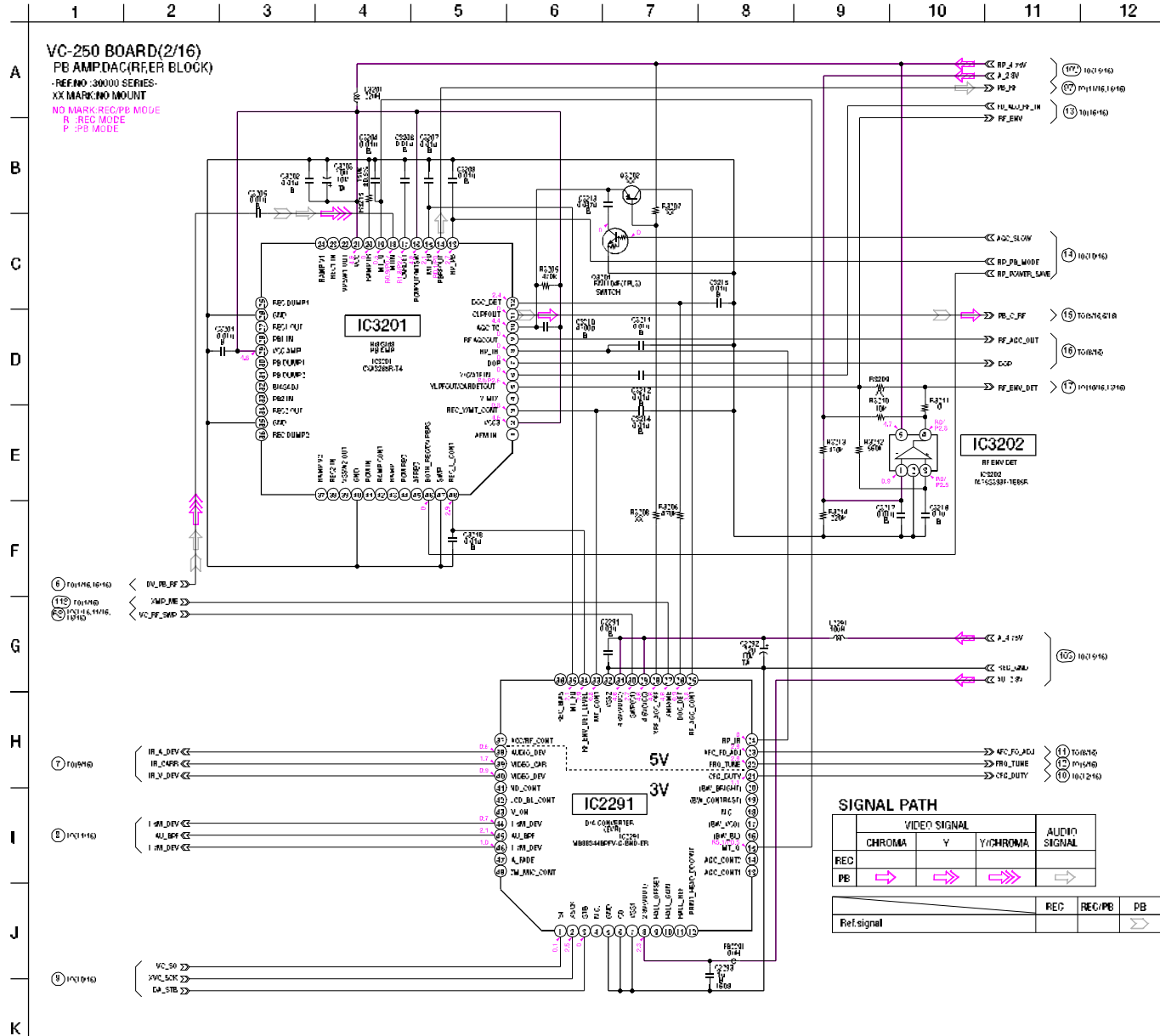

For Schematic Diagram
 • Refer to page 4-7 for printed wiring board.
 • Refer to page 4-68 for waveforms.

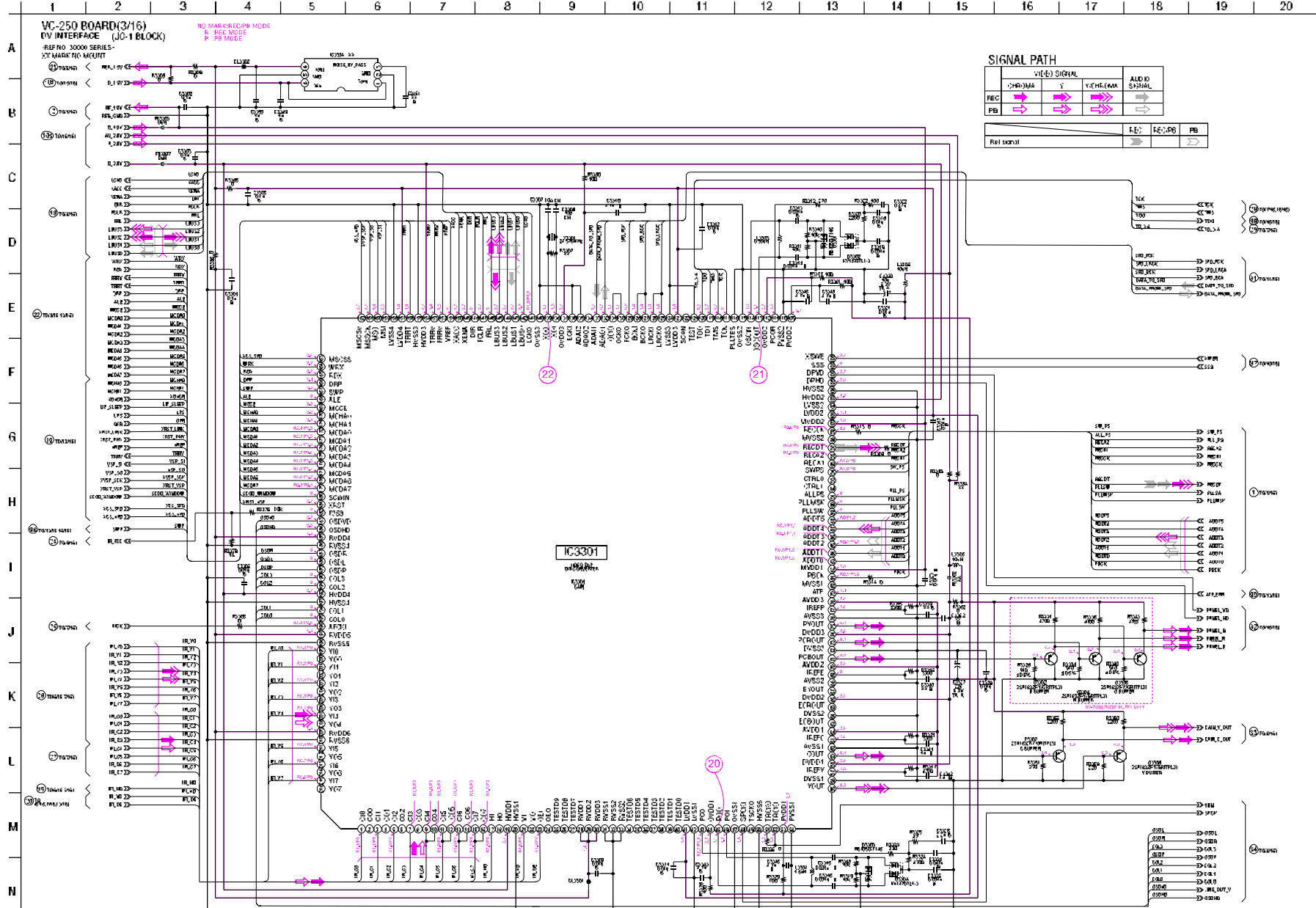

For Schematic Diagram
 • Refer to page 4-7 for printed wiring board.

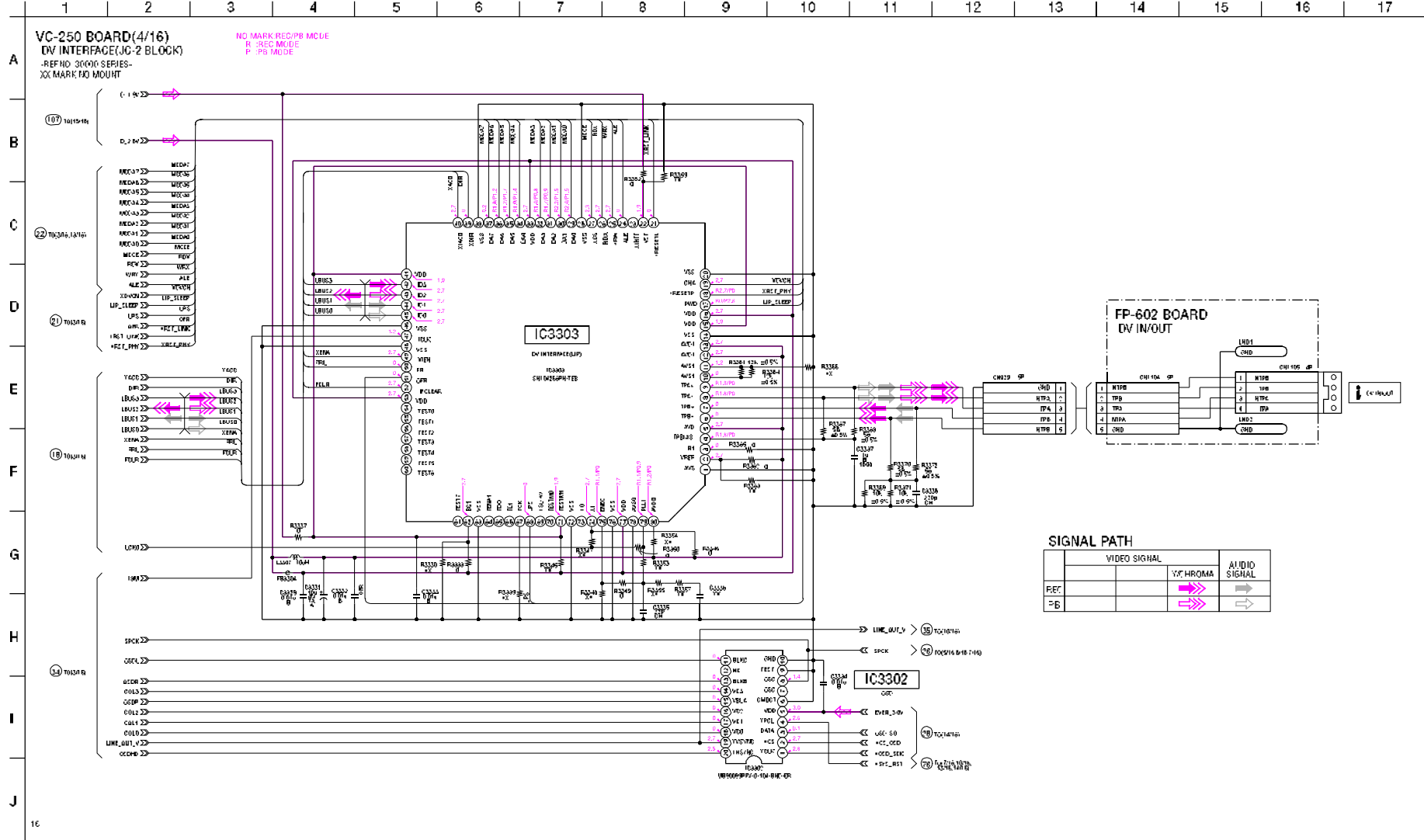

For Schematic Diagram
 • Refer to page 4-7 for printed wiring board.
 • Refer to page 4-88 for waveforms.

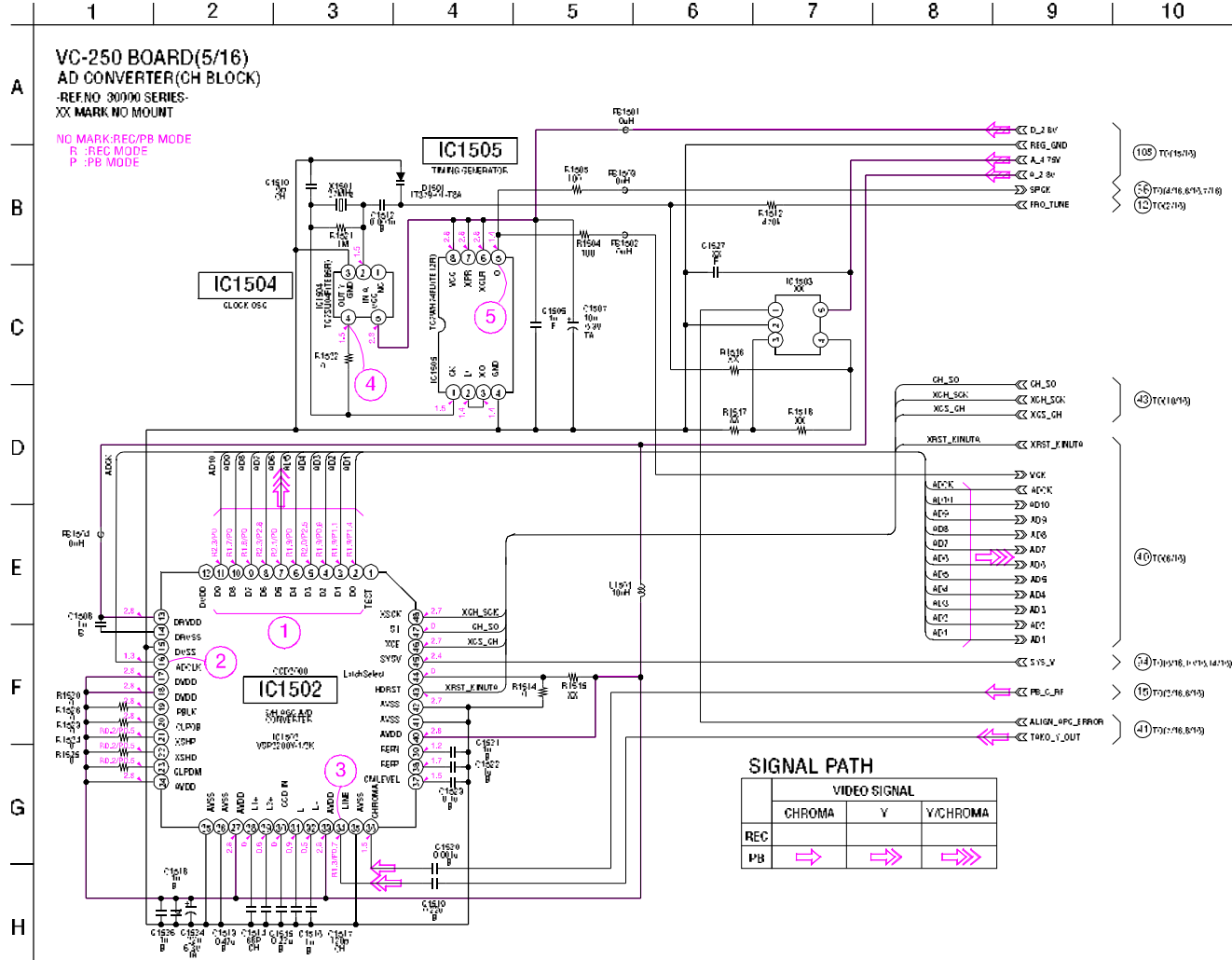

For Schematic Diagram
 Refer to page 4-7 for printed wiring board.

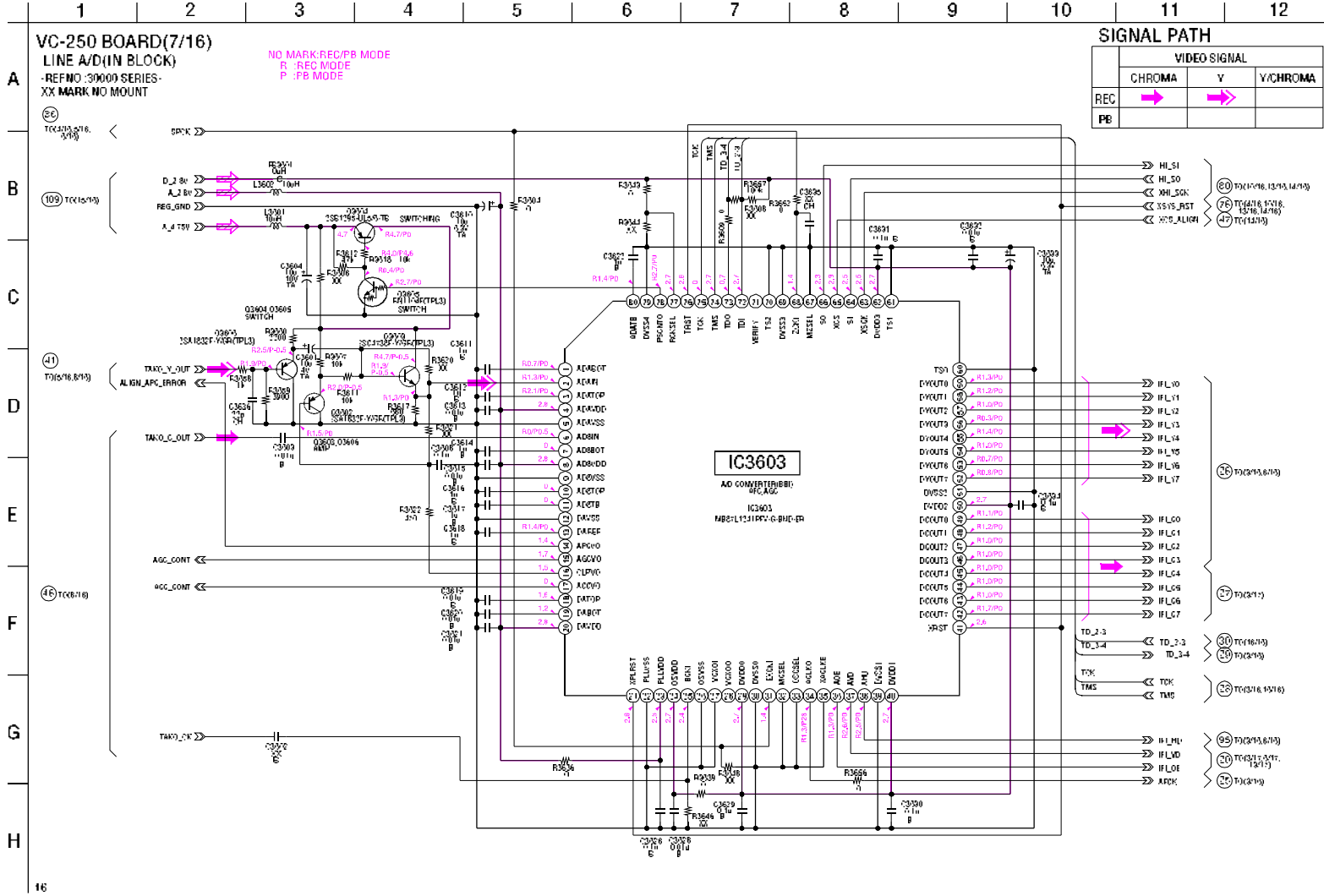

For Schematic Diagram
 • Refer to page 4-7 for printed wiring board.

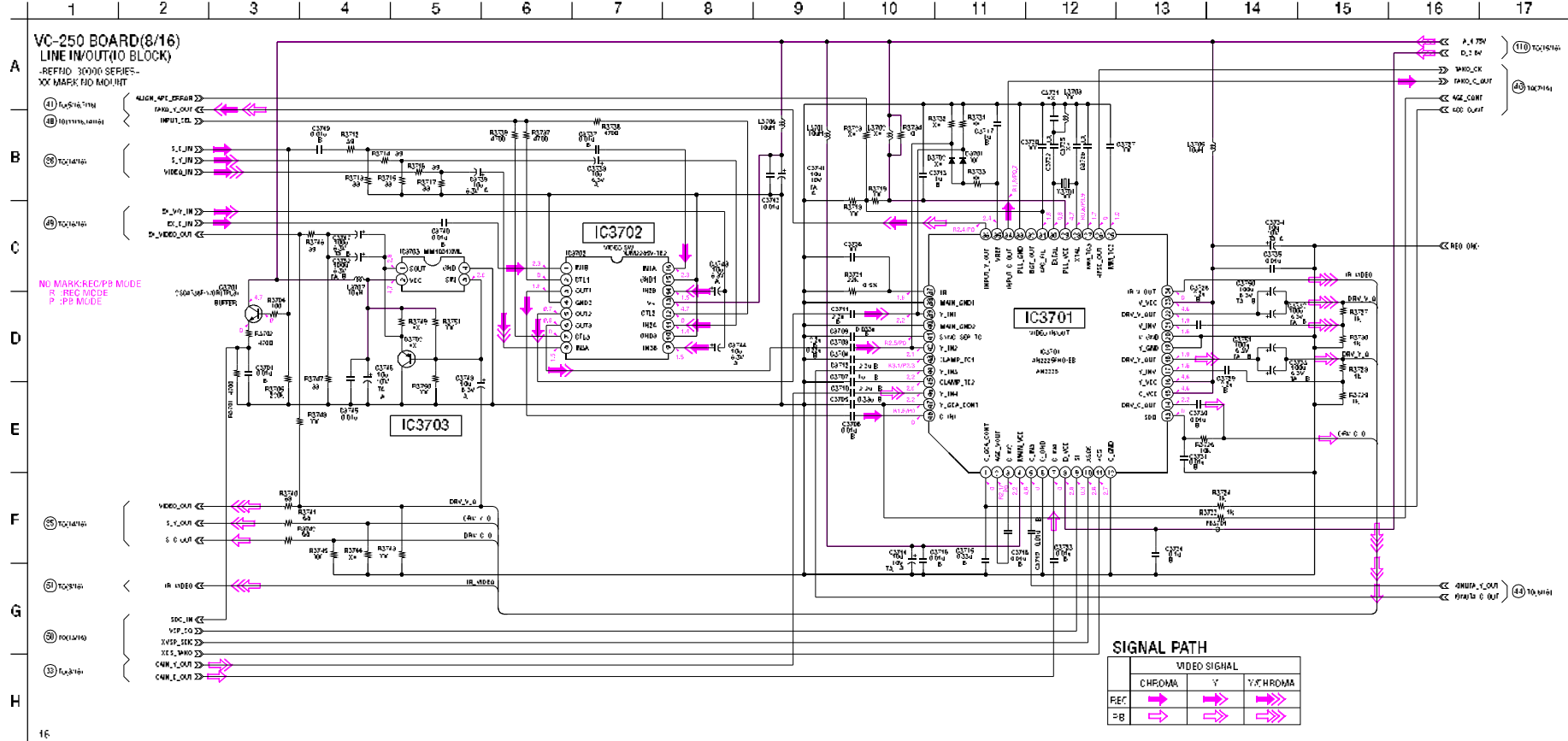

For Schematic Diagram

- Refer to page 4-7 for VC-250 printed wiring board.
- Refer to page 4-59 for IR-38 printed wiring board.
- Refer to page 4-69 for waveform.

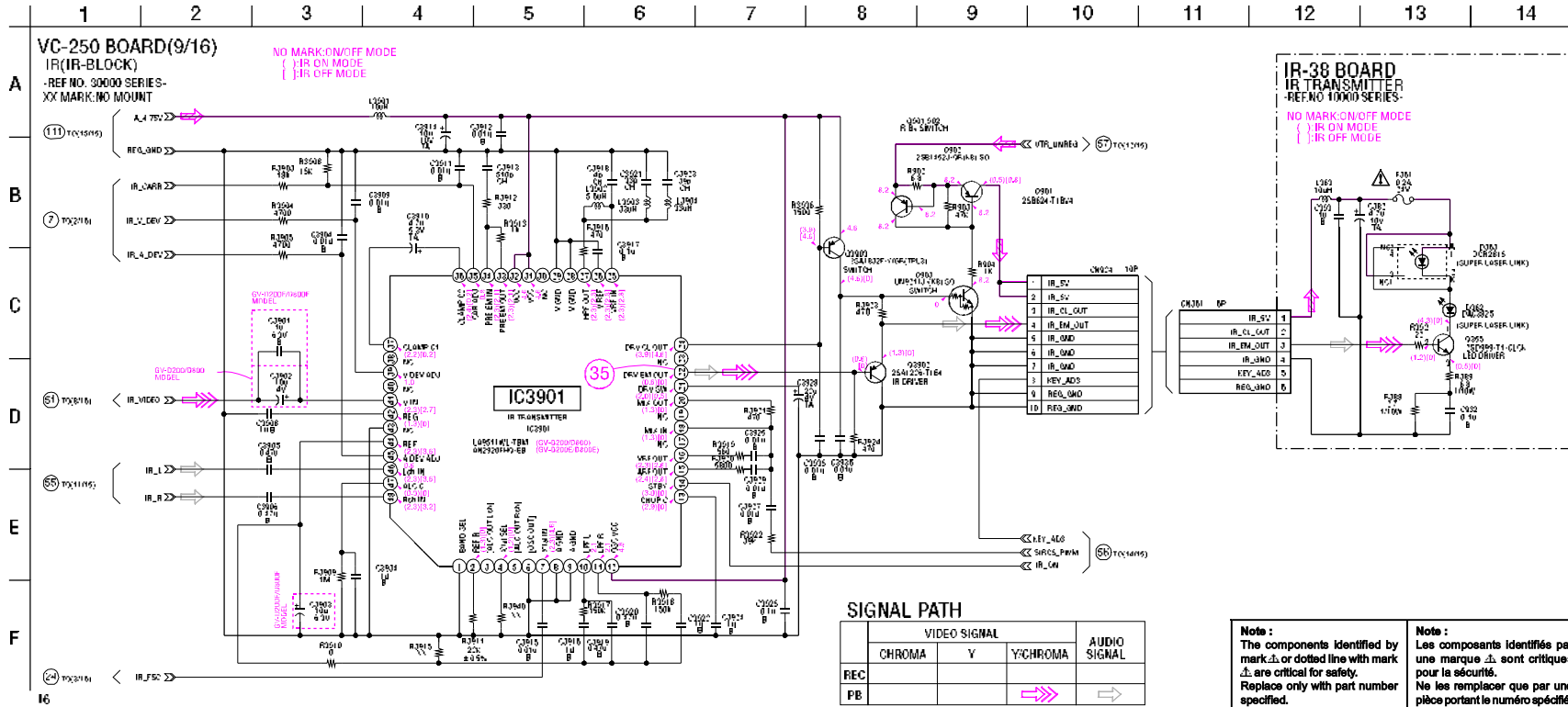

For Schematic Diagram
 • Refer to page 4-7 for printed wiring board.
 • Refer to page 4-69 for waveform.

1 2 3 4 5 6 7 8 9 10 11 12 13 14 15 16 17

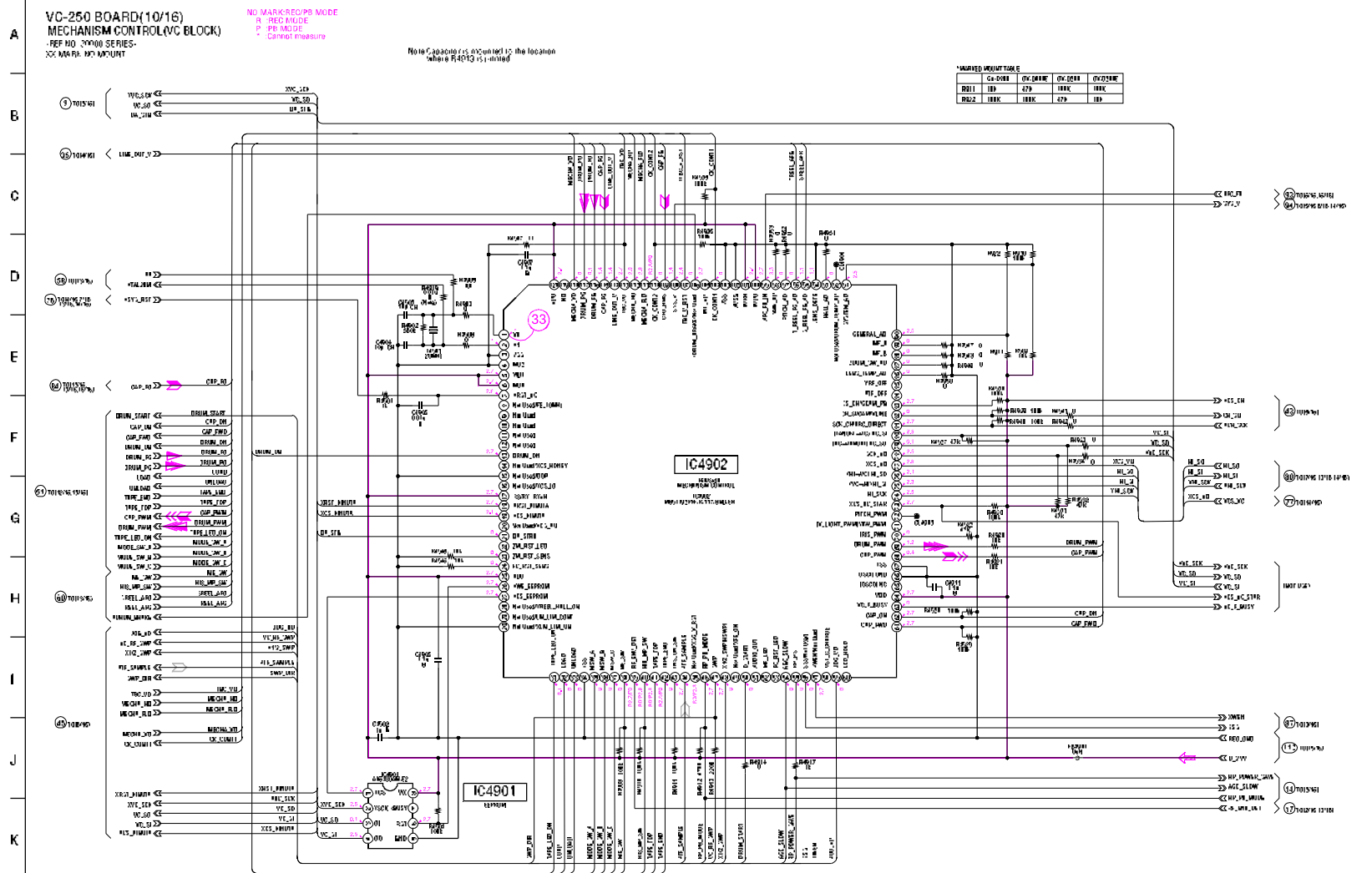

SIGNAL PATH

	REC	REC/PB	PE
Drum 4-801 servo			▶
Drum phase servo			▶
Drum servo (speed and phase)			▶
S-tapstan speed servo			▶
Capstan servo (speed and phase)			▶
Play signal			▶

GV-D200/D200E/D800/D800E

For Schematic Diagram

- Refer to page 4-7 for printed wiring board.
- Refer to page 4-69 for waveform.

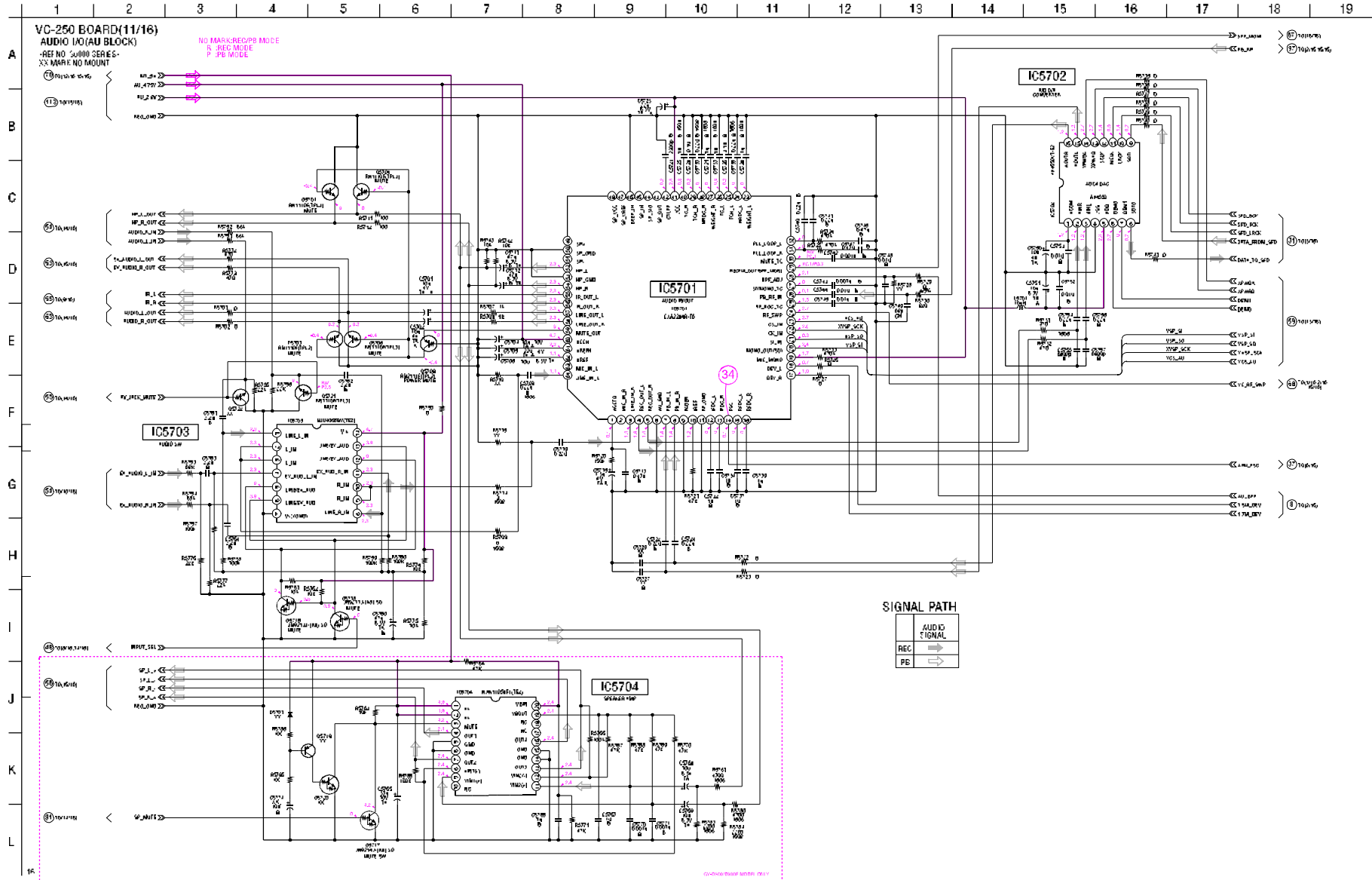

For Schematic Diagram

- Refer to page 4-7 for VC-250 printed wiring board.
- Refer to page 4-67 for FP-249, FP-355, FP-356 printed wiring boards.
- Refer to page 4-68,69 for waveforms.

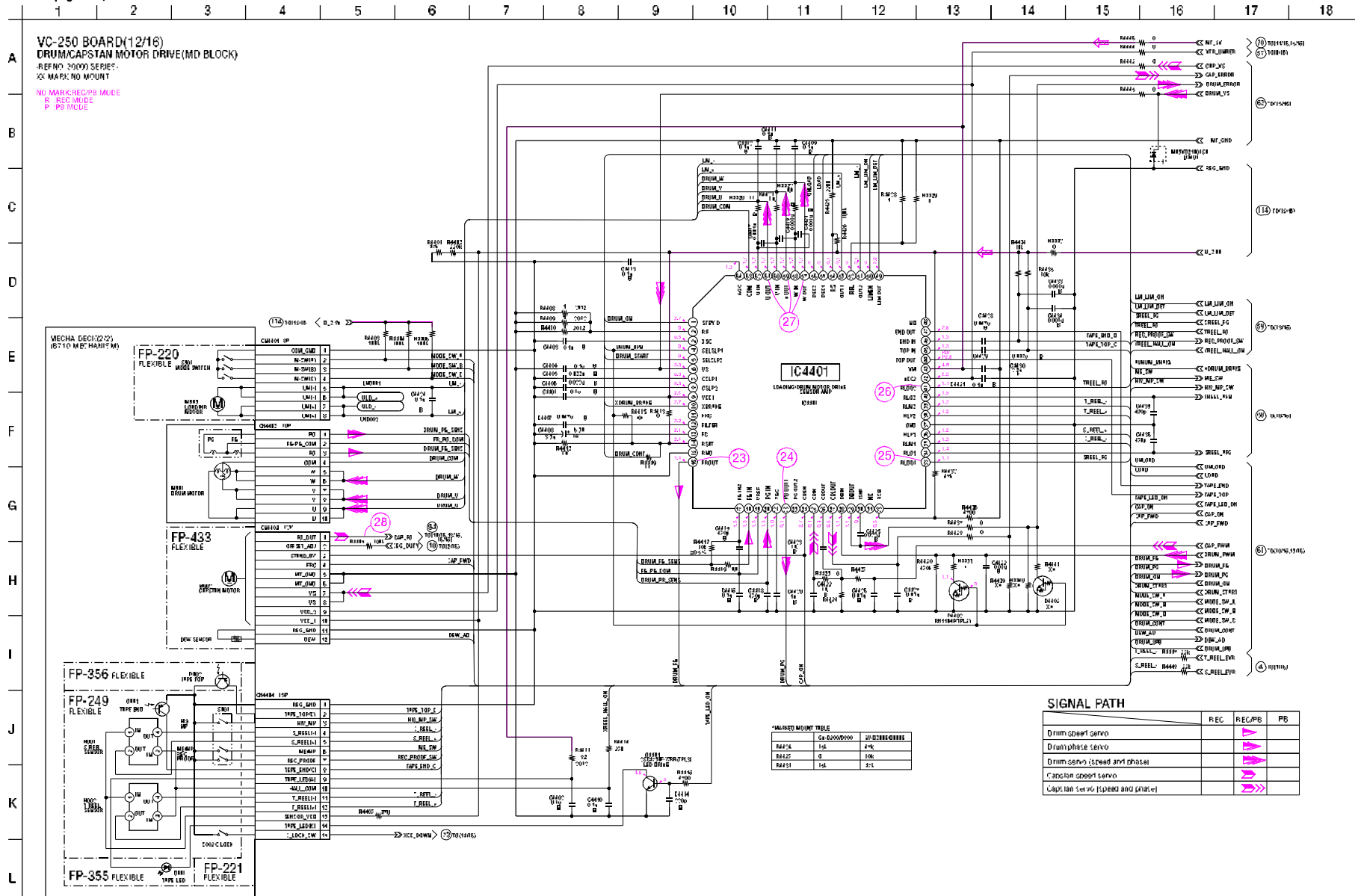

For Schematic Diagram

- Refer to page 4-7 for printed wiring board.
- Refer to page 4-69 for waveforms.

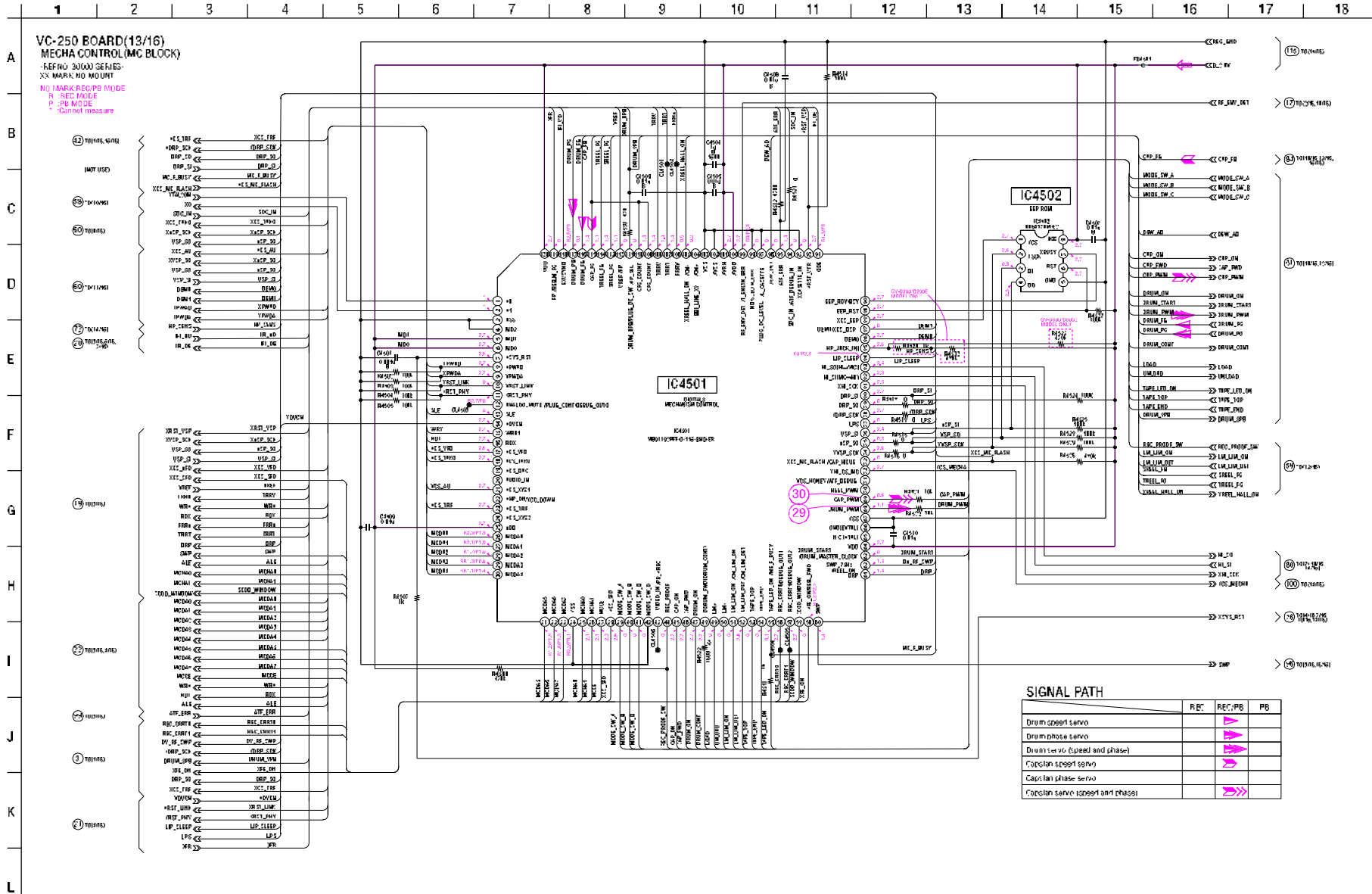

For Schematic Diagram

- Refer to page 4-7 for VC-250 printed wiring board.
- Refer to page 4-67 for FP-571 printed wiring board.
- Refer to page 4-69 for waveforms.

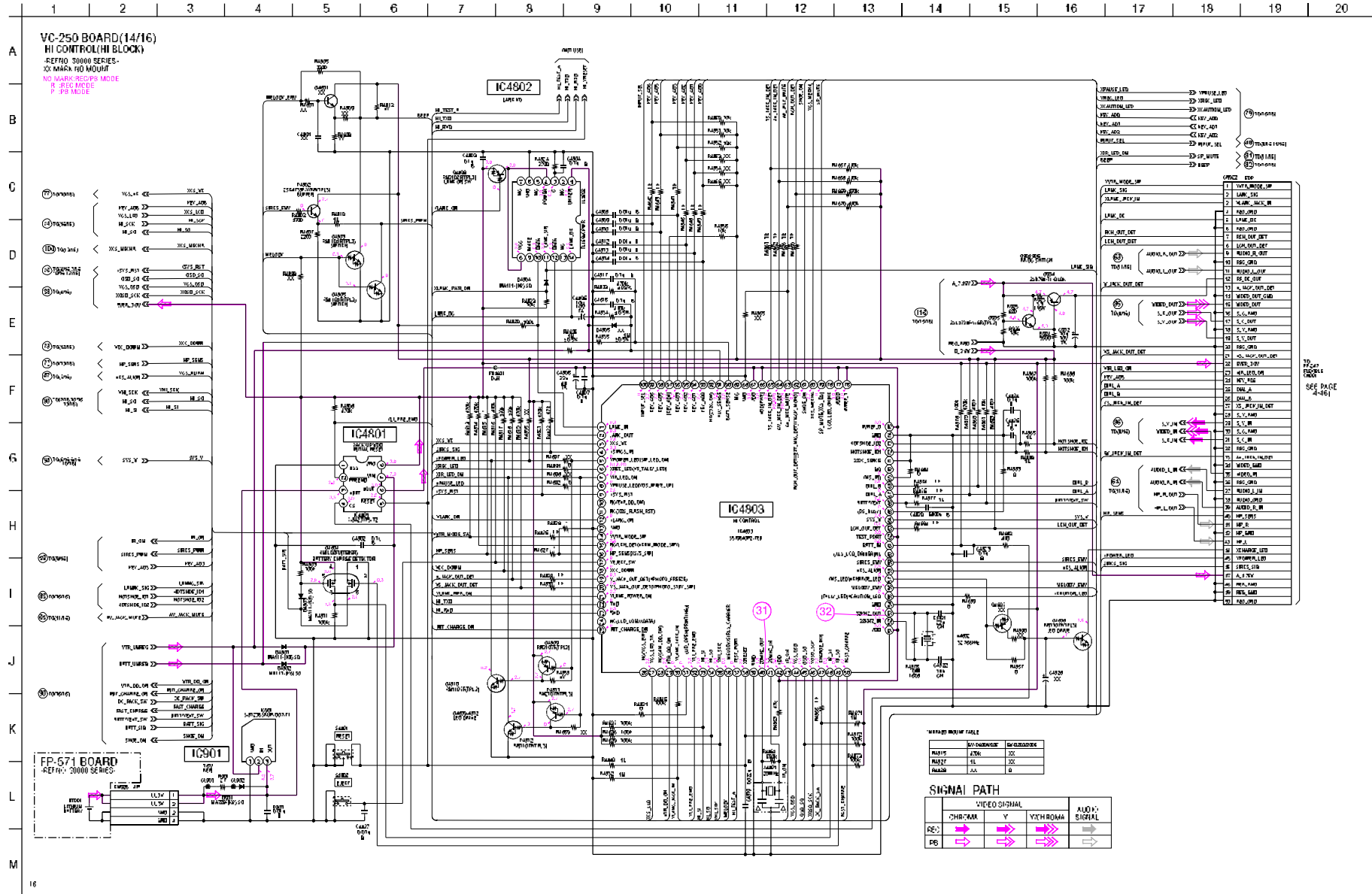

For Schematic Diagram
 Refer to page 4-7 for printed wiring board.

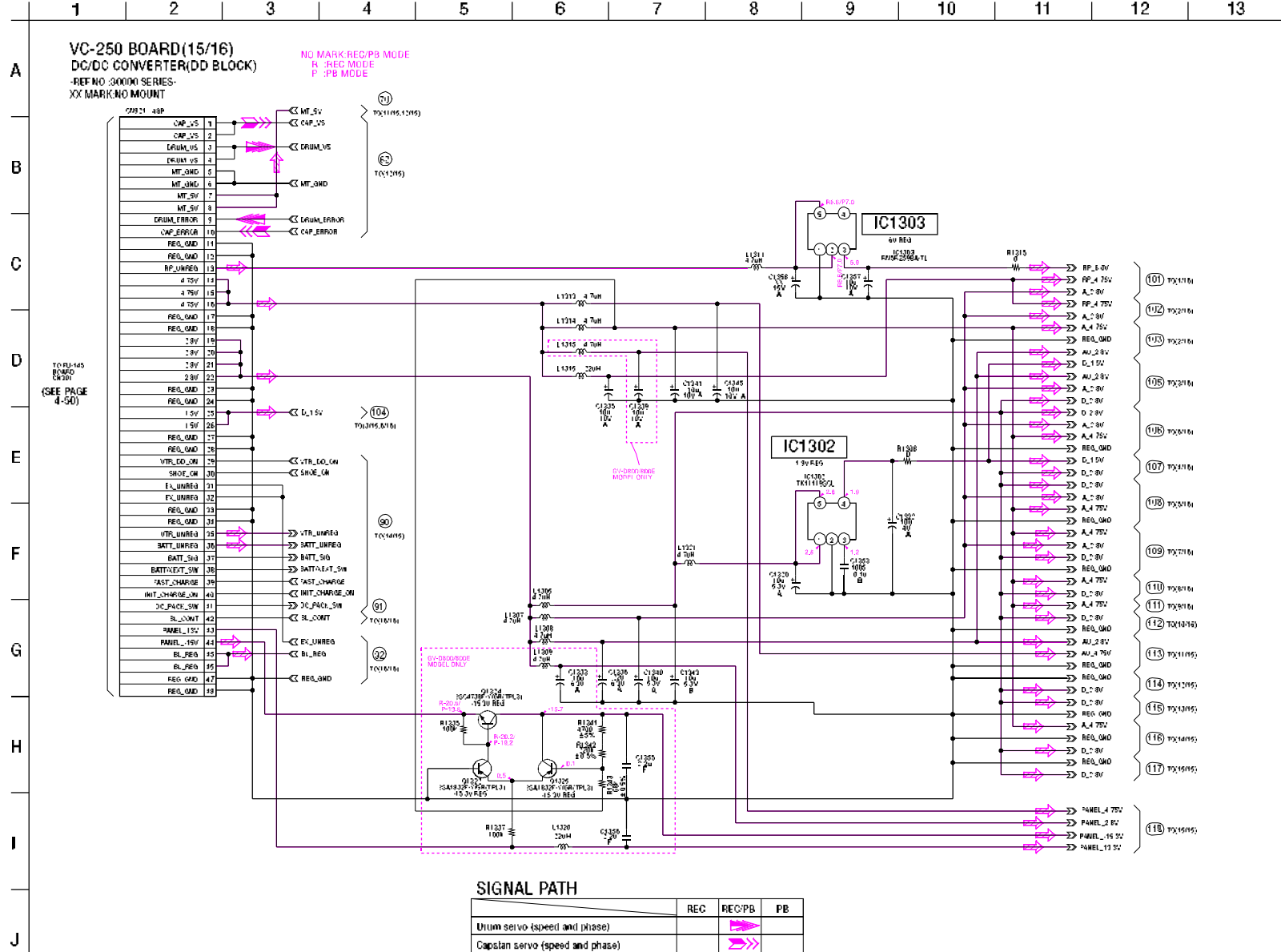

For Schematic Diagram
 • Refer to page 4-7 for printed wiring board.

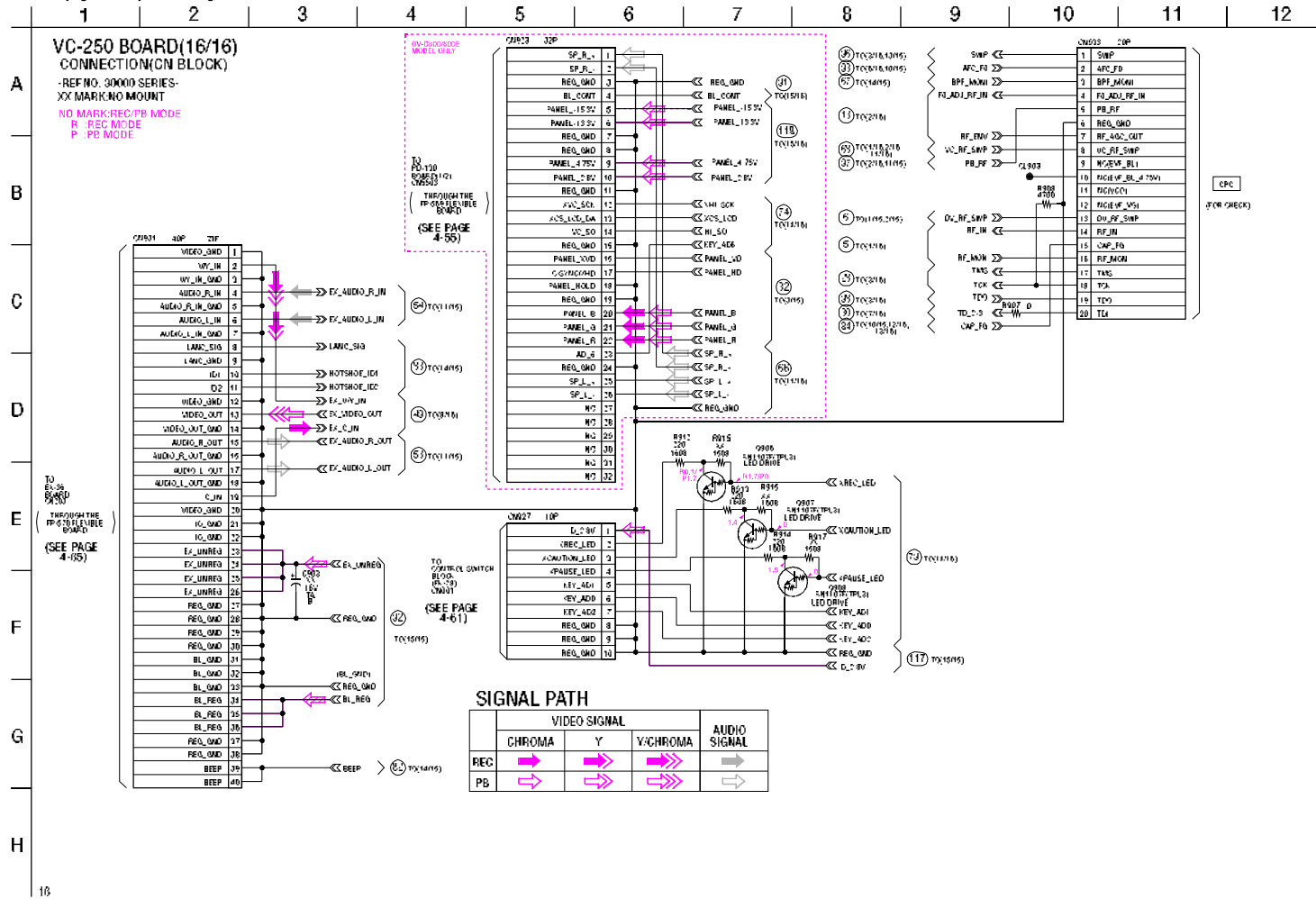

FP-575 (LANC), IO-68 (AV IN/OUT) PRINTED WIRING BOARDS

— Ref. No. IO-68 Board; 10,000 Series —

FP-575 FLEXIBLE BOARD

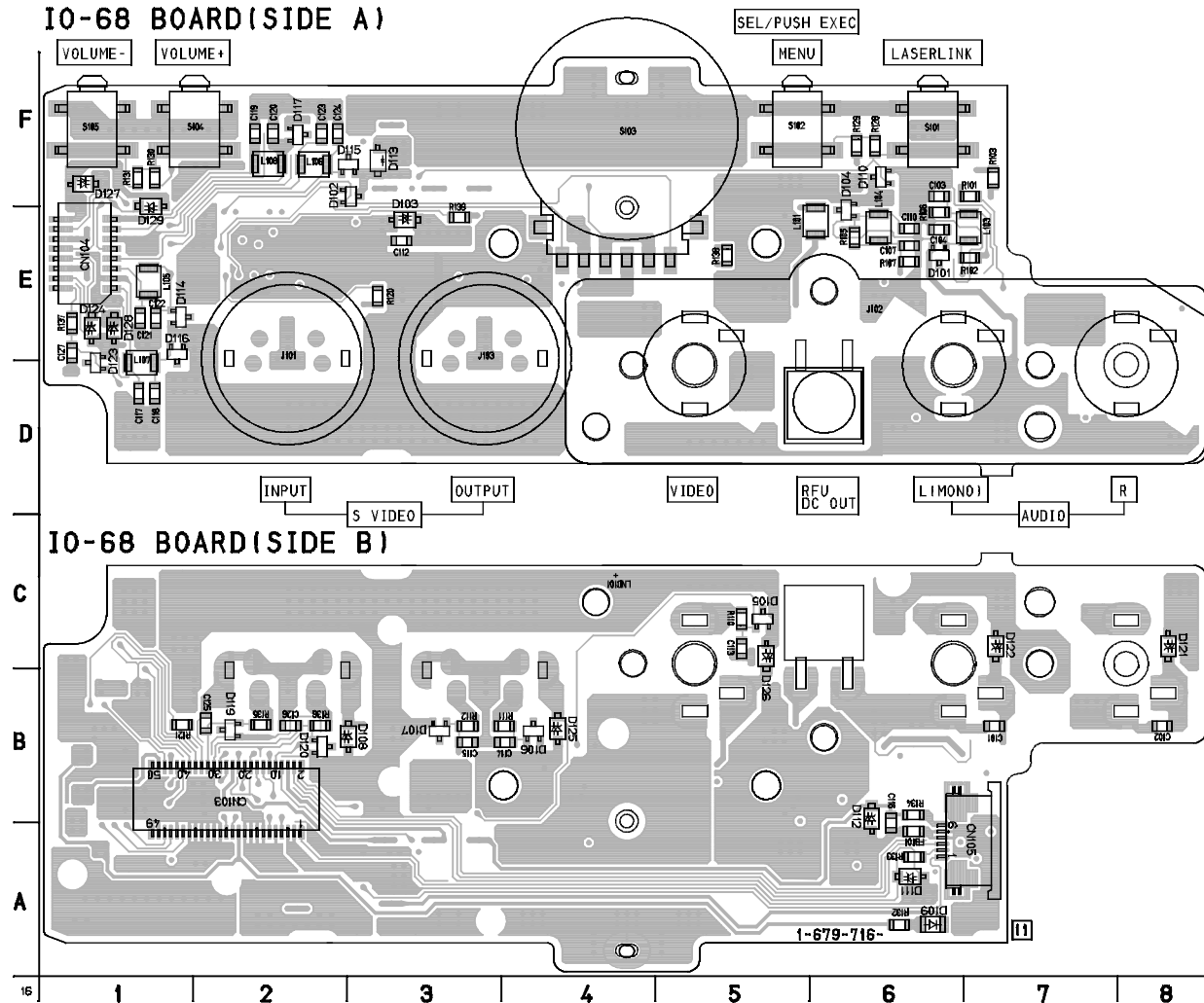
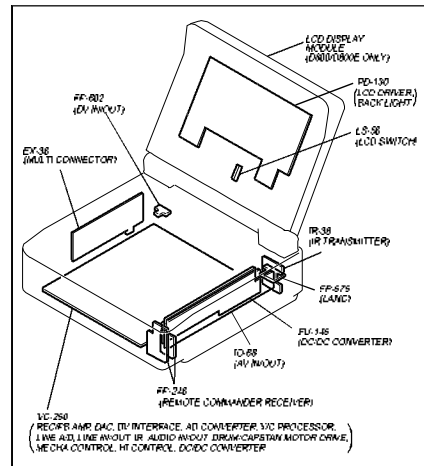
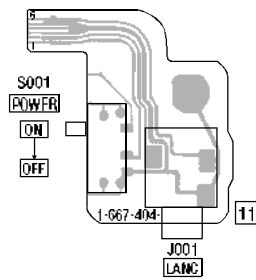

For printed wiring board
 • Refer to page 4-72 for parts location.
 • IO-68 board consists of multiple layers. However, only the sides (layers) A and B are shown.
 • Chip parts



There are few cases that the part printed on this diagram isn't mounted in this model.

1 2 3 4 5 6 7 8 9 10 11 12 13 14 15 16 17 18 19 20

A IO-69 BOARD
AV IN/OUT
REF: 10000 SERIES
NO MOUNT

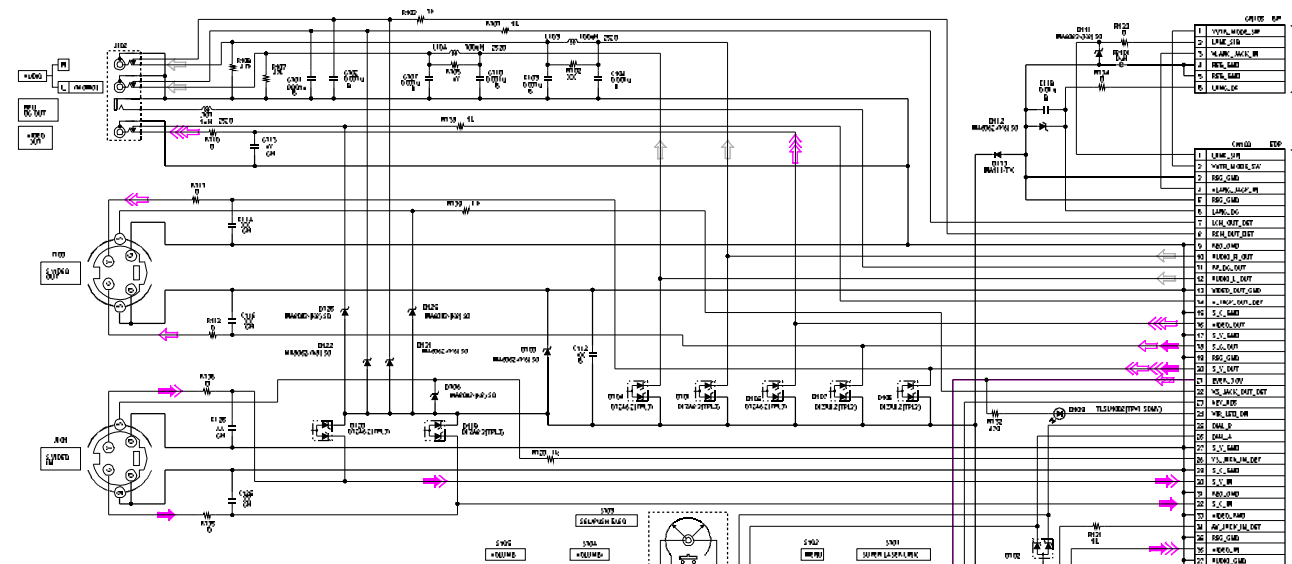

CON	NAME	TYPE
1	VYNA_WIDE_LP	1
2	VYNA_WIDE_LP	2
3	VYNA_WIDE_LP	3
4	VYNA_WIDE_LP	4
5	VYNA_WIDE_LP	5
6	VYNA_WIDE_LP	6
7	VYNA_WIDE_LP	7
8	VYNA_WIDE_LP	8
9	VYNA_WIDE_LP	9
10	VYNA_WIDE_LP	10
11	VYNA_WIDE_LP	11
12	VYNA_WIDE_LP	12
13	VYNA_WIDE_LP	13
14	VYNA_WIDE_LP	14
15	VYNA_WIDE_LP	15
16	VYNA_WIDE_LP	16
17	VYNA_WIDE_LP	17
18	VYNA_WIDE_LP	18
19	VYNA_WIDE_LP	19
20	VYNA_WIDE_LP	20
21	VYNA_WIDE_LP	21
22	VYNA_WIDE_LP	22
23	VYNA_WIDE_LP	23
24	VYNA_WIDE_LP	24
25	VYNA_WIDE_LP	25
26	VYNA_WIDE_LP	26
27	VYNA_WIDE_LP	27
28	VYNA_WIDE_LP	28
29	VYNA_WIDE_LP	29
30	VYNA_WIDE_LP	30
31	VYNA_WIDE_LP	31
32	VYNA_WIDE_LP	32
33	VYNA_WIDE_LP	33
34	VYNA_WIDE_LP	34
35	VYNA_WIDE_LP	35
36	VYNA_WIDE_LP	36
37	VYNA_WIDE_LP	37
38	VYNA_WIDE_LP	38
39	VYNA_WIDE_LP	39
40	VYNA_WIDE_LP	40
41	VYNA_WIDE_LP	41
42	VYNA_WIDE_LP	42
43	VYNA_WIDE_LP	43
44	VYNA_WIDE_LP	44
45	VYNA_WIDE_LP	45
46	VYNA_WIDE_LP	46
47	VYNA_WIDE_LP	47
48	VYNA_WIDE_LP	48
49	VYNA_WIDE_LP	49
50	VYNA_WIDE_LP	50

SEE PAGE 4-381

H FP-246 BOARD
REMOTE COMMAND RECEIVER
REF: 30000 SERIES
NO MOUNT

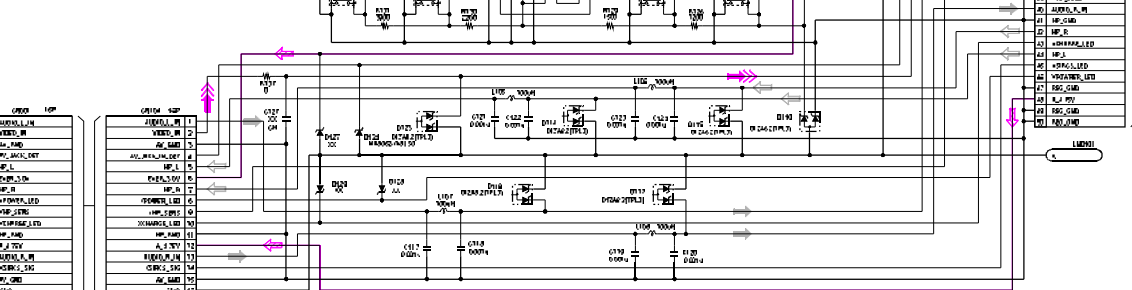
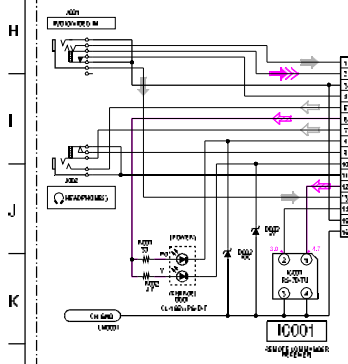

FP-247 FLEXIBLE

SEE PAGE 4-381

SIGNAL PATH

	VIDEO SIGNAL	CHROMA	Y	YCHROMA	AUDIO SIGNAL
REC	→	→	→	→	→
PG	→	→	→	→	→

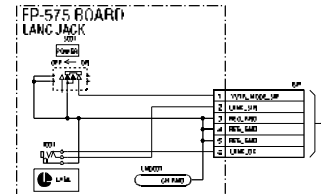

DO NOT CONNECT FP-246 BOARD TO THIS BOARD
DO NOT CONNECT FP-246 BOARD TO THIS BOARD
DO NOT CONNECT FP-246 BOARD TO THIS BOARD

FU-145 (DC/DC CONVERTER) PRINTED WIRING BOARD

— Ref. No. FU-145 Board; 10,000 Series —

FU-145 BOARD (SIDE A)

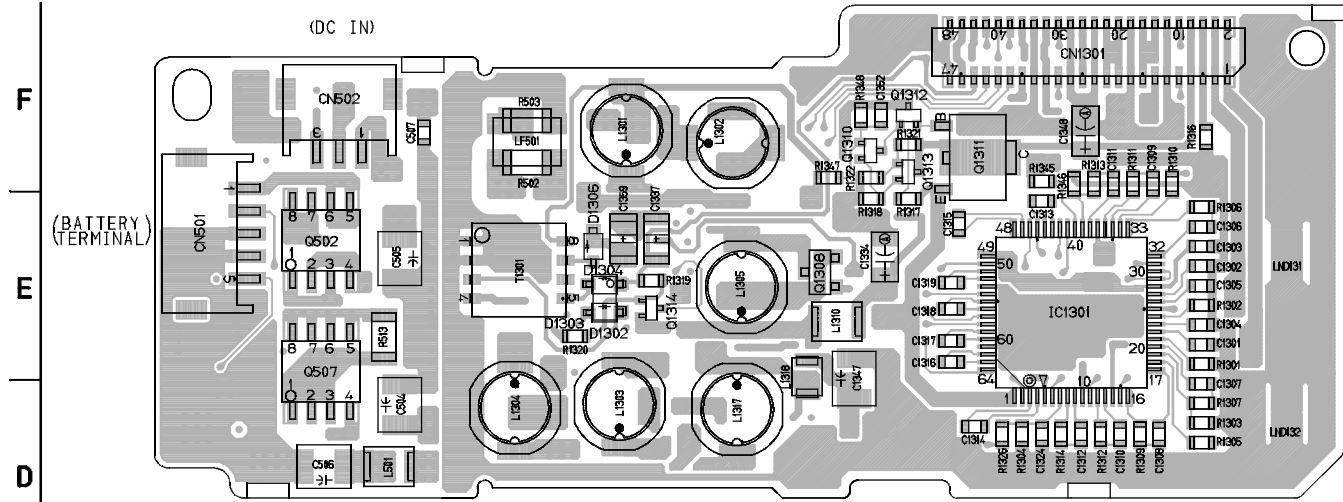

For printed wiring board

- Refer to page 4-72 for parts location.
- FU-145 board consists of multiple layers. However, only the sides (layers) A and B are shown.
- Chip parts

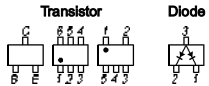

There are few cases that the part printed on this diagram isn't mounted in this model.

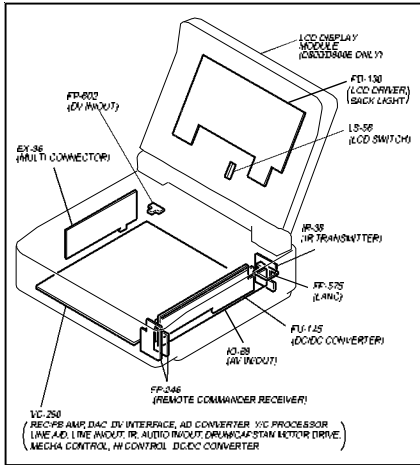

FU-145 BOARD (SIDE B)



For Schematic Diagram
 • Refer to page 4-7 for printed wiring board.

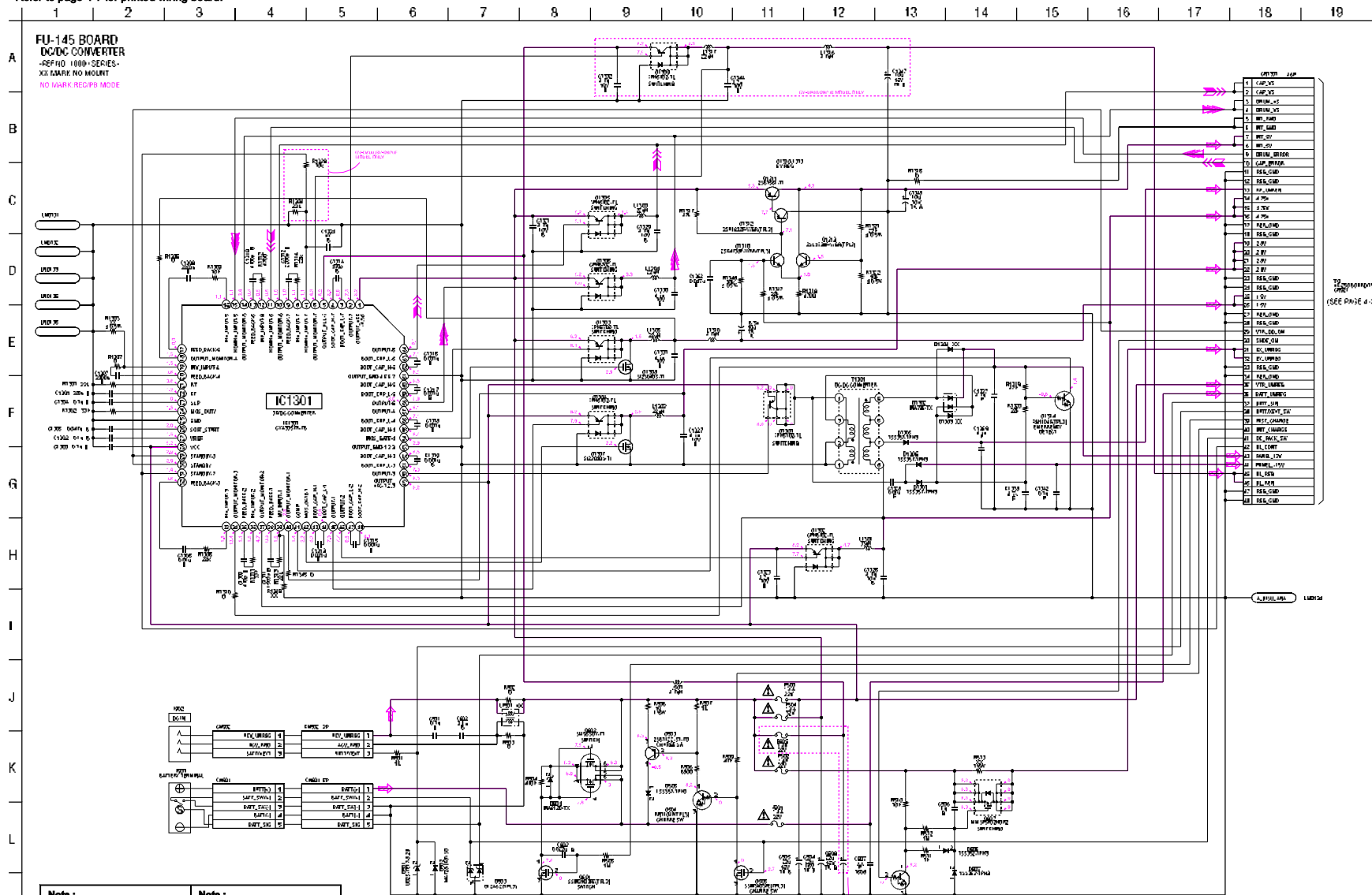

72
 (SEE PAGE 4-39)

Note :
 The components identified by mark \triangle or dotted line with mark \triangle are critical for safety. Replace only with part number specified.

Note :
 Les composants identifiés par une marque \triangle sont critiques pour la sécurité. Ne les remplacer que par une pièce portant le numéro spécifié.

SIGNAL PATH

	REC?	REC/PB	PB
3-wire SERVO (S481 and S482)			
4-wire SERVO (S482 and S483)			

PD-130 (LCD DRIVER, BACK-LIGHT) PRINTED WIRING BOARD

— Ref. No. PD-130 Board; 10,000 Series —

PD-130 BOARD (SIDE A)

For printed wiring board

- Refer to page 4-73 for parts location.
- PD-130 board consists of multiple layers. However, only the sides (layers) A and B are shown.
- Chip parts

Transistor



Diode



There are few cases that the part printed on this diagram isn't mounted in this model.

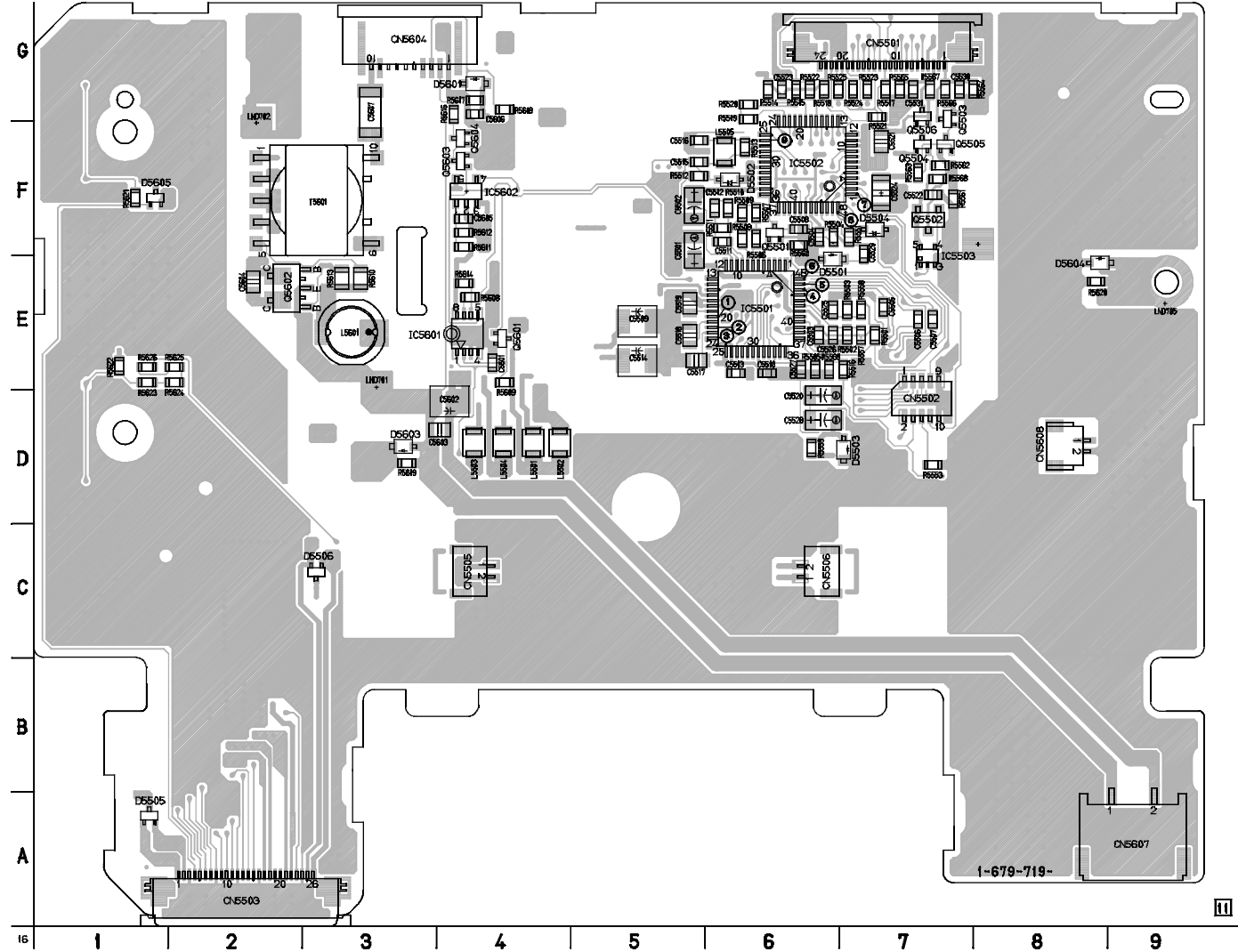
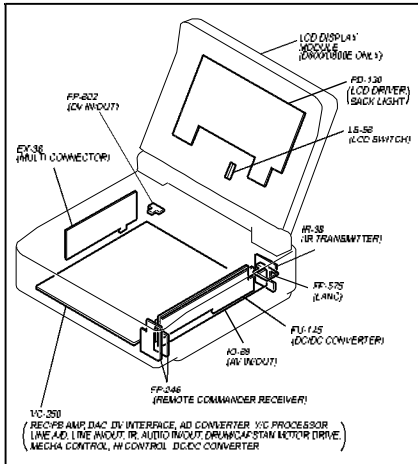

LS-56 (LCD SWITCH) PRINTED WIRING BOARD
— Ref. No. LS-56 Board; 20,000 Series —

LS-56 BOARD

PD-130 BOARD (SIDE B)

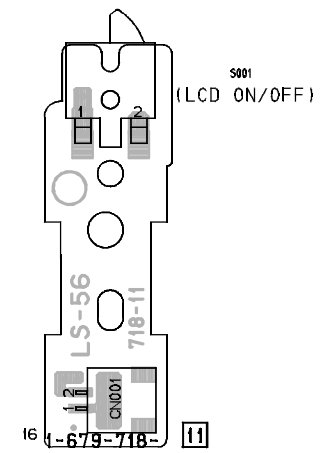

For Schematic Diagram

- Refer to page 4-51 for printed wiring board.
- Refer to page 4-69 for waveforms.

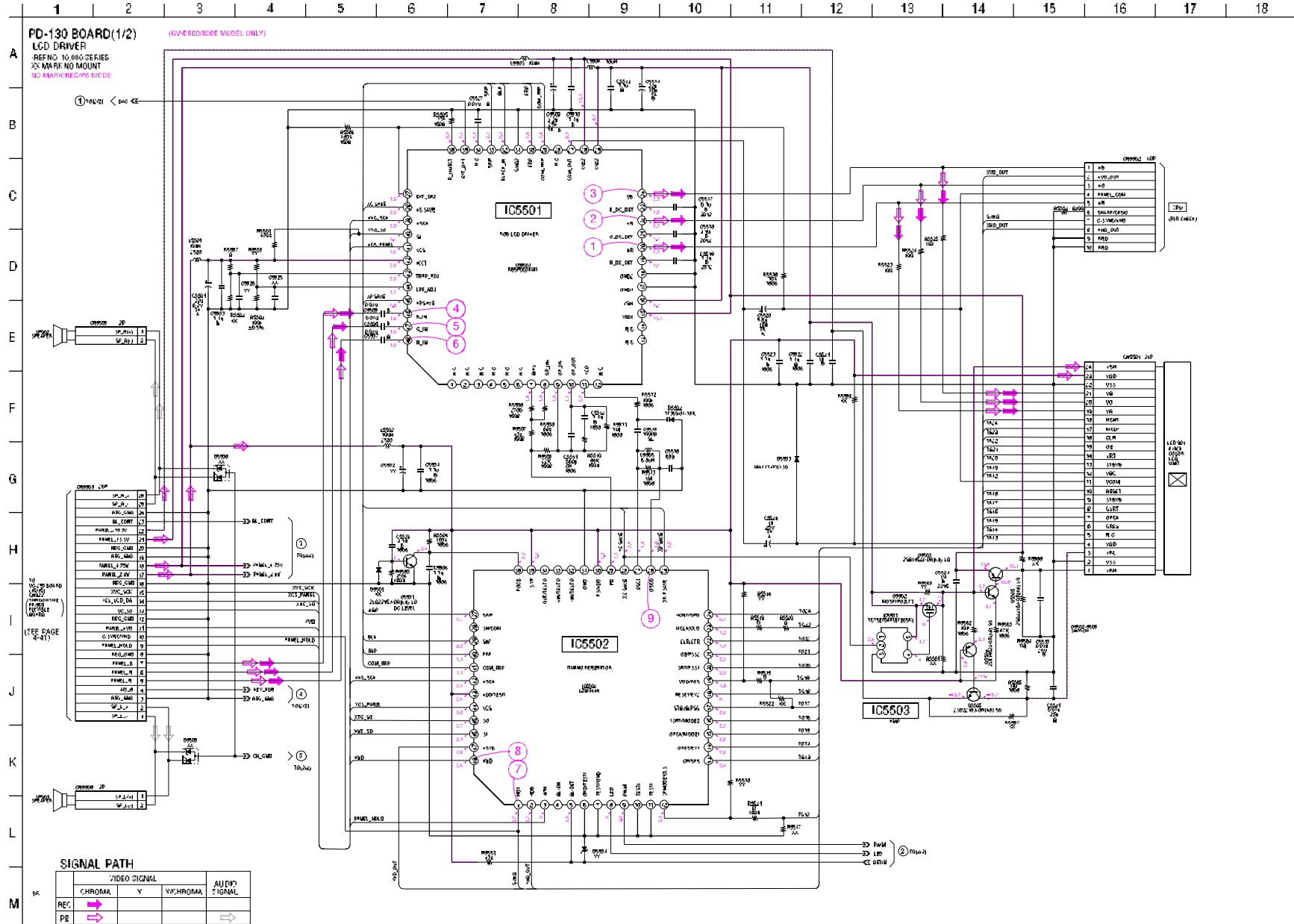

For Schematic Diagram

- Refer to page 4-51 for PD-130 printed wiring board.
- Refer to page 4-54 for LS-56 printed wiring board.

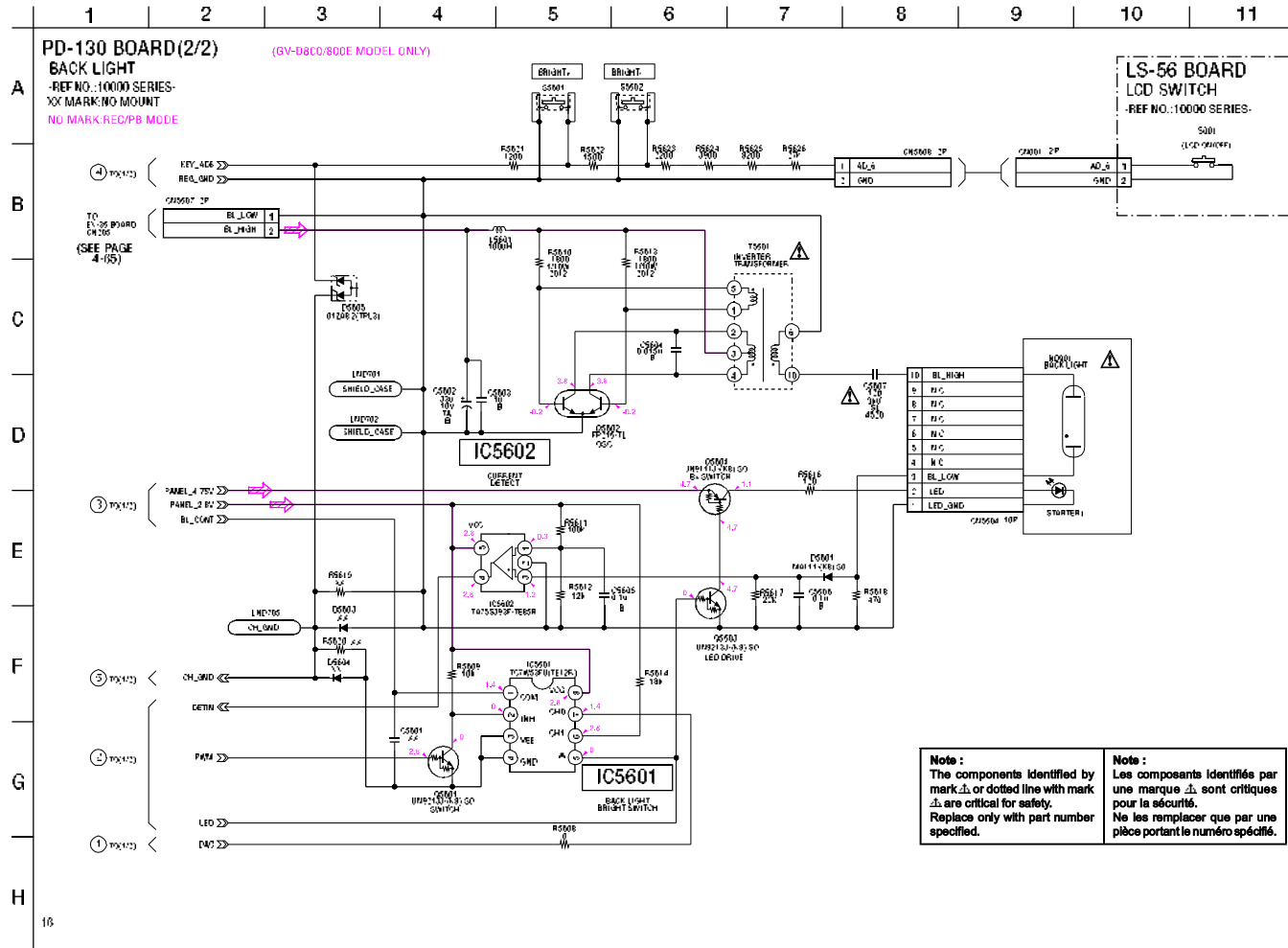

IR-38 (IR TRANSMITTER), CONTROL SWITCH BLOCK (FK-78) PRINTED WIRING BOARDS

— Ref. No. IR-38 Board; 10,000 Series, Control switch block (FK-78) Board; 40,000 Series —
 • Refer to page 4-28 for IR-38 schematic diagram.

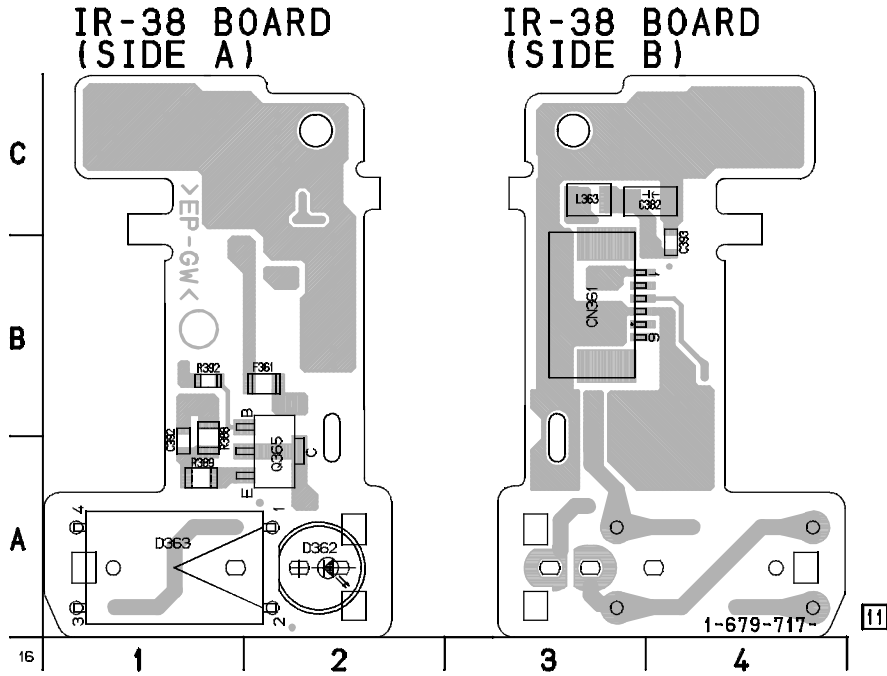

For printed wiring board

- Refer to page 4-73 for parts location.
- IR-38 board consists of multiple layers. However, only the sides (layers) A and B are shown.
- Chip parts

Transistor



Diode



There are few cases that the part printed on this diagram isn't mounted in this model.

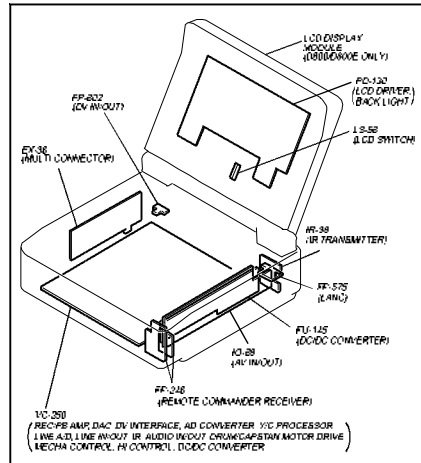

CONTROL SWITCH BLOCK (FK-78)

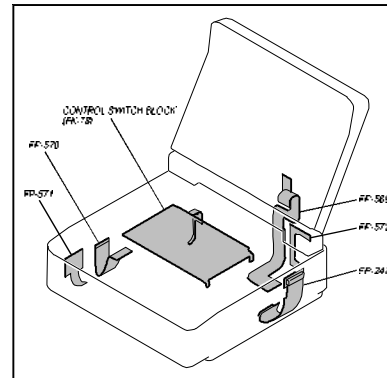
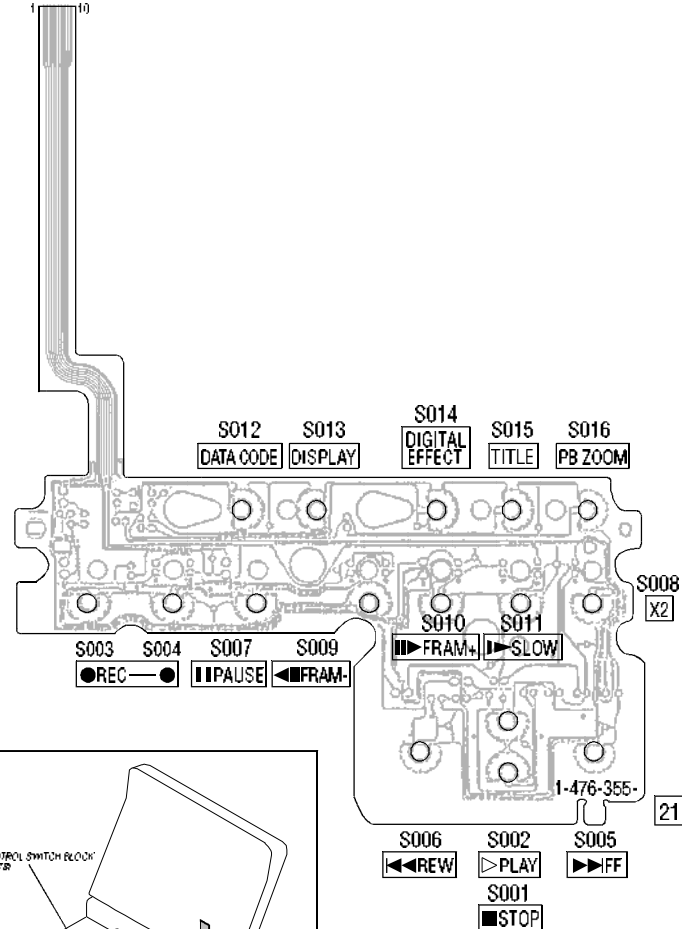

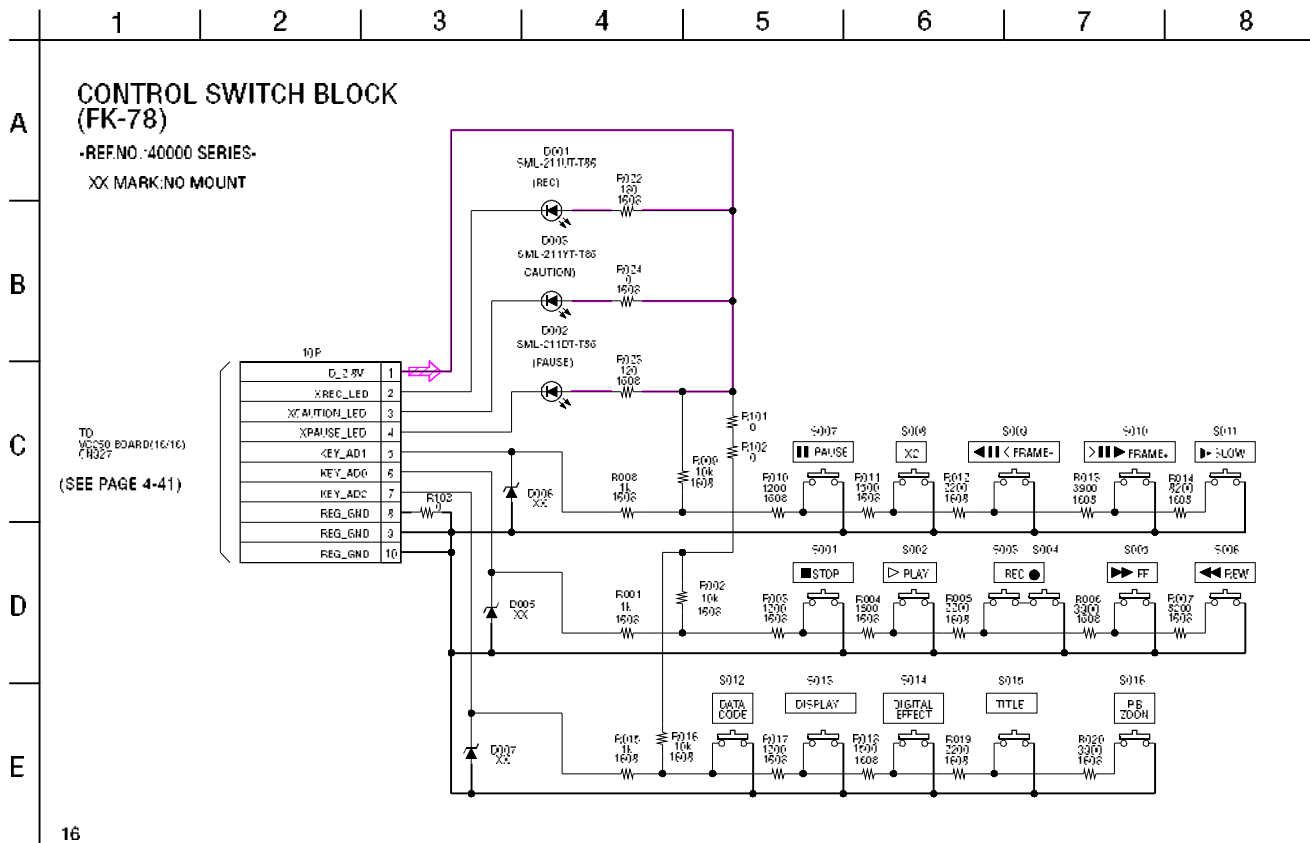

EX-36 (MULTI CONNECTOR) PRINTED WIRING BOARD

— Ref. No. EX-36 Board; 10,000 Series —

EX-36 BOARD (SIDE A)

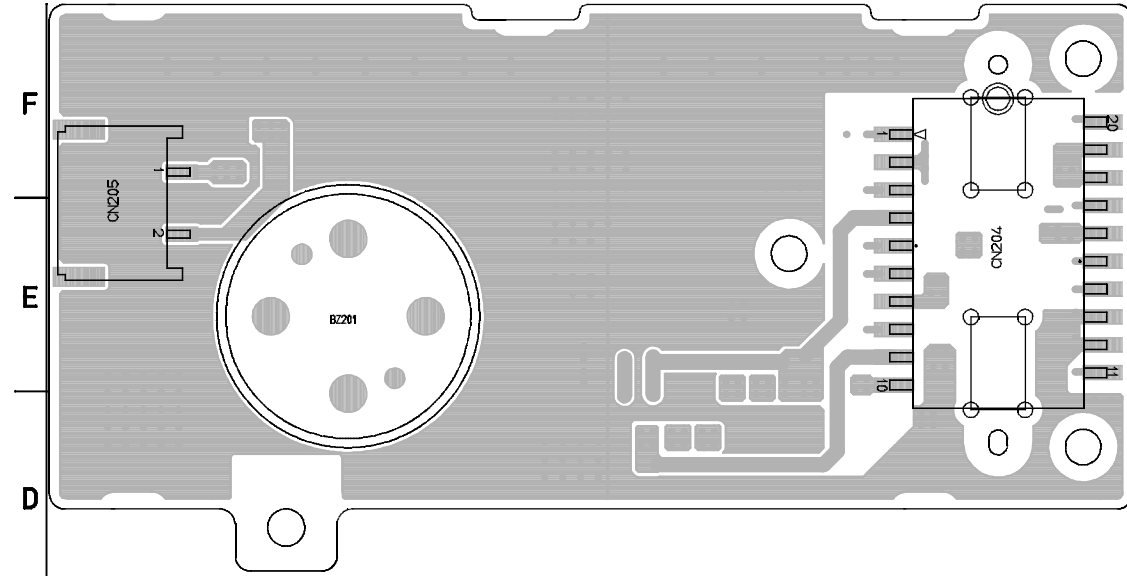

For printed wiring board

- Refer to page 4-73 for parts location.
- EX-36 board consists of multiple layers. However, only the sides (layers) A and B are shown.
- Chip parts

Diode



There are few cases that the part printed on this diagram isn't mounted in this model.

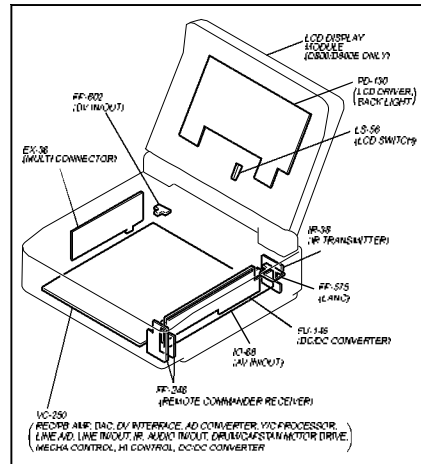

EX-36 BOARD (SIDE B)

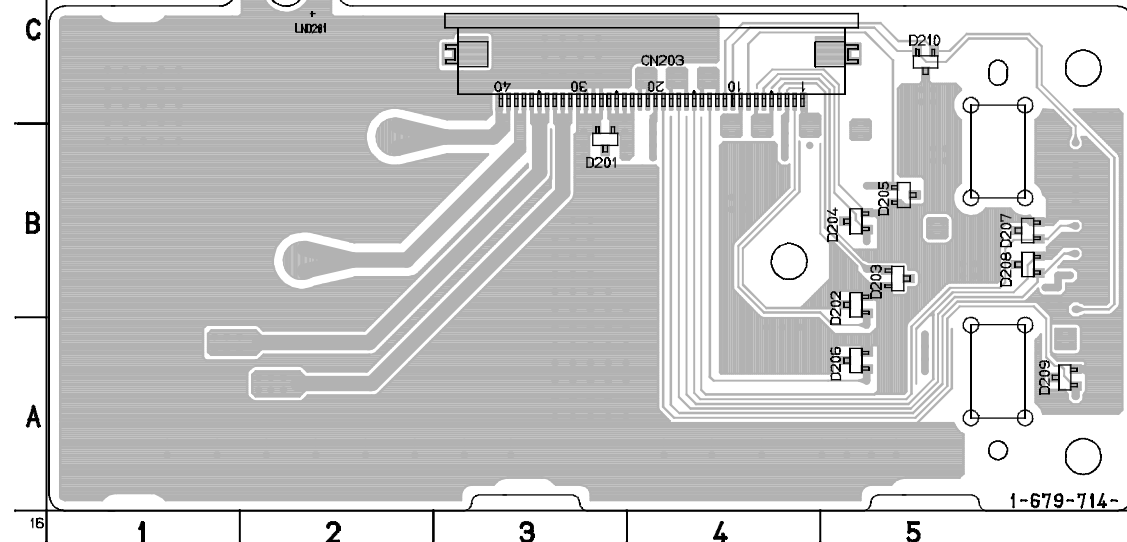

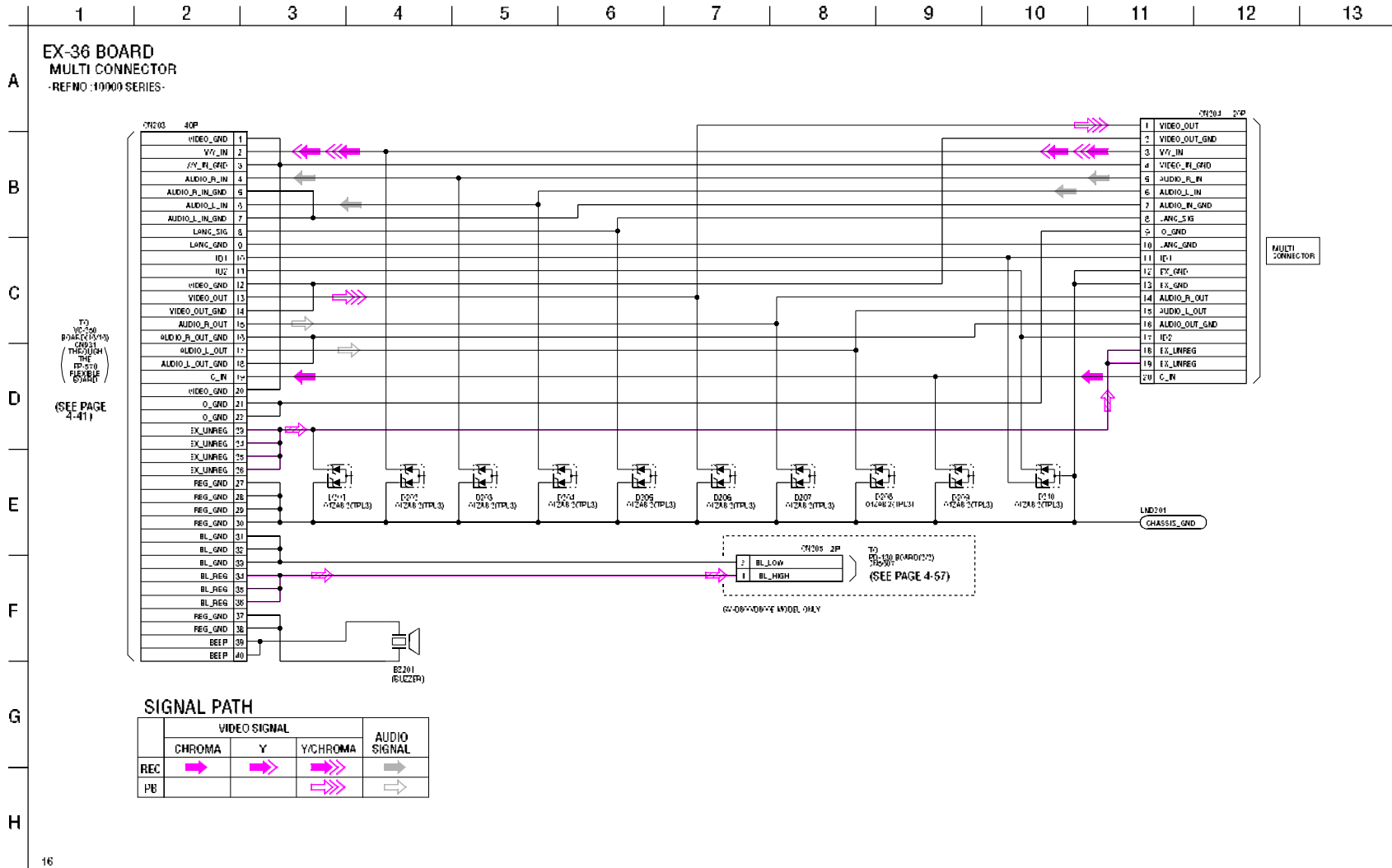

GV-D200/D200E/D800/D800E

FP-571 (BATTERY), FP-249 (S/T REEL) PRINTED WIRING BOARDS

- Ref. No. FP-571, FP-249 Boards; 20,000 Series —
- Refer to page 4-37 for FP-571 schematic diagram.
- Refer to page 4-33 for FP-249, FP-355, FP-356 schematic diagrams.

FP-571 FLEXIBLE BOARD

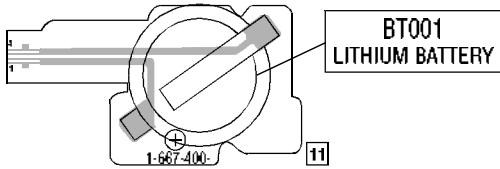

FP-249 BOARD

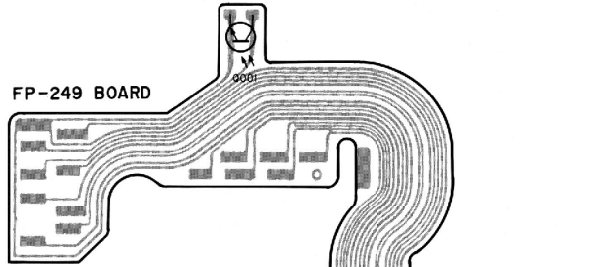

FP-355 BOARD

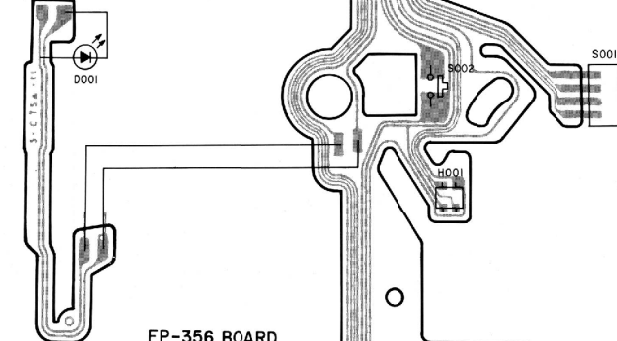

FP-356 BOARD

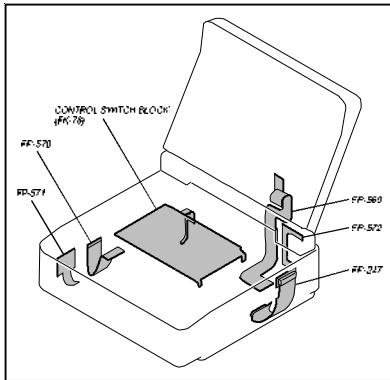
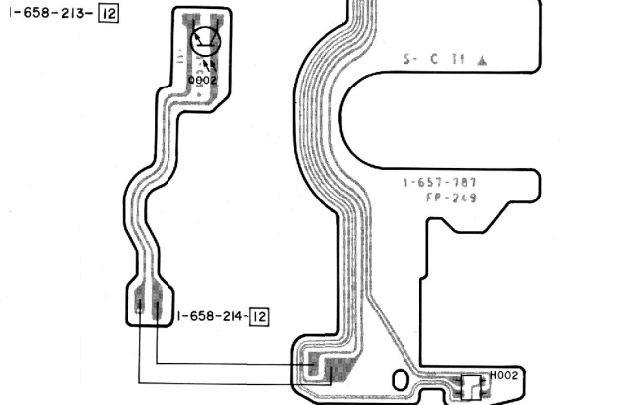

4-3. WAVEFORMS

VC-250 BOARD

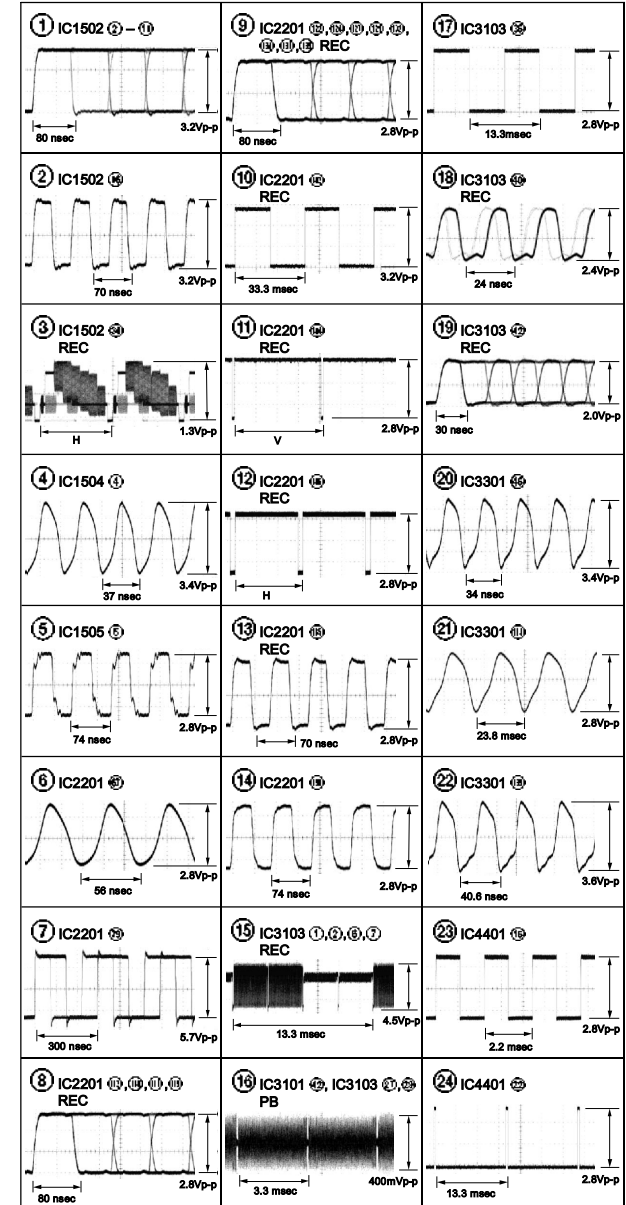

VC-250 BOARD

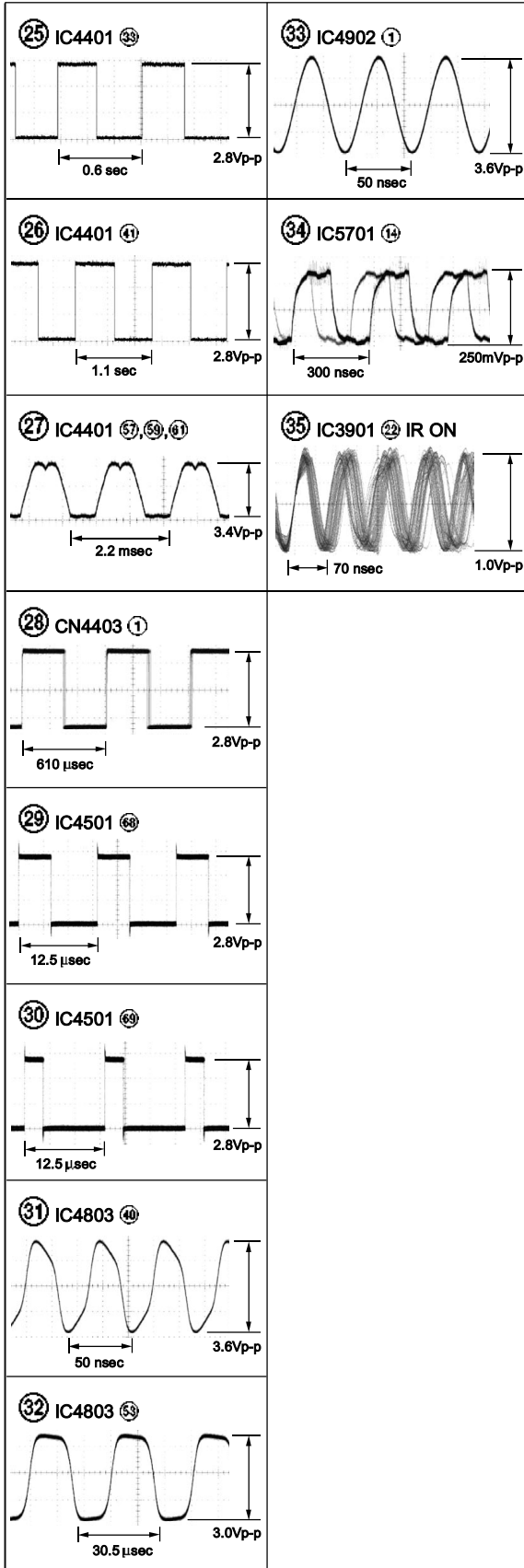

PD-130 BOARD

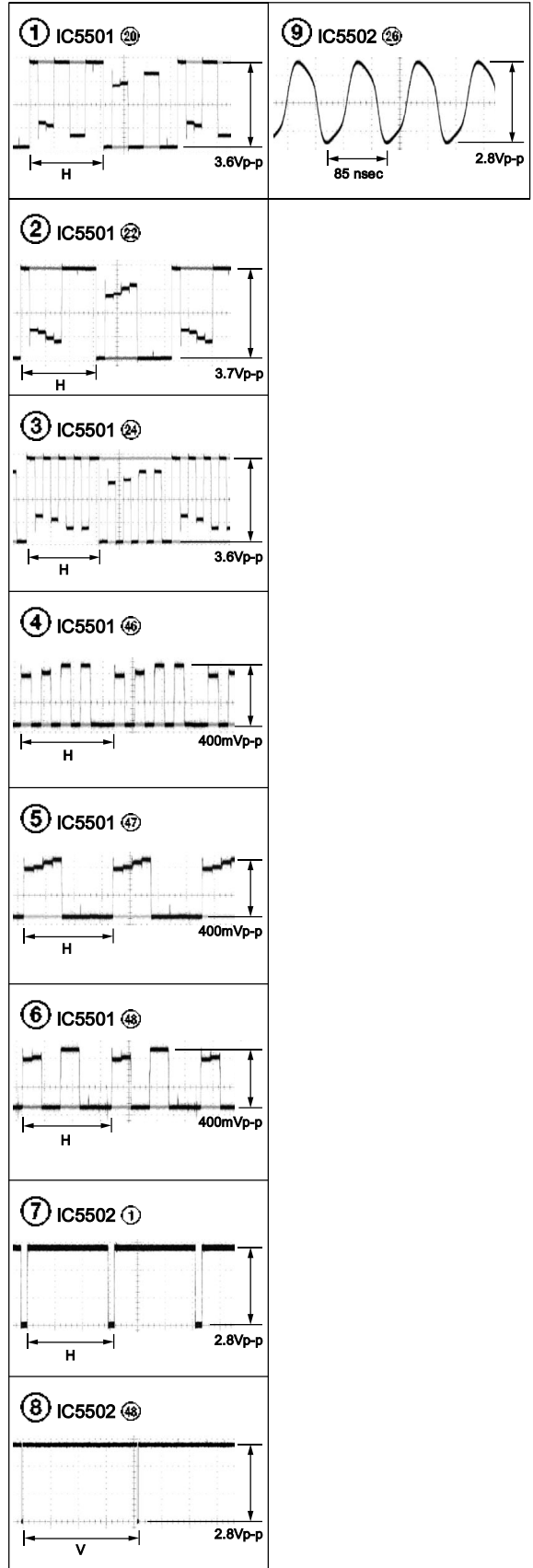

GV-D200/D200E/D800/D800E

IO-68 BOARD (SIDE A)

C103	F-6	L101	E-6
C104	E-6	L103	E-7
C107	E-6	L104	E-6
C110	E-6	L105	E-1
C112	E-3	L106	F-2
C117	D-1	L107	E-1
C118	D-1	L108	F-2
C119	F-2		
C120	F-2	R101	F-7
C121	E-1	R102	E-7
C122	E-1	R103	F-7
C123	F-2	R105	E-6
C124	F-2	R106	E-6
C127	E-1	R107	E-6
		R120	E-3
CN104	E-1	R128	F-6
		R129	F-6
D101	E-6	R130	F-1
D102	F-3	R131	F-1
D103	E-3	R137	E-1
D104	E-6	R138	E-5
D110	F-6	R139	E-3
D113	F-3		
D114	E-1	S101	F-6
D115	F-3	S102	F-5
D116	E-1	S103	F-4
D117	F-2	S104	F-2
D123	E-1	S105	F-1
D124	E-1		
D127	F-1		
D128	E-1		
D129	E-1		
J101	E-2		
J102	E-6		
J103	E-3		

IO-68 BOARD (SIDE B)

C101	B-7
C102	B-8
C113	C-5
C114	B-4
C115	B-3
C116	A-6
C125	B-2
C126	B-2
CN103	B-2
CN105	A-7
D105	C-5
D106	B-4
D107	B-3
D108	B-3
D109	A-6
D111	A-6
D112	A-6
D119	B-2
D120	B-2
D121	C-8
D122	C-7
D125	B-4
D126	C-5
FB101	A-6
R110	C-5
R111	B-4
R112	B-3
R121	B-1
R132	A-6
R133	A-6
R134	B-6
R135	B-2
R136	B-2

FU-145 BOARD (SIDE A)

C504	D-2
C505	E-2
C506	D-2
C507	F-3
C1301	E-7
C1302	E-7
C1303	E-7
C1304	E-7
C1305	E-7
C1306	E-7
C1307	E-7
C1308	D-6
C1309	F-6
C1310	D-6
C1311	F-6
C1312	D-6
C1313	E-6
C1314	D-6
C1315	E-5
C1316	E-5
C1317	E-5
C1318	E-5
C1319	E-5
C1324	D-6
C1334	E-5
C1337	E-4
C1347	E-5
C1348	F-6
C1352	F-5
C1359	E-4
CN501	E-1
CN502	F-2
CN1301	F-6
D1302	E-4
D1303	E-3
D1304	E-4
D1306	E-3
IC1301	E-6
L501	D-2
L1301	F-4
L1302	F-4
L1303	D-4
L1304	D-3

FU-145 BOARD (SIDE B)

L1305	E-4
L1310	E-5
L1317	D-4
L1318	E-5
LF501	F-3
O502	E-2
O507	E-2
Q1308	E-5
Q1310	F-5
Q1311	F-6
Q1312	F-5
Q1313	F-5
Q1314	E-4
R502	F-3
R503	F-3
R513	E-2
R1301	E-7
R1302	E-7
R1303	D-7
R1304	D-6
R1305	D-7
R1306	E-7
R1307	D-7
R1309	D-6
R1310	F-6
R1311	F-6
R1312	D-6
R1313	F-6
R1314	D-6
R1316	F-7
R1317	E-5
R1318	E-5
R1319	E-4
R1320	E-3
R1321	F-5
R1322	F-5
R1326	D-6
R1345	F-6
R1346	F-6
R1347	F-5
R1348	F-5
T1301	E-3
C501	A-2
C502	A-2
C503	B-2
C508	C-2
C1321	B-3
C1323	A-3
C1326	A-4
C1327	A-4
C1328	B-3
C1329	B-4
C1330	C-3
C1331	B-4
C1332	C-4
C1338	B-4
C1342	B-4
C1344	C-4
D501	A-2
D502	A-2
D503	B-1
D504	B-2
D505	A-2
D506	C-2
D507	C-2
D1301	B-3
D1305	B-3
F501	A-3
F502	B-2
F503	B-2
F504	B-2
F505	C-2
Q501	B-2
Q503	B-1
Q504	B-1
Q505	B-1
Q506	B-2
Q1301	B-3
Q1302	A-3
Q1303	B-4
Q1304	A-4
Q1305	C-4
Q1306	C-3
Q1307	A-4
Q1309	C-4
R501	A-2
R504	B-2
R505	B-2
R506	B-2
R507	B-2
R508	B-1
R509	B-1
R510	B-2
R511	C-2
R512	C-2

PD-130 BOARD (SIDE A)

C5501 F-5
 C5502 F-5
 C5503 E-6
 C5504 F-6
 C5505 E-7
 C5506 E-7
 C5507 E-7
 C5508 F-6
 C5509 E-5
 C5510 E-6
 C5511 F-6
 C5512 F-6
 C5513 E-6
 C5514 E-5
 C5515 F-5
 C5516 F-5
 C5517 E-5
 C5518 E-5
 C5519 E-5
 C5520 D-6
 C5521 F-7
 C5522 F-7
 C5523 G-6
 C5524 F-7
 C5525 E-6
 C5526 E-6
 C5527 E-6
 C5528 D-6
 C5529 F-7
 C5530 G-7
 C5531 G-7
 C5601 E-4
 C5602 D-4
 C5603 D-4
 C5604 E-2
 C5605 F-4
 C5606 G-4
 C5607 G-3

 CN5501 G-7
 CN5502 D-7
 CN5503 A-2
 CN5505 C-4
 CN5506 C-6
 CN5604 G-3
 CN5607 A-9
 CN5608 D-8

 D5501 E-6
 D5502 F-6
 D5503 D-7
 D5504 F-7
 D5505 A-1
 D5506 C-3
 D5601 G-4
 D5603 D-3
 D5604 E-8
 D5605 F-1

 IC5501 E-6
 IC5502 F-6
 IC5503 F-7
 IC5601 E-4
 IC5602 F-4

 L5501 D-4
 L5502 D-4
 L5503 D-4
 L5504 D-4
 L5505 F-6
 L5601 E-3

Q5501 F-6
 Q5502 F-7
 Q5503 G-7
 Q5604 F-7
 Q5505 F-7
 Q5506 G-7
 Q5601 E-4
 Q5602 E-2
 Q5603 F-4
 Q5604 F-4

 R5501 E-7
 R5502 E-7
 R5503 E-7
 R5504 F-6
 R5505 E-6
 R5506 F-6
 R5507 F-6
 R5508 F-6
 R5509 F-6
 R5510 F-6
 R5511 F-6
 R5512 F-5
 R5513 F-6
 R5514 G-6
 R5515 G-6
 R5516 E-7
 R5517 G-7
 R5518 G-6
 R5519 G-6
 R5520 G-6
 R5521 G-7
 R5522 G-6
 R5523 G-7
 R5524 G-7
 R5525 G-6
 R5551 F-7
 R5553 D-7
 R5557 E-7
 R5558 E-7
 R5559 D-6
 R5560 F-6
 R5561 F-7
 R5562 F-7
 R5563 F-7
 R5564 G-7
 R5565 G-7
 R5566 G-7
 R5567 G-7
 R5568 F-7
 R5569 E-6
 R5608 E-4
 R5609 E-4
 R5610 E-3
 R5611 F-4
 R5612 F-4
 R5613 E-3
 R5614 E-4
 R5616 G-4
 R5617 G-4
 R5618 G-4
 R5619 D-3
 R5620 E-8
 R5621 F-1
 R5622 E-1
 R5623 E-1
 R5624 E-2
 R5625 E-2
 R5626 E-1

 T5601 F-3

IR-38 BOARD (SIDE A)

C392 A-1
 D362 A-2
 D363 A-1

 F361 B-2

 Q365 A-2

 R368 A-1
 R369 A-1
 R392 B-1

IR-38 BOARD (SIDE B)

C382 C-3
 C393 B-4

 CN361 B-3

 L363 C-3

EX-36 BOARD (SIDE A)

BZ201 E-2
 CN204 E-5
 CN205 E-1

EX-36 BOARD (SIDE B)

CN203 C-4

 D201 B-3
 D202 B-5
 D203 B-5
 D204 B-5
 D205 B-5
 D206 A-5
 D207 B-5
 D208 B-5
 D209 A-5
 D210 C-5

PD-130 BOARD (SIDE B)

S5601 G-18
 S5602 D-18

SECTION 5 ADJUSTMENTS

1. Before starting adjustment

EVR Data Re-writing Procedure When Replacing Board

The data that is stored in the repair board, is not necessarily correct.
Perform either procedure 1 or procedure 2 or procedure 3 when replacing board.

Procedure 1

Save the EVR data of the machine in which a board is going to be replaced. Download the saved data after a board is replaced.

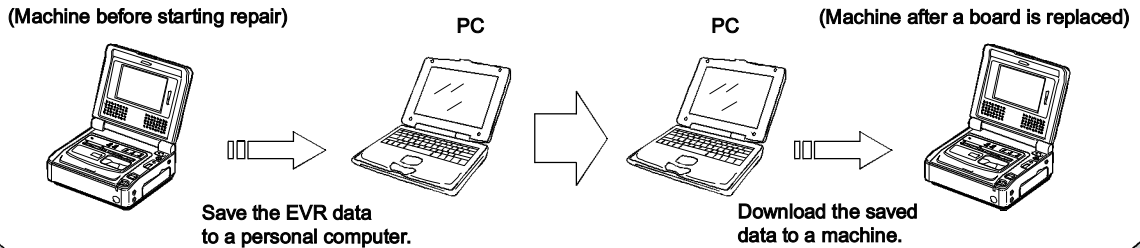

Procedure 2

Remove the EEPROM from the board of the machine that is going to be repaired. Install the removed EEPROM to the replaced board.

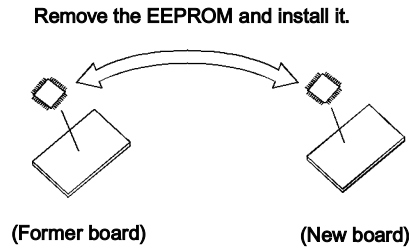

Procedure 3

When the data cannot be saved due to defective EEPROM, or when the EEPROM cannot be removed or installed, save the data from the same model of the same destination, and download it.

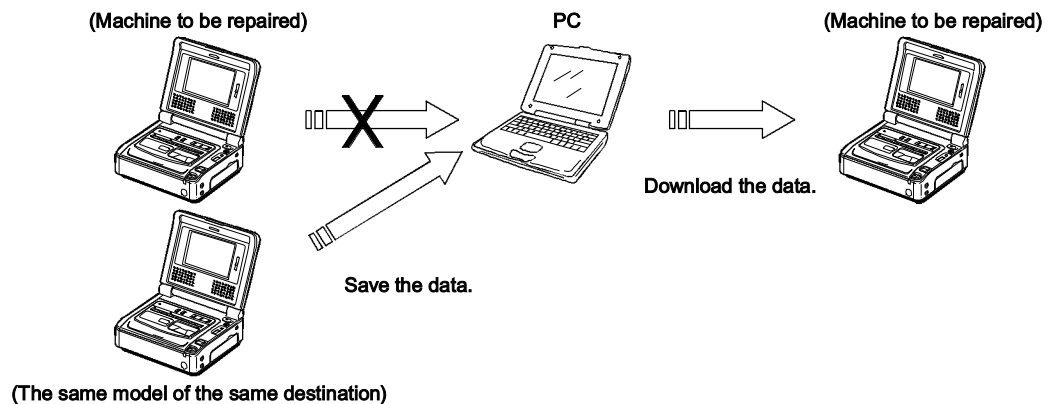

After the EVR data is saved and downloaded, check the respective items of the EVR data.
(Refer to page 5-3 for the items to be checked.)

1-1. Adjusting items when replacing main parts and boards.

When replacing main parts, adjust the items indicated by ● in the following table.

*1: When replacing the drum assy. or mechanism deck, reset the data of page: 2, address: A2 to A4 to "00". (Refer to "Record of Use check" of "5-4. SERVICE MODE")

*2: GV-D800/D800E only

Adjustment Section	Adjustment	Replaced parts													Board replacement	EEPROM replacement															
		Block replacement			Parts replacement																										
		Mechanism deck *1	Mechanism deck M901 (Drum assy) *1	Mechanism deck M902 (Capstan motor)	Mechanism deck LS chassis assy	LCD block ND901 (Fluorescent tube) *2	LCD block LCD901 (LCD panel) *2	PD-130 board IC5501 (RGB driver (LCD)) *2	PD-130 board IC5502 (Timing generator (LCD)) *2	PD-130 board Q5602, T5601 (Inverter) *2	VC-250 board IC3103 (REC/PB AMP)	VC-250 board IC3101 (EQ, A/D conv. PLL)	VC-250 board IC3701 (LINE IN/OUT)	VC-250 board IC3301 (DV signal process)	VC-250 board IC1504, X1501 (X'tal OSC)	VC-250 board IC2291 (EVR)	VC-250 board IC2201 (Hi8/Std8 Y/C process)	VC-250 board IC3901 (IR transmitter)	VC-250 board IC5701 (AUDIO IN/OUT)	PD-130 board (COMPLETE) *2	VC-250 board (COMPLETE)	VC-250 board IC4502 (EEPROM)	VC-250 board IC4901 (EEPROM)								
Initialization of C,D,E,F,7,8 page data	Initialization of C, D, 8 page data																								●	●					
	Initialization of E, F, 7 page data																											●			
System control	Serial No. input																										●	●			
	Battery end adj.																											●			
Servo & RF	REEL FG adj.	●			●																						●	●			
	Switching position adj.	●	●																									●	●		
	AGC center level adj.									●	●																	●	●		
	APC & AEQ adj.									●	●																	●	●		
	PLL fo & LPF fo adj.										●	●																●	●		
	Hi8/Std8 switching position adj.	●	●																										●		
Video	CAP FG duty adj.	●		●																								●	●		
	27MHz origin oscillation adj.															●	●											●	●		
	Chroma BPF fo adj.													●														●	●		
	S VIDEO OUT Y level adj.													●	●													●	●		
	S VIDEO OUT chroma level adj.													●	●													●	●		
	Hi8/Std8 Y/C output level setting																	●										●	●		
IR	Hi8/Std8 AFC fo adj.															●	●											●	●		
	IR video carrier frequency adj.																●		●									●	●		
	IR video deviation adj.														●				●									●	●		
Audio	IR audio deviation adj.																●		●									●	●		
	Hi8/Std8 AFM BPF fo adj.																	●			●							●	●		
	Hi8/Std8 AFM 1.5MHz deviation adj.																		●			●						●	●		
LCD *2	Hi8/Std8 AFM 1.7MHz deviation adj.																		●			●						●	●		
	LCD initial data input																											●	●		
	VCO adj.																										●	●	●	●	
	RGB AMP adj.																											●	●	●	●
	Contrast adj.																											●	●	●	●
	COM-AMP adj.																											●	●	●	●
Mechanism	V-COM adj.																											●	●	●	●
	White balance adj.																											●	●	●	●
Tape path adj.		●	●	●	●																										

Table 5-1-1

5-1. ADJUSTMENT PREPARATIONS

For details of the adjustment remote commander, refer to “5-4. SERVICE MODE”.

With 4-inch LCD panel: **GV-D800/D800E**
 Without 4-inch LCD panel: **GV-D200/D200E**

1-1. PREPARATIONS BEFORE ADJUSTMENT

1-1-1. List of Service Tools

- Oscilloscope
- Regulated power supply
- Frequency counter
- Monitor TV
- Digital voltmeter
- Pattern generator

Ref. No.	Name	Parts Code	Usage
J-1	Adjustment remote commander (RM-95 upgraded). (Note 1)	J-6082-053-B	
J-2	CPC-13 jig	J-6082-443-A	For adjusting the video section
J-3	Multi CPC jig	J-6082-311-A	For adjusting the LCD block
J-4	Power cord (Note 2)	J-6082-223-A	For connecting the battery terminal and DC power supply
J-5	IR receiver jig	J-6082-383-A	For adjusting the IR transmitter

Note 1: If the micro processor IC in the adjustment remote commander is not the new micro processor (UPD7503G-C56-12), the pages cannot be switched. In this case, replace with the new micro processor (8-759-148-35).

Note 2: Connect the adjustment remote commander to the LANC jack, and set to HOLD switch to the “ADJ” side.

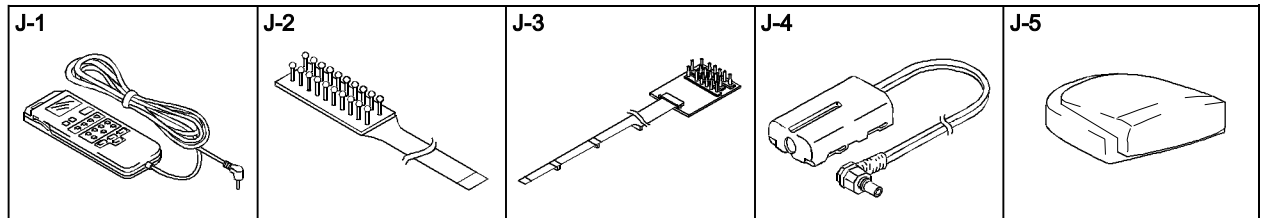

Fig. 5-1-1.

5-2. MECHANISM SECTION ADJUSTMENT

Mechanism Section adjustments, checks, and replacement of mechanism parts, refer to the separate volume "8mm Video Mechanism Adjustment Manual VII [B Mechanism]".

Note 1: NTSC model: GV-D200/D800
PAL model: GV-D200E/D800E

2-1. Hi8/STANDARD8 MODE

2-1-1. OPERATING WITHOUT CASSETTE

- 1) Refer to "Section 2. DISASSEMBLY" and supply the power with the cabinet assembly removed. (So that the mechanical deck can be operated.)
- 2) Connect the adjustment remote commander to the LANC jack.
- 3) Turn on the HOLD switch of the adjustment remote commander.
- 4) Close the cassette compartment without loading a cassette and complete loading.
- 5) Select page: 0, address: 01, and set data: 01.
- 6) Select page: F, address: 22, set data: 81, and press the PAUSE button of the adjustment remote commander.
- 7) Select page: D, address: 10, and press the PAUSE button of the adjustment remote commander.
- 8) Disconnect the power supply of the unit.

By carrying out the above procedure, the unit can be operated without loading a cassette. (Note2)

Be sure to carry out "Processing after Operations" after checking the operations.

Set the data of page: D, address: 10 to "12", if the sensor ineffective mode, forced VTR power supply ON mode is to be used together.

Note 2: Except for the recording mode.

[Procedure after checking operations]

- 1) Select page: 0, address: 01, and set data: 01.
- 2) Select page: F, address: 22, set data: 80, and press the PAUSE button of the adjustment remote commander.
- 3) Select page: D, address: 10, set data: 00, and press the PAUSE button of the adjustment remote commander.
- 4) Select page: 0, address: 01, and set data: 00.
- 5) Disconnect the power supply of the unit.

2-1-2. TAPE PATH ADJUSTMENT

1. Preparations for Adjustment

- 1) Clean the tape path face (tape guide, capstan shaft, pinch roller).
- 2) Connect the adjustment remote commander to the LANC jack.
- 3) Turn on the HOLD switch of the adjustment remote commander.
- 4) Select page: 0, address: 01, and set data: 01.
- 5) Select page: 2, address: 2E, and set data: 02.
- 6) Select page: F, address: 22, set data: 88, and press the PAUSE button of the adjustment remote commander.
(Be sure to perform "Processing after operation" after completing adjustments.)
- 7) Connect the oscilloscope to VC-250 board CN933 via CPC-13 jig (J-6082-443-A).
Channel 1: VC-250 board, CN933 Pin ⑤
External trigger: VC-250 board, CN933 Pin ⑧
- 8) Playback Hi8/standard8 alignment tape for tracking.
(WR5-1NP(NTSC))
(WR5-1CP(PAL))
- 9) Check that the oscilloscope RF waveform is flat at the entrance and exit.
If not flat, adjust according to the separate volume "8mm Video Mechanical Adjustment Manual VII [B Mechanism]".
- 10) Perform "Processing after operations", after completing adjustment.

CN933 of VC-250board

Pin No.	Signal Name	Pin No.	Signal Name
1	SWP	11	NC
2	AFC F0	12	NC
3	BPF MONI	13	DV RF SWP
4	F0 ADJ RF IN	14	RF IN
5	PB RF	15	CAP FG
6	REG GND	16	RF MON
7	RF AGC OUT	17	TMS
8	VC RF SWP	18	TCK
9	NC	19	TDO
10	NC	20	TDI

Table 5-2-1.

[Procedure after operations]

- 1) Connect the adjustment remote commander, and turn on the HOLD switch.
- 2) Select page: 0, address: 01, and set data: 01.
- 3) Select page: 2, address: 2E, and set data: 00.
- 4) Select page: F, address: 22, set data: 80, and press the PAUSE button of the adjustment remote commander.
- 5) Select page: 0, address: 01, and set data: 00.
- 6) Remove the power supply from the unit.

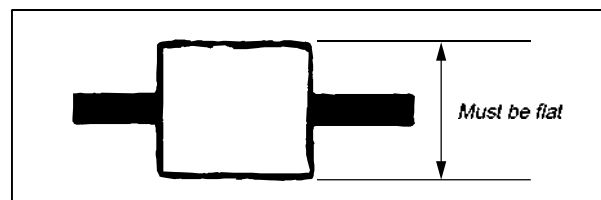

Fig. 5-2-1.

2-2. DIGITAL8 MODE

2-2-1. HOW TO ENTER RECORD MODE WITHOUT CASSETTE

- 1) Connect the adjustment remote commander to the LANC jack.
- 2) Turn the HOLD switch of the adjustment remote commander to the ON position.
- 3) Close the cassette compartment without the cassette.
- 4) Select page: 3, address: 01, and set data: 0C, and press the PAUSE button of the adjustment remote commander. (The mechanism enters the record mode automatically.)
Note: The function buttons becomes inoperable.
- 5) To quit the record mode, select page: 3, address: 01, set data: 00, and press the PAUSE button of the adjustment remote commander. (Whenever you want to quit the record mode, be sure to quit following this procedure.)

2-2-2. HOW TO ENTER PLAYBACK MODE WITHOUT CASSETTE

- 1) Connect the adjustment remote commander to the LANC jack.
- 2) Turn the HOLD switch of the adjustment remote commander to the ON position.
- 3) Close the cassette compartment without the cassette.
- 4) Select page: 3, address: 01, and set data: 0B, and press the PAUSE button of the adjustment remote commander. (The mechanism enters the playback mode automatically.)
Note: The function buttons becomes inoperable.
- 5) To quit the playback mode, select page: 3, address: 01, set data: 00, and press the PAUSE button of the adjustment remote commander. (Whenever you want to quit the playback mode, be sure to quit following this procedure.)

2-2-3. OVERALL TAPE PATH CHECK

1. Recording of the tape path check signal

- 1) Clean the tape running side (tape guide, capstan shaft, pinch roller).
- 2) Input a color bar signal to the AUDIO/VIDEO INPUT jack.
- 3) Connect the adjustment remote commander to the LANC jack.
- 4) Turn the HOLD switch of the adjustment remote commander to the ON position.
- 5) Set to the recording mode.
- 6) Select page: 3, address: 1C, set data: 5D, and press the PAUSE button of the adjustment remote commander.
- 7) Record for several minutes.
- 8) Release the recording mode.
- 9) Select page: 3, address: 1C, set data: 00, and press the PAUSE button.

2. Tape path check

- 1) Clean the tape running side (tape guide, capstan shaft, pinch roller).
- 2) Connect the adjustment remote commander to the LANC jack.
- 3) Turn the HOLD switch of the adjustment remote commander to the ON position.
- 4) Connect an oscilloscope to VC-250 board CN933 via the CPC-13 jig (J-6082-443-A).
Channel 1: VC-250 board, CN933 Pin ⑩ (Note)
External trigger: VC-250 board, CN933 Pin ⑬
Note: Connect a 75Ω resistor between Pins ⑩ of CN910 and ⑥ (GND).
- 5) Select page: 2, address: 2E, and set data: 01.
- 6) Playback the tape path check signal.
- 7) Select page: 3, address: 33, and set data: 08.
- 8) Select page: 3, address: 26, and set data: 31.
- 9) Check that the oscilloscope RF waveform is flat at the entrance and exit.
If not flat, perform "2-1-2. TAPE PATH ADJUSTMENT " of "2-1. Hi8/STANDARD 8mm MODE".
- 10) Select page: 3, address: 26, and set data: 00.
- 11) Select page: 3, address: 33, and set data: 00.
- 12) Select page: 2, address: 2E, and set data: 00.

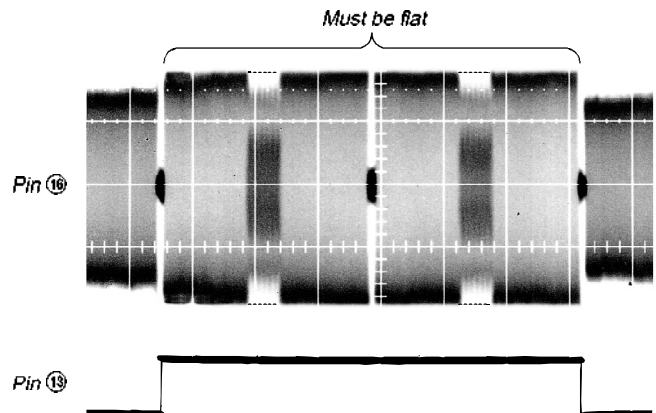

Fig. 5-2-2.

5-3. ELECTRICAL ADJUSTMENT

For details of the adjustment remote commander, refer to “5-4. SERVICE MODE”.

3-1. PREPARATIONS BEFORE ADJUSTMENTS

Use the following measuring instruments for video section adjustments.

Note: NTSC model: GV-D200/D800
PAL model: GV-D200E/D800E

3-1-1. Equipment to Required

- 1) TV monitor
- 2) Oscilloscope (dual-phenomenon, band width above 30 MHz with delay mode) (Unless specified otherwise, use a 10 : 1 probe.)
- 3) Frequency counter
- 4) Pattern generator with video output terminal
- 5) Digital voltmeter
- 6) Audio generator
- 7) Audio level meter
- 8) Audio distortion meter
- 9) Audio attenuator
- 10) Regulated power supply
- 11) Digital8 alignment tapes
 - SW/OL standard (WR5-2D)
Parts code: 8-967-993-22
 - Audio operation check for NTSC (WR5-3ND)
Parts code: 8-967-993-32
 - System operation check for NTSC (WR5-5ND)
Parts code: 8-967-993-42
 - Audio operation check for PAL (WR5-3CD)
Parts code: 8-967-993-37
 - System operation check for PAL (WR5-5CD)
Parts code: 8-967-993-47
- 12) NTSC Hi8/standard8 alignment tapes (For NTSC model)
 - For tracking adjustment (WR5-1NP)
Parts code : 8-967-995-02
 - For video frequency characteristics adjustment (WR5-7NE)
Parts code : 8-967-995-13
 - For checking Standard 8 mode operations
For LP (WR5-4NL)
Parts code : 8-967-995-51
For SP (WR5-5NSP)
Parts code : 8-967-995-42
- Note :** The following alignment tapes can also be used.
WR5-4NSP (8-967-995-41)
 - For checking Hi8 mode operations
For LP (WR5-8NLE)
Parts code : 8-967-995-52
For SP (WR5-8NSE)
Parts code : 8-967-995-43
 - For Checking AFM stereo operations (WR5-9NS)
Parts code : 8-967-995-23
 - For BPF adjustment (WR5-11NS)
Parts code : 8-967-995-71
- 13) PAL Hi8/standard8 alignment tapes (For PAL model)
 - For tracking adjustment (WR5-1CP)
Parts code : 8-967-995-07
 - For video frequency characteristics adjustment (WR5-7CE)
Parts code : 8-967-995-18
 - For checking Standard 8 mode operations
For LP (WR5-4CL)
Parts code : 8-967-995-56
For SP (WR5-5CSP)
Parts code : 8-967-995-47
- Note :** The following alignment tapes can also be used.
 - 1) WR5-3CL (8-967-995-36)
 - 2) WR5-4CSP (8-967-995-46)
- For checking Hi8 mode operations
For LP (WR5-8CLE)
Parts code : 8-967-995-57
For SP (WR5-8CSE)
Parts code : 8-967-995-48
- For Checking AFM stereo operations (WR5-9CS)
Parts code : 8-967-995-28
- For BPF adjustment (WR5-11CS)
Parts code : 8-967-995-76
- 14) Adjustment remote commander (J-6082-053-B)
- 15) CPC-13 jig (J-6082-443-A)
- 16) Power code (J-6082-223-A)
 - Note :** Connect the adjustment remote commander to the LANC jack, and set the HOLD switch to the “ADJ” side.
- 17) IR receiver jig (J-6082-383-A)
- 18) Multi CPC jig (J-6082-311-A)

3-1-2. Precautions on Adjusting

- 1) Disconnecting the VC-250 board CN926 (4P, 0.8mm) means disconnecting the lithium 3V power supply (FP-571 board BT001), data such as date, time, user-set menus will be lost. After completing adjustments, reset these data. If the CN926 has been disconnected, the self-diagnosis data, data on history of use (total drum rotation time etc.) will be lost. Before disconnecting, note down the self-diagnosis data (data of page: 2, address: B0 to C6) and data on history use (data of page: 2, address: A2 to AA). (Refer to "5-4. SERVICE MODE" for the self-diagnosis data and the data on the history use.)
- 2) To remove the cabinet (upper) and LCD block (GV-D800/D800E only), disconnect the following connectors.
 - VC-250 board CN926 (4P 0.8mm)
(Lithium battery)
 - VC-250 board CN931 (40P 0.5mm)
(EX-36 board (Multi connector))
 - VC-250 board CN929 (5P 0.8mm)
(DV jack)
 - VC-250 board CN923 (32P 0.5mm) (GV-D800/D800E only)
(PD-130 board (LCD panel))
 - VC-250 board CN924 (10P 0.5mm)
(IR-38 board (IR transmitter))
 - VC-250 board CN922 (50P 0.5mm)
(IO-68 board, FP-575 flexibles, FP-246 flexible)

As the video and audio jacks and LANC jack are provided on the IO-68 board and the power switch is provided on the FP-575 flexible board, these boards must be connected to the VC-250 board. So remove the cabinet (R) assembly (IO-68 board and FP-575 flexible and FP-246 flexible) from the cabinet (upper) assembly and connect it to the following connector.
VC-250 board CN922 (50P 0.5mm)
- 3) By setting the "Forced VTR Power ON mode", the video section can be operate even if the FP-575 flexible board (power switch) has been removed.

Note 1: Setting the "Forced VTR Power ON" mode (VTR mode)

- 1) Select page: 0, address: 01, and set data: 01.
- 2) Select page: D, address: 10, set data: 02, and press the PAUSE button of the adjustment remote commander.
The above procedure will enable the VTR power to be turned on with the FP-575 flexible board removed.
After completing adjustments, be sure to exit the "Forced VTR Power ON mode".

Note 2: Exiting the "Forced Power ON" mode

- 1) Select page: 0, address: 01, and set data: 01.
- 2) Select page: D, address: 10, set data: 00, and press the PAUSE button of the adjustment remote commander.
- 3) Select page: 0, address: 01, and set data: 00.

3-1-3. Adjusting Connectors

Some of the adjusting points of the video section are concentrated at VC-250 board CN933. Connect the measuring instruments via the CPC-13 jig (J-6082-443-A). The following table lists the pin numbers and signal names of CN933.

Pin No.	Signal Name	Pin No.	Signal Name
1	SWP	11	NC
2	AFC F0	12	NC
3	BPF MONI	13	DV RF SWP
4	FO ADJ RF IN	14	RF IN
5	PB RF	15	CAP FG
6	REG GND	16	RF MON
7	RF AGC OUT	17	TMS
8	VC RF SWP	18	TCK
9	NC	19	TDO
10	NC	20	TDI

Table. 5-3-1.

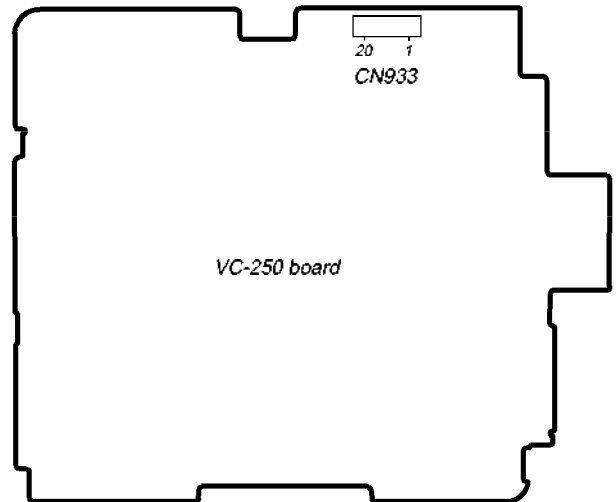

Fig. 5-3-1.

3-1-4. Connecting the Equipment

Connect the measuring instruments as shown in Fig. 5-3-2, and perform the adjustments.

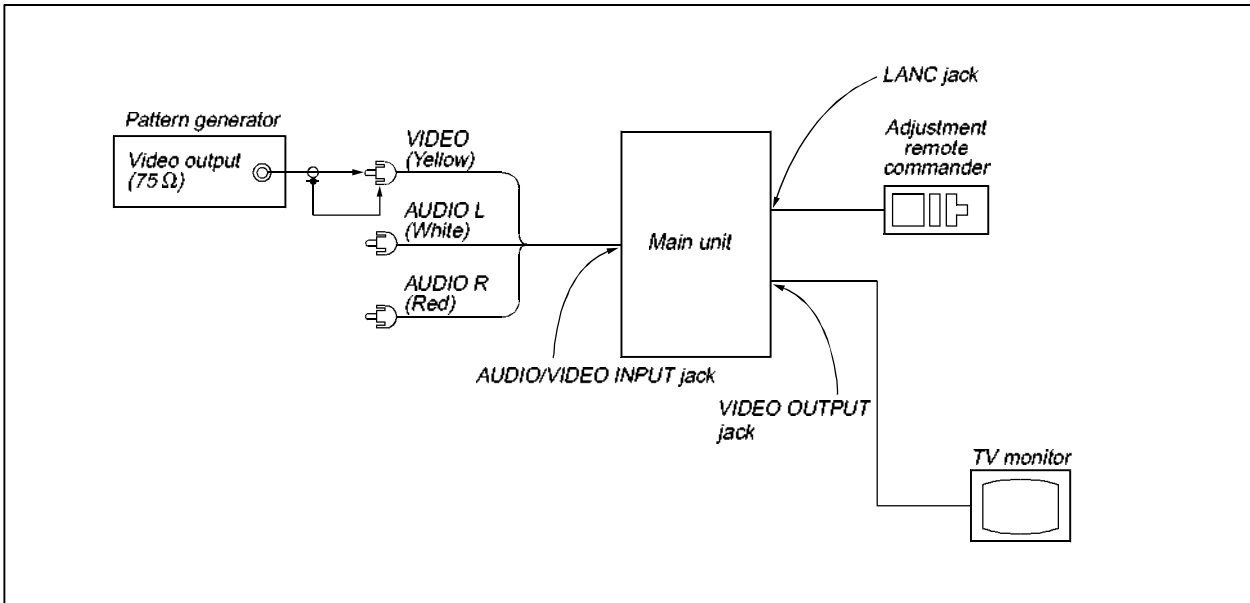

Fig. 5-3-2

3-1-5. Alignment Tape

The following table lists alignment tapes which are available. Use the tape specified in the signal column for each adjustment. If the type of tape to be used for checking operations is not specified, use whichever type.

Digital8 alignment tape

Name	Usage
SW/OL standard (WR5-2D)	Switching position adjustment
Audio operation check (WR5-3ND (NTSC), WR5-3CD (PAL))	Audio system adjustment
System operation check (WR5-5ND (NTSC), WR5-5CD (PAL))	Operation check

Hi8/standard8 alignment tape

Name	Recording mode	Tape type	Tape speed	Usage
Tracking (WR5-1NP(NTSC), WR5-1CP(PAL))	Standard8	MP	SP	Tape path adjustment, Switching position adjustment
Video frequency characteristics (WR5-7NE(NTSC), WR5-7CE(PAL))	Hi8	ME	SP(NTSC) LP(PAL)	Frequency characteristics adjustment
Operation check (WR5-5NSP(NTSC), WR5-5CSP(PAL))	Standard8	MP	SP	Operation check
Operation check (WR5-8NSE(NTSC), WR5-8CSE(PAL))	Hi8	ME	SP	
Operation check (WR5-4NL(NTSC), WR5-4CL(PAL))	Standard8	MP	LP	
Operation check (WR5-8NLE(NTSC), WR5-8CLE(PAL))	Hi8	ME	LP	
AFM stereo operation check (WR5-9NS(NTSC), WR5-9CS(PAL))	Standard8	MP	SP	AFM stereo Operation check
BPF adjustment (WR5-11NS(NTSC), WR5-11CS(PAL))	Standard8	MP	SP	BPF adjustment

Tape type

- ME Particle type metal tape
- MP Evaporated type metal tape

Table. 5-3-2.

Fig. 5-3-3. Shows the color bar signals recorded on the alignment tape.

Note : Measure using the VIDEO terminal (Terminated at 75 Ω).

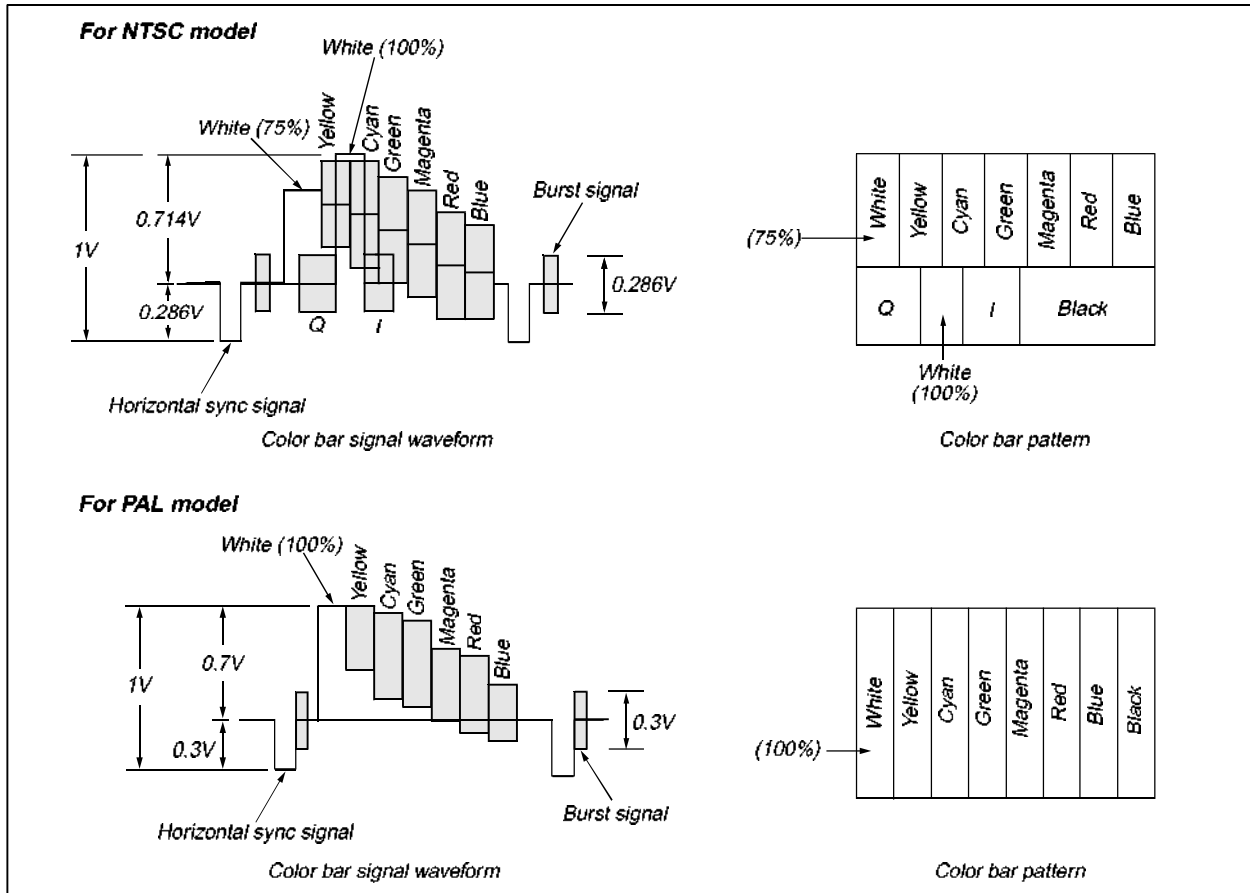

Fig. 5-3-3. Color Bar Signal of the Alignment Tape

3-1-6. Input/output Level and Impedance

Video input/output

Phono jack, 1Vp-p, 75Ω, unbalanced, sync negative

S video input/output

4-pin mini DIN

Luminance signal:

1Vp-p, 75Ω, unbalanced, sync negative

Chrominance signal:

0.286Vp-p, 75Ω, unbalanced (NTSC)

0.300Vp-p, 75Ω, unbalanced (PAL)

Audio input/output

Phono jack:

Input: -7.5dBs, input impedance more than 47kΩ

Output: -7.5dBs, (at load impedance 47kΩ), output impedance less than 2.2kΩ

3-2. INITIALIZATION OF C, D, E, F, 7, 8 PAGE DATA

3-2-1. INITIALIZATION OF C, D, 8 PAGE DATA

1. Initializing the C, D, 8 Page Data

Note 1: If “Initializing the C, D, 8 Page Data” is performed, all data of the C page, D page and 8 page will be initialized. (It is impossible to initialize a single page.)

Note 2: If the C, D, 8 page data has been initialized, the following adjustments need to be performed again.

- 1) Modification of C, D, 8 page data
- 2) Serial No. input
- 3) Servo and RF system adjustments
- 4) Video system adjustments
- 5) LCD system adjustments
- 6) Battery end adjustments

Adjusting page	C
Adjusting Address	10 to FF
Adjusting page	D
Adjusting Address	10 to FF
Adjusting page	8
Adjusting Address	00 to FF

Initializing Method:

Order	Page	Address	Data	Procedure
1	0	01	01	Set the data
2	3	81	10	Set the data
3	3	80	0A	Set the data, and press the PAUSE button.
4	3	80		Check that the data changes to “1A”
5				Perform “Modification of C, D, 8 Page Data”.

2. Modification of C, D, 8 Page Data

If the C, D, 8 page data has been initialized, change the data of the “Fixed data-2” address shown in the following tables by manual input.

Modifying Method:

- 1) Before changing the data, select page: 0, address: 01, and set data: 01.
- 2) New data for changing are not shown in the tables because they are different in destination. When changing the data, copy the data built in the same model.
Note: If copy the data built in the different model, the camcorder may not operate.
- 3) When changing the data, press the PAUSE button of the adjustment remote commander each time when setting new data to write the data in the non-volatile memory.
- 4) Check that the data of adjustment addresses is the initial value. If not, change the data to the initial value.

Processing after Completing Modification of C, D, 8 Page data

Order	Page	Address	Data	Procedure
1	2	00	29	Set the data
2	2	01	29	Set the data, and press the PAUSE button.

Note: If the following symptoms occur after completing of the “Modification of C, D, 8 page data”, check that the data of the “Fixed data-2” addresses of D page are same as those of the same model of the same destination.

- 1) The battery end mark on the LCD screen is flashing.
- 2) The power is shut off so that unit cannot operate.

3. C Page Table

Note: Fixed data-1: Initialized data. (Refer to “1. Initializing the C, D, 8 Page Data”.)

Fixed data-2: Modified data. (Refer to “2. Modification of C, D, 8 Page Data”.)

Address	Initial value		Remark
	NTSC	PAL	
00 to 0F			
10	EE	EE	Switching position adj.
11	00	00	
12	00	00	
13	00	00	
14 to 16			Fixed data-1
17	E0	E0	REEL FG adj.
18	25	25	AEQ adj.
19	25	25	
1A			Fixed data-1
1B	25	25	AEQ adj.
1C	25	25	
1D			Fixed data-1
1E	25	25	AGC center level adj.
1F	3E	3E	PLL fo adj.
20	3E	3E	
21	CA	CA	APC adj.
22	99	99	LPF fo adj.
23 to 24			Fixed data-1
25	88	88	S VIDEO out Y level adj.
26	E3	E3	S VIDEO out Cr level adj.
27	A1	A1	S VIDEO out Cb level adj.
28	04	04	Chroma BPF fo adj.
29	20	20	PLL fo fine adj.
2A to 2B			Fixed data-1
2C	03	03	APC adj.
2D to 2E			Fixed data-1
2F			Fixed data-2
30	E0	E0	REEL FG adj.
31 to 45			Fixed data-1
46			Fixed data-2
47 to 4C			Fixed data-1
4D			Fixed data-2
4E to 85			Fixed data-1
86			Fixed data-2
87 to 88			Fixed data-1
89			Fixed data-2
8A to 91			Fixed data-1
92			Fixed data-2

Address	Initial value		Remark
	NTSC	PAL	
93 to 99			Fixed data-1
9A			Fixed data-2
9B to A4			Fixed data-1
A5			Fixed data-2
A6			
A7 to AA			Fixed data-1
AB			Fixed data-2
AC			Fixed data-1
AD			Fixed data-2
AE			Fixed data-1
AF			Fixed data-2
B0			
B1			Fixed data-1
B2			Fixed data-2
B3			(Modified data. Copy the data built in the same model.)
B4			
B5			
B6			
B7			
B8			
B9			
BA			
BB to D5			Fixed data-1
D6			Fixed data-2
D7			(Modified data. Copy the data built in the same model.)
D8			
D9			
DA			
DB			
DC			
DD			
DE to E5			
E6			Fixed data-2
E7			Fixed data-1
E8	08	08	Serial No. input
E9	00	00	
EA	46	46	
EB	01	01	
EC	02	02	
ED	00	00	
EE	00	00	
EF	00	00	
F0 to F3			Fixed data-1
F4	00	00	Emergency memory address
F5	00	00	
F6	00	00	
F7	00	00	
F8	00	00	
F9	00	00	
FA	00	00	
FB	00	00	
FC	00	00	
FD	00	00	
FE	00	00	
FF	00	00	

Table 5-3-3.

4. D Page Table

Note: Fixed data-1: Initialized data. (Refer to “1. Initializing the C, D, 8 Page Data”.)
Fixed data-2: Modified data. (Refer to “2. Modification of C, D, 8 Page Data”).

Address	Initial value		Remark
	NTSC	PAL	
00 to 0F			
10	00	00	Test mode
11 to 12			Fixed data-1
13			Fixed data-2
14			
15 to 19			Fixed data-1
1A			Fixed data-2 (Modified data. Copy the data built in the same model.)
1B			
1C			
1D			
1E			
1F			
20			
21			
22			
23			
24			Fixed data-1
25			Fixed data-2
26			Fixed data-1
27			Fixed data-2
28 to 2A			Fixed data-1
2B			Fixed data-2
2C			Fixed data-1
2D			Fixed data-2
2E			
2F			
30			
31 to 42			
43			Fixed data-2
44 to 47			Fixed data-1
48	90	90	Battery end adj.
49	98	98	
4A to 4C			Fixed data-1
4D			Fixed data-2
4E			
4F to 50			Fixed data-1
51			Fixed data-2
52			
53			
54			
55 to 57			Fixed data-1
58			Fixed data-2
59			
5A to 5B			Fixed data-1
5C			Fixed data-2
5D to 64			Fixed data-1
65			Fixed data-2
66			
67			
68			

Address	Initial value		Remark
	NTSC	PAL	
69			Fixed data-2
6A to 83			Fixed data-1
84			Fixed data-2
85 to 86			Fixed data-1
87			Fixed data-2
88 to 8D			Fixed data-1
8E			Fixed data-2
8F			Fixed data-2
90 to 9F			Fixed data-1
A0			Fixed data-2
A1			Fixed data-2
A2	80	80	VCO adj. (LCD) (GV-D800/D800E)
A3	70	70	VCO adj. (LCD) (GV-D800E)
A4	80	80	V-COM adj. (LCD) (GV-D800/D800E)
A5	30	30	RGB AMP adj.(LCD) (GV-D800/D800E)
A6			Fixed data-1
A7	C0	C0	COM AMP adj.(LCD) (GV-D800/D800E)
A8	80	80	White balance adj. (LCD)
A9	80	80	(GV-D800/D800E)
AA	50	50	Contrast adj. (LCD) (GV-D800/D800E)
AB			Fixed data-1
AC			Fixed data-2
AD			(Modified data. Copy the data built in the same model.)
AE			(Modified data. Copy the data built in the same model.)
AF			(Modified data. Copy the data built in the same model.)
B0			(Modified data. Copy the data built in the same model.)
B1			(Modified data. Copy the data built in the same model.)
B2 to B8			Fixed data-1
B9			Fixed data-2
BA			Fixed data-2
BB to C3			Fixed data-1
C4			Fixed data-2
C5			Fixed data-1
C6			Fixed data-2
C7 to FF			Fixed data-1

Table. 5-3-4.

5. 8 Page Table

Note: Fixed data-1: Initialized data. (Refer to “1. Initializing the C, D, 8 Page Data”.)
Fixed data-2: Modified data. (Refer to “2. Modification of C, D, 8 Page Data”.)

Address	Remark
00 to 20	Fixed data-1
21	Fixed data-2
22	Fixed data-1
23	Fixed data-2
24 to 98	Fixed data-1
99	Fixed data-2
9A to A2	Fixed data-1
A3	Fixed data-2
A4 to FF	Fixed data-1

Table. 5-3-5.

3-2-2. INITIALIZATION OF E, F, 7 PAGE DATA

1. Initializing the E, F, 7 Page Data

Note1: If “Initializing the E, F, 7 Page Data” is performed, all data of the E page, F page and 7 page will be initialized. (It is impossible to initialize a single page.)

Note2: If the E, F, 7 page data has been initialized, following adjustments need to be performed again.

- 1) Modification of E, F, 7 page data
- 2) Servo and RF system adjustments
- 3) Video system adjustments
- 4) IR transmitter adjustments

Adjusting page	F
Adjusting Address	10 to FF
Adjusting page	E
Adjusting Address	00 to FF
Adjusting page	7
Adjusting Address	00 to FF

Initializing Method:

Order	Page	Address	Data	Procedure
1	0	01	01	Set the data.
2	6	00		Set the following data. 55: GV-D200/D800 (NTSC) 51: GV-D200E/D800E (PAL)
3	6	01		Set the following data, and press PAUSE button. 55: GV-D200/D800 (NTSC) 51: GV-D200E/D800E (PAL)
4	6	02		Check that the data changes to “01”.
5				Perform “Modification of E, F, 7 Page Data”.

2. Modification of E, F, 7 Page Data

If the E, F, 7 page data has been initialized, change the data of the “Fixed data-2” address shown in the following table by manual input.

Modifying Method:

- 1) Before changing the data, select page: 0, address: 01, and set data: 01.
- 2) New data for changing are not shown in the tables because they are different in destination. When changing the data, copy the data built in the same model.
Note: If copy the data built in the different model, the camcorder may not operate.
- 3) When changing the data, press the PAUSE button of the adjustment remote commander each time when setting new data to write the data in the non-volatile memory.
- 4) Check that the data of adjustment addresses is the initial value. If not, change the data to the initial value.

Processing after Completing Modification of E, F, 7 Page data

Order	Page	Address	Data	Procedure
1	2	00	29	Set the data
2	2	01	29	Set the data, and press the PAUSE button.

3. F Page Table

Note: Fixed data-1: Initialized data. (Refer to “1. Initializing the E, F, 7 Page Data”.)

Fixed data-2: Modified data. (Refer to “2. Modification of E, F, 7 Page Data”.)

Address	Initial value		Remark
	NTSC	PAL	
00 to 0F			
10	00	00	Emergency memory address
11	00	00	
12	00	00	
13	00	00	
14	00	00	
15	00	00	
16	00	00	
17	00	00	
18	00	00	
19	00	00	
1A	00	00	
1B	00	00	
1C			Fixed data-2
1D to 22			Fixed data-1
23			Fixed data-2
24			
25			Fixed data-1
26			Fixed data-2
27 to 2B			Fixed data-1
2C			Fixed data-2
2D			Fixed data-1
2E			Fixed data-2
2F to 32			Fixed data-1
33			Fixed data-2
34 to 3A			Fixed data-1
3B			Fixed data-2
3C to 4C			Fixed data-1
4D	8C	8C	27MHz origin osc. adj.
4F to 5D			Fixed data-1
5E			Fixed data-2
5F			
60 to 61			Fixed data-1
62	0A	0A	Hi8/Std8 switching position adj.
63	00	00	
64	83	83	CAP FG duty adj.
65	40	40	Hi8/Std8 AFC fo adj.
66			Fixed data-1
67	69	65	Hi8/Std8 Y output level setting
68	64	72	Hi8/Std8 chroma output level setting
69 to 7A			Fixed data-1
7B	A6	A6	Hi8/Std8 1.5MHz deviation adj.
7C	94	94	Hi8/Std8 1.7MHz deviation adj.
7D	80	80	Hi8/Std8 AFM BPF adj.
7E	41	41	IR video deviation adj.
7F	33	33	IR audio deviation adj.
80	C7	C7	IR video carrier freq. adj.
81 to 8A			Fixed data-1
8B			Fixed data-2
8C to 93			Fixed data-1

Address	Initial value		Remark
	NTSC	PAL	
94			Fixed data-2
95 to 97			Fixed data-1
98			Fixed data-2
99 to 9B			Fixed data-1
9C			Fixed data-2
9D to 9F			Fixed data-1
A0			Fixed data-2
A1 to AA			Fixed data-1
AB			Fixed data-2
AC to CA			Fixed data-1
CB			Fixed data-2
CC			
CD			
CE			Fixed data-1
CF			Fixed data-2
D0 to D2			Fixed data-1
D3			Fixed data-2
D4 to DE			Fixed data-1
DF			Fixed data-2
E0			Fixed data-1
E1			Fixed data-2
E2 to F2			Fixed data-1
F3			Fixed data-2
F4 to F5			Fixed data-1
F6			Fixed data-2
F7 to FF			Fixed data-1

Table. 5-3-6.

4. E Page Table

Note: Fixed data-1: Initialized data. (Refer to “1. Initializing the E, F, 7 Page Data”.)
Fixed data-2: Modified data. (Refer to “2. Modification of E, F, 7 Page Data”.)

Address	Remark
00 to 01	Fixed data-1
02	Fixed data-2
03	
04	
05	
06 to 07	
08	Fixed data-2
09 to 0D	Fixed data-1
0E	Fixed data-2 (Modified data. Copy the data built in the same model.)
0F	
10	
11	
12	
13	
14	
15	
16	
17	
18	
19	
1A to 27	Fixed data-1
28	Fixed data-2
29 to 33	Fixed data-1
34	Fixed data-2
35	Fixed data-1
36	Fixed data-2
37	Fixed data-1
38	Fixed data-2
39	
3A to 3C	Fixed data-1
3D	Fixed data-2
3E to 42	Fixed data-1
43	Fixed data-2
44	Fixed data-1
45	Fixed data-2
46	
47	
48	
49 to 50	Fixed data-1
51	Fixed data-2
52 to 56	Fixed data-1
57	Fixed data-2
58 to 5B	Fixed data-1
5C	Fixed data-2
5D	
5E	
5F to 71	Fixed data-1
72	Fixed data-2
73 to 7B	Fixed data-1

Address	Remark
7C	Fixed data-2
7D	
7E	
7F	Fixed data-1
80	Fixed data-2
81	
82 to 8B	Fixed data-1
8C	Fixed data-2
8D	
8E	
8F	
90	Fixed data-2
91 to 93	Fixed data-1
94	Fixed data-2
95 to FF	Fixed data-1

Table. 5-3-7.

5. 7 Page Table

Note: Fixed data-1: Initialized data.

(Refer to "1. Initializing the E, F, 7 Page Data".)

Fixed data-2: Modified data.

(Refer to "2. Modification of E, F, 7 Page Data").

Address	Remark
00 to 05	Fixed data-1
06	Fixed data-2
07	
08 to 25	Fixed data-1
26	Fixed data-2
27 to FF	Fixed data-1

Table. 5-3-8.

3-3. SYSTEM CONTROL SYSTEM ADJUSTMENT

1. Serial No. Input

1-1. Company ID Input

Write the company ID in the EEPROM (nonvolatile memory).

Page	C
Address	E8, E9, EA, EB, EC

Input method:

1) Select page: 0, address: 01, and set data: 01.

2) Input the following data to page: C, addresses: E8 to EC.

Note: Press the PAUSE button of the adjustment remote commander each time to set the data.

Address	Data
E8	08
E9	00
EA	46
EB	01
EC	02

3) Select page: 0, address: 01, and set data: 00.

1-2. Serial No. Input

Write the serial No. and model code in the EEPROM (nonvolatile memory). Convert the serial No. on the name plate from decimal to hexadecimal, and write in the EEPROM.

Page	C
Address	ED, EE, EF

Input method:

1) Select page: 0, address: 01, and set data: 01.

2) Read the serial No. on the name plate, and take it as D₁.

Example: If the serial No. is 77881.

D₁=77881

3) Obtain D₂ and H₁ corresponding to D₁ from Table 5-3-9.

Example: If D₁ is "77881".

D₂=D₁-65536=12345

H₁=FE

D ₁ (Decimal)	D ₂ (Decimal)	H ₁ (Hexadecimal) (Service model code)
000001 to 065535	D ₁	FE
065536 to 131071	D ₁ -65536	FE
131072 to 196607	D ₁ -131072	FE

Table 5-3-9.

4) Input H₁ to page: C, address: ED. (Model code input)

Example: If H₁ is "FE".

Select page: C, address: ED, set data: FE, and press the PAUSE button.

5) Obtain the maximum decimal not exceeding D₂ from Table 5-3-10, and take this as D₃.

Example: If D₂ is "12345".

D₃=12288

6) Obtain the hexadecimal corresponding to D₃ from Table 5-3-10, and take this as H₃.

Example: If D₃ is "12288".

H₃=3000

7) Obtain the difference D₄ between D₂ and D₃. (Decimal calculation, 0 ≤ D₄ ≤ 255)

D₄=D₂-D₃

Example: If D₂ is "12345" and D₃ is "12288".

D₄=12345-12288=57

8) Convert D₄ to hexadecimal, and take this as H₄.

(Refer to "Hexadecimal-decimal conversion table" in "5-4. Service Mode".)

Example: If D₄ is "57".

H₄=39

9) Input the upper 2 digits of H₃ to page: C, address: EE.

Example: If H₃ is "3000".

Select page: C, address: EE, set data: 30, and press the PAUSE button.

10) Input H₄ to page: C, address: EF.

Example: If H₄ is "39".

Select page: C, address: EF, set data: 39, and press the PAUSE button.

11) Select page: 0, address: 01, and set data: 00.

Decimal (D ₃)	Hexa-decimal (H ₃)	Decimal (D ₃)	Hexa-decimal (H ₃)	Decimal (D ₃)	Hexa-decimal (H ₃)	Decimal (D ₃)	Hexa-decimal (H ₃)	Decimal (D ₃)	Hexa-decimal (H ₃)	Decimal (D ₃)	Hexa-decimal (H ₃)	Decimal (D ₃)	Hexa-decimal (H ₃)	Decimal (D ₃)	Hexa-decimal (H ₃)
0	0000	8192	2000	16384	4000	24576	6000	32768	8000	40960	A000	49152	C000	57344	E000
256	0100	8448	2100	16640	4100	24832	6100	33024	8100	41216	A100	49408	C100	57600	E100
512	0200	8704	2200	16896	4200	25088	6200	33280	8200	41472	A200	49664	C200	57856	E200
768	0300	8960	2300	17152	4300	25344	6300	33536	8300	41728	A300	49920	C300	58112	E300
1024	0400	9216	2400	17408	4400	25600	6400	33792	8400	41984	A400	50176	C400	58368	E400
1280	0500	9472	2500	17664	4500	25856	6500	34048	8500	42240	A500	50432	C500	58624	E500
1536	0600	9728	2600	17920	4600	26112	6600	34304	8600	42496	A600	50688	C600	58880	E600
1792	0700	9984	2700	18176	4700	26368	6700	34560	8700	42752	A700	50944	C700	59136	E700
2048	0800	10240	2800	18432	4800	26624	6800	34816	8800	43008	A800	51200	C800	59392	E800
2304	0900	10496	2900	18688	4900	26880	6900	35072	8900	43264	A900	51456	C900	59648	E900
2560	0A00	10752	2A00	18944	4A00	27136	6A00	35328	8A00	43520	AA00	51712	CA00	59904	EA00
2816	0B00	11008	2B00	19200	4B00	27392	6B00	35584	8B00	43776	AB00	51968	CB00	60160	EB00
3072	0C00	11264	2C00	19456	4C00	27648	6C00	35840	8C00	44032	AC00	52224	CC00	60416	EC00
3328	0D00	11520	2D00	19712	4D00	27904	6D00	36096	8D00	44288	AD00	52480	CD00	60672	ED00
3584	0E00	11776	2E00	19968	4E00	28160	6E00	36352	8E00	44544	AE00	52736	CE00	60928	EE00
3840	0F00	12032	2F00	20224	4F00	28416	6F00	36608	8F00	44800	AF00	52992	CF00	61184	EF00
4096	1000	12288	3000	20480	5000	28672	7000	36864	9000	45056	B000	53248	D000	61440	F000
4352	1100	12544	3100	20736	5100	28928	7100	37120	9100	45312	B100	53504	D100	61696	F100
4608	1200	12800	3200	20992	5200	29184	7200	37376	9200	45568	B200	53760	D200	61952	F200
4864	1300	13056	3300	21248	5300	29440	7300	37632	9300	45824	B300	54016	D300	62208	F300
5120	1400	13312	3400	21504	5400	29696	7400	37888	9400	46080	B400	54272	D400	62464	F400
5376	1500	13568	3500	21760	5500	29952	7500	38144	9500	46336	B500	54528	D500	62720	F500
5632	1600	13824	3600	22016	5600	30208	7600	38400	9600	46592	B600	54784	D600	62976	F600
5888	1700	14080	3700	22272	5700	30464	7700	38656	9700	46848	B700	55040	D700	63232	F700
6144	1800	14336	3800	22528	5800	30720	7800	38912	9800	47104	B800	55296	D800	63488	F800
6400	1900	14592	3900	22784	5900	30976	7900	39168	9900	47360	B900	55552	D900	63744	F900
6656	1A00	14848	3A00	23040	5A00	31232	7A00	39424	9A00	47616	BA00	55808	DA00	64000	FA00
6912	1B00	15104	3B00	23296	5B00	31488	7B00	39680	9B00	47872	BB00	56064	DB00	64256	FB00
7168	1C00	15360	3C00	23552	5C00	31744	7C00	39936	9C00	48128	BC00	56320	DC00	64512	FC00
7424	1D00	15616	3D00	23808	5D00	32000	7D00	40192	9D00	48384	BD00	56576	DD00	64768	FD00
7680	1E00	15872	3E00	24064	5E00	32256	7E00	40448	9E00	48640	BE00	56832	DE00	65024	FE00
7936	1F00	16128	3F00	24320	5F00	32512	7F00	40704	9F00	48896	BF00	57088	DF00	65280	FF00

Table 5-3-10.

2. Battery End Adjustment

Set the battery end voltage.

If the voltage is incorrect, the life of the battery will shorten.

The image at the battery end will also be rough.

Mode	Playback
Signal	Arbitrary
Measurement Point	Display data of page: 2, address: 5D
Measuring Instrument	Adjustment remote commander
Adjustment Page	D
Adjustment Address	48, 49

Connection:

- 1) Connect the regulated power supply and the digital voltmeter to the battery terminal as shown in Fig. 5-3-4.

Preparations before adjustments:

- 1) Adjust the output voltage of the regulated power supply so that the digital voltmeter display is $6.1 \pm 0.1Vdc$.
- 2) Turn off the power supply.
- 3) Turn on the HOLD switch of the adjustment remote commander.
- 4) Turn on the power supply.
- 5) Load a cassette, and set to the playback mode.

Adjusting method:

Order	Page	Address	Data	Procedure
1	0	01	01	Set the data.
2				Decrease the output voltage of the regulated power supply so that the digital voltmeter display is $5.30 \pm 0.01Vdc$.
3	2	5D		Read the data, and this data is named Dref.
4	D	48	Dref	Set the data, and press PAUSE button.
5				Convert Dref to decimal notation, and obtain Dref'. (Note1)
6				Calculate D ₄₉ ' using following equation. (decimal calculation) $D_{49}' = Dref' + 8$
7				Convert D ₄₉ ' to decimal notation, and obtain D ₄₉ . (Note1)
8	D	49	D ₄₉	Set the data, and press PAUSE button.
9	0	01	00	Set the data.

Note 1: Refer to Table 5-4-1. "Hexadecimal-decimal conversion table" of "5-4.Service mode".

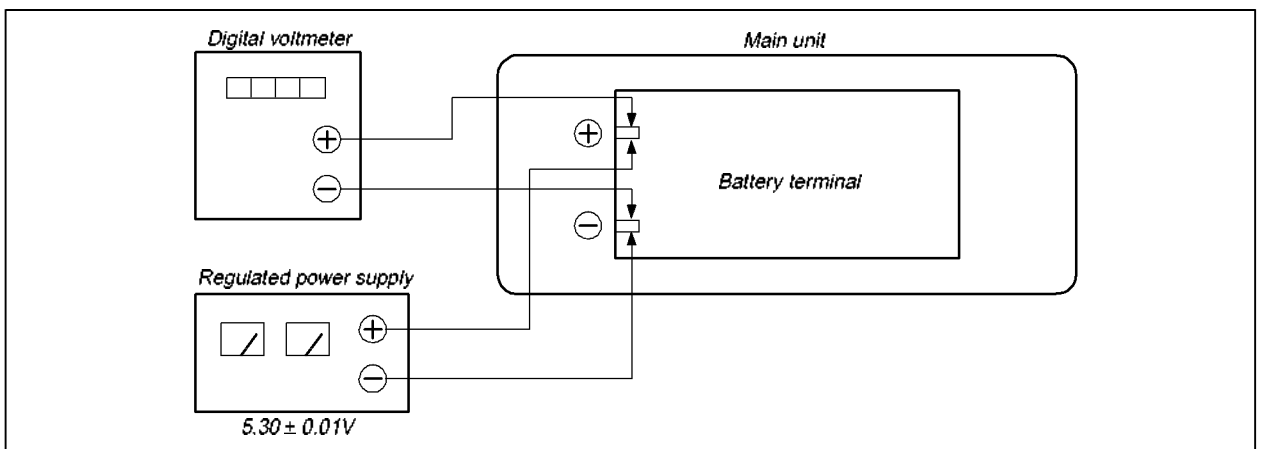

Fig. 5-3-4.

3-4. SERVO AND RF SYSTEM ADJUSTMENT

Before perform the servo and RF system adjustments, check that the specified value of "27MHz Origin Oscillation Adjustment" of "VIDEO SYSTEM ADJUSTMENT" is satisfied.

Adjusting Procedure:

1. REEL FG adjustment
2. PLL fo & LPF fo pre-adjustment
3. Switching position adjustment
4. AGC center level
5. APC & AEQ adjustment
6. PLL fo & LPF fo final adjustment
7. Hi8/Standrd8 switching position adjustment
8. Cap FG duty adjustment

1. REEL FG Adjustment (VC-250 Board)

Compensates the dispersion of the hall elements.

Measurement Point	Display data of page: 3, address: 03
Measuring Instrument	Adjustment remote commander
Adjustment Page	C
Adjustment Address	17, 30
Specified Value	00 or 01 or 04 or 05

Adjusting method:

Order	Page	Address	Data	Procedure
1				Close the cassette compartment without inserting a cassette.
2	0	01	01	Set the data.
3	3	01	1C	Set the data, and press PAUSE button.
4	3	02		Check that the data changes to "00",
5	3	03		Check that the data is "00" or "01" or "04" or "05". (Note)
6	0	01	00	Set the data.

Note: If the data is other value, adjustment has errors. (Take an appropriate remedial measures according to the errors referring to the following table.)

Data	Contents of defect
02, 03, 06, 07	T reel is defective
08, 09, 0C, 0D	S reel is defective
0A, 0B, 0E, 0F	S reel and T reel are defective

2. PLL fo & LPF fo Pre-Adjustment (VC-250 Board)

Mode	VTR stop
Measurement Point	Display data of page: 3, address: 03
Measuring Instrument	Adjustment remote commander
Adjustment Page	C
Adjustment Address	1F, 20, 22, 29
Specified Value	Bit2, bit3 and bit6 are "0"

Adjusting method:

Order	Page	Address	Data	Procedure
1	0	01	01	Set the data.
2	3	01	30	Set the data, and press PAUSE button.
3	3	02		Check that the data changes to "00".
4	3	03		Check that bit2, bit3 and bit6 are "0". (Note)
5	0	01	00	Set the data.

Note: If bit2, bit3 or bit6 is "1", there are errors.

For the error contents, see the following table. (For the bit values, refer to "5-4. SERVICE MODE", "4-3. 3. Bit value discrimination".)

Bit value of page: 3, address: 03 data	Error contents
bit 2 = 1	PLL fo final adjustment is defective
bit 3 = 1	PLL fo final adjustment is defective
bit 6 = 1	LPF fo is defective

If bit 2 or bit 3 is "1", select page: C, address: 21, set the following data, and press the PAUSE button, and repeat steps 2 to 4.

	Setting data
When the data of page: C, address: 21 is "CA".	CE
When the data of page: C, address: 21 is "CE".	C6
When the data of page: C, address: 21 is "C6".	D2
When the data of page: C, address: 21 is "D2"	C2

3. Switching Position Adjustment (VC-250 Board)

To obtain normal playback waveform output during the Digital8 playback mode, adjust the switching position.

Mode	VTR playback
Signal	SW/OL reference tape (WR5-2D)
Measurement Point	Display data of page: 3, address: 03
Measuring Instrument	Adjustment remote commander
Adjustment Page	C
Adjustment Address	10, 11, 12, 13
Specified Value	00

Adjusting method:

Order	Page	Address	Data	Procedure
1				Insert the SW/OL reference tape and enter the VTR STOP mode.
2	0	01	01	Set the data.
3	3	21		Check that the data is "02". (Note1)
4	3	01	0D	Set the data, and press PAUSE button.
5	3	02		Check that the data changes to "00".
6	3	03		Check that the data is "00". (Note2)
7	C	10		Check that the data is other than "EE". (Note3)
8	0	01	00	Set the data.

Note 1: If the data of page: 3, address: 21 is "72", the tape top being played. After playing the tape for 1 to 2 seconds, perform step 4 and higher.

Note 2: If bit 0 of the data is "1", the A channel is defective. If bit 1 is "1", the B channel is defective. Contents of the defect is written into page: C, addresses: 10 and 12. See the following table. (For the bit values, refer to "5-4. SERVICE MODE", "4-3. 3. Bit value discrimination".)

Note 3: If the data is "EE" rewind the tape and repeat steps 1 to 7.

When the A channel is defective

Data of page:C, address:10	Contents of defect
EE	Writing into EEPROM (IC4502) is defective
E8	Adjustment data is out of range
E7	No data is returned from IC3301 (CAIN)

When the B channel is defective

Data of page:C, address:12	Contents of defect
EE	Writing into EEPROM (IC4502) is defective
E8	Adjustment data is out of range
E7	No data is returned from IC3301 (CAIN)

4. AGC Center Level and APC & AEQ Adjustment

4-1. Preparations before adjustments

Mode	Recording
Signal	Color bar

Note: Use a Hi8 MP tape.

Adjusting method:

Order	Page	Address	Data	Procedure
1	0	01	01	Set the data.
2	8	2A	C8	Set the data.
3				Record the color bar signal for three minutes.

4-2. AGC Center Level Adjustment (VC-250 Board)

Mode	Playback
Signal	Recorded signal at "Preparations before adjustments"
Measurement Point	Pin ⑩ of CN933 (RF MON) (Note 1) Ext. trigger: Pin ⑬ of CN933 (DVRFSWP)
Measuring Instrument	Oscilloscope
Adjustment Page	C
Adjustment Address	1E
Specified Value	The data of page: 3, address: 03 is "00"

Note 1: Connect a 75Ω resistor between Pin ⑩ and Pin ⑤ (GND) of CN933. 75Ω resistor (Parts code: 1-247-804-11)

Adjusting method:

Order	Page	Address	Data	Procedure
1				Playback the recorded signal at "Preparations before adjustments"
2	0	01	01	Set the data.
3	2	2E	01	Set the data.
4	3	33	08	Set the data.
5				Confirm that the playback RF signal is stable. (Fig. 5-3-5.)
6	3	01	23	Set the data, and press PAUSE button.
7	3	02		Check that the data is "00".
8	3	03		Check that the data is "00". (Note2)
9				Perform "APC & AEQ Adjustment".

Note 2: If the data of page: 3, address: 03 is other than "00", adjustment has errors.

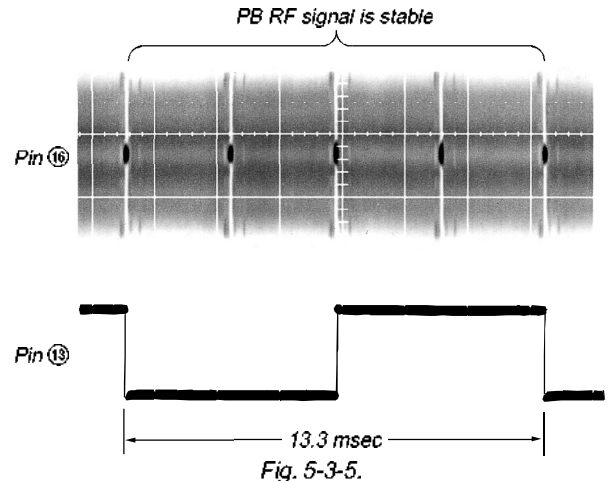

4-3. APC & AEQ Adjustment (VC-250 Board)

Mode	Playback
Signal	Recorded signal at "Preparations before adjustments"
Measurement Point	Pin ⑱ of CN933 (RF MON) (Note 1) Ext. trigger: Pin ⑲ of CN933 (DV RF SWP)
Measuring Instrument	Oscilloscope
Adjustment Page	C
Adjustment Address	18, 19, 1B, 1C, 21, 2C
Specified Value	The data of page: 3, address: 03 is "00"

Note 1: Connect a 75Ω resistor between Pin ⑱ and Pin ⑥ (GND) of CN933.

75Ω resistor (Parts code: 1-247-804-11)

Note 2: The "AGC Center Level Adjustment" must have already been completed before starting this adjustment.

Adjusting method:

Order	Page	Address	Data	Procedure
1	0	01	01	Set the data.
2	C	18	25	Set the data, and press PAUSE button.
3	C	19	25	Set the data, and press PAUSE button.
4	C	1B	25	Set the data, and press PAUSE button.
5	C	1C	25	Set the data, and press PAUSE button.
6	C	21	CA	Set the data, and press PAUSE button.
7	C	2C	03	Set the data, and press PAUSE button.
8				Playback the recorded signal at "Preparations before adjustments"
9	2	2E	01	
10	3	33	08	Set the data.
11				Confirm that the playback RF signal is stable. (Fig. 5-3-6.)
12	3	01	07	Set the data, and press PAUSE button.
13	3	02		Check that the data changes from "07" to "00" in about 20 seconds after pressing PAUSE button.
14	3	03		Check that the data is "00". (Note3)
15				Perform "Processing after Completing Adjustments".

Note 3: If the data is other than "00", adjustment has errors.

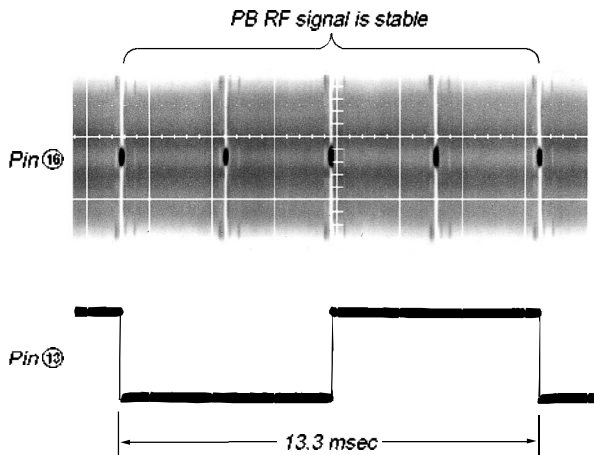

Fig. 5-3-6.

4-4. Processing after Completing Adjustments

Order	Page	Address	Data	Procedure
1	0	01	01	Set the data.
2	2	2E	00	Set the data.
3	3	33	00	Set the data.
4	8	2A	00	Set the data, and press PAUSE button.
5	0	01	00	Set the data.

5. PLL fo & LPF fo Final Adjustment (VC-250 Board)

Mode	VTR stop
Signal	Arbitrary
Measurement Point	Display data of page: 3, address: 03
Measuring Instrument	Adjustment remote commander
Adjustment Page	C
Adjustment Address	1F, 20, 22, 29
Specified Value	Bit2, bit3 and bit6 are "0"

Adjusting method:

Order	Page	Address	Data	Procedure
1	0	01	01	Set the data.
2	3	01	30	Set the data, and press PAUSE button.
3	3	02		Check that the data changes to "00".
4	3	03		Check that bit2, bit3 and bit6 are "00". (Note)
5	0	01	00	Set the data.

Note: If bit2, bit3 or bit 6 of the data is "1", there are errors.
For the error contents, see the following table. (For the bit values, refer to "5-4. SERVICE MODE", "4-3. 3. Bit value discrimination".)

Bit value of page: 3, address: 03	Error contents
bit 2 = 1	PLL fo final adjustment is defective
bit 3 = 1	PLL fo final adjustment is defective
bit 6 = 1	LPF fo is defective

6. Hi8/Standard8 Switching Position Adjustment (VC-250 Board)

If deviated in this case causes switching noise or jitter on the Hi8/Standard8 mode played back screen.

Mode	Playback
Signal	Hi8/Standard8 alignment tape: For tracking adjustment (WR5-1NP(NTSC))(WR5-1CP(PAL))
Measurement Point	CH1: Pin ⑧ of CN933 (VC RF SWP) CH2: Pin ⑤ of CN933 (PB RF)
Measuring Instrument	Oscilloscope
Adjustment Page	F
Adjustment Address	62, 63
Specified Value	t1=0 ± 10 sec

Adjusting Method:

Order	Page	Address	Data	Procedure
1				Set to the stop mode.
2	0	01	01	Set the data.
3	F	22	C0	Set the data, and press PAUSE button.
4	2	0E	02	Set the data.
5				Set to the playback mode.
6	F	62		Change the data and minimize "t1". (Coarse adjustment)
7	F	62		Press PAUSE button
8	F	63		Change the data and adjust so that the switching position (t1) becomes the specified value. (Fine adjustment)
9	F	63		Press PAUSE button
10	F	22	80	Set the data, and press PAUSE button.
11	2	0E	00	Set the data.
12	0	01	00	Set the data.

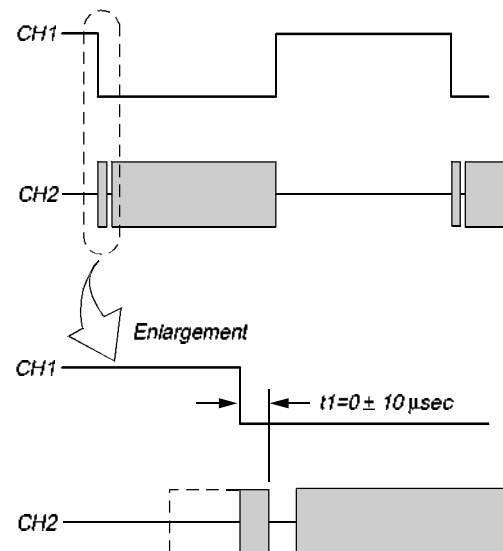

Fig. 5-3-7.

7. CAP FG Offset Adjustment (VC-250 board)

Set the Cap FG signal duty cycle to 50% to establish an appropriate capstan servo. If deviated, the uneven rotation of capstan and noise can occur in the Hi8/Standard8 LP mode.

Mode	Playback
Signal	Hi8/standard 8 alignment tape : For checking operation (WR5-5NSP(NTSC)) (WR5-5CSP(PAL))
Measurement Point	Pin ⑬ of CN933 (CAP FG)
Measuring Instrument	Oscilloscope
Adjustment Page	F
Adjustment Address	64
Specified value	Duty = 50 ± 1 %

Adjusting method:

Order	Page	Address	Data	Procedure
1				Set to the stop mode.
2	0	01	01	Set the data.
3	2	0E	02	Set the data.
4				Set to the playback mode.
5	6	01	81	Set the data, and press PAUSE button.
6	3	02		Check that the data changes to "01".
7	6	01	00	Set the data, and press PAUSE button.
8				Check that Duty of CAP FG signal satisfies the specified value. If not, repeat steps 5 to 8.
9	2	0E	00	Set the data.
10	0	01	00	Set the data.

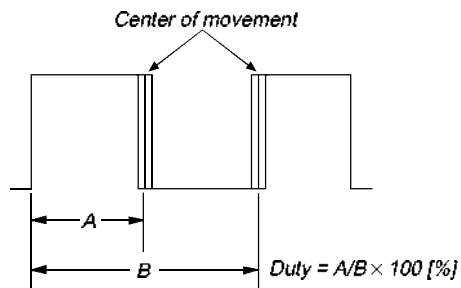

Fig. 5-3-8.

3-5. VIDEO SYSTEM ADJUSTMENTS

Switch setting:

DEMO MODE (Menu setting) OFF

1. 27MHz Origin Oscillation Adjustment (VC-250 board)

Set the frequency of the clock for synchronization. If deviated, the synchronization will be disrupted and the color will become inconsistent.

Mode	VTR stop
Signal	Not required
Measurement Point	Pin ⑤ of IC1505
Measuring Instrument	Frequency counter
Adjustment Page	F
Adjustment Address	4D
Specified Value	$f=13500000 \pm 68\text{Hz}$

Adjusting method:

Order	Page	Address	Data	Procedure
1	0	01	01	Set the data.
2	F	4D		Change the data and set the frequency (f) to the specified value.
3	F	4D		Press PAUSE button.
4	0	01	00	Set the data.

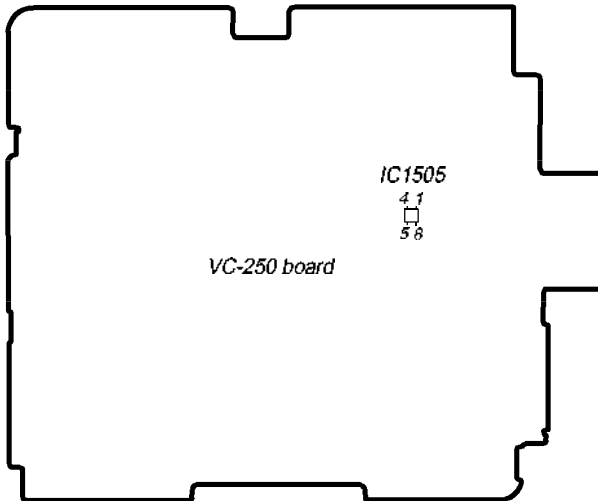

Fig. 5-3-9.

2. Chroma BPF Adjustment (VC-250 Board)

Set the center frequency of IC3701 chroma band-pass filter.

Mode	VTR stop
Signal	No signal
Measurement Point	CH1: Chroma signal terminal of S VIDEO OUT jack (75Ω terminated) CH2: Y signal terminal of S VIDEO OUT jack (75Ω terminated)
Measuring Instrument	Oscilloscope
Adjustment Page	C
Adjustment Address	28
Specified Value	A = 100mVp-p or less B = 200mVp-p or more

Adjusting method:

Order	Page	Address	Data	Procedure
1	0	01	01	Set the data.
2	D	11	10	Set the data, and press PAUSE button.
3				Check that the burst signal (B) is output to the chroma signal terminal of S VIDEO OUT jack.
4	3	0C	04	Set the data, and press PAUSE button.
5	C	28		Change the data for minimum amplitude of the burst signal level (A). (The data should be "00" to "07".)
6	C	28		Press PAUSE button.
7	3	0C	00	Set the data, and press PAUSE button.
8				Check that the burst signal level (B) satisfies the specified value.
9	D	11	00	Set the data, and press PAUSE button.
10	0	01	00	Set the data.

When the data of page: 3, address: 0C, is 04:

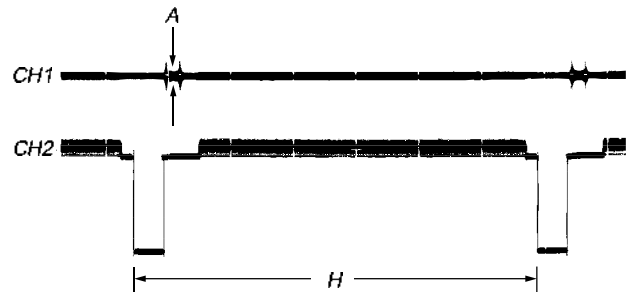

When the data of page: 3, address: 0C, is 00:

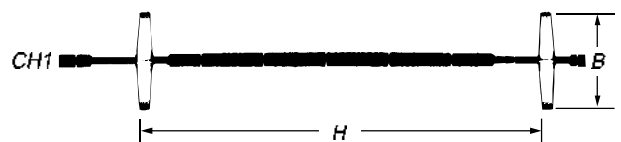

Fig. 5-3-10.

3. S VIDEO OUT Y Level Adjustment (VC-250 Board)

Mode	VTR stop
Signal	No signal
Measurement Point	Y signal terminal of S VIDEO OUT jack (75Ω terminated)
Measuring Instrument	Oscilloscope
Adjustment Page	C
Adjustment Address	25
Specified Value	A = 1000 ± 20mV

Adjusting method:

Order	Page	Address	Data	Procedure
1	0	01	01	Set the data.
2	D	11	10	Set the data, and press PAUSE button.
3	3	0C	02	Set the data, and press PAUSE button.
4	C	25		Change the data and set the Y signal level (A) to the specified value.
5	C	25		Press PAUSE button.
6	3	0C	00	Set the data, and press PAUSE button.
7	D	11	00	Set the data, and press PAUSE button.
8	0	01	00	Set the data.

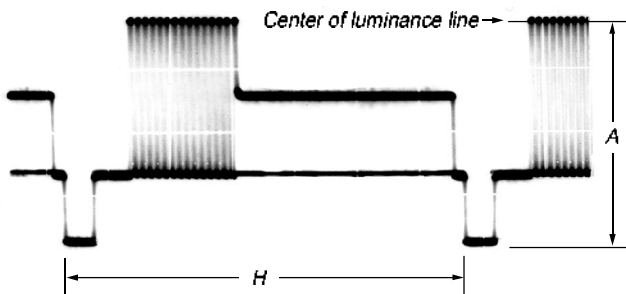

Fig. 5-3-11.

4. S VIDEO OUT Chroma Level Adjustment (VC-250 Board)

Mode	VTR stop
Signal	No signal
Measurement Point	Chroma signal terminal of S VIDEO OUT jack (75Ω terminated) External trigger: Y signal terminal of S VIDEO OUT jack
Measuring Instrument	Oscilloscope
Adjustment Page	C
Adjustment Address	26, 27
Specified Value	Cr level: A = 714 ± 14mV(NTSC) A = 700 ± 14mV(PAL) Cb level: B = 714 ± 14mV(NTSC) B = 700 ± 14mV(PAL) Burst level: C = 286 ± 6mV(NTSC) C = 300 ± 6mV(PAL)

Adjusting method:

Order	Page	Address	Data	Procedure
1	0	01	01	Set the data.
2	D	11	10	Set the data, and press PAUSE button.
3	3	0C	02	Set the data, and press PAUSE button.
4	C	26		Change the data and set the Cr signal level (A) to the specified value.
5	C	26		Press PAUSE button.
6	C	27		Change the data and set the Cb signal level (B) to the specified value.
7	C	27		Press PAUSE button.
8				Check that the burst signal level (C) is satisfied the specified value.
9	3	0C	00	Set the data, and press PAUSE button.
10	D	11	00	Set the data, and press PAUSE button.
11	0	01	00	Set the data.

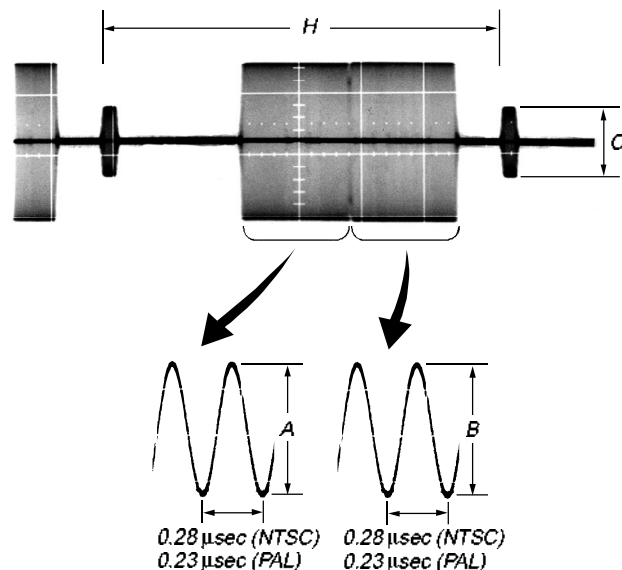

Fig. 5-3-12.

5. VIDEO OUT Y, Chroma Level Check (VC-250 Board)

Mode	VTR stop
Signal	No signal
Measurement Point	VIDEO OUT jack (75Ω terminated)
Measuring Instrument	Oscilloscope
Specified Value	Sync level: A = 293 ± 18mV(NTSC) A = 307 ± 18mV(PAL) Burst level: B = 286 ± 18mV(NTSC) B = 300 ± 18mV(PAL)

Adjusting method:

Order	Page	Address	Data	Procedure
1	0	01	01	Set the data.
2	D	11	10	Set the data, and press PAUSE button.
3	3	0C	02	Set the data, and press PAUSE button.
4				Check that the sync signal level (A) satisfies the specified value.
5				Check that the burst signal level (B) satisfies the specified value.
6	3	0C	00	Set the data, and press PAUSE button.
7	D	11	00	Set the data, and press PAUSE button.
8	0	01	00	Set the data.

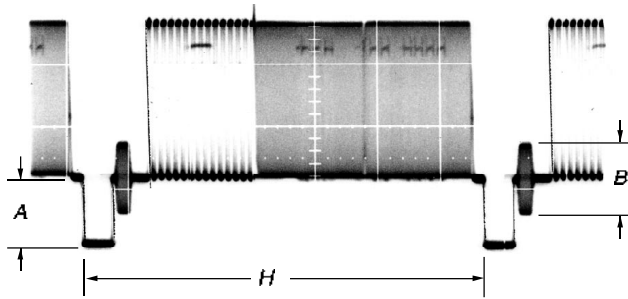

Fig. 5-3-13.

6. Hi8/Standard8 Y/C Output Level Setting (VC-250 Board)

Set the Y/C signal output level during the Hi8/Standard8 playback mode.

Mode	VTR stop
Signal	No signal
Adjustment Page	F
Adjustment Address	67, 68

Adjusting method:

Order	Page	Address	Data	Procedure
1	0	01	01	Set the data.
2	D	10	02	Set the data, and press PAUSE button.
3	6	6F	01	Set the data.
4	6	7F		Check that the data. When the data is "00", proceed to step 8. When the data is "03", proceed to step 5.
5	F	67		Set the following data, and press PAUSE button. 69: GV-D200/D800 (NTSC) 65: GV-D200E/D800E (PAL)
6	F	68		Set the following data, and press PAUSE button. 64: GV-D200/D800 (NTSC) 72: GV-D200E/D800E (PAL)
7				Proceed to step 10.
8	F	67		Set the following data, and press PAUSE button. A0: GV-D200/D800 (NTSC) A0: GV-D200E/D800E (PAL)
9	F	68		Set the following data, and press PAUSE button. AA: GV-D200/D800 (NTSC) B8: GV-D200E/D800E (PAL)
10	6	6F	00	Set the data.
11	D	10	00	Set the data, and press PAUSE button.
12	0	01	00	Set the data.

**7. Hi8/standard 8mm AFC fo Adjustment
(VC-250 board)**

Adjust the pull-in range of the clock generator (IC2201) for A/D conversion during Hi8/standard 8mm playback.

Mode	VTR stop
Signal	No signal
Measurement Point	Pin ② of CN933 (AFC f0)
Measuring Instrument	Digital voltmeter
Adjustment Page	F
Adjustment Address	65
Specified Value	A=1.40 ± 0.05Vdc Or the data of page: 6, address: 6E is “7C” to “84”

Adjusting method:

Order	Page	Address	Data	Procedure
1	0	01	01	Set the data.
2	D	10	02	Set the data, and press PAUSE button.
3	3	0D	04	Set the data, and press PAUSE button.
4	6	63	04	Set the data.
5	6	6F	01	Set the data.
6	6	01	C5	Set the data, and press PAUSE button.
7	6	02		Check that the data is “00”.
8	6	6E		Check that the data satisfies the specifies value. Or check that the DC voltage (A) satisfies the specifies value.
9	3	0D	00	Set the data, and press PAUSE button.
10	6	01	00	Set the data, and press PAUSE button.
11	6	63	00	Set the data.
12	6	6F	00	Set the data.
13	D	10	00	Set the data, and press PAUSE button.
14	0	01	00	Set the data.

3-6. IR TRANSMITTER ADJUSTMENTS

Adjust using the IR receiver jig (J-6082-383-A).

Note: If the distance between the IR receiver jig and the VCR is below 1m, cover the LASER LINK emitter with a ND filter. (For example, when the distance is 30cm to 50cm, cover the LASER LINK emitter with a ND filter 1.0.)

Switch setting:

LASER LINK ON (Red LED is lit)

1. IR Video Carrier Frequency Adjustment (VC-250 board)

Mode	VTR stop
Signal	Arbitrary
Measurement Point	Pin ⑤ of CN003 of IR receiver jig (RF) (Or Pin ⑩ of IC3901 of VC-250 board)
Measuring Instrument	Frequency counter
Adjustment Page	F
Adjustment Address	80
Specified Value	$f = 11.85 \pm 0.05$ MHz

Connection of Equipment:

Connect the measuring device as shown in the following figure, and adjust.

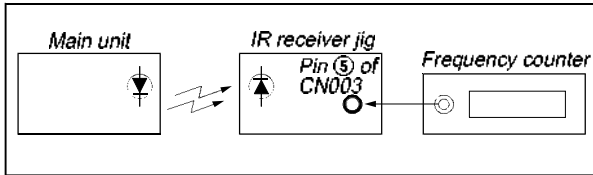

Fig. 5-3-14.

Adjusting method:

Order	Page	Address	Data	Procedure
1	0	01	01	Set the data.
2	3	0C	08	Set the data, and press PAUSE button.
3	F	80		Change the data, and set the video carrier frequency (f) to the specified value.
4	F	80		Press PAUSE button.
5	3	0C	00	Set the data, and press PAUSE button.
6	0	01	00	Set the data.

2. IR Video Deviation Adjustment (VC-250 board)

Mode	VTR stop
Signal	Arbitrary
Measurement Point	VIDEO OUT terminal of IR receiver jig (Terminated at 75Ω)
Measuring Instrument	Oscilloscope
Adjustment Page	F
Adjustment Address	7E
Specified Value	$A = 0.82 \pm 0.05$ V

Connection of Equipment:

Connect the measuring device as shown in the following figure, and adjust.

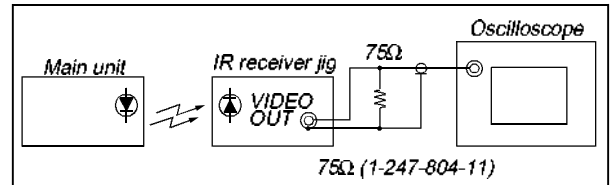

Fig. 5-3-15.

Adjusting method:

Order	Page	Address	Data	Procedure
1	0	01	01	Set the data.
2	3	0C	01	Set the data, and press PAUSE button.
3	F	7E		Change the data, set the video signal amplitude (A) to the specified value.
4	F	7E		Press PAUSE button.
5	3	0C	00	Set the data, and press PAUSE button.
6	0	01	00	Set the data.

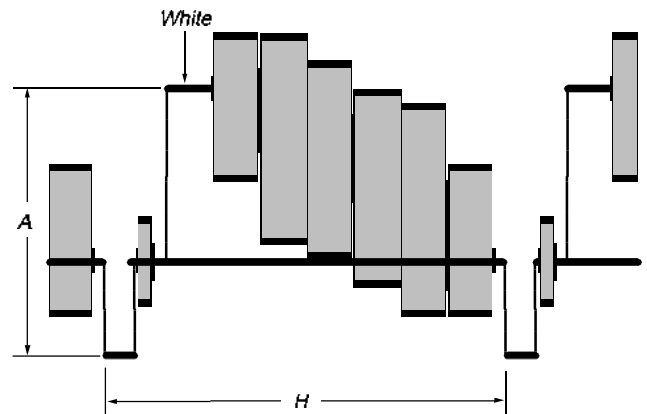

Fig. 5-3-16.

3. IR Audio Deviation Adjustment (VC-250 board)

Mode	VTR stop
Signal	Video : No signal Audio : -400Hz, -7.5dBs, Audio left and right terminal of AUDIO/VIDEO jack
Measurement Point	AUDIO L terminal and AUDIO R terminal of IR receiver jig (Terminated at 47k Ω)
Measuring Instrument	Audio level meter
Adjustment Page	F
Adjustment Address	7F
Specified Value	Signal level: -7.5 \pm 1.0 dBs Level difference of L and R: Below 2dB

Connection of Equipment:

Connect the measuring device as shown in the following figure, and adjust.

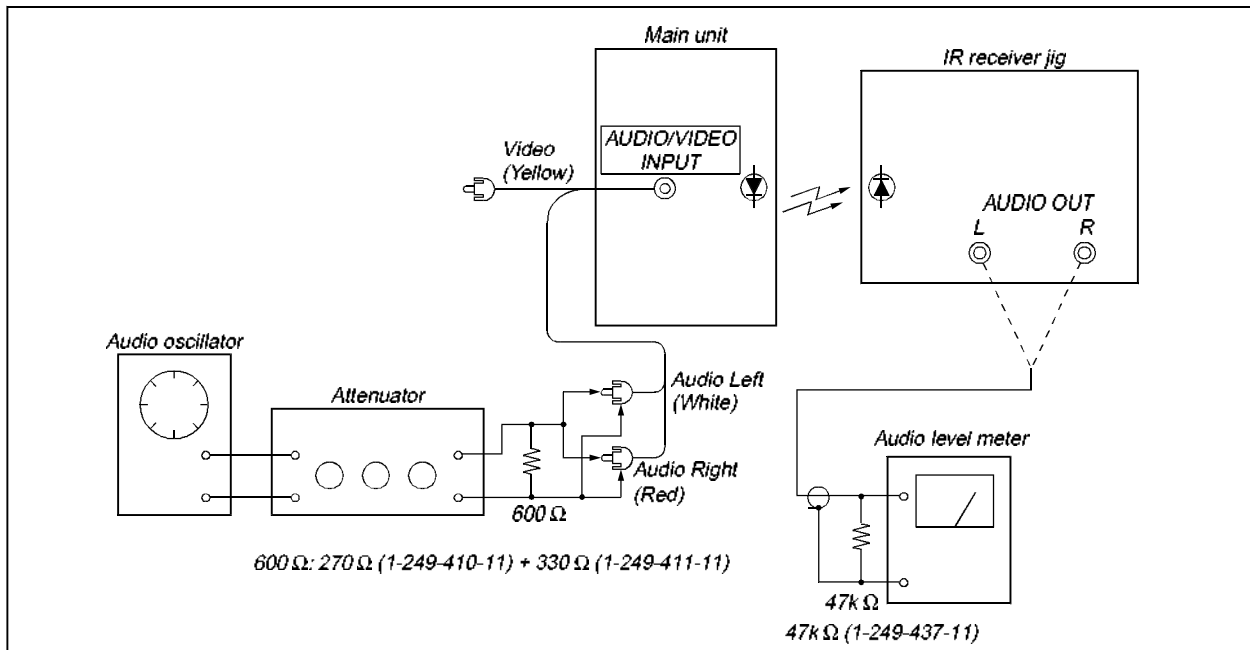

Fig. 5-3-17.

Adjusting method:

Order	Page	Address	Data	Procedure
1	0	01	01	Set the data.
2				Connect the audio level meter to the AUDIO L terminal of the IR receiver jig.
3	F	7F		Change the data and set the 400Hz audio signal level to the specified value.
4	F	7F		Press PAUSE button.
5				Connect the audio level meter to the AUDIO R terminal of the IR receiver jig.
6	F	7F		Check that the 400Hz audio signal level is within the specified value. If outside, repeat from step 2.
7	0	01	00	Set the data.

3-7. AUDIO SYSTEM ADJUSTMENTS

[Connecting the measuring instruments for the audio]

Connect the audio system measuring instruments in addition to the video system measuring instruments as shown in Fig. 5-3-18.

[Adjustment Procedure]

- 1) Hi8/Standard8 AFM BPF fo adjustment
- 2) Hi8/Standard8 AFM 1.5MHz deviation adjustment
- 3) Hi8/Standard8 AFM 1.7MHz deviation adjustment
- 4) Digital8 playback level check
- 5) Overall level characteristics check
- 6) Overall distortion check
- 7) Overall noise level check
- 8) Overall separation check

1. Hi8/Standard8 AFM BPF fo Adjustment (VC-250 board)

Sets the BPF passing frequency of IC760 so that the AFM signal can separate from the playback RF signal properly. If deviated, the mono/stereo mode will be differentiated incorrectly, and noises and distortions will increase during high volume playback.

Mode	Playback
Signal	Hi8/Standard8 alignment tape: For BPF adjustment (WR5-11NS (NTSC)) (WR5-11CS (PAL))
Measurement Point	AUDIO OUT jack LEFT or RIGHT
Measuring Instrument	Distortion meter
Adjustment Page	F
Adjustment Address	7D
Specified Value	The Main and Sub channel distortion rate should be almost the same (within $\pm 1\%$) and minimum.

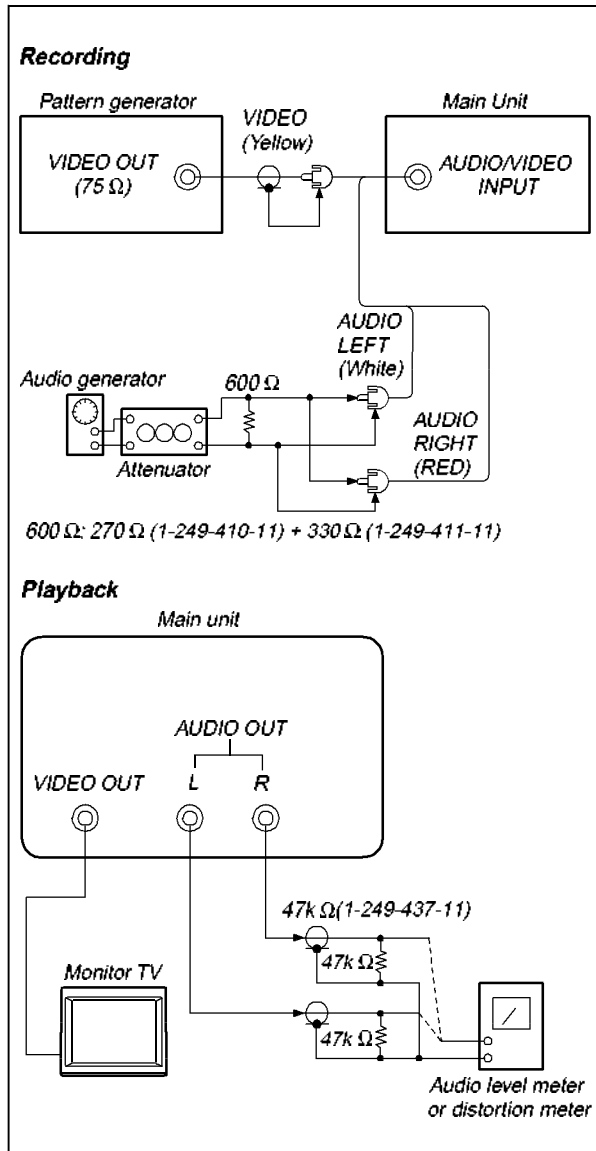

Fig. 5-3-18.

Adjusting method:

- 1) Select page: 0, address: 01, and set data: 01.
- 2) Set the Hi-Fi SOUND switch (menu display) to "2".
- 3) Select page: F, address: 7D, change the data and minimize the distortion rate.
- 4) Press the PAUSE button.
- 5) Set the Hi-Fi SOUND switch (menu display) to "1".
- 6) Select page: F, address: 7D, change the data and minimize the distortion rate.
- 7) Press the PAUSE button.
- 8) Repeat steps 2) to 7) and set the data of address: 7D so that the distortions rates when the Hi-Fi SOUND switch is set to "2" and set to "1" respectively are almost the same and minimum.
- 9) Press the PAUSE button.
- 10) Select page: 0, address: 01, and set data: 00.
- 11) Set the Hi-Fi SOUND switch to "STEREO".

2. Hi8/Standard8 AFM 1.5 MHz Deviation Adjustment (VC-250 board)

Adjust to the optimum 1.5MHz audio FM signal deviation. If the adjustment is not correct, its playback level will differ from that of other units.

Mode	Playback
Signal	Hi8/Standard8 alignment tape: For checking AFM stereo operation Monoscope section (WR5-9NS (NTSC)) (WR5-9CS (PAL))
Measurement Point	AUDIO OUT jack LEFT or RIGHT
Measuring Instrument	Audio level meter
Adjustment Page	F
Adjustment Address	7B
Specified Value	-7.5 ± 2.0dBs

Adjusting method:

- 1) Select page: 0, address: 01, and set data: 01.
- 2) Set the Hi-Fi SOUND switch (menu display) to "1".
- 3) Select page: F, address: 7B, change the data and set the 400Hz signal level to the specified value.
- 4) Press the PAUSE button.
- 5) Set the Hi-Fi SOUND switch (menu display) to "STEREO".
- 6) Select page: 0, address: 01, and set data: 00.

3. Hi8/Standard8 AFM 1.7 MHz Deviation Adjustment (VC-250 board)

Adjust to the optimum 1.7MHz audio FM signal deviation. If improper, this causes deteriorated separation (with stereo signal).

Mode	Playback
Signal	Hi8/Standard8 alignment tape: For checking AFM stereo operation Monoscope section (WR5-9NS (NTSC)) (WR5-9CS (PAL))
Measurement Point	AUDIO OUT jack LEFT or RIGHT
Measuring Instrument	Oscilloscope
Adjustment Page	F
Adjustment Address	7C
Specified Value	-7.5 ± 2.0dBs

Adjusting method:

- 1) Select page: 0, address: 01, and set data: 01.
- 2) Set the Hi-Fi SOUND switch (menu display) to "2".
- 3) Select page: F, address: 7C, change the data and set the 1kHz signal level to the specified value.
- 4) Press the PAUSE button.
- 5) Set the Hi-Fi SOUND switch (menu display) to "STEREO".
- 6) Select page: 0, address: 01, and set data: 00.

4. Digital8 Playback Level Check

Mode	Playback
Signal	Digital8 alignment tape: For audio operation check (WR5-3ND (NTSC)) (WR5-3CD (PAL))
Measurement Point	AUDIO OUT jack LEFT or RIGHT
Measuring Instrument	Audio level meter and frequency counter
Specified Value	32 kHz mode: 1 kHz, +3.0 ± 2.0dBs 48 kHz mode: 1 kHz, +3.0 ± 2.0dBs 44.1 kHz mode: The 7.35kHz signal level during EMP OFF is +2.0 ± 2.0dBs. The 7.35kHz signal level during EMP ON is -6 ± 2 dB from the signal level during EMP OFF.

Checking Method:

- 1) Check that the playback signal level is the specified value.

5. Overall Level Characteristics Check

Mode	Recording and playback
Signal	400Hz, -7.5dBs signal: Audio terminal left and right of AUDIO/VIDEO INPUT jack
Measurement Point	AUDIO OUT jack LEFT or RIGHT
Measuring Instrument	Audio level meter
Specified Value	-7.5 ± 3.0dBs

Checking Method:

- 1) Input the 400Hz, -7.5dBs signal in the audio terminal left and right of AUDIO/VIDEO INPUT jack.
- 2) Record the signal.
- 3) Playback the recorded section.
- 4) Check that the 400Hz signal level is the specified value.

6. Overall Distortion Check

Mode	Recording and playback
Signal	400Hz, -7.5dBs signal: Audio terminal left and right of AUDIO/VIDEO INPUT jack
Measurement Point	AUDIO OUT jack LEFT or RIGHT
Measuring Instrument	Audio distortion meter
Specified Value	Below 0.4% (200Hz to 6kHz BPF ON)

Checking Method:

- 1) Input the 400Hz, -7.5dBs signal in the audio terminal left and right of AUDIO/VIDEO INPUT jack.
- 2) Record the signal.
- 3) Playback the recorded section.
- 4) Check that the distortion is the specified value.

7. Overall Noise Level Check

Mode	Recording and playback
Signal	No signal: Audio terminal left and right of AUDIO/VIDEO INPUT jack
Measurement Point	AUDIO OUT jack LEFT or RIGHT
Measuring Instrument	Audio level meter
Specified Value	Below -45dBs (IHF-A filter ON, 20kHz LPF ON)

Checking Method:

- 1) Connect the audio terminal left of AUDIO/VIDEO INPUT jack and its ground terminal with a jumper wire.
- 2) Connect the audio terminal right of AUDIO/VIDEO INPUT jack and its ground terminal with a jumper wire.
- 3) Record the signal.
- 4) Playback the recorded section.
- 5) Check that the noise level is the specified value.
- 6) Remove the jumper wires.

8. Overall Separation Check

Mode	Recording and playback
Signal	No signal: Audio terminal <left> [right] of AUDIO/VIDEO INPUT jack 400Hz, -7.5dBs signal: Audio terminal <right> [left] of AUDIO/VIDEO INPUT jack
Measurement Point	AUDIO OUT jack <LEFT> [RIGHT]
Measuring Instrument	Audio level meter
Specified Value	Below -40dBs

<> : Left channel check

[] : Right channel check

Checking Method:

- 1) Connect the audio terminal <left> [right] of AUDIO/VIDEO INPUT jack and its ground terminal with a jumper wire.
- 2) Input the 400Hz, -7.5dBs signal in the audio terminal <right> [left] of AUDIO/VIDEO INPUT jack.
- 3) Record the signal.
- 4) Playback the recorded section.
- 5) Check that the signal level of the AUDIO OUT <LEFT> [RIGHT] jack is the specified value.
- 6) Remove the jumper wires.

3-8. LCD SYSTEM ADJUSTMENT (GV-D800/D800E)

Note 1: The back light (fluorescent tube) is driven by a high voltage AC power supply. Therefore, do not touch the back light holder to avoid electrical shock.

Note 2: When replacing the LCD unit, be careful to prevent damages caused by static electricity.

Note 3: Set the LCD BRIGHT to the center.
Set the LCD COLOR (Menu display) to the center.

[Adjusting connector]

Most of the measuring points for adjusting the LCD system are concentrated in CN5502 of the PD-130 board. Connect the measuring instruments via the multi CPC jig (J-6082-311-A). The following table shows the Pin No. and signal name of CN5502.

Pin No.	Signal Name	Pin No.	Signal Name
1	VB	2	XVD OUT
3	VG	4	PANEL COM
5	VR	6	SH/CA
7	C SYNC/HD	8	XHD OUT
9	GND	10	GND

Table. 5-3-11.

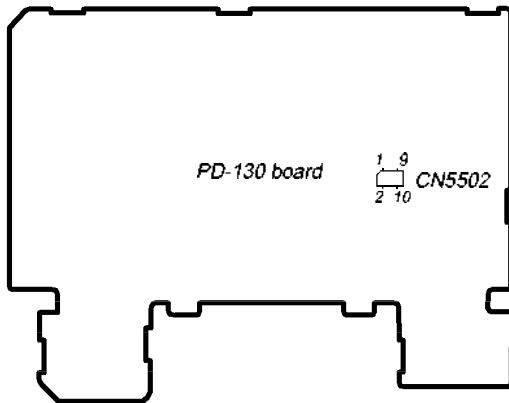

Fig. 5-3-19.

1. LCD Initial Data Input (1)

Mode	VTR stop
Signal	No signal
Adjustment Page	C
Adjustment Address	AB to BA

Adjusting method:

- 1) Select page: 0, address: 01, and set data: 01.
- 2) Select page: C, and input the data in the following table.

Note: To write in the non-volatile memory (EEPROM), press the PAUSE button of the adjustment remote commander each time to set the data.

- 3) Select page: 0, address: 01, and set data: 00.

Address	Data	Remark
AB	53	Fixed data
AC	00	Fixed data
AD	90	Fixed data
AE	CB	Fixed data
AF	6C	Fixed data
B0	2C	Fixed data
B1	00	Fixed data
B2	00	Fixed data
B3	20	Fixed data
B4	0A	Fixed data
B5	24	Fixed data
B6	1A	Fixed data
B7	0F	Fixed data
B8	17	Fixed data
B9	21	Fixed data
BA	23	Fixed data

Table. 5-3-12.

2. LCD Initial Data Input (2)

Mode	VTR stop
Signal	No signal
Adjustment Page	D
Adjustment Address	A0 to B1

Adjusting method:

- 1) Select page: 0, address: 01, and set data: 01.
- 2) Select page: D, and input the data in the following table.
Note: To write in the non-volatile memory (EEPROM), press the PAUSE button of the adjustment remote commander each time to set the data.
- 3) Select page: 0, address: 01, and set data: 00.

Address	Data	Remark
A0	7D	Fixed data
A1	A6	Fixed data
A2	80	VCO adj.
A3	70	Fixed data
A4	80	V-COM adj.
A5	30	RGB AMP adj.
A6	00	Fixed data
A7	C0	COM AMP adj.
A8	80	White balance adj.
A9	80	White balance adj.
AA	50	Contrast adj.
AB	00	Fixed data
AC	33	Fixed data
AD	14	Fixed data
AE	9F	Fixed data
AF	1F	Fixed data
B0	FC	Fixed data
B1	FF	Fixed data

Table. 5-3-13.

3. VCO Adjustment (PD-130 board)

Set the VCO free-run frequency. If deviated, the LCD screen will be blurred.

Mode	VTR stop
Signal	No signal
Measurement Point	Pin ⑧ of CN5502 (XHD OUT)
Measuring Instrument	Frequency counter
Adjustment Page	D
Adjustment Address	A2 (NTSC) A2, A3 (PAL)
Specified Value	f = 15734 ± 30Hz (NTSC) f = 15625 ± 30Hz (PAL)

Note 1: NTSC: GV-D800
PAL: GV-D800E

Adjusting method:

Order	Page	Address	Data	Procedure
1	0	01	01	Set the data.
2	D	A2		Change the data and set the VCO frequency (f) to the specified value.
3	D	A2		Press PAUSE button.
4				Only for NTSC model, proceed to step 10.
5	D	A2		Read the data, and this data is named DA ₂ .
6				Convert DA ₂ to decimal notation, and obtain DA ₂ '. (Note2)
7				Calculate DA ₃ ' using following equations (Decimal calculation) When DA ₂ ' ≥ 23 DA ₃ ' = DA ₂ ' - 23 When DA ₂ ' < 23 DA ₃ ' = 00
8				Convert DA ₃ ' to a hexadecimal number, and obtain DA ₃ . (Note2)
9	D	A3	DA ₃	Set the data, and press PAUSE button.
10	0	01	00	Set the data.

Note 2: Refer to "Table 5-4-1. Hexadecimal-decimal Conversion Table".

4. RGB AMP Adjustment (PD-130 board)

Set the D range of the RGB decoder used to drive the LCD to the specified value. If deviated, the LCD screen will become blackish or saturated (whitish).

Mode	VTR stop
Signal	No signal
Measurement Point	Pin ③ of CN5502 (VG) External trigger: Pin ④ of CN5502 (PANEL COM)
Measuring Instrument	Oscilloscope
Adjustment Page	D
Adjustment Address	A5
Specified Value	$A = 3.59 \pm 0.05V$

Note: Press the DISPLAY button and erase the screen indicators.

Adjusting method:

Order	Page	Address	Data	Procedure
1	0	01	01	Set the data.
2	D	A5		Change the data and set the voltage (A) between the reversed waveform pedestal and non-reversed waveform pedestal to the specified value. (The data should be "00" to "3F".)
3	D	A5		Press PAUSE button.
4	0	01	00	Set the data.

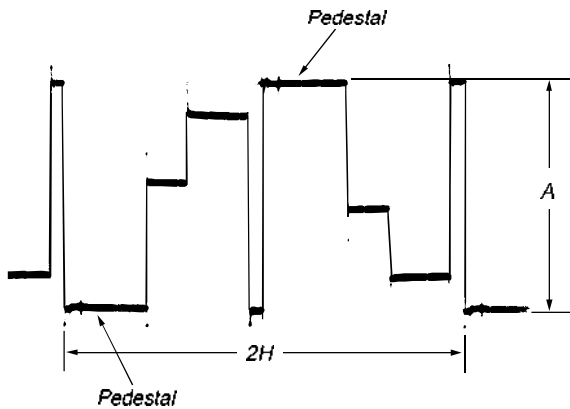

Fig. 5-3-20.

5. Contrast Adjustment (PD-130 board)

Set the level of the VIDEO signal for driving the LCD to the specified value. If deviated, the screen image will be blackish or saturated (whitish).

Mode	VTR stop
Signal	No signal
Measurement Point	Pin ③ of CN5502 (VG) External trigger: Pin ④ of CN5502 (PANEL COM)
Measuring Instrument	Oscilloscope
Adjustment Page	D
Adjustment Address	AA
Specified Value	$A = 3.34 \pm 0.07V$

Adjusting method:

Order	Page	Address	Data	Procedure
1	0	01	01	Set the data.
2	D	AA		Change the data and set the voltage (A) between the 100 IRE and 0 IRE (pedestal) to the specified value. (The data should be "00" to "7F".)
3	D	AA		Press PAUSE button.
4	0	01	00	Set the data.

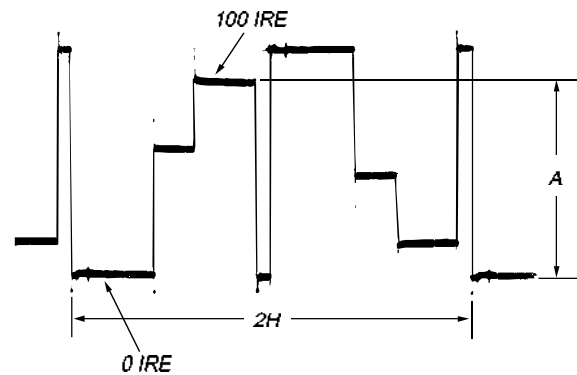

Fig. 5-3-21.

6. COM AMP Adjustment (PD-130 board)

Set the common electrode drive signal level of LCD to the specified value.

Mode	VTR stop
Signal	No signal
Measurement Point	Pin ④ of CN5502 (PANEL COM)
Measuring Instrument	Oscilloscope
Adjustment Page	D
Adjustment Address	A7
Specified Value	$A = 6.33 \pm 0.05V_{dc}$

Adjusting method:

Order	Page	Address	Data	Procedure
1	0	01	01	Set the data.
2	D	A7		Change the data and set the PANEL COM signal level (A) to the specified value.
3	D	A7		Press PAUSE button.
4	0	01	00	Set the data.

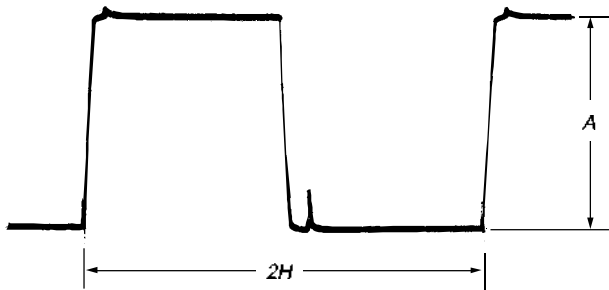

Fig. 5-3-22.

7. V-COM Adjustment (PD-130 board)

Set the DC bias of the common electrode drive signal of LCD to the specified value.

If deviated, the LCD display will move, producing flicker and conspicuous vertical lines.

Mode	VTR stop
Signal	No signal
Measurement Point	Check on LCD display
Measuring Instrument	
Adjustment Page	D
Adjustment Address	A4
Specified Value	The brightness difference between the section A and section B is minimum.

Note: Perform “RGB AMP Adjustment”, “Contrast Adjustment” and “COM AMP Adjustment” before this adjustment.

Adjusting method:

Order	Page	Address	Data	Procedure
1	0	01	01	Set the data.
2	D	A4		Change the data so that the brightness of the section A and that of the section B is equal.
3	D	A4		Subtract 8 from the data.
4	D	A4		Press PAUSE button.
5	0	01	00	Set the data.

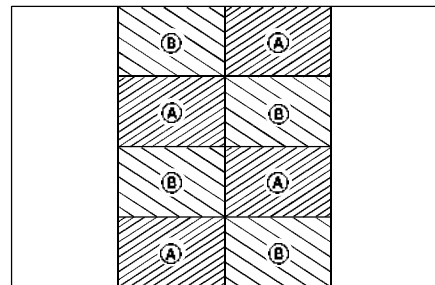

Fig. 5-3-23.

8. White Balance Adjustment (PD-130 board)

Correct the white balance.

If deviated, the reproduction of the LCD screen may degenerate.

Mode	VTR stop
Signal	No signal
Measurement Point	Check on LCD screen
Measuring Instrument	
Adjustment Page	D
Adjustment Address	A8, A9
Specified Value	The LCD screen should not be colored.

Note 1: Check the white balance only when replacing the following parts.

If necessary, adjust them.

1. LCD panel
2. Light induction plate
3. IC5501

Adjusting method:

Order	Page	Address	Data	Procedure
1	0	01	01	Set the data.
2	D	A8	80	Set the data, and press PAUSE button.
3	D	A9	80	Set the data, and press PAUSE button.
4	D	A9		Check that the LCD screen is not colored. If not colored, proceed to step 10.
5	D	A8		Change the data so that the LCD screen is not colored.
6	D	A8		Press PAUSE button.
7	D	A9		Change the data so that the LCD screen is not colored.
8	D	A9		Press PAUSE button.
9	D	A9		If the LCD screen is colored, repeat steps 5 to 9.
10	0	01	00	Set the data.

5-4. SERVICE MODE

4-1. ADJUSTMENT REMOTE COMMANDER

The adjustment remote commander is used for changing the calculation coefficient in signal processing, EVR data, etc. The adjustment remote commander performs bi-directional communication with the unit using the remote commander signal line (LANC). The resultant data of this bi-directional communication is written in the non-volatile memory.

1. Using the Adjustment Remote Commander

- 1) Connect the adjustment remote commander to the LANC terminal.
- 2) Set the HOLD switch of the adjustment remote commander to "HOLD" (SERVICE position). If it has been properly connected, the LCD on the adjustment remote commander will display as shown in Fig. 5-4-1.

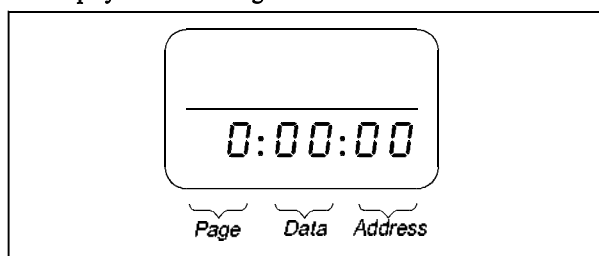

Fig. 5-4-1.

- 3) Operate the adjustment remote commander as follows.
 - Changing the page
The page increases when the EDIT SEARCH+ button is pressed, and decreases when the EDIT SEARCH- button is pressed. There are altogether 16 pages, from 0 to F.

Hexadecimal notation	0 1 2 3 4 5 6 7 8 9 A B C D E F
LCD Display	0 1 2 3 4 5 6 7 8 9 A b c d E F
Decimal notation conversion value	0 1 2 3 4 5 6 7 8 9 10 11 12 13 14 15

- Changing the address
The address increases when the FF (▶▶) button is pressed, and decreases when the REW (◀◀) button is pressed. There are altogether 256 addresses, from 00 to FF.
 - Changing the data (Data setting)
The data increases when the PLAY (▶) button is pressed, and decreases when the STOP (■) button is pressed. There are altogether 256 data, from 00 to FF.
 - Writing the adjustment data
The PAUSE button must be pressed to write the adjustment data (C, D, E, F, 7, 8 page) in the nonvolatile memory. (The new adjusting data will not be recorded in the nonvolatile memory if this step is not performed.)
- 4) After completing all adjustments, turn off the main power supply (8.4 V) once.

2. Precautions Upon Using the Adjustment Remote Commander

Mishandling of the adjustment remote commander may erase the correct adjustment data at times. To prevent this, it is recommended that all adjustment data be noted down before beginning adjustments and new adjustment data after each adjustment.

4-2. DATA PROCESS

The calculation of the DDS display and the adjustment remote commander display data (hexadecimal notation) are required for obtaining the adjustment data of some adjustment items. In this case, after converting the hexadecimal notation to decimal notation, calculate and convert the result to hexadecimal notation, and use it as the adjustment data. Indicates the hexadecimal-decimal conversion table.

Hexadecimal-decimal Conversion Table																
Lower digit of hexadecimal Upper digit of hexadecimal	②															
	0	1	2	3	4	5	6	7	8	9	A (F)	B (b)	C (c)	D (d)	E (E)	F (F)
0	0	1	2	3	4	5	6	7	8	9	10	11	12	13	14	15
1	16	17	18	19	20	21	22	23	24	25	26	27	28	29	30	31
2	32	33	34	35	36	37	38	39	40	41	42	43	44	45	46	47
3	48	49	50	51	52	53	54	55	56	57	58	59	60	61	62	63
4	64	65	66	67	68	69	70	71	72	73	74	77	76	77	78	79
5	80	81	82	83	84	85	86	87	88	89	90	91	92	93	94	95
6	96	97	98	99	100	101	102	103	104	105	106	107	108	109	110	111
7	112	113	114	115	116	117	118	119	120	121	122	123	124	125	126	127
8	128	129	130	131	132	133	134	135	136	137	138	139	140	141	142	143
9	144	145	146	147	148	149	150	151	152	153	154	155	156	157	158	159
A (F)	160	161	162	163	164	165	166	167	168	169	170	171	172	173	174	175
① B (b)	176	177	178	179	180	181	182	183	184	185	186	187	188	189	190	191
C (c)	192	193	194	195	196	197	198	199	200	201	202	203	204	205	206	207
D (d)	208	209	210	211	212	213	214	215	216	217	218	219	220	221	222	223
E (E)	224	225	226	227	228	229	230	231	232	233	234	235	236	237	238	239
F (F)	240	241	242	243	244	245	246	247	248	249	250	251	252	253	254	255

Note: The characters shown in the parenthesis () shown the display on the adjustment remote commander.
(Example) If the DDS display or the adjustment remote commander shows BD (b d);
 Because the upper digit of the adjustment number is B (b), and the lower digit is D (d), the meeting point “189” of ① and ② in the above table is the corresponding decimal number.

Table 5-4-1.

4-3. SERVICE MODE

Additional note on adjustment

Note: After the completion of the all adjustments, cancel the service mode by either of the following ways.

- 1) After data on page: D and F is restored, unplug the main power supply and remove the coin lithium battery. (In this case, date and time and menu setting have been set by users are canceled. Perform resetting.)
- 2) After data on page: D and F is restored, select page: 0, address: 01, and return the data to 00. And when data on page:2 and 3 are changed, return data to the original condition.

1. Setting the Test Mode

Page F	Address 22
--------	------------

Data	Function
80	Normal
81	Test mode Various emergency prohibitions and releases Drum emergency, capstan emergency, loading motor emergency, reel emergency, tape top and end, DEW detection

Page D	Address 10
--------	------------

Data	Function
00	Normal
02	Forced VTR power ON

- Before setting the data , select page: 0, address: 01, and set data: 01.
- For page D and F, the data set will be recorded in the non-volatile memory by pressing the PAUSE button of the adjustment remote commander. In this case, take note that the test mode will not be exited even when the main power is turned off (8.4Vdc).
- After completing adjustments/repairs, be sure to return the data of page: D address: 10 to 00, and the data of page: F address: 22 to 80, and press the PAUSE button of the adjustment remote commander. And select page: 0, address: 01, and set data: 00.

2. Emergence Memory Address

2-1. C Page Emergence Memory Address

Page C	Address F4 to FF
--------	------------------

Address	Contents
F4	EMG code when first error occurs
F6	Upper: MSW code when shift starts when first error occurs Lower: MSW code when first error occurs
F7	Lower: MSW code to be moved when first error occurs
F8	EMG code when second error occurs
FA	Upper: MSW code when shift starts when second error occurs Lower: MSW code when second error occurs
FB	Lower: MSW code to be moved when second error occurs
FC	EMG code when last error occurs
FE	Upper: MSW code when shift starts when last error occurs Lower: MSW code when last error occurs
FF	Lower: MSW code to be moved when last error occurs

When no error occurs in this unit, data "00" is written in the above addresses (F4 to FF). when first error occurs in the unit, the data corresponding to the error is written in the first emergency address (F4 to F7). In the same way, when the second error occurs, the data corresponding to the error is written in the second emergency address (F8 to FB).

Finally, when the last error occurs, the data corresponding to the error is written in the last emergency address (FC to FF).

Note : After completing adjustments, be sure to initialize the data of addresses F4 to FF to "00".

Initializing method:

- 1) Select page: 0, address: 01, and set data: 01.
- 2) Select page: 3, address: 01, set data: 37, and press the PAUSE button.
- 3) Select page: 0, address: 01, and set data: 00.

2-2. F Page Emergence Memory Address

Note 1: Emergence of PB mode only.

Page F	Address 10 to 1B
Address	Contents
10	EMG code when first error occurs
12	Upper: MSW code when shift starts when first error occurs Lower: MSW code when first error occurs
13	Lower: MSW code to be moved when first error occurs
14	EMG code when second error occurs
16	Upper: MSW code when shift starts when second error occurs Lower: MSW code when second error occurs
17	Lower: MSW code to be moved when second error occurs
18	EMG code when last error occurs
1A	Upper: MSW code when shift starts when last error occurs Lower: MSW code when last error occurs
1B	Lower: MSW code to be moved when last error occurs

When no error occurs in this unit, data "00" is written in the above addresses (10 to 1B). when first error occurs in the unit, the data corresponding to the error is written in the first emergency address (10 to 13). In the same way, when the second error occurs, the data corresponding to the error is written in the second emergency address (14 to 17).

Finally, when the last error occurs, the data corresponding to the error is written in the last emergency address (18 to 1B).

Note 2: After completing adjustments, be sure to initialize the data of addresses 10 to 1B to "00".

Initializing method:

- 1) Select page: 0, address: 01, and set data: 01.
- 2) Select page: F, address: 10, set data: 00, and press the PAUSE button.
- 3) Select address: 11 to 1B and set data "00" into them in the same way as in address: 10.
- 4) Select page: 0, address: 01, and set data: 00.

2-3. EMG Code (Emergency Code)

Codes corresponding to the errors which occur are written in C page, addresses F4, F8 and FC (or F page, addresses 10, 14 and 18). The type of error indicated by the code are shown in the following table.

Code	Emergency Type
00	No error
10	Loading motor emergency during loading
11	Loading motor emergency during unloading
22	T reel emergency during normal rotation
23	S reel emergency during normal rotation
24	T reel emergency (Short circuit between S reel terminal and T reel terminal)
30	FG emergency at the start up of the capstan
40	FG emergency at the start up of the drum
42	FG emergency during normal rotation of the drum

2-4. MSW Code

- The lower parts of the data of C page, addresses F6, FA and FE (or F page, addresses 12, 16 and 1A) represent the MSW codes (mode switch mechanism position) when errors occurs.
- The upper parts of the data of C page, addresses F6, FA and FE (or F page, addresses 12, 16 and 1A) represent, when the mechanism position is to be moved, the MSW codes at the start movement (when moving the loading motor).
- The lower parts of the data of C page, addresses F7, FB and FF (or F page, addresses 13, 17 and 1B) represent the MSW codes of the desired movement when the mechanism position is to be moved.

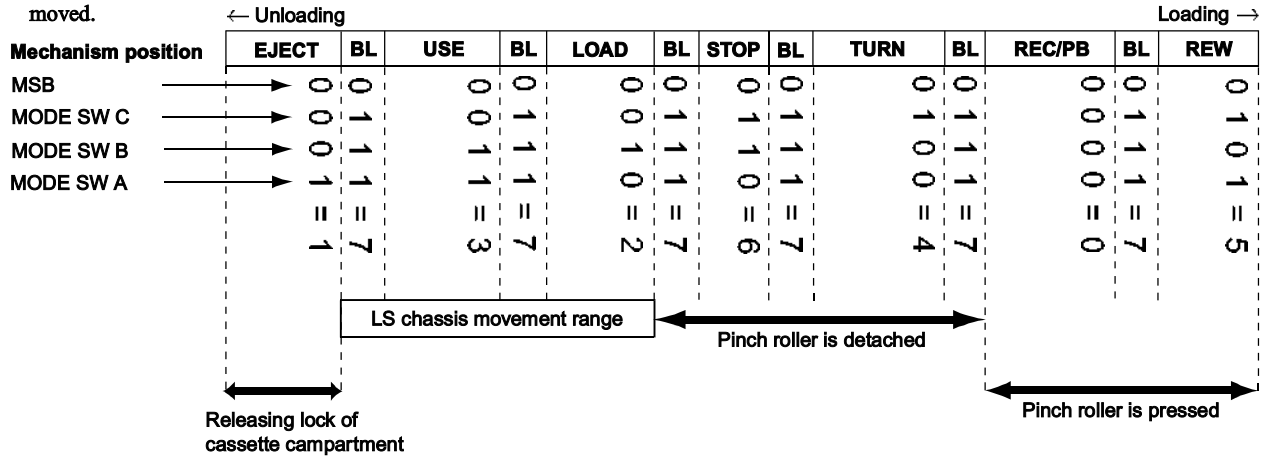

Mechanism Position	MSW Code	Contents
EJECT	1	Position at which the cassette compartment lock is released. The mechanism will not move any further in the unloading direction.
BL	7	BLANC code. Between two codes. The mechanism will not be stopped by this code while it is operating.
USE	3	EJECT completion position. When the cassette is ejected, the mechanism will stop at this position.
LOAD	2	Code during loading/unloading. Code that is used while the LS chassis is moving.
STOP	6	Normal stop position. The pinch roller separates, the tension regulator returns, and the brakes of both reels turn on.
TURN	4	Position at which is used when the pendulum gear swings from S to T or from T to S.
REC/PB	0	PB, REC, CUE, REV, PAUSE, FF positions. The pinch roller is pressed and tension regulator is on.
REW	5	REW position. REW are carried at this position. The mechanism will not move any further in the loading direction.

3. Bit Value Discrimination

Bit values must be discriminated using the display data of the adjustment remote commander for the following items. Use the table below to discriminate if the bit value is "1" or "0".

Display on the adjustment remote commander

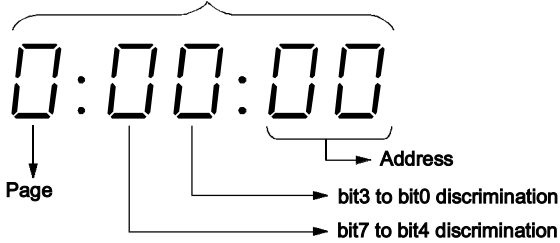

(Example) If the remote commander display is "8E", bit value from bit 7 to bit 4 can be discriminated from the column (A), and those from bit 3 to bit 0 from column (B).

Display on the adjustment remote commander	Bit values			
	bit3 or bit7	bit2 or bit6	bit1 or bit5	bit0 or bit4
0	0	0	0	0
1	0	0	0	1
2	0	0	1	0
3	0	0	1	1
4	0	1	0	0
5	0	1	0	1
6	0	1	1	0
7	0	1	1	1
(A) 8	1	0	0	0
9	1	0	0	1
A (F)	1	0	1	0
B (b)	1	0	1	1
C (L)	1	1	0	0
D (d)	1	1	0	1
(B) E (E)	1	1	1	0
F (F)	1	1	1	1

4. Switch check (1)

Page 2	Address 43
--------	------------

Bit	Function	When bit value = 1	When bit value = 0
0	POWER switch (FP-575 flexible S001)	OFF	ON
1			
2	Headphone jack (FP-246 flexible J002)	Used	Not used
3	EJECT switch (VC-250 board S4802)	OFF	ON
4	CC DOWN switch (Mechanism chassis)	OFF (UP)	ON (DOWN)
5	VIDEO OUTPUT jack (IO-68 board J102)	Used	Not used
6	S VIDEO OUTPUT jack (IO-68 board J103)	Not used	Used
7			

Using method:

- 1) Select page: 2, address: 43.
- 2) By discriminating the bit value of display data, the state of the switch can be discriminated.

5. Switch check (2)

Page 2	Address 48
--------	------------

Bit	Function	When bit value = 1	When bit value = 0
0	AUDIO OUTPUT LEFT jack (IO-68 board J102)	Used	Not used

Using method:

- 1) Select page: 2, address: 48.
- 2) By discriminating the bit value of display data, the state of the switch can be discriminated.

6. Switch check (3)

Page 2	Address 49
--------	------------

Bit	Function	When bit value = 1	When bit value = 0
4	AUDIO OUTPUT RIGHT jack (IO-68 board J102)	Used	Not used
5	AUDIO/VIDEO INPUT jack (FP-246 flexible J001)	Used	Not used
6			
7	S VIDEO INPUT jack (IO-68 board J103)	Not used	Used

Using method:

- 1) Select page: 2, address: 49.
- 2) By discriminating the bit value of display data, the state of the switch can be discriminated.

7. Switch check (4)

Page 2	Address 60, 61, 62, 65, 66
--------	----------------------------

Using method:

- 1) Select page: 2, address: 60, 61, 62, 65, 66.
- 2) By discriminating the display data, the pressed key can be discriminated.

Address	Data							
	00 to 0C	0D to 24	25 to 3F	40 to 5D	5E to 81	82 to AA	AB to D7	D8 to FF
60 (KEY AD0) (IC4803 ㉔)		STOP (FK-78 board) (S001)	PLAY (FK-78 board) (S002)	REC (FK-78 board) (S003, 004)	FF (FK-78 board) (S005)	REW (FK-78 board) (S006)		No key input
61 (KEY AD1) (IC4803 ㉕)		PAUSE (FK-78 board) (S007)	X2 (FK-78 board) (S008)	FRAME - (FK-78 board) (S009)	FRAME + (FK-78 board) (S010)	SLOW (FK-78 board) (S011)		No key input
62 (KEY AD2) (IC4803 ㉖)	DATA CODE (FK-78 board) (S012)	DISPLAY (FK-78 board) (S013)	DIGITAL EFFECT (FK-78 board) (S014)	TITLE (FK-78 board) (S015)	PB ZOOM (FK-78 board) (S016)			No key input
65 (KEY AD5) (IC4803 ㉘)	SUPER LASER LINK (IO-68 board) (S101)	MENU (IO-68 board) (S102)	MENU EXECUTE (IO-68 board) (S103)	VOLUME + (IO-68 board) (S104)	VOLUME - (IO-68 board) (S105)			No key input
66 (KEY AD6) (IC4803 ㉙)		LCD BRIGHT + (PD-130 board) (S601)	LCD BRIGHT - (PD-130 board) (S602)				PANEL CLOSE (LS-56 board) (S001)	PANEL OPEN (LS-56 board) (S001)

8. Record of Use check

Note: When replacing the drum assembly, initialize the data of address: A2 to AA.

Page 2	Address A2 to AA
--------	------------------

Bit	Function		Remarks
A2	Drum rotation	Minute	
A3	counted time	Hour (L)	10th place digit and 1st place digit of counted time (decimal digit)
A4	(BCD code)	Hour (H)	1000th place digit and 100th place digit of counted time (decimal digit)
A5	User initial power	Year	After setting the clock, set the date of power on next
A6	on date	Month	
A7	(BCD code)	Day	
A8	Final condensation	Year	
A9	occurrence date	Month	
AA	(BCD code)	Day	

Using method:

- 1) The record of use data is displayed at page: 2, addresses: A2 to AA.

Note: This data will be erased (reset) when the FP-571 flexible (VC-250 board CN926 (4P)) is removed.

Initializing method:

- 1) Using the adjustment remote commander, select the object address and set data: 00.

9. Record of Self-diagnosis check

Page 2	Address B0 to C6
--------	------------------

Address	Self-diagnosis code
B0	"Repaired by" code (Occurred 1st time) *1
B1	"Block function" code (Occurred 1st time)
B2	"Detailed" code (Occurred 1st time)
B4	"Repaired by" code (Occurred 2nd time) *1
B5	"Block function" code (Occurred 2nd time)
B6	"Detailed" code (Occurred 2nd time)
B8	"Repaired by" code (Occurred 3rd time) *1
B9	"Block function" code (Occurred 3rd time)
BA	"Detailed" code (Occurred 3rd time)
BC	"Repaired by" code (Occurred 4th time) *1
BD	"Block function" code (Occurred 4th time)
BE	"Detailed" code (Occurred 4th time)
C0	"Repaired by" code (Occurred 5th time) *1
C1	"Block function" code (Occurred 5th time)
C2	"Detailed" code (Occurred 5th time)
C4	"Repaired by" code (Occurred the last time) *1
C5	"Block function" code (Occurred the last time)
C6	"Detailed" code (Occurred the last time)

*1 : "01" → "C", "03" → "E"

Using method:

- 1) The past self-diagnosis codes are displayed at page:2, addresses: BC to C6. Refer to "SELF-DIAGNOSIS FUNCTION" for detail of the self-diagnosis code.

Note: This data will be erased (reset) when the FP-571 flexible (VC-250 board CN926 (4P)) is removed.

SECTION 6 REPAIR PARTS LIST

6-1. EXPLODED VIEWS

NOTE:

- -XX, -X mean standardized parts, so they may have some differences from the original one.
- Items marked "*" are not stocked since they are seldom required for routine service. Some delay should be anticipated when ordering these items.
- The mechanical parts with no reference number in the exploded views are not supplied.
- Abbreviation
CND: Canadian model

The components identified by mark \triangle or dotted line with mark \triangle are critical for safety. Replace only with part number specified.

Les composants identifiés par une marque \triangle sont critiques pour la sécurité. Ne les remplacer que par une pièce portant le numéro spécifié.

6-1-1. OVERALL SECTION-1

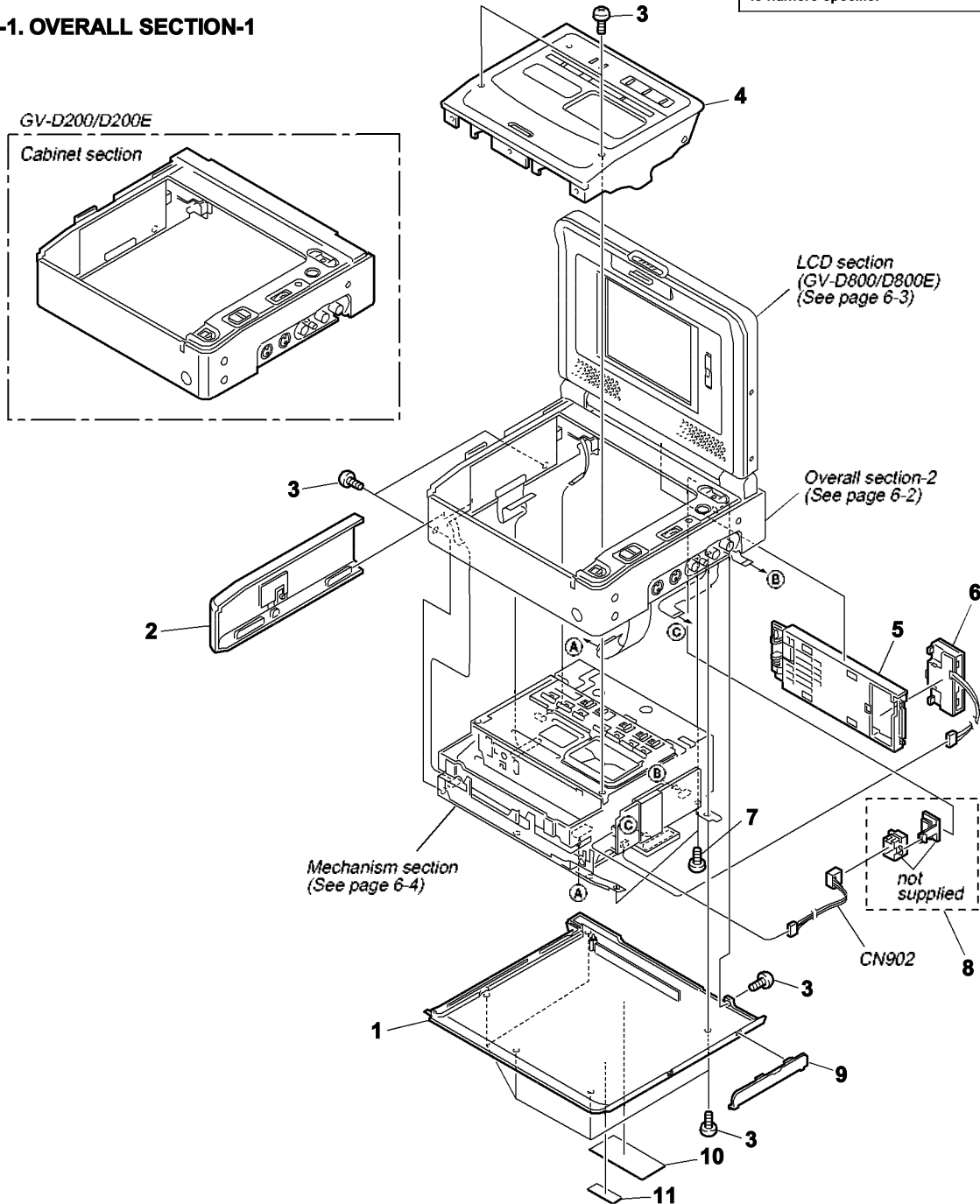

Ref. No.	Part No.	Description	Remarks	Ref. No.	Part No.	Description	Remarks
1	X-3951-050-1	CABINET (BOTTOM) ASSY		6	1-694-076-11	TERMINAL BOARD, BATTERY	
2	X-3947-873-1	CABINET (LID) ASSY		7	3-948-339-61	TAPPING	
3	3-968-729-01	SCREW(M2X4), LOCK ACE, P2		8	X-3951-052-1	JACK ASSY, DC	
4	X-3951-054-1	LID ASSY, CASSETTE (D800)		9	X-3951-060-1	LID ASSY, JACK (D200/D800)	
4	X-3951-055-1	LID ASSY, CASSETTE (D800E)		9	X-3951-061-1	LID ASSY, JACK (D200E/D800E)	
4	X-3951-057-1	LID ASSY, CASSETTE (D200)		10	3-703-845-01	LABEL (N) (U/C), MAIN CAUTION (D200/D800)	
4	X-3951-058-1	LID ASSY, CASSETTE (D200E)		* 11	3-704-367-01	LABEL (D200/D800)	
5	X-3947-753-2	PANEL ASSY, BATTERY		CN902	1-785-247-21	CONNECTOR, DC-IN 3P	

6-1-2. OVERALL SECTION-2

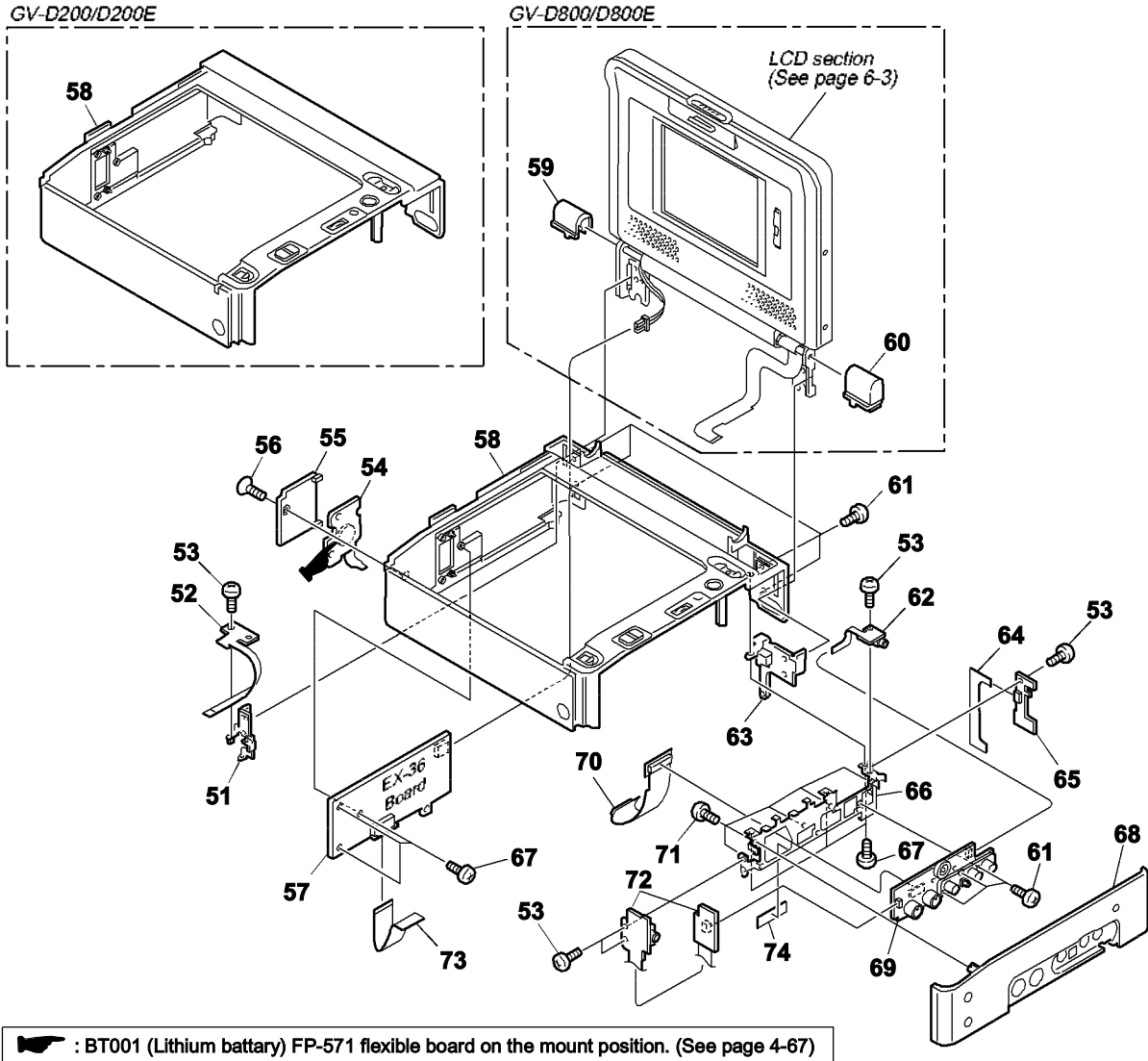

Ref. No.	Part No.	Description	Remarks	Ref. No.	Part No.	Description	Remarks
* 51	3-978-678-01	SHEET METAL (L), STRAP		63	3-064-416-01	SHEET METAL (R), STRAP	
52	1-669-797-11	FP-602 FLEXIBLE BOARD 5P		64	1-667-401-11	FP-572 FLEXIBLE BOARD 6, 10P	
53	3-968-729-51	SCREW (M2X3), LOCK ACE, P2		65	A-7074-570-A	IR-38 BOARD, COMPLETE	
54	1-667-400-11	FP-571 FLEXIBLE BOARD 4P		66	3-064-417-01	FRAME, JACK	
55	3-978-710-01	LID, LITHIUM		67	3-948-339-61	TAPPING	
56	7-685-203-19	SCREW +KTP 2X5 TYPE2 NON-SLIT		68	3-064-410-11	CABINET (R) (D200/D800)	
57	A-7074-567-A	EX-36 BOARD, COMPLETE (D800/D800E)		68	3-064-410-21	CABINET (R) (D200E/D800E)	
57	A-7074-610-A	EX-36 BOARD, COMPLETE (D200/D200E)		69	A-7074-569-A	IO-68 BOARD, COMPLETE	
58	X-3951-063-1	CABINET (UPPER) ASSY (D800/D800E)		70	1-679-721-11	FP-247 FLEXIBLE BOARD 50P	
58	X-3951-065-1	CABINET (UPPER) ASSY (D200/D200E)		71	3-945-884-11	SCREW (2X6)	
59	3-064-401-01	COVER (L), SHAFT (D800/D800E)		72	A-7074-573-A	FP-246 BOARD, COMPLETE	
60	3-064-402-01	COVER (R), SHAFT (D800/D800E)		73	1-667-399-11	FP-570 FLEXIBLE BOARD 40P	
61	3-968-729-01	SCREW (M2X4), LOCK ACE, P2		74	3-066-145-01	SHEET (JK FRAME)	
62	1-667-404-11	FP-575 FLEXIBLE BOARD 6P					

6-1-3. LCD SECTION (D800/D800E MODEL)

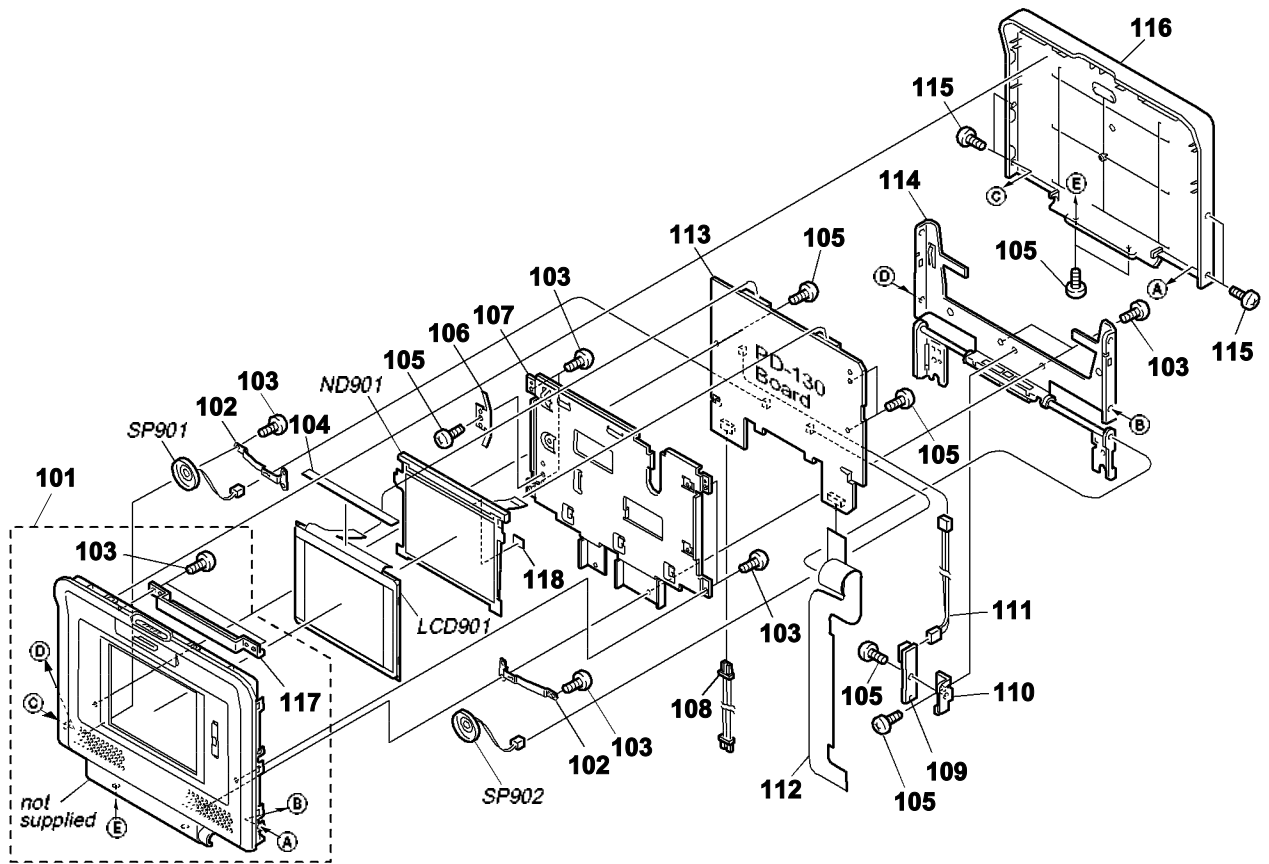

Ref. No.	Part No.	Description	Remarks	Ref. No.	Part No.	Description	Remarks
101	X-3951-049-1	CABINET ASSY, LCD WINDOW		113	A-7074-572-A	PD-130 BOARD, COMPLETE	
102	3-064-405-01	PLATE, SP GROUND		114	3-065-218-01	HINGE UNIT	
103	3-948-339-61	TAPPING		115	3-968-729-71	SCREW (M2X4), LOCK ACE, P2	
104	3-064-400-01	SHEET (LCD BLIND)		116	X-3951-046-1	CABINET ASSY, LCD (D800)	
105	3-968-729-51	SCREW (M2X3), LOCK ACE, P2		116	X-3951-047-1	CABINET ASSY, LCD (D800E)	
106	3-064-406-01	PLATE, LCD GROUND		117	3-718-233-01	NUT, PLATE	
107	3-064-403-01	FRAME, PD		118	3-064-766-01	SHEET (PD)	
108	1-958-004-11	HARNESS (EP-51) 2P		LCD901	1-803-893-21	INDICATOR MODULE, LIQUID CRYST	
109	A-7074-571-A	LS-56 BOARD, COMPLETE		△ND901	1-517-852-21	TUBE, FLUORESCENT, COLD CATHODE	
110	3-064-404-01	BRACKET, LS		SP901	1-529-590-11	SPEAKER (2.0CM)	
111	1-960-864-11	HARNESS (PL-53) 2P		SP902	1-529-590-11	SPEAKER (2.0CM)	
112	1-667-398-11	FP-569 FLEXIBLE BOARD 26, 32P					

Note:
The components identified by mark Δ or dotted line with mark Δ are critical for safety. Replace only with part number specified.

Note:
Les composants identifiés par une marque Δ sont critiques pour la sécurité. Ne les remplacer que par une pièce portant le numéro spécifié.

6-1-4. MECHANISM SECTION

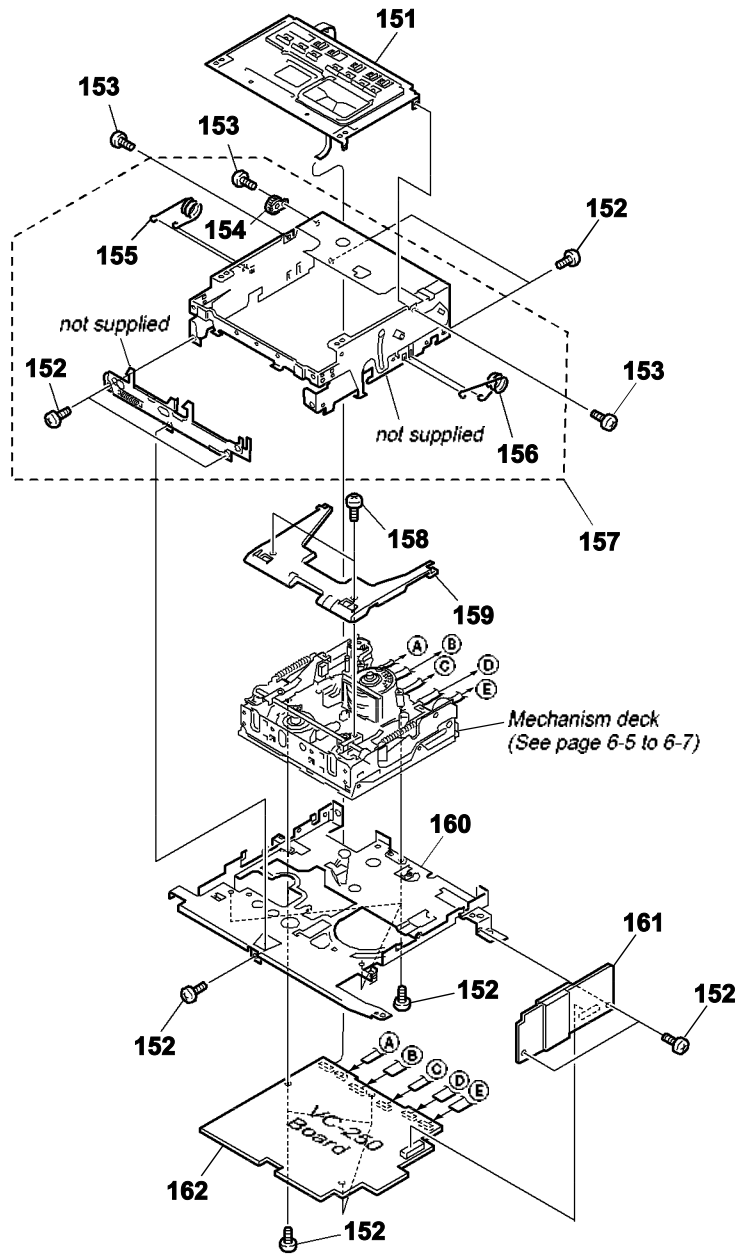

Ref. No.	Part No.	Description	Remarks	Ref. No.	Part No.	Description	Remarks
151	1-476-355-21	SWITCH BLOCK, CONTROL (FK-78) 10P		159	3-978-711-01	LID, LOADING	
152	3-968-729-51	SCREW (M2X3), LOCK ACE, P2		* 160	X-3947-997-1	FRAME ASSY, MAIN	
153	3-703-816-33	SCREW (M1.4X1.6), SPECIAL HEAD		161	A-7074-568-A	FU-145 BOARD, COMPLETE (D800/D800E)	
154	3-965-303-01	DAMPER		161	A-7074-612-A	FU-145 BOARD, COMPLETE (D200/D200E)	
155	3-978-702-01	SPRING (L), FRAME RETURN		162	A-7074-617-A	VC-250 BOARD, COMPLETE (SERVICE) (D800)	
156	3-978-713-01	SPRING (R), FRAME RETURN		162	A-7074-618-A	VC-250 BOARD, COMPLETE (SERVICE)(D800E)	
* 157	X-3947-755-1	FRAME ASSY, LID		162	A-7074-619-A	VC-250 BOARD, COMPLETE (SERVICE)(D200)	
158	3-968-729-01	SCREW (M2X4), LOCK ACE, P2		162	A-7074-620-A	VC-250 BOARD, COMPLETE (SERVICE)(D200E)	

6-1-5. CASSETTE COMPARTMENT ASSEMBLY

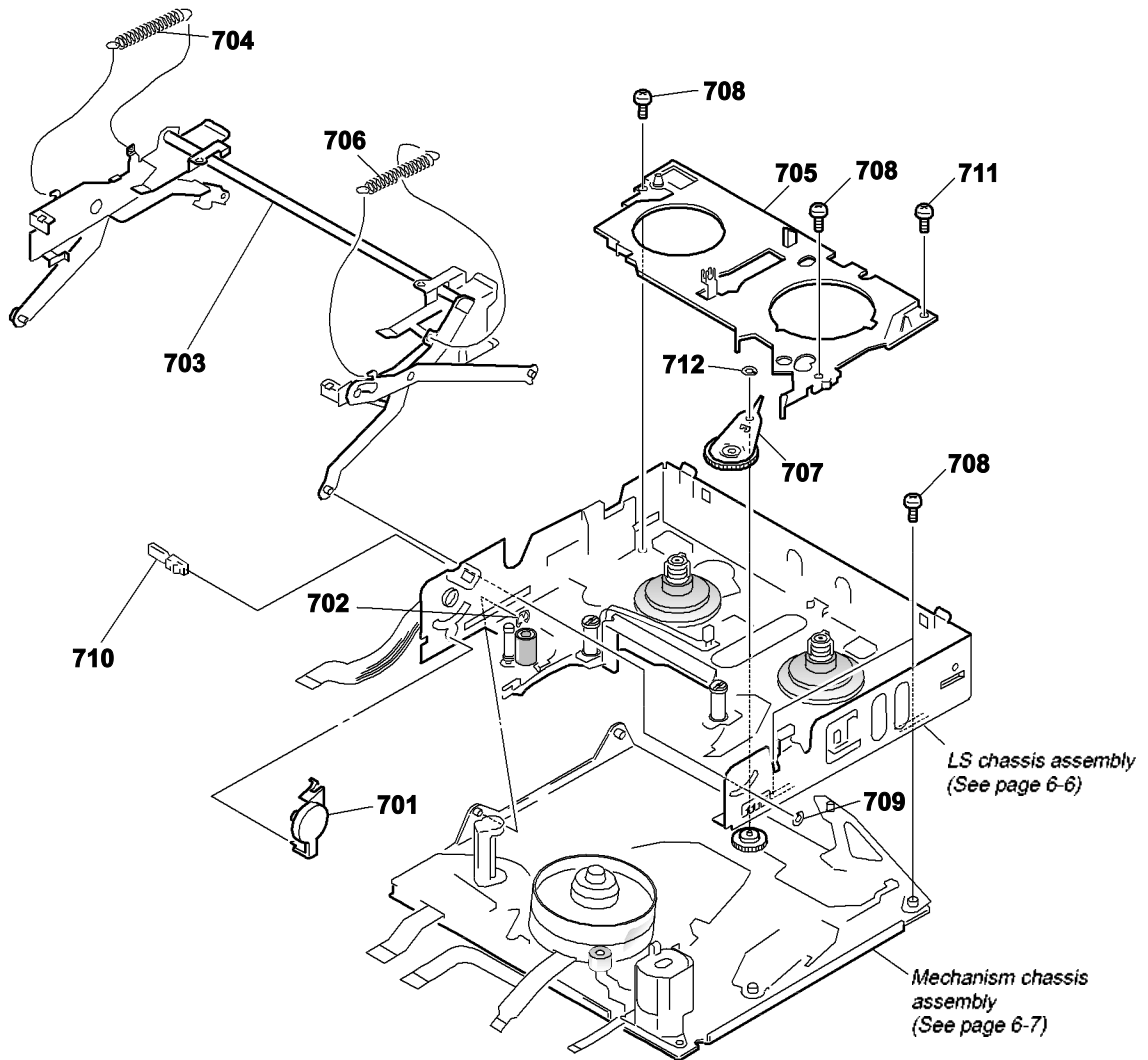

Ref. No.	Part No.	Description	Remarks	Ref. No.	Part No.	Description	Remarks
701	A-7040-421-A	DAMPER ASSY		707	X-3945-399-1	GEAR ASSY, GOOSENECK	
702	7-624-102-04	STOP RING 1.5, TYPE -E		708	3-947-503-01	SCREW (M1.4)	
703	X-3949-153-2	CASSETTE COMPARTMENT ASSY		709	3-979-686-01	WASHER, STOPPER	
704	3-965-587-03	SPRING (POWER TENSION), TENSION		710	3-971-076-01	FASTENER, D	
705	3-989-479-01	RETAINER (2), GOOSENECK		711	3-976-055-01	SCREW (M1.4X1)	
706	3-973-268-01	SPRING (POWER TENSION), TENSION		712	3-331-007-21	WASHER	

6-1-6. LS CHASSIS ASSEMBLY

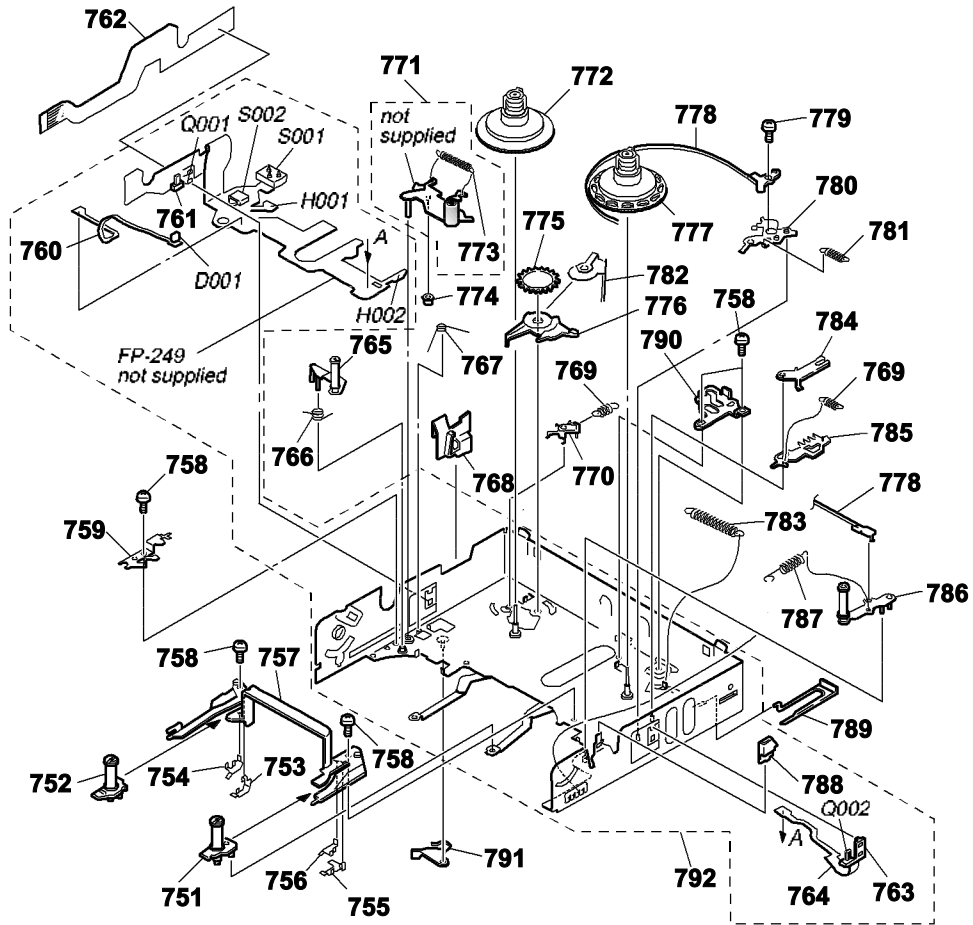

Ref. No.	Part No.	Description	Remarks	Ref. No.	Part No.	Description	Remarks
751	A-7040-419-A	BASE (S) BLOCK ASSY, GUIDE		776	3-965-565-01	CLAW, T SOFT	
752	A-7040-418-B	BASE (T) BLOCK ASSY, GUIDE		777	X-3945-397-4	DECK ASSY, REEL, S	
753	3-965-559-01	STOPPER (T)		778	X-3945-396-1	BAND ASSY, TENSION REGULATOR	
754	3-965-557-01	STOPPER (T), GB		779	3-945-756-01	SCREW (M1.4X3)	
755	3-965-558-01	STOPPER (S)		780	3-965-583-01	ARM, RVS	
756	3-965-556-01	STOPPER (S), GB		781	3-965-580-01	SPRING (ARM, RVS), TENSION	
757	3-965-553-01	RAIL, GUIDE		782	3-966-384-01	SPRING, T SOFT	
758	3-947-503-01	SCREW (M1.4)		783	3-965-578-01	SPRING, TENSION COIL	
759	3-965-573-01	RETAINER, TG4		784	3-965-560-01	RATCHET, S	
760	1-658-213-11	FP-355 FLEXIBLE BOARD		785	3-965-561-01	PLATE, RELEASE, S RATCHET	
761	3-965-552-01	HOLDER (T REEL) SENSOR		786	X-3945-395-1	ARM ASSY, TG1	
762	1-657-786-13	FP-221 FLEXIBLE BOARD		787	3-965-576-01	SPRING (TG1), TENSION	
763	3-965-551-01	HOLDER (S REEL) SENSOR		788	3-965-567-01	LID OPEN	
764	1-658-214-11	FP-356 FLEXIBLE BOARD		789	3-965-566-01	COVER, LS GUIDE	
765	A-7040-417-A	ARM BLOCK ASSY, TG4		* 790	3-965-577-01	PLATE, CAM, LS	
766	3-965-574-01	SPRING (RETURN, TG4), TORSION		791	3-965-569-01	ARM, EJ	
767	3-965-575-01	SPRING (PINCH), TORSION		792	A-7040-427-B	CHASSIS (S1) ASSY, LS	
768	3-965-568-11	GUIDE, LOCK		D001	8-719-988-42	DIODE GL453 (TAPE LED)	
769	3-965-562-01	SPRING (RATCHET), TENSION		H001	8-719-033-37	ELEMENT, HOLE HW-105C (T REEL)	
770	3-965-581-03	RATCHET, T		H002	8-719-033-37	ELEMENT, HOLE HW-105C (S REEL)	
771	X-3950-856-1	ARM ASSY (E) (M), PINCH		Q001	8-729-907-25	PHOTO TRANSISTOR PT4850F (TAPE TOP)	
772	X-3945-398-6	DECK ASSY, REEL, T		Q002	8-729-907-25	PHOTO TRANSISTOR PT4850F (TAPE END)	
773	3-965-648-01	SPRING (PINCH), TENSION		S001	1-692-614-11	SWITCH, PUSH (3 KEY) (Hi8 MP,ME/MP,REC PROOF)	
774	3-965-579-01	ROLLER, PINCH PRESS		S002	1-572-688-12	SWITCH, PUSH (1 KEY) (C.C. LOCK)	
775	3-965-563-01	GEAR, T SOFT					

6-1-7. MECHANISM CHASSIS ASSEMBLY

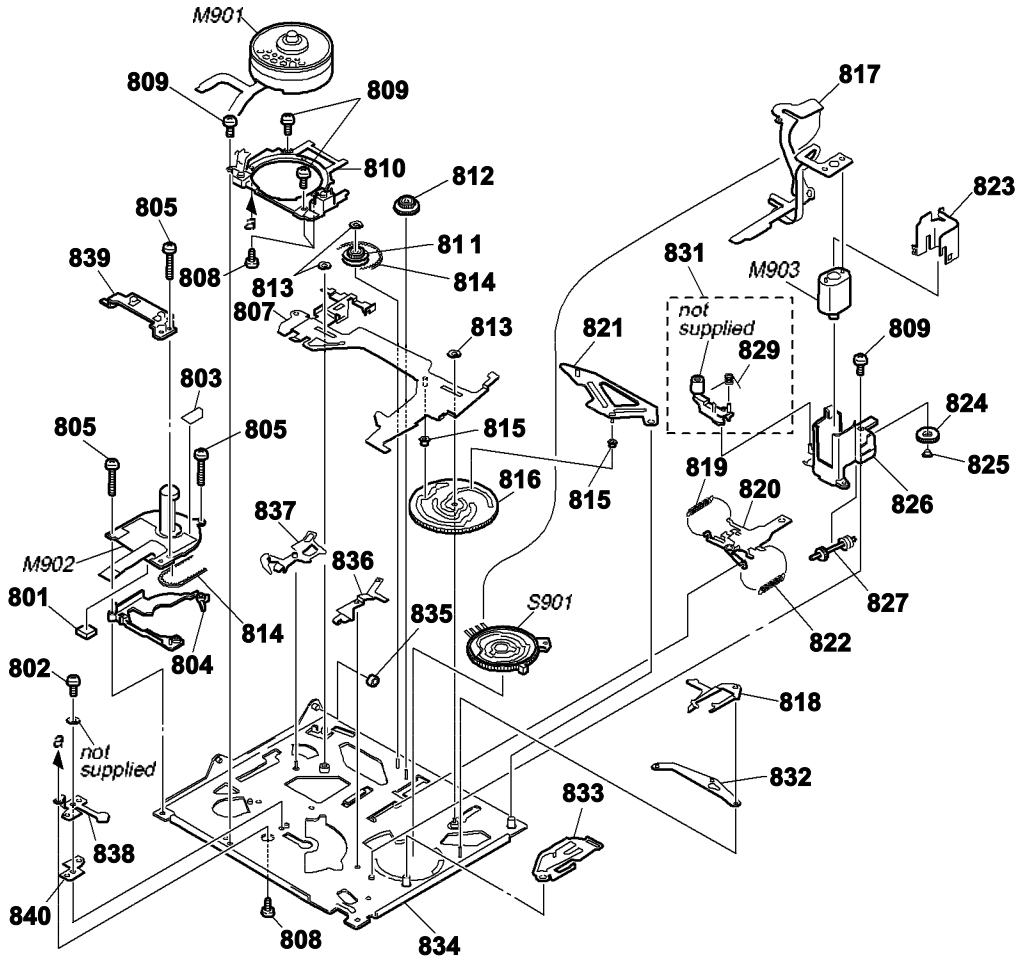

Ref. No.	Part No.	Description	Remarks	Ref. No.	Part No.	Description	Remarks
801	3-987-953-01	SPACER, RUBBER		823	3-965-542-01	SHIELD, MOTOR	
802	3-965-550-02	SCREW (M1.7X1.6)		824	3-965-539-01	GEAR (A)	
803	1-657-785-11	FP-248 FLEXIBLE BOARD		825	3-965-538-01	SLEEVE, MOTOR HOLDER	
804	3-054-404-01	SPACER, CAPSTAN		826	3-965-540-01	HOLDER, MOTOR	
805	3-965-549-01	SCREW (M1.4 X 6.5)		827	3-965-541-01	SHAFT, WORM	
807	3-971-644-02	SLIDER (2), M		829	3-965-724-01	SPRING (RETURN, HC), TORSION	
808	X-3947-895-1	SCREW ASSY, DRUM ATTACHED		831	A-7094-701-A	ARM BLOCK ASSY (VA), HC	
809	3-947-503-01	SCREW (M1.4)		832	3-965-531-01	ARM, GL	
810	A-7096-321-A	DRUM BASE BLOCK ASSY (BA)		833	3-965-530-01	PLATE (2), REGULATOR, TENSION	
811	3-965-527-01	GEAR, CHANGE		834	X-3949-589-3	CHASSIS ASSY, MECHANICAL	
812	3-965-544-01	GEAR, RELAY		835	3-965-526-02	ROLLER, LS GUIDE	
813	3-331-007-21	WASHER		836	3-965-547-01	ARM, HC DRIVING	
814	3-965-546-01	BELT, TIMING		837	3-965-534-01	PLATE, PRESS, PINCH	
815	3-965-533-01	ROLLER, LS		838	3-974-320-02	GROUND (IM), SHAFT	
816	3-965-528-01	GEAR, CAM		839	3-966-349-01	HOLDER, FLEXIBLE	
817	1-657-784-11	FP-220 FLEXIBLE BOARD		840	3-975-900-03	SPACER, GROUND	
818	3-965-529-01	PLATE, REGULATOR, TENSION		M901	A-7048-945-A	DRUM BLOCK ASSY (DKH-03A-R)	
819	3-965-536-01	SPRING (LIMITER ARM T), COILO		M902	8-835-531-32	MOTOR, DC SCE-0601A/C-NP (CAPSTAN)	
820	X-3945-388-1	SLIDER ASSY, GL		M903	X-3945-401-1	MOTOR ASSY, DC (LOADING)	
821	3-965-532-21	ARM, LS		S901	1-762-436-15	SWITCH (ENCODER), ROTARY	
822	3-965-535-01	SPRING (LIMITER ARM S), COIL					

EX-36**FP-246****FP-249****FP-355****FP-356****FP-571****FU-145****6-2. ELECTRICAL PARTS LIST****NOTE:**

- Due to standardization, replacements in the parts list may be different from the parts specified in the diagrams or the components used on the set.
- -XX, -X mean standardized parts, so they may have some difference from the original one.
- Items marked "*" are not stocked since they are seldom required for routine service. Some delay should be anticipated when ordering these items.
- CAPACITORS:
uF: μ F

- COILS
uH: μ H
- RESISTORS
All resistors are in ohms.
METAL: metal-film resistor
METAL OXIDE: Metal Oxide-film resistor
F: nonflammable
- SEMICONDUCTORS
In each case, u: μ , for example:
uA...: μ A..., uPA..., μ PA...,
uPB..., μ PB..., uPC..., μ PC...,
uPD..., μ PD...

When indicating parts by reference number, please include the board name.

The components identified by mark Δ or dotted line with mark Δ are critical for safety. Replace only with part number specified.

Les composants identifiés par une marque Δ sont critiques pour la sécurité. Ne les remplacer que par une pièce portant le numéro spécifié.

- Abbreviation
CND: Canadian model

Ref. No.	Part No.	Description	Remarks	Ref. No.	Part No.	Description	Remarks
	A-7074-567-A	EX-36 BOARD, COMPLETE (D800/D800E)				< SWITCH >	
	A-7074-610-A	EX-36 BOARD, COMPLETE (D200/D200E)	(Ref.No.;10000 Series)	S001	1-692-614-11	SWITCH, PUSH (3 KEY)	
				S002	1-572-688-11	SWITCH, PUSH (1 KEY) (CG DOWN)	
		< BUZZER >			1-658-213-11	FP-355 FLEXIBLE BOARD	(Ref.No.;20000 Series)
BZ201	1-529-107-11	BUZZER, PIEZOELECTRIC				< DIODE >	
		< CONNECTOR >		D001	8-719-988-42	DIODE GL453	
CN203	1-770-542-21	CONNECTOR, FFC/FPC 40P			1-658-214-11	FP-356 FLEXIBLE BOARD	(Ref.No.;20000 Series)
CN204	1-537-439-11	TARMINAL BOARD, CONNECTOR			3-965-551-01	HOLDER (S), SENSOR	
CN205	1-778-330-21	PIN, CONNECTOR (PC BOARD) 2P	(D800/D800E)			< TRANSISTOR >	
		< DIODE >		Q002	8-729-907-25	PHOTO TRANSISTOR PT4850F (TAPE END)	
D201	8-719-062-16	DIODE 01ZA8.2 (TPL3)			1-667-400-11	FP-571 FLEXIBLE BOARD	(Ref.No.;20000 Series)
D202	8-719-062-16	DIODE 01ZA8.2 (TPL3)				< BATTERY >	
D203	8-719-062-16	DIODE 01ZA8.2 (TPL3)		BT001	1-528-724-21	BATTERY, V/L RICHARGEABL	
D204	8-719-062-16	DIODE 01ZA8.2 (TPL3)			A-7074-568-A	FU-145 BOARD, COMPLETE (D800/D800E)	
D205	8-719-062-16	DIODE 01ZA8.2 (TPL3)			A-7074-612-A	FU-145 BOARD, COMPLETE (D200/D200E)	(Ref.No.;10000 Series)
D206	8-719-062-16	DIODE 01ZA8.2 (TPL3)				< CAPACITOR >	
D207	8-719-062-16	DIODE 01ZA8.2 (TPL3)		C501	1-107-826-11	CERAMIC CHIP 0.1uF 10.00% 16V	
D208	8-719-062-16	DIODE 01ZA8.2 (TPL3)		C502	1-107-826-11	CERAMIC CHIP 0.1uF 10.00% 16V	
D209	8-719-062-16	DIODE 01ZA8.2 (TPL3)		C503	1-164-227-11	CERAMIC CHIP 0.022uF 10% 25V	
D210	8-719-062-16	DIODE 01ZA8.2 (TPL3)		C504	1-119-751-11	TANTAL CHIP 22uF 20% 16V	
				C505	1-119-751-11	TANTAL CHIP 22uF 20% 16V	
	A-7074-573-A	FP-246 BOARD, COMPLETE	(Ref.No.;20000 Series)	C506	1-119-751-11	TANTAL CHIP 22uF 20% 16V	(D800/D800E)
		< JACK >		C508	1-109-982-11	CERAMIC CHIP 1uF 10.00% 10V	
J001	1-778-040-11	JACK (SMALL TYPE) (AUDIO/VIDEO)		C1301	1-162-960-11	CERAMIC CHIP 220PF 10% 50V	
J002	1-695-514-21	JACK (SMALL TYPE) 1P (HEADPHONES)		C1302	1-107-826-11	CERAMIC CHIP 0.1uF 10.00% 16V	
				C1303	1-107-826-11	CERAMIC CHIP 0.1uF 10.00% 16V	
		FP-249 BOARD, COMPLETE (Not supplied)	(Ref.No.;20000 Series)				
	3-965-552-01	HOLDER (T), SENSOR					
		< HOLE ELEMENT >					
H001	8-719-033-37	ELEMENT, HALL HW-105C (T REEL)					
H002	8-719-033-37	ELEMENT, HALL HW-105C (S REEL)					
		< TRANSISTOR >					
Q001	8-729-907-25	PHOTO TRANSISTOR PT4850F (TAPE TOP)					

Ref. No.	Part No.	Description	Remarks	Ref. No.	Part No.	Description	Remarks
C1304	1-107-826-11	CERAMIC CHIP	0.1uF 10.00% 16V			< FUSE >	
C1305	1-165-176-11	CERAMIC CHIP	0.047uF 10.00% 16V				
C1306	1-162-970-11	CERAMIC CHIP	0.01uF 10% 25V	△F501	1-576-406-21	FUSE, MICRO (1.4A)	
C1307	1-162-967-11	CERAMIC CHIP	0.0033uF 10% 50V	△F502	1-576-406-21	FUSE, MICRO (1.4A)	
C1308	1-162-966-11	CERAMIC CHIP	0.0022uF 10% 50V	△F503	1-576-406-21	FUSE, MICRO (1.4A)	
				△F504	1-576-406-21	FUSE, MICRO (1.4A)	
				△F505	1-576-406-21	FUSE, MICRO (1.4A)	
C1309	1-162-962-11	CERAMIC CHIP	470PF 10% 50V			< IC >	
C1310	1-162-968-11	CERAMIC CHIP	0.0047uF 10% 50V	IC1301	8-752-090-20	IC CXA3057R-T6	
C1311	1-162-965-11	CERAMIC CHIP	0.0015uF 10% 50V			< COIL >	
C1312	1-162-966-11	CERAMIC CHIP	0.0022uF 10% 50V				
C1313	1-162-964-11	CERAMIC CHIP	0.001uF 10% 50V				
C1314	1-162-962-11	CERAMIC CHIP	470PF 10% 50V	L501	1-412-056-11	INDUCTOR 4.7uH (D800/D800E)	
C1315	1-162-964-11	CERAMIC CHIP	0.001uF 10% 50V	L1301	1-416-670-11	INDUCTOR 33uH	
C1316	1-162-964-11	CERAMIC CHIP	0.001uF 10% 50V	L1302	1-416-669-11	INDUCTOR 22uH	
C1317	1-162-964-11	CERAMIC CHIP	0.001uF 10% 50V	L1303	1-416-669-11	INDUCTOR 22uH	
C1318	1-162-964-11	CERAMIC CHIP	0.001uF 10% 50V	L1304	1-416-669-11	INDUCTOR 22uH	
C1319	1-162-964-11	CERAMIC CHIP	0.001uF 10% 50V	L1305	1-416-669-11	INDUCTOR 22uH	
C1321	1-115-566-11	CERAMIC CHIP	4.7uF 10.00% 10V	L1310	1-412-056-11	INDUCTOR 4.7uH	
C1323	1-115-566-11	CERAMIC CHIP	4.7uF 10.00% 10V	L1317	1-416-669-11	INDUCTOR 22uH (D800/D800E)	
C1326	1-115-566-11	CERAMIC CHIP	4.7uF 10.00% 10V	L1318	1-469-524-91	INDUCTOR 4.7uH (D800/D800E)	
C1327	1-115-566-11	CERAMIC CHIP	4.7uF 10.00% 10V			< TRANSISTOR >	
C1328	1-162-974-11	CERAMIC CHIP	0.01uF 50V	Q501	8-729-047-68	TRANSISTOR SSM3K03FE (TPL3)	
C1329	1-115-566-11	CERAMIC CHIP	4.7uF 10.00% 10V	Q502	8-729-046-77	TRANSISTOR SI4963DY-T1	
C1330	1-115-566-11	CERAMIC CHIP	4.7uF 10.00% 10V	Q503	8-729-804-41	TRANSISTOR 2SB1122-ST-TD	
C1331	1-115-566-11	CERAMIC CHIP	4.7uF 10.00% 10V	Q504	8-729-042-29	TRANSISTOR RN1104F (TPL3)	
C1332	1-115-566-11	CERAMIC CHIP	4.7uF 10.00% 10V (D800/D800E)	Q505	8-729-047-68	TRANSISTOR SSM3K03FE (TPL3)	
C1334	1-135-259-11	TANTAL CHIP	10uF 20% 6.3V	Q506	8-729-042-29	TRANSISTOR RN1104F (TPL3)	
C1337	1-164-506-11	CERAMIC CHIP	4.7uF 16V	Q507	8-729-041-69	TRANSISTOR MMSF5P02HDR2	
C1338	1-164-506-11	CERAMIC CHIP	4.7uF 16V	Q1301	8-729-043-60	TRANSISTOR CPH6102-TL	
C1342	1-164-156-11	CERAMIC CHIP	0.1uF 25V	Q1302	8-729-046-98	TRANSISTOR CPH6702-TL	
C1344	1-115-566-11	CERAMIC CHIP	4.7uF 10.00% 10V (D800/D800E)	Q1303	8-729-046-98	TRANSISTOR CPH6702-TL	
C1347	1-104-913-11	TANTAL CHIP	10uF 20% 16V (D800/D800E)	Q1304	8-729-046-98	TRANSISTOR CPH6702-TL	
C1348	1-104-851-11	TANTAL CHIP	10uF 20% 10V	Q1305	8-729-046-98	TRANSISTOR CPH6702-TL	
C1352	1-165-176-11	CERAMIC CHIP	0.047uF 10.00% 16V	Q1306	8-729-046-98	TRANSISTOR CPH6702-TL	
C1359	1-164-506-11	CERAMIC CHIP	4.7uF 16V	Q1307	8-729-044-58	TRANSISTOR SI2304DS-T1	
				Q1308	8-729-044-58	TRANSISTOR SI2304DS-T1	
				Q1309	8-729-046-98	TRANSISTOR CPH6702-TL (D800/D800E)	
				Q1310	8-729-037-52	TRANSISTOR 2SC4738F-Y/GR (TPL3)	
				Q1311	8-729-017-61	TRANSISTOR 2SB1581-T1	
				Q1312	8-729-037-53	TRANSISTOR 2SA1832F-Y/GR (TPL3)	
				Q1313	8-729-037-52	TRANSISTOR 2SC4738F-Y/GR (TPL3)	
				Q1314	8-729-042-29	TRANSISTOR RN1104F (TPL3)	
						< RESISTOR >	
				R501	1-216-821-11	METAL CHIP 1K 5% 1/16W	
				R502	1-216-296-91	SHORT 0	
				R503	1-216-296-91	SHORT 0	
				R504	1-216-853-11	METAL CHIP 470K 5% 1/16W	
				R505	1-216-857-11	METAL CHIP 1M 5% 1/16W	
				R506	1-216-150-91	RES-CHIP 10 5% 1/8W	
				R507	1-216-821-11	METAL CHIP 1K 5% 1/16W	
				R508	1-216-831-11	METAL CHIP 6.8K 5% 1/16W	
				R509	1-216-841-11	METAL CHIP 47K 5% 1/16W	
				R510	1-216-833-11	METAL CHIP 10K 5% 1/16W	

- < CONNECTOR >
- * CN501 1-569-775-21 PIN, CONNECTOR (SMD) 5P
 - * CN502 1-580-056-21 PIN, CONNECTOR (SMD) 3P
 - CN1301 1-691-520-11 CONNECTOR, BOARD TO BOARD 48P

- < DIODE >
- D501 8-719-056-85 DIODE UDZS-TE17-8.2B
 - D502 8-719-421-27 DIODE MA728-(K8).S0
 - D503 8-719-062-16 DIODE 01ZA8.2 (TPL3)
 - D504 8-719-158-49 DIODE MA8120-TX
 - D505 8-719-027-76 DIODE 1SS357-TPH3
 - D506 8-719-016-74 DIODE 1SS352-TPH3
 - D507 8-719-016-74 DIODE 1SS352-TPH3
 - D1301 8-719-027-76 DIODE 1SS357-TPH3
 - D1302 8-719-027-77 DIODE MA796-TX
 - D1305 8-719-027-76 DIODE 1SS357-TPH3
 - D1306 8-719-027-76 DIODE 1SS357-TPH3

<p>Note : The components identified by mark △ or dotted line with mark △ are critical for safety. Replace only with part number specified.</p>	<p>Note : Les composants identifiés par une marque △ sont critiques pour la sécurité. Ne les remplacer que par une pièce portant le numéro spécifié.</p>
---	---

Ref. No.	Part No.	Description	Remarks
R511	1-216-821-11	METAL CHIP	1K 5% 1/16W
R512	1-216-857-11	METAL CHIP	1M 5% 1/16W
R1301	1-216-837-11	METAL CHIP	22K 5% 1/16W
R1302	1-216-839-11	METAL CHIP	33K 5% 1/16W
R1304	1-216-839-11	METAL CHIP	33K 5% 1/16W (D800/D800E)
R1305	1-216-864-11	METAL CHIP	0 5% 1/16W
R1306	1-216-837-11	METAL CHIP	22K 5% 1/16W
R1307	1-216-864-11	METAL CHIP	0 5% 1/16W
R1309	1-216-833-11	METAL CHIP	10K 5% 1/16W
R1310	1-216-864-11	METAL CHIP	0 5% 1/16W
R1311	1-216-839-11	METAL CHIP	33K 5% 1/16W
R1312	1-216-829-11	METAL CHIP	4.7K 5% 1/16W
R1313	1-216-837-11	METAL CHIP	22K 5% 1/16W
R1314	1-216-837-11	METAL CHIP	22K 5% 1/16W
R1316	1-216-864-11	METAL CHIP	0 5% 1/16W
R1317	1-216-841-11	METAL CHIP	47K 5% 1/16W
R1318	1-216-829-11	METAL CHIP	4.7K 5% 1/16W
R1319	1-216-841-11	METAL CHIP	47K 5% 1/16W
R1320	1-216-837-11	METAL CHIP	22K 5% 1/16W
R1321	1-218-879-11	METAL CHIP	22K 0.5% 1/16W
R1322	1-218-871-11	METAL CHIP	10K 0.5% 1/16W
R1326	1-216-833-11	METAL CHIP	10K 5% 1/16W (D800/D800E)
R1345	1-216-864-11	METAL CHIP	0 5% 1/16W
R1347	1-218-879-11	METAL CHIP	22K 0.5% 1/16W
R1348	1-218-871-11	METAL CHIP	10K 0.5% 1/16W

< TRANSFORMER >

△ T1301 1-435-252-21 TRANSFORMER, DC-DC CONVERTER

A-7074-569-A IO-68 BOARD, COMPLETE

 (Ref.No.:10000 Series)

< CAPACITOR >

C101	1-162-964-11	CERAMIC CHIP	0.001uF 10% 50V
C102	1-162-964-11	CERAMIC CHIP	0.001uF 10% 50V
C103	1-162-964-11	CERAMIC CHIP	0.001uF 10% 50V
C104	1-162-964-11	CERAMIC CHIP	0.001uF 10% 50V
C107	1-162-964-11	CERAMIC CHIP	0.001uF 10% 50V
C110	1-162-964-11	CERAMIC CHIP	0.001uF 10% 50V
C116	1-162-970-11	CERAMIC CHIP	0.01uF 10% 25V
C117	1-162-964-11	CERAMIC CHIP	0.001uF 10% 50V
C118	1-162-964-11	CERAMIC CHIP	0.001uF 10% 50V
C119	1-162-964-11	CERAMIC CHIP	0.001uF 10% 50V
C120	1-162-964-11	CERAMIC CHIP	0.001uF 10% 50V
C121	1-162-964-11	CERAMIC CHIP	0.001uF 10% 50V
C122	1-162-964-11	CERAMIC CHIP	0.001uF 10% 50V
C123	1-162-964-11	CERAMIC CHIP	0.001uF 10% 50V
C124	1-162-964-11	CERAMIC CHIP	0.001uF 10% 50V

< CONNECTOR >

CN103	1-778-597-21	CONNECTOR, BOARD TO BOARD 50P
CN104	1-573-525-21	CONNECTOR, BOARD TO BOARD 16P
CN105	1-774-631-21	CONNECTOR, FFC/FPC 6P

Ref. No.	Part No.	Description	Remarks
		< DIODE >	
D101	8-719-062-16	DIODE 01ZA8.2 (TPL3)	
D102	8-719-062-16	DIODE 01ZA8.2 (TPL3)	
D103	8-719-073-03	DIODE MA8082-(K8).S0	
D104	8-719-062-16	DIODE 01ZA8.2 (TPL3)	
D105	8-719-062-16	DIODE 01ZA8.2 (TPL3)	
D106	8-719-062-16	DIODE 01ZA8.2 (TPL3)	
D107	8-719-062-16	DIODE 01ZA8.2 (TPL3)	
D108	8-719-073-03	DIODE MA8082-(K8).S0	
D109	8-719-061-82	DIODE TLSU1002 (TPX1,SONY)	
D110	8-719-062-16	DIODE 01ZA8.2 (TPL3)	
D111	8-719-073-03	DIODE MA8082-(K8).S0	
D112	8-719-073-03	DIODE MA8082-(K8).S0	
D113	8-719-073-01	DIODE MA111-TX	
D114	8-719-062-16	DIODE 01ZA8.2 (TPL3)	
D115	8-719-062-16	DIODE 01ZA8.2 (TPL3)	
D116	8-719-062-16	DIODE 01ZA8.2 (TPL3)	
D117	8-719-062-16	DIODE 01ZA8.2 (TPL3)	
D119	8-719-062-16	DIODE 01ZA8.2 (TPL3)	
D120	8-719-062-16	DIODE 01ZA8.2 (TPL3)	
D121	8-719-073-03	DIODE MA8082-(K8).S0	
D122	8-719-073-03	DIODE MA8082-(K8).S0	
D123	8-719-062-16	DIODE 01ZA8.2 (TPL3)	
D124	8-719-073-03	DIODE MA8082-(K8).S0	
D125	8-719-073-03	DIODE MA8082-(K8).S0	
D126	8-719-073-03	DIODE MA8082-(K8).S0	

< FERRITE BEAD >

FB101 1-414-760-21 INDUCTOR 00H

< JACK >

J101	1-566-850-31	CONNECTOR, (S) TERMINAL 4P (S VIDEO IN)
J102	1-537-747-31	TERMINAL BOARD (AUDIO R,L/RFU DC OUT/VIDEO OUT)
J103	1-566-850-31	CONNECTOR, (S) TERMINAL 4P (S VIDEO OUT)

< COIL >

L101	1-414-072-11	INDUCTOR	1uH
L103	1-412-963-11	INDUCTOR	100uH
L104	1-412-963-11	INDUCTOR	100uH
L105	1-412-963-11	INDUCTOR	100uH
L106	1-412-963-11	INDUCTOR	100uH
L107	1-412-963-11	INDUCTOR	100uH
L108	1-412-963-11	INDUCTOR	100uH

< RESISTOR >

R101	1-216-821-11	METAL CHIP	1K 5% 1/16W
R103	1-216-821-11	METAL CHIP	1K 5% 1/16W
R106	1-216-841-11	METAL CHIP	47K 5% 1/16W
R107	1-216-841-11	METAL CHIP	47K 5% 1/16W
R110	1-216-864-11	METAL CHIP	0 5% 1/16W
R111	1-216-864-11	METAL CHIP	0 5% 1/16W
R112	1-216-864-11	METAL CHIP	0 5% 1/16W
R120	1-216-821-11	METAL CHIP	1K 5% 1/16W
R121	1-216-821-11	METAL CHIP	1K 5% 1/16W
R128	1-216-822-11	METAL CHIP	1.2K 5% 1/16W

Note :
 The components identified by mark △ or dotted line with mark △ are critical for safety.
 Replace only with part number specified.

Note :
 Les composants identifiés par une marque △ sont critiques pour la sécurité.
 Ne les remplacer que par une pièce portant le numéro spécifié.

Ref. No.	Part No.	Description	Remarks		
R129	1-216-823-11	METAL CHIP	1.5K	5%	1/16W
R130	1-216-825-11	METAL CHIP	2.2K	5%	1/16W
R131	1-216-828-11	METAL CHIP	3.9K	5%	1/16W
R132	1-216-817-11	METAL CHIP	470	5%	1/16W
R133	1-216-864-11	METAL CHIP	0	5%	1/16W
R134	1-216-864-11	METAL CHIP	0	5%	1/16W
R135	1-216-864-11	METAL CHIP	0	5%	1/16W
R136	1-216-864-11	METAL CHIP	0	5%	1/16W
R137	1-216-864-11	METAL CHIP	0	5%	1/16W
R138	1-216-821-11	METAL CHIP	1K	5%	1/16W
R139	1-216-821-11	METAL CHIP	1K	5%	1/16W
< SWITCH >					
S101	1-692-088-41	SWITCH, TACTILE (SUPER LASER LINK)			
S102	1-692-088-41	SWITCH, TACTILE (MENU)			
S103	1-771-025-21	SWITCH, ROTARY (ENCODER)			
(SEL/PUSH EXEC)					
S104	1-692-088-41	SWITCH, TACTILE (VOLUME +)			
S105	1-692-088-41	SWITCH, TACTILE (VOLUME -)			
A-7074-570-A IR-38 BOARD, COMPLETE ***** (Ref.No.,10000 Series)					
< CAPACITOR >					
C382	1-135-210-11	TANTALUM CHIP	4.7uF	20%	10V
C392	1-107-826-11	CERAMIC CHIP	0.1uF	10.00%	16V
C393	1-125-837-91	CERAMIC CHIP	1uF	10%	6.3V
< CONNECTOR >					
CN361	1-766-866-21	CONNECTOR, FFC/FPC 6P			
< DIODE >					
D362	8-719-060-65	DIODE DAC3825			
D363	8-719-078-23	DIODE DCR2815			
< FUSE >					
△F361	1-533-874-11	FUSE, MICRO (0.2A/24V)			
< COIL >					
L363	1-414-078-11	INDUCTOR	10uH		
< TRANSISTOR >					
Q365	8-729-140-75	TRANSISTOR	2SD999-T1-CLCK		
< RESISTOR >					
R388	1-216-302-00	METAL CHIP	2.7	5%	1/10W
R389	1-216-311-00	METAL CHIP	6.8	5%	1/10W
R392	1-216-801-11	METAL CHIP	22	5%	1/16W
A-7074-571-A LS-56 BOARD, COMPLETE (D800/D800E) ***** (Ref.No.,10000 Series)					
< CONNECTOR >					
* CN001	1-770-619-11	PIN, CONNECTOR 2P			

Ref. No.	Part No.	Description	Remarks		
< SWITCH >					
S001	1-771-091-21	SWITCH, PUSH (1 KEY) (LCD ON/OFF)			
A-7074-572-A PD-130 BOARD, COMPLETE (D800/D800E) ***** (Ref.No.,10000 Series)					
< CAPACITOR >					
C5501	1-119-750-11	TANTAL. CHIP	22uF	20%	6.3V
C5503	1-107-826-11	CERAMIC CHIP	0.1uF	10.00%	16V
C5504	1-107-826-11	CERAMIC CHIP	0.1uF	10.00%	16V
C5505	1-162-970-11	CERAMIC CHIP	0.01uF	10%	25V
C5506	1-162-970-11	CERAMIC CHIP	0.01uF	10%	25V
C5507	1-162-970-11	CERAMIC CHIP	0.01uF	10%	25V
C5508	1-107-826-11	CERAMIC CHIP	0.1uF	10.00%	16V
C5509	1-135-213-21	TANTAL. CHIP	3.3uF	20%	25V
C5510	1-107-826-11	CERAMIC CHIP	0.1uF	10.00%	16V
C5511	1-164-739-11	CERAMIC CHIP	560PF	5%	50V
C5512	1-107-826-11	CERAMIC CHIP	0.1uF	10.00%	16V
C5513	1-107-826-11	CERAMIC CHIP	0.1uF	10.00%	16V
C5514	1-104-852-11	TANTAL. CHIP	22uF	20%	10V
C5515	1-164-357-11	CERAMIC CHIP	0.001uF	5%	50V
C5516	1-162-925-11	CERAMIC CHIP	68PF	5%	50V
C5517	1-164-004-11	CERAMIC CHIP	0.1uF	10%	25V
C5518	1-164-004-11	CERAMIC CHIP	0.1uF	10%	25V
C5519	1-164-004-11	CERAMIC CHIP	0.1uF	10%	25V
C5520	1-113-994-11	TANTAL. CHIP	6.8uF	20%	16V
C5521	1-127-573-11	CERAMIC CHIP	1uF	10%	16V
C5522	1-107-826-11	CERAMIC CHIP	0.1uF	10.00%	16V
C5523	1-107-826-11	CERAMIC CHIP	0.1uF	10.00%	16V
C5524	1-107-682-11	CERAMIC CHIP	1uF	10.00%	16V
C5527	1-162-970-11	CERAMIC CHIP	0.01uF	10%	25V
C5528	1-135-177-21	TANTALUM CHIP	1uF	20%	20V
C5529	1-107-826-11	CERAMIC CHIP	0.1uF	10.00%	16V
C5530	1-162-970-11	CERAMIC CHIP	0.01uF	10%	25V
C5531	1-162-970-11	CERAMIC CHIP	0.01uF	10%	25V
C5602	1-113-682-11	TANTAL. CHIP	33uF	20%	10V
C5603	1-109-982-11	CERAMIC CHIP	1uF	10.00%	10V
C5604	1-164-657-11	CERAMIC CHIP	0.015uF	10.00%	50V
C5605	1-107-826-11	CERAMIC CHIP	0.1uF	10.00%	16V
C5606	1-107-826-11	CERAMIC CHIP	0.1uF	10.00%	16V
C5607	1-131-959-91	CERAMIC CHIP	12PF	10%	3KV
< CONNECTOR >					
CN5501	1-573-364-11	CONNECTOR, FFC/FPC 24P			
* CN5502	1-573-984-11	CONNECTOR, BOARD TO BOARD 10P			
CN5503	1-573-366-21	CONNECTOR, FFC/FPC 26P			
CN5505	1-778-506-21	PIN, CONNECTOR (PC BOARD) 2P			
CN5506	1-778-506-21	PIN, CONNECTOR (PC BOARD) 2P			
* CN5604	1-569-352-11	HOUSING, CONNECTOR 10P			
CN5607	1-778-330-21	PIN, CONNECTOR (PC BOARD) 2P			
CN5608	1-784-342-21	HOUSING, CONNECTOR 2P			

Note :
The components identified by mark △ or dotted line with mark △ are critical for safety.
Replace only with part number specified.

Note :
Les composants identifiés par une marque △ sont critiques pour la sécurité.
Ne les remplacer que par une pièce portant le numéro spécifié.

Ref. No.	Part No.	Description	Remarks
< DIODE >			
D5502	8-713-102-80	DIODE 1T369-01-T8A	
D5503	8-719-073-01	DIODE MA111-(K8).SO	
D5601	8-719-073-01	DIODE MA111-(K8).SO	
D5605	8-719-062-16	DIODE 01ZA8.2 (TPL3)	
< IC >			
IC5501	8-759-660-92	IC RB5P003AM1	
IC5502	8-759-682-96	IC LZ9FF444	
IC5503	8-759-478-92	IC TC7SET04FU (TE85R)	
IC5601	8-759-564-49	IC TC7W53FU (TE12R)	
IC5602	8-759-075-70	IC TA75S393F-TE85R	
< COIL >			
L5501	1-469-525-91	INDUCTOR 10uH	
L5502	1-469-525-91	INDUCTOR 10uH	
L5503	1-469-525-91	INDUCTOR 10uH	
L5504	1-469-525-91	INDUCTOR 10uH	
L5505	1-412-949-21	INDUCTOR 6.8uH	
L5601	1-419-387-21	INDUCTOR 100uH	
< TRANSISTOR >			
Q5501	8-729-037-52	TRANSISTOR 2SD2216J-QR(K8).SO	
Q5502	8-729-041-23	TRANSISTOR MG5F1P02LT1	
Q5503	8-729-042-26	TRANSISTOR 2SB1462J-QR(K8).SO	
Q5504	8-729-042-26	TRANSISTOR 2SB1462J-QR(K8).SO	
Q5505	8-729-037-52	TRANSISTOR 2SD2216J-QR(K8).SO	
Q5506	8-729-037-52	TRANSISTOR 2SD2216J-QR(K8).SO	
Q5601	8-729-037-74	TRANSISTOR UN9213J-(K8).SO	
Q5602	8-729-039-43	TRANSISTOR FP216-TL	
Q5603	8-729-037-74	TRANSISTOR UN9213J-(K8).SO	
Q5604	8-729-042-58	TRANSISTOR UN9111J-(K8).SO	
< RESISTOR >			
R5501	1-216-853-11	METAL CHIP 470K 5%	1/16W
R5503	1-218-895-11	METAL CHIP 100K 0.5%	1/16W
R5504	1-216-845-11	METAL CHIP 100K 5%	1/16W
R5505	1-216-835-11	METAL CHIP 15K 5%	1/16W
R5506	1-216-826-11	METAL CHIP 2.7K 5%	1/16W
R5507	1-216-841-11	METAL CHIP 47K 5%	1/16W
R5508	1-216-843-11	METAL CHIP 68K 5%	1/16W
R5509	1-216-837-11	METAL CHIP 22K 5%	1/16W
R5510	1-216-843-11	METAL CHIP 68K 5%	1/16W
R5511	1-216-857-11	METAL CHIP 1M 5%	1/16W
R5512	1-216-845-11	METAL CHIP 100K 5%	1/16W
R5513	1-216-857-11	METAL CHIP 1M 5%	1/16W
R5515	1-216-864-11	METAL CHIP 0 5%	1/16W
R5516	1-216-833-11	METAL CHIP 10K 5%	1/16W
R5519	1-216-864-11	METAL CHIP 0 5%	1/16W
R5520	1-216-864-11	METAL CHIP 0 5%	1/16W
R5521	1-216-864-11	METAL CHIP 0 5%	1/16W
R5523	1-216-809-11	METAL CHIP 100 5%	1/16W
R5524	1-216-809-11	METAL CHIP 100 5%	1/16W
R5525	1-216-809-11	METAL CHIP 100 5%	1/16W
R5551	1-216-841-11	METAL CHIP 47K 5%	1/16W
R5553	1-216-832-11	METAL CHIP 8.2K 5%	1/16W
R5557	1-216-864-11	METAL CHIP 0 5%	1/16W
R5560	1-216-853-11	METAL CHIP 470K 5%	1/16W
R5562	1-216-833-11	METAL CHIP 10K 5%	1/16W

Ref. No.	Part No.	Description	Remarks
R5563	1-216-841-11	METAL CHIP 47K 5%	1/16W
R5564	1-216-857-11	METAL CHIP 1M 5%	1/16W
R5565	1-216-857-11	METAL CHIP 1M 5%	1/16W
R5569	1-216-848-11	METAL CHIP 180K 5%	1/16W
R5608	1-216-864-11	METAL CHIP 0 5%	1/16W
R5609	1-216-833-11	METAL CHIP 10K 5%	1/16W
R5610	1-216-055-00	METAL CHIP 1.8K 5%	1/10W
R5611	1-216-845-11	METAL CHIP 100K 5%	1/16W
R5612	1-216-834-11	METAL CHIP 12K 5%	1/16W
R5613	1-216-055-00	METAL CHIP 1.8K 5%	1/10W
R5614	1-216-836-11	METAL CHIP 18K 5%	1/16W
R5616	1-216-810-11	METAL CHIP 120 5%	1/16W
R5617	1-216-837-11	METAL CHIP 22K 5%	1/16W
R5618	1-216-817-11	METAL CHIP 470 5%	1/16W
R5621	1-216-822-11	METAL CHIP 1.2K 5%	1/16W
R5622	1-216-823-11	METAL CHIP 1.5K 5%	1/16W
R5623	1-216-825-11	METAL CHIP 2.2K 5%	1/16W
R5624	1-216-828-11	METAL CHIP 3.9K 5%	1/16W
R5625	1-216-832-11	METAL CHIP 8.2K 5%	1/16W
R5626	1-216-838-11	METAL CHIP 27K 5%	1/16W
< SWITCH >			
S5601	1-572-921-11	SWITCH, KEY BOARD (BRIGHT +)	
S5602	1-572-921-11	SWITCH, KEY BOARD (BRIGHT -)	
< TRANSFORMER >			
△T5601	1-435-229-21	TRANSFORMER, INVERTER	
A-7074-617-A	VC-250 BOARD, COMPLETE (D800) *****		
A-7074-618-A	VC-250 BOARD, COMPLETE (D800E) *****		
A-7074-619-A	VC-250 BOARD, COMPLETE (D200) *****		
A-7074-620-A	VC-250 BOARD, COMPLETE (D200E) ***** (Ref.No.,3000 Series)		
< CAPACITOR >			
C901	1-164-943-11	CERAMIC CHIP 0.01uF 10%	16V
C902	1-104-851-11	TANTAL CHIP 10uF 20%	10V
C1320	1-127-688-21	TANTAL CHIP 10uF 20%	6.3V
C1322	1-135-201-11	TANTALUM CHIP 10uF 20%	4V
C1333	1-127-688-21	TANTAL CHIP 10uF 20%	6.3V (D800/D800E)
C1335	1-104-851-11	TANTAL CHIP 10uF 20%	10V
C1336	1-119-750-11	TANTAL CHIP 22uF 20%	6.3V
C1339	1-104-851-11	TANTAL CHIP 10uF 20%	10V (D800/D800E)
C1340	1-127-688-21	TANTAL CHIP 10uF 20%	6.3V
C1341	1-104-851-11	TANTAL CHIP 10uF 20%	10V
C1343	1-135-157-21	TANTALUM CHIP 10uF 20%	6.3V
C1345	1-104-851-11	TANTAL CHIP 10uF 20%	10V
C1353	1-125-777-11	CERAMIC CHIP 0.1uF 10%	10V
C1355	1-164-505-11	CERAMIC CHIP 2.2uF	16V (D800/D800E)
C1356	1-164-505-11	CERAMIC CHIP 2.2uF	16V (D800/D800E)

Note :
The components identified by mark △ or dotted line with mark △ are critical for safety.
Replace only with part number specified.

Note :
Les composants identifiés par une marque △ sont critiques pour la sécurité.
Ne les remplacer que par une pièce portant le numéro spécifié.

Ref. No.	Part No.	Description	Remarks			Ref. No.	Part No.	Description	Remarks		
C1357	1-125-822-11	TANTALUM	10uF	20%	10V	C3111	1-104-851-11	TANTAL. CHIP	10uF	20%	10V
C1505	1-115-156-11	CERAMIC CHIP	1uF		10V	C3112	1-164-935-11	CERAMIC CHIP	470PF	10%	16V
C1507	1-135-259-11	TANTAL. CHIP	10uF	20%	6.3V	C3113	1-164-943-11	CERAMIC CHIP	0.01uF	10%	16V
C1508	1-125-837-91	CERAMIC CHIP	1uF	10%	6.3V	C3114	1-164-866-11	CERAMIC CHIP	47PF	5%	16V
C1510	1-164-846-11	CERAMIC CHIP	6PF	0.50PF	16V	C3115	1-125-777-11	CERAMIC CHIP	0.1uF	10%	10V
C1512	1-164-937-11	CERAMIC CHIP	0.001uF	10%	16V	C3116	1-164-677-11	CERAMIC CHIP	0.033uF	10%	16V
C1513	1-117-863-11	CERAMIC CHIP	0.47uF	10%	6.3V	C3117	1-164-935-11	CERAMIC CHIP	470PF	10%	16V
C1514	1-162-925-11	CERAMIC CHIP	68PF	5%	50V	C3118	1-164-943-11	CERAMIC CHIP	0.01uF	10%	16V
C1515	1-115-467-11	CERAMIC CHIP	0.22uF	10%	10V	C3119	1-164-866-11	CERAMIC CHIP	47PF	5%	16V
C1516	1-109-982-11	CERAMIC CHIP	1uF	10%	10V	C3120	1-164-943-11	CERAMIC CHIP	0.01uF	10%	16V
C1517	1-162-928-11	CERAMIC CHIP	120PF	5%	50V	C3121	1-164-943-11	CERAMIC CHIP	0.01uF	10%	16V
C1518	1-125-837-91	CERAMIC CHIP	1uF	10%	6.3V	C3122	1-104-851-11	TANTAL. CHIP	10uF	20%	10V
C1519	1-115-467-11	CERAMIC CHIP	0.22uF	10%	10V	C3123	1-164-942-11	CERAMIC CHIP	0.0068uF	10%	16V
C1520	1-164-937-11	CERAMIC CHIP	0.001uF	10%	16V	C3124	1-164-942-11	CERAMIC CHIP	0.0068uF	10%	16V
C1521	1-125-837-91	CERAMIC CHIP	1uF	10%	6.3V	C3126	1-164-943-11	CERAMIC CHIP	0.01uF	10%	16V
C1522	1-125-837-91	CERAMIC CHIP	1uF	10%	6.3V	C3127	1-164-943-11	CERAMIC CHIP	0.01uF	10%	16V
C1523	1-107-826-11	CERAMIC CHIP	0.1uF	10%	16V	C3128	1-164-943-11	CERAMIC CHIP	0.01uF	10%	16V
C1524	1-119-750-11	TANTAL. CHIP	22uF	20%	6.3V	C3131	1-164-943-11	CERAMIC CHIP	0.01uF	10%	16V
C1526	1-125-837-91	CERAMIC CHIP	1uF	10%	6.3V	C3133	1-164-943-11	CERAMIC CHIP	0.01uF	10%	16V
C2201	1-164-943-11	CERAMIC CHIP	0.01uF	10%	16V	C3134	1-125-777-11	CERAMIC CHIP	0.1uF	10%	10V
C2202	1-104-851-11	TANTAL. CHIP	10uF	20%	10V	C3135	1-164-874-11	CERAMIC CHIP	100PF	5%	16V
C2203	1-164-943-11	CERAMIC CHIP	0.01uF	10%	16V	C3136	1-164-872-11	CERAMIC CHIP	82PF	5%	16V
C2204	1-125-777-11	CERAMIC CHIP	0.1uF	10%	10V	C3137	1-164-943-11	CERAMIC CHIP	0.01uF	10%	16V
C2208	1-164-392-11	CERAMIC CHIP	390PF	5%	50V	C3138	1-164-874-11	CERAMIC CHIP	100PF	5%	16V
C2210	1-125-837-91	CERAMIC CHIP	1uF	10%	6.3V	C3139	1-164-878-11	CERAMIC CHIP	150PF	5%	16V
C2211	1-119-660-11	TANTAL. CHIP	4.7uF	20%	6.3V	C3141	1-164-882-11	CERAMIC CHIP	220PF	5%	16V
C2212	1-125-837-91	CERAMIC CHIP	1uF	10%	6.3V	C3142	1-164-882-11	CERAMIC CHIP	220PF	5%	16V
C2213	1-164-943-11	CERAMIC CHIP	0.01uF	10%	16V	C3143	1-164-882-11	CERAMIC CHIP	220PF	5%	16V
C2214	1-107-826-11	CERAMIC CHIP	0.1uF	10%	16V	C3144	1-164-882-11	CERAMIC CHIP	220PF	5%	16V
C2215	1-125-837-91	CERAMIC CHIP	1uF	10%	6.3V	C3201	1-164-943-11	CERAMIC CHIP	0.01uF	10%	16V
C2222	1-107-826-11	CERAMIC CHIP	0.1uF	10%	16V	C3202	1-164-943-11	CERAMIC CHIP	0.01uF	10%	16V
C2223	1-107-826-11	CERAMIC CHIP	0.1uF	10%	16V	C3203	1-104-851-11	TANTAL. CHIP	10uF	20%	10V
C2224	1-107-826-11	CERAMIC CHIP	0.1uF	10%	16V	C3204	1-164-943-11	CERAMIC CHIP	0.01uF	10%	16V
C2225	1-164-943-11	CERAMIC CHIP	0.01uF	10%	16V	C3205	1-164-943-11	CERAMIC CHIP	0.01uF	10%	16V
C2226	1-164-943-11	CERAMIC CHIP	0.01uF	10%	16V	C3206	1-164-943-11	CERAMIC CHIP	0.01uF	10%	16V
C2227	1-107-823-11	CERAMIC CHIP	0.47uF	10%	16V	C3207	1-164-943-11	CERAMIC CHIP	0.01uF	10%	16V
C2228	1-135-259-11	TANTAL. CHIP	10uF	20%	6.3V	C3208	1-164-943-11	CERAMIC CHIP	0.01uF	10%	16V
C2229	1-164-943-11	CERAMIC CHIP	0.01uF	10%	16V	C3210	1-164-941-11	CERAMIC CHIP	0.0047uF	10%	16V
C2230	1-164-938-11	CERAMIC CHIP	0.0015uF	10%	16V	C3211	1-164-943-11	CERAMIC CHIP	0.01uF	10%	16V
C2232	1-135-259-11	TANTAL. CHIP	10uF	20%	6.3V	C3212	1-164-943-11	CERAMIC CHIP	0.01uF	10%	16V
C2233	1-164-943-11	CERAMIC CHIP	0.01uF	10%	16V	C3213	1-165-176-11	CERAMIC CHIP	0.047uF	10%	16V
C2234	1-164-943-11	CERAMIC CHIP	0.01uF	10%	16V	C3214	1-164-943-11	CERAMIC CHIP	0.01uF	10%	16V
C2236	1-107-826-11	CERAMIC CHIP	0.1uF	10%	16V	C3215	1-164-943-11	CERAMIC CHIP	0.01uF	10%	16V
C2238	1-125-837-91	CERAMIC CHIP	1uF	10%	6.3V	C3216	1-125-777-11	CERAMIC CHIP	0.1uF	10%	10V
C2240	1-125-837-91	CERAMIC CHIP	1uF	10%	6.3V	C3217	1-164-943-11	CERAMIC CHIP	0.01uF	10%	16V
C2242	1-115-156-11	CERAMIC CHIP	1uF		10V	C3218	1-164-943-11	CERAMIC CHIP	0.01uF	10%	16V
C2243	1-125-837-91	CERAMIC CHIP	1uF	10%	6.3V	C3301	1-107-826-11	CERAMIC CHIP	0.1uF	10%	16V
C2244	1-164-943-11	CERAMIC CHIP	0.01uF	10%	16V	C3302	1-107-826-11	CERAMIC CHIP	0.1uF	10%	16V
C2247	1-125-837-91	CERAMIC CHIP	1uF	10%	6.3V	C3303	1-107-826-11	CERAMIC CHIP	0.1uF	10%	16V
C2250	1-135-201-11	TANTALUM CHIP	10uF	20%	4V	C3305	1-107-826-11	CERAMIC CHIP	0.1uF	10%	16V
C2291	1-164-943-11	CERAMIC CHIP	0.01uF	10%	16V	C3306	1-164-943-11	CERAMIC CHIP	0.01uF	10%	16V
C2292	1-104-852-11	TANTAL. CHIP	22uF	20%	10V	C3307	1-164-850-11	CERAMIC CHIP	10PF	0.50PF	16V
C2293	1-125-837-91	CERAMIC CHIP	1uF	10%	6.3V	C3308	1-164-850-11	CERAMIC CHIP	10PF	0.50PF	16V
C3102	1-164-943-11	CERAMIC CHIP	0.01uF	10%	16V	C3309	1-164-943-11	CERAMIC CHIP	0.01uF	10%	16V
C3104	1-164-943-11	CERAMIC CHIP	0.01uF	10%	16V	C3310	1-127-760-11	CERAMIC CHIP	4.7uF	10%	6.3V
C3105	1-164-943-11	CERAMIC CHIP	0.01uF	10%	16V	C3311	1-164-943-11	CERAMIC CHIP	0.01uF	10%	16V
C3107	1-164-943-11	CERAMIC CHIP	0.01uF	10%	16V	C3312	1-164-943-11	CERAMIC CHIP	0.01uF	10%	16V
C3108	1-135-259-11	TANTAL. CHIP	10uF	20%	6.3V	C3313	1-164-937-11	CERAMIC CHIP	0.001uF	10%	16V
C3109	1-164-943-11	CERAMIC CHIP	0.01uF	10%	16V	C3314	1-164-937-11	CERAMIC CHIP	0.001uF	10%	16V
C3110	1-164-943-11	CERAMIC CHIP	0.01uF	10%	16V	C3315	1-164-937-11	CERAMIC CHIP	0.001uF	10%	16V

VC-250

Ref. No.	Part No.	Description	Remarks	Ref. No.	Part No.	Description	Remarks
C3316	1-164-937-11	CERAMIC CHIP	0.001uF 10% 16V	C3708	1-125-838-11	CERAMIC CHIP	2.2uF 10% 6.3V
C3317	1-164-943-11	CERAMIC CHIP	0.01uF 10% 16V	C3709	1-164-677-11	CERAMIC CHIP	0.033uF 10% 16V
C3318	1-164-943-11	CERAMIC CHIP	0.01uF 10% 16V	C3710	1-125-838-11	CERAMIC CHIP	2.2uF 10% 6.3V
C3319	1-164-937-11	CERAMIC CHIP	0.001uF 10% 16V	C3711	1-125-838-11	CERAMIC CHIP	2.2uF 10% 6.3V
C3320	1-135-259-11	TANTAL. CHIP	10uF 20% 6.3V	C3712	1-125-838-11	CERAMIC CHIP	2.2uF 10% 6.3V
C3321	1-164-943-11	CERAMIC CHIP	0.01uF 10% 16V	C3713	1-125-837-91	CERAMIC CHIP	1uF 10% 6.3V
C3322	1-117-863-11	CERAMIC CHIP	0.47uF 10% 6.3V	C3714	1-104-851-11	TANTAL. CHIP	10uF 20% 10V
C3323	1-164-943-11	CERAMIC CHIP	0.01uF 10% 16V	C3715	1-110-501-11	CERAMIC CHIP	0.33uF 10% 16V
C3324	1-119-923-81	CERAMIC CHIP	0.047uF 10% 10V	C3716	1-164-943-11	CERAMIC CHIP	0.01uF 10% 16V
C3325	1-164-937-11	CERAMIC CHIP	0.001uF 10% 16V	C3717	1-125-837-91	CERAMIC CHIP	1uF 10% 6.3V
C3326	1-125-838-11	CERAMIC CHIP	2.2uF 10% 6.3V	C3718	1-164-943-11	CERAMIC CHIP	0.01uF 10% 16V
C3327	1-119-750-11	TANTAL. CHIP	22uF 20% 6.3V	C3719	1-164-943-11	CERAMIC CHIP	0.01uF 10% 16V
C3328	1-164-943-11	CERAMIC CHIP	0.01uF 10% 16V	C3723	1-164-943-11	CERAMIC CHIP	0.01uF 10% 16V
C3329	1-164-943-11	CERAMIC CHIP	0.01uF 10% 16V	C3724	1-125-777-11	CERAMIC CHIP	0.1uF 10% 10V
C3331	1-135-201-11	TANTALUM CHIP	10uF 20% 4V	C3728	1-125-838-11	CERAMIC CHIP	2.2uF 10% 6.3V
C3332	1-164-943-11	CERAMIC CHIP	0.01uF 10% 16V	C3729	1-125-838-11	CERAMIC CHIP	2.2uF 10% 6.3V
C3333	1-162-970-11	CERAMIC CHIP	0.01uF 10% 25V	C3730	1-164-943-11	CERAMIC CHIP	0.01uF 10% 16V
C3334	1-164-943-11	CERAMIC CHIP	0.01uF 10% 16V	C3731	1-164-943-11	CERAMIC CHIP	0.01uF 10% 16V
C3335	1-125-777-11	CERAMIC CHIP	0.1uF 10% 10V	C3732	1-128-964-91	TANTAL. CHIP	100uF 20% 6.3V
C3337	1-125-837-91	CERAMIC CHIP	1uF 10% 6.3V	C3733	1-128-964-91	TANTAL. CHIP	100uF 20% 6.3V
C3338	1-164-882-11	CERAMIC CHIP	220PF 5% 16V	C3734	1-104-851-11	TANTAL. CHIP	10uF 20% 10V
C3341	1-125-837-91	CERAMIC CHIP	1uF 10% 6.3V	C3735	1-162-970-11	CERAMIC CHIP	0.01uF 10% 25V
C3342	1-125-837-91	CERAMIC CHIP	1uF 10% 6.3V	C3737	1-164-943-11	CERAMIC CHIP	0.01uF 10% 16V
C3343	1-127-760-11	CERAMIC CHIP	4.7uF 10% 6.3V	C3738	1-127-688-21	TANTAL. CHIP	10uF 20% 6.3V
C3345	1-127-760-11	CERAMIC CHIP	4.7uF 10% 6.3V	C3739	1-127-688-21	TANTAL. CHIP	10uF 20% 6.3V
C3346	1-127-760-11	CERAMIC CHIP	4.7uF 10% 6.3V	C3740	1-164-943-11	CERAMIC CHIP	0.01uF 10% 16V
C3348	1-127-760-11	CERAMIC CHIP	4.7uF 10% 6.3V	C3741	1-104-851-11	TANTAL. CHIP	10uF 20% 10V
C3349	1-125-837-91	CERAMIC CHIP	1uF 10% 6.3V	C3742	1-162-970-11	CERAMIC CHIP	0.01uF 10% 25V
C3350	1-125-837-91	CERAMIC CHIP	1uF 10% 6.3V	C3743	1-127-688-21	TANTAL. CHIP	10uF 20% 6.3V
C3601	1-135-201-11	TANTALUM CHIP	10uF 20% 4V	C3744	1-127-688-21	TANTAL. CHIP	10uF 20% 6.3V
C3603	1-164-943-11	CERAMIC CHIP	0.01uF 10% 16V	C3745	1-162-970-11	CERAMIC CHIP	0.01uF 10% 25V
C3604	1-104-851-11	TANTAL. CHIP	10uF 20% 10V	C3746	1-104-851-11	TANTAL. CHIP	10uF 20% 10V
C3608	1-125-777-11	CERAMIC CHIP	0.1uF 10% 10V	C3747	1-128-964-91	TANTAL. CHIP	100uF 20% 6.3V
C3610	1-135-259-11	TANTAL. CHIP	10uF 20% 6.3V	C3748	1-127-688-21	TANTAL. CHIP	10uF 20% 6.3V
C3611	1-125-837-91	CERAMIC CHIP	1uF 10% 6.3V	C3749	1-164-943-11	CERAMIC CHIP	0.01uF 10% 16V
C3612	1-125-837-91	CERAMIC CHIP	1uF 10% 6.3V	C3750	1-128-964-91	TANTAL. CHIP	100uF 20% 6.3V
C3613	1-164-943-11	CERAMIC CHIP	0.01uF 10% 16V	C3751	1-128-964-91	TANTAL. CHIP	100uF 20% 6.3V
C3614	1-125-837-91	CERAMIC CHIP	1uF 10% 6.3V	C3752	1-128-964-91	TANTAL. CHIP	100uF 20% 6.3V
C3615	1-164-943-11	CERAMIC CHIP	0.01uF 10% 16V	C3901	1-125-837-91	CERAMIC CHIP	1uF 10% 6.3V
C3616	1-125-837-91	CERAMIC CHIP	1uF 10% 6.3V	C3902	1-135-201-11	TANTALUM CHIP	10uF 20% 4V (D200E/D800E) (D200/D800)
C3617	1-125-837-91	CERAMIC CHIP	1uF 10% 6.3V	C3903	1-127-688-21	TANTAL. CHIP	10uF 20% 6.3V (D200/D800)
C3618	1-125-837-91	CERAMIC CHIP	1uF 10% 6.3V	C3904	1-164-943-11	CERAMIC CHIP	0.01uF 10% 16V
C3619	1-164-943-11	CERAMIC CHIP	0.01uF 10% 16V	C3905	1-117-863-11	CERAMIC CHIP	0.47uF 10% 6.3V
C3620	1-164-943-11	CERAMIC CHIP	0.01uF 10% 16V	C3906	1-117-863-11	CERAMIC CHIP	0.47uF 10% 6.3V
C3621	1-164-943-11	CERAMIC CHIP	0.01uF 10% 16V	C3908	1-125-837-91	CERAMIC CHIP	1uF 10% 6.3V
C3622	1-125-837-91	CERAMIC CHIP	1uF 10% 6.3V	C3909	1-164-943-11	CERAMIC CHIP	0.01uF 10% 16V
C3626	1-107-826-11	CERAMIC CHIP	0.1uF 10% 16V	C3910	1-119-660-11	TANTAL. CHIP	4.7uF 20% 6.3V
C3628	1-164-943-11	CERAMIC CHIP	0.01uF 10% 16V	C3911	1-164-943-11	CERAMIC CHIP	0.01uF 10% 16V
C3629	1-125-777-11	CERAMIC CHIP	0.1uF 10% 10V	C3912	1-164-943-11	CERAMIC CHIP	0.01uF 10% 16V
C3630	1-125-777-11	CERAMIC CHIP	0.1uF 10% 10V	C3913	1-164-668-11	CERAMIC CHIP	510PF 5% 50V
C3631	1-125-777-11	CERAMIC CHIP	0.1uF 10% 10V	C3914	1-104-851-11	TANTAL. CHIP	10uF 20% 10V
C3632	1-164-943-11	CERAMIC CHIP	0.01uF 10% 16V	C3915	1-164-943-11	CERAMIC CHIP	0.01uF 10% 16V
C3633	1-127-688-21	TANTAL. CHIP	10uF 20% 6.3V	C3916	1-125-837-91	CERAMIC CHIP	1uF 10% 6.3V
C3634	1-125-777-11	CERAMIC CHIP	0.1uF 10% 10V	C3917	1-107-826-11	CERAMIC CHIP	0.1uF 10% 16V
C3636	1-164-858-11	CERAMIC CHIP	22PF 5% 16V	C3918	1-164-844-11	CERAMIC CHIP	4PF 0.25PF 16V
C3701	1-164-943-11	CERAMIC CHIP	0.01uF 10% 16V				
C3704	1-115-467-11	CERAMIC CHIP	0.22uF 10% 10V				
C3705	1-110-501-11	CERAMIC CHIP	0.33uF 10% 16V				
C3706	1-164-943-11	CERAMIC CHIP	0.01uF 10% 16V				
C3707	1-125-837-91	CERAMIC CHIP	1uF 10% 6.3V				

Ref. No.	Part No.	Description	Remarks	Ref. No.	Part No.	Description	Remarks
C3919	1-117-863-11	CERAMIC CHIP	0.47uF 10% 6.3V	C4806	1-119-749-11	TANTAL. CHIP	33uF 20% 4V
C3920	1-117-863-11	CERAMIC CHIP	0.47uF 10% 6.3V	C4807	1-125-777-11	CERAMIC CHIP	0.1uF 10% 10V
C3921	1-164-862-11	CERAMIC CHIP	33PF 5% 16V	C4808	1-164-943-11	CERAMIC CHIP	0.01uF 10% 16V
C3922	1-125-837-91	CERAMIC CHIP	1uF 10% 6.3V	C4809	1-164-943-11	CERAMIC CHIP	0.01uF 10% 16V
C3923	1-164-864-11	CERAMIC CHIP	39PF 5% 16V	C4810	1-164-943-11	CERAMIC CHIP	0.01uF 10% 16V
C3924	1-125-837-91	CERAMIC CHIP	1uF 10% 6.3V	C4812	1-164-943-11	CERAMIC CHIP	0.01uF 10% 16V
C3925	1-107-826-11	CERAMIC CHIP	0.1uF 10% 16V	C4813	1-164-943-11	CERAMIC CHIP	0.01uF 10% 16V
C3926	1-164-943-11	CERAMIC CHIP	0.01uF 10% 16V	C4814	1-164-943-11	CERAMIC CHIP	0.01uF 10% 16V
C3927	1-164-943-11	CERAMIC CHIP	0.01uF 10% 16V	C4816	1-125-777-11	CERAMIC CHIP	0.1uF 10% 10V
C3928	1-104-847-11	TANTAL. CHIP	22uF 20% 4V	C4817	1-125-777-11	CERAMIC CHIP	0.1uF 10% 10V
C3929	1-164-943-11	CERAMIC CHIP	0.01uF 10% 16V	C4819	1-107-819-11	CERAMIC CHIP	0.022uF 10% 16V
C3934	1-125-837-91	CERAMIC CHIP	1uF 10% 6.3V	C4820	1-164-942-11	CERAMIC CHIP	0.0068uF 10% 16V
C3935	1-164-943-11	CERAMIC CHIP	0.01uF 10% 16V	C4821	1-164-858-11	CERAMIC CHIP	22PF 5% 16V
C3936	1-164-943-11	CERAMIC CHIP	0.01uF 10% 16V	C4822	1-164-856-81	CERAMIC CHIP	18PF 5% 16V
C4401	1-125-777-11	CERAMIC CHIP	0.1uF 10% 10V	C4823	1-125-777-11	CERAMIC CHIP	0.1uF 10% 10V
C4402	1-125-777-11	CERAMIC CHIP	0.1uF 10% 10V	C4824	1-125-777-11	CERAMIC CHIP	0.1uF 10% 10V
C4403	1-125-777-11	CERAMIC CHIP	0.1uF 10% 10V	C4825	1-125-777-11	CERAMIC CHIP	0.1uF 10% 10V
C4404	1-125-777-11	CERAMIC CHIP	0.1uF 10% 10V	C4827	1-164-943-11	CERAMIC CHIP	0.01uF 10% 16V
C4405	1-107-819-11	CERAMIC CHIP	0.022uF 10% 16V	C4902	1-125-837-91	CERAMIC CHIP	1uF 10% 6.3V
C4406	1-107-819-11	CERAMIC CHIP	0.022uF 10% 16V	C4903	1-164-850-11	CERAMIC CHIP	10PF 0.50PF 16V
C4407	1-119-923-81	CERAMIC CHIP	0.047uF 10% 10V	C4904	1-164-850-11	CERAMIC CHIP	10PF 0.50PF 16V
C4408	1-104-912-11	TANTAL. CHIP	3.3uF 10% 6.3V	C4905	1-164-943-11	CERAMIC CHIP	0.01uF 10% 16V
C4409	1-125-777-11	CERAMIC CHIP	0.1uF 10% 10V	C4906	1-125-777-11	CERAMIC CHIP	0.1uF 10% 10V
C4410	1-125-777-11	CERAMIC CHIP	0.1uF 10% 10V	C4907	1-125-777-11	CERAMIC CHIP	0.1uF 10% 10V
C4411	1-125-777-11	CERAMIC CHIP	0.1uF 10% 10V	C4911	1-125-777-11	CERAMIC CHIP	0.1uF 10% 10V
C4412	1-125-777-11	CERAMIC CHIP	0.1uF 10% 10V	C5701	1-135-201-11	TANTALUM CHIP	10uF 20% 4V
C4413	1-125-777-11	CERAMIC CHIP	0.1uF 10% 10V	C5702	1-135-201-11	TANTALUM CHIP	10uF 20% 4V
C4414	1-164-933-11	CERAMIC CHIP	220PF 10% 16V	C5704	1-104-851-11	TANTAL. CHIP	10uF 20% 10V
C4415	1-164-935-11	CERAMIC CHIP	470PF 10% 16V	C5705	1-104-847-11	TANTAL. CHIP	22uF 20% 4V
C4416	1-125-777-11	CERAMIC CHIP	0.1uF 10% 10V	C5706	1-127-688-21	TANTAL. CHIP	10uF 20% 6.3V
C4417	1-164-937-11	CERAMIC CHIP	0.001uF 10% 16V	C5709	1-115-467-11	CERAMIC CHIP	0.22uF 10% 10V
C4418	1-164-935-11	CERAMIC CHIP	470PF 10% 16V	C5711	1-110-569-11	TANTAL. CHIP	47uF 20% 6.3V
C4419	1-164-937-11	CERAMIC CHIP	0.001uF 10% 16V	C5712	1-110-569-11	TANTAL. CHIP	47uF 20% 6.3V
C4420	1-125-837-91	CERAMIC CHIP	1uF 10% 6.3V	C5713	1-117-863-11	CERAMIC CHIP	0.47uF 10% 6.3V
C4421	1-164-937-11	CERAMIC CHIP	0.001uF 10% 16V	C5715	1-104-912-11	TANTAL. CHIP	3.3uF 20% 4V
C4424	1-125-777-11	CERAMIC CHIP	0.1uF 10% 10V	C5719	1-115-467-11	CERAMIC CHIP	0.22uF 10% 10V
C4425	1-107-819-11	CERAMIC CHIP	0.022uF 10% 16V	C5721	1-164-939-11	CERAMIC CHIP	0.0022uF 10% 16V
C4426	1-164-943-11	CERAMIC CHIP	0.01uF 10% 16V	C5722	1-115-467-11	CERAMIC CHIP	0.22uF 10% 10V
C4427	1-164-943-11	CERAMIC CHIP	0.01uF 10% 16V	C5723	1-119-750-11	TANTAL. CHIP	22uF 20% 6.3V
C4428	1-119-923-81	CERAMIC CHIP	0.047uF 10% 10V	C5724	1-115-467-11	CERAMIC CHIP	0.22uF 10% 10V
C4429	1-119-923-81	CERAMIC CHIP	0.047uF 10% 10V	C5725	1-125-837-91	CERAMIC CHIP	1uF 10% 6.3V
C4430	1-164-505-11	CERAMIC CHIP	2.2uF 10% 16V	C5728	1-125-777-11	CERAMIC CHIP	0.1uF 10% 10V
C4431	1-125-777-11	CERAMIC CHIP	0.1uF 10% 10V	C5730	1-115-467-11	CERAMIC CHIP	0.22uF 10% 10V
C4432	1-164-943-11	CERAMIC CHIP	0.01uF 10% 16V	C5731	1-125-837-91	CERAMIC CHIP	1uF 10% 6.3V
C4433	1-164-937-11	CERAMIC CHIP	0.001uF 10% 16V	C5732	1-125-837-91	CERAMIC CHIP	1uF 10% 6.3V
C4434	1-164-937-11	CERAMIC CHIP	0.001uF 10% 16V	C5733	1-125-837-91	CERAMIC CHIP	1uF 10% 6.3V
C4435	1-164-935-11	CERAMIC CHIP	470PF 10% 16V	C5734	1-125-837-91	CERAMIC CHIP	1uF 10% 6.3V
C4436	1-164-935-11	CERAMIC CHIP	470PF 10% 16V	C5735	1-125-777-11	CERAMIC CHIP	0.1uF 10% 10V
C4501	1-164-937-11	CERAMIC CHIP	0.001uF 10% 16V	C5736	1-115-467-11	CERAMIC CHIP	0.22uF 10% 10V
C4504	1-125-837-91	CERAMIC CHIP	1uF 10% 6.3V	C5737	1-125-837-91	CERAMIC CHIP	1uF 10% 6.3V
C4505	1-164-943-11	CERAMIC CHIP	0.01uF 10% 16V	C5738	1-125-837-91	CERAMIC CHIP	1uF 10% 6.3V
C4506	1-164-943-11	CERAMIC CHIP	0.01uF 10% 16V	C5739	1-125-837-91	CERAMIC CHIP	1uF 10% 6.3V
C4507	1-164-943-11	CERAMIC CHIP	0.01uF 10% 16V	C5740	1-115-467-11	CERAMIC CHIP	0.22uF 10% 10V
C4508	1-164-943-11	CERAMIC CHIP	0.01uF 10% 16V	C5741	1-115-467-11	CERAMIC CHIP	0.22uF 10% 10V
C4509	1-164-943-11	CERAMIC CHIP	0.01uF 10% 16V	C5742	1-164-937-11	CERAMIC CHIP	0.001uF 10% 16V
C4510	1-164-943-11	CERAMIC CHIP	0.01uF 10% 16V	C5743	1-164-937-11	CERAMIC CHIP	0.001uF 10% 16V
C4802	1-125-777-11	CERAMIC CHIP	0.1uF 10% 10V	C5744	1-164-943-11	CERAMIC CHIP	0.01uF 10% 16V
C4803	1-125-777-11	CERAMIC CHIP	0.1uF 10% 10V	C5745	1-164-943-11	CERAMIC CHIP	0.01uF 10% 16V
C4804	1-125-777-11	CERAMIC CHIP	0.1uF 10% 10V	C5746	1-117-863-11	CERAMIC CHIP	0.47uF 10% 6.3V
C4805	1-125-822-11	TANTALUM	10uF 20% 10V	C5747	1-117-863-11	CERAMIC CHIP	0.47uF 10% 6.3V

VC-250

Ref. No.	Part No.	Description	Remarks	Ref. No.	Part No.	Description	Remarks
C5748	1-164-943-11	CERAMIC CHIP	0.01uF 10% 16V			< FERRITE BEAD >	
C5749	1-164-870-11	CERAMIC CHIP	68PF 5% 16V				
C5750	1-135-201-11	TANTALUM CHIP	10uF 20% 4V	FB1501	1-414-760-21	FERRITE	0UH
C5751	1-135-259-11	TANTAL. CHIP	10uF 20% 6.3V	FB1502	1-500-284-21	INDUCTOR	0UH
C5752	1-164-943-11	CERAMIC CHIP	0.01uF 10% 16V	FB1503	1-500-284-21	INDUCTOR	0UH
				FB1504	1-414-760-21	FERRITE	0UH
C5753	1-164-943-11	CERAMIC CHIP	0.01uF 10% 16V	FB2202	1-414-760-21	FERRITE	0UH
C5754	1-115-467-11	CERAMIC CHIP	0.22uF 10% 10V				
C5755	1-164-942-11	CERAMIC CHIP	0.0068uF 10% 16V	FB2203	1-414-760-21	FERRITE	0UH
C5756	1-115-467-11	CERAMIC CHIP	0.22uF 10% 10V	FB2204	1-414-760-21	FERRITE	0UH
C5757	1-164-942-11	CERAMIC CHIP	0.0068uF 10% 16V	FB2205	1-414-760-21	FERRITE	0UH
				FB2291	1-414-760-21	FERRITE	0UH
C5760	1-110-569-11	TANTAL. CHIP	47uF 20% 6.3V	FB3303	1-414-760-21	FERRITE	0UH
C5761	1-125-838-11	CERAMIC CHIP	2.2uF 10% 6.3V				
C5762	1-125-838-11	CERAMIC CHIP	2.2uF 10% 6.3V	FB3304	1-414-760-21	FERRITE	0UH
C5763	1-125-838-11	CERAMIC CHIP	2.2uF 10% 6.3V	FB3307	1-414-760-21	FERRITE	0UH
C5764	1-125-838-11	CERAMIC CHIP	2.2uF 10% 6.3V	FB3601	1-414-760-21	FERRITE	0UH
				FB3701	1-414-760-21	FERRITE	0UH
C5765	1-113-682-11	TANTAL. CHIP	33uF 20% 10V (D800/D800E)	FB4501	1-414-760-21	FERRITE	0UH
C5766	1-125-837-91	CERAMIC CHIP	1uF 10% 6.3V (D800/D800E)	FB4801	1-414-760-21	FERRITE	0UH
C5767	1-125-837-91	CERAMIC CHIP	1uF 10% 6.3V (D800/D800E)	FB4901	1-414-760-21	FERRITE	0UH
C5768	1-127-688-21	TANTAL. CHIP	10uF 20% 6.3V (D800/D800E)			< IC >	
C5769	1-127-688-21	TANTAL. CHIP	10uF 20% 6.3V (D800/D800E)	IC901	8-759-580-27	IC S-81236SGUP-DQ7-T1	
				IC1302	8-759-652-10	IC TK11119SCL	
C5770	1-164-937-11	CERAMIC CHIP	0.001uF 10% 16V (D800/D800E)	IC1303	8-759-650-28	IC RN5RZ59BA-TL	
C5771	1-164-937-11	CERAMIC CHIP	0.001uF 10% 16V (D800/D800E)	IC1502	8-759-684-90	IC VSP2200Y-1/2K	
				IC1504	8-759-243-19	IC TC7SU04F (TE85R)	
		< CONNECTOR >		IC1505	8-759-447-77	IC TC7WH74FU (TE12R)	
CN921	1-691-542-21	CONNECTOR, BOARD TO BOARD 48P		IC2201	8-759-670-78	IC HG75C012SFL	
CN923	1-774-932-21	CONNECTOR, FFC/FPC (ZIF) 32P (D800/D800E)		IC2202	8-759-058-60	IC TC7SU04FU (TE85R)	
CN922	1-778-597-21	CONNECTOR, BOARD TO BOARD 50P		IC2291	8-759-169-02	IC MB98344BPFV-G-BND-ER	
CN924	1-691-374-11	CONNECTOR, FFC/FPC 10P		IC3101	8-752-086-52	IC CXA2071R-T4	
CN926	1-766-759-11	CONNECTOR, FFC/FPC 4P		IC3102	8-759-195-81	IC TC7S86FU (TE85R)	
CN927	1-766-340-21	CONNECTOR, FFC/FPC 10P		IC3103	8-752-086-53	IC CXA2072R-T4	
CN929	1-764-704-21	CONNECTOR, FFC/FPC (LIF) 5P		IC3201	8-752-093-69	IC CXA3265R-T4	
CN931	1-770-543-21	CONNECTOR, FFC/FPC 40P		IC3202	8-759-075-70	IC TA75S393F-TE85R	
CN933	1-766-350-21	CONNECTOR, FFC/FPC 20P		IC3301	8-759-650-74	IC CAIN	
CN3101	1-766-346-21	CONNECTOR, FFC/FPC 16P		IC3302	8-759-678-25	IC MB90099PFV-G-104-BND-ER	
CN4401	1-766-644-21	CONNECTOR, FFC/FPC 8P		IC3303	8-759-566-52	IC SN104266PN-TEB	
CN4402	1-766-340-21	CONNECTOR, FFC/FPC 10P		IC3603	8-759-653-60	IC MB87L1241PFV-G-BND-ER	
CN4403	1-766-342-21	CONNECTOR, FFC/FPC 12P		IC3701	8-759-599-37	IC AN2225FHQ-EB	
CN4404	1-766-345-21	CONNECTOR, FFC/FPC 15P		IC3702	8-759-284-49	IC NJM2285V-TE2	
		< DIODE >		IC3703	8-759-433-44	IC MM1031XML	
D901	8-719-421-27	DIODE MA728-(K8).S0		IC3901	8-759-498-52	IC LA9511WL-TBM (D200/D800)	
D1501	8-713-103-84	DIODE 1T379-01-T8A		IC3901	8-759-566-96	IC AN2920FHQ-EB (D200E/D800E)	
D2201	8-719-055-86	DIODE KV1470TL1-3		IC4401	8-759-640-85	IC CXA8096R-TBM	
D2202	8-719-055-86	DIODE KV1470TL1-3		IC4501	8-759-684-49	IC MB91192PFF-G-116-BND-ER	
D3301	8-719-992-02	DIODE RB705D-T146		IC4502	8-759-593-47	IC AK6417AM-E2	
D3302	8-719-055-86	DIODE KV1470TL1-3		IC4801	8-759-424-79	IC S-8423YFS-T2	
D3303	8-719-992-02	DIODE RB705D-T146		IC4802	8-759-642-45	IC TL1596CPWR	
D3304	8-719-055-86	DIODE KV1470TL1-3		IC4803	8-759-697-34	IC S579640PZ-TEB	
D4401	8-719-075-12	DIODE MA3XD21001S0		IC4901	8-759-445-94	IC AK6480AM-E2	
D4801	8-719-073-01	DIODE MA111-(K8).S0		IC4902	8-759-686-05	IC MB91192PFF-G-117-BND-ER	
D4802	8-719-073-01	DIODE MA111-(K8).S0		IC5701	8-752-093-72	IC CXA3284R-T6	
D4803	8-719-073-01	DIODE MA111-(K8).S0		IC5702	8-759-647-71	IC AK4550VT-E2	
D4804	8-719-073-01	DIODE MA111-(K8).S0		IC5703	8-759-075-69	IC NJU4066BV (TE2)	
				IC5704	8-759-676-19	IC NJW1105VF1 (TE2) (D800/D800E)	

Ref. No.	Part No.	Description	Remarks	Ref. No.	Part No.	Description	Remarks
		< COIL >					
L1306	1-412-056-11	INDUCTOR	4.7uH	Q1326	8-729-037-53	TRANSISTOR	2SA1832F-Y/GR (TPL3) (D800/D800E)
L1307	1-412-056-11	INDUCTOR	4.7uH	Q2204	8-729-037-53	TRANSISTOR	2SA1832F-Y/GR (TPL3)
L1308	1-469-524-91	INDUCTOR	4.7uH	Q2206	8-729-037-52	TRANSISTOR	2SC4738F-Y/GR (TPL3)
L1309	1-469-524-91	INDUCTOR	4.7uH (D800/D800E)	Q3102	8-729-037-53	TRANSISTOR	2SA1832F-Y/GR (TPL3)
L1311	1-469-524-91	INDUCTOR	4.7uH	Q3103	8-729-042-29	TRANSISTOR	RN1104F (TPL3)
L1313	1-469-524-91	INDUCTOR	4.7uH	Q3104	8-729-037-52	TRANSISTOR	2SC4738F-Y/GR (TPL3)
L1314	1-469-524-91	INDUCTOR	4.7uH	Q3105	8-729-042-29	TRANSISTOR	RN1104F (TPL3)
L1315	1-469-524-91	INDUCTOR	4.7uH (D800/D800E)	Q3106	8-729-042-29	TRANSISTOR	RN1104F (TPL3)
L1316	1-414-400-11	INDUCTOR	22uH	Q3107	8-729-037-52	TRANSISTOR	2SC4738F-Y/GR (TPL3)
L1320	1-469-526-91	INDUCTOR	22uH (D800/D800E)	Q3108	8-729-037-53	TRANSISTOR	2SA1832F-Y/GR (TPL3)
L1321	1-469-524-91	INDUCTOR	4.7uH	Q3109	8-729-042-58	TRANSISTOR	RN2102F (TPL3)
L1501	1-469-525-91	INDUCTOR	10uH	Q3110	8-729-042-58	TRANSISTOR	RN2102F (TPL3)
L2201	1-469-525-91	INDUCTOR	10uH	Q3111	8-729-037-53	TRANSISTOR	2SA1832F-Y/GR (TPL3)
L2202	1-469-525-91	INDUCTOR	10uH	Q3112	8-729-037-52	TRANSISTOR	2SC4738F-Y/GR (TPL3)
L2203	1-469-525-91	INDUCTOR	10uH	Q3113	8-729-037-52	TRANSISTOR	2SC4738F-Y/GR (TPL3)
L2204	1-469-525-91	INDUCTOR	10uH	Q3114	8-729-037-52	TRANSISTOR	2SC4738F-Y/GR (TPL3)
L2207	1-412-945-11	INDUCTOR	3.3uH	Q3115	8-729-037-52	TRANSISTOR	2SC4738F-Y/GR (TPL3)
L2208	1-469-525-91	INDUCTOR	10uH	Q3116	8-729-047-19	TRANSISTOR	2SA1965-S-TL
L2209	1-469-525-91	INDUCTOR	10uH	Q3201	8-729-042-29	TRANSISTOR	RN1104F (TPL3)
L2291	1-469-525-91	INDUCTOR	10uH	Q3302	8-729-037-53	TRANSISTOR	2SA1832F-Y/GR (TPL3) (D800/D800E)
L3102	1-469-525-91	INDUCTOR	10uH	Q3304	8-729-037-53	TRANSISTOR	2SA1832F-Y/GR (TPL3) (D800/D800E)
L3103	1-469-525-91	INDUCTOR	10uH	Q3306	8-729-037-53	TRANSISTOR	2SA1832F-Y/GR (TPL3) (D800/D800E)
L3104	1-469-525-91	INDUCTOR	10uH	Q3307	8-729-037-53	TRANSISTOR	2SA1832F-Y/GR (TPL3)
L3105	1-414-406-11	INDUCTOR	220uH	Q3308	8-729-037-53	TRANSISTOR	2SA1832F-Y/GR (TPL3)
L3106	1-412-952-11	INDUCTOR	12uH	Q3602	8-729-037-53	TRANSISTOR	2SA1832F-Y/GR (TPL3)
L3201	1-469-526-91	INDUCTOR	22uH	Q3603	8-729-037-52	TRANSISTOR	2SC4738F-Y/GR (TPL3)
L3303	1-412-936-11	INDUCTOR	0.56uH	Q3604	8-729-807-86	TRANSISTOR	2SB1295-UL5/6-TB
L3304	1-414-246-11	INDUCTOR	1.8uH	Q3605	8-729-042-29	TRANSISTOR	RN1104F (TPL3)
L3305	1-469-525-91	INDUCTOR	10uH	Q3606	8-729-037-53	TRANSISTOR	2SA1832F-Y/GR (TPL3)
L3306	1-469-525-91	INDUCTOR	10uH	Q3701	8-729-037-52	TRANSISTOR	2SC4738F-Y/GR (TPL3)
L3307	1-469-525-91	INDUCTOR	10uH	Q3902	8-729-122-63	TRANSISTOR	2SA1226-T1E4
L3601	1-469-525-91	INDUCTOR	10uH	Q3903	8-729-037-53	TRANSISTOR	2SA1832F-Y/GR (TPL3)
L3602	1-469-525-91	INDUCTOR	10uH	Q4401	8-729-037-52	TRANSISTOR	2SC4738F-Y/GR (TPL3)
L3701	1-469-525-91	INDUCTOR	10uH	Q4402	8-729-042-29	TRANSISTOR	RN1104F (TPL3)
L3705	1-469-525-91	INDUCTOR	10uH	Q4802	8-729-037-52	TRANSISTOR	2SC4738F-Y/GR (TPL3)
L3706	1-469-525-91	INDUCTOR	10uH	Q4803	8-729-042-29	TRANSISTOR	RN1104F (TPL3)
L3707	1-469-525-91	INDUCTOR	10uH	Q4804	8-729-041-43	TRANSISTOR	HN1L02FU (TE85F)
L3901	1-469-525-91	INDUCTOR	10uH	Q4805	8-729-042-29	TRANSISTOR	RN1104F (TPL3)
L3902	1-412-948-11	INDUCTOR	5.6uH	Q4806	8-729-042-58	TRANSISTOR	RN2102F (TPL3)
L3903	1-412-957-11	INDUCTOR	33uH	Q4808	8-729-042-72	TRANSISTOR	RN1107F (TPL3)
L3904	1-412-957-11	INDUCTOR	33uH	Q4809	8-729-045-86	TRANSISTOR	RN2107F (TPL3)
L5701	1-414-754-11	INDUCTOR	10uH	Q4810	8-729-042-72	TRANSISTOR	RN1107F (TPL3)
		< TRANSISTOR >		Q4811	8-729-045-86	TRANSISTOR	RN2107F (TPL3)
Q901	8-729-141-48	TRANSISTOR	2SB624-T1BV4	Q4812	8-729-042-72	TRANSISTOR	RN1107F (TPL3)
Q902	8-729-042-26	TRANSISTOR	2SB1462J-QR (K8).SO	Q5701	8-729-042-74	TRANSISTOR	RN1110F (TPL3)
Q903	8-729-037-72	TRANSISTOR	UN9211J-(K8).SO	Q5703	8-729-042-74	TRANSISTOR	RN1110F (TPL3)
Q904	8-729-101-07	TRANSISTOR	2SB798-T1-DLDK	Q5704	8-729-042-74	TRANSISTOR	RN1110F (TPL3)
Q905	8-729-037-52	TRANSISTOR	2SC4738F-Y/GR (TPL3)	Q5706	8-729-042-74	TRANSISTOR	RN1110F (TPL3)
Q906	8-729-042-72	TRANSISTOR	RN1107F (TPL3)	Q5708	8-729-037-63	TRANSISTOR	RN2111F (TPL3)
Q907	8-729-042-72	TRANSISTOR	RN1107F (TPL3)	Q5716	8-729-037-74	TRANSISTOR	UN9213J-(K8).SO
Q908	8-729-042-72	TRANSISTOR	RN1107F (TPL3)	Q5717	8-729-042-72	TRANSISTOR	UN9214J-(K8).SO (D800/D800E)
Q1322	8-729-037-53	TRANSISTOR	2SA1832F-Y/GR (TPL3) (D800/D800E)	Q5718	8-729-037-72	TRANSISTOR	UN9211J-(K8).SO
Q1324	8-729-037-52	TRANSISTOR	2SC4738F-Y/GR (TPL3) (D800/D800E)	Q5721	8-729-042-74	TRANSISTOR	RN1110F (TPL3)

VC-250

Ref. No.	Part No.	Description	Remarks	Ref. No.	Part No.	Description	Remarks
		< RESISTOR >					
R901	1-218-934-11	RES-CHIP	27 5% 1/16W	R2213	1-218-962-11	RES-CHIP	5.6K 5% 1/16W
R902	1-216-311-00	METAL CHIP	6.8 5% 1/10W	R2215	1-218-953-11	RES-CHIP	1K 5% 1/16W
R903	1-216-089-11	RES-CHIP	47K 5% 1/10W	R2216	1-218-963-11	RES-CHIP	6.8K 5% 1/16W
R904	1-216-049-11	RES-CHIP	1K 5% 1/10W	R2218	1-218-949-11	RES-CHIP	470 5% 1/16W
R907	1-218-990-11	SHORT	0	R2219	1-218-941-11	RES-CHIP	100 5% 1/16W
R908	1-218-961-11	RES-CHIP	4.7K 5% 1/16W	R2220	1-218-972-11	RES-CHIP	39K 5% 1/16W
R909	1-218-965-11	RES-CHIP	10K 5% 1/16W	R2221	1-218-952-11	RES-CHIP	820 5% 1/16W
R910	1-218-977-11	RES-CHIP	100K 5% 1/16W	R2222	1-218-959-11	RES-CHIP	3.3K 5% 1/16W
R911	1-218-965-11	RES-CHIP	10K 5% 1/16W	R2223	1-218-964-11	RES-CHIP	8.2K 5% 1/16W
			(D800)	R2224	1-218-966-11	RES-CHIP	12K 5% 1/16W
R911	1-218-973-11	RES-CHIP	47K 5% 1/16W	R2225	1-218-949-11	RES-CHIP	470 5% 1/16W
			(D800E)	R2230	1-218-990-11	SHORT	0
R911	1-218-977-11	RES-CHIP	100K 5% 1/16W	R2240	1-218-989-11	RES-CHIP	1M 5% 1/16W
			(D200/D200E)	R2242	1-218-967-11	RES-CHIP	15K 5% 1/16W
R912	1-216-813-11	METAL CHIP	220 5% 1/16W	R2243	1-218-967-11	RES-CHIP	15K 5% 1/16W
R913	1-216-813-11	METAL CHIP	220 5% 1/16W	R2244	1-218-966-11	RES-CHIP	12K 5% 1/16W
R914	1-216-813-11	METAL CHIP	220 5% 1/16W	R2245	1-218-949-11	RES-CHIP	470 5% 1/16W
R922	1-218-965-11	RES-CHIP	10K 5% 1/16W	R2247	1-218-953-11	RES-CHIP	1K 5% 1/16W
			(D200E)	R2248	1-218-965-11	RES-CHIP	10K 5% 1/16W
R922	1-218-973-11	RES-CHIP	47K 5% 1/16W	R2254	1-218-990-11	SHORT	0
			(D200)	R2255	1-218-990-11	SHORT	0
R922	1-218-977-11	RES-CHIP	100K 5% 1/16W	R2256	1-216-807-11	METAL CHIP	68 5% 1/16W
			(D800/D800E)	R3103	1-218-965-11	RES-CHIP	10K 5% 1/16W
R923	1-216-138-00	METAL CHIP	3.3 5% 1/8W	R3104	1-218-963-11	RES-CHIP	6.8K 5% 1/16W
R924	1-216-830-11	METAL CHIP	5.6K 5% 1/16W	R3105	1-218-990-11	SHORT	0
R925	1-216-820-11	METAL CHIP	820 5% 1/16W	R3106	1-218-990-11	SHORT	0
R926	1-216-836-11	METAL CHIP	18K 5% 1/16W	R3107	1-218-979-11	RES-CHIP	150K 5% 1/16W
R1308	1-218-990-11	SHORT	0	R3108	1-218-989-11	RES-CHIP	1M 5% 1/16W
R1315	1-218-990-11	SHORT	0	R3109	1-218-966-11	RES-CHIP	12K 5% 1/16W
R1335	1-218-977-11	RES-CHIP	100K 5% 1/16W	R3110	1-218-965-11	RES-CHIP	10K 5% 1/16W
			(D800/D800E)				(D200/D200E:AEP,E/D800/D800E)
R1337	1-218-977-11	RES-CHIP	100K 5% 1/16W	R3111	1-218-949-11	RES-CHIP	470 5% 1/16W
			(D800/D800E)				(D200/D200E:AEP,E/D800/D800E)
R1341	1-218-961-11	RES-CHIP	4.7K 5% 1/16W	R3112	1-218-939-11	RES-CHIP	68 5% 1/16W
			(D800/D800E)				(D200/D200E:AEP,E/D800/D800E)
R1342	1-208-943-11	METAL CHIP	220K 0.5% 1/16W	R3113	1-218-966-11	RES-CHIP	12K 5% 1/16W
			(D800/D800E)				(D200/D200E:AEP,E/D800/D800E)
R1343	1-208-931-11	METAL CHIP	68K 0.5% 1/16W	R3114	1-218-961-11	RES-CHIP	4.7K 5% 1/16W
			(D800/D800E)				(D200/D200E:AEP,E/D800/D800E)
R1504	1-218-941-11	RES-CHIP	100 5% 1/16W	R3115	1-218-965-11	RES-CHIP	10K 5% 1/16W
R1505	1-218-941-11	RES-CHIP	100 5% 1/16W				(D200/D200E:AEP,E/D800/D800E)
R1512	1-218-985-11	RES-CHIP	470K 5% 1/16W	R3116	1-218-990-11	SHORT	0
R1514	1-218-990-11	SHORT	0				(D200/D200E:AEP,E/D800/D800E)
R1520	1-218-990-11	SHORT	0	R3117	1-218-969-11	RES-CHIP	22K 5% 1/16W
R1521	1-218-989-11	RES-CHIP	1M 5% 1/16W				(D200/D200E:AEP,E/D800/D800E)
R1522	1-218-990-11	SHORT	0	R3118	1-220-196-11	METAL CHIP	13K 0.5% 1/16W
R1523	1-218-990-11	SHORT	0				(D200/D200E:AEP,E/D800/D800E)
R1524	1-218-990-11	SHORT	0	R3119	1-218-970-11	METAL CHIP	27K 0.5% 1/16W
R1525	1-218-990-11	SHORT	0				(D200/D200E:AEP,E/D800/D800E)
R1526	1-218-990-11	SHORT	0	R3120	1-208-715-11	METAL CHIP	22K 0.5% 1/16W
R2205	1-218-965-11	RES-CHIP	10K 5% 1/16W				(D200/D200E:AEP,E/D800/D800E)
R2206	1-218-977-11	RES-CHIP	100K 5% 1/16W	R3121	1-208-709-11	METAL CHIP	12K 0.5% 1/16W
R2208	1-218-990-11	SHORT	0				(D200/D200E:AEP,E/D800/D800E)
R2209	1-218-965-11	RES-CHIP	10K 5% 1/16W	R3122	1-208-931-11	METAL CHIP	68K 0.5% 1/16W
R2210	1-218-954-11	RES-CHIP	1.2K 5% 1/16W				(D200/D200E:AEP,E/D800/D800E)
R2211	1-218-990-11	SHORT	0	R3123	1-218-969-11	RES-CHIP	22K 5% 1/16W
							(D200/D200E:AEP,E/D800/D800E)
				R3124	1-218-969-11	RES-CHIP	22K 5% 1/16W
							(D200/D200E:AEP,E/D800/D800E)
				R3125	1-218-945-11	METAL CHIP	220 0.5% 1/16W
							(D200/D200E:AEP,E/D800/D800E)

Ref. No.	Part No.	Description	Remarks	Ref. No.	Part No.	Description	Remarks
R3126	1-218-969-11	RES-CHIP	22K 5% 1/16W (D200/D200E:AEP,E/D800/D800E)	R3310	1-218-965-11	RES-CHIP	10K 5% 1/16W (D200/D200E:AEP,E/D800/D800E)
R3127	1-218-971-11	RES-CHIP	33K 5% 1/16W (D200/D200E:AEP,E/D800/D800E)	R3311	1-218-965-11	RES-CHIP	10K 5% 1/16W (D200/D200E:AEP,E/D800/D800E)
R3128	1-218-965-11	RES-CHIP	10K 5% 1/16W (D200/D200E:AEP,E/D800/D800E)	R3312	1-218-946-11	RES-CHIP	270 5% 1/16W (D200/D200E:AEP,E/D800/D800E)
R3129	1-218-945-11	METAL CHIP	220 0.5% 1/16W (D200/D200E:AEP,E/D800/D800E)	R3313	1-218-990-11	SHORT	0 (D200/D200E:AEP,E/D800/D800E)
R3130	1-218-945-11	METAL CHIP	220 0.5% 1/16W (D200/D200E:AEP,E/D800/D800E)	R3314	1-218-990-11	SHORT	0 (D200/D200E:AEP,E/D800/D800E)
R3131	1-218-945-11	METAL CHIP	220 0.5% 1/16W (D200/D200E:AEP,E/D800/D800E)	R3315	1-218-959-11	RES-CHIP	3.3K 5% 1/16W (D200/D200E:AEP,E/D800/D800E)
R3132	1-218-946-11	RES-CHIP	270 5% 1/16W (D200/D200E:AEP,E/D800/D800E)	R3316	1-218-959-11	RES-CHIP	3.3K 5% 1/16W (D200/D200E:AEP,E/D800/D800E)
R3133	1-218-945-11	RES-CHIP	220 5% 1/16W (D200/D200E:AEP,E/D800/D800E)	R3317	1-218-961-11	RES-CHIP	4.7K 5% 1/16W (D200/D200E:AEP,E/D800/D800E)
R3136	1-218-957-11	RES-CHIP	2.2K 5% 1/16W (D200/D200E:AEP,E/D800/D800E)	R3318	1-218-965-11	RES-CHIP	10K 5% 1/16W (D200/D200E:AEP,E/D800/D800E)
R3137	1-218-961-11	RES-CHIP	4.7K 5% 1/16W (D200/D200E:AEP,E/D800/D800E)	R3319	1-218-965-11	RES-CHIP	10K 5% 1/16W (D200/D200E:AEP,E/D800/D800E)
R3138	1-218-941-11	RES-CHIP	100 5% 1/16W (D200/D200E:AEP,E/D800/D800E)	R3320	1-218-957-11	RES-CHIP	2.2K 5% 1/16W (D200/D200E:AEP,E/D800/D800E)
R3139	1-218-960-11	RES-CHIP	3.9K 5% 1/16W (D200/D200E:AEP,E/D800/D800E)	R3321	1-218-959-11	RES-CHIP	3.3K 5% 1/16W (D200/D200E:AEP,E/D800/D800E)
R3140	1-218-960-11	RES-CHIP	3.9K 5% 1/16W (D200/D200E:AEP,E/D800/D800E)	R3322	1-218-941-11	RES-CHIP	100 5% 1/16W (D200/D200E:AEP,E/D800/D800E)
R3141	1-218-960-11	RES-CHIP	3.9K 5% 1/16W (D200/D200E:AEP,E/D800/D800E)	R3323	1-218-947-11	RES-CHIP	330 5% 1/16W (D200/D200E:AEP,E/D800/D800E)
R3142	1-218-960-11	RES-CHIP	3.9K 5% 1/16W (D200/D200E:AEP,E/D800/D800E)	R3324	1-218-961-11	RES-CHIP	4.7K 5% 1/16W (D200/D200E:AEP,E/D800/D800E)
R3143	1-218-938-11	RES-CHIP	56 5% 1/16W (D200/D200E:AEP,E/D800/D800E)	R3325	1-218-937-11	RES-CHIP	47 5% 1/16W (D200/D200E:AEP,E/D800/D800E)
R3144	1-218-950-11	RES-CHIP	560 5% 1/16W (D200/D200E:AEP,E/D800/D800E)	R3326	1-218-990-11	SHORT	0 (D200/D200E:AEP,E/D800/D800E)
R3146	1-216-295-11	SHORT	0 (D200/D200E:AEP,E/D800/D800E)	R3328	1-208-886-81	METAL CHIP	910 0.5% 1/16W (D800/D800E)
R3205	1-218-985-11	RES-CHIP	470K 5% 1/16W (D200/D200E:AEP,E/D800/D800E)	R3331	1-218-961-11	RES-CHIP	4.7K 5% 1/16W (D800/D800E)
R3206	1-218-985-11	RES-CHIP	470K 5% 1/16W (D200/D200E:AEP,E/D800/D800E)	R3333	1-218-990-11	SHORT	0 (D200/D200E:AEP,E/D800/D800E)
R3210	1-218-965-11	RES-CHIP	10K 5% 1/16W (D200/D200E:AEP,E/D800/D800E)	R3334	1-208-886-81	METAL CHIP	910 0.5% 1/16W (D800/D800E)
R3211	1-218-990-11	SHORT	0 (D200/D200E:AEP,E/D800/D800E)	R3336	1-218-961-11	RES-CHIP	4.7K 5% 1/16W (D800/D800E)
R3212	1-218-986-11	RES-CHIP	560K 5% 1/16W (D200/D200E:AEP,E/D800/D800E)	R3337	1-218-990-11	SHORT	0
R3213	1-218-985-11	RES-CHIP	470K 5% 1/16W (D200/D200E:AEP,E/D800/D800E)	R3340	1-208-886-81	METAL CHIP	910 0.5% 1/16W (D800/D800E)
R3214	1-218-981-11	RES-CHIP	220K 5% 1/16W (D200/D200E:AEP,E/D800/D800E)	R3343	1-218-961-11	RES-CHIP	4.7K 5% 1/16W (D800/D800E)
R3215	1-208-939-11	METAL CHIP	150K 0.5% 1/16W (D200/D200E:AEP,E/D800/D800E)	R3346	1-218-990-11	SHORT	0
R3305	1-218-990-11	SHORT	0 (D200/D200E:AEP,E/D800/D800E)	R3349	1-218-990-11	SHORT	0
R3306	1-216-864-11	METAL CHIP	0 5% 1/16W (D200/D200E:AEP,E/D800/D800E)	R3350	1-218-990-11	SHORT	0
R3308	1-216-864-11	METAL CHIP	0 5% 1/16W (D200/D200E:AEP,E/D800/D800E)	R3351	1-218-946-11	RES-CHIP	270 5% 1/16W
R3309	1-218-990-11	SHORT	0 (D200/D200E:AEP,E/D800/D800E)	R3352	1-218-990-11	SHORT	0
				R3356	1-218-957-11	RES-CHIP	2.2K 5% 1/16W
				R3358	1-218-945-11	RES-CHIP	220 5% 1/16W
				R3360	1-218-957-11	RES-CHIP	2.2K 5% 1/16W
				R3361	1-208-709-11	METAL CHIP	12K 0.5% 1/16W
				R3362	1-218-990-11	SHORT	0
				R3364	1-208-709-11	METAL CHIP	12K 0.5% 1/16W
				R3365	1-218-990-11	SHORT	0
				R3367	1-218-938-11	METAL CHIP	56 0.5% 1/16W
				R3368	1-218-938-11	METAL CHIP	56 0.5% 1/16W
				R3369	1-208-707-11	METAL CHIP	10K 0.5% 1/16W

VC-250

Ref. No.	Part No.	Description	Quantity	Unit Cost	Material	Remarks	Ref. No.	Part No.	Description	Quantity	Unit Cost	Material	Remarks
R3370	1-218-938-11	METAL CHIP	56	0.5%	1/16W		R3905	1-218-961-11	RES-CHIP	4.7K	5%	1/16W	
R3371	1-208-707-11	METAL CHIP	10K	0.5%	1/16W		R3908	1-218-967-11	RES-CHIP	15K	5%	1/16W	
R3372	1-218-938-11	METAL CHIP	56	0.5%	1/16W		R3909	1-218-989-11	RES-CHIP	1M	5%	1/16W	
R3375	1-218-965-11	RES-CHIP	10K	5%	1/16W		R3910	1-218-990-11	SHORT	0			
R3376	1-218-953-11	RES-CHIP	1K	5%	1/16W		R3911	1-208-715-11	METAL CHIP	22K	0.5%	1/16W	
R3377	1-218-941-11	RES-CHIP	100	5%	1/16W		R3912	1-218-947-11	RES-CHIP	330	5%	1/16W	
R3378	1-218-941-11	RES-CHIP	100	5%	1/16W		R3913	1-218-953-11	RES-CHIP	1K	5%	1/16W	
R3379	1-218-941-11	RES-CHIP	100	5%	1/16W		R3916	1-218-949-11	RES-CHIP	470	5%	1/16W	
R3380	1-218-941-11	RES-CHIP	100	5%	1/16W		R3917	1-218-979-11	RES-CHIP	150K	5%	1/16W	
R3381	1-218-941-11	RES-CHIP	100	5%	1/16W		R3918	1-218-979-11	RES-CHIP	150K	5%	1/16W	
R3382	1-218-990-11	SHORT	0				R3919	1-218-950-11	RES-CHIP	560	5%	1/16W	
R3383	1-218-990-11	SHORT	0				R3920	1-218-963-11	RES-CHIP	6.8K	5%	1/16W	
R3385	1-216-864-11	METAL CHIP	0	5%	1/16W		R3921	1-218-949-11	RES-CHIP	470	5%	1/16W	
R3386	1-216-864-11	METAL CHIP	0	5%	1/16W		R3922	1-218-972-11	RES-CHIP	39K	5%	1/16W	
R3604	1-218-990-11	SHORT	0				R3923	1-218-949-11	RES-CHIP	470	5%	1/16W	
R3607	1-218-965-11	RES-CHIP	10K	5%	1/16W		R3924	1-218-949-11	RES-CHIP	470	5%	1/16W	
R3609	1-218-990-11	SHORT	0				R3936	1-218-955-11	RES-CHIP	1.5K	5%	1/16W	
R3611	1-218-965-11	RES-CHIP	10K	5%	1/16W		R4401	1-218-973-11	RES-CHIP	47K	5%	1/16W	
R3612	1-218-973-11	RES-CHIP	47K	5%	1/16W		R4402	1-218-983-11	RES-CHIP	330K	5%	1/16W	
R3617	1-218-951-11	RES-CHIP	680	5%	1/16W		R4403	1-218-977-11	RES-CHIP	100K	5%	1/16W	
R3618	1-218-965-11	RES-CHIP	10K	5%	1/16W		R4404	1-218-977-11	RES-CHIP	100K	5%	1/16W	
R3622	1-218-949-11	RES-CHIP	470	5%	1/16W		R4405	1-218-977-11	RES-CHIP	100K	5%	1/16W	
R3636	1-218-990-11	SHORT	0				R4406	1-218-977-11	RES-CHIP	100K	5%	1/16W	
R3639	1-218-990-11	SHORT	0				R4407	1-218-949-11	RES-CHIP	470	5%	1/16W	
R3643	1-218-990-11	SHORT	0				R4408	1-217-671-11	METAL CHIP	1	5%	1/10W	
R3652	1-218-990-11	SHORT	0				R4409	1-217-671-11	METAL CHIP	1	5%	1/10W	
R3656	1-218-990-11	SHORT	0				R4410	1-217-671-11	METAL CHIP	1	5%	1/10W	
R3657	1-218-977-11	RES-CHIP	100K	5%	1/16W		R4411	1-216-023-00	METAL CHIP	82	5%	1/10W	
R3658	1-218-953-11	RES-CHIP	1K	5%	1/16W		R4413	1-218-990-11	SHORT	0			
R3659	1-218-960-11	RES-CHIP	3.9K	5%	1/16W		R4414	1-218-946-11	RES-CHIP	270	5%	1/16W	
R3660	1-218-957-11	RES-CHIP	2.2K	5%	1/16W		R4416	1-218-961-11	RES-CHIP	4.7K	5%	1/16W	
R3701	1-218-961-11	RES-CHIP	4.7K	5%	1/16W		R4417	1-208-707-11	METAL CHIP	10K	0.5%	1/16W	
R3702	1-218-961-11	RES-CHIP	4.7K	5%	1/16W		R4423	1-218-990-11	SHORT	0			
R3704	1-218-941-11	RES-CHIP	100	5%	1/16W		R4424	1-218-967-11	RES-CHIP	15K	5%	1/16W	
R3705	1-218-981-11	RES-CHIP	220K	5%	1/16W		R4424	1-218-973-11	RES-CHIP	47K	5%	1/16W	(D200/D800)
R3712	1-218-936-11	RES-CHIP	39	5%	1/16W							(D200E/D800E)	
R3713	1-218-935-11	RES-CHIP	33	5%	1/16W								
R3714	1-218-936-11	RES-CHIP	39	5%	1/16W		R4425	1-218-959-11	RES-CHIP	3.3K	5%	1/16W	
R3715	1-218-935-11	RES-CHIP	33	5%	1/16W		R4426	1-218-977-11	RES-CHIP	100K	5%	1/16W	
R3716	1-218-936-11	RES-CHIP	39	5%	1/16W		R4427	1-218-965-11	RES-CHIP	10K	5%	1/16W	
R3717	1-218-935-11	RES-CHIP	33	5%	1/16W							(D200E/D800E)	
R3721	1-208-715-11	METAL CHIP	22K	0.5%	1/16W		R4427	1-218-990-11	SHORT	0 (D200/D800)			
R3722	1-218-953-11	RES-CHIP	1K	5%	1/16W		R4428	1-217-671-11	METAL CHIP	1	5%	1/10W	
R3724	1-218-953-11	RES-CHIP	1K	5%	1/16W		R4429	1-217-671-11	METAL CHIP	1	5%	1/10W	
R3726	1-218-965-11	RES-CHIP	10K	5%	1/16W		R4430	1-218-985-11	RES-CHIP	470K	5%	1/16W	
R3727	1-218-953-11	RES-CHIP	1K	5%	1/16W		R4431	1-218-967-11	RES-CHIP	15K	5%	1/16W	
R3728	1-218-953-11	RES-CHIP	1K	5%	1/16W							(D200/D800)	
R3729	1-218-953-11	RES-CHIP	1K	5%	1/16W		R4431	1-218-973-11	RES-CHIP	47K	5%	1/16W	
R3730	1-218-953-11	RES-CHIP	1K	5%	1/16W							(D200E/D800E)	
R3734	1-216-295-11	SHORT	0				R4432	1-218-973-11	RES-CHIP	47K	5%	1/16W	
R3737	1-218-961-11	RES-CHIP	4.7K	5%	1/16W		R4434	1-218-965-11	RES-CHIP	10K	5%	1/16W	
R3738	1-218-961-11	RES-CHIP	4.7K	5%	1/16W		R4435	1-218-965-11	RES-CHIP	10K	5%	1/16W	
R3739	1-218-961-11	RES-CHIP	4.7K	5%	1/16W		R4436	1-218-961-11	RES-CHIP	4.7K	5%	1/16W	
R3740	1-218-939-11	RES-CHIP	68	5%	1/16W		R4437	1-218-990-11	SHORT	0			
R3741	1-218-939-11	RES-CHIP	68	5%	1/16W		R4438	1-218-990-11	SHORT	0			
R3742	1-218-939-11	RES-CHIP	68	5%	1/16W		R4442	1-218-990-11	SHORT	0			
R3746	1-218-936-11	RES-CHIP	39	5%	1/16W		R4443	1-218-990-11	SHORT	0			
R3747	1-218-935-11	RES-CHIP	33	5%	1/16W		R4444	1-218-990-11	SHORT	0			
R3903	1-218-968-11	RES-CHIP	18K	5%	1/16W		R4445	1-218-990-11	SHORT	0			
R3904	1-218-961-11	RES-CHIP	4.7K	5%	1/16W		R4446	1-218-990-11	SHORT	0			

Ref. No.	Part No.	Description			Remarks	Ref. No.	Part No.	Description			Remarks
R4447	1-218-971-11	RES-CHIP	33K	5%	1/16W	R4833	1-218-985-11	METAL CHIP	470K	0.5%	1/16W
R4448	1-218-971-11	RES-CHIP	33K	5%	1/16W	R4834	1-218-985-11	METAL CHIP	470K	0.5%	1/16W
R4502	1-218-977-11	RES-CHIP	100K	5%	1/16W	R4835	1-218-989-11	METAL CHIP	1M	0.5%	1/16W
R4503	1-218-977-11	RES-CHIP	100K	5%	1/16W	R4836	1-218-989-11	METAL CHIP	1M	0.5%	1/16W
R4504	1-218-977-11	RES-CHIP	100K	5%	1/16W	R4837	1-218-977-11	RES-CHIP	100K	5%	1/16W
R4505	1-218-977-11	RES-CHIP	100K	5%	1/16W	R4838	1-218-977-11	RES-CHIP	100K	5%	1/16W
R4507	1-218-953-11	RES-CHIP	1K	5%	1/16W	R4839	1-218-977-11	RES-CHIP	100K	5%	1/16W
R4508	1-218-985-11	RES-CHIP	470K	5%	1/16W	R4840	1-218-953-11	RES-CHIP	1K	5%	1/16W
R4511	1-218-953-11	RES-CHIP	1K	5%	1/16W	R4841	1-218-953-11	RES-CHIP	1K	5%	1/16W
R4512	1-218-961-11	RES-CHIP	4.7K	5%	1/16W	R4842	1-218-953-11	RES-CHIP	1K	5%	1/16W
R4514	1-218-977-11	RES-CHIP	100K	5%	1/16W	R4843	1-218-953-11	RES-CHIP	1K	5%	1/16W
R4515	1-218-990-11	SHORT	0			R4845	1-218-977-11	RES-CHIP	100K	5%	1/16W
R4516	1-218-990-11	SHORT	0			R4846	1-218-953-11	RES-CHIP	1K	5%	1/16W
R4517	1-218-990-11	SHORT	0			R4848	1-218-953-11	RES-CHIP	1K	5%	1/16W
R4518	1-218-990-11	SHORT	0			R4849	1-218-953-11	RES-CHIP	1K	5%	1/16W
R4520	1-218-953-11	RES-CHIP	1K	5%	1/16W (D200/D200E)	R4850	1-218-965-11	RES-CHIP	10K	5%	1/16W
R4521	1-218-965-11	RES-CHIP	10K	5%	1/16W	R4851	1-218-965-11	RES-CHIP	10K	5%	1/16W
R4522	1-218-965-11	RES-CHIP	10K	5%	1/16W	R4852	1-218-965-11	RES-CHIP	10K	5%	1/16W
R4523	1-218-985-11	RES-CHIP	470K	5%	1/16W (D800/D800E)	R4856	1-218-965-11	RES-CHIP	10K	5%	1/16W
R4524	1-218-977-11	RES-CHIP	100K	5%	1/16W	R4857	1-218-990-11	SHORT	0		
R4525	1-218-977-11	RES-CHIP	100K	5%	1/16W	R4860	1-218-953-11	RES-CHIP	1K	5%	1/16W
R4526	1-218-985-11	RES-CHIP	470K	5%	1/16W	R4861	1-218-953-11	RES-CHIP	1K	5%	1/16W
R4527	1-218-977-11	RES-CHIP	100K	5%	1/16W	R4862	1-218-953-11	RES-CHIP	1K	5%	1/16W
R4528	1-218-977-11	RES-CHIP	100K	5%	1/16W	R4863	1-218-973-11	RES-CHIP	47K	5%	1/16W
R4529	1-218-977-11	RES-CHIP	100K	5%	1/16W	R4864	1-218-986-11	RES-CHIP	560K	5%	1/16W
R4530	1-218-949-11	RES-CHIP	470	5%	1/16W	R4866	1-218-953-11	RES-CHIP	1K	5%	1/16W
R4531	1-218-990-11	SHORT	0			R4867	1-218-985-11	RES-CHIP	470K	5%	1/16W
R4532	1-218-985-11	RES-CHIP	470K	5%	1/16W (D200/D200E)	R4868	1-218-985-11	RES-CHIP	470K	5%	1/16W
R4802	1-218-961-11	RES-CHIP	4.7K	5%	1/16W	R4869	1-218-985-11	RES-CHIP	470K	5%	1/16W
R4803	1-218-977-11	RES-CHIP	100K	5%	1/16W	R4870	1-218-985-11	RES-CHIP	470K	5%	1/16W
R4805	1-218-959-11	RES-CHIP	3.3K	5%	1/16W	R4871	1-218-989-11	RES-CHIP	1M	5%	1/16W
R4807	1-218-957-11	RES-CHIP	2.2K	5%	1/16W	R4872	1-218-977-11	RES-CHIP	100K	5%	1/16W
R4808	1-218-985-11	RES-CHIP	470K	5%	1/16W	R4873	1-218-977-11	RES-CHIP	100K	5%	1/16W
R4810	1-218-953-11	RES-CHIP	1K	5%	1/16W	R4874	1-218-953-11	RES-CHIP	1K	5%	1/16W
R4811	1-218-977-11	RES-CHIP	100K	5%	1/16W	R4875	1-218-953-11	RES-CHIP	1K	5%	1/16W
R4813	1-218-985-11	RES-CHIP	470K	5%	1/16W	R4876	1-219-570-11	RES-CHIP	10M	5%	1/16W
R4814	1-218-985-11	RES-CHIP	470K	5%	1/16W	R4877	1-218-953-11	RES-CHIP	1K	5%	1/16W
R4815	1-218-985-11	RES-CHIP	470K	5%	1/16W (D800/D800E)	R4878	1-218-977-11	RES-CHIP	100K	5%	1/16W
R4816	1-218-985-11	RES-CHIP	470K	5%	1/16W	R4879	1-218-985-11	RES-CHIP	470K	5%	1/16W
R4817	1-218-985-11	RES-CHIP	470K	5%	1/16W	R4880	1-218-985-11	RES-CHIP	470K	5%	1/16W
R4818	1-218-985-11	RES-CHIP	470K	5%	1/16W	R4881	1-218-985-11	RES-CHIP	470K	5%	1/16W
R4819	1-218-985-11	RES-CHIP	470K	5%	1/16W	R4882	1-218-949-11	RES-CHIP	470	5%	1/16W
R4820	1-218-977-11	RES-CHIP	100K	5%	1/16W	R4883	1-218-990-11	SHORT	0		
R4821	1-218-985-11	RES-CHIP	470K	5%	1/16W	R4884	1-218-990-11	SHORT	0		
R4822	1-218-973-11	RES-CHIP	47K	5%	1/16W	R4885	1-218-953-11	RES-CHIP	1K	5%	1/16W
R4823	1-218-965-11	RES-CHIP	10K	5%	1/16W	R4886	1-218-953-11	RES-CHIP	1K	5%	1/16W
R4824	1-218-958-11	RES-CHIP	2.7K	5%	1/16W	R4887	1-218-977-11	RES-CHIP	100K	5%	1/16W
R4825	1-218-953-11	RES-CHIP	1K	5%	1/16W	R4888	1-218-977-11	RES-CHIP	100K	5%	1/16W
R4826	1-218-953-11	RES-CHIP	1K	5%	1/16W	R4889	1-218-990-11	SHORT	0		
R4827	1-218-953-11	RES-CHIP	1K	5%	1/16W (D800/D800E)	R4891	1-218-990-11	SHORT	0		
R4828	1-218-990-11	SHORT	0		(D200/D200E)	R4892	1-218-990-11	SHORT	0		
R4829	1-218-953-11	RES-CHIP	1K	5%	1/16W	R4893	1-218-985-11	RES-CHIP	470K	5%	1/16W
R4830	1-218-953-11	RES-CHIP	1K	5%	1/16W	R4894	1-218-953-11	RES-CHIP	1K	5%	1/16W
R4831	1-218-990-11	SHORT	0			R4901	1-218-953-11	RES-CHIP	1K	5%	1/16W
R4832	1-218-989-11	RES-CHIP	1M	5%	1/16W	R4902	1-218-986-11	RES-CHIP	560K	5%	1/16W
						R4903	1-218-990-11	SHORT	0		
						R4904	1-218-977-11	RES-CHIP	100K	5%	1/16W
						R4906	1-218-990-11	SHORT	0		
						R4908	1-218-977-11	RES-CHIP	100K	5%	1/16W
						R4910	1-218-977-11	RES-CHIP	100K	5%	1/16W

VC-250

Ref. No.	Part No.	Description	Quantity	Percentage	Remarks	Ref. No.	Part No.	Description	Quantity	Percentage	Remarks
R4911	1-218-977-11	RES-CHIP	100K	5%	1/16W	R5741	1-218-990-11	SHORT	0		
R4912	1-218-961-11	RES-CHIP	4.7K	5%	1/16W	R5742	1-218-965-11	RES-CHIP	10K	5%	1/16W
R4913	1-218-957-11	RES-CHIP	2.2K	5%	1/16W	R5743	1-218-965-11	RES-CHIP	10K	5%	1/16W
R4914	1-218-990-11	SHORT	0			R5750	1-218-990-11	SHORT	0		
R4917	1-218-953-11	RES-CHIP	1K	5%	1/16W	R5751	1-216-843-11	METAL CHIP	68K	5%	1/16W
R4919	1-164-943-11	CERAMIC CHIP	0.01UF	10%	16V (Note)	R5752	1-216-843-11	METAL CHIP	68K	5%	1/16W
R4920	1-218-965-11	RES-CHIP	10K	5%	1/16W	R5753	1-216-843-11	METAL CHIP	68K	5%	1/16W
R4921	1-218-965-11	RES-CHIP	10K	5%	1/16W	R5754	1-216-843-11	METAL CHIP	68K	5%	1/16W
R4922	1-218-973-11	RES-CHIP	47K	5%	1/16W	R5755	1-216-837-11	METAL CHIP	22K	5%	1/16W
R4927	1-218-973-11	RES-CHIP	47K	5%	1/16W	R5756	1-216-837-11	METAL CHIP	22K	5%	1/16W
R4928	1-218-977-11	RES-CHIP	100K	5%	1/16W	R5757	1-218-977-11	RES-CHIP	100K	5%	1/16W
R4929	1-218-977-11	RES-CHIP	100K	5%	1/16W	R5758	1-218-977-11	RES-CHIP	100K	5%	1/16W
R4930	1-218-977-11	RES-CHIP	100K	5%	1/16W	R5759	1-218-977-11	RES-CHIP	100K	5%	1/16W
R4931	1-218-973-11	RES-CHIP	47K	5%	1/16W	R5760	1-218-977-11	RES-CHIP	100K	5%	1/16W
R4932	1-218-973-11	RES-CHIP	47K	5%	1/16W	R5761	1-218-965-11	RES-CHIP	10K	5%	1/16W
R4933	1-218-990-11	SHORT	0			R5762	1-218-965-11	RES-CHIP	10K	5%	1/16W
R4934	1-218-990-11	SHORT	0			R5763	1-216-833-11	METAL CHIP	10K	5%	1/16W (D800/D800E)
R4935	1-218-977-11	RES-CHIP	100K	5%	1/16W	R5764	1-218-973-11	RES-CHIP	47K	5%	1/16W (D800/D800E)
R4936	1-218-977-11	RES-CHIP	100K	5%	1/16W	R5765	1-218-977-11	RES-CHIP	100K	5%	1/16W (D800/D800E)
R4938	1-218-977-11	RES-CHIP	100K	5%	1/16W	R5766	1-218-977-11	RES-CHIP	100K	5%	1/16W (D800/D800E)
R4939	1-218-977-11	RES-CHIP	100K	5%	1/16W	R5767	1-218-973-11	RES-CHIP	47K	5%	1/16W (D800/D800E)
R4940	1-218-977-11	RES-CHIP	100K	5%	1/16W	R5768	1-218-973-11	RES-CHIP	47K	5%	1/16W (D800/D800E)
R4941	1-218-990-11	SHORT	0			R5769	1-218-973-11	RES-CHIP	47K	5%	1/16W (D800/D800E)
R4942	1-218-990-11	SHORT	0			R5770	1-218-973-11	RES-CHIP	47K	5%	1/16W (D800/D800E)
R4945	1-218-965-11	RES-CHIP	10K	5%	1/16W	R5771	1-218-973-11	RES-CHIP	47K	5%	1/16W (D800/D800E)
R4946	1-218-965-11	RES-CHIP	10K	5%	1/16W	R5772	1-218-949-11	RES-CHIP	470	5%	1/16W
R4947	1-218-990-11	SHORT	0			R5773	1-218-949-11	RES-CHIP	470	5%	1/16W
R4948	1-218-990-11	SHORT	0			R5774	1-218-965-11	RES-CHIP	10K	5%	1/16W
R4949	1-218-990-11	SHORT	0			R5775	1-218-965-11	RES-CHIP	10K	5%	1/16W
R4950	1-218-990-11	SHORT	0			R5776	1-216-837-11	METAL CHIP	22K	5%	1/16W
R4951	1-218-990-11	SHORT	0			R5777	1-216-837-11	METAL CHIP	22K	5%	1/16W
R4952	1-218-990-11	SHORT	0			R5780	1-216-829-11	METAL CHIP	4.7K	5%	1/16W (D800/D800E)
R4953	1-218-990-11	SHORT	0			R5781	1-216-829-11	METAL CHIP	4.7K	5%	1/16W (D800/D800E)
R5701	1-218-990-11	SHORT	0			R5783	1-216-825-11	METAL CHIP	2.2K	5%	1/16W (D800/D800E)
R5702	1-218-990-11	SHORT	0			R5784	1-216-825-11	METAL CHIP	2.2K	5%	1/16W (D800/D800E)
R5707	1-218-953-11	RES-CHIP	1K	5%	1/16W	< SWITCH >					
R5708	1-218-953-11	RES-CHIP	1K	5%	1/16W	S4801	1-692-111-11	SWITCH, KEY BOARD (RESET)			
R5709	1-216-864-11	METAL CHIP	0	5%	1/16W	S4802	1-762-805-21	SWITCH, PUSH (1 KEY) (EJECT)			
R5711	1-218-941-11	RES-CHIP	100	5%	1/16W	< VIBRATOR >					
R5712	1-218-941-11	RES-CHIP	100	5%	1/16W	X1501	1-767-586-21	VIBRATOR, CRYSTAL (27MHz)			
R5714	1-216-864-11	METAL CHIP	0	5%	1/16W	X3301	1-767-399-11	VIBRATOR, CRYSTAL (24.576MHz)			
R5720	1-218-979-11	RES-CHIP	150K	5%	1/16W	X4801	1-767-980-21	VIBRATOR, CERAMIC (20MHz)			
R5721	1-218-973-11	RES-CHIP	47K	5%	1/16W	X4802	1-760-458-21	VIBRATOR, CRYSTAL (32.768KHz)			
R5722	1-218-990-11	SHORT	0			X4901	1-760-655-41	VIBRATOR, CRYSTAL (20MHz)			
R5723	1-218-990-11	SHORT	0								
R5724	1-218-985-11	RES-CHIP	470K	5%	1/16W						
R5725	1-218-985-11	RES-CHIP	470K	5%	1/16W						
R5726	1-218-990-11	SHORT	0								
R5727	1-218-990-11	SHORT	0								
R5729	1-218-990-11	SHORT	0								
R5730	1-218-952-11	RES-CHIP	820	5%	1/16W						
R5731	1-218-949-11	RES-CHIP	470	5%	1/16W						
R5732	1-218-949-11	RES-CHIP	470	5%	1/16W						
R5733	1-218-985-11	RES-CHIP	470K	5%	1/16W						
R5735	1-218-990-11	SHORT	0								
R5736	1-218-990-11	SHORT	0								
R5737	1-218-990-11	SHORT	0								
R5738	1-218-990-11	SHORT	0								
R5739	1-218-990-11	SHORT	0								
R5740	1-218-990-11	SHORT	0								

Note : Capacitor is mounted to the location where R4919 is printed.

Ref. No.	Part No.	Description	Remarks
		ACCESSORIES *****	
△	1-475-599-11	ADAPTOR, AC (AC-L10A)	
△	1-569-008-21	ADAPTOR, CONVERSION 2P (D200E:E/D800E:E)	
	1-573-291-11	ADAPTOR, CONVERSION 21P (D200E:AEP,UK/D800E:AEP,UK)	
	1-575-334-11	CORD, CONNECTION (A/V)(1.5m)	
△	1-769-608-11	CORD, POWER (D200E:AEP,E/D800E:AEP,E)	
△	1-783-374-11	CORD, POWER (D200E:UK/D800E:UK)	
△	1-790-107-22	CORD, POWER (D200,D800)	
	1-790-690-11	CORD, CONNECTION (A/V CONVERTING)(1.5m)	
	3-064-176-11	MANUAL, INSTRUCTION (ENGLISH) (D800)	
	3-064-176-21	MANUAL, INSTRUCTION (FRENCH) (D800)	
	3-064-176-31	MANUAL, INSTRUCTION (SPANISH) (D800)	
	3-064-177-11	MANUAL, INSTRUCTION (ENGLISH/RUSSIAN) (D800E:AEP,UK)	
	3-064-177-21	MANUAL, INSTRUCTION (FRENCH/GERMAN) (D800E:AEP)	
	3-064-177-31	MANUAL, INSTRUCTION (SPANISH/PORTUGUESE) (D800E:AEP)	
	3-064-177-41	MANUAL, INSTRUCTION (ITALIAN/DUTCH) (D800E:AEP)	
	3-064-177-51	MANUAL, INSTRUCTION (ENGLISH/RUSSIAN) (D800E:E)	
	3-064-177-61	MANUAL, INSTRUCTION (ARABIC/PERSIAN) (D800E:E)	
	3-064-177-71	MANUAL, INSTRUCTION (SIMPLIFIED CHINESE) (D800E:E)	
	3-064-177-81	MANUAL, INSTRUCTION (FRENCH/GERMAN) (D800E:E)	
	3-064-178-11	MANUAL, INSTRUCTION (ENGLISH) (D200)	
	3-064-178-21	MANUAL, INSTRUCTION (FRENCH) (D200)	
	3-064-178-31	MANUAL, INSTRUCTION (SPANISH) (D200)	
	3-064-179-11	MANUAL, INSTRUCTION (ENGLISH/RUSSIAN) (D200E:AEP,UK)	
	3-064-179-21	MANUAL, INSTRUCTION (FRENCH/GERMAN) (D200E:AEP)	
	3-064-179-31	MANUAL, INSTRUCTION (SPANISH/PORTUGUESE) (D200E:AEP)	
	3-064-179-41	MANUAL, INSTRUCTION (ITALIAN/DUTCH) (D200E:AEP)	
	3-064-179-51	MANUAL, INSTRUCTION (ENGLISH/RUSSIAN) (D200E:E)	
	3-064-179-61	MANUAL, INSTRUCTION (ARABIC/PERSIAN) (D200E:E)	
	3-064-179-71	MANUAL, INSTRUCTION (SIMPLIFIED CHINESE) (D200E:E)	
	3-064-179-81	MANUAL, INSTRUCTION (FRENCH/GERMAN) (D200E:E)	

Note :

The components identified by mark △ or dotted line with mark △ are critical for safety. Replace only with part number specified.

Note :

Les composants identifiés par une marque △ sont critiques pour la sécurité. Ne les remplacer que par une pièce portant le numéro spécifié.