

# EV-C2000E/EUB/EVP

## RMT-V160

## SERVICE MANUAL

*AEP Model*  
EV-C2000E

*UK Model*  
EV-C2000EUB

*German Model*  
EV-C2000EVP



Remote commander  
is available as a  
unit. See page 5-1  
for repair parts.

**video Hi8**

F MECHANISM

For MECHANICAL ADJUSTMENT, refer to the "8mm  
Video MECHANICAL ADJUSTMENT MANUAL V  
(F MECHANISM)" (9-973-445-11).

### SPECIFICATIONS

#### System

**Video-Aufzeichnungssystem**  
Helix-FM-Abtastsystem mit  
zwei Drehköpfen

**Audio-Aufzeichnungssystem**  
Standard: Drehkopf-FM-  
System (2 Kanäle)

**Videosignal**  
Standard CCIR, Farbe PAL

**Verwendbare Kassetten**  
Videokassetten im 8-mm-  
Format

**Bandgeschwindigkeit**  
SP: 20,051 mm/s  
LP: 10,058 mm/s

**Aufnahme-/Wiedergabedauer**  
SP: 2 Std., LP: 4 Std. (mit einer  
E5-120-Kassette von Sony)  
SP: 1,5 Std., LP: 3 Std. (mit  
einer E5/P5-90-Kassette von  
Sony)

**Vorspul-/Rückspulzeit**  
2 min 15 s  
1 min (mit  
Höchstgeschwindigkeit)

(mit einer E5/P5-90-Kassette  
von Sony)

#### Ein- und Ausgänge

**EURO-AV: LINE 1**  
21polig  
Videoeingang: Stift 20  
Audioeingang: Stift 2 und 6  
Video/  
Luminanzausgang: Stift 19  
Chrominanzausgang: Stift 15  
Audioausgang: Stift 1 und 3

**LINE IN 2 und 3**  
S VIDEO IN (4polig, Mini-  
DIN), jeweils 1  
Y: 1 V<sub>p-p</sub>, 75 Ohm  
(unsymmetrisch),  
sync-negativ  
C: 0,3 V<sub>p-p</sub>  
(Farbsynchronsignal),  
75 Ohm (unsymmetrisch)  
VIDEO IN (Phonobuchse),  
jeweils 1  
Eingangssignal: 1 V<sub>p-p</sub>,  
75 Ohm (unsymmetrisch),  
sync-negativ  
AUDIO IN (Phonobuchse),

jeweils 2  
Eingangspegel: -7,5 dBs  
(0 dBs = 0,775 V<sub>rms</sub>)  
Eingangswiderstand: über  
47 kOhm

#### LINE OUT 2

S VIDEO OUT (4polig, Mini-  
DIN)  
Y: 1 V<sub>p-p</sub>, 75 Ohm  
(unsymmetrisch),  
sync-negativ  
C: 0,3 V<sub>p-p</sub>  
(Farbsynchronsignal),  
75 Ohm (unsymmetrisch)  
VIDEO OUT (Phonobuchse)  
Ausgangssignal: 1 V<sub>p-p</sub>,  
75 Ohm (unsymmetrisch),  
sync-negativ  
AUDIO OUT (Phonobuchse)  
Standardpegel: -7,5 dBs bei  
einem  
Lastwiderstand von 47 kOhm  
Ausgangswiderstand:  
weniger als 10 kOhm

#### LINE OUT 3

VIDEO OUT (Phonobuchse)  
Ausgangssignal: 1 V<sub>p-p</sub>,  
75 Ohm (unsymmetrisch)

- continued on next page -

**Hi8 VIDEO CASSETTE RECORDER**  
**SONY®**



sync-negativ  
AUDIO OUT (Phonobuchsen)  
Standardpegel: -7,5 dBs bei  
einem  
Lastwiderstand von 47 kOhm  
Ausgangswiderstand:  
weniger als 10 kOhm  
RFU DC OUT (Spezial-  
Minibuchse)  
5 V Gleichstrom

#### CONTROLS IN

Minibuchse

#### LANC

Stereo-Mini-Minibuchse

### Allgemeines

#### Stromversorgung

220 - 240 V  
Wechselspannung, 50 Hz

#### Leistungsaufnahme

20 W

#### Betriebstemperatur

5 °C bis 40 °C

#### Lagertemperatur

-20 °C bis 60 °C

#### Abmessungen

Ca. 430 x 86 x 390 mm  
(B/H/T)  
einschließlich vorstehender  
Teile und Bedienelemente

#### Gewicht

ca. 5,0 kg

### Mitgeliefertes Zubehör

Fernbedienung (1)  
R6-Batterien (Größe AA) (2)  
Netzkabel (1)  
S-Videokabel (1)  
LANC-Kabel (1)



Änderungen, die dem technischen  
Fortschritt dienen, bleiben vorbehalten.

## SAFETY CHECK-OUT

After correcting the original service problem, perform the following safety checks before releasing the set to the customer:

1. Check the area of your repair for unsoldered or poorly-soldered connections. Check the entire board surface for solder splashes and bridges.
2. Check the interboard wiring to ensure that no wires are "pinched" or contact high-wattage resistors.
3. Look for unauthorized replacement parts, particularly transistors, that were installed during a previous repair. Point them out to the customer and recommend their replacement.
4. Look for parts which, though functioning, show obvious signs of deterioration. Point them out to the customer and recommend their replacement.
5. Check the line cord for cracks and abrasion. Recommend the replacement of any such line cord to the customer.
6. Flexible Circuit Board Repairing
  - Keep the temperature of the soldering iron around 270°C during repairing.
  - Do not touch the soldering iron on the same conductor of the circuit board (within 3 times).
  - Be careful not to apply force on the conductor when soldering or unsoldering.

#### SAFETY-RELATED COMPONENT WARNING!!

COMPONENTS IDENTIFIED BY MARK  OR DOTTED LINE WITH MARK  ON THE SCHEMATIC DIAGRAMS AND IN THE PARTS LIST ARE CRITICAL TO SAFE OPERATION. REPLACE THESE COMPONENTS WITH SONY PARTS WHOSE PART NUMBERS APPEAR AS SHOWN IN THIS MANUAL OR IN SUPPLEMENTS PUBLISHED BY SONY.

## TABLE OF CONTENTS

<u>Section</u>	<u>Title</u>	<u>Page</u>	<u>Section</u>	<u>Title</u>	<u>Page</u>
<b>SERVICE NOTE</b>					
1.	Removal of Cassette at Failure with Cassette Inserted	5		• This Note is Common for Printed Wiring Boards and Schematic Diagrams	4-4
2.	Replacement of External Parts	5		• RP-165 Board	4-5
3.	Replacement of Cassette Door Assembly	5		• VI-131 Board	4-11
4.	Cleaning of Video Head and Run System	6		• DI-55 Boards	4-19
5.	Replacement of Upper Rotary Drum	6		• MA-205 Board	4-26
<b>1. GENERAL</b>					
	• Willkommen!	1-1		• MD-59 Board	4-47
	• Überprüfen der Typenbezeichnung	1-1		• AU-176 Board	4-49
	• Hi8-Videosystem (High Eight)	1-1		• FL-64, FR-89 and PL-26 Boards	4-54
	• Schritt1. Auspacken	1-2		• RJ-57 and RJ-58 Boards	4-60
	• Schritt2. Vorbereiten der Fernbedienung	1-2		• PS-324 and PS-325 Boards	4-65
	• Schritt3. Anschließen des Videorecorders	1-3	<b>5. REPAIR PARTS LIST</b>		
	• Wiedergabe einer kassette	1-4	5-1.	EXPLODED VIEWS	5-1
	• Aufnahme von TV-Programmen	1-5	5-1-1.	Cabinet and Front Panel Assemblies	5-1
	• Wiedergabe/Suchen mit verschiedenen Geschwindigkeiten	1-6	5-1-2.	Main Chassis Assembly	5-2
	• Einstellen des Spurlage	1-7	5-1-3.	Main Boards Assembly	5-3
	• Suchen mit der Indexfunktion-Indexsuche	1-7	5-1-4.	Cassette Compartment Assembly	5-4
	• Aufzeichnen des RC-Zeitcodes	1-9	5-1-5.	Mechanical Assembly (1)	5-5
	• Anzeigen von Menüoptionen	1-9	5-1-6.	Mechanical Assembly (2)	5-6
	• Shuttle-Schnitt	1-9	5-1-7.	Mechanical Assembly (3)	5-7
	• Überspielen mit einem anderen Videorecorder	1-10	5-2.	ELECTRICAL PARTS LIST	5-8
	• Synchron-Schnitt	1-11		• AU-176 Board	5-8
	• Verzeichnis der Teile and Bedienelemente	1-12		• DI-55 Board	5-10
<b>2. DISASSEMBLY</b>					
2-1.	Removal of Cabinet Assembly	2-1		• FL-64 Board	5-13
2-2.	Removal of Control Switch Block	2-1		• FR-89 Board	5-14
2-3.	Removal of FL-64 Board, FR-89 Board and PL-26 Board	2-2		• MA-205 Board	5-15
2-4.	Removal of PS-324 Board and PS-325 Board	2-2		• MD-59 Board	5-25
2-5.	Removal of DI-55 Board	2-3		• PL-26 Board	5-25
2-6.	Removal of AU-176 Board	2-3		• PS-324 Board	5-26
2-7.	Removal of Mechanical Block and Cassette Compartment	2-4		• PS-325 Board	5-26
2-8.	Removal of MA-205 Board and VI-131 Board	2-4		• RJ-57 Board	5-26
2-9.	Mechanical Internal Views	2-5		• RJ-58 Board	5-27
2-10.	Circuit Boards Location	2-6		• RP-165 Board	5-27
<b>3. BLOCK DIAGRAMS</b>					
3-1.	Overall Block Diagram	3-1		• VI-131 Board	5-29
3-2.	Head Amp Block Diagram	3-5		• Hardware List	5-36
3-3.	Video Block Diagram	3-6	<b>6. INTERFACE AND IC PIN FUNCTION</b>		
3-4.	Digital Block Diagram	3-9	6-1.	Servo/System Control Micro Computer CXP87140 (MA-205 Board IC003) Port Function Description	6-1
3-5.	Servo, System Control Block Diagram	3-12	6-2.	System Control—Video•Audio Block Interface	6-3
3-6.	Timer, MODE Control Block Diagram	3-15	6-3.	Servo Control—Servo Block Interface	6-4
3-7.	Index Block Diagram	3-17	6-4.	Mode Control Micro computer MB89096 (MA-205 Board IC002) Port Function Description	6-5
3-8.	Audio Block Diagram	3-19	6-5.	Timer Control Micro computer MB89096 (MA-205 Board IC901) Port Function Description	6-6
3-9.	Power Block Diagram	3-21	6-6.	AFM Audio Output Control	6-7
<b>4. PRINTED WIRING BOARDS AND SCHEMATIC DIAGRAMS</b>					
4-1.	Frame Schematic Diagram	4-1	<b>7. ADJUSTMENTS</b>		
4-2.	Printed wiring Boards and Schematic Diagrams	4-4	SERVICE MODE		
				1. Setting the Service Mode	7-1
				2. Test Mode Setting	7-4
				3. Emergency Codes	7-5
				4. D Page Memory Map	7-6
			7-1.	MECHANICAL ADJUSTMENTS	7-7
			1-1.	Tape Path Adjustment	7-7

<u>Section</u>	<u>Title</u>	<u>Page</u>
1-1-1.	Setting the Track Shift Mode .....	7-7
1-1-2.	Preparation before Adjustment .....	7-7
7-2.	ELECTRICAL ADJUSTMENTS .....	7-8
2-1.	Preparation before Adjustment .....	7-8
2-1-1.	Equipment Required .....	7-8
2-1-2.	Equipment Connection .....	7-9
2-1-3.	Input Signal Check .....	7-10
2-1-4.	Alignment Tapes .....	7-11
2-1-5.	Input/Output Levels and Impedance .....	7-12
2-2.	Power Supply Check .....	7-12
2-2-1.	Output Voltage Check .....	7-12
2-3.	System Control System Check .....	7-13
2-3-1.	Timer Clock Check .....	7-13
2-4.	Servo System Adjustments .....	7-13
2-4-1.	PWM Frequency Adjustment .....	7-13
2-4-2.	Switching Position Adjustment .....	7-14
2-4-3.	PCM VCO Adjustment .....	7-14
2-4-4.	CAP Duty Adjustment .....	7-15
2-4-5.	SP/LP Discrimination Check .....	7-15
2-4-6.	Slow Adjustment .....	7-16
2-4-7.	×2 Adjustment .....	7-16
2-5.	Video System Adjustments .....	7-17
2-5-1.	Playback Frequency Characteristic Adjustment .....	7-17
2-5-2.	Sync AGC Adjustment .....	7-18
2-5-3.	Chroma Comb Filter Adjustment .....	7-18
2-5-4.	Pre-emphasis Input Level Adjustment .....	7-19
2-5-5.	L Mode Y FM Carrier Frequency, Y FM Deviation Adjustment .....	7-19
2-5-6.	E Mode Y FM Carrier Frequency, Y FM Deviation Adjustment .....	7-20
2-5-7.	Chroma Emphasis Adjustment .....	7-21

<u>Section</u>	<u>Title</u>	<u>Page</u>
2-5-8.	L Mode De-emphasis Level Adjustment .....	7-22
2-5-9.	E Mode De-emphasis Level Adjustment .....	7-22
2-5-10.	E Mode Playback Level Adjustment .....	7-23
2-5-11.	Recording Y-FM Level Adjustment .....	7-23
2-5-12.	E Mode Recording Chroma Level Adjustment .....	7-24
2-6.	Digital System Adjustments .....	7-24
2-6-1.	Read Clock Adjustment .....	7-24
2-6-2.	Encode FSC Adjustment .....	7-25
2-6-3.	AFC Adjustment .....	7-25
2-6-4.	APC Adjustment .....	7-26
2-7.	Audio System Adjustments .....	7-26
2-7-1.	Carrier Frequency 1.5MHz .....	7-27
2-7-2.	Carrier Frequency 1.7MHz .....	7-27
2-7-3.	1.5MHz Deviation Adjustment .....	7-28
2-7-4.	1.7MHz Deviation Adjustment .....	7-28
2-7-5.	Playback Separation 1 Check .....	7-28
2-7-6.	Playback Separation 2 Check .....	7-28
2-7-7.	E-E Output Level Check .....	7-28
2-7-8.	Overall Frequency Characteristic Check .....	7-28
2-7-9.	Overall Distortion Factor Check .....	7-29
2-7-10.	Overall Noise Level Check .....	7-29
2-8.	Adjustment Parts Location Diagram .....	7-30

## SERVICE NOTE

### 1. REMOVAL OF CASSETTE AT FAILURE WITH CASSETTE INSERTED

- 1) If tape is wound on the drum and it cannot be removed: Rotate the capstan motor wheel in either direction and rotate the S or R reel to house the tape. Then, perform Procedure ②.
- 2) If tape is housed in the cassette half and cannot be removed:
  - ① Remove the MD block. (For removal, refer to Section 2-7.)
  - ② Rotate the drive arms at both sides of L frame and cassette compartment in the arrow direction ①.
  - ③ Rotate the connecting gear in the arrow direction ② with both the thumbs.

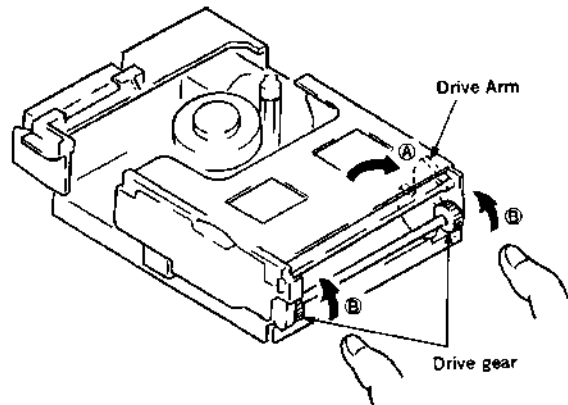

### 2. REPLACEMENT OF EXTERNAL PARTS

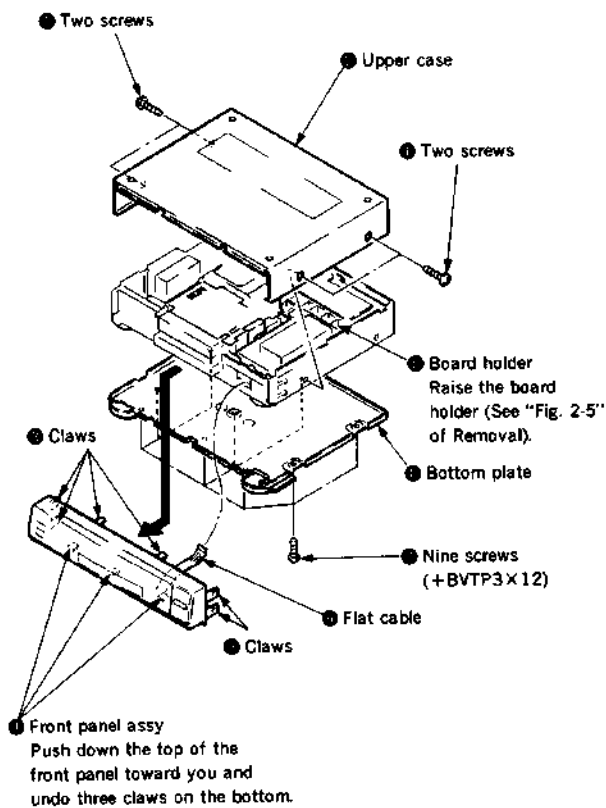

### 3. REPLACEMENT OF CASSETTE DOOR ASSEMBLY

- 1) Remove the front panel.
- 2) First undo ① portion toward you and then undo ②.

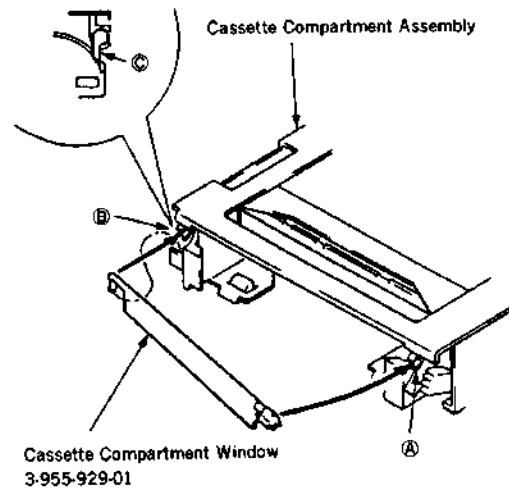

- 3) When installing, as shown above, first put in ② portion by setting the claw ③. Then, put in ① portion and install so that the door hangs almost vertically.

## 4. CLEANING OF VIDEO HEAD AND RUN SYSTEM

### Method 1

(Cleaning Method with Cleaning Tape)

- A cleaning cassette should be used. (When using, the attached manual for the cleaning cassette should be thoroughly read.)

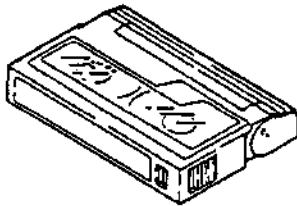

### Method 2

(Cleaning Method with Cleaning Liquid)

- ① Remove the upper case of the video deck.
- ② Apply cleaning liquid to a head cleaner stick.
- ③ As shown in the right figure, press the head cleaner stick lightly. Turn the rubber of the rotary upper drum gradually and clean the video deck.

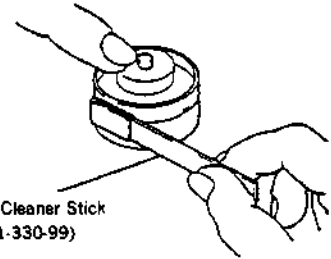

Head Cleaner Stick  
(3-601-330-99)

(Cleaning Method for Run System)

- ① Apply cleaning liquid to a head cleaner stick.
- ② Clean the guides which tape touches directly and the pinch roller with the head cleaner.

## 5. REPLACEMENT OF UPPER ROTARY DRUM

### Method 3

#### Caution

- Particular care must be taken when handling the video head and the terminals
- When handling the rotary upper drum, do not touch the side (A portion) and hold the top (B portion) (See Fig. 1)

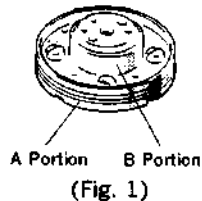

#### Removal of Rotary Upper Drum

- 1) Remove the two screws ① (See Fig. 2).

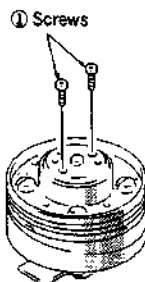

(Fig. 2)

- 2) Mount the jig ② with the two supplied screws ③, then screw the attached hexagon socket screws ④ to the jig ②. The rotary upper drum ⑤ will move upward and come off (See Fig. 3).

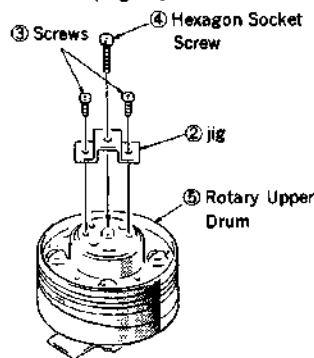

(Fig. 3)

#### Installation of New Rotary Upper Drum

- 1) Wipe clean the flange surface and the rotary upper drum ⑤ surface that makes contact with it, and confirm that they are free from dirt and scratches. (See fig. 4)
- 2) Insert the jig ⑥ into the lower drum positioning hole ⑦, then set then set the rotary upper drum ⑤ by passing the jig ⑥ through its positioning hole ⑧. (See Fig. 4)

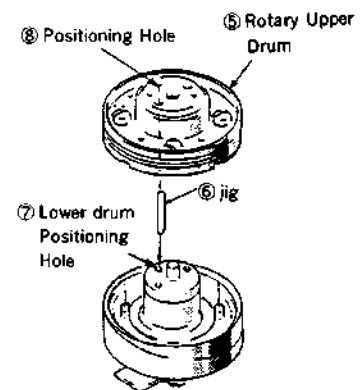

(Fig. 4)

- 3) Remove the jig ⑥ and push down the rotary upper drum ⑤ gently by hand. If it does not go all the way down, secure it temporarily by tightening the two screws ① alternately.
- 4) Remove the jig ⑥ and tighten strongly both two screws ①, and loosen both screws once, then tighten them again (for stable seating).
- 5) Insert the jig ⑥ into the positioning hole ⑧ again and confirm that it goes in smoothly. If it does not, loosen the two screws ①, repeat step 2) of the Removal paragraph and restart setting procedure.
- 6) Once the drum has been replaced, clean the video head and the run system with a head cleaner stick (See "Cleaning Method 2 for Video Head and Run System).

## Willkommen!

Sie haben sich für den Kauf eines Hi8-Videorecorders (VCR) von SONY entschieden. Im folgenden lernen Sie einige der Vorzüge dieses Geräts kennen:

- Mit dem RC-Zeitcode können Sie das gewünschte, auf Band gespeicherte Programm mühelos finden.
- JOG-Dial-Ring und SHUTTLE-Ring vereinfachen die Suchfunktionen.
- Buchse LANC zum Anschluß peripherer Geräte, z.B. eines anderen Videorecorders, mit dem dieser Videorecorder gesteuert werden kann.

### Kompatible Farbsysteme

Dieser Videorecorder ist für die Aufnahme und Wiedergabe mit dem Farbsystem PAL ausgelegt. Aufnahmen von Videoquellen, die auf anderen Farbsystemen basieren, sind unter Umständen nicht möglich.

Die Anleitungen in diesem Handbuch gelten für die Modelle EV-C2000E, EV-C2000E UB und EV-C2000E VP. Überprüfen Sie die Modellnummer Ihres Videorecorders auf der Rückseite des Geräts. Unterschiede in der Bedienung der anderen Modelle sind im Text deutlich gekennzeichnet, z.B. "nur Modell EV-C2000E VP".

## Hi8-Videosystem (High Eight)

Für diesen Videorecorder können sowohl Hi8- als auch Standard-8-Kassetten verwendet werden. In den folgenden Tabellen finden Sie Erläuterungen zur Kompatibilität zwischen dem Hi8-Videosystem und dem Standard-8-System.

### Wiedergabe einer Kassette

Dieser Videorecorder erkennt automatisch den Typ des abzuspielenden Bandes: Hi8 oder Standard-8. Außerdem erkennt das Gerät automatisch die Geschwindigkeit (SP oder LP), mit der das Band aufgenommen wurde.

Bandtyp	Aufnahmeformat	Wiedergabemodus
Hi8-Kassette	Hi8 (High Eight)	Hi8 (High Eight)
	8 mm Standard	8 mm Standard
Standard-8-Kassette	8 mm Standard	8 mm Standard

### Aufnahmen mit einer Kassette

Sie können diesen Videorecorder entweder für die Aufnahme mit dem Format Hi8 oder dem Format Standard-8 einstellen. Hinweise finden Sie im Abschnitt "Anzeigen von Menüoptionen" auf Seite 20.

Bandtyp	Aufnahmeformat	Einstellung im Menü SET UP MENU
Hi8-Kassette	Hi8 (High Eight)	AUTO
	8 mm Standard	OFF
Standard-8-Kassette	8 mm Standard	AUTO oder OFF

### Sichern einer Aufnahme

Schieben Sie die Löschschilder auf der Kassette heraus, so daß Sie die rote Farbmarkierung sehen können.

Um erneut auf der Kassette aufzeichnen zu können, schieben Sie die Lasche wieder zurück.

### Hinweise

- Aufnahme und Wiedergabe mit dem Hi8-System können nur mit einer Hi8-Kassette durchgeführt werden.
- Auf Standard-8 Kassetten sind Aufnahmen im Hi8-Format nicht möglich.

## Überprüfen der Typenbezeichnung

## Schritt 1 Auspacken

Überprüfen Sie den Packungsinhalt. Die folgenden Teile müssen enthalten sein:

- Fernbedienung



- R6-Batterien (Größe AA)



- S-Videokabel



- Netzkabel (nur Modell EV-C2000E/C2000E UP)



- Netzkabel (nur Modell EV-C1000E UB)

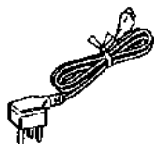

- LANC-Kabel



1-2

## Schritt 2 Vorbereiten der Fernbedienung

Legen Sie zwei R6-Batterien (Größe AA) in das Batteriefach der Fernbedienung ein. Achten Sie dabei auf richtige Polarität: Plus- und Minus-Pol der Batterien müssen wie im Batteriefach markiert liegen.

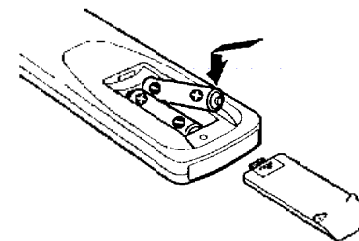

### Hinweise

- Bei normalem Betrieb sollten die Batterien für drei bis sechs Monate ausreichend sein.
- Wird die Fernbedienung längere Zeit nicht benutzt, nehmen Sie die Batterien heraus, um mögliche Schäden durch ein Auslaufen der Batterien zu vermeiden.
- Verwenden Sie neue Batterien nicht zusammen mit alten Batterien.
- Verwenden Sie nie zwei verschiedene Arten von Batterien.

### Einstellen des Befehlsmodus

Für die Einstellung des Befehlsmodus (COMMAND MODE) stehen drei Möglichkeiten zur Verfügung.

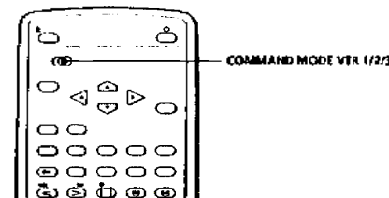

- 1** Schalten Sie den Videorecorder ein, und stellen Sie den Wählschalter **COMMAND MODE VTR OFF/1/2/3** des Videorecorders auf "VTR 2". Wenn Sie den Wählschalter auf "OFF" stellen, empfängt der Videorecorder keine Signale mehr von der Fernbedienung.
- 2** Stellen Sie den Wählschalter **COMMAND MODE VTR 1/2/3** der Fernbedienung auf "VTR 2".

### Tip

- Wenn Sie einen anderen Videorecorder von Sony steuern, bringen Sie den Wählschalter **COMMAND MODE** an der Fernbedienung und an dem anderen Videogerät in eine andere Position als die, die Sie an diesem Videorecorder eingestellt haben.



## Schritt 3 Anschließen des Videorecorders

Bevor Sie Ihren Videorecorder benutzen können, müssen Sie ihn an Ihr Fernsehgerät anschließen. Dieser Videorecorder verfügt über keinen eigenen Tuner (Empfangsteil). Wollen Sie Fernsehprogramme aufnehmen, müssen Sie daher ein Gerät mit Tuner an die Buchsen LINE IN oder an den Anschluß EURO-AV anschließen. Im folgenden ist erläutert, wie Sie die nötigen Anschlüsse vornehmen müssen, um Ihren Videorecorder benutzen zu können.

### Vorbereitungen

- Schalten Sie die Geräte aus.
- Schließen Sie das Netzkabel erst dann wieder an, wenn Sie alle Anschlüsse vorgenommen haben.
- Verbinden Sie Stecker und Buchsen fest miteinander. Lose Verbindungen können zu Bildstörungen führen.
- Entspricht Ihr Fernsehgerät keinem der dargestellten Beispiele, wenden Sie sich bitte an Ihren Sony-Händler oder an qualifiziertes Fachpersonal.

### Audio-Video-Anschluß (AV)

Verfügt Ihr Fernsehgerät über einen S-Videoeingang, schließen Sie Ihren Videorecorder bitte über das mitgelieferte S-Videokabel an. So erhalten Sie eine bessere Bildqualität. Andernfalls verwenden Sie nur ein Audio-/Videokabel (A/V-Kabel).

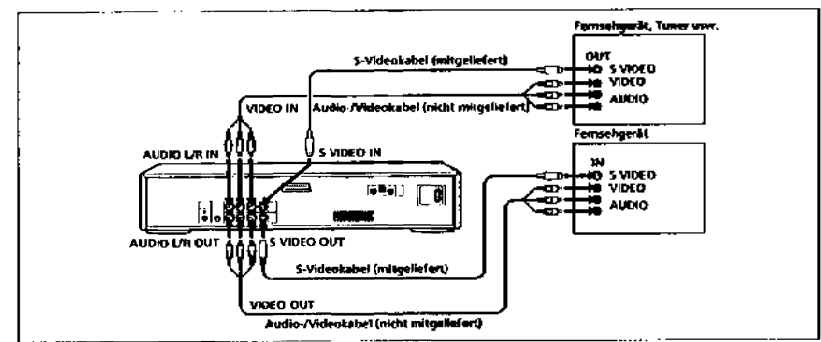

1-3

### EURO-AV-Anschluß

Verfügt Ihr Fernsehgerät über einen S-EURO-AV-Anschluß (Scart-Anschluß), erhalten Sie mit dieser Verbindung eine bessere Bildqualität.

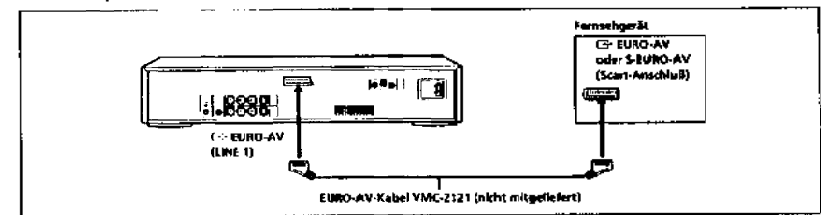

8 Erste Schritte

Wenn Sie Ihren Videorecorder an einen S-EURO-AV-Anschluß angeschlossen haben, setzen Sie die Option EURO AV OUT im Menü SET UP MENU auf 5.

- 1) Drücken Sie MENU.
- 2) Wählen Sie mit CURSOR ▲/▼ die Option SET UP MENU und drücken dann EXECUTE.
- 3) Wählen Sie mit CURSOR ▲/▼/◀/▶ die Option EURO AV OUT und setzen sie auf 5.

### Hinweis

- Verfügt Ihr Fernsehgerät über einen S-Video-/Video-Wählschalter, stellen Sie diesen in die Position für S-Video.

So sehen Sie beim obigen Anschlußbeispiel das Wiedergabebild

Wählen Sie am angeschlossenen Fernsehgerät den Videoeingang für diesen Videorecorder.

### RFU DC OUT-Anschluß

Verfügt Ihr Fernsehgerät nicht über Audio-/Video-Eingangsbuchsen (A/V-Eingangsbuchsen) oder einen EURO-AV-Anschluß, nehmen Sie einen RFU DC OUT-Anschluß vor. Dazu benötigen Sie den nicht mitgelieferten RFU-Satz RFU-B9EKA. Mit dieser Verbindung können Sie jedoch keine Fernsehprogramme über den Tuner des angeschlossenen Fernsehgeräts aufzeichnen. Wie Sie diesen Anschluß vornehmen, schlagen Sie bitte auch in der Bedienungsanleitung zum RFU-Satz nach.

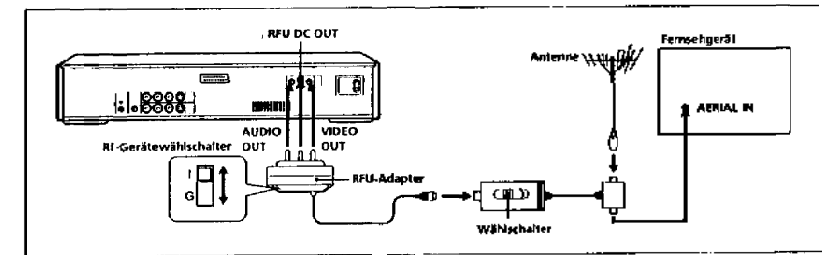

So sehen Sie beim obigen Anschlußbeispiel das Wiedergabebild

Stellen Sie den RF-Gerätewählschalter am RFU-Adapter je nach der Fernsehform Ihres Landes auf Letter G. Stellen Sie den Wählschalter auf VTR, und wählen Sie eine Programmposition am Fernsehgerät, die noch nicht für den Empfang eines Fernsehprogramms verwendet wird.

### Hinweis

- Bei dieser Verbindung ist der Ton immer monaural, auch wenn Sie ein Stereosystem wiedergeben.

### Anschließen eines Stereosystems

Sie können die Tonqualität verbessern, indem Sie das Gerät wie unten gezeigt an ein Stereosystem anschließen.

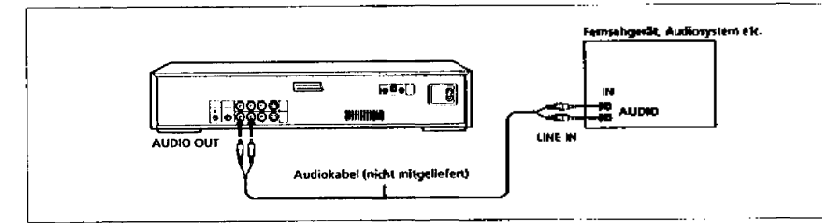

Erste Schritte 9

## Grundfunktionen

### Wiedergabe einer Kassette

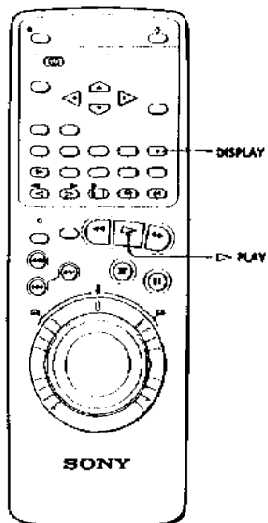

1-4

#### Hinweise

- Wird eine Kassette neu eingelegt, wird die Zeitzählung auf "01:00:00" zurückgesetzt.
- Bei Bandabschlüssen ohne Aufnahme ist die Zeitzählung außer Funktion.

#### Tip

- Weitere Informationen zu Such- und Wiedergabefunktionen sind auf Seite 14, Abschnitt "Wiedergabe/Suchen mit verschiedenen Geschwindigkeiten", zu finden.

Dieser Abschnitt beschreibt die Wiedergabe einer Videokassette.

- Schalten Sie das Fernsehgerät ein, und stimmen Sie es auf den Videorecorder ab:**
  - Ist das Fernsehgerät mit Hilfe des EURO-AV-Kabels, des S-Videokabels oder des AV-Kabels an den Videorecorder angeschlossen, stellen Sie das Fernsehgerät auf Videoeingang.
  - Ist das Fernsehgerät mit Hilfe des RFU-Satzes an den Videorecorder angeschlossen, stellen Sie am Fernsehgerät den Programmspeicherplatz für den Videorecorder ein.
- Legen Sie eine Kassette ein.**  
Der Videorecorder schaltet sich automatisch ein.
- Drücken Sie die Taste  $\triangleright$  PLAY. Die Wiedergabe beginnt.**  
Sobald die Kassette bis zum Ende abgespielt ist, spult sie der Videorecorder automatisch zurück. Das Gerät bleibt eingeschaltet.

#### Zusätzliche Funktionen

Um	Drücken Sie
die Wiedergabe zu stoppen	■ STOP
die Wiedergabe zu unterbrechen	II PAUSE
die Wiedergabe nach einer Pausenfortsetzung	II PAUSE oder $\triangleright$ PLAY
vorwärts zu suchen	$\triangleright$ FF während der Wiedergabe, oder drücken Sie $\text{SEARCH}$
rückwärts zu suchen	$\triangleleft$ REW während der Wiedergabe, oder drücken Sie $\text{SEARCH}$
die Kassette schnell vorwärtszuspulen	bei gestoppter Kassette die Taste $\triangleright$ FF
die Kassette zurückzuspulen	bei gestoppter Kassette die Taste $\triangleleft$ REW
die Kassette schnell zurückzuspulen	auf $\triangleleft$ HI-SPEED REW

#### Anzeige der restlichen Bandlänge, Zeitzählung

Drücken Sie die Taste DISPLAY, um das Display ein- bzw. auszuschalten.



Wiedergabeanzeige

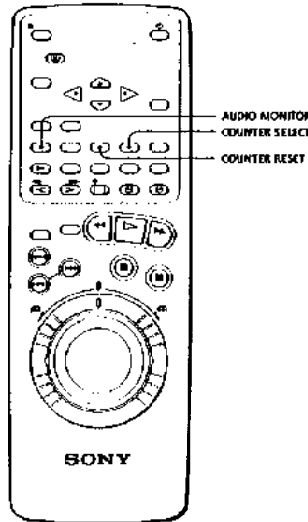

#### Hinweise

- Bei folgenden Bandtypen wird die restliche Bandlänge unter Umständen nicht korrekt angezeigt:
  - Leerkassetten
  - Kassetten, bei denen das Band am Anfang nicht korrekt aufgespult ist
  - Bänder mit unbespielten Passagen oder mit Passagen, die in unterschiedlichen Geschwindigkeiten aufgenommen wurden
  - Bänder schlechter Qualität oder Nicht-Standard-Bänder
  - Reinigungskassetten
- Im Display erscheint "—" wenn das Gerät die restliche Bandlänge nicht feststellen kann.
- Die Bandrestanzeige eignet sich nur für eine ungefähre Messung der restlichen Bandlänge.

#### Zweck der Zeitzählung

An der Stelle des Bandes, die Sie später wiederfinden möchten, drücken Sie die Taste COUNTER RESET. Die Zeitzählung wird auf "01:00:00" zurückgesetzt. Wenn Sie das Band an diese Stelle vor- oder zurückspulen, richten Sie sich immer nach der Zeitzählungsangabe.

#### Überprüfen der restlichen Bandlänge

Zum Überprüfen der restlichen Bandlänge drücken Sie während der Wiedergabe oder der Aufnahme zweimal hintereinander die Taste COUNTER SELECT. Beim ersten Tastendruck erscheint der Zeitcode im Display. Beim zweiten Tastendruck wird die restliche Bandlänge angezeigt. Um die Zeitzählung wieder aufzurufen, drücken Sie nochmals COUNTER SELECT.

#### Anzeigen des DATA CODE

Setzen Sie im Menü SET UP MENU die Option DATA CODE auf ON. Im Display erscheinen Zählerdaten. Wenn Sie Bänder wiedergeben, die mit DATA CODE-Signalen aufgezeichnet wurden, erscheinen Tag, Monat und Jahr der Aufnahme auf dem Fernsehschirm.

#### Auswahl des Wiedergabetons bei Stereo- bzw. Zweikanaltonkassetten

Drücken Sie auf der Fernbedienung die Taste AUDIO MONITOR, um den gewünschten Ton zu wählen. Mit jedem Tastendruck wechselt die Anzeige auf dem Bildschirm des Fernsehgeräts. Wenn Sie ein Band wiedergeben, das in Stereo- oder Zweikanalton aufgenommen wurde, leuchtet die Anzeige HI-FI STEREO am Videorecorder auf.

#### Stereoprogramme

Zum Hören	Drücken Sie die Taste AUDIO MONITOR, bis folgende Anzeige auf dem TV-Bildschirm erscheint
von Stereoton	"STEREO"
des linken Kanals	"L"
des rechten Kanals	"R"

#### Zweikanaltonprogramme

Zum Hören von	Drücken Sie die Taste AUDIO MONITOR, bis folgende Anzeige auf dem TV-Bildschirm erscheint
Hauptton	"MAIN"
Nebenton	"SUB"
Haupt- und Nebenton	"MAIN/SUB"

## Aufnahme von TV-Programmen

### Hinweise

- Beim Aufnehmen eines Fernsehprogramms müssen Sie das Fernsehgerät eingeschaltet lassen.
- Wenn Sie Ihr Fernsehgerät über den RFU-Satz an diesen Videorecorder angeschlossen haben, ist es nicht möglich, Fernsehprogramme über den Tuner des Fernsehgeräts aufzunehmen.
- Wenn Sie eine Kassette einlegen, bei der die Überspielschutzlasche herausgeschoben wurde, so daß die rote Farbmarkierung sichtbar ist, und die Taste **REC** drücken, wird sie vom Videorecorder ausgeworfen.

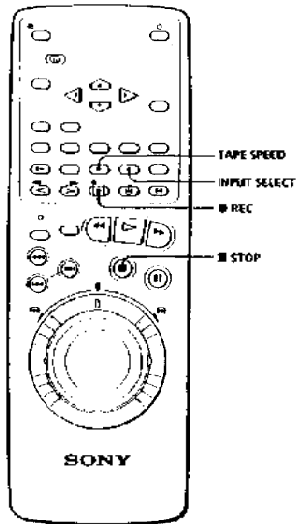

1-5

Dieser Abschnitt beschreibt die grundlegende Bedienung des Geräts zur Aufnahme von Fernsehsendungen. Dieser Videorecorder verfügt über keinen Tuner. Um Fernsehprogramme aufnehmen zu können, schließen Sie ein Gerät mit Tuner an die Buchsen LINE IN oder den Anschluß EURO-AV an.

### 1 Schalten Sie das Fernsehgerät ein, und stimmen Sie es auf den Videorecorder ab:

- Ist das Fernsehgerät mit dem EURO-AV-Kabel, dem S-Videokabel oder dem AV-Kabel an den Videorecorder angeschlossen, stellen Sie das Fernsehgerät auf Videoeingang.
- Ist das Fernsehgerät mit dem RFU-Satz an den Videorecorder angeschlossen, stellen Sie am Fernsehgerät den Programmspeicherplatz für den Videorecorder ein.

### 2 Legen Sie eine Kassette ein, bei der die Überspielschutzlasche zurückgeschoben ist, so daß die rote Farbmarkierung nicht sichtbar ist.

### 3 Drücken Sie die Taste INPUT SELECT, bis im Display des Videorecorders das Eingangssignal des angeschlossenen Fernsehgeräts erscheint.

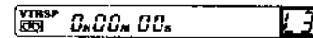

### 4 Wählen Sie an dem angeschlossenen Fernsehgerät das gewünschte Programm.

### 5 Wählen Sie mit der Taste TAPE SPEED die Bandgeschwindigkeit SP (Standardplay) oder LP (Longplay). Nähere Einzelheiten finden Sie im Abschnitt "Auswahl von Bandgeschwindigkeiten" auf der folgenden Seite.

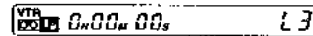

### 6 Starten Sie mit der Taste REC die Aufnahme. Sobald das Ende des Bandes erreicht ist, spult es der Videorecorder automatisch zum Anfang zurück.

**Stoppen der Aufnahme**  
Drücken Sie die Taste **STOP**.

### Hinweis

- Wenn Sie über den Tuner des Fernsehgeräts ein Fernsehprogramm aufzeichnen, können Sie kein anderes Fernsehprogramm ansehen.

### Tips

- Sie können beim Aufnehmen eine unerwünschte Szene herauslösen. Näheres dazu finden Sie unter "Spalte-Schnitt" auf Seite 21.
- Auf dem Bildschirm des Fernsehgeräts wird das Display zur Anzeige von Informationen über das Band eingeblendet. Diese Informationen werden auf dem Band nicht aufgezeichnet.

### Auswahl von Bandgeschwindigkeiten

Bei der Aufnahme muß entweder die Bandgeschwindigkeit SP oder LP gewählt werden. Mit der Geschwindigkeit LP können Sie doppelt so lange aufnehmen wie mit der Geschwindigkeit SP, letztere bietet aber eine bessere Bildqualität. SP und LP können auf ein- und denselben Band gemischt werden. Bei der Wiedergabe erkennt der Videorecorder automatisch die betreffende Bandgeschwindigkeit. In der folgenden Tabelle ist die maximale Aufnahme- und Wiedergabedauer für jede Geschwindigkeit angegeben.

Bandtyp	Maximale Aufnahme-/Wiedergabedauer	
	SP	LP
ES/PS-30	30 min.	1 Std.
ES/PS-60	1 Std.	2 Std.
ES/PS-90	1 Std. 30 min.	3 Std.
ES-120	2 Std.	4 Std.

Wenn Sie andere Bandtypen als die oben genannten verwenden, wird die restliche Bandlänge unter Umständen nicht korrekt angezeigt.

### Schützen einer Aufnahme

Videokassetten werden mit einer Überspielschutzlasche geliefert, um sie vor versehentlichem Überspielen zu schützen. Um ein versehentliches Löschen der Aufnahmen zu vermeiden, schieben Sie die Überspielschutzlasche auf der Kassette heraus, so daß die rote Farbmarkierung sichtbar ist. Eine Kassette, bei der sich die Überspielschutzlasche in dieser Position befindet, wird ausgeworfen, wenn Sie versuchen, etwas darauf aufzunehmen.

Wollen Sie eine geschützte Kassette erneut bespielen, schieben Sie die Lasche zurück, so daß die rote Farbmarkierung nicht zu sehen ist.

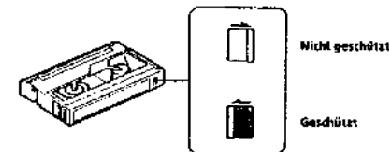

### Zusätzliche Funktionen

## Wiedergabe/Suchen mit verschiedenen Geschwindigkeiten

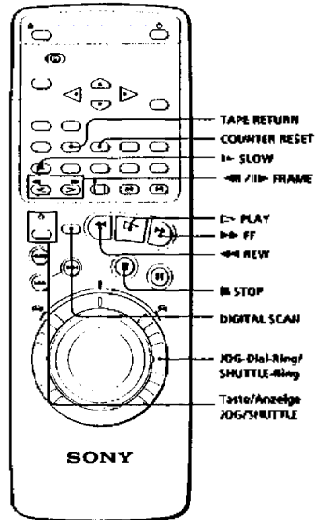

1-6

#### Hinweise

- Wenn im Display der TIME CODE oder die restliche Bandlaufzeit angezeigt wird, ist die Taste TAPE RETURN außer Funktion.

#### Tip

- Während der Wiedergabe mit verschiedenen Geschwindigkeiten können Sie die Bildqualität verbessern (siehe Abschnitt "Einstellen der Spurlage" auf Seite 16).

Sie können eine Kassette mit verschiedenen Geschwindigkeiten wiedergeben: schnell, langsam, Bild für Bild usw. Diese Optionen sind außerdem bei der Suche nach einer bestimmten Stelle während der Wiedergabe von Vorteil. Der Ton ist bei diesen Vorgängen ausgeschaltet. Wenn Sie den JOG-Dial-Ring/SHUTTLE-Ring an der Fernbedienung verwenden, drücken Sie zunächst die Taste JOG/SHUTTLE. Achten Sie dann darauf, daß die Anzeige JOG/SHUTTLE aufleuchtet.

Wiedergabeoptionen	Aktion	Wiederaufnahme der normalen Wiedergabe
Wiedergabe mit verschiedenen Geschwindigkeiten: Normalgeschwindigkeit Ein Fünftel der Normalgeschwindigkeit Doppelt Normalgeschwindigkeit Höhere Geschwindigkeit	Drehen Sie den SHUTTLE-Ring während der Wiedergabe nach rechts oder links auf: 1 1/5 ×2 H oder H	Lassen Sie den Ring los, und drücken Sie ▷ PLAY.
Schwacher Vor- und Rücklauf mit Wiedergabe des Bildes	Drücken Sie während des schnellen Vorlaufs die Taste ▷ FF und während des Rücklaufs die Taste ◀◀ REW.	Drücken Sie die Taste ▷ PLAY.
Anhalten eines Bildes bei hoher Geschwindigkeit	Drücken Sie während des schnellen Vor- oder Rücklaufs die Taste DIGITAL SCAN.	Drücken Sie die Taste ▷ PLAY.
Anhalten eines Zeitlupenbildes	Drücken Sie während der Wiedergabe oder Pause die Taste SLOW. Um die Richtung zu wechseln, drücken Sie die Taste ◀◀ FRAME (rückwärts) oder H FRAME (vorwärts).	Drücken Sie die Taste ▷ PLAY.
Bild für Bild Wiedergabe	Drücken Sie während der Pause die Taste H FRAME, um ein Bild weiterzuspringen, oder die Taste ◀◀ FRAME, um ein Bild zurückzuspringen.	Drücken Sie die Taste ▷ PLAY.
Wiedergabe rückwärts	Drücken Sie während der Wiedergabe die Taste ◀◀ FRAME.	Drücken Sie die Taste ▷ PLAY.
Erneute Wiedergabe einer Szene	Drücken Sie während einer Wiedergabe zunächst die Taste COUNTER RESET, sobald Sie bei einer Szene angelangt sind, die Sie später nochmals wiedergeben wollen. Für die Wiedergabe der Szene drücken Sie S STOP und dann kurz hintereinander die Tasten TAPE RETURN und ▷ PLAY.	

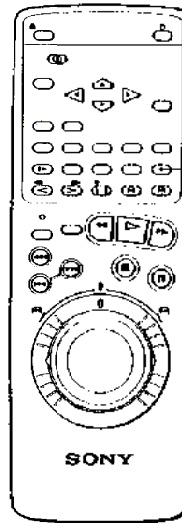

#### Hinweise

- Beim Rücklauf mit hoher Geschwindigkeit ist die Zeitzählung nicht erkennbar. Nachdem das Band bis zum Anfang zurückgespult ist, zeigt die Zeitzählung "01:00:00" an.
- Wenn Sie bei Kassetten, die nicht mit einem Camcorder aufgenommen wurden, die Funktion VOICE BOOST benutzen, ist die Audioqualität des Bandes nur schwer zu hören.

Wiedergabeoptionen	Aktion	Wiederaufnahme der normalen Wiedergabe
Rücklauf und erneuter Start der Wiedergabe	Drücken Sie im Stop-Modus die Taste C ▷ PLAY, am Videorecorder, und halten Sie gleichzeitig am Videorecorder die Taste ◀◀ REW oder ◀◀ HI-SPEED REW gedrückt.	

## So können Sie die Tonqualität einer per Videokamera aufgenommenen Unterhaltung verbessern

Bei der Wiedergabe einer mit einem Camcorder aufgenommenen Kassette können Sie mit der Funktion VOICE BOOST Außengeräusche wie Wind und Verkehrslärm reduzieren und die menschliche Stimme verstärken.

- 1 Drücken Sie auf der Fernbedienung die Taste VB (VOICE BOOST). Die Anzeige VB (Voice Boost) am Videorecorder leuchtet auf.
- 2 Um eine Kassette im Normalton anhören zu können, drücken Sie erneut die Taste VB (VOICE BOOST) und schalten so diese Funktion aus. Die Anzeige VB (Voice Boost) am Videorecorder erlischt.



## Suchen mit der Indexfunktion - Indexsuche (Fortsetzung)

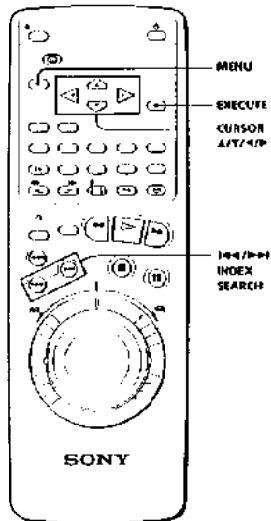

4 Drücken Sie wiederholt die Taste **INDEX SEARCH**, bis die gewünschte Indexnummer auf dem Fernsehschirm angezeigt wird:

- Drücken Sie für die Suche von nachfolgenden Aufnahmen die Taste **INDEX SEARCH**.
- Drücken Sie für die Suche nach vorübergehenden Aufnahmen die Taste **INDEX SEARCH**.

Der Videorecorder beginnt mit der Suche, wobei die Indexnummer auf dem Fernsehschirm in numerischer Reihenfolge rückwärts bis zur Null läuft. Die Wiedergabe startet dann automatisch an dieser Stelle.



## Auffinden eines Index nach dem Datum - "Datum" - Indexsuche

Sie können eine gewünschte Szene suchen, wenn die von Ihnen verwendete Kassette mit einem Camcorder aufgenommen wurde, die eine Datumscodefunktion besitzt. Sie können bis zu 19 Indexsignale finden, indem Sie nach den DATA CODE-Signalen suchen. Angaben zur Einstellung der Menüoption INDEX finden Sie im Abschnitt "Anzeigen von Menüoptionen" auf Seite 28.

1 Legen Sie eine Kassette mit Index in den Videorecorder ein, und drücken Sie die Taste MENU.

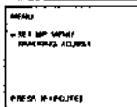

2 Drücken Sie die Tasten CURSOR **A/V**, und stellen Sie den Cursor (**▶**) damit auf SET UP MENU. Drücken Sie danach die Taste EXECUTE.

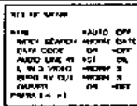

3 Drücken Sie die Tasten CURSOR **A/V/4/▶**, und stellen Sie den Cursor (**▶**) damit auf INDEX SEARCH. Wählen Sie danach DATE.

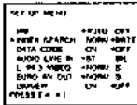

4 Drücken Sie wiederholt die Taste **INDEX SEARCH**, bis die gewünschte Indexnummer auf dem Fernsehschirm angezeigt wird:

- Drücken Sie für die Suche nach nachfolgenden Aufnahmen die Taste **INDEX SEARCH**.
- Drücken Sie für die Suche nach vorübergehenden Aufnahmen die Taste **INDEX SEARCH**.

Der Videorecorder beginnt mit der Suche, wobei die Indexnummer auf dem Fernsehschirm rückwärts bis zur Null läuft, und zwar in der Reihenfolge des Datums. Die Wiedergabe startet dann automatisch an dieser Stelle.

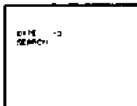

## Minweise

- Lassen Sie zwischen den Indexpunkten eine Pause von mindestens 2 Minuten beim SP-Modus und von mindestens 4 Minuten beim EI-Modus, damit der Videorecorder die Signale richtig erkennen kann.
- Auf Kassetten, bei denen die Überspielschutzblende herausgeschoben wurde, so daß die rote Farbmackierung sichtbar ist, können Indexsignale nicht gesetzt oder gelöscht werden.
- Indexsignale am Anfang einer Kassette und solche auf Kassetten, die von einem Camcorder oder einem anderen Videorecorder gesetzt wurden, können nicht gelöscht werden.
- Wenn Sie auf einer Kassette, die mit Datumscodes markiert wurde, ein Indexsignal setzen oder löschen, werden die Datumscodes möglicherweise gelöscht.

## Setzen von Indexsignalen

Sie können an jeder beliebigen Stelle auf dem Band ein Indexsignal setzen, so daß Sie eine bestimmte Szene später leicht wiederfinden. Drücken Sie dazu im Aufnahme- oder Wiedergabemodus die Taste INDEX MARK.



Mit diesem Videorecorder ist es nicht möglich, ein Datumindexsignal zu setzen.

## Löschen von Indexsignalen

Mit dieser Funktion können Sie unerwünschte normale Indexsignale nach Betrieben löschen. Das Löschen von Datumindexsignalen ist jedoch nicht möglich.

1 Drücken Sie im Stop- oder Wiedergabemodus die Taste **INDEX SEARCH**.

Der Videorecorder spult die Kassette automatisch schnell zurück oder vor. Die Wiedergabe startet, sobald die auf dem Fernsehschirm angegebene Indexnummer "0" liest.

2 Drücken Sie während der zehn Sekunden langen Vorschau für den Index, den Sie löschen wollen, die Taste INDEX ERASE.



So beenden Sie das Löschen von Indexsignalen. Drücken Sie die Taste **▶ PLAY** oder **■ STOP**.

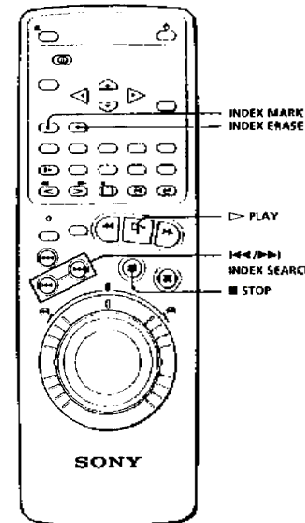

## Aufzeichnen des RC-Zeitcodes

### Hinweise

- Die Funktion TIME CODE WRITE dieses Videorecorders ist mit der entsprechenden Funktion bei berufsmäßig verwendeten Videorecordern nicht kompatibel.
- Wenn Sie eine Kassette benutzen, auf der sowohl mit der Bandgeschwindigkeit SP als auch mit der Bandgeschwindigkeit LP aufgenommen wurde, arbeitet die Funktion TIME CODE WRITE möglicherweise nicht korrekt.

### Tip

- Um mit Hilfe der Funktion TIME CODE präzise schneiden zu können, müssen Sie den Zeitcode in dem gesamten Bandteil aufzeichnen, den Sie schneiden wollen.

Mit dem RC-Zeitcode (RC = Rewritable Consumer) können Sie eine gewünschte Stelle auf dem Band mühelos finden und Ihr Band präzise schneiden. Die RC-Zeitcodefunktion fügt in das Band Bildpositionssignale ein, versteht das Band also gewissermaßen mit einem (Nummern-)Index.

### Aufzeichnen des RC-Zeitcodes auf ein Wiedergabeband

- Spulen Sie das Band an den Anfang zurück.
- Drücken Sie **▷ PLAY** und dann **II PAUSE**.
- Drücken Sie am Videorecorder **TIME CODE WRITE**. Am unteren Bildschirmrand kann ein schwarzer Streifen erscheinen. Dieser schwarze Streifen erscheint nicht in den Szenen, die Sie überspielen wollen.
- Starten Sie mit **II PAUSE** die Wiedergabe. Die Zeitcodedaten werden automatisch auf dem Band aufgezeichnet.

So beenden Sie das Aufzeichnen von RC-Zeitcodes  
Drücken Sie **■ STOP**.

Mit dem Menü SET UP MENU können Sie verschiedene Optionen für die Einrichtung und Anpassung Ihres Videorecorders auswählen. In der folgenden Tabelle finden Sie die zur Verfügung stehenden Menüpunkte. Die Anfangseinstellungen des Geräts sind durch Fettdruck gekennzeichnet.

### Menüauswahl

Menüoption	Stellen Sie die Option wie folgt ein
HIS	<ul style="list-style-type: none"> <li>Auf <b>AUTO</b>, wenn Sie auf einer <b>Hi8</b>-Kassette im <b>Hi8</b>-Format aufnehmen wollen.</li> <li>Auf <b>OFF</b>, wenn Sie auf einer <b>Hi8</b>-Kassette im Standardformat 8 mm aufnehmen wollen.</li> </ul>
INDEX SEARCH	<ul style="list-style-type: none"> <li>Auf <b>NORM</b> zur Suche nach Indexsignalen in numerischer Reihenfolge.</li> <li>Auf <b>DATE</b> zur Suche nach Indexsignalen in der Reihenfolge des Datums.</li> </ul>
DATA CODE	<ul style="list-style-type: none"> <li>Auf <b>OFF</b>, wenn Tag, Monat und Jahr nicht auf der Kassette aufgezeichnet werden sollen.</li> <li>Auf <b>ON</b>, wenn Tag, Monat und Jahr auf der Kassette aufgezeichnet werden sollen. Diese Option können Sie benutzen, wenn Ihr Camcorder mit dieser Funktion ausgestattet ist.</li> </ul>
AUDIO LINE IN	<ul style="list-style-type: none"> <li>Auf <b>ST</b>, um mit den Buchsen <b>AUDIO LINE IN</b> Stereoton hören und aufnehmen zu können.</li> <li>Auf <b>BL</b>, um mit den Buchsen <b>AUDIO LINE IN</b> zweisprachige Programme hören und aufnehmen zu können.</li> </ul>
LINE 3 VIDEO	<ul style="list-style-type: none"> <li>Auf <b>NORM</b>, wenn Sie die Videoausgangsbuchse des anderen Videorecorders an die Buchse <b>LINE IN 3 VIDEO</b> dieses Videorecorders angeschlossen haben.</li> <li>Auf <b>S</b>, wenn Sie die S-Video-Ausgangsbuchse des anderen Videorecorders an die Buchse <b>LINE IN 3S VIDEO</b> dieses Videorecorders angeschlossen haben.</li> </ul>
EURO AV OUT	<ul style="list-style-type: none"> <li>Auf <b>NORM</b> bei Verwendung des <b>EURO-AV-Kabels (Scart)</b>.</li> <li>Auf <b>S</b> bei Verwendung eines <b>EURO-AV-Kabels (Scart)</b>, das mit einer <b>S-EURO-AV-Buchse (Scart)</b> an ein Fernsehgerät angeschlossen ist.</li> </ul>
DIMMER	<ul style="list-style-type: none"> <li>Auf <b>ON</b>, um das Display dunkler einzustellen.</li> <li>Auf <b>OFF</b>, um das Display heller einzustellen.</li> </ul>

## Schneiden Shuttle-Schnitt

### Hinweis

- Beim Shuttle-Schnitt müssen der **JOG-Dial-Ring** und der **SHUTTLE-Ring** am Videorecorder und nicht auf der Fernbedienung benutzt werden.

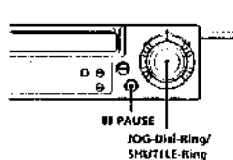

Dieser Abschnitt beschreibt, wie Sie Aufnahmen mit dem Videorecorder auf die grundlegendste Weise bearbeiten können: mit dem Shuttle-Schnitt. Außerdem stehen folgende zusätzliche Schneidemöglichkeiten bei diesem Videorecorder zur Verfügung:

- Überspielen auf oder von einem anderen Videorecorder oder einem Camcorder - "Überspielen mit einem anderen Videorecorder" (Seite 23).
- Überspielen über die Buchsen **LANC C** oder **CONTROL 5** von zwei Videorecordern - "Synchron-Schnitt" (Seite 25).

### Während der Aufnahme

Wenn Sie bestimmte Szenen, z.B. Werbespots, ausschneiden wollen, können Sie die Aufnahme unterbrechen und die Kassette rückwärts abspielen, bis der Anfang der unerwünschten Szene erreicht ist. Danach überspielen Sie einfach die Stelle. Diese Funktion kann nur vom Videorecorder aus aktiviert werden.

- Drücken Sie während der Aufnahme die Taste **II PAUSE**. Der Videorecorder schaltet in den Aufnahme-pausenmodus.
- Drehen Sie den **JOG-Dial-Ring/SHUTTLE-Ring** am Videorecorder gegen den Uhrzeigersinn, um die Kassette bis zum Beginn der unerwünschten Szene zurückzuspielen. Stellen Sie den **JOG-Dial-Ring/SHUTTLE-Ring** auf die gewünschte Wiedergabegeschwindigkeit. Sobald Sie loslassen, wechselt der Videorecorder zum Aufnahme-pausenmodus.
- Drücken Sie die Taste **II PAUSE**, sobald eine erwünschte Szene auf dem Bildschirm erscheint. Die Aufnahme beginnt.

### Zum Stoppen der Aufnahme

Drücken Sie die Taste **■ STOP**.

## Anzeigen von Menüoptionen

## Shuttle-Schnitt (Fortsetzung)

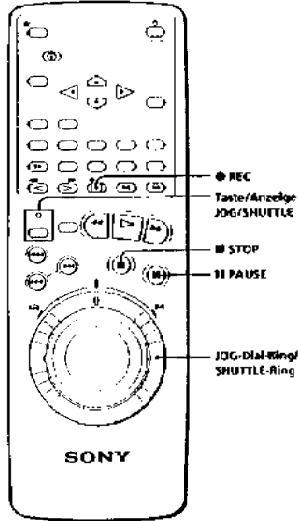

1-10

### Hinweis

- Das Bild kann an der Stelle, an der das Band geschaltet wurde (Aufnahmende), kurzzeitig verzerrt sein.

## Während der Wiedergabe

Eine unerwünschte Stelle auf einer bereits aufgenommenen Kassette kann überspielt werden. Wenn Sie den JOG-Dial-Ring/SHUTTLE-Ring an der Fernbedienung verwenden, drücken Sie zunächst die Taste JOG/SHUTTLE. Achten Sie dann darauf, daß die Anzeige JOG/SHUTTLE aufleuchtet.

- 1 Wird während der Wiedergabe eine unerwünschte Szene angezeigt, drücken Sie die Taste II PAUSE. Der Videorecorder wechselt zum Wiedergabepausenmodus.
- 2 Drehen Sie den JOG-Dial-Ring/SHUTTLE-Ring, bis der Anfang der unerwünschten Szene auf dem Bildschirm erscheint. Stellen Sie den JOG-Dial-Ring/SHUTTLE-Ring auf die gewünschte Wiedergabegeschwindigkeit. Sobald Sie loslassen, wechselt der Videorecorder zum Wiedergabepausenmodus.
- 3 Drücken Sie die Taste ● REC am Videorecorder oder auf der Fernbedienung. Der Videorecorder wechselt zum Aufnahme-pausenmodus.
- 4 Wählen Sie für den Überspielvorgang ein neues Programm.
- 5 Drücken Sie die Taste II PAUSE, sobald die Szene, die Sie aufnehmen wollen, auf dem Bildschirm angezeigt wird. Die Aufnahme beginnt.

**Zum Stoppen der Aufnahme**  
Drücken Sie die Taste ■ STOP.

## Überspielen mit einem anderen Videorecorder

### Hinweise

- Wenn Sie den Anschluß LINE IN 3 S VIDEO verwenden, stellen Sie L IN 3 VIDEO im Menü SET UP MENU auf S.
- Wenn Sie die Buchse LINE IN 2 VIDEO und den Anschluß LINE IN 2 S VIDEO gleichzeitig verwenden, besitzt der Anschluß LINE IN 2 S VIDEO Priorität.
- Wenn Sie den anderen Videorecorder anschließen, stellen Sie nicht gleichzeitig einen Anschluß mit den Buchsen LINE IN und LINE OUT dieses Videorecorders und den Eingangs- und Ausgangsbuchsen des anderen Videorecorders her. Andernfalls könnte ein Störgeräusch entstehen.

### Tips

- Achten Sie beim Anschließen darauf, daß die Farben der Stecker immer gut übereinstimmen.
- Wenn es sich bei dem Wiedergabe-Videorecorder um einen monauralen Typ handelt und Sie die Buchse LINE IN 2 an der Vorderseite des Videorecorders benutzen, schließen Sie den weißen Stecker an die (rechte) Buchse AUDIO L an.

Dieser Abschnitt beschreibt, wie Sie von oder auf einen anderen Videorecorder bzw. Camcorder überspielen können. Sie können mit dem hier beschriebenen Videorecorder als Aufnahme- oder Wiedergabegerät eine Kopie einer Kassette anfertigen.

## Anschließen für die Aufnahme mit diesem Videorecorder

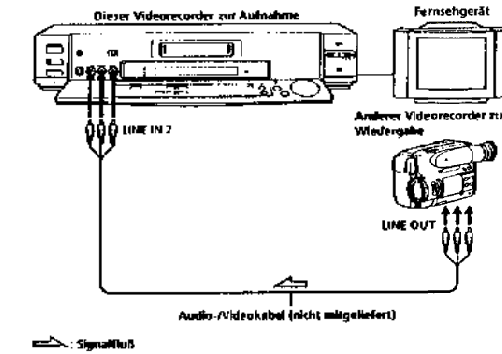

## Anschließen für die Aufnahme mit einem anderen Videorecorder

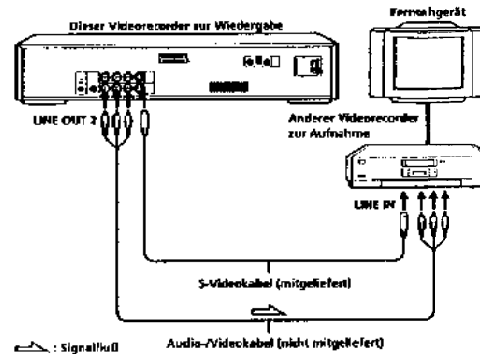



## Überspielen mit einem anderen Videorecorder (Fortsetzung)

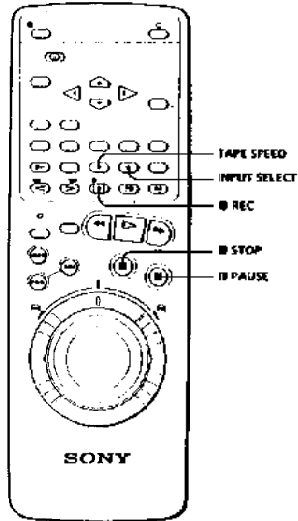

1-11

### Hinweis

- Vergewissern Sie sich, daß sich die Überspielschutzblende in der richtigen Stellung befindet. Handelt es sich bei dem Wiedergabe-Videorecorder um ein VHS-Modell, muß die Überspielschutzblende auf der Ausgangskassette entfernt sein.

### Tips

- Um den Überspielvorgang präzise steuern zu können, berühren Sie den Pausenmodus beider Videorecorder durch Drücken der Taste II PAUSE an den Videorecordern, nicht auf der Fernbedienung.
- Zum Herzschnellen unerwünschter Szenen während des Überspielvorgangs drücken Sie die Taste II PAUSE an diesem Videorecorder, sobald die unerwünschte Szene beginnt. Sobald sie endet, drücken Sie erneut die Taste II PAUSE, um die Aufnahme fortzusetzen (Assembly-Schnitt).

24 | Schneiden

## Vorgehen bei der Aufnahme mit diesem Videorecorder

### Vor Beginn des Überspielvorgangs

- Drücken Sie die Taste INPUT SELECT. Im Displayfenster wird "L2" eingeblendet.
- Drücken Sie zur Auswahl der Aufnahmegeschwindigkeit (SP/LP) die Taste TAPE SPEED.
- Besitzt der zweite (Wiedergabe-)Videorecorder eine EDIT-Funktion, stellen Sie diese auf ON.

- 1 Legen Sie eine Ausgangskassette in den anderen Videorecorder (für die Wiedergabe) ein. Suchen Sie die Stelle, an der die Wiedergabe beginnen soll, und schalten Sie den Videorecorder in den Wiedergabe-Pause-Modus.
- 2 Legen Sie eine Kassette in diesen (Aufnahme-) Videorecorder ein. Suchen Sie die Stelle für den Beginn der Aufnahme, und drücken Sie die Taste II PAUSE.
- 3 Drücken Sie die Taste REC an diesem Videorecorder, um ihn in den Aufnahme-Pause-Modus zu schalten.
- 4 Drücken Sie die Taste II PAUSE an beiden Videorecordern, um das Überspielen zu starten. Für bestmögliche Resultate drücken Sie zuerst die Pausetaste auf dem Wiedergabe-Videorecorder und kurz danach die Taste II PAUSE auf diesem Videorecorder.

### Zum Stoppen des Überspielvorgangs

Drücken Sie auf beiden Videorecordern die Taste III STOP.

## Synchron-Schnitt

### Hinweis

- Besitzt der Aufnahme-Videorecorder einen S-Video-Eingangsanschluss, verwenden Sie das mitgelieferte S-Videokabel. Auf diese Weise erhalten Sie eine bessere Bildqualität als mit dem Videokabel.
- Wenn Sie diesen Videorecorder für die Wiedergabe verwenden, drücken Sie die Taste EDIT ON/OFF am Videorecorder.
- Ein Synchron-Schnitt ist bei Videorecordern ohne Buchse LANC II und dem LANC-Modus M oder einer entsprechenden Funktion nicht möglich.

### Tip

- Wenn Sie die Buchse LANC II an der Vorder- und der Rückseite gleichzeitig besitzen, hat die Buchse LANC II an der Vorderseite Priorität.

Besitzt der Aufnahme-Videorecorder eine Buchse LANC II oder CONTROL S, verbinden Sie die Videorecorder über eine dieser beiden Buchsen. Durch diese zusätzliche Verbindung können Sie zum leichteren Überspielen beide Geräte von einem Videorecorder aus steuern.

## Anschließen über die Buchsen LANC II

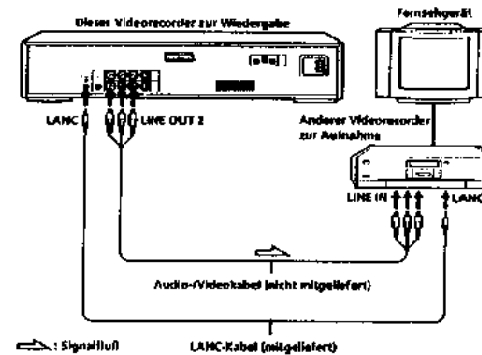

## Einstellen des LANC-Modus

Die Einstellung des LANC-Modus bestimmt, welcher Videorecorder welchen steuert. Der LANC-Modus dieses Videorecorders ist auf S eingestellt. Stellen Sie daher den LANC-Modus des anderen Videorecorders auf M, und steuern Sie diesen Videorecorder über den anderen.

## Hinweis zu LANC II

LANC steht für Local Application Control System (lokales Anwendungsteuersystem). Die Buchse LANC II dient zur Steuerung des Bandtransports in den angeschlossenen Video- und sonstigen Peripheriegeräten. Diese Buchse hat die gleichen Funktionen wie die Buchsen mit der Bezeichnung CONTROL L oder REMOTE.

## Synchron-Schnitt (Fortsetzung)

### Hinweise

- Verfügt der als Aufnahmegerät verwendete Videorecorder über einen S-VIDEO-Eingangsanschluß, stellen Sie mit dem mitgelieferten S-VIDEOKabel eine zusätzliche Verbindung zwischen den Videorecordern her.
- Wenn es sich bei dem Aufnahme-Videorecorder um einen monauralen Typ handelt, schließen Sie den weißen Stecker an die (weiße) Buchse LINE OUT 2 AUDIO L an diesem Videorecorder an.

## Anschließen über die Buchsen CONTROL 5

Mit der Buchse CONTROL 5 können Sie zum Pausenmodus wechseln und diesen wieder beenden, dies allerdings nur dann, wenn der andere Videorecorder über eine Synchron-Schnittfunktion verfügt. Besitzt der Aufnahme-Videorecorder sowohl die Buchse LANC als auch die Buchse CONTROL 5, benutzen Sie die Buchse LANC.

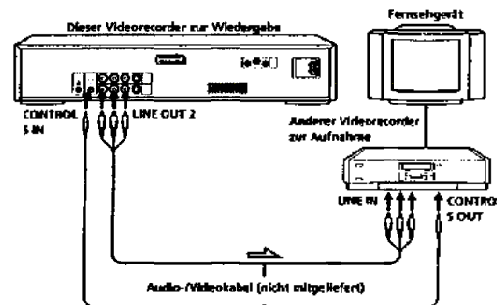

— : signalfuß  
CONTROL 5-Kabel RK-GE9 (nicht mitgeliefert)

## Vorgehen bei der Aufnahme mit dem anderen Videorecorder

### Vor Beginn des Überspielvorgangs

#### An diesem Videorecorder

- Schalten Sie das Gerät mit der Taste EDIT ON/OFF ein.

#### An dem als Aufnahmegerät verwendeten Videorecorder

- Wählen Sie LANC-Modus M.
- Wählen Sie die Bandgeschwindigkeit SP oder LP.
- Aktivieren Sie gegebenenfalls den EDIT-Modus.

**1** Legen Sie eine Ausgangskassette in diesen Videorecorder (für die Wiedergabe) ein. Suchen Sie mit  $\Rightarrow$  PLAY die Stelle, an der die Wiedergabe beginnen soll, und drücken Sie  $\parallel$  PAUSE.

**2** Legen Sie eine andere Kassette zum Aufnehmen in den anderen Videorecorder (für die Aufnahme) ein. Suchen Sie die Stelle, an der die Aufnahme beginnen soll, und schalten Sie den Videorecorder in den Pausenmodus.

**3** Drücken Sie am anderen Videorecorder die Aufnahmetaste, um ihn in den Aufnahme-Pause-Modus zu schalten.

**4** Um mit dem Überspielen zu beginnen, drücken Sie SYNCHRO EDIT am anderen Videorecorder.

**5** Wenn die Aufnahme enden soll, drücken Sie SYNCHRO EDIT nochmals. Beide Videorecorder schalten wieder in den Pausenmodus.

### Zum Stoppen des Überspielvorgangs

Drücken Sie die Taste  $\parallel$  STOP an beiden Videorecordern.

## Verzeichnis der Teile und Bedienelemente

Erläuterungen zu den einzelnen Teilen und Bedienelementen sind auf den Seiten in Klammern () zu finden.

### Vorderseite (Klappe geschlossen)

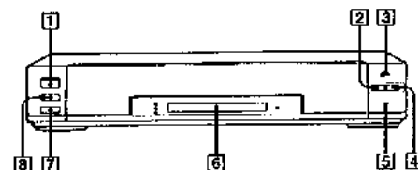

- 1 Netzschalter/ Anzeige ON/STANDBY
- 2 Taste/Anzeige  $\lll$  REW (10)
- 3 Taste/Anzeige  $\Rightarrow$  PLAY (10)
- 4 Taste/Anzeige  $\ggg$  FF (10)
- 5 Taste  $\parallel$  STOP (10)
- 6 Display
- 7 Fernbedienungssensor
- 8 Taste  $\square$  EJECT

### Vorderseite (Klappe offen)

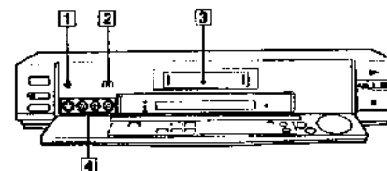

- 1 Buchse LANC (25)
- 2 Wählschalter COMMAND MODE VTR/OFF/1/2/3 (7)
- 3 Kassetteneinloch
- 4 Buchsen LINE IN 2 AUDIO/VIDEO/S VIDEO (23)

### Rückseite

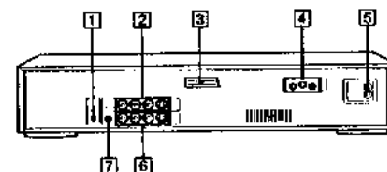

- 1 Buchse LANC (25)
- 2 Audio/Video-Eingangsbuchsen (LINE IN 3 AUDIO/VIDEO/S VIDEO) (23)
- 3 AV-Buchse ( $\Rightarrow$  EURO-AV (LINE 1)) (8)
- 4 Audio/Video-Ausgangsbuchsen (LINE OUT 3 AUDIO/VIDEO/RR/DC OUT) (9)
- 5 Netzanschluß (AC IN)
- 6 Audio/Video-Ausgangsbuchsen (LINE OUT 2 AUDIO/VIDEO/S VIDEO) (23)
- 7 Steuereingangsbuchse (CONTROL 5 IN) (26)

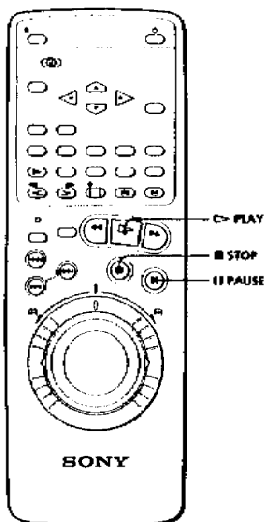

## Verzeichnis der Teile und Bedienelemente (Fortsetzung)

### Display an der Vorderseite

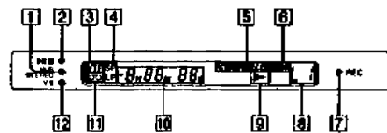

- 1 Anzeige HI-FI STEREO (11)
- 2 Anzeige (5)
- 3 Anzeige VTR
- 4 Anzeigen SP/LP (Bandgeschwindigkeit) (12)
- 5 Anzeigen REMAIN TIME/TIME CODE (11)
- 6 Anzeige EDIT (26)
- 7 Anzeige REC (12)
- 8 Eingangsmodusanzeige (12)
- 9 Bandfunktionsanzeige
- 10 Linearzeitzähler/Bandenstanzeige (11)
- 11 Bandanzeige
- 12 Anzeige VB (Voice Boost) (15)

### Bedienfeld

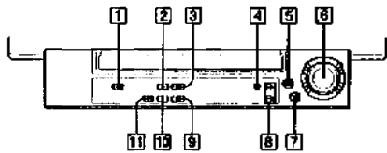

- 1 Taste INPUT SELECT (12)
- 2 Taste/Anzeige TIME CODE WRITE (20)
- 3 Taste COUNTER SELECT (11)
- 4 Taste EDIT ON/OFF (26)
- 5 Taste HI-SPEED REW (10)
- 6 JOG-Dial-/SHUTTLE-Ring (14)
- 7 Taste PAUSE (10)
- 8 Tasten INDEX SEARCH (18)
- 9 Taste COUNTER RESET (11)
- 10 Taste TAPE SPEED (SP/LP) (12)
- 11 Taste REC (12)

### Fernbedienung

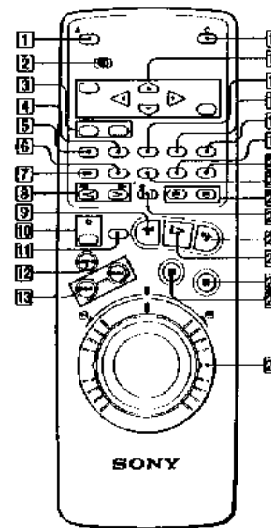

- 1 Taste EJECT
- 2 Wählschalter COMMAND MODE VTR 1/2/3 (7)
- 3 Tasten INDEX MARK/ERASE (19)
- 4 Taste TAPE RETURN (18)
- 5 Taste AUDIO MONITOR (11)
- 6 Taste X2 (doppelte Geschwindigkeit) (14)
- 7 Taste SLOW (14)
- 8 Tasten FRAME </> (14)
- 9 Taste REW (10)
- 10 Taste/Anzeige JOG/SHUTTLE (14)
- 11 Taste DIGITAL SCAN (14)
- 12 Taste HI-SPEED REW (14)
- 13 Tasten INDEX SEARCH (18)
- 14 Taste (Ein/Bereit)
- 15 Menüasten (16)
  - Taste MENU
  - Tasten CURSOR
  - Taste EXECUTE
- 16 Taste COUNTER RESET (11)
- 17 Taste COUNTER SELECT (11)
- 18 Taste DISPLAY (10)
- 19 Taste INPUT SELECT (12)
- 20 Taste V/VOICE BOOST (15)
- 21 Taste TAPE SPEED (SP/LP) (12)
- 22 Tasten SEARCH (10)
- 23 Taste REC (12)
- 24 Taste FF (10)
- 25 Taste PLAY (10)
- 26 Taste PAUSE (10)
- 27 Taste STOP (10)
- 28 JOG-Dial-/SHUTTLE-Ring (14)

## SECTION 2 DISASSEMBLY

### 2-1. REMOVAL OF CABINET ASSEMBLY

**Note:** This disassembly only describes the EV-C2000EVP. Therefore, certain parts are used in EV-C2000EVP, but not used in EV-C2000E/C2000EUB.

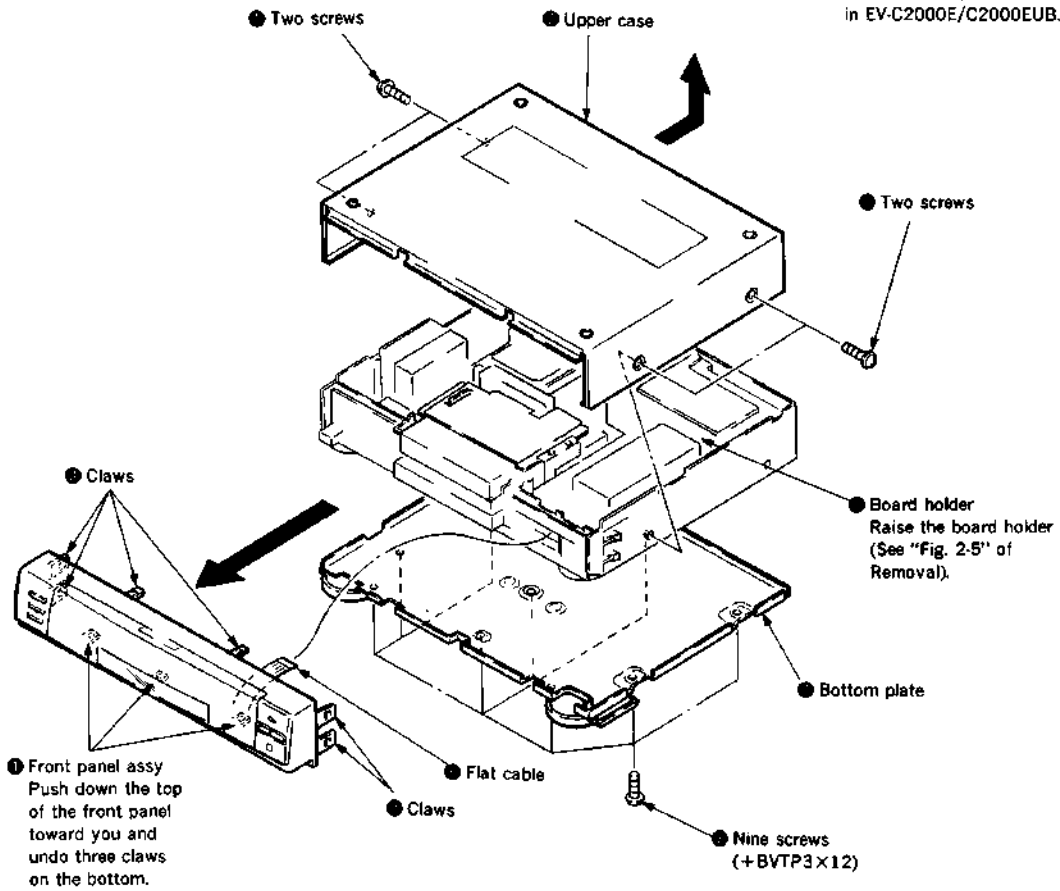

### 2-2. REMOVAL OF CONTROL SWITCH BLOCK

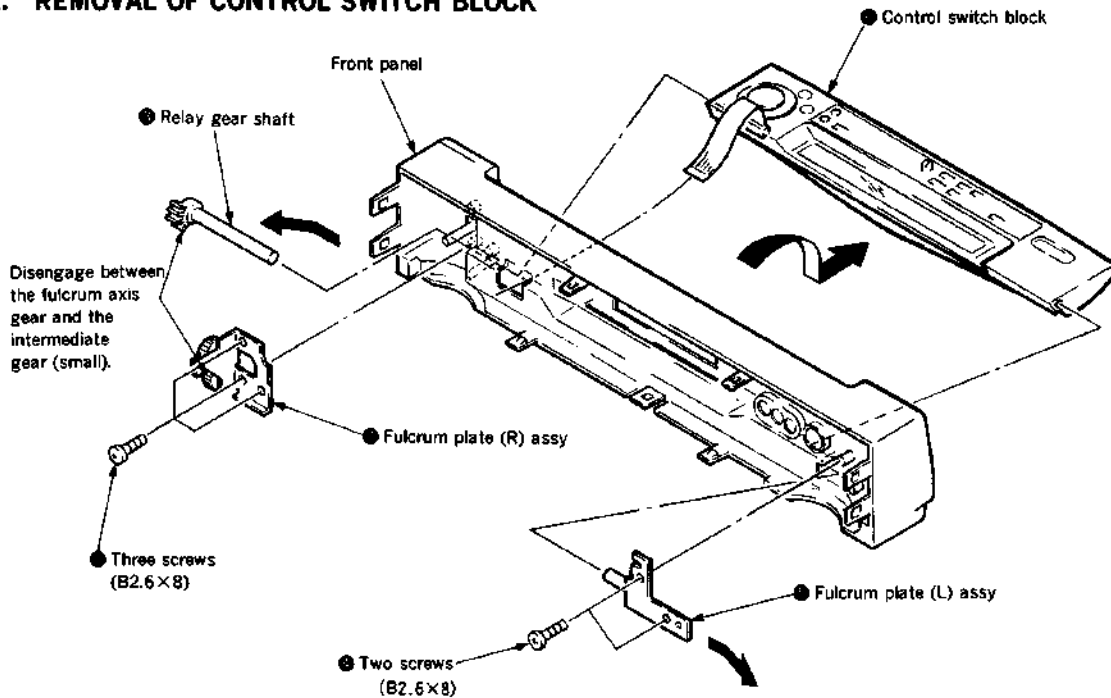

### 2-3. REMOVAL OF FL-64 BOARD, FR-89 BOARD AND PL-26 BOARD

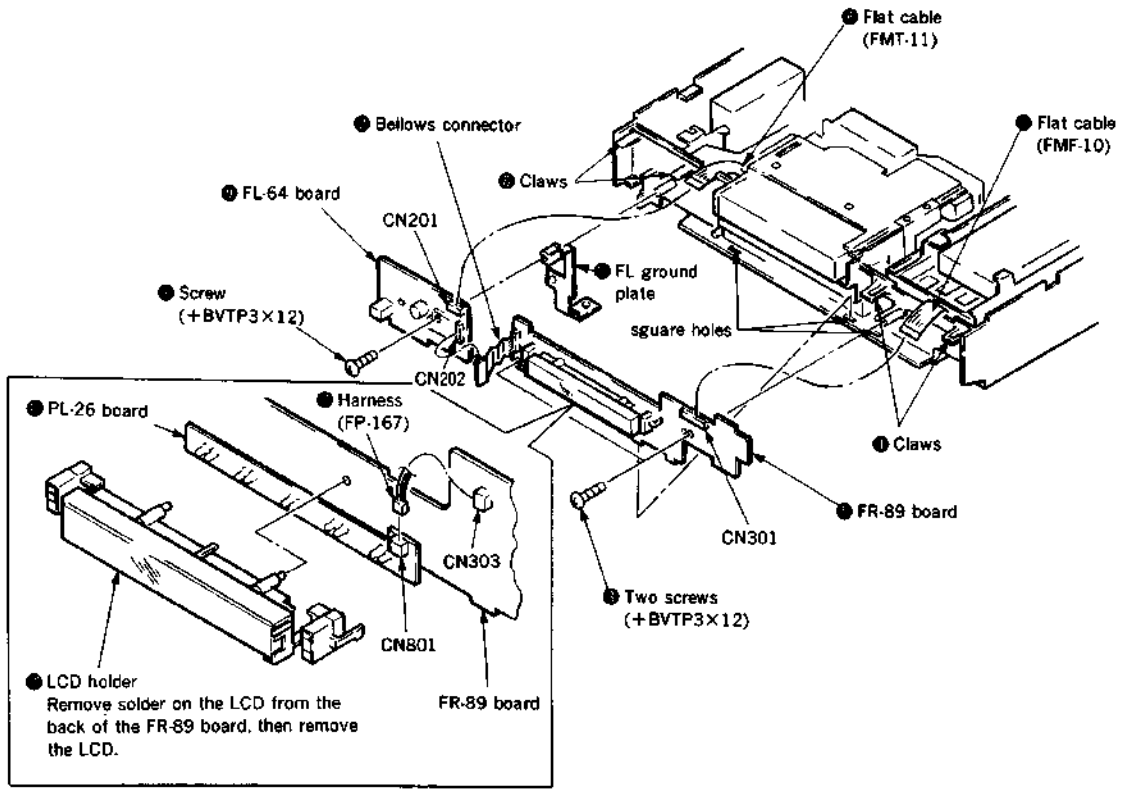

### 2-4. REMOVAL OF PS-324 BOARD AND PS-325 BOARD

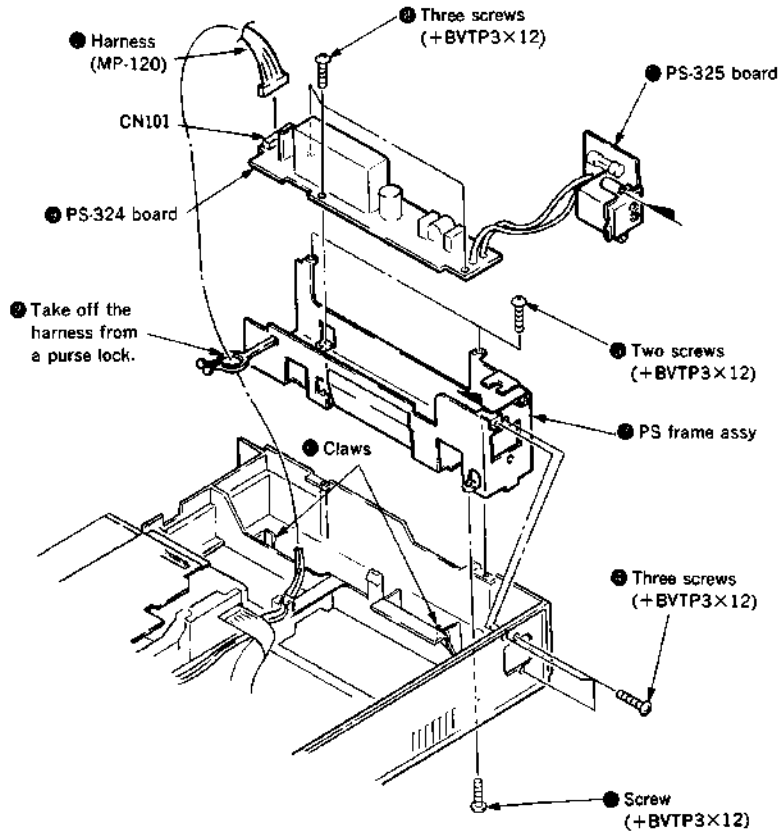

## 2-5. REMOVAL OF DI-55 BOARD

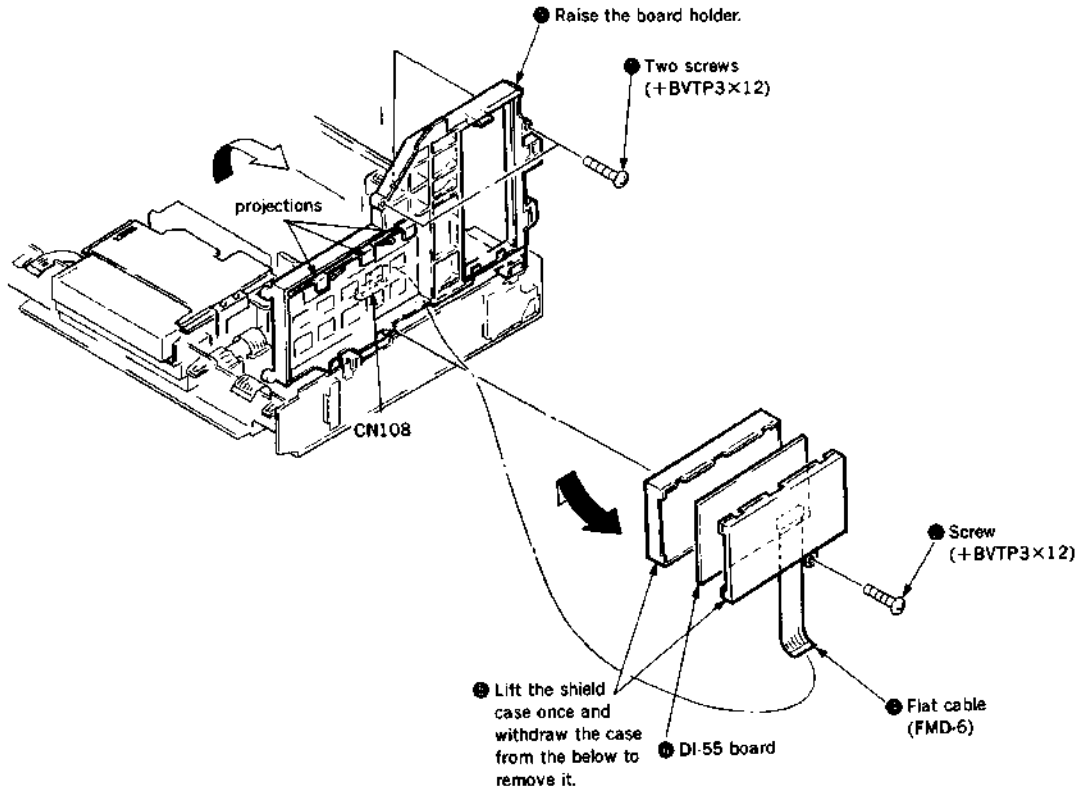

## 2-6. REMOVAL OF AU-176 BOARD

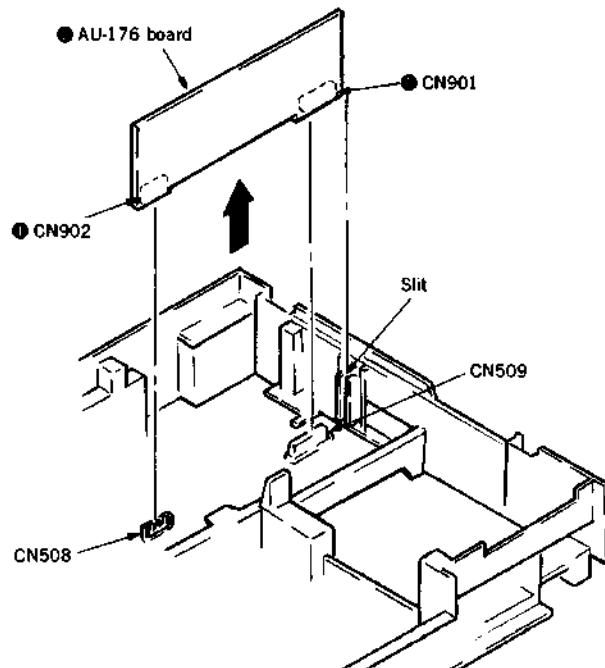

## 2-7. REMOVAL OF MECHANICAL BLOCK AND CASSETTE COMPATMENT

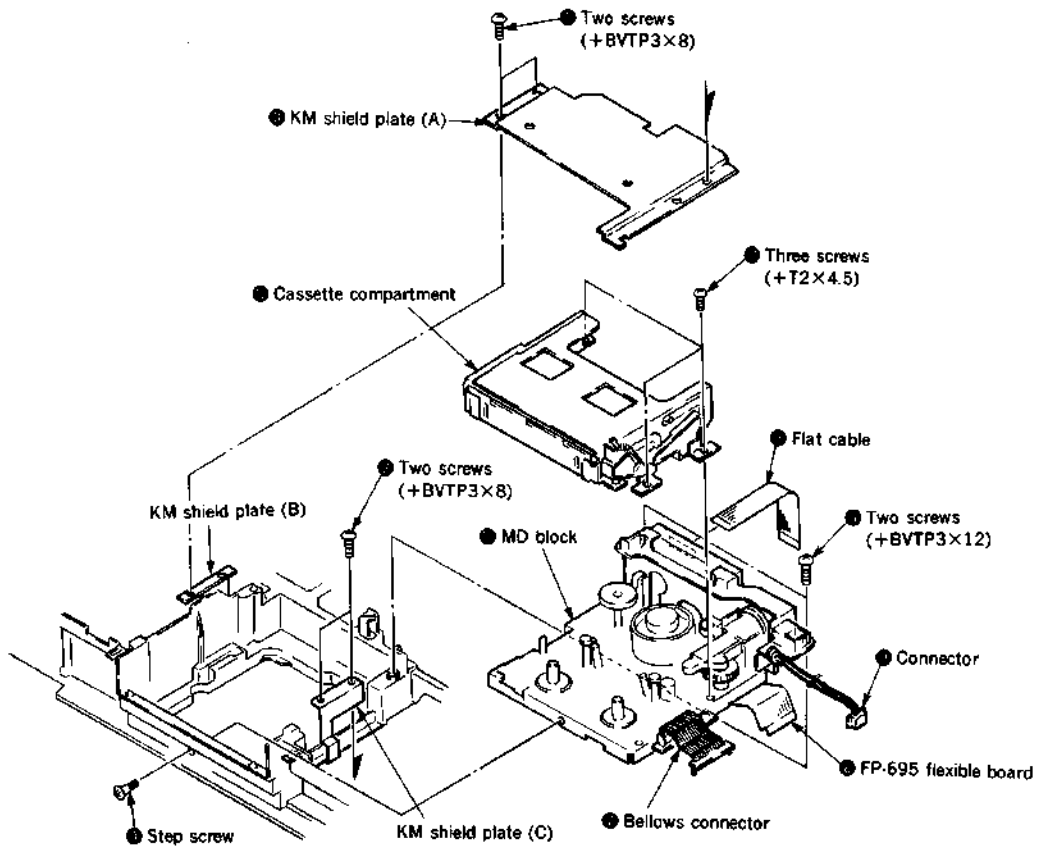

## 2-8. REMOVAL OF MA-205 BOARD AND VI-131 BOARD

● Disconnect the bellows connector and put the bottom surface upside.

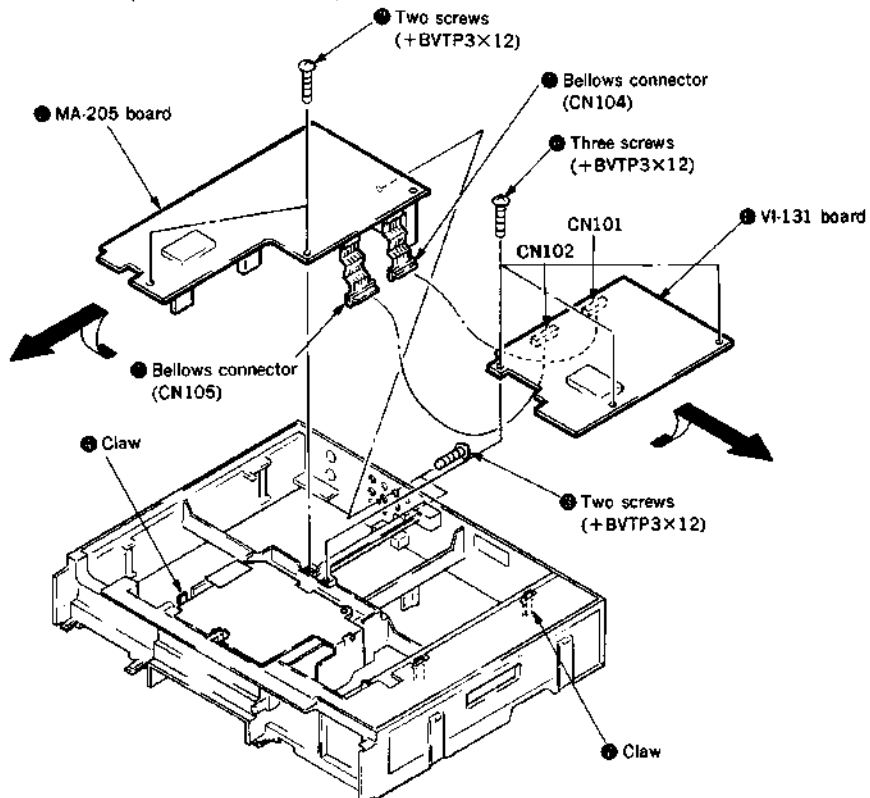

## 2-9. MECHANICAL INTERNAL VIEWS

—Upper side—

M901

Drum ASSY (DGH-0B0A-R)	A-7048-696-A
Upper Drum Assy (DGR-0B0-R)	A-7049-629-A

M903  
Cam Motor Assy  
X-3942-946-1

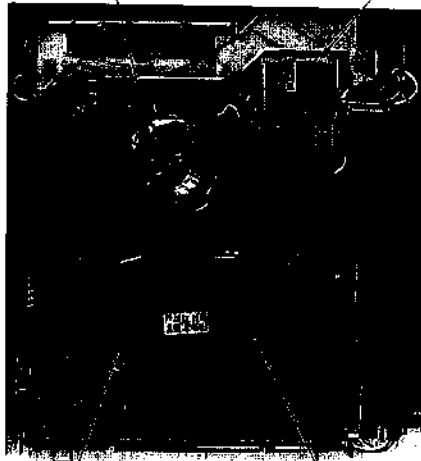

S Reel Table Assy  
X-3942-954-1

T Reel Table Assy  
X-3942-953-1

—Lower side—

M902  
Capstan Motor  
8-835-499-02

Belt Pulley Assy  
X-3943-016-1

Main Cam  
3-954-050-01

FL Pulley Gear  
3-953-983-01

Rotary Switch  
1-692-498-11

FL Selectiton Gear  
3-953-980-01

FL Pulley Gear (Driving)  
3-953-981-01

Reel Relay Gear  
3-954-061-01



**2-10. CIRCUIT BOARDS LOCATION**

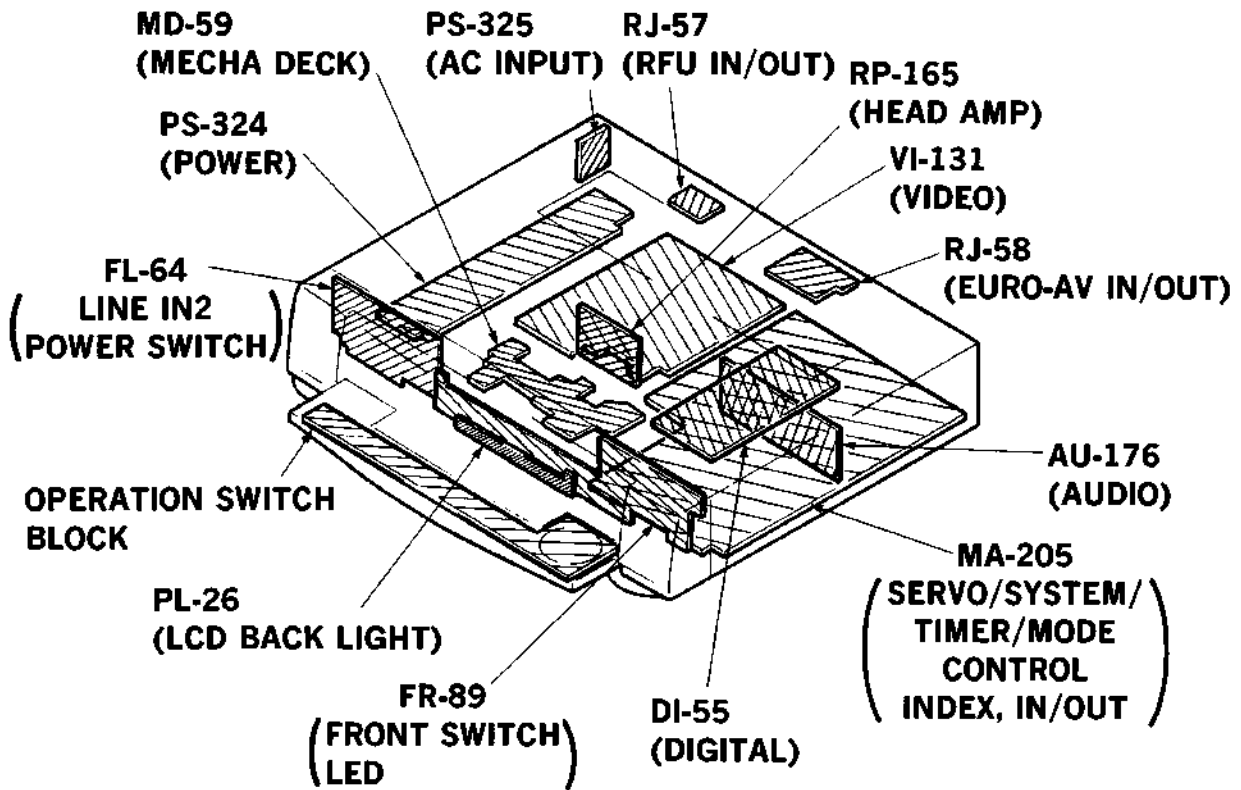

# 5-1-1. CABINET AND FRONT PANEL ASSEMBLIES

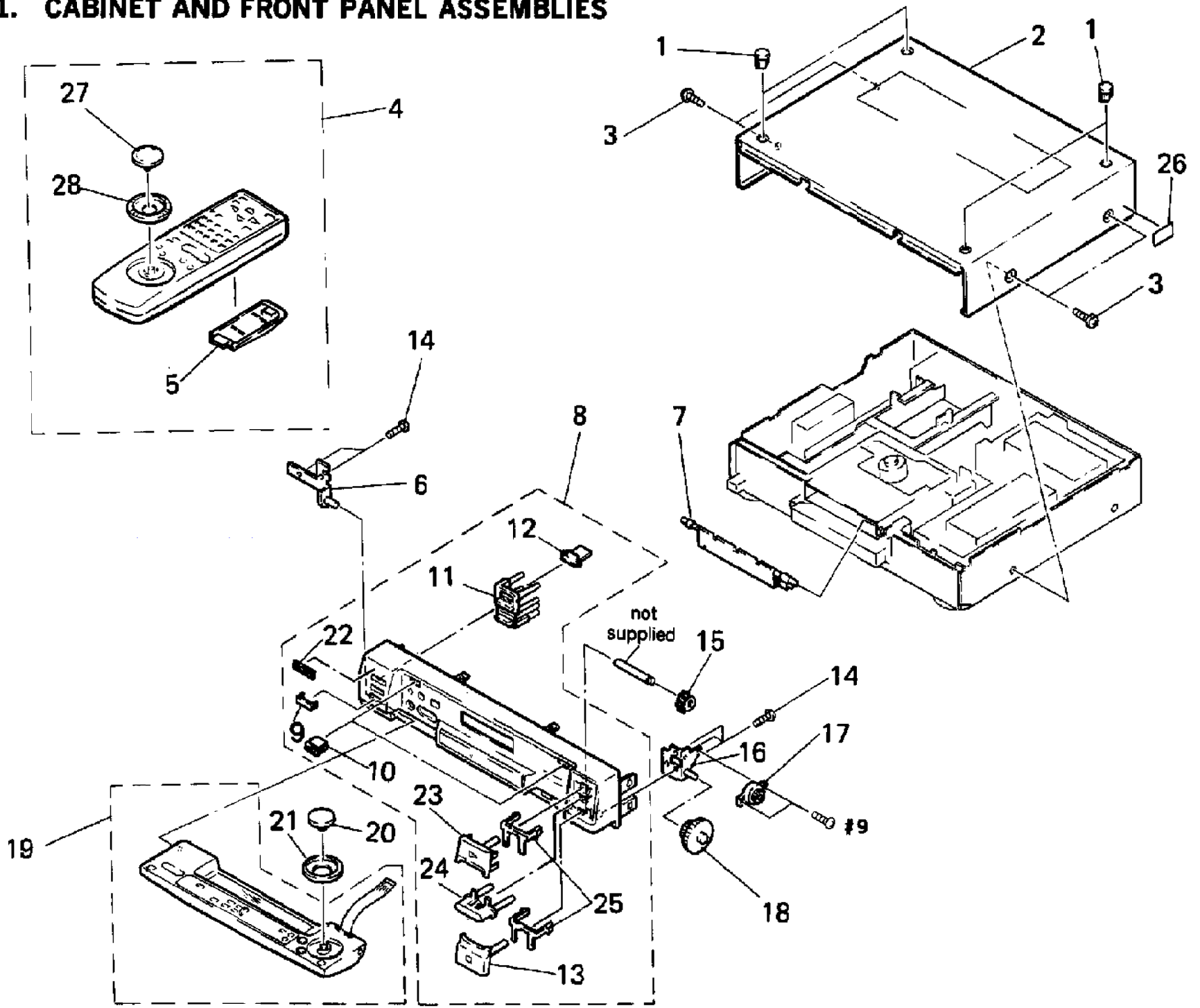

## 5-1-2. MAIN CHASSIS ASSEMBLY

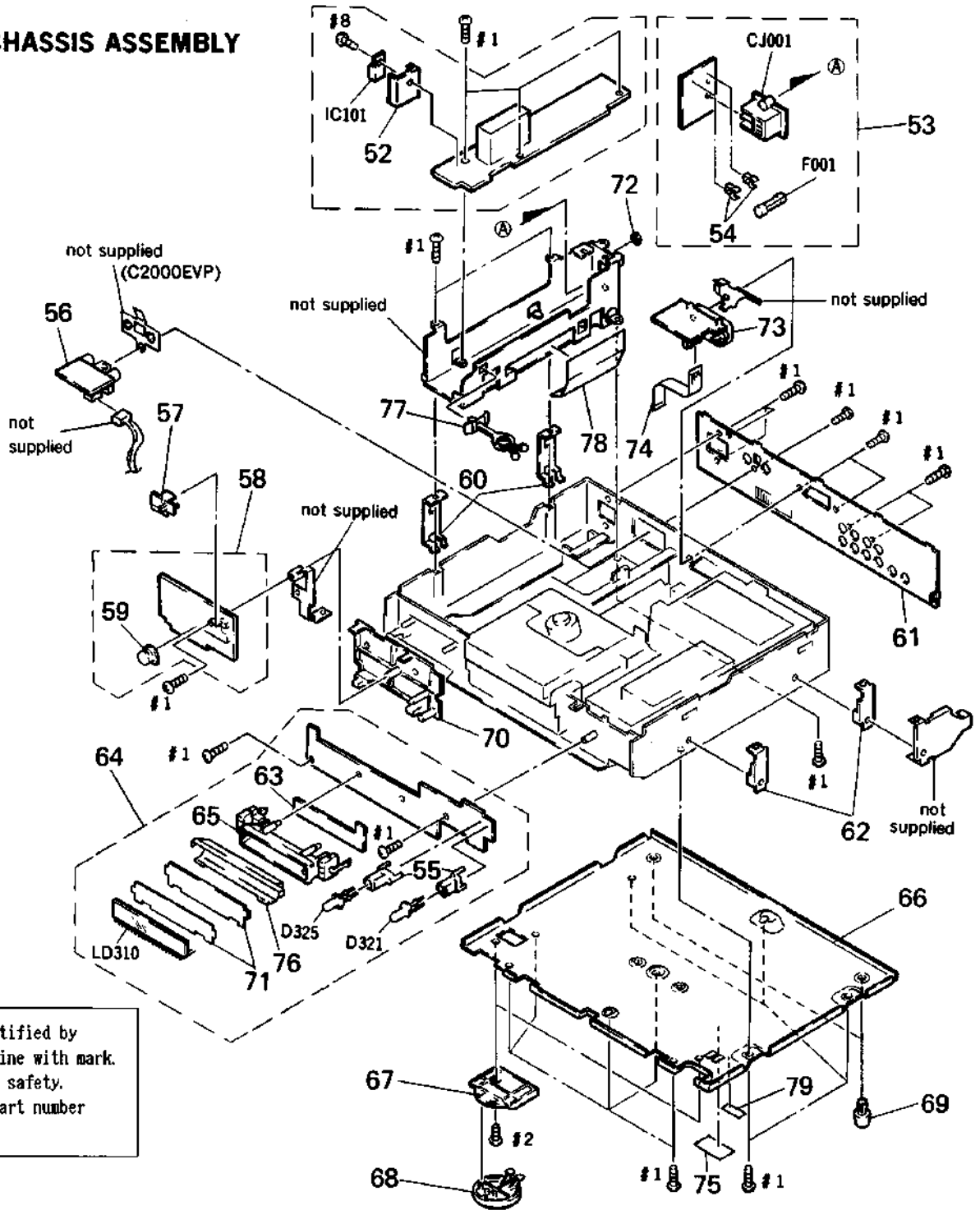

The components identified by mark **▲** or dotted line with mark **▲** are critical for safety. Replace only with part number specified.

### 5-1-3. MAIN BOARDS ASSEMBLY

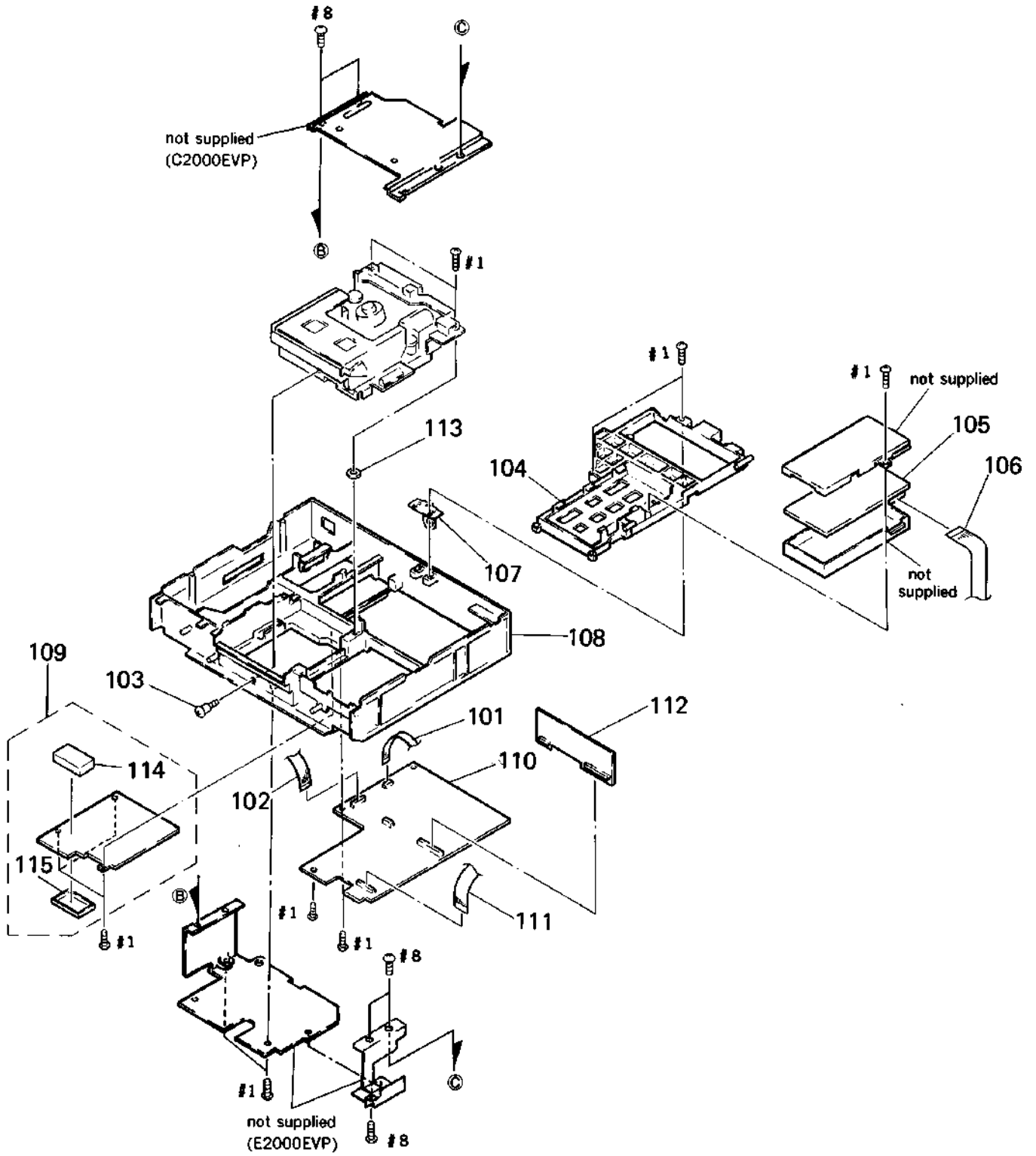

# 5-1-4. CASSETTE COMPARTMENT ASSEMBLY

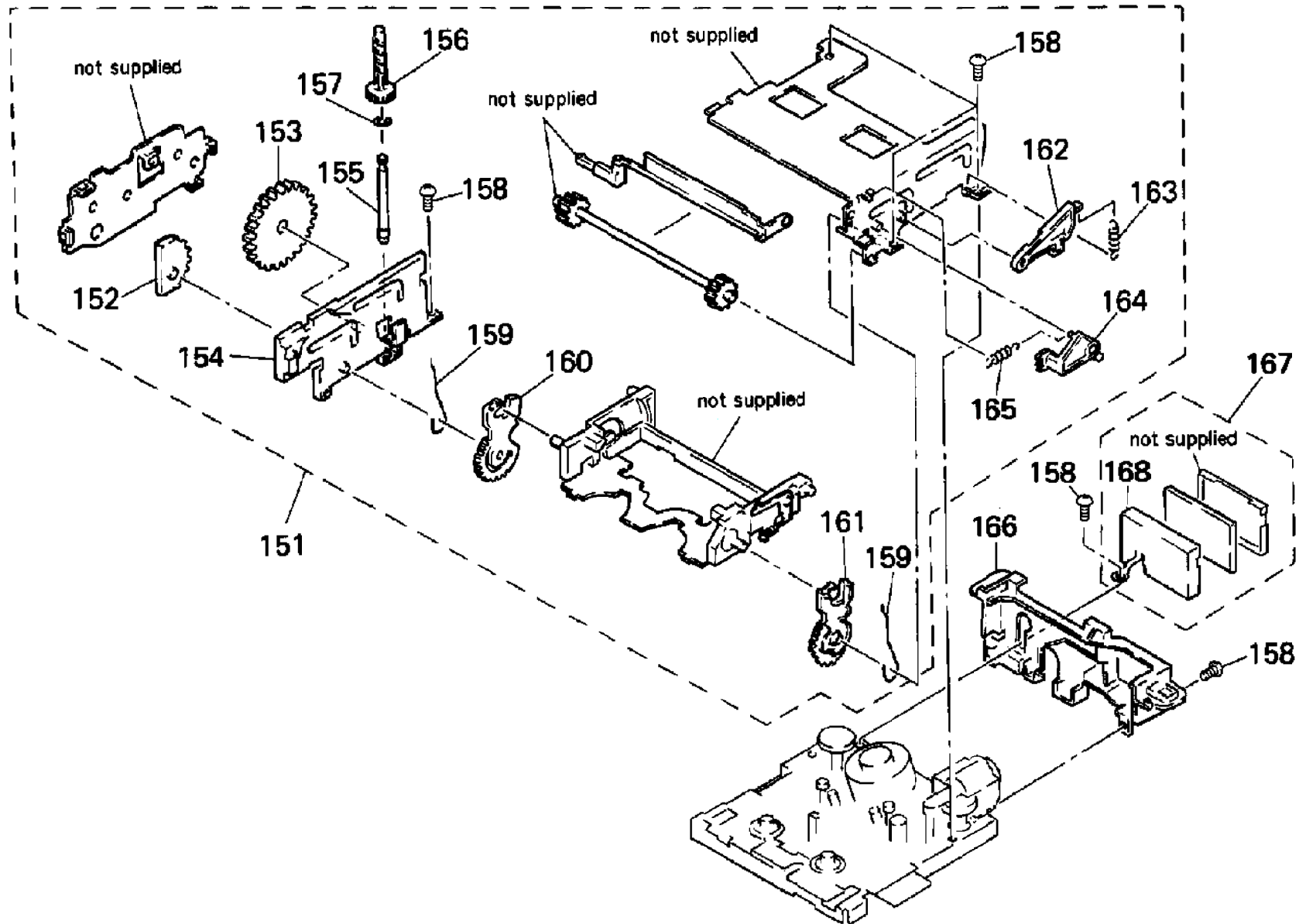

5-1-5. MECHANICAL ASSEMBLY (1)

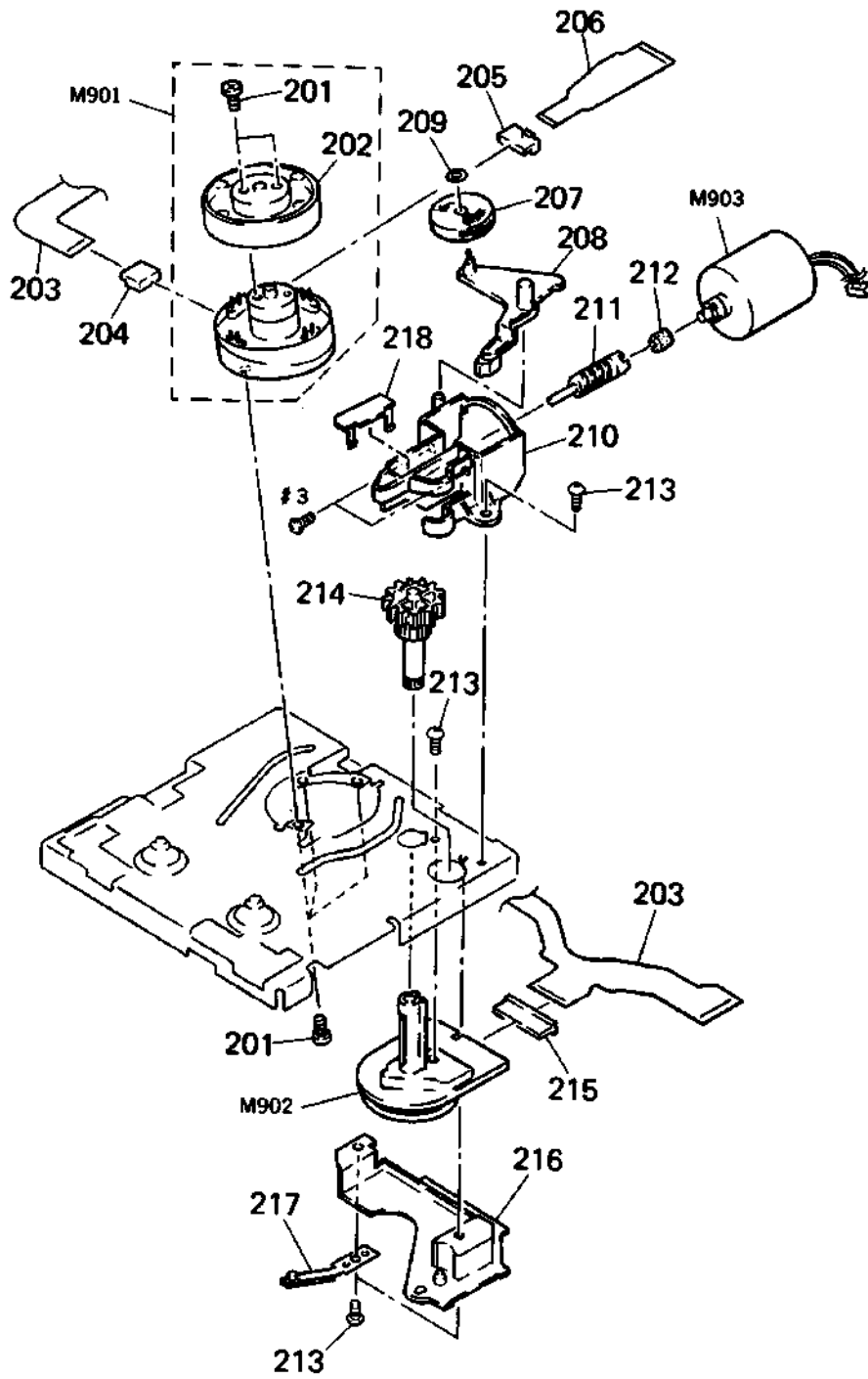

**5-1-6. MECHANICAL  
ASSEMBLY (2)**

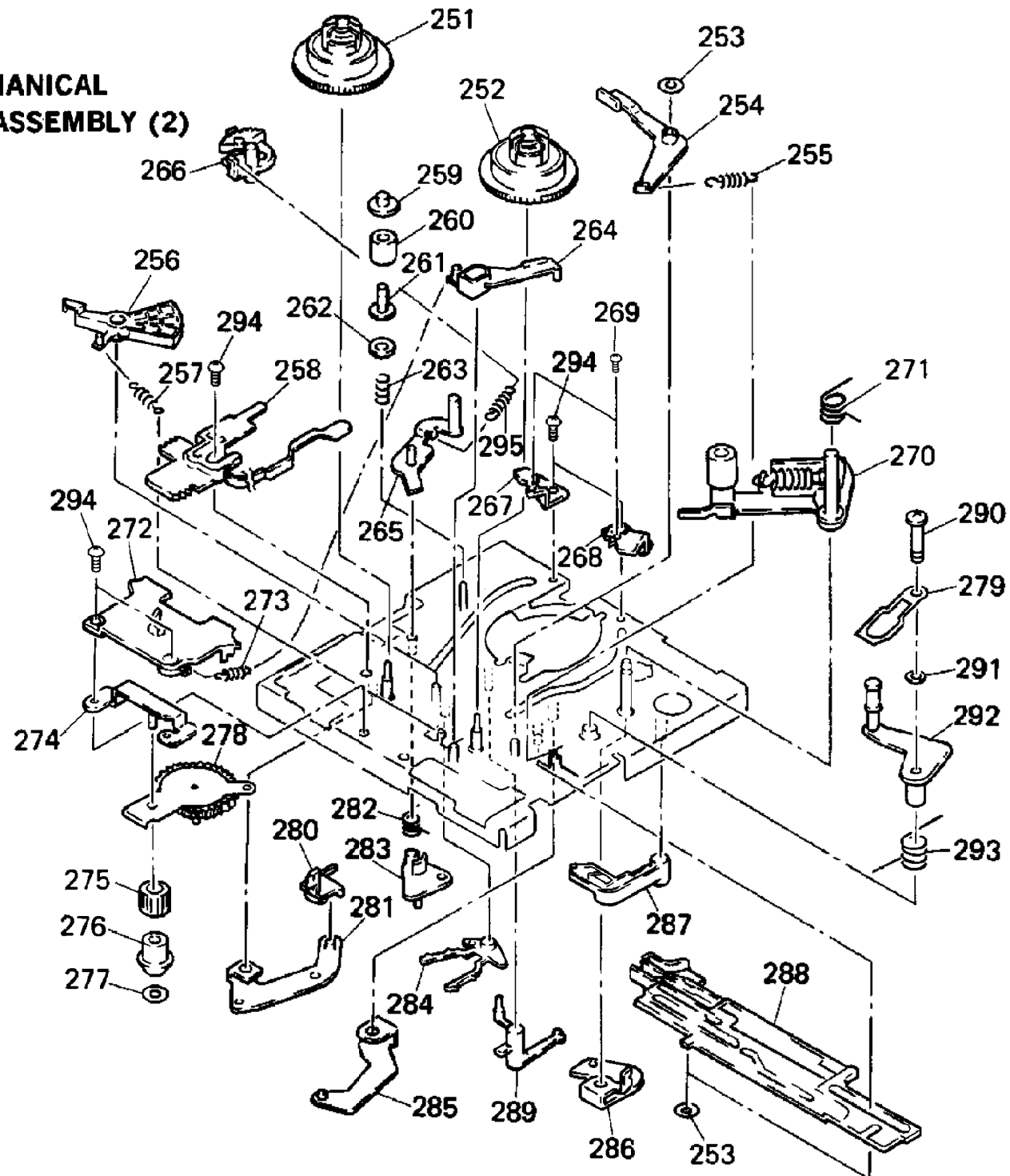

### 5-1-7. MECHANICAL ASSEMBLY (3)

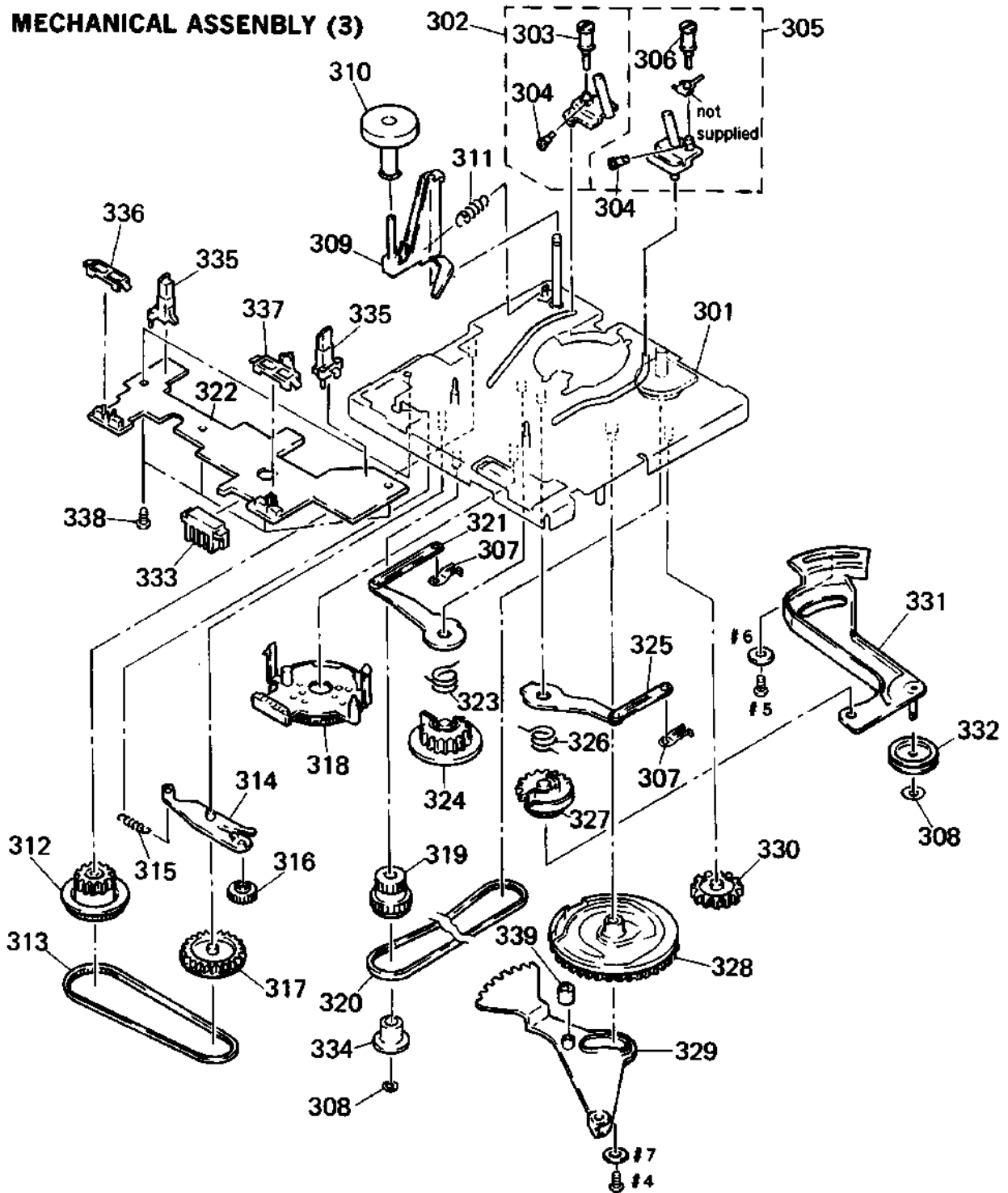



**6-1. SERVO/SYSTEM CONTROL MICROPROCESSOR CXP87140 (MA-205 BOARD IC003)  
PORT FUNCTION DESCRIPTION**

Pin No.	Signal	I/O	Function
1	PAL V	O	Burst insert pulse.
2	JOG VD	O	Pseudo V timing output in speed change playback mode.
3	DI CHG	O	Video memory write control.
4	JOG	O	*H* in speed change playback mode.
5	RF PB MODE	O	*L* in any mode other than record mode.
6	FE ON	O	*L* when flying erase is turned on.
7	INTERNAL VD	O	Internal VD.
8	SP/LP	O	*H* in SP mode.
9	X ENV REQ	O	Envelope detect waveform control.
10	H18/NOR	O	*H* in H18 mode.
11	$\times 20$	O	$\times 20$ mode control.
12	N. C.	I	Not used.
13	CC DOWN SW	I	Cassette down switch input.
14	REC PRF SW	I	REC inhibit switch input.
15	ME MP SW	I	ME/MP switch input.
16	MPHG MP SW	I	MPHG/MP switch input.
17	8/9 SW	I	8 $\mu$ /9 $\mu$ switch input.
18	10/13 SW	I	10 $\mu$ /13 $\mu$ switch input.
19	MODE 3 SW	I	Mechanical deck matrix input.
20	MODE 2 SW	I	
21	MODE 1 SW	I	
22	MODE 0 SW	I	
23	SLOW $\times 2$	O	*L* in SLOW, $\times 2$ mode.
24	$-\times 2, -\times 1.5$	O	*H* in $-\times 2, -\times 1.5$ mode.
25	VIDEO CS	O	CS output to video IC.
26	VSC CS	O	CS output to VSC IC.
27	N. C.	O	Not used.
28	MEMORY CS	O	CS output to memory control IC.
29	N. C.	O	Not used.
30	N. C.	O	
31	N. C.	O	
32	N. C.	O	
33	N. C.	O	
34	VB ON	O	*L* in VOICE BOOST ON mode.
35	INSEL 2	O	Input signal select. * 1
36	INSEL 1	O	Input signal select. * 1
37	N. C.	O	Not used.
38	TOP/END LED	O	Tape top/end sensor LED control.

Pin No.	Signal	I/O	Function
39	MP		GND.
40	RESET	I/O	Reset input.
41	VSS		GND.
42	XTAL	O	X'tal 16MHz.
43	EXTAL	I	X'tal 16MHz.
44	COSMO CS	I	CS input for communication with mode control microprocessor.
45	SI BUS	I	Data input for communication with mode control microprocessor.
46	SO BUS	O	Data output for communication with mode control microprocessor.
47	SCK	I	Clock input for communication with mode control microprocessor.
48	ME/MP	O	ME/MP determination output. ME: *H*
49	MPHG/MP	O	H18MP, NORMAL MP determination output. H18MP: *H*
50	H18 DET	I	H18 determination input.
51	AFM MODE DET	I	Audio multiplex discrimination input.
52	A VSS		Analog GND.
53	A VREF	I	Analog reference 5V.
54	A VDD		Analog V <sub>DD</sub> 5V.
55	N. C.	I	Not used.
56	CLOG DET	I	Clog detect input.
57	PB SP/LP DET	I	In playback mode, SP/LP discrimination input. SP: H
58	N. C.	I	Not used.
59	TOP SENS	I	Tape top determination input.
60	END SENS	I	Tape end determination input.
61	ATF ERR	I	ATF error input.
62	THERM	I	Temperature compensation input.
63	LM7 SYNC	I	Composite SYNC input.
64	S REEL FG	I	S reel FG input.
65	LM7 SYNC	I	Composite SYNC input.
66	DI SYNC	I	Composite sync input.
67	T REEL FG	I	T reel FG input.
68	DRUM PG	I	Drum FG input.
69	DRUM FG	I	Drum FG input.
70	CAP FG	I	Capstan FG input.
71	V MUTE	O	Video mute output.
72	AFM MUTE	O	AFM mute output.
73	FE WE	O	*L* in linecode after RIFC mode.
74	DRUM RVS	O	Drum direction control output.
75	CAP PWM	O	PWM output for capstan.
76	DRUM PWM	O	PWM output for drum.

6-1

INTERFACE AND IC PIN FUNCTION SECTION 6

EV-C2000E/EUB/EVP

96	CAM UNLOAD	0	Cassette compartment motor control.
97	EDIT	0	"L" in edit mode.
98	VA PB MODE	0	"H" in playback mode.
99	RF SWP	0	RF switching pulse output
100	N. C.	0	Not used.

\* I. INPUT SELECT CONTROL

	LINE1	LINE2	LINE3
MA-205 BOARD			
INSEL1 (IC003 <sup>⑤</sup> )	H	L	L
INSEL2 (IC003 <sup>⑤</sup> )	L	H	L

● H=4V or more, L=0.8V or less

## 6-2. SYSTEM CONTROL — VIDEO · AUDIO BLOCK INTERFACE (MA-205 BOARD)

Signal	Pin No.	I/O	VTR MODE													
			STOP	FF	REW	×2 [×4]	-×2 -×4	PB	×1 AUDIO MUTE	PICTURE SEARCH		PB · PAUSE	SLOW	REVERSE SLOW	REC	REC PAUSE
										(Hi) CUE	(Hi) REVIEW					
SP/LP	IC003 ㉔	O	* 1	H	H	* 1 [* 2]	* 2	* 2	* 2	* 2	* 2	* 1	* 1	* 1	* 9	H/L
VA PB MODE	IC003 ㉕	O	L	L	L	H	H	H	H	H	H	H	H	H	L	L
JOG VD * 3	IC003 ㉖	O	L	L	L	L	L	L	L	L	L	L	L	L	L	L
RP PB MODE	IC003 ㉗	O	L	L	L	L	L	L	L	L	L	L	L	L	H	L
FE ON	IC003 ㉘	O	H	H	H	H	H	H	H	H	H	H	H	H	L	H
RF SWP	IC003 ㉙	O	L	* 4	* 4	* 4	* 4	* 4	* 4	* 4	* 4	* 4	* 4	* 4	* 4	* 4
JOG	IC003 ㉚	O	L	L	L	H	H	L	H	H	H	H	H	H	L	L
SP/LP DET	IC003 ㉛	I	L	* 5	* 5	* 5	* 5	L	L	* 5	* 5	* 5	—	—	H	H
CLOG DET	IC003 ㉜	I	H	* 6	* 6	* 6	* 6	* 6	* 6	* 6	* 6	* 6	* 6	* 6	H	* 6
DI COMP SYNC	IC003 ㉝	I	* 7	* 7	* 7	* 7	* 7	* 7	* 7	* 7	* 7	* 7	* 7	* 7	* 7	* 7
AUDIO PB	IC003 ㉞	O	L	L	L	* 8	* 8	H	* 8	* 8	* 8	H	* 8	* 8	L	L
AFM MUTE	IC003 ㉟	O	L	L	L	H	H	L	H	H	H	H	H	H	L	L
VIDEO CS	IC003 ㊱	O	V-cycle "L" pulse													
SO2	IC003 ㊲	O	V-cycle pulse rank													
SCK2	IC003 ㊳	O	V-cycle "L" pulse rank													

- \* 1. This outputs the result of determining what was the previous mode. "H" output in SP mode, "L" output in LP mode.
- \* 2. This outputs the result of determining which record mode the playback tape has. "H" output in SP mode, "L" output in LP mode.
- \* 3. False VD signal.
- \* 4. Pulse of 25Hz, 50% duty (synchronized with the rotation of the drum).
- \* 5. "H" at the SP record portion and "L" at the LP record portion of tape.

- \* 6. "H" at the blank portion or at any drop out portion of tape. Head clogging detection input.
- \* 7. Composite sync signal input separated from line input video signal, camera video signal or playback video signal. (This signal has positive polarity).
- \* 8. "L" during shuttle editing from REC PAUSE, "H" while in any other mode.
- \* 9. This varies according to SP/LP switching. It becomes "H" when SP mode is entered and "L" when LP mode is entered.

**6-3. SERVO CONTROL — SERVO BLOCK INTERFACE (MA-205 BOARD)**

Signal	Pin No.	I/O	VTR MODE												
			STOP	FF	REW	×2 ×4	-×2 -×4	PB (X1)	PICTURE SEARCH		PB · PAUSE	SLOW	REVERSE SLOW	REC	REC PAUSE
									(Hi) CUE	(Hi) REVIEW					
T.REEL FG	IC003 ⑥	I	—	* 1	* 1	* 1	* 1	* 1	* 1	* 1	—	* 1	* 1	* 1	—
S.REEL FG	IC003 ⑦	I	—	* 1	* 1	* 1	* 1	* 1	* 1	* 1	—	* 1	* 1	* 1	—
ATF ERROR	IC003 ⑧	I	—	* 2	* 2	* 2	* 2	* 2	* 2	* 2	* 2	* 2	* 2	* 2	* 2
DRUM FG	IC003 ⑨	I	—	* 3	* 3	* 3	* 3	* 3	* 3	* 3	* 3	* 3	* 3	* 3	* 3
DRUM FG	IC003 ⑩	I	—	* 4	* 4	* 4	* 4	* 4	* 4	* 4	* 4	* 4	* 4	* 4	* 4
CAP FG/HMS CAP FG	IC003 ⑪ ⑫	I	—	* 5	* 5	* 5	* 5	* 5	* 5	* 5	—	* 5	* 5	* 5	—
CAP ON	IC003 ⑬	O	L	H	H	H	H	H	H	H	L	* 8	* 8	H	L
REF PILOT	IC003 ⑭	O	* 7	* 6	* 6	* 6	* 6	* 6	* 6	* 6	* 6	* 6	* 6	* 6	* 6
DRUM RVS* 11	IC003 ⑮	O	H	H	H	H	H	H	H	H	H	H	Π	H	H
CAP FWD	IC003 ⑯	O	L	H	L	H	L	H	H	L	L	* 8	* 9	H	L
DRUM PWM	IC003 ⑰	O	* 10	* 10	* 10	* 10	* 10	* 10	* 10	* 10	* 10	* 10	* 10	* 10	* 10
CAP PWM	IC003 ⑱	O	L	* 10	* 10	* 10	* 10	* 10	* 10	* 10	L	* 10	* 10	* 10	L

6-4

- \* 1. The amplitude modulated pulse is input by the rotation of the reel.
- \* 2. ATF error voltage input.
- \* 3. Approximately 25Hz.
- \* 4. Approximately 150Hz.
- \* 5. 520 FC pulses are input by one rotation of the capstan. Approximately 1388Hz during REC/PB (SP) mode.
- \* 6. Four frequencies are output as synchronized with the rotation of the drum.  
f1=101.024kHz, f2=117.188kHz, f3=162.760kHz, f4=146.484kHz
- \* 7. f1(101.024kHz) or f3(162.760kHz) is output.
- \* 8. "H" pulse when tape is delivered.
- \* 9. "L" pulse when tape is delivered.
- \* 10. PWM signal with a period.
- \* 11. Normally "H".

**6-4. MODE CONTROL MICROPROCESSOR MB89096 (MA-205 BOARD IC002)  
PORT FUNCTION DESCRIPTION**

Pin No.	Signal	I/O	Function
1	XTAL 32K	O	32KHz oscillator connecting pin.
2	EXTAL 32K	I	
3	MOD 0	I	Connected to ground.
4	MOD 1	I	Connected to ground.
5	XTAL 12M	O	12MHz main oscillator connecting pin.
6	EXTAL 12M	I	
7	VSS		GND.
8	MC RSET	I	Reset signal input.
9	LANC P CONT	O	LANC IC power control.
10	S/LINE	O	Switch output between Line Video input and S/V.
11	N. C.	O	Not used.
12	SYS 3	O	*H* : Power on mode.
13	N. C.	O	Not used.
14	COSMO CS	O	CS output for communications with system control.
15	COSMO REST	O	System control reset signal output.
16	TTTT CS	O	TT microprocessor chip select signal.
17	POWER FAIL	I	Power failure detect input.
18	CG VD	I	V sync signal input.
19	N. C.	O	Not used.
20	N. C.	I	
21	N. C.	O	
22	N. C.	O	
23	N. C.	I	
24	N. C.	I	
25	H8 LED	O	H8 LED control.
26	N. C.	O	Not used.
27	REC LED	O	REC LED control.
28	C MOD		GND.
29	AV CONT	O	EURO AV (Pin 21) AV Control.
30	SYS RESET	O	System reset output.
31	N. C.	O	Not used.
32	SIRCS IN	I	SIRCS signal input.
33	LANC WP	I	LANC wakeup pin.
34	EVR STB	O	D/A strobe signal for EVR (MA-205 board IC010).
35	N. C.	O	Not used.

6-5

Pin No.	Signal	I/O	Function
36	JOG 1	I	JOG dial port input.
37	JOG 2	I	JOG dial port input.
38	MC V OUT	O	V sync signal output.
39-48	S01-S10	O	Not used.
49	VCC		+5V.
50-52	S11-S13	O	Not used.
53	VFDP		GND.
54-57	S14-S17	O	Not used.
58	GND		GND.
59-61	S18-S20	O	Not used.
62-66	G12-G08	O	Not used.
67	VCC		+5V.
68-74	G07-G01	O	Not used.
75	N. C.	O	Not used.
76	N. C.	O	Not used.
77	MC SI	I	Serial data input.
78	MC SO	O	Serial data output.
79	MC SCK	O	Clock output for serial communication.
80	MEM CS	O	EEPROM chip select signal output (MA-205 board IC004).
81	MEM CLK	O	EEPROM clock output (MA-205 board IC004).
82	MEM DATA	I/O	EEPROM data input/output (MA-205 board IC004).
83	GND		GND.
84-91	A/D0-A/D7	I	A/D input for key read.
92	AVCC		+5V.
93	DESTINATION	I	Fixed 2.5V in the present.
94	S SW INPUT	I	S terminal input determination detect input.
95	N. C.	O	Not used.
96	N. C.	O	Not used.
97	LANC IN	I	LANC input.
98	LANC OUT	O	LANC output.
99	N. C.	O	Not used.
100	VCC		+5V.

\* 1 PUSHING KEY AND TERMINAL INPUT VOLTAGE

INPUT VOLTAGE INPUT PORT	0V (0—0.625V)	0.90V (0.625—1.25V)	1.53V (1.25—1.875V)	2.18V (1.875—2.5V)	2.77V (2.5—3.125V)	3.46V (3.125—3.75V)	4.08V (3.75—4.375V)	5.0V (4.375—5.0V)
AD0	POWER (ON/OFF)	EJECT	STOP	PLAY				
AD1	FF	REW			REMOCON MODE			
					VTR1	VTR2	VTR3	OFF
AD2						EDIT (ON/OFF)		NO KEY INPUT
AD3	JOG/SHUTTLE b4	PAUSE	H. S. REW	COUNTER RESET				NO KEY INPUT
AD4	JOG/SHUTTLE b2	COUNTER SELECT	TIMECODE WRITE			INDEX SEARCH (◀◀)	INDEX SERACH (▶▶)	NO KEY INPUT
AD5	JOG/SHUTTLE b1			INPUT SELECT				NO KEY INPUT
AD6	JOG/SHUTTLE b3	REC	TAPE SPEED (SP/LP)					NO KEY INPUT

**6-5. TIMER CONTROL MICROPROCESSOR MB89096 (MA-205 BOARD IC901)  
PORT FUNCTION DESCRIPTION**

Pin No.	Signal	I/O	Function
1	XTAL 32K	O	32kHz oscillator connecting pin.
2	EXTAL 32K	I	
3	MOD 0	I	Connected to ground.
4	MOD 1	I	Connected to ground.
5	XTAL 10M	O	10MHz main oscillator connecting pin.
6	EXTAL 10M	I	
7	VSS		GND.
8	RESET SW	I/O	Reset signal input.
9	N. C.	O	Not used.
10	N. C.	O	
11	N. C.	O	
12	N. C.	O	
13	N. C.	O	
14	TIME AF REC LED	O	Time code after record LED control output.
15	MC RESET	O	Reset output for mode control microprocessor which is driven "L" to reset.
16	HIFT CS	I	CS input for communications with mode control microprocessor.
17	POWER FAIL	I	Power failure detect input which is driven "L" when power failure is detected.
18	V SYNC	I	V synchronize output from mode control microprocessor.
19	N. C.	I	Not used.
20	CG CS	O	CS output for character generator control.
21	N. C.	O	Not used.
22	POWER FAIL OUT	O	Power failure detect output which is driven "L" when power failure is detected.
23	N. C.	O	N. C.
24	VB LED	O	Voice boost LED control.
25	REWIND LED	O	REWIND in LED control.
26	PLAY LED	O	PLAY in LED control.
27	FF LED	O	FF in LED control.
28	0V		Connected to ground.
29	MC SO	I	Data input for communications with mode control microprocessor.
30	MC SI	O	Data output for communications with mode control microprocessor.
31	MC SCK	I	Clock input for communications with mode control microprocessor.
32	LCD CS	O	CS output for LCD controller.
33	N. C.	O	Not used.
34	CG V DET	I	Signal presence determination input (Blue back).
35	LCD BL CONT	O	LCD Back light control.
36	N. C.	O	N. C.

Pin No.	Signal	I/O	Function
37	POWER CONT	O	Power on: L.
38	POWER CONT	O	Power on: H.
39-48	N. C.	O	Not used.
49	VCC		+5V.
50-52	N. C.	O	Not used.
53	VFDP		Minus voltage for display tube.
54-57	N. C.	O	Not used.
58	VSS		GND.
59-61	N. C.	O	Not used.
62-66	N. C.	O	Not used.
67	VCC		+5V.
68-74	N. C.	O	Not used.
75	N. C.	O	Not used.
76	N. C.	O	Not used.
77	TT OSD SI	I	Serial data input (for character generator and LCD).
78	TT OSD SO	O	Serial data output (for character generator and LCD).
79	TT OSD SCK	O	Serial communication clock output. (for character generator and LCD)
80	MEM CS	O	EEPROM chip select signal output. Not used.
81	MEM CLK	O	EEPROM clock output. Not used.
82	MEM DATA	I/O	EEPROM data in/output. Not used.
83	AVSS		GND.
84	N. C.	I	Not used.
85	N. C.	I	Not used.
86	N. C.	O	Not used.
87	N. C.	O	Not used.
88	N. C.	O	Not used.
89	HiFi LED	O	HiFi LED control.
90	N. C.	O	Not used.
91	N. C.	O	Not used.
92	AVCC		+5V.
93	N. C.	O	Not used.
94	N. C.	O	Not used.
95	N. C.	O	Not used.
96	N. C.	O	Not used.
97	N. C.	O	Not used.
98	N. C.	O	Not used.
99	BUZZER OUT	O	Buzzer out.
100	VCC		+5V.

## 6-6. AFM AUDIO OUTPUT CONTROL

### 1) PB MODE OUTPUT CONTROL

AFM MODE DET	MAIN/SUB	DISPLAY	OUTPUT PATTERN (MA-205 BOARD)		
			AFM OUT SEL IC003②	AFM MUTE IC003②	AFM MODE IC003②
L	STEREO	STEREO	L	L	M
	L	L	H	L	M
	R	R	M	L	M
H	MAIN+SUB	MAIN+SUB	L	L	M
	MAIN	MAIN	H	L	M
	SUB	SUB	M	L	M
M	No change	—	H	L	M

### 2) EE MODE OUTPUT CONTROL

INPUT STEREO MODE	MAIN/SUB	DISPLAY	OUTPUT PATTERN (MA-205 BOARD)		
			AFM OUT SEL IC003②	AFM MUTE IC008⑦	AFM MODE IC003②
LINE MONO	—	—	H	H	L
			H	L	L
LINE ST	—	STEREO	L	H	H
			L	L	H
LINE BIL	MAIN+SUB	MAIN+SUB	L	H	M
	MAIN	MAIN	H	H	M
	SUB	SUB	M	H	M
	MAIN - SUB	MAIN+SUB	L	L	M
	MAIN	MAIN	H	L	M
	SUB	SUB	M	L	M

● Disp HiFi is lit when STEREO/BILINGUAL is displayed. However, it is lit off when After Record (including PAUSE) is selected.

● EE System is followed in SHUTTLE EDIT mode.

● Each signal has the levels shown below.

AFM OUTSEL ...H=3.9V or more, M=2.1 to 2.7V, L=0.8V or less.

AFM MODE DET...H=3.4 to 4.75V, M=1.5 to 2.6V, L=0 to 0.8V.

AFM MODE ...H=3.9V or more, M=2.1 to 2.7V, L=0.8V or less.

● In MUTE mode, AFM MUTE="H"



## SECTION 7 ADJUSTMENTS

# EV-C2000E/EUB/EVP

### <SERVICE MODE>

#### 1. SETTING THE SERVICE MODE

The service mode consists of the adjustment mode which adjusts the EVR and the test mode which shows the condition of the unit.

The unit can be set into the test mode and adjustment mode by connecting the adjusting remote commander (Set the HOLD switch to "HOLD").

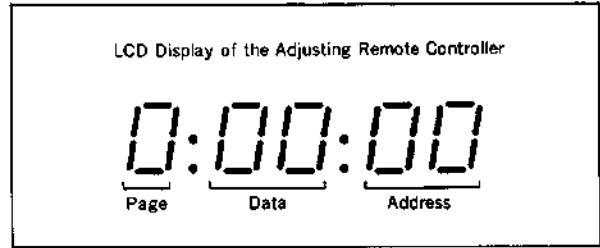

#### (1) Service LANC memory map

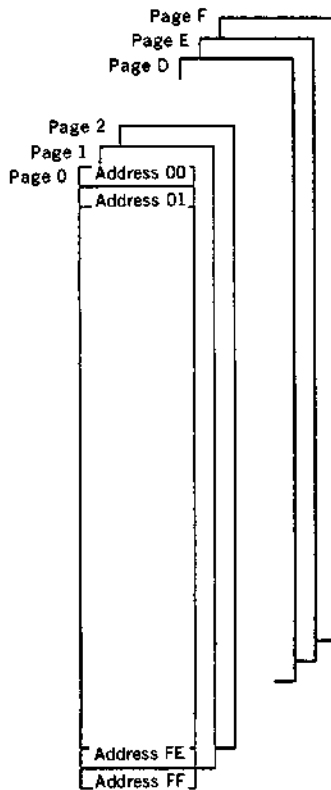

Page	Page Layout
0	
1	Shared by VTR section
2	Mode controller RAM, I/O (Note 1)
3	Mechanism controller RAM, I/O (Note 1)
4	
5	
6	F page write protect
7	
8	
9	
A	
B	T/T controller RAM, I/O (Note 1)
C	
D	VTR EEPROM (Note 2)
E	
F	

Adjusting remote commander RM-95 (J-6082-053-B)

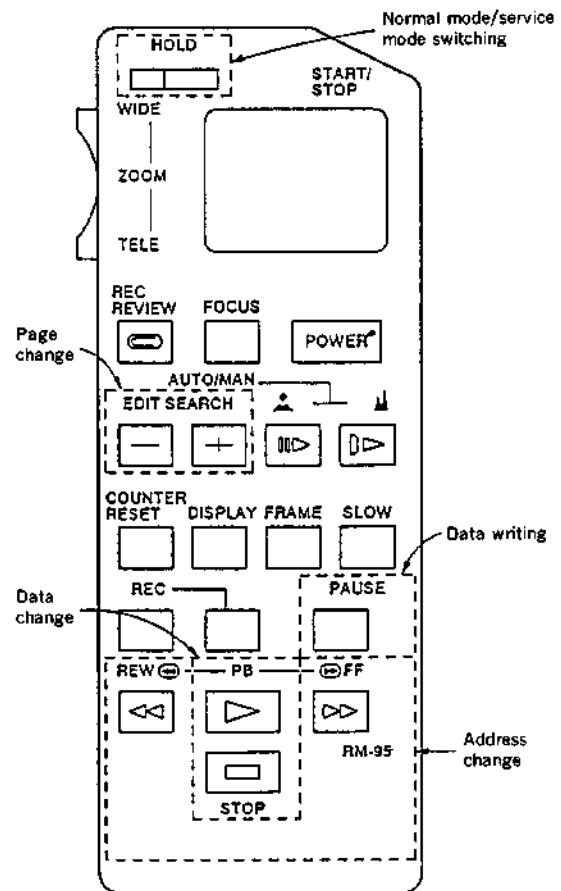

**Note 1:** When data on this page is rewritten with adjustment remote control to set the adjustment mode or test mode, that data will not be written to EEPROM. Therefore, simply disconnect the main power to return to the original state (normal state).

**Note 2:** The data of this page is written in the EEPROM (IC004 of MA-205 board).

**(2) Category codes**

This unit uses category codes for pages 2 and 3. The 256 addresses from 00 to FF are insufficient for the mode controller and mechanism controller to access the RAM. Therefore, new category codes have been used to seemingly increase addresses (Addresses 0000 to FFFF).

However, the data of address 00 are actually used as page numbers to form the 256 pages from 00 to FF, as shown in the following figure. This address 00 data are called category codes to discriminate them from the real page numbers. The new pages are called categories.

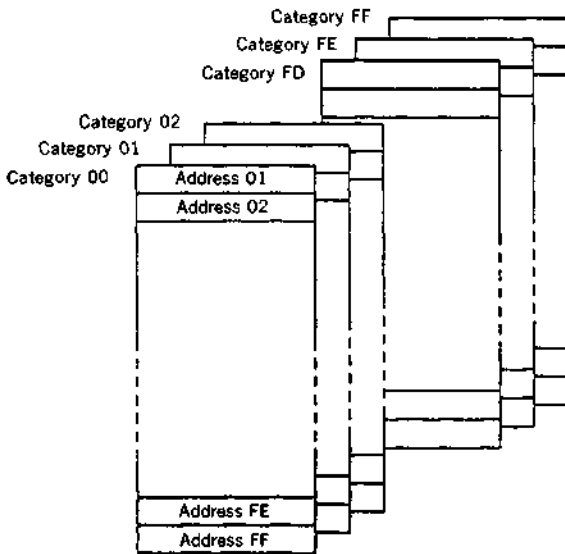

**(Supplement)** As each category no longer has address 00 as it is, this address cannot be accessed using the adjusting remote commander. Therefore, category 3F is used for accessing address 00.

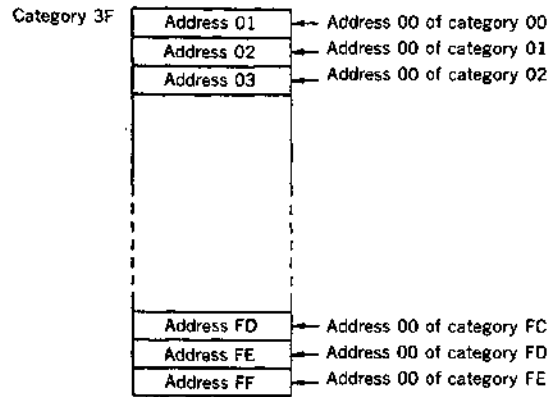

(Example)

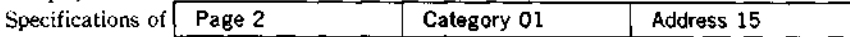

- ↑
- Page 2 is the mode controller
- Page 3 is the mechanism controller
- Page B is the T/T controller

The actual category and address are specified by the adjusting remote commander as follows.

Order	Page	Address	Data	Procedure
1	2	00	01	Select category 01 using the data of page 2, address 00. From here onwards, category 01 will be selected at page 2 until the data of page 2, address 01 is rewritten.
2	2	10		As the data of page 2, address 00 is 01, select page 2, address 10 to select page 2, category 01, address 10. (The data of this address is the LED light up of the mode controller input.)

[Shifting to the service mode using the adjusting remote commander]

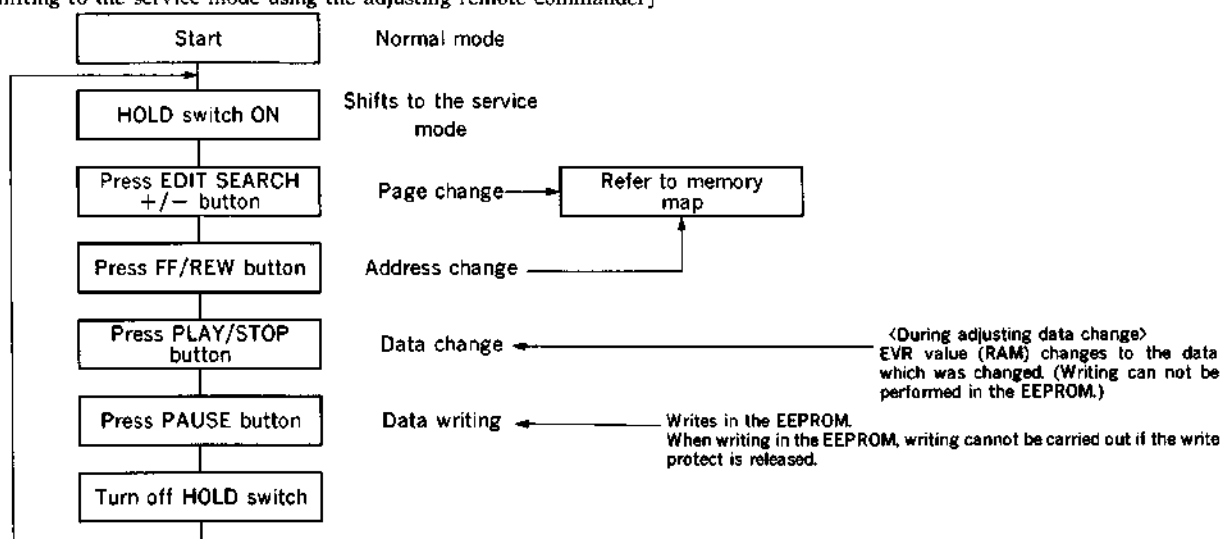

Command Name	Command Function	Normal LANC Command
Page Up	Page+1	Edit Search+
Page Down	Page-1	Edit Search-
Direct Page Set	Sets to the specified page	Event Clear
Address Up	Address+1	Fast Forward
Address Down	Address-1	Rewind
Data Up	Data+1	Play Back
Data Down	Data-1	Stop
Store	Writes data in the EEPROM, RAM	Pause

## 2. TEST MODE SETTING

### (1) Servo/System Control Micom

Page 3	Category 02	Address 01
--------	-------------	------------

Data	Function
01	<b>Track Shift Playback</b> <ul style="list-style-type: none"> <li>• Automatic discrimination between SP and LP is also inhibited and REC SP/LP is followed.</li> <li>• Data at address 08 in category 02 should be changed if you want to change track shift amount.</li> </ul>
02	<b>Rear Lock Playback</b> <ul style="list-style-type: none"> <li>• Automatic discrimination between SP and LP is also inhibited and REC SP/LP is followed.</li> </ul>
03	Video Test Mode 1
04	Video Test Mode 2
05	Video Test Mode 3
06	<b>Assembling Inhibit</b> <ul style="list-style-type: none"> <li>• All assembling operations are inhibited.</li> </ul>
80	<b>Port Check Mode</b> <ul style="list-style-type: none"> <li>• The system controller stops all the operations other than communication with the mode controller. Reset is the only way to return from the port check mode.</li> </ul>

### (2) Mode Control Micom

Page 2	Category 01	Address 10
--------	-------------	------------

Data	Function																																				
01	<b>Test Mode LED ON</b> <ul style="list-style-type: none"> <li>• LED's ON (Hi8, REC).</li> </ul>																																				
05	<b>Test Mode Port Check</b> <ul style="list-style-type: none"> <li>• Port refresh inhibit for mode control micro-computer.</li> <li>• Sensor LANC can be used to control the port directly.</li> </ul> <b>Test Mode Key Check</b> <ul style="list-style-type: none"> <li>• When a key is pressed, there will be no actual action. The data on address FC can be used to check the key that was pressed.</li> </ul> <table border="0"> <tr> <td>TIME CODE WRITE</td> <td>85</td> <td>PLAYBACK</td> <td>1A</td> </tr> <tr> <td>EDIT (ON/OFF)</td> <td>00</td> <td>STOP</td> <td>18</td> </tr> <tr> <td>INPUT SELECT</td> <td>4F</td> <td>PAUSE</td> <td>19</td> </tr> <tr> <td>H. S. REW</td> <td>7D</td> <td>REC</td> <td>1D</td> </tr> <tr> <td>INDEX ◀◀</td> <td>57</td> <td>INDEX ▶▶</td> <td>56</td> </tr> <tr> <td>COUNTER SELECT</td> <td>41</td> <td>COUNTER RESET</td> <td>46</td> </tr> <tr> <td>REW</td> <td>1B</td> <td>TAPE SPEED (SP/LP)</td> <td>58</td> </tr> <tr> <td>FF</td> <td>1C</td> <td>ON/STANDBY</td> <td>15</td> </tr> <tr> <td>EJECT</td> <td>16</td> <td></td> <td></td> </tr> </table>	TIME CODE WRITE	85	PLAYBACK	1A	EDIT (ON/OFF)	00	STOP	18	INPUT SELECT	4F	PAUSE	19	H. S. REW	7D	REC	1D	INDEX ◀◀	57	INDEX ▶▶	56	COUNTER SELECT	41	COUNTER RESET	46	REW	1B	TAPE SPEED (SP/LP)	58	FF	1C	ON/STANDBY	15	EJECT	16		
TIME CODE WRITE	85	PLAYBACK	1A																																		
EDIT (ON/OFF)	00	STOP	18																																		
INPUT SELECT	4F	PAUSE	19																																		
H. S. REW	7D	REC	1D																																		
INDEX ◀◀	57	INDEX ▶▶	56																																		
COUNTER SELECT	41	COUNTER RESET	46																																		
REW	1B	TAPE SPEED (SP/LP)	58																																		
FF	1C	ON/STANDBY	15																																		
EJECT	16																																				

### (3) Timer Micom

Page B	Category 01	Address 10
--------	-------------	------------

Data	Function
01	<b>Test Mode LED ON</b> (LED's other than Hi8 and REC)
02	<b>Test Mode LCD ON</b> <ul style="list-style-type: none"> <li>• All segments on.</li> </ul>
03	<b>Timer Adjustment</b> <ul style="list-style-type: none"> <li>• BUZZER OUT signal is oscillated at 4096Hz.</li> </ul>
05	<b>Test Mode Port Check</b> <ul style="list-style-type: none"> <li>• TT microcomputer will not refresh the port.</li> </ul>

### 3. EMERGENCY CODES

These codes can be used to check the condition of failure (abnormality) that occurred.

Page D	Address EC
--------	------------

#### First Emergency Code

...The code of the first failure that occurred.

Page D	Address E8
--------	------------

#### Second Emergency Code

...The code of the second failure that occurred.

Page D	Address E4
--------	------------

#### Last Emergency Code

...The code of the last failure that occurred (This data will be renewed each time a failure occurs.

**Note 1 :** After completing necessary adjustments/repairs, be sure to rewrite the data address EC, E8 and E4 to 00.

**Note 2 :** When writing data, after setting the data, be sure to press the PAUSE button on the adjustment remote control.

Code	Condition of Failure
00	No failure
10	Load Direction, Cam Encoder Failure
11	Unload Direction, Cam Encoder Failure
20	Not used.
21	Not used.
22	T Reel Rotational Failure
23	S Reel Rotational Failure
24	FG Failure at Start of T Reel
25	FG Failure at Start of S Reel
30	Failure at Start of Capstan
31	Failure During Stationary Operation of Capstan
40	FG Failure at Start of Drum
41	PG Failure at Start of Drum
42	FG Failure During Stationary Operation of Drum
43	Not used.
44	Not used.
50	Not used.
60	FL Cassette Compartment Failure
70	DEW EJECT Failure

#### 4. D PAGE MEMORY MAP

Note) When replacing EEPROM on the MA board, set data on page D as follows.

Address	Function	Initial Value	Memo Column
00		00	
01		00	
02			
03	Adjustment Mode	00	
04	Switching Position Adjustment (LOW)	00	
05	Switching Position Adjustment (HIGH)	07	
06-09			
0A-0C		85	
0D		45	
0E		86	
0F		85	
10-12		21	
13	SP/LP Voltage Adjustment	1A	
14-16			
17	Capstan Duty Adjustment	90	
18	PB VCO Adjustment	90	
19			
1A	FF VCO Adjustment	80	
1B	REW VCO Adjustment	80	
1C	High Speed FF VCO Adjustment	80	
1D	High Speed REW VCO Adjustment	80	
1E, 1F			
20-23			
24	SP×2 Adjustment	80	
25	LP×2 Adjustment	80	
26-DF			
E0-E3			
E4	Emergency Code (LAST)	00	
E5-E7		00	
E8	Emergency Code (2nd)	00	
E9 -EB		00	
EC	Emergency Code (1st)	00	
ED-EF		00	
F0-FF	Factory Data		

## 7-1. MECHANICAL ADJUSTMENTS

### For Mechanical Adjustments

For the procedures how to adjust and check the mechanism, as well as how to replace mechanical parts, refer to the separate 8mm Video Mechanical Adjustment Manual V (F MECHANISM) (9-973-445-11).

However, for the procedures how to set the Track Shift mode, refer to the following text.

#### 1-1. TAPE PATH ADJUSTMENT (TRACK SHIFT)

The 8mm Video Tape Recorder system uses the ATF (Automatic Track Finding) function in which four different pilot signals are used for controlling the tape speed instantaneously to provide high precision tracking. This eliminates the Tracking Adjustment control, thus allowing accurate tracing.

In spite of its advantageous feature, the ATF system may have a difficulty in adjusting the tape path system. The ATF will automatically corrects tracing even if the head has only a little tracing distortion. This may make it impossible to perform a complete adjustment.

Therefore, when performing a fine adjustment for tracking, the Track Shift mode should be entered before starting this adjustment. This mode will force to operate the ATF to shift the amount of tracking by a given quantity (approximately 1/4), so that tracking can be easily fine adjusted. Furthermore, no track shift jig is needed.

##### 1-1-1. Setting the Track Shift Mode

- 1) Place the adjustment remote control RM-95 (J-6082-053-B) in the HOLD ON position.
- 2) Category code setting  
Page: 3, address: 00, data: 02.
- 3) Track shift playback  
Page: 3, address: 01, data: 01.

(To change the quantity of track shift, data stored at category 02, address 08 should be changed.)

**Note 1** :For details of the Test Mode, refer to "SECTION 7. SERVICE MODE."

**Note 2** :If the LP mode is recognized by the system wrongly, operate the Recording Time SP/LP button to enter the SP mode.

**Note 3** :After adjustment, operate the PB/STOP button to reset to adjustment data 00. Place the remote control in the HOLD OFF position to return to the normal mode.

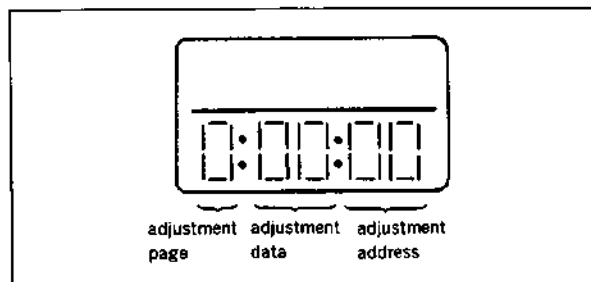

Fig. 7-1-1.

#### 1-1-2. Preparation before Adjustment

- 1) Clean the surfaces over which tape moves past (of the tape guides, drum, capstan shaft and pinch rollers).
- 2) Oscilloscope Connection and Waveform Output:  
1 ch: Drum head's RF signal output, RP-165 board CN001 pin ③ (PB Y)  
External trigger input: RP-165 board CN001 pin ② (RF SWP)  
GND: RP-165 board CN001 pin ① (GND)
- 3) Play back alignment tape for tracking (WR5-1CP).
- 4) Check that RF waveform observed on the oscilloscope is flat on both entrance and exit sides.  
If not flat, perform necessary adjustment according to the separate 8 mm Video Mechanical Adjustment V (F MECHANISM).

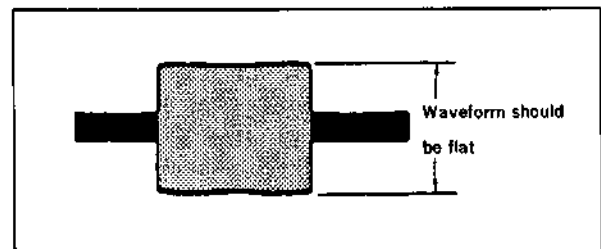

Fig. 7-1-2.

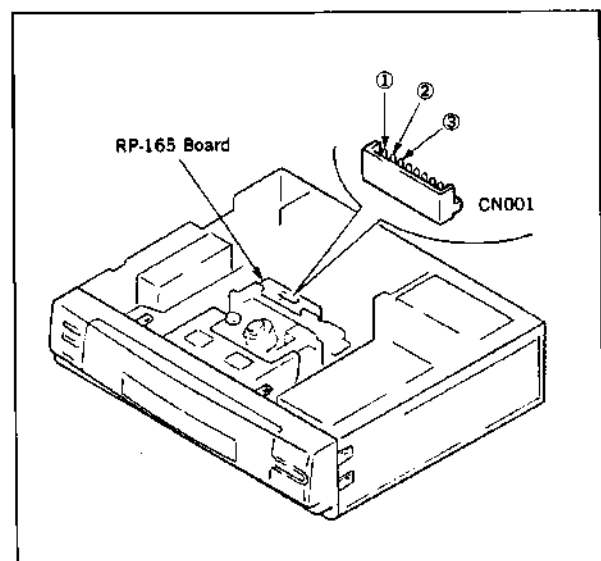

Fig. 7-1-3.

## 7-2. ELECTRICAL ADJUSTMENTS

See the adjusting part location diagram from on page 7-30 for the adjustment.

For details of the SENSER LANC , refer to 7-1 page <SERVICE MODE> .

### 2-1. PREPARATION BEFORE ADJUSTMENT

#### 2-1-1. Equipment Required

The measuring instruments used for this alignment include :

- 1) Monitor TV
- 2) Oscilloscope, dual-trace, bandwidth of 30MHz or more, with delay mode (A probe 10:1 should be used unless otherwise specified.)
- 3) Frequency counter
- 4) Pattern generator (with Video Output terminal; refer to Section 7-2-1. Equipment Connection.)
- 5) Digital voltmeter
- 6) Audio generator
- 7) Audio level meter
- 8) Audio distortion meter
- 9) Audio attenuator
- 10) Vector scope
- 11) Alignment tapes
  - For tracking adjustment (WR5-1CP)  
Part No.: 8-967-995-07
  - For video frequency adjustment (WR5-7CE)  
Part No.: 8-967-995-18
  - For L mode operation check
    - For SP (WR5-5CSP)  
Part No.: 8-967-995-46
    - or (WR5-4CSP)  
Part No.: 8-967-995-47
    - For LP (WR5-4CL)  
Part No.: 8-967-995-56
  - For E mode operation check (ME tape)
    - For SP (WR5-8CSE)  
Part No.: 8-967-995-48
    - For LP (WR5-8CLE)  
Part No.: 8-967-995-57
  - For AFM stereo operation check (WR5-9CS)  
Part No.: 8-967-995-28
- 12) Adjustment remote control (J-6082-053-B)



### 2-1-2. Equipment Connection

According to the specification of the input terminal (S VIDEO or VIDEO), connect required measuring instruments as shown in Fig. 7-2-1. and perform adjustment. The input terminal is specified in the parentheses ( ) in the signal column. Unless otherwise specified, either terminal may be used. Note that the S VIDEO input terminal takes precedence. When performing adjustment with the VIDEO input terminal, pull out the connector from the S VIDEO input terminal.

**Note 1 :**When S VIDEO input is specified for a specific adjustment, if the adjustment is performed with VIDEO input, the product specifications for this unit may not be satisfied. The specified input must be always used.

**Note 2 :**If an adjustment is performed by using a VTR with S Video output terminal as a signal source, the performance of this unit will be affected by that VTR. A pattern generator with Y/C separation output terminal should be used wherever possible.

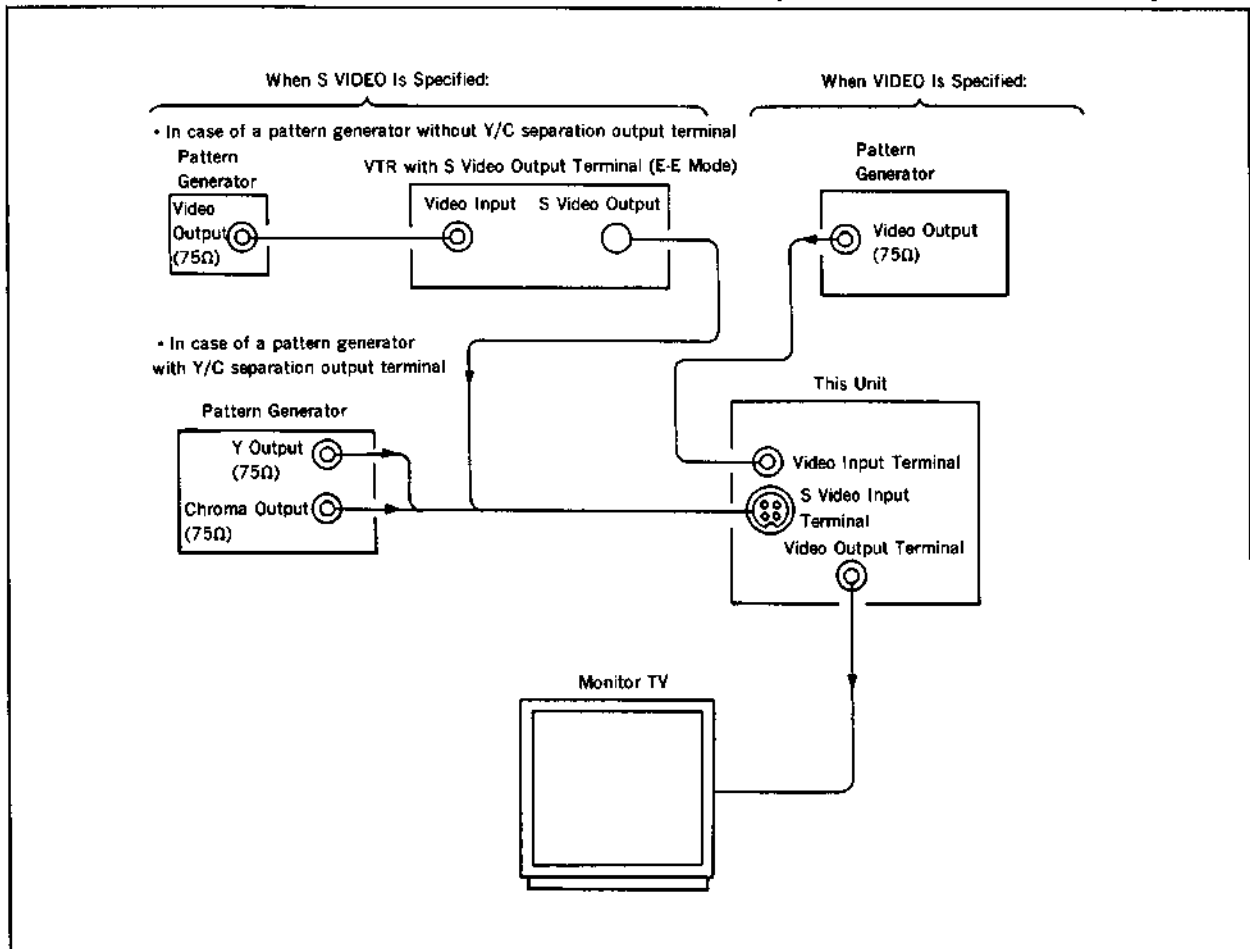

Fig. 7-2-1.

### 2-1-3. Input Signal Check

Video signal produced by a pattern generator is used as an adjustment signal to perform electrical alignment for this unit. This video signal must satisfy the specification.

#### 1) S VIDEO Input

Connect an oscilloscope to the Y Signal terminal of the S Video Input terminal. Check that the synchronizing signal of the Y signal is approximately at 0.3Vp-p and that its video portion has an amplitude of approximately 0.7Vp-p. (When a VTR with S video output terminal is used, in addition to these checks, make sure that there are no residual chroma and burst signals.) Then, connect the scope to the Chroma signal terminal of the S Video Input terminal and check that the chroma signal has a burst signal amplitude of 0.3Vp-p and the burst signal waveform is flat. And check that the amplitude ratio of burst signal to chroma signal is 0.30 : 0.66. The Y and chroma signals used for electrical alignment are shown in Fig. 7-2-2.

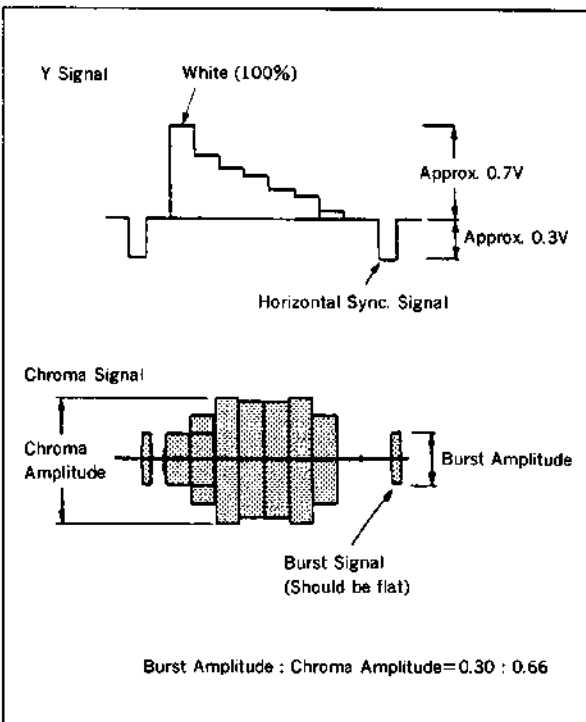

Fig. 7-2-2. Color Bar Signals of Pattern Generator

**Note)** VIDEO input is usually selected in this set. To select S VIDEO input, use remote commander to enter the MENU mode and change Video Input of Line 3 in mode setting from Video to S Video.

Unless otherwise specified, place the switches and controls of this unit in the following positions:

- **Input Select** switch .....LINE 3

#### 2) VIDEO Input

Connect an oscilloscope to the Video Input terminal. Check that the synchronizing signal of the Y signal has an amplitude of approximately 0.7V and that the burst signal has an amplitude of approximately 0.3V and its waveform is flat. And check that the level ratio of burst signal to "red" signal is 0.30 : 0.66.

The video signal (color bar) used for electrical aligning this unit is shown in Fig. 7-2-3.

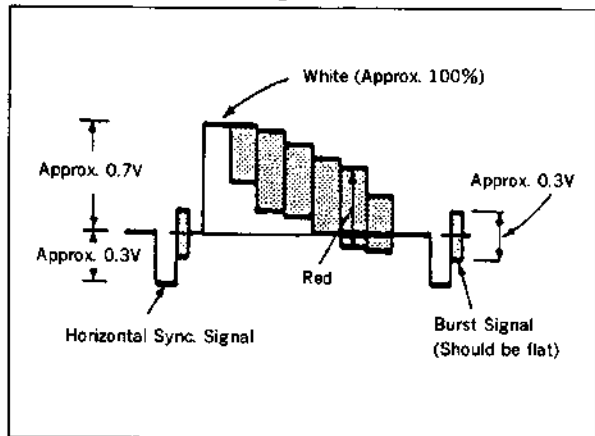

Fig. 7-2-3. Color Bar Signals of Pattern Generator

### 2-1-4. Alignment Tapes

The following alignment tapes are available.  
The tape specified in the signal column for the adjustment to be performed should be used.

Note that if no tape code is specified for the adjustments in which alignment tapes for operation check are used, any tape for operation check may be used.

Alignment Tape	Record Mode	Tape Type	Tape Speed	Contents of Record		Applications
				Video Area	PCM Area	
Tracking WR5-1CP	L	MP	SP	CH2: 1MHz tape path adjustment signal Switching position adjustment marker (CH1: 9MHz)		Tape path adjustment Switching position adjustment
Video frequency characteristic WR5-7CE	E	ME	SP	RF sweep 0~15MHz Marker 2, 4.5, 7, 8.5, 10MHz		Frequency characteristic
Operation check WR5-5CSP	L	MP	SP	<ul style="list-style-type: none"> <li>Video signal Color bar 4 min. Monoscope 4 min.</li> <li>Audio signal (AFM) 400Hz 60% modulated</li> </ul>	<ul style="list-style-type: none"> <li>Audio signal (PCM) Monoscope portion 20Hz 20sec. This cycle 400Hz 20sec. is repeated 14kHz 20sec. 4 times Color bar portion 1kHz, 4min.</li> </ul>	Operation check
WR5-8CSE	E	ME	SP		400Hz, 8min.	
WR5-4CL	L	MP	LP	<ul style="list-style-type: none"> <li>Video signal Color bar 4 min. Monoscope 4 min.</li> </ul>		
WR5-3CL	L	MP	LP	<ul style="list-style-type: none"> <li>Audio signal (AFM) 400Hz 60% modulated</li> </ul>	<ul style="list-style-type: none"> <li>Audio signal (PCM) 400Hz</li> </ul>	
WR5-8CLE	E	ME	LP			
AFM stereo operation check WR5-9CS	L	MP	SP	<ul style="list-style-type: none"> <li>Video signal Color bar 4 min. Monoscope 4 min.</li> <li>Audio signal (AFM) Stereo portion (color bar) Lch: 400Hz Rch: 1kHz (L+R 1.5MHz±60kHz DEV) (L-R 1.5MHz±30kHz DEV) Bilingual portion (monoscope) MAIN: 400Hz (1.5MHz±60kHz DEV) SUB: 1kHz (1.7MHz±30kHz DEV)</li> </ul>	<ul style="list-style-type: none"> <li>Audio signal (PCM) 400Hz, 8 min.</li> </ul>	AFM stereo operation check

#### Note: Recording Mode

L ..... Conventional mode  
E ..... Hi 8 (High Band) mode

#### Tape Type

MP ..... Metal powder tape  
ME ..... Metal evaporated tape

The color bar signal recorded on these alignment tapes are shown in Fig. 7-2-4.

Note: This waveform is measured at the VIDEO OUT terminal (terminated at 75Ω).

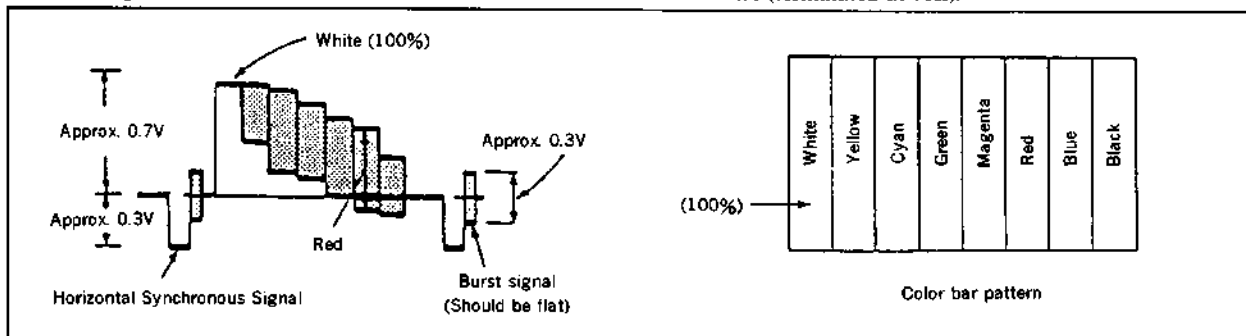

Fig. 7-2-4. Color Bar Signal of Alignment Tape

### 2-1-5. Input/Output Levels and Impedance

Video input : LINE 1 (EURO-AV)  
 Pin 20  
 LINE IN 2/3  
 (phono jack) (1 each)  
 Input signal : 1Vp-p, 75 ohms, unbalanced,  
 sync negative

Video output : LINE 1 (EURO-AV)  
 Pin 19  
 : LINE OUT 2/3  
 (phono jack) (1 each)  
 Output signal : 1Vp-p, 75ohms, unbalanced,  
 sync negative

S VIDEO input : LINE IN 2/3  
 (4-pin, mini-DIN) (1 each)  
 Luminance (Y) : 1 Vp-p, 75 ohms,  
 unbalanced, sync negative  
 Chrominance (C) : 0.3 Vp-p (colour burst),  
 75 ohms, unbalanced

S VIDEO output : LINE 1 (EURO-AV)  
 Y : Pin 19  
 C : Pin 15  
 : LINE OUT 2  
 (4-pin, mini-DIN)  
 Y : 1 Vp-p, 75 ohms, unbalanced, sync  
 negative  
 C : 0.3 Vp-p (color burst), 75 ohms,  
 unbalanced

Audio input : LINE 1 (EURO-AV)  
 R : Pin 2  
 L : Pin 6  
 LINE IN 2/3  
 (phono jack) (2 each)  
 Input level : -7.5 dBs  
 (0dBs=0.775Vrms)  
 Input impedance : more than 47 kilohms

Audio output : LINE 1 (EURO-AV)  
 R : Pin 1  
 L : Pin 3  
 LINE OUT 2  
 (phono jack) (2)  
 Standard level : -7.5dBs at load  
 impedance 47 kilohms  
 Output impedance : less than 10 kilohms  
 : LINE OUT 3  
 (phono jack) (1)  
 Standard level : -7.5dBs at load  
 impedance 47 kilohms  
 Output impedance : less than 10 kilohms

RFU DC output : LINE OUT 3  
 (Special minijack)  
 DC 5V

CONTROL S IN : Minijack  
 LANC : Stereo mini-mini jack ( $\phi$ 2.5)

### 2-2. POWER SUPPLY CHECK

#### 2-2-1. Output Voltage Check (PS-324 Board)

Mode	E-E
Measurement instrument	Digital voltmeter
UN 13V check	
Measurement point	CN101 pin ①②
Specified value	13.5 ±0.3 Vdc
UN 6V check	
Measurement point	CN101 pin ③
Specified value	5.9 ±0.2Vdc
SW 5V check	
Measurement point	CN101 pin ④⑦
Specified value	5.0 ±0.2Vdc
UN -8V check	
Measurement point	CN101 pin ⑤
Specified value	-9.0 ±0.2 Vdc

#### [Check Method]

- Each of these supply voltages must meet its specified value.

### 2-3. SYSTEM CONTROL SYSTEM CHECK

#### 2-3-1. Timer Clock Check (MA-205 Board)

Mode	E-E
Signal	Arbitrary
Measurement point	IC901 pin ⑩ (BUZZER OUT) or JL974
Measuring instrument	Frequency counter
Specified value	4096.04 ± 0.01Hz

**Note:** A frequency counter should be connected through a buffer amplifier (oscilloscope, etc.) having a high impedance and a low capacitance.

#### [Adjustment Method]

- 1) Place the adjustment remote control RM-95 (J-6082-053-B) in the HOLD ON position.
- 2) Category code setting.  
Page: B, address: 00, data: 01.
- 3) Clock check mode setting.  
Page: B, address: 10, data: 03.
- 4) Check for at 4096.04 ± 0.01Hz.
- 5) After this adjustment, Push on the **RESET** key.

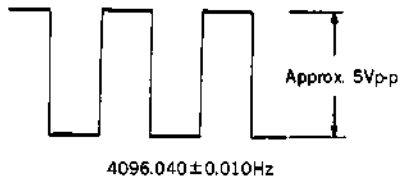

Fig. 7-2-5.

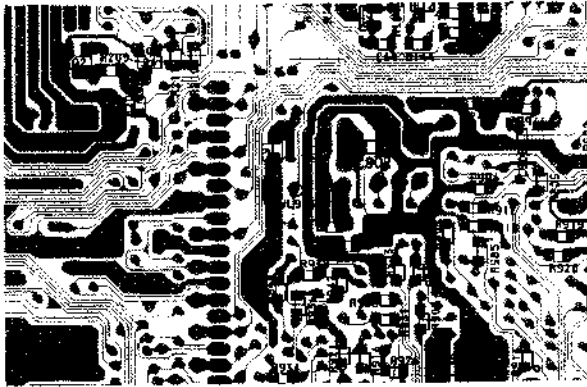
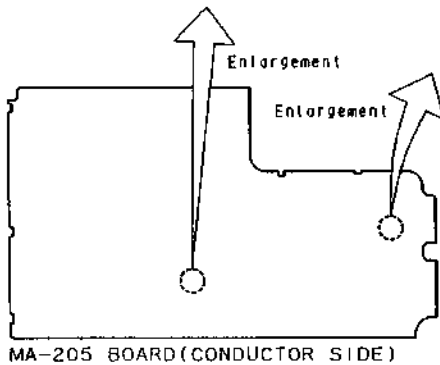

Fig. 7-2-6.



MA-205 BOARD (CONDUCTOR SIDE)

### 2-4. SERVO SYSTEM ADJUSTMENTS

#### [Adjustment sequence]

1. PWM Frequency Adjustment
2. Switching Position Adjustment
3. PCM VCO Adjustment
4. CAP Duty Adjustment
5. SP/LP Discrimination Check
6. SLOW Adjustment
7. ×2 Adjustment

#### 2-4-1. PWM Frequency Adjustment (MA-205 Board)

Mode	Record
Signal	Arbitrary
Measurement point	IC302 pin ⑩ or JL329
Measuring instrument	Frequency counter Oscilloscope
Adjustment element	RV301
Specified value	475 ± 25kHz

#### [Adjustment Method]

- 1) Set Recording Time to SP mode.
- 2) Use RV301 to adjust to 475 ± 25kHz.
- 3) Set Recording Time to LP mode.
- 4) Check for at 475 ± 25kHz.
- 5) If the specification is not met, repeat Steps 1) to 4).

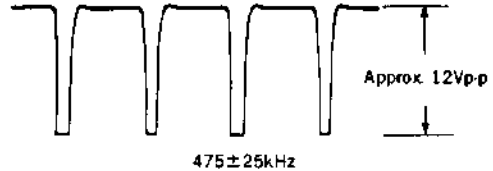

Fig. 7-2-7.

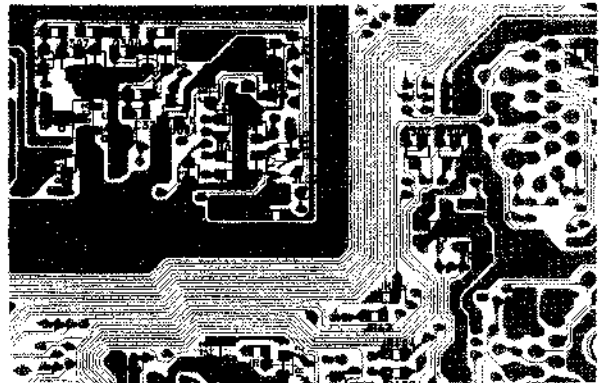

Fig. 7-2-8.

### 2-4-2. Switching Position Adjustment

#### [Adjustment Object]

Switching timing of the video head setting. If deviated, in this case causes switching noise or jitter on the played back screen.

Mode	Playback
Signal	Alignment tape: For operation check (WR5-1CP)
Measurement point	CH-1: RP-165 board CN001 pin ② (RF SWP) CH-2: RP-165 board CN001 pin ⑤ (PB RF 2CH)
Measuring instrument	Oscilloscope
Adjustment page	D
Adjustment address	05 (Coarse) 04 (Fine)
Specified value	$t = 0 \pm 5 \mu\text{sec}$

#### [Adjustment Method]

- 1) Release the protect.  
Page : 1, address : 00, data : 01.
- 2) Change the data of page : D, address : 05 and minimize "t". (Coarse adjustment)
- 3) Press the PAUSE button of the remote control unit.
- 4) Change the data of page : D, address : 04, and adjust so that the switching position (t) becomes the specified value. (Fine adjustment)
- 5) Press the PAUSE button of the adjusting remote control unit.

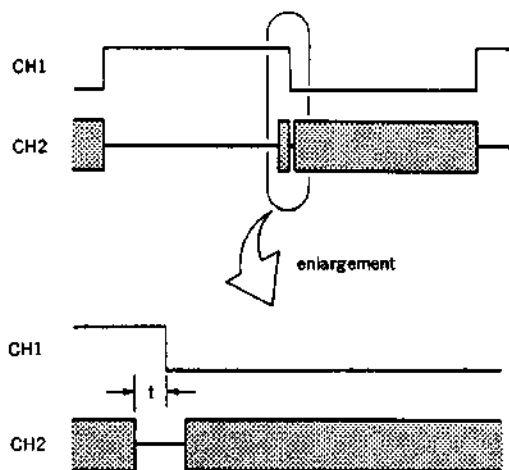

Fig. 7-2-9.

### 2-4-3. PCM VCO Adjustment (MA-205 Board)

Mode	PB, FF, REW, FF Search, REW Search
Signal	Arbitrary tape (Tape which does not contain PCM signal.)
Measurement point	CN503 pin ② (PB VCO)
Measuring instrument	Frequency counter
Adjustment page	D
Adjustment address	18 (PB) 1A (FF) 1B (REW) 1C (FF Search) 1D (REW Search)
Specified value	Playback : $11.50 \pm 0.05 \text{MHz}$ Fast Forward Search : $11.59 \pm 0.05 \text{MHz}$ Rewind Search : $12.20 \pm 0.05 \text{MHz}$ FF : $11.98 \pm 0.05 \text{MHz}$ REW : $12.20 \pm 0.05 \text{MHz}$

**Note 1 :** A frequency counter should be connected through a buffer amplifier (oscilloscope, etc.) having a high impedance and a low capacitance.

#### [Connection]

- 1) Connect pin ① to 5V, pin ③ to GND of CN503.

#### [Adjustment Method]

- 1) Release the protect.  
Page : 1, address : 00, data : 01.
- 2) Playback by remote commander.
- 3) Change the data of page : D, address : 18, and adjust so that the frequency becomes the specified value.
- 4) Press the PAUSE button of the adjusting remote control unit.
- 5) Adjust FF REW in the same manner.
- 6) After this adjustment, open pin ① and pin ③ of CN503.



During Playback	: $11.50 \pm 0.05 \text{MHz}$
During Fast Forward Search	: $11.59 \pm 0.05 \text{MHz}$
During Rewind Search	: $12.20 \pm 0.05 \text{MHz}$
During FF	: $11.98 \pm 0.05 \text{MHz}$
During REW	: $12.20 \pm 0.05 \text{MHz}$

Fig. 7-2-10.

#### 2-4-4. CAP Duty Adjustment (MA-205 Board)

Mode	Record (LP mode)
Signal	Arbitrary
Measurement point	CN303 pin ① (CAP FG)
Measuring instrument	Oscilloscope
Adjustment page	D
Adjustment address	17
Specified value	$t_1 = t_2$ (50±1%)

##### [Adjustment Method]

- 1) Release the protect  
Page : 1, address : 00, data : 01
- 2) Change data at address 17 on page D and adjust so that  $t_1 = t_2$  (50% duty).

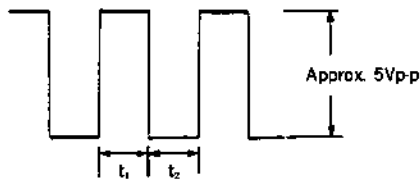

Fig. 7-2-11.

- 3) Press PAUSE button to store the adjustment data.

#### 2-4-5. SP/LP Discrimination Check (MA-205 Board)

Mode	Record
Signal	Arbitrary
Measurement point	CN303 pin ④ (SP/LP DET) pin ⑤ (V REF)
Measuring instrument	Oscilloscope
Adjustment Page	D
Adjustment address	13
Specified value	SP/LP DET—V REF SP mode : 0.15Vdc or more LP mode : 0.35Vdc or more

##### [Check Method]

- 1) Connect CH1 of an oscilloscope with CN303 pin ④ and CH2 with CN303 pin ⑤.
- SP mode
- 2) Recording SP mode.
  - 3) Check the difference in voltage at between SP/LP DET and V REF.
  - 4) If the specification is not satisfied, change data at address 13 on page D and adjust so that the difference falls into the specified range.

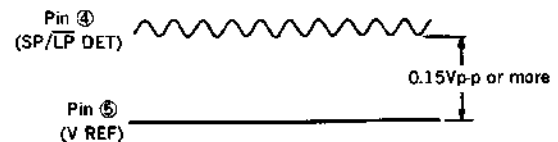

Fig. 7-2-12. (SP mode).

- LP mode

- 5) Recording LP mode.
  - 6) Check the difference in voltage at between SP/LP DET and V REF.
  - 7) If the specification is not satisfied, change data at address 13 on page D and adjust so that the difference falls into the specified range.
- After adjustment, perform the discrimination check in SP mode again.

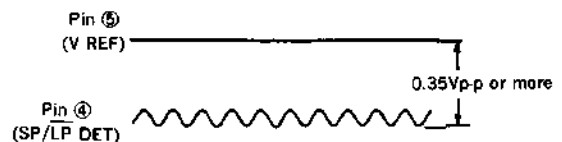

Fig. 7-2-13. (LP mode)

#### 2-4-6. SLOW Adjustment

Mode	Self-record playback (SP and LP modes)
Signal	Color bar
Measurement point	CH-1: RP-165 board CN001 pin ② (RF SWP) CH-2: RP-165 board CN001 pin ③ (PB Y)
Measuring instrument	Oscilloscope
Adjustment page	D
Adjustment address	21 (SLOW TRACON DATA (LP)) 20 (SLOW TRACON DATA (SP)) 23 (-SLOW TRACON DATA (LP)) 22 (-SLOW TRACON DATA (SP))
Specified value	A = B

##### [Adjustment Method]

- 1) Record color bar signal in SP mode.
- 2) Play back the recorded signal.
- 3) Use the remote commander or the EDIT SHUTTLE SLOW on the set to enter SLOW 1/5 mode.
- 4) Release the protect.  
Page : 1, address : 00, data : 01.
- 5) Change the data of page : D, address : 20 and adjust so that the A = B.
- 6) Press PAUSE button on the remote control to store the adjustment data.
- 7) In the same manner, select adjustment address 21 for SP Mode SLOW (1/5) mode, adjustment address 23 for LP Mode -SLOW (-1/5) mode, and address 22 for SP Mode -SLOW (-1/5) mode and adjust so that A = B.

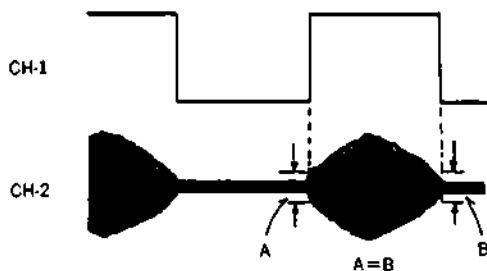

Fig. 7-2-14.

#### 2-4-7. ×2 Adjustment

Mode	Self-record playback (SP and LP mode)
Signal	Color bar
Measurement point	CH-1: RP-165 board CN001 pin ② (RF SWP) CH-2: RP-165 board CN001 pin ③ (PB Y)
Measuring instrument	oscilloscope
Adjustment page	D
Adjustment address	24 (SP×2) 25 (LP×2)
Specified value	A = B

##### [Adjustment Method]

- 1) Insert ME type cassette tape.
- 2) Record color bar signal in SP mode.
- 3) Use the remote commander or the SHUTTLE RING on the set to enter ×2 play back.
- 4) Release the protect.  
Page : 1, address : 00, data : 01.
- 5) Change a data of page : D, address : 24 and adjust so that the A = B.
- 6) Then make sure that no noise appears on the monitor screen.
- 7) Press PAUSE button on the remote control to store the adjustment data.
- 8) Adjust and check the LP×2 mode in the same manner.

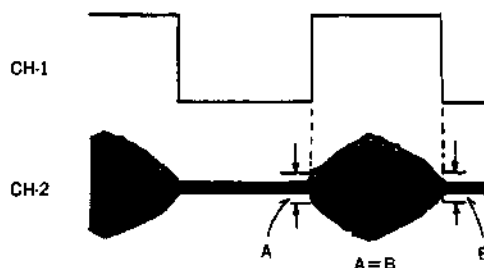

Fig. 7-2-15.



## 2-5. VIDEO SYSTEM ADJUSTMENTS

Color video signal supplied from a pattern generator is used as a video input signal for Video System Alignment in the Recording mode. This signal should be checked to ensure that it meets the specifications provided in Figs. 7-2-2 and 7-2-3 and "INPUT SIGNAL CHECK".

The adjustments in Video System Alignment should be performed in the following sequence.

### [Adjustment sequence]

1. Playback Frequency Characteristic Adjustment
2. SYNC AGC Adjustment
3. Chroma Comb Filter Adjustment
4. Pre-emphasis Input Level Adjustment
5. L Mode Y FM Carrier Frequency, Y FM Deviation Adjustment
6. E Mode Y FM Carrier Frequency, Y FM Deviation Adjustment
7. Chroma Emphasis Adjustment
8. L Mode De-emphasis Level Adjustment
9. E Mode De-emphasis Level Adjustment
10. E Mode Playback Level Adjustment
11. Recording Y-FM Level Pre Adjustment
12. Recording Chroma Level Pre Adjustment

## 2-5-1. Playback Frequency Characteristic Adjustment (RP-165 Board)

### [Adjustment Object]

To set the RF output of each head an optimum frequency level. If improper, granularity or black and white dot noise is produced. In particular, deviation at 1 channel leads to this symptom in speed change mode such as slow still.

**Note:** The designation ( ) stands for adjustment on CH-2.

Mode	Playback
Signal	Alignment tape: for frequency characteristic adjustment (WR5-7CE)
Measurement point	CN001 pin ⑥ (PB RF 1CH) [CN001 pin ⑤ (PB RF 2CH)] External trigger: CN001 pin ② (RF SWP) Trigger slope: -(+)
Measuring instrument	Oscilloscope
Adjustment element	RV001 [RV002]
Specified value	4.5MHz level: 8.5MHz level = 3 : (2±0.2)

### [Adjustment Method]

- 1) Use RV001 [RV002] to adjust so that the ratio of 4.5MHz level to 8.5MHz of PB RF output waveform is 3 : (2±0.2).

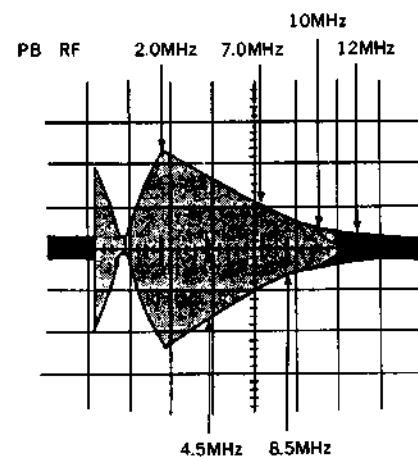

Fig. 7-2-16.

### 2-5-2. SYNC AGC Adjustment (VI-131 Board)

#### [Adjustment Object]

Set the record Y signal level. Misalignment will result in excessive darkness or brightness of EE screen or self-recorded screen and cause improper color reproduction.

Mode	E-E
Signal	Color bar
Measurement point	CN101 pin ④ (DI Y (X)) or JL133
Measuring instrument	Oscilloscope
Adjustment element	RV101
Specified value	$A = 2.0 \pm 0.1V_{p-p}$

#### [Adjustment Method]

- 1) Use RV101 to adjust to  $A = 2.0 \pm 0.1V_{p-p}$ .

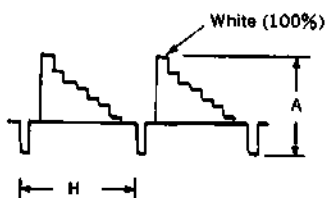

Fig. 7-2-17.

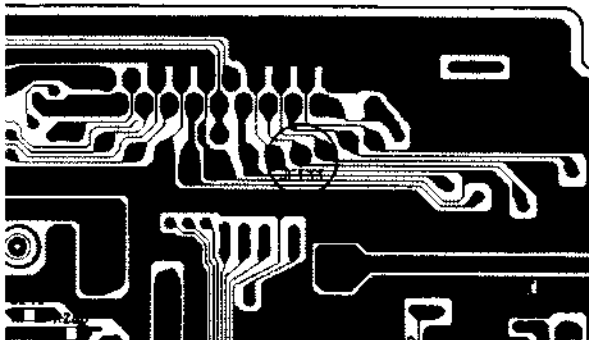
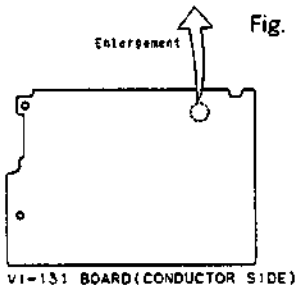
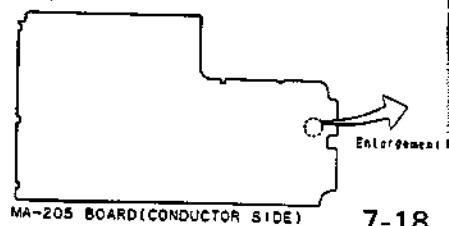

Fig. 7-2-18.



VI-131 BOARD (CONDUCTOR SIDE)



MA-205 BOARD (CONDUCTOR SIDE) 7-18

### 2-5-3. Chroma Comb Filter Adjustment (VI-131 Board)

#### [Adjustment Object]

Set the level and the phase of the playback system's chroma comb filter. Misalignment will result in aberrant hue and deteriorated S/N ratio of chroma.

Mode	Playback
Signal	Alignment tape: For operation check, color bar portion (WR5-5CSP)
Measurement point	Line Video out terminal
Measuring instrument	Vectorscope
Adjustment element	RV102 (GAIN) RV108 (PHASE)
Specified value	No difference on the scope screen when <input type="checkbox"/> EDIT key is turned ON/OFF.

#### [Adjustment Method]

- 1) Connect a vector scope to the line output video terminal.
- 2) Playback alignment tape.
- 3) Turn on  EDIT switch and adjust the vector scope screen.
- 4) Turn off  EDIT switch and adjust RV102 and 108 so that there is no difference between this screen and the screen displayed when the switch is turned on.

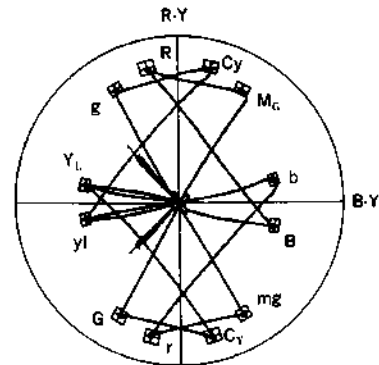

Fig. 7-2-19.

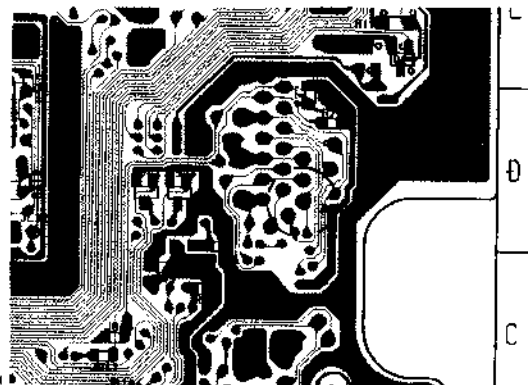

Fig. 7-2-20.

**2-5-4. Pre-emphasis Input Level Adjustment  
(VI-131 Board)**

**[Adjustment Object]**

Set the level of the brightness signal before input to the emphasis circuit. Misalignment will result in excessively dark or bright recorded picture and cause smearing.

Mode	E-E
Signal	Color bar (VIDEO)
Measurement point	IC105 pin ⑤
Measuring instrument	Oscilloscope
Adjustment element	RV109
Specified value	$A = 0.50 \pm 0.02V_{p-p}$

**[Adjustment Method]**

- 1) Use RV109 and adjust to  $A = 0.50 \pm 0.02V_{p-p}$ .

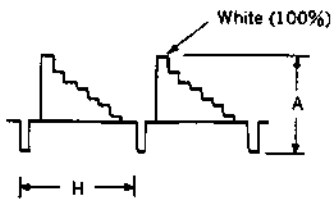

Fig. 7-2-21.

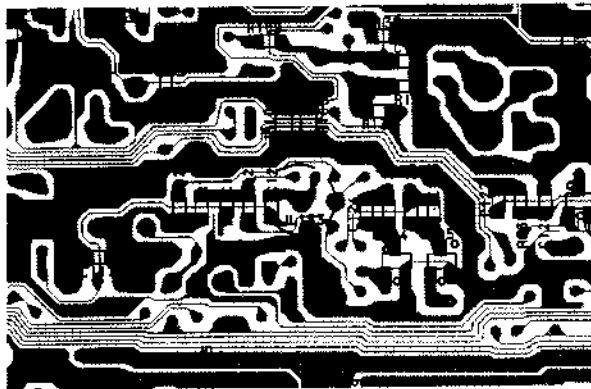
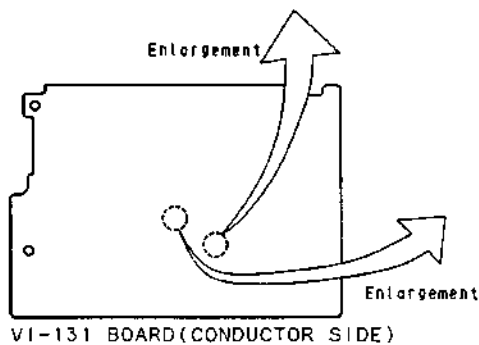

Fig. 7-2-22.



**2-5-5. L Mode Y FM Carrier Frequency,  
Y FM Deviation Adjustment**

**Note 1:** After this adjustment, be sure to perform "2-5-8. E Mode Y FM Carrier Frequency, Y FM Deviation Adjustment".

**Note 2:** The S Video Line output terminal should be terminated at  $75\Omega$ .

**[Adjustment Object]**

Set the frequency deviation of the modulated brightness signal during normal mode recording. Misalignment will cause recorded picture to be excessively bright or dark. Black or white stretching may occur.

- (1) L Mode Y FM Carrier Frequency Adjustment  
(VI-131 Board)

Mode	E-E
Signal	No signal
Measurement point	IC104 pin ⑧ (Y RF OUT) or JL167
Measuring instrument	Frequency counter Oscilloscope
Adjustment element	RV106
Specified value	$4.38 \pm 0.05MHz$

**Note:** A frequency counter should be connected through a buffer amplifier (oscilloscope, etc.) having a high impedance and a low capacitance.

**[Adjustment Method]**

- 1) Insert MP type cassette tape.
- 2) Use RV106 to adjust to  $4.38 \pm 0.05MHz$ .



Fig. 7-2-23.

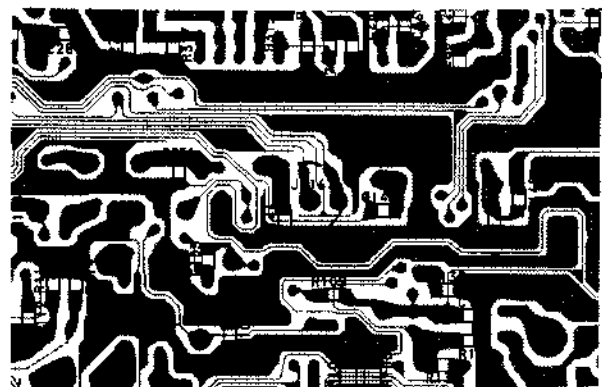

Fig. 7-2-24.

(2) L Mode Y FM Deviation Adjustment (VI-131 Board)

Mode	Record and playback
Signal	Color bar (S VIDEO)
Measurement point	S Video Line Output, Y Signal terminal
Measuring instrument	Oscilloscope
Adjustment element	RV107
Specified value	Playback level should be at $1.00 \pm 0.05V_{p-p}$ .

[Adjustment Method]

- 1) Insert MP type cassette tape.
- 2) Record color bar signal.
- 3) Play back the recorded signal.
- 4) Check the playback output level.  
Specification:  $1.00 \pm 0.05V_{p-p}$
- 5) If the specification is not met, rotate RV107 as directed below and then repeat Steps 1) to 4).

	Direction of Rotating RV107
Over specified value	Clockwise ( $\odot$ )
Below specified value	Counterclockwise ( $\ominus$ )

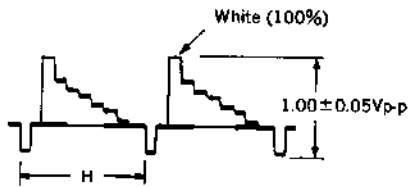

Fig. 7-2-25.

2-5-6. E Mode Y FM Carrier Frequency, Y FM Deviation Adjustment

**Note 1:** When performing this adjustment, it is a prerequisite that "2-5-7. L Mode FM Carrier Frequency, Y FM Deviation Adjustment" has been completed.

**Note 2:** The S Video Line output terminal should be terminated at  $75\Omega$ .

[Adjustment Object]

Set the frequency deviation of the modulated brightness signal during Hi8 mode recording. Misalignment will cause recorded picture to be excessively bright or dark. Black or white stretching may occur.

(1) E Mode Y FM Carrier Frequency Adjustment (VI-131 Board)

Mode	E-E
Signal	No signal (select Line in)
Measurement point	IC104 pin ② (Y RF OUT)
Measuring instrument	Frequency counter Oscilloscope
Adjustment element	RV104
Specified value	$5.96 \pm 0.05MHz$

**Note:** A frequency counter should be connected through a buffer amplifier (oscilloscope, etc.) having a high impedance and a low capacitance.

[Adjustment Method]

- 1) Insert ME type cassette tape.
- 2) Use RV104 to adjust to  $5.96 \pm 0.05MHz$ .



$5.96 \pm 0.05MHz$

Fig. 7-2-26.

(2) E Mode Y FM Deviation Adjustment (VI-131 Board)

Mode	Record and playback
Signal	Color bar (S VIDEO)
Measurement point	S Video Line Output, Y Signal terminal
Measuring instrument	Oscilloscope
Adjustment element	RV105
Specified value	Playback level should be at $1.00 \pm 0.05V_{p-p}$ .

[Adjustment Method]

- 1) Insert ME type cassette tape.
- 2) Record color bar signal.
- 3) Play back the recorded signal.
- 4) Check the playback output level.  
Specification:  $1.00 \pm 0.05V_{p-p}$
- 5) If the specification is not met, rotate RV105 as directed below and then repeat Steps 1) to 4).

	Direction of Rotating RV105
Over specified value	Clockwise ( ⌚ )
Below specified value	Counterclockwise ( ⌚ )

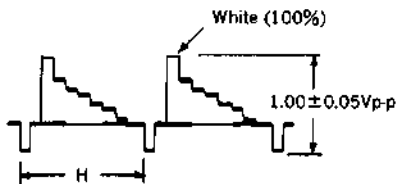

Fig. 7-2-27.

2-5-7. Chroma Emphasis Adjustment (VI-131 Board)

[Adjustment Object]

Emphasis frequency setting. If deviated, this causes unnatural color.

Mode	E-E
Signal	Color bar
Measurement point	IC104 pin ⑧ (B.EMPH ①) or JL155
Measuring instrument	Oscilloscope
Adjustment element	RV103
Specified value	fo component should be reduced to a minimum.

[Adjustment Method]

- 1) Adjust RV103 to allow the latter half of the yellow component in the chroma signal to have a minimum amplitude.

Allow the latter half of the yellow component to have a minimum amplitude.

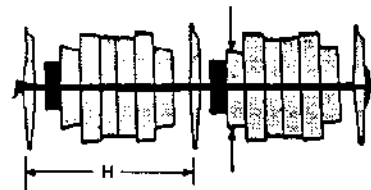

Fig. 7-2-28.

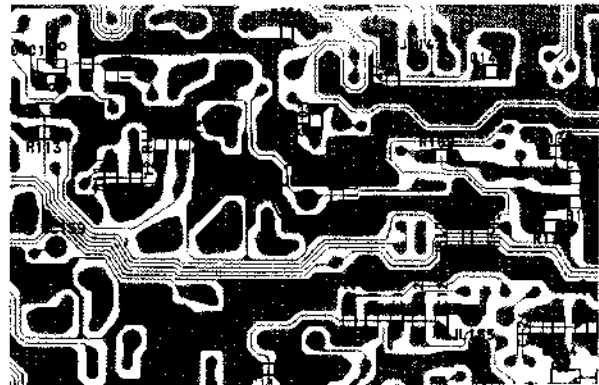
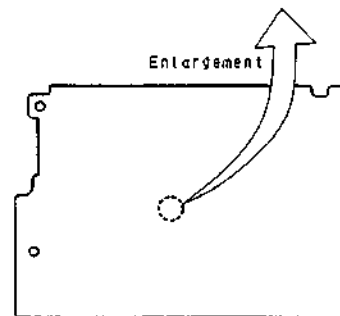

Fig. 7-2-29.



VI-131 BOARD (CONDUCTOR SIDE)

**2-5-8. L Mode De-emphasis Level Adjustment  
(VI-131 Board)**

**[Adjustment Object]**

Set the de-emphasis level of the brightness signal during normal playback. Misalignment will cause played picture to be excessively bright or dark. Black or white stretching may occur.

Mode	Playback
Signal	Alignment tape: For operation check, color bar portion (WR5-5CSP)
Measurement point	IC104 pin ⑩ (Y CCD OUT) or JL159
Measuring instrument	Oscilloscope
Adjustment element	RV112
Specified value	$A = 0.50 \pm 0.05V_{p-p}$

**[Adjustment Method]**

- 1) Use RV112 to adjust to  $A = 0.50 \pm 0.05V_{p-p}$ .



Fig. 7-2-30.

**2-5-9. E Mode De-emphasis Level Adjustment  
(VI-131 Board)**

**[Adjustment Object]**

Sets the luminance De-emphasis level for Hi8 playback. If deviated, this causes excessive brightness or darkness.

Mode	Playback
Signal	Alignment tape: For operation check, color bar portion (WR5-8CSE)
Measurement point	IC104 pin ⑩ (Y CCD OUT)
Measuring instrument	Oscilloscope
Adjustment element	RV111
Specified value	$A = 0.50 \pm 0.05V_{p-p}$

**[Adjustment Method]**

- 1) Use RV111 to adjust to  $A = 0.50 \pm 0.05V_{p-p}$ .



Fig. 7-2-32.

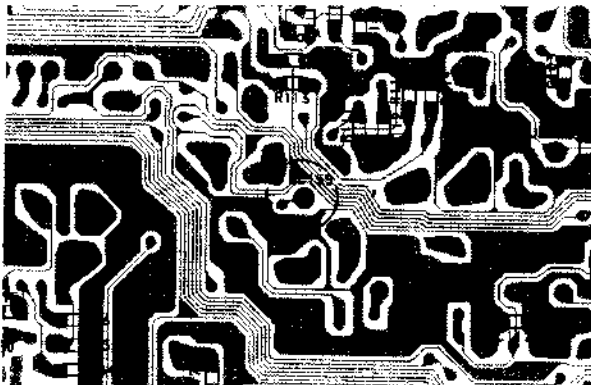
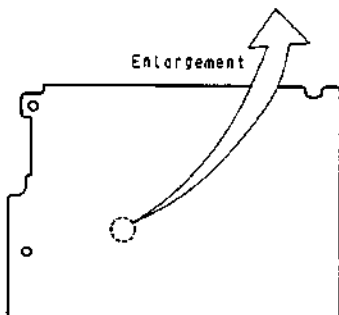

Fig. 7-2-31.



VI-131 BOARD (CONDUCTOR SIDE)

**2-5-10. E Mode Playback Level Adjustment  
(VI-131 Board)**

**[Adjustment Object]**

Set the output level of the brightness signal during Hi8 mode. Misalignment will cause played picture to be excessively bright or dark.

Mode	Playback
Signal	Alignment tape: For operation check, color bar portion (WR5-8CSE)
Measurement point	CN101 pin ⑩ (DI Y (X)) or JL133
Measuring instrument	Oscilloscope
Adjustment element	RV110
Specified value	$A = 2.00 \pm 0.02V_{p-p}$

**[Adjustment Method]**

- 1) Use RV110 to adjust to  $A = 2.00 \pm 0.02V_{p-p}$ .



Fig. 7-2-33.

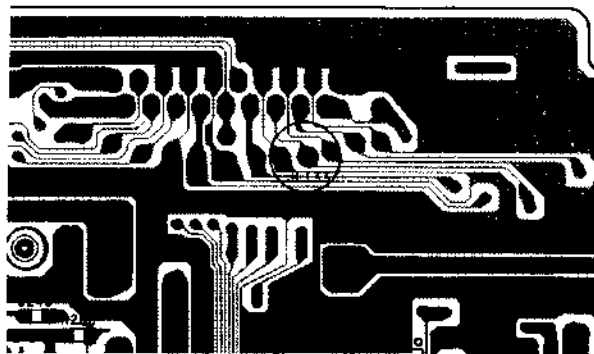
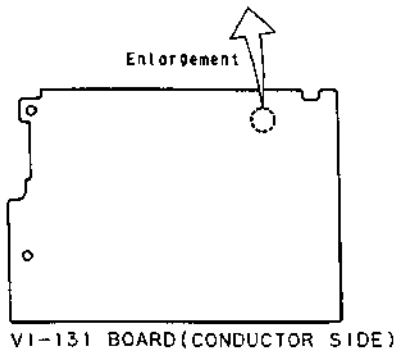

Fig. 7-2-34.



VI-131 BOARD (CONDUCTOR SIDE)

**2-5-11. Recording Y-FM Level Adjustment  
(VI-131 Board)**

**[Adjustment Object]**

Set the level of Y-FM signal to be recorded on tape. Shift to lower level will result in deteriorated S/N ratio of self-recorded picture.

Shift to higher level will cause over-modulation noise (black stretching noise) on self-recorded picture.

Mode	E-E
Signal	No signal
Measurement point	CN102 pin ⑩ (REC RF (X)) or JL118
Measuring instrument	Oscilloscope (20MHz bandwidth)
Adjustment element	RV113
Specified value	$A = 880 \pm 10mV_{p-p}$

**Note :** Set an oscilloscope to 20MHz bandwidth.

**[Adjustment Method]**

- 1) Take off AU-176 Board.
- 2) Insert ME tape.
- 3) Use RV113 to adjust to  $A = 880 \pm 10mV_{p-p}$ .
- 4) Give back AU-176 Board.



Fig. 7-2-35.

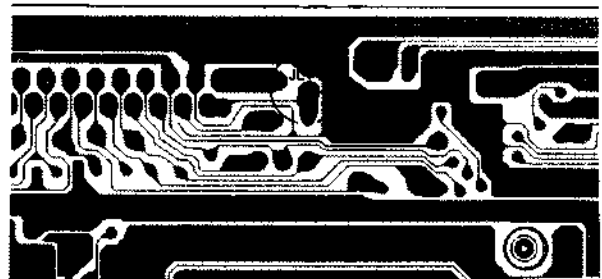
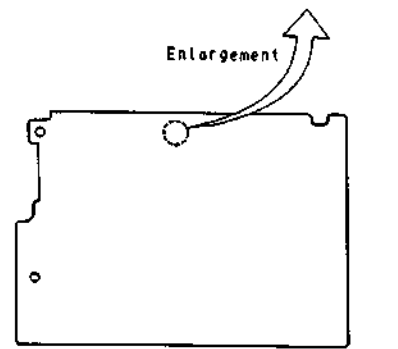

Fig. 7-2-36.



VI-131 BOARD (CONDUCTOR SIDE)

### 2-5-12. Recording Chroma Level Adjustment (VI-131 Board)

#### [Adjustment Object]

Set the level of the chroma signal to be recorded on tape. Shift to lower level will result in deteriorated S/N ratio of the chroma signal of self-recorded picture.

Shift to higher level will result in deteriorated S/N ratio of the Y signal in darker color portion of self-recorded picture and cause white stretching noise.

Mode	E-E
Signal	Color bar
Measurement point	CN102 pin ⑩ (REC RF (X)) or JL118
Measuring instrument	Oscilloscope
Adjustment element	RV114
Specified value	Adjust so that the red color portion of the chroma signal is at $180 \pm 20 \text{mVp-p}$ .

#### [Adjustment Method]

- 1) Short across R304 with a jumper wire.
- 2) Take off AU-176 Board.
- 3) Insert ME type cassette tape.
- 4) Adjust RV114 so that the flat portion of the chroma signal red component has the level  $180 \pm 20 \text{mVp-p}$ .
- 5) Remove adjustment jumper wire and attach the AU-176 board.

Adjustment so that the flat portion of the chroma signal RED component has the level  $180 \pm 20 \text{mVp-p}$ .

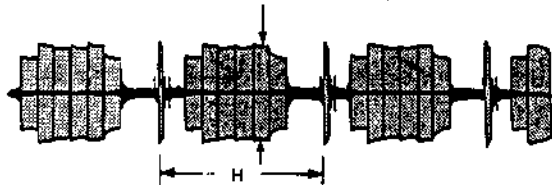

Fig. 7-2-37.

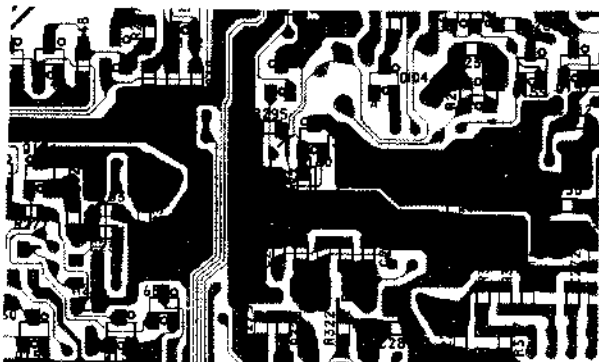
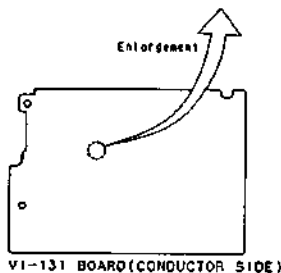

Fig. 7-2-38.



VI-131 BOARD (CONDUCTOR SIDE)

### 2-6. DIGITAL SYSTEM ADJUSTMENTS

The adjustments provided in Digital System Adjustments should be performed in following sequence.

#### [Adjustment sequence]

1. Read Clock Adjustment
2. Encode FSC Adjustment
3. AFC Adjustment
4. APC Adjustment

#### 2-6-1. Read Clock Adjustment (DI-55 Board)

##### [Adjustment Object]

Adjust the basic carrier of the digital picture circuit. Misalignment will cause E-E picture and the picture played back at changed speeds to be lost in color or to be dim.

Mode	Playback + Pause
Signal	Alignment tape: For operation check (WR5-5CSP or WR5-8CSE)
Measurement point	IC803 pin ⑩ or JL828
Measuring instrument	Frequency counter
Adjustment element	CT802
Specified value	$14218900 \text{Hz} \pm 50 \text{Hz}$

**Note:** A frequency counter should be connected through a buffer amplifier (oscilloscope, etc.) having a high impedance and a low capacitance.

##### [Adjustment Method]

- 1) Use CT802 to adjust to  $14218900 \text{Hz} \pm 50 \text{Hz}$ .



$14218900 \pm 50 \text{Hz}$

Fig. 7-2-39.

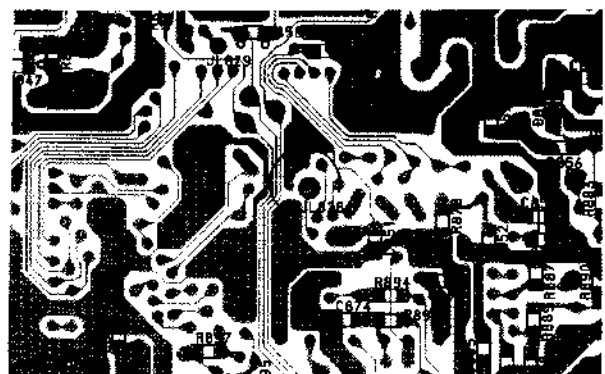
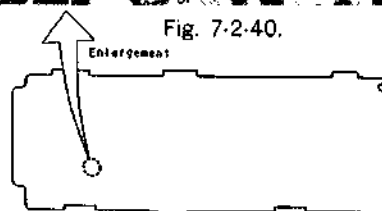

Fig. 7-2-40.



DI-55 BOARD (CONDUCTOR SIDE)



### 2-6-2. Encode FSC Adjustment (DI-55 Board)

#### [Adjustment Object]

This adjustment of VXO original oscillation is performed for write of chroma signal for the digital picture circuit. Shift will cause disorder or disappearance of color during variable signal playback.

Mode	Playback + Pause
Signal	Alignment tape: For operation check (WR5-5 CSP or WR5-8 CSE)
Measurement point	IC803 pin ④ (ENC FSC) or JL829
Measuring instrument	Frequency counter
Adjustment element	CT803
Specified value	4433630Hz ± 25Hz

**Note:** A frequency counter should be connected through a buffer amplifier (oscilloscope, etc.) having a high impedance and a low capacitance.

#### [Adjustment Method]

- 1) Use CT803 to adjust to 4433636Hz ± 25Hz.

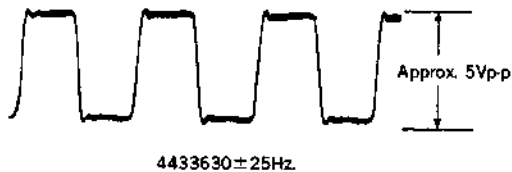

Fig. 7-2-41.

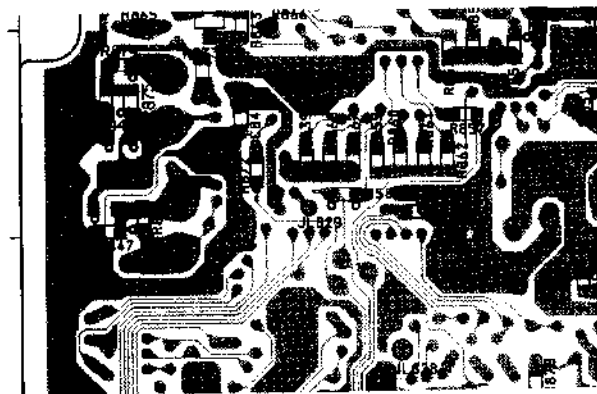

Fig. 7-2-42.

### 2-6-3. AFC Adjustment (DI-55 Board)

#### [Adjustment Object]

Adjust the VCO of the chroma read clock.

Misalignment will result in disturbances such as drift on the picture played back at changed speeds.

Mode	E-E
Signal	Color bar
Measurement point	IC804 pin ⑧ (PEO) or JL831
Measuring instrument	Digital voltmeter
Adjustment element	CT804
Specified value	2.80 ± 0.05VdC

**Note:** A high-impedance digital voltmeter should be used.

#### [Adjustment Method]

- 1) Adjust with CT804 so that the DC voltage is within the specified range.

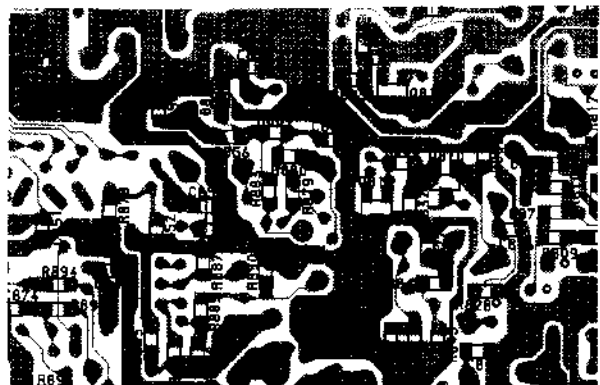
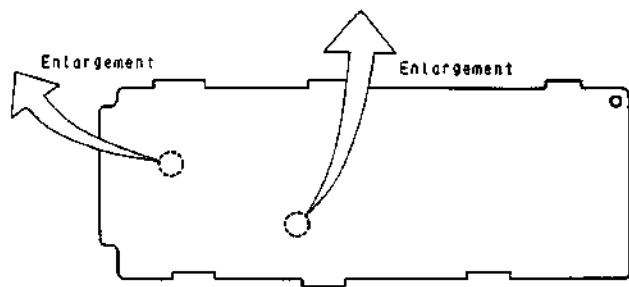

Fig. 7-2-43.



DI-55 BOARD (CONDUCTOR SIDE)

**2-6-4. APC Adjustment (DI-55 Board)**

**[Adjustment Object]**

Adjust the VXO of the chroma read clock.  
Misalignment will cause the picture played back at changed speeds to be lost in color or to be disturbed, for example, stripe-patterned.

Mode	E-E
Signal	Alignment tape: For operation check (WR5-5CSP or WR5-8CSE)
Measurement point	IC803 pin ⑩ (OPO) or JL830
Measuring instrument	Digital voltmeter
Adjustment element	CT801
Specified value	$2.30 \pm 0.05V_{dc}$

**Note :** A high-impedance digital voltmeter should be used.

**[Adjustment Method]**

- 1) Adjust with CT801 so that the DC voltage is within the specified range.

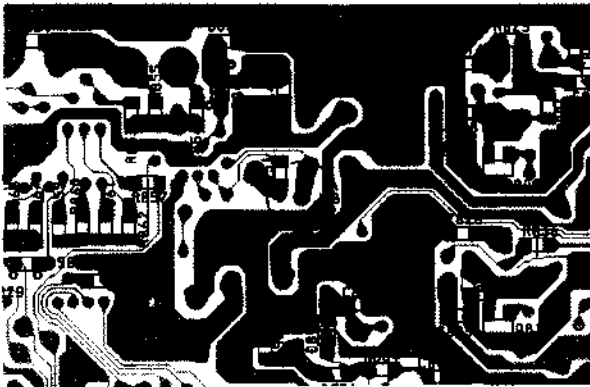
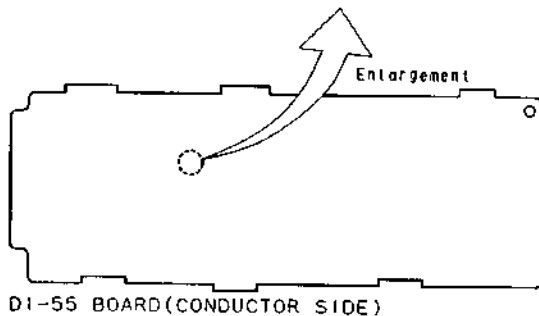

Fig. 7-2-44.



**2-7. AUDIO SYSTEM ADJUSTMENTS**

Color bar signal should be used as Video signal input for performing this adjustment.

**[Connection of Equipment for Audio Measurement]**

In addition to equipment for video measurement, the audio measurement equipment should be connected as illustrated below.

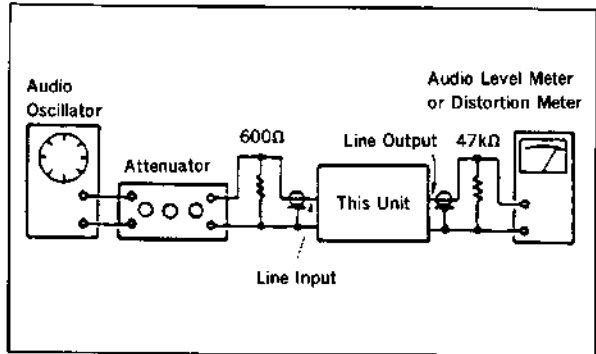

Fig. 7-2-45.

Unless otherwise specified, place the switches and controls of this unit in the following positions:

- **Input Select** switch ..... LINE 3

The adjustments should be performed in the following sequence.

**[Adjustment sequence]**

1. Carrier Frequency 1.5MHz Check
2. Carrier Frequency 1.7MHz Check
3. 1.5MHz Deviation Adjustment
4. 1.7MHz Deviation Adjustment
5. Playback Separation 1 Adjustment
6. Playback Separation 2 Adjustment
7. E-E Output Level Check
8. Overall Frequency Characteristic Check
9. Overall Distortion Factor Check
10. Overall Noise Check

**2-7-1. Carrier Frequency 1.5MHz Check  
(AU-176 Board)**

Mode	Record
Signal	No signal
Measurement point	IC901 pin ⑤ (VCO OUT) or JL929
Measuring instrument	Frequency counter
Specified value	1500 ± 3kHz

**Note 1:** A frequency counter should be connected through a buffer amplifier (oscilloscope, etc.) having a high impedance and a low capacitance.

**[Check Method]**

- 1) Check to 1500 ± 3kHz.

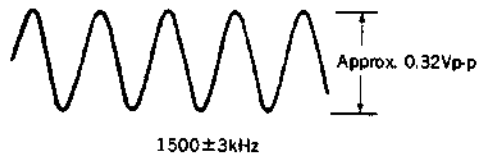

Fig. 7-2-46.

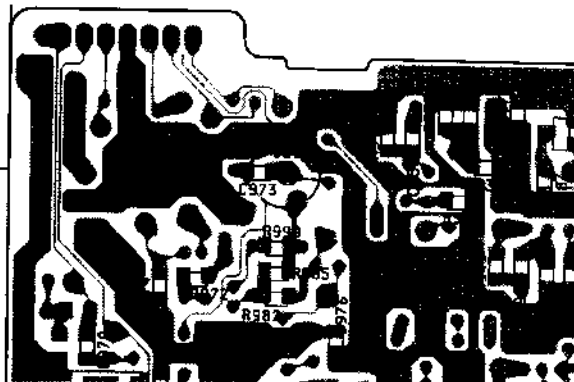
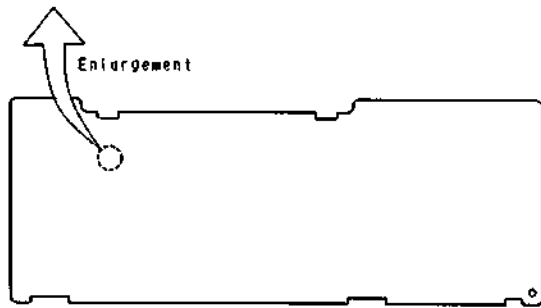

Fig. 7-2-47.



AU-176 BOARD (CONDUCTOR SIDE)

**2-7-2. Carrier Frequency 1.7MHz Check  
(AU-176 Board)**

Mode	Record
Signal	No signal
Measurement point	IC901 pin ⑤ (VCO OUT) or JL930
Measuring instrument	Frequency counter
Specified value	1700 ± 3kHz

**Note 1:** A frequency counter should be connected through a buffer amplifier (oscilloscope, etc.) having a high impedance and a low capacitance.

**[Check Method]**

- 1) Check to 1700 ± 3kHz.

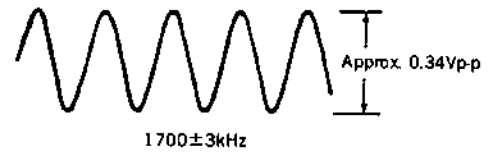

Fig. 7-2-48.

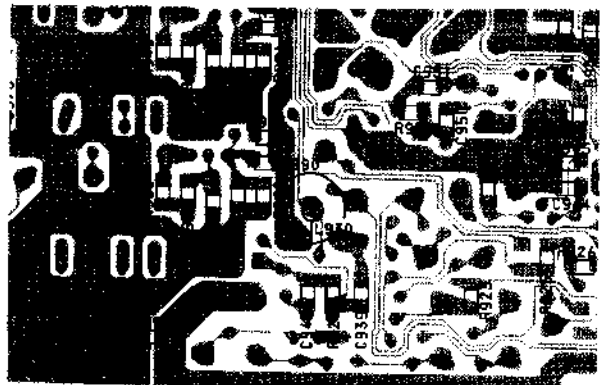
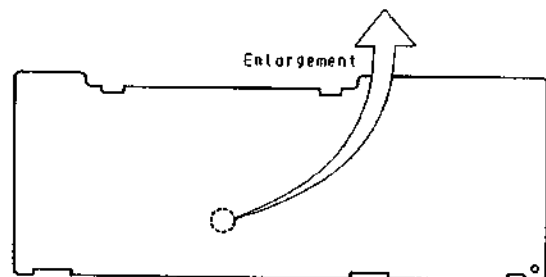

Fig. 7-2-49.



AU-176 BOARD (CONDUCTOR SIDE)

**2-7-3. 1.5MHz Deviation Adjustment  
(AU-176 Board)**

**[Adjustment Object]**

To set the spectrum at modulated L-channel (L+R/2 signal) level. If improper, crosstalk of audio signal is worse or audio level is reduced for both record and playback modes.

Mode	Playback
Signal	Alignment tape: For operation check (WR5-9CS)
Measurement point	Audio Line Output terminal, left
Measuring instrument	Audio level meter
Adjustment element	RV901
Specified value	$-7.5 \pm 0.5\text{dB}$ s

**[Adjustment Method]**

- 1) Use RV901 to adjust to  $-7.5 \pm 0.5\text{dB}$ s.

**2-7-4. 1.7MHz Deviation Adjustment  
(AU-176 Board)**

**[Adjustment Object]**

To set the spectrum at modulated R-channel (L-R/2 signal) level. If improper, crosstalk of audio signal is worse or audio level is reduced for both record and playback modes.

Mode	Playback
Signal	Alignment tape: For operation check (WR5-9CS)
Measurement point	Audio Line Output terminal, right
Measuring instrument	Audio level meter
Adjustment element	RV902
Specified value	$-7.5 \pm 0.5\text{dB}$ s

**[Adjustment Method]**

- 1) Use RV902 to adjust to  $-7.5 \pm 0.5\text{dB}$ s.

**2-7-5. Playback Separation 1 Check  
(AU-176 Board)**

Mode	Playback
Signal	Alignment tape: For operation check, stereo portion (WR5-9CS)
Measurement point	Audio Line Output terminal, right
Measuring instrument	Oscilloscope
Specified value	400Hz component minimum (no distortion should be present on 1kHz waveform.)

**[Check Method]**

- 1) Check that 400Hz component on the right level is at minimum.

**2-7-6. Playback Separation 2 Check  
(AU-176 Board)**

Mode	Playback
Signal	Alignment tape: For operation check, stereo portion (WR5-9CS)
Measurement point	Audio Line Output terminal, left
Measuring instrument	Oscilloscope
Specified value	1kHz component minimum (no distortion should be present on 400Hz waveform.)

**[Check Method]**

- 1) Check that 1kHz component on the left level is at minimum.

**2-7-7. E-E Output Level Check**

Mode	E-E
Signal	400Hz, $-7.5\text{dB}$ s: Audio Line Input terminals, left and right
Measurement point	Audio Line Output terminals, left and right
Measuring instrument	Audio level meter
Specified value	$-7.5 \pm 3\text{dB}$ s

**[Check Method]**

- 1) Check that the respective levels of Audio Line Output terminals, left and right are  $-7.5 \pm 3\text{dB}$ s.

**2-7-8. Overall Frequency Characteristic Check**

Mode	Self-record playback
Signal	Ⓐ 400Hz, $-17.5\text{dB}$ s Ⓑ 20Hz, $-17.5\text{dB}$ s Ⓒ 14kHz, $-17.5\text{dB}$ s : Audio Line Input terminals, left and right
Measurement point	Audio Line Output terminals, left and right
Measuring instrument	Audio level meter
Specified value	The playback output levels of 20Hz and 14kHz should be $0 \pm 3\text{dB}$ s with 400Hz playback output level at 0dBs.

**[Check Method]**

- 1) Record signals Ⓐ to Ⓒ in turn.
- 2) Play back the recorded portion.
- 3) Check that the respective playback output levels of 20Hz and 14kHz are  $0 \pm 3\text{dB}$ s with 400Hz playback output level at 0dBs.

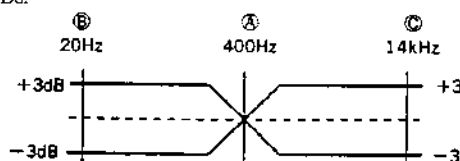

Fig. 7-2-50.

### 2-7-9. Overall Distortion Factor Check

Mode	Self-record playback
Signal	400Hz, -7.5dBs : Audio Line Input terminals, left and right
Measurement point	Audio Line Output terminals, left and right
Measuring instrument	Distortion meter
Specified value	Left side: 1.0% or less <i>Note)</i> Right side: 1.5% or less <i>Note)</i>

#### [Check Method]

- 1) Record signal.
- 2) Play back the recorded portion.
- 3) Check that the distortion factor is 1.0% or less on the left side and 1.5% or less on the right side *Note)*.

**Note :** These are values when a 200Hz - 6kHz BPF is used.

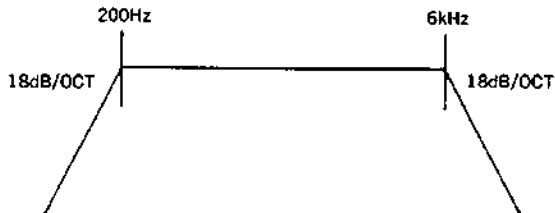

Fig. 7-2-51.

### 2-7-10. Overall Noise Level Check

Mode	Self-record playback
Signal	No signal (Insert a shorting plug into the Audio Line Input jacks, left and right.)
Measurement point	Audio Line Output terminals, left and right
Measuring instrument	Audio level meter
Specified value	Left side: -68dBs or less <i>Note)</i> Right side: -63dBs or less <i>Note)</i>

#### [Check Method]

- 1) Record.
- 2) Play back recorded portion.
- 3) Check that the noise level is -68dBs or less on the left side and -63dBs on the right side.

**Note :** These are values when an IHF-A weighing filter is used.

2-8. ADJUSTMENT PARTS LOCATION DIAGRAM

MA-205 BOARD (COMPONENT SIDE)

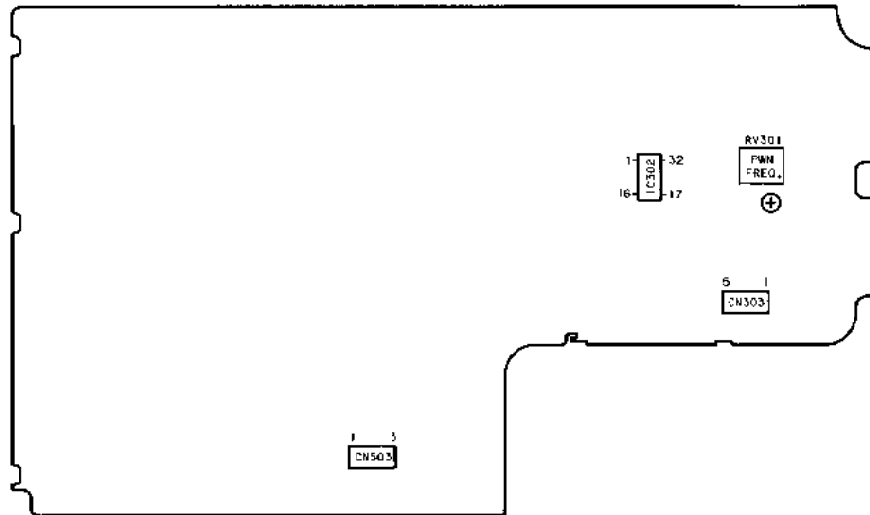

VI-131 BOARD (COMPONENT SIDE)

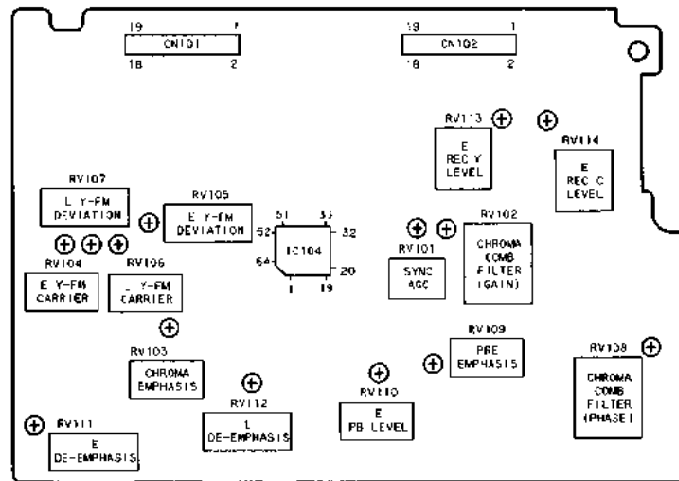

7-30

RP-165 BOARD (COMPONENT SIDE)

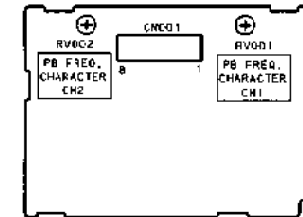

DI-55 BOARD (COMPONENT SIDE)

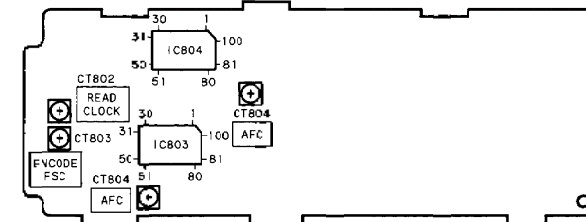

AU-176 BOARD (COMPONENT SIDE)

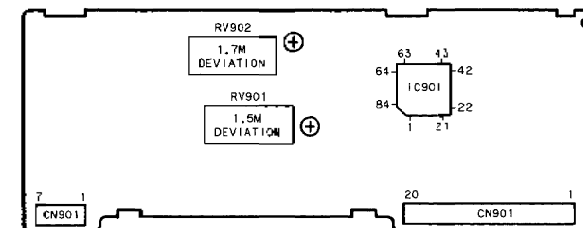

7-31E

# 8 mm Video MECHANICAL ADJUSTMENT MANUAL V

---

## F MECHANISM

Video 8

File with the SERVICE MANUAL

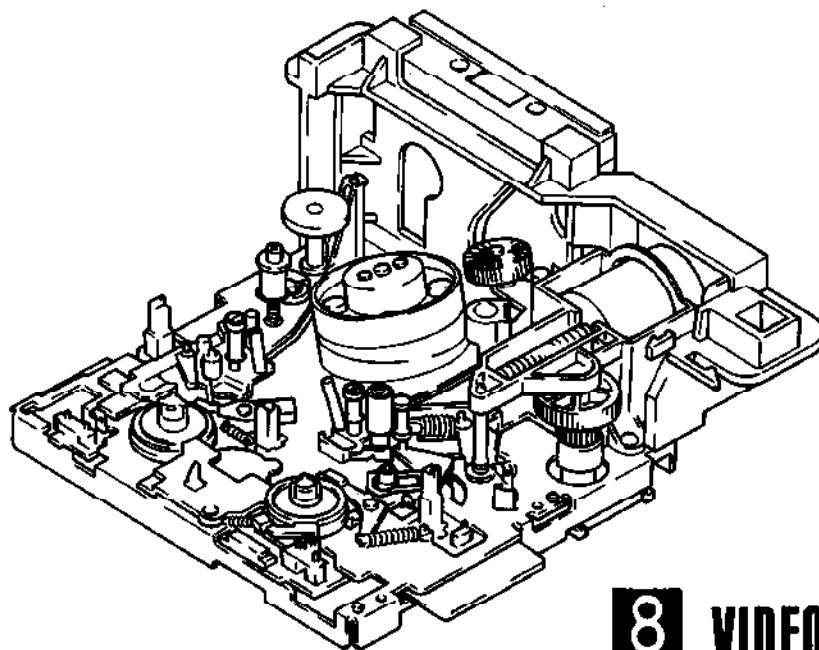
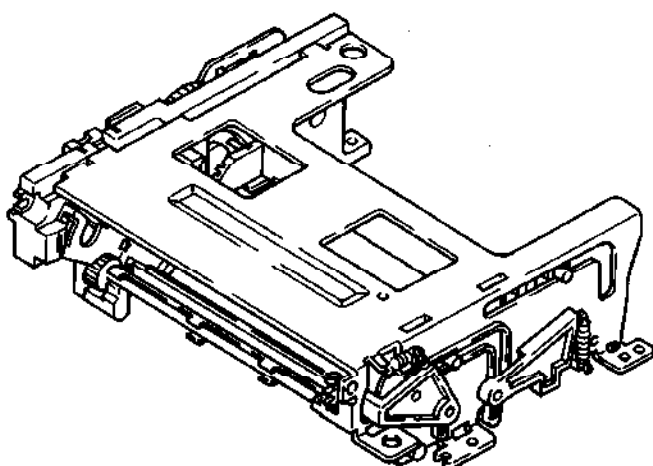

**8** VIDEO RECORDER  
**SONY**®

## TABLE OF CONTENTS

<u>Section</u>	<u>Title</u>	<u>Page</u>	<u>Section</u>	<u>Title</u>	<u>Page</u>
<b>1. MAIN FEATURES</b>		3	4-15.	Loading Drive Lever	25
<b>2. PREPARATION FOR MECHANICAL CHECK, ADJUSTMENT AND REPLACEMENT</b>		4	4-16.	Rotary Switch and Main Cam	26
2-1.	FL Cassette Compartment Assembly	4	4-17.	Slide Plate	27
2-2.	Operation with FL Cassette Compartment Assembly Removed	5	4-18.	Loading Gear (S) Assembly	28
2-2-1.	Activating Loading	5	4-19.	Loading Gear (T) Assembly	29
2-2-2.	Activating Play Status	5	4-20.	Coaster (S)	30
2-2-3.	Activating Ejection	5	4-21.	Coaster (T) Assembly	30
2-3.	Handling of Mode Selector II	6	4-22.	Rotary Upper Drum Replacement	31
2-3-1.	General	6	4-23.	Adjustment of Tension Regulator Position	32
2-3-2.	Operation	7	4-24.	FWD Back Tension Adjustment	32
<b>3. PERIODIC CHECK AND MAINTENANCE</b>		9	4-25.	Reel Torque Check	32
3-1.	Cleaning of Rotary Drum Assembly	9	4-26.	FL Worm Wheel	33
3-2.	Cleanign of Tape Path	9	<b>5. TAPE PATH ADJUSTMENT</b>		34
3-3.	Periodic Check Items	10	5-1.	Preparation for Adjustment	35
3-4.	Service Jigs List	11	5-2.	Tracking Adjustment	36
<b>4. MECHANICAL CHECK, ADJUSTMENT AND REPLACEMENT</b>		12	5-3.	No.2 Guide (TG2) Adjustment	36
4-1.	RP Block	12	5-3-1.	No.2 Guide (TG2) Height Presetting	36
4-2.	Impedance Roller	13	5-3-2.	No.2 Guide (TG2) Adjustment	37
4-3.	HC Roller Assembly	13	5-4.	No.7 Guide (TG7) Adjustment	37
4-4.	Pendulum Base Assembly and Soft Brake Assembly (T)	14	5-5.	CUE and REV Waveform Check	37
4-5.	Brake (S) Arm and Brake (T) Arm Assembly	15	5-6.	Check After Adjustment	38
4-6.	Tension Regulator Assembly, Reel Table (S) Assembly and Reel Table (T) Assembly	16	5-6-1.	Tracking Check	38
4-7.	TG2 Assembly	17	5-6-2.	Rising Check	38
4-8.	TG7 Arm Assembly	18	5-6-3.	Tape Path Check	38
4-9.	Cam Motor Assembly	19	<b>6. EXPLODED VIEWS</b>		39
4-10.	Pinch Arm Assembly	20	6-1.	Front Loading Assembly	39
4-11.	Worm Wheel Bracket	21	6-2.	MD Chassis Assembly (1)	40
4-12.	Capstan Motor	22	6-3.	MD Chassis Assembly (2)	41
4-13.	Drum Assembly	23	6-4.	MD Chassis Assembly (3)	42
4-14.	Pulley Base Assembly	24	<b>7. DIAGRAMS</b>		43
			<b>8. ELECTRICAL PARTS LIST</b>		46



## **1. MAIN FEATURES**

The mechanism developed exclusively for the 8mm video provides the following features.

1. Faster rewind time than U mechanism.  
4 times high speed. (about 1 minute in case of P120 cassette.)
2. Jog shuttle supporting by addition of forced swing mechanism.
3. High speed start on Picture mechanism.  
Stop → playback about 0.8 sec.
4. Head clogging prevention by adoption of new cleaning roller.
5. Reduction of the number of parts. (about 40 parts less than U mechanism.)
6. FL capstan motor drive.

## 2. PREPARATION FOR MECHANICAL CHECK, ADJUSTMENT AND REPLACEMENT

For removal of the cabinet and boards, refer to "Disassembly" in each Service Manual.

Mechanical adjustment is done in the **EJECT** mode. (To select the **EJECT** mode, refer to "2-3, Handling of Mode Selector II".)

### 2-1. FL CASSETTE COMPARTMENT ASSEMBLY (Fig. 1)

#### 1. Removal

- 1) Select the **EJECT** mode.
- 2) Remove three screws ① and remove the FL cassette compartment ② toward the arrow.

#### 2. Mounting

- 1) Select the **EJECT** mode.
- 2) Mount the FL cassette compartment ② with its tab ③ engaged with the hole ④ in mechanical chassis.
- 3) Tighten three screws ①.

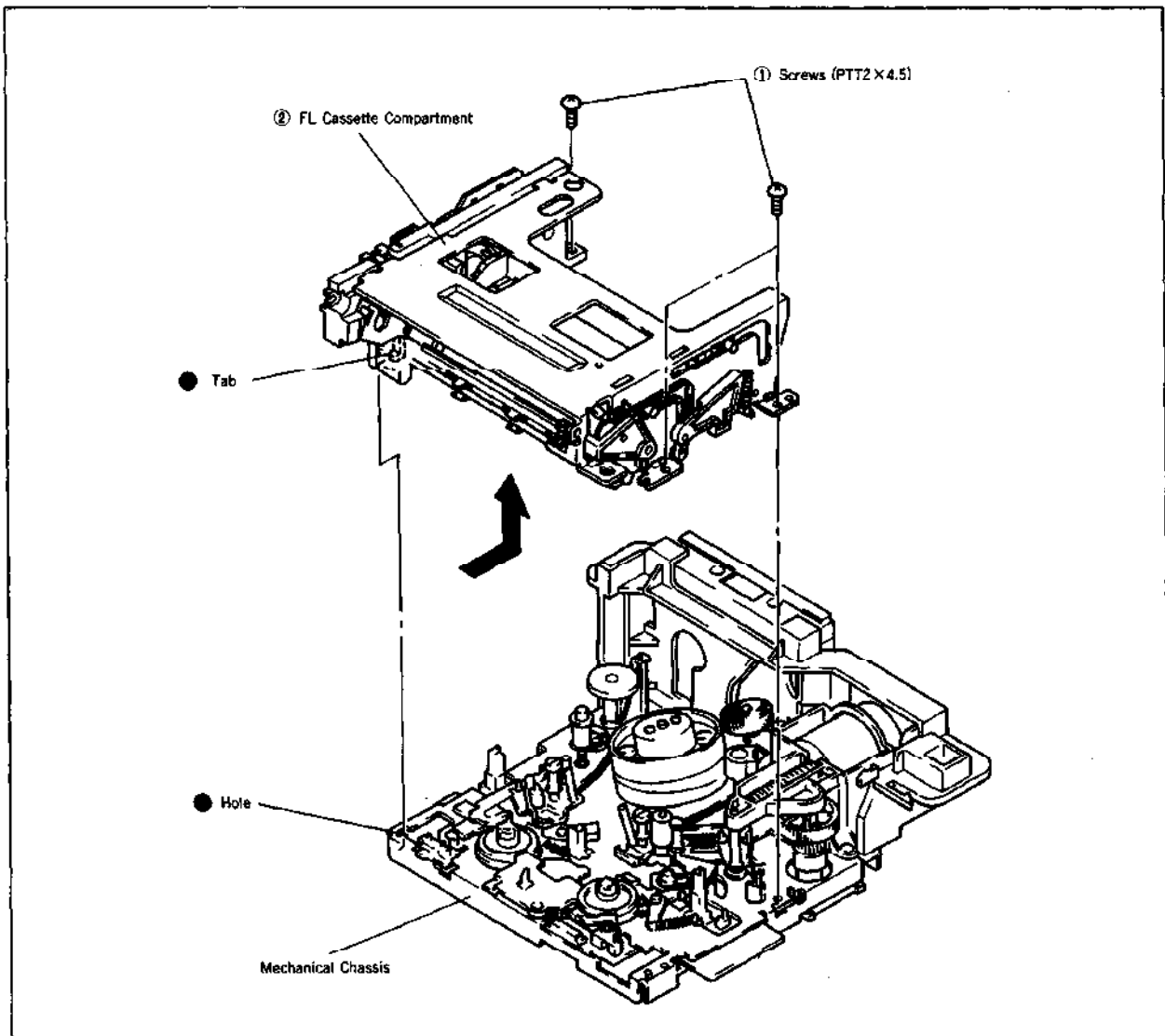

Fig. 1

**2-2. OPERATION WITH FL CASSETTE  
COMPARTMENT ASSEMBLY REMOVED (Fig. 2)**

**2-2-1. Activating Loading**

- 1) Referring to the Service Guide, supply the power with the cabinet removed.
- 2) Cover the LED ① with an opaque cap ②.
- 3) Press the cassette down switch ③ three times.

**2-2-2. Activating Play Status**

- 1) Perform each step in 2-2-1. Activating Loading.
- 2) Press the PLAY button while keeping the cassette down switch pressed.

**2-2-3. Activating Ejection**

- 1) Press the EJECT button.

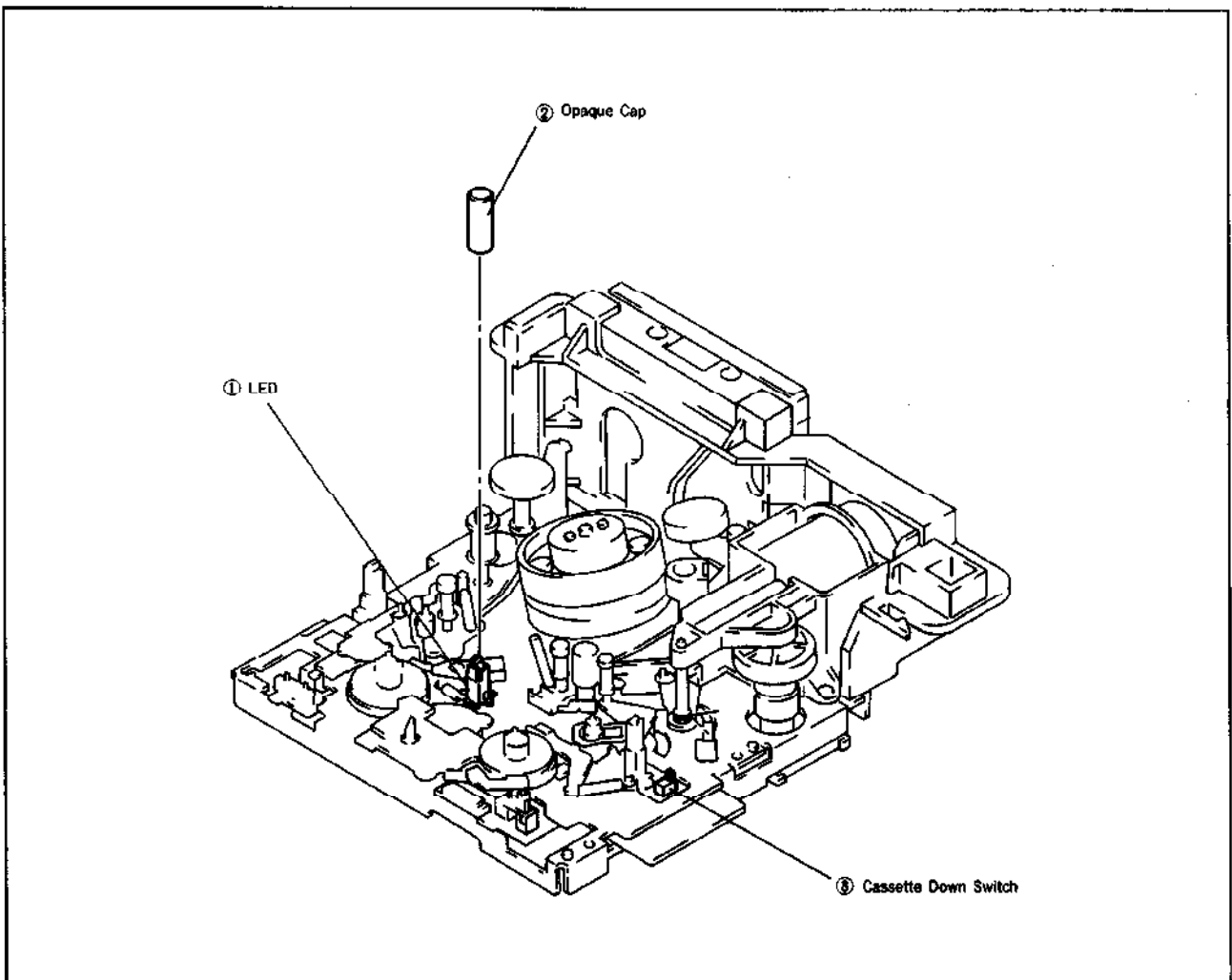

Fig. 2

## 2-3. HANDLING OF MODE SELECTOR I

### 2-3-1. General

The mode selector is used as a mechanism drive tool to help maintenance of various mechanical decks, and it provides the following functions.

#### 1. MANUAL test

In this mode, the motor is driven only during the time that the switch is pressed, so that the operator can control the motor freely.

#### 2. STEP test

In this mode, the motor is driven from the present status attained from sensor until the status changes to another status, so that the operator can confirm every operations.

#### 3. AUTO test

This mode checks if the mechanism operates normally following the status change table registered to each mechanical deck through a sequence of operation in all statuses of the mechanism. If it detects a faulty status change during operation, it displays "NG" and stops operation.

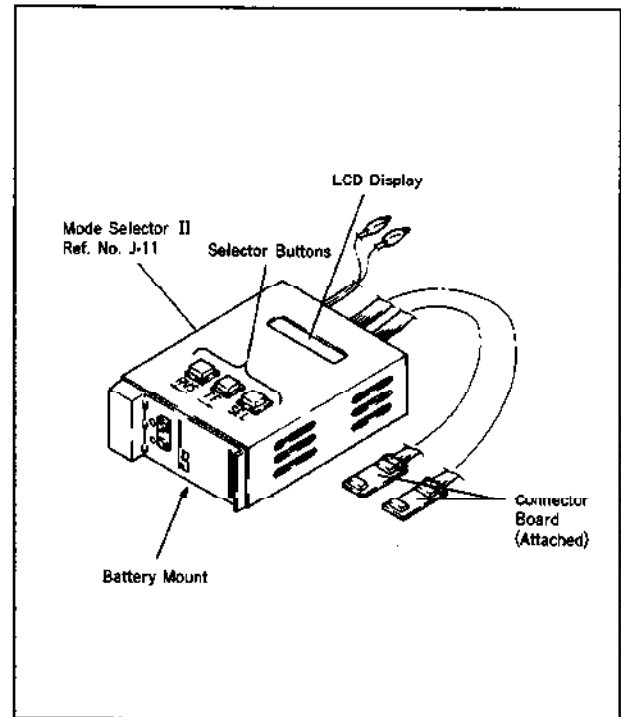

Fig. 3

## MODE SELECTOR II (J-6082-282-A) CONNECTION

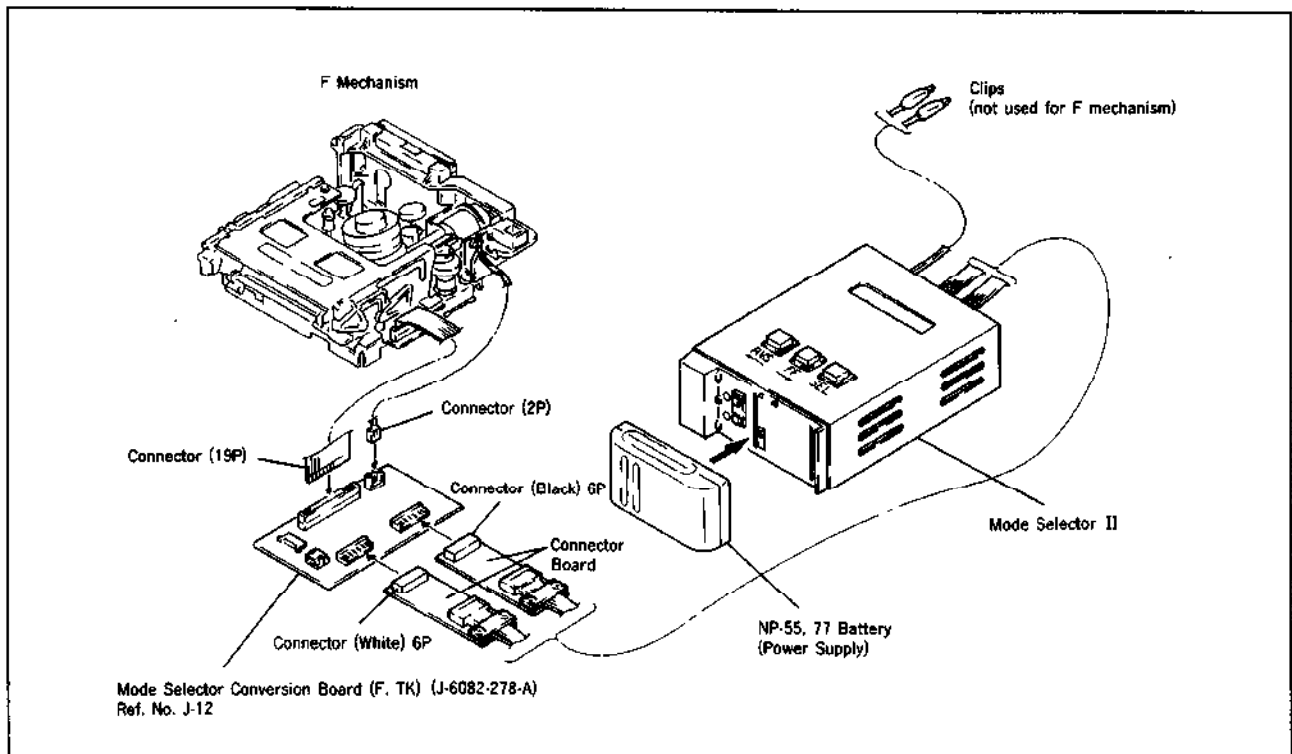
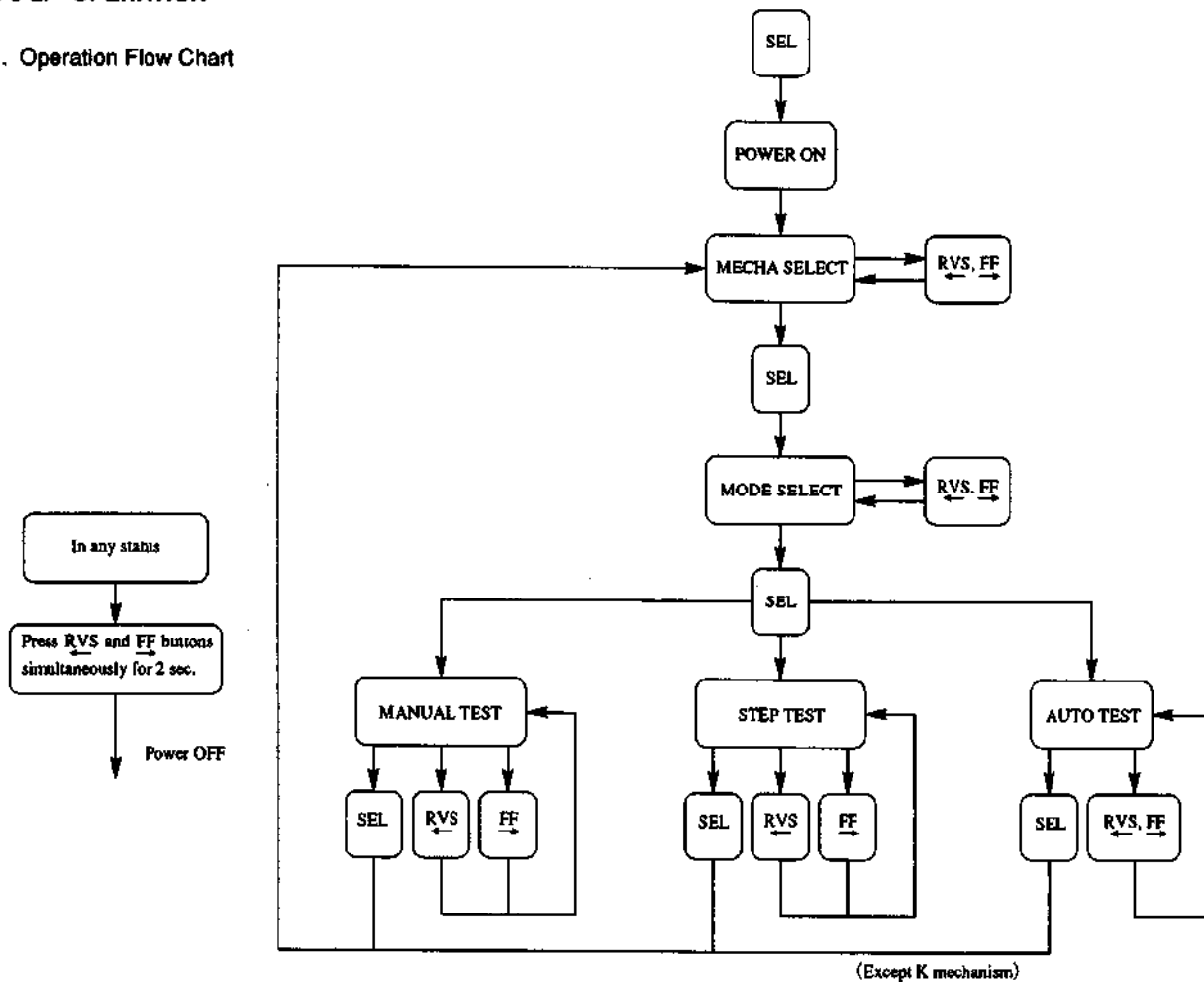

Fig. 4

## 2-3-2. OPERATION

### 1. Operation Flow Chart



### 2. Mode Selector II power ON

Press the SEL button to turn on the power supply.

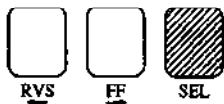

### 3. Mode Selector II power OFF

At the power ON, press RVS and FF buttons simultaneously for more than 2 seconds to turn off the power supply.

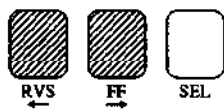

### 4. Mechanism selection

The "MECHA SELECT" is displayed on LCD immediately after the power supply is turned on. Call the desired mechanism by pressing the RVS or FF button, and press the SEL button. Thus, the mechanism has been selected. (Fig. 5-1 indicates F mechanism.)

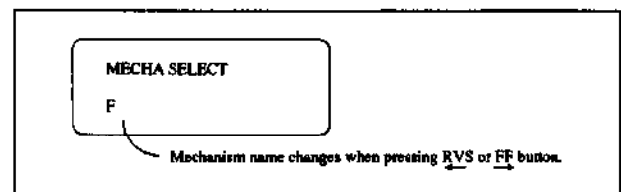

Fig. 5-1

### 5. Mode selection

Select the test mode "MANUAL", "STEP" or "AUTO" to be executed.

Call the desired mode by pressing the RVS or FF button, and press the SEL button. Thus, the mode has been selected.

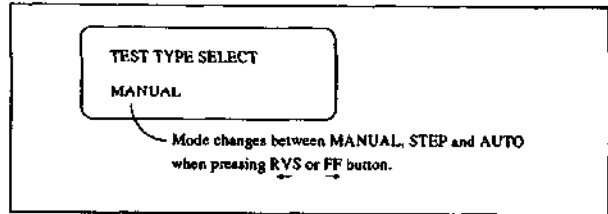

Fig. 5-2

### 6. MANUAL test

This mode drives the motor only during the time that the RVS or FF button is pressed.

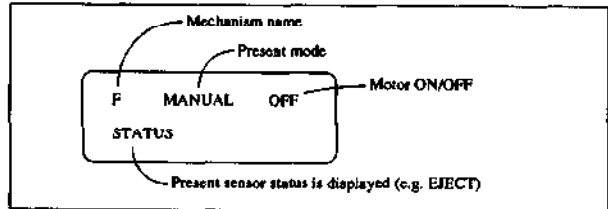

Fig. 5-3

### 7. STEP test

This mode drives the motor from the present status until the status changes in the direction selected with RVS or FF button.

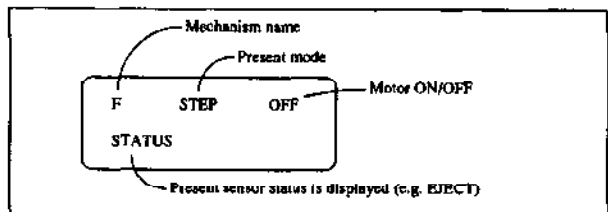

Fig. 5-4

### 8. AUTO test

This mode checks if the operation sequence stored for each mechanical deck is normal, and if the signals from sensors that execute a sequence of operation meet the stored sequence. The same operation is executed if either RVS or FF is pressed.

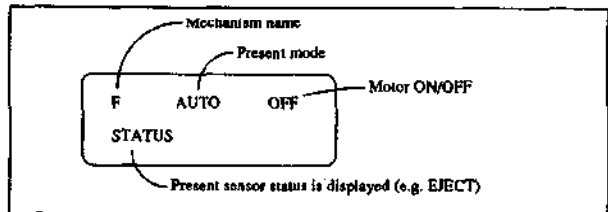

Fig. 5-5

### Mechanism status (position) change sequence

After selection of mechanism, if either MANUAL or STEP mode is selected and the RVS or FF button is pressed, the mechanism status (position) can be designated. (Designated status is displayed at STATUS position.)

EJECT ↔ UNLOAD END ↔ STOP 1 ↔ HIGH SPEED REW ↔ DEW ↔ LOAD END ↔ STOP 2 ↔ FWD. P ↔ RVS. P

MD name				F mechanism	
Code	A	B	C	D	
0	1	1	1	1	EJECT
0	0	1	1	1	UNLOAD END
1	0	1	0	1	STOP 1
1	0	1	1	1	HIGH SPEED REW
1	0	0	0	1	DEW
1	1	0	0	1	LOAD END
1	1	1	0	1	STOP 2
0	1	1	0	0	FWD. P
0	1	0	0	0	RVS. P
1	1	0	1	1	FWD. P/FWD
0	0	0	1	1	RVS. P/RVS
1	0	0	1	1	

### 9. Battery alarm display

In case of low voltage of battery, which is a power supply of Mode Selector, the alarm message is displayed (not synchronous display).

In such a case, no operation is available, requiring battery replacement.

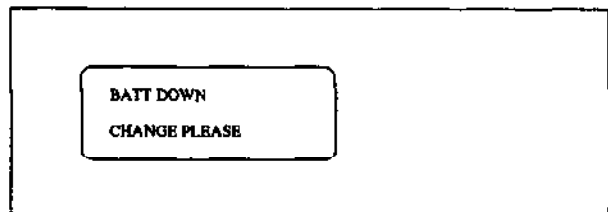

Fig. 5-6

### 3. PERIODIC CHECK AND MAINTENANCE

- Carry out the following maintenance and periodic checks in order not only to fully exhibit the functions and performance of the set, but also for the equipment and tape. After repairing, service the set as follows, regardless of the length of use.

#### 3-1. CLEANING OF ROTARY DRUM ASSEMBLY

- 1) Gently apply chamois cloth (Ref. No. J-2) soaked in cleaning liquif (Ref. No. J-1) to the rotary drum assembly.  
Clean it by rotating the upper rotary drum assembly slowly counterclockwise by hand.

**Note :** Do not rotate the motor by power or rotate the upper rotary drum assembly clockwise by hand. Also, the head tip is highly likely to be damaged if the chamois cloth is moved in a pependicular direction to the it. make sure to follow the instructions above for cleaning the rotarydrum assembly.

#### 3-2. CLEANING OF TAPE PATH (Fig.6)

- 1) In the **EJECT** mode, clean the tape running system (TG1, 2, 3, 4, 5, 6, 7, pinch roller, and capstan shaft) and the lower drum, using a super fine applicator (Ref. No. J - 3) soaked in the cleaning liquid.

**Note :** Note that no oil or grease of each link mechanism adheres to the super fine applicator (Ref. No. J - 3).

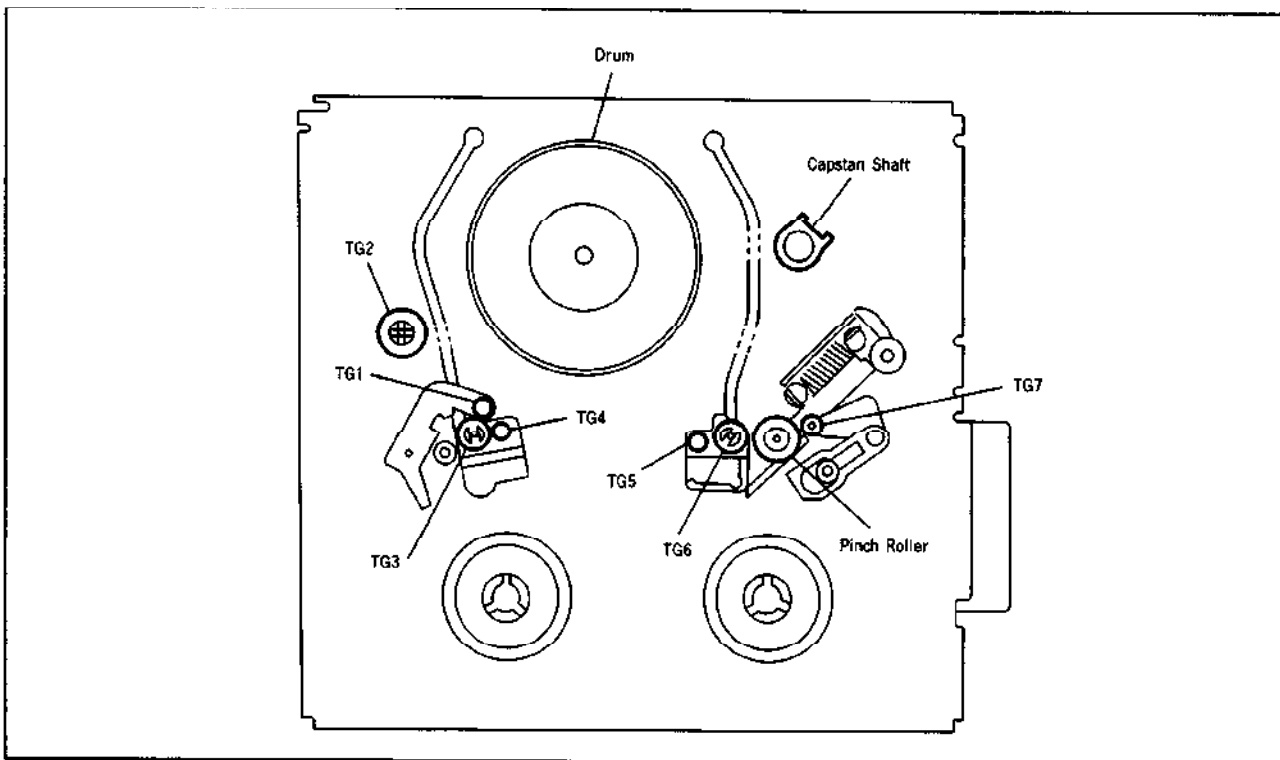

Fig. 6

### 3.3. PERIODIC CHECK ITEMS

Location of Maintenance and check		Hours of Use (H)										Remarks
		500	1000	1500	2000	2500	3000	3500	4000	4500	5000	
Tape trans- portion System	Cleaning of tape path surface	○	○	○	○	○	○	○	○	○	○	Be careful of oil
	Cleaning and degaussing of rotary assembly	○	○	○	○	○	○	○	○	○	○	Be careful of oil
Driving System	Timing belt	-	☆	-	☆	-	☆	-	☆	-	☆	3-953-986-01 3-954-079-01
	Timing belt (FL)	-	☆	-	☆	-	☆	-	☆	-	☆	
	Capstan shaft	-	⊙	-	⊙	-	⊙	-	⊙	-	⊙	Be absolutely careful not to get oil on the tape path surface.
	Relay pulley shaft	-	⊙	-	⊙	-	⊙	-	⊙	-	⊙	
	Loading motor	-	☆	-	☆	-	☆	-	☆	-	☆	X-3942-946-1
Performance Confirmation	Abnormal noise	☆	☆	☆	☆	☆	☆	☆	☆	☆	☆	
	Back tension measurement	-	☆	-	☆	-	☆	-	☆	-	☆	
	Brake system	-	☆	-	☆	-	☆	-	☆	-	☆	
	FWD, RVS torque measurement	-	☆	-	☆	-	☆	-	☆	-	☆	

○ : Cleaning    ⊙ : Oil    ☆ : Confirmation

**Note :** When overhauling, refer to the items above to replace parts.

**Note :** Concerning oil

- Be sure to use specified oil. (If you use oil with different viscosity, etc., it may cause troubles.)  
Oil : Part No. 7-661-018-18 (Mitsubishi Diamond Oil Hydrofluid NT-68)
- When lubricating bearings, be sure use oil free from dust, etc. (If you use oil with dust, etc. contained, it may cause bearings to be worn out or seized.)
- A drip of oil refers to an amount attached to the tip of a  $\phi$  2mm stick shown in the right figure.

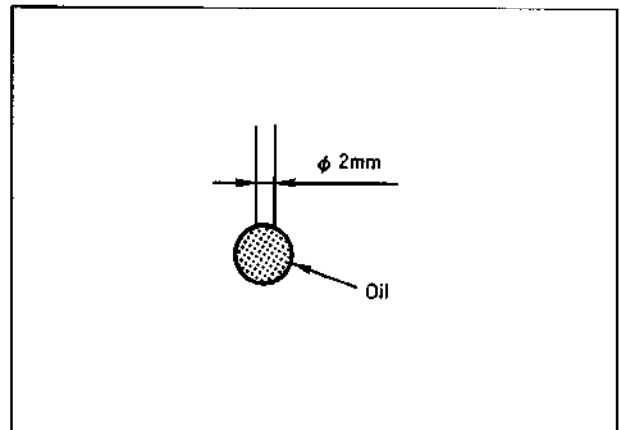



### 3-4. SERVICE JIGS LIST

Ref. No.	Name	Part No.	Fixture No.	Usage and Others
J-1	Cleaning fluid	Y-2031-001-0		
J-2	Chamois cloth	2-034-697-00		
J-3	Super fine applicator (Made by NIPPON APPLICATOR, P752D)			
J-4	Head degausser	Widely available		
J-5	Small mirror for adjustment Spare mirror	J-6080-029-A J-6080-030-1	SL-5052	Tape path
J-6	Alignment tape NTSC (WRS-1NP) PAL (WRS-1CP)	8-967-995-02 8-967-995-07		Tape path
J-7	FWD and RVS winding torque cassette	J-6080-824-A	GD-2086	
J-8	Rotary drum jig	(Attached to the maintenance rotary upper drum)		
J-9	Screwdriver for tape path	J-6082-026-A		For tape guide adjustment
J-10	Adjusting remote controller (Modified RM-95)	J-6082-053-B		Tape path (Setting of PATH mode)
J-11	Mode selector II	J-6082-282-A		For all models
J-12	Mode selector conversion board (F, TK)	J-6082-278-A		
J-13	FWD B.T. adjusting driver chip	J-6082-187-A		

Other equipment ♦ Oscilloscope

♦ Analog tester (20 k $\Omega$ )

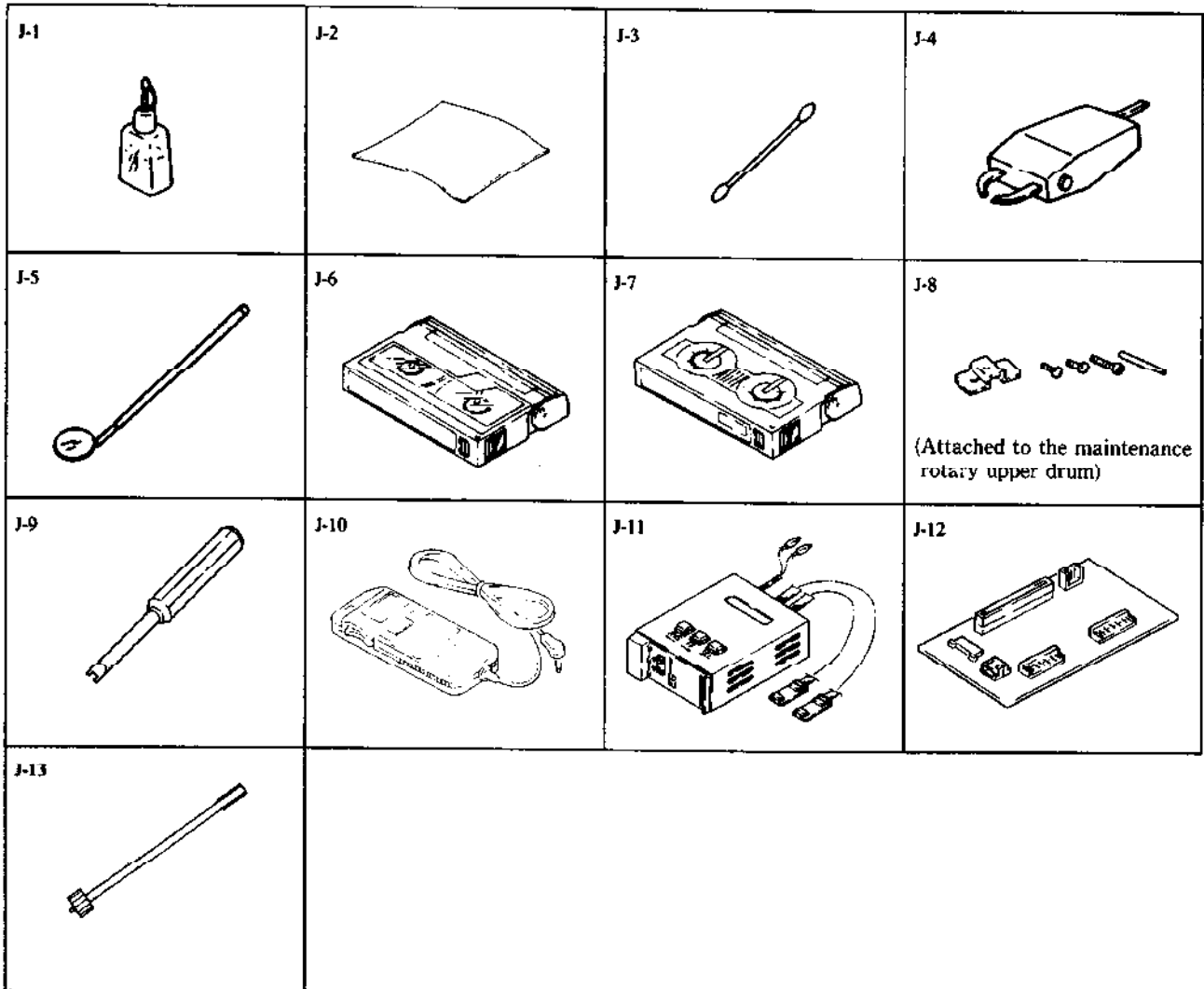

#### 4. MECHANICAL CHECK, ADJUSTMENT AND REPLACEMENT

**Note :** Use the Mode selector (Ref. No. J-11) for the following mechanical checks, adjustments and replacements.

**Note :** The modes in  are those set by pressing the Mode selector buttons.

##### 4-1. RP BLOCK (Fig.7)

###### 1. Removal

- 1) Remove a screw ①.
- 2) Disconnect the connector ②.
- 3) Disengage claws ④ at two places and remove the RP block ③.
- 4) Remove a screw ④, then the RP frame ⑤ in arrow direction.

###### 2. Mounting

- 1) Mount the RP frame with its slot ⑥ engaged with the chassis ⑦.
- 2) Tighten a screw ④.
- 3) Mount the RP block ③ and tighten a screw ①.
- 4) Connect the connector ②.

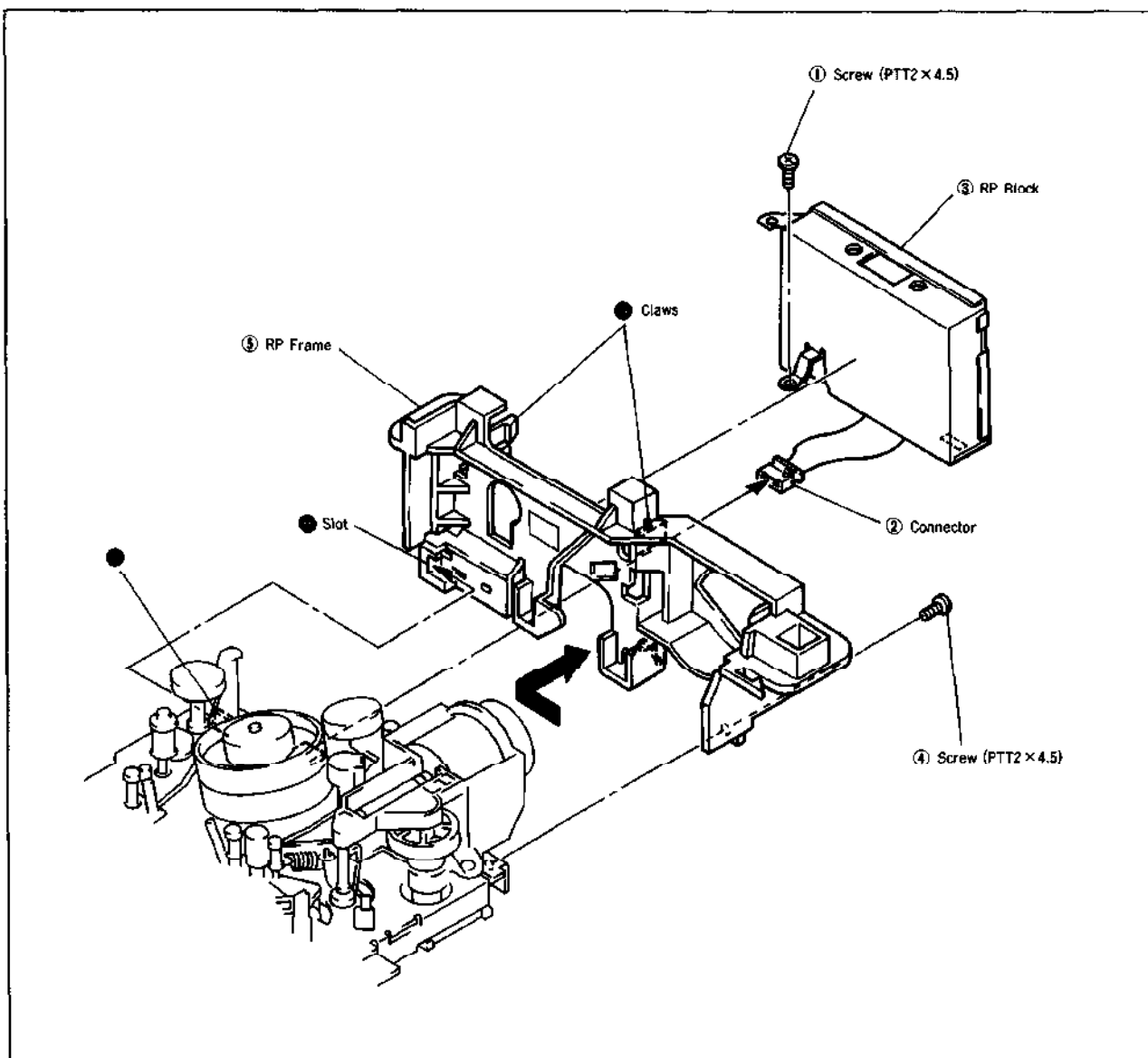

Fig. 7

#### 4-2. IMPEDANCE ROLLER (Fig. 8)

##### 1. Removal

- 1) Referring to 2-1, remove the FL cassette compartment assembly.
- 2) Referring to 4-1, remove the RP block.
- 3) Remove a tension coil spring ①.
- 4) Disengage a claw ④ and remove the impedance roller base assembly ②.
- 5) Disengage a claw ⑤ and remove the impedance roller ③.

##### 2. Mounting

- 1) Mount the impedance roller ③, then the impedance roller base assembly ②.
- 2) Attach a tension coil spring ①.
- 3) Referring to 4-1, mount the RP block.
- 4) Referring to 2-1, mount the FL cassette compartment assembly.

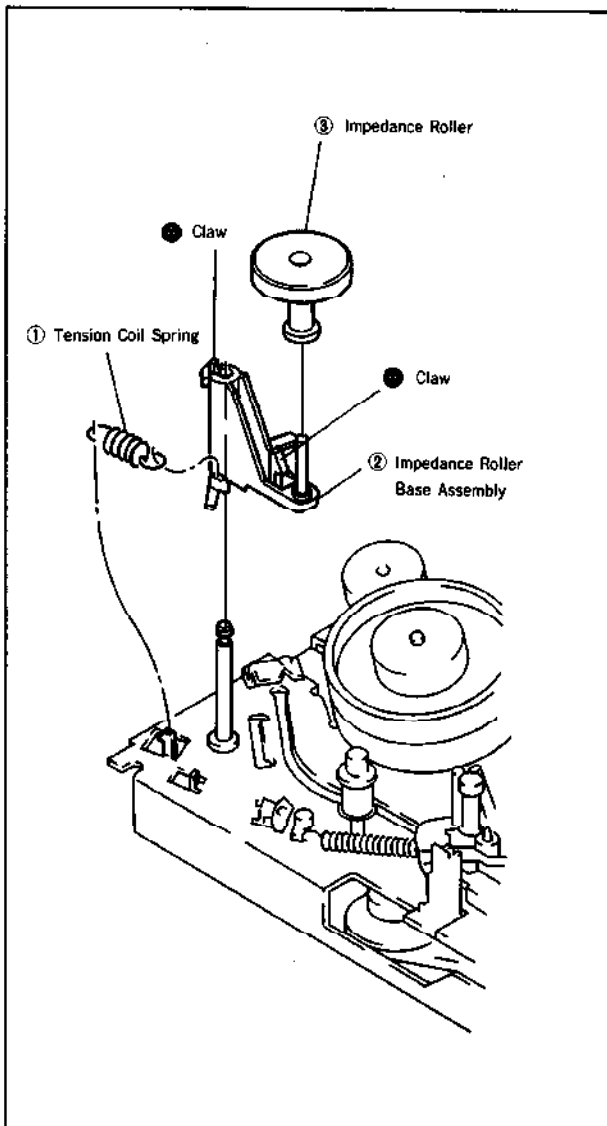

Fig. 8

#### 4-3. HC ROLLER ASSEMBLY (Fig. 9)

##### 1. Removal

- 1) Referring to 4-1, remove the RP block.
- 2) Disengage a claw ④ and remove the HC arm assembly ①.
- 3) Remove a lock washer ②, then the HC roller assembly ③.

##### 2. Mounting

- 1) Mount the HC roller assembly ③ and fix with a lock washer ②.
- 2) Mount the HC arm assembly ①.
- 3) Referring to 4-1, mount the RP block.

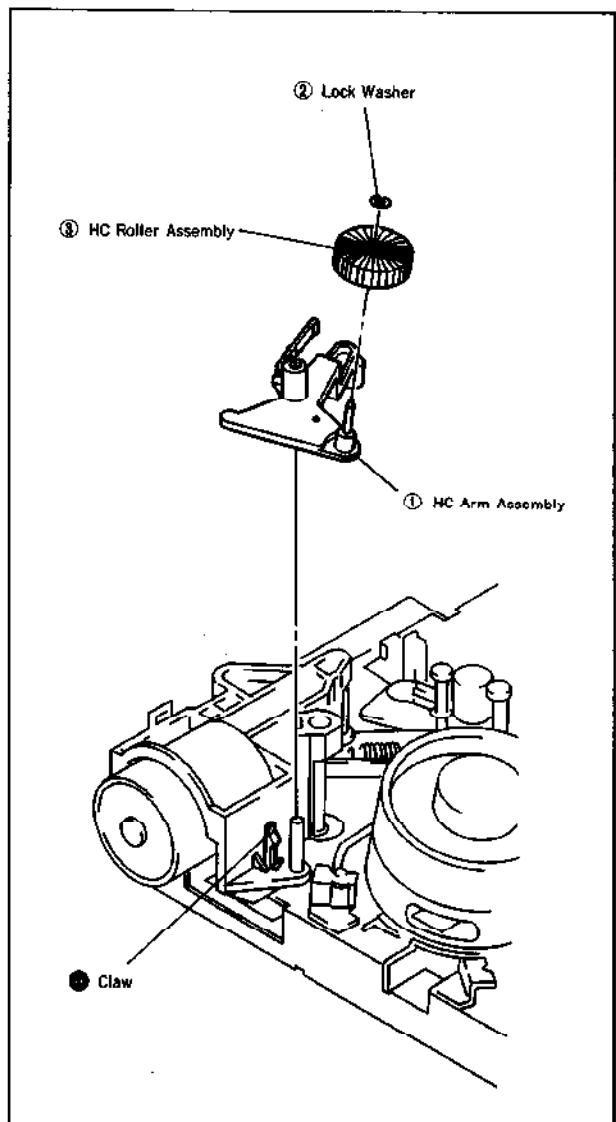

Fig. 9

#### 4-4. PENDULUM BASE ASSEMBLY AND SOFT BRAKE ASSEMBLY (T) (Fig. 10)

##### 1. Removal

- 1) Referring to 2-1, remove the FL cassette compartment assembly.
- 2) Remove a tension coil spring ①.
- 3) Disengage a claw ④ and remove the soft brake (T) assembly ②.
- 4) Remove two screws ③, then the reel unlock plate ④.
- 5) Remove the pendulum base assembly ⑤.

##### 2. Mounting

- 1) Mount the pendulum base assembly ⑤ with its shaft ⑥ inserted in the ⑦ of pendulum forcing arm.
- 2) Mount the reel unlock plate ④ and tighten two screws (3).
- 3) Mount the soft brake (T) assembly ② and attach a tension coil spring ①.
- 4) Referring to 2-1, mount the FL cassette compartment assembly.

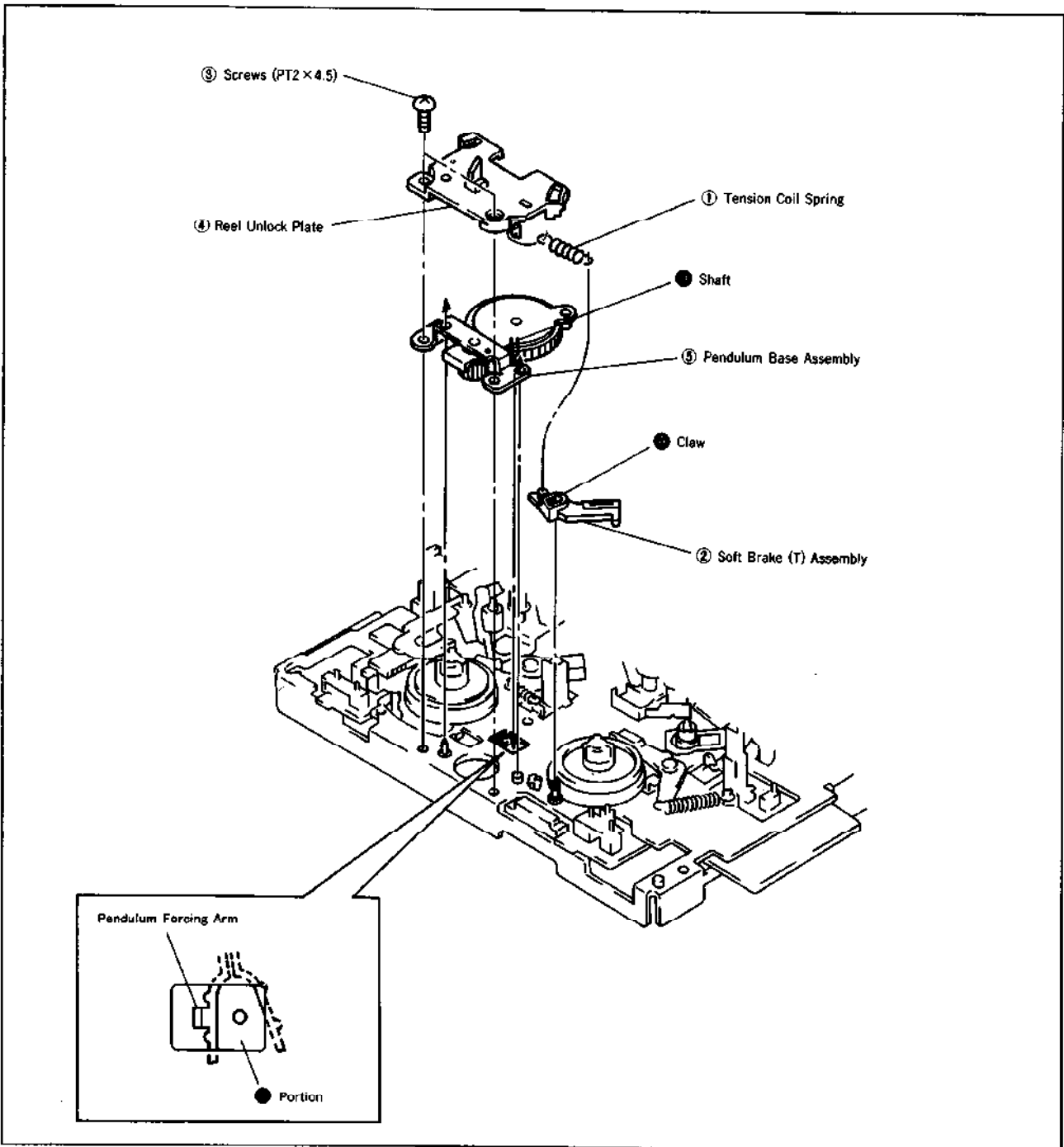

Fig. 10

**4-5. BRAKE (S) ARM AND BRAKE (T) ARM ASSEMBLY  
(Fig. 11)**

**1. Removal**

- 1) Referring to 2-1, remove the FL cassette compartment assembly.
- 2) Remove a tension coil spring ①.
- 3) Disengage a claw ② and remove the brake (S) arm ②.
- 4) Remove a tension coil spring ③.
- 5) Remove a lock washer 1.5 ④, then the brake (T) arm assembly ⑤.

**2. Mounting**

- 1) Mount the brake (T) arm assembly ⑤ with its shaft inserted into a hole ⑥ in mechanical chassis.
- 2) Attach a lock washer ④.
- 3) Attach a tension coil spring ③.
- 4) Insert the shaft ⑦ of brake (S) arm ② into a groove ⑧ of slide plate, and the shaft ⑧ of brake (S) drive lever into a hole ⑨ in brake (S) arm respectively.
- 5) Attach a tension spring ①.
- 6) Referring to 2-1, mount the FL cassette compartment assembly.

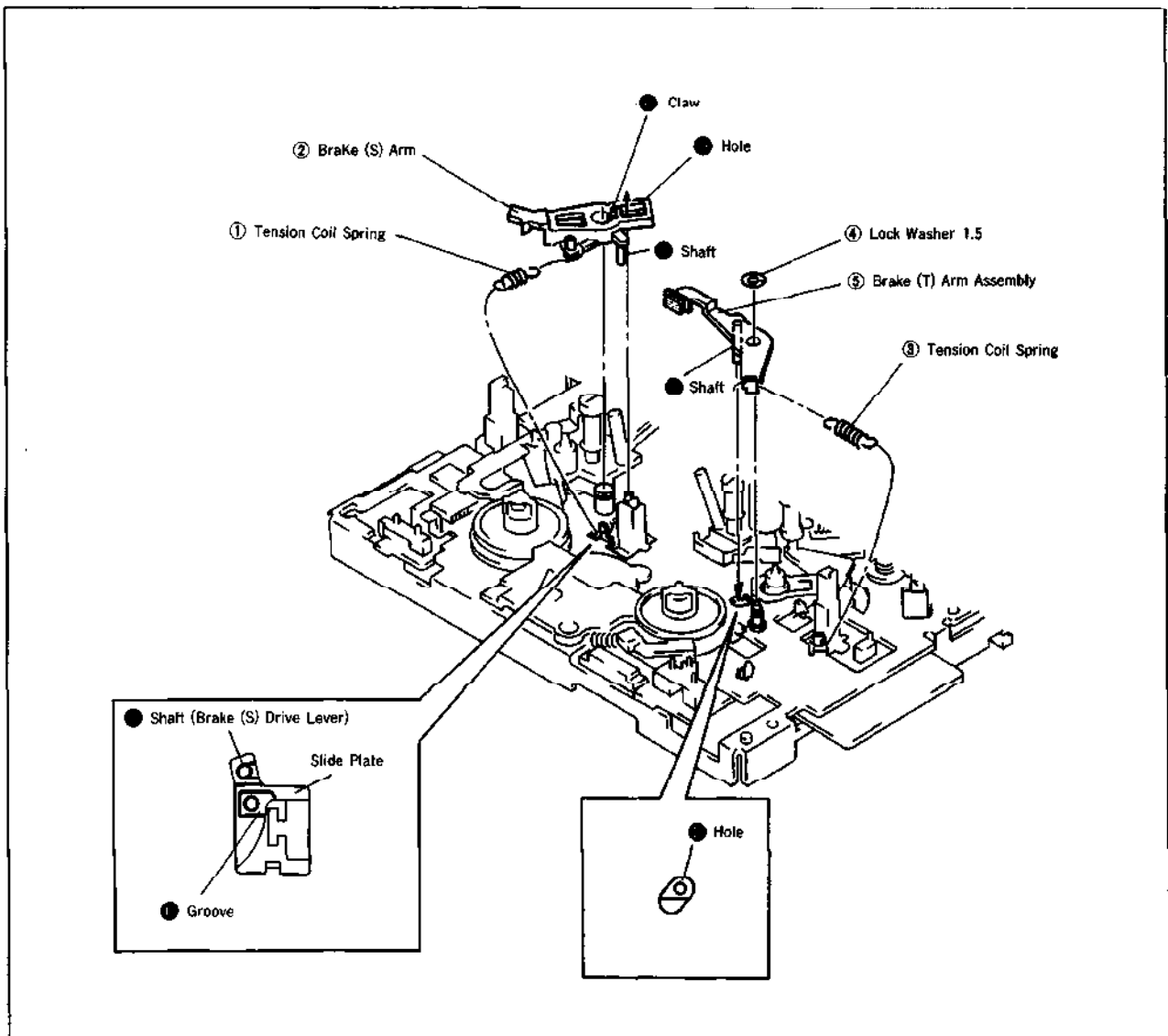

Fig. 11

**4-6. TENSION REGULATOR ASSEMBLY, REEL TABLE (S) ASSEMBLY AND REEL TABLE (T) ASSEMBLY (Fig. 12)**

**1. Removal**

- 1) Referring to 2-1, remove the FL cassette compartment assembly.
- 2) Referring to 4-5, remove the brake (S) arm and brake (T) arm assembly.
- 3) Remove a tension coil spring ①.
- 4) Remove a screw ②, then the tension regulator band assembly ③ and the tension regulator assembly ④.

**Note :** Do not twist or bend, or do not touch the felt surface when removing the tension regulator band assembly.

- 5) Remove the reel table (S) assembly ⑤ and the reel table (T) assembly ⑥.

**2. Mounting**

- 1) Mount the reel table (S) assembly ⑤ and the reel table (T) assembly ⑥.
- 2) Mount the tension regulator assembly ④ with its shafts ④, ⑤ inserted into holes ⑥, ⑦ in chassis respectively.
- 3) Wind the tension regulator band assembly ③ onto the reel table (S) assembly ⑤.

**Note :** Do not twist or bend, or do not touch the felt surface when mounting the tension regulator band assembly.

- 4) Mount the tension regulator band assembly ③, meeting with the dowels ⑧ of the chassis.
- 5) Tighten a screw ②.
- 6) Attach a tension coil spring ①.
- 7) Referring to 4-5, mount the brake (S) arm and the brake (T) arm assembly.
- 8) Referring to 2-1, mount the FL cassette compartment assembly.
- 9) Referring to 4-23, adjust the tension regulator position.
- 10) Referring to 4-24, adjust the FWD back tension.

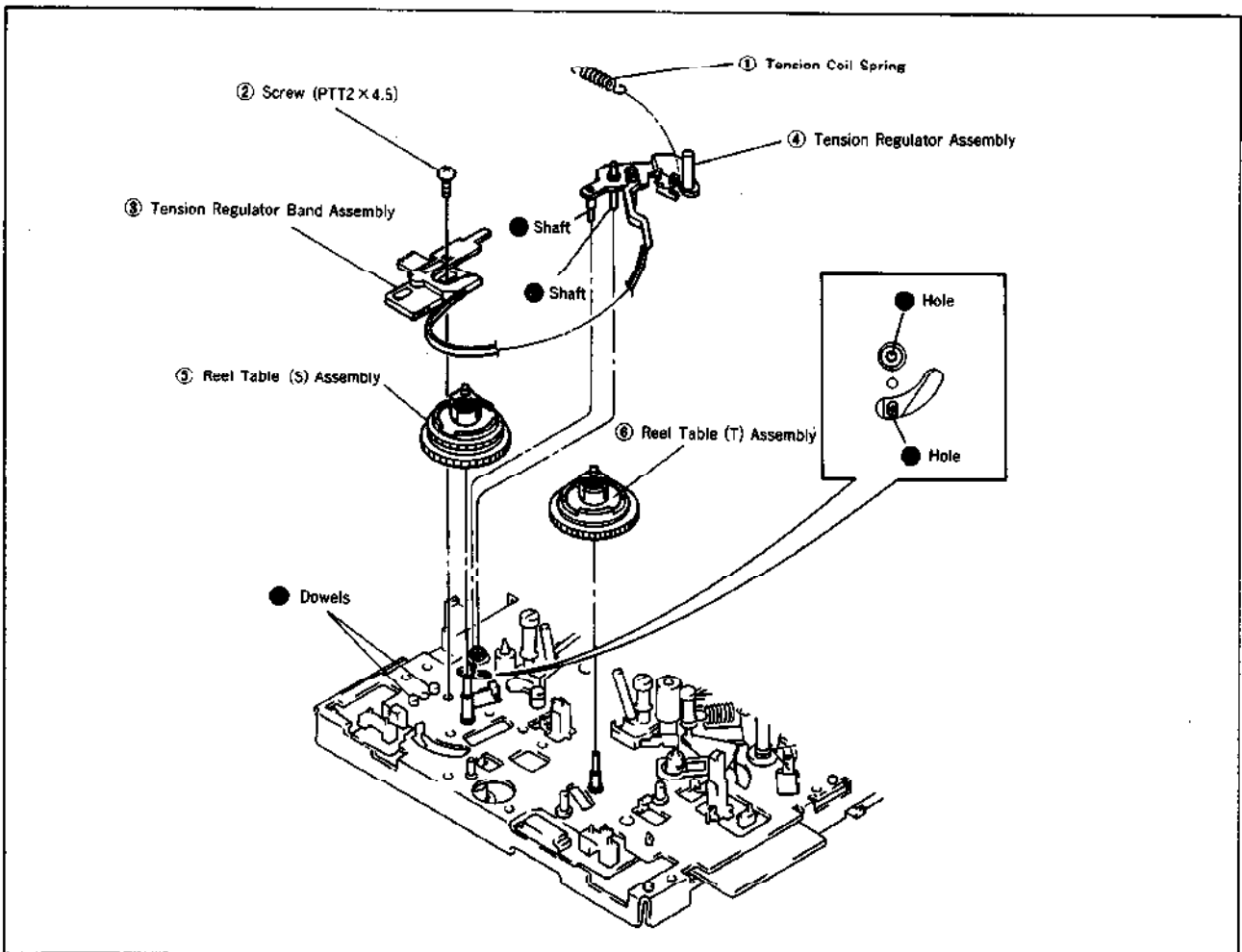

Fig. 12

#### 4-7. TG2 ASSEMBLY (Fig. 13)

##### 1. Removal

- 1) Remove the TG2 upper flange ①.
- 2) Remove the TG2 roller ②, TG2 sleeve ③, TG2 lower flange ④ and compression coil spring ⑤.

##### 2. Mounting

- 1) Mount the compression coil spring ⑤, TG2 lower flange ④, TG2 sleeve ③ and TG2 roller ②.
- 2) Rotate the TG2 upper flange ① by 4 to 6 turns to fix on the shaft.

##### 3. Presetting of TG2 Height

- 1) Rotate to adjust the TG2 upper flange ① so that the height from top surface of mechanical chassis to top surface of TG2 upper flange is 22.12mm.

**Note :** After mounting, perform 5. Tape Path Adjustment.

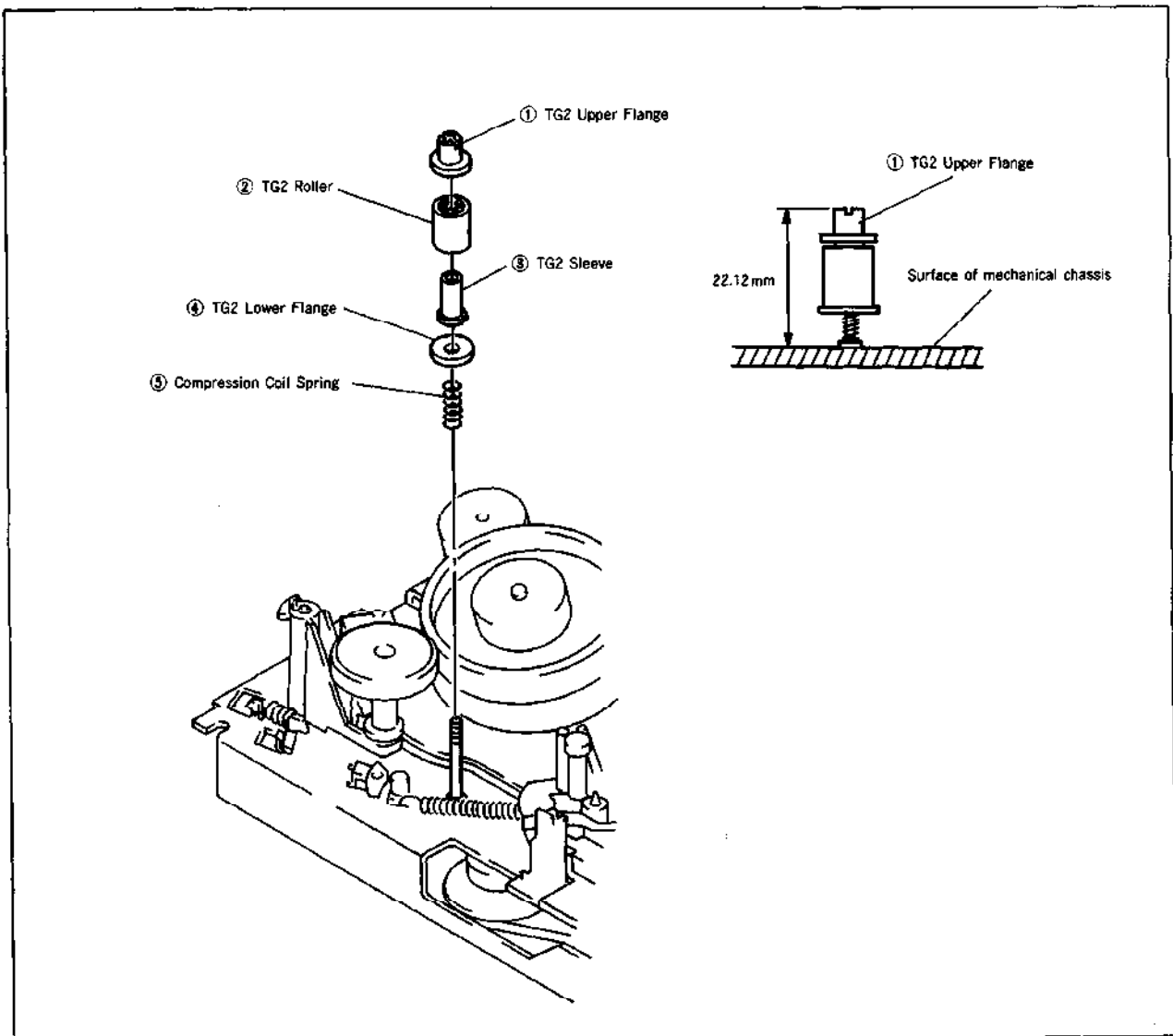

Fig. 13

#### 4-8. TG7 ARM ASSEMBLY (Fig.14)

##### 1. Removal

- 1) Referring to 2-1, remove the FL cassette compartment assembly.
- 2) Remove the TG7 height adjusting screw ①, then the TG7 spacer ② and reel table thrust washer ③.
- 3) Remove the TG7 arm assembly ④ and a torsion coil spring ⑤.

##### 2. Mounting

- 1) Insert the shaft ⑥ of TG7 arm assembly ④ into a groove ⑦ in TG7 drive lever, and attach a torsion coil spring ⑤ as shown below.
- 2) Mount a reel table thrust washer ③ and a TG7 spacer ②, and tighten tentatively the TG7 height adjusting screw. At this time, the height from mechanical chassis top surface to TG7 arm top surface should be 3.3mm.
- 3) Referring to 2-1, mount the FL cassette compartment assembly.

**Note :** After mounting, perform 5. Tape Path Adjustment.

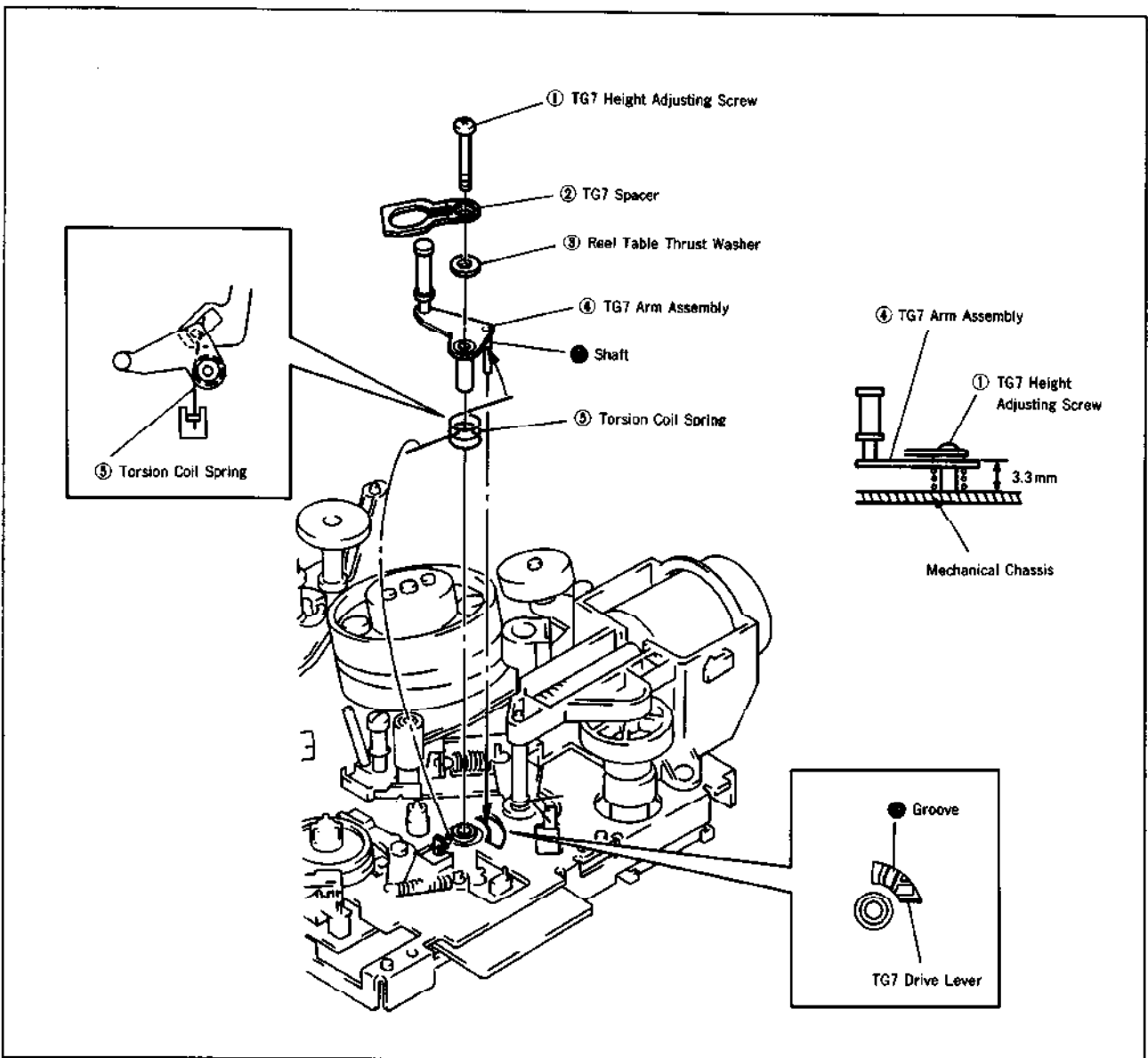

Fig. 14



#### 4-9. CAM MOTOR ASSEMBLY (Fig. 15)

##### 1. Removal

- 1) Referring to 4-1, remove the RP block.
- 2) Remove a screw ①.
- 3) Disengage a claw ④ and remove the cam motor assembly ② in the arrow direction.

##### 2. Mounting

- 1) Mount the cam motor assembly ② with its hole ⑤ inserted into the shaft ⑥ of chassis.
- 2) Tighten a screw ①.
- 3) Referring to 4-1, mount the RP block.

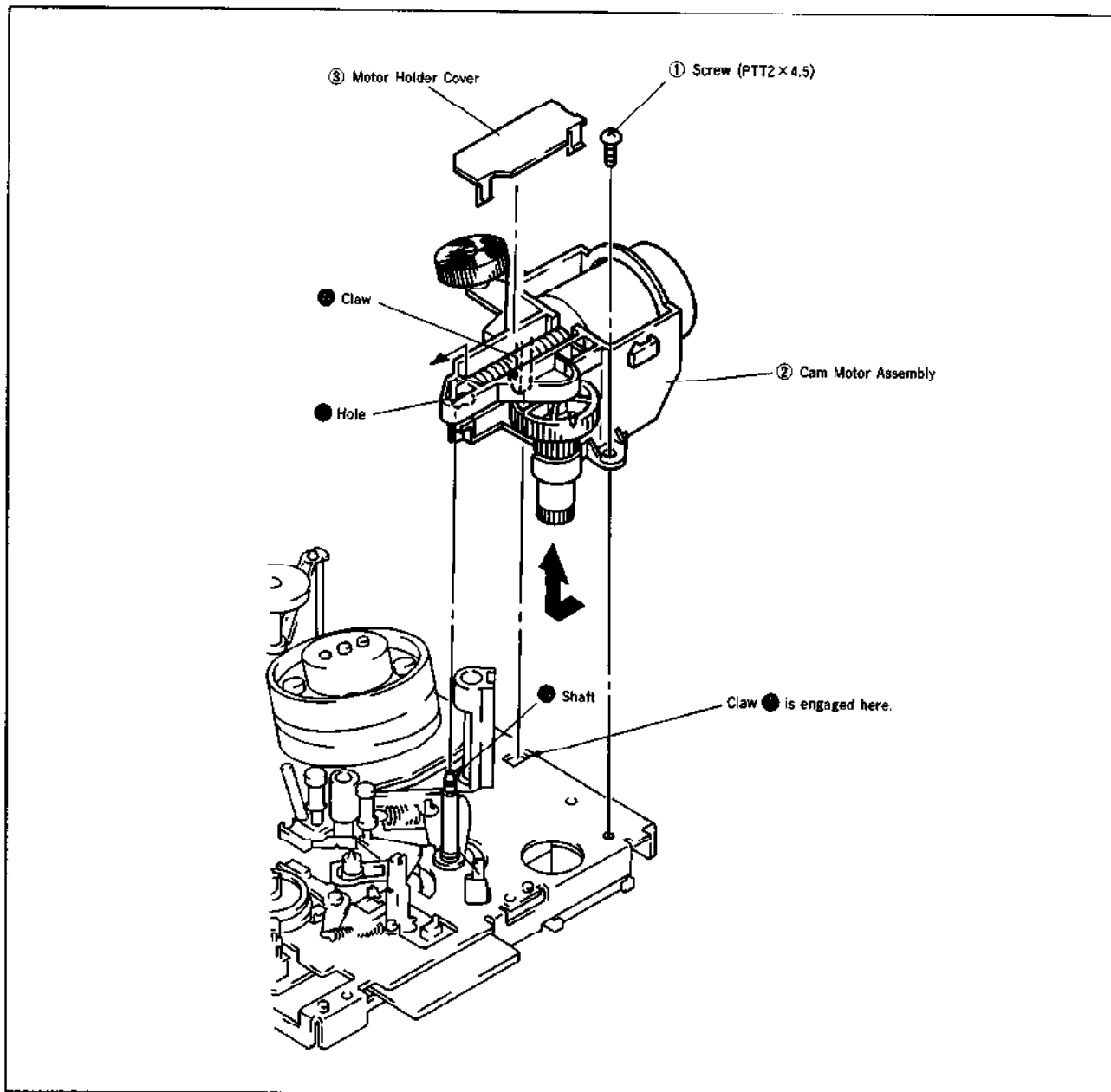

Fig. 15

#### 4-10. PINCH ARM ASSEMBLY (Fig. 16)

##### 1. Removal

- 1) Referring to 2-1, remove the FL cassette compartment assembly.
- 2) Execute the loading until the pinch arm assembly ② becomes level.
- 3) Referring to 4-9, remove the cam motor assembly.
- 4) Remove a torsion coil spring ①, then the pinch arm assembly ②.

##### 2. Mounting

- 1) Mount the pinch arm assembly ② with its hole ④ inserted into the claw ③ of pinch drive lever on the chassis.
- 2) Attach a torsion coil spring ① as shown below.
- 3) Referring to 4-9, mount the cam motor assembly.
- 4) Referring to 2-1, mount the FL cassette compartment assembly.

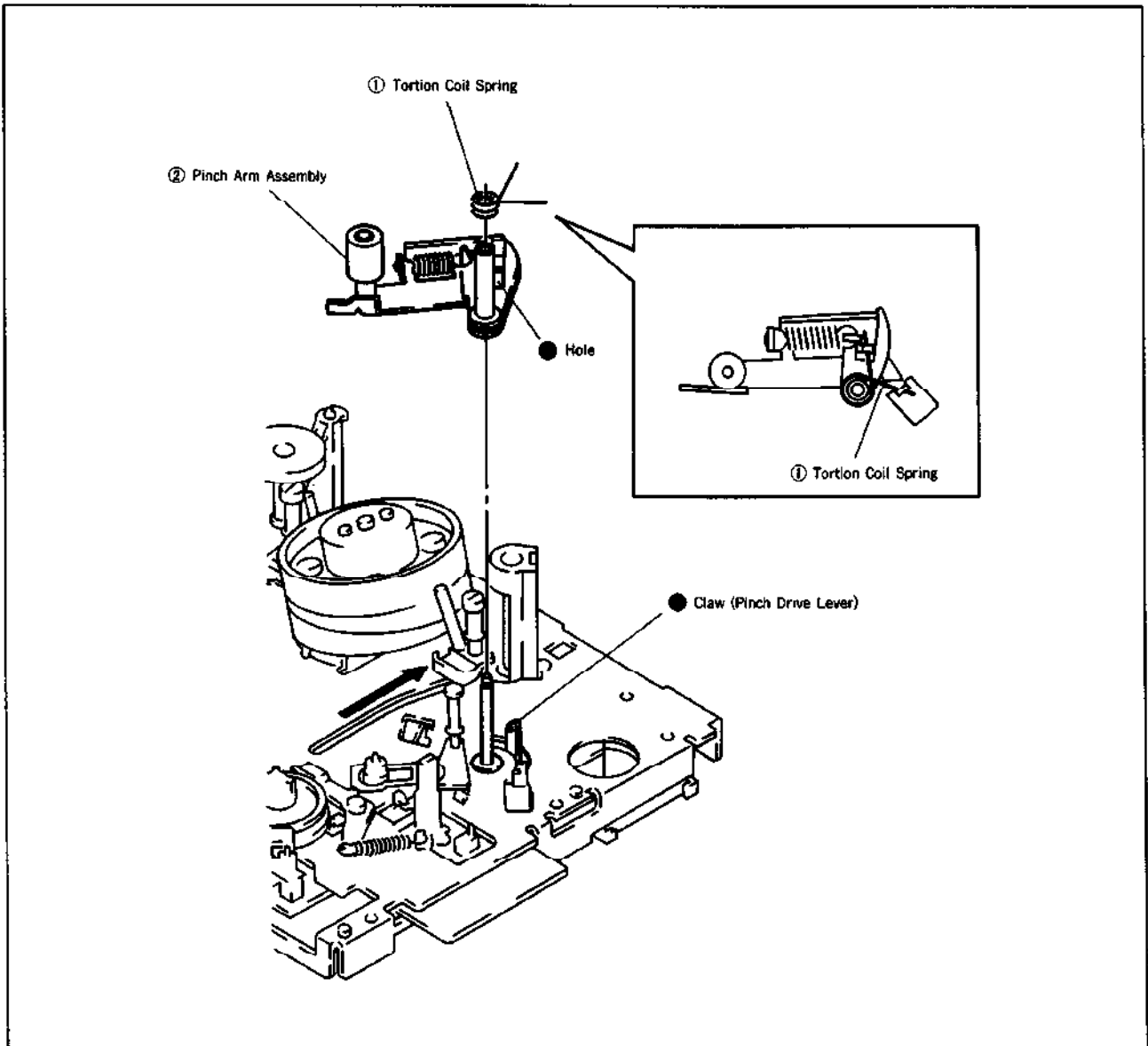

Fig. 16

#### 4-11. WORM WHEEL BRACKET (Fig. 17)

##### 1. Removal

- 1) Remove a screw ①, then the shaft earth assembly ②.
- 2) Remove a screw ③, then the worm wheel bracket ④ in the arrow direction.

##### 2. Mounting

- 1) Mount the worm wheel bracket ④ with its hole ⑤ inserted into the shaft ⑥ of mechanical chassis.
- 2) Tighten a screw ③.
- 3) Mount the shaft earth assembly ② and tighten a screw ①.

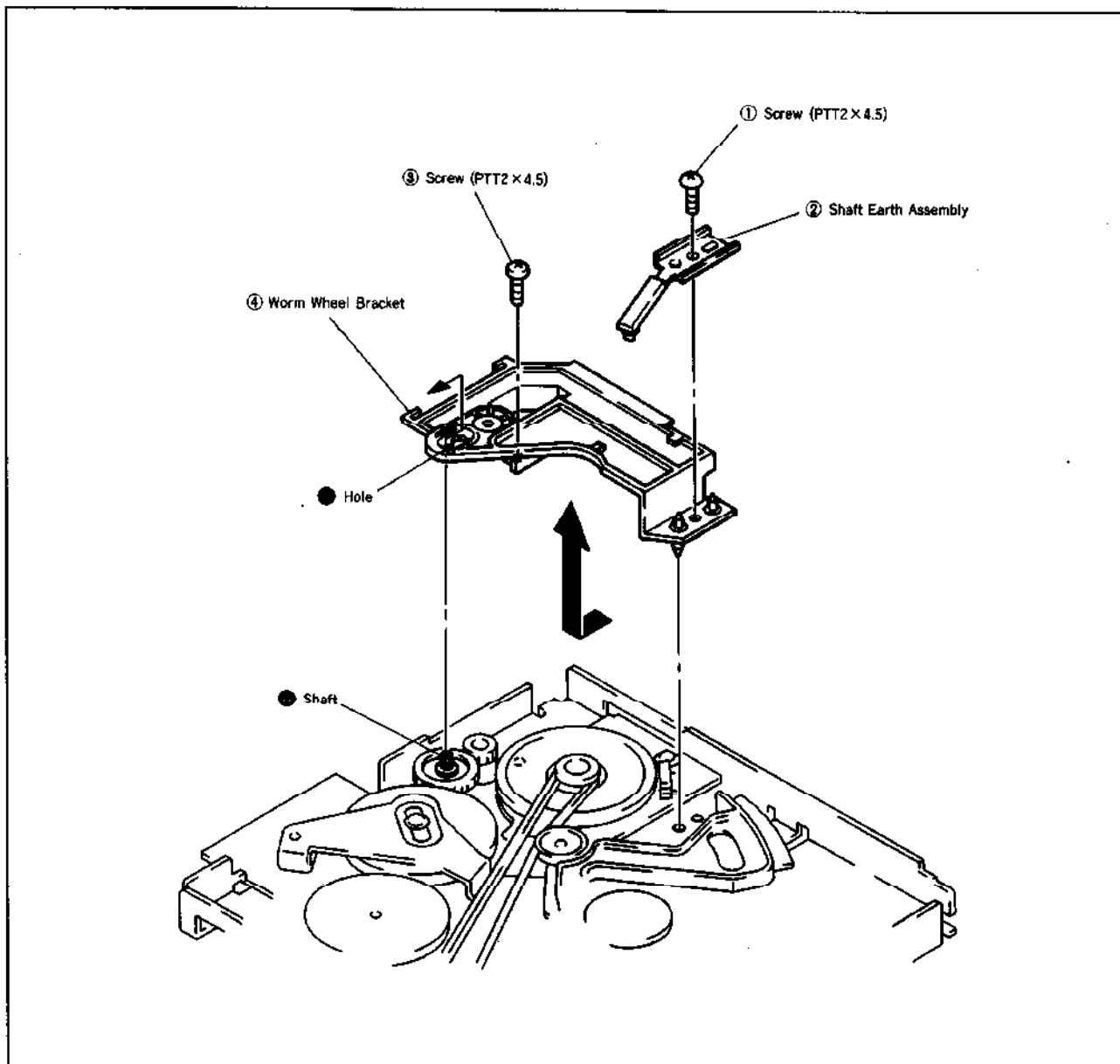

Fig. 17

#### 4-12. CAPSTAN MOTOR (Fig. 18)

##### 1. Removal

- 1) Referring to 4-11, remove the worm wheel bracket.
- 2) Disengage the timing belt ①.
- 3) Remove a screw ②, then the capstan motor ③.

##### 2. Mounting

- 1) Mount the capstan motor ③ with its dowels ④ inserted into holes ⑤ in the mechanical chassis at two places.

**Note :** Do not touch the capstan motor shaft, oil seal and rotor.

- 2) Tighten a screw ②.
- 3) Engage the timing belt ①.
- 4) Referring to 4-11, mount the worm wheel bracket.

**Note :** After mounting, perform 5. Tape Path Adjustment.

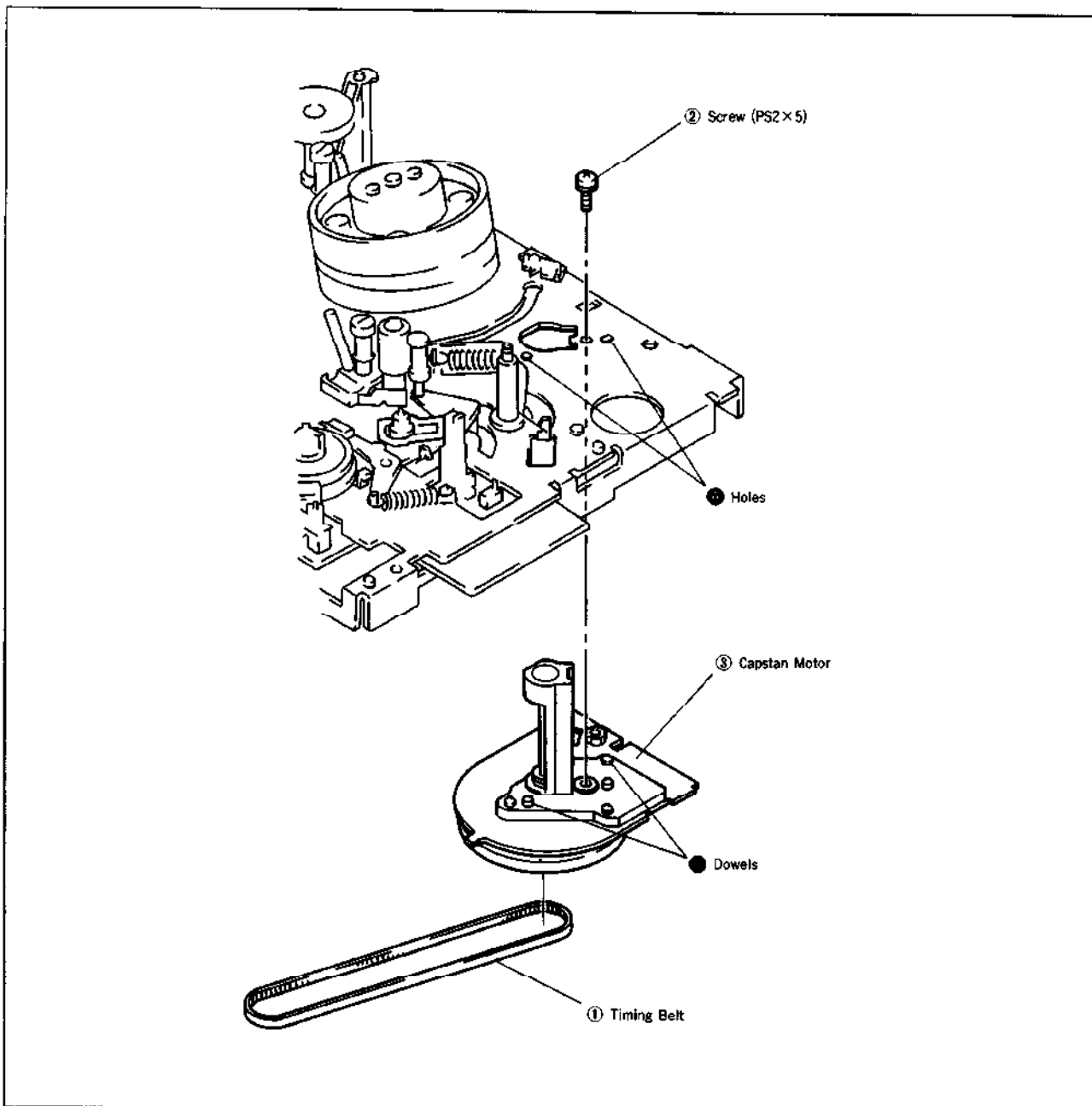

Fig. 18

#### 4-13. DRUM ASSEMBLY (Fig. 19)

##### 1. Removal

- 1) Referring to 4-1. RP Block, disconnect the connector for drum.
- 2) Remove three screws (M2x5) ①.
- 3) Remove the drum assembly ②.

**Note :** Do not touch the outer surface of drum; hold portions (A) and (B) of drum.

##### 2. Mounting

- 1) Mount the drum ② while aligning with dowels ④ of chassis at two places.

**Note :** Do not touch the outer surface of drum; hold portions (A) and (B) of drum.

- 2) Tighten three screws (M2x5) ①.

2)-1 Tighten a screw ⑤ to the torque  $29.42\text{mN}\cdot\text{m}$  ( $300\text{g}\cdot\text{cm}$ ).

2)-2 Tighten a screw ⑥ to the torque  $29.42\text{mN}\cdot\text{m}$  ( $300\text{g}\cdot\text{cm}$ ), then return  $45^\circ$ . (Apply a screw locking agent.)

2)-3 Tighten a screw ⑦ to the torque  $29.42\text{mN}\cdot\text{m}$  ( $300\text{g}\cdot\text{cm}$ ), then return  $45^\circ$ . (Apply a screw locking agent.)

**Note :** After mounting, perform 5. Tape Path Adjustment.

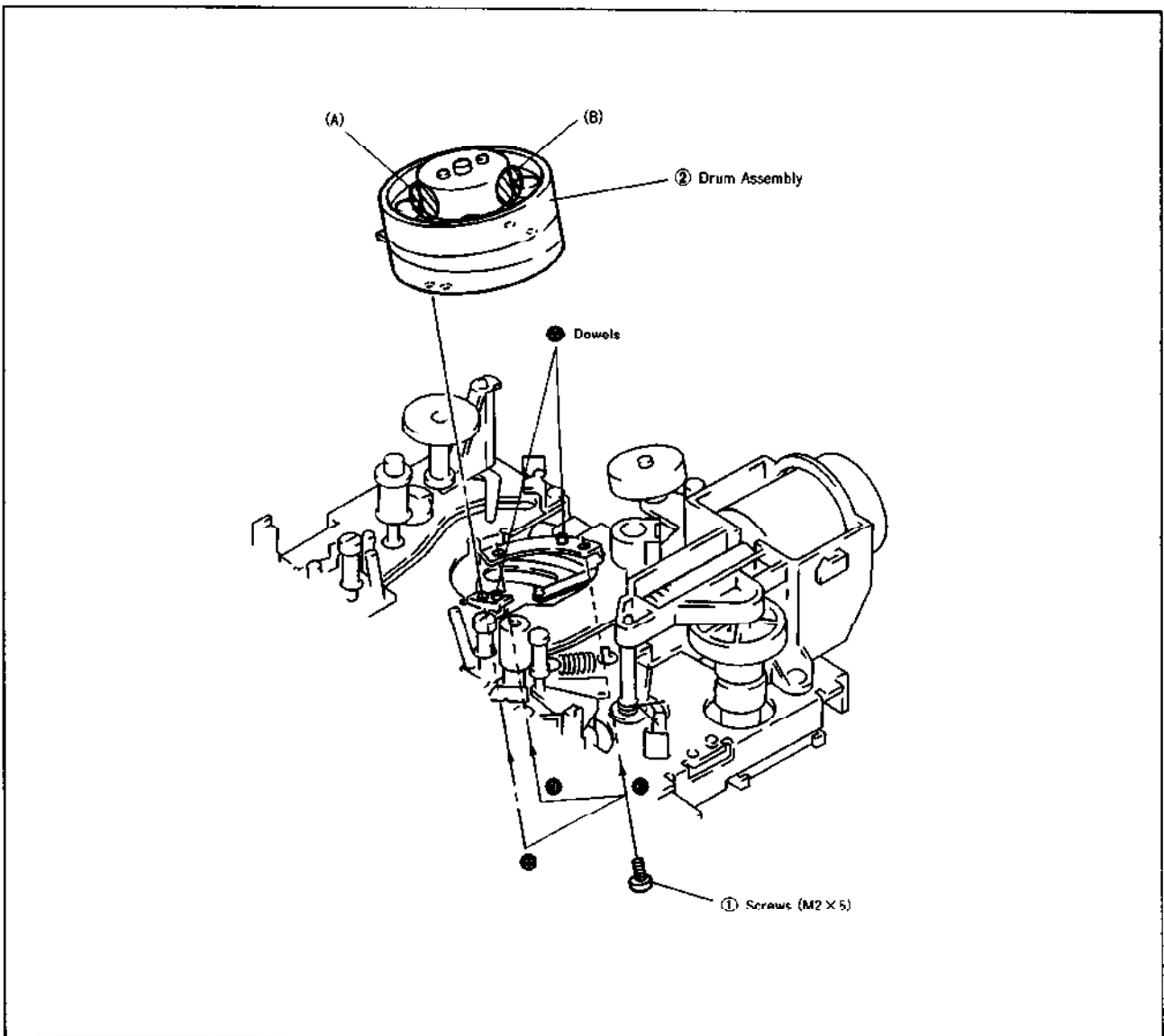

Fig. 19

#### 4-14. PULLEY BASE ASSEMBLY (Fig. 20)

##### 1. Removal

- 1) Remove a screw ①, then the W2, middle ②.
- 2) Disengage a claw ④ and remove the pulley base assembly ③.

##### 2. Mounting

- 1) Mount the pulley base assembly ③ on the shaft ⑤ of mechanical chassis, and engage the timing belt ⑥ with the pulley ③.
- 2) Mount the W2, middle ② and tighten tentatively the screw ①.
- 3) Tighten the screw ① at the position where the portion (A) of pulley base assembly ③ is pushed with 14g force.

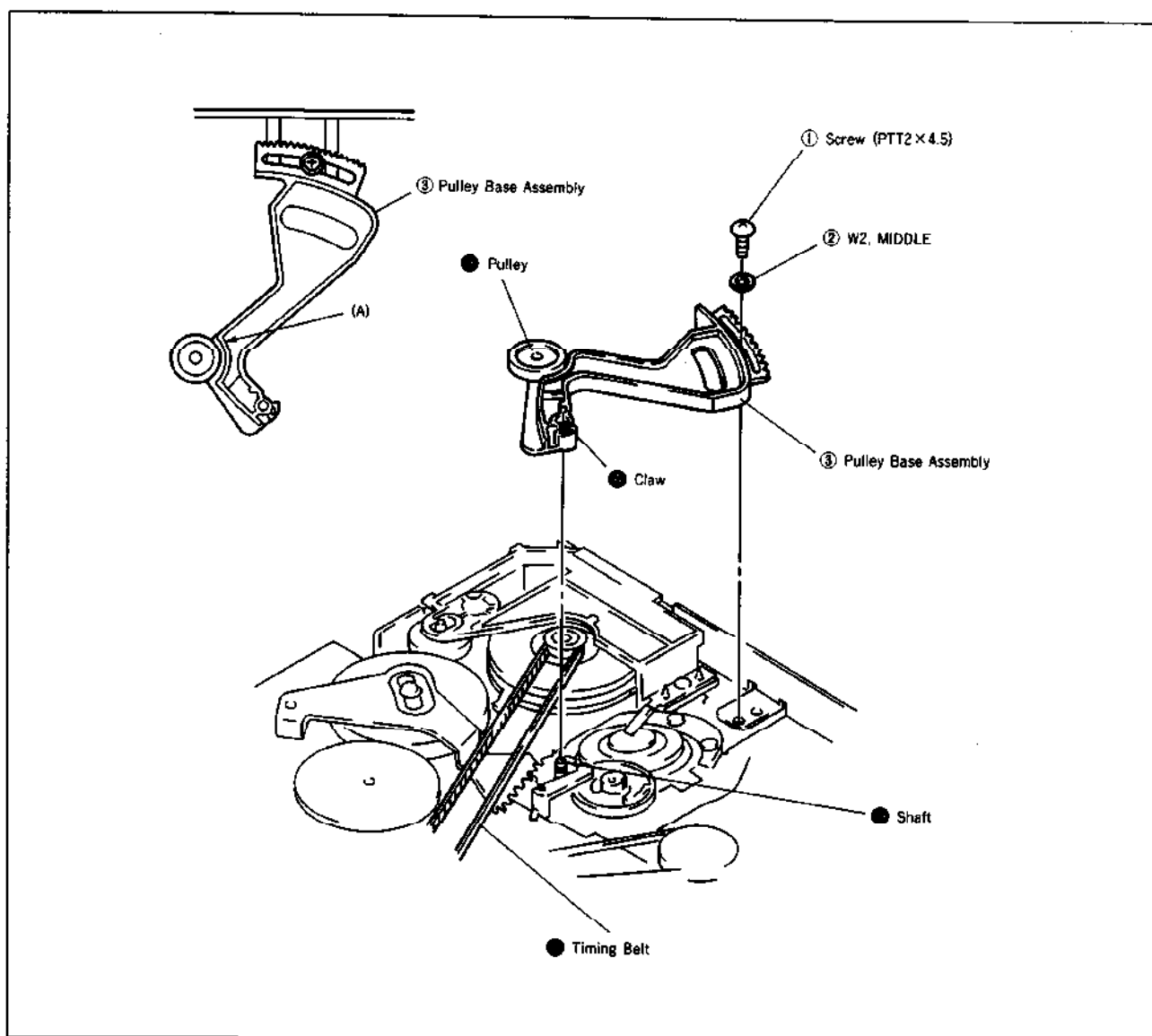

Fig. 20

#### 4-15. LOADING DRIVE LEVER (Fig. 21)

##### 1. Removal

- 1) Disengage the timing belt ①.
- 2) Remove a screw ②, then the W3, small ③.
- 3) Remove the loading drive lever ④.

##### 2. Mounting

- 1) Mount the loading drive lever ④ on the shaft ⑥ of chassis with its shaft ⑦ inserted into the loading roller ⑤.  
At this time, insert the shaft ⑧ of main cam into the hole ⑨ in loading drive lever, the shaft ⑩ of loading drive lever into a slot ⑪ in main cam, and align a line ⑫ on loading drive lever with a line ⑬ on loading gear (T) respectively.
- 2) Mount the W3, small ③ and tighten tentatively the screw ②.
- 3) Engage the timing belt ①.

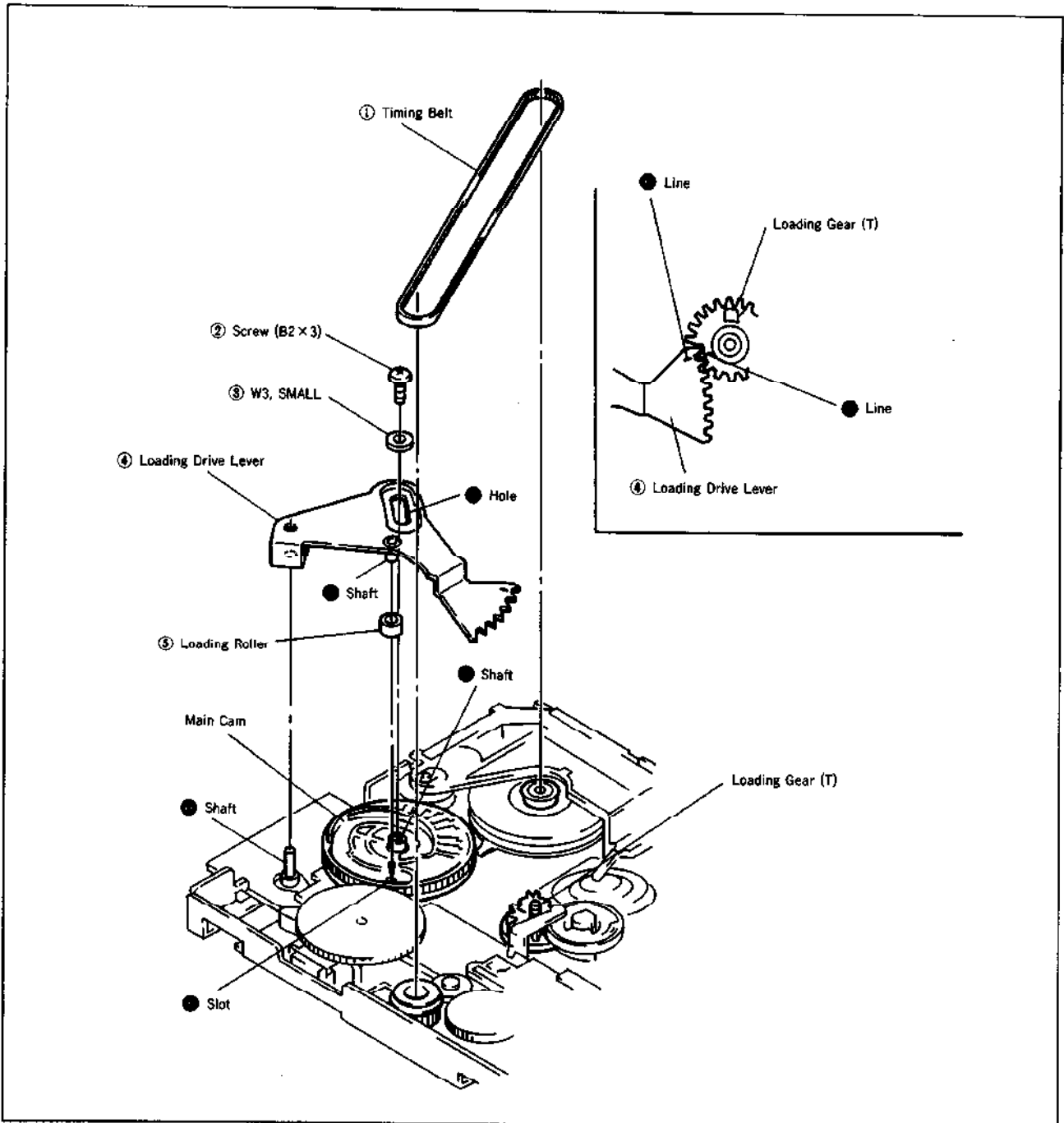

Fig. 21

#### 4-16. ROTARY SWITCH AND MAIN CAM (Fig. 22)

##### 1. Removal

- 1) Referring to 4-11, remove the worm wheel bracket.
- 2) Referring to 4-15, remove the loading drive lever.
- 3) Remove the cam relay gear ①.
- 4) Disengage claws ④ at two places, and disconnect the rotary switch ② from the connector ⑤.
- 5) Remove the main cam ③.

##### 2. Mounting

- 1) Mount the main cam ③ with its cam groove ⑥ inserted into the shaft ⑦ of slide plate drive lever, and cam groove ⑥ into the shaft ⑧ of pinch drive lever respectively.
- 2) Referring to 4-15, mount the loading drive lever.
- 3) Mount the cam relay gear ①.
- 4) Referring to 4-11, mount the worm wheel bracket.
- 5) Connect the rotary switch ② to the connector ⑤ while aligning ▲ marks each other, and its recess ⑨ with the recess ⑩ of main cam ③.

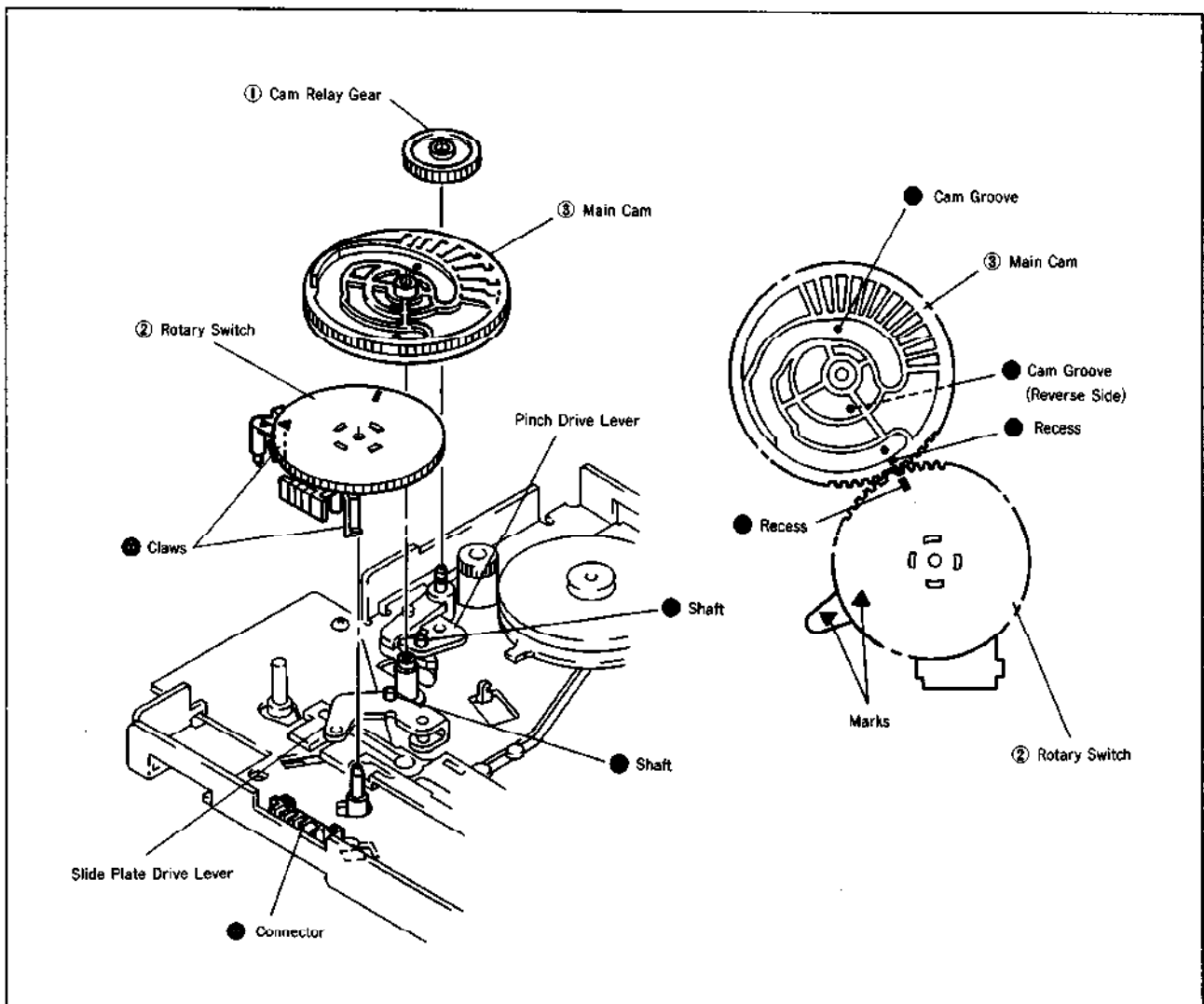

Fig. 22



#### 4-17. SLIDE PLATE (Fig. 23)

##### 1. Removal

- 1) Referring to 4-11, remove the worm wheel bracket.
- 2) Referring to 4-15, remove the loading drive lever.
- 3) Referring to 4-16, remove the rotary switch and main cam.
- 4) Remove the slide plate drive lever ①.
- 5) Disengage the timing belt ②.
- 6) Disengage a claw ④ and remove the FL pulley gear (drive) ③.
- 7) Remove a tension coil spring ④, then the FL switching arm assembly ⑤.
- 8) Remove the brake (S) drive lever ⑧.
- 9) Remove two lock washers 1.5 ⑥, then the slide plate ⑦.

##### 2. Mounting

- 1) Mount the slide plate ⑦ with its groove ⑩ inserted into the shaft ⑨ of chassis, the groove ⑪ into the shaft ⑫ of S take-up assembly, and the groove ⑬ into the shaft ⑭ respectively. At this time, insert the shaft ⑮ into the groove ⑯ in slide plate while holding the tension regulator sub-arm toward the arrow.
- 2) Mount two lock washers 1.5 ⑥.
- 3) Referring to 3) of Mounting in 4-18, mount the brake (S) drive lever ⑧.
- 4) Mount the FL switching arm assembly ⑤ and a tension coil spring ④.
- 5) Mount the FL pulley gear (drive) ③ and engage the timing belt ②.
- 6) Mount the slide plate drive lever ① with its shaft ⑰ inserted into a groove ⑱ in slide plate ⑦, and its hole into the shaft ⑲ of chassis.
- 7) Referring to 4-16, mount the rotary switch and main cam.
- 8) Referring to 4-15, mount the loading drive lever.
- 9) Referring to 4-11, mount the worm wheel bracket.

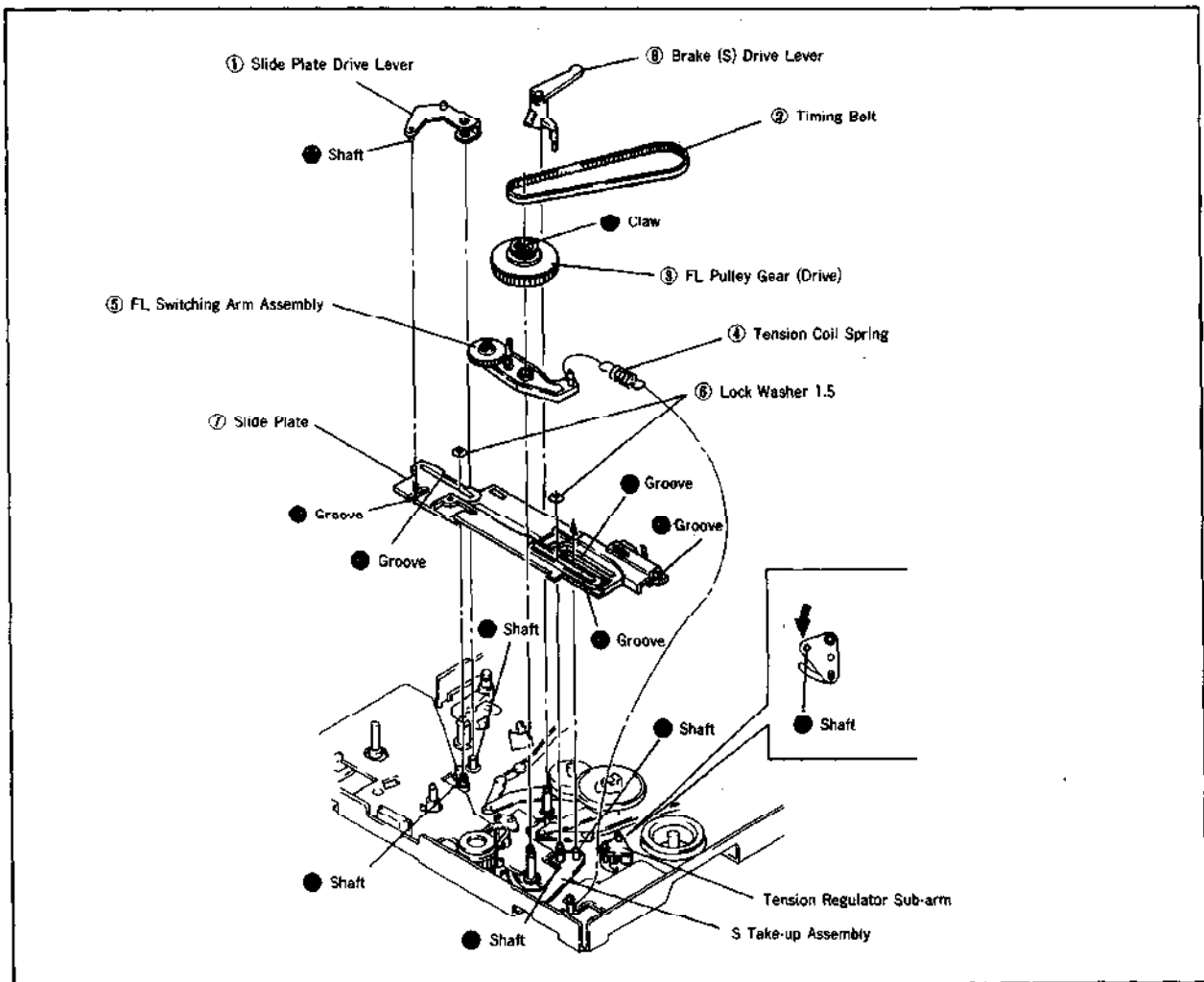

Fig. 23

#### 4-18. LOADING GEAR (S) ASSEMBLY (Fig. 24)

##### 1. Removal

- 1) Referring to 4-15, remove the loading drive lever.
- 2) Disengage a claw **(A)** and remove the brake (S) drive lever **(1)**.
- 3) Remove the coaster leaf spring **(2)**.
- 4) Disengage a claw **(B)** and remove the loading gear (S) assembly **(3)**.

##### 2. Mounting

- 1) Mount the loading gear (S) assembly **(3)** on the shaft **(C)** of chassis with its arm engaged with the shaft **(D)** of coaster.  
At this time, align the portion **(E)** of loading gear (T) assembly with the portion **(F)** of loading gear (S) assembly.
- 2) Mount the coaster leaf spring **(2)**.
- 3) Mount the brake (S) drive lever **(1)** on the shaft **(H)** of chassis with its shaft **(I)** inserted into the portion **(G)** of brake (S) arm, and the shaft **(J)** into the groove **(K)** in loading gear (S) assembly **(3)**.
- 4) Referring to 4-15, mount the loading drive lever.

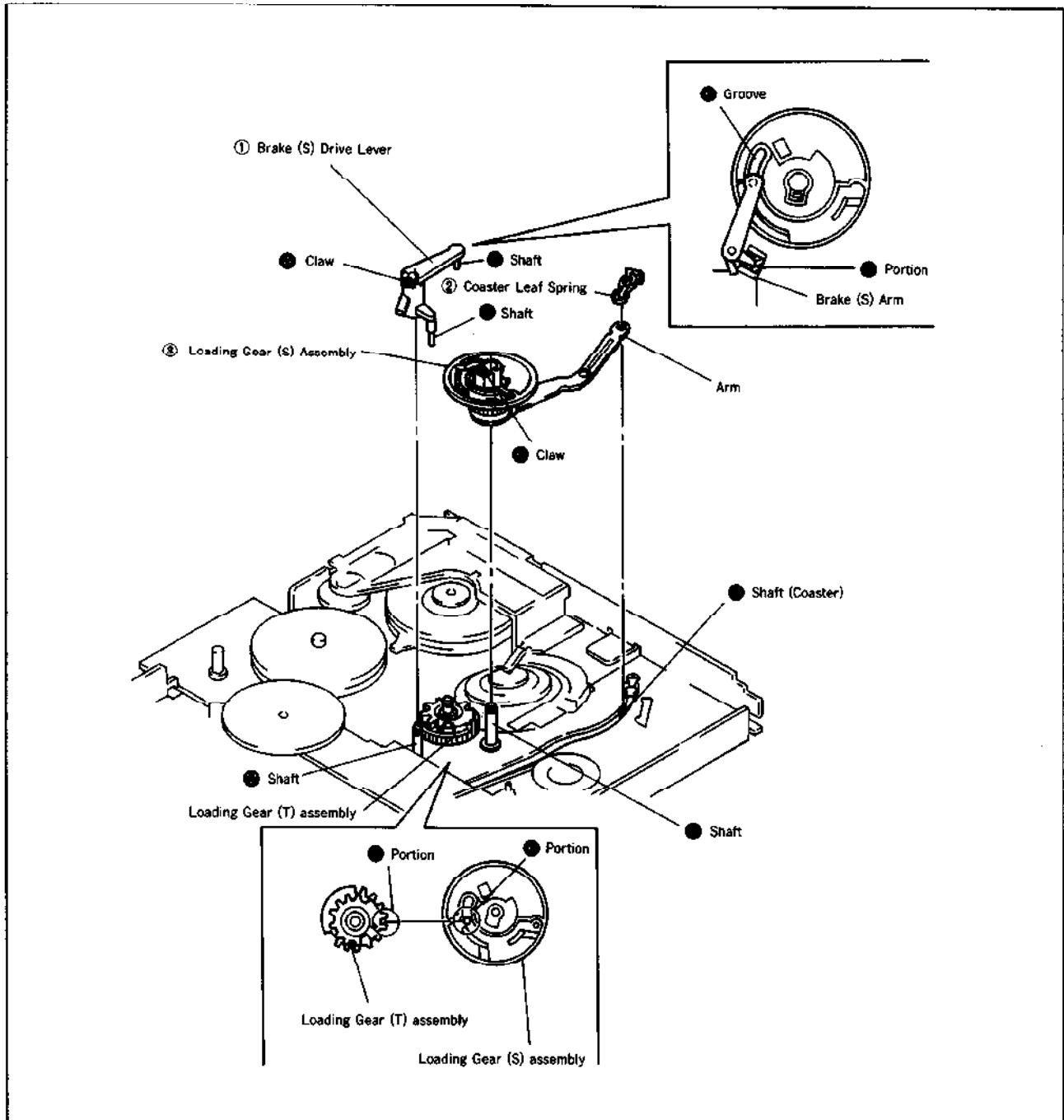

Fig. 24

#### 4-19. LOADING GEAR (T) ASSEMBLY (Fig. 25)

##### 1. Removal

- 1) Referring to 4-15, remove the loading drive lever.
- 2) Referring to 4-18, remove the loading gear (S) assembly.
- 3) Remove the coaster leaf spring ①, then the loading gear (T) assembly ②.

##### 2. Mounting

- 1) Mount the loading gear (T) assembly ② on the shaft ③ of chassis with its arm engaged with the shaft ④ of coaster.
- 2) Mount the coaster leaf spring ①.
- 3) Referring to 4-18, mount the loading gear (S) assembly.
- 4) Referring to 4-15, remove the loading drive lever.

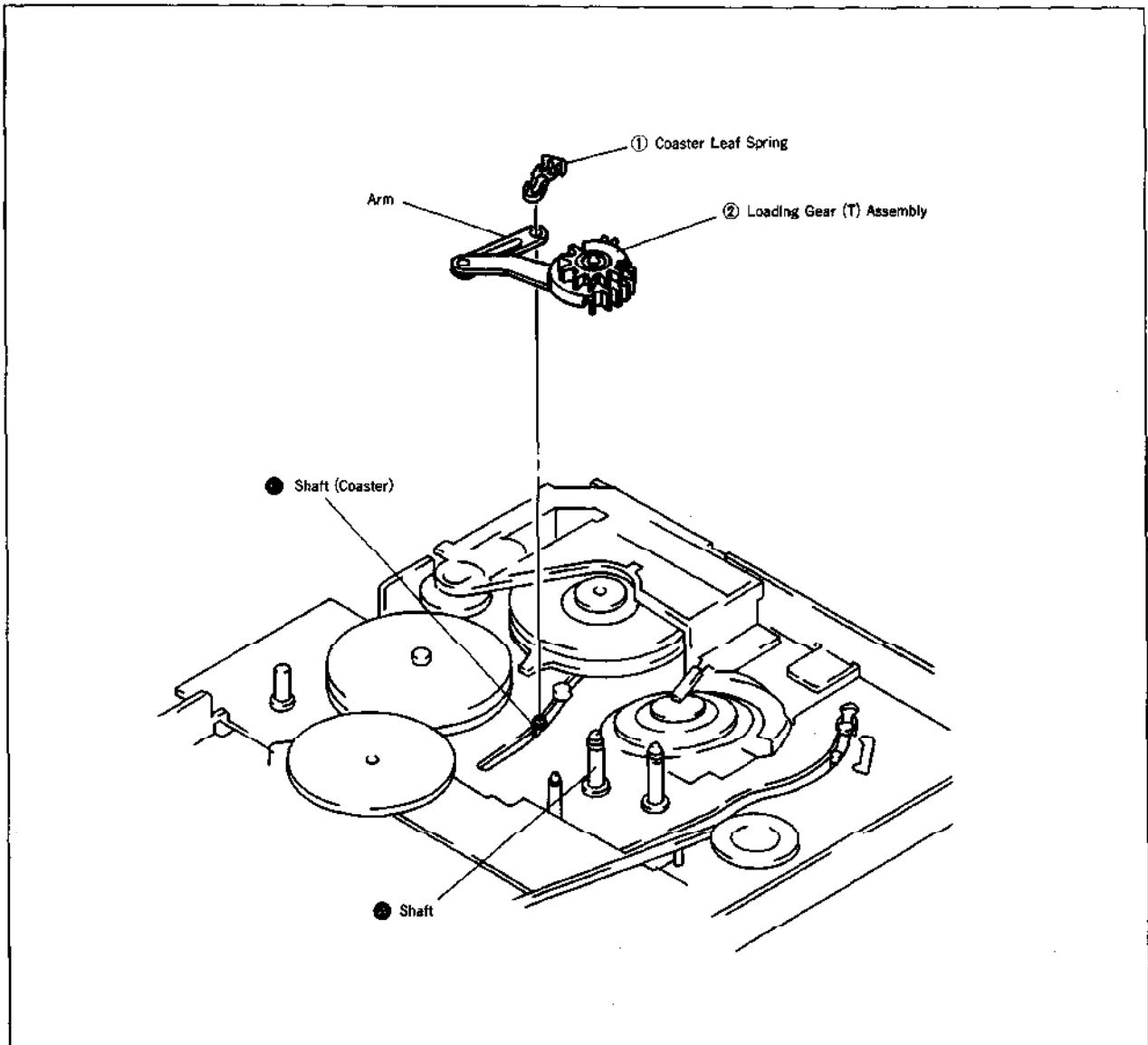

Fig. 25

#### 4-20. COASTER (S) (Fig. 26)

##### 1. Removal

- 1) Referring to 4-2, remove the impedance roller assembly.
- 2) Remove a screw ①, then the catcher (S) ②.
- 3) Remove the coaster leaf spring ③, then the coaster (S) ④.

##### 2. Mounting

- 1) Mount the coaster (S) ④.
- 2) Mount the catcher (S) ② with its holes inserted into dowels ⑤ of chassis at two places.
- 3) Tighten a screw ①.
- 4) Referring to 4-18 Loading Gear (S) Assembly, mount the coaster leaf spring ③.
- 5) Referring to 4-2, mount the impedance roller assembly.

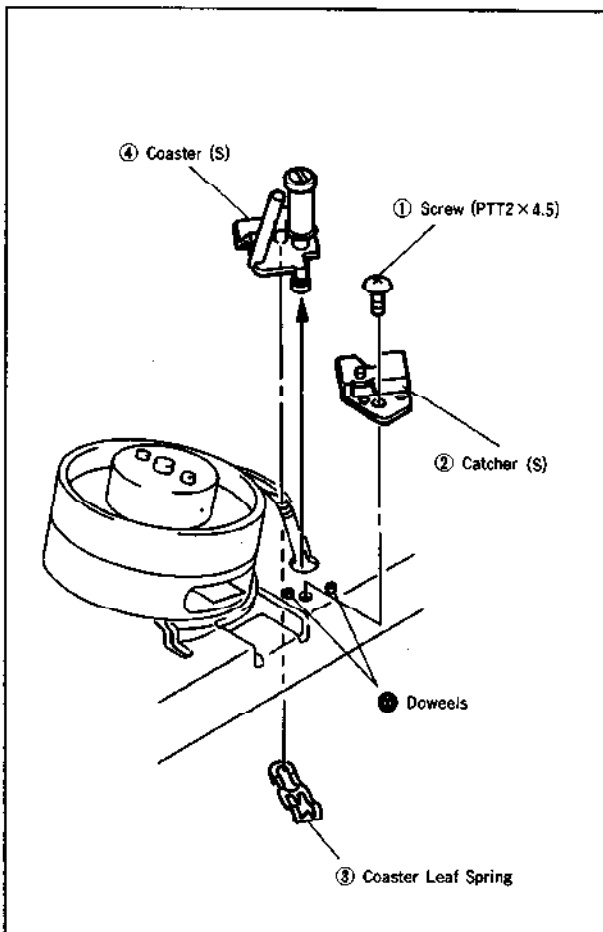

Fig. 26

#### 4-21. COASTER (T) (Fig. 27)

##### 1. Removal

- 1) Remove a screw ①, then the catcher (T) ②.
- 2) Remove the coaster leaf spring ③, then the coaster (T) ④.

##### 2. Mounting

- 1) Mount the coaster (T) ④.
- 2) Mount the catcher (T) ② with its holes inserted into dowels ⑤ of chassis at two places.
- 3) Referring to 4-19 Loading Gear (T) Assembly, mount the coaster leaf spring ③.

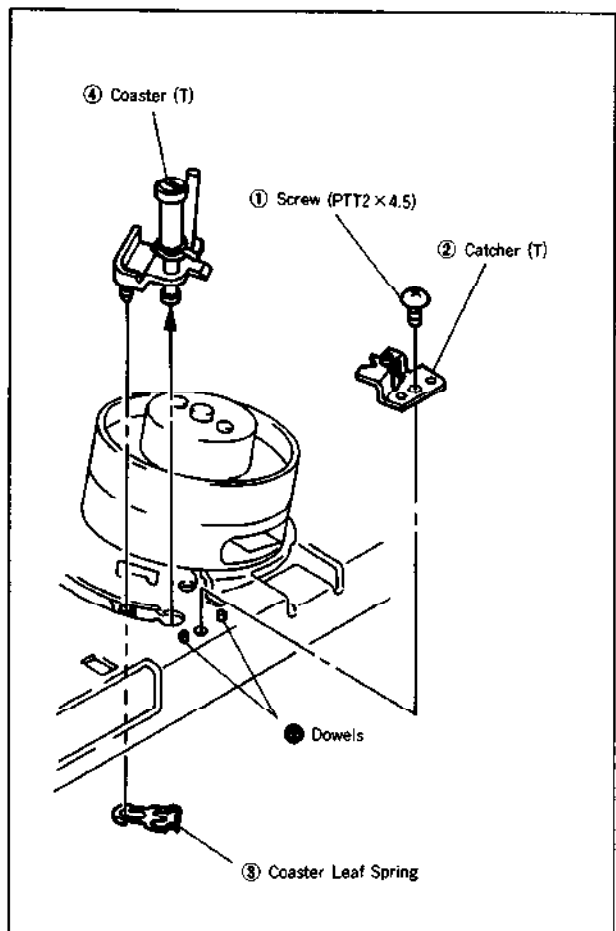

Fig. 27

## 4-22. ROTARY UPPER DRUM REPLACEMENT

### 1. Removal

- If possible, make a recording before removal.

- 1) Remove the two screws ① (Fig. 28).
- 2) Mount the jig ② (Ref. No. J-8) with the two supplied screws ③, then screw the attached hexagon socket screws ④ to the jig ②. The rotary upper drum ⑤ will move upward and come off (Fig. 29).

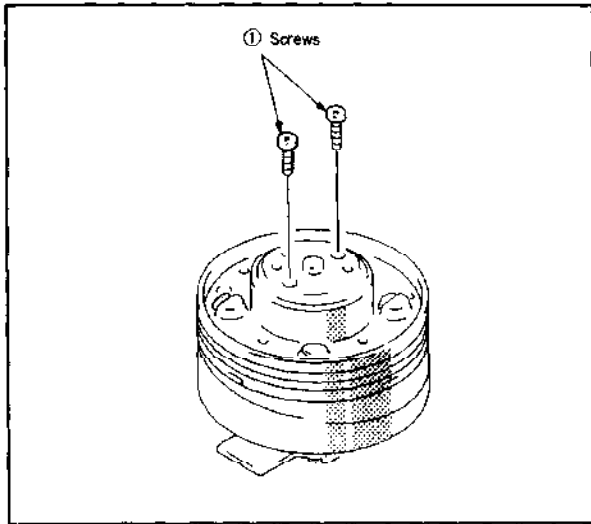

Fig. 28

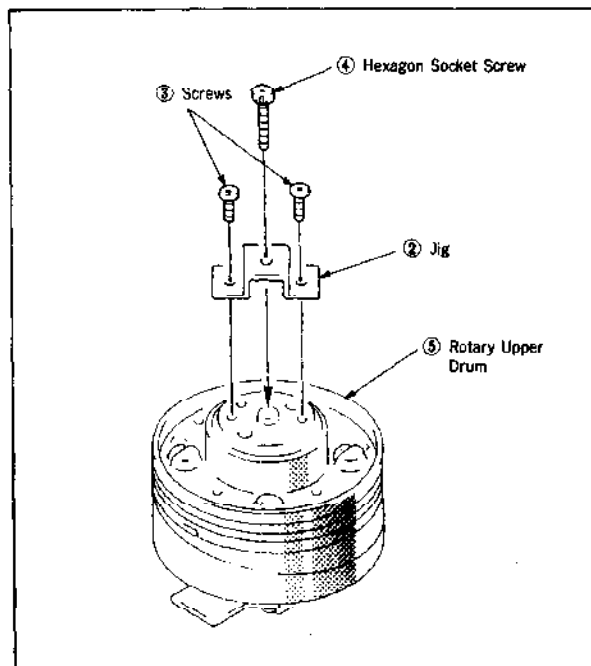

Fig. 29

### 2. Installation

- 1) Wipe clean the flange surface and the rotary upper drum ⑤ surface that makes contact with it, and confirm that they are free from dirt and scratches.
- 2) Insert the jig ⑥ (Ref. No. J-8) into the drum positioning hole ⑦. (Fig.30)
- 3) Remove the jig ⑥ and push down the rotary upper drum ⑤ gently by hand. If it does not go all the way down, secure it temporarily by tightening the two screws ① alternately (Fig.28).
- 4) Tighten strongly both two screws ①, and loosen both screws once, then tighten them again (for stable seating).
- 5) Insert the jig ⑥ into the positioning hole ⑦ again and confirm that it goes in smoothly. If it does not, loosen the two screws ①, repeat step 2) of the Removal paragraph and restart the setting procedure.
- 6) Tighten the screws ①.

**Note :** After installing, be sure to perform tape path adjustment as described in section 5.

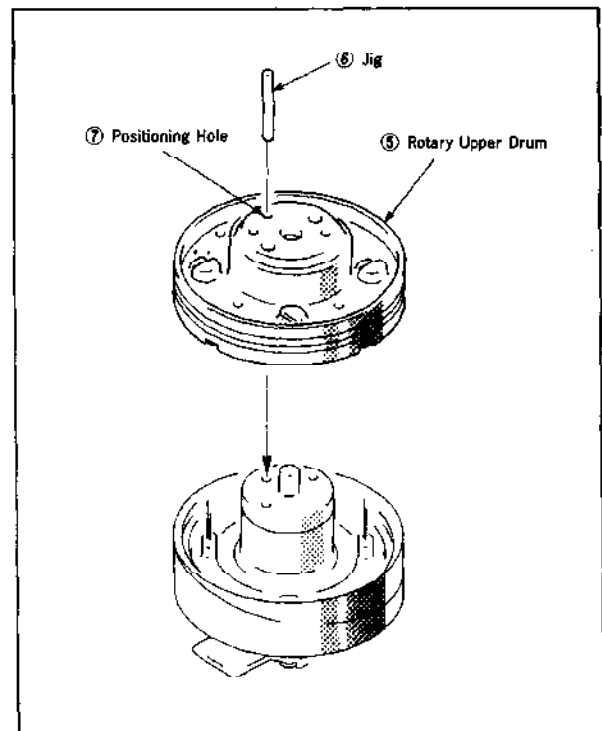

Fig. 30

#### 4-23. ADJUSTMENT OF TENSION REGULATOR POSITION (Fig. 31)

##### 1. Adjustment

- 1) Set a cassette tape and run the tape in the PB mode.
- 2) With the tape running, check that the distance from No.1 guide to No. 2 guide upper flange is 5.5 mm. (On the centerline of TG2 guide)
- 3) If they are not at the specified positions, perform adjustment in step 4) and subsequent steps.
- 4) Loosen the screw ①.
- 5) If No.1 guide is located inside the specified position, shift the tension adjusting base toward the arrow ② using the FWD B.T. adjusting driver (Ref No. J-13). Or, if it is located outside, shift toward the arrow ③.
- 6) Tighten the screw ①.

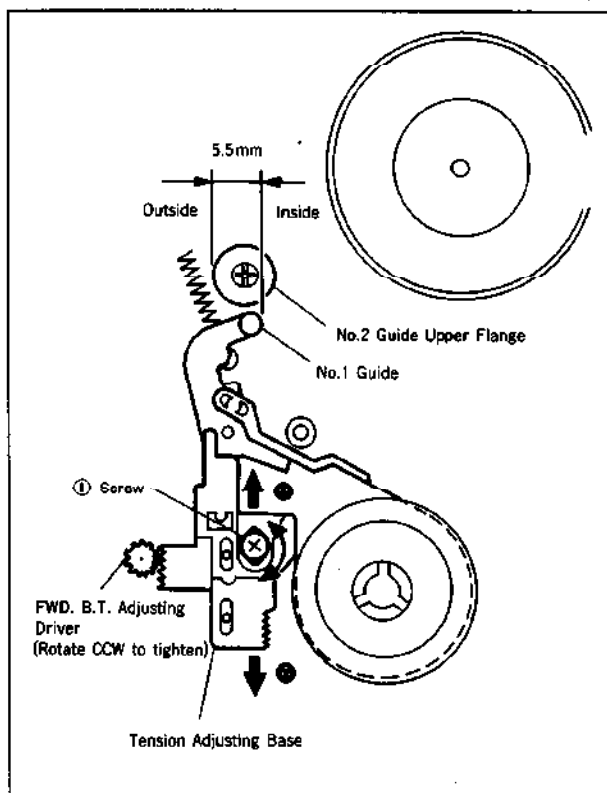

Fig. 31

#### 4-24. FWD BACK TENSION ADJUSTMENT (Fig. 32)

- 1) Select the TEST mode 1 using the adjusting remote controller (Ref No. J-10).
- 2) Set the torque cassette (Ref No. J-7).
- 3) Select the FWD mode, and check that the torque of S reel table is  $0.88 \sim 1.17\text{mN}\cdot\text{m}$  ( $9 \sim 12\text{g}\cdot\text{cm}$ ). If it is out of standard, adjust the tension adjusting arm position.

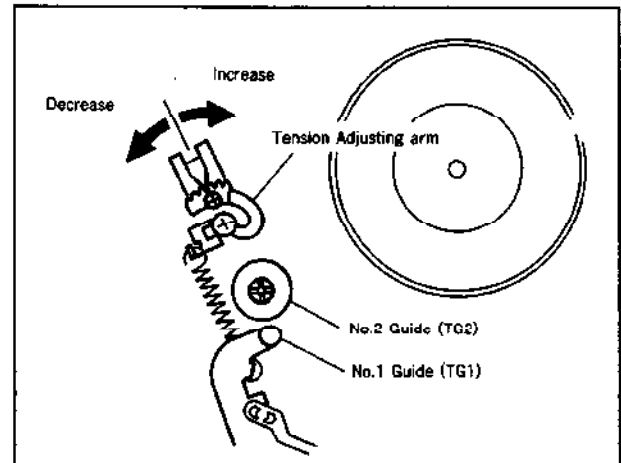

Fig. 32

#### 4-25. REEL TORQUE CHECK

- 1) Set the torque cassette.
- 2) Select the FWD mode, and check that the torque fluctuation center of T reel table is  $0.98 \sim 1.96\text{mN}\cdot\text{m}$  ( $10 \sim 20\text{g}\cdot\text{cm}$ ).
- 3) Select the RVS mode, and check that the torque fluctuation center of S reel table is  $1.77 \sim 2.75\text{mN}\cdot\text{m}$  ( $18 \sim 28\text{g}\cdot\text{cm}$ ).
- 4) Select the REV mode, and check that the torque of T reeltable is  $0.98 \sim 1.96\text{mN}\cdot\text{m}$  ( $10 \sim 20\text{g}\cdot\text{cm}$ ).
- 5) If the above data is not satisfied, the tension regulator band, T hard tab or T soft assembly will be faulty. Check them first, and if no abnormality is found, replace respective reel tables.

4-26. FL WORM WHEEL (Fig. 33)

1. Removal

- 1) Disengage tabs ④ at four places and remove the gear cover ①.
- 2) Remove the drive gear ②, then the FL worm wheel ③.

2. Mounting

- 1) Mount the FL worm wheel ③.
- 2) Meet a hole ⑤ in drive arm (T) on right side with a hole in chassis, and also a hole ⑥ in FL worm wheel ③ with a hole in side plate.  
Meet a hole ⑦ in drive gear ② with a hole in side plate.  
Meeting respective holes, mount the drive gear ②.
- 3) Mount the gear cover ①.

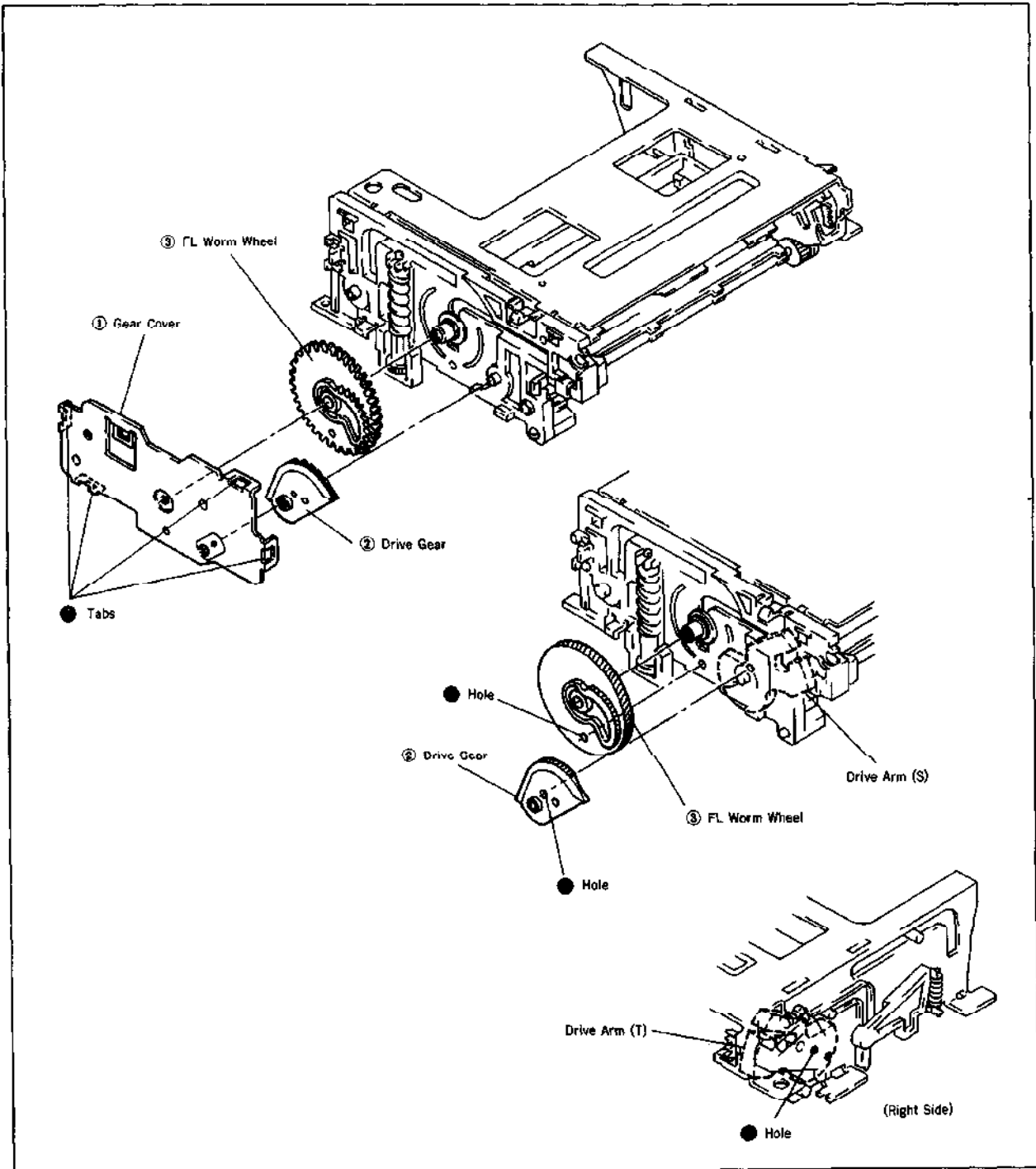

Fig. 33

## 5. TAPE PATH ADJUSTMENT

The 8mm video system uses ATF (Automatic Track Finding) which instantaneously controls a tape running speed based on 4 types of pilot signals and performs high-precision tracking.

This does away a tracking control knob and allows accurate track tracing.

On the other hand, however, the ATF system has a problem in adjusting the tape path system. That is, if head tracing is out of order a little, the ATF automatically corrects it, which means that perfect adjustment cannot be done.

Therefore, in the F mechanism, the ATF system is forcibly operated to shift a tracking amount constantly (approx. 1/4) by setting the PATH mode with the adjusting remote controller (Ref No. J-10). So, fine tracking adjustment can be easily done.

Also, the PATH mode setting varies with the model, and therefore, refer to the Service Manual.

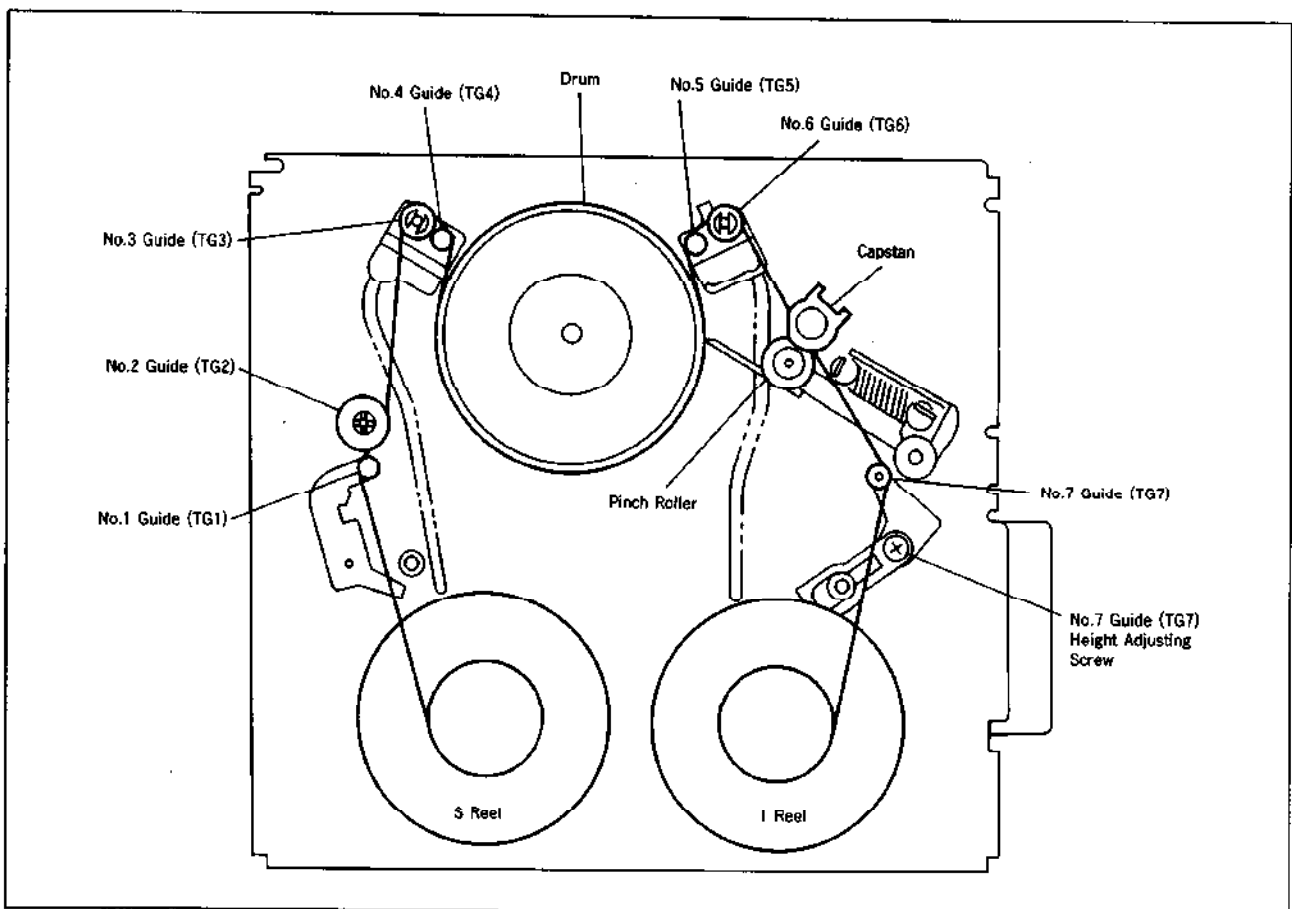

Fig. 34



**[Note on Adjustment of No.7 Guide (TG7)]**

The height adjustment screw for No.7 guide (TG7) is located at some distance from the guide (refer to Fig.42).

Therefore, when performing section 5-4. No.7 Guide (TG7)

Adjustment it is convenient to use the alignment tape for tracking (Ref. No. J-6), modified as follows, and perform adjustment in playback mode.

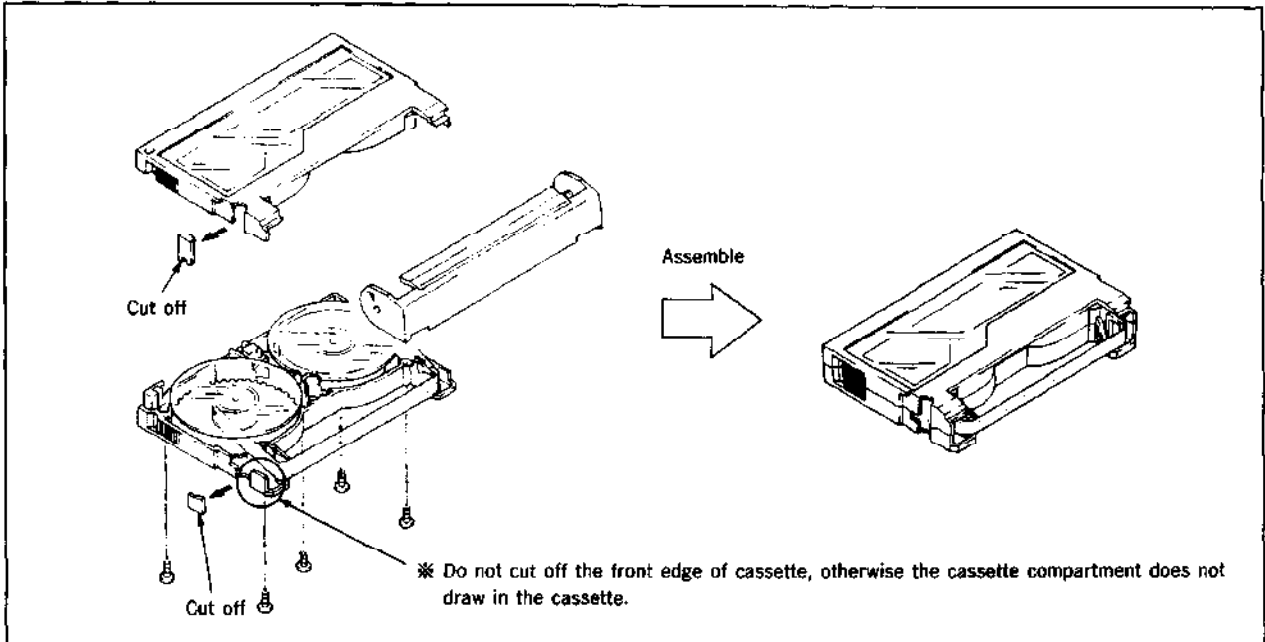

Fig. 35

**5-1. PREPARATION FOR ADJUSTMENT**

- 1) Clean the tape running surface (tape guides, drum, capstan shaft, pinch roller) (Fig. 34).
  - 2) Set the PATH mode using the adjusting remote controller.
  - 3) connect an oscilloscope to the check pin connector of the set.
  - 4) Play back a tracking alignment tape (NTSC : WR5-1NP, or PAL : WR5-1CP).
  - 5) Check that a RF waveform is flat at the inlet and outlet of the oscilloscope (Fig. 36 ㉑).
- If not flat, make adjustment with the procedures below.  
When the RF waveform is not flat at the inlet/outlet ; See Fig. 36 ㉒ and ㉓.

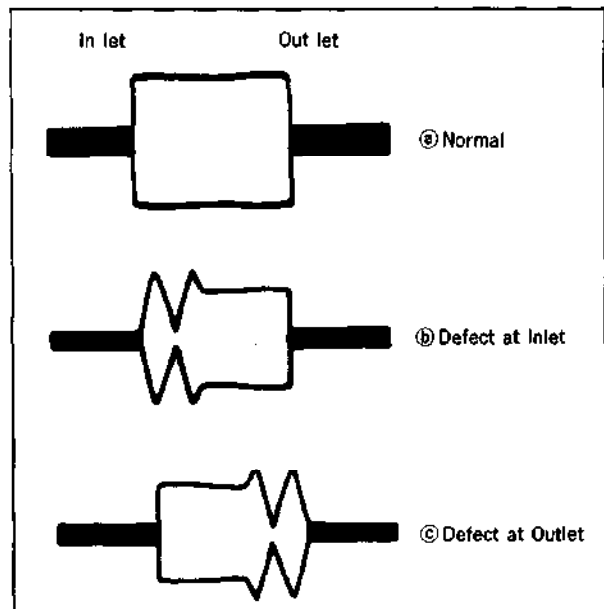

Fig. 36

## 5-2. TRACKING ADJUSTMENT (Fig. 37, 38)

- 1) Play back the tracking alignment tape.
- 2) Loosen the No.3 guide (TG3) lock screw ① and turn the No.3 guide to flatten the waveform at the inlet.
- 3) Tighten the No.3 guide (TG3) lock screw ① to lock the No.3 guide.
- 4) Loosen the No.6 guide (TG6) lock screw ② and turn the No.6 guide to flatten the waveform at the outlet.
- 5) Tighten the No.6 guide (TG6) lock screw ② to lock the No.6 guide. When this is done, make sure that the waveform does not change at the outlet.

**Note :** Be careful not to loosen the lock screw too much because the guide is easily moved.

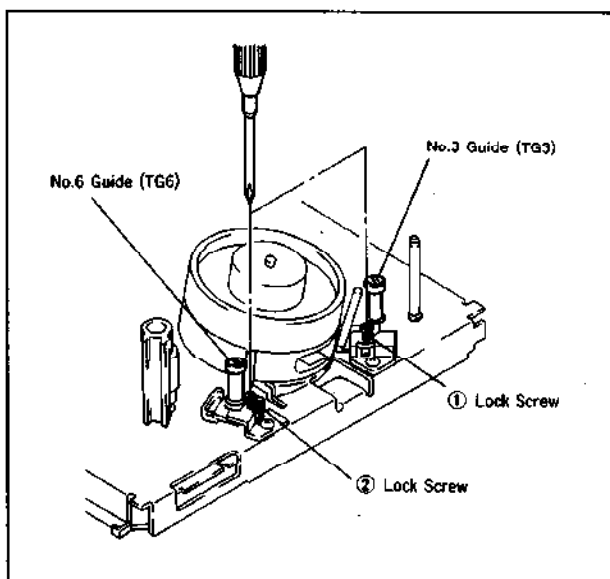

Fig. 37

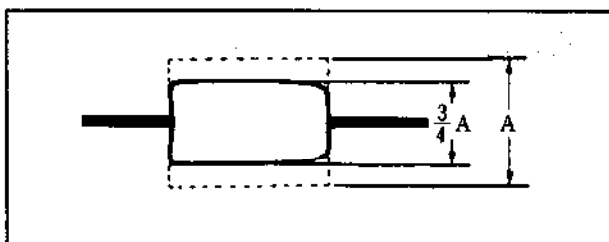

Fig. 38

## 5-3. No.2 GUIDE (TG2) ADJUSTMENT

When the No.2 guide has been turned or replaced, perform height presetting before this adjustment.

### 5-3-1. No. 2 GUIDE (TG2) HEIGHT PRESETTING (Fig. 39)

- 1) Rotating the TG2 upper flange, adjust the height from top surface of mechanical chassis to top surface of TG2 upper flange to 22.12mm.

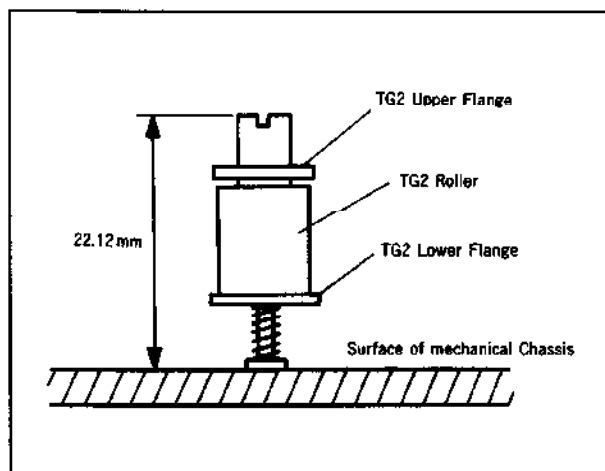

Fig. 39

#### [Reference]

This F mechanism is equipped with four adjustable guides (TG2, 3, 6 and 7). To raise or lower the respective guide rotate the corresponding adjustment screw as shown below.

Guide	Guide adjustment	Rotating direction of adjustment screw
TG2, 3, 6	Raise	Counterclockwise
	Lower	Clockwise
TG7	Raise	Clockwise
	Lower	Counterclockwise

### 5-3-2. No. 2 GUIDE (TG2) ADJUSTMENT (Fig. 40, 41)

- 1) Play back a thin tape like the P6-120MP, etc. and set the REV mode.
  - 2) Confirm that the tape is not bent at the lower flange ② of the No.2 guide (TG2) ① (Fig. 40). If it is, turn the upper flange ③ of the No.2 guide (TG2) clockwise with a screwdriver, lowering it until the tape is straightened.
  - 3) Play back the alignment tape for tracking adjustment.
  - 4) Perform tracking adjustment and tracking fine adjustment as described in sections 5-2.
  - 5) In the track shift mode, CUE/REV the tape, then play it back and confirm that the RF waveform rises flat within 2 seconds.
  - 6) If the waveform is not normal (Fig. 41), turn the upper flange ③ of the No. 2 guide (TG2) ① 90° counterclockwise and repeat step 5.
- Repeat steps 5) and 6) until a normal waveform is obtained. Then, confirm that the tracking waveform has not changed. If it has, perform fine adjustment of entrance side tracking and repeat step 5).

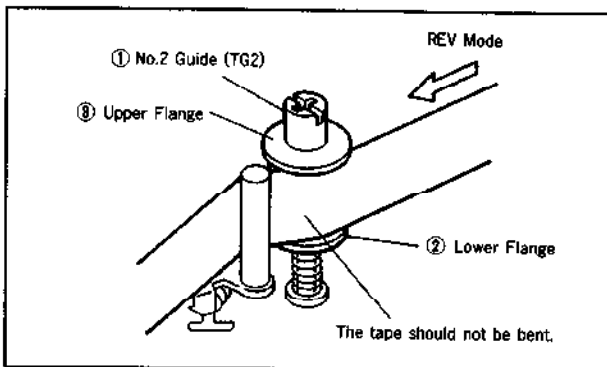

Fig. 40

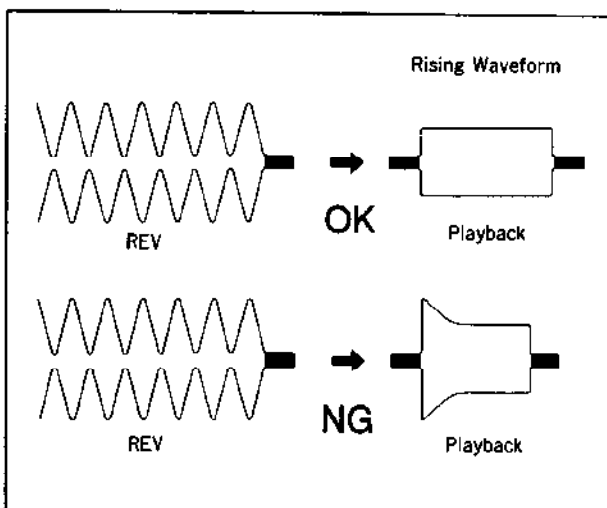

Fig. 41

### 5-4. No.7 GUIDE (TG7) ADJUSTMENT (Fig. 42)

**Note:** This adjustment requires the No. 7 guide adjusting cassette (Fig. 35).

- 1) Play back the No.7 guide adjusting cassette and set the REV mode.
- 2) Confirm that the tape is not bent between the No.6 guide (TG6) ① and the capstan ②. If it is, turn the height adjusting screw ④ of the No.7 guide (TG7) ③ until the tape is straightened.
- 3) Set the playback mode again and confirm that the tape is not bent between the capstan ② and the No.7 guide (TG7) ③ (specification : 0.5mm or less). If the tape is bent beyond the specification, turn the height adjusting screw ④ until bending is within the specification (0.5mm).

If in the REV mode tape bending between the No. 6 guide (TG6) ① and the capstan ② is 0.3mm or less, adjustment can be considered completed.

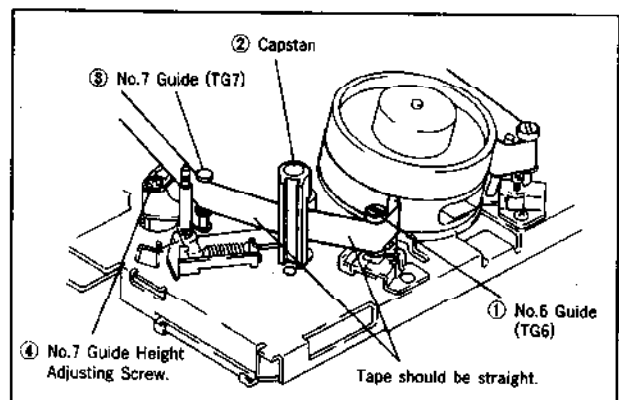

Fig. 42

### 5-5. CUE AND REV WAVEFORM CHECK (Fig. 43)

- 1) Play back the alignment tape for tracking adjustment and set the REV mode. Confirm that waveform peaks maintain a constant pitch of 5 seconds or more (Fig. 43). In case pitch is not constant, perform section 5-2.Tracking Fine Adjustment and section 5-4. No.7 Guide Adjustment.
- 2) Set the CUE mode. Confirm that waveform peaks still maintain a constant pitch of 5 seconds or more (Fig. 43). Otherwise, perform section 5-2 Tracking Fine Adjustment.

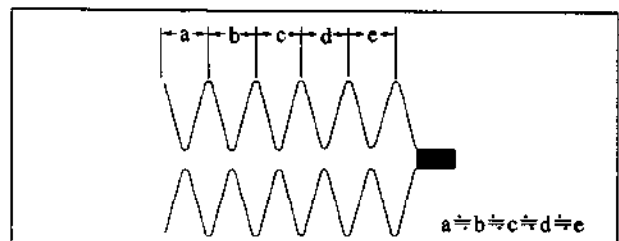

Fig. 43

## 5-6. CHECK AFTER ADJUSTMENT

### 5-6-1. TRACKING CHECK

- 1) Confirm that the amplitude of RF waveform is reduced to approx. 3/4 when the track shift mode is set (Fig. 44).
- 2) Then, confirm that the minimum amplitude value (EMIN) is 65% of the maximum value (EMAX) or larger (Fig. 45).
- 3) Confirm that no large fluctuations occur on the waveform (Fig. 45).

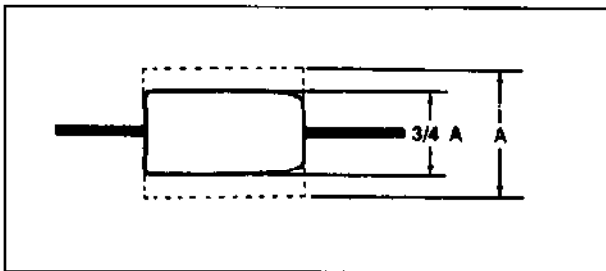

Fig. 44

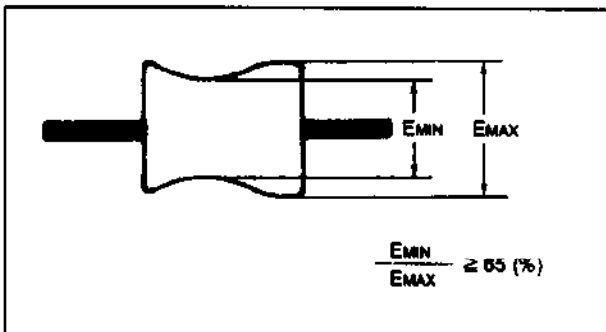

Fig. 45

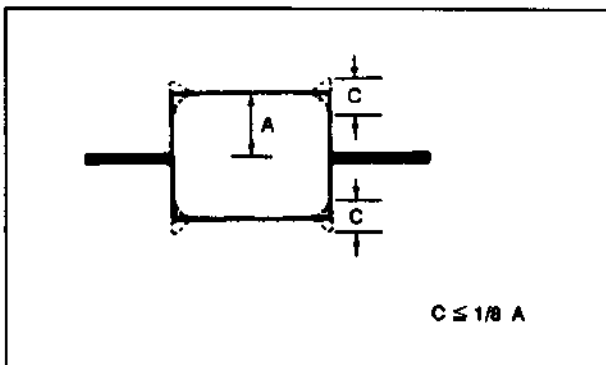

Fig. 46

### 5-6-2. RISING CHECK (Fig. 47)

- 1) Play back the alignment tape for tracking adjustment.
- 2) Cancel the track shift mode.
- 3) Eject the tape, then load it again.
- 4) Set the playback mode and confirm that the RF wave form rises flat within 2 seconds. Also confirm that the tape is not bent around the pinch roller.
- 5) CUE/REV and FF/REW the tape, then play it back and confirm that the RF waveform rises flat within 2 seconds, Also confirm that the tape is not bent around the pinch roller.
- 6) Repeat steps 3) to 5) once more.

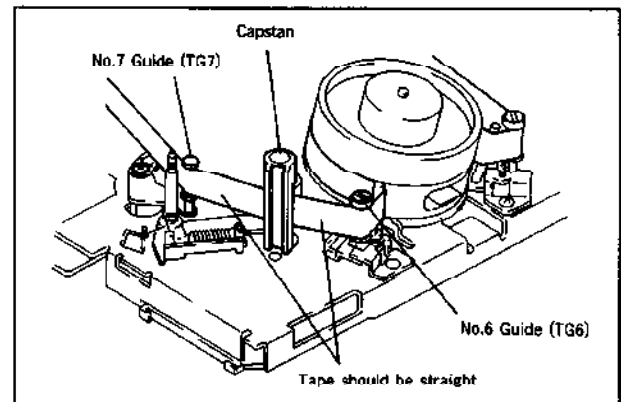

Fig. 47

### 5-6-3. TAPE PATH CHECK (Fig. 48)

- 1) Play back a thin tape like the P6-120MP (NTSC) or P5-90MP (PAL), etc. and confirm that no tape rising occurs, and that curling is less than 0.3mm, at the lower flange of the No. 2 guide, the upper flange of the No.3 guide, the upper flange of the No. 6 guide and the No.7 guide upper and lower flanges.
- 2) Confirm that no tape rising occurs and that curling is less than 0.3mm at the flange of all guide when pressing the FF button in the playback mode to set the CUE mode, or the REW button to set the REV mode.

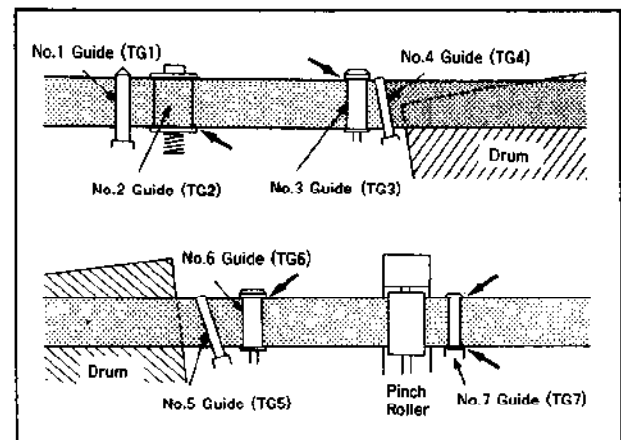

Fig. 48

## SECTION 6 EXPLODED VIEWS

**NOTE:**

● Items marked "\*" are not stocked since they are seldom required for routine service. Some delay should be anticipated when ordering these items.

● The mechanical parts with no reference number in the exploded views are not supplied.

● Hardware (#mark) list is given in the last of this parts list.

The components identified by mark  $\Delta$  or dotted line with mark  $\Delta$  are critical for safety. Replace only with part number specified.

**6-1. FRONT LOADING ASSEMBLY**

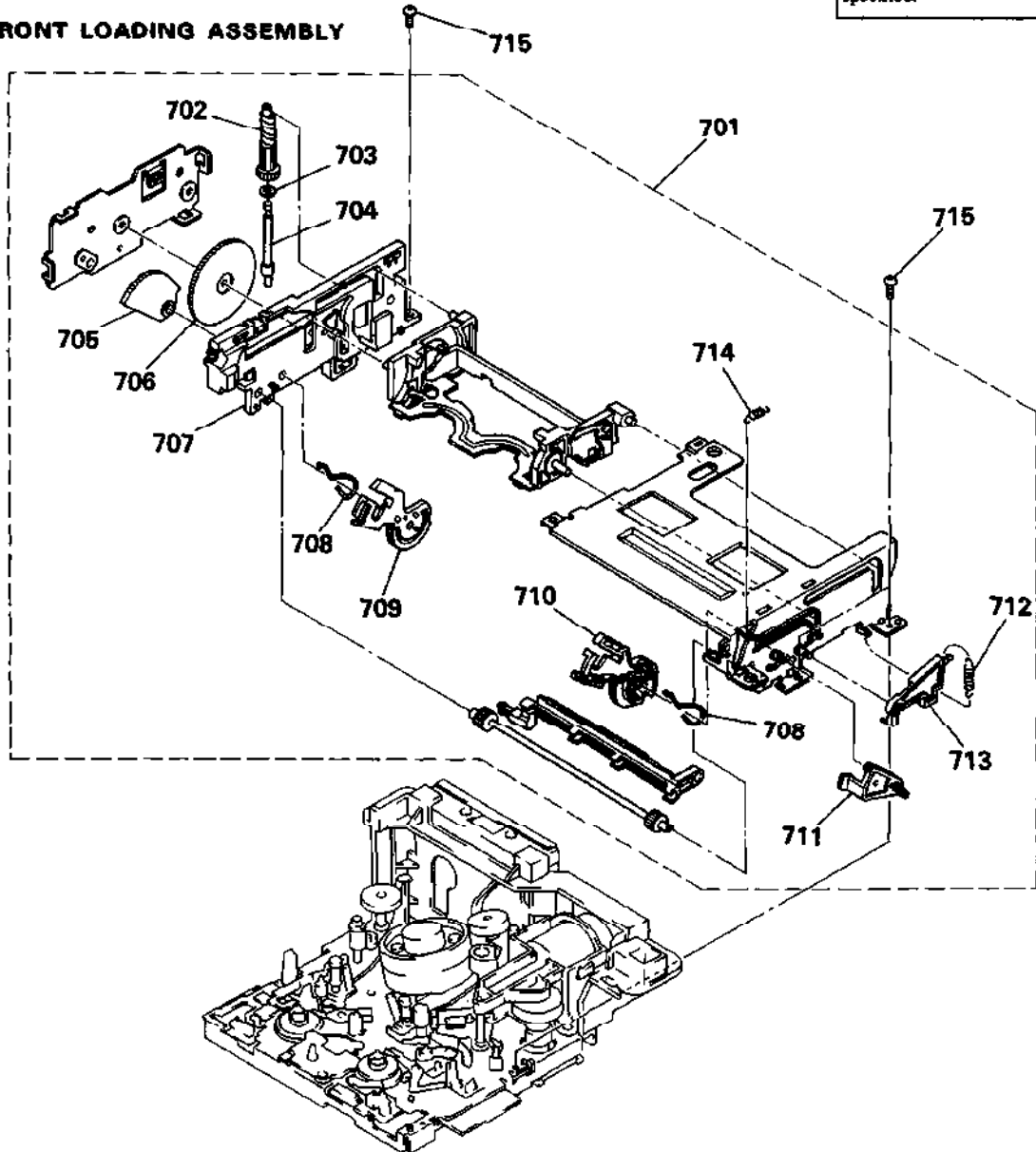

Ref.No.	Part No.	Description	Remark
701	A-7091-041-A	FL BLOCK ASSY	
702	3-954-028-01	GEAR, FL WORM	
703	3-738-212-11	RETAINER, THRUST, REEL TABLE	
*704	3-954-029-01	SHAFT, FL WORM GEAR	
705	3-954-020-01	GEAR, DRIVING	
706	3-954-019-01	WHEEL, FL WORM	
*707	3-954-032-01	PLATE (S), SIDE	
708	3-954-042-01	SPRING, PRESS	

Ref.No.	Part No.	Description	Remark
709	3-954-034-01	ARM (S), DRIVING	
710	3-954-033-01	ARM (T), DRIVING	
*711	3-954-041-01	ARM, DOOR SWITCHING	
712	3-954-043-01	SPRING, TENSION	
*713	3-954-040-01	ARM, CASSETTE IN SWITCH	
714	3-954-044-01	SPRING, TENSION	
715	3-732-817-01	SCREW (2X4.5), TAPPING	

## 6-2. MD CHASSIS ASSEMBLY (1)

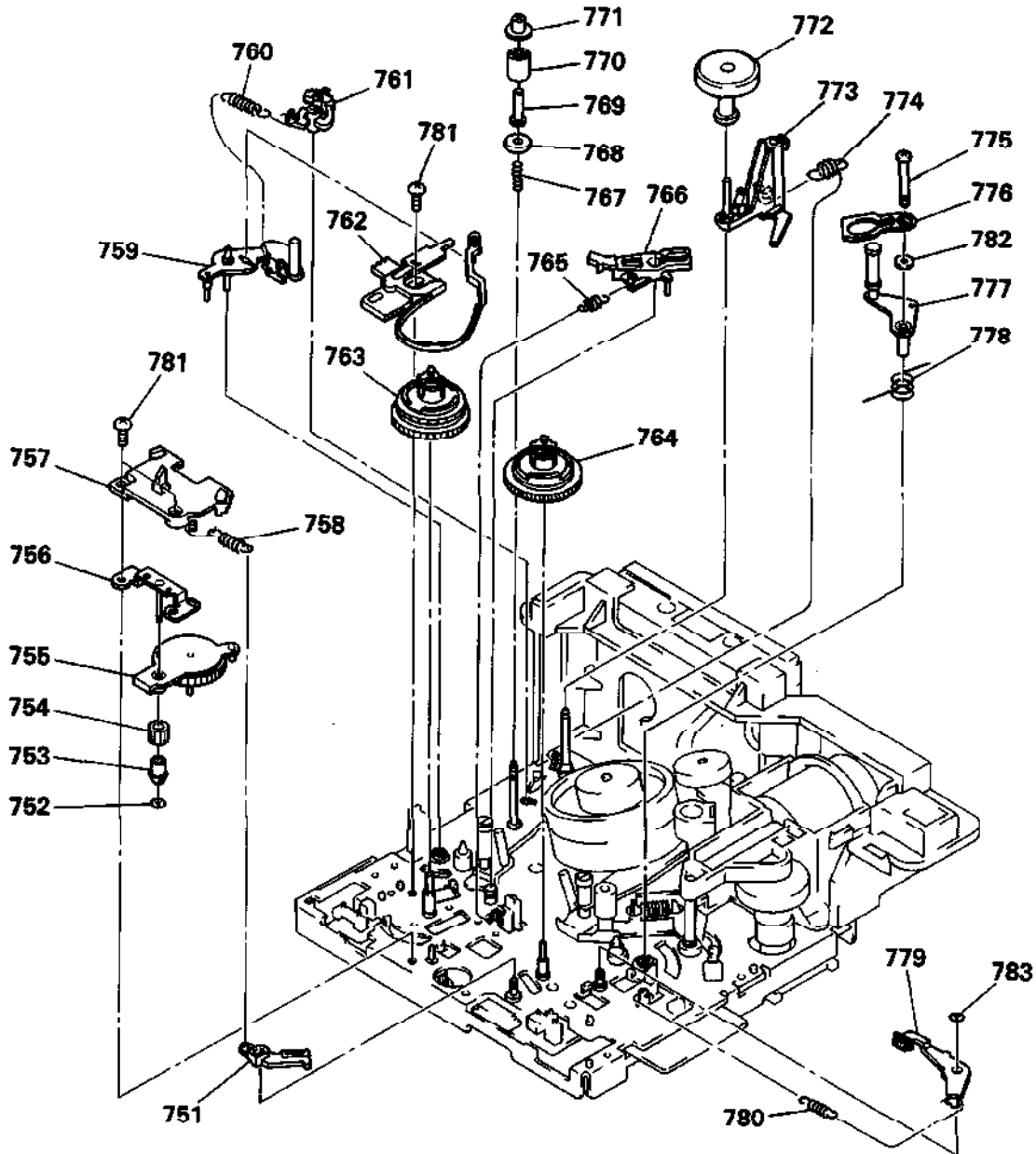

Ref.No.	Part No.	Description	Remark
751	X-3943-111-1	BRAKE (T) ASSY, SOFT	
752	3-726-829-01	WASHER, STOPPER	
753	3-954-321-01	BEARING, PENDULUM DRIVING	
754	3-954-059-01	GEAR, PENDULUM DRIVING	
755	X-3942-951-1	GEAR ASSY, PENDULUM	
756	X-3943-162-1	BASE ASSY, PENDULUM	
*757	3-954-063-01	PLATE, RELEASE, REEL LOCK	
758	3-955-142-01	SPRING, TENSION	
759	X-3942-955-1	TENSION REGULATOR ASSY	
760	3-954-074-01	SPRING, TENSION	
761	3-954-103-01	ARM, TENSION ADJUSTMENT	
762	X-3942-956-1	BAND ASSY, TENSION REGULATOR	
763	X-3942-954-1	TABLE (S) ASSY, REEL	
764	X-3942-953-1	TABLE (T) ASSY, REEL	
765	3-954-085-01	SPRING, TENSION	
766	3-954-071-01	ARM, BRAKE (S)	
767	3-954-001-01	SPRING, COMPRESSION	

Ref.No.	Part No.	Description	Remark
768	3-726-882-02	FLANGE, LOWER, TG2	
769	3-726-885-01	SLEEVE, TG2	
770	3-726-883-31	ROLLER, TG2	
771	3-726-884-01	FLANGE, UPPER, TG2	
772	3-954-282-01	ROLLER (M)	
773	X-3943-015-1	BASE ASSY, ROLLER	
774	3-954-284-01	SPRING, TENSION	
775	3-954-096-01	SCREW, TC7 HEIGHT ADJUSTMENT	
776	3-954-093-01	SPACER, TC7	
777	X-3942-958-1	ARM ASSY, TC7	
778	3-954-003-01	SPRING (TC7), TENSION	
779	X-3943-161-1	BRAKE (T) ASSY	
780	3-953-978-01	SPRING, TENSION	
781	3-732-817-01	SCREW (2X4.5), TAPPING	
782	3-738-212-11	RETAINER, THRUST, REEL TABLE	
783	3-669-465-00	WASHER (1.5), STOPPER	

6-3. MD CHASSIS ASSEMBLY (2)

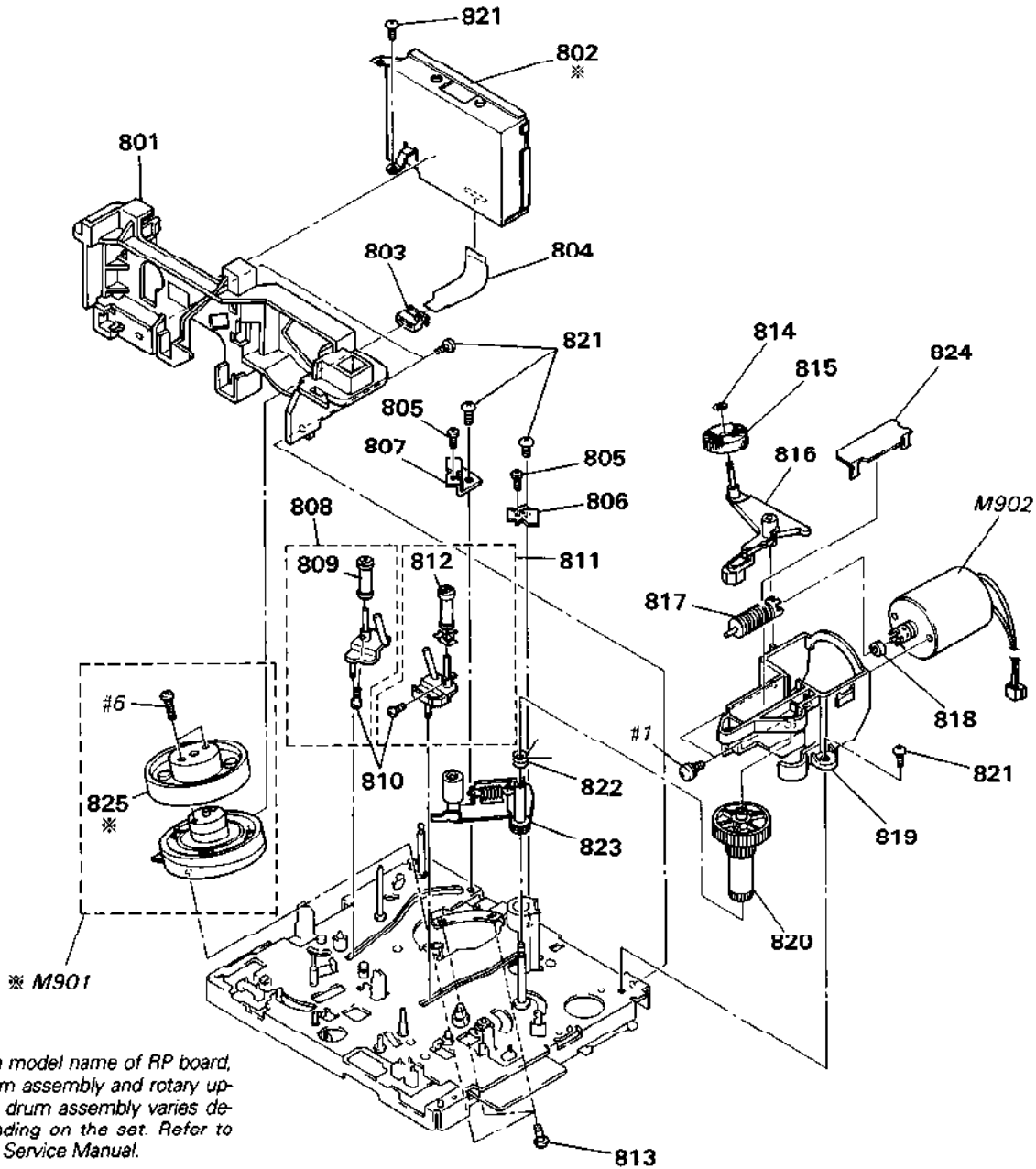

Ref.No.	Part No.	Description	Remark	Ref.No.	Part No.	Description	Remark
*801	3-955-623-01	FRAME, RP		815	X-3943-192-1	ROLLER ASSY, HC	
*802	※	RP BOARD, COMPLETE		816	X-3942-947-1	ARM ASSY, HC	
803	1-691-471-11	CONNECTOR, TRANSLATION 11P		817	3-733-395-01	GEAR (CAM), WORM	
804	1-649-565-11	FP-696 FLEXIBLE BOARD		818	3-696-388-01	RUBBER, JOINT	
805	3-954-285-01	SCREW (M1.4X0.2)		819	3-954-024-01	HOLDER, MOTOR	
806	3-954-091-01	CATCHER (T)		820	3-954-023-01	WHEEL, CAM WORM	
807	3-954-090-01	CATCHER (S)		821	3-732-817-01	SCREW (2X4.5), TAPPING	
808	A-7040-338-A	COASTER (S) BLOCK ASSY		822	3-954-105-01	SPRING (PINCH DRIVING)	
809	X-3941-755-1	ROLLER ASSY (2), TG3		823	X-3942-945-1	ARM ASSY, PINCH	
810	3-947-504-01	SCREW (M1.2X2)		824	3-958-047-02	MOTOR HOLDER COVER	
811	A-7040-339-A	COASTER (T) BLOCK ASSY		825	※	DRUM, UPPER, ROTARY	
812	X-3941-756-1	ROLLER ASSY (2), TG6		M901	※	DRUM ASSY	
813	3-686-493-01	SCREW (M2X5), P1		M902	X-3942-946-1	MOTOR ASSY, CAM	
814	3-321-393-01	WASHER, STOPPER					

6-4. MD CHASSIS ASSEMBLY (3)

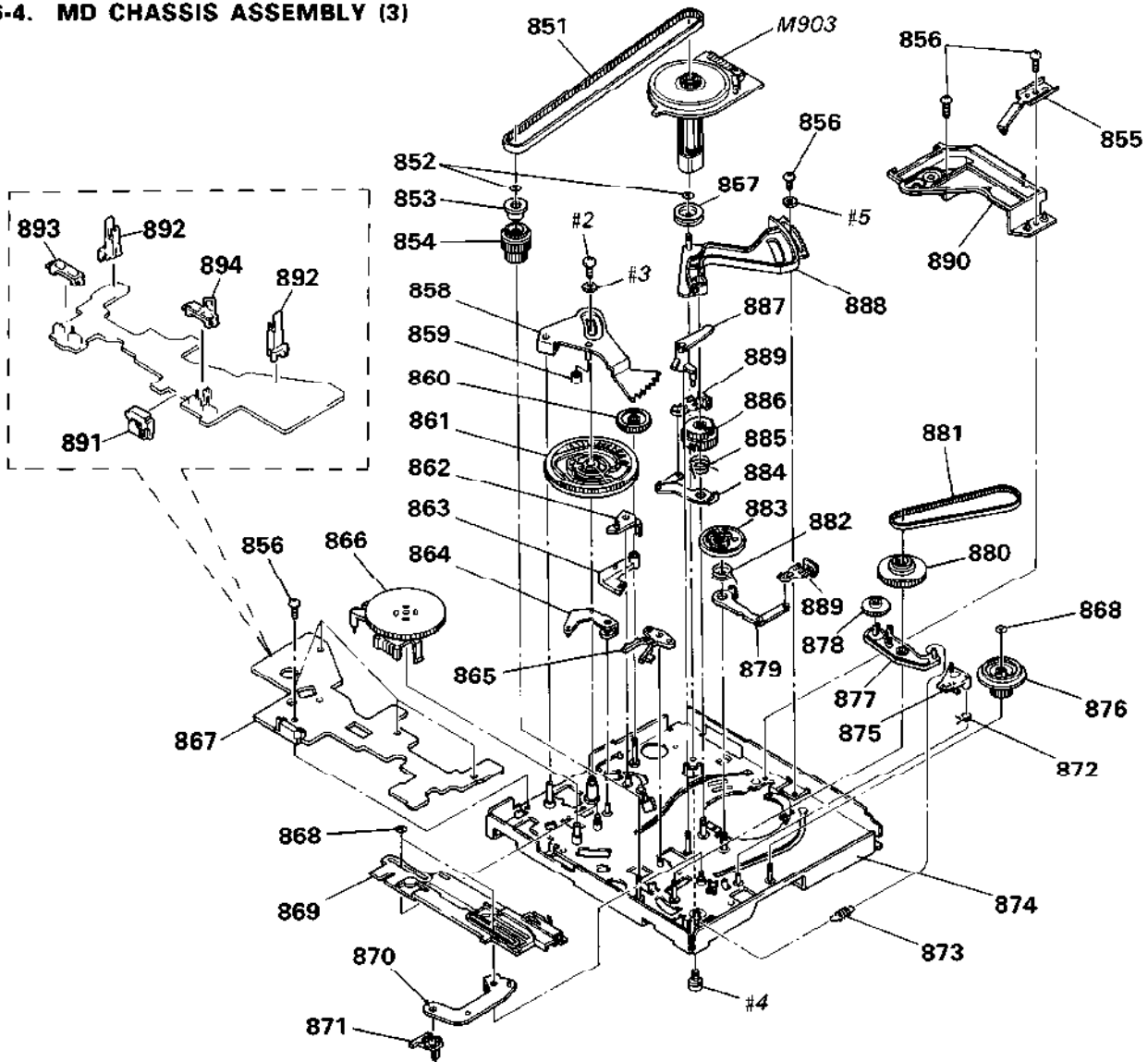

Ref.No.	Part No.	Description	Remark
851	3-953-986-01	BELT. TIMING	
852	3-726-829-01	WASHER, STOPPER	
853	3-954-102-02	FLANGE, REEL RELAY	
854	3-954-061-01	GEAR, REEL RELAY	
855	X-3942-960-1	GROUND ASSY, SHAFT	
856	3-732-817-01	SCREW (2X4.5), TAPPING	
857	X-3943-016-1	PULLEY ASSY, BELT	
* 858	3-954-014-01	LEVER, LOADING DRIVING	
859	3-954-323-01	ROLLER, LOADING	
860	3-954-015-01	GEAR, CAM RELAY	
861	3-954-050-01	CAM, MAIN	
* 862	3-954-009-01	LEVER, PINCH DRIVING	
863	3-954-016-01	LEVER, TG7 DRIVING	
* 864	3-954-007-01	LEVER, SLIDE PLATE DRIVING	
865	3-953-973-01	ARM, PENDULUM COMPUSSION	
866	1-692-498-11	SWITCH, ROTARY	
* 867	1-648-300-11	MD-59 BOARD	
868	3-669-465-00	WASHER (1.5), STOPPER	
869	3-953-972-01	PLATE, SLIDE	
* 870	3-953-974-01	ARM, S TAKE-UP	
871	3-953-975-01	CLAW, S TAKE-UP	
872	3-956-366-01	SPRING, TORSION	
873	3-953-982-01	SPRING, TENSION	

Ref.No.	Part No.	Description	Remark
* 874	X-3942-952-1	CHASSIS ASSY. MECHANICAL	
875	3-954-100-01	ARM, TENSION REGULATOR SUB	
876	3-953-983-01	GEAR, FL PULLEY	
877	3-953-979-01	ARM, FL SELECTION	
878	3-953-980-01	GEAR, FL SELECTION	
879	X-3942-949-1	ARM (S) ASSY, LOADING	
880	3-953-981-01	GEAR (DRIVING), FL PULLEY	
881	3-954-079-01	BELT (FL). TIMING	
882	3-953-998-01	SPRING (S), TORSION	
883	3-953-991-01	GEAR (S), LOADING	
884	X-3942-948-1	ARM (T) ASSY, LOADING	
885	3-954-000-01	SPRING (T), TORSION	
886	3-953-992-01	GEAR (T), LOADING	
887	3-954-072-01	LEVER, BRAKE (S) DRIVING	
888	X-3942-962-1	BASE ASSY, PULLEY	
889	3-956-649-01	SPRING, LEAF, COASTER	
* 890	3-954-049-01	RETAINER, WORM WHEET	
891	1-750-620-11	CONNECTOR (MM8 MD)	
892	3-953-985-01	HOLDER, ST SENSOR	
893	3-954-638-01	HOLDER (S), PUSH SWITCH	
894	3-954-639-01	HOLDER (T), PUSH SWITCH	
M903	8-835-499-01	MOTOR, DC SCE-0501A	







# 8 mm Video MECHANICAL ADJUSTMENT MANUAL V

## SECTION 8

### ELECTRICAL PARTS LIST

#### MD-59

**NOTE:**

- Due to standardization, replacements in the parts list may be different from the parts specified in the diagrams or the components used on the set.
- -XX and -X mean standardized parts, so they may have some difference from the original one.
- RESISTORS  
All resistors are in ohms.  
METAL: Metal-film resistor.  
METAL OXIDE: Metal oxide-film resistor.  
F: nonflammable

- Items marked "\*" are not stocked since they are seldom required for routine service. Some delay should be anticipated when ordering these items.
- SEMICONDUCTORS  
In each case, u :  $\mu$ , for example:  
uA :  $\mu$ A, uPA :  $\mu$ PA,  
uPB :  $\mu$ PB, uPC :  $\mu$ PC, uPD :  $\mu$ PD
- CAPACITORS  
uF :  $\mu$ F
- COILS  
uH :  $\mu$ H

When indicating parts by reference number, please include the board.

Ref.No.	Part No.	Description	Remark
*	1-648-300-11	MD-59 BOARD *****	
	3-953-985-01	HOLDER, SF SENSOR	
	3-954-638-01	HOLDER (S), PUSH SWITCH	
	3-954-639-01	HOLDER (T), PUSH SWITCH	
		< CONNECTOR >	
	CN001	1-569-341-11 CONNECTOR, BOARD TO BOARD 19P	
*	CN002	1-750-620-11 CONNECTOR (MM8 MD)	
		< DIODE >	
	D001	8-719-988-42 DIODE GL453S	
	D002	8-719-106-79 DIODE RD13M-B1	
	D003	8-719-106-23 DIODE RD7.5M-B2	
	D004	8-719-106-23 DIODE RD7.5M-B2	
	D005	8-719-106-23 DIODE RD7.5M-B2	
		< HOLE ELEMENT >	
	H001	1-808-118-11 ELEMENT, HALL HW-300A	
	H002	1-808-118-11 ELEMENT, HALL HW/300A	
		< JUMPER RESISTOR >	
	JR001	1-216-296-00 METAL CHIP 0 5% 1/8W	
	JR002	1-216-296-00 METAL CHIP 0 5% 1/8W	
	JR003	1-216-296-00 METAL CHIP 0 5% 1/8W	
		< TRANSFORMER >	
	PT001	8-729-907-25 TRANSISTOR PT4850F	
	PT002	8-729-907-25 TRANSISTOR PT4850F	
		< RESISTOR >	
	R001	1-216-190-00 METAL GLAZE 470 5% 1/8W	
	R002	1-216-190-00 METAL GLAZE 470 5% 1/8W	
	R003	1-216-190-00 METAL GLAZE 470 5% 1/8W	
	R004	1-216-190-00 METAL GLAZE 470 5% 1/8W	
		< SWITCH >	
	S001	1-692-497-11 SWITCH, PUSH (TAPE 8/9)	
	S002	1-692-497-11 SWITCH, PUSH (TAPE 10/13)	

Ref.No.	Part No.	Description	Remark
	S003	1-692-497-11 SWITCH, PUSH (ME/MP)	
	S004	1-692-497-11 SWITCH, PUSH (H18 MP)	
	S005	1-692-497-11 SWITCH, PUSH (REC PROOF)	
	S006	1-570-953-11 SWITCH, PUSH (1 KEY) (CC DOWN)	
		*****	
		MISCELLANEOUS *****	
	803	1-691-471-11 CONNECTOR, TRANSLATION 11P	
	804	1-649-565-11 FP-696 FLEXIBLE BOARD	
	825	* DRUM ASSY	
	866	1-692-498-11 SWITCH, ROTARY	
	891	1-750-620-11 CONNECTOR (MM8 MD)	
	M901	* DRUM ASSY	
	M902	X-3942-946-1 MOTOR ASSY, CAM	
	M903	8-835-499-01 MOTOR, DC SCE-0501A	
		*****	
		HARDWARE LIST *****	
	#1	7-682-645-01 SCREW +PS 3X4	
	#2	7-621-772-08 SCREW +B 2X3	
	#3	7-688-003-01 W 3, SMALL	
	#4	7-628-253-15 SCREW +PS 2X5	
	#5	7-688-001-01 W 2, MIDDLE	
	#6	7-627-853-57 PRECISION SCREW +P 2X5 TYPE3	

9-973-445-11

Sony Corporation  
Personal Video Group

English  
94B18150-1  
Printed in Japan  
© 1994.2

Published by CV Quality Engineering DIV.