

DTC-1000ES

SERVICE MANUAL

AEP Model
UK Model

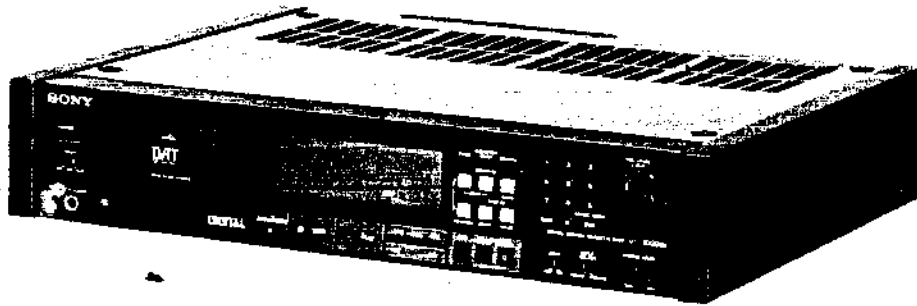

SPECIFICATIONS

System	Digital audio tape recorder
Tape	Digital audio tape
Recording system	Rotary head
Recording time	120 minutes (with DT-120)
Tape speed	8.15 mm/s
Drum rotation	Approx. 2,000 rpm
Error correction	Double Reed Solomon code
Number of channel	2 channels, stereo
D/A conversion	16-bit linear
Frequency response	2-22,000 Hz ± 0.5 dB
Signal to noise ratio	More than 92 dB
Dynamic range	More than 90 dB
Total harmonic distortion	Less than 0.0055%
Wow and flutter	Below measurable limit

General

Power requirements	220V AC, 50/60Hz (AEP model) 240V AC, 50Hz (UK model)
Power consumption	48 W
Dimensions	Approx. 470 x 100 x 420 mm (w/h/d) (18 $\frac{1}{2}$ x 3 $\frac{15}{16}$ x 16 $\frac{1}{2}$ inches) incl. side wood Approx. 430 x 100 x 420 mm (w/h/d) (16 $\frac{15}{16}$ x 3 $\frac{15}{16}$ x 16 $\frac{1}{2}$ inches) excl. side wood
Weight	Approx. 12 kg (26 lb 7 oz) incl. side wood

Supplied accessories

Remote commander (1)RM-R1
Sony batteries SUM-3 (NS) (2)
Audio connecting cords (2 phono plugs x 2 phono plugs, stereo, for line inputs and outputs) (2)
Screws to secure the cabinet (4)*

Remote commander (supplied)RM-R1

Remote control system	Infrared control
Power requirements	3 V DC, with R6 (size AA) batteries
Dimensions	Approx. 67 x 175 x 18 mm (w/h/d) (2 $\frac{5}{8}$ x 6 $\frac{7}{8}$ x 1 $\frac{1}{16}$ inches)
Weight	Approx. 145 g (5 oz) incl. batteries

* The side wood panels on both sides of the deck are detachable. After removing the screws, secure the cabinet with the supplied lock screws (four M4 x 6).
For safety, before doing this, be sure to disconnect the AC power cord from the AC outlet.

Input jacks	Jack type	Impedance	Rated input level
LINE IN	Phono	50 kohms	-10 dBs
DIGITAL	Phono	75 ohms	0.5 Vp-p

Output

Output jacks	Jack type	Impedance	Rated output	Load impedance
LINE OUT	Phono	470 ohms	-10 dBs	More than 10 kohms
HEAD-PHONES	Stereo phone	150 ohms	0-28 mW	32 ohms
DIGITAL OUT	Phono	75 ohms	0.5 Vp-p	75 ohms

Tape

Track pitch	13.6 μ m (20.4 μ m)
Sampling frequency	48 kHz, 44.1 kHz, 32 kHz
Modulation system	8-10 Modulation
Transfer rate	2.46 Mbit/sec. (before modulation)



DIGITAL AUDIO TAPE DECK
SONY®

AUD

SAFETY-RELATED COMPONENT WARNING!!

COMPONENTS IDENTIFIED BY SHADING AND MARK  ON THE SCHEMATIC DIAGRAMS AND IN THE PARTS LIST ARE CRITICAL TO SAFE OPERATION. REPLACE THESE COMPONENTS WITH SONY PARTS WHOSE PART NUMBERS APPEAR AS SHOWN IN THIS MANUAL OR IN SUPPLEMENTS PUBLISHED BY SONY.

Flexible Circuit Board Repairing

- Keep the temperature of the soldering iron around 270°C during repairing.
- Do not touch the soldering iron on the same conductor of the circuit board (within 3 times).
- Be careful not to apply force on the conductor when soldering or unsoldering.

Notes on chip component replacement

- Never reuse a disconnected chip component.
- Notice that the minus side of a tantalum capacitor may be damaged by heat.

TABLE OF CONTENTS.

<u>Title</u>	<u>Description</u>	<u>Page</u>
Section 1.	Outline	3
Section 2.	Block Diagram	7
Section 3.	Disassembly	13
Section 4.	Adjustments	17
4-1.	Mechanical Adjustment	17
4-2.	Electrical Adjustment	20
Section 5.	Diagrams.	32
5-1.	Mounting Diagram (MD Servo & Digital Block)	33
5-2.	Schematic Diagram (MD Servo Block).	37
5-3.	Mounting Diagram (Power Block).	43
5-4.	Schematic Diagram (Power Block)	44
5-4.	Schematic Diagram (Digital Block)	47
5-5.	Mounting Diagram (Analog & Microcomputer Block)	53
5-6.	Schematic Diagram (Analog & Microcomputer Block).	57
Section 6.	Exploded Views and Parts List	69
Section 7.	Electrical Parts List	79

SECTION 1 OUTLINE

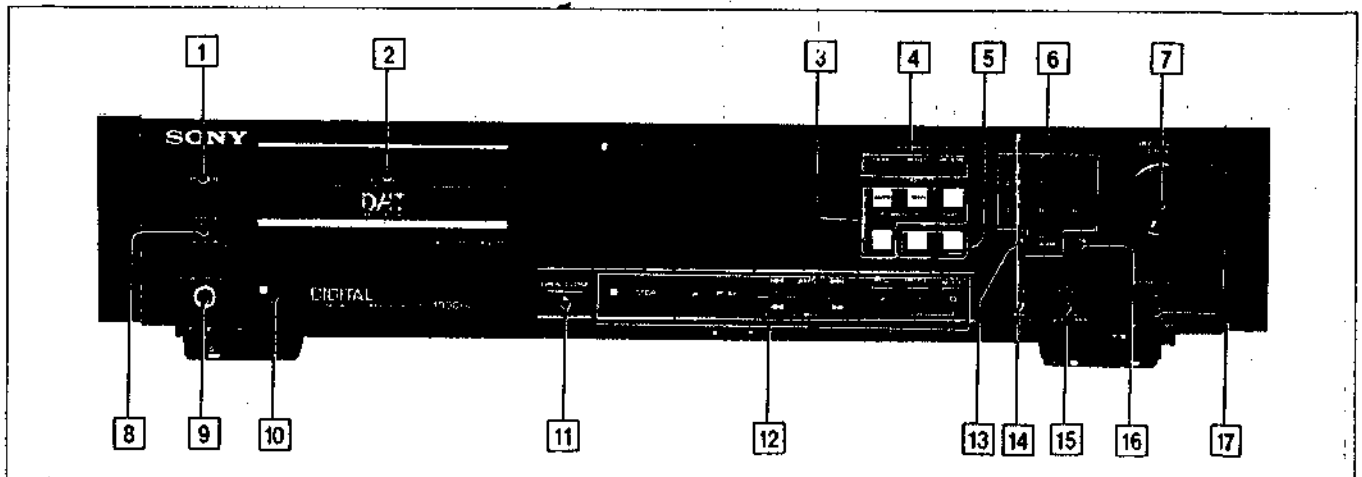

1 POWER switch

2 Cassette compartment

Insert a cassette with the window side up and the safety tab facing toward you.

3 START ID buttons and indicators

Used to write and erase the start ID codes, and to renumber and erase the program numbers.

AUTO (automatic): Press to write the start ID automatically during recording. When the recording level returns to the fixed level after having been below it for more than 3 seconds, the start ID is written on the tape for 9 seconds.

MAN (manual): Press to write the start ID at the desired point during recording. The MAN indicator lights. The start ID is written on the tape for 9 seconds.

ERASE: Press to erase a start ID. When a start ID and a program number are written on the tape, both codes are simultaneously erased by pressing this button.

RENUMBER: Press to renumber the program numbers. When only the start IDs are written, pressing this button will insert program numbers. When this button is pressed, the tape is rewound to the beginning automatically and program numbers are assigned from "1" in numerical order.

4 COUNTER buttons

MODE: Changes the counter indication in the display window from the tape running time, to elapsed time of the selection, to total remaining time of the tape, and back to the tape running time again.

RESET: Resets the counter to "00:00".

MEMORY: Stores the point where the counter is reset in memory.

5 SKIP ID buttons and indicators

WRITE: Press to write a skip ID onto the tape.

ERASE: Press to erase a skip ID which is written at the point just before the current position.

6 Numeric buttons (0-9)

Press to designate the program number.

7 REC LEVEL (recording level) controls

Adjust the recording level. The outer knob controls the left channel level and the inner knob the right channel level.

8 TIMER switch

Normally set to OFF. Used to start recording or playback at the desired time using a commercially available audio timer.

9 HEADPHONES jack (stereo phone jack)

10 Remote sensor

11 OPEN/CLOSE button and indicator

12 Tape operation buttons

■ STOP button

▶ PLAY button

▶▶ CUE (fast-forward/cue) button

◀◀ REVIEW (rewind/review) button

◀◀ AMS: Press to locate the beginning of the selection in reverse direction.

▶▶ AMS: Press to locate the beginning of the selection in forward direction.

● REC (recording) button

⏸ PAUSE button: If the pause mode continues for about 10 minutes, it will be released automatically and the deck will enter the stop mode.

○ REC MUTE (record muting) button

13 CLEAR button

Used to cancel the selection number which has been entered mistakenly.

14 SKIP switch

Set this switch to ON to skip during playback the selections coded with a skip ID code. Set it to OFF to play back the whole tape as it is.

15 INPUT SELECT switch

ANALOG: For recording from the equipment

connected to the LINE IN jacks on the rear panel.

DIGITAL: For recording from the equipment connected to the DIGITAL IN jack on the rear panel.

16 START button

Starts playback from the designated selection or activates the music scan operation.

17 PHONES LEVEL (headphones level) control

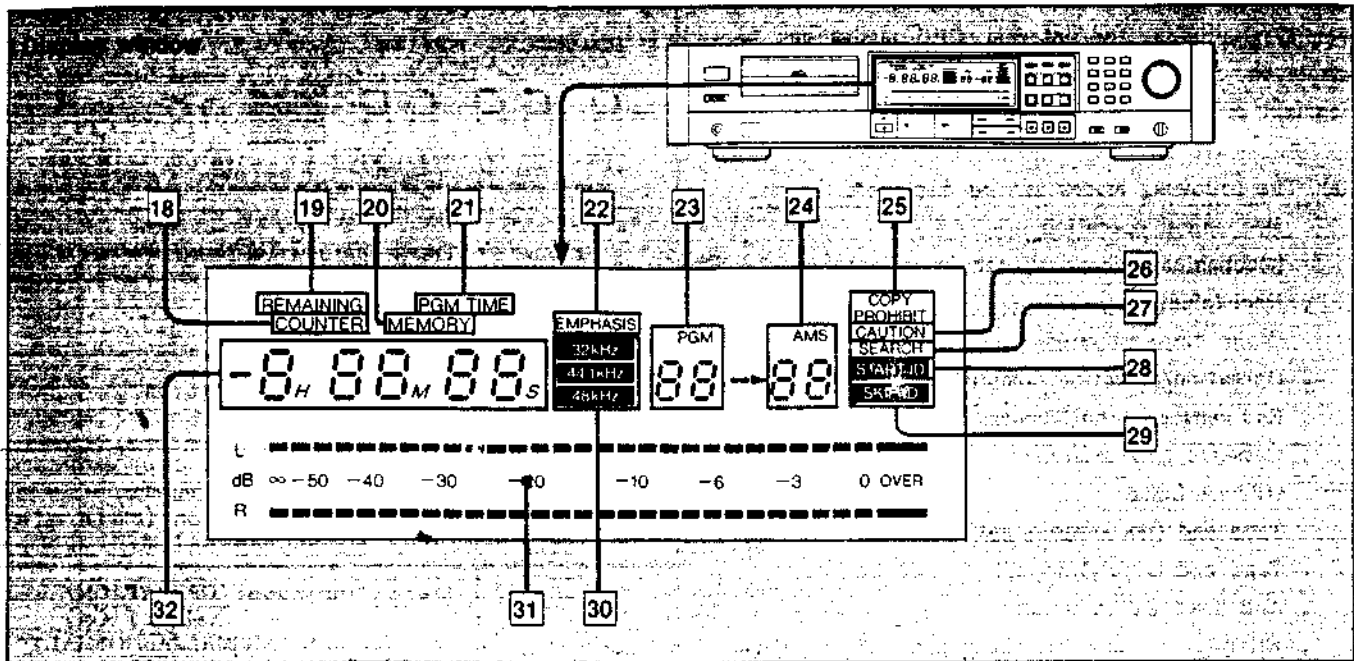

- 18** **COUNTER indicator**
Lights up to show that the counter is displaying the tape running time.
- 19** **REMAINING indicator**
Lights up to show that the counter is displaying the remaining time. The remaining time is not displayed during search operation (the SEARCH indicator lights), fast-forwarding or rewinding.
- 20** **MEMORY indicator**
Lights up when the MEMORY button is pressed to show that the "0M 00S" point is stored in memory.
- 21** **PGM TIME (program time) indicator**
Lights up to show that the counter is displaying the elapsed time of the current selection.
- 22** **EMPHASIS indicator**
Lights up when recording a digital signal input from the DIGITAL IN jack contains a pre-emphasized signal. In the playback mode, it also lights up while the detected pre-emphasized signal is being de-emphasized.
- 23** **PGM (program number) display**
Shows the program number of the selection being played.
- 24** **AMS (automatic music sensor) display**
Shows the number of selections to be skipped ahead or behind in AMS operation. When a numeric button is pressed, the display shows the program number of the target selection while the selection is being searched for.
- 25** **COPY PROHIBIT (digital copy prohibit) indicator**
Blinks when the digital signal to be recorded contains a "digital copy prohibit" code. In this case, digital-to-digital recording cannot be done.
- 26** **CAUTION indicator**
Blinks when moisture condensation occurs. If this happens, the deck stops automatically.
- 27** **SEARCH indicator**
Lights up while a selection is being searched for.
- 28** **START ID indicator**
Blinks when writing or erasing a start ID code, or when the start ID is detected during playback.
- 29** **SKIP ID indicator**
Lights up momentarily when writing or erasing a skip ID code, or when the skip ID is detected during playback.
- 30** **Sampling frequency indicators**
Indicates the sampling frequencies (32 kHz, 44.1 kHz, 48 kHz) with which the digital program is encoded.
44.1 kHz: For playback of pre-recorded DAT tape (Digital-to-digital recording cannot be done).
48 kHz: For recording/playback with DAT tape
- 31** **Peak level meters**
Indicate the level of the audio signal being recorded during recording, and the peak values of the audio signal recorded on the tape during playback.
- 32** **Counter**
Displays the tape running time, elapsed time of the selection being played, and the total remaining time of the tape. Each time COUNTER MODE is pressed, the display mode changes in turn.

DTC-1000ES DTC-1000ES

DTC-1000ES TEST MODE

For DTC-1000ES, the internal CPU modes can be displayed for servicing on the counter's seven-segment display.

(a) The following modes can be displayed:

- Mechanical operation
(Mechanical microcomputer operation)
- Mechanical instruction
(Main microcomputer instruction)
- Operation/operation completion
- End sensor normal/abnormal
- Cassette half existence
- OPEN/CLOSE
- Tape end (take-up)/normal
- Tape end (supply)/normal
- A/B head RF existence
- WIDTH 1.5 times normal speed/NOT 1.5 times normal speed
- Soft tape/normal tape
- REC inhibit/OK
- Drum normal/abnormal
- Tray in/out
- TEST mode/NOT TEST mode
- Take-up end hold/NOT hold
- Tray loading normal/abnormal
- Position EJECT/NOT EJECT
- Measure End
- Preend
- Take-up Reel Stop
- Supply Reel Stop
- Measure completion

(b) To display the test modes, connect pin 67 of mechanical microcomputer IC512 to GND, and press the counter's MODE switch for three times.

(c) The indicator display is described below.

Using indicators (1) through (9), data in main microcomputer is displayed by four bits (hexadecimal).

(Items (1), (3), (4), (5), and (6) are mechanical microcomputer data; (2) and (9) are main microcomputer data; and (8) is reel microcomputer data.)

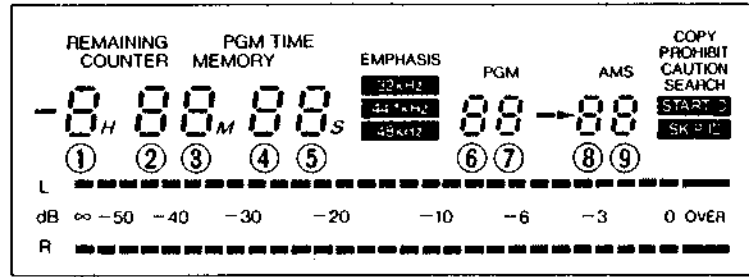

Display position	Description
①	Mechanical operation
②	Mechanical instruction (main microcomputer to mechanical microcomputer)
③	0 Operation mode (OPERATION/COMPLETION) 1 End sensor (NORMAL/ABNORMAL) 2 Cassette half (YES/NO) 3 OPEN (OPEN/CLOSE)
④	0 Tape end take-up reel (TOP/NOR) 1 Tape end supply reel (END/NOR) 2 RF (NO RF/RF) 3 WIDTH (1.5 TIMES NORMAL SPEED/NOT 1.5 TIMES NORMAL SPEED)
⑤	0 Tape (SOFT/NORMAL) 1 REC (INHIBIT/OK) 2 DRMERR (DRUM NORMAL/ABNORMAL) 3 TOUT (TRAY IN/OUT)
⑥	0 FTEST (TEST MODE/NOT TEST MODE) 1 TEUDH (TAKE-UP END HOLD/NOT HOLD) 2 TLABF (TRAY LOADING NORMAL/ABNORMAL) 3 PEJCT (EJECT POSITION/NOT EJECT POSITION)
⑦	0 1 2 3 Not Used. (Digit may vary.)
⑧	0 Measure End 1 Preend 2 Take-up Reel Stop 3 Supply Reel Stop
⑨	0 1 2 3 Not Used. (Digit may vary.) Measure completion (COMPLETED/NOT COMPLETED)

(d) Display positions (1) and (2) are shown below.
(The same data as in (2) is displayed in (1) at all times with a slight delay.)

Code	Display	Description
0	0	FWD x 1
1	1	FWD x 2
2	2	FWD x 16
3	3	REC FWD
4	4	FF
5	5	FF SEARCH
6	6	FWD x 16 (measure)
7	7	OPEN/CLOSE
8	8	STOP
9	9	PAUSE
A	-	REV x 16 (measure)
B	b	REW
C	c	REW SEARCH
D	d	REV x 1
E	e	REV x 2
F	Blank	REV x 16

(e) Operations in the TEST mode are described below (as compared with those in the normal mode).

1. Cassette compartment is not activated.
2. Cassette is not detected.
3. CAUTION indication does not appear.

The DTC-1000ES cannot enter the TEST mode from PLAY mode. When the AMS button (▶) is pressed using a 1.5 times normal speed tape, FS (sampling frequency) indication changes to flashing 32 kHz and the set enters the FWD mode. When the AMS button (◀) is pressed, it enters the REV mode. When the former button is pressed using a normal speed tape, the set enters the FWD x 16 mode. When the latter button is pressed, it enters the REV x 16 mode.

SECTION 2
BLOCK DIAGRAM

Audio/Microcomputer

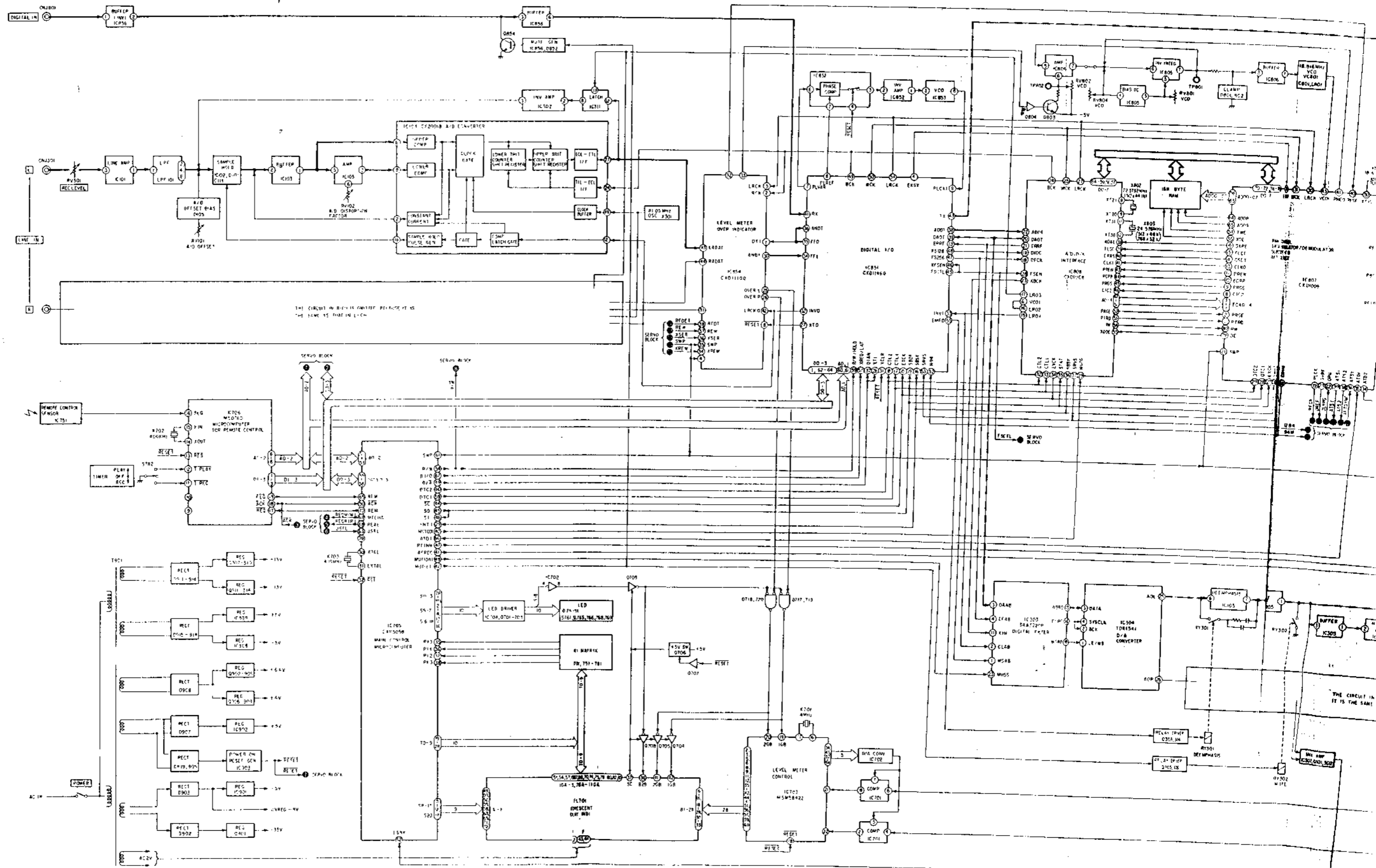

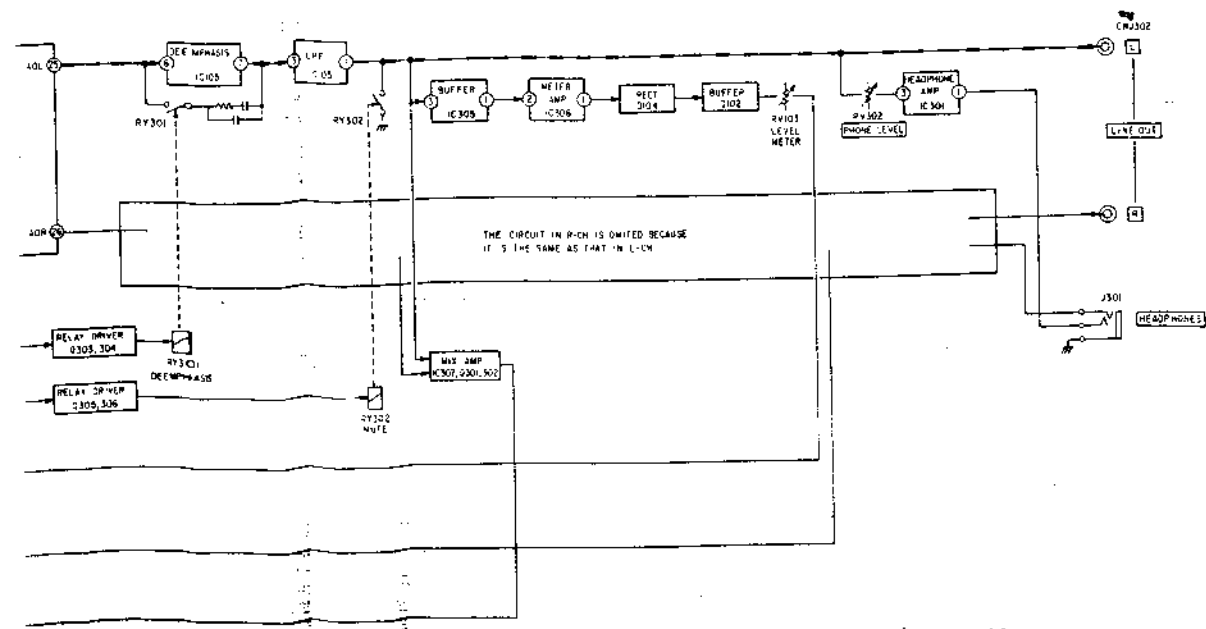
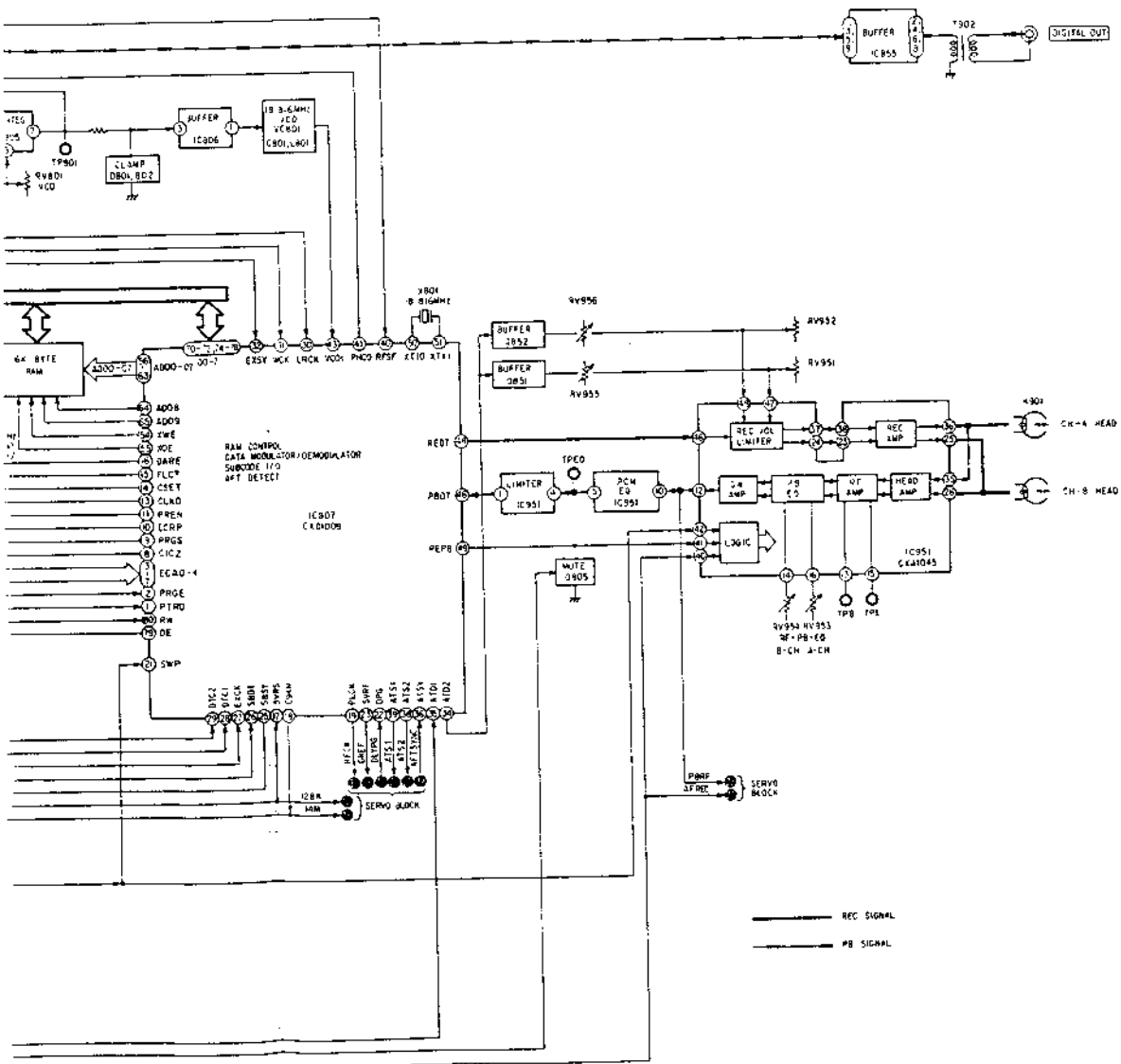

DTC-1000ES DTC-1000ES

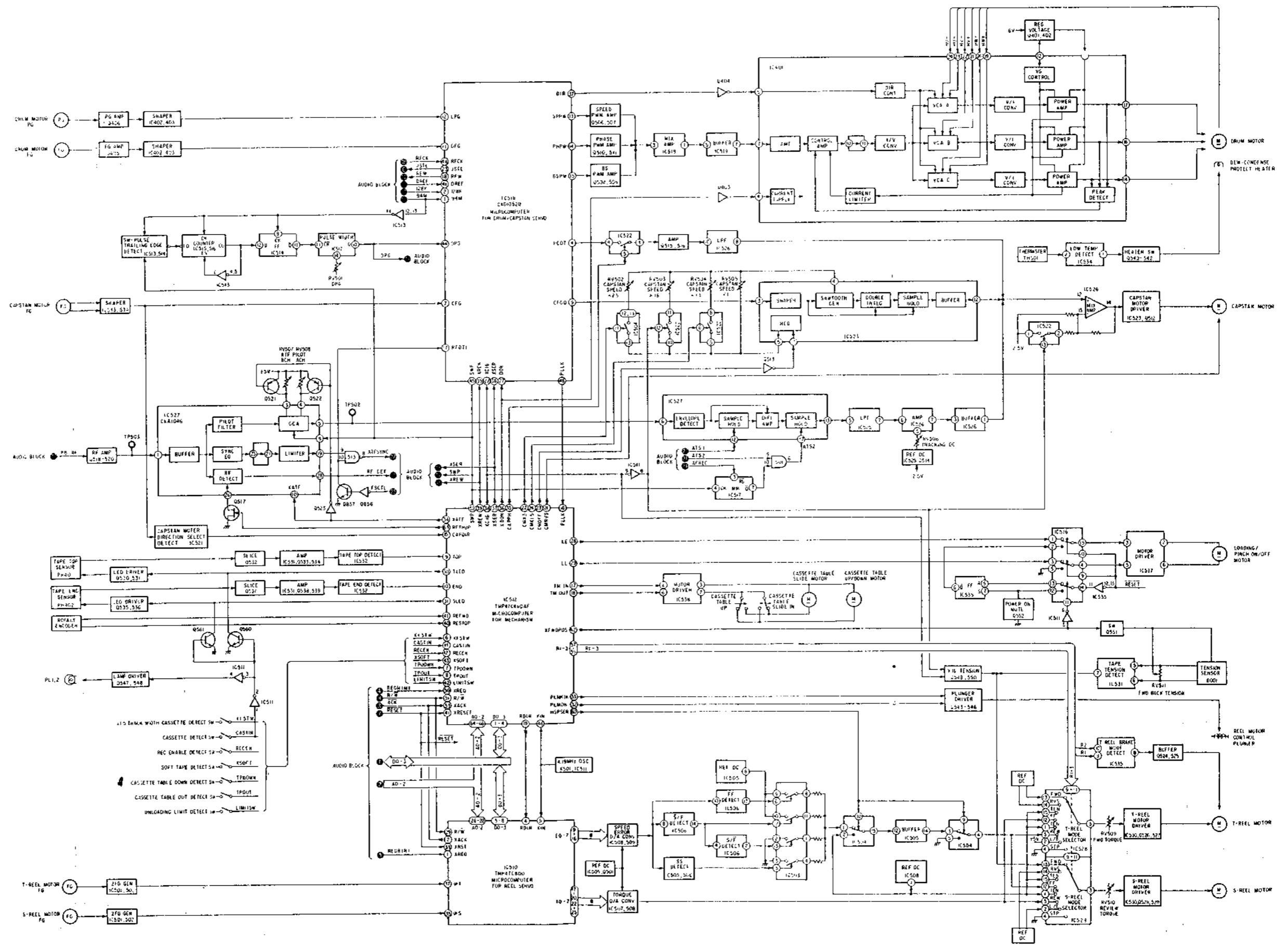

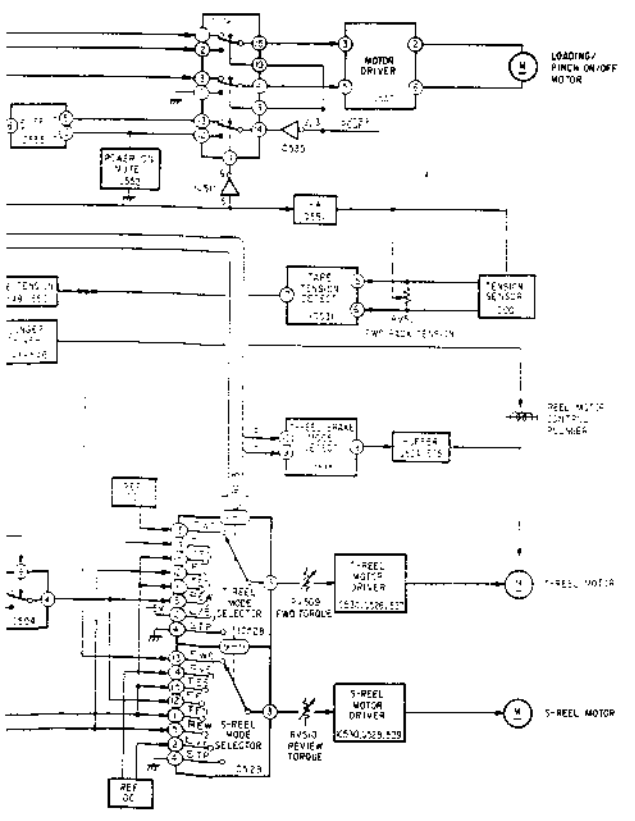
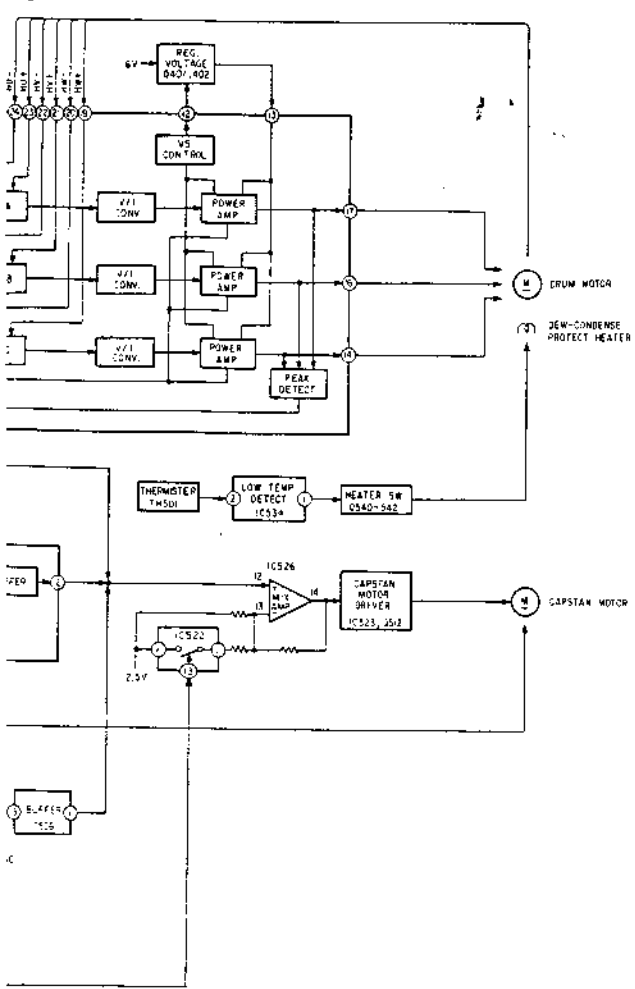

SECTION 3
DISASSEMBLY

When numbers are assigned in the illustration, remove parts in numerical order.

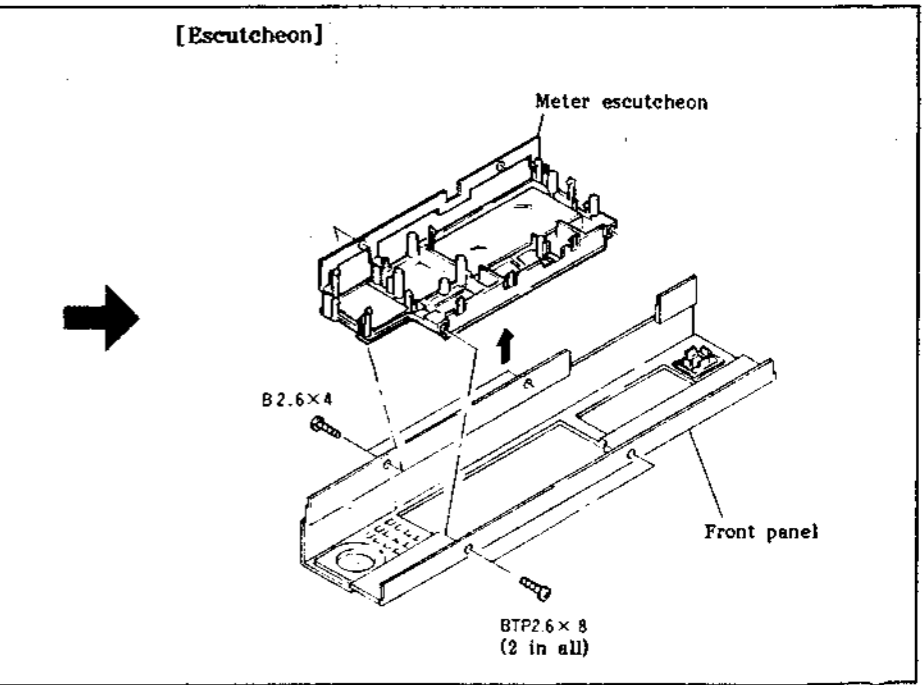
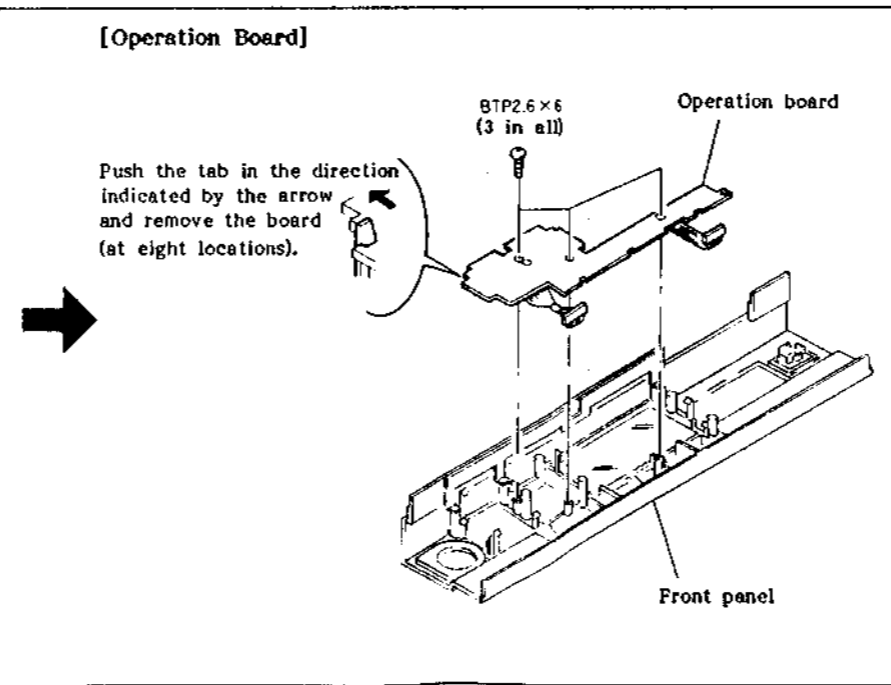
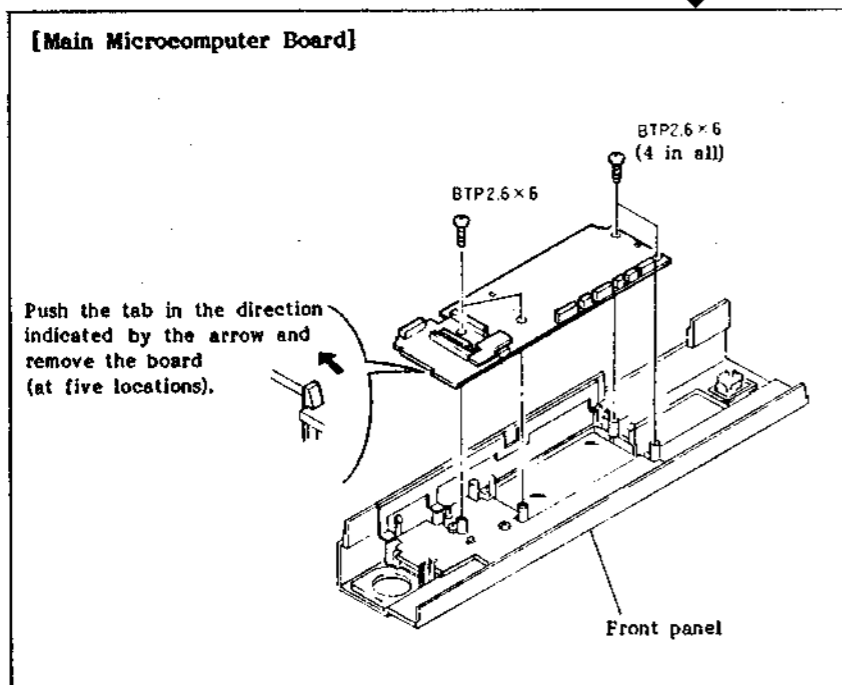
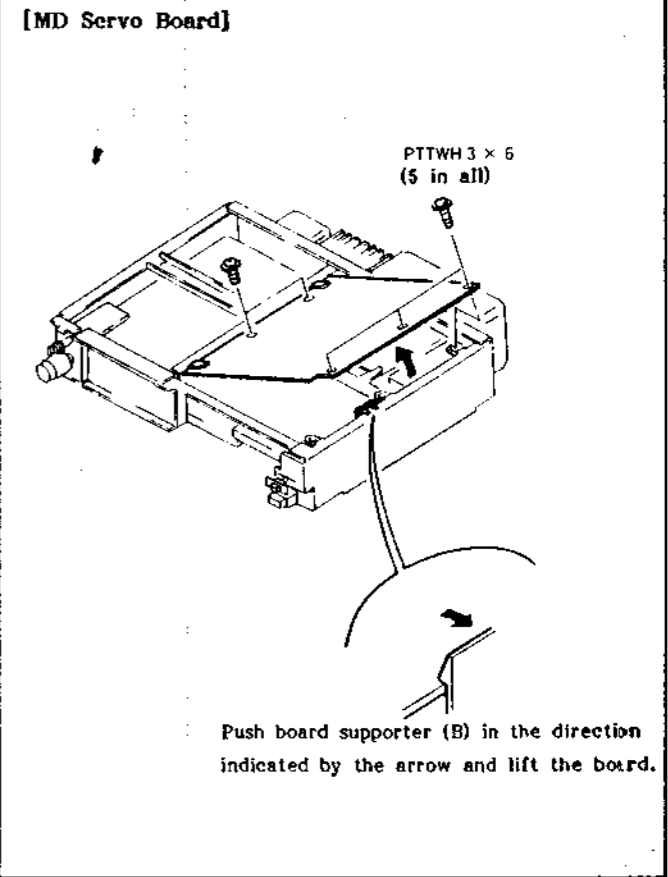
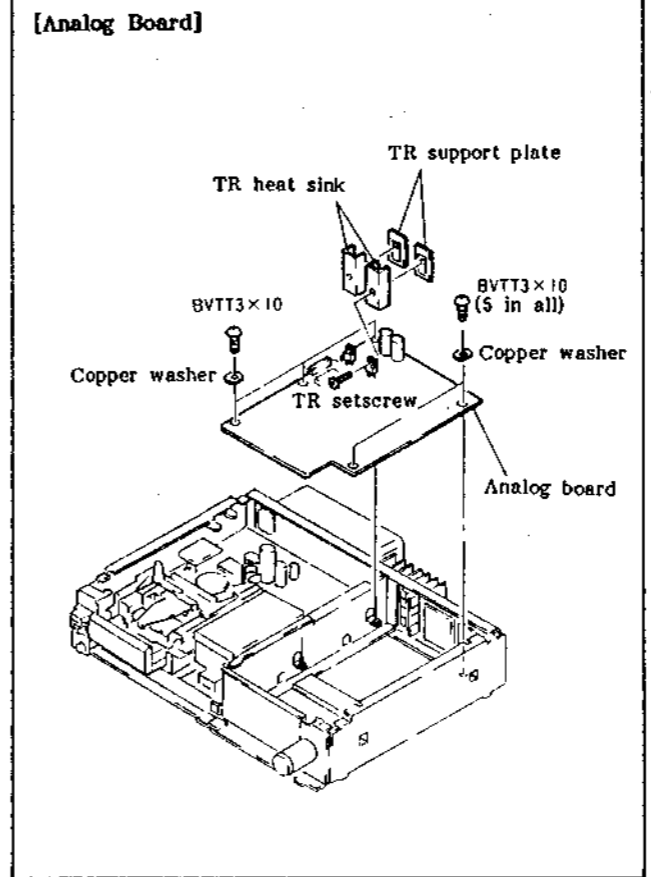
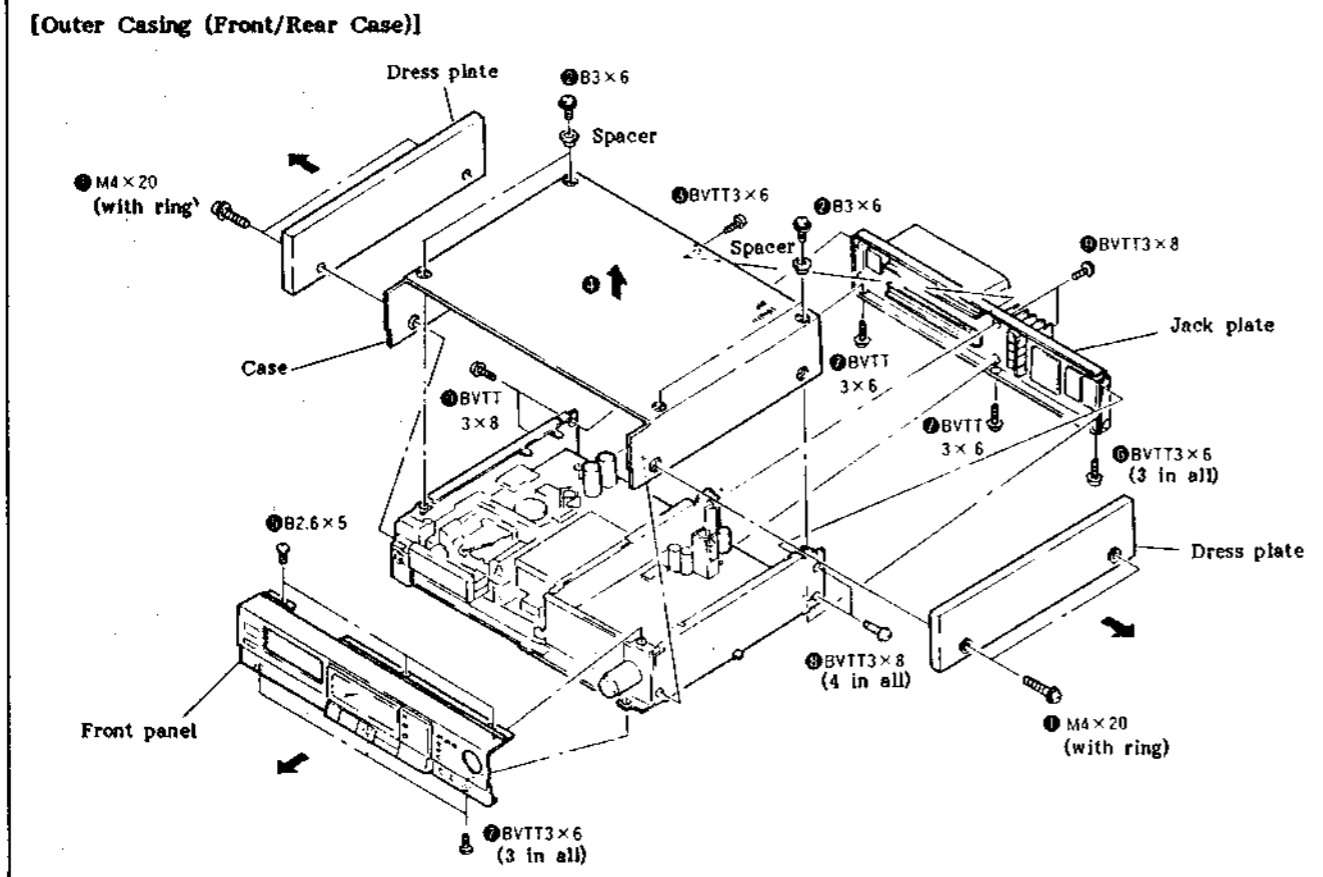

[Mechanical Block]

Note: Remove the cassette control block while it is set to OPEN.

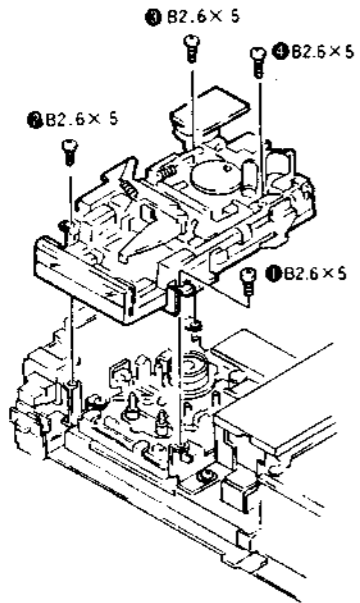

Note: The numbers in the illustration indicate the installation order. (Check a UD gear for its hole position.)

[UD Motor]

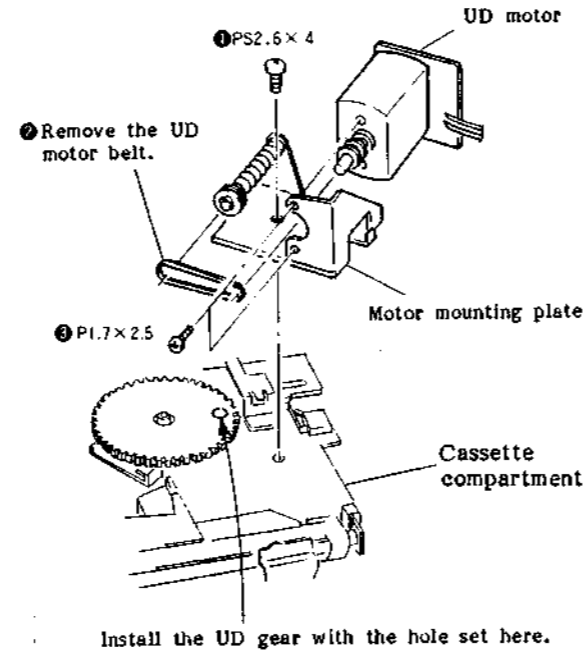

[Loading Motor]

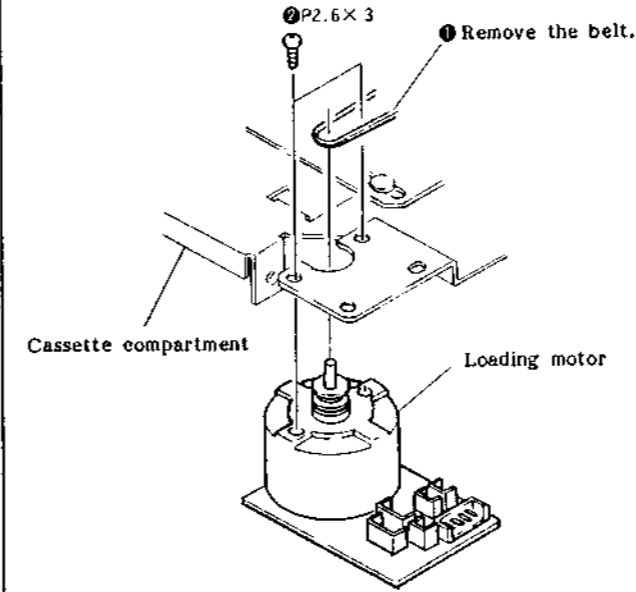

[Transistor Board]

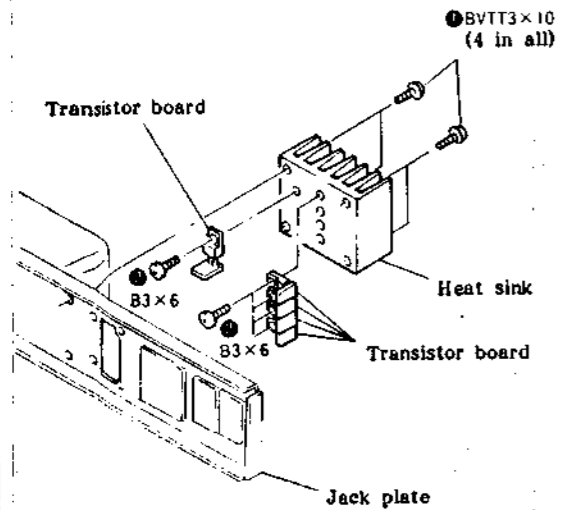

[DAT Mechanical Deck]

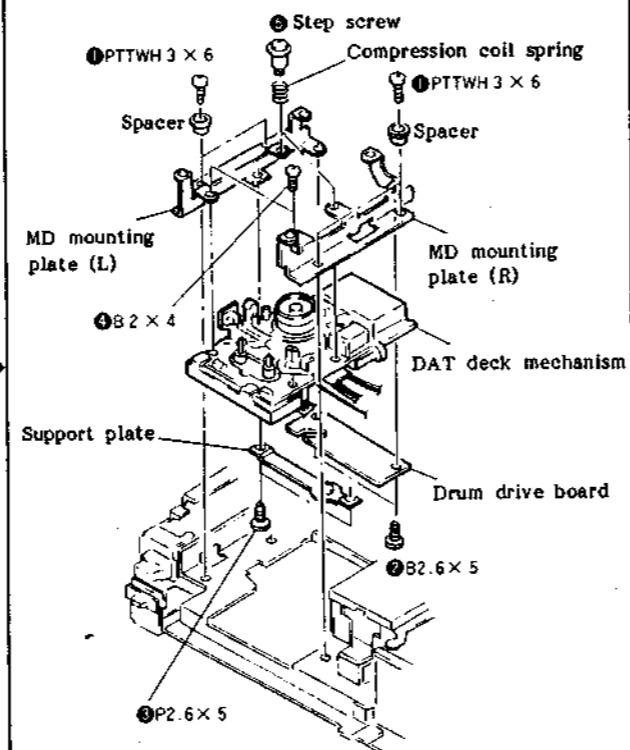

[Control Motor]

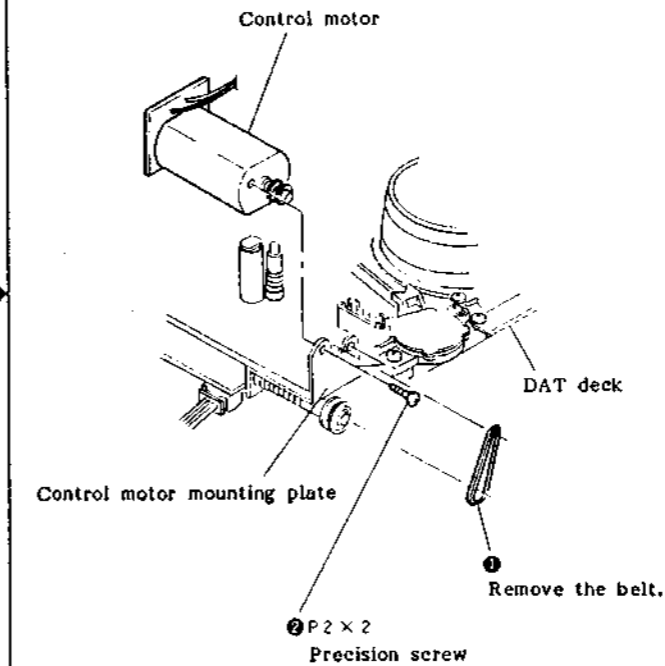

SECTION 4 ADJUSTMENTS

4-1. MECHANICAL ADJUSTMENT

When the drum related block is replaced, finely adjust the tape path (in 1.5 times normal speed FWD mode).

4-1-1. T2 Guide Adjustment

Adjustment

1. Connect CH-1 of an oscilloscope to pin 1 (RF) of CNT52 and CH-2 of an oscilloscope to pin 6 (SWP) of CNT51.
2. Turn on the power switch, insert alignment tape TY-7251 (8-909-813-00), and put the set into the TEST mode.

Press the AMS button, then press the PLAY (▶) button.

3. Raise guide T1 so that the RF signal waveform is as shown below.

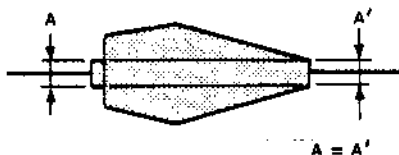

4. Raise guide T2 and align it with the lower edge of the tape.
5. Lower guide T1 so that the RF signal waveform is normal.
6. Check that the tape is aligned with the lower edge of guide T3.
If it is not, repeat Step 4.

Adjustment Point

Mechanism assembly

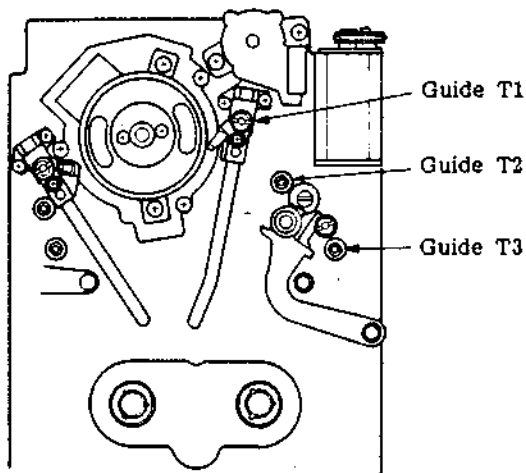

4-1-2. S2 Guide Adjustment

Adjustment

1. Turn on the power switch, insert blank tape TY-30B (8-892-358-00), and put the set into the PLAY (▶) mode.
2. Raise guide S2 and align it with the lower edge of the tape.

Note: Check that no curl occurs at guide S2 in the REW (◀) mode.

Adjustment Point

Mechanism assembly

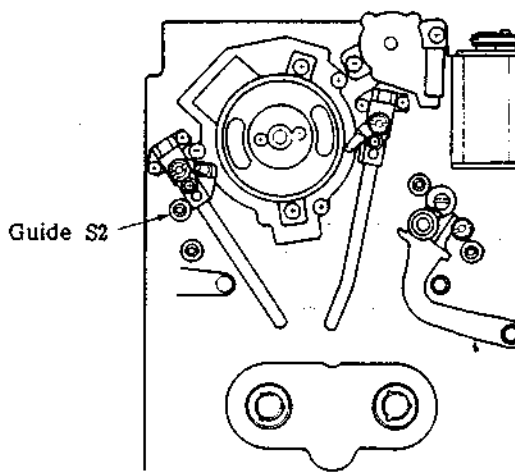

4-1-3. F Guide Adjustment**Adjustment**

1. Turn on the power switch, insert blank tape TY-30B (8-892-358-00), and put the set into the PLAY (▶) mode.
2. Align guide F with the lower edge of the tape.

Note: Check that the tape is aligned with the lower edge of guide T3 and is not curled.

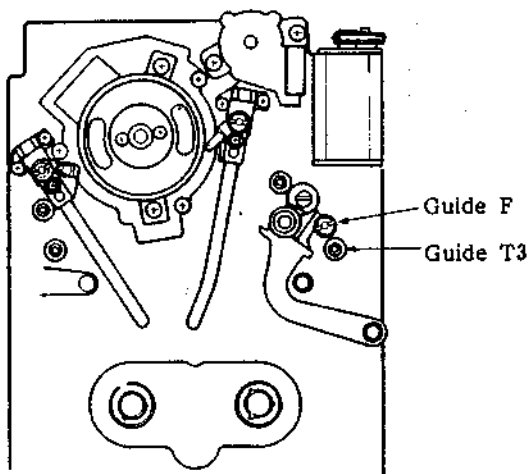
Adjustment Point**Mechanism assembly****4-1-4. S3 Guide Adjustment****Adjustment**

1. Turn on the power switch, insert blank tape TY-30B (8-892-358-00), and put the set into the PLAY (▶) mode.
2. Align guide S3 with the lower edge of the tape.

Note: Check that the tape is aligned with the lower edge of guide S3 and is not curled.

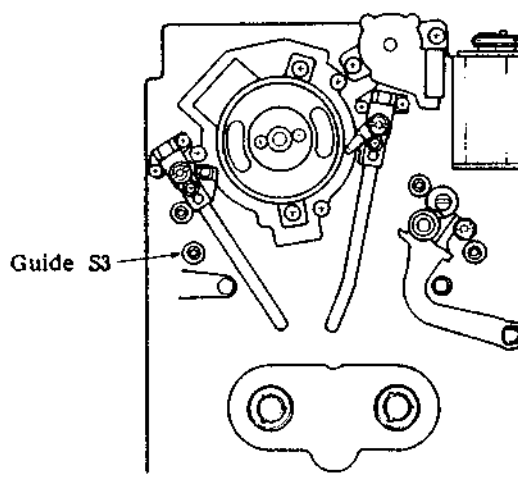
Adjustment Point**Mechanism assembly**

4-1-5. T3 Guide Adjustment**Adjustment**

1. Turn on the power switch, insert blank tape TY-30B (8-892-358-00), and put the set into the PLAY (▶) mode.
2. Align guide T3 with the lower edge of the tape.

Note: Check that the tape is aligned with the lower edge of guide T3 and is not curled.

Adjustment Point

Mechanism assembly

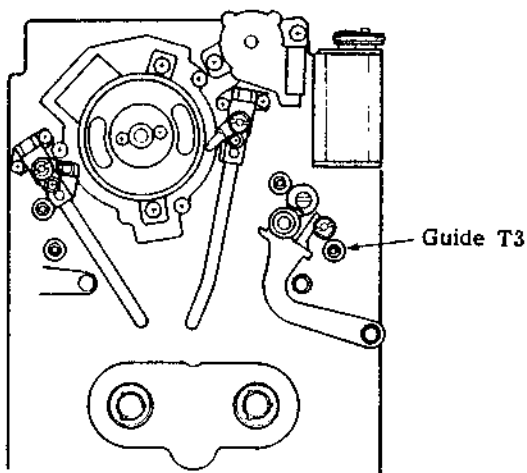

4-2. ELECTRICAL ADJUSTMENT

MD servo board (component side)

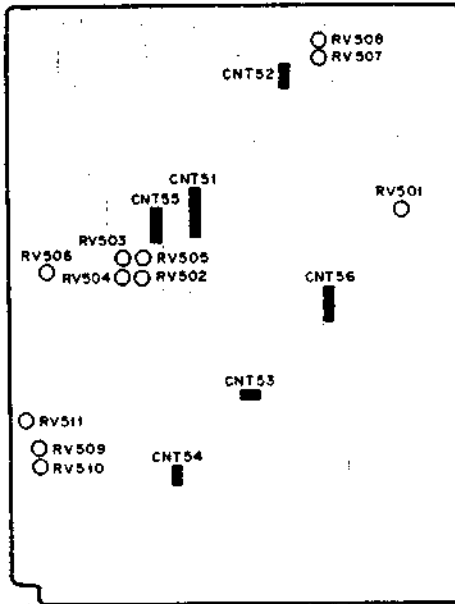

1. Perform the adjustment in the order described.

2. Use the following alignment tapes:

TY-7111 (8-909-812-00)

TY-7251 (8-909-813-00)

TY-7551 (8-909-814-00)

TY-30B (8-892-358-00)

Use the following torque meters:

TW-7131 (8-909-708-71)

TW-7231 (8-909-708-72)

3. Initial settings are as follows:

Timer	OFF
Skip	OFF
INPUT select	DIGITAL
REC volume	MIN
HEADPHONE volume	MIN
Counter mode	AUTO

4-2-1. FF/REW Torque Adjustment

Adjustment

1. Turn on the power switch and insert FF/REW torque meter TW-7231.

2. Put the set into the TEST mode.

3. Put the set into the FF (▶▶) and REW (◀◀) modes and check that the torque is 17 to 18 gcm.

If it is not, adjust RV509 (FF mode) and RV510 (REW mode).

4. After adjustment is completed, cancel the TEST mode.

Note: Be sure to adjust the torque in the following order:

- (1) FF torque
- (2) REW torque
- (3) FWD back tension

Adjustment Point

MD servo board (component side)

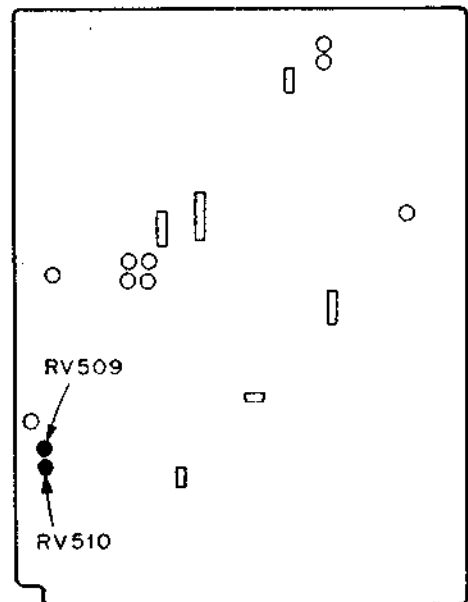

4-2-2. FWD Back Tension Adjustment

1. Turn on the power switch and insert FWD torque meter TW-7131.
2. Put the set into the TEST mode.
3. Put the set into the FWD (▶) mode.
4. Adjust RV511 so that the back tension (at the supply side) is 3 to 4 gcm.
5. Check the torque meter reading while it makes one cycle.
6. After adjustment is completed, cancel the TEST mode.

Adjustment Point

MD servo board (component side)

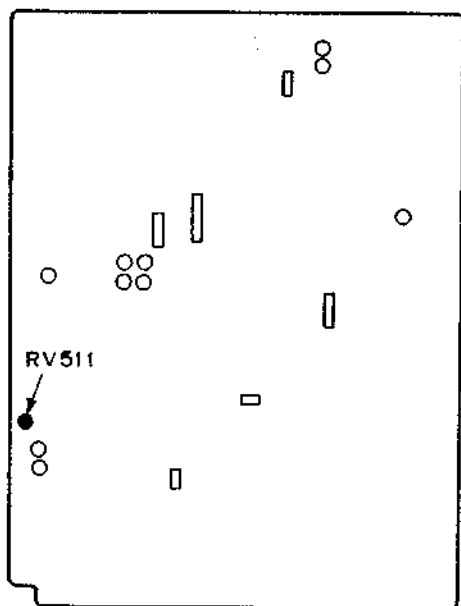

4-2-3. FWD Torque Check

Adjustment

1. Turn on the power switch and insert FWD torque meter TW-7131.
2. Put the set into the TEST mode.
3. Put the set into the PLAY (▶) mode.
4. Check that the FWD torque (take-up rewinding torque) is 12 to 14 gcm.
5. Check the torque meter reading while it makes one cycle.
6. If the torque is not 12 to 14 gcm, readjust the FF torque.
7. After adjustment is completed, cancel the TEST mode.

Adjustment Point

MD servo board (component side)

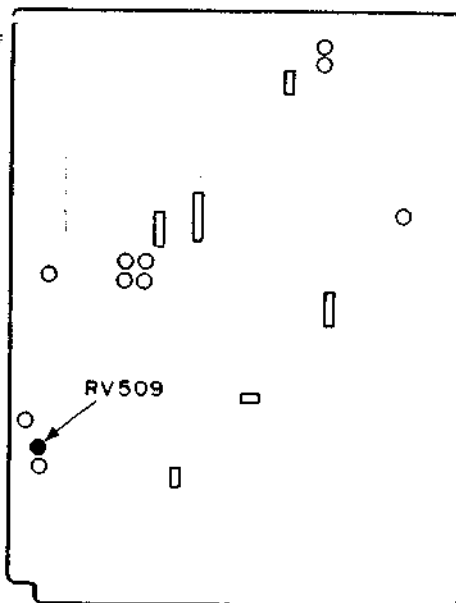

4-2-4. REVIEW Torque Check

1. Turn on the power switch and insert FWD torque meter TW-7131.
2. Put the set into the TEST mode.
3. Put the set into the REVIEW (▶ + ◀◀) mode.
(Press the REW (◀◀) button continuously in the FWD mode.)
4. Check that the rewinding torque at the supply side is 16 to 18 gcm.
5. If the torque is not 16 to 18 gcm, readjust the REW torque.
6. After adjustment is completed, cancel the TEST mode.

Adjustment Point

MD servo board (component side)

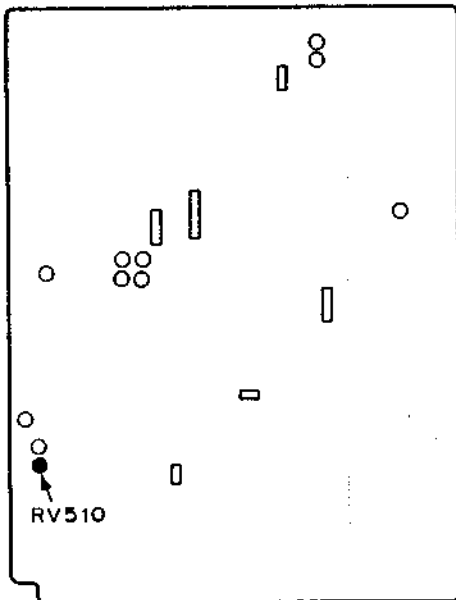
**4-2-5. Tracking Voltage Adjustment Adjustment**

1. Connect a digital tester between pin 7 of IC525 and pin 1 of IC526.
2. Turn on the power switch, insert blank tape TY-30B, and put the set into the STOP (■) mode.
3. Adjust RV506 so that the tester reading is 0 ± 2 mV.

Note: When performing this adjustment, be sure to adjust the capstan speed at x1, x1.5, x2.5, and x16.

Adjustment Point

MD servo board (component side)

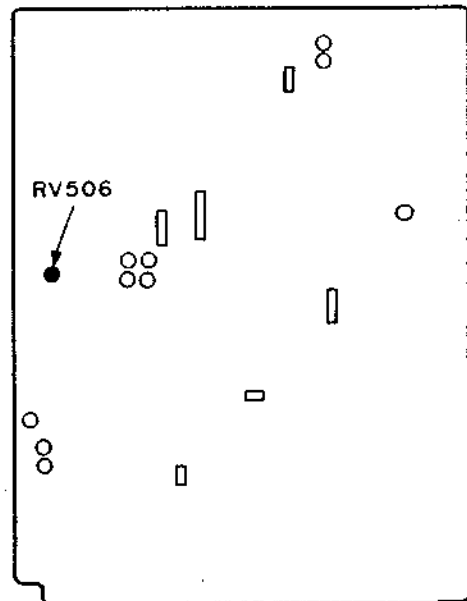

4-2-6. Capstan Speed Adjustment (x 1)**Adjustment**

1. Connect a frequency counter to pin 3 (CFG) of CNT53.
2. Turn on the power switch, insert blank tape TY-30B, and put the set into the PLAY (▶) mode.
3. Adjust RV505 so that the frequency counter reading is 678 ± 1 Hz.

Note: When performing this adjustment, be sure to adjust the capstan speed at x1.5, x2.5, and x16.

Adjustment Point

MD servo board (component side)

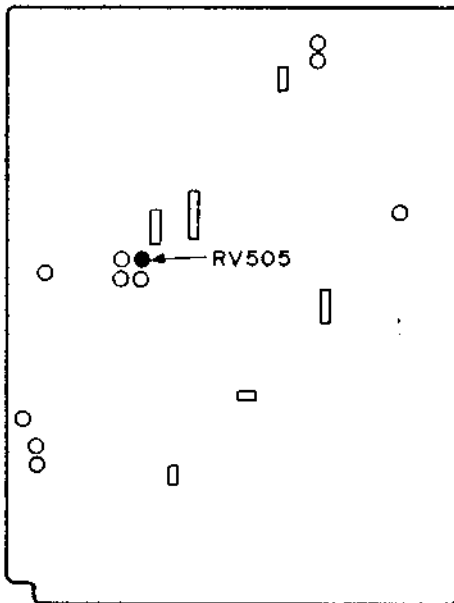
**4-2-7. Capstan Speed Adjustment (x 1.5)****Adjustment**

1. Connect a frequency counter to pin 3 (CFG) of CNT53.
2. Turn on the power switch, insert blank tape TY-30B (for 1.5 times normal speed), and put the set into the PLAY (▶) mode.
3. Adjust RV504 so that the frequency counter reading is 1017 ± 2 Hz.

Note: When recognition hole (3) of blank tape TY-30B is opened, the set is into the 1.5 times normal speed mode. When the hole is blocked using an adhesive tape, the mode is changed from 1.5 times normal speed to normal speed (x1).

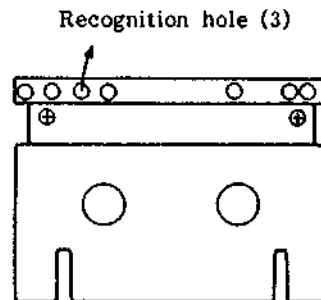
**Adjustment Point**

MD servo board (component side)

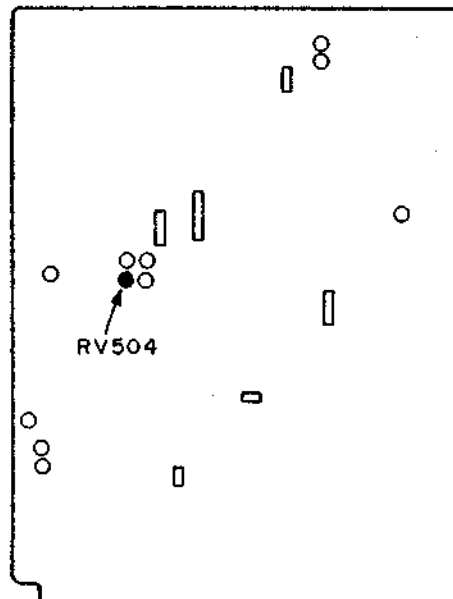

4-2-8. Capstan Speed Adjustment (x 2.5)

Adjustment

1. Connect a frequency counter to pin 3 (CFG) of CNT53.
2. Turn on the power switch, insert blank tape TY-30B, and put the set into the CUE (▶ + ▶▶) mode.
Press the FF (▶▶) button continuously in the FWD mode.
3. Adjust RV502 so that the frequency counter reading is 1685 ± 10 Hz.

Note: This adjustment can be made independently.

Adjustment Point

MD servo board (component side)

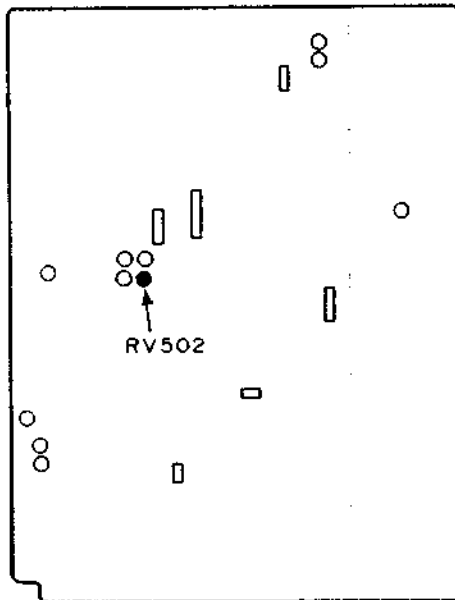

4-2-9. Capstan Speed adjustment (x 16)

Adjustment

1. Connect an oscilloscope to pin 2 (PCOT) of CNT55.
2. Turn on the power switch, insert blank tape TY-30B, and press the FF (▶▶) or REW (◀◀) button (press the FF or REW button for every one or two seconds to obtain the capstan speed at 16 times normal speed).
3. Adjust RV503 so that the signal waveform on the oscilloscope is as shown below.

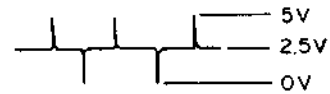

Note: This adjustment can be made independently.

Adjustment Point

MD servo board (component side)

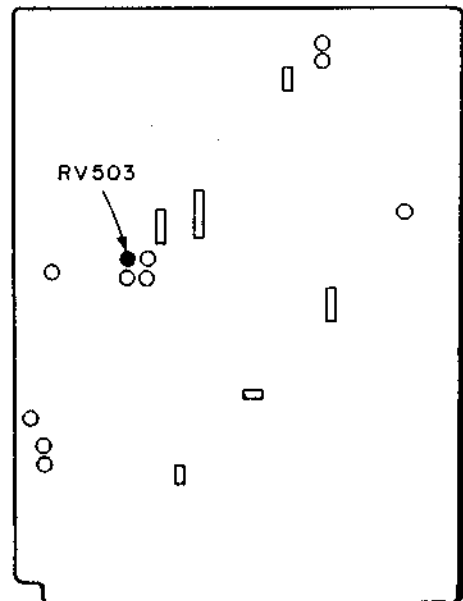

4-2-10. Tape Path Fine-Adjustment (x 1.5 FWD Mode)

Adjustment

1. Connect CH-1 of an oscilloscope to pin (A) of the offset jig.
Connect CH-2 of an oscilloscope to pin (B) of the offset jig.
2. Connect a 3.3 k-ohm resistor between pins 3 (GAIN 2) and 4 (GAIN 1) of CNT51.
3. Connect an offset jig to CNT51 and CNT52.

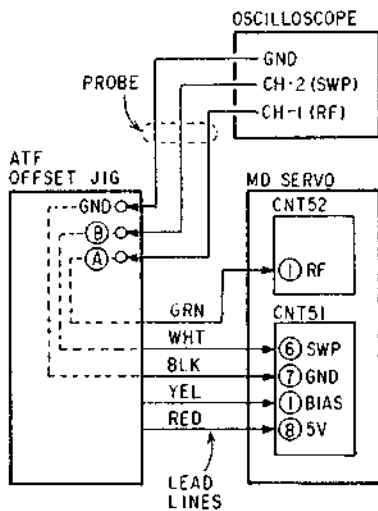

Adjustment Point

Mechanical guides T1 and S1

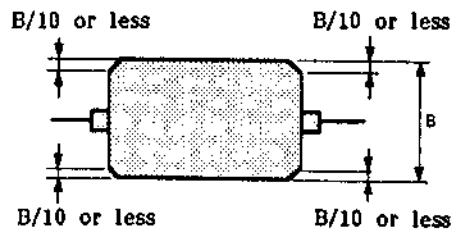
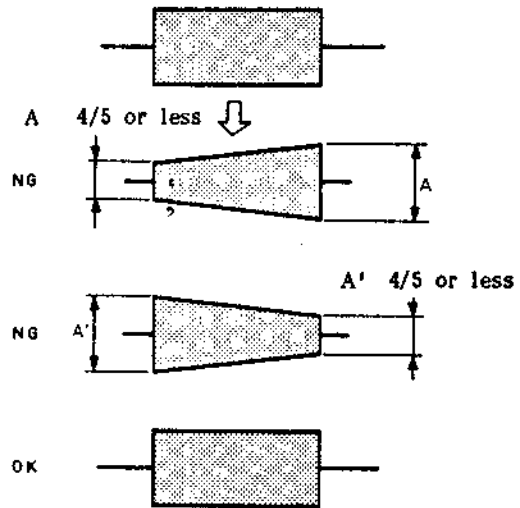
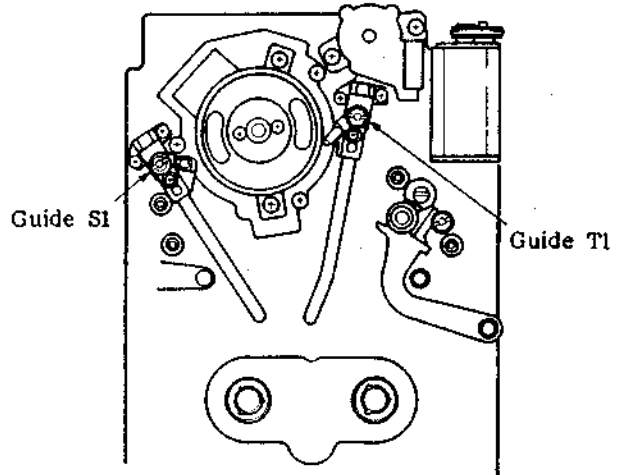

4. Turn on the power switch, insert alignment tape TY-7251, and put the set into the TEST mode.
5. Press the AMS button, then press the PLAY (▶) button.
6. Adjust guides S1 and T1 so that the shape of an RF signal waveform on the oscilloscope is close to a square when the offset jig volume control is turned. (Turn the ATF control carefully so that the waveform varies slowly.)
7. Remove the two leads (YEL and RED) of the jig from CNT51.
 - (1) Check that peak value (B) of the RF signal waveform is 60 mV or more.
 - (2) Check that the undershoot level of the RF signal waveform's flat portion is within 10%.
8. If the specification is not satisfied, repeat Steps 3 through 7.

Note: Make this adjustment when replacing the drum.

4-2-11. DPG Adjustment

Adjustment

1. Connect CH-1 of an oscilloscope to pin 1 (RF) of CNT52 and CH-2 of an oscilloscope to pin 5 (DPG) of CNT56.
2. Select tap pattern 8 and make a solder bridge to check the original delay value of a PG pulse. (The delay time for one DPG SW code is about 100μsec.)
3. Turn on the power switch, insert alignment tape TY-7251, and put the set into the TEST mode.
4. Press the AMS button, then press the PLAY (▶) button.
5. Select the tap pattern and adjust so that it satisfies the specified value (for approximate adjustment).
6. Put the set into the PLAY (▶) mode and finely adjust RV501 so that the signal waveform on the oscilloscope is 650 ± 15 usec.

Notes:

- . When the drum related block is replaced, remove the former solder bridges from the DPG tap pattern on the MD servo board.
- . Press the AMS button before the PLAY button is pressed so that the ATF servo system may be properly locked.

(Reference)

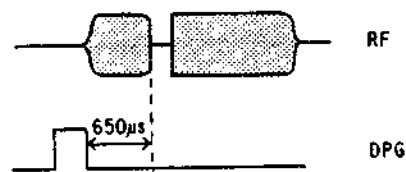

Adjustment Point

MD servo board (component side)

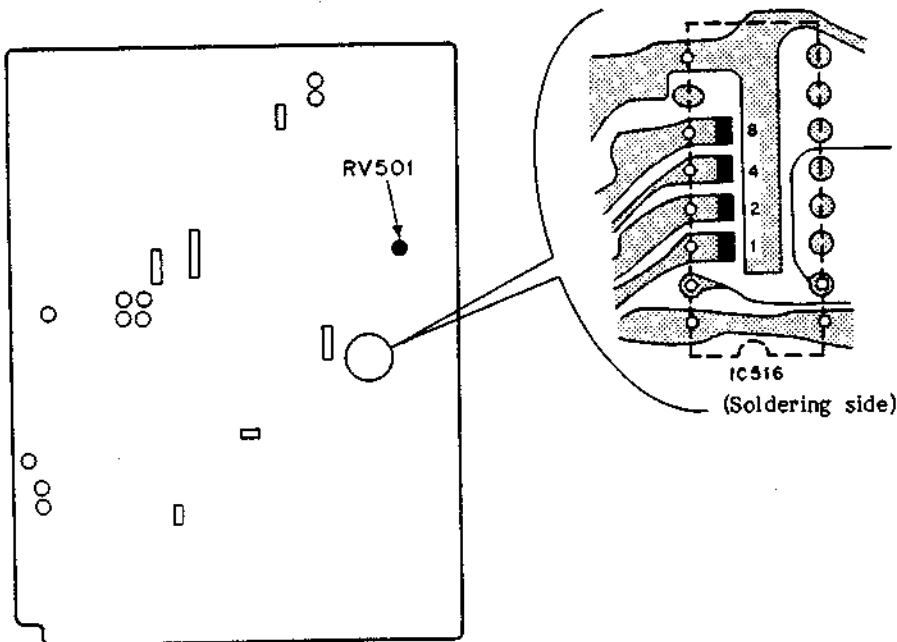

	Tap pattern				
	1	2	4	8	
DPG SW codes	1	○			
	2		○		
	3	○	○		
	4			○	
	5	○		○	
	6		○	○	
	7	○	○	○	
	8				○
	9	○			○
	A		○		○
	B	○	○		○
	C			○	○
	D	○		○	○
	E		C	○	○
	F	○	C	○	○

4-2-12. ATF Pilot Adjustment

Adjustment

1. Connect CH-1 of an oscilloscope to pin 3 (S/H3) of CNT52.
Connect CH-2 of an oscilloscope to pin 6 (SWP) of CNT51 (TRIGGER).
2. Turn on the power switch, insert alignment tape TY-7111, and put the set into the STOP (■) mode.
Set the TEST mode to ON.
3. Adjust so that the luminescent spot is located on the scale center.
(Never align the spot with the center when the input is set to GND.)
4. Put the set into the PLAY (▶) mode and adjust RV508 (A-CH) and RV507 (B-CH) so that the signal waveform is 600 mV after two or three seconds.

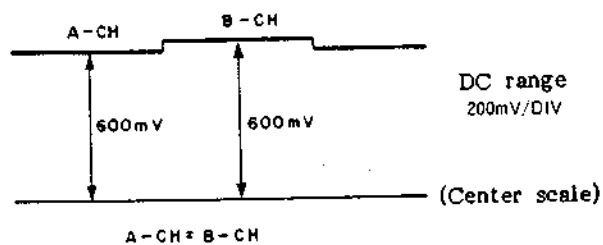
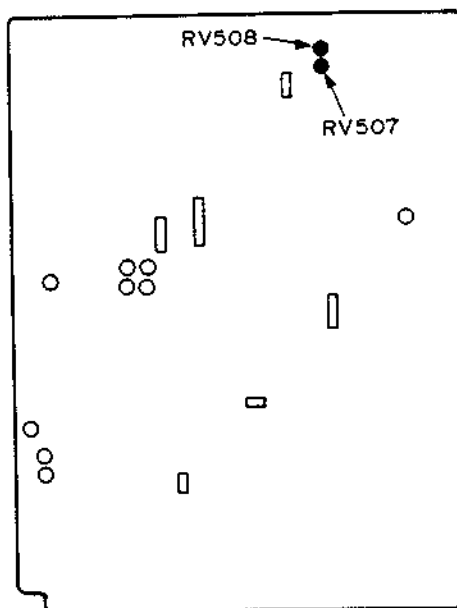

Note: If the signal waveform deflects vertically, adjust it in the deflection center.

Adjustment Point

MD servo board (component side)

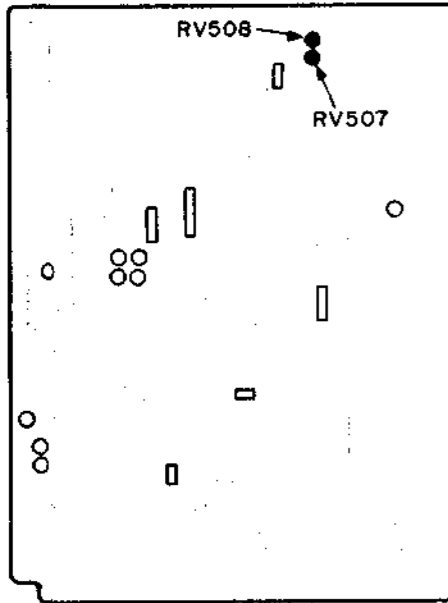

4-2-13. Level Meter Adjustment
Adjustment

1. Set the INPUT select switch to ANALOG and input a 1 kHz signal (-6dB) from the oscillator.
2. Turn on the power switch, insert blank tape TY-30B, and put the set into the REC MUTE mode.
3. Check the setting of the REC volume control.
4. Adjust RV103 (R-CH) and RV203 (L-CH) so that the level meter reads -6dB.

Adjustment Point
Audio board (component side)

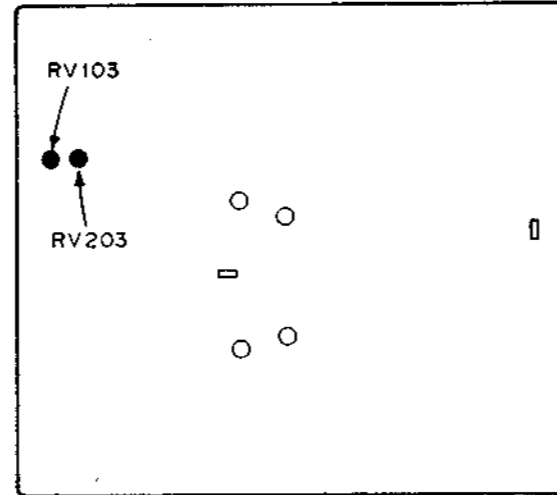

4-2-14. A/D Distortion Factor Adjustment
Adjustment

1. Set the INPUT select switch to ANALOG and input a 1 kHz signal (0dB) from the oscillator through an attenuator.
2. Connect an oscilloscope to the LINE OUT terminal.
3. Turn on the power switch, insert blank tape TY-30B, and put the set into the REC MUTE mode.
4. Turn the REC volume control until the "OVER" indicator lights, then attenuate the input signal by 1.5dB using an attenuator.
5. Adjust RV102 (R-CH) and RV202 (L-CH) so that the signal at the LINE OUT terminal is minimized.

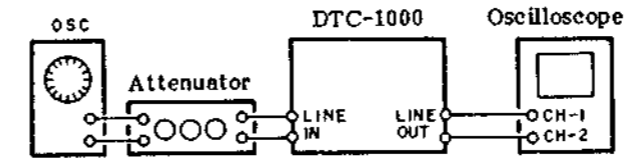

Reference value: -84.5dB or less (20kHz LPF ON)

Adjustment Point
Audio board (component side)

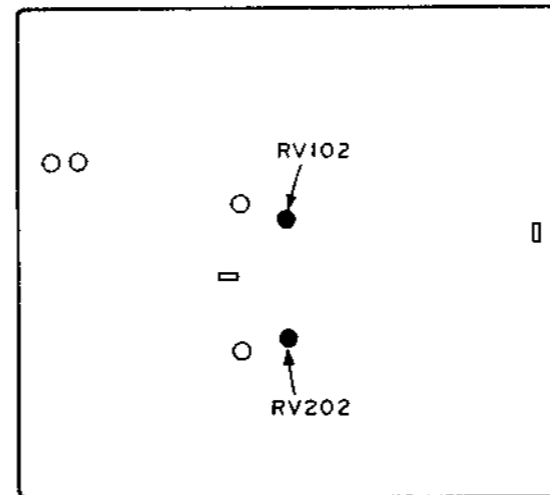

4-2-15. VCO Adjustment
Adjustment

1. Unsolder tap pattern (A) on the digital board and open it.
2. Connect CH-1 of an oscilloscope to TP801 (on the digital board) and CH-2 of an oscilloscope to TP802 (on the digital board).
3. Turn on the power switch, insert recorded blank tape TY-30B, put the set into the TEST mode, and then put the set into the PLAY mode.
(In the self-REC mode, set the REC volume control to MIN.)
4. Adjust RV802 so that the the DC voltage difference of C819 is approximately -3.0 V.
5. Adjust RV801 so that the signal waveform at TP801 satisfies the specification.

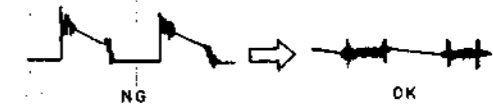

6. Adjust RV804 so that the signal waveform at TP801 satisfies the specification.



7. Put the set into the CUE mode and finely adjust RV802 so that the signal waveform at TP801 satisfies the specification.
(The specified waveform is the same as in Step 6.)
8. Put the set into the REVIEW mode and finely adjust RV802 so that the signal waveform at TP801 satisfies the specification.
(The specified waveform is the same as in Step 6.)
9. Alternate putting the set into the CUE and REVIEW modes two or three times and check that the signal waveform at TP801 satisfies the specification.
(The specified waveform is the same as in Step 6.)

VCO Adjustment

Remove the tap pattern (A) on the digital board and solder-bridge it.

Set CH-1 of an oscilloscope to TP801 (on the digital board) and CH-2 of an oscilloscope to TP802 (on the digital board).

Turn on the power switch, insert recorded tape TY-30B, put the set into the FF AMS mode, and then put the set into the CUE mode.

Adjust RV802 so that the DC voltage of C819 is approximately -3.0 V.

Adjust RV801 so that the signal waveform at TP801 satisfies the specification.

Adjust RV804 so that the signal waveform at TP801 satisfies the specification.

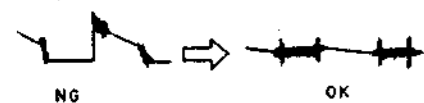

Adjust RV804 so that the signal waveform at TP801 satisfies the specification.



Put the set into the CUE mode and finely adjust RV802 so that the signal waveform at TP801 satisfies the specification.

The specified waveform is the same as in Step 5.)

Put the set into the REVIEW mode and finely adjust RV802 so that the signal waveform at TP801 satisfies the specification.

The specified waveform is the same as in Step 5.)

After putting the set into the CUE and FF AMS modes two or three times and check the signal waveform at TP801 satisfies the specification.

The specified waveform is the same as in Step 5.)

After putting the set into the CUE and FF AMS modes two or three times and check the signal waveform at TP801 satisfies the specification.

The specified waveform is the same as in Step 5.)

10. Turn off the power switch and solder-bridge the tap pattern.

11. Turn on the power switch and put the set into the PLAY (▶) mode again.

12. Readjust RV802 so that the signal waveform at TP801 satisfies the specification.

(The specified waveform is the same as in Step 6.)

13. Put the set into the CUE mode and finely adjust RV802 so that the signal waveform at TP801 satisfies the specification.

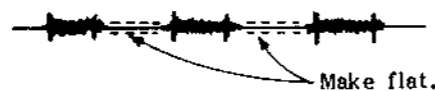

14. Put the set into the REVIEW mode and check the signal waveforms at TP801 and C819.

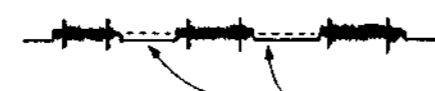

15. Put the set into the PLAY mode and check the signal waveform at TP801.

(The specified waveform is the same as in Step 11.)

16. Put the set into the FF AMS and REW AMS modes and check the signal waveforms at TP801 and C819 (in the 16 times normal speed mode).



17. Set the TEST mode to OFF, put the set into the FF AMS and REW AMS modes, and check the signal waveforms at TP801 and C819 (in the AMS mode).

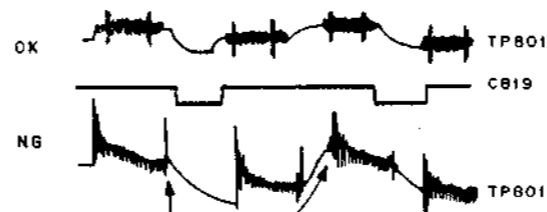

Voltages deflect significantly in the plus (+) direction.

Connected to oscilloscope.

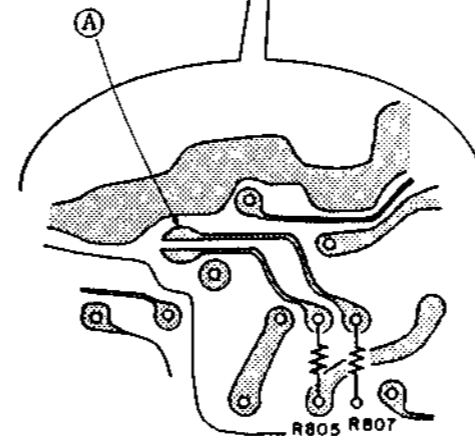
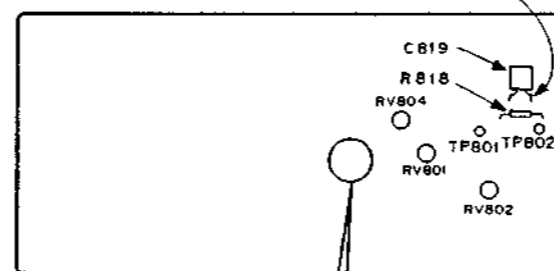







SECTION 5
DIAGRAMS

Note:

- All capacitors are in μF unless otherwise noted. pF : μF 50 WV or less are not indicated except for electrolytics and tantalums.
- All resistors are in Ω and $\frac{1}{4}W$ or less unless otherwise specified.

Note: The components identified by shading and mark Δ are critical for safety. Replace only with part number specified.

- Δ : internal component.
-  : fusible resistor.
-  : B+ bus.
-  : B- bus.
-  : adjustment for repair.
- Voltages are dc with respect to ground unless otherwise noted.
- Readings are taken under no-signal (detuned) conditions with a VOM (50 $k\Omega/V$).
- Voltage variations may be noted due to normal production tolerances.
- Waveforms are taken to ground in STOP mode by using oscilloscope.
- Voltage variations may be noted due to normal production tolerances.

-  : playback signal path.
-  : reference signal path.





Semiconductor Location

Ref. No.		Ref. No.		Ref. No.	
D001	B-6	IC532	I-12	Q525	F-12
D401	E-4	IC533	E-11	Q526	F-11
D402	E-4	IC534	E-12	Q527	F-11
D501	H-20	IC535	D-14	Q528	G-11
D502	E-14	IC536	D-14	Q529	G-11
D503	E-20	IC537	C-14	Q530	H-11
D504	F-11	IC538	H-13	Q531	H-11
D505	G-11	IC801	C-29	Q532	H-12
D506	H-11	IC802	C-29	Q533	H-12
D507	D-14	IC805	D-30	Q534	H-12
D508	D-12	IC806	D-30	Q535	J-11
D509	I-13	IC807	D-28	Q536	J-11
D510	G-13	IC808	D-27	Q537	J-12
D511	E-14	IC851	I-27	Q538	J-12
D801	D-31	IC852	I-29	Q539	J-12
D802	D-31	IC853	I-29	Q540	E-12
IC401	G-3	IC854	I-30	Q541	E-12
IC402	E-3	IC855	H-22	Q542	D-12
IC403	D-4	IC856	I-23	Q543	I-13
IC501	F-20	IC951	C-23	Q544	J-13
IC502	G-20	Q401	H-2	Q545	I-12
IC503	H-20	Q402	H-2	Q546	I-13
IC504	H-20	Q403	G-2	Q547	I-13
IC505	I-19	Q404	G-2	Q548	I-13
IC506	I-19	Q405	D-2	Q549	E-17
IC507	I-18	Q406	E-3	Q550	E-16
IC508	J-19	Q501	J-20	Q551	G-13
IC509	J-18	Q502	E-14	Q552	E-14
IC510	H-18	Q503	E-15	Q560	H-10
IC511	E-16	Q504	E-15	Q561	I-10
IC512	G-14	Q505	E-15	Q803	D-31
IC513	D-16	Q506	F-18	Q804	C-31
IC514	C-15	Q507	F-19	Q805	E-30
IC515	D-16	Q508	E-18	Q851	J-28
IC516	D-15	Q509	E-19	Q852	J-28
IC517	C-16	Q510	E-18	Q856	H-29
IC518	E-17	Q511	E-19	Q857	H-29
IC519	D-18	Q512	H-14		
IC520	D-19	Q513	I-15		
IC521	I-14	Q514	J-15		
IC522	I-16	Q515	I-15		
IC523	H-15	Q516	I-16		
IC524	J-14	Q517	C-20		
IC525	I-15	Q518	E-20		
IC526	J-16	Q519	E-19		
IC527	D-20	Q520	E-19		
IC528	G-12	Q521	O-20		
IC529	F-12	Q522	D-20		
IC530	F-11	Q523	D-20		
IC531	I-11	Q524	F-12		

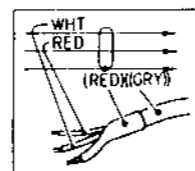
Note:

- Color code of sleeving over the end of the jacket.



-  : parts extracted from the component side.
-  : parts extracted from the conductor side.
-  : part mounted on the conductor side.
-  : Through hole.

5-1. MOUNTING DIAGRAM (MD SERVO & DIGITAL BLOCK)

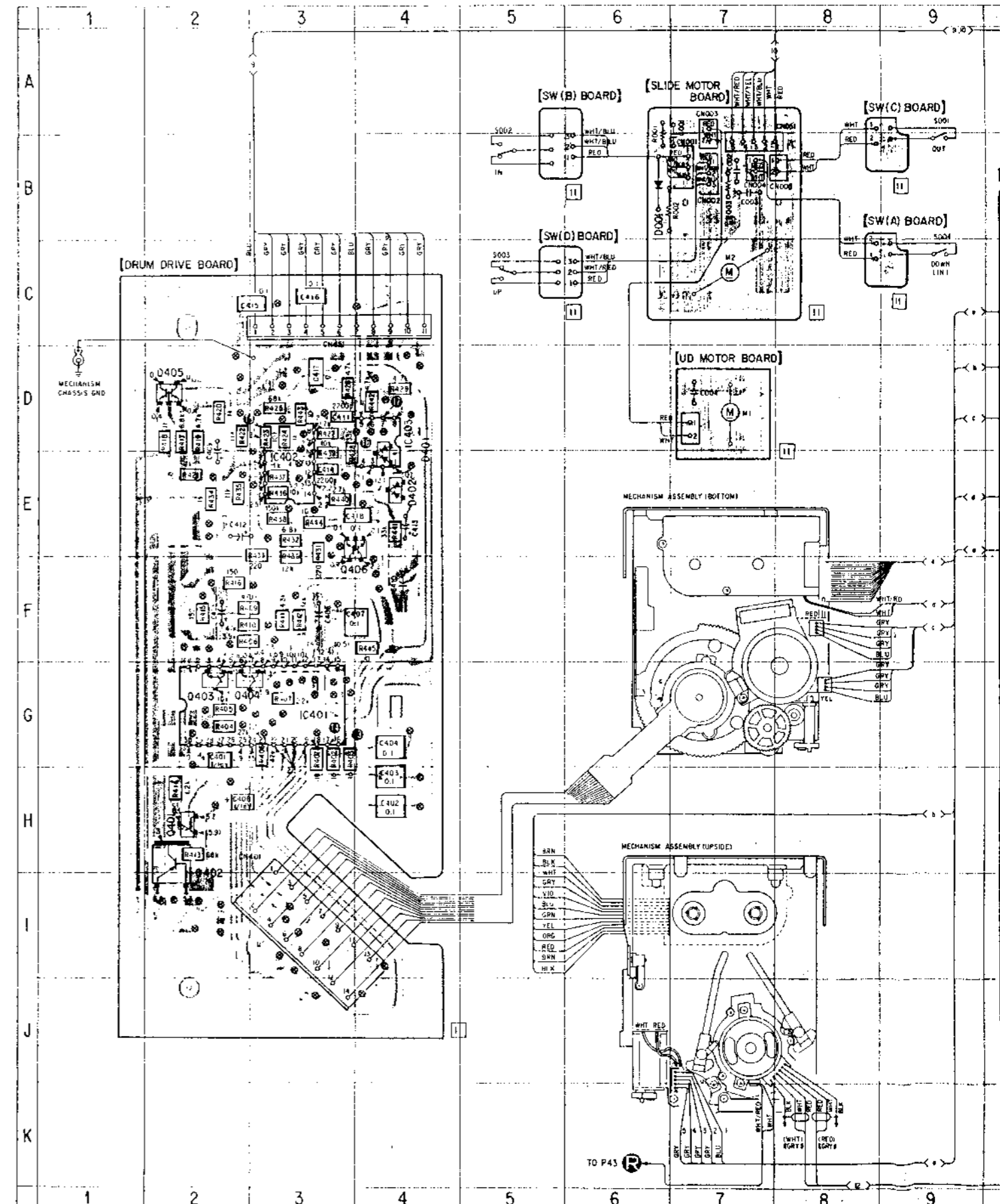

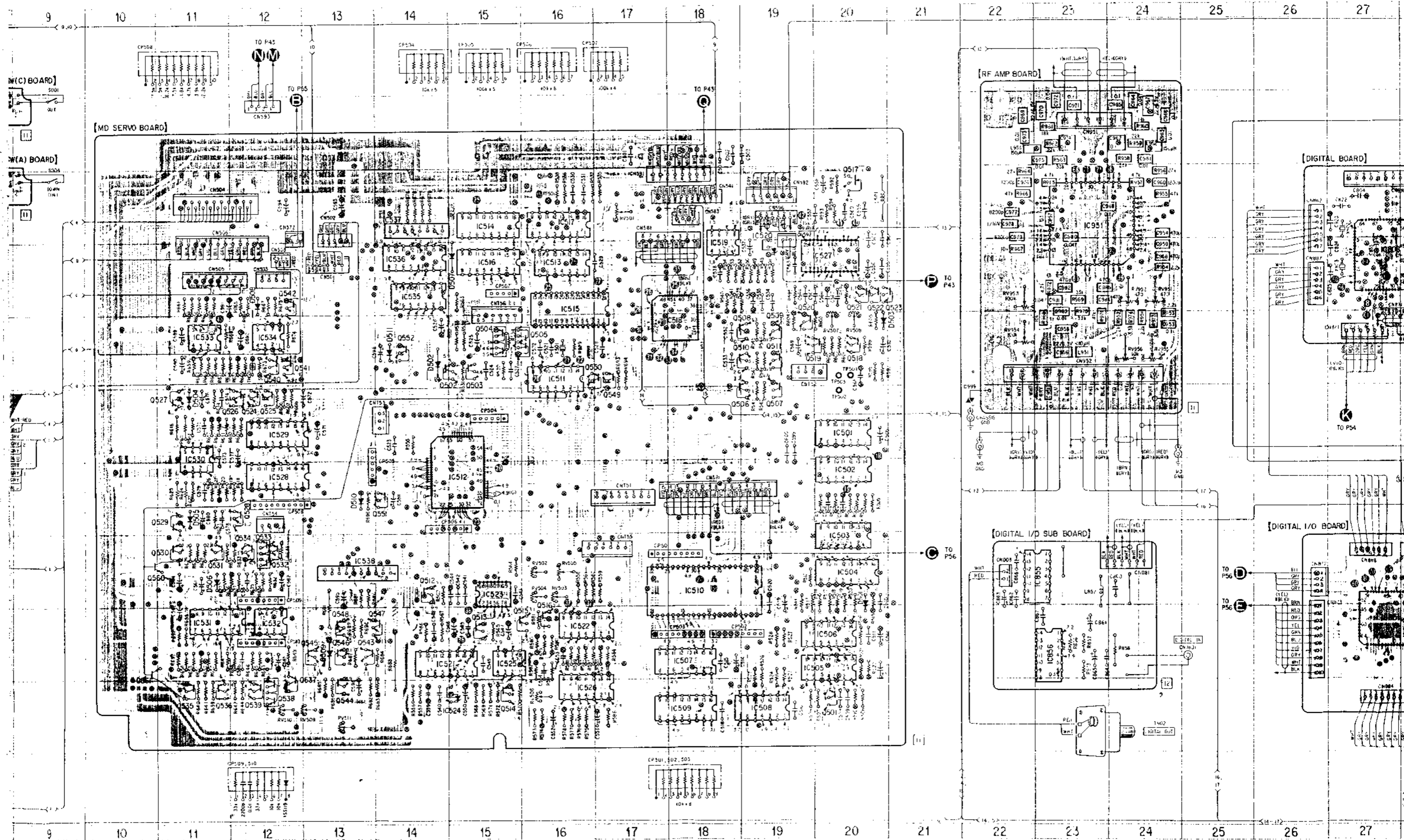

3 24 25 26 27 28 29 30 31

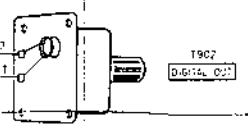
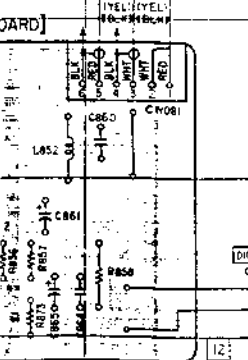
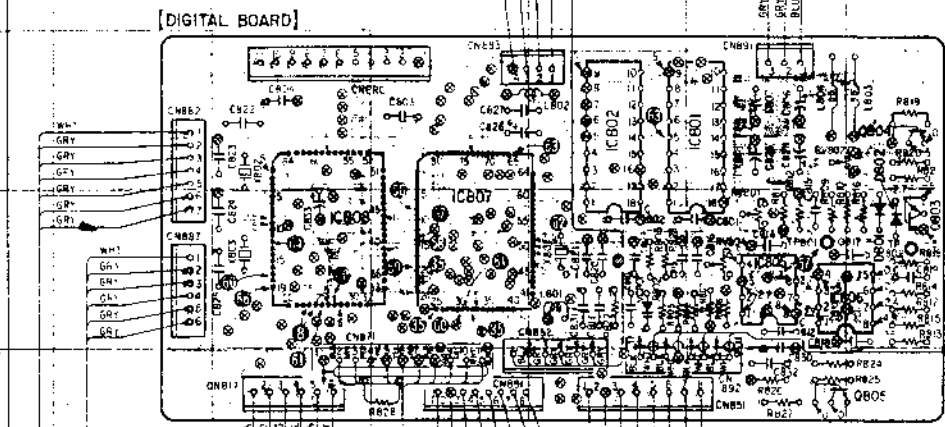
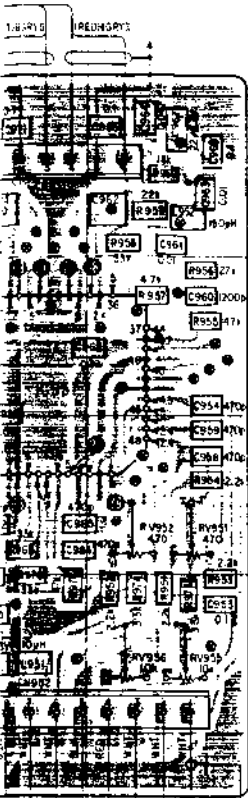

24 25 26 27 28 29 30 31

5-2. SCHEMATIC DIAGRAM (MD SERVO BLOCK)

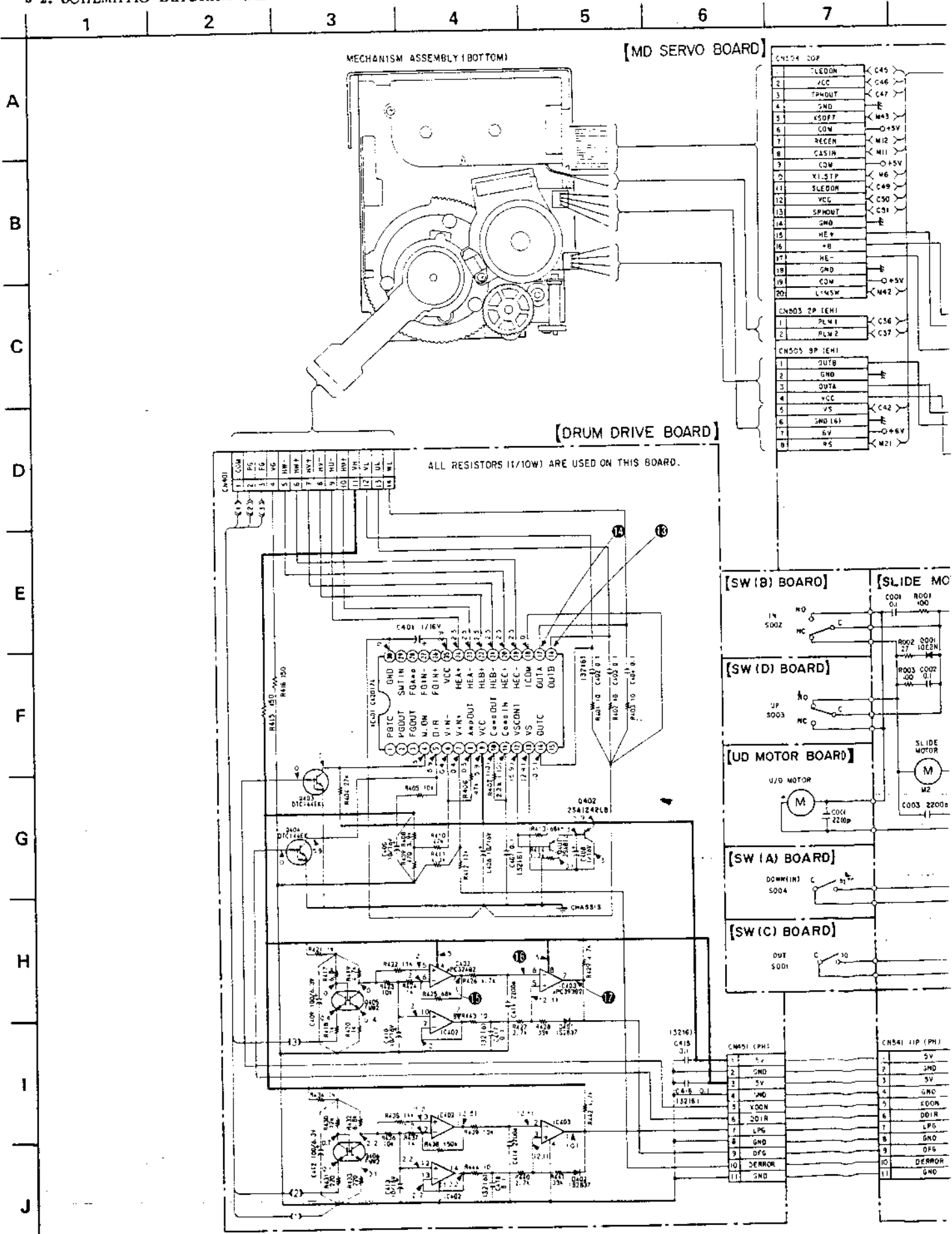

MECHANISM ASSEMBLY (BOTTOM)

[MD SERVO BOARD]

[DRUM DRIVE BOARD]

ALL RESISTORS (1/10W) ARE USED ON THIS BOARD.

[SW (B) BOARD]

[SLIDE MOTOR BOARD]

[SW (D) BOARD]

[UD MOTOR BOARD]

[SW (A) BOARD]

[SW (C) BOARD]

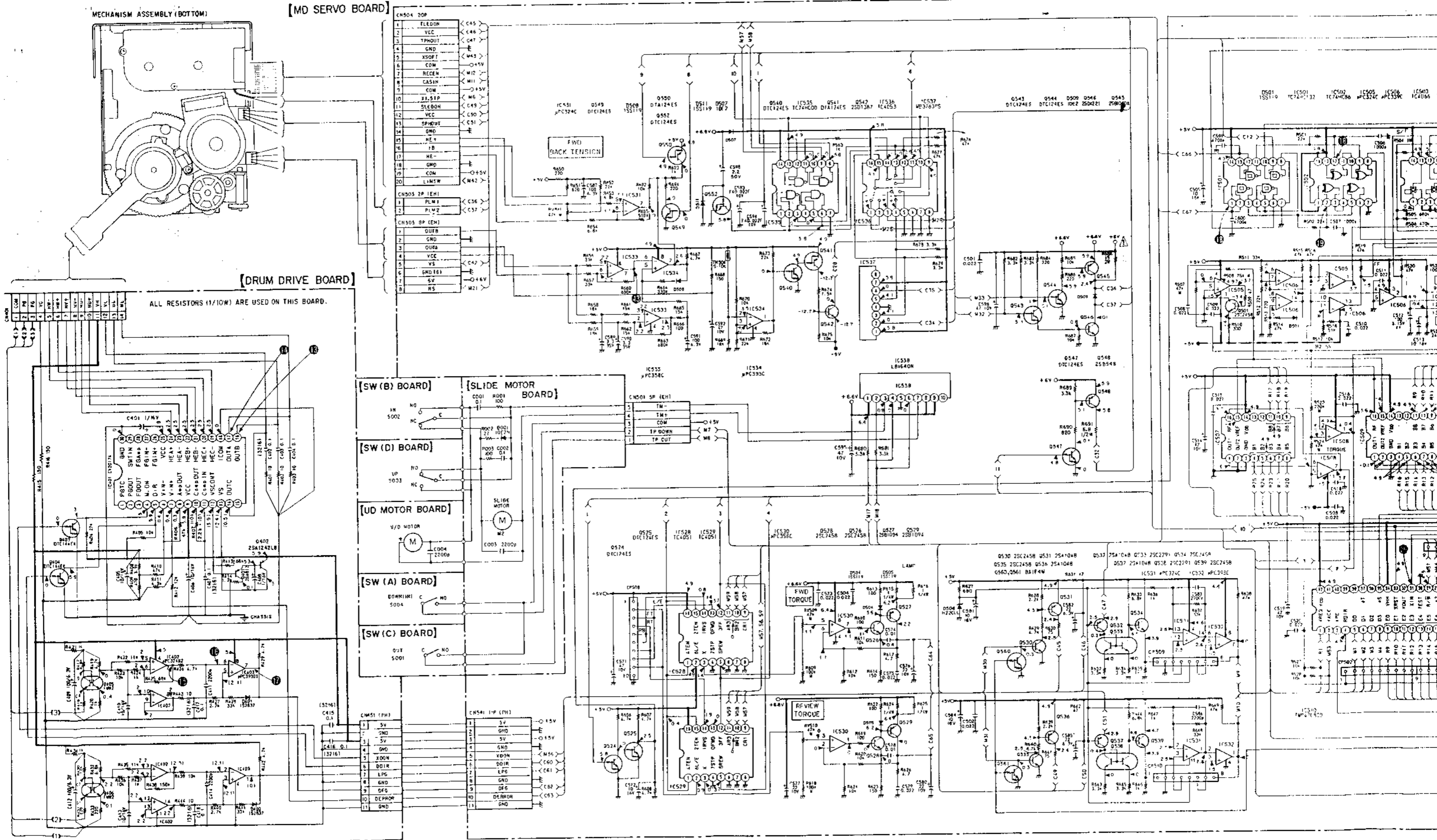

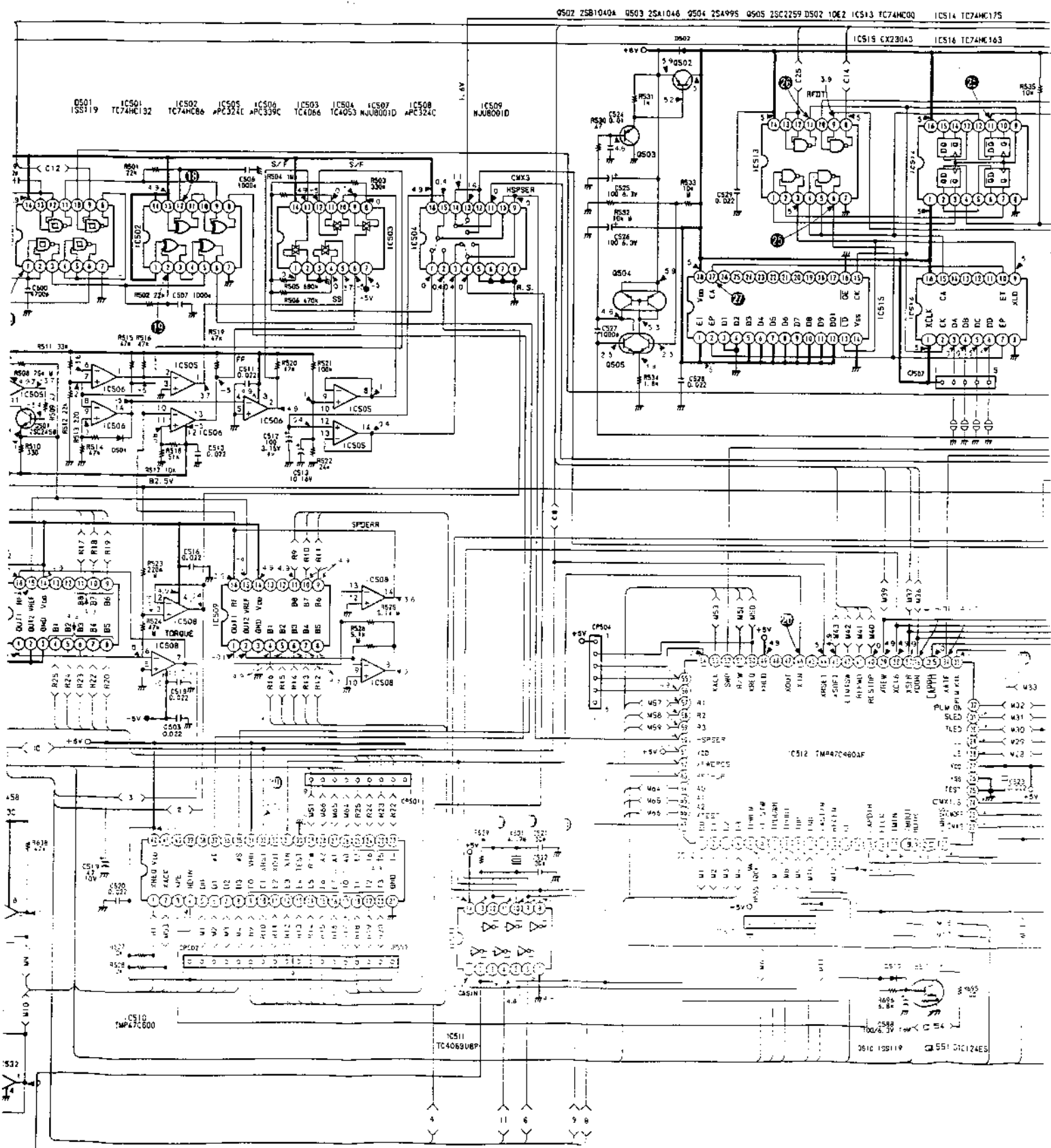

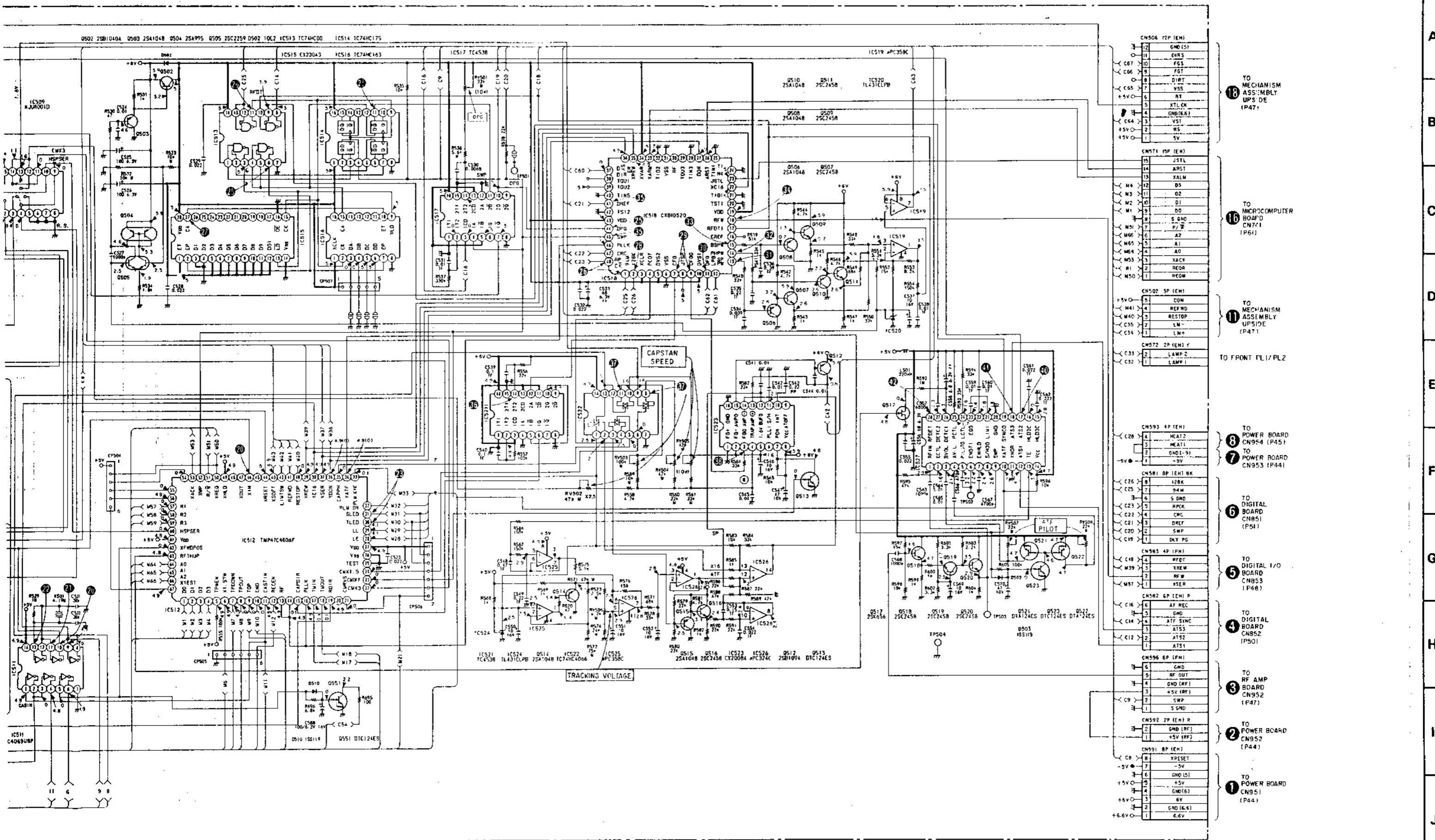

TO MECHANISM ASSEMBLY UPSIDE (P47)

TO MICROCOMPUTER BOARD CN701 (P61)

TO MECHANISM ASSEMBLY UPSIDE (P47)

TO FRONT FL1/PL2

TO POWER BOARD CN954 (P45)
TO POWER BOARD CN953 (P44)

TO DIGITAL BOARD CN851 (P51)

TO DIGITAL I/O BOARD CN853 (P48)

TO DIGITAL BOARD CN852 (P50)

TO RF AMP BOARD CN952 (P47)

TO POWER BOARD CN952 (P44)

TO POWER BOARD CN951 (P44)

A
B
C
D
E
F
G
H
I
J

5-3. MOUNTING DIAGRAM (POWER BLOCK)

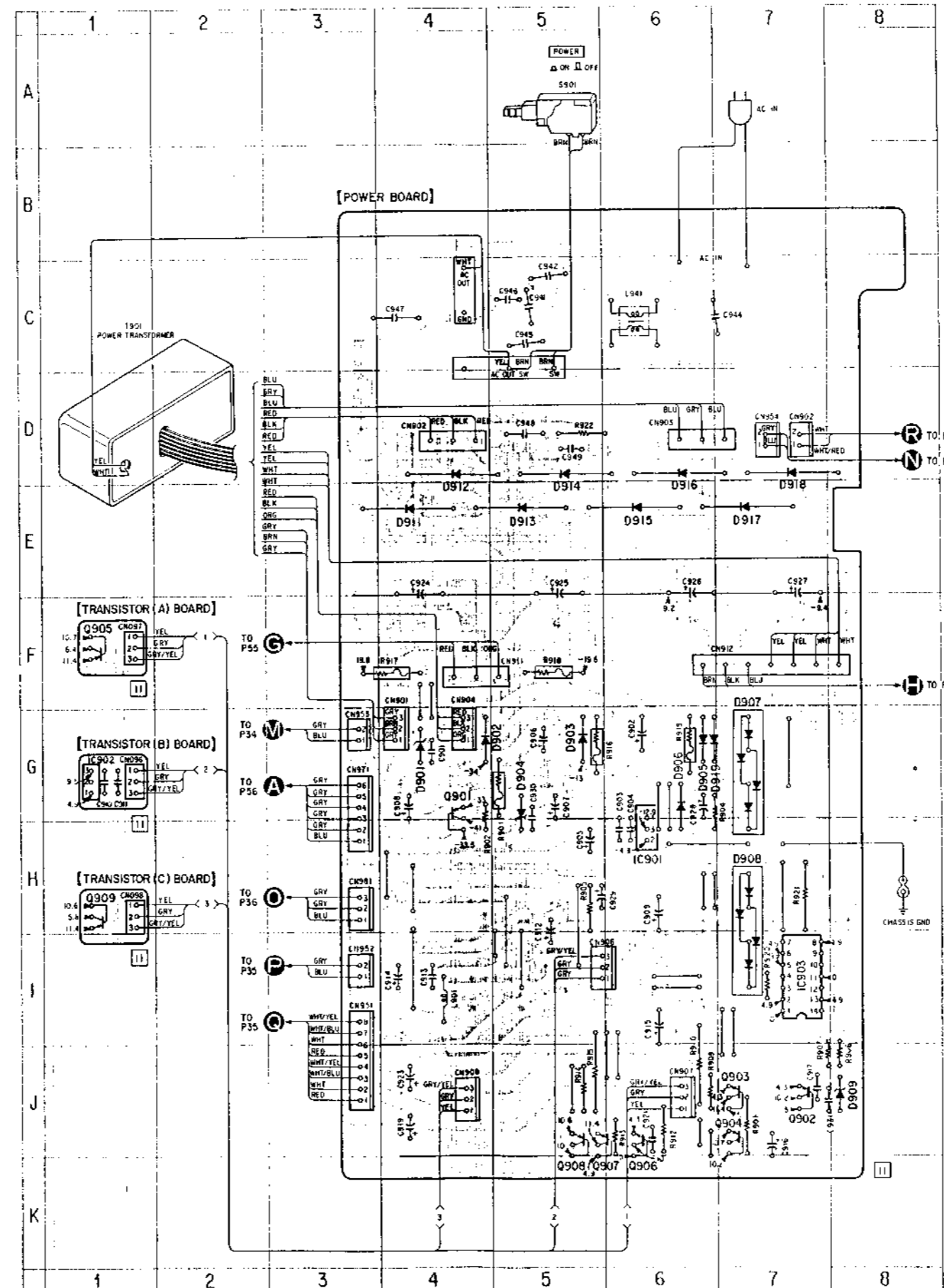

Semiconductor Location

Ref. No.	Location
D901	G-4
D902	G-4
D903	G-5
D904	G-5
D905	G-6
D906	G-6
D907	G-7
D908	H-7
D909	J-7
D911	E-4
D912	D-4
D913	E-5
D914	D-5
D915	E-6
D916	D-6
D917	E-7
D918	D-7
D919	G-6
IC901	H-6
IC902	G-1
IC903	I-7
Q901	G-4
Q902	J-7
Q903	J-7
Q904	J-7
Q905	F-1
Q906	J-6
Q907	J-5
Q908	J-5
Q909	H-1

5-4. SCHEMATIC DIAGRAM (POWER BLOCK)

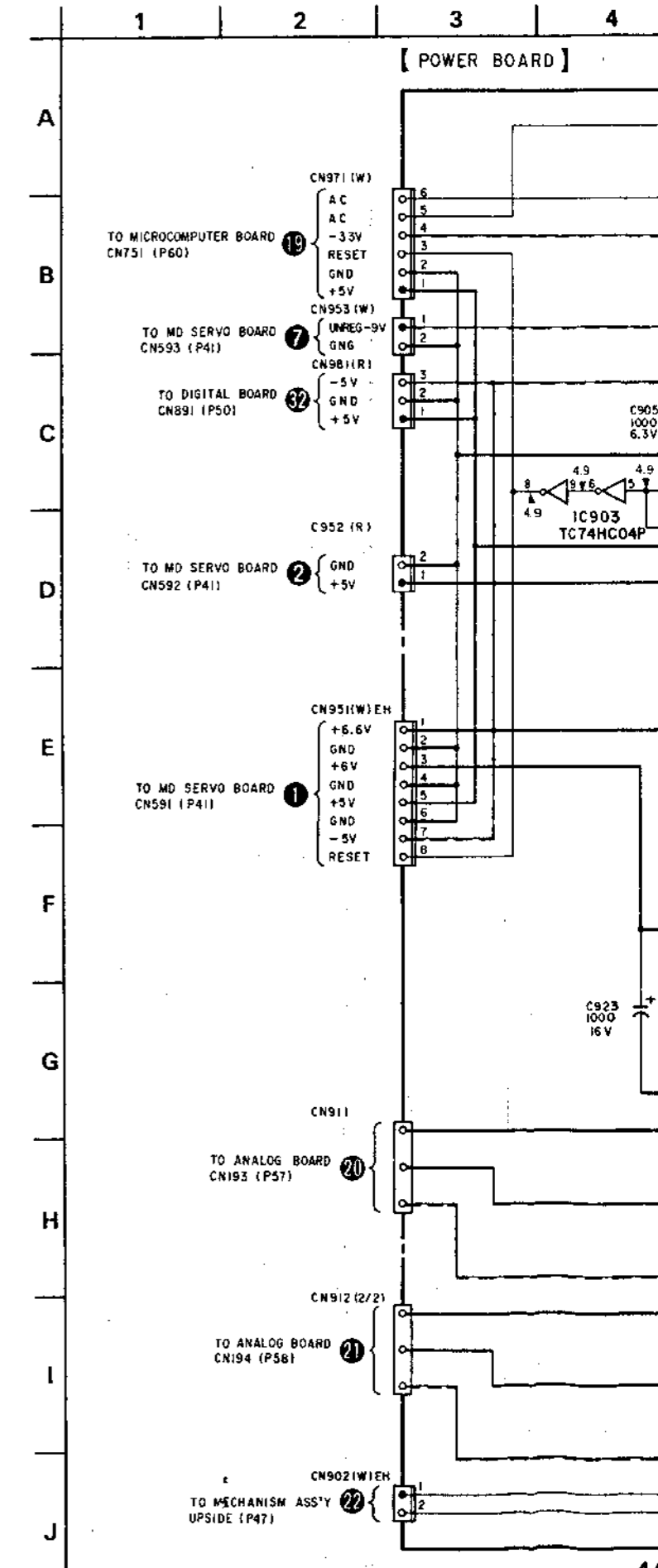

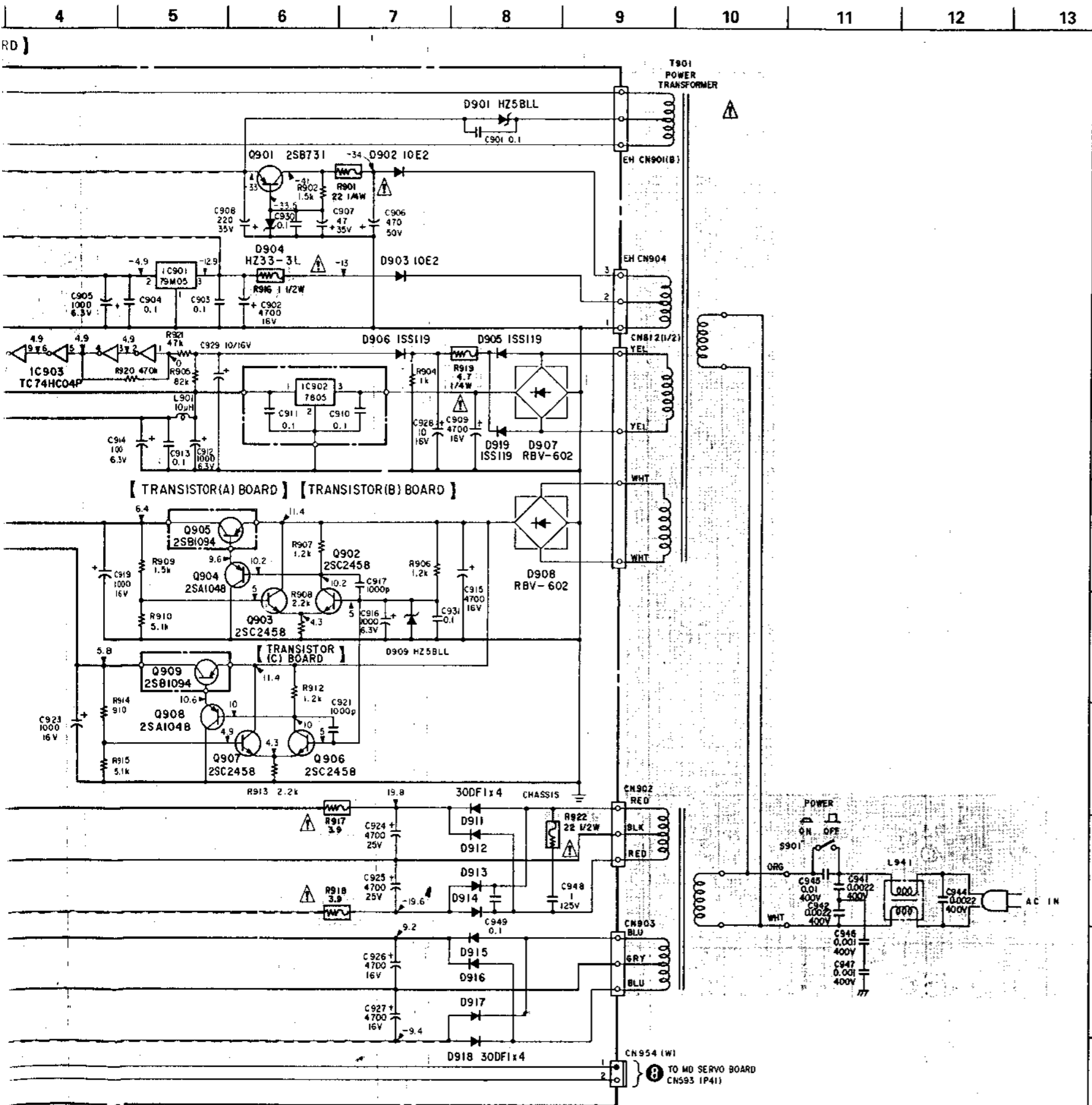

Board Layout

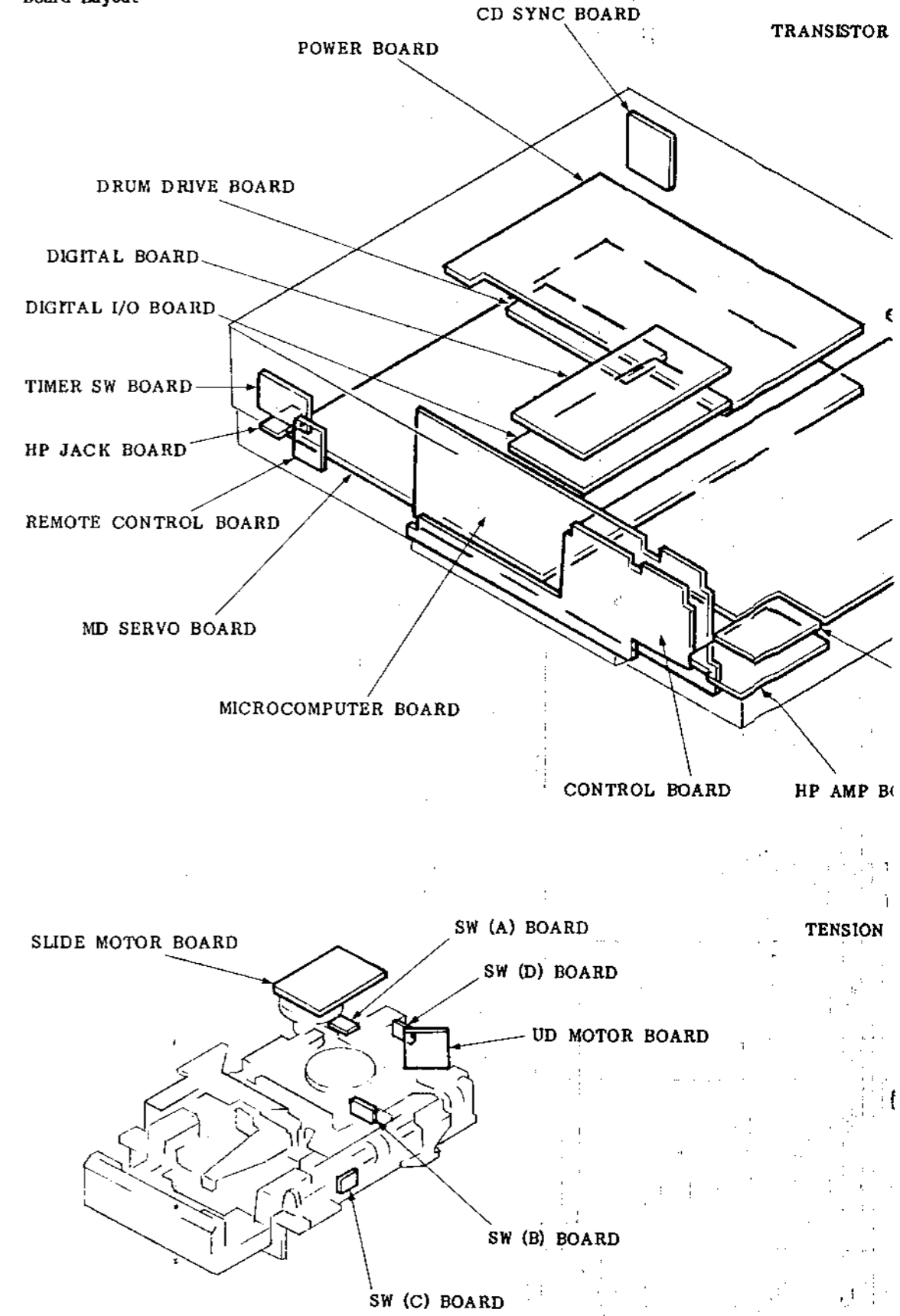

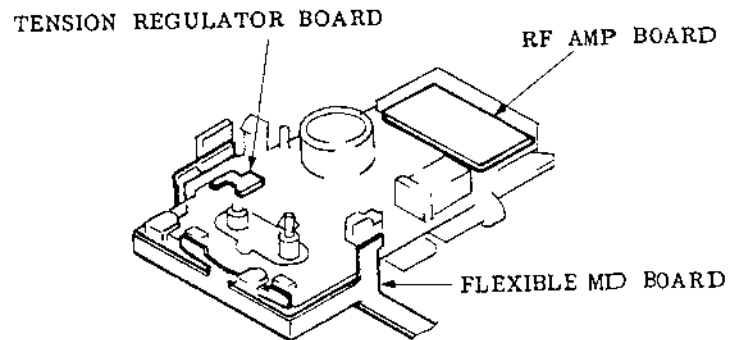
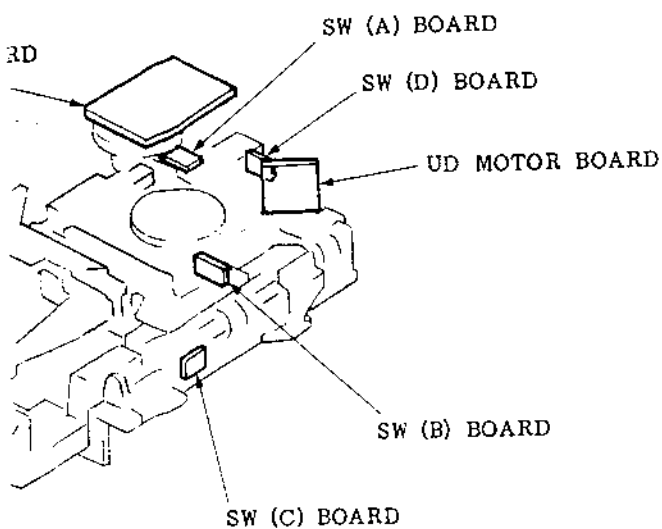
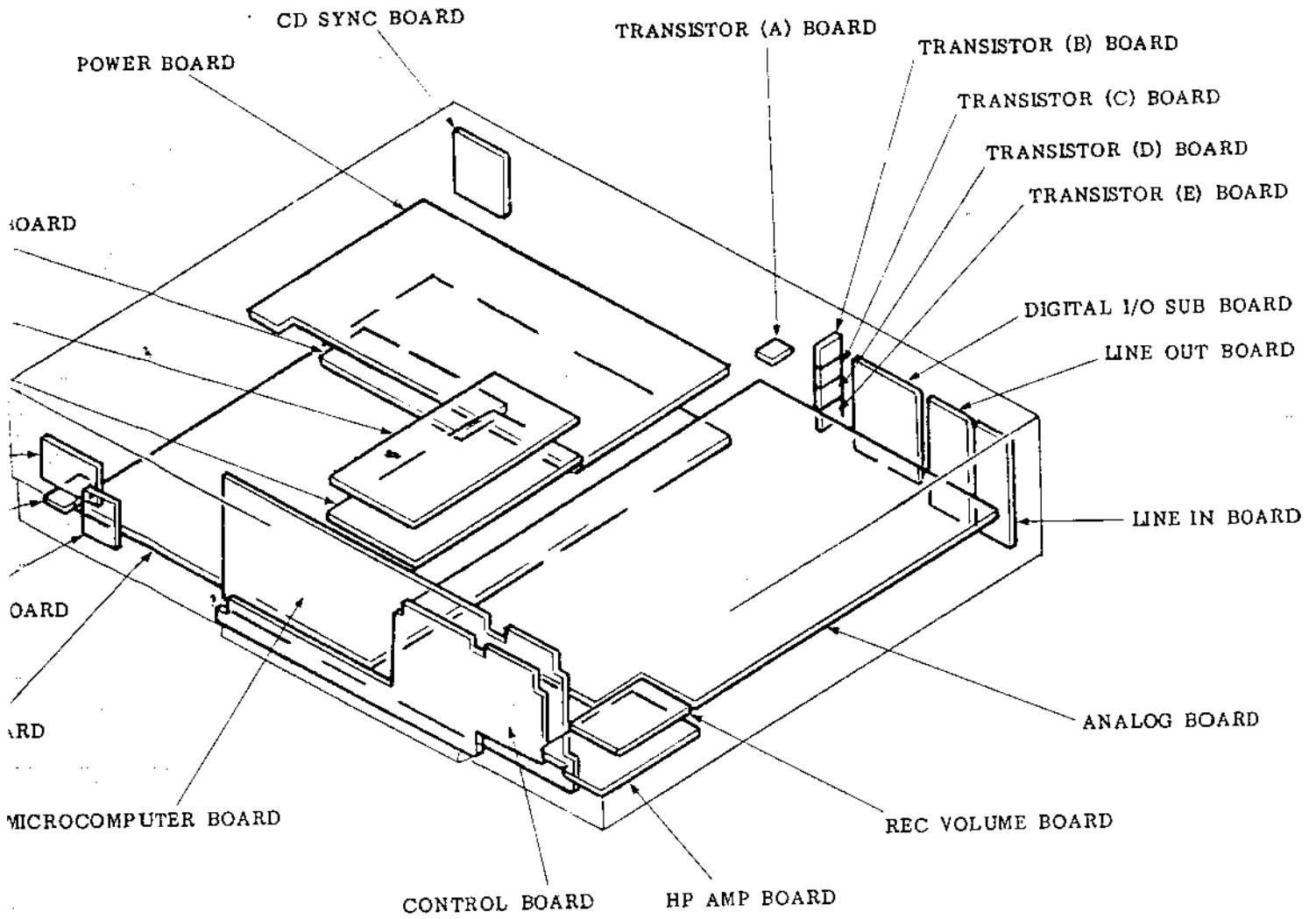

5-4. SCHEMATIC DIAGRAM (DIGITAL BLOCK)

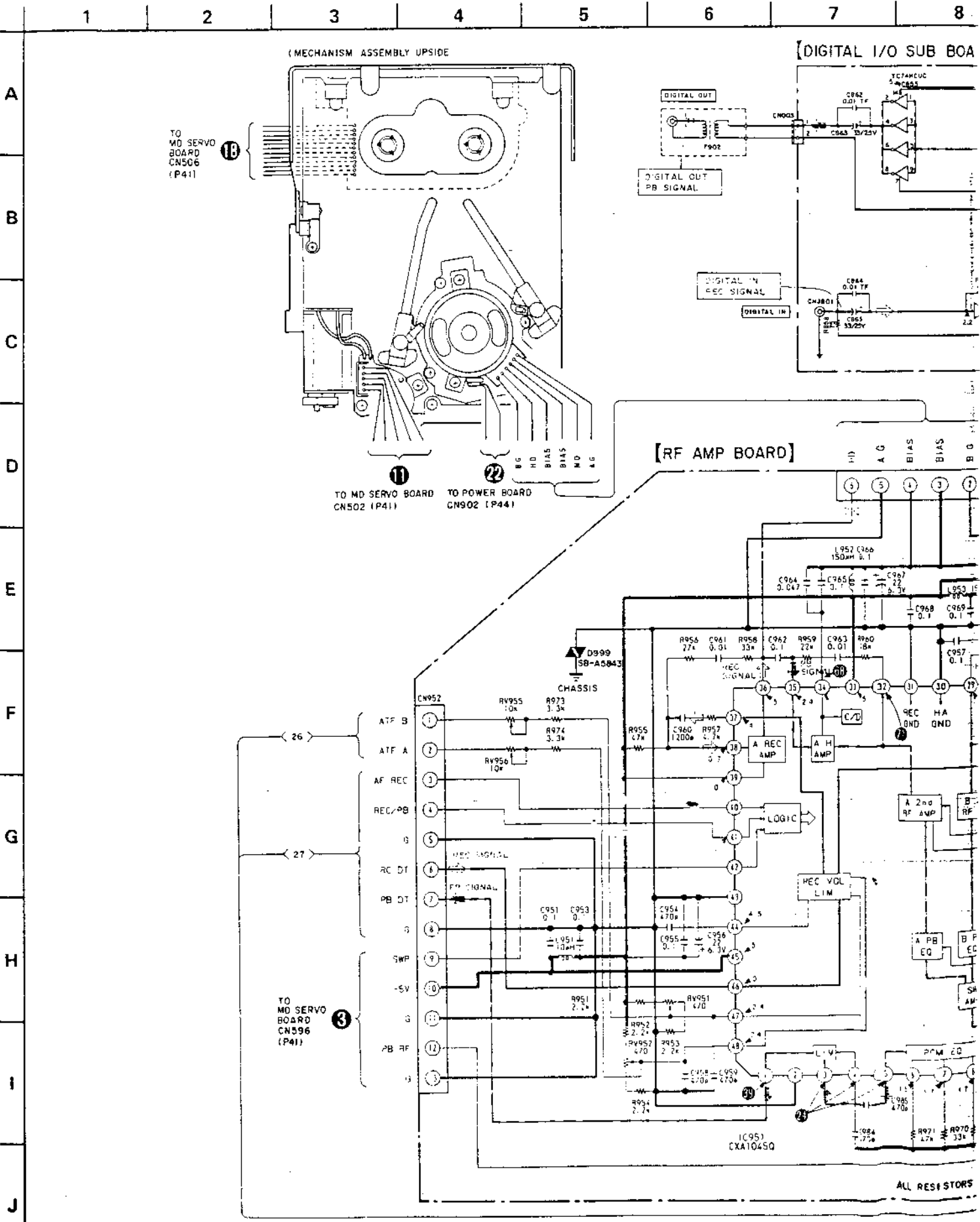

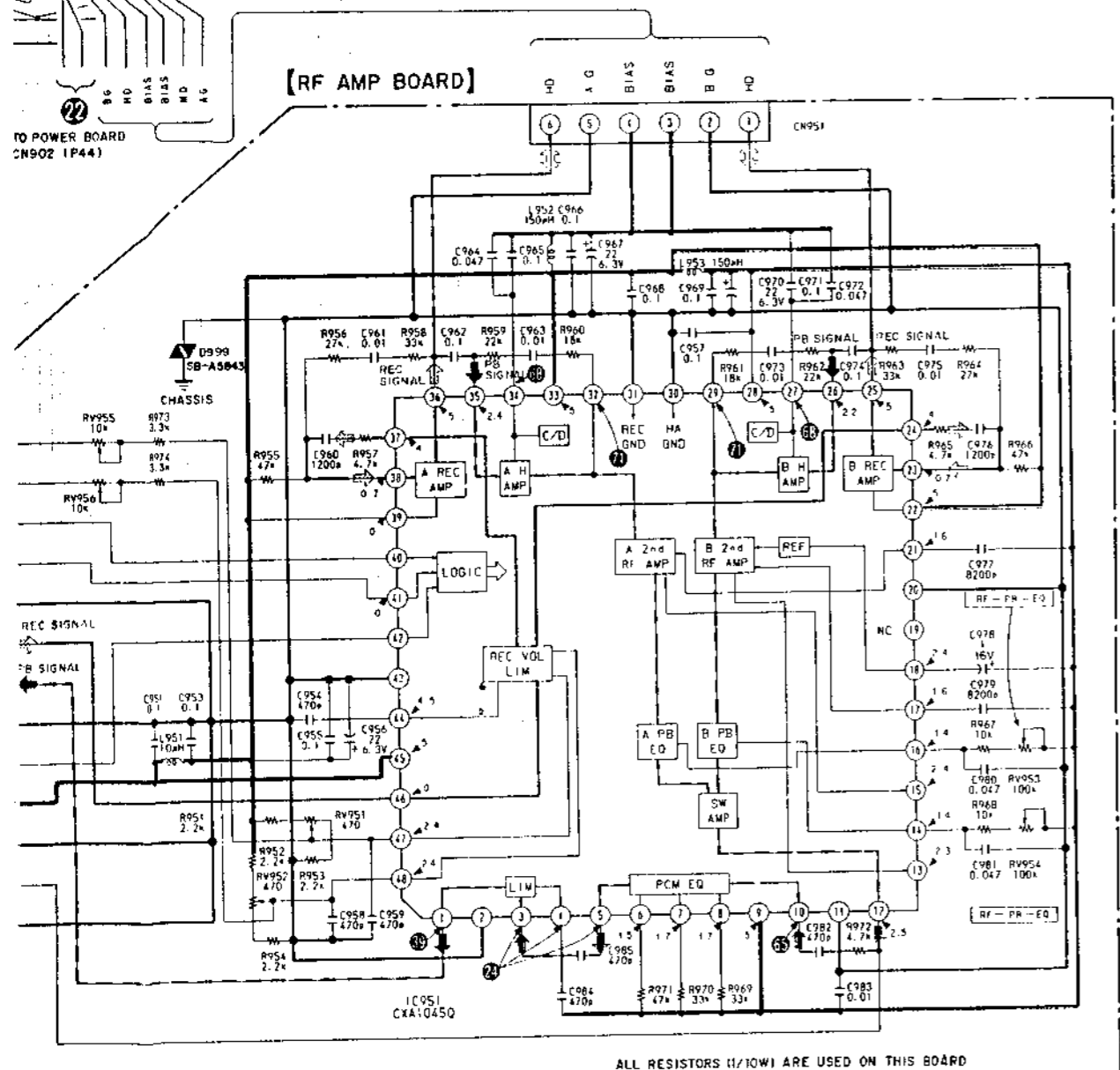
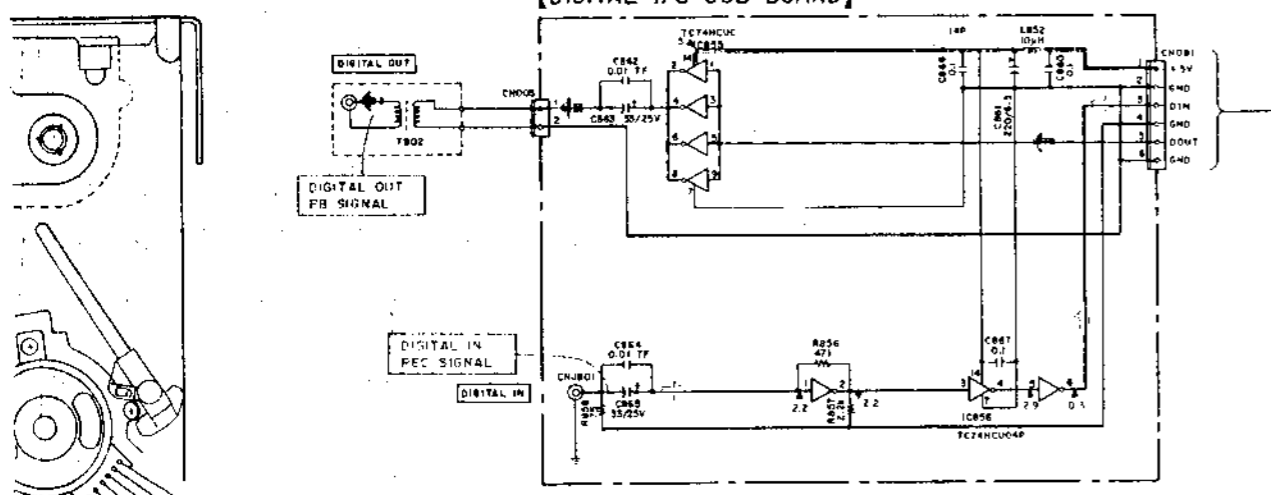

ALL RESISTORS (1/10W) ARE USED ON THIS BOARD

[DIGITAL I/O BOARD]

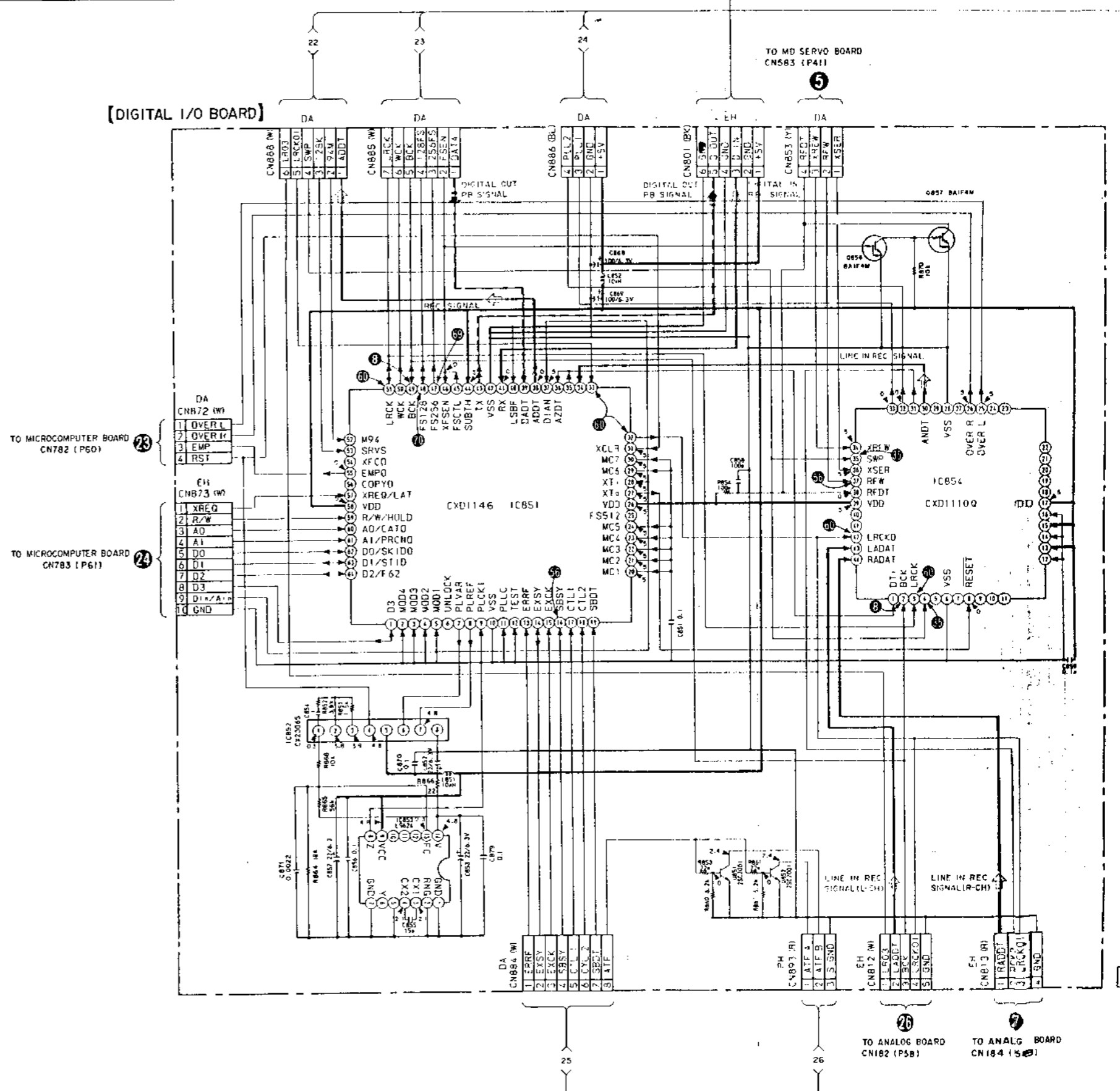

20 21 22 23 24 25 26 27 28 29 30 31 32 33 34 35

[DIGITAL BOARD]

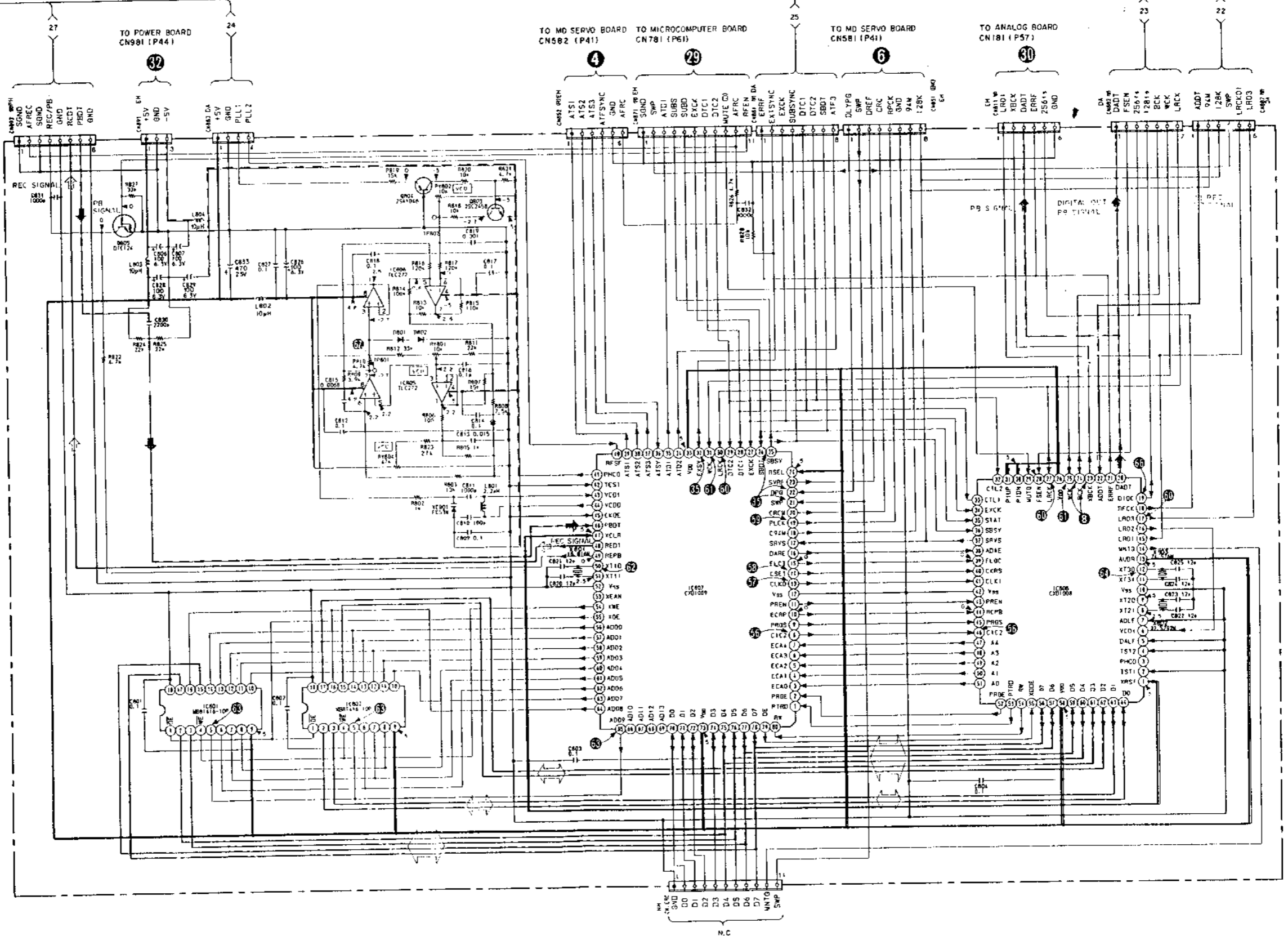

A
B
C
D
E
F
G
H
I
J

3 LRCLO1
4 GND
12

5-5. MOUNTING DIAGRAM (ANALOG & MICROCOMPUTER BLOCK)

Note:

- All capacitors are in μF unless otherwise noted. pF : μF 50 WV or less are not indicated except for electrolytics and tantalums.
- All resistors are in Ω and $1/4\text{W}$ or less unless otherwise specified.

Note: The components identified by shading and mark Δ are critical for safety. Replace only with part number specified.

- Δ : internal component.
- : fusible resistor.
- : B+ bus.
- : B- bus.
- : adjustment for repair.
- Voltages are dc with respect to ground unless otherwise noted.
- Readings are taken under no-signal (detuned) conditions with a VOM (50 $\text{k}\Omega/\text{V}$).
- Voltage variations may be noted due to normal production tolerances.
- Waveforms are taken to ground in STOP mode by using oscilloscope.
- Voltage variations may be noted due to normal production tolerances.
- : playback signal path
- : record signal path

Semiconductor Location

Ref. No.		Ref. No.	
D101	E-12	IC205	I-10
D102	E-6	IC301	D-13
D103	E-6	IC302	F-15
D104	F-6	IC303	I-12
D105	E-10	IC304	G-11
D201	C-12	IC305	H-7
D202	E-6	IC306	E-6
D203	E-6	IC307	H-6
D204	F-6	IC308	A-16
D205	D-10	IC309	A-15
D301	H-15	IC310	H-3
D302	H-15	IC311	F-14
D304	I-15	IC701	G-19
D305	H-9	IC702	F-19
D306	H-8	IC703	F-21
D307	G-3	IC704	G-25
D308	G-3	IC705	F-24
D701	F-28	IC706	G-27
D702	F-27	IC751	J-22
D703	F-27	Q101	F-11
D704	F-27	Q102	F-6
D705	F-27	Q201	D-11
D706	F-27	Q202	F-7
D707	F-27	Q301	H-6
D708	F-27	Q302	H-7
D709	F-27	Q303	I-7
D710	G-23	Q304	I-7
D711	G-26	Q305	H-7
D712	F-26	Q306	H-7
D713	F-27	Q307	G-15
D714	F-27	Q308	G-14
D715	F-27	Q309	F-15
D717	F-22	Q310	G-15
D718	F-22	Q311	I-15
D719	F-22	Q312	I-14
D720	F-22	Q313	I-14
D721	F-26	Q314	I-15
D751	C-22	Q701	G-25
D752	C-27	Q702	G-24
D753	D-25	Q703	G-24
D754	C-22	Q704	F-22
IC101	E-8	Q705	F-22
IC102	E-10	Q706	G-22
IC103	E-12	Q707	G-22
IC104	E-13	Q708	F-22
IC105	G-10	Q709	F-22
IC201	D-8		
IC202	D-10		
IC203	C-12		
IC204	C-13		

Note:

- Color code of sleeving over the end of the jacket.

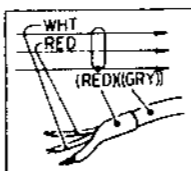

- : parts extracted from the component side.
- : parts extracted from the conductor side.
- : part mounted on the conductor side.
- : Through hole.

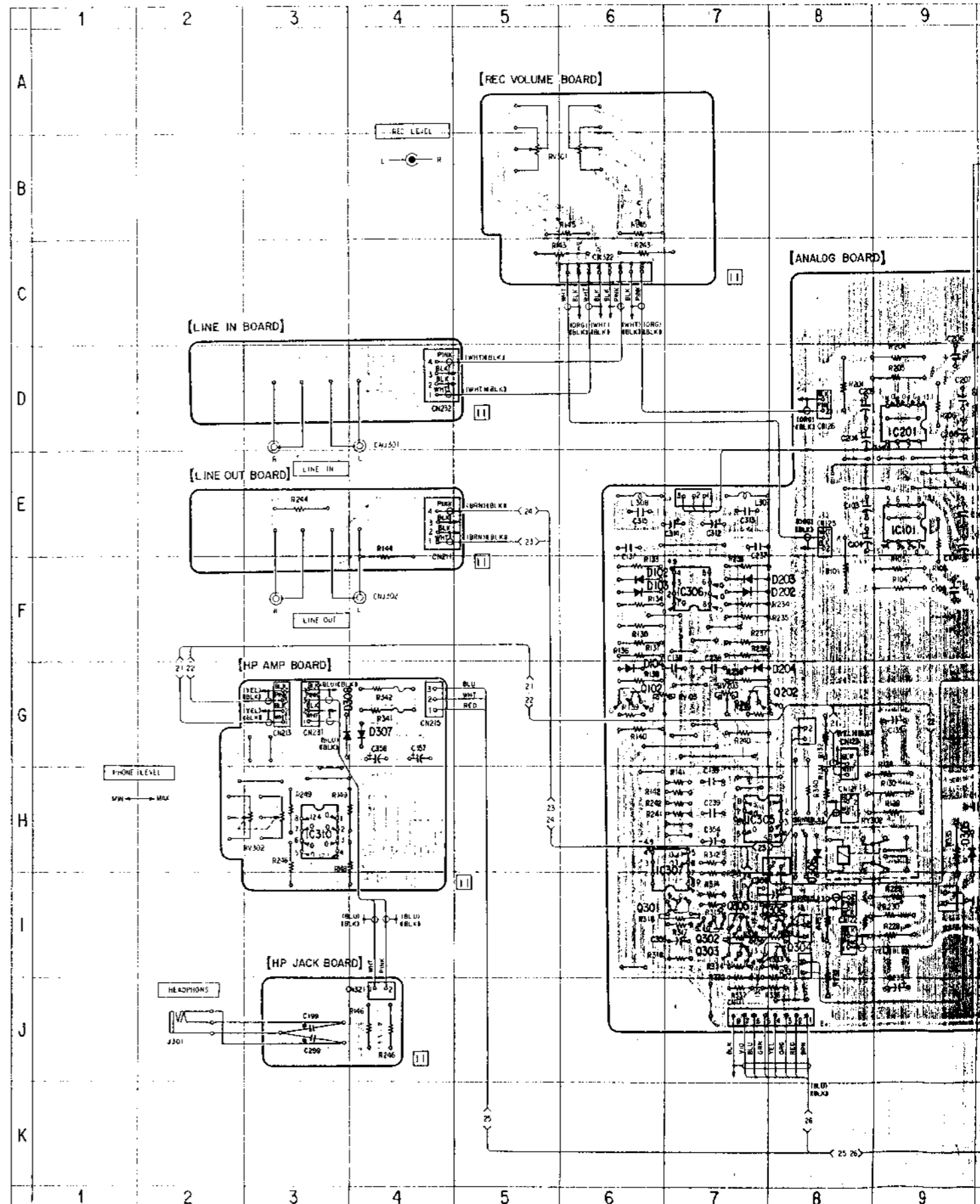

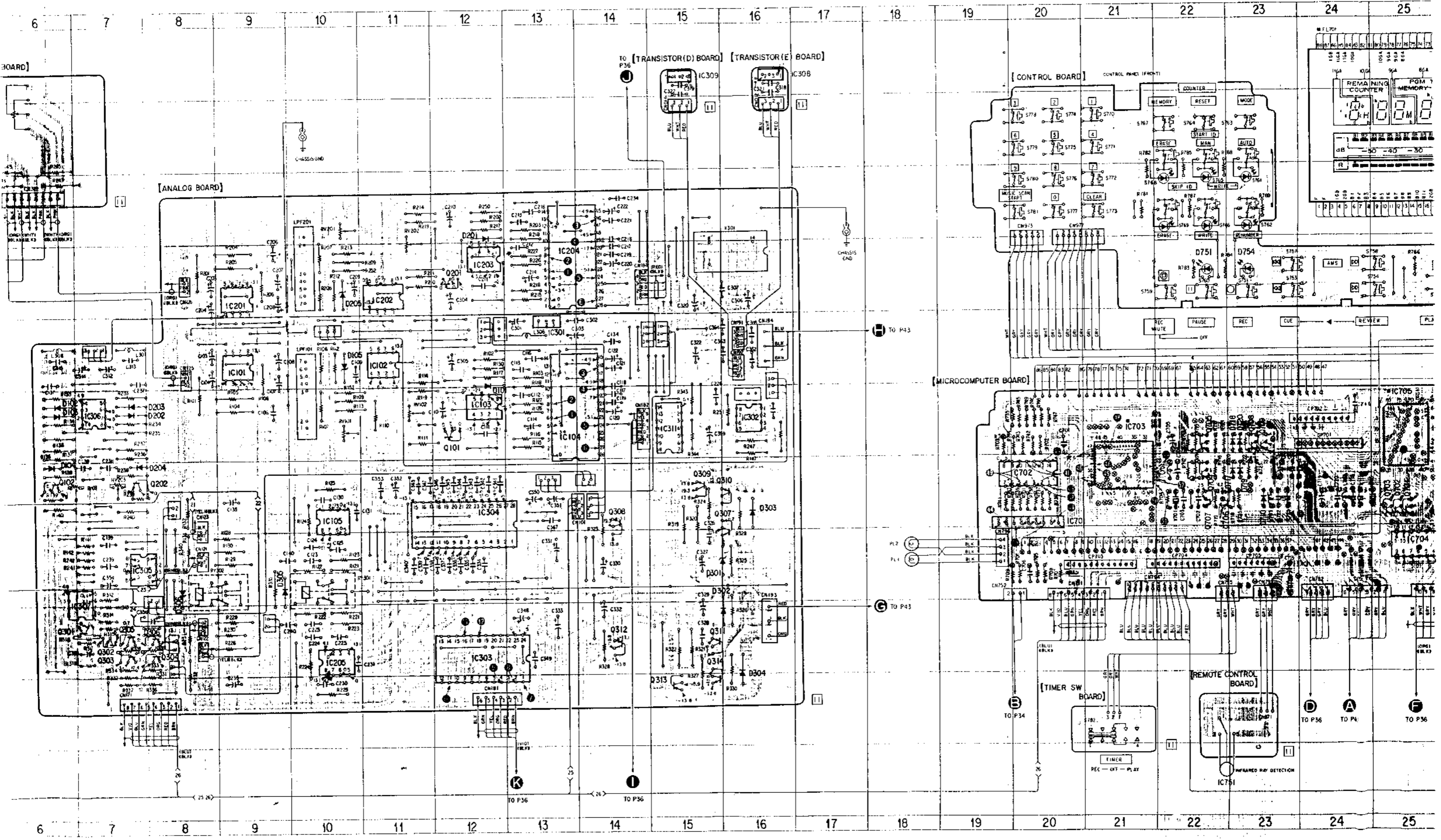

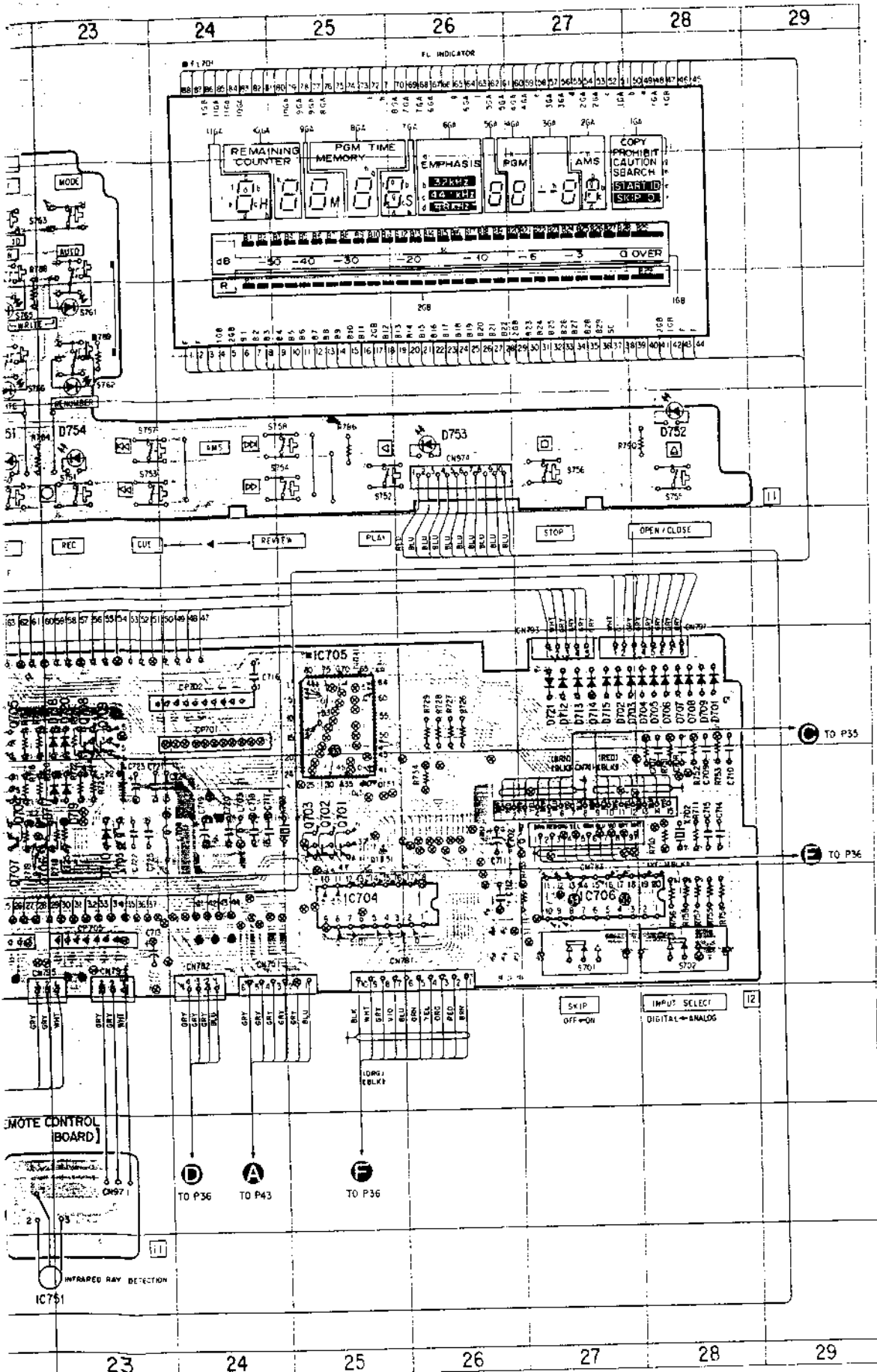

5-6. SCHEMATIC DIAGRAM (ANALOG & MICROCOMPUTER BLOCK)

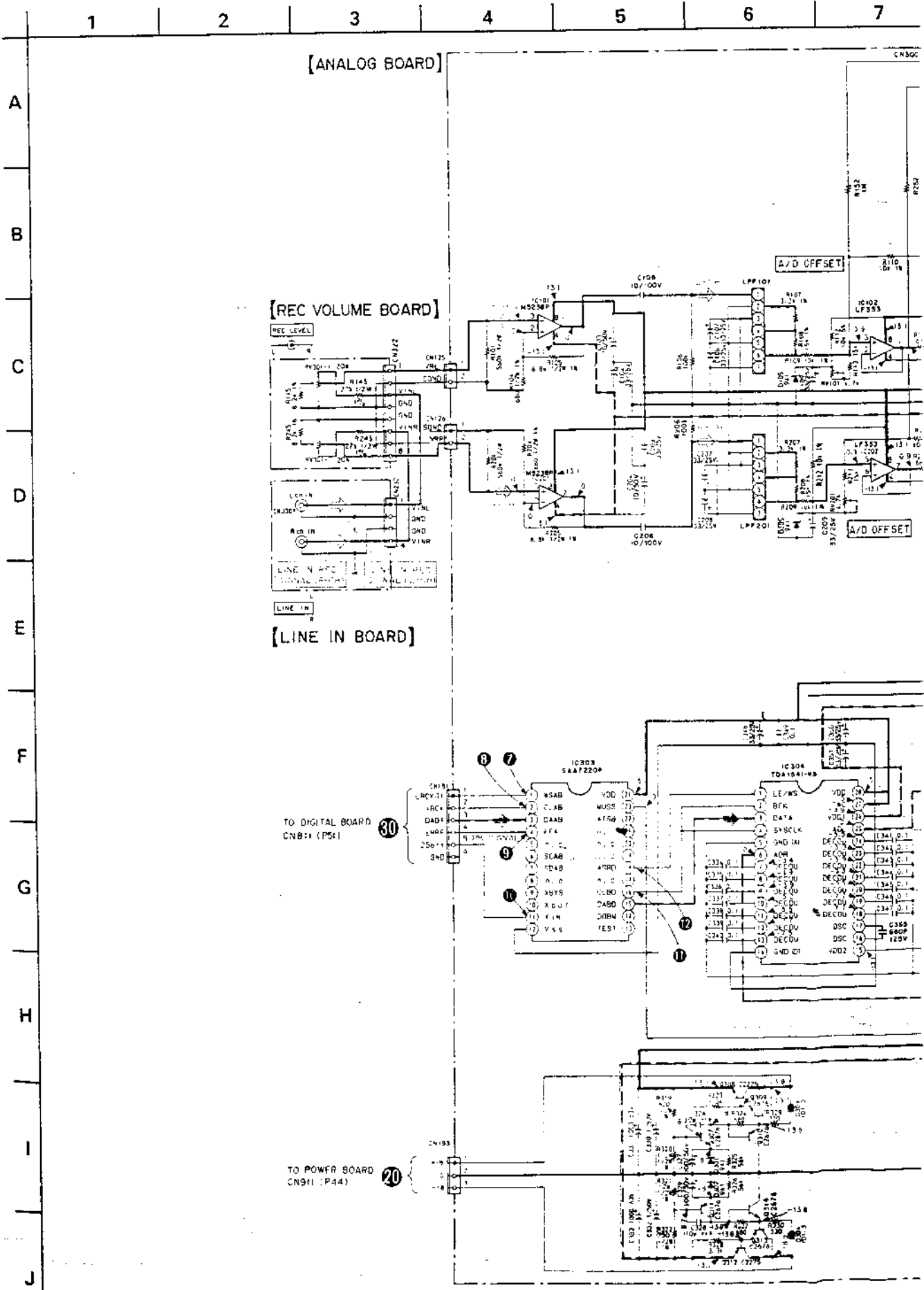

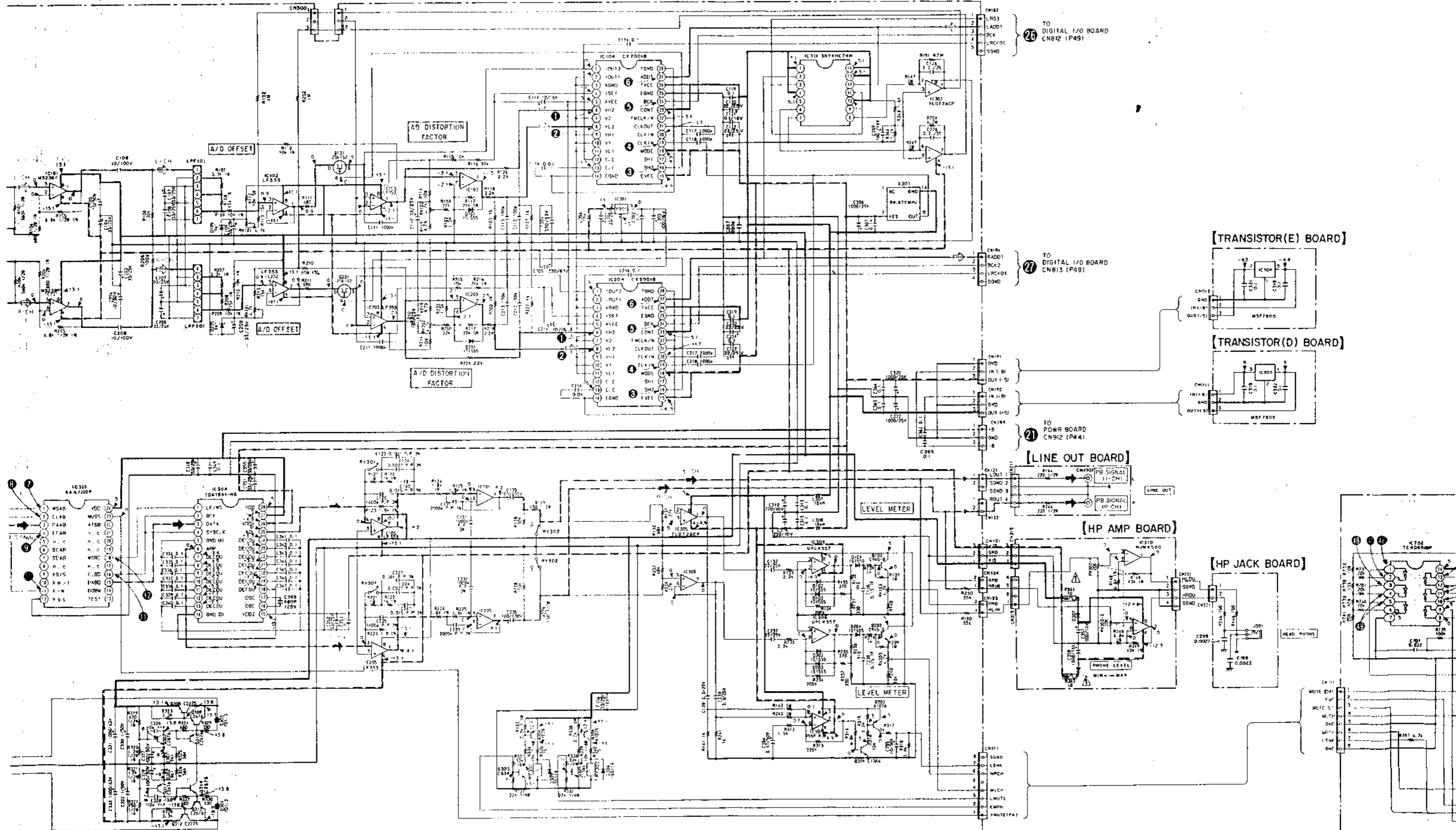

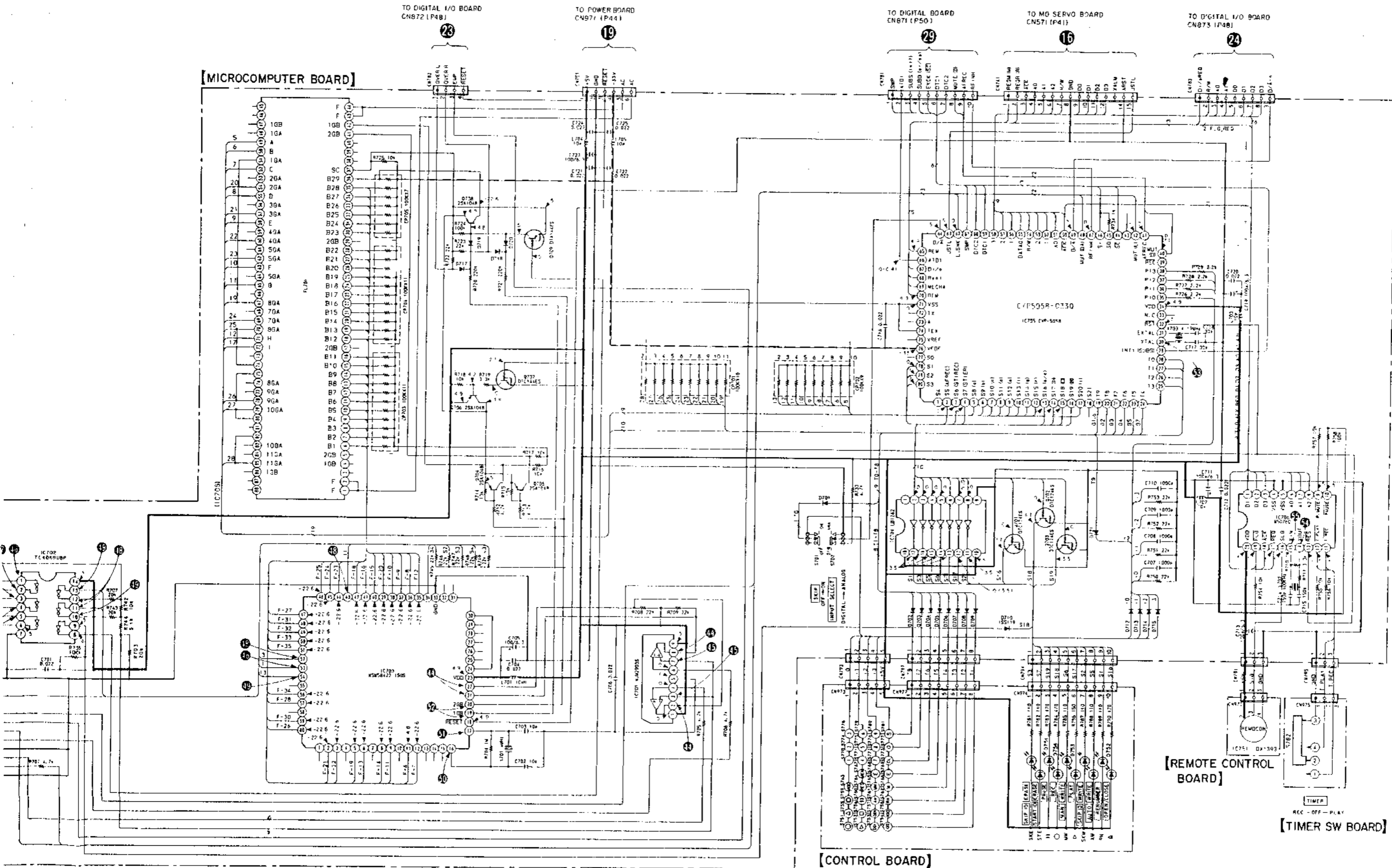











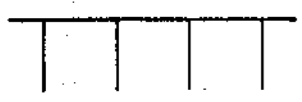



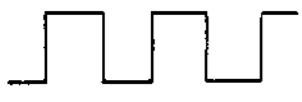









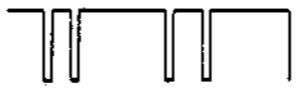
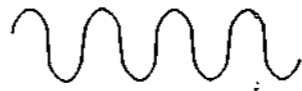
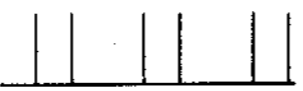
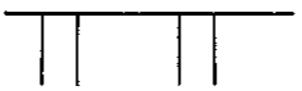

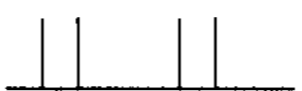

A
B
C
D
E
F
G
H
I
J





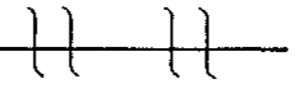
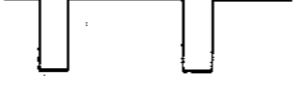







Waveform List

<p>① IC104 (6), IC204 (6)</p> <p>1.6Vp-p T = 2.04 μs</p>	<p>⑧ IC303 (2), IC851 (49), IC808 (23), (24), IC854 (2)</p> <p>5Vp-p T = 0.32 μs</p>	<p>⑭ IC401 (17)</p> <p>PLAY mode { 1.8Vp-p T = 7.5 mS EE mode DC 0.5V</p>
<p>② IC104 (8), IC204 (8)</p> <p>2Vp-p T = 2.04 μs</p>	<p>⑨ IC303 (4)</p> <p>5Vp-p T = 10.2 μs</p>	<p>⑮ IC402 (7)</p> <p>PLAY mode { 1.9Vp-p T = 2 mS EE mode DC 2.5V</p>
<p>③ IC104 (16), IC204 (16)</p> <p>5Vp-p T = 2.04 μs</p>	<p>⑩ IC303 (11)</p> <p>5Vp-p T = 0.08 μs</p>	<p>⑯ IC403 (6)</p> <p>PLAY mode { 1.9Vp-p T = 1.2 mS EE mode DC 2.1V</p>
<p>④ IC104 (19), IC204 (19)</p> <p>200mVp-p T = 12 μs</p>	<p>⑪ IC303 (16), IC304 (2), (4)</p> <p>5Vp-p T = 0.16 μs</p>	<p>⑰ IC403 (7)</p> <p>PLAY mode { 5 Vp-p T = 1.2 mS EE mode DC 0V</p>
<p>⑤ IC104 (24), IC204 (24)</p> <p>5Vp-p T = 3.2 μs</p>	<p>⑫ IC303 (18), IC304 (1)</p> <p>5Vp-p T = 5.1 μs</p>	<p>⑱ IC501 (1), IC502 (12)</p> <p>5Vp-p T = 0.24~0.58 S</p>
<p>⑥ IC104 (27), IC204 (27)</p> <p>5Vp-p T = 21 μs</p>	<p>⑬ IC401 (16)</p> <p>PLAY mode { 1.8Vp-p T = 7.5 mS EE mode DC 0.5V</p>	<p>⑳ IC510 (31), IC511 (10), IC512 (46)</p> <p>5Vp-p T = 0.24 μs</p>
<p>⑦ IC303 (1)</p> <p>5Vp-p T = 20.6 μs</p>	<p>⑲ IC502 (2)</p> <p>5Vp-p T = 0.24~0.58 S</p>	<p>㉑ IC511 (11)</p> <p>5Vp-p T = 0.24 μs</p>

<p>②⑥ IC513 (11), IC518 (1)</p> <p>5Vp-p T = 0.24 μs</p>	<p>②⑦ IC515 (27)</p> <p>4Vp-p T = 0.24 μs</p>
<p>②⑧ IC518 (2)</p> <p>5Vp-p T = 0.24 μs</p>	<p>②⑨ IC518 (7)</p> <p>0.7Vp-p T = 1 mS</p>
<p>②⑩ IC518 (11)</p> <p>REC mode { 1.5Vp-p T = 15 mS PLAY mode { (3), (4) DC 2.6V (5) DC 1.7V</p>	<p>③① IC518 (13)</p> <p>5Vp-p T = 30 mS</p>
<p>③② IC518 (14)</p> <p>5Vp-p T = 30 mS</p>	<p>③③ IC518 (14)</p> <p>5Vp-p T = 30 mS</p>

<p>26 IC513 (11) IC518 (1, 48)</p>  <p>5Vp-p T ≈ 0.1 μs</p>	<p>33 IC518 (15)</p>  <p>5Vp-p T = 430 μs</p>
<p>27 IC515 (27)</p>  <p>4Vp-p T = 30 mS</p>	<p>34 IC518 (18)</p>  <p>5Vp-p T = 15 mS</p>
<p>28 IC518 (2)</p>  <p>5Vp-p T ≈ 80 μs</p>	<p>35 IC518 (41, 45) IC807 (21, 25, 32) IC854 (4, 35)</p>  <p>5Vp-p T = 30 mS</p>
<p>29 IC518 (7, 9)</p>  <p>5Vp-p f ≈ 674 Hz</p>	<p>36 IC521 (14)</p>  <p>1.5Vp-p T ≈ 1.5 mS</p>
<p>30 IC518 (11)</p>  <p>5Vp-p T = 1.25 mS</p>	<p>37 IC522 (8, 11)</p>  <p>1.4Vp-p T ≈ 1.5 mS</p>
<p>31 IC518 (13)</p>  <p>5Vp-p T ≈ 6.7 μs</p>	<p>38 IC523 (3)</p>  <p>1.6Vp-p T ≈ 1.5 mS</p>
<p>32 IC518 (14)</p>  <p>5Vp-p T = 110 μs</p>	<p>39 IC951 (1)</p>  <p>1.4Vp-p T = 2.4 μs</p>

<p>40 IC527 (17)</p>  <p>5Vp-p T = 15 mS</p>	<p>47 IC702 (2)</p>  <p>5Vp-p T = 8.5 mS</p>	<p>54 IC706 (14)</p>  <p>5Vp-p T = 2.6 μs</p>
<p>41 IC527 (18)</p>  <p>5Vp-p T = 30 mS</p>	<p>48 IC702 (3, 11, 12) IC703 (43, 52)</p>  <p>5Vp-p T = 19 mS</p>	<p>55 IC706 (15)</p>  <p>4.5Vp-p T = 2.6 μs</p>
<p>42 IC527 (28)</p>  <p>5Vp-p T = 30 mS</p>	<p>49 IC702 (4, 5, 10, 13) IC703 (54)</p>  <p>5Vp-p T = 19 mS</p>	<p>56 IC807 (8) IC808 (46) IC851 (16) IC854 (37)</p>  <p>5Vp-p T = 15 mS</p>
<p>43 IC533 (7)</p>  <p>2Vp-p T ≈ 1.5 mS</p>	<p>50 IC703 (16)</p>  <p>3.5Vp-p T = 0.25 μs</p>	<p>57 IC807 (13)</p>  <p>5Vp-p T = 51.5 nS</p>
<p>44 IC701 (2, 8) IC703 (21, 22)</p>  <p>4Vp-p T = 19 mS</p>	<p>51 IC703 (17)</p>  <p>1.8Vp-p T = 0.25 μs</p>	<p>58 IC807 (14)</p>  <p>5Vp-p T = 0.22 μs</p>
<p>45 IC701 (3, 7)</p>  <p>3Vp-p T = 19 mS</p>	<p>52 IC703 (19, 20)</p>  <p>5Vp-p T = 10 mS</p>	<p>59 IC807 (19)</p>  <p>5Vp-p T = 0.1 μs</p>
<p>46 IC702 (1) IC703 (53)</p>  <p>5Vp-p T = 85 mS</p>	<p>53 IC705 (30)</p>  <p>5.2Vp-p T = 6 mS</p>	

<p>60 IC807 (30) IC808 (17, 27) IC851 (32, 33, 51) IC854 (3, 42)</p>  <p>5Vp-p T = 20 μs</p>	<p>66 IC808</p>  <p>5Vp-p</p>
<p>61 IC807 (31) IC808 (25)</p>  <p>5Vp-p T = 10 μs</p>	<p>67 TP801</p>  <p>0.7Vp-p</p>
<p>62 IC807 (50)</p>  <p>2.4Vp-p T = 55 nS</p>	<p>68 IC951</p>  <p>REC mode PLAY mode</p>
<p>63 IC801 (5) IC802 (5) IC807 (65)</p>  <p>5Vp-p T = 0.21 μs</p>	<p>69 IC851 (1)</p>  <p>5Vp-p</p>
<p>64 IC808 (12)</p>  <p>2.5Vp-p T = 40 nS</p>	<p>70 IC851 (1)</p>  <p>5Vp-p</p>
<p>65 IC951 (10)</p>  <p>REC mode { 1.2Vp-p T = 15 mS PLAY mode DC 3V</p>	<p>71 IC951 (1)</p>  <p>REC mode PLAY mode</p>

60 IC807 (30)
 IC808 (17), (27)
 IC851 (32), (33), (51)
 IC854 (3), (42)



5Vp-p T = 20 μs

61 IC807 (31)
 IC808 (25)



5Vp-p T = 10 μs

62 IC807 (50)



2.4Vp-p T = 55 ns

63 IC801 (5)
 IC802 (5)
 IC807 (65)



5Vp-p T = 0.21 μs

64 IC808 (12)



2.5Vp-p T = 40 ns

65 IC951 (10)

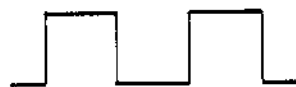

REC mode { 1.2Vp-p
 T = 15 mS
 PLAY mode DC 3V

66 IC808 (19)



5Vp-p T = 0.16 μs

67 TP801



0.7Vp-p T = 15 mS

68 IC951 (27), (34)



REC mode { 3.2Vp-p
 T = 15 mS
 PLAY mode DC 1.6V

69 IC851 (47)



5Vp-p T = 82 ns

70 IC851 (48)



5Vp-p T = 0.32 μs

71 IC951 (29), (32)



REC mode { 1.4Vp-p
 T = 15 mS
 PLAY mode DC 3V

Semiconductor Lead Layouts

<p>2SA812 DTC144EK</p>	<p>2SA1385 2SJ1040A 2SD1221</p>	<p>BX1393</p>	<p>CX20018 CX23014 TDA1541</p>	<p>LB1640N</p>	<p>M50760-428P</p>	<p>μPC324G2</p>	<p>FC53M</p>	<p>1S2837</p>
<p>2SA985A 2SB1015 2SB1094 2SB1094-L 2SC2275-P</p>	<p>2SB731</p>	<p>CXA1046M</p>	<p>CX20084 TC4051BP</p>	<p>LF353N/GLEA312 M5238P NJM4560D-D TL072ACP μPC358C μPC393C μPC4557C μPC4558C</p>	<p>M5F7905</p>	<p>μPC393G2</p>	<p>HZ2CLL HZ5BLL HZ9B2L 1S1532 1S1555 10E2 10E2N 10YD1.3A</p>	<p>30DF1-FC</p>
<p>2SA995 2SC2291</p>	<p>2SC634SP 2SC3399 2SC3400</p>	<p>CXD1009Q CXP5058</p>	<p>CX20174</p>	<p>MB3763PS</p>	<p>NJM2903S</p>	<p>7805</p>		<p>SLR-34DU5 SLR-34PC5</p>
<p>2SA1015 2SC945-P 2SC1387 2SC2001</p>	<p>2SC2259</p>	<p>CXD1008Q CXD1111Q</p>	<p>CX23065</p>	<p>MC74HC132N SN74LS624N SN74LS74N TC4066BP TC4069UBP TC74HC04P TC74HC00P TC74HC04P TC74HC86P μPC324C μPC339C</p>	<p>SAA7220P</p>	<p>TLC272P</p>	<p>RBV-602-01</p>	<p>TLR123</p>
<p>2SA1138 2SC2676</p>	<p>2SK152-2</p>	<p>CXD1052Q CX1045Q</p>	<p>HD14538BP NJU8001D TC4053BP TC74HC163P TC74HC175P</p>	<p>141317110 8 8</p>	<p>TMP47C460AF</p>	<p>TMP47C600N</p>	<p>THS105</p>	<p>1S5119</p>
<p>2SA1175</p>	<p>FMW2</p>	<p>CXD1110Q</p>	<p>LB1262 MB81416-10P</p>	<p>MSM58422-15GS</p>	<p>TMP47C600N</p>	<p>TMP47C600N</p>	<p>THS105</p>	<p>1S5119</p>

SECTION 6
EXPLODED VIEWS AND PARTS LIST

NOTE:

The mechanical parts with no reference number in the exploded views are not supplied.

Items marked "*" are not stocked since they are seldom required for routine service. Some delay should be anticipated when ordering these items.

The construction parts of an assembled part are indicated with a collation number in the remark column.

The components identified by shading and mark  are critical for safety. Replace only with part number specified.

Outer Casing Block

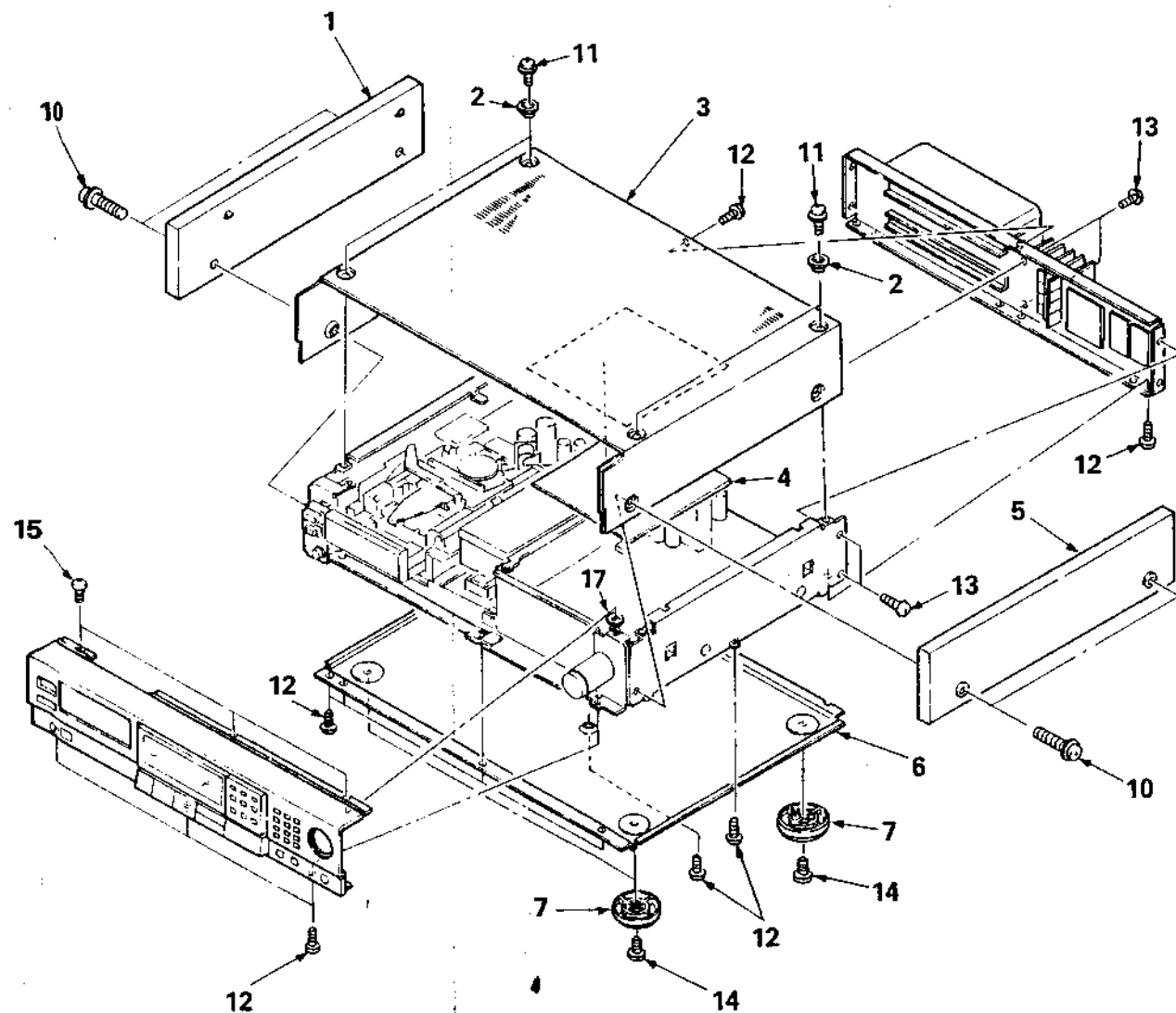

No.	Part No.	Description	Remarks	No.	Part No.	Description	Remarks
1	X-4918-929-1	PLATE (LEFT) ASSY, SIDE		10	4-919-060-01	SCREW (M4X20), RING (+)	
2	3-576-298-11	ESCUTCHEON		11	7-682-547-09	SCREW, FLAT WASHER (+B)(3X6)	
3	4-919-037-11	CASE		12	7-682-547-09	SCREW +BV 3X6, S TIGHT	
4	*4-919-043-01	DUMPER (A)		13	3-703-685-21	SCREW (+BV 3X8)	
5	X-4918-930-1	PLATE (RIGHT) ASSY, SIDE		14	7-682-561-09	SCREW +B 4X8	
6	*4-919-036-01	PLATE, BOTTOM		15	7-621-775-20	SCREW +B 2.6X5	
7	X-4918-919-1	LEG ASSY		17	*3-311-623-31	SPACER	

Front Panel Block

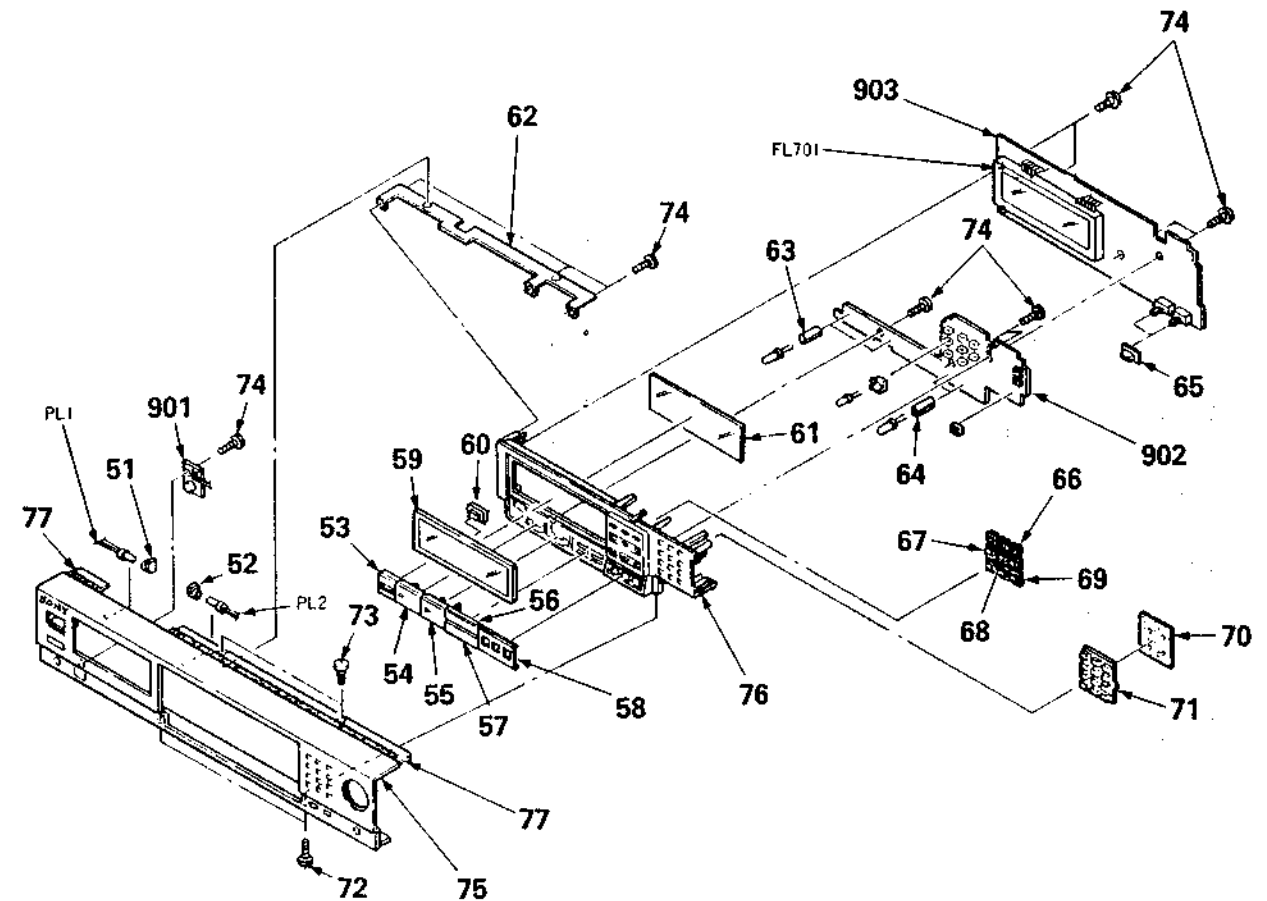

No.	Part No.	Description	Remarks	No.	Part No.	Description	Remarks
51	*4-918-989-01	COVER (LEFT), LAMP		67	4-918-975-01	BUTTON, ID	
52	*4-918-990-01	COVER (RIGHT), LAMP		68	4-918-975-11	BUTTON, ID	
53	X-4918-916-1	BASE ASSY, EJECT		69	4-918-975-21	BUTTON, ID	
54	X-4918-907-1	BUTTON ASSY, STOP		70	*4-918-982-01	CUSHION, TEN KEY	
55	X-4918-906-1	BUTTON ASSY, FWD		71	4-918-998-01	KEY, TEN	
56	X-4918-908-1	BUTTON ASSY, AMS		72	7-685-534-19	SCREW +BTP 2.6X8 TYPE2 N-S	
57	X-4918-909-1	BUTTON ASSY, FR		73	7-621-775-10	SCREW +B 2.6X4	
58	X-4918-915-1	BASE ASSY, REC		74	7-685-531-19	SCREW +BTP 2.6X4 TYPE2 N-S	
59	4-918-927-01	GLASS, WINDOW, METER		75	X-4918-933-1	PANEL ASSY, FRONT	
60	*4-918-928-01	PLATE, INDICATION, EJECT		76	X-4918-934-1	ESCUTCHEON ASSY, METER	
61	4-918-981-01	FILTER, FL TUBE		77	3-831-441-XX	CUSHION (B), CABINET	
62	*4-919-015-01	BRACKET, METER		901	*1-621-617-11	PC BOARD, REMOTE CONTROL	
63	*4-911-676-01	SPACER, LED		902	*1-621-615-11	PC BOARD, CONTROL	
64	*4-911-676-21	SPACER, LED		903	*A-2019-199-A	MOUNTED PCB, MICRO COMPUTER	
65	4-918-972-01	KNOB, SLIDE SW		PL1	1-518-614-11	LAMP, PILOT	
66	4-918-924-01	BUTTON, COUNTER		PL2	1-518-614-11	LAMP, PILOT	

Audio Block

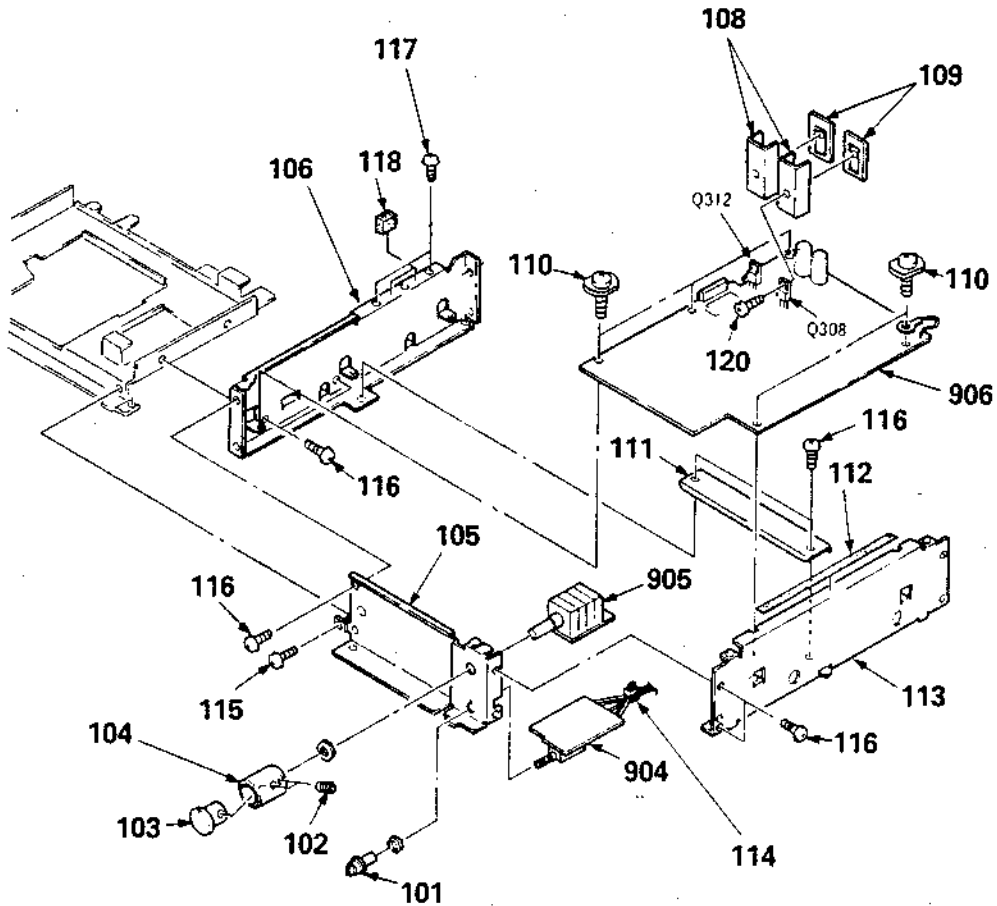

No.	Part No.	Description	Remarks	No.	Part No.	Description	Remarks
101	4-918-936-01	KNOB, HEADPHONE		112	3-831-441-XX	SPACER (8)	
102	3-701-505-00	SET SCREW, DOUBLE POINT 3X3		113	*4-919-026-01	PLATE (R), SIDE	
103	4-918-994-01	KNOB (RIGHT), REC		114	3-701-748-00	CLAMP	
104	4-918-943-01	KNOB (LEFT), REC		115	4-886-821-11	SCREW, S TIGHT, +PTWH 3X6	
105	*4-919-017-01	CHASSIS, FRONT		116	3-703-685-21	SCREW (+BV 3X8)	
106	*4-919-027-01	PLATE (C), SIDE		117	7-685-871-01	SCREW +BYTT 3X6 (S)	
108	*4-908-954-01	HEAT SINK, TR		118	*4-911-608-01	CUSHION, RUBBER	
109	4-887-707-00	RETAINER, TRANSFORMER		120	7-682-147-15	SCREW, TR	
110	X-4908-910-1	SCREW ASSY (+ BYTT)		904	*1-621-610-11	PC BOARD, HEADPHONE AMPLIFIER	
111	*4-919-011-01	PLATE, RELAY		905	*1-621-609-11	PC BOARD, REC VOLUME	
				906	A-2010-245-A	MOUNTED PCB, ANALOGUE	

Servo Mechanism Block

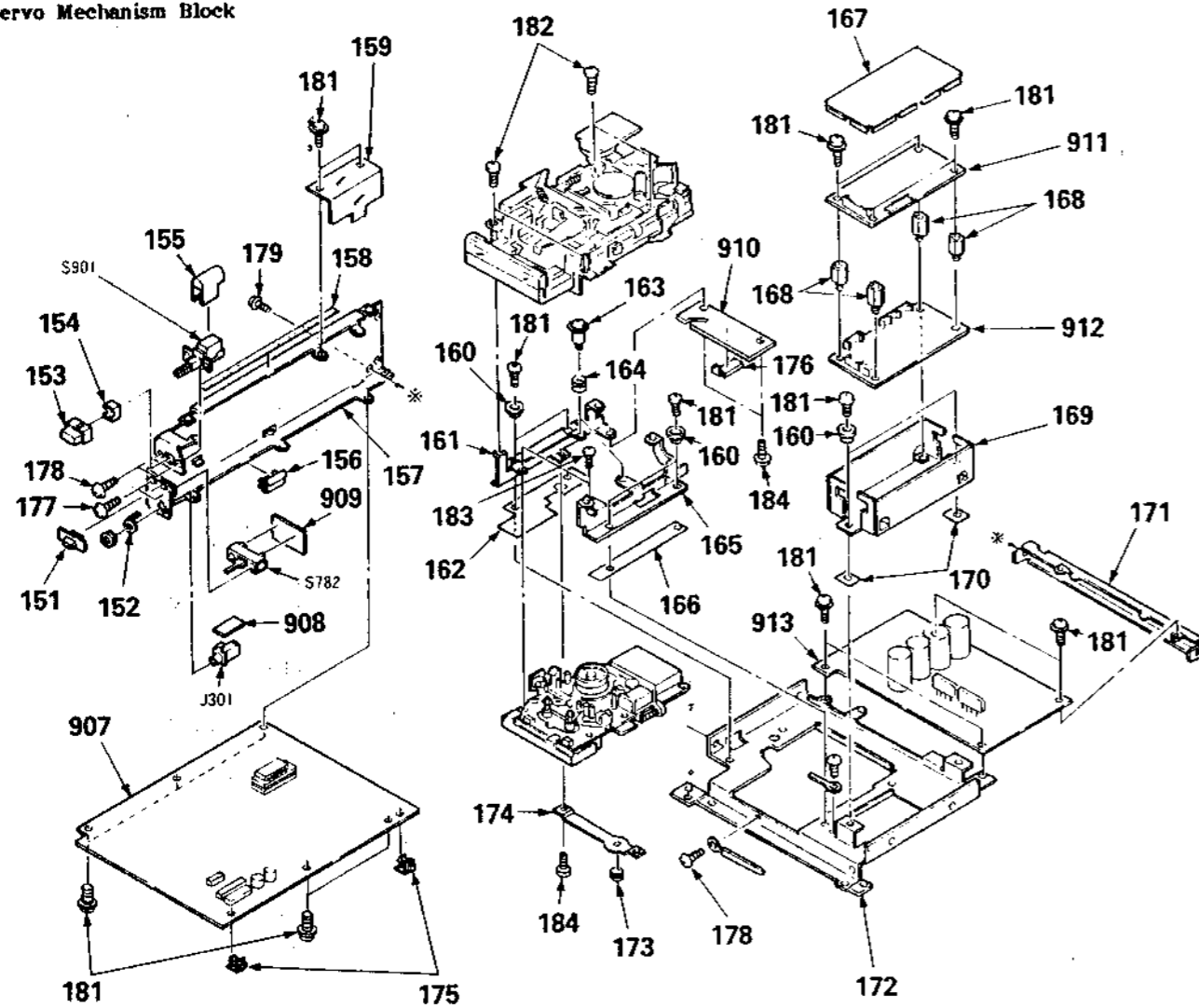

No.	Part No.	Description
151	4-918-937-01	KNOB, TIMER SW
152	*4-919-065-01	LUG, JACK
153	4-908-046-01	KNOB, SQUARE
154	*4-864-307-00	RING
155	3-575-524-00	COVER, POWER SWITCH
156	*4-919-020-01	SUPPORT (B), PC BOARD
157	*4-919-029-01	PLATE (L), SIDE
158	3-831-441-XX	SPACER (B)
159	*4-919-041-01	COVER, INSULATING
160	*4-919-042-01	SPACER
161	*4-919-012-01	BRACKET (LEFT), MD
162	*4-919-038-01	SHEET (A), INSULATING
163	4-918-991-01	SCREW, STEP
164	3-564-121-00	SPRING, COMPRESSION
165	*4-919-013-01	BRACKET (RIGHT), MD
166	*4-919-039-01	SHEET (B), INSULATING
167	*4-919-009-01	COVER, DIGITAL SHIELD
168	*2-375-791-01	SUPPORT
169	*4-919-010-01	CASE, SHIELD, DIGITAL
170	*4-919-040-01	SHEET (C), INSULATING
171	*4-919-018-01	BRACKET, PC BOARD
172	*4-919-028-01	CHASSIS, MD FITTING

No.	Part No.	Description	Remarks
173	3-489-073-00	SCREW, THRUST	
174	*4-918-983-01	SUPPORT	
175	*3-701-832-00	HINGE, CIRCUIT BOARD	
176	*4-918-985-01	HEAT SINK (B)	
177	7-621-775-10	SCREW +B 2.6X4	
178	7-685-871-01	SCREW +BYTT 3X6 (S)	
179	3-703-685-21	SCREW (+BV 3X8)	
181	4-886-821-11	SCREW, S TIGHT, +PTWH 3X6	
182	7-621-770-87	SCREW +B 2.6X5	
183	7-621-772-18	SCREW +B 2X4	
184	7-621-775-20	SCREW +B 2.6X5	
907	A-2020-081-A	MOUNTED PCB, MD SERVO	
908	*1-621-611-11	PC BOARD, HEADPHONE	
909	*1-621-616-11	PC BOARD, TIMER	
910	A-2095-597-A	MOUNTED PCB, DRUM DRIVE	
911	A-2097-007-A	MOUNTED PCB, DIGITAL	
912	A-2097-006-A	MOUNTED PCB, DIGITAL I/O	
913	*A-2012-126-A	MOUNTED PCB, POWER	
918	A-558-566-21	CORD, POWER	
J301	1-507-796-21	JACK	
S782	1-553-206-00	SWITCH, SLIDE (TIMER)	
S901	A-553-318-00	SWITCH, PUSH (POWER)	

The components identified by shading and mark are critical for safety. Replace only with part number specified.

Rear Panel Block

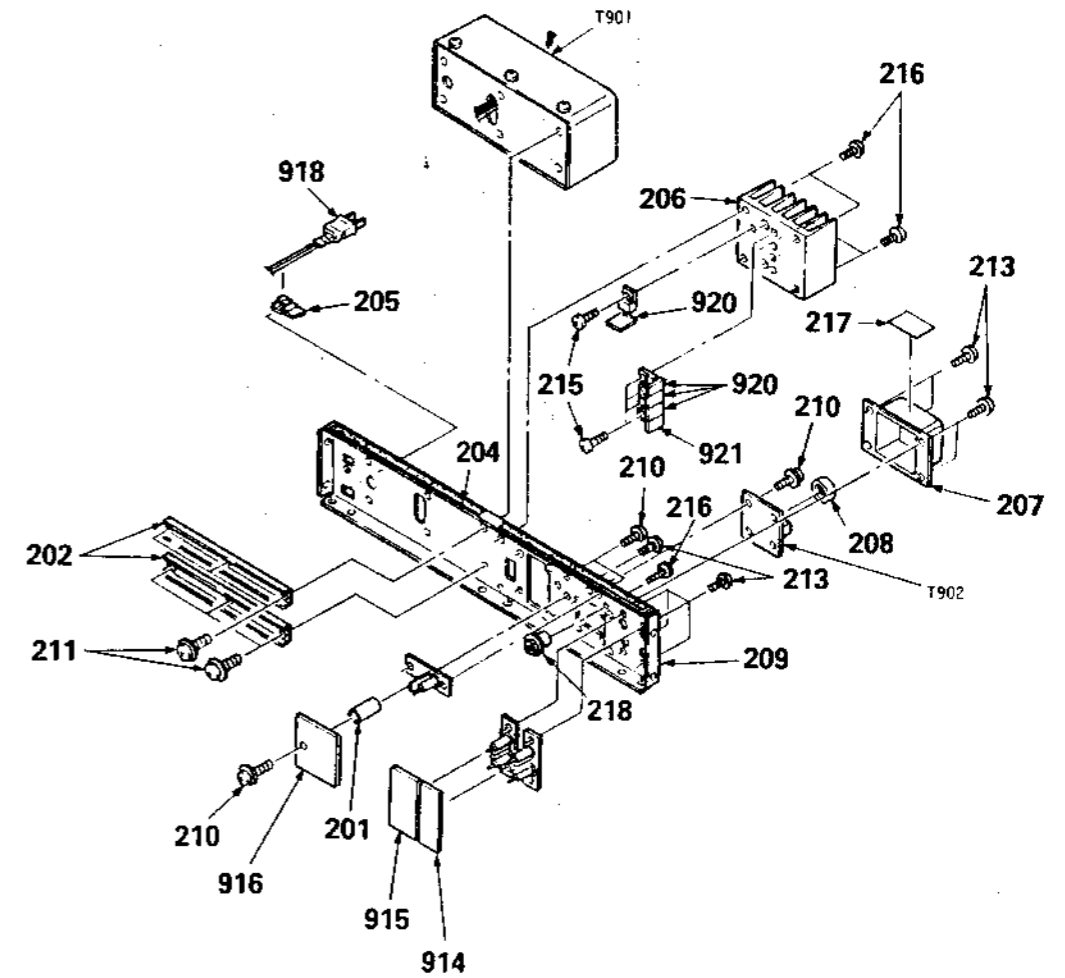

No.	Part No.	Description	Remarks
201	2-066-111-08	STUD	
202	*4-918-987-01	REINFORCEMENT	
204	3-831-441-XX	SPACER (B)	
205	*3-703-244-00	BUSHING (2104), CORD	
206	*4-919-021-01	HEAT SINK	
207	*4-918-979-01	CASE, DIGITAL OUT	
208	4-908-991-01	ESCUTCHEON (OUT)	
209	*4-919-030-11	PLATE, JACK	
210	4-886-821-11	SCREW, S TIGHT, +PTWH 3X6	
211	7-682-961-01	SCREW +PSW 4X8	
213	7-682-547-09	SCREW +BV 3X6, S TIGHT	
214	7-685-531-19	SCREW +BTP 2.6X4 TYPE2 N-S	

No.	Part No.	Description	Remarks
215	7-682-547-09	SCREW +B 3X6	
216	7-685-873-04	SCREW +BYTT 3X10 (S)	
217	4-919-068-11	(AEP)...LABEL, MODEL NUMBER	
217	4-919-069-11	(UK)...LABEL, MODEL NUMBER	
218	4-859-606-01	NUT, FLANGE (M3)	
914	*1-621-608-11	PC BOARD, LINE IN	
915	*1-621-613-11	PC BOARD, LINE OUT	
916	*1-621-306-11	PC BOARD, DIGITAL I/O SUB	
920	*1-621-618-11	PC BOARD, TRANSISTOR	
921	*1-621-619-11	PC BOARD, TRANSISTOR	
T901	1-449-018-11	TRANSFORMER, POWER	
T902	1-464-763-11	COIL UNIT, DIGITAL I/O	

Cassette Table Block (1)

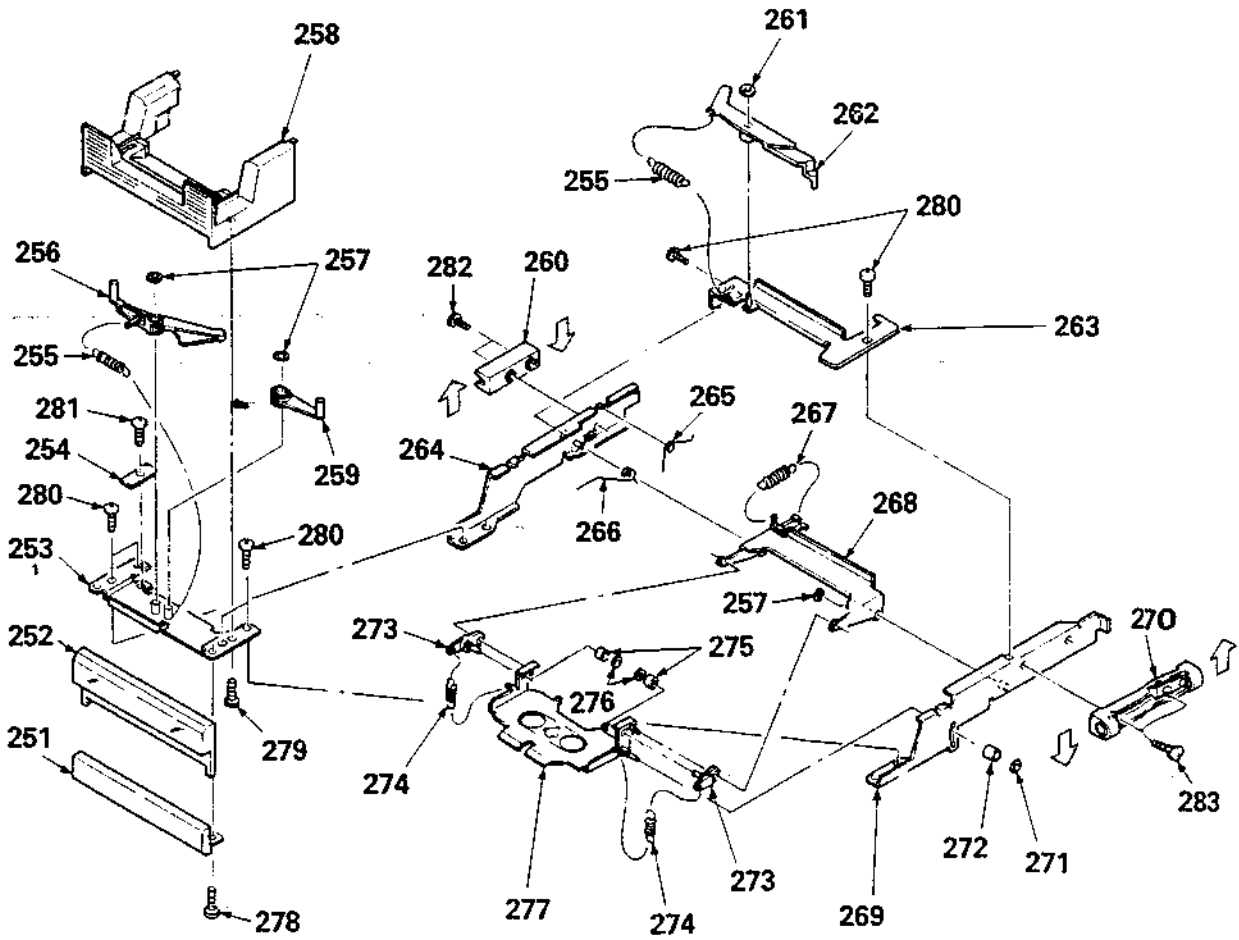

Notes: Attach 260 to 264 and 210 to 269 as follows:

- Tighten the screws with the play removed (counterclockwise).
- When the screws are not tightened as described above, a play occurs in the tray spring.

No.	Part No.	Description	Remarks	No.	Part No.	Description	Remarks
251	4-918-921-01	PANEL, TRAY		268	*X-4918-922-1	ARM ASSY	
252	4-918-922-01	WINDOW, TRAY		269	*X-4918-927-1	PLATE (RIGHT) ASSY, SIDE	
253	*X-4918-924-1	JOINT (REAR) ASSY		270	4-912-538-01	BEARING (RIGHT), GUIDE	
254	*4-918-974-01	SLIDE BLOCK		271	3-315-414-00	WASHER	
255	3-489-310-XX	SPRING, TENSION		272	*4-918-977-01	ROLLER, STABILITY	
256	4-919-004-01	LEVER (LEFT)		273	*4-918-945-01	LEVER, PRESS	
257	3-307-948-31	WASHER, NYLON		274	3-570-587-00	SPRING, TENSION	
258	*4-919-035-01	TRAY		275	4-918-946-01	ROLLER, PRESS	
259	4-919-003-01	LEVER (RIGHT)		276	3-701-436-11	WASHER, STOPPER	
260	*4-919-016-01	BEARING, SLIDER		277	*X-4918-925-1	HOLDER ASSY, CASSETTE	
261	3-307-948-21	WASHER, NYLON		278	7-621-773-86	SCREW +B 2.6X4	
262	4-919-007-01	LEVER, PUSH-OUT		279	7-685-534-19	SCREW +BTP 2.6X8 TYPE2 N-1	
263	*X-4918-923-1	JOINT (FRONT) ASSY		280	7-621-775-00	SCREW +B 2.6X3	
264	*X-4918-926-1	PLATE (LEFT) ASSY, SIDE		281	7-621-772-00	SCREW +B 2X3	
265	4-918-962-01	SPRING		282	7-621-775-20	SCREW +B 2.6X5	
266	4-918-971-01	SPRING		283	7-682-146-01	SCREW +P 3X5	
267	4-919-047-01	SPRING					

Cassette Table Block (2)

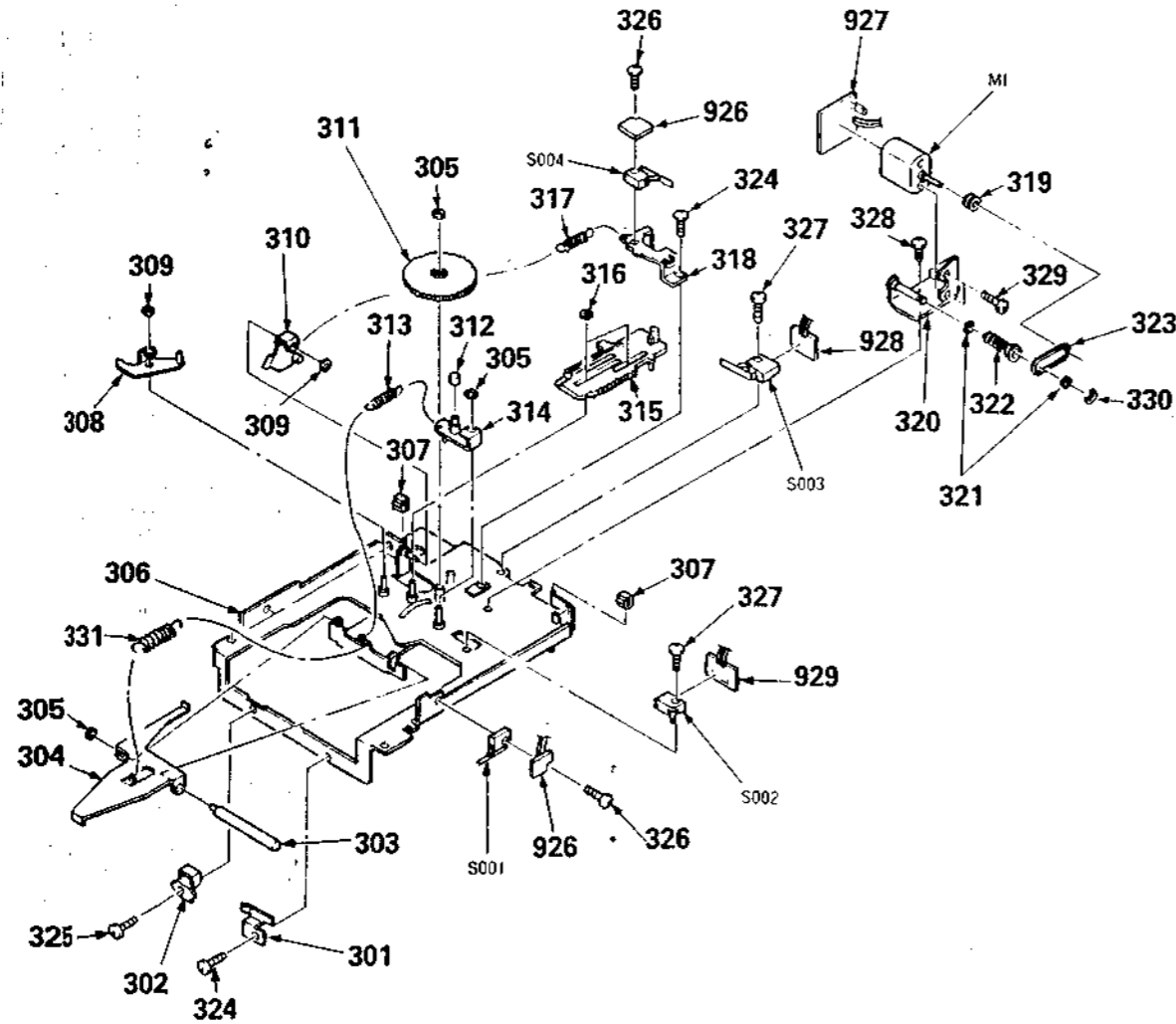

No.	Part No.	Description	Remarks	No.	Part No.	Description	Remarks
301	*4-918-952-01	PLATE (C), AGAINST		321	3-701-438-21	WASHER	
302	*4-918-978-01	HOUSING, POSITIONING		322	4-918-954-01	WORM	
303	*4-918-942-01	SHAFT, PULL LEVER		323	4-918-923-01	BELT, UD MOTOR	
304	*4-918-999-01	LEVER, PULL		324	7-621-259-10	SCREW +P 2.6X3	
305	3-701-436-11	WASHER, STOPPER		325	7-621-775-00	SCREW +B 2.6X3	
306	*X-4918-932-1	CHASSIS ASSY		326	7-621-255-40	SCREW +P 2X6	
307	4-887-175-00	RUBBER, STOPPER		327	7-621-255-55	SCREW +P 2X8	
308	*X-4918-905-1	ARM ASSY, TRAY LOCK		328	7-628-253-90	SCREW +PS 2.6X4	
309	3-307-948-31	WASHER, NYLON		329	7-627-852-37	PRECISION SCREW +P1.7X1.8 TYPE3	
310	*X-4918-901-1	PLATE ASSY, FUNCTION		330	7-624-104-04	STOP RING 2.0, TYPE -E	
311	4-919-008-01	GEAR, UD		331	3-701-788-XX	SPRING, TENSION	
312	*4-918-913-01	ROLLER, CAM		926	*1-621-623-11	PC BOARD	
313	3-578-387-00	SPRING, TENSION		927	*1-621-625-11	PC BOARD, UD MOTOR	
314	*X-4918-902-1	LEVER ASSY, CAM		928	*1-621-626-11	PC BOARD	
315	*4-919-002-01	SLIDER, UD		929	*1-621-624-11	PC BOARD	
316	3-307-948-21	WASHER, NYLON		MI	1-541-445-11	MOTOR	
317	3-567-028-00	SPRING, TENSION		S001	1-570-975-11	SWITCH, SLIDE (OUT)	
318	*4-918-961-01	BRACKET, SW		S002	1-570-972-11	SWITCH (IN)	
319	4-918-970-01	PULLEY, MOTOR		S003	1-570-973-11	SWITCH (UP)	
320	*X-4918-921-1	BRACKET ASSY, MOTOR		S004	1-570-975-11	SWITCH, SLIDE (DOWN (IN))	

Cassette Table Block (3)

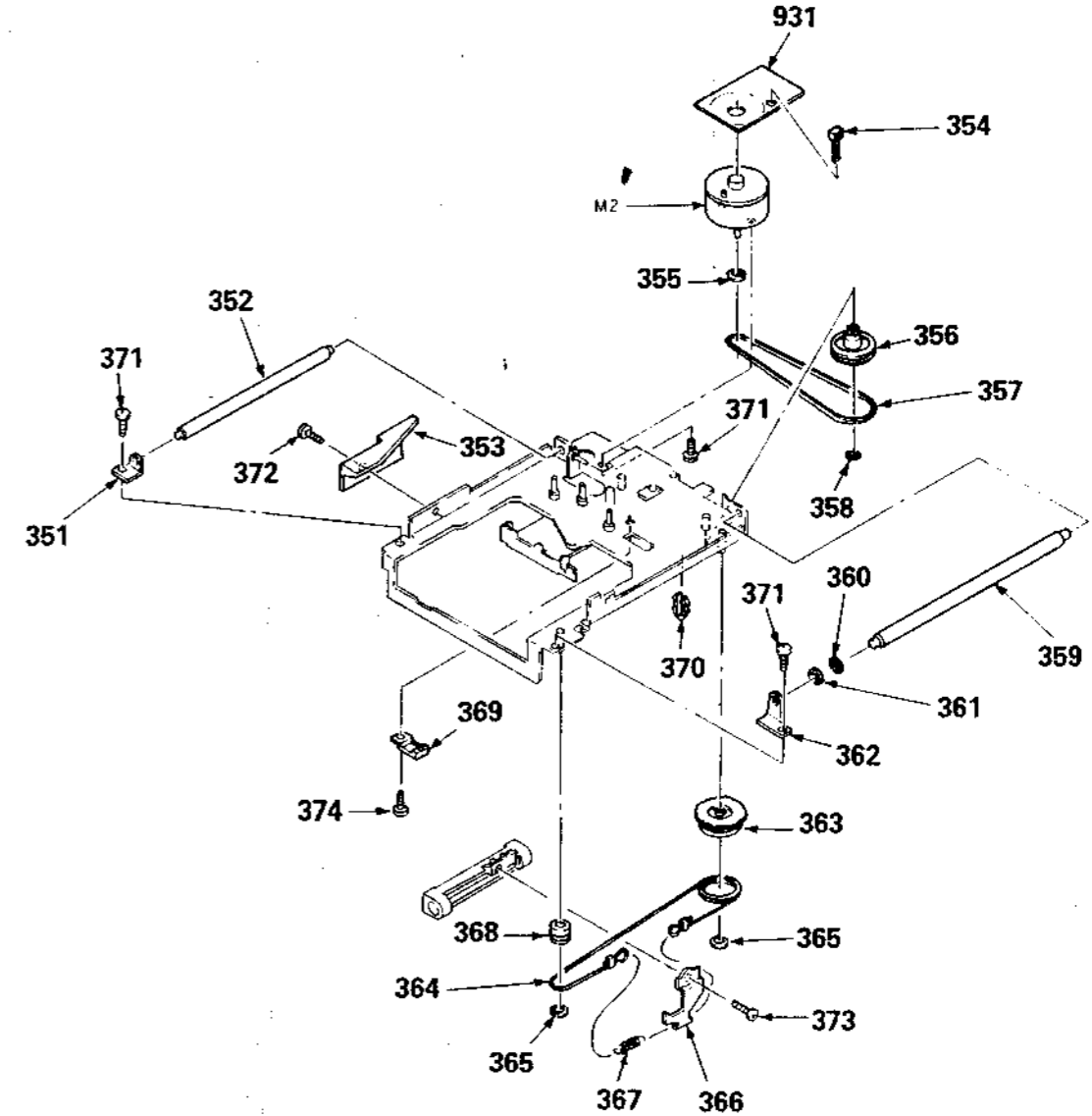

No.	Part No.	Description	Remarks	No.	Part No.	Description	Remarks
351	*4-918-947-01	PLATE (L), AGAINST		364	4-918-949-01	WIRE	
352	*4-918-959-01	SHAFT (L), SLIDE		365	3-307-948-21	WASHER, NYLON	
353	*4-919-006-01	GUIDE		366	4-918-904-01	HOOK, WIRE	
354	3-701-748-00	CLAMP		367	3-548-757-00	SPRING, TENSION	
355	3-554-222-00	WASHER (2), CAPSTAN		368	4-918-907-01	PULLEY	
356	4-918-901-01	PULLEY (2)		369	*4-918-984-01	STOPPER, WIRE	
357	4-918-963-01	BELT, SLIDE MOTOR		370	*3-660-815-00	CLIP, CABLE	
358	3-701-436-11	WASHER, STOPPER		371	7-621-775-00	SCREW +B 2.6X3	
359	*4-918-914-01	SHAFT (RIGHT), SLIDE		372	7-621-775-08	SCREW +B 2.6X3	
360	*4-918-980-01	CUSHION		373	7-685-531-19	SCREW +BTP 2.6X4 TYPE2 M-S	
361	4-908-550-01	STOPPER, RUBBER		374	7-621-772-08	SCREW +B 2X3	
362	*4-918-951-01	PLATE (R), AGAINST		931	*1-621-622-11	PC BOARD	
363	4-918-906-01	GEAR, WIRE		M2	A-608-303-A	MOTOR ASSY, LOADING	

DTC-1000ES DTC-1000ES

Mechanism Assembly

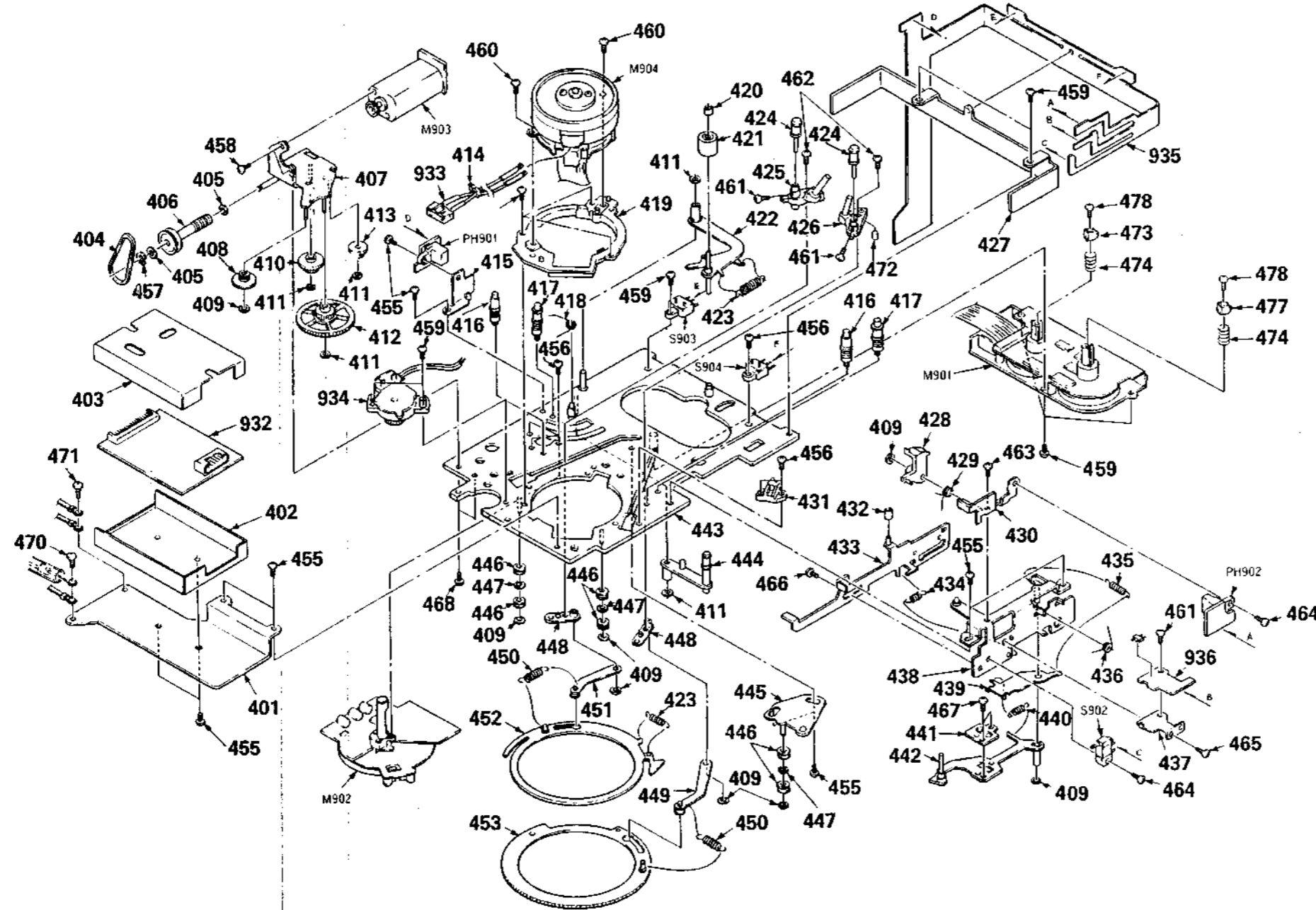

No.	Part No.	Description	Remarks
431	*3-337-685-01	CATCHER	
432	3-337-664-01	ROLLER	
433	X-3337-618-1	SLIDER ASSY, MODE	
434	3-570-892-00	SPRING, TENSION	
435	3-561-626-00	SPRING, TENSION	
436	3-337-673-01	SPRING	
437	*3-337-662-01	BRACKET, HOLE ELEMENT	
438	*X-3337-619-1	CHASSIS ASSY, TENSION REGULATOR	
439	*3-337-657-01	LEVER, LIMITER	
440	3-307-377-00	SPRING, TENSION	
441	X-3337-611-1	HOLDER ASSY, MAGNET	
442	X-3337-609-1	ARM ASSY, TENSION REGULATOR	
443	*X-3337-625-1	CHASSIS ASSY, MECHANICAL	
444	X-3337-613-1	ARM ASSY, F	
445	*X-3337-605-1	ARM ASSY, RING ROLLER	
446	3-337-622-01	ROLLER, RING	
447	3-701-436-11	WASHER, 1.6 POLYETHYLENE	
448	X-3337-604-1	PLATE ASSY, LOADING	
449	*X-3337-607-1	ARM (LEFT) ASSY, LOADING	
450	3-337-653-01	SPRING, TENSION	
451	*X-3337-603-1	ARM (RIGHT) ASSY, LOADING	
452	X-3337-601-1	RING (RIGHT) ASSY, LOADING	
453	X-3337-602-1	RING (LEFT) ASSY, LOADING	
455	7-621-772-08	SCREW +B 2X3	
456	7-627-552-47	SCREW, PRECISION +P 1.7X4	
457	7-624-102-04	STOP RING 1.5, TYPE -E	
458	7-627-553-17	SCREW, PRECISION +P 2X2	
459	7-621-772-18	SCREW +B 2X4	
460	7-621-255-25	SCREW +P 2X4	
461	7-627-551-17	SCREW, PRECISION +P 1.4X2	
462	3-703-502-81	SCREW	
463	7-627-552-18	SCREW, PRECISION +P 1.7X1.6	
464	7-621-772-20	SCREW +B 2X5	
465	7-627-552-27	SCREW, PRECISION +P 1.7X2	
466	3-703-502-11	SCREW	
467	7-627-551-87	PRECISION SCREW +P 1.4X1.8	
468	7-628-253-00	SCREW +PS 2X4	
470	7-621-773-86	SCREW +B 2.6X4	
471	7-621-770-67	SCREW +B 2.6X6	
473	2-623-736-01	REEL (L)	
474	2-623-754-01	SPRING	
477	2-623-752-01	REEL (R)	
478	2-623-756-01	SCREW B1.7X3	
932	*A-2096-052-A	MOUNTED PCB, RF AMPLIFIER	
933	*9-831-249-48	WIRE KIT	
934	1-464-724-11	ENCODER, ROTARY	
935	1-620-725-11	PC BOARD, MD FLEXIBLE	
936	*1-620-186-11	PC BOARD, TENTION REGULATOR	
M901	8-835-205-01	MOTOR, DC V-2A	
M902	8-835-206-01	MOTOR, DC BHF-2803A	
M903	X-3337-626-1	MOTOR ASSY, L	
M904	8-848-500-01	DRUM ASSY DDH-01A	
PH901	1-807-698-11	PHOTO SENSOR	
PH902	1-807-698-11	PHOTO SENSOR	
S902	1-570-771-11	SWITCH LIMIT	
S903	1-570-883-11	SWITCH, PUSH (2 KEY) CASSETTE DETECT	
S904	1-570-883-21	SWITCH, PUSH (2 KEY) CASSETTE DETECT B	

No.	Part No.	Description
401	*3-337-666-01	BRACKET, RF
402	*3-337-686-01	CASE (LOWER), SHIELD
403	*3-337-682-01	CASE (UPPER), SHIELD
404	3-337-652-01	BELT, CONTROL
405	3-701-437-21	WASHER
406	3-337-650-01	GEAR, WORM
407	*X-3337-617-1	BRACKET ASSY, CONTROL MOTOR
408	3-337-669-01	GEAR, MIDWAY
409	3-559-408-11	WASHER, POLYETHYLENE, DIA. 1.2
410	3-337-649-01	WHEEL, WORM

No.	Part No.	Description	Remarks
411	3-701-436-11	WASHER, STOPPER	
412	3-337-647-01	GEAR (A), LOADING	
413	3-337-648-01	GEAR (B), LOADING	
414	3-701-748-00	CLAMP	
415	*3-337-610-01	BRACKET (RIGHT), E DETECTION	
416	X-3337-623-1	GUIDE (5.0) ASSY, FIXED	
417	X-3337-621-1	GUIDE (4.0) ASSY, FIXED	
418	3-337-654-01	SPRING	
419	*X-3337-614-1	SLANT ASSY	
420	3-337-626-01	CAP, PINCH ROLLER	

No.	Part No.	Description	Remarks
421	X-3337-610-1	PINCH ROLLER ASSY	
422	X-3337-608-1	ARM ASSY, PINCH ROLLER	
423	3-547-659-00	SPRING, TENSION	
424	X-3337-622-1	GUIDE (POM) ASSY, ROLLER	
425	X-3337-616-1	SLANT BLOCK (RIGHT) ASSY	
426	X-3337-615-1	SLANT BLOCK (LEFT) ASSY	
427	*3-337-679-01	HOLDER, PC BOARD	
428	3-337-608-01	OPENER, LID	
429	3-337-607-01	SPRING	
430	*X-3337-612-1	BRACKET (L) ASSY, E DETECTION	

SECTION 7 ELECTRICAL PARTS LIST

NOTE:

Items marked "*" are not stocked since they are seldom required for routine service. Some delay should be anticipated when ordering these items.

If there are two or more same circuits in a set such as a stereophonic machine, only typical circuit parts may be indicated and capacitors and resistors in other same circuits may be omitted.

CAPACITORS:

MF:µF, PF:µµF.

RESISTORS

All resistors are in ohms.
F : nonflammable

COILS

MMH : mH, UH : µH

SEMICONDUCTORS

In each case, U : µ, for example:
UA...: µA..., UPA...: µPA..., UPC...: µPC,
UPD...: µPD...

The components identified by shading and mark **△** are critical for safety. Replace only with part number specified.

ELECTRICAL PARTS

Ref.No.	Part No.	Description
901	*1-621-617-11	PC BOARD, REMOTE CONTROL
902	*1-621-615-11	PC BOARD, CONTROL
903	*A-2019-199-A	MOUNTED PCB, MICRO COMPUTER
904	*1-621-610-11	PC BOARD, HEADPHONE AMPLIFIER
905	*1-621-609-11	PC BOARD, REC VOLUME
906	A-2010-245-A	MOUNTED PCB, ANALOGUE
907	A-2020-081-A	MOUNTED PCB, MD SERVO
908	*1-621-611-11	PC BOARD, HEADPHONE
909	*1-621-616-11	PC BOARD, TIMER
910	A-2095-597-A	MOUNTED PCB, DRUM DRIVE
911	A-2097-007-A	MOUNTED PCB, DIGITAL
912	A-2097-006-A	MOUNTED PCB, DIGITAL I/O
913	*A-2012-127-A	MOUNTED PCB, POWER
914	*1-621-608-11	PC BOARD, LINE IN
915	*1-621-613-11	PC BOARD, LINE OUT
916	*1-621-606-11	PC BOARD, DIGITAL I/O SUB
917	*1-555-795-00	(AEP) ... COORD. POWER
918	*1-556-035-11	(UR) ... COORD. POWER
920	*1-621-618-11	PC BOARD, TRANSISTOR
921	*1-621-619-11	PC BOARD, TRANSISTOR
922	*1-506-534-11	PIN, CONNECTOR 11P
923	*1-535-139-00	BASE POST 19MM (10MM PITCH) 2P
924	1-535-416-00	TERMINAL
925	*1-560-242-11	BUS BAR 3P
926	*1-621-623-11	PC BOARD
927	*1-621-625-11	PC BOARD, UD MOTOR
928	*1-621-626-11	PC BOARD
929	*1-621-624-11	PC BOARD
930	*1-560-242-31	BUS BAR 5P
931	*1-621-622-11	PC BOARD
932	*A-2096-052-A	MOUNTED PCB, RF AMPLIFIER
933	*9-831-249-48	WIRE KIT
934	1-464-724-11	ENCODER, ROTARY
935	1-620-725-11	PC BOARD, MD FLEXIBLE
936	*1-620-186-11	PC BOARD, TENSION LEGULATOR
937	*1-560-242-41	BUS BAR 11P
938	*1-560-242-51	BUS BAR 7P
939	*1-560-242-81	BUS BAR 8P
C001	1-136-165-00	FILM 0.1MF 5% 50V
C002	1-136-165-00	FILM 0.1MF 5% 50V
C003	1-130-475-00	MYLAR 0.0022MF 5% 50V
C004	1-130-475-00	MYLAR 0.0022MF 5% 50V
C103	1-123-356-00	ELECT 10MF 20% 50V
C104	1-123-356-00	ELECT 10MF 20% 50V
C106	1-124-614-00	ELECT 10MF 20% 100V
C107	1-123-343-00	ELECT 33MF 20% 25V
C108	1-123-343-00	ELECT 33MF 20% 25V

ELECTRICAL PARTS

Ref.No.	Part No.	Description			
C109	1-123-343-00	ELECT	33MF	20%	25V
C110	1-123-343-00	ELECT	33MF	20%	25V
C111	1-104-240-00	POLYSTYRENE	0.001MF	5%	125V
C112	1-162-282-31	CERAMIC	100PF	10%	50V
C113	1-162-282-31	CERAMIC	100PF	10%	50V
C114	1-131-365-00	TANTALUM	10MF	10%	16V
C116	1-161-379-00	CERAMIC	0.01MF	30%	16V
C117	1-162-294-31	CERAMIC	0.001MF	10%	50V
C118	1-162-294-31	CERAMIC	0.001MF	10%	50V
C119	1-162-851-11	CERAMIC	0.1MF	20%	16V
C120	1-123-330-00	ELECT	22MF	20%	25V
C121	1-162-851-11	CERAMIC	0.1MF	20%	16V
C122	1-123-330-00	ELECT	22MF	20%	25V
C123	1-136-250-11	FILM	0.001MF	3%	100V
C124	1-130-967-00	FILM	0.0027MF	3%	100V
C125	1-136-229-11	FILM	0.0016MF	3%	100V
C126	1-124-275-00	ELECT	2.2MF	20%	35V
C130	1-136-254-11	FILM	0.002MF	3%	100V
C131	1-136-250-11	FILM	0.001MF	3%	100V
C134	1-162-851-11	CERAMIC	0.1MF	20%	16V
C135	1-126-164-11	ELECT	100MF	20%	100V
C137	1-124-282-00	ELECT	22MF	20%	25V
C138	1-136-167-00	FILM	0.15MF	5%	50V
C139	1-124-279-11	ELECT	3.3MF	20%	25V
C140	1-130-892-00	FILM	0.015MF	3%	100V
C199	1-162-111-00	CERAMIC	0.0022MF	30%	25V
C301	1-123-343-00	ELECT	33MF	20%	25V
C302	1-162-851-11	CERAMIC	0.1MF	20%	16V
C303	1-123-333-00	ELECT	100MF	20%	16V
C304	1-123-376-00	ELECT	330MF	20%	63V
C305	1-123-376-00	ELECT	330MF	20%	63V
C306	1-126-027-11	ELECT	1000MF	20%	25V
C307	1-162-851-11	CERAMIC	0.1MF	20%	16V
C312	1-124-995-11	ELECT	220MF	20%	10V
C313	1-162-851-11	CERAMIC	0.1MF	20%	16V
C314	1-124-995-11	ELECT	220MF	20%	10V
C315	1-162-851-11	CERAMIC	0.1MF	20%	16V
C318	1-162-851-11	CERAMIC	0.1MF	20%	16V
C319	1-162-851-11	CERAMIC	0.1MF	20%	16V
C320	1-126-027-11	ELECT	1000MF	20%	25V
C321	1-162-851-11	CERAMIC	0.1MF	20%	16V
C322	1-126-027-11	ELECT	1000MF	20%	25V
C326	1-107-202-00	MICA	10PF	5%	500V
C327	1-124-725-00	ELECT	100MF	20%	50V
C328	1-107-202-00	MICA	10PF	5%	500V
C329	1-124-725-00	ELECT	100MF	20%	50V

DTC-1000ES

ELECTRICAL PARTS

Ref.No.	Part No.	Description			
C330	1-131-450-00	TANTALUM	1MF	20%	50V
C331	1-123-378-00	ELECT	1000MF	20%	63V
C332	1-131-450-00	TANTALUM	1MF	20%	50V
C333	1-123-378-00	ELECT	1000MF	20%	63V
C334	1-136-165-00	FILM	0.1MF	5%	50V
C335	1-136-165-00	FILM	0.1MF	5%	50V
C336	1-136-165-00	FILM	0.1MF	5%	50V
C337	1-136-165-00	FILM	0.1MF	5%	50V
C338	1-136-165-00	FILM	0.1MF	5%	50V
C339	1-136-165-00	FILM	0.1MF	5%	50V
C340	1-136-165-00	FILM	0.1MF	5%	50V
C341	1-136-165-00	FILM	0.1MF	5%	50V
C342	1-136-165-00	FILM	0.1MF	5%	50V
C343	1-136-165-00	FILM	0.1MF	5%	50V
C344	1-136-165-00	FILM	0.1MF	5%	50V
C345	1-136-165-00	FILM	0.1MF	5%	50V
C346	1-136-165-00	FILM	0.1MF	5%	50V
C347	1-136-165-00	FILM	0.1MF	5%	50V
C348	1-123-343-00	ELECT	33MF	20%	25V
C349	1-162-851-11	CERAMIC	0.1MF	20%	16V
C350	1-123-343-00	ELECT	33MF	20%	25V
C351	1-123-343-00	ELECT	33MF	20%	25V
C352	1-123-343-00	ELECT	33MF	20%	25V
C353	1-162-851-11	CERAMIC	0.1MF	20%	16V
C354	1-124-902-00	ELECT	0.47MF	20%	50V
C355	1-123-875-11	ELECT	10MF	20%	50V
C356	1-123-343-00	ELECT	33MF	20%	25V
C357	1-126-013-11	ELECT	1000MF	20%	16V
C358	1-126-013-11	ELECT	1000MF	20%	16V
C359	1-123-333-00	ELECT	100MF	20%	16V
C362	1-162-851-11	CERAMIC	0.1MF	20%	16V
C363	1-162-851-11	CERAMIC	0.1MF	20%	16V
C364	1-162-851-11	CERAMIC	0.1MF	20%	16V
C365	1-104-150-00	POLYSTYRENE	680PF	5%	125V
C366	1-162-851-11	CERAMIC	0.1MF	20%	16V
C367	1-162-289-31	CERAMIC	390PF	10%	50V
C401	1-135-091-00	TANTAL. CHIP	1MF	10%	16V
C402	1-163-077-00	CERAMIC CHIP	0.1MF	10%	25V
C403	1-163-077-00	CERAMIC CHIP	0.1MF	10%	25V
C404	1-163-077-00	CERAMIC CHIP	0.1MF	10%	25V
C405	1-124-779-00	CAP.ELECT	10MF	20%	16V
C406	1-124-779-00	CAP.ELECT	10MF	20%	16V
C407	1-163-077-00	CERAMIC CHIP	0.1MF	10%	25V
C408	1-135-091-00	TANTAL. CHIP	1MF	10%	16V
C409	1-124-225-00	ELECT	100MF	20%	6.3V
C410	1-124-779-00	CAP.ELECT	10MF	20%	16V
C411	1-163-013-00	CERAMIC CHIP	0.0022MF	10%	50V
C412	1-124-225-00	ELECT	100MF	20%	6.3V
C413	1-124-779-00	CAP.ELECT	10MF	20%	16V
C414	1-163-013-00	CERAMIC CHIP	0.0022MF	10%	50V
C415	1-163-077-00	CERAMIC CHIP	0.1MF	50V	
C416	1-163-077-00	CERAMIC CHIP	0.1MF	50V	
C417	1-163-077-00	CERAMIC CHIP	0.1MF	50V	
C418	1-163-077-00	CERAMIC CHIP	0.1MF	50V	
C501	1-161-494-00	CERAMIC	0.022MF	25V	
C502	1-161-494-00	CERAMIC	0.022MF	25V	
C503	1-161-494-00	CERAMIC	0.022MF	25V	
C504	1-161-494-00	CERAMIC	0.022MF	25V	

ELECTRICAL PARTS

Ref.No.	Part No.	Description			
C505	1-124-462-00	ELECT	10MF	20%	16V
C506	1-162-294-31	CERAMIC	0.001MF	10%	50V
C507	1-162-294-31	CERAMIC	0.001MF	10%	50V
C508	1-161-494-00	CERAMIC	0.022MF	25V	
C509	1-161-494-00	CERAMIC	0.022MF	25V	
C510	1-161-494-00	CERAMIC	0.022MF	25V	
C511	1-161-494-00	CERAMIC	0.022MF	25V	
C512	1-131-395-00	TANTALUM	100MF	10%	3.15V
C513	1-124-462-00	ELECT	10MF	20%	16V
C514	1-124-236-00	ELECT	47MF	20%	10V
C515	1-161-494-00	CERAMIC	0.022MF	25V	
C516	1-161-494-00	CERAMIC	0.022MF	25V	
C518	1-161-494-00	CERAMIC	0.022MF	25V	
C519	1-124-236-00	ELECT	47MF	20%	10V
C520	1-161-494-00	CERAMIC	0.022MF	25V	
C521	1-102-962-00	CERAMIC	30PF	5%	50V
C522	1-102-962-00	CERAMIC	30PF	5%	50V
C523	1-161-494-00	CERAMIC	0.022MF	25V	
C524	1-161-379-00	CERAMIC	0.01MF	30%	16V
C525	1-123-661-00	ELECT	100MF	20%	6.3V
C526	1-123-661-00	ELECT	100MF	20%	6.3V
C527	1-162-294-31	CERAMIC	0.001MF	10%	50V
C528	1-161-494-00	CERAMIC	0.022MF	25V	
C529	1-161-494-00	CERAMIC	0.022MF	25V	
C530	1-130-481-00	FILM	0.0068MF	5%	50V
C531	1-136-153-00	FILM	0.01MF	5%	50V
C532	1-161-494-00	CERAMIC	0.022MF	25V	
C533	1-131-388-00	TANTALUM	68MF	10%	6.3V
C534	1-136-160-00	FILM	0.039MF	5%	50V
C535	1-136-169-00	FILM	0.22MF	5%	50V
C536	1-136-172-00	FILM	0.39MF	5%	50V
C537	1-124-462-00	ELECT	10MF	20%	16V
C538	1-136-153-00	FILM	0.01MF	5%	50V
C539	1-136-165-00	FILM	0.1MF	5%	50V
C540	1-136-165-00	FILM	0.1MF	5%	50V
C541	1-161-379-00	CERAMIC	0.01MF	30%	16V
C542	1-161-379-00	CERAMIC	0.01MF	30%	16V
C543	1-136-266-00	FILM	0.22MF	5%	100V
C544	1-161-379-00	CERAMIC	0.01MF	30%	16V
C545	1-136-153-00	FILM	0.01MF	5%	50V
C546	1-124-462-00	ELECT	10MF	20%	16V
C547	1-124-236-00	ELECT	47MF	20%	10V
C548	1-136-173-00	FILM	0.47MF	5%	50V
C549	1-136-169-00	FILM	0.22MF	5%	50V
C550	1-124-462-00	ELECT	10MF	20%	16V
C551	1-124-462-00	ELECT	10MF	20%	16V
C552	1-124-462-00	ELECT	10MF	20%	16V
C553	1-136-167-00	FILM	0.15MF	5%	50V
C554	1-136-157-00	FILM	0.022MF	5%	50V
C555	1-161-494-00	CERAMIC	0.022MF	25V	
C556	1-131-388-00	TANTALUM	68MF	10%	6.3V
C557	1-161-329-00	CERAMIC	0.0068MF	30%	16V
C558	1-131-382-00	TANTALUM	6.8MF	10%	6.3V
C559	1-136-153-00	FILM	0.01MF	5%	50V
C560	1-136-153-00	FILM	0.01MF	5%	50V
C561	1-136-157-00	FILM	0.022MF	5%	50V
C562	1-136-157-00	FILM	0.022MF	5%	50V

ELECTRICAL PARTS

Ref.No.	Part No.	Description			
C563	1-162-294-31	CERAMIC	0.001MF	10%	50V
C564	1-161-379-00	CERAMIC	0.01MF	30%	16V
C565	1-161-379-00	CERAMIC	0.01MF	30%	16V
C566	1-162-290-31	CERAMIC	470PF	10%	50V
C567	1-161-377-00	CERAMIC	0.0047MF	30%	16V
C568	1-162-294-31	CERAMIC	0.001MF	10%	50V
C569	1-124-462-00	ELECT	10MF	20%	16V
C570	1-124-236-00	ELECT	47MF	20%	10V
C571	1-124-236-00	ELECT	47MF	20%	10V
C572	1-124-462-00	ELECT	10MF	20%	16V
C573	1-161-494-00	CERAMIC	0.022MF		25V
C574	1-161-379-00	CERAMIC	0.01MF	30%	16V
C575	1-161-494-00	CERAMIC	0.022MF		25V
C576	1-124-638-11	ELECT	22MF	20%	10V
C577	1-124-638-11	ELECT	22MF	20%	10V
C578	1-161-379-00	CERAMIC	0.01MF	30%	16V
C579	1-161-494-00	CERAMIC	0.022MF		25V
C580	1-124-638-11	ELECT	22MF	20%	10V
C581	1-124-462-00	ELECT	10MF	20%	16V
C582	1-124-638-11	ELECT	22MF	20%	6.3V
C583	1-161-375-00	CERAMIC	0.0022MF	30%	16V
C584	1-124-462-00	ELECT	10MF	20%	16V
C585	1-124-638-11	ELECT	22MF	20%	6.3V
C586	1-161-375-00	CERAMIC	0.0022MF	30%	16V
C587	1-123-661-00	ELECT	100MF	20%	6.3V
C588	1-123-661-00	ELECT	100MF	20%	6.3V
C589	1-124-258-00	ELECT	3.3MF	20%	35V
C590	1-124-258-00	ELECT	3.3MF	20%	35V
C591	1-123-661-00	ELECT	100MF	20%	6.3V
C592	1-124-236-00	ELECT	47MF	20%	10V
C593	1-125-332-00	CAP,DOUBLE LAYERS	22000MF		
C594	1-125-332-00	CAP,DOUBLE LAYERS	22000MF		
C595	1-124-236-00	ELECT	47MF	20%	10V
C596	1-124-236-00	ELECT	47MF	20%	10V
C598	1-124-257-00	ELECT	2.2MF	20%	50V
C599	1-161-377-00	CERAMIC	0.0047MF	30%	16V
C600	1-161-377-00	CERAMIC	0.0047MF	30%	16V
C701	1-161-494-00	CERAMIC	0.022MF		25V
C702	1-162-199-31	CERAMIC	10PF	5%	50V
C703	1-162-199-31	CERAMIC	10PF	5%	50V
C704	1-161-494-00	CERAMIC	0.022MF		25V
C705	1-123-661-00	ELECT	100MF	20%	6.3V
C706	1-161-494-00	CERAMIC	0.022MF		25V
C707	1-162-294-31	CERAMIC	0.001MF	10%	50V
C708	1-162-294-31	CERAMIC	0.001MF	10%	50V
C709	1-162-294-31	CERAMIC	0.001MF	10%	50V
C710	1-162-294-31	CERAMIC	0.001MF	10%	50V
C711	1-123-661-00	ELECT	100MF	20%	6.3V
C712	1-161-494-00	CERAMIC	0.022MF		25V
C713	1-123-661-00	ELECT	100MF	20%	6.3V
C714	1-162-284-31	CERAMIC	150PF	10%	50V
C715	1-162-284-31	CERAMIC	150PF	10%	50V
C716	1-130-487-00	MYLAR	0.022MF	5%	50V
C717	1-102-962-00	CERAMIC	30PF	5%	50V
C718	1-102-962-00	CERAMIC	30PF	5%	50V
C719	1-123-661-00	ELECT	100MF	20%	6.3V
C720	1-161-494-00	CERAMIC	0.022MF		25V

ELECTRICAL PARTS

Ref.No.	Part No.	Description			
C721	1-161-494-00	CERAMIC	0.022MF		25V
C722	1-130-487-00	MYLAR	0.022MF	5%	50V
C723	1-123-661-00	ELECT	100MF	20%	6.3V
C724	1-161-494-00	CERAMIC	0.022MF		25V
C725	1-130-487-00	MYLAR	0.022MF	5%	50V
C801	1-162-851-11	CERAMIC	0.1MF	20%	16V
C802	1-162-851-11	CERAMIC	0.1MF	20%	16V
C803	1-162-851-11	CERAMIC	0.1MF	20%	16V
C804	1-162-851-11	CERAMIC	0.1MF	20%	16V
C806	1-123-661-00	ELECT	100MF	20%	6.3V
C807	1-123-661-00	ELECT	100MF	20%	6.3V
C809	1-162-851-11	CERAMIC	0.1MF	20%	16V
C810	1-102-973-00	CERAMIC	100PF	5%	50V
C811	1-162-294-31	CERAMIC	0.001MF	10%	50V
C812	1-162-851-11	CERAMIC	0.1MF	20%	16V
C813	1-136-155-00	FILM	0.015MF	5%	50V
C814	1-162-851-11	CERAMIC	0.1MF	20%	16V
C815	1-130-481-00	MYLAR	0.0068MF	5%	50V
C816	1-162-851-11	CERAMIC	0.1MF	20%	16V
C817	1-162-851-11	CERAMIC	0.1MF	20%	16V
C818	1-162-851-11	CERAMIC	0.1MF	20%	16V
C819	1-130-471-00	MYLAR	0.001MF	5%	50V
C820	1-162-201-31	CERAMIC	12PF	5%	50V
C821	1-162-201-31	CERAMIC	12PF	5%	50V
C822	1-162-201-31	CERAMIC	12PF	5%	50V
C823	1-162-201-31	CERAMIC	12PF	5%	50V
C824	1-162-201-31	CERAMIC	12PF	5%	50V
C825	1-162-201-31	CERAMIC	12PF	5%	50V
C826	1-123-661-00	ELECT	100MF	20%	6.3V
C827	1-162-851-11	CERAMIC	0.1MF	20%	16V
C828	1-123-661-00	ELECT	100MF	20%	6.3V
C829	1-123-661-00	ELECT	100MF	20%	6.3V
C830	1-161-375-00	CERAMIC	0.0022MF	30%	16V
C831	1-162-294-31	CERAMIC	0.001MF	10%	50V
C832	1-162-294-31	CERAMIC	0.001MF	10%	50V
C833	1-123-336-00	ELECT	470MF	20%	25V
C852	1-124-638-11	ELECT	22MF	20%	6.3V
C853	1-124-638-11	ELECT	22MF	20%	6.3V
C854	1-124-182-00	CAP,ELECT	1MF	20%	50V
C855	1-102-951-00	CERAMIC	15PF	5%	50V
C856	1-162-851-11	CERAMIC	0.1MF	20%	16V
C857	1-124-638-11	ELECT	22MF	20%	6.3V
C858	1-162-282-31	CERAMIC	100PF	10%	50V
C859	1-162-851-11	CERAMIC	0.1MF	20%	16V
C860	1-162-851-11	CERAMIC	0.1MF	20%	16V
C861	1-124-444-00	ELECT	220MF	20%	6.3V
C862	1-136-153-00	FILM	0.01MF	5%	50V
C863	1-124-482-11	ELECT	33MF	20%	5V
C864	1-136-153-00	FILM	0.01MF	5%	50V
C865	1-124-482-11	ELECT	33MF	20%	5V
C866	1-162-851-11	CERAMIC	0.1MF	20%	16V
C867	1-162-851-11	CERAMIC	0.1MF	20%	16V
C868	1-123-661-00	ELECT	100MF	20%	6.3V
C869	1-123-661-00	ELECT	100MF	20%	6.3V
C870	1-162-851-11	CERAMIC	0.1MF	20%	16V
C871	1-161-375-00	CERAMIC	0.0022MF	30%	16V
C872	1-162-851-11	CERAMIC	0.1MF	20%	16V

DTC-1000ES

ELECTRICAL PARTS

Ref.No.	Part No.	Description			
C879	1-162-851-11	CERAMIC	0.1MF	20%	16V
C901	1-162-851-11	CERAMIC	0.1MF	20%	16V
C902	1-124-898-11	ELECT	4700MF	20%	16V
C903	1-162-851-11	CERAMIC	0.1MF	20%	16V
C904	1-162-851-11	CERAMIC	0.1MF	20%	16V
C905	1-124-471-00	ELECT	1000MF	20%	6.3V
C906	1-124-913-11	ELECT	470MF	20%	50V
C907	1-124-910-11	ELECT	47MF	20%	35V
C908	1-124-484-11	ELECT	220MF	20%	35V
C909	1-124-898-11	ELECT	4700MF	20%	16V
C910	1-162-851-11	CERAMIC	0.1MF	20%	16V
C911	1-162-851-11	CERAMIC	0.1MF	20%	16V
C912	1-124-471-00	ELECT	1000MF	20%	6.3V
C913	1-162-851-11	CERAMIC	0.1MF	20%	16V
C914	1-124-468-11	ELECT	100MF	20%	6.3V
C915	1-124-898-11	ELECT	4700MF	20%	16V
C916	1-124-471-00	ELECT	1000MF	20%	6.3V
C917	1-162-294-31	CERAMIC	0.001MF	10%	50V
C919	1-126-013-11	ELECT	1000MF	20%	16V
C921	1-162-294-31	CERAMIC	0.001MF	10%	50V
C923	1-126-013-11	ELECT	1000MF	20%	16V
C924	1-125-471-11	ELECT(BLOCK)	4700MF	20%	25V
C925	1-125-471-11	ELECT(BLOCK)	4700MF	20%	25V
C926	1-124-365-00	ELECT	4700MF	20%	16V
C927	1-124-365-00	ELECT	4700MF	20%	16V
C928	1-123-356-00	ELECT	10MF	20%	16V
C929	1-123-356-00	ELECT	10MF	20%	16V
C930	1-136-165-00	FILM	0.1MF	5%	50V
C931	1-162-851-11	CERAMIC	0.1MF	20%	16V
C941	1-161-742-00	CERAMIC	0.0022MF	20%	400V
C942	1-161-742-00	CERAMIC	0.0022MF	20%	400V
C944	1-161-742-00	CERAMIC	0.0022MF	20%	400V
C945	1-161-744-00	CERAMIC	0.01MF	10%	400V
C946	1-161-741-00	CERAMIC	0.001MF	10%	400V
C947	1-161-741-00	CERAMIC	0.001MF	10%	400V
C948	1-130-691-00	FILM	1MF	10%	125V
C949	1-136-165-00	FILM	0.1MF	5%	50V
C951	1-163-038-00	CERAMIC CHIP	0.1MF		25V
C953	1-163-038-00	CERAMIC CHIP	0.1MF		25V
C954	1-163-033-00	CERAMIC CHIP	470PF	10%	50V
C955	1-163-038-00	CERAMIC CHIP	0.1MF		25V
C956	1-135-101-21	TANTAL. CHIP	22MF	10%	6.3V
C957	1-163-038-00	CERAMIC CHIP	0.1MF		25V
C958	1-163-133-00	CERAMIC CHIP	470PF	10%	50V
C959	1-163-133-00	CERAMIC CHIP	470PF	10%	50V
C960	1-163-143-00	CERAMIC CHIP	0.0012MF	10%	50V
C961	1-163-021-00	CERAMIC CHIP	0.01MF	10%	50V
C962	1-163-818-00	CERAMIC CHIP	0.1MF	10%	50V
C963	1-163-021-00	CERAMIC CHIP	0.01MF	10%	50V
C964	1-163-035-00	CERAMIC CHIP	0.047MF	10%	25V
C965	1-163-077-00	CERAMIC CHIP	0.1MF	10%	25V
C966	1-163-038-00	CERAMIC CHIP	0.1MF		25V
C967	1-135-101-21	TANTAL. CHIP	22MF	10%	6.3V
C968	1-163-038-00	CERAMIC CHIP	0.1MF		25V
C969	1-163-038-00	CERAMIC CHIP	0.1MF		25V
C970	1-135-101-21	TANTAL. CHIP	22MF	10%	6.3V
C971	1-163-077-00	CERAMIC CHIP	0.1MF	10%	25V

ELECTRICAL PARTS

Ref.No.	Part No.	Description		
C972	1-163-035-00	CERAMIC CHIP	0.047MF	10% 25V
C973	1-163-021-00	CERAMIC CHIP	0.01MF	10% 50V
C974	1-163-818-00	CERAMIC CHIP	0.1MF	10% 50V
C975	1-163-021-00	CERAMIC CHIP	0.01MF	10% 50V
C976	1-163-143-00	CERAMIC CHIP	0.0012MF	10% 50V
C977	1-163-020-00	CERAMIC CHIP	0.0082MF	10% 50V
C978	1-135-091-00	TANTAL. CHIP	1MF	10% 16V
C979	1-163-020-00	CERAMIC CHIP	0.0082MF	10% 50V
C980	1-163-035-00	CERAMIC CHIP	0.047MF	10% 25V
C981	1-163-035-00	CERAMIC CHIP	0.047MF	10% 25V
C982	1-163-133-00	CERAMIC CHIP	470PF	10% 50V
C983	1-163-021-00	CERAMIC CHIP	0.01MF	10% 50V
C984	1-163-133-00	CERAMIC CHIP	470PF	10% 50V
C985	1-163-133-00	CERAMIC CHIP	470PF	10% 50V
CN001	*1-564-506-11	PLUG, CONNECTOR	3P	
CN002	*1-564-506-11	PLUG, CONNECTOR	3P	
CN003	*1-564-505-11	PLUG, CONNECTOR	2P	
CN004	*1-564-505-31	PLUG, CONNECTOR	2P	
CN005	*1-564-505-41	PLUG, CONNECTOR	2P	
CN051	*1-564-520-11	PLUG, CONNECTOR	5P	
CN081	1-564-521-21	PLUG, CONNECTOR	6P	
CN101	*1-564-506-11	PLUG, CONNECTOR	3P	
CN121	*1-564-505-11	PLUG, CONNECTOR	2P	
CN122	*1-564-505-31	PLUG, CONNECTOR	2P	
CN123	*1-564-505-11	PLUG, CONNECTOR	2P	
CN124	*1-564-505-31	PLUG, CONNECTOR	2P	
CN125	*1-564-505-11	PLUG, CONNECTOR	2P	
CN126	*1-564-505-31	PLUG, CONNECTOR	2P	
CN171	*1-564-511-11	PLUG, CONNECTOR	8P	
CN181	*1-564-509-11	PLUG, CONNECTOR	6P	
CN182	*1-564-508-11	PLUG, CONNECTOR	5P	
CN184	*1-564-507-31	PLUG, CONNECTOR	4P	
CN191	*1-564-506-11	PLUG, CONNECTOR	3P	
CN192	*1-564-506-11	PLUG, CONNECTOR	3P	
CN193	*1-535-116-00	TERMINAL		
CN194	*1-535-116-00	TERMINAL		
CN211	*1-564-519-11	PLUG, CONNECTOR	4P	
CN213	*1-564-507-31	PLUG, CONNECTOR	4P	
CN215	*1-564-506-11	PLUG, CONNECTOR	3P	
CN231	*1-564-507-11	PLUG, CONNECTOR	4P	
CN232	1-564-519-31	PLUG, CONNECTOR	4P	
CN300	*1-564-506-11	PLUG, CONNECTOR	3P	
CN321	*1-564-505-11	PLUG, CONNECTOR	2P	
CN322	*1-564-511-11	PLUG, CONNECTOR	8P	
CN401	*1-563-370-11	CONNECTOR, F.P.C	14P	
CN451	*1-564-727-11	PIN, CONNECTOR (SMALL TYPE)	11P	
CN501	*1-564-508-11	PLUG, CONNECTOR	5P	
CN502	*1-564-707-11	PIN, CONNECTOR (SMALL TYPE)	5P	
CN503	*1-564-505-11	PLUG, CONNECTOR	2P	
CN504	*1-562-883-11	SOCKET, CONNECTOR	20P	
CN505	*1-564-511-11	PLUG, CONNECTOR	8P	
CN506	*1-564-515-11	PLUG, CONNECTOR	12P	
CN541	*1-564-713-11	PIN, CONNECTOR (SMALL TYPE)	11P	
CN571	*1-564-596-11	PLUG, CONNECTOR	15P	
CN572	*1-564-505-41	PLUG, CONNECTOR	2P	
CN581	*1-564-511-21	PLUG, CONNECTOR	8P	

The components identified by shading and mark **A** are critical for safety. Replace only with part number specified.

ELECTRICAL PARTS

Ref.No.	Part No.	Description
CN582	*1-564-509-11	PLUG, CONNECTOR 6P
CN583	*1-564-706-11	PIN, CONNECTOR (SMALL TYPE) 4P
CN591	*1-564-511-11	PLUG, CONNECTOR 8P
CN592	*1-564-505-31	PLUG, CONNECTOR 2P
CN593	*1-564-507-11	PLUG, CONNECTOR 4P
CN596	*1-564-708-11	PIN, CONNECTOR (SMALL TYPE) 6P
CN711	*1-564-511-11	PLUG, CONNECTOR 8P
CN741	*1-564-596-11	PLUG, CONNECTOR 15P
CN751	*1-564-509-11	PLUG, CONNECTOR 6P
CN752	*1-564-505-41	PLUG, CONNECTOR 2P
CN781	*1-564-513-11	PLUG, CONNECTOR 10P
CN782	*1-564-706-11	PIN, CONNECTOR (SMALL TYPE) 4P
CN783	*1-564-512-11	PLUG, CONNECTOR 9P
CN791	*1-564-337-41	PIN, CONNECTOR 3P
CN793	*1-564-339-00	PIN, CONNECTOR 5P
CN794	*1-564-666-11	PIN, CONNECTOR 10P
CN795	*1-564-337-81	PIN, CONNECTOR 3P
CN796	*1-564-507-11	PLUG, CONNECTOR 4P
CN797	*1-564-342-11	PIN, CONNECTOR 8P
CN801	*1-564-509-11	PLUG, CONNECTOR 6P
CN811	*1-564-509-11	PLUG, CONNECTOR 6P
CN812	*1-564-508-11	PLUG, CONNECTOR 5P
CN813	*1-564-507-31	PLUG, CONNECTOR 4P
CN851	*1-564-511-21	PLUG, CONNECTOR 8P
CN852	*1-564-509-11	PLUG, CONNECTOR 6P
CN853	*1-564-706-11	PIN, CONNECTOR (SMALL TYPE) 4P
CN871	*1-564-514-11	PLUG, CONNECTOR 11P
CN872	*1-564-706-11	PIN, CONNECTOR (SMALL TYPE) 4P
CN873	*1-564-513-31	PLUG, CONNECTOR 10P
CN881	*1-564-342-51	PIN, CONNECTOR 8P
CN882	*1-564-341-51	PIN, CONNECTOR 7P
CN883	*1-564-338-61	PIN, CONNECTOR 4P
CN887	*1-564-340-51	PIN, CONNECTOR 6P
CN891	*1-564-506-11	PLUG, CONNECTOR 3P
CN892	*1-564-710-11	PIN, CONNECTOR (SMALL TYPE) 8P
CN893	*1-564-705-11	PIN, CONNECTOR (SMALL TYPE) 3P
CN901	*1-564-506-11	PLUG, CONNECTOR 3P
CN902	*1-535-116-00	TERMINAL
CN903	*1-535-116-00	TERMINAL
CN904	*1-564-506-11	PLUG, CONNECTOR 3P
CN906	*1-564-506-11	PLUG, CONNECTOR 3P
CN907	*1-564-506-11	PLUG, CONNECTOR 3P
CN908	*1-564-506-11	PLUG, CONNECTOR 3P
CN911	*1-535-116-00	TERMINAL
CN912	*1-535-120-00	TERMINAL
CN951	1-564-722-11	PIN, CONNECTOR (SMALL TYPE) 6P
CN952	1-564-729-11	PIN, CONNECTOR (SMALL TYPE) 13P
CN953	*1-564-505-11	PLUG, CONNECTOR 2P
CN954	*1-564-505-11	PLUG, CONNECTOR 2P
CN971	*1-564-509-11	PLUG, CONNECTOR 6P
CN981	*1-564-506-11	PLUG, CONNECTOR 3P
CNJ301	1-507-898-11	JACK, PIN 2P
CNJ302	1-507-898-11	JACK, PIN 2P
CNT51	*1-560-065-00	PIN, CONNECTOR 8P
CNT52	*1-560-062-00	PIN, CONNECTOR 4P
CNT53	*1-564-506-11	PLUG, CONNECTOR 3P

ELECTRICAL PARTS

Ref.No.	Part No.	Description
CNT54	*1-564-506-11	PLUG, CONNECTOR 3P
CNT55	*1-560-064-00	PIN, CONNECTOR 6P
CNT56	*1-564-509-11	PLUG, CONNECTOR 6P
CP501	1-232-976-11	COMPOSITION CIRCUIT BLOCK
CP502	1-232-976-11	COMPOSITION CIRCUIT BLOCK
CP503	1-232-976-11	COMPOSITION CIRCUIT BLOCK
CP504	1-233-061-11	COMPOSITION CIRCUIT BLOCK
CP505	1-232-955-11	COMPOSITION CIRCUIT BLOCK
CP506	1-233-093-11	COMPOSITION CIRCUIT BLOCK
CP507	1-232-997-11	COMPOSITION CIRCUIT BLOCK
CP508	1-233-094-11	COMPOSITION CIRCUIT BLOCK
CP509	1-233-092-11	COMPOSITION CIRCUIT BLOCK
CP510	1-233-092-11	COMPOSITION CIRCUIT BLOCK
CP701	1-233-006-11	COMPOSITION CIRCUIT BLOCK
CP702	1-232-953-11	COMPOSITION CIRCUIT BLOCK
CP703	1-232-8.6-11	COMPOSITION CIRCUIT BLOCK
CP704	1-232-816-11	COMPOSITION CIRCUIT BLOCK
CP705	1-233-081-11	COMPOSITION CIRCUIT BLOCK
D001	8-719-200-77	DIODE 10E2N
D101	8-719-940-76	DIODE 1S5132
D102	8-719-815-55	DIODE 1S1555
D103	8-719-815-55	DIODE 1S1555
D104	8-719-815-55	DIODE 1S1555
D105	8-719-910-95	DIODE HZ982L
D201	8-719-940-76	DIODE 1S5132
D202	8-719-815-55	DIODE 1S1555
D203	8-719-815-55	DIODE 1S1555
D204	8-719-815-55	DIODE 1S1555
D205	8-719-910-95	DIODE HZ982L
D301	8-719-910-95	DIODE HZ982L
D302	8-719-910-95	DIODE HZ982L
D303	8-719-209-12	DIODE 10YD1.3-A
D304	8-719-209-12	DIODE 10YD1.3-A
D305	8-719-940-76	DIODE 1S5132
D306	8-719-940-76	DIODE 1S5132
D307	8-719-940-76	DIODE 1S5132
D308	8-719-940-76	DIODE 1S5132
D401	8-719-910-05	DIODE 1S2837
D402	8-719-910-05	DIODE 1S2837
D501	8-719-940-76	DIODE 1S5132
D502	8-719-200-77	DIODE 10E2N
D503	8-719-940-76	DIODE 1S5132
D504	8-719-940-76	DIODE 1S5132
D505	8-719-940-76	DIODE 1S5132
D506	8-719-921-13	DIODE HZ2CLL
D507	8-719-200-77	DIODE 10E2N
D508	8-719-940-76	DIODE 1S5132
D509	8-719-200-77	DIODE 10E2N
D510	8-719-940-76	DIODE 1S5132
D511	8-719-940-76	DIODE 1S5132
D701	8-719-940-76	DIODE 1S5132
D702	8-719-940-76	DIODE 1S5132
D703	8-719-940-76	DIODE 1S5132
D704	8-719-940-76	DIODE 1S5132
D705	8-719-940-76	DIODE 1S5132
D706	8-719-940-76	DIODE 1S5132
D707	8-719-940-76	DIODE 1S5132

DTC-1000ES

ELECTRICAL PARTS

Ref.No.	Part No.	Description
D708	8-719-940-76	DIODE 1SS132
D709	8-719-940-76	DIODE 1SS132
D710	8-719-940-76	DIODE 1SS132
D711	8-719-940-76	DIODE 1SS132
D712	8-719-940-76	DIODE 1SS132
D713	8-719-940-76	DIODE 1SS132
D714	8-719-940-76	DIODE 1SS132
D715	8-719-940-76	DIODE 1SS132
D717	8-719-940-76	DIODE 1SS132
D718	8-719-940-76	DIODE 1SS132
D719	8-719-940-76	DIODE 1SS132
D720	8-719-940-76	DIODE 1SS132
D721	8-719-911-19	DIODE 1SS119
D751	8-719-902-25	DIODE SLR-34005
D752	8-719-812-31	DIODE TLR-123
D753	8-719-902-77	DIODE SLR-34PC5
D754	8-719-812-31	DIODE TLR-123
D801	8-719-940-76	DIODE 1SS132
D802	8-719-940-76	DIODE 1SS132
D901	8-719-951-12	DIODE HZ58LL
D902	8-719-200-77	DIODE 10E2N
D903	8-719-200-77	DIODE 10E2N
D904	8-719-913-33	DIODE HZ33-3L
D905	8-719-940-76	DIODE 1SS132
D906	8-719-940-76	DIODE 1SS132
D907	8-719-302-38	DIODE RBV-602-01
D908	8-719-302-38	DIODE RBV-602-01
D909	8-719-951-12	DIODE HZ58LL
D911	8-719-230-11	DIODE 300F1-FA
D912	8-719-230-11	DIODE 300F1-FA
D913	8-719-230-11	DIODE 300F1-FA
D914	8-719-230-11	DIODE 300F1-FA
D915	8-719-230-11	DIODE 300F1-FA
D916	8-719-230-11	DIODE 300F1-FA
D917	8-719-230-11	DIODE 300F1-FA
D918	8-719-230-11	DIODE 300F1-FA
D919	8-719-940-76	DIODE 1SS132
D999	1-807-823-11	BARISTOR
FL701	1-519-414-11	INDICATOR TUBE, FLUORESCENT
W001	8-719-800-11	THS105-SONY1-TE85L
IC101	8-759-602-83	IC M5238P
IC102	8-759-910-77	IC LF353N/GLEA312
IC103	8-759-910-77	IC LF353N/GLEA312
IC104	8-752-001-80	IC CX20018
IC105	8-759-910-77	IC LF353N/GLEA312
IC201	8-759-602-83	IC M5238P
IC202	8-759-910-77	IC LF353N/GLEA312
IC203	8-759-910-77	IC LF353N/GLEA312
IC204	8-752-001-80	IC CX20018
IC205	8-759-910-77	IC LF353N/GLEA312
IC301	8-759-700-20	IC NJM79M05A
IC302	8-759-990-72	IC TL072CP
IC303	8-759-933-62	IC SAA7220P
IC304	8-759-939-94	IC TDA1541-N5
IC305	8-759-990-72	IC TL072CP

ELECTRICAL PARTS

Ref.No.	Part No.	Description
IC306	8-759-145-57	IC UPC4557C
IC307	8-759-145-58	IC NJM4558C
IC308	8-759-604-47	IC MSF7905
IC309	8-759-604-29	IC MSF7805
IC310	8-759-745-61	IC NJM4560D-D
IC311	8-759-916-29	IC SN74HC74N
IC401	8-752-017-40	IC CX20174
IC402	8-759-100-95	IC UPC324G2
IC403	8-759-100-93	IC UPC393G2
IC501	8-759-001-00	IC MC74HC132N
IC502	8-759-202-24	IC TC74HC86P
IC503	8-759-240-66	IC TC40668P
IC504	8-759-240-53	IC TC40538P
IC505	8-759-132-40	IC UPC324C
IC506	8-759-133-90	IC UPC339C
IC507	8-759-701-42	IC NJU8001D
IC508	8-759-132-40	IC UPC324C
IC509	8-759-701-42	IC NJU8001D
IC510	8-759-208-61	IC TMP47C800N-2111
IC511	8-759-240-69	IC TC4069UBP
IC512	8-759-208-77	IC TMP47C460AF-9469
IC513	8-759-202-11	IC TC74HC00P
IC514	8-759-203-01	IC TC74HC175P
IC515	8-752-304-30	IC CX23043
IC516	8-759-202-32	IC TC74HC163P
IC517	8-759-245-38	IC TC45388P
IC518	8-759-933-80	IC CXD1052Q
IC519	8-759-135-80	IC UPC358C
IC520	8-759-914-44	IC TL431CLPB
IC521	8-759-345-38	IC HD145388P
IC522	8-759-203-73	IC TC74HC4066P
IC523	8-759-909-45	IC CX20084
IC524	8-759-914-44	IC TL431CLPB
IC525	8-759-135-80	IC UPC358C
IC526	8-759-132-40	IC UPC324C
IC527	8-752-030-63	IC CXA1046M
IC528	8-759-240-51	IC TC40518P
IC529	8-759-240-51	IC TC40518P
IC530	8-759-135-80	IC UPC358C
IC531	8-759-132-40	IC UPC324C
IC532	8-759-103-93	IC UPC393C
IC533	8-759-135-80	IC UPC358C
IC534	8-759-103-93	IC UPC393C
IC535	8-759-202-11	IC TC74HC00P
IC536	8-759-240-53	IC TC40538P
IC537	8-759-910-70	IC M83763PS
IC538	8-759-801-60	IC LB1640N
IC701	8-759-700-48	IC NJM2903S
IC702	8-759-240-69	IC TC4069UBP
IC703	8-759-906-34	IC MSMS8422-15GS
IC704	8-759-800-57	IC LB1262
IC705	8-752-802-84	IC CXP5058H-033Q
IC706	8-759-603-83	IC MS0760-428P
IC751	8-749-900-36	IC BX-1393
IC801	8-759-927-60	IC M881416-10P
IC802	8-759-927-60	IC M881416-10P
IC805	8-759-932-23	IC TLC272CP

ELECTRICAL PARTS

Ref.No.	Part No.	Description
IC806	8-759-932-23	IC TLC272CP
IC807	8-759-933-85	IC CXD1009Q
IC808	8-759-933-84	IC CXD1008Q
IC851	8-759-945-98	IC CXD1146Q
IC852	8-759-918-71	IC CX23065
IC853	8-759-906-24	IC SN74LS624N
IC854	8-759-938-76	IC CXD1110Q
IC855	8-759-202-13	IC TC74HC04P
IC856	8-759-202-13	IC TC74HC04P
IC901	8-759-700-20	IC NJM79M05A
IC902	8-759-604-29	IC M5F7805
IC903	8-759-202-74	IC TC74HC04P
IC951	8-752-030-73	IC CXA1045Q
J301	1-507-796-21	JACK
L306	1-408-563-00	MICRO INDUCTOR 10UH
L307	1-408-563-00	MICRO INDUCTOR 10UH
L308	1-408-563-00	MICRO INDUCTOR 10UH
L501	1-410-336-11	MICRO INDUCTOR 220UH
L701	1-410-328-11	MICRO INDUCTOR 10UH
L702	1-410-328-11	MICRO INDUCTOR 10UH
L703	1-410-328-11	MICRO INDUCTOR 10UH
L704	1-410-328-11	MICRO INDUCTOR 10UH
L705	1-410-328-11	MICRO INDUCTOR 10UH
L801	1-407-182-XX	MICRO INDUCTOR 2.2UH
L802	1-410-328-11	MICRO INDUCTOR 10UH
L803	1-408-117-00	MICRO INDUCTOR 10UH
L804	1-410-328-11	MICRO INDUCTOR 10UH
L851	1-410-328-11	MICRO INDUCTOR 10UH
L852	1-410-328-11	MICRO INDUCTOR 10UH
L901	1-410-328-11	MICRO INDUCTOR 10UH
L941	1-421-915-11	COIL, LINE FILTER
L951	1-408-777-00	INDUCTOR CHIP 10UH
L952	1-408-791-00	INDUCTOR CHIP 150UH
L953	1-408-791-00	INDUCTOR CHIP 150UH
LPF101	1-464-764-11	FILTER UNIT, LOW PASS
LPF201	1-464-764-11	FILTER UNIT, LOW PASS
M1	1-541-445-11	MOTOR
M2	A-4608-303-A	MOTOR ASSY, LOADING
M901	8-835-205-01	MOTOR, DC U-2A
M902	8-835-206-01	MOTOR, DC BHF-2803A
M903	X-3337-626-1	MOTOR ASSY, L
M904	8-848-500-01	DRUM ASSY DOH-01A
PH901	1-807-698-11	PHOTO SENSOR
PH902	1-807-698-11	PHOTO SENSOR
PL1	1-518-614-11	LAMP, PILOT
PL2	1-518-614-11	LAMP, PILOT
Q101	8-729-800-42	TRANSISTOR 2SK152
Q102	8-729-194-57	TRANSISTOR 2SC945-P
Q201	8-729-800-42	TRANSISTOR 2SK152
Q202	8-729-194-57	TRANSISTOR 2SC945-P
Q301	8-729-600-27	TRANSISTOR 2SC634SP
Q302	8-729-201-52	TRANSISTOR 2SA1015
Q303	8-729-600-27	TRANSISTOR 2SC634SP
Q304	8-729-201-52	TRANSISTOR 2SA1015
Q305	8-729-600-27	TRANSISTOR 2SC634SP

ELECTRICAL PARTS

Ref.No.	Part No.	Description
Q306	8-729-201-52	TRANSISTOR 2SA1015
Q307	8-729-167-62	TRANSISTOR 2SC2676
Q308	8-729-127-53	TRANSISTOR 2SC2275-P
Q309	8-729-167-62	TRANSISTOR 2SC2676
Q310	8-729-113-82	TRANSISTOR 2SA1138
Q311	8-729-113-82	TRANSISTOR 2SA1138
Q312	8-729-190-53	TRANSISTOR 2SA985A
Q313	8-729-113-82	TRANSISTOR 2SA1138
Q314	8-729-167-62	TRANSISTOR 2SC2676
Q401	8-729-100-76	TRANSISTOR 2SAB12
Q402	8-729-202-86	TRANSISTOR 2SA1242LB
Q403	8-729-901-01	TRANSISTOR DTC144EK
Q404	8-729-901-01	TRANSISTOR DTC144EK
Q405	8-729-903-82	TRANSISTOR FMW2
Q406	8-729-903-82	TRANSISTOR FMW2
Q501	8-729-600-27	TRANSISTOR 2SC634SP
Q502	8-729-104-93	TRANSISTOR 2SB1040A
Q503	8-729-117-54	TRANSISTOR 2SA1175
Q504	8-729-699-51	TRANSISTOR 2SA995
Q505	8-729-625-91	TRANSISTOR 2SC2259
Q506	8-729-117-54	TRANSISTOR 2SA1175
Q507	8-729-600-27	TRANSISTOR 2SC634SP
Q508	8-729-117-54	TRANSISTOR 2SA1175
Q509	8-729-600-27	TRANSISTOR 2SC634SP
Q510	8-729-117-54	TRANSISTOR 2SA1175
Q511	8-729-600-27	TRANSISTOR 2SC634SP
Q512	8-729-202-02	TRANSISTOR 2SB1015
Q513	8-729-806-34	TRANSISTOR 2SC3400
Q514	8-729-117-54	TRANSISTOR 2SA1175
Q515	8-729-117-54	TRANSISTOR 2SA1175
Q516	8-729-600-27	TRANSISTOR 2SC634SP
Q517	8-729-402-02	TRANSISTOR 2SK656
Q518	8-729-600-27	TRANSISTOR 2SC634SP
Q519	8-729-600-27	TRANSISTOR 2SC634SP
Q520	8-729-600-27	TRANSISTOR 2SC634SP
Q521	8-729-CJ6-16	TRANSISTOR 2SA1346
Q522	8-729-806-16	TRANSISTOR 2SA1346
Q523	8-729-806-34	TRANSISTOR 2SC3400
Q524	8-729-806-34	TRANSISTOR 2SC3400
Q525	8-729-806-34	TRANSISTOR 2SC3400
Q526	8-729-600-27	TRANSISTOR 2SC634SP
Q527	8-729-111-67	TRANSISTOR 2SB1094-L
Q528	8-729-600-27	TRANSISTOR 2SC634SP
Q529	8-729-111-67	TRANSISTOR 2SB1094-L
Q530	8-729-600-27	TRANSISTOR 2SC634SP
Q531	8-729-204-83	TRANSISTOR 2SA1048
Q532	8-729-204-83	TRANSISTOR 2SA1048
Q533	8-729-629-12	TRANSISTOR 2SC2291
Q534	8-729-600-27	TRANSISTOR 2SC634SP
Q535	8-729-600-27	TRANSISTOR 2SC634SP
Q536	8-729-204-83	TRANSISTOR 2SA1048
Q537	8-729-204-83	TRANSISTOR 2SA1048
Q538	8-729-629-12	TRANSISTOR 2SC2291
Q539	8-729-600-27	TRANSISTOR 2SC634SP
Q540	8-729-806-34	TRANSISTOR 2SC3400
Q541	8-729-806-16	TRANSISTOR 2SA1346
Q542	8-729-801-92	TRANSISTOR 2SD1387

The components identified by shading and mark  are critical for safety. Replace only with part number specified.

DTC-1000ES

ELECTRICAL PARTS

Ref.No.	Part No.	Description			
Q543	8-729-806-34	TRANSISTOR 2SC3400			
Q544	8-729-806-34	TRANSISTOR 2SC3400			
Q545	8-729-801-83	TRANSISTOR 2SB1013			
Q546	8-729-801-92	TRANSISTOR 2SD1387			
Q547	8-729-806-34	TRANSISTOR 2SC3400			
Q548	8-729-154-83	TRANSISTOR 2SB548			
Q549	8-729-806-34	TRANSISTOR 2SC3400			
Q550	8-729-806-16	TRANSISTOR 2SA1346			
Q551	8-729-806-34	TRANSISTOR 2SC3400			
Q552	8-729-806-34	TRANSISTOR 2SC3400			
Q560	8-729-806-34	TRANSISTOR 2SC3400			
Q561	8-729-806-34	TRANSISTOR 2SC3400			
Q701	8-729-806-34	TRANSISTOR 2SC3400			
Q702	8-729-806-34	TRANSISTOR 2SC3400			
Q703	8-729-806-34	TRANSISTOR 2SC3400			
Q704	8-729-204-83	TRANSISTOR 2SA1048			
Q705	8-729-204-83	TRANSISTOR 2SA1048			
Q706	8-729-204-83	TRANSISTOR 2SA1048			
Q707	8-729-806-34	TRANSISTOR 2SC3400			
Q708	8-729-204-83	TRANSISTOR 2SA1048			
Q709	8-729-806-16	TRANSISTOR 2SA1346			
Q803	8-729-600-27	TRANSISTOR 2SC634SP			
Q804	8-729-204-83	TRANSISTOR 2SA1048			
Q805	8-729-806-34	TRANSISTOR 2SC3400			
Q851	8-729-100-13	TRANSISTOR 2SC2001-K2			
Q852	8-729-100-13	TRANSISTOR 2SC2001-K2			
Q856	8-729-806-34	TRANSISTOR 2SC3400			
Q857	8-729-806-34	TRANSISTOR 2SC3400			
Q901	8-729-173-13	TRANSISTOR 2SB731			
Q902	8-729-600-27	TRANSISTOR 2SC634SP			
Q903	8-729-600-27	TRANSISTOR 2SC634SP			
Q904	8-729-204-83	TRANSISTOR 2SA1048			
Q905	8-729-111-67	TRANSISTOR 2SB1094-L			
Q906	8-729-600-27	TRANSISTOR 2SC634SP			
Q907	8-729-600-27	TRANSISTOR 2SC634SP			
Q908	8-729-204-83	TRANSISTOR 2SA1048			
Q909	8-729-111-67	TRANSISTOR 2SB1094-L			
RO01	1-249-405-11	CARBON	100	5%	1/4W
RO02	1-247-693-11	CARBON	27	5%	1/4W
RO03	1-249-405-11	CARBON	100	5%	1/4W
R101	1-249-739-11	CARBON	560K		1/2W
R102	1-249-556-11	CARBON	1.5K		1/4W
R103	1-247-713-11	CARBON	1K		1/4W
R104	1-249-798-11	CARBON	680	1%	1/2W
R105	1-247-259-00	CARBON	6.8K	1%	1/2W
R106	1-249-469-11	CARBON	100K		1/4W
R107	1-247-719-11	CARBON	3.3K	1%	1/4W
R108	1-249-951-11	CARBON	15K	1%	1/4W
R109	1-249-947-11	CARBON	10K	1%	1/4W
R110	1-249-947-11	CARBON	10K	1%	1/4W
R111	1-247-711-11	CARBON	680		1/4W
R112	1-247-725-11	CARBON	10K		1/4W
R113	1-214-757-11	METAL	15K		1/4W
R114	1-214-753-00	METAL	10K	1%	1/4W
R115	1-214-753-00	METAL	10K	1%	1/4W
R116	1-214-767-00	METAL	39K	1%	1/4W
R117	1-249-462-11	CARBON	22K		1/4W
R118	1-247-717-11	CARBON	2.2K		1/4W

ELECTRICAL PARTS

Ref.No.	Part No.	Description			
R119	1-214-745-00	METAL	4.7K	1%	1/4W
R121	1-246-545-00	CARBON	1M		1/4W
R122	1-247-713-11	CARBON	1K	1%	1/4W
R123	1-249-929-11	CARBON	1.8K	1%	1/4W
R124	1-249-929-11	CARBON	1.8K	1%	1/4W
R125	1-249-929-11	CARBON	1.8K	1%	1/4W
R126	1-247-717-11	CARBON	2.2K		1/4W
R127	1-247-713-11	CARBON	1K		1/4W
R128	1-249-469-11	CARBON	100K		1/4W
R129	1-247-741-11	CARBON	150		1/2W
R130	1-249-497-11	CARBON	33K		1/4W
R131	1-249-586-11	CARBON	27K		1/4W
R132	1-249-596-11	CARBON	68K		1/4W
R133	1-249-421-11	CARBON	2.2K	5%	1/4W
R134	1-215-476-00	CARBON	200K	5%	1/4W
R135	1-249-410-11	CARBON	270	5%	1/4W
R136	1-215-420-00	CARBON	910	5%	1/4W
R137	1-249-411-11	CARBON	330	5%	1/4W
R138	1-249-417-11	CARBON	1K	5%	1/4W
R139	1-215-493-00	CARBON	1M	5%	1/4W
R140	1-249-429-11	CARBON	10K	5%	1/4W
R141	1-249-417-11	CARBON	1K	5%	1/4W
R142	1-215-493-00	CARBON	1M	5%	1/4W
R143	1-249-836-11	CARBON	27K	1%	1/2W
R144	1-249-657-11	CARBON	220		1/2W
R145	1-249-945-11	CARBON	8.2K	1%	1/4W
R146	1-247-702-11	CARBON	150		1/4W
R147	1-246-545-00	CARBON	1M		1/4W
R148	1-249-943-11	CARBON	6.8K	1%	1/4W
R149	1-249-962-11	CARBON	43K	1%	1/4W
R150	1-249-462-11	CARBON	22K		1/4W
R151	1-249-753-85	CARBON	4.7M	5%	1/4W
R152	1-246-545-00	CARBON	1M		1/4W
R312	1-249-419-11	CARBON	1.5K	5%	1/4W
R313	1-247-887-00	CARBON	220K	5%	1/4W
R314	1-249-427-11	CARBON	6.8K	5%	1/4W
R315	1-249-421-11	CARBON	2.2K	5%	1/4W
R316	1-249-429-11	CARBON	10K	5%	1/4W
R317	1-249-417-11	CARBON	1K	5%	1/4W
R318	1-249-424-11	CARBON	3.9K	5%	1/4W
R319	1-214-859-00	METAL	620	1%	1/2W
R320	1-214-866-00	METAL	1.2K	1%	1/2W
R321	1-214-866-00	METAL	1.2K	1%	1/2W
R322	1-214-861-00	METAL	750	1%	1/2W
R323	1-247-719-11	CARBON	3.3K		1/4W
R324	1-247-711-11	CARBON	680		1/4W
R325	1-249-466-11	CARBON	56K		1/4W
R326	1-249-466-11	CARBON	56K		1/4W
R327	1-247-711-11	CARBON	680		1/4W
R328	1-247-719-11	CARBON	3.3K		1/4W
R329	1-247-706-11	CARBON	330		1/4W
R330	1-247-706-11	CARBON	330		1/4W
R331	1-249-435-11	CARBON	33K	5%	1/4W
R332	1-249-433-11	CARBON	22K	5%	1/4W
R333	1-249-421-11	CARBON	2.2K	5%	1/4W
R334	1-249-429-11	CARBON	10K	5%	1/4W
R335	1-247-104-00	CARBON	75	5%	1/4W

ELECTRICAL PARTS

Ref.No.	Part No.	Description			
R336	1-249-435-11	CARBON	33K	5%	1/4W
R337	1-249-433-11	CARBON	22K	5%	1/4W
R338	1-249-421-11	CARBON	2.2K	5%	1/4W
R339	1-249-429-11	CARBON	10K	5%	1/4W
R340	1-247-104-00	CARBON	75	5%	1/4W
R341	Δ 1-212-857-00	FUSIBLE	10	5%	1/4W F
R342	Δ 1-212-857-00	FUSIBLE	10	5%	1/4W F
R343	1-214-734-00	METAL	1.6K	1%	1/4W
R344	1-214-730-00	METAL	1.1K	1%	1/4W
R401	1-216-001-00	METAL CHIP	10	5%	1/10W
R402	1-216-001-00	METAL CHIP	10	5%	1/10W
R403	1-216-001-00	METAL CHIP	10	5%	1/10W
R404	1-216-083-00	METAL CHIP	27K	5%	1/10W
R405	1-216-073-00	METAL CHIP	10K	5%	1/10W
R406	1-216-089-00	METAL CHIP	47K	5%	1/10W
R407	1-216-057-00	METAL CHIP	2.2K	5%	1/10W
R408	1-216-063-00	METAL CHIP	3.9K	5%	1/10W
R409	1-216-041-00	METAL CHIP	470	5%	1/10W
R410	1-216-089-00	METAL CHIP	47K	5%	1/10W
R411	1-216-064-00	METAL CHIP	4.3K	5%	1/10W
R412	1-216-075-00	METAL CHIP	12K	5%	1/10W
R413	1-216-093-00	METAL CHIP	68K	5%	1/10W
R414	1-216-051-00	METAL CHIP	1.2K	5%	1/10W
R415	1-216-029-00	METAL CHIP	150	5%	1/10W
R416	1-216-029-00	METAL CHIP	150	5%	1/10W
R417	1-216-069-00	METAL CHIP	6.8K	5%	1/10W
R418	1-216-049-00	METAL CHIP	1K	5%	1/10W
R419	1-216-065-00	METAL CHIP	4.7K	5%	1/10W
R420	1-216-049-00	METAL CHIP	1K	5%	1/10W
R421	1-216-049-00	METAL CHIP	1K	5%	1/10W
R422	1-216-074-00	METAL CHIP	11K	5%	1/10W
R423	1-216-073-00	METAL CHIP	10K	5%	1/10W
R424	1-216-049-00	METAL CHIP	1K	5%	1/10W
R425	1-216-093-00	METAL CHIP	68K	5%	1/10W
R426	1-216-065-00	METAL CHIP	4.7K	5%	1/10W
R427	1-216-059-00	METAL CHIP	2.7K	5%	1/10W
R428	1-216-085-00	METAL CHIP	33K	5%	1/10W
R429	1-216-065-00	METAL CHIP	4.7K	5%	1/10W
R430	1-216-075-00	METAL CHIP	12K	5%	1/10W
R431	1-216-033-00	METAL CHIP	220	5%	1/10W
R432	1-216-069-00	METAL CHIP	6.8K	5%	1/10W
R433	1-216-033-00	METAL CHIP	220	5%	1/10W
R434	1-216-049-00	METAL CHIP	1K	5%	1/10W
R435	1-216-074-00	METAL CHIP	11K	5%	1/10W
R436	1-216-073-00	METAL CHIP	10K	5%	1/10W
R437	1-216-049-00	METAL CHIP	1K	5%	1/10W
R438	1-216-101-00	METAL CHIP	150K	5%	1/10W
R439	1-216-073-00	METAL CHIP	10K	5%	1/10W
R440	1-216-059-00	METAL CHIP	2.7K	5%	1/10W
R441	1-216-085-00	METAL CHIP	33K	5%	1/10W
R442	1-216-065-00	METAL CHIP	4.7K	5%	1/10W
R443	1-216-001-00	METAL CHIP	10	5%	1/10W
R444	1-216-001-00	METAL CHIP	10	5%	1/10W
R501	1-249-433-11	CARBON	22K	5%	1/4W
R502	1-249-433-11	CARBON	22K	5%	1/4W
R503	1-247-891-00	CARBON	330K	5%	1/4W
R504	1-215-493-00	CARBON	1M	5%	1/4W
R505	1-215-489-00	CARBON	680K	5%	1/4W

ELECTRICAL PARTS

Ref.No.	Part No.	Description			
R506	1-247-895-00	CARBON	470K	5%	1/4W
R507	1-215-461-00	METAL	47K	1%	1/6W
R508	1-215-466-00	METAL	75K	1%	1/6W
R509	1-249-401-11	CARBON	47	5%	1/4W
R510	1-249-411-11	CARBON	330	5%	1/4W
R511	1-249-435-11	CARBON	33K	5%	1/4W
R512	1-249-433-11	CARBON	22K	5%	1/4W
R513	1-249-409-11	CARBON	220	5%	1/4W
R514	1-249-437-11	CARBON	47K	5%	1/4W
R515	1-249-437-11	CARBON	47K	5%	1/4W
R516	1-249-437-11	CARBON	47K	5%	1/4W
R517	1-249-429-11	CARBON	10K	5%	1/4W
R518	1-215-462-00	CARBON	51K	5%	1/4W
R519	1-249-437-11	CARBON	47K	5%	1/4W
R520	1-249-437-11	CARBON	47K	5%	1/4W
R521	1-249-441-11	CARBON	100K	5%	1/4W
R522	1-215-454-00	CARBON	24K	5%	1/4W
R523	1-215-477-00	METAL	220K	1%	1/6W
R524	1-215-461-00	METAL	47K	1%	1/6W
R525	1-215-438-00	METAL	5.1K	1%	1/6W
R526	1-215-438-00	METAL	5.1K	1%	1/6W
R527	1-249-429-11	CARBON	10K	5%	1/4W
R528	1-249-429-11	CARBON	10K	5%	1/4W
R529	1-215-493-00	CARBON	1M	5%	1/4W
R530	1-249-401-11	CARBON	47	5%	1/4W
R531	1-249-417-11	CARBON	1K	5%	1/4W
R532	1-215-445-00	METAL	10K	1%	1/6W
R533	1-215-445-00	METAL	10K	1%	1/6W
R534	1-249-420-11	CARBON	1.8K	5%	1/4W
R535	1-249-429-11	CARBON	10K	5%	1/4W
R536	1-215-439-00	METAL	5.6K	1%	1/6W
R537	1-247-891-00	CARBON	330K	5%	1/4W
R538	1-249-433-11	CARBON	22K	5%	1/4W
R539	1-215-462-00	CARBON	51K	5%	1/4W
R540	1-249-433-11	CARBON	22K	5%	1/4W
R541	1-249-435-11	CARBON	33K	5%	1/4W
R542	1-249-425-11	CARBON	4.7K	5%	1/4W
R543	1-249-417-11	CARBON	1K	5%	1/4W
R544	1-249-425-11	CARBON	4.7K	5%	1/4W
R545	1-249-417-11	CARBON	1K	5%	1/4W
R546	1-249-425-11	CARBON	4.7K	5%	1/4W
R547	1-249-417-11	CARBON	1K	5%	1/4W
R548	1-249-435-11	CARBON	33K	5%	1/4W
R549	1-249-439-11	CARBON	68K	5%	1/4W
R550	1-249-435-11	CARBON	33K	5%	1/4W
R551	1-249-423-11	CARBON	3.3K	5%	1/4W
R552	1-249-431-11	CARBON	15K	5%	1/4W
R553	1-249-428-11	CARBON	8.2K	5%	1/4W
R554	1-247-883-00	CARBON	150K	5%	1/4W
R555	1-249-441-11	CARBON	100K	5%	1/4W
R556	1-249-433-11	CARBON	22K	5%	1/4W
R557	1-249-441-11	CARBON	100K	5%	1/4W
R558	1-249-425-11	CARBON	4.7K	5%	1/4W
R559	1-215-445-00	METAL	10K	1%	1/6W
R560	1-215-453-00	METAL	22K	1%	1/6W
R561	1-215-457-00	METAL	33K	1%	1/6W
R562	1-249-433-11	CARBON	22K	5%	1/4W
R563	1-249-417-11	CARBON	1K	5%	1/4W

The components identified by shading and mark  are critical for safety. Replace only with part number specified.

DTC-1000ES

ELECTRICAL PARTS

Ref.No.	Part No.	Description			
R564	1-249-435-11	CARBON	33K	5%	1/4W
R565	1-249-429-11	CARBON	10K	5%	1/4W
R566	1-247-883-00	CARBON	150K	5%	1/4W
R567	1-247-883-00	CARBON	150K	5%	1/4W
R568	1-249-417-11	CARBON	1K	5%	1/4W
R569	1-249-417-11	CARBON	1K	5%	1/4W
R570	1-249-401-11	CARBON	47	5%	1/4W
R571	1-215-461-00	METAL	47K	1%	1/6W
R572	1-215-466-00	METAL	75K	1%	1/6W
R573	1-215-442-00	METAL	7.5K	1%	1/6W
R574	1-215-454-00	METAL	24K	1%	1/6W
R575	1-215-438-00	CARBON	5.1K	5%	1/4W
R576	1-249-431-11	CARBON	15K	5%	1/4W
R577	1-249-439-11	CARBON	68K	5%	1/4W
R578	1-249-435-11	CARBON	33K	5%	1/4W
R579	1-249-433-11	CARBON	22K	5%	1/4W
R580	1-249-433-11	CARBON	22K	5%	1/4W
R581	1-249-425-11	CARBON	4.7K	5%	1/4W
R582	1-249-417-11	CARBON	1K	5%	1/4W
R583	1-249-431-11	CARBON	15K	5%	1/4W
R584	1-249-435-11	CARBON	33K	5%	1/4W
R585	1-249-417-11	CARBON	1K	5%	1/4W
R586	1-249-433-11	CARBON	22K	5%	1/4W
R587	1-249-433-11	CARBON	22K	5%	1/4W
R588	1-249-437-11	CARBON	47K	5%	1/4W
R589	1-249-437-11	CARBON	47K	5%	1/4W
R590	1-249-433-11	CARBON	22K	5%	1/4W
R591	1-249-433-11	CARBON	22K	5%	1/4W
R592	1-215-493-00	CARBON	1M	5%	1/4W
R593	1-249-435-11	CARBON	33K	5%	1/4W
R594	1-249-435-11	CARBON	33K	5%	1/4W
R595	1-249-437-11	CARBON	47K	5%	1/4W
R596	1-249-429-11	CARBON	10K	5%	1/4W
R597	1-249-431-11	CARBON	15K	5%	1/4W
R598	1-249-429-11	CARBON	10K	5%	1/4W
R599	1-249-417-11	CARBON	1K	5%	1/4W
R600	1-249-417-11	CARBON	1K	5%	1/4W
R601	1-249-423-11	CARBON	3.3K	5%	1/4W
R602	1-249-423-11	CARBON	3.3K	5%	1/4W
R603	1-249-421-11	CARBON	2.2K	5%	1/4W
R604	1-249-417-11	CARBON	1K	5%	1/4W
R605	1-249-441-11	CARBON	100K	5%	1/4W
R606	1-249-425-11	CARBON	4.7K	5%	1/4W
R607	1-249-425-11	CARBON	4.7K	5%	1/4W
R608	1-249-425-11	CARBON	4.7K	5%	1/4W
R609	1-215-469-00	METAL	100K	1%	1/6W
R610	1-249-405-11	CARBON	100	5%	1/4W
R611	1-249-429-11	CARBON	10K	5%	1/4W
R612	1-249-429-11	CARBON	10K	5%	1/4W
R613	1-249-405-11	CARBON	100	5%	1/4W
R614	1-249-407-11	CARBON	150	5%	1/4W
R615	1-249-447-11	CARBON	1	5%	1/4W
R616	1-249-447-11	CARBON	1	5%	1/4W
R617	1-249-389-11	CARBON	4.7	5%	1/4W
R618	1-215-469-00	METAL	100K	1%	1/6W
R619	1-249-405-11	CARBON	100	5%	1/4W
R620	1-249-429-11	CARBON	10K	5%	1/4W

ELECTRICAL PARTS

Ref.No.	Part No.	Description			
R621	1-249-429-11	CARBON	10K	5%	1/4W
R622	1-249-405-11	CARBON	100	5%	1/4W
R623	1-249-407-11	CARBON	150	5%	1/4W
R624	1-249-447-11	CARBON	1	5%	1/4W
R625	1-249-447-11	CARBON	1	5%	1/4W
R626	1-249-389-11	CARBON	4.7	5%	1/4W
R627	1-249-415-11	CARBON	680	5%	1/4W
R628	1-249-421-11	CARBON	2.2K	5%	1/4W
R629	1-249-425-11	CARBON	4.7K	5%	1/4W
R630	1-215-394-00	CARBON	75	5%	1/4W
R631	1-249-401-11	CARBON	47	5%	1/4W
R632	1-249-423-11	CARBON	3.3K	5%	1/4W
R633	1-249-427-11	CARBON	6.8K	5%	1/4W
R634	1-249-423-11	CARBON	3.3K	5%	1/4W
R635	1-249-417-11	CARBON	1K	5%	1/4W
R636	1-249-417-11	CARBON	1K	5%	1/4W
R637	1-249-435-11	CARBON	33K	5%	1/4W
R638	1-249-437-11	CARBON	47K	5%	1/4W
R639	1-249-421-11	CARBON	2.2K	5%	1/4W
R640	1-249-425-11	CARBON	4.7K	5%	1/4W
R641	1-215-394-00	CARBON	75	5%	1/4W
R642	1-249-401-11	CARBON	47	5%	1/4W
R643	1-249-423-11	CARBON	3.3K	5%	1/4W
R644	1-249-427-11	CARBON	6.8K	5%	1/4W
R645	1-249-423-11	CARBON	3.3K	5%	1/4W
R646	1-249-417-11	CARBON	1K	5%	1/4W
R647	1-249-417-11	CARBON	1K	5%	1/4W
R648	1-249-435-11	CARBON	33K	5%	1/4W
R649	1-249-437-11	CARBON	47K	5%	1/4W
R650	1-249-409-11	CARBON	220	5%	1/4W
R651	1-247-826-00	CARBON	620	5%	1/4W
R652	1-249-433-11	CARBON	22K	5%	1/4W
R653	1-249-427-11	CARBON	6.8K	5%	1/4W
R654	1-249-427-11	CARBON	6.8K	5%	1/4W
R655	1-215-486-00	CARBON	510K	5%	1/4W
R656	1-249-435-11	CARBON	33K	5%	1/4W
R657	1-249-435-11	CARBON	33K	5%	1/4W
R658	1-249-432-11	CARBON	18K	5%	1/4W
R659	1-249-432-11	CARBON	18K	5%	1/4W
R660	1-215-489-00	CARBON	680K	5%	1/4W
R661	1-249-431-11	CARBON	15K	5%	1/4W
R662	1-249-431-11	CARBON	15K	5%	1/4W
R663	1-215-489-00	CARBON	680K	5%	1/4W
R664	1-247-891-00	CARBON	330K	5%	1/4W
R665	1-249-431-11	CARBON	15K	5%	1/4W
R666	1-249-405-11	CARBON	100	5%	1/4W
R667	1-249-425-11	CARBON	4.7K	5%	1/4W
R668	1-249-407-11	CARBON	150	5%	1/4W
R669	1-249-432-11	CARBON	18K	5%	1/4W
R670	1-249-429-11	CARBON	10K	5%	1/4W
R671	1-249-433-11	CARBON	22K	5%	1/4W
R672	1-249-432-11	CARBON	18K	5%	1/4W
R673	1-249-433-11	CARBON	22K	5%	1/4W
R674	1-249-419-11	CARBON	1.5K	5%	1/4W
R675	1-249-429-11	CARBON	10K	5%	1/4W
R676	1-249-437-11	CARBON	47K	5%	1/4W
R677	1-249-437-11	CARBON	47K	5%	1/4W

ELECTRICAL PARTS

Ref.No.	Part No.	Description			
R678	1-249-423-11	CARBON	3.3K	5%	1/4W
R679	1-249-423-11	CARBON	3.3K	5%	1/4W
R680	1-249-423-11	CARBON	3.3K	5%	1/4W
R681	1-249-423-11	CARBON	3.3K	5%	1/4W
R682	1-249-423-11	CARBON	3.3K	5%	1/4W
R683	1-249-423-11	CARBON	3.3K	5%	1/4W
R684	1-249-409-11	CARBON	220	5%	1/4W
R685	1-249-429-11	CARBON	10K	5%	1/4W
R686	1-249-409-11	CARBON	220	5%	1/4W
R687	1-249-429-11	CARBON	10K	5%	1/4W
R688	1-215-881-11	METAL OXIDE	15	5%	2W
R689	1-249-423-11	CARBON	3.3K	5%	1/4W
R690	1-249-416-11	CARBON	820	5%	1/4W
R691	1-249-484-11	CARBON	6.8	5%	1/2W
R692	1-249-429-11	CARBON	10K	5%	1/4W
R693	1-249-417-11	CARBON	1K	5%	1/4W
R694	1-249-409-11	CARBON	220	5%	1/4W
R695	1-249-405-11	CARBON	100	5%	1/4W
R696	1-249-427-11	CARBON	6.8K	5%	1/4W
R701	1-215-452-00	CARBON	20K	5%	1/4W
R702	1-215-452-00	CARBON	20K	5%	1/4W
R703	1-215-452-00	CARBON	20K	5%	1/4W
R704	1-215-493-00	CARBON	1M	5%	1/4W
R705	1-249-425-11	CARBON	4.7K	5%	1/4W
R706	1-249-425-11	CARBON	4.7K	5%	1/4W
R707	1-249-425-11	CARBON	4.7K	5%	1/4W
R708	1-249-433-11	CARBON	22K	5%	1/4W
R709	1-249-433-11	CARBON	22K	5%	1/4W
R710	1-215-493-00	CARBON	1M	5%	1/4W
R711	1-249-423-11	CARBON	3.3K	5%	1/4W
R712	1-249-425-11	CARBON	4.7K	5%	1/4W
R713	1-249-425-11	CARBON	4.7K	5%	1/4W
R714	1-249-429-11	CARBON	10K	5%	1/4W
R715	1-249-429-11	CARBON	10K	5%	1/4W
R716	1-249-429-11	CARBON	10K	5%	1/4W
R717	1-249-429-11	CARBON	10K	5%	1/4W
R718	1-249-429-11	CARBON	10K	5%	1/4W
R719	1-249-423-11	CARBON	3.3K	5%	1/4W
R720	1-247-887-00	CARBON	220K	5%	1/4W
R721	1-247-887-00	CARBON	220K	5%	1/4W
R722	1-249-433-11	CARBON	22K	5%	1/4W
R723	1-249-433-11	CARBON	22K	5%	1/4W
R724	1-249-441-11	CARBON	100K	5%	1/4W
R725	1-249-429-11	CARBON	10K	5%	1/4W
R726	1-249-421-11	CARBON	2.2K	5%	1/4W
R727	1-249-421-11	CARBON	2.2K	5%	1/4W
R728	1-249-421-11	CARBON	2.2K	5%	1/4W
R729	1-249-421-11	CARBON	2.2K	5%	1/4W
R730	1-249-405-11	CARBON	100	5%	1/4W
R731	1-249-405-11	CARBON	100	5%	1/4W
R732	1-249-405-11	CARBON	100	5%	1/4W
R733	1-249-425-11	CARBON	4.7K	5%	1/4W
R734	1-249-417-11	CARBON	1K	5%	1/4W
R735	1-249-441-11	CARBON	100K	5%	1/4W
R736	1-249-429-11	CARBON	10K	5%	1/4W
R737	1-215-452-00	CARBON	20K	5%	1/4W
R738	1-249-429-11	CARBON	10K	5%	1/4W

ELECTRICAL PARTS

Ref.No.	Part No.	Description			
R739	1-249-429-11	CARBON	10K	5%	1/4W
R740	1-215-452-00	CARBON	20K	5%	1/4W
R741	1-215-452-00	CARBON	20K	5%	1/4W
R742	1-249-429-11	CARBON	10K	5%	1/4W
R743	1-215-452-00	CARBON	20K	5%	1/4W
R744	1-215-438-00	CARBON	5.1K	5%	1/4W
R745	1-249-433-11	CARBON	22K	5%	1/4W
R746	1-249-433-11	CARBON	22K	5%	1/4W
R747	1-249-433-11	CARBON	22K	5%	1/4W
R748	1-249-433-11	CARBON	22K	5%	1/4W
R749	1-249-433-11	CARBON	22K	5%	1/4W
R750	1-249-433-11	CARBON	22K	5%	1/4W
R751	1-249-433-11	CARBON	22K	5%	1/4W
R752	1-249-433-11	CARBON	22K	5%	1/4W
R753	1-249-433-11	CARBON	22K	5%	1/4W
R754	1-249-429-11	CARBON	10K	5%	1/4W
R755	1-249-429-11	CARBON	10K	5%	1/4W
R756	1-249-429-11	CARBON	10K	5%	1/4W
R757	1-249-429-11	CARBON	10K	5%	1/4W
R758	1-249-441-11	CARBON	100K	5%	1/4W
R761	1-215-398-00	CARBON	110	5%	1/4W
R782	1-215-398-00	CARBON	110	5%	1/4W
R783	1-249-413-11	CARBON	470	5%	1/4W
R784	1-249-413-11	CARBON	470	5%	1/4W
R785	1-215-398-00	CARBON	110	5%	1/4W
R786	1-249-407-11	CARBON	150	5%	1/4W
R787	1-215-398-00	CARBON	110	5%	1/4W
R788	1-215-398-00	CARBON	110	5%	1/4W
R789	1-215-398-00	CARBON	110	5%	1/4W
R790	1-249-413-11	CARBON	470	5%	1/4W
R802	1-249-417-11	CARBON	1K	5%	1/4W
R803	1-249-429-11	CARBON	10K	5%	1/4W
R805	1-249-417-11	CARBON	1K	5%	1/4W
R806	1-249-405-11	CARBON	100	5%	1/4W
R807	1-249-431-11	CARBON	15K	5%	1/4W
R808	1-215-442-00	CARBON	7.5K	5%	1/4W
R809	1-249-424-11	CARBON	3.9K	5%	1/4W
R810	1-249-425-11	CARBON	4.7K	5%	1/4W
R811	1-249-433-11	CARBON	22K	5%	1/4W
R812	1-249-435-11	CARBON	33K	5%	1/4W
R813	1-249-429-11	CARBON	10K	5%	1/4W
R814	1-249-441-11	CARBON	100K	5%	1/4W
R815	1-215-470-00	CARBON	110K	5%	1/4W
R816	1-247-881-00	CARBON	120K	5%	1/4W
R817	1-247-881-00	CARBON	120K	5%	1/4W
R818	1-249-429-11	CARBON	10K	5%	1/4W
R819	1-249-431-11	CARBON	15K	5%	1/4W
R820	1-249-429-11	CARBON	10K	5%	1/4W
R821	1-249-425-11	CARBON	4.7K	5%	1/4W
R822	1-249-425-11	CARBON	4.7K	5%	1/4W
R823	1-249-434-11	CARBON	27K	5%	1/4W
R824	1-215-453-00	METAL	22K	1%	1/6W
R825	1-215-453-00	METAL	22K	1%	1/6W
R826	1-249-425-11	CARBON	4.7K	5%	1/4W
R827	1-249-435-11	CARBON	33K	5%	1/4W
R828	1-249-429-11	CARBON	10K	5%	1/4W
R851	1-249-419-11	CARBON	1.5K	5%	1/4W

The components identified by shading and mark  are critical for safety. Replace only with part number specified.

DTC-1000ES

ELECTRICAL PARTS

Ref.No.	Part No.	Description			
R852	1-247-845-00	CARBON	3.9K	5%	1/4W
R853	1-249-433-11	CARBON	22K	5%	1/4W
R854	1-249-441-11	CARBON	100K	5%	1/4W
R856	1-249-437-11	CARBON	47K	5%	1/4W
R857	1-249-421-11	CARBON	2.2K	5%	1/4W
R858	1-247-104-00	CARBON	75	5%	1/4W
R860	1-215-440-00	CARBON	6.2K	5%	1/4W
R861	1-249-433-11	CARBON	22K	5%	1/4W
R862	1-215-440-00	CARBON	6.2K	5%	1/4W
R864	1-249-432-11	CARBON	18K	5%	1/4W
R865	1-249-438-11	CARBON	56K	5%	1/4W
R866	1-249-397-11	CARBON	22	5%	1/4W
R868	1-249-429-11	CARBON	10K	5%	1/4W
R870	1-249-429-11	CARBON	10K	5%	1/4W
R901	△1-212-865-00	FUSIBLE	22	5%	1/4W F
R902	1-249-419-11	CARBON	1.5K	5%	1/4W
R904	1-249-417-11	CARBON	1K	5%	1/4W
R905	1-249-440-11	CARBON	82K	5%	1/4W
R906	1-249-418-11	CARBON	1.2K	5%	1/4W
R907	1-249-418-11	CARBON	1.2K	5%	1/4W
R908	1-249-421-11	CARBON	2.2K	5%	1/4W
R909	1-249-419-11	CARBON	1.5K	5%	1/4W
R910	1-215-438-00	CARBON	5.1K	5%	1/4W
R912	1-249-418-11	CARBON	1.2K	5%	1/4W
R913	1-249-421-11	CARBON	2.2K	5%	1/4W
R914	1-215-420-00	CARBON	910	5%	1/4W
R915	1-215-438-00	CARBON	5.1K	5%	1/4W
R916	△1-217-422-00	FUSIBLE	1	5%	1/2W F
R917	△1-212-948-91	FUSIBLE	3.9	5%	1/2W F
R918	△1-212-948-91	FUSIBLE	3.9	5%	1/2W F
R919	△1-217-383-00	FUSIBLE	4.7	5%	1/4W F
R920	1-247-895-00	CARBON	470K	5%	1/4W
R921	1-249-437-11	CARBON	47K	5%	1/4W
R922	△1-212-865-00	FUSIBLE	22	5%	1/4W F
R951	1-216-057-00	METAL CHIP	2.2K	5%	1/10W
R952	1-216-057-00	METAL CHIP	2.2K	5%	1/10W
R953	1-216-057-00	METAL CHIP	2.2K	5%	1/10W
R954	1-216-057-00	METAL CHIP	2.2K	5%	1/10W
R955	1-216-089-00	METAL CHIP	47K	5%	1/10W
R956	1-216-083-00	METAL CHIP	27K	5%	1/10W
R957	1-216-065-00	METAL CHIP	4.7K	5%	1/10W
R958	1-216-085-00	METAL CHIP	33K	5%	1/10W
R959	1-216-081-00	METAL CHIP	22K	5%	1/10W
R960	1-216-079-00	METAL CHIP	18K	5%	1/10W
R961	1-216-079-00	METAL CHIP	18K	5%	1/10W
R962	1-216-081-00	METAL CHIP	22K	5%	1/10W
R963	1-216-085-00	METAL CHIP	33K	5%	1/10W
R964	1-216-083-00	METAL CHIP	27K	5%	1/10W
R965	1-216-065-00	METAL CHIP	4.7K	5%	1/10W
R966	1-216-089-00	METAL CHIP	47K	5%	1/10W
R967	1-216-073-00	METAL CHIP	10K	5%	1/10W
R968	1-216-073-00	METAL CHIP	10K	5%	1/10W
R969	1-216-085-00	METAL CHIP	33K	5%	1/10W
R970	1-216-085-00	METAL CHIP	33K	5%	1/10W
R971	1-216-089-00	METAL CHIP	47K	5%	1/10W
R972	1-216-065-00	METAL CHIP	4.7K	5%	1/10W
R973	1-216-061-00	METAL CHIP	3.3K	5%	1/10W
R974	1-216-061-00	METAL CHIP	3.3K	5%	1/10W

ELECTRICAL PARTS

Ref.No.	Part No.	Description
RV101	1-224-251-XX	RES. ADJ. METAL GLAZE 4.7K
RV102	1-224-251-XX	RES. ADJ. METAL GLAZE 4.7K
RV103	1-230-522-11	RES. ADJ. METAL GLAZE 4.7K
RV201	1-224-251-XX	RES. ADJ. METAL GLAZE 4.7K
RV202	1-224-251-XX	RES. ADJ. METAL GLAZE 4.7K
RV203	1-230-522-11	RES. ADJ. METAL GLAZE 4.7K
RV301	1-228-127-00	RES. VAR. CARBON 20K
RV302	1-237-590-11	RES. VAR. CARBON 20K/20K
RV501	1-224-253-XX	RES. ADJ. METAL GLAZE 22K
RV502	1-226-774-00	RES. ADJ. METAL GLAZE 47K
RV503	1-230-527-11	RES. ADJ. METAL GLAZE 100K
RV504	1-226-774-00	RES. ADJ. METAL GLAZE 47K
RV505	1-224-254-XX	RES. ADJ. METAL GLAZE 47K
RV506	1-230-522-11	RES. ADJ. METAL GLAZE 4.7K
RV507	1-230-524-11	RES. ADJ. METAL GLAZE 22K
RV508	1-230-524-11	RES. ADJ. METAL GLAZE 22K
RV509	1-226-774-00	RES. ADJ. METAL GLAZE 47K
RV510	1-226-774-00	RES. ADJ. METAL GLAZE 47K
RV511	1-226-774-00	RES. ADJ. METAL GLAZE 47K
RV801	1-230-523-11	RES. ADJ. METAL GLAZE 10K
RV802	1-230-523-11	RES. ADJ. METAL GLAZE 10K
RV804	1-226-774-00	RES. ADJ. METAL GLAZE 47K
RV951	1-237-433-21	RES. ADJ. METAL GLAZE 470
RV952	1-237-433-21	RES. ADJ. METAL GLAZE 470
RV953	1-237-091-11	RES. ADJ. METAL GLAZE 100K
RV954	1-237-091-11	RES. ADJ. METAL GLAZE 100K
RV955	1-230-870-11	RES. ADJ. METAL GLAZE 10K
RV956	1-230-870-11	RES. ADJ. METAL GLAZE 10K
RY301	1-515-448-00	RELAY
RY302	1-515-448-00	RELAY
S001	1-570-975-11	SWITCH, SLIDE (OUT)
S002	1-570-972-11	SWITCH (IN)
S003	1-570-973-11	SWITCH (UP)
S004	1-570-975-11	SWITCH, SLIDE (DOWN (IN))
S701	1-570-974-11	SWITCH, SLIDE (SKIP OFF/ON)
S702	1-570-974-11	SWITCH, SLIDE (INPUT SELECT)
S751	1-554-937-11	SWITCH, KEY BOARD (REC)
S752	1-554-937-11	SWITCH, KEY BOARD (PLAY)
S753	1-554-937-11	SWITCH, KEY BOARD (CVE)
S754	1-554-937-11	SWITCH, KEY BOARD (REVIEW)
S755	1-554-937-11	SWITCH, KEY BOARD (OPNE/CLOSE)
S756	1-554-937-11	SWITCH, KEY BOARD (STOP)
S757	1-554-937-11	SWITCH, KEY BOARD (AMS)
S758	1-554-937-11	SWITCH, KEY BOARD (AMS)
S759	1-554-937-11	SWITCH, KEY BOARD (REC MUTE)
S760	1-554-937-11	SWITCH, KEY BOARD (PAUSE OFF)
S761	1-571-267-11	SWITCH, KEY BOARD (WITH LED)(AUTO)
S762	1-571-267-11	SWITCH, KEY BOARD (WITH LED)(RENUMBER)
S763	1-554-937-11	SWITCH, KEY BOARD (MODE)
S764	1-554-937-11	SWITCH, KEY BOARD (RESET)
S765	1-571-267-11	SWITCH, KEY BOARD (WITH LED)(MAN)
S766	1-571-267-11	SWITCH, KEY BOARD (WITH LED)(WRITE)
S767	1-554-937-11	SWITCH, KEY BOARD (MEMORY)
S768	1-571-267-11	SWITCH, KEY BOARD (WITH LED)(ERACE)
S769	1-571-267-11	SWITCH, KEY BOARD (WITH LED)(ERACE)
S770	1-554-937-11	SWITCH, KEY BOARD (1)
S771	1-554-937-11	SWITCH, KEY BOARD (4)

The components identified by shading and mark **△** are critical for safety. Replace only with part number specified.

ELECTRICAL PARTS

<u>Ref.No.</u>	<u>Part No.</u>	<u>Description</u>
S772	1-554-937-11	SWITCH, KEY BOARD (7)
S773	1-554-937-11	SWITCH, KEY BOARD (CLEAR)
S774	1-554-937-11	SWITCH, KEY BOARD (2)
S775	1-554-937-11	SWITCH, KEY BOARD (5)
S776	1-554-937-11	SWITCH, KEY BOARD (8)
S777	1-554-937-11	SWITCH, KEY BOARD (0)
S778	1-554-937-11	SWITCH, KEY BOARD (3)
S779	1-554-937-11	SWITCH, KEY BOARD (6)
S780	1-554-937-11	SWITCH, KEY BOARD (9)
S781	1-554-937-11	SWITCH, KEY BOARD (MUSIC SCAN START)
S782	1-553-206-00	SWITCH, SLIDE (TIMER)
S901	1-553-318-00	SWITCH, PUSH (POWER)
S902	1-570-771-11	SWITCH LIMIT
S903	1-570-883-11	SWITCH, PUSH (2 KEY) CASSETTE DETECT A
S904	1-570-883-21	SWITCH, PUSH (2 KEY) CASSETTE DETECT B
T901	1-449-017-11	TRANSFORMER, POWER
T902	1-464-763-11	COIL UNIT, DIGITAL I/O
TH501	1-800-202-XX	THERMISTOR S-10K
VC801	8-719-915-30	DIODE FC53M
X301	1-464-770-11	OSCILLATION UNIT, CRYSTAL (84.672MHz)
X501	1-567-170-00	OSCILLATOR, CERAMIC (4.19MHz)
X701	1-567-192-11	OSCILLATOR, CERAMIC (4MHz)
X702	1-527-532-00	OSCILLATOR, CERAMIC (400MHz)
X703	1-567-170-00	OSCILLATOR, CERAMIC (4.19MHz)
X801	1-567-816-11	VIBRATOR, CRYSTAL (18.816MHz)
X802	1-567-815-11	VIBRATOR, CRYSTAL (22.5792MHz)
X803	1-567-814-11	VIBRATOR, CRYSTAL (24.576MHz)

ACCESSORY & PACKING MATERIAL

<u>Part No.</u>	<u>Description</u>
1-463-828-11	REMOTE COMMANDER (RM-R1)
1-551-315-00	CORD, CONNECTION
2-394-123-01	COVER, BATTERY
3-701-613-00	BAG, POLYETHYLENE
3-701-630-00	BAG, POLYETHYLENE
3-703-450-01	INSTRUCTION
3-765-649-11	(AEP, UK)...MANUAL, INSTRUCTION
3-765-649-41	(AEP).....MANUAL, INSTRUCTION
4-919-071-01	CUSHION (RIGHT)
4-919-072-01	CUSHION (LEFT)
4-919-073-01	INDIVIDUAL CARTON

The components identified by shading and marking  are critical for safety. Replace only with part number specified.