

DTC-55ES/75ES/700

SERVICE MANUAL

US Model

DTC-75ES/700

Canadian Model

DTC-75ES

AEP Model

UK Model

DTC-55ES



Model Name Using Similar Mechanism	New Mechanism
Tape Transport Mechanism Type	DTAM-13

SPECIFICATIONS

<p>Tape Recording head Recording time</p> <p>Tape speed</p> <p>Drum rotation</p> <p>Error correction</p> <p>Tape Track pitch Sampling frequency Modulation system Transfer rate Number of channel D/A conversion</p> <p>Frequency response</p> <p>Signal to noise ratio</p>	<p>Digital audio tape Rotary head Standard: 120 minutes, Long-play mode: 240 minutes (with DT-120)</p> <p>Standard: 8.15 mm/s, Long-play mode: 4.075 mm/s</p> <p>Standard: 2,000 rpm, Long-play mode: 1,000 rpm</p> <p>Double Read Solomon code</p> <p>13.6 μm (20.4 μm) 48 kHz, 44.1 kHz, 32 kHz 8 - 10 Modulation 2.46 Mbit/sec. 2 channels, stereo Standard: 16-bit linear Long-play mode: 12-bit non-linear Standard: 2 - 22,000 Hz (± 0.5 dB) Long-play mode: 2 - 14,500 Hz (± 0.5 dB)</p> <p>DTC-55ES/700 : Standard : more than 92dB Long-play mode : more than 92dB DTC-75ES : Standard : more than 93dB Long-play mode : more than 92dB</p>	<p>Dynamic range</p> <p>Total harmonic distortion</p> <p>Wow and flutter</p> <p>Input</p>	<p>DTC-55ES/700 Standard : more than 92dB Long-play mode : more than 92dB DTC-75ES : Standard : more than 93dB Long-play mode : more than 92dB DTC-55ES : Standard : less than 0.005% (1kHz) Long-play mode : less than 0.08% (1kHz) DTC-75ES : Standard : less than 0.004% (1kHz) Long-play mode : less than 0.08% (1kHz) DTC-700 : Standard : less than 0.0045% (1kHz) Long-play mode : less than 0.08% (1kHz) Below measurable limit ($\pm 0.001\%$ W.PEAK)</p> <table border="1" style="margin-left: auto; margin-right: auto;"> <thead> <tr> <th></th> <th>Jack type</th> <th>Impedance</th> <th>Rated input level</th> </tr> </thead> <tbody> <tr> <td>LINE IN</td> <td>phono jack</td> <td>47 kohms</td> <td>-4 dBs</td> </tr> <tr> <td>DIGITAL IN</td> <td>phono jack</td> <td>75 ohms</td> <td>0.5 Vp-p, 20%</td> </tr> <tr> <td>DIGITAL IN</td> <td>optical jack</td> <td>—</td> <td>—</td> </tr> </tbody> </table>		Jack type	Impedance	Rated input level	LINE IN	phono jack	47 kohms	-4 dBs	DIGITAL IN	phono jack	75 ohms	0.5 Vp-p, 20%	DIGITAL IN	optical jack	—	—
	Jack type	Impedance	Rated input level																
LINE IN	phono jack	47 kohms	-4 dBs																
DIGITAL IN	phono jack	75 ohms	0.5 Vp-p, 20%																
DIGITAL IN	optical jack	—	—																

- Continued on next page -

DIGITAL AUDIO TAPE DECK
SONY[®]



Output

	Jack type	Impedance	Rated output	Load impedance
LINE OUT	phono jack	470 ohms	-4 dBs	More than 10 kohms
PHONES	stereo phono jack	220 ohms	0.6 mW	32 ohms
DIGITAL OUT	phono jack (DTC-75ES/700)	75 ohms	0.5 Vp-p ±20%	—

DIGITAL OUT (optical jack): wavelength 660 nm

General

Power requirements US, Canadian model: 120V AC, 60Hz
AEP model: 220V AC, 50/60Hz
UK model: 240V AC, 50/60Hz

Power consumption 32 W

Dimensions DTC-55ES/75ES :
Approx. 470 × 115 × 330 mm (w/h/d)
(18³/₈ × 4³/₈ × 12⁷/₈ inches) incl.
projecting parts and controls
DTC-700 :
Approx. 430 × 115 × 330 mm (w/h/d)
(17 × 4³/₈ × 12⁷/₈ inches) incl.
projecting parts and controls
Weight DTC-55ES/75ES :
Approx. 8.3 kg (18 lb 5 oz)
DTC-700 :
Approx. 7.5 kg (16 lb 8 oz)

Remote comander (supplied, RM-D55)

Remote control system Infrared control
Power requirements 3 V DC, with two size AA (R6) batteries
Dimensions Approx. 63 × 19 × 175 mm (w/h/d)
(2¹/₂ × 3/4 × 6⁷/₈ inches)
Weight Approx. 130 g (4 oz) incl. batteries

Supplied accessories

Sony batteries SUM-3(NS) (2)
Audio connecting cords (2 phono plugs - 2 phono plugs, stereo for line inputs and outputs) (2)
Screws (4) (DTC-55ES/75ES)
Digital audio tape DT-60 (1)

SAFETY-RELATED COMPONENT WARNING!!



COMPONENTS IDENTIFIED BY MARK  OR DOTTED LINE WITH MARK  ON THE SCHEMATIC DIAGRAMS AND IN THE PARTS LIST ARE CRITICAL TO SAFE OPERATION. REPLACE THESE COMPONENTS WITH SONY PARTS WHOSE PART NUMBERS APPEAR AS SHOWN IN THIS MANUAL OR IN SUPPLEMENTS PUBLISHED BY SONY.

TABLE OF CONTENTS

<u>Section</u>	<u>Title</u>	<u>Page</u>
	Specifications	1
	Model Identification	3
	Safety Check-out	3
1. GENERAL		
	Location and Function of Controls	4
	Connections	7
2. DISASSEMBLY		9
3. ADJUSTMENT		12
	3-1. Mechanism Adjustment	14
	3-2. Electrical Adjustment	16
4. DIAGRAMS		
	4-1. Pin Functions	18
	4-2. Block Diagram	23
	4-3. Waveforms	27
	4-4. Semiconductor Lead Layout	29
	4-5. Circuit Boards Location	30
	4-6. Printed Wiring Boards	
	- Power Supply/Display Section -	31
	4-7. Schematic Diagram	
	- Power Supply/Display Section -	33
	4-8. Printed Wiring Boards	
	- Main Section -	36
	4-9. Schematic Diagram	
	- Main Section -	41
	4-10. IC Block Diagram	46
5. EXPLODED VIEWS		49
6. ELECTRICAL PARTS LIST		58

ATTENTION AU COMPOSANT AYANT RAPPORT À LA SÉCURITÉ!

LES COMPOSANTS IDENTIFIÉS PAR UNE MARQUE  SUR LES DIAGRAMMES SCHÉMATIQUES ET LA LISTE DES PIÈCES SONT CRITIQUES POUR LA SÉCURITÉ DE FONCTIONNEMENT. NE REMPLACER CES COMPOSANTS QUE PAR DES PIÈCES SONY DONT LES NUMÉROS SONT DONNÉS DANS CE MANUEL OU DANS LES SUPPLÉMENTS PUBLIÉS PAR SONY.

MODEL IDENTIFICATION

- Specification Label -

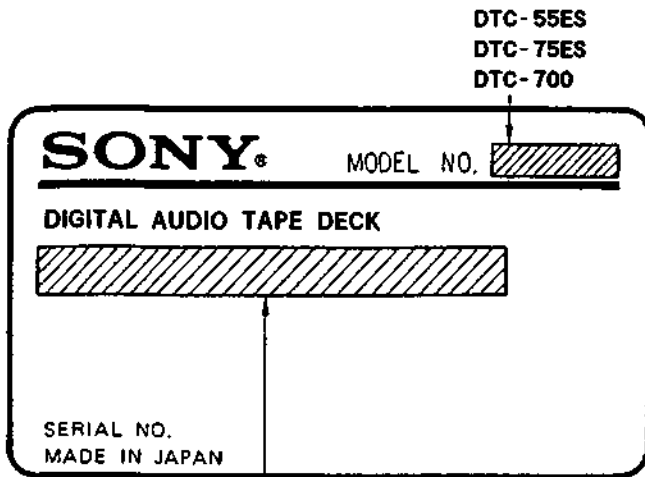

US, Canadian model : AC 120V 60Hz 32W
 AEP model : AC 220V~50/60Hz 32W
 UK model : AC 240V~50/60Hz 32W

SAFETY CHECK-OUT

After correcting the original service problem, perform the following safety check before releasing the set to the customer:

Check the antenna terminals, metal trim, "metallized" knobs, screws, and all other exposed metal parts for AC leakage. Check leakage as described below.

LEAKAGE TEST

The AC leakage from any exposed metal part to earth ground and from all exposed metal parts to any exposed metal part having a return to chassis, must not exceed 0.5 mA (500 microamperes). Leakage current can be measured by any one of three methods.

1. A commercial leakage tester, such as the Simpson 229 or RCA WT-540A. Follow the manufacturers' instructions to use these instruments.
2. A battery-operated AC milliammeter. The Data Precision 245 digital multimeter is suitable for this job.
3. Measuring the voltage drop across a resistor by means of a VOM or battery-operated AC voltmeter. The "limit" indication is 0.75 V, so analog meters must have an accurate low-voltage scale. The Simpson 250 and Sanwa SH-63Trd are examples of a passive VOM that is suitable. Nearly all battery operated digital multimeters that have a 2V AC range are suitable. (See Fig. A)

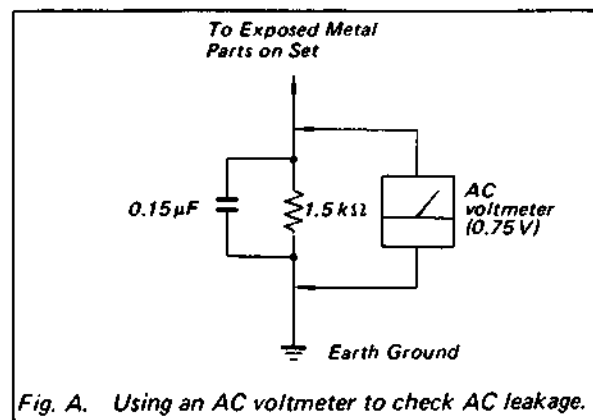
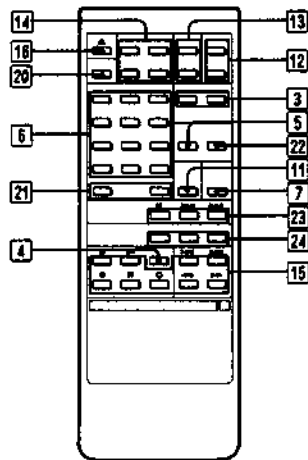
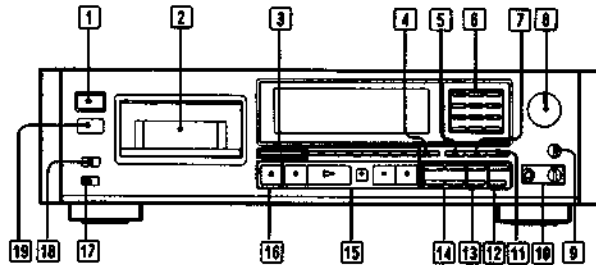

Fig. A. Using an AC voltmeter to check AC leakage.

Location and Function of Controls



Front Panel Remote Commander

- 1 **POWER switch**
Turns the power on and off.
- 2 **Cassette compartment**
Insert a cassette with the window side up and the safety tab facing you.
- 3 **COUNTER buttons**
MODE: Selects the counter indication in the display window among the linear counter (tape running time), absolute time, elapsed time of the selection, and total remaining time of the tape. Each time you press the button, the indication changes sequentially.
RESET: Resets the linear counter to "00:00".
- 4 **FADER button**
Press to fade in or fade out during recording or playback.
- 5 **REPEAT button**
Press to play a desired portion repeatedly. Each time you press the button, the indication changes as follows:
REPEAT 1 → REPEAT ALL → Nothing
- 6 **Music select buttons**
Numeric buttons (0 - 9): Designate the desired program number to be played back before starting playback.
CLEAR: Use to cancel the program number which has been mistakenly entered.
MUSIC SCAN: Use this feature to listen to the beginning of each selection successively.
- 7 **SKIP PLAY button**
Press to activate the skip ID code function. The portion of the tape previously marked will be skipped.
- 8 **REC LEVEL (recording level) controls**
Adjust the recording level for the analog input signals. The outer knob controls the L (left) channel level and the inner knob the R (right) channel level. The knobs can be adjusted together.
When recording digital signals, it is not necessary to adjust the recording level.
- 9 **INPUT selector**
Set according to the signal to be recorded.
ANALOG: For recording from the equipment connected to the LINE IN jacks.
OPTICAL: For recording from the equipment connected to the DIGITAL IN (OPTICAL) jack.
COAXIAL: For recording from the equipment connected to the DIGITAL IN (COAXIAL) jack.
- 10 **PHONES (Headphones) jack and LEVEL controls**
The LEVEL controls adjust the headphones volume level.
- 11 **MARGIN RESET button**
Press to reset the margin of peak level.
- 12 **END ID buttons**
WRITE: Press to write the ID signifying the end of playback or recording.
ERASE: Press to erase the end ID.
- 13 **SKIP ID buttons**
WRITE: Press at the beginning of the portion you may wish to skip later. A skip ID will be written from the point where you pressed this button.
ERASE: Press to erase the nearest skip ID which is before the current position.
- 14 **START ID buttons**
AUTO: Press to turn on and off the AUTO indicator. When the AUTO indicator is lit, the start ID will automatically be written during recording. When the AUTO indicator is not lit, press START ID WRITE at the point where you want to write a start ID.
WRITE: Press to write the start ID at the desired point during recording or playback.
ERASE: Press to erase a start ID. When a start ID and a program number are written on the tape, both codes are simultaneously erased by pressing this button.
RENUMBER: Press to renumber all programs on the tape. When only the start IDs are written, pressing this button will insert the proper program numbers beginning with "1". The tape will rewind and start from the beginning to accomplish this function.
- 15 **Tape operating buttons**
■ (stop): Press to stop recording or playback.
▷ (play): Press to play back the tape.
REC (recording): Press to start recording. After pressing this button, press **■** or **▷**.
■ PAUSE (pause): Press to stop for a moment during recording or playback. To restart recording or playback, press this button again or press **▷**.
If the unit is left in the pause mode for about 10 minutes, it will be automatically released and the deck will enter the stop mode. To restart recording or playback from the stop mode, press REC or ▷ respectively.
REC MUTE (record muting): Inserts a sound-muted portion (space).
◀◀, ▶▶ (AMS): Press to locate the beginning of the selection during the playback.
◀, ▶ (rewind/review, fast-forward/cue): In the stop mode, press to rewind/fast-forward the tape. During playback, press to rewind or fast-forward the tape while listening to the sound.

SECTION 1
GENERAL

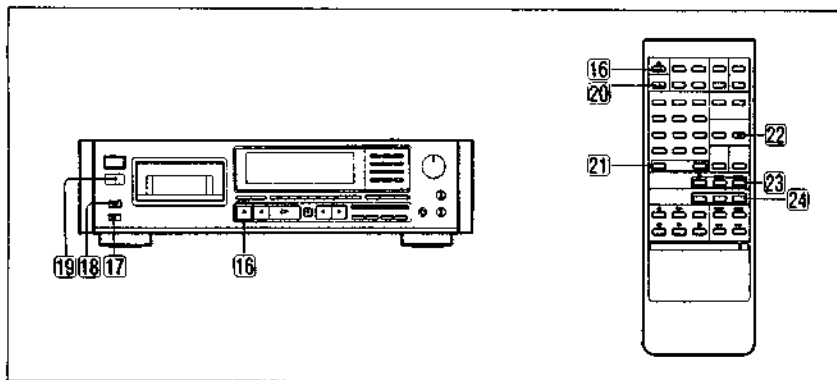

- 16** **OPEN/CLOSE** (load/eject): Press when inserting or removing the cassette.
- 17** **REC MODE selector**: Normally set to STANDARD. When this selector is set to LONG, you can record analog input signals and digital input signals with 32 kHz in the long-play mode.
- 18** **TIMER switch**: Normally set to OFF. Use to start recording or playback at the desired time using a commercially available audio timer.
- 19** **Remote sensor**: Receives the signal from the Remote Commander.

Remote Commander

- 20** **DISPLAY MODE button**: Press to turn on and off the indicators in the display.
- 21** **RMS play buttons**
ENTER: To program the selections in a desired order, press this button after pressing the numeric buttons.
CHECK: Press to check the programmed contents.

- 22** **REPEAT A->B button**: Press to play back a desired portion repeatedly.
- 23** **CD operation buttons**
 Operative only for the Sony CD player equipped with a Remote Commander.
|| (pause): Sets the CD player in the pause mode during playback. Press again to release pause. If pressed twice when the player is in the stop mode, playback starts.
⏮ (AMS): Press to locate the desired selection on the Compact Disc during playback or in the stop mode.
- 24** **CD SYNCHRO (CD synchronized recording) buttons**
STANDBY: Press to set the unit in the record-standby mode.
START: Press to start recording of the DAT deck and then playback of the CD player.
STOP: Press to stop the DAT deck recording and the CD player playback.

Remote Commander Operation

Each button on the Remote Commander functions in the same way as those having the same name on the front panel. However, the following operations cannot be performed using the Remote Commander. Use the front panel controls instead.

- Turning the power on and off
- Selecting digital (optical/coaxial)/analog input source
- Adjusting the recording level and headphones level
- Setting the timer recording/playback
- Selecting the recording mode (standard or long)

The following operations can be performed only with the Remote Commander.

- Activating CD synchronized recording using a Sony CD player and controlling the CD player
 - Locating the desired selection on the Compact Disc or setting the CD player in the pause mode (possible only when a Sony CD player is used.)
 - Repeat play (A-B)
 - RMS* play
- *RMS: Random Music Sensor

Installing Batteries

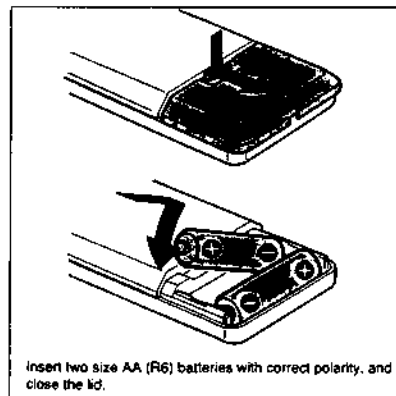

Insert two size AA (R6) batteries with correct polarity, and close the lid.

Notes on remote control

- Do not expose the remote sensor on the deck to strong light such as direct sunlight, lighting apparatus, etc.
- Do not place any obstructions between the Remote Commander and the remote sensor, or else operations will not be performed correctly.
- The controllable range is limited. Point the Remote Commander directly at the remote sensor on the deck.
- When remote control operation distance becomes shorter, the batteries are weak. Replace both batteries with new ones.

To avoid battery leakage

When the commander will not be used for a long period of time, remove the batteries to avoid damage caused by battery leakage and corrosion.

Battery life

About half a year of normal operation can be expected when using the Sony SUR-3 (NS) batteries.

Display Window

To turn off the display window

When the power is turned on, the display window also is turned on. During recording or playback, the display window can be turned off as follows:

- When operating with the front panel controls
- While pressing COUNTER MODE, press 0.
- When operating with the Remote Commander
- Press DISPLAY MODE.

Each time you press the above buttons, the indicators changes as follows:

Normal indicators

Peak level meters and margin indicators go off. (DISPLAY OFF indicator lights)

All the indicators go off during recording or playback.* (DISPLAY OFF AUTO indicator lights momentarily just before the indicators go off.)

* When pressing COUNTER MODE or DISPLAY MODE, except during recording or playback, DISPLAY OFF AUTO lights. In this case, all the indicators go off immediately after recording or playback starts.

To change the brightness of the display window

While pressing COUNTER MODE, press one of the numeric buttons 1, 2 and 3. The greater number pressed, the darker the display window becomes.

(When operating with the Remote Commander, also press COUNTER MODE.)

25 TOC (Table of contents) indicator

When a pre-recorded DAT cassette is played back, this indicator will light.

26 REMAINING (remaining time) indicator

Lights when the counter shows the remaining time of the tape.

PGM TIME (program time) indicator

Lights when the counter shows the elapsed time of the current selection.

ABS TIME (absolute time) indicator

Lights when the counter shows the tape running time from the beginning.

During normal tape counter mode, the above three indicators all go off.

27 Fade-in/out indicators

FADE IN: Blinks when recording or playback fades in.
FADE OUT: Blinks when recording or playback fades out.

28 Indicators of the INPUT selector

The OPTICAL or COAXIAL indicator lights according to the position of the INPUT selector. No indicator lights when the INPUT selector is set to ANALOG.

29 REPEAT indicators

REPEAT 1: Lights when a desired selection is played back repeatedly.
REPEAT ALL: Lights when all the selections are played back repeatedly.
REPEAT A-B: Lights when a desired portion is played back repeatedly.

30 DISPLAY mode Indicators

DISPLAY OFF indicator lights when peak level meters and margin indicators are turned off. DISPLAY OFF AUTO lights momentarily before all the indicators are turned off.

31 MUSIC SCAN indicator

Lights after pressing the MUSIC SCAN button to listen to the beginning of each selection successively.

32 SKIP PLAY indicator

When this indicator is lit during playback, the portion marked by the skip ID is skipped and playback continues from the next start ID.

33 CAUTION indicator

Lights when moisture condensation occurs. If this happens, the deck stops functioning automatically.

34 START ID mode Indicators

AUTO: Lights when the AUTO button is pressed to write the start ID automatically.
RENUMBER: Lights when the RENUMBER button is pressed to renumber the program numbers.
WRITE: Lights when writing the start ID manually.
ERASE: Lights when erasing the start ID.

35 START ID Indicator

Blinks when writing (for 9 or 18 seconds) or erasing a start ID code, and lights when the start ID is detected during playback.

36 SKIP ID indicator

Lights when writing or erasing a skip ID code or when the skip ID is detected during playback.

37 SKIP ID mode indicators

WRITE: Lights when writing the skip ID.
ERASE: Lights when erasing the skip ID.

38 END ID mode indicators

WRITE: Lights when writing the end ID.
ERASE: Lights when erasing the end ID.

39 MARGN indicators

Show how much margin there is between the peak level of input audio signal and 0 dB.

40 REHEARSAL indicator

Lights while the rehearsal function is activated.

41 Frequencies map

When pressing 4 while keeping COUNTER MODE pressed, bars indicating the sampling frequencies with which the tape was recorded appear on the peak level meters.

42 AMS (automatic music sensor)

Shows the number of selections to be skipped ahead or behind in the AMS operation. When designating a selection directly by the numeric buttons and the > button, the display shows the program number of the target selection while the selection is being searched for. When programming the desired selections in the RMS operation, the display shows the program number of the selection to be programmed.

43 PGM NO./STEP indicators

Show the program number of the selection being played. When programming the desired selections in the RMS operation, the display shows the step number of the programmed selection.

44 Sampling frequency Indicators

48 kHz: For recording/playback of analog input signals (standard mode)
 44.1 kHz: For recording/playback of CD and a pre-recorded DAT cassette
 32 kHz: For recording/playback of analog input signals (long-play mode)

45 Counter

Displays the linear counter, absolute time, elapsed time of the selection being played, and the total remaining time of the tape. Each time COUNTER MODE is pressed, the display mode changes in turn.

46 Peak level meters

Indicate the level of the audio signal being recorded during recording, and the peak values of the audio signal recorded on the tape during playback.

47 Tape operation indicators

REC: Lights during recording or in the record-pause mode.
▶: Lights during recording or playback. It also lights in the record-pause mode or in the play-pause mode.
■: Lights in the record-pause mode or in the play-pause mode.

48 LONG mode Indicator

Lights when recording or playback is being performed in the long play mode.

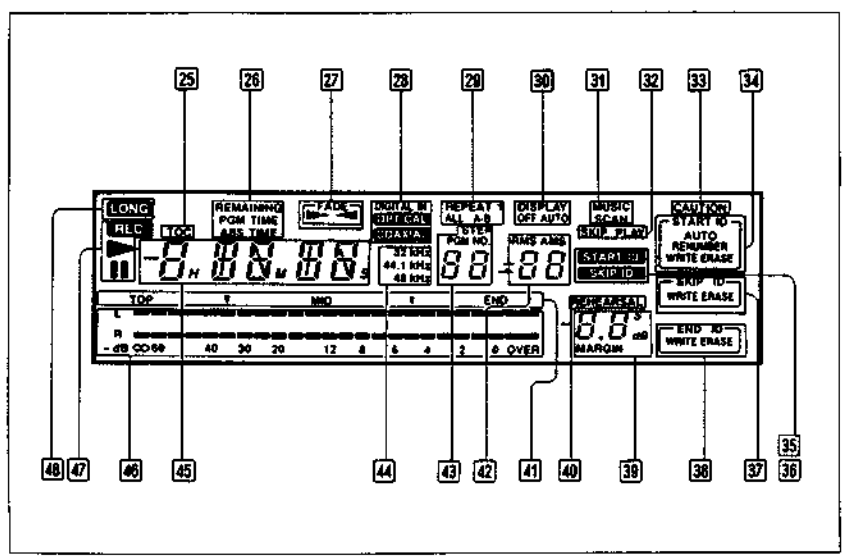

Connections

Rear Panel Jacks

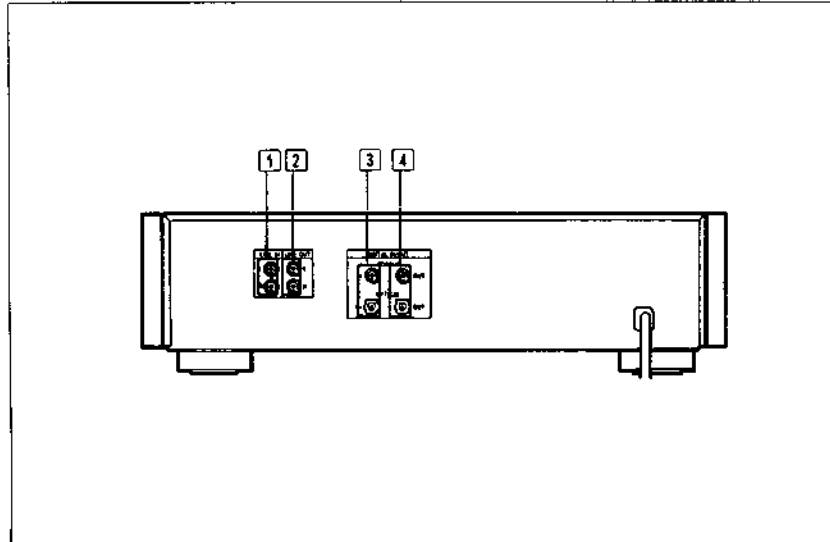

- 1 **LINE IN (line input) jacks (phono jack)**
Connect to the recording outputs of a preamplifier/receiver. Signals supplied by the preamplifier/receiver can be recorded using the sampling frequency of 48 kHz or 32 kHz.
- 2 **LINE OUT (line output) jacks (phono jack)**
Connect to the DAT or tape inputs of a preamplifier/receiver. The playback signal of this deck will be output.

- 3 **COAXIAL/OPTICAL DIGITAL IN (digital input) jacks (phono jack/optical jack)**
Connect to the digital outputs of a preamplifier/receiver having a built-in D/A converter or other digital source, such as a CD player for digital-to-digital recording.
- 4 **COAXIAL (DTC-75ES/700 ONLY) / OPTICAL DIGITAL OUT (digital output) jacks (phono jack/optical jack)**
Connect to the digital inputs of a preamplifier/receiver having a built-in D/A converter or another DAT deck, for playback of a DAT cassette or digital-to-digital recording.

Connecting Cord

There are the following three types of connecting jacks at the rear of the deck. Each type of jack requires a different type of connecting cord.

Jack	Required cord
LINE IN/OUT (analog input/output) jacks	<p>Audio signal connecting cord (supplied, or optional RK-C77 etc.)</p>
COAXIAL IN/OUT (digital input/output) jacks	<p>Coaxial digital connecting cord (optional VMC-1ES etc.)</p>
OPTICAL IN/OUT (optical transmission digital input/output) jacks	<p>Optical cable (optional POC-15 etc.)</p> <p>Remove the cap. Plug in firmly.</p>

Before connection

- Use the connecting cords specified in the illustrations.
- Turn off the power for all equipment before making connections.
- Be sure to insert the plugs firmly into the jacks. Loose connections may cause hum and noise. When unplugging, grasp the plug and not the cord.

Notes on the optical cable

- Do not bend the cord. When the cord is not used, cut it with a diameter of more than 15 cm (5 7/8 inches).
- Do not use it under high temperatures.
- When the optical cable is not connected, cover the OPTICAL IN/OUT jacks with the supplied caps.

Note on sound signals

When connecting a digital connecting cord or an optical cable to the DIGITAL IN/DIGITAL OUT jacks, sound signals (LR) are transmitted together through the cord or the cable.

SECTION 2 DISASSEMBLY

Note: Follow the disassembly procedure numerical order given.

CASE

Unscrew the four case attachment screws and remove the case.

MECHANISM BLOCK

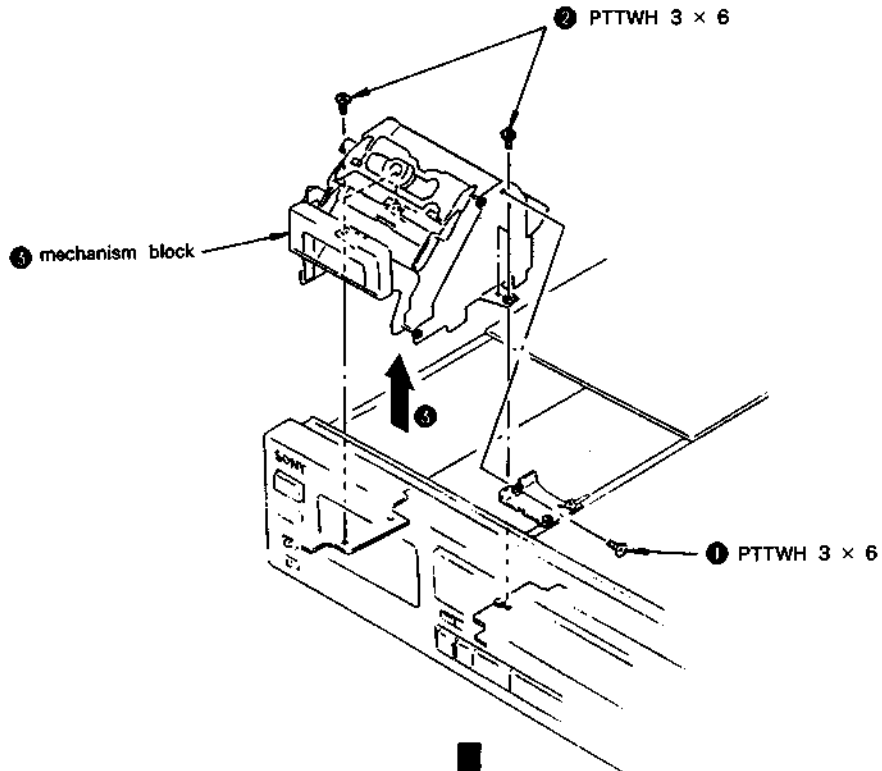

HOLDER

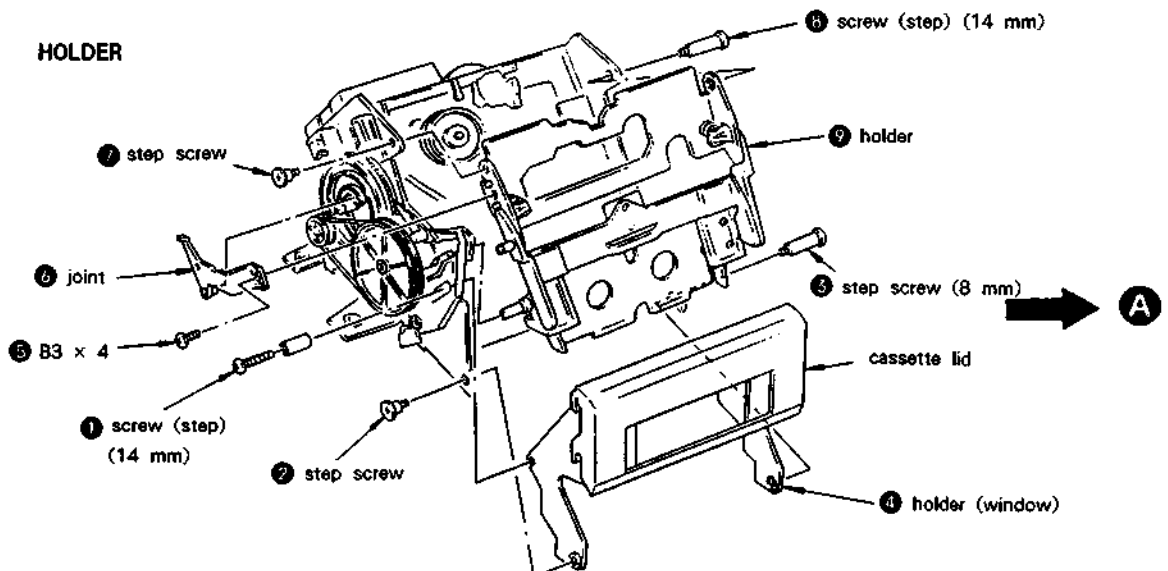

CASSETTE COMPARTMENT MOTOR (M901), PULLEY, GEAR (CAM), SLIDER (CAM)

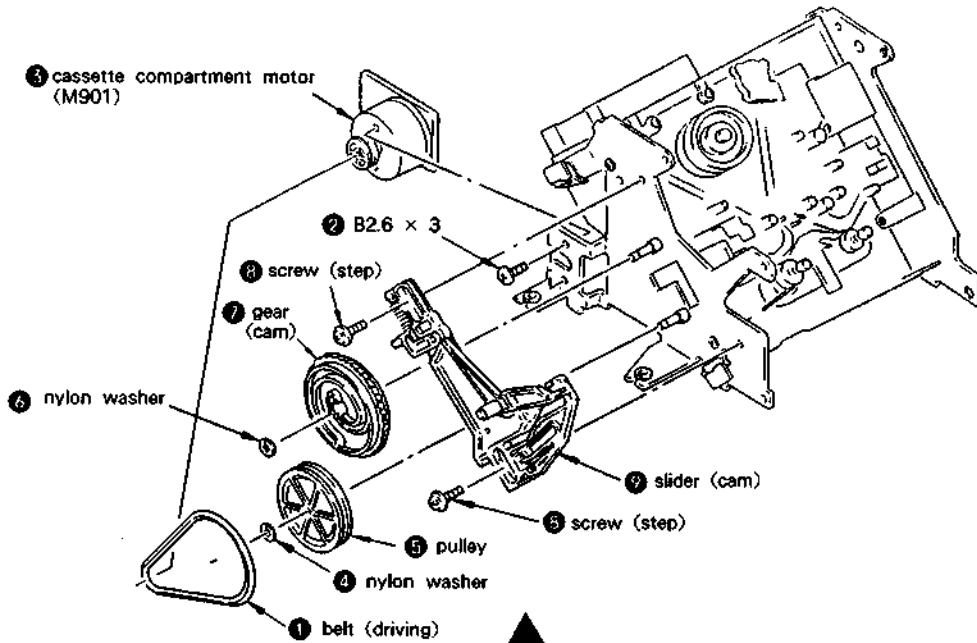

A

DRUM

- 1 Unsolder the drum lead wires and remove the flexible board on rear side of the drum from the connector.

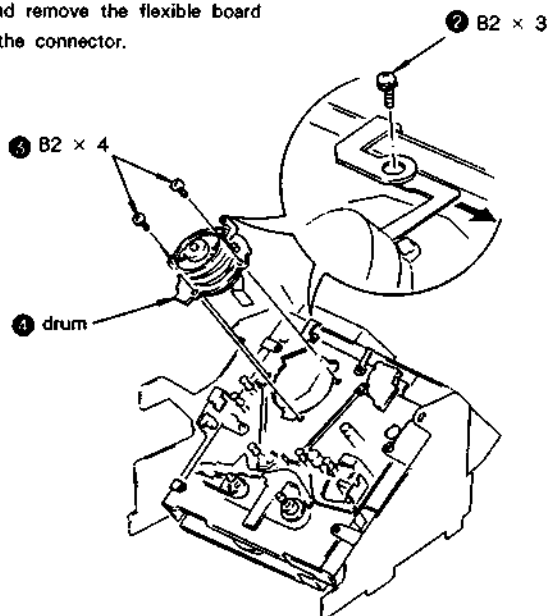

DRUM DRIVE BOARD, DRIVING CHASSIS, CONTROL MOTOR (M903)

① Remove the connector on the drum drive board.

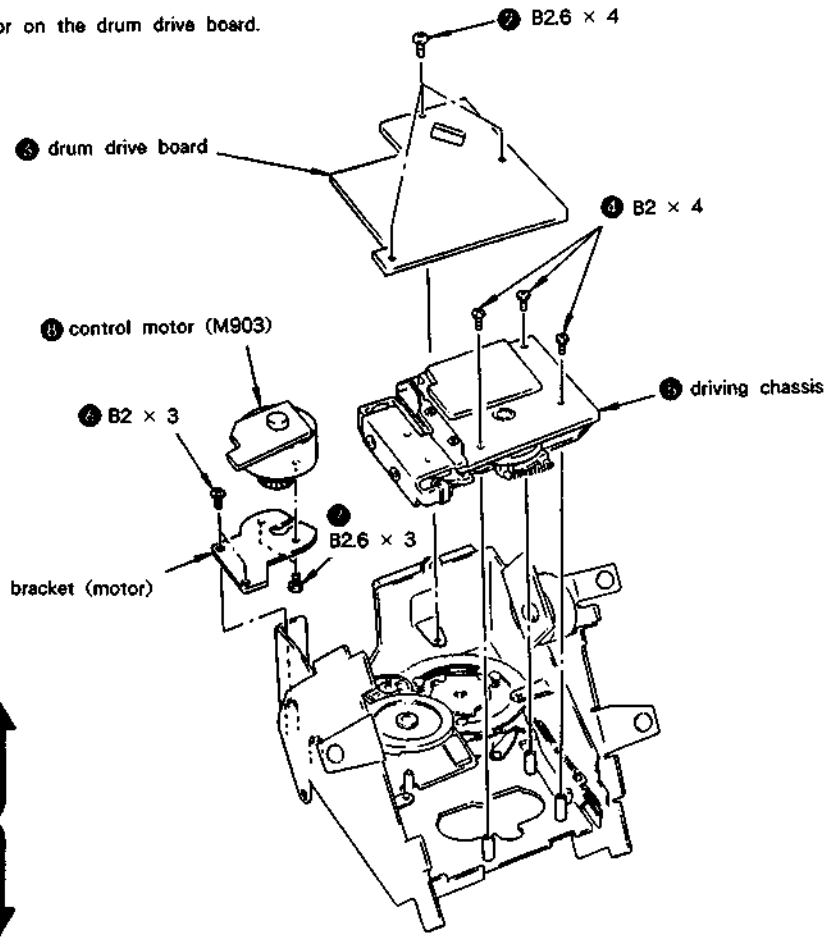

CAPSTAN MOTOR (M902)

① precision screw
M 1.7 × 4

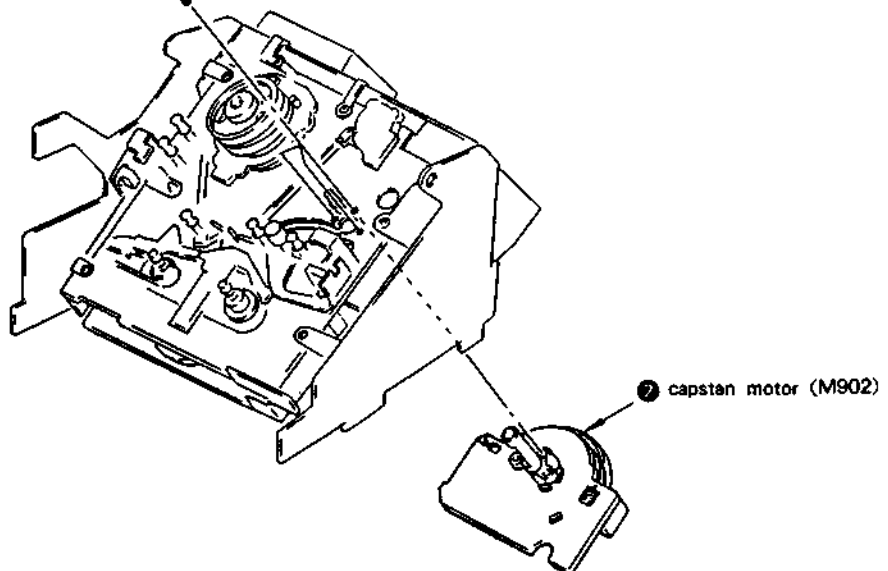

SECTION 3 ADJUSTMENTS

Notes When Making Adjustments

1. Adjustments should be performed in the order listed.
2. Use the following test tapes :

TY-7111 (8-909-812-00)	Level
TY-7252 (8-909-822-00)	Tracking
TY-7551 (8-909-814-00)	Functions
TY-30B (8-892-358-00)	Blank

Use the following torque meter :

TW-7131 (8-909-708-71) FWD

3. Switches and controls should be set as follows unless otherwise specified.

TIMER switch :	OFF
REC MODE switch :	LONG
INPUT switch :	COAXIAL
REC LEVEL control :	Min.
PHONES LEVEL control :	Min.

4. Creating an end sensor cassette

- (1) Press the tape slider lock and move the slider in the direction indicated by the arrow.

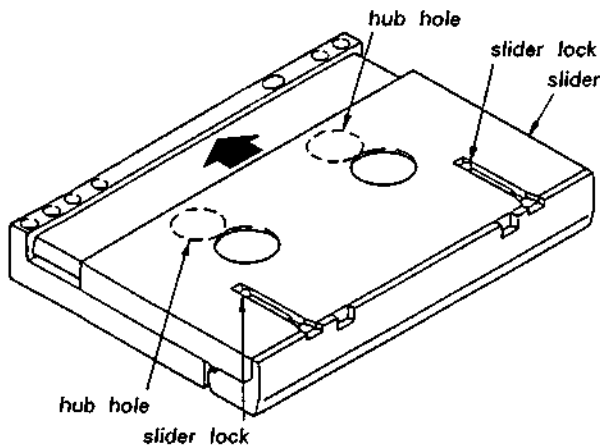

- (2) Open the lid and cut the tape.

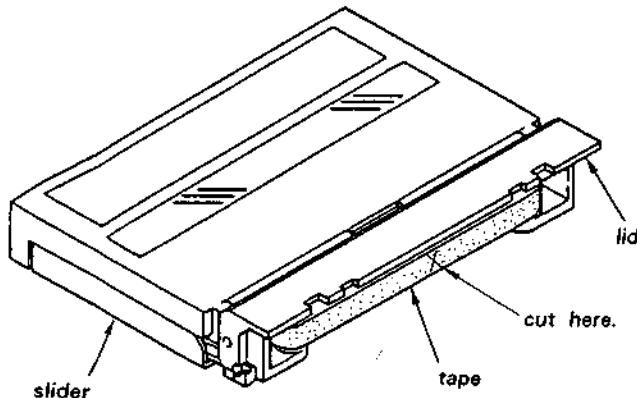

- (3) Turn the hubs until the tape is completely inside the cassette (both T and S sides).
The end sensor cassette for end sensor adjustment is now ready for use.

5. Be careful not to move RV951 and RV952 on the RF AMP board in the mechanism assembly.

6. To adjust the tape path and guides, remove the holder assembly as shown in the diagram and use the DAT holder jig (J-2000-002-A). This will make it easier to perform adjustments.

- First turning the pulley counterclockwise to put it in loading out status will make removal and reattachment of the holder assembly easier.
- To perform adjustments, turn the pulley clockwise to put it in loading in status, load the cassette tape and set the IN switch to the ON position.

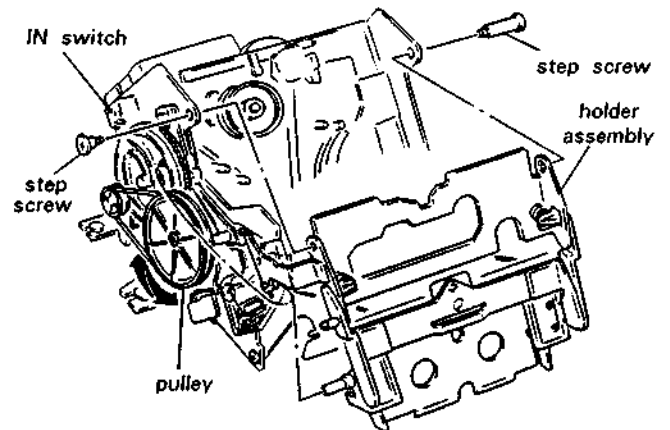

7. Test mode

To switch to the test mode, connect TP XTEST and GND on the main board and turn power on. In the test mode, when a $\times 1.5$ speed tape (prerecorded tape or test tape) is used and the AMS $\blacktriangleright\blacktriangleright$ key is pressed, the sampling frequency (FS) indication switches to 30 kHz and the set switches to FWD status. Pressing the AMS $\blacktriangleleft\blacktriangleleft$ key causes the set to switch to REV status. With a $\times 1$ tape, pressing the AMS $\blacktriangleright\blacktriangleright$ key initiates FWD $\times 16$ speed and pressing the AMS $\blacktriangleleft\blacktriangleleft$ key initiates REV $\times 16$ speed.

To cancel the test mode, turn power off and remove the connection between TP XTEST and GND. Be sure to cancel the test mode after adjustments are completed.

8. After adjustments are completed, check the following items to confirm tape speed accuracy :

- (1) Set the REC MODE switch to STANDARD and confirm that recording and playback operate correctly ($\times 1$ speed).
- (2) Set the REC MODE switch to LONG and confirm that recording and playback operate correctly ($\times 0.5$ speed).
- (3) Confirm that a chirping sound is heard during cue ($\blacktriangleright + \blacktriangleright\blacktriangleright$) and review ($\blacktriangleright + \blacktriangleleft\blacktriangleleft$) ($\times 2.5$ speed).
- (4) Confirm that the time display is appropriate after FF ($\blacktriangleright\blacktriangleright$) and REW ($\blacktriangleleft\blacktriangleleft$) ($\times 16$ speed).
- (5) Confirm that the search ($\blacktriangleright\blacktriangleright$ and $\blacktriangleleft\blacktriangleleft$) function operates properly.

Adjustment Parts Location

- Mechanism assembly -

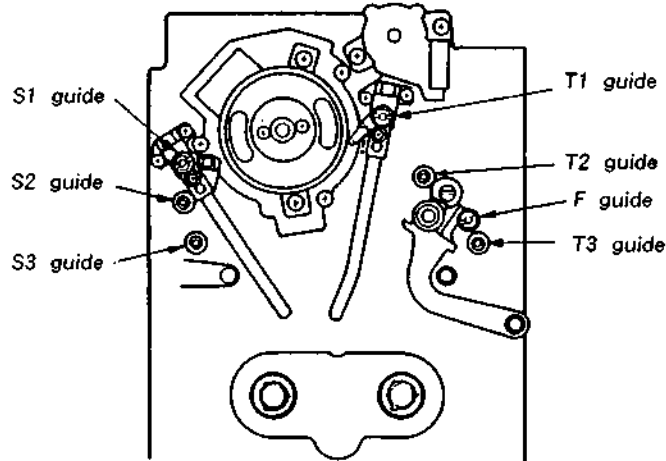

- Main board -

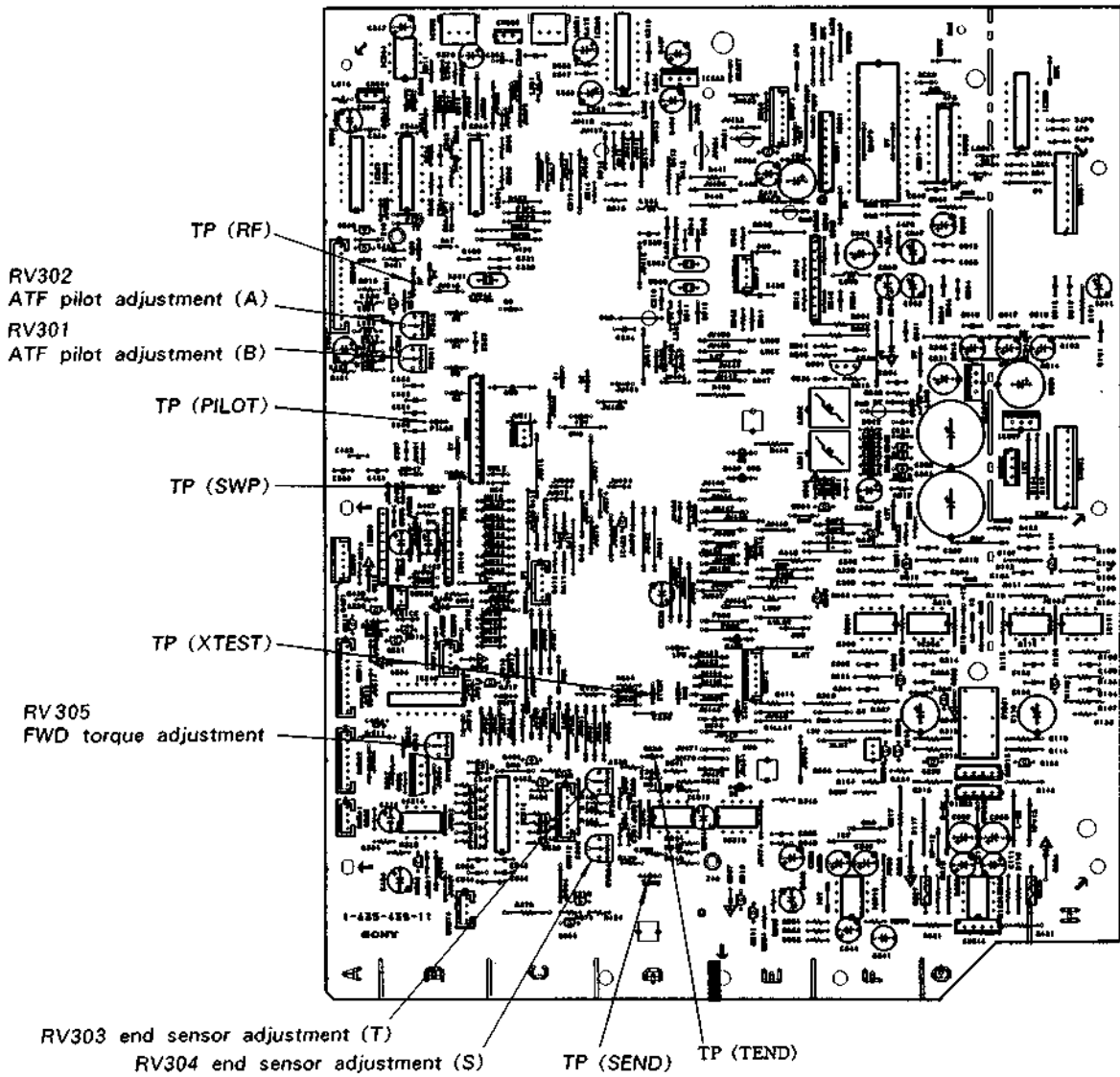

3-1. MECHANICAL ADJUSTMENTS

After replacing the drum or related parts, adjust the T2 and F guides and then perform the tape path ($\times 1.5$ FWD mode) fine adjustment of electrical adjustments.

T2 Guide/F Guide Adjustment

Adjustment Procedure :

1. Put the set into the test mode and load test tape TY-7252 (8-909-822-00).
2. Set the REC MODE switch to STANDARD (ATF : OFF) and press the AMS \blacktriangleright key.
3. Check for curling at the T3 guide. Adjust as described below.
 - 3-1. If there is curling near the top of the T3 guide, adjust the F guide to remove it.
 - 3-2. If there is no curling at the T3 guide no adjustments are necessary.
 - 3-3. If there is curling near the bottom of the T3 guide, adjust the T2 guide to remove it.

* Curling :

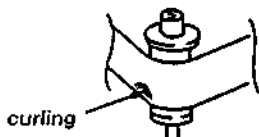

"Curling" refers to distortion on the tape during FWD operation. It can be identified by directing a light at the tape.

Rotary Encoder Adjustment

Adjustment Procedure :

1. Remove the rotary encoder.

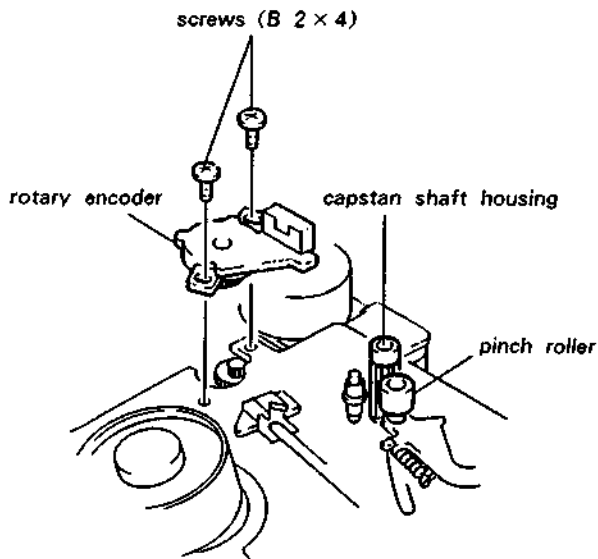

2. As shown in Figure A, turn the gear at the back of the chassis clockwise. Stop it at the point where the capstan shaft housing and pinch roller make contact as shown in Figure B.

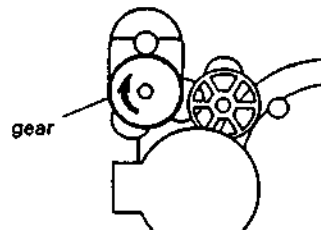

Figure A. Rear of Chassis

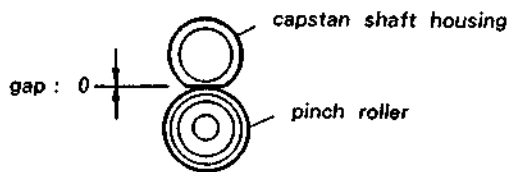

Figure B. Top View

3. In this position, align the line on the gear in the rotary encoder with the Δ mark and temporarily fasten it in place.

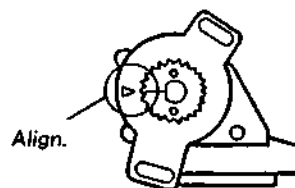
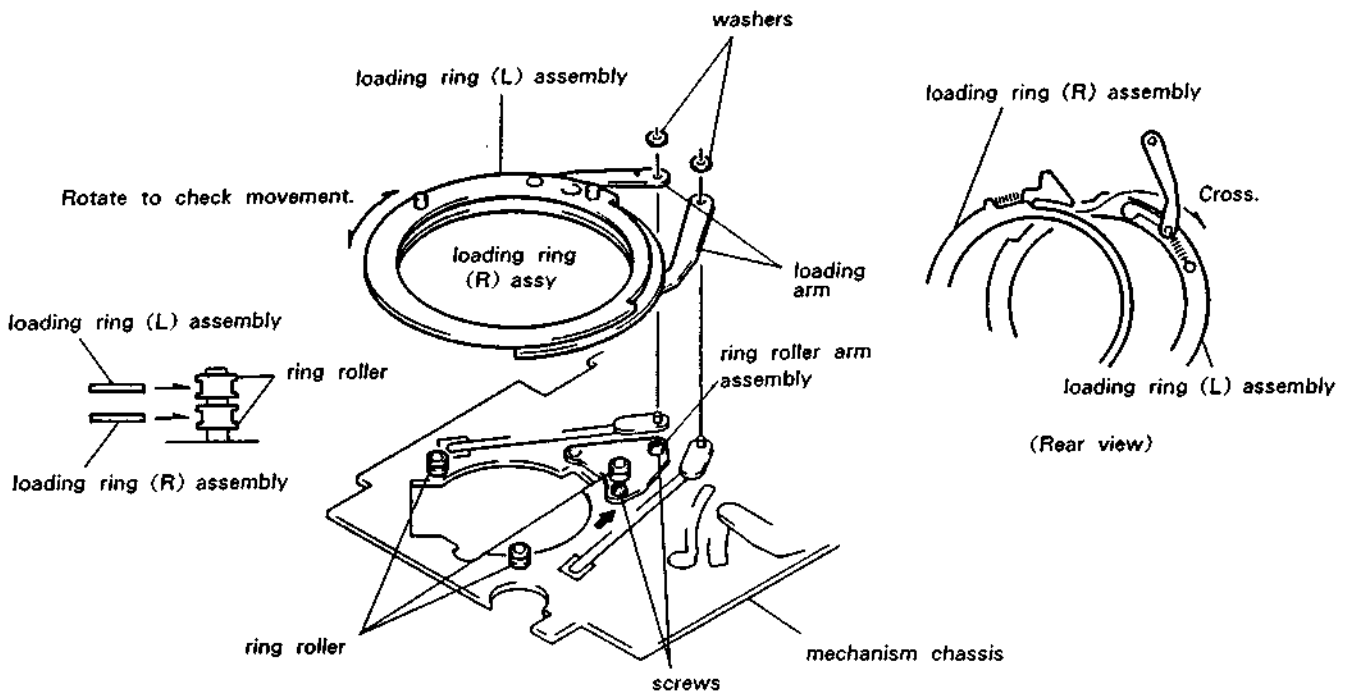

Figure C. Rear of Rotary Encoder

4. Put the set into the test mode.
5. Alternate between PLAY (\blacktriangleright) and STOP (\blacksquare) a few times. Confirm that during PLAY (\blacktriangleright) the pinch roller makes contact with the capstan shaft and that during STOP (\blacksquare) status they are as shown in Figure B above. Then tighten the screw securely.
6. If the above conditions are not satisfied, readjust starting from step 1. above.

Loading Ring Attachment

1. Join the loading ring (R) and loading ring (L) assemblies by crossing the portion indicated in the diagram.
2. Insert the A ring rollers (2 places).
3. Mount the B ring rollers so that they match up with the loading rings by pressing on the ring roller assembly in the direction indicated by the arrow and tightening the two screws.
4. Slowly turn the loading rings and confirm that they rotate freely and do not rattle.
5. Insert the loading arms (2) into the shafts and secure them with washers.



3-2. ELECTRICAL ADJUSTMENTS

End Sensor Adjustment

Perform the following adjustment when the holder has been removed or part of the mechanism deck section replaced.

Adjustment Procedure :

1. Connect an oscilloscope to TP (SEND) (supply side) and TP (TEND) (take-up side) on the main board.
2. Load an end sensor cassette and put the set into the STOP (■) mode.
3. Adjust RV304 (supply side) and RV303 (take-up side) on the main board so that the oscilloscope waveform p-p value is 1.2 V_{p-p}.

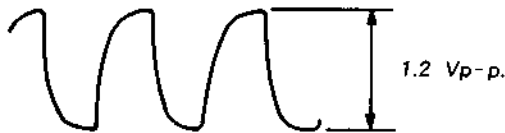

Adjustment Point : main board

FWD Torque Adjustment

Adjustment Procedure :

1. Put the set into the test mode and load the FWD torque meter TW-7131 (8-909-708-71).
2. Put the set into the PLAY (▶) mode.
3. Adjust RV305 so that the FWD torque value (take-up side rewinding torque) is between 10 - 13 g · cm (0.14 - 0.18 oz · inch).
4. Confirm that the value indicated by the torque meter is maintained for one full cycle.

Adjustment Point : main board

FWD Back Tension Check

Check Procedure :

1. Put the set into the test mode and load the FWD torque meter TW-7131 (8-909-708-71).
2. Put the set into the PLAY (▶) mode.
3. Confirm that the back tension (supply side) is between 4.5 - 6.5 g · cm (0.063 - 0.09 oz · inch).
4. Confirm that the value indicated by the torque meter is maintained for 1/2-cycle.

Tape Path Fine Adjustment (× 1.5 FWD Mode)

Perform the following adjustment when the drum has been replaced.

Adjustment Procedure :

1. Connect an oscilloscope CH-1 to TP (RF) and CH-2 to TP (SWP) on the main board.
2. Put the set into the test mode and load test tape TY-7252 (8-909-822-00).
3. Press the AMS (▶▶) key.
4. With the REC MODE switch set to STANDARD (ATF : OFF) and the TIMER switch set to PLAY or REC (OFFSET : + or -), fine adjust the S1 and T1 guides so that the oscilloscope RF signal waveform remains the same when high-low is repeated.

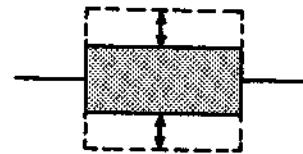

5. Check the RF signal waveform with the REC MODE switch set to LONG (ATF : ON) and the TIMER switch set to PLAY or REC (OFFSET : + or -).

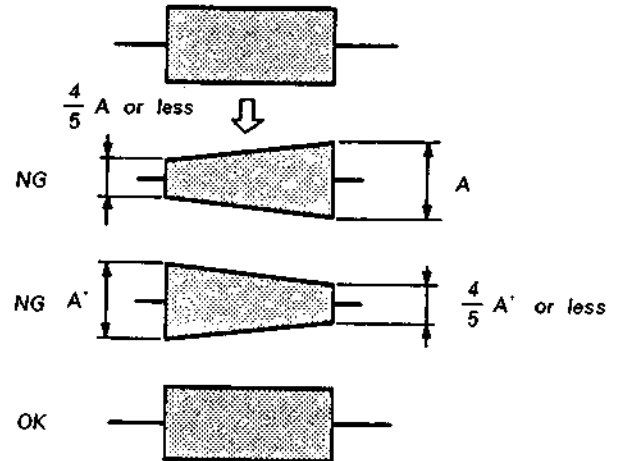

6. Check the RF signal waveform with the REC MODE switch set to LONG (ATF : ON) and the TIMER switch set to OFF (OFFSET : 0).
 - (1) Confirm that the RF signal waveform peak value is 60 mV or more.
 - (2) Confirm that the undershoot level of the RF signal waveform's flat portion is within 10%.

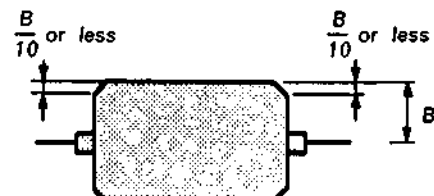

7. When the measured values are not within the above tolerances, repeat items 3 - 6 above.
8. In the case of the S2, T2 and F guides, check to make sure that there is no gap between the tape and the bottom flange. Also confirm that there is no curling where the tape makes contact with the bottom flange. When there are any gaps or curling, adjust according to the instructions on page 14.

Adjustment Point : mechanism assembly

DPG Adjustment

Perform the following adjustment without fail when the drum has been replaced.

Adjustment Procedure :

1. Connect oscilloscope CH-1 to TP (RF) and CH-2 to TP (SWP) on the main board.(Use CH-2 as the trigger. When the CH-2 signal is inverted, the trailing edge can be used for synchronization.)
2. Put the set into the test mode and load test tape TY-7252 (8-909-822-00).
3. Set the REC MODE switch to LONG (ATF : ON) and the TIMER switch to OFF (OFFSET : 0).
4. Press the AMS (▶▶) key.
5. Press the ◀◀ and ▶▶ keys as appropriate so that the gap between the oscilloscope SWP and RF signals becomes $650 \pm 15 \mu\text{sec}$.(Hold the ◀◀ and ▶▶ keys down for more than 1 second to perform rough adjustment. Hold them down for approximately 0.2 seconds for fine adjustment.)

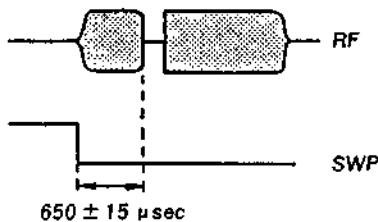

ATF Pilot Adjustment

Perform this adjustment after cleaning the heads with a cleaning cassette.

Adjustment Procedure :

1. Connect oscilloscope CH-1 to TP (PILOT) and CH-2 to TP (SWP) on the main board.(Use CH-2 as the trigger.)
2. Put the set into the test mode and load test tape TY-7111 (8-909-812-00).
3. Put the set into the PLAY (▶) mode and adjust RV301 (B-CH) and RV302 (A-CH) on the main board so that the oscilloscope PILOT waveform p-p value is $230 \pm 23 \text{ mV}$.

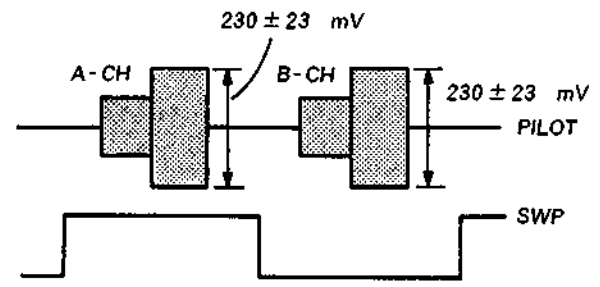

Adjustment Point : main board

SECTION 4 DIAGRAMS

4-1. PIN FUNCTIONS

IC306, CXD1136Q

Pin No.	Pin Name	I/O	Description
1	DIGO	O	Serial data output synchronized with BCK (complement of 2)
2	DIGI	I	Serial data input synchronized with BCK (complement of 2)
3	ERFO	O	Signal output for discriminating whether or not DADT has interpolated data
4	UNDF	O	Detect result for ADDT L, R channel data of -54 dB or less ("L": -54 dB or less)
5	OVFL	O	Detect result for ADDT L channel overflow ("L": overflow detected)
6	OVFR	O	Detect result for ADDT R channel overflow ("L": overflow detected)
7	VSS		GND
8	SUBT	I	Selects whether subcode or 18-bit data is output to ADDT and DIGO ("H" or open: 18-bit data output, "L": subcode output)
9	LSB1	I	MSB/LSB fast switching for DADT, ADDT, DIGI, DIGO ("H" or open: MSB fast, L: LSB fast)
10	LSB2	I	MSB/LSB fast switching for DAC2, ADC2L (ADC2R) ("H" or open: MSB fast, L: LSB fast)
11	OVON	I	Overflow detect result on/off ("H" or open: OVFL, OVFR output valid, L: OVFL, OVFR fixed "H")
12	LCF	I	Low-cut filter on/off ("H" or open: on)
13	ADDA	O	"H" in AD mode (DASL = DIAN = "L")
14	DIAN	I	Sets AD and DA modes
15	DASL	I	Sets AD and DA modes
16	MUTE	I	Soft muting on/off ("H": mute on)
17	ATLV	I	Digital volume range setting ("H" or open: 0--60, <infinity> dB, "L": +12--48, <infinity> dB)
18	ATON	I	Digital volume on/off ("H" or open: off)
19	ATDN	I	Digital volume level down
20	ATUP	I	Digital volume level up
21	ATCK	I	Digital volume level setting clock and soft muting external clock
22	ATEX	I	Soft muting operation clock selection ("H" or open: internal clock, "L": ATCK)
23	VDD		Power supply (+5 V)
24	NC		
25	VDD*		Oscillator circuit power supply (+5 V)
26	SCK	O	Oscillator clock output

Pin No.	Pin Name	I/O	Description
27	NC		
28	XTLI	I	Crystal connector and clock input pin
29	NC		
30	XTLO	O	Crystal connector pin (24.576 MHz oscillation frequency possible)
31	VSS		Oscillator circuit GND
32	CKSL	I	Oscillator clock division selection ("H" or open: no division, "L": 1/2 division)
33	NC		
34	NC		
35	DOFF	I	DAC2 digital offset on/off ("H" or open: on)
36	APSL	I	Aperture correction filter coefficient selection (not valid in AD mode) ("H" or open: correction active)
37	LRSL	I	L, R channel phase difference correction selection ("H" or open: correction active)
38	DAC2	O	Serial data output to 2-times oversampling DA converter (complement of 2)
39	VSS		Power supply (+5 V)
40	BRSL	I	LRCK, BCK input timing switch ("H" or open: LRCK change point and BCK leading edge synchronized, "L": LRCK change point and BCK trailing edge synchronized)
41	INSL	I	DADT, DIGI, ADC2L (ADC2R) data incorporation clock selection ("H" or open: BCK, "L": INCK)
42	ADSL	I	ADC2L, ADC2R data selection ("H" or open: ADC2L, "L": ADC2L and ADC2R switched by LRCK2)
43	NC		
44	WCK2	O	Clock equivalent to 4fs
45	LR21	O	DAC2 L, R channel discrimination signal in I ² S format
46	APTL	O	Aperture signal
47	APTR	O	Aperture signal
48	LRCK2	O	DAC2, ADC2L (ADC2R) L, R channel discrimination signal (equivalent to 2fs) ("L": L channel, "H": R channel)
49	XLCK2	O	LRCK2 inverted output
50	XBCK	O	BCK inverted output
51	BCK	I	Clock equivalent to 64fs for DADT, ADDT, DIGI, DIGO data incorporation

Pin No.	Pin Name	I/O	Description
5 2	INCK	I	DADT, DIGI, ADC2L (ADC2R) data incorporation clock
5 3	VDD		Power supply (+5 V)
5 4	ADC2L	I	Serial data input from 2-times oversampling AD converter (complement of 2)
5 5	ADC2R	I	Serial data input from 2-times oversampling AD converter (complement of 2)
5 6	LRCK	I	DADT, ADDT, DIGI, DIGO L, R channel discrimination signal (fs) ("L": L channel, "H": R channel)
5 7	ADDT	O	Serial data output synchronized with BCK (complement of 2)
5 8	BRF1	I	Signal input for discriminating whether or not DADT has interpolated data (complement of 2)
5 9	DADT	I	Serial data input synchronized with BCK (complement of 2)
6 0	OVCM	I	Clock input which determines detect time for OVPL, OVPR and UNDF

IC 307, CXD2601Q

Pin No.	Pin Name	I/O	Description
1	A08	I/O	RAM address A08
2	A09	I/O	RAM address A09
3	VDD	-	5V
4	A10	I/O	RAM address A10
5	A11	I/O	RAM address A11
6	A12	I/O	RAM address A12
7	A13	O	RAM address A13
8	A14	O	RAM address A14
9	XWE	O	RAM write enable signal
10	XOE	O	RAM output enable signal
11	XEAN	O	External addressing bus interrupt enable signal
12	TST1	I	Test pin (normally "L")
13	XT10	O	18.816 MHz crystal oscillator output
14	XT11	I	18.816 MHz crystal oscillator input
15	VSS	-	GND
16	XRST	I	Reset pin (normally "H")
17	CLKO	I/O	18.816 MHz clock output
18	XCST	I/O	SYEK (internal system clock) generation CLKO division timing signal
19	ATSY	I	ATF sync signal input
20	MCLK	O	9.408 MHz clock output
21	DREF	O	Drum servo reference signal
22	SBPM	O	Discrimination signal determining whether the subcode I/O clock (EXCK) is accepted ("L": accept, "H": ignore)
23	EXCK	I	Subcode I/O data transfer clock (DUTY50)
24	SDSI	I	Subcode serial data input
25	SDSO	O	Subcode serial data output
26	SBSY	O	Subcode I/O sync signal
27	COPY	O	Copy data output
28	EMP	O	Emphasis data output
29	MUTE	I	Mute pin
30	MUTM	O	Mute discrimination signal ("H": muted)
31	UNLK	O	RX PLL lock discrimination signal ("H": locked)
32	ERMN	O	Detects presence or absence of RF ("H": RF present, "L" during RBC)
33	SYMN	O	C1 check result for RF ("H": OK)
34	CHBR	I	Signal for discriminating whether C2 is 1 or 2 times (C2 → C1 → C2 or C1 → C2) ("H": 1 time, "L": 2 times)

Pin No.	Pin Name	I/O	Description
3 5	PLCK	I/O	RF PLL clock output
3 6	TST2	I	Test pin (normally "L")
3 7	RFDT	I	RF signal input
3 8	XCS	I	Subcode I/O chip select ("L": select)
3 9	SWP	O	RF switching pulse ("L": A-CH, "H": B-CH)
4 0	VSS	-	GND
4 1	PIPC	O	REC data PILOT/PCM discrimination signal ("H": PILOT, during playback: always "L")
4 2	REPB	O	Record/playback switching signal ("H": record)
4 3	REDT	O	Recording signal output, fixed "L" during playback
4 4	TST4	I	Test pin (normally "L")
4 5	TST3	O	RX APLL PD output (comparator output)
4 6	TST5	I	RX APLL oscillator cell amp input
4 7	TST6	O	RX APLL oscillator cell amp inverted output
4 8	PLCO	I	RX APLL external VCO clock input
4 9	PLVR	O	RX APLL comparison signal when external comparator is active (Vin)
5 0	PLVF	O	RX APLL comparison signal when external comparator is active (Rin)
5 1	MSSL	I	Master/slave setting ("H": master, "L": slave)
5 2	RX	I	Digital input
5 3	VDD	-	5V
5 4	TX	O	Digital output
5 5	AUDR	I	Audio mode/data recorder mode setting ("H": audio mode, "L": data recorder mode)
5 6	EXSY	I/O	Complete copy sync signal (25/3 - 100/3 Hz)
5 7	EXSN	I/O	Complete copy sync signal (25/3 - 100/3 Hz)
5 8	F128	I/O	128fsCK (normal)/256fsCK (x2) (DUTY50)
5 9	F256	O	256fsCK (normal)/512fsCK (x2) (DUTY50)
6 0	F512	O	512fsCK (normal)/512fsCK (x2) (DUTY50)
6 1	ADLF	O	Signal for discriminating whether ADDT serial data is MSB fast or LSB fast ("H": LSB fast)
6 2	DALF	O	Signal for discriminating whether DADT serial data is MSB fast or LSB fast ("H": LSB fast)
6 3	XT20	O	22.5792 MHz crystal oscillator output
6 4	XT21	I	22.5792 MHz crystal oscillator input

Pin No.	Pin Name	I/O	Description
6 5	VSS	-	GND
6 6	XT30	O	49.152 MHz crystal oscillator output (24.576 MHz in B mode)
6 7	XT31	I	49.152 MHz crystal oscillator input (24.576 MHz in B mode)
6 8	PSEN	I	F128, BCK, LRCK input/output switch ("H": output)
6 9	LR03	O	LR02 inversion
7 0	LR02	O	LRCK 16BCK delay signal
7 1	LR01	O	LRCK 15BCK delay signal
7 2	LRCK	I/O	fs (normal)/2fs (x2) ("L": L-CH, "H": R-CH)
7 3	WCK	I/O	2fs (normal)/4fs (x2) (input mode only for testing)
7 4	XBCK	O	BCK inversion
7 5	BCK	I/O	64fs (normal)/128fs (x2)
7 6	ADDT	I	Serial AD data (complement of 2)
7 7	DADT	O	Serial DA data (complement of 2)
7 8	DADO	I	Digital output (DA) data (normally connected to DADT)
7 9	ADDI	O	Digital input (AD) data output (normally connected to ADDN)
8 0	ADDN	I	Digital input (DA) data input
8 1	ERRI	I	Digital output V-FLA data input (normally connected to ERRF)
8 2	ERRF	O	Signal output for discriminating whether or not DADT has interpolated data ("H": interpolated data)
8 3	WNTG	O	Error correction status monitor trigger
8 4	D7	I/O	RAM data bus D7
8 5	D6	I/O	RAM data bus D6
8 6	D5	I/O	RAM data bus D5
8 7	D4	I/O	RAM data bus D4
8 8	D3	I/O	RAM data bus D3
8 9	D2	I/O	RAM data bus D2
9 0	VSS	-	GND
9 1	D1	I/O	RAM data bus D1
9 2	D0	I/O	RAM data bus D0
9 3	A00	I/O	RAM address A00
9 4	A01	I/O	RAM address A01
9 5	A02	I/O	RAM address A02
9 6	A03	I/O	RAM address A03
9 7	A04	I/O	RAM address A04
9 8	A05	I/O	RAM address A05
9 9	A06	I/O	RAM address A06
1 0 0	A07	I/O	RAM address A07

IC311, CXA1046M

Pin No.	Pin Name	I/O	Description
1	RF IN	I	RF signal input
2	F CTL	I	External resistor connector pin for determining pilot filter (LPP) characteristics
3	B VOL	I	Gain control amp B-CH gain adjustment resistor and bypass capacitor connector pin
4	A VOL	I	Gain control amp A-CH gain adjustment resistor and bypass capacitor connector pin
5	PILOT OUT	O	Pilot signal output
6	ENV DET IN	I	Envelope detect signal
7	ENV HOLD	I	Envelope detect hold capacitor connector pin
8	S/H 3 OUT	O	Sample-hold 3 output pin
9	SWP	I	Processing signal A-CH, B-CH switching control pin ("H": B-CH, "L": A-CH)
10	ATF ON/OFF	I	ATF block (portions other than RF detect) on/off ("L": on)
11	NORM PLAY	I	Determines whether the mode is normal or not ("L": normal mode)
12	ATS1	I	Sample-hold 1 sample pulse input pin
13	TE	O	Tracking error output pin
14	VCC	--	Power supply pin
15	HOLD3C	I	Sample-hold 3 hold capacitor connector pin
16	HOLD2C	I	Sample-hold 2 hold capacitor connector pin
17	ATS2	I	Sample-hold 2 sample pulse input pin
18	ATS3	I	Sample-hold 3 sample pulse input pin
19	SYNC OUT	O	ATF sync output
20	GND	-	GND
21	LIM PC	I	Limiter block bypass capacitor connector pin (-) input (can be exchanged with pin 22)
22	LIM IN	I	Limiter block bypass capacitor connector pin (+) input (can be exchanged with pin 21)
23	BQ OUT	O	ATF sync equalizer output pin
24	PCTL	I	Resistor connector pin for determining sync equalizer phase characteristics
25	LCTL	I	Resistor connector pin for determining sync equalizer low frequency characteristics
26	DET C1	I	Smoothing capacitor connector pin for determining RF detector threshold level
27	DET C2	I	RF envelope wave waveform adjustment capacitor connector pin
28	RF DBT OUT	O	RF detector output pin

Pin No.	Pin Name	I/O	Description
1	NC		
2	NC		
3	L PLN ON	O	Loading plunger on
4	REEL CCW	O	Reel motor counterclockwise (loading plunger kick)
5	REEL CW	O	Reel motor clockwise (loading plunger kick)
6	CAP DIR RVS	O	Capstan direction ("L": normal, "H": reverse, brake)
7	PLN ON	O	Plunger on
8	PLN KICK	O	Plunger kick
9	DRUM ON	O	Drum on
10	DRUM DIR RVS	O	Drum direction ("L": normal, "H": reverse, brake)
11	COA/XOPT	O	Coaxial ("H")/optical ("L") switch
12	DIG/XANA	O	Fade in/out digital ("H")/analog ("L") switch
13	RBC/XPB	O	Fade in/out record ("H")/playback ("L") switch
14	ATCK	O	Fade in/out clock
15	NC		
16	NC		
17	LE	O	Loading motor eject
18	LL	O	Loading motor load
19	D/A MUTE	O	D/A converter muting
20	L MUTE	O	Line muting
21	TR MUTE	O	Transistor muting
22	X DISP SL	O	Display controller select ("L": active)
23	NC		
24	LIM SW	I	Limit switch (eject position detect)
25	RE FWD	I	Rotary encoder FWD
26	RE STOP	I	Rotary encoder STOP
27	CAS M IN	O	Cassette compartment motor IN
28	CAS M OUT	O	Cassette compartment motor OUT
29	T LBD ON	O	End sensor T ON (DUTY 50)
30	S LBD ON	O	End sensor S ON (DUTY 50)
31	MP	I	Microprocessor mode ("L" for this model)
32	X RST	I	System reset (active low)
33	V _{SS}	-	GND
34	XTAL	O	System clock output
35	EXTAL	I	System clock input
36	DISP SYNC	I	
37	DISP DT I	I	Serial data input from display controller

Pin No.	Pin Name	I/O	Description
3 8	DISP DT O	O	Serial data output to display controller
3 9	DISP CK	I	Serial data clock from display controller
4 0	SB SYNC	I	
4 1	SB DT I	I	Subcode signal input
4 2	SB DT O	O	Subcode signal output
4 3	X SB CK	O	Subcode interface serial clock
4 4	AV _{SS}	—	A/D GND
4 5	AV _{REF}	—	A/D reference voltage
4 6	AV _{DD}	—	A/D power supply
4 7	T END	I	Take-up side end sensor input
4 8	S END	I	Supply side end sensor input
4 9	CAS IN	I	Cassette in detect
5 0	RBC EN	I	Erasurc prevention slider detect
5 1	CAS LCKed	I	Cassette compartment lock detect
5 2	CAS OUTed	I	Cassette compartment out detect
5 3	LVL SYNC	I	Level sync input
5 4	ATF IN	I	ATF pilot input
5 5	FG T	I	Take-up side reel FG signal input
5 6	FG S	I	Supply side reel FG signal input
5 7	C FG	I	Capstan FG signal input
5 8	D FG	I	Drum FG signal input
5 9	D PG	I	Drum PG signal input
6 0	D REF	I	Drum reference signal input
6 1	MST CK	I	Hardware master clock (max. 9.408 MHz)
6 2	PB DT	I	ATF sync signal playback data
6 3	SWP	O	Switching pulse
6 4	D PWM	O	Drum PWM output
6 5	C PWM	O	Capstan PWM output
6 6	PWM R	O	Reel PWM output
6 7	NC		
6 8	AGC PWM	O	AGC PWM output
6 9	ER MON	I	Error monitor
7 0	X TEST	I	Test mode
7 1	POW DN	I	
7 2	V _{DD}	—	
7 3	V _{SS}	—	
7 4	NC		Power down detect
7 5	ATF S2	O	ATF sampling pulse #2
7 6	ATT EXT	O	External attenuator clock
7 7	ATF S3	O	ATF sampling pulse #3

Pin No.	Pin Name	I/O	Description
7 8	MUTE2	O	CXD1136Q mute
7 9	MUTE1	O	CXD2601Q mute
8 0	X DTR	O	Audio ("H")/data recorder ("L")

4-2. BLOCK DIAGRAM

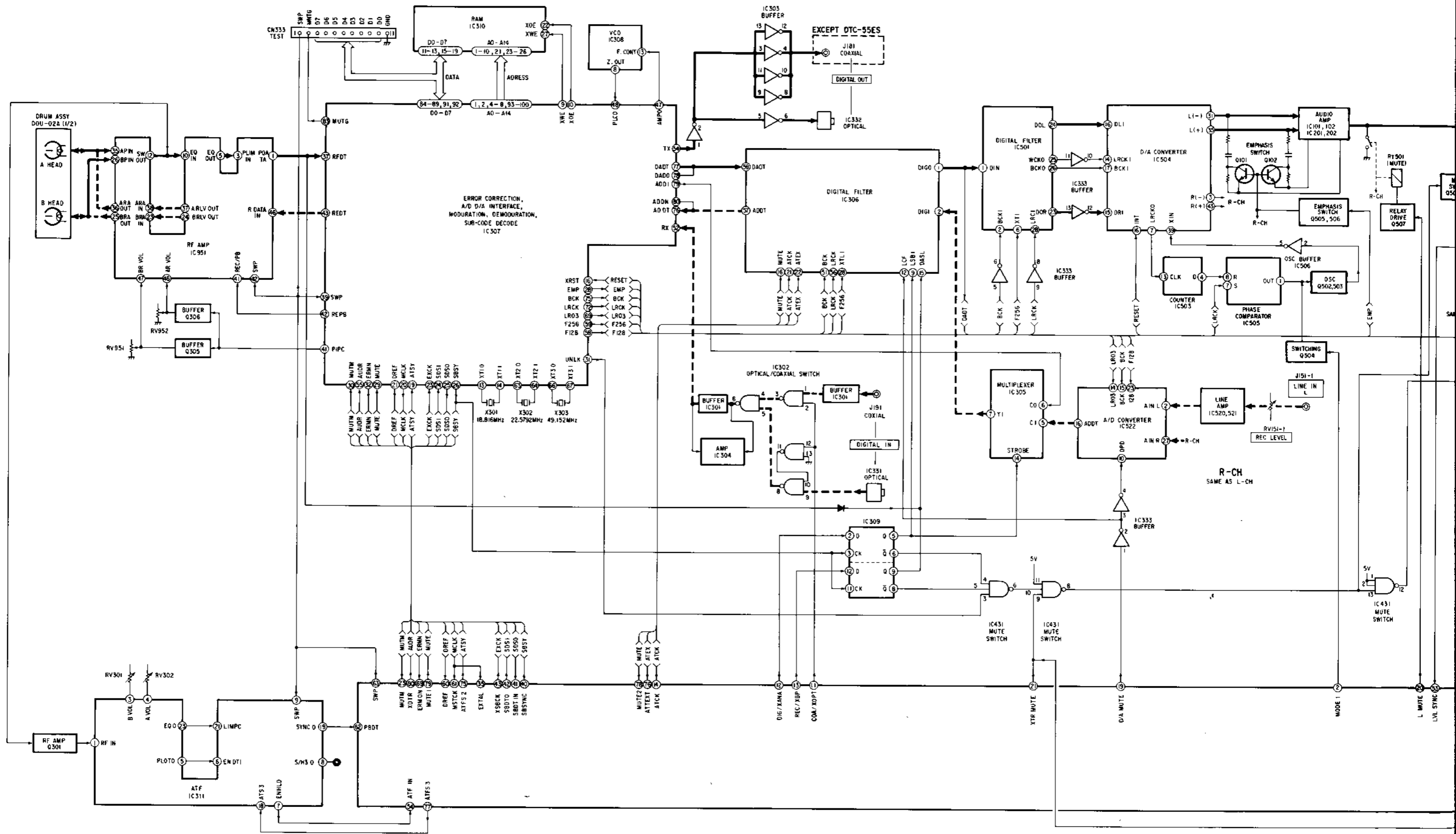

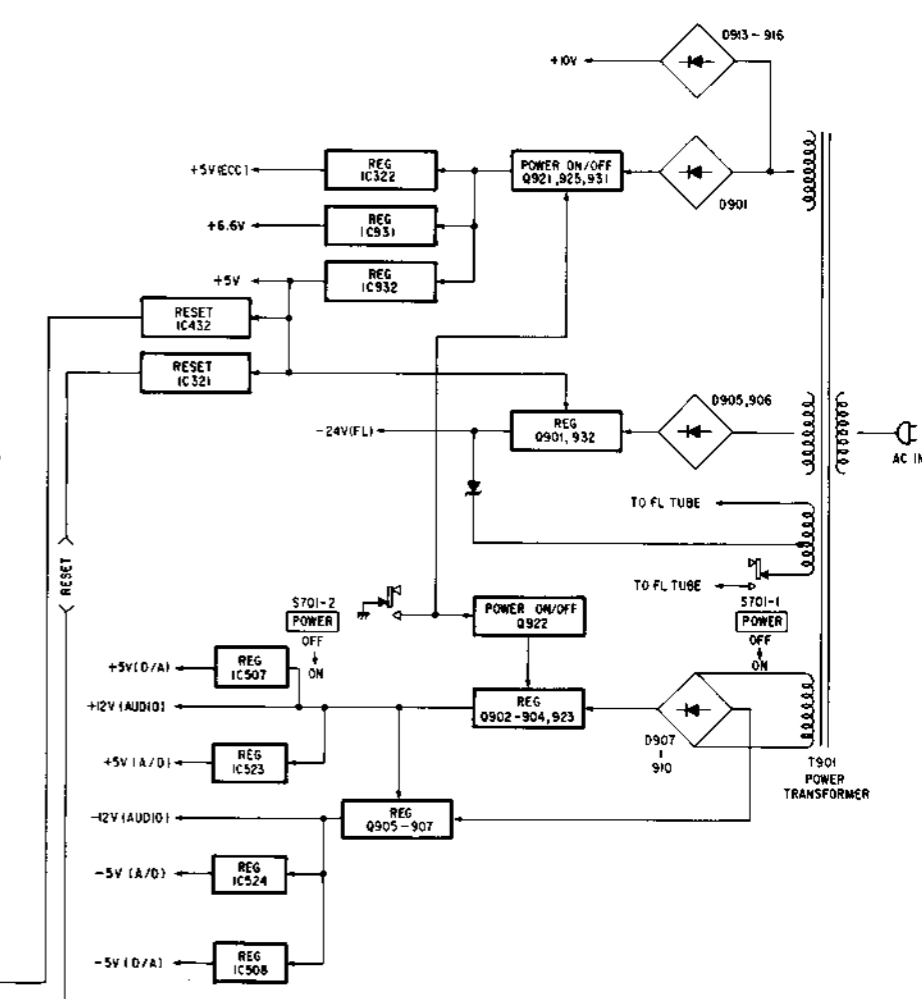
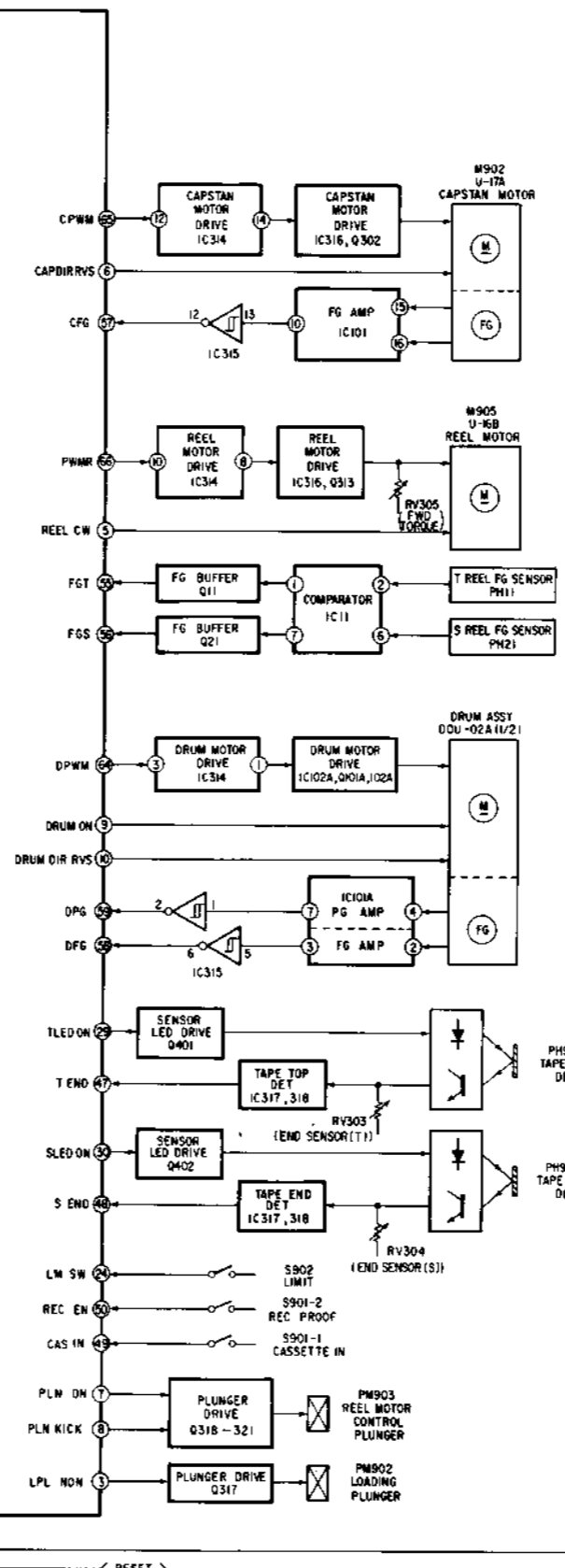
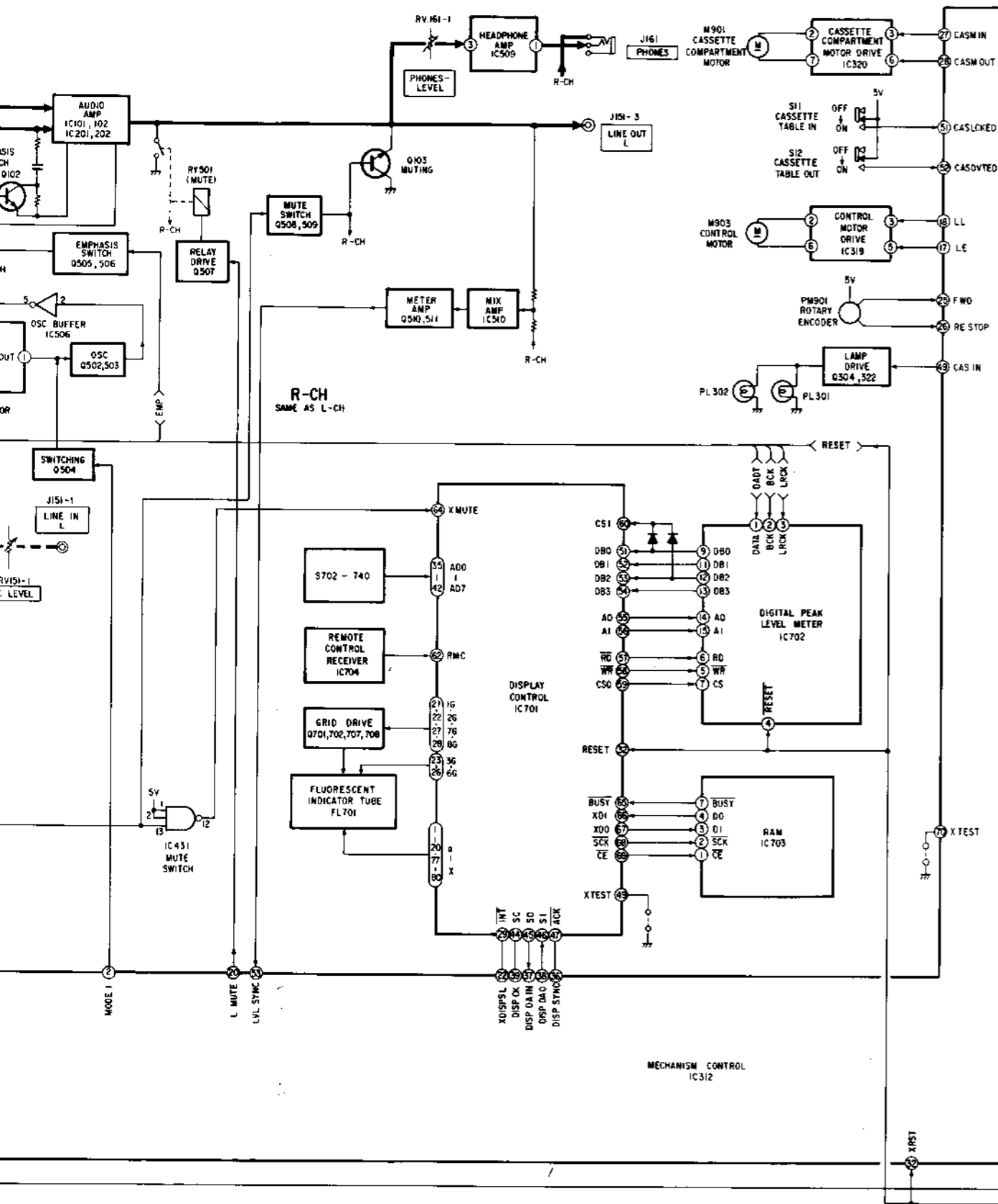

4-3. WAVEFORMS

① Q701, Q702 RMITTER



⑦ IC702 ③pin



⑬ IC311 ⑨pin PLAY



⑲ IC306 ⑤pin

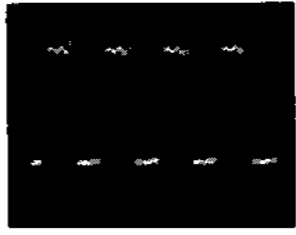

⑳ IC307 ⑤pin

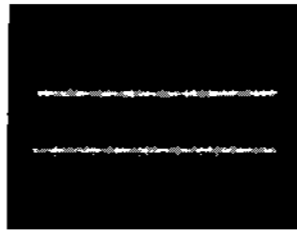

⑳ IC501 ②⑥pin BCK



⑳ IC311 ⑤pin PLAY



⑳ IC312 ⑧pin



⑳ IC315 ⑬pin



② IC701 ②①-②⑧pin



⑧ IC702 ②pin



⑭ IC307 ③⑦pin PLAY



⑳ IC306 ②⑧pin XTLI

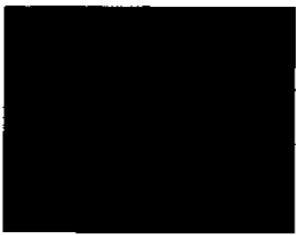

⑳ IC307 ④⑧pin



⑳ IC501 ②⑤pin WCK



⑳ IC311 ③pin PLAY



⑳ IC315 ①pin PLAY



⑵ IC504 ③⑨pin

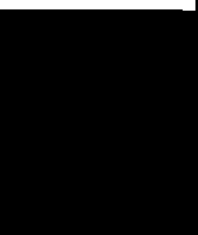

③ IC701 ①-⑲
⑳-⑸①pin



⑨ IC702 ①pin

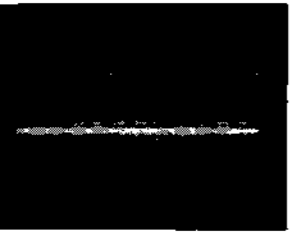

⑮ IC306 ①pin



⑳ IC307 ⑧pin



⑳ IC307 ④③pin REC

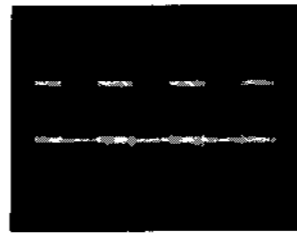

⑳ IC501 ⑲, ⑳pin



⑳ IC311 ①⑨pin PLAY



⑵ IC315 ②pin PLAY



⑵ IC504 ⑦pin

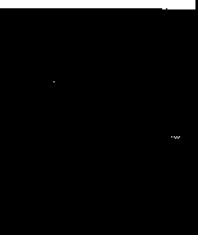

④ IC701 ③①pin



⑩ IC951 ⑲, ⑳pin REC



⑮ IC306 ⑤⑨pin

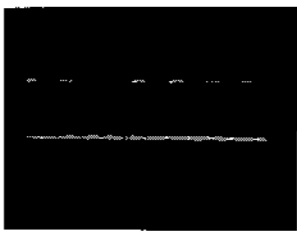

⑳ IC307 ⑤⑧pin

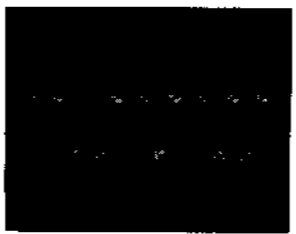

⑳ IC307 ④④pin REC



⑳ IC359 ⑲pin



⑳ IC312 ⑤⑤, ⑤⑥pin PLAY

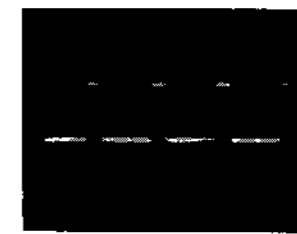

⑵ IC315 ⑤pin PLAY



⑵ IC505 ⑧pin

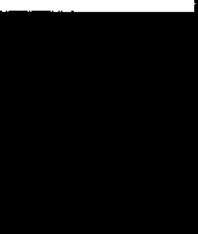

⑤ IC701 ③①pin

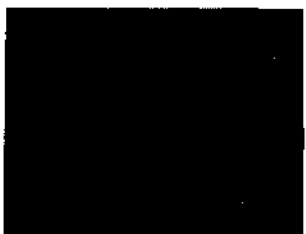

⑪ IC951 ⑲, ⑳pin PLAY

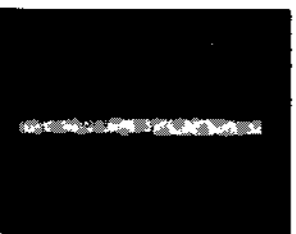

⑰ IC306 ⑤⑨pin

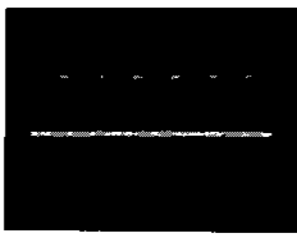

⑳ IC307 ⑥⑦pin

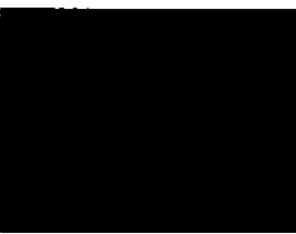

⑳ IC307 ④④pin



⑶ Q305, 306 COLLECTOR REC

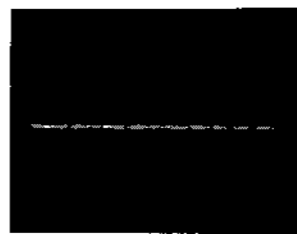

⑳ IC312 ⑥④pin PLAY



⑵ IC315 ⑥pin PLAY



⑶ IC505 ①pin

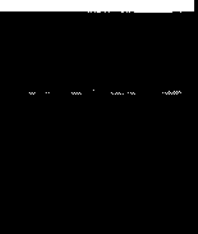

⑥ IC312 ③⑥-③⑨pin

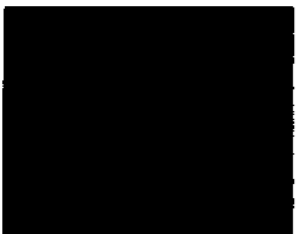

⑫ IC307 ④②pin REC



⑱ IC306 ⑤⑤pin

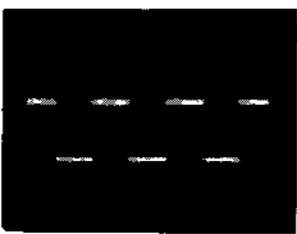

⑳ IC307 ⑥⑥pin

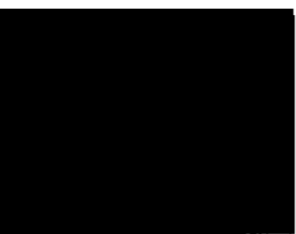

⑳ IC307 ④③pin

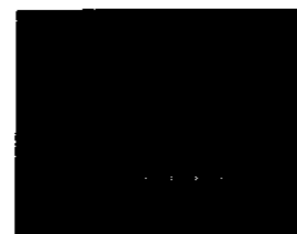

⑶ Q301 EMITTER



⑳ IC312 ⑥①pin PLAY



⑵ IC315 ④pin



⑶ IC502 Source

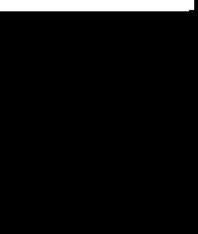

pin

49 IC315 13pin



pin PLAY

50 IC504 39pin XIN



pin PLAY

51 IC504 7pin LRCK



pin PLAY

52 IC505 8pin



pin PLAY

53 IC505 1pin



pin

54 IC502 Source

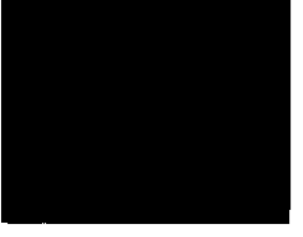

4-4. SEMICONDUCTOR LEAD LAYOUT

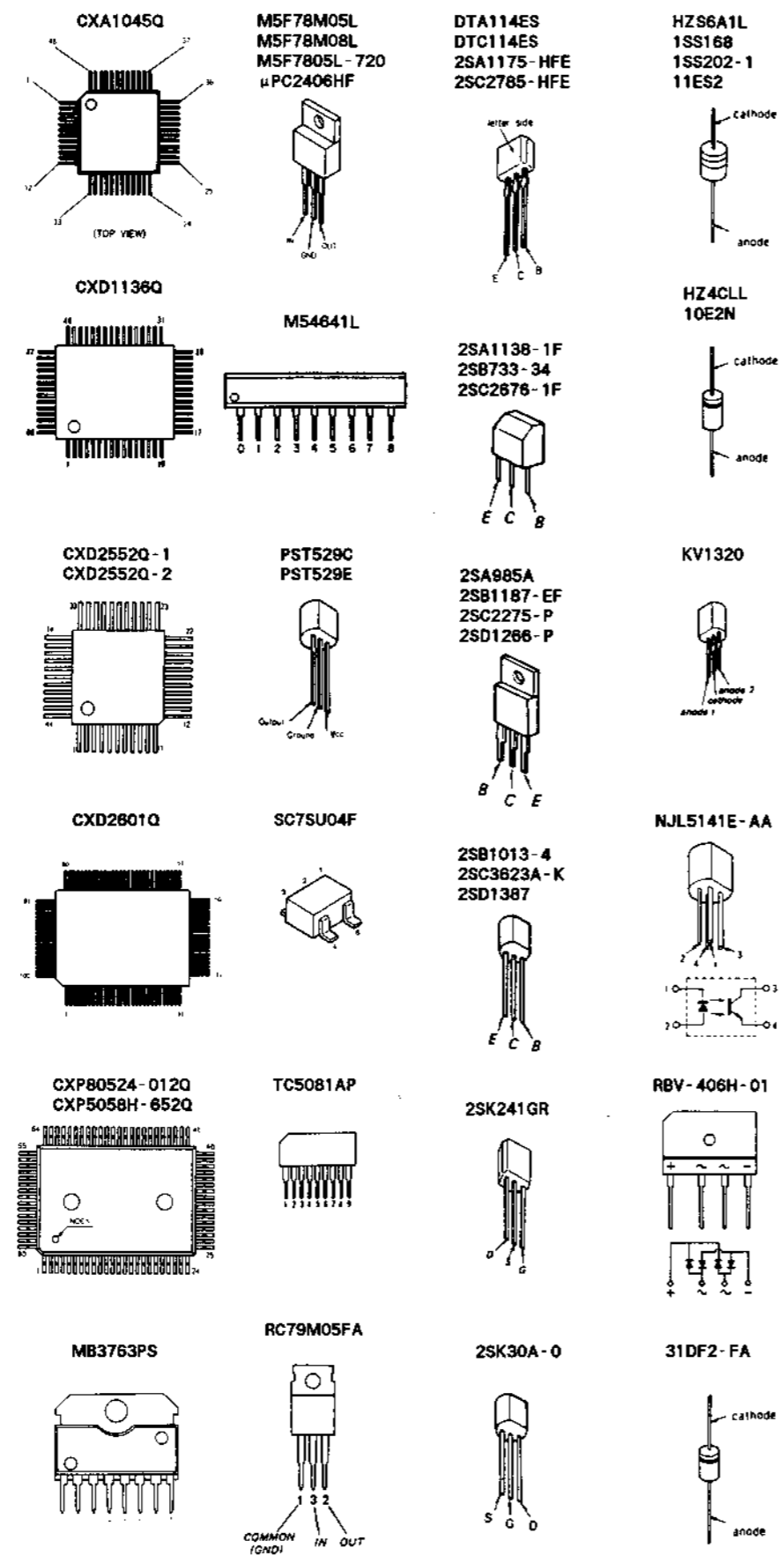

4-5. CIRCUIT BOARDS LOCATION

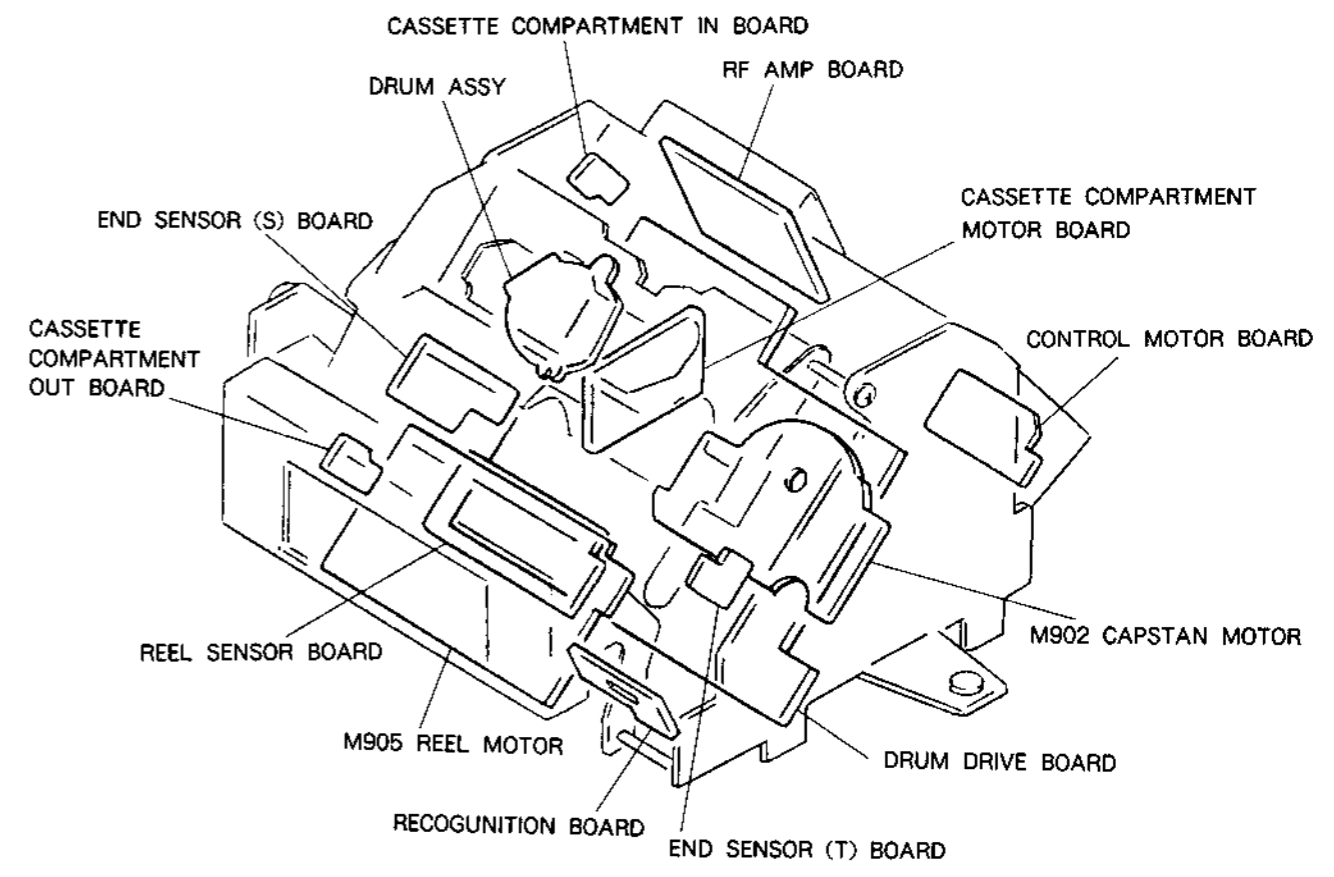
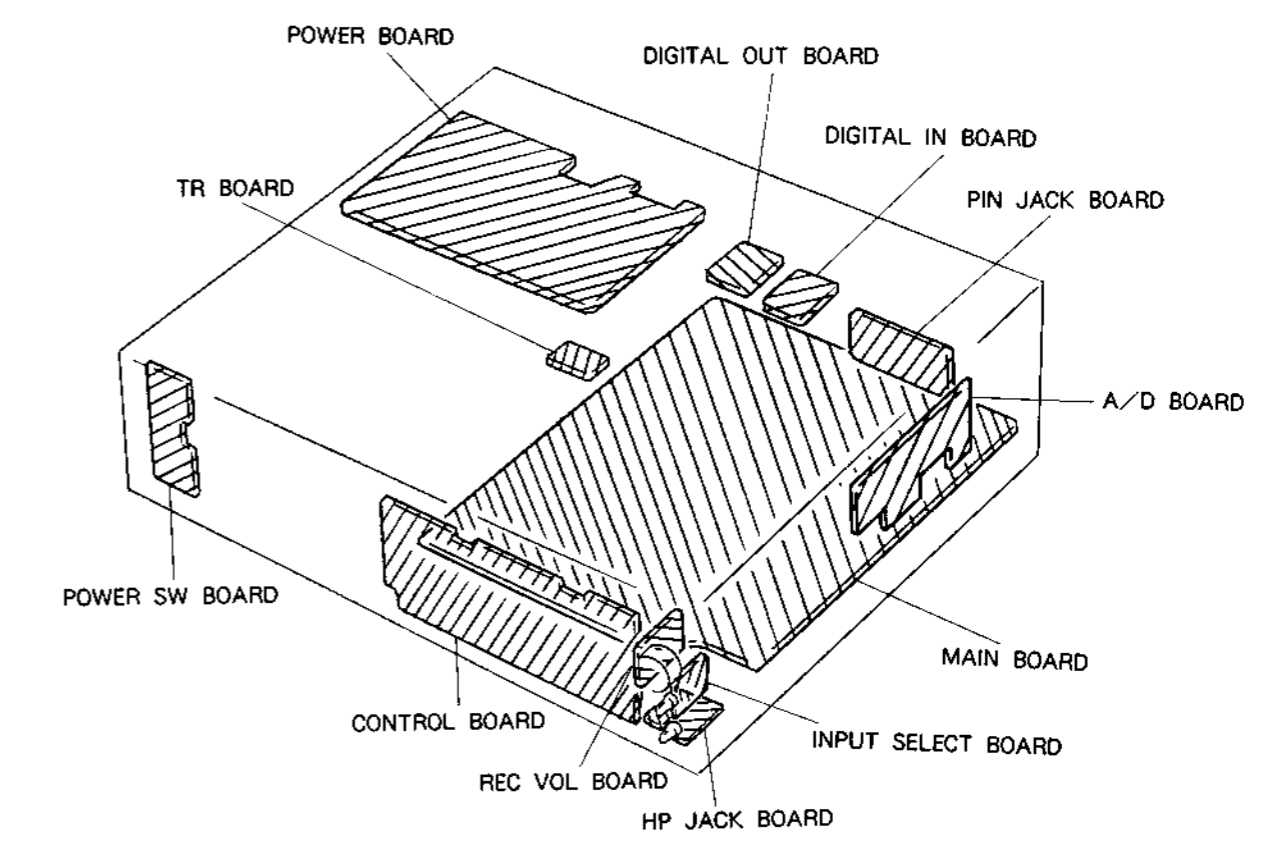

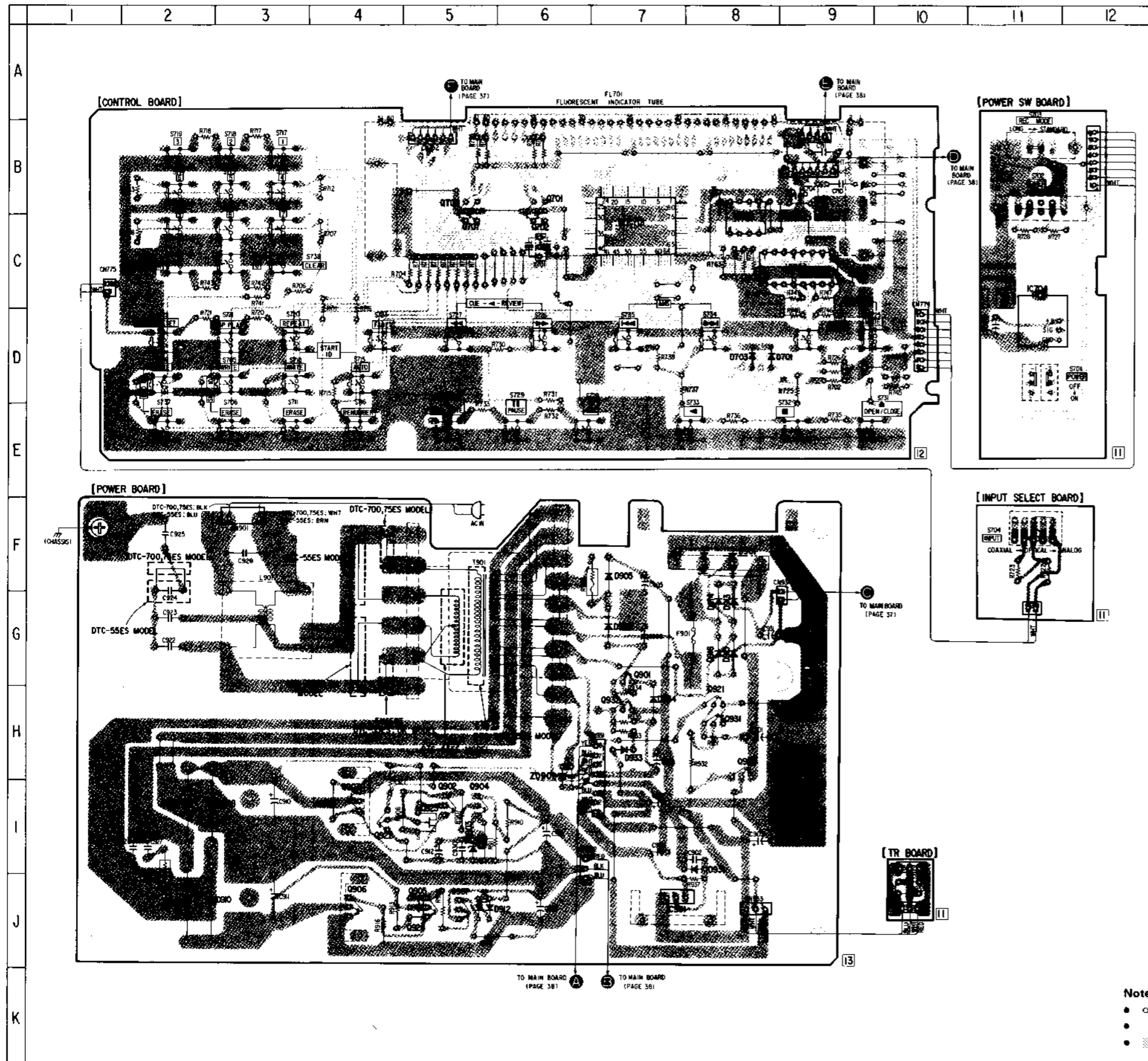

• Semiconductor Location

Ref. No.	Location
D701	D-9
D703	D-8
D901	F-8
D905	F-7
D906	G-7
D907	I-2
D908	I-3
D909	J-2
D910	J-3
D911	J-5
D912	J-6
D913	G-8
D914	G-8
D915	G-8
D916	G-8
D931	I-8
D933	H-7
D934	H-7
IC701	C-7
IC702	C-9
IC703	C-8
IC704	C-11
IC931	J-7
IC932	J-10
Q701	B-6
Q702	C-6
Q707	C-5
Q708	B-5
Q901	G-7
Q902	I-5
Q903	I-4
Q904	I-5
Q905	J-5
Q906	J-4
Q907	J-5
Q921	H-8
Q922	I-4
Q923	I-5
Q924	J-5
Q925	H-8
Q931	H-8
Q932	H-7
ZD902	H-6
ZD903	I-5

Note on Mounting Diagram:

- : parts extracted from the component side.
- : parts mounted on the conductor side.
- ▨ : Pattern on the side which is seen.

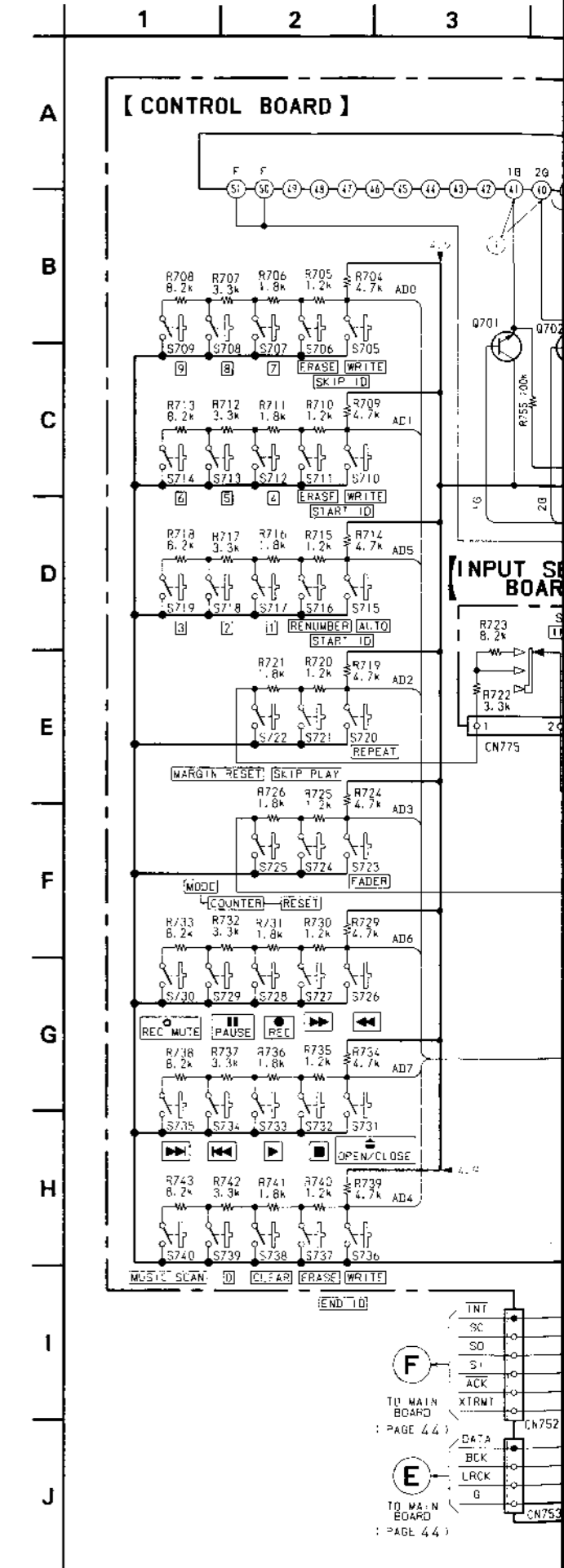

4-7. SCHEMATIC DIAGRAM - POWER SUPPLY/DISPLAY SECTION -

Semiconductor Location

Ref. No.	Location
D701	D-9
D703	D-8
D901	F-8
D905	F-7
D906	G-7
D907	I-2
D908	I-3
D909	J-2
D910	J-3
D911	J-5
D912	J-6
D913	G-8
D914	G-8
D915	G-8
D916	G-8
D931	I-8
D933	H-7
D934	H-7
IC701	C-7
IC702	C-9
IC703	C-8
IC704	C-11
IC931	J-7
IC932	J-10
Q701	B-6
Q702	C-5
Q707	C-6
Q708	B-5
Q901	G-7
Q902	I-5
Q903	I-4
Q904	I-5
Q905	J-5
Q906	J-4
Q907	J-5
Q921	H-8
Q922	I-4
Q923	I-5
Q924	J-5
Q925	H-8
Q931	H-8
Q932	H-7
ZD902	H-6
ZD903	I-5

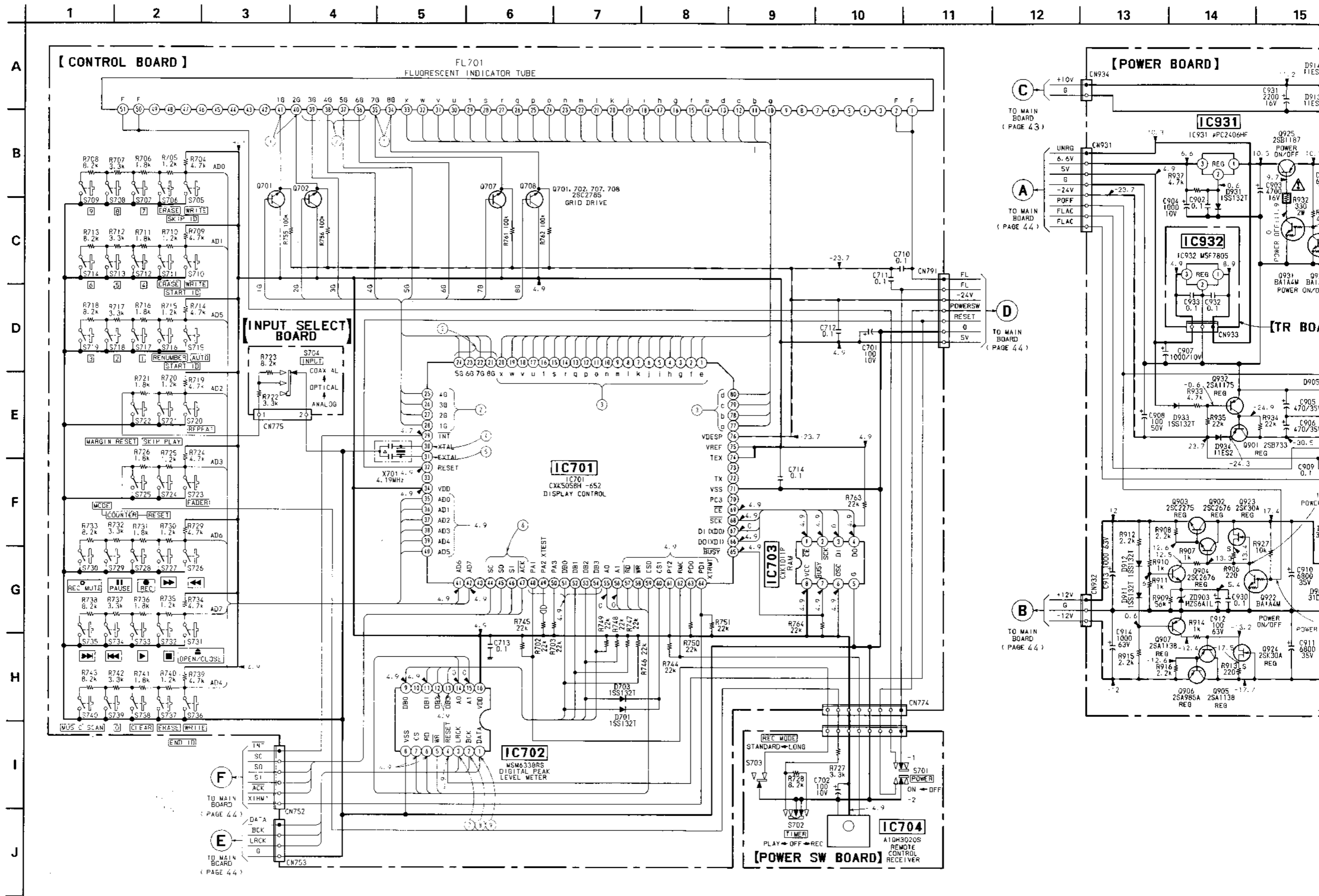

ram:
 ted from the component side,
 ted on the conductor side.
 the side which is seen.

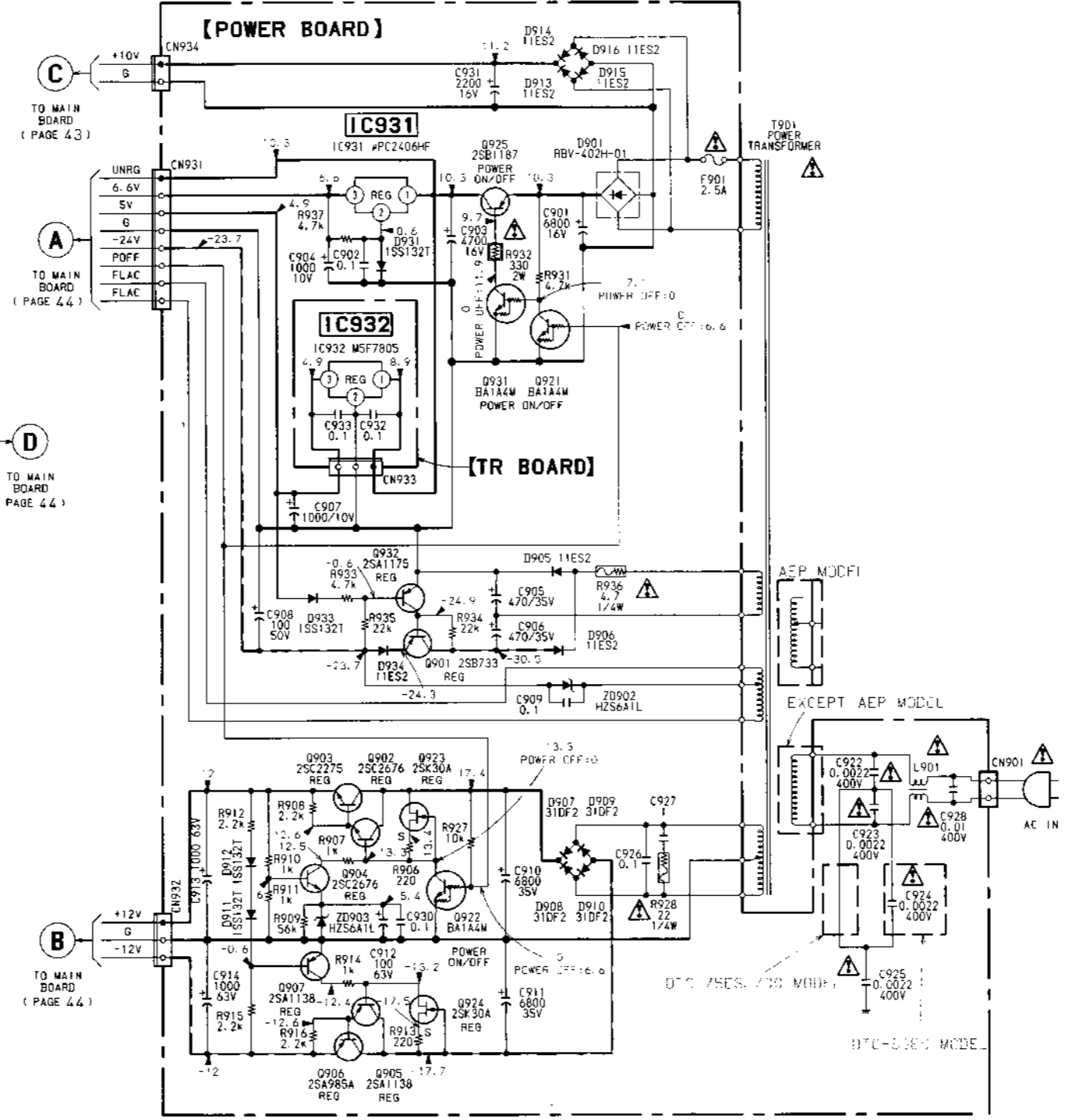
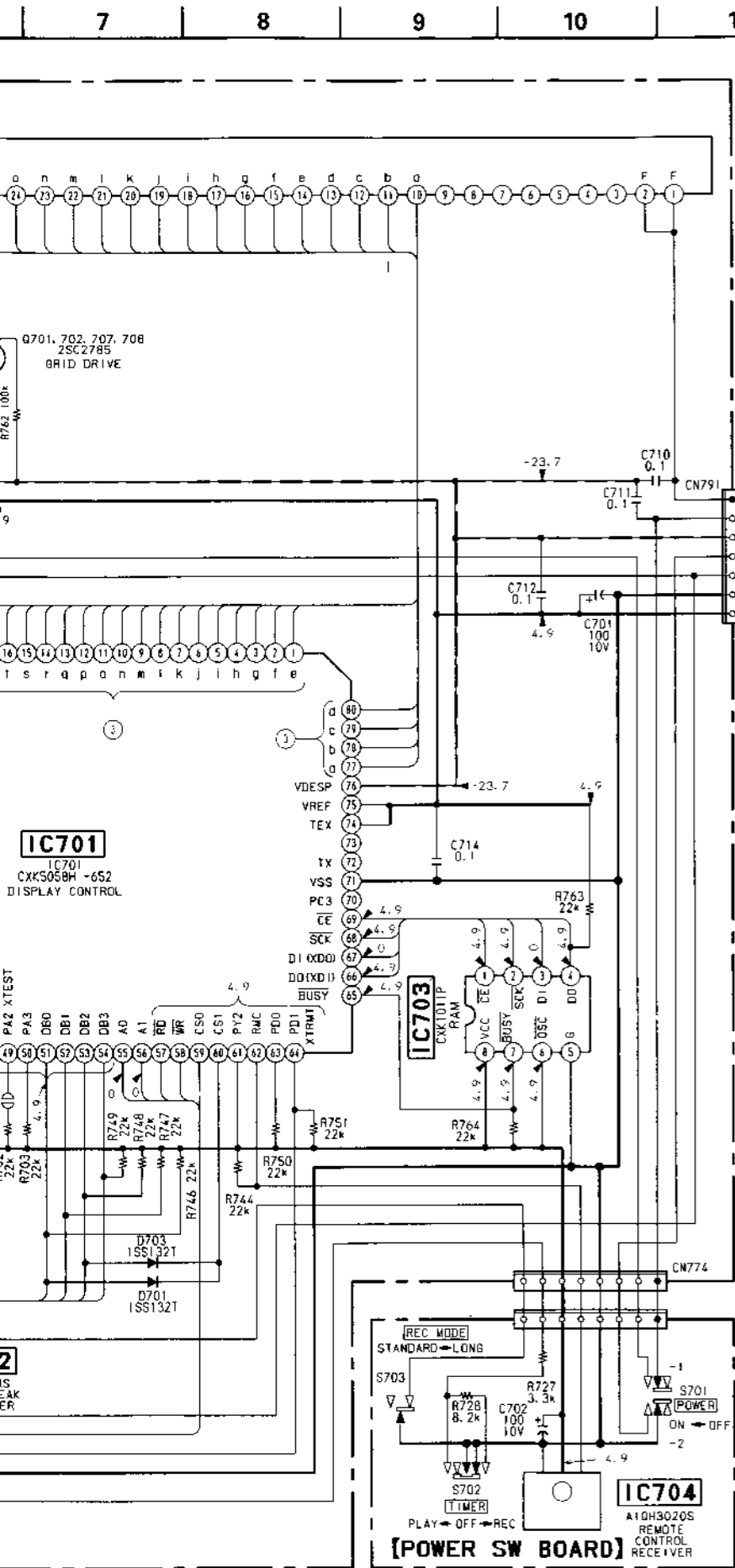

A
B
C
D
E
F
G
H
I
J

Note on Schematic Diagram:

- All capacitors are in μF unless otherwise noted. pF : μpF 50WV or less are not indicated except for electrolytics and tantalums.
- All resistors are in Ω and $\frac{1}{4}\text{W}$ or less unless otherwise specified.
- \triangle : internal component.
- \square : nonflammable resistor.
- --- : fusible resistor.

Note:
The components identified by mark \triangle or dotted line with mark \triangle are critical for safety. Replace only with part number specified.

Note:
Les composants identifiés par une marque \triangle sont critiques pour la sécurité. Ne les remplacer que par une pièce portant le numéro spécifié.

- --- : B+ Line
- --- : B- Line
- Voltage and waveforms are dc with respect to ground under no-signal conditions. no mark: STOP
- Voltages are taken with a VOM (input impedance $10\text{M}\Omega$). Voltage variations may be noted due to normal production tolerances.
- Waveforms are taken with an oscilloscope. Voltage variations may be noted due to normal production tolerances.
- Circled numbers refer to waveforms.

• Semiconductor Location

Ref. No.	Location	Ref. No.	Location
D305	I-7	IC505	E-12
D306	J-7	IC506	D-11
D313	J-8	IC507	B-10
D314	I-8	IC508	C-10
D320	G-12	IC509	C-4
D501	D-11	IC510	E-4
D502	E-9	IC520	G-1
D503	C-7	IC521	E-1
D504	D-11	IC522	B-1
D505	D-5	IC523	E-1
D506	B-5	IC524	E-2
D507	F-4	IC951	I-27
D510	D-1		
D511	D-2	PH11	J-23
D512	D-1	PH21	J-24
D513	D-1	PH901	G-21
		PH902	J-22
IC11	J-23		
IC101A	C-22	Q11	I-23
IC101	B-7	Q21	J-23
IC102A	B-22	Q101A	B-23
IC102	B-7	Q101	B-8
IC201	D-8	Q102A	C-23
IC202	D-8	Q102	B-7
KC301	I-13	Q103	B-6
KC302	J-13	Q201	D-8
KC303	K-13	Q202	D-7
KC304	J-15	Q203	C-6
KC305	H-11	Q301	J-12
KC306	G-10	Q302	J-4
KC307	H-12	Q303	J-6
KC308	G-15	Q304	H-4
IC309	H-10	Q305	K-12
IC310	I-11	Q306	J-12
IC311	J-10	Q317	I-7
IC312	G-8	Q318	J-7
IC314	I-5	Q319	K-8
IC315	J-7	Q320	J-8
IC316	J-5	Q321	J-7
IC317	G-5	Q322	H-4
IC318	F-5	Q401	I-6
IC319	I-8	Q402	I-6
KC320	J-9	Q502	D-9
KC321	F-13	Q503	D-10
KC322	F-14	Q504	E-9
KC331	H-15	Q505	E-8
KC332	I-15	Q506	D-9
KC333	B-14	Q507	C-7
KC431	H-10	Q508	D-6
KC432	G-8	Q509	D-6
IC501	D-14	Q510	F-4
IC503	C-13	Q511	F-4
IC504	C-12		

Note on Mounting Diagram:

- : parts extracted from the component side.
- : parts extracted from the conductor side.
- : parts mounted on the conductor side.
- : Through hole.
- : Jumper wire connected to the ground pattern on the component side.
- ⏏ : Pattern on the side which is seen.
- ⏏ : Pattern of the rear side.

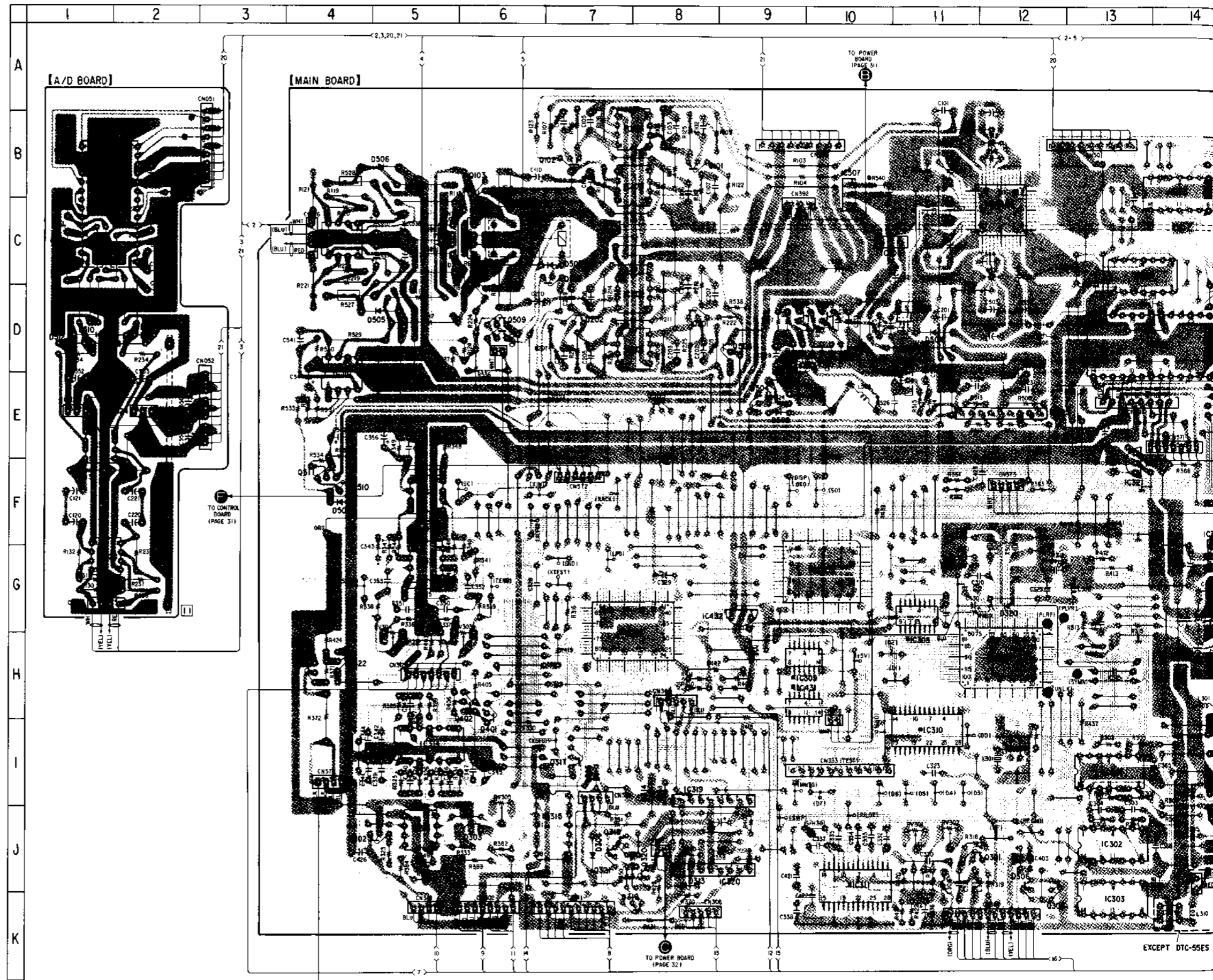

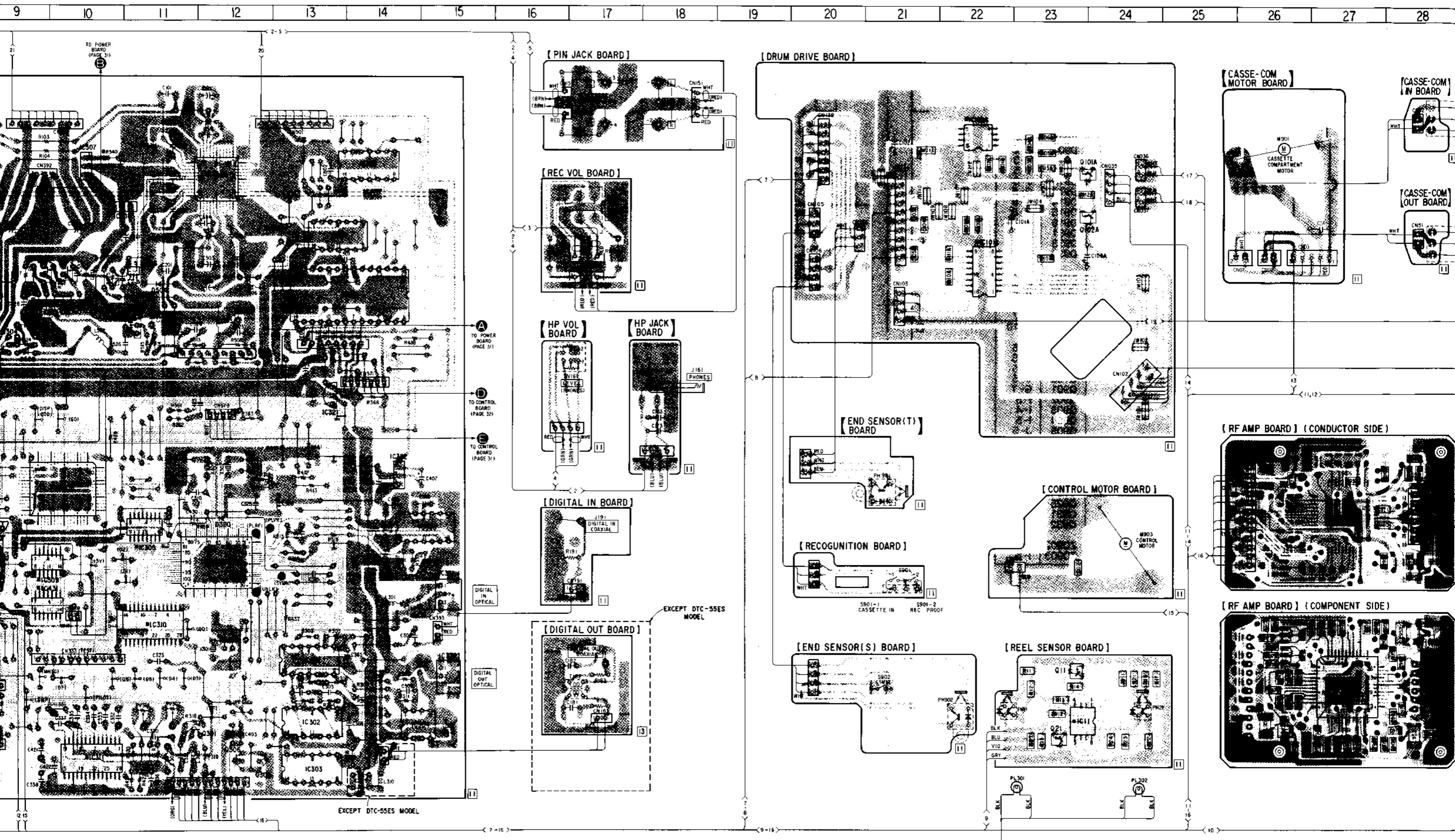

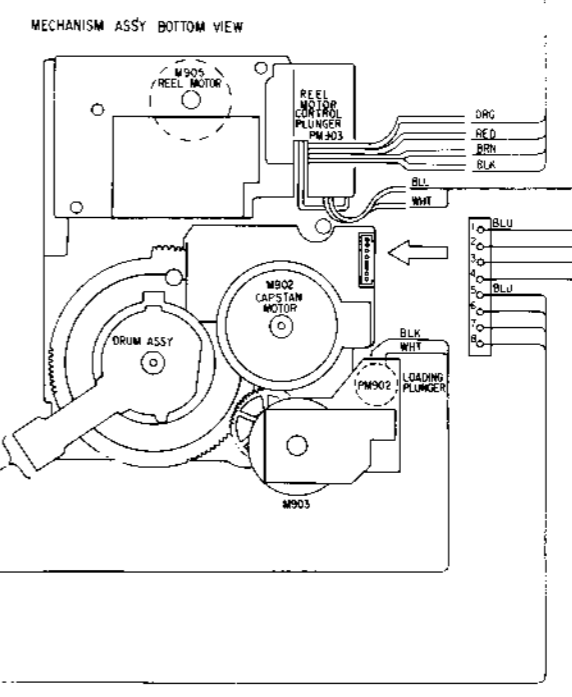
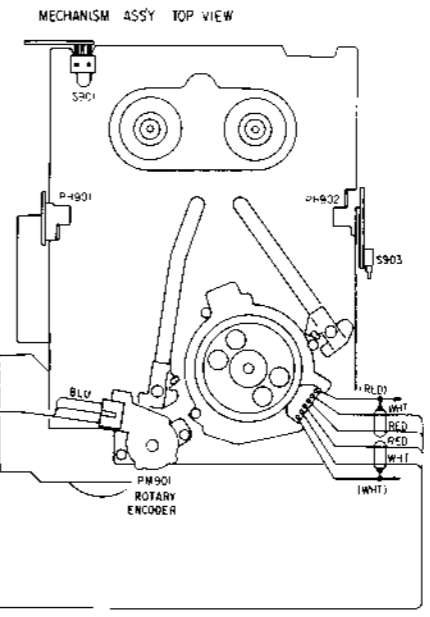
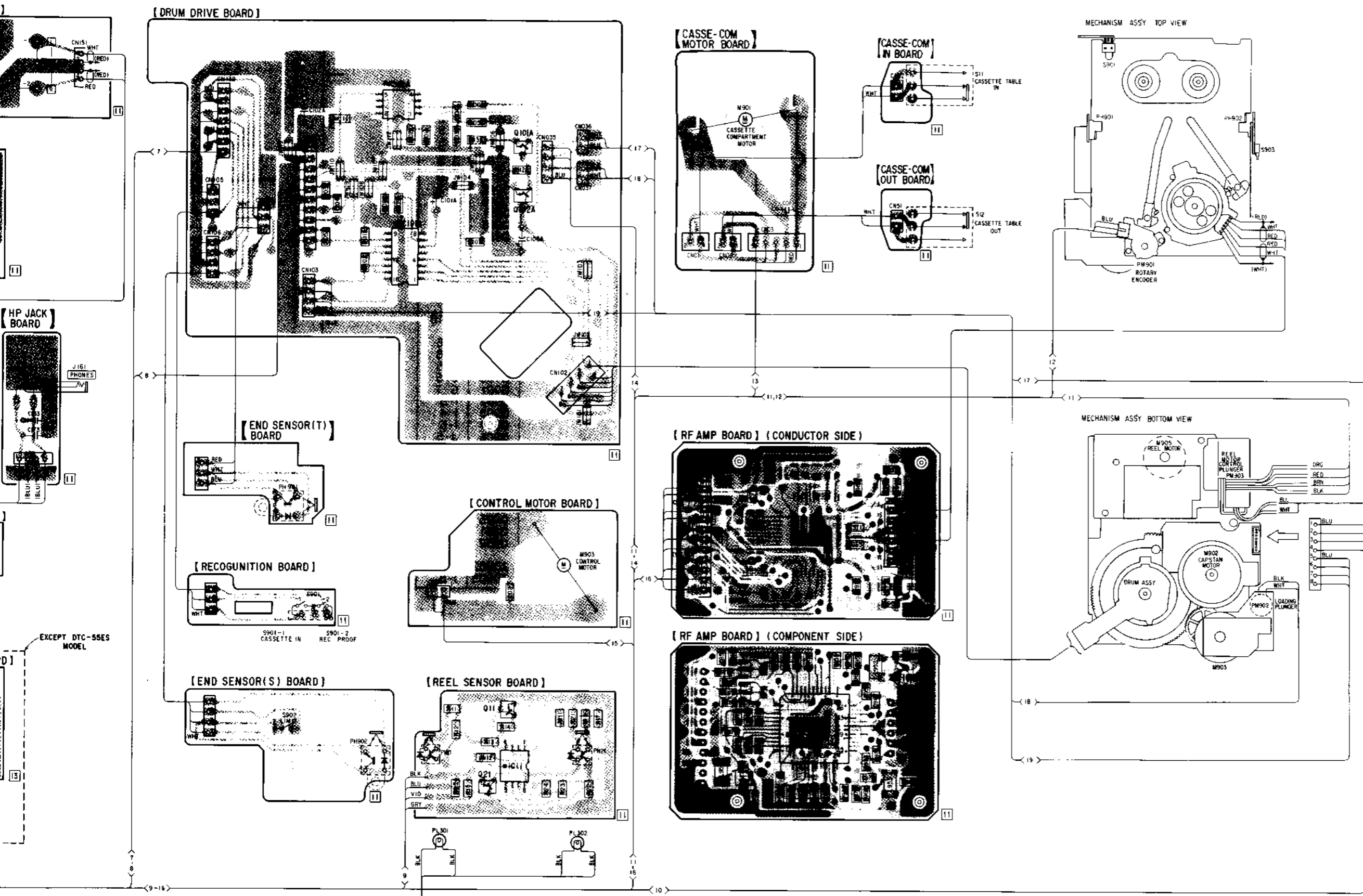

4-9. SCHEMATIC DIAGRAM - MAIN SECTION -

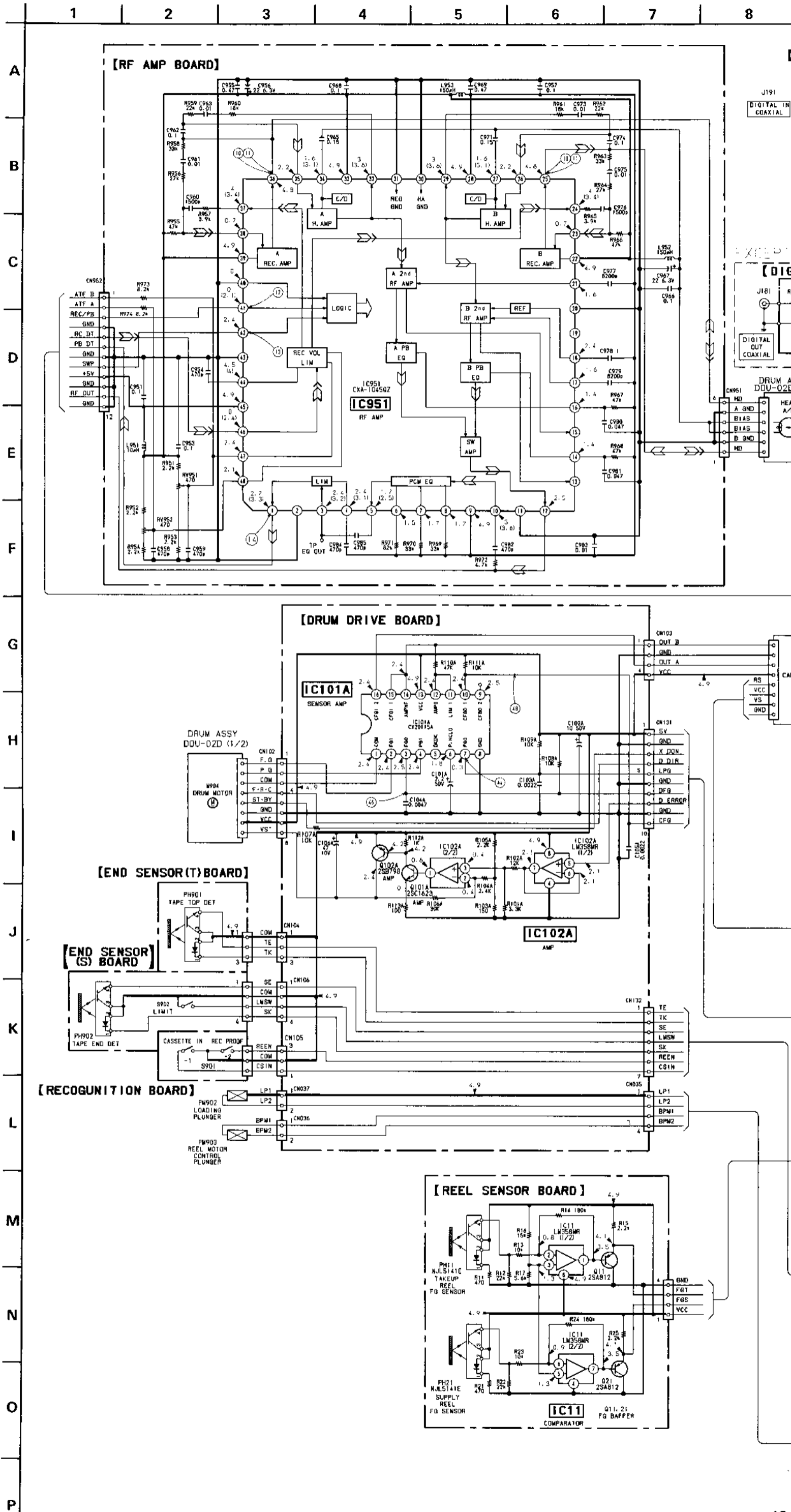

Note on Schematic Diagram:

- All capacitors are in μF unless otherwise noted. pF : μF 50WV or less are not indicated except for electrolytics and tantalums.
- All resistors are in Ω and $\frac{1}{4}\text{W}$ or less unless otherwise specified.
- % : indicates tolerance.
- : fusible resistor.

<p>Note: The components identified by mark or dotted line with mark are critical for safety. Replace only with part number specified.</p>	<p>Note: Les composants identifiés par une marque sont critiques pour la sécurité. Ne les remplacer que par une pièce portant le numéro spécifié.</p>
--	---

- : B+ Line
- : B- Line
- : adjustment for repair.
- Voltage and waveforms are dc with respect to ground under no-signal conditions.
no mark : STOP
() : PLAY
- Voltages are taken with a VOM (input impedance 10M Ω). Voltage variations may be noted due to normal production tolerances.
- Waveforms are taken with an oscilloscope. Voltage variations may be noted due to normal production tolerances.
- Circled numbers refer to waveforms.
- Signal path,
 : PB
 : REC

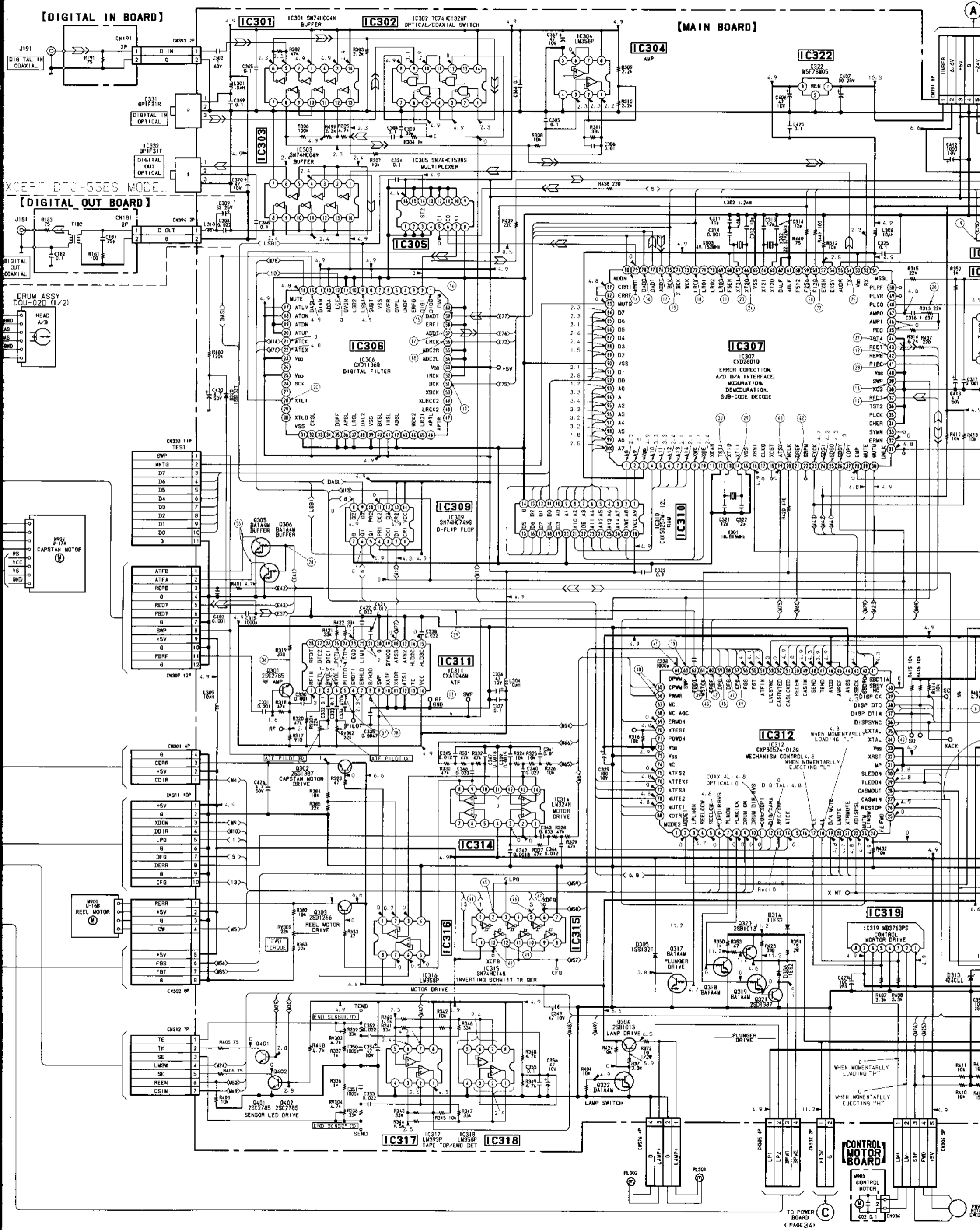

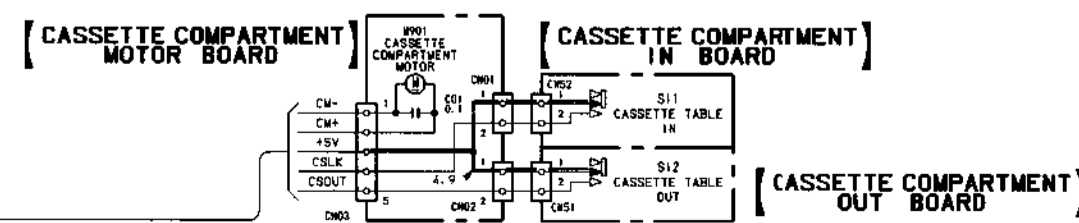
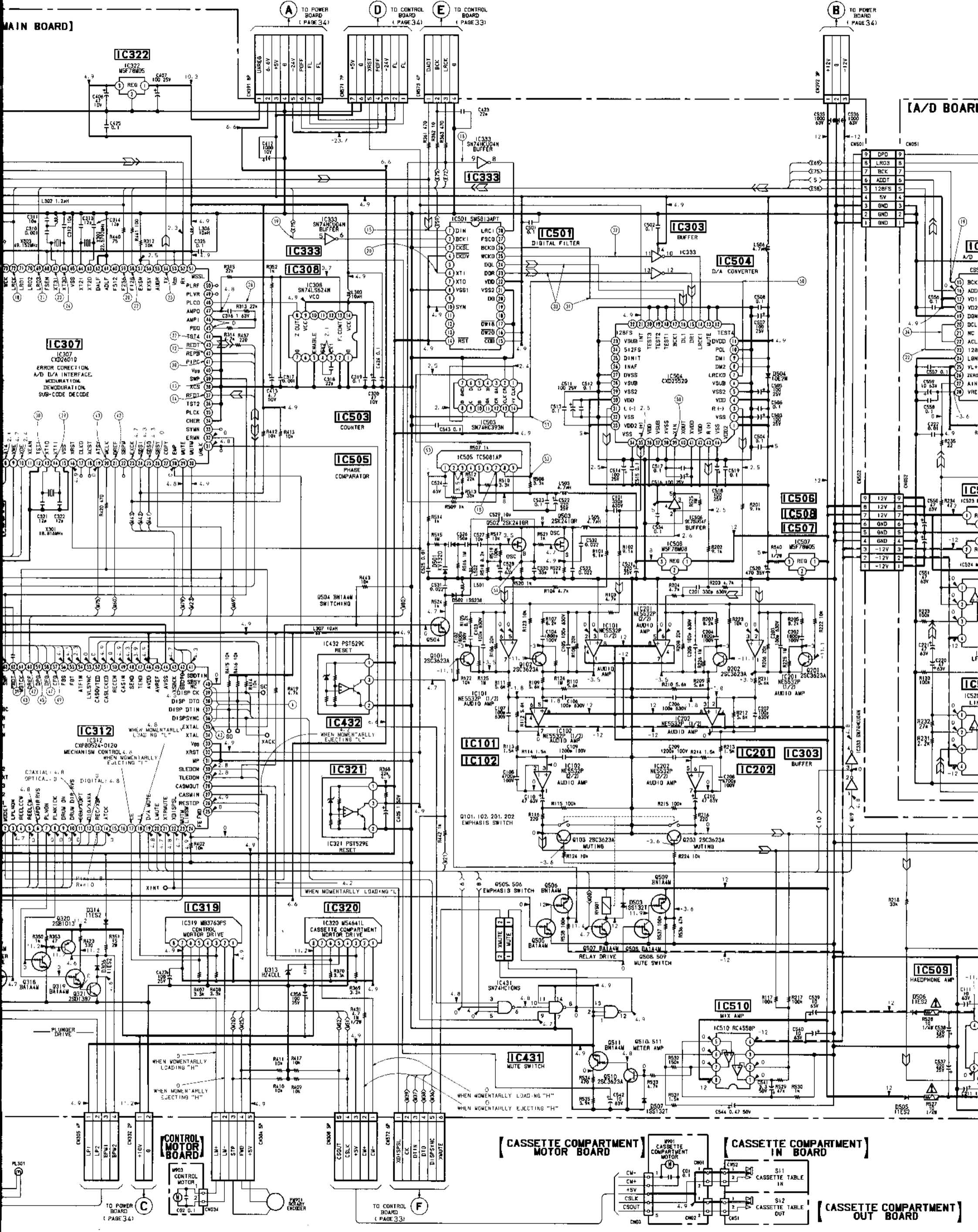

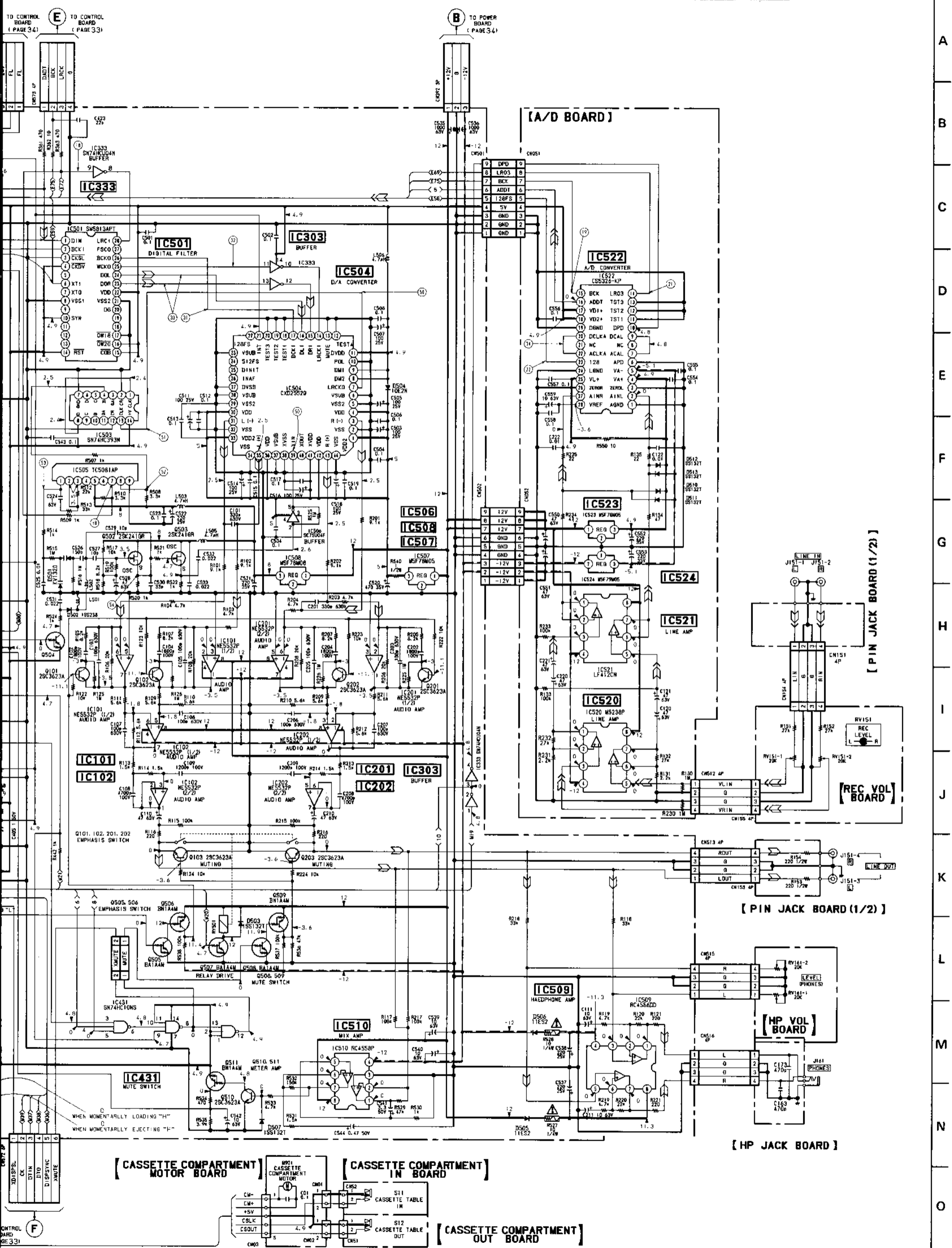

A
B
C
D
E
F
G
H
I
J
K
L
M
N
O
P

4-10. IC BLOCK DIAGRAM

IC101 CX20115A

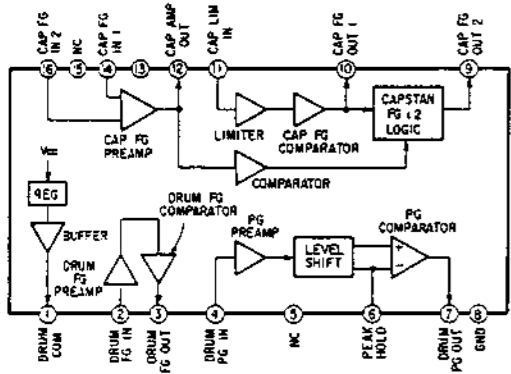

IC305 SN74HC153NS

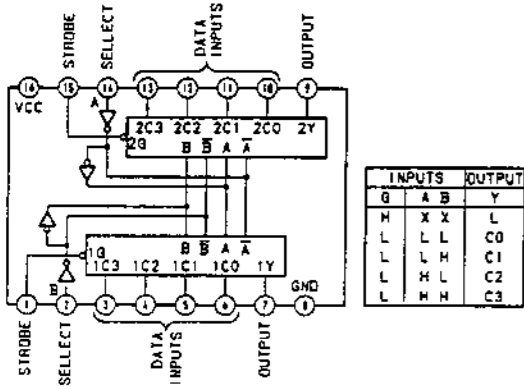

IC306 CXD1136Q

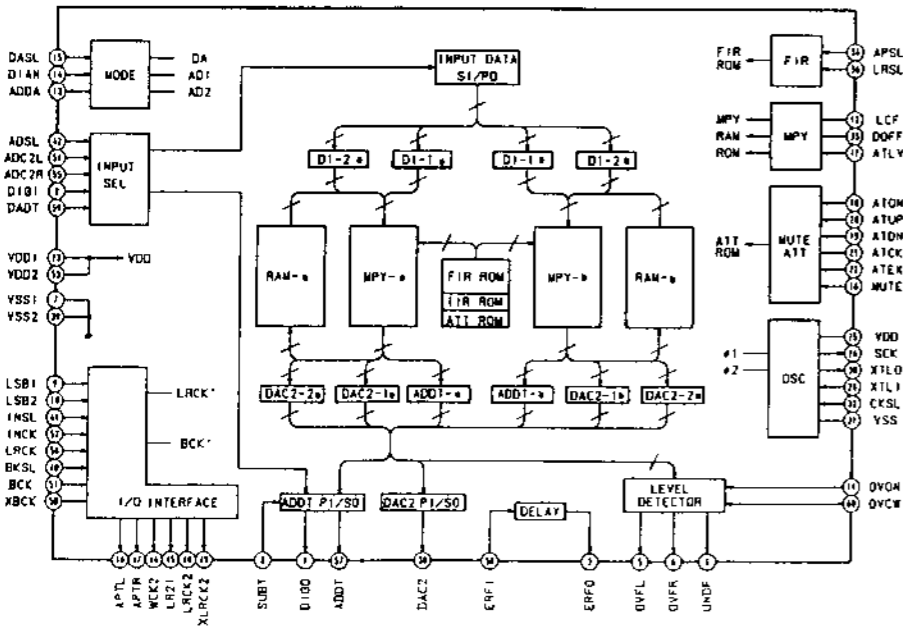

IC308 SN74LS624N

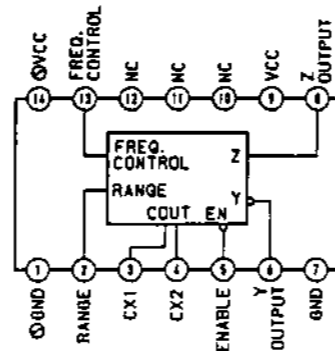

IC311 CXA1046M

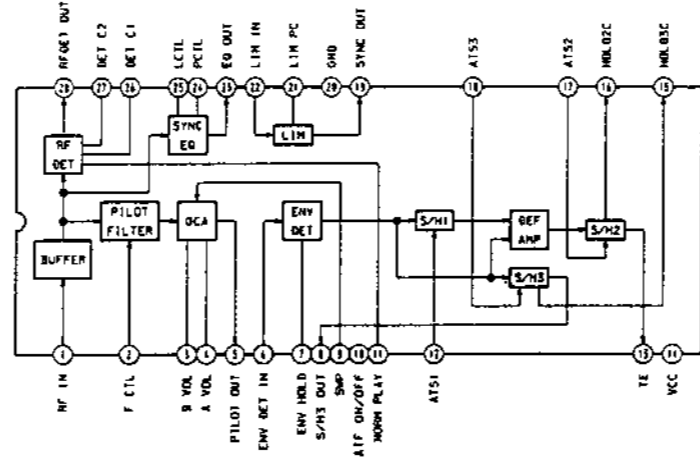

IC320 M54641L

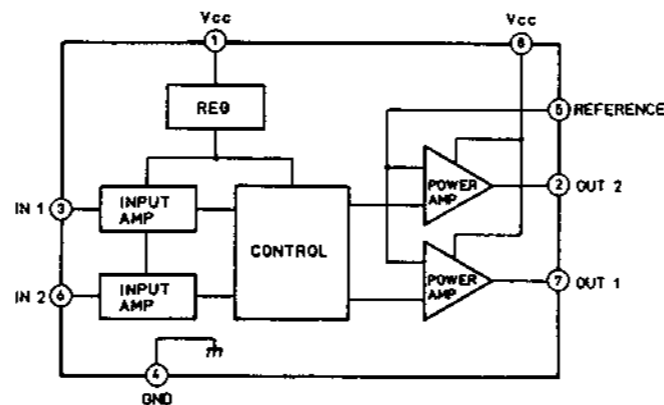

IC309 SN74HC74NS

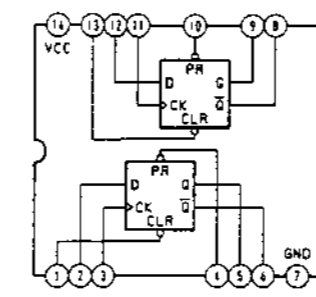

IC319 MB3763PS

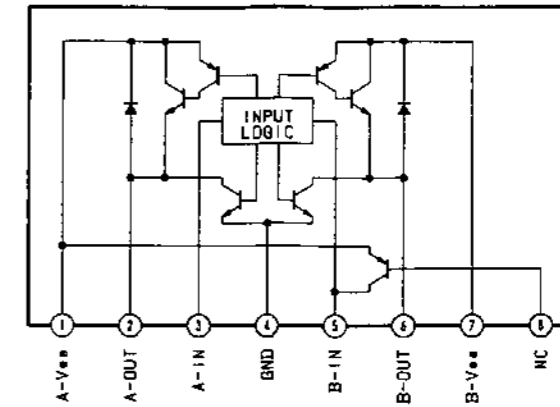

IC501 SM5813ATP

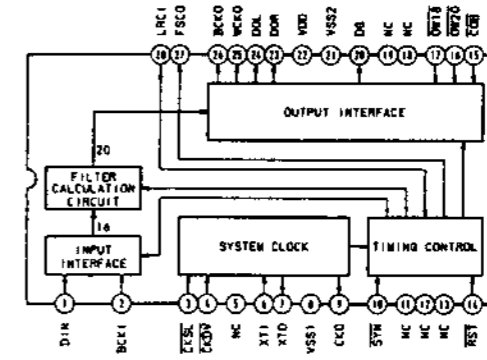

IC503 SN74HC393N

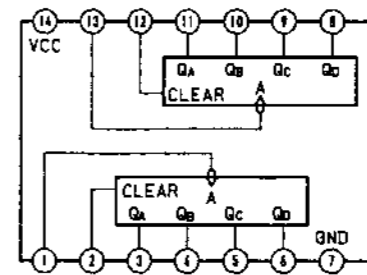

IC504 CXD2552

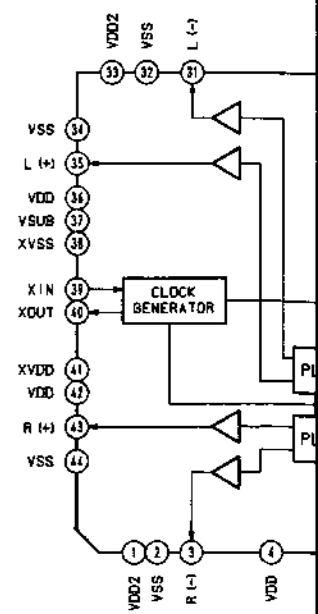

IC505 TC5081AP

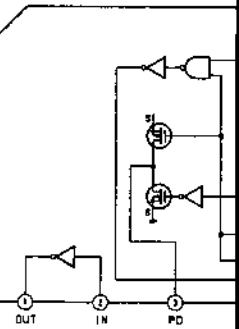

IC522 CS5326-KP

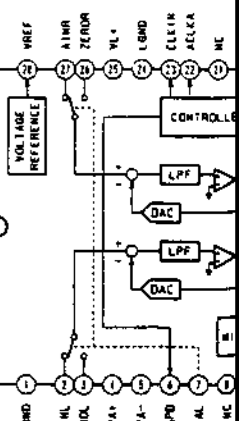

SECTION 5 EXPLODED VIEWS

IC504 CXD2552

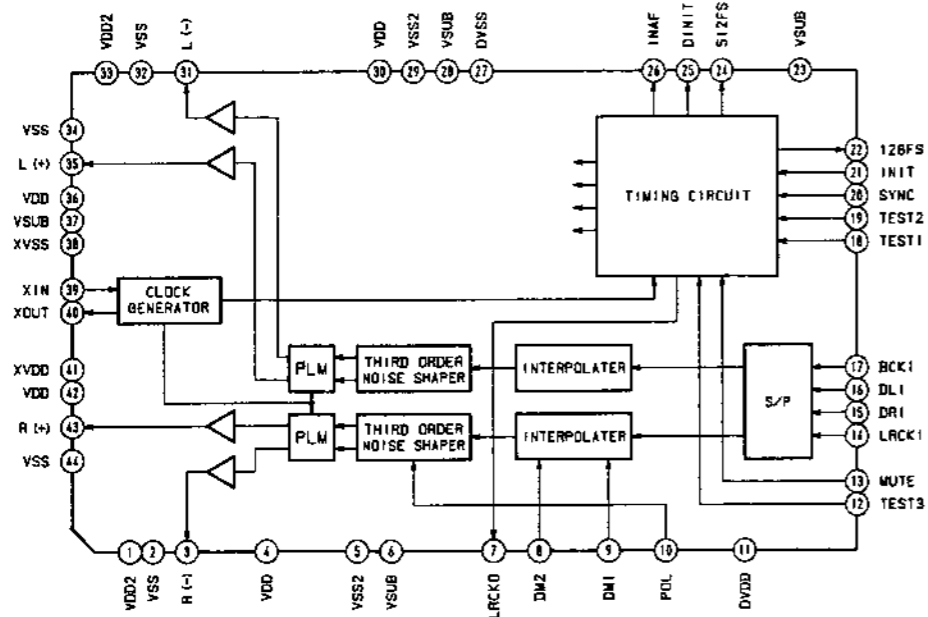

IC505 TC5081AP

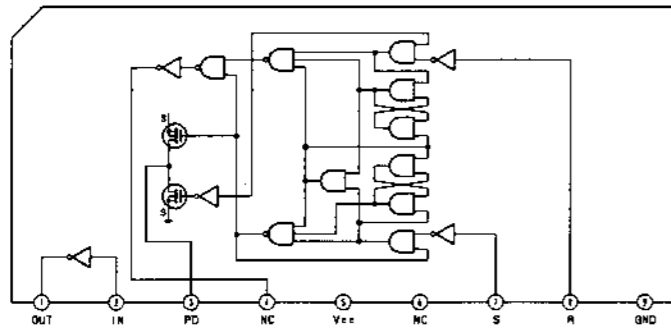

IC522 CS5326-KP

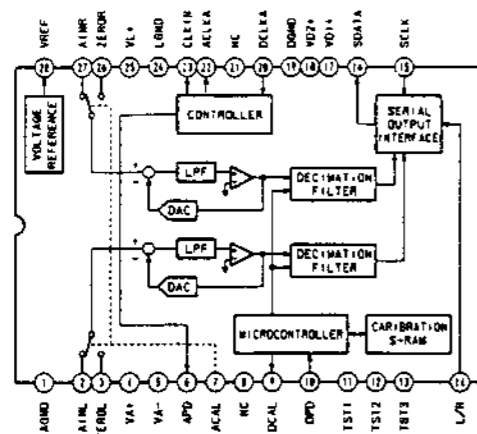

NOTE:

- The mechanical parts with no reference number in the exploded views are not supplied.
- The construction parts of an assembled part are indicated with a collation number in the remark column.
- Items marked "*" are not stocked since they are seldom required for routine service. Some delay should be anticipated when ordering these items.
- Due to standardization, parts with part number suffix -XX and -X may be different from the parts specified in the components used on the set.
- Color Indication of Appearance Parts
Example:
(RED) ... KNOB, BALANCE (WHITE)
↑ Cabinet's Color ↑ Parts' Color

The components identified by mark or dotted line with mark are critical for safety. Replace only with part number specified.

Les composants identifiés par une marque sont critiques pour la sécurité. Ne les remplacer que par une pièce portant le numéro spécifié.

5-1. CABINET SECTION

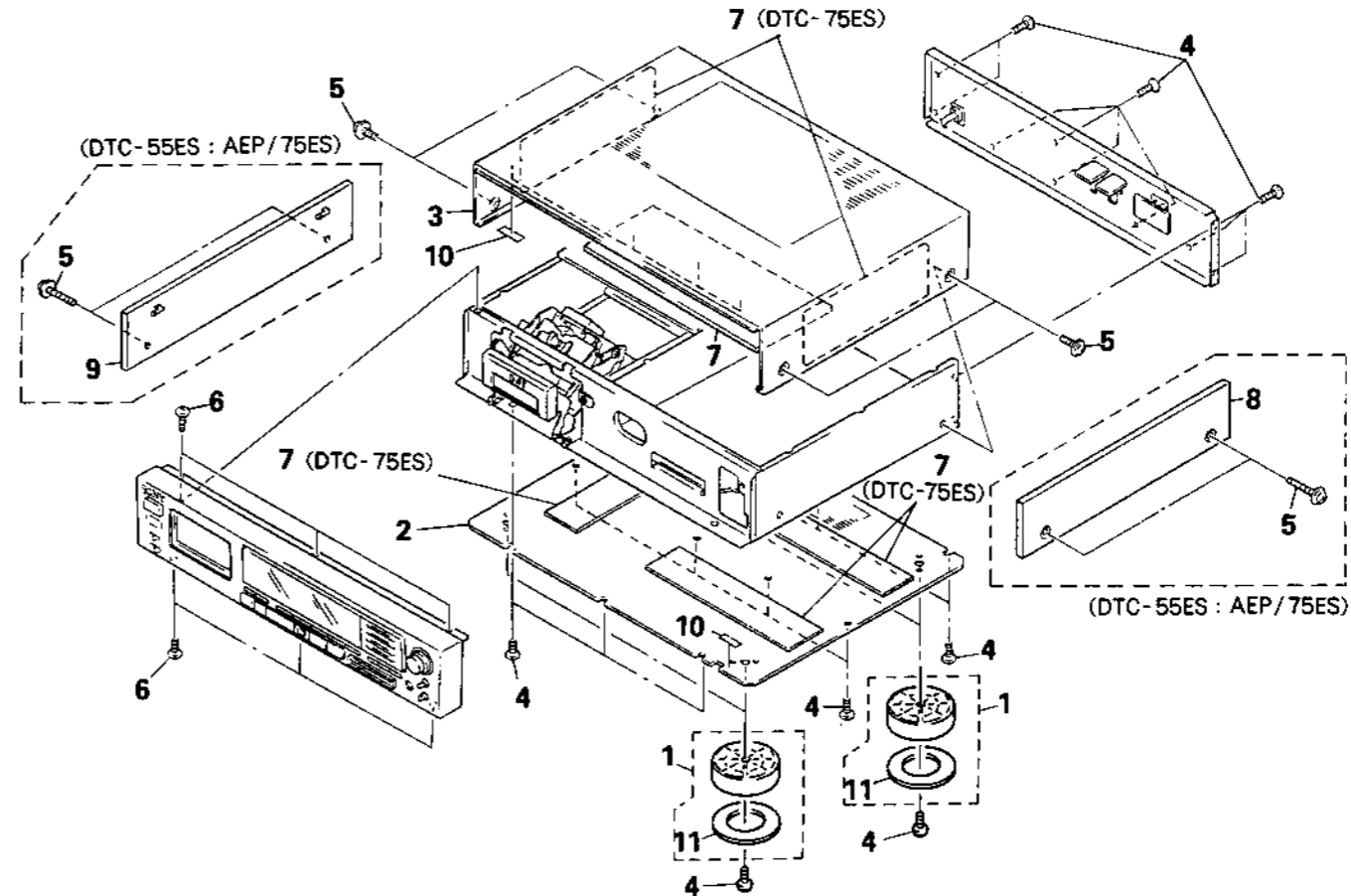

5-2. FRONT PANEL SECTION

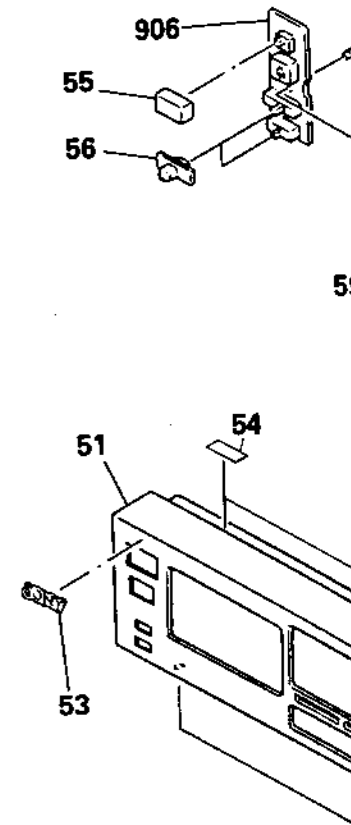

No.	Part No.	Description	Remarks	No.	Part No.	Description	Remarks
1	X-3304-938-2	FOOT ASSY		6	7-682-547-09	SCREW +B 3X6	
2	*4-931-433-11	PLATE, BOTTOM		7	*4-936-612-01	RUBBER (DAMPER)	
3	3-350-407-41	CASE		8	*X-4919-028-1	(55ES:AEP/75ES)...PANEL (R) ASSY, SIDE	
4	7-682-548-09	SCREW +BVT 3X8 (S)		9	*X-4919-027-1	(55ES:AEP/75ES)...PANEL (L) ASSY, SIDE	
5	3-704-366-01	(55ES:UK/700)...SCREW (CASE) (M3X8)		10	3-831-441-XX	CUSHION, SPEAKER	
	4-933-446-01	(55ES:AEP/75ES)...SCREW (SIDE PANEL)		11	4-923-836-11	CUSHION	

No.	Part No.	Description
51	4-936-605-11	(700).....
	4-936-605-21	(55ES:AEP)...
	4-936-605-31	(55ES:UK)...
	4-936-605-41	(75ES).....
52	3-332-590-01	KNOB (REC V)
53	4-908-848-01	EMBLEM, SON
54	3-831-441-XX	CUSHION, SP
55	4-922-921-01	BUTTON (POW
56	4-931-421-01	KNOB (T & S
57	4-931-482-01	WINDOW (FL
58	*4-925-758-11	COVER (L),
59	X-4919-024-1	ESCUTCHEON
60	4-923-782-21	BUTTON (10
61	4-931-483-01	PLATE (HP V

SECTION 5 EXPLODED VIEWS

NOTE:

- The mechanical parts with no reference number in the exploded views are not supplied.
- The construction parts of an assembled part are indicated with a collation number in the remark column.
- Items marked "*" are not stocked since they are seldom required for routine service. Some delay should be anticipated when ordering these items.

- Due to standardization, parts with part number suffix -XX and -X may be different from the parts specified in the components used on the set.
- Color Indication of Appearance Parts
Example:
(RED) ... KNOB, BALANCE (WHITE)
↑ Cabinet's Color ↑ Parts' Color

The components identified by mark or dotted line with mark are critical for safety. Replace only with part number specified.

Les composants identifiés par une marque sont critiques pour la sécurité. Ne les remplacer que par une pièce portant le numéro spécifié.

5-1. CABINET SECTION

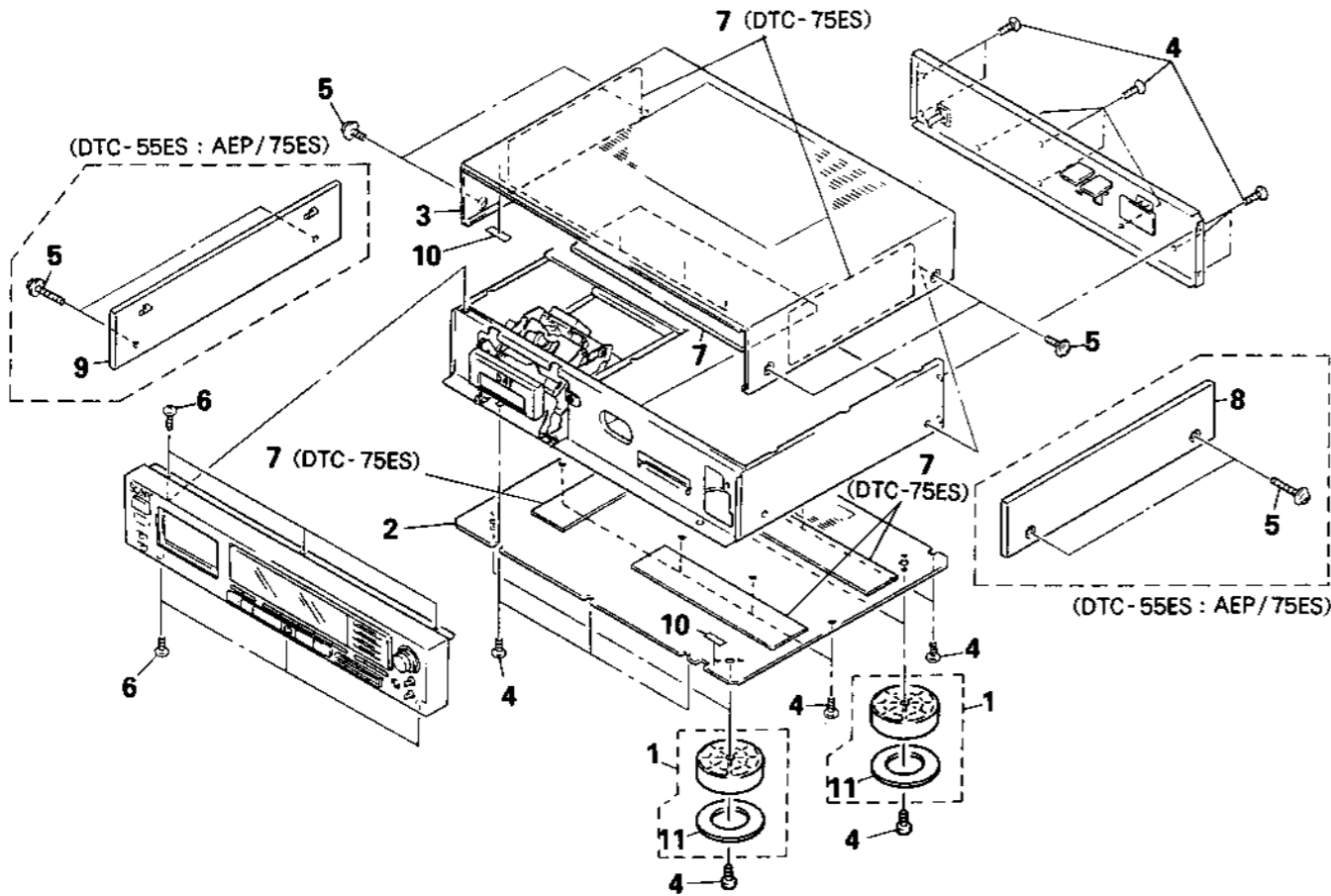

No.	Part No.	Description	Remarks	No.	Part No.	Description	Remarks
1	X-3304-938-2	FOOT ASSY		6	7-682-547-09	SCREW +B 3X6	
2	*4-931-433-11	PLATE, BOTTOM		7	*4-936-612-01	RUBBER (DAMPER)	
3	3-350-407-41	CASE		8	*X-4919-028-1	(55ES:AEP/75ES)...PANEL (R) ASSY, SIDE	
4	7-682-548-09	SCREW +BVT 3X8 (S)		9	*X-4919-027-1	(55ES:AEP/75ES)...PANEL (L) ASSY, SIDE	
5	3-704-366-01	(55ES:UK/700)...SCREW (CASE) (M3X8)		10	3-831-441-XX	CUSHION, SPEAKER	
	4-933-446-01	(55ES:AEP/75ES)...SCREW (SIDE PANEL)		11	4-923-836-11	CUSHION	

5-2. FRONT PANEL SECTION

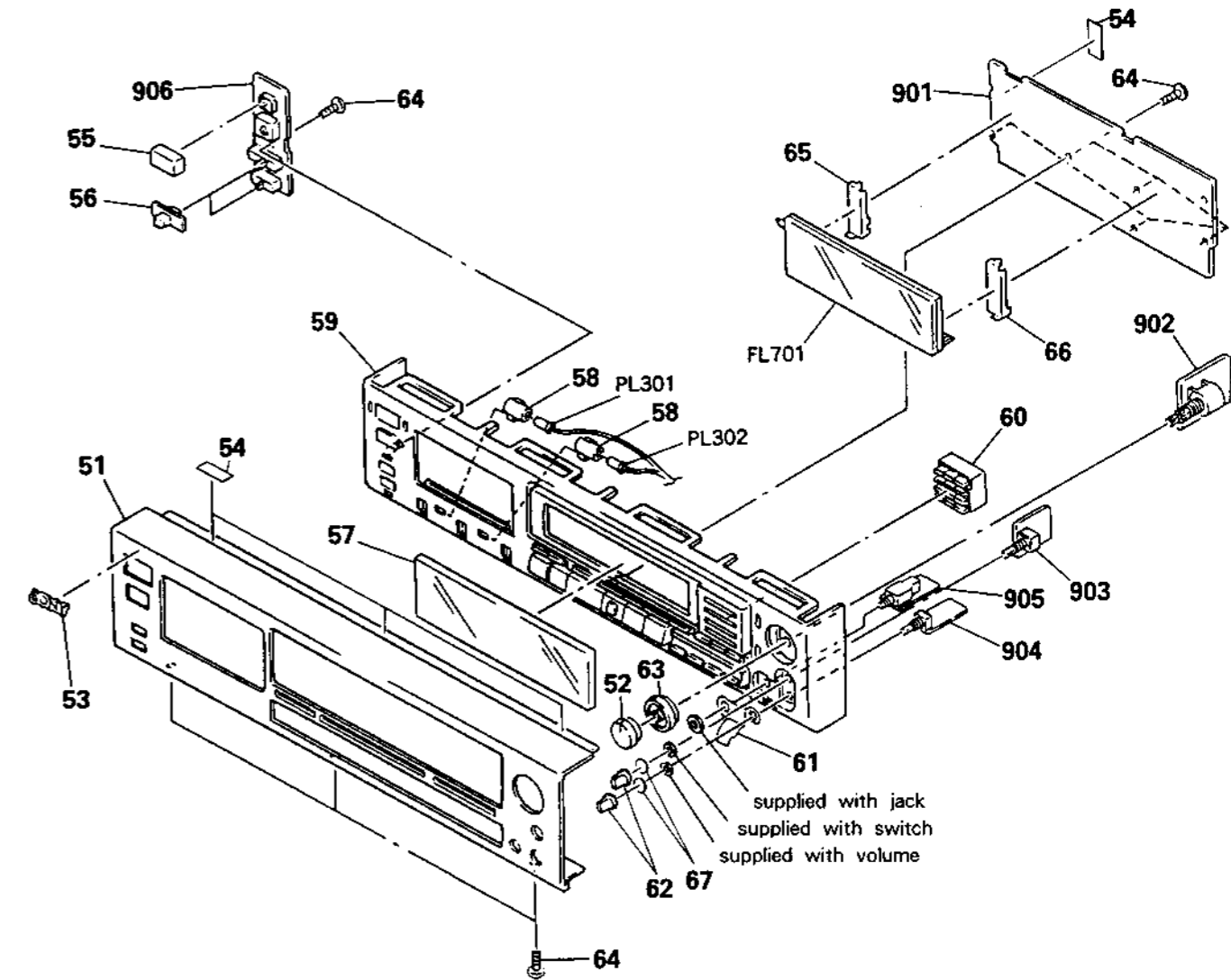

No.	Part No.	Description	Remarks	No.	Part No.	Description	Remarks
51	4-936-605-11	(700).....PANEL (FRONT)		62	3-354-931-01	KNOB (DIA.10)	
	4-936-605-21	(55ES:AEP)...PANEL (FRONT)		63	3-332-589-01	KNOB (REC VOL-LEFT)	
	4-936-605-31	(55ES:UK)...PANEL (FRONT)		64	7-685-534-19	SCREW +BTP 2.6X8 TYPE2 N-S	
	4-936-605-41	(75ES).....PANEL (FRONT)		65	*4-922-524-01	HOLDER (LEFT)	
52	3-332-590-01	KNOB (REC VOL-RIGHT)		66	*4-922-523-01	HOLDER (RIGHT)	
53	4-908-848-01	EMBLEM, SONY		67	3-354-981-01	SPRING (SUS), RING	
54	3-831-441-XX	CUSHION, SPEAKER		901	*A-2006-274-A	MOUNTED PCB, CONTROL SW	
55	4-922-921-01	BUTTON (POWER)		902	*1-633-721-11	PC BOARD, REC VOL	
56	4-931-421-01	KNOB (T & S)		903	*1-633-724-11	PC BOARD, INPUT SELECT	
57	4-931-482-01	WINDOW (FL TUBE)		904	*1-633-722-11	PC BOARD, HEADPHONE VOL	
58	*4-925-758-11	COVER (L), LAMP		905	*1-633-723-11	PC BOARD, HEADPHONE JACK	
59	X-4919-024-1	ESCUTCHEON (PANEL) ASSY		906	*1-633-725-11	PC BOARD, POWER SW	
60	4-923-782-21	BUTTON (10 KEY)		FL701	1-519-562-11	INDICATOR TUBE, FLUORESCENT	
61	4-931-483-01	PLATE (HP VOL), GROUND		PL301	1-518-664-11	LAMP, PILOT	
				PL302	1-518-664-11	LAMP, PILOT	

5-3. BACK PANEL SECTION

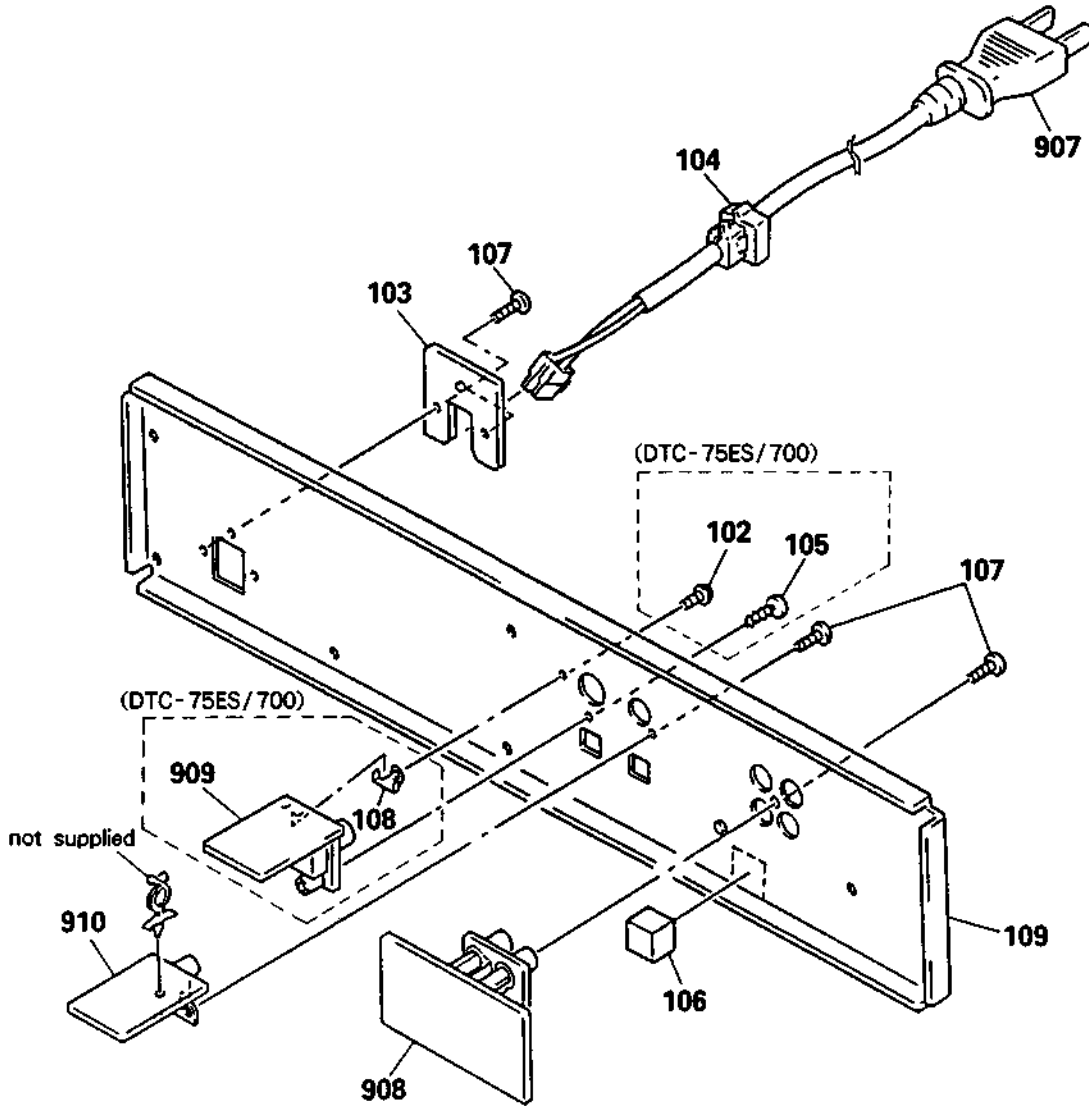

No.	Part No.	Description	Remarks	No.	Part No.	Description	Remarks
102	7-621-771-06	(75ES/700)...SCREW, LOCK		109	*4-931-498-11	(700).....PANEL, BACK	
103	*4-923-873-01	BRACKET, CORD STOPPER			*4-931-498-22	(55ES:AEP)...PANEL, BACK	
104	*3-703-244-00	(55ES/700)...BUSHING (2104), CORD			*4-931-498-32	(55ES:UK)...PANEL, BACK	
	4-916-783-01	(75ES).....BUSHING, CORD			*4-931-498-41	(75ES).....PANEL, BACK	
105	7-685-646-79	(75ES/700)...SCREW +BVTP 3X8 TYPE2 N-S		907	▲.1-559-479-11	(75ES).....CORD, POWER	
106	*4-936-607-01	BUSHING, RUBBER			▲.1-575-695-11	(700).....CORD, POWER	
107	7-682-548-09	SCREW +BVTT 3X8 (S)			▲.1-575-912-11	(55ES:AEP)...CORD, POWER	
108	*4-916-318-01	(75ES/700)...PLATE, GROUND			▲.1-575-913-11	(55ES:UK)...CORD, POWER	
				908	*1-633-719-11	PC BOARD, PIN JACK	
				909	*1-633-718-11	(75ES/700)...PC BOARD, DIGITAL OUT	
				910	*1-633-717-11	PC BOARD, DIGITAL IN	

<p>Note: The components identified by mark ▲ or dotted line with mark ▲ are critical for safety. Replace only with part number specified.</p>	<p>Note: Les composants identifiés par une marque ▲ sont critiques pour la sécurité. Ne les remplacer que par une pièce portant le numéro spécifié.</p>
--	--

5-4. CHASSIS SECTION

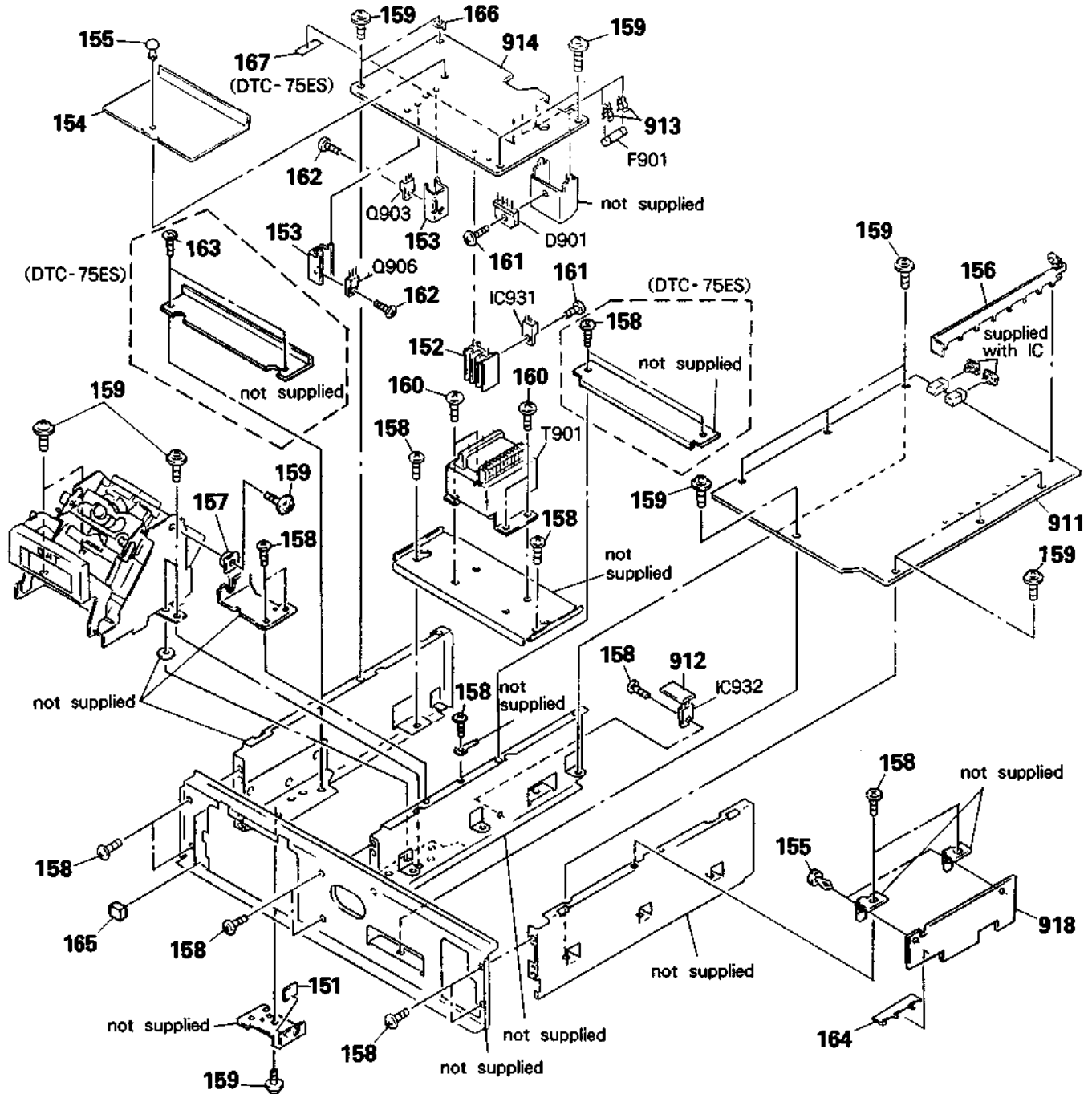

No.	Part No.	Description	Remarks	No.	Part No.	Description	Remarks
151	2-272-609-00	SPACER		912	*1-633-814-11	PC BOARD, TRANSISTOR	
152	*4-363-146-71	HEAT SINK, V.OUT		913	*1-533-213-31	HOLDER, FUSE	
153	4-902-345-01	HEAT SINK		914	*A-2006-244-A	(55ES:AEP)...MOUNTED PCB, POWER	
154	*4-931-491-01	COVER (POWER)			*A-2006-293-A	(75ES/700)...MOUNTED PCB, POWER	
155	3-531-576-01	RIVET			*A-2006-296-A	(55ES:UK)...MOUNTED PCB, POWER	
156	*4-931-489-01	PLATE (BUS BAR), GROUND		918	*1-635-440-11	PC BOARD, A/D	
157	4-931-466-01	SPACER		D901	8-719-311-72	DIODE RBV-406H-01	
158	7-682-548-09	SCREW +BYTT 3X8 (S)		F901	△.1-532-286-00	(55ES).....FUSE, TIME-LAG (2.5A)	
159	4-886-821-11	SCREW, S TIGHT, +PTTWH 3X6		F901	△.1-532-744-11	(75ES/700)...FUSE, GLASS TUBE (2.5A)	
160	7-682-560-04	SCREW +BYTT 4X6 (S)		IC931	8-759-148-79	IC UPC2406HF	
161	7-682-548-09	SCREW +B 3X8		IC932	8-759-634-55	IC M5F7805L-720	
162	7-682-147-15	SCREW, TR		Q903	8-729-127-53	TRANSISTOR 2SC2275-P	
163	7-682-545-09	(75ES)...SCREW +P 3X4		Q906	8-729-190-53	TRANSISTOR 2SA985A	
164	*3-311-617-11	REINFORCEMENT, PCB		T901	△.1-450-080-11	(75ES/700)...TRANSFORMER, POWER	
165	9-911-842-XX	CUSHION, PC BOARD		T901	△.1-450-164-11	(55ES).....TRANSFORMER, POWER	
166	4-870-539-00	PLATE, GROUND					
167	3-701-947-15	(55ES)...LABEL (T2.5A), FUSE					
911	*A-2006-291-A	(700)...MOUNTED PCB, MAIN					
	*A-2006-292-A	(75ES)...MOUNTED PCB, MAIN					
	*A-2006-303-A	(55ES)...MOUNTED PCB, MAIN					

Note:
The components identified by mark Δ or dotted line with mark Δ are critical for safety. Replace only with part number specified.

Note:
Les composants identifiés par une marque Δ sont critiques pour la sécurité. Ne les remplacer que par une pièce portant le numéro spécifié.

5-5. MECHANISM SECTION 1

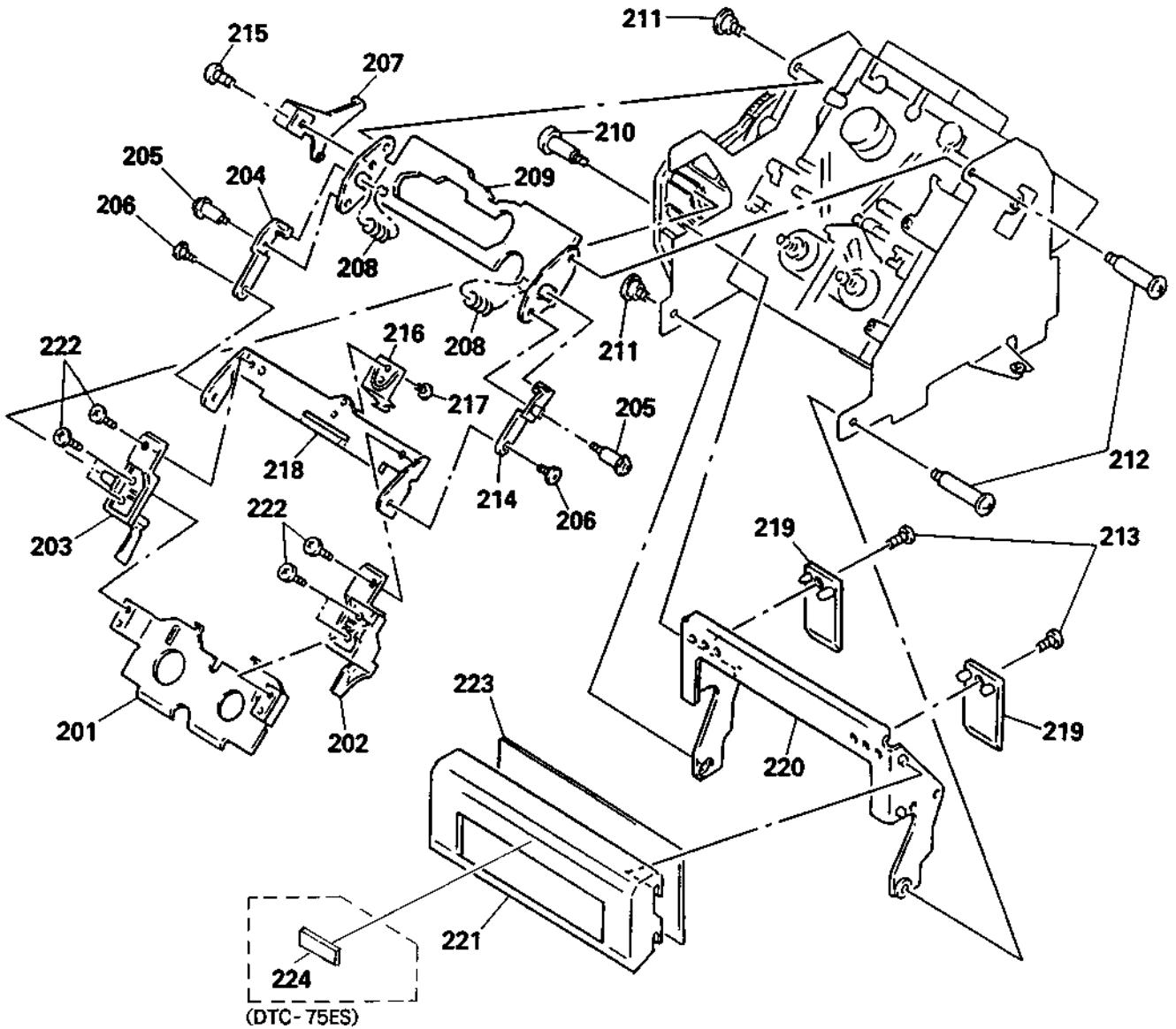

No.	Part No.	Description	Remarks	No.	Part No.	Description	Remarks
201	4-931-476-01	HOLDER (LOWER)		214	4-931-481-01	ARM (LIMITER L)	
202	4-931-486-01	HOLDER (C-RIGHT)		215	7-682-545-09	SCREW +B 3X4	
203	4-931-484-01	HOLDER (C-LEFT)		216	4-931-461-01	SPRING (CENTER), LEAF	
204	4-931-473-01	ARM (LIMITER R)		217	3-352-517-01	SCREW (M2X2.5)	
205	4-918-991-01	SCREW, STEP		218	*4-931-485-01	HOLDER (C-INNER)	
206	3-312-161-00	SCREW, STEP, PRECISION		219	4-931-469-01	PLATE, ORNAMENTAL	
207	*X-4919-020-1	JOINT ASSY		220	4-931-474-01	HOLDER (WINDOW)	
208	3-537-214-00	SPRING, COMPRESSION		221	4-931-480-01	(700)...LID, CASSETTE	
209	*4-931-475-01	PLATE, FULCRUM		4-931-480-11	(75ES)...LID, CASSETTE		
210	4-931-471-01	SCREW (STEP)		222	7-621-772-10	SCREW +B 2X4	
211	2-236-956-00	SCREW, STEP		223	4-931-462-01	WINDOW	
212	4-931-463-01	SCREW (STEP)		224	4-936-615-01	(75ES)...PLATE (DAT LOGO), ORNAMENTAL	
213	7-621-772-08	SCREW +B 2X3					

5-6. MECHANISM SECTION 2

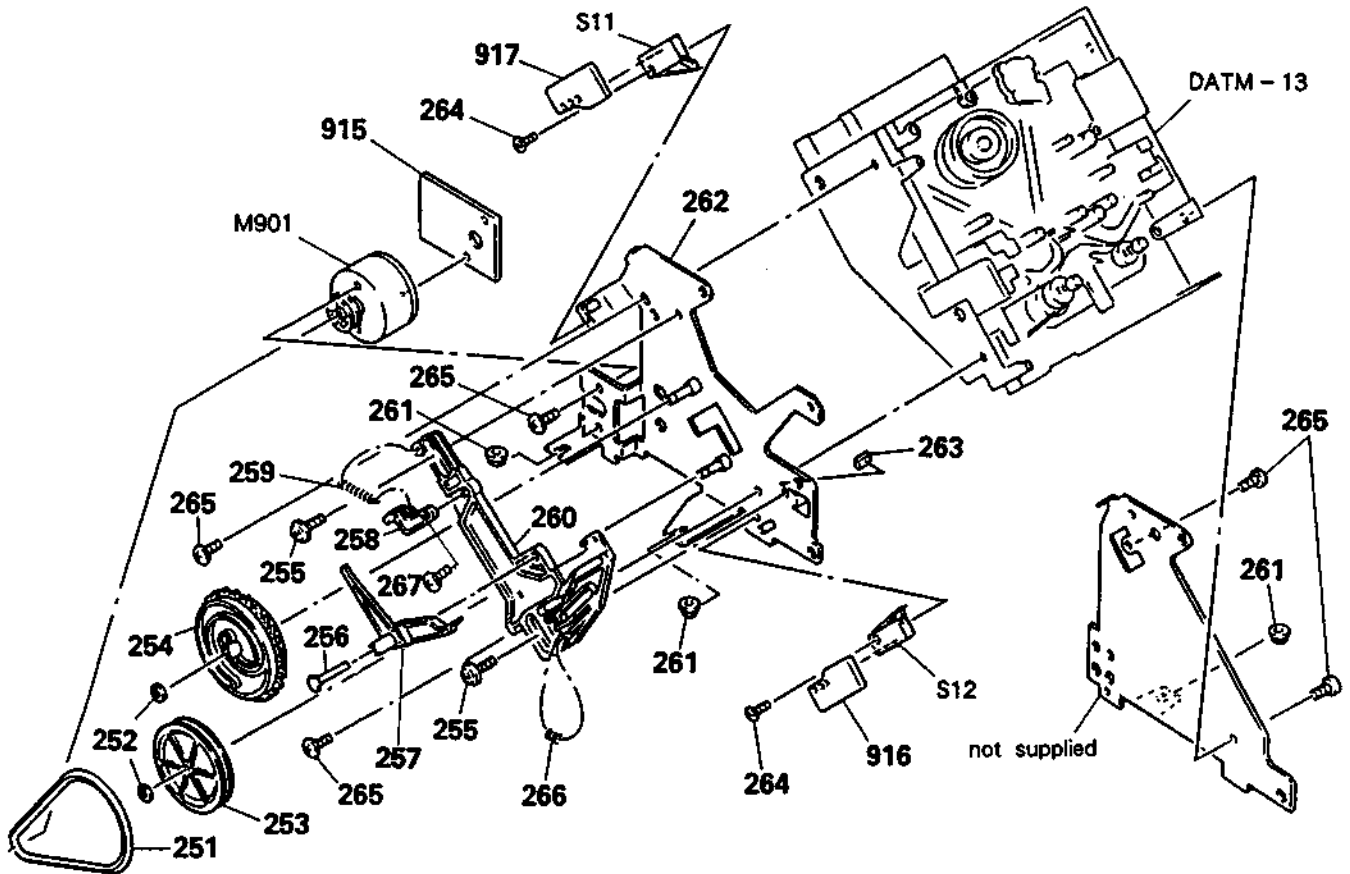

No.	Part No.	Description	Remarks	No.	Part No.	Description	Remarks
251	4-931-470-01	BELT (DRIVING)		263	9-911-863-XX	SPACER	
252	3-307-948-21	WASHER, NYLON		264	7-621-255-45	SCREW +P 2X6	
253	4-931-459-01	PULLEY		265	7-621-775-08	SCREW +B 2.6X3	
254	4-931-477-01	GEAR (CAM)		266	3-537-215-00	SPRING, COMPRESSION	
255	4-932-336-01	SCREW (STEP)		267	4-936-626-01	SHAFT (ARM PRESS FITTING)	
256	4-931-468-01	SHAFT (PRESS FITTING)		915	*1-633-726-11	PC BOARD, CASSETTE COMPARTMENT MOTOR	
257	4-931-490-01	LEVER (LINK)		916	*1-633-727-11	PC BOARD, CASSETTE COMPARTMENT IN	
258	4-931-460-01	ARM (SLIDER)		917	*1-633-728-11	PC BOARD, CASSETTE COMPARTMENT OUT	
259	3-549-810-00	SPRING, TENSION		M901	A-2003-448-A	MOTOR ASSY (CASSETTE COMPARTMENT)	
260	4-931-492-01	SLIDER (CAM)		S11	1-570-975-11	SWITCH, SLIDE (CASSETTE TABLE IN)	
261	4-931-466-01	SPACER		S12	1-572-247-11	SWITCH, SLIDE (CASSETTE TABLE OUT)	
262	*X-4919-023-1	PLATE ASSY, SIDE				not supplied	

5-7. MECHANISM SECTION 3 (DATM-13)

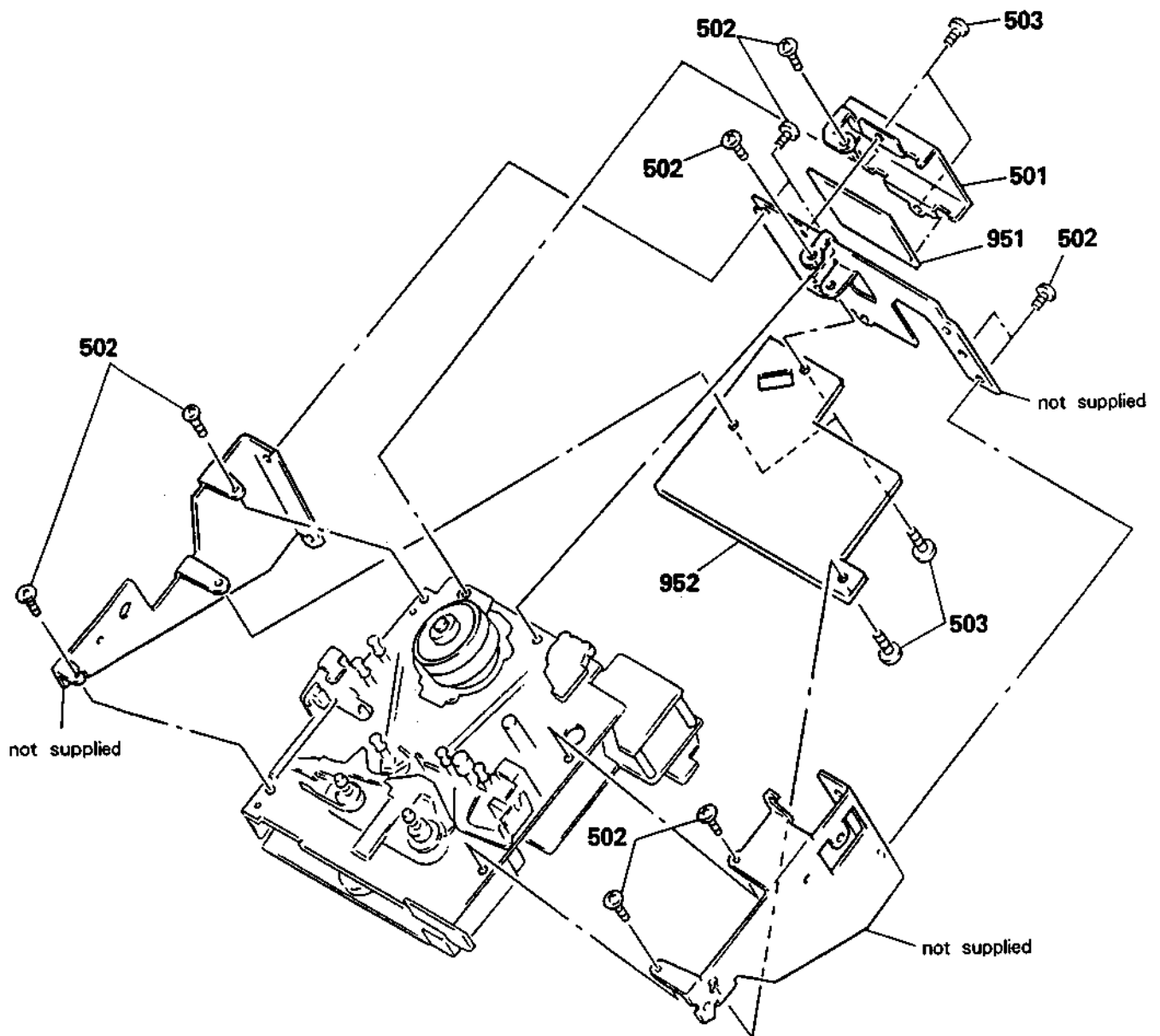

No.	Part No.	Description	Remarks
501	*3-352-522-01	CASE, SHIELD	
502	7-621-775-08	SCREW +B 2.6X3	
503	7-621-775-10	SCREW +B 2.6X4	
951	*A-2006-139-A	MOUNTED PCB, RF AMPLIFIER	
952	*A-2006-140-A	MOUNTED PCB, DRUM DRIVE	

5-8. MECHANISM SECTION 4 (DATM-13)

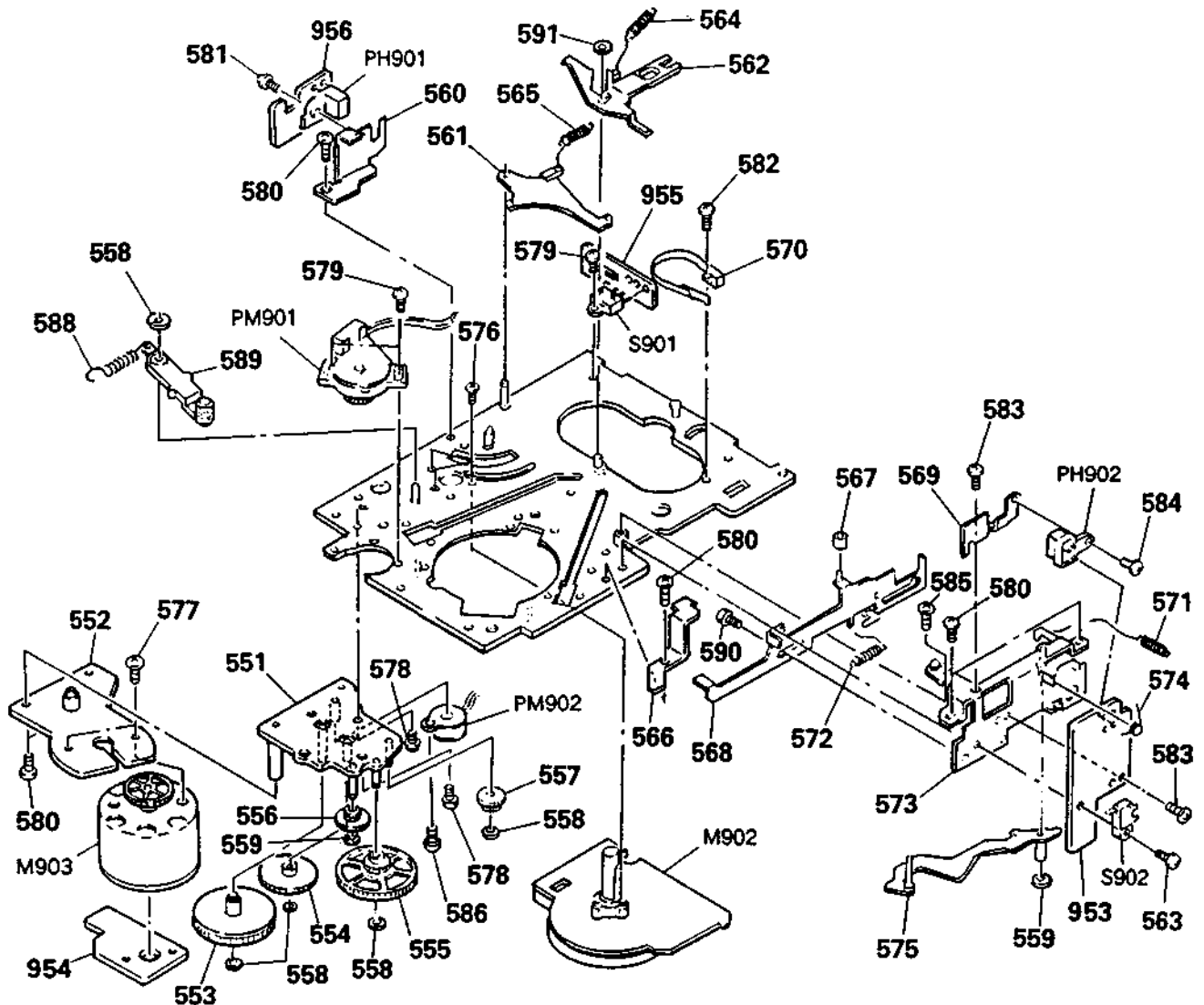

No.	Part No.	Description	Remarks	No.	Part No.	Description	Remarks
551	*X-3337-656-1	CHASSIS (DECELERATION GEAR) ASSY		577	7-621-775-00	SCREW +B 2.6X3	
552	*X-3337-659-1	BRACKET (MOTOR) ASSY		578	7-628-253-00	SCREW +PS 2X4	
553	X-3337-630-3	GEAR (B) ASSY		579	7-621-772-18	SCREW +B 2X4	
554	3-345-129-01	GEAR (A)		580	7-621-772-08	SCREW +B 2X3	
555	3-345-181-01	GEAR (LOADING A)		581	7-621-772-20	SCREW +B 2X5	
556	3-337-669-01	GEAR, MIDWAY		582	7-627-852-27	+P 1.7X3	
557	3-345-182-01	GEAR (LOADING B)		583	7-627-552-18	SCREW, PRECISION +P 1.7X1.6	
558	3-701-436-11	WASHER, 1.6 POLYETHYLENE		584	3-884-232-00	SCREW M 1.7X2.5	
559	3-559-408-11	WASHER, POLYETHYLENE, DIA.1.2		585	3-352-517-01	SCREW (M2X2.5)	
560	*3-352-507-01	HOLDER (R)		586	7-621-255-10	SCREW +P 2X3	
561	3-345-145-01	LEVER (T LOCK)		588	3-307-377-00	SPRING, TENSION	
562	X-3337-638-1	LEVER (SLIDER) ASSY		589	A-2003-438-A	CLEANER ASSY, HEAD	
563	7-621-772-38	SCREW +B 2X6		590	3-703-502-11	SCREW	
564	3-570-898-00	SPRING, TENSION		591	3-321-813-01	WASHER, COTTER POLYETHYLENE	
565	3-547-661-00	SPRING, TENSION		953	*1-633-711-11	PC BOARD, END SENSOR (S)	
566	*3-352-506-01	HOLDER (L)		954	*1-633-713-11	PC BOARD, CONTROL MOTOR	
567	3-352-525-01	ROLLER (TENSION REGULATOR)		955	*1-633-710-11	PC BOARD, RECOGNITION	
568	X-3337-618-1	SLIDER ASSY, MODE		956	*1-633-712-11	PC BOARD, END SENSOR (T)	
569	*3-352-515-01	HOLDER (E SENSOR L)		M902	8-835-306-01	MOTOR, DC U-17A (CAPSTAN)	
570	X-3337-632-1	BAND (TENSION REGULATOR) ASSY		M903	A-2003-545-A	MOTOR ASSY (CONTROL)	
571	3-352-527-01	SPRING, TENSION		PH901	1-808-957-11	PHOTO SENSOR (END T)	
572	3-570-892-00	SPRING, TENSION		PH902	1-808-957-11	PHOTO SENSOR (END S)	
573	*X-3337-657-1	CHASSIS (TENSION REGULATOR) ASSY		PM901	1-464-724-31	ENCODER, ROTARY	
574	3-337-673-01	SPRING		PM902	1-454-462-21	SOLENOID, PLUNGER (LOADING)	
575	*X-3337-654-1	LEVER (TENSION REGULATOR) ASSY		S901	1-571-878-11	SWITCH, PUSH(2 KEY)(CASSETTE IN/REC PROOF)	
576	7-627-552-47	SCREW, PRECISION +P 1.7X4		S902	1-570-771-21	SWITCH (LIMIT)	

5-9. MECHANISM SECTION 5 (DATM-13)

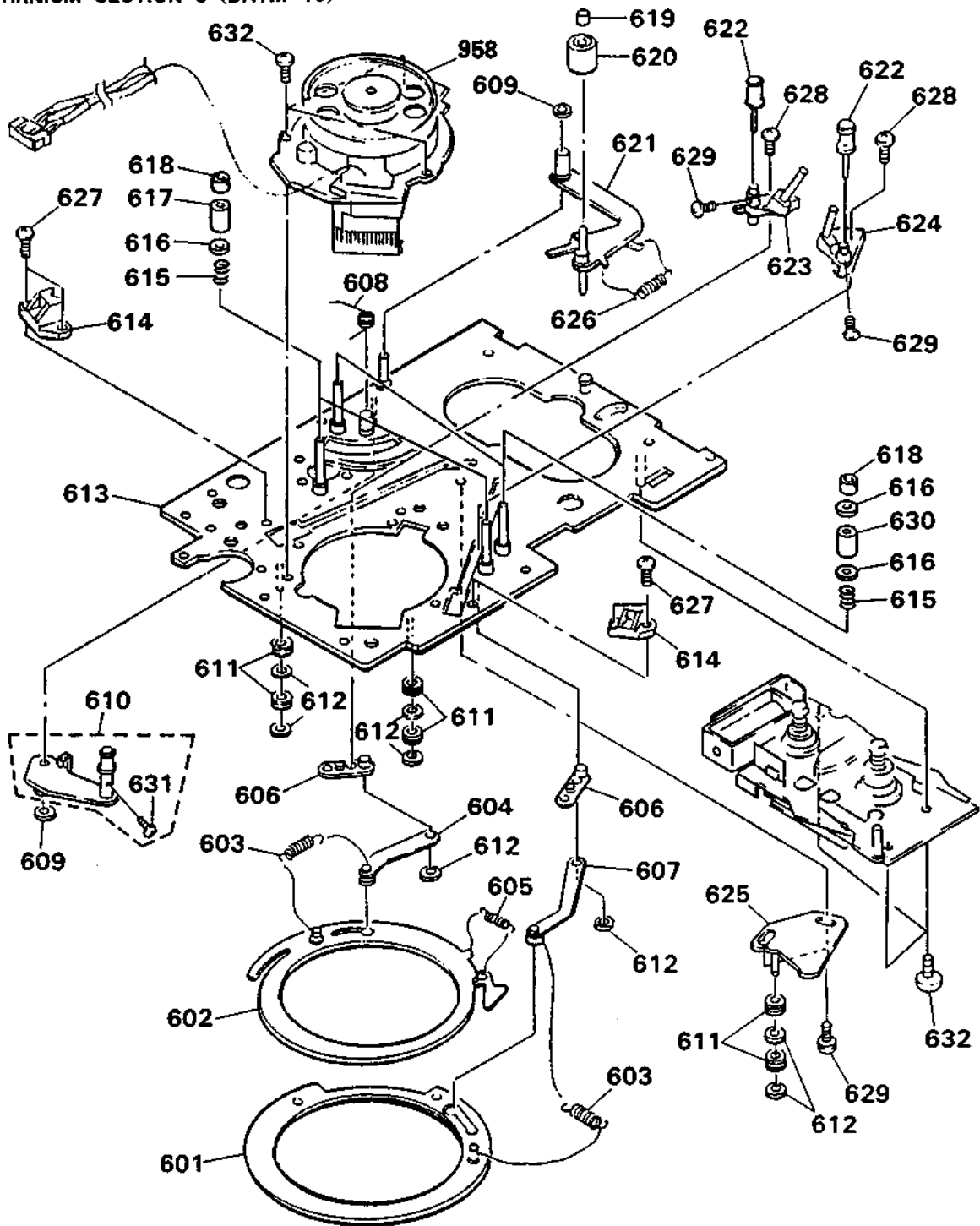

No.	Part No.	Description	Remarks	No.	Part No.	Description	Remarks
601	X-3337-602-1	RING (LEFT) ASSY, LOADING		618	3-337-605-01	NUT, ADJUSTMENT	
602	X-3337-601-1	RING (RIGHT) ASSY, LOADING		619	3-337-626-01	CAP, PINCH ROLLER	
603	3-337-653-01	SPRING, TENSION		620	X-3337-610-1	PINCH ROLLER ASSY	
604	*X-3337-603-1	ARM (RIGHT) ASSY, LOADING		621	X-3337-660-1	ARM (PINCH ROLLER) ASSY	
605	3-352-603-01	SPRING, TENSION		622	X-3337-622-1	GUIDE (POM) ASSY, ROLLER	
606	X-3337-604-1	PLATE ASSY, LOADING		623	X-3337-652-1	SLANT BLOCK (RIGHT) ASSY	
607	*X-3337-607-1	ARM (LEFT) ASSY, LOADING		624	X-3337-651-1	SLANT BLOCK (LEFT) ASSY	
608	3-352-513-01	SPRING (F GUIDE RETURN)		625	*X-3337-605-1	ARM ASSY, RING ROLLER	
609	3-701-436-11	WASHER, 1.6 POLYETHYLENE		626	3-547-659-00	SPRING, TENSION	
610	A-2003-408-A	LEVER (F ARM) ASSY		627	7-627-852-17	+P 1.7X4	
611	3-337-622-01	ROLLER, RING		628	3-703-502-81	SCREW	
612	3-559-408-11	WASHER, POLYETHYLENE, DIA.1.2		629	7-627-551-17	SCREW, PRECISION +P 1.4X2	
613	*X-3337-658-1	CHASSIS (MECHANICAL) ASSY		630	3-337-676-01	GUIDE, FIXED	
614	*3-345-195-01	CATCHER		631	7-627-551-27	SCREW, PRECISION +P 1.4X2.5	
615	3-573-470-00	SPRING, COMPRESSION		632	7-621-772-18	SCREW +B 2X4	
616	3-337-677-01	FLANGE		958	8-848-513-11	DRUM ASSY DOU-02D	
617	3-337-676-11	GUIDE, FIXED					

5-10. MECHANISM SECTION 6
(DATM-13)

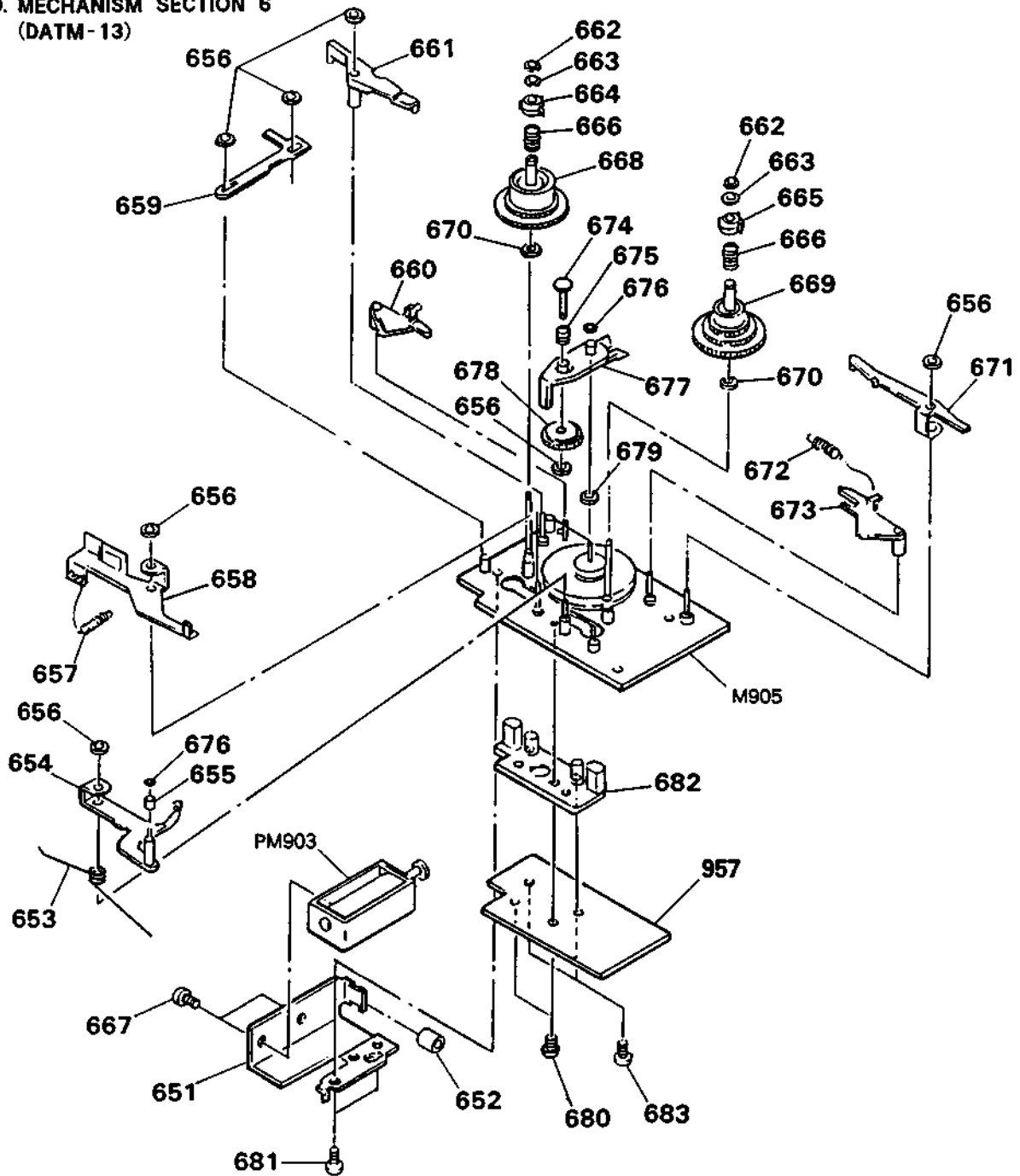

No.	Part No.	Description	Remarks	No.	Part No.	Description	Remarks
651	*3-345-118-01	BRACKET (SOLENOID)		669	X-3337-642-1	TABLE (T) ASSY, REEL	
652	*3-576-990-01	CUSHION		670	3-701-438-11	WASHER, 2.5	
653	3-345-169-01	SPRING, TORSION		671	*X-3337-637-1	LEVER (BRAKE RELEASE) ASSY	
654	*X-3337-628-1	LEVER ASSY		672	3-527-190-00	SPRING, TENSION	
655	3-345-104-01	COLLAR		673	X-3337-636-1	LEVER (BRAKE S) ASSY	
656	3-559-408-11	WASHER, POLYETHYLENE, DIA.1.2		674	*3-345-114-01	SHAFT (MIDWAY GEAR)	
657	3-345-168-01	SPRING, TENSION		675	3-345-115-01	SPRING, COMPRESSION	
658	*X-3337-640-1	LEVER (REVERSE SB) ASSY		676	3-315-384-11	WASHER, STOPPER	
659	*3-345-166-01	LEVER (SOLENOID)		677	3-345-113-01	LEVER (FR)	
660	X-3337-635-1	LEVER (BRAKE T) ASSY		678	X-3337-633-1	GEAR (MIDWAY) ASSY	
661	3-345-110-01	LEVER (BRAKE ARM)		679	3-701-436-11	WASHER, 1.6 POLYETHYLENE	
662	3-578-224-00	WASHER		680	7-621-772-18	SCREW +B 2X4	
663	3-345-112-01	RING, RETAINING		681	7-621-772-08	SCREW +B 2X3	
664	*2-623-736-01	CLAW (C) (LEFT), REEL		682	*3-345-142-01	HOLDER (FG SENSOR)	
665	*2-623-752-01	CLAW (C) (RIGHT), REEL		683	7-685-102-19	SCREW +P 2X4 TYPE2 SLIT	
666	2-623-754-01	SPRING, COMPRESSION		957	*1-633-709-11	PC BOARD, REEL FG	
667	7-621-775-00	SCREW +B 2.6X3		M905	8-835-346-11	MOTOR, DC U-16B (REEL)	
668	X-3337-634-1	TABLE (S) ASSY, REEL		PM903	1-454-482-21	SOLENOID, PLUNGER (REEL MOTOR CONTROL)	

SECTION 6 ELECTRICAL PARTS LIST

NOTE:

- Due to standardization, replacements in the parts list may be different from the parts specified in the diagrams or the components used on the set.
- Items marked "*" are not stocked since they are seldom required for routine service. Some delay should be anticipated when ordering these items.
- If there are two or more same circuits in a set such as a stereophonic machine, only typical circuit parts may be indicated and capacitors and resistors in other same circuits may be omitted.

CAPACITORS:
MF: μ F, PF: μ PF.

RESISTORS
• All resistors are in ohms.
• F: nonflammable

COILS
• MMH: mH, UH: μ H

SEMICONDUCTORS
In each case, U: μ , for example:
UA...: μ A..., UPA...: μ PA...,
UPC...: μ PC, UPD...: μ PD...

The components identified by mark Δ or dotted line with mark Δ are critical for safety. Replace only with part number specified.

Les composants identifiés par une marque Δ sont critiques pour la sécurité. Ne les remplacer que par une pièce portant le numéro spécifié.

Ref.No.	Part No.	Description	Ref.No.	Part No.	Description
901	*A-2006-274-A	MOUNTED PCB, CONTROL SW	C106	1-136-433-11	FILM 100PF 5% 630V
902	*1-633-721-11	PC BOARD, REC VOL	C106A	1-124-446-11	ELECT 47MF 20% 10V
903	*1-633-724-11	PC BOARD, INPUT SELECT			
904	*1-633-722-11	PC BOARD, HEADPHONE VOL	C107	1-136-433-11	FILM 100PF 5% 630V
905	*1-633-723-11	PC BOARD, HEADPHONE JACK	C108	1-136-233-11	FILM 0.0047MF 3% 100V
906	*1-633-725-11	PC BOARD, POWER SW	C109	1-136-228-11	FILM 0.0012MF 3% 100V
907	Δ .1-559-479-11	(75ES).....CORD, POWER	C110	1-126-062-11	ELECT 47MF 20% 63V
	Δ .1-575-695-11	(700).....CORD, POWER	C111	1-126-059-11	ELECT 10MF 20% 63V
	Δ .1-575-912-11	(55ES:AEP)...CORD, POWER	C120	1-126-062-11	ELECT 47MF 20% 63V
	Δ .1-575-913-11	(55ES:UK)....CORD, POWER			
908	*1-633-719-11	PC BOARD, PIN JACK	C121	1-126-062-11	ELECT 47MF 20% 63V
909	*1-633-718-11	(75ES/700)...PC BOARD, DIGITAL OUT	C122	1-136-153-00	FILM 0.01MF 5% 50V
910	*1-633-717-11	PC BOARD, DIGITAL IN	C163	1-162-290-31	CERAMIC 470PF 10% 50V
911	*A-2006-291-A	(700)...MOUNTED PCB, MAIN	C173	1-162-290-31	CERAMIC 470PF 10% 50V
	*A-2006-292-A	(75ES)...MOUNTED PCB, MAIN	C181	1-162-279-31	(75ES/700)...CERAMIC 75PF 10% 50V
	*A-2006-303-A	(55ES)...MOUNTED PCB, MAIN	C182	1-162-179-11	(75ES/700)...CERAMIC 0.1MF 50V
912	*1-633-814-11	PC BOARD, TRANSISTER	C201	1-136-439-11	FILM 330PF 5% 630V
913	*1-533-213-31	HOLDER, FUSE	C202	1-136-253-11	FILM 0.0018MF 3% 100V
914	*A-2006-244-A	(55ES:AEP)...MOUNTED PCB, POWER	C203	1-136-433-11	FILM 100PF 5% 630V
	*A-2006-293-A	(75ES/700)...MOUNTED PCB, POWER	C204	1-136-253-11	FILM 0.0018MF 3% 100V
	*A-2006-296-A	(55ES:UK)...MOUNTED PCB, POWER	C205	1-136-433-11	FILM 100PF 5% 630V
915	*1-633-726-11	PC BOARD, CASSETTE COMPARTMENT MOTOR	C206	1-136-433-11	FILM 100PF 5% 630V
916	*1-633-727-11	PC BOARD, CASSETTE COMPARTMENT IN	C207	1-136-433-11	FILM 100PF 5% 630V
917	*1-633-728-11	PC BOARD, CASSETTE COMPARTMENT OUT	C208	1-136-233-11	FILM 0.0047MF 3% 100V
918	*1-635-440-11	PC BOARD, A/D	C209	1-136-228-11	FILM 0.0012MF 3% 100V
951	*A-2006-139-A	MOUNTED PCB, RF AMPLIFIER	C210	1-126-062-11	ELECT 47MF 20% 63V
952	*A-2006-140-A	MOUNTED PCB, DRUM DRIVE	C211	1-126-059-11	ELECT 10MF 20% 63V
953	*1-633-711-11	PC BOARD, END SENSOR (S)	C220	1-126-062-11	ELECT 47MF 20% 63V
954	*1-633-713-11	PC BOARD, CONTROL MOTOR	C221	1-126-062-11	ELECT 47MF 20% 63V
955	*1-633-710-11	PC BOARD, RECOGNITION	C222	1-136-153-00	FILM 0.01MF 5% 50V
956	*1-633-712-11	PC BOARD, END SENSOR (T)	C302	1-130-834-00	FILM 1MF 10% 63V
957	*1-633-709-11	PC BOARD, REEL FG			
958	8-848-513-11	DRUM ASSY DOU-02D	C303	1-162-211-31	CERAMIC 33PF 5% 50V
C01	1-162-851-11	CERAMIC 0.1MF 16V	C304	1-136-165-00	FILM 0.1MF 5% 50V
C02	1-163-038-00	CERAMIC CHIP 0.1MF 25V	C305	1-136-165-00	FILM 0.1MF 5% 50V
C101	1-136-439-11	FILM 330PF 5% 630V	C306	1-136-153-00	FILM 0.01MF 5% 50V
C101A	1-124-925-11	ELECT 2.2MF 20% 50V	C308	1-136-157-00	(75ES/700)...FILM 0.022MF 5% 50V
C102	1-136-253-11	FILM 0.0018MF 3% 100V	C309	1-124-482-11	(75ES/700)...ELECT 33MF 20% 25V
C102A	1-123-875-11	ELECT 10MF 20% 50V	C310	1-162-294-31	CERAMIC 0.001MF 10% 50V
C103	1-136-433-11	FILM 100PF 5% 630V	C311	1-162-199-31	CERAMIC 10PF 5% 50V
C103A	1-164-161-11	CERAMIC CHIP 0.0022MF 10% 50V	C312	1-162-199-31	CERAMIC 10PF 5% 50V
C104	1-136-253-11	FILM 0.0018MF 3% 100V	C313	1-162-201-31	CERAMIC 12PF 5% 50V
C104A	1-163-017-00	CERAMIC CHIP 0.0047MF 10% 50V	C314	1-162-201-31	CERAMIC 12PF 5% 50V
C105	1-136-433-11	FILM 100PF 5% 630V	C315	1-162-294-31	CERAMIC 0.001MF 10% 50V
C105A	1-164-161-11	CERAMIC CHIP 0.0022MF 10% 50V	C316	1-130-834-00	FILM 1MF 10% 63V
			C317	1-162-294-31	CERAMIC 0.001MF 10% 50V
			C318	1-102-959-00	CERAMIC 22PF 5% 50V

Ref.No.	Part No.	Description			
C714	1-164-159-11	CERAMIC	0.1MF		50V
C901	1-126-017-11	ELECT	6800MF	20%	16V
C902	1-164-159-11	CERAMIC	0.1MF		50V
C903	1-126-016-11	ELECT	4700MF	20%	16V
C904	1-124-473-11	ELECT	1000MF	20%	10V
C905	1-126-104-11	ELECT	470MF	20%	35V
C906	1-126-104-11	ELECT	470MF	20%	35V
C907	1-124-473-11	ELECT	1000MF	20%	10V
C908	1-126-052-11	ELECT	100MF	20%	50V
C909	1-164-159-11	CERAMIC	0.1MF		50V
C910	1-126-129-11	ELECT	6800MF	20%	35V
C911	1-126-129-11	ELECT	6800MF	20%	35V
C912	1-124-130-00	ELECT	100MF	20%	63V
C913	1-124-922-11	ELECT	1000MF	20%	63V
C914	1-124-922-11	ELECT	1000MF	20%	63V
C922	△.1-161-742-00	CERAMIC	0.0022MF	20%	400V
C923	△.1-161-742-00	CERAMIC	0.0022MF	20%	400V
C924	△.1-161-742-00	(55ES)...CERAMIC	0.0022MF	20%	400V
C925	△.1-161-742-00	CERAMIC	0.0022MF	20%	400V
C926	1-136-165-00	FILM	0.1MF	5%	50V
C927	1-136-177-00	FILM	1MF	5%	50V
C928	△.1-161-744-00	CERAMIC	0.01MF		400V
C930	1-164-159-11	CERAMIC	0.1MF		50V
C931	1-124-556-11	ELECT	2200MF	20%	16V
C932	1-164-159-11	CERAMIC	0.1MF		50V
C933	1-164-159-11	CERAMIC	0.1MF		50V
C951	1-163-038-00	CERAMIC CHIP	0.1MF		25V
C953	1-163-038-00	CERAMIC CHIP	0.1MF		25V
C954	1-163-005-11	CERAMIC CHIP	470PF	10%	50V
C955	1-164-005-11	CERAMIC CHIP	0.47MF		25V
C956	1-124-778-00	ELECT CHIP	22MF	20%	6.3V
C957	1-163-038-00	CERAMIC CHIP	0.1MF		25V
C958	1-163-005-11	CERAMIC CHIP	470PF	10%	50V
C959	1-163-005-11	CERAMIC CHIP	470PF	10%	50V
C960	1-163-011-11	CERAMIC CHIP	0.0015MF	10%	50V
C961	1-164-232-11	CERAMIC CHIP	0.01MF	10%	50V
C962	1-164-004-11	CERAMIC CHIP	0.1MF	10%	25V
C963	1-164-232-11	CERAMIC CHIP	0.01MF	10%	50V
C965	1-164-298-11	CERAMIC CHIP	0.15MF	10%	25V
C966	1-163-038-00	CERAMIC CHIP	0.1MF		25V
C967	1-124-778-00	ELECT CHIP	22MF	20%	6.3V
C968	1-163-038-00	CERAMIC CHIP	0.1MF		25V
C969	1-164-005-11	CERAMIC CHIP	0.47MF		25V
C971	1-164-298-11	CERAMIC CHIP	0.15MF	10%	25V
C973	1-164-232-11	CERAMIC CHIP	0.01MF	10%	50V
C974	1-164-004-11	CERAMIC CHIP	0.1MF	10%	25V
C975	1-164-232-11	CERAMIC CHIP	0.01MF	10%	50V
C976	1-163-011-11	CERAMIC CHIP	0.0015MF	10%	50V
C977	1-163-020-00	CERAMIC CHIP	0.0082MF	10%	50V
C978	1-162-638-11	CERAMIC CHIP	1MF		16V
C979	1-163-020-00	CERAMIC CHIP	0.0082MF	10%	50V
C980	1-163-809-11	CERAMIC CHIP	0.047MF	10%	25V
C981	1-163-809-11	CERAMIC CHIP	0.047MF	10%	25V
C982	1-163-005-11	CERAMIC CHIP	470PF	10%	50V
C983	1-164-232-11	CERAMIC CHIP	0.01MF	10%	50V
C984	1-163-005-11	CERAMIC CHIP	470PF	10%	50V
C985	1-163-005-11	CERAMIC CHIP	470PF	10%	50V

Ref.No.	Part No.	Description			
CN01	*1-564-336-00	PIN, CONNECTOR	2P		
CN02	*1-564-336-61	PIN, CONNECTOR	2P		
CN03	*1-564-498-11	PIN, CONNECTOR	5P		
CN034	*1-564-718-11	PIN, CONNECTOR (SMALL TYPE)	2P		
CN035	*1-564-706-11	PIN, CONNECTOR (SMALL TYPE)	4P		
CN036	*1-564-704-11	PIN, CONNECTOR (SMALL TYPE)	2P		
CN037	*1-564-704-11	PIN, CONNECTOR (SMALL TYPE)	2P		
CN051	*1-563-660-11	CONNECTOR	9P		
CN052	*1-563-660-11	CONNECTOR	9P		
CN102	*1-568-369-11	HOUSING,CONNECTOR(PC BOARD)	8P		
CN103	*1-564-706-11	PIN, CONNECTOR (SMALL TYPE)	4P		
CN104	*1-564-337-61	PIN, CONNECTOR	3P		
CN105	*1-564-337-00	PIN, CONNECTOR	3P		
CN106	*1-564-338-00	PIN, CONNECTOR	4P		
CN131	*1-564-712-11	PIN, CONNECTOR (SMALL TYPE)	10P		
CN132	*1-564-709-11	PIN, CONNECTOR (SMALL TYPE)	7P		
CN151	*1-564-519-11	PLUG, CONNECTOR	4P		
CN301	*1-564-706-31	PIN, CONNECTOR (SMALL TYPE)	4P		
CN302	*1-564-710-11	PIN, CONNECTOR (SMALL TYPE)	8P		
CN304	*1-564-707-11	PIN, CONNECTOR (SMALL TYPE)	5P		
CN305	*1-564-706-11	PIN, CONNECTOR (SMALL TYPE)	4P		
CN307	*1-564-714-11	PIN, CONNECTOR (SMALL TYPE)	12P		
CN308	*1-564-339-00	PIN, CONNECTOR	5P		
CN311	*1-564-712-11	PIN, CONNECTOR (SMALL TYPE)	10P		
CN312	*1-564-709-11	PIN, CONNECTOR (SMALL TYPE)	7P		
CN332	*1-564-336-00	PIN, CONNECTOR	2P		
CN333	*1-564-514-11	PLUG, CONNECTOR	11P (TEST)		
CN391	*1-564-511-11	PLUG, CONNECTOR	8P		
CN392	*1-564-506-11	PLUG, CONNECTOR	3P		
CN393	*1-564-505-11	PLUG, CONNECTOR	2P		
CN394	*1-564-505-11	(75ES/700)...PLUG, CONNECTOR	2P		
CN501	*1-560-339-00	PIN, CONNECTOR	9P		
CN502	*1-560-339-00	PIN, CONNECTOR	9P		
CN512	*1-564-519-11	PLUG, CONNECTOR	4P		
CN513	*1-564-507-11	PLUG, CONNECTOR	4P		
CN515	*1-564-507-11	PLUG, CONNECTOR	4P		
CN516	*1-564-507-11	PLUG, CONNECTOR	4P		
CN571	*1-564-341-11	PIN, CONNECTOR	7P		
CN572	*1-564-340-61	PIN, CONNECTOR	6P		
CN573	*1-564-338-00	PIN, CONNECTOR	4P		
CN576	*1-564-706-11	PIN, CONNECTOR (SMALL TYPE)	4P		
CN774	*1-564-342-11	PIN, CONNECTOR	8P		
CN775	*1-564-336-00	PIN, CONNECTOR	2P		
CN901	*1-564-321-00	PIN, CONNECTOR	2P		
CN933	*1-564-518-11	PLUG, CONNECTOR	3P		
CN951	*1-564-722-11	PIN, CONNECTOR (SMALL TYPE)	6P		
CN952	*1-564-728-11	PIN, CONNECTOR (SMALL TYPE)	12P		
D305	8-719-107-94	DIODE 1SS202-1			
D306	8-719-200-82	DIODE 11ES2			
D313	8-719-914-13	DIODE HZ4CLL			
D314	8-719-200-82	DIODE 11ES2			
D320	8-719-107-94	DIODE 1SS202-1			
D501	8-719-901-59	DIODE KV1320			
D502	8-719-903-27	DIODE 1SS168			
D503	8-719-107-94	DIODE 1SS202-1			
D504	8-719-200-77	DIODE 10E2N			
D505	8-719-200-82	DIODE 11ES2			

<p>Note: The components identified by mark △ or dotted line with mark △ are critical for safety. Replace only with part number specified.</p>	<p>Note: Les composants identifiés par une marque △ sont critiques pour la sécurité. Ne les remplacer que par une pièce portant le numéro spécifié.</p>
--	---

DTC-55ES/75ES/700



Ref.No.	Part No.	Description
D506	8-719-200-82	DIODE 11ES2
D507	8-719-107-94	DIODE 1SS202-1
D510	8-719-107-94	DIODE 1SS202-1
D511	8-719-107-94	DIODE 1SS202-1
D512	8-719-107-94	DIODE 1SS202-1
D513	8-719-107-94	DIODE 1SS202-1
D701	8-719-107-94	DIODE 1SS202-1
D703	8-719-107-94	DIODE 1SS202-1
D901	8-719-311-72	DIODE R8V-406H-01
D905	8-719-200-82	DIODE 11ES2
D906	8-719-200-82	DIODE 11ES2
D907	8-719-200-89	DIODE 31DF2-FA
D908	8-719-200-89	DIODE 31DF2-FA
D909	8-719-200-89	DIODE 31DF2-FA
D910	8-719-200-89	DIODE 31DF2-FA
D911	8-719-107-94	DIODE 1SS202-1
D912	8-719-107-94	DIODE 1SS202-1
D913	8-719-200-82	DIODE 11ES2
D914	8-719-200-82	DIODE 11ES2
D915	8-719-200-82	DIODE 11ES2
D916	8-719-200-82	DIODE 11ES2
D931	8-719-107-94	DIODE 1SS202-1
D933	8-719-107-94	DIODE 1SS202-1
D934	8-719-200-82	DIODE 11ES2
F901	△.1-532-286-00	(55ES).....FUSE, TIME-LAG (2.5A)
F901	△.1-532-744-11	(75ES/700)...FUSE, GLASS TUBE (2.5A)
FL701	1-519-562-11	INDICATOR TUBE, FLUORESCENT
IC11	8-759-013-22	IC LM358M
IC101	8-759-900-72	IC NE5532P
IC101A	8-759-107-68	IC CX20115A
IC102	8-759-900-72	IC NE5532P
IC102A	8-759-013-22	IC LM358M
IC201	8-759-900-72	IC NE5532P
IC202	8-759-900-72	IC NE5532P
IC301	8-759-917-18	IC SN74HC04N
IC302	8-759-232-49	IC TC74HC132AP
IC303	8-759-917-18	IC SN74HC04N
IC304	8-759-135-80	IC UPC358C
IC305	8-759-926-17	IC SN74HC153NS
IC306	8-759-947-57	IC CXD1136Q
IC307	8-752-334-27	IC CXD2601Q
IC308	8-759-906-24	IC SN74LS624N
IC309	8-759-925-90	IC SN74HC74NS
IC310	8-752-330-68	IC CXK58257M-12L
IC311	8-752-030-63	IC CXA1046M
IC312	8-752-816-04	IC CXP80524-012Q
IC314	8-759-008-71	IC LM324N
IC315	8-759-916-20	IC SN74HC14N
IC316	8-759-135-80	IC UPC358C
IC317	8-759-987-16	IC LM393P
IC318	8-759-135-80	IC UPC358C
IC319	8-759-910-70	IC MB3763PS
IC320	8-759-633-65	IC M54641L
IC321	8-759-971-12	IC PST529E
IC322	8-759-604-35	IC MSF78M05L
IC331	8-759-977-72	IC GP1F31R (DIGITAL IN OPTICAL)

Ref.No.	Part No.	Description
IC332	8-759-977-71	IC GP1F31T (DIGITAL OUT OPTICAL)
IC333	8-759-917-18	IC SN74HC04N
IC431	8-759-925-78	IC SN74HC10NS
IC432	8-759-995-76	IC PST529C
IC501	8-759-999-32	IC SM5813APT
IC503	8-759-917-11	IC SN74HC393N
IC504	8-752-335-51	(75ES).....IC CXD2552Q-1
IC504	8-752-335-52	(55ES/700)...IC CXD2552Q-2
IC505	8-759-250-81	IC TC5081AP
IC506	8-759-031-58	IC SC75U04F
IC507	8-759-604-35	IC MSF78M05L
IC508	8-759-604-36	IC MSF78M08L
IC509	8-759-981-98	IC RC4560DD
IC510	8-759-945-58	IC RC4558P
IC520	8-759-602-83	IC M5238P
IC521	8-759-972-47	IC LF412CN
IC522	8-759-999-09	IC C55326-KP
IC523	8-759-604-35	IC MSF78M05L
IC524	8-759-982-52	IC RC79M05FA
IC701	8-752-811-84	IC CXP5058H-652Q
IC702	8-759-995-09	IC MSM6338RS
IC703	8-752-330-59	IC CXK1011P
IC704	8-749-920-59	IC A1QH3020S
IC931	8-759-148-79	IC UPC2406HF
IC932	8-759-634-55	IC MSF7805L-720
IC951	8-752-032-26	IC CXA1045Q
J151	1-568-101-11	JACK, PIN 4P (LINE IN/OUT)
J161	1-565-327-11	JACK, LARGE TYPE 1P (PHONES)
J181	1-566-922-21	(75ES/700)...JACK, PIN 1P (DIGITAL OUT COAXIAL)
J191	1-568-750-21	JACK, PIN (1P SHIELD TYPE) (DIGITAL IN COAXIAL)
JW11	1-216-295-00	METAL GLAZE 0 5% 1/10W
JW12	1-216-295-00	METAL GLAZE 0 5% 1/10W
JW101	1-216-296-00	METAL GLAZE 0 5% 1/8W
JW102	1-216-296-00	METAL GLAZE 0 5% 1/8W
JW103	1-216-296-00	METAL GLAZE 0 5% 1/8W
JW104	1-216-296-00	METAL GLAZE 0 5% 1/8W
JW105	1-216-296-00	METAL GLAZE 0 5% 1/8W
JW106	1-216-296-00	METAL GLAZE 0 5% 1/8W
JW107	1-216-296-00	METAL GLAZE 0 5% 1/8W
JW108	1-216-296-00	METAL GLAZE 0 5% 1/8W
JW109	1-216-296-00	METAL GLAZE 0 5% 1/8W
JW110	1-216-296-00	METAL GLAZE 0 5% 1/8W
JW111	1-216-296-00	METAL GLAZE 0 5% 1/8W
JW112	1-216-296-00	METAL GLAZE 0 5% 1/8W
JW113	1-216-296-00	METAL GLAZE 0 5% 1/8W
L301	1-410-509-11	INDUCTOR 10UH
L302	1-410-498-11	INDUCTOR 1.2UH
L303	1-410-509-11	INDUCTOR 10UH
L304	1-410-509-11	INDUCTOR 10UH
L305	1-410-509-11	INDUCTOR 10UH
L306	1-410-509-11	INDUCTOR 10UH
L307	1-410-509-11	INDUCTOR 10UH
L310	1-410-953-11	(75ES/700)...INDUCTOR, SMALL TYPE
L501	1-460-042-11	COIL (WITH CORE) 4.7UH

<p>Note: The components identified by mark △ or dotted line with mark △ are critical for safety. Replace only with part number specified.</p>	<p>Note: Les composants identifiés par une marque △ sont critiques pour la sécurité. Ne les remplacer que par une pièce portant le numéro spécifié.</p>
--	---

Ref.No.	Part No.	Description
L502	1-460-042-11	COIL (WITH CORE) 4.7UH
L503	1-410-324-11	INDUCTOR 4.7UH
L505	1-410-324-11	INDUCTOR 4.7UH
L506	1-410-324-11	INDUCTOR 4.7UH
L901	△.1-424-051-11	COIL, LINE FILTER
L951	1-408-777-00	INDUCTOR CHIP 10UH
L952	1-408-791-00	INDUCTOR CHIP 150UH
L953	1-408-791-00	INDUCTOR CHIP 150UH
M901	A-2003-448-A	MOTOR ASSY (CASSETTE COMPARTMENT)
M902	8-835-306-01	MOTOR, DC U-17A (CAPSTAN)
M903	A-2003-545-A	MOTOR ASSY (CONTROL)
M905	8-835-346-11	MOTOR, DC U-16B (REEL)
PH11	8-719-751-42	DIODE NJL5141E-AA
PH21	8-719-751-42	DIODE NJL5141E-AA
PH901	1-808-957-11	PHOTO SENSOR (END T)
PH902	1-808-957-11	PHOTO SENSOR (END S)
PL301	1-518-664-11	LAMP, PILOT
PL302	1-518-664-11	LAMP, PILOT
PM901	1-464-724-31	ENCODER, ROTARY
PM902	1-454-462-21	SOLENOID, PLUNGER (LOADING)
PM903	1-454-482-21	SOLENOID, PLUNGER (REEL MOTOR CONTROL)
Q11	8-729-216-22	TRANSISTOR 2SA1162
Q21	8-729-216-22	TRANSISTOR 2SA1162
Q101	8-729-107-85	TRANSISTOR 2SC3623A-K
Q101A	8-729-100-66	TRANSISTOR 2SC1623
Q102	8-729-107-85	TRANSISTOR 2SC3623A-K
Q102A	8-729-101-07	TRANSISTOR 2SB798-DL
Q103	8-729-107-85	TRANSISTOR 2SC3623A-K
Q201	8-729-107-85	TRANSISTOR 2SC3623A-K
Q202	8-729-107-85	TRANSISTOR 2SC3623A-K
Q203	8-729-107-85	TRANSISTOR 2SC3623A-K
Q301	8-729-119-78	TRANSISTOR 2SC2785-HFE
Q302	8-729-801-93	TRANSISTOR 2SD1387
Q303	8-729-400-82	TRANSISTOR 2SD1266-P
Q304	8-729-801-84	TRANSISTOR 2SB1013-4
Q305	8-729-900-80	TRANSISTOR DTC114ES
Q306	8-729-900-80	TRANSISTOR DTC114ES
Q317	8-729-900-80	TRANSISTOR DTC114ES
Q318	8-729-900-80	TRANSISTOR DTC114ES
Q319	8-729-900-80	TRANSISTOR DTC114ES
Q320	8-729-801-84	TRANSISTOR 2SB1013-4
Q321	8-729-801-93	TRANSISTOR 2SD1387
Q322	8-729-900-80	TRANSISTOR DTC114ES
Q401	8-729-119-78	TRANSISTOR 2SC2785-HFE
Q402	8-729-119-78	TRANSISTOR 2SC2785-HFE
Q502	8-729-200-56	TRANSISTOR 2SK241GR
Q503	8-729-200-56	TRANSISTOR 2SK241GR
Q504	8-729-900-61	TRANSISTOR DTA114ES
Q505	8-729-900-80	TRANSISTOR DTC114ES
Q506	8-729-900-61	TRANSISTOR DTA114ES
Q507	8-729-900-80	TRANSISTOR DTC114ES
Q508	8-729-900-80	TRANSISTOR DTC114ES
Q509	8-729-900-61	TRANSISTOR DTA114ES
Q510	8-729-107-85	TRANSISTOR 2SC3623A-K
Q511	8-729-900-61	TRANSISTOR DTA114ES
Q701	8-729-119-78	TRANSISTOR 2SC2785-HFE
Q702	8-729-119-78	TRANSISTOR 2SC2785-HFE

Ref.No.	Part No.	Description			
Q707	8-729-119-78	TRANSISTOR 2SC2785-HFE			
Q708	8-729-119-78	TRANSISTOR 2SC2785-HFE			
Q901	8-729-140-93	TRANSISTOR 2SB733-34			
Q902	8-729-167-72	TRANSISTOR 2SC2676-1F			
Q903	8-729-127-53	TRANSISTOR 2SC2275-P			
Q904	8-729-167-72	TRANSISTOR 2SC2676-1F			
Q905	8-729-113-92	TRANSISTOR 2SA1138-1F			
Q906	8-729-190-53	TRANSISTOR 2SA985A			
Q907	8-729-113-92	TRANSISTOR 2SA1138-1F			
Q921	8-729-900-80	TRANSISTOR DTC114ES			
Q922	8-729-900-80	TRANSISTOR DTC114ES			
Q923	8-729-203-02	TRANSISTOR 2SK30A-0			
Q924	8-729-203-02	TRANSISTOR 2SK30A-0			
Q925	8-729-920-97	TRANSISTOR 2SB1187-EF			
Q931	8-729-900-80	TRANSISTOR DTC114ES			
Q932	8-729-119-76	TRANSISTOR 2SA1175-HFE			
R11	1-216-041-00	METAL GLAZE	470	5%	1/10W
R12	1-216-081-00	METAL GLAZE	22K	5%	1/10W
R13	1-216-073-00	METAL GLAZE	10K	5%	1/10W
R14	1-216-103-00	METAL GLAZE	180K	5%	1/10W
R15	1-216-057-00	METAL GLAZE	2.2K	5%	1/10W
R16	1-216-077-00	METAL GLAZE	15K	5%	1/10W
R17	1-216-067-00	METAL GLAZE	5.6K	5%	1/10W
R21	1-216-041-00	METAL GLAZE	470	5%	1/10W
R22	1-216-081-00	METAL GLAZE	22K	5%	1/10W
R23	1-216-073-00	METAL GLAZE	10K	5%	1/10W
R24	1-216-103-00	METAL GLAZE	180K	5%	1/10W
R25	1-216-057-00	METAL GLAZE	2.2K	5%	1/10W
R101	1-247-154-00	CARBON	9.1K	5%	1/4W
R101A	1-216-061-00	METAL GLAZE	3.3K	5%	1/10W
R102	1-247-154-00	CARBON	9.1K	5%	1/4W
R102A	1-216-075-00	METAL GLAZE	12K	5%	1/10W
R103	1-247-721-11	CARBON	4.7K	5%	1/4W
R103A	1-216-029-00	METAL GLAZE	150	5%	1/10W
R104	1-247-721-11	CARBON	4.7K	5%	1/4W
R104A	1-216-058-00	METAL GLAZE	2.4K	5%	1/10W
R105	1-247-152-00	CARBON	8.2K	5%	1/4W
R105A	1-216-057-00	METAL GLAZE	2.2K	5%	1/10W
R106	1-249-583-11	CARBON	20K	5%	1/4W
R106A	1-216-084-00	METAL GLAZE	30K	5%	1/10W
R107	1-247-152-00	CARBON	8.2K	5%	1/4W
R107A	1-216-073-00	METAL GLAZE	10K	5%	1/10W
R108	1-249-583-11	CARBON	20K	5%	1/4W
R108A	1-216-073-00	METAL GLAZE	10K	5%	1/10W
R109	1-247-722-11	CARBON	5.6K	5%	1/4W
R109A	1-216-073-00	METAL GLAZE	10K	5%	1/10W
R110	1-247-722-11	CARBON	5.6K	5%	1/4W
R110A	1-216-089-00	METAL GLAZE	47K	5%	1/10W
R111	1-247-722-11	CARBON	5.6K	5%	1/4W
R111A	1-216-073-00	METAL GLAZE	10K	5%	1/10W
R112	1-247-722-11	CARBON	5.6K	5%	1/4W
R112A	1-216-049-00	METAL GLAZE	1K	5%	1/10W
R113	1-249-556-11	CARBON	1.5K	5%	1/4W
R113A	1-216-025-00	METAL GLAZE	100	5%	1/10W



Note:
The components identified by mark  or dotted line with mark  are critical for safety. Replace only with part number specified.

Note:
Les composants identifiés par une marque  sont critiques pour la sécurité. Ne les remplacer que par une pièce portant le numéro spécifié.

DTC-55ES/75ES/700

Ref.No.	Part No.	Description			
R114	1-249-556-11	CARBON	1.5K	5%	1/4W
R115	1-249-469-11	CARBON	100K	5%	1/4W
R116	1-247-704-11	CARBON	220	5%	1/4W
R117	1-249-469-11	CARBON	100K	5%	1/4W
R118	1-249-497-11	CARBON	33K	5%	1/4W
R119	1-247-721-11	CARBON	4.7K	5%	1/4W
R120	1-249-462-11	CARBON	22K	5%	1/4W
R121	1-247-704-11	CARBON	220	5%	1/4W
R122	1-249-429-11	CARBON	10K	5%	1/4W
R123	1-249-429-11	CARBON	10K	5%	1/4W
R124	1-249-429-11	CARBON	10K	5%	1/4W
R125	1-246-545-00	CARBON	1M	5%	1/4W
R126	1-246-545-00	CARBON	1M	5%	1/4W
R130	1-246-545-00	CARBON	1M	5%	1/4W
R131	1-247-717-11	CARBON	2.2K	5%	1/4W
R132	1-249-586-11	CARBON	27K	5%	1/4W
R133	1-249-469-11	CARBON	100K	5%	1/4W
R134	1-249-520-11	CARBON	47	5%	1/4W
R135	1-249-512-11	CARBON	22	5%	1/4W
R151	1-249-586-11	CARBON	27K	5%	1/4W
R152	1-249-586-11	CARBON	27K	5%	1/4W
R153	1-249-657-11	CARBON	220	5%	1/2W
R154	1-249-657-11	CARBON	220	5%	1/2W
R181	1-249-405-11	(75ES/700)...CARBON	100	5%	1/4W
R183	1-247-804-11	(75ES/700)...CARBON	75	5%	1/4W
R191	1-247-804-11	CARBON	75	5%	1/4W
R201	1-247-154-00	CARBON	9.1K	5%	1/4W
R202	1-247-154-00	CARBON	9.1K	5%	1/4W
R203	1-247-721-11	CARBON	4.7K	5%	1/4W
R204	1-247-721-11	CARBON	4.7K	5%	1/4W
R205	1-247-152-00	CARBON	8.2K	5%	1/4W
R206	1-249-583-11	CARBON	20K	5%	1/4W
R207	1-247-152-00	CARBON	8.2K	5%	1/4W
R208	1-249-583-11	CARBON	20K	5%	1/4W
R209	1-247-722-11	CARBON	5.6K	5%	1/4W
R210	1-247-722-11	CARBON	5.6K	5%	1/4W
R211	1-247-722-11	CARBON	5.6K	5%	1/4W
R212	1-247-722-11	CARBON	5.6K	5%	1/4W
R213	1-249-556-11	CARBON	1.5K	5%	1/4W
R214	1-249-556-11	CARBON	1.5K	5%	1/4W
R215	1-249-469-11	CARBON	100K	5%	1/4W
R216	1-247-704-11	CARBON	220	5%	1/4W
R217	1-249-469-11	CARBON	100K	5%	1/4W
R218	1-249-497-11	CARBON	33K	5%	1/4W
R219	1-247-721-11	CARBON	4.7K	5%	1/4W
R220	1-249-462-11	CARBON	22K	5%	1/4W
R221	1-247-704-11	CARBON	220	5%	1/4W
R222	1-249-429-11	CARBON	10K	5%	1/4W
R223	1-249-429-11	CARBON	10K	5%	1/4W
R224	1-249-429-11	CARBON	10K	5%	1/4W
R225	1-246-545-00	CARBON	1M	5%	1/4W
R226	1-246-545-00	CARBON	1M	5%	1/4W
R230	1-246-545-00	CARBON	1M	5%	1/4W
R231	1-247-717-11	CARBON	2.2K	5%	1/4W
R232	1-249-586-11	CARBON	27K	5%	1/4W
R233	1-249-469-11	CARBON	100K	5%	1/4W
R234	1-249-520-11	CARBON	47	5%	1/4W

Ref.No.	Part No.	Description			
R235	1-249-512-11	CARBON	22	5%	1/4W
R302	1-249-437-11	CARBON	47K	5%	1/4W
R303	1-249-421-11	CARBON	2.2K	5%	1/4W
R304	1-249-417-11	CARBON	1K	5%	1/4W
R305	1-249-425-11	CARBON	4.7K	5%	1/4W
R306	1-249-441-11	CARBON	100K	5%	1/4W
R307	1-249-429-11	CARBON	10K	5%	1/4W
R308	1-249-429-11	CARBON	10K	5%	1/4W
R309	1-249-421-11	CARBON	2.2K	5%	1/4W
R310	1-249-421-11	CARBON	2.2K	5%	1/4W
R311	1-249-435-11	CARBON	33K	5%	1/4W
R312	1-249-429-11	CARBON	10K	5%	1/4W
R313	1-249-433-11	CARBON	22K	5%	1/4W
R314	1-249-425-11	CARBON	4.7K	5%	1/4W
R315	1-249-433-11	CARBON	22K	5%	1/4W
R316	1-249-429-11	CARBON	10K	5%	1/4W
R317	1-247-830-11	CARBON	910	5%	1/4W
R318	1-249-437-11	CARBON	47K	5%	1/4W
R319	1-249-411-11	CARBON	330	5%	1/4W
R320	1-249-437-11	CARBON	47K	5%	1/4W
R323	1-249-401-11	CARBON	47	5%	1/4W
R324	1-249-429-11	CARBON	10K	5%	1/4W
R325	1-249-429-11	CARBON	10K	5%	1/4W
R326	1-249-429-11	CARBON	10K	5%	1/4W
R327	1-249-437-11	CARBON	47K	5%	1/4W
R328	1-249-437-11	CARBON	47K	5%	1/4W
R329	1-249-437-11	CARBON	47K	5%	1/4W
R330	1-249-437-11	CARBON	47K	5%	1/4W
R331	1-249-437-11	CARBON	47K	5%	1/4W
R332	1-249-437-11	CARBON	47K	5%	1/4W
R333	1-249-401-11	CARBON	47	5%	1/4W
R336	1-249-417-11	CARBON	1K	5%	1/4W
R337	1-249-417-11	CARBON	1K	5%	1/4W
R338	1-249-435-11	CARBON	33K	5%	1/4W
R339	1-249-435-11	CARBON	33K	5%	1/4W
R340	1-249-419-11	CARBON	1.5K	5%	1/4W
R341	1-249-435-11	CARBON	33K	5%	1/4W
R342	1-249-429-11	CARBON	10K	5%	1/4W
R343	1-249-435-11	CARBON	33K	5%	1/4W
R344	1-249-419-11	CARBON	1.5K	5%	1/4W
R345	1-249-429-11	CARBON	10K	5%	1/4W
R346	1-249-435-11	CARBON	33K	5%	1/4W
R347	1-249-435-11	CARBON	33K	5%	1/4W
R348	1-249-425-11	CARBON	4.7K	5%	1/4W
R349	1-249-425-11	CARBON	4.7K	5%	1/4W
R350	1-249-417-11	CARBON	1K	5%	1/4W
R351	△.1-215-881-11	METAL OXIDE	15	5%	2W F
R352	1-249-417-11	CARBON	1K	5%	1/4W
R353	1-249-401-11	CARBON	47	5%	1/4W
R361	1-249-413-11	CARBON	470	5%	1/4W
R362	1-249-393-11	CARBON	10	5%	1/4W
R363	1-249-413-11	CARBON	470	5%	1/4W
R368	1-249-433-11	CARBON	22K	5%	1/4W
R369	1-249-423-11	CARBON	3.3K	5%	1/4W
R370	1-249-423-11	CARBON	3.3K	5%	1/4W
R371	1-249-423-11	CARBON	3.3K	5%	1/4W
R372	1-247-727-11	CARBON	10	5%	1/2W

<p>Note: The components identified by mark  or dotted line with mark  are critical for safety. Replace only with part number specified.</p>	<p>Note: Les composants identifiés par une marque  sont critiques pour la sécurité. Ne les remplacer que par une pièce portant le numéro spécifié.</p>
--	--

Ref.No.	Part No.	Description				Ref.No.	Part No.	Description			
R382	1-249-429-11	CARBON	10K	5%	1/4W	R529	1-249-437-11	CARBON	47K	5%	1/4W
R383	1-249-433-11	CARBON	22K	5%	1/4W	R530	1-249-417-11	CARBON	1K	5%	1/4W
R384	1-249-429-11	CARBON	10K	5%	1/4W	R531	1-249-419-11	CARBON	1.5K	5%	1/4W
R385	1-249-433-11	CARBON	22K	5%	1/4W	R532	1-247-883-00	CARBON	150K	5%	1/4W
R401	1-249-425-11	CARBON	4.7K	5%	1/4W	R533	1-249-425-11	CARBON	4.7K	5%	1/4W
R402	1-249-429-11	CARBON	10K	5%	1/4W	R534	1-249-413-11	CARBON	470	5%	1/4W
R403	1-249-429-11	CARBON	10K	5%	1/4W	R535	1-249-424-11	CARBON	3.9K	5%	1/4W
R404	1-249-429-11	CARBON	10K	5%	1/4W	R536	1-249-437-11	CARBON	47K	5%	1/4W
R405	1-247-804-11	CARBON	75	5%	1/4W	R537	1-249-441-11	CARBON	100K	5%	1/4W
R406	1-247-804-11	CARBON	75	5%	1/4W	R538	1-249-441-11	CARBON	100K	5%	1/4W
R407	1-249-423-11	CARBON	3.3K	5%	1/4W	R540	1-216-349-00	CARBON	1	5%	1/2W
R408	1-249-423-11	CARBON	3.3K	5%	1/4W	R550	1-249-504-11	CARBON	10	5%	1/4W
R409	1-249-429-11	CARBON	10K	5%	1/4W	R702	1-249-433-11	CARBON	22K	5%	1/4W
R410	1-249-429-11	CARBON	10K	5%	1/4W	R703	1-249-433-11	CARBON	22K	5%	1/4W
R411	1-249-429-11	CARBON	10K	5%	1/4W	R704	1-249-425-11	CARBON	4.7K	5%	1/4W
R412	1-249-429-11	CARBON	10K	5%	1/4W	R705	1-249-418-11	CARBON	1.2K	5%	1/4W
R413	1-249-429-11	CARBON	10K	5%	1/4W	R706	1-249-420-11	CARBON	1.8K	5%	1/4W
R414	1-249-429-11	CARBON	10K	5%	1/4W	R707	1-249-423-11	CARBON	3.3K	5%	1/4W
R415	1-249-429-11	CARBON	10K	5%	1/4W	R708	1-249-428-11	CARBON	8.2K	5%	1/4W
R416	1-249-429-11	CARBON	10K	5%	1/4W	R709	1-249-425-11	CARBON	4.7K	5%	1/4W
R417	1-249-429-11	CARBON	10K	5%	1/4W	R710	1-249-418-11	CARBON	1.2K	5%	1/4W
R418	1-249-425-11	CARBON	4.7K	5%	1/4W	R711	1-249-420-11	CARBON	1.8K	5%	1/4W
R419	1-249-425-11	CARBON	4.7K	5%	1/4W	R712	1-249-423-11	CARBON	3.3K	5%	1/4W
R420	1-249-413-11	CARBON	470	5%	1/4W	R713	1-249-428-11	CARBON	8.2K	5%	1/4W
R421	1-249-435-11	CARBON	33K	5%	1/4W	R714	1-249-425-11	CARBON	4.7K	5%	1/4W
R422	1-249-435-11	CARBON	33K	5%	1/4W	R715	1-249-418-11	CARBON	1.2K	5%	1/4W
R423	1-249-411-11	CARBON	330	5%	1/4W	R716	1-249-420-11	CARBON	1.8K	5%	1/4W
R424	1-249-429-11	CARBON	10K	5%	1/4W	R717	1-249-423-11	CARBON	3.3K	5%	1/4W
R431	1-214-808-11	METAL	4.7	1%	1/2W	R718	1-249-428-11	CARBON	8.2K	5%	1/4W
R437	1-249-409-11	CARBON	220	5%	1/4W	R719	1-249-425-11	CARBON	4.7K	5%	1/4W
R438	1-249-409-11	CARBON	220	5%	1/4W	R720	1-249-418-11	CARBON	1.2K	5%	1/4W
R439	1-249-409-11	CARBON	220	5%	1/4W	R721	1-249-420-11	CARBON	1.8K	5%	1/4W
R440	1-247-804-11	CARBON	75	5%	1/4W	R722	1-249-423-11	CARBON	3.3K	5%	1/4W
R441	1-249-405-11	CARBON	100	5%	1/4W	R723	1-249-428-11	CARBON	8.2K	5%	1/4W
R442	1-249-417-11	CARBON	1K	5%	1/4W	R724	1-249-425-11	CARBON	4.7K	5%	1/4W
R443	1-249-429-11	CARBON	10K	5%	1/4W	R725	1-249-418-11	CARBON	1.2K	5%	1/4W
R480	1-247-881-00	CARBON	120K	5%	1/4W	R726	1-249-420-11	CARBON	1.8K	5%	1/4W
R499	1-249-421-11	CARBON	2.2K	5%	1/4W	R727	1-249-423-11	CARBON	3.3K	5%	1/4W
R507	1-249-417-11	CARBON	1K	5%	1/4W	R728	1-249-428-11	CARBON	8.2K	5%	1/4W
R508	1-249-423-11	CARBON	3.3K	5%	1/4W	R729	1-249-425-11	CARBON	4.7K	5%	1/4W
R509	1-249-417-11	CARBON	1K	5%	1/4W	R730	1-249-418-11	CARBON	1.2K	5%	1/4W
R510	1-249-423-11	CARBON	3.3K	5%	1/4W	R731	1-249-420-11	CARBON	1.8K	5%	1/4W
R512	1-249-433-11	CARBON	22K	5%	1/4W	R732	1-249-423-11	CARBON	3.3K	5%	1/4W
R513	1-249-435-11	CARBON	33K	5%	1/4W	R733	1-249-428-11	CARBON	8.2K	5%	1/4W
R514	1-249-417-11	CARBON	1K	5%	1/4W	R734	1-249-425-11	CARBON	4.7K	5%	1/4W
R515	1-247-903-00	CARBON	1M	5%	1/4W	R735	1-249-418-11	CARBON	1.2K	5%	1/4W
R516	1-247-903-00	CARBON	1M	5%	1/4W	R736	1-249-420-11	CARBON	1.8K	5%	1/4W
R517	1-249-429-11	CARBON	10K	5%	1/4W	R737	1-249-423-11	CARBON	3.3K	5%	1/4W
R518	1-249-428-11	CARBON	8.2K	5%	1/4W	R738	1-249-428-11	CARBON	8.2K	5%	1/4W
R519	1-249-441-11	CARBON	100K	5%	1/4W	R739	1-249-425-11	CARBON	4.7K	5%	1/4W
R520	1-249-417-11	CARBON	1K	5%	1/4W	R740	1-249-418-11	CARBON	1.2K	5%	1/4W
R521	1-249-417-11	CARBON	1K	5%	1/4W	R741	1-249-420-11	CARBON	1.8K	5%	1/4W
R522	1-249-417-11	CARBON	1K	5%	1/4W	R742	1-249-423-11	CARBON	3.3K	5%	1/4W
R524	1-249-417-11	CARBON	1K	5%	1/4W	R743	1-249-428-11	CARBON	8.2K	5%	1/4W
R525	1-247-903-00	CARBON	1M	5%	1/4W	R744	1-249-433-11	CARBON	22K	5%	1/4W
R527	△.1-212-857-00	FUSIBLE	10	5%	1/4W	R745	1-249-433-11	CARBON	22K	5%	1/4W
R528	△.1-212-857-00	FUSIBLE	10	5%	1/4W	R746	1-249-433-11	CARBON	22K	5%	1/4W

Note:
The components identified by mark \triangle or dotted line with mark \triangle are critical for safety. Replace only with part number specified.

Note:
Les composants identifiés par une marque \triangle sont critiques pour la sécurité. Ne les remplacer que par une pièce portant le numéro spécifié.

DTC-55ES/75ES/700

Ref.No.	Part No.	Description				
R747	1-249-433-11	CARBON	22K	5%	1/4W	
R748	1-249-433-11	CARBON	22K	5%	1/4W	
R749	1-249-433-11	CARBON	22K	5%	1/4W	
R750	1-249-433-11	CARBON	22K	5%	1/4W	
R751	1-249-433-11	CARBON	22K	5%	1/4W	
R755	1-249-441-11	CARBON	100K	5%	1/4W	
R756	1-249-441-11	CARBON	100K	5%	1/4W	
R761	1-249-441-11	CARBON	100K	5%	1/4W	
R762	1-249-441-11	CARBON	100K	5%	1/4W	
R763	1-249-433-11	CARBON	22K	5%	1/4W	
R764	1-249-433-11	CARBON	22K	5%	1/4W	
R771	1-247-764-11	CARBON	10K	5%	1/2W	
R906	1-247-704-11	CARBON	220	5%	1/4W	
R907	1-247-713-11	CARBON	1K	5%	1/4W	
R908	1-247-717-11	CARBON	2.2K	5%	1/4W	
R909	1-249-466-11	CARBON	56K	5%	1/4W	
R910	1-247-713-11	CARBON	1K	5%	1/4W	
R911	1-247-713-11	CARBON	1K	5%	1/4W	
R912	1-247-717-11	CARBON	2.2K	5%	1/4W	
R913	1-247-704-11	CARBON	220	5%	1/4W	
R914	1-247-713-11	CARBON	1K	5%	1/4W	
R915	1-247-717-11	CARBON	2.2K	5%	1/4W	
R916	1-247-717-11	CARBON	2.2K	5%	1/4W	
R927	1-249-429-11	CARBON	10K	5%	1/4W	
R928	△.1-212-865-00	FUSIBLE	22	5%	1/4W	F
R931	1-249-425-11	CARBON	4.7K	5%	1/4W	
R932	△.1-215-889-00	METAL OXIDE	330	5%	2W	F
R933	1-249-425-11	CARBON	4.7K	5%	1/4W	
R934	1-249-433-11	CARBON	22K	5%	1/4W	
R935	1-249-433-11	CARBON	22K	5%	1/4W	
R936	△.1-212-849-00	FUSIBLE	4.7	5%	1/4W	F
R937	1-249-425-11	CARBON	4.7K	5%	1/4W	
R951	1-216-057-00	METAL GLAZE	2.2K	5%	1/10W	
R952	1-216-057-00	METAL GLAZE	2.2K	5%	1/10W	
R953	1-216-057-00	METAL GLAZE	2.2K	5%	1/10W	
R954	1-216-057-00	METAL GLAZE	2.2K	5%	1/10W	
R955	1-216-089-00	METAL GLAZE	47K	5%	1/10W	
R956	1-216-083-00	METAL GLAZE	27K	5%	1/10W	
R957	1-216-063-00	METAL GLAZE	3.9K	5%	1/10W	
R958	1-216-085-00	METAL GLAZE	33K	5%	1/10W	
R959	1-216-081-00	METAL GLAZE	22K	5%	1/10W	
R960	1-216-079-00	METAL GLAZE	18K	5%	1/10W	
R961	1-216-079-00	METAL GLAZE	18K	5%	1/10W	
R962	1-216-081-00	METAL GLAZE	22K	5%	1/10W	
R963	1-216-085-00	METAL GLAZE	33K	5%	1/10W	
R964	1-216-083-00	METAL GLAZE	27K	5%	1/10W	
R965	1-216-063-00	METAL GLAZE	3.9K	5%	1/10W	
R966	1-216-089-00	METAL GLAZE	47K	5%	1/10W	
R967	1-216-089-00	METAL GLAZE	47K	5%	1/10W	
R968	1-216-089-00	METAL GLAZE	47K	5%	1/10W	
R969	1-216-085-00	METAL GLAZE	33K	5%	1/10W	
R970	1-216-085-00	METAL GLAZE	33K	5%	1/10W	
R971	1-216-095-00	METAL GLAZE	82K	5%	1/10W	
R972	1-216-065-00	METAL GLAZE	4.7K	5%	1/10W	
R973	1-216-071-00	METAL GLAZE	8.2K	5%	1/10W	
R974	1-216-071-00	METAL GLAZE	8.2K	5%	1/10W	

Ref.No.	Part No.	Description
RV151	1-238-885-11	RES, VAR 20K/20K (REC LEVEL)
RV161	1-238-359-11	RES, VAR, CARBON 20K/20K (LEVEL)
RV301	1-238-017-11	RES, ADJ, CARBON 22K
RV302	1-238-017-11	RES, ADJ, CARBON 22K
RV303	1-238-015-11	RES, ADJ, CARBON 4.7K
RV304	1-238-015-11	RES, ADJ, CARBON 4.7K
RV305	1-238-017-11	RES, ADJ, CARBON 22K
RV951	1-238-237-11	RES, ADJ, CERMET 470
RV952	1-238-237-11	RES, ADJ, CERMET 470
RY501	1-515-726-11	RELAY
S11	1-570-975-11	SWITCH, SLIDE (CASSETTE TABLE IN)
S12	1-572-247-11	SWITCH, SLIDE (CASSETTE TABLE OUT)
S701	1-571-305-11	SWITCH, PUSH (1 KEY)(POWER)
S702	1-571-520-11	SWITCH, SLIDE (TIMER)
S703	1-570-974-11	SWITCH, SLIDE (REC MODE)
S704	1-572-230-11	SWITCH, ROTARY (INPUT)
S705	1-554-596-21	SWITCH, KEY BOARD (SKIP ID/WRITE)
S706	1-554-596-21	SWITCH, KEY BOARD (SKIP ID/ERASE)
S707	1-554-596-21	SWITCH, KEY BOARD (7)
S708	1-554-596-21	SWITCH, KEY BOARD (8)
S709	1-554-596-21	SWITCH, KEY BOARD (9)
S710	1-554-596-21	SWITCH, KEY BOARD (START ID/WRITE)
S711	1-554-596-21	SWITCH, KEY BOARD (START ID/ERASE)
S712	1-554-596-21	SWITCH, KEY BOARD (4)
S713	1-554-596-21	SWITCH, KEY BOARD (5)
S714	1-554-596-21	SWITCH, KEY BOARD (6)
S715	1-554-596-21	SWITCH, KEY BOARD (START ID/AUDIO)
S716	1-554-596-21	SWITCH, KEY BOARD (START ID/RENUMBER)
S717	1-554-596-21	SWITCH, KEY BOARD (1)
S718	1-554-596-21	SWITCH, KEY BOARD (2)
S719	1-554-596-21	SWITCH, KEY BOARD (3)
S720	1-554-596-21	SWITCH, KEY BOARD (REPEAT)
S721	1-554-596-21	SWITCH, KEY BOARD (SKIP PLAY)
S722	1-554-596-21	SWITCH, KEY BOARD (MARGIN RESET)
S723	1-554-596-21	SWITCH, KEY BOARD (FADER)
S724	1-554-596-21	SWITCH, KEY BOARD (MODE/RESET)
S725	1-554-596-21	SWITCH, KEY BOARD (MODE/COUNTER)
S726	1-554-596-21	SWITCH, KEY BOARD (◀)
S727	1-554-596-21	SWITCH, KEY BOARD (▶)
S728	1-554-937-11	SWITCH, KEY BOARD (●REC)
S729	1-554-937-11	SWITCH, KEY BOARD (■ PAUSE)
S730	1-554-937-11	SWITCH, KEY BOARD (○ REC MUTE)
S731	1-554-937-11	SWITCH, KEY BOARD (▲ OPEN/CLOSE)
S732	1-554-937-11	SWITCH, KEY BOARD (■)
S733	1-554-937-11	SWITCH, KEY BOARD (▶)
S734	1-554-596-21	SWITCH, KEY BOARD (◀)
S735	1-554-596-21	SWITCH, KEY BOARD (▶)
S736	1-554-596-21	SWITCH, KEY BOARD (END ID/WRITE)
S737	1-554-596-21	SWITCH, KEY BOARD (END ID/ERASE)
S738	1-554-596-21	SWITCH, KEY BOARD (CLEAR)
S739	1-554-596-21	SWITCH, KEY BOARD (0)
S740	1-554-596-21	SWITCH, KEY BOARD (MUSIC SCAN)
S901	1-571-878-11	SWITCH, PUSH (2 KEY) (CASSETTE IM/REC PROOF)
S902	1-570-771-21	SWITCH (LIMIT)
T182	1-421-946-11	(75ES/700)...TRANSFORMER, PULSE

Note:
The components identified by mark △ or dotted line with mark △ are critical for safety. Replace only with part number specified.

Note:
Les composants identifiés par une marque △ sont critiques pour la sécurité. Ne les remplacer que par une pièce portant le numéro spécifié.

Ref.No.	Part No.	Description
T901	△.1-450-080-11	(75ES/700)...TRANSFORMER, POWER
T901	△.1-450-164-11	(55ES).....TRANSFORMER, POWER
X301	1-567-816-11	VIBRATOR, CRYSTAL (18.816MHz)
X302	1-567-815-11	VIBRATOR, CRYSTAL (22.5792MHz)
X303	1-578-667-11	VIBRATOR, CRYSTAL (49.152MHz)
X701	1-577-359-21	VIBRATOR, CERAMIC (4.19MHz)
ZD902	8-719-933-33	DIODE HZS6A1L
ZD903	8-719-933-33	DIODE HZS6A1L

ACCESSORY & PACKING MATERIAL

1-465-312-11	REMOTE COMMANDER (RM-D55)
1-558-271-11	(75ES)...CORD, CONNECTION
1-559-533-11	(700)...CORD, CONNECTION
*3-701-613-00	(55ES:AEP/75ES)...BAG, POLYETHYLENE
3-703-450-01	(75ES:US/700)...INSTRUCTION
3-704-366-01	(55ES:AEP/75ES)...SCREW (CASE) (M3X8)
3-751-364-11	(55ES).....MANUAL, INSTRUCTION
3-751-364-21	(700).....MANUAL, INSTRUCTION
3-751-364-41	(55ES:AEP).....MANUAL, INSTRUCTION
3-751-688-21	(75ES).....MANUAL, INSTRUCTION
3-751-688-31	(75ES:Canadian)...MANUAL, INSTRUCTION
3-707-584-01	COVER, BATTERY (for RM-D55)
*4-936-610-01	(55ES)...INDIVIDUAL CARTON
*4-936-611-01	(700)...INDIVIDUAL CARTON
*4-936-623-01	(75ES)...INDIVIDUAL CARTON
*4-931-451-01	(700).....CUSHION
*4-936-624-01	(55ES/75ES)...CUSHION

Note:
The components identified by mark △ or dotted line with mark △ are critical for safety. Replace only with part number specified.

Note:
Les composants identifiés par une marque △ sont critiques pour la sécurité. Ne les remplacer que par une pièce portant le numéro spécifié.