

DTC-57ES/750

SERVICE MANUAL



Photo : DTC-57ES

US Model
 Canadian Model
 AEP Model
 E Model
 DTC-57ES
 US Model
 Canadian Model
 UK Model
 DTC-750

SPECIFICATIONS

Tape	Digital audio tape
Recording head	Rotary head
Recording time	Standard: 120 minutes. Long-play mode: 240 minutes (with DT-120)
Tape speed	Standard: 8.15 mm/s, Long play mode: 4.075 mm/s
Drum rotation	Standard: 2,000 rpm, Long-play mode: 1,000 rpm
Error correction	Double Read Solomon code
Tape	
Track pitch	13.6 μ m (20.4 μ m)
Sampling frequency	48 kHz, 44.1 kHz, 32 kHz
Modulation system	8-10 Modulation
Transfer rate	2.46 Mbit/sec.
Number of channel	2 channels, stereo
D/A conversion (Quantization)	Standard: 16-bit linear Long-play mode: 12-bit non-linear
Frequency response	Standard: 2-22,000 Hz (\pm 0.5 dB) Long-play mode: 2-14,500 Hz (\pm 0.5 dB)

		DTC-57ES (AEP, E model), DTC-750	DTC-57ES (US, Canadian model)
Signal to noise ratio	SP	more than 92dB	more than 93dB
	LP		more than 92dB
Dynamic range	SP	more than 92dB	more than 93dB
	LP		more than 92dB
Total harmonic distortion (1kHz)	SP	less than 0.0045%	less than 0.004%
	LP	less than 0.08%	less than 0.08%

*SP: Standard
 LP: Long-play mode



Model Name Using Similar Mechanism	NEW
Tape Transport Mechanism Type	DATM-100

Wow and flutter Below measurable limit
 (\pm 0.001% W. PEAK)

Input	Jack type	Impedance	Rated input level
LINE IN	phono jack	47 kohms	-4 dBs
DIGITAL IN	phono jack	75 ohms	0.5 Vp-p, 20%
DIGITAL IN	optical jack	—	—

Output	Jack type	Impedance	Rated output	Load impedance
LINE OUT	phono jack	470 ohms	-4 dBs	More than 10 kohms
PHONES	stereo phone jack	220 ohms	0.6 mW	32 ohms
DIGITAL OUT (DTC-57ES)	phono jack	75 ohms	0.5 Vp-p \pm 20%	—

DIGITAL OUT (optical jack): wavelength 660 nm

- continued on next page -

DIGITAL AUDIO TAPE DECK
SONY[®]

General	
Power requirements	120V AC, 60Hz (US, Canadian models) 240V AC, 50Hz (UK model) 220-230V AC, 50/60Hz (AEP model) 110-120, 220-240V AC adjustable, 50/60Hz (E model)
Power consumption	32 W
Dimensions (w/h/d) & Weight	DTC-57ES: Approx. 470x125x350mm (18 5/8x5x13 7/8 inches) Approx. 8kg (17 lb 10oz) DTC-750: Approx. 430x125x350mm (17x5x13 7/8 inches) Approx. 7.2kg (15 lb 14oz)
Remote commander (supplied)	
Remote control system	Infrared control
Power requirements	3V DC, with two size AA (R6) batteries
Dimensions	Approx. 63 x 19 x 175 mm (w/h/d) (2 1/2 x 3/4 x 7 inches)
Weight	Approx. 130 g (4 oz) incl. batteries.
Supplied accessories	
Sony batteries SUM-3(NS) (2)	
Audio connecting cords (2 phono plugs - 2 phono plugs, stereo for line inputs and outputs) (2)	
Screws (4) (DTC-57ES only)	

Design and specifications subject to change without notice.

SAFETY-RELATED COMPONENT WARNING!!

COMPONENTS IDENTIFIED BY MARK Δ OR DOTTED LINE WITH MARK Δ ON THE SCHEMATIC DIAGRAMS AND IN THE PARTS LIST ARE CRITICAL TO SAFE OPERATION. REPLACE THESE COMPONENTS WITH SONY PARTS WHOSE PART NUMBERS APPEAR AS SHOWN IN THIS MANUAL OR IN SUPPLEMENTS PUBLISHED BY SONY.

ATTENTION AU COMPOSANT AYANT RAPPORT À LA SÉCURITÉ!

LES COMPOSANTS IDENTIFIÉS PAR UNE MARQUE Δ SUR LES DIAGRAMMES SCHÉMATIQUES ET LA LISTE DES PIÈCES SONT CRITIQUES POUR LA SÉCURITÉ DE FONCTIONNEMENT. NE REMPLACER SES COMPOSANTS QUE PAR DES PIÈCES SONY DONT LES NUMÉROS SONT DONNÉS DANS CE MANUEL OU DANS LES SUPPLÉMENTS PUBLIÉS PAR SONY.

TABLE OF CONTENTS

<u>Section</u>	<u>Title</u>	<u>Page</u>
1. GENERAL		
	Features	4
	Location and Function of Controls	5
	Connections	8
	Block Diagram	8
	Clock Setting	9
2. DISASSEMBLY		10
3. ADJUSTMENTS		13
3-1.	Electrical Adjustments	15
3-2.	Checks for Date Function	17
4. DIAGRAMS		
4-1.	Circuit Boards Location	18
4-2.	Block Diagram	19
4-3.	Waveforms	23
4-4.	Semiconductor Lead Layouts	25
4-5.	Printed Wiring Boards - Power supply / Display / MD section -	28
4-6.	Schematic Diagram - Power supply / Display / MD section -	31
4-7.	Printed Wiring Boards - Main section -	36
4-8.	Schematic Diagram - Main section -	39
4-9.	IC Block Diagrams	43
4-10.	Pin Functions	47
5. EXPLODED VIEWS		
5-1.	Cabinet Section	57
5-2.	Front Panel Section	58
5-3.	Chassis Section	59
5-4.	Mechanism Section 1	60
5-5.	Mechanism Section 2	61
5-6.	Mechanism Section 3	62
5-7.	Mechanism Section 4	63
6. ELECTRICAL PARTS LIST		64

PRECAUTIONS FOR INSPECTIONS AND REPAIR WITH POWER OFF

Before beginning repair work after turning OFF the main switch, be sure to first remove CN932 (EH8P) of the power board. When assembling the equipment, be sure to plug this connector last.

This is because, even with the main switch turned OFF, electric charges still remain in the smoothing capacitor in the power board. Therefore, if another flexible board is inserted or removed, a terminal of the power supply may short an adjacent terminal while destroying the device.

MODEL IDENTIFICATION

- SPECIFICATION LABEL -

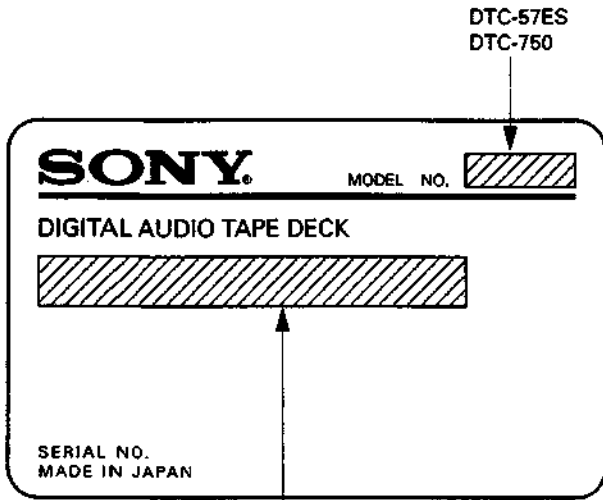

- US, Canadian model : AC 120V 60Hz 32W
- AEP model : AC 220-230V~ 50/60Hz 32W
- UK model : AC 240V 50Hz 32W
- E model : AC 110-120, 220-240V~ adjustable, 50/60Hz 32W

CAUTION

Danger of explosion if battery is incorrectly replaced. Replace only with the same or equivalent type recommended by the equipment manufacturer. Discard used batteries according to manufacturer's instructions.

ADVERSEL !
 Lithiumbatteri – Eksplosionsfare ved fejlagtig håndtering. Udskiftning må kun ske med batteri af samme fabrikat og type. Lever det brugte batteri tilbage til leverandren.

ADVARSEL

Lithiumbatteri – Eksplosjonsfare. Ved utskifting benyttes kun batteri som anbefalt av apparatfabrikanten. Brukt batteri returneres apparatleverandren.

VARNING

Explosionsfara ved felaktigt batteribyte. Använd samma batterityp eller en ekvivalent typ som rekommenderas av apparattillverkaren. Kassera använt batteri enligt fabrikantens instruktion.

VAROITUS

Paristo voi räjähtää, jos se on virheellisesti asennettu. Vaihda paristo ainoastaan laitevalmistajan suosittelemaan tyyppiin. Hävitä käytetty paristo valmistajan ohjeiden mukaisesti.

SAFETY CHECK-OUT

After correcting the original service problem, perform the following safety check before releasing the set to the customer: Check the antenna terminals, metal trim, "metallized" knobs, screws, and all other exposed metal parts for AC leakage. Check leakage as described below.

LEAKAGE TEST

The AC leakage from any exposed metal part to earth ground and from all exposed metal parts to any exposed metal part having a return to chassis, must not exceed 0.5mA (500 microampers). Leakage current can be measured by any one of three methods.

1. A commercial leakage tester, such as the Simpson 229 or RCA WT-540A. Follow the manufacturers' instructions to use these instruments.
2. A battery-operated AC milliammeter. The Data Precision 245 digital multimeter is suitable for this job.

3. Measuring the voltage drop across a resistor by means of a VOM or battery-operated AC voltmeter. The "limit" indication is 0.75V, so analog meters must have an accurate low-voltage scale. The Simpson 250 and Sanwa SH-63Trd are examples of a passive VOM that is suitable. Nearly all battery operated digital multimeters that have a 2V AC range are suitable. (See Fig.A)

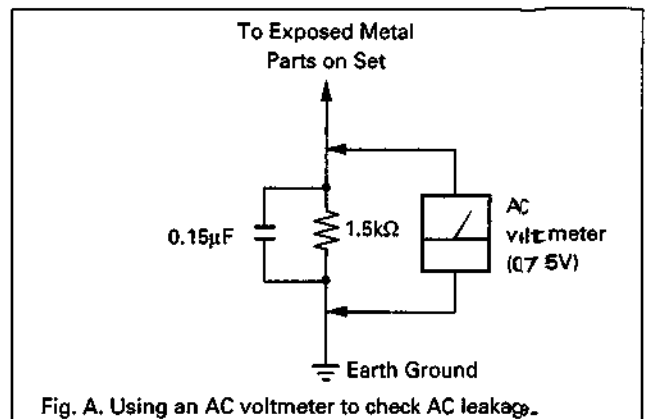

Fig. A. Using an AC voltmeter to check AC leakage.

**SECTION 1
GENERAL**

This section is extracted from
instruction manual.

Features**Serial copy management system**

This unit utilizes the serial copy management system that permits digital-to-digital recording for one generation. You can record CD sound or other digital formats through a digital-to-digital connection. (See page 42.)

Date Function automatically memories the recording date and time

The year, month, day, day of the week, hour, minute and second are automatically memorized in the subcode area during recording, so that during playback you can display this data to check when the tape was recorded. This function is especially convenient when recording live performances, etc.

Three sampling frequencies

Recording/playback can be done with three sampling frequencies (48 kHz, 44.1 kHz and 32 kHz).

48 kHz: For analog and digital input signals in a standard mode.

44.1 kHz: For compact disc and pre-recorded DAT tape.

32 kHz: For analog input signals in a long-play mode.

Long play mode

This unit can operate in a long-play mode. Analog input signals can be recorded or playback for up to four consecutive hours when the DT-120 DAT cassette tape is used. The sampling frequency will be 32 kHz in the long-play mode.

Visible cassette loading

You can view the tape operation through the lid of the cassette compartment. Due to a revolutionary new transport mechanism, cassette loading time has been significantly reduced.

Excellent sound quality**1-bit A/D converter**

For the A/D converter section which converts analog input signals to digital signals, the unit employs a 1-bit A/D converter which theoretically generates no zero-cross distortion for a clear, elegant sound quality.

Pulse D/A converter

Superior playback performance is achieved with a 1-bit D/A converter.

Rich variety of subcode information

This unit can record subcode information such as Start IDs, program numbers, Skip IDs, and absolute time data, enabling you to quickly locate tunes and display the playback time in the same manner as when playing compact discs.

Digital fade-in/fade-out

Professional sounding fade-in/fade-out of either digital or analog signals can be accomplished by use of the FADER button.

Post edit recording of sub codes

You can record or rewrite the following sub codes after the audio signal recording has been completed.

Start ID: Signifies the beginning of a selection.

Program number: Gives a number to the selection.

Skip ID: Signifies the beginning of a portion to be skipped.

End ID: Signifies the end position of recording/playback.

Since sub codes are written on the tape separately from audio signals, the audio signals are not affected.

Location and Function of Controls

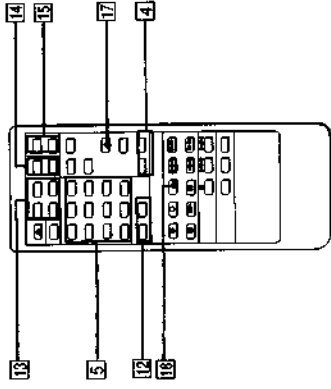

Front Panel Remote Commander

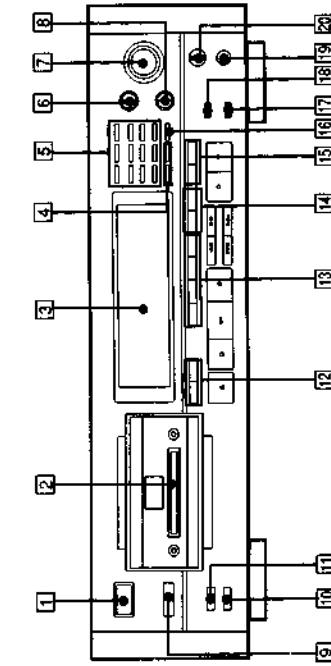

- 1 POWER switch**
Turns the power on and off.
- 2 Cassette compartment**
Insert a cassette with the window side up and the safety tab facing you.
- 3 Display window**
- 4 DATE buttons**
RECORDED: Press to display the recording day of the tape being played.
PRESENT: Press to display the current time. Each time the RECORDED or PRESENT button is pressed, day, month and year display, the day of the week display or hour, minute and second display is switched sequentially.
- 5 Music select buttons**
Numeric buttons (0-9): Designate the desired program number to be played back before starting playback. Designate the desired number in the record-pause mode, the program number is written consecutively from the designated number.
CLEAR: Use to cancel the program number which has been mistakenly entered.
MUSIC SCAN: Use this feature to listen to the beginning of each selection successively.
- 6 INPUT selector**
Set according to the signal to be recorded.
ANALOG: For recording from the equipment connected to the LINE IN jacks.
OPTICAL: For recording from the equipment connected to the DIGITAL IN (OPTICAL) jack.
COAXIAL: For recording from the equipment connected to the DIGITAL IN (COAXIAL) jack.
- 7 REC LEVEL (recording level) control**
Adjust the recording level for the analog input signals. When recording digital signals, it is not necessary to adjust the recording level.
- 8 BALANCE control**
Adjust the recording balance for the analog input signals. When recording digital signals, it is not necessary to adjust the recording balance.
- 9 Remote sensor**
Receives the signal from the Remote Commander.
- 10 REC MODE selector**
Normally set to the STANDARD position. When this selector is set to the LONG position, you can record analog input signals or digital signals with 32 kHz in the long-play mode.
- 11 TIMER switch**
Normally set to the OFF position. When recording or playing back at the desired time using a commercially available audio timer, set to the REC position or the PLAY position respectively.
- 12 COUNTER buttons**
MODE: Selects the counter display in the display window among the linear counter (tape running time), absolute time, elapsed time of the selection, and total remaining time of tape. Each time you press the button, the display changes sequentially.
RESET: Resets the linear counter to "00:00".
- 13 START ID buttons**
AUTO: Press to turn on and off the AUTO indicator. When the AUTO indicator is lit, the start ID will automatically be written during recording. When the AUTO indicator is not lit, press the START ID WRITE button at the point where you want to write a start ID.
WRITE: Press to write the start ID at the desired point during recording or playback.
ERASE: Press to erase a start ID. When a start ID and a program number are written on the tape, both codes are simultaneously erased by pressing this button.
RENUMBER: Press to renumber all programs on the tape. When only the start IDs are written, pressing this button will insert the proper program numbers beginning with "1". The tape will rewind and start from the beginning to accomplish this function.
- 14 SKIP ID buttons**
WRITE: Press at the beginning of the portion you may wish to skip later. A skip ID will be written from the point where you pressed this button.
ERASE: Press to erase the nearest skip ID which is before the current position.
- 15 END ID buttons**
WRITE: Press to write the ID signifying the end of playback or recording.
ERASE: Press to erase the end ID.
- 16 CLOCK SET button**
Press to adjust the time of the clock built in this unit. In this mode, the MUSIC SCAN button and the 0 button function as the + and - buttons respectively.
- 17 MARGIN RESET button**
Press to reset the margin of peak level.
- 18 FADER button**
Press to fade in or fade out during recording or playback.
- 19 Headphones jack**
Insert the headphones plug to this jack.
- 20 PHONE LEVEL control**
The PHONE LEVEL control adjusts the headphones volume level.

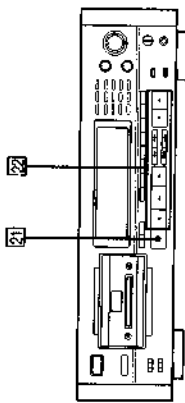

Front Panel Remote Commander

- 21 OPEN/CLOSE button**
Press to open or close the cassette compartment.
- 22 Tape operating buttons**
 - (stop): Press to stop recording or playback
 - ▶ (play): Press to play back the tape.
 - REC (recording): Press to enter the record-pause mode. After pressing this button, press the ■ or ▶ button.
 - ⏸ PAUSE (pause): Press to stop for a moment during recording or playback. To restart recording or playback, press this button again or press the ▶ button. If the unit is left in the pause mode for about 10 minutes, it will automatically be released and the deck will enter the stop mode. To restart recording or playback from the stop mode, press the ● REC or ▶ button respectively.
 - ⏻ OREC MUTE (record muting): Inserts a sound-muted portion (space).
 - ⏪ (AMS): Press to locate the beginning of the selection during the playback.
 - ⏩ (rewind/review, fast-forward cue): In the stop mode, press to rewind/fast-forward the tape. During playback, press to rewind or fast-forward the tape while listening to the sound.
- 23 DISPLAY MODE button**
Changes the display mode. (Refer to page 10.)
- 24 RMS play buttons**
 - ENTER: To program the selections in a desired order, press this button after pressing the numeric buttons.
 - CHECK: Press to check the programmed contents.

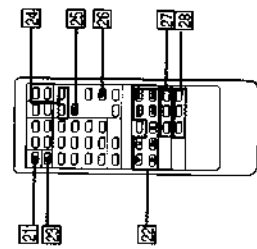

Remote Commander Operation

Each button on the remote commander functions in the same way as those having the same name on the front panel. However, the following operations cannot be performed using the remote commander. Use the front panel controls instead:

- Turning the power on and off
- Selecting digital (optical/coaxial)/analog input source
- Setting the clock
- Adjusting the recording level and balance
- Adjusting the headphones level
- Setting the tuner recording/playback
- Selecting the record mode (standard or long)

The following operations can be performed only with the remote commander.

- Activating CD synchronized recording using a Sony CD player and controlling the CD player
- Locating the desired selection on the Compact Disc or when a Sony CD player in the pause mode (possible only when a Sony CD player is used.)
- Repeat play
- Skip play
- RMS* play
- *RMS: Random Music Sensor

- 25 REPEAT 1/ALL button**
Press to play a desired portion repeatedly. Each time you press the button, the indicator changes as follows:
REPEAT 1 → REPEAT ALL → off
- 26 SKIP PLAY button**
Press to activate the skip ID code function. The portion of the tape previously marked will be skipped.
- 27 CD operation buttons**
Operative only for the Sony CD player equipped with a Remote Commander
⏪ (pause): Press this button twice to start playback. Press this button once in the playback mode, the deck enters the pause mode.
⏻ (AMS): Press to locate the desired selection on the Compact Disc during playback or in the stop mode
- 28 CD SYNCHRO (CD synchronized recording) buttons**
(The playback of the Sony CD player equipped with a Remote Commander and the recording of the DAT deck can be performed simultaneously.)
STANDBY: Press to set the unit in the record-standby mode.
START: Press to start recording of the DAT deck and then playback of the CD player.
STOP: Press to stop the DAT deck recording and the CD player playback.

Installing Batteries

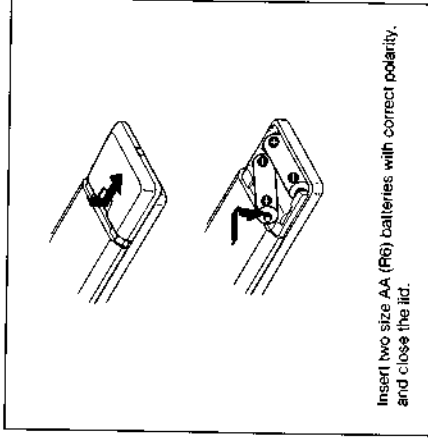

Insert two size AA (R6) batteries with correct polarity, and close the lid.

Notes on remote control

- Do not expose the remote sensor on the deck to strong light such as direct sunlight, lightning apparatus, etc.
- Do not place any obstructions between the Remote Commander and the remote sensor, or else operations will not be performed correctly.
- The controllable range is limited. Point the Remote Commander directly at the remote sensor on the deck.
- When remote control operation distance becomes shorter, the batteries are weak. Replace both batteries with new ones.

To avoid battery leakage

When the commander will not be used for a long period of time, remove the batteries to avoid damage caused by battery leakage and corrosion.

Battery life

About half a year of normal operation can be expected when using the Sony SUM-3 (MS) batteries.

Display Window

- To turn off the display window**
When the power is turned on, the display window also is turned on. During recording or playback, all display or some parts of the display can be turned off as follows:
When operating with the front panel controls
While pressing the COUNTER MODE button, press the 0 button.
- When operating with the remote commander**
Press the DISPLAY MODE button
Each time you press the above buttons, the indicators change as follows:

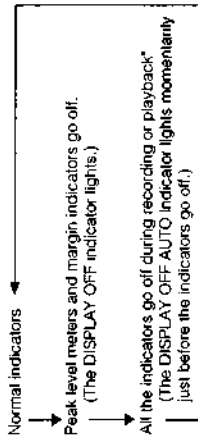

Normal indicators

Peak level meters and margin indicators go off.
(The DISPLAY OFF indicator lights.)

All the indicators go off during recording or playback*
(The DISPLAY OFF AUTO indicator lights momentarily just before the indicators go off.)

* When pressing the COUNTER MODE or DISPLAY MODE button except during recording or playback, the DISPLAY OFF AUTO indicator lights. In this case, all the indicators go off immediately after recording or playback starts.

To change the brightness of the display window
While pressing the COUNTER MODE button, press one of the numeric buttons 1, 2 and 3. The greater number pressed, the darker the display window becomes.
(When operating with the remote commander, also press the COUNTER MODE button.)

- 1 LONG PLAY mode indicator**
Lights when recording or playback is being performed in the long play mode.
- 2 TOC (Table Of Contents) indicator**
When a pre-recorded DAT cassette is played back, this indicator will light.
- 3 DATE indicator**
Lights when pressing the RECORDED button to display the recording day of the tape being played. Flashes when pressing the PRESENT button to display the current time.
- 4 REMAINING (remaining time) indicator**: Lights when the counter shows the remaining time of the tape.
PGM TIME (program time) indicator: Lights when the counter shows the elapsed time of the current selection.
ABS TIME (absolute time) indicator: Lights when the counter shows the elapsed time from the beginning of the tape.
- 5 Time indicator**
Indicates the tape running time, absolute time, elapsed time of the current selection, remaining time or recording day. Each time the COUNTER MODE button is pressed, the display is changed.
- 6 Fade In/out indicator**
[AMS]: Flashes when recording or playback fades in.
[MARG]: Flashes when recording or playback fades out.
- 7 AMP/PM indicators**
Show AM or PM of the time.

- 8 INPUT selector indicators**
The OPTICAL or COAXIAL indicator lights according to the position of the INPUT selector. No indicator lights when the INPUT selector is set to the ANALOG position.
- 9 SAMPLING FREQ. (Sampling frequency) indicator**
48 KHZ: For recording/playback of CD or a pre-recorded (standard mode)
44.1 KHZ: For recording/playback of CD or a pre-recorded DAT cassette
32 KHZ: For recording/playback of analog input signals (long-play mode)
- 10 REPEAT indicators**
REPEAT 1: Lights when a desired selection is played back repeatedly.
REPEAT ALL: Lights when all the selections are played back repeatedly.
- 11 AMS (Automatic Music Sensor)/RMS (Random Music Sensor) indicators**
Show the number of selections to be skipped ahead or behind in the AMS operation. When designating a selection directly by the numeric button and the **▶** button, the display shows the program number of the target selection while the selection is being searched for. When programming the desired selections in the RMS operation (page 38), the display shows the program number of the selection to be programmed.
- 12 DISPLAY OFF/AUTO indicators**
The DISPLAY OFF indicator lights when peak level meters and margin indicators are turned off. The DISPLAY OFF AUTO indicator lights momentarily before all the indicators are turned off.
- 13 SKIP PLAY indicator**
When this indicator is lit during playback, the portion marked by the skip ID is skipped and playback continues from the next start ID.
- 14 MUSIC SCAN indicator**
Lights after pressing the MUSIC SCAN button to listen to the beginning of each selection successively.
- 15 CAUTION indicator**
Lights when moisture condensation occurs. If this happens, the deck stops functioning automatically. (See page 4.)
- 16 START ID mode indicators**
AUTO: Lights when the AUTO button is pressed to write the start ID automatically.
RENUMBER: Lights when the RENUMBER button is pressed to renumber the program numbers.
WRITE: Lights when writing the start ID manually.
AUTO RENUMBER: Lights when renumbering program numbers automatically.

- SHIFT RENUMBER**: Lights when shifting the start ID and program number position.
- 17 SKIP ID mode indicator**
WRITE: Lights when writing the skip ID.
ERASE: Lights when erasing the skip ID.
- 18 END ID mode indicator**
WRITE: Lights when writing the end ID.
ERASE: Lights when erasing the end ID.
- 19 START ID indicator**
Flashes when writing (for 9 or 18 seconds) or erasing a start ID code, and lights when the start ID is detected during playback.
- 20 SKIP ID indicator**
Lights when writing (for 1 or 2 seconds) or erasing a skip ID code or when the skip ID is detected during playback.
- 21 MARGIN indicator**
Shows how much margin there is between the peak level of input audio signal and 0 dB.
- 22 REHEARSAL indicator**
Lights while the rehearsal function is activated (page 28).
- 23 COPY PROHIBIT indicator**
Lights when recording the digital signal with the copy prohibit code. In this case, record with the LINE IN jacks.
- 24 STEP/PGM NO. indicator**
Shows the program number of the selection being played when programming the desired selection in the RMS operation (page 38), the display shows the step number of the programmed selection.
- 25 Frequencies map**
When pressing the 4 button while keeping the COUNTER MODE button pressed, bars indicating the sampling frequencies with which the tape was recorded appear on the peak level meters.
- 26 Peak level meters**
Indicate the level of the audio signal being recorded during recording, and the peak values of the audio signal recorded on the tape during playback.
- 27 Tape operation indicators**
REC: Lights during recording or in the record-pause mode.
▶: Lights during recording or playback. It also lights in the record-pause mode or in the play-pause mode.
⏸: Lights in the record-pause mode or in the play-pause mode.

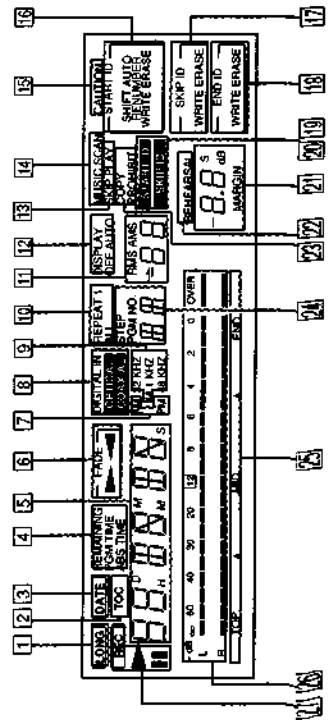

Block Diagram

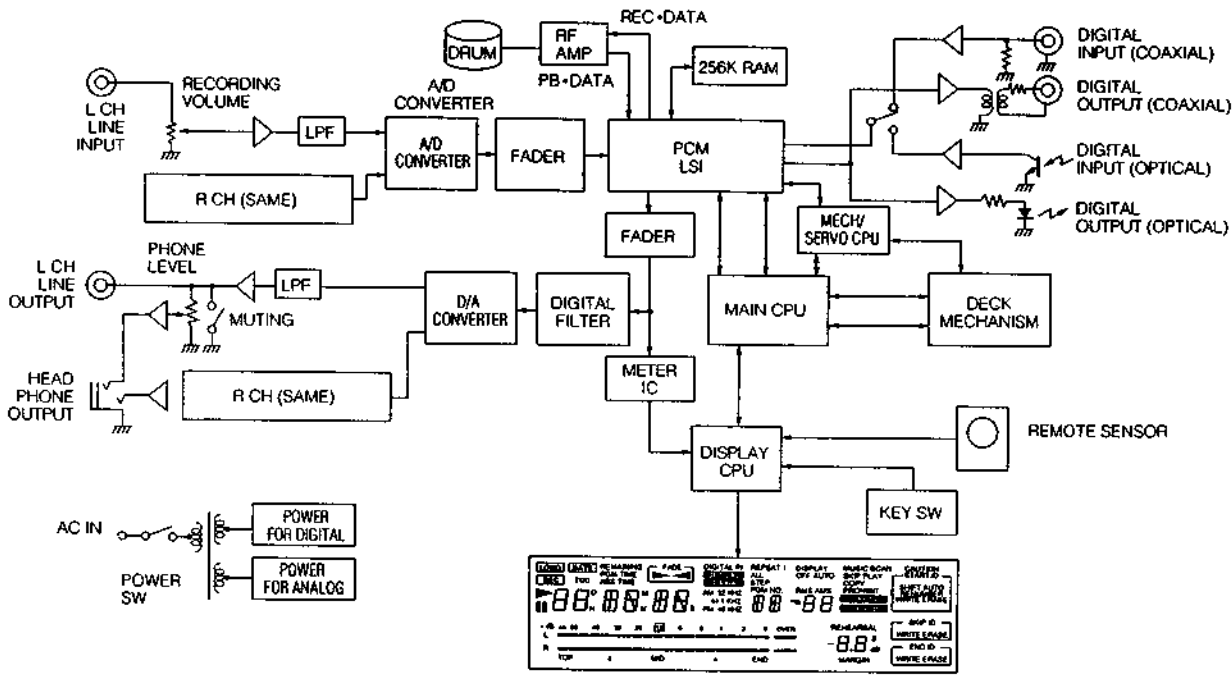

Connections

Rear Panel Jacks

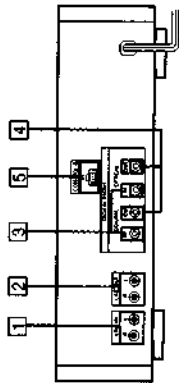

- 1 **LINE IN (line input) jacks (phono jack)**
Connect to the recording outputs of an amplifier. Signals supplied by the amplifier can be recorded using the sampling frequency of 48 kHz in the standard play mode or 32 kHz in the long play mode.
- 2 **LINE OUT (line output) jacks (phono jack)**
Connect to the DAT or tape inputs of an amplifier. The playback signal of this deck will be output.
- 3 **COAXIAL/OPTICAL, DIGITAL IN (digital input) jacks (coaxial phono jack/optical jack)**
Connect to the digital outputs of an amplifier having a built-in D/A converter or other digital source, such as a CD player for digital-to-digital recording.
- 4 **COAXIAL/OPTICAL DIGITAL OUT (digital output) jack (coaxial phono jack/optical jack)**
Connect to the digital inputs of an amplifier having a built-in D/A converter or another DAT deck, for playback of a DAT cassette or digital-to-digital recording.
- 5 **CONTROL-S IN jack**
Connect to the CONTROL-S output of a Sony amplifier or receiver for remote control.

- Notes on connection**
 - Use the connecting cords specified in the illustrations.
 - Turn off the power for all equipments before making connections.
 - Be sure to insert the plugs firmly into the jacks. Loose connections may cause hum and noise. When unplugging, grasp the plug and not the cord.
- Notes on the optical cable**
 - Do not bend the cord. When the cord is not used, curl it with a diameter of more than 15 cm (5 7/8 inches).
 - Do not use it under high temperatures.
 - When the optical cable is not connected, cover the OPTICAL IN/OUT jacks with the supplied caps.
- Note on sound signals**
When connecting an optical cable to the DIGITAL IN/ DIGITAL OUT jacks, sound signals (L/R) are transmitted together through the cable.
- Note on the CONTROL-S IN jack**
To remotely control this unit through a receiver or amplifier, connect the input of this unit to the CONTROL-S output of a Sony receiver or amplifier with a CONTROL-S cable. When this connection is used, only remote control commands sent through the receiver or amplifier will be executed. The remote sensor of this unit will not function.





Clock Setting

This unit employs a built-in clock to keep track of the current date and time. Once you set the date and time, this information will be recorded on the tape along with the audio signal during recording. This function is very convenient because it allows you to check when the tape was recorded when playing the tape later.

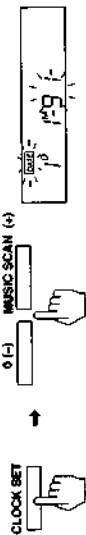

Setting the date and time

Example: Setting the clock to 10:30:00 AM, July 4, 1991 (Thursday)



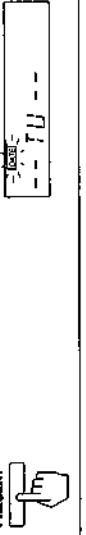

Setting the day

- 1 **Display the date.**

- 2 **Set the year.**

- 3 **Set the month.**

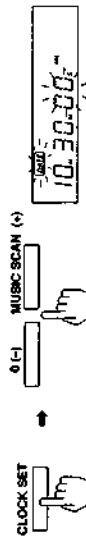
- 4 **Set the day.**

- 5 **Complete the setting procedure.**

Setting the day of the week

- 1 **Display the day of the week.**

 - 2 **Set the day of the week.**

- 3 **Complete the setting procedure.**

Setting the time

- 1 **Display the time.**

- 2 **Set the hour.**

- 3 **Set the minutes.**

- 4 **Set the seconds to 0.**

- 5 **Start the clock simultaneously with the signal from a timecast (telephone, etc.).**

To confirm the date or time

Press the PRESENT button to display the date, the day of the week or time. When pressing the PRESENT button once, the date is displayed, when pressing twice, the day of the week is displayed and when pressing three times, the time is displayed. To return to the original counter display, press the COUNTER button.

Time display

AEP, UK, E models:
 The time is displayed in 24-hour format.

US, Canadian models:
 The time is displayed in 12-hour format.

Midnight, 12:00 AM
 Noon, 12:00 PM

Built-in clock

This unit's built-in clock operates using a quartz oscillator, and time variations caused by changes in temperature, etc., may accumulate. For precise recording of hour, minute, and second data by the built-in date function, it is recommended that you set the clock once a week.

Precautions when setting the clock

- Set the clock while the tape is stopped.
- Although this unit's clock automatically adjusts for leap years and long and short months, do not enter a date which does not exist.

The day of the week is displayed as follows.

Sunday	SU
Monday	MO
Tuesday	TU
Wednesday	WE
Thursday	TH
Friday	FR
Saturday	SA

Note

This unit uses a back-up battery to keep the clock running when the power is turned off. The life of the battery under normal use is approximately five years. When the battery starts to run down, the clock will stop operating normally. When this occurs, have the battery replaced at your dealer or nearest Sony Service Center (a battery replacement fee is required).

SECTION 2 DISASSEMBLY

- Remove the following devices shown by ❶, etc. in the order of the numbers.

<p>[CASE]</p> <p>Unscrew the four case attachment screws and remove the case.</p>	<p>[CASSETTE WINDOW]</p> <ol style="list-style-type: none"> ❶ Press the OPEN/CLOSE switch to effect LOADING OUT STATE (if power is not supplied) rotate the pulley in the left side of the Mechanism Deck counterclockwise.) ❷ Remove the cassette by lifting the window up.
--	---

MECHANISM SECTION

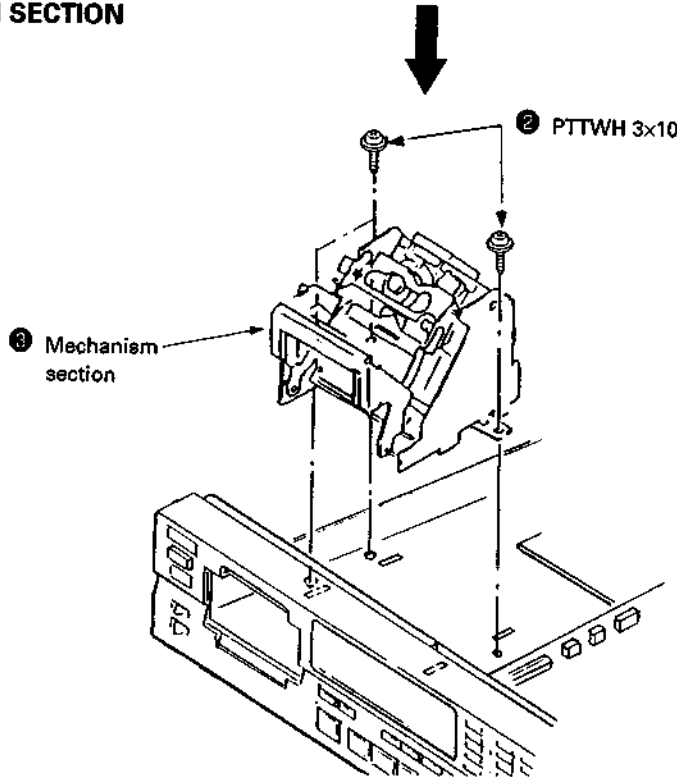

HOLDER

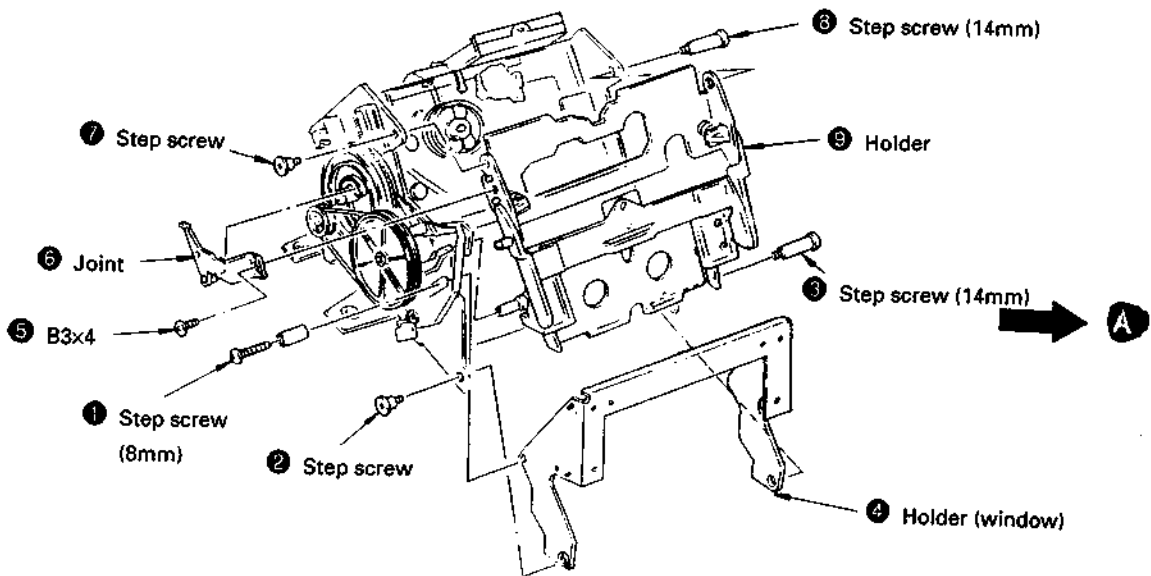

CASSETTE COMPARTMENT MOTOR (M901), PULLEY, GEAR (CAM) AND SLIDER

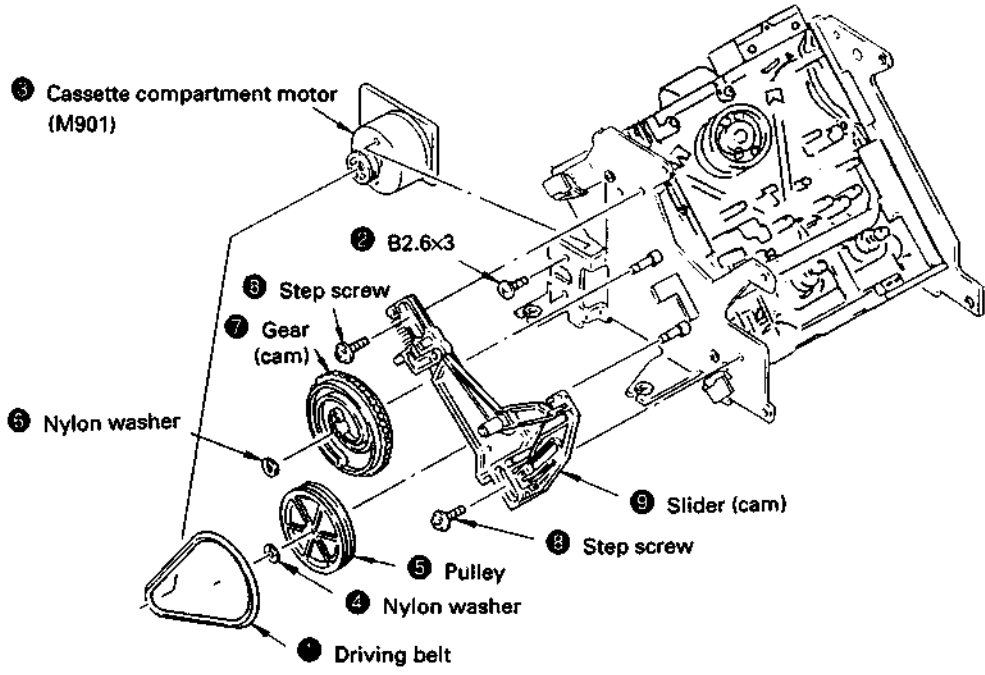

A

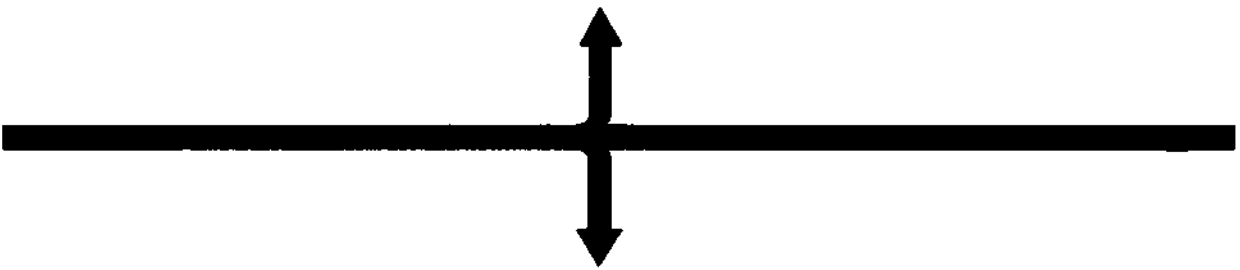

DRUM

- ① Remove the drum lead wires on rear side of the drum from the connector.

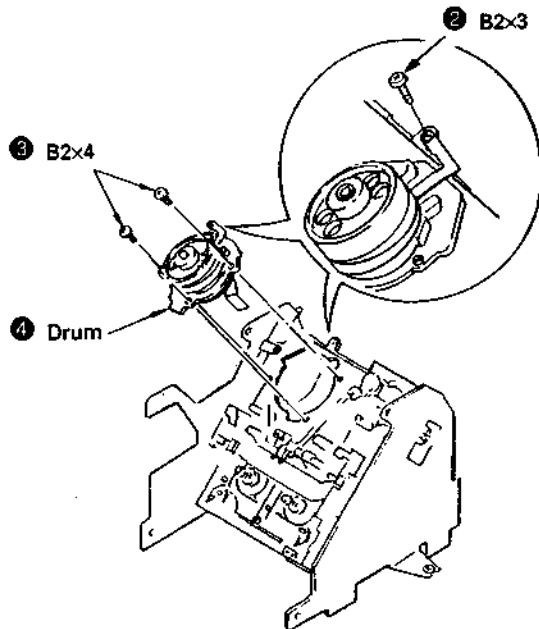

DRUM DRIVE BOARD, DRIVING CHASSIS

- 1 Remove the connector on the drum drive board.

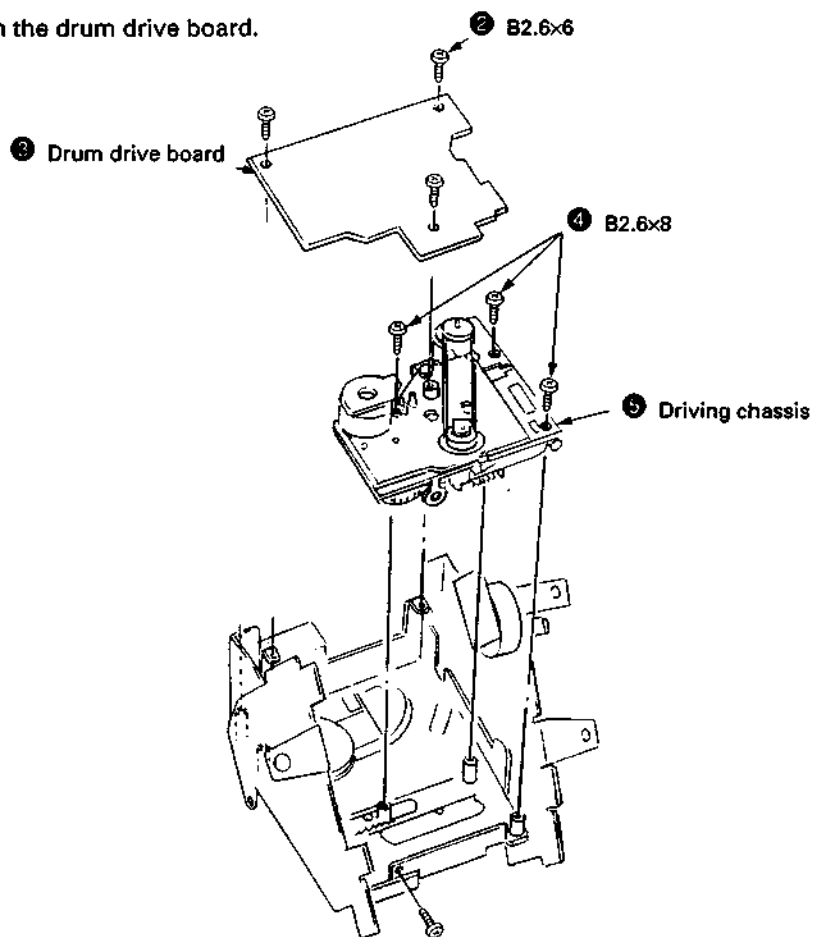

CAPSTAN MOTOR (M902)

- 1 Precision screw M1.7x4

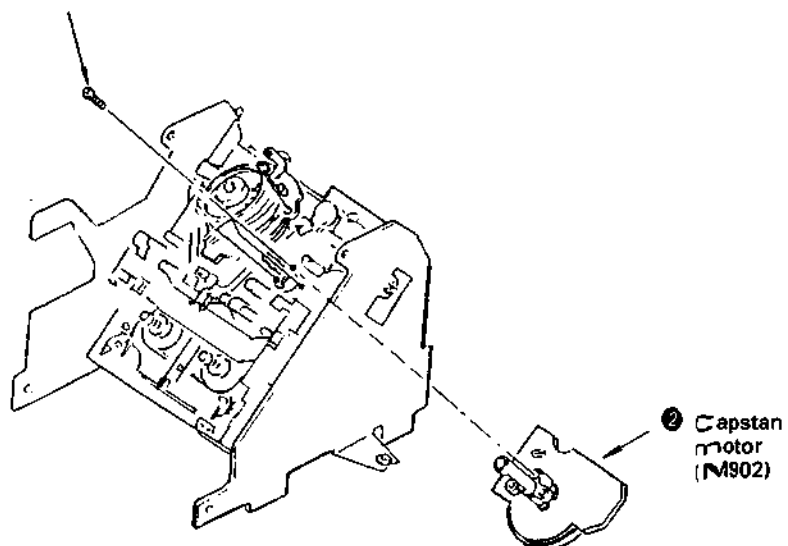

SECTION 3 ADJUSTMENTS

Notes When Making Adjustments

1. Adjustments should be performed in the order listed.
2. Use the following test tapes :
 - TY-7111 (8-909-812-00).....Level
 - TY-7252 (8-909-822-00).....Tracking
 - TY-7551 (8-909-814-00).....Functions
 - TY-30B (8-892-358-00).....Blank

Use the following torque meter:

TW-7131 (8-909-708-71).....FWD

3. Switches and controls should be set as follows unless otherwise specified.

TIMER switch	: OFF
REC MODE switch	: LONG
INPUT switch	: COAXIAL
REC LEVEL control	: Min.
PHONES LEVEL control	: Min.

4. Creating an end sensor cassette

- (1) Press the tape slider lock and move the slider in the direction indicated by the arrow.

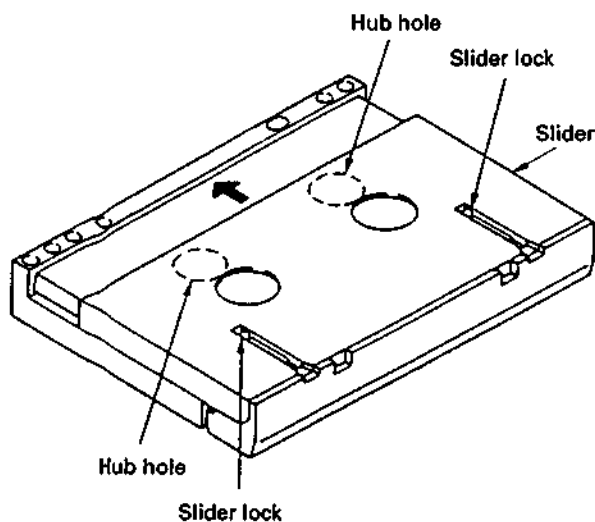

- (2) Open the lid and cut the tape.

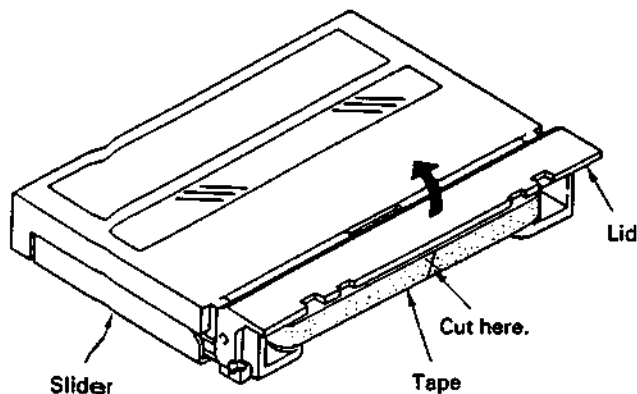

- (3) Turn the hubs until the tape is completely inside the cassette (both T and S sides).
The end sensor cassette for end sensor adjustment is now ready for use.

5. Be careful not to move RV1 and RV2 on the RF AMP board in the mechanism assembly.

6. To adjust the tape path and guides, remove the holder assembly as shown in the diagram and use the DAT holder jig (J-8000-002-A). This will make it easier to perform adjustments.

- First turning the pulley counterclockwise to put it in loading out status will make removal and reattachment of the holder assembly easier.
- To perform adjustments, turn the pulley clockwise to put it in loading in status, load the cassette tape and set the IN switch to the ON position.

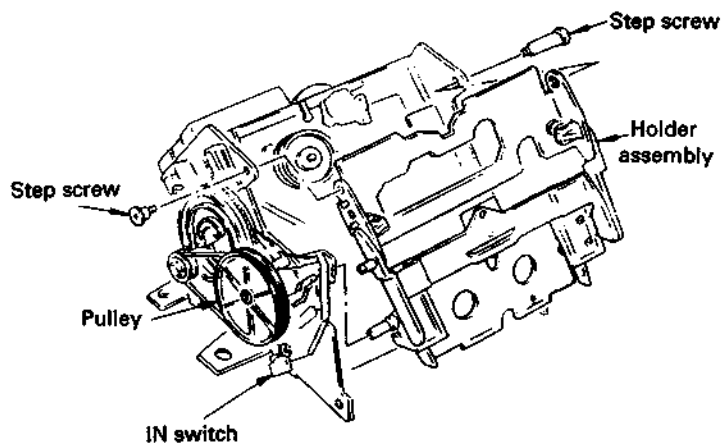

7. Test mode

The test mode is effected by shorting TP (XTEST MA IN, XTEST SERVO and XTEST DISP) on the main board and the operation switch board and GND.

- (1) Test mode (main)
 - Turn OFF the main switch, connect XTEST MAIN on the main board to GND and perform the following adjustments.
 - Tape path adjustment
 - DPG adjustment
 - ATF pilot (GCA) checking
- (2) Test mode (servo)
 - Turn OFF the main switch, connect XTEST SERVO on the main board to GND and perform the following adjustments.
 - End sensor checking
 - FWD torque checking
 - FWD back tension checking
- (3) Test mode (display)
 - You can check the following FL display tube and the panel switch by turning OFF the main switch, disconnecting CN932 on the power board, removing flexible board CN752 on the operation switch board, connecting XTEST DISP to GND, connecting CN932 again and then turning ON the main switch.

Each grid of the FL display tube sequentially lights up while all tubes being lighted up finally.



Level meters go out one after one.



Press any of the remote controller for DAT in this state. Thus, all level meters go out. (It may sometimes occur that one or two meters remain lighting up according to switch setting at that time.)



Everytime a switch on the panel is pressed, display tubes light up sequentially one after one. With all keys once pressed, all level meters go out.

- To reset the test mode, disconnect the wire shorting XTEST and GND. After completion of adjusting, be sure to reset the test mode.

8. Check the following items for correct tape speed, after completion of adjusting.

- (1) Set the REC MODE switch to STANDARD and check for normal recording and playback. (× 1)
- (2) Set the REC MODE switch to LONG and check for normal recording and playback. (× 0.5)
- (3) With QUE (▶ + ▶▶) or REVIEW (▶ + ◀◀), check that qurrr, qurrr sound is heard. (× 3, × 8)
- (4) Check that correct time is displayed after FF (▶▶▶) or REV (◀◀◀). (× 16)
- (5) Check that SEARCH (▶▶▶, ◀◀◀) is normal.

Adjust Parts Location

— Mechanism assembly —

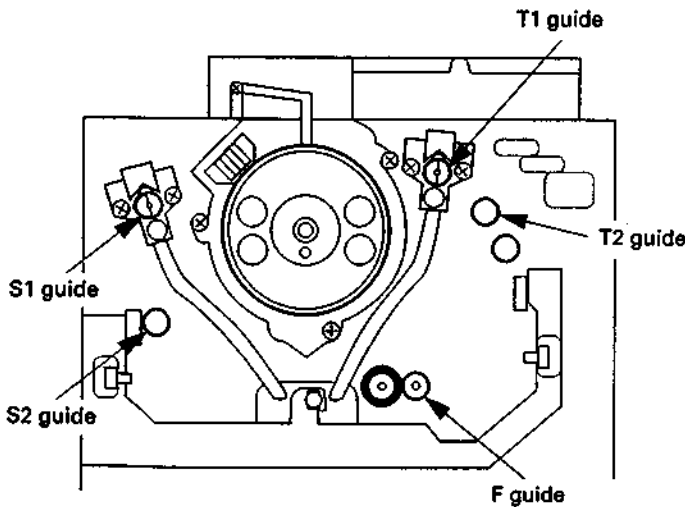

— Main board —

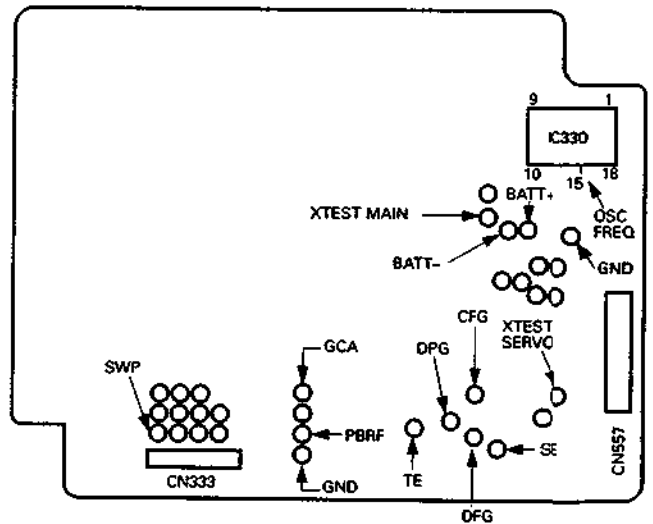

— Display board —

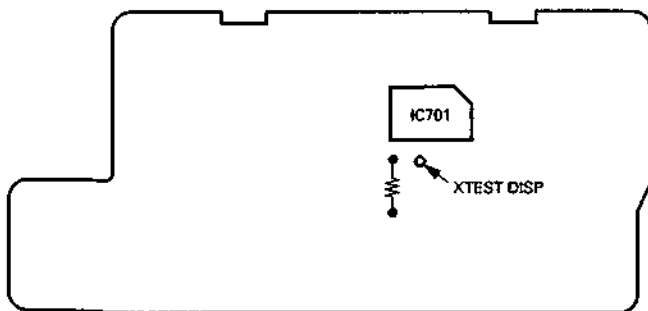

3-1. ELECTRICAL ADJUSTMENTS

End Sensor Adjustment

Perform the following adjustment when the holder has been removed or part of the mechanism deck section replaced.

Adjustment Procedure:

1. Connect an oscilloscope to the test land SE (in the S side) and TE (in the T side) of the main board.
2. Actuate the test mode (servo), mount an end sensor cassette and effect the STOP (■) mode.
3. Check that p-p values of waveform of the oscilloscope satisfy the following.

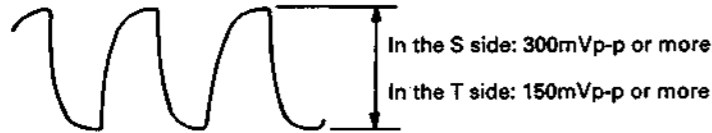

FWD Torque Adjustment

Adjustment Procedure:

1. Put the set into the test mode and load the FWD torque meter TW-7131 (8-909-708-71).
2. Put the set into the PLAY (▶) mode.
3. Confirm that the FWD torque value (take-up side rewinding torque) is between 10 – 20 g-cm (0.14 – 0.28 oz-inch).
4. Confirm that the value indicated by the torque meter is maintained for one full cycle.

Adjustment Point: main board

FWD Back Tension Check

Check procedure:

1. Put the set into the test mode and load the FWD torque meter TW-7131 (8-909-708-71).
2. Put the set into the PLAY (▶) mode.
3. Confirm that the back tension (supply side) is between 5 – 6 g-cm (0.07 – 0.09 oz-inch).
If this is not satisfied, adjust back tension by rotating the FWD back tension adjustment screw equipped on the side surface of the mechanical deck. After completion of adjusting, be sure to apply screw lock.
4. Confirm that value indicated by the torque meter is maintained for one full cycle.

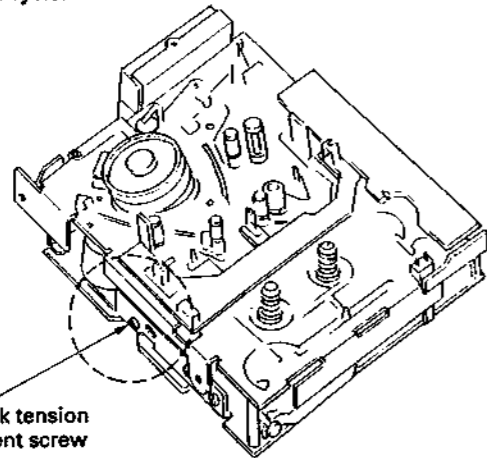

FWD back tension adjustment screw

To tighten (clockwise) — back tension becomes larger.
To loosen (counterclockwise) — back tension becomes smaller.

Tape Path Fine Adjustments (× 1.5 FWD Mode)

Perform the following adjustment when the drum has been replaced.

Adjustment Procedure :

1. Connect an oscilloscope CH-1 to TP (PBRF) and CH-2 to TP (SWP) on the main board.
2. Put the set into the test mode and load test tape TY-7252 (8-909-822-00).
3. Press the AMS (▶▶) key.
Each part of switches on Test Mode.

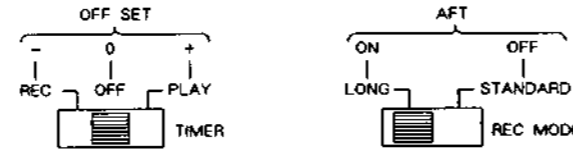

4. With the REC MODE switch set to STANDARD (ATF: OFF) and the TIMER REC switch set to PLAY or REC (OFFSET: + or -), fine adjust the S1 and T1 guides so that the oscilloscope RF signal waveform remains the same when high-low is repeated.

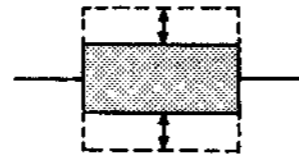

* Finish the adjustment by screwing in.

5. Check the RF signal waveform with the REC MODE switch set to LONG (ATF: ON) and the TIMER REC switch set to PLAY or REC (OFFSET: + or -).

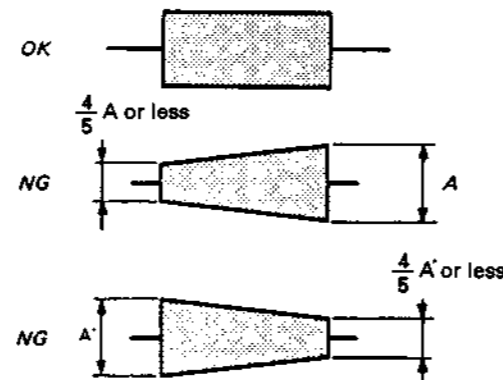

6. Check the RF signal waveform with the REC MODE switch set to LONG (ATF: ON) and the TIMER REC switch set to PLAY or REC (OFFSET: 0).

- (1) Confirm that the RF signal waveform peak value (B) is 60 mV or more.

- (2) Confirm that the undershoot level of the RF signal waveform's flat portion is within 10%.

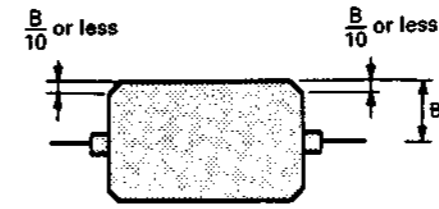

7. When the measured values are not within the above tolerances, repeat items 3 – 6 above.

Adjustment Point: mechanism assembly

DPG Adjustment

Perform the following adjustment without fail when the drum has been replaced.

Adjustment Procedure:

1. Connect oscilloscope CH-1 to TP (PBRF) and CH-2 to TP (SWP) on the main board. (Use CH-2 as the trigger. When the CH-2 signal is inverted, the trailing edge can be used for synchronization.)
2. Put the set into the test mode and load test tape TY-7252 (8-909-822-00).
3. Set the REC MODE switch to LONG (ATF: ON) and the TIMER REC switch to OFF (OFFSET: 0).
4. Press the AMS (▶▶) key.
5. Press the ◀◀ and ▶▶ keys as appropriate so that the gap between the oscilloscope SWP and RF signals becomes $650 \pm 15 \mu\text{sec}$. (Hold the ◀◀ and ▶▶ keys down for more than 1 second to perform rough adjustment. Hold them down for approximately 0.2 seconds for fine adjustment.)

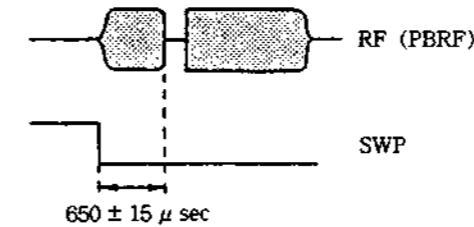

ATF Pilot (GCA) Adjustment

Perform this adjustment after cleaning the heads with a cleaning cassette.

Adjustment Procedure:

1. Connect oscilloscope CH-1 to TP (GCA: Gain Control Amp.) and CH-2 to TP (SWP) on the main board. (When the CH-2 signal is inverted, the trailing edge can be used for synchronization.)
2. Put the set into the test mode and load test tape TY-7111 (8-909-812-00).

3. Actuate the PLAY (▶) mode and check that the GCA waveform on the oscilloscope is as follows.

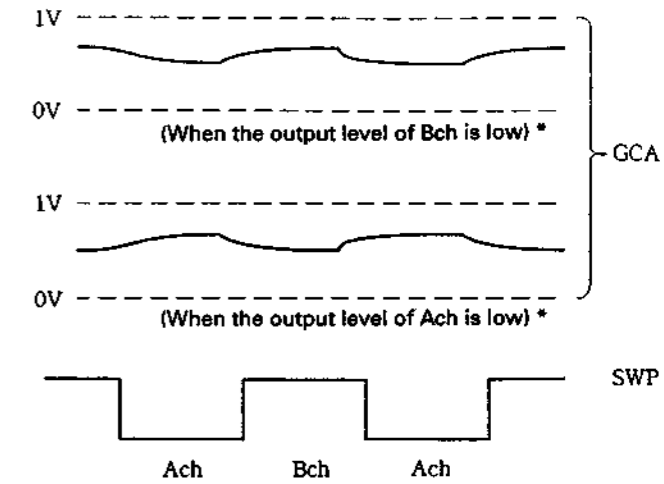

* Slightly changes depending on the state of the head. NG if the GCA waveform is 1V or more or equal to the GND level.

SECTION 4 DIAGRAMS

3-2. CHECKS FOR DATE FUNCTION

Clock IC Back-up Check

- When there is the short-circuit position on the pattern around the lithium battery (BAT301) or the clock IC (IC330) or disconnecting CN398 on removing the front panel assembly the clock is reset. (In spite of pressing PRESET button, the data indication becomes “_ _ Y _ _ M _ _ D” “_ _ H _ _ M _ _ S”)

At this time, check the back-up function by the procedures given below.

- Connect DC voltmeter to TP (BATT+) and TP (BATT-) on the main board.
- When the power is off, the voltage value of the item (1) should be less than +30 mV.
(When the voltage value becomes +30 mV or more, Check around IC330 or replace IC330.)
- When the power is on, the voltage value of the item (1) should be less than 0 mV (- (minus) indication).
(When the voltage value becomes + (plus) indication, Check around IC321 or replace IC321.)
- When the above voltage values are normal, set the preset date and time (year, month, day, day of the week, hour, minute, second) according to the instruction manual.
- After setting the time on the item (4), turn power off and turn power on several seconds later, and check the clock works normally.

Back-up Battery Replacement

The life of the back-up battery under normal use (normal temperature, normal humidity) is approximately ten years or more. (On the instruction manual, described “approximately five years”.)

Be careful about the following points on the battery replacement.

- Repair the cause of the battery wastage by performing mentioned above “Clock IC Back-up Check”.
- The open-circuit voltage of the replaced battery is 3.0 V or more as the new one, and when it is 2.0 V or less, it is completely consumed, replace it with new one.
- After the battery replacement, perform “Clock IC Back-up Check” again and set the time.

Clock Frequency Adjustment

Adjustment Procedure:

- Connect a frequency counter to pin ⑮ of IC330 and GND on the main board.
- Turn power on and confirm that the reading on the frequency counter is 2048.00 ± 0.02 Hz. (in normal temperature)
- Perform “Clock IC Back-up Check” described above.

* Time setting procedure described on page 9.

4-1. CIRCUIT BOARDS LOCATION

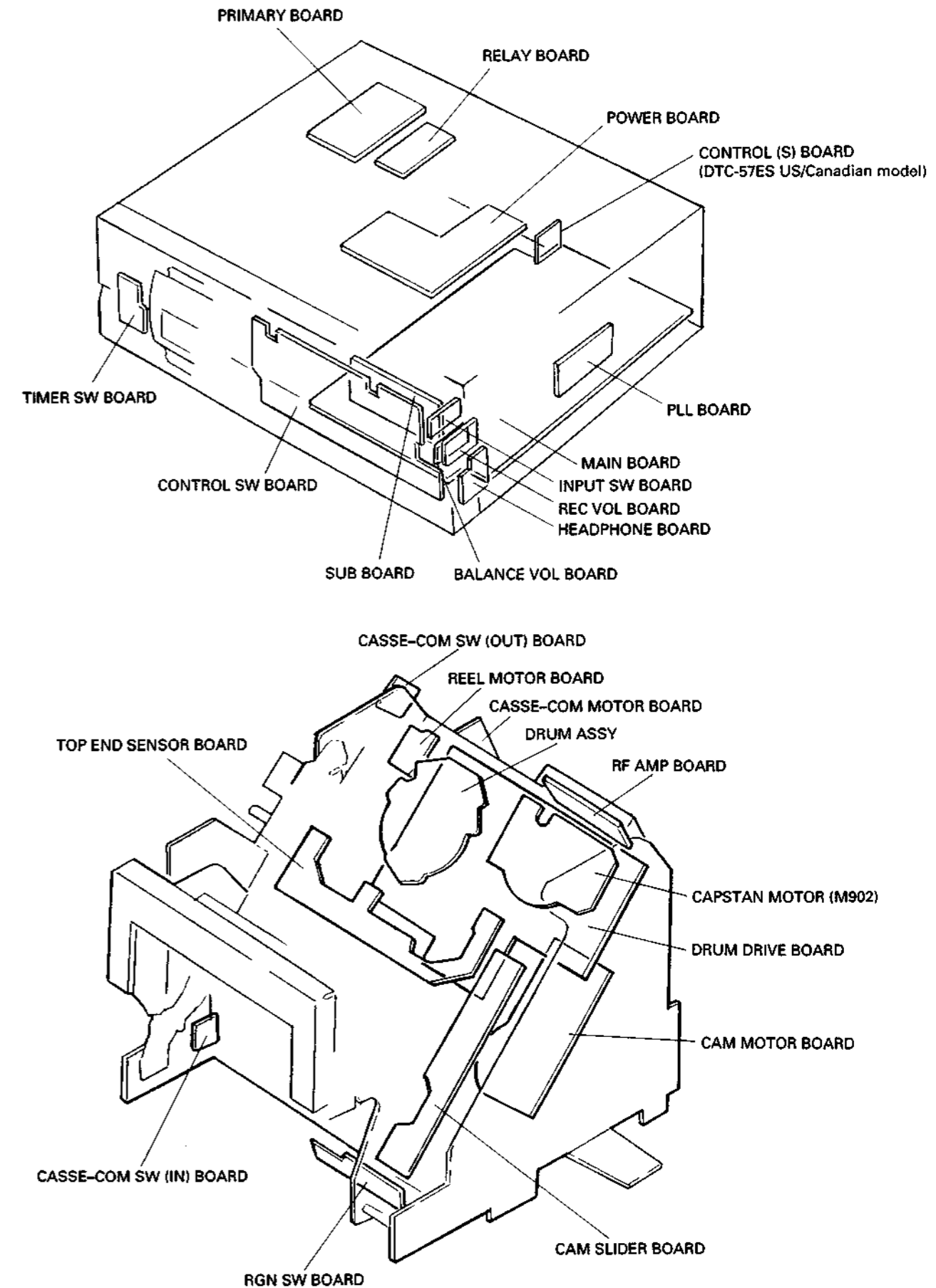

4-2. BLOCK DIAGRAM

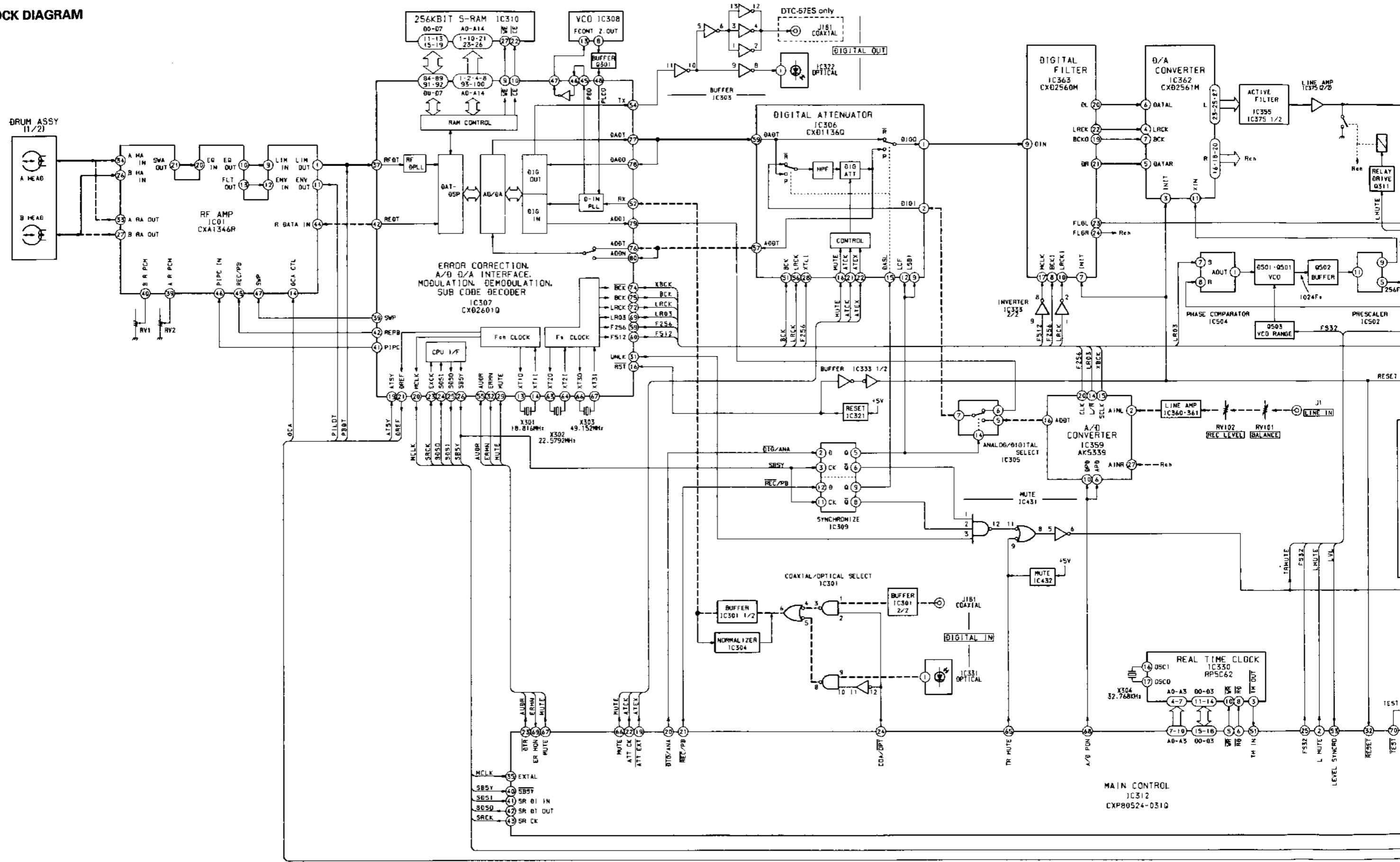

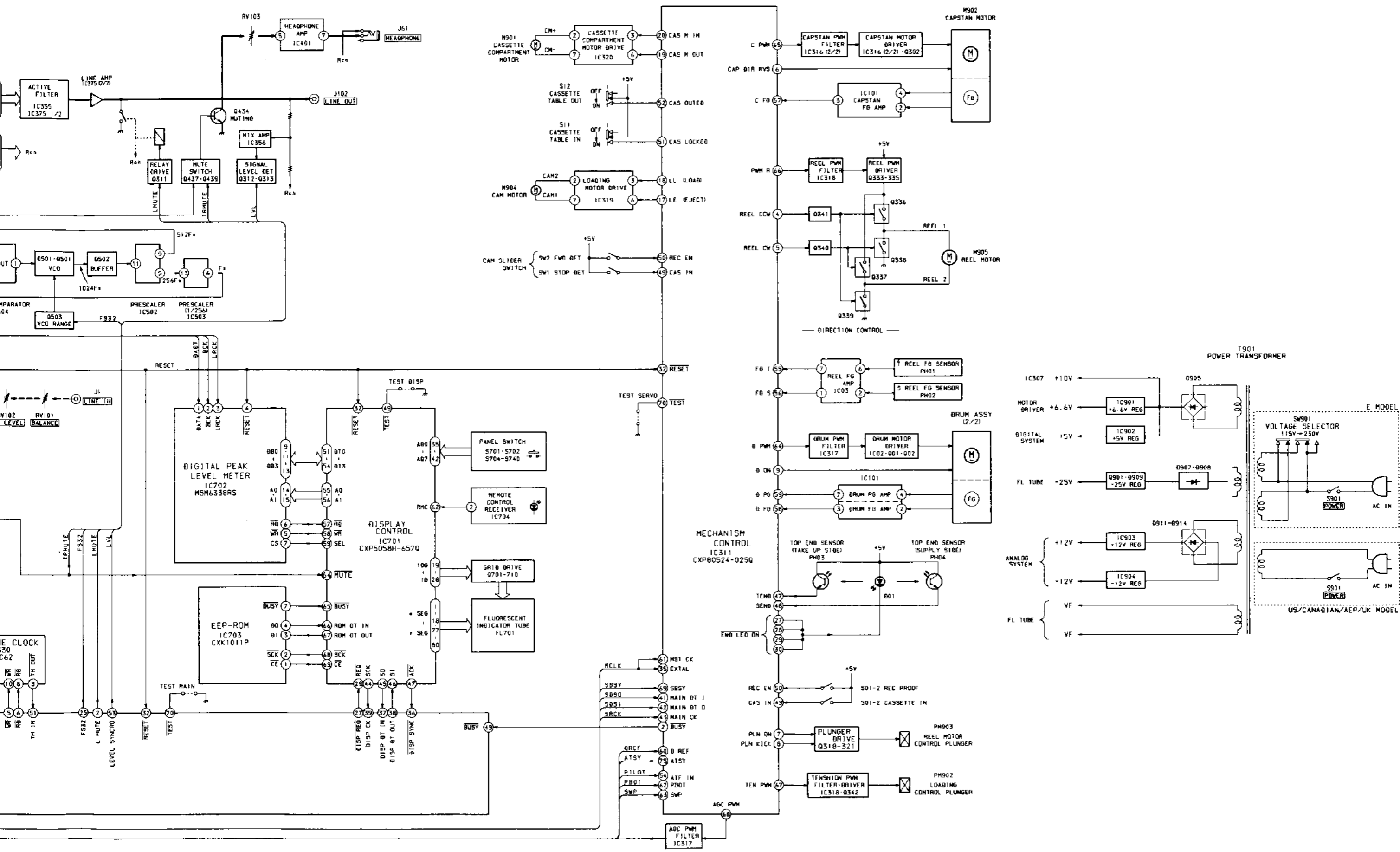

4-3. WAVEFORMS

① FL701 ①-⑧pin
36Vp-p, 1ms

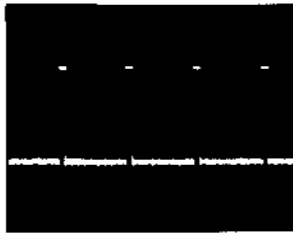

⑦ IC702 ①pin
5Vp-p, 0.5μs

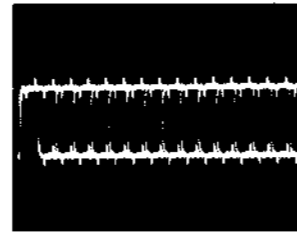

⑬ IC307 ⑬pin
4.2Vp-p, 18MHz

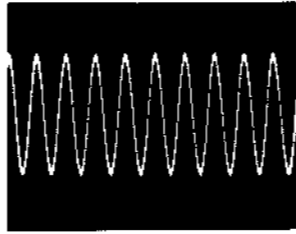

⑲ IC307 ⑲pin
4Vp-p, 0.5μs

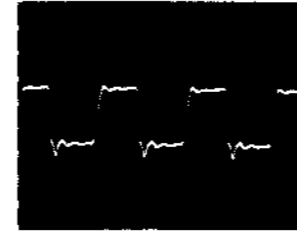

⑳ IC307 ⑳pin, ㉒pin
5Vp-p, 5μs



㉓ IC312 ㉓, ㉔, ㉕pin
5Vp-p, 10ms

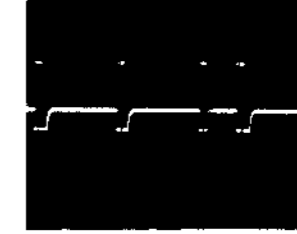

㉖ IC362 ⑦pin
5Vp-p, 0.5μs

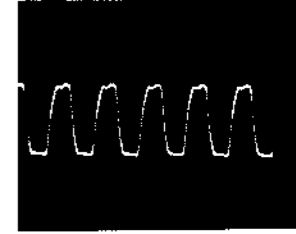

② IC701 ②-⑩pin
38Vp-p, 0.5μs

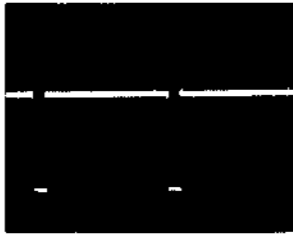

⑧ IC306 ⑧pin
5Vp-p, 0.5μs

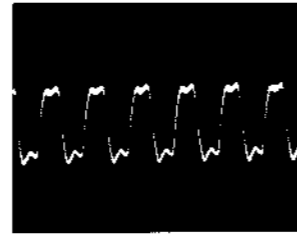

⑭ IC307 ⑭pin
3Vp-p, 18MHz

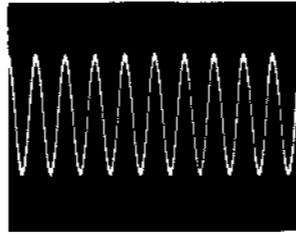

⑳ IC307 ⑳pin
6Vp-p, 1μs

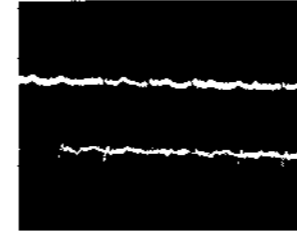

㉑ IC307 ㉑pin
6Vp-p, 0.1μs

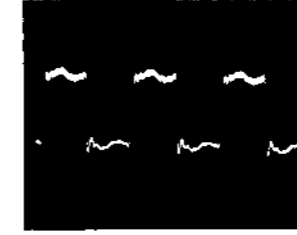

㉔ IC312 ㉔pin
5Vp-p, 10ms

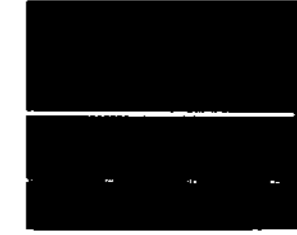

㉗ IC363 ⑧pin
6.4Vp-p, 0.1μs

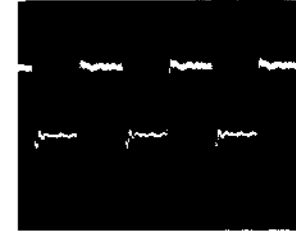

③ IC701 ①-⑩pin
36Vp-p, 2μs

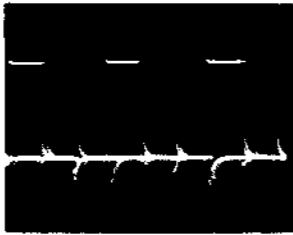

⑨ IC306 ⑤pin
6Vp-p, 0.1μs

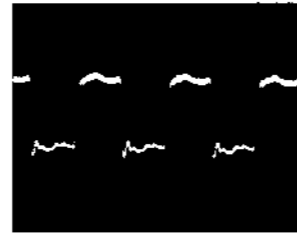

⑮ IC307 ㉑pin
5.2Vp-p, 5ms



㉒ IC307 ㉓pin
6Vp-p, 0.5μs

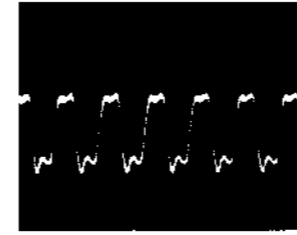

㉒ IC307 ㉒pin
5Vp-p, 1μs

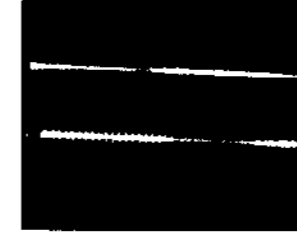

㉕ IC359 ⑬pin
5Vp-p, 0.5μs

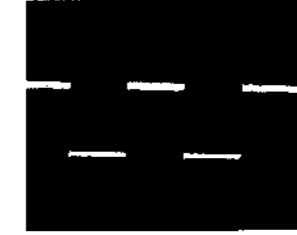

㉘ IC362 ⑩pin
7Vp-p, 0.5μs

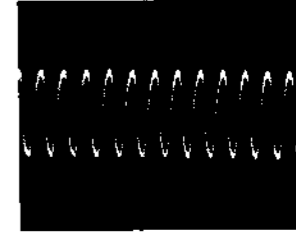

④ IC701 ④-⑩pin
5.2Vp-p, 10ms

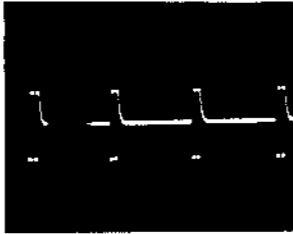

⑩ IC306 ⑤pin
5Vp-p, 5μs



⑯ IC307 ㉑pin
5Vp-p, 10ms



㉔ IC307 ㉓pin
6Vp-p, 0.5μs



㉔ IC307 ㉒pin
5Vp-p, 5μs

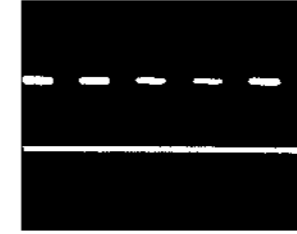

㉔ IC359 ⑬pin
6Vp-p, 0.1μs

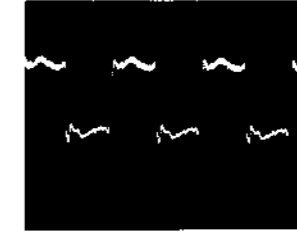

㉙ IC363 ⑦pin
4.8Vp-p, 1μs

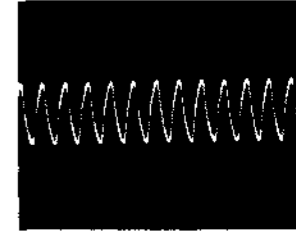

⑤ IC702 ③pin
5.2Vp-p, 5μs

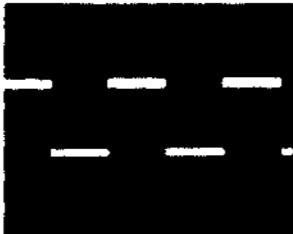

⑪ IC306 ⑤pin
5Vp-p, 5μs

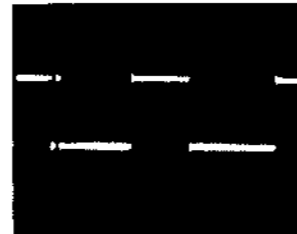

⑰ IC307 ㉑pin
100mVp-p, 2ms



㉕ IC307 ㉓pin
3.6Vp-p, 49MHz

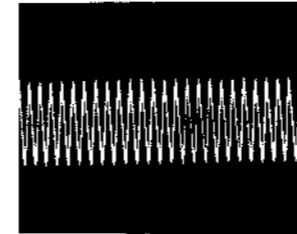

㉕ IC307 ㉒pin
5Vp-p, 2μs

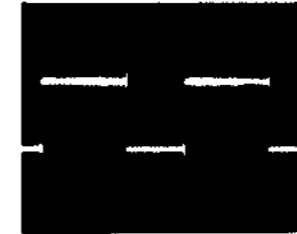

㉕ IC359 ㉑pin
5.6Vp-p, 0.5μs

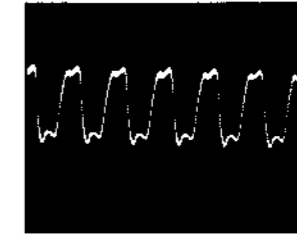

㉚ IC362 ⑬, ⑭, ⑮, ㉕, ㉖pin
6Vp-p, 0.1μs

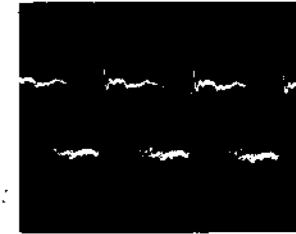

⑥ IC702 ②pin
6.4Vp-p, 1μs

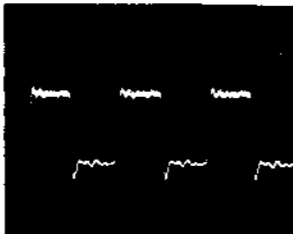

⑫ IC306 ①, ㉑pin
5Vp-p, 1μs

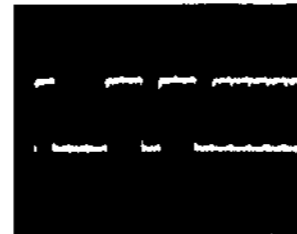

⑱ IC306 ④pin
5Vp-p, 0.2μs

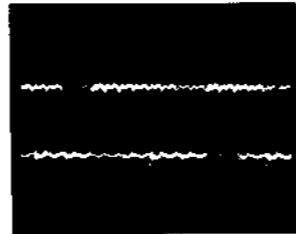

㉔ IC307 ㉒pin
1Vp-p, 49MHz

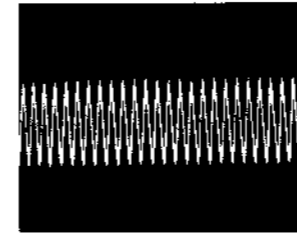

㉖ IC312 ㉓pin
3.8Vp-p, 0.5μs

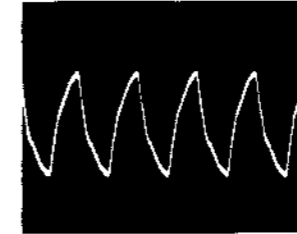

㉖ IC362 ⑤, ⑥pin
5Vp-p, 0.5μs

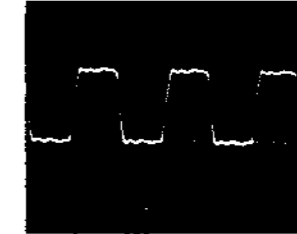

㉛ X304 ⑬pin
1Vp-p, 32.768kHz

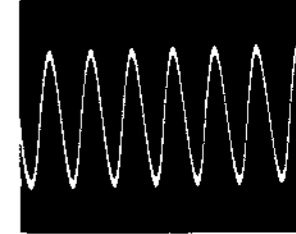

IC330 17pin
16Vp-p

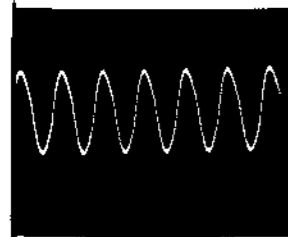

IC311 15pin
4.5Vp-p, 0.5μs

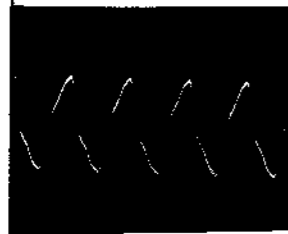

IC311 15pin
5Vp-p, 2ms

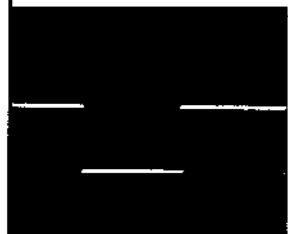

IC311 15pin
5Vp-p, 2ms

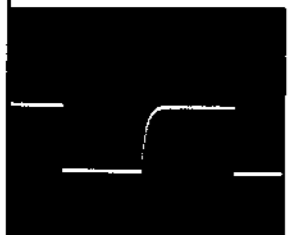

IC311 15pin
5Vp-p, 10ms

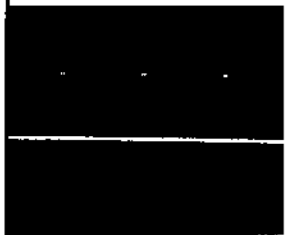

IC311 15pin
5Vp-p, 10ms

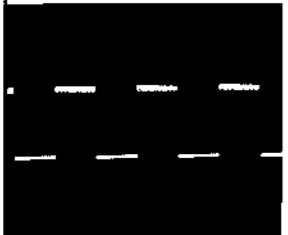

IC311 16pin
3.5Vp-p, 10μs

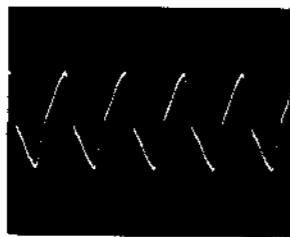

IC311 16pin
100mVp-p, 10μs

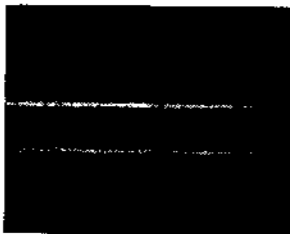

IC311 16pin
5Vp-p, 10μs

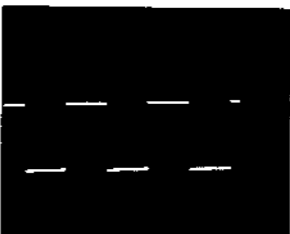

IC311 16, 16pin
5Vp-p, 10μs

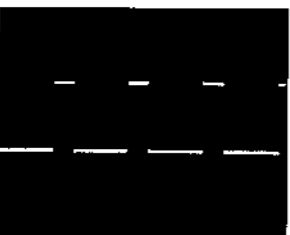

IC311 16pin
15mVp-p, 10μs



4-4. SEMICONDUCTOR LEAD LAYOUTS

CX5339-KP
CXD2561M

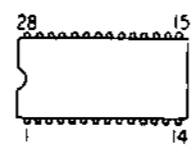

CX20115A

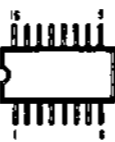

M5F7805L
M5F7805L-720
M5F7808L
M5F7812L
TA7805S
μPC2406HF

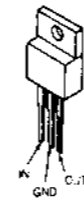

M5F7912L
TA7905S

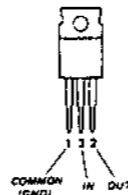

DTA114ES
DTC114ES



2SA1585S-OR
2SC4115S-OR
2SC2785-HFE



2SA933S-OR
2SC3623A-K
2SD1387



2SD2012

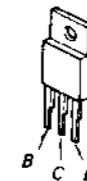

2SK241GR



HZS24-3L
HZS6A1L
1SS168
1SS202-1
11EQS04
11ES2

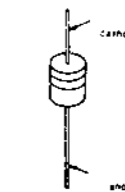

CXK1011P
LF412CN
M5238P
NE5532P
RC4558P
RC4560DD
μPC358C

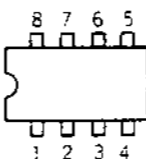

LM358M-FL63

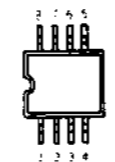

M54641L

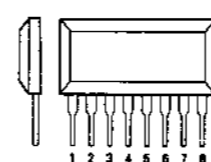

CXA1364R

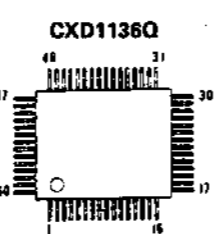

CXD1136Q

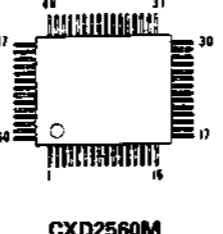

CXD2560M

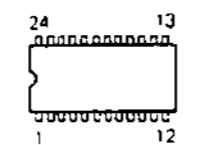

MC74AC74N
MC14011BCP
SN74HCU04AN
SN74HC10ANS
SN74HC393AN
SN74HC74ANS
SN74LS624N
TC74HC132AP

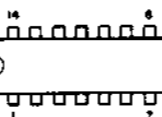

PST529C
PST529E



RP5C62

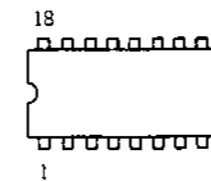

2SB1370-EF



2SB734-34



2SB798-DL

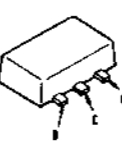

2SC1623

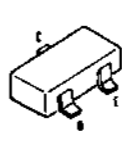

KV1320

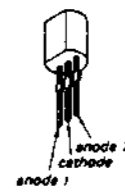

RBA-406B

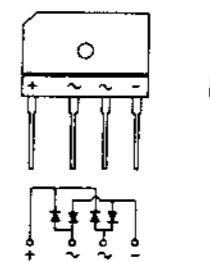

1SS106
30D2-FC

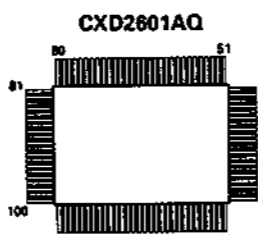
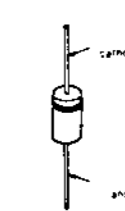

CXK58257M-12L

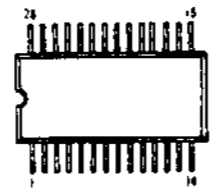

MSM6338RS
SN74HC153ANS

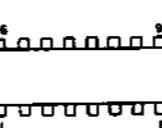

CXP5058H-657Q
CXP80524-040Q
CXP80524-025Q

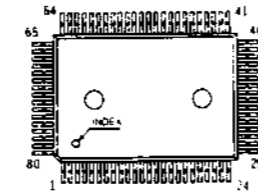

● SEMICONDUCTOR LOCATION

Ref. No.	LOCATION
D01	G - 21
D905	J - 9
D906	I - 7
D907	J - 8
D908	J - 8
D909	J - 7
D910	J - 8
D911	H - 9
D912	H - 10
D913	H - 9
D914	H - 10
D915	J - 10
D916	J - 10
IC1	F - 13
IC01	F - 17
IC02	F - 18
IC03	G - 19
IC701	D - 7
IC702	E - 8
IC703	D - 8
IC704	B - 8
IC901	J - 6
IC902	J - 6
IC903	I - 9
IC904	I - 10
PH01	H - 17
PH02	H - 18
PH03	I - 21
PH04	E - 21
Q01	F - 18
Q02	F - 18
Q701	D - 6
Q702	D - 6
Q703	D - 6
Q704	D - 6
Q705	D - 6
Q706	D - 6
Q707	D - 5
Q708	D - 5
Q709	D - 5
Q710	D - 5
Q901	J - 8

Note:

- — : indicated a lead wire mounted on the component side.
- ■ : parts mounted on the conductor side.
- ● : Through hole.
- ▨ : Pattern from the side which enables seeing.
- ▩ : Pattern of the rear side.

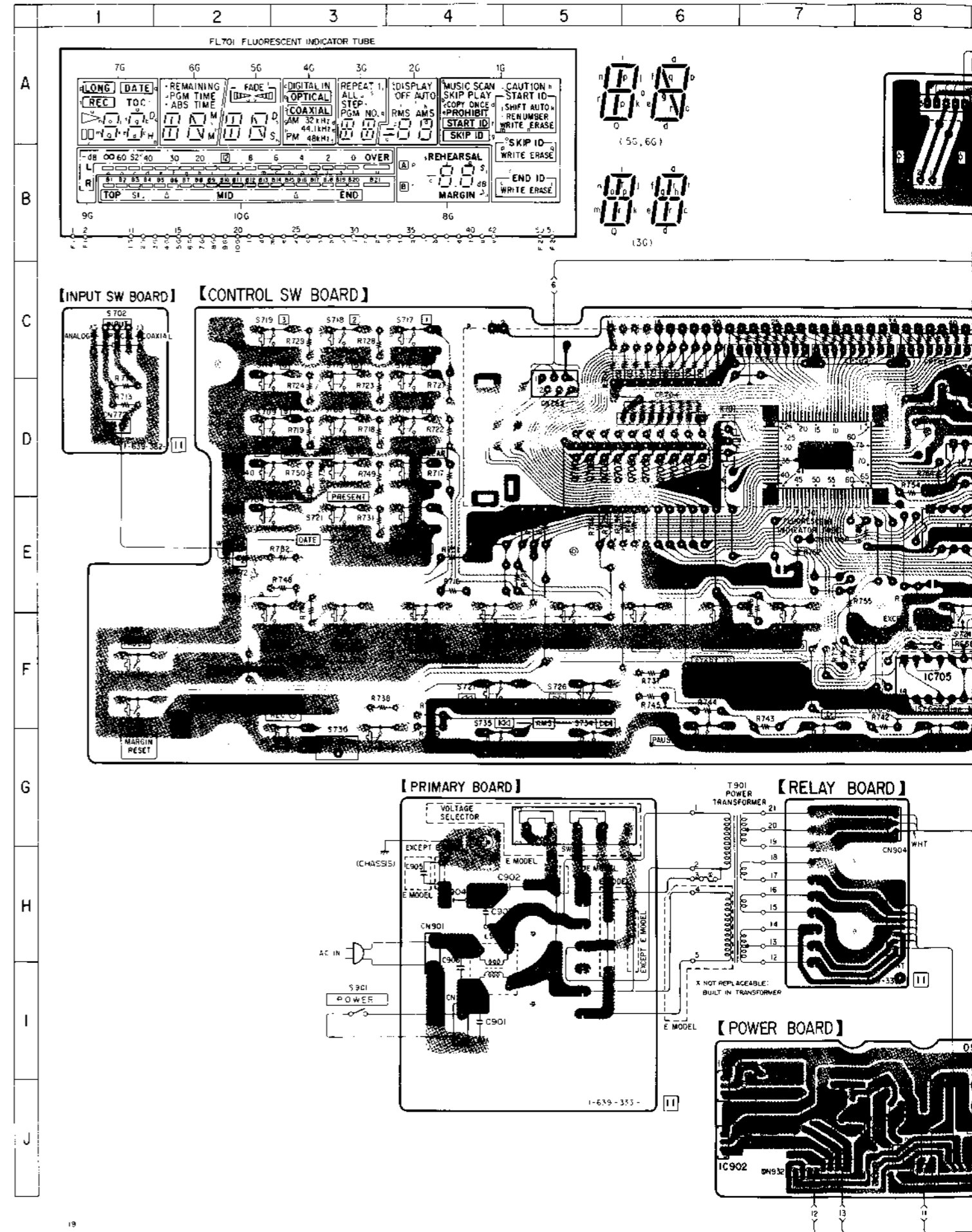

7 8 9 10 11 12 13 14 15 16 17 18 19 20 21

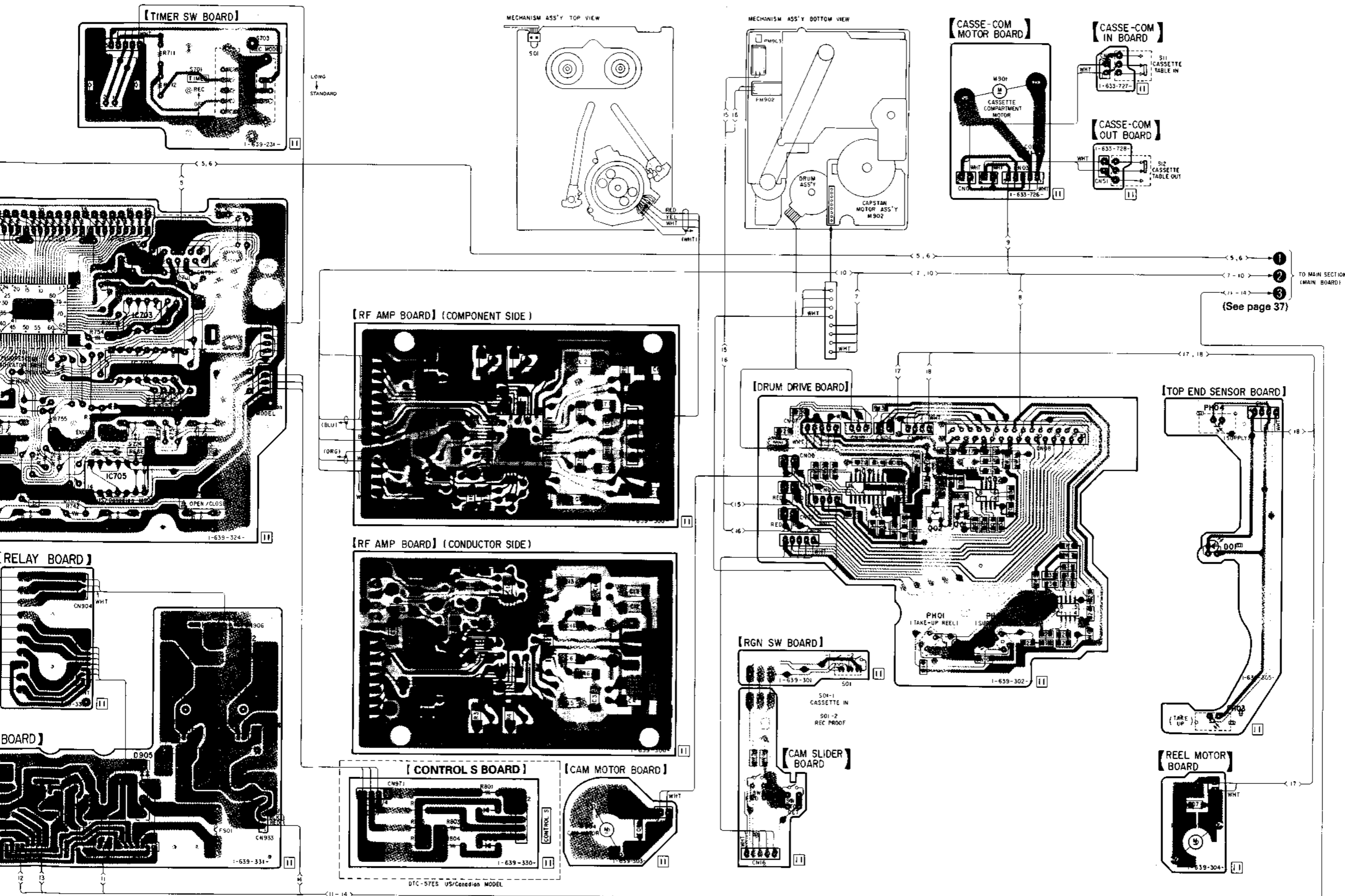

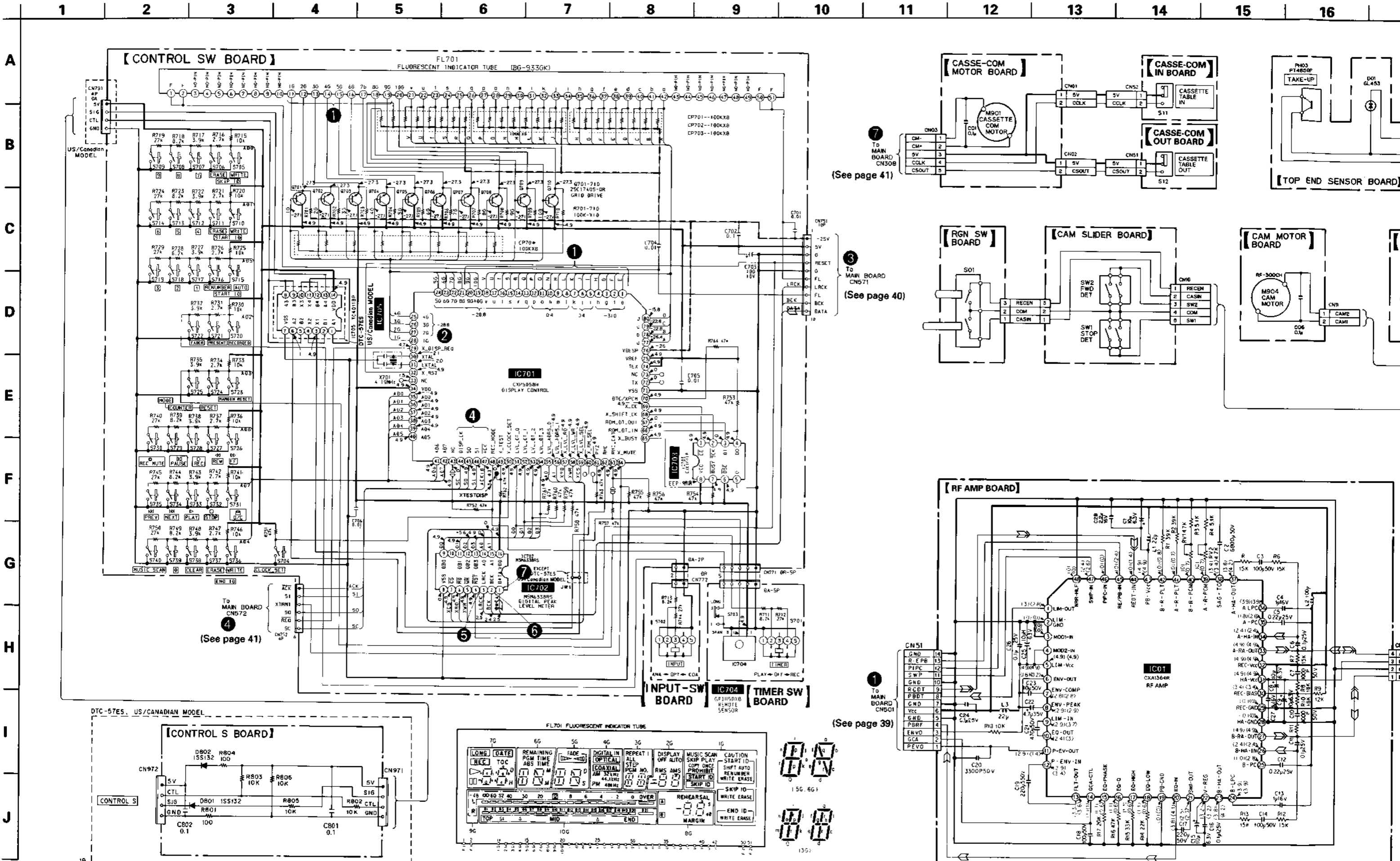

(See page 41)

(See page 41)

(See page 40)

(See page 39)

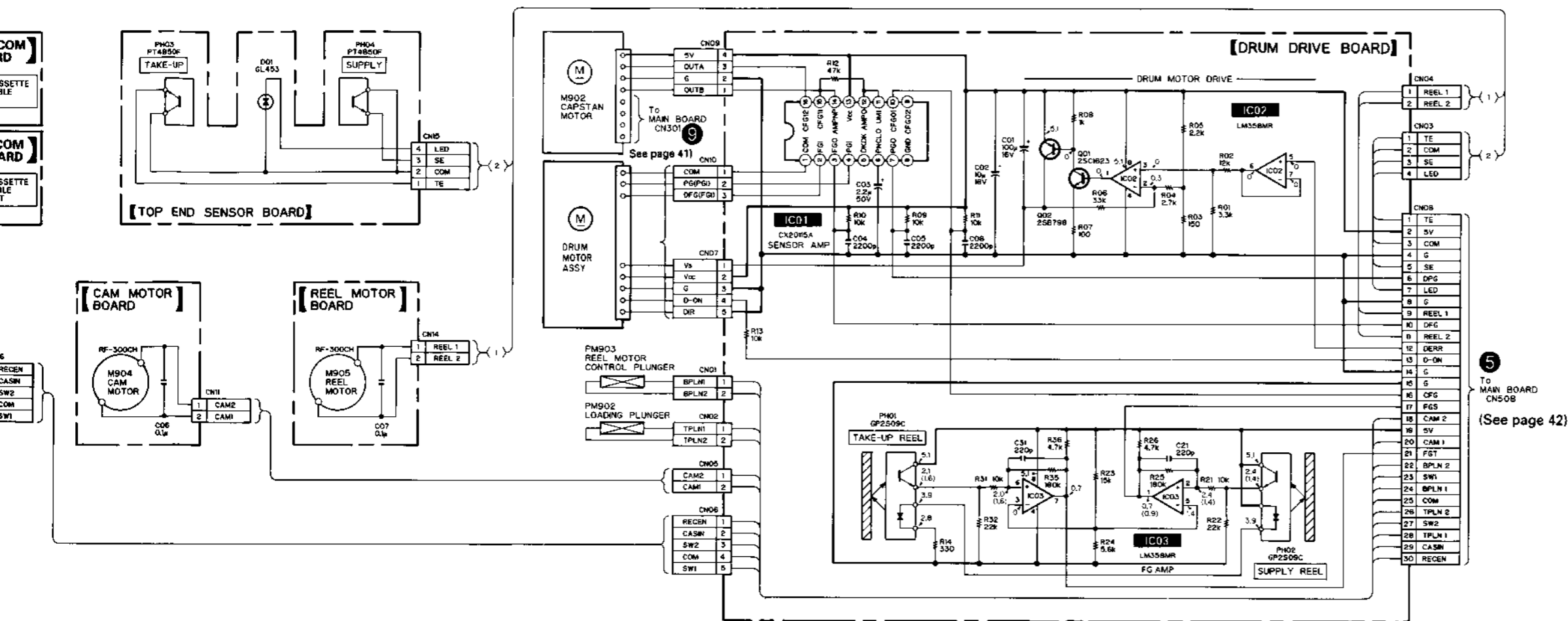

5
To MAIN BOARD
CN508
(See page 42)

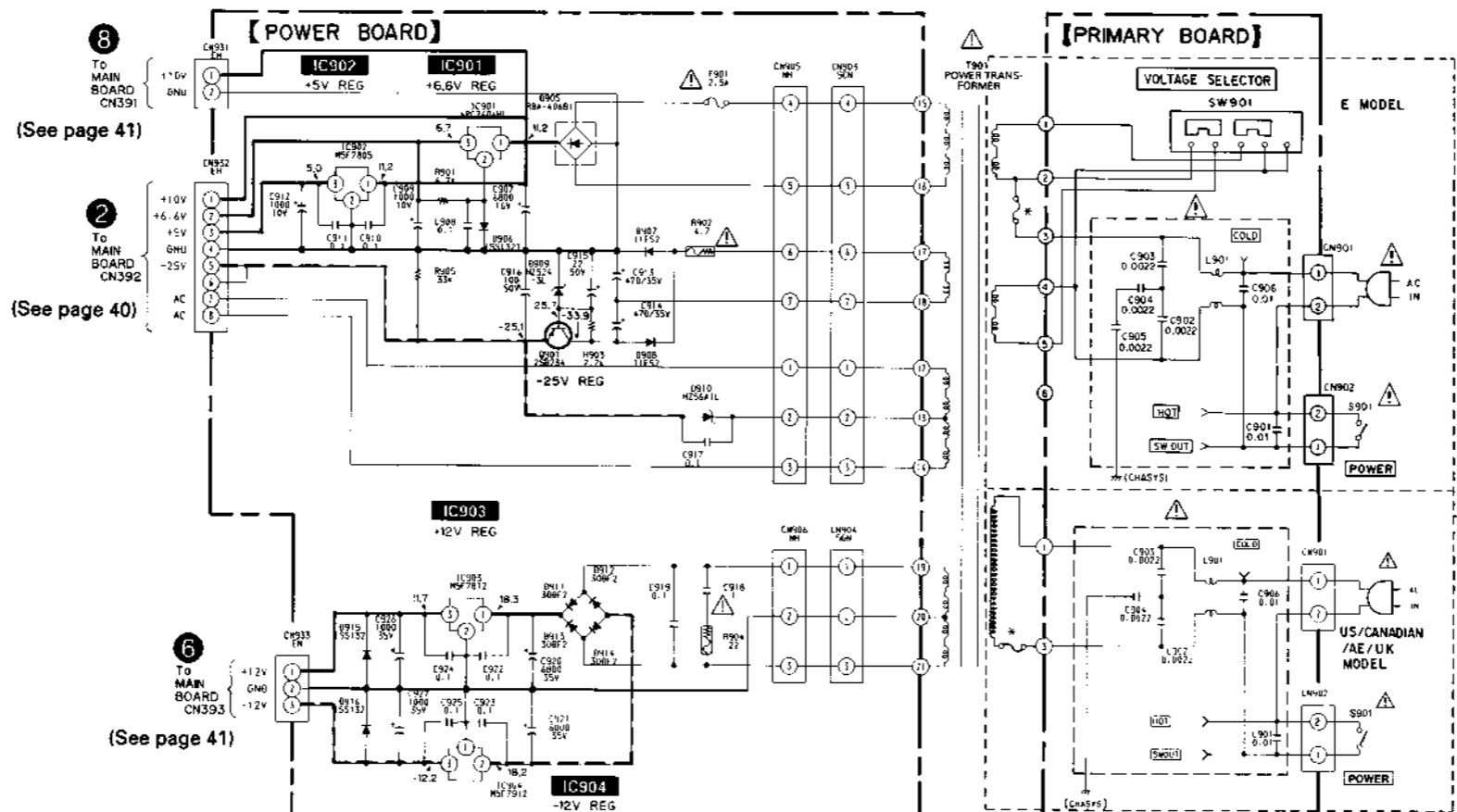
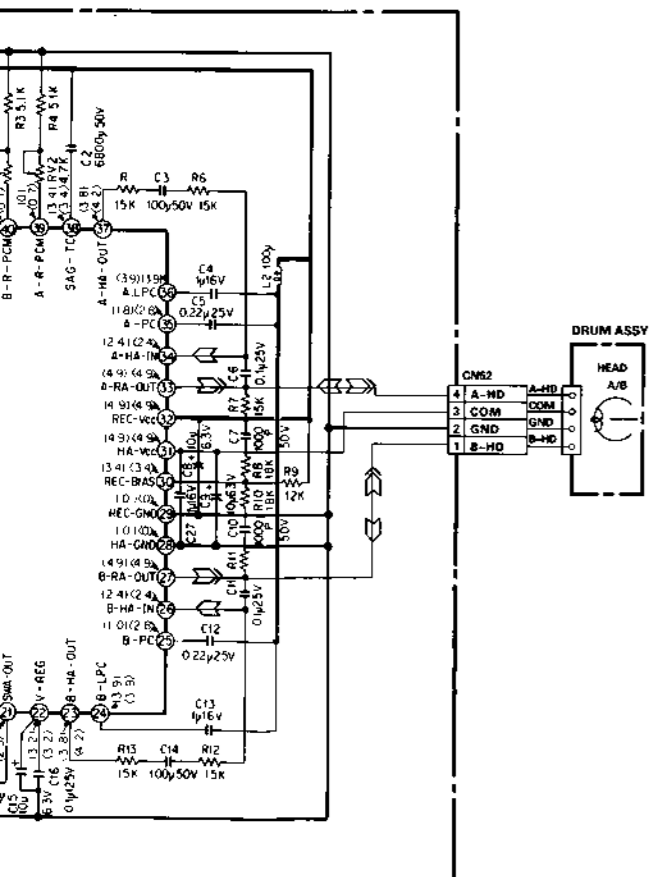

Note:

- All capacitors are in μF unless otherwise noted. pF: μF 50WV or less are not indicated except for electrolytics and tantalums.
- All resistors are in ohms, 1/4W or less unless otherwise noted.
- Δ : internal component.
- $\text{---}\text{---}\text{---}$: Fuse resistor

The components identified by mark Δ or dotted line with mark Δ are critical for safety. Replace only with part number specified.

Les composants identifiés par une marque Δ sont critiques pour la sécurité. Ne les remplacer que par une pièce portant le numéro spécifié.

- --- : B+ Line.
- $\text{---}\text{---}\text{---}$: B- Line.
- \square : adjustment for repair.
- Voltage are dc with respect to ground under no-signal (STOP) conditions.
- no mark: Stop
- { } : PLAY
- < > : REC
- Voltagés are taken with a VOM (input impedance 10M Ω). Voltage variations may be noted due to normal production tolerances.
- Circled numbers refer to waveforms.
- Waveforms are taken with a oscilloscope. Voltage variations may be noted due to normal production tolerances.
- Signal path
- $\text{---}\text{---}\text{---}$: PB
- $\text{---}\text{---}\text{---}$: REC

4-7. PRINTED WIRING BOARDS - MAIN SECTION -

● SEMICONDUCTOR LOCATION

Ref. No.	LOCATION	Ref. No.	LOCATION
D101	B - 10	IC361	B - 7
D102	B - 10	IC362	D - 12
D201	B - 10	IC363	D - 13
D202	B - 10	IC374	C - 13
D306	H - 8	IC375	C - 8
D307	E - 6	IC376	E - 8
D308	D - 6	IC401	C - 2
D314	H - 8	IC431	F - 8
D321	B - 5	IC432	H - 7
D322	B - 5	IC501	G - 15
D323	I - 8	IC502	G - 16
D324	B - 5	IC503	G - 16
D401	C - 2	IC504	E - 16
D402	C - 1		
D403	E - 11		
D404	C - 12	Q301	I - 12
D501	F - 16	Q302	G - 2
D503	E - 16	Q311	D - 6
		Q312	E - 6
		Q313	E - 7
IC301	F - 13	Q318	H - 9
IC302	H - 13	Q319	H - 8
IC303	I - 13	Q320	H - 8
IC304	G - 13	Q321	H - 8
IC305	E - 11	Q333	D - 2
IC306	G - 6	Q334	E - 2
IC307	G - 11	Q335	E - 3
IC308	I - 12	Q336	H - 1
IC309	G - 5	Q337	H - 1
IC310	H - 10	Q338	H - 2
IC311	H - 5	Q339	H - 2
IC312	D - 4	Q340	H - 2
IC316	G - 2	Q341	H - 1
IC317	F - 2	Q342	E - 2
IC318	E - 2	Q343	I - 8
IC319	I - 8	Q399	D - 6
IC320	I - 8	Q432	C - 6
IC321	F - 9	Q433	C - 6
IC322	G - 9	Q434	C - 6
IC330	C - 4	Q435	C - 6
IC331	G - 14	Q436	C - 6
IC332	H - 14	Q437	C - 6
IC333	G - 8	Q438	D - 6
IC354	D - 10	Q439	B - 6
IC355	E - 10	Q440	I - 9
IC356	D - 6	Q501	F - 16
IC357	B - 12	Q502	F - 16
IC358	B - 12	Q503	E - 16
IC359	B - 10		
IC360	B - 9		

Note:

- : indicated a lead wire mounted on the component side.
- : indicated a lead wire mounted on the conductor side.
- : parts mounted on the conductor side.
- : indicates side identified with part number.
- : Through hole.
- : Pattern from the side which enables seeing.
- : Pattern of the rear side.

• See page 25 for semiconductor lead layouts.

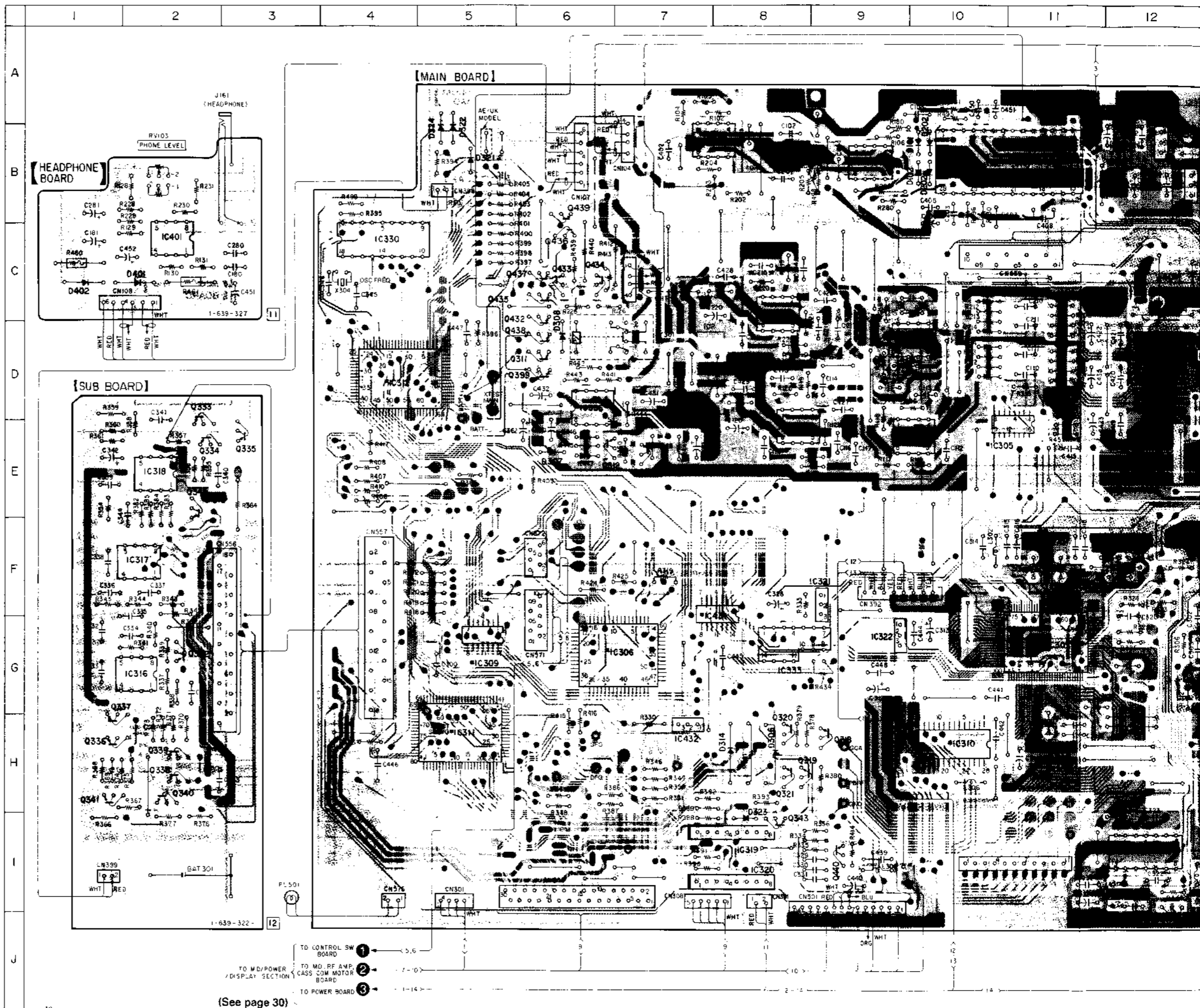

[MAIN BOARD]

[REC VOLUME BOARD]

[BALANCE VOLUME BOARD]

[PLL BOARD]

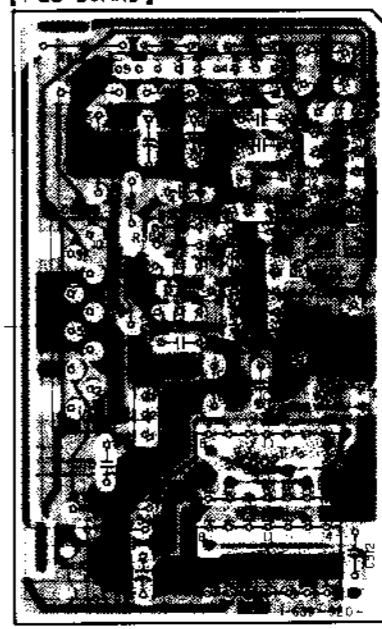
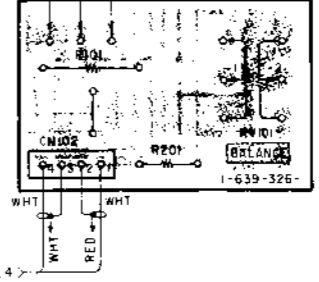
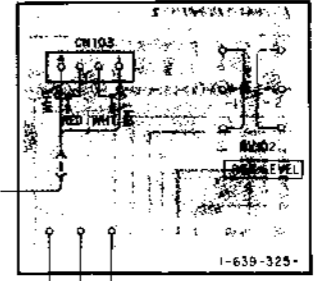
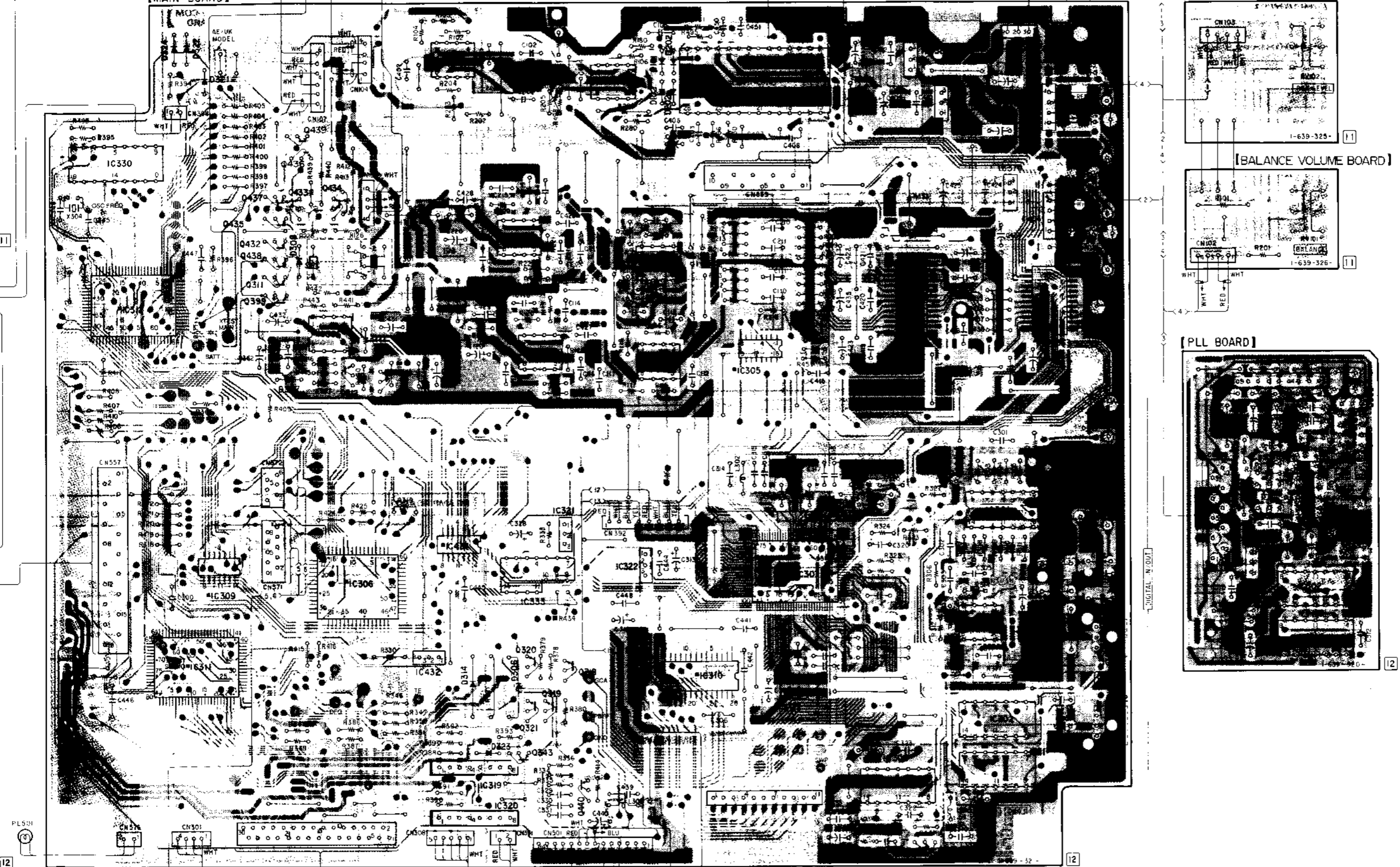

- 1 TO CONTROL SW BOARD
- 2 TO MD/POWER BOARD
- 3 TO MD/POWER BOARD
- 4 TO MD/POWER BOARD
- 5 TO MD/POWER BOARD
- 6 TO MD/POWER BOARD
- 7 TO MD/POWER BOARD
- 8 TO MD/POWER BOARD
- 9 TO MD/POWER BOARD
- 10 TO MD/POWER BOARD
- 11 TO MD/POWER BOARD
- 12 TO MD/POWER BOARD
- 13 TO MD/POWER BOARD
- 14 TO MD/POWER BOARD
- 15 TO MD/POWER BOARD
- 16 TO MD/POWER BOARD
- 17 TO MD/POWER BOARD

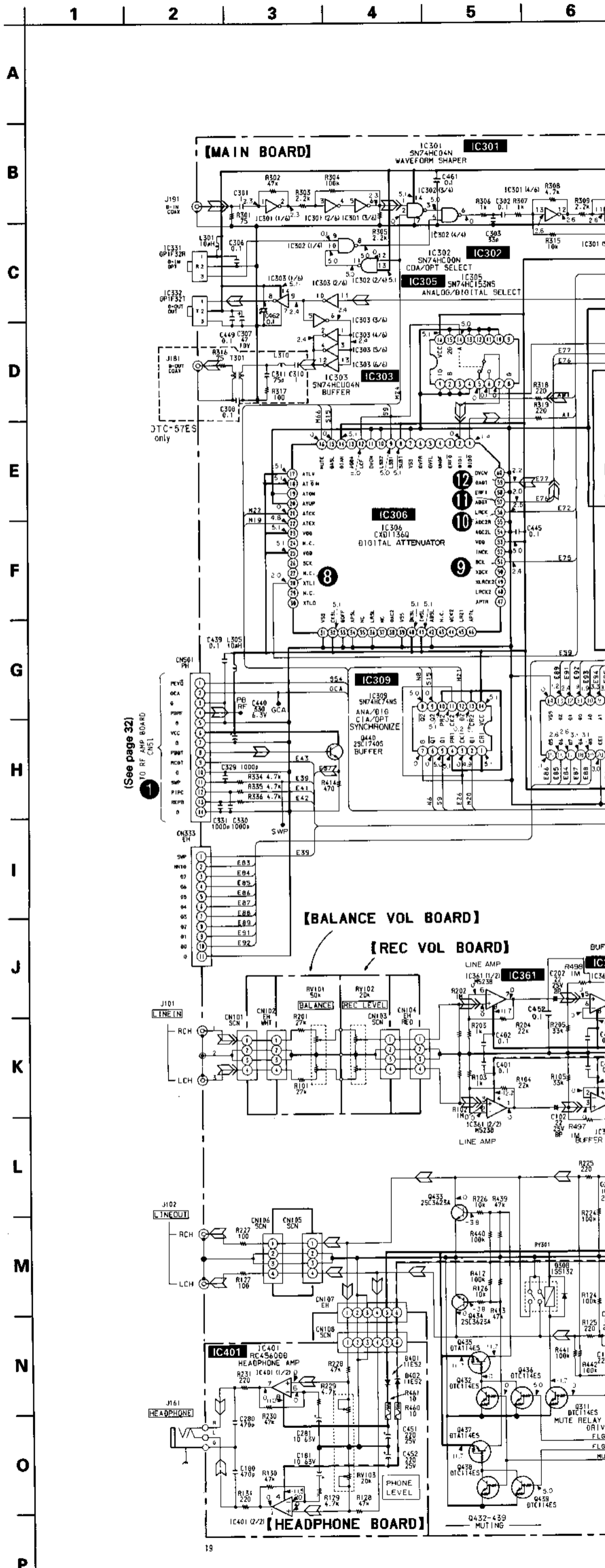

Note:

- All capacitors are in μF unless otherwise noted. pF : μF 50WV or less are not indicated except for electrolytic and tantalums.
- All resistors are in ohms, 1/4W or less unless otherwise noted.
- : Fuse resistor

The components identified by mark Δ or dotted line with mark Δ are critical for safety. Replace only with part number specified.

Les composants identifiés par une marque Δ sont critiques pour la sécurité. Ne les remplacer que par une pièce portant le numéro spécifié.

- : B+ Line.
- : B- Line.
- : adjustment for repair.
- Voltage are dc with respect to ground under no-signal (STOP) conditions.
no mark : Stop
- Voltages are taken with a VOM (input impedance 10M Ω). Voltage variations may be noted due to normal production tolerances.
- Circled numbers refer to waveforms.
- Waveforms are taken with a oscilloscope. Voltage variations may be noted due to normal production tolerances.
- Signal path
 : PB
 : REC

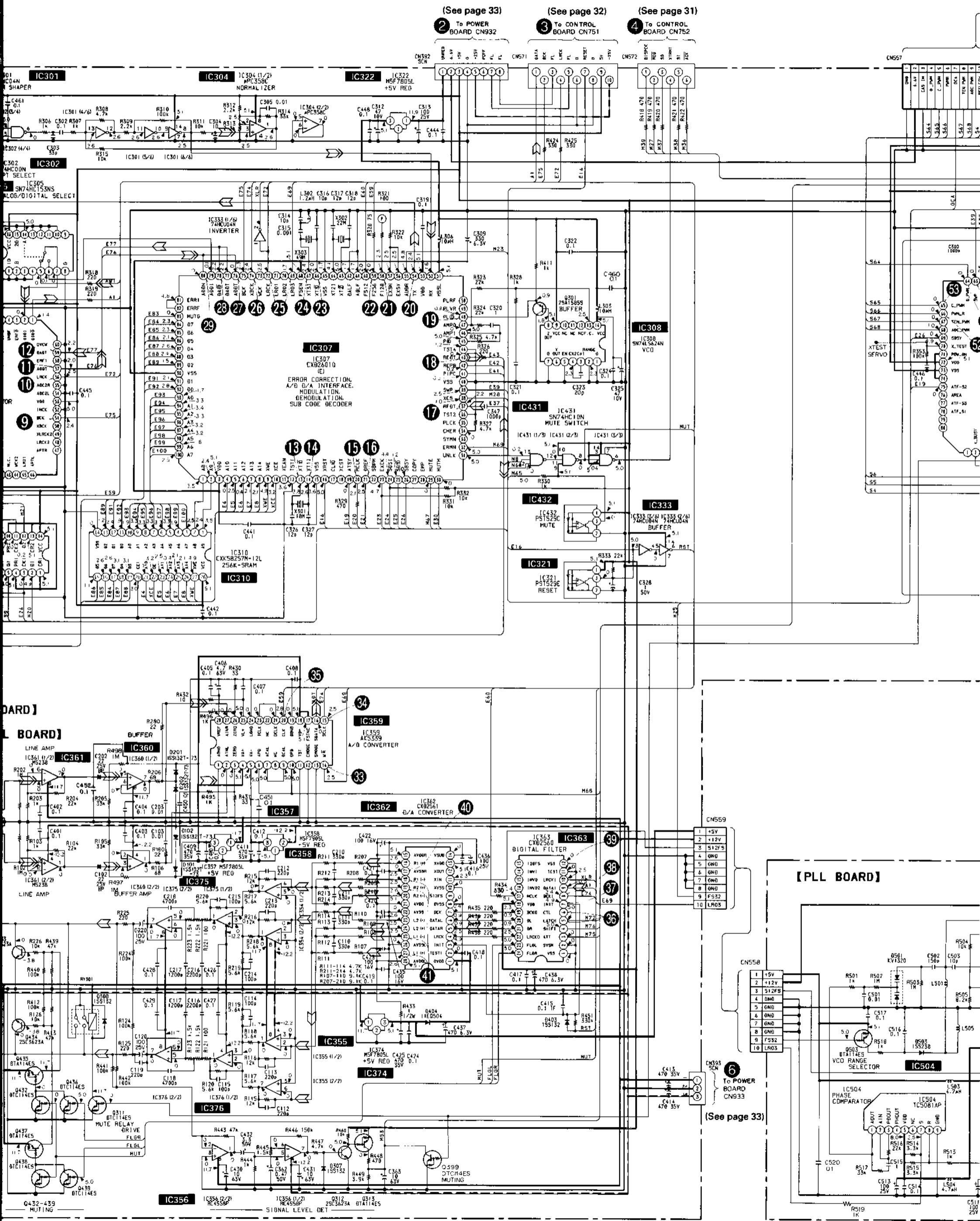

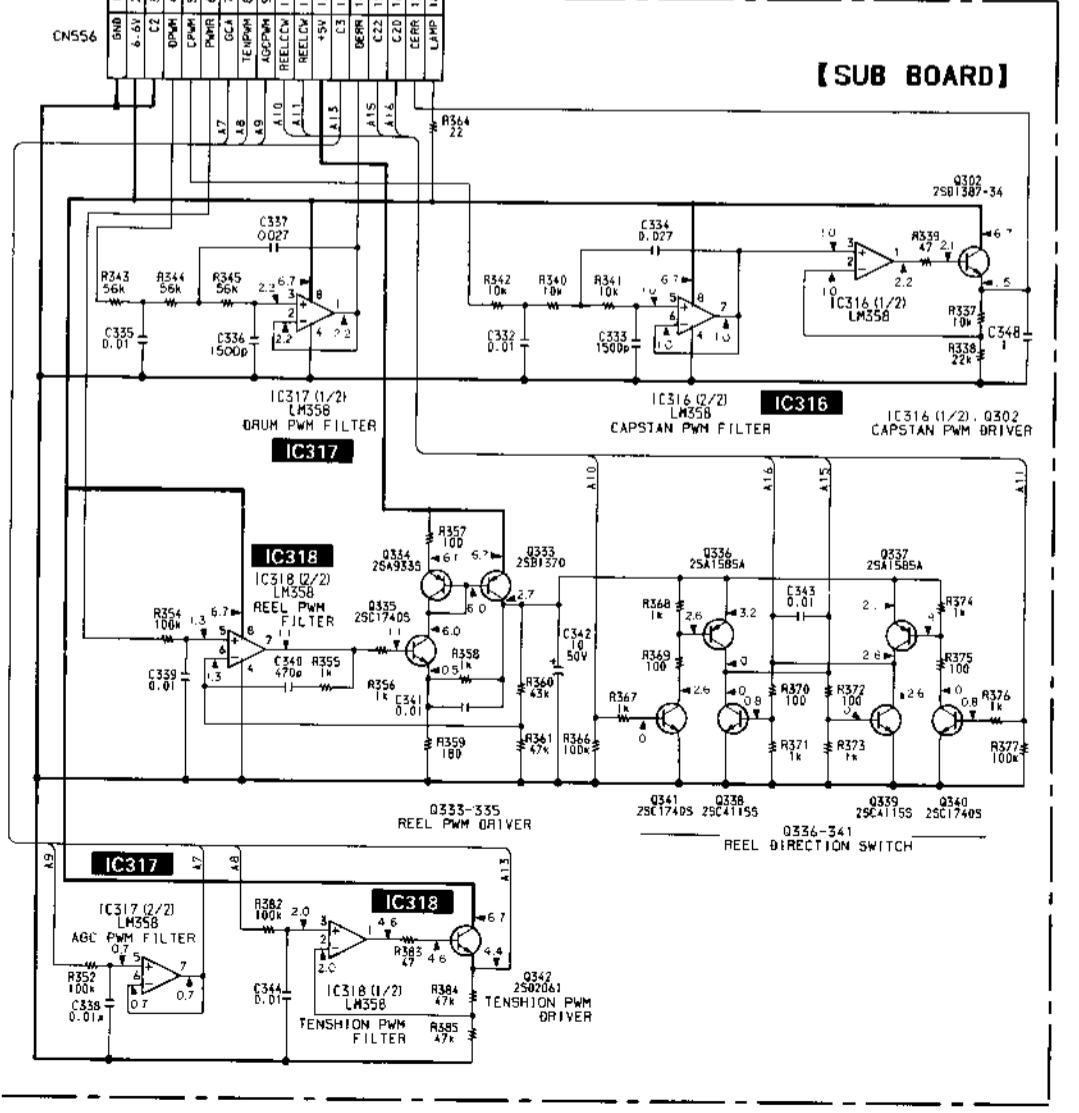
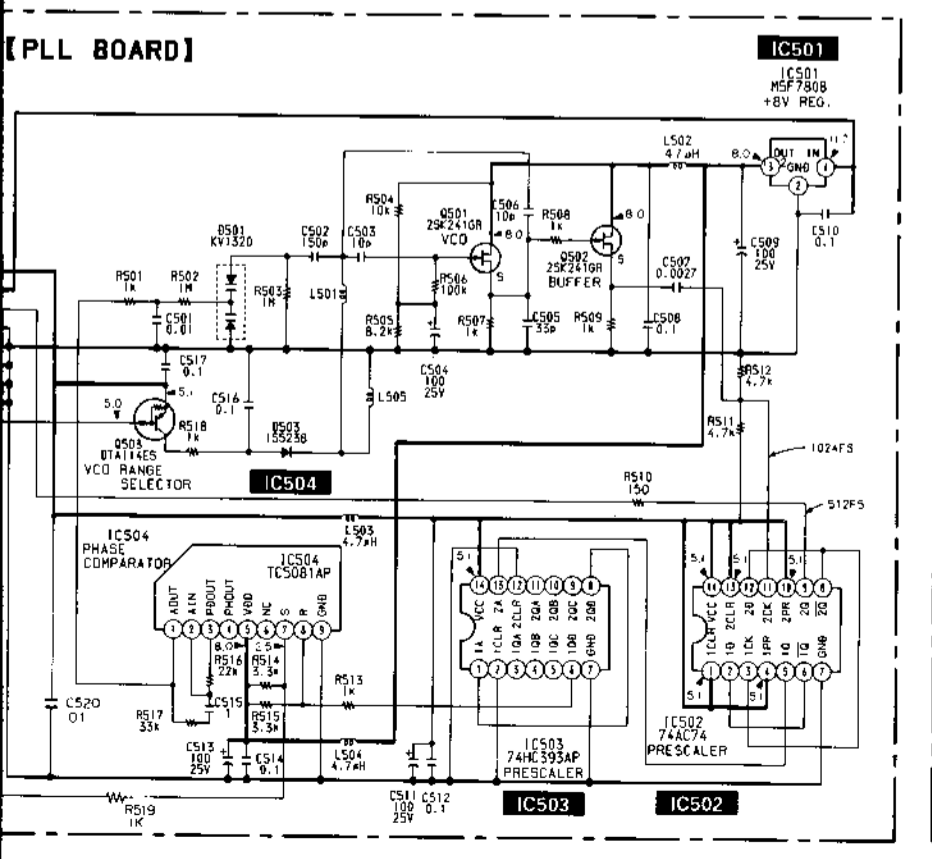
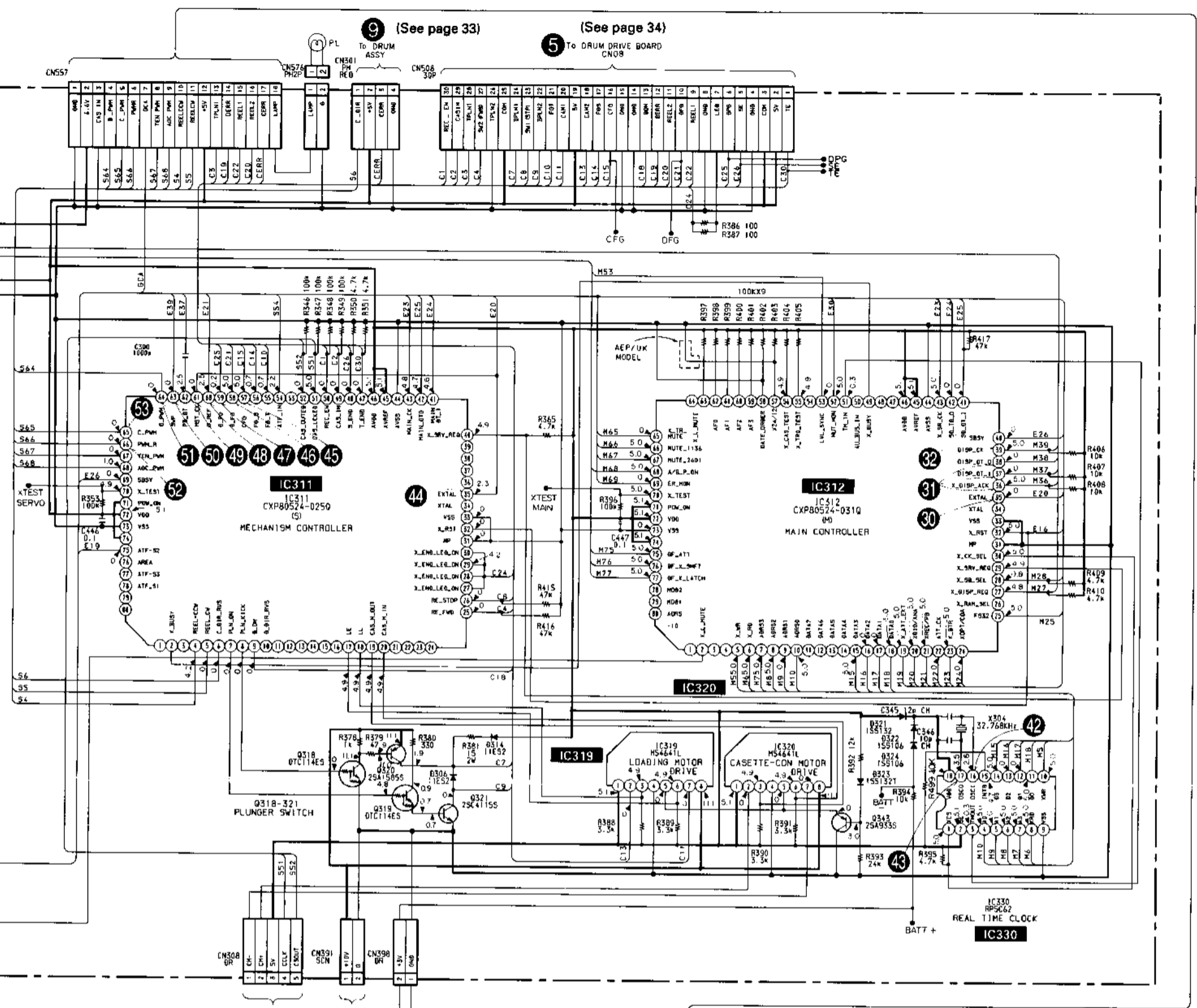

4-9. IC BLOCK DIAGRAMS

IC01 CX20115A

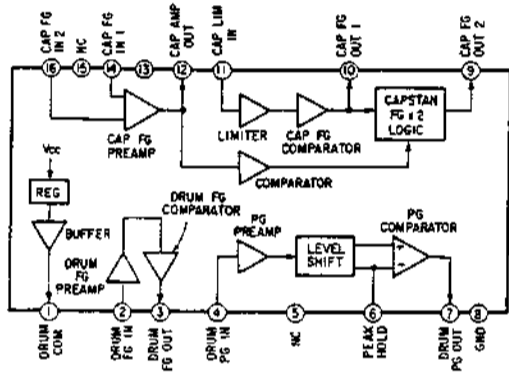

IC308 SN74LS624N

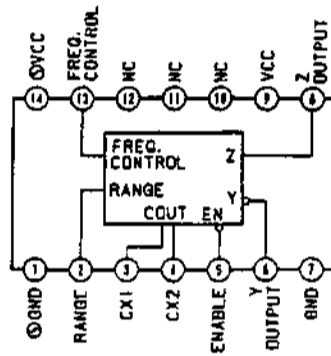

IC305 SN74HC153NS

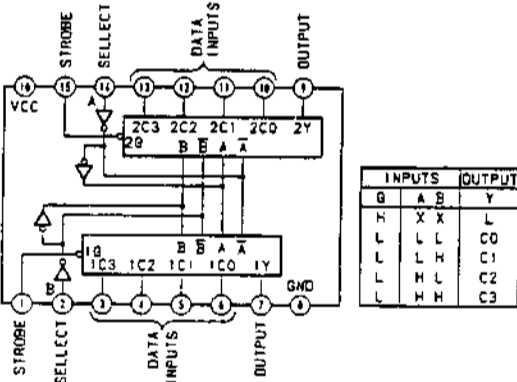

IC309 SN74HC74NS

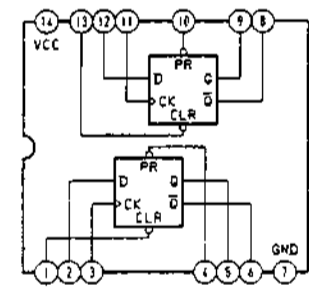

IC306 CXD1136Q

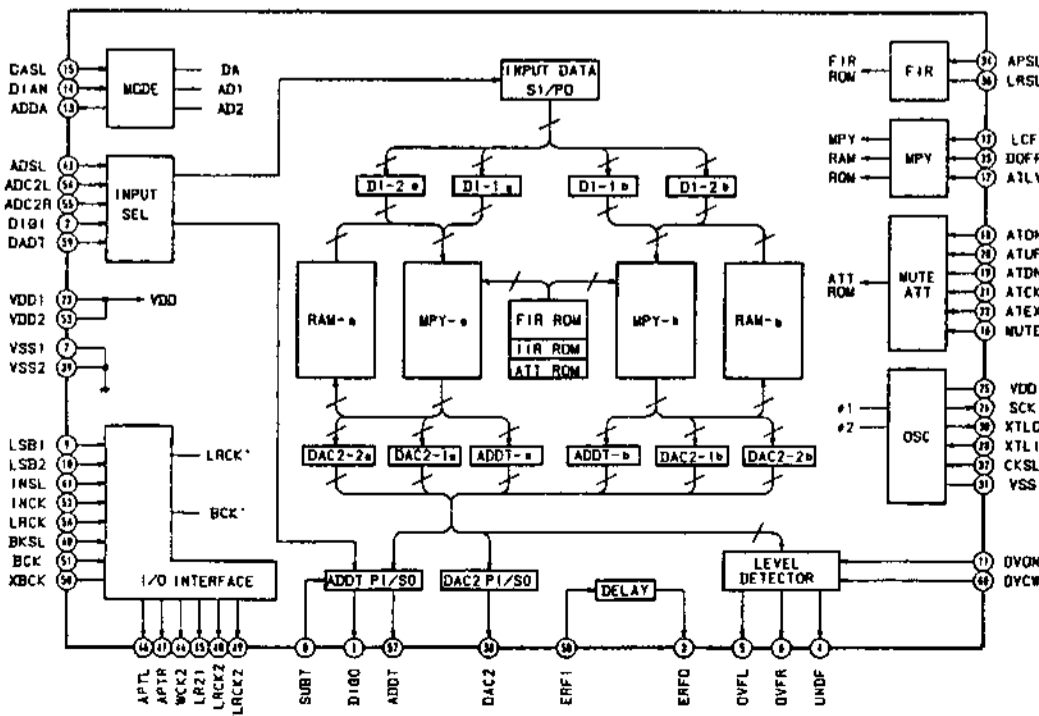

IC319,320 M54641L

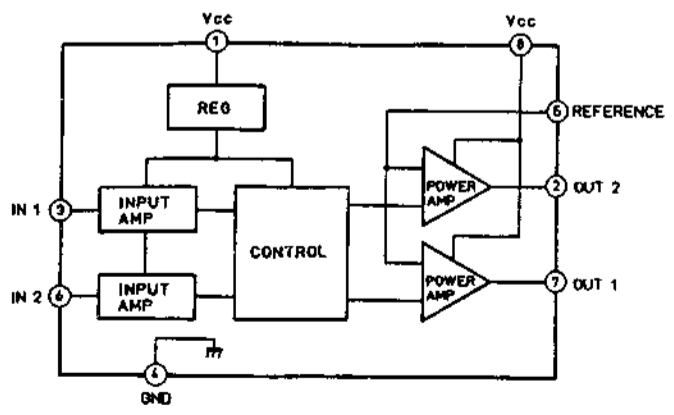

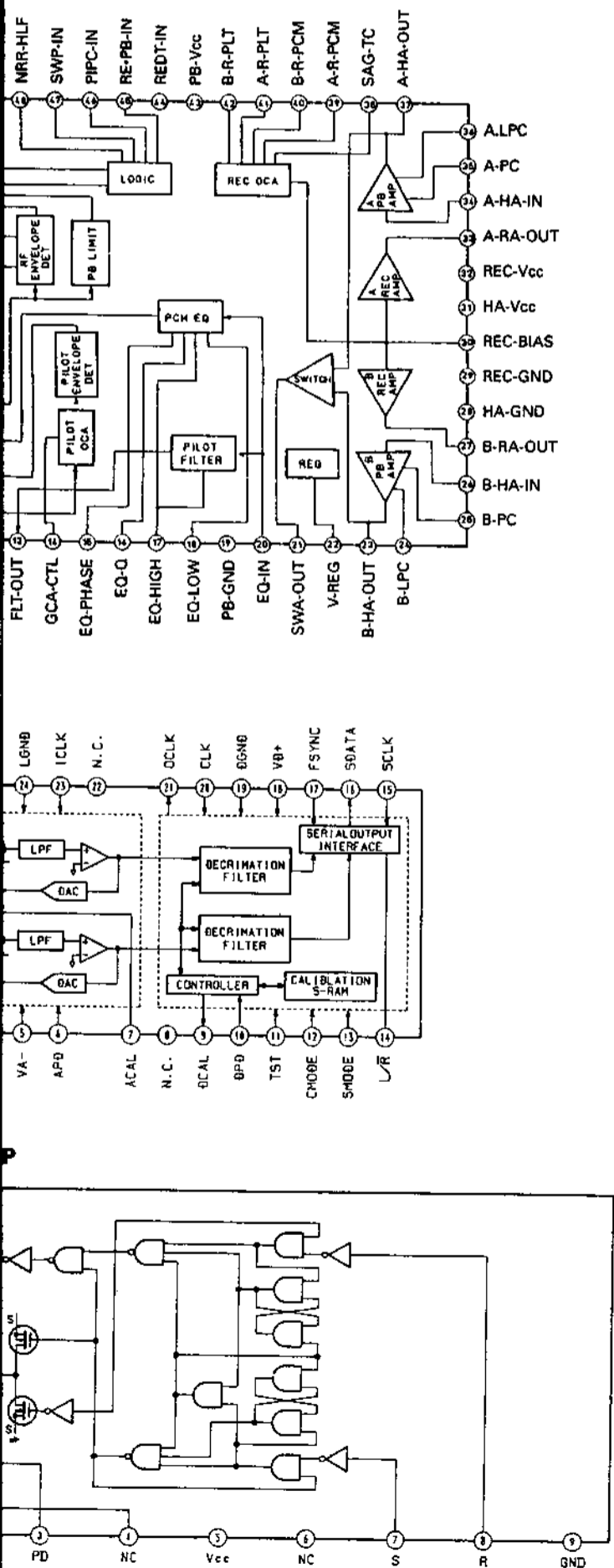

IC362 CXD2561M

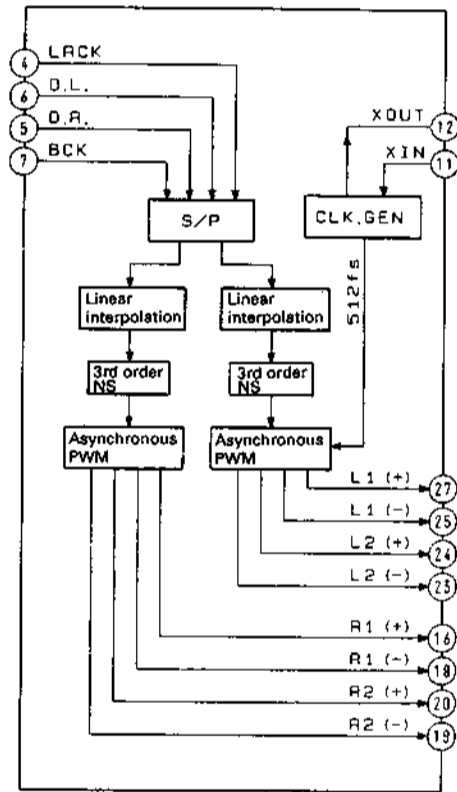

IC363 CXD2560M

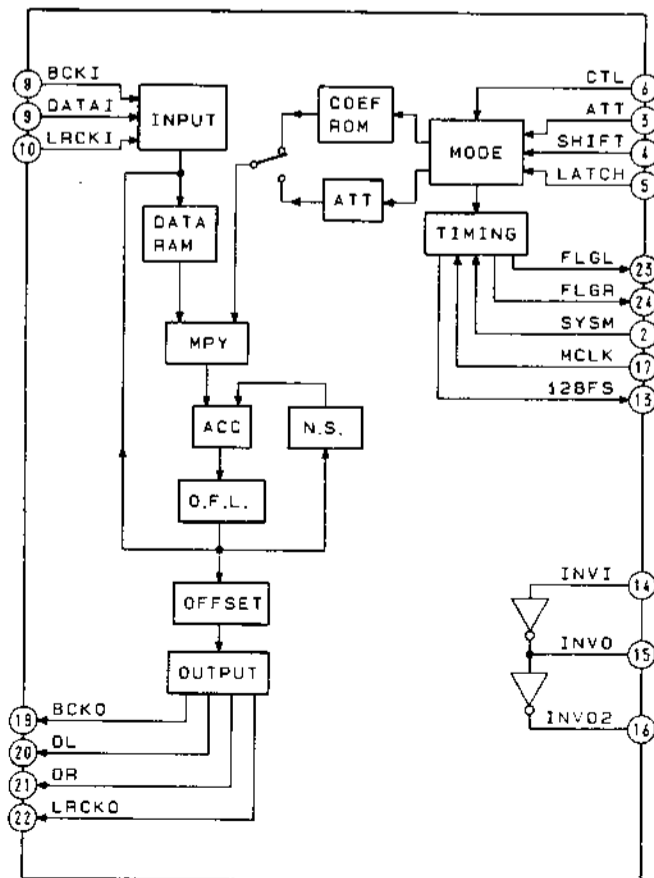

IC307 CXD2601AQ

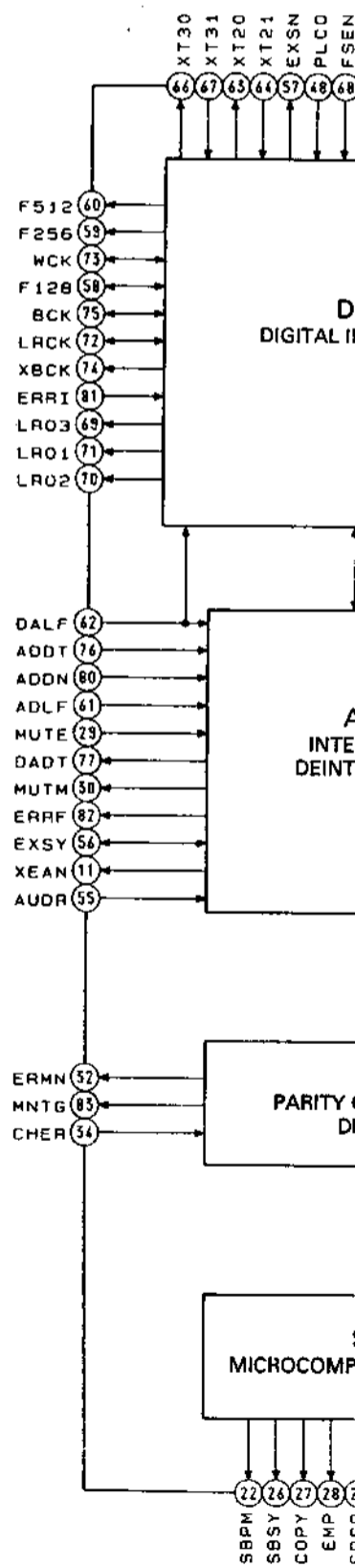

IC307 CXD2601AQ

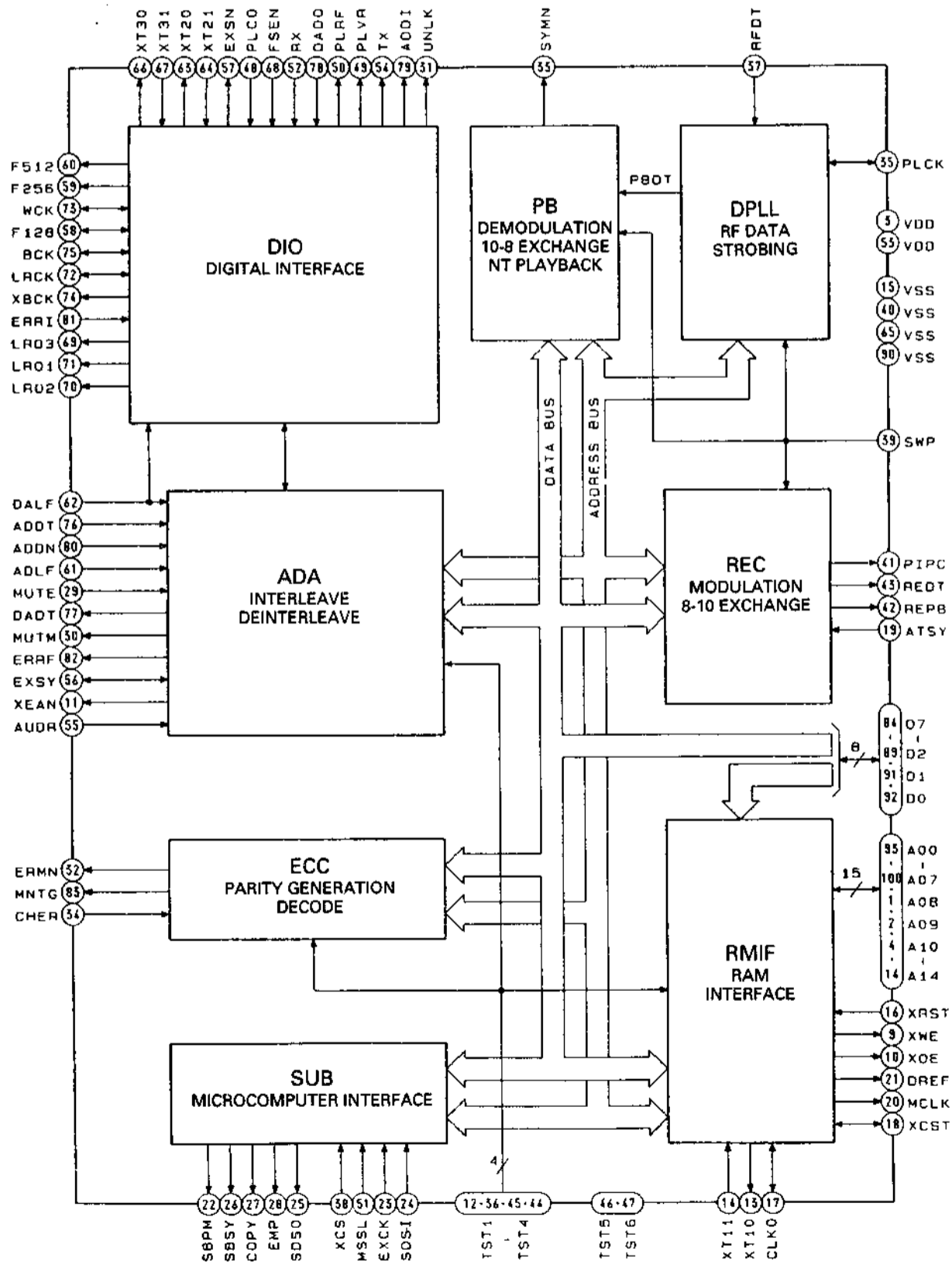
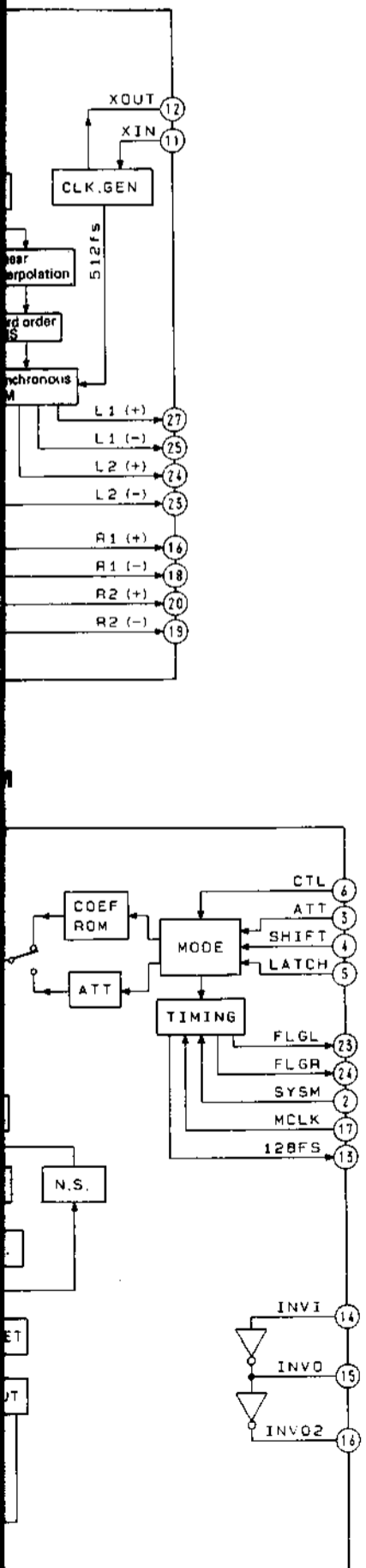

4-10. PIN FUNCTIONS

IC306 Digital Attenuator (CXD1136Q)

The captioned attenuator is used with the equipment as a digital attenuator in fade IN and fade OUT.

Pin No.	Pin Name	I/O	Description
1	DIGO	O	Serial data output synchronized with BCK (complement of 2)
2	DIGI	I	Serial data input synchronized with BCK (complement of 2)
3	ERFO	O	Signal output for discriminating whether or not DADT has interpolated data
4	UNDF	O	Detect result for ADDT L, R channel data of -54 dB or less ("L": -54 dB or less)
5	OVFL	O	Detect result for ADDT L channel overflow ("L": overflow detected)
6	OVFR	O	Detect result for ADDT R channel overflow ("L": overflow detected)
7	VSS		GND
8	SUBT	I	Selects whether subcode or 18-bit data is output to ADDT and DIGO ("H" or open: 18-bit data output, "L": subcode output)
9	LSB1	I	MSB/LSB fast switching for DADT, ADDT, DIGI, DIGO ("H" or open MSB fast, L: LSB fast)
10	LSB2	I	MSB/LSB fast switching for DAC2, ADC2L (ADC2R) ("H" or open MSB fast, L: LSB fast)
11	OVON	I	Overflow detect result on/off ("H" or open: OVFL, OVFR output valid, L: OVFL, OVFR fixed "H")
12	LCF	I	Low-cut filter on/off ("H" or open: on)
13	ADDA	O	"H" in AD mode (DASL = DIAN = "L")
14	DIAN	I	Sets AD and DA modes
15	DASL	I	Sets AD and DA modes
16	MUTE	I	Soft muting on/off ("H": mute on)
17	ATLV	I	Digital volume range setting ("H" or open: 0 - -60, -∞ dB, "L": +12 - -48, ∞ dB)
18	ATON	I	Digital volume on/off ("H" or open: off)
19	ATDN	I	Digital volume level down
20	ATUP	I	Digital volume level up
21	ATCK	I	Digital volume level setting clock and soft muting external clock
22	ATEX	I	Soft muting operation clock selection ("H" or open: internal clock, "L": ATCK)
23	VDD	—	Power supply (+5 V)
24	NC		
25	VDD'	—	Oscillator circuit power supply (+5 V)
26	SCK	O	Oscillator clock output
27	NC		
28	XTLI	I	Crystal connector and clock input pin
29	NC		
30	XTLO	O	Crystal connector pin (24.576 MHz oscillation frequency possible)
31	VSS'	—	Oscillator circuit GND
32	CKSL	I	Oscillator clock division selection ("H" or open: no division, "L": 1/2 division)
33	NC		
34	NC		
35	DOFF	I	DAC2 digital offset on/off ("H" or open: on)
36	APSL	I	Aperture correction filter coefficient selection (not valid in AD mode) ("H" or open: correction active)
37	LRSL	I	L, R channel phase difference correction selection ("H" or open: correction active)
38	DAC2	O	Serial data output to 2-times oversampling DA converter (complement of 2)
39	VSS	—	Power supply (+5 V)
40	BKSL	I	LRCK, BCK input timing switch ("H" or open: LRCK change point and BCK leading edge synchronized, "L": LRCK change point and BCK trailing edge synchronized)
41	INSL	I	DADT, DIGI, ADC2L (ADC2R) data incorporation clock selection ("H" or open: BCK, "L": LRCK)
42	ADSL	I	ADC2L, ADC2R data selection ("H" or open: ADC2L, "L": ADC2L and ADC2R switched by LRCK2)
43	NC		
44	WCK2	O	Clock equivalent to 4fs
45	LR21	O	DAC2 L, R channel discrimination signal in I ² S format

Pin No.	Pin Name	I/O	Description
46	APTL	O	Aperture signal
47	APTR	O	Aperture signal
48	LRCK2	O	DAC2, ADC2L (ADC2R) L, R channel discrimination signal (equivalent to 2fs) ("L": L channel, "H": R channel)
49	XLRCK2	O	LRCK2 inverted output
50	XBCK	O	BCK inverted output
51	BCK	I	Clock equivalent to 64fs for DADT, ADDT, DIGI, DIGO data incorporation
52	INCK	I	DADT, DIGI, ADC2L (ADC2R) data incorporation clock
53	VDD	—	Power supply (+5 V)
54	ADC2L	I	Serial data input from 2-times oversampling AD converter (complement of 2)
55	ADC2R	I	Serial data input from 2-times oversampling AD converter (complement of 2)
56	LRCK	I	DADT, ADDT, DIGI, DIGO L, R channel discrimination signal (fs) ("L": L channel, "H": R channel)
57	ADDT	O	Serial data output synchronized with BCK (complement of 2)
58	ERFI	I	Signal input for discriminating whether or not DADT has interpolated data (complement of 2)
59	DADT	I	Serial data input synchronized with BCK (complement of 2)
60	OVCW	I	Clock input which determines detect time for OVFL, OVFR and UNDF

IC307 DAT Signal Processor (CXD2601Q)

This processor is an LSI to process recording and playback signals of the R-DAT system, in a single chip and provided with digital PLL, modem, error correction circuit, digital I/O, RAM control circuit, etc.

Pin No.	Pin Name	I/O	Description
1, 2	A08, A09	I/O	RAM address A08, A09
3	VDD	—	5 V
4-6	A10-A12	I/O	RAM address A10-A12
7, 8	A13, A14	O	RAM address A13, A14
9	XWE	O	RAM write enable signal
10	XOE	O	RAM output enable signal
11	XEAN	O	External addressing bus interrupt enable signal
12	TST1	I	Test pin (normally "L")
13	XTIO	O	18.816 MHz crystal oscillator output
14	XTII	I	18.816 MHz crystal oscillator input
15	VSS	—	GND
16	XRST	I	Reset pin (normally "H")
17	CLKO	I/O	18.816 MHz clock output
18	XCST	I/O	SYEK (internal system clock) generation CLKO division timing signal
19	ATSY	I	ATF sync signal input
20	MCLK	O	9.408 MHz clock output
21	DREF	O	Drum servo reference signal
22	SBPM	O	Discrimination signal determining whether the subcode I/O clock (EXCK) is accepted ("L": accept, "H": ignore)
23	EXCK	I	Subcode I/O data transfer clock (DUTY50)
24	SDSI	I	Subcode serial data input
25	SDSO	O	Subcode serial data output
26	SBSY	O	Subcode I/O sync signal
27	COPY	O	Copy data output
28	EMP	O	Emphasis data output
29	MUTE	I	Mute pin
30	MUTM	O	Mute discrimination signal ("H": muted)
31	UNLK	O	RX PLL lock discrimination signal ("H": locked)
32	ERMN	O	Detects presence or absence of RF ("H": RF present, "L" during REC)

Pin No.	Pin Name	I/O	Description
33	SYMN	O	C1 check result for RF ("H": OK)
34	CHER	I	Signal for discriminating whether C2 is 1 or 2 times (C2 → C1 → C2 or C1 → C2) ("H": 1 time, "L": 2 times)
35	PLCK	I/O	RF PLL clock output
36	TST2	I	Test pin (normally "L")
37	RFDT	I	RF signal input
38	XCS	I	Subcode I/O chip select ("L": select)
39	SWP	I	RF switching pulse ("L": A-CH, "H": B-CH)
40	VSS	—	GND
41	PIPC	O	REC data PILOT/PCM discrimination signal ("H": PILOT, during playback: always "L")
42	REPB	O	Record/playback switching signal ("H": record)
43	REDT	O	Recording signal output, fixed "L" during playback
44	TST4	I	Test pin (normally "L")
45	TST3	O	RX APLL PD output (comparator output)
46	TST5	I	RX APLL oscillator cell amp input
47	TST6	O	RX APLL oscillator cell amp inverted output
48	PLCO	I	RX APLL external VCO clock input
49	PLVR	O	RX APLL comparison signal when external comparator is active (Vin) Not in use
50	PLVF	O	RX APLL comparison signal when external comparator is active (Rin) Not in use
51	MSSL	I	Master/slave setting ("H": master (fixed with the equipment), "L": slave)
52	RX	I	Digital input
53	VDD	—	5 V
54	TX	O	Digital output
55	AUDR	I	Audio mode/data recorder mode setting ("H": audio mode, "L": data recorder mode)
56	EXSY	I/O	Complete copy sync signal (25/3 - 100/3 Hz)
57	EXSN	I/O	Complete copy sync signal (25/3 - 100/3 Hz)
58	F128	I/O	128fsCK (normal)/256fsCK (×2) (DUTY50)
59	F256	O	256fsCK (normal)/512fsCK (×2) (DUTY50)
60	F512	O	512fsCK (normal)/512fsCK (×2) (DUTY50)
61	ADLF	I	Signal for discriminating whether ADDT serial data is MSB first or LSB first ("H": LSB first)
62	DALF	I	Signal for discriminating whether DADT serial data is MSB first or LSB first ("H": LSB first)
63	XT20	O	22.5792 MHz crystal oscillator output
64	XT21	I	22.5792 MHz crystal oscillator input
65	VSS	—	GND
66	XT30	O	49.152 MHz crystal oscillator output (24.576 MHz in B mode)
67	XT31	I	49.152 MHz crystal oscillator input (24.576 MHz in B mode)
68	FSEN	I	F128, BCK, LRCK input/output switch ("H": output)
69	LR03	O	LR02 inversion
70	LR02	O	LRCK 16BCK delay signal
71	LR01	O	LRCK 15BCK delay signal
72	LRCK	I/O	fs (normal)/2fs (×2) ("L": L-CH, "H": R-CH)
73	WCK	I/O	2fs (normal)/4fs (×2) (input mode only for testing)
74	XBCK	O	BCK inversion
75	BCK	I/O	64fs (normal)/128fs (×2)
76	ADDT	I	Serial AD data (complement of 2)
77	DADT	O	Serial DA data (complement of 2)
78	DADO	I	Digital output (DA) data input (normally connected to DADT)
79	ADDI	O	Digital input (AD) data output (normally connected to ADDN)
80	ADDN	I	Digital input (DA) data input
81	ERRI	I	Digital output V-FLAG data input (normally connected to ERRF)
82	ERRF	O	Signal output for discriminating whether or not DADT has interpolated data ("H": interpolated data)

Pin No.	Pin Name	I/O	Description
83	MNTG	O	Error correction status monitor trigger
84-89	D7-D2	I/O	RAM data bus D7-D2
90	VSS	—	GND
91, 92	D1, D0	I/O	RAM data bus D1, D0
93-100	A00-A07	I/O	RAM address A00-A07

IC311 Mechanism/Servo Micon (CXP80524-025Q)

The mechanical deck servo systems are controlled by the captioned micon according to instructions from the main micon (IC312).

Pin No.	Pin Name	I/O	Connected to	Description
1		O		Not in use
2	<u>BUSY</u>	O	Main Micon	Busy (Active "L") to the Main Micon
3		O		Not in use
4	REEL_CCW	O	Mechanism	Reel motor CCW ("L": RVS direction) } *1
5	REEL_CW	O	Mechanism	
6	C_DIR_RVS	O	Mechanism	Capstan Direction ("L": FWD, "H": RVS)
7	PLN_ON	O	Mechanism	Plunger On
8	PLN_KICK	O	Mechanism	Plunger Kick
9	D_ON	O	Mechanism	Drum On ("H": The drum is revolving)
10	D_DIR_RVS	O	Mechanism	Not in use
11-16		O		Not in use
17	LE	O	Mechanism	Loading Motor Eject } *2
18	LL	O	Mechanism	
19	CAS_M_OUT	O	Mechanism	Cassette control motor Out } *3
20	CAS_M_IN	O	Mechanism	
21-24		—		Not in use
25	RE_FWD	I	Mechanism	Encoder SW2 } *4
26	RE_STOP	I	Mechanism	
27-30	<u>END_LED_ON</u>	O	Mechanism	End sensor ON Illuminated upon "L" (rectangular wave of about 1kHz). It is not output unless a cassette is mounted ("H").
31	MP	I		Microprocessor mode selected (the equipment is fixed at "L").
32	RST	I		System Reset (low active)
33	Vss	—		Power terminal (GND)
34	XTAL	O		System Clock Output
35	EXTAL	I	CXD2601AQ	System Clock Input (9.408 MHz)
36-39		—		Not in use
40	X_SRV_REQ	I	Main Micon	Request for communication from the Main Micon
41	MAIN_DT_I	I	Main Micon	Serial Input from the Main Micon
42	MAIN_DT_O	O	Main Micon	Serial Output to the Main Micon
43	MAIN_CK	I	Main Micon	Serial Clock with the Main Micon
44	AVss	—		GND for A/D
45	AVref	—		Reference Voltage for A/D (+5 V)
46	AVdd	—		Power Supply for A/D (+5 V)
47	T_END	I	Mechanism	Take-up side end sensor input (analog) } Magnetic matter: 0V, Supply side end sensor input (analog) } Leader tape: AC (*5)
48	S_END	I	Mechanism	
49	CAS_IN	I	Mechanism	Cassette-in switch (S01). "H": Cassette is mounted.
50	REC_EN	I	Mechanism	Rec-enable switch (S01). "H": REC enabled.
51	CAS_LCKed	I	Mechanism	Casecon locked Upon completion of loading: "H"
52	CAS_OUTed	I	Mechanism	Casecon outed Upon completion of loading OUT: "H"
53		I		Not in use
54	ATF_IN	I	RF Amp	ATF PILOT input
55	FG_T	I	Mechanism	Reel FG (T Side) } 6/24Hz (Small reel diameter) - Reel FG (S Side) } 15/24Hz (Large reel diameter) (In SP FWD)
56	FG_S	I	Mechanism	
57	C_FG	I	Mechanism	Capstan FG SP: 674 Hz, LP: 337 Hz
58	D_FG	I	Mechanism	Drum FG 400 Hz: LP REC, 800 Hz: Other modes
59	D_PG	I	Mechanism	Drum PG } Other than LP REC: 800/24Hz Drum Reference } In LP REC: 400/24Hz
60	D_REF	I	CXD2601AQ	

Pin No.	Pin Name	I/O	Connected to	Description
61	MST_CK	I	CXD2601AQ	Master clock (9.408MHz)
62	PB_DT	I	RF Amp	PB Data input to create ATF Sync
63	SWP	O	CXD2601AQ	Switching Pulse "L": Ach, "H": Bch
64	D_PWM	O	Mechanism	PWM Out for Drum
65	C_PWM	O	Mechanism	PWM Out for Capstan
66	PWM_R	O	Mechanism	PWM Out for Reel
67	TEN_PWM	O	Mechanism	PWM Out for Tension Regulator Plunger
68	AGC_PWM	O	RF Amp	PWM Out for AGC
69	SBSY	I	CXD2601AQ	↓ of subsync is detected (XINT2).
70	TEST	I	Pull-up	Test Mode (active "L")
71	POW_DN	I		Not in use
72	Vdd	—		Power terminal (+5 V)
73	Vss	—		Power terminal (GND)
74		—		Not in use
75	ATF_S2	O	CXD2601AQ	ATF Sampling Pulse
76-80		—		Not in use

*1 Reel motor control

	CCW (counterclockwise)	CW (clockwise)
STOP (only in POWER ON)	L	L
FWD	L	H
RVS	H	L
Prohibit	H	H

*4 Encoder

RF-FWD	RE_STOP	Position
L	L	EJECT
L	H	STOP UNLD-STOP
H	L	FWD
H	H	STOP-FWD

*2 Loading motor control

	LE	LL
—	L	L
LOAD	L	H
EJECT	H	L
Brake	H	H

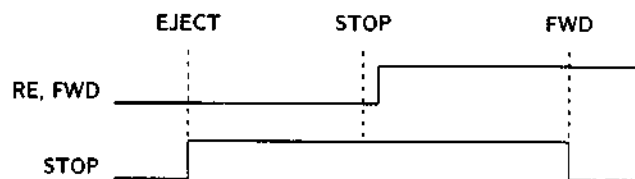

*3 Caseon motor control

	OUT	IN
—	L	L
IN	L	H
OUT	H	L
Brake	H	H

*5 End sensor

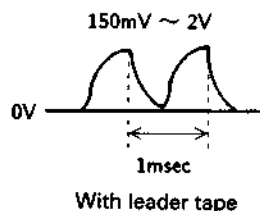

IC312 Main Micon (CXP80524-040Q)

This Micon generally controls the operation of the equipment while exchanging data with the display micon (IC701) and mechanism/servo micon (IC311) in serial communications, including the DAT signal processor (IC307), attenuator (IC306), clock (IC330), digital filter (IC363) and other IC.

Pin No.	Pin Name	I/O	Connected to	Description
1		O		Not in use
2	$\overline{\text{L_MUTE}}$	O	Line Out	Line Mute (Active "L")
3		O		Not in use
4		O		Not in use
5	$\overline{\text{WRT}}$	O	Clock IC	Write request (Active "L")
6	RD	O	Clock IC	Read request (Active "L")
7-10	ADRS_3-0	O	Clock IC	Address 3-0 (Address BUS)
11-14	DATA_7-4	I/O		DATA 7-4 (DATA BUS). Not in use with the equipment
15-18	DATA_3-0	I/O	Clock IC	DATA 3-0 (DATA BUS)
19	$\overline{\text{ATT_EXT}}$	O	CXD1136Q	Fade attenuator ck externally selected (Active "L")
20	$\overline{\text{DIG/ANA}}$	O	CXD1136Q	Fade In/Out switching for DIG ("L")/ANA ("H")
21	$\overline{\text{REC/PB}}$	O	CXD1136Q	Fade In/Out REC switching for ("L")/PB ("H")
22	$\overline{\text{ATT_CK}}$	O	CXD1136Q	Clock for fade In/Out
23	$\overline{\text{DTR}}$	O	CXD2601AQ	Audio use ("H")/Data Recorder use ("L"). Becomes "L" in after-recording and searching.
24	$\overline{\text{OPT/COA}}$	O	Digital I/O	Switching for Optical ("L")/Coaxial ("H")
25	FS32	O	1Bit DAC	"H" upon Fs = 32kHz. "L" for others.
26	$\overline{\text{RAM_SEL}}$	O		Not in use
27	$\overline{\text{DISP_REQ}}$	O	Display Micon	Request for communication with the Display Micon ("L" Active)
28	$\overline{\text{SD_REQ}}$	O	CXD2601AQ	Request for communication with CXD2601 ("L" Active)
29	$\overline{\text{SRV_REQ}}$	O	Mechanism Micon	Request for communication with the Mechanism Micon ("L" Active)
30	$\overline{\text{CLOCK_SEL}}$	O	Clock IC	Clock IC chip selected
31	MP	I		Microprocessor mode selected (fixed at "L" with the equipment)
32	$\overline{\text{RST}}$	I		System Reset ("L" Active)
33	Vss	—		Power terminal (GND)
34	XTAL	O		System Clock Output
35	EXTAL	I	CXD2601AQ	System Clock Input (9.048 MHz)
36	$\overline{\text{DISP_ACK}}$	I	Display Micon	ACKnowledge (Active "L")
37	$\overline{\text{DISP_DT_I}}$	I	Display Micon	Serial Input
38	$\overline{\text{DISP_DT_O}}$	O	Display Micon	Serial Output
39	$\overline{\text{DISP_CK}}$	I	Display Micon	Serial clock
40	$\overline{\text{SBSY}}$	I	CXD2601AQ	Subcode sync
41	$\overline{\text{SR_DT_IN}}$	I	CXD2601AQ & Mechanism Micon	Serial Data In
42	$\overline{\text{SR_DT_OUT}}$	O		Serial Data Out
43	$\overline{\text{SR_CK}}$	I/O		Serial clock (In/Out) to Sub Code Interface
44	AVss	—		GND for A/D
45	AVref	—		Reference Voltage for A/D (+5 V)
46	AVdd	—		Power Supply for A/D (+5 V)
47		I		Not in use
48		I		Not in use
49	$\overline{\text{BUSY}}$	I	Mechanism Micon	Mechanism servo micon Busy (Active "L")
50	AU_BUS_IN	I	Audio Bus	Not in use

Pin No.	Pin Name	I/O	Connected to	Description
51	TM_IN	I	Clock IC	TM_OUT for clock IC
52	MUT_MON	I	CXD2601AQ	Mute monitor (Active "H")
53	LVL_SYNC	I	Audio Block	Start ID is written by entering Level Sync Input audio.
54		I		Not in use
55	TRQ_TEST	I	Pull-up	Not in use
56	NO_CAS_TEST	I	Pull-up	Not in use
57	TIME_24/12	I	Pull-up	Time indication "H": 12 hours (AM, PM) "L": 24 hours display
58	DATE_ORDER	I	Pull-up	Order of DATA display "H": Year, month and day "L": Month, day and year
59-62	AF_3-0	I	Pull-up	Not in use
63		O		Not in use
64	L_MUTE	O	Pull-up	Line Mute (Active "L"). Not in use with the equipment
65	TR_MUTE	O	Line Out	Transistor Mute (Active "L")
66	MUTE_1136	O	CXD1136Q	Mute for CXD1136 (Active "H")
67	MUTE_2061	O	CXD2601AQ	Mute for CXD2601 (Active "H")
68	A_D_PWR_DWN	O	AK5339	A/D Converter Power Down Mode (Active "H"). The AD converter is turned OFF upon digital input/output.
69	ER_MON	I	CXD2601AQ	Error Monitor (Data Valid)
70	TEST	I	Pull-up	Test Mode (Active "L")
71	POW_DN	I	+5 V	Not in use
72	Vdd	—		Power terminal (+5V)
73	Vss	—		Power terminal (GND)
74		—		Not in use
75	D_F_ATT	O	CXD2560M	Communication line (Serial Data) with Digital Filter
76	D_F_SHIFT	O	CXD2560M	Communication line with Digital Filter (Shift Clock; shifted by ↓ and taken in by ↑)
77	D_F_LATCH	O	CXD2560M	Communication line (Latch Pulse) with Digital Filter
78, 79	MODE2, 1	O	CXA1364R	Mode Control of the RF amplifier
80		O		Not in use

IC330 Real Time Clock (RP5C62)

The Clock is an IC for clock and calendar and backed up by a lithium battery when the power supply to the set is OFF.

Pin No.	Pin Name	I/O	Description
1	CS	I	Chip select input. Active "L"
2	CE	I	Chip enable input. Active "H"
3	TMOUT	O	Interval output
4-7	A0-3	I	4 bit address input
8	RD	I	Read-out control input
9	Vss	—	Power terminal (GND)
10	WR	I	Write-in control input
11-14	D0-3	I/O	4 bit data input/output
15	INTR	O	Interrupt output. A 2048Hz signal is output here with the equipment.
16	OSCIN	I	Clock input (32.768kHz)
17	OSCOU	O	Clock output
18	VDD	—	Power terminal (+5 V)

IC362 Pulse D/A Converter (CXD2561M)

The Converter is a small, high-performance 1 bit pulse D/A converter that provides 4 asymmetrical PWM wave outputs in each ch of L/R.

Pin No.	Pin Name	I/O	Description
1	DV _{DD}	—	Digital power supply
2	TEST	I	Test terminal. Normally fixed at "L."
3	INIT	I	Again synchronized at the buildup edge of the signal.
4	LRCKI	I	LRCK input
5	DRI	I	Rch data input
6	DLI	I	Lch data input
7	BCKI	I	BCK input
8	DV _{SS}	—	Digital GND
9	512Fs	O	512Fs output
10	XV _{SS}	—	Clock GND
11	XIN	I	X'tal oscillator input terminal (512Fs)
12	XOUT	O	X'tal oscillator output terminal
13	XV _{DD}	—	Clock power supply
14	VSUB	—	Substrate. Connected to GND.
15	AV _{DD} R	—	Analog power supply
16	R1 (+)	O	Rch PLM output 1 (normal phase)
17	AV _{SS} R	—	Analog GND
18	R1 (-)	O	Rch PLM output 1 (reverse phase)
19	R2 (+)	O	Rch PLM output 2 (normal phase)
20	R2 (-)	O	Rch PLM output 2 (reverse phase)
21	AV _{DD}	—	Analog power supply
22	AV _{SS}	—	Analog GND
23	L2 (-)	O	Lch PLM output 2 (reverse phase)
24	L2 (+)	O	Lch PLM output 2 (normal phase)
25	L1 (-)	O	Lch PLM output 1 (reverse phase)
26	AV _{SS} L	—	Analog GND
27	L1 (+)	O	Lch PLM output 1 (normal phase)
28	AV _{DD} L	—	Analog power supply

IC363 Digital Filter (CXD2560M)

The Filter is a digital audio 8x oversampling digital filter with builtin L/R 2ch filter, noise shaping attenuator, soft muting deemphasis, etc.

Pin No.	Pin Name	I/O	Description
1	V _{SS}	—	Power terminal (GND)
2	SYSM	I	System mute input. Effective upon "H"
3	ATT	I	ATT data input in CTL "L." EMP input upon CLT "H."
4	SHIFT	I	Shift clock input upon CTL "L." FS32 input upon CTL "H."
5	LATCH	I	Latch clock input upon CTL "L." FS48 input upon CLT "H."
6	CTL	I	Pull-down in the IC. Direct input mode upon "H." Serial transfer mode upon "L."
7	INIT	I	Synchronized again at the buildup edge of the signal.
8	BCKI	I	BCK input
9	DATAI	I	Data input
10	LACKI	I	LRCK input
11	TEST	I	Test terminal. Fixed at "L." during normal use.
12	V _{SS}	—	Power terminal (GND)
13	128Fs	O	128Fs clock output
14	INVI	I	Inverter input
15	INVO	O	Inverter output
16	INVO2	O	Inverter output
17	MCLK	I	Master clock input (f=512Fs)
18	V _{DD}	—	Power terminal (+2 V)
19	BCKO	O	BCK output
20	DL	O	Lch data output
21	DR	O	Rch data output
22	LRCKO	O	LRCK output
23	FLGL	O	Lch \emptyset mute flag output
24	FLGR	O	Rch \emptyset mute flag output

IC701 Display Micon (CXP5058H-657Q)

The Micon controls key input, FL tube display, remote control signal input, level meter (IC702) and EEPROM (IC703) according to instructions from the Main Micon (IC312).

Pin No.	Pin Name	I/O	Connected to	Description
1-18	e_v_SEG	O	FL tube FL701	FL Segment 'e'- 'v'
19-28	10_I_G	O	FL tube FL701	FL Grid #10-#1
29	DSP_REQ	I	MAIN Micon	Communication request ("L" Active)
30	XTAL	—	Ceramic oscillator	
31	EXTAL	I	Ceramic oscillator	4.19MHz ceramic oscillator
32	RST	I		System Reset ("L" active)
33	NC	—		Not in use
34	Vdd	I		Power terminal (+5 V)
35-42	AD_0-7	I	Panel switch	Key input A/D converter input #0 - #7
43	NC	—		Not in use
44	DISP_CK	O	MAIN Micon	Shift clock
45	SO	O	MAIN Micon	Serial data OUT
46	SI	I	MAIN Micon	Serial data IN
47	DSP_ACK	O	MAIN Micon	Acknowledge (Active "L")
48	REC_MODE	I	S703	REC MODE "H": Standard, "L": Long
49	TEST	I	Pull-down	Test mode (Active "L")
50	CLOCK_SET	I	S704	CLOCK SET switch S704 (Active "L")
51-54	LVL_DT_0-3	I/O	Level Meter IC	Level Meter Data 0-3
55, 56	LVL_ADRS_0, 1	O	Level Meter IC	Level Meter Data 0, 1
57	LVL_RD	O	Level Meter IC	Level Meter Read Mode (Active "L")
58	LVL_WR	O	Level Meter IC	Level Meter Write Mode (Active "L")
59	LVL_SEL	O	Level Meter IC	Level Meter IC Select (Active "L")
60	RM_SEL	O	Open	External remote controller selected (not in use)
61	PY2	I	Pull-up	Not in use
62	RMC	I	Open	Not in use
63	RMC_CAT	I	Pull-down	Remote control category "L": DAT1, "H": DAT2. Fixed at "L" with the equipment.
64	TR_MUTE	I	IC431	Level meter mute (Active "L")
65	BUSY	I	EEPROM	BUSY signal (Active "L")
66	ROM_DT_IN	I	EEPROM	Data input
67	ROM_DT_OUT	O	EEPROM	Data output
68	SHIFT_CK	O	EEPROM	Shift clock
69	CE	O	EEPROM	Chip enable
70	DTC/XPCM	I	Pull-up	Equipment model discrimination input. Fixed at "H" with the equipment
71	Vss	I		Power terminal (GND)
72	TX	—	Open	Not in use
73	NC	—	Open	Not in use
74	TEX	—	+5 V	Not in use
75	Vref	I	+5 V	Analog board reference voltage
76	Vfdp	I	-25 V	FL display tube driving voltage
77-80	a_d_SEG	O	FL tube	FL Segment 'a'- 'd'

SECTION 5 EXPLODED VIEWS

NOTE:

- -XX, -X mean standardized parts, so they may have some differences from the original one.
- Color Indication of Appearance Parts
Example:
KNOB, BALANCE (WHITE)... (RED)
 ↑ ↑
 Parts color Cabinet's color

- Items marked "*" are not stocked since they are seldom required for routine service. Some delay should be anticipated when ordering these items.
- The mechanical parts with no reference number in the exploded views are not supplied.
- Hardware (# mark) list is given in the last of this parts list.
- CND : Canadian model

The components identified by mark Δ or dotted line with mark Δ are critical for safety.
Replace only with part number specified.

Les composants identifiés par une marque Δ sont critiques pour la sécurité.
Ne les remplacer que par une pièce portant le numéro spécifié.

5-1. CABINET SECTION

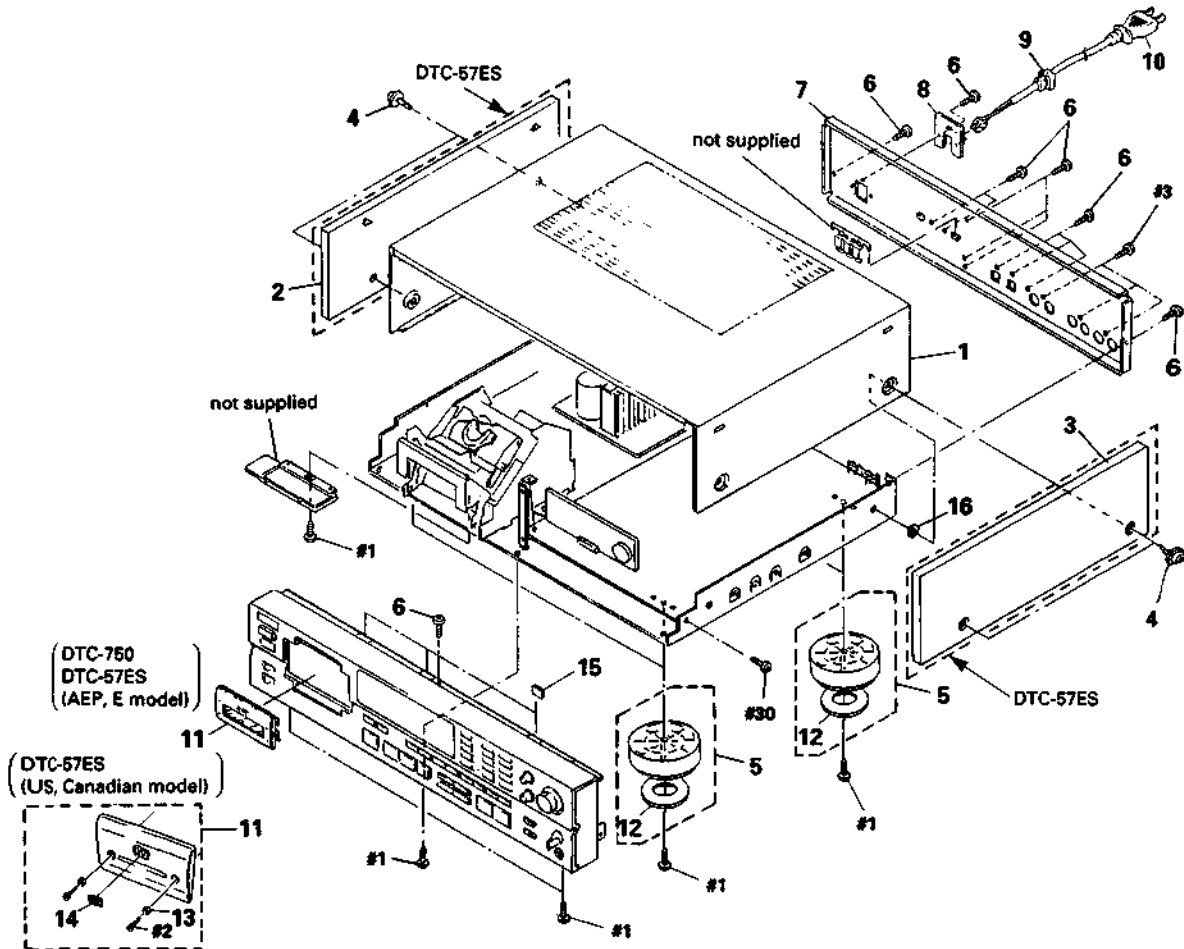

Ref. No.	Part No.	Description	Remarks	Ref. No.	Part No.	Description	Remarks
1	3-350-407-41	CASE (BLACK)		8	* 4-923-873-01	BRACKET, CORD STOPPER	
1	3-350-407-71	CASE (GOLD)		9	4-916-783-01	BUSHING, CORD (57ES:US,CND,E)	
2	* X-4919-027-2	PANEL (L) ASSY, SIDE (BLACK) (57ES)		9	* 3-703-244-00	BUSHING (2104), CORD (57ES:AEP/750)	
2	* X-3363-390-1	PANEL (L) ASSY, SIDE (GOLD) (57ES)		10	Δ 1-559-479-11	CORD, POWER (57ES:US,CND)	
3	* X-4919-028-2	PANEL (R) ASSY, SIDE (BLACK) (57ES)		10	Δ 1-559-297-31	CODE, POWER (57ES:E)	
3	* X-3363-389-1	PANEL (R) ASSY, SIDE (GOLD) (57ES)		10	Δ 1-575-912-11	CODE, POWER (57ES:AEP)	
4	4-933-446-01	SCREW (SIDE PANEL) (57ES)		10	Δ 1-575-913-11	CODE, POWER (750:UK)	
4	3-704-366-01	SCREW (CASE M3X8) (750)		10	Δ 1-575-695-11	CODE, POWER (750:US,CND)	
5	X-3304-938-2	FOOT ASSY (BLACK)		11	A-2003-671-A	PANEL (CASSETTE) ASSY (57ES:US,CND)	
5	X-4928-110-1	FOOT ASSY (GOLD)		11	A-2003-773-A	WINDOW ASSY, CASSETTE (BLACK) (57ES:AR, E/750)	
6	3-703-685-21	SCREW (+BV 3X8)		11	A-2003-893-A	WINDOW ASSY, CASSETTE (GOLD) (57ES:AEP)	
7	* 3-368-712-51	PANEL, BACK (57ES:US,CND)		12	4-923-836-11	CUSHION	
7	* 3-368-712-21	PANEL, BACK (BLACK) (57ES:AEP)		13	4-884-635-00	BASE, ORNAMENTAL (57ES:US,CND)	
7	* 3-368-712-71	PANEL, BACK (GOLD) (57ES:AEP)		14	4-936-615-01	PLATE (DAT LOGO), ORNAMENTAL	
7	* 3-368-712-42	PANEL, BACK (57ES:E)		14	3-831-441-XX	CUSHION, SPEAKER	
7	* 3-368-712-11	PANEL, BACK (750:US,CND)		15	3-942-525-01	BLIND (1), KNOB	
7	* 3-368-712-31	PANEL, BACK (750:UK)		16			

5-2. FRONT PANEL SECTION

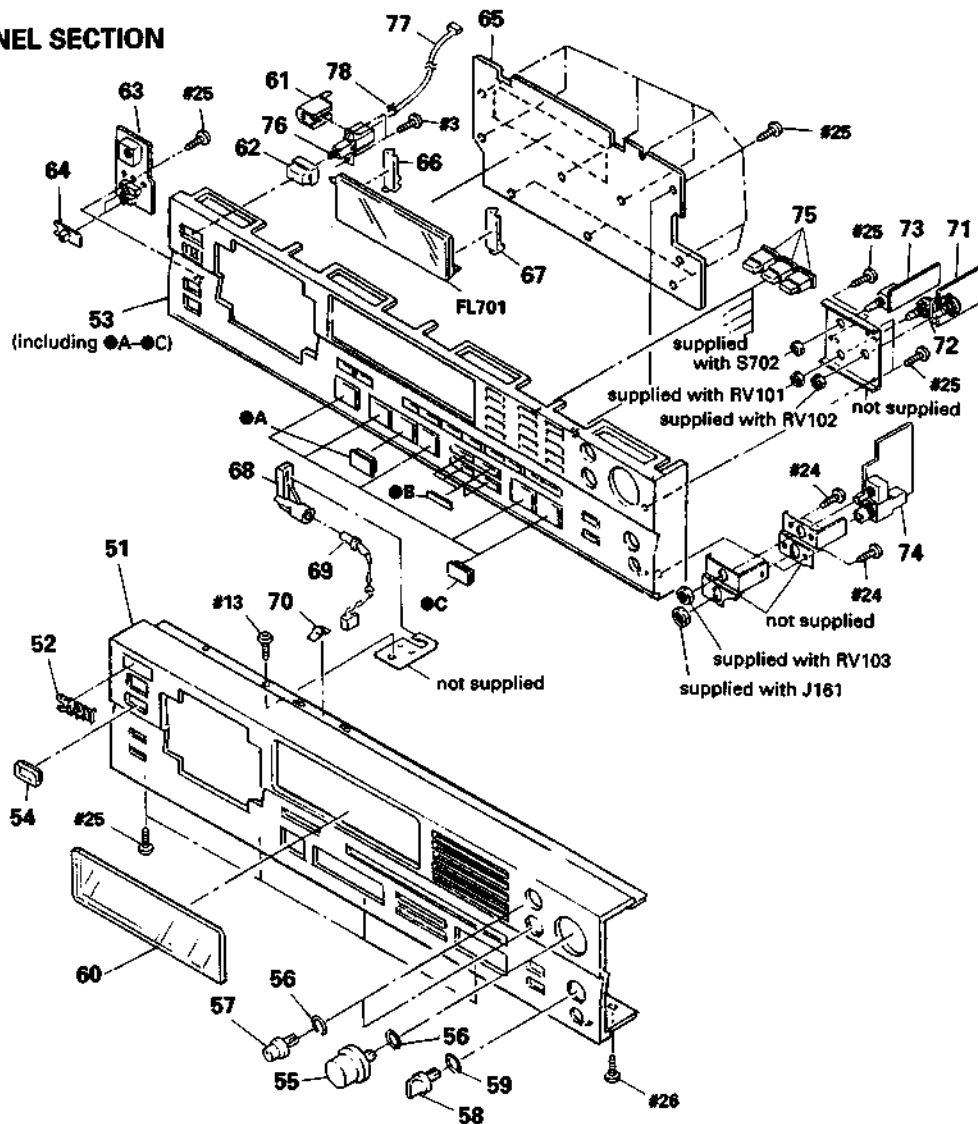

Ref. No.	Part No.	Description	Remarks	Ref. No.	Part No.	Description	Remarks
51	3-368-713-32	PANEL (FRONT) (57ES:US, CND)		63	* 1-639-329-11	TIMMER SW BOARD	
51	3-368-713-01	PANEL (FRONT) (BLACK) (57ES:AEP, E)		64	4-931-421-11	KNOB (T & S) (BLACK)	
51	3-368-713-11	PANEL (FRONT) (GOLD) (57ES:AEP, E)		64	4-931-421-21	KNOB (T & S) (GOLD)	
51	3-368-713-21	PANEL (FRONT) (750)		65	* A-2006-555-A	CONTROL SW BOARD, COMPLETE (57ES:US, CND)	
52	4-908-848-01	EMBLEM, SONY (BLACK)		65	* A-2006-444-A	CONTROL SW BOARD, COMPLETE (57ES:AEP, E/750)	
52	4-908-848-21	EMBLEM, SONY (GOLD)					
53	X-3363-047-2	ESCUTCHEON (PANEL) ASSY (BLACK)		66	* 4-922-524-01	HOLDER (LEFT)	
53	X-3363-191-1	ESCUTCHEON (PANEL) ASSY (GOLD)		67	* 4-922-523-01	HOLDER (RIGHT)	
54	3-364-919-01	FILTER		68	* 4-925-758-11	COVER (L), LAMP	
55	3-368-707-01	KNOB (REC LEVEL) (BLACK)		69	1-518-634-11	LAMP, PILOT	
55	3-368-707-11	KNOB (REC LEVEL) (GOLD)		70	3-846-312-00	SPACER	
56	3-356-957-01	SPRING		71	* 1-639-325-11	REC VOL BOARD	
57	3-364-173-11	KNOB (BAL) (BLACK)		72	* 1-639-326-11	BALANCE VOL BOARD	
57	3-364-173-21	KNOB (BAL) (GOLD)		73	* 1-639-328-11	INPUT SW BOARD	
58	3-354-931-01	KNOB (DIA. 10) (BLACK)		74	* 1-639-327-11	HEADPHONE BOARD	
58	3-354-931-31	KNOB (DIA. 10) (GOLD)		75	3-364-927-01	BUTTON (10 KEY) (BLACK)	
59	3-354-981-01	SPRING (SUS), RING (BLACK)		75	3-364-927-11	BUTTON (10 KEY) (GOLD)	
59	3-356-935-01	SPRING (GOLD)		76	1-554-920-21	SWITCH, PUSH (AC POWER) (1 KEY)	
60	3-368-698-01	WINDOW (FL TUBE)		77	1-590-321-71	LEAD (WITH CONNECTOR)	
61	3-575-524-00	COVER, POWER SWITCH		78	3-701-748-00	CLAMP	
62	4-917-460-01	KNOB, POWER (BLACK)		FL701	1-519-672-11	INDICATOR TUBE, FLUORESCENT	
62	4-917-460-51	KNOB, POWER (GOLD)					

5-3. CHASSIS SECTION

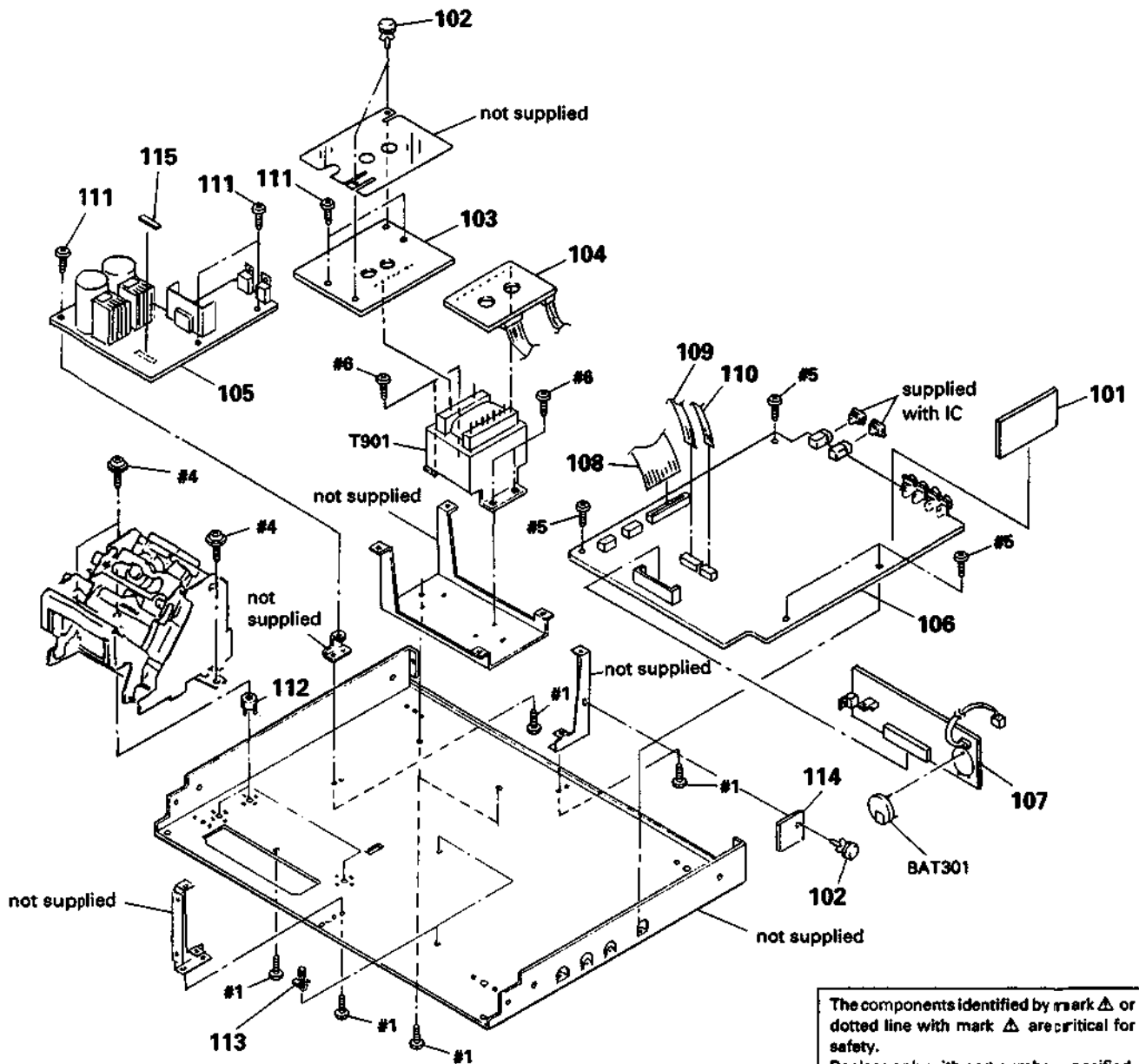

The components identified by mark Δ or dotted line with mark Δ are critical for safety. Replace only with part number specified.

Les composants identifiés par une marque Δ sont critiques pour la sécurité. Ne les remplacer que par une pièce portant le numéro spécifié.

Ref. No.	Part No.	Description	Remarks	Ref. No.	Part No.	Description	Remarks
101	* 1-639-920-11	PLL BOARD		109	1-590-916-11	WIRE, FLAT TYPE (10 CORE)	
102	4-812-134-00	RIVET NYLON, 3.5		110	1-590-914-11	WIRE, FLAT TYPE (6 CORE)	
103	* 1-639-333-11	PC BOARD, PRIMARY		111	4-886-821-11	SCREW, S TIGHT, +PTTW 3X6	
104	* 1-639-332-11	RELAY BOARD		112	3-368-709-01	HOLDER (MD)	
105	* A-2006-463-A	POWER BOARD, COMPLETE		113	* 3-670-570-00	SPACER, SUPPORT	
106	* A-2006-572-A	MAIN BOARD, COMPLETE (57ES:US, CND, E)		114	* 1-639-330-11	CONTROL (S) BOARD (57ES:US, CND)	
106	* A-2006-614-A	MAIN BOARD, COMPLETE (57ES:AEP)		115	3-701-947-15	LABEL (T2.5A), FUSE (57ES:AEP, E/750:UK)	
106	* A-2006-681-A	MAIN BOARD, COMPLETE (750:US, CND)		BAT301	Δ 1-528-229-11	BATTERY, LITHIUM CR-2450	
106	* A-2006-682-A	MAIN BOARD, COMPLETE (750:UK)		T901	Δ 1-450-556-11	TRANSFORMER, POWER (US, CND)	
107	* A-2006-553-A	SUB BOARD, COMPLETE		T901	Δ 1-450-557-11	TRANSFORMER, POWER (57ES:AEP/750:UK)	
108	1-590-915-11	WIRE, FLAT TYPE (30 CORE)		T901	Δ 1-450-558-11	TRANSFORMER, POWER (57ES:E)	

5-4. MECHANISM SECTION 1

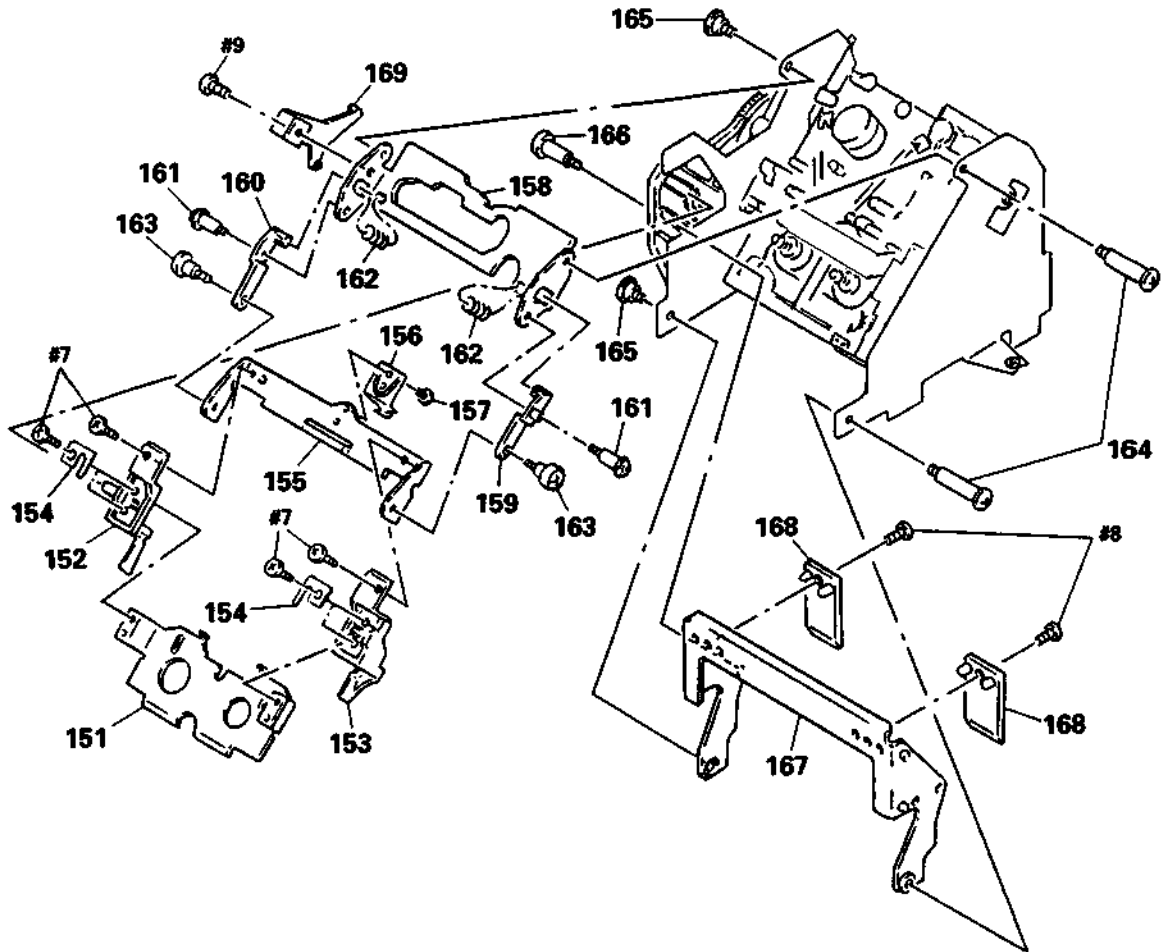

Ref. No.	Part No.	Description	Remarks	Ref. No.	Part No.	Description	Remarks
151	4-931-476-01	HOLDER (LOWER)		161	4-918-991-01	SCREW, STEP	
152	4-931-484-01	HOLDER (C-LEFT)		162	3-537-214-00	SPRING, COMPRESSION	
153	4-931-486-01	HOLDER (C-RIGHT)		163	3-312-161-00	SCREW, STEP, PRECISION	
154	3-366-308-01	SPRING (SIDE), PLATE		164	4-931-463-01	SCREW (STEP)	
155	* 4-931-485-01	HOLDER (C-INNER)		165	2-236-956-00	SCREW, STEP	
156	4-931-461-01	SPRING (CENTER), LEAF		166	4-931-471-01	SCREW (STEP)	
157	3-352-517-01	SCREW (M2X2.5)		167	4-931-474-01	HOLDER (WINDOW)	
158	* 3-369-235-01	PLATE, FULCRUM		168	4-931-469-01	PLATE, ORNAMENTAL	
159	4-931-481-01	ARM (LIMITER L)		169	* X-4919-020-1	JOINT ASSY	
160	4-931-473-01	ARM (LIMITER R)					

5-5. MECHANISM SECTION 2

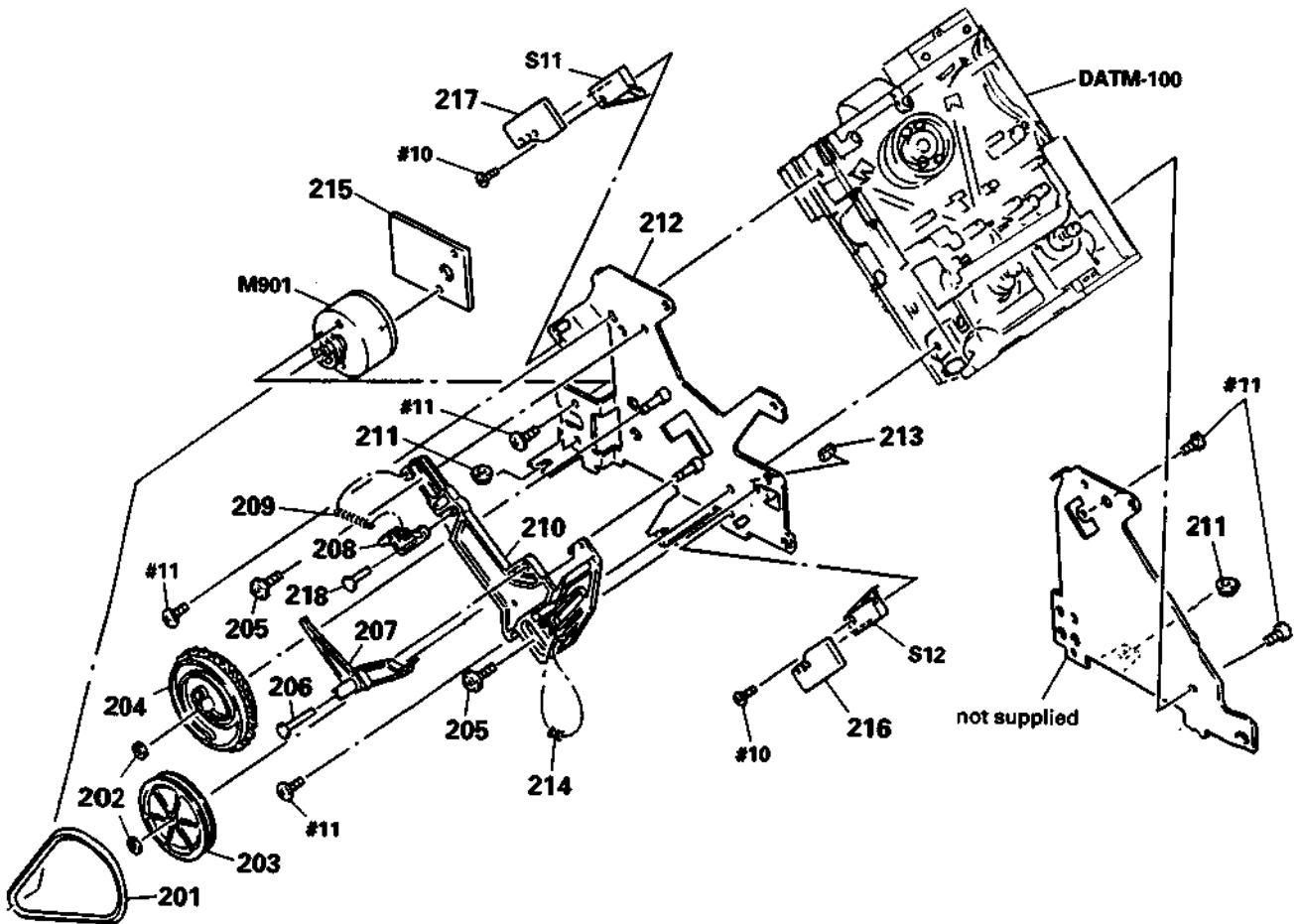

Ref. No.	Part No.	Description	Remarks	Ref. No.	Part No.	Description	Remarks
201	4-931-470-01	BELT (DRIVING)		212	* X-4919-023-1	PLATE ASSY. SIDE	
202	3-307-948-21	WASHER, NYLON		213	9-911-863-XX	SPACER	
203	4-931-459-01	PULLEY		214	3-537-215-00	SPRING, COMPRESSION	
204	4-931-477-01	GEAR (CAM)		215	* 1-639-646-11	MOTOR BOARD	
205	4-932-336-01	SCREW (STEP)		216	* 1-639-647-11	SW (IN) BOARD	
206	4-931-468-01	SHAFT (PRESS FITTING)		217	* 1-639-648-11	SW (OUT) BOARD	
207	4-931-490-01	LEVER (LINK)		218	4-936-626-01	SHAFT (ARM PRESS FITTING)	
208	4-931-460-01	ARM (SLIDER)		M901	A-2003-448-A	MOTOR ASSY	
209	3-549-810-00	SPRING, TENSION		S11	1-570-975-11	SWITCH, SLIDE (CASSETTE TABL OUT)	
210	4-931-492-01	SLIDER (CAM)		S12	1-572-247-11	SWITCH, SLIDE (CASSETTE TABL IN)	

5-6. MECHANISM SECTION 3 (DATM-100)

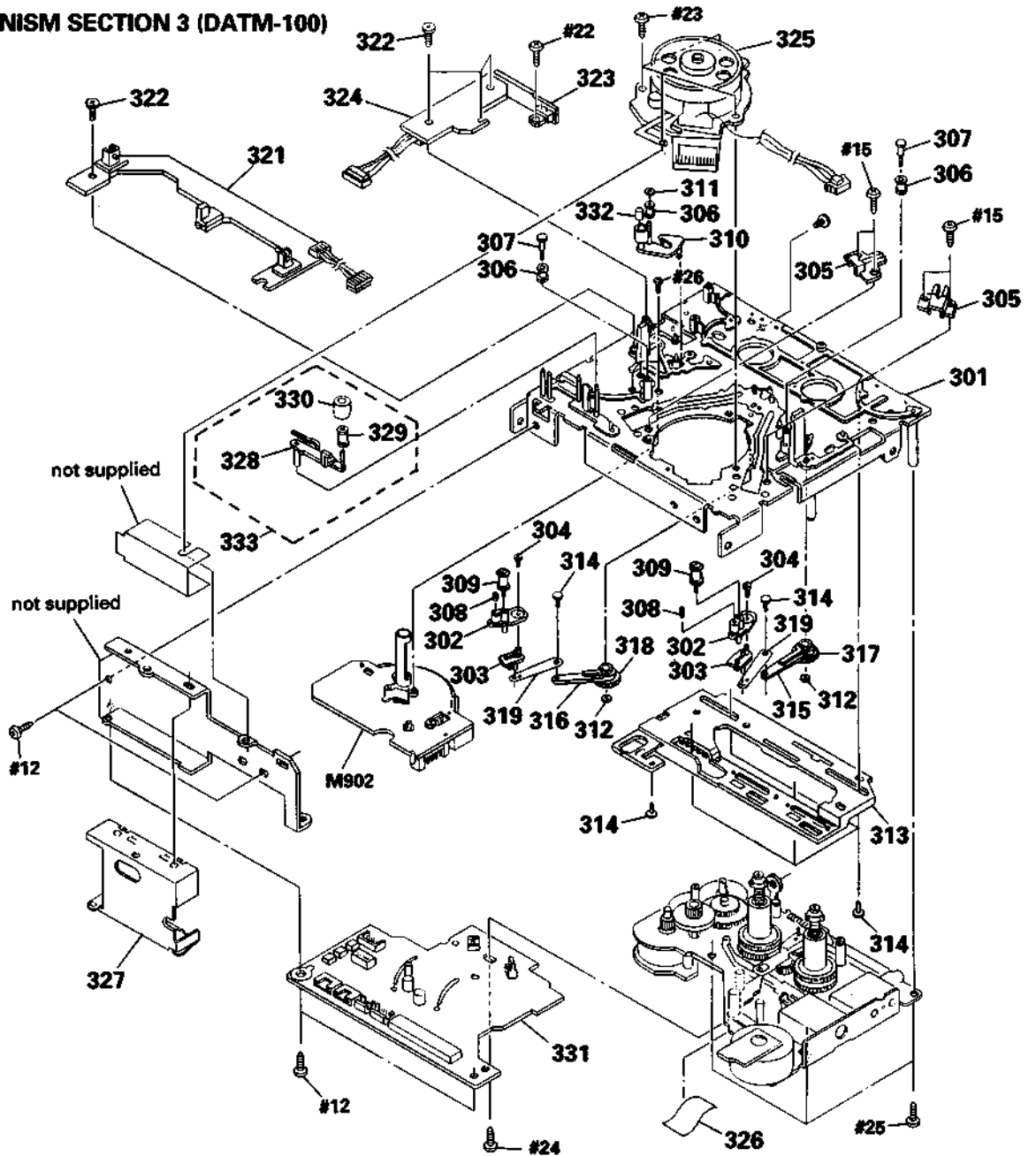

Ref. No.	Part No.	Description	Remarks	Ref. No.	Part No.	Description	Remarks
301	* 3-368-462-01	CHSSIS (OUTSERT), MECHANIAL		317	3-368-444-01	GEAR (LOAD-T)	
302	* 3-368-390-01	BASE (#1 GUIDE)		318	3-368-443-01	GEAR (LOAD-S)	
303	3-368-409-01	JOINT (#1 GUIDE)		319	3-368-415-01	SHAFT (LOAD LEVER JOINT)	
304	3-368-413-01	SCREW, +P (1) B1. 4X2. 5		321	* 1-639-305-11	TOP END SENSOR BOARD	
305	* 3-368-442-01	CATCHER		323	* 1-639-301-11	RGN SW BOARD	
306	3-368-399-01	GUIDE, ROLLER		324	* 1-639-306-11	CAM SLIDER BOARD	
307	3-368-428-01	SHAFT (ROLLER GUIDE)		325	8-848-567-01	DRUM ASSY DOU-03A	
308	3-368-436-01	SPRING (#1 GUIDE), COMPRESSION		326	9-911-835-XX	SPACER	
309	X-3337-643-1	GUIDE (RIC) ASSY, ROLLER		327	* A-2001-587-A	RF COMPLETE ASSY	
310	X-3363-025-1	PINCH (LEVER) ASSY		328	3-368-459-01	LEVER (CLEANER)	
311	3-315-384-31	WASHER, STOPPER		329	3-353-812-01	COLLAR (ROLLER)	
312	3-368-398-01	BUSHING		330	3-352-518-01	ROLLER (CLEANER)	
313	* A-2003-708-A	SLIDER ASSY, CAM		331	* A-2056-488-A	DRUM DRIVE BOARD, COMPLETE	
314	3-368-414-01	SHAFT (CAM SLIDER GUIDE)		332	3-337-626-01	CAP, PINCH ROLLER	
315	3-368-427-01	LEVER (LOAD-T)		333	X-3337-655-1	ROLLER (CLEANER) ASSY	
316	3-368-426-01	LEVER (LOAD-S)		M902	8-835-361-01	MOTOR, DC U-17B (CAPSTAN)	

5-7. MECHANISM SECTION 4 (DATM-100)

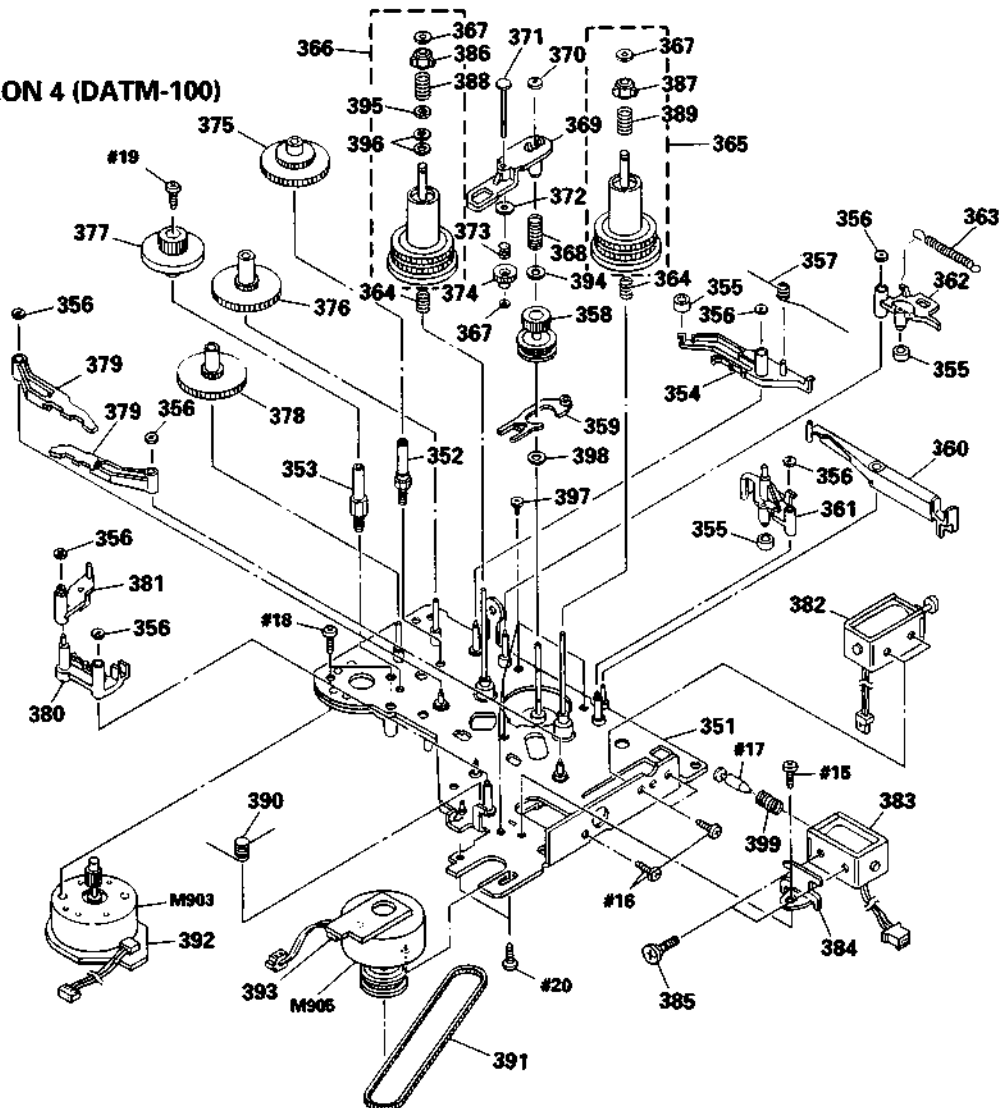

Ref. No.	Part No.	Description	Remarks	Ref. No.	Part No.	Description	Remarks
351	* A-2003-857-A	CHASSIS (REEL) ASSY		376	3-368-402-11	GEAR (CAM DRIVE A, B)	
352	* 3-368-420-01	SHAFT (CAM DRIVE GEAR C)		377	3-368-403-01	GEAR (CAM DRIVE D)	
353	* 3-368-419-01	SHAFT (CAM DRIVE GEAR D)		378	3-368-402-01	GEAR (CAM DRIVE A, B)	
354	* 3-368-455-01	LEVER (GEAR LOCK)		379	X-3363-024-1	LEVER (BT) ASSY	
355	3-368-418-01	TUBE (BREAK)		380	* 3-368-451-01	LEVER (BT SOLENOID)	
356	3-368-398-01	BUSHING		381	* 3-368-454-01	LEVER (BT SELECTION)	
357	3-368-430-01	SPRING (GEAR LOCK)		382	1-454-535-11	SOLENOID, PLUNGER (BRAKE)	
358	X-3363-022-1	GEAR (REEL DRIVE) ASSY		383	1-454-536-11	SOLENOID, PLUNGER (BT CONTROL)	
359	* 3-368-411-01	SLIDER (REEL LOCK)		384	* 3-368-416-01	BRACKET (B. T SOLENOID)	
360	* 3-368-453-01	LEVER (BRAKE SOLENOID)		385	3-368-423-01	SCREW (M2.6), STEP	
361	* 3-368-447-01	LEVER (BRAKE S)		386	2-623-736-01	CLAW (C) (LEFT), REEL	
362	* 3-368-446-01	LEVER (BRAKE T)		387	2-623-752-01	CLAW (C) (RIGHT), REEL	
363	3-368-438-01	SPRING (BREAK), TENSION		388	3-370-481-01	SPRING (T), COMPRESSION	
364	3-368-432-01	SPRING (FF/REW), COMPRESSION		389	3-370-482-01	SPRING (S), COMPRESSION	
365	A-2003-709-A	TABLE (S) ASSY, REEL		390	3-368-431-01	SPRING (B. T SOLENOID)	
366	A-2003-710-A	TABLE (T) ASSY, REEL		391	3-368-417-01	BELT (170TN10-1.0T), TIMING	
367	3-578-224-00	WASHER		392	* 1-639-303-11	CAM MOTOR BOARD	
368	3-368-435-01	SPRING (FR LEVER), COMPRESSION		393	* 1-639-304-11	REEL MOTOR BOARD	
369	3-368-450-01	LEVER (F/R)		394	3-738-212-21	RETAINER, THRUST, REEL TABLE	
370	3-315-384-31	WASHER, STOPPER		396	3-701-443-21	WASHER, 5 DIA.	
371	3-368-429-01	SHAFT (NECK)		397	2-623-756-01	SCREW, (B1.7X3), TAPPING	
372	3-368-422-01	POLY-SLIDER (DIA. 4.5-DIA. 1.5)		398	3-701-436-01	WASHER, 1.6	
373	3-368-437-01	SPRING (GEAR NECK), COMPRESSION		399	3-370-480-01	SPRING (BT), COMPRESSION	
374	3-368-406-01	GEAR (NECK)		M903	X-3363-109-1	MOTOR (CAM) ASSY	
375	3-368-421-01	GEAR (CAM DRIVE C)		M905	X-3363-110-1	MOTOR (REEL) ASSY	

SECTION 6 ELECTRICAL PARTS LIST

CONTROL SW

NOTE:

The components identified by mark Δ or dotted line with mark Δ are critical for safety.
Replace only with part number specified.

Les composants identifiés par une marque Δ sont critiques pour la sécurité.
Ne les remplacer que par une pièce portant le numéro spécifié.

When indicating parts by reference number, please include the board name.

- Due to standardization, replacements in the parts list may be different from the parts specified in the diagrams or the components used on the set.
- -XX, -X mean standardized parts, so they may have some difference from the original one.
- RESISTORS
All resistors are in ohms
METAL : Metal-film resistor
METAL OXIDE : Metal Oxide-film resistor
F : nonflammable
- CND : Canadian model
- Items marked "*" are not stocked since they are seldom required for routine service. Some delay should be anticipated when ordering these items.
- SEMICONDUCTORS
In each case, μ : μ , for example :
 $\mu A...$: $\mu A...$, $\mu PA...$: $\mu PA...$,
 $\mu PB...$: $\mu PB...$, $\mu PC...$: $\mu PC...$,
 $\mu PD...$: $\mu PD...$
- CAPACITORS
 μF : μF
- COILS
 μH : μH

Ref. No.	Part No.	Description	Remarks	Ref. No.	Part No.	Description	Remarks
* A-2006-555-A CONTROL SW BOARD, COMPLETE (57ES:US, CND) * A-2006-444-A CONTROL SW BOARD, COMPLETE(57ES:AEP, E/750) *****				(RESISTOR)			
				R701	1-249-441-11	CARBON	100K 5% 1/4W
				R702	1-249-441-11	CARBON	100K 5% 1/4W
				R703	1-249-441-11	CARBON	100K 5% 1/4W
				R704	1-249-441-11	CARBON	100K 5% 1/4W
				R705	1-249-441-11	CARBON	100K 5% 1/4W
		(CAPACITOR)		R706	1-249-441-11	CARBON	100K 5% 1/4W
				R707	1-249-441-11	CARBON	100K 5% 1/4W
C701	1-161-379-00	CERAMIC	0.01 μF 20% 25V	R708	1-249-441-11	CARBON	100K 5% 1/4W
C702	1-161-379-00	CERAMIC	0.01 μF 20% 25V	R709	1-249-441-11	CARBON	100K 5% 1/4W
C703	1-124-584-00	ELECT	100 μF 20% 10V	R710	1-249-441-11	CARBON	100K 5% 1/4W
C704	1-161-379-00	CERAMIC	0.01 μF 20% 25V	R715	1-249-429-11	CARBON	10K 5% 1/4W
				R716	1-249-422-11	CARBON	2.7K 5% 1/4W
C705	1-161-379-00	CERAMIC	0.01 μF 20% 25V	R717	1-249-424-11	CARBON	3.9K 5% 1/4W
C706	1-161-379-00	CERAMIC	0.01 μF 20% 25V	R718	1-249-428-11	CARBON	8.2K 5% 1/4W
		(CONNECTOR)		R719	1-249-434-11	CARBON	27K 5% 1/4W
CN751	1-568-853-11	SOCKET, CONNECTOR 10P		R720	1-249-429-11	CARBON	10K 5% 1/4W
CN752	1-568-849-11	SOCKET, CONNECTOR 6P		R721	1-249-422-11	CARBON	2.7K 5% 1/4W
		(INDICATOR TUBE)		R722	1-249-424-11	CARBON	3.9K 5% 1/4W
FL701	1-519-672-11	INDICATOR TUBE, FLUORESCENT		R723	1-249-428-11	CARBON	8.2K 5% 1/4W
		(IC)		R724	1-249-434-11	CARBON	27K 5% 1/4W
IC701	8-752-818-86	IC CXP5058H-657Q		R725	1-249-429-11	CARBON	10K 5% 1/4W
IC702	8-759-995-09	IC MSM6338RS		R726	1-249-422-11	CARBON	2.7K 5% 1/4W
IC703	8-752-330-59	IC CXX1011P		R727	1-249-424-11	CARBON	3.9K 5% 1/4W
IC705	8-759-140-11	IC MC14011BCP		R728	1-249-428-11	CARBON	8.2K 5% 1/4W
		(TRANSISTOR)		R729	1-249-434-11	CARBON	27K 5% 1/4W
Q701	8-729-119-78	TRANSISTOR	2SC2785-HFE	R730	1-249-429-11	CARBON	10K 5% 1/4W
Q702	8-729-119-78	TRANSISTOR	2SC2785-HFE	R731	1-249-422-11	CARBON	2.7K 5% 1/4W
Q703	8-729-119-78	TRANSISTOR	2SC2785-HFE	R732	1-249-424-11	CARBON	3.9K 5% 1/4W
Q704	8-729-119-78	TRANSISTOR	2SC2785-HFE	R733	1-249-429-11	CARBON	10K 5% 1/4W
Q705	8-729-119-78	TRANSISTOR	2SC2785-HFE	R734	1-249-422-11	CARBON	2.7K 5% 1/4W
				R735	1-249-424-11	CARBON	3.9K 5% 1/4W
Q706	8-729-119-78	TRANSISTOR	2SC2785-HFE	R736	1-249-429-11	CARBON	10K 5% 1/4W
Q707	8-729-119-78	TRANSISTOR	2SC2785-HFE	R737	1-249-422-11	CARBON	2.7K 5% 1/4W
Q708	8-729-119-78	TRANSISTOR	2SC2785-HFE	R738	1-249-424-11	CARBON	3.9K 5% 1/4W
Q709	8-729-119-78	TRANSISTOR	2SC2785-HFE	R739	1-249-428-11	CARBON	8.2K 5% 1/4W
Q710	8-729-119-78	TRANSISTOR	2SC2785-HFE	R740	1-249-434-11	CARBON	27K 5% 1/4W
				R741	1-249-429-11	CARBON	10K 5% 1/4W
				R742	1-249-422-11	CARBON	2.7K 5% 1/4W

CONTROL SW

BALANCE VOL

CAM MOTOR

CAM SLIDER

Ref. No.	Part No.	Description	Remarks	Ref. No.	Part No.	Description	Remarks
R743	1-249-424-11	CARBON	3.9K 5% 1/4W	S732	1-554-937-11	SWITCH, KEY BOARD (STOP □)	
R744	1-249-428-11	CARBON	8.2K 5% 1/4W	S733	1-554-937-11	SWITCH, KEY BOARD (PLAY ▷)	
R745	1-249-434-11	CARBON	27K 5% 1/4W	S734	1-554-937-11	SWITCH, KEY BOARD (PREV ◀)	
R746	1-249-429-11	CARBON	10K 5% 1/4W	S735	1-554-937-11	SWITCH, KEY BOARD (NEXT ▶)	
R747	1-249-422-11	CARBON	2.7K 5% 1/4W	S736	1-554-937-11	SWITCH, KEY BOARD (END ID WRITE)	
R748	1-249-424-11	CARBON	3.9K 5% 1/4W	S737	1-554-937-11	SWITCH, KEY BOARD (END ID ERASE)	
R749	1-249-428-11	CARBON	8.2K 5% 1/4W	S738	1-554-937-11	SWITCH, KEY BOARD (CLEAR)	
R750	1-249-434-11	CARBON	27K 5% 1/4W	S739	1-554-937-11	SWITCH, KEY BOARD (0 -)	
R751	1-249-437-11	CARBON	47K 5% 1/4W	S740	1-554-937-11	SWITCH, KEY BOARD (MUSIC SCAN †)	
R752	1-249-437-11	CARBON	47K 5% 1/4W			(CRYSTAL)	
R753	1-249-437-11	CARBON	47K 5% 1/4W	X701	1-577-359-21	VIBRATOR, CERAMIC (4.19MHz)	
R754	1-249-437-11	CARBON	47K 5% 1/4W			*****	
R755	1-249-437-11	CARBON	47K 5% 1/4W			* 1-639-326-11 BALANCE VOL BOARD	
R756	1-249-437-11	CARBON	47K 5% 1/4W			*****	
R757	1-249-437-11	CARBON	47K 5% 1/4W			(CONNECTOR)	
R758	1-249-437-11	CARBON	47K 5% 1/4W	CN102	* 1-564-507-11	PLUG, CONNECTOR 4P	
R759	1-249-437-11	CARBON	47K 5% 1/4W			(RESISTOR)	
R760	1-249-437-11	CARBON	47K 5% 1/4W	R101	1-259-462-11	CARBON 27K 5% 1/6W	
R761	1-249-437-11	CARBON	47K 5% 1/4W	R201	1-259-462-11	CARBON 27K 5% 1/6W	
R762	1-249-437-11	CARBON	47K 5% 1/4W			(VARIABLE RESISTOR)	
R763	1-249-437-11	CARBON	47K 5% 1/4W	RV101	1-238-687-11	RES, VAR, CARBON 50K/50K (BALANCE)	
R764	1-249-437-11	CARBON	47K 5% 1/4W			*****	
		(SWITCH)				* 1-639-303-11 CAM MOTOR BOARD	
S704	1-554-937-11	SWITCH, KEY BOARD (CLOCK SET)				*****	
S705	1-554-937-11	SWITCH, KEY BOARD (SKIP ID WRITE)				(CAPACITOR)	
S706	1-554-937-11	SWITCH, KEY BOARD (SKIP ID ERASE)		C06	1-163-077-00	CERAMIC CHIP 0.1uF 10% 25V	
S707	1-554-937-11	SWITCH, KEY BOARD (7)				*****	
S708	1-554-937-11	SWITCH, KEY BOARD (8)				* 1-639-306-11 CAM SLIDER BOARD	
S709	1-554-937-11	SWITCH, KEY BOARD (9)				*****	
S710	1-554-937-11	SWITCH, KEY BOARD (START ID WRITE)				(CHIP JUMPER)	
S711	1-554-937-11	SWITCH, KEY BOARD (START ID ERASE)		JW04	1-216-296-00	METAL CHIP 0 5% 1/8W	
S712	1-554-937-11	SWITCH, KEY BOARD (4)		JW05	1-216-296-00	METAL CHIP 0 5% 1/8W	
S713	1-554-937-11	SWITCH, KEY BOARD (5)				(SWITCH)	
S714	1-554-937-11	SWITCH, KEY BOARD (6)		SW1	1-570-953-11	SWITCH, PUSH (1 KEY) (STOP DET)	
S715	1-554-937-11	SWITCH, KEY BOARD (START ID AUTO)		SW2	1-570-953-11	SWITCH, PUSH (1 KEY) (FWD DET)	
S716	1-554-937-11	SWITCH, KEY BOARD (START ID RENUMBER)				*****	
S717	1-554-937-11	SWITCH, KEY BOARD (1)				*****	
S718	1-554-937-11	SWITCH, KEY BOARD (2)					
S719	1-554-937-11	SWITCH, KEY BOARD (3)					
S720	1-554-937-11	SWITCH, KEY BOARD (RECORDED)					
S721	1-554-937-11	SWITCH, KEY BOARD (PRESENT)					
S722	1-554-937-11	SWITCH, KEY BOARD (FADER)					
S723	1-554-937-11	SWITCH, KEY BOARD (MARGIN RESET)					
S724	1-554-937-11	SWITCH, KEY BOARD (COUNTER RESET)					
S725	1-554-937-11	SWITCH, KEY BOARD (COUNTER MODE)					
S726	1-554-937-11	SWITCH, KEY BOARD (REW ◀)					
S727	1-554-937-11	SWITCH, KEY BOARD (FF ▶)					
S728	1-554-937-11	SWITCH, KEY BOARD (REC ○)					
S729	1-554-937-11	SWITCH, KEY BOARD (PAUSE ◻)					
S730	1-554-937-11	SWITCH, KEY BOARD (REC MUTE ⊙)					
S731	1-554-937-11	SWITCH, KEY BOARD (O/C ⊕)					

When indicating parts by reference number, please include the board name.

CONTROL (S) DRUM DRIVE

Ref. No.	Part No.	Description	Remarks	Ref. No.	Part No.	Description	Remarks
* 1-639-330-11 CONTROL (S) BOARD (57ES:US, CND)				(CHIP JUMPER)			

(CAPACITOR)							
C801	1-136-165-00	FILM	0.1uF 5% 50V	JW06	1-216-296-00	METAL CHIP 0 5% 1/8W	
C802	1-136-165-00	FILM	0.1uF 5% 50V	JW07	1-216-296-00	METAL CHIP 0 5% 1/8W	
(CONNECTOR)				JW08	1-216-296-00	METAL CHIP 0 5% 1/8W	
CN971	* 1-564-497-11	PIN, CONNECTOR 4P		JW09	1-216-296-00	METAL CHIP 0 5% 1/8W	
CN972	1-558-350-21	CORD (WITH CONNECTOR)		JW10	1-216-296-00	METAL CHIP 0 5% 1/8W	
(DIODE)				JW11	1-216-296-00	METAL CHIP 0 5% 1/8W	
D801	8-719-107-94	DIODE 1SS202-1		JW12	1-216-296-00	METAL CHIP 0 5% 1/8W	
D802	8-719-107-94	DIODE 1SS202-1		JW13	1-216-296-00	METAL CHIP 0 5% 1/8W	
(RESISTOR)				JW14	1-216-296-00	METAL CHIP 0 5% 1/8W	
R801	1-249-393-11	CARBON	10 5% 1/4W	JW15	1-216-296-00	METAL CHIP 0 5% 1/8W	
R802	1-249-429-11	CARBON	10K 5% 1/4W	JW16	1-216-296-00	METAL CHIP 0 5% 1/8W	
R803	1-249-429-11	CARBON	10K 5% 1/4W	JW17	1-216-296-00	METAL CHIP 0 5% 1/8W	
R804	1-249-405-11	CARBON	100 5% 1/4W	JW18	1-216-296-00	METAL CHIP 0 5% 1/8W	
R805	1-249-429-11	CARBON	10K 5% 1/4W	JW19	1-216-296-00	METAL CHIP 0 5% 1/8W	
R806	1-249-429-11	CARBON	10K 5% 1/4W	JW20	1-216-296-00	METAL CHIP 0 5% 1/8W	
*****				JW21	1-216-296-00	METAL CHIP 0 5% 1/8W	
* A-2056-488-A DRUM DRIVE BOARD, COMPLETE				JW22	1-216-296-00	METAL CHIP 0 5% 1/8W	
*****				JW23	1-216-296-00	METAL CHIP 0 5% 1/8W	
* 3-343-491-01 HOLDER (S SENSOR B)				JW24	1-216-296-00	METAL CHIP 0 5% 1/8W	
4-870-539-00 PLATE, GROUND				JW25	1-216-296-00	METAL CHIP 0 5% 1/8W	
(CAPACITOR)				JW26	1-216-296-00	METAL CHIP 0 5% 1/8W	
C01	1-124-584-00	ELECT	100uF 20% 10V	JW27	1-216-296-00	METAL CHIP 0 5% 1/8W	
C02	1-126-157-11	ELECT	10uF 20% 16V	JW28	1-216-296-00	METAL CHIP 0 5% 1/8W	
C03	1-124-257-00	ELECT	2.2uF 20% 50V	JW29	1-216-296-00	METAL CHIP 0 5% 1/8W	
C04	1-164-161-11	CERAMIC CHIP	0.0022uF 10% 100V	JW30	1-216-296-00	METAL CHIP 0 5% 1/8W	
C05	1-164-161-11	CERAMIC CHIP	0.0022uF 10% 100V	(PHOTO INTERRUPTER)			
(RESISTOR)				PH01	8-719-939-23	GP2S09-C	
C08	1-163-001-11	CERAMIC CHIP	220PF 10% 50V	PH02	8-719-939-23	GP2S09-C	
C21	1-163-001-11	CERAMIC CHIP	220PF 10% 50V	(TRANSISTOR)			
C31	1-163-001-11	CERAMIC CHIP	220PF 10% 50V	Q01	8-729-100-66	TRANSISTOR 2SC1623	
(CONNECTOR)				Q02	8-729-101-07	TRANSISTOR 2SB798-DL	
CN01	* 1-564-704-11	PIN, CONNECTOR (SMALL TYPE) 2P		(RESISTOR)			
CN02	* 1-564-704-11	PIN, CONNECTOR (SMALL TYPE) 2P		R01	1-216-061-00	METAL CHIP 3.3K 5% 1/10W	
CN03	* 1-564-338-00	PIN, CONNECTOR 4P		R02	1-216-075-00	METAL CHIP 12K 5% 1/10W	
CN04	* 1-564-336-00	PIN, CONNECTOR 2P		R03	1-216-029-00	METAL CHIP 150 5% 1/10W	
CN05	* 1-564-336-61	PIN, CONNECTOR 2P		R04	1-216-059-00	METAL CHIP 2.7K 5% 1/10W	
CN06	* 1-564-339-00	PIN, CONNECTOR 5P		R05	1-216-057-00	METAL CHIP 2.2K 5% 1/10W	
CN07	1-564-721-11	PIN, CONNECTOR (SMALL TYPE) 5P		R06	1-216-085-00	METAL CHIP 33K 5% 1/10W	
CN08	* 1-568-872-11	SOCKET, CONNECTOR 30P		R07	1-216-025-00	METAL CHIP 100 5% 1/10W	
CN09	* 1-564-706-11	PIN, CONNECTOR (SMALL TYPE) 4P		R08	1-216-049-00	METAL CHIP 1K 5% 1/10W	
CN10	* 1-564-719-11	PIN, CONNECTOR (SMALL TYPE) 3P		R09	1-216-073-00	METAL CHIP 10K 5% 1/10W	
(IC)				R10	1-216-073-00	METAL CHIP 10K 5% 1/10W	
IC01	8-759-107-68	IC CX20115A		R11	1-216-073-00	METAL CHIP 10K 5% 1/10W	
IC02	8-759-502-80	IC LM358M-FL63		R12	1-216-089-00	METAL CHIP 47K 5% 1/10W	
IC03	8-759-502-80	IC LM358M-FL63		R13	1-216-073-00	METAL CHIP 10K 5% 1/10W	
				R14	1-216-037-00	METAL CHIP 330 5% 1/10W	
				R21	1-216-073-00	METAL CHIP 10K 5% 1/10W	
				R22	1-216-081-00	METAL CHIP 22K 5% 1/10W	

When indicating parts by reference number, please include the board name.

DRUM DRIVE HEADPHONE INPUT SW MAIN

Ref. No.	Part No.	Description	Remarks	Ref. No.	Part No.	Description	Remarks
R23	1-216-077-00	METAL CHIP	15K 5% 1/10W		* 1-639-328-11	INPUT SW BOARD	
R24	1-216-067-00	METAL CHIP	5.6K 5% 1/10W			*****	
R25	1-216-103-00	METAL CHIP	180K 5% 1/10W			(CONNECTOR)	
R26	1-216-065-00	METAL CHIP	4.7K 5% 1/10W				
R31	1-216-073-00	METAL CHIP	10K 5% 1/10W				
R32	1-216-081-00	METAL CHIP	22K 5% 1/10W		CN772	* 1-584-336-00	PIN, CONNECTOR 2P
R35	1-216-103-00	METAL CHIP	180K 5% 1/10W		CNP702	* 1-566-910-11	HOUSING, CONNECTOR 3P
R36	1-216-065-00	METAL CHIP	4.7K 5% 1/10W				(RESISTOR)

	* 1-639-327-11	HEADPHONE BOARD		R713	1-249-428-11	CARBON	8.2K 5% 1/4W
		*****		R714	1-249-434-11	CARBON	27K 5% 1/4W
		(CAPACITOR)					(SWITCH)
C180	1-162-290-31	CERAMIC	470PF 10% 50V	S702	1-572-758-11	SWITCH, ROTARY (INPUT)	
C181	1-126-059-11	ELECT	10uF 20% 63V	*****			
C280	1-162-290-31	CERAMIC	470PF 10% 50V		* A-2006-572-A	MAIN BOARD, COMPLETE (57ES:US, CND, E)	
C281	1-126-059-11	ELECT	10uF 20% 63V		* A-2006-614-A	MAIN BOARD, COMPLETE (57ES:AEP)	
C451	1-126-024-11	ELECT	220uF 20% 25V		* A-2006-681-A	MAIN BOARD, COMPLETE (750:US, CND)	
C452	1-126-024-11	ELECT	220uF 20% 25V		* A-2006-682-A	MAIN BOARD, COMPLETE (750:UK)	
		(CONNECTOR)				*****	
CNP701	* 1-566-910-11	HOUSING, CONNECTOR 3P				(CAPACITOR)	
		(DIODE)		C102	1-126-233-11	ELECT	22uF 20% 50V
D401	8-719-200-82	DIODE 11ES2		C103	1-130-955-00	FILM	0.01uF 5% 100V
D402	8-719-200-82	DIODE 11ES2		C110	1-136-439-11	FILM	330PF 5% 630V
		(IC)		C111	1-136-439-11	FILM	330PF 5% 630V
IC401	8-759-981-98	IC RC4560DD		C112	1-136-437-11	FILM	220PF 5% 630V
		(JACK)		C113	1-136-437-11	FILM	220PF 5% 630V
J161	1-565-327-11	JACK, LARGE TYPE 1P		C114	1-136-433-11	FILM	100PF 5% 630V
		(RESISTOR)		C115	1-136-433-11	FILM	100PF 5% 630V
R128	1-259-468-11	CARBON	47K 5% 1/6W	C116	1-136-230-00	FILM	0.0022uF 5% 100V
R129	1-259-444-11	CARBON	4.7K 5% 1/6W	C117	1-136-228-11	FILM	0.0012uF 5% 100V
R130	1-259-468-11	CARBON	47K 5% 1/6W	C118	1-136-233-11	FILM	0.0047uF 5% 100V
R131	1-259-412-11	CARBON	220 5% 1/6W	C120	1-124-122-11	ELECT	100uF 20% 50V
R228	1-259-468-11	CARBON	47K 5% 1/6W	C202	1-126-233-11	ELECT	22uF 20% 50V
R229	1-259-444-11	CARBON	4.7K 5% 1/6W	C203	1-130-955-00	FILM	0.01uF 5% 100V
R230	1-259-468-11	CARBON	47K 5% 1/6W	C210	1-136-439-11	FILM	330PF 5% 630V
R231	1-259-412-11	CARBON	220 5% 1/6W	C211	1-136-439-11	FILM	330PF 5% 630V
R460	△ 1-212-857-00	FUSIBLE	10 5% 1/4W F	C212	1-136-437-11	FILM	220PF 5% 630V
R461	△ 1-212-857-00	FUSIBLE	10 5% 1/4W F	C213	1-136-437-11	FILM	220PF 5% 630V
R799	1-249-437-11	CARBON	47K 5% 1/4W	C214	1-136-433-11	FILM	100PF 5% 630V
		(VARIABLE RESISTOR)		C215	1-136-433-11	FILM	100PF 5% 630V
RV103	1-241-537-11	RES, VAR, CARBON 20K/20K (PHONE LEVEL)		C216	1-136-230-00	FILM	0.0022uF 5% 100V

				C217	1-136-228-11	FILM	0.0012uF 5% 100V
				C218	1-136-233-11	FILM	0.0047uF 5% 100V
				C220	1-124-122-11	ELECT	100uF 20% 50V
				C300	1-162-294-31	CERAMIC	0.001uF 10% 50V
				C301	1-130-834-00	FILM	1uF 10% 63V
				C302	1-164-159-11	CERAMIC	0.1uF 50V
				C303	1-162-211-31	CERAMIC	33PF 5% 50V
				C304	1-126-059-11	ELECT	10uF 20% 63V
				C305	1-136-153-00	FILM	0.01uF 5% 50V

The components identified by mark Δ or dotted line with mark Δ are critical for safety. Replace only with part number specified.

Les composants identifiés par une marque Δ sont critiques pour la sécurité. Ne les remplacer que par une pièce portant le numéro spécifié.

When indicating parts by reference number, please include the board name.

MAIN

Ref. No.	Part No.	Description	Remarks	Ref. No.	Part No.	Description	Remarks
C306	1-164-159-11	CERAMIC	0.1uF	50V	C422	1-126-023-11	ELECT 100uF 20% 25V
C307	1-126-022-11	ELECT	47uF	20% 10V	C423	1-126-023-11	ELECT 100uF 20% 25V
C308	1-164-159-11	CERAMIC	0.1uF	50V (57ES)	C424	1-136-165-00	FILM 0.1uF 5% 50V
C309	1-124-983-11	ELECT	330uF	20% 6.3V	C425	1-126-104-11	ELECT 470uF 20% 35V
C310	1-130-834-00	FILM	1uF	10% 63V (57ES)	C426	1-136-165-00	FILM 0.1uF 5% 50V
C311	1-162-279-31	CERAMIC	75PF	10% 50V (57ES)	C427	1-136-165-00	FILM 0.1uF 5% 50V
C312	1-126-022-11	ELECT	47uF	20% 10V	C428	1-136-165-00	FILM 0.1uF 5% 50V
C313	1-126-023-11	ELECT	100uF	20% 25V	C429	1-136-165-00	FILM 0.1uF 5% 50V
C314	1-162-199-31	CERAMIC	10PF	5% 50V	C430	1-126-059-11	ELECT 10uF 20% 63V
C315	1-162-294-31	CERAMIC	0.001uF	10% 50V	C431	1-126-059-11	ELECT 10uF 20% 63V
C316	1-162-199-31	CERAMIC	10PF	5% 50V	C432	1-124-273-00	ELECT 3.3uF 20% 50V
C317	1-162-201-31	CERAMIC	12PF	5% 50V	C435	1-126-023-11	ELECT 100uF 20% 25V
C318	1-162-201-31	CERAMIC	12PF	5% 50V	C436	1-126-023-11	ELECT 100uF 20% 25V
C319	1-164-159-11	CERAMIC	0.1uF	50V	C437	1-124-997-11	ELECT 470uF 20% 6.3V
C320	1-130-834-00	FILM	1uF	10% 63V	C438	1-124-997-11	ELECT 470uF 20% 6.3V
C321	1-136-165-00	FILM	0.1uF	5% 50V	C439	1-164-159-11	CERAMIC 0.1uF 50V
C322	1-164-159-11	CERAMIC	0.1uF	50V	C440	1-124-983-11	ELECT 330uF 20% 6.3V
C323	1-162-206-31	CERAMIC	20PF	5% 50V	C441	1-164-159-11	CERAMIC 0.1uF 50V
C324	1-164-159-11	CERAMIC	0.1uF	50V	C442	1-164-159-11	CERAMIC 0.1uF 50V
C325	1-126-022-11	ELECT	47uF	20% 10V	C444	1-164-159-11	CERAMIC 0.1uF 50V
C326	1-162-201-31	CERAMIC	12PF	5% 50V	C445	1-164-159-11	CERAMIC 0.1uF 50V
C327	1-162-201-31	CERAMIC	12PF	5% 50V	C446	1-164-159-11	CERAMIC 0.1uF 50V
C328	1-124-903-11	ELECT	1uF	20% 50V	C447	1-164-159-11	CERAMIC 0.1uF 50V
C329	1-162-294-31	CERAMIC	0.001uF	10% 50V	C448	1-164-159-11	CERAMIC 0.1uF 50V
C330	1-162-294-31	CERAMIC	0.001uF	10% 50V	C449	1-164-159-11	CERAMIC 0.1uF 50V
C331	1-162-294-31	CERAMIC	0.001uF	10% 50V	C450	1-136-165-00	FILM 0.1uF 5% 50V
C345	1-162-201-31	CERAMIC	12PF	5% 50V	C451	1-136-165-00	FILM 0.1uF 5% 50V
C346	1-162-199-31	CERAMIC	10PF	5% 50V	C452	1-136-165-00	FILM 0.1uF 5% 50V
C347	1-162-294-31	CERAMIC	0.001uF	10% 50V	C460	1-164-159-11	CERAMIC 0.1uF 50V
C362	1-126-043-11	ELECT	0.47uF	20% 50V			
C363	1-126-059-11	ELECT	10uF	20% 63V			
C401	1-136-165-00	FILM	0.1uF	5% 50V			
C402	1-136-165-00	FILM	0.1uF	5% 50V			
C403	1-136-165-00	FILM	0.1uF	5% 50V			
C404	1-136-165-00	FILM	0.1uF	5% 50V			
C405	1-136-165-00	FILM	0.1uF	5% 50V			
C406	1-126-058-11	ELECT	4.7uF	20% 63V			
C407	1-136-165-00	FILM	0.1uF	5% 50V			
C408	1-136-165-00	FILM	0.1uF	5% 50V			
C409	1-126-104-11	ELECT	470uF	20% 35V			
C410	1-136-165-00	FILM	0.1uF	5% 50V			
C411	1-126-104-11	ELECT	470uF	20% 35V			
C412	1-136-165-00	FILM	0.1uF	5% 50V			
C413	1-126-104-11	ELECT	470uF	20% 35V			
C414	1-126-104-11	ELECT	470uF	20% 35V			
C415	1-136-165-00	FILM	0.1uF	5% 50V			
C416	1-136-165-00	FILM	0.1uF	5% 50V			
C417	1-164-159-11	CERAMIC	0.1uF	50V			
C418	1-136-165-00	FILM	0.1uF	5% 50V			
C419	1-136-165-00	FILM	0.1uF	5% 50V			
C420	1-136-165-00	FILM	0.1uF	5% 50V			
C421	1-136-165-00	FILM	0.1uF	5% 50V			

(CONNECTOR)

CN104	* 1-564-507-11	PLUG, CONNECTOR 4P
CN107	* 1-564-509-11	PLUG, CONNECTOR 6P
CN301	* 1-564-706-11	PIN, CONNECTOR (SMALL TYPE) 4P
CN308	* 1-564-339-00	PIN, CONNECTOR 5P
CN333	* 1-564-514-11	PLUG, CONNECTOR 11P
CN398	* 1-564-336-00	PIN, CONNECTOR 2P
CN501	* 1-564-716-11	PIN, CONNECTOR (SMALL TYPE) 14P
CN508	* 1-568-933-11	SOCKET, CONNECTOR 30P
CN557	1-573-297-11	CONNECTOR, BOARD TO BOARD 18P
CN571	* 1-568-829-11	SOCKET, CONNECTOR 10P
CN572	* 1-568-825-11	SOCKET, CONNECTOR 6P
CN576	* 1-564-704-11	PIN, CONNECTOR (SMALL TYPE) 2P

(DIODE)

D101	8-719-107-94	DIODE 1SS202-1
D102	8-719-107-94	DIODE 1SS202-1
D201	8-719-107-94	DIODE 1SS202-1
D202	8-719-107-94	DIODE 1SS202-1
D306	8-719-200-82	DIODE 11ES2
D307	8-719-107-94	DIODE 1SS202-1
D308	8-719-107-94	DIODE 1SS202-1
D314	8-719-200-82	DIODE 11ES2

When indicating parts by reference number, please include the board name.

MAIN

Ref. No.	Part No.	Description	Remarks	Ref. No.	Part No.	Description	Remarks
D321	8-719-107-94	DIODE 1SS202-1		L302	1-410-498-11	INDUCTOR 1.2uH	
D322	8-719-911-06	DIODE 1SS106		L303	1-410-509-11	INDUCTOR 10uH	
D323	8-719-107-94	DIODE 1SS202-1		L305	1-410-509-11	INDUCTOR 10uH	
D324	8-719-911-06	DIODE 1SS106		L306	1-410-509-11	INDUCTOR 10uH	
D403	8-719-107-94	DIODE 1SS202-1		L310	1-410-953-11	INDUCTOR, SMALL TYPE (57ES)	
D404	8-719-210-21	DIODE 11E0S04				(TRANSISTOR)	
		(IC)		Q301	8-729-927-11	TRANSISTOR 2SA1585S-OR	
IC301	8-759-917-18	IC SN74HC04AN		Q311	8-729-900-80	TRANSISTOR DTC114ES	
IC302	8-759-232-49	IC TC74HC132AP		Q312	8-729-107-85	TRANSISTOR 2SC3623A-K	
IC303	8-759-917-18	IC SN74HC04AN		Q313	8-729-900-61	TRANSISTOR DTA114ES	
IC304	8-759-135-80	IC uPC358C		Q318	8-729-900-80	TRANSISTOR DTC114ES	
IC305	8-759-926-17	IC SN74HC153ANS		Q319	8-729-900-80	TRANSISTOR DTC114ES	
IC306	8-759-947-57	IC CXD1136Q		Q320	8-729-927-11	TRANSISTOR 2SA1585S-OR	
IC307	8-752-339-43	IC CXD2601AQ		Q321	8-729-927-12	TRANSISTOR 2SC4115S-OR	
IC308	8-759-906-24	IC SN74LS624M		Q343	8-729-920-68	TRANSISTOR 2SA933S-OR	
IC309	8-759-925-90	IC SN74HC74ANS		Q399	8-729-900-80	TRANSISTOR DTC114ES	
IC310	8-752-330-68	IC CXK58257M-12L		Q432	8-729-900-80	TRANSISTOR DTC114ES	
IC311	8-752-818-91	IC CXP80524-025Q		Q433	8-729-107-85	TRANSISTOR 2SC3623A-K	
IC312	8-752-832-33	IC CXP80524-040Q		Q434	8-729-107-85	TRANSISTOR 2SC3623A-K	
IC319	8-759-633-65	IC M54641L		Q435	8-729-900-61	TRANSISTOR DTA114ES	
IC320	8-759-633-65	IC M54641L		Q436	8-729-900-80	TRANSISTOR DTC114ES	
IC321	8-759-971-12	IC PST529E		Q437	8-729-900-61	TRANSISTOR DTA114ES	
IC322	8-759-231-53	IC TA7805S		Q438	8-729-900-80	TRANSISTOR DTC114ES	
IC330	8-759-984-34	IC RPF5C62		Q439	8-729-900-80	TRANSISTOR DTC114ES	
IC331	8-749-921-11	IC GP1F32R		Q440	8-729-119-78	TRANSISTOR 2SC2785-HFE	
IC332	8-749-921-12	IC GP1F32T				(RESISTOR)	
IC333	8-759-917-18	IC SN74HC04AN		R102	1-247-903-00	CARBON 1M 5% 1/4I	
IC354	8-759-900-72	IC NE5532P		R103	1-249-417-11	CARBON 1K 5% 1/4I	
IC355	8-759-900-72	IC NE5532P		R104	1-249-433-11	CARBON 22K 5% 1/4I	
IC356	8-759-945-58	IC RC4558P		R105	1-249-435-11	CARBON 33K 5% 1/4I	
IC357	8-759-231-53	IC TA7805S		R106	1-249-403-11	CARBON 68 5% 1/4I	
IC358	8-759-245-79	IC TA7905S		R107	1-247-854-11	CARBON 9.1K 5% 1/4I	
IC359	8-759-504-36	IC CS5339-KP		R108	1-247-854-11	CARBON 9.1K 5% 1/4I	
IC360	8-759-972-47	IC LF412CM		R109	1-247-854-11	CARBON 9.1K 5% 1/4I	
IC361	8-759-602-83	IC M5238P		R110	1-247-854-11	CARBON 9.1K 5% 1/4I	
IC362	8-752-344-10	IC CXD2561M		R111	1-249-425-11	CARBON 4.7K 5% 1/4I	
IC363	8-752-342-65	IC CXD2560M		R112	1-249-425-11	CARBON 4.7K 5% 1/4I	
IC374	8-759-634-55	IC M5F7805L-720		R113	1-249-425-11	CARBON 4.7K 5% 1/4I	
IC375	8-759-900-72	IC NE5532P		R114	1-249-425-11	CARBON 4.7K 5% 1/4I	
IC376	8-759-900-72	IC NE5532P		R115	1-249-430-11	CARBON 12K 5% 1/4I	
IC431	8-759-925-78	IC SN74HC10ANS		R116	1-249-430-11	CARBON 12K 5% 1/4I	
IC432	8-759-995-76	IC PST529C		R117	1-249-426-11	CARBON 5.6K 5% 1/4I	
		(JACK)		R118	1-249-426-11	CARBON 5.6K 5% 1/4I	
J101	1-568-751-61	JACK, PIN (2P SHIELD TYPE)		R119	1-249-426-11	CARBON 5.6K 5% 1/4I	
J102	1-568-751-61	JACK, PIN (2P SHIELD TYPE)		R120	1-249-426-11	CARBON 5.6K 5% 1/4I	
J181	1-565-406-41	JACK, PIN 1P (57ES)		R121	1-249-405-11	CARBON 100 5% 1/4I	
J191	1-568-750-21	JACK, PIN (1P SHIELD TYPE)		R122	1-249-419-11	CARBON 1.5K 5% 1/4I	
		(COIL)		R123	1-249-419-11	CARBON 1.5K 5% 1/4I	
L301	1-410-509-11	INDUCTOR 10uH		R124	1-249-441-11	CARBON 100K 5% 1/4I	
				R125	1-249-409-11	CARBON 220 5% 1/4I	
				R126	1-249-429-11	CARBON 10K 5% 1/4I	

When indicating parts by reference number, please include the bag # and name.

MAIN

Ref. No.	Part No.	Description	Quantity	Unit	Remarks	Ref. No.	Part No.	Description	Quantity	Unit	Remarks
R127	1-249-405-11	CARBON	100	5%	1/4W	R325	1-249-425-11	CARBON	4.7K	5%	1/4W
R180	1-249-397-11	CARBON	22	5%	1/4W	R326	1-249-409-11	CARBON	220	5%	1/4W
R202	1-247-903-00	CARBON	1M	5%	1/4W	R327	1-249-425-11	CARBON	4.7K	5%	1/4W
R203	1-249-417-11	CARBON	1K	5%	1/4W	R328	1-249-417-11	CARBON	1K	5%	1/4W
R204	1-249-433-11	CARBON	22K	5%	1/4W	R329	1-249-413-11	CARBON	470	5%	1/4W
R205	1-249-435-11	CARBON	33K	5%	1/4W	R330	1-249-417-11	CARBON	1K	5%	1/4W
R206	1-249-403-11	CARBON	68	5%	1/4W	R331	1-249-429-11	CARBON	10K	5%	1/4W
R207	1-247-854-11	CARBON	9.1K	5%	1/4W	R332	1-249-429-11	CARBON	10K	5%	1/4W
R208	1-247-854-11	CARBON	9.1K	5%	1/4W	R333	1-249-433-11	CARBON	22K	5%	1/4W
R209	1-247-854-11	CARBON	9.1K	5%	1/4W	R334	1-249-425-11	CARBON	4.7K	5%	1/4W
R210	1-247-854-11	CARBON	9.1K	5%	1/4W	R335	1-249-425-11	CARBON	4.7K	5%	1/4W
R211	1-249-425-11	CARBON	4.7K	5%	1/4W	R336	1-249-425-11	CARBON	4.7K	5%	1/4W
R212	1-249-425-11	CARBON	4.7K	5%	1/4W	R346	1-249-441-11	CARBON	100K	5%	1/4W
R213	1-249-425-11	CARBON	4.7K	5%	1/4W	R347	1-249-441-11	CARBON	100K	5%	1/4W
R214	1-249-425-11	CARBON	4.7K	5%	1/4W	R348	1-249-441-11	CARBON	100K	5%	1/4W
R215	1-249-430-11	CARBON	12K	5%	1/4W	R349	1-249-441-11	CARBON	100K	5%	1/4W
R216	1-249-430-11	CARBON	12K	5%	1/4W	R350	1-249-425-11	CARBON	4.7K	5%	1/4W
R217	1-249-426-11	CARBON	5.6K	5%	1/4W	R351	1-249-425-11	CARBON	4.7K	5%	1/4W
R218	1-249-426-11	CARBON	5.6K	5%	1/4W	R353	1-249-441-11	CARBON	100K	5%	1/4W
R219	1-249-426-11	CARBON	5.6K	5%	1/4W	R365	1-249-425-11	CARBON	4.7K	5%	1/4W
R220	1-249-426-11	CARBON	5.6K	5%	1/4W	R378	1-249-417-11	CARBON	1K	5%	1/4W
R221	1-249-405-11	CARBON	100	5%	1/4W	R379	1-249-401-11	CARBON	47	5%	1/4W
R222	1-249-419-11	CARBON	1.5K	5%	1/4W	R380	1-249-411-11	CARBON	330	5%	1/4W
R223	1-249-419-11	CARBON	1.5K	5%	1/4W	R381	△ 1-215-881-11	METAL OXIDE	15	5%	2W F
R224	1-249-441-11	CARBON	100K	5%	1/4W	R386	△ 1-249-405-11	CARBON	100	5%	1/4W
R225	1-249-409-11	CARBON	220	5%	1/4W	R387	1-249-405-11	CARBON	100	5%	1/4W
R226	1-249-429-11	CARBON	10K	5%	1/4W	R388	1-249-423-11	CARBON	3.3K	5%	1/4W
R227	1-249-405-11	CARBON	100	5%	1/4W	R389	1-249-423-11	CARBON	3.3K	5%	1/4W
R280	1-249-397-11	CARBON	22	5%	1/4W	R390	1-249-423-11	CARBON	3.3K	5%	1/4W
R301	1-247-804-11	CARBON	75	5%	1/4W	R391	1-249-423-11	CARBON	3.3K	5%	1/4W
R302	1-249-437-11	CARBON	47K	5%	1/4W	R392	1-249-430-11	CARBON	12K	5%	1/4W
R303	1-249-421-11	CARBON	2.2K	5%	1/4W	R393	1-247-864-11	CARBON	24K	5%	1/4W
R304	1-249-441-11	CARBON	100K	5%	1/4W	R394	1-249-429-11	CARBON	10K	5%	1/4W
R305	1-249-421-11	CARBON	2.2K	5%	1/4W	R395	1-249-425-11	CARBON	4.7K	5%	1/4W
R306	1-249-417-11	CARBON	1K	5%	1/4W	R396	1-249-441-11	CARBON	100K	5%	1/4W
R307	1-249-417-11	CARBON	1K	5%	1/4W	R397	1-249-441-11	CARBON	100K	5%	1/4W
R308	1-249-425-11	CARBON	4.7K	5%	1/4W	R398	1-249-441-11	CARBON	100K	5%	1/4W
R309	1-249-421-11	CARBON	2.2K	5%	1/4W	R399	1-249-441-11	CARBON	100K	5%	1/4W
R310	1-249-441-11	CARBON	100K	5%	1/4W	R400	1-249-441-11	CARBON	100K	5%	1/4W
R311	1-249-429-11	CARBON	10K	5%	1/4W	R401	1-249-441-11	CARBON	100K	5%	1/4W
R312	1-249-421-11	CARBON	2.2K	5%	1/4W	R402	1-249-441-11	CARBON	100K	5%	1/4W
R313	1-249-421-11	CARBON	2.2K	5%	1/4W	R403	1-249-441-11	CARBON	100K	5%	1/4W
R314	1-249-435-11	CARBON	33K	5%	1/4W	R404	1-249-441-11	CARBON	100K	5%	1/4W
R315	1-249-429-11	CARBON	10K	5%	1/4W	R405	1-249-441-11	CARBON	100K	5%	1/4W
R316	1-247-804-11	CARBON	75	5%	1/4W (57ES)	R406	1-249-429-11	CARBON	10K	5%	1/4W
R317	1-249-405-11	CARBON	100	5%	1/4W (57ES)	R407	1-249-429-11	CARBON	10K	5%	1/4W
R318	1-249-409-11	CARBON	220	5%	1/4W	R408	1-249-429-11	CARBON	10K	5%	1/4W
R319	1-249-409-11	CARBON	220	5%	1/4W	R409	1-249-425-11	CARBON	4.7K	5%	1/4W
R320	1-247-804-11	CARBON	75	5%	1/4W	R410	1-249-425-11	CARBON	4.7K	5%	1/4W
R321	1-249-405-11	CARBON	100	5%	1/4W	R411	1-249-417-11	CARBON	1K	5%	1/4W
R322	1-249-429-11	CARBON	10K	5%	1/4W	R412	1-249-441-11	CARBON	100K	5%	1/4W
R323	1-249-433-11	CARBON	22K	5%	1/4W	R413	1-249-437-11	CARBON	47K	5%	1/4W
R324	1-249-433-11	CARBON	22K	5%	1/4W	R414	1-249-413-11	CARBON	470	5%	1/4W

The components identified by mark △ or dotted line with mark △ are critical for safety.
Replace only with part number specified.

Les composants identifiés par une marque △ sont critiques pour la sécurité.
Ne les remplacer que par une pièce portant le numéro spécifié.

When indicating parts by reference number, please include the board name.

MAIN

MOTOR

PLL

Ref. No.	Part No.	Description	Remarks	Ref. No.	Part No.	Description	Remarks
R415	1-249-437-11	CARBON	47K 5% 1/4W		* 1-639-646-11	MOTOR BOARD	
R416	1-249-437-11	CARBON	47K 5% 1/4W		*****		
R417	1-249-437-11	CARBON	47K 5% 1/4W			(CAPACITOR)	
R418	1-249-413-11	CARBON	470 5% 1/4W				
R419	1-249-413-11	CARBON	470 5% 1/4W				
R420	1-249-413-11	CARBON	470 5% 1/4W		C06	1-162-851-11 CERAMIC 0.1MF	16V
R421	1-249-413-11	CARBON	470 5% 1/4W			(CONNECTOR)	
R422	1-249-413-11	CARBON	470 5% 1/4W				
R424	1-249-411-11	CARBON	330 5% 1/4W		CN01	* 1-564-336-00 PIN, CONNECTOR 2P	
R425	1-249-411-11	CARBON	330 5% 1/4W		CN02	* 1-564-336-61 PIN, CONNECTOR 2P	
					CN03	* 1-564-498-11 PIN, CONNECTOR 5P	
R430	1-249-399-11	CARBON	33 5% 1/4W		*****		
R431	1-249-399-11	CARBON	33 5% 1/4W			* 1-639-920-11 PLL BOARD	
R432	1-249-393-11	CARBON	10 5% 1/4W		*****		
R433	1-216-349-00	CARBON	1 5% 1/2W				
R434	1-249-411-11	CARBON	330 5% 1/4W			1-543-563-11 FERRITE BOARD, MULTI HOLE	
R435	1-249-409-11	CARBON	220 5% 1/4W			(CAPACITOR)	
R436	1-249-409-11	CARBON	220 5% 1/4W				
R437	1-249-409-11	CARBON	220 5% 1/4W				
R438	1-249-409-11	CARBON	220 5% 1/4W				
R439	1-249-437-11	CARBON	47K 5% 1/4W		C501	1-136-153-00 FILM 0.01uF	5% 50V
R440	1-249-441-11	CARBON	100K 5% 1/4W		C502	1-162-284-31 CERAMIC 150PF	10% 50V
R441	1-249-441-11	CARBON	100K 5% 1/4W		C503	1-162-199-31 CERAMIC 10PF	5% 50V
R442	1-249-441-11	CARBON	100K 5% 1/4W		C504	1-126-023-11 ELECT 100uF	20% 25V
R443	1-249-437-11	CARBON	47K 5% 1/4W		C505	1-162-211-31 CERAMIC 33PF	5% 50V
R444	1-249-417-11	CARBON	1K 5% 1/4W		C506	1-162-199-31 CERAMIC 10PF	5% 50V
R445	1-249-419-11	CARBON	1.5K 5% 1/4W		C507	1-136-158-00 FILM 0.027uF	5% 50V
R446	1-247-883-00	CARBON	150K 5% 1/4W		C508	1-136-165-00 FILM 0.1uF	5% 50V
R447	1-249-425-11	CARBON	4.7K 5% 1/4W		C509	1-126-023-11 ELECT 100uF	20% 25V
R448	1-249-413-11	CARBON	470 5% 1/4W		C510	1-136-165-00 FILM 0.1uF	5% 50V
R449	1-249-424-11	CARBON	3.9K 5% 1/4W		C511	1-126-023-11 ELECT 100uF	20% 25V
R451	1-247-891-00	CARBON	330K 5% 1/4W		C512	1-164-159-11 CERAMIC 0.1uF	50V
R460	1-249-429-11	CARBON	10K 5% 1/4W		C513	1-126-023-11 ELECT 100uF	20% 25V
R495	1-249-417-11	CARBON	1K 5% 1/4W		C514	1-136-165-00 FILM 0.1uF	5% 50V
R496	1-249-417-11	CARBON	1K 5% 1/4W		C515	1-130-834-00 FILM 1uF	10% 63V
R497	1-247-903-00	CARBON	1M 5% 1/4W		C516	1-136-165-00 FILM 0.1uF	5% 50V
R498	1-247-903-00	CARBON	1M 5% 1/4W		C517	1-164-159-11 CERAMIC 0.1uF	50V
R499	1-249-429-11	CARBON	10K 5% 1/4W		C520	1-164-159-11 CERAMIC 0.1uF	50V
						(CONNECTOR)	
		(RELAY)			CN558	* 1-573-299-11 CONNECTOR, BOARD TO BOARD 10P	
RY301	1-515-726-11	RELAY				(DIODE)	
		(COIL)			D501	8-719-901-59 DIODE KV1320	
T301	1-459-795-11	COIL (WITH CORE) (57ES)			D503	8-719-903-27 DIODE 1SS168	
		(CRYSTAL)				(IC)	
X301	1-567-816-11	VIBRATOR, CRYSTAL (18MHz)			IC501	8-759-604-30 IC MSF7808L	
X302	1-567-815-11	VIBRATOR, CRYSTAL (22MHz)			IC502	8-759-036-44 IC MC74AC74M	
X303	1-578-667-11	VIBRATOR, CRYSTAL (49MHz)			IC503	8-759-917-11 IC SN74HC393AN	
X304	1-567-098-00	VIBRATOR, CRYSTAL (32.768kHz)			IC504	8-759-250-81 IC TC5081AP	
						(COIL)	
					L501	1-460-042-11 COIL (WITH CORE)	

When indicating parts by reference number, please include the lot and name.

PLL POWER

Ref. No.	Part No.	Description	Remarks	Ref. No.	Part No.	Description	Remarks
L502	1-410-324-11	INDUCTOR 4.7uH		C921	1-126-129-11	ELECT 6800uF 20%	35V
L503	1-410-324-11	INDUCTOR 4.7uH		C922	1-164-159-11	CERAMIC 0.1uF	50V
L504	1-410-324-11	INDUCTOR 4.7uH		C923	1-164-159-11	CERAMIC 0.1uF	50V
L505	1-460-042-11	COIL (WITH CORE)		C924	1-164-159-11	CERAMIC 0.1uF	50V
		(TRANSISTOR)		C925	1-164-159-11	CERAMIC 0.1uF	50V
Q501	8-729-200-56	TRANSISTOR 2SK241GR		C926	1-126-105-11	ELECT 1000uF 20%	35V
Q502	8-729-200-56	TRANSISTOR 2SK241GR		C927	1-126-105-11	ELECT 1000uF 20%	35V
Q503	8-729-900-61	TRANSISTOR DTA114ES				(CONNECTOR)	
		(RESISTOR)		CN905	* 1-560-338-00	PIN, CONNECTOR 7P	
R501	1-249-417-11	CARBON 1K 5% 1/4W		CN906	* 1-560-061-00	PIN, CONNECTOR 3P	
R502	1-247-903-00	CARBON 1M 5% 1/4W		CN931	* 1-564-505-11	PLUG, CONNECTOR 2P	
R503	1-247-903-00	CARBON 1M 5% 1/4W		CN932	* 1-564-511-11	PLUG, CONNECTOR 8P	
R504	1-249-429-11	CARBON 10K 5% 1/4W		CN933	* 1-564-506-11	PLUG, CONNECTOR 3P	
R505	1-249-428-11	CARBON 8.2K 5% 1/4W				(DIODE)	
R506	1-249-441-11	CARBON 100K 5% 1/4W		D905	8-719-312-47	DIODE RBA-406B	
R507	1-249-417-11	CARBON 1K 5% 1/4W		D906	8-719-107-94	DIODE 1SS202-1	
R508	1-249-417-11	CARBON 1K 5% 1/4W		D907	8-719-200-82	DIODE 11ES2	
R509	1-249-417-11	CARBON 1K 5% 1/4W		D908	8-719-200-82	DIODE 11ES2	
R510	1-249-407-11	CARBON 150 5% 1/4W		D909	8-719-934-15	DIODE HZS24-3L	
R511	1-249-425-11	CARBON 4.7K 5% 1/4W		D910	8-719-933-33	DIODE HZS6A1L	
R512	1-249-425-11	CARBON 4.7K 5% 1/4W		D911	8-719-230-02	DIODE 30D2-FC	
R513	1-249-417-11	CARBON 1K 5% 1/4W		D912	8-719-230-02	DIODE 30D2-FC	
R514	1-249-423-11	CARBON 3.3K 5% 1/4W		D913	8-719-230-02	DIODE 30D2-FC	
R515	1-249-423-11	CARBON 3.3K 5% 1/4W		D914	8-719-230-02	DIODE 30D2-FC	
R516	1-249-433-11	CARBON 22K 5% 1/4W		D915	8-719-107-94	DIODE 1SS202-1	
R517	1-249-435-11	CARBON 33K 5% 1/4W		D916	8-719-107-94	DIODE 1SS202-1	
R518	1-249-417-11	CARBON 1K 5% 1/4W				(FUSE)	
R519	1-249-417-11	CARBON 1K 5% 1/4W		F901	△ 1-532-744-11	FUSE, GLASS TUBE(2.5A) (US, CND)	
		*****		F901	△ 1-532-286-11	FUSE, TIME-LAG(T2.5A) (57ES:AEP, E/750:UK)	
		* A-2006-463-A POWER BOARD, COMPLETE				(IC)	
		*****		IC901	8-759-148-79	IC uPC2406HF	
		* 1-533-213-31 HOLDER, FUSE		IC902	8-759-231-53	IC M5F7805L	
		* 4-363-146-71 HEAT SINK, V. OUT		IC903	8-759-231-58	IC M5F7812L	
		7-682-147-15 SCREW, TR		IC904	8-759-604-51	IC M5F7912L	
		(CAPACITOR)				(TRANSISTOR)	
C907	1-126-946-11	ELECT 6800uF 20%	25V	Q901	8-729-140-97	TRANSISTOR 2SB734-34	
C908	1-164-159-11	CERAMIC 0.1uF	50V			(RESISTOR)	
C909	1-124-473-11	ELECT 1000uF 20%	10V	R901	1-249-425-11	CARBON 4.7K 5% 1/4W	
C910	1-164-159-11	CERAMIC 0.1uF	50V	R902	△ 1-212-849-00	FUSIBLE 4.7 5% 1/4W F	
C911	1-164-159-11	CERAMIC 0.1uF	50V	R903	1-249-421-11	CARBON 2.2K 5% 1/4W	
C912	1-124-473-11	ELECT 1000uF 20%	10V	R904	△ 1-212-865-00	FUSIBLE 22 5% 1/4W F	
C913	1-126-104-11	ELECT 470uF 20%	35V	R905	1-249-433-11	CARBON 22K 5% 1/4W	
C914	1-126-104-11	ELECT 470uF 20%	35V			(TRANSFORMER)	
C915	1-126-049-11	ELECT 22uF 20%	50V	T901	△ 1-450-556-11	TRANSFORMER, POWER (US, CND)	
C916	1-126-052-11	ELECT 100uF 20%	50V	T901	△ 1-450-557-11	TRANSFORMER, POWER (57ES:AEP/750:UK)	
C917	1-136-165-00	FILM 0.1uF 5%	50V	T901	△ 1-450-558-11	TRANSFORMER, POWER (57ES:E)	
C918	1-130-834-00	FILM 1uF 10%	63V				
C919	1-136-165-00	FILM 0.1uF 5%	50V				
C920	1-126-129-11	ELECT 6800uF 20%	35V				

The components identified by mark △ or dotted line with mark △ are critical for safety.
Replace only with part number specified.

Les composants identifiés par une marque △ sont critiques pour la sécurité.
Ne les remplacer que par une pièce portant le numéro spécifié.

When indicating parts by reference number, please include the board name.

RELAY

PRIMARY

REC VOL

REEL MOTOR

RF AMP

Ref. No.	Part No.	Description	Remarks	Ref. No.	Part No.	Description	Remarks
	* 1-639-332-11	RELAY BOARD *****		C5	1-164-299-11	CERAMIC CHIP 0.22uF	10% 25V
*****				C6	1-164-004-11	CERAMIC CHIP 0.1uF	10% 25V
	* 1-639-333-11	PRIMARY BOARD *****		C7	1-163-009-11	CERAMIC CHIP 0.001uF	10% 50V
	* 3-685-232-01	SPACER, VI		C8	1-124-778-00	ELECT CHIP 22uF	20% 6.3V
	* 3-346-266-12	PLATE, GROUND		C9	1-124-778-00	ELECT CHIP 22uF	20% 6.3V
		(CAPACITOR)		C10	1-163-009-11	CERAMIC CHIP 0.001uF	10% 50V
C901	1-161-744-00	CAP, CERAMIC 0.01uF	400V	C11	1-164-004-11	CERAMIC CHIP 0.1uF	10% 25V
C902	1-161-742-00	CAP, CERAMIC 0.0022uF	20% 400V	C12	1-164-299-11	CERAMIC CHIP 0.22uF	10% 25V
C903	1-161-742-00	CAP, CERAMIC 0.0022uF	20% 400V	C13	1-162-638-11	CERAMIC CHIP 1uF	16V
C904	1-161-742-00	CAP, CERAMIC 0.0022uF	20% 400V	C14	1-163-117-00	CERAMIC CHIP 100PF	5% 50V
C905	1-161-742-00	CAP, CERAMIC 0.0022uF	20% 400V				
C906	1-161-744-00	CAP, CERAMIC 0.01uF	400V	C15	1-124-778-00	ELECT CHIP 22uF	20% 6.3V
		(57ES:AEP, E/750:UK)		C16	1-163-038-00	CERAMIC CHIP 0.1uF	25V
		(CONNECTOR)		C17	1-163-001-11	CERAMIC CHIP 220PF	10% 50V
CN901	* 1-564-321-00	PIN, CONNECTOR 2P		C18	1-163-117-00	CERAMIC CHIP 100PF	5% 50V
		(COIL)		C19	1-163-001-11	CERAMIC CHIP 220PF	10% 50V
L901	1-421-915-11	COIL, LINE FILTER		C20	1-164-182-11	CERAMIC CHIP 0.0033uF	10% 50V
		(SWITCH)		C21	1-163-005-11	CERAMIC CHIP 470PF	10% 50V
SW901	* 1-571-722-11	SWITCH, VOLTAGE SELECTION (VOLTAGE SELECTOR) (57ES:E)		C22	1-126-603-11	ELECT CHIP 4.7uF	20% 35V
		(IC)		C23	1-163-117-00	CERAMIC CHIP 100PF	5% 50V
		*****		C24	1-163-038-00	CERAMIC CHIP 0.1uF	25V
	* 1-639-325-11	REC VOL BOARD *****		C25	1-124-778-00	ELECT CHIP 22uF	20% 6.3V
		(VARIABLE RESISTOR)		C26	1-163-038-00	CERAMIC CHIP 0.1uF	25V
RV102	1-238-833-21	RES, VAR, CARBON 20K/20K (REC LEVEL)		C27	1-162-638-11	CERAMIC CHIP 1uF	16V
		*****		C28	1-164-505-11	CERAMIC CHIP 2.2uF	16V
	* 1-639-304-11	REEL MOTOR BOARD *****					
		(CAPACITOR)		CN51	* 1-566-207-11	PIN, CONNECTOR (PC BOARD) 14P	
C07	1-163-077-00	CERAMIC CHIP 0.1uF	10% 25V	CN52	* 1-564-720-11	PIN, CONNECTOR (SMALL TYPE) 4P	

	* A-2001-587-A	RF AMP BOARD, COMPLETE *****		IC1	8-752-039-01	IC CXA1364R	
		(CAPACITOR)					
C1	1-124-778-00	ELECT CHIP 22uF	20% 6.3V	L1	1-408-781-00	INDUCTOR CHIP 22uH	
C2	1-163-019-00	CERAMIC CHIP 0.0068uF	10% 50V	L2	1-408-789-21	INDUCTOR, CHIP 100uH	
C3	1-163-117-00	CERAMIC CHIP 100PF	5% 50V	L3	1-408-781-00	INDUCTOR CHIP 22uH	
C4	1-162-638-11	CERAMIC CHIP 1uF	16V				

		(RESISTOR)		R1	1-216-082-00	METAL GLAZE 24K 5%	1/10W
		*****		R2	1-216-082-00	METAL GLAZE 24K 5%	1/10W
		(CAPACITOR)		R3	1-216-066-00	METAL CHIP 5.1K 5%	1/10W
		*****		R4	1-216-066-00	METAL CHIP 5.1K 5%	1/10W
		(CAPACITOR)		R5	1-216-077-00	METAL CHIP 15K 5%	1/10W
		*****		R6	1-216-077-00	METAL CHIP 15K 5%	1/10W
		(CAPACITOR)		R7	1-216-077-00	METAL CHIP 15K 5%	1/10W
		*****		R8	1-216-079-00	METAL CHIP 18K 5%	1/10W
		(CAPACITOR)		R9	1-216-075-00	METAL CHIP 12K 5%	1/10W
		*****		R10	1-216-079-00	METAL CHIP 18K 5%	1/10W
		(CAPACITOR)		R11	1-216-077-00	METAL CHIP 15K 5%	1/10W
		*****		R12	1-216-077-00	METAL CHIP 15K 5%	1/10W
		(CAPACITOR)		R13	1-216-077-00	METAL CHIP 15K 5%	1/10W
		*****		R14	1-216-081-00	METAL CHIP 22K 5%	1/10W
		(CAPACITOR)		R15	1-216-234-00	METAL GLAZE 33K 5%	1/8W

When indicating parts by reference number, please include the board name.

RF AMP **RGN SW** **SUB** **SW (IN)**

Ref. No.	Part No.	Description	Remarks
R16	1-216-238-00	METAL GLAZE 47K 5% 1/8W	
R17	1-216-080-00	METAL CHIP 20K 5% 1/10W	
R18	1-216-222-00	METAL GLAZE 10K 5% 1/8W	
(VARIABLE RESISTOR)			
RV1	1-238-181-11	RES, ADJ, CERMET 4.7K	
RV2	1-238-181-11	RES, ADJ, CERMET 4.7K	

	* 1-639-301-11	RGN SW BOARD	

(SWITCH)			
S01	1-571-878-11	SWITCH, PUSH (2 KEY) (CASSETTE IN, REC PROOF)	

	* A-2006-553-A	SUB BOARD, COMPLETE	

(CAPACITOR)			
C332	1-136-153-00	FILM 0.01uF 5% 50V	
C333	1-130-473-00	MYLAR 0.0015uF 5% 50V	
C334	1-136-158-00	FILM 0.027uF 5% 50V	
C335	1-136-153-00	FILM 0.01uF 5% 50V	
C336	1-130-473-00	MYLAR 0.0015uF 5% 50V	
C337	1-136-158-00	FILM 0.027uF 5% 50V	
C338	1-162-306-11	CERAMIC 0.01uF 20% 16V	
C339	1-162-306-11	CERAMIC 0.01uF 20% 16V	
C340	1-162-290-31	CERAMIC 470PF 10% 50V	
C341	1-162-306-11	CERAMIC 0.01uF 20% 16V	
C342	1-126-059-11	ELECT 10uF 20% 63V	
C343	1-162-306-11	CERAMIC 0.01uF 20% 16V	
C344	1-162-306-11	CERAMIC 0.01uF 20% 16V	
C348	1-130-834-00	FILM 1uF 10% 63V	
(CONNECTOR)			
CN556	1-573-300-11	CONNECTOR, BOARD TO BOARD 18P	
(IC)			
IC316	8-759-135-80	IC uPC358C	
IC317	8-759-135-80	IC uPC358C	
IC318	8-759-135-80	IC uPC358C	
(TRANSISTOR)			
Q302	8-729-801-93	TRANSISTOR 2SD1387	
Q333	8-729-924-90	TRANSISTOR 2SB1370-EF	
Q334	8-729-920-68	TRANSISTOR 2SA933S-OR	
Q335	8-729-119-78	TRANSISTOR 2SC2785-HFE	
Q336	8-729-927-11	TRANSISTOR 2SA1585S-QR	
Q337	8-729-927-11	TRANSISTOR 2SA1585S-QR	
Q338	8-729-927-12	TRANSISTOR 2SC4115S-QR	

Ref. No.	Part No.	Description	Remarks
Q339	8-729-927-12	TRANSISTOR 2SC4115S-QR	
Q340	8-729-119-78	TRANSISTOR 2SC2785-HFE	
Q341	8-729-119-78	TRANSISTOR 2SC2785-HFE	
Q342	8-729-209-15	TRANSISTOR 2SD2012	
(RESISTOR)			
R337	1-249-429-11	CARBON 10K 5% 1/4W	
R338	1-249-433-11	CARBON 22K 5% 1/4W	
R339	1-249-401-11	CARBON 47 5% 1/4W	
R340	1-249-429-11	CARBON 10K 5% 1/4W	
R341	1-249-429-11	CARBON 10K 5% 1/4W	
R342	1-249-429-11	CARBON 10K 5% 1/4W	
R343	1-249-438-11	CARBON 56K 5% 1/4W	
R344	1-249-438-11	CARBON 56K 5% 1/4W	
R345	1-249-438-11	CARBON 56K 5% 1/4W	
R352	1-249-441-11	CARBON 100K 5% 1/4W	
R354	1-249-441-11	CARBON 100K 5% 1/4W	
R355	1-249-417-11	CARBON 1K 5% 1/4W	
R356	1-249-417-11	CARBON 1K 5% 1/4W	
R357	1-249-405-11	CARBON 100 5% 1/4W	
R358	1-249-417-11	CARBON 1K 5% 1/4W	
R359	1-249-408-11	CARBON 180 5% 1/4W	
R360	1-247-870-11	CARBON 43K 5% 1/4W	
R361	1-249-437-11	CARBON 47K 5% 1/4W	
R364	1-247-731-11	CARBON 22 5% 1/2W	
R366	1-249-441-11	CARBON 100K 5% 1/4W	
R367	1-249-417-11	CARBON 1K 5% 1/4W	
R368	1-249-417-11	CARBON 1K 5% 1/4W	
R369	1-249-405-11	CARBON 100 5% 1/4W	
R370	1-249-405-11	CARBON 100 5% 1/4W	
R371	1-249-417-11	CARBON 1K 5% 1/4W	
R372	1-249-405-11	CARBON 100 5% 1/4W	
R373	1-249-417-11	CARBON 1K 5% 1/4W	
R374	1-249-417-11	CARBON 1K 5% 1/4W	
R375	1-249-405-11	CARBON 100 5% 1/4W	
R376	1-249-417-11	CARBON 1K 5% 1/4W	
R377	1-249-441-11	CARBON 100K 5% 1/4W	
R382	1-249-441-11	CARBON 100K 5% 1/4W	
R383	1-249-401-11	CARBON 47 5% 1/4W	
R384	1-249-437-11	CARBON 47K 5% 1/4W	
R385	1-249-437-11	CARBON 47K 5% 1/4W	

	* 1-639-647-11	SW (IN) BOARD	

(SWITCH)			
S12	1-572-247-11	SWITCH, SLIDE (CASSETTE TABLE OUT)	

When indicating parts by reference number, please include the board name.

SW (OUT)

TIMER SW

TOP END SENSOR

Ref. No.	Part No.	Description	Remarks
	* 1-639-648-11	SW (OUT) BOARD *****	
		(SWITCH)	
S11	1-570-975-11	SWITCH, SLIDE (CASSETTE TABLE IN)	

	* 1-639-329-11	TIMER SW BOARD *****	
		(IC)	
IC704	8-749-922-36	IC GPIU50XB	
		(RESISTOR)	
R711	1-249-428-11	CARBON 8.2K 5% 1/4W	
R712	1-249-434-11	CARBON 27K 5% 1/4W	
		(SWITCH)	
S701	1-571-520-11	SWITCH, SLIDE (TIMER)	
S703	1-570-974-11	SWITCH, SLIDE (REC MODE)	

	* 1-639-305-11	TOP END SENSOR BOARD *****	
	* 3-368-456-01	HOLDER (END SENSOR LIGHT)	
	* 3-368-457-01	HOLDER (END SENSOR) (RECEIVE)	
		(DIODE)	
D01	8-719-951-03	DIODE GL453	
		(PHOTO INTERRUPTER)	
PH03	8-729-907-25	PT4850F	
PH04	8-729-907-25	PT4850F	

Ref. No.	Part No.	Description	Remarks
		MISCELLANEOUS *****	
10	△ 1-559-297-31	CODE, POWER (57ES:E)	
10	△ 1-559-479-11	CORD, POWER (57ES:US, CND)	
10	△ 1-575-695-11	CODE, POWER (750:US, CND)	
10	△ 1-575-912-11	CODE, POWER (57ES:AEP)	
10	△ 1-575-913-11	CODE, POWER (750:UK)	
108	1-590-915-11	WIRE, FLAT TYPE (30 CORE)	
109	1-590-916-11	WIRE, FLAT TYPE (10 CORE)	
110	1-590-914-11	WIRE, FLAT TYPE (6 CORE)	
325	8-848-567-01	DRUM ASSY DOU-03A	
382	1-454-535-11	SOLENOID, PLUNGER (BRAKE)	
383	1-454-536-11	SOLENOID, PLUNGER (BT CONTROL)	
69	1-518-634-11	LAMP, PILOT	
76	1-554-920-21	SWITCH, PUSH (AC POWER) (1 KEY)	
77	1-590-321-71	LEAD (WITH CONNECTOR)	
BAT301	△ 1-528-229-11	BATTERY, LITHIUM CR-2450	
M901	A-2003-448-A	MOTOR ASSY (CASSETTE COM)	
M902	8-835-361-01	MOTOR, DC U-17B (CAPSTAN)	
M903	X-3363-109-1	MOTOR (CAM) ASSY	
M905	X-3363-110-1	MOTOR (REEL) ASSY	

		ACCESSORIES & PACKING MATERIALS *****	
	1-465-737-11	REMOTE COMMANDER (RM-D57A) (BLACK)	
	1-465-777-11	REMOTE COMMANDER (RM-D57A) (GOLD)	
	1-559-533-11	CORD, CONNECTION	
*	3-369-495-01	INDIVIDUAL CARTON	
	3-703-450-01	INSTRUCTION (US)	
	3-704-366-01	SCREW (CASE) (M3X8)	
	3-707-584-01	COVER, BATTERY (for RM-D57A)	
	3-753-349-11	MANUAL, INSTRUCTION (57ES:AEP, E) (English, French, Spanish, Portuguese)	
	3-753-349-21	MANUAL, INSTRUCTION (750:US, CND, LJK) (English)	
	3-753-349-31	MANUAL, INSTRUCTION (750:CND) (French)	
	3-753-349-41	MANUAL, INSTRUCTION (57ES:AEP) (German, Dutch, Swedish, Italian)	
	3-753-349-51	MANUAL, INSTRUCTION (57ES:AEP) (Danish, Finnish)	
	3-753-350-21	MANUAL, INSTRUCTION (57ES:US, CND) (English)	
	3-753-350-31	MANUAL, INSTRUCTION (57ES:CND) (French)	
*	4-936-624-01	CUSHION	

The components identified by mark △ or dotted line with mark △ are critical for safety. Replace only with part number specified.

Les composants identifiés par une marque △ sont critiques pour la sécurité. Ne les remplacer que par une pièce portant le numéro spécifié.

When indicating parts by reference number, please include the board name.

Ref. No.	Part No.	Description	Remarks
----------	----------	-------------	---------

HARDWARE LIST

#1	7-682-548-09	SCREW +BVTT 3X8 (S)	
#2	7-683-412-05	BOLT, HEXAGON SOCKET 2.6X6	
#3	7-685-646-79	SCREW +BVTP 3X8 TYPE2 N-S	
#4	7-685-647-79	SCREW, TAPPING (M3X10)	
#5	7-682-547-04	SCREW +BVTT 3X6 (S)	
#6	7-682-560-04	SCREW +BVTT 4X6 (S)	
#7	7-621-772-10	SCREW +B 2X4	
#8	7-621-772-00	SCREW +B 2X3	
#9	7-682-545-09	SCREW +B 3X4	
#10	7-621-255-45	SCREW +P 2X6	
#11	7-621-775-08	SCREW +B 2.6X3	
#12	7-621-773-86	SCREW +B 2.6X4	
#13	7-621-775-20	SCREW +B 2.6X5	
#14	7-682-147-15	SCREW, TR	
#15	7-621-255-20	SCREW +BVTT 2X4 (S)	
#16	7-627-854-07	PRECISION SCREW +P 2X2.5 TYPE3	
#17	7-627-556-17	SCREW, PRECISION +P 2.6X3 TYPE1	
#18	7-627-852-27	+P 1.7X3	
#19	7-621-255-15	SCREW +P 2X3	
#20	7-627-552-27	SCREW, PRECISION +P 1.7X2	
#21	7-627-552-47	SCREW, PRECISION +P 1.7X4	
#22	7-621-772-08	SCREW +B 2X3	
#23	7-621-772-18	SCREW +B 2X4	
#24	7-685-133-19	SCREW +BTP 2.6X6 TYPE2 N-S	
#25	7-685-534-19	SCREW +BTP 2.6X8 TYPE2 N-S	
#26	7-682-550-09	SCREW +BVTT 3X12 (S)	