

D-E990/EJ915

SERVICE MANUAL

Ver 1.1 2000.02



Photo: D-E990

US Model
Canadian Model
AEP Model
UK Model
E Model
Australian Model
Chinese Model
D-EJ915
Tourist Model
D-E990

Model Name Using Similar Mechanism	NEW
CD Mechanism Type	US, Canadian, AEP, UK : CDM-3022EBG E, Australian, Chinese, Tourist : CDM-3022EBA
Optical Pick-up Name	US, Canadian, AEP, UK : DAX-22EG E, Australian, Chinese, Tourist : DAX-22E

SPECIFICATIONS

System

Compact disc digital audio system

Laser diode properties

Material: GaAlAs

Wavelength: $\lambda = 780 \text{ nm}$

Emission duration: Continuous

Laser output: Less than $44.6 \mu\text{W}$

(This output is the value measured at a distance of 200 mm from the objective lens surface on the optical pick-up block with 7 mm aperture.)

D-A conversion

1-bit quartz time-axis control

Frequency response

20 - 20,000 Hz $_{-2}^{+1}$ dB (measured by EIAJ CP-307)

Output (at 4.5 V input level)

Line output (stereo minijack)

Output level 0.7 V rms at 47 kilohms

Recommended load impedance over 10 kilohms

Headphones (stereo minijack)

Approx. 5 mW + Approx. 5 mW at 16 ohms

(Approx. 0.15 mW + Approx. 0.15 mW at 16 ohms)*

*For the customers in France

Optical digital output (optical output connector)

Output level: -21 - -15 dBm

Wavelength: 630 - 690 nm at peak level

Power requirements

For the area code of the model you purchased, check the upper left side of the bar code on the package.

- Two Sony NH-14WM rechargeable batteries: 2.4 V DC
- Two LR6 (size AA) batteries: 3 V DC

- AC power adaptor (DC IN 4.5 V jack):
US/Canadian model: 120 V, 60 Hz
AEP/E13 model: 220 - 230 V, 50/60 Hz
UK model: 230 - 240 V, 50 Hz
Australian model: 240 V, 50 Hz
Tourist/E33 model: 100 - 240 V, 50/60 Hz
Hong Kong model: 220 V, 50/60 Hz
Korean model: 220 V, 60 Hz
Chinese model: 220 V, 50 Hz
- Sony DCC-E245 car battery cord for use on car battery: 4.5 V DC

Battery life* (approx hours)

(When you use the CD player on a flat and stable surface.)

Playing time varies depending on how the CD player is used.

Two NH-14WM (charged for about 4 hours**)	23 (US/Canadian/AEP/UK model) 25 (E/Australian/Chinese/Tourist model)
Battery case (two alkaline batteries)	37 (US/Canadian/AEP/UK model) 40 (E/Australian/Chinese/Tourist model)
Rechargeable batteries NH-14WM and battery case (two alkaline batteries)	57 (US/Canadian/AEP/UK model) 62 (E/Australian/Chinese/Tourist model)

* Measured value by the standard of EIAJ (Electronic Industries Association of Japan).

** Charging time varies depending on how the rechargeable battery is used.

Operating temperature

5°C - 35°C (41°F - 95°F)

Dimensions (w/h/d) (excluding projecting parts and controls)

Approx. 127.2 × 19 × 130.1 mm
(5 1/8 × 3/4 × 5 1/8 in.)

Mass (excluding rechargeable batteries)

Approx. 167.5 g (6.0 oz)

Supplied accessories

- AC power adaptor (1)
- Headphones/earphones with remote control (1)
- Rechargeable batteries (2)
- Battery carrying case (2)
- Carrying case (1)
- Battery case (1)
- AC plug adaptor (1)*
- * Supplied with Tourist and E33 models

Design and specifications are subject to change without notice.

- Abbreviation
E13: 220 - 230 V AC area in E model
E33: 100 - 240 V AC area in E model

PORTABLE CD PLAYER

SONY®

TABLE OF CONTENTS

1. SERVICING NOTES	3
2. GENERAL	4
3. DISASSEMBLY	5
4. ELECTRICAL CHECKING	7
5. DIAGRAMS	
5-1. Block Diagram – MAIN Section (1/2) –	9
5-2. Block Diagram – MAIN Section (2/2) –	11
5-3. Block Diagram – POWER SUPPLY Section –	13
5-4. Printed Wiring Board	16
5-5. Schematic Diagram	19
5-6. IC Pin Function Description	27
6. EXPLODED VIEWS	29
7. ELECTRICAL PARTS LIST	32

This appliance is classified as a CLASS 1 LASER product. The CLASS 1 LASER PRODUCT MARKING is located on the rear exterior.

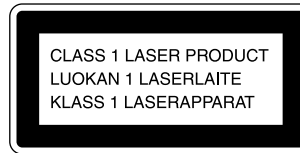

CAUTION

Use of controls or adjustments or performance of procedures other than those specified herein may result in hazardous radiation exposure.

Flexible Circuit Board Repairing

- Keep the temperature of the soldering iron around 270 °C during repairing.
- Do not touch the soldering iron on the same conductor of the circuit board (within 3 times).
- Be careful not to apply force on the conductor when soldering or unsoldering.

Notes on chip component replacement

- Never reuse a disconnected chip component.
- Notice that the minus side of a tantalum capacitor may be damaged by heat.

On AC power adaptor

- Use only the AC power adaptor supplied or recommended in "Accessories (supplied/optional)." Do not use any other AC power adaptor. It may cause a malfunction.

Polarity of the plug



- When disconnecting the AC power adaptor from the AC outlet, grasp the adaptor itself. Do not pull it by the cord.
- Do not touch the AC power adaptor with wet hands.

SAFETY-RELATED COMPONENT WARNING!!

COMPONENTS IDENTIFIED BY MARK \triangle OR DOTTED LINE WITH MARK \triangle ON THE SCHEMATIC DIAGRAMS AND IN THE PARTS LIST ARE CRITICAL TO SAFE OPERATION. REPLACE THESE COMPONENTS WITH SONY PARTS WHOSE PART NUMBERS APPEAR AS SHOWN IN THIS MANUAL OR IN SUPPLEMENTS PUBLISHED BY SONY.

ATTENTION AU COMPOSANT AYANT RAPPORT À LA SÉCURITÉ!

LES COMPOSANTS IDENTIFIÉS PAR UNE MARQUE \triangle SUR LES DIAGRAMMES SCHÉMATIQUES ET LA LISTE DES PIÈCES SONT CRITIQUES POUR LA SÉCURITÉ DE FONCTIONNEMENT. NE REMPLACER CES COMPOSANTS QUE PAR DES PIÈCES SONY DONT LES NUMÉROS SONT DONNÉS DANS CE MANUEL OU DANS LES SUPPLÉMENTS PUBLIÉS PAR SONY.

SECTION 1 SERVICING NOTES

NOTES ON HANDLING THE OPTICAL PICK-UP BLOCK OR BASE UNIT

The laser diode in the optical pick-up block may suffer electrostatic breakdown because of the potential difference generated by the charged electrostatic load, etc. on clothing and the human body. During repair, pay attention to electrostatic breakdown and also use the procedure in the printed matter which is included in the repair parts.

The flexible board is easily damaged and should be handled with care.

NOTES ON LASER DIODE EMISSION CHECK

The laser beam on this model is concentrated so as to be focused on the disc reflective surface by the objective lens in the optical pick-up block. Therefore, when checking the laser diode emission, observe from more than 30 cm away from the objective lens.

BEFORE REPLACING THE OPTICAL PICK-UP BLOCK

Please be sure to check thoroughly the parameters as per the "Optical Pick-Up Block Checking Procedures" (Part No.: 9-960-027-11) issued separately before replacing the optical pick-up block. Note and specifications required to check are given below.

- FOK output: IC601 ③ pin
When checking FOK, remove the lead wire to disc motor.
- RF signal P-to-P value: 0.35 to 0.55 Vp-p

LASER DIODE AND FOCUS SEARCH OPERATION CHECK

During normal operation of the equipment, emission of the laser diode is prohibited unless the upper lid is closed while turning ON the S801. (push switch type)

The following checking method for the laser diode is operable.

• Method: Emission of the laser diode is visually checked.

1. Open the upper lid.
2. With a disc not set, turn on the S801 with a screwdriver having a thin tip as shown in Fig.1.
3. Press the  button.
4. Observing the objective lens, check that the laser diode emits light.

When the laser diode does not emit light, automatic power control circuit or optical pickup is faulty.

In this operation, the objective lens will move up and down 5 times along with inward motion for the focus search.

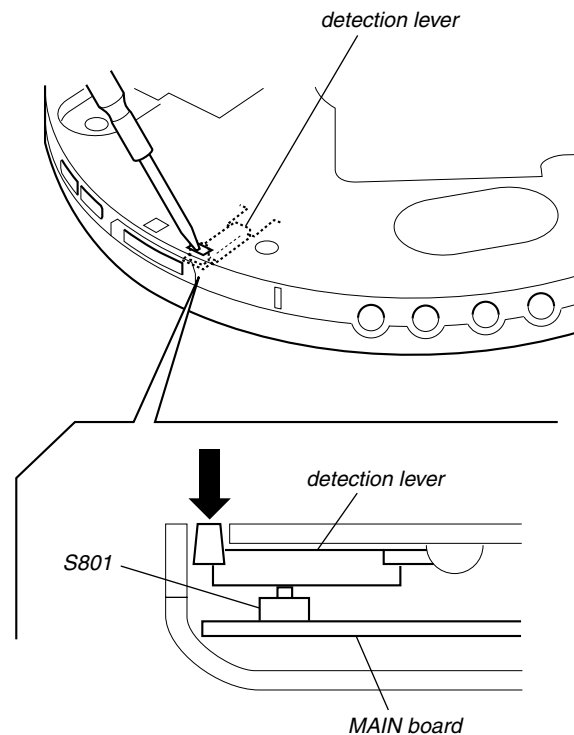

Fig. 1 Method to push the S801

SECTION 2 GENERAL

This section is extracted from instruction manual.

Getting started

Locating the Controls

For details, see pages in parentheses.

CD player (front)

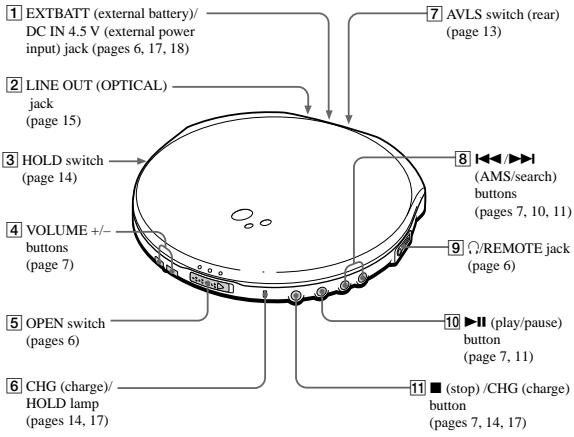

CD player (inside)

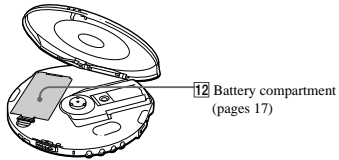

Remote control

(Front)

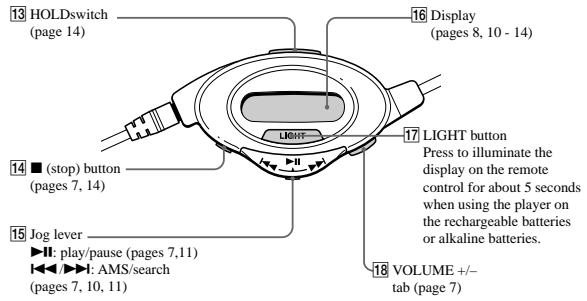

(Rear)

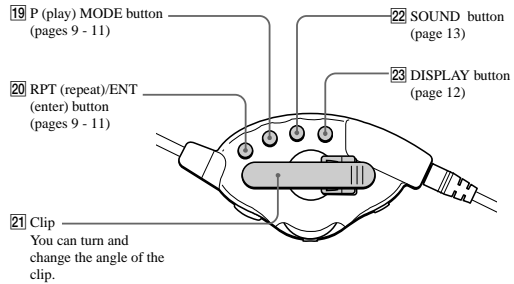

Note

Use only the supplied remote control. You cannot operate this CD player with the remote control supplied with other CD players.

Getting started

Using the carrying case

You can carry your player and its battery case together using the supplied carrying case.

Insert them into the proper places in the case as illustrated below

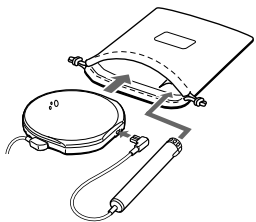

SECTION 3 DISASSEMBLY

Note: Follow the disassembly procedure in the numerical order given.

UPPER LID ASSY

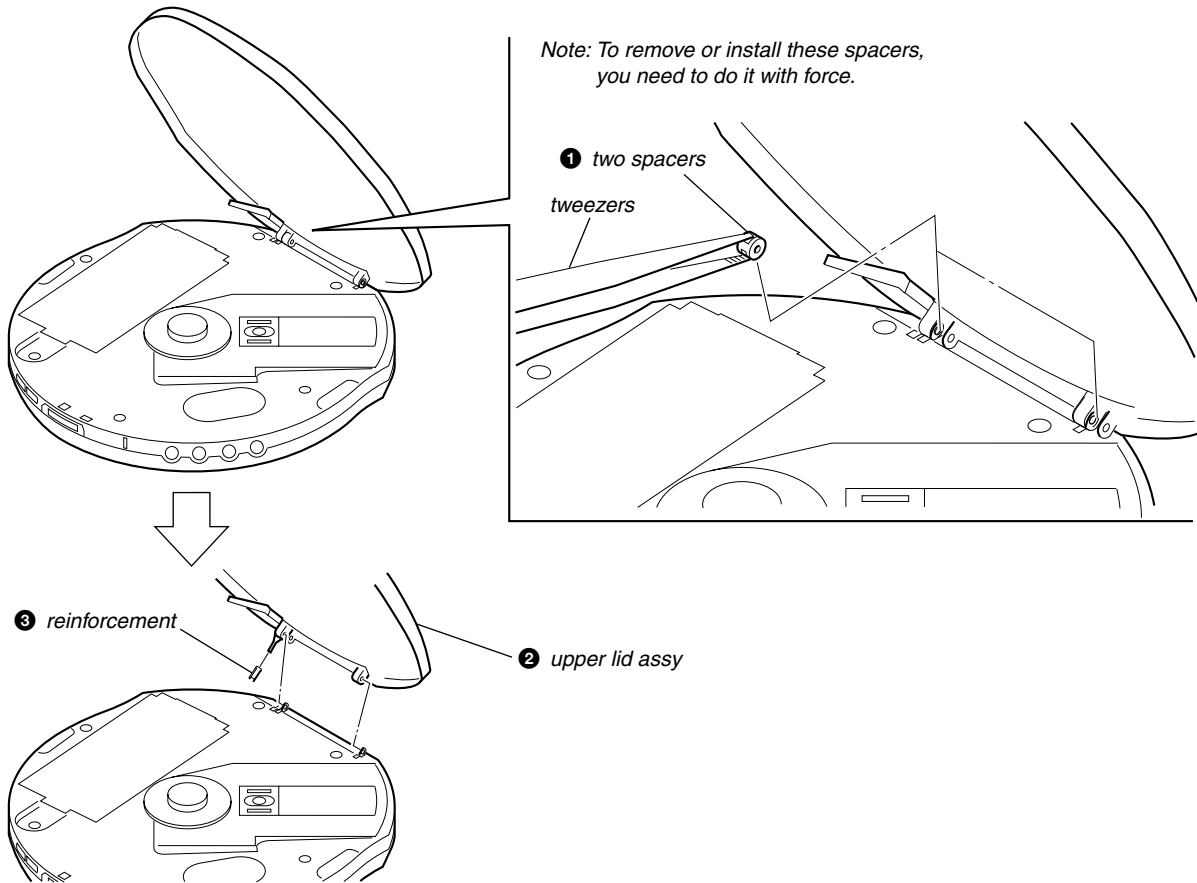

CABINET (UPPER) SUB ASSY

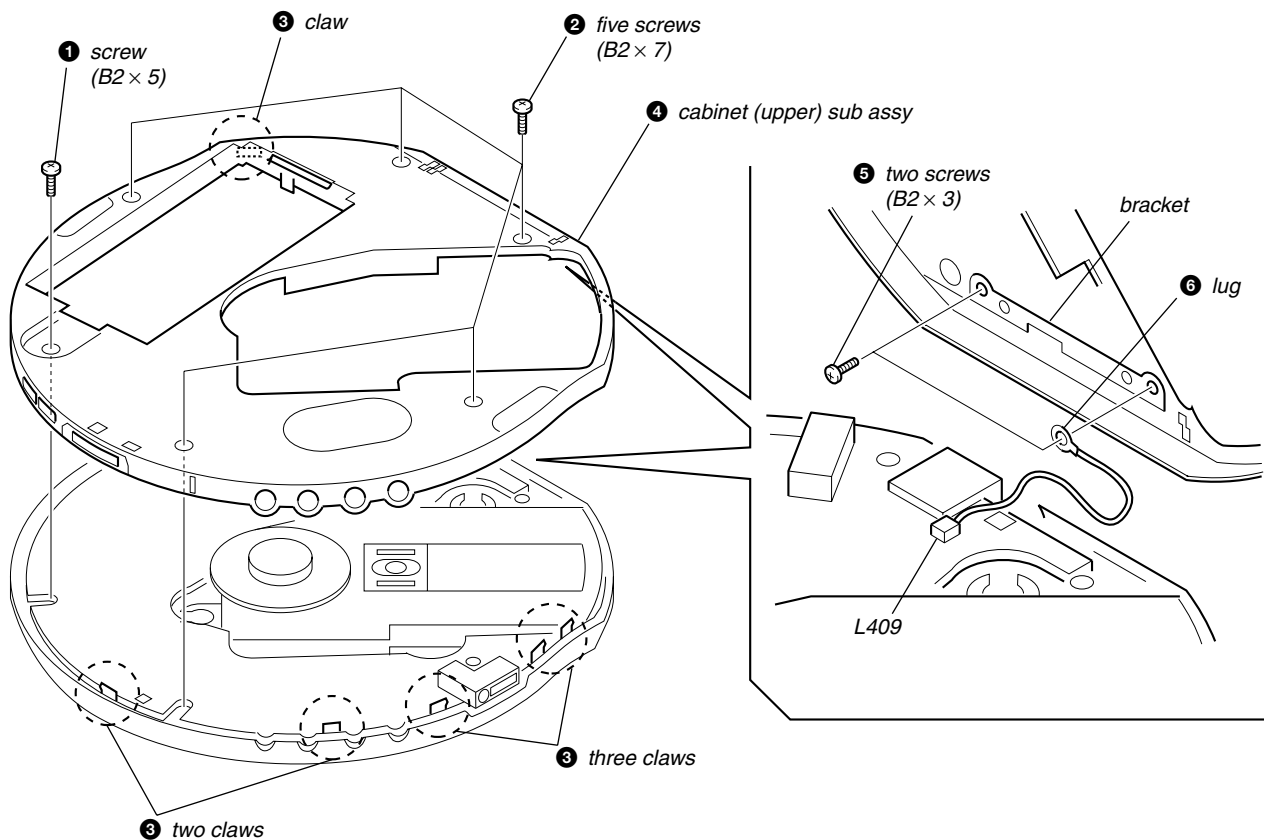

INSTALLATION OF MAIN BOARD

When installing MAIN board, adjust the S803, 804 and knobs (AVLS, HOLD)

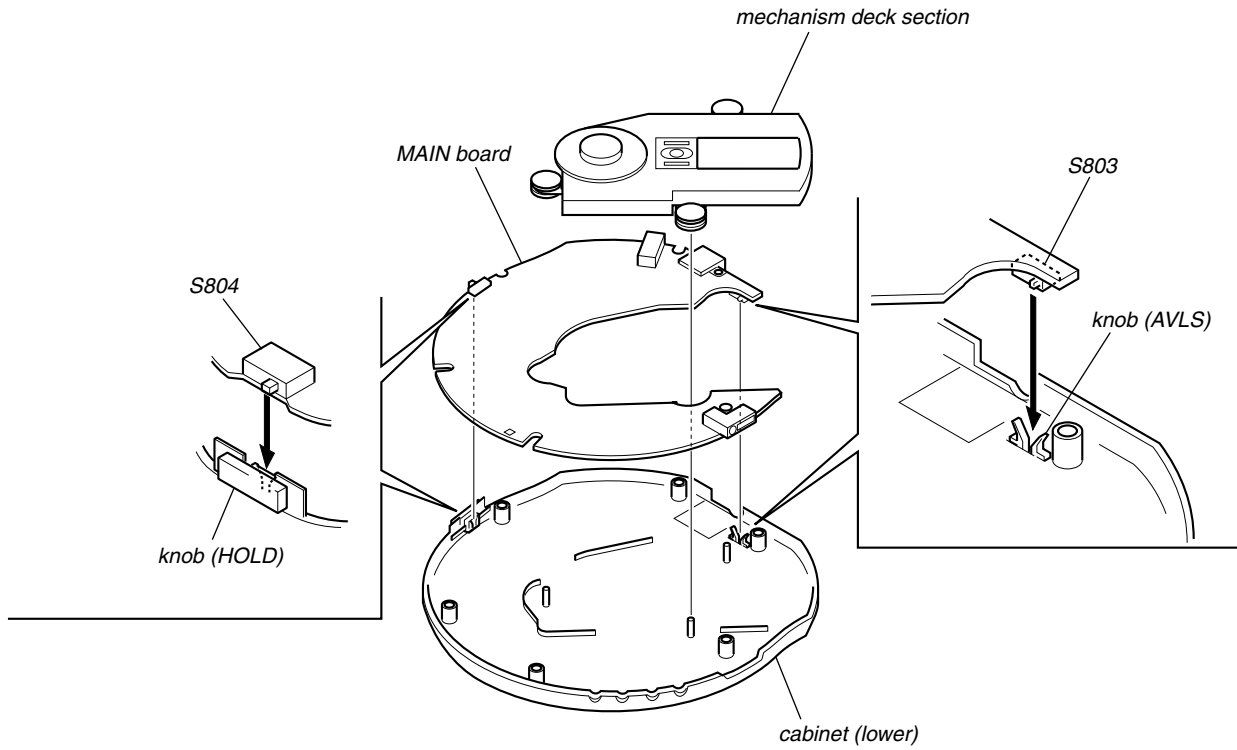

SECTION 4 ELECTRICAL CHECKING

The CD section adjustments are done automatically in this set.

Precautions for Check

1. Perform check in the order given.
2. Use YEDS-18 disc (Part No.: 3-702-101-01) unless otherwise indicated.
3. Power supply voltage requirement: DC4.5 V in DC IN jack.
(J401)

VOLUME button : Minimum
AVLS switch : NORM
HOLD switch : OFF

Checking Location:

– MAIN board (Side A) –

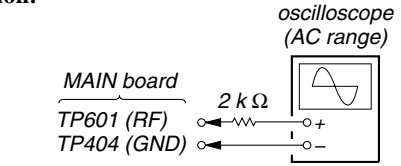
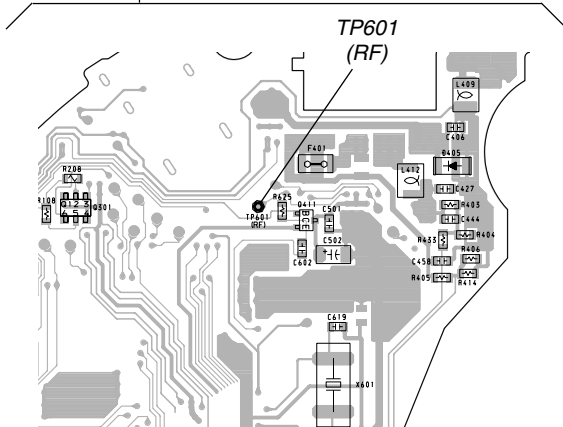
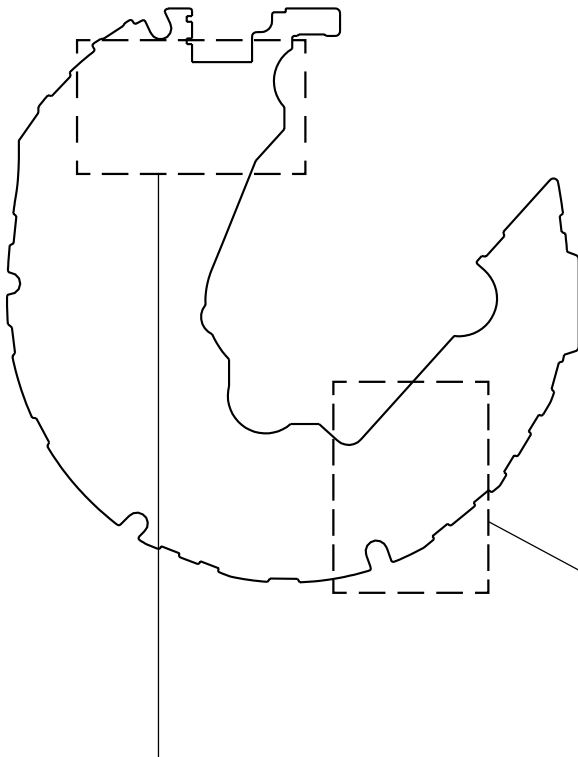

Procedure:

1. Connect the oscilloscope to the test points TP601 (RF) and TP404 (GND) on the MAIN board.
2. Set a disc. (YEDS-18)
3. Press the button.
4. Check the oscilloscope waveform is as shown below.
A good eye pattern means that the diamond shape (◇) in the center of the waveform can be clearly distinguished.

RF Signal reference Waveform (Eye Pattern)

VOLT/DIV : 100 mV (With the 10:1 probe in use)
TIME/DIV : 500 ns

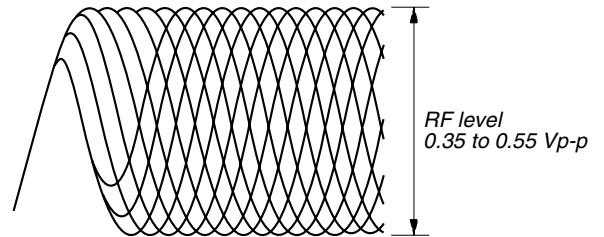

To watch the eye pattern, set the oscilloscope to AC range and increase the vertical sensitivity of the oscilloscope for easy watching.

5. Stop revolving of the disc motor by pressing the button.

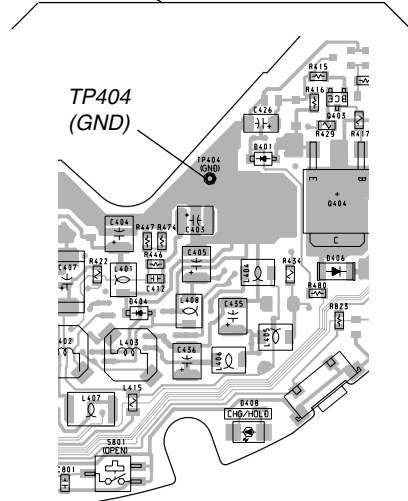

**SECTION 5
DIAGRAMS**

5-1. BLOCK DIAGRAM – MAIN Section (1/2) –

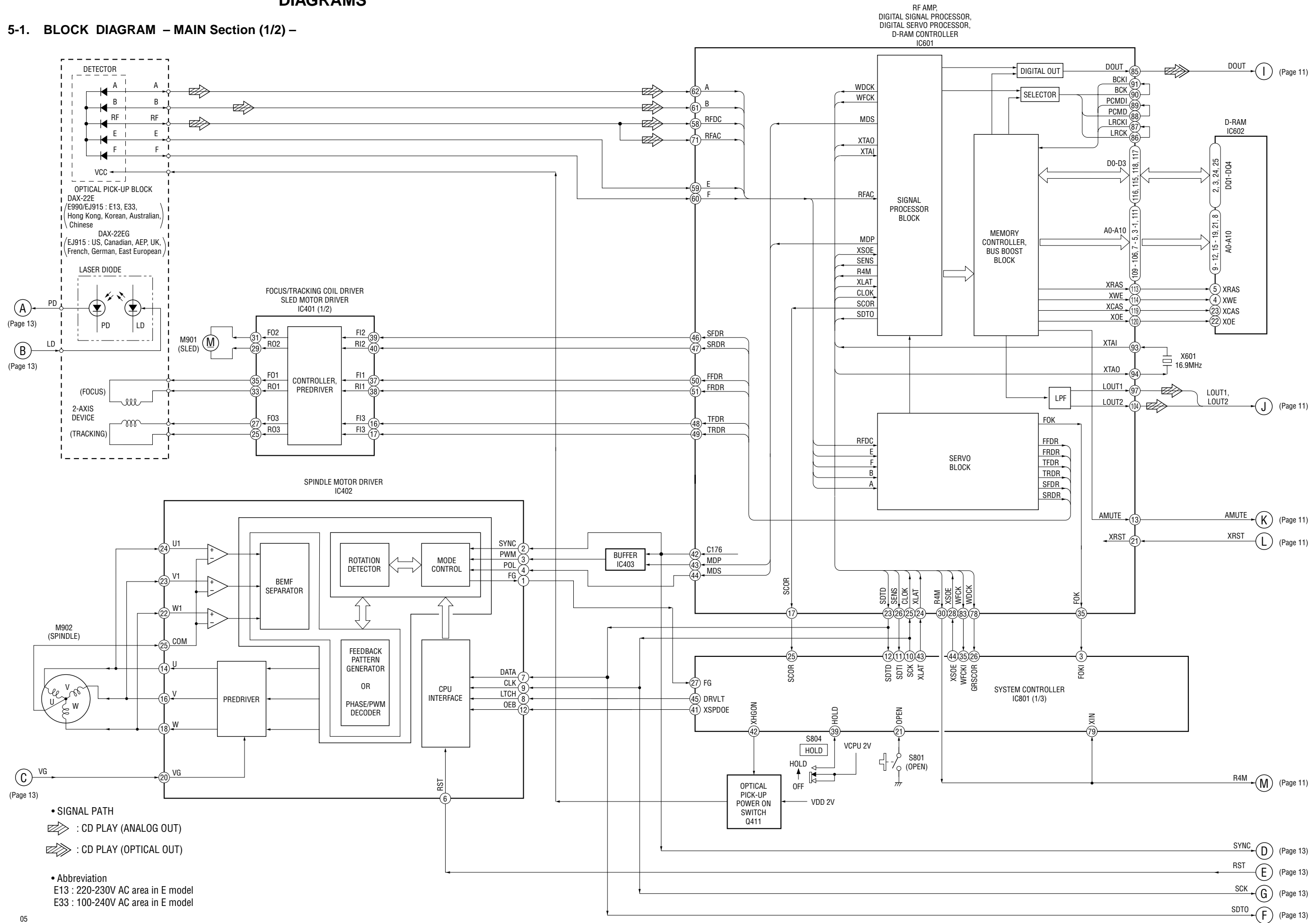

5-2. BLOCK DIAGRAM – MAIN Section (2/2) –

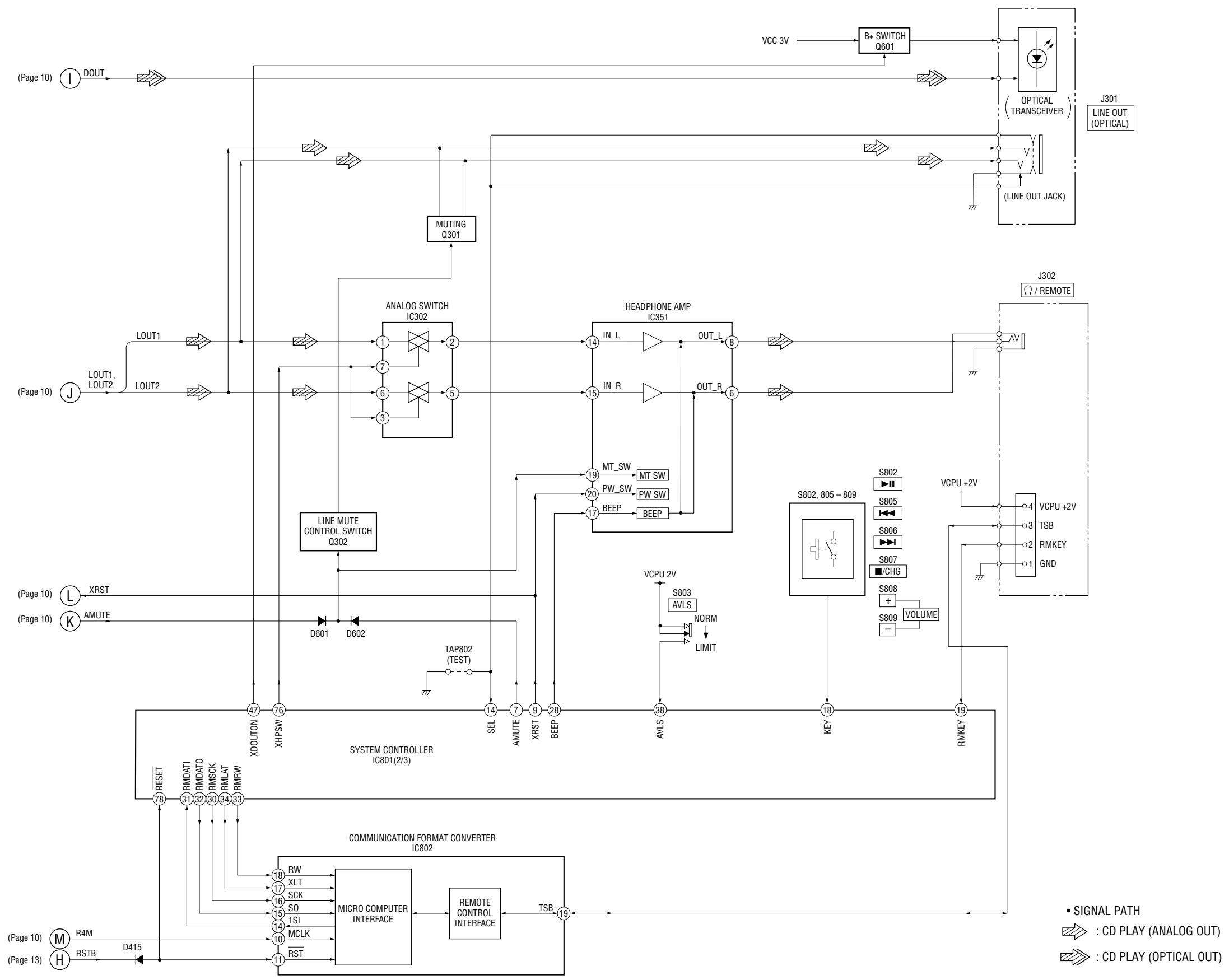

• SIGNAL PATH
 : CD PLAY (ANALOG OUT)
 : CD PLAY (OPTICAL OUT)

5-3. BLOCK DIAGRAM – POWER SUPPLY Section –

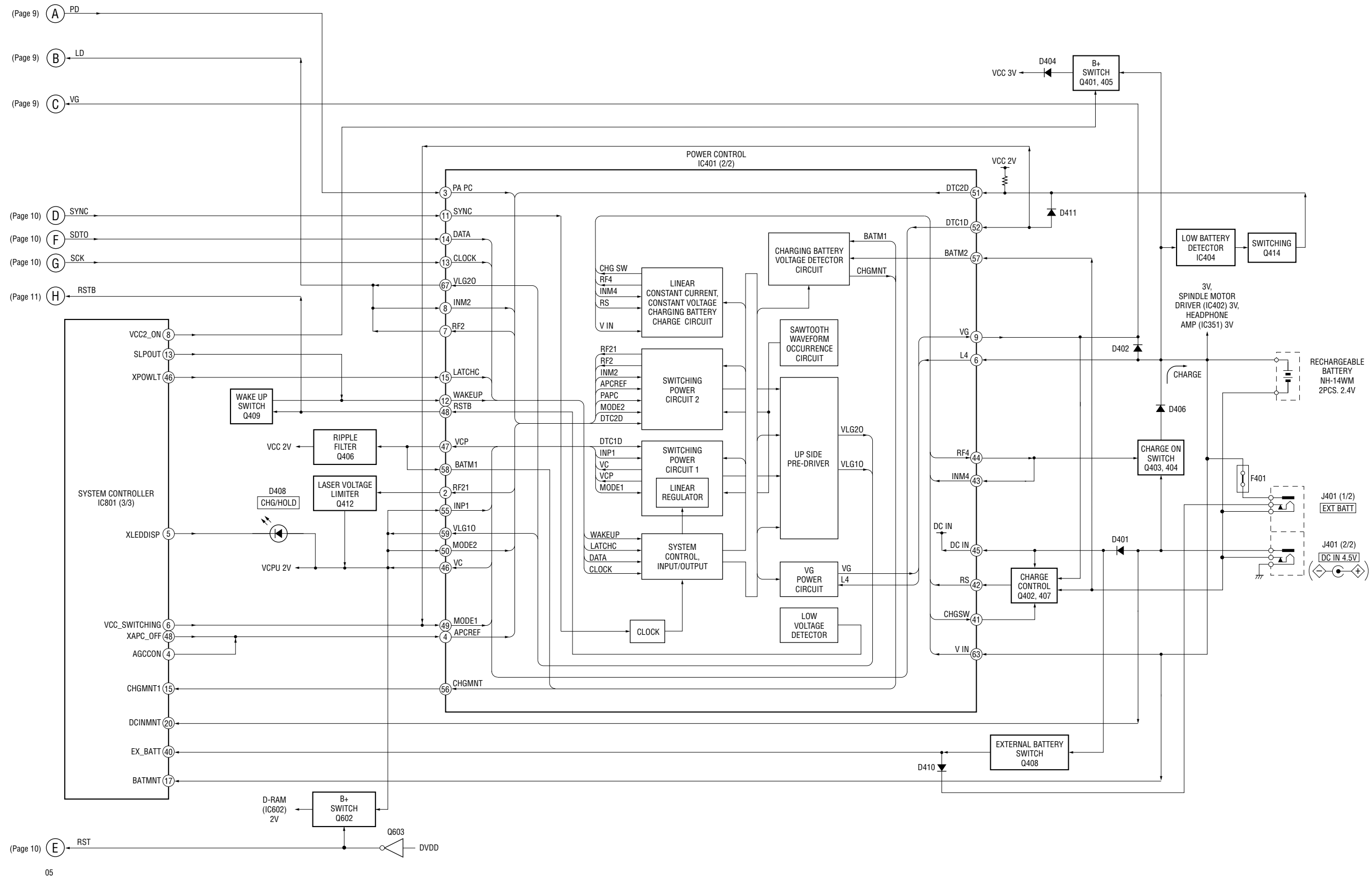

• Waveforms

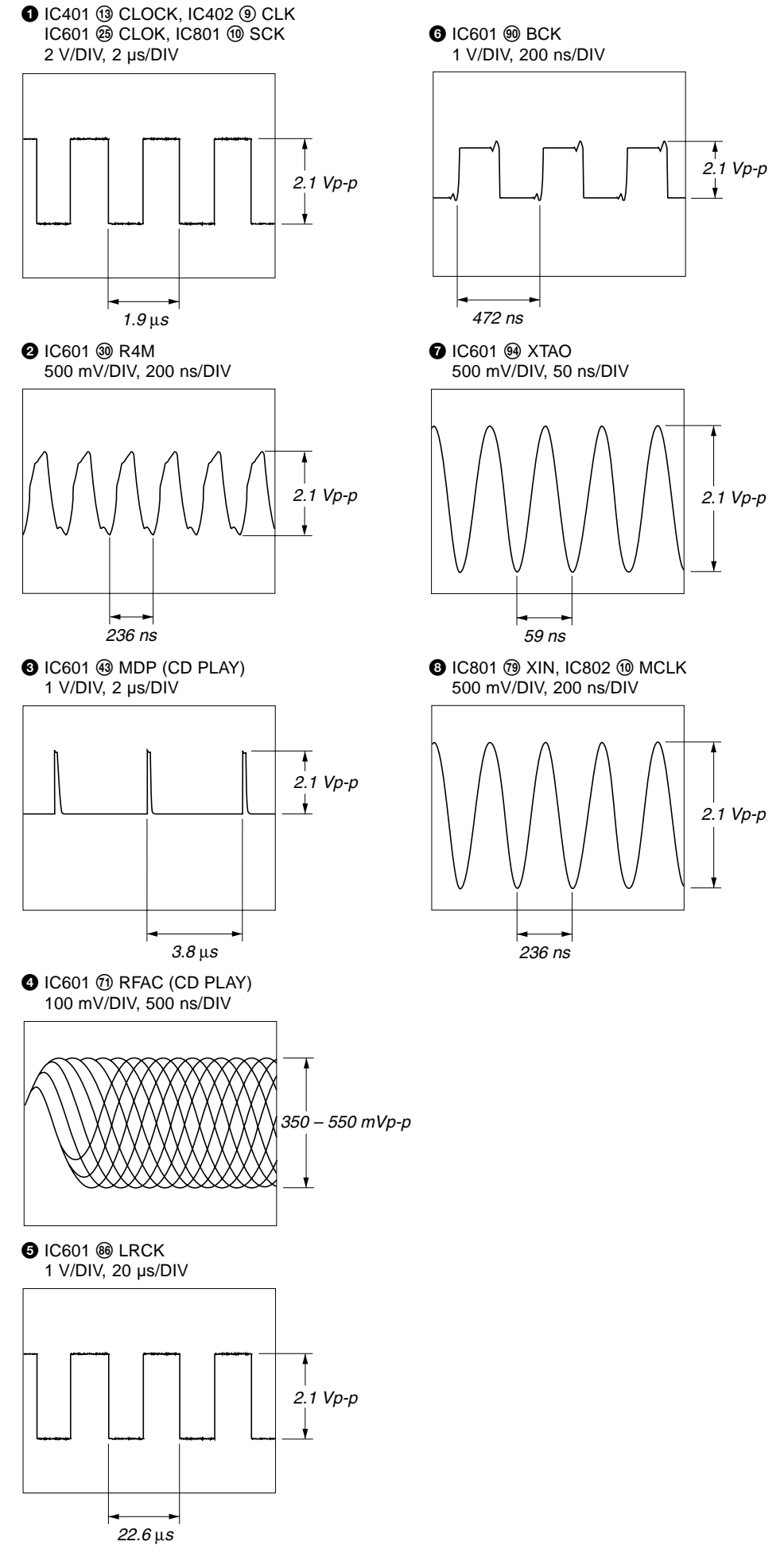

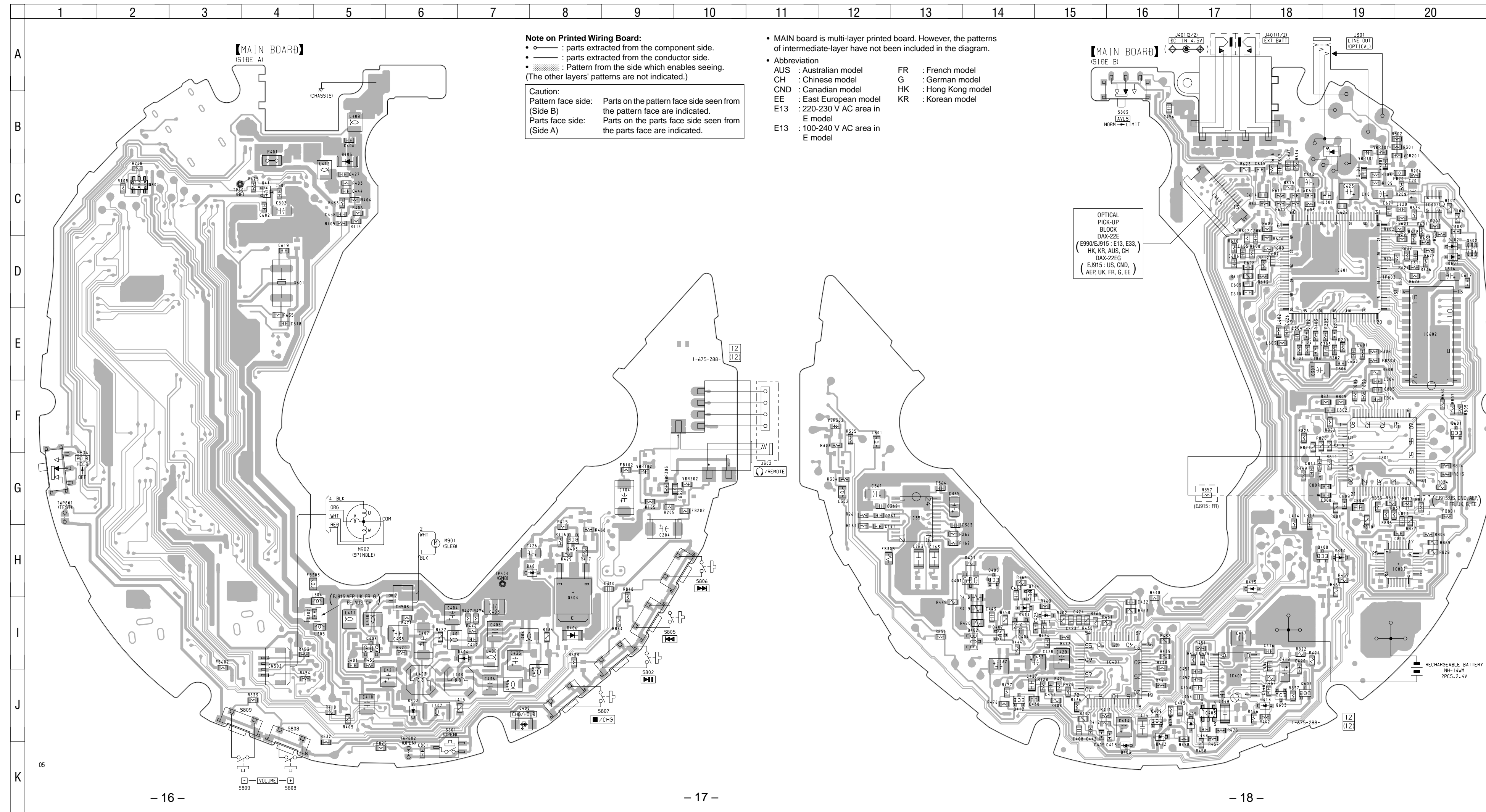

• Semiconductor Location

Ref. No.	Location
D401	H-8
D402	J-6
D403	K-16
D404	I-7
D405	B-5
D406	I-8
D408	J-7
D409	J-17
D410	H-19
D411	I-15
D412	J-16
D413	J-18
D414	I-14
D415	H-18
D601	D-20
D602	D-20
IC302	C-20
IC351	G-13
IC401	J-16
IC402	J-17
IC403	J-17
IC404	I-14
IC601	D-19
IC602	E-20
IC801	F-19
IC802	H-20
Q301	C-2
Q302	D-20
Q401	H-14
Q402	I-14
Q403	H-8
Q404	H-8
Q405	H-14
Q406	I-5
Q407	I-14
Q408	H-18
Q409	J-16
Q411	C-4
Q412	J-14
Q414	H-14
Q601	F-20
Q602	J-18
Q603	J-18

Note on Printed Wiring Board:

- : parts extracted from the component side.
- : parts extracted from the conductor side.
- ▨ : Pattern from the side which enables seeing. (The other layers' patterns are not indicated.)

Caution:

Pattern face side: Parts on the pattern face side seen from the pattern face are indicated. (Side B)

Parts face side: Parts on the parts face side seen from the parts face are indicated. (Side A)

• MAIN board is multi-layer printed board. However, the patterns of intermediate-layer have not been included in the diagram.

• Abbreviation

AUS : Australian model	FR : French model
CH : Chinese model	G : German model
CND : Canadian model	HK : Hong Kong model
EE : East European model	KR : Korean model
E13 : 220-230 V AC area in E model	
E13 : 100-240 V AC area in E model	

OPTICAL PICK-UP BLOCK
DAX-22E
(E990/EJ915: E13, E33, HK, KR, AUS, CH, DAX-22EG)
(EJ915: US, CND, AEP, UK, FR, G, EE)

RECHARGEABLE BATTERY
NH-14WM
2PC5.2.4V

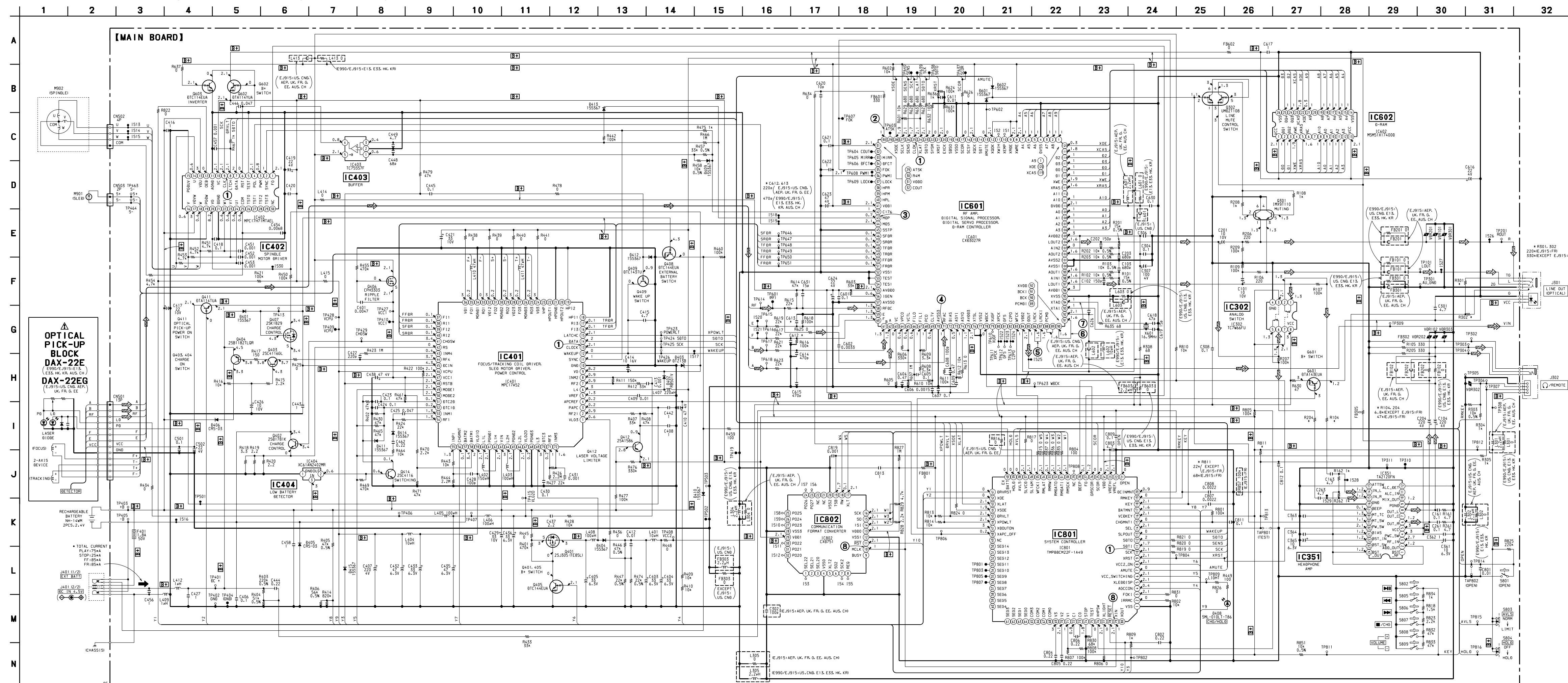

Note on Schematic Diagram:

- All capacitors are in μF unless otherwise noted. pF: μF 50 W or less are not indicated except for electrolytics and tantalums.
- All resistors are in Ω and $\frac{1}{4}$ W or less unless otherwise specified.
- % : indicates tolerance.
- [] : panel designation.

Note: The components identified by mark Δ or dotted line with mark Δ are critical for safety. Replace only with part number specified.

Note: Les composants identifiés par une marque Δ sont critiques pour la sécurité. Ne les remplacer que par une pièce portant le numéro spécifié.

- [B+]: B+ Line.
- Total current is measured with CD installed.
- Power voltage is dc 4.5 V and fed with regulated dc power supply from DC IN jack (J401).
- Voltages and waveforms are dc with respect to ground in playback mode. no mark : CD PLAY.
- Voltages are taken with a VOM (Input impedance 10 M Ω). Voltage variations may be noted due to normal production tolerances.
- Waveforms are taken with an oscilloscope. Voltage variations may be noted due to normal production tolerances.
- Circled numbers refer to waveforms.
- Signal path.
 - ➡ : CD PLAY (ANALOG OUT)
 - ➡ : CD PLAY (OPTICAL OUT)
- Abbreviation

AUS : Australian model	FR : French model
CH : Chinese model	G : German model
CND : Canadian model	HK : Hong Kong model
EE : East European model	KR : Korean model
E13 : 220-230 V AC area in E model	
E33 : 100-240 V AC area in E model	

• IC Block Diagrams

IC351 TA2120FN (EL)

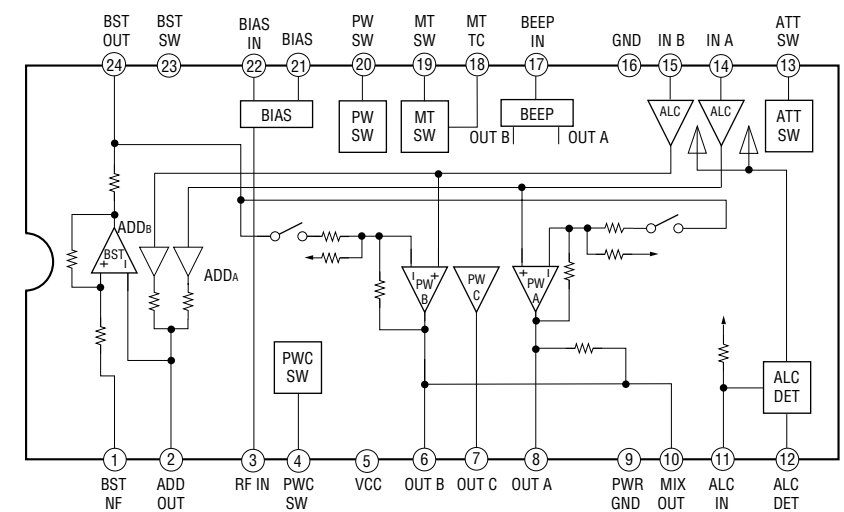

IC402 MPC17H71MTAEL

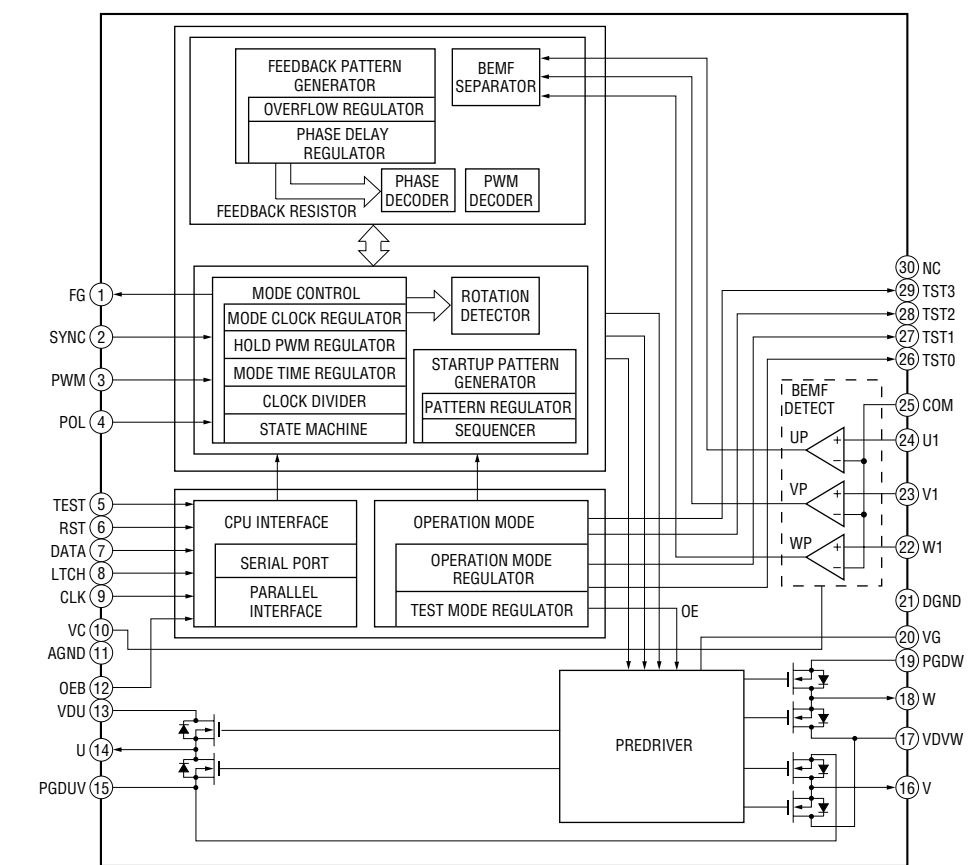

IC401 MPC17A52ZFTA

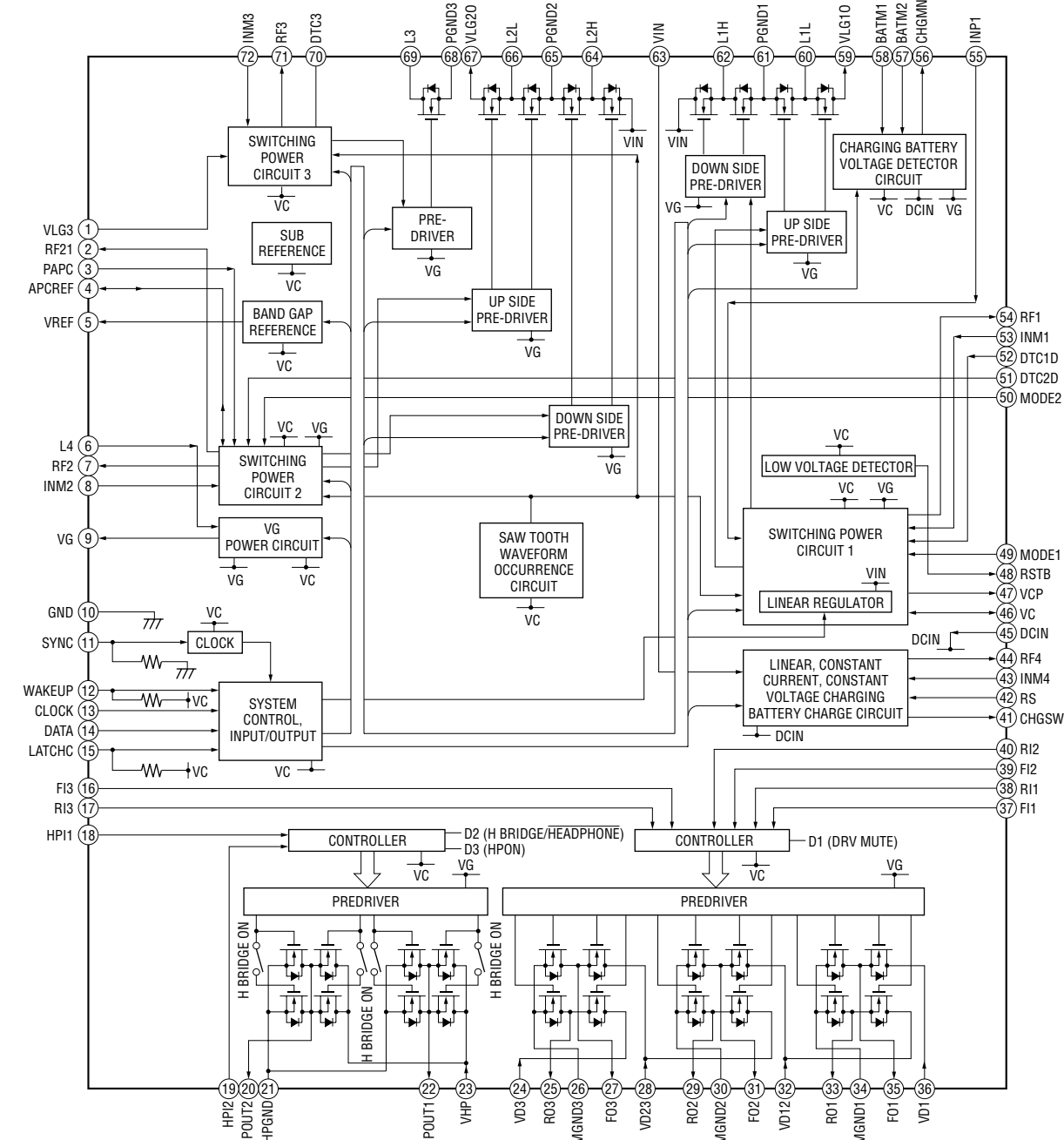

IC601 CXD3027R

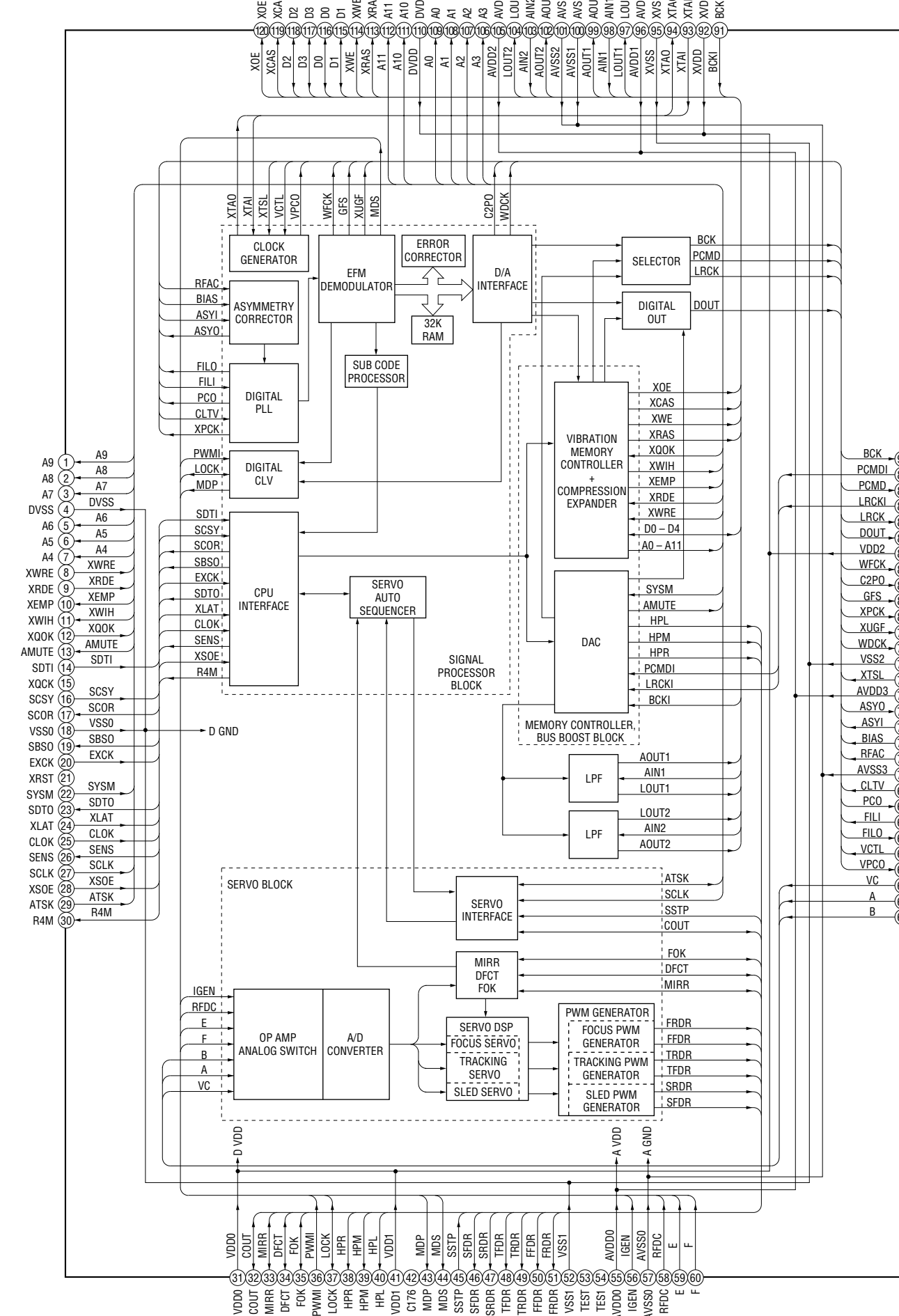

IC802 CXD751-103R

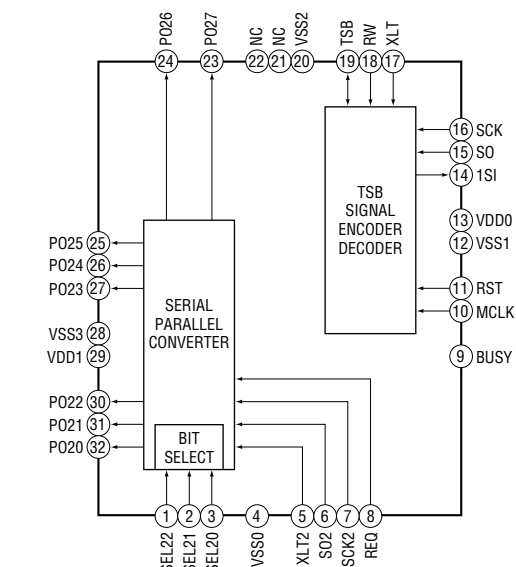

5-6. IC PIN FUNCTION DESCRIPTION

• IC801 TMP88CM22F-1A49 (SYSTEM CONTROLLER)

Pin No.	Pin Name	I/O	Description
1	VSS	—	Ground terminal
2	IRPMC	I	Not used (fixed at “L”)
3	FOKI	I	Focus OK signal input from the CXD3027R (IC601) “L”: NG, “H”: OK
4	AGCCON	O	AGC control pulse signal output terminal
5	XLEDDISP	O	CHG/HOLD LED (D408) control signal output terminal
6	VCC SWITCHING	O	Control signal output terminal for the switching power supply circuit
7	AMUTE	O	Analog audio muting ON/OFF control signal output terminal “H”: muting ON
8	VCC2 ON	O	VCC2 voltage control signal output terminal
9	XRST	O	Reset signal output to the headphone amp (IC351) and CXD3027R (IC601) “L”: reset
10	SCK	O	Serial data transfer clock signal output to the power control (IC401), spindle motor driver (IC402), and CXD3027R (IC601)
11	SDTI	I	Serial data input from the CXD3027R (IC601)
12	SDTO	O	Serial data output to the power control (IC401), spindle motor driver (IC402), and CXD3027R (IC601)
13	SLPOUT	O	Wake-up control signal output to the power control (IC401) (for system standby reset)
14	SEL	I	Plug-in detection signal input terminal of LINE OUT (OPTICAL) jack (J301) (A/D input)
15	CHGMNT1	I	Battery charge voltage detection input from the power control (IC401) (A/D input)
16	VCDKEY	I	Key input terminal Not used (Fixed at “H”)
17	BATMNT	I	Battery voltage detection signal input terminal
18	KEY	I	Key input from the S802, S805 to S809 (▶ , ◀◀, ▶▶, ■, VOLUME +/-) (A/D input)
19	RMKEY	I	Key input from the headphone with remote commander (A/D input)
20	DCINMNT	I	DC input voltage detection input terminal (A/D input) and DC input jack use/no use detection input terminal (A/D input)
21	OPEN	I	CD door open/close detection switch (S801) input terminal The stop status is reset with the falling edge of input signal
22	VREFL	I	Reference voltage input terminal (0V) for A/D converter
23	VREFH	I	Reference voltage input terminal (+2V) for A/D converter
24	VDD	—	Power supply terminal (+2V)
25	SCOR	I	Sub-code sync (S0+S1) detection signal input from the CXD3027R (IC601)
26	GRSCOR	I	Communication clock signal input from the CXD3027R (IC601)
27	FG	I	FG pulse signal input from the spindle motor driver (IC402)
28	BEEP	O	Beep sound signal output to the headphone amplifier (IC351)
29	NC	—	Not used (open)
30	RMSCK	O	Communication clock output to the communication format converter (IC802)
31	RMDATI	I	Communication data bus input of headphone with remote commander from the communication format converter (IC802)
32	RMDATO	O	Communication data bus output of headphone with remote commander to the communication format converter (IC802)
33	RMRW	O	Read/write control signal output of headphone with remote commander to the communication format converter (IC802) “L”: read mode, “H”: write mode
34	RMLAT	O	Serial data latch pulse signal output of headphone with remote commander to the communication format converter (IC802)
35	WFCKI	I	Demodulation signal input from the CXD3027R (IC601)
36	SL16M	I	E990/EJ915: E13, E33, Hong Kong, Korean, Australian, and Chinese models: Not used (open) EJ915: US, Canadian, AEP, UK, French, German, and East European models: Not used (pull up)

• Abbreviation E13: 220 to 230V AC area in E model, E33: 100 to 240V AC area in E model

Pin No.	Pin Name	I/O	Description
37	SLVCD	I	Not used (fixed at "H")
38	AVLS	I	AVLS (Automatic Volume Limiter System) switch (S803) input terminal "L": normal mode, "H": limit mode
39	HOLD	I	HOLD switch (S804) input terminal "L": hold ON, "H": hold OFF
40	EX BATT	I	External battery detection signal input terminal "H": external battery
41	DRVRST	O	Control signal output to the spindle motor driver (IC402)
42	XOE	O	Optical pick-up power ON/OFF control signal output terminal "L": ON
43	XLAT	O	Serial data latch pulse signal output to the CXD3027R (IC601)
44	XSOE	O	Serial data output enable signal output to the CXD3027R (IC601)
45	DRVLT	O	Latch signal output to the spindle motor driver (IC402)
46	XPOWLT	O	Latch signal output to the power control (IC401)
47	XDOUTON	O	Digital output LED control signal output terminal "L": ON
48	XAPC OFF	O	APC mute signal output terminal "L": mute
49	NC	—	Not used (open)
50 to 64	SEG14 to SEG0	O	Segment drive signal output terminal for the display Not used (open)
65 to 68	COM3 to COM0	O	Common drive signal output terminal for the display Not used (open)
69 to 71	V3 to V1	O	Bias signal output terminal for the display driver Not used
72, 73	C1, C0	O	Capacitor connected terminal for the display driver voltage-up (for bias)
74	STOP	I	Not used (fixed at "L")
75	TEST	I	Test terminal for internal connection (normally: fixed at "L")
76	XHPSW	O	ON/OFF control signal output to the headphone amp (IC351) "L": ON
77	XLIGHT	O	Back light control signal output terminal for the display Not used (fixed at "L")
78	$\overline{\text{RESET}}$	I	System reset signal input from the power control (IC401) "L": reset For several hundreds msec. after the power supply rises, "L" is input, then it changes to "H"
79	XIN	I	System clock input from the CXD3027R (IC601) (4.2336MHz: 1/4 dividing of 16.9MHz)
80	XOUT	O	System clock output terminal Not used (open)

SECTION 6 EXPLODED VIEWS

NOTE:

- -XX and -X mean standardized parts, so they may have some difference from the original one.

- Color Indication of Appearance Parts

Example:

KNOB, BALANCE (WHITE) . . . (RED)

↑
↑
 Parts Color Cabinet's Color

- Abbreviation

AUS : Australian model

CH : Chinese model

CND: Canadian model

EE : East European model

E13 : 220-230 V AC area in E model

E33 : 100-240 V AC area in E model

FR : French model

G : German model

HK : Hong Kong model

KR : Korean model

- Items marked “*” are not stocked since they are seldom required for routine service. Some delay should be anticipated when ordering these items.

- The mechanical parts with no reference number in the exploded views are not supplied.

- Accessories and packing materials are given in the last of the electrical parts list.

The components identified by mark \triangle or dotted line with mark \triangle are critical for safety. Replace only with part number specified.

Les composants identifiés par une marque \triangle sont critiques pour la sécurité. Ne les remplacer que par une pièce portant le numéro spécifié.

(1) CABINET SECTION-1

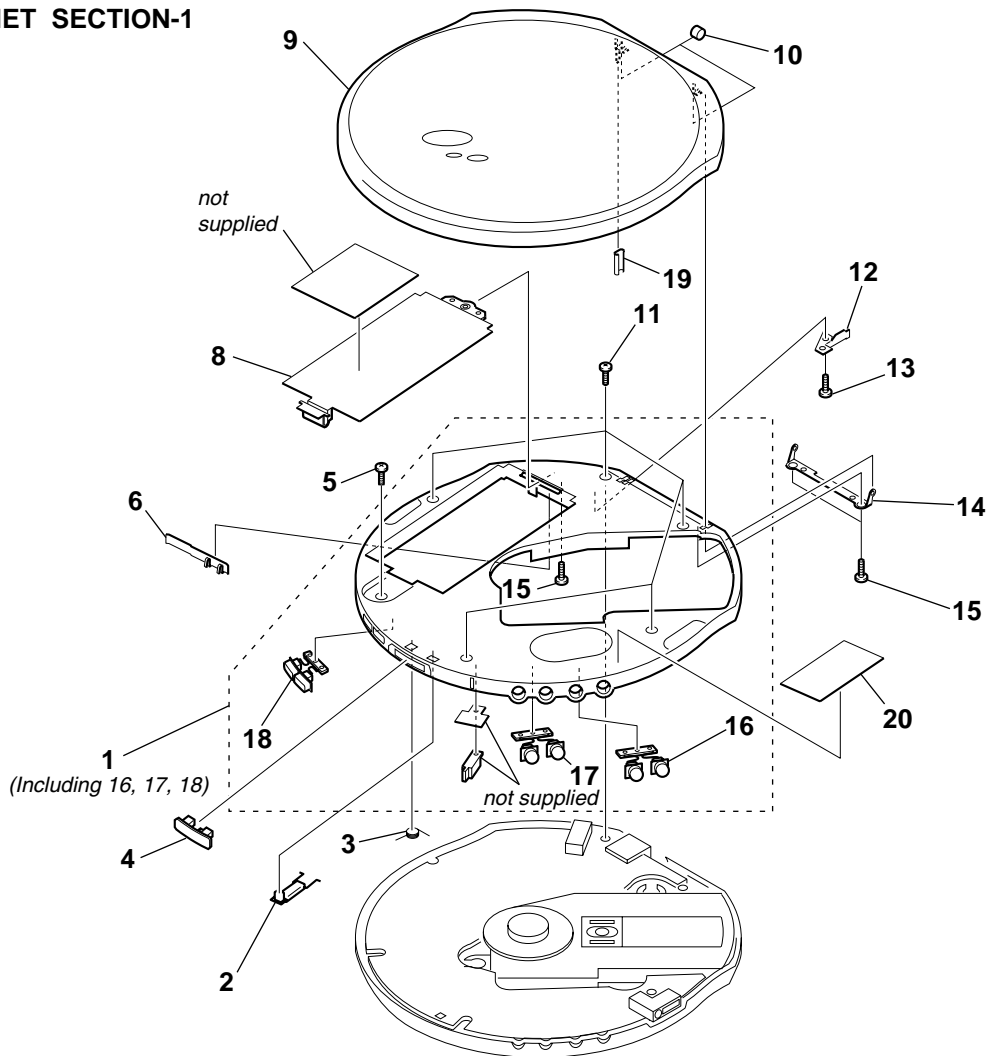

Ref. No.	Part No.	Description	Remark	Ref. No.	Part No.	Description	Remark
1	X-4952-197-1	CABINET (UPPER) SUB ASSY		11	4-908-792-91	SCREW (B2)	
2	4-224-036-01	LEVER, DETECTION		12	4-224-032-01	PLATE, CLICK	
3	4-224-035-01	SPRING (OPEN)		13	3-318-382-91	SCREW (1.7X2.5), TAPPING	
4	4-224-031-01	KNOB (OPEN)		14	4-224-046-01	BRACKET	
5	4-908-792-51	SCREW (B2)		15	4-908-792-01	SCREW (B2)	
6	4-224-026-01	TERMINAL BOARD (RELAY), BATTERY		16	4-224-029-01	BUTTON (FF)	
8	X-4952-199-1	LID SUB ASSY, BATTERY CASE		17	4-224-030-01	BUTTON (PLAY)	
9	X-4952-434-1	LID ASSY, UPPER (EJ915:AEP, UK, FR, G, EE)		18	4-224-028-01	BUTTON (VOL)	
9	X-4952-206-1	LID ASSY, UPPER (E990/EJ915:US, CND, E13, E33, HK, KR, CH, AUS)		19	3-044-608-01	REINFORCEMENT	
10	4-224-227-01	SPACER		* 20	3-378-433-01	SARANET CUSHION	

(2) CABINET SECTION-2

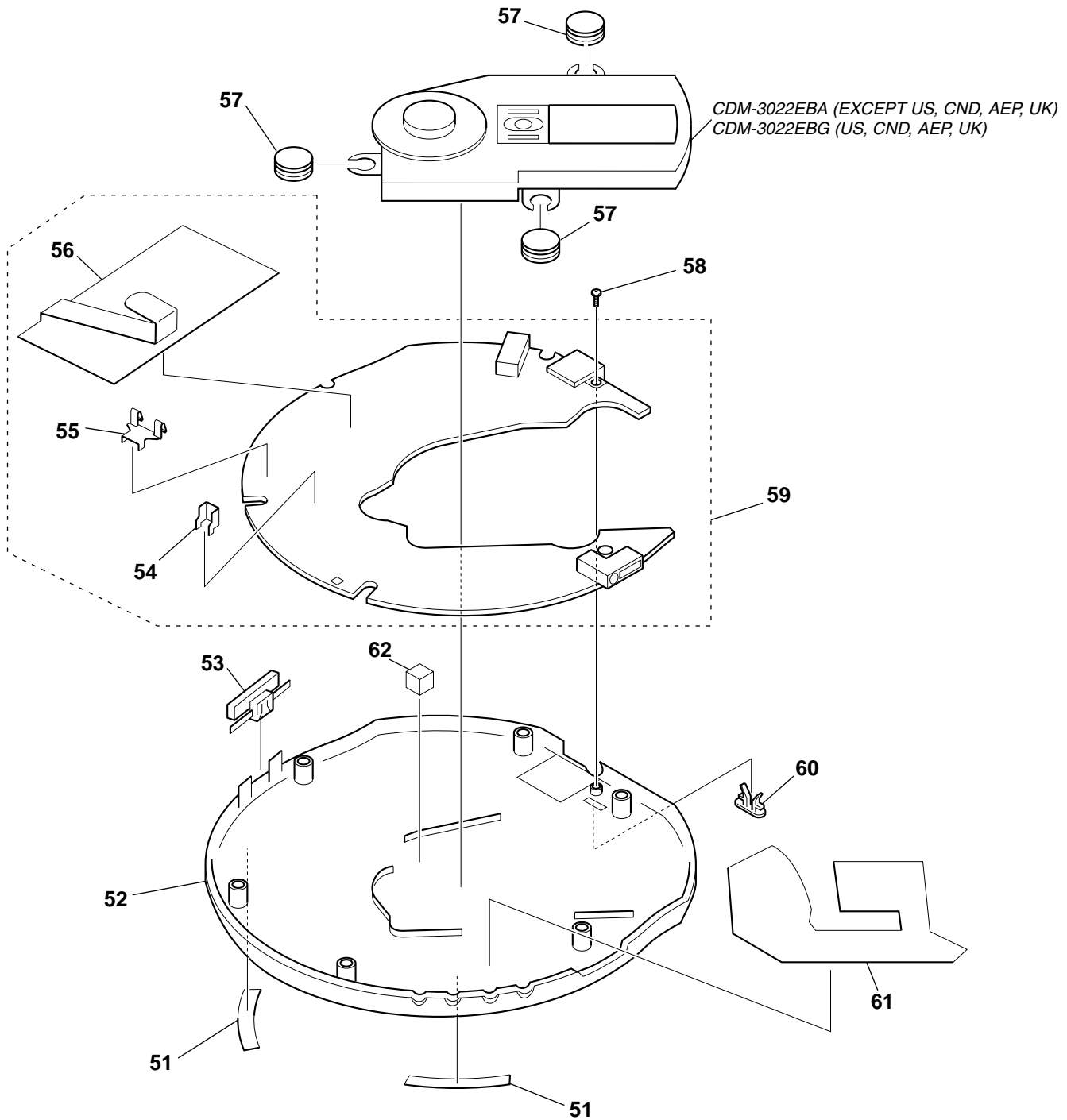

Ref. No.	Part No.	Description	Remark	Ref. No.	Part No.	Description	Remark
51	4-224-048-01	FOOT, RUBBER		59	A-3323-345-A	MAIN BOARD, COMPLETE	
52	4-224-039-01	CABINET (LOWER) (E990)				(E990/EJ915: E13, E33, HK, KR)	
52	4-224-039-11	CABINET (LOWER)		59	A-3323-360-A	MAIN BOARD, COMPLETE (EJ915: FR)	
		(EJ915: EXCEPT E13, HK)		59	A-3323-458-A	MAIN BOARD, COMPLETE (EJ915: US, CND)	
52	4-224-039-21	CABINET (REAR) (EJ915: E13, HK)		59	A-3323-490-A	MAIN BOARD, COMPLETE	
53	4-224-040-01	KNOB (HOLD)				(EJ915: AEP, UK, G, EE)	
54	4-224-024-01	TERMINAL BOARD (+), BATTERY		59	A-3323-508-A	MAIN BOARD, COMPLETE (EJ915: CH, AUS)	
55	3-045-365-01	TERMINAL BOARD (-), BATTERY		60	4-984-751-01	KNOB (AVLS)	
56	4-224-045-01	SHEET (LOWER), BATTERY		61	3-043-218-01	SHEET, RADIATION	
57	4-221-927-11	INSULATOR		62	3-043-420-01	CUSHION (MD)	
58	3-318-201-01	SCREW (B) (1.4X3), TAPPING					

(3) MECHANISM DECK SECTION
(CDM-3022EBA EXCEPT US, CND, AEP, UK)
(CDM-3022EBG US, CND, AEP, UK)

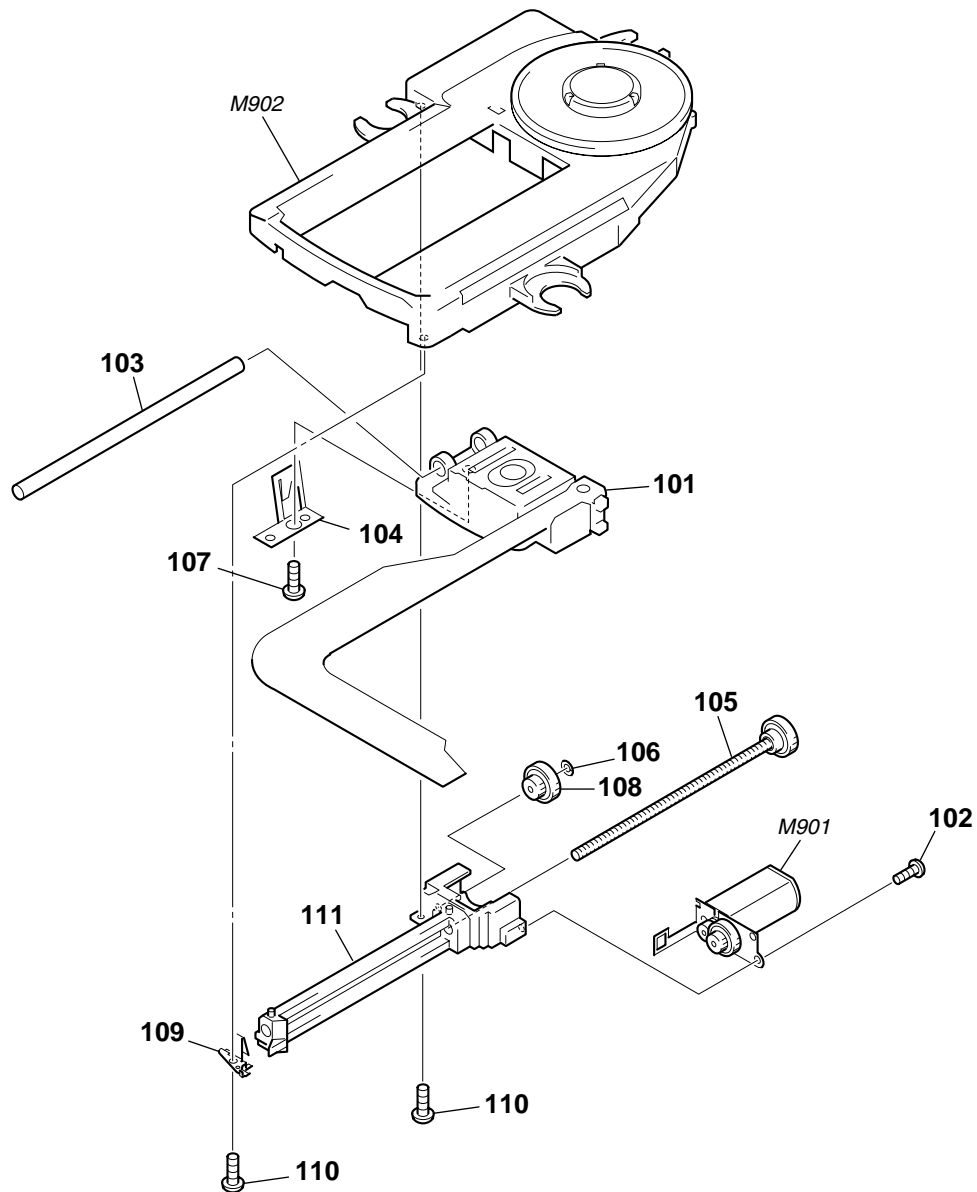

<p>The components identified by mark Δ or dotted line with mark Δ are critical for safety. Replace only with part number specified.</p>	<p>Les composants identifiés par une marque Δ sont critiques pour la sécurité. Ne les remplacer que par une pièce portant le numéro spécifié.</p>
---	---

Ref. No.	Part No.	Description	Remark	Ref. No.	Part No.	Description	Remark
Δ 101	X-3378-495-1	OPTICAL PICK-UP (DAX-22EG) (US, CND, AEP, UK)		106	3-338-645-31	WASHER (0.8-2.5)	
Δ 101	X-4952-079-1	OPTICAL PICK-UP (DAX-22E) (EXCEPT US, CND, AEP, UK)		107	3-686-458-03	SCREW (P1.4X3.5), TAPPING	
102	3-704-197-92	SCREW (M1.4X1.8), LOCKING		108	4-220-648-01	GEAR (C)	
103	4-220-645-01	SHAFT, STANDARD		109	X-4951-688-1	BRACKET ASSY, SLED	
104	4-220-646-01	RACK		110	3-348-998-61	SCREW (M1.4X4), TAPPING, PAN	
105	A-3328-298-A	SCREW ASSY, FEED		111	X-4951-687-1	BASE ASSY, SLED	
				M901	A-3328-299-A	MOTOR BLOCK ASSY, SLED	
				M902	A-3328-418-A	CHASSIS ASSY (SPINDLE)	

SECTION 7 ELECTRICAL PARTS LIST

NOTE:

- Due to standardization, replacements in the parts list may be different from the parts specified in the diagrams or the components used on the set.
- -XX and -X mean standardized parts, so they may have some difference from the original one.
- **RESISTORS**
All resistors are in ohms.
METAL: Metal-film resistor.
METAL OXIDE: Metal oxide-film resistor.
F: nonflammable
- **Abbreviation**
AUS : Australian model E33 : 100-240 V AC area in
CH : Chinese model E model
CND: Canadian model FR : French model
EE : East European model G : German model
E13 : 220-230 V AC area in E HK : Hong Kong model
 KR : Korean model

- Items marked “*” are not stocked since they are seldom required for routine service.
Some delay should be anticipated when ordering these items.
- **SEMICONDUCTORS**
In each case, u: μ , for example:
uA. . : μ A. . uPA. . : μ PA. .
uPB. . : μ PB. . uPC. . : μ PC. .
uPD. . : μ PD. .
- **CAPACITORS**
uF: μ F
• **COILS**
uH: μ H

The components identified by mark Δ or dotted line with mark Δ are critical for safety.
Replace only with part number specified.

Les composants identifiés par une marque Δ sont critiques pour la sécurité.
Ne les remplacer que par une pièce portant le numéro spécifié.

When indicating parts by reference number, please include the board.

<u>Ref. No.</u>	<u>Part No.</u>	<u>Description</u>	<u>Remark</u>	<u>Ref. No.</u>	<u>Part No.</u>	<u>Description</u>	<u>Remark</u>
	A-3323-345-A	MAIN BOARD, COMPLETE (E990/EJ915: E13, E33, HK, KR)		C406	1-164-156-11	CERAMIC CHIP 0.1uF	25V
	A-3323-360-A	MAIN BOARD, COMPLETE (EJ915: FR)		C407	1-125-899-11	TANTALUM CHIP 220uF	20% 4V
	A-3323-458-A	MAIN BOARD, COMPLETE (EJ915: US, CND)		C408	1-109-982-11	CERAMIC CHIP 1uF	10% 10V
	A-3323-490-A	MAIN BOARD, COMPLETE (EJ915: AEP, UK, G, EE)		C409	1-162-970-11	CERAMIC CHIP 0.01uF	10% 25V
	A-3323-508-A	MAIN BOARD, COMPLETE (EJ915: CH, AUS) *****		C410	1-110-569-11	TANTALUM CHIP 47uF	20% 4V
	3-045-365-01	TERMINAL BOARD (-), BATTERY		C412	1-162-970-11	CERAMIC CHIP 0.01uF	10% 25V
	4-224-024-01	TERMINAL BOARD (+), BATTERY		C413	1-162-964-11	CERAMIC CHIP 0.001uF	10% 50V
	4-224-045-01	SHEET (LOWER), BATTERY		C414	1-104-913-11	TANTALUM CHIP 10uF	20% 16V
	< CAPACITOR >			C415	1-115-566-11	CERAMIC CHIP 4.7uF	10% 10V
C101	1-104-851-11	TANTALUM CHIP 10uF	20% 10V	C416	1-115-156-11	CERAMIC CHIP 1uF	10V
C102	1-164-217-11	CERAMIC CHIP 150PF	5% 50V	C417	1-104-852-11	TANTALUM CHIP 22uF	20% 10V
C103	1-162-963-11	CERAMIC CHIP 680PF	10% 50V	C418	1-164-156-11	CERAMIC CHIP 0.1uF	25V
C104	1-125-899-11	TANTALUM CHIP 220uF	20% 4V	C419	1-104-847-11	TANTALUM CHIP 22uF	20% 4V
C161	1-107-826-11	CERAMIC CHIP 0.1uF	10% 16V	C420	1-115-156-11	CERAMIC CHIP 1uF	10V
C163	1-115-566-11	CERAMIC CHIP 4.7uF	10% 10V	C421	1-113-682-11	TANTALUM CHIP 33uF	20% 10V
C201	1-104-851-11	TANTALUM CHIP 10uF	20% 10V	C422	1-162-960-11	CERAMIC CHIP 220PF	10% 50V
C202	1-164-217-11	CERAMIC CHIP 150PF	5% 50V	C423	1-164-156-11	CERAMIC CHIP 0.1uF	25V
C203	1-162-963-11	CERAMIC CHIP 680PF	10% 50V	C424	1-164-156-11	CERAMIC CHIP 0.1uF	25V
C204	1-125-899-11	TANTALUM CHIP 220uF	20% 4V	C425	1-165-176-11	CERAMIC CHIP 0.047uF	10% 16V
C261	1-107-826-11	CERAMIC CHIP 0.1uF	10% 16V	C426	1-104-851-11	TANTALUM CHIP 10uF	20% 10V
C263	1-115-566-11	CERAMIC CHIP 4.7uF	10% 10V	C427	1-115-156-11	CERAMIC CHIP 1uF	10V
C301	1-117-720-11	CERAMIC CHIP 4.7uF	10V	C428	1-162-927-11	CERAMIC CHIP 100PF	5% 50V
C302	1-162-927-11	CERAMIC CHIP 100PF	5% 50V	C429	1-113-682-11	TANTALUM CHIP 33uF	20% 10V
C304	1-164-156-11	CERAMIC CHIP 0.1uF	25V	C430	1-107-826-11	CERAMIC CHIP 0.1uF	10% 16V
C306	1-115-156-11	CERAMIC CHIP 1uF	10V	C431	1-162-964-11	CERAMIC CHIP 0.001uF	10% 50V
C307	1-127-569-11	TANTALUM CHIP 100uF	20% 4V	C432	1-110-569-11	TANTALUM CHIP 47uF	20% 6.3V
C308	1-164-156-11	CERAMIC CHIP 0.1uF	25V	C433	1-104-752-11	TANTALUM CHIP 33uF	20% 6.3V
C361	1-135-259-11	TANTALUM CHIP 10uF	20% 6.3V	C435	1-110-569-11	TANTALUM CHIP 47uF	20% 6.3V
C362	1-115-156-11	CERAMIC CHIP 1uF	10V	C436	1-104-752-11	TANTALUM CHIP 33uF	20% 6.3V
C363	1-125-837-11	CERAMIC CHIP 1uF	10% 6.3V	C437	1-125-838-11	CERAMIC CHIP 2.2uF	10% 6.3V
C364	1-115-156-11	CERAMIC CHIP 1uF	10V	C438	1-110-569-11	TANTALUM CHIP 47uF	20% 4V
C365	1-135-259-11	TANTALUM CHIP 10uF	20% 6.3V	C442	1-115-156-11	CERAMIC CHIP 1uF	10V
C401	1-162-968-11	CERAMIC CHIP 0.0047uF	10% 50V	C443	1-115-156-11	CERAMIC CHIP 1uF	10V
C403	1-104-752-11	TANTALUM CHIP 33uF	20% 6.3V	C444	1-115-467-11	CERAMIC CHIP 0.22uF	10% 10V
C404	1-104-752-11	TANTALUM CHIP 33uF	20% 6.3V	C445	1-164-156-11	CERAMIC CHIP 0.1uF	25V
C405	1-104-752-11	TANTALUM CHIP 33uF	20% 6.3V	C446	1-165-176-11	CERAMIC CHIP 0.047uF	10% 16V
				C448	1-162-925-11	CERAMIC CHIP 68PF	5% 50V
				C449	1-115-566-11	CERAMIC CHIP 4.7uF	10% 10V
				C451	1-162-964-11	CERAMIC CHIP 0.001uF	10% 50V
				C452	1-162-964-11	CERAMIC CHIP 0.001uF	10% 50V

Ref. No.	Part No.	Description	Remark	Ref. No.	Part No.	Description	Remark
C453	1-162-964-11	CERAMIC CHIP	0.001uF 10%	50V		< DIODE >	
C454	1-162-969-11	CERAMIC CHIP	0.0068uF 10%	25V			
C456	1-115-156-11	CERAMIC CHIP	1uF	10V	D401	8-719-049-09	DIODE 1SS367-T3SONY
C457	1-162-964-11	CERAMIC CHIP	0.001uF 10%	50V	D402	8-719-058-24	DIODE RBS01V-40TE-17
C458	1-115-156-11	CERAMIC CHIP	1uF	10V	D403	8-719-977-40	DIODE UDZ-TE-17-13B
C462	1-115-467-11	CERAMIC CHIP	0.22uF 10%	10V	D404	8-719-049-09	DIODE 1SS367-T3SONY
C501	1-164-156-11	CERAMIC CHIP	0.1uF	25V	D405	8-719-077-01	DIODE CRS03 (TE85L)
C502	1-104-847-11	TANTALUM CHIP	22uF 20%	4V	D406	8-719-077-01	DIODE CRS03 (TE85L)
C601	1-164-156-11	CERAMIC CHIP	0.1uF	25V	D408	8-719-078-28	LED SML-010LT-T86 (CHG/HOLD)
C602	1-162-967-11	CERAMIC CHIP	0.0033uF 10%	50V	D409	8-719-049-09	DIODE 1SS367-T3SONY
C604	1-125-891-11	CERAMIC CHIP	0.47uF 10%	10V	D410	8-719-049-09	DIODE 1SS367-T3SONY
C605	1-107-826-11	CERAMIC CHIP	0.1uF 10%	16V	D411	8-719-049-09	DIODE 1SS367-T3SONY
C606	1-162-965-11	CERAMIC CHIP	0.0015uF 10%	50V	D412	8-719-049-09	DIODE 1SS367-T3SONY
C607	1-164-156-11	CERAMIC CHIP	0.1uF	25V	D413	8-719-049-09	DIODE 1SS367-T3SONY
C608	1-162-927-11	CERAMIC CHIP	100PF 5%	50V	D414	8-719-049-09	DIODE 1SS367-T3SONY
C609	1-125-891-11	CERAMIC CHIP	0.47uF 10%	10V	D415	8-719-049-09	DIODE 1SS367-T3SONY
C611	1-162-970-11	CERAMIC CHIP	0.01uF 10%	25V	D601	8-719-049-09	DIODE 1SS367-T3SONY
C612	1-162-960-11	CERAMIC CHIP	220PF 10%	50V	D602	8-719-049-09	DIODE 1SS367-T3SONY
			(EJ915: US, CND, AEP, UK, FR, G, EE)			< IC RINK >	
C612	1-162-962-11	CERAMIC CHIP	470PF 10%	50V	F401	1-576-427-21	RINK, CHIP IC 1.8A 50V
			(E990/EJ915: E13, E33, HK, KR, AUS, CH)			< FERRITE BEAD/COIL/RESISTOR >	
C613	1-162-960-11	CERAMIC CHIP	220PF 10%	50V			
			(EJ915: US, CND, AEP, UK, FR, G, EE)				
C613	1-162-962-11	CERAMIC CHIP	470PF 10%	50V	FB101	1-216-864-11	METAL CHIP 0 5% 1/16W
			(E990/EJ915: E13, E33, HK, KR, AUS, CH)				(E990/EJ915: US, CND, E13, E33, HK, KR)
C614	1-162-962-11	CERAMIC CHIP	470PF 10%	50V	FB101	1-414-760-21	FERRITE BEAD
C615	1-162-962-11	CERAMIC CHIP	470PF 10%	50V			(EJ915: AEP, UK, FR, G, EE, AUS, CH)
C616	1-104-847-11	TANTALUM CHIP	22uF 20%	4V	FB102	1-216-864-11	METAL CHIP 0 5% 1/16W
C617	1-115-156-11	CERAMIC CHIP	1uF	10V			(E990/EJ915: US, CND, E13, E33, HK, KR)
C618	1-162-923-11	CERAMIC CHIP	47PF 5%	50V	FB102	1-414-760-21	FERRITE BEAD
C619	1-162-917-11	CERAMIC CHIP	15PF 5%	50V			(EJ915: AEP, UK, FR, G, EE, AUS, CH)
C620	1-162-915-11	CERAMIC CHIP	10PF 0.5PF	50V	FB201	1-216-864-11	METAL CHIP 0 5% 1/16W
C621	1-164-156-11	CERAMIC CHIP	0.1uF	25V			(E990/EJ915: US, CND, E13, E33, HK, KR)
C622	1-115-156-11	CERAMIC CHIP	1uF	10V	FB201	1-414-760-21	FERRITE BEAD
C623	1-110-569-11	TANTALUM CHIP	47uF 20%	4V			(EJ915: AEP, UK, FR, G, EE, AUS, CH)
C624	1-104-847-11	TANTALUM CHIP	22uF 20%	4V	FB202	1-216-864-11	METAL CHIP 0 5% 1/16W
C626	1-115-156-11	CERAMIC CHIP	1uF	10V			(E990/EJ915: US, CND, E13, E33, HK, KR)
C630	1-164-156-11	CERAMIC CHIP	0.1uF	25V	FB202	1-414-760-21	FERRITE BEAD
C631	1-162-917-11	CERAMIC CHIP	15PF 5%	50V			(EJ915: AEP, UK, FR, G, EE, AUS, CH)
C801	1-162-970-11	CERAMIC CHIP	0.01uF 10%	25V	FB301	1-216-864-11	METAL CHIP 0 5% 1/16W
C802	1-115-467-11	CERAMIC CHIP	0.22uF 10%	10V			(E990/EJ915: US, CND, E13, E33, HK, KR)
C803	1-117-720-11	CERAMIC CHIP	4.7uF	10V	FB301	1-414-760-21	FERRITE BEAD
							(EJ915: AEP, UK, FR, G, EE, AUS, CH)
C804	1-165-128-11	CERAMIC CHIP	0.22uF	16V	FB302	1-414-760-21	FERRITE BEAD
C805	1-165-128-11	CERAMIC CHIP	0.22uF	16V	FB303	1-216-295-00	SHORT 0 (EXCEPT EJ915: US, CND)
C806	1-165-128-11	CERAMIC CHIP	0.22uF	16V	FB303	1-410-997-22	INDUCTOR CHIP 2.2uH (EJ915: US, CND)
C807	1-162-966-11	CERAMIC CHIP	0.0022uF 10%	50V	FB305	1-216-295-00	SHORT 0
C808	1-162-966-11	CERAMIC CHIP	0.0022uF 10%	50V	FB601	1-216-815-11	METAL CHIP 330 5% 1/16W
C809	1-164-156-11	CERAMIC CHIP	0.1uF	25V	FB602	1-216-864-11	METAL CHIP 0 5% 1/16W
C811	1-164-156-11	CERAMIC CHIP	0.1uF	25V	FB603	1-216-864-11	METAL CHIP 0 5% 1/16W
C812	1-164-156-11	CERAMIC CHIP	0.1uF	25V			(E990/EJ915: US, CND, E13, E33, HK, KR)
C813	1-115-156-11	CERAMIC CHIP	1uF	10V	FB603	1-410-997-22	INDUCTOR CHIP 2.2uH
C819	1-162-964-11	CERAMIC CHIP	0.001uF 10%	50V			(EJ915: AEP, UK, FR, G, EE, AUS, CH)
					FB801	1-216-864-11	METAL CHIP 0 5% 1/16W
			< CONNECTOR >			< IC >	
CN501	1-573-922-21	CONNECTOR, FFC/FPC (ZIF) 13P			IC302	8-759-488-29	IC TC7W66FU (TE12R)
* CN502	1-785-877-21	HOUSING, CONNECTOR 4P			IC351	8-759-522-87	IC TA2120FN (EL)
CN503	1-784-342-21	HOUSING, CONNECTOR 2P			IC401	8-759-655-73	IC MPC17A52ZFTA
					IC402	8-759-594-58	IC MPC17H71MTAEL

MAIN

Ref. No.	Part No.	Description	Remark	Ref. No.	Part No.	Description	Remark
IC403	8-759-594-55	IC TC75S57F (TE85R)				< TRANSISTOR >	
IC404	8-759-653-10	IC XC61AN2402MR		Q301	8-729-043-90	TRANSISTOR	IMX9T110
IC601	8-752-398-18	IC CXD3027R		Q302	8-729-930-00	TRANSISTOR	UMD2
IC602	8-759-594-56	IC MSM51X17400D-10TFSR1		Q401	8-729-023-89	FET	2SJ305 (TE85L)
IC801	8-759-658-93	IC TMP88CM22F-1A49		Q402	8-729-921-73	TRANSISTOR	2SD1781K-QR
IC802	8-752-397-55	IC CXD751-103R		Q403	8-729-231-74	TRANSISTOR	2SC4116-GL
		< JACK >		Q404	8-729-921-93	TRANSISTOR	2SB1182F5-QR
J301	1-793-659-11	JACK, OPTICAL OUT (LINE OUT (OPTICAL))		Q405	8-729-029-14	TRANSISTOR	DTC144EUA-T106
J302	1-793-288-11	JACK (○/REMOTE)		Q406	8-729-047-36	FET	CPH3303-TL
J401	1-793-156-12	JACK, DC (EXT BATT/DC IN 4.5V)		Q407	8-729-028-26	FET	2SK1829 (TE85L)
		< COIL/FERRITE BEAD/RESISTOR >		Q408	8-729-029-14	TRANSISTOR	DTC144EUA-T106
L301	1-216-295-00	SHORT 0		Q409	8-729-029-10	TRANSISTOR	DTC143TUA-T106
		(E990/EJ915: US, CND, E13, E33, HK, KR)		Q411	8-729-028-74	TRANSISTOR	DTA114TUA-T106
L301	1-410-997-22	INDUCTOR CHIP 2.2uH		Q412	8-729-230-60	TRANSISTOR	2SA1586-YG
		(EJ915: AEP, UK, FR, G, EE, AUS, CH)		Q414	8-729-231-74	TRANSISTOR	2SC4116-GL
L302	1-216-295-00	SHORT 0		Q601	8-729-028-86	TRANSISTOR	DTA143EUA-T106
		(E990/EJ915: E13, E33, HK, KR)		Q602	8-729-028-76	TRANSISTOR	DTA114YUA-T106
L302	1-410-997-22	INDUCTOR CHIP 2.2uH (EJ915: US, CND, AEP, UK, FR, G, EE, AUS, CH)		Q603	8-729-907-00	TRANSISTOR	DTC114EU
L304	1-216-295-00	SHORT 0				< RESISTOR >	
		(EJ915: AEP, UK, FR, G, EE, AUS, CH)		R101	1-218-875-11	METAL CHIP	15K 0.5% 1/16W
L304	1-410-997-22	INDUCTOR CHIP 2.2uH		R102	1-218-871-11	METAL CHIP	10K 0.5% 1/16W
		(E990/EJ915: US, CND, E13, E33, HK, KR)		R103	1-218-871-11	METAL CHIP	10K 0.5% 1/16W
L305	1-216-295-00	SHORT 0		R104	1-216-831-11	METAL CHIP	6.8K 5% 1/16W
		(EJ915: AEP, UK, FR, G, EE, AUS, CH)					(EXCEPT EJ915: FR)
L305	1-410-997-22	INDUCTOR CHIP 2.2uH		R104	1-216-841-11	METAL CHIP	47K 5% 1/16W
		(E990/EJ915: US, CND, E13, E33, HK, KR)					(EJ915: FR)
L401	1-414-398-11	INDUCTOR 10uH		R105	1-216-815-11	METAL CHIP	330 5% 1/16W
L402	1-419-189-21	INDUCTOR 150uH		R106	1-216-813-11	METAL CHIP	220 5% 1/16W
L403	1-419-188-21	INDUCTOR 100uH		R107	1-216-845-11	METAL CHIP	100K 5% 1/16W
L404	1-414-398-11	INDUCTOR 10uH		R108	1-216-821-11	METAL CHIP	1K 5% 1/16W
L405	1-414-404-41	INDUCTOR 100uH		R109	1-216-845-11	METAL CHIP	100K 5% 1/16W
L406	1-414-404-41	INDUCTOR 100uH		R161	1-216-793-11	RES, CHIP	4.7 5% 1/16W
L407	1-414-435-21	INDUCTOR 220uH		R162	1-216-821-11	METAL CHIP	1K 5% 1/16W
L408	1-414-404-41	INDUCTOR 100uH		R201	1-218-875-11	METAL CHIP	15K 0.5% 1/16W
L409	1-414-392-41	INDUCTOR 1uH		R202	1-218-871-11	METAL CHIP	10K 0.5% 1/16W
L410	1-414-402-11	INDUCTOR 47uH		R203	1-218-871-11	METAL CHIP	10K 0.5% 1/16W
L411	1-414-402-11	INDUCTOR 47uH		R204	1-216-831-11	METAL CHIP	6.8K 5% 1/16W
L412	1-414-392-41	INDUCTOR 1uH					(EXCEPT EJ915: FR)
L413	1-216-864-11	METAL CHIP 0 5% 1/16W		R204	1-216-841-11	METAL CHIP	47K 5% 1/16W
		(E990/EJ915: E13, E33, HK, KR)					(EJ915: FR)
L413	1-414-760-21	FERRITE BEAD		R205	1-216-815-11	METAL CHIP	330 5% 1/16W
		(EJ915: US, CND, AEP, UK, FR, G, EE, AUS, CH)		R206	1-216-813-11	METAL CHIP	220 5% 1/16W
L414	1-216-864-11	METAL CHIP 0 5% 1/16W		R207	1-216-845-11	METAL CHIP	100K 5% 1/16W
L415	1-216-295-00	SHORT 0		R208	1-216-821-11	METAL CHIP	1K 5% 1/16W
L601	1-216-864-11	METAL CHIP 0 5% 1/16W		R209	1-216-845-11	METAL CHIP	100K 5% 1/16W
		(E990/EJ915: E13, E33, HK, KR)		R261	1-216-793-11	RES, CHIP	4.7 5% 1/16W
L601	1-410-997-22	INDUCTOR CHIP 2.2uH		R262	1-216-821-11	METAL CHIP	1K 5% 1/16W
		(EJ915: AEP, UK, FR, G, EE, AUS, CH)		R301	1-216-849-11	METAL CHIP	220K 5% 1/16W
L601	1-414-760-21	FERRITE BEAD (EJ915: US, CND)					(EJ915: FR)
L602	1-414-760-21	FERRITE BEAD		R301	1-216-851-11	METAL CHIP	330K 5% 1/16W
		(EJ915: US, CND, AEP, UK, FR, G, EE, AUS, CH)					(EXCEPT EJ915: FR)
L602	1-414-521-11	INDUCTOR CHIP 10uH		R302	1-216-849-11	METAL CHIP	220K 5% 1/16W
		(E990/EJ915: E13, E33, HK, KR)					(EJ915: FR)
L603	1-216-864-11	METAL CHIP 0 5% 1/16W		R302	1-216-851-11	METAL CHIP	330K 5% 1/16W
		(E990/EJ915: US, CND, E13, E33, HK, KR)					(EXCEPT EJ915: FR)
L603	1-414-760-21	FERRITE BEAD		R303	1-218-871-11	METAL CHIP	10K 0.5% 1/16W
		(EJ915: AEP, UK, FR, G, EE, AUS, CH)		R304	1-216-821-11	METAL CHIP	1K 5% 1/16W

Ref. No.	Part No.	Description			Remark	Ref. No.	Part No.	Description			Remark
R305	1-216-821-11	METAL CHIP	1K	5%	1/16W	R466	1-216-857-11	METAL CHIP	1M	5%	1/16W
R308	1-216-807-11	METAL CHIP	68	5%	1/16W	R467	1-216-821-11	METAL CHIP	1K	5%	1/16W
R401	1-216-853-11	METAL CHIP	470K	5%	1/16W						
R402	1-216-841-11	METAL CHIP	47K	5%	1/16W	R469	1-216-853-11	METAL CHIP	470K	5%	1/16W
R403	1-218-903-11	METAL CHIP	220K	0.5%	1/16W	R470	1-216-825-11	METAL CHIP	2.2K	5%	1/16W
						R471	1-216-841-11	METAL CHIP	47K	5%	1/16W
R404	1-218-888-11	METAL CHIP	51K	0.5%	1/16W	R474	1-218-879-11	METAL CHIP	22K	0.5%	1/16W
R405	1-218-887-11	METAL CHIP	47K	0.5%	1/16W	R475	1-216-821-11	METAL CHIP	1K	5%	1/16W
R406	1-218-889-11	METAL CHIP	56K	0.5%	1/16W						
R407	1-216-839-11	METAL CHIP	33K	5%	1/16W	R476	1-216-851-11	METAL CHIP	330K	5%	1/16W
R408	1-216-841-11	METAL CHIP	47K	5%	1/16W	R477	1-216-845-11	METAL CHIP	100K	5%	1/16W
						R478	1-216-864-11	METAL CHIP	0	5%	1/16W
R409	1-216-833-11	RES. CHIP	10K	5%	1/16W	R479	1-216-841-11	METAL CHIP	47K	5%	1/16W
R410	1-216-833-11	RES. CHIP	10K	5%	1/16W	R601	1-216-833-11	RES. CHIP	10K	5%	1/16W
R411	1-216-847-11	METAL CHIP	150K	5%	1/16W						
R412	1-216-839-11	METAL CHIP	33K	5%	1/16W	R602	1-216-833-11	RES. CHIP	10K	5%	1/16W
R414	1-218-917-11	METAL CHIP	820K	0.5%	1/16W	R603	1-216-839-11	METAL CHIP	33K	5%	1/16W
						R605	1-216-864-11	METAL CHIP	0	5%	1/16W
R415	1-216-825-11	METAL CHIP	2.2K	5%	1/16W	R606	1-216-851-11	METAL CHIP	330K	5%	1/16W
R416	1-216-833-11	RES. CHIP	10K	5%	1/16W	R607	1-216-857-11	METAL CHIP	1M	5%	1/16W
R417	1-216-811-11	METAL CHIP	150	5%	1/16W						
R418	1-216-304-11	METAL CHIP	3.3	5%	1/10W	R608	1-216-827-11	METAL CHIP	3.3K	5%	1/16W
R419	1-216-298-00	METAL CHIP	2.2	5%	1/10W	R609	1-216-827-11	METAL CHIP	3.3K	5%	1/16W
						R610	1-216-833-11	RES. CHIP	10K	5%	1/16W
R420	1-216-298-00	METAL CHIP	2.2	5%	1/10W	R611	1-216-845-11	METAL CHIP	100K	5%	1/16W
R421	1-216-845-11	METAL CHIP	100K	5%	1/16W	R612	1-216-833-11	RES. CHIP	10K	5%	1/16W
R422	1-216-845-11	METAL CHIP	100K	5%	1/16W						
R423	1-216-857-11	METAL CHIP	1M	5%	1/16W	R613	1-216-864-11	METAL CHIP	0	5%	1/16W
R424	1-216-837-11	METAL CHIP	22K	5%	1/16W	R614	1-216-841-11	METAL CHIP	47K	5%	1/16W
						R615	1-216-837-11	METAL CHIP	22K	5%	1/16W
R426	1-216-861-11	METAL CHIP	2.2M	5%	1/16W	R616	1-216-845-11	METAL CHIP	100K	5%	1/16W
R427	1-216-837-11	METAL CHIP	22K	5%	1/16W	R617	1-216-837-11	METAL CHIP	22K	5%	1/16W
R428	1-216-833-11	RES. CHIP	10K	5%	1/16W						
R429	1-216-864-11	METAL CHIP	0	5%	1/16W	R618	1-216-845-11	METAL CHIP	100K	5%	1/16W
R430	1-216-841-11	METAL CHIP	47K	5%	1/16W	R619	1-216-837-11	METAL CHIP	22K	5%	1/16W
						R621	1-216-837-11	METAL CHIP	22K	5%	1/16W
R433	1-216-839-11	METAL CHIP	33K	5%	1/16W	R623	1-216-837-11	METAL CHIP	22K	5%	1/16W
R434	1-216-864-11	METAL CHIP	0	5%	1/16W	R624	1-216-845-11	METAL CHIP	100K	5%	1/16W
R436	1-216-864-11	METAL CHIP	0	5%	1/16W						
R438	1-216-864-11	METAL CHIP	0	5%	1/16W	R625	1-216-864-11	METAL CHIP	0	5%	1/16W
R439	1-216-864-11	METAL CHIP	0	5%	1/16W	R626	1-216-864-11	METAL CHIP	0	5%	1/16W
						R627	1-216-819-11	METAL CHIP	680	5%	1/16W
R440	1-216-864-11	METAL CHIP	0	5%	1/16W	R628	1-216-819-11	METAL CHIP	680	5%	1/16W
R441	1-216-864-11	METAL CHIP	0	5%	1/16W	R629	1-216-819-11	METAL CHIP	680	5%	1/16W
R442	1-216-845-11	METAL CHIP	100K	5%	1/16W						
R443	1-216-833-11	RES. CHIP	10K	5%	1/16W	R630	1-216-805-11	METAL CHIP	47	5%	1/16W
R444	1-216-861-11	METAL CHIP	2.2M	5%	1/16W	R631	1-216-845-11	METAL CHIP	100K	5%	1/16W
						R632	1-216-845-11	METAL CHIP	100K	5%	1/16W
R445	1-216-864-11	METAL CHIP	0	5%	1/16W	R633	1-216-819-11	METAL CHIP	680	5%	1/16W
R446	1-218-887-11	METAL CHIP	47K	0.5%	1/16W	R634	1-216-864-11	METAL CHIP	0	5%	1/16W
R447	1-218-879-11	METAL CHIP	22K	0.5%	1/16W						
R448	1-216-864-11	METAL CHIP	0	5%	1/16W	R635	1-216-807-11	METAL CHIP	68	5%	1/16W
R449	1-216-809-11	METAL CHIP	100	5%	1/16W	R636	1-216-821-11	METAL CHIP	1K	5%	1/16W
						R637	1-216-864-11	METAL CHIP	0	5%	1/16W
R450	1-216-845-11	METAL CHIP	100K	5%	1/16W	R801	1-216-845-11	METAL CHIP	100K	5%	1/16W
R451	1-216-829-11	METAL CHIP	4.7K	5%	1/16W	R802	1-216-833-11	RES. CHIP	10K	5%	1/16W
R452	1-216-829-11	METAL CHIP	4.7K	5%	1/16W						
R453	1-216-829-11	METAL CHIP	4.7K	5%	1/16W	R804	1-216-809-11	METAL CHIP	100	5%	1/16W
R454	1-216-829-11	METAL CHIP	4.7K	5%	1/16W	R805	1-216-845-11	METAL CHIP	100K	5%	1/16W
						R806	1-216-864-11	METAL CHIP	0	5%	1/16W
R455	1-216-853-11	METAL CHIP	470K	5%	1/16W	R807	1-216-845-11	METAL CHIP	100K	5%	1/16W
R457	1-218-883-11	METAL CHIP	33K	0.5%	1/16W	R808	1-216-845-11	METAL CHIP	100K	5%	1/16W
R458	1-218-871-11	METAL CHIP	10K	0.5%	1/16W						
R459	1-216-809-11	METAL CHIP	100	5%	1/16W	R809	1-216-821-11	METAL CHIP	1K	5%	1/16W
R460	1-216-845-11	METAL CHIP	100K	5%	1/16W	R810	1-216-833-11	RES. CHIP	10K	5%	1/16W
						R811	1-216-837-11	METAL CHIP	22K	5%	1/16W
R461	1-216-841-11	METAL CHIP	47K	5%	1/16W						(EXCEPT EJ915: FR)
R464	1-216-833-11	RES. CHIP	10K	5%	1/16W	R811	1-216-843-11	METAL CHIP	68K	5%	1/16W
R465	1-216-841-11	METAL CHIP	47K	5%	1/16W						(EJ915: FR)

MAIN

Ref. No.	Part No.	Description	Remark
R813	1-216-833-11	RES, CHIP 10K 5%	1/16W
R814	1-216-833-11	RES, CHIP 10K 5%	1/16W
R815	1-216-864-11	METAL CHIP 0 5%	1/16W
R816	1-216-864-11	METAL CHIP 0 5%	1/16W
(EJ915: US, CND, AEP, UK, FR, G, EE)			
R817	1-216-864-11	METAL CHIP 0 5%	1/16W
R818	1-216-823-11	METAL CHIP 1.5K 5%	1/16W
R819	1-216-864-11	METAL CHIP 0 5%	1/16W
R820	1-216-864-11	METAL CHIP 0 5%	1/16W
R821	1-216-864-11	METAL CHIP 0 5%	1/16W
R822	1-216-864-11	METAL CHIP 0 5%	1/16W
R823	1-216-825-11	METAL CHIP 2.2K 5%	1/16W
R824	1-216-864-11	METAL CHIP 0 5%	1/16W
R825	1-216-849-11	METAL CHIP 220K 5%	1/16W
R826	1-216-864-11	METAL CHIP 0 5%	1/16W
R827	1-216-857-11	METAL CHIP 1M 5%	1/16W
R828	1-216-825-11	METAL CHIP 2.2K 5%	1/16W
R829	1-216-829-11	METAL CHIP 4.7K 5%	1/16W
R830	1-216-843-11	METAL CHIP 68K 5%	1/16W
R831	1-216-864-11	METAL CHIP 0 5%	1/16W
R832	1-216-841-11	METAL CHIP 47K 5%	1/16W
R833	1-216-841-11	METAL CHIP 47K 5%	1/16W
R834	1-216-821-11	METAL CHIP 1K 5%	1/16W
R835	1-216-864-11	METAL CHIP 0 5%	1/16W
R836	1-216-864-11	METAL CHIP 0 5%	1/16W
R837	1-216-864-11	METAL CHIP 0 5%	1/16W
R851	1-218-871-11	METAL CHIP 10K 0.5%	1/16W
R857	1-216-845-11	METAL CHIP 100K 5%	1/16W (EJ915: FR)
< SWITCH >			
S801	1-762-805-41	SWITCH, PUSH (1 KEY) (OPEN)	
S802	1-771-248-11	SWITCH, TACTILE (▶▶)	
S803	1-762-078-11	SWITCH, SLIDE (AVLS)	
S804	1-762-078-11	SWITCH, SLIDE (HOLD)	
S805	1-771-248-11	SWITCH, TACTILE (◀◀)	
S806	1-771-248-11	SWITCH, TACTILE (▶▶▶)	
S807	1-771-248-11	SWITCH, TACTILE (■/CHG)	
S808	1-771-248-11	SWITCH, TACTILE (VOLUME +)	
S809	1-771-248-11	SWITCH, TACTILE (VOLUME -)	
< VARISTOR >			
VDR101	1-801-923-11	VARISTOR, CHIP	
VDR102	1-801-862-11	VARISTOR, CHIP	
VDR201	1-801-923-11	VARISTOR, CHIP	
VDR202	1-801-862-11	VARISTOR, CHIP	
VDR301	1-801-923-11	VARISTOR, CHIP	
VDR302	1-801-923-11	VARISTOR, CHIP	
VDR303	1-801-862-11	VARISTOR, CHIP	
< VIBRATOR >			
X601	1-767-605-11	VIBRATOR, LITHIUM TANTALATE (16.9MHz)	

Ref. No.	Part No.	Description	Remark
		MISCELLANEOUS *****	
△ 101	X-3378-495-1	OPTICAL PICK-UP (DAX-22EG) (US, CND, AEP, UK)	
△ 101	X-4952-079-1	OPTICAL PICK-UP (DAX-22E) (EXCEPT US, CND, AEP, UK)	
M901	A-3328-299-A	MOTOR BLOCK ASSY, SLED	
M902	A-3328-418-A	CHASSIS ASSY (SPINDLE)	

ACCESSORIES & PACKING MATERIALS *****			
	1-418-608-11	REMOTE CONTROL UNIT	
△	1-418-264-11	ADAPTOR, AC (AC-E455A) (EJ915: AUS)	
△	1-467-009-21	ADAPTOR, AC (AC-E455) (EJ915: US, CND)	
△	1-467-550-11	ADAPTOR, AC (AC-E455A) (EJ915: E33/E990)	
△	1-473-115-11	ADAPTOR, AC (AC-E455D) (EJ915: UK)	
△	1-473-116-35	ADAPTOR, AC (AC-E455D) (EJ915: AEP, E13, FR, G, EE)	
△	1-475-622-11	ADAPTOR, AC (AC-E455) (EJ915: CH)	
△	1-475-623-11	ADAPTOR, AC (AC-E455) (EJ915: HK)	
△	1-569-007-11	ADAPTOR, CONVERSION 2P (EJ915: E33/E990)	
	1-756-008-11	CASE, BATTERY	
	1-756-036-11	BATTERY, NICKEL HYDROGEN (NH-14WM)	
	3-008-521-01	CASE, BATTERY CHARGE	
	3-044-132-01	CASE, CARRYING (EJ915: US)	
	3-043-928-11	MANUAL, INSTRUCTION (EJ915: US) (ENGLISH)	
	3-045-458-11	MANUAL, INSTRUCTION (EJ915: AEP) (SPANISH)	
	3-045-458-21	MANUAL, INSTRUCTION (EJ915: CND, AEP, UK, FR, G, EE) (ENGLISH)	
	3-045-458-31	MANUAL, INSTRUCTION (EJ915: CND, AEP, FR) (FRENCH)	
	3-045-458-41	MANUAL, INSTRUCTION (EJ915: AEP, EE) (DUTCH)	
	3-045-458-51	MANUAL, INSTRUCTION (EJ915: AEP) (SWEDISH)	
	3-045-458-61	MANUAL, INSTRUCTION (EJ915: AEP) (PORTUGUESE)	
	3-045-458-71	MANUAL, INSTRUCTION (EJ915: AEP, G) (GERMAN)	
	3-045-458-81	MANUAL, INSTRUCTION (EJ915: AEP) (ITALIAN)	
	3-045-458-91	MANUAL, INSTRUCTION (EJ915: AEP) (FINNISH)	
	3-045-564-11	MANUAL, INSTRUCTION (EJ915: KR) (KOREAN)	
	3-867-738-01	MANUAL, INSTRUCTION (E990) (JAPANESE, ENGLISH, CHINESE, KOREAN)	
	3-867-738-11	MANUAL, INSTRUCTION (EJ915: AEP, E33/E990) (SPANISH)	
	3-867-738-21	MANUAL, INSTRUCTION (EJ915: US, CND, AEP, UK, E33, FR, G, EE, AUS/E990) (ENGLISH)	
	3-867-738-31	MANUAL, INSTRUCTION (EJ915: CND, AEP, UK/E990) (FRENCH)	
	3-867-739-11	MANUAL, INSTRUCTION (EJ915: E13, HK) (CHINESE)	
	3-867-739-21	MANUAL, INSTRUCTION (EJ915: E13, HK, CH) (ENGLISH)	

The components identified by mark △ or dotted line with mark △ are critical for safety. Replace only with part number specified.

Les composants identifiés par une marque △ sont critiques pour la sécurité. Ne les remplacer que par une pièce portant le numéro spécifié.

<u>Ref. No.</u>	<u>Part No.</u>	<u>Description</u>	<u>Remark</u>
	3-867-739-31	MANUAL, INSTRUCTION (EJ915: CH)	
		(CHINESE)	
	3-867-740-11	MANUAL, INSTRUCTION (EJ915: EE)	
		(RUSSIAN)	
	3-867-740-21	MANUAL, INSTRUCTION (EJ915: EE) (CZECK)	
	3-867-740-31	MANUAL, INSTRUCTION (EJ915: EE)	
		(HUNGARIAN)	
	3-867-740-41	MANUAL, INSTRUCTION (EJ915: EE) (POLISH)	
	3-867-740-51	MANUAL, INSTRUCTION (EJ915: EE)	
		(SLOVAKIAN)	
	3-867-740-61	MANUAL, INSTRUCTION (EJ915: KR)	
		(KOREAN)	
	4-223-953-01	CASE (MIS), CARRYING (EJ915: CND, AEP, UK, E13, E33, FR, G, EE, HK, KR, CH, AUS/ E990)	
	8-953-276-90	HEADPHONE MDR-24SP (EJ915: US)	
	8-953-304-90	RECEIVER MDR-E805SP (EJ915: CND, AEP, UK, E13, E33, FR, G, EE, HK, KR, CH, AUS/E990)	

