

D-E220/E225/E226CK

SERVICE MANUAL

Ver 1.2 2001.07



(Photo: D-E220 (Silver))

US Model
E Model
D-E220/E225/E226CK
Canadian Model
UK Model
Australian Model
D-E226CK
AEP Model
D-E220/E226CK
Chinese Model
D-E225

Model Name Using Similar Mechanism	NEW
CD Mechanism Type	CDM-3123EBA
Optical Pick-up Name	DAX-23E

SPECIFICATIONS

CD player System

Compact disc digital audio system

Laser diode properties

Material: GaAlAs
Wavelength: $\lambda = 780$ nm
Emission duration: Continuous
Laser output: Less than $44.6 \mu\text{W}$ (This output is the value measured at a distance of 200 mm from the objective lens surface on the optical pick-up block with 7 mm aperture.)

Error correction

Sony Super Strategy Cross Interleave Reed Solomon Code

D-A conversion

1-bit quartz time-axis control

Frequency response

20 - 20,000 Hz $\pm 1/-3$ dB
(measured by EIAJ CP-307)

Output (at 4.5 V input level)

Headphones (stereo minijack)
Approx. 12 mW + Approx. 12 mW
at 16 ohms

General

Power requirements

For the area code of the model you purchased, check the upper left side of the bar code on the package.

- Two sony NC-WMAA rechargeable batteries (D-E225): 2.4 V DC
- Two sony NH-WM2AA rechargeable batteries (D-E225): 2.4 V DC
- Two LR6 (size AA) batteries: 3 V DC
- AC power adaptor (DC IN 4.5 V jack): 120 V, 60Hz (US, CND, E92, MX model) 220 - 230 V, 50/60 Hz (AEP, FR, EE, E13 model) 230 - 240 V, 50 Hz (UK model) 240 V, 50 Hz (AUS model) 100 - 240 V, 50/60 Hz (E33 model) 220 V, 50/60 Hz (HK model) 220 V, 50 Hz (CH model)

D-E220/E226CK

Battery life (approx. hours) (EIAJ*)

Battery life varies depending on how the player is used.

	ESP OFF	ESP ON
Two sony alkaline batteries LR6(SG)	25	24

* Measured value by the standard of EIAJ (Electronic Industries Association of Japan).
(When the unit is used on a flat and stable place.)

D-E225

Battery life (approx. hours) (EIAJ*)

Battery life varies depending on how the player is used.

	ESP OFF	ESP ON
Two NC-WMAA (charged about 3 hours**)	8	8

Two NH-WM2AA (charged about 8 hours**)	14.5	14
--	------	----

Two sony alkaline batteries LR6(SG)	25	24
-------------------------------------	----	----

* Measured value by the standard of EIAJ (Electronic Industries Association of Japan).
(When the unit is used on a flat and stable place.)

** Charging time varies depending on how the rechargeable battery is used.

Dimensions (w/h/d) (without projecting parts and controls)

Approx. 130 × 26.3 × 150.5 mm
(5 1/8 × 1 1/16 × 6 in.)

Mass (excluding accessories)

Approx. 205 g (7.3 oz.)

Operating temperature

5°C - 35°C (41°F - 95°F)

Supplied accessories

For the area code of the model you purchased, check the upper left side of the bar code on the package.

D-E220

Headphones (1)

D-E225

AC power adaptor (1)
Headphones with remote control (1)
Rechargeable batteries NC-WMAA (2)
Battery carrying cases (1)

D-E226CK

AC power adaptor (1)
Headphones (1)
Car connecting pack (1)
Car battery cord (1)
Spiral tube (1)
Velcro tape (3)

Design and specifications are subject to change without notice.

• Abbreviation

- CND : Canadian model
- E92 : AC 120V area in E model
- FR : France model
- EE : East European model
- E13 : AC 220 - 230V area in E model
- AUS : Australian model
- E33 : AC 100 - 240V area in E model
- HK : Hong Kong model
- CH : Chinese model
- MX : Mexican model

PORTABLE CD PLAYER

9-873-044-13

2001G0400-1

© 2001.7

Sony Corporation

Personal Audio Company

Shinagawa Tec Service Manual Production Group

SONY®

**SECTION 1
SERVICE NOTE**

TABLE OF CONTENTS

1. SERVICE NOTE 2

2. GENERAL 4

3. DISASSEMBLY

3-1. "Lid, Battery Case", Cabinet (Front) Assy 8

3-2. Lid Assy, Upper 8

3-3. Main Board, MD Assy 9

3-4. Optical Pick-up, Motor 9

4. ELECTRICAL ADJUSTMENTS

4-1. Focus Bias Check 10

5. DIAGRAMS

5-1. IC Pin Description 11

5-2. Block Diagram –CD Section (Former Type)– 12

5-3. Block Diagram –Audio Section (Former Type)– 13

5-4. Block Diagram –Power Supply Section (Former Type)– .. 14

5-5. Block Diagram –CD Section (New Type)– 15

5-6. Block Diagram –Audio Section (New Type)– 16

5-7. Block Diagram –Power Supply Section (New Type)– 17

5-8. Printed Wiring Board –Main Section (Former Type)– 18

5-9. Printed Wiring Board –Main Section (New Type)– 20

5-10. Schematic Diagram –Main Section (1/2) (Former Type)– .. 22

5-11. Schematic Diagram –Main Section (2/2) (Former Type)– .. 23

5-12. Schematic Diagram –Main Section (1/2) (New Type)– 24

5-13. Schematic Diagram –Main Section (2/2) (New Type)– 25

5-14. IC Block Diagrams 26

6. EXPLODED VIEWS

6-1. Cabinet (Front) Section 27

6-2. Cabinet (Rear) Section 28

6-3. CD Mechanism Deck Section (CDM-3123EBA) 29

7. ELECTRICAL PARTS LIST 30

NOTE ON PERFORMING SERVICE AND INSPECTION ON THE MAIN BOARD

The main board has two types, former type and new type.
When performing service and inspection, check the part number on the main board.

– MAIN BOARD (SIDE A) –

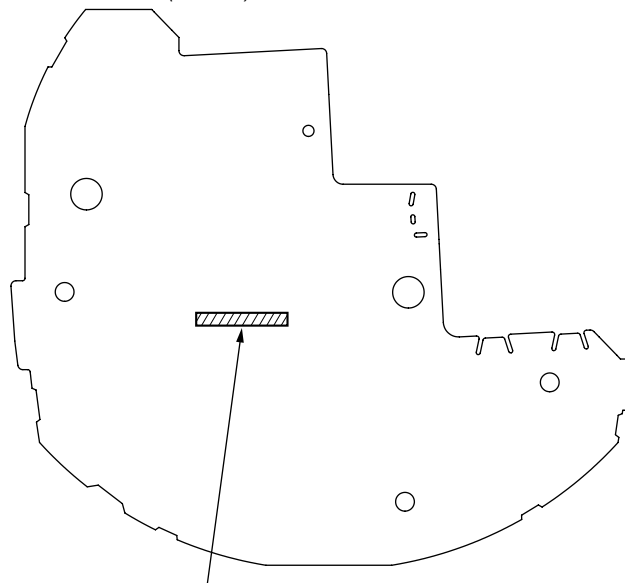

MAIN Board Part No.
Former type : 1-680-271-11
New type : 1-681-329-11

Flexible Circuit Board Repairing

- Keep the temperature of the soldering iron around 270°C during repairing.
- Do not touch the soldering iron on the same conductor of the circuit board (within 3 times).
- Be careful not to apply force on the conductor when soldering or unsoldering.

Notes on Chip Component Replacement

- Never reuse a disconnected chip component.
- Notice that the minus side of a tantalum capacitor may be damaged by heat.

SAFETY-RELATED COMPONENT WARNING!!

COMPONENTS IDENTIFIED BY MARK \triangle OR DOTTED LINE WITH MARK \triangle ON THE SCHEMATIC DIAGRAMS AND IN THE PARTS LIST ARE CRITICAL TO SAFE OPERATION. REPLACE THESE COMPONENTS WITH SONY PARTS WHOSE PART NUMBERS APPEAR AS SHOWN IN THIS MANUAL OR IN SUPPLEMENTS PUBLISHED BY SONY.

ATTENTION AU COMPOSANT AYANT RAPPORT À LA SÉCURITÉ!!

LES COMPOSANTS IDENTIFIÉS PAR UNE MARQUE \triangle SUR LES DIAGRAMMES SCHÉMATIQUES ET LA LISTE DES PIÈCES SONT CRITIQUES POUR LA SÉCURITÉ DE FONCTIONNEMENT. NE REMPLACER CES COMPOSANTS QUE PAR DES PIÈCES SONY DONT LES NUMÉROS SONT DONNÉS DANS CE MANUEL OU DANS LES SUPPLÉMENTS PUBLIÉS PAR SONY.

NOTES ON HANDLING THE OPTICAL PICK-UP BLOCK OR BASE UNIT

The laser diode in the optical pick-up block may suffer electrostatic breakdown because of the potential difference generated by the charged electrostatic load, etc. on clothing and the human body. During repair, pay attention to electrostatic breakdown and also use the procedure in the printed matter which is included in the repair parts.

The flexible board is easily damaged and should be handled with care.

Precautions for Checking Emission of Laser Diode

Laser light of the equipment is focused by the object lens in the optical pick-up so that the light focuses on the reflection surface of the disc. Therefore, be sure to keep your eyes more than 30 cm apart from the object lens when you check the emission of laser diode.

Before Replacing the Optical Pick-Up Block

Please be sure to check thoroughly the parameters as per the "Optical Pick-Up Block Checking Procedures" (Part No.: 9-960-027-11) issued separately before replacing the optical pick-up block. Note and specifications required to check are given below.

- FOK output : IC601 ③ pin
When checking FOK, remove the lead wire to disc motor.
- RF signal P-to-P value : 0.45 ± 0.1 Vp-p
- The repairing grating holder is impossible.

Laser Diode Checking Methods

During normal operation of the equipment, emission of the laser diode is prohibited unless the upper lid is closed while turning ON the S801. (push switch type)

The following two checking methods for the laser diode are operable.

• Method:

Emission of the laser diode is visually checked.

1. Open the upper lid.
2. With a disc not set, turn on the S801 with a screwdriver having a thin tip as shown in Fig.1.
or TAP802 is shorted as shown in Fig.2.
- Note:** Do not push the detection lever strongly, or it may be bent or damaged.
3. Press the  button.
4. Observing the objective lens, check that the laser diode emits light.

When the laser diode does not emit light, automatic power control circuit or optical pick-up is faulty.

In this operation, the objective lens will move up and down 5 times along with inward motion for the focus search.

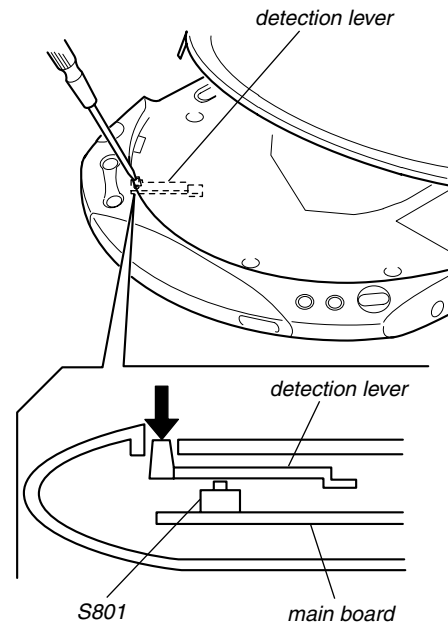
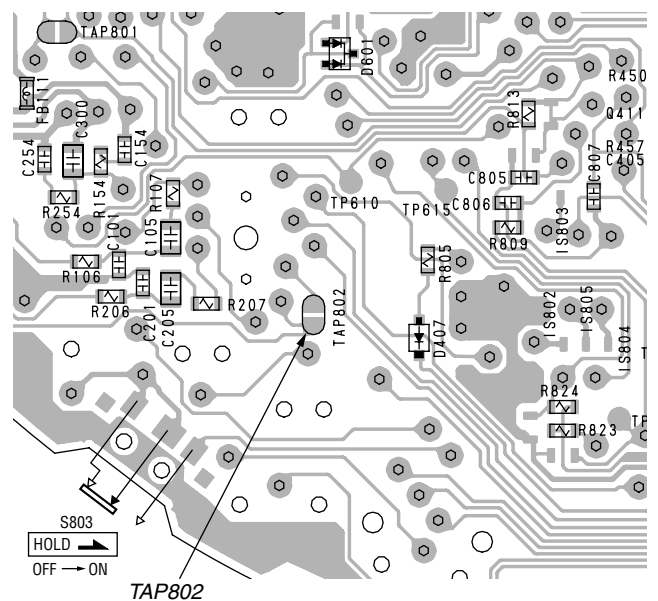

Fig. 1

- MAIN BOARD - (SIDE A)



- MAIN BOARD - (SIDE B)

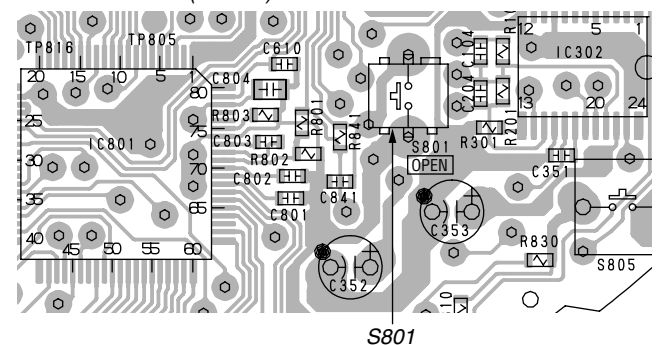

Fig. 2

This section is extracted from instruction manual.

Playing a CD right away!

If you want to play a CD right now, choose to use your CD player on house current. Other choices are the following two: dry batteries (see "Power Sources" on the reverse side) and car battery.

1 Connect

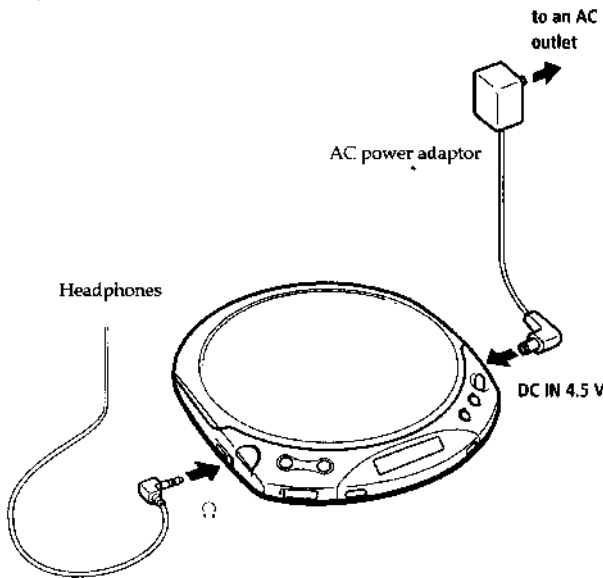

2 Place a CD

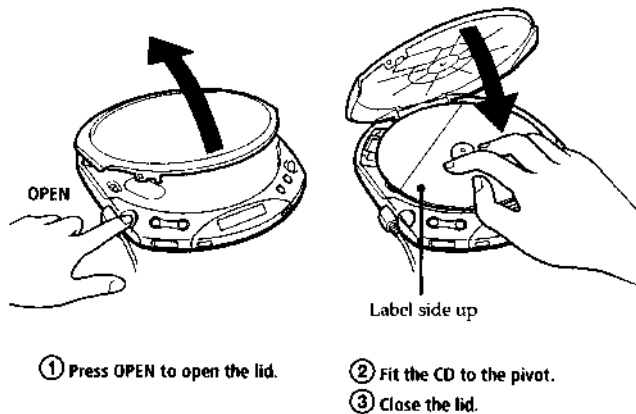

3 Play

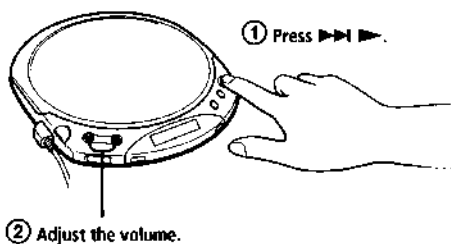

To stop play, press ■/CHG.

To	Press
Find the beginning of the current track (AMS*)	◀◀ once
Find the beginning of previous tracks (AMS)	◀◀ repeatedly
Find the beginning of the next track (AMS)	▶▶ once
Find the beginning of succeeding tracks (AMS)	▶▶ repeatedly
Go forward quickly	Hold down ▶▶▶▶
Go backwards quickly	Hold down ◀◀◀◀

* AMS = Automatic Music Sensor

To remove the CD
Remove the CD while pressing the pivot.



Notes on display

- When you press ▶▶▶▶, the total number of tracks in the CD and the total playing time appear.
- During play, the track number and the elapsed playing time of the current track appear.

Notes on handling CDs

- To keep the CD clean, handle it by its edge. Do not touch the surface.
- Do not stick paper or tape onto the CD.
- Do not expose the CD to direct sunlight or heat sources such as hot air ducts. Do not leave the CD in a car parked under direct sunlight.

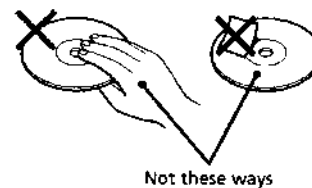

About CD-Rs

This CD player is compatible with CD-Rs but playback capability may vary depending on the quality of the disc, the recording device and application software.

► **Other Operations**

Selecting play mode

You can enjoy the following five play modes: "Normal play", "Repeat play — all the tracks", "Single track play", "Repeat play — a single track" and "Repeat shuffle play".

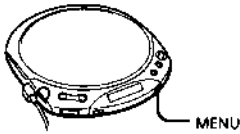

Press MENU during play. Each time you press the button, the play mode indication in the display changes as follows:



* During Repeat play, you can locate the first track after the last track by pressing **▶▶▶** repeatedly. You can also locate the last track after first track by pressing **◀◀◀** repeatedly.

Using other functions

To maximize the skip protection performance (ESP MAX)

The typical ESP (Electronic Shock Protection) function minimizes skipping by using a buffer memory that stores music data and plays it back in the event of a shock. The ESP MAX system is an extremely sophisticated technology. Due to the light weight and improved anti-shock characteristics of the optical block, this system recovers from the skipping much quicker than conventional technology such as ESP or ESP².

* Although ESP MAX provides excellent protection, skipping may occasionally occur.

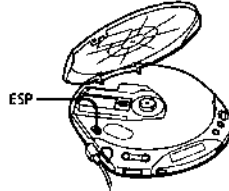

Set ESP to "ON." - The ESP indication appears.

To release the ESP MAX function, set ESP to "OFF."



Notes

- Playing may stop when the CD player gets a strong shock even with the ESP MAX function on.
- You may hear a noise or sound may skip:
 - when listening to a dirty or scratched CD,
 - when listening to an audio test CD,
 - when the player receives continuous shock or
 - when using poor-quality CD-Rs or if there is a problem with the recording device or application software.

To enjoy more powerful bass sound (Digital MEGA BASS)

You can emphasize the bass-boosted sound.

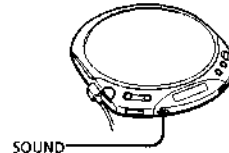

Press SOUND to select "BASS ■■■" or "BASS ■■■."

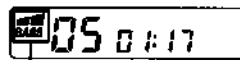
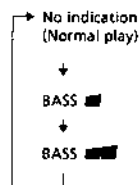

The selected sound mode is displayed.

"BASS ■■■" enhances the bass sound more than "BASS ■■■."

Note

- If the sound is distorted when using the SOUND function, turn down the volume.

To lock the buttons

You can lock your CD player against any accidental operations.

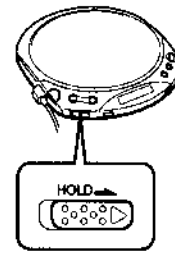

Slide HOLD in the direction of the arrow. When you press any button, "Hold" appears in the display and you cannot operate the CD player.

To unlock, slide HOLD in the opposite direction of the arrow.

To protect your hearing (AVLS)

The AVLS (Automatic Volume Limiter System) function keeps down the maximum volume to protect your ears.

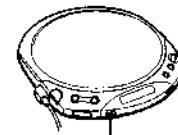

Hold down SOUND until "AVLS" appears in the display.

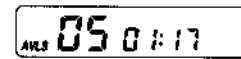

If you turn up the volume to "3", you cannot turn up the volume any more.

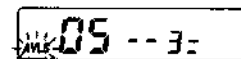

If you want to turn up the volume to more than "3", hold down SOUND until "AVLS" disappears from the display.

* For the customers in France This level is set to "6".

Note

- If you use the sound function and the AVLS function at the same time, sound may be distorted. If this happens, turn down the volume.

Connecting to other stereo equipment

You can listen to the CD through other stereo equipment or record a CD on a cassette tape. Refer to the instruction manual of the other equipment for details. Before making connections, turn off each piece of equipment.

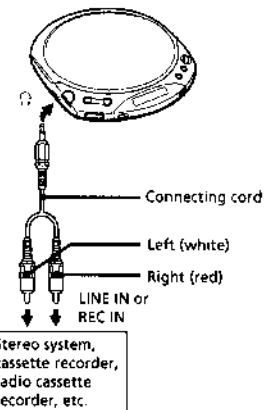

Notes

- Before you play the CD, turn down the volume of the connected equipment so as not to damage the connected speakers.
- If you turn up the volume to more than "8", the sound may be distorted.

Continue to the reverse side →

Playing a CD in a car

You can use your CD player in a car as illustrated below.

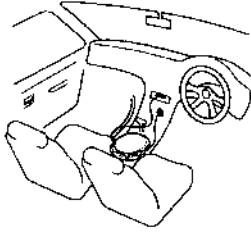

To connect your CD player to a car cassette deck, you need the following accessories:

- Car connecting pack
 - Car battery cord
- You can use the car mount plate for this CD player. Refer to the instruction manual of each accessory for details.

Notes

- Do not put the CD player on the dashboard.
- Do not leave the CD player in a car parked under sunlight.
- If the sound is distorted, press SOUND until the BASS indication disappears from the display.
- Use a Sony car connecting pack for reducing noise.
- Use only the car battery cord listed in the optional accessories. If you use any other car battery cord, smoke, fire or malfunction may occur.

Switched Ignition function (when using the car battery cord)

With this feature, your CD player stops automatically when you turn off the engine of the car. (This function is not possible with some cars depending on the model.)

►Power Sources (E220/E226CK)

Using the dry batteries

Use only the following dry battery type for your CD player:

- LR6 (size AA) alkaline batteries

Note

Be sure to remove the AC power adaptor when using the dry batteries.

- 1 Open the battery compartment lid.

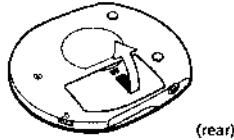

- 2 Insert two LR6 (size AA) alkaline batteries by matching the ⊕ to the diagram in the battery compartment.

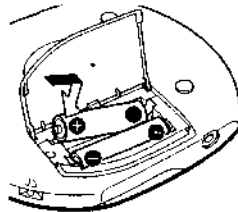

To remove the batteries

Remove the batteries as illustrated below.

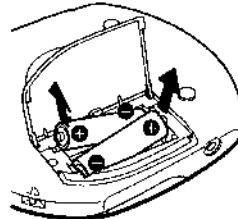

When to replace the batteries

You can check the remaining power of the batteries in the display.

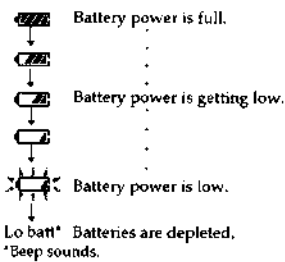

When the batteries are depleted, replace both batteries with new ones.

Notes

- The indicator sections of roughly shows the remaining battery power. One section does not always indicate one-fourth of the battery power.
- Depending on operating conditions, the indicator sections of may increase or decrease.

To attach the battery compartment lid

If the battery compartment lid is detached by an accidental drop, excessive force, etc., attach it as illustrated below.

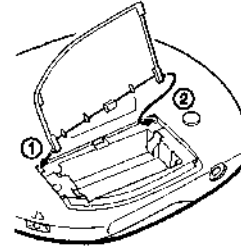

Battery life (approx. hours)(EIAJ*)

Battery life varies depending on how the player is used.

	ESP OFF	ESP ON
Two Sony alkaline batteries LR6(SG)	25	24

* Measured value by the standard of EIAJ (Electronic Industries Association of Japan). (When the unit is used on a flat and stable place.)

** Charging time varies depending on how the rechargeable battery is used.

► **Power Sources (E225)**

Using the rechargeable batteries

Charge the rechargeable batteries before using them for the first time. You can use only the following rechargeable batteries for your CD player.

- NC-WMAA
- NH-WM2AA

1 Open the battery compartment lid.

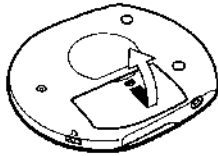

(rear)

2 Insert two rechargeable batteries by matching the ⊕ to the diagram in the battery compartment and close the lid.

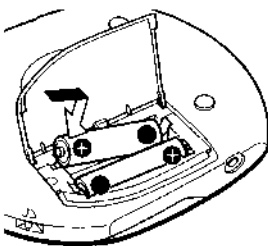

3 Connect the AC power adaptor to the DC IN 4.5 V jack of your CD player and an AC outlet, then press ■/CHG to start charging.

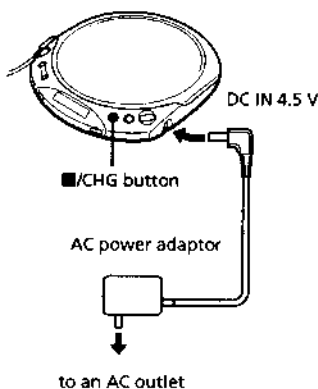

The CD player charges the batteries. The "CHG" indicator turns on in the display, and the indicator sections of light up in succession. When the batteries are completely charged, the "CHG" and indicators turn off.

If you press ■/CHG after the charge has already been completed, the indicator flashes and "Full" appears in the display.

4 Disconnect the AC power adaptor.

To remove the rechargeable batteries

Remove the batteries as illustrated below.

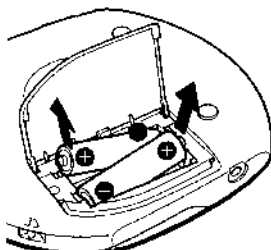

When to charge the rechargeable batteries

You can check the remaining power of the batteries in the display.

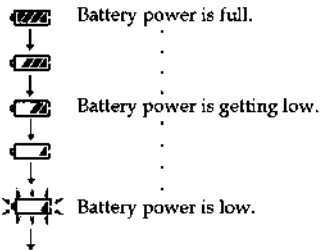

Lo batt* Batteries are depleted.
*Beep sounds.

To keep the original battery capacity for a long time, charge the batteries only when they are completely depleted.

Notes

- The indicator sections of roughly shows the remaining battery power. One section does not always indicate one-fourth of the battery power.
- Depending on operating conditions, the indicator sections of may increase or decrease.

When to replace the rechargeable batteries

If the battery life becomes shorter by about half, replace the batteries with new rechargeable batteries.

Note on the rechargeable batteries

If the battery is new or has not been used for a long time, it may not be charged completely until you charge and discharge it several times.

Note on carrying the rechargeable batteries

Use the supplied battery carrying case to prevent unexpected heat. If the rechargeable batteries and the metallic objects are contacted, heat or fire may occur due to a short circuit.

To attach the battery compartment lid

If the battery compartment lid is detached by an accidental drop, excessive force, etc., attach it as illustrated below.

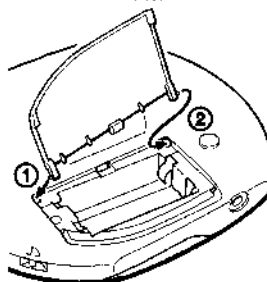

Using the dry batteries

Use only the following dry battery type for your CD player:

- LR6 (size AA) alkaline batteries

Note

Be sure to remove the AC power adaptor when using the dry batteries.

1 Open the lid of the battery compartment.

2 Insert two LR6 (size AA) alkaline batteries by matching the ⊕ to the diagram in the battery compartment.

To remove the batteries

Remove the batteries in the same way as rechargeable batteries.

When to replace the batteries

You can check the remaining power of the batteries in the display.

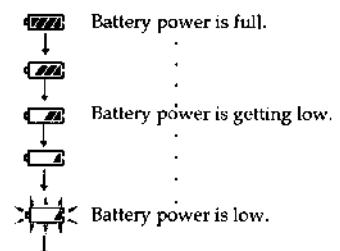

Lo batt* Batteries are depleted.
*Beep sounds.

When the batteries are depleted, replace both batteries with new ones.

Battery life (approx. hours)(EIAJ*)

Battery life varies depending on how the player is used.

	ESP OFF	ESP ON
Two NC-WMAA (charged for about 3 hours**)	8	8
Two NH-WM2AA (charged for about 8 hours**)	14.5	14
Two Sony alkaline batteries LR6(SC)	25	24

* Measured value by the standard of EIAJ (Electronic Industries Association of Japan). (When the unit is used on a flat and stable place.)

** Charging time varies depending on how the rechargeable battery is used.

Using the supplied remote control

You can use the remote control as the wired remote control.

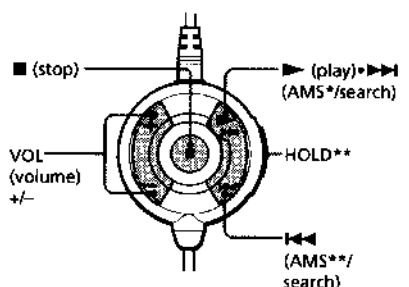

* Automatic Music Sensor

**When you are not using the remote control, slide HOLD in the direction of the arrow to prevent any accidental operations. To unlock, slide HOLD back.

SECTION 3 DISASSEMBLY

Note : Follow the disassembly procedure in the numerical order given.

3-1. "LID, BATTERY CASE", CABINET (FRONT) ASSY

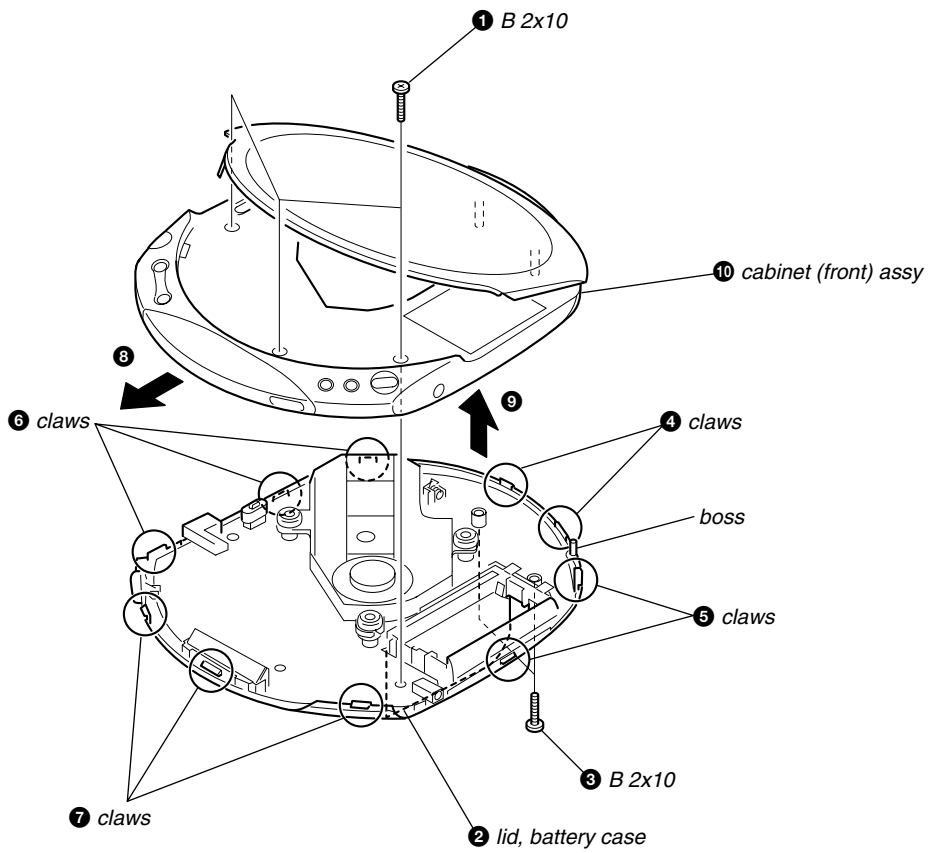

3-2. LID ASSY, UPPER

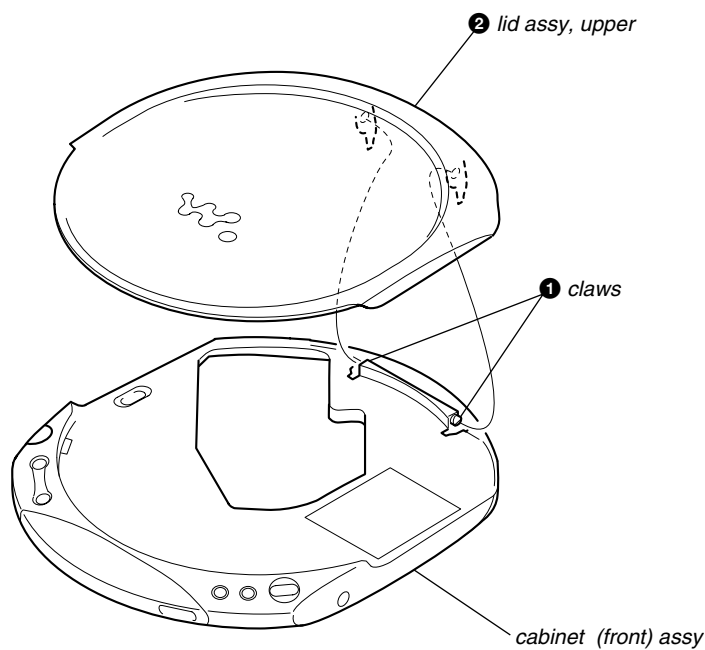

3-3. MAIN BOARD, MD ASSY

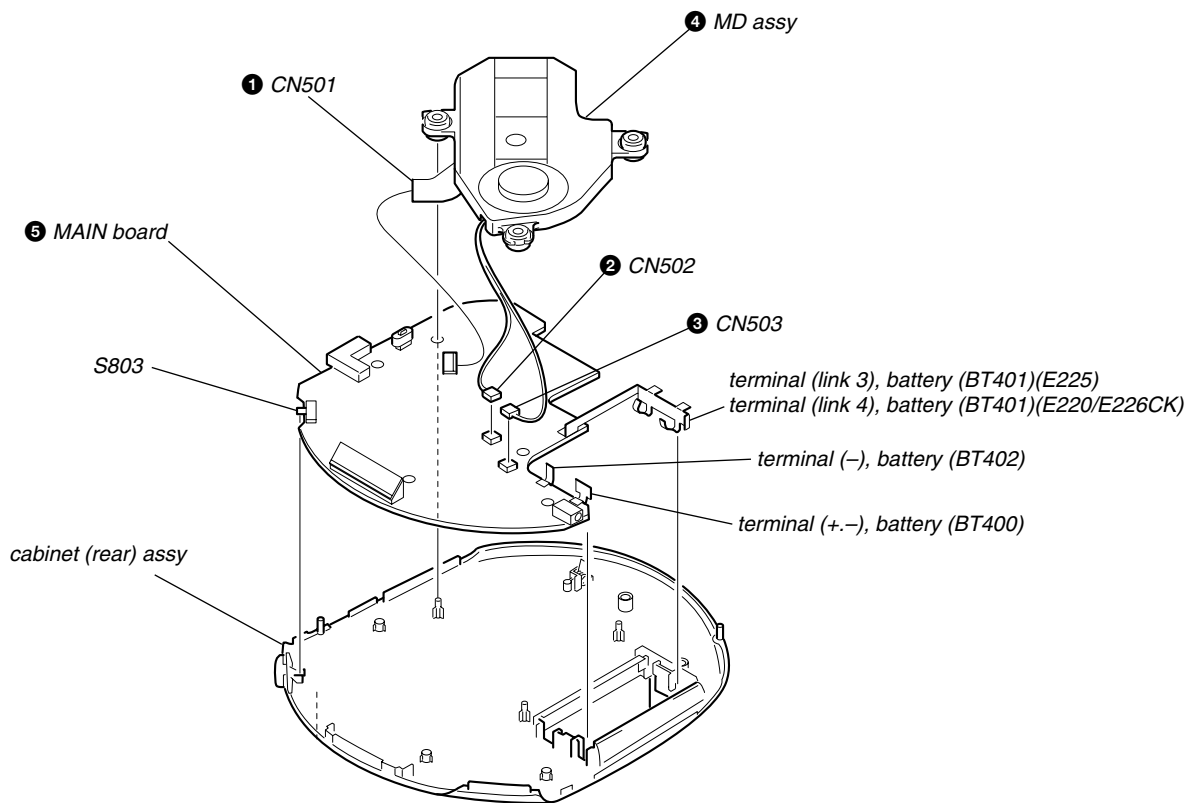

3-4. OPTICAL PICK-UP, MOTOR

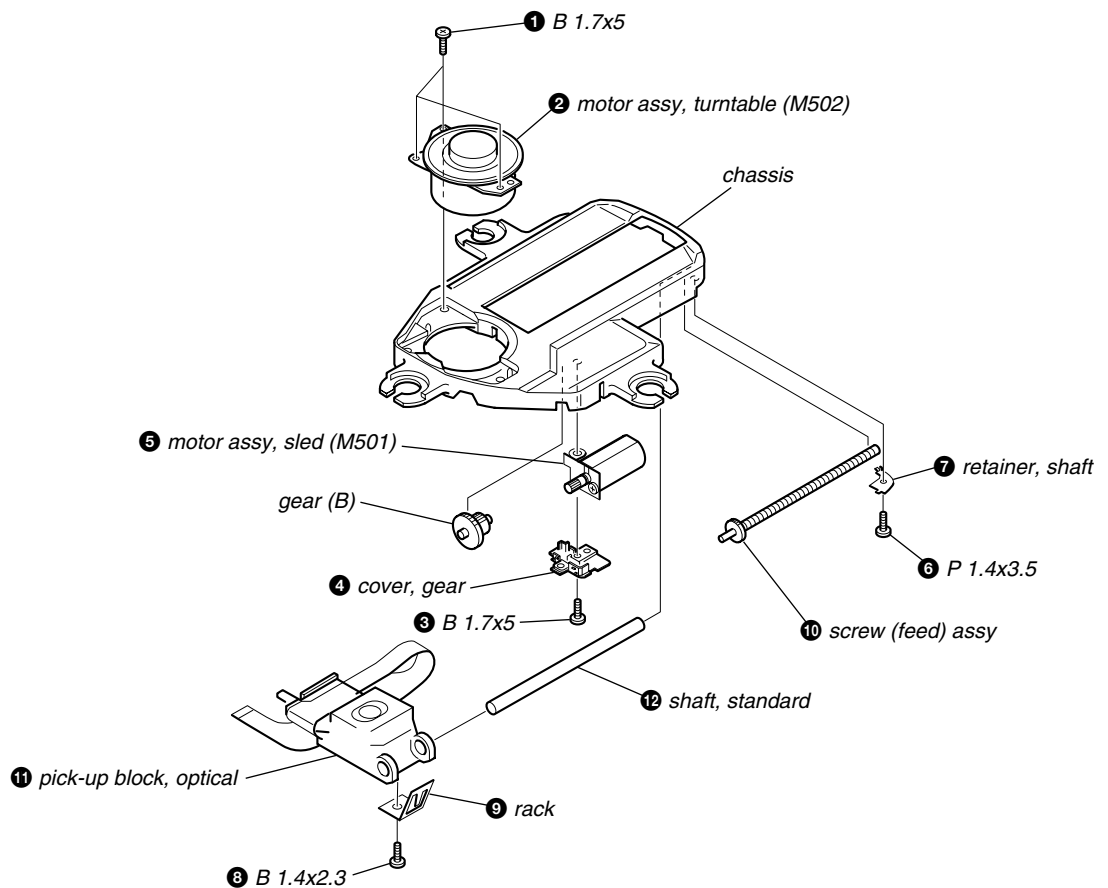

SECTION 4 ELECTRICAL ADJUSTMENTS

CD section adjustments are done automatically in this set.
In case of operation check, confirm that focus bias.

4-1. FOCUS BIAS CHECK

1. Connect the oscilloscope between TP629 (RF) and GND on main board.
2. Insert the disc (YEDS-18). (Part No. : 3-702-101-01)
3. Press the  button.
4. Confirm that the oscilloscope waveform is as shown in the figure below. (eye pattern)
A good eye pattern means that the diamond shape (◇) in the center of the waveform can be clearly distinguished.

- RF signal reference waveform (eye pattern)

VOLT/DIV : 20 mV (10 : 1 probe in use)
TIME/DIV : 500 nS

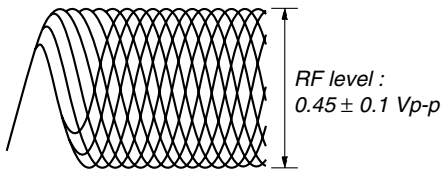

When observing the eye pattern, set the oscilloscope for AC range and raise vertical sensitivity.

Test Points:

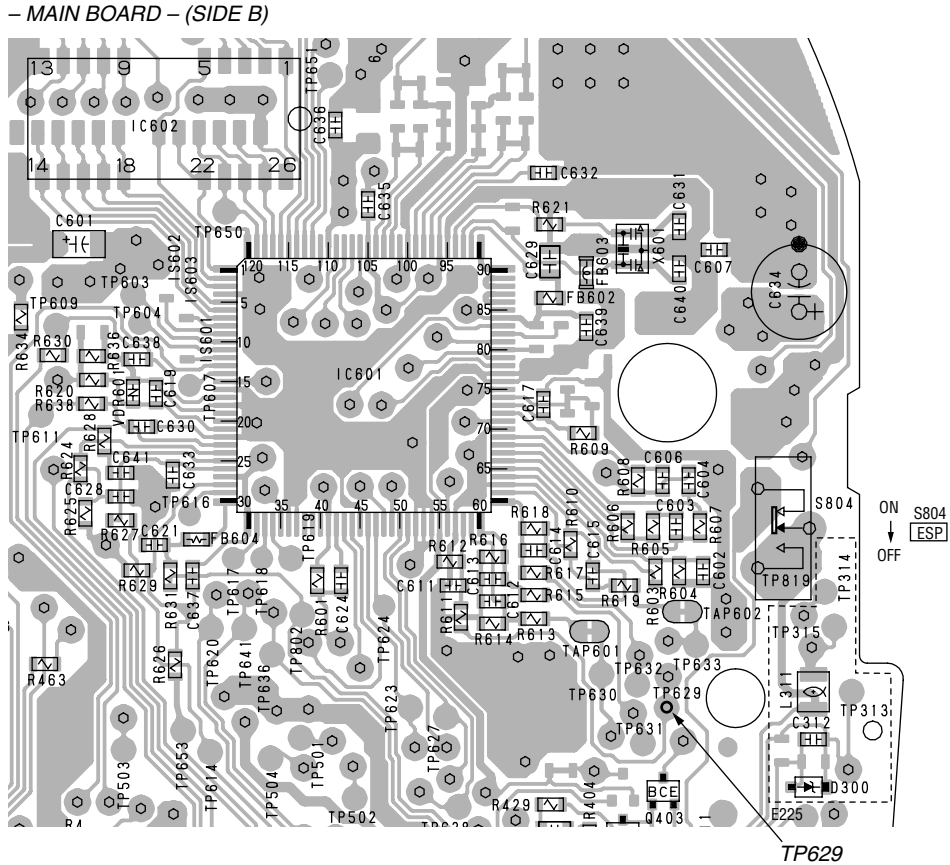

SECTION 5 DIAGRAMS

5-1. IC PIN DESCRIPTION

• IC801 TMP88CM22AF-3A51 (SYSTEM CONTROLLER) (FORMER TYPE)

• IC801 TMP88CM22F-Z3-2 (SYSTEM CONTROLLER) (NEW TYPE)

Pin No.	Pin Name	I/O	Pin Description
1	VSS	—	Ground
2	RESERVE	—	Not used (Open)
3	FOK_I	I	Focus OK signal input from CXD3028R (IC601) (Former Type) or CXD3037R (IC601) (New Type).
4	AGCPWM_O	O	AGC control pulse output (Open)
5, 6	RESERVE	—	Not used. (Open)
7	AMUTE_O	O	Analog audio muting ON/OFF signal control signal output (H: Mute ON)
8	RESERVE	—	Not used. (Open)
9	XRST_O	O	Reset signal output to CXD3028R (IC601). (L: Reset)
10	SCK_O	O	Serial data transfer clock signal output to CXD3028R (IC601) (Former Type) or CXD3037R (IC601) (New Type).
11	(SENS) MSDTL_I	I	Serial data input from CXD3028R (IC601) (Former Type) or CXD3037R (IC601) (New Type).
12	MSDTO_O	O	Serial data output to CXD3028R (IC601) (Former Type) or CXD3037R (IC601) (New Type).
13	WAKEUP_O	O	WAKE-UP control signal output (for system standby reset)
14	AD_SEL	I	Plug-in detection signal input
15	AD_CHGMNT	I	Battery charge voltage detection input from TB2125F (IC401).
16	RESERVE	—	Fixed at H.
17	AD_BATMNT	I	Battery voltage detection input
18	AD_KEY1	I	Key input from switch unit (A/D input)
19	ADRMKEY	I	Key input from headphones with remote controller (A/D input).
20	AD_DCINMNT	I	DC input voltage detection input (A/D input) DC input jack use/no-use detect input
21	WP_OPEN	I	CD door open/close detection input
22	VREFL	I	Reference voltage (0 V) input for A/D converter. (Connect to ground.)
23	VREFH	I	Reference voltage (+2 V) input for A/D converter.
24	VDD	—	Power supply pin (+2 V)
25	SCOR_I	I	Sub code sync detection input from CXD3028R (IC601) (Former Type) or CXD3037R (IC601) (New Type).
26	GRSCOR_I	I	GRSCOR signal input
27	FG_I	I	FG pulse input
28	BEEP_O	O	Beep sound output to TA2120FN (IC302) (Former Type) or AN17880A-EAL (IC302) (New Type).
29 – 32	RESERVE	—	Not used. (Open)
33	XWRE0	O	XWRE signal output (Open)
34	XQOK	O	XQOK signal output (Open)
35	WFCK_I	I	WFCK signal input
36	COMPON	I	Key input from ESP switch (S804).
37	DBB	I	MEGA BASS switch input (L: OFF, H: ON) (Open)
38	RESERVE	—	Not used. (Open)
39	HOLD_I	I	HOLD switch (S803) input (L: HOLD on, H: HOLD off)
40	RESERVE	—	Not used. (Open)
41	BATTEST	O	Charging current control signal output (Open)
42	XHGON_O	O	Optical pick-up VCC control signal output (L: ON) (Open)
43	XLAT_O	O	Serial data latch pulse output to CXD3028R (IC601) (Former Type) or CXD3037R (IC601) (New Type). (for ESP)
44	XSOE_O	O	Output enable signal output (for ESP)
45	VOLUME_IC_LATCH_O	O	Headphone AMP ON/OFF control signal output (L: ON) (Fixed at H.)
46	XPOWLT_O	O	Latch output to TB2125F (IC401).
47	RESERVE	—	Not used (Open)
48	XAPC_OFF_O	O	APC mute signal output (L: mute)
49	SEG15	O	LCD drive segment output (Open)
50 – 62	SEG14 – 2	O	LCD drive segment output

Pin No.	Pin Name	I/O	Pin Description
63	SEG1	O	LCD drive segment output (Open)
64	SEG0	O	LCD drive segment output
65 – 68	COM3 – 0	O	LCD drive common output
69 – 71	V3 – 1	O	LCD drive bias output
72, 73	C1, 0	O	Capacitor connected terminal of LCD driver for voltage-up.
74	STOP	O	Stop signal output (Connect to ground.)
75	TEST	I	Test terminal for IC. (Fixed at L.)
76	XHPSW_O	O	Headphone AMP ON/OFF control signal output (L: ON) (Open)
77	XLIGHT_O	O	LCD back light control signal output to LCD. (Open)
78	RESET_I	I	System reset signal input from TB2125F (IC401). (L: Reset)
79	XIN_I	I	Oscillation input
80	XOUT	O	Oscillation output (Open)

5-2. BLOCK DIAGRAM — CD SECTION (FORMER TYPE) —

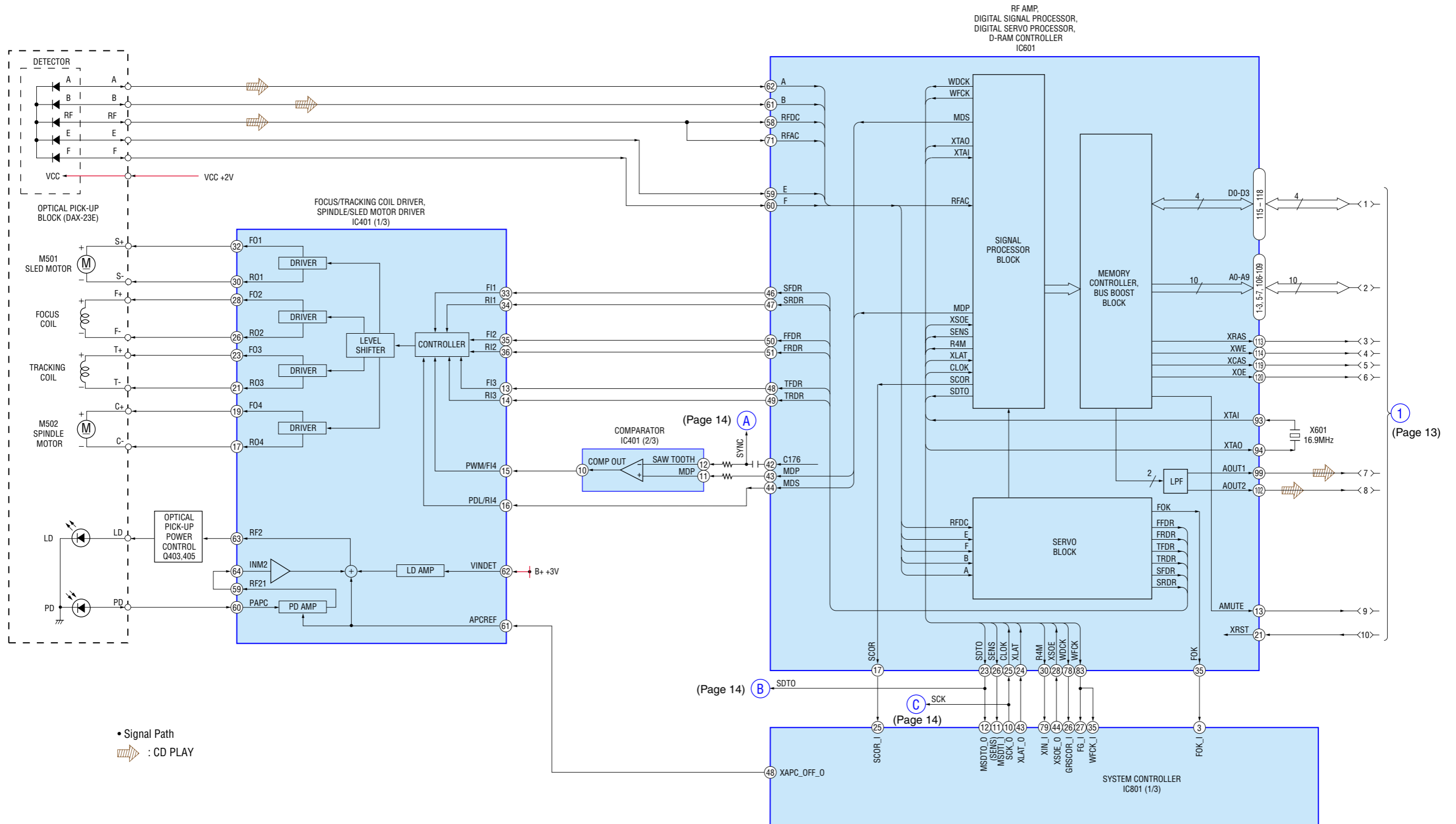

5-3. BLOCK DIAGRAM — AUDIO SECTION (FOREMER TYPE) —

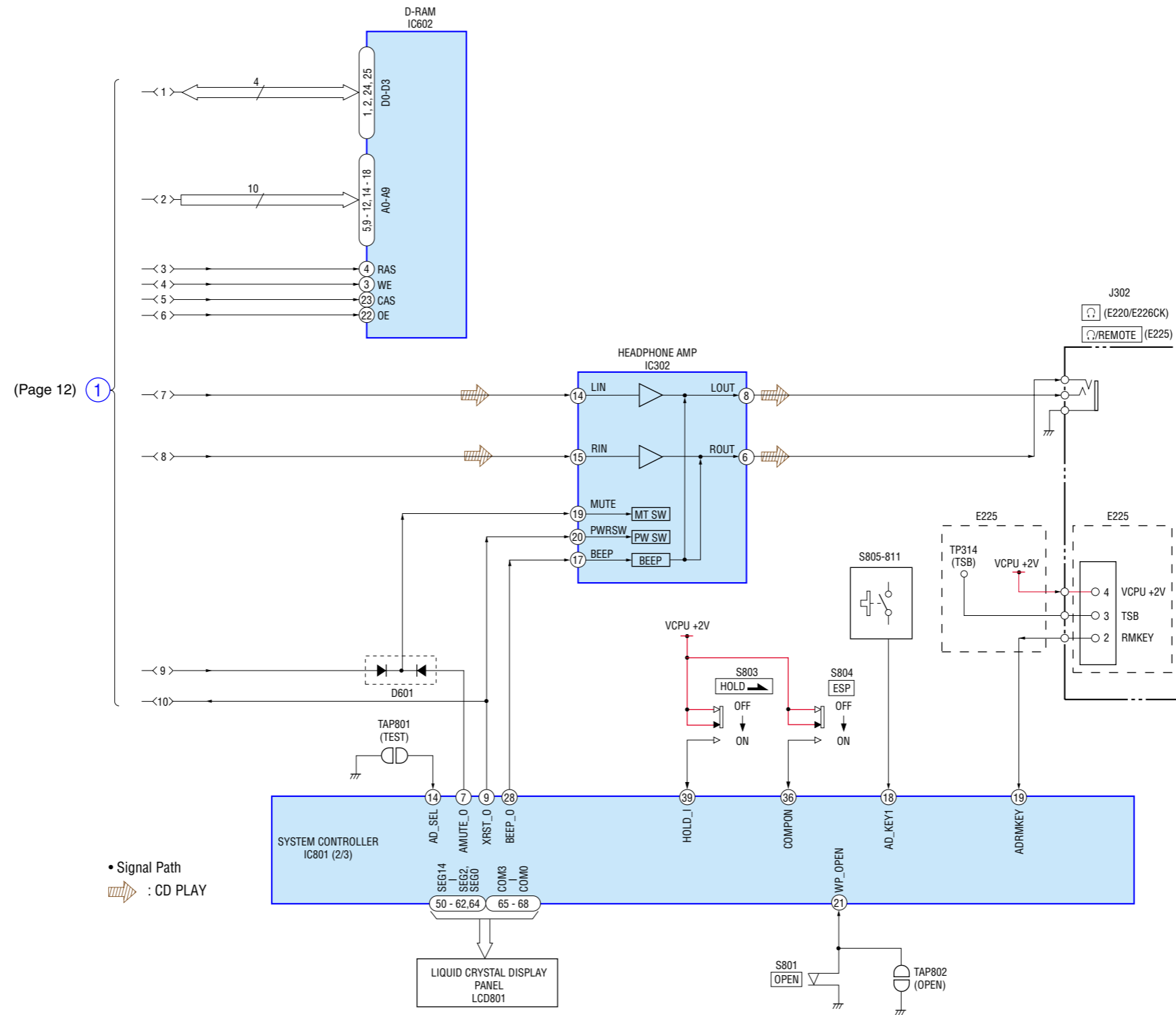

(Page 12) 1

5-4. BLOCK DIAGRAM — POWER SUPPLY SECTION (FORMER TYPE) —

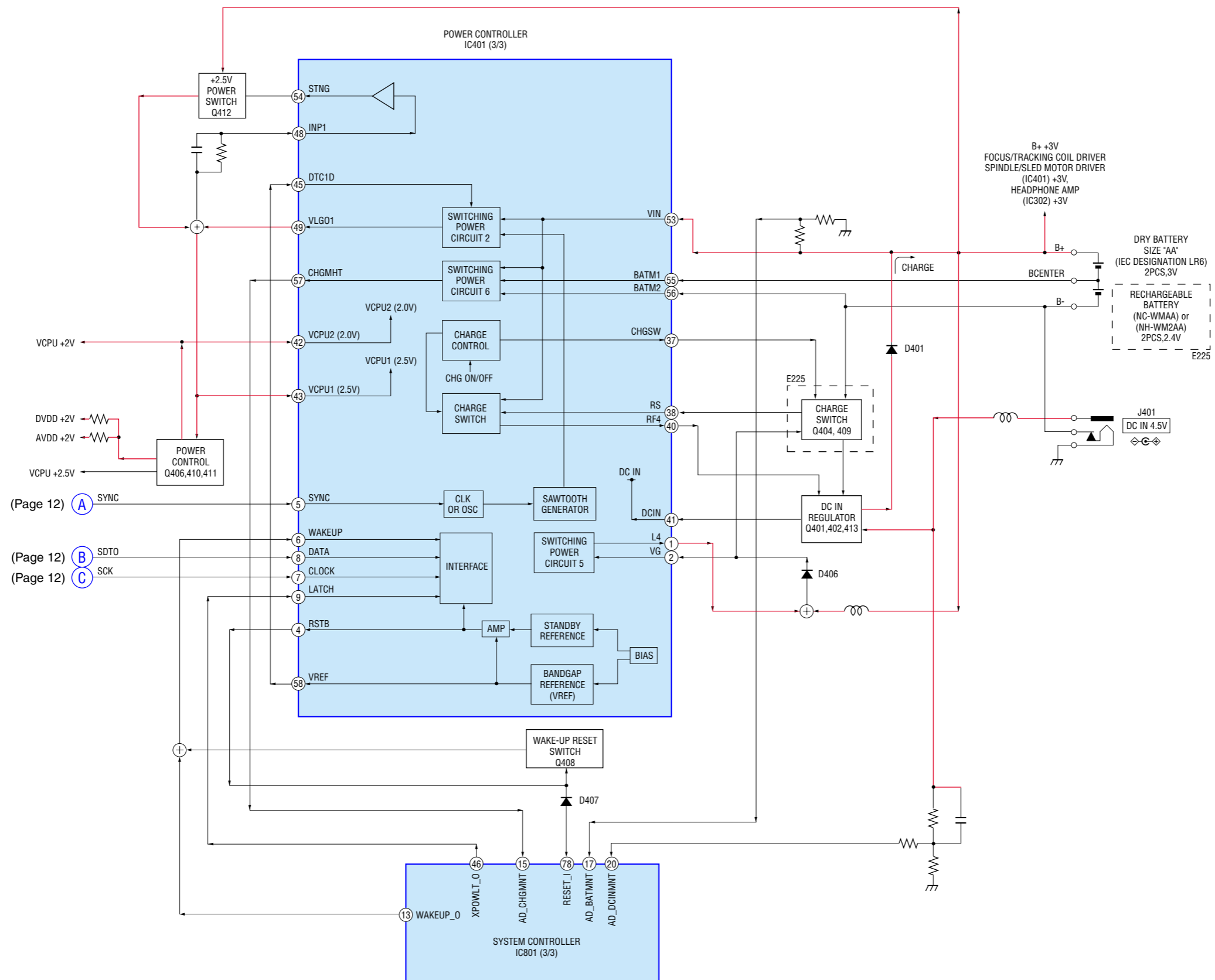

5-5. BLOCK DIAGRAM — CD SECTION (NEW TYPE) —

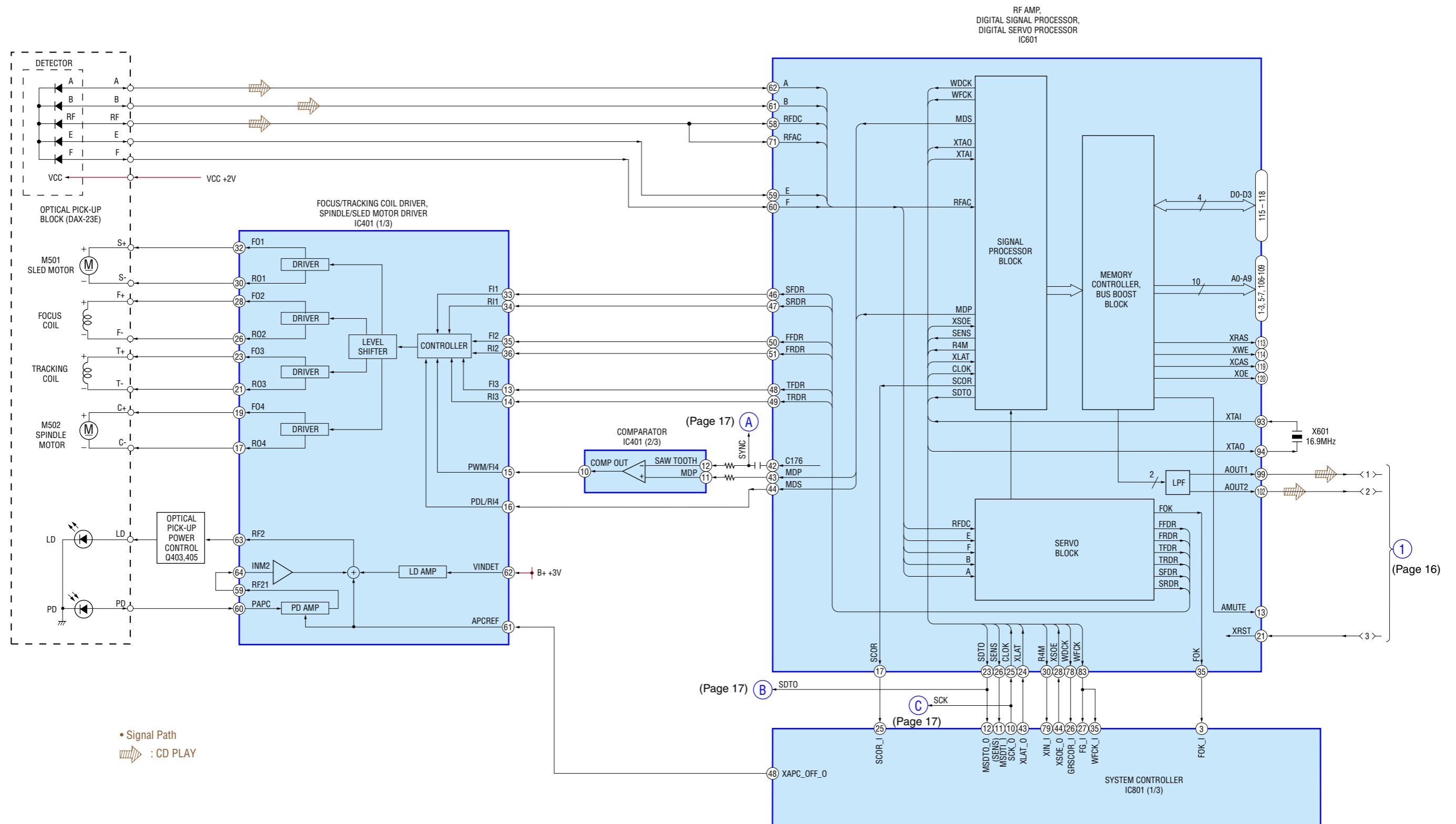

5-6. BLOCK DIAGRAM — AUDIO SECTION (NEW TYPE) —

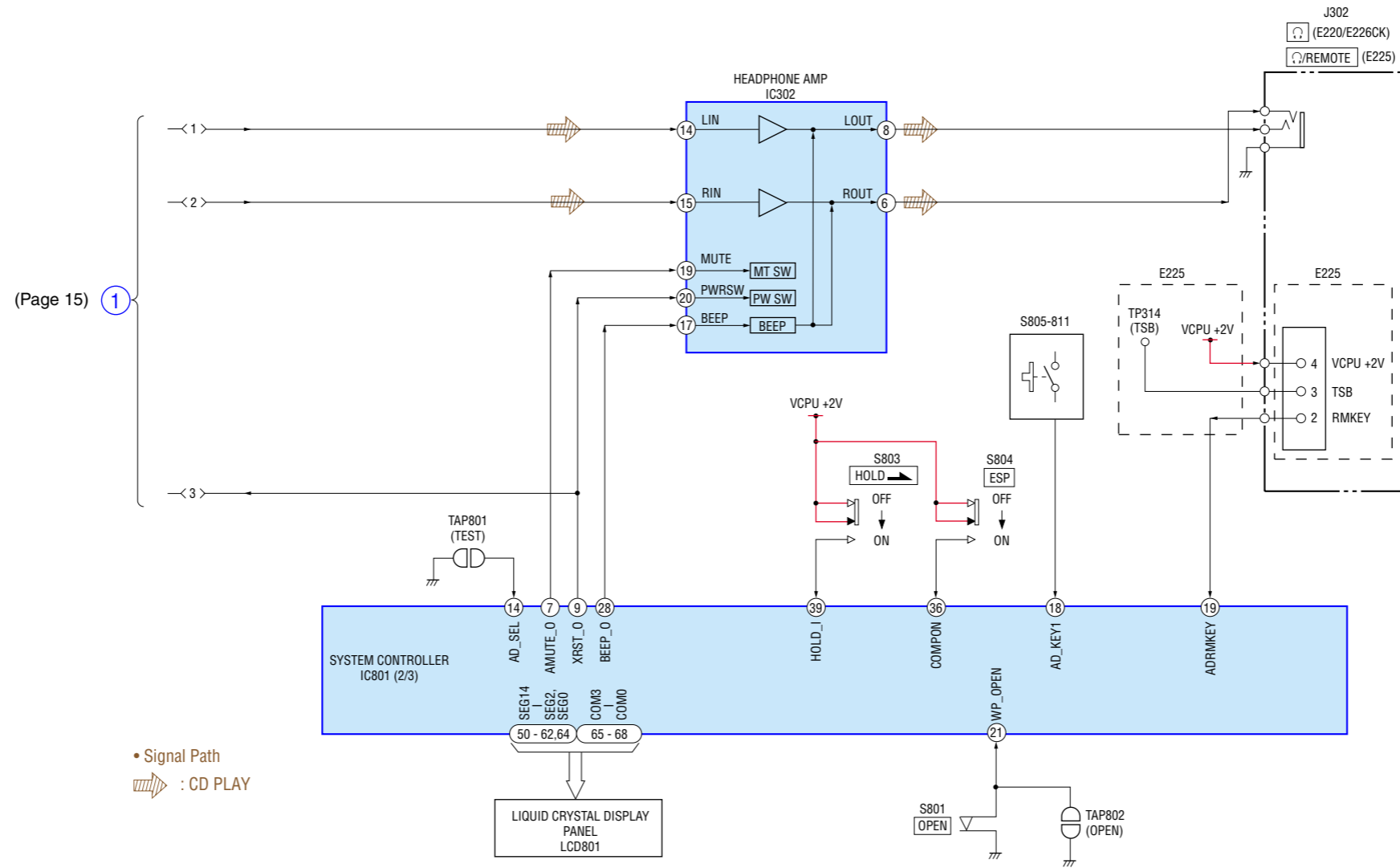

5-7. BLOCK DIAGRAM — POWER SUPPLY SECTION (NEW TYPE) —

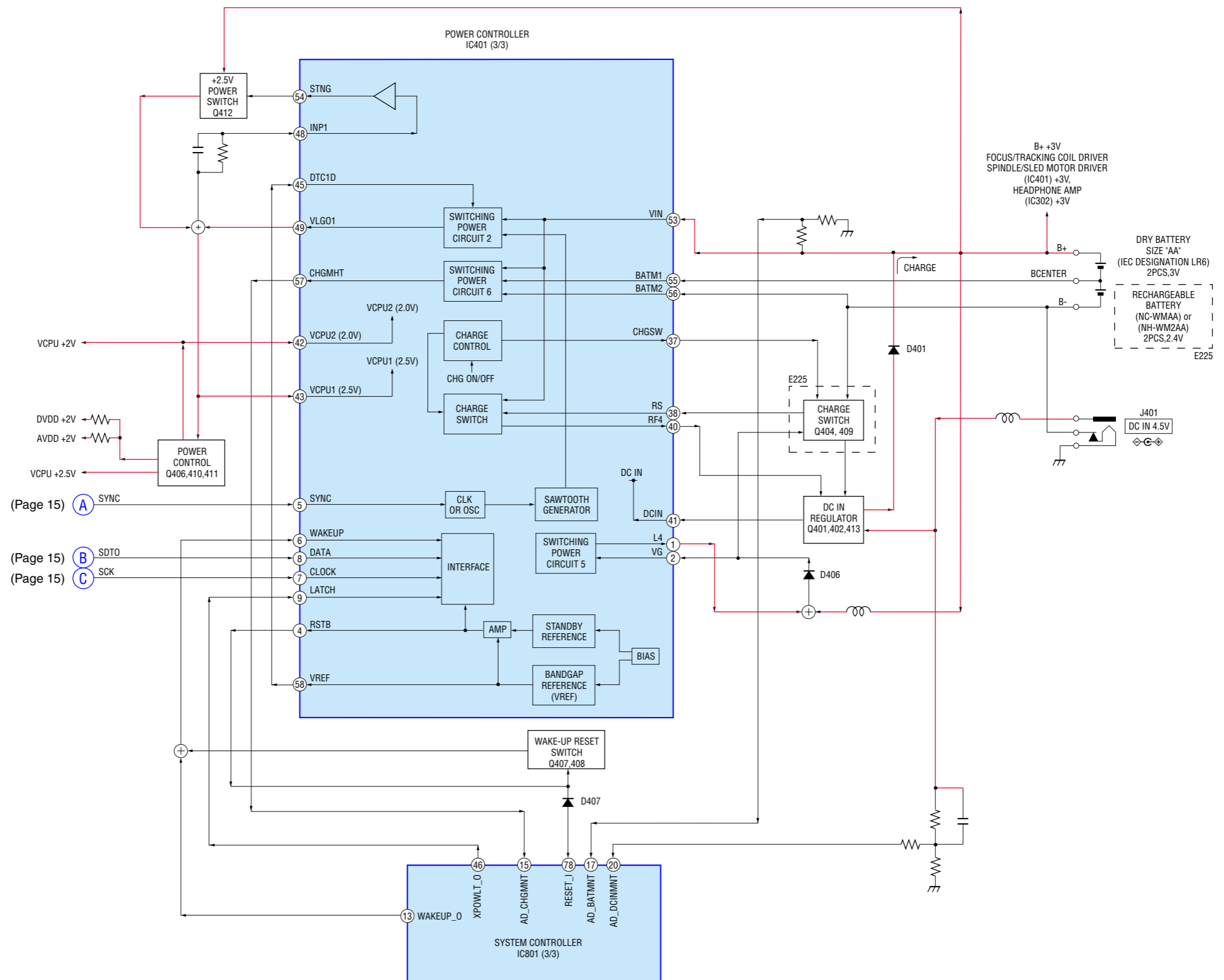

5-8. PRINTED WIRING BOARD — MAIN SECTION (FORMER TYPE) —

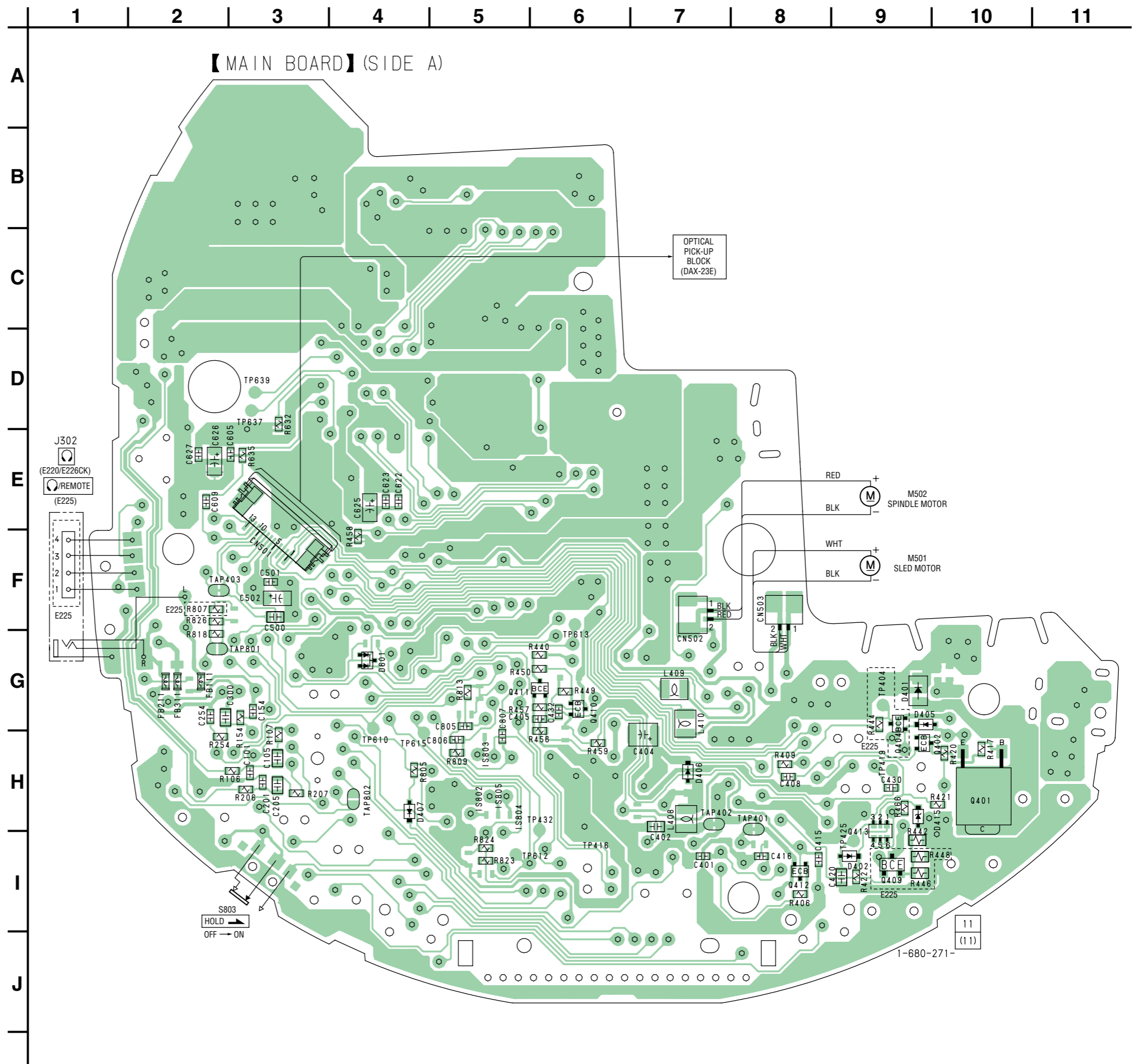

• Semiconductor Location (Side A)

Ref. No.	Location
D401	G-9
D402	I-9
D405	G-9
D406	H-7
D407	H-4
D415	H-9
D601	G-4
Q401	H-10
Q402	H-9
(Q404)	G-9
(Q409)	I-9
Q410	G-6
Q411	G-6
Q412	I-8
Q413	H-9

() : D-E225 only

Common Note on Schematic Diagram:

- All capacitors are in μF unless otherwise noted. pF : μF 50 WV or less are not indicated except for electrolytics and tantalums.
- All resistors are in Ω and $1/4\text{W}$ or less unless otherwise specified.
- % : indicates tolerance.
- Δ : internal component.
- \square : panel designation.

Note:
The components identified by mark Δ or dotted line with mark Δ are critical for safety. Replace only with part number specified.

Note:
Les composants identifiés par une marque Δ sont critiques pour la sécurité. Ne les remplacer que par une pièce portant le numéro spécifié.

- **B+ Line.**
- Power voltage is dc 4.5 V and fed with regulated dc power supply from external power voltage jack.
- Voltages and waveforms are dc with respect to ground in playback mode.
no mark : CD PLAY
* : Impossible to measure
- Voltages are taken with a VOM (Input impedance 10 M Ω). Voltage variations may be noted due to normal production tolerances.
- Waveforms are taken with a oscilloscope. Voltage variations may be noted due to normal production tolerances.
- Circled numbers refer to waveforms.
- Signal path.
- \Rightarrow : CD
- Abbreviation
FR : France model.

Common Note on Printed Wiring Boards:

- \circ : parts extracted from the component side.
- \square : parts extracted from the conductor side.
- \circ : Through hole.
- Δ : internal component.
- \square : Pattern from the side which enables seeing.

Caution:
Pattern face side: Parts on the pattern face side seen from the (Side B) pattern face are indicated.
Parts face side: Parts on the parts face side seen from the (Side A) parts face are indicated.

• Refer to page 18 for Common Note on Printed Wiring Board.

12 | 11 | 10 | 9 | 8 | 7 | 6 | 5 | 4 | 3 | 2 | 1

【MAIN BOARD】(SIDE B)

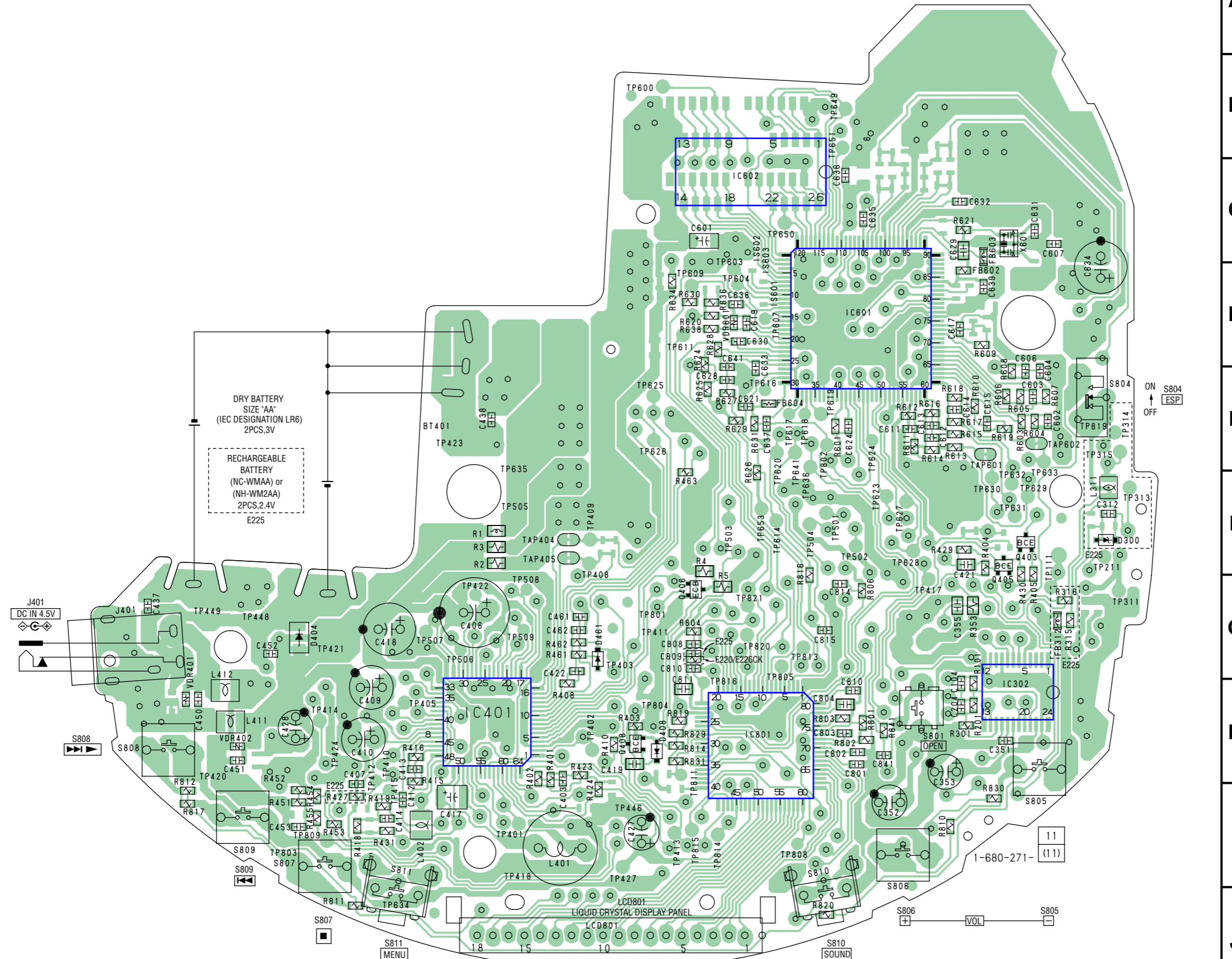

• Semiconductor Location (Side B)

Ref. No.	Location
(D300)	F-2
D404	G-9
D408	H-6
D461	G-7
IC302	H-2
IC401	H-7
IC601	D-4
IC602	C-5
IC801	H-5
Q403	F-2
Q405	F-3
Q406	G-6
Q408	H-6

() : D-E225 only

5-9. PRINTED WIRING BOARD — MAIN SECTION (NEW TYPE) — • Refer to page 18 for Common Note on Printed Wiring Board.

1 2 3 4 5 6 7 8 9 10 11 12

• Semiconductor Location (Side A)

Ref. No.	Location
D401	G-9
D402	I-9
D405	G-9
D406	H-7
D407	H-4
D409	H-6
D415	H-9
Q401	H-10
Q402	H-9
(Q404)	G-9
Q407	H-6
(Q409)	I-9
Q410	G-6
Q411	G-6
Q412	I-8
Q413	H-9

() : D-E225 only

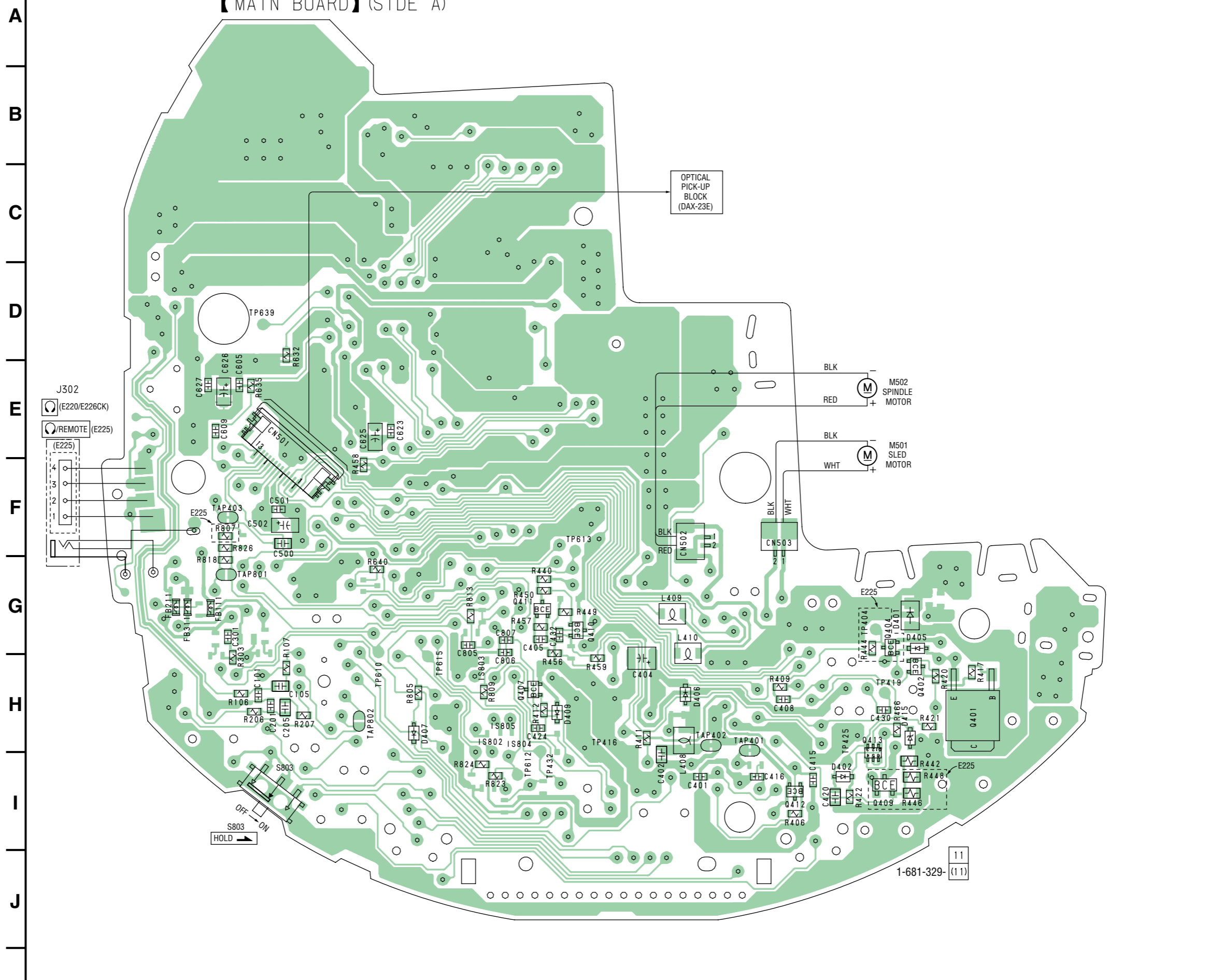

• Refer to page 18 for Common Note on Printed Wiring Board.

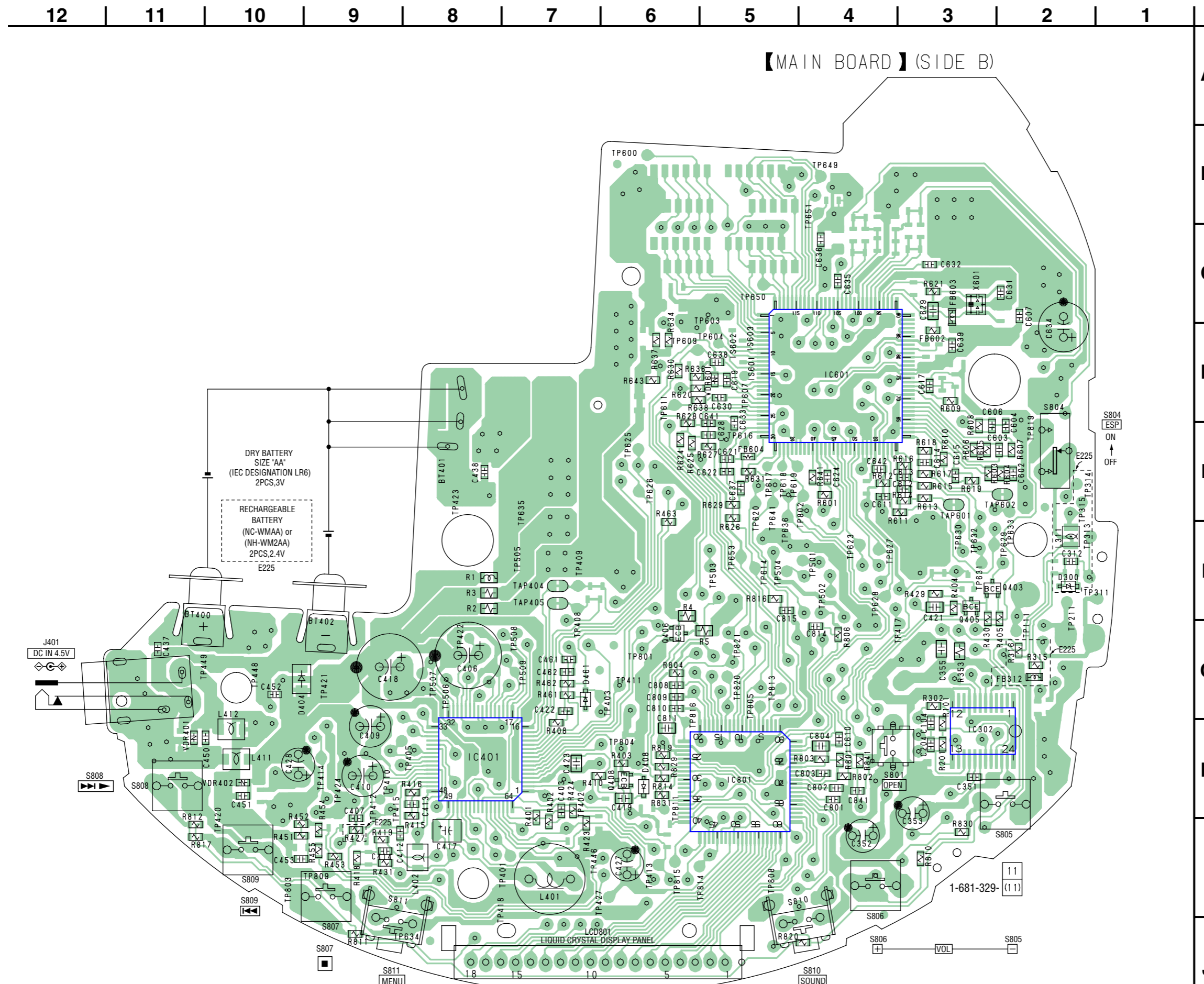

• Waveforms (Play mode)

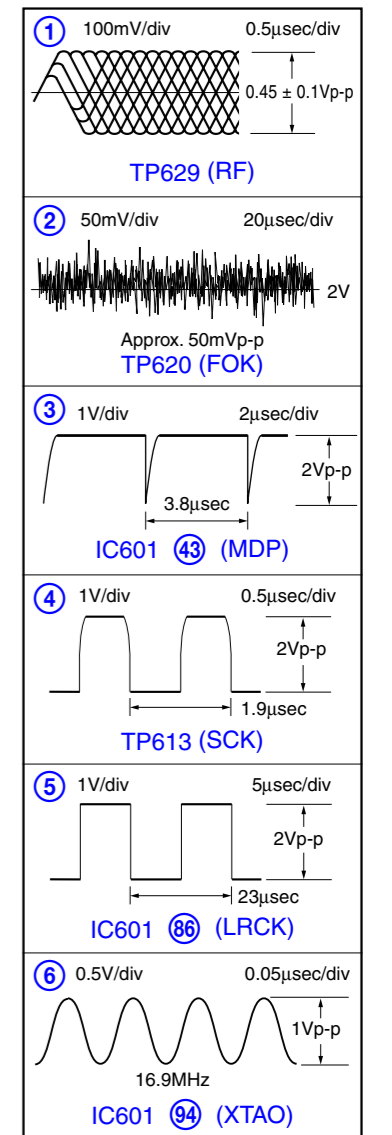

• Semiconductor Location (Side B)

Ref. No.	Location
(D300)	F-2
D404	G-9
D408	H-6
D461	G-7
IC302	H-2
IC401	H-7
IC601	D-4
IC801	H-5
Q403	F-2
Q405	F-3
Q406	G-6
Q408	H-6

() : D-E225 only

5-10. SCHEMATIC DIAGRAM — MAIN SECTION (1/2) (FORMER TYPE) —

- Refer to page 21 for Waveforms.
- Refer to page 26 for IC Block Diagrams.
- Refer to page 18 for Common Note on Schematic Diagram.

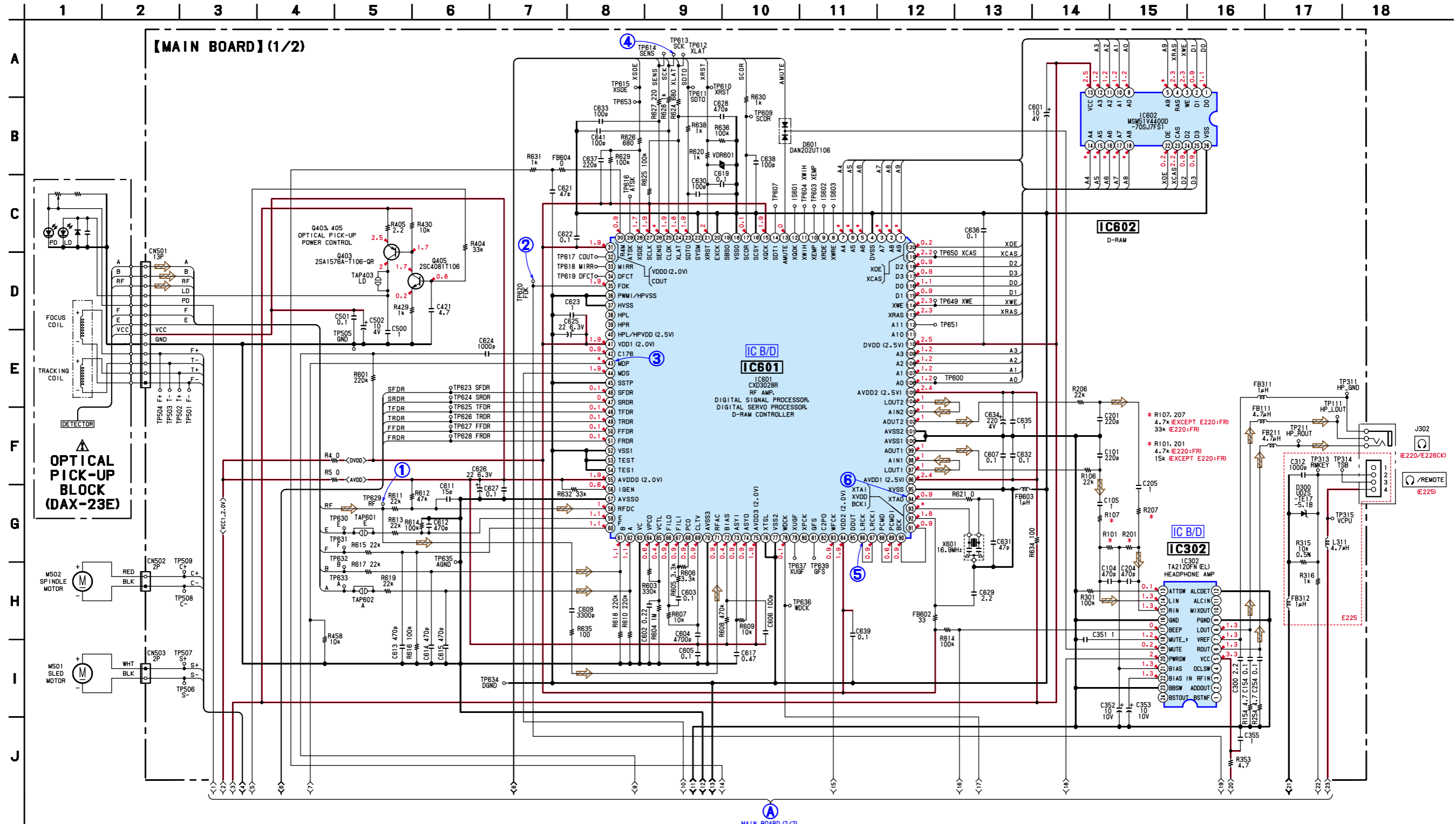

MAIN BOARD (2/2)
(Page 23)

5-11. SCHEMATIC DIAGRAM — MAIN SECTION (2/2) (FORMER TYPE) — • Refer to page 26 for IC Block Diagrams.
• Refer to page 18 for Common Note on Schematic Diagram.

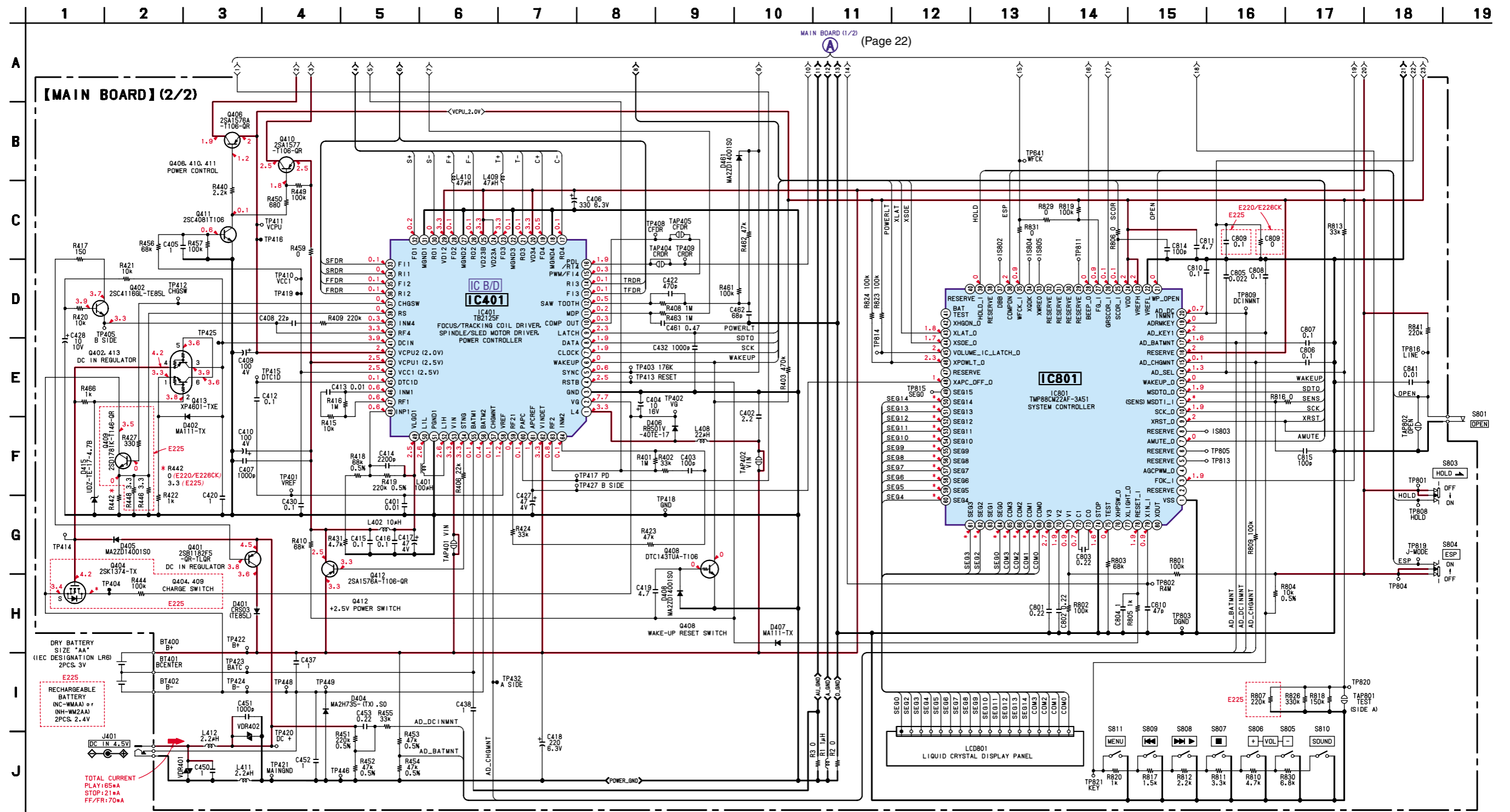

5-12. SCHEMATIC DIAGRAM — MAIN SECTION (1/2) (NEW TYPE) —

- Refer to page 21 for Waveforms.
- Refer to page 26 for IC Block Diagrams.
- Refer to page 18 for Common Note on Schematic Diagram.

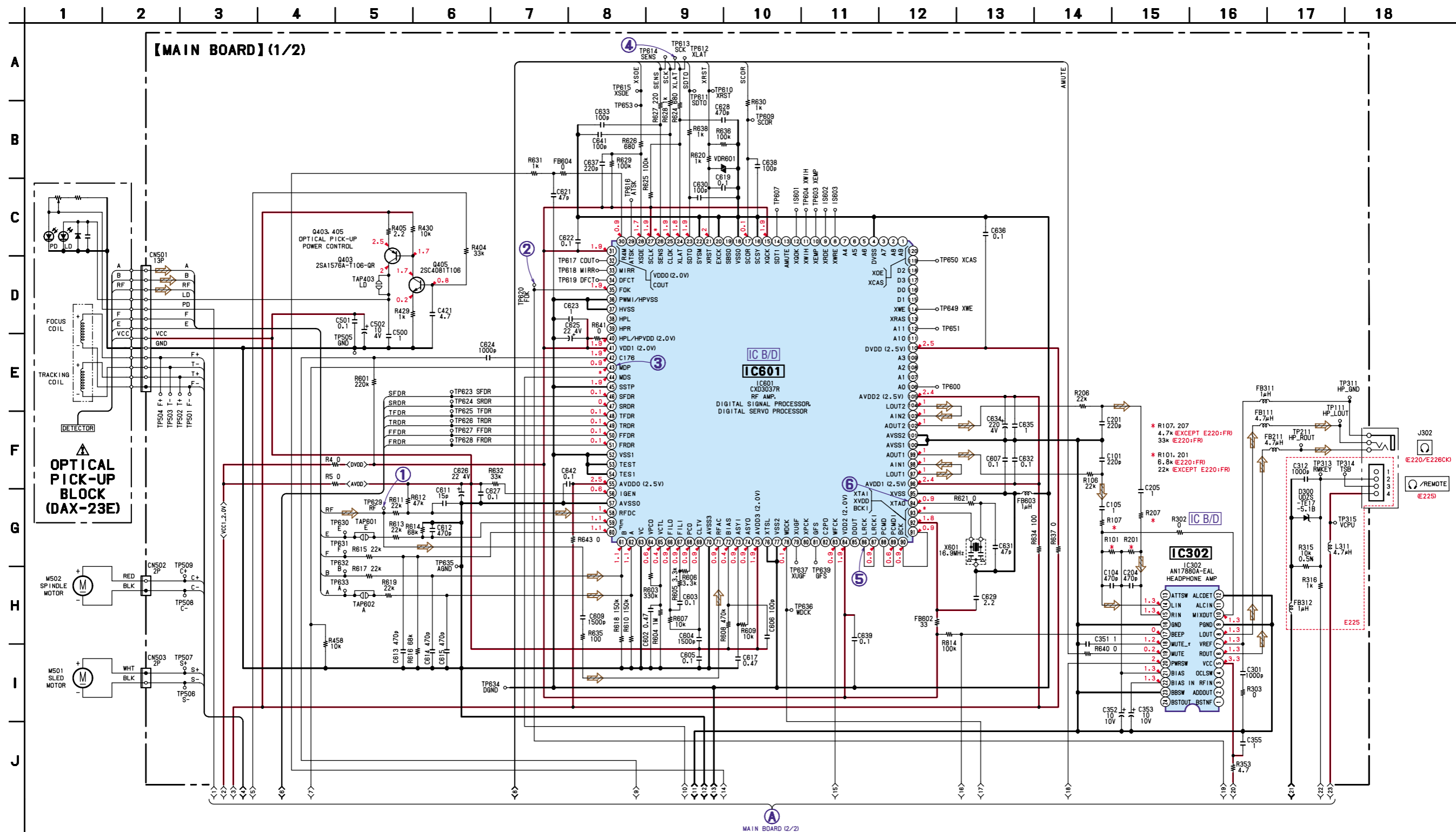

MAIN BOARD (2/2)
(Page 25)

5-13. SCHEMATIC DIAGRAM — MAIN SECTION (2/2) (NEW TYPE) — • Refer to page 26 for IC Block Diagrams.
• Refer to page 18 for Common Note on Schematic Diagram.

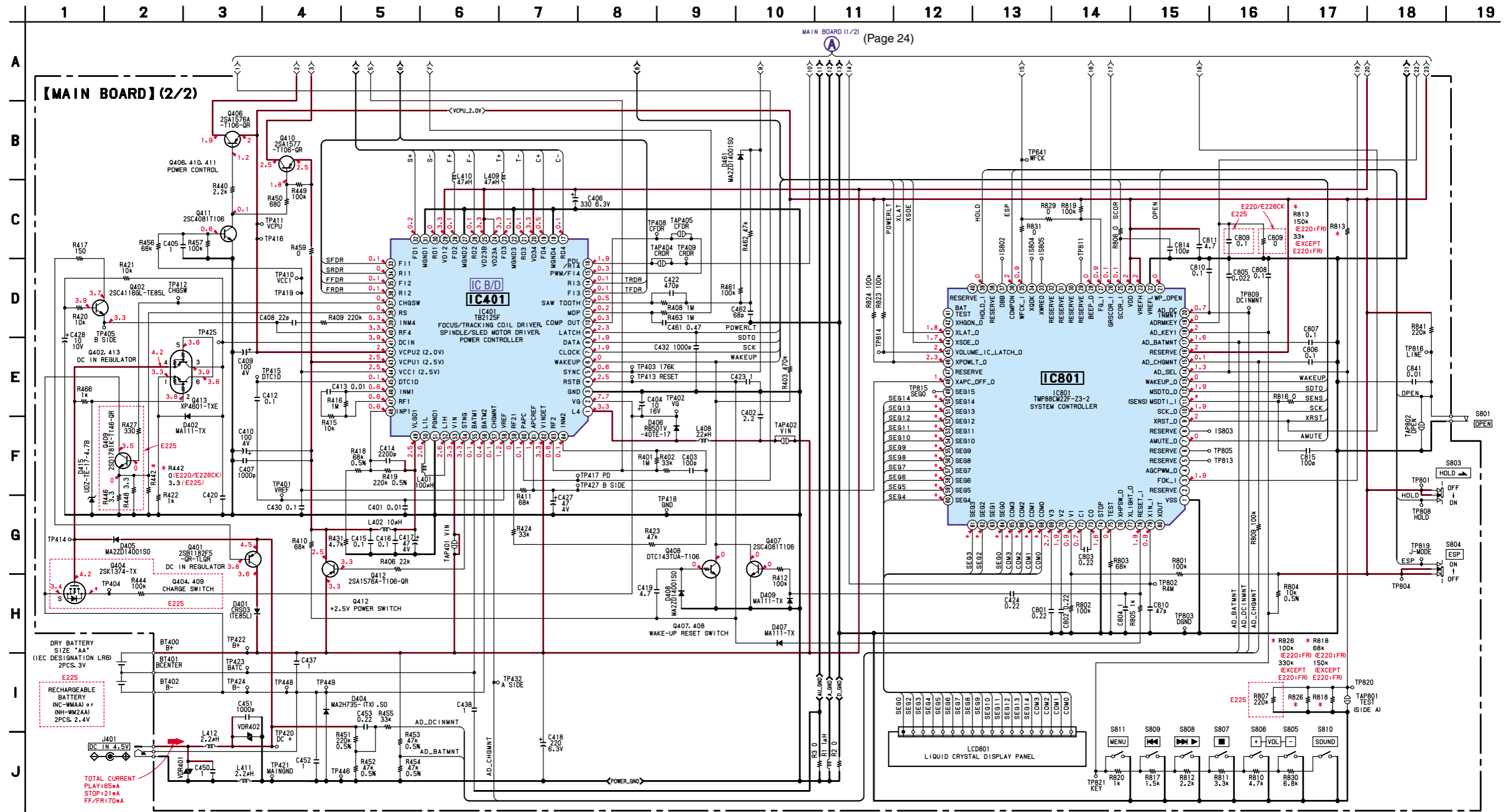

D-E220/E225/E226CK

5-14. IC Block Diagrams

IC601 CXD3028R (Former Type)

IC601 CXD3037R (New Type)

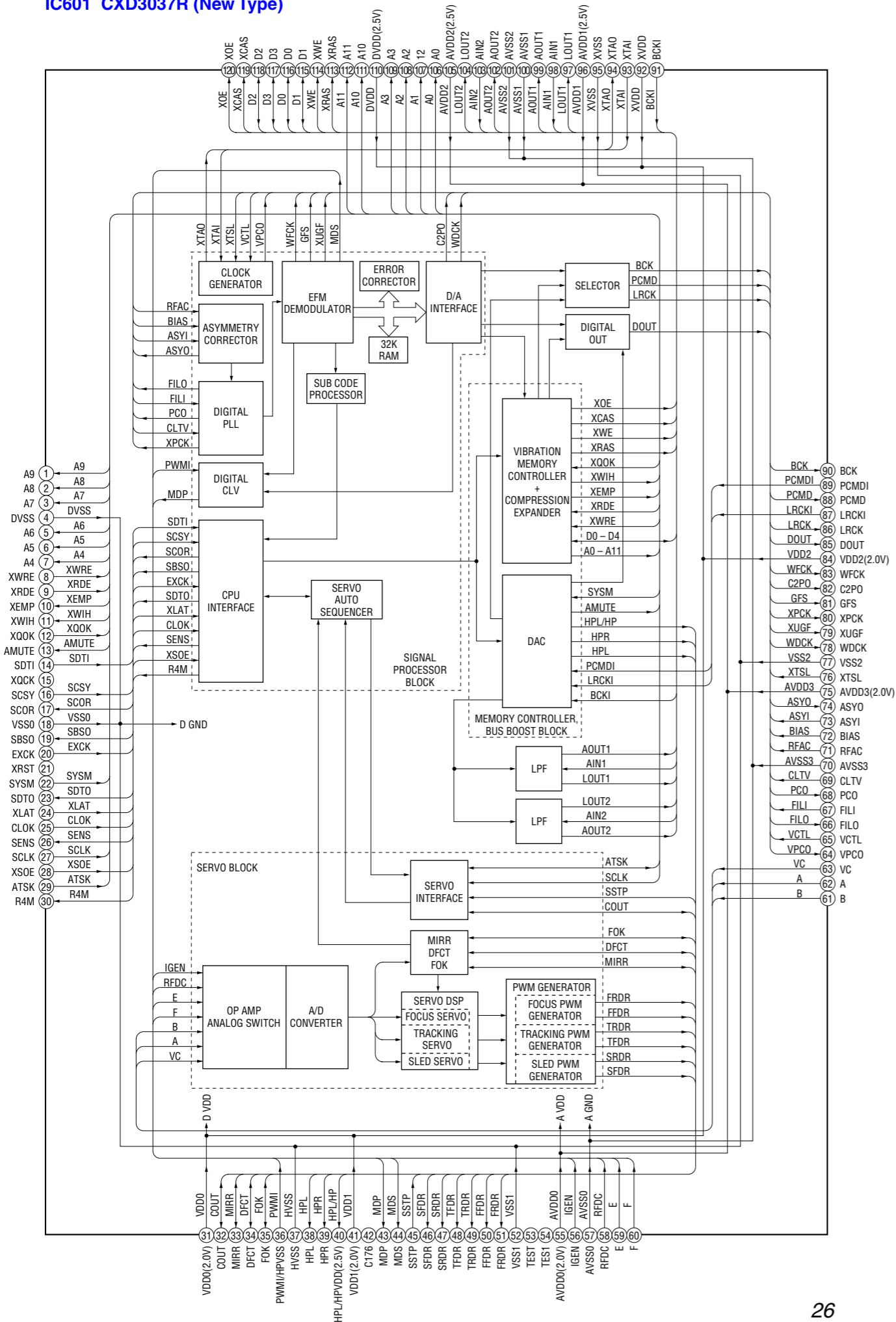

IC302 TA2120FN(EL) (Former Type)

IC302 AN17880A-EAL (New Type)

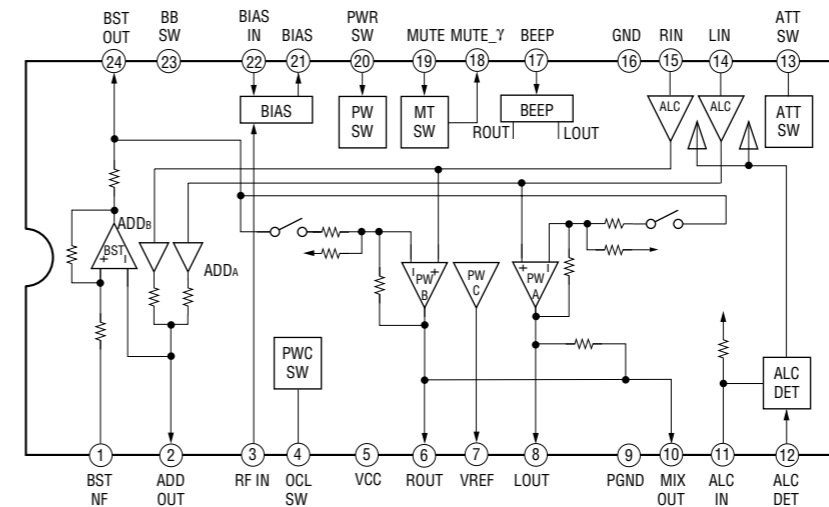

IC401 TB2125F

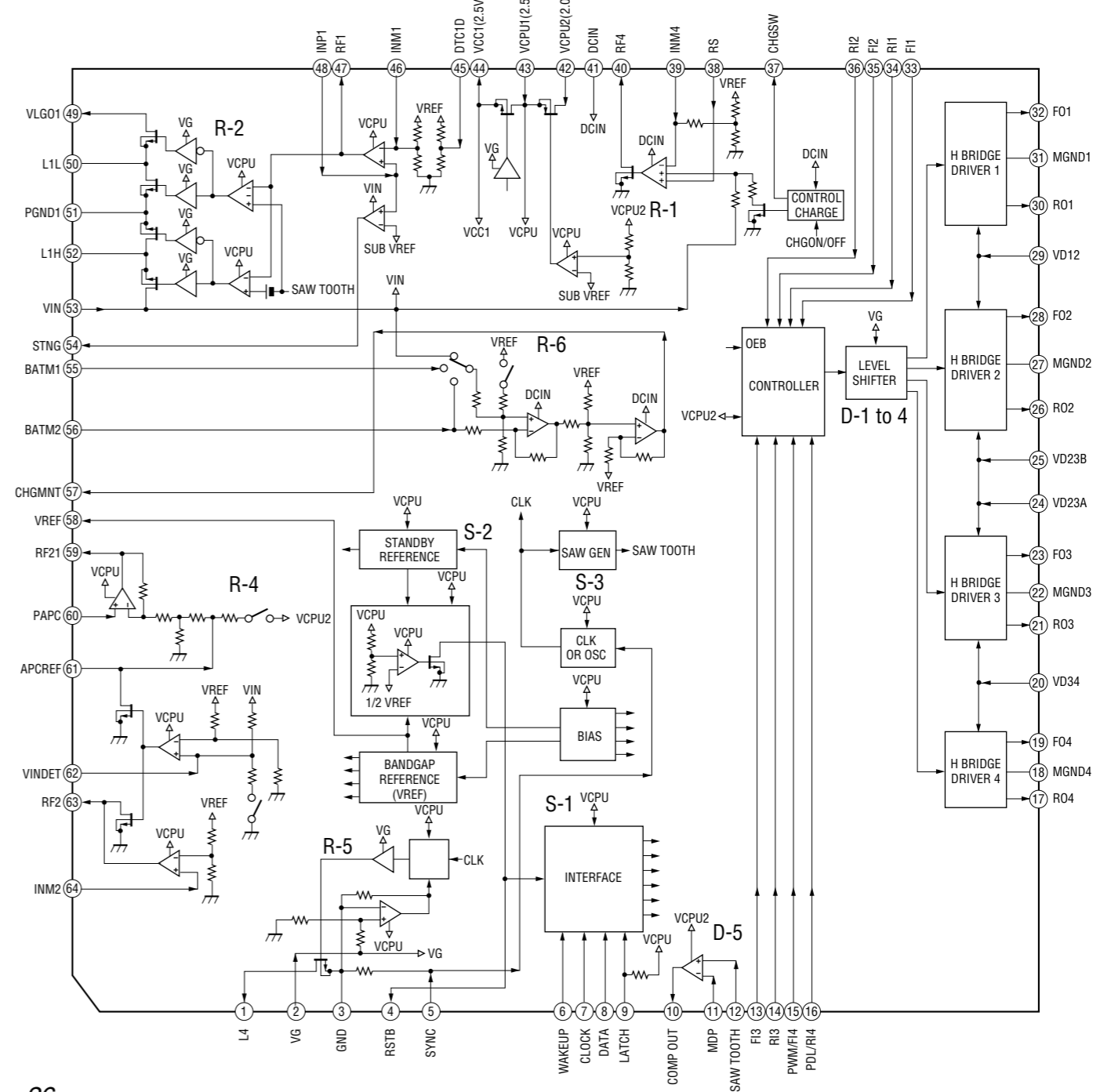

SECTION 6 EXPLODED VIEWS

NOTE:

- The mechanical parts with no reference number in the exploded views are not supplied.
- Items marked “*” are not stocked since they are seldom required for routine service. Some delay should be anticipated when ordering these items.
- -XX and -X mean standardized parts, so they may have some difference from the original one.

- Color Indication of Appearance Parts
Example :
 KNOB, BALANCE (WHITE) ... (RED)
 ↑ ↑
 Parts Color Cabinet’s Color
- Accessories and packing materials are given in the last of this parts list.

The components identified by mark \triangle or dotted line with mark \triangle are critical for safety. Replace only with part number specified.

Les composants identifiés par une marque \triangle sont critiques pour la sécurité. Ne les remplacer que par une pièce portant le numéro spécifié.

- Abbreviation
FR : France model
EE : East European model
CH : Chinese model
HK : Hong Kong model

6-1. CABINET (FRONT) SECTION

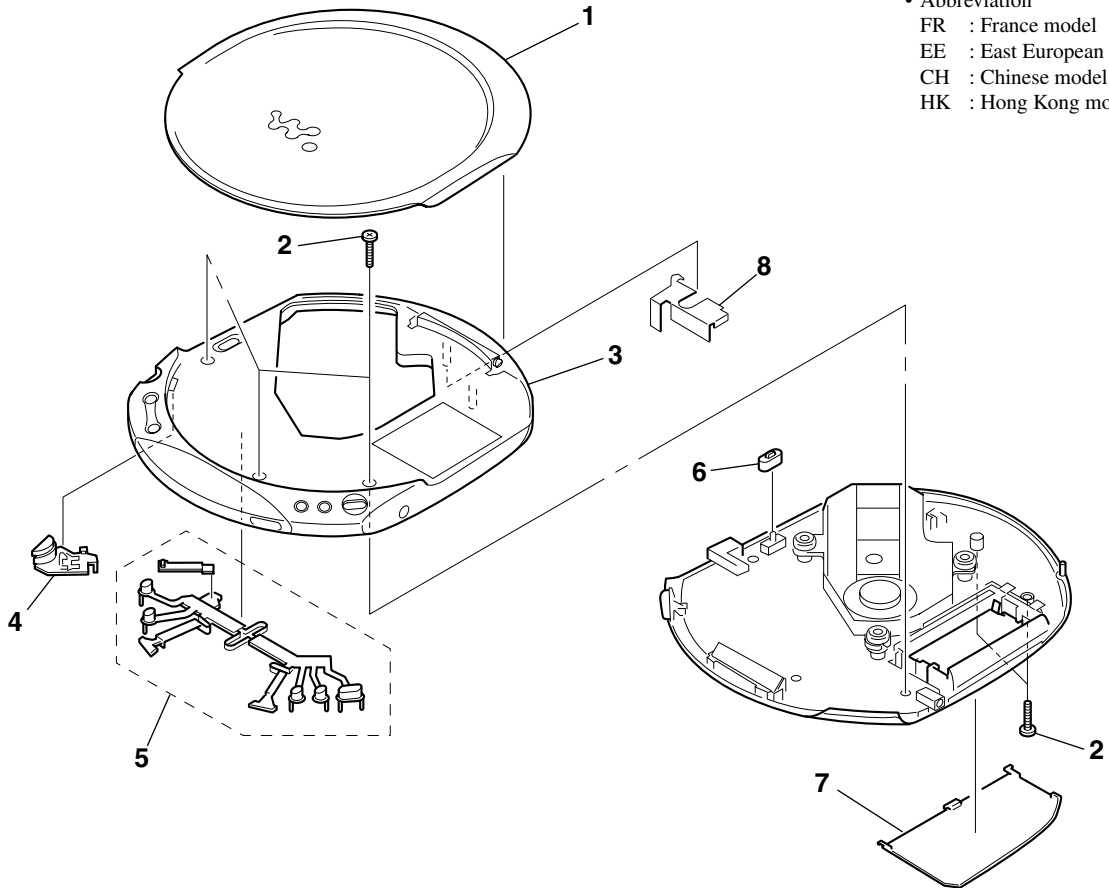

Ref. No.	Part No.	Description	Remark	Ref. No.	Part No.	Description	Remark
1	X-3379-844-1	LID ASSY, UPPER (SILVER)		4	3-222-855-01	BUTTON (OPEN) (SILVER)	
1	X-3379-845-1	LID ASSY, UPPER (BLUE)	(E220:US,AEP,E,EE,FR)	4	3-222-855-11	BUTTON (OPEN) (BLUE)	(E220:US,AEP,EE,FR/E225:E,CH,HK)
1	X-3379-849-1	LID ASSY, UPPER (SILVER)	(E226CK)	4	3-222-855-31	BUTTON (OPEN) (RED)	(E220:US)
1	X-3379-850-1	LID ASSY, UPPER (SILVER)	(E225)	4	3-222-855-41	BUTTON (OPEN) (DARK BLUE)	(E220:US)
1	X-3380-114-1	LID ASSY, UPPER (RED)	(E220:US)	4	3-222-855-51	BUTTON (OPEN) (YELLOW)	(E220:US)
1	X-3380-115-1	LID ASSY, UPPER (DARK BLUE)	(E220:US)	4	3-222-855-61	BUTTON (OPEN) (BLACK)	(E226CK:US)
1	X-3380-116-1	LID ASSY, UPPER (YELLOW)	(E220:US)	5	3-222-854-01	BUTTON (OPERATE)	
1	X-3380-345-1	LID ASSY, UPPER (BLUE)	(E225:E,CH,HK)	6	3-232-612-01	KNOB (JOGGABLE)	
1	X-3380-349-1	LID ASSY, UPPER (BLUE)	(E226CK:US)	7	3-222-856-01	LID, BATTERY CASE	
1	X-3380-355-1	LID ASSY, UPPER (BLACK)	(E226CK:US)	8	3-229-481-01	PLATE (CABINET UPPER), SUPPORT	
2	3-336-395-01	SCREW (B2X10) (G), TAPPING					
3	X-3380-139-1	CABINET (FRONT) ASSY (SILVER)	(E220/E226CK)				
3	X-3380-140-1	CABINET (FRONT) ASSY (BLUE)	(E220:US,AEP,EE,FR/E225:E,CH,HK/E226CK:US)				
3	X-3380-141-1	CABINET (FRONT) ASSY (SILVER)	(E225)				
3	X-3380-142-1	CABINET (FRONT) ASSY (RED)	(E220:US)				
3	X-3380-143-1	CABINET (FRONT) ASSY (DARK BLUE)	(E220:US)				
3	X-3380-144-1	CABINET (FRONT) ASSY (YELLOW)	(E220:US)				
3	X-3380-145-1	CABINET (FRONT) ASSY (BLACK)	(E226CK:US)				

6-2. CABINET (REAR) SECTION

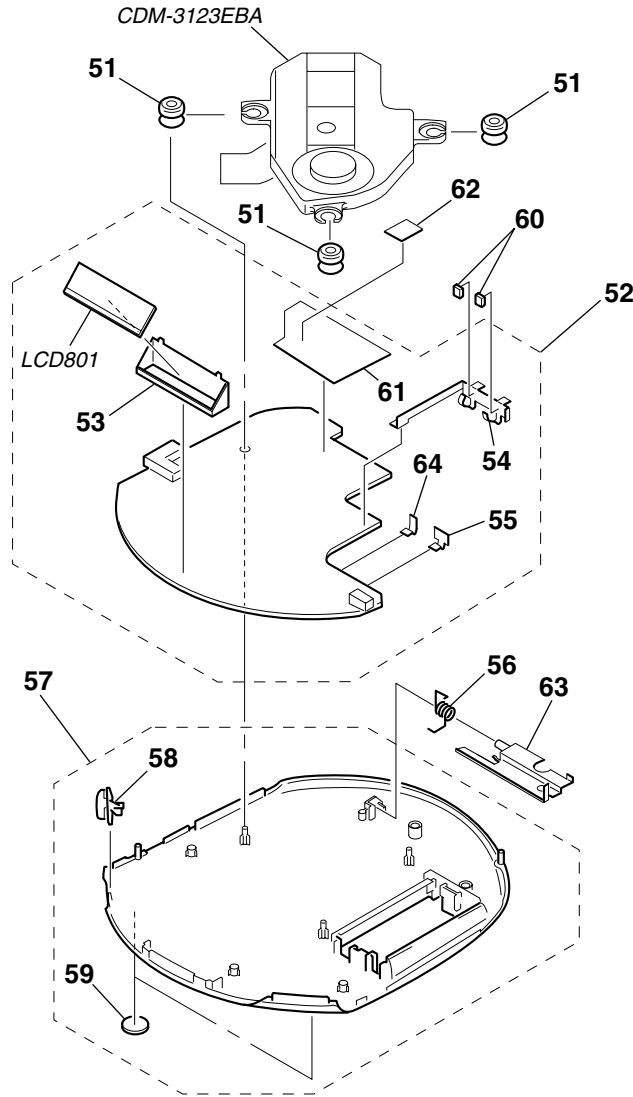

Ref. No.	Part No.	Description	Remark	Ref. No.	Part No.	Description	Remark
51	4-222-765-11	INSULATOR		56	3-222-862-01	SPRING (TORSION)	
* 52	A-3323-643-A	MAIN BOARD, COMPLETE (E220:EXCEPT FR/ E226CK)		57	X-3379-851-1	CABINET (REAR) ASSY	
* 52	A-3323-671-A	MAIN BOARD, COMPLETE (E225)		58	3-222-857-01	KNOB (HOLD)	
* 52	A-3323-708-A	MAIN BOARD, COMPLETE (E220:FR)		59	4-974-607-11	FOOT, RUBBER	
53	3-222-858-01	HOLDER, LCD		60	4-218-592-01	CUSHION	
54	3-222-859-01	TERMINAL (LINK), BATTERY (BT401) (FORMER)		61	3-231-769-01	SHEET (2), INSULATING (NEW)	
54	3-231-550-01	TERMINAL (LINK 3), BATTERY (BT401) (E225) (NEW)		62	3-047-194-01	SHEET (CDM), ADHESIVE	
54	3-231-676-01	TERMINAL (LINK 4), BATTERY (BT401) (E220/E226CK) (NEW)		63	X-3380-456-1	HOLDER ASSY	
55	3-222-860-01	TERMINAL (+.-), BATTERY (BT400)		64	3-222-860-01	TERMINAL (+.-), BATTERY (BT402) (FORMER)	
				64	3-231-411-01	TERMINAL (-), BATTERY (BT402) (NEW)	
				LCD801	1-804-248-11	DISPLAY PANEL, LIQUID CRYSTAL	

6-3. CD MECHANISM DECK SECTION
(CDM-3123EBA)

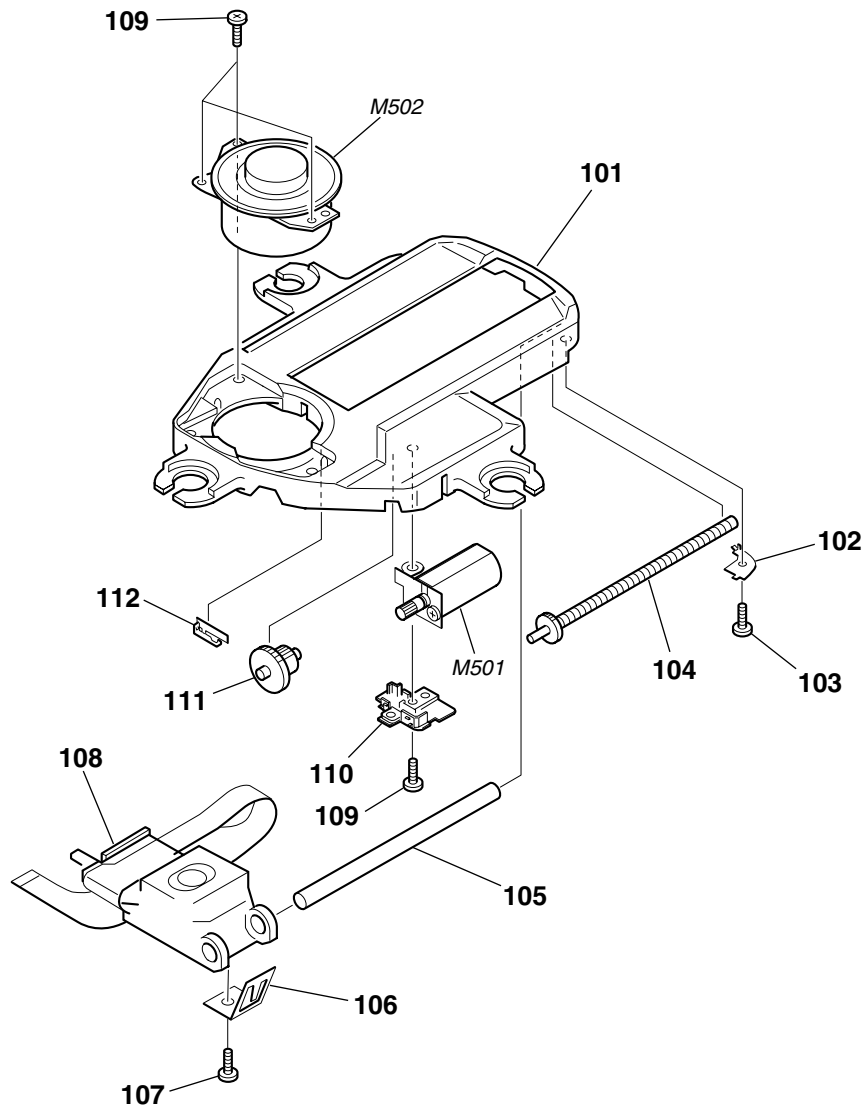

The components identified by mark \triangle or dotted line with mark \triangle are critical for safety. Replace only with part number specified.	Les composants identifiés par une marque \triangle sont critiques pour la sécurité. Ne les remplacer que par une pièce portant le numéro spécifié.
--	--

Ref. No.	Part No.	Description	Remark	Ref. No.	Part No.	Description	Remark
101	4-218-820-01	CHASSIS		\triangle 108	X-4952-506-1	PICK-UP BLOCK, OPTICAL (DAX-23E)	
102	4-218-827-01	RETAINER, SHAFT		109	3-318-203-71	SCREW (B1.7X5), TAPPING	
103	3-686-458-03	SCREW (P1.4X3.5), TAPPING		110	4-218-821-01	COVER, GEAR	
104	A-3328-628-A	SCREW (FEED) ASSY		111	4-218-823-01	GEAR (B)	
105	4-220-645-01	SHAFT, STANDARD		112	4-218-825-01	SPRING, SLED	
106	4-223-600-01	RACK		M501	A-3328-627-A	MOTOR ASSY, SLED (SLED)	
107	3-895-823-61	SCREW (B1.4X2.3), TAPPING		M502	A-3328-759-A	MOTOR ASSY, TURNTABLE (SPINDLE)	

SECTION 7

ELECTRICAL PARTS LIST

MAIN

NOTE:

- Due to standardization, replacements in the parts list may be different from the parts specified in the diagrams or the components used on the set.
- -XX and -X mean standardized parts, so they may have some difference from the original one.
- RESISTORS
All resistors are in ohms.
METAL: Metal-film resistor.
METAL OXIDE: Metal oxide-film resistor.
F: nonflammable
- Abbreviation
FR : France model CND : Canadian model
AUS : Australian model E92 : AC 120V area in E model
EE : East European model HK : Hong Kong model

- Items marked "***" are not stocked since they are seldom required for routine service. Some delay should be anticipated when ordering these items.
- SEMICONDUCTORS
In each case, u : μ , for example:
uA.. : μ A.. uPA.. : μ PA..
uPB.. : μ PB.. uPC.. : μ PC.. uPD.. : μ PD..
- CAPACITORS
uF : μ F
- COILS
uH : μ H

The components identified by mark Δ or dotted line with mark Δ are critical for safety. Replace only with part number specified.

Les composants identifiés par une marque Δ sont critiques pour la sécurité. Ne les remplacer que par une pièce portant le numéro spécifié.

When indicating parts by reference number, please include the board.

Ref. No.	Part No.	Description	Remark	Ref. No.	Part No.	Description	Remark
*	A-3323-643-A	MAIN BOARD, COMPLETE (E220:EXCEPT FR/ E226CK)		C408	1-162-919-11	CERAMIC CHIP 22PF 5%	50V
				C409	1-124-584-00	ELECT 100uF 20%	10V
*	A-3323-671-A	MAIN BOARD, COMPLETE (E225)		C410	1-124-584-00	ELECT 100uF 20%	10V
*	A-3323-708-A	MAIN BOARD, COMPLETE (E220:FR) *****		C412	1-164-156-11	CERAMIC CHIP 0.1uF	25V
				C413	1-162-970-11	CERAMIC CHIP 0.01uF 10%	25V
	3-047-194-01	SHEET (CDM), ADHESIVE		C414	1-162-966-11	CERAMIC CHIP 0.0022uF 10%	50V
	3-222-858-01	HOLDER, LCD		C415	1-164-156-11	CERAMIC CHIP 0.1uF	25V
	3-222-859-01	TERMINAL (LINK), BATTERY (BT401) (FORMER)		C416	1-164-156-11	CERAMIC CHIP 0.1uF	25V
	3-222-860-01	TERMINAL (+,-), BATTERY (BT400)		C417	1-110-569-11	TANTAL. CHIP 47uF 20%	4V
	3-222-860-01	TERMINAL (+,-), BATTERY (BT402) (FORMER)		C418	1-126-369-11	ELECT 220uF 20%	6.3V
	3-231-411-01	TERMINAL (-), BATTERY (BT402) (NEW)		C419	1-127-760-11	CERAMIC CHIP 4.7uF 10%	6.3V
	3-231-550-01	TERMINAL (LINK 3), BATTERY (BT401) (E225) (NEW)		C420	1-109-982-11	CERAMIC CHIP 1uF 10%	10V
	3-231-676-01	TERMINAL (LINK 4), BATTERY (BT401) (E220/E226CK) (NEW)		C421	1-127-760-11	CERAMIC CHIP 4.7uF 10%	6.3V
	3-231-769-01	SHEET (2), INSULATING (NEW)		C422	1-162-962-11	CERAMIC CHIP 470PF 10%	50V
		< CAPACITOR >		C423	1-109-982-11	CERAMIC CHIP 1uF 10%	10V (NEW)
				C424	1-115-467-11	CERAMIC CHIP 0.22uF 10%	10V (NEW)
C101	1-162-960-11	CERAMIC CHIP 220PF 10%	50V	C427	1-126-154-11	ELECT 47uF 20%	6.3V
C104	1-162-962-11	CERAMIC CHIP 470PF 10%	50V	C428	1-124-261-00	ELECT 10uF 20%	50V
C105	1-109-982-11	CERAMIC CHIP 1uF 10%	10V	C430	1-164-156-11	CERAMIC CHIP 0.1uF	25V
C154	1-107-826-11	CERAMIC CHIP 0.1uF 10%	16V (FORMER)	C432	1-162-964-11	CERAMIC CHIP 0.001uF 10%	50V
C201	1-162-960-11	CERAMIC CHIP 220PF 10%	50V	C437	1-115-156-11	CERAMIC CHIP 1uF	10V
C204	1-162-962-11	CERAMIC CHIP 470PF 10%	50V	C438	1-115-156-11	CERAMIC CHIP 1uF	10V
C205	1-109-982-11	CERAMIC CHIP 1uF 10%	10V	C450	1-115-156-11	CERAMIC CHIP 1uF	10V
C254	1-107-826-11	CERAMIC CHIP 0.1uF 10%	16V (FORMER)	C451	1-162-964-11	CERAMIC CHIP 0.001uF 10%	50V
C300	1-125-838-11	CERAMIC CHIP 2.2uF 10%	6.3V (FORMER)	C452	1-115-156-11	CERAMIC CHIP 1uF	10V
C301	1-162-964-11	CERAMIC CHIP 0.001uF 10%	50V (NEW)	C453	1-115-467-11	CERAMIC CHIP 0.22uF 10%	10V
C312	1-162-964-11	CERAMIC CHIP 0.001uF 10%	50V (E225)	C461	1-125-891-11	CERAMIC CHIP 0.47uF 10%	10V
C351	1-115-156-11	CERAMIC CHIP 1uF	10V	C462	1-162-925-11	CERAMIC CHIP 68PF 5%	50V
C352	1-124-261-00	ELECT 10uF 20%	50V	C500	1-109-982-11	CERAMIC CHIP 1uF 10%	10V
C353	1-124-261-00	ELECT 10uF 20%	50V	C501	1-164-156-11	CERAMIC CHIP 0.1uF	25V
C355	1-109-982-11	CERAMIC CHIP 1uF 10%	10V	C502	1-135-201-11	TANTALUM CHIP 10uF 20%	4V
C401	1-162-970-11	CERAMIC CHIP 0.01uF 10%	25V	C601	1-135-201-11	TANTALUM CHIP 10uF 20%	4V (FORMER)
C402	1-164-505-11	CERAMIC CHIP 2.2uF	16V	C602	1-115-467-11	CERAMIC CHIP 0.22uF 10%	10V (FORMER)
C403	1-162-927-11	CERAMIC CHIP 100PF 5%	50V	C602	1-125-891-11	CERAMIC CHIP 0.47uF 10%	10V (NEW)
C404	1-104-913-11	TANTAL. CHIP 10uF 20%	16V	C603	1-107-826-11	CERAMIC CHIP 0.1uF 10%	16V
C405	1-115-156-11	CERAMIC CHIP 1uF	10V	C604	1-162-965-11	CERAMIC CHIP 0.0015uF 10%	50V (NEW)
C406	1-128-057-11	ELECT 330uF 20%	6.3V	C604	1-162-968-11	CERAMIC CHIP 0.0047uF 10%	50V (FORMER)
C407	1-162-964-11	CERAMIC CHIP 0.001uF 10%	50V	C605	1-164-156-11	CERAMIC CHIP 0.1uF	25V
				C606	1-162-927-11	CERAMIC CHIP 100PF 5%	50V

Ref. No.	Part No.	Description	Remark	Ref. No.	Part No.	Description	Remark
C607	1-107-826-11	CERAMIC CHIP	0.1uF 10% 16V	C814	1-162-927-11	CERAMIC CHIP 100PF 5% 50V	
C609	1-162-965-11	CERAMIC CHIP	0.0015uF 10% 50V	C815	1-162-927-11	CERAMIC CHIP 100PF 5% 50V	
			(NEW)	C841	1-162-970-11	CERAMIC CHIP 0.01uF 10% 25V	
C609	1-162-967-11	CERAMIC CHIP	0.0033uF 10% 50V			< CONNECTOR >	
			(FORMER)				
C610	1-162-923-11	CERAMIC CHIP	47PF 5% 50V	* CN501	1-815-270-21	CONNECTOR, FFC/FPC (ZIF) 13P	
C611	1-162-917-11	CERAMIC CHIP	15PF 5% 50V	CN502	1-784-342-11	HOUSING, CONNECTOR 2P	
				CN503	1-784-342-21	HOUSING, CONNECTOR 2P	
C612	1-162-962-11	CERAMIC CHIP	470PF 10% 50V			< DIODE >	
C613	1-162-962-11	CERAMIC CHIP	470PF 10% 50V				
C614	1-162-962-11	CERAMIC CHIP	470PF 10% 50V	D300	8-719-069-54	DIODE UDZS-TE17-5.1B (E225)	
C615	1-162-962-11	CERAMIC CHIP	470PF 10% 50V	D401	8-719-081-83	DIODE CRG01(TE85L)	
C617	1-125-891-11	CERAMIC CHIP	0.47uF 10% 10V	D402	8-719-073-01	DIODE MA111-(K8).SO	
				D404	8-719-067-42	DIODE MA2H735-(TX).SO	
C619	1-107-826-11	CERAMIC CHIP	0.1uF 10% 16V	D405	8-719-072-70	DIODE MA2ZD14001S0	
C621	1-162-923-11	CERAMIC CHIP	47PF 5% 50V				
C622	1-164-156-11	CERAMIC CHIP	0.1uF 25V	D406	8-719-058-24	DIODE RB501V-40TE-17	
C623	1-115-156-11	CERAMIC CHIP	1uF 10V	D407	8-719-073-01	DIODE MA111-(K8).SO	
C624	1-162-964-11	CERAMIC CHIP	0.001uF 10% 50V	D408	8-719-072-70	DIODE MA2ZD14001S0	
				D409	8-719-073-01	DIODE MA111-(K8).SO (NEW)	
C625	1-104-847-11	TANTAL. CHIP	22uF 20% 4V	D415	8-719-976-96	DIODE DTZ4.7C	
			(NEW)				
C625	1-119-750-11	TANTAL. CHIP	22uF 20% 6.3V	D461	8-719-072-70	DIODE MA2ZD14001S0	
			(FORMER)	D601	8-719-941-86	DIODE DAN202U (FORMER)	
C626	1-104-847-11	TANTAL. CHIP	22uF 20% 4V			< FERRITE BEAD >	
			(NEW)				
C626	1-119-750-11	TANTAL. CHIP	22uF 20% 6.3V	FB111	1-412-987-31	INDUCTOR 4.7uH	
			(FORMER)	FB211	1-412-987-31	INDUCTOR 4.7uH	
C627	1-164-156-11	CERAMIC CHIP	0.1uF 25V	FB311	1-412-979-21	INDUCTOR 1uH	
				FB312	1-412-979-21	INDUCTOR 1uH (E225)	
C628	1-162-962-11	CERAMIC CHIP	470PF 10% 50V	FB602	1-216-803-11	METAL CHIP 33 5% 1/16W	
C629	1-164-505-11	CERAMIC CHIP	2.2uF 16V				
C630	1-162-927-11	CERAMIC CHIP	100PF 5% 50V	FB603	1-412-979-21	INDUCTOR 1uH	
C631	1-162-923-11	CERAMIC CHIP	47PF 5% 50V	FB604	1-216-864-11	SHORT 0	
C632	1-164-156-11	CERAMIC CHIP	0.1uF 25V			< IC >	
				IC302	8-759-681-65	IC TA2120FN(EL) (FORMER)	
C633	1-162-927-11	CERAMIC CHIP	100PF 5% 50V	IC302	8-759-830-22	IC AN17880A-EAL (NEW)	
C634	1-124-434-00	ELECT	220uF 20% 4V	IC401	8-759-714-74	IC TB2125F (FORMER)	
C635	1-115-156-11	CERAMIC CHIP	1uF 10V	IC401	8-759-714-74	IC TB2125F (NEW)	
C636	1-164-156-11	CERAMIC CHIP	0.1uF 25V	IC601	8-752-401-56	IC CXD3037R (NEW)	
C637	1-164-230-11	CERAMIC CHIP	220PF 5% 50V				
				IC601	8-752-409-05	IC CXD3028R (FORMER)	
C638	1-162-927-11	CERAMIC CHIP	100PF 5% 50V	IC602	8-759-670-17	IC MSM51V4400D-70SJ7FS1 (FORMER)	
C639	1-164-156-11	CERAMIC CHIP	0.1uF 25V	IC801	8-759-828-35	IC TMP88CM22AF-3A51 (FORMER)	
C641	1-162-927-11	CERAMIC CHIP	100PF 5% 50V	IC801	8-759-828-36	IC TMP88CM22F-Z3-2 (NEW)	
C642	1-164-156-11	CERAMIC CHIP	0.1uF 25V			< JACK >	
			(NEW)	J302	1-815-088-21	JACK, HEADPHONE (⊘/REMOTE) (E225)	
C801	1-165-128-11	CERAMIC CHIP	0.22uF 16V			(FORMER)	
				J302	1-815-088-41	JACK, HEADPHONE (⊘/REMOTE) (E225) (NEW)	
C802	1-165-128-11	CERAMIC CHIP	0.22uF 16V	J302	1-815-135-21	JACK, HEADPHONE (⊘) (E220/E226CK)	
C803	1-165-128-11	CERAMIC CHIP	0.22uF 16V			(FORMER)	
C804	1-109-982-11	CERAMIC CHIP	1uF 10% 10V	J302	1-815-135-31	JACK, HEADPHONE (⊘) (E220/E226CK) (NEW)	
C805	1-164-227-11	CERAMIC CHIP	0.022uF 10% 25V	J401	1-778-153-21	JACK, DC (POLARITY UNIFIED TYPE)	
C806	1-164-156-11	CERAMIC CHIP	0.1uF 25V			(DC IN 4.5V)	
C807	1-164-156-11	CERAMIC CHIP	0.1uF 25V				
C808	1-164-156-11	CERAMIC CHIP	0.1uF 25V				
C809	1-164-156-11	CERAMIC CHIP	0.1uF 25V				
			(E225)				
C809	1-216-864-11	SHORT	0 (E220/E226CK)				
C810	1-164-156-11	CERAMIC CHIP	0.1uF 25V				
C811	1-117-720-11	CERAMIC CHIP	4.7uF 10V				

D-E220/E225/E226CK

MAIN

Ref. No.	Part No.	Description	Remark	Ref. No.	Part No.	Description	Remark
		< COIL >					
L311	1-412-002-31	INDUCTOR	4.7uH (E225)	R201	1-216-835-11	METAL CHIP	15K 5% 1/16W (EXCEPT E220:FR) (FORMER)
L401	1-419-544-21	COIL, CHOKE	100uH	R201	1-216-831-11	METAL CHIP	6.8K 5% 1/16W (E220:FR) (NEW)
L402	1-469-525-91	INDUCTOR	10uH	R201	1-216-837-11	METAL CHIP	22K 5% 1/16W (EXCEPT E220:FR) (NEW)
L408	1-414-400-41	INDUCTOR	22uH	R206	1-216-837-11	METAL CHIP	22K 5% 1/16W
L409	1-469-527-91	INDUCTOR	47uH	R207	1-216-829-11	METAL CHIP	4.7K 5% 1/16W (EXCEPT E220:FR)
L410	1-469-527-91	INDUCTOR	47uH				
L411	1-412-054-21	INDUCTOR	2.2uH	R207	1-216-839-11	METAL CHIP	33K 5% 1/16W (E220:FR)
L412	1-412-054-21	INDUCTOR	2.2uH	R254	1-216-793-11	RES-CHIP	4.7 5% 1/16W (FORMER)
		< LIQUID CRYSTAL DISPLAY >		R301	1-216-845-11	METAL CHIP	100K 5% 1/16W (FORMER)
LCD801	1-804-248-11	DISPLAY PANEL, LIQUID CRYSTAL		R302	1-216-864-11	SHORT	0 (NEW)
		< TRANSISTOR >		R303	1-216-864-11	SHORT	0 (NEW)
Q401	8-729-921-93	TRANSISTOR	2SB1182F5-QR	R315	1-218-871-11	METAL CHIP	10K 0.5% 1/16W (E225)
Q402	8-729-231-74	TRANSISTOR	2SC4116-GL	R316	1-216-821-11	METAL CHIP	1K 5% 1/16W (E225)
Q403	8-729-026-53	TRANSISTOR	2SA1576A-T106-QR	R353	1-216-308-00	METAL CHIP	4.7 5% 1/10W
Q404	8-729-425-41	FET	2SK1374-TX (E225)	R401	1-216-857-11	METAL CHIP	1M 5% 1/16W
Q405	8-729-905-40	TRANSISTOR	2SC4081T106	R402	1-216-839-11	METAL CHIP	33K 5% 1/16W
Q406	8-729-026-53	TRANSISTOR	2SA1576A-T106-QR	R403	1-216-853-11	METAL CHIP	470K 5% 1/16W
Q407	8-729-905-40	TRANSISTOR	2SC4081T106 (NEW)	R404	1-216-839-11	METAL CHIP	33K 5% 1/16W
Q408	8-729-029-10	TRANSISTOR	DTC143TUA-T106	R405	1-216-789-11	METAL CHIP	2.2 5% 1/16W
Q409	8-729-921-73	TRANSISTOR	2SD1781K-T146-QR (E225)	R406	1-216-837-11	METAL CHIP	22K 5% 1/16W
Q410	8-729-922-10	TRANSISTOR	2SA1577-QR	R408	1-216-857-11	METAL CHIP	1M 5% 1/16W
Q411	8-729-905-40	TRANSISTOR	2SC4081T106	R409	1-216-849-11	METAL CHIP	220K 5% 1/16W
Q412	8-729-026-53	TRANSISTOR	2SA1576A-T106-QR	R410	1-216-843-11	METAL CHIP	68K 5% 1/16W
Q413	8-729-427-74	TRANSISTOR	XP4601	R411	1-216-843-11	METAL CHIP	68K 5% 1/16W (NEW)
		< RESISTOR >		R412	1-216-845-11	METAL CHIP	100K 5% 1/16W (NEW)
R1	1-410-993-41	INDUCTOR	1uH (FORMER)	R415	1-216-833-11	METAL CHIP	10K 5% 1/16W
R1	1-410-993-42	INDUCTOR	1uH (NEW)	R416	1-216-857-11	METAL CHIP	1M 5% 1/16W
R2	1-216-295-11	SHORT	0	R417	1-216-811-11	METAL CHIP	150 5% 1/16W
R3	1-216-295-11	SHORT	0	R418	1-218-891-11	METAL CHIP	68K 0.5% 1/16W
R4	1-216-295-11	SHORT	0	R419	1-218-903-11	METAL CHIP	220K 0.5% 1/16W
R5	1-216-295-11	SHORT	0	R420	1-216-833-11	METAL CHIP	10K 5% 1/16W
R101	1-216-829-11	METAL CHIP	4.7K 5% 1/16W (E220:FR) (FORMER)	R421	1-216-833-11	METAL CHIP	10K 5% 1/16W
R101	1-216-835-11	METAL CHIP	15K 5% 1/16W (EXCEPT E220:FR) (FORMER)	R422	1-216-821-11	METAL CHIP	1K 5% 1/16W
R101	1-216-831-11	METAL CHIP	6.8K 5% 1/16W (E220:FR) (NEW)	R423	1-216-841-11	METAL CHIP	47K 5% 1/16W
R101	1-216-837-11	METAL CHIP	22K 5% 1/16W (EXCEPT E220:FR) (NEW)	R424	1-216-839-11	METAL CHIP	33K 5% 1/16W
R106	1-216-837-11	METAL CHIP	22K 5% 1/16W	R427	1-216-815-11	METAL CHIP	330 5% 1/16W (E225)
R107	1-216-829-11	METAL CHIP	4.7K 5% 1/16W (EXCEPT E220:FR)	R429	1-216-821-11	METAL CHIP	1K 5% 1/16W
R107	1-216-839-11	METAL CHIP	33K 5% 1/16W (E220:FR)	R430	1-216-833-11	METAL CHIP	10K 5% 1/16W
R154	1-216-793-11	RES-CHIP	4.7 5% 1/16W (FORMER)	R431	1-216-829-11	METAL CHIP	4.7K 5% 1/16W
R201	1-216-829-11	METAL CHIP	4.7K 5% 1/16W (E220:FR) (FORMER)	R440	1-216-825-11	METAL CHIP	2.2K 5% 1/16W
				R442	1-216-295-11	SHORT	0 (E220/E226CK)
				R442	1-216-304-11	METAL CHIP	3.3 5% 1/10W (E225)

Ref. No.	Part No.	Description	Remark	Ref. No.	Part No.	Description	Remark
R444	1-216-845-11	METAL CHIP	100K 5% 1/16W (E225)	R626	1-216-819-11	METAL CHIP	680 5% 1/16W
R446	1-216-304-11	METAL CHIP	3.3 5% 1/10W (E225)	R627	1-216-813-11	METAL CHIP	220 5% 1/16W
R448	1-216-304-11	METAL CHIP	3.3 5% 1/10W (E225)	R628	1-216-821-11	METAL CHIP	1K 5% 1/16W
R449	1-216-845-11	METAL CHIP	100K 5% 1/16W	R629	1-216-845-11	METAL CHIP	100K 5% 1/16W
R450	1-216-819-11	METAL CHIP	680 5% 1/16W	R630	1-216-821-11	METAL CHIP	1K 5% 1/16W
R451	1-218-903-11	METAL CHIP	220K 0.5% 1/16W	R631	1-216-821-11	METAL CHIP	1K 5% 1/16W
R452	1-218-887-11	METAL CHIP	47K 0.5% 1/16W	R632	1-216-839-11	METAL CHIP	33K 5% 1/16W
R453	1-218-887-11	METAL CHIP	47K 0.5% 1/16W	R634	1-216-809-11	METAL CHIP	100 5% 1/16W
R454	1-218-887-11	METAL CHIP	47K 0.5% 1/16W	R635	1-216-809-11	METAL CHIP	100 5% 1/16W
R455	1-216-839-11	METAL CHIP	33K 5% 1/16W	R636	1-216-845-11	METAL CHIP	100K 5% 1/16W
R456	1-216-843-11	METAL CHIP	68K 5% 1/16W	R637	1-216-864-11	SHORT	0 (NEW)
R457	1-216-845-11	METAL CHIP	100K 5% 1/16W	R638	1-216-821-11	METAL CHIP	1K 5% 1/16W
R458	1-216-833-11	METAL CHIP	10K 5% 1/16W	R640	1-216-864-11	SHORT	0 (NEW)
R459	1-216-864-11	SHORT	0	R641	1-216-864-11	SHORT	0 (NEW)
R461	1-216-845-11	METAL CHIP	100K 5% 1/16W	R643	1-216-864-11	SHORT	0 (NEW)
R462	1-216-841-11	METAL CHIP	47K 5% 1/16W	R801	1-216-845-11	METAL CHIP	100K 5% 1/16W
R463	1-216-857-11	METAL CHIP	1M 5% 1/16W	R802	1-216-845-11	METAL CHIP	100K 5% 1/16W
R466	1-216-821-11	METAL CHIP	1K 5% 1/16W	R803	1-216-843-11	METAL CHIP	68K 5% 1/16W
R601	1-216-849-11	METAL CHIP	220K 5% 1/16W	R804	1-218-871-11	METAL CHIP	10K 0.5% 1/16W
R603	1-216-851-11	METAL CHIP	330K 5% 1/16W	R805	1-216-821-11	METAL CHIP	1K 5% 1/16W
R604	1-216-857-11	METAL CHIP	1M 5% 1/16W	R806	1-216-864-11	SHORT	0
R605	1-216-827-11	METAL CHIP	3.3K 5% 1/16W	R807	1-216-849-11	METAL CHIP	220K 5% 1/16W (E225)
R606	1-216-827-11	METAL CHIP	3.3K 5% 1/16W	R809	1-216-845-11	METAL CHIP	100K 5% 1/16W
R607	1-216-833-11	METAL CHIP	10K 5% 1/16W	R810	1-216-829-11	METAL CHIP	4.7K 5% 1/16W
R608	1-216-853-11	METAL CHIP	470K 5% 1/16W	R811	1-216-827-11	METAL CHIP	3.3K 5% 1/16W
R609	1-216-833-11	METAL CHIP	10K 5% 1/16W	R812	1-216-825-11	METAL CHIP	2.2K 5% 1/16W
R610	1-216-847-11	METAL CHIP	150K 5% 1/16W (NEW)	R813	1-216-839-11	METAL CHIP	33K 5% 1/16W (EXCEPT E220:FR)
R610	1-216-849-11	METAL CHIP	220K 5% 1/16W (FORMER)	R813	1-216-847-11	METAL CHIP	150K 5% 1/16W (E220:FR)
R611	1-216-837-11	METAL CHIP	22K 5% 1/16W	R814	1-216-845-11	METAL CHIP	100K 5% 1/16W
R612	1-216-841-11	METAL CHIP	47K 5% 1/16W	R816	1-216-864-11	SHORT	0
R613	1-216-837-11	METAL CHIP	22K 5% 1/16W	R817	1-216-823-11	METAL CHIP	1.5K 5% 1/16W
R614	1-216-843-11	METAL CHIP	68K 5% 1/16W (NEW)	R818	1-216-843-11	METAL CHIP	68K 5% 1/16W (E220:FR)
R614	1-216-845-11	METAL CHIP	100K 5% 1/16W (FORMER)	R818	1-216-847-11	METAL CHIP	150K 5% 1/16W (EXCEPT E220:FR)
R615	1-216-837-11	METAL CHIP	22K 5% 1/16W	R819	1-216-845-11	METAL CHIP	100K 5% 1/16W
R616	1-216-843-11	METAL CHIP	68K 5% 1/16W (NEW)	R820	1-216-821-11	METAL CHIP	1K 5% 1/16W
R616	1-216-845-11	METAL CHIP	100K 5% 1/16W (FORMER)	R823	1-216-845-11	METAL CHIP	100K 5% 1/16W
R617	1-216-837-11	METAL CHIP	22K 5% 1/16W	R824	1-216-845-11	METAL CHIP	100K 5% 1/16W
R618	1-216-847-11	METAL CHIP	150K 5% 1/16W (NEW)	R826	1-216-845-11	METAL CHIP	100K 5% 1/16W (E220:FR)
R618	1-216-849-11	METAL CHIP	220K 5% 1/16W (FORMER)	R826	1-216-851-11	METAL CHIP	330K 5% 1/16W (EXCEPT E220:FR)
R619	1-216-837-11	METAL CHIP	22K 5% 1/16W	R829	1-216-864-11	SHORT	0
R620	1-216-821-11	METAL CHIP	1K 5% 1/16W	R830	1-216-831-11	METAL CHIP	6.8K 5% 1/16W
R621	1-216-864-11	SHORT	0	R831	1-216-864-11	SHORT	0
R624	1-216-819-11	METAL CHIP	680 5% 1/16W	R841	1-216-849-11	METAL CHIP	220K 5% 1/16W
R625	1-216-845-11	METAL CHIP	100K 5% 1/16W			< SWITCH >	
				S801	1-692-440-11	SWITCH, PUSH (OPEN)	
				S803	1-762-078-11	SWITCH, SLIDE (HOLD →)	

D-E220/E225/E226CK

MAIN

Ref. No.	Part No.	Description	Remark
S804	1-553-977-00	SWITCH, SLIDE (ESP)	
S805	1-692-014-11	SWITCH, KEYBOARD (VOL -)	
S806	1-692-014-11	SWITCH, KEYBOARD (VOL +)	
S807	1-692-014-11	SWITCH, KEYBOARD (■)	
S808	1-692-014-11	SWITCH, KEYBOARD (▶▶▶ ▶▶▶)	
S809	1-692-014-11	SWITCH, KEYBOARD (◀◀◀)	
S810	1-771-482-11	SWITCH, PUSH (1 KEY) (SOUND)	
S811	1-771-482-11	SWITCH, PUSH (1 KEY) (MENU)	
< VARISTOR >			
VDR401	1-801-862-11	VARISTOR, CHIP	
VDR402	1-801-862-11	VARISTOR, CHIP	
VDR601	1-801-862-11	VARISTOR, CHIP	
< VIBRATOR >			
X601	1-795-101-21	VIBRATOR, CERAMIC (16.9MHz) (E225)	
X601	1-795-218-21	VIBRATOR, CERAMIC (16.9MHz) (E220/E226CK)	

MISCELLANEOUS *****			
△ 108	X-4952-506-1	PICK-UP BLOCK, OPTICAL (DAX-23E)	
M501	A-3328-627-A	MOTOR ASSY, SLED (SLED)	
M502	A-3328-759-A	MOTOR ASSY, TURNTABLE (SPINDLE)	

ACCESSORIES & PACKING MATERIALS *****			
	1-251-696-11	CONNECTING PACK, CAR (CPA-9) (E226CK)	
	1-418-670-12	REMOTE CONTROL UNIT (RM-CD6) (E225)	
△	1-467-007-21	ADAPTOR, AC (AC-E455A) (E226CK:AUS)	
△	1-467-009-21	ADAPTOR, AC (AC-E455) (E225:US/ E226CK:US,CND,E92,MX)	
△	1-473-116-31	ADAPTOR, AC (AC-E455F) (E225:E13/ E226CK:AEP,UK)	
△	1-475-622-21	ADAPTOR, AC (AC-E455) (E225:CH)	
△	1-475-623-12	ADAPTOR, AC (AC-E455) (E225:HK)	
	1-756-158-31	BATTERY PACK (NC-WMAA) (E225)	
△	1-784-619-11	CORD DCC-E2455//C SET (E226CK)	
	2-201-810-00	TAPE, MAGIC (E226CK)	
	3-048-268-11	MANUAL, INSTRUCTION (SPANISH) (E226CK:AEP,E92,MX)	
	3-048-268-31	MANUAL, INSTRUCTION (FRENCH) (E226CK:CND,AEP)	
	3-048-268-41	MANUAL, INSTRUCTION (DUTCH) (E226CK:AEP)	
	3-048-268-51	MANUAL, INSTRUCTION (SWEDISH) (E226CK:AEP)	
	3-048-268-61	MANUAL, INSTRUCTION (PORTUGUESE) (E226CK:AEP,E92,MX)	
	3-048-268-71	MANUAL, INSTRUCTION (GERMAN) (E226CK:AEP)	
	3-048-268-81	MANUAL, INSTRUCTION (ITALIAN) (E226CK:AEP)	

Ref. No.	Part No.	Description	Remark
	3-048-268-91	MANUAL, INSTRUCTION (FINNISH) (E226CK:AEP)	
	3-048-323-11	MANUAL, INSTRUCTION (ENGLISH) (E226CK)	
	3-225-997-11	MANUAL, INSTRUCTION (SPANISH) (E220:AEP/ E226CK:AEP,E92,MX)	
	3-225-997-21	MANUAL, INSTRUCTION (ENGLISH,ARABIC) (E220:AEP,EE/ E226CK:CND,AEP,UK,E92,AUS,MX)	
	3-225-997-31	MANUAL, INSTRUCTION (FRENCH) (E220:AEP,FR/E226CK:CND,AEP)	
	3-225-997-41	MANUAL, INSTRUCTION (DUTCH) (E220:AEP,EE/E226CK:AEP)	
	3-225-997-51	MANUAL, INSTRUCTION (SWEDISH) (E220:AEP/E226CK:AEP)	
	3-225-997-61	MANUAL, INSTRUCTION (PORTUGUESE) (E220:AEP/E226CK:AEP,E92,MX)	
	3-225-997-71	MANUAL, INSTRUCTION (GERMAN) (E220:AEP/E226CK:AEP)	
	3-225-997-81	MANUAL, INSTRUCTION (ITALIAN) (E220:AEP/E226CK:AEP)	
	3-225-997-91	MANUAL, INSTRUCTION (FINNISH) (E220:AEP/E226CK:AEP)	
	3-225-998-11	MANUAL, INSTRUCTION (TRADITIONAL CHINESE) (E220:E33)	
	3-225-998-21	MANUAL, INSTRUCTION (ENGLISH) (E220:E33)	
	3-225-999-11	MANUAL, INSTRUCTION (RUSSIAN) (E220:EE)	
	3-225-999-21	MANUAL, INSTRUCTION (CZECH) (E220:EE)	
	3-225-999-31	MANUAL, INSTRUCTION (HUNGARIAN) (E220:EE)	
	3-225-999-41	MANUAL, INSTRUCTION (POLISH) (E220:EE)	
	3-225-999-51	MANUAL, INSTRUCTION (SLOVAKIAN) (E220:EE)	
	3-225-999-62	MANUAL, INSTRUCTION (ENGLISH) (E220:US/ E226CK:US)	
	3-227-575-11	MANUAL, INSTRUCTION (TRADITIONAL CHINESE) (E225:E13,HK)	
	3-227-575-21	MANUAL, INSTRUCTION (ENGLISH) (E225:E13,CH,HK)	
	3-227-575-31	MANUAL, INSTRUCTION (SIMPLIFIED CHINESE) (E225:CH)	
	3-227-576-72	MANUAL, INSTRUCTION (ENGLISH) (E225:US)	
	8-953-130-90	HEADPHONE MDR-E801 (E220:AEP,E33,EE,FR/ E226CK:CND,AEP,UK,E92,AUS,MX)	
	8-953-276-90	HEADPHONE MDR-24SP (E225:US)	
	8-953-304-90	RECEIVER MDR-E805SP (E225:E13,CH,HK)	
	8-953-342-93	HEADPHONE MDR-24 (E220:US/E226CK:US)	

The components identified by mark △ or dotted line with mark △ are critical for safety. Replace only with part number specified.	Les composants identifiés par une marque △ sont critiques pour la sécurité. Ne les remplacer que par une pièce portant le numéro spécifié.
--	--

MEMO

