

D-170AN/171/171V/172CK/173/175

SERVICE MANUAL



Photo : D-175

US Model

D-173

Canadian Model

Australian Model

D-171/172CK/173

AEP Model

D-170AN/171/171V/172CK/173/175

UK Model

D-170AN/171/172CK/173/175

E Model

D-171/172CK/173/175

Chinese Model

D-171/172CK/173/175

Tourist Model

D-170AN/175

SPECIFICATIONS

System

Compact disc digital audio system

Laser diode properties

Material: GaAlAs

Wavelength: $\lambda = 780 \text{ nm}$

Emission duration: Continuous

Laser output: Less than 44.6 μW (measured at 200 mm away from the objective lens surface)

Error correction

Sony Super Strategy Cross Interleave Reed Solomon Code

D-A conversion

1-bit quartz time-axis control

Frequency response

20 - 20,000 Hz $\pm 1 \text{ dB}$ (measured by EIAJ CP-307)

Output (at 4.5 V input level)

Headphones (stereo minijack)

15 mW + 15 mW at 16 ohms

Line output (stereo minijack)

Output level 0.7 V rms at 50 kilohms

Recommended load impedance over 10 kilohms

General

Power requirements

- Sony BP-DM10 Rechargeable battery: 2.4 V DC, Ni-Cd, 650 mAh
- Sony BP-DM20 Rechargeable battery: 2.4 V DC, Ni-MH, 1,200 mAh
- Two LR6 (size AA) batteries: 3 V DC
- AC power adaptor (DC IN 4.5 V jack):
 US, Canadian,
 Central & South America model: 120V, 60Hz
 AEP, E13 (AC220 - 230V area),
 Chinese model: 220 - 230V, 50Hz
 UK model: 230 - 240V, 50Hz
 Saudi Arabia model: 110 - 240V, 50/60Hz
 Australian model: 240V, 50Hz
 Tourist, E33 (AC100 - 240V area) model:
 100 - 240V, 50/60Hz
- Sony CPM-300P mount plate for use on car battery: 4.5 V DC

Dimensions (w/h/d) (without projecting parts and controls)

Approx. 135 x 29.9 x 159.5 mm
(5 1/4 x 1 1/8 x 6 3/8 in.)

Mass (without rechargeable battery)

Approx. 250 g (8.8 oz)

Operating temperature

5°C - 35°C (41°F - 95°F)

Supplied accessories

D-170AN

Stereo headphones (1)

D-171

AC power adaptor (1)

Stereo headphones (1)

Connecting cord (1/Phono plug x 2 ↔ stereo miniplug) (1)

D-171V

AC power adaptor (1)

Connecting cord (1/Phono plug x 2 ↔ stereo miniplug) (1)

Stereo headphones with volume control (1)

D-172CK

AC power adaptor (1)*

Stereo headphones (1)

Connecting cord (1/Phono plug x 2 ↔ stereo miniplug) (1)*

Model Name Using Similar Mechanism	NEW
CD Mechanism Type	CDM-2411AAA
Optical Pick-up Type	DAX-11A

Car connecting pack (1)

Car mount plate (1)

Car battery cord (1)

Velcro tapes (2)

Spare fuse (1)

Spiral tube (1)

* Not supplied with AEP and UK model

D-173

AC power adaptor (1)

Stereo headphones (1)

Rechargeable battery (1)

Connecting cord (1/Phono plug x 2 ↔ stereo miniplug) (1)

D-175

AC power adaptor (1)*

Stereo headphones with remote commander (1)

Rechargeable battery (1)*

Connecting cord (1/Phono plug x 2 ↔ stereo miniplug) (1)*

Alkaline batteries (2)**

* Not supplied with Tourist model

** Supplied with Tourist model only

Design and specifications are subject to change without notice.

COMPACT DISC COMPACT PLAYER

SONY®



TABLE OF CONTENTS

Specification	1
1. SERVICING NOTES	2
2. GENERAL	4
3. DISASSEMBLY	
3-1. Lid Assy, Upper Removal	5
3-2. Cabinet (Front) Assy, MD Assy Removal	5
3-3. Main Board Removal	6
4. SERVICE MODE	7
5. ADJUSTMENTS	8
6. EXPLANATION OF IC TERMINALS	11
7. DIAGRAMS	
7-1. Block Diagram	13
7-2. Printed Wiring Boards	16
7-3. Schematic Diagram	19
8. EXPLODED VIEWS	
8-1. Cabinet Section	27
8-2. Optical Pick-up Section	28
9. ELECTRICAL PARTS LIST	29

D-171 "La Fiesta" model

The "La Fiesta" model is same as the D-171 C&SA model except for upper lid assy.

See page 27 for part No. of upper lid assy.

SAFETY-RELATED COMPONENT WARNING!!

COMPONENTS IDENTIFIED BY MARK Δ OR DOTTED LINE WITH MARK Δ ON THE SCHEMATIC DIAGRAMS AND IN THE PARTS LIST ARE CRITICAL TO SAFE OPERATION. REPLACE THESE COMPONENTS WITH SONY PARTS WHOSE PART NUMBERS APPEAR AS SHOWN IN THIS MANUAL OR IN SUPPLEMENTS PUBLISHED BY SONY.

DANGER

Invisible laser radiation when open and interlock failed or defeated. Avoid direct exposure to beam.

CAUTION

Use of controls or adjustments or performance of procedures other than those specified herein may result in hazardous radiation exposure.

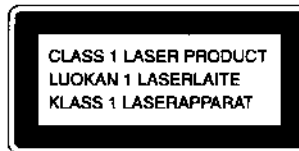

This Compact Disc player is classified as a CLASS 1 LASER product. The CLASS 1 LASER PRODUCT label is located on the bottom exterior.

Flexible Circuit Board Repairing

- Keep the temperature of the soldering iron around 270°C during repairing.
- Do not touch the soldering iron on the same conductor of the circuit board (within 3 times).
- Be careful not to apply force on the conductor when soldering or unsoldering.

Notes on chip component replacement

- Never reuse a disconnected chip component.
- Notice that the minus side of a tantalum capacitor may be damaged by heat.

ATTENTION AU COMPOSANT AYANT RAPPORT À LA SÉCURITÉ!

LES COMPOSANTS IDENTIFIÉS PAR UNE MARQUE Δ SUR LES DIAGRAMMES SCHÉMATIQUES ET LA LISTE DES PIÈCES SONT CRITIQUES POUR LA SÉCURITÉ DE FONCTIONNEMENT. NE REMPLACER CES COMPOSANTS QUE PAR DES PIÈCES SONY DONT LES NUMÉROS SONT DONNÉS DANS CE MANUEL OU DANS LES SUPPLÉMENTS PUBLIÉS PAR SONY.

SECTION 1 SERVICING NOTES

NOTES ON HANDLING THE OPTICAL PICK-UP BLOCK OR BASE UNIT

The laser diode in the optical pick-up block may suffer electrostatic breakdown because of the potential difference generated by the charged electrostatic load, etc. on clothing and the human body. During repair, pay attention to electrostatic breakdown and also use the procedure in the printed matter which is included in the repair parts.

The flexible board is easily damaged and should be handled with care.

NOTES ON LASER DIODE EMISSION CHECK

The laser beam on this model is concentrated so as to be focused on the disc reflective surface by the objective lens in the optical pick-up block. Therefore, when checking the laser diode emission, observe from more than 30cm away from the objective lens.

Before Replacing the Optical pick-up Block

Please be sure to check thoroughly the parameters as per the "Optical pick-up Block Checking Procedure" (Part No. : 9-960-027-11) issued separately before replacing the optical Pick-up block. Note and specifications required to check are given below.

- FOK output : IC501 ⑫ pin
When checking FOK, remove the lead wire to disc motor.
- S curve P-to-P value : $1.2 \pm 0.3V_{p-p}$ IC501 ⑩ pin.
When checking S curve P-to-P value, remove the lead wire to disc motor.
- Adjusted part for focus gain adjustment : RV503
- RF signal P-to-P value : $0.8 - 1.2V_{p-p}$
- Traverse signal P-to-P value : $1.0 - 2.4V_{p-p}$
- The repairing grating holder is impossible.
- Adjusted part for tracking gain adjustment : RV502

Precautions for Checking Emission of Laser Diode

Laser light of the equipment is focused by the object lens in the optical pick-up so that the light focuses on the reflection surface of the disc. Therefore, be sure to keep your eyes more than 30cm apart from the object lens when you check the emission of laser diode.

Laser Diode Checking Methods

During normal operation of the equipment, emission of the laser diode is prohibited unless the upper panel is closed while turning ON the S801 (push switch type).

The following two checking methods for the laser diode are operable.

Method-1 (In the service mode or normal operation) :

Emission of the laser diode is visually checked.

1. Open the upper lid.
2. Push the S801 as shown in Fig. 1.
3. Check the object lens for confirming normal emission of the laser diode. If not emitting, there is a trouble in the automatic power control circuit or the optical pick-up. During normal operation, the laser diode is turned ON about 2.5 seconds for focus searching.

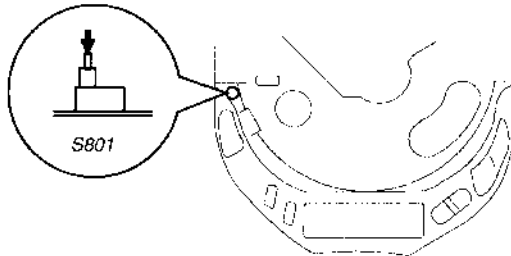
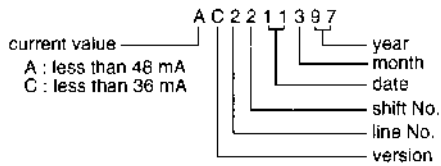

Fig.1 Method to push S801

Method-2 (In the service mode or normal operation) :

Check the value of current flowing in the laser diode.

1. Remove the upper panel.
2. Read the current printed on the rear side of the optical pick-up.
(Print on the rear side of the optical pick-up)



3. Connect a level meter as shown in Fig. 2
4. Press the ► key.
5. Calculate the current value by the reading of the VOM .
Reading of the tester (V) ÷ 4.7 (Ω) = current value (A)
(Example) Reading of the VOM of 0.2256 V :
0.2256 V ÷ 4.7 Ω = 0.048 (A) = 48 mA

6. Check that the current value is within the following range.
 - Current value of the label ± 5 mA(25°C)
 - Variation by temperature : 0.4mA / °C
 - Current increases with temperature increased.
 - Current decreases with temperature decreased.

If the current is more than the range above, there is a trouble in the automatic power control circuit or the laser diode is in deterioration.

If less than the range, a trouble exists in the automatic power control circuit or the optical pick-up.

[MAIN BOARD] (Conductor side)

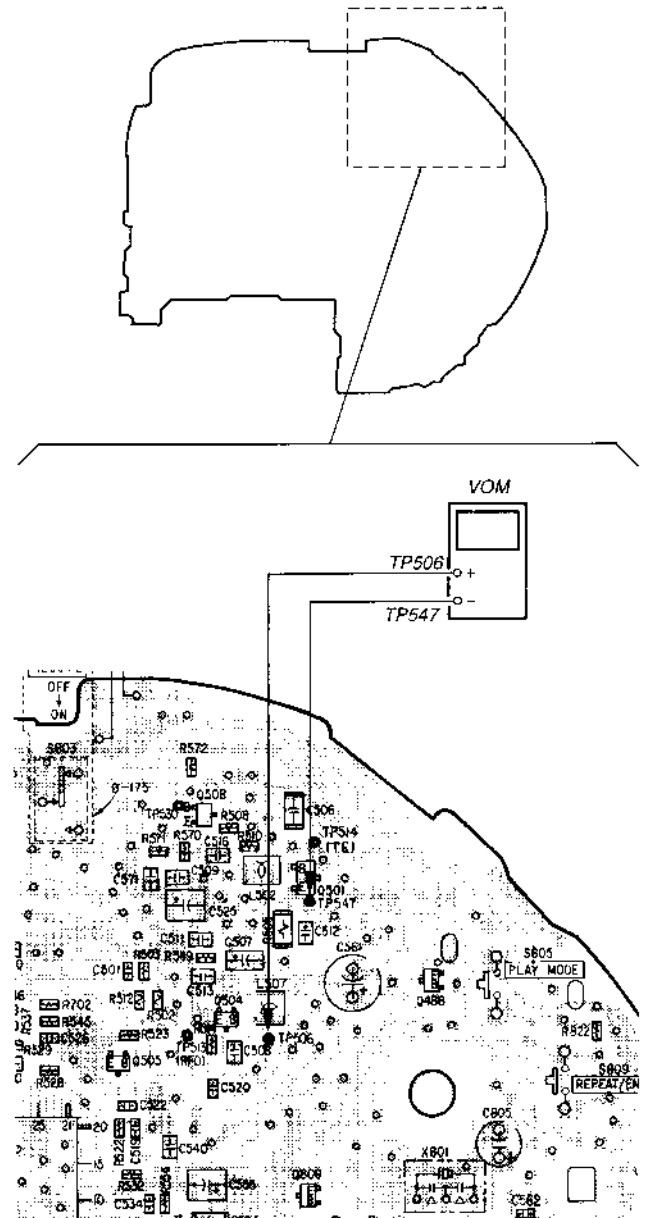
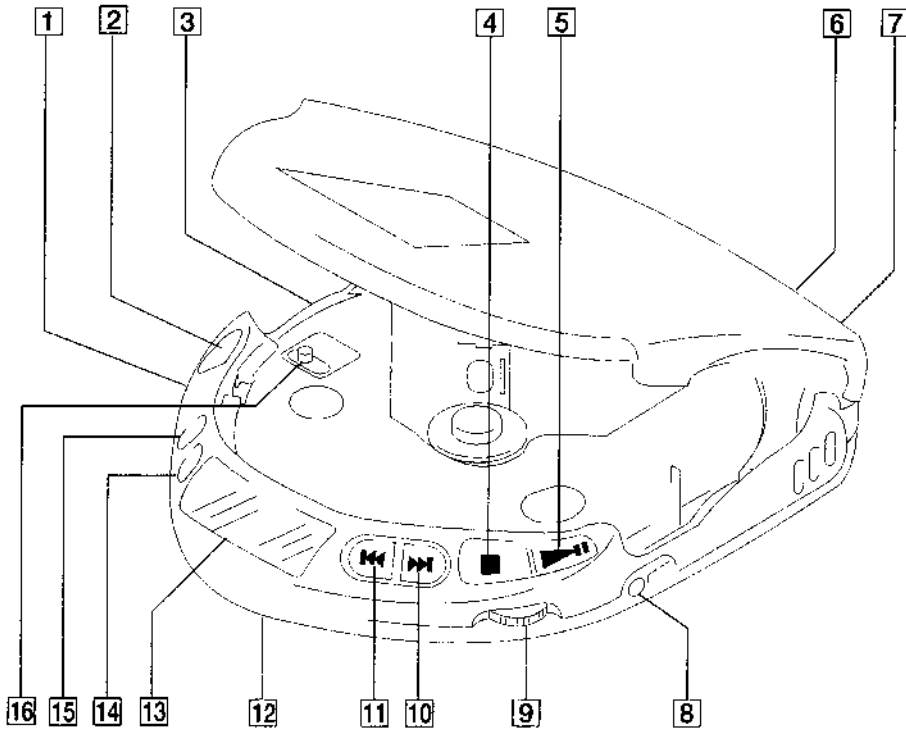

Fig.2 VOM Connecting Location

SECTION 2 GENERAL

LOCATION AND FUNCTION OF CONTROLS



- | | |
|-----------------------------------|-------------------------------------|
| 1 HOLD switch | 9 VOLUME control |
| 2 OPEN button | 10 ►► FF button |
| 3 DIGITAL MEGA BASS button | 11 ◀◀ FR button |
| 4 ■ STOP button | 12 AVLS switch |
| 5 ► Play/pause button | 13 Information display panel |
| 6 DC IN 4.5V jack | 14 REPEAT/ENTER button |
| 7 LINE OUT jack | 15 PLAY MODE button |
| 8 Ⓞ/REMOTE jack (D-175) | 16 RESUME switch (D-175) |
| Ⓞ jack (Except D-175) | |

SECTION 3 DISASSEMBLY

● The equipment can be removed using the following procedure.

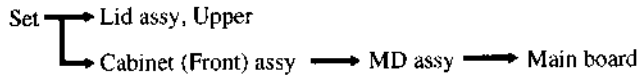

Note : Follow the disassembly procedure in the numerical order given.

3-1. LID ASSY, UPPER REMOVAL

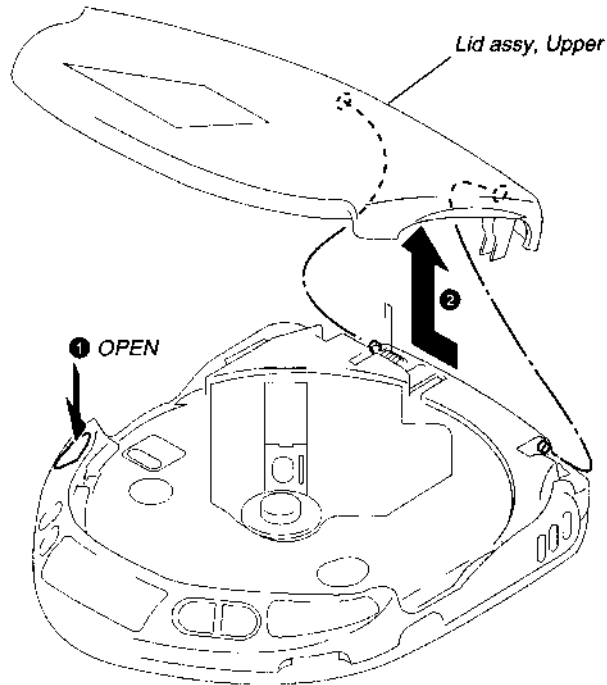

3-2. CABINET (FRONT) ASSY, MD ASSY REMOVAL

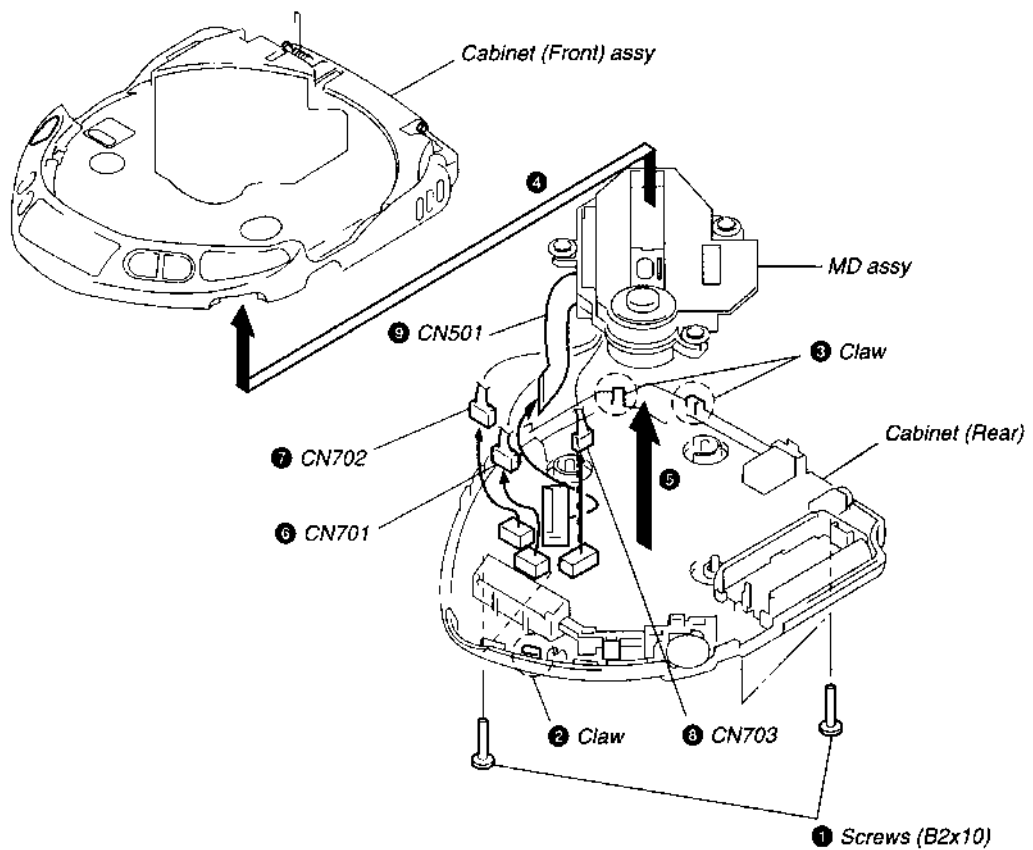

3-3. MAIN BOARD REMOVAL

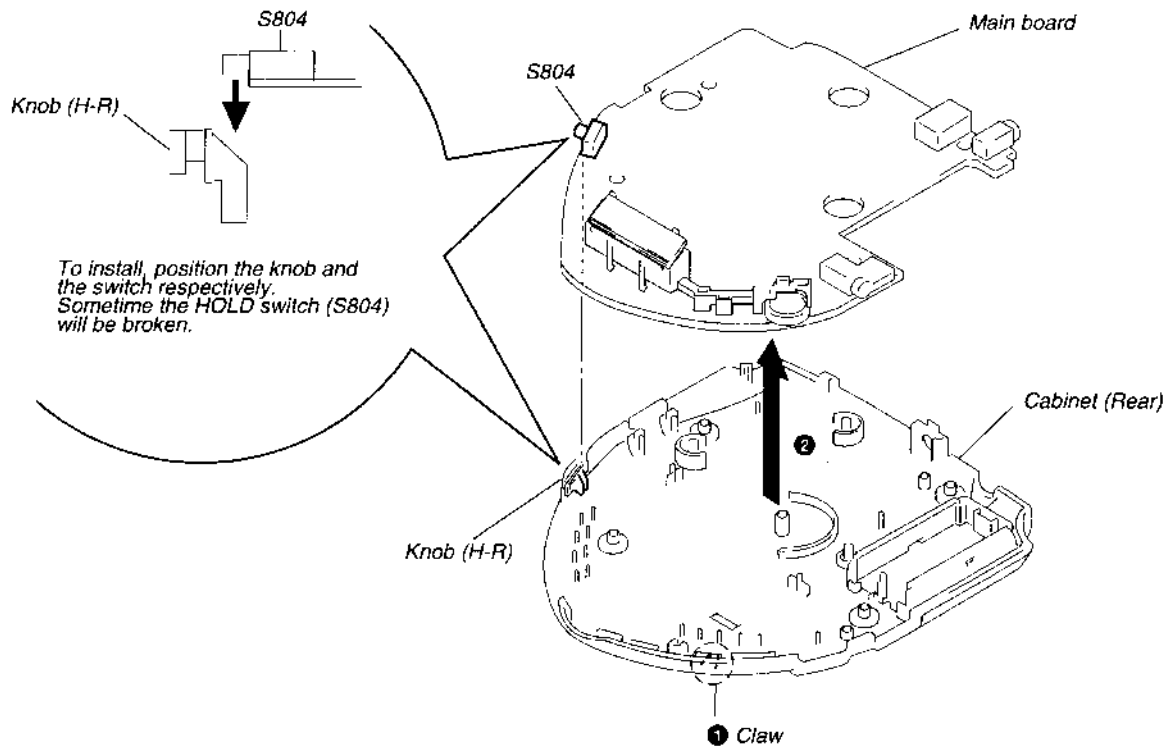

SECTION 4 SERVICE MODE

Service Mode (service program)

The equipment is provided with a service program built in the microcomputer, like conventional models.

Service program operation methods are described in the following.

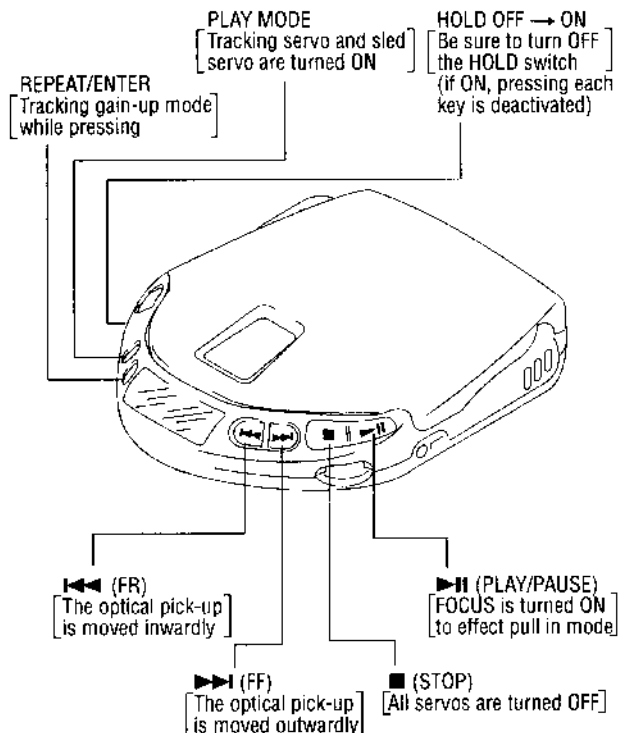

Fig. 3 Layout of each key

• Step 1 (Service mode setting method)

1. Turn OFF the HOLD switch the external power supply disconnected (power is not applied to the set).
2. Solder across the TAP802 (TEST) terminals (pin 52, IC801 (TEST) is grounded).
3. Connect an external power supply.
Thus, the set is switched to the service mode.

• Step 2 (Operation in the service mode)

1. Once the service mode is effected, the LCD displays 5 indications each of which is repeatedly displayed.
However, the following operations can be activated even if LCD indication is effected.
2. By pressing the ▶▶ or ◀◀ key, the optical pick-up movable inwardly or outwardly. However, if this is activated, tracking servo and sled servo are turned OFF, so it can be turned ON by pressing the PLAY MODE key, if required.
3. By pressing the REPEAT/ENTER key, the tracking gain-up mode becomes active.
4. By pressing the ▶▶ key, focus is turned ON from focus searching while entering CLV-S (pull-in mode).
Without disc, focus searching is repeated continuously.
5. By pressing the PLAY MODE key, tracking servo, sled servo and CLV-A (servo in PLAY) are turned ON.
6. When 4. and 5. are performed, playing begins. No muting is ON in the service mode.
7. By pressing the ■ key, all servos (focus tracking and sled) are turned OFF. However, the disc motor revolves for a while by inertia.

• Step 3 (Resetting service mode)

1. Be sure to disconnect the external power supply and remove the solder bridge at the TEST terminals connected in setting.
2. The set thus becomes available for normal operation.

– MAIN BOARD – (component side)

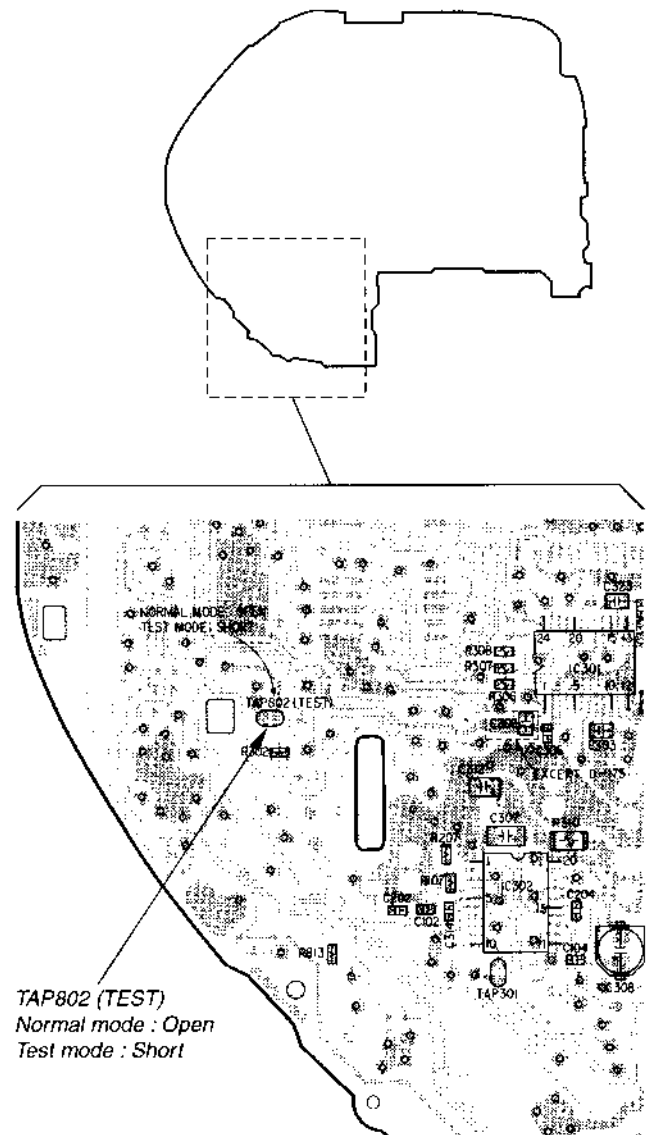

Fig. 4 Location of test terminal

SECTION 5 ADJUSTMENTS

CD SECTION

Precautions for Adjustment

1. Before beginning adjustment, set the equipment to service mode.
After the completion of adjustment, be sure to reset the service mode.

For more information, see "Service Mode (service program)" on page 7.

2. Perform adjustments in the order given.
3. Use the disc (YEDS-18, Part No. 3-702-101-01) unless otherwise indicated.
4. Power supply voltage requirement : DC 4.5 V

HOLD switch	: OFF
VOLUME	: Minimum
BASS BOOST switch	: NORM
AVLS switch	: OFF

Before Beginning Adjustment

Set the equipment to service mode (See page 7) and check the following.

If there is an error, repair the equipment.

● Checking of the sled motor

1. Open the upper panel.
2. Press the ►► and ◄◄ keys and check that the optical pick-up can move smoothly without sluggishness or abnormal noise in innermost periphery → outermost periphery → innermost periphery
 ►► : The optical pick-up moves outwardly
 ◄◄ : The optical pick-up moves inwardly

● Checking of focus searching

1. Open the upper panel.
2. Press the ►► key. (Focus searching operation is activated continuously).
3. Check the object lens of the optical pick-up for smooth up/down motion without sluggishness or abnormal noise.
4. Press the ■ key.
Check that focus searching operation is deactivated. If not, again press the ■ key slightly longer.

Tracking Balance Adjustment

Condition :

- Hold the set in horizontal state.

Procedure :

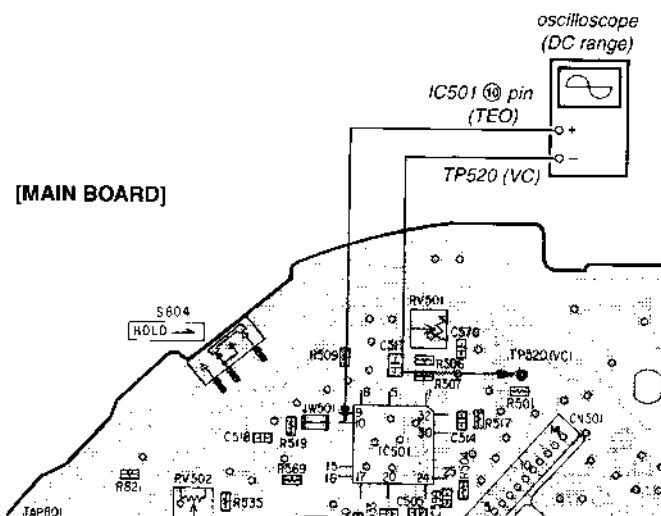

Fig. 5

[MAIN BOARD] (Conductor side)

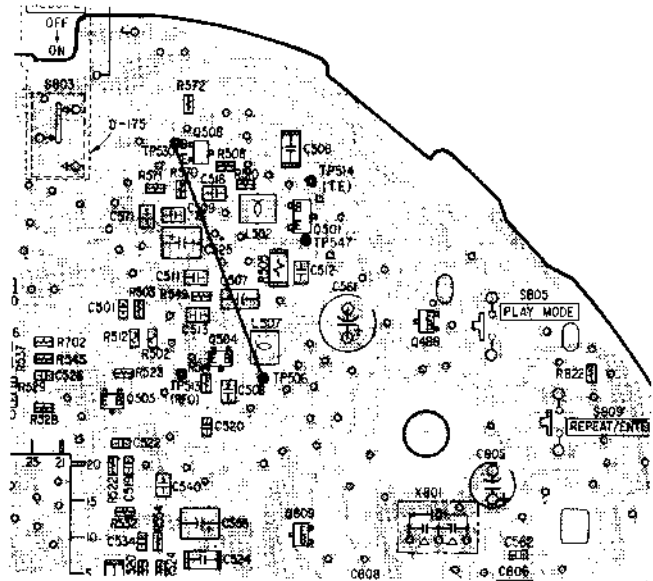
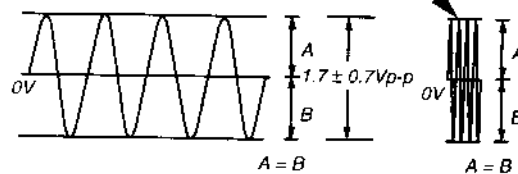

Fig. 6

1. Connect the oscilloscope between IC501 ⑩ pin (TEO) and TP520 (VC) on the MAIN board as shown in Fig. 5.
2. Connect the lead wire between TP530 (Q508, Base) and TP506 (Vcc : IC501 ⑫ pin) as shown in Fig. 6.
3. Set the equipment to service mode stop state (See page 7).
4. Move the optical pick-up by Pressing the ►► and ◄◄ keys.
5. Put the disc (YEDS-18).
6. Press the ►► key.
(From focus searching, focus is turned ON while entering CLV drawing-in mode. Tracking and sled are turned OFF.)
7. Adjust RV501 so that the waveform on the oscilloscope becomes up/down symmetrical with an axis of 0V.

Note : Take Long sweep time for easy monitoring



8. Stop removing of the motor by pressing the ■ key.
9. After the completion of adjustment, reset service mode. (See page 7)

Adjustment Location : Main board (page 10)

Focus Bias Check

Condition :

- Hold the set in horizontal state.

Procedure :

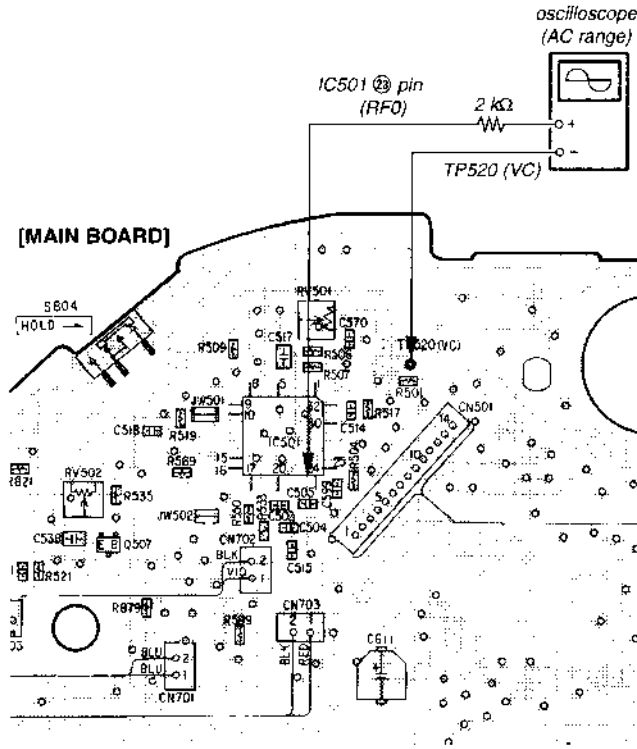

1. Set the equipment to service mode stop state (See page 7).
2. Connect the oscilloscope between IC501 ⑩ pin (RF0) and TP520 (VC) on the MAIN board.
3. Move the optical pick-up by Pressing the ►► and ◀◀ keys.
4. Put the disc (YEDS-18).
5. Press the ►► key.
(From focus searching, focus is turned ON while entering CLV drawing-in mode. Tracking and sled are turned OFF.)
6. Press the PLAY MODE key. (Both tracking and sled are turned ON).
7. Check the oscilloscope waveform is as shown below.
A good eye pattern means that the diamond shape (◇) in the center of the waveform can be clearly distinguished.

VOLT DIV : 200mV (with the 10 : 1 probe in use)

TIME DIV : 500nS

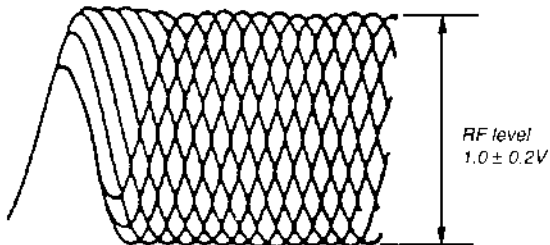

● RF Signal Reference Waveform (eye pattern)

To watch the eye pattern, set the oscilloscope to AC range and increase the vertical sensitivity of the oscilloscope for easy watching.

8. Stop removing of the motor by pressing the ■ key.
9. After the completion of adjustment, reset service mode. (See page 7)

Focus/Tracking Gain Adjustment

A servo analyzer is necessary in order to perform this adjustment exactly.

However, this gain has a margin, so even if it is slightly off, there is no problem. Therefore, do not perform this adjustment.

Focus/tracking gain determines the pick-up follow-up relative to mechanical noise and mechanical shock when the 2-axis device operate. However, as these reciprocate, the adjustment is at the point where both are satisfied.

- When gain is raised, the noise when 2-axis device operates increases.
- When gain is lowered, it is more susceptible to mechanical shock and skipping occurs more easily.

This adjustment has to be performed upon replacing any of the following parts :

- Optical pick-up
- RV503 (Focus gain)
- RV502 (Tracking gain)

Normally, be sure not to move RV503 (focus gain) and RV502 (tracking gain).

– Focus Gain Adjustment –

Procedure :

This adjustment is not performed. If focus gain RV503 is turned, set to mechanical center

– Tracking Gain Adjustment –

(perform at normal operation)

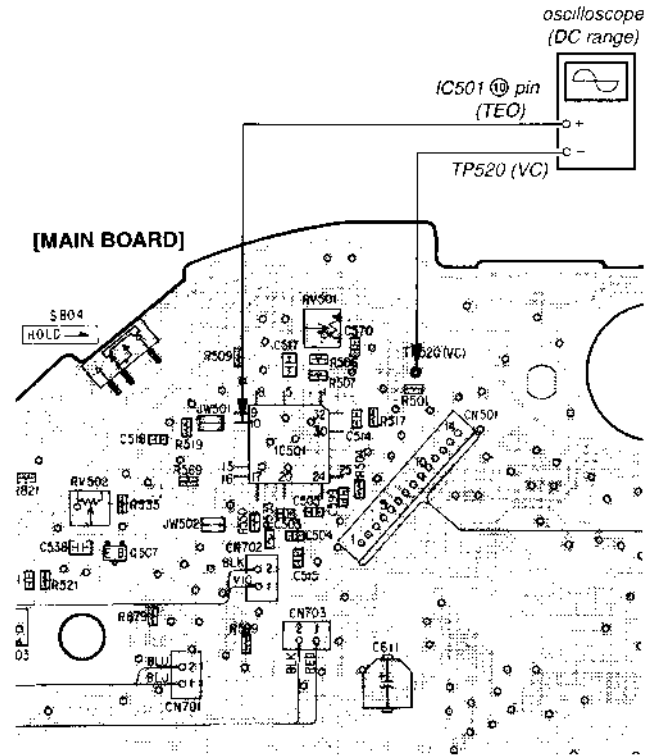

1. Place the optical pick-up level, horizontally. (If the optical pick-up is not level, the 2-axis device will be weighted and adjustment cannot be done.)
2. Connect the oscilloscope between IC501 ⑩ pin (TEO) and TP520 (VC) on the MAIN board.
3. Set the disc (YEDS-18) and Press the▶▶ key (▶▶▶▶ key).
4. Turn RV502 slightly clockwise (tracking gain drops) and obtain a waveform with a fundamental wave (waveform has large waves) as in Figure 1 .
5. Turn RV502 slowly counterclockwise (tracking gain rises) until the fundamental wave disappears (no large waves) as in Figure 2.
6. Set RV502 to the position about 30 °counterclockwise form the position obtained in step 5. If RV502 contact point is more than 90 ° counterclockwise from mechanical center, tracking gain is too high. In this case, readjust from step 4.
7. Press ▶▶ (▶▶▶▶) or ◀◀ keys and observe the 100 track jump waveform. Check that no traverse waveform appears for both ▶▶ (▶▶▶▶) or ◀◀ directions. (See Figures 3 and 4.) It is acceptable if the traverse waveform appears only now and then, but if it appears constantly raise tracking gain slightly and check step 7 again.
8. Check that there is not abnormal amount of operation noise (white noise) from the 2-axis device. If there is, tracking gain is too high, readjust starting with step 4.

Adjustment Location :

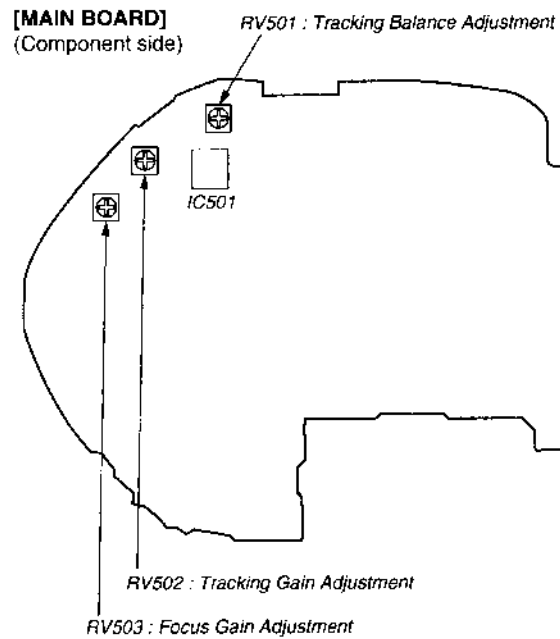

The waveforms are those measured with the oscilloscope set as shown below.

- VOLT/DIV : 50mV
- TIME/DIV : 5mS
- Waveform when tracking gain lowered.
Fundamental wave appears (large waves).



Fig. 1

- Waveform when fundamental wave disappears (no large waves).



Fig. 2

- Waveform when no traverse waveform during 100 track jump.
(Brake application is smooth because of adjustment.)



100 track jump waveform

Fig. 3

- Waveform when no traverse waveform during 100 track jump.
(Brake application is poor because of adjustment.)

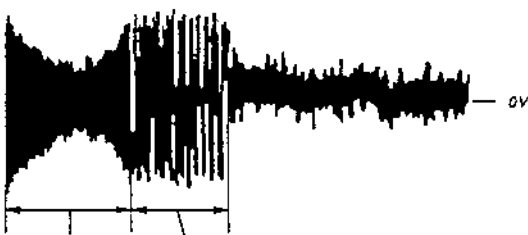

100 track jump waveform
traverse waveform

Fig. 4

SECTION 6

EXPLANATION OF IC TERMINALS

IC801 MC68HC05L15SC442705CPB (SYSTEM CONTROL)

Pin No.	Pin name	I/O	Description
1 - 3	SEG 12-14	O	LCD segment signal output terminal.
4	FP26	-	Not used (Open).
5	XRST-DSP	O	Reset output terminal.
6	AMUTE-HP	O	Audio mute output terminal.
7	XSOE-ESP/XBRAKE	-	Not used (Open).
8	ESPON-PWE	O	ESP POWER ON control output.
9	DACLT-DAC	I/O	CPU serial data input, latch signal output (For DAC only).
10	C2POEN	O	C2PO signal control output. "L" : stop "H" : searching
11	MIRR-RF/CHGON-PWR	I	Charge ON signal input terminal.
12	RMDAT-WRMT	O	Serial data output to LCD remote controller. (D-175)
13	VLCD (GND)	-	Connect to ground.
14	VSS (GND)	-	Connect to ground.
15	NDLY (GND)	-	Connect to ground.
16	LIGHT-LED	-	Not used (Open).
17	PCON-PWR	O	Power ON/OFF control output. "L" : ON "H" : OFF
18	XMCRST-PWR	I	System reset input terminal.
19	OSC 1	I	System clock oscillator input terminal (4.1943 MHz).
20	OSC 2	O	System clock oscillator output terminal (4.1943 MHz).
21	SDT-ESP	-	Not used (Open).
22	SDT-ESP	-	Not used (Open).
23	SCK-ESP	-	Not used (Open).
24	MUTE-DRV	O	Motor drive mute output terminal.
25	XLT-ESP	-	Not used (Open).
26	HOLD-SW	I	Hold switch input terminal. "L" : HOLD ON "H" : HOLD OFF
27	XLMT-MD	I	Limit switch input terminal. "L" : Inside Track
28	XRSM-SW	I	RESUME switch input terminal. "L" : ON "H" : OFF (D-175)
29	WP XDC-DT PWR	I	DC in voltage detection terminal.
30	WP XOPEN-SW	I	Door open switch input terminal. "L" : Close "H" : Open
31	WP XPLAY-SW	I	Play/pause key input terminal.
32	WP RMKEY WRMT	I	Remote control key input terminal. (D-175)
33	XL/O DCT	I	LINE OUT jack detection terminal. "L" : Present "H" : No
34	XRCHG-SW	I	Rechargeable battery detection terminal. "L" : Present "H" : No
35	XAVLS-SW	I	AVLS switch input terminal.
36	R/W DSP	O	Read/Write switching signal output terminal. "L" : Read "H" : Write
37	SDT-DSP	I	SUB-Q signal input terminal.
38	SDT-DSP	O	Serial data output to DSP (IC502).
39	SCK-DSP	O	Clock signal to enter SUB-Q signal form DSP (IC502).
40	FOK-RF	I	FOK signal input terminal.

Pin No.	Pin name	I/O	Description
41	BUSY-DSP	I	BUSY signal input terminal from DSP (IC502).
42	BEEP-HP	O	Beep sound output terminal.
43	INT SCOR-DSP	I	Sub code sync SO+SI input terminal.
44	INT RMC-WLRMT	-	Not used (Open).
45	V _{DD} (VCPU)	-	Power supply terminal.
46 - 49	COM 0-3	O	LCD common signal output terminal.
50	VREFH	I	Reference voltage input terminal (connect to V _{DD}).
51	VREFL	-	Connect to ground.
52	AD ESPSL/TEST	I	Test mode terminal. "L" : Test mode "H" : Normal mode
53	AD-KEY	I	A/D input terminal for main unit key.
54	AD-WRMT	I	A/D input terminal for remote control key (D-175).
55	AD-HI DC	I	A/D input terminal for DC IN voltage detection.
56	AD - BAT	I	Rechargeable battery/dry cell detection input.
57	AD - CHG	I	A/D input terminal for charging voltage monitor.
58	AD - VCC	I	A/D input terminal for VCC voltage monitor.
59	AD - DSP OFFSET	I	A/D input terminal for DSP off-set monitor.
60	FP10	-	Not used (Open).
61 - 72	SEG 0 - 11	O	LCD segment signal output terminal.

SECTION 7 DIAGRAMS

7-1. BLOCK DIAGRAM

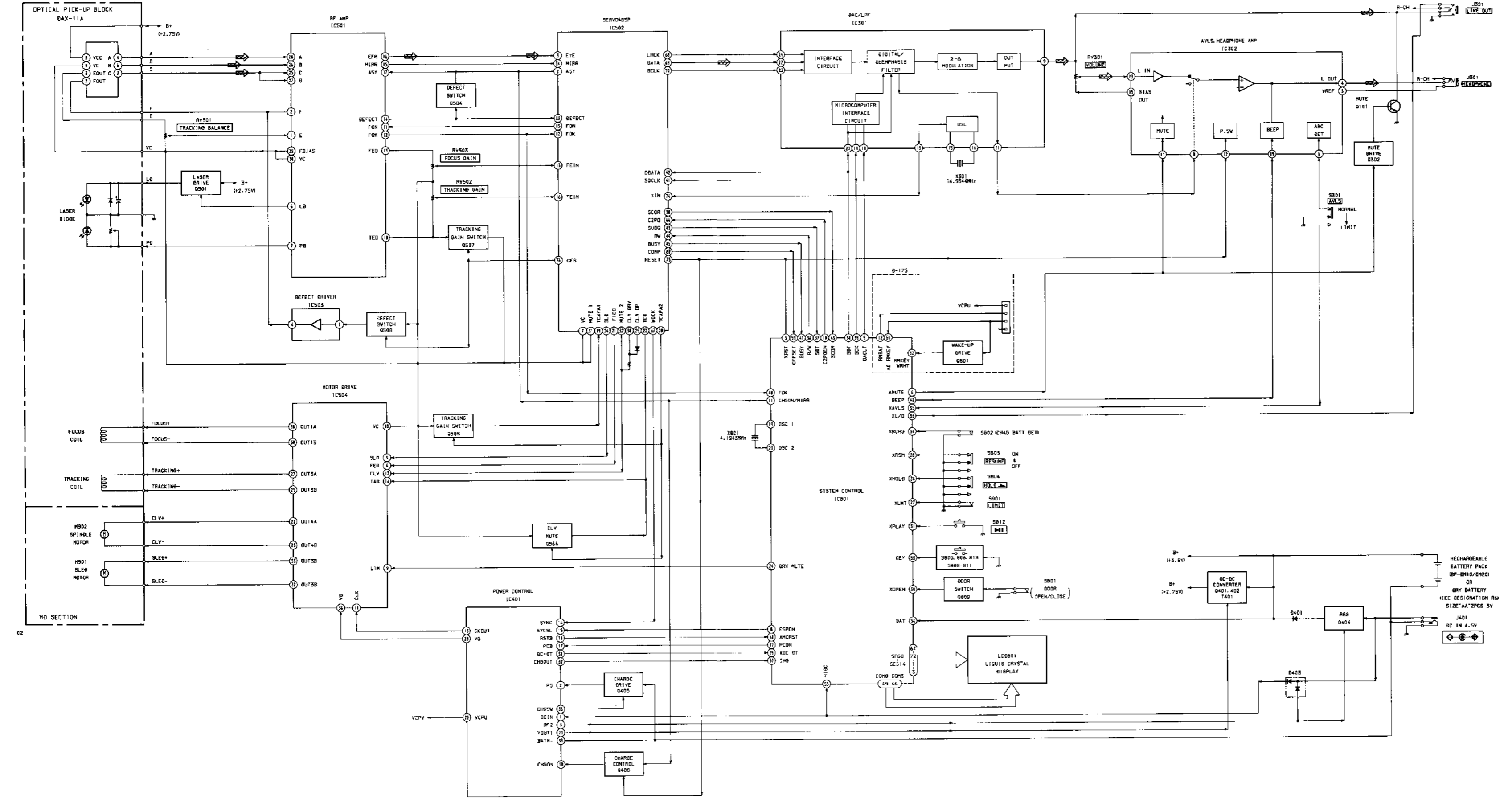

R-CH IS OMITTED; SAME AS L-CH

• Signal path.
- - - - - : CD

7-2. PRINTED WIRING BOARDS

• SEMICONDUCTOR LOCATION

Ref. No.	Location
D101	G-17
D105	F-12
D201	H-17
D205	F-12
D302	H-17
D401	F-14
D403	E-13
D404	E-14
D407	C-14
D409	D-15
D414	F-14
D502	C-16
D801	H-18
D803	H-5
D804	F-12
IC301	F-4
IC302	G-4
IC401	D-14
IC501	B-4
IC502	D-16
IC503	B-15
IC504	B-13
IC801	E-19
Q101	F-9
Q201	F-9
Q302	F-6
Q401	E-13
Q402	E-13
Q404	E-14
Q405	D-9
Q488	C-19
Q501	B-18
Q504	C-17
Q505	C-17
Q507	C-3
Q508	B-17
Q566	B-15
Q801	H-17
Q809	D-18

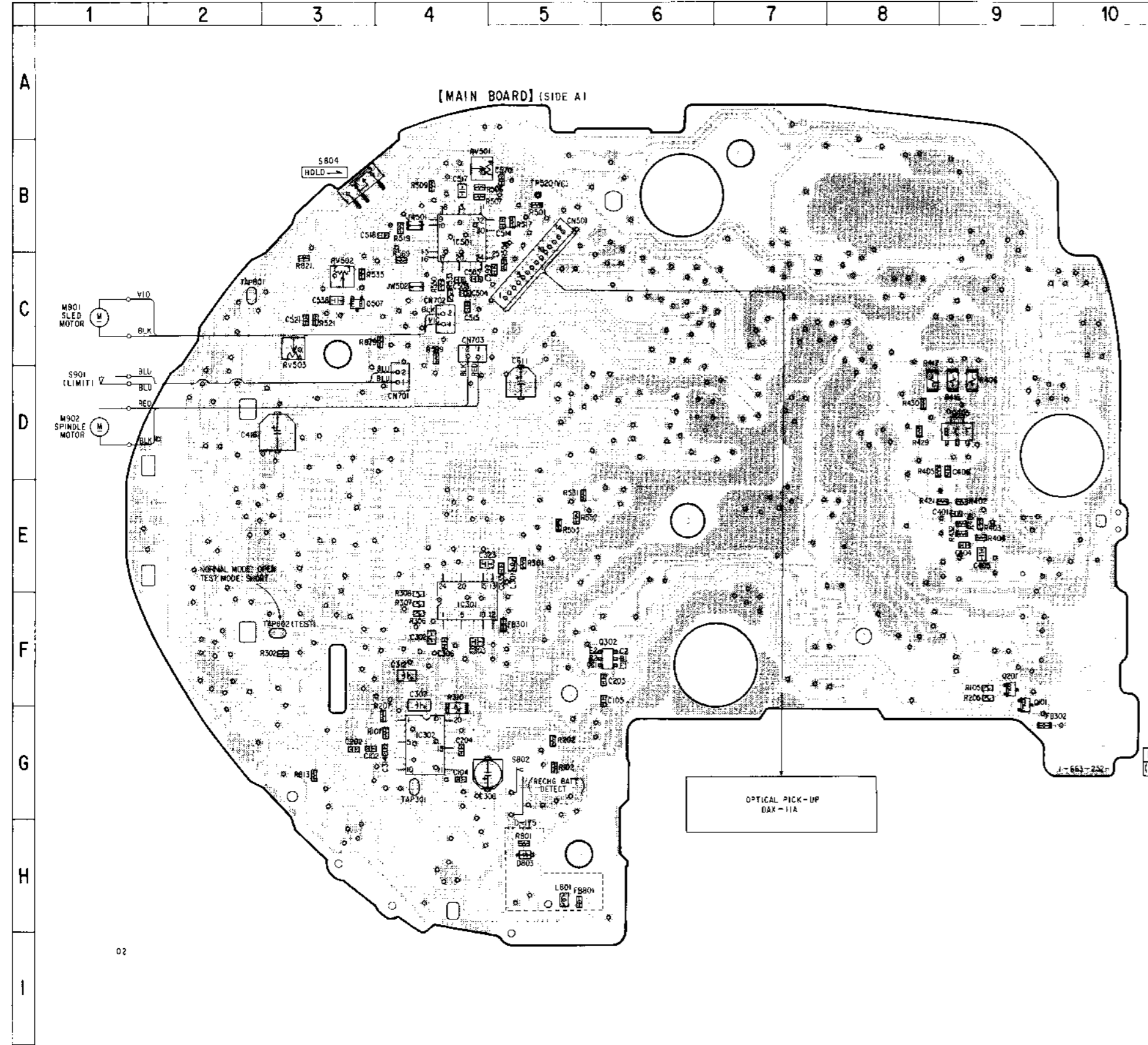

Note:
 • ○ — parts extracted from the component side.
 • ○ — Through hole.
 • [Pattern] — Pattern on the side which is seen.

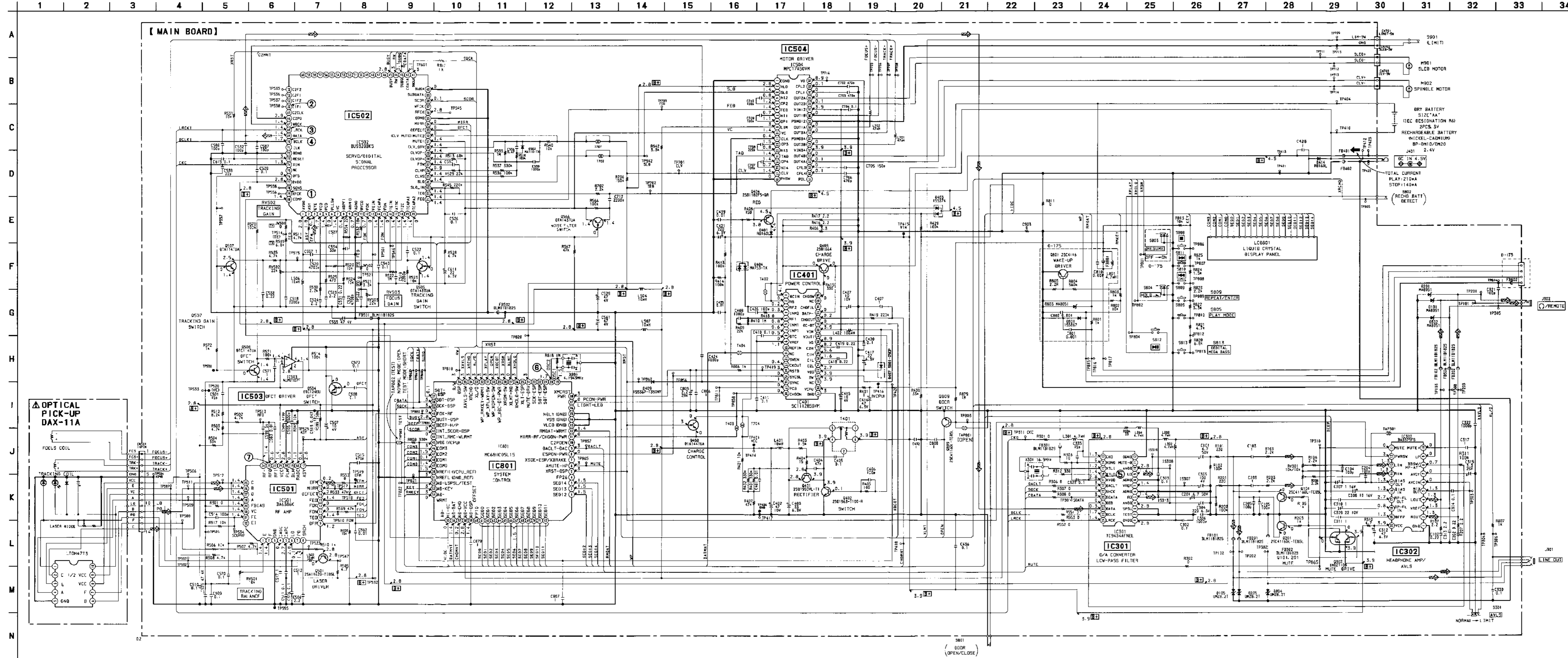

• WAVEFORMS

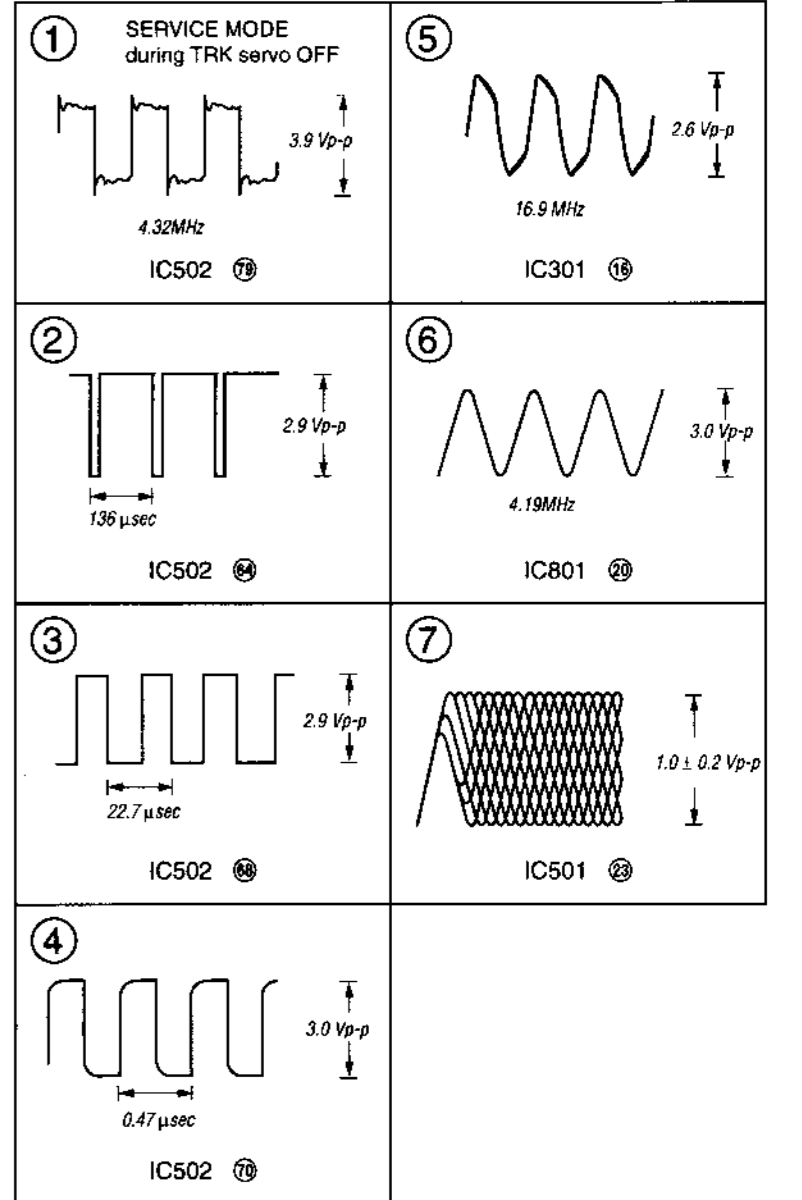

Note:
 • All capacitors are in μF unless otherwise noted. pF: μF 50WV or less are not indicated except for electrolytics and tantalums.
 • All resistors are in Ω and 1/4 W or less unless otherwise specified.
 • Δ: Internal component.

Note:
 The components identified by mark Δ or dotted line with mark Δ are critical for safety. Replace only with part number specified.

Note:
 Les composants identifiés par une marque Δ sont critiques pour la sécurité. Ne les remplacer que par une pièce portant le numéro spécifié.

• B +: B+ Line
 □: adjustment for repair.
 • Power voltage is dc 4.5 V and fed with regulated dc power supply from external power voltage jack (J401).
 • Voltage and waveforms are dc with respect to ground under no-signal conditions.
 no mark: STOP
 (): PLAY
 • Voltages are taken with a VOM (Input impedance 10MΩ). Voltage variations may be noted due to normal production tolerances.
 • Waveforms are taken with an oscilloscope. Voltage variations may be noted due to normal production tolerances.
 • Circled numbers refer to waveforms.
 • Signal path.
 ⇨: CD

● IC BLOCK DIAGRAMS

IC301 TC9434AFNEL

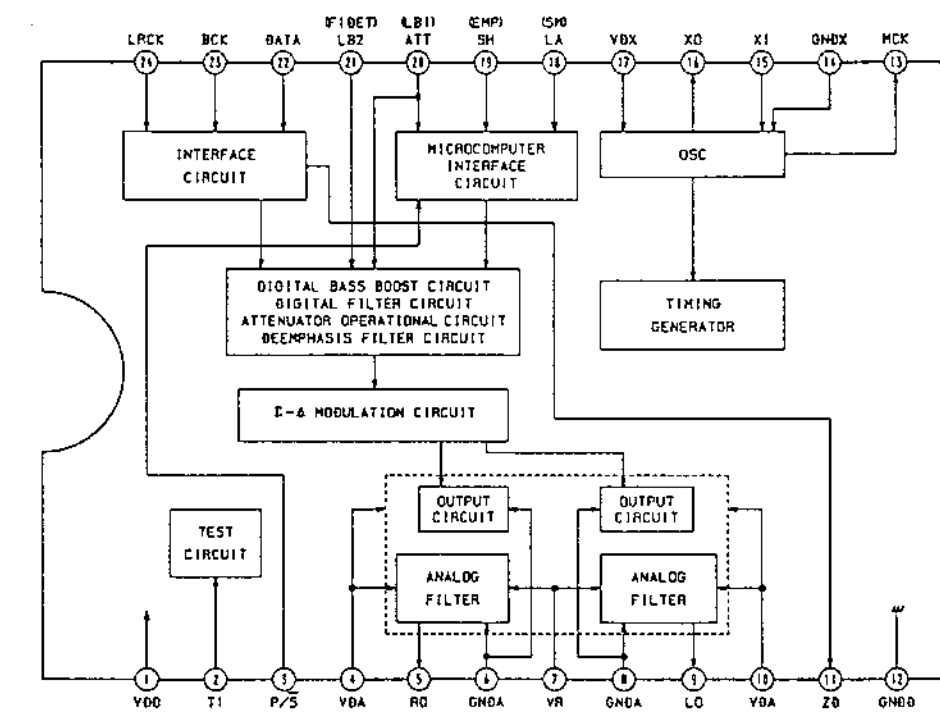

IC502 BU9320BKS

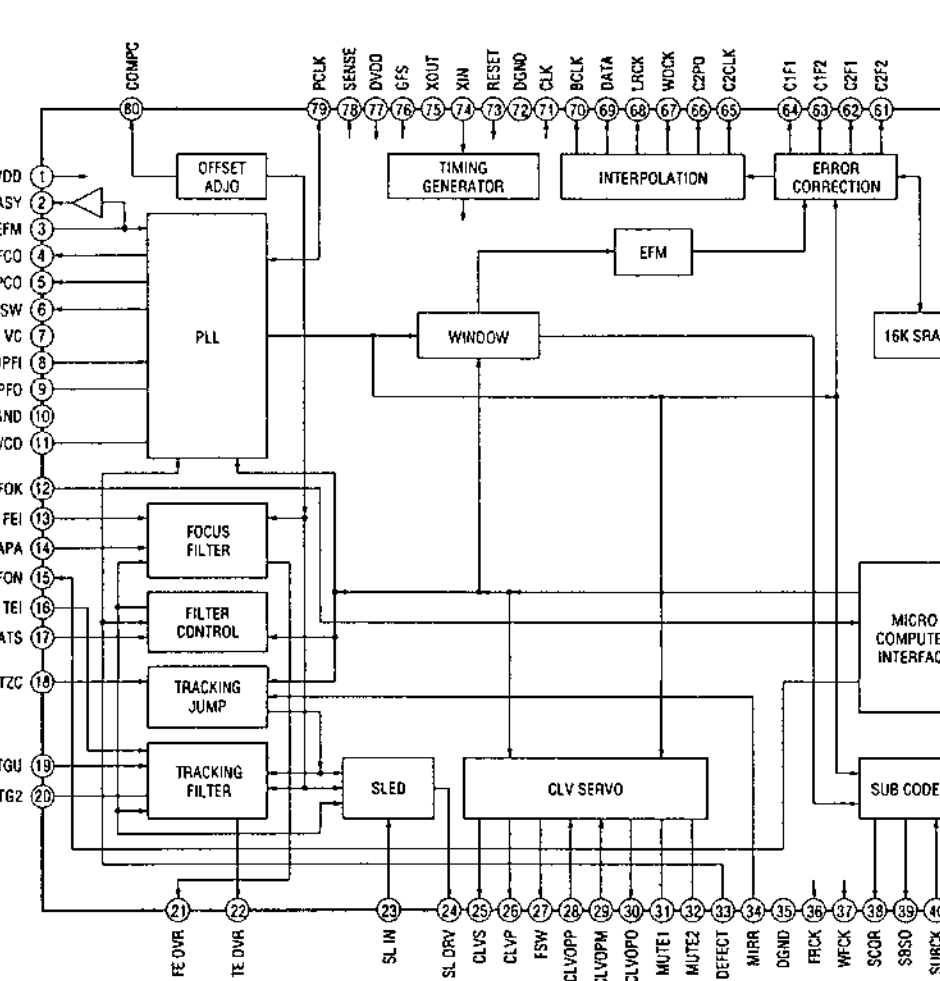

IC501 BA6386K

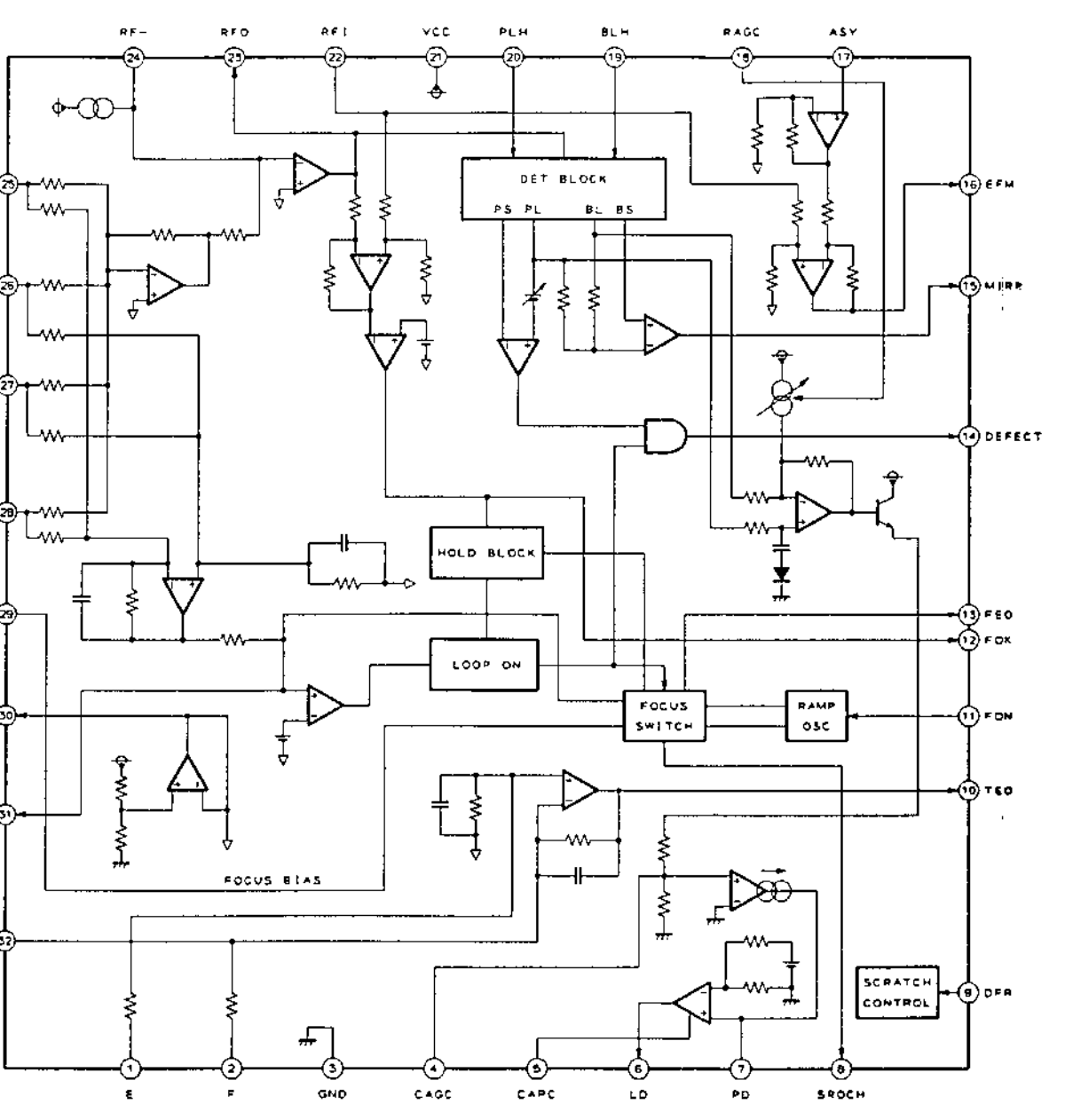

IC504 MPC17A50/SC250VMEI

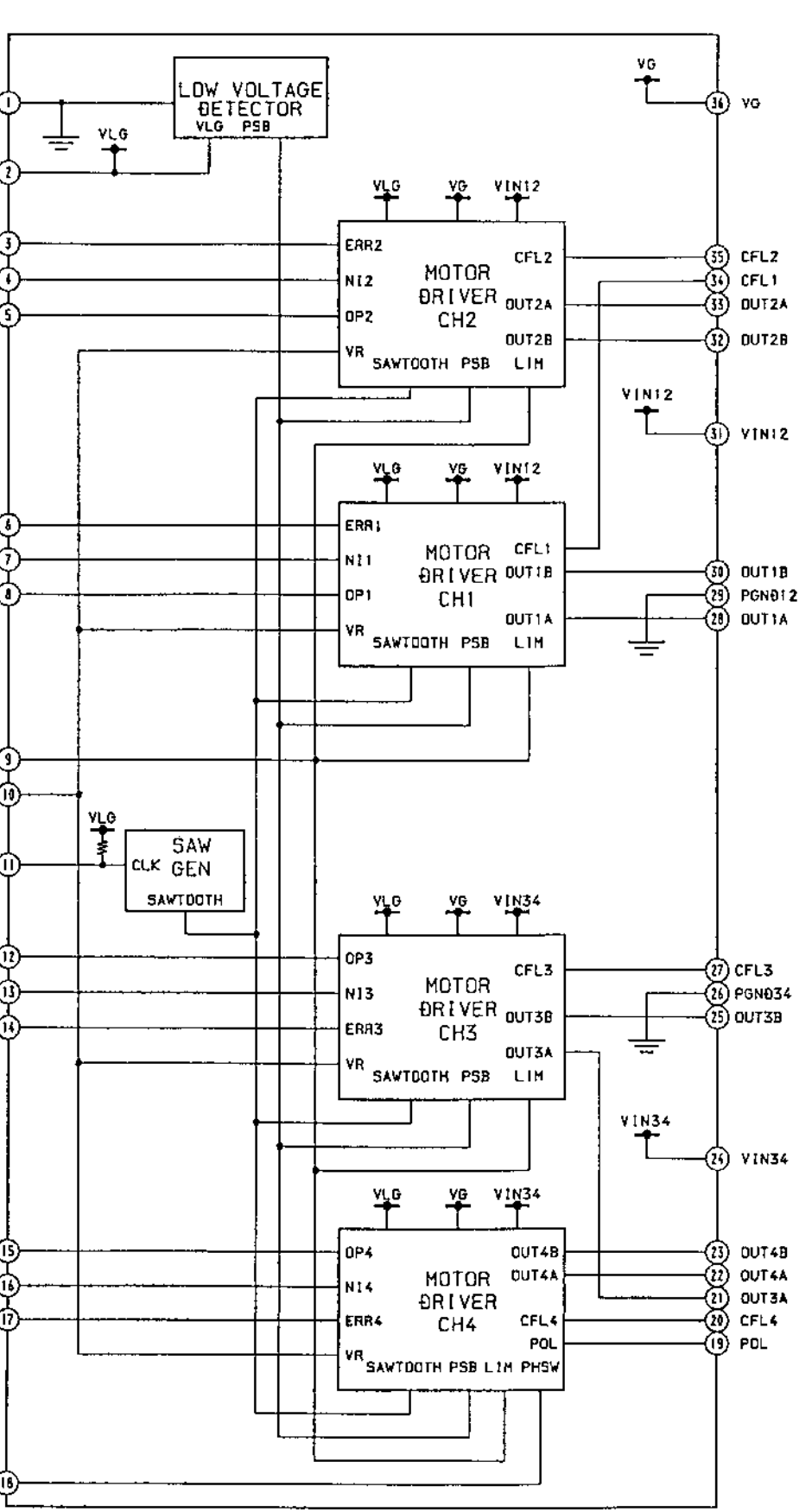

SECTION 8
EXPLODED VIEWS

NOTE:
 ● -XX, -X mean standardized parts, so they may have some difference from the original one.
 ● Color indication of Appearance Parts
 Example:
 KNOB, BALANCE (WHITE) --- (RED)
 ↑ ↑
 Parts color Cabinet's color

● Items marked "*" are not stocked since they are seldom required for routine service. Some delay should be anticipated when ordering these items.
 ● The mechanical parts with no reference number in the exploded views are not supplied.
 ● Hardware (# mark) list and accessories and packing materials are given in the last of this parts list.
 ● Abbreviation
 C&SA: Central and South America

The components identified by mark Δ or dotted line with mark Δ are critical for safety.
 Replace only with part number specified.
 Les composants identifiés par une marque Δ sont critiques pour la sécurité.
 Ne les remplacer que par une pièce portant le numéro spécifié.

8-1. CABINET SECTION

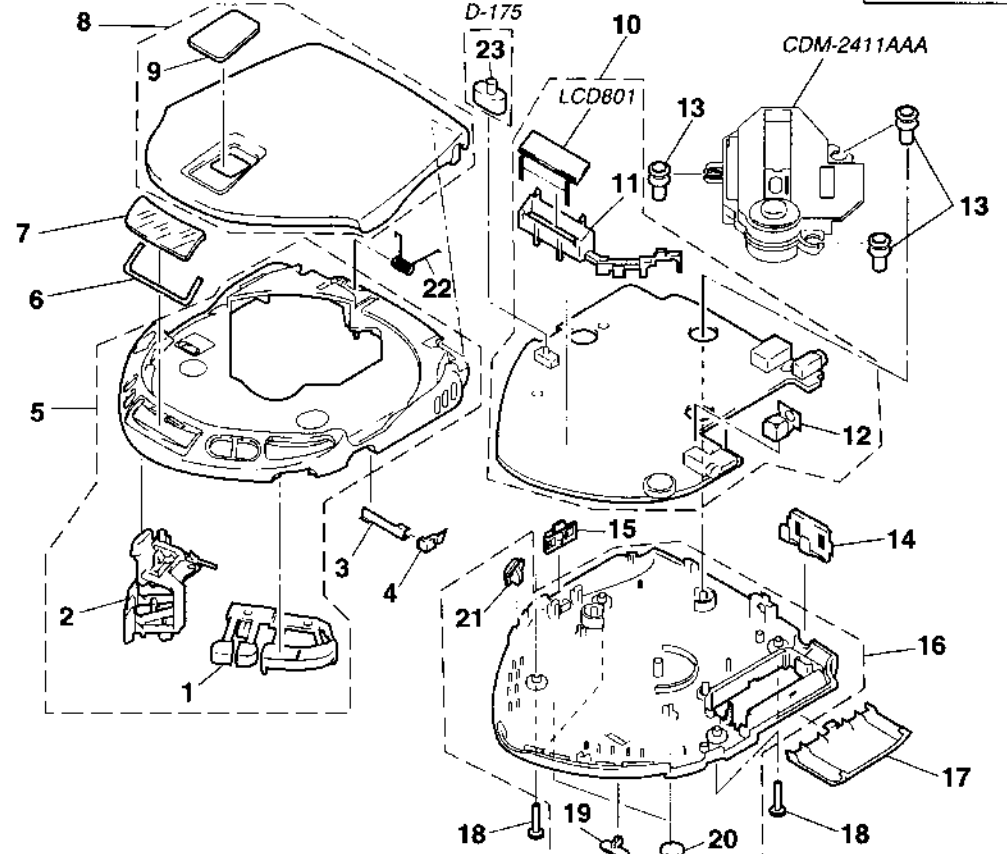

Ref. No.	Part No.	Description	Remark	Ref. No.	Part No.	Description	Remark
1	4-986-056-11	BUTTON (OPERATE)		8	X-4948-266-1	LID ASSY, UPPER (GRAY) (D-171V)	
2	4-986-057-01	BUTTON (OPEN)		8	X-4948-267-1	LID ASSY, UPPER (BLUE) (D-171V)	
3	4-982-219-01	SPRING (DETECTOR)		8	X-4948-268-1	LID ASSY, UPPER (GREEN) (D-171V)	
4	4-982-218-01	DETECTOR		8	X-4948-269-1	LID ASSY, UPPER (RED) (D-171V)	
5	X-4947-857-1	CABINET(FRONT) SUB ASSY (EXCEPT D-175)		9	4-986-060-01	WINDOW (DISC)	
5	X-4948-040-1	CABINET(FRONT) SUB ASSY (D-175)		10	A-3293-313-A	MAIN BOARD, COMPLETE (EXCEPT D-175)	
6	4-986-063-01	SHEET (LCD WINDOW), ADHESIVE		10	A-3293-318-A	MAIN BOARD, COMPLETE (D-175)	
7	4-986-059-01	WINDOW (LCD)		11	4-986-058-01	HOLDER, LCD	
8	X-4947-856-1	LID ASSY, UPPER (GRAY) (D-173)		12	4-978-695-01	PLATE, TERMINAL, BATTERY	
8	X-4948-031-1	LID ASSY, UPPER (GRAY) (D-171)		13	4-990-219-01	INSULATOR	
8	X-4948-032-1	LID ASSY, UPPER (BLUE) (D-171)		14	4-978-696-01	TERMINAL BOARD (RELAY), BATTERY	
8	X-4948-033-1	LID ASSY, UPPER (GREEN) (D-171)		15	4-975-821-21	BUTTON (CHARGE)	
8	X-4948-034-1	LID ASSY, UPPER (RED) (D-171)		16	X-4947-858-1	CABINET (REAR) SUB ASSY (BLACK) (EXCEPT D-175)	
8	X-4948-035-1	LID ASSY, UPPER (BLACK) (D-171)		16	X-4948-080-1	CABINET (REAR) SUB ASSY (BLACK) (D-175)	
8	X-4948-036-1	LID ASSY, UPPER (BLACK) (D-170AN)		17	4-986-055-01	LID, BATTERY CASE (D-170AN, D-171)	
8	X-4948-037-1	LID ASSY, UPPER (BLACK) (D-175)		17	4-986-055-11	LID, BATTERY CASE (D-171V, D-172CK, D-173, D-175)	
8	X-4948-038-1	LID ASSY, UPPER (GRAY) (D-172CK)		18	3-336-395-01	SCREW (B2X10) (G), TAPPING	
8	X-4948-058-1	LID ASSY, UPPER (La Fiesta) (GRAY)	(D-171: C&SA)	19	4-984-751-11	KNOB (AVLS)	
8	X-4948-059-1	LID ASSY, UPPER (BLUE) (D-170AN)		20	4-966-278-01	FOOT, RUBBER	
8	X-4948-060-1	LID ASSY, UPPER (GREEN) (D-170AN)		21	4-984-747-11	KNOB (H-R)	
8	X-4948-187-1	LID ASSY, UPPER (La Fiesta) (BLUE)	(D-171: C&SA)	22	4-986-065-01	SPRING, TORSION	
8	X-4948-188-1	LID ASSY, UPPER (La Fiesta) (GREEN)	(D-171: C&SA)	23	4-986-062-01	KNOB (RESUME) (D-175)	
8	X-4948-189-1	LID ASSY, UPPER (La Fiesta) (RED)	(D-171: C&SA)	LCDB01	1-801-544-11	DISPLAY PANEL, LIQUID CRYSTAL	
8	X-4948-190-1	LID ASSY, UPPER (La Fiesta) (BLACK)	(D-171: C&SA)	56	3-719-401-11	SCREW (B1.7), TAPPING	M902
				* 57	4-972-162-01	CHASSIS	S901

8-2. OPTICAL PICK-UP SECTION (CDM-2411AAA)

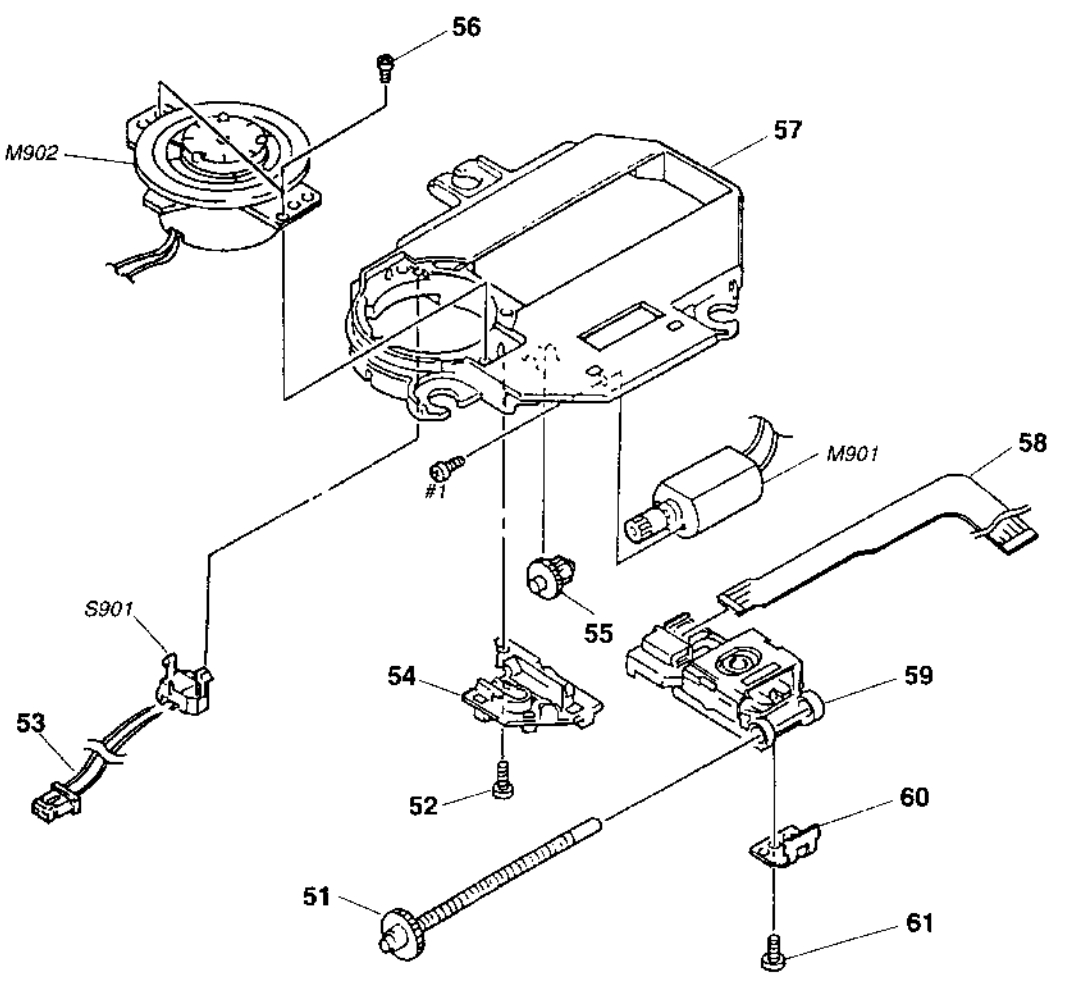

Ref. No.	Part No.	Description	Remark	Ref. No.	Part No.	Description	Remark
51	A-3303-970-A	SCREW ASSY, FEED		58	1-660-985-11	PC BOARD, SLIDE FLEXIBLE	
52	3-318-203-11	SCREW (B1.7X6), TAPPING		Δ 59	X-4946-311-1	OPTICAL PICK-UP (DAX-11A)	
53	1-690-530-21	LEAD (WITH CONNECTOR)		60	4-972-165-01	RACK	
54	4-972-163-01	SPRING, SLED		61	4-973-631-01	SCREW	
55	4-974-003-01	GEAR (B)		M901	A-3303-403-A	MOTOR ASSY, SLED	
56	3-719-401-11	SCREW (B1.7), TAPPING		M902	A-3303-971-A	MOTOR ASSY, TURNTABLE (SPINDLE)	
* 57	4-972-162-01	CHASSIS		S901	1-571-099-21	SWITCH (1 KEY) (LIMIT)	

The components identified by mark Δ or dotted line with mark Δ are critical for safety.
 Replace only with part number specified.
 Les composants identifiés par une marque Δ sont critiques pour la sécurité.
 Ne les remplacer que par une pièce portant le numéro spécifié.

SECTION 9 ELECTRICAL PARTS LIST

MAIN

NOTE :

- Due to standardization, replacements in the parts list may be different from the parts specified in the diagrams or the components used on the set.
- -XX, -X mean standardized parts, so they may have some difference from the original one.
- RESISTORS
All resistors are in ohms
METAL : Metal-film resistor
METAL OXIDE : Metal oxide-film resistor
F : nonflammable
- Items marked " * " are not stocked since they are seldom required for routine service. Some delay should be anticipated when ordering these items.

● SEMICONDUCTORS

In each case, u : μ , for example :
uA : μ A, uPA : μ PA, ...
uPB : μ PB, uPC : μ PC, ...
uPD : μ PD, ...

● CAPACITORS

uF : μ F

● COILS

uH : μ H

● Abbreviation

CND : Canadian AUS : Australian
JE : Tourist EA : Saudi Arabia
CH : Chinese
C&SA : Central and South America
E13 : AC 220-230V area model
E33 : AC 100-240V area model

The components identified by mark Δ or dotted line with mark Δ are critical for safety.
Replace only with part number specified.

Les composants identifiés par une marque Δ sont critiques pour la sécurité. Ne les remplacer que par une pièce portant le numéro spécifié.

When indicating parts by reference number, please include the board.

Ref. No.	Part No.	Description	Remark	Ref. No.	Part No.	Description	Remark
	A-3293-313-A	MAIN BOARD, COMPLETE (EXCEPT D-175)		C410	1-164-360-11	CERAMIC CHIP 0.1uF	16V
	A-3293-318-A	MAIN BOARD, COMPLETE (D-175)		C411	1-163-038-91	CERAMIC CHIP 0.1uF	25V

	4-986-058-01	HOLDER, LCD		C415	1-135-201-11	TANTALUM CHIP 10uF	20% 4V
	4-978-695-01	PLATE, TERMINAL, BATTERY		C416	1-126-205-11	ELECT CHIP 47uF	20% 6.3V
		< CAPACITOR >		C417	1-104-852-11	TANTAL. CHIP 22uF	20% 6.3V
				C418	1-165-128-11	CERAMIC CHIP 0.22uF	16V
				C419	1-165-128-11	CERAMIC CHIP 0.22uF	16V
C101	1-126-794-11	ELECT 4.7uF	20% 50V	C420	1-163-038-91	CERAMIC CHIP 0.1uF	25V
C102	1-165-128-11	CERAMIC CHIP 0.22uF	16V	C421	1-124-635-00	ELECT 220uF	20% 6.3V
C103	1-164-346-11	CERAMIC CHIP 1uF	16V	C424	1-162-964-11	CERAMIC CHIP 0.001uF	10% 50V
C104	1-162-953-11	CERAMIC CHIP 100PF	5% 50V	C425	1-162-970-11	CERAMIC CHIP 0.01uF	10% 25V
C105	1-162-953-11	CERAMIC CHIP 100PF	5% 50V	C426	1-162-953-11	CERAMIC CHIP 100PF	5% 50V
C201	1-126-794-11	ELECT 4.7uF	20% 50V	C427	1-135-216-11	TANTALUM CHIP 10uF	20% 10V
C202	1-165-128-11	CERAMIC CHIP 0.22uF	16V	C428	1-164-346-11	CERAMIC CHIP 1uF	16V
C203	1-164-346-11	CERAMIC CHIP 1uF	16V	C432	1-164-346-11	CERAMIC CHIP 1uF	16V
C204	1-162-953-11	CERAMIC CHIP 100PF	5% 50V	C436	1-107-826-11	CERAMIC CHIP 0.1uF	10% 16V
C205	1-162-953-11	CERAMIC CHIP 100PF	5% 50V	C439	1-162-970-11	CERAMIC CHIP 0.01uF	10% 25V
C302	1-163-038-91	CERAMIC CHIP 0.1uF	25V	C501	1-162-917-11	CERAMIC CHIP 15PF	5% 50V
C303	1-163-038-91	CERAMIC CHIP 0.1uF	25V	C503	1-162-970-11	CERAMIC CHIP 0.01uF	10% 25V
C304	1-124-635-00	ELECT 220uF	20% 6.3V	C504	1-162-962-11	CERAMIC CHIP 470PF	10% 50V
C305	1-124-433-00	ELECT 100uF	20% 4V	C505	1-162-967-11	CERAMIC CHIP 0.0033uF	10% 50V
C306	1-162-964-11	CERAMIC CHIP 0.001uF	10% 50V	C506	1-109-994-11	CERAMIC CHIP 2.2uF	10% 10V
C307	1-135-091-00	TANTALUM CHIP 1uF	20% 16V	C507	1-135-201-11	TANTALUM CHIP 10uF	20% 4V
C308	1-124-779-00	ELECT CHIP 10uF	20% 16V	C508	1-163-038-91	CERAMIC CHIP 0.1uF	25V
C309	1-126-783-11	ELECT 22uF	20% 10V	C509	1-163-038-91	CERAMIC CHIP 0.1uF	25V
C310	1-164-346-11	CERAMIC CHIP 1uF	16V	C510	1-163-038-91	CERAMIC CHIP 0.1uF	25V
C311	1-164-346-11	CERAMIC CHIP 1uF	16V	C511	1-163-038-91	CERAMIC CHIP 0.1uF	25V
C312	1-126-205-11	ELECT CHIP 47uF	20% 6.3V	C512	1-164-346-11	CERAMIC CHIP 1uF	16V
C313	1-164-337-11	CERAMIC CHIP 2.2uF	16V	C513	1-163-809-11	CERAMIC CHIP 0.047uF	10% 25V
C314	1-164-360-11	CERAMIC CHIP 0.1uF	16V	C514	1-162-953-11	CERAMIC CHIP 100PF	5% 50V
C315	1-126-162-11	ELECT 3.3uF	20% 50V	C515	1-162-962-11	CERAMIC CHIP 470PF	10% 50V
C317	1-164-346-11	CERAMIC CHIP 1uF	16V	C516	1-163-038-91	CERAMIC CHIP 0.1uF	25V
C321	1-162-953-11	CERAMIC CHIP 100PF	5% 50V	C517	1-109-982-11	CERAMIC CHIP 1uF	10% 10V
C322	1-162-964-11	CERAMIC CHIP 0.001uF	10% 50V	C518	1-162-966-11	CERAMIC CHIP 0.0022uF	10% 50V
C323	1-163-038-91	CERAMIC CHIP 0.1uF	25V	C519	1-162-966-11	CERAMIC CHIP 0.0022uF	10% 50V
C330	1-107-826-11	CERAMIC CHIP 0.1uF	10% 16V	C520	1-162-968-11	CERAMIC CHIP 0.0047uF	10% 50V
C335	1-162-917-11	CERAMIC CHIP 15PF	5% 50V	C521	1-162-968-11	CERAMIC CHIP 0.0047uF	10% 50V
C401	1-162-970-11	CERAMIC CHIP 0.01uF	10% 25V	C522	1-107-826-11	CERAMIC CHIP 0.1uF	10% 16V
C402	1-126-785-11	ELECT 47uF	20% 10V	C523	1-109-994-11	CERAMIC CHIP 2.2uF	10% 10V
C403	1-127-485-00	ELECT(SOLID) 33uF	20% 6.3V	C524	1-109-994-11	CERAMIC CHIP 2.2uF	10% 10V
C404	1-162-923-11	CERAMIC CHIP 47PF	5% 50V	C525	1-104-908-11	TANTAL. CHIP 47uF	20% 4V
C405	1-164-004-11	CERAMIC CHIP 0.1uF	10% 25V	C526	1-164-360-11	CERAMIC CHIP 0.1uF	16V
C406	1-162-953-11	CERAMIC CHIP 100PF	5% 50V	C527	1-113-677-11	CERAMIC CHIP 1uF	25V
C407	1-164-346-11	CERAMIC CHIP 1uF	16V	C528	1-163-038-91	CERAMIC CHIP 0.1uF	25V
C408	1-162-964-11	CERAMIC CHIP 0.001uF	10% 50V	C529	1-126-513-11	ELECT 47uF	20% 4V

MAIN

Ref. No.	Part No.	Description	Remark	Ref. No.	Part No.	Description	Remark
C530	1-164-346-11	CERAMIC CHIP 1uF	16V	D409	8-719-049-09	DIODE 1SS367-T3SONY	
C531	1-164-489-11	CERAMIC CHIP 0.22uF	10% 16V	D414	8-719-048-98	DIODE RB160L-40TE25	
C532	1-162-953-11	CERAMIC CHIP 100PF	5% 50V	D502	8-719-404-46	DIODE MA110	
C534	1-162-921-11	CERAMIC CHIP 33PF	5% 50V	D801	8-719-049-09	DIODE 1SS367-T3SONY (D-175)	
C538	1-164-489-11	CERAMIC CHIP 0.22uF	10% 16V	D803	8-719-420-90	DIODE MA8051-M (D-175)	
C539	1-162-919-11	CERAMIC CHIP 22PF	5% 50V	D804	8-719-039-99	DIODE UMZ8.2T	
C540	1-164-004-11	CERAMIC CHIP 0.1uF	10% 25V			< FERRITE BEAD >	
C555	1-104-908-11	TANTAL. CHIP 47uF	20% 4V	FB101	1-500-444-11	INDUCTOR 0UH	
C556	1-164-005-11	CERAMIC CHIP 0.47uF	25V	FB102	1-500-444-11	INDUCTOR 0UH	
C557	1-164-346-11	CERAMIC CHIP 1uF	16V	FB201	1-500-444-11	INDUCTOR 0UH	
C559	1-162-964-11	CERAMIC CHIP 0.001uF	10% 50V	FB202	1-500-444-11	INDUCTOR 0UH	
C561	1-126-513-11	ELECT 47uF	20% 4V	FB301	1-500-444-11	INDUCTOR 0UH	
C562	1-162-970-11	CERAMIC CHIP 0.01uF	10% 25V	FB302	1-500-444-11	INDUCTOR 0UH	
C570	1-164-360-11	CERAMIC CHIP 0.1uF	16V	FB306	1-500-444-11	INDUCTOR 0UH	
C571	1-109-982-11	CERAMIC CHIP 1uF	10% 10V	FB401	1-500-451-11	INDUCTOR 0UH	
C572	1-163-038-91	CERAMIC CHIP 0.1uF	25V	FB402	1-500-451-11	INDUCTOR 0UH	
C587	1-162-953-11	CERAMIC CHIP 100PF	5% 50V	FB501	1-500-444-11	INDUCTOR 0UH	
C588	1-162-953-11	CERAMIC CHIP 100PF	5% 50V	FB502	1-500-444-11	INDUCTOR 0UH	
C599	1-162-910-11	CERAMIC CHIP 5PF	0.25PF 50V	FB801	1-500-444-11	INDUCTOR 0UH (D-175)	
C611	1-124-778-00	ELECT CHIP 22uF	20% 6.3V	FB802	1-216-864-11	METAL CHIP 0 5% 1/16W (D-175)	
C615	1-163-038-91	CERAMIC CHIP 0.1uF	25V			< IC >	
C702	1-162-962-11	CERAMIC CHIP 470PF	10% 50V	IC301	8-759-459-18	IC TC9434AFNEL	
C703	1-162-962-11	CERAMIC CHIP 470PF	10% 50V	IC302	8-759-450-64	IC BA3575FS-E2	
C704	1-163-038-91	CERAMIC CHIP 0.1uF	25V	IC401	8-759-450-67	IC SC111285BVMEL	
C705	1-162-955-11	CERAMIC CHIP 150PF	5% 50V	IC501	8-759-432-83	IC BA6386K	
C706	1-162-962-11	CERAMIC CHIP 470PF	10% 50V	IC502	8-759-455-04	IC BU9320BK	
C707	1-162-953-11	CERAMIC CHIP 100PF	5% 50V	IC503	8-759-710-79	IC NJM2107F	
C708	1-162-957-11	CERAMIC CHIP 220PF	5% 50V	IC504	8-759-453-86	IC MPC17A50/SC250VMEL	
C709	1-162-953-11	CERAMIC CHIP 100PF	5% 50V	IC801	8-759-462-34	IC MC68HC05L15SC442705CPB	
C710	1-162-953-11	CERAMIC CHIP 100PF	5% 50V			< JACK >	
C712	1-162-966-11	CERAMIC CHIP 0.0022uF	10% 50V	J301	1-778-696-11	JACK (LINE OUT)	
C801	1-162-964-11	CERAMIC CHIP 0.001uF	10% 50V (D-175)	J302	1-580-680-31	JACK (⊕/REMOTE) (D-175)	
C802	1-162-964-11	CERAMIC CHIP 0.001uF	10% 50V (D-175)	J302	1-774-804-11	JACK (⊕) (EXCEPT D-175)	
C805	1-124-257-00	ELECT 2.2uF	20% 50V	J401	1-778-153-21	JACK,DC (POLARITY UNIFIED TYPE) (DC IN 4.5V)	
C806	1-113-677-11	CERAMIC CHIP 1uF	25V			< JUMPER RESISTOR >	
C807	1-164-346-11	CERAMIC CHIP 1uF	16V	JW501	1-216-295-00	METAL CHIP 0 5% 1/10W	
C808	1-113-677-11	CERAMIC CHIP 1uF	25V	JW502	1-216-295-00	METAL CHIP 0 5% 1/10W	
C810	1-162-964-11	CERAMIC CHIP 0.001uF	10% 50V (D-175)			< COIL >	
C879	1-164-346-11	CERAMIC CHIP 1uF	16V	L301	1-412-002-31	INDUCTOR CHIP 4.7uH	
C903	1-216-864-11	METAL CHIP 0	5% 1/16W	L302	1-412-002-31	INDUCTOR CHIP 4.7uH	
		< CONNECTOR >		L303	1-412-002-31	INDUCTOR CHIP 4.7uH	
CN501	1-566-530-11	CONNECTOR, FPC (ZIF) 14P		L304	1-412-002-31	INDUCTOR CHIP 4.7uH	
* CN701	1-695-320-51	PIN, CONNECTOR (1.5MM) (SMD) 2P		L401	1-414-398-11	INDUCTOR 10uH	
* CN702	1-695-320-31	PIN, CONNECTOR (1.5MM) (SMD) 2P		L402	1-414-404-11	INDUCTOR 100uH	
* CN703	1-695-320-21	PIN, CONNECTOR (1.5MM) (SMD) 2P		L502	1-414-398-11	INDUCTOR 10uH	
		< DIODE >		L504	1-414-398-11	INDUCTOR 10uH	
D101	8-719-420-90	DIODE MA8051-M		L506	1-414-398-11	INDUCTOR 10uH	
D105	8-719-039-99	DIODE UMZ8.2T		L507	1-414-398-11	INDUCTOR 10uH	
D201	8-719-420-90	DIODE MA8051-M		L701	1-414-402-11	INDUCTOR 47uH	
D205	8-719-039-99	DIODE UMZ8.2T		L702	1-414-402-11	INDUCTOR 47uH	
D302	8-719-420-90	DIODE MA8051-M		L801	1-412-002-31	INDUCTOR CHIP 4.7uH (D-175)	
D401	8-719-048-98	DIODE RB160L-40TE25					
D403	8-719-049-10	DIODE 1SS374-TE85L					
D404	8-719-800-76	DIODE 1SS226					
D407	8-719-938-72	DIODE SB01-05CP					

Ref. No.	Part No.	Description	Remark	Ref. No.	Part No.	Description	Remark
		< LIQUID CRYSTAL DISPLAY >					
LCD801	1-801-544-11	DISPLAY PANEL, LIQUID CRYSTAL		R418	1-216-864-11	METAL CHIP 0	5% 1/16W
				R419	1-216-849-11	METAL CHIP 220K	5% 1/16W
				R421	1-216-833-11	METAL CHIP 10K	5% 1/16W
				R429	1-218-895-11	METAL GLAZE 100K	0.50% 1/16W
		< TRANSISTOR >		R430	1-218-883-11	METAL GLAZE 33K	0.50% 1/16W
Q101	8-729-231-74	TRANSISTOR 2SC4116-GL		R431	1-216-864-11	METAL CHIP 0	5% 1/16W
Q201	8-729-231-74	TRANSISTOR 2SC4116-GL		R432	1-218-907-11	METAL GLAZE 330K	0.50% 1/16W
Q302	8-729-907-39	TRANSISTOR IMD2		R501	1-216-864-11	METAL CHIP 0	5% 1/16W
Q401	8-729-320-66	TRANSISTOR 2SD1870		R502	1-216-829-11	METAL CHIP 4.7K	5% 1/16W
Q402	8-729-923-40	TRANSISTOR 2SD1963-T101-R		R503	1-216-829-11	METAL CHIP 4.7K	5% 1/16W
Q404	8-729-921-93	TRANSISTOR 2SB1182F5-QR		R504	1-216-839-11	METAL CHIP 33K	5% 1/16W
Q405	8-729-920-85	TRANSISTOR 2SD1664-QR		R505	1-216-142-00	METAL GLAZE 4.7	5% 1/8W
Q488	8-729-028-92	TRANSISTOR DTA144TUA-T106		R506	1-216-833-11	METAL CHIP 10K	5% 1/16W
Q501	8-729-216-22	TRANSISTOR 2SA1162-G		R507	1-216-829-11	METAL CHIP 4.7K	5% 1/16W
Q504	8-729-029-06	TRANSISTOR DTC124EUA-T106		R508	1-216-829-11	METAL CHIP 4.7K	5% 1/16W
Q505	8-729-028-87	TRANSISTOR DTA143TUA-T106		R509	1-216-835-11	METAL CHIP 15K	5% 1/16W
Q507	8-729-028-74	TRANSISTOR DTA114TUA-T106		R510	1-216-821-11	METAL CHIP 1K	5% 1/16W
Q508	8-729-028-97	TRANSISTOR DTC114TUA-T106		R511	1-216-829-11	METAL CHIP 4.7K	5% 1/16W
Q566	8-729-028-87	TRANSISTOR DTA143TUA-T106		R512	1-216-832-11	METAL CHIP 8.2K	5% 1/16W
Q801	8-729-231-74	TRANSISTOR 2SC4116-GL (D-175)		R513	1-216-843-11	METAL CHIP 68K	5% 1/16W
Q809	8-729-231-74	TRANSISTOR 2SC4116-GL		R514	1-216-845-11	METAL CHIP 100K	5% 1/16W
		< RESISTOR >		R517	1-216-833-11	METAL CHIP 10K	5% 1/16W
R101	1-216-813-11	METAL CHIP 220	5% 1/16W	R518	1-216-845-11	METAL CHIP 100K	5% 1/16W
R102	1-216-845-11	METAL CHIP 100K	5% 1/16W	R519	1-216-831-11	METAL CHIP 6.8K	5% 1/16W
R103	1-216-825-11	METAL CHIP 2.2K	5% 1/16W	R520	1-218-871-11	METAL GLAZE 10K	0.50% 1/16W
R105	1-216-821-11	METAL CHIP 1K	5% 1/16W	R521	1-216-827-11	METAL CHIP 3.3K	5% 1/16W
R106	1-216-825-11	METAL CHIP 2.2K	5% 1/16W	R522	1-216-857-11	METAL CHIP 1M	5% 1/16W
R107	1-216-789-11	METAL CHIP 2.2	5% 1/16W	R523	1-216-833-11	METAL CHIP 10K	5% 1/16W
R201	1-216-813-11	METAL CHIP 220	5% 1/16W	R524	1-218-871-11	METAL GLAZE 10K	0.50% 1/16W
R202	1-216-845-11	METAL CHIP 100K	5% 1/16W	R525	1-216-817-11	METAL CHIP 470	5% 1/16W
R203	1-216-825-11	METAL CHIP 2.2K	5% 1/16W	R528	1-216-829-11	METAL CHIP 4.7K	5% 1/16W
R205	1-216-821-11	METAL CHIP 1K	5% 1/16W	R529	1-216-837-11	METAL CHIP 22K	5% 1/16W
R206	1-216-825-11	METAL CHIP 2.2K	5% 1/16W	R530	1-216-825-11	METAL CHIP 2.2K	5% 1/16W
R207	1-216-789-11	METAL CHIP 2.2	5% 1/16W	R531	1-216-833-11	METAL CHIP 10K	5% 1/16W
R301	1-216-864-11	METAL CHIP 0	5% 1/16W	R532	1-218-877-11	METAL GLAZE 18K	0.50% 1/16W
R302	1-216-864-11	METAL CHIP 0	5% 1/16W	R533	1-216-841-11	METAL CHIP 47K	5% 1/16W
R303	1-216-797-11	METAL CHIP 10	5% 1/16W	R535	1-216-829-11	METAL CHIP 4.7K	5% 1/16W
R304	1-216-803-11	METAL CHIP 33	5% 1/16W	R536	1-216-845-11	METAL CHIP 100K	5% 1/16W
R306	1-216-864-11	METAL CHIP 0	5% 1/16W	R537	1-216-851-11	METAL CHIP 330K	5% 1/16W
R307	1-216-864-11	METAL CHIP 0	5% 1/16W	R539	1-216-857-11	METAL CHIP 1M	5% 1/16W
R308	1-216-864-11	METAL CHIP 0	5% 1/16W	R540	1-216-833-11	METAL CHIP 10K	5% 1/16W
R310	1-216-142-00	METAL GLAZE 4.7	5% 1/8W	R542	1-216-827-11	METAL CHIP 3.3K	5% 1/16W
R311	1-216-845-11	METAL CHIP 100K	5% 1/16W	R545	1-216-849-11	METAL CHIP 220K	5% 1/16W
R312	1-216-815-11	METAL CHIP 330	5% 1/16W	R549	1-216-833-11	METAL CHIP 10K	5% 1/16W
R401	1-218-907-11	METAL GLAZE 330K	0.50% 1/16W	R550	1-216-864-11	METAL CHIP 0	5% 1/16W
R402	1-218-887-11	METAL GLAZE 47K	0.50% 1/16W	R551	1-216-864-11	METAL CHIP 0	5% 1/16W
R403	1-216-823-11	METAL CHIP 1.5K	5% 1/16W	R552	1-216-864-11	METAL CHIP 0	5% 1/16W
R404	1-216-799-11	METAL CHIP 15	5% 1/16W	R553	1-216-864-11	METAL CHIP 0	5% 1/16W
R405	1-216-809-11	METAL CHIP 100	5% 1/16W	R554	1-218-879-11	METAL GLAZE 22K	0.50% 1/16W
R406	1-216-138-00	METAL CHIP 3.3	5% 1/8W	R566	1-216-845-11	METAL CHIP 100K	5% 1/16W
R408	1-216-811-11	METAL CHIP 150	5% 1/16W	R567	1-216-841-11	METAL CHIP 47K	5% 1/16W
R409	1-216-837-11	METAL CHIP 22K	5% 1/16W	R569	1-216-841-11	METAL CHIP 47K	5% 1/16W
R410	1-216-857-11	METAL CHIP 1M	5% 1/16W	R570	1-216-845-11	METAL CHIP 100K	5% 1/16W
R413	1-216-845-11	METAL CHIP 100K	5% 1/16W	R571	1-216-845-11	METAL CHIP 100K	5% 1/16W
R414	1-216-845-11	METAL CHIP 100K	5% 1/16W	R572	1-216-821-11	METAL CHIP 1K	5% 1/16W
R415	1-216-815-11	METAL CHIP 330	5% 1/16W	R599	1-216-847-11	METAL CHIP 150K	5% 1/16W
R416	1-216-134-00	METAL CHIP 2.2	5% 1/8W	R702	1-216-825-11	METAL CHIP 2.2K	5% 1/16W
R417	1-216-134-00	METAL CHIP 2.2	5% 1/8W	R706	1-216-847-11	METAL CHIP 150K	5% 1/16W
				R801	1-216-821-11	METAL CHIP 1K	5% 1/16W (D-175)

MAIN

Ref. No.	Part No.	Description	Remark
R802	1-216-833-11	METAL CHIP 10K 5%	1/16W
R803	1-216-821-11	METAL CHIP 1K 5%	1/16W
R804	1-216-854-11	METAL CHIP 560K 5%	1/16W (D-175)
R805	1-216-861-11	METAL CHIP 2.2M 5%	1/16W (D-175)
R806	1-216-821-11	METAL CHIP 1K 5%	1/16W
R807	1-216-821-11	METAL CHIP 1K 5%	1/16W
R808	1-216-851-11	METAL CHIP 330K 5%	1/16W
R813	1-216-833-11	METAL CHIP 10K 5%	1/16W
R817	1-216-821-11	METAL CHIP 1K 5%	1/16W
R818	1-216-857-11	METAL CHIP 1M 5%	1/16W
< VARIABLE RESISTOR >			
RV301	1-225-226-11	RES. VAR, CARBON 10K/10K (VOLUME)	
RV501	1-223-586-11	RES. ADJ. CARBON 10K (TRACKING BALANCE)	
RV502	1-223-587-11	RES. ADJ. CARBON 22K (TRACKING GAIN)	
RV503	1-223-587-11	RES. ADJ. CARBON 22K (FOCUS GAIN)	
< SWITCH >			
S301	1-572-922-11	SWITCH, SLIDE (AVLS)	
S801	1-762-822-11	SWITCH, PUSH (1 KEY) (DOOR OPEN/CLOSE)	
S802	1-762-455-21	SWITCH, PUSH (1 KEY) (RECHARGEABLE BATT DETECT)	
S803	1-553-977-00	SWITCH, SLIDE (RESUME) (D-175)	
S804	1-572-922-11	SWITCH, SLIDE (HOLD \rightarrow)	
S805	1-692-014-11	SWITCH, KEY BOARD (PLAY MODE)	
S808	1-692-014-11	SWITCH, KEY BOARD (■)	
S809	1-692-014-11	SWITCH, KEY BOARD (REPEAT/ENTER)	
S810	1-692-014-11	SWITCH, KEY BOARD (◀▶)	
S811	1-692-014-11	SWITCH, KEY BOARD (▶▶)	
S812	1-692-014-11	SWITCH, KEY BOARD (▶▶)	
S813	1-554-088-00	SWITCH, KEY BOARD (DIGITAL MEGA BASS)	
< TRANSFORMER >			
T401	1-429-951-11	TRANSFORMER, DC/DC CONVERTER	
< VIBRATOR >			
X301	1-760-307-11	VIBRATOR, CERAMIC (16.9MHz)	
X801	1-577-101-11	VIBRATOR, CERAMIC (4.1943MHz)	

MISCELLANEOUS *****			
53	1-690-530-21	LEAD (WITH CONNECTOR)	
58	1-660-965-11	PC BOARD, SLIDE FLEXIBLE	
△59	X-4946-311-1	OPTICAL PICK-UP (DAX-11A)	
LCD801	1-801-544-11	DISPLAY PANEL, LIQUID CRYSTAL	
M901	A-3303-403-A	MOTOR ASSY, SLED	

Ref. No.	Part No.	Description	Remark
M902	A-3303-971-A	MOTOR ASSY, TURNTABLE (SPINDLE)	
S901	1-571-099-21	SWITCH (1 KEY) (LIMIT)	

ACCESSORIES& PACKING MATERIALS *****			
△	1-467-007-21	ADAPTOR, AC (AC-E455) (AUS)	
△	1-467-009-11	ADAPTOR, AC (AC-E455) (US,CND,C&SA)	
△	1-467-012-11	ADAPTOR, AC (AC-E455) (EA)	
△	1-467-550-11	ADAPTOR, AC (AC-E455A) (E33)	
△	1-473-115-11	ADAPTOR, AC (AC-E455D) (D-171/D-173/D-175:UK)	
△	1-473-116-31	ADAPTOR, AC (AC-E455D) (D-171/D-173/D175:AEP,E13,CH,D-171V/ D-172CK:E13,CH)	
	1-528-444-11	BATTERY PACK (BP-DM10) (D-173:CND,E,AUS,CH,D-175:E13,E33,CH)	
	1-528-444-31	BATTERY PACK (BP-DM10) (US)	
	1-528-444-81	BATTERY PACK (BP-DM10) (D-173/D-175:AEP,UK)	
	1-532-433-11	FUSE, GLASS TUBE (1A) (D-172CK:EXEPT EA)	
	1-559-906-32	CORD, CONNECTION (EXEPT D-170AN/D-172CK:AEP,UK,D-175:JE)	
△	1-569-007-11	ADAPTOR, CONVERSION 2P (E33,D-170AN:JE,172CK:CH)	
△	1-569-008-11	ADAPTOR, CONVERSION 2P (E13,EA,D-171/D-173/D-175:CH)	
	2-201-810-00	TAPE, MAGIC (D-172CK:EXCEPT EA)	
	3-810-764-11	MANUAL, INSTRUCTION (SPANISH) (D-172CK:E33,C&SA)	
	3-810-764-21	MANUAL, INSTRUCTION (ENGLISH) (D-172CK:EXCEPT EA)	
	3-810-764-31	MANUAL, INSTRUCTION (FRENCH) (D-172CK:CND)	
	3-810-764-41	MANUAL, INSTRUCTION (DUTCH) (D-172CK:AEP)	
	3-810-764-51	MANUAL, INSTRUCTION (SWEDISH) (D-172CK:AEP)	
	3-810-764-61	MANUAL, INSTRUCTION (PORTUGUESE) (D-172CK:AEP)	
	3-810-764-71	MANUAL, INSTRUCTION (GERMAN) (D-172CK:AEP)	
	3-810-764-81	MANUAL, INSTRUCTION (ITALIAN) (D-172CK:AEP)	
	3-856-478-11	MANUAL, INSTRUCTION (CHINESE) (D-172CK:E13)	
	3-856-478-21	MANUAL, INSTRUCTION (ENGLISH) (D-172CK:E13)	
	3-859-280-01	MANUAL, INSTRUCTION (ENGLISH,JAPANESE) (JE)	
	3-859-280-11	MANUAL, INSTRUCTION (SPANISH) (AEP,E33,C&SA,JE)	
	3-859-280-21	MANUAL, INSTRUCTION (ENGLISH) (CND,AEP,UK,E33,C&SA,AUS,JE,EA)	
	3-859-280-31	MANUAL, INSTRUCTION (FRENCH) (CND,AEP,JE)	
	3-859-280-41	MANUAL, INSTRUCTION (DUTCH) (AEP)	
	3-859-280-51	MANUAL, INSTRUCTION (SWEDISH) (AEP)	
	3-859-280-61	MANUAL, INSTRUCTION (PORTUGUESE) (AEP)	

The components identified by mark △ or dotted line with mark △ are critical for safety. Replace only with part number specified.	Les composants identifiés par une marque △ sont critiques pour la sécurité. Ne les remplacer que par une pièce portant le numéro spécifié.
---	---

Ref. No.	Part No.	Description	Remark
	3-859-280-71	MANUAL, INSTRUCTION (GERMAN) (AEP)	
	3-859-280-81	MANUAL, INSTRUCTION (ITALIAN) (AEP)	
	3-859-280-91	MANUAL, INSTRUCTION (CHINESE) (JE)	
	3-859-281-11	MANUAL, INSTRUCTION (CHINESE) (CH)	
	3-859-281-21	MANUAL, INSTRUCTION (E13,CH) (ENGLISH)	
	3-859-282-11	MANUAL, INSTRUCTION (JE) (KOREAN)	
	8-916-813-90	CORD,CAR BATTERY DCC-E2455 (D-172CK:EXCEPT AEP,UK)	
	8-917-547-90	REMOTE COMMANDER,SONY RM-DM23 (D-170AN:JE,D175)	
	8-951-804-90	PACK, CAR CONNECTING CPA-7 SET (D-172CK:C&SA)	
	8-951-804-92	CD ACCESSORY CPA-7//C1 (D-172CK:CND,E33,AUS)	
	8-951-814-90	PLATE, MOUNT CPM-401P SET (D-172CK:EXCEPT EA,CH)	
	8-953-342-93	HEADPHONE MDR-24/K1 SET (US)	
	8-953-537-90	HEADPHONE MDR-E741MP//K3 SET (D-170AN:JE,D-175)	
	8-953-538-90	HEADPHONE MDR-E741//K2 SET (D-170AN:AEP,UK,D-171/D-172CK/D-173:EXCEPT US)	
	8-953-546-91	HEADPHONE MDR-E741V//K SET (D-171V)	

HARDWARE LIST			

#1	7-627-850-17	SCREW,PRECISION +P 1.4X2.5	

D-170AN/171/171V/172CK/173/175

SONY.

SERVICE MANUAL

US Model

D-173

Canadian Model

Australian Model

D-171/172CK/173

AEP Model

D-170AN/171/171V/172CK/173/175

UK Model

D-170AN/171/172CK/173/175

E Model

D-171/172CK/173/175

Chinese Model

D-171/172CK/173/175

Tourist Model

D-170AN/175

SUPPLEMENT - 1

File this Supplement with the Service Manual.

Subject :

- **ADDITION OF METALLIC BLUE AND METALLIC GREEN MODEL FOR D-173 (Australian) MODEL.**

(ECN-CD750337)

The color of D-173 (Australian) model was originally gray, but a metallic blue and a metallic green model has been added.

Consequently, added parts are listed for new type.

Refer to original service manual previously issued for the other information.

Page	Ref. No.	Part No.	Description
27	8	X-4948-911-1	LID ASSY, UPPER (METALLIC BLUE)
		X-4948-912-1	LID ASSY, UPPER (METALLIC GREEN)

D-170AN/171/171V/ 172CK/173/175

SONY. SERVICE MANUAL

US Model
D-173

Canadian Model
Australian Model
D-171/172CK/173

AEP Model
D-170AN/171/171V/172CK/173/175

UK Model
D-170AN/171/172CK/173/175

E Model
D-171/172CK/173/175

Chinese Model
D-171/172CK/173/
175

Tourist Model
D-170AN/175

SUPPLEMENT - 2

File this Supplement with the Service Manual.

Subject :
● CHANGE OF MAIN BOARD.
● CORRECTION

(ECN-CD750459)

● CHANGE OF MAIN BOARD

The main board have been changed.
Printed wiring board and schematic diagram of new type, and changed parts list are described in this Supplement-2.
Refer to original service manual (9-923-149-11), and Supplement-1 (9-923-149-81) previously issued for the other information.

NEW TYPE IDENTIFICATION

[MAIN BOARD] (Side B)

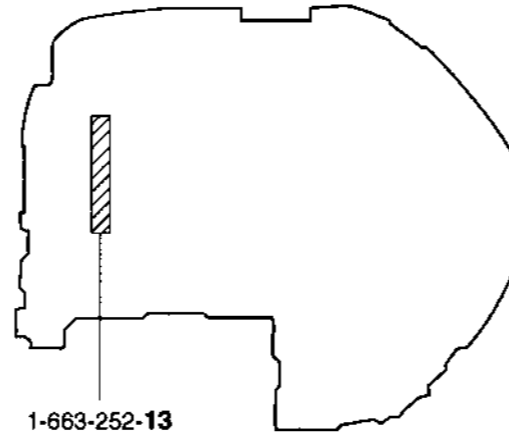

● CHANGE OF ELECTRICAL PARTS LIST

MAIN (Service Manual See page 29 to 32)

Ref. No.	Former Type					New type					Remark
	Part No.	Description				Part No.	Description				
C309	1-126-783-11	ELECT	22uF	20%	10V	1-126-794-11	ELECT	4.7uF	20%	50V	Changed
C330	1-107-826-11	CERAMIC CHIP	0.1uF	10%	16V						Deleted
C507	1-135-201-11	TANTALUM CHIP	10uF	20%	4V						Deleted
C508	1-163-038-91	CERAMIC CHIP	0.1uF		25V						Deleted
C513	1-163-809-11	CERAMIC CHIP	0.047uF	10%	25V						Deleted
C522	1-107-826-11	CERAMIC CHIP	0.1uF	10%	16V	1-216-833-11	METAL CHIP	10K	5%	1/16W	Changed
C533						1-164-004-11	CERAMIC CHIP	0.1uF	10%	25V	Added
C535						1-164-346-11	CERAMIC CHIP	1uF		16V	Added
C562	1-162-970-11	CERAMIC CHIP	0.01uF	10%	25V	1-165-176-11	CERAMIC CHIP	0.047uF	10%	16V	Changed
C570	1-164-360-11	CERAMIC CHIP	0.1uF		16V						Deleted
C709	1-162-953-11	CERAMIC CHIP	100PF	5%	50V	1-162-962-11	CERAMIC CHIP	470PF	10%	50V	Changed
C712	1-162-966-11	CERAMIC CHIP	0.0022uF	10%	50V	1-162-962-11	CERAMIC CHIP	470PF	10%	50V	Changed
C715						1-164-346-11	CERAMIC CHIP	1uF		16V	Added
C805	1-124-257-00	ELECT	2.2uF	20%	50V						Deleted
C806	1-113-677-11	CERAMIC CHIP	1uF		25V	1-164-337-11	CERAMIC CHIP	2.2uF		16V	Changed
C903	1-216-864-11	METAL CHIP	0	5%	1/16W	1-216-864-11	METAL CHIP	0	5%	1/16W	Changed (D-175)
D806						8-719-420-90	DIODE	MA8051-M			Added (D-175)
IC401	8-759-450-67	IC	SC111285BVMEL			8-759-474-73	IC	MPC1825B/SC285BVMEL			Changed
IC502	8-759-455-04	IC	BU9320BKS			8-759-474-74	IC	BU9321BKS			Changed
Q504	8-729-029-06	TRANSISTOR	DTC124EUA-T106								Deleted
Q505	8-729-028-87	TRANSISTOR	DTA143TUA-T106								Deleted
Q566	8-729-028-87	TRANSISTOR	DTA143TUA-T106								Deleted
R514	1-216-845-11	METAL CHIP	100K	5%	1/16W						Deleted
R519	1-216-831-11	METAL CHIP	6.8K	5%	1/16W	1-216-827-11	METAL CHIP	3.3K	5%	1/16W	Changed
R523	1-216-833-11	METAL CHIP	10K	5%	1/16W	1-107-826-11	CERAMIC CHIP	0.1uF	10%	16V	Changed
R526						1-216-864-11	METAL CHIP	0	5%	1/16W	Added
R546						1-216-825-11	METAL CHIP	2.2K	5%	1/16W	Added
R547						1-216-845-11	METAL CHIP	100K	5%	1/16W	Added
R566	1-216-845-11	METAL CHIP	100K	5%	1/16W	1-216-864-11	METAL CHIP	0	5%	1/16W	Changed
R567	1-216-841-11	METAL CHIP	47K	5%	1/16W						Deleted
R570	1-216-845-11	METAL CHIP	100K	5%	1/16W	1-216-837-11	METAL CHIP	22K	5%	1/16W	Changed
R571	1-216-845-11	METAL CHIP	100K	5%	1/16W	1-216-837-11	METAL CHIP	22K	5%	1/16W	Changed
R815						1-216-857-11	METAL CHIP	1M	5%	1/16W	Added
R817						1-216-821-11	METAL CHIP	1K	5%	1/16W	Added

● CORRECTION

MAIN (Service Manual See page 30)

Ref. No.	INCORRECT			CORRECT		
	Part No.	Description		Part No.	Description	
IC801	8-759-462-34	IC	MC68HC05L15SC442705CPB	8-759-462-33	IC	MC68HC05L15SC442704CPB

PRINTED WIRING BOARDS

• SEMICONDUCTOR LOCATION

Ref. No.	Location
D101	G-17
D105	F-12
D201	H-17
D205	F-12
D302	H-17
D401	F-14
D403	E-13
D404	E-14
D407	C-14
D409	D-15
D414	F-14
D502	C-16
D801	H-18
D803	H-5
D804	F-12
D806	H-17
IC301	F-4
IC302	G-4
IC401	D-14
IC501	B-4
IC502	D-16
IC503	B-15
IC504	B-13
IC801	E-19
Q101	F-9
Q201	F-9
Q302	F-6
Q401	E-13
Q402	E-13
Q404	E-14
Q405	D-9
Q488	C-19
Q501	B-18
Q507	C-3
Q508	B-17
Q801	H-17
Q809	D-18

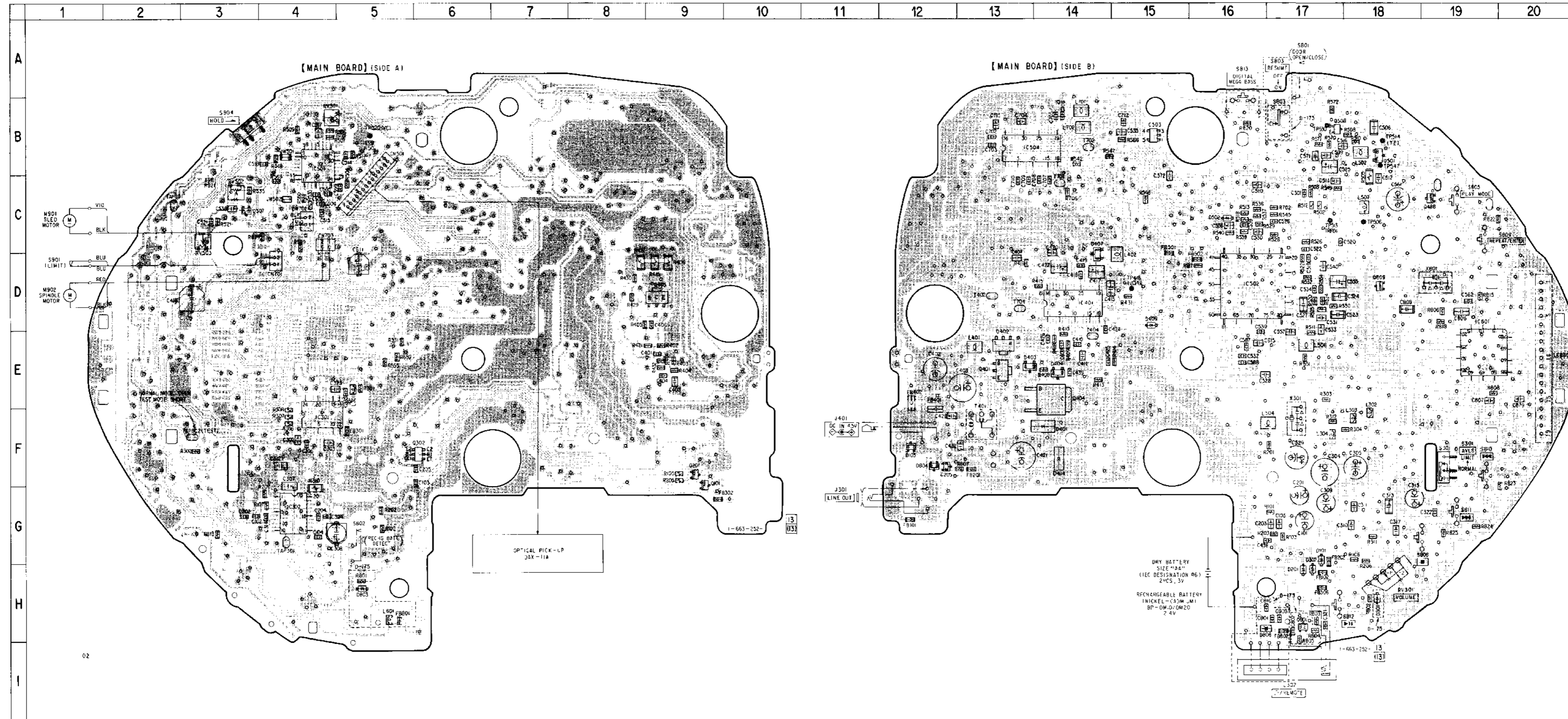

Note:
 • — : parts extracted from the component side.
 • ○ : Through hole.
 • : Pattern on the side which is seen.

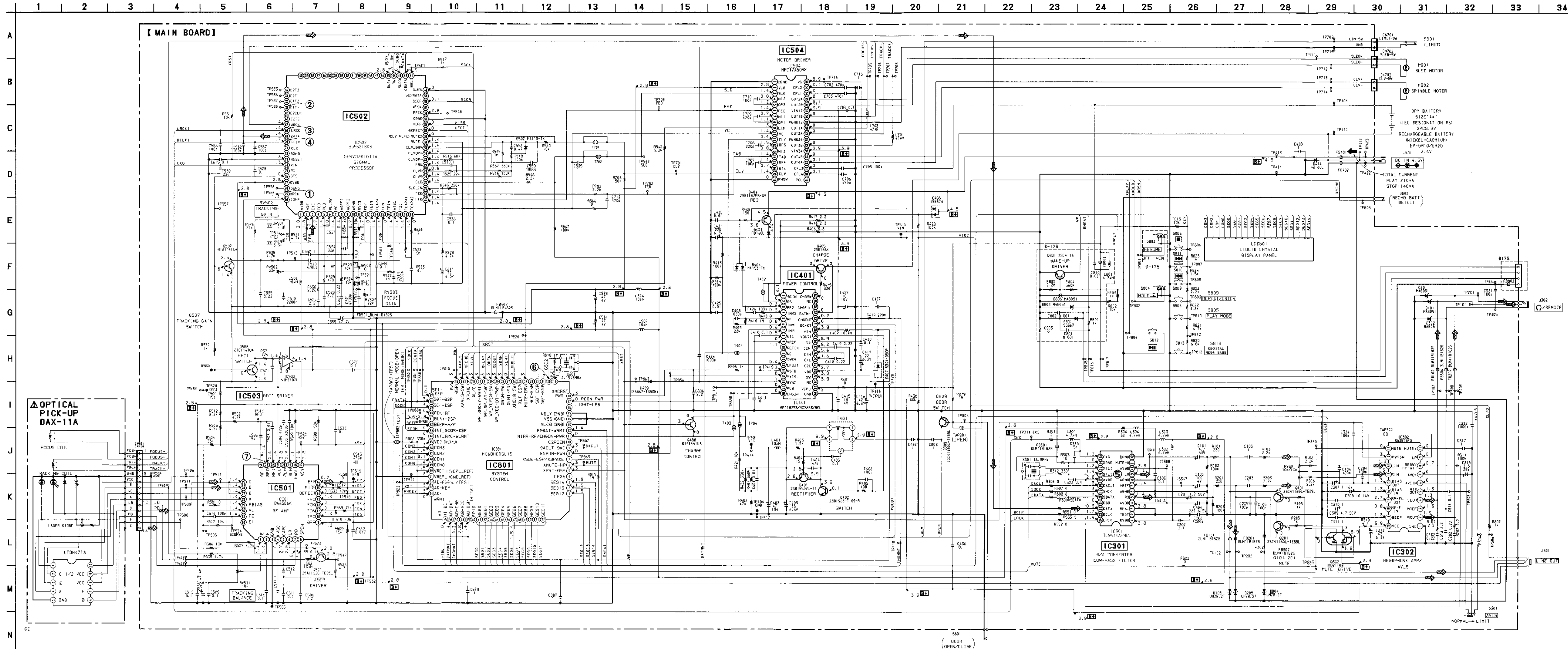

WAVEFORMS

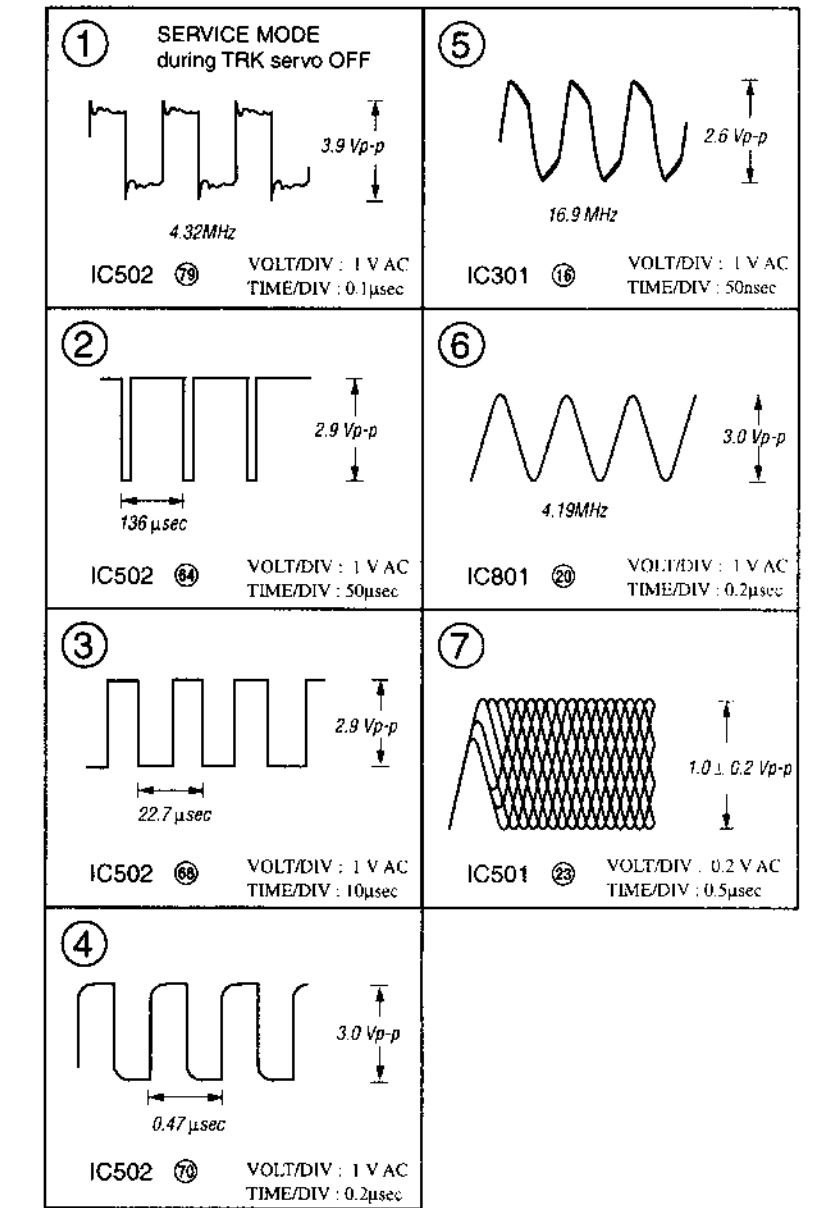

Note:
 • All capacitors are in µF unless otherwise noted. pF, µF, 50WV or less are not indicated except for electrolytics and tantalums.
 • All resistors are in Ω and 1/4W or less unless otherwise specified.
 • Δ: Internal component.

Note:
 The components identified by mark Δ, or dotted line with mark Δ are critical for safety. Replace only with part number specified.

Note:
 Les composants identifiés par une marque Δ sont critiques pour la sécurité. Ne les remplacer que par une pièce portant le numéro spécifié.

- [B +]: B+ Line
- []: adjustment for repair.
- Power voltage is dc 4.5 V and fed with regulated dc power supply from external power voltage jack (J401).
- Voltage and waveforms are dc with respect to ground under no-signal conditions.
- () : PLAY
- () : STOP
- Voltages are taken with a VOM (Input impedance 10MΩ). Voltage variations may be noted due to normal production tolerances.
- Waveforms are taken with an oscilloscope. Voltage variations may be noted due to normal production tolerances.
- Circled numbers refer to waveforms.
- Signal path.
- CD