

D-66

SERVICE MANUAL

*US Model
Canadian Model
AEP Model
UK Model
E Model
Australian Model*

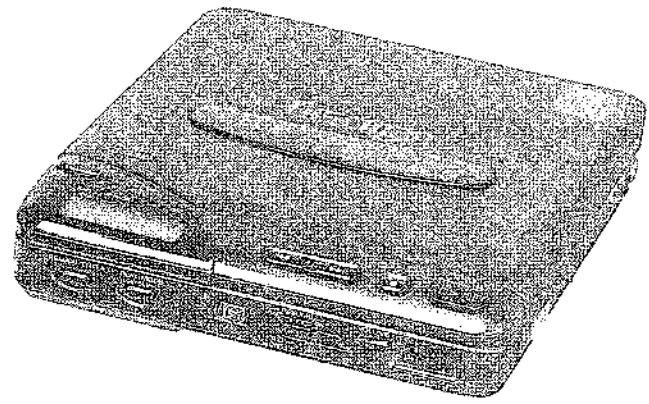

Discman

Model Name Using Similar Mechanism	New
CD Mechanism Type	CDM-66

SPECIFICATIONS

CD section

System Compact disc digital audio system
 Laser diode properties Material: GaAlAs
 Wavelength: 780 nm
 Emission duration: Continuous
 Laser output: Max. 44.6 μ W*
 * This output is the value measured at a distance of 200 mm from the objective lens surface on the Optical Pick-up Block.

Spindle speed 500 r.p.m. to 200 r.p.m. (CLV)
 Scan velocity 1.2 - 1.4 m/sec.
 Error correction Sony Super Strategy Cross Interleave Reed Solomon Code

D-A conversion 16-bit linear 8 fs digital filter
 Frequency response 20 - 20,000 Hz \pm 1dB
 Wow and flutter Below measurable limit**
 Outputs (at 6 V input level)
 Line output (stereo minijack)
 Output level 0.6 V rms at 50 kilohms
 Load impedance over 10 kilohms
 Headphones (stereo minijack)
 9 mW + 9 mW at 16 ohms

** Measured by EIAJ CP-307

General

Power requirements Rechargeable battery pack BP-2EX (supplied)
 Battery case EBP-2 (supplied) and two size AA (LR6) alkaline batteries (not supplied)
 DC IN 6 V jack accepts:
 Sony AC power adaptor (supplied) for use on 120 V AC, 60 Hz
 Sony CPM-200P mount plate for use on 12 V car battery (not supplied)

Power consumption 1.4 W DC

Dimensions Approx. 128 x 30.2 x 145 mm
 (5 1/8 x 1 1/4 x 5 3/4 in.) (w/h/d)
 not incl. Inclined part (depth), projecting parts and controls
 Approx. 130 x 31.5 x 146 mm
 (5 1/8 x 1 1/4 x 5 3/4 in.) incl. projecting parts and controls

Weight Approx. 310 g (11 oz) not incl. rechargeable battery
 Approx. 395 g (14 oz) incl. rechargeable battery

Supplied accessories AC power adaptor (1)
 Rechargeable battery pack (1)
 Hand strap (1)
 Connecting cord (1) (stereo miniplug \leftrightarrow two phono plugs)
 Battery case (1)
 Headphones (1)

For the Customers in the United Kingdom and European Countries

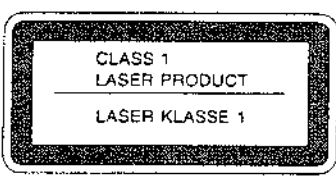

This Compact Disc player is classified as a CLASS 1 LASER product. The CLASS 1 LASER PRODUCT label is located on the bottom exterior.

Design and specifications subject to change without notice.

CAUTION
 Use of controls or adjustments or performance of procedures other than those specified herein may result in hazardous radiation exposure.

COMPACT DISC COMPACT PLAYER

SONY®

SECTION 1
GENERAL



TABLE OF CONTENTS

Section	Title	Page
Specifications		1
1. GENERAL		2
2. SERVICING NOTES		3
	Before Replacing the Optical Block	3
	Note on Laser Diode Emission Check	4
	Laser Diode Check Procedure	4
	Service Mode (service program)	4
3. ELECTRICAL ADJUSTMENTS		5
4. DIAGRAMS		
	4-1. Block Diagrams	8
	4-2. PC Board/Switch/Motor Layouts	10
	4-3. Semiconductor Lead Layouts	11
	4-4. Printed Wiring Boards	12
	4-5. Schematic Diagrams	17
	4-6. IC Block Diagrams	20
5. EXPLODED VIEWS		22
6. ELECTRICAL PARTS LIST		24

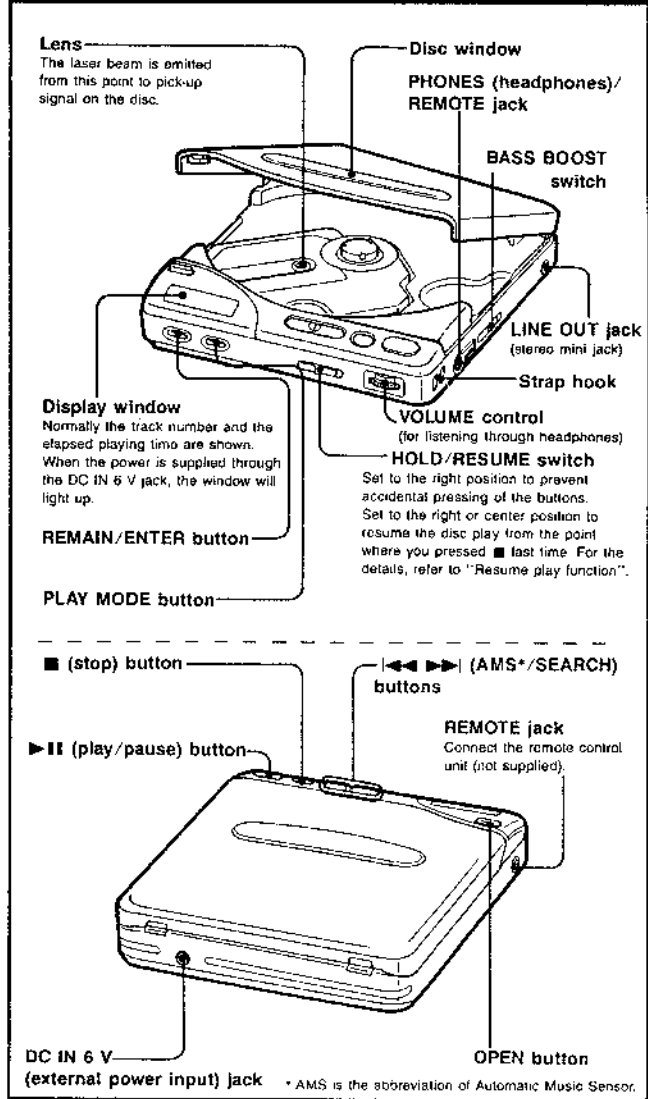
Location and Function of Controls



SAFETY-RELATED COMPONENT WARNING!!

COMPONENTS IDENTIFIED BY MARK  OR DOTTED LINE WITH MARK  ON THE SCHEMATIC DIAGRAMS AND IN THE PARTS LIST ARE CRITICAL TO SAFE OPERATION. REPLACE THESE COMPONENTS WITH SONY PARTS WHOSE PART NUMBERS APPEAR AS SHOWN IN THIS MANUAL OR IN SUPPLEMENTS PUBLISHED BY SONY.

ATTENTION AU COMPOSANT AYANT RAPPORT À LA SÉCURITÉ!

LES COMPOSANTS IDENTIFIÉS PAR UNE MARQUE  SUR LES DIAGRAMMES SCHÉMATIQUES ET LA LISTE DES PIÈCES SONT CRITIQUES POUR LA SÉCURITÉ DE FONCTIONNEMENT. NE REMPLACER CES COMPOSANTS QUE PAR DES PIÈCES SONY DONT LES NUMÉROS SONT DONNÉS DANS CE MANUEL OU DANS LES SUPPLÉMENTS PUBLIÉS PAR SONY.

SECTION 2

SERVICING NOTES

NOTES ON HANDLING THE OPTICAL PICK-UP BLOCK OR BASE UNIT

The laser diode in the optical pick-up block may suffer electrostatic breakdown because of the potential difference generated by the charged electrostatic load, etc. on clothing and the human body.

During repair, pay attention to electrostatic breakdown and also use the procedure in the printed matter which is included in the repair parts.

The flexible board is easily damaged and should be handled with care.

Before Replacing the Optical Block

Please be sure to check thoroughly the parameters as per the "Optical Block Checking Procedures" (Part No. : 9-960-027-11) issued separately before replacing the optical block. Note and specifications required to check are given below.

- FOK output : IC501⑨pin
When checking FOK, remove the lead wire to spindle motor and unsolder and open IC801②pin (FOK).
- S carve P-to-P value : 2.5Vp-p
When checking S carve P-to-P value, remove the lead wire to spindle motor.
- Adjusted part for focus gain adjustment : RV505
- RF signal P-to-P value : 0.8 - 1.35Vp-p
- Traverse signal P-to-P value : 1.8Vp-p
- The repairing grating holder is impossible.
- Adjusted part for tracking gain adjustment : RV501

Flexible Circuit Board Repairing

- Keep the temperature of the soldering iron around 270°C during repairing.
- Do not touch the soldering iron on the same conductor of the circuit board (within 3 times).
- Be careful not to apply force on the conductor when soldering or unsoldering.

Notes on chip component replacement

- Never reuse a disconnected chip component.
- Notice that the minus side of a tantalum capacitor may be damaged by heat.

NOTES ON LASER DIODE EMISSION CHECK

The laser beam on this model is concentrated so as to be focused on the disc reflective surface by the objective lens in the Optical pick-up block. Therefore, when checking the laser diode emission, observe more than 30cm away from the objective lens.

Laser Diode Check Procedure

The laser diode on this set will not emit unless the top panel is closed and S901 is turned on. The laser diode will always emit even if focus search is not performed in service mode.

Procedure 1 (service mode or normal operation)

Check the laser diode emission with the eye.

1. Open top panel.
2. Turn on S901 in Fig. 1.
(In service mode, this operation is not necessary.)
3. Press the **▶▶** key.
(In service mode, this operation is not necessary.)
4. Observe the objective lens and confirm that the laser diode is emitting light. At this time, the laser diode goes on about 10 seconds due to focus search.

Procedure 2 (service mode or normal operation)

Check by the current with flows in the laser diode.

1. Close the top panel.
2. Remove the main board and read the current value on the label affixed to the Optical pick-up block.

(Label attached to the flexible circuit board of the optical pick up.)

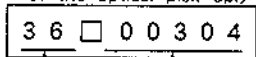

This figure shows the machine number of the optical pick up.

This figure shows the electric current value. In this case, it shows 36mA.

The electric current values differs depending on the model.

3. Connect a VOM to TP1 and TP2 (both side of R510: 10 Ω)
4. Press the **▶▶** key.
5. Calculate the current by the VOM reading.
VOM reading (V) ÷ resistance of R510 = current (A)
ex. VOM reading = 0.37V
 $0.37 \div 10 = 0.037$ (A) = 37 (mA)
6. Confirm that the ammeter reading is within the range given below.
value on label ± 5% mA (25°C)
variation relative to temperature : 0.4mA/°C
(Current increases when temperature rises and decreases when it drops.)

SERVICE MODE (service program)

• Step 1 (Service Mode setting method)

1. Turn the HOLD switch to OFF with the external power supply not plugged in (no power applied to set).
2. Press the **▶▶** key.
3. Solder jumper TEST terminal.
(IC801 pin⑧ BAT-E is grounded.)
4. Plug in external power supply.
This puts the set into service mode.

• Step 2 (Service Mode operation)

1. When service mode is set, the display will change 6 times, and those 6 changes will be repeated over and over.
Even if LCD dose not display, other operations will be performed.
2. When **▶▶** or **◀◀** key is pressed, the optical pick-up block moves to the inside or outside circumference. Tracking servo and sled servo go off when this is done, so press KEY-MODE to turn on the tracking servo if necessary.
3. When REMAIN is pressed, the display stops. When REMAIN is released, the display continues to change. This allows check of each segment.
4. When **▶▶** Key is pressed, CLV-S (pull-in mode) starts while performing focus search. When there is no disc installed, focus search is repeated with rotating disc motor.
5. When KEY-MODE is pressed, tracking servo, sled servo and CLV-A (servo during PLAY) go ON.
6. When 4 and 5 are performed, the disc begins to play. At this time, the top panel should be closed and S901 are to be ON. A sound is not produced as muting is ON.
7. All servo (focus, tracking, sled and spindle) go off when **■** key is pressed. Disc motor rotate by inertia for a some time.

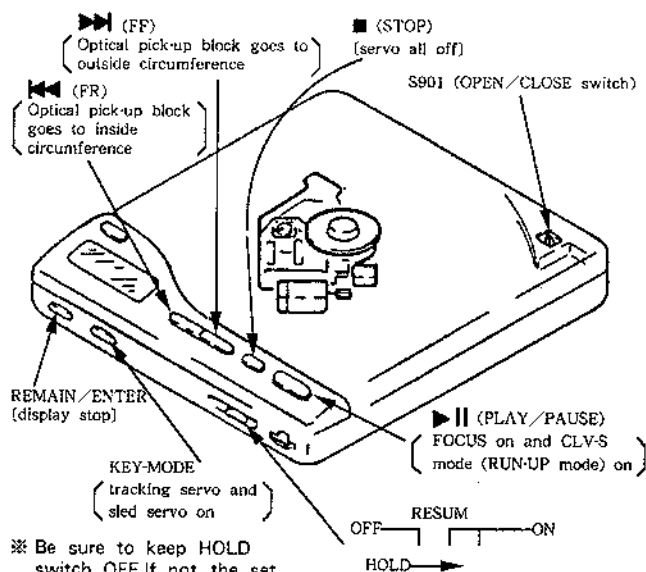

Fig.1

• Step 3 (Service Mode release)

1. First be sure to unplug the external power supply.
2. Then remove the solder jumper TEST terminal.
3. The set will now operated normally.

SECTION 3

ELECTRICAL ADJUSTMENTS

Notes on Adjustment

- Perform adjustments except for BATTERY REMAINS ADJUSTMENT in service mode.
Be sure to release service mode after completing adjustment.
(Refer to "Service Mode (service program)" on page 4.)
- Perform adjustments in the order given.
- Use YEDS-18 disc (part No. : 3-702-101-01) only indicated.
- Power supply voltage : DC 6V
HOLD switch : OFF
VOLUME knob : MIN

PREPARATION

Put the set into service mode (See page 4.) and perform the following checks.

• Sled Motor Check

- Press the OPEN button and open the top panel.
- Press the **▶▶**, **◀◀** keys and make sure that the optical pick-up block moves smoothly, without catching, from the inmost → outmost → inmost circumference.
▶▶ : UPF moves outward
◀◀ : UPF moves inward

• Focus Search Check

- Press the OPEN button and open the top panel.
- Press the **▶▶** key. (Focus search is performed continuously.)
- Observe the UPF objective lens and check that it moves smoothly up and down with no catching or noises.
- Press the **■** key.
Check that focus search operation stops. If it does not, press the **■** key again.

Recharging voltage Adjustment

Adjustment method :

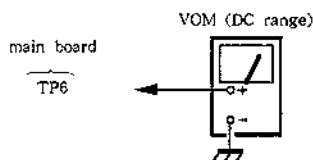

- Connect a tester to TP6 of the main circuit board.
- Apply 6V DC from the external power jack CN401.
- Adjust RV402 so that the reading of the tester becomes 4.9V - 5V.

Note : Read the value after that the read of the tester becomes clam.

+ 3.6V Adjustment

Adjustment method :

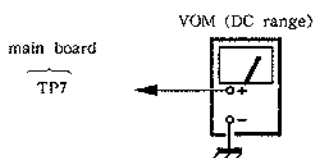

- Adjust the power voltage after applying +3.0V between the terminals of BATT (AM3).
- Set the set to the service mode stop status. (see page 4.)
- Connect a tester to TP7 of the main circuit board.
- Adjust RV403 so that the reading of the tester becomes 3.55V - 3.65V.
- After performing adjustment, release the service mode.

+ 5V Adjustment

Adjustment Procedure :

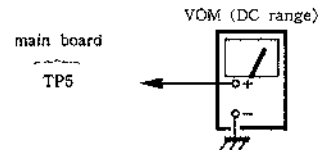

- Put the set into STOP state service mode (see page 4).
- Connect the VOM to main board test point TP5
- Adjust RV401 for $5V \pm 0.5V$ on the VOM reading.
- After adjustment, release service mode (see page 4).

Battery Remains Indication Adjustment

Adjustment procedure :

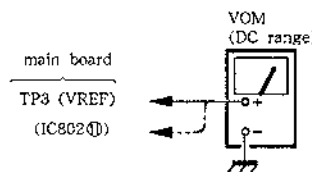

- Make sure to turn ON S401
- Apply DC 3.5V both side of battery terminal.
- Insert the disc (YEDS-18) and press the **▶▶** key.
- Adjust RV801 so that the voltage of TP4 (IC802) is the same as TP3 (V REF).

PLL Free Run Frequency Check and Adjustment

Check/Adjustment Procedure :

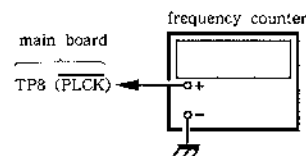

- Open the jumper terminal of Z3 (EFM).
- Connect a frequency counter to test point TP8 (PLCK) of the main circuit board.
- Set the unit to the service mode stop status. (see page 4.)
- Confirm that the reading of the frequency counter is $4.31 \pm 0.01\text{MHz}$.

If that is not the case, adjust RV504 so that the reading of the frequency counter becomes $4.31 \pm 0.01\text{MHz}$.

- After performing adjustment, release the service mode. (see page 4.)
- Short circuit the jumper terminal which was opened in step 1 above

Tracking Balance Adjustment

Conditions :

The set should be placed either horizontally.

Adjustment Procedure :

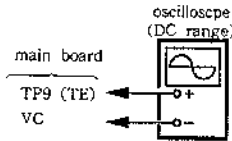

1. Connect the oscilloscope to main board TP9 (IC501①).
2. Put the set into service mode (See page 4.)
3. Press the **▶▶** and **◀◀** keys to move the UPF to the center.
4. Insert the disc (YEDS-18) and close the top panel.
5. Press the **▶▶** key.

It will go from focus search to focus on, and CLV pull-in mode state. Tracking and sled are OFF.

6. Adjust RV502 so that the oscilloscope waveform is symmetrical on the top and bottom in relation to 0V.

Note : Take sweep time as long as possible to obtain best waveform.

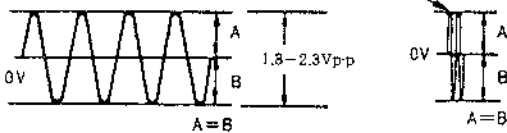

7. Unplug the external power supply to stop spindle motor from rotating.
8. After adjustment, release service mode (see page 4).

Focus Bias Adjustment

Conditions :

The set should be placed either horizontally.

Adjustment Procedure :

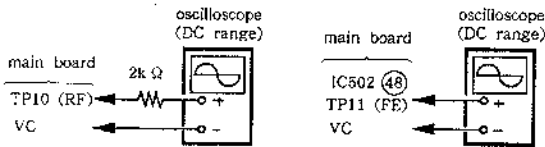

1. Put the set into STOP state in service mode (See page 4).
2. Connect the oscilloscope to main board test point TP10 (IC501④).
3. Press the **▶▶** and **◀◀** key to move the UPF to the center. (Move the UPF to the music area on the disc to enable easy visibility of the eye pattern).
4. Insert the disc (YEDS-18) and close the top panel.
5. Press the **▶▶** key.

6. Press the KEY-MODE button.
7. Adjust RV503 so that the oscilloscope waveform eye pattern is good. A good eye pattern means that the diamond shape (◊) in the center of the waveform can be clearly distinguished.

RF Signal Reference Waveform (eye pattern)

VOLT/DIV : 200mV

TIME/DIV : 500ns

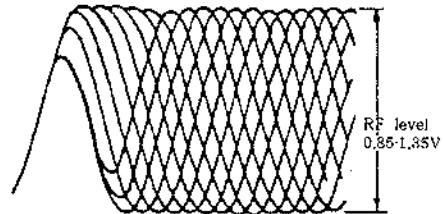

When observing the eye pattern, set the oscilloscope for AC range and raise vertical sensitivity.

8. Measure the voltage of TP11 (IC502④). (Service mode stop status)
Readjust RV503 according to the voltage range as follows :
When minimum +10mV, set to +10mV, and when less than -50mV, set to -50mV.
9. Remove the external power supply and stop the spindle motor.
10. Release the service mode.

Adjustment Parts Location Diagram

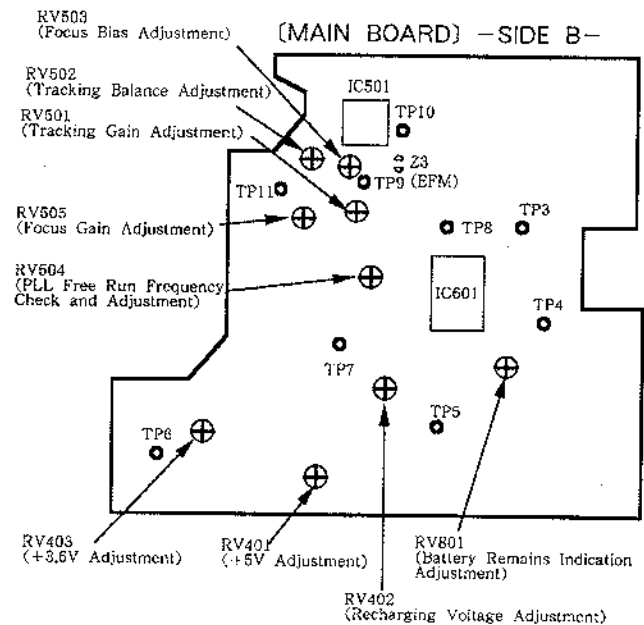

Reference

Focus/Tracking Gain Adjustment

On this set, it is very difficult to simplify this adjustment.

A frequency response analyzer or CD jig is necessary in order to perform this adjustment exactly.

However, this gain has a margin, so even if it is slightly off, there is no problem. Therefore, do not perform this adjustment.

Focus/tracking gain determines the pick-up followup (vertical and horizontal) relative to mechanical noise and mechanical shock when the 2-axis device operate.

- When gain is high, the noise when the 2-axis device operates increases.
- When gain is low, it is more susceptible to mechanical shock and skipping occurs more easily.

However, as these reciprocate, the adjustment is at the point where both are satisfied.

This adjustment is to be performed with using when replacing the following parts :

- UPF (optical pick-up block)
- RV501 (tracking gain volume)
- RV505 (focus gain volume)

CD jig connection :

Remove the solder jumpers at the TE and FE locations and connect the CD jig.

The adjustment procedure is described in the separate CD jig Instruction Manual.

Adjustment Parts Location Diagram
(MAIN BOARD) -SIDE B-

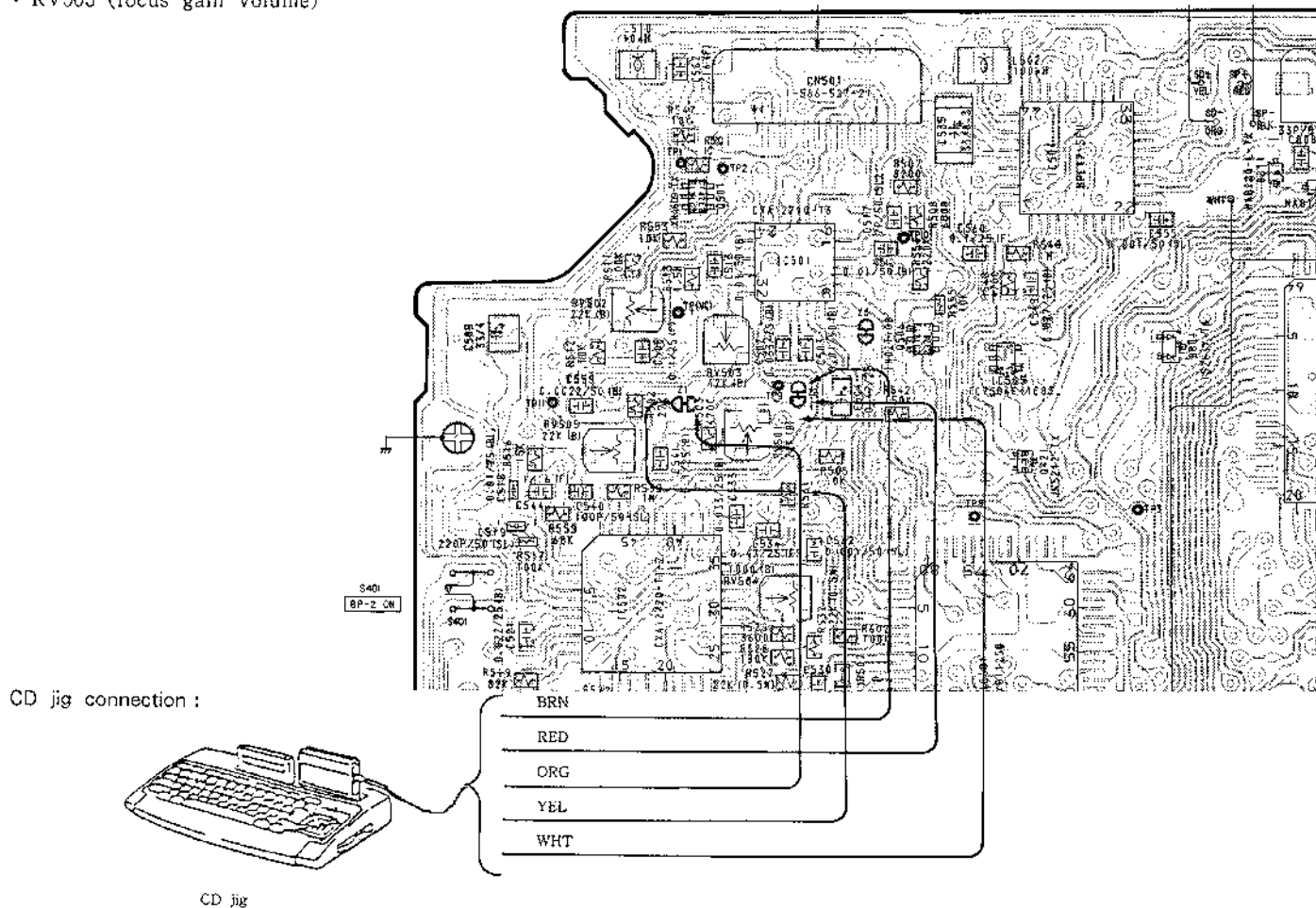
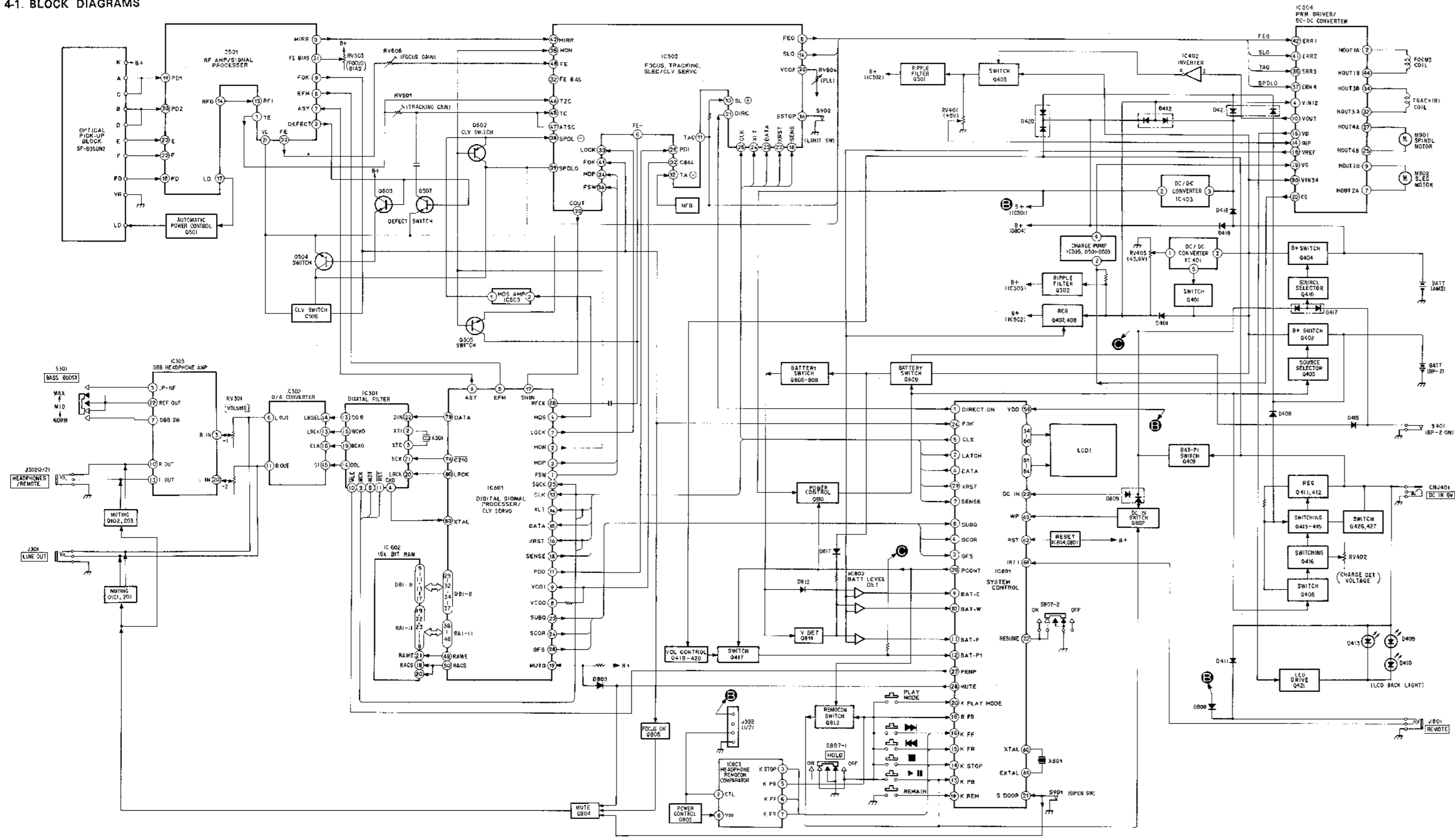

Fig.3

**SECTION 4
DIAGRAMS**

4-1. BLOCK DIAGRAMS



4-2. CIRCUIT BOARDS/SWITCHES/MOTORS LOCATION

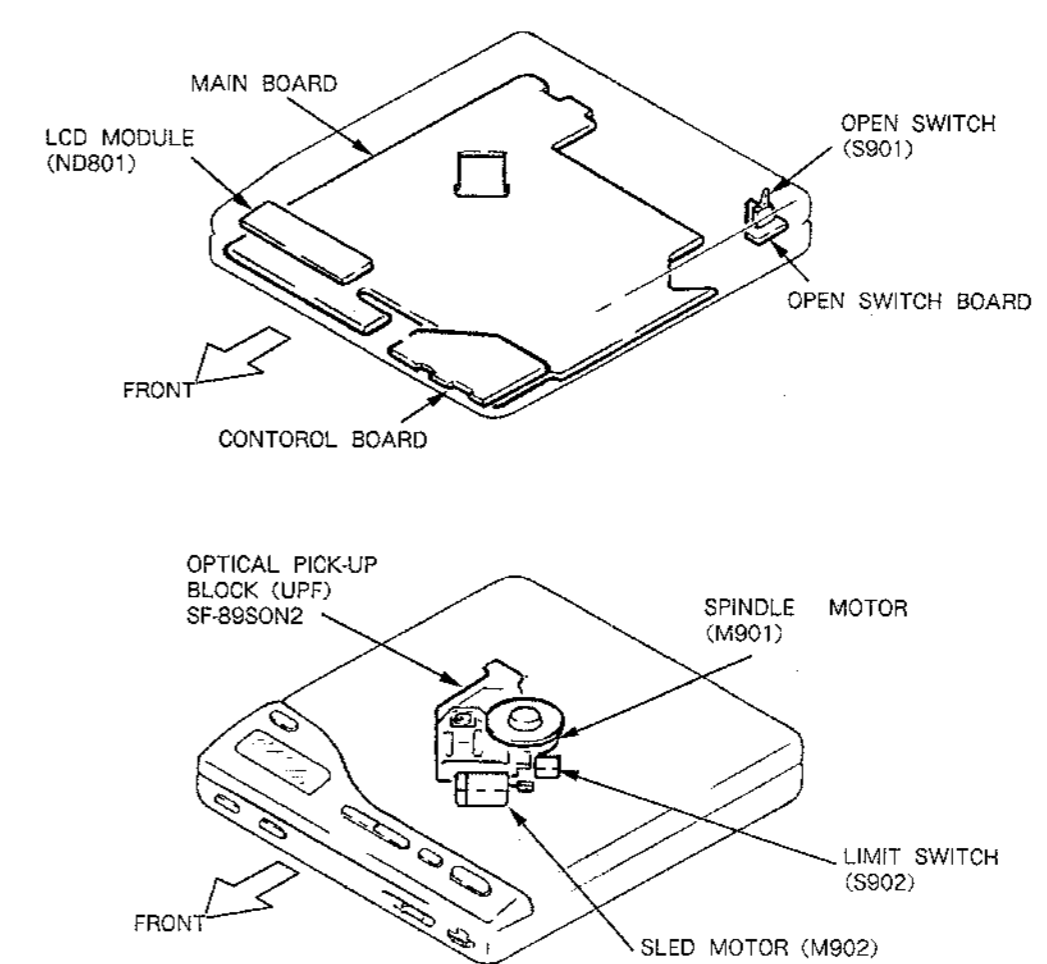

• LCD MODULE (LCD 1)

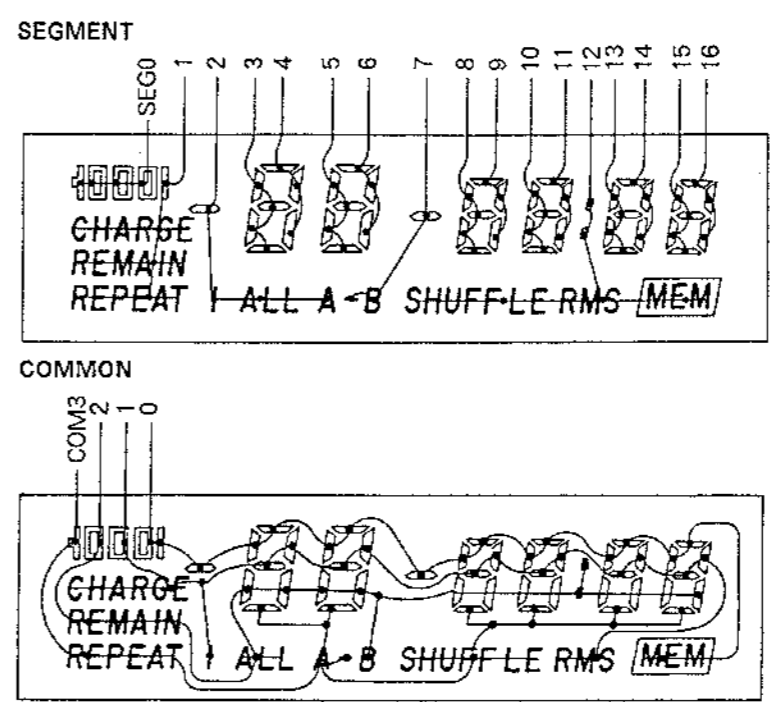

4-3. SEMICONDUCTOR LEAD LAYOUTS

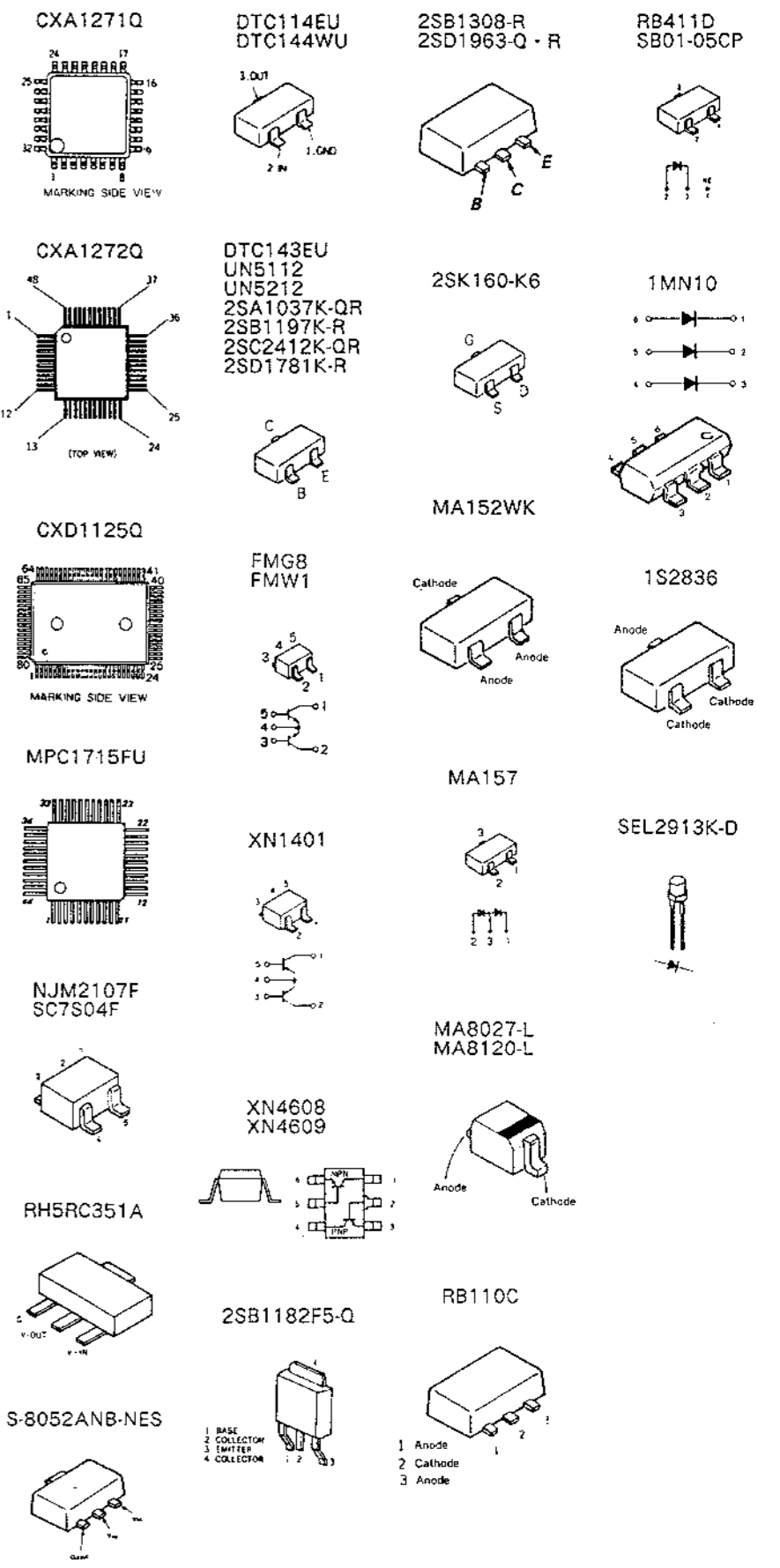

• Semiconductor Location

Ref. No	Location	Ref. No	Location
IC301	H-29	Q507	E-15
IC302	I-26	Q801	E-9
IC303	I-28	Q802	C-10
IC401	J-22	Q803	E-10
IC402	J-14	Q804	G-7
IC403	J-24	Q805	G-8
IC501	C-25	Q806	F-10
IC502	E-24	Q807	F-9
IC503	C-12	Q808	F-9
IC504	B-27	Q809	F-9
IC505	D-16	Q810	J-13
IC601	F-26	Q811	H-18
IC602	F-11	Q812	E-9
IC801	D-29		
IC802	G-28		
IC803	E-10	D301	K-27
IC804	C-11	D302	K-26
		D401	I-22
		D402	J-23
		D403	H-25
Q101	K-11		
Q103	I-7	D404	J-24
Q201	J-10	D405	H-24
Q203	J-7	D407	K-14
Q301	I-11	D408	J-21
		D409	D-7
Q302	J-8		
Q401	J-22	D410	C-7
Q402	I-21	D411	H-22
Q403	J-15	D412	G-23
Q404	J-17	D413	B-7
		D414	H-21
Q405	J-14		
Q406	H-11	D415	H-22
Q407	I-15	D416	J-20
Q408	I-15	D417	H-22
Q409	D-10	D418	J-15
		D419	J-16
Q410	J-20		
Q411	H-23	D420	I-15
Q412	I-13	D421	I-16
Q413	H-12	D501	C-11
Q414	H-12	D502	D-11
		D503	D-11
Q415	H-12		
Q416	H-24	D801	D-27
Q417	J-13	D802	G-27
Q418	J-25	D803	F-29
Q419	J-24	D804	D-11
		D805	D-10
Q420	J-25		
Q421	D-26	D806	D-9
Q425	H-25	D808	E-11
Q427	H-25	D809	D-10
Q501	B-24	D810	B-28
		D811	B-28
Q502	D-13		
Q503	D-14	D815	H-28
Q504	D-13	D816	E-9
Q505	D-13	D817	G-8
Q506	D-26		

Note on Printed Wiring Boards:
 ○ : parts extracted from the component side.
 ● : parts extracted from the conductor side.
 ■ : parts mounted on the conductor side.
 ◆ : Through h.o.a.
 [Pattern on the side which is seen.]
 [Pattern of the rear side.]

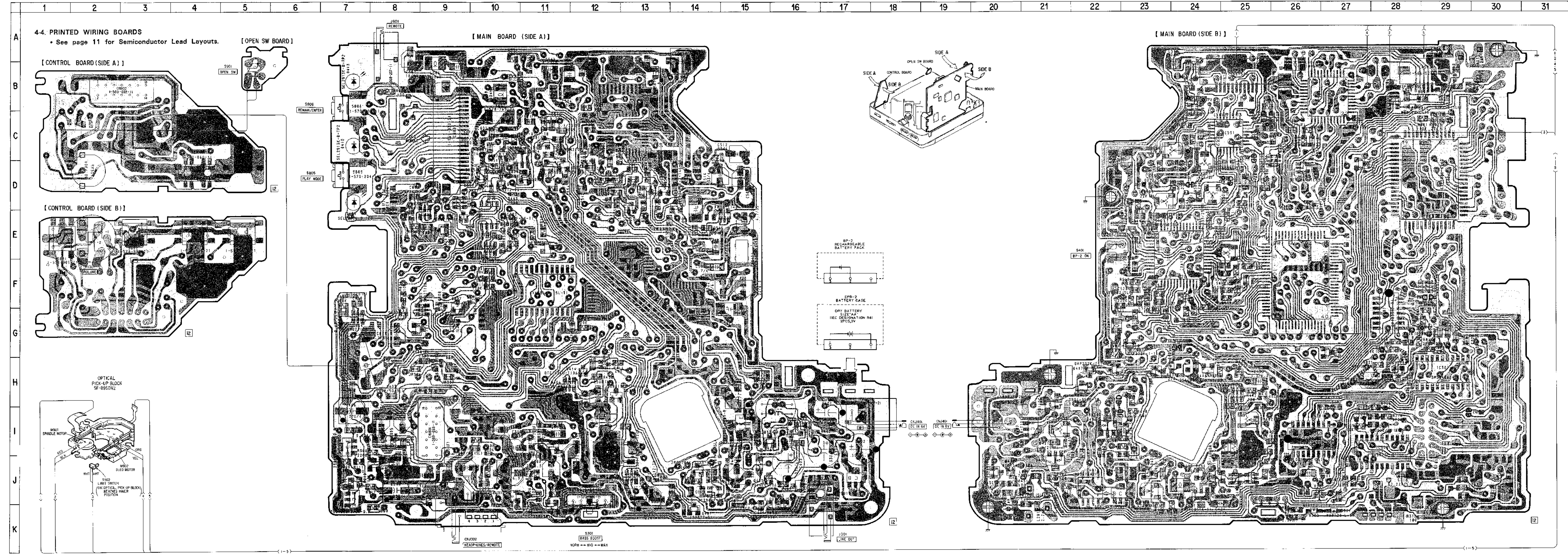

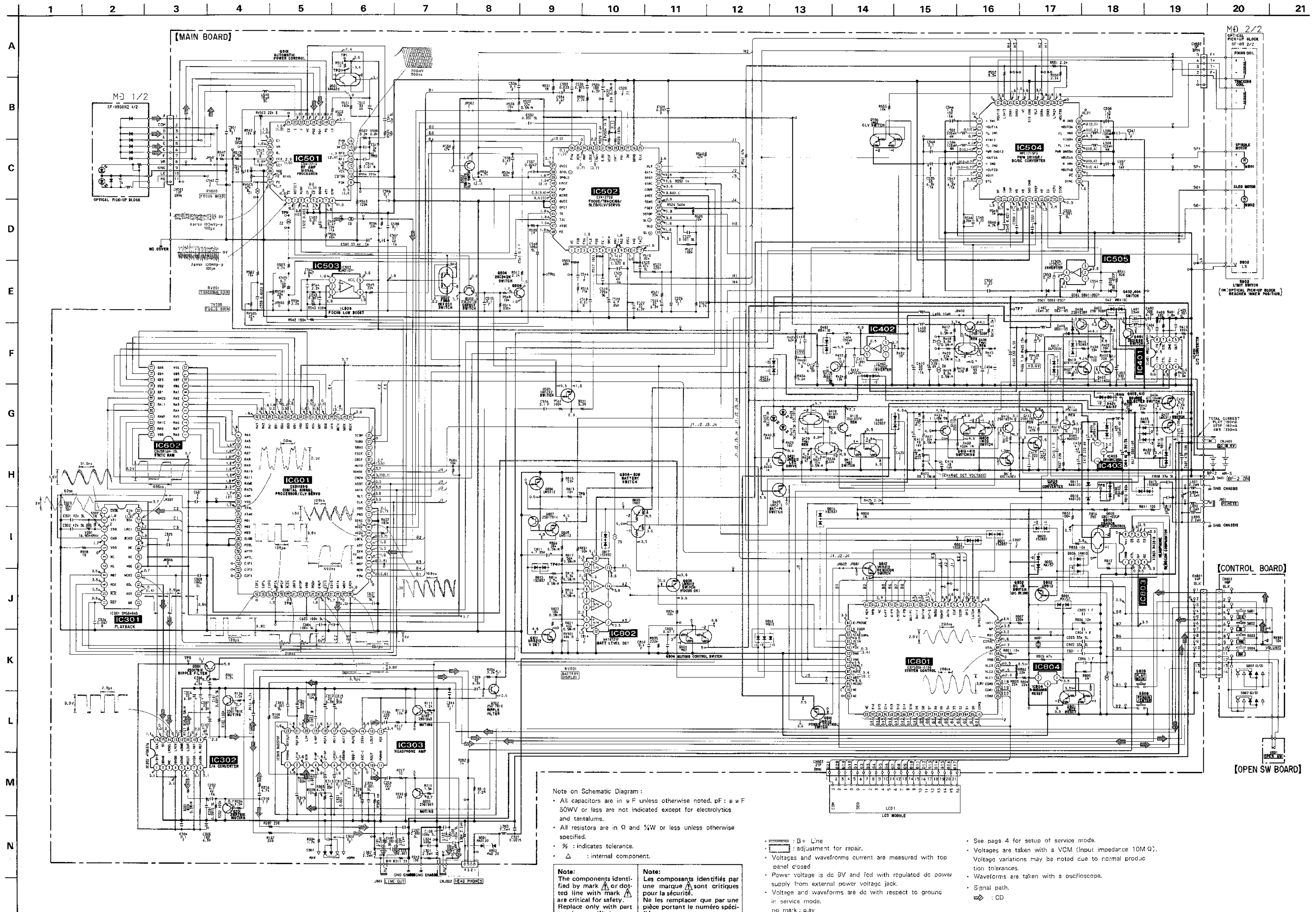

Note on Schematic Diagram :

- All capacitors are in μF unless otherwise noted, pF : μF 50WV or less are not indicated except for electrolytics and tantalums.
- All resistors are in Ω and $\frac{1}{4}W$ or less unless otherwise specified.
- % : indicates tolerance.
- Δ : internal component.

Note: The components identified by mark Δ or dotted line with mark Δ are critical for safety. Replace only with part number specified.

Note: Les composants identifiés par une marque Δ sont critiques pour la sécurité. Ne les remplacer que par une pièce portant le numéro spécifié.

- --- : B+ Line
- --- : adjustment for repair.
- Voltages and waveforms current are measured with top panel closed
- Power voltage is dc 9V and fed with regulated dc power supply from external power voltage jack.
- Voltage and waveforms are dc with respect to ground in service mode.
- no mark : play
- () : play (Battery operation)

- See page 4 for setup of service mode.
- Voltages are taken with a VOM (Input impedance 10M Ω). Voltage variations may be noted due to normal production tolerances.
- Waveforms are taken with a oscilloscope.
- Signal path.
- --- : CD

IC301 SM5840AS

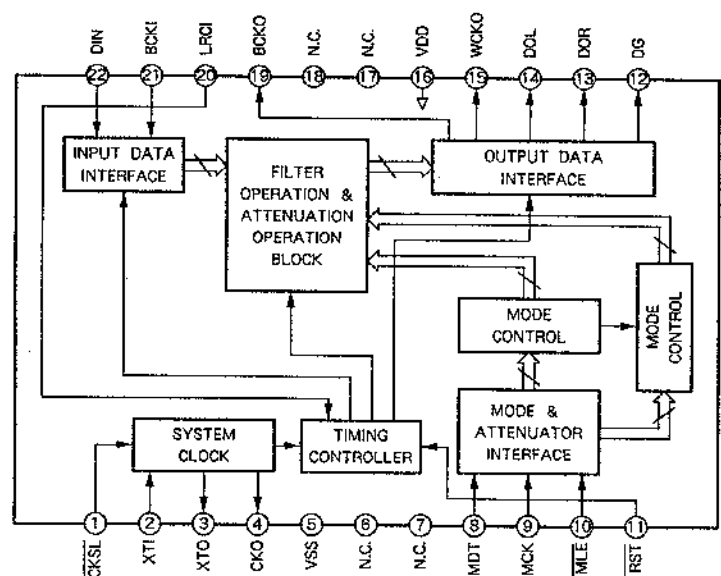

IC401 MB3776APF

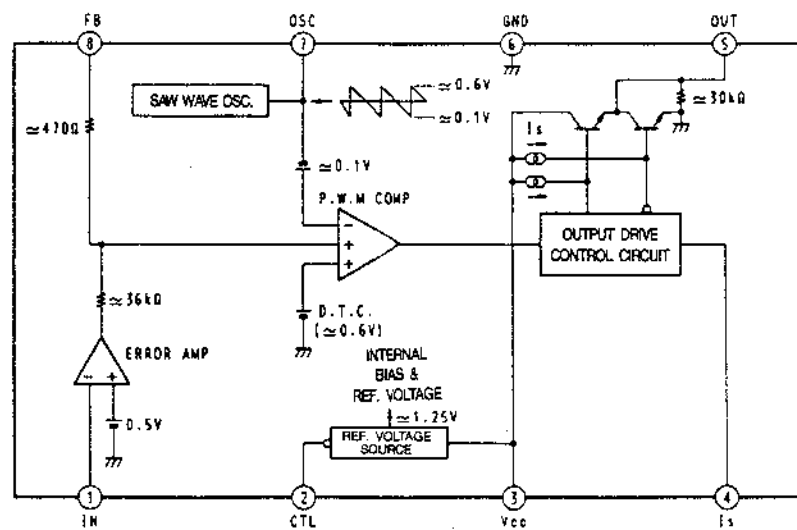

IC504 MPC1715

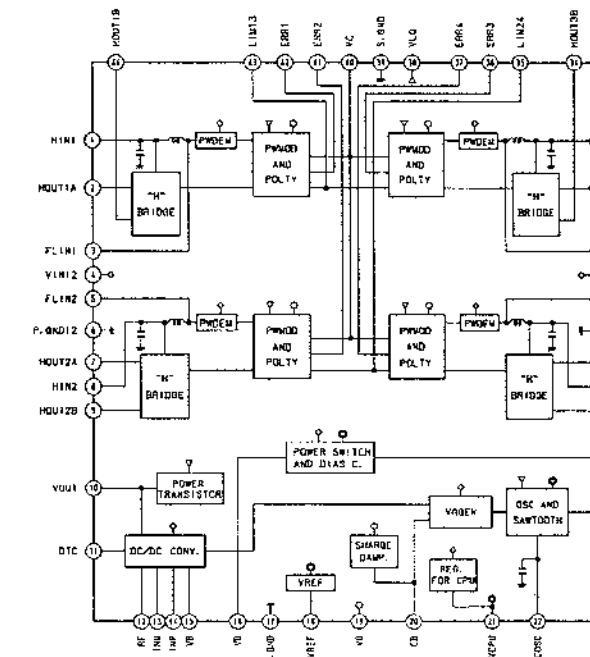

IC302 μPD6376

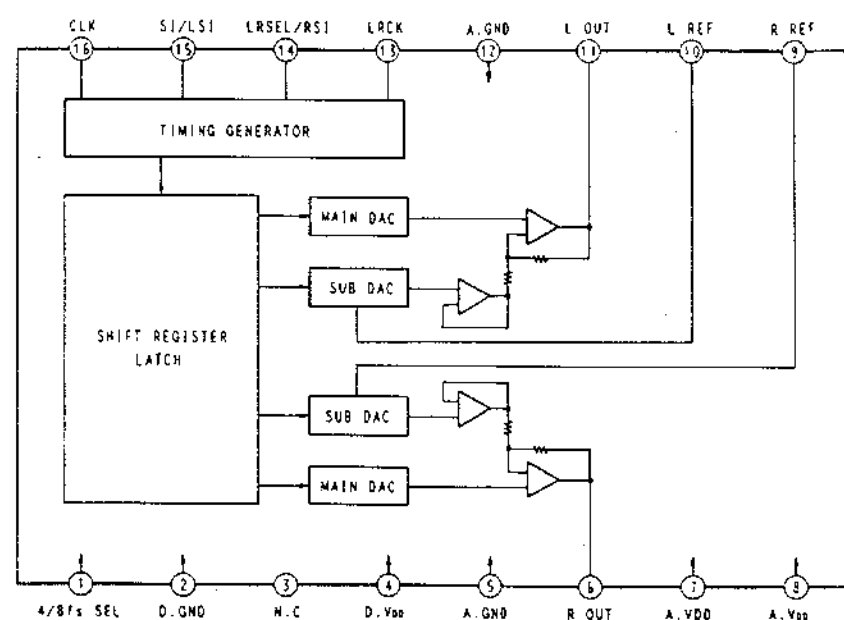

IC501 CXA1271Q

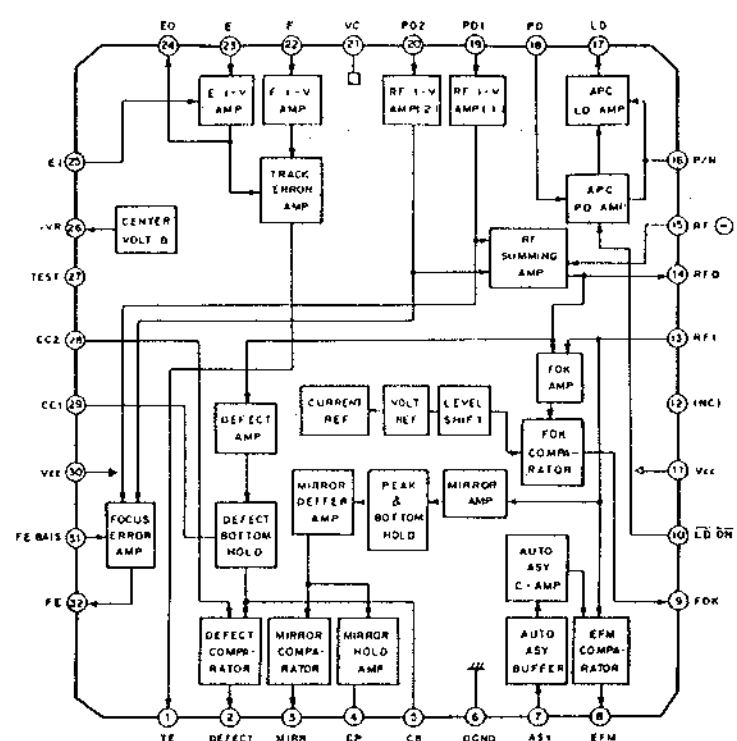

IC803 BA3818F-SY

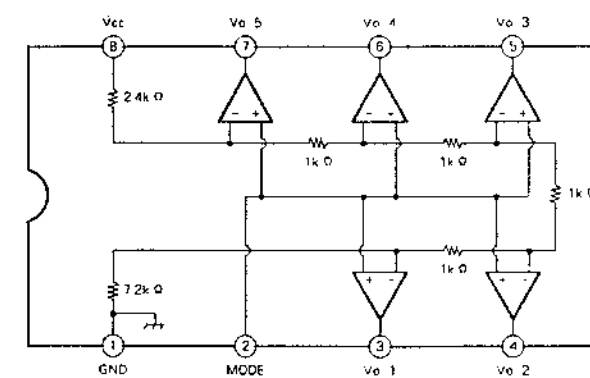

IC303 BA3570F

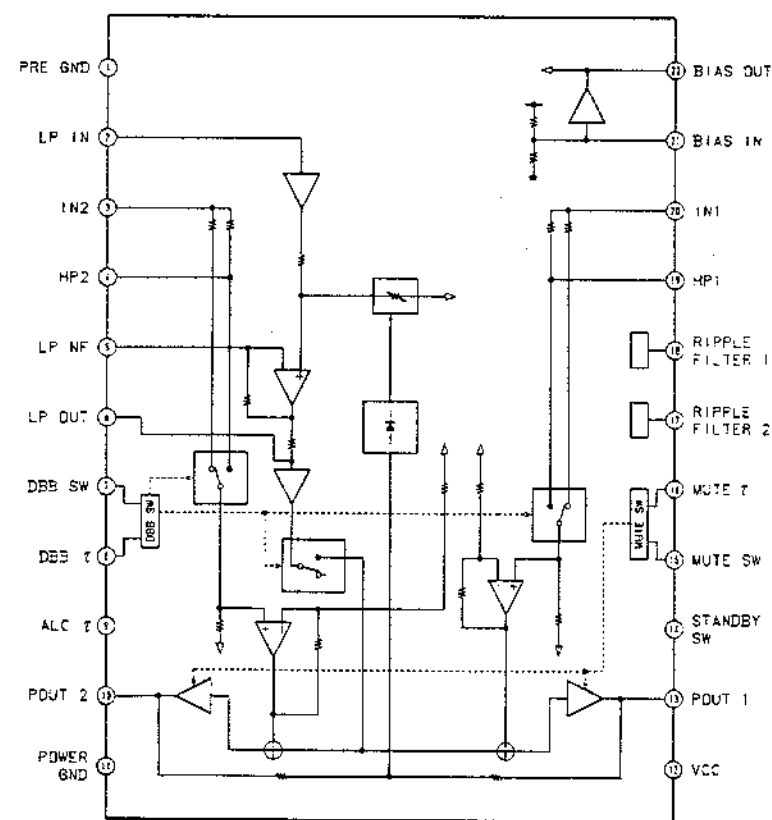

IC502 CXA1272Q

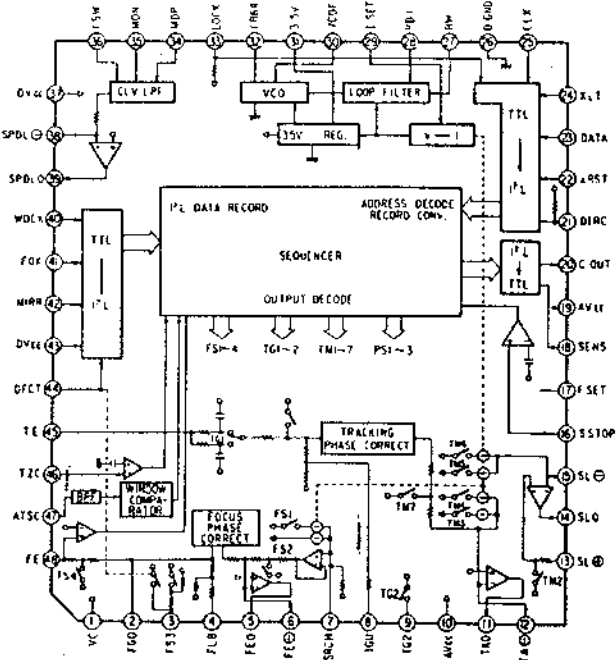

IC601 CXD1125Q

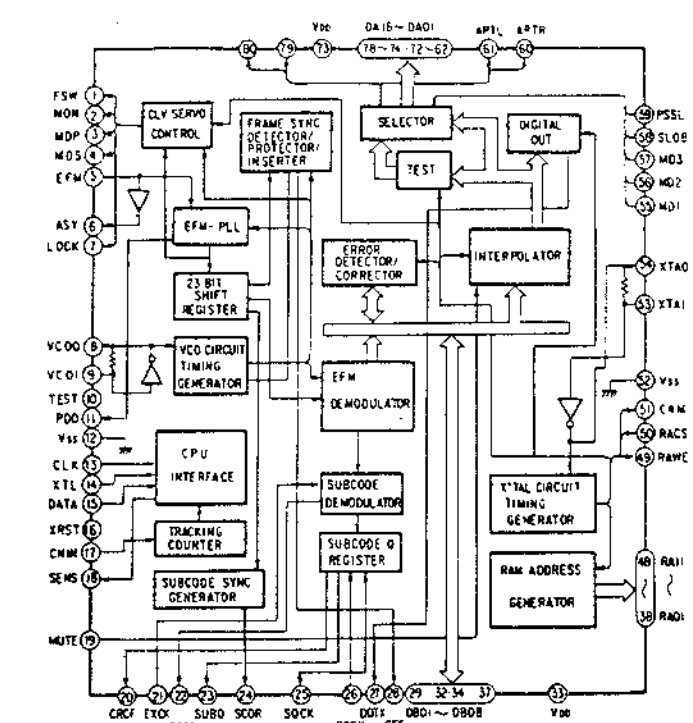

SECTION 5 EXPLODED VIEWS

NOTE:

- The mechanical parts with no reference number in the exploded views are not supplied.
- The construction parts of an assembled part are indicated with a collation number in the remark column.
- Items marked "*" are not stocked since they are seldom required for routine service. Some delay should be anticipated when ordering these items.

- Due to standardization, parts with part number suffix -XX and -X may be different from the parts specified in the components used on the set.
- Color Indication of Appearance Parts
Example:
(RED) ... KNOB, BALANCE (WHITE)
↑ Cabinet's Color ↑ Parts' Color

The components identified by mark or dotted line with mark are critical for safety. Replace only with part number specified.

Les composants identifiés par une marque sont critiques pour la sécurité. Ne les remplacer que par une pièce portant le numéro spécifié.

• AUS ... Australian model

(1) UPPER/BOTTOM SECTION

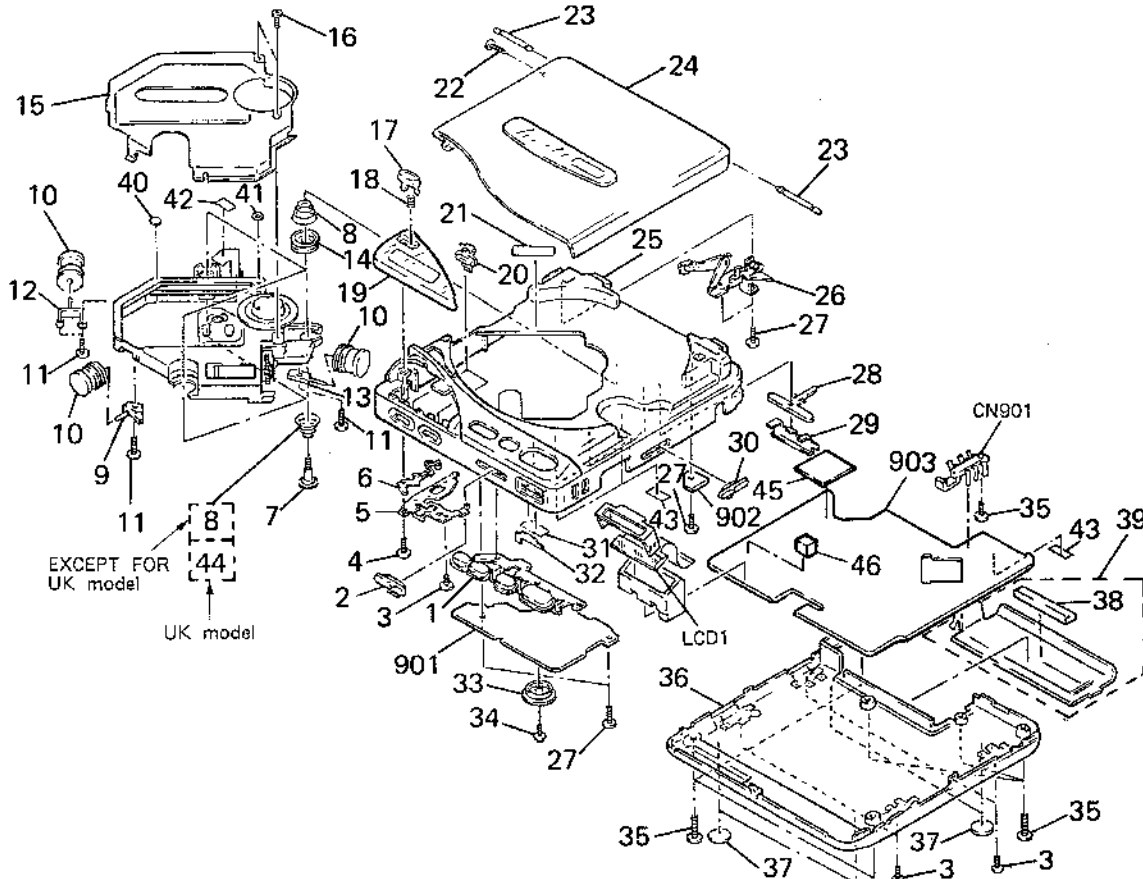

No.	Part No.	Description	Remarks	No.	Part No.	Description	Remarks
1	4-931-847-01	BUTTON (FRS)		27	3-342-073-01	SCREW (1.7X4), TAPPING	
2	4-931-841-01	KNOB (HOLD)		28	4-931-839-01	ARM, DETECTION	
3	3-703-816-42	SCREW (M1.4X2.5), SPECIAL HEAD		29	4-931-824-01	PLATE (DETECTION), FIXED	
4	3-703-816-22	SCREW (M1.4X5.0), SPECIAL HEAD		30	4-931-840-01	KNOB (DBB)	
5	4-931-851-01	PLATE (LOCK), FIXED		31	*4-926-115-01	CUSHION (P)	
6	4-931-850-01	CLAW, LOCK		32	*4-931-884-01	PAPER (VOL), SHIELD	
7	4-924-718-01	SCREW, INSULATOR		33	4-931-848-01	KNOB (VOLUME)	
8	4-931-835-01	SPRING		34	3-335-797-21	SCREW (M1.4X3), TOOTHED LOCK	
9	4-931-868-01	SHAFT (C), DAMPER		35	7-621-283-10	SCREW (B2X10) (G), TAPPING	
10	3-323-234-11	DAMPER (2), HYPER		36	X-4930-132-1	PANEL ASSY, BOTTOM	
11	3-318-203-71	SCREW (B1.7X5), TAPPING		37	4-912-641-01	FOOT, RUBBER	
12	4-931-867-01	SHAFT (B), DAMPER		38	9-911-815-01	CUSHION (A)	
13	4-931-866-01	SHAFT (A), DAMPER		39	X-4930-136-1	LID ASSY, BATTERY CASE	
14	4-931-834-01	RETAINER, SPRING		40	4-917-784-01	SPACER (S)	
15	4-931-854-01	COVER, MD		41	4-927-949-01	WASHER	
16	3-893-942-01	SCREW (1.7X4), TAPPING (B)		42	4-941-190-01	SPACER (PAL)	
17	4-931-845-01	BUTTON (OPEN)		43	*3-561-902-11	CLOTH, RETAINING, CASSETTE	
18	4-931-833-01	SPRING (OPEN)		44	4-931-893-01	(UK)...SPRING (B)	
19	X-4930-131-1	WINDOW (LCD) ASSY		45	3-831-441-XX	SHIELD (MAIN)	
20	4-931-844-01	BUTTON (MODE)		46	9-911-841-XX	CUSHION, CASSETTE LID	
21	4-908-711-01	LABEL, CAUTION, LENS		901	*1-635-025-11	PC BOARD, CONTROL	
22	4-931-890-01	SCREW (M1.7X0.35)		902	*1-635-416-11	PC BOARD, OPEN SW	
23	4-931-825-01	SHAFT (FULCRUM)		903	*A-3015-900-A	(EXCEPT UK)...PC BOARD ASSY, MAIN	
24	X-4930-135-1	LID ASSY, UPPER			*A-3015-922-A	(UK).....PC BOARD ASSY, MAIN	
25	4-931-858-01	CABINET		CN901	4-931-852-01	TERMINAL, BATTERY	
26	X-4930-130-1	PLATE ASSY, SWITCHING		LCD1	1-809-047-11	DISPLAY PANEL, LIQUID CRYSTAL	

(2) MECHANISM SECTION
(CDM-66)

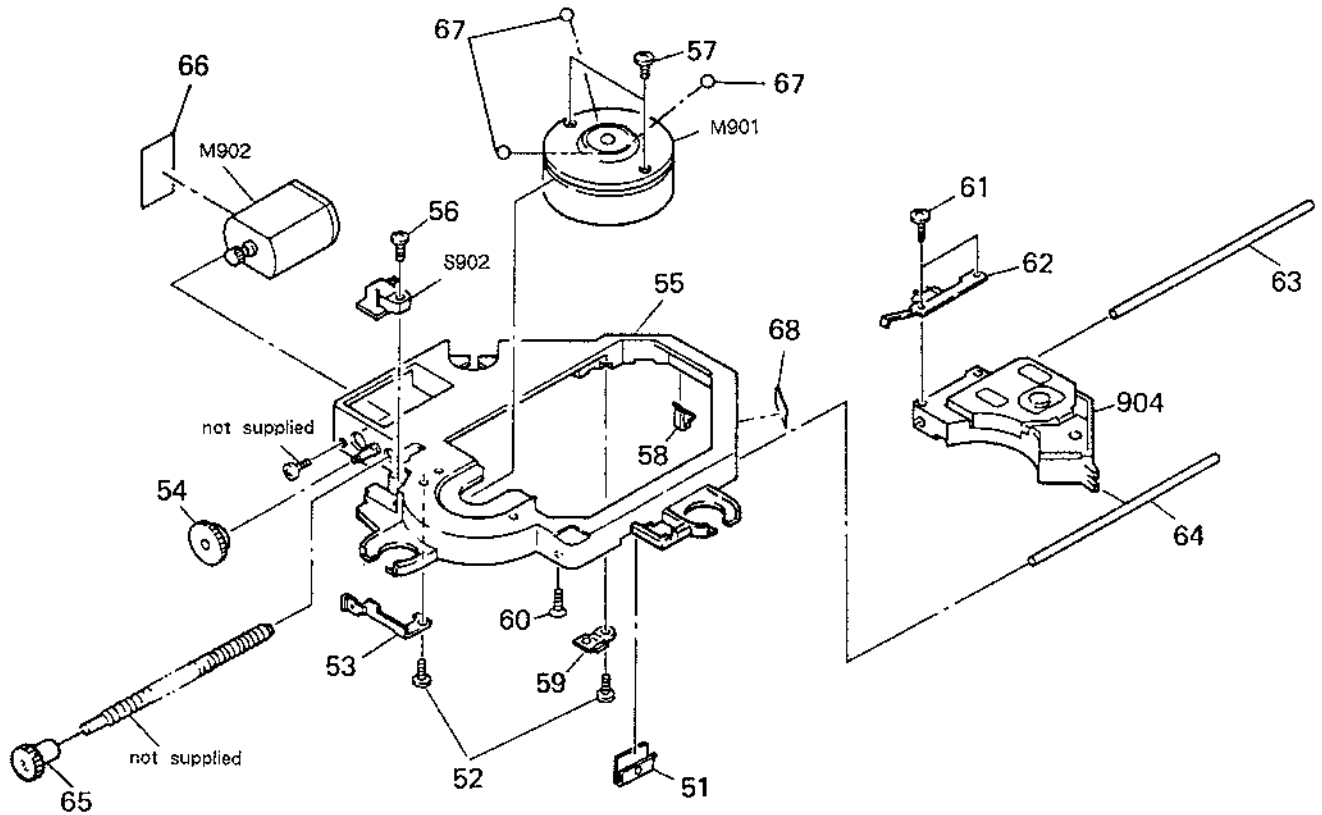

<p>Note: The components identified by mark Δ or dotted line with mark Δ are critical for safety. Replace only with part number specified.</p>	<p>Note: Les composants identifiés par une marque Δ sont critiques pour la sécurité. Ne les remplacer que par une pièce portant le numéro spécifié.</p>
--	--

No.	Part No.	Description	Remarks	No.	Part No.	Description	Remarks
51	4-932-779-11	RETAINER (A), FLEXIBLE		62	4-932-785-11	RACK (OUTSERT)	
52	3-895-823-41	SCREW (B1.4X4), TAPPING		63	4-932-784-01	SHAFT (A)	
53	4-931-863-01	SPRING, LEAF		64	4-931-862-21	SHAFT (B)	
54	4-931-861-01	GEAR (B)		65	4-932-774-01	GEAR (C)	
55	4-931-864-01	CHASSIS, MD		66	3-831-441-11	CUSHION (B)	
56	4-908-792-91	SCREW (B2X7), TAPPING, P1		67	7-671-155-01	STEEL BALL 3.0	
57	7-627-450-48	SCREW, PRECISION #K1.7X2.5 TYPE1		68	3-831-441-XX	SPACER, KNOB	
58	4-932-777-01	RETAINER (B), FLEXIBLE		904	Δ X-4930-137-1	OPTICAL PICK-UP (SF-89SON2)	
59	4-932-776-01	RETAINER, SHAFT		M901	A-3133-413-A	MOTOR ASSY, CLV (SPINDLE MOTOR)	
60	4-941-983-01	SCREW (B1.7X6), SPECIAL		M902	X-4921-256-1	FEED MOTOR (SLED MOTOR)	
61	3-303-809-01	SCREW (M1.7X2.0), SPECIAL HEAD		S902	1-570-771-11	SWICH, MICRO	

SECTION 6

ELECTRICAL PARTS LIST

NOTE:

- Due to standardization, replacements in the parts list may be different from the parts specified in the diagrams or the components used on the set.
- Items marked "*" are not stocked since they are seldom required for routine service. Some delay should be anticipated when ordering these items.
- If there are two or more same circuits in a set such as a stereophonic machine, only typical circuit parts may be indicated and capacitors and resistors in other same circuits may be omitted.

CAPACITORS:MF: μ F, PF: μ μ F.**RESISTORS**

- All resistors are in ohms.
- F: nonflammable

COILS

- MMH: mH, UH: μ H

SEMICONDUCTORSIn each case, U: μ , for example:UA...: μ A..., UPA...: μ PA...,
UPC...: μ PC, UPD...: μ PD...

The components identified by mark Δ or dotted line with mark Δ are critical for safety. Replace only with part number specified.

Les composants identifiés par une marque Δ sont critiques pour la sécurité. Ne les remplacer que par une pièce portant le numéro spécifié.

• AUS ... Australian model





Ref.No.	Part No.	Description	Ref.No.	Part No.	Description
901	*1-635-025-11	PC BOARD, CONTROL	C326	1-163-809-11	CERAMIC CHIP 0.047MF 10% 25V
902	*1-635-416-11	PC BOARD, OPEN SW	C327	1-163-145-00	CERAMIC CHIP 0.0015MF 5% 50V
903	*A-3015-900-A *A-3015-922-A	(EXCEPT UK)...PC BOARD ASSY, MAIN (UK).....PC BOARD ASSY, MAIN	C328	1-163-117-00	CERAMIC CHIP 100PF 5% 50V
904	Δ X-4930-137-1	OPTICAL PICK-UP (SF-89S0N2)	C401	1-124-472-11	ELECT 470MF 20% 10V
C101	1-163-145-00	CERAMIC CHIP 0.0015MF 5% 50V	C402	1-126-245-11	ELECT 330MF 20% 6.3V
C102	1-135-151-21	TANTAL. CHIP 4.7MF 20% 4V	C403	1-126-245-11	ELECT 330MF 20% 6.3V
C106	1-126-246-11	ELECT CHIP 220MF 20% 4V	C404	1-163-038-00	CERAMIC CHIP 0.1MF 25V
C107	1-163-141-00	CERAMIC CHIP 0.001MF 5% 50V	C405	1-163-141-00	CERAMIC CHIP 0.001MF 5% 50V
C108	1-163-117-00	CERAMIC CHIP 100PF 5% 50V	C406	1-164-346-11	CERAMIC CHIP 1MF 16V
C109	1-164-161-11	CERAMIC CHIP 0.0022MF 10% 50V	C407	1-126-207-11	ELECT CHIP 33MF 20% 4V
C110	1-164-346-11	CERAMIC CHIP 1MF 16V	C408	1-126-246-11	ELECT CHIP 220MF 20% 4V
C201	1-163-145-00	CERAMIC CHIP 0.0015MF 5% 50V	C409	1-126-245-11	ELECT 330MF 20% 6.3V
C202	1-135-151-21	TANTAL. CHIP 4.7MF 20% 4V	C410	1-135-162-21	TANTAL. CHIP 33MF 20% 4V
C206	1-126-246-11	ELECT CHIP 220MF 20% 4V	C411	1-163-141-00	CERAMIC CHIP 0.001MF 5% 50V
C207	1-163-141-00	CERAMIC CHIP 0.001MF 5% 50V	C412	1-126-206-11	ELECT CHIP 100MF 20% 6.3V
C208	1-163-117-00	CERAMIC CHIP 100PF 5% 50V	C413	1-164-346-11	CERAMIC CHIP 1MF 16V
C209	1-164-161-11	CERAMIC CHIP 0.0022MF 10% 50V	C414	1-135-157-21	TANTAL. CHIP 10MF 20% 6.3V
C210	1-164-346-11	CERAMIC CHIP 1MF 16V	C415	1-126-246-11	ELECT CHIP 220MF 20% 4V
C301	1-163-095-00	CERAMIC CHIP 12PF 5% 50V	C416	1-164-346-11	CERAMIC CHIP 1MF 16V
C302	1-163-095-00	CERAMIC CHIP 12PF 5% 50V	C417	1-163-037-11	CERAMIC CHIP 0.022MF 10% 25V
C303	1-163-105-00	CERAMIC CHIP 33PF 5% 50V	C418	1-124-779-00	ELECT CHIP 10MF 20% 16V
C304	1-163-038-00	CERAMIC CHIP 0.1MF 25V	C419	1-124-779-00	ELECT CHIP 10MF 20% 16V
C305	1-126-206-11	ELECT CHIP 100MF 20% 6.3V	C420	1-164-346-11	CERAMIC CHIP 1MF 16V
C306	1-124-778-00	ELECT CHIP 22MF 20% 6.3V	C421	1-163-038-00	CERAMIC CHIP 0.1MF 25V
C307	1-124-778-00	ELECT CHIP 22MF 20% 6.3V	C422	1-135-180-21	TANTAL. CHIP 3.3MF 20% 6.3V
C308	1-124-778-00	ELECT CHIP 22MF 20% 6.3V	C423	1-163-117-00	CERAMIC CHIP 100PF 5% 50V
C309	1-124-778-00	ELECT CHIP 22MF 20% 6.3V	C424	1-135-151-21	TANTAL. CHIP 4.7MF 20% 4V
C310	1-163-141-00	CERAMIC CHIP 0.001MF 5% 50V	C501	1-163-038-00	CERAMIC CHIP 0.1MF 25V
C311	1-126-207-11	ELECT CHIP 33MF 20% 4V	C502	1-163-989-11	CERAMIC CHIP 0.033MF 10% 25V
C312	1-124-778-00	ELECT CHIP 22MF 20% 6.3V	C503	1-164-232-11	CERAMIC CHIP 0.01MF 10% 50V
C313	1-126-603-11	ELECT CHIP 4.7MF 20% 35V	C504	1-135-145-11	TANTAL. CHIP 0.47MF 20% 25V
C314	1-163-038-00	CERAMIC CHIP 0.1MF 25V	C505	1-126-603-11	ELECT CHIP 4.7MF 20% 16V
C315	1-163-038-00	CERAMIC CHIP 0.1MF 25V	C506	1-163-038-00	CERAMIC CHIP 0.1MF 25V
C316	1-126-603-11	ELECT CHIP 4.7MF 20% 35V	C507	1-135-162-21	TANTAL. CHIP 33MF 20% 4V
C317	1-163-038-00	CERAMIC CHIP 0.1MF 25V	C508	1-163-038-00	CERAMIC CHIP 0.1MF 25V
C318	1-164-222-11	CERAMIC CHIP 0.22MF 25V	C509	1-135-162-21	TANTAL. CHIP 33MF 20% 4V
C319	1-124-778-00	ELECT CHIP 22MF 20% 6.3V	C510	1-164-232-11	CERAMIC CHIP 0.01MF 10% 50V
C320	1-163-141-00	CERAMIC CHIP 0.001MF 5% 50V	C511	1-163-095-00	CERAMIC CHIP 12PF 5% 50V
C321	1-163-141-00	CERAMIC CHIP 0.001MF 5% 50V	C512	1-126-207-11	ELECT CHIP 33MF 20% 4V
C322	1-164-156-11	CERAMIC CHIP 0.1MF 25V	C513	1-164-232-11	CERAMIC CHIP 0.01MF 10% 50V
C323	1-163-141-00	CERAMIC CHIP 0.001MF 5% 50V	C514	1-126-207-11	ELECT CHIP 33MF 20% 4V
C324	1-162-953-11	CERAMIC CHIP 100PF 5% 50V	C515	1-163-038-00	CERAMIC CHIP 0.1MF 25V
C325	1-164-346-11	CERAMIC CHIP 1MF 16V	C516	1-163-038-00	CERAMIC CHIP 0.1MF 25V
			C517	1-163-085-00	CERAMIC CHIP 2PF 0.25PF 50V
			C518	1-162-970-11	CERAMIC CHIP 0.01MF 10% 25V

Ref.No.	Part No.	Description				Ref.No.	Part No.	Description
C519	1-162-957-11	CERAMIC CHIP 220PF	5%	50V		CN501	1-566-527-11	CONNECTOR, FPC (ZIF) 11P
C520	1-126-603-11	ELECT CHIP 4.7MF	20%	35V		CN502	1-566-521-11	CONNECTOR, FPC (ZIF) 5P
C521	1-163-037-11	CERAMIC CHIP 0.022MF	10%	25V		CN801	1-569-693-11	SOCKET, CONNECTOR (RECEPTACLE)
C522	1-124-778-00	ELECT CHIP 22MF	20%	6.3V		CN802	1-569-692-11	SOCKET, CONNECTOR (PLUG) 14P
C523	1-163-109-00	CERAMIC CHIP 47PF	5%	50V		CN803	1-569-030-11	CONNECTOR, FPC (ZIF) 21P
C524	1-124-778-00	ELECT CHIP 22MF	20%	6.3V		CN901	4-931-852-01	TERMINAL, BATTERY
C525	1-135-151-21	TANTAL. CHIP 4.7MF	20%	4V		CNJ302	1-568-758-11	JACK (HEADPHONES)
C526	1-163-038-00	CERAMIC CHIP 0.1MF		25V		CNJ401	1-568-907-21	JACK, EXTERNAL POWER (DC IN 6V)
C527	1-163-141-00	CERAMIC CHIP 0.001MF	5%	50V		D301	8-719-421-21	DIODE MA8120-L
C528	1-163-809-11	CERAMIC CHIP 0.047MF	10%	25V		D302	8-719-421-21	DIODE MA8120-L
C529	1-164-346-11	CERAMIC CHIP 1MF		16V		D401	8-719-975-33	DIODE RB110C
C530	1-163-023-00	CERAMIC CHIP 0.015MF	10%	50V		D402	8-719-975-40	DIODE RB411D
C531	1-126-206-11	ELECT CHIP 100MF	20%	6.3V		D403	8-719-951-22	DIODE IMN10
C532	1-163-141-00	CERAMIC CHIP 0.001MF	5%	50V		D404	8-719-975-40	DIODE RB411D
C533	1-163-989-11	CERAMIC CHIP 0.033MF	10%	25V		D405	8-719-421-15	DIODE MA8027-L
C534	1-164-005-11	CERAMIC CHIP 0.47MF		25V		D407	8-719-400-18	DIODE MA152WK
C535	1-135-162-21	TANTAL. CHIP 33MF	20%	6.3V		D408	8-719-975-33	DIODE RB110C
C536	1-163-038-00	CERAMIC CHIP 0.1MF		25V		D409	8-719-302-88	LED SEL2913K-D
C537	1-163-017-00	CERAMIC CHIP 0.0047MF	10%	50V		D410	8-719-302-88	LED SEL2913K-D
C538	1-162-637-11	CERAMIC CHIP 0.47MF		16V		D411	8-719-938-72	DIODE SB01-05CP
C540	1-163-117-00	CERAMIC CHIP 100PF	5%	50V		D412	8-719-104-34	DIODE 1S2836
C541	1-163-038-00	CERAMIC CHIP 0.1MF		25V		D413	8-719-302-88	LED SEL2913K-D
C542	1-163-809-11	CERAMIC CHIP 0.047MF	10%	25V		D414	8-719-975-33	DIODE RB110C
C543	1-163-141-00	CERAMIC CHIP 0.001MF	5%	50V		D415	8-719-400-18	DIODE MA152WK
C544	1-164-346-11	CERAMIC CHIP 1MF		16V		D416	8-719-400-18	DIODE MA152WK
C546	1-135-148-21	TANTAL. CHIP 1.5MF	20%	10V		D417	8-719-104-34	DIODE 1S2836
C547	1-135-157-21	TANTAL. CHIP 10MF	20%	6.3V		D418	8-719-938-72	DIODE SB01-05CP
C548	1-164-222-11	CERAMIC CHIP 0.22MF		25V		D419	8-719-938-72	DIODE SB01-05CP
C549	1-163-986-00	CERAMIC CHIP 0.027MF	10%	25V		D420	8-719-400-18	DIODE MA152WK
C550	1-164-346-11	CERAMIC CHIP 1MF		16V		D421	8-719-403-80	DIODE MA157
C551	1-163-038-00	CERAMIC CHIP 0.1MF		25V		D501	8-719-938-72	DIODE SB01-05CP
C552	1-164-222-11	CERAMIC CHIP 0.22MF		25V		D502	8-719-938-72	DIODE SB01-05CP
C553	1-164-005-11	CERAMIC CHIP 0.47MF		25V		D503	8-719-938-72	DIODE SB01-05CP
C554	1-164-346-11	CERAMIC CHIP 1MF		16V		D801	8-719-400-18	DIODE MA152WK
C555	1-163-141-00	CERAMIC CHIP 0.001MF	5%	50V		D802	8-719-400-18	DIODE MA152WK
C557	1-124-779-00	ELECT CHIP 10MF	20%	16V		D803	8-719-951-22	DIODE IMN10
C558	1-135-148-21	TANTAL. CHIP 1.5MF	20%	10V		D804	8-719-403-80	DIODE MA157
C559	1-164-161-11	CERAMIC CHIP 0.0022MF	10%	50V		D805	8-719-403-80	DIODE MA157
C560	1-163-038-00	CERAMIC CHIP 0.1MF		25V		D806	8-719-951-22	DIODE IMN10
C561	1-163-038-00	CERAMIC CHIP 0.1MF		25V		D808	8-719-938-72	DIODE SB01-05CP
C562	1-164-346-11	CERAMIC CHIP 1MF		16V		D809	8-719-400-18	DIODE MA152WK
C601	1-164-346-11	CERAMIC CHIP 1MF		16V		D810	8-719-421-21	DIODE MA8120-L
C604	1-163-117-00	CERAMIC CHIP 100PF	5%	50V		D811	8-719-421-21	DIODE MA8120-L
C605	1-163-117-00	CERAMIC CHIP 100PF	5%	50V		D815	8-719-400-18	DIODE MA152WK
C607	1-163-117-00	CERAMIC CHIP 100PF	5%	50V		D816	8-719-400-18	DIODE MA152WK
C801	1-164-346-11	CERAMIC CHIP 1MF		16V		D817	8-719-400-18	DIODE MA152WK
C802	1-163-105-00	CERAMIC CHIP 33PF	5%	50V		IC301	8-759-502-48	IC SM5840AS
C803	1-163-105-00	CERAMIC CHIP 33PF	5%	50V		IC302	8-759-148-30	IC UPD6376
C804	1-164-346-11	CERAMIC CHIP 1MF		16V		IC303	8-759-991-27	IC BA3570F
C805	1-164-346-11	CERAMIC CHIP 1MF		16V		IC401	8-759-995-27	IC MB3776APF
C806	1-164-346-11	CERAMIC CHIP 1MF		16V		IC402	8-759-031-84	IC SC7S04F
C807	1-164-346-11	CERAMIC CHIP 1MF		16V		IC403	8-759-994-55	IC RH5RC351A
C808	1-163-105-00	CERAMIC CHIP 33PF	5%	50V		IC501	8-752-033-55	IC CXA1271Q
C809	1-164-005-11	CERAMIC CHIP 0.47MF		25V		IC502	8-752-033-54	IC CXA1272Q-Z
C810	1-163-038-00	CERAMIC CHIP 0.1MF		25V		IC503	8-759-710-79	IC NJM2107F
C811	1-126-603-11	ELECT CHIP 4.7MF	20%	35V				
C812	1-163-105-00	CERAMIC CHIP 33PF	5%	50V				
C814	1-164-346-11	CERAMIC CHIP 1MF		16V				

Ref.No.	Part No.	Description	Ref.No.	Part No.	Description
IC504	8-759-030-17	IC MPC1715FU	Q407	8-729-926-71	TRANSISTOR 2SB1308-R
IC505	8-759-031-84	IC SC7504F	Q408	8-729-903-10	TRANSISTOR FMW1
IC601	8-752-332-38	IC CXD1125Q	Q409	8-729-402-45	TRANSISTOR UN5212
IC602	8-752-323-65	IC CXX5816M-15L	Q410	8-729-907-00	TRANSISTOR DTC114EU
IC801	8-752-814-90	IC CXP5086-616Q	Q411	8-729-116-06	TRANSISTOR 2SK160-K6
IC802	8-759-982-77	IC BA10339F	Q412	8-729-921-84	TRANSISTOR 2SB1182F5-Q
IC803	8-759-998-45	IC BA3818F-SY	Q413	8-729-402-45	TRANSISTOR UN5212
IC804	8-759-945-21	IC S-8052ANB-NE-S	Q414	8-729-924-36	TRANSISTOR DTC143EU
J301	1-568-257-21	JACK (LINE OUT)	Q415	8-729-904-87	TRANSISTOR 2SB1197K-R
J801	1-568-257-11	JACK (REMOTE)	Q416	8-729-920-71	TRANSISTOR 2SA1037K-QR
JR306	1-216-295-00	METAL GLAZE 0 5% 1/10W	Q417	8-729-907-39	TRANSISTOR IMD2
JR307	1-216-295-00	METAL GLAZE 0 5% 1/10W	Q418	8-729-403-42	TRANSISTOR XN1401
JR401	1-216-864-11	METAL GLAZE 0 5% 1/16W	Q419	8-729-920-71	TRANSISTOR 2SA1037K-QR
JR402	1-216-864-11	METAL GLAZE 0 5% 1/16W	Q420	8-729-903-10	TRANSISTOR FMW1
JR501	1-216-295-00	METAL GLAZE 0 5% 1/10W	Q421	8-729-402-45	TRANSISTOR UN5212
JR502	1-216-295-00	METAL GLAZE 0 5% 1/10W	Q426	8-729-905-15	TRANSISTOR DTC144WU
JR503	1-216-295-00	METAL GLAZE 0 5% 1/10W	Q427	8-729-402-45	TRANSISTOR UN5212
JR801	1-216-864-11	METAL GLAZE 0 5% 1/16W	Q501	8-729-402-90	TRANSISTOR XN4609
JR802	1-216-864-11	METAL GLAZE 0 5% 1/16W	Q502	8-729-904-87	TRANSISTOR 2SB1197K-R
L101	1-410-997-31	INDUCTOR CHIP 2.2UH	Q503	8-729-920-74	TRANSISTOR 2SC2412K-QR
L102	1-410-997-31	INDUCTOR CHIP 2.2UH	Q504	8-729-920-74	TRANSISTOR 2SC2412K-QR
L201	1-410-997-31	INDUCTOR CHIP 2.2UH	Q505	8-729-402-45	TRANSISTOR UN5212
L202	1-410-997-31	INDUCTOR CHIP 2.2UH	Q506	8-729-907-39	TRANSISTOR IMD2
L301	1-410-997-31	INDUCTOR CHIP 2.2UH	Q507	8-729-924-79	TRANSISTOR FMG8
L302	1-410-997-31	INDUCTOR CHIP 2.2UH	Q801	8-729-907-39	TRANSISTOR IMD2
L303	1-410-997-31	INDUCTOR CHIP 2.2UH	Q802	8-729-402-51	TRANSISTOR UN5112
L304	1-410-997-31	INDUCTOR CHIP 2.2UH	Q803	8-729-402-16	TRANSISTOR XN4608
L401	1-460-061-11	COIL (WITH CORE)	Q804	8-729-907-39	TRANSISTOR IMD2
L402	1-412-029-11	INDUCTOR CHIP 10UH	Q805	8-729-402-51	TRANSISTOR UN5112
L403	1-412-029-11	INDUCTOR CHIP 10UH	Q806	8-729-402-45	TRANSISTOR UN5212
L404	1-412-039-51	INDUCTOR CHIP 100UH	Q807	8-729-921-72	TRANSISTOR 2SD1781K-R
L405	1-412-039-51	INDUCTOR CHIP 100UH	Q808	8-729-402-51	TRANSISTOR UN5112
L406	1-412-029-11	INDUCTOR CHIP 10UH	Q809	8-729-907-39	TRANSISTOR IMD2
L502	1-412-039-51	INDUCTOR CHIP 100UH	Q810	8-729-402-51	TRANSISTOR UN5112
L504	1-412-039-51	INDUCTOR CHIP 100UH	Q811	8-729-402-45	TRANSISTOR UN5212
L506	1-412-039-51	INDUCTOR CHIP 100UH	Q812	8-729-402-45	TRANSISTOR UN5212
L508	1-412-039-51	INDUCTOR CHIP 100UH	R101	1-216-649-11	METAL CHIP 820 0.50% 1/10W
L510	1-412-029-11	INDUCTOR CHIP 10UH	R102	1-216-097-00	METAL GLAZE 100K 5% 1/10W
L801	1-410-997-31	INDUCTOR CHIP 2.2UH	R106	1-216-053-00	METAL GLAZE 1.5K 5% 1/10W
L802	1-410-997-31	INDUCTOR CHIP 2.2UH	R107	1-216-033-00	METAL GLAZE 220 5% 1/10W
L803	1-410-997-31	INDUCTOR CHIP 2.2UH	R108	1-216-845-11	METAL GLAZE 100K 5% 1/16W
L804	1-410-997-31	INDUCTOR CHIP 2.2UH	R109	1-216-073-00	METAL GLAZE 10K 5% 1/10W
LCD1	1-809-047-11	DISPLAY PANEL, LIQUID CRYSTAL	R110	1-216-073-00	METAL GLAZE 10K 5% 1/10W
M901	A-3133-413-A	MOTOR ASSY, CLV (SPINDLE MOTOR)	R111	1-216-053-00	METAL GLAZE 1.5K 5% 1/10W
M902	X-4921-256-1	FEED MOTOR (SLED MOTOR)	R116	1-216-065-00	METAL GLAZE 4.7K 5% 1/10W
Q101	8-729-921-72	TRANSISTOR 2SD1781K-R	R117	1-216-001-00	METAL GLAZE 10 5% 1/10W
Q103	8-729-921-92	TRANSISTOR 2SD1781K-R	R201	1-216-649-11	METAL CHIP 820 0.50% 1/10W
Q201	8-729-921-72	TRANSISTOR 2SD1781K-R	R202	1-216-097-00	METAL GLAZE 100K 5% 1/10W
Q203	8-729-921-72	TRANSISTOR 2SD1781K-R	R206	1-216-053-00	METAL GLAZE 1.5K 5% 1/10W
Q301	8-729-921-72	TRANSISTOR 2SD1781K-R	R207	1-216-033-00	METAL GLAZE 220 5% 1/10W
Q302	8-729-921-72	TRANSISTOR 2SD1781K-R	R208	1-216-097-00	METAL GLAZE 100K 5% 1/10W
Q401	8-729-923-36	TRANSISTOR 2SD1963-Q.R	R209	1-216-073-00	METAL GLAZE 10K 5% 1/10W
Q402	8-729-926-71	TRANSISTOR 2SB1308-R	R210	1-216-073-00	METAL GLAZE 10K 5% 1/10W
Q403	8-729-907-00	TRANSISTOR DTC114EU	R211	1-216-053-00	METAL GLAZE 1.5K 5% 1/10W
Q404	8-729-926-71	TRANSISTOR 2SB1308-R	R216	1-216-065-00	METAL GLAZE 4.7K 5% 1/10W
Q405	8-729-921-72	TRANSISTOR 2SD1781K-R	R217	1-216-001-00	METAL GLAZE 10 5% 1/10W
Q406	8-729-907-39	TRANSISTOR IMD2	R301	1-216-057-00	METAL GLAZE 2.2K 5% 1/10W









Ref.No.	Part No.	Description			
R302	1-216-049-00	METAL GLAZE	1K	5%	1/10W
R303	1-216-065-00	METAL GLAZE	4.7K	5%	1/10W
R304	1-216-051-00	METAL GLAZE	1.2K	5%	1/10W
R305	1-216-121-00	METAL GLAZE	1M	5%	1/10W
R306	1-216-057-00	METAL GLAZE	2.2K	5%	1/10W
R307	1-216-121-00	METAL GLAZE	1M	5%	1/10W
R308	1-216-001-00	METAL GLAZE	10	5%	1/10W
R310	1-216-129-00	METAL GLAZE	2.2M	5%	1/10W
R311	1-216-013-00	METAL GLAZE	33	5%	1/10W
R312	1-216-809-11	METAL GLAZE	100	5%	1/16W
R401	1-216-055-00	METAL GLAZE	1.8K	5%	1/10W
R402	1-216-840-11	METAL GLAZE	39K	5%	1/16W
R403	1-216-033-00	METAL GLAZE	220	5%	1/10W
R404	1-216-055-00	METAL GLAZE	1.8K	5%	1/10W
R405	1-216-835-11	METAL GLAZE	15K	5%	1/16W
R406	1-216-054-00	METAL GLAZE	1.6K	5%	1/10W
R407	1-216-073-00	METAL GLAZE	10K	5%	1/10W
R408	1-216-158-00	METAL GLAZE	22	5%	1/8W
R409	1-216-037-00	METAL GLAZE	330	5%	1/10W
R410	1-216-081-00	METAL GLAZE	22K	5%	1/10W
R411	1-216-041-00	METAL GLAZE	470	5%	1/10W
R412	1-216-073-00	METAL GLAZE	10K	5%	1/10W
R413	1-216-097-00	METAL GLAZE	100K	5%	1/10W
R414	1-216-827-11	METAL GLAZE	3.3K	5%	1/16W
R415	1-216-049-00	METAL GLAZE	1K	5%	1/10W
R416	1-216-817-11	METAL GLAZE	470	5%	1/16W
R417	1-216-662-11	METAL CHIP	3K	0.50%	1/10W
R418	1-216-663-11	METAL CHIP	3.3K	0.50%	1/10W
R419	1-216-663-11	METAL CHIP	3.3K	0.50%	1/10W
R421	1-216-682-11	METAL CHIP	20K	0.50%	1/10W
R422	1-216-073-00	METAL GLAZE	10K	5%	1/10W
R423	1-217-806-11	METAL GLAZE	1	5%	1/8W
R424	1-217-806-11	METAL GLAZE	1	5%	1/8W
R425	1-216-825-11	METAL GLAZE	2.2K	5%	1/16W
R426	1-216-081-00	METAL GLAZE	22K	5%	1/10W
R427	1-216-675-11	METAL CHIP	10K	0.50%	1/10W
R428	1-216-017-00	METAL GLAZE	47	5%	1/10W
R429	1-216-025-00	METAL GLAZE	100	5%	1/10W
R430	1-216-748-11	METAL GLAZE	39K	5%	1/10W
R431	1-216-025-00	METAL GLAZE	100	5%	1/10W
R432	1-216-857-11	METAL GLAZE	1M	5%	1/16W
R433	1-216-049-00	METAL GLAZE	1K	5%	1/10W
R434	1-216-073-00	METAL GLAZE	10K	5%	1/10W
R435	1-216-092-00	METAL GLAZE	62K	5%	1/10W
R436	1-216-067-00	METAL GLAZE	5.6K	5%	1/10W
R437	1-216-814-11	METAL GLAZE	270	5%	1/16W
R438	1-216-100-00	METAL CHIP	130K	0.50%	1/10W
R439	1-216-041-00	METAL GLAZE	470	5%	1/10W
R440:	1-216-034-00	METAL GLAZE	240	5%	1/10W
R441	1-216-801-11	METAL GLAZE	22	5%	1/16W
R442	1-216-081-00	METAL GLAZE	22K	5%	1/10W
R443	1-216-821-11	METAL GLAZE	1K	5%	1/16W
R502	1-216-073-00	METAL GLAZE	10K	5%	1/10W
R503	1-216-065-00	METAL GLAZE	4.7K	5%	1/10W
R505	1-216-073-00	METAL GLAZE	10K	5%	1/10W
R506	1-216-081-00	METAL GLAZE	22K	5%	1/10W
R507	1-216-071-00	METAL GLAZE	8.2K	5%	1/10W

Ref.No.	Part No.	Description			
R508	1-216-069-00	METAL GLAZE	6.8K	5%	1/10W
R509	1-216-073-00	METAL GLAZE	10K	5%	1/10W
R510	1-216-001-00	METAL GLAZE	10	5%	1/10W
R511	1-216-097-00	METAL GLAZE	100K	5%	1/10W
R512	1-216-073-00	METAL GLAZE	10K	5%	1/10W
R513	1-216-125-00	METAL GLAZE	1.5M	5%	1/10W
R514	1-216-109-00	METAL GLAZE	330K	5%	1/10W
R515	1-216-057-00	METAL GLAZE	2.2K	5%	1/10W
R516	1-216-077-00	METAL GLAZE	15K	5%	1/10W
R517	1-216-845-11	METAL GLAZE	100K	5%	1/16W
R519	1-216-095-00	METAL GLAZE	82K	5%	1/10W
R520	1-216-105-00	METAL GLAZE	220K	5%	1/10W
R521	1-216-081-00	METAL GLAZE	22K	5%	1/10W
R522	1-216-097-00	METAL GLAZE	100K	5%	1/10W
R523	1-216-065-00	METAL GLAZE	4.7K	5%	1/10W
R524	1-216-115-00	METAL GLAZE	560K	5%	1/10W
R525	1-216-073-00	METAL GLAZE	10K	5%	1/10W
R526	1-216-065-00	METAL GLAZE	4.7K	5%	1/10W
R527	1-216-683-11	METAL CHIP	22K	0.50%	1/10W
R528	1-216-103-00	METAL GLAZE	180K	5%	1/10W
R529	1-216-062-00	METAL GLAZE	3.6K	5%	1/10W
R530	1-216-059-00	METAL GLAZE	2.7K	5%	1/10W
R531	1-216-121-00	METAL GLAZE	1M	5%	1/10W
R532	1-216-683-11	METAL CHIP	22K	0.50%	1/10W
R533	1-216-073-00	METAL GLAZE	10K	5%	1/10W
R535	1-216-133-00	METAL GLAZE	3.3M	5%	1/10W
R536	1-216-095-00	METAL GLAZE	82K	5%	1/10W
R538	1-216-089-00	METAL GLAZE	47K	5%	1/10W
R539	1-216-121-00	METAL GLAZE	1M	5%	1/10W
R540	1-216-073-00	METAL GLAZE	10K	5%	1/10W
R541	1-216-047-00	METAL GLAZE	820	5%	1/10W
R542	1-216-101-00	METAL GLAZE	150K	5%	1/10W
R543	1-216-101-00	METAL GLAZE	150K	5%	1/10W
R544	1-216-057-00	METAL GLAZE	2.2K	5%	1/10W
R545	1-216-081-00	METAL GLAZE	22K	5%	1/10W
R546	1-216-748-11	METAL GLAZE	39K	5%	1/10W
R547	1-216-073-00	METAL GLAZE	10K	5%	1/10W
R548	1-216-065-00	METAL GLAZE	4.7K	5%	1/10W
R549	1-216-121-00	METAL GLAZE	1M	5%	1/10W
R550	1-216-057-00	METAL GLAZE	2.2K	5%	1/10W
R551	1-216-057-00	METAL GLAZE	2.2K	5%	1/10W
R552	1-216-061-00	METAL GLAZE	3.3K	5%	1/10W
R553	1-216-073-00	METAL GLAZE	10K	5%	1/10W
R554	1-216-105-00	METAL GLAZE	220K	5%	1/10W
R555	1-216-833-11	METAL GLAZE	10K	5%	1/16W
R556	1-216-825-11	METAL GLAZE	2.2K	5%	1/16W
R557	1-216-049-00	METAL GLAZE	1K	5%	1/10W
R559	1-216-093-00	METAL GLAZE	68K	5%	1/10W
R560	1-216-089-00	METAL GLAZE	47K	5%	1/10W
R561	1-216-089-00	METAL GLAZE	47K	5%	1/10W
R562	1-216-097-00	METAL GLAZE	100K	5%	1/10W
R563	1-216-099-00	METAL GLAZE	120K	5%	1/10W
R601	1-216-073-00	METAL GLAZE	10K	5%	1/10W
R602	1-216-097-00	METAL GLAZE	100K	5%	1/10W
R801	1-216-073-00	METAL GLAZE	10K	5%	1/10W
R802	1-216-081-00	METAL GLAZE	22K	5%	1/10W
R803	1-216-081-00	METAL GLAZE	22K	5%	1/10W



Ref.No.	Part No.	Description
R804	1-216-081-00	METAL GLAZE 22K 5% 1/10W
R805	1-216-089-00	METAL GLAZE 47K 5% 1/10W
R806	1-216-073-00	METAL GLAZE 10K 5% 1/10W
R807	1-216-109-00	METAL GLAZE 330K 5% 1/10W
R808	1-216-121-00	METAL GLAZE 1M 5% 1/10W
R809	1-216-121-00	METAL GLAZE 1M 5% 1/10W
R810	1-216-845-11	METAL GLAZE 100K 5% 1/16W
R811	1-216-025-00	METAL GLAZE 100 5% 1/10W
R812	1-216-121-00	METAL GLAZE 1M 5% 1/10W
R813	1-216-073-00	METAL GLAZE 10K 5% 1/10W
R814	1-216-661-11	METAL CHIP 2.7K 0.50% 1/10W
R815	1-216-097-00	METAL GLAZE 100K 5% 1/10W
R816	1-216-039-00	METAL GLAZE 390 5% 1/10W
R817	1-216-693-11	METAL CHIP 56K 0.50% 1/10W
R818	1-216-663-11	METAL CHIP 3.3K 0.50% 1/10W
R819	1-216-663-11	METAL CHIP 3.3K 0.50% 1/10W
R821	1-216-690-11	METAL CHIP 43K 0.50% 1/10W
R822	1-216-681-11	METAL CHIP 18K 0.50% 1/10W
R826	1-216-682-11	METAL CHIP 20K 0.50% 1/10W
R831	1-216-097-00	METAL GLAZE 100K 5% 1/10W
R832	1-216-097-00	METAL GLAZE 100K 5% 1/10W
R833	1-216-073-00	METAL GLAZE 10K 5% 1/10W
R834	1-216-073-00	METAL GLAZE 10K 5% 1/10W
R835	1-216-105-00	METAL GLAZE 220K 5% 1/10W
RV301	1-241-017-11	RES, VAR, CARBON 10K/10K (VOLUME)
RV401	1-241-066-11	RES, ADJ, METAL GRAZE 4.7K (CHARGE DET VOLTAGE)
RV402	1-241-068-11	RES, ADJ, METAL GRAZE 22K (+5V)
RV403	1-241-065-11	RES, ADJ, METAL GRAZE 2.2K (+3.6V)
RV501	1-241-068-11	RES, ADJ, METAL GRAZE 22K (TRACKING GAIN)
RV502	1-241-068-11	RES, ADJ, METAL GRAZE 22K (TRACKING BALANCE)
RV503	1-241-069-11	RES, ADJ, METAL GRAZE 47K (FOCUS BIAS)
RV504	1-241-064-11	RES, ADJ, METAL GRAZE 1K (PLL)
RV505	1-241-068-11	RES, ADJ, METAL GRAZE 22K (FOCUS GAIN)
RV801	1-241-067-11	RES, ADJ, METAL GRAZE 10K (BATTERY DISPLAY)
S301	1-570-386-21	SWITCH, SLIDE (BASS BOOST NORM MID MAX)
S401	1-570-953-11	SWITCH, PUSH (1 KEY)(PB 2 ON)
S801	1-570-909-21	SWITCH, TACTIL (REFLOW TYPE)()
S802	1-570-909-21	SWITCH, TACTIL (REFLOW TYPE)()
S803	1-570-909-21	SWITCH, TACTIL (REFLOW TYPE)()
S804	1-570-909-21	SWITCH, TACTIL (REFLOW TYPE)()

Ref.No.	Part No.	Description
S805	1-570-204-11	SWITCH, KEY BOARD (PLAY MODE)
S806	1-570-204-11	SWITCH, KEY BOARD (REMAIN/ENTER)
S807	1-571-860-11	SWITCH, SLIDE (RESUME OFF/ON HOLD)
S901	1-570-953-11	SWITCH, PUSH (1 KEY)(OPEN)
S902	1-570-771-11	SWITCH, MICRO
X301	1-577-576-11	VIBRATOR, CRYSTAL (15.9344MHz)
X801	1-578-769-11	VIBLATOR, CERAMIC (3.58MHz)

ACCESSORY & PACKING MATERIAL

	1-465-265-11	(US).....ADAPTOR, AC (AC-64N (U))
	1-465-266-11	(Canadian)...ADAPTOR, AC (AC-64N (CA))
	1-465-267-11	(AEP).....ADAPTOR, AC (AC-64N (AE))
	1-465-269-11	(UK).....ADAPTOR, AC (AC-64N (UK))
	1-465-270-11	(AUS).....ADAPTOR, AC (AC-64N (AU))
	1-465-520-11	(E).....ADAPTOR, AC (AC-64N)(110-240V)
	1-465-520-21	(E).....ADAPTOR, AC (AC-64N)(100-240V)
	1-569-007-11	(E).....ADAPTOR, CONVERSION 2P
	1-528-297-11	BATTERY PACK (BP-2EX)
	1-555-658-21	CORD, CONNECTION
	1-555-658-21	CORD, CONNECTION
	1-555-658-21	CORD, CONNECTION
	3-751-754-11	(Canadian,AEP,UK,E,AUS) ...MANUAL, INSTRUCTION
	3-751-754-21	(US).....MANUAL, INSTRUCTION
	3-751-754-41	(AEP).....MANUAL, INSTRUCTION
	3-752-086-01	INSTRUCTION
	*4-920-407-01	BAG, PROTECTION
	*4-931-874-01	CUSHION (UPPER)
	*4-931-875-01	(US,Canadian,E)...CUSHION (LOWER)
	*4-931-879-01	(AEP,UK,AUS).....CUSHION (LOWER)
	*4-931-877-01	(US,E).....INDIVIDUAL CARTON
	*4-931-878-01	(Canadian).....INDIVIDUAL CARTON
	*4-931-880-01	(AEP,UK,AUS)...INDIVIDUAL CARTON
	4-931-885-11	STRAP, HAND
	1-505-113-14	(Canadian)...HEADPHONE (WITH REMOTE CONTROL)
	8-952-478-90	(E,AUS).....HEADPHONE MDR-E472 SET
	8-953-307-90	(US,AEP,UK)...HEADPHONE MDR-A10D SET
	X-4930-117-1	CASE ASSY, BATTERY

Note:

The components identified by mark  or dotted line with mark  are critical for safety. Replace only with part number specified.

Note:

Les composants identifiés par une marque  sont critiques pour la sécurité. Ne les remplacer que par une pièce portant le numéro spécifié.