

CFS-W301L

SERVICE MANUAL

PRELIMINARY

*AEP Model
UK Model*

BP17.

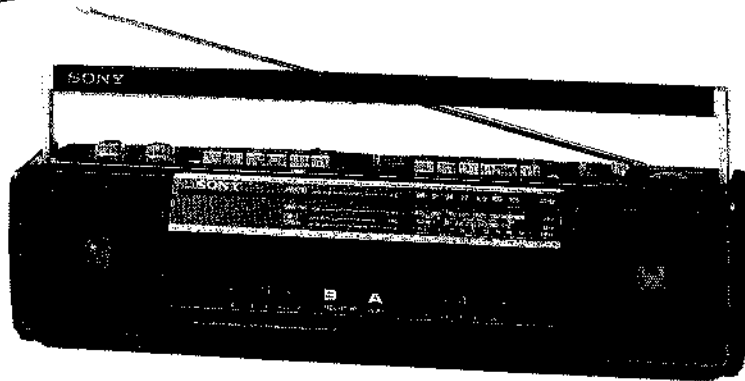

Frequency range

	FM	MW	LW	SW
Europe, United Kingdom	87.6–107 MHz	530–1605 kHz	150–285 kHz	5.95–18 MHz
Italy	87.5–108 kHz	148.5–526.5 kHz	148.5–283.5 kHz	

Tape Transport	MF-W301 PB-75D (Deck A)
Mechanism Type	MF-W301 RP-75D (Deck B)

Antennas	FM/SW: Telescopic antenna MW/LW: Built-in ferrite bar antenna
Frequency response	80–10,000 Hz (with normal tapes)
Speakers	Full-range: 10 cm (4 inches) dia. x 2
Peak music power output	11W (5.5W + 5.5W)
Inputs	MIX MIC input jack (minijack) Mixing: sensitivity 4.4 mV, for low impedance External mic: sensitivity 0.775 mV, for low impedance
Outputs	Headphones jack (stereo minijack) for 8–300 ohm impedance headphones
Power requirements	9 V DC, six R20 (size D) batteries

In AC operation:

AEP model (incl. Italy)	220 V AC, 50 Hz
UK model	240 V AC, 50 Hz

Power consumption	AEP model (incl. Italy): 14 W UK model: 20 W
-------------------	---

Battery life (hours)

Batteries	FM recording
Sony SUM-1 (NS)	Approx. 15
Sony AM1 alkaline	Approx. 26

Dimensions	Approx. 530 x 145 x 122 mm (w/h/d) (20 ⁷ / ₈ x 5 ³ / ₈ x 4 ⁷ / ₈ inches) incl. projecting parts and controls, not incl. handle
Weight	Approx. 3.5 kg (7 lb 11 oz) incl. batteries
Accessory supplied	AC power cord (1)

SAFETY-RELATED COMPONENT WARNING!!

COMPONENTS IDENTIFIED BY SHADING AND MARK  ON THE SCHEMATIC DIAGRAMS AND IN THE PARTS LIST ARE CRITICAL TO SAFE OPERATION. REPLACE THESE COMPONENTS WITH SONY PARTS WHOSE PART NUMBERS APPEAR AS SHOWN IN THIS MANUAL OR IN SUPPLEMENTS PUBLISHED BY SONY.

**FM/MW/LW/SW
STEREO CASSETTE-CORDER
SONY®**



TC

SECTION 1 EXPLODED VIEWS

NOTE:

- The mechanical parts with no reference number in the exploded views are not supplied.
- Items marked "*" are not stocked since they are seldom required for routine service. Some delay should be anticipated when ordering these items.

- The construction parts of an assembled part are indicated with a collation number in the remark column.

• Color Indication of Appearance Parts
Example: (RED) KNOB, BALANCE
(WHITE)

Cabinet's Color Parts' Color

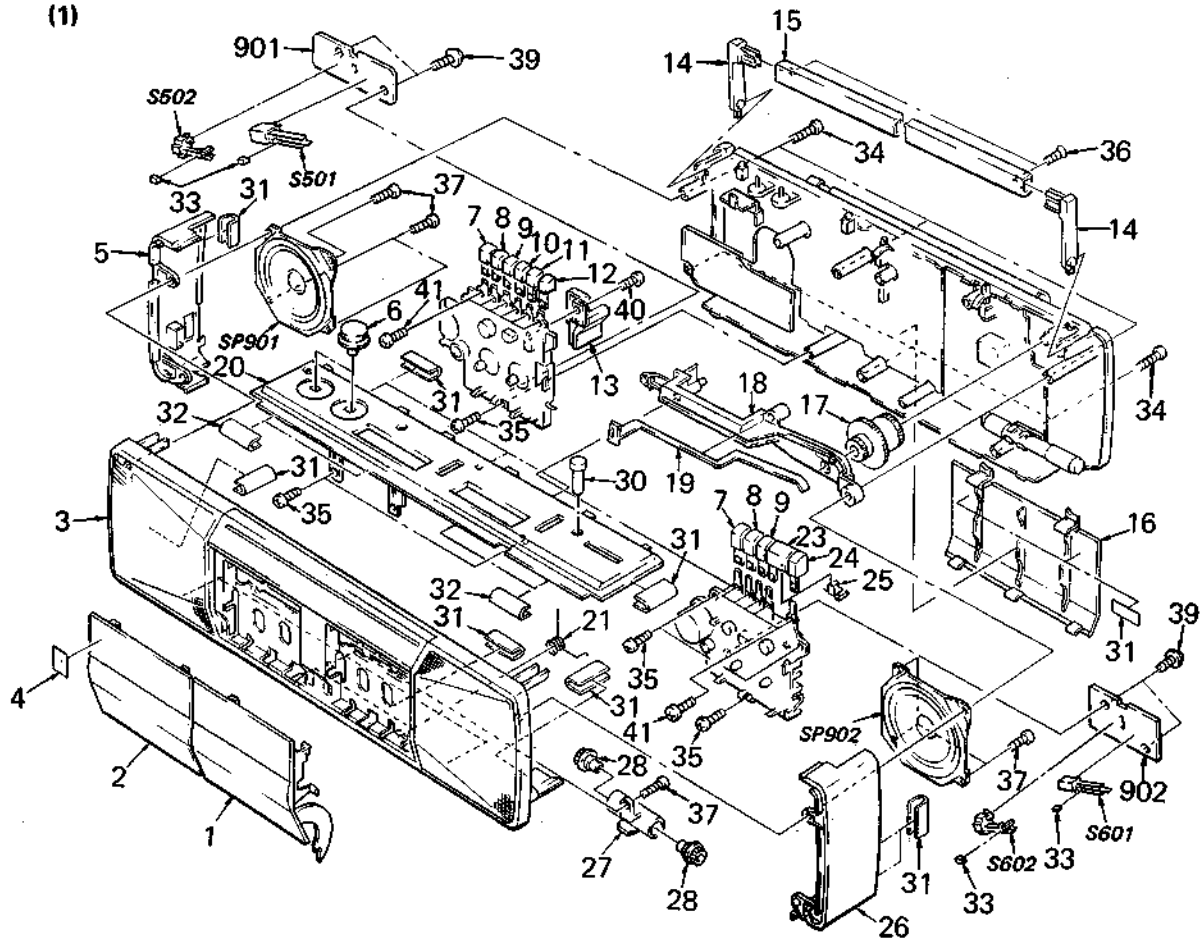

No.	Part No.	Description	Remarks	No.	Part No.	Description	Remarks
4	3-703-710-01	STICKER, SONY SYMBOL (12)		21	3-339-318-01	SPRING	
5	3-339-341-01	(BLACK)...PLATE (LEFT), SIDE (BLACK)		23	3-339-335-01	BUTTON (B), PLAY	
	3-339-341-11	(BLUE)...PLATE (LEFT), SIDE (BLUE)		24	3-339-336-01	BUTTON (B), STOP	
6	3-339-348-01	KNOB, VOL		25	3-339-315-01	SPRING	
7	3-339-330-01	BUTTON (A), PAUSE		26	3-339-343-01	(BLACK)...PLATE (RIGHT), SIDE (BLACK)	
8	3-339-331-01	BUTTON (A), FF			3-339-343-11	(BLUE)...PLATE (RIGHT), SIDE (BLUE)	
9	3-339-332-01	BUTTON (A), REW		27	3-339-314-01	BRACKET, EJECT	
10	3-339-334-01	BUTTON (A), PLAY		28	3-326-411-01	GEAR, EJECT	
11	3-339-322-01	BUTTON (A), REC		30	3-339-309-01	KNOB, FINE TUNE	
12	3-339-333-01	BUTTON (A), STOP		31	3-831-441-XX	CUSHION	
13	3-339-308-01	LEVER, REC		32	3-831-441-11	CUSHION	
14	3-326-423-21	PLATE, SIDE, HANDLE		33	9-911-844-XX	SPACER, LEAF	
15	3-326-454-51	(BLACK)...HANDLE (BLACK)		34	7-685-651-79	SCREW +BVTP 3X20 TYPE2	
	3-326-454-61	(BLUE)...HANDLE (BLUE)		35	7-685-648-79	SCREW +BVTP 3X12 TYPE2 N-S	
16	3-339-350-01	LID, BATTERY CASE		36	7-685-246-19	SCREW +KTP 3X8 TYPE2 NON-SLIT	
17	3-339-329-01	KNOB, TUNING		37	7-685-647-79	SCREW +BVTP 3X10 TYPE2 N-S	
18	3-339-340-01	CHASSIS, DIAL		39	7-687-233-11	SCREW (+ PTPWH) (2.6X6)	
19	3-339-324-01	RACK, POINTER		40	7-685-793-04	SCREW +BVTT 2.6X8 (S)	
20	3-339-351-21	(BLACK)...PANEL, CONTROL (BLACK)		41	7-685-790-04	SCREW +PTT 2.6X4 (S)	
	3-339-351-31	(BLUE)...PANEL, CONTROL (BLUE)		901	*1-621-580-11	PC BOARD, SW (A)	
				902	*1-621-581-11	PC BOARD, SW (B)	
				SP901	1-503-750-11	SPEAKER (LEFT)	
				SP902	1-503-750-11	SPEAKER (RIGHT)	

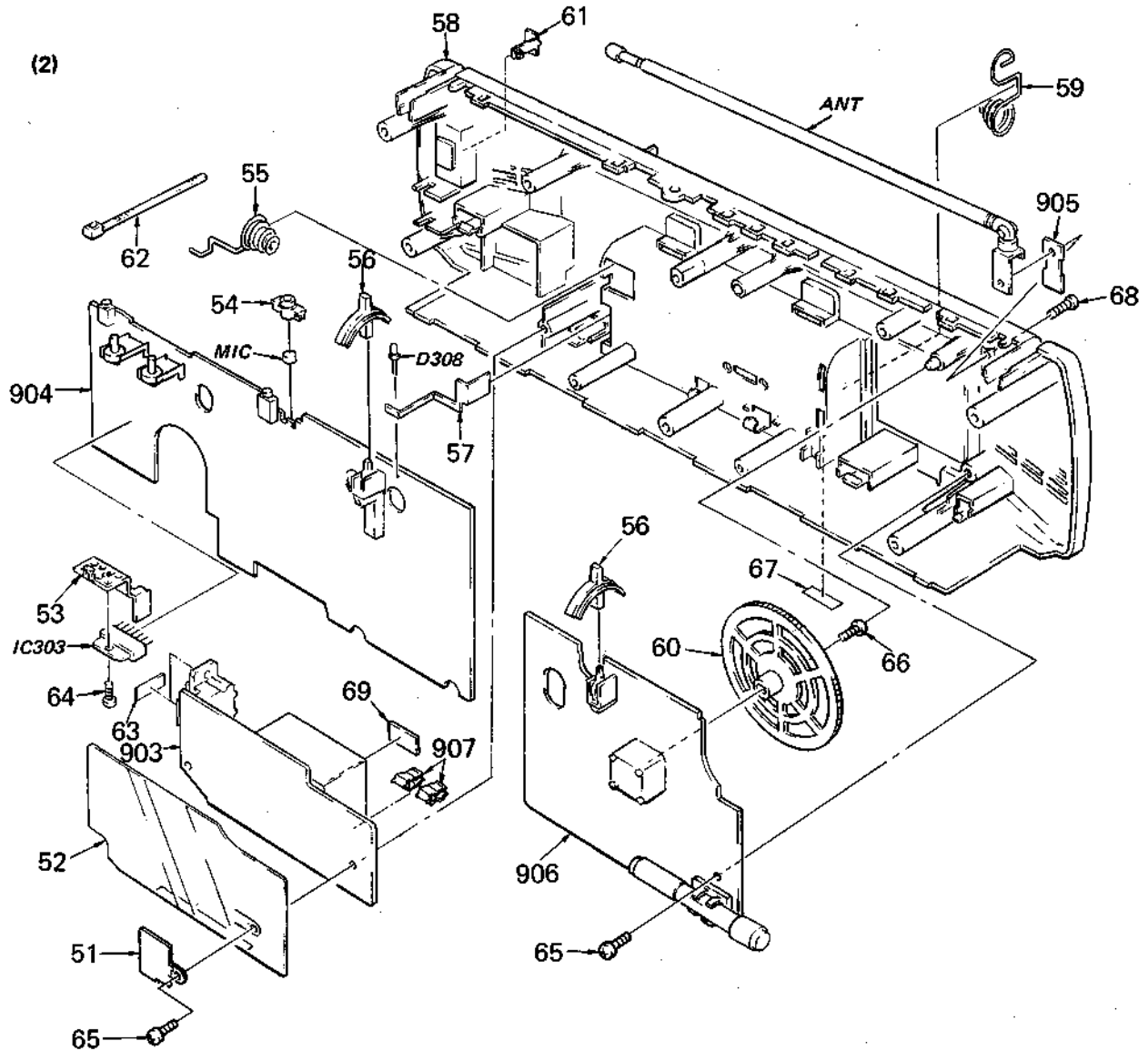

No.	Part No.	Description	Remarks	No.	Part No.	Description	Remarks
51	3-340-331-01	CLAMP, POWER PC BOARD		65	7-685-647-79	SCREW +BVTP 3X10 TYPE2 N-S	
52	*3-339-320-01	COVER, POWER		66	7-621-770-87	SCREW +B 2.6X5	
53	*3-339-310-01	HEAT SINK		67	3-527-213-00	LABEL, SERIAL NUMBER	
54	3-321-122-01	CUSHION, MICROPHONE		68	7-682-548-09	SCREW +B 3X8	
55	3-339-316-01	SPRING (-)		69	4-836-922-01	CUSHION	
56	3-339-328-01	KNOB, FUNCTION		903	*1-621-583-11	PC BOARD, POWER	
57	3-339-317-01	TERMINAL BOARD (+), BATTERY		904	*A-3270-379-A	(AEP)...PC BOARD ASSY, MAIN	
58	3-339-301-21	(AEP)...CABINET (REAR)			*A-3270-380-A	(UK)...PC BOARD ASSY, MAIN	
	3-339-301-31	(UK)...CABINET (REAR)		905	*1-621-578-11	PC BOARD, ANT	
59	3-339-319-01	SPRING (+,-)		906	*A-3266-372-A	PC BOARD ASSY, TUNER	
60	3-339-304-01	DRUM, TUNING CAPACITOR		907	1-553-183-11	HOLDER, FUSE	
61	3-326-452-01	KNOB, ISS		ANT	1-501-338-31	ANTENNA, TELESCOPIC	
62	3-339-311-00	CLAMP		D308	1-807-738-11	SLR-34VR70F/30 (LED)	
63	3-831-441-XX	CUSHION		IC303	8-759-205-82	IC TA7282AP	
64	7-682-546-04	SCREW +BVTT 3X5 (S)		MIC	8-814-186-00	MICROPHONE, ELECTRET CONDENSER	

CFS-W301L

(3) Deck A: MF-W301PB-75D
Deck B: MF-W301RP-75D

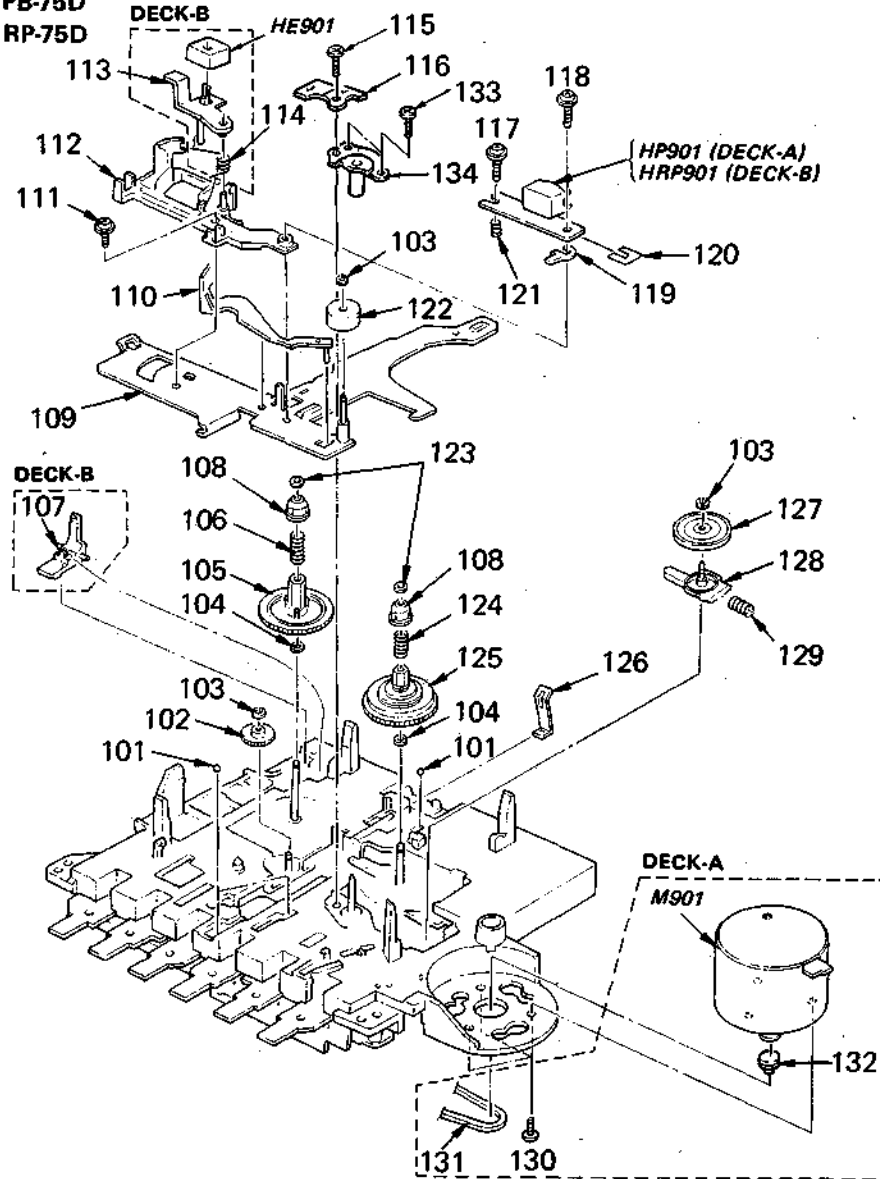

No.	Part No.	Description	Remarks	No.	Part No.	Description	Remarks
101	7-671-112-11	BALL, STEEL		120	3-578-138-01	SEAM (t=0.1)	
102	3-558-620-11	GEAR, REWIND			3-578-138-11	SEAM (t=0.2)	
103	3-307-948-01	WASHER, NYLON			3-578-138-21	SEAM (t=0.3)	
104	3-701-437-21	WASHER		121	3-313-340-00	SPRING, COMPRESSION	
105	3-313-305-00	TABLE, REEL, SUPPLY		122	3-703-597-41	PINCH ROLLER, STANDARD	
106	3-313-344-00	SPRING, COMPRESSION		123	3-558-708-01	WASHER, STOPPER	
107	3-313-357-00	(DECK B)...CLAW, REC PREVENTION		124	3-313-345-00	SPRING, COMPRESSION	
108	3-313-333-00	CLAW, REEL		125	A-3130-031-A	TABLE ASSY, REEL, TAKE-UP	
109	X-3313-311-1	CHASSIS ASSY		126	3-313-902-00	SPRING	
110	3-313-316-00	PULLEY		127	X-3313-307-0	PULLEY ASSY, FWD	
111	7-621-255-35	SCREW (2MMX5), + PMH		128	X-3313-301-0	BRACKET ASSY, T PULLEY	
112	3-334-717-01	BRACKET (M), HEAD		129	3-573-464-00	SPRING, COMPRESSION	
113	3-313-361-00	(DECK B)...ARM, ERASE HEAD		130	7-621-259-35	(DECK A)...SCREW +P 2.6X5	
114	3-313-339-00	(DECK B)...SPRING		131	3-313-389-01	BELT	
115	3-324-220-01	SCREW (B2.6), TAPPING		132	X-3330-617-1	(DECK A)...PULLEY (S), MOTOR ASSY	
116	*3-332-309-01	SPRING (B)		133	3-318-203-71	SCREW (B1.7X5), TAPPING	
117	3-701-465-00	SCREW, LOCK		134	X-3319-945-1	BEARING ASSY, CAPSTAN	
118	7-621-255-50	SCREW +B 2X8		HE901	8-658-096-02	(DECK B)...HEAD, ERASE EBF5-36	
119	3-331-108-01	LUG (T), SEAM (t=0.1)		HP901	1-543-283-11	(DECK A)...HEAD, MAGNETIC (REC/PB)	
	3-331-108-11	LUG (T), SEAM (t=0.2)		HRP901	1-543-283-11	(DECK B)...HEAD, MAGNETIC (REC/PB)	
	3-331-108-21	LUG (T), SEAM (t=0.3)		M901	1-541-330-11	(DECK A)...MOTOR (CW)	
	3-331-108-31	LUG (T), SEAM (t=0.4)					
	3-331-108-41	LUG (T), SEAM (t=0.5)					

(4)

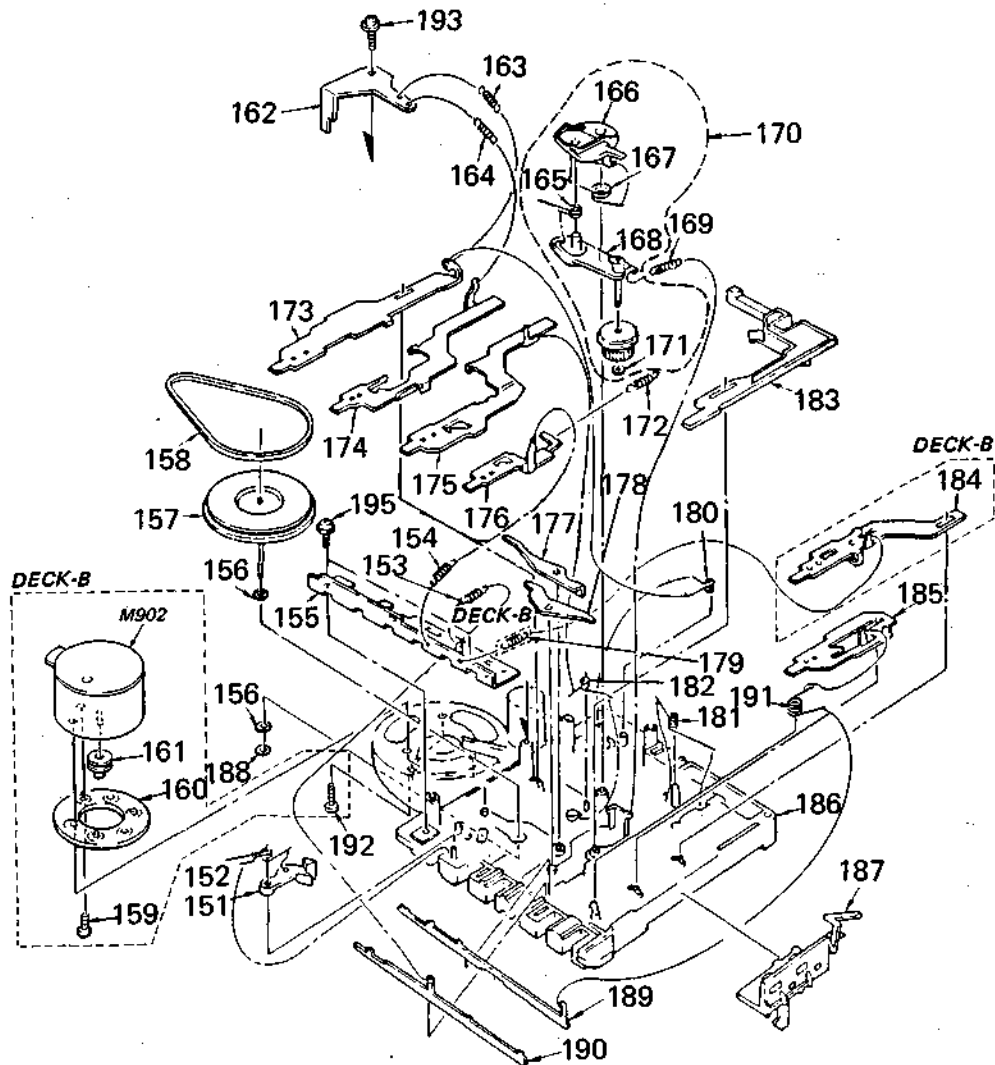

No.	Part No.	Description	Remarks	No.	Part No.	Description	Remarks
151	3-313-322-02	LEVER (A), S.OFF		173	*3-313-381-01	LEVER (B), PAUSE BUTTON	
152	3-313-323-00	SPRING		174	*3-313-353-00	LEVER, FF BUTTON	
153	3-313-343-00	SPRING, TENSION		175	*3-313-354-00	LEVER, REW BUTTON	
154	3-313-369-00	SPRING, TENSION		176	*3-313-326-00	LEVER, FWD BUTTON	
155	*3-313-359-00	RETAINER, LEVER		177	*3-313-320-11	LEVER, RCP	
156	3-701-438-11	WASHER, 2.5		178	*3-313-321-00	LEVER, PREVENTION, RFR	
157	X-3592-309-1	FLYWHEEL (E) ASSY		179	3-322-529-01	(DECK B)...SPRING, TENSION	
158	3-313-389-01	BELT		180	3-313-378-01	SPRING (A)	
159	7-621-259-25	(DECK B)...SCREW +P 2.6X4		181	3-313-327-00	SPRING	
160	3-330-679-01	(DECK B)...BRACKET (M), MOTOR		182	3-313-338-00	SPRING	
161	X-3330-617-1	(DECK B)...PULLEY (S), MOTOR ASSY		183	3-313-356-00	BRAKE	
162	*3-332-310-01	HOOK, SPRING		184	*3-313-350-00	(DECK B)...LEVER, REC BUTTON	
163	3-313-349-00	SPRING, TENSION		185	*3-313-325-00	LEVER, STOP BUTTON	
164	3-313-348-00	SPRING, TENSION		186	A-3102-092-A	CHASSIS ASSY, MECHANICAL	
165	3-313-313-00	SPRING		187	3-313-380-01	CLAW (A), EJECT	
166	3-313-314-00	LEVER (S1), FR		188	3-307-948-41	WASHER, NYLON	
167	3-313-315-00	SPRING		189	*3-313-352-11	PLATE (B), LOCK	
168	X-3313-304-0	ARM ASSY, REW		190	*3-313-351-11	PLATE (A), LOCK	
169	3-313-365-00	SPRING, TENSION		191	3-313-331-00	SPRING	
170	A-3136-041-B	TOLER COMPLETE ASSY, FR	165-168,171	192	3-324-219-01	SCREW, PAN	
171	3-558-708-01	WASHER, STOPPER		193	7-687-233-11	SCREW (+ PTPWH) (2.6X6)	
172	3-313-342-00	SPRING, TENSION		M902	1-541-317-11	(DECK B)...MOTOR	

2-1. MOUNTING DIAGRAM

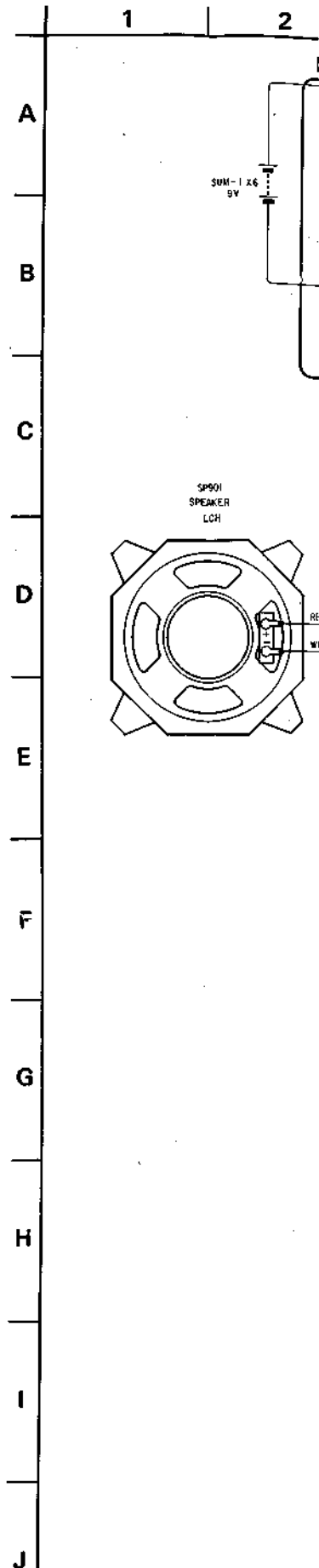

SECTION 2
DIAGRAMS

WIRING DIAGRAM

1 2 3 4 5 6 7 8 9 10 11 12 13 14 15 16 17

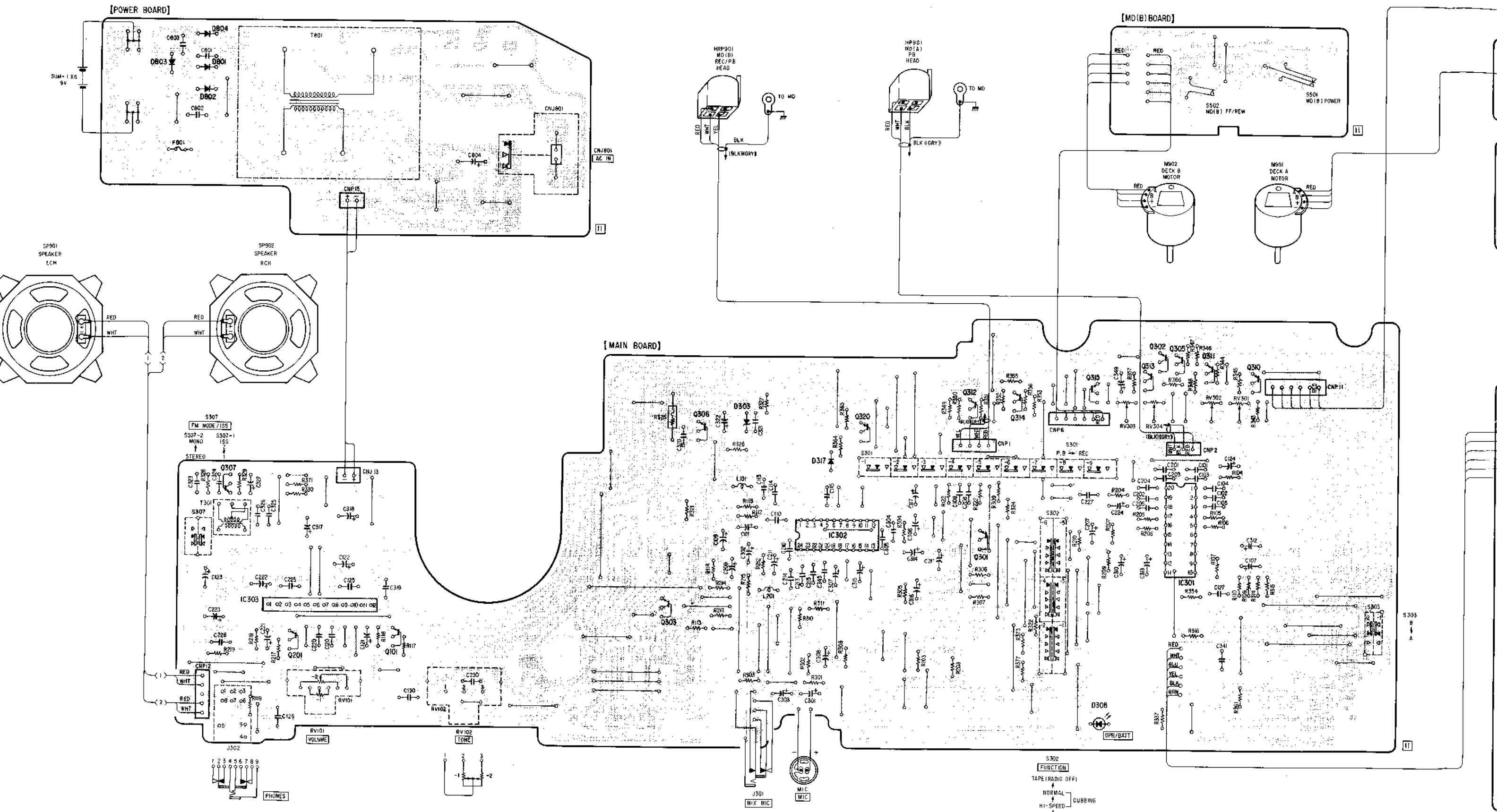

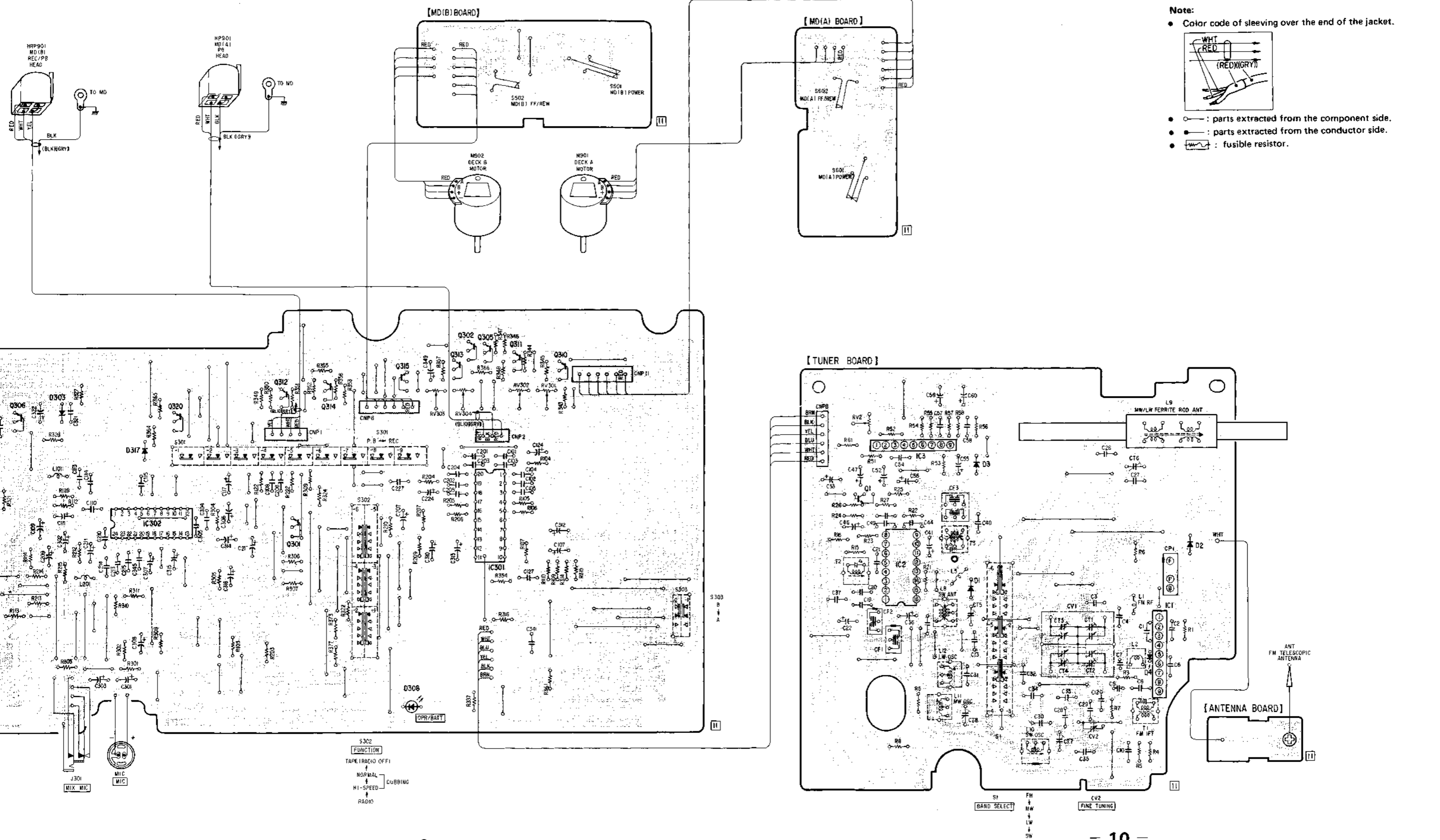



Note:

- Color code of sleeving over the end of the jacket.

- : parts extracted from the component side.
- : parts extracted from the conductor side.
- ⊞ : fusible resistor.

12 13 14 15 16 17 18 19 20 21 22 23

- Note:**
- All capacitors are in μF unless otherwise noted. pF: pF, μF 50 WV or less are not indicated except for electrolytics and tantalums.
 - All resistors are in Ω and $1/4\text{W}$ or less unless otherwise specified.
 -  : sliding resistor.
 -  : Switch with sliding contact indicated by hatched lines shows shorting type.

- Voltages are dc with respect to ground unless otherwise noted.
 - Readings are taken under no-signal (detuned) conditions with a VOM (50 K Ω /V).
 - No mark : FM
 - { } : PB
 - < > : REC
- Note:** The components identified by shading and mark  are critical for safety. Replace only with part number specified.

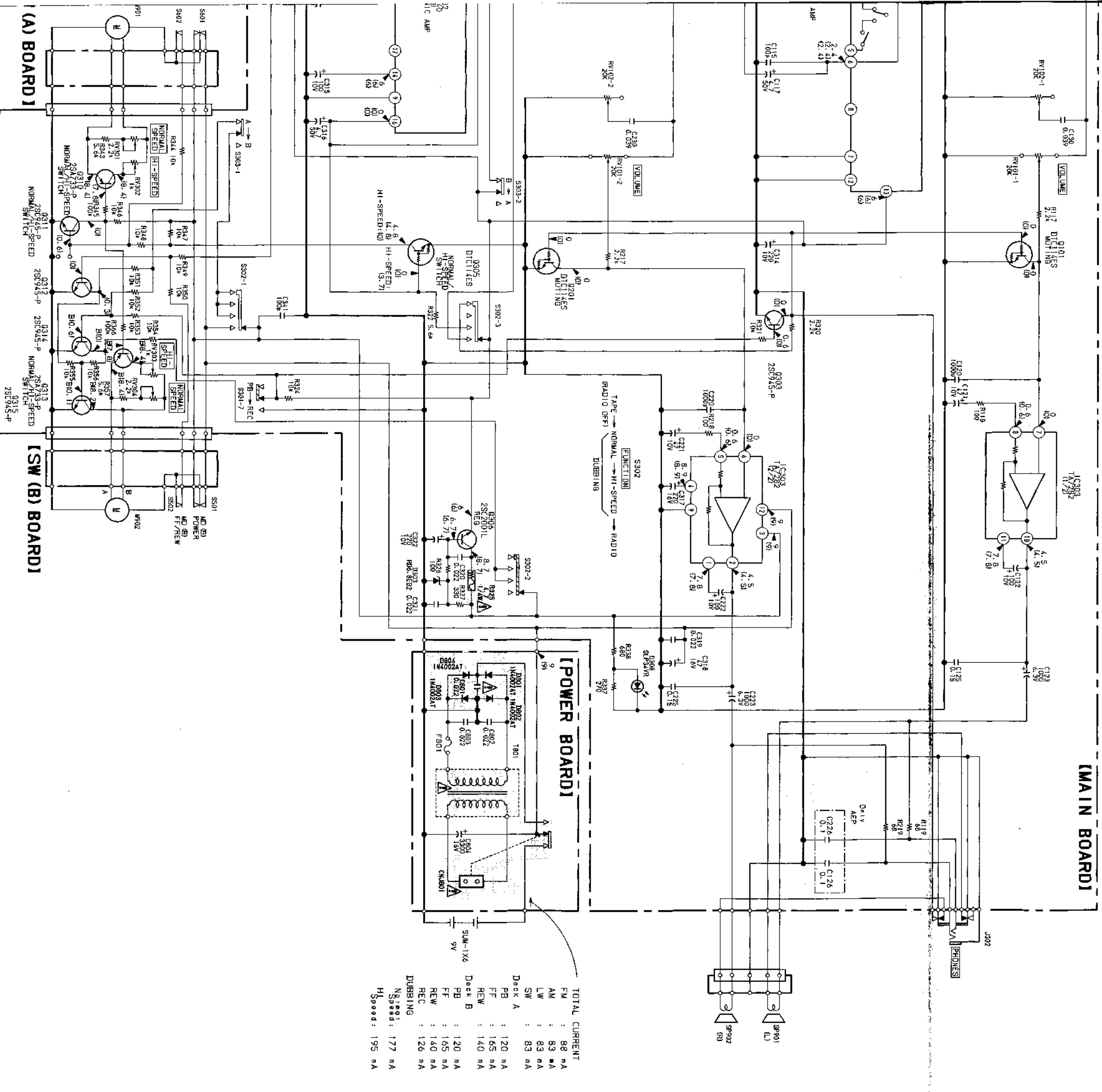

TOTAL CURRENT

FM	: 88 mA
AM	: 83 mA
LW	: 83 mA
SW	: 83 mA
Deck A	
PB	: 120 mA
FF	: 165 mA
REW	: 140 mA
Deck B	
PB	: 120 mA
FF	: 165 mA
REW	: 140 mA
REC	: 126 mA
DUBBING	
NC	: 177 mA
Speed	: 195 mA

- Note:
- All capacitors are in μF unless otherwise noted. pF: μpF 50 WV or less are not indicated except for electrolytics and tantalums.
 - All resistors are in Ω and $\frac{1}{4}\text{W}$ or less unless otherwise specified.
 - Δ : Internal component.
 - Voltages are dc with respect to ground unless otherwise noted.
 - Readings are taken under no-signal (detuned) conditions with a VOM (50 $\text{k}\Omega/\text{V}$).
- No mark: FM

2-3. SCHEMATIC DIAGRAM - TUNER SECTION -

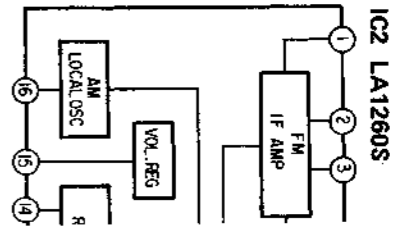
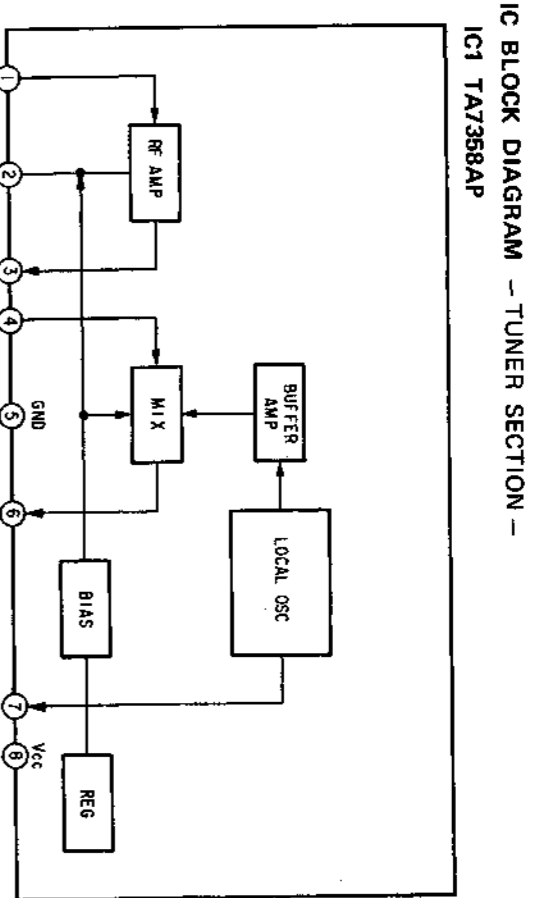
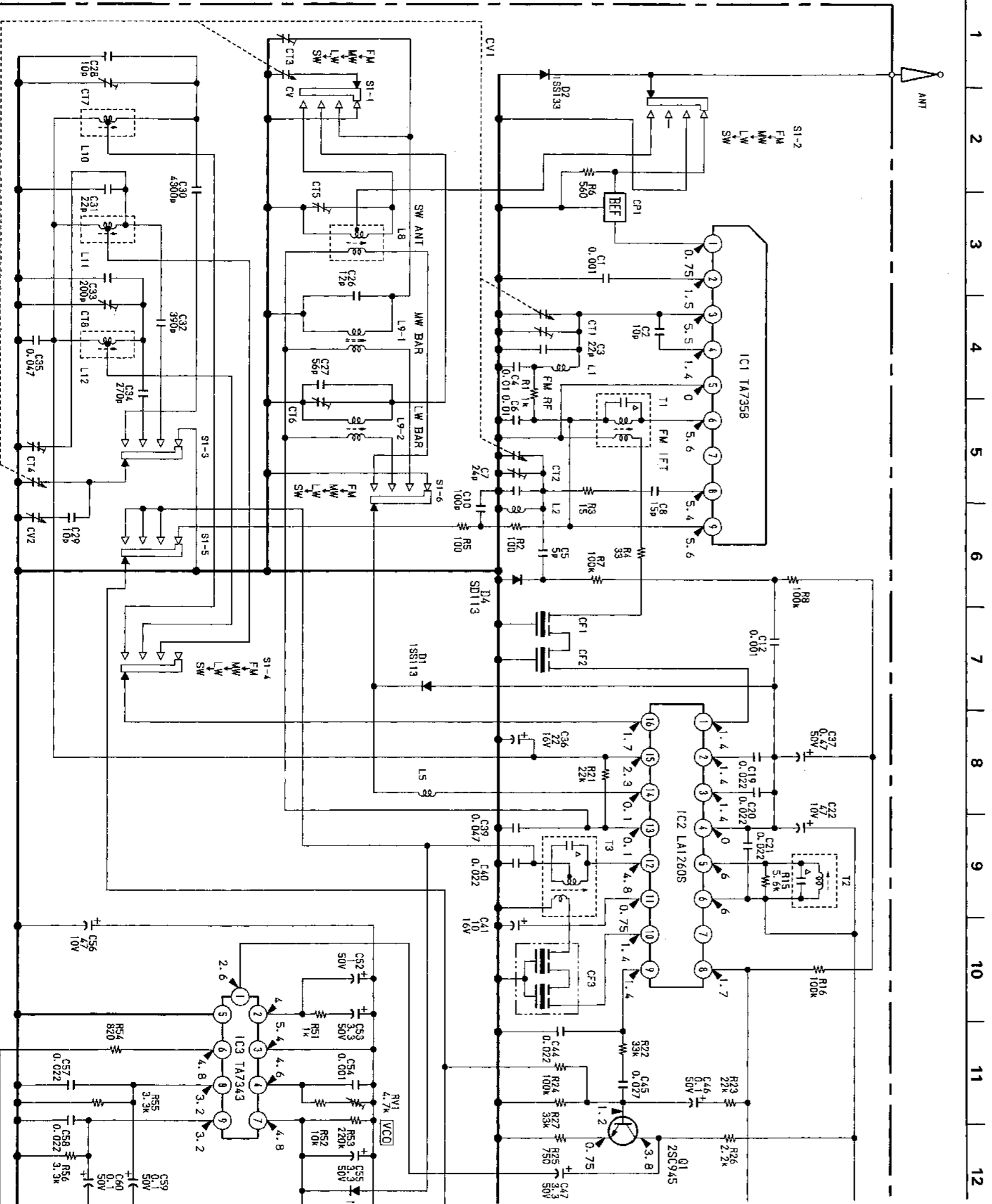

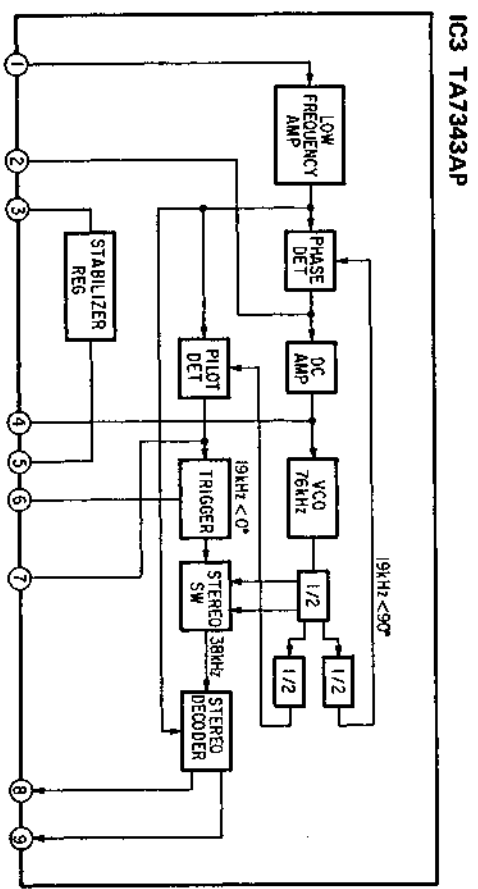
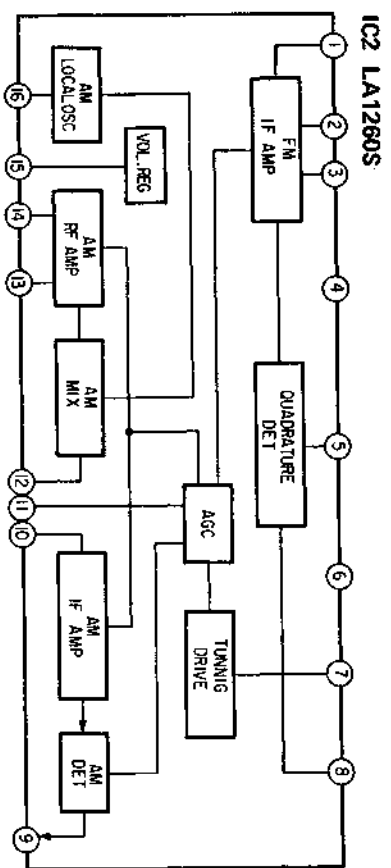

IC BLOCK DIAGRAM - MAIN SECTION -

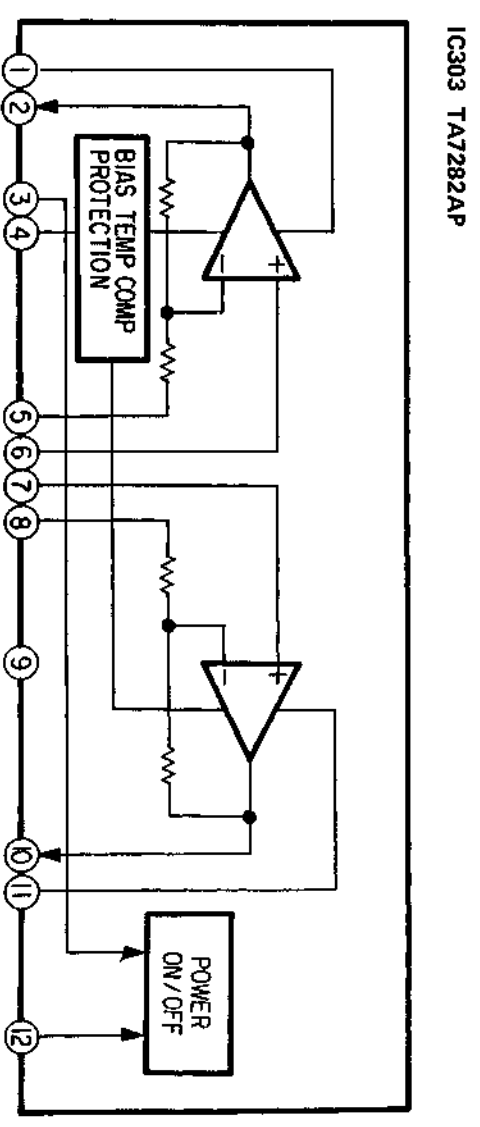
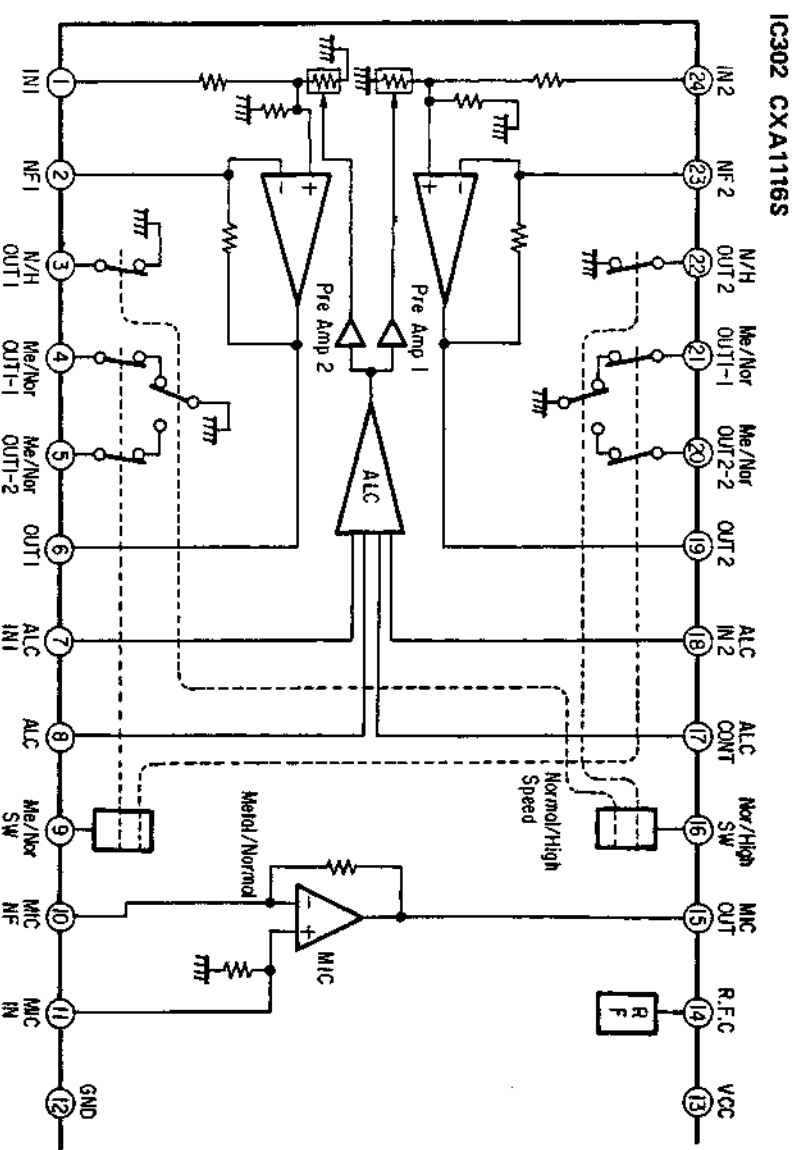
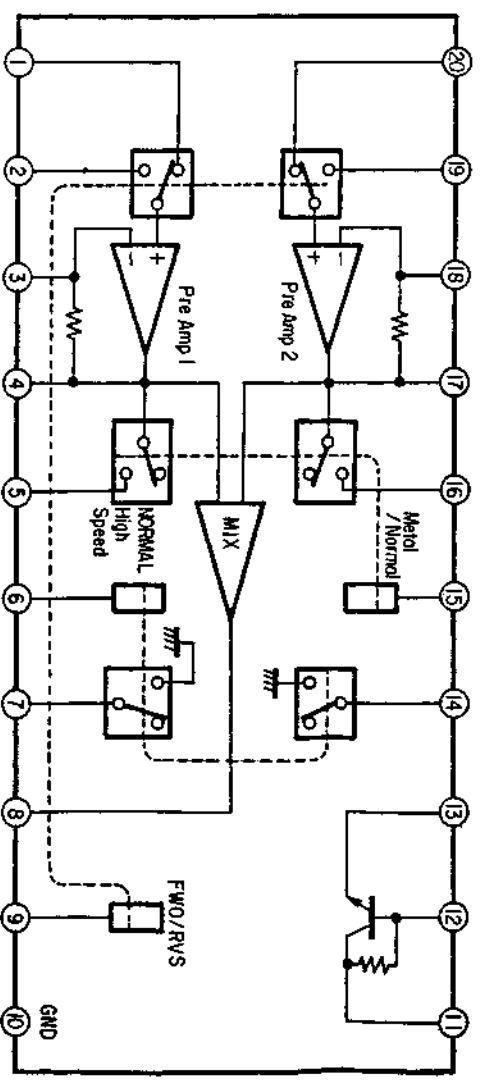

11 12 13 14 15 16

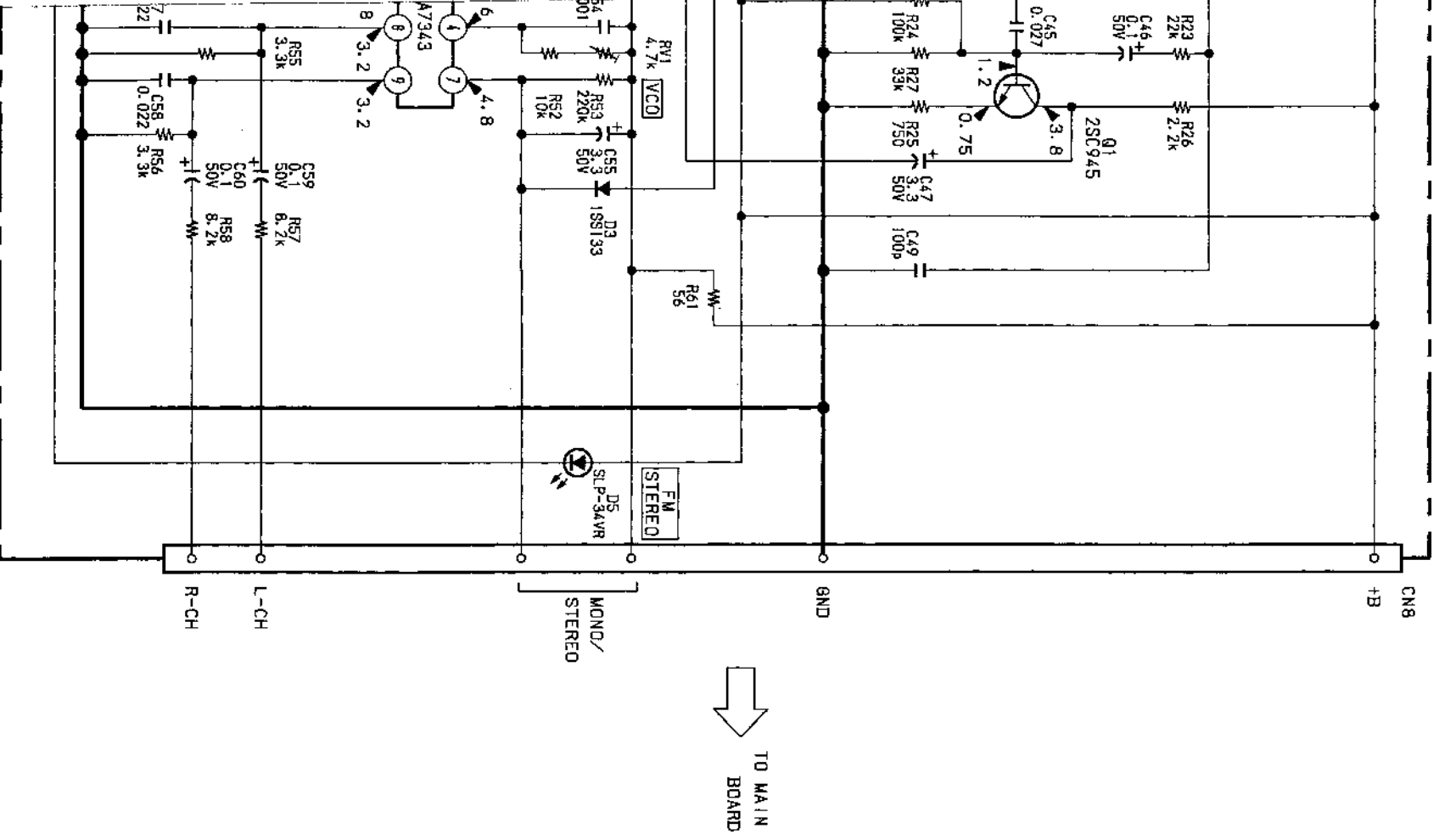

TO MAIN BOARD

SECTION 3 ELECTRICAL PARTS LIST

NOTE:

Items marked " * " are not stocked since they are seldom required for routine service. Some delay should be anticipated when ordering these items.

If there are two or more same circuits in a set such as a stereophonic machine, only typical circuit parts may be indicated and capacitors and resistors in other same circuits may be omitted.

CAPACITORS:

MF:μF, PF:μμF.

RESISTORS

· All resistors are in ohms.

· F : nonflammable

COILS

· MMH : mH, UH : μH

SEMICONDUCTORS

In each case, U : μ, for example:

UA...: μA..., UPA...: μPA..., UPC...: μPC,

UPD...: μPD...

The components identified by shading and mark **A** are critical for safety. Replace only with part number specified.

ELECTRICAL PARTS

Ref.No.	Part No.	Description				
901	*1-621-580-11	PC BOARD, SW (A)				
902	*1-621-581-11	PC BOARD, SW (B)				
903	*1-621-583-11	PC BOARD, POWER				
904	*A-3270-379-A	(AEP)...PC BOARD ASSY, MAIN				
	*A-3270-380-A	(UK)...PC BOARD ASSY, MAIN				
905	*1-621-578-11	PC BOARD, ANT				
906	*A-3266-372-A	PC BOARD ASSY, TUNER				
907	1-533-183-11	HOLDER, FUSE				
ANT	1-501-338-31	ANTENNA, TELESCOPIC				
C1	1-102-074-00	CERAMIC	0.001MF	10%	50V	
C2	1-102-947-00	CERAMIC	10PF	5%	50V	
C3	1-102-959-00	CERAMIC	22PF	5%	50V	
C4	1-161-013-00	CERAMIC	0.01MF	10%	25V	
C5	1-102-864-00	CERAMIC	5PF	0.5PF	50V	
C6	1-161-013-00	CERAMIC	0.01MF	10%	25V	
C7	1-102-642-00	CERAMIC	24PF	5%	50V	
C8	1-102-951-00	CERAMIC	15PF	5%	50V	
C10	1-102-973-00	CERAMIC	100PF	5%	50V	
C12	1-102-074-00	CERAMIC	0.001MF	10%	50V	
C13	1-102-942-00	CERAMIC	5PF	0.5PF	50V	
C19	1-101-005-00	CERAMIC	0.022MF		50V	
C20	1-101-005-00	CERAMIC	0.022MF		50V	
C21	1-101-005-00	CERAMIC	0.022MF		50V	
C22	1-123-306-00	ELECT	47MF	20%	10V	
C26	1-102-749-00	CERAMIC	12PF	5%	50V	
C27	1-101-884-00	CERAMIC	56PF	5%	50V	
C28	1-102-947-00	CERAMIC	10PF	0.5PF	50V	
C29	1-102-947-00	CERAMIC	10PF	5%	50V	
C30	1-103-740-00	POLYSTYRENE	0.0043MF	5%	50V	
C31	1-102-751-00	CERAMIC	22PF	5%	50V	
C32	1-104-067-00	POLYSTYRENE	390PF	5%	50V	
C33	1-104-060-00	POLYSTYRENE	200PF	5%	50V	
C34	1-103-711-00	POLYSTYRENE	270PF	5%	50V	
C35	1-161-059-00	CERAMIC	0.047MF	10%	25V	
C36	1-123-330-00	ELECT	22MF	20%	16V	
C37	1-123-379-00	ELECT	0.47MF	20%	50V	
C39	1-161-059-00	CERAMIC	0.047MF	10%	25V	
C40	1-161-055-00	CERAMIC	0.022MF	10%	25V	
C41	1-123-356-00	ELECT	10MF	20%	16V	
C44	1-161-055-00	CERAMIC	0.022MF	10%	25V	
C45	1-161-056-00	CERAMIC	0.027MF	10%	25V	
C46	1-123-607-00	ELECT	0.1MF	20%	50V	
C47	1-123-382-00	ELECT	3.3MF	20%	50V	
C49	1-102-973-00	CERAMIC	100PF	5%	50V	
C52	1-123-380-00	ELECT	1MF	20%	50V	
C53	1-123-382-00	ELECT	3.3MF	20%	50V	

ELECTRICAL PARTS

Ref.No.	Part No.	Description				
C54	1-104-077-00	POLYSTYRENE	0.001MF	5%	50V	
C55	1-123-382-00	ELECT	3.3MF	20%	50V	
C56	1-123-306-00	ELECT	47MF	20%	10V	
C57	1-161-055-00	CERAMIC	0.022MF	10%	25V	
C58	1-161-055-00	CERAMIC	0.022MF	10%	25V	
C59	1-123-607-00	ELECT	0.1MF	20%	50V	
C60	1-123-607-00	ELECT	0.1MF	20%	50V	
C101	1-102-115-00	CERAMIC	560PF	10%	50V	
C102	1-102-110-00	CERAMIC	220PF	10%	50V	
C103	1-102-115-00	CERAMIC	560PF	10%	50V	
C104	1-102-110-00	CERAMIC	220PF	10%	50V	
C105	1-161-052-00	CERAMIC	0.012MF	10%	25V	
C107	1-123-369-00	ELECT	4.7MF	20%	50V	
C108	1-102-074-00	CERAMIC	0.001MF	10%	50V	
C109	1-123-369-00	ELECT	4.7MF	20%	50V	
C110	1-102-110-00	CERAMIC	220PF	10%	50V	
C111	1-123-306-00	ELECT	47MF	20%	10V	
C113	1-161-054-00	CERAMIC	0.018MF	10%	25V	
C114	1-161-055-00	CERAMIC	0.022MF	10%	25V	
C115	1-102-106-00	CERAMIC	100PF	10%	50V	
C117	1-123-369-00	ELECT	4.7MF	20%	50V	
C120	1-102-074-00	CERAMIC	0.001MF	10%	50V	
C121	1-123-306-00	ELECT	47MF	20%	10V	
C122	1-123-307-00	ELECT	100MF	20%	10V	
C123	1-123-299-00	ELECT	1000MF	20%	6.3V	
C124	1-123-306-00	ELECT	47MF	20%	10V	
C125	1-130-497-00	MYLAR	0.15MF	5%	50V	
C126	1-136-165-00	FILM	0.1MF	5%	50V	
C127	1-102-106-00	CERAMIC	100PF	10%	50V	
C130	1-161-058-00	CERAMIC	0.039MF	10%	25V	
C201	1-102-115-00	CERAMIC	560PF	10%	50V	
C202	1-102-110-00	CERAMIC	220PF	10%	50V	
C203	1-102-115-00	CERAMIC	560PF	10%	50V	
C204	1-102-110-00	CERAMIC	220PF	10%	50V	
C205	1-161-052-00	CERAMIC	0.012MF	10%	25V	
C207	1-123-369-00	ELECT	4.7MF	20%	50V	
C208	1-102-074-00	CERAMIC	0.001MF	10%	50V	
C209	1-123-369-00	ELECT	4.7MF	20%	50V	
C210	1-102-110-00	CERAMIC	220PF	10%	50V	
C211	1-123-306-00	ELECT	47MF	20%	10V	
C213	1-161-054-00	CERAMIC	0.018MF	10%	25V	
C214	1-161-055-00	CERAMIC	0.022MF	10%	25V	
C215	1-102-106-00	CERAMIC	100PF	10%	50V	
C217	1-123-369-00	ELECT	4.7MF	20%	50V	
C220	1-102-074-00	CERAMIC	0.001MF	10%	50V	
C221	1-123-306-00	ELECT	47MF	20%	10V	

ELECTRICAL PARTS

Ref.No.	Part No.	Description			
C222	1-123-307-00	ELECT	100MF	20%	10V
C223	1-123-299-00	ELECT	1000MF	20%	6.3V
C224	1-123-306-00	ELECT	47MF	20%	10V
C225	1-130-497-00	MYLAR	0.15MF	5%	50V
C226	1-136-165-00	FILM	0.1MF	5%	50V
C227	1-102-106-00	CERAMIC	100PF	10%	50V
C230	1-161-058-00	CERAMIC	0.039MF	10%	25V
C301	1-123-379-00	ELECT	0.47MF	20%	50V
C302	1-123-379-00	ELECT	0.47MF	20%	50V
C303	1-124-464-11	ELECT	0.22MF	20%	50V
C304	1-102-074-00	CERAMIC	0.001MF	10%	50V
C305	1-161-053-00	CERAMIC	0.015MF	10%	25V
C306	1-123-330-00	ELECT	22MF	20%	16V
C307	1-123-369-00	ELECT	4.7MF	20%	50V
C308	1-123-307-00	ELECT	100MF	20%	10V
C310	1-123-306-00	ELECT	47MF	20%	10V
C312	1-123-369-00	ELECT	4.7MF	20%	50V
C313	1-124-124-00	ELECT	220MF	20%	10V
C314	1-124-124-00	ELECT	220MF	20%	10V
C315	1-123-307-00	ELECT	100MF	20%	10V
C316	1-123-369-00	ELECT	4.7MF	20%	50V
C317	1-123-321-00	ELECT	220MF	20%	16V
C318	1-123-332-00	ELECT	47MF	20%	16V
C319	1-101-005-00	CERAMIC	0.022MF		50V
C320	1-101-005-00	CERAMIC	0.022MF		50V
C321	1-101-005-00	CERAMIC	0.022MF		50V
C322	1-124-124-00	ELECT	220MF	20%	10V
C323	1-130-479-00	MYLAR	0.0047MF	5%	50V
C324	1-102-074-00	CERAMIC	0.001MF	10%	50V
C325	1-130-467-00	MYLAR	470PF	5%	50V
C326	1-102-106-00	CERAMIC	100PF	10%	50V
C327	1-123-306-00	ELECT	47MF	20%	10V
C341	1-102-106-00	CERAMIC	100PF	10%	50V
C345	1-162-294-31	CERAMIC	0.001MF	10%	50V
C801	1-101-005-00	CERAMIC	0.022MF		50V
C802	1-101-005-00	CERAMIC	0.022MF		50V
C803	1-101-005-00	CERAMIC	0.022MF		50V
C804	1-124-887-00	ELECT	3300MF	20%	16V
CF1	1-567-802-11	FILTER, CERAMIC			
CF2	1-567-802-11	FILTER, CERAMIC			
CF3	1-567-670-11	FILTER, CERAMIC			
CNJ13	*1-563-307-11	CONNECTOR (SOCKET) 2P			
CNJ801A	1-526-838-11	INLET, AC 2P			
CNP1	*1-564-778-11	PLUG, CONNECTOR (2.5MM) 4P			
CNP2	*1-506-707-11	PLUG, CONNECTOR (2.5MM) 3P			
CNP6	*1-564-779-11	PLUG, CONNECTOR (2.5MM) 6P			

ELECTRICAL PARTS

Ref.No.	Part No.	Description
CNP8	*1-564-779-11	PLUG, CONNECTOR (2.5MM) 6P
CNP11	*1-564-779-11	PLUG, CONNECTOR (2.5MM) 6P
CNP12	*1-506-708-11	PLUG, CONNECTOR (2.5MM) 5P
CNP13	*1-560-530-00	PIN, CONNECTOR 2P
CP1	1-235-911-21	FILTER, BAND PASS
CT1-4	1-151-387-00	CAP, TUNING, POLYETHYLENE CV1
CV2	1-141-328-11	CAP, TRIMMER
CT5	1-141-290-11	CAP, VAR FILM TRIMMER
CT6	1-141-260-00	TRIMMER, CERAMIC
CT7	1-141-290-11	CAP, VAR FILM TRIMMER
CT8	1-141-245-00	TRIMMER, CERAMIC
D1	8-719-901-33	DIODE 1SS133
D2	8-719-901-33	DIODE 1SS133
D3	8-719-901-33	DIODE 1SS133
D4	8-719-768-75	DIODE 1S2687CS
D303	8-719-100-41	DIODE RD6.8EB2
D308	1-807-738-11	SLR-34VR70F/30 (LED)
D317	8-719-901-33	DIODE 1SS133
D801	1-807-739-11	DIODE IN4002AT-92
D802	1-807-739-11	DIODE IN4002AT-92
D803	1-807-739-11	DIODE IN4002AT-92
D804	1-807-739-11	DIODE IN4002AT-92
F801	1-532-285-00	FUSE, TIME-LAG
HE901	8-658-096-02	HEAD, ERASE EBF5-36
HP901	1-543-283-11	(DECK A)...HEAD, MAGNETIC (REC/PB)
HRP901	1-543-283-11	(DECK B)...HEAD, MAGNETIC (REC/PB)
IC1	8-759-204-03	IC TA7358AP
IC2	8-759-801-24	IC LA1260S
IC3	8-759-203-87	IC TA7343AP
IC301	8-759-803-27	IC CXA1115P
IC302	8-759-803-28	IC CXA1116S
IC303	8-759-205-82	IC TA7282AP
J301	1-507-643-00	JACK
J302	1-507-948-11	JACK
L1	*1-422-126-00	COIL, AIR-CORE
L2	1-459-694-11	COIL, VHF (WITH CORE)
L5	*1-409-293-00	COIL, AIR CORE
L8	1-402-262-11	COIL, SW ANT
L9	1-402-247-11	ANTENNA, FERRITE-ROD (LW/MW)
L10	1-406-229-11	COIL, OSCILLATION (SW)

The components identified by shading and mark  are critical for safety. Replace only with part number specified.

ELECTRICAL PARTS

Ref.No.	Part No.	Description			
L11	1-406-059-00	COIL, OSC			
L12	1-406-151-11	COIL, OSCILLATION (LW)			
L101	1-407-961-00	MICRO INDUCTOR 2.7MMH			
L201	1-407-961-00	MICRO INDUCTOR 2.7MMH			
M901	1-541-330-11	(DECK A)...MOTOR (CW)			
M902	1-541-317-11	(DECK B)...MOTOR			
MIC	8-814-186-00	MICROPHONE, ELECTRET CONDENSER			
Q1	1-807-533-21	TRANSISTOR KSC945C-G			
Q101	8-729-900-80	TRANSISTOR DTC114ES			
Q201	8-729-900-80	TRANSISTOR DTC114ES			
Q301	1-807-533-21	TRANSISTOR KSC945C-G			
Q302	8-729-900-80	TRANSISTOR DTC114ES			
Q303	1-807-533-21	TRANSISTOR KSC945C-G			
Q305	8-729-900-80	TRANSISTOR DTC114ES			
Q306	8-729-100-12	TRANSISTOR 2SC2001-L			
Q307	1-807-533-21	TRANSISTOR KSC945C-G			
Q310	1-807-537-21	TRANSISTOR KSA733C-Y			
Q311	1-807-533-21	TRANSISTOR KSC945C-G			
Q312	1-807-533-21	TRANSISTOR KSC945C-G			
Q313	1-807-537-21	TRANSISTOR KSA733C-Y			
Q314	1-807-533-21	TRANSISTOR KSC945C-G			
Q315	1-807-533-21	TRANSISTOR KSC945C-G			
Q320	1-807-537-21	TRANSISTOR KSA733C-Y			
R1	1-249-417-11	CARBON	1K	5%	1/6W
R2	1-249-405-11	CARBON	100	5%	1/6W
R3	1-247-787-00	CARBON	15	5%	1/6W
R4	1-247-795-00	CARBON	33	5%	1/6W
R5	1-249-405-11	CARBON	100	5%	1/6W
R6	1-249-414-11	CARBON	560	5%	1/6W
R7	1-249-441-11	CARBON	100K	5%	1/6W
R8	1-249-441-11	CARBON	100K	5%	1/6W
R15	1-247-849-00	CARBON	5.6K	5%	1/6W
R16	1-249-441-11	CARBON	100K	5%	1/6W
R21	1-249-433-11	CARBON	22K	5%	1/6W
R22	1-249-435-11	CARBON	33K	5%	1/6W
R23	1-249-433-11	CARBON	22K	5%	1/6W
R24	1-249-441-11	CARBON	100K	5%	1/6W
R25	1-247-828-00	CARBON	750	5%	1/6W
R26	1-249-421-11	CARBON	2.2K	5%	1/6W
R27	1-249-435-11	CARBON	33K	5%	1/6W
R51	1-249-417-11	CARBON	1K	5%	1/6W
R52	1-249-429-11	CARBON	10K	5%	1/6W
R53	1-215-477-00	CARBON	220K	5%	1/6W
R54	1-249-422-11	CARBON	2.7K	5%	1/6W

ELECTRICAL PARTS

Ref.No.	Part No.	Description			
R55	1-249-423-11	CARBON	3.3K	5%	1/6W
R56	1-249-423-11	CARBON	3.3K	5%	1/6W
R57	1-249-427-11	CARBON	6.8K	5%	1/6W
R58	1-249-427-11	CARBON	6.8K	5%	1/6W
R61	1-249-402-11	CARBON	56	5%	1/6W
R103	1-249-429-11	CARBON	10K	5%	1/6W
R104	1-249-405-11	CARBON	100	5%	1/6W
R105	1-249-429-11	CARBON	10K	5%	1/6W
R106	1-249-429-11	CARBON	10K	5%	1/6W
R107	1-249-421-11	CARBON	2.2K	5%	1/6W
R109	1-249-429-11	CARBON	10K	5%	1/6W
R110	1-249-421-11	CARBON	2.2K	5%	1/6W
R112	1-247-813-00	CARBON	180	5%	1/6W
R113	1-247-874-00	CARBON	62K	5%	1/6W
R114	1-249-429-11	CARBON	10K	5%	1/6W
R115	1-249-413-11	CARBON	470	5%	1/6W
R117	1-249-421-11	CARBON	2.2K	5%	1/6W
R118	1-249-405-11	CARBON	100	5%	1/6W
R119	1-247-803-00	CARBON	68	5%	1/6W
R122	1-249-429-11	CARBON	10K	5%	1/6W
R203	1-249-429-11	CARBON	10K	5%	1/6W
R204	1-249-405-11	CARBON	100	5%	1/6W
R205	1-249-429-11	CARBON	10K	5%	1/6W
R206	1-249-429-11	CARBON	10K	5%	1/6W
R207	1-249-421-11	CARBON	2.2K	5%	1/6W
R209	1-249-429-11	CARBON	10K	5%	1/6W
R210	1-249-421-11	CARBON	2.2K	5%	1/6W
R212	1-247-813-00	CARBON	180	5%	1/6W
R213	1-247-874-00	CARBON	62K	5%	1/6W
R214	1-249-429-11	CARBON	10K	5%	1/6W
R215	1-249-413-11	CARBON	470	5%	1/6W
R217	1-249-421-11	CARBON	2.2K	5%	1/6W
R218	1-249-405-11	CARBON	100	5%	1/6W
R219	1-247-803-00	CARBON	68	5%	1/6W
R222	1-249-429-11	CARBON	10K	5%	1/6W
R301	1-247-821-00	CARBON	390	5%	1/6W
R302	1-249-413-11	CARBON	470	5%	1/6W
R303	1-249-413-11	CARBON	470	5%	1/6W
R304	1-247-817-00	CARBON	270	5%	1/6W
R305	1-249-441-11	CARBON	100K	5%	1/6W
R306	1-249-417-11	CARBON	1K	5%	1/6W
R307	1-249-441-11	CARBON	100K	5%	1/6W
R308	1-249-409-11	CARBON	220	5%	1/6W
R309	1-247-849-00	CARBON	5.6K	5%	1/6W
R310	1-249-429-11	CARBON	10K	5%	1/6W

ELECTRICAL PARTS

Ref.No.	Part No.	Description			
R311	1-249-429-11	CARBON	10K	5%	1/6W
R314	1-249-441-11	CARBON	100K	5%	1/6W
R315	1-249-429-11	CARBON	10K	5%	1/6W
R316	1-249-402-11	CARBON	56	5%	1/6W
R320	1-249-421-11	CARBON	2.2K	5%	1/6W
R321	1-249-429-11	CARBON	10K	5%	1/6W
R322	1-247-849-00	CARBON	5.6K	5%	1/6W
R324	1-249-429-11	CARBON	10K	5%	1/6W
A R325	1-217-383-00	FUSIBLE	4.7	5%	1/4W F
R326	1-249-405-11	CARBON	100	5%	1/6W
R327	1-249-411-11	CARBON	330	5%	1/6W
R328	1-249-429-11	CARBON	10K	5%	1/6W
R329	1-249-393-11	CARBON	10	5%	1/6W
R330	1-247-820-00	CARBON	360	5%	1/6W
R337	1-247-817-00	CARBON	270	5%	1/6W
R343	1-247-849-00	CARBON	5.6K	5%	1/6W
R344	1-249-429-11	CARBON	10K	5%	1/6W
R345	1-249-441-11	CARBON	100K	5%	1/6W
R346	1-249-429-11	CARBON	10K	5%	1/6W
R347	1-249-429-11	CARBON	10K	5%	1/6W
R348	1-249-429-11	CARBON	10K	5%	1/6W
R349	1-249-429-11	CARBON	10K	5%	1/6W
R350	1-249-429-11	CARBON	10K	5%	1/6W
R351	1-249-429-11	CARBON	10K	5%	1/6W
R352	1-249-429-11	CARBON	10K	5%	1/6W
R353	1-249-429-11	CARBON	10K	5%	1/6W
R354	1-249-429-11	CARBON	10K	5%	1/6W
R355	1-249-429-11	CARBON	10K	5%	1/6W
R356	1-249-429-11	CARBON	10K	5%	1/6W
R357	1-247-849-00	CARBON	5.6K	5%	1/6W
R361	1-249-415-11	CARBON	680	5%	1/6W
R363	1-249-437-11	CARBON	47K	5%	1/6W
R364	1-249-421-11	CARBON	2.2K	5%	1/6W
R366	1-249-441-11	CARBON	100K	5%	1/6W
R371	1-249-402-11	CARBON	56	5%	1/6W
R373	1-247-787-00	CARBON	15	5%	1/6W
R377	1-247-787-00	CARBON	15	5%	1/6W
RV1	1-228-993-00	RES, ADJ, CARBON	4.7K		
RV101	1-230-093-00	RES, VAR, CARBON	20K/20K		
RV102	1-237-570-11	RES, VAR			
RV301	1-228-991-00	RES, ADJ, CARBON	2.2K		
RV302	1-228-990-00	RES, ADJ, CARBON	1K		
RV303	1-228-990-00	RES, ADJ, CARBON	1K		
RV304	1-228-991-00	RES, ADJ, CARBON	2.2K		

ELECTRICAL PARTS

Ref.No.	Part No.	Description
S1	1-554-885-11	SWITCH, LEVER SLIDE
S301	1-570-942-11	SWITCH, SLIDE
S302	1-570-944-11	SWITCH, LEVER SLIDE
S303	1-570-068-11	SWITCH, PUSH (1 KEY)
S307	1-554-123-00	SWITCH, SLIDE
S501	1-554-495-00	SWITCH, LEAF
S502	1-570-012-11	SWITCH, LEAF
S601	1-554-495-00	SWITCH, LEAF
S602	1-570-012-11	SWITCH, LEAF
SP901	1-503-750-11	SPEAKER (LEFT)
SP902	1-503-750-11	SPEAKER (RIGHT)
T1	1-403-872-00	I.F.T CONVERTER FM (SMALL TYPE)
T2	1-404-249-00	COIL, FM DETECTOR
T3	1-404-355-00	TRANSFORMER, IF
T301	1-433-222-00	TRANSFORMER, BIAS OSCILLATOR.
T801	1-448-779-11	(UK)...TRANSFORMER, POWER
T801	1-448-780-11	(AEP)...TRANSFORMER, POWER

ACCESSORY & PACKING MATERIAL

Part No.	Description
1-555-234-00	(AEP)...CORD, POWER
1-558-032-11	(UK)...CORD, POWER
3-339-354-01	CUSHION (UPPER)
3-339-355-01	CUSHION (LOWER)
3-339-357-01	INDIVIDUAL CARTON
3-339-382-01	SHEET, PROTECTION
3-701-626-00	BAG, POLYETHYLENE
3-703-895-01	LABEL, COLOR
*3-764-430-01	(AEP)...INSTRUCTION, DBP CAUTION
3-765-963-11	MANUAL, INSTRUCTION

The components identified by shading and mark  are critical for safety. Replace only with part number specified.

Sony Corporation
Audio Group