

CFD-E100/E100L

SERVICE MANUAL

Ver. 1.1 2005.05



Photo : CFD-E100

US Model
Canadian Model
E Model
CFD-E100
AEP Model
UK Model
CFD-E100L

CD Section	Model Name Using Similar Mechanism	NEW
	Optical Pick-up Block Name	KSM-900AAA
TAPE Section	Model Name Using Similar Mechanism	NEW
	Tape Transport Mechanism Type	MF-E100

SPECIFICATIONS

AUDIO POWER SPECIFICATIONS (US model only)

POWER OUTPUT AND TOTAL HARMONIC DISTORTION

With 3.2-ohm loads, both channels driven from 100 - 10,000 Hz; rated 1.5 W per channel-minimum RMS power, with no more than 10 % total harmonic distortion in AC operation.

CD player section

System

Compact disc digital audio system

Laser diode properties

Emission duration: Continuous

Laser output: Less than 44.6 μ W

(This output is the value measured at a distance of about 200 mm from the objective lens surface on the optical pick-up block with 7 mm aperture.)

Spindle speed

200 r/min (rpm) to 500 r/min (rpm)

(CLV)

Number of channels

2

Frequency response

20 - 20 000 Hz $\pm 1/-2$ dB

Wow and flutter

Below measurable limit

Radio section

Frequency range

CFD-E100L

FM 87.5 - 108 MHz

MW 531 - 1 611 kHz (9 kHz step)
530 - 1 610 kHz (10 kHz step)

LW 153 - 279 kHz

CFD-E100

FM 87.5 - 108 MHz

AM 531 - 1 611 kHz (9 kHz step)
530 - 1 610 kHz (10 kHz step)

IF

FM: 10.7 MHz

AM/MW/LW: 450 kHz

Aerials

FM: Telescopic aerials

AM/MW/LW: Built-in ferrite bar aerials

Cassette-corder section

Recording system

4-track 2 channel stereo

Fast winding time

Approx. 120 s (sec.) with Sony cassette C-60

Frequency response

TYPE I (normal): 80 - 13 000 Hz

General

Speaker

Full range: 8 cm dia., 3.2 Ω , cone type (2)

Outputs

Headphones jack (stereo minijack)

For 16 - 68 Ω impedance headphones

Maximum Power output

3.6 W

Power requirements

For CD radio cassette-corder:

US, Canadian, Taiwan models:

120 V AC, 60Hz

Korean model: 220 V AC, 60Hz

Other models: 230 V AC, 50Hz

9 V DC, 6 R14 (size C) batteries

For remote control:

3 V DC, 2 R03 (size AAA) batteries

Power consumption

AC 14 W

Battery life

For CD radio cassette-corder:

FM recording

Sony R14P: approx. 13.5 h

Sony alkaline LR14: approx. 20 h

Tape playback

Sony R14P: approx. 7.5 h

Sony alkaline LR14: approx. 15 h

CD playback

Sony R14P: approx. 2.5 h

Sony alkaline LR14: approx. 7 h

Dimensions

Approx. 385 \times 190.5 \times 170 mm (w/h/d)
(incl. projecting parts)

Mass

Approx. 3.1 kg (incl. batteries)

Supplied accessory

Mains lead (1)

Remote control (1)

Design and specifications are subject to change without notice.

CD RADIO CASSETTE-CORDER

9-879-702-02
2005E05-1
© 2005.05

Sony Corporation
Personal Audio Group
Published by Sony Engineering Corporation

SONY®

CAUTION

Use of controls or adjustments or performance of procedures other than those specified herein may result in hazardous radiation exposure.

Notes on chip component replacement

- Never reuse a disconnected chip component.
- Notice that the minus side of a tantalum capacitor may be damaged by heat.

Flexible Circuit Board Repairing

- Keep the temperature of the soldering iron around 270 °C during repairing.
- Do not touch the soldering iron on the same conductor of the circuit board (within 3 times).
- Be careful not to apply force on the conductor when soldering or unsoldering.

About CD-Rs/CD-RWs

This player can play CD-Rs/CD-RWs recorded in the CD-DA format*, but playback capability may vary depending on the quality of the disc and the condition of the recording device.

* CD-DA is the abbreviation for Compact Disc Digital Audio. It is a recording standard used for Audio CDs.

SAFETY CHECK-OUT

After correcting the original service problem, perform the following safety check before releasing the set to the customer:

Check the antenna terminals, metal trim, “metallized” knobs, screws, and all other exposed metal parts for AC leakage.

Check leakage as described below.

LEAKAGE TEST

The AC leakage from any exposed metal part to earth ground and from all exposed metal parts to any exposed metal part having a return to chassis, must not exceed 0.5 mA (500 microamperes.). Leakage current can be measured by any one of three methods.

1. A commercial leakage tester, such as the Simpson 229 or RCA WT-540A. Follow the manufacturers’ instructions to use these instruments.
2. A battery-operated AC milliammeter. The Data Precision 245 digital multimeter is suitable for this job.
3. Measuring the voltage drop across a resistor by means of a VOM or battery-operated AC voltmeter. The “limit” indication is 0.75 V, so analog meters must have an accurate low-voltage scale. The Simpson 250 and Sanwa SH-63Trd are examples of a passive VOM that is suitable. Nearly all battery operated digital multimeters that have a 2 V AC range are suitable. (See Fig. A)

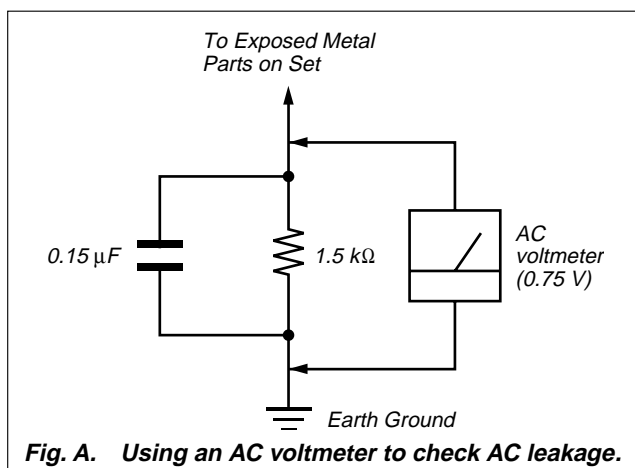

Fig. A. Using an AC voltmeter to check AC leakage.

SAFETY-RELATED COMPONENT WARNING!!

COMPONENTS IDENTIFIED BY MARK \triangle OR DOTTED LINE WITH MARK \triangle ON THE SCHEMATIC DIAGRAMS AND IN THE PARTS LIST ARE CRITICAL TO SAFE OPERATION. REPLACE THESE COMPONENTS WITH SONY PARTS WHOSE PART NUMBERS APPEAR AS SHOWN IN THIS MANUAL OR IN SUPPLEMENTS PUBLISHED BY SONY.

ATTENTION AU COMPOSANT AYANT RAPPORT À LA SÉCURITÉ!

LES COMPOSANTS IDENTIFIÉS PAR UNE MARQUE \triangle SUR LES DIAGRAMMES SCHÉMATIQUES ET LA LISTE DES PIÈCES SONT CRITIQUES POUR LA SÉCURITÉ DE FONCTIONNEMENT. NE REMPLACER CES COM- POSANTS QUE PAR DES PIÈCES SONY DONT LES NUMÉROS SONT DONNÉS DANS CE MANUEL OU DANS LES SUPPLÉMENTS PUBLIÉS PAR SONY.

TABLE OF CONTENTS

1. SERVICING NOTES	4
2. GENERAL	6
3. DISASSEMBLY	
3-1. Disassembly Flow	7
3-2. Cover (Handle)	8
3-3. Handle Block	8
3-4. Cabinet (Rear) Block	9
3-5. CD Tray Block	10
3-6. Optical Pick-up Block	10
3-7. Optical Pick-up (KSM-900AAA)	11
3-8. Panel (Upper) Block	11
3-9. MD Block	12
3-10. MAIN Board	12
3-11. POWER Board	13
3-12. Tape Mechanism Deck (MF-E100)	13
3-13. RP Head (HRP301)	14
3-14. Motor Sub Assy (CAPSTAN/REEL) (M901)	14
3-15. TU Board	15
4. MECHANICAL ADJUSTMENTS	16
5. ELECTRICAL ADJUSTMENTS	16
6. DIAGRAMS	
6-1. Block Diagram – SERVO Section –	21
6-2. Block Diagram – TUNER Section –	22
6-3. Block Diagram – AUDIO Section –	23
6-4. Block Diagram – PANEL, POWER SUPPLY Section –	24
6-5. Printed Wiring Boards – CD Section –	26
6-6. Schematic Diagram – CD Section –	27
6-7. Printed Wiring Board – TUNER Section (CFD-E100 Only) –	28
6-8. Schematic Diagram – TUNER Section (CFD-E100 Only) –	29
6-9. Printed Wiring Board – TUNER Section (CFD-E100L Only) –	30
6-10. Schematic Diagram – TUNER Section (CFD-E100L Only) –	31
6-11. Printed Wiring Board – TAPE Section –	32
6-12. Schematic Diagram – TAPE Section –	33
6-13. Printed Wiring Board – MAIN Section –	34
6-14. Schematic Diagram – MAIN Section –	35
6-15. Printed Wiring Boards – POWER Section –	36
6-16. Schematic Diagram – POWER Section –	37
6-17. Printed Wiring Boards – LCD Section –	38
6-18. Schematic Diagram – LCD Section –	39
7. EXPLODED VIEWS	
7-1. Handle Section	45
7-2. Main Section	46
7-3. Cabinet (Front) Section	47
7-4. Panel (Upper) Section	48
7-5. Cabinet (Rear) Section	49
7-6. MAIN Board Section	50
7-7. CD Tray Section (KSM-900AAA)	51
7-8. MD Block Section-1	52
7-9. MD Block Section-2	53
7-10. Tape Mechanism Deck Section (MF-E100)	54
8. ELECTRICAL PARTS LIST	55

SECTION 1 SERVICING NOTES

NOTES ON HANDLING THE OPTICAL PICK-UP BLOCK OR BASE UNIT

The laser diode in the optical pick-up block may suffer electrostatic break-down because of the potential difference generated by the charged electrostatic load, etc. on clothing and the human body.

During repair, pay attention to electrostatic break-down and also use the procedure in the printed matter which is included in the repair parts.

The flexible board is easily damaged and should be handled with care.

NOTES ON LASER DIODE EMISSION CHECK

The laser beam on this model is concentrated so as to be focused on the disc reflective surface by the objective lens in the optical pick-up block. Therefore, when checking the laser diode emission, observe from more than 30 cm away from the objective lens.

UNLEADED SOLDER

Boards requiring use of unleaded solder are printed with the lead-free mark (LF) indicating the solder contains no lead.

(Caution: Some printed circuit boards may not come printed with the lead free mark due to their particular size)

LEAD FREE MARK

Unleaded solder has the following characteristics.

- Unleaded solder melts at a temperature about 40 °C higher than ordinary solder.

Ordinary soldering irons can be used but the iron tip has to be applied to the solder joint for a slightly longer time.

Soldering irons using a temperature regulator should be set to about 350 °C.

Caution: The printed pattern (copper foil) may peel away if the heated tip is applied for too long, so be careful!

- Strong viscosity
Unleaded solder is more viscous (sticky, less prone to flow) than ordinary solder so use caution not to let solder bridges occur such as on IC pins, etc.
- Usable with ordinary solder
It is best to use only unleaded solder but unleaded solder may also be added to ordinary solder.

[MODEL IDENTIFICATION]

The CFD-E100/E100L are available with three types and four different color variations. How to identify the destination, type, and color variation is shown below.

– CD LID Top View –



ORIGINAL TYPE
(CFD-E100)



ORIGINAL TYPE
(CFD-E100L)

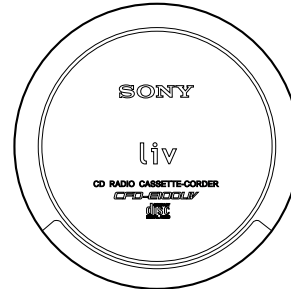

LIV TYPE
(CFD-E100: US)

• COLOR VARIATION

		ORIGINAL TYPE			LIV TYPE
		WHITE	SILVER	BLUE	WHITE
CFD-E100	US	○	—	—	○
	CND	○	—	—	—
	SP	—	○	○	—
	TW	—	○	○	—
	KR	—	○	○	—
CFD-E100L	AEP	—	○	○	—
	UK	—	○	—	—
	EE, RU	—	○	—	—
	IT	—	○	—	—

- Abbreviation
- CND : Canadian model
- EE : East European model
- IT : Italian model
- KR : Korean model
- RU : Russian model
- SP : Singapore model
- TW : Taiwan model

SECTION 2 GENERAL

This section is extracted from instruction manual.

Location of controls

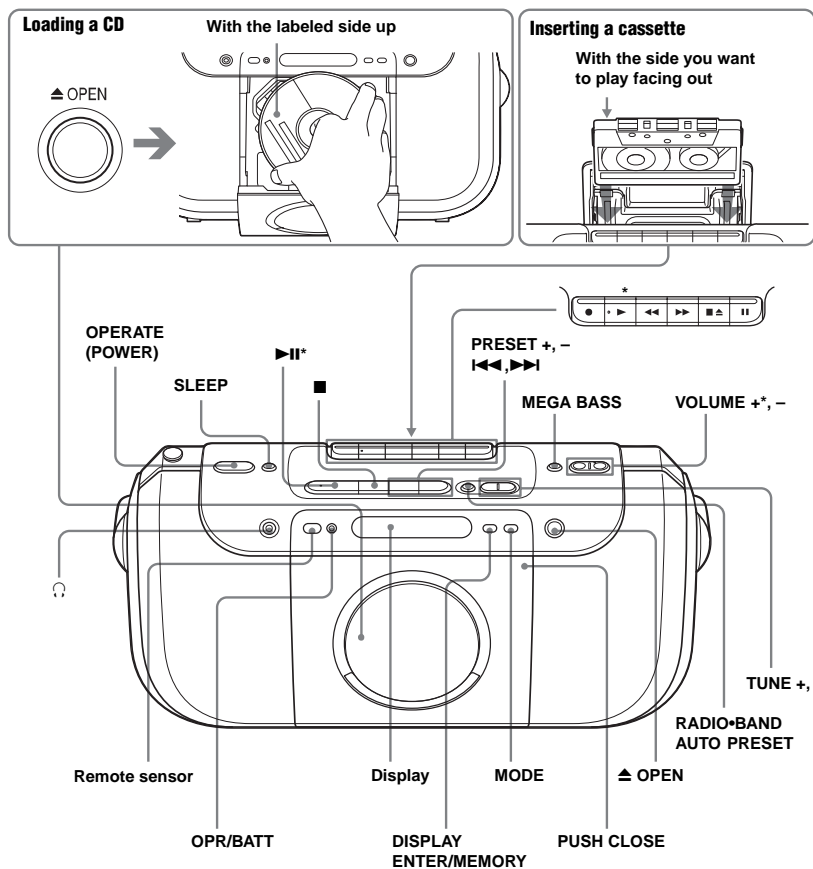

Remote Control

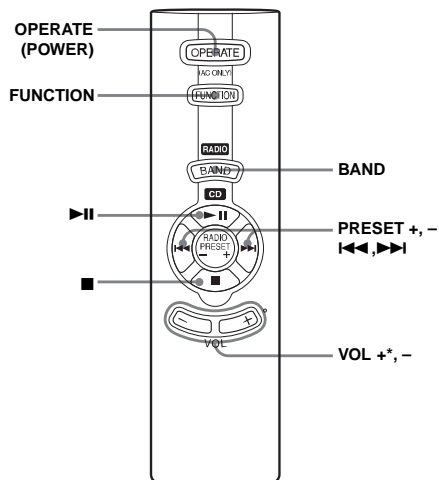

*The button has a tactile dot.



To turn on/off the power
CFD-E100L: Press OPERATE.
CFD-E100: Press POWER.

SECTION 3 DISASSEMBLY

- This set can be disassembled in the order shown below.

3-1. DISASSEMBLY FLOW

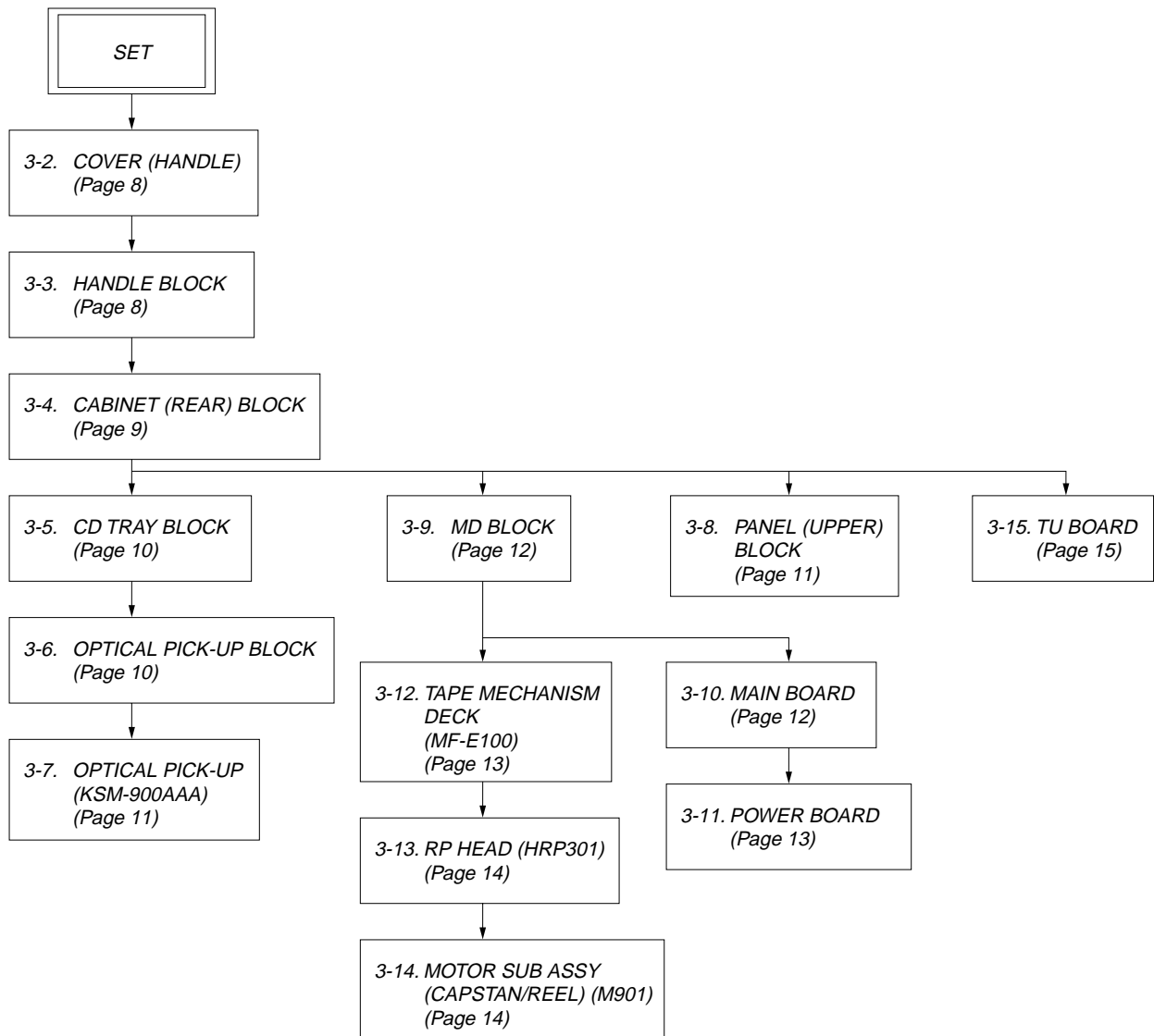

Note: Follow the disassembly procedure in the numerical order given.

3-2. COVER (HANDLE)

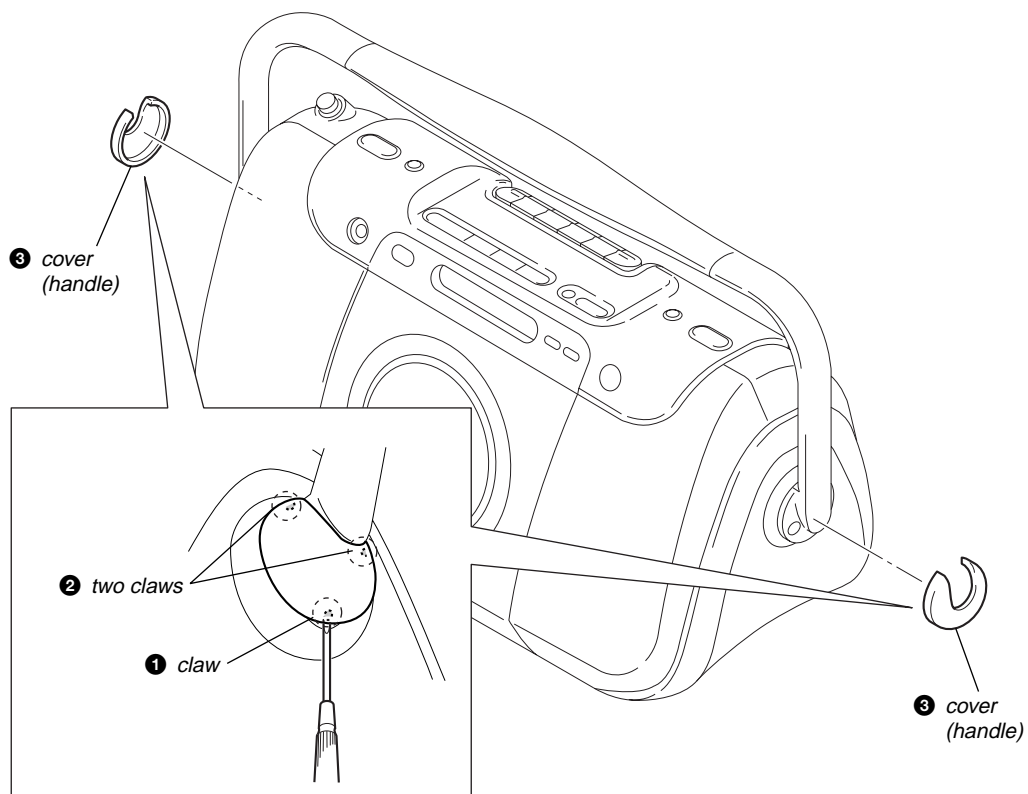

3-3. HANDLE BLOCK

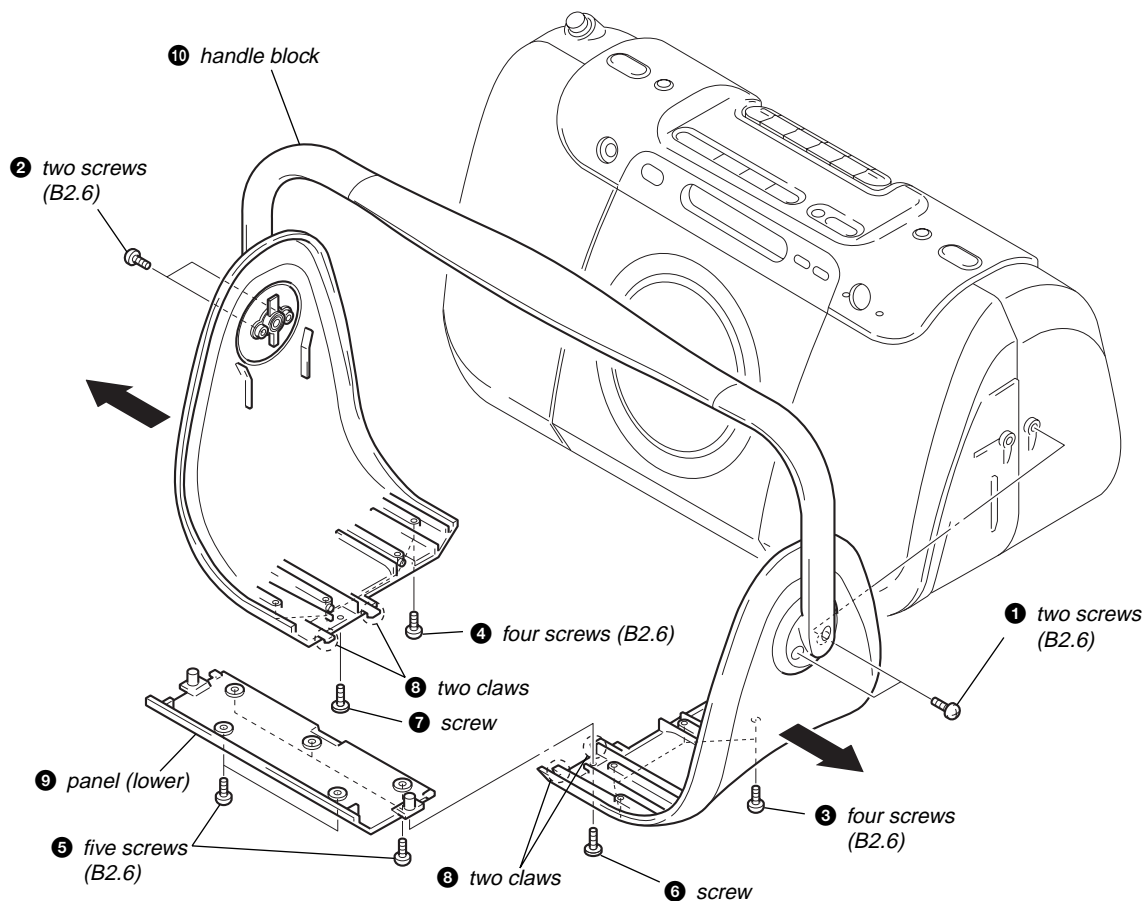

3-4. CABINET (REAR) BLOCK

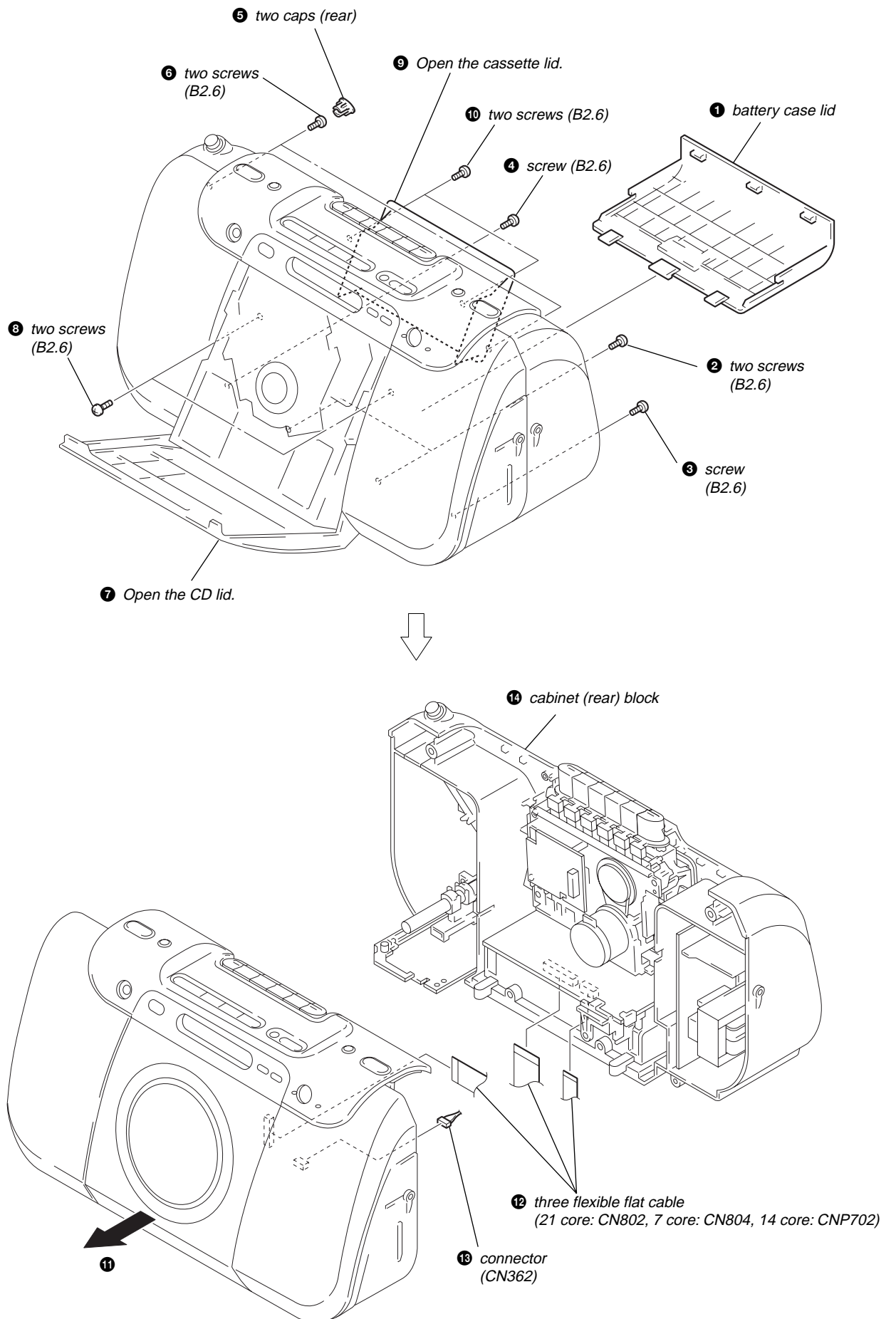

3-5. CD TRAY BLOCK

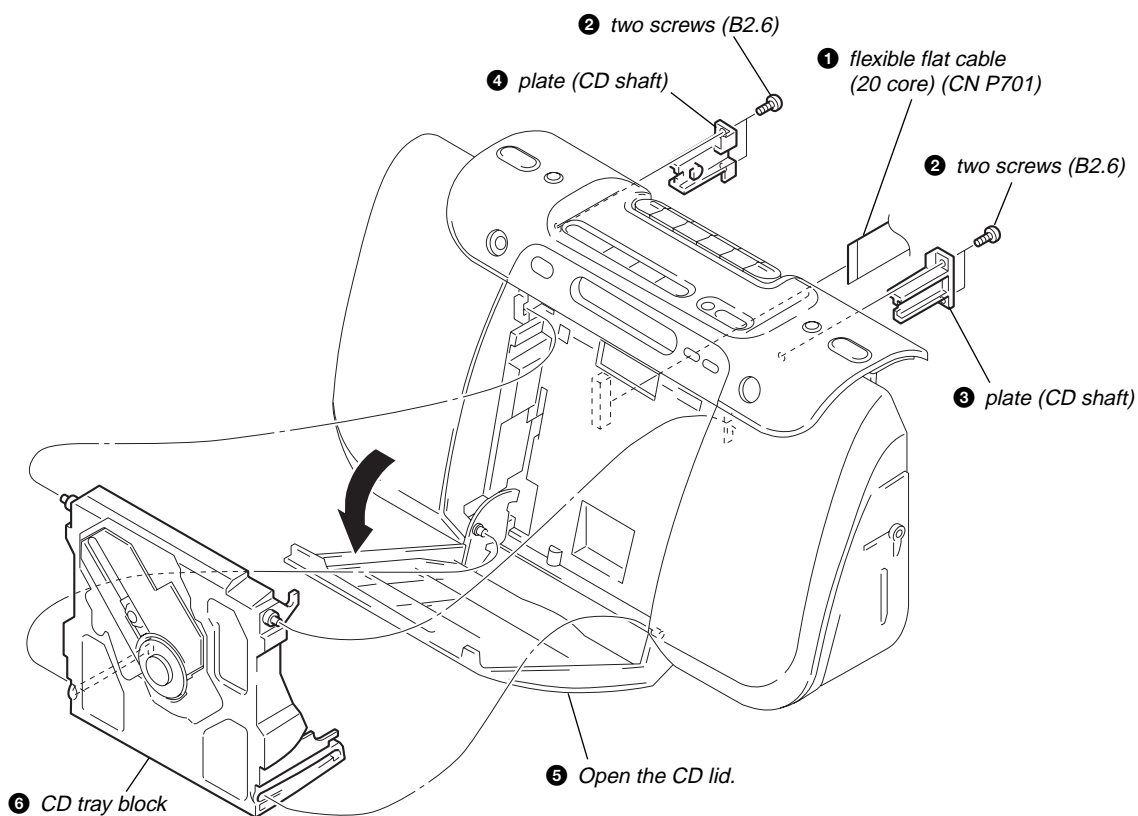

3-6. OPTICAL PICK-UP BLOCK

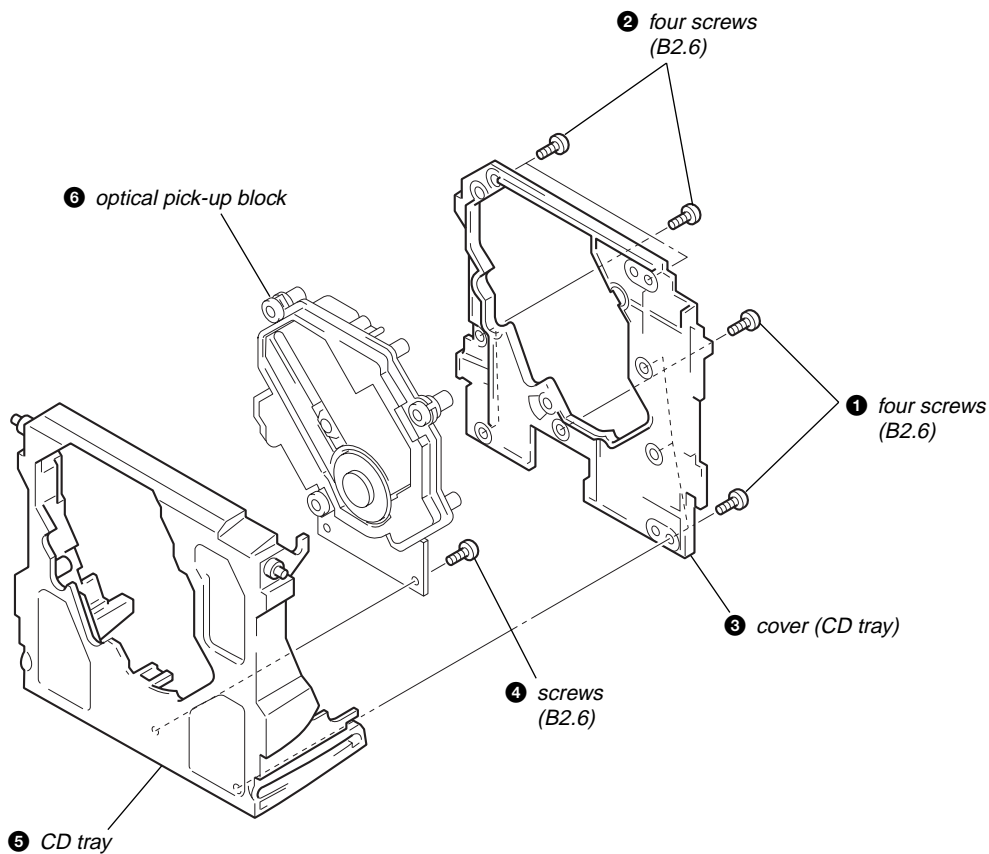

3-7. OPTICAL PICK-UP (KSM-900AAA)

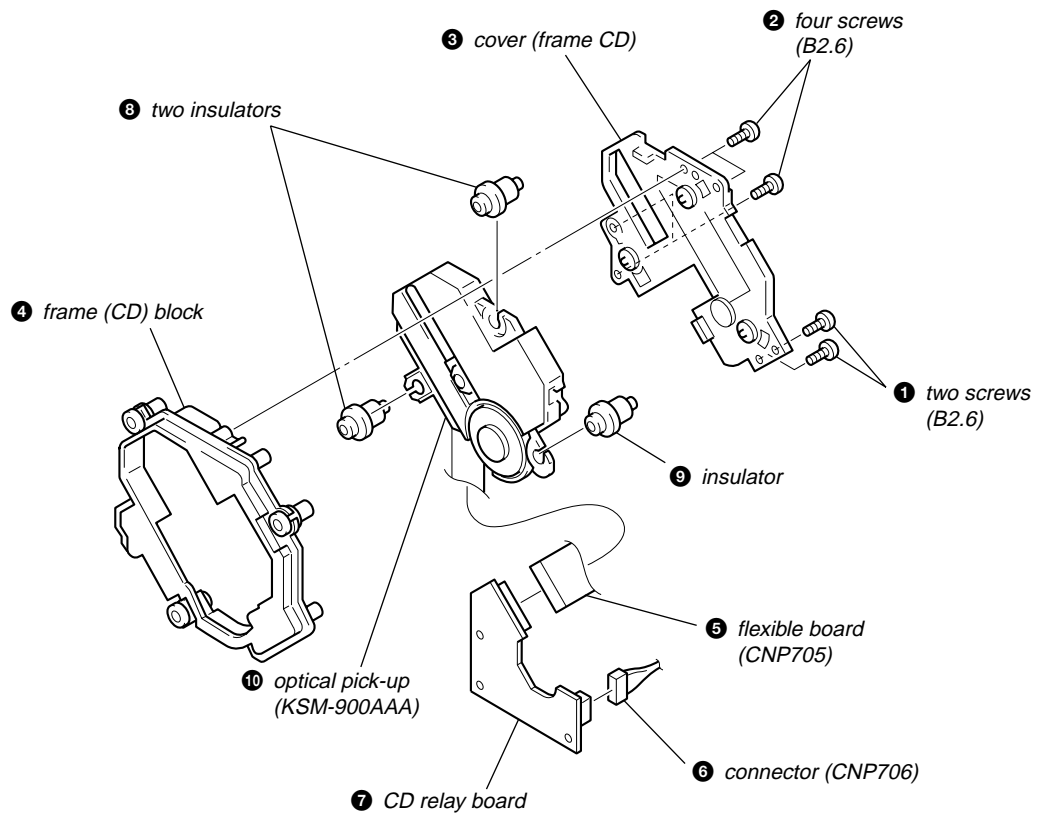

3-8. PANEL (UPPER) BLOCK

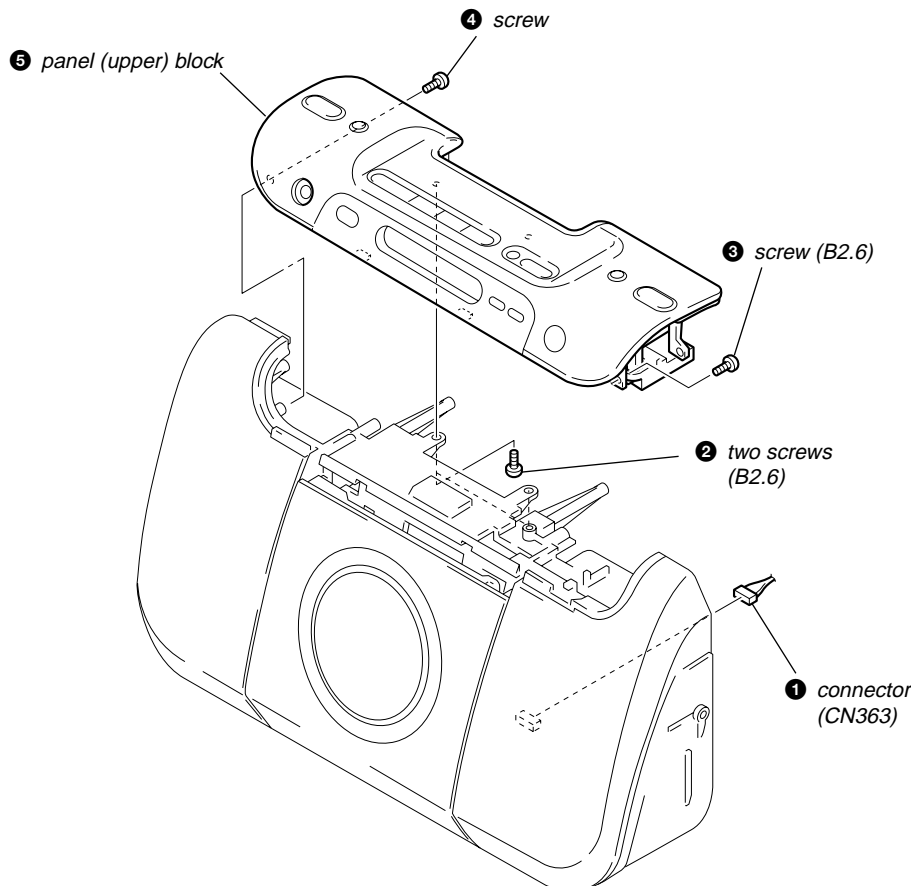

3-9. MD BLOCK

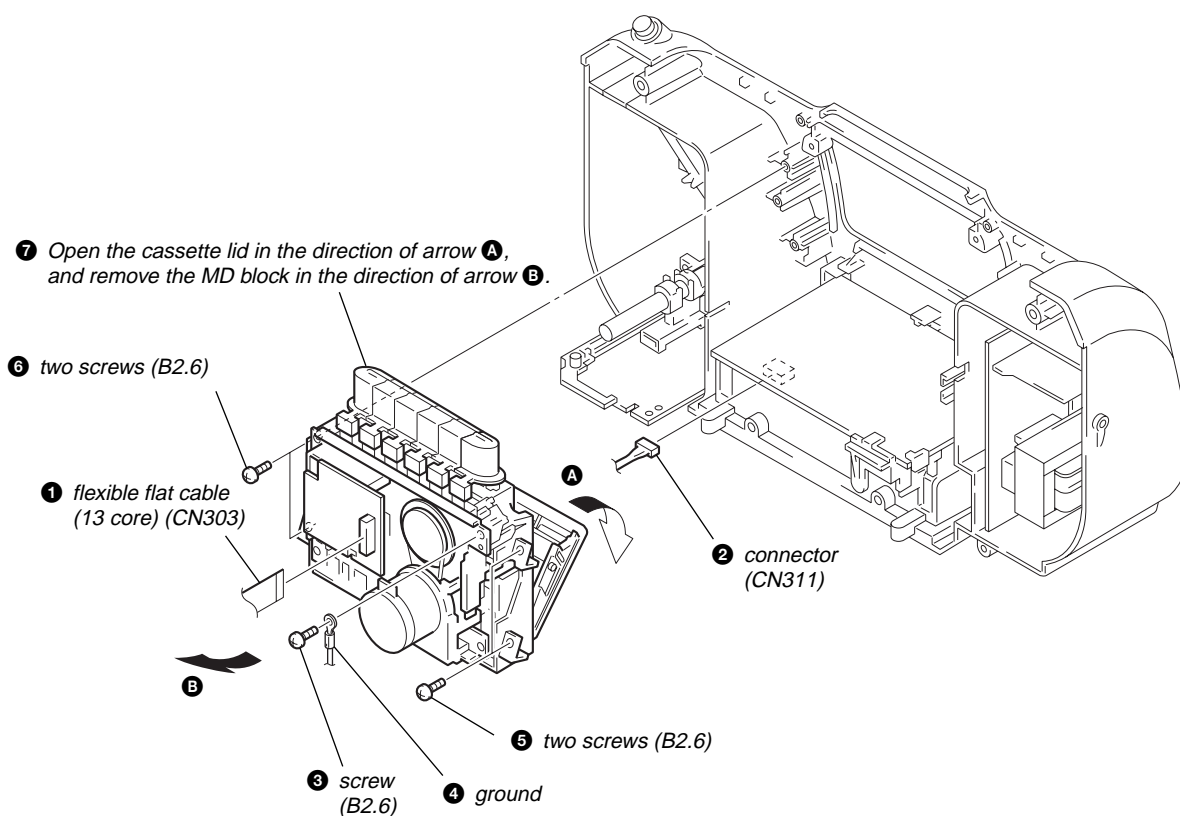

3-10. MAIN BOARD

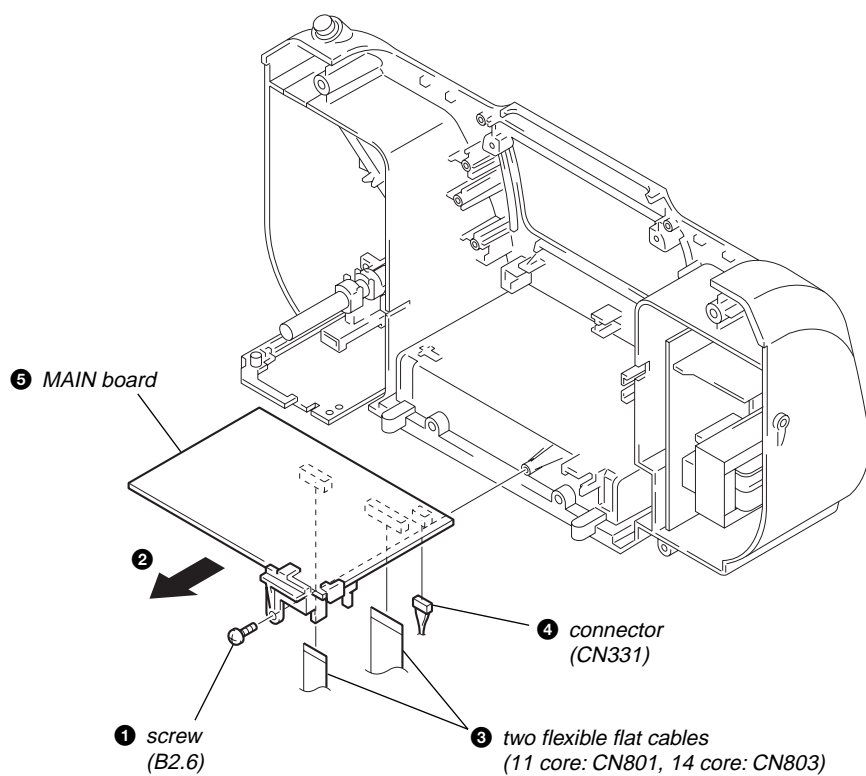

3-11. POWER BOARD

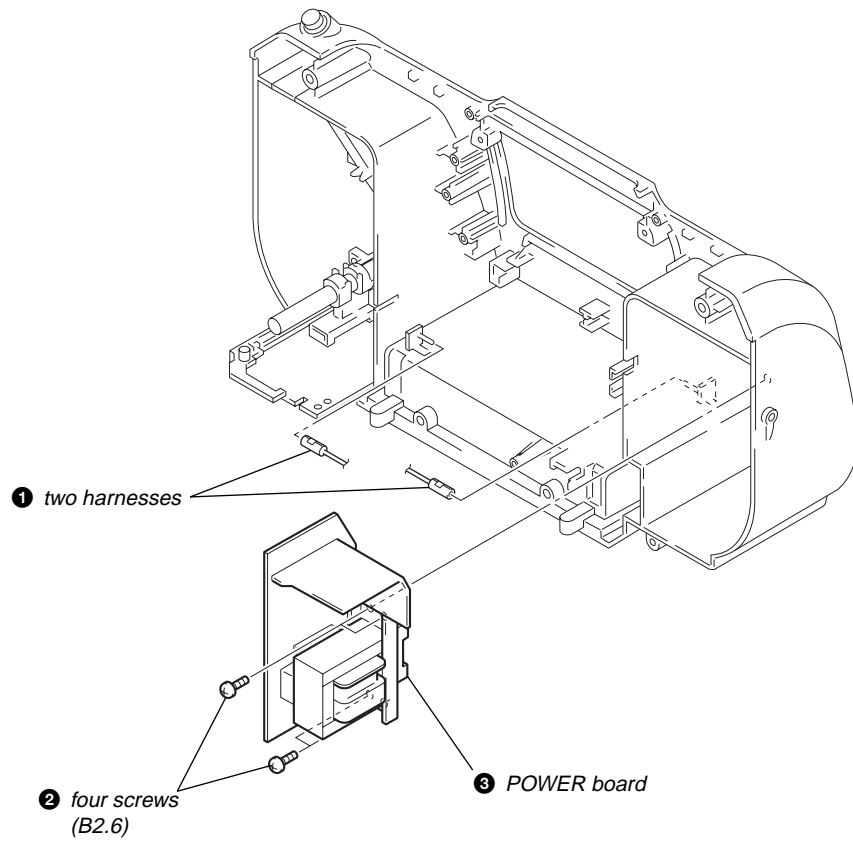

3-12. TAPE MECHANISM DECK (MF-E100)

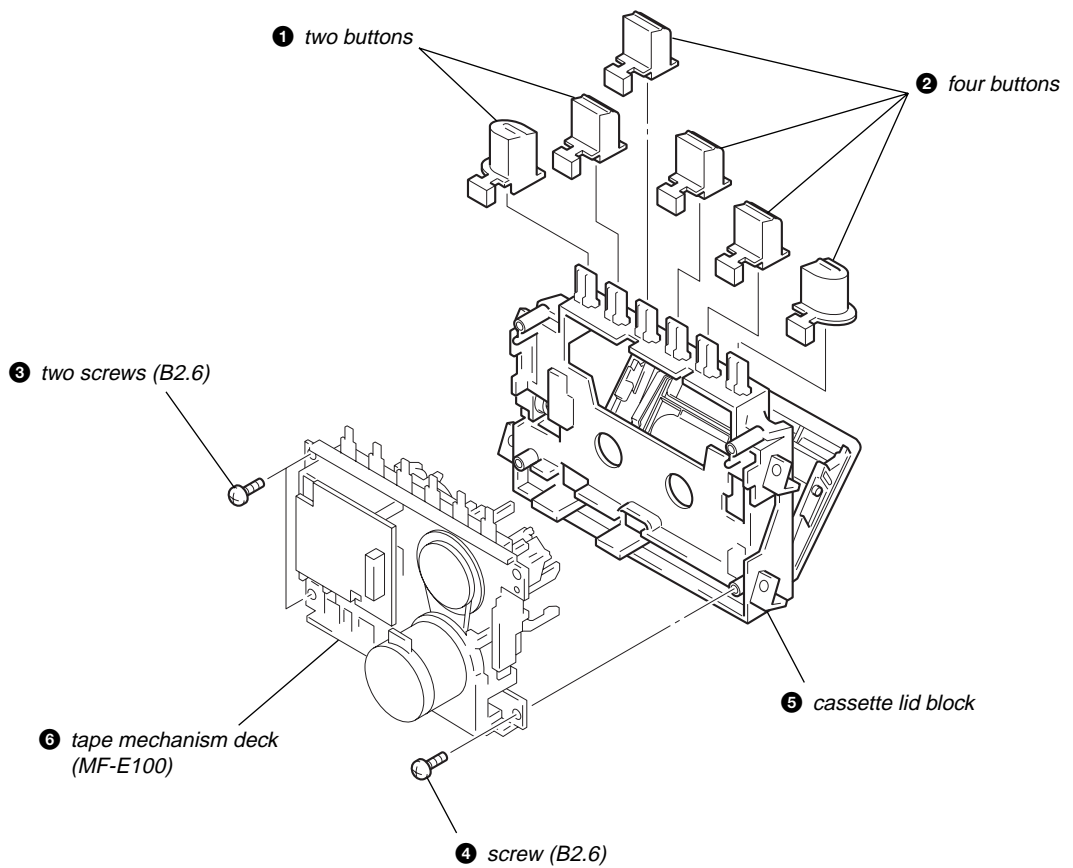

3-13. RP HEAD (HRP301)

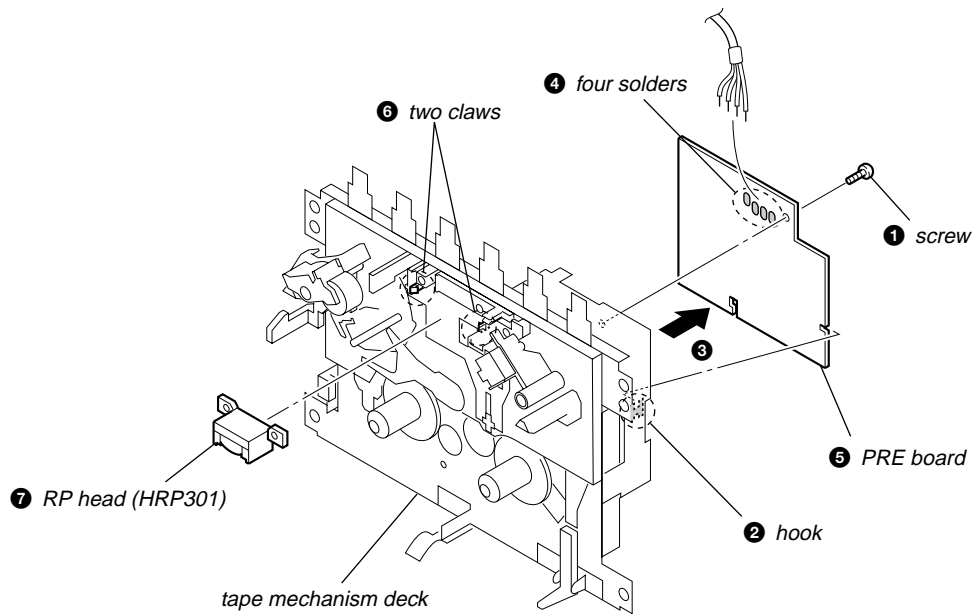

3-14. MOTOR SUB ASSY (CAPSTAN/REEL) (M901)

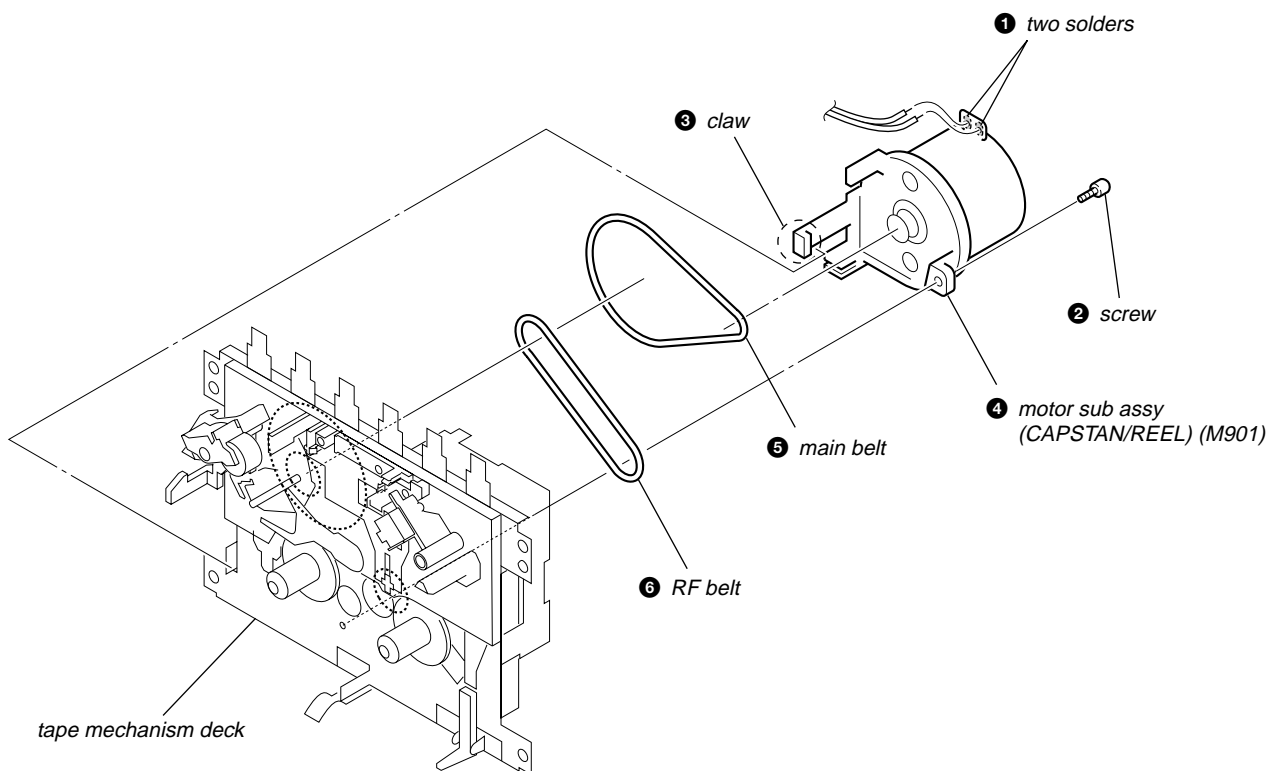

3-15. TU BOARD

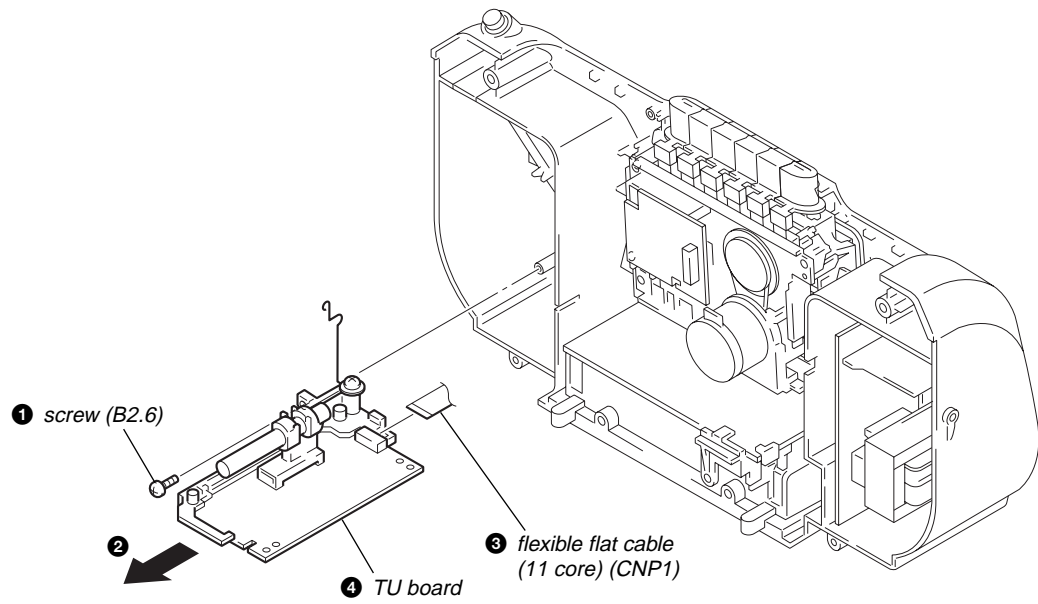

SECTION 4 MECHANICAL ADJUSTMENTS

PRECAUTION

- Clean the following parts with a denatured-alcohol-moistened swab :

record/playback head	pinch roller
erase head	rubber belts
capstan	idlers
- Demagnetize the record/playback head with a head demagnetizer. (Do not bring the head magnetizer close to the erase head.)
- Do not use a magnetized screwdriver for the adjustments.
- The adjustments should be performed with the rated power supply voltage unless otherwise noted.

• Torque Measurement

Mode	Torque Meter	Meter Reading
FWD	CQ-102C	2.95 – 6.86 mN•m (30 – 70 g•cm) (0.42 – 0.97 oz•inch)
FWD Back Tension	CQ-102C	0.15 – 5.39 mN•m (1.5 – 5.5 g•cm) (0.021 – 0.076 oz•inch)
FF	CQ-201B	more than 5.89 mN•m (more than 60 g•cm) (more than 0.83 oz•inch)
REW	CQ-201B	more than 5.89 mN•m (more than 60 g•cm) (more than 0.83 oz•inch)

• Tape Tension Measurement

Mode	Tension Meter	Meter Reading
FWD	CQ-403A	more than 100 g (more than 3.53 oz)

SECTION 5 ELECTRICAL ADJUSTMENTS

PRECAUTION

- Setting
MEGABASS control : OFF

TAPE DECK SECTION	0 dB=0.775 V
--------------------------	--------------

Test tape

Type	Signal	Used for
WS-48B	3 kHz, 0 dB	Tape Speed Adjustment

TAPE SPEED ADJUSTMENT

Setting:

Function: TAPE

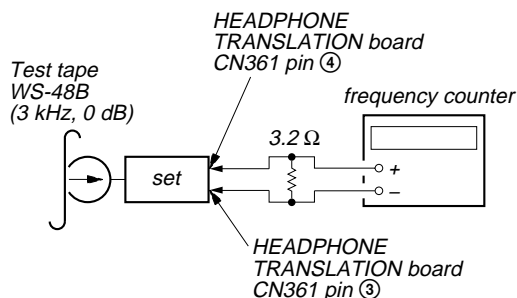

Procedure:

- Playback WS-48B (tape center) in the FWD state.
- Adjust the volume in CAPSTAN/REEL motor (M901) so that the frequency counter reading becomes 3,000 Hz.

Specified Value: 2,910 to 3,090 Hz

- Confirm that the frequency at the beginning and that at the end of tape winding are between 2,940 to 3,060 Hz.

Adjustment Location:

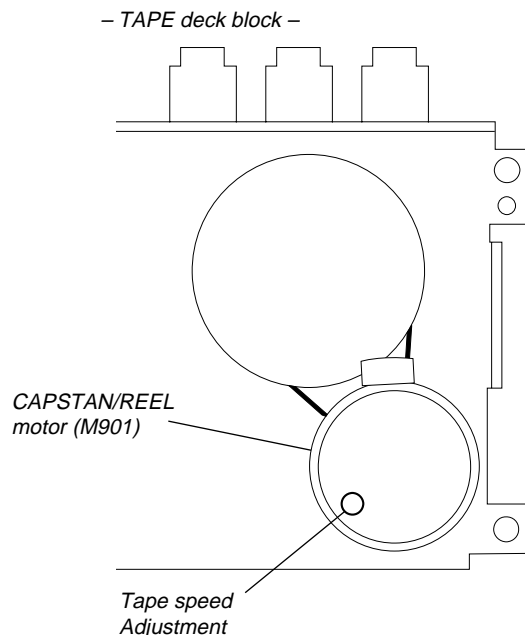

Sample Value of Wow and Flutter: 03% or less W. RMS (JIS)
(WS-48B)

TUNER SECTION

0 dB=1 μ V

[AM]

Setting:

Function: RADIO

Band: AM

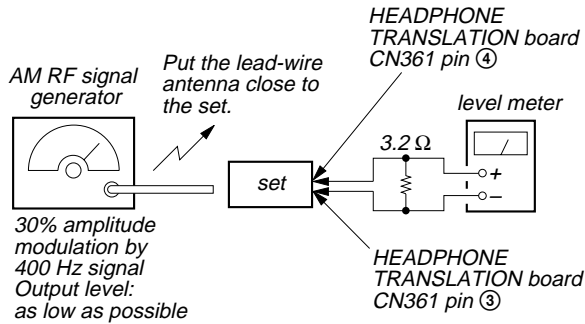

[FM]

Setting:

Function: RADIO

Band: FM

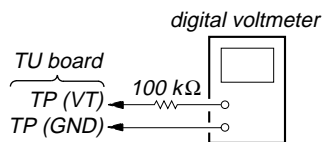
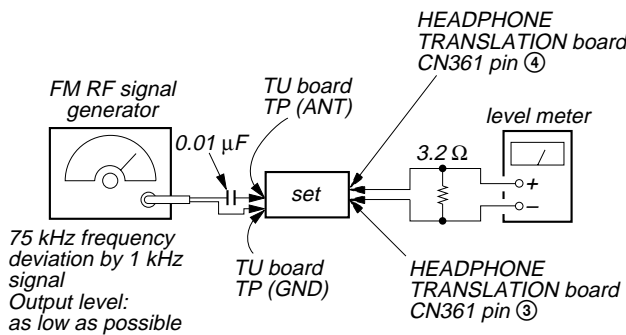

- Repeat the procedures in each adjustment several times, and the tracking adjustments should be finally done by the trimmer capacitors.
- Remove FM antenna in FM adjustment.

AM IF ADJUSTMENT	
Adjust for a maximum reading on level meter	
T1	450 kHz

(): Singapore, Taiwan, Korean model

AM CV VOLTAGE ADJUSTMENT (CFD-E100 only)		
Adjustment Part	Frequency Display	Reading on Digital Voltmeter
L4	530 kHz (531 kHz)	1.0 \pm 0.05 V
Confirmation	1,710 kHz (1,611 kHz)	5.3 \pm 0.7 V (4.8 \pm 0.7 V)

LW CV VOLTAGE ADJUSTMENT (CFD-E100L only)		
Adjustment Part	Frequency Display	Reading on Digital Voltmeter
L4	153 kHz	0.6 \pm 0.05 V
Confirmation	279 kHz	5.3 \pm 0.7 V

MW CV VOLTAGE ADJUSTMENT (CFD-E100L only)		
Adjustment Part	Frequency Display	Reading on Digital Voltmeter
Confirmation	531 kHz	0.9 \pm 0.4 V
Confirmation	1,611 kHz	5.2 \pm 0.5 V

(): Singapore, Taiwan, Korean model

AM TRACKING ADJUSTMENT (CFD-E100 only)	
Adjust for a maximum reading on level meter	
L3	620 kHz (621 kHz)
CT3	1,400 kHz (1,404 kHz)

MW TRACKING ADJUSTMENT (CFD-E100L only)	
Adjust for a maximum reading on level meter	
L3-1	621 kHz
CT3	1,404 kHz

LW TRACKING ADJUSTMENT (CFD-E100L only)	
Adjust for a maximum reading on level meter	
L3-2	162 kHz
CT5	261 kHz

FM IF ADJUSTMENT	
Adjust for a minimum reading on level meter	
T2	10.7 MHz

FM CV VOLTAGE ADJUSTMENT		
Adjustment Part	Frequency Display	Reading on Digital Voltmeter
L2	108 MHz	3.0 \pm 0.2 V
Confirmation	87.5 MHz	1.3 \pm 0.3 V

FM TRACKING ADJUSTMENT	
Adjust for a maximum reading on level meter	
L1	87.5 MHz
CT1	108 MHz

Adjustment Location: TU board (See page 18)

CFD-E100/E100L

Adjustment Location:

- TU BOARD (Component Side) -

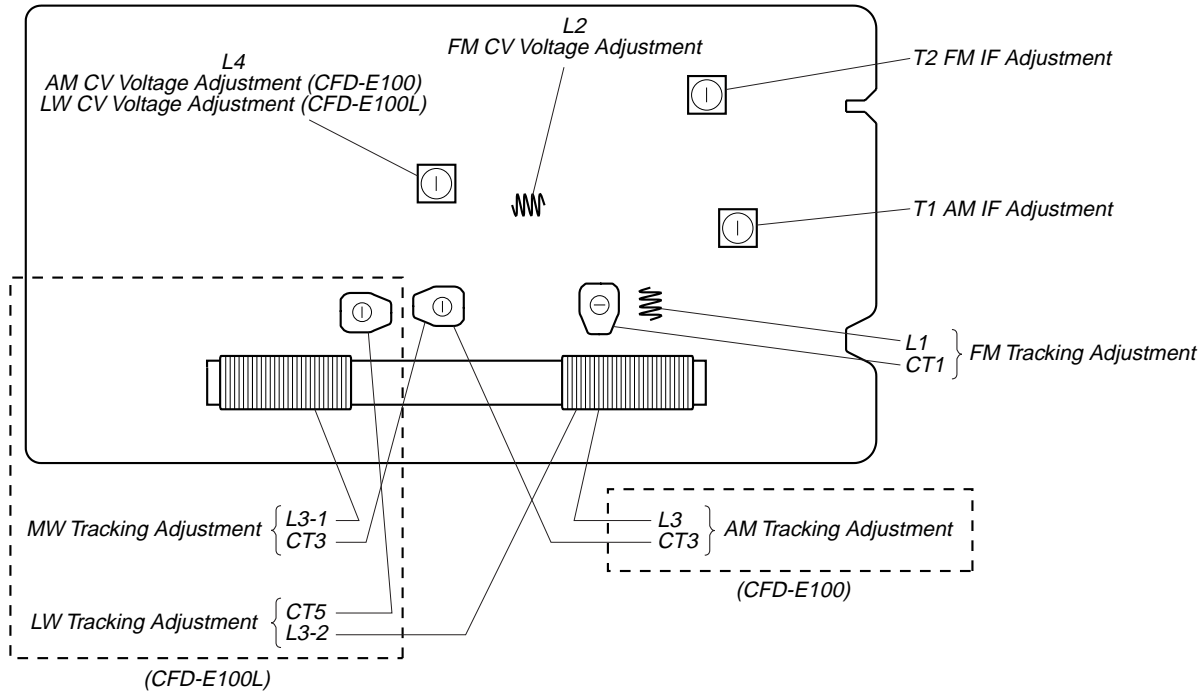

- TU BOARD (Conductor Side) -



CD SECTION

Perform all CD section check in the test mode.

ENTERING THE CD TEST MODE**Procedure:**

1. Insert the test disc (YEDS-18 (part No. 3-702-101-01)).
2. Press the **[POWER]** button to turn the power on.
3. While pressing the **[DISPLAY, ENTER]** and **[VOLUME+]** buttons, open and close the CD lid, and release two buttons.
4. If the CD test mode is activated, all segments of the LCD light up.
5. To release this mode, press the **[POWER]** button to turn the power off.

TRAVERSE CHECK**Procedure:**

1. Connect an oscilloscope to TP (TE) and TP (VREF) on the CD board.
2. Set the CD test mode.
3. Press the **[▶||]** button twice to display "FC".
4. Confirm that the center of the oscilloscope waveform is at 0 V.
5. Confirm that the oscilloscope waveform V_{p-p} value is at 1 ± 0.5 V.

VOLT/DIV: 0.2 V (with the 10:1 probe in use)
TIME/DIV: 1 ms

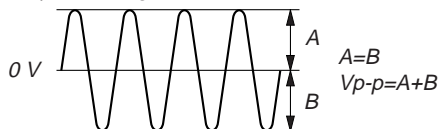
**RF LEVEL CHECK****Procedure:**

1. Connect the oscilloscope to TP (RF) and TP (VREF) on the CD board.
2. Set the CD test mode.
3. Press the **[▶||]** button twice to display "A-".

Note: If this check is performed continuously after the TRAVERSE CHECK, press the **[▶||]** button once.

4. Confirm that the oscilloscope waveform is as shown in the figure below. (eye pattern)
A good eye pattern means that the diamond shape (◇) in the center of the waveform can be clearly distinguished.

• RF signal reference waveform (eye pattern)

VOLT/DIV: 0.2 V (with the 10:1 probe in use.)
TIME/DIV: 500 ns

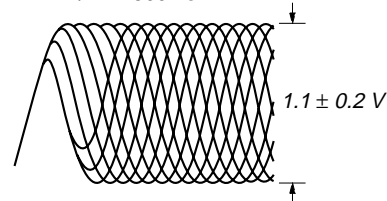

When observing the eye pattern, set the oscilloscope for AC range and raise vertical sensitivity.

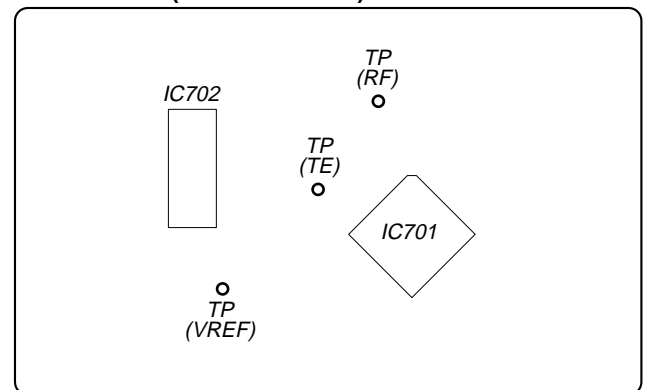
Connecting Location:**– CD BOARD (Conductor Side) –**

MEMO

**SECTION 6
DIAGRAMS**

6-1. BLOCK DIAGRAM – SERVO Section –

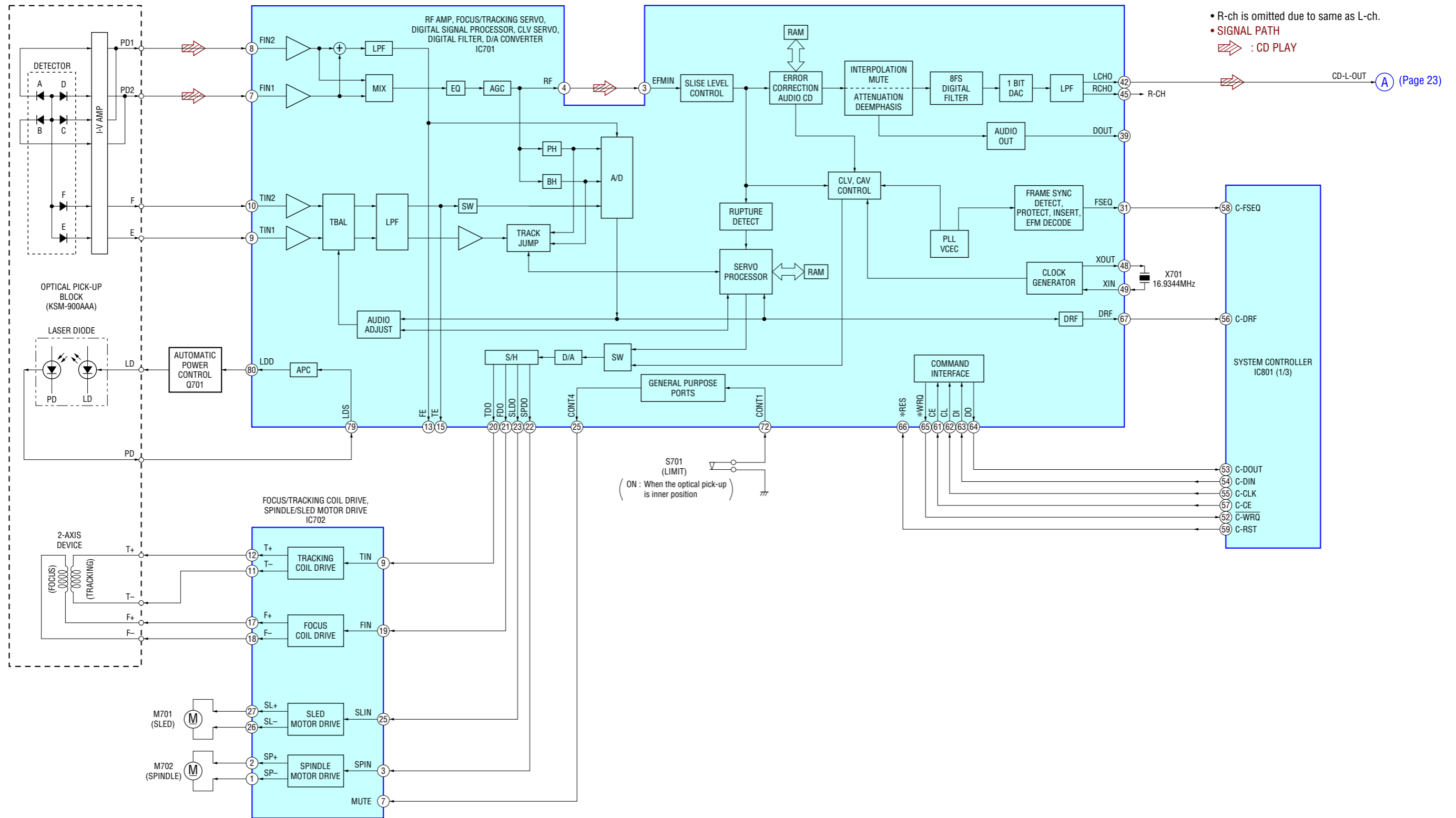

6-2. BLOCK DIAGRAM – TUNER Section –

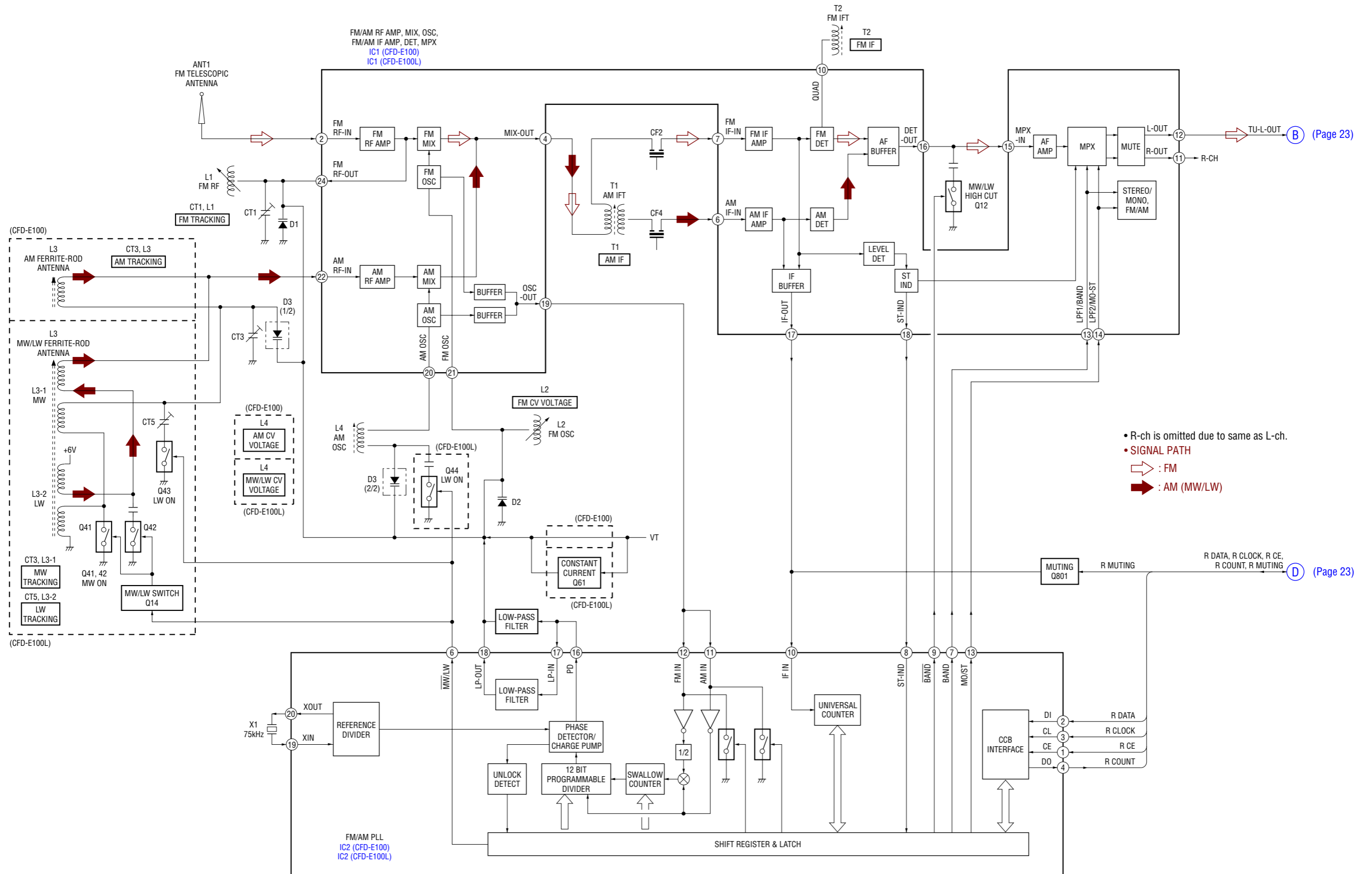

(Page 23)

(Page 23)

6-3. BLOCK DIAGRAM – AUDIO Section –

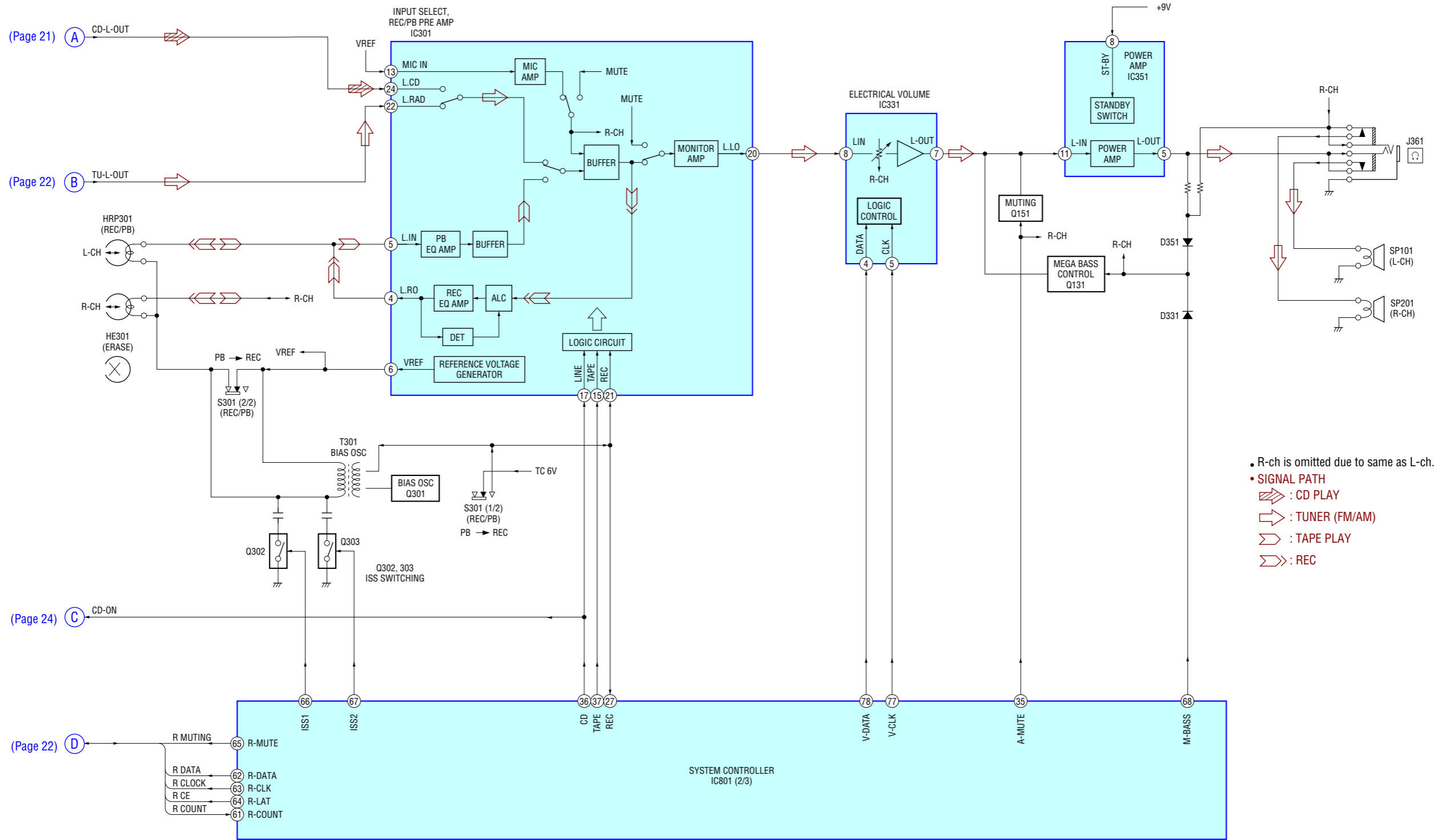

6-4. BLOCK DIAGRAM – PANEL, POWER SUPPLY Section –

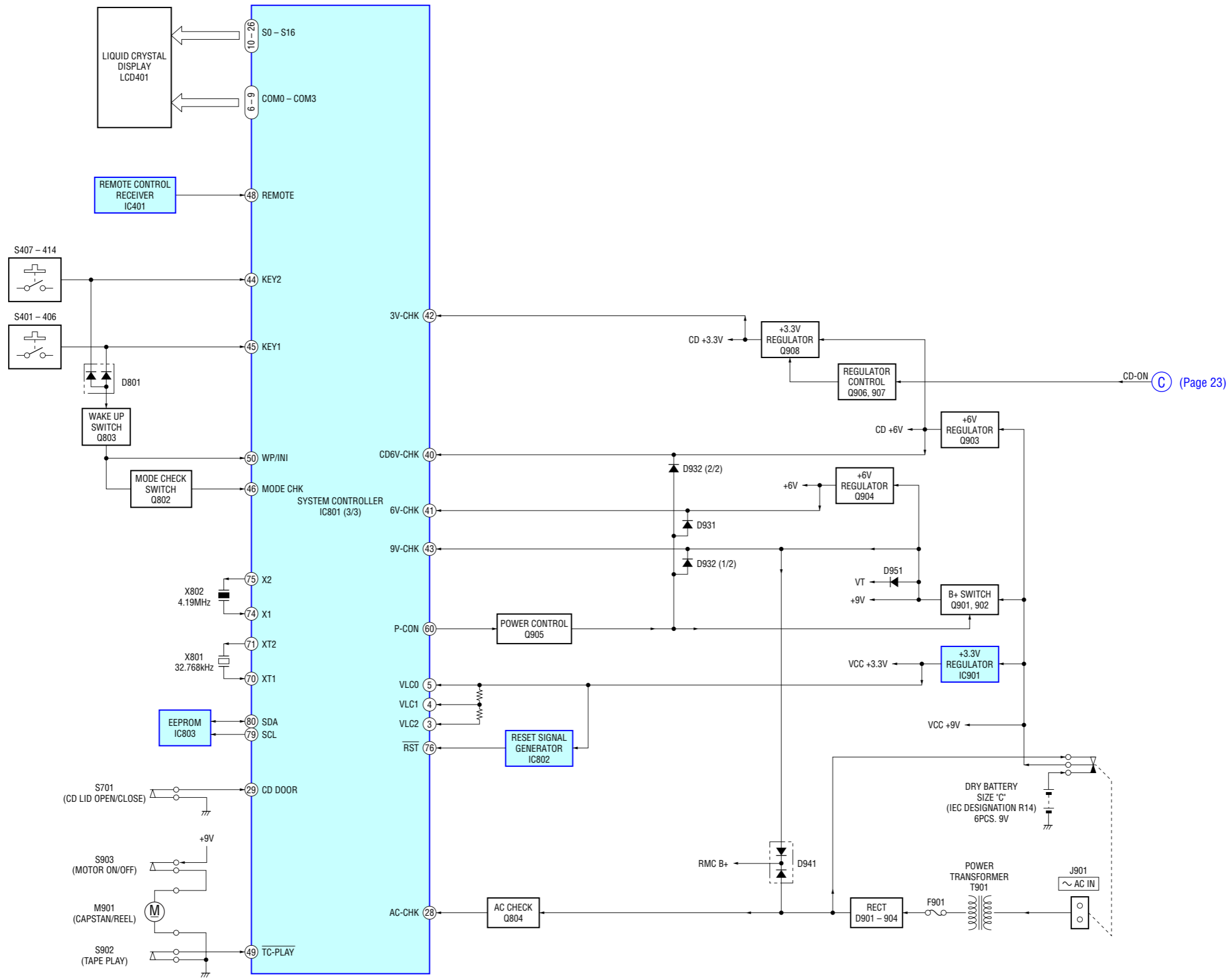

CD-ON (Page 23)

• Note for Printed Wiring Boards and Schematic Diagrams

Note on Printed Wiring Board:

- : parts extracted from the component side.
- : parts extracted from the conductor side.
- : indicates side identified with part number.
- △ : internal component.
- : Pattern from the side which enables seeing.

Note on Schematic Diagram:

- All capacitors are in μF unless otherwise noted. (p: pF) 50 WV or less are not indicated except for electrolytics and tantalums.
- All resistors are in Ω and $1/4\text{ W}$ or less unless otherwise specified.
- △ : internal component.
- : panel designation.

Note:

The components identified by mark △ or dotted line with mark △ are critical for safety. Replace only with part number specified.

Note:

Les composants identifiés par une marque △ sont critiques pour la sécurité. Ne les remplacer que par une pièce portant le numéro spécifié.

- : B+ Line.
- : adjustment for repair.
- Power voltage is dc 9V and fed with regulated dc power supply from battery terminal.
- CD Section -
[] : CD PLAY
- TUNER Section -
no mark : FM
() : AM (MW)
< > : LW
- Other Section -
no mark : TUNER
() : CD PLAY
<< >> : TAPE PLAY
[] : REC
- Voltages are taken with a VOM (Input impedance 10 M Ω). Voltage variations may be noted due to normal production tolerances.
- Waveforms are taken with a oscilloscope. Voltage variations may be noted due to normal production tolerances.
- Circled numbers refer to waveforms.
- Signal path.
◁ : FM
▶ : AM (MW/LW)
◁▶ : CD PLAY
◁▶ : TAPE PLAY
◁▶ : REC
- Abbreviation
CND : Canadian model
EE : East European model
IT : Italian model
KR : Korean model
RU : Russian model
SP : Singapore model
TW : Taiwan model

• Circuit Boards Location

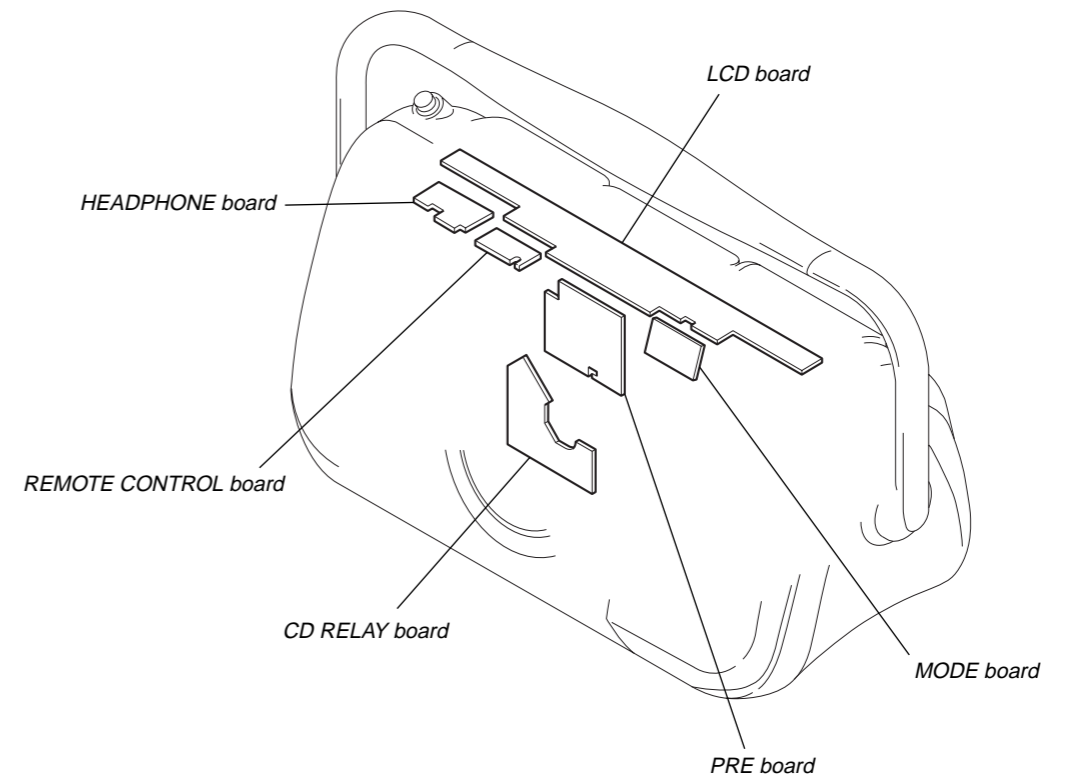
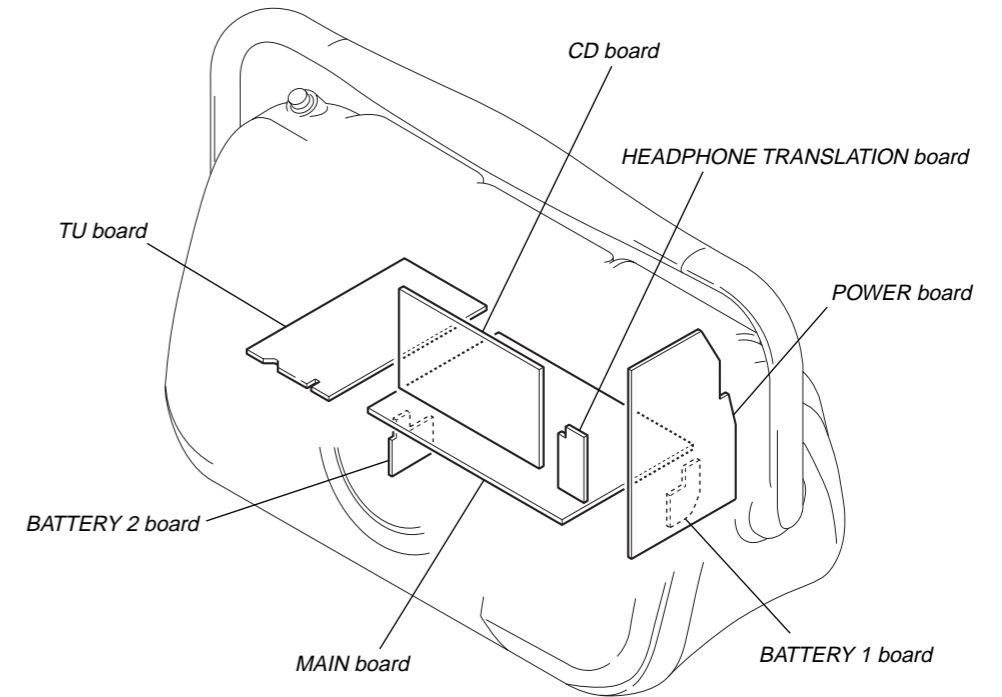

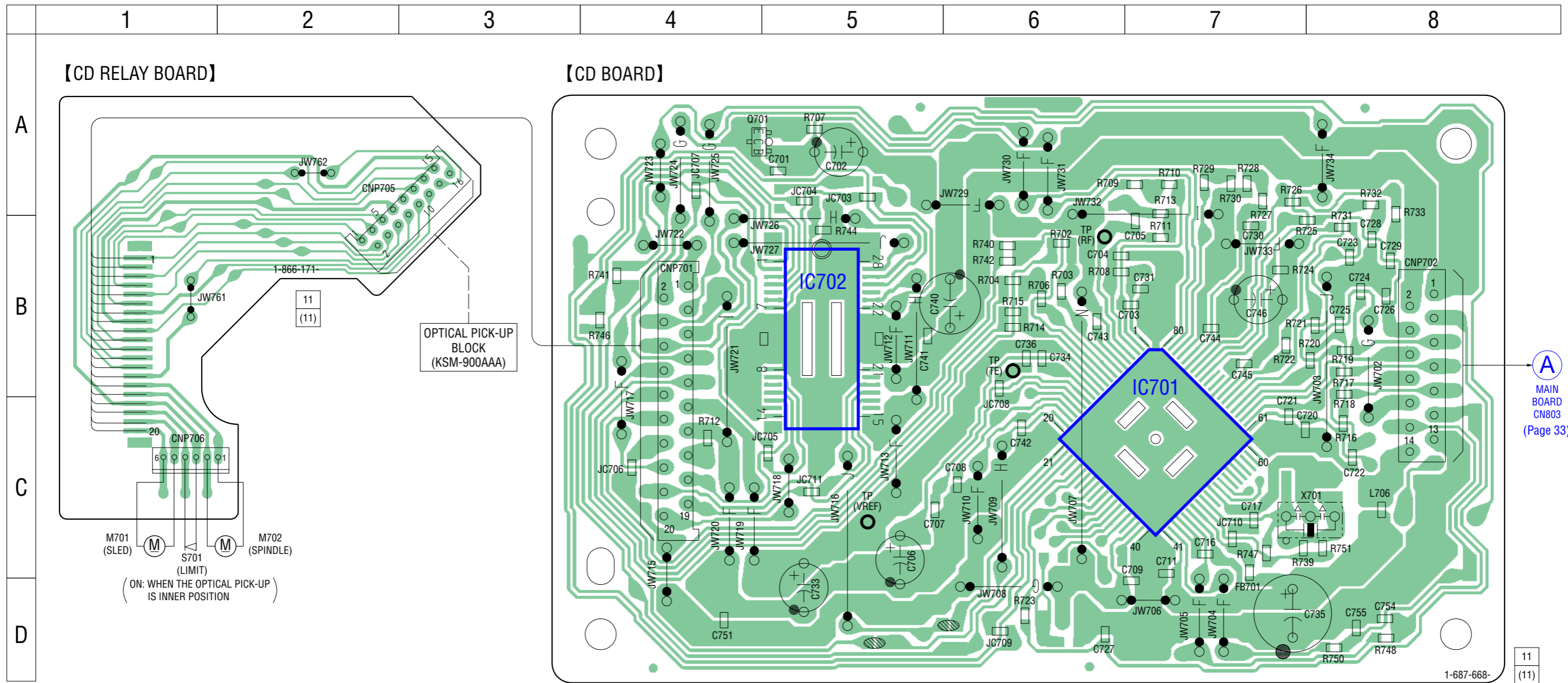

6-6. SCHEMATIC DIAGRAM – CD Section – • See page 40, 41 for IC Block Diagrams. • See page 39 for Waveforms.

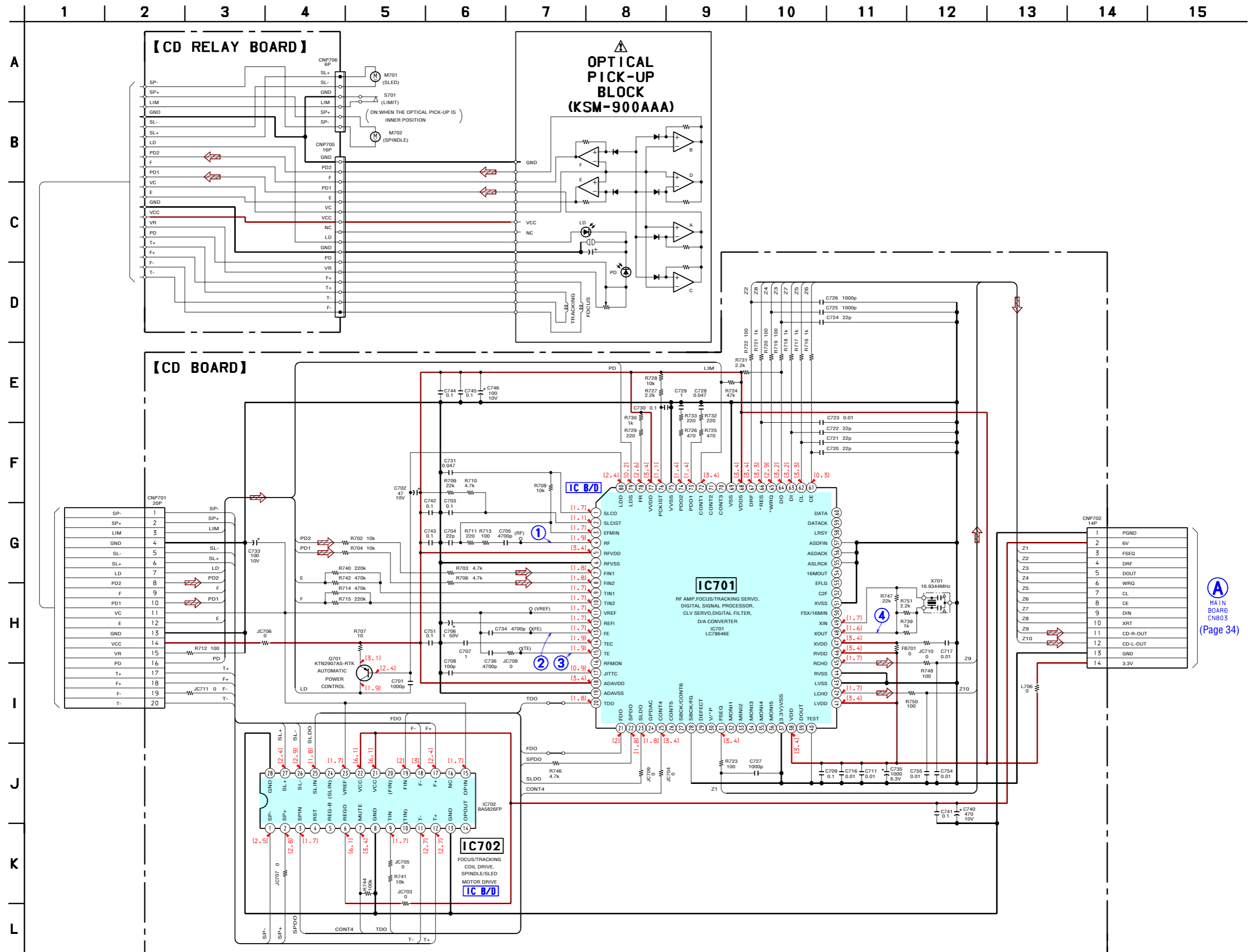

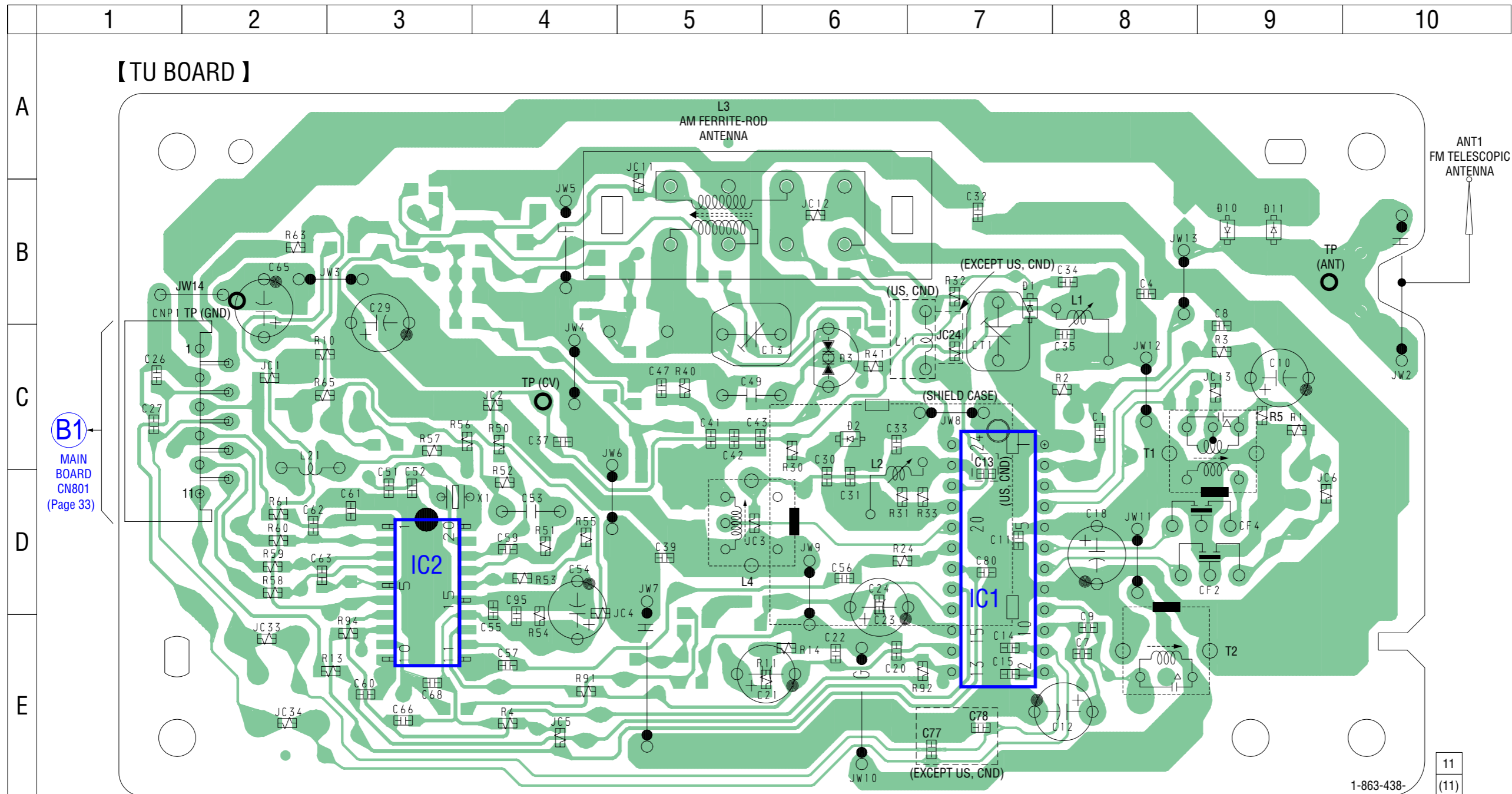

• Semiconductor Location

Ref. No.	Location
D1	B-7
D2	C-6
D3	C-6
D10	B-9
D11	B-9
IC1	D-7
IC2	D-3

6-8. SCHEMATIC DIAGRAM – TUNER Section (CFD-E100 Only) – • See page 41, 42 for IC Block Diagrams. • See page 39 for Waveform.

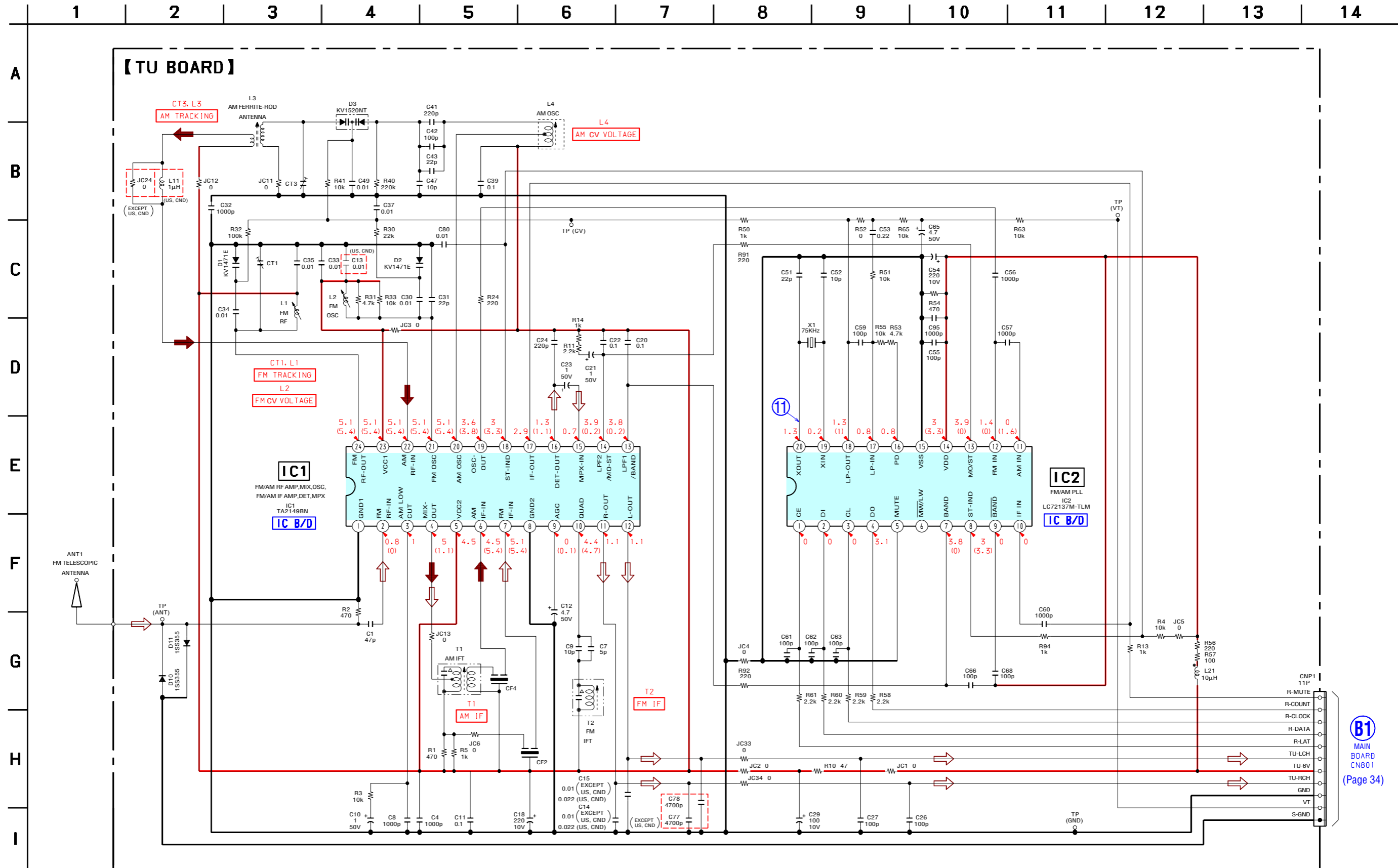

B1
MAIN BOARD
CN801
(Page 34)

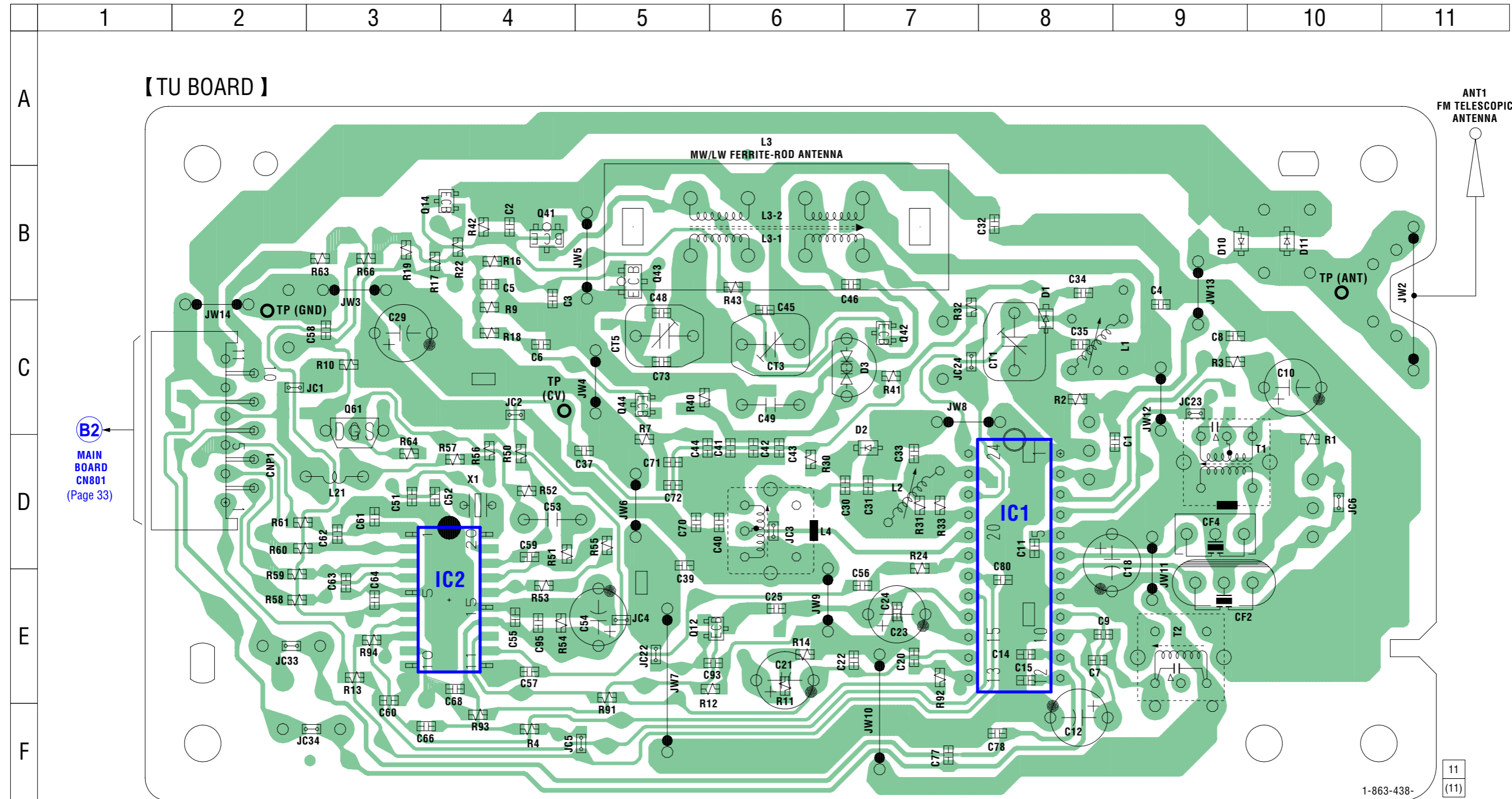

• Semiconductor Location

Ref. No.	Location
D1	C-8
D2	D-7
D3	C-7
D10	B-9
D11	B-10
IC1	D-8
IC2	E-4
Q12	E-6
Q14	B-4
Q41	B-4
Q42	C-7
Q43	B-5
Q44	C-5
Q61	C-3

6-10. SCHEMATIC DIAGRAM - TUNER Section (CFD-E100L Only) - See page 41, 42 for IC Block Diagrams. See page 39 for Waveform.

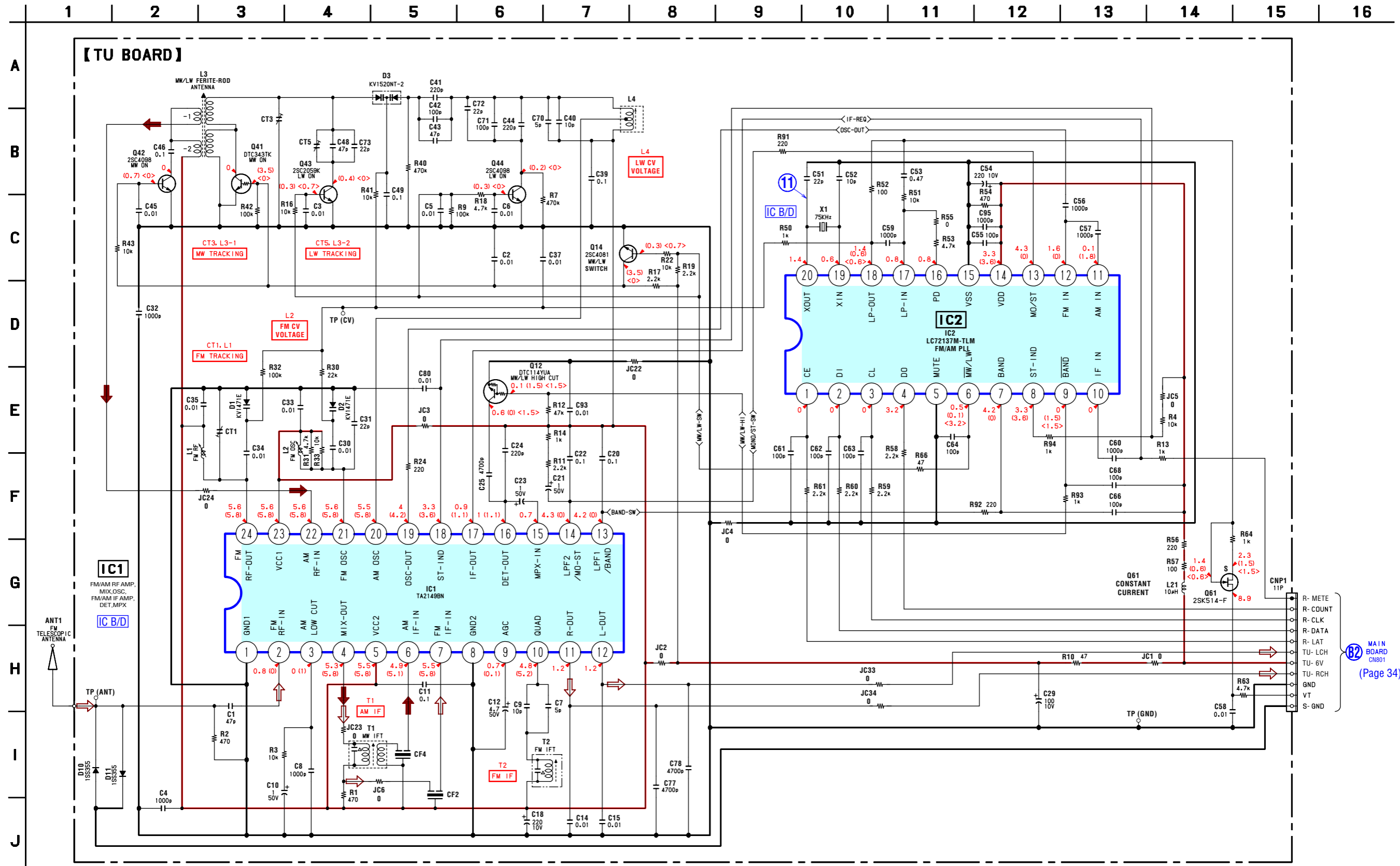

6-11. PRINTED WIRING BOARD – TAPE Section –

• See page 25 for Circuit Boards Location.  :Uses unleaded solder.

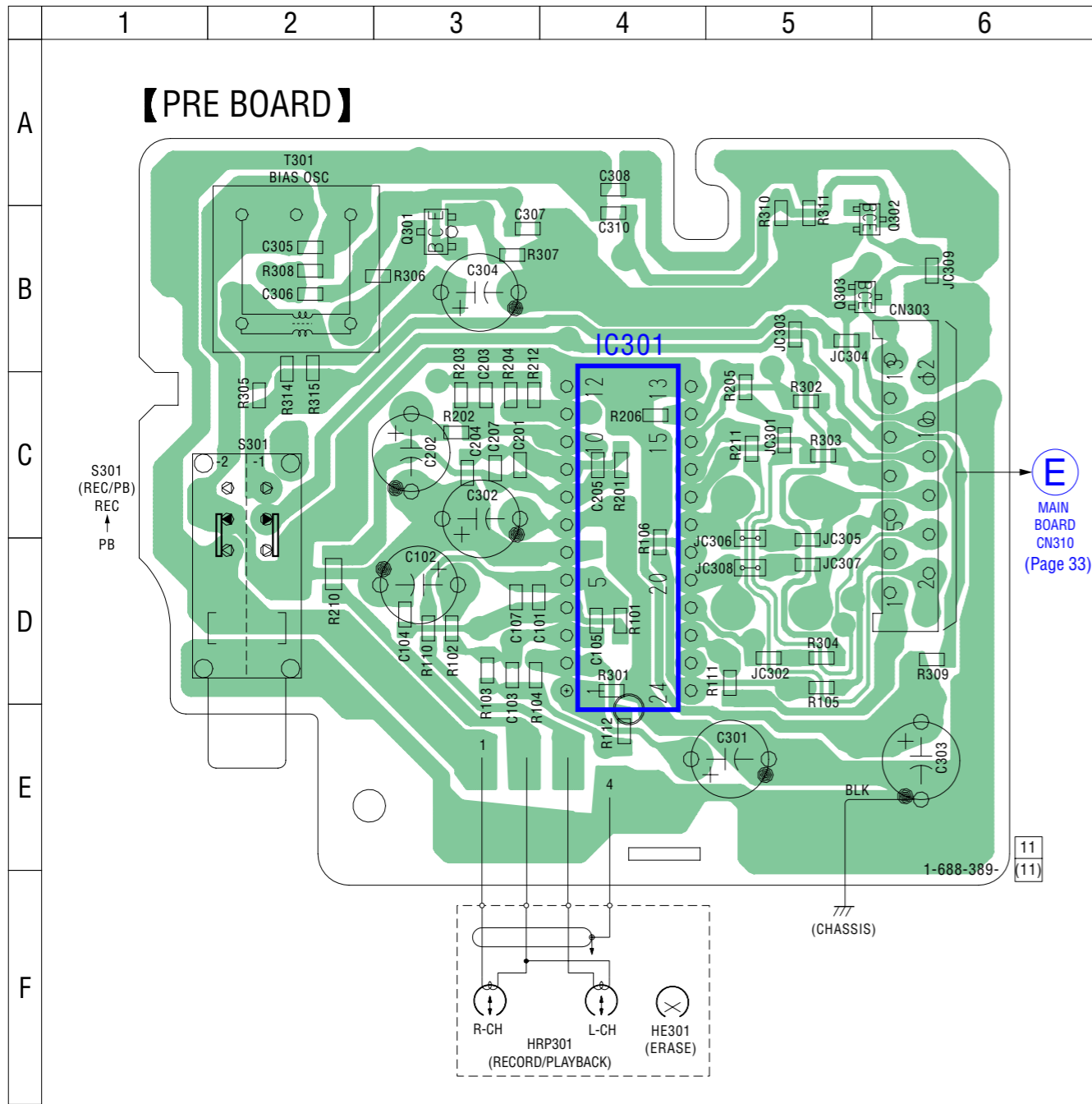

6-12. SCHEMATIC DIAGRAM – TAPE Section –

• See page 42 for IC Block Diagram. • See page 39 for Waveform.

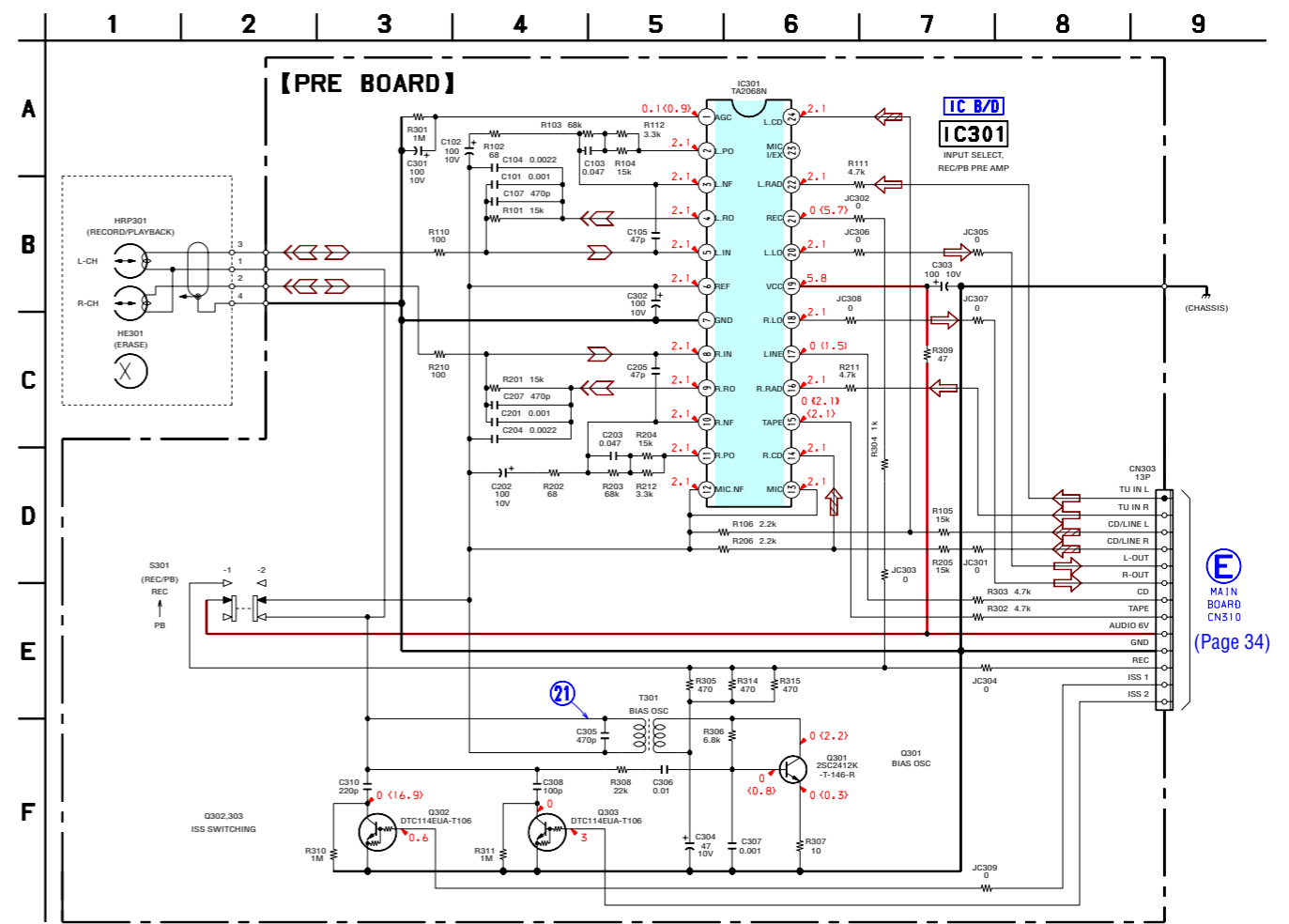

6-13. PRINTED WIRING BOARD – MAIN Section – • See page 25 for Circuit Boards Location.  :Uses unleaded solder.

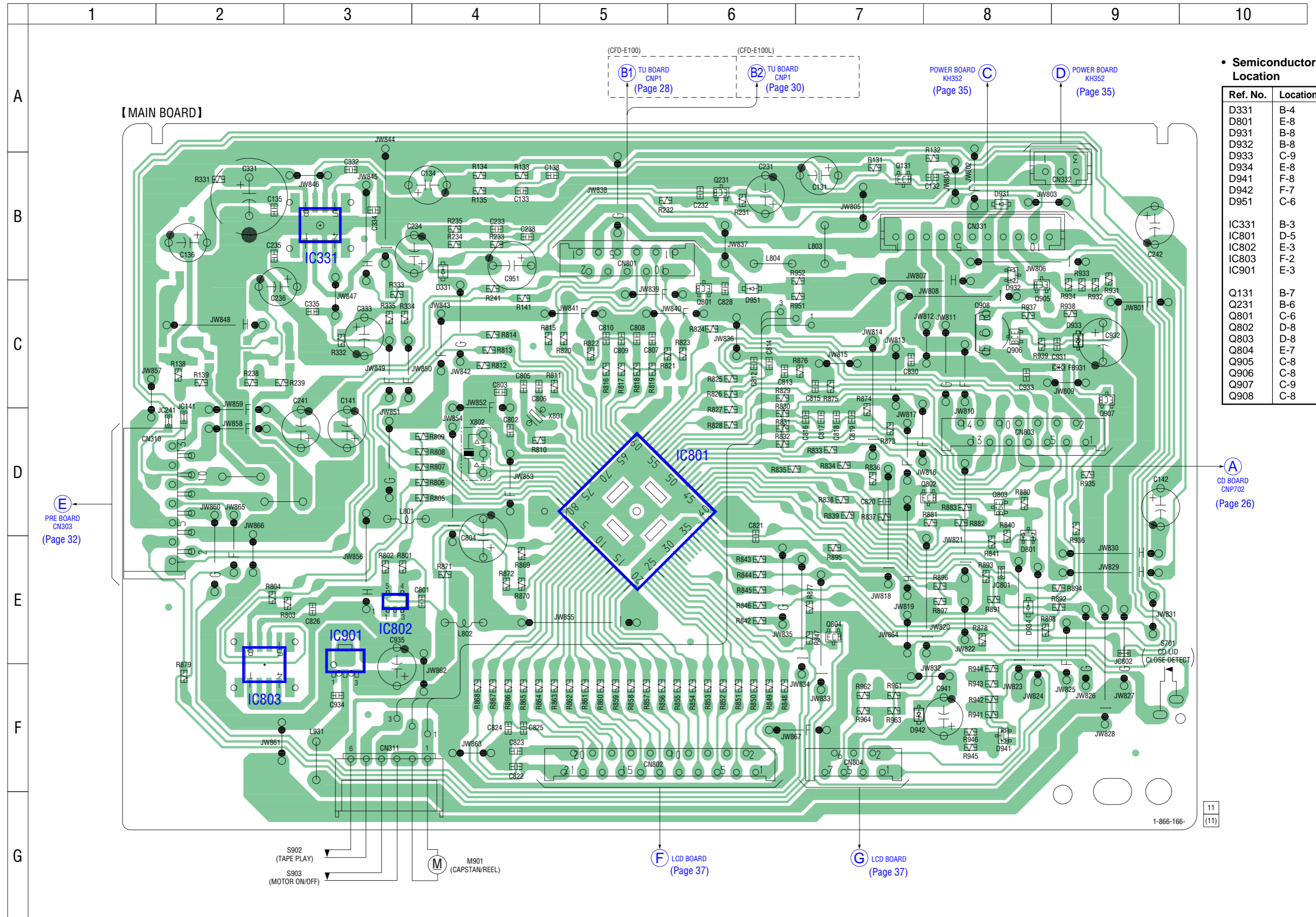

• Semiconductor Location

Ref. No.	Location
D331	B-4
D801	E-8
D931	B-8
D932	B-8
D933	C-9
D934	E-8
D941	F-8
D942	F-7
D951	C-6
IC331	B-3
IC801	D-5
IC802	E-3
IC803	F-2
IC901	E-3
Q131	B-7
Q231	B-6
Q801	C-6
Q802	D-8
Q803	D-8
Q804	E-7
Q905	C-8
Q906	C-8
Q907	C-9
Q908	C-8

E
PRE BOARD
CNP303
(Page 32)

A
CD BOARD
CNP702
(Page 26)

F
LCD BOARD
(Page 37)

G
LCD BOARD
(Page 37)

S902 (TAPE PLAY)
S903 (MOTOR ON/OFF)
M901 (CAPSTAN/REEL)

1-866-166-
(11)

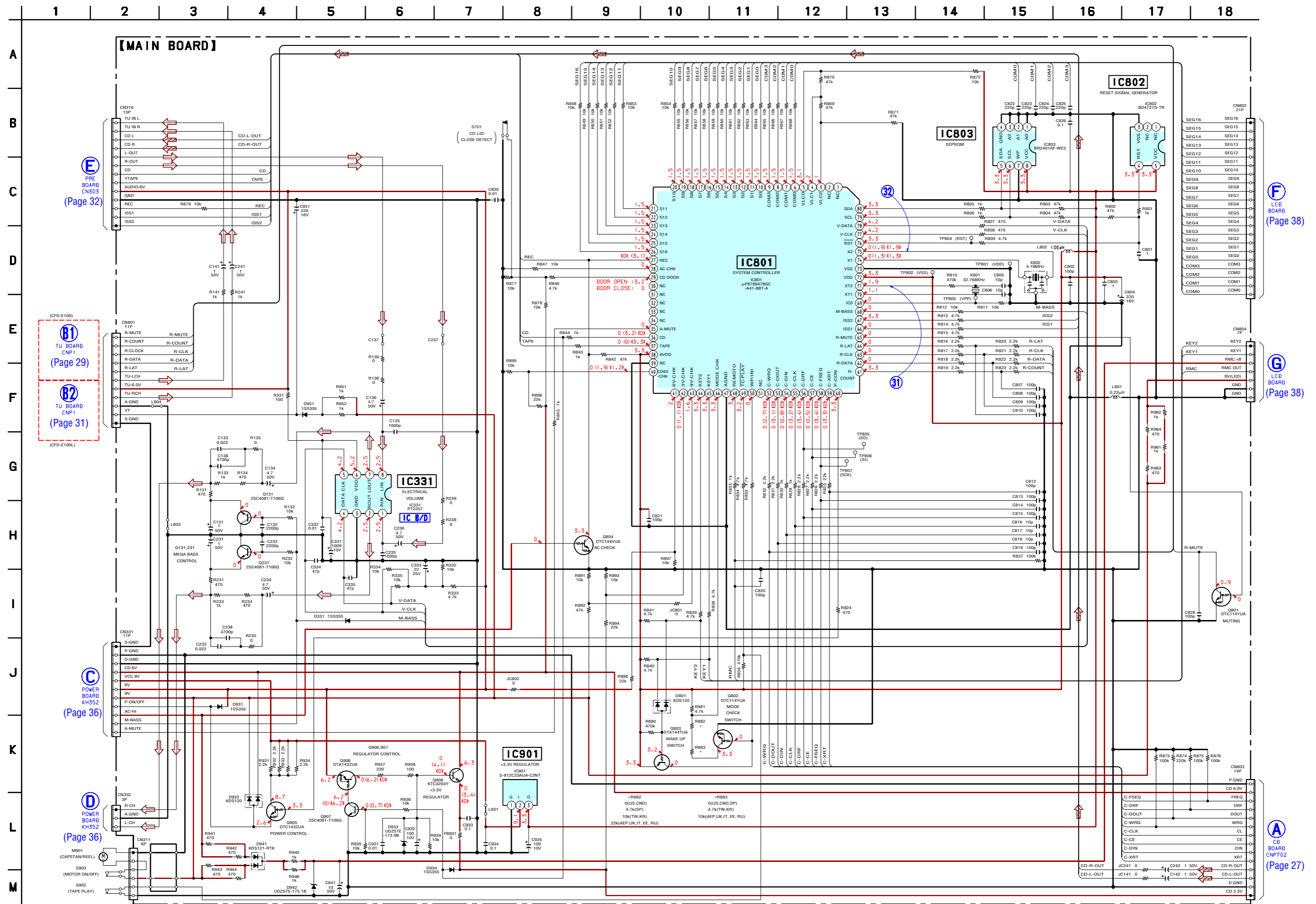

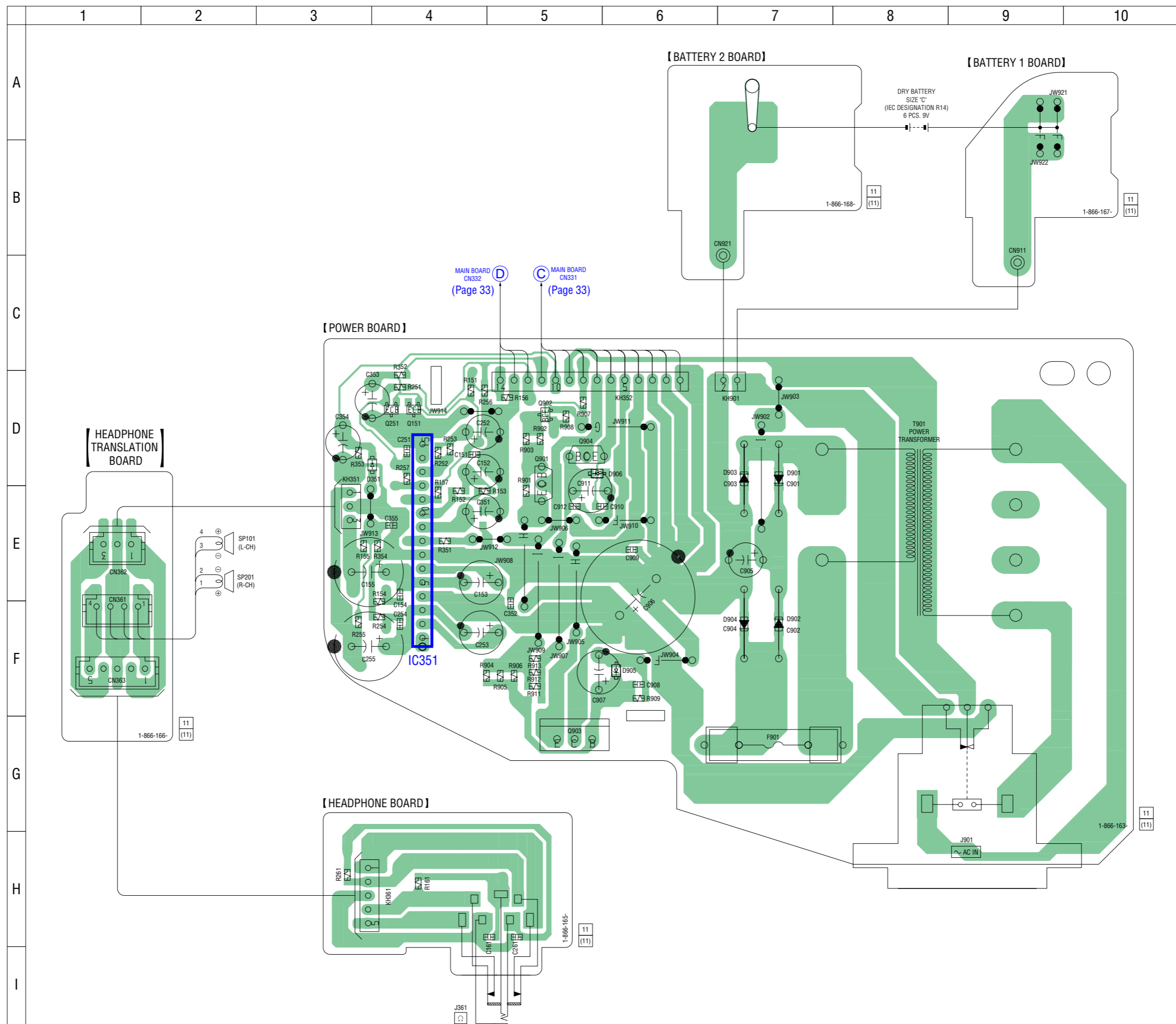

6-15. PRINTED WIRING BOARDS – POWER Section – • See page 25 for Circuit Boards Location.  :Uses unleaded solder.

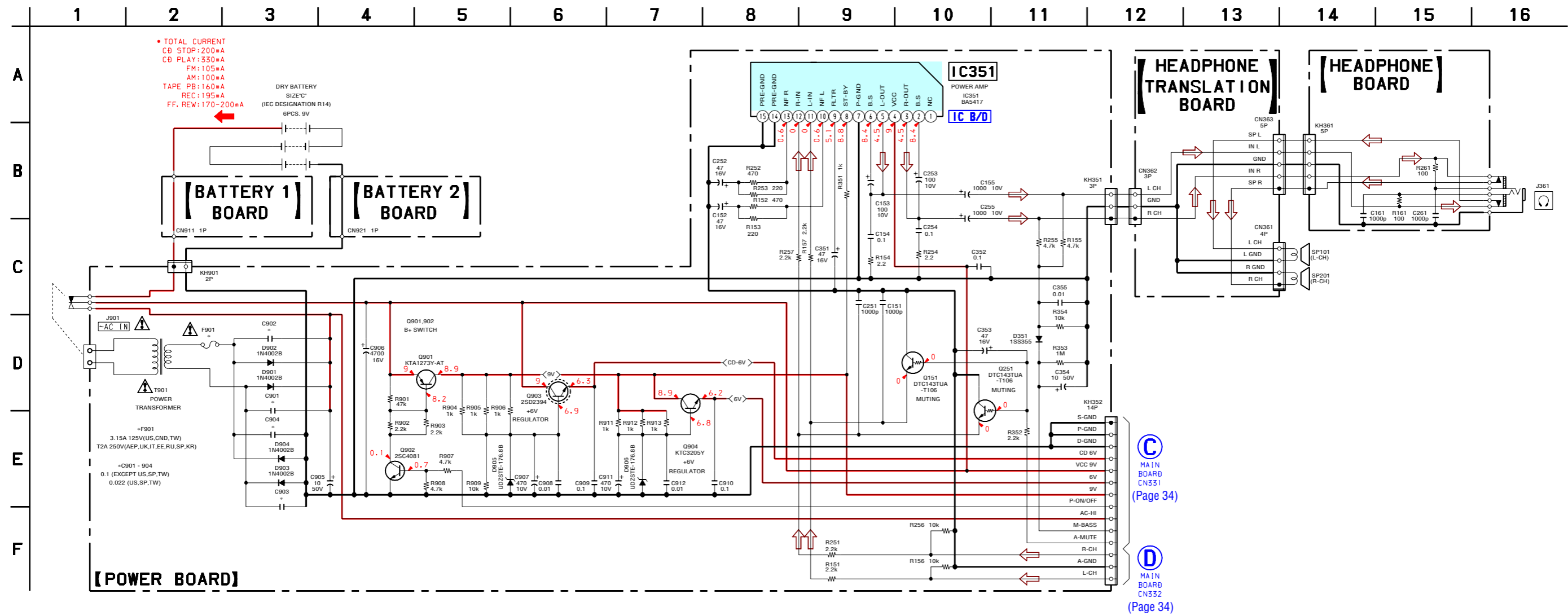

• Semiconductor Location

Ref. No.	Location
D351	D-4
D901	D-7
D902	F-7
D903	D-7
D904	F-7
D905	F-6
D906	D-5
IC351	E-4
Q151	D-4
Q251	D-4
Q901	D-5
Q902	D-5
Q903	G-5
Q904	D-5



6-17. PRINTED WIRING BOARDS – LCD Section – • See page 25 for Circuit Boards Location.  :Uses unleaded solder.

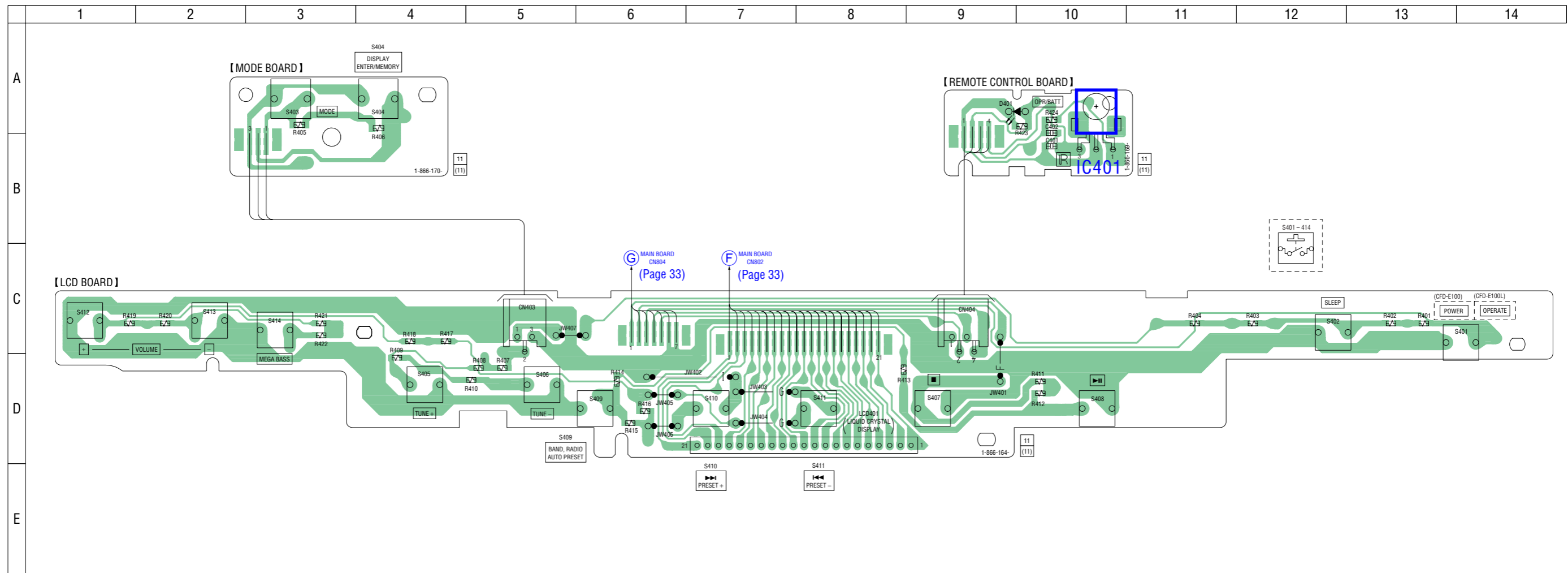

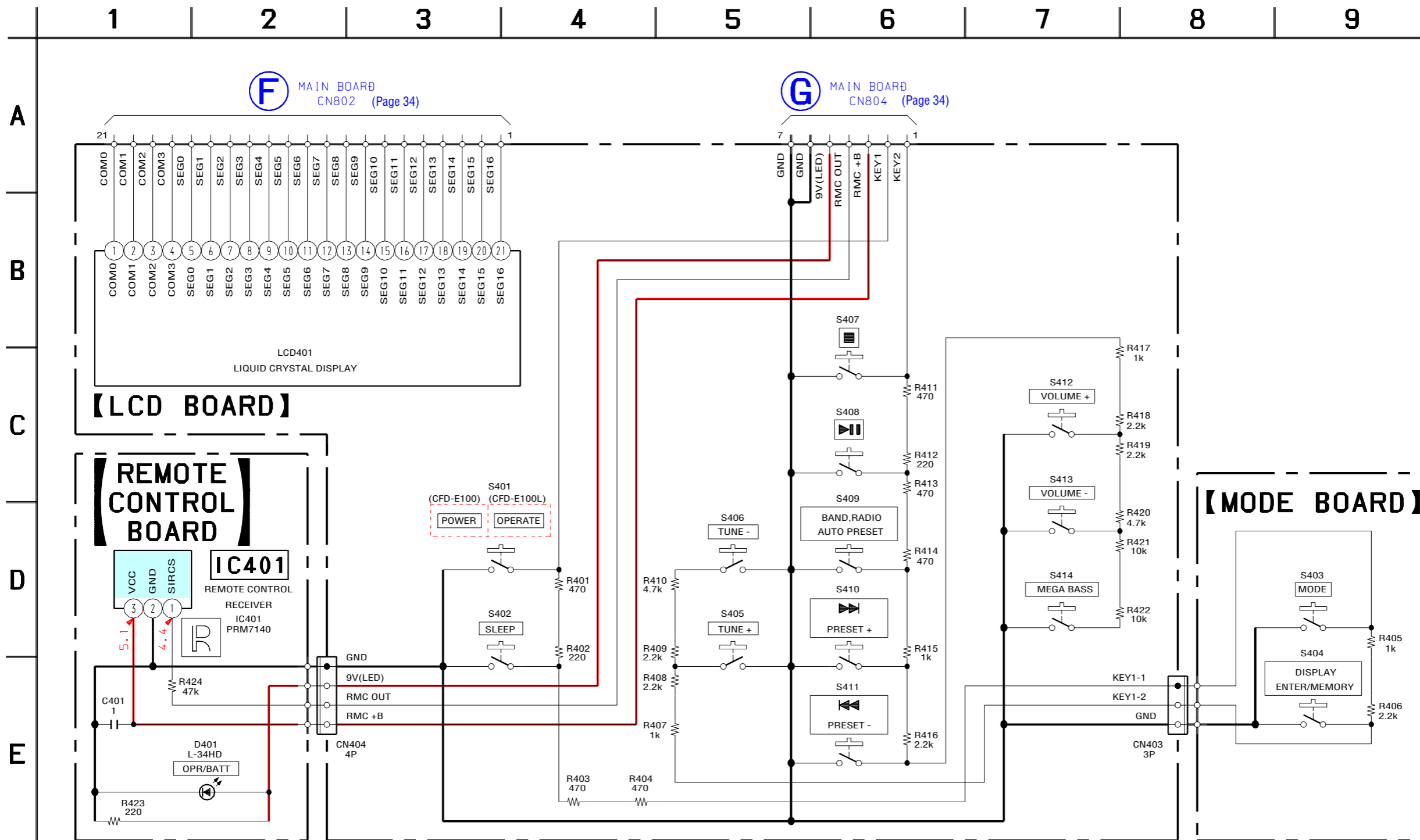

• Waveforms

– CD Board –

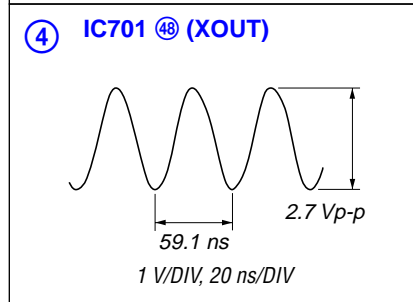
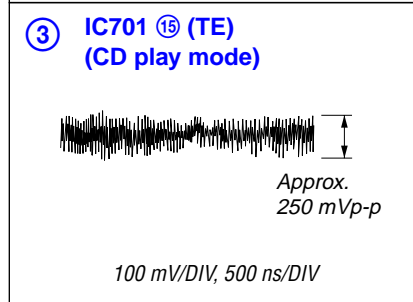
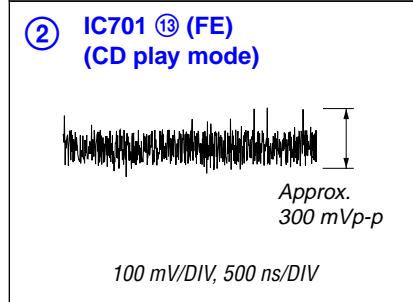
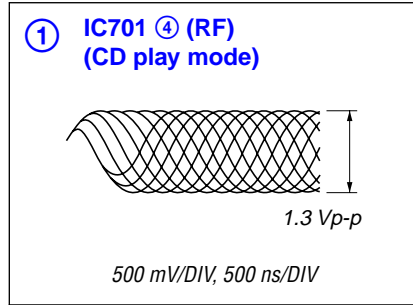

– TU Board –

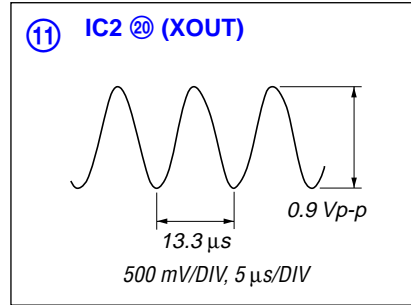

– PRE Board –

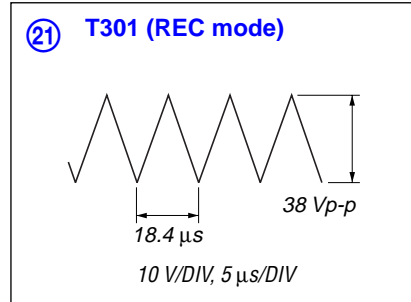

– MAIN Board –

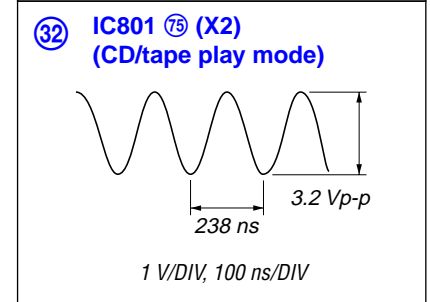
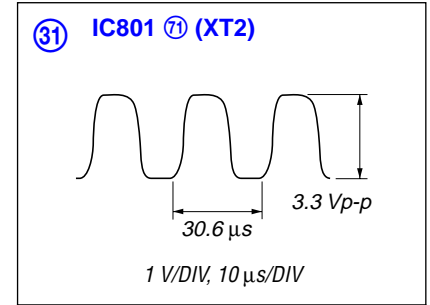

CFD-E100/E100L

• IC Block Diagrams

– CD Board –

IC701 LC78646E-US-E

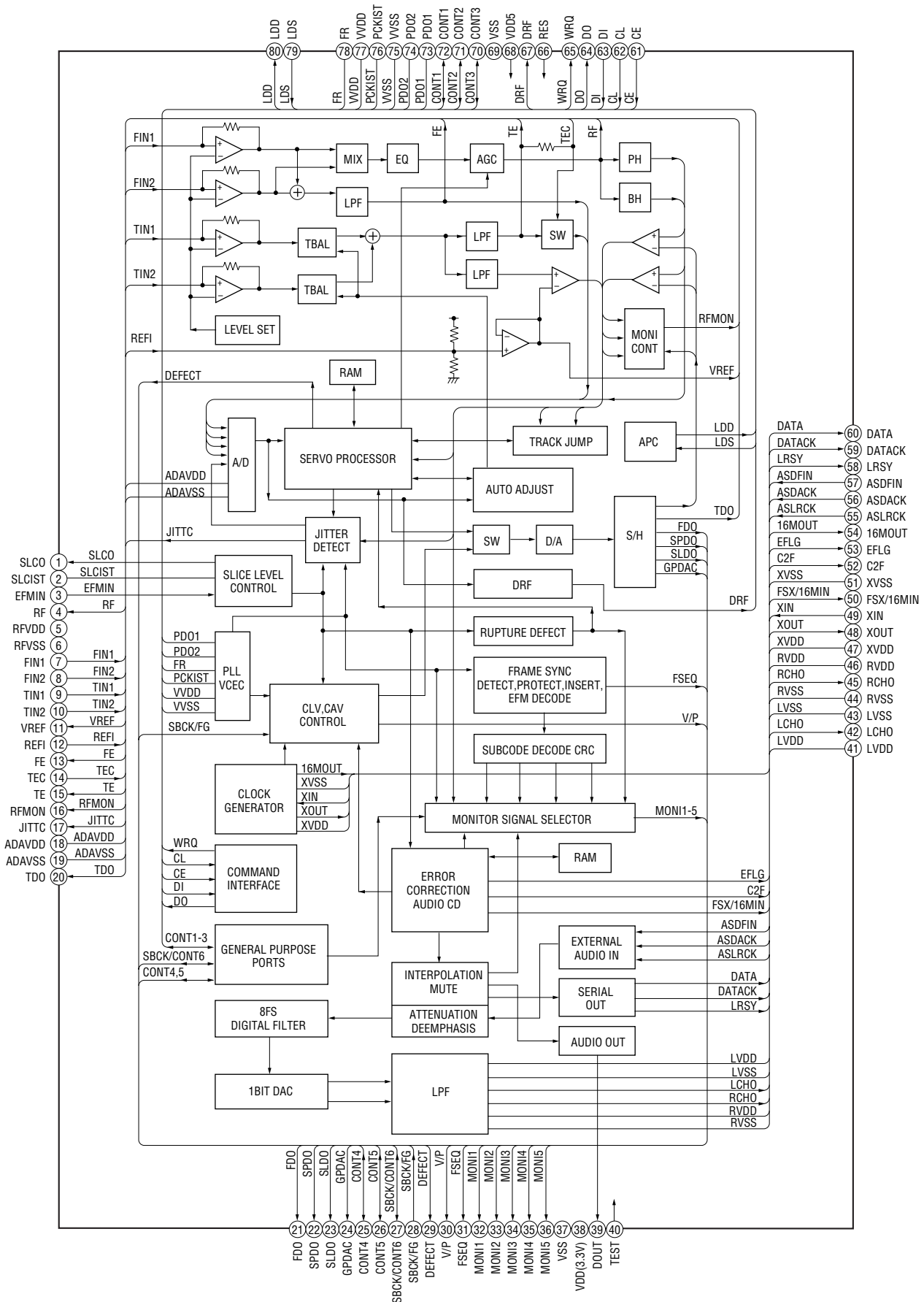

IC702 BA5826FP-E2

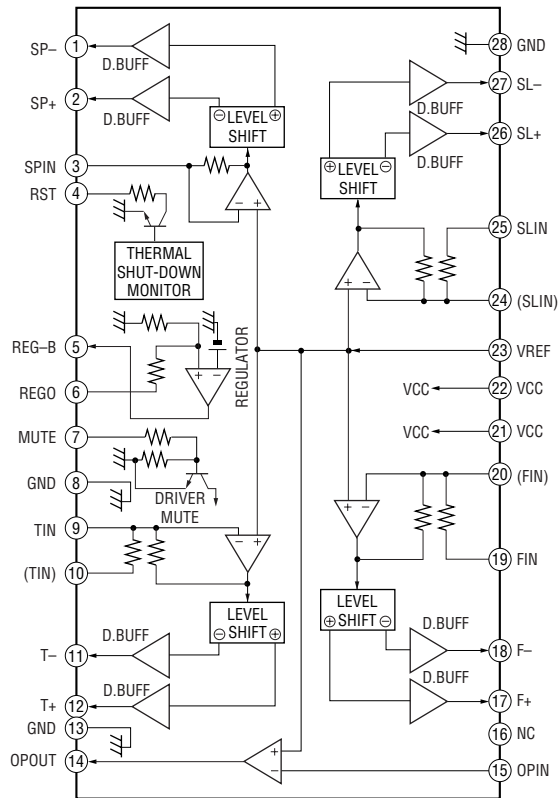

-TU Board-

IC1 TA2149BN

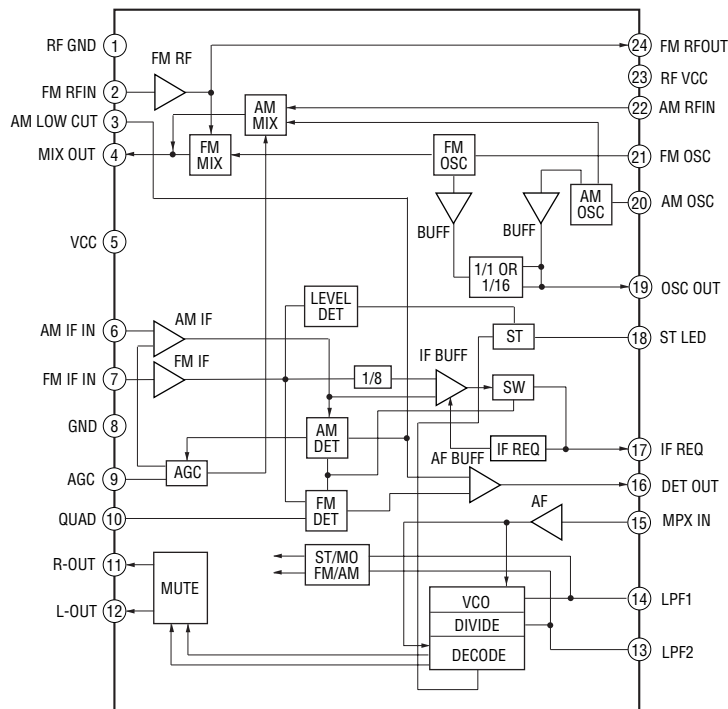

IC2 LC72137M-TLM-E

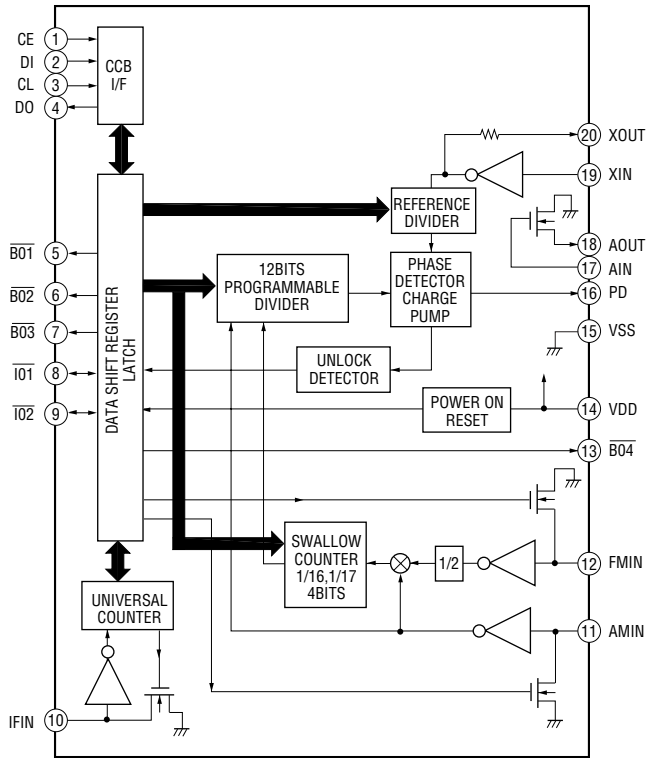

- MAIN Board -

IC331 PT2257-S

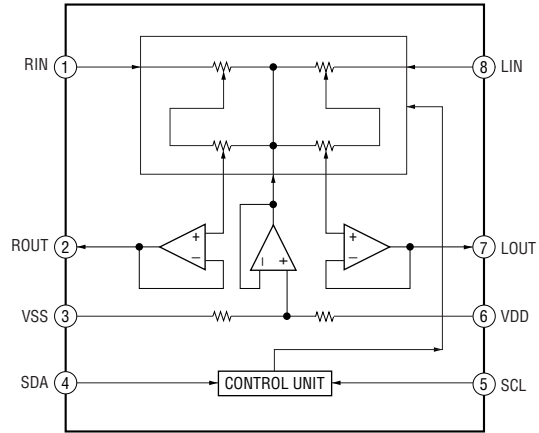

- PRE Board -

IC301 TA2068N

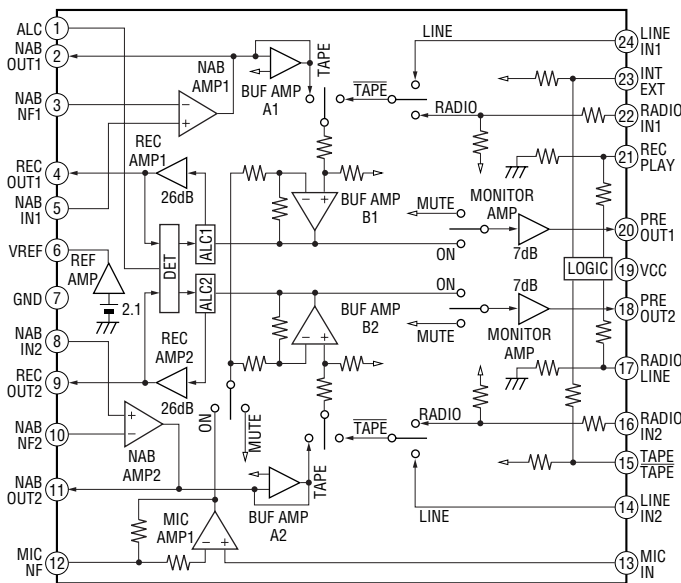

- POWER Board -

IC351 BA5417

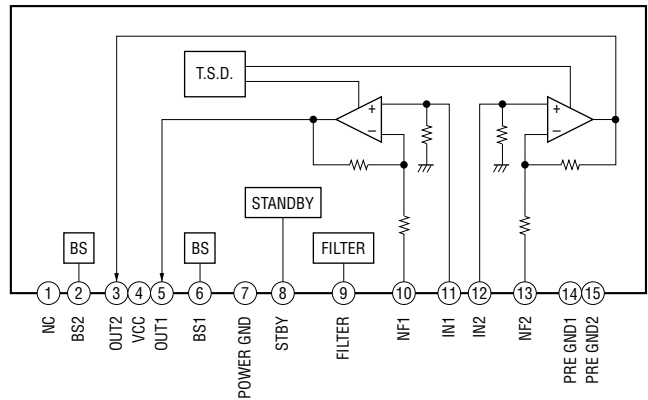

• IC Pin Function Description

MAIN BOARD IC801 μ PD789478GC-A41-8BT-A (SYSTEM CONTROLLER)

Pin No.	Pin Name	I/O	Description
1, 2	NC	-	Not used
3 to 5	VLC2 to VLC0	-	Terminal for doubler circuit capacitor connection to develop liquid crystal display drive voltage
6 to 9	COM0 to COM3	O	Common drive signal output to the liquid crystal display
10 to 26	S0 to S16	O	Segment drive signal output to the liquid crystal display
27	REC	I	Recording/playback detection signal input terminal "L": playback mode, "H": recording mode
28	AC-CHK	I	AC voltage detection signal input terminal "L": AC IN
29	CD DOOR	I	CD lid close detection switch input terminal "L": close
30 to 34	NC	-	Not used
35	A-MUTE	O	Audio muting on/off control signal output terminal "H": muting on
36	CD	O	CD function control signal output terminal "H": CD on
37	TAPE	O	Tape function control signal output terminal "H": tape on
38	AVDD	-	Power supply terminal (+3.3V)
39	NC	-	Not used
40	CD6V-CHK	I	Power supply voltage (+6V) for CD block monitoring terminal
41	6V-CHK	I	Power supply voltage (+6V) monitoring terminal
42	3V-CHK	I	Power supply voltage (+3V) monitoring terminal
43	9V-CHK	I	Power supply voltage (+9V) monitoring terminal
44, 45	KEY2, KEY1	I	Front panel key input terminal (A/D input)
46	MODE CHK	I	Model destination setting terminal
47	AGND	-	Ground terminal
48	REMOTE	I	Remote control signal input from the remote control receiver
49	TC-PLAY	I	Tape play detection switch input terminal "L": tape play mode
50	WP/INI	I/O	Interrupt status input terminal Output terminal for wake up/Initial reset signal reading
51	NC	-	Not used
52	C-WRQ	I	Interruption detection signal input from the digital signal processor
53	C-DOUT	I	Serial data input from the digital signal processor
54	C-DIN	O	Serial data output to the digital signal processor
55	C-CLK	O	Serial data transfer clock signal output to the digital signal processor
56	C-DRF	I	Focus on/off detection signal input from the digital signal processor
57	C-CE	O	Chip enable signal output to the digital signal processor
58	C-FSEQ	I	Synchronizing signal detection signal input from the digital signal processor
59	C-XRT	O	System reset signal output to the digital signal processor "L": reset
60	P-CON	O	Power on/off control signal output terminal "L": standby mode, "H": power on
61	R-COUNT	I	PLL serial count data input from the FM/AM PLL
62	R-DATA	O	PLL serial data output to the FM/AM PLL
63	R-CLK	O	PLL serial data transfer clock signal output to the FM/AM PLL
64	R-LAT	O	PLL chip enable signal output to the FM/AM PLL
65	R-MUTE	O	Tuner muting on/off control signal output to the FM/AM PLL "H": muting on
66	ISS1	O	ISS 1 on/off control signal output terminal "H": ISS 1 on
67	ISS2	O	ISS 2 on/off control signal output terminal "H": ISS 2 on
68	M-BASS	O	MEGA BASS on/off control signal output terminal "L": MEGA BASS on
69	IC0	I	Not used
70	XT1	I	Sub system clock input terminal (32.768 kHz)

CFD-E100/E100L

Pin No.	Pin Name	I/O	Description
71	XT2	O	Sub system clock output terminal (32.768 kHz)
72	VDD	-	Power supply terminal (+3.3V)
73	VSS	-	Ground terminal
74	X1	I	Main system clock input terminal (4.19 MHz)
75	X2	O	Main system clock output terminal (4.19 MHz)
76	$\overline{\text{RST}}$	I	System reset signal input "L": reset For several hundreds msec. after the power supply rises, "L" is input, then it changes to "H"
77	V-CLK	O	Serial data transfer clock signal output to the electrical volume
78	V-DATA	O	Serial data output to the electrical volume
79	SCL	O	Serial data transfer clock signal output to EEPROM
80	SDA	I/O	Two-way data bus with the EEPROM

SECTION 7 EXPLODED VIEWS

NOTE:

- -XX and -X mean standardized parts, so they may have some difference from the original one.
- Color Indication of Appearance Parts Example: KNOB, BALANCE (WHITE) . . . (RED)

↑ ↑
 Parts of Color Cabinet's Color
- Please refer to "SERVICING NOTES" on page 5 about model variation.

- Items marked "*" are not stocked since they are seldom required for routine service. Some delay should be anticipated when ordering these items.
- Accessories are given in the last of electrical parts list.
- Abbreviation
 CND : Canadian model
 EE : East European model
 IT : Italian model
 KR : Korean model
 RU : Russian model
 SP : Singapore model
 TW : Taiwan model

The components identified by mark \triangle or dotted line with mark \triangle are critical for safety. Replace only with part number specified.

Les composants identifiés par une marque \triangle sont critiques pour la sécurité. Ne les remplacer que par une pièce portant le numéro spécifié.

7-1. HANDLE SECTION

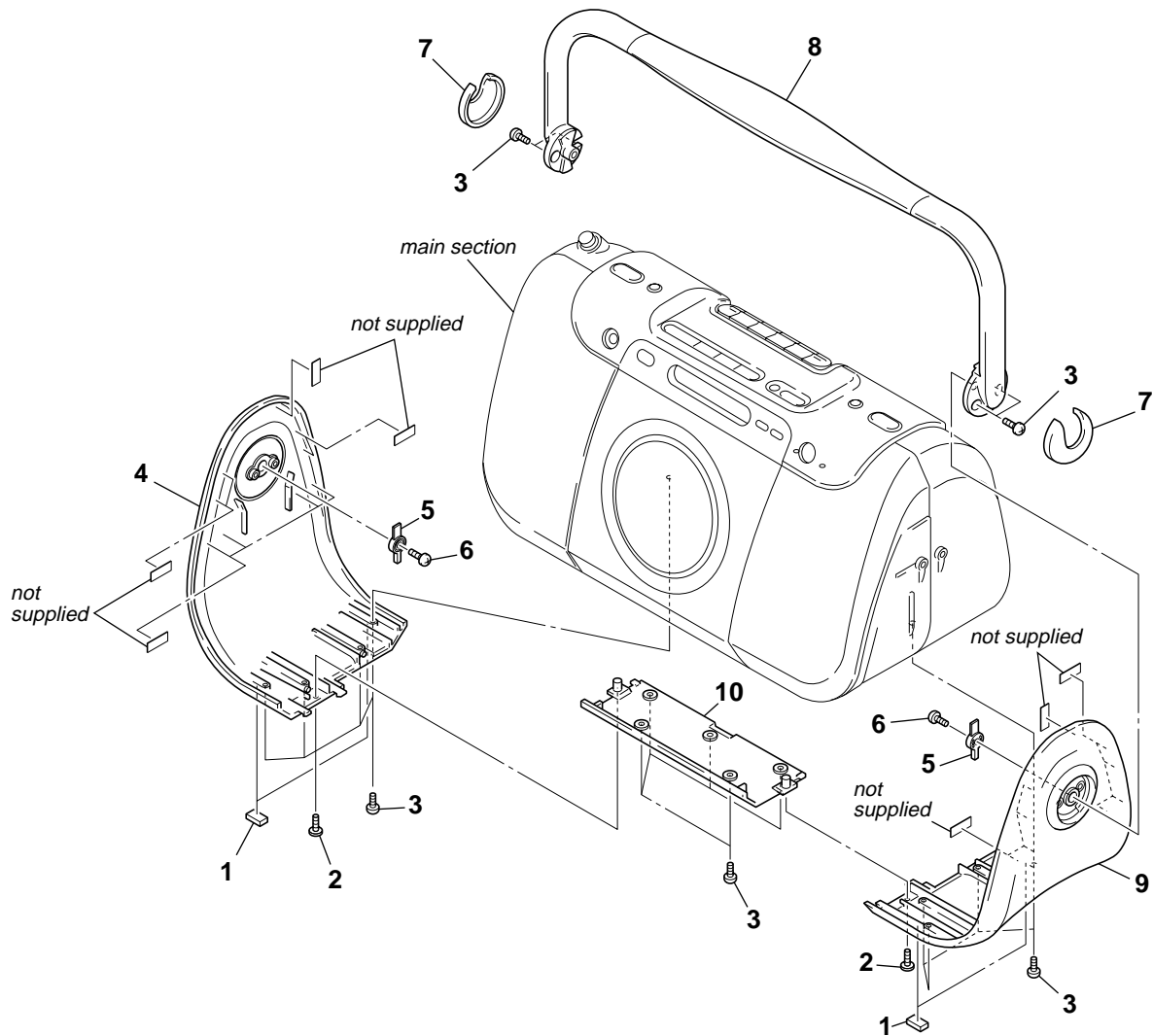

Ref. No.	Part No.	Description	Remark	Ref. No.	Part No.	Description	Remark
1	3-040-916-01	FOOT (FRONT), RUBBER		8	2-587-577-01	HANDLE (for SILVER, WHITE)	
2	3-254-081-01	SCREW		8	2-587-577-11	HANDLE (for BLUE)	
3	3-252-827-01	SCREW (B2.6), (+) BV TAPPING		9	2-587-573-01	PANEL (R) (E100: US, CND)	
4	2-587-572-01	PANEL (L) (E100: US, CND)		9	2-587-573-11	PANEL (R) (EXCEPT E100: US, CND)	
4	2-587-572-11	PANEL (L) (EXCEPT E100: US, CND)		10	2-587-571-01	PANEL (LOWER) (E100:US, CND)	
5	2-592-674-01	ARM (HANDLE)		10	2-587-571-11	PANEL (LOWER) (E100L)	
6	3-254-151-01	SCREW (B2.6), (+) P TAPPING		10	2-587-571-21	PANEL (LOWER) (E100: SP, TW, KR)	
7	2-587-590-01	COVER (HANDLE) (EXCEPT for WHITE: LIV)					
7	2-587-590-11	COVER (HANDLE) (for WHITE: LIV)					

7-2. MAIN SECTION

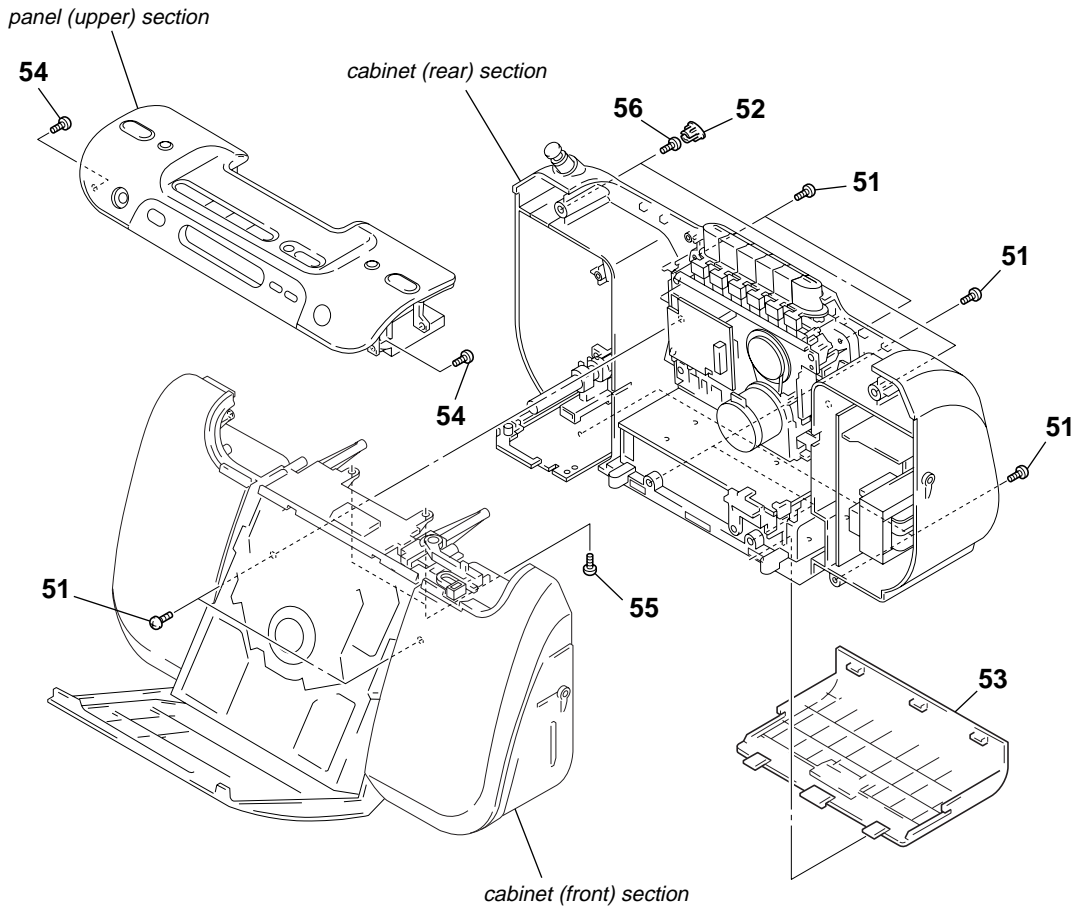

Ref. No.	Part No.	Description	Remark	Ref. No.	Part No.	Description	Remark
51	3-252-827-01	SCREW (B2.6), (+) BV TAPPING		53	2-587-576-11	LID, BATTERY CASE (for WHITE: LIV)	
52	2-587-607-01	CAP (REAR) (for WHITE: ORIGINAL)		53	2-587-576-21	LID, BATTERY CASE (for SILVER)	
52	2-587-607-11	CAP (REAR) (for WHITE: LIV)		53	2-587-576-31	LID, BATTERY CASE (for BLUE)	
52	2-587-607-21	CAP (REAR) (for SILVER)		54	3-253-143-01	SCREW (B2.6), (+) P TAPPING	
52	2-587-607-31	CAP (REAR) (for BLUE)		55	3-254-151-01	SCREW (B2.6), (+) P TAPPING	
53	2-587-576-01	LID, BATTERY CASE (for WHITE: ORIGINAL)		56	3-254-140-01	SCREW (B2.6), (+) BV TAPPING	

7-3. CABINET (FRONT) SECTION

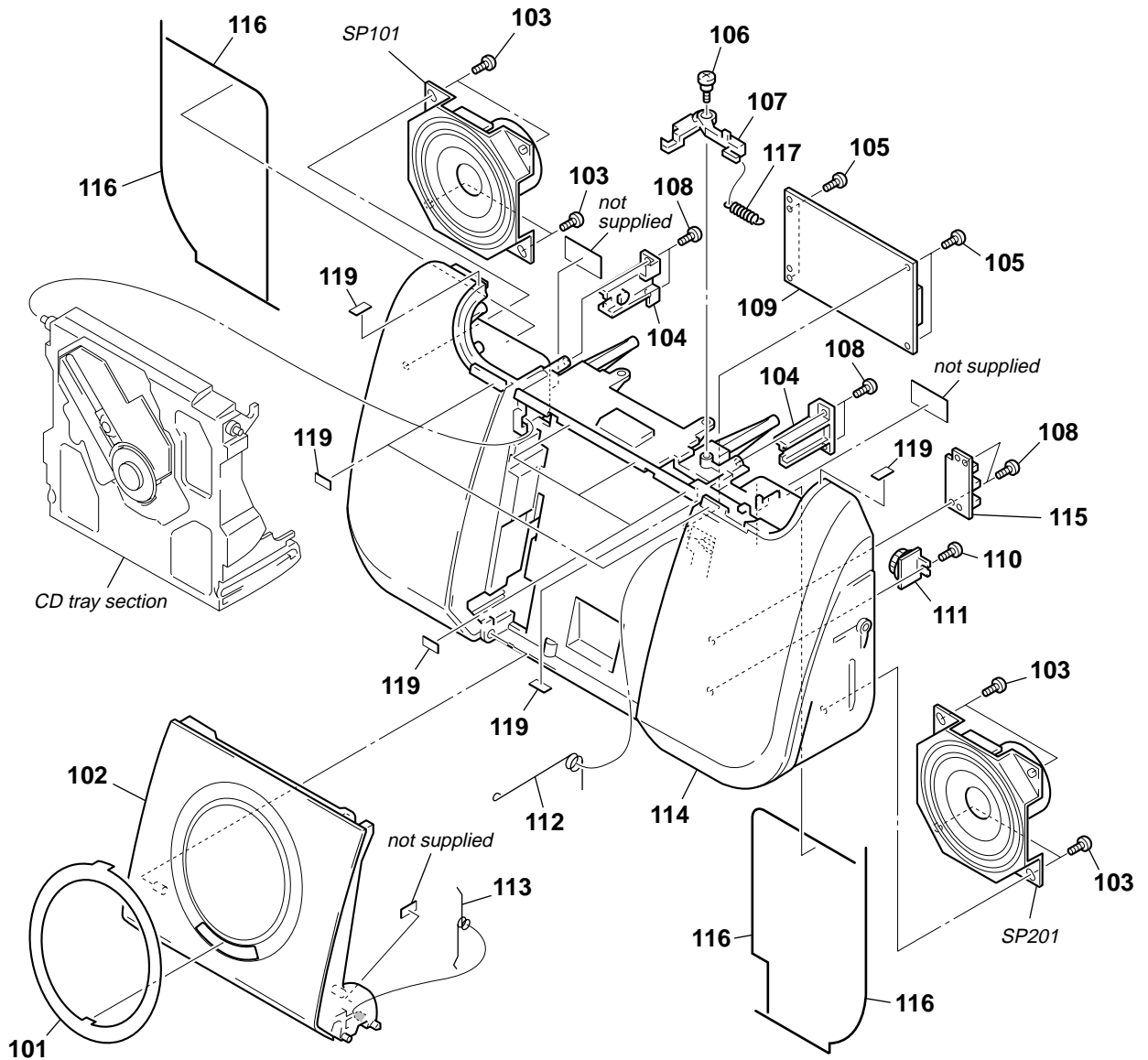

Ref. No.	Part No.	Description	Remark	Ref. No.	Part No.	Description	Remark
101	2-587-579-01	WINDOW (CD) (for WHITE: ORIGINAL)		* 109	A-4542-926-A	CD BOARD, COMPLETE	
101	2-587-579-11	WINDOW (CD) (for WHITE: LIV)		110	3-254-142-01	SCREW (B3), (+) BV TAPPING	
101	2-587-579-21	WINDOW (CD) (for SILVER)		111	3-047-468-21	DAMPER	
101	2-587-579-31	WINDOW (CD) (for BLUE)		112	2-587-613-01	SPRING (CD PANEL)	
102	2-587-574-01	LID, CD (for WHITE: ORIGINAL)		113	2-587-614-01	SPRING (CD LID)	
102	2-587-574-11	LID, CD (for WHITE: LIV)		114	X-2055-195-1	CABINET (FRONT) SUB ASSY (for WHITE: ORIGINAL)	
102	2-587-574-21	LID, CD (for SILVER) (E100: SP, TW, KR)		114	X-2055-952-1	CABINET (FRONT) SUB ASSY (for SILVER)	
102	2-587-574-31	LID, CD (for SILVER) (E100L)		114	X-2059-391-1	CABINET (FRONT) SUB ASSY (for BLUE)	
102	2-587-574-41	LID, CD (for BLUE) (E100L: AEP)		114	X-2059-689-1	CABINET (FRONT) SUB ASSY (for WHITE: LIV)	
102	2-587-574-51	LID, CD (for BLUE) (E100: SP, TW, KR)					
103	3-252-827-01	SCREW (B2.6), (+) BV TAPPING		* 115	1-866-166-11	HEADPHONE TRANSLATION BOARD	
104	2-587-605-01	PLATE (CD SHAFT)		116	2-024-906-01	CUSHION (REAR)	
105	3-253-143-01	SCREW (B2.6), (+) P TAPPING		117	2-592-673-01	SPRING (LEVER LOCK)	
* 106	4-233-649-01	SCREW, STEP		119	3-356-122-01	CUSHION	
107	2-587-604-01	LEVER (LOCK)		SP101	1-826-150-11	SPEAKER (8cm) (L-ch)	
108	3-254-151-01	SCREW (B2.6), (+) P TAPPING		SP201	1-826-150-11	SPEAKER (8cm) (R-ch)	

7-4. PANEL (UPPER) SECTION

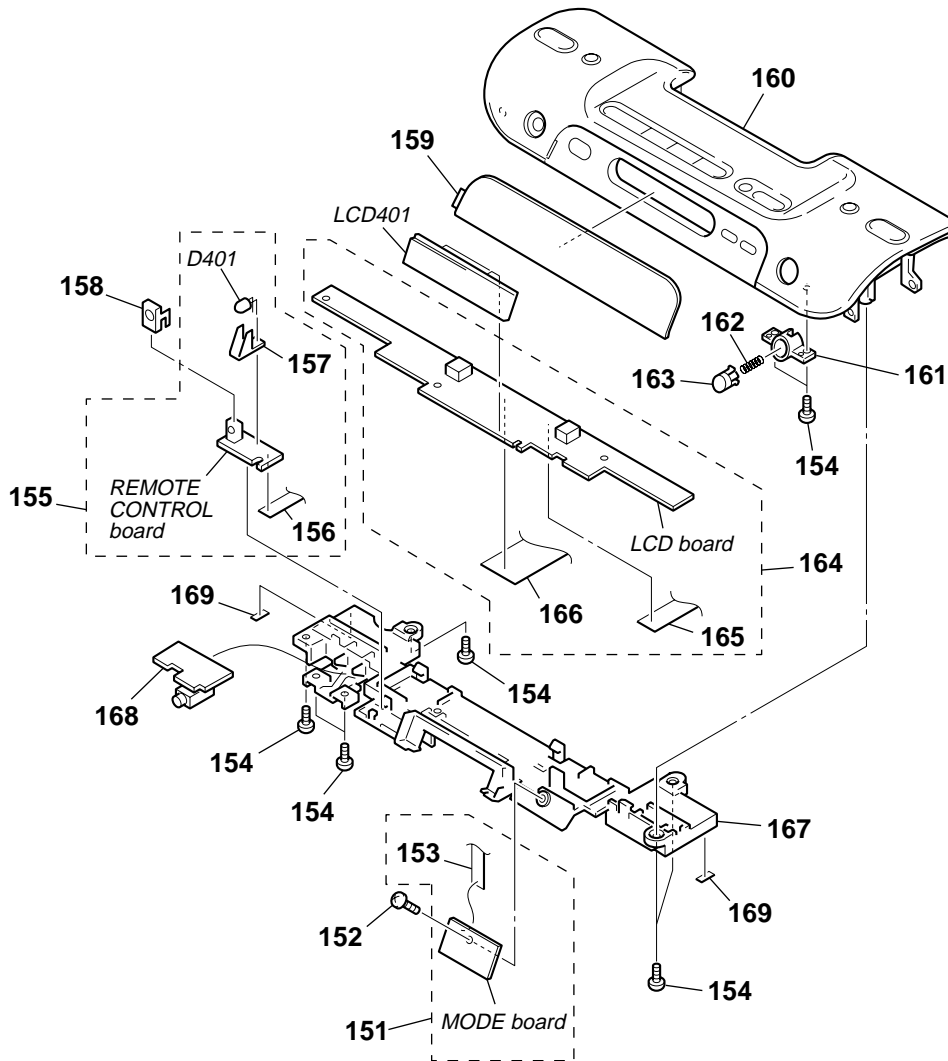

Ref. No.	Part No.	Description	Remark	Ref. No.	Part No.	Description	Remark
151	A-1109-063-A	MODE BOARD, COMPLETE		160	X-2059-691-1	PANEL (UPPER) SUB ASSY (for WHITE: LIV)	
152	3-253-143-01	SCREW (B2.6), (+) P TAPPING		160	X-2059-694-1	PANEL (UPPER) SUB ASSY (for BLUE, SILVER) (E100L)	
153	1-830-508-11	CABLE, FLEXIBLE FLAT (3 CORE)		161	2-587-600-01	HOLDER (LOCK)	
154	3-254-151-01	SCREW (B2.6), (+) P TAPPING		162	2-587-612-01	SPRING (OPEN)	
155	A-1109-065-A	REMOTE CONTROL BOARD, COMPLETE		163	2-587-589-01	BUTTON (OPEN)	
156	1-830-509-11	CABLE, FLEXIBLE FLAT (4 CORE)		164	A-1109-061-A	LCD BOARD, COMPLETE	
157	2-587-601-01	HOLDER (LED)		165	1-830-510-11	CABLE, FLEXIBLE FLAT (7 CORE)	
158	2-587-611-01	HOLDER (REMOTE CONTROL)		166	1-830-511-11	CABLE, FLEXIBLE FLAT (21 CORE)	
159	2-587-578-01	WINDOW (LCD) (for WHITE: ORIGINAL)		167	2-587-599-01	HOLDER (LCD)	
159	2-587-578-11	WINDOW (LCD) (for WHITE: LIV)		* 168	1-866-165-11	HEADPHONE BOARD	
159	2-587-578-21	WINDOW (LCD) (for SILVER)		169	3-356-122-01	CUSHION	
159	2-587-578-31	WINDOW (LCD) (for BLUE)					
160	X-2055-197-1	PANEL (UPPER) SUB ASSY (for WHITE: ORIGINAL)		D401	8-719-059-97	DIODE L-34HD (OPR/BATT)	
160	X-2055-954-1	PANEL (UPPER) SUB ASSY (for BLUE, SILVER) (E100: SP, TW, KR)		LCD401	1-805-845-11	DISPLAY PANEL, LIQUID CRYSTAL	

7-5. CABINET (REAR) SECTION

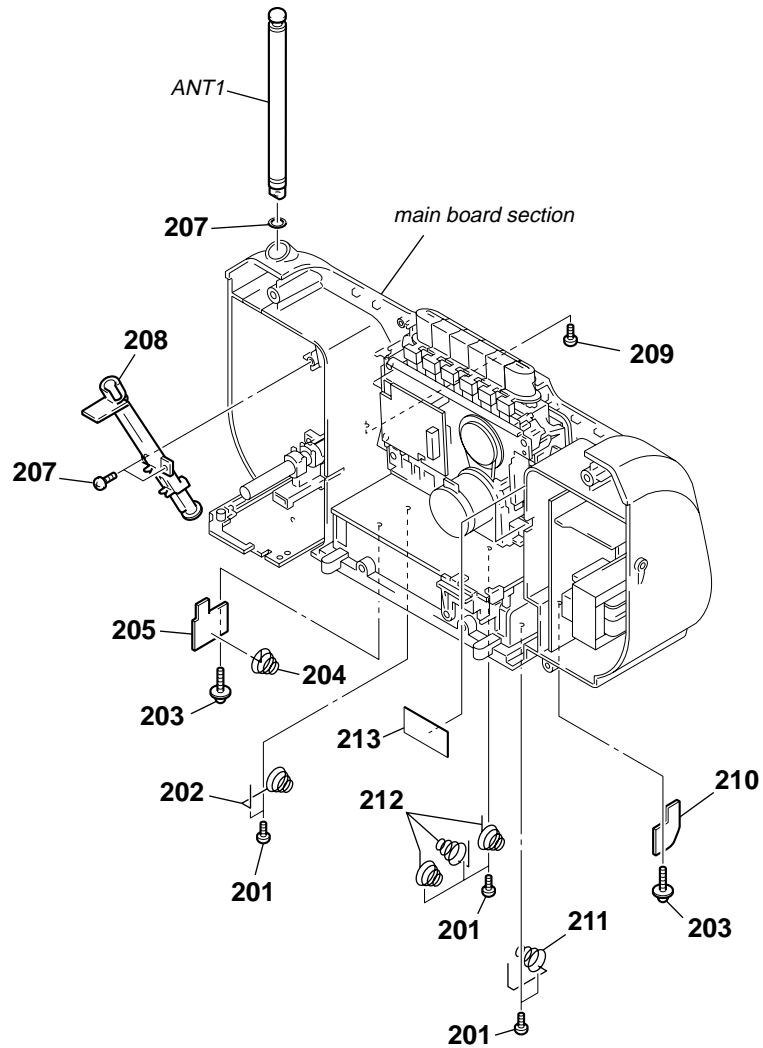

Ref. No.	Part No.	Description	Remark	Ref. No.	Part No.	Description	Remark
201	3-252-827-01	SCREW (B2.6), (+) BV TAPPING		209	3-918-696-11	SCREW (M3X6 LOCK ACE)	
202	2-587-619-01	TERMINAL (+/-) (B), BATTERY		* 210	1-866-167-11	BATTERY 1 BOARD	
203	3-252-828-01	SCREW (B2.6), (+) PWH TAPPING		211	2-587-618-01	TERMINAL (+/-) (A), BATTERY	
204	3-229-975-01	SPRING BATTERY (-)		212	3-252-540-01	SPRING (+, -), BATTERY	
* 205	1-866-168-11	BATTERY 2 BOARD		213	4-855-637-21	CUSHION (B)	
207	3-241-386-01	SPACER (JOG)		ANT1	1-754-282-11	ANTENNA, TELESCOPIC	
208	2-587-598-01	HOLDER (ROD ANT)					

7-6. MAIN BOARD SECTION

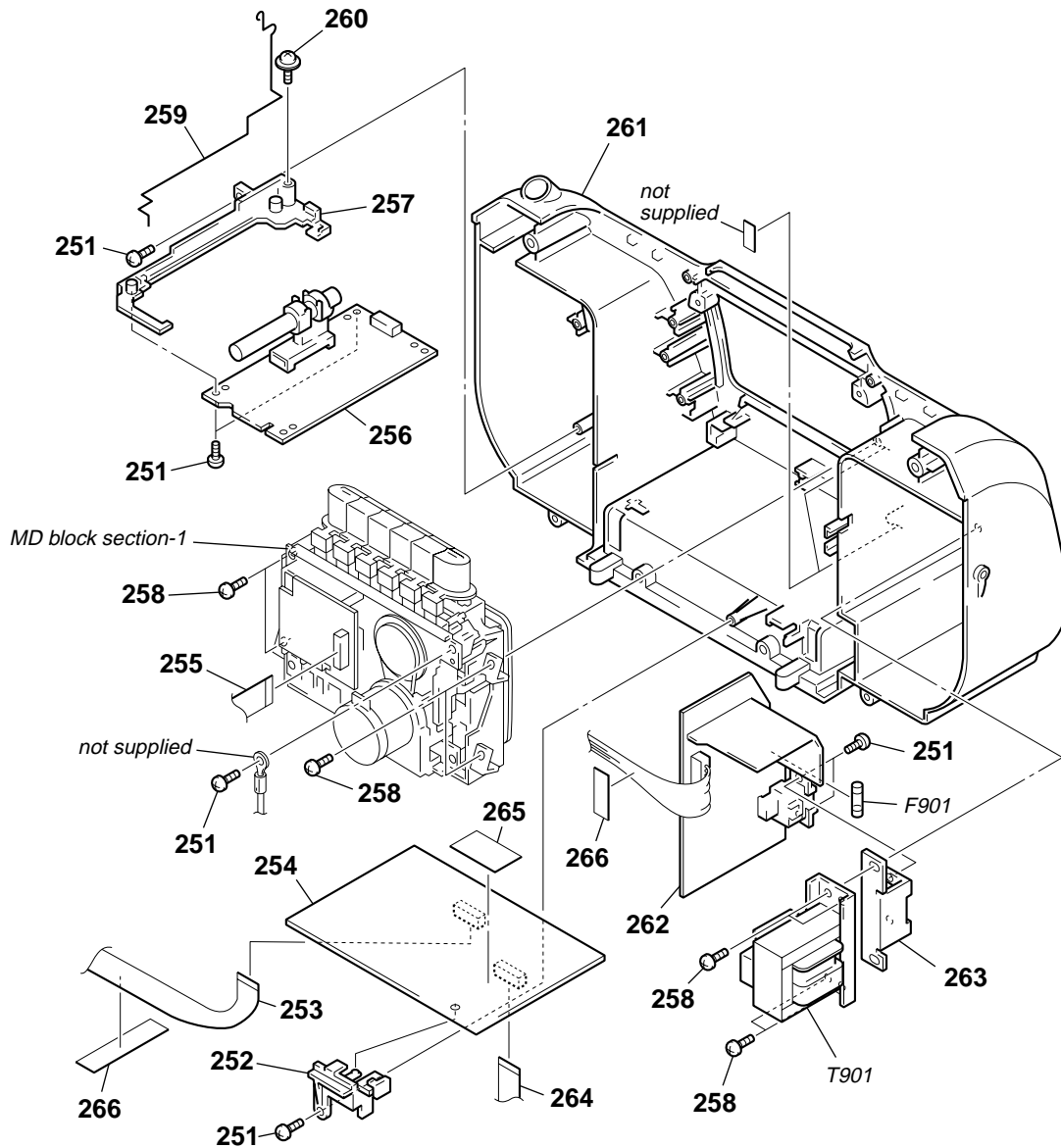

Ref. No.	Part No.	Description	Remark	Ref. No.	Part No.	Description	Remark
251	3-254-151-01	SCREW (B2.6), (+) P TAPPING		261	2-587-569-31	CABINET (REAR) (for BLUE)	
252	2-587-603-01	HOLDER (PWB)		262	A-1109-054-A	POWER BOARD, COMPLETE (US)	
253	1-829-241-11	CABLE, FLEXIBLE FLAT (11 CORE)		262	A-1119-538-A	POWER BOARD, COMPLETE	
254	A-1109-052-A	MAIN BOARD, COMPLETE (US, CND)		262	A-1124-796-A	POWER BOARD, COMPLETE (SP)	(AEP, UK, IT, EE, RU, KR)
254	A-1119-536-A	MAIN BOARD, COMPLETE (TW, KR)		262	A-1124-986-A	POWER BOARD, COMPLETE (CND)	
254	A-1126-046-A	MAIN BOARD, COMPLETE (AEP, UK, IT, EE, RU)		262	A-1126-631-A	POWER BOARD, COMPLETE (TW)	
254	A-1126-671-A	MAIN BOARD, COMPLETE (SP)		263	2-587-620-01	HOLDER (INLET, AC)	
255	1-830-507-11	CABLE, FLEXIBLE FLAT (13 CORE)		264	1-829-252-11	CABLE, FLEXIBLE FLAT (14 CORE)	
256	A-1070-126-A	TU BOARD, COMPLETE (SP, TW, KR)		265	2-598-401-01	SHEET, INSULATING	
256	A-1109-056-A	TU BOARD, COMPLETE (US, CND)		266	4-855-637-21	CUSHION (B)	
256	A-1126-048-A	TU BOARD, COMPLETE (E100L)		△ F901	1-533-451-12	FUSE, GLASS TUBE (DIA. 5) (3.15A/125V)	(US, CND, TW)
257	2-587-602-01	HOLDER (TUNE)		△ F901	1-533-468-12	FUSE, GLASS TUBE (DIA. 5) (T2A/250V)	(AEP, UK, IT, EE, RU, SP, KR)
258	3-252-827-01	SCREW (B2.6), (+) BV TAPPING		△ T901	1-435-917-21	TRANSFORMER, POWER (US, CND, TW)	
259	2-587-617-01	SPRING (TUNE), CONTACT		△ T901	1-435-918-21	TRANSFORMER, POWER	(AEP, UK, IT, EE, RU, SP, KR)
260	3-252-828-01	SCREW (B2.6), (+) PWH TAPPING					
261	2-587-569-01	CABINET (REAR) (for WHITE: ORIGINAL)					
261	2-587-569-11	CABINET (REAR) (for WHITE: LIV)					
261	2-587-569-21	CABINET (REAR) (for SILVER)					

7-7. CD TRAY SECTION (KSM-900AAA)

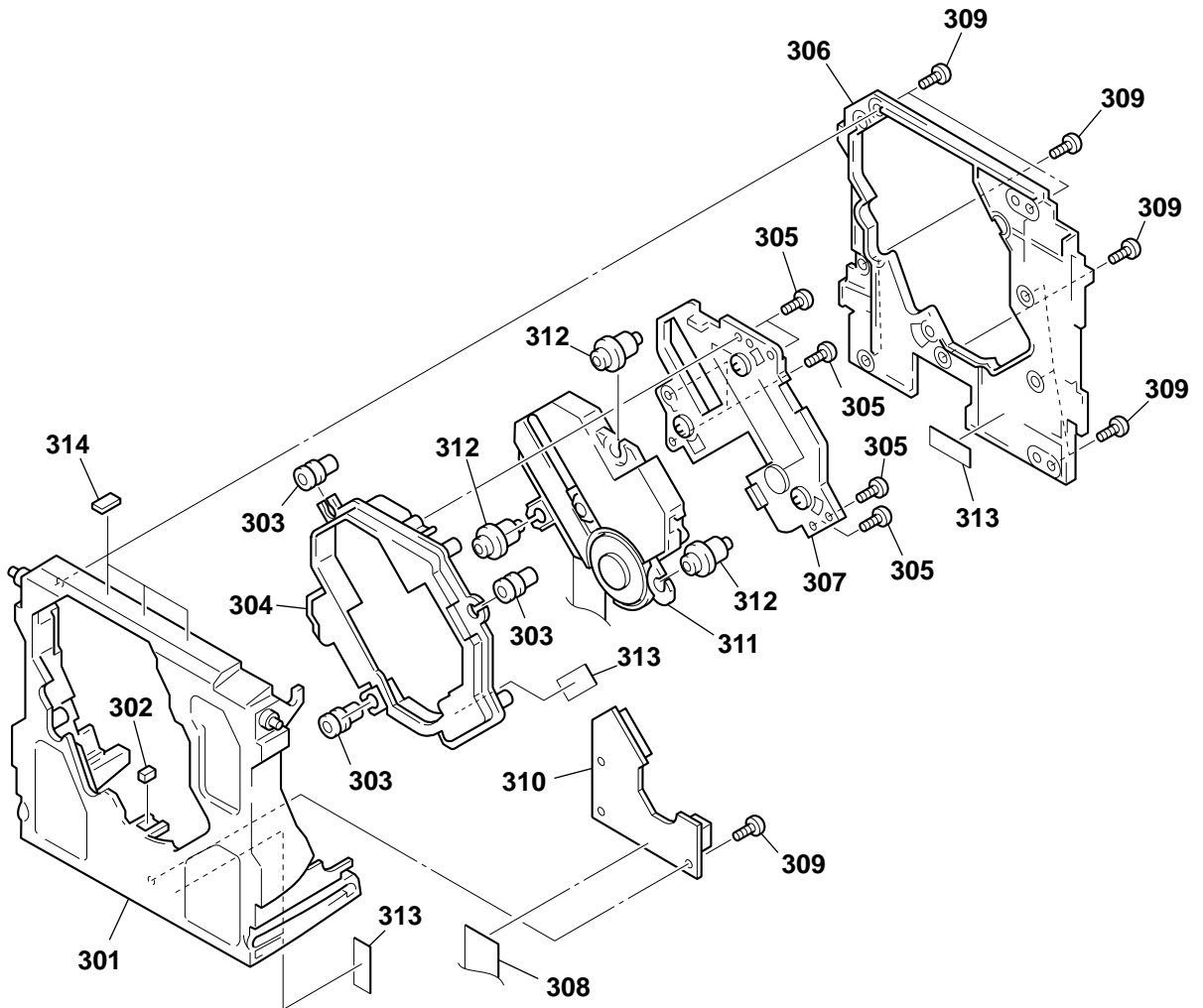

Ref. No.	Part No.	Description	Remark	Ref. No.	Part No.	Description	Remark
301	2-587-594-01	TRAY, CD (for WHITE: ORIGINAL)		307	2-587-593-01	COVER (FRAME CD)	
301	2-587-594-11	TRAY, CD (for WHITE: LIV)		308	1-830-506-11	CABLE, FLEXIBLE FLAT (20 CORE)	
301	2-587-594-21	TRAY, CD (for SILVER)		309	3-253-143-01	SCREW (B2.6), (+) P TAPPING	
301	2-587-594-31	TRAY, CD (for BLUE)		310	A-1109-048-A	CD RELAY BOARD, COMPLETE	
302	3-265-479-01	CUSHION (OP)		△311	8-820-138-13	OPTICAL PICK-UP (KSM-900AAA)	
303	4-975-811-01	INSULATOR		312	4-975-762-11	INSULATOR	
304	2-587-595-01	FRAME (CD)		313	2-637-461-01	CUSHION (CD)	
305	3-254-151-01	SCREW (B2.6), (+) P TAPPING		314	2-637-764-01	CUSHION (TRAY)	
306	2-587-591-01	COVER (CD TRAY)					

7-8. MD BLOCK SECTION-1

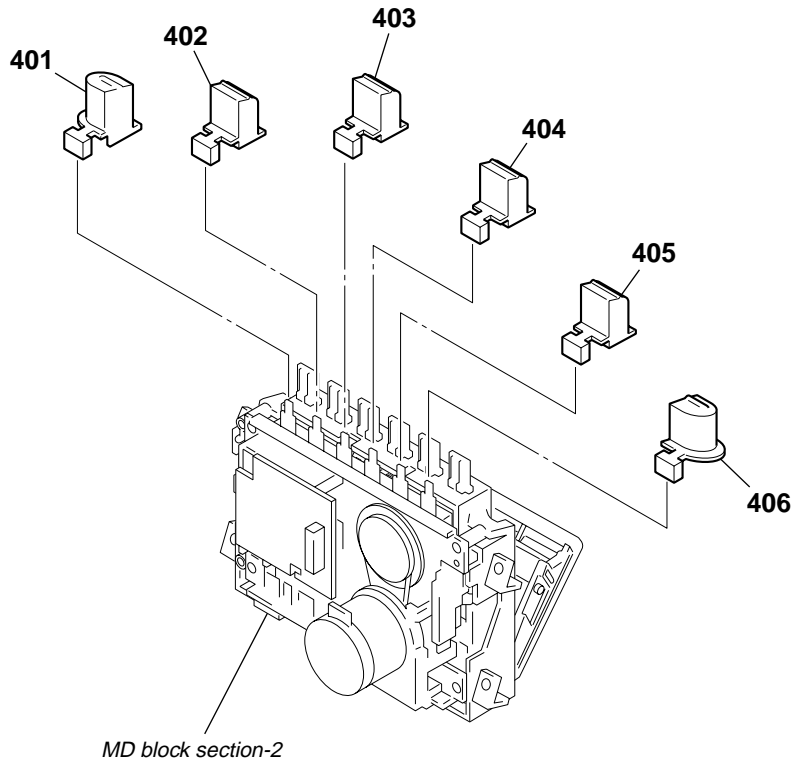

Ref. No.	Part No.	Description	Remark	Ref. No.	Part No.	Description	Remark
401	2-587-584-01	BUTTON (MD REC) (●) (for WHITE: ORIGINAL)		404	2-587-581-11	BUTTON (MD FWD) (▶▶) (for WHITE: LIV)	
401	2-587-584-11	BUTTON (MD REC) (●) (for WHITE: LIV)		404	2-587-581-21	BUTTON (MD FWD) (▶▶) (for SILVER, BLUE)	
401	2-587-584-21	BUTTON (MD REC) (●) (for SILVER, BLUE)		405	2-587-586-01	BUTTON (MD STOP) (■▲)	
402	2-587-583-01	BUTTON (MD PLAY) (▶)	(for WHITE: ORIGINAL)	405	2-587-586-11	BUTTON (MD STOP) (■▲) (for WHITE: LIV)	
402	2-587-583-11	BUTTON (MD PLAY) (▶) (for WHITE: LIV)		405	2-587-586-21	BUTTON (MD STOP) (■▲) (for SILVER, BLUE)	
402	2-587-583-21	BUTTON (MD PLAY) (▶) (for SILVER, BLUE)		406	2-587-582-01	BUTTON (MD PAUSE) (▬▬)	
403	2-587-585-01	BUTTON (MD RWD) (◀◀)	(for WHITE: ORIGINAL)	406	2-587-582-11	BUTTON (MD PAUSE) (▬▬) (for WHITE: LIV)	
403	2-587-585-11	BUTTON (MD RWD) (◀◀) (for WHITE: LIV)		406	2-587-582-21	BUTTON (MD PAUSE) (▬▬) (for SILVER, BLUE)	
403	2-587-585-21	BUTTON (MD RWD) (◀◀) (for SILVER, BLUE)					
404	2-587-581-01	BUTTON (MD FWD) (▶▶)	(for WHITE: ORIGINAL)				

7-9. MD BLOCK SECTION-2

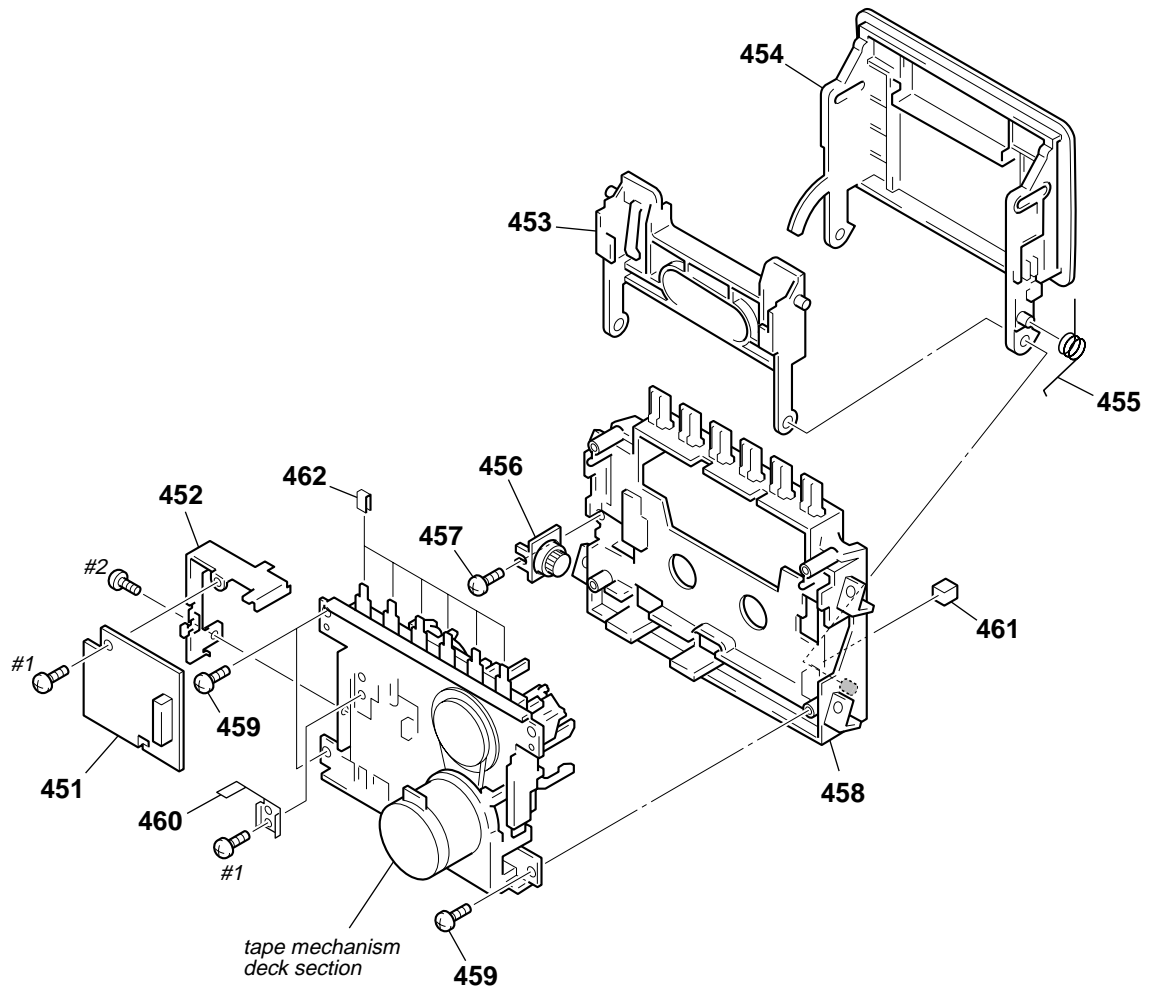

Ref. No.	Part No.	Description	Remark	Ref. No.	Part No.	Description	Remark
451	A-3683-864-A	PRE BOARD, COMPLETE		458	2-587-596-01	HOLDER (MD) (for WHITE: ORIGINAL)	
452	3-252-614-01	CHASSIS, TC		458	2-587-596-11	HOLDER (MD) (for WHITE: LIV)	
453	2-587-597-01	HOLDER (CASSETTE)		458	2-587-596-21	HOLDER (MD) (for SILVER)	
454	X-2055-196-1	LID SUB ASSY, CASSETTE		458	2-587-596-31	HOLDER (MD) (for BLUE)	
		(for WHITE: ORIGINAL)		459	3-254-151-01	SCREW (B2.6), (+) P TAPPING	
454	X-2055-953-1	LID SUB ASSY, CASSETTE (for SILVER)		460	3-252-612-01	LEVER, REC	
454	X-2059-392-1	LID SUB ASSY, CASSETTE (for BLUE)		461	3-246-344-11	FOOT, RUBBER	
454	X-2059-690-1	LID SUB ASSY, CASSETTE (for WHITE: LIV)		462	3-356-122-01	CUSHION	
455	2-587-616-01	SPRING (CASSETTE)		#1	7-685-851-04	SCREW +BVTT 2X4 (S)	
456	3-047-468-01	DAMPER		#2	7-685-850-09	SCREW +BVTT 2X3 (S)	
457	3-254-142-01	SCREW (B3), (+) BV TAPPING					

7-10. TAPE MECHANISM DECK SECTION (MF-E100)

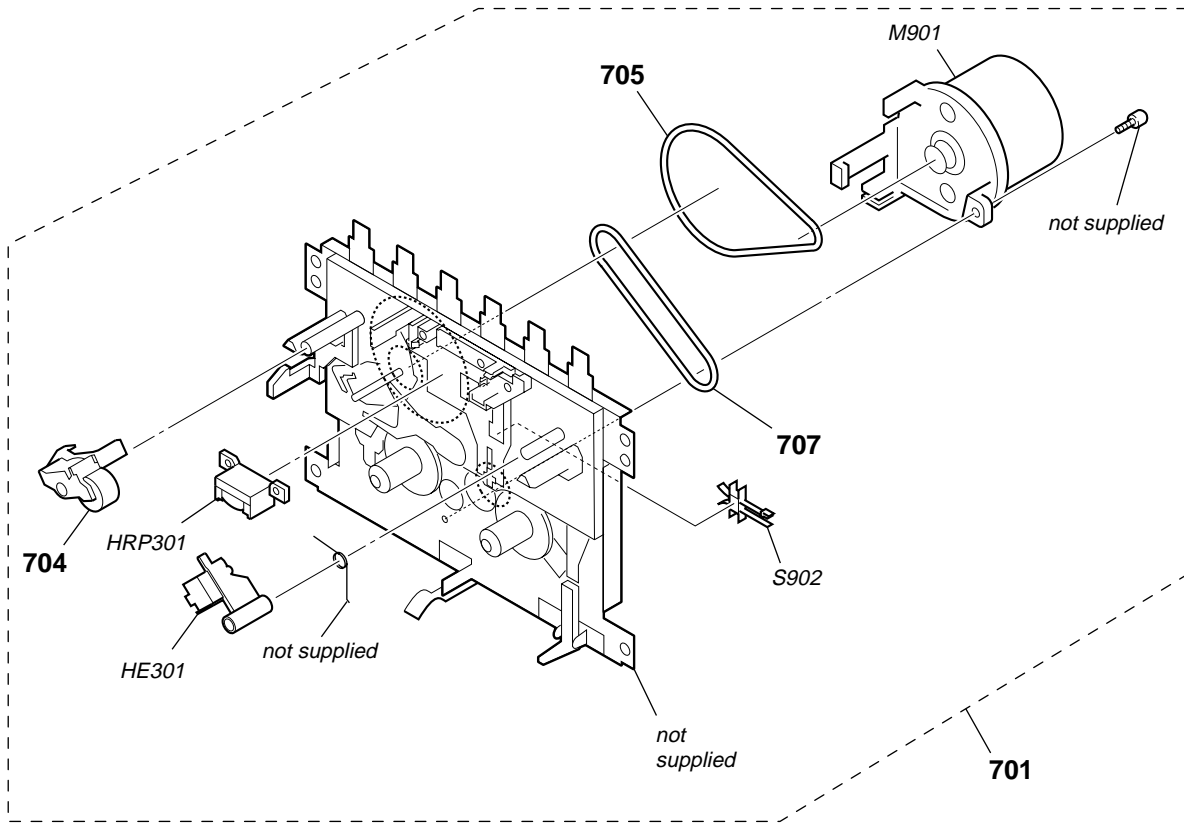

Ref. No.	Part No.	Description	Remark	Ref. No.	Part No.	Description	Remark
701	A-1119-419-A	MECHANISM DECK ASSY (MF-E100)		HRP301	3-266-053-01	HEAD, RP (RECORD/PLAYBACK)	
704	3-933-825-01	ARM ASSY, PINCH ROLLER		M901	X-3385-048-1	MOTOR SUB ASSY (CAPSTAN/REEL)	
705	3-266-054-01	BELT, MAIN		S902	1-762-819-11	SWITCH, LEAF (TAPE PLAY)	
707	3-933-833-01	BELT, RF					
HE301	1-500-813-11	HEAD, ERASE					

SECTION 8 ELECTRICAL PARTS LIST

BATTERY 1	BATTERY 2	CD
-----------	-----------	----

NOTE:

- Due to standardization, replacements in the parts list may be different from the parts specified in the diagrams or the components used on the set.
- -XX and -X mean standardized parts, so they may have some difference from the original one.
- Items marked "*" are not stocked since they are seldom required for routine service. Some delay should be anticipated when ordering these items.
- CAPACITORS
uF: μ F
- COILS
uH: μ H

- RESISTORS
All resistors are in ohms.
METAL: Metal-film resistor.
METAL OXIDE: Metal oxide-film resistor.
F: nonflammable
- SEMICONDUCTORS
In each case, u: μ , for example:
uA. . : μ A. ., uPA. . : μ PA. .,
uPB. . : μ PB. ., uPC. . : μ PC. .,
uPD. . : μ PD. .
- Abbreviation
CND : Canadian model
EE : East European model SP : Singapore model
IT : Italian model TW : Taiwan model
KR : Korean model
RU : Russian model

When indicating parts by reference number, please include the board name.

The components identified by mark Δ or dotted line with mark Δ are critical for safety. Replace only with part number specified.

Les composants identifiés par une marque Δ sont critiques pour la sécurité. Ne les remplacer que par une pièce portant le numéro spécifié.

Ref. No.	Part No.	Description	Remark	Ref. No.	Part No.	Description	Remark
*	1-866-167-11	BATTERY 1 BOARD *****		C743	1-164-156-11	CERAMIC CHIP 0.1uF	25V
*****				C744	1-164-156-11	CERAMIC CHIP 0.1uF	25V
*****				C745	1-164-156-11	CERAMIC CHIP 0.1uF	25V
*****				C746	1-104-665-11	ELECT 100uF	20% 25V
*	1-866-168-11	BATTERY 2 BOARD *****		C751	1-164-156-11	CERAMIC CHIP 0.1uF	25V
*****				C754	1-162-970-11	CERAMIC CHIP 0.01uF	10% 25V
*****				C755	1-162-970-11	CERAMIC CHIP 0.01uF	10% 25V
	3-229-975-01	SPRING BATTERY (-) *****		< CONNECTOR >			
*****				CNP701	1-784-781-11	CONNECTOR, FFC 20P	
*	A-4542-926-A	CD BOARD, COMPLETE *****		* CNP702	1-784-736-11	CONNECTOR, FFC 14P	
*****				< JUMPER RESISTOR >			
< CAPACITOR >				FB701	1-216-864-11	SHORT CHIP 0	
C701	1-162-964-11	CERAMIC CHIP	0.001uF 10% 50V	< IC >			
C702	1-126-947-11	ELECT	47uF 20% 35V	IC701	6-701-796-01	IC LC78646E-US-E	
C703	1-107-826-11	CERAMIC CHIP	0.1uF 10% 16V	IC702	6-701-787-11	IC BA5826FP-E2	
C704	1-162-919-11	CERAMIC CHIP	22PF 5% 50V	< JUMPER RESISTOR >			
C705	1-162-968-11	CERAMIC CHIP	0.0047uF 10% 50V	JC703	1-216-864-11	SHORT CHIP 0	
C706	1-126-960-11	ELECT	1uF 20% 50V	JC704	1-216-864-11	SHORT CHIP 0	
C707	1-115-156-11	CERAMIC CHIP	1uF 10V	JC705	1-216-864-11	SHORT CHIP 0	
C708	1-162-927-11	CERAMIC CHIP	100PF 5% 50V	JC706	1-216-864-11	SHORT CHIP 0	
C709	1-164-156-11	CERAMIC CHIP	0.1uF 25V	JC707	1-216-864-11	SHORT CHIP 0	
C711	1-162-974-11	CERAMIC CHIP	0.01uF 50V	JC708	1-216-864-11	SHORT CHIP 0	
C716	1-162-974-11	CERAMIC CHIP	0.01uF 50V	JC709	1-216-864-11	SHORT CHIP 0	
C717	1-162-970-11	CERAMIC CHIP	0.01uF 10% 25V	JC710	1-216-864-11	SHORT CHIP 0	
C720	1-162-919-11	CERAMIC CHIP	22PF 5% 50V	JC711	1-216-864-11	SHORT CHIP 0	
C721	1-162-919-11	CERAMIC CHIP	22PF 5% 50V	L706	1-216-864-11	SHORT CHIP 0	
C722	1-162-919-11	CERAMIC CHIP	22PF 5% 50V	< TRANSISTOR >			
C723	1-162-974-11	CERAMIC CHIP	0.01uF 50V	Q701	8-729-054-57	TRANSISTOR	KTN2907AS-RTK
C724	1-162-919-11	CERAMIC CHIP	22PF 5% 50V	< RESISTOR >			
C725	1-162-964-11	CERAMIC CHIP	0.001uF 10% 50V	R702	1-216-833-11	METAL CHIP 10K	5% 1/10W
C726	1-162-964-11	CERAMIC CHIP	0.001uF 10% 50V	R703	1-216-829-11	METAL CHIP 4.7K	5% 1/10W
C727	1-162-964-11	CERAMIC CHIP	0.001uF 10% 50V	R704	1-216-833-11	METAL CHIP 10K	5% 1/10W
C728	1-165-176-11	CERAMIC CHIP	0.047uF 10% 16V	R706	1-216-829-11	METAL CHIP 4.7K	5% 1/10W
C729	1-125-837-11	CERAMIC CHIP	1uF 10% 6.3V	R707	1-216-797-11	METAL CHIP 10	5% 1/10W
C730	1-107-826-11	CERAMIC CHIP	0.1uF 10% 16V	R708	1-216-833-11	METAL CHIP 10K	5% 1/10W
C731	1-165-176-11	CERAMIC CHIP	0.047uF 10% 16V	R709	1-216-837-11	METAL CHIP 22K	5% 1/10W
C733	1-104-665-11	ELECT	100uF 20% 25V	R710	1-216-829-11	METAL CHIP 4.7K	5% 1/10W
C734	1-162-968-11	CERAMIC CHIP	0.0047uF 10% 50V	R711	1-216-813-11	METAL CHIP 220	5% 1/10W
C735	1-126-916-11	ELECT	1000uF 20% 6.3V				
C736	1-162-968-11	CERAMIC CHIP	0.0047uF 10% 50V				
C740	1-126-935-11	ELECT	470uF 20% 16V				
C741	1-164-156-11	CERAMIC CHIP	0.1uF 25V				
C742	1-164-156-11	CERAMIC CHIP	0.1uF 25V				

CFD-E100/E100L

CD **CD RELAY** **HEADPHONE** **HEADPHONE TRANSLATION** **LCD**

Ref. No.	Part No.	Description	Remark
R712	1-216-809-11	METAL CHIP	100 5% 1/10W
R713	1-216-809-11	METAL CHIP	100 5% 1/10W
R714	1-216-853-11	METAL CHIP	470K 5% 1/10W
R715	1-216-849-11	METAL CHIP	220K 5% 1/10W
R716	1-216-821-11	METAL CHIP	1K 5% 1/10W
R717	1-216-821-11	METAL CHIP	1K 5% 1/10W
R718	1-216-821-11	METAL CHIP	1K 5% 1/10W
R719	1-216-809-11	METAL CHIP	100 5% 1/10W
R720	1-216-809-11	METAL CHIP	100 5% 1/10W
R721	1-216-821-11	METAL CHIP	1K 5% 1/10W
R722	1-216-809-11	METAL CHIP	100 5% 1/10W
R723	1-216-809-11	METAL CHIP	100 5% 1/10W
R724	1-216-841-11	METAL CHIP	47K 5% 1/10W
R725	1-216-817-11	METAL CHIP	470 5% 1/10W
R726	1-216-817-11	METAL CHIP	470 5% 1/10W
R727	1-216-825-11	METAL CHIP	2.2K 5% 1/10W
R728	1-216-833-11	METAL CHIP	10K 5% 1/10W
R729	1-216-813-11	METAL CHIP	220 5% 1/10W
R730	1-216-821-11	METAL CHIP	1K 5% 1/10W
R731	1-216-825-11	METAL CHIP	2.2K 5% 1/10W
R732	1-216-813-11	METAL CHIP	220 5% 1/10W
R733	1-216-813-11	METAL CHIP	220 5% 1/10W
R739	1-216-821-11	METAL CHIP	1K 5% 1/10W
R740	1-216-849-11	METAL CHIP	220K 5% 1/10W
R741	1-216-833-11	METAL CHIP	10K 5% 1/10W
R742	1-216-853-11	METAL CHIP	470K 5% 1/10W
R744	1-216-845-11	METAL CHIP	100K 5% 1/10W
R746	1-216-829-11	METAL CHIP	4.7K 5% 1/10W
R747	1-216-837-11	METAL CHIP	22K 5% 1/10W
R748	1-216-809-11	METAL CHIP	100 5% 1/10W
R750	1-216-809-11	METAL CHIP	100 5% 1/10W
R751	1-216-825-11	METAL CHIP	2.2K 5% 1/10W
		< VIBRATOR >	
X701	1-781-801-21	VIBRATOR, CERAMIC (16.9344MHz)	

	A-1109-048-A	CD RELAY BOARD, COMPLETE	

		< CONNECTOR >	
CNP705	1-779-553-21	CONNECTOR, FFC (LIF (NON-ZIF)) 16P	
CNP706	1-565-878-11	PIN, CONNECTOR (PC BOARD) 6P	

*	1-866-165-11	HEADPHONE BOARD	

		< CAPACITOR >	
C161	1-162-964-11	CERAMIC CHIP	0.001uF 10% 50V
C261	1-162-964-11	CERAMIC CHIP	0.001uF 10% 50V
		< JACK >	
J361	1-815-325-11	JACK (♫)	
		< RESISTOR >	
R161	1-216-809-11	METAL CHIP	100 5% 1/10W

Ref. No.	Part No.	Description	Remark
R261	1-216-809-11	METAL CHIP	100 5% 1/10W

*	1-866-166-11	HEADPHONE TRANSLATION BOARD	

		< CONNECTOR >	
CN361	1-815-445-11	PIN, CONNECTOR (PWB) 4P	
CN362	1-815-444-11	PIN, CONNECTOR (PWB) 3P	
CN363	1-815-446-11	PIN, CONNECTOR (PWB) 5P	

	A-1109-061-A	LCD BOARD, COMPLETE	

	1-830-510-11	CABLE, FLEXIBLE FLAT (7 CORE)	
	1-830-511-11	CABLE, FLEXIBLE FLAT (21 CORE)	
		< CONNECTOR >	
CN403	1-695-364-31	PIN, CONNECTOR (PC BOARD) 3P	
CN404	1-784-726-11	CONNECTOR, FFC 4P	
		< RESISTOR >	
R401	1-216-817-11	METAL CHIP	470 5% 1/10W
R402	1-216-813-11	METAL CHIP	220 5% 1/10W
R403	1-216-817-11	METAL CHIP	470 5% 1/10W
R404	1-216-817-11	METAL CHIP	470 5% 1/10W
R407	1-216-821-11	METAL CHIP	1K 5% 1/10W
R408	1-216-825-11	METAL CHIP	2.2K 5% 1/10W
R409	1-216-825-11	METAL CHIP	2.2K 5% 1/10W
R410	1-216-829-11	METAL CHIP	4.7K 5% 1/10W
R411	1-216-817-11	METAL CHIP	470 5% 1/10W
R412	1-216-813-11	METAL CHIP	220 5% 1/10W
R413	1-216-817-11	METAL CHIP	470 5% 1/10W
R414	1-216-817-11	METAL CHIP	470 5% 1/10W
R415	1-216-821-11	METAL CHIP	1K 5% 1/10W
R416	1-216-825-11	METAL CHIP	2.2K 5% 1/10W
R417	1-216-821-11	METAL CHIP	1K 5% 1/10W
R418	1-216-825-11	METAL CHIP	2.2K 5% 1/10W
R419	1-216-825-11	METAL CHIP	2.2K 5% 1/10W
R420	1-216-829-11	METAL CHIP	4.7K 5% 1/10W
R421	1-216-833-11	METAL CHIP	10K 5% 1/10W
R422	1-216-833-11	METAL CHIP	10K 5% 1/10W
		< SWITCH >	
S401	1-771-349-21	SWITCH, TACT (POWER) (E100)	
S401	1-771-349-21	SWITCH, TACT (OPERATE) (E100L)	
S402	1-771-349-21	SWITCH, TACT (SLEEP)	
S405	1-771-349-21	SWITCH, TACT (TUNE +)	
S406	1-771-349-21	SWITCH, TACT (TUNE -)	
S407	1-771-349-21	SWITCH, TACT (■)	
S408	1-771-349-21	SWITCH, TACT (▶▶)	
S409	1-771-349-21	SWITCH, TACT (BAND, RADIO, AUTO PRESET)	
S410	1-771-349-21	SWITCH, TACT (▶▶ PRESET +)	
S411	1-771-349-21	SWITCH, TACT (◀◀ PRESET -)	
S412	1-771-349-21	SWITCH, TACT (VOLUME +)	
S413	1-771-349-21	SWITCH, TACT (VOLUME -)	
S414	1-771-349-21	SWITCH, TACT (MEGA BASS)	

Ref. No.	Part No.	Description	Remark	Ref. No.	Part No.	Description	Remark
A-1109-052-A		MAIN BOARD, COMPLETE (US, CND)		C932	1-126-382-11	ELECT 100uF 20%	16V
A-1119-536-A		MAIN BOARD, COMPLETE (TW, KR)		C933	1-164-156-11	CERAMIC CHIP 0.1uF	25V
A-1126-046-A		MAIN BOARD, COMPLETE (AEP, UK, IT, EE, RU)		C934	1-164-156-11	CERAMIC CHIP 0.1uF	25V
A-1126-671-A		MAIN BOARD, COMPLETE (SP)		C935	1-126-382-11	ELECT 100uF 20%	16V

		< CAPACITOR >					
C131	1-115-871-11	ELECT	1uF 20%	50V			
C132	1-162-966-11	CERAMIC CHIP	0.0022uF 10%	50V			
C133	1-164-227-11	CERAMIC CHIP	0.022uF 10%	25V			
C134	1-126-794-11	ELECT	4.7uF 20%	50V			
C135	1-162-964-11	CERAMIC CHIP	0.001uF 10%	50V			
C136	1-126-794-11	ELECT	4.7uF 20%	50V			
C138	1-162-968-11	CERAMIC CHIP	0.0047uF 10%	50V			
C141	1-115-871-11	ELECT	1uF 20%	50V			
C142	1-115-871-11	ELECT	1uF 20%	50V			
C231	1-115-871-11	ELECT	1uF 20%	50V			
C232	1-162-966-11	CERAMIC CHIP	0.0022uF 10%	50V			
C233	1-164-227-11	CERAMIC CHIP	0.022uF 10%	25V			
C234	1-126-794-11	ELECT	4.7uF 20%	50V			
C235	1-162-964-11	CERAMIC CHIP	0.001uF 10%	50V			
C236	1-126-794-11	ELECT	4.7uF 20%	50V			
C238	1-162-968-11	CERAMIC CHIP	0.0047uF 10%	50V			
C241	1-115-871-11	ELECT	1uF 20%	50V			
C242	1-115-871-11	ELECT	1uF 20%	50V			
C331	1-126-926-11	ELECT	1000uF 20%	10V			
C332	1-162-970-11	CERAMIC CHIP	0.01uF 10%	25V			
C333	1-126-796-11	ELECT	22uF 20%	50V			
C334	1-162-923-11	CERAMIC CHIP	47PF 5PF	50V			
C335	1-162-923-11	CERAMIC CHIP	47PF 5PF	50V			
C801	1-115-156-11	CERAMIC CHIP	1uF	10V			
C802	1-162-927-11	CERAMIC CHIP	100PF 5%	50V			
C803	1-115-156-11	CERAMIC CHIP	1uF	10V			
C804	1-128-499-11	ELECT	220uF 20%	16V			
C805	1-162-915-11	CERAMIC CHIP	10PF 0.5PF	50V			
C806	1-162-915-11	CERAMIC CHIP	10PF 0.5PF	50V			
C807	1-162-927-11	CERAMIC CHIP	100PF 5%	50V			
C808	1-162-927-11	CERAMIC CHIP	100PF 5%	50V			
C809	1-162-927-11	CERAMIC CHIP	100PF 5%	50V			
C810	1-162-927-11	CERAMIC CHIP	100PF 5%	50V			
C812	1-162-927-11	CERAMIC CHIP	100PF 5%	50V			
C813	1-162-927-11	CERAMIC CHIP	100PF 5%	50V			
C814	1-162-927-11	CERAMIC CHIP	100PF 5%	50V			
C815	1-162-927-11	CERAMIC CHIP	100PF 5%	50V			
C816	1-162-915-11	CERAMIC CHIP	10PF 0.5PF	50V			
C817	1-162-915-11	CERAMIC CHIP	10PF 0.5PF	50V			
C818	1-162-915-11	CERAMIC CHIP	10PF 0.5PF	50V			
C819	1-162-927-11	CERAMIC CHIP	100PF 5%	50V			
C820	1-162-927-11	CERAMIC CHIP	100PF 5%	50V			
C821	1-162-927-11	CERAMIC CHIP	100PF 5%	50V			
C822	1-162-960-11	CERAMIC CHIP	220PF 10%	50V			
C823	1-162-960-11	CERAMIC CHIP	220PF 10%	50V			
C824	1-162-960-11	CERAMIC CHIP	220PF 10%	50V			
C825	1-162-960-11	CERAMIC CHIP	220PF 10%	50V			
C826	1-164-156-11	CERAMIC CHIP	0.1uF	25V			
C828	1-162-927-11	CERAMIC CHIP	100PF 5%	50V			
C830	1-162-970-11	CERAMIC CHIP	0.01uF 10%	25V			
C931	1-162-970-11	CERAMIC CHIP	0.01uF 10%	25V			
		< CONNECTOR >					
CN310	1-784-735-11	CONNECTOR, FFC 13P					
CN311	1-815-554-11	PIN, CONNECTOR (PWB) 6P					
CN331	1-816-478-11	PIN, CONNECTOR (PWB) 11P					
CN332	1-815-444-11	PIN, CONNECTOR (PWB) 3P					
CN801	1-568-830-11	CONNECTOR, FFC 11P					
CN802	1-568-838-11	CONNECTOR, FFC 21P					
CN803	1-784-775-11	CONNECTOR, FFC 14P					
CN804	1-568-826-11	CONNECTOR, FFC 7P					
		< DIODE >					
D331	8-719-988-61	DIODE 1SS355TE-17					
D801	8-719-083-93	DIODE KDS120-RTK					
D931	8-719-988-61	DIODE 1SS355TE-17					
D932	8-719-083-93	DIODE KDS120-RTK					
D933	8-719-083-58	DIODE UDZSTE-173.9B					
D934	8-719-988-61	DIODE 1SS355TE-17					
D941	8-719-082-07	DIODE KDS121-RTK					
D942	8-719-069-54	DIODE UDZSTE-175.1B					
D951	8-719-988-61	DIODE 1SS355TE-17					
		< JUMPER RESISTOR >					
FB931	1-216-864-11	SHORT CHIP 0					
		< IC >					
IC331	6-701-919-01	IC PT2257-S					
IC801	6-805-452-01	IC uPD789478GC-A41-8BT-A					
IC802	6-701-560-01	IC BD4727G-TR					
IC803	6-703-769-01	IC BR24L01AF-WE2					
IC901	6-703-285-01	IC S-812C33AUA-C2NT2G					
		< JUMPER RESISTOR >					
JC141	1-216-864-11	SHORT CHIP 0					
JC241	1-216-864-11	SHORT CHIP 0					
JC801	1-216-864-11	SHORT CHIP 0					
JC802	1-216-864-11	SHORT CHIP 0					
		< COIL >					
L801	1-414-137-31	INDUCTOR 0.22uH					
L802	1-410-521-11	INDUCTOR 100uH					
		< TRANSISTOR >					
Q131	8-729-905-35	TRANSISTOR 2SC4081-R					
Q231	8-729-905-35	TRANSISTOR 2SC4081-R					
Q801	8-729-028-99	TRANSISTOR DTC114YUA-T106					
Q802	8-729-028-99	TRANSISTOR DTC114YUA-T106					
Q803	8-729-028-92	TRANSISTOR DTA144TUA-T106					
Q804	8-729-029-16	TRANSISTOR DTC144VUA-T106					
Q905	8-729-029-13	TRANSISTOR DTC143ZUA-T106					
Q906	8-729-028-90	TRANSISTOR DTA143ZUA-T106					
Q907	8-729-905-35	TRANSISTOR 2SC4081-R					

CFD-E100/E100L

Ver. 1.1

MAIN

Ref. No.	Part No.	Description	Remark	Ref. No.	Part No.	Description	Remark
Q908	8-729-036-86	TRANSISTOR	KTC3203Y-AT				
		< RESISTOR >					
R131	1-216-817-11	METAL CHIP	470	5%	1/10W		
R132	1-216-833-11	METAL CHIP	10K	5%	1/10W		
R133	1-216-821-11	METAL CHIP	1K	5%	1/10W		
R134	1-216-817-11	METAL CHIP	470	5%	1/10W		
R135	1-216-864-11	SHORT CHIP	0				
R138	1-216-864-11	SHORT CHIP	0				
R139	1-216-864-11	SHORT CHIP	0				
R141	1-216-821-11	METAL CHIP	1K	5%	1/10W		
R231	1-216-817-11	METAL CHIP	470	5%	1/10W		
R232	1-216-833-11	METAL CHIP	10K	5%	1/10W		
R233	1-216-821-11	METAL CHIP	1K	5%	1/10W		
R234	1-216-817-11	METAL CHIP	470	5%	1/10W		
R235	1-216-864-11	SHORT CHIP	0				
R238	1-216-864-11	SHORT CHIP	0				
R239	1-216-864-11	SHORT CHIP	0				
R241	1-216-821-11	METAL CHIP	1K	5%	1/10W		
R331	1-216-809-11	METAL CHIP	100	5%	1/10W		
R332	1-216-833-11	METAL CHIP	10K	5%	1/10W		
R333	1-216-829-11	METAL CHIP	4.7K	5%	1/10W		
R334	1-216-833-11	METAL CHIP	10K	5%	1/10W		
R335	1-216-833-11	METAL CHIP	10K	5%	1/10W		
R801	1-216-821-11	METAL CHIP	1K	5%	1/10W		
R802	1-216-841-11	METAL CHIP	47K	5%	1/10W		
R803	1-216-841-11	METAL CHIP	47K	5%	1/10W		
R804	1-216-841-11	METAL CHIP	47K	5%	1/10W		
R805	1-216-821-11	METAL CHIP	1K	5%	1/10W		
R806	1-216-821-11	METAL CHIP	1K	5%	1/10W		
R807	1-216-817-11	METAL CHIP	470	5%	1/10W		
R808	1-216-817-11	METAL CHIP	470	5%	1/10W		
R809	1-216-829-11	METAL CHIP	4.7K	5%	1/10W		
R810	1-216-853-11	METAL CHIP	470K	5%	1/10W		
R811	1-216-833-11	METAL CHIP	10K	5%	1/10W		
R812	1-216-833-11	METAL CHIP	10K	5%	1/10W		
R813	1-216-829-11	METAL CHIP	4.7K	5%	1/10W		
R814	1-216-829-11	METAL CHIP	4.7K	5%	1/10W		
R815	1-216-829-11	METAL CHIP	4.7K	5%	1/10W		
R816	1-216-825-11	METAL CHIP	2.2K	5%	1/10W		
R817	1-216-825-11	METAL CHIP	2.2K	5%	1/10W		
R818	1-216-825-11	METAL CHIP	2.2K	5%	1/10W		
R819	1-216-825-11	METAL CHIP	2.2K	5%	1/10W		
R820	1-216-825-11	METAL CHIP	2.2K	5%	1/10W		
R821	1-216-825-11	METAL CHIP	2.2K	5%	1/10W		
R822	1-216-825-11	METAL CHIP	2.2K	5%	1/10W		
R823	1-216-825-11	METAL CHIP	2.2K	5%	1/10W		
R824	1-216-817-11	METAL CHIP	470	5%	1/10W		
R825	1-216-837-11	METAL CHIP	22K	5%	1/10W		
R826	1-216-825-11	METAL CHIP	2.2K	5%	1/10W		
R827	1-216-825-11	METAL CHIP	2.2K	5%	1/10W		
R828	1-216-825-11	METAL CHIP	2.2K	5%	1/10W		
R829	1-216-821-11	METAL CHIP	1K	5%	1/10W		
R830	1-216-821-11	METAL CHIP	1K	5%	1/10W		
R831	1-216-825-11	METAL CHIP	2.2K	5%	1/10W		
R832	1-216-825-11	METAL CHIP	2.2K	5%	1/10W		
R833	1-216-829-11	METAL CHIP	4.7K	5%	1/10W		
R834	1-216-829-11	METAL CHIP	4.7K	5%	1/10W		
R835	1-216-821-11	METAL CHIP	1K	5%	1/10W		
R836	1-216-853-11	METAL CHIP	470K	5%	1/10W		
R837	1-216-845-11	METAL CHIP	100K	5%	1/10W		
R838	1-216-829-11	METAL CHIP	4.7K	5%	1/10W		
R839	1-216-829-11	METAL CHIP	4.7K	5%	1/10W		
R840	1-216-829-11	METAL CHIP	4.7K	5%	1/10W		
R841	1-216-829-11	METAL CHIP	4.7K	5%	1/10W		
R842	1-216-841-11	METAL CHIP	47K	5%	1/10W		
R843	1-216-821-11	METAL CHIP	1K	5%	1/10W		
R844	1-216-821-11	METAL CHIP	1K	5%	1/10W		
R845	1-216-821-11	METAL CHIP	1K	5%	1/10W		
R846	1-216-829-11	METAL CHIP	4.7K	5%	1/10W		
R847	1-216-833-11	METAL CHIP	10K	5%	1/10W		
R848	1-216-833-11	METAL CHIP	10K	5%	1/10W		
R849	1-216-833-11	METAL CHIP	10K	5%	1/10W		
R850	1-216-833-11	METAL CHIP	10K	5%	1/10W		
R851	1-216-833-11	METAL CHIP	10K	5%	1/10W		
R852	1-216-833-11	METAL CHIP	10K	5%	1/10W		
R853	1-216-833-11	METAL CHIP	10K	5%	1/10W		
R854	1-216-833-11	METAL CHIP	10K	5%	1/10W		
R855	1-216-833-11	METAL CHIP	10K	5%	1/10W		
R856	1-216-833-11	METAL CHIP	10K	5%	1/10W		
R857	1-216-833-11	METAL CHIP	10K	5%	1/10W		
R858	1-216-833-11	METAL CHIP	10K	5%	1/10W		
R859	1-216-833-11	METAL CHIP	10K	5%	1/10W		
R860	1-216-833-11	METAL CHIP	10K	5%	1/10W		
R861	1-216-833-11	METAL CHIP	10K	5%	1/10W		
R862	1-216-833-11	METAL CHIP	10K	5%	1/10W		
R863	1-216-833-11	METAL CHIP	10K	5%	1/10W		
R864	1-216-833-11	METAL CHIP	10K	5%	1/10W		
R865	1-216-833-11	METAL CHIP	10K	5%	1/10W		
R866	1-216-833-11	METAL CHIP	10K	5%	1/10W		
R867	1-216-833-11	METAL CHIP	10K	5%	1/10W		
R868	1-216-833-11	METAL CHIP	10K	5%	1/10W		
R869	1-216-841-11	METAL CHIP	47K	5%	1/10W		
R870	1-216-841-11	METAL CHIP	47K	5%	1/10W		
R871	1-216-841-11	METAL CHIP	47K	5%	1/10W		
R872	1-216-833-11	METAL CHIP	10K	5%	1/10W		
R873	1-216-845-11	METAL CHIP	100K	5%	1/10W		
R874	1-216-849-11	METAL CHIP	220K	5%	1/10W		
R875	1-216-845-11	METAL CHIP	100K	5%	1/10W		
R876	1-216-845-11	METAL CHIP	100K	5%	1/10W		
R877	1-216-833-11	METAL CHIP	10K	5%	1/10W		
R878	1-216-833-11	METAL CHIP	10K	5%	1/10W		
R879	1-216-833-11	METAL CHIP	10K	5%	1/10W		
R880	1-216-853-11	METAL CHIP	470K	5%	1/10W		
R881	1-216-829-11	METAL CHIP	4.7K	5%	1/10W		
R882	1-216-829-11	METAL CHIP	4.7K	5%	1/10W		
R882	1-216-837-11	METAL CHIP	22K	5%	1/10W	(SP)	
R882	1-216-841-11	METAL CHIP	47K	5%	1/10W	(TW, KR)	
						(AEP, UK, IT, EE, RU)	
R882	1-216-864-11	SHORT CHIP	0 (US, CND)				
R883	1-216-829-11	METAL CHIP	4.7K	5%	1/10W		
						(TW, KR)	
R883	1-216-833-11	METAL CHIP	10K	5%	1/10W		
						(AEP, UK, IT, EE, RU)	

Ref. No.	Part No.	Description	Remark	Ref. No.	Part No.	Description	Remark
R883	1-216-864-11	SHORT CHIP	0 (US, CND, SP)		A-1109-054-A	POWER BOARD, COMPLETE (US)	
R891	1-216-833-11	METAL CHIP	10K 5%	1/10W	A-1119-538-A	POWER BOARD, COMPLETE (AEP, UK, IT, EE, RU, KR)	
R892	1-216-841-11	METAL CHIP	47K 5%	1/10W	A-1124-796-A	POWER BOARD, COMPLETE (SP)	
R893	1-216-833-11	METAL CHIP	10K 5%	1/10W	A-1124-986-A	POWER BOARD, COMPLETE (CND)	
R894	1-216-837-11	METAL CHIP	22K 5%	1/10W	A-1126-631-A	POWER BOARD, COMPLETE (TW)	
R895	1-216-833-11	METAL CHIP	10K 5%	1/10W		*****	
R896	1-216-837-11	METAL CHIP	22K 5%	1/10W			
R897	1-216-833-11	METAL CHIP	10K 5%	1/10W	1-533-233-21	FUSE HOLDER	
R898	1-216-837-11	METAL CHIP	22K 5%	1/10W	3-254-151-01	SCREW (B2.6), (+) P TAPPING	
R931	1-216-825-11	METAL CHIP	2.2K 5%	1/10W		< CAPACITOR >	
R932	1-216-825-11	METAL CHIP	2.2K 5%	1/10W			
R933	1-216-825-11	METAL CHIP	2.2K 5%	1/10W	C151	1-162-964-11 CERAMIC CHIP	0.001uF 10% 50V
R934	1-216-825-11	METAL CHIP	2.2K 5%	1/10W	C152	1-126-786-11 ELECT	47uF 20% 16V
R935	1-216-833-11	METAL CHIP	10K 5%	1/10W	C153	1-126-382-11 ELECT	100uF 20% 16V
R936	1-216-833-11	METAL CHIP	10K 5%	1/10W	C154	1-107-826-11 CERAMIC CHIP	0.1uF 10% 16V
R937	1-216-813-11	METAL CHIP	220 5%	1/10W	C155	1-126-926-11 ELECT	1000uF 20% 10V
R938	1-216-809-11	METAL CHIP	100 5%	1/10W			
R939	1-216-833-11	METAL CHIP	10K 5%	1/10W	C251	1-162-964-11 CERAMIC CHIP	0.001uF 10% 50V
R941	1-216-817-11	METAL CHIP	470 5%	1/10W	C252	1-126-786-11 ELECT	47uF 20% 16V
R942	1-216-817-11	METAL CHIP	470 5%	1/10W	C253	1-126-382-11 ELECT	100uF 20% 16V
R943	1-216-817-11	METAL CHIP	470 5%	1/10W	C254	1-107-826-11 CERAMIC CHIP	0.1uF 10% 16V
R944	1-216-817-11	METAL CHIP	470 5%	1/10W	C255	1-126-926-11 ELECT	1000uF 20% 10V
R945	1-216-821-11	METAL CHIP	1K 5%	1/10W	C351	1-126-786-11 ELECT	47uF 20% 16V
R946	1-216-821-11	METAL CHIP	1K 5%	1/10W	C352	1-164-156-11 CERAMIC CHIP	0.1uF 25V
R951	1-216-821-11	METAL CHIP	1K 5%	1/10W	C353	1-126-786-11 ELECT	47uF 20% 16V
R952	1-216-821-11	METAL CHIP	1K 5%	1/10W	C354	1-126-795-11 ELECT	10uF 20% 50V
R961	1-216-821-11	METAL CHIP	1K 5%	1/10W	C355	1-162-970-11 CERAMIC CHIP	0.01uF 10% 25V
R962	1-216-821-11	METAL CHIP	1K 5%	1/10W	C901	1-162-995-11 CERAMIC CHIP	0.022uF 50V (EXCEPT US, SP, TW)
R963	1-216-817-11	METAL CHIP	470 5%	1/10W	C901	1-165-319-11 CERAMIC CHIP	0.1uF 50V (US, SP, TW)
R964	1-216-817-11	METAL CHIP	470 5%	1/10W	C902	1-162-995-11 CERAMIC CHIP	0.022uF 50V (EXCEPT US, SP, TW)
		< SWITCH >			C902	1-165-319-11 CERAMIC CHIP	0.1uF 50V (US, SP, TW)
S701	1-571-936-11	SWITCH, LEAF (CD LID CLOSE DETECT)			C903	1-162-995-11 CERAMIC CHIP	0.022uF 50V (EXCEPT US, SP, TW)
		< VIBRATOR >			C903	1-165-319-11 CERAMIC CHIP	0.1uF 50V (US, SP, TW)
X801	1-795-950-11	VIBRATOR, CRYSTAL (32.768kHz)			C904	1-162-995-11 CERAMIC CHIP	0.022uF 50V (EXCEPT US, SP, TW)
X802	1-795-054-21	VIBRATOR, CERAMIC (4.19MHz)			C904	1-165-319-11 CERAMIC CHIP	0.1uF 50V (US, SP, TW)
		*****			C905	1-126-795-11 ELECT	10uF 20% 50V
	A-1109-063-A	MODE BOARD, COMPLETE			C906	1-126-937-11 ELECT	4700uF 20% 16V

	1-830-508-11	CABLE, FLEXIBLE FLAT (3 CORE)			C907	1-126-935-11 ELECT	470uF 20% 16V
		< RESISTOR >			C908	1-162-970-11 CERAMIC CHIP	0.01uF 10% 25V
R405	1-216-821-11	METAL CHIP	1K 5%	1/10W	C909	1-164-156-11 CERAMIC CHIP	0.1uF 25V
R406	1-216-825-11	METAL CHIP	2.2K 5%	1/10W	C910	1-164-156-11 CERAMIC CHIP	0.1uF 25V
		< SWITCH >			C911	1-126-935-11 ELECT	470uF 20% 16V
S403	1-771-349-21	SWITCH, TACT (MODE)			C912	1-162-970-11 CERAMIC CHIP	0.01uF 10% 25V
S404	1-771-349-21	SWITCH, TACT (DISPLAY, ENTER MEMORY)				< DIODE >	
		*****			D351	8-719-988-61 DIODE	1SS355TE-17
					D901	8-719-063-79 DIODE	1N4002B
					D902	8-719-063-79 DIODE	1N4002B
					D903	8-719-063-79 DIODE	1N4002B
					D904	8-719-063-79 DIODE	1N4002B
					D905	8-719-978-33 DIODE	DTZ-TT11-6.8B
					D906	8-719-978-33 DIODE	DTZ-TT11-6.8B

CFD-E100/E100L

Ver. 1.1

POWER **PRE**

Ref. No.	Part No.	Description	Remark
		< IC >	
IC351	8-759-426-51	IC BA5417	
		< JACK >	
△ J901	1-526-838-11	INLET, AC 2P (∼ AC IN) (EXCEPT US, CND)	
△ J901	1-540-009-11	INLET, AC (∼ AC IN) (US, CND)	
		< TRANSISTOR >	
Q151	8-729-029-10	TRANSISTOR DTC143TUA-T106	
Q251	8-729-029-10	TRANSISTOR DTC143TUA-T106	
Q901	8-729-040-76	TRANSISTOR KTA1273-Y-AT	
Q902	8-729-905-35	TRANSISTOR 2SC4081-R	
Q903	8-729-018-99	TRANSISTOR 2SD2394-F	
Q904	8-729-028-54	TRANSISTOR KTC3205	
		< RESISTOR >	
R151	1-216-825-11	METAL CHIP 2.2K 5% 1/10W	
R152	1-216-817-11	METAL CHIP 470 5% 1/10W	
R153	1-216-813-11	METAL CHIP 220 5% 1/10W	
R154	1-216-789-11	METAL CHIP 2.2 5% 1/10W	
R155	1-216-829-11	METAL CHIP 4.7K 5% 1/10W	
R156	1-216-833-11	METAL CHIP 10K 5% 1/10W	
R157	1-216-825-11	METAL CHIP 2.2K 5% 1/10W	
R251	1-216-825-11	METAL CHIP 2.2K 5% 1/10W	
R252	1-216-817-11	METAL CHIP 470 5% 1/10W	
R253	1-216-813-11	METAL CHIP 220 5% 1/10W	
R254	1-216-789-11	METAL CHIP 2.2 5% 1/10W	
R255	1-216-829-11	METAL CHIP 4.7K 5% 1/10W	
R256	1-216-833-11	METAL CHIP 10K 5% 1/10W	
R257	1-216-825-11	METAL CHIP 2.2K 5% 1/10W	
R351	1-216-821-11	METAL CHIP 1K 5% 1/10W	
R352	1-216-825-11	METAL CHIP 2.2K 5% 1/10W	
R353	1-216-857-11	METAL CHIP 1M 5% 1/10W	
R354	1-216-833-11	METAL CHIP 10K 5% 1/10W	
R901	1-216-841-11	METAL CHIP 47K 5% 1/10W	
R902	1-216-825-11	METAL CHIP 2.2K 5% 1/10W	
R903	1-216-825-11	METAL CHIP 2.2K 5% 1/10W	
R904	1-216-821-11	METAL CHIP 1K 5% 1/10W	
R905	1-216-821-11	METAL CHIP 1K 5% 1/10W	
R906	1-216-821-11	METAL CHIP 1K 5% 1/10W	
R907	1-216-829-11	METAL CHIP 4.7K 5% 1/10W	
R908	1-216-829-11	METAL CHIP 4.7K 5% 1/10W	
R909	1-216-833-11	METAL CHIP 10K 5% 1/10W	
R911	1-216-821-11	METAL CHIP 1K 5% 1/10W	
R912	1-216-821-11	METAL CHIP 1K 5% 1/10W	
R913	1-216-821-11	METAL CHIP 1K 5% 1/10W	

	A-3683-864-A	PRE BOARD, COMPLETE	*****
		< CAPACITOR >	
C101	1-162-964-11	CERAMIC CHIP 0.001uF 10% 50V	
C102	1-104-665-11	ELECT 100uF 20% 25V	
C103	1-165-176-11	CERAMIC CHIP 0.047uF 10% 16V	
C104	1-162-966-11	CERAMIC CHIP 0.0022uF 10% 50V	
C105	1-162-923-11	CERAMIC CHIP 47PF 5% 50V	

Ref. No.	Part No.	Description	Remark
C107	1-162-962-11	CERAMIC CHIP 470PF 10% 50V	
C201	1-162-964-11	CERAMIC CHIP 0.001uF 10% 50V	
C202	1-104-665-11	ELECT 100uF 20% 25V	
C203	1-165-176-11	CERAMIC CHIP 0.047uF 10% 16V	
C204	1-162-966-11	CERAMIC CHIP 0.0022uF 10% 50V	
C205	1-162-923-11	CERAMIC CHIP 47PF 5% 50V	
C207	1-162-962-11	CERAMIC CHIP 470PF 10% 50V	
C301	1-104-665-11	ELECT 100uF 20% 25V	
C302	1-104-665-11	ELECT 100uF 20% 25V	
C303	1-104-665-11	ELECT 100uF 20% 25V	
C304	1-126-947-11	ELECT 47uF 20% 35V	
C305	1-162-962-11	CERAMIC CHIP 470PF 10% 50V	
C306	1-162-970-11	CERAMIC CHIP 0.01uF 10% 25V	
C307	1-162-964-11	CERAMIC CHIP 0.001uF 10% 50V	
C308	1-162-927-11	CERAMIC CHIP 100PF 5% 50V	
C310	1-164-230-11	CERAMIC CHIP 220PF 5% 50V	
		< CONNECTOR >	
CN303	1-784-774-11	CONNECTOR, FFC 13P	
		< IC >	
IC301	8-759-264-71	IC TA2068N	
		< JUMPER RESISTOR >	
JC301	1-216-864-11	SHORT CHIP 0	
JC302	1-216-864-11	SHORT CHIP 0	
JC303	1-216-864-11	SHORT CHIP 0	
JC304	1-216-864-11	SHORT CHIP 0	
JC305	1-216-864-11	SHORT CHIP 0	
JC306	1-216-295-00	SHORT CHIP 0	
JC307	1-216-864-11	SHORT CHIP 0	
JC308	1-216-295-00	SHORT CHIP 0	
JC309	1-216-864-11	SHORT CHIP 0	
		< TRANSISTOR >	
Q301	8-729-901-81	TRANSISTOR 2SC2412K-T-146-R	
Q302	8-729-907-00	TRANSISTOR DTC114EU	
Q303	8-729-907-00	TRANSISTOR DTC114EU	
		< RESISTOR >	
R101	1-216-835-11	METAL CHIP 15K 5% 1/10W	
R102	1-216-807-11	METAL CHIP 68 5% 1/10W	
R103	1-216-843-11	METAL CHIP 68K 5% 1/10W	
R104	1-216-835-11	METAL CHIP 15K 5% 1/10W	
R105	1-216-835-11	METAL CHIP 15K 5% 1/10W	
R106	1-216-825-11	METAL CHIP 2.2K 5% 1/10W	
R110	1-216-809-11	METAL CHIP 100 5% 1/10W	
R111	1-216-829-11	METAL CHIP 4.7K 5% 1/10W	
R112	1-216-827-11	METAL CHIP 3.3K 5% 1/10W	
R201	1-216-835-11	METAL CHIP 15K 5% 1/10W	
R202	1-216-807-11	METAL CHIP 68 5% 1/10W	
R203	1-216-843-11	METAL CHIP 68K 5% 1/10W	
R204	1-216-835-11	METAL CHIP 15K 5% 1/10W	
R205	1-216-835-11	METAL CHIP 15K 5% 1/10W	
R206	1-216-825-11	METAL CHIP 2.2K 5% 1/10W	
R210	1-216-025-11	RES-CHIP 100 5% 1/10W	

Ref. No.	Part No.	Description	Remark	Ref. No.	Part No.	Description	Remark
R211	1-216-829-11	METAL CHIP	4.7K 5% 1/10W	C6	1-162-970-11	CERAMIC CHIP	0.01uF 10% 25V (E100L)
R212	1-216-827-11	METAL CHIP	3.3K 5% 1/10W	C7	1-162-910-11	CERAMIC CHIP	5PF 0.25PF 50V
R301	1-216-857-11	METAL CHIP	1M 5% 1/10W	C8	1-162-964-11	CERAMIC CHIP	0.001uF 10% 50V
R302	1-216-829-11	METAL CHIP	4.7K 5% 1/10W	C9	1-162-915-11	CERAMIC CHIP	10PF 0.5PF 50V
R303	1-216-829-11	METAL CHIP	4.7K 5% 1/10W	C10	1-126-960-11	ELECT	1uF 20% 50V
R304	1-216-821-11	METAL CHIP	1K 5% 1/10W	C11	1-107-826-11	CERAMIC CHIP	0.1uF 10% 16V
R305	1-216-817-11	METAL CHIP	470 5% 1/10W	C12	1-126-963-11	ELECT	4.7uF 20% 50V
R306	1-218-867-11	METAL CHIP	6.8K 0.5% 1/10W	C13	1-162-970-11	CERAMIC CHIP	0.01uF 10% 25V (US, CND)
R307	1-216-797-11	METAL CHIP	10 5% 1/10W	C14	1-162-970-11	CERAMIC CHIP	0.01uF 10% 25V (EXCEPT US, CND)
R308	1-216-837-11	METAL CHIP	22K 5% 1/10W	C14	1-164-227-11	CERAMIC CHIP	0.022uF 10% 25V (US, CND)
R309	1-216-805-11	METAL CHIP	47 5% 1/10W	C15	1-162-970-11	CERAMIC CHIP	0.01uF 10% 25V (EXCEPT US, CND)
R310	1-216-857-11	METAL CHIP	1M 5% 1/10W	C15	1-164-227-11	CERAMIC CHIP	0.022uF 10% 25V (US, CND)
R311	1-216-857-11	METAL CHIP	1M 5% 1/10W	C18	1-126-934-11	ELECT	220uF 20% 16V
R314	1-216-817-11	METAL CHIP	470 5% 1/10W	C20	1-107-826-11	CERAMIC CHIP	0.1uF 10% 16V
R315	1-216-817-11	METAL CHIP	470 5% 1/10W	C21	1-126-960-11	ELECT	1uF 20% 50V
		< SWITCH >		C22	1-107-826-11	CERAMIC CHIP	0.1uF 10% 16V
S301	1-786-126-11	SWITCH, SLIDE (REC/PB)		C23	1-126-960-11	ELECT	1uF 20% 50V
		< TRANSFORMER >		C24	1-162-960-11	CERAMIC CHIP	220PF 10% 50V
T301	1-416-041-11	TRANSFORMER, BIAS OSCILLATION		C25	1-162-968-11	CERAMIC CHIP	0.0047uF 10% 50V (E100L)
		*****		C26	1-162-927-11	CERAMIC CHIP	100PF 5% 50V (E100)
	A-1109-065-A	REMOTE CONTROL BOARD, COMPLETE		C27	1-162-927-11	CERAMIC CHIP	100PF 5% 50V (E100)
		*****		C29	1-104-665-11	ELECT	100uF 20% 25V
	1-830-509-11	CABLE, FLEXIBLE FLAT (4 CORE)		C30	1-162-970-11	CERAMIC CHIP	0.01uF 10% 25V
	2-587-601-01	HOLDER (LED)		C31	1-162-919-11	CERAMIC CHIP	22PF 5% 50V
		< CAPACITOR >		C32	1-162-964-11	CERAMIC CHIP	0.001uF 10% 50V
C401	1-115-156-11	CERAMIC CHIP	1uF 10V	C33	1-162-970-11	CERAMIC CHIP	0.01uF 10% 25V
		< LED >		C34	1-162-970-11	CERAMIC CHIP	0.01uF 10% 25V
D401	8-719-059-97	LED L-34HD (OPR/BATT)		C35	1-162-970-11	CERAMIC CHIP	0.01uF 10% 25V
		< IC >		C37	1-162-970-11	CERAMIC CHIP	0.01uF 10% 25V
IC401	6-600-108-01	IC RPM7140		C39	1-107-826-11	CERAMIC CHIP	0.1uF 10% 16V
		< RESISTOR >		C40	1-162-915-11	CERAMIC CHIP	10PF 0.5PF 50V (E100L)
R423	1-216-813-11	METAL CHIP	220 5% 1/10W	C41	1-164-230-11	CERAMIC CHIP	220PF 5% 50V
R424	1-216-841-11	METAL CHIP	47K 5% 1/10W	C42	1-162-927-11	CERAMIC CHIP	100PF 5% 50V
		*****		C43	1-162-919-11	CERAMIC CHIP	22PF 5% 50V (E100)
	A-1070-126-A	TU BOARD, COMPLETE (SP, TW, KR)		C43	1-162-923-11	CERAMIC CHIP	47PF 5% 50V (E100L)
	A-1109-056-A	TU BOARD, COMPLETE (US, CND)		C44	1-164-230-11	CERAMIC CHIP	220PF 5% 50V (E100L)
	A-1126-048-A	TU BOARD, COMPLETE (E100L)		C45	1-162-970-11	CERAMIC CHIP	0.01uF 10% 25V (E100L)
		*****		C46	1-107-826-11	CERAMIC CHIP	0.1uF 10% 16V (E100L)
		< CAPACITOR >		C47	1-162-915-11	CERAMIC CHIP	10PF 0.5PF 50V (E100)
C1	1-162-923-11	CERAMIC CHIP	47PF 5% 50V	C48	1-162-923-11	CERAMIC CHIP	47PF 5% 50V (E100L)
C2	1-162-970-11	CERAMIC CHIP	0.01uF 10% 25V (E100L)	C49	1-161-051-00	CERAMIC	0.01uF 10% 25V (E100)
C3	1-162-970-11	CERAMIC CHIP	0.01uF 10% 25V (E100L)	C49	1-161-772-11	CERAMIC	0.1uF 10% 25V (E100L)
C4	1-162-964-11	CERAMIC CHIP	0.001uF 10% 50V				
C5	1-162-970-11	CERAMIC CHIP	0.01uF 10% 25V (E100L)				

CFD-E100/E100L

Ver. 1.1

TU

Ref. No.	Part No.	Description	Remark	Ref. No.	Part No.	Description	Remark
C51	1-162-919-11	CERAMIC CHIP	22PF 5% 50V	D10	8-719-988-61	DIODE 1SS355TE-17	
C52	1-162-915-11	CERAMIC CHIP	10PF 0.5PF 50V	D11	8-719-988-61	DIODE 1SS355TE-17	
C53	1-136-169-00	FILM	0.22uF 5% 50V (E100)			< IC >	
C53	1-137-194-81	FILM	0.47uF 5% 50V (E100L)	IC1	6-700-512-01	IC TA2149BN	
C54	1-126-934-11	ELECT	220uF 20% 16V	IC2	8-759-483-40	IC LC72137M-TLM-E	
C55	1-162-927-11	CERAMIC CHIP	100PF 5% 50V			< JUMPER RESISTOR >	
C56	1-162-964-11	CERAMIC CHIP	0.001uF 10% 50V	JC1	1-216-864-11	SHORT CHIP 0	
C57	1-162-964-11	CERAMIC CHIP	0.001uF 10% 50V	JC2	1-216-864-11	SHORT CHIP 0	
C58	1-162-970-11	CERAMIC CHIP	0.01uF 10% 25V (E100L)	JC3	1-216-864-11	SHORT CHIP 0	
C59	1-162-927-11	CERAMIC CHIP	100PF 5% 50V (E100)	JC4	1-216-864-11	SHORT CHIP 0	
C59	1-162-964-11	CERAMIC CHIP	0.001uF 10% 50V (E100L)	JC5	1-216-864-11	SHORT CHIP 0	
C60	1-162-964-11	CERAMIC CHIP	0.001uF 10% 50V	JC6	1-216-864-11	SHORT CHIP 0	
C61	1-162-927-11	CERAMIC CHIP	100PF 5% 50V	JC11	1-216-864-11	SHORT CHIP 0 (E100)	
C62	1-162-927-11	CERAMIC CHIP	100PF 5% 50V	JC12	1-216-864-11	SHORT CHIP 0 (E100)	
C63	1-162-927-11	CERAMIC CHIP	100PF 5% 50V	JC13	1-216-864-11	SHORT CHIP 0 (E100)	
C64	1-162-927-11	CERAMIC CHIP	100PF 5% 50V (E100L)	JC22	1-216-864-11	SHORT CHIP 0 (E100L)	
C65	1-126-963-11	ELECT	4.7uF 20% 50V (E100)	JC23	1-216-864-11	SHORT CHIP 0 (E100L)	
C66	1-162-927-11	CERAMIC CHIP	100PF 5% 50V	JC24	1-216-864-11	SHORT CHIP 0 (EXCEPT US, CND)	
C68	1-162-927-11	CERAMIC CHIP	100PF 5% 50V	JC33	1-216-864-11	SHORT CHIP 0	
C70	1-162-910-11	CERAMIC CHIP	5PF 0.25PF 50V (E100L)	JC34	1-216-864-11	SHORT CHIP 0	
C71	1-162-927-11	CERAMIC CHIP	100PF 5% 50V (E100L)			< COIL >	
C72	1-162-919-11	CERAMIC CHIP	22PF 5% 50V (E100L)	L1	1-409-775-11	COIL, AIR-CORE	
C73	1-162-919-11	CERAMIC CHIP	22PF 5% 50V (E100L)	L2	1-416-509-11	COIL, AIR-CORE	
C77	1-162-968-11	CERAMIC CHIP	0.0047uF 10% 50V (EXCEPT US, CND)	L3	1-754-116-12	ANTENNA, FERRITE-ROD (LW MW) (E100L)	
C78	1-162-968-11	CERAMIC CHIP	0.0047uF 10% 50V (EXCEPT US, CND)	L3	1-754-117-12	ANTENNA, FERRITE-ROD (MW) (E100)	
C80	1-162-970-11	CERAMIC CHIP	0.01uF 10% 25V	L4	1-411-199-31	COIL, MW/LW OSC (E100L)	
C93	1-162-970-11	CERAMIC CHIP	0.01uF 10% 25V (E100L)	L4	1-411-234-21	COIL, AM OSC (E100)	
C95	1-162-964-11	CERAMIC CHIP	0.001uF 10% 50V	L11	1-414-142-11	INDUCTOR 1uH (US, CND)	
		< FILTER >		L21	1-410-509-11	INDUCTOR 10uH	
CF2	1-795-426-11	FILTER, CERAMIC (E100L)				< TRANSISTOR >	
CF2	1-760-235-81	FILTER, CERAMIC (E100)		Q12	8-729-028-99	TRANSISTOR DTC114YUA-T106 (E100L)	
CF4	1-781-962-21	FILTER, CERAMIC		Q14	8-729-905-35	TRANSISTOR 2SC4081-R (E100L)	
		< CONNECTOR >		Q41	8-729-920-31	TRANSISTOR DTC343TK (E100L)	
CNP1	1-568-854-11	CONNECTOR, FFC 11P		Q42	8-729-054-77	TRANSISTOR 2SC4098-T106-PQ (E100L)	
		< TRIMMER >		Q43	8-729-920-38	TRANSISTOR 2SC2059K-N (E100L)	
CT1	1-141-442-91	CAP, CERAMIC TRIMMER		Q44	8-729-054-77	TRANSISTOR 2SC4098-T106-PQ (E100L)	
CT3	1-141-304-21	CAP, CERAMIC TRIMMER		Q61	8-729-106-07	FET 2SK514-H (E100L)	
CT5	1-141-459-11	CAP, TRIMMER (SEAL TYPE) (E100L)				< RESISTOR >	
		< DIODE >		R1	1-216-817-11	METAL CHIP 470 5% 1/10W	
D1	8-719-078-48	DIODE KV1471ETR-G		R2	1-216-817-11	METAL CHIP 470 5% 1/10W	
D2	8-719-078-48	DIODE KV1471ETR-G		R3	1-216-833-11	METAL CHIP 10K 5% 1/10W	
D3	8-719-050-69	DIODE KV1520N		R4	1-216-833-11	METAL CHIP 10K 5% 1/10W	
				R5	1-216-821-11	METAL CHIP 1K 5% 1/10W (E100)	
				R7	1-216-853-11	METAL CHIP 470K 5% 1/10W (E100L)	
				R9	1-216-845-11	METAL CHIP 100K 5% 1/10W (E100L)	
				R10	1-216-805-11	METAL CHIP 47 5% 1/10W	
				R11	1-216-825-11	METAL CHIP 2.2K 5% 1/10W	
				R12	1-216-841-11	METAL CHIP 47K 5% 1/10W (E100L)	
				R13	1-216-821-11	METAL CHIP 1K 5% 1/10W	

Ref. No.	Part No.	Description	Remark	Ref. No.	Part No.	Description	Remark
R14	1-216-821-11	METAL CHIP	1K 5%	1/10W		< TRANSFORMER >	
R16	1-216-833-11	METAL CHIP	10K 5%	1/10W			
R17	1-216-825-11	METAL CHIP	2.2K 5%	1/10W	T1	1-433-741-11	TRANSFORMER, IF
R18	1-216-829-11	METAL CHIP	4.7K 5%	1/10W	T2	1-419-465-11	COIL (DET)
				(E100L)			< VIBRATOR >
R19	1-216-825-11	METAL CHIP	2.2K 5%	1/10W	X1	1-795-449-11	VIBRATOR, CRYSTAL (75kHz)
				(E100L)			*****
R22	1-216-833-11	METAL CHIP	10K 5%	1/10W		MISCELLANEOUS	
				(E100L)		*****	
R24	1-216-813-11	METAL CHIP	220 5%	1/10W			
R30	1-216-837-11	METAL CHIP	22K 5%	1/10W	253	1-829-241-11	CABLE, FLEXIBLE FLAT (11 CORE)
R31	1-216-829-11	METAL CHIP	4.7K 5%	1/10W	255	1-830-507-11	CABLE, FLEXIBLE FLAT (13 CORE)
					264	1-829-252-11	CABLE, FLEXIBLE FLAT (14 CORE)
R32	1-216-845-11	METAL CHIP	100K 5%	1/10W	308	1-830-506-11	CABLE, FLEXIBLE FLAT (20 CORE)
R33	1-216-833-11	METAL CHIP	10K 5%	1/10W	△311	8-820-138-13	OPTICAL PICK-UP (KSM-900AAA)
R40	1-216-849-11	METAL CHIP	220K 5%	1/10W			
				(E100)	701	A-1119-419-A	MECHANISM DECK ASSY (MF-E100)
R40	1-216-853-11	METAL CHIP	470K 5%	1/10W	ANT1	1-754-282-11	ANTENNA, TELESCOPIC
				(E100L)	△F901	1-533-451-12	FUSE, GLASS TUBE (DIA. 5) (3.15A/125V)
R41	1-216-833-11	METAL CHIP	10K 5%	1/10W			(US, CND, TW)
R42	1-216-845-11	METAL CHIP	100K 5%	1/10W	△F901	1-533-468-12	FUSE, GLASS TUBE (DIA. 5) (T2A/250V)
				(E100L)			(AEP, UK, IT, EE, RU, SP, KR)
R43	1-216-833-11	METAL CHIP	10K 5%	1/10W	HE301	1-500-813-11	HEAD, ERASE
				(E100L)	HRP301	3-266-053-01	HEAD, RP (RECORD/PLAYBACK)
R50	1-216-821-11	METAL CHIP	1K 5%	1/10W	LCD401	1-805-845-11	DISPLAY PANEL, LIQUID CRYSTAL
R51	1-216-833-11	METAL CHIP	10K 5%	1/10W	M901	X-3385-048-1	MOTOR SUB ASSY (CAPSTAN/REEL)
R52	1-216-809-11	METAL CHIP	100 5%	1/10W	S902	1-762-819-11	SWITCH, LEAF (TAPE PLAY)
				(E100L)	SP101	1-826-150-11	SPEAKER (8cm) (L-ch)
R52	1-216-864-11	SHORT CHIP	0 (E100)		SP201	1-826-150-11	SPEAKER (8cm) (R-ch)
R53	1-216-829-11	METAL CHIP	4.7K 5%	1/10W	△T901	1-435-917-21	TRANSFORMER, POWER (US, CND, TW)
R54	1-216-817-11	METAL CHIP	470 5%	1/10W	△T901	1-435-918-21	TRANSFORMER, POWER
R55	1-216-833-11	METAL CHIP	10K 5%	1/10W			(AEP, UK, IT, EE, RU, SP, KR)
				(E100)			*****
R55	1-216-864-11	SHORT CHIP	0 (E100L)			ACCESSORIES	

R56	1-216-813-11	METAL CHIP	220 5%	1/10W	△	1-769-412-22	CORD, POWER (AEP, UK, EE, RU, IT, SP)
R57	1-216-809-11	METAL CHIP	100 5%	1/10W	△	1-770-019-51	ADAPTOR, CONVERSION PLUG 3P (UK)
R58	1-216-825-11	METAL CHIP	2.2K 5%	1/10W	△	1-776-985-12	CORD, POWER (KR)
R59	1-216-825-11	METAL CHIP	2.2K 5%	1/10W	△	1-783-878-11	CORD, POWER (US, CND)
R60	1-216-825-11	METAL CHIP	2.2K 5%	1/10W	△	1-829-433-11	CORD, POWER (TW)
R61	1-216-825-11	METAL CHIP	2.2K 5%	1/10W			
R63	1-216-829-11	METAL CHIP	4.7K 5%	1/10W			
				(E100L)			
R63	1-216-833-11	METAL CHIP	10K 5%	1/10W		2-587-606-12	MANUAL, INSTRUCTION (ENGLISH)
				(E100)			(E100: US, CND)
R64	1-216-821-11	METAL CHIP	1K 5%	1/10W		2-587-606-21	MANUAL, INSTRUCTION (FRENCH)
				(E100L)			(E100: CND)
R64	1-216-825-11	METAL CHIP	2.2K 5%	1/10W		2-587-606-31	MANUAL, INSTRUCTION (ENGLISH) (TW)
				(E100L)		2-587-606-51	MANUAL, INSTRUCTION (ENGLISH)
							(E100: SP, KR/E100L: AEP, UK)
R65	1-216-833-11	METAL CHIP	10K 5%	1/10W		2-587-606-61	MANUAL, INSTRUCTION (SPANISH)
				(E100)			(E100: SP/E100L: AEP)
R66	1-216-805-11	METAL CHIP	47 5%	1/10W		2-587-606-71	MANUAL, INSTRUCTION (FRENCH)
				(E100L)			(E100: SP/E100L: AEP)
R91	1-216-813-11	METAL CHIP	220 5%	1/10W		2-587-606-81	MANUAL, INSTRUCTION (GERMAN)
R92	1-216-813-11	METAL CHIP	220 5%	1/10W			(E100L: AEP)
R93	1-216-821-11	METAL CHIP	1K 5%	1/10W		2-587-606-91	MANUAL, INSTRUCTION (DUTCH)
				(E100L)			(E100L: AEP)
R94	1-216-821-11	METAL CHIP	1K 5%	1/10W		2-596-560-11	MANUAL, INSTRUCTION (PORTUGUESE)
							(E100L: AEP)
						2-596-560-21	MANUAL, INSTRUCTION (ITALIAN) (E100L: IT)

CFD-E100/E100L

Ver. 1.1

<u>Ref. No.</u>	<u>Part No.</u>	<u>Description</u>	<u>Remark</u>
	2-596-560-31	MANUAL, INSTRUCTION (SWEDISH)	(E100L: EE, RU)
	2-596-560-41	MANUAL, INSTRUCTION (FINNISH)	(E100L: EE, RU)
	2-596-560-51	MANUAL, INSTRUCTION (POLISH)	(E100L: EE, RU)
	2-596-560-61	MANUAL, INSTRUCTION (CZECH)	(E100L: EE, RU)
	2-596-560-71	MANUAL, INSTRUCTION (HUNGARIAN)	(E100L: EE, RU)
	2-596-560-81	MANUAL, INSTRUCTION (SLOVAKIAN)	(E100L: EE, RU)
	2-596-560-91	MANUAL, INSTRUCTION (RUSSIAN)	(E100L: EE, RU)
	2-596-561-11	MANUAL, INSTRUCTION (KOREAN) (E100: KR)	
	2-596-561-21	MANUAL, INSTRUCTION (TRADITIONAL CHINESE) (E100: TW)	
	2-109-740-01	LID, BATTERY CASE (for RMT-CE90A/RMT-CE90AD) (for BLUE) (E100: SP, TW, KR/E100L: AEP)	
	3-238-070-01	LID, BATTERY CASE (for RMT-CE95A/RMT-CE95AD) (for SILVER) (E100: SP, TW, KR/E100L)	
	3-267-151-11	LID BATTERY (for RMT-CE100A) (for WHITE) (E100: US, CND)	
	A-1108-694-A	REMOTE CONTROL UNIT (RMT-CE100A/C (SET)) (for WHITE) (E100: US, CND)	
	A-1128-611-A	REMOTE CONTROL UNIT (RMT-CE90A/LC (SET)) (for BLUE) (E100: SP, TW, KR)	
	A-3172-070-A	REMOTE CONTROL UNIT (RMT-CE95AD/SC (SET)) (for SILVER) (E100L)	
	A-3172-079-A	REMOTE CONTROL UNIT (RMT-CE95A/SC (SET)) (for SILVER) (E100: SP, TW, KR)	
	A-3172-202-A	REMOTE CONTROL UNIT (RMT-CE90AD/LC (SET)) (for BLUE) (E100L: AEP)	

MEMO

