

CDP-X559ES

SERVICE MANUAL

AEP Model
UK Model
E Model

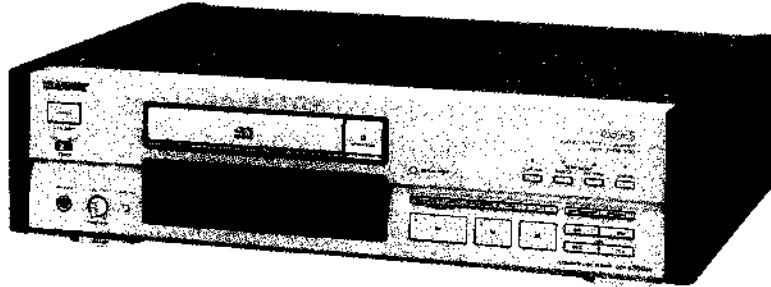

(GOLD)

COMPACT
disc
DIGITAL AUDIO

SPECIFICATIONS

Compact disc player

Frequency response	2 Hz–20 kHz±0.3 dB
Signal to noise ratio	More than 118 dB
Dynamic range	More than 100 dB
Harmonic distortion	Less than 0.0017%
Channel separation	More than 110 dB
Laser output	Max. 44.6μW This output is the value measured at a distance of about 200 mm from the objective lens surface on the Optical Pick-up Block.

Outputs

LINE OUT (FIXED)
(phono jacks)

Output level 2V (at 50 kilohms)
Load impedance over 10 kilohms

LINE OUT (VARIABLE)
(phono jacks)

Output level max. 2V (at 50 kilohms)
Load impedance over 50 kilohms

DIGITAL OUT (OPTICAL)
(optical output connector)

HEADPHONES
(Stereo phone jack)

Wave length 660 nm
Output level -18 dBm

Output level max. 28 mW
Load impedance 32 ohms

General

Power requirements

AEP model:
220–230 V AC, 50/60 Hz
UK model:
240 V AC, 50/60 Hz
E model:
110–120 or 220–240 V AC adjustable, 50/60 Hz

Model Name Using Similar Mechanism	NEW
CD Mechanism Type	CDM19C-6G50 : (BLACK) CDM19D-6G50 : (GOLD)
Optical Pick-up Block Type	BU-6G

Power consumption	29 W
Dimensions (approx., including projections)	AEP model: 470×125×375 mm (w/h/d) (18 5/8×5×14 7/8 inches) UK model: 430×125×375 mm (w/h/d) (17×5×14 7/8 inches) E model: 470×125×375 mm (w/h/d) (18 5/8×5×14 7/8 inches)
Weight (approx.)	AEP model: 13 kg UK model: 12 kg E model: 12.2 kg

Remote commander (RM-D891) (GOLD) (AEP model) (RM-D991) (BLACK)

Remote control system	Infrared control
Power requirements	3 V DC with two batteries size AA (IEC designation R6)
Dimensions	62×18×175 mm (w/h/d) (2 1/2×23/32×7 inches)
Weight	135 g (4.6 oz) Including batteries

Supplied accessories

Connecting cord	1 (2 phono plugs → 2 phono plugs)
Remote commander	1
Sony SUM-3(NS) batteries	2
Screws	8 (except for UK model)

Design and specifications are subject to change without notice.



COMPACT DISC PLAYER
SONY®

TABLE OF CONTENTS

<u>Section</u>	<u>Title</u>	<u>Page</u>
1. GENERAL		
1-1. Identifying the Parts	3
2. ELECTRICAL BLOCK CHECKING		5
3. DIAGRAMS		
3-1. Block Diagram	7
3-2. Circuit Boards Location	10
3-3. Printed Wiring Boards	11
3-4. Schematic Diagram	15
3-5. Semiconductor Lead Layouts	22
4. EXPLODED VIEWS		
4-1. Cabinet Section	23
4-2. Front Panel Section	24
4-3. Chassis Section	25
4-4. CD Mechanism Block Section	26
4-5. Base Unit Section	27
5. ELECTRICAL PARTS LIST		28

For the United Kingdom and European countries

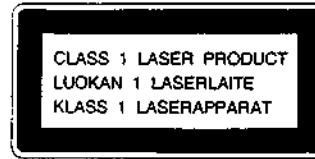

This Compact Disc player is classified as a CLASS 1 LASER product. The CLASS 1 LASER PRODUCT label is located on the rear exterior.

NOTES ON HANDLING THE OPTICAL PICK-UP BLOCK OR BASE UNIT

The laser diode in the optical pick-up block may suffer electrostatic breakdown because of the potential difference generated by the charged electrostatic load, etc. on clothing and the human body. During repair, pay attention to electrostatic breakdown and also use the procedure in the printed matter which is included in the repair parts. The flexible board is easily damaged and should be handled with care.

NOTES ON LASER DIODE EMISSION CHECK

The laser beam on this model is concentrated so as to be focused on the disc reflective surface by the objective lens in the optical pick-up block. Therefore, when checking the laser diode emission, observe from more than 30cm away from the objective lens.

MODEL IDENTIFICATION

—Model Number Label—

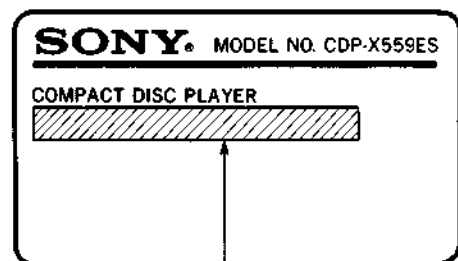

AEP model: AC: 220-230V~50/60Hz
 UK model: AC: 240V~50/60Hz
 E model: AC: 110, 120, 220, 240V~50/60Hz 29W

SAFETY-RELATED COMPONENT WARNING!!
 COMPONENTS IDENTIFIED BY MARK OR DOTTED LINE WITH MARK ON THE SCHEMATIC DIAGRAMS AND IN THE PARTS LIST ARE CRITICAL TO SAFE OPERATION. REPLACE THESE COMPONENTS WITH SONY PARTS WHOSE PART NUMBERS APPEAR AS SHOWN IN THIS MANUAL OR IN SUPPLEMENTS PUBLISHED BY SONY.

SECTION 1 GENERAL

1-1. IDENTIFYING THE PARTS

This section is extracted from instruction manual.

Front Panel

Refer to the pages indicated in () for details.

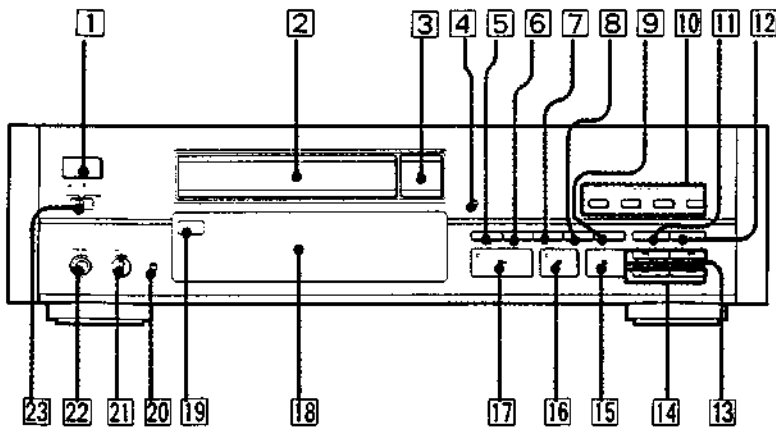

- 1 POWER switch (22)
- 2 Disc tray (22)
- 3 ▲ OPEN/CLOSE button (22)
- 4 DISPLAY MODE button (24)
- 5 TIME/MEMO button (24)
- 6 REPEAT button (42)
- 7 FILE RECALL button (78)
- 8 FILE (custom file) button (78)
- 9 ERASE (memory erase) button (78)
- 10 PLAY MODE buttons
CONTINUE button and indicator (22)
SHUFFLE button and indicator (32)
PROGRAM button and indicator (46)
C. (custom) INDEX button and indicator (92)
- 11 EDIT/TIME FADE button (70)
- 12 P. (peak) SEARCH button (74)
- 13 ◀▶ (manual search) buttons (28)
- 14 ◀▶▶ AMS* buttons (26)
- 15 ■ (stop) button (22)
- 16 || (pause) button and indicator (22)
- 17 ▶ (play) button and indicator (22)
- 18 Display window (24)
- 19 Remote sensor
- 20 LEVEL FILE button (98)
- 21 LINE OUT/PHONE LEVEL control (22)
- 22 PHONES jack (22)
- 23 TIMER switch (100)

* AMS is the abbreviation of Automatic Music Sensor.

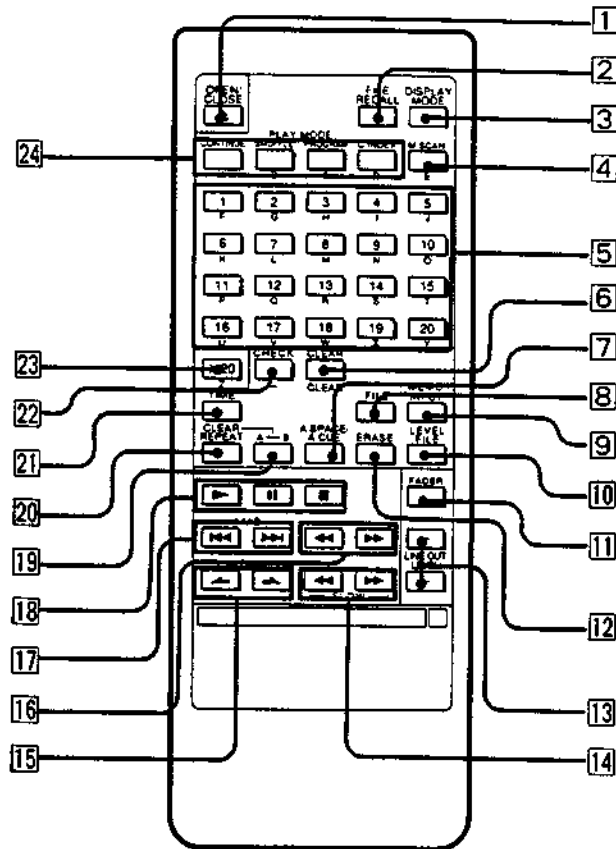

Remote Commander

Refer to the pages indicated in () for details.

- 1 ▲ OPEN/CLOSE button (22)
- 2 FILE RECALL button (78)
- 3 DISPLAY MODE button (24)
- 4 M. (music) SCAN button (38)
- 5 Numeric buttons (26)
- 6 CLEAR button (36, 46)
- 7 A. SPACE (auto space)/A.CUE (auto cue) button (30, 72)
- 8 FILE (custom file) button (78)
- 9 MEMO INPUT button (80)
- 10 LEVEL FILE button (98)
- 11 FADER (fade in/fade out) button (72)
- 12 ERASE button (78)
- 13 LINE OUT LEVEL (line out/headphones level) buttons (22)
- 14 ◀ ▶ SLOW (low speed manual search) buttons (28)
- 15 — — INDEX buttons (28)
- 16 ◀ ▶ (manual search) buttons (28)
- 17 ◀▶▶ AMS* buttons (26)
- 18 ■ (stop) button (22)
- 19 || (pause) button (22)
- ▶ (play) button (22)
- 19 A ↔ B repeat button (44)
- 20 REPEAT (repeat/A-B repeat clear) button (42)
- 21 TIME button (24)
- 22 CHECK button (46)
- 23 > 20 (over 20) button (26)
- 24 PLAY MODE buttons
 CONTINUE button (22)
 SHUFFLE button (32)
 PROGRAM button (46)
 C. INDEX button (92)

Buttons with orange letters (A, B, -- --) are for writing a disc memo (page 80).

* AMS is the abbreviation of Automatic Music Sensor.

SECTION 2 ELECTRICAL BLOCK CHECKING

Note :

1. CD Block basically constructed to operate without adjustment. Therefore, check each item in order given.
2. Use YEDS-18 disc (3-702-101-01) unless otherwise indicated.
3. Use the oscilloscope with more than 10MΩ impedance.
4. Clean an object lens by an applicator with neutral detergent when the signal level is low than specified value with the following checks.

S Curve Check

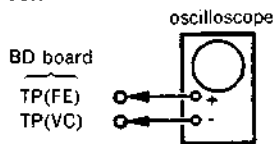

Procedure :

1. Connect oscilloscope to test point TP (FE) on BD board.
2. Connect between test point TP (FEI) and TP (VC) with lead wire.
3. Turned Power switch on and actuate the focus serch. (actuate the focus serch when disc table is moving in and out.)
4. Check the oscilloscope waveform (S curve) is symmetrical between A and B. And confirm peak to peak level within $3 \pm 1V_{p-p}$.

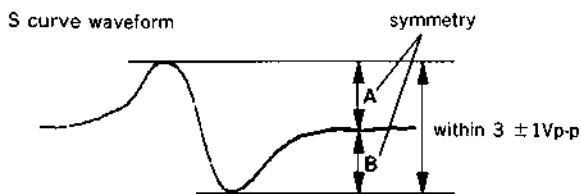

5. After check, remove the lead wire connected in step 2.
- Note :**
- Try to mesure several times to make sure that the ratio of A : B or B : A is more than 10 : 7.
 - Take sweep time as long as possible and light up the brightness to obtain best waveform.

RF Level Check

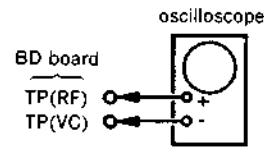

Procedure :

1. Connect oscilloscope to test point TP (RF) on BD board.
2. Turn Power switch on.
3. Put disc (YEDS-18) in and playback.
4. Confirm that oscilloscope waveform is clear and check RF signal level is correct or not.

Note :

Clear RF signal waveform means that the shape “◇” can be clearly distinguished at the center of the waveform.

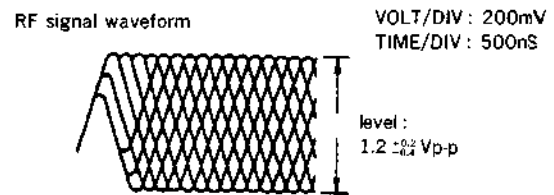

E-F Balance Check

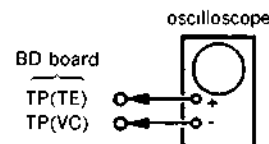

Procedure :

1. Connect test point TP (ADJ) to ground and TP (TEI) to TP (VC) with lead wires.
2. Connect oscilloscope to test point TP (TE) on BD board.
3. Turn Power switch on.
4. Put disc (YEDS-18) in and playback.
5. Confirm that the osilloscope waveform is symmetrical on the top and bottom in relation to 0V, and check this level.

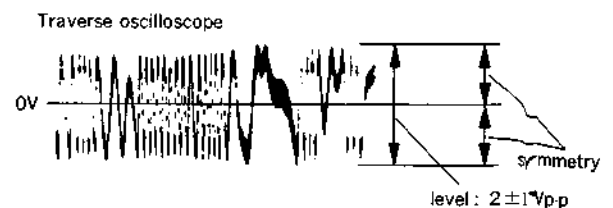

6. Remove the lead wires connected in step 1.

RF PLL Free-run Frequency Check

Procedure :

1. Connect frequency counter to test point TP (PLCK) with lead wire.

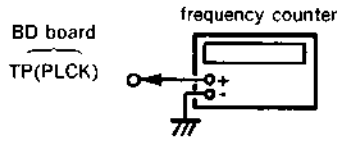

2. Turn Power switch on.
3. Put disc (YEDS-18) in and playback.
4. Confirm that reading on frequency counter is 4.3218MHz.

Focus/Tracking Gain

This gain has a margin, so even if it is slightly off.

There is no problem.

Therefore, do not perform, this adjustment.

Please note that it should be fixed to mechanical center position when you moved and do not know original position.

Check Point Location : BD board—side A—

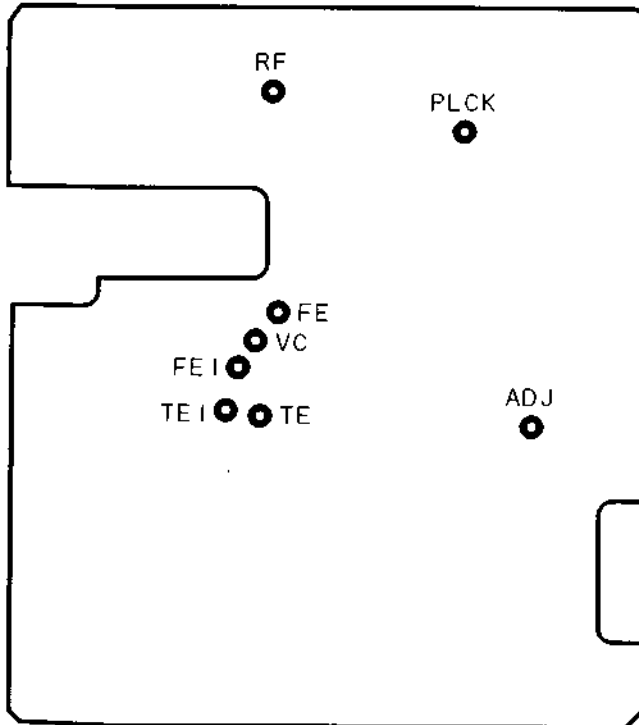

SECTION 3 DIAGRAMS

3-1. BLOCK DIAGRAM

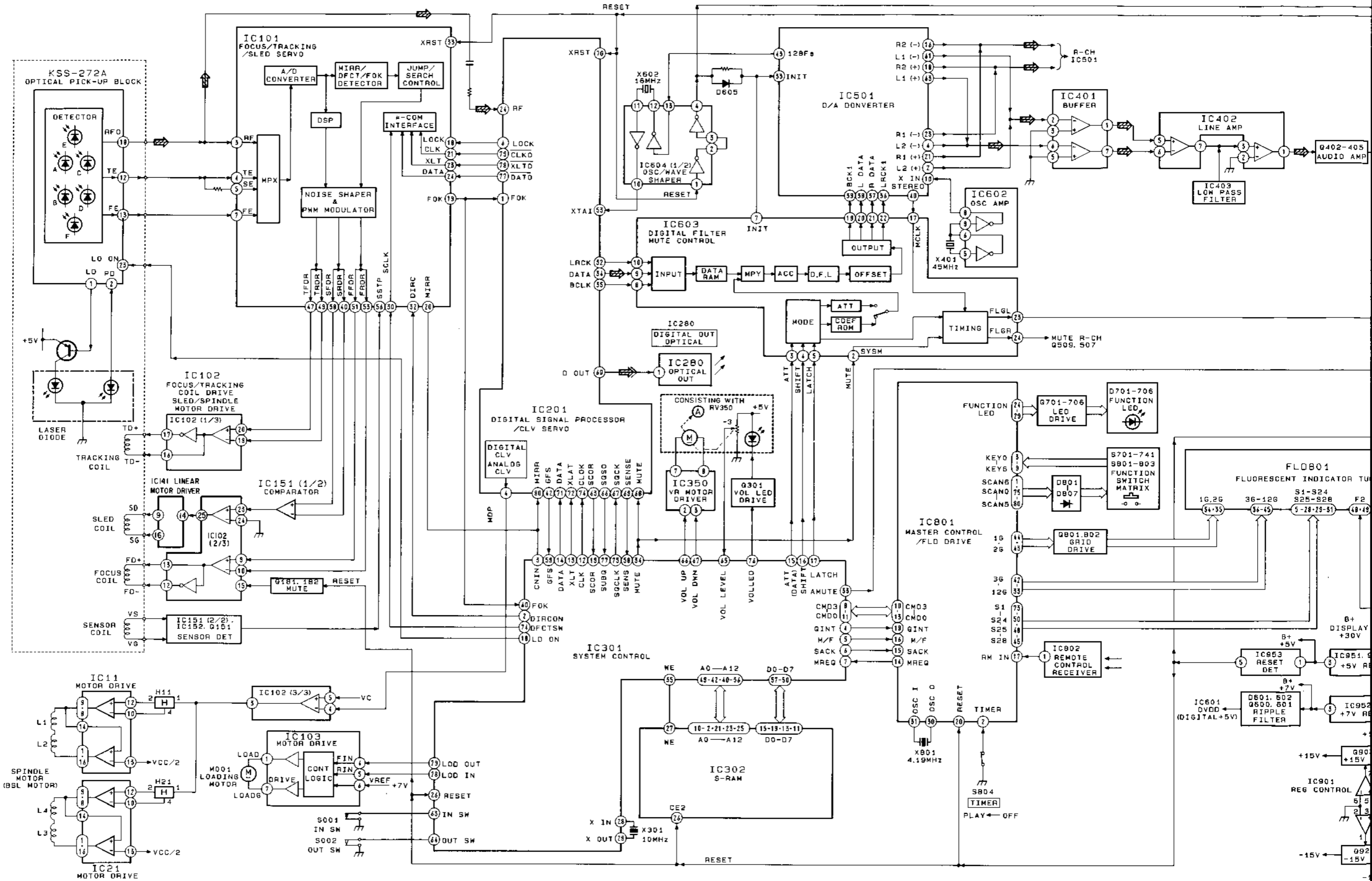

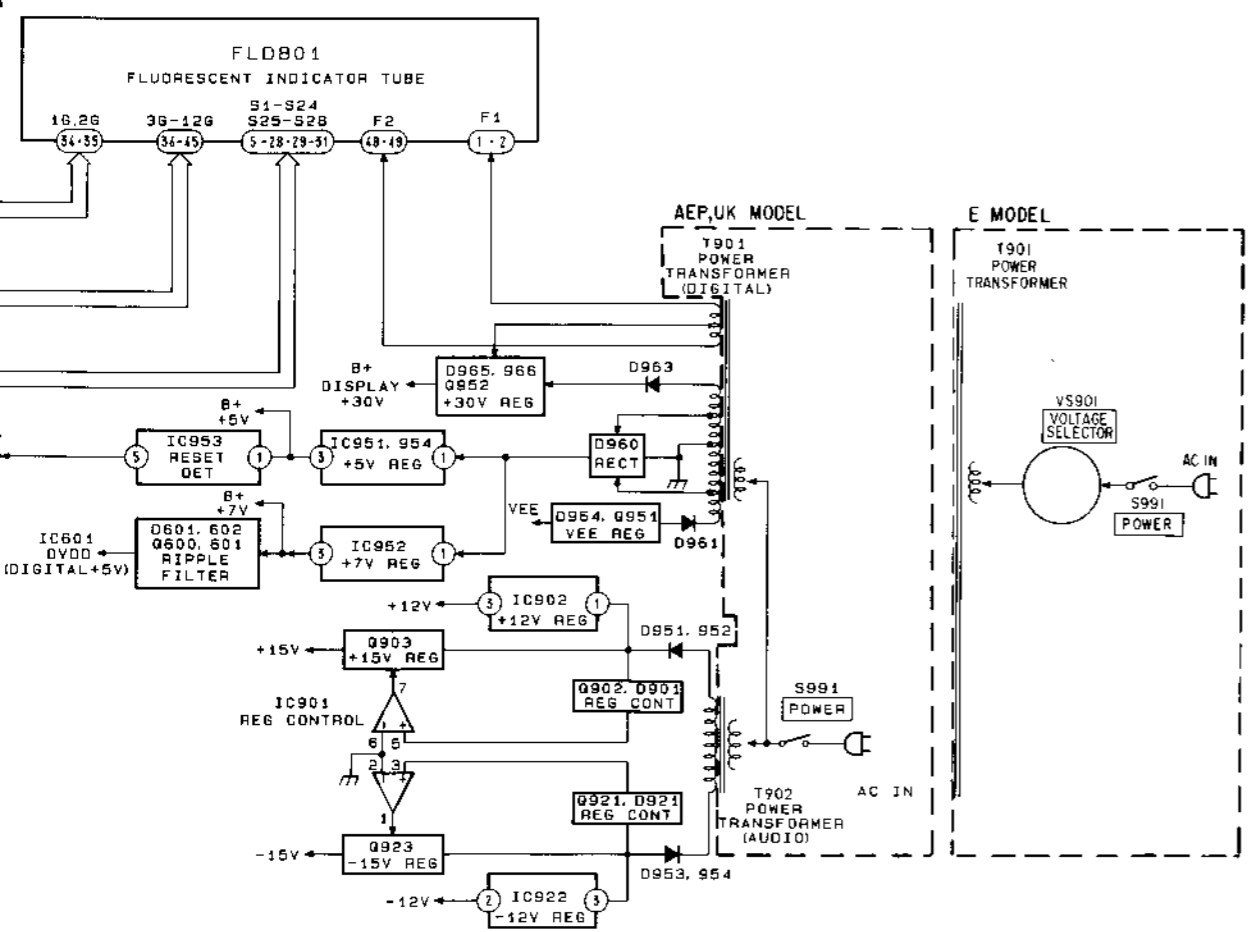
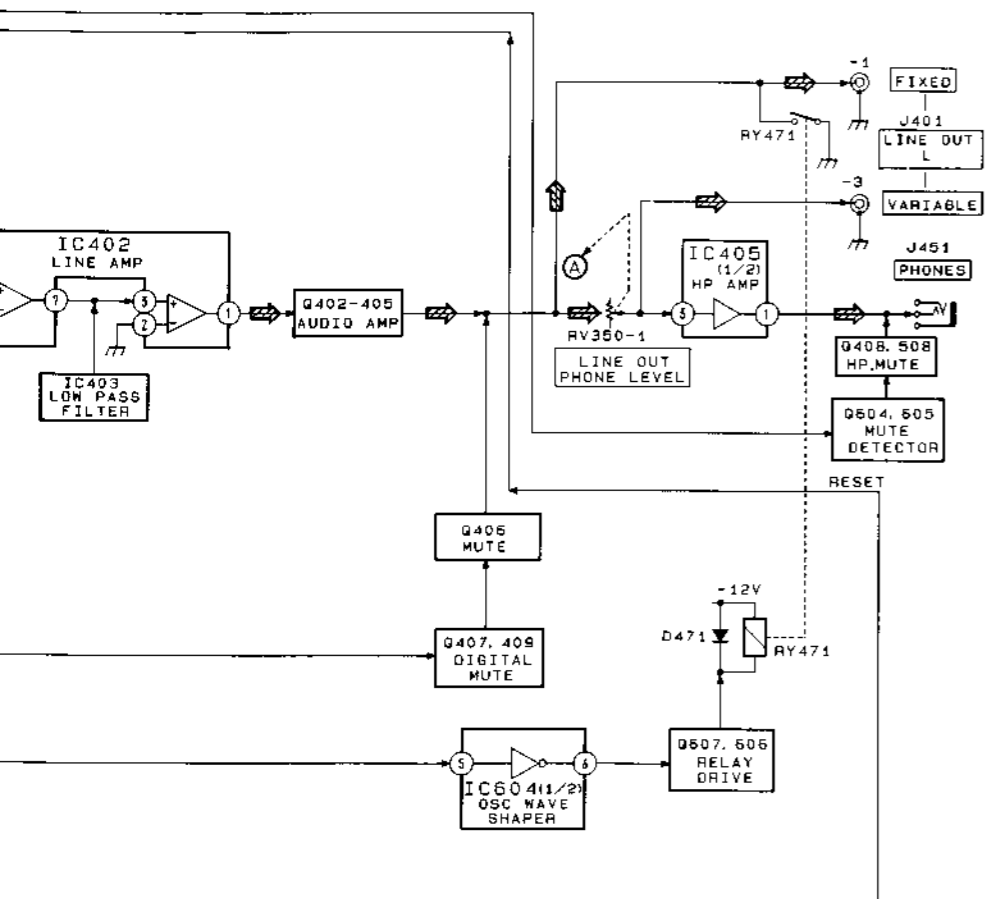

3-2. CIRCUIT BOARDS LOCATION

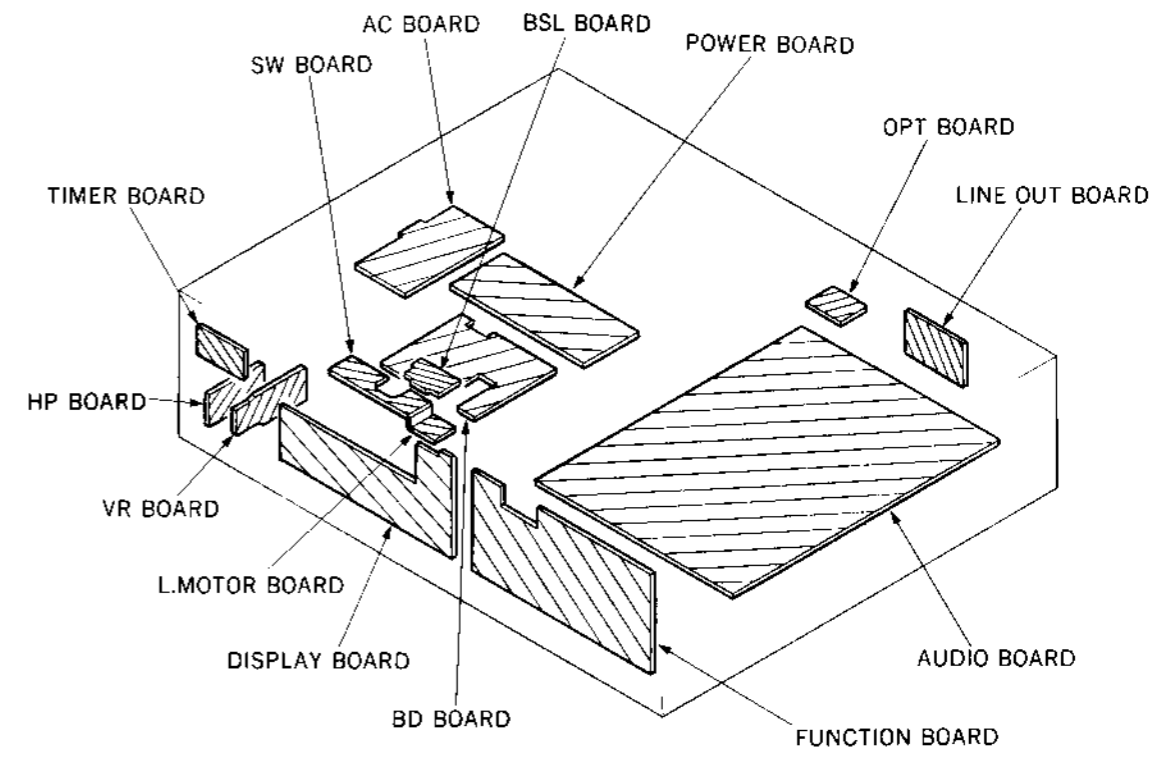

• Semiconductor Location

Ref. No.	Location	Ref. No.	Location	Ref. No.	Location	Ref. No.	Location
D301	J-10	IC11	C-18	IC951	I-30	Q701	J-27
D471	D-12	IC21	D-18	IC952	I-29	Q702	J-26
D601	H-7	IC101	I-12	IC953	K-29	Q703	H-26
D602	H-7	IC102	J-16	IC954	I-30	Q704	I-26
D603	G-6	IC103	K-17			Q705	I-26
D604	I-7	IC141	I-15	Q151	I-16	Q706	I-26
D605	J-6	IC142	J-15	Q181	J-10	Q801	G-23
D606	J-6	IC151	K-12	Q182	K-11	Q802	F-23
D701	J-27	IC152	K-11	Q350	B-13	Q902	C-6
D702	J-25	IC201	H-10	Q402	E-6	Q903	B-7
D703	I-24	IC280	B-10	Q403	D-7	Q921	B-3
D704	I-23	IC301	H-17	Q904	D-6	Q923	B-2
D705	I-22	IC302	I-10	Q405	D-7	Q951	I-29
D706	I-22	IC350	B-12	Q406	C-5	Q952	E-30
D801	F-25	IC401	E-7	Q407	H-2		
D802	F-25	IC402	E-6	Q408	J-2		
D803	F-25	IC403	E-6	Q409	H-2		
D804	F-25	IC404	E-5	Q502	E-3		
D805	F-25	IC405	J-3	Q503	D-2		
D806	F-25	IC501	E-2	Q504	D-3		
D807	F-25	IC502	E-3	Q505	D-2		
D901	D-6	IC503	E-4	Q506	C-4		
D921	B-3	IC504	E-4	Q507	I-2		
D951	F-29	IC601	I-5	Q508	K-2		
D952	F-30	IC602	G-4	Q509	I-2		
D953	F-29	IC603	J-4	Q600	H-6		
D954	F-29	IC604	J-6	Q601	H-6		
D960	G-30	IC605	G-6	Q602	F-5		
D961	G-30	IC606	J-6	Q603	G-6		
D963	E-30	IC801	F-24	Q604	I-2		
D964	J-29	IC802	G-26	Q605	I-3		
D965	F-30	IC901	B-5	Q606	H-7		
D966	F-30	IC902	C-7	Q607	I-7		
D971	K-30	IC922	C-7	Q608	K-6		

17 18 19 20 21 22 23 24 25 26 27 28 29 30 31 32 33 34 35 36

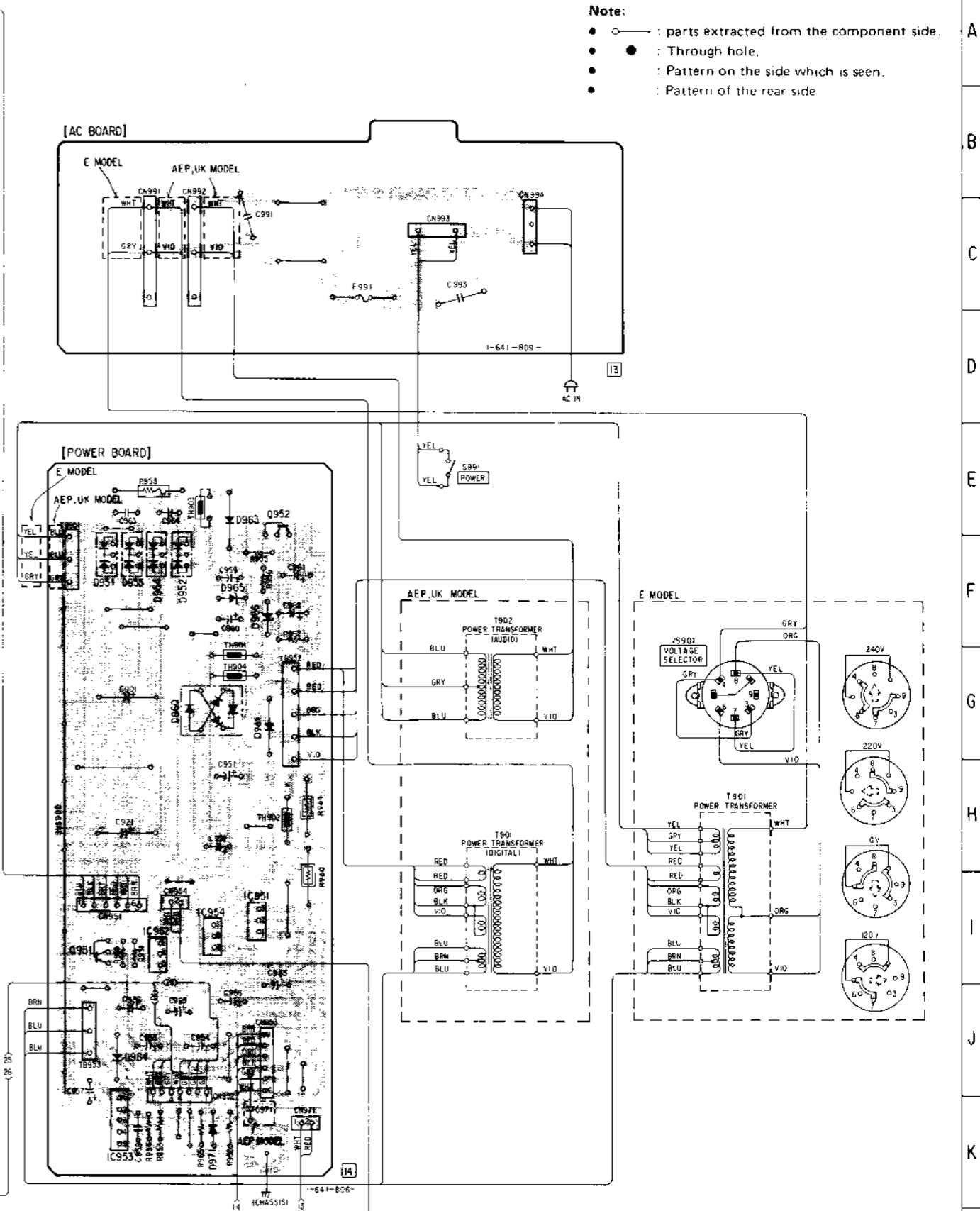
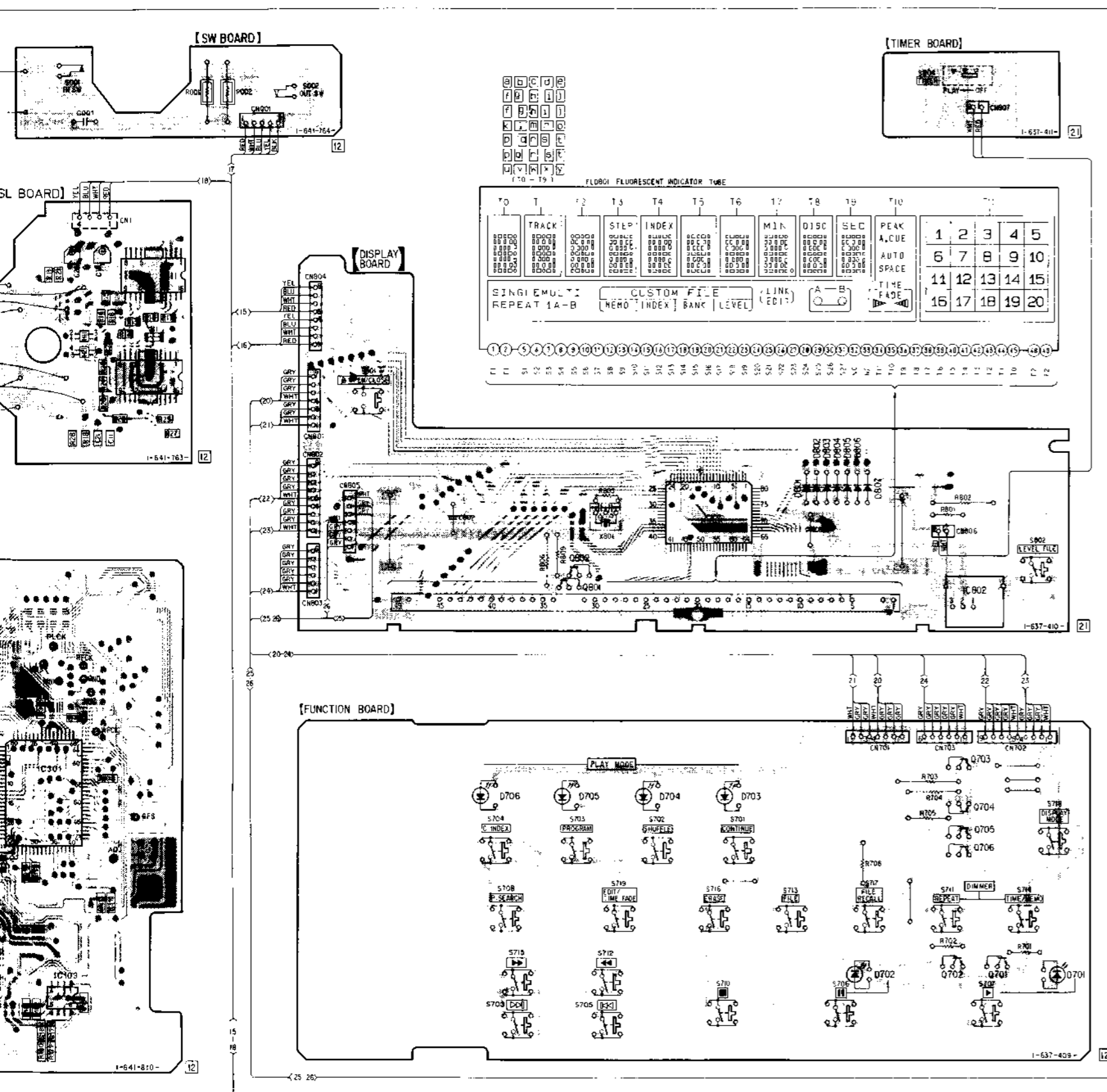

3-4. SCHEMATIC DIAGRAM • Refer to page 20 for IC Block Diagrams.

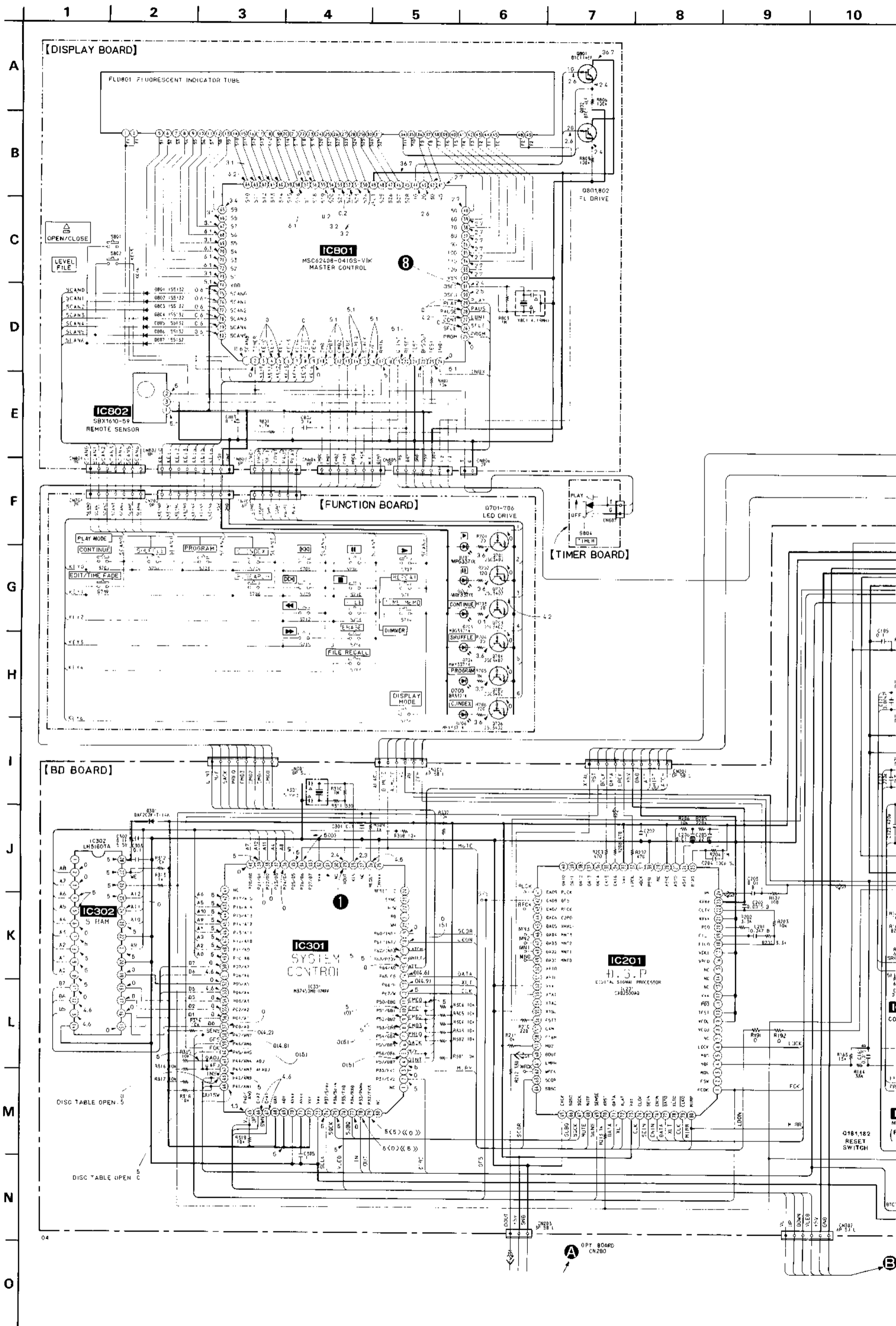

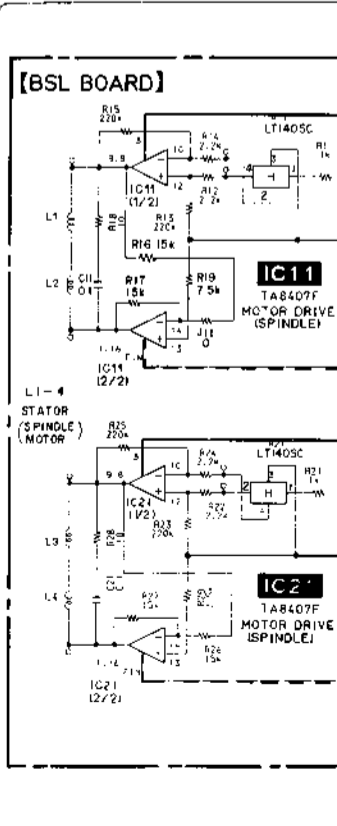
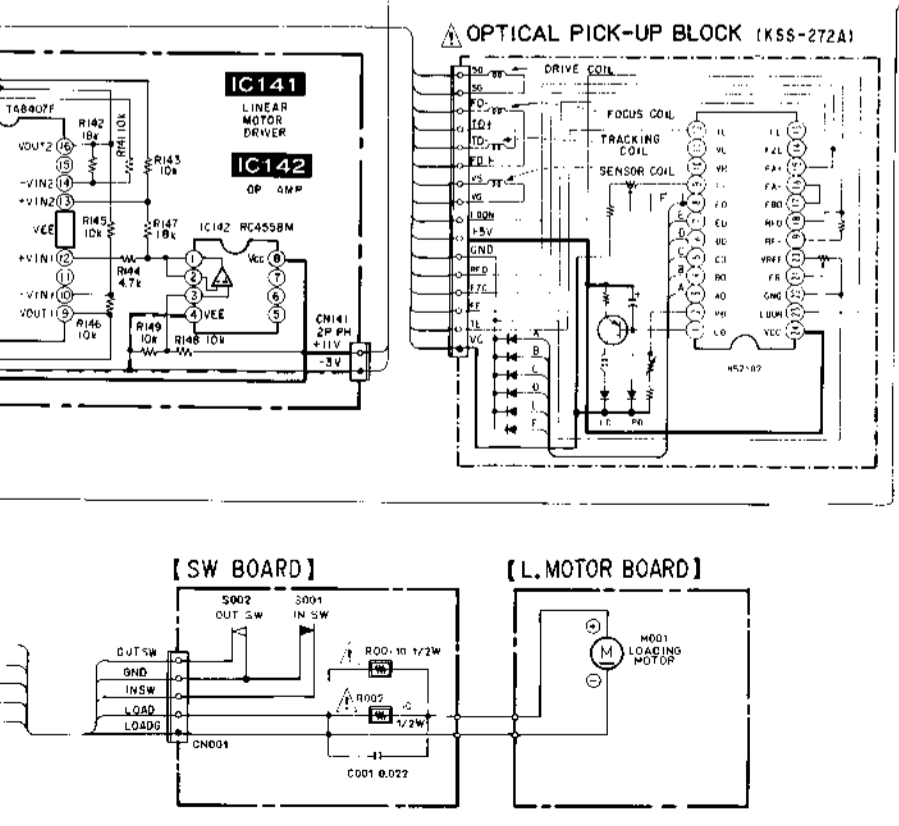
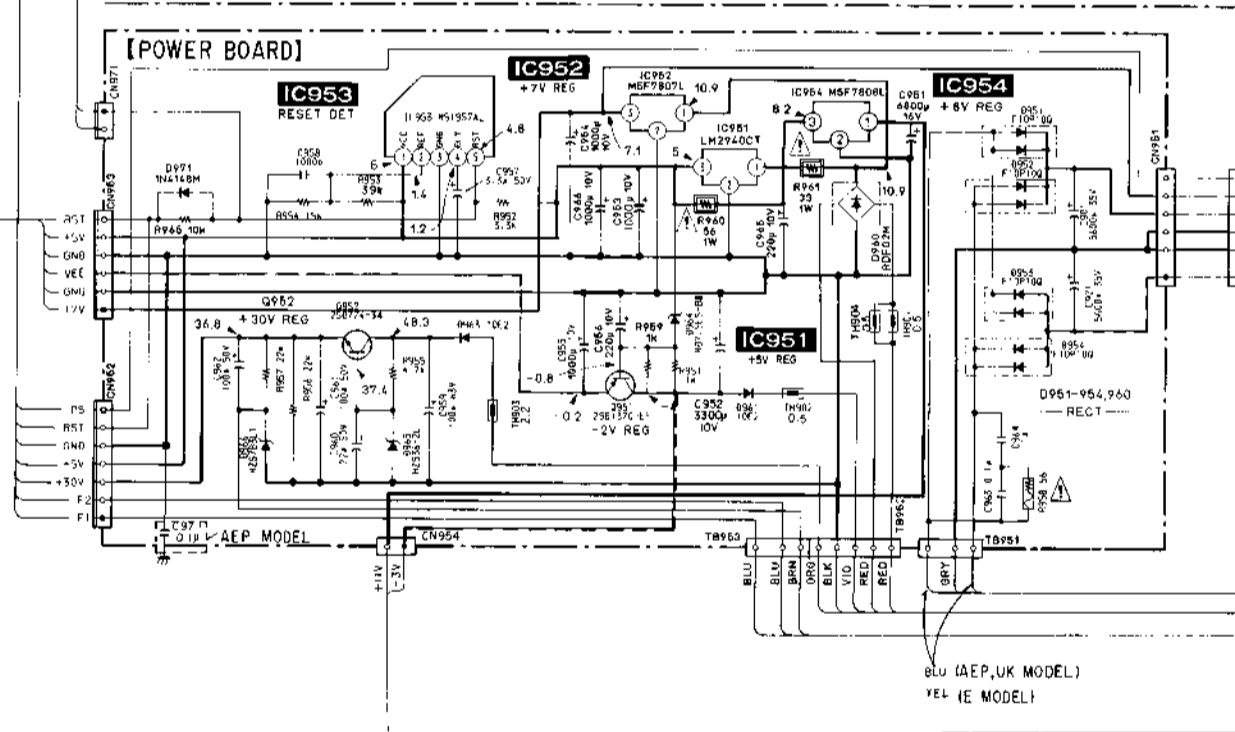
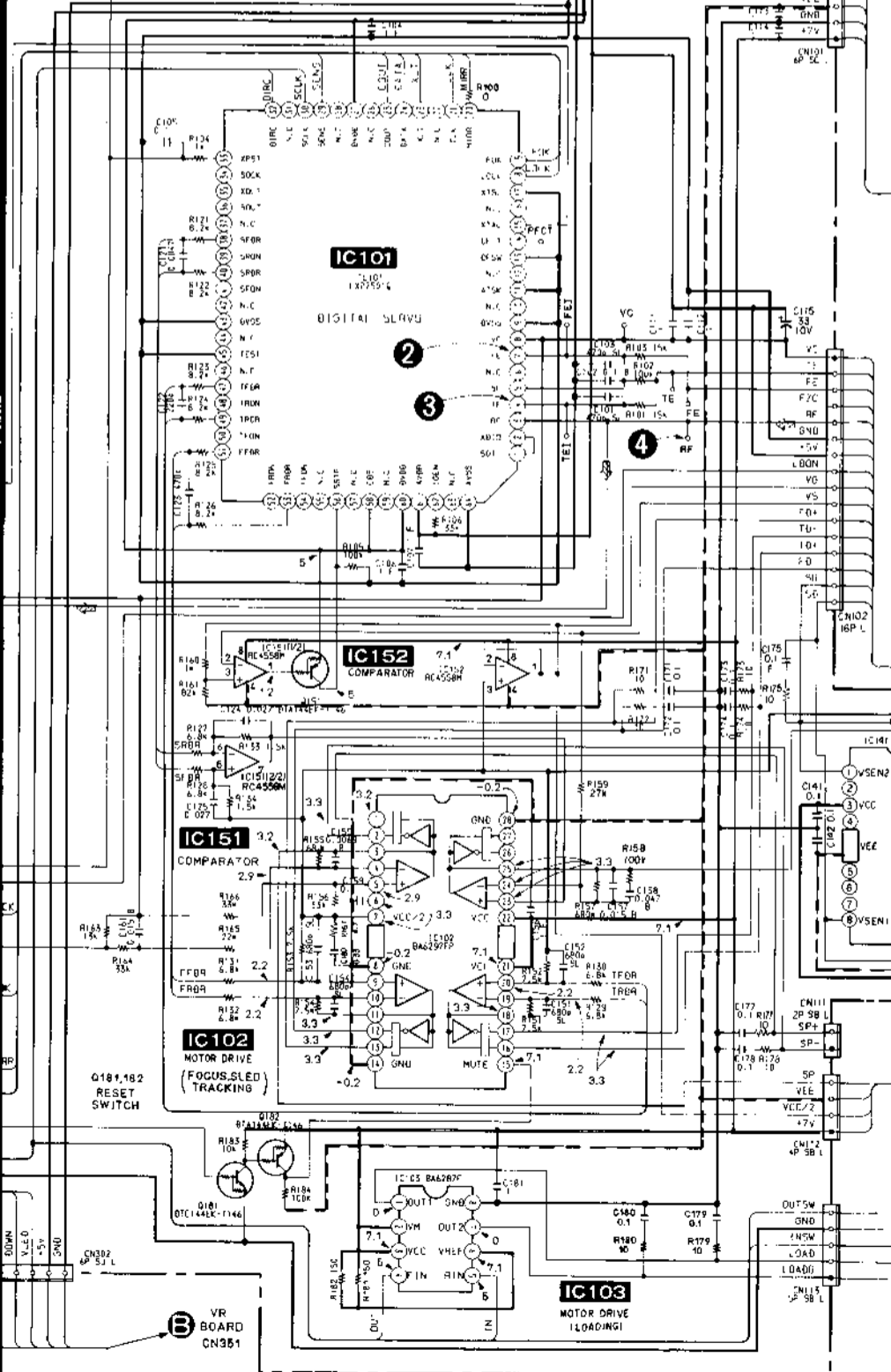
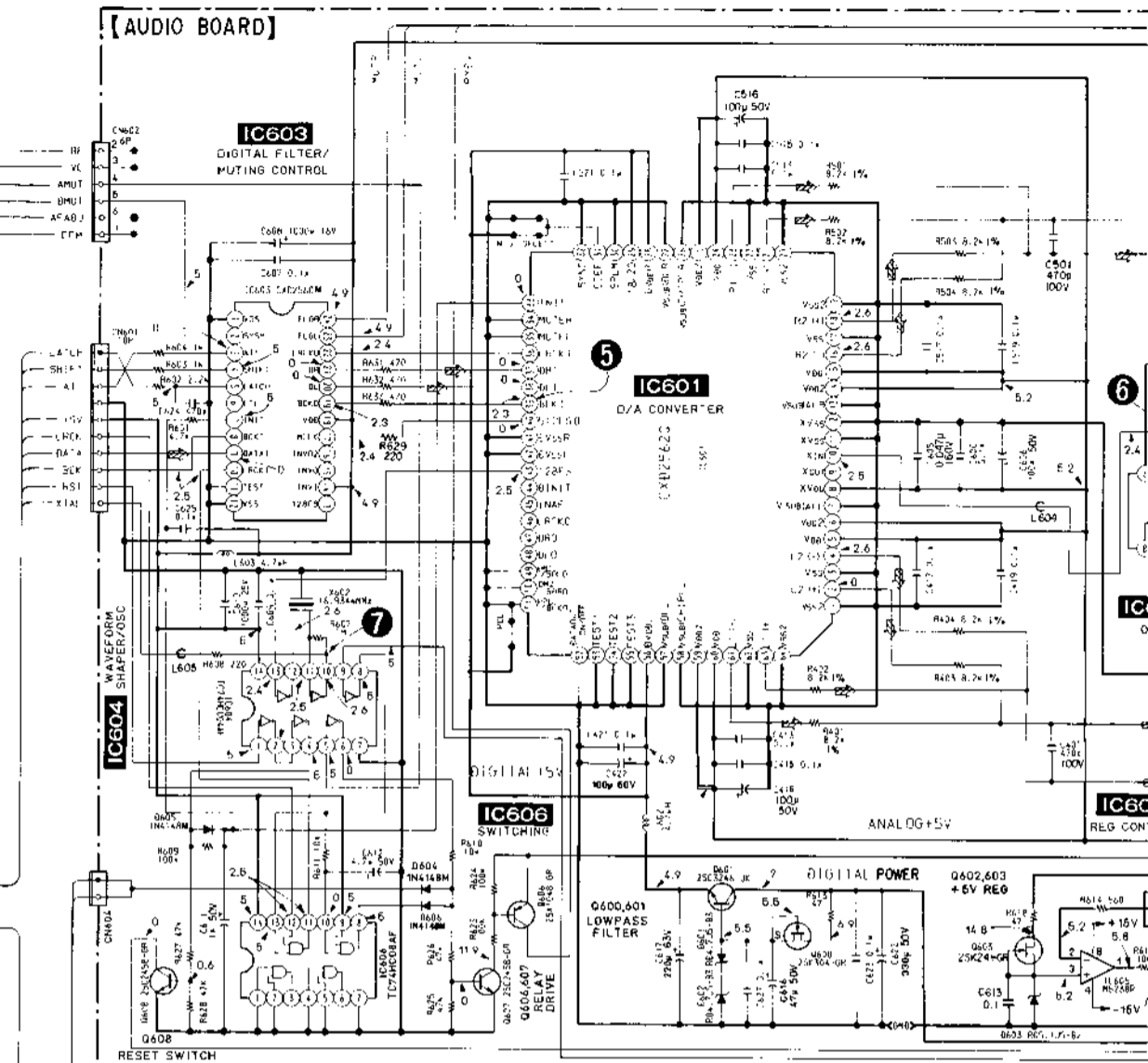
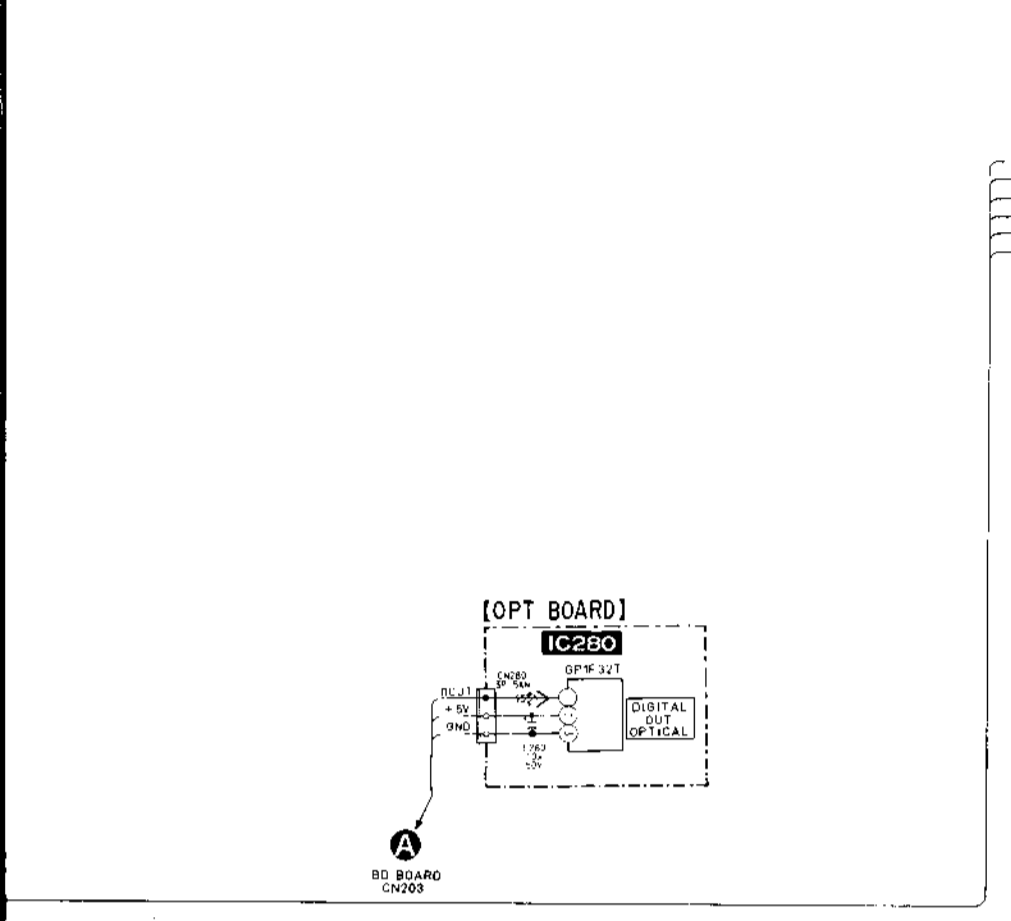

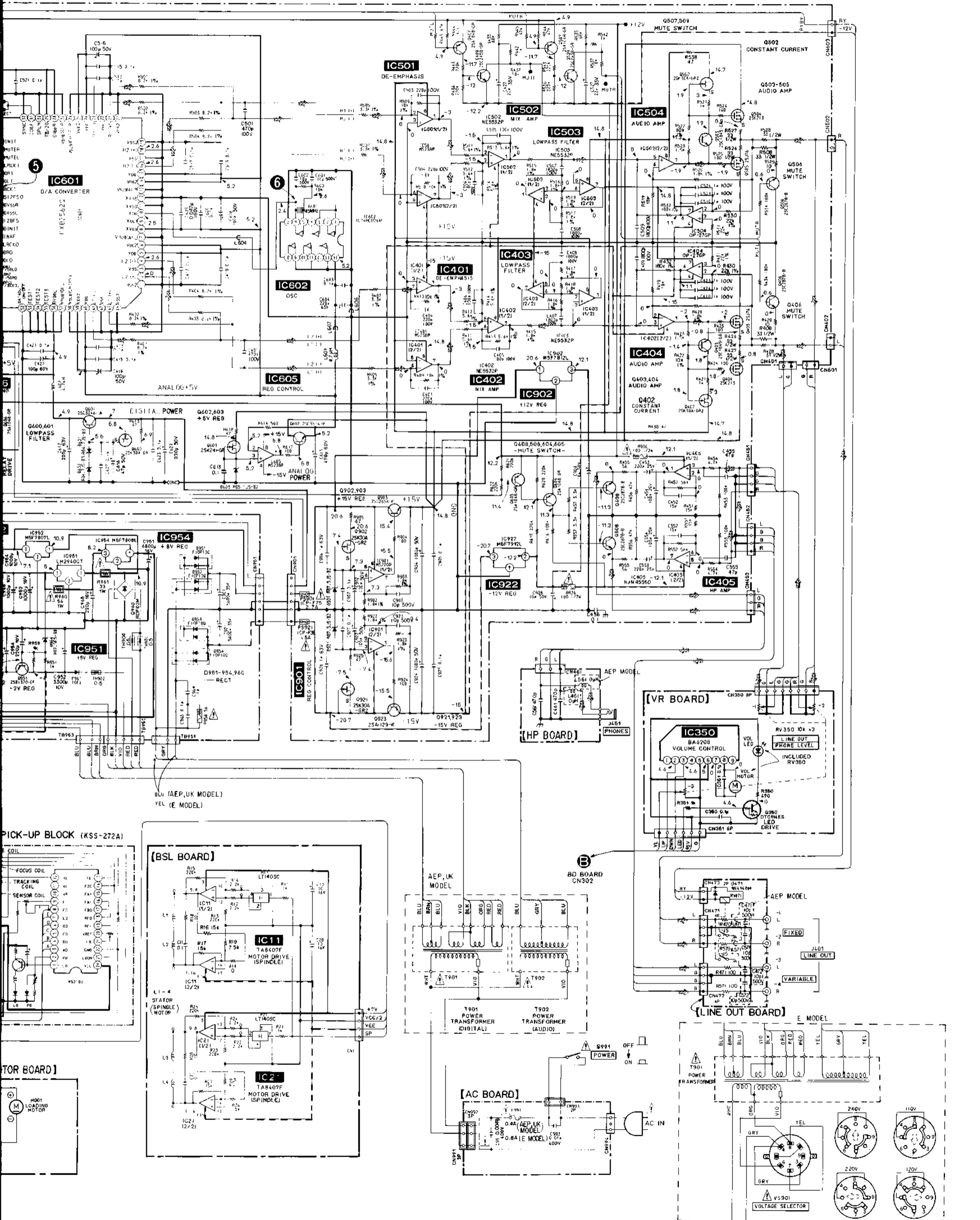

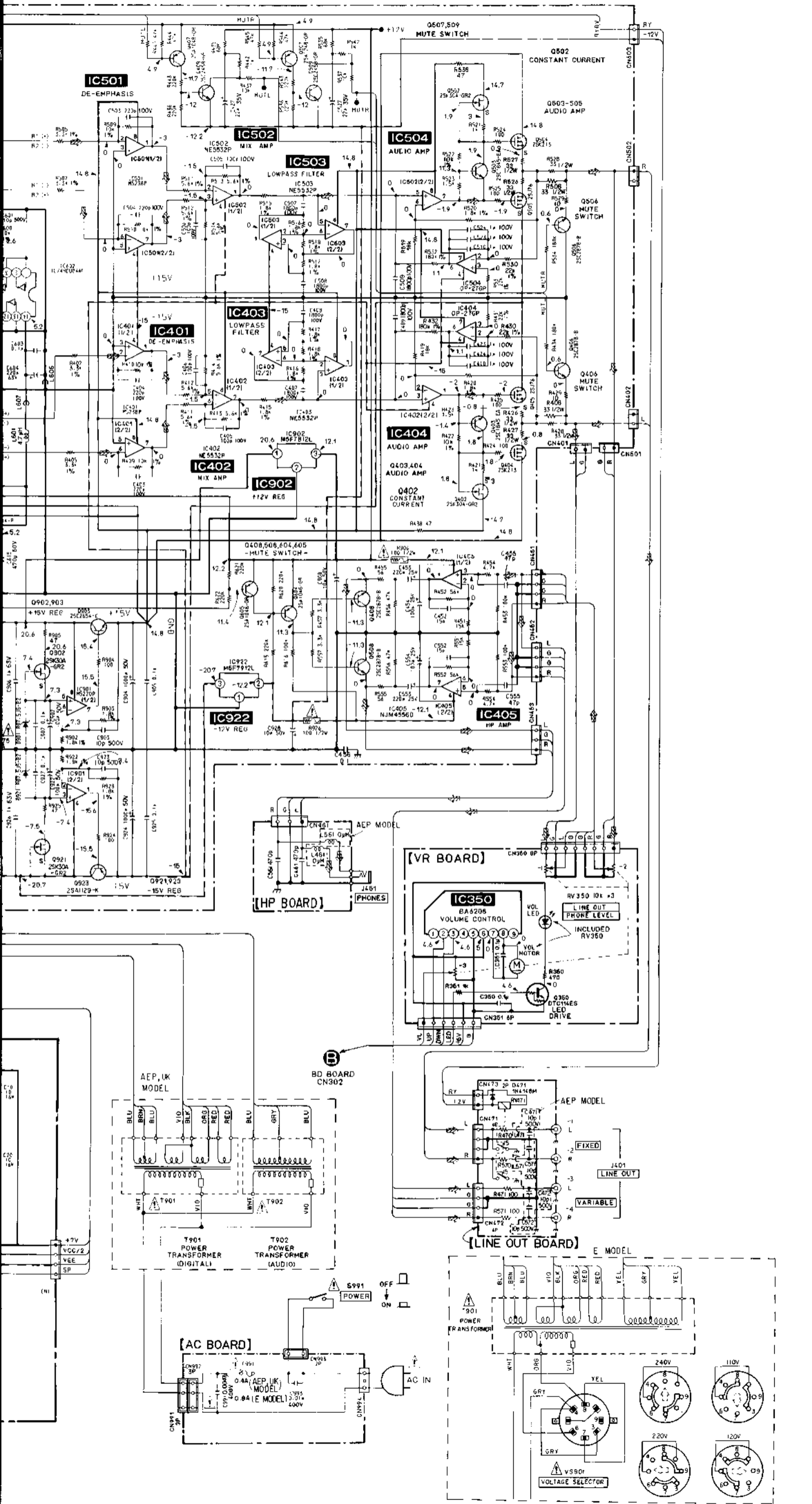

• Waveforms

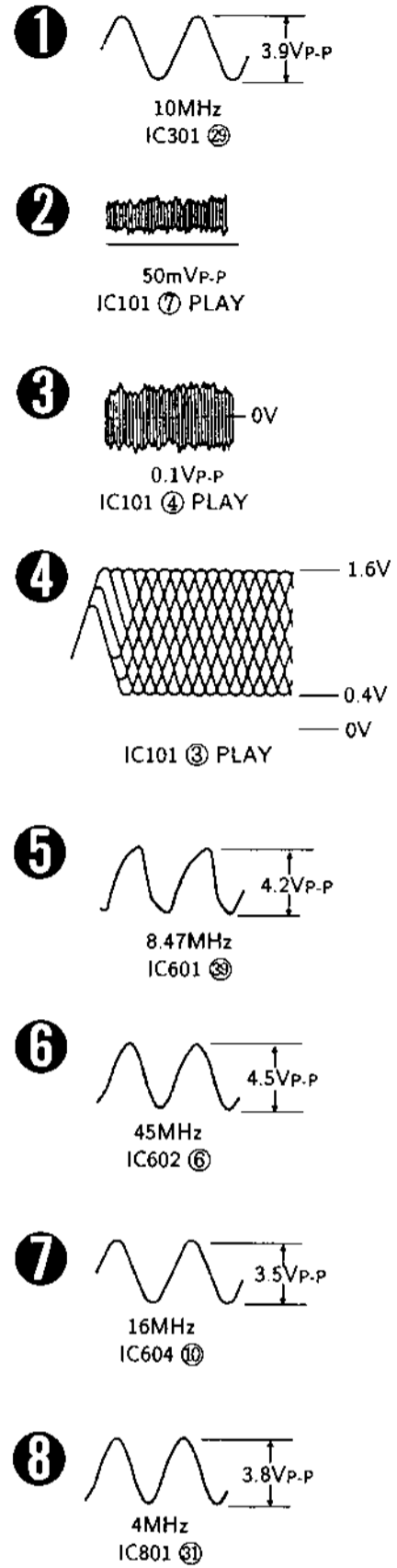

Note:

- All capacitors are in μF unless otherwise noted. pF : μF
- 50WV or less are not indicated except for electrolytics and tantalums.
- All resistors are in Ω and $\frac{1}{2}W$ or less unless otherwise specified.
- \triangle : internal component.
- \square : nonflammable resistor.
- --- : fusible resistor.

Note: The components identified by mark \triangle or dotted line with mark \triangle are critical for safety. Replace only with part number specified.

- --- : B+ Line
- --- : B- Line
- Voltage and waveforms are dc with respect to ground under no-signal conditions.
- no mark: STOP
- (): PLAY
- Voltages are taken with a VOM (input Impedance $10M\Omega$). Voltage variations may be noted due to normal production tolerances.
- Waveforms are taken with a oscilloscope. Voltage variations may be noted due to normal production tolerances.
- Circled numbers refer to waveforms.
- Signal path.
- --- : CD
- --- : digital out

• Display Panel Terminal (FLD801)

	T0	T1	T2	T3	T4	T5	T6	T7	T8	T9	T10	T11
S1	a	a	a	a	a	a	a	a	a	a	REPEAT	1
S2	b	b	b	b	b	b	b	b	b	b	1	2
S3	c	c	c	c	c	c	c	c	c	c	A-	3
S4	d	d	d	d	d	d	d	d	d	d	B	4
S5	e	e	e	e	e	e	e	e	e	e	A CUE	5
S6	f	f	f	f	f	f	f	f	f	f	AUTO SPACE	6
S7	g	g	g	g	g	g	g	g	g	g	SINGLE	7
S8	h	h	h	h	h	h	h	h	h	h	MULTI	8
S9	i	i	i	i	i	i	i	i	i	i	CUSTOM FAL	9
S10	j	j	j	j	j	j	j	j	j	j	MEMO	10
S11	k	k	k	k	k	k	k	k	k	k	INDEX	11
S12	l	l	l	l	l	l	l	l	l	l	BANK	12
S13	m	m	m	m	m	m	m	m	m	m	LEVEL	13
S14	n	n	n	n	n	n	n	n	n	n	[LIM]	14
S15	o	o	o	o	o	o	o	o	o	o	EDIT	15
S16	p	p	p	p	p	p	p	p	p	p	-	16
S17	q	q	q	q	q	q	q	q	q	q	A	17
S18	r	r	r	r	r	r	r	r	r	r	B	18
S19	s	s	s	s	s	s	s	s	s	s	[0.0]	19
S20	t	t	t	t	t	t	t	t	t	t	TIME	20
S21	u	u	u	u	u	u	u	u	u	u	[FAC]	-
S22	v	v	v	v	v	v	v	v	v	v	▶	-
S23	w	w	w	w	w	w	w	w	w	w	◀	-
S24	x	x	x	x	x	x	x	x	x	x	-	-
S25	y	y	y	y	y	y	y	y	y	y	-	-
S26	-	TRACK	-	STEP	INDEX	-	-	MIN	DISC	SEC	PEAK	▷
S27	-	-	-	-	-	-	-	0	-	-	-	-

• IC Block Diagrams

IC101 CXD2501Q

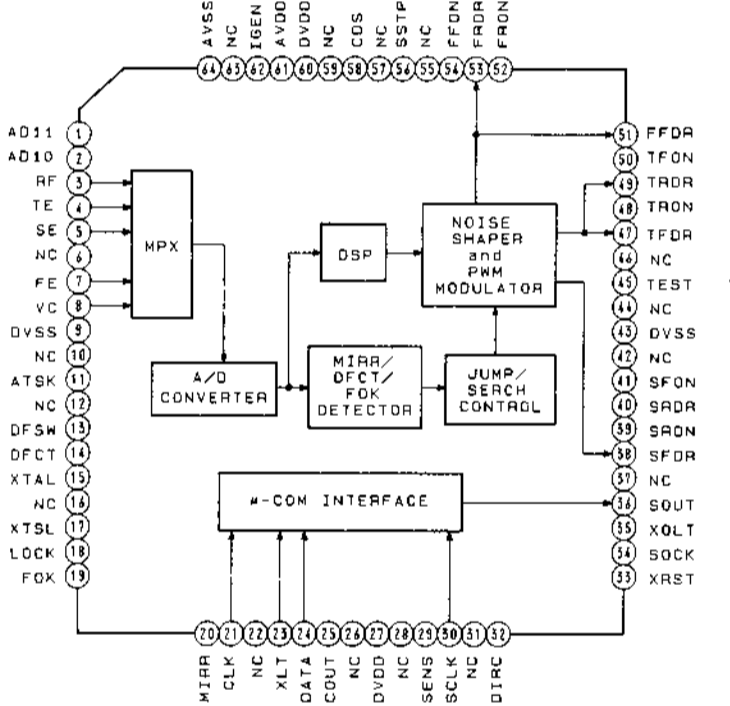

IC11, 12 TA8407F

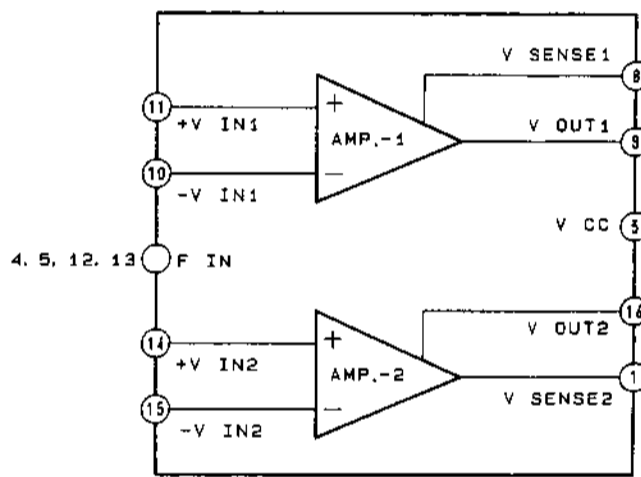

IC350 BA6208

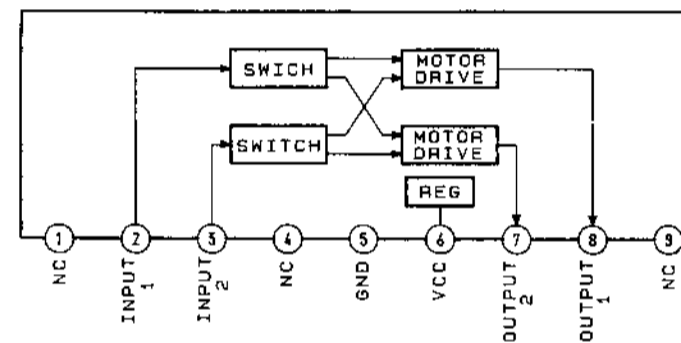

IC603 CXD2560M

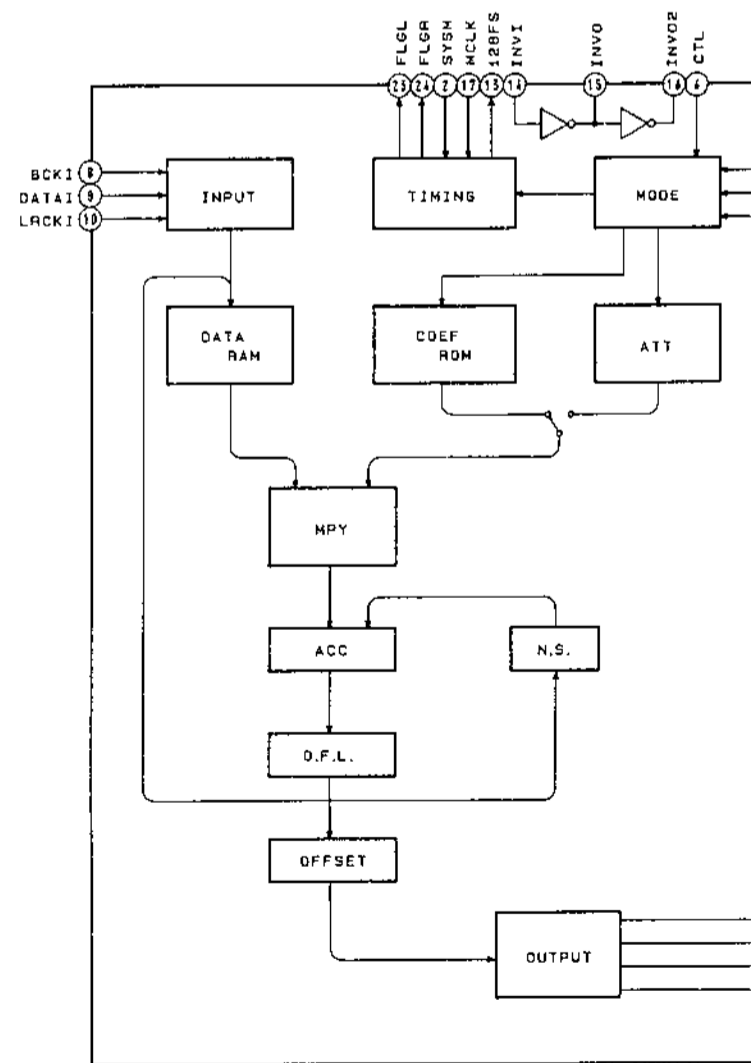

IC103 BA6287F

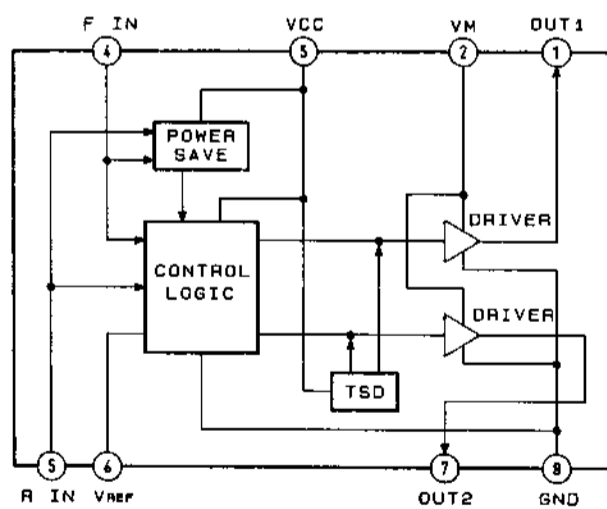

IC953 M51957AL

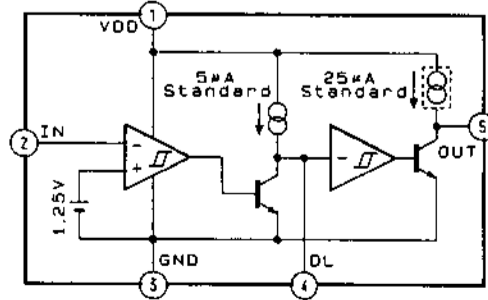

IC201 CXD2500AQ

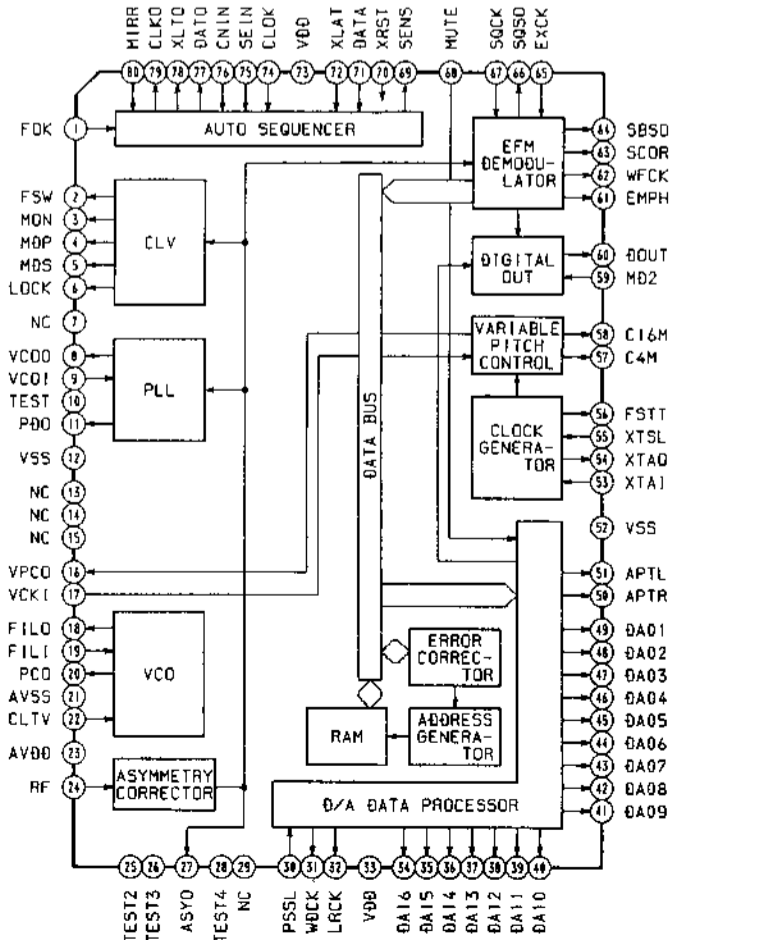

3-5. SEMICONDUCTOR LEAD LAYOUTS

BA6208

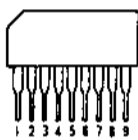

GP1F32T

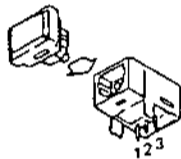

TA7912S

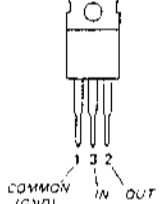

2SA1175-HFE
2SC2785-HFE
2SC3246-JK



F10P10Q

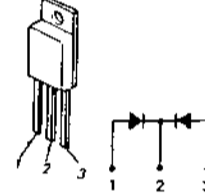

BA6287F
RC4558M

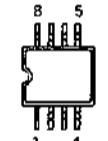

(TOP VIEW)

LH5160N-10L

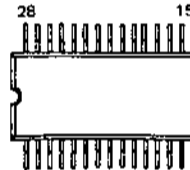

(TOP VIEW)

TA8407F

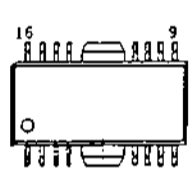

2SC1845-EA
2SC2878-AB

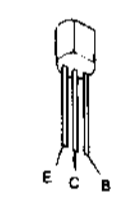

HZS7B3L
RD4.7JS-B3
RD5.1JS-B2
RD7.5ES-B3
RD7.5JS-B2
1SS202-1

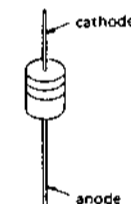

BA6297FP

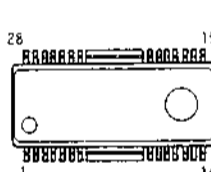

LM2940CT-5.0
M5F7807
M5F7808
M5F7812L

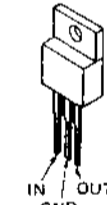

DTC114ES



2SD774-34

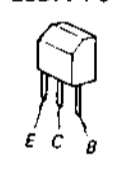

HZ36-2L
RD5.1JS-B2
1N4148M
10E2

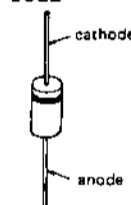

CXD2500AQ
MSC6240B-041GS-V1K
M37451M8-174FP

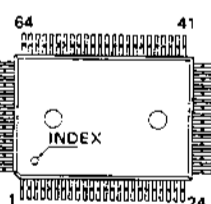

MARKING SIDE VIEW

M51957AL

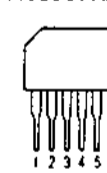

DTC114EF



2SJ76
2SK213

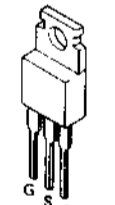

RDF02M

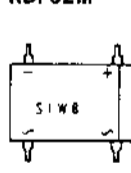

CXD2501Q
DXD2562Q

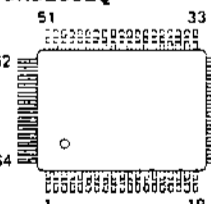

(TOP VIEW)

M5220P
M5238P
NE5532P
OP-27GP
RC4556D

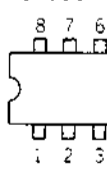

(TOP VIEW)

DTA144EK
DTC144EK



2SK241-GR

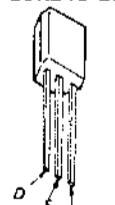

1S2836

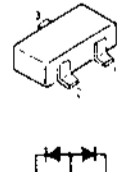

CXD2560M

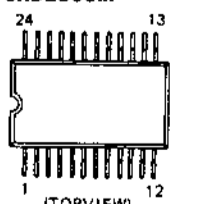

(TOPVIEW)

SN74HC08ANS
TC74HCU04AF

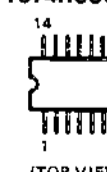

(TOP VIEW)

2SA1129-K
2SB1370-EF
2SC3514
2SC2654



22SK246-BR

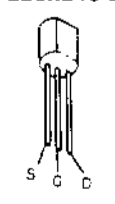

BR3371X
MAY3371X-M-177
MBG3371X
MPG3371X-150
MPY3371X-177

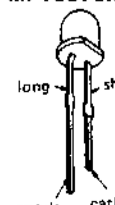

NOTE:

- The mechanical parts with no reference number in the exploded views are not supplied.
- Items marked "*" are not stocked since they are seldom required for routine service. Some delay should be anticipated when ordering these items.

4-1. CABINET SECTION

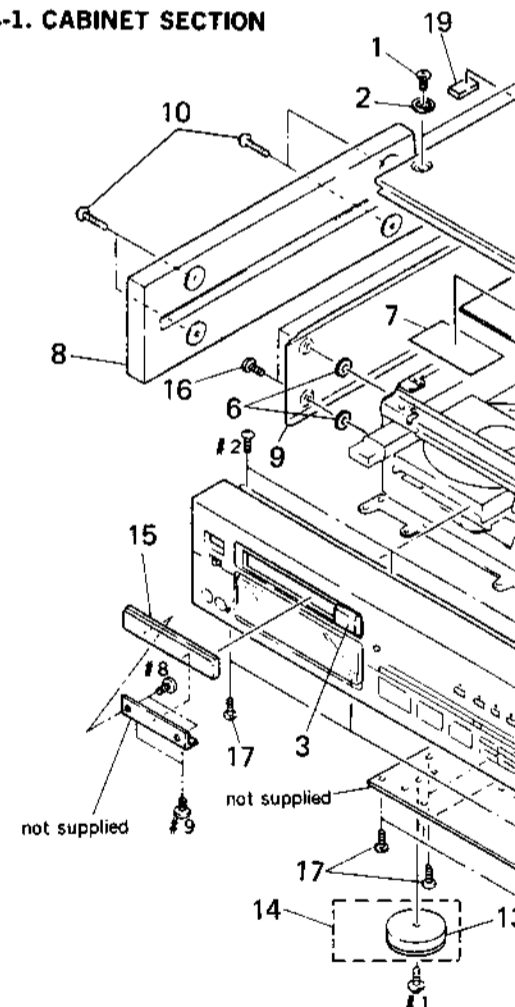

Ref. No.	Part No.	Description	Remarks
1	4-924-242-01	SCREW (M3X6), FLAT HEAD (GOLD) (AEP)	
1	4-924-242-11	SCREW (M3X6), FLAT HEAD (BLACK)	
2	4-928-025-11	ESCUTCHEON (TOP PLATE) (BLACK)	
2	4-928-025-41	ESCUTCHEON (TOP PLATE) (GOLD) (AEP)	
3	X-4941-988-1	BUTTON (OPEN/CLOSE) ASSY (BLACK)	
3	X-4942-040-1	BUTTON (OPEN/CLOSE) ASSY (GOLD) (AEP)	
4	4-925-367-21	CASE (TOP PLATE) (BLACK)	
4	4-925-367-31	CASE (TOP PLATE) (GOLD) (AEP)	
* 5	4-913-189-11	FELT (B), ACOUSTIC ABSORBENT	
6	4-935-917-01	WASHER (CASE)	
* 7	4-923-563-11	CUSHION	
8	X-4922-574-2	PLATE (LEFT) ASSY, SIDE (BLACK) (AEP)	
8	X-4928-001-1	PLATE (LEFT) ASSY, SIDE (E)	
8	X-4941-168-2	PLATE (L) ASSY, SIDE, ORNAMENTAL (GOLD) (AEP)	
9	4-925-368-11	CASE (LEFT) (BLACK)	
9	4-925-368-21	CASE (LEFT) (GOLD) (AEP)	
10	4-885-979-11	SCREW (4X25) (AEP, E)	

SECTION 4 EXPLODED VIEWS

F10P10Q

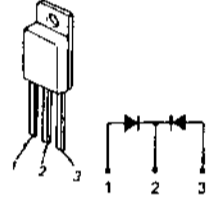

HZS7B3L
RD4.7JS-B3
RD5.1JS-B2
RD7.5ES-B3
RD7.5JS-B2
1S5202-1

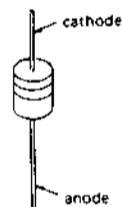

HZ36-2L
RD5.1JS-B2
1N4148M
10E2

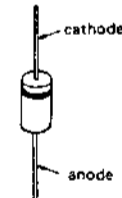

RDF02M

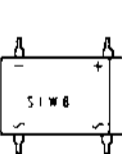

1S2836

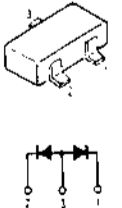

NOTE:

- The mechanical parts with no reference number in the exploded views are not supplied.
- Items marked "*" are not stocked since they are seldom required for routine service. Some delay should be anticipated when ordering these items.
- -XX, -X mean standardized parts, so they may have some differences from the original one.
- Color Indication of Appearance Parts
Example:
KNOB, BALANCE (WHITE)...(RED)
Parts Color Cabinet's Color
- Hardware (# mark) list is given in the last of this parts list.

The components identified by mark or dotted line with mark are critical for safety. Replace only with part number specified.

4-1. CABINET SECTION

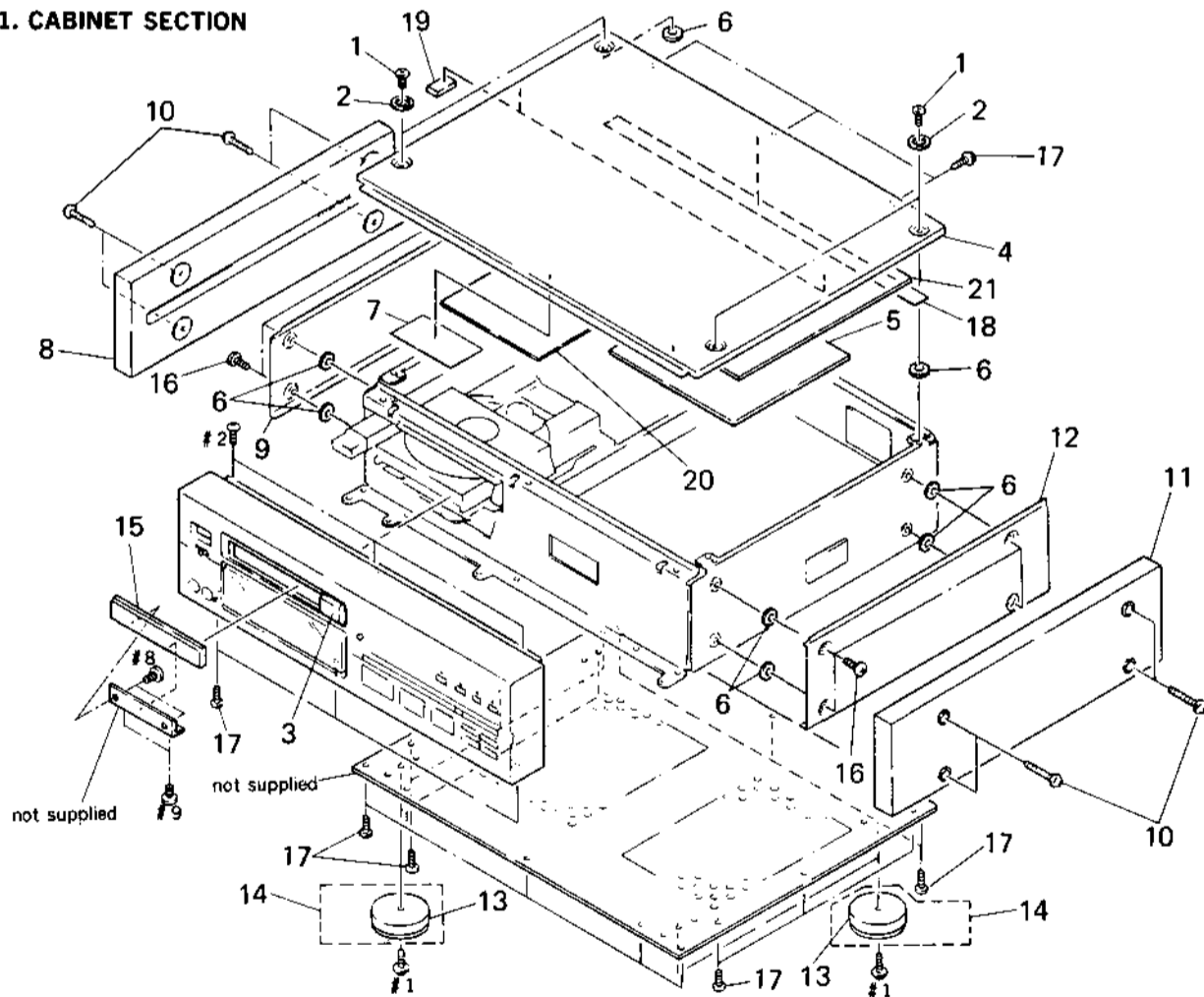

Ref. No.	Part No.	Description	Remark
1	4-924-242-01	SCREW (M3X6), FLAT HEAD (GOLD) (AEP)	
1	4-924-242-11	SCREW (M3X6), FLAT HEAD (BLACK)	
2	4-928-025-11	ESCUTCHEON (TOP PLATE) (BLACK)	
2	4-928-025-41	ESCUTCHEON (TOP PLATE) (GOLD) (AEP)	
3	X-4941-988-1	BUTTON (OPEN/CLOSE) ASSY (BLACK)	
3	X-4942-040-1	BUTTON (OPEN/CLOSE) ASSY (GOLD) (AEP)	
4	4-925-367-21	CASE (TOP PLATE) (BLACK)	
4	4-925-367-31	CASE (TOP PLATE) (GOLD) (AEP)	
* 5	4-913-189-11	FELT (B), ACOUSTIC ABSORBENT	
6	4-935-917-01	WASHER (CASE)	
* 7	4-923-563-11	CUSHION	
8	X-4922-574-2	PLATE (LEFT) ASSY, SIDE (BLACK) (AEP)	
8	X-4928-001-1	PLATE (LEFT) ASSY, SIDE (E)	
8	X-4941-168-2	PLATE (L) ASSY, SIDE, ORNAMENTAL (GOLD) (AEP)	
9	4-925-368-11	CASE (LEFT) (BLACK)	
9	4-925-368-21	CASE (LEFT) (GOLD) (AEP)	
10	4-885-979-11	SCREW (4X25) (AEP, E)	

Ref. No.	Part No.	Description	Remark
11	X-4922-575-2	PLATE (RIGHT) ASSY, SIDE (BLACK) (AEP)	
11	X-4928-002-1	PLATE (RIGHT) ASSY, SIDE (E)	
11	X-4941-169-2	PLATE (R) ASSY, SIDE, ORNAMENTAL (GOLD) (AEP)	
12	4-925-369-11	CASE (RIGHT) (BLACK)	
12	4-925-369-21	CASE (RIGHT) (GOLD) (AEP)	
* 13	4-925-370-02	BASE, FOOT (BLACK)	
14	X-4922-549-1	FOOT ASSY (BLACK)	
14	X-4941-711-1	FOOT ASSY (GOLD) (AEP)	
15	4-948-001-01	PANEL, LOADING (GOLD) (AEP)	
15	4-948-001-11	PANEL, LOADING (BLACK)	
16	4-847-802-00	SCREW (UK)	
17	4-929-074-01	SCREW (3X8)	
* 18	4-378-254-31	SHEET	
* 19	4-929-017-01	CUSHION	
* 20	4-935-913-11	CUSHION	
21	A-4675-309-A	REINFORCEMENT (TOP PLATE) ASSY	

4-2. FRONT PANEL SECTION

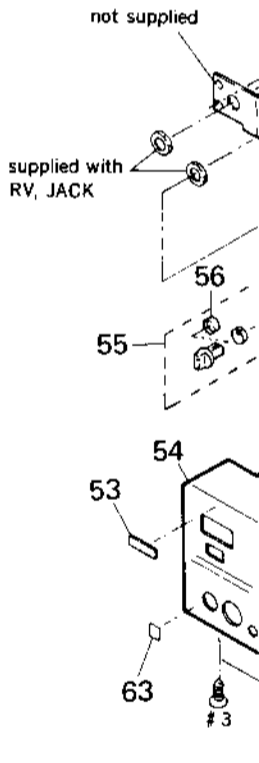

Ref. No.	Part No.	Description
51	3-655-653-21	BA
* 52	1-637-409-11	FU
53	4-908-848-01	EM
53	4-908-848-21	EM
* 54	4-948-000-21	PA
* 54	4-948-000-31	PA
* 54	4-948-000-41	PA
55	A-4604-901-A	KN
55	A-4604-952-A	KN
		(A)
56	4-948-469-01	SP
57	4-922-978-01	HO
* 58	1-637-410-11	DI
59	4-941-647-01	BU
59	4-941-647-21	BU
60	4-922-518-11	KN
60	4-922-518-62	KN
* 61	4-928-053-01	HO

WS

Standardized parts, so they
differences from the origi-

Appearance Parts
(WHITE) (RED)
↑ ↑
Color Cabinet's Color

• Hardware (# mark) list is given in
the last of this parts list.

The components identified by mark
▲ or dotted line with mark ▲ are
critical for safety.
Replace only with part number
specified.

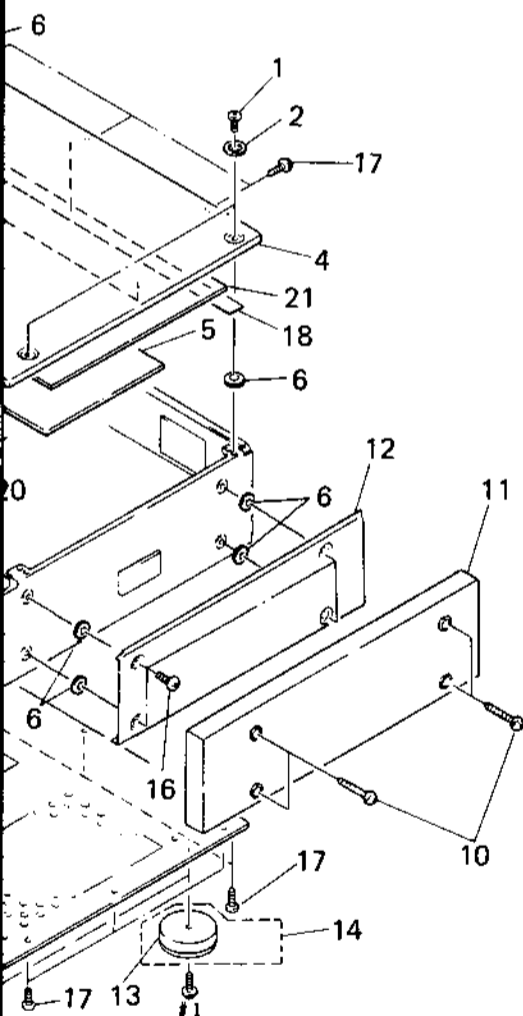

No.	Part No.	Description	Remark
	X-4922-575-2	PLATE (RIGHT) ASSY, SIDE (BLACK) (AEP)	
	X-4928-002-1	PLATE (RIGHT) ASSY, SIDE (E)	
	X-4941-169-2	PLATE (R) ASSY, SIDE, ORNAMENTAL (GOLD) (AEP)	
	4-925-369-11	CASE (RIGHT) (BLACK)	
	4-925-369-21	CASE (RIGHT) (GOLD) (AEP)	
	4-925-370-02	BASE, FOOT (BLACK)	
	X-4922-549-1	FOOT ASSY (BLACK)	
	X-4941-711-1	FOOT ASSY (GOLD) (AEP)	
	4-948-001-01	PANEL, LOADING (GOLD) (AEP)	
	4-948-001-11	PANEL, LOADING (BLACK)	
	4-847-802-00	SCREW (UK)	
	4-929-074-01	SCREW (3X8)	
	4-378-254-31	SHEET	
	4-929-017-01	CUSHION	
	4-935-913-11	CUSHION	
	A-4675-309-A	REINFORCEMENT (TOP PLATE) ASSY	

4-2. FRONT PANEL SECTION

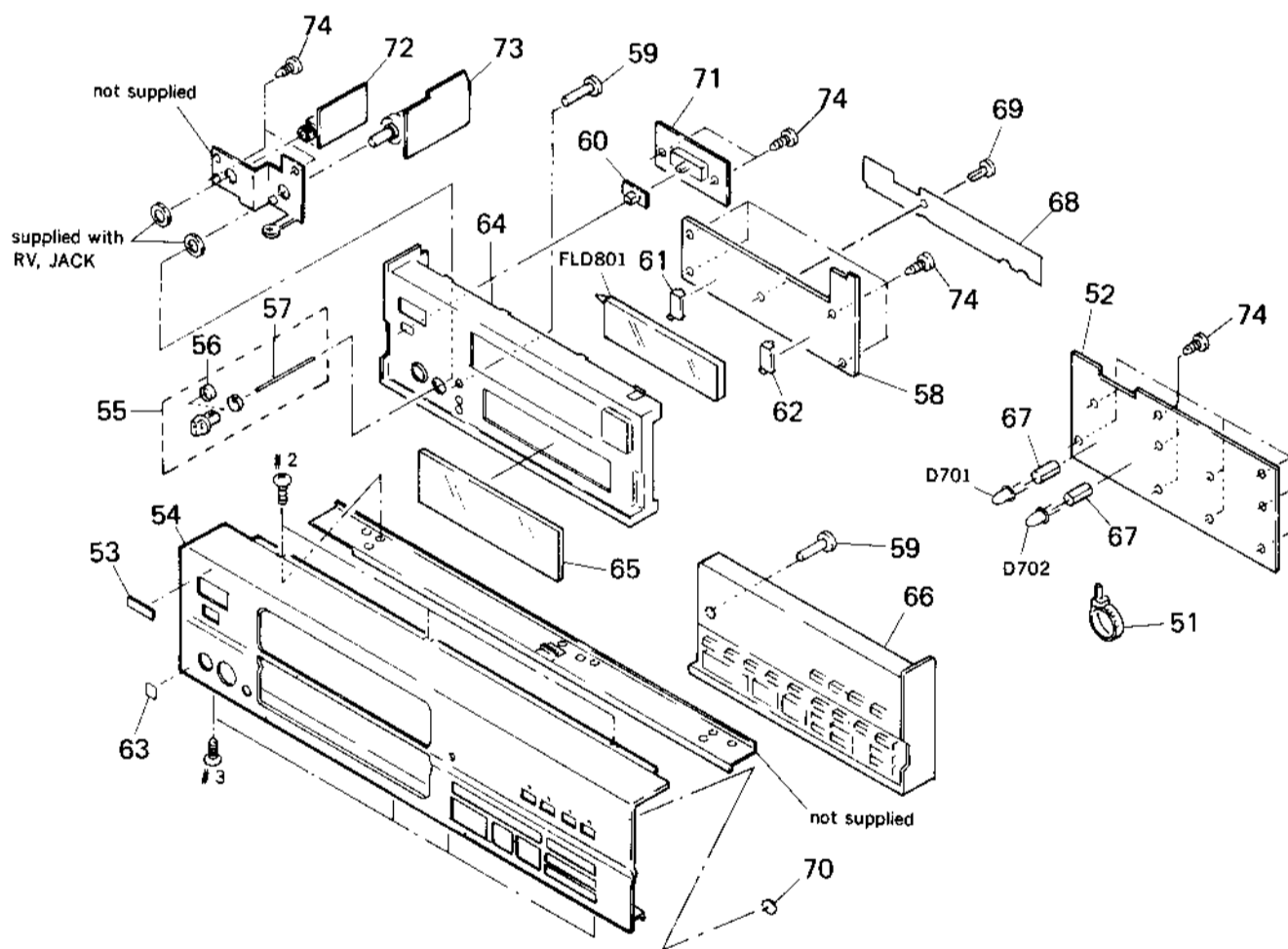

Ref. No.	Part No.	Description	Remark
	51	3-655-653-21 BAND (TAITON), BINDING	
•	52	1-637-409-11 FUNCTION BOARD	
	53	4-908-848-01 EMBLEM, SONY (BLACK)	
	53	4-908-848-21 EMBLEM, SONY (GOLD) (AEP)	
•	54	4-948-000-21 PANEL, FRONT (BLACK) (UK)	
•	54	4-948-000-31 PANEL, FRONT (BLACK) (AEP, E)	
•	54	4-948-000-41 PANEL, FRONT (GOLD) (AEP)	
	55	A-4604-901-A KNOB (LINE OUT/PHONE LEVEL) ASSY (BLACK)	
	55	A-4604-952-A KNOB (LINE OUT/PHONE LEVEL) ASSY (GOLD) (AEP)	
	56	4-948-469-01 SPRING, RING	
	57	4-922-978-01 HOLDER (FIBER) (GOLD) (AEP)	
•	58	1-637-410-11 DISPLAY BOARD	
	59	4-941-647-01 BUTTON (DISPLAY) (BLACK)	
	59	4-941-647-21 BUTTON (DISPLAY) (GOLD) (AEP)	
	60	4-922-518-11 KNOB (TIMER) (BLACK)	
	60	4-922-518-62 KNOB (TIMER) (GOLD) (AEP)	
•	61	4-928-053-01 HOLDER (LEFT)	

Ref. No.	Part No.	Description	Remark
•	62	4-928-052-01 HOLDER (RIGHT)	
	63	3-703-710-41 STICKER, SONY SYMBOL (12) (UK)	
	64	X-4941-986-1 PANEL (BASE) (L) ASSY (BLACK)	
	64	X-4941-987-1 PANEL (BASE) (L) ASSY (GOLD) (AEP)	
	65	4-941-087-01 PLATE, INDICATION	
	66	X-4941-210-1 BASE (R) ASSY, PANEL (BLACK)	
	66	X-4941-678-1 BASE (R) ASSY, PANEL (GOLD) (AEP)	
•	67	4-923-532-21 SPACER, LED	
•	68	4-941-220-01 COVER (CABLE)	
	69	3-531-576-11 RIVET	
	70	4-941-648-01 INDICATOR (MODE)	
•	71	1-637-411-11 TIMER BOARD	
	72	1-641-074-11 HP BOARD	
•	73	1-641-804-11 VR BOARD	
	74	4-951-620-01 SCREW (2.6X8), +BVTP	
	D701	8-719-970-07 LED MPG3371X-150 (▶)	
	D702	8-719-971-52 LED MAY3371X-M-177 (■)	
	FLD801	1-519-622-11 INDICATOR TUBE, FLUORESCENT	

4-3. CHASSIS SECTION

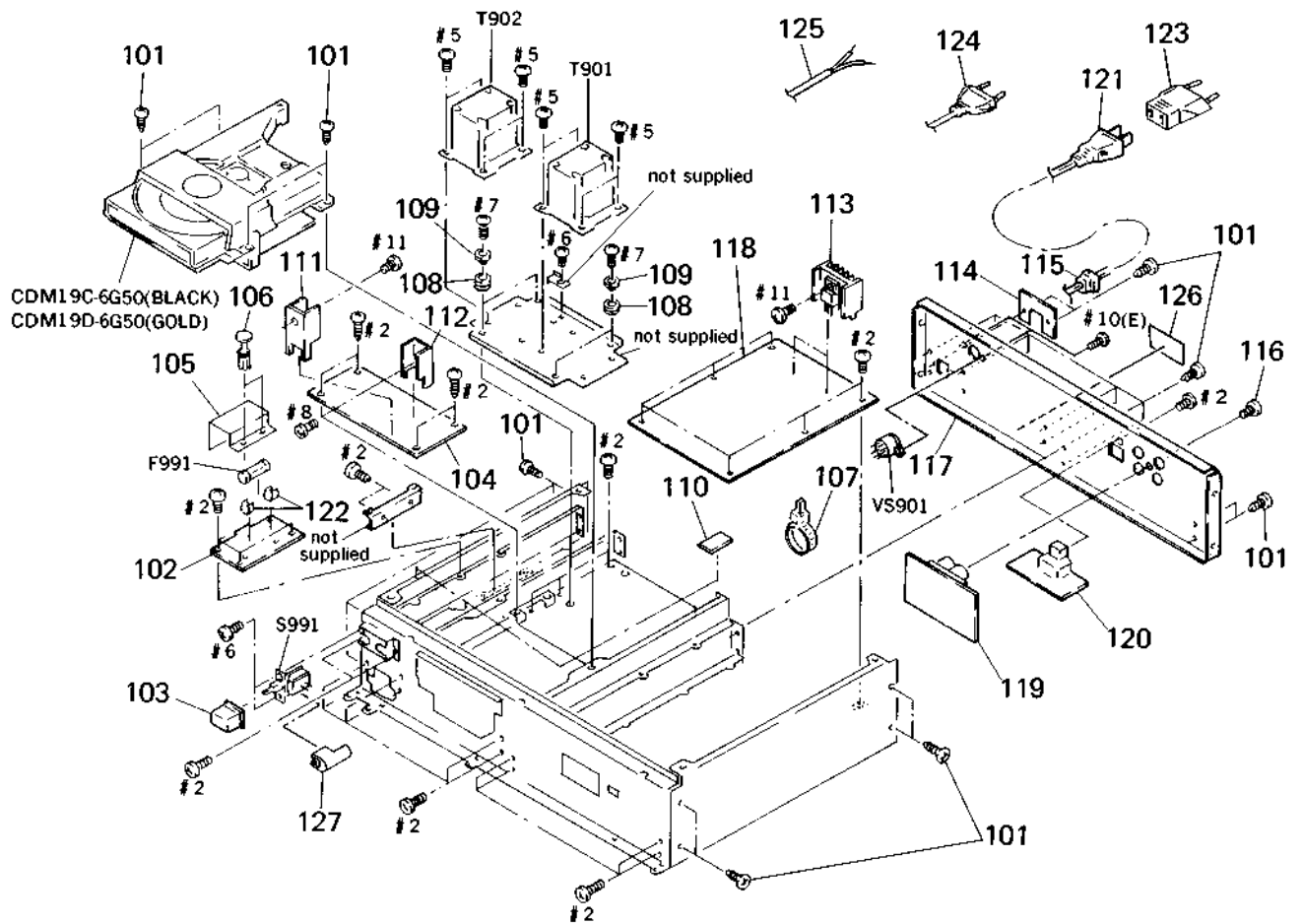

Note: The components identified by mark Δ or dotted line with mark Δ are critical for safety. Replace only with part number specified.

Ref. No.	Part No.	Description	Remark
101	4-929-074-01	SCREW (3X8)	
* 102	1-641-809-11	AC BOARD	
103	4-923-520-41	KNOB, POWER (GOLD) (AEP)	
103	4-923-520-51	KNOB, POWER (BLACK)	
* 104	A-4649-002-A	POWER BOARD, COMPLETE (UK, E)	
* 104	A-4649-377-A	POWER BOARD, COMPLETE (AEP)	
* 105	4-949-240-01	COVER (POWER PCB)	
106	3-531-576-11	RIVET	
107	3-655-653-21	BAND (TAITON), BINDING	
* 108	4-888-798-00	BUSHING, RUBBER	
109	4-928-032-01	COLLAR (A)	
110	3-831-441-XX	CUSHION	
* 111	4-941-237-01	HEAT SINK	
112	4-902-345-01	HEAT SINK	
* 113	4-363-146-00	HEAT SINK, V. OUT	
* 114	4-923-873-01	BRACKET, CORD STOPPER (BLACK)	
* 114	4-923-873-11	BRACKET, CORD STOPPER (GOLD) (AEP)	
* 115	3-703-244-00	BUSHING (2104), CORD	
116	3-703-685-21	SCREW (+BV 3X8)	
* 117	4-947-996-11	PANEL, BACK (BLACK) (AEP)	

Ref. No.	Part No.	Description	Remark
* 117	4-947-996-21	PANEL, BACK (BLACK) (UK)	
* 117	4-947-996-41	PANEL, BACK (BLACK) (E)	
* 117	4-947-997-11	PANEL, BACK (GOLD) (AEP)	
* 118	A-4649-344-A	AUDIO BOARD, COMPLETE	
* 119	1-641-808-11	LINE OUT BOARD	
* 120	1-641-807-11	OPT BOARD	
Δ 121	1-558-181-21	CORD, POWER (E)	
122	1-533-183-11	HOLDER, FUSE	
Δ 123	1-569-007-11	ADAPTER, CONVERSION 2P (E)	
Δ 124	1-558-568-21	CORD, POWER (AEP)	
Δ 125	1-559-555-21	CORD, POWER (UK)	
* 126	4-941-548-01	LABEL, CLASS 1	
127	3-575-524-00	COVER, POWER SWITCH	
Δ F991	1-532-066-00	FUSE, TIME-LAG (0.4A) (AEP, UK)	
Δ F991	1-532-215-00	FUSE, TIME-LAG (0.8A) (E)	
Δ S991	1-570-156-11	SWITCH, PUSH (AC POWER) (1 KEY) (POWER)	
Δ T901	1-450-850-11	TRANSFORMER, POWER (AEP, UK)	
Δ T901	1-450-851-11	TRANSFORMER, POWER (E)	
Δ T902	1-450-852-11	TRANSFORMER, POWER (AEP, UK)	
Δ VS901	1-526-576-51	SELECTOR, POWER VOLTAGE (VOLTAGE SELECTOR) (E)	

4-4. CD MECHANISM BLOCK SECTION
(CDM19C-6G50) : BLACK
(CDM19D-6G50) : GOLD

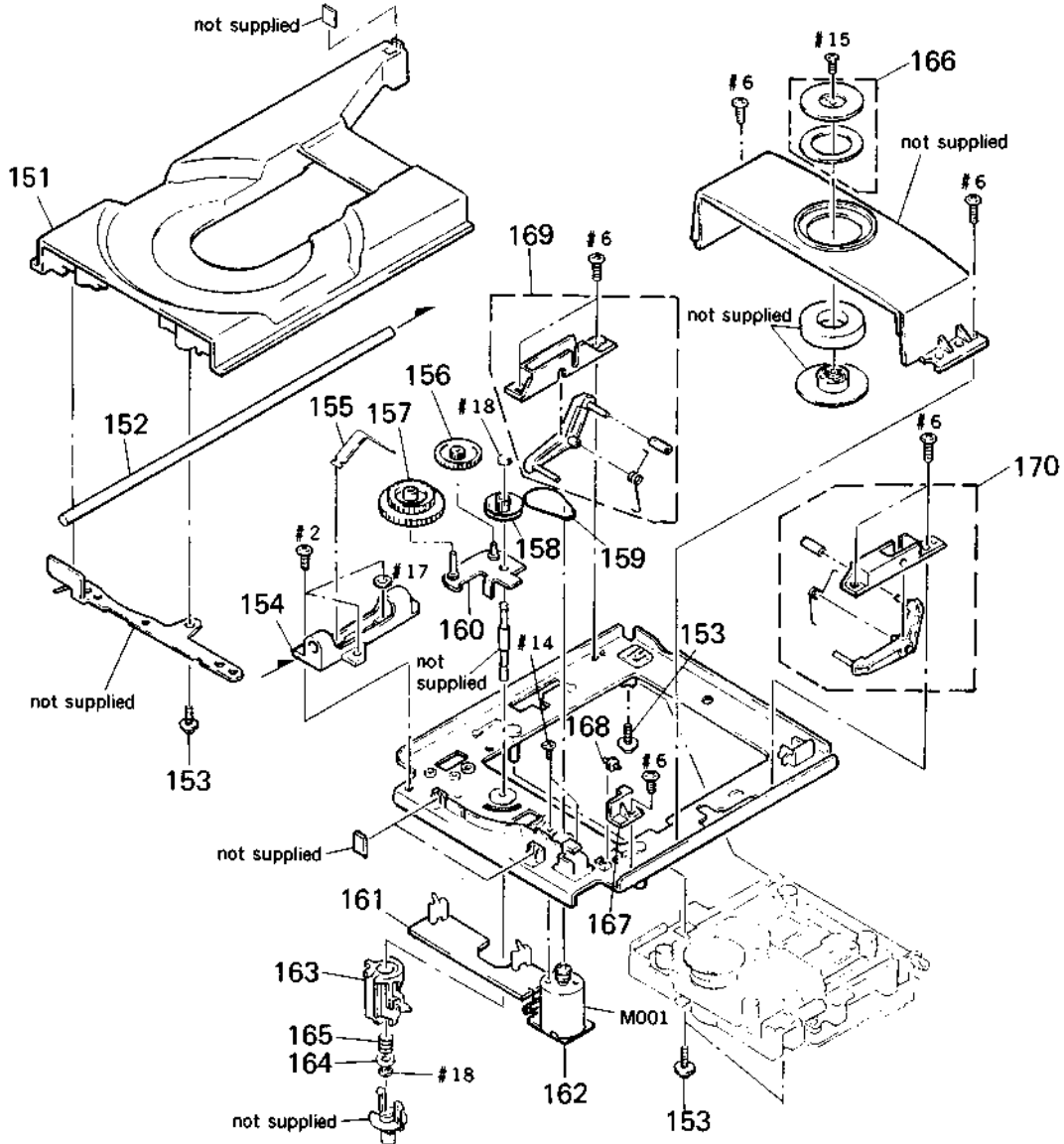

Ref. No.	Part No.	Description	Remark	Ref. No.	Part No.	Description	Remark
151	4-948-353-01	TABLE, DISK (BLACK)		* 161	1-641-764-11	SW BOARD	
151	4-948-353-11	TABLE, DISK (GOLD) (AEP)		* 162	1-641-765-11	L. MOTOR BOARD	
* 152	4-948-368-01	BAR (MAIN), GUIDE		* 163	4-948-371-01	CAM (BU)	
* 153	4-917-583-21	BRACKET, YOKE		164	4-927-654-01	WASHER (LIMITER)	
* 154	4-948-360-01	BEARING, LOADING		165	3-659-338-00	SPRING, COMPRESSION	
* 155	4-927-648-01	SLIDER (GROUND)		166	A-4604-912-A	MAGNET ASSY	
156	4-927-628-01	GEAR (C)		* 167	4-948-361-01	GUIDE, LOADING	
157	4-927-620-01	GEAR (P)		168	4-927-627-01	ROLLER (S, G)	
158	4-929-724-01	PULLEY (B)		169	A-4604-913-A	LOCK (L) ASSY, STABLE	
159	4-927-649-01	BELT		170	A-4604-914-A	LOCK (R) ASSY, STABLE	
160	X-4927-608-1	ARM ASSY, SWING		M001	A-4604-347-A	MOTOR (L) ASSY	

4-5. BASE UNIT SECTION
(BU-6G)

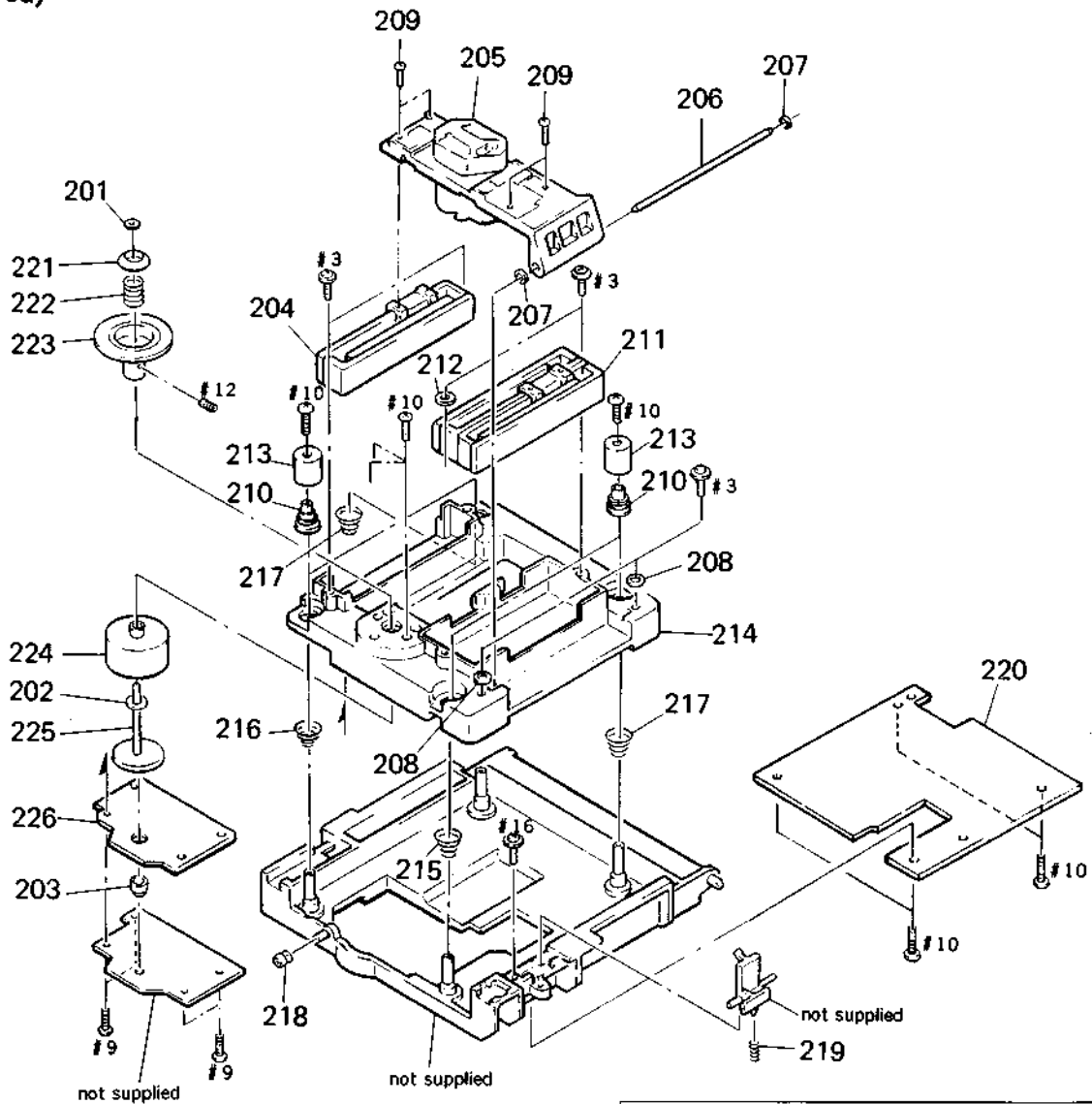

Note: The components identified by mark ▲ or dotted line with mark ▲ are critical for safety. Replace only with part number specified.

Ref. No.	Part No.	Description	Remark	Ref. No.	Part No.	Description	Remark
201	4-947-420-01	RING (DIA. 2.53), RETAINING		214	4-922-671-02	MECHANISM BASE (M, 6)	
202	3-701-439-11	WASHER		215	4-948-375-01	SPRING (F), COIL	
203	4-943-342-01	BEARING		216	4-917-573-01	SPRING (E)	
204	A-4638-084-A	SENSOR ASSY, SPEED		217	4-917-571-01	SPRING (A)	
▲205	8-848-244-11	DEVICE, OPTICAL KSS-272A		218	4-927-631-01	ROLLER (L)	
* 206	4-910-431-01	SHAFT, SLIDE		219	3-305-423-00	SPRING, COMPRESSION	
* 207	4-917-582-01	CUSHION, SLIDE		+ 220	A-4649-007-A	BD BOARD, COMPLETE	
208	4-927-318-01	WASHER		221	4-948-381-01	CAP, CENTERING	
209	3-318-203-61	SCREW (B1. 7X4), TAPPING		222	4-908-213-01	SPRING, COMPRESSION	
* 210	4-917-584-11	INSULATOR		223	X-4942-049-1	PULLEY ASSY. DISK	
211	A-4608-335-A	MOTOR ASSY, LINEAR		224	4-948-382-02	BEARING (SPINDLE)	
212	4-927-669-01	WASHER (BU)		* 225	A-4660-055-B	PULLEY ASSY, MOTOR	
213	4-927-634-01	HOLDER (SP)		+ 226	A-4617-993-A	BSL BOARD, COMPLETE	

AC **AUDIO**

SECTION 5
ELECTRICAL PARTS LIST

NOTE:

- Due to standardization, replacements in the parts list may be different from the parts specified in the diagrams or the components used on the set.
- -XX and -X mean standardized parts, so they may have some difference from the original one.
- RESISTORS
All resistors are in ohms.
METAL: Metal-film resistor.
METAL OXIDE: Metal oxide-film resistor.
F: nonflammable

- Items marked "*" are not stocked since they are seldom required for routine service. Some delay should be anticipated when ordering these items.
- SEMICONDUCTORS
In each case, u: μ , for example:
uA.: μ A., uPA.: μ PA.,
uPB.: μ PB., uPC.: μ PC., uPD.: μ PD.
- CAPACITORS
uF: μ F
- COILS
uH: μ H

The components identified by mark Δ or dotted line with mark Δ are critical for safety. Replace only with part number specified.

When indicating parts by reference number, please include the board.

Ref. No.	Part No.	Description	Remark
*	1-641-809-11	AC BOARD *****	
	1-533-183-11	HOLDER, FUSE < CAPACITOR >	
Δ C991	1-162-599-12	CERAMIC 0.0047uF	400V
Δ C993	1-161-744-00	CERAMIC 0.01uF	400V
		< CONNECTOR >	
* CN991	1-535-140-00	BASE POST 22MM (10MM PITCH) 3P	
* CN992	1-535-140-00	BASE POST 22MM (10MM PITCH) 3P	
CN993	1-564-321-00	PIN, CONNECTOR 2P	
* CN994	1-580-230-11	PIN, CONNECTOR (PC BOARD) 3P	

*	A-4649-344-A	AUDIO BOARD, COMPLETE *****	
	1-535-988-11	TERMINAL, TAB	
*	4-363-146-00	HEAT SINK, V. OUT	
	7-682-147-15	SCREW, TR	
		< BUS BAR >	
* BUS901	1-691-279-11	BUS BAR 5P	
* BUS903	1-691-279-11	BUS BAR 5P	
* BUS904	1-566-959-11	BUS BAR 7P	
		< CAPACITOR >	
C401	1-136-812-11	FILM 470PF	5% 100V
C403	1-136-810-11	FILM 220PF	5% 100V
C404	1-136-810-11	FILM 220PF	5% 100V
C405	1-136-808-11	FILM 100PF	5% 100V
C406	1-136-808-11	FILM 100PF	5% 100V
C407	1-136-192-11	FILM 0.0018uF	2% 100V
C408	1-136-192-11	FILM 0.0018uF	2% 100V
C409	1-136-192-11	FILM 0.0018uF	2% 100V
C410	1-137-531-11	FILM 1uF	5% 100V
C413	1-130-495-00	MYLAR 0.1uF	5% 50V
C415	1-162-806-11	CERAMIC 0.1uF	10% 50V
C416	1-126-052-11	ELECT 100uF	20% 50V
C417	1-130-495-00	MYLAR 0.1uF	5% 50V

Ref. No.	Part No.	Description	Remark
C419	1-162-806-11	CERAMIC 0.1uF	10% 50V
C421	1-136-165-00	FILM 0.1uF	5% 50V
C422	1-126-052-11	ELECT 100uF	20% 50V
C423	1-137-531-11	FILM 1uF	5% 100V
C424	1-137-531-11	FILM 1uF	5% 100V
C427	1-126-851-11	ELECT 22uF	20% 35V
C452	1-162-203-31	CERAMIC 15PF	5% 50V
C453	1-124-120-11	ELECT 220uF	20% 25V
C454	1-124-478-11	ELECT 100uF	20% 25V
C455	1-162-215-31	CERAMIC 47PF	5% 50V
C456	1-164-159-11	CERAMIC 0.1uF	50V
C501	1-136-812-11	FILM 470PF	5% 100V
C503	1-136-810-11	FILM 220PF	5% 100V
C504	1-136-810-11	FILM 220PF	5% 100V
C505	1-136-808-11	FILM 100PF	5% 100V
C506	1-136-808-11	FILM 100PF	5% 100V
C507	1-136-192-11	FILM 0.0018uF	2% 100V
C508	1-136-192-11	FILM 0.0018uF	2% 100V
C509	1-136-192-11	FILM 0.0018uF	2% 100V
C510	1-137-531-11	FILM 1uF	5% 100V
C513	1-130-495-00	MYLAR 0.1uF	5% 50V
C515	1-162-806-11	CERAMIC 0.1uF	10% 50V
C516	1-126-052-11	ELECT 100uF	20% 50V
C517	1-130-495-00	MYLAR 0.1uF	5% 50V
C519	1-162-806-11	CERAMIC 0.1uF	10% 50V
C521	1-136-165-00	FILM 0.1uF	5% 50V
C523	1-137-531-11	FILM 1uF	5% 100V
C524	1-137-531-11	FILM 1uF	5% 100V
C527	1-126-851-11	ELECT 22uF	20% 35V
C552	1-162-203-31	CERAMIC 15PF	5% 50V
C553	1-124-120-11	ELECT 220uF	20% 25V
C554	1-124-478-11	ELECT 100uF	20% 25V
C555	1-162-215-31	CERAMIC 47PF	5% 50V
C600	1-162-806-11	CERAMIC 0.1uF	10% 50V
C601	1-107-202-00	MICA 10PF	5% 500V
C602	1-107-202-00	MICA 10PF	5% 500V
C603	1-162-806-11	CERAMIC 0.1uF	10% 50V
C604	1-126-064-11	ELECT 220uF	20% 63V
C605	1-136-961-11	FILM 0.047uF	10% 160V
C606	1-126-052-11	ELECT 100uF	20% 50V

AUDIO

Ref. No.	Part No.	Description	Remark
C607	1-162-806-11	CERAMIC	0.1uF 10% 50V
C608	1-124-360-00	ELECT	1000uF 20% 16V
C609	1-136-165-00	FILM	0.1uF 5% 50V
C610	1-126-027-11	ELECT	1000uF 20% 25V
C611	1-126-301-11	ELECT	1uF 20% 50V
C612	1-126-163-11	ELECT	4.7uF 20% 50V
C613	1-162-806-11	CERAMIC	0.1uF 10% 50V
C615	1-124-921-11	ELECT	470uF 20% 63V
C616	1-124-910-11	ELECT	47uF 20% 50V
C617	1-123-604-00	ELECT	220uF 20% 63V
C622	1-124-912-11	ELECT	330uF 20% 50V
C623	1-136-165-00	FILM	0.1uF 5% 50V
C624	1-162-290-31	CERAMIC	470PF 10% 50V
C625	1-164-159-11	CERAMIC	0.1uF 50V
C627	1-136-165-00	FILM	0.1uF 5% 50V
C902	1-124-122-11	ELECT	100uF 20% 50V
C903	1-107-202-00	MICA	10PF 5% 500V
C904	1-126-170-11	ELECT	1000uF 20% 50V
C905	1-162-806-11	CERAMIC	0.1uF 10% 50V
C906	1-137-507-11	FILM	1uF 10% 63V
C907	1-162-806-11	CERAMIC	0.1uF 10% 50V
C908	1-126-059-11	ELECT	10uF 20% 50V
C922	1-124-122-11	ELECT	100uF 20% 50V
C923	1-107-202-00	MICA	10PF 5% 500V
C924	1-126-170-11	ELECT	1000uF 20% 50V
C925	1-162-806-11	CERAMIC	0.1uF 10% 50V
C926	1-137-507-11	FILM	1uF 10% 63V
C927	1-162-806-11	CERAMIC	0.1uF 10% 50V
C928	1-126-059-11	ELECT	10uF 20% 50V
< CONNECTOR >			
* CN401	1-573-261-11	PIN, CONNECTOR 2P	
* CN402	1-573-261-11	PIN, CONNECTOR 2P	
* CN451	1-573-263-11	PIN, CONNECTOR 4P	
* CN452	1-573-263-21	PIN, CONNECTOR 4P	
* CN453	1-573-262-11	PIN, CONNECTOR 3P	
* CN501	1-573-261-21	PIN, CONNECTOR 2P	
* CN502	1-573-261-21	PIN, CONNECTOR 2P	
* CN601	1-569-997-11	PIN, CONNECTOR (PC BOARD) 10P	
* CN602	1-569-993-11	PIN, CONNECTOR (PC BOARD) 6P	
* CN603	1-573-261-31	PIN, CONNECTOR 2P	
* CN604	1-564-704-11	PIN, CONNECTOR (SMALL TYPE) 2P	
* CN901	1-573-865-21	PIN, CONNECTOR (PC BOARD) 6P	
< DIODE >			
D601	8-719-114-27	DIODE RD4. 7JS-B3	
D602	8-719-114-27	DIODE RD4. 7JS-B3	
D603	8-719-114-30	DIODE RD5. 1JS-B2	
D604	8-719-987-63	DIODE 1N4148M	

Ref. No.	Part No.	Description	Remark
D605	8-719-987-63	DIODE 1N4148M	
D606	8-719-987-63	DIODE 1N4148M	
D901	8-719-114-49	DIODE RD7. 5JS-B2	
D921	8-719-114-49	DIODE RD7. 5JS-B2	
< IC >			
IC401	8-759-602-83	IC M5238P	
IC402	8-759-900-72	IC NE5532P	
IC403	8-759-900-72	IC NE5532P	
IC404	8-759-053-07	IC OP-27GP	
IC405	8-759-981-85	IC RC4556D	
IC501	8-759-602-83	IC M5238P	
IC502	8-759-900-72	IC NE5532P	
IC503	8-759-900-72	IC NE5532P	
IC504	8-759-053-07	IC OP-27GP	
IC601	8-759-044-10	IC CXD2562Q	
IC602	8-759-233-64	IC TC74HC004AF	
IC603	8-752-342-65	IC CXD2560M	
IC604	8-759-233-64	IC TC74HC004AF	
IC605	8-759-602-83	IC M5238P	
IC606	8-759-925-76	IC SN74HC08ANS	
IC901	8-759-602-01	IC M5220P	
IC902	8-759-231-58	IC M5F7812L	
IC922	8-759-245-86	IC TA7912S	
< COIL >			
L601	1-410-969-11	INDUCTOR 4.7uH	
L602	1-410-969-11	INDUCTOR 4.7uH	
L603	1-410-969-11	INDUCTOR 4.7uH	
L604	1-410-397-21	FERRITE BEAD INDUCTOR	
L605	1-410-397-21	FERRITE BEAD INDUCTOR	
L606	1-410-397-21	FERRITE BEAD INDUCTOR	
L607	1-410-397-21	FERRITE BEAD INDUCTOR	
< IC LINK >			
△PS901	1-532-686-00	LINK, IC (ICP-F75) 2.7A	
△PS921	1-532-675-00	LINK, IC (ICP-F38) 1.5A	
< TRANSISTOR >			
Q402	8-729-203-06	TRANSISTOR 2SK30A-GR2	
Q403	8-729-184-53	TRANSISTOR 2SC1845-EA	
Q404	8-729-321-35	TRANSISTOR 2SK213	
Q405	8-729-307-65	TRANSISTOR 2SJ76	
Q406	8-729-231-55	TRANSISTOR 2SC2878-AB	
Q407	8-729-119-76	TRANSISTOR 2SA1175-HFE	
Q408	8-729-231-55	TRANSISTOR 2SC2878-AB	
Q409	8-729-119-78	TRANSISTOR 2SC2785-HFE	
Q502	8-729-203-06	TRANSISTOR 2SK30A-GR2	
Q503	8-729-184-53	TRANSISTOR 2SC1845-EA	

The components identified by mark △ or dotted line with mark △ are critical for safety. Replace only with part number specified.

AUDIO

Ref. No.	Part No.	Description	Remark	Ref. No.	Part No.	Description	Remark
Q504	8-729-321-35	TRANSISTOR	2SK213	R430	1-214-761-00	METAL	22K 1% 1/4W
Q505	8-729-307-65	TRANSISTOR	2SJ76	R431	1-214-761-00	METAL	22K 1% 1/4W
Q506	8-729-231-55	TRANSISTOR	2SC2878-AB	R432	1-214-783-00	METAL	180K 1% 1/4W
Q507	8-729-119-76	TRANSISTOR	2SA1175-HFE	R434	1-259-482-11	CARBON	180K 5% 1/6W
Q508	8-729-231-55	TRANSISTOR	2SC2878-AB	R435	1-259-472-11	CARBON	68K 5% 1/6W
Q509	8-729-119-78	TRANSISTOR	2SC2785-HFE	R436	1-259-484-11	CARBON	220K 5% 1/6W
Q600	8-729-203-06	TRANSISTOR	2SK30A-GR2	R437	1-259-452-11	CARBON	10K 5% 1/6W
Q601	8-729-620-23	TRANSISTOR	2SC3246-JK	R438	1-249-520-11	CARBON	47 5% 1/4W
Q602	8-729-104-18	TRANSISTOR	2SC3514	R442	1-259-428-11	CARBON	1K 5% 1/6W
Q603	8-729-200-56	TRANSISTOR	2SK241-GR	R443	1-259-484-11	CARBON	220K 5% 1/6W
Q604	8-729-119-76	TRANSISTOR	2SA1175-HFE	R444	1-259-468-11	CARBON	47K 5% 1/6W
Q605	8-729-119-76	TRANSISTOR	2SA1175-HFE	R445	1-259-468-11	CARBON	47K 5% 1/6W
Q606	8-729-119-76	TRANSISTOR	2SA1175-HFE	R451	1-259-456-11	CARBON	15K 5% 1/6W
Q607	8-729-119-78	TRANSISTOR	2SC2785-HFE	R452	1-259-470-11	CARBON	56K 5% 1/6W
Q608	8-729-119-78	TRANSISTOR	2SC2785-HFE	R453	1-259-476-11	CARBON	100K 5% 1/6W
Q902	8-729-203-06	TRANSISTOR	2SK30A-GR2	R454	1-259-444-11	CARBON	4.7K 5% 1/6W
Q903	8-729-101-68	TRANSISTOR	2SC2854	R455	1-249-522-11	CARBON	56 5% 1/4W
Q921	8-729-203-06	TRANSISTOR	2SK30A-GR2	R456	1-259-468-11	CARBON	47K 5% 1/6W
Q923	8-729-015-44	TRANSISTOR	2SA1129-K	R457	1-249-423-11	CARBON	3.3K 5% 1/4W
< RESISTOR >				R501	1-249-945-11	CARBON	8.2K 1% 1/4W
R401	1-249-945-11	CARBON	8.2K 1% 1/4W	R502	1-249-945-11	CARBON	8.2K 1% 1/4W
R402	1-249-945-11	CARBON	8.2K 1% 1/4W	R503	1-249-945-11	CARBON	8.2K 1% 1/4W
R403	1-249-945-11	CARBON	8.2K 1% 1/4W	R504	1-249-945-11	CARBON	8.2K 1% 1/4W
R404	1-249-945-11	CARBON	8.2K 1% 1/4W	R505	1-247-719-11	CARBON	3.3K 5% 1/4W
R405	1-247-719-11	CARBON	3.3K 5% 1/4W	R507	1-247-719-11	CARBON	3.3K 5% 1/4W
R407	1-247-719-11	CARBON	3.3K 5% 1/4W	R508	1-249-637-11	CARBON	33 5% 1/2W
R408	1-249-637-11	CARBON	33 5% 1/2W	R509	1-249-947-11	CARBON	10K 1% 1/4W
R409	1-249-947-11	CARBON	10K 1% 1/4W	R510	1-249-947-11	CARBON	10K 1% 1/4W
R410	1-249-947-11	CARBON	10K 1% 1/4W	R511	1-249-941-11	CARBON	5.6K 1% 1/4W
R411	1-249-941-11	CARBON	5.6K 1% 1/4W	R512	1-249-941-11	CARBON	5.6K 1% 1/4W
R412	1-249-941-11	CARBON	5.6K 1% 1/4W	R513	1-249-941-11	CARBON	5.6K 1% 1/4W
R413	1-249-941-11	CARBON	5.6K 1% 1/4W	R514	1-249-941-11	CARBON	5.6K 1% 1/4W
R414	1-249-941-11	CARBON	5.6K 1% 1/4W	R515	1-249-929-11	CARBON	1.8K 1% 1/4W
R415	1-249-929-11	CARBON	1.8K 1% 1/4W	R516	1-249-929-11	CARBON	1.8K 1% 1/4W
R416	1-249-929-11	CARBON	1.8K 1% 1/4W	R517	1-249-929-11	CARBON	1.8K 1% 1/4W
R417	1-249-929-11	CARBON	1.8K 1% 1/4W	R518	1-249-929-11	CARBON	1.8K 1% 1/4W
R418	1-249-929-11	CARBON	1.8K 1% 1/4W	R519	1-249-461-11	CARBON	18K 5% 1/4W
R419	1-249-461-11	CARBON	18K 5% 1/4W	R520	1-249-929-11	CARBON	1.8K 1% 1/4W
R420	1-249-929-11	CARBON	1.8K 1% 1/4W	R521	1-247-713-11	CARBON	1K 5% 1/4W
R421	1-247-713-11	CARBON	1K 5% 1/4W	R522	1-249-947-11	CARBON	10K 1% 1/4W
R422	1-249-947-11	CARBON	10K 1% 1/4W	R523	1-249-556-11	CARBON	1.5K 5% 1/4W
R423	1-249-556-11	CARBON	1.5K 5% 1/4W	R524	1-247-700-11	CARBON	100 5% 1/4W
R424	1-247-700-11	CARBON	100 5% 1/4W	R525	1-247-700-11	CARBON	100 5% 1/4W
R425	1-247-700-11	CARBON	100 5% 1/4W	R526	1-249-637-11	CARBON	33 5% 1/2W
R426	1-249-637-11	CARBON	33 5% 1/2W	R527	1-249-637-11	CARBON	33 5% 1/2W
R427	1-249-637-11	CARBON	33 5% 1/2W	R528	1-249-637-11	CARBON	33 5% 1/2W
R428	1-249-637-11	CARBON	33 5% 1/2W	R529	1-249-504-11	CARBON	10 5% 1/4W
R429	1-249-504-11	CARBON	10 5% 1/4W	R530	1-214-761-00	METAL	22K 1% 1/4W
				R531	1-214-761-00	METAL	22K 1% 1/4W

BD

Ref.No.	Part No.	Description	Remark
C171	1-163-038-00	CERAMIC CHIP 0.1uF	25V
C172	1-163-038-00	CERAMIC CHIP 0.1uF	25V
C173	1-163-038-00	CERAMIC CHIP 0.1uF	25V
C174	1-163-038-00	CERAMIC CHIP 0.1uF	25V
C175	1-163-038-00	CERAMIC CHIP 0.1uF	25V
C177	1-163-038-00	CERAMIC CHIP 0.1uF	25V
C178	1-163-038-00	CERAMIC CHIP 0.1uF	25V
C179	1-163-038-00	CERAMIC CHIP 0.1uF	25V
C180	1-163-038-00	CERAMIC CHIP 0.1uF	25V
C181	1-164-346-11	CERAMIC CHIP 1uF	16V
C201	1-163-809-11	CERAMIC CHIP 0.047uF	10% 25V
C202	1-163-011-11	CERAMIC CHIP 0.0015uF	10% 50V
C203	1-164-232-11	CERAMIC CHIP 0.01uF	50V
C204	1-163-117-00	CERAMIC CHIP 100PF	5% 50V
C205	1-164-489-11	CERAMIC CHIP 0.22uF	10% 16V
C206	1-164-232-11	CERAMIC CHIP 0.01uF	50V
C207	1-164-346-11	CERAMIC CHIP 1uF	16V
C301	1-163-038-00	CERAMIC CHIP 0.1uF	25V
C302	1-125-622-11	CAP, DOUBLE LAYERS 0.1F	5.5V
C303	1-163-038-00	CERAMIC CHIP 0.1uF	25V
C305	1-164-346-11	CERAMIC CHIP 1uF	16V
< CONNECTOR >			
* CN101	1-573-276-11	PIN, CONNECTOR 6P	
CN102	1-568-799-11	SOCKET, CONNECTOR 16P	
* CN111	1-569-998-11	PIN, CONNECTOR (PC BOARD) 2P	
* CN112	1-580-001-11	PIN, CONNECTOR (PC BOARD) 4P	
* CN113	1-580-002-11	PIN, CONNECTOR (PC BOARD) 5P	
* CN141	1-564-704-11	PIN, CONNECTOR (SMALL TYPE) 2P	
* CN201	1-580-007-11	PIN, CONNECTOR (PC BOARD) 10P	
* CN202	1-580-003-11	PIN, CONNECTOR (PC BOARD) 6P	
* CN203	1-564-719-11	PIN, CONNECTOR (SMALL TYPE) 3P	
* CN301	1-691-464-11	PIN, CONNECTOR 8P	
* CN302	1-691-462-11	PIN, CONNECTOR 6P	
< DIODE >			
D301	8-719-104-34	DIODE 1S2836	
< IC >			
IC101	8-752-344-48	IC CXD2501Q	
IC102	8-759-040-80	IC BA6297FP	
IC103	8-759-040-83	IC BA6287F	
IC141	8-759-055-78	IC TA8407F	
IC142	8-759-981-92	IC RC4558M	
IC151	8-759-981-92	IC RC4558M	
IC152	8-759-981-92	IC RC4558M	
IC201	8-752-337-26	IC CXD2500AQ	
IC301	8-759-069-47	IC M37451M8-174FP	

Ref.No.	Part No.	Description	Remark
IC302	8-759-512-81	IC LH5160N-10L	
< TRANSISTOR >			
Q151	8-729-901-06	TRANSISTOR DTA144EK	
Q181	8-729-901-01	TRANSISTOR DTC144EK	
Q182	8-729-901-06	TRANSISTOR DTA144EK	
< RESISTOR >			
R101	1-216-077-00	METAL CHIP 15K 5%	1/10W
R102	1-216-097-00	METAL CHIP 100K 5%	1/10W
R103	1-216-077-00	METAL CHIP 15K 5%	1/10W
R104	1-216-049-00	METAL CHIP 1K 5%	1/10W
R105	1-216-097-00	METAL CHIP 100K 5%	1/10W
R106	1-216-085-00	METAL CHIP 33K 5%	1/10W
R107	1-216-025-00	METAL CHIP 100 5%	1/10W
R108	1-216-295-00	METAL CHIP 0 5%	1/10W
R121	1-216-071-00	METAL CHIP 8.2K 5%	1/10W
R122	1-216-071-00	METAL CHIP 8.2K 5%	1/10W
R123	1-216-071-00	METAL CHIP 8.2K 5%	1/10W
R124	1-216-071-00	METAL CHIP 8.2K 5%	1/10W
R125	1-216-071-00	METAL CHIP 8.2K 5%	1/10W
R126	1-216-071-00	METAL CHIP 8.2K 5%	1/10W
R127	1-216-069-00	METAL CHIP 6.8K 5%	1/10W
R128	1-216-069-00	METAL CHIP 6.8K 5%	1/10W
R129	1-216-069-00	METAL CHIP 6.8K 5%	1/10W
R130	1-216-069-00	METAL CHIP 6.8K 5%	1/10W
R131	1-216-069-00	METAL CHIP 6.8K 5%	1/10W
R132	1-216-069-00	METAL CHIP 6.8K 5%	1/10W
R133	1-216-053-00	METAL CHIP 1.5K 5%	1/10W
R134	1-216-053-00	METAL CHIP 1.5K 5%	1/10W
R141	1-216-073-00	METAL CHIP 10K 5%	1/10W
R142	1-216-079-00	METAL CHIP 18K 5%	1/10W
R143	1-216-073-00	METAL CHIP 10K 5%	1/10W
R144	1-216-065-00	METAL CHIP 4.7K 5%	1/10W
R145	1-216-073-00	METAL CHIP 10K 5%	1/10W
R146	1-216-073-00	METAL CHIP 10K 5%	1/10W
R147	1-216-079-00	METAL CHIP 18K 5%	1/10W
R148	1-216-073-00	METAL CHIP 10K 5%	1/10W
R149	1-216-073-00	METAL CHIP 10K 5%	1/10W
R151	1-216-070-00	METAL CHIP 7.5K 5%	1/10W
R152	1-216-070-00	METAL CHIP 7.5K 5%	1/10W
R153	1-216-070-00	METAL CHIP 7.5K 5%	1/10W
R154	1-216-070-00	METAL CHIP 7.5K 5%	1/10W
R155	1-216-093-00	METAL CHIP 68K 5%	1/10W
R156	1-216-085-00	METAL CHIP 33K 5%	1/10W
R157	1-216-117-00	METAL CHIP 680K 5%	1/10W
R158	1-216-097-00	METAL CHIP 100K 5%	1/10W
R159	1-216-083-00	METAL CHIP 27K 5%	1/10W



Ref. No.	Part No.	Description	Remark
R160	1-216-049-00	METAL CHIP	1K 5% 1/10W
R161	1-216-095-00	METAL CHIP	82K 5% 1/10W
R163	1-216-076-00	METAL CHIP	13K 5% 1/10W
R164	1-216-085-00	METAL CHIP	33K 5% 1/10W
R165	1-216-081-00	METAL CHIP	22K 5% 1/10W
R166	1-216-085-00	METAL CHIP	33K 5% 1/10W
R167	1-216-308-00	METAL CHIP	4.7 5% 1/10W
R171	1-216-001-00	METAL CHIP	10 5% 1/10W
R172	1-216-001-00	METAL CHIP	10 5% 1/10W
R173	1-216-001-00	METAL CHIP	10 5% 1/10W
R174	1-216-001-00	METAL CHIP	10 5% 1/10W
R175	1-216-001-00	METAL CHIP	10 5% 1/10W
R177	1-216-001-00	METAL CHIP	10 5% 1/10W
R178	1-216-001-00	METAL CHIP	10 5% 1/10W
R179	1-216-001-00	METAL CHIP	10 5% 1/10W
R180	1-216-001-00	METAL CHIP	10 5% 1/10W
R181	1-216-029-00	METAL CHIP	150 5% 1/10W
R182	1-216-029-00	METAL CHIP	150 5% 1/10W
R183	1-216-073-00	METAL CHIP	10K 5% 1/10W
R184	1-216-097-00	METAL CHIP	100K 5% 1/10W
R191	1-216-295-00	METAL CHIP	0 5% 1/10W
R192	1-216-295-00	METAL CHIP	0 5% 1/10W
R201	1-216-061-00	METAL CHIP	3.3K 5% 1/10W
R202	1-216-061-00	METAL CHIP	3.3K 5% 1/10W
R203	1-216-073-00	METAL CHIP	10K 5% 1/10W
R204	1-216-121-00	METAL CHIP	1M 5% 1/10W
R205	1-216-105-00	METAL CHIP	220K 5% 1/10W
R206	1-216-073-00	METAL CHIP	10K 5% 1/10W
R207	1-216-041-00	METAL CHIP	470 5% 1/10W
R208	1-216-041-00	METAL CHIP	470 5% 1/10W
R209	1-216-041-00	METAL CHIP	470 5% 1/10W
R210	1-216-033-00	METAL CHIP	220 5% 1/10W
R211	1-216-073-00	METAL CHIP	10K 5% 1/10W
R212	1-216-037-00	METAL CHIP	330 5% 1/10W
R213	1-216-049-00	METAL CHIP	1K 5% 1/10W
R301	1-216-073-00	METAL CHIP	10K 5% 1/10W
R302	1-216-073-00	METAL CHIP	10K 5% 1/10W
R303	1-216-073-00	METAL CHIP	10K 5% 1/10W
R304	1-216-073-00	METAL CHIP	10K 5% 1/10W
R305	1-216-073-00	METAL CHIP	10K 5% 1/10W
R306	1-216-073-00	METAL CHIP	10K 5% 1/10W
R307	1-216-073-00	METAL CHIP	10K 5% 1/10W
R308	1-216-073-00	METAL CHIP	10K 5% 1/10W
R309	1-216-049-00	METAL CHIP	1K 5% 1/10W
R310	1-216-121-00	METAL CHIP	1M 5% 1/10W
R311	1-216-037-00	METAL CHIP	330 5% 1/10W
R312	1-216-073-00	METAL CHIP	10K 5% 1/10W
R313	1-216-049-00	METAL CHIP	1K 5% 1/10W
R314	1-216-073-00	METAL CHIP	10K 5% 1/10W

Ref. No.	Part No.	Description	Remark
R315	1-216-073-00	METAL CHIP	10K 5% 1/10W
R316	1-216-073-00	METAL CHIP	10K 5% 1/10W
R317	1-216-073-00	METAL CHIP	10K 5% 1/10W
R318	1-216-073-00	METAL CHIP	10K 5% 1/10W
R319	1-216-073-00	METAL CHIP	10K 5% 1/10W
< VIBRATOR >			
X301	1-577-377-11	VIBRATOR, CERAMIC (10MHz)	

* A-4617-993-A	BSL BOARD, COMPLETE		

< CAPACITOR >			
C10	1-124-779-00	ELECT CHIP	10uF 20% 16V
C11	1-163-077-00	CERAMIC CHIP	0.1uF 10% 25V
C20	1-124-779-00	ELECT CHIP	10uF 20% 16V
C21	1-163-077-00	CERAMIC CHIP	0.1uF 10% 25V
< CONNECTOR >			
* CN1	1-564-519-11	PLUG, CONNECTOR 4P	
< HOLE ELEMENT >			
H11	8-719-987-62	HALL DEVICE LT140SC	
H21	8-719-987-62	HALL DEVICE LT140SC	
< IC >			
IC11	8-759-055-78	IC TA8407F	
IC21	8-759-055-78	IC TA8407F	
< JUMPER RESISTOR >			
J11	1-216-296-00	METAL CHIP	0 5% 1/8W
< RESISTOR >			
R11	1-216-049-00	METAL CHIP	1K 5% 1/10W
R12	1-216-057-00	METAL CHIP	2.2K 5% 1/10W
R13	1-216-105-00	METAL CHIP	220K 5% 1/10W
R14	1-216-057-00	METAL CHIP	2.2K 5% 1/10W
R15	1-216-105-00	METAL CHIP	220K 5% 1/10W
R16	1-216-077-00	METAL CHIP	15K 5% 1/10W
R17	1-216-077-00	METAL CHIP	15K 5% 1/10W
R18	1-216-150-00	METAL GLAZE	10 5% 1/8W
R19	1-216-070-00	METAL CHIP	7.5K 5% 1/10W
R21	1-216-049-00	METAL CHIP	1K 5% 1/10W
R22	1-216-057-00	METAL CHIP	2.2K 5% 1/10W
R23	1-216-105-00	METAL CHIP	220K 5% 1/10W
R24	1-216-057-00	METAL CHIP	2.2K 5% 1/10W
R25	1-216-105-00	METAL CHIP	220K 5% 1/10W
R26	1-216-077-00	METAL CHIP	15K 5% 1/10W

BSL

DISPLAY

FUNCTION

TIMER

Ref. No.	Part No.	Description	Remark		
R27	1-216-077-00	METAL CHIP	15K	5%	1/10W
R28	1-216-150-00	METAL GLAZE	10	5%	1/8W
R29	1-216-070-00	METAL CHIP	7.5K	5%	1/10W

*	1-637-410-11	DISPLAY BOARD			

*	1-637-409-11	FUNCTION BOARD			

*	1-637-411-11	TIMER BOARD			

*	4-923-532-21	SPACER, LED			
*	4-928-052-01	HOLDER (RIGHT)			
*	4-928-053-01	HOLDER (LEFT)			
<p style="text-align: center;">< CAPACITOR ></p>					
C802	1-164-159-11	CERAMIC	0.1uF		50V
C803	1-164-159-11	CERAMIC	0.1uF		50V
<p style="text-align: center;">< CONNECTOR ></p>					
* CN801	1-564-341-11	PIN, CONNECTOR 7P			
* CN802	1-506-503-11	PIN, CONNECTOR 9P			
* CN803	1-564-340-00	PIN, CONNECTOR 6P			
<p style="text-align: center;">< DIODE ></p>					
D701	8-719-970-07	LED	MPG3371X-150 (▶)		
D702	8-719-971-52	LED	MAY3371X-M-177 (■)		
D703	8-719-971-50	LED	MBG3371X (CONTINUE)		
D704	8-719-971-52	LED	MAY3371X-M-177 (SHUFFLE)		
D705	8-719-987-97	LED	BR3371X (PROGRAM)		
D706	8-719-970-98	LED	MPY3371X-177 (C. INDEX)		
D801	8-719-107-94	DIODE	1SS202-1		
D802	8-719-107-94	DIODE	1SS202-1		
D803	8-719-107-94	DIODE	1SS202-1		
D804	8-719-107-94	DIODE	1SS202-1		
D805	8-719-107-94	DIODE	1SS202-1		
D806	8-719-107-94	DIODE	1SS202-1		
D807	8-719-107-94	DIODE	1SS202-1		
<p style="text-align: center;">< FLUORESCENT INDICATOR ></p>					
FLD801	1-519-622-11	INDICATOR TUBE, FLUORESCENT			
<p style="text-align: center;">< IC ></p>					
IC801	8-759-074-98	IC	MSC62408-041GS-V1K		
IC802	8-741-100-48	IC	SBX1610-59		
<p style="text-align: center;">< TRANSISTOR ></p>					
Q701	8-729-900-80	TRANSISTOR	DTC114ES		
Q702	8-729-900-80	TRANSISTOR	DTC114ES		

Ref. No.	Part No.	Description	Remark		
Q703	8-729-900-80	TRANSISTOR	DTC114ES		
Q704	8-729-900-80	TRANSISTOR	DTC114ES		
Q705	8-729-900-80	TRANSISTOR	DTC114ES		
Q706	8-729-900-80	TRANSISTOR	DTC114ES		
Q801	8-729-900-45	TRANSISTOR	DTC114EF		
Q802	8-729-900-45	TRANSISTOR	DTC114EF		
<p style="text-align: center;">< RESISTOR ></p>					
R701	1-249-406-11	CARBON	120	5%	1/4W
R702	1-249-406-11	CARBON	120	5%	1/4W
R703	1-249-406-11	CARBON	120	5%	1/4W
R704	1-249-406-11	CARBON	120	5%	1/4W
R705	1-249-417-11	CARBON	1K	5%	1/4W
R706	1-249-409-11	CARBON	220	5%	1/4W
R801	1-249-425-11	CARBON	4.7K	5%	1/4W
R802	1-249-429-11	CARBON	10K	5%	1/4W
R803	1-247-903-00	CARBON	1M	5%	1/4W
R806	1-249-441-11	CARBON	100K	5%	1/4W
R809	1-249-441-11	CARBON	100K	5%	1/4W
<p style="text-align: center;">< SWITCH ></p>					
S701	1-554-937-11	SWITCH, KEY BOARD (PLAY MODE CONTINUE)			
S702	1-554-937-11	SWITCH, KEY BOARD (PLAY MODE SHUFFLE)			
S703	1-554-937-11	SWITCH, KEY BOARD (PLAY MODE PROGRAM)			
S704	1-554-937-11	SWITCH, KEY BOARD (PLAY MODE C. INDEX)			
S705	1-554-937-11	SWITCH, KEY BOARD (K3)			
S706	1-554-937-11	SWITCH, KEY BOARD (■)			
S707	1-554-937-11	SWITCH, KEY BOARD (▶)			
S708	1-554-937-11	SWITCH, KEY BOARD (P. SEARCH)			
S709	1-554-937-11	SWITCH, KEY BOARD (▶▶)			
S710	1-554-937-11	SWITCH, KEY BOARD (■)			
S711	1-554-937-11	SWITCH, KEY BOARD (DIMMER REPEAT)			
S712	1-554-937-11	SWITCH, KEY BOARD (◀◀)			
S713	1-554-937-11	SWITCH, KEY BOARD (FILE)			
S714	1-554-937-11	SWITCH, KEY BOARD (DIMMER TIME/MEMO)			
S715	1-554-937-11	SWITCH, KEY BOARD (▶▶)			
S716	1-554-937-11	SWITCH, KEY BOARD (ERASE)			
S717	1-554-937-11	SWITCH, KEY BOARD (FILE RECALL)			
S718	1-554-937-11	SWITCH, KEY BOARD (DISPLAY MODE)			
S719	1-554-937-11	SWITCH, KEY BOARD (EDIT/TIME FADE)			
S801	1-554-937-11	SWITCH, KEY BOARD (△OPEN/CLOSE)			
S802	1-554-937-11	SWITCH, KEY BOARD (LEVEL FILE)			
S804	1-570-157-51	SWITCH, SLIDE (TIMER)			
<p style="text-align: center;">< VIBRATOR ></p>					
X801	1-577-359-21	VIBRATOR, CERAMIC (4.19MHz)			

HP **L.MOTOR** **OPT** **LINE OUT** **POWER**

Ref. No.	Part No.	Description	Remark		
*	1-642-074-11	HP BOARD *****			
		< CAPACITOR >			
C461	1-162-290-31	CERAMIC	470PF	10%	50V
C561	1-162-290-31	CERAMIC	470PF	10%	50V
		< JACK >			
J451	1-568-519-31	JACK, LARGE TYPE (PHONES) (BLACK)			
J451	1-568-519-61	JACK, LARGE TYPE (PHONES) (GOLD) (AEP)			
		< COIL >			
L461	1-412-473-21	INDUCTOR	OuH (AEP)		
L561	1-412-473-21	INDUCTOR	OuH (AEP)		

*	1-641-765-11	L. MOTOR BOARD *****			

*	1-641-807-11	OPT BOARD *****			
		< CAPACITOR >			
C280	1-126-059-11	ELECT	10uF	20%	50V
		< CONNECTOR >			
* CN280	1-564-705-11	PIN, CONNECTOR (SMALL TYPE) 3P			
		< IC >			
IC280	8-749-921-12	IC GP1F32T (DIGITAL OUT OPTICAL)			

*	1-641-808-11	LINE OUT BOARD *****			
		< CAPACITOR >			
C471	1-107-202-00	MICA	10PF	5%	500V (AEP)
C472	1-107-202-00	MICA	10PF	5%	500V (AEP)
C571	1-107-202-00	MICA	10PF	5%	500V (AEP)
C572	1-107-202-00	MICA	10PF	5%	500V (AEP)
		< DIODE >			
D471	8-719-987-63	DIODE 1N4148M			
		< JACK >			
J401	1-568-101-11	JACK, PIN 4P (LINE OUT)			

Ref. No.	Part No.	Description	Remark		
		< COIL >			
L471	1-410-397-21	FERRITE BEAD INDUCTOR (AEP)			
L571	1-410-397-21	FERRITE BEAD INDUCTOR (AEP)			
		< RESISTOR >			
R470	1-247-690-11	CARBON	15	5%	1/4W
R471	1-247-700-11	CARBON	100	5%	1/4W
R570	1-247-690-11	CARBON	15	5%	1/4W
R571	1-247-700-11	CARBON	100	5%	1/4W
		< RELAY >			
RY471	1-515-727-11	RELAY			

*	A-4649-002-A	POWER BOARD, COMPLETE (UK, E)			
*	A-4649-377-A	POWER BOARD, COMPLETE (AEP)			

	7-682-147-15	SCREW, TR			
	4-902-345-01	HEAT SINK			
*	4-941-237-01	HEAT SINK			
	7-682-545-09	SCREW +B 3X4			
		< BUS BAR >			
* BUS905	1-566-940-11	BUS BAR 6P			
		< CAPACITOR >			
C901	1-126-982-11	ELECT	5600uF	20%	35V
C921	1-126-982-11	ELECT	5600uF	20%	35V
C951	1-126-017-11	ELECT	6800uF	20%	16V
C952	1-126-832-51	ELECT	3300uF	20%	10V
C953	1-124-473-11	ELECT	1000uF	20%	10V
C954	1-124-473-11	ELECT	1000uF	20%	10V
C955	1-124-473-11	ELECT	1000uF	20%	10V
C956	1-126-335-11	ELECT	220uF	20%	10V
C957	1-126-162-11	ELECT	3.3uF	20%	50V
C958	1-162-294-31	CERAMIC	0.001uF	10%	50V
C959	1-124-572-11	ELECT	100uF	20%	63V
C960	1-126-233-11	ELECT	22uF	20%	50V
C961	1-124-122-11	ELECT	100uF	20%	50V
C962	1-124-122-11	ELECT	100uF	20%	50V
C963	1-136-177-00	FILM	1uF	5%	50V
C964	1-136-165-00	FILM	0.1uF	5%	50V
C965	1-126-335-11	ELECT	220uF	20%	10V
C966	1-124-473-11	ELECT	1000uF	20%	10V
C971	1-164-159-11	CERAMIC	0.1uF		50V (AEP)
		< CONNECTOR >			
* CN952	1-564-341-11	PIN, CONNECTOR 7P			

CDP-X559ES

POWER

SW

VR

Ref. No.	Part No.	Description	Remark
* CN953	1-573-265-11	PIN, CONNECTOR 6P	
< DIODE >			
D951	8-719-210-29	DIODE F10P10Q	
D952	8-719-210-29	DIODE F10P10Q	
D953	8-719-210-29	DIODE F10P10Q	
D954	8-719-210-29	DIODE F10P10Q	
D960	8-719-937-49	DIODE RDF02M	
D961	8-719-200-02	DIODE 10E2	
D963	8-719-200-02	DIODE 10E2	
D964	8-719-110-04	DIODE RD7.5ES-B3	
D965	8-719-913-62	DIODE HZ36-2L	
D966	8-719-933-48	DIODE HZS7E3L	
D971	8-719-987-63	DIODE 1N4148M	
< IC >			
IC951	8-759-925-54	IC LM2940CT-5.0	
IC952	8-759-604-86	IC M5F7807	
IC953	8-759-636-16	IC M51957AL	
IC954	8-759-604-30	IC M5F7808	
< TRANSISTOR >			
Q951	8-729-924-90	TRANSISTOR 2SB1370-EF	
Q952	8-729-140-96	TRANSISTOR 2SD774-34	
< RESISTOR >			
R951	1-249-417-11	CARBON 1K 5% 1/4W	
R952	1-249-423-11	CARBON 3.3K 5% 1/4W	
R953	1-249-436-11	CARBON 39K 5% 1/4W	
R954	1-249-431-11	CARBON 15K 5% 1/4W	
R955	1-249-425-11	CARBON 4.7K 5% 1/4W	
R956	1-249-433-11	CARBON 22K 5% 1/4W	
R957	1-249-433-11	CARBON 22K 5% 1/4W	
△R958	1-212-875-00	FUSIBLE 56 5% 1/4W F	
R959	1-249-417-11	CARBON 1K 5% 1/4W	
△R960	1-216-425-11	METAL OXIDE 56 5% 1W F	
△R961	1-215-860-11	METAL OXIDE 33 5% 1W F	
R965	1-249-429-11	CARBON 10K 5% 1/4W	
< TERMINAL >			
* TB951	1-535-116-00	TERMINAL	
* TB952	1-535-118-00	TERMINAL	
* TB953	1-535-116-00	TERMINAL	
< THERMISTOR >			
TH901	1-808-065-11	THERMISTOR, POSITIVE 0.5	
TH902	1-808-065-11	THERMISTOR, POSITIVE 0.5	
TH903	1-806-882-11	THERMISTOR, POSITIVE 2.2	

Ref. No.	Part No.	Description	Remark
TH904	1-808-065-11	THERMISTOR, POSITIVE 0.5	

* 1-641-764-11	SW BOARD		

< CAPACITOR >			
C001	1-161-494-00	CERAMIC 0.022uF	25V
< RESISTOR >			
△R001	1-247-727-11	CARBON 10 5% 1/2W F	
△R002	1-247-727-11	CARBON 10 5% 1/2W F	
< SWITCH >			
S001	1-571-300-21	SWITCH, ROTARY (IN SW)	
S002	1-571-300-21	SWITCH, ROTARY (OUT SW)	

* 1-641-804-11	VR BOARD		

< CAPACITOR >			
C350	1-164-159-11	CERAMIC 0.1uF	50V
C351	1-164-159-11	CERAMIC 0.1uF	50V
< IC >			
IC350	8-759-962-08	IC BA6208	
< TRANSISTOR >			
Q350	8-729-900-80	TRANSISTOR DTC114ES	
< RESISTOR >			
R350	1-249-413-11	CARBON 470 5% 1/4W	
R351	1-249-417-11	CARBON 1K 5% 1/4W	
< VARIABLE RESISTOR >			
RV350	1-241-321-11	RES. VAR. CARBON 10KX3 (LINE OUT/PHONE LEVEL) (INCLUDING VOL MOTOR AND VOL LED)	

The components identified by mark △ or dotted line with mark △ are critical for safety. Replace only with part number specified.

Ref. No.	Part No.	Description	Remark
MISCELLANEOUS *****			
△121	1-558-181-21	CORD, POWER (E)	
△123	1-569-007-11	ADAPTER, CONVERSION 2P (E)	
△124	1-558-568-21	CORD, POWER (AEP)	
△125	1-559-555-21	CORD, POWER (UK)	
△205	8-848-244-11	DEVICE, OPTICAL KSS-272A	
△F991	1-532-066-00	FUSE, TIME-LAG (0.4A) (AEP, UK)	
△F991	1-532-215-00	FUSE, TIME-LAG (0.8A) (E)	
MD01	A-4604-347-A	MOTOR (L) ASSY	
△S991	1-570-156-11	SWITCH, PUSH (AC POWER) (1 KEY) (POWER)	
△T901	1-450-850-11	TRANSFORMER, POWER (AEP, UK)	
△T901	1-450-851-11	TRANSFORMER, POWER (E)	
△T902	1-450-852-11	TRANSFORMER, POWER (AEP, UK)	
△VS901	1-526-576-51	SELECTOR, POWER VOLTAGE (VOLTAGE SELECTOR) (E)	

ACCESSORIES & PACKING MATERIALS *****			
	1-465-592-11	COMMANDER, REMOTE (RM-D891) (GOLD) (INCLUDING ※1) (AEP)	
	1-465-593-11	COMMANDER, REMOTE (RM-D991) (BLACK) (INCLUDING ※1) (AEP, UK, E)	
	1-558-271-11	CORD, CONNECTION	
	1-590-925-31	CORD, CONNECTION	
	3-707-584-01	COVER, BATTERY (※1)	
	3-754-117-11	MANUAL, INSTRUCTION (ENGLISH, FRENCH, SPANISH, PORTUGUESE)	
	3-754-117-41	MANUAL, INSTRUCTION (GERMAN, DUTCH, SWEDISH, ITALIAN) (AEP)	
	4-847-802-00	SCREW (BLACK) (AEP, E)	
	4-847-802-11	SCREW (GOLD) (AEP)	
*	4-925-305-01	CUSHION (SIDE) (UK)	
*	4-942-314-01	CUSHION (UPPER)	
*	4-942-315-01	CUSHION (LOWER)	
*	4-951-271-01	INDIVIDUAL CARTON	

Ref. No.	Part No.	Description	Remark
***** HARDWARE LIST *****			
#1	7-682-664-09	SCREW +PSW 4X14	
#2	7-682-548-09	SCREW +BVTT 3X8 (S)	
#3	7-685-646-79	SCREW, TAPPING	
#4	7-685-870-01	SCREW +BVTT 3X5 (S)	
#5	7-682-560-04	SCREW +BVTT 4X6 (S)	
#6	7-682-547-04	SCREW +BVTT 3X6 (S)	
#7	7-682-549-09	SCREW +BVTT 3X10 (S)	
#8	7-682-545-09	SCREW +B 3X4	
#9	7-685-647-79	SCREW +P 3X10 TYPE2 SLIT	
#10	7-682-547-09	SCREW +BVTT 3X6 (S)	
#11	7-682-147-15	SCREW, TR	
#12	7-621-734-09	SET-SCT, HEX. 2.6X3	
#13	7-621-770-XX	SCREW +P 2.6X8	
#14	7-682-544-04	SCREW +P 3X3	
#15	7-685-131-19	SCREW +BTP 2.6X4 TYPE2 N-S	
#16	7-685-132-19	+ PTPWH (2.6X5)	
#17	7-688-003-12	W 3, MIDDLE	
#18	7-624-105-04	STOP RING 2.3. TYPE -E	

The components identified by mark △ or dotted line with mark △ are critical for safety. Replace only with part number specified.