

# CDP-X333ES

## SERVICE MANUAL

Canadian Model  
AEP Model  
UK Model

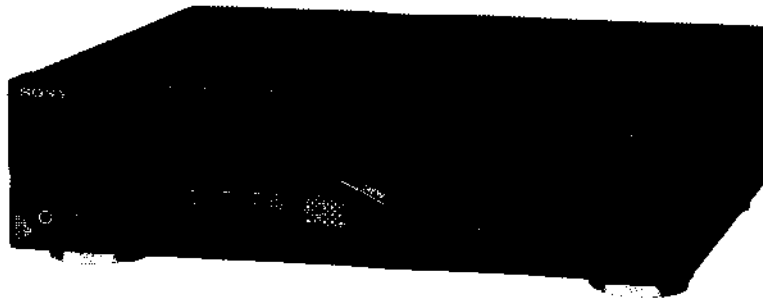

### SPECIFICATIONS

#### Compact disc player

Frequency response	2 Hz – 20 kHz $\pm 0.3$ dB
Signal to noise ratio	More than 115 dB
Dynamic range	More than 100 dB
Harmonic distortion	Less than 0.0018%
Channel separation	More than 110 dB

#### Outputs

LINE OUT (FIXED) (phono jacks)	Output level 2 V (at 50 kilohms) Load impedance over 10 kilohms
LINE OUT (VARIABLE) (phone jacks)	Output level max. 2 V (at 50 kilohms) Load impedance over 50 kilohms
DIGITAL OUT (OPTICAL) (optical output connector)	Wave length 660 nm Output level $-18$ dBm
HEADPHONES (Stereo phone jack)	Output level max. 28 mW Load impedance 32 ohms

#### General

Power requirements	AEP model: 220–230V AC, 50/60Hz UK model: 240V AC, 50/60Hz Canadian model: 120V AC, 60Hz
--------------------	---------------------------------------------------------------------------------------------------------

Model Name Using Similar Mechanism	CDP-X555ES
CD Transport Mechanism Type	CDM11H-6C
Optical Pick-Up Block Type	BU-6C

Power consumption	23 W
Dimensions (approx., including projections)	430×125×375 mm (w/h/d) (17×5×14 $7/8$ inches)
Weight (approx.)	10.7 kg (23 lbs 10 oz) Model for other countries 11 kg (24 lbs 5 oz)

#### Remote commander RM-D991

Remote control system	Infrared control
Power requirements	3 V DC with two batteries size AA (IEC designation R6)
Dimensions	62×18×175 mm (w/h/d) (2 $1/2$ × $23/32$ ×7 inches)
Weight	130 g (4.6 oz) Including batteries

#### Supplied accessories

Connecting cord	1 (2 phono plugs – 2 phono plugs)
Remote commander	1
R6 (size AA) batteries	2

Design and specifications subject to change without notice.



COMPACT DISC PLAYER  
**SONY**®



**TABLE OF CONTENTS**

<u>Section</u>	<u>Title</u>	<u>Page</u>
<b>1. GENERAL</b>		4
<b>2. ELECTRICAL BLOCK CHECKING</b>		5
<b>3. DIAGRAMS</b>		
3-1.	Block Diagram	6
3-2.	Semiconductor Lead Layouts	9
3-3.	Circuit Boards Location	10
3-4.	Printed Wiring Boards	11
3-5.	Schematic Diagram	15
<b>4. EXPLODED VIEWS</b>		
4-1.	Cabinet Section	20
4-2.	Front Panel Assy	21
4-3.	Chassis Assy	22
4-4.	Mechanism Block	23
4-5.	Base Unit	24
<b>5. ELECTRICAL PARTS LIST</b>		25

**SAFETY-RELATED COMPONENT WARNING!!**

COMPONENTS IDENTIFIED BY MARK  OR DOTTED LINE WITH MARK  ON THE SCHEMATIC DIAGRAMS AND IN THE PARTS LIST ARE CRITICAL TO SAFE OPERATION. REPLACE THESE COMPONENTS WITH SONY PARTS WHOSE PART NUMBERS APPEAR AS SHOWN IN THIS MANUAL OR IN SUPPLEMENTS PUBLISHED BY SONY.

**ATTENTION AU COMPOSANT AYANT RAPPORT À LA SÉCURITÉ!**

LES COMPOSANTS IDENTIFIÉS PAR UNE MARQUE  SUR LES DIAGRAMMES SCHÉMATIQUES ET LA LISTE DES PIÈCES SONT CRITIQUES POUR LA SÉCURITÉ DE FONCTIONNEMENT. NE REMPLACER CES COMPOSANTS QUE PAR DES PIÈCES SONY DONT LES NUMÉROS SONT DONNÉS DANS CE MANUEL OU DANS LES SUPPLÉMENTS PUBLIÉS PAR SONY.

For the European Countries

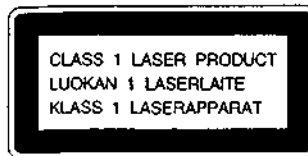

This Compact Disc player is classified as a CLASS 1 LASER Product. The CLASS 1 LASER PRODUCT label is located on the rear exterior.

**NOTES ON HANDLING THE OPTICAL PICK-UP BLOCK OR BASE UNIT**

The laser diode in the optical pick-up block may suffer electrostatic breakdown because of the potential difference generated by the charged electrostatic load, etc. on clothing and the human body.

During repair, pay attention to electrostatic breakdown and also use the procedure in the printed matter which is included in the repair parts.

The flexible board is easily damaged and should be handled with care.

**NOTES ON LASER DIODE EMISSION CHECK**

The laser beam on this model is concentrated so as to be focused on the disc reflective surface by the objective lens in the optical pick-up block. Therefore, when checking the laser diode emission, observe from more than 30cm away from the objective lens.

**MODEL IDENTIFICATION**

—Model Number Label—

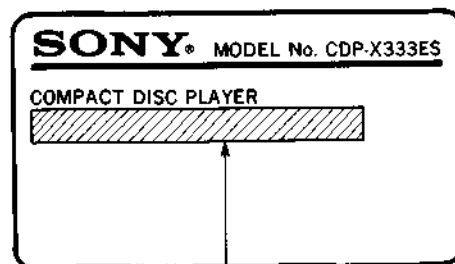

Canadian Model : AC: 120V 60Hz 23W  
 AEP Model : AC: 220-230V~50/60Hz  
 UK Model : AC: 240V~50/60Hz

## PROTECTION OF EYES FROM LASER BEAM DURING SERVICING

This set employs a laser. Therefore, be sure to follow carefully the instructions below when servicing.

### CAUTION

Use of controls or adjustments or performance of procedures other than those specified herein may result in hazardous radiation exposure.

### 1. Laser Diode Properties

- Material: GaAlAs
  - Wavelength: 780 nm
  - Emission Duration: continuous
  - Laser Output Power: less than 44.6  $\mu$ W\*
- \* This output is the value measured at a distance of 200 mm from the objective lens surface on the Optical Pick-up Block.

2. During service, do not take the Optical Pick-up Block apart, and do not adjust the APC circuit. If there is a breakdown in the APC circuit (including laser diode), replace the entire Optical Pick-up Block (including APC board).

## BESKYTTELSE AF ØJNE MOD LASERSTRÅLING UNDER SERVICE

I dette apparat anvendes laserlys. Derfor skal nedenstående instruktioner nøje følges under service.

Følg iverigt instruktionerne i servicemanualen.

### ADVARSEL!!

Under service må øjnene ikke komme nær objektiv-linsen på den optiske pick-up enhed. I tilfælde af at det er nødvendigt at kontrollere udsendelsen af laserlys, skal det ske i en afstand af mere end 25 cm fra den optiske pick-up.

### 1. Laser-dioe data

- Materiale: GaAlAs
  - Bølgelængde: 780 nm
  - Udstråling: Kontinuerlig
  - Laseroutput: Max. 0,4 mW\*
- \* Målt i 1,6 mm afstand fra overfladen af objektiv-linsen på den optiske pick-up enhed.
- Klassifikation: Klasse IIIb.

2. Adskil aldrig den optiske pick-up enhed under service, og juster ikke APC kredsløbet (Automatic Power Control). Hvis APC kredsløbet (incl. laser-dioden) bryder ned, skal hele den optiske pick-up enhed (incl. APC printkortet) udskiftes.

## LASER ADVARSEL MÆRKNING

Følgende mærkning findes indvendig i apparatet:

### 1. Advarsel Mærkning

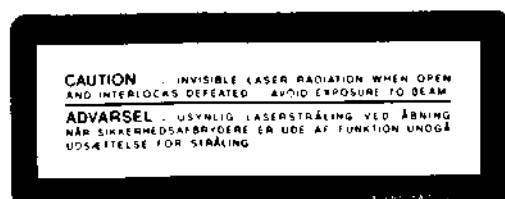

**VAROITUS:** Laite sisältää, laserdiodin, joka lähettää (näkyvätöntä) silmille vaarallista lasersäteilyä.

Front Panel

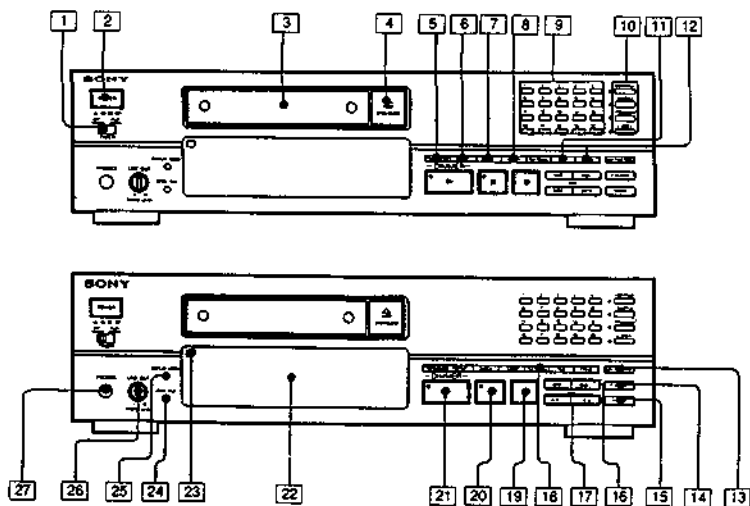

Refer to the pages indicated in ● for details.

- 1 TIMER switch ●
- 2 POWER switch ●
- 3 Disc tray ●
- 4 ▲ OPEN/CLOSE button ●
- 5 TIME/MEMO button ●
- 6 REPEAT button ●
- 7 CHECK (program check) button ●
- 8 CLEAR (program clear) button ●
- 9 Numeric buttons ●
- 10 Play mode buttons ●
- CONTINUE button ●
- SHUFFLE button ●
- PROGRAM button ●
- C. (custom) INDEX button ●
- 11 FILE (custom file) button ●
- 12 ERASE (memory erase) button ●
- 13 EDI/TIME FADE button ●
- 14 P.(peak) SEARCH button ●
- 15 FADER (fade in/fade out) button ●
- 16 ◀▶ (manual search) buttons ●
- 17 ◀▶▶AMS\* buttons ●
- 18 FILE RECALL button ●
- 19 ■ (stop) button ●
- 20 || (pause) button ●
- 21 ▶ (play) button ●
- 22 Display window ●
- 23 Remote sensor ●
- 24 LEVEL FILE button ●
- 25 DISPLAY MODE button ●
- 26 LINE OUT/PHONE LEVEL control ●
- 27 PHONES jack ●

\* AMS is the abbreviation of Automatic Music Sensor

Remote Commander (RM-D991)

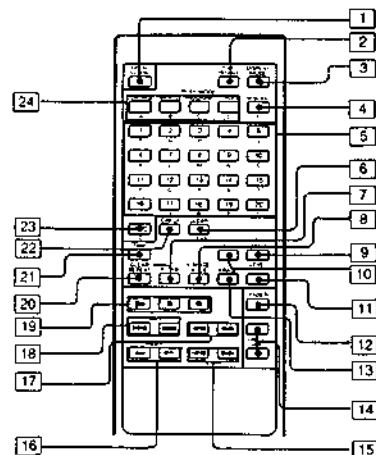

Refer to the pages indicated in ● for details.

- 1 ▲ OPEN/CLOSE button ●
- 2 FILE RECALL button ●
- 3 DISPLAY MODE button ●
- 4 M.(music) SCAN button ●
- 5 Numeric buttons ●
- 6 CLEAR button ●
- 7 A → B repeat button ●
- 8 AUTO SPACE (auto space)/A.CUE (auto cue) button ●, ●
- 9 MEMO INPUT button ●
- 10 FILE (custom file) button ●
- 11 LEVEL FILE button ●
- 12 FADER (fade in/fade out) button ●
- 13 ERASE button ●
- 14 LINE OUT LEVEL (line out/headphone level) buttons ●
- 15 ◀▶ SLOW (low speed manual search) buttons ●
- 16 ◀▶ INDEX buttons ●
- 17 ◀▶▶ (manual search) buttons ●
- 18 ◀▶▶AMS\* buttons ●
- 19 ■ (stop) button ●
- || (pause) button ●
- ▶ (play) button ●
- 20 CLEAR REPEAT (A → B repeat clear/repeat) button ●
- 21 TIME button ●
- 22 CHECK button ●
- 23 > 20 (over 20) button ●
- 24 PLAY MODE buttons ●
- CONTINUE button ●
- SHUFFLE button ●
- PROGRAM button ●
- C. INDEX button ●

Buttons with yellow letters (A, B, . . . . .) are for writing a disc memo (page 78)

SECTION 1  
GENERAL

This section is extracted from  
instruction manual.





3-2. SEMICONDUCTOR LEAD LAYOUTS

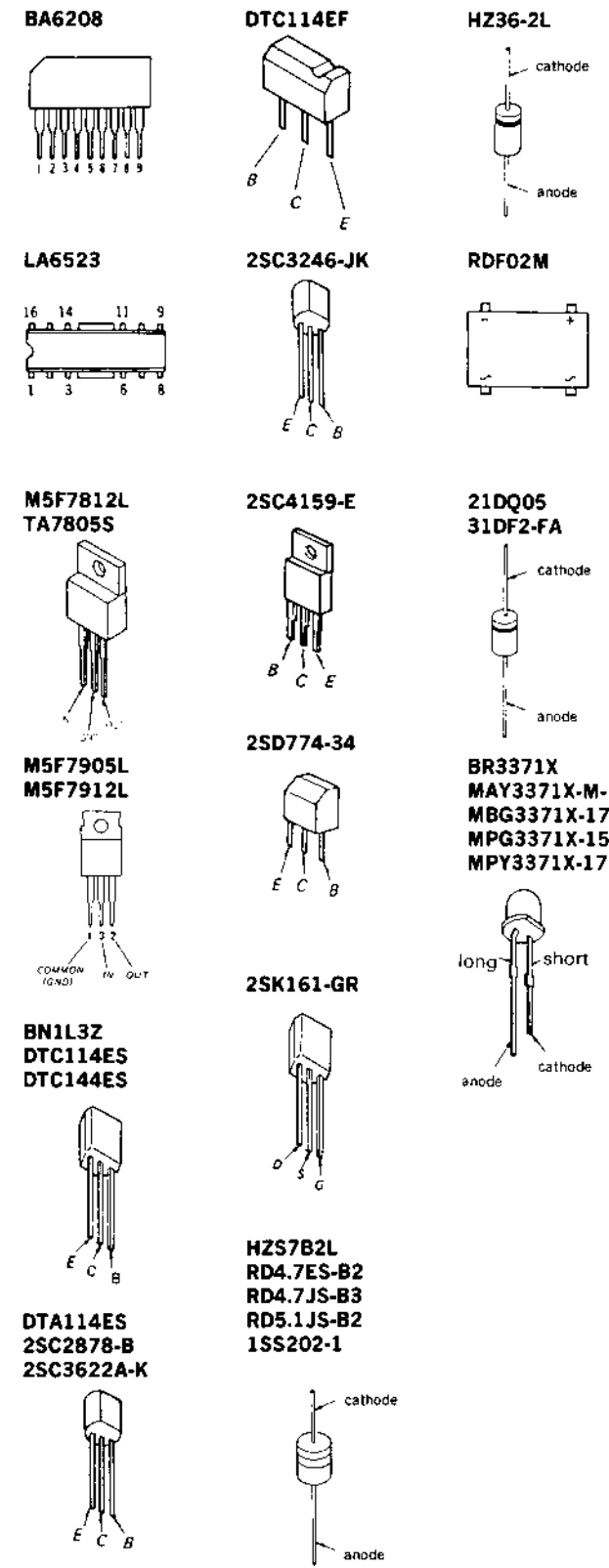
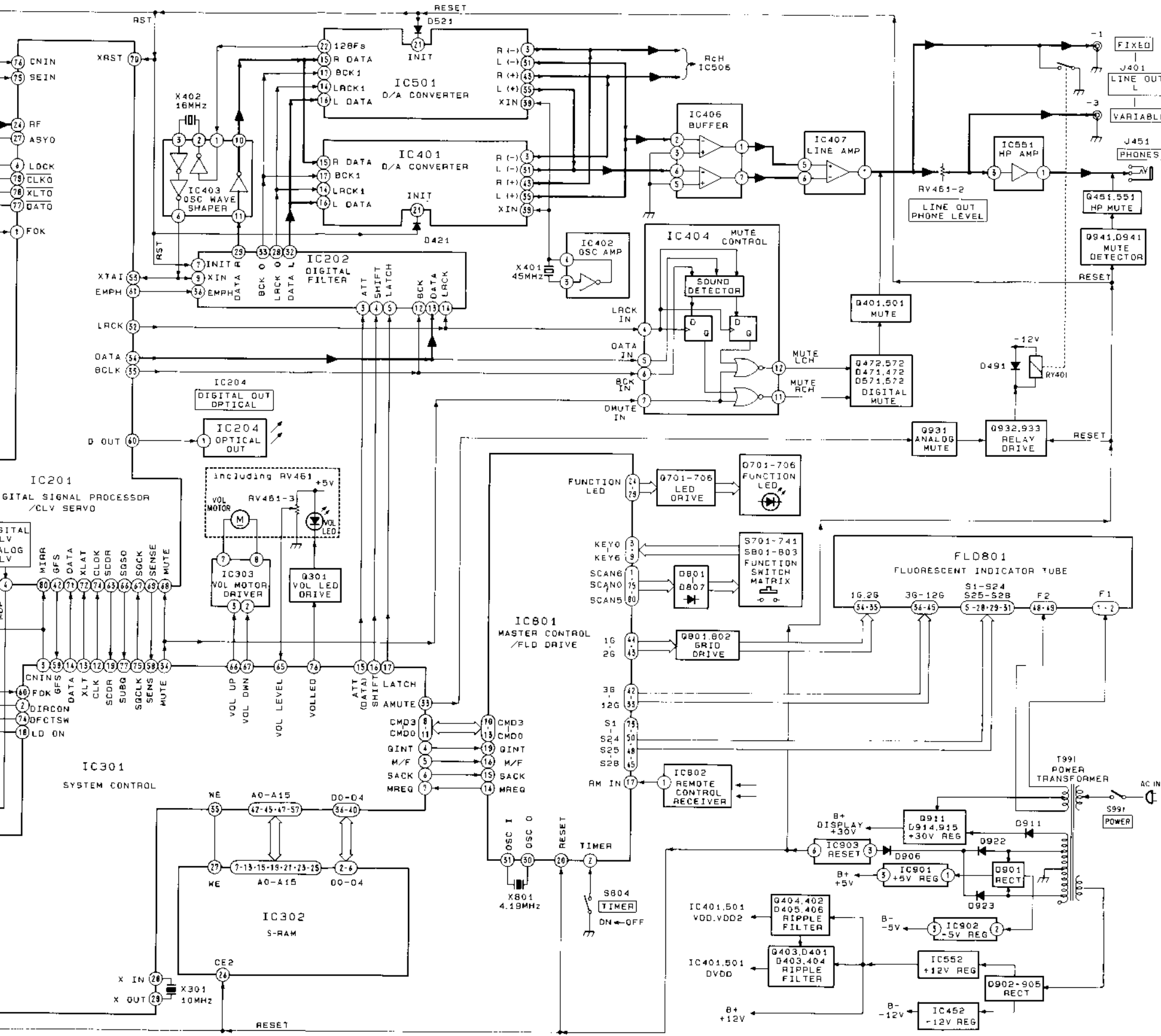

3-3. CIRCUIT BOARDS LOCATION

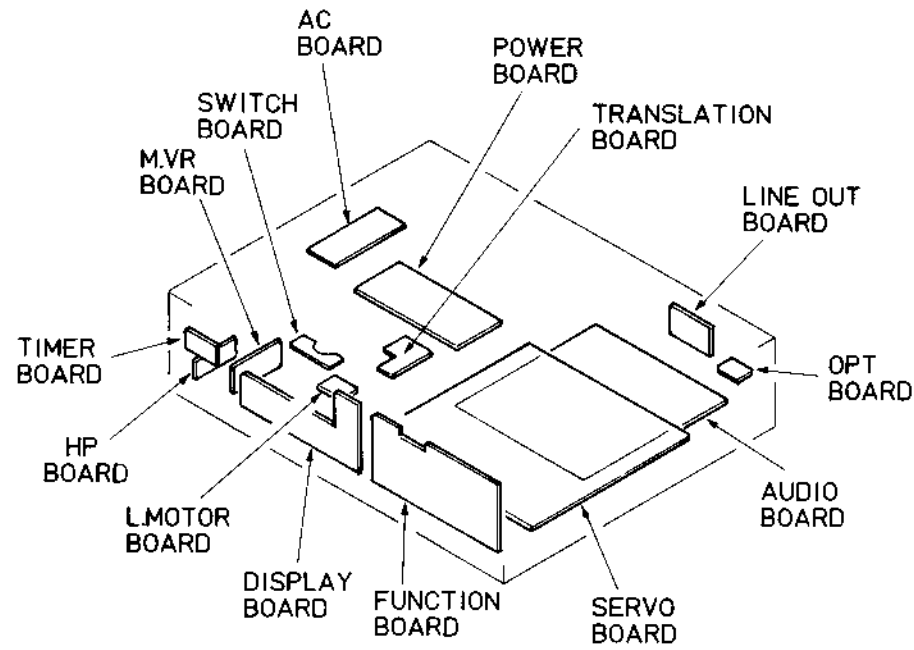

Note:

- — parts extracted from the component side.
- — parts mounted on the conductor side.
- — Through hole.
- — Pattern on the side which is seen.
- — Pattern on the other side.

• Semiconductor Location

Ref. No.	Location	Ref. No.	Location
D401	K-17	IC902	F-2
D403	J-16	IC903	I-2
D404	J-16		
D405	F-16	Q101	G-6
D406	F-16	Q301	I-8
D421	F-18	Q401	G-14
D471	F-14	Q402	G-16
D472	F-14	Q403	K-16
D491	E-10	Q404	G-16
D501	I-13	Q451	G-20
D521	I-18	Q472	F-13
D571	J-14	Q501	I-14
D572	F-14	Q551	G-20
D701	B-23	Q572	J-14
D702	B-24	Q701	D-23
D703	D-28	Q702	D-23
D704	D-28	Q703	C-23
D705	C-28	Q704	C-23
D706	C-28	Q705	C-24
D801	I-27	Q706	C-24
D802	I-27	Q801	J-24
D803	I-27	Q802	J-24
D804	I-27	Q911	B-3
D805	I-27	Q931	F-14
D806	I-27	Q932	F-14
D807	I-27	Q933	F-14
D901	B-5	Q941	E-19
D902	C-4		
D903	C-4		
D904	C-4		
D905	B-4		
D906	I-2		
D907	J-5		
D911	B-4		
D914	A-3		
D915	A-4		
D922	A-5		
D923	A-6		
D941	E-19		
IC101	G-4		
IC102	F-6		
IC103	F-7		
IC104	F-9		
IC201	I-4		
IC202	I-20		
IC204	K-1		
IC301	I-7		
IC302	J-6		
IC303	I-9		
IC401	G-18		
IC402	J-16		
IC403	H-19		
IC404	G-19		
IC406	G-15		
IC407	G-15		
IC452	G-13		
IC501	I-18		
IC506	I-15		
IC507	I-15		
IC551	F-20		
IC552	I-13		
IC801	J-26		
IC802	K-28		
IC901	F-3		

3-4. PRINTED WIRING BOARDS • Refer to page 9 for Semiconductor Lead Layouts.

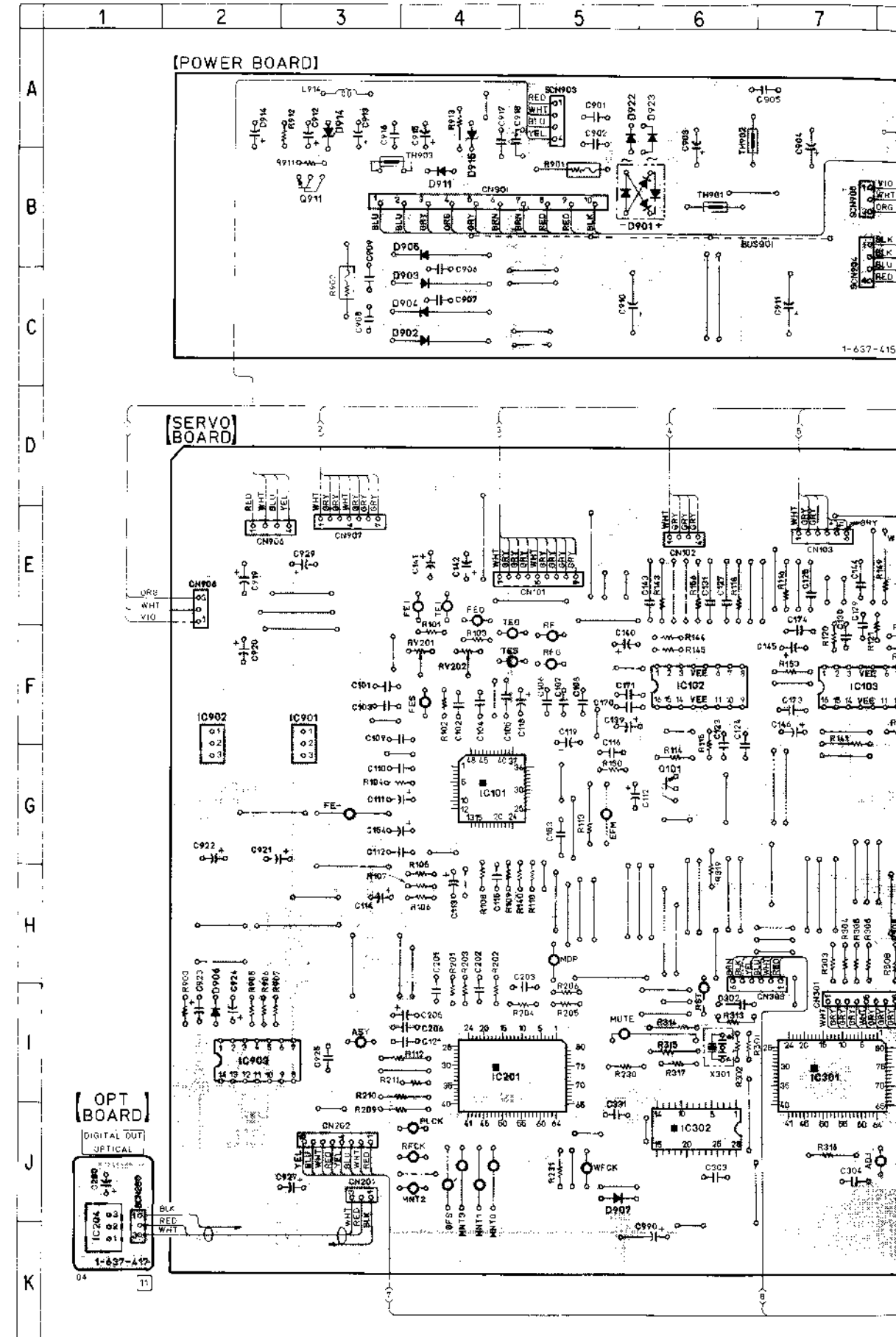



3-4. PRINTED WIRING BOARDS • Refer to page 9 for Semiconductor Lead Layouts.

Location	Location
02	F-2
03	I-2
01	G-6
01	I-8
01	G-14
02	G-16
03	K-16
04	G-16
51	G-20
72	F-13
01	I-14
51	G-20
72	J-14
01	D-23
02	D-23
03	C-23
04	C-23
05	C-24
06	C-24
01	J-24
02	J-24
11	B-3
31	F-14
32	F-14
33	F-14
41	E-19

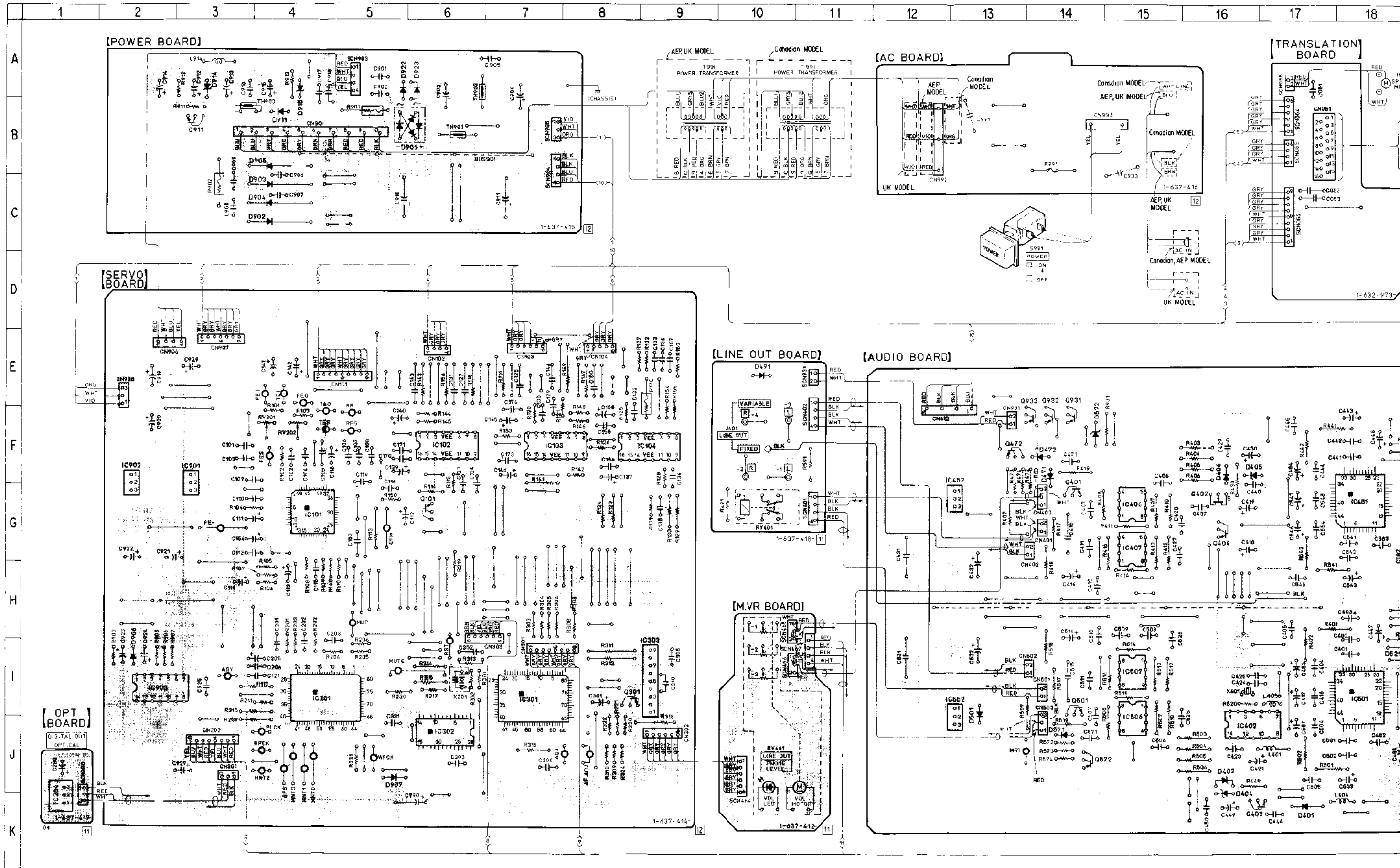

11 12 13 14 15 16 17 18 19 20 21 22 23 24 25 26 27 28 29

[AC BOARD]

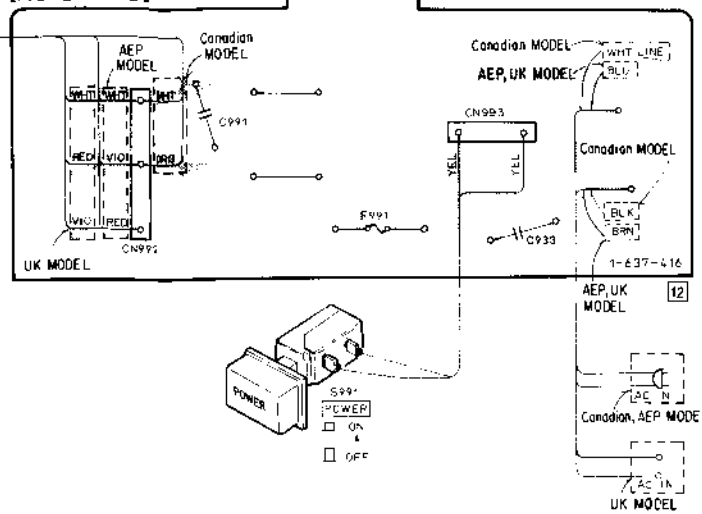

[TRANSLATION BOARD]

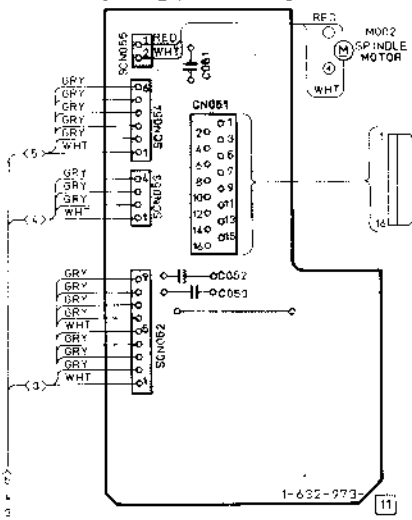

[L MOTOR BOARD]

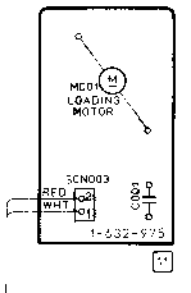

[SWITCH BOARD]

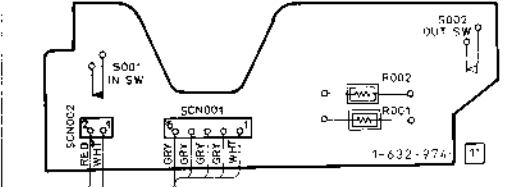

[FUNCTION BOARD]

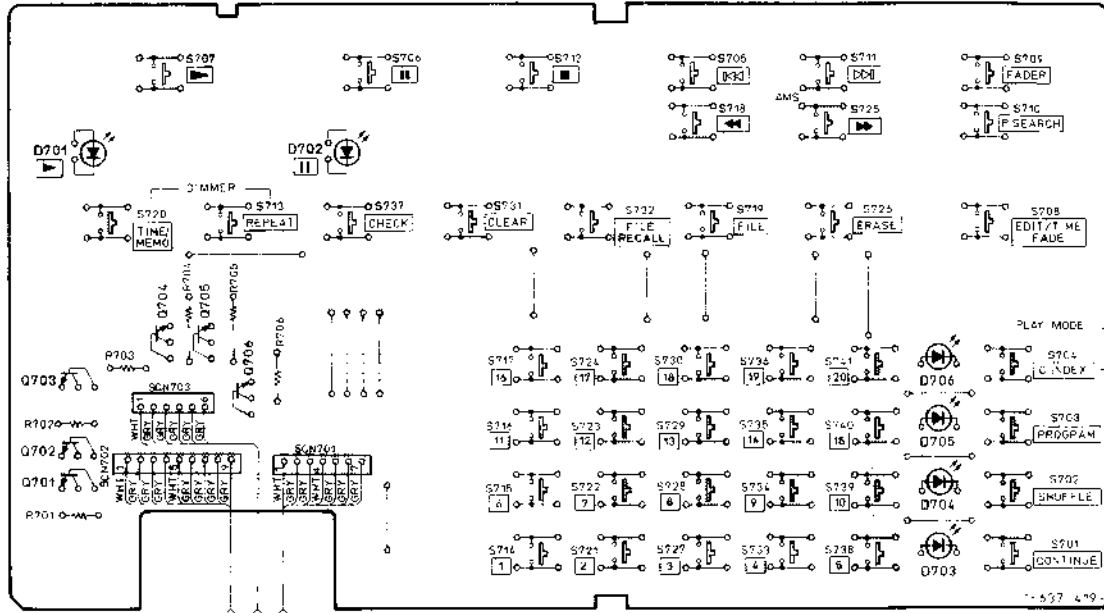

[AUDIO BOARD]

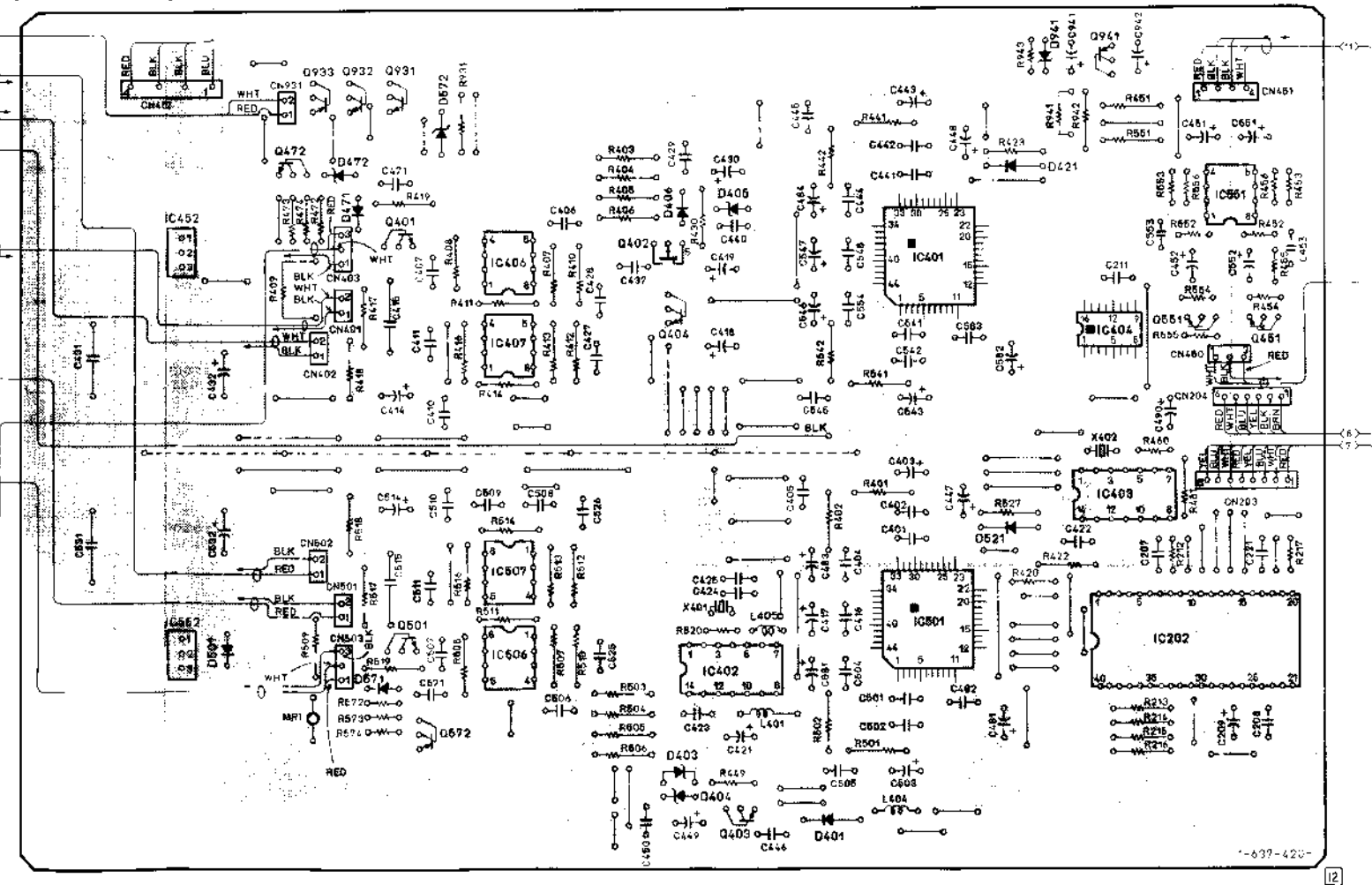

[DISPLAY BOARD]

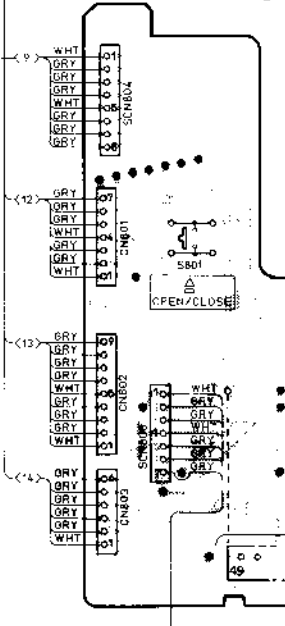

[HP BOARD]

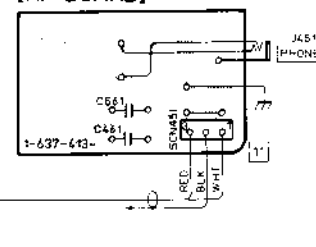

[TIMER BOARD]

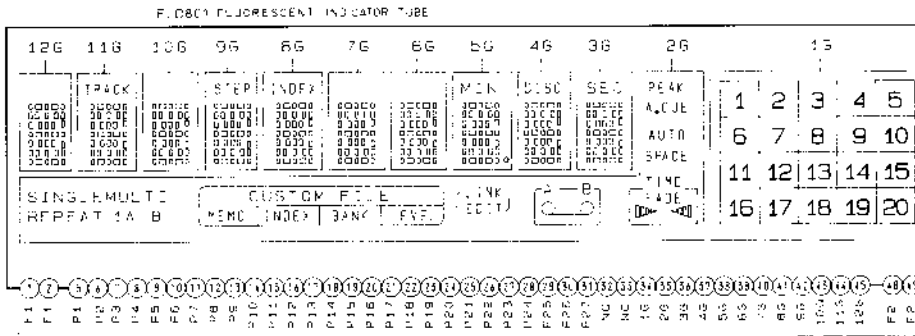
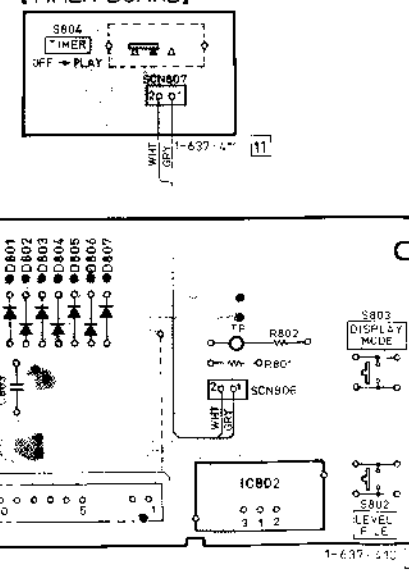

3-5. SCHEMATIC DIAGRAM • Refer to page 19 for IC Block Diagrams.

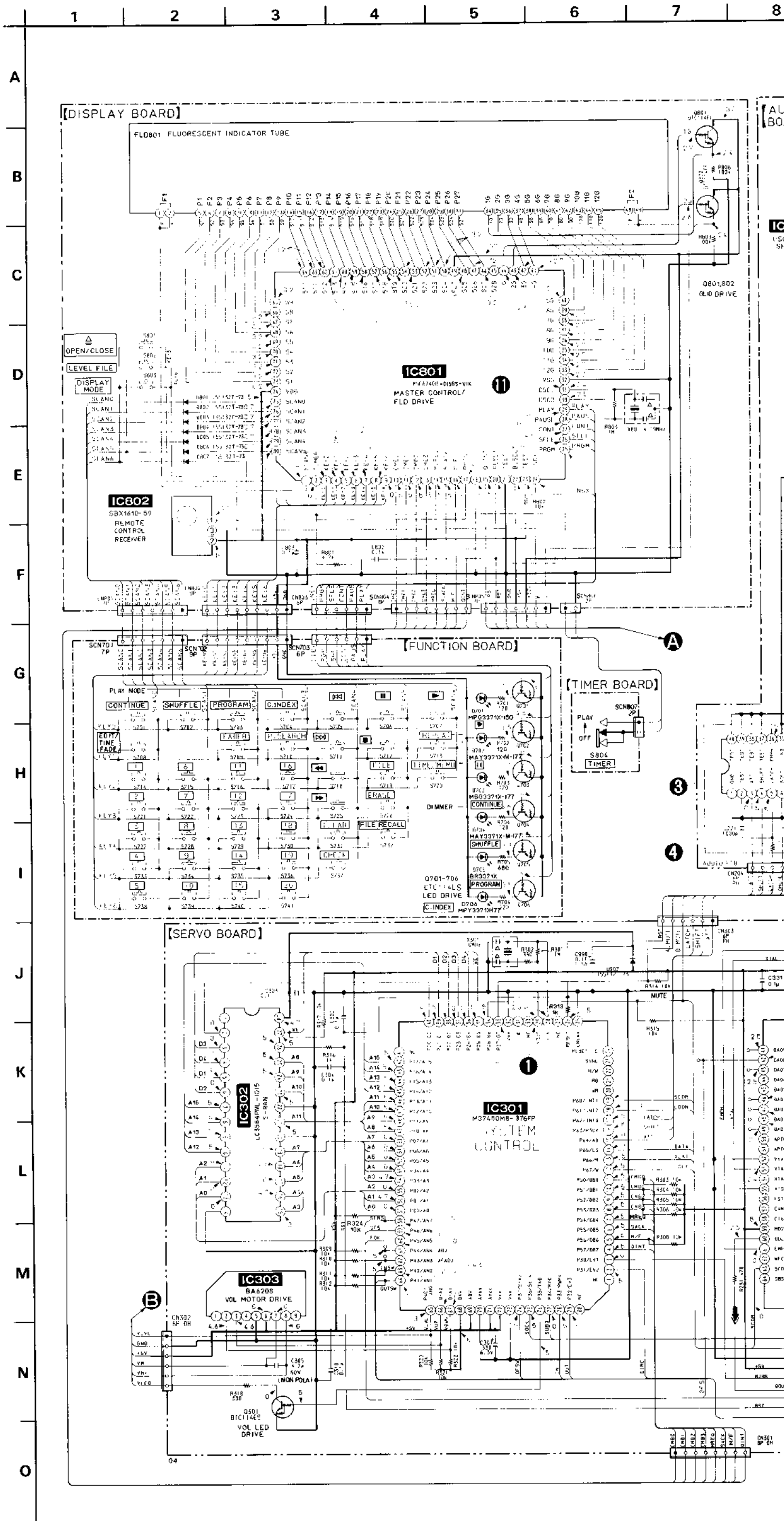

Note:

- All capacitors are in  $\mu\text{F}$  unless otherwise noted.  $\text{pF}$ :  $\mu\text{F}$  50WV or less are not indicated except for electrolytics and tantalums.
- All resistors are in  $\Omega$  and  $\frac{1}{4}\text{W}$  or less unless otherwise specified.
- % : indicates tolerance.
- $\Delta$  : internal component.
- $\square$  : nonflammable resistor.
- $\square$  : fusible resistor.

<p><b>Note:</b> The components identified by mark <math>\Delta</math> or dotted line with mark <math>\Delta</math> are critical for safety. Replace only with part number specified.</p>	<p><b>Note:</b> Les composants identifiés par une marque <math>\Delta</math> sont critiques pour la sécurité. Ne les remplacer que par une pièce portant le numéro spécifié.</p>
----------------------------------------------------------------------------------------------------------------------------------------------------------------------------------------------	--------------------------------------------------------------------------------------------------------------------------------------------------------------------------------------

- $\text{---}$  : B+ Line
- $\text{---}$  : B- Line
- $\square$  : adjustment for repair.
- Voltage and waveforms are dc with respect to ground under on signal conditions  
no mark: POWER ON
- Voltages are taken with a VOM (input Impedance 10M $\Omega$ )  
Voltage variations may be noted due to normal production tolerances
- Waveforms are taken with an oscilloscope.  
Voltage variations may be noted due to normal production tolerances.
- Circled numbers refer to waveforms.
- Signal path.  
  - ➔ : CD
  - ➔➔ : DIGITAL OUT

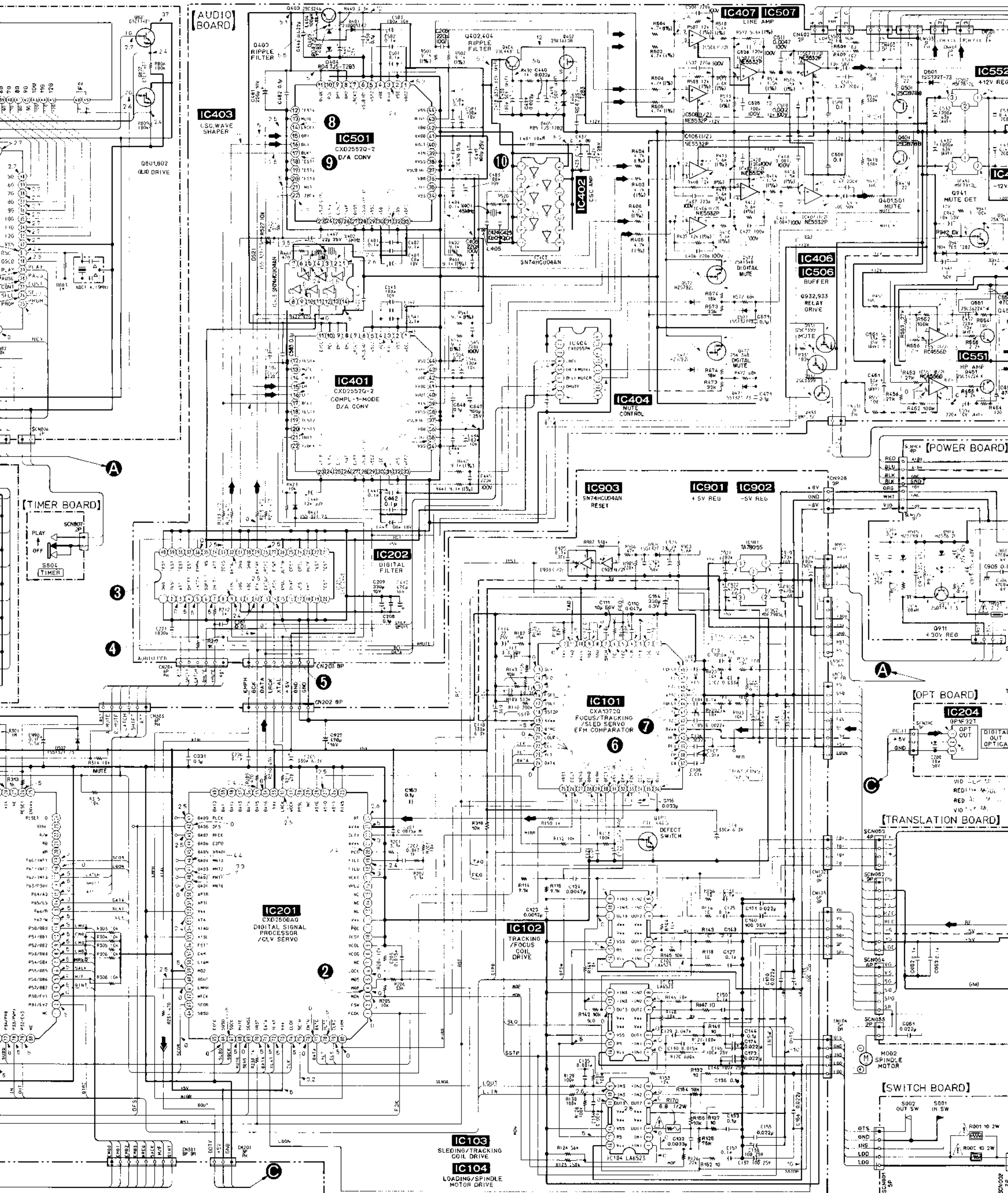

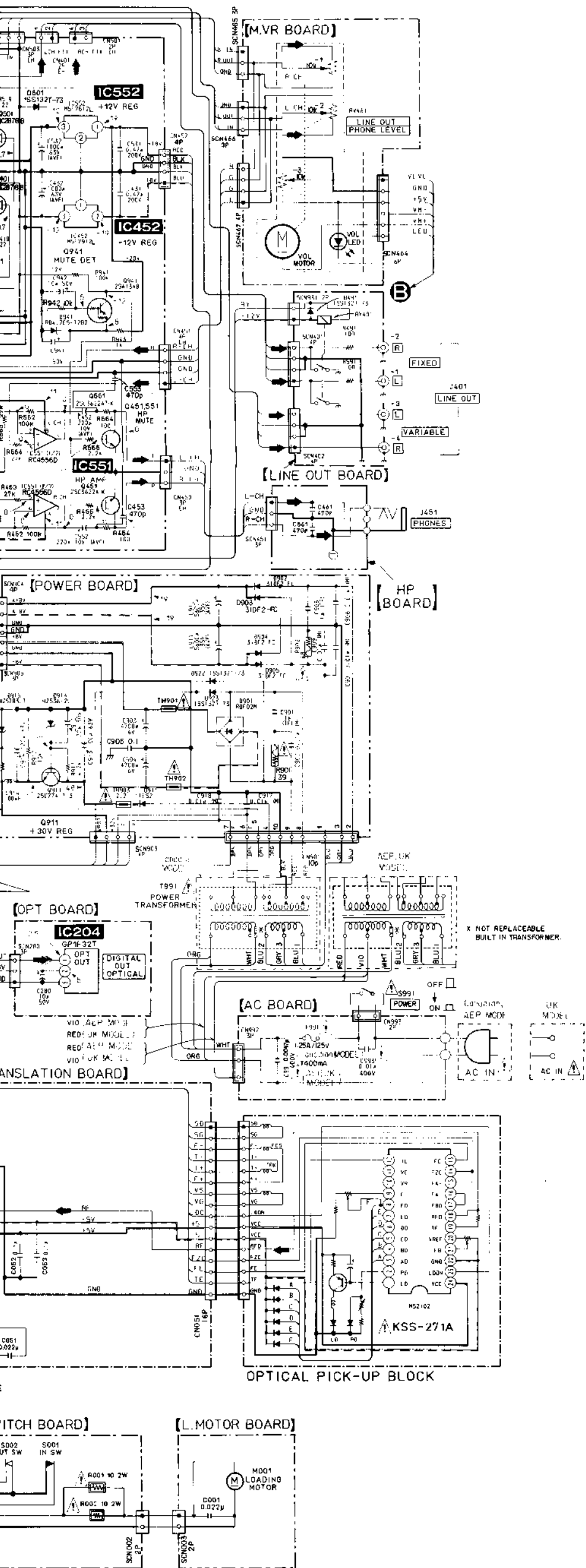

• Display Panel Terminal

	12G	11G	10G	9G	8G	7G	6G	5G	4G	3G	2G	1G
P1	a	a	a	a	a	a	a	a	a	a	REPEAT	1
P2	b	b	b	b	b	b	b	b	b	b	1	2
P3	c	c	c	c	c	c	c	c	c	c	A-	3
P4	d	d	d	d	d	d	d	d	d	d	B	4
P5	e	e	e	e	e	e	e	e	e	e	A.CUE	5
P6	f	f	f	f	f	f	f	f	f	f	AUTO SPACE	6
P7	g	g	g	g	g	g	g	g	g	g	SINGLE	7
P8	h	h	h	h	h	h	h	h	h	h	MULTI	8
P9	i	i	i	i	i	i	i	i	i	i	CUSTOM FILE	9
P10	j	j	j	j	j	j	j	j	j	j	MEMO	10
P11	k	k	k	k	k	k	k	k	k	k	INDEX	11
P12	l	l	l	l	l	l	l	l	l	l	BANK	12
P13	m	m	m	m	m	m	m	m	m	m	LEVEL	13
P14	n	n	n	n	n	n	n	n	n	n	[LINK]	14
P15	o	o	o	o	o	o	o	o	o	o	EDIT	15
P16	p	p	p	p	p	p	p	p	p	p	-	16
P17	q	q	q	q	q	q	q	q	q	q	A	17
P18	r	r	r	r	r	r	r	r	r	r	B	18
P19	s	s	s	s	s	s	s	s	s	s	OO	19
P20	t	t	t	t	t	t	t	t	t	t	TIME	20
P21	u	u	u	u	u	u	u	u	u	u	FADE	-
P22	v	v	v	v	v	v	v	v	v	v	▶▶	-
P23	w	w	w	w	w	w	w	w	w	w	◀◀	-
P24	x	x	x	x	x	x	x	x	x	x	-	-
P25	y	y	y	y	y	y	y	y	y	y	-	-
P26	-	TRACK	-	STEP	INDEX	-	-	MIN	DISC	SEC	PEAK	▶
P27	-	-	-	-	-	-	-	O	-	-	-	-

• Waveforms

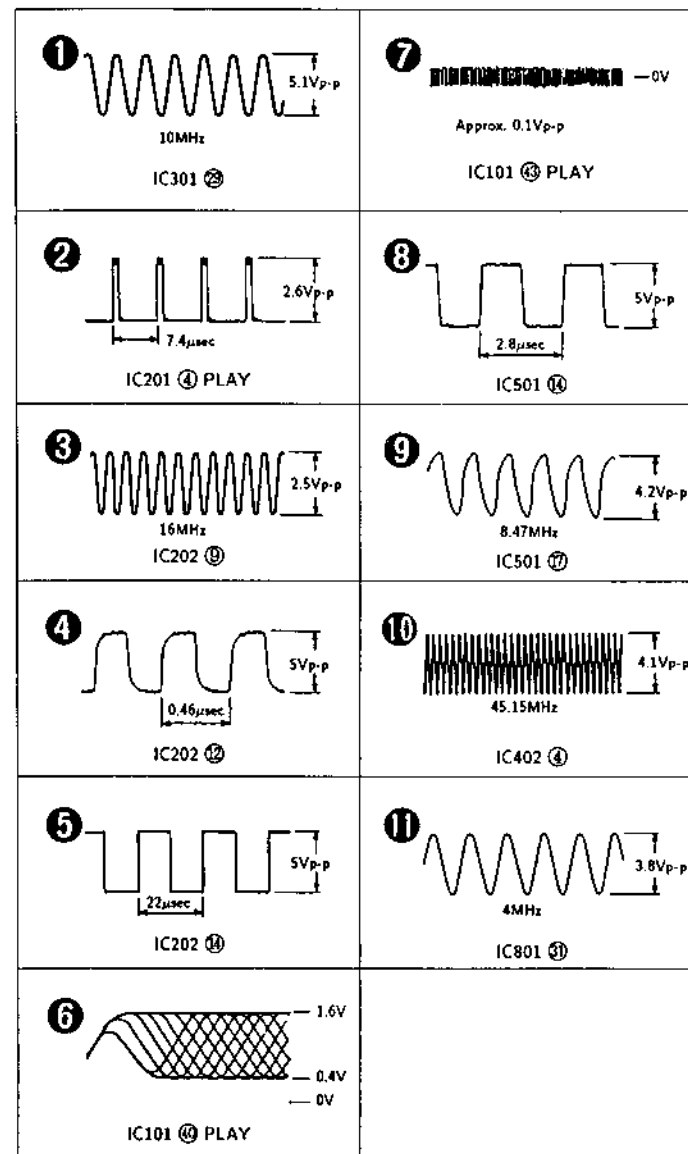





## SECTION 4 EXPLODED VIEWS

reference  
are not  
checked since  
or routine  
be anticipated.

- XX, -X mean standardized parts, so they may have some differences from the original one.



- Color Indication of Appearance Parts

Example:

KNOB, BALANCE (WHITE)...(RED)

Parts Color Cabinet's Color

- Hardware(# mark) list is given in the last of this parts list.

The components identified by mark  or dotted line with mark  are critical for safety. Replace only with part number specified.

Les composants identifiés par une marque  sont critiques pour la sécurité. Ne les remplacer que par une pièce portant le numéro spécifié.

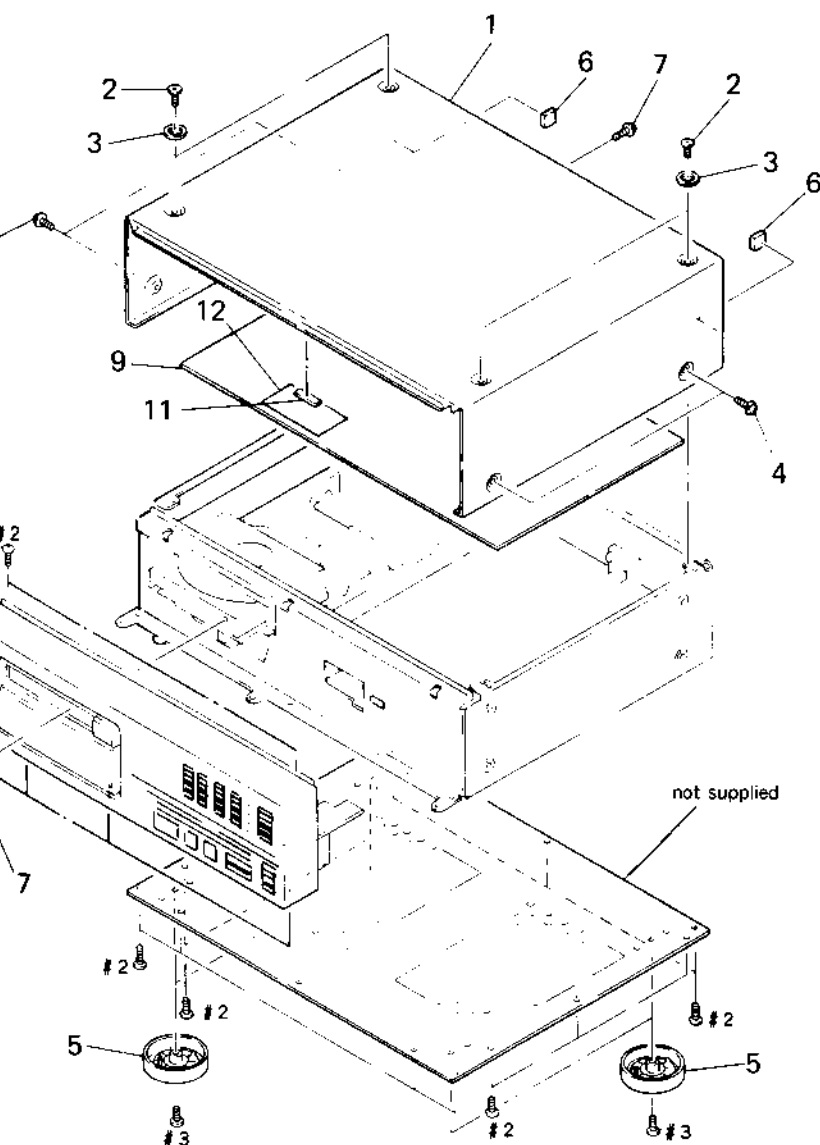

Description	Remark	Ref.No.	Part No.	Description	Remark
BASE		7	4-929-074-01	SCREW (3X8)	
SCREW (M3X6), FLAT HEAD		8	X-4941-212-1	PANEL ASSY, LOADING	
CUTCHEON (TOP PLATE)		9	A-4675-309-A	REINFORCEMENT (TOP PLATE) ASSY	
SCREW		10	4-884-635-00	BASE, ORNAMENTAL	
DOT ASSY (AEP, UK)		11	* 4-918-690-01	SHEET, ADHESIVE	
DOT ASSY (Canadian)		12	* 4-923-563-11	CUSHION	
SHIM (CASE)					

### 4-2. FRONT PANEL ASSY

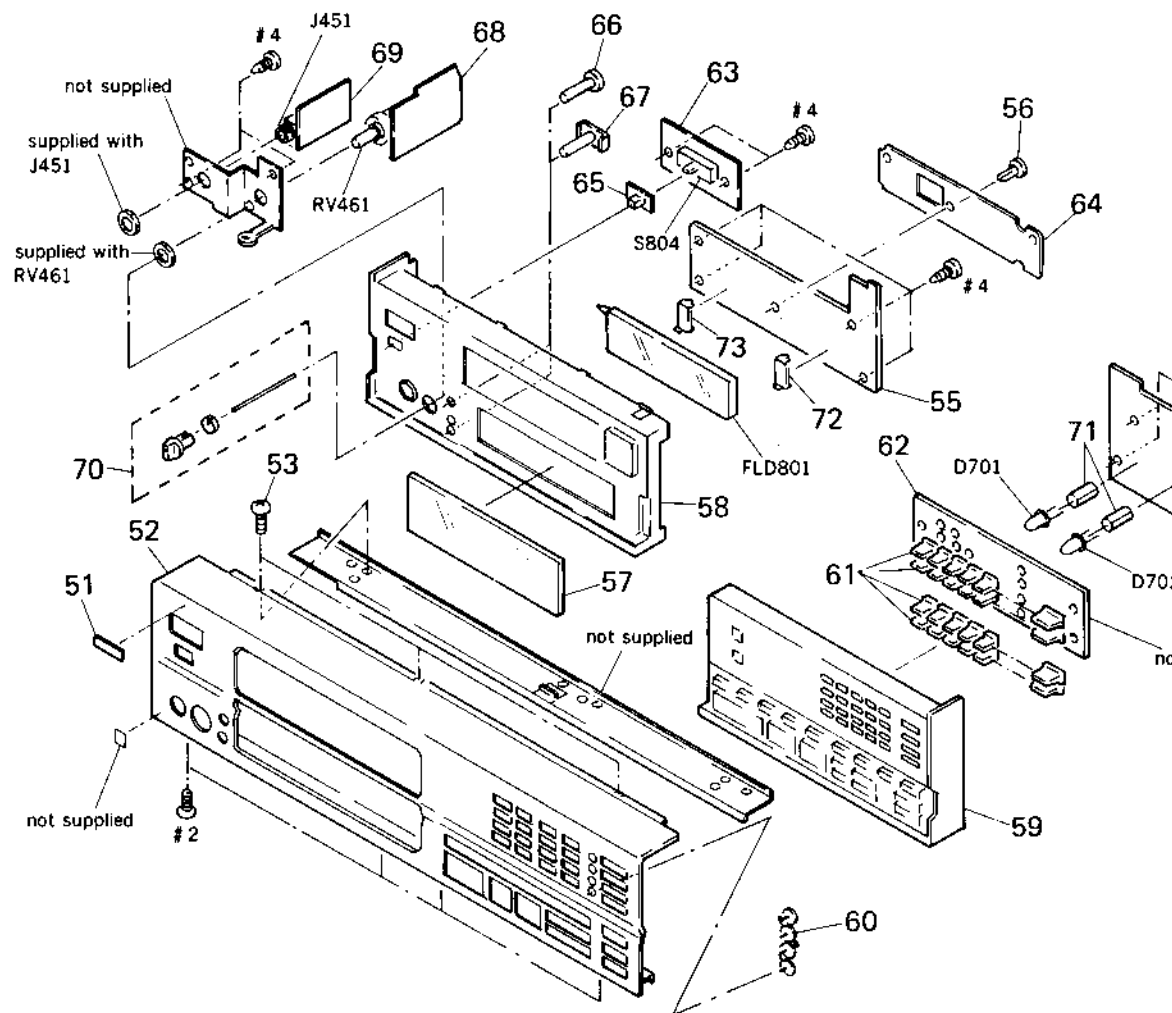

Ref.No.	Part No.	Description	Remark	Ref.No.	Part No.	Description
51	4-908-848-01	EMBLEM, SONY		66	4-941-084-01	BUTTON (DISPLAY MO)
52	4-941-221-01	PANEL (FRONT) (AEP)		67	4-941-085-01	BUTTON (LEVEL FILE)
53	3-703-685-21	SCREW (+BV 3X8)		68	* 1-637-412-11	M.V.R. BOARD
54	* 1-637-419-11	FUNCTION BOARD		69	* 1-637-413-11	HP BOARD
55	* 1-637-410-11	DISPLAY BOARD		70	A-4604-698-A	KNOB (HP) ASSY
56	3-531-576-11	RIVET		71	* 4-923-532-21	SPACER, LED
57	4-941-087-01	PLATE, INDICATION		72	* 4-928-052-01	HOLDER (RIGHT)
58	X-4941-208-1	PANEL (BASE) (L) ASSY		73	* 4-928-053-01	HOLDER (LEFT)
59	X-4941-549-1	PANEL (R) ASSY		D701	8-719-970-07	DIODE MPG3371X-150
60	4-941-093-01	INDICATOR		D702	8-719-971-52	DIODE MAY3371X-M-1
61	4-941-079-01	BUTTON (20 KEY)		FLD801	1-519-622-11	INDICATOR TUBE, FLU
62	* 4-941-092-01	ABSORBENT (20 KEY), VIBRATION		J451	1-568-519-31	JACK, LARGE TYPE (
63	* 1-637-411-11	TIMER BOARD		RV461	1-241-321-11	RES. VAR. CARBON 10
64	* 4-941-220-01	COVER (CABLE)				(LINE OUT/PHONE LEV
65	4-922-518-11	KNOB (TIMER)		S804	1-570-157-51	SWITCH, SLIDE (TIM





4-4. MECHANISM BLOCK  
(CDM11H-6C)

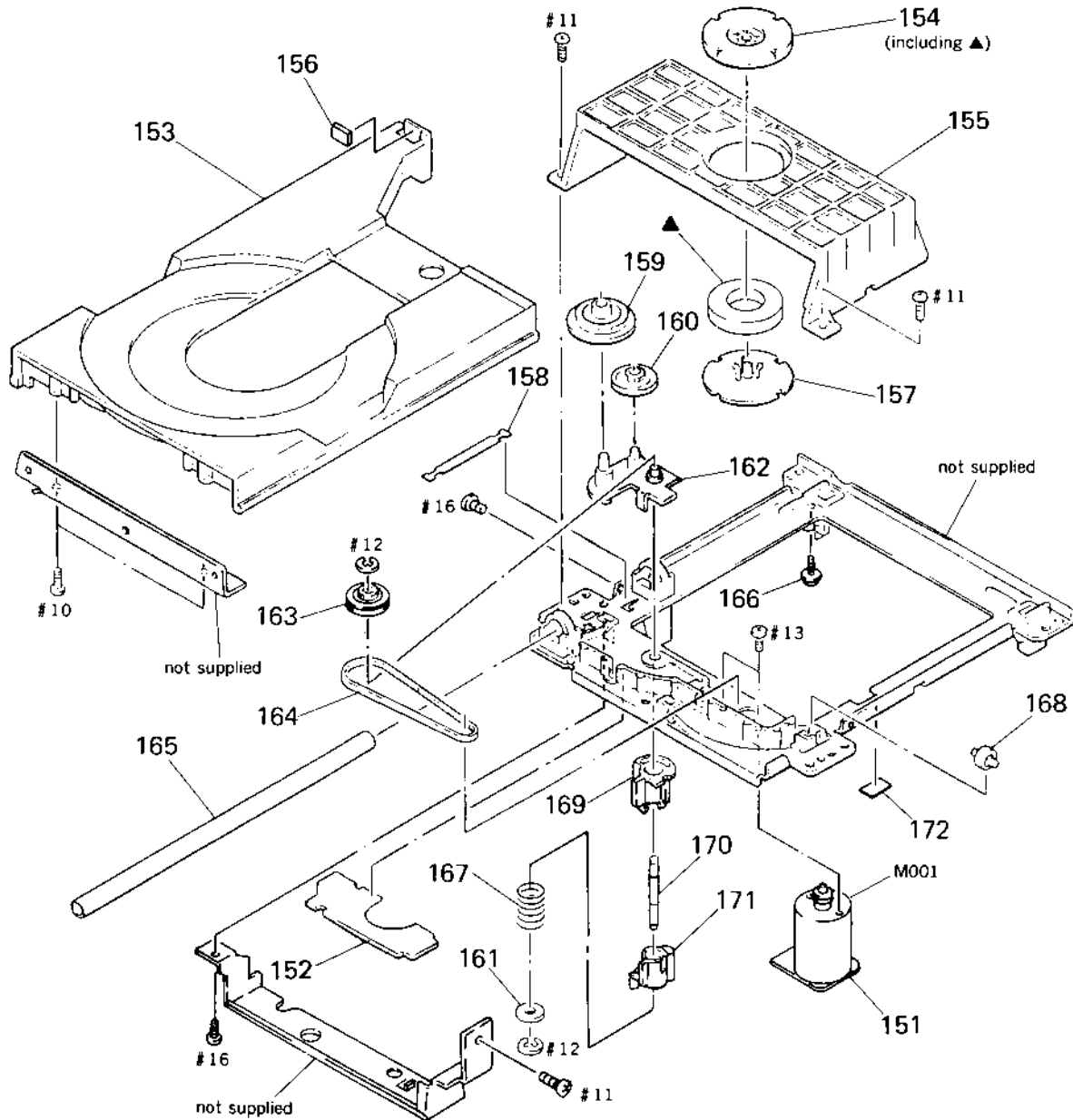

Ref. No.	Part No.	Description	Remark	Ref. No.	Part No.	Description	Remark
151	* 1-632-975-11	L. MOTOR BOARD		163	4-929-724-01	PULLEY (B)	
152	* 1-632-974-11	SWITCH BOARD		164	4-927-649-01	BELT	
153	* 4-927-642-01	TABLE (EXL). DISK		165	4-927-617-01	BAR, GUIDE	
154	A-4665-024-A	MAGNET ASSY		166	* 4-917-583-21	BRACKET, YOKE	
155	* 4-927-638-03	HOLDER (A, P)		167	3-659-338-00	SPRING, COMPRESSION	
156	* 4-927-670-01	CUSHION (MO)		168	4-927-627-01	ROLLER (S, G)	
157	* 4-918-679-04	PULLEY, PRESS		169	4-927-624-01	CAM (L, A)	
158	* 4-927-648-01	SLIDER (GROUND)		170	4-927-665-01	SHAFT (S)	
159	4-927-620-01	GEAR (P)		171	4-927-635-01	CAM (L, B)	
160	4-927-628-01	GEAR (C)		172	3-831-441-XX	CUSHION	
161	4-927-654-01	WASHER (LIMITER)		M001	A-4604-347-A	MOTOR (L) ASSY (LOADING)	
162	X-4927-608-1	ARM ASSY. SWING					

4-5. BASE UNIT  
(BU-6C)

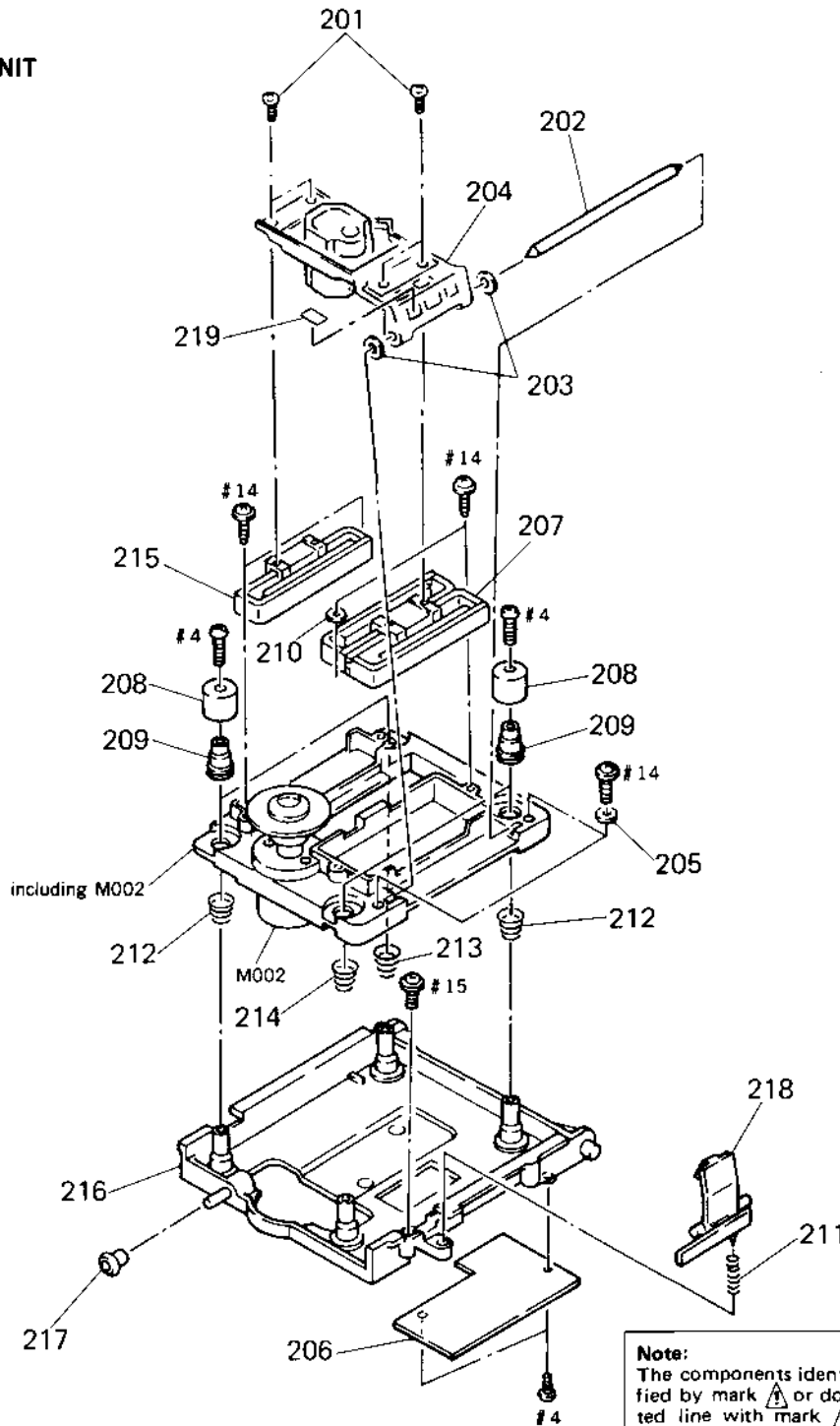

<p><b>Note:</b> The components identified by mark <math>\triangle</math> or dotted line with mark <math>\triangle</math> are critical for safety. Replace only with part number specified.</p>	<p><b>Note:</b> Les composants identifiés par une marque <math>\triangle</math> sont critiques pour la sécurité. Ne les remplacer que par une pièce portant le numéro spécifié.</p>
----------------------------------------------------------------------------------------------------------------------------------------------------------------------------------------------------	-----------------------------------------------------------------------------------------------------------------------------------------------------------------------------------------

Ref. No.	Part No.	Description	Remark
201	3-318-203-61	SCREW (B1.7X4), TAPPING	
202	* 4-910-431-01	SHAFT, SLIDE	
203	* 4-917-582-01	CUSHION, SLIDE	
204	$\triangle$ 8-848-209-11	DEVICE, OPTICAL KSS-271A	
205	4-927-318-01	WASHER	
206	* 1-632-973-11	TRANSLATION BOARD	
207	A-4608-335-A	MOTOR ASSY, LINEAR	
208	4-927-634-01	HOLDER (SP)	
209	* 4-917-584-11	INSULATOR	
210	4-927-669-01	WASHER (BU)	

Ref. No.	Part No.	Description	Remark
211	3-305-423-00	SPRING, COMPRESSION	
212	4-917-572-01	SPRING (B)	
213	4-917-571-01	SPRING (A)	
214	4-917-573-01	SPRING (E)	
215	A-4638-084-A	SENSOR ASSY, SPEED	
216	* 4-927-637-01	HOLDER (BU-6)	
217	4-927-631-01	ROLLER (L)	
218	4-927-626-01	LEVER (L)	
219	4-922-694-01	CUSHION	
M002	X-4927-605-3	BASE ASSY, MECHANICAL (SPINDLE MOTOR)	

## SECTION 5 ELECTRICAL PARTS LIST

**AC**

**AUDIO**

**NOTE:**

- Due to standardization, replacements in the parts list may be different from the parts specified in the diagrams or the components used on the set.
- Items marked "\*" are not stocked since they are seldom required for routine service. Some delay should be anticipated when ordering these items.
- -XX, -X mean standardized parts, so they may have some differences from the original one.
- CAPACITORS  
uF:  $\mu$ F

- RESISTORS  
All resistors are in ohms  
METAL: Metal-film resistor  
METAL OXIDE: Metal Oxide-film resistor  
F: nonflammable
- COILS  
uH:  $\mu$ H
- SEMICONDUCTORS  
In each case, u:  $\mu$ , for example:  
uA...:  $\mu$ A... uPA...:  $\mu$ PA...  
uPB...:  $\mu$ PB... uPC...:  $\mu$ PC...  
uPD...:  $\mu$ PD...

The components identified by mark or dotted line with mark are critical for safety. Replace only with part number specified.

Les composants identifiés par une marque sont critiques pour la sécurité. Ne les remplacer que par une pièce portant le numéro spécifié.

When indicating parts by reference number, please include the board name.

Ref. No.	Part No.	Description	Remark	Ref. No.	Part No.	Description	Remark
	* 1-637-416-11	AC BOARD *****		C407	1-136-810-11	FILM 220PF 5% 100V	
	1-533-183-11	HOLDER, FUSE		C410	1-136-228-11	FILM 0.0012uF 2% 100V	
	* 1-535-771-11	TERMINAL		C411	1-136-233-11	FILM 0.0047uF 2% 100V	
		< CAPACITOR >		C414	1-124-572-11	ELECT 100uF 20% 63V	
C991	1-162-599-12	CERAMIC 0.0047uF	400V	C415	1-136-580-11	FILM 0.47uF 10% 200V	
C993	1-161-744-00	CERAMIC 0.01uF	400V	C416	1-162-806-11	CERAMIC 0.1uF 10% 50V	
		< CONNECTOR >		C417	1-124-122-11	ELECT 100uF 20% 50V	
CN992	* 1-535-140-00	BASE POST 22MM (10MM PITCH) 3P		C418	1-124-920-11	ELECT 330uF 20% 63V	
CN993	1-535-139-00	BASE POST 22MM (10MM PITCH) 2P		C419	1-124-910-11	ELECT 47uF 20% 50V	
*****							
	* A-4617-944-A	AUDIO BOARD, COMPLETE *****		C421	1-124-122-11	ELECT 100uF 20% 50V	
	7-682-147-15	SCREW, TR		C422	1-136-165-00	FILM 0.1uF 5% 50V	
	* 4-363-146-00	HEAT SINK, V. OUT		C423	1-130-495-00	MYLAR 0.1uF 5% 50V	
		< CAPACITOR >		C424	1-162-199-31	CERAMIC 10PF 5% 50V	
C207	1-162-306-11	CERAMIC 0.01uF 20% 16V		C425	1-162-199-31	CERAMIC 10PF 5% 50V	
C208	1-136-165-00	FILM 0.1uF 5% 50V		C427	1-136-808-11	FILM 100PF 5% 100V	
C209	1-124-604-00	ELECT 330uF 20% 10V		C428	1-136-808-11	FILM 100PF 5% 100V	
C211	1-136-165-00	FILM 0.1uF 5% 50V		C429	1-130-487-00	MYLAR 0.022uF 5% 50V	
C221	1-162-294-31	CERAMIC 0.001uF 10% 50V		C430	1-126-052-11	ELECT 100uF 20% 50V	
C401	1-130-495-00	MYLAR 0.1uF 5% 50V		C431	1-136-580-11	FILM 0.47uF 10% 200V	
C402	1-130-495-00	MYLAR 0.1uF 5% 50V		C432	1-124-922-11	ELECT 1000uF 20% 63V	
C403	1-124-994-11	ELECT 100uF 20% 10V		C437	1-136-165-00	FILM 0.1uF 5% 50V	
C404	1-130-495-00	MYLAR 0.1uF 5% 50V		C440	1-130-487-00	MYLAR 0.022uF 5% 50V	
C405	1-136-810-11	FILM 220PF 5% 100V		C441	1-130-495-00	MYLAR 0.1uF 5% 50V	
C406	1-136-810-11	FILM 220PF 5% 100V		C442	1-130-495-00	MYLAR 0.1uF 5% 50V	
				C443	1-124-994-11	ELECT 100uF 20% 10V	
				C444	1-130-495-00	MYLAR 0.1uF 5% 50V	
				C445	1-136-810-11	FILM 220PF 5% 100V	
				C446	1-130-487-00	MYLAR 0.022uF 5% 50V	
				C447	1-126-049-11	ELECT 22uF 20% 25V	
				C448	1-126-059-11	ELECT 10uF 20% 50V	
				C449	1-124-122-11	ELECT 100uF 20% 50V	
				C450	1-130-495-00	MYLAR 0.1uF 5% 50V	
				C451	1-123-343-00	ELECT 33uF 20% 35V	
				C452	1-126-335-11	ELECT 220uF 20% 10V	

## AUDIO

Ref. No.	Part No.	Description	Remark	Ref. No.	Part No.	Description	Remark
C453	1-162-290-31	CERAMIC	470PF 10% 50V	CN450	* 1-564-506-11	PLUG, CONNECTOR 3P	
C471	1-130-495-00	MYLAR	0.1uF 5% 50V	CN451	* 1-564-507-11	PLUG, CONNECTOR 4P	
C481	1-126-335-11	ELECT	220uF 20% 10V	CN452	* 1-535-117-00	TERMINAL, 4P	
C482	1-136-165-00	FILM	0.1uF 5% 50V	CN501	* 1-564-505-11	PLUG, CONNECTOR 2P	
C483	1-124-994-11	ELECT	100uF 20% 10V	CN502	* 1-564-505-11	PLUG, CONNECTOR 2P	
C484	1-124-994-11	ELECT	100uF 20% 10V	CN503	* 1-564-506-11	PLUG, CONNECTOR 3P	
C490	1-126-012-11	ELECT	470uF 20% 16V	CN931	* 1-564-505-11	PLUG, CONNECTOR 2P	
C501	1-130-495-00	MYLAR	0.1uF 5% 50V			< DIODE >	
C502	1-130-495-00	MYLAR	0.1uF 5% 50V	D401	8-719-200-31	DIODE 21DQ05	
C503	1-124-994-11	ELECT	100uF 20% 10V	D403	8-719-114-27	DIODE RD4. 7JS-B3	
C504	1-130-495-00	MYLAR	0.1uF 5% 50V	D404	8-719-114-27	DIODE RD4. 7JS-B3	
C505	1-136-810-11	FILM	220PF 5% 100V	D405	8-719-114-30	DIODE RD5. 1JS-B2	
C506	1-136-810-11	FILM	220PF 5% 100V	D406	8-719-114-27	DIODE RD4. 7JS-B3	
C507	1-136-810-11	FILM	220PF 5% 100V	D421	8-719-107-94	DIODE 1SS202-1	
C508	1-162-806-11	CERAMIC	0.1uF 10% 50V	D471	8-719-107-94	DIODE 1SS202-1	
C509	1-162-806-11	CERAMIC	0.1uF 10% 50V	D472	8-719-933-47	DIODE HZS7B2L	
C510	1-136-228-11	FILM	0.0012uF 2% 100V	D501	8-719-107-94	DIODE 1SS202-1	
C511	1-136-233-11	FILM	0.0047uF 2% 100V	D521	8-719-107-94	DIODE 1SS202-1	
C514	1-124-572-11	ELECT	100uF 20% 63V	D571	8-719-107-94	DIODE 1SS202-1	
C515	1-136-580-11	FILM	0.47uF 10% 200V	D572	8-719-933-47	DIODE HZS7B2L	
C525	1-136-808-11	FILM	100PF 5% 100V	D941	8-719-109-81	DIODE RD4. 7ES-B2	
C526	1-136-808-11	FILM	100PF 5% 100V			< IC >	
C531	1-136-580-11	FILM	0.47uF 10% 200V	IC202	8-752-328-61	IC CXD1244S	
C532	1-124-922-11	ELECT	1000uF 20% 63V	IC401	8-752-335-52	IC CXD2552Q-2	
C541	1-130-495-00	MYLAR	0.1uF 5% 50V	IC402	8-759-917-18	IC SN74HC04AN	
C542	1-130-495-00	MYLAR	0.1uF 5% 50V	IC403	8-759-917-18	IC SN74HC04AN	
C543	1-124-994-11	ELECT	100uF 20% 10V	IC404	8-752-339-86	IC CXD2557M	
C545	1-136-810-11	FILM	220PF 5% 100V	IC406	8-759-900-72	IC NE5532P	
C546	1-124-994-11	ELECT	100uF 20% 10V	IC407	8-759-900-72	IC NE5532P	
C547	1-124-122-11	ELECT	100uF 20% 50V	IC452	8-759-604-51	IC M5F7912L	
C548	1-162-806-11	CERAMIC	0.1uF 10% 50V	IC501	8-752-335-52	IC CXD2552Q-2	
C551	1-123-343-00	ELECT	33uF 20% 35V	IC506	8-759-900-72	IC NE5532P	
C552	1-126-335-11	ELECT	220uF 20% 10V	IC507	8-759-900-72	IC NE5532P	
C553	1-162-290-31	CERAMIC	470PF 10% 50V	IC551	8-759-981-85	IC RC4556D	
C554	1-130-495-00	MYLAR	0.1uF 5% 50V	IC552	8-759-604-33	IC M5F7812L	
C571	1-130-495-00	MYLAR	0.1uF 5% 50V			< COIL >	
C581	1-124-994-11	ELECT	100uF 20% 10V	L401	1-410-509-11	INDUCTOR 10uH	
C582	1-126-335-11	ELECT	220uF 20% 10V	L404	1-410-521-11	INDUCTOR 100uH	
C583	1-136-165-00	FILM	0.1uF 5% 50V	L405	1-410-397-21	FERRITE BEAD INDUCTOR	
C941	1-123-380-00	ELECT	1uF 20% 50V				
C942	1-126-059-11	ELECT	10uF 20% 50V				
		< CONNECTOR >					
CN203	* 1-564-710-11	PIN, CONNECTOR (SMALL TYPE) 8P					
CN204	* 1-564-708-11	PIN, CONNECTOR (SMALL TYPE) 6P					
CN401	* 1-564-505-11	PLUG, CONNECTOR 2P					
CN402	* 1-564-505-11	PLUG, CONNECTOR 2P					
CN403	* 1-564-506-11	PLUG, CONNECTOR 3P					

AUDIO

Ref. No.	Part No.	Description	Remark	Ref. No.	Part No.	Description	Remark
< TRANSISTOR >							
Q401	8-729-201-05	TRANSISTOR 2SC2878-B		R449	1-249-423-11	CARBON 3.3K	5% 1/4W
Q402	8-729-216-13	TRANSISTOR 2SK161-GR		R451	1-247-700-11	CARBON 100	5% 1/4W
Q403	8-729-620-23	TRANSISTOR 2SC3246-JK		R452	1-249-441-11	CARBON 100K	5% 1/4W
Q404	8-729-809-29	TRANSISTOR 2SC4159-E		R453	1-249-434-11	CARBON 27K	5% 1/4W
Q451	8-729-107-85	TRANSISTOR 2SC3622A-K		R454	1-249-405-11	CARBON 100	5% 1/4W
Q472	8-729-900-61	TRANSISTOR DTA114ES		R455	1-249-421-11	CARBON 2.2K	5% 1/4W
Q501	8-729-201-05	TRANSISTOR 2SC2878-B		R456	1-249-434-11	CARBON 27K	5% 1/4W
Q551	8-729-107-85	TRANSISTOR 2SC3622A-K		R460	1-247-903-00	CARBON 1M	5% 1/4W
Q572	8-729-900-61	TRANSISTOR DTA114ES		R461	1-249-413-11	CARBON 470	5% 1/4W
Q931	8-729-900-89	TRANSISTOR DTC144ES		R472	1-249-439-11	CARBON 68K	5% 1/4W
Q932	8-729-900-89	TRANSISTOR DTC144ES		R473	1-249-435-11	CARBON 33K	5% 1/4W
Q933	8-729-142-36	TRANSISTOR 8N1L3Z		R474	1-249-432-11	CARBON 18K	5% 1/4W
Q941	8-729-900-61	TRANSISTOR DTA114ES		R501	1-249-946-11	CARBON 9.1K	1% 1/4W
< RESISTOR >							
R212	1-249-417-11	CARBON 1K	5% 1/4W	R504	1-247-721-11	CARBON 4.7K	5% 1/4W
R213	1-249-413-11	CARBON 470	5% 1/4W	R505	1-247-721-11	CARBON 4.7K	5% 1/4W
R214	1-249-413-11	CARBON 470	5% 1/4W	R506	1-247-721-11	CARBON 4.7K	5% 1/4W
R215	1-249-413-11	CARBON 470	5% 1/4W	R507	1-249-949-11	CARBON 12K	1% 1/4W
R216	1-249-413-11	CARBON 470	5% 1/4W	R508	1-249-949-11	CARBON 12K	1% 1/4W
R217	1-249-417-11	CARBON 1K	5% 1/4W	R509	1-247-700-11	CARBON 100	5% 1/4W
R401	1-249-946-11	CARBON 9.1K	1% 1/4W	R510	1-249-941-11	CARBON 5.6K	1% 1/4W
R402	1-249-946-11	CARBON 9.1K	1% 1/4W	R511	1-249-941-11	CARBON 5.6K	1% 1/4W
R403	1-247-721-11	CARBON 4.7K	5% 1/4W	R512	1-249-941-11	CARBON 5.6K	1% 1/4W
R404	1-247-721-11	CARBON 4.7K	5% 1/4W	R513	1-249-941-11	CARBON 5.6K	1% 1/4W
R405	1-247-721-11	CARBON 4.7K	5% 1/4W	R514	1-247-715-11	CARBON 1.5K	5% 1/4W
R406	1-247-721-11	CARBON 4.7K	5% 1/4W	R516	1-247-715-11	CARBON 1.5K	5% 1/4W
R407	1-249-949-11	CARBON 12K	1% 1/4W	R517	1-247-700-11	CARBON 100	5% 1/4W
R408	1-249-949-11	CARBON 12K	1% 1/4W	R518	1-247-891-00	CARBON 330K	5% 1/4W
R409	1-247-700-11	CARBON 100	5% 1/4W	R519	1-249-512-11	CARBON 22	5% 1/4W
R410	1-249-941-11	CARBON 5.6K	1% 1/4W	R520	1-249-429-11	CARBON 10K	5% 1/4W
R411	1-249-941-11	CARBON 5.6K	1% 1/4W	R527	1-249-429-11	CARBON 10K	5% 1/4W
R412	1-249-941-11	CARBON 5.6K	1% 1/4W	R541	1-249-946-11	CARBON 9.1K	1% 1/4W
R413	1-249-941-11	CARBON 5.6K	1% 1/4W	R542	1-249-946-11	CARBON 9.1K	1% 1/4W
R414	1-247-715-11	CARBON 1.5K	5% 1/4W	R551	1-247-700-11	CARBON 100	5% 1/4W
R416	1-247-715-11	CARBON 1.5K	5% 1/4W	R552	1-249-441-11	CARBON 100K	5% 1/4W
R417	1-247-700-11	CARBON 100	5% 1/4W	R553	1-249-434-11	CARBON 27K	5% 1/4W
R418	1-247-891-00	CARBON 330K	5% 1/4W	R554	1-249-405-11	CARBON 100	5% 1/4W
R419	1-249-512-11	CARBON 22	5% 1/4W	R555	1-249-421-11	CARBON 2.2K	5% 1/4W
R420	1-249-442-11	CARBON 510	5% 1/4W	R556	1-249-434-11	CARBON 27K	5% 1/4W
R422	1-249-413-11	CARBON 470	5% 1/4W	R572	1-249-439-11	CARBON 68K	5% 1/4W
R423	1-249-429-11	CARBON 10K	5% 1/4W	R573	1-249-435-11	CARBON 33K	5% 1/4W
R430	1-247-713-11	CARBON 1K	5% 1/4W	R574	1-249-432-11	CARBON 18K	5% 1/4W
R441	1-249-946-11	CARBON 9.1K	1% 1/4W	R931	1-249-441-11	CARBON 100K	5% 1/4W
R442	1-249-946-11	CARBON 9.1K	1% 1/4W	R941	1-249-441-11	CARBON 100K	5% 1/4W
				R942	1-249-429-11	CARBON 10K	5% 1/4W
				R943	1-249-417-11	CARBON 1K	5% 1/4W

**AUDIO**    **DISPLAY**    **FUNCTION**    **TIMER**

Ref. No.	Part No.	Description	Remark
< CRYSTAL >			
X401	1-577-686-11	VIBRATOR, CRYSTAL 45MHz	
X402	1-577-685-11	FILTER, CRYSTAL 16MHz	
*****			
* 1-637-410-11	DISPLAY BOARD *****		
* 1-637-419-11	FUNCTION BOARD *****		
* 1-637-411-11	TIMER BOARD *****		
* 4-923-532-21	SPACER, LED		
* 4-928-052-01	HOLDER (RIGHT)		
* 4-928-053-01	HOLDER (LEFT)		
< CAPACITOR >			
C802	1-164-159-11	CERAMIC    0.1uF	50V
C803	1-164-159-11	CERAMIC    0.1uF	50V
< CONNECTOR >			
CN801	* 1-564-341-11	PIN. CONNECTOR 7P	
CN802	* 1-506-503-11	PIN. CONNECTOR 9P	
CN803	* 1-564-340-00	PIN. CONNECTOR 6P	
< DIODE >			
D701	8-719-970-07	DIODE    MPG3371X-150	
D702	8-719-971-52	DIODE    MAY3371X-M-177	
D703	8-719-971-50	DIODE    MBG3371X-177	
D704	8-719-971-52	DIODE    MAY3371X-M-177	
D705	8-719-987-97	DIODE    BR3371X	
D706	8-719-970-98	DIODE    MPY3371X-177	
D801	8-719-107-94	DIODE    1SS202-1	
D802	8-719-107-94	DIODE    1SS202-1	
D803	8-719-107-94	DIODE    1SS202-1	
D804	8-719-107-94	DIODE    1SS202-1	
D805	8-719-107-94	DIODE    1SS202-1	
D806	8-719-107-94	DIODE    1SS202-1	
D807	8-719-107-94	DIODE    1SS202-1	
< FLUORESCENT INDICATOR TUBE >			
FLD801	1-519-622-11	INDICATOR TUBE, FLUORESCENT	
< IC >			
IC801	8-759-505-50	IC    MSC52408-015GS-V1K	
IC802	8-741-100-48	IC    SBX1610-59	

Ref. No.	Part No.	Description	Remark
< TRANSISTOR >			
Q701	8-729-900-80	TRANSISTOR    DTC114ES	
Q702	8-729-900-80	TRANSISTOR    DTC114ES	
Q703	8-729-900-80	TRANSISTOR    DTC114ES	
Q704	8-729-900-80	TRANSISTOR    DTC114ES	
Q705	8-729-900-80	TRANSISTOR    DTC114ES	
Q706	8-729-900-80	TRANSISTOR    DTC114ES	
Q801	8-729-900-45	TRANSISTOR    DTC114EF	
Q802	8-729-900-45	TRANSISTOR    DTC114EF	
< RESISTOR >			
R701	1-249-406-11	CARBON    120    5%    1/4W	
R702	1-249-406-11	CARBON    120    5%    1/4W	
R703	1-249-406-11	CARBON    120    5%    1/4W	
R704	1-249-406-11	CARBON    120    5%    1/4W	
R705	1-249-415-11	CARBON    680    5%    1/4W	
R706	1-249-409-11	CARBON    220    5%    1/4W	
R801	1-249-425-11	CARBON    4.7K    5%    1/4W	
R802	1-249-429-11	CARBON    10K    5%    1/4W	
R803	1-247-903-00	CARBON    1M    5%    1/4W	
R806	1-249-441-11	CARBON    100K    5%    1/4W	
R809	1-249-441-11	CARBON    100K    5%    1/4W	
< SWITCH >			
S701	1-554-937-11	SWITCH, KEY BOARD (CONTINUE)	
S702	1-554-937-11	SWITCH, KEY BOARD (SHUFFLE)	
S703	1-554-937-11	SWITCH, KEY BOARD (PROGRAM)	
S704	1-554-937-11	SWITCH, KEY BOARD (C. INDEX)	
S705	1-554-937-11	SWITCH, KEY BOARD ( [ ] )	
S706	1-554-937-11	SWITCH, KEY BOARD ( [ ] )	
S707	1-554-937-11	SWITCH, KEY BOARD ( [ ] )	
S708	1-554-937-11	SWITCH, KEY BOARD (EDIT/TIME FADE)	
S709	1-554-937-11	SWITCH, KEY BOARD (FADER)	
S710	1-554-937-11	SWITCH, KEY BOARD (P. SEARCH)	
S711	1-554-937-11	SWITCH, KEY BOARD ( [ ] )	
S712	1-554-937-11	SWITCH, KEY BOARD ( [ ] )	
S713	1-554-937-11	SWITCH, KEY BOARD (REPEAT)	
S714	1-554-937-11	SWITCH, KEY BOARD (1)	
S715	1-554-937-11	SWITCH, KEY BOARD (6)	
S716	1-554-937-11	SWITCH, KEY BOARD (11)	
S717	1-554-937-11	SWITCH, KEY BOARD (16)	
S718	1-554-937-11	SWITCH, KEY BOARD ( [ ] )	
S719	1-554-937-11	SWITCH, KEY BOARD (FILE)	
S720	1-554-937-11	SWITCH, KEY BOARD (TIME/MEMO)	
S721	1-554-937-11	SWITCH, KEY BOARD (2)	
S722	1-554-937-11	SWITCH, KEY BOARD (7)	
S723	1-554-937-11	SWITCH, KEY BOARD (12)	
S724	1-554-937-11	SWITCH, KEY BOARD (17)	
S725	1-554-937-11	SWITCH, KEY BOARD ( [ ] )	

DISPLAY

FUNCTION

TIMER

HP

L. MOTOR

LINE OUT

M. VR

OPT

Ref. No.	Part No.	Description	Remark
S726	1-554-937-11	SWITCH, KEY BOARD (ERASE)	
S727	1-554-937-11	SWITCH, KEY BOARD (3)	
S728	1-554-937-11	SWITCH, KEY BOARD (8)	
S729	1-554-937-11	SWITCH, KEY BOARD (13)	
S730	1-554-937-11	SWITCH, KEY BOARD (18)	
S731	1-554-937-11	SWITCH, KEY BOARD (CLEAR)	
S732	1-554-937-11	SWITCH, KEY BOARD (FILE RECALL)	
S733	1-554-937-11	SWITCH, KEY BOARD (4)	
S734	1-554-937-11	SWITCH, KEY BOARD (9)	
S735	1-554-937-11	SWITCH, KEY BOARD (14)	
S736	1-554-937-11	SWITCH, KEY BOARD (19)	
S737	1-554-937-11	SWITCH, KEY BOARD (CHECK)	
S738	1-554-937-11	SWITCH, KEY BOARD (5)	
S739	1-554-937-11	SWITCH, KEY BOARD (10)	
S740	1-554-937-11	SWITCH, KEY BOARD (15)	
S741	1-554-937-11	SWITCH, KEY BOARD (20)	
S801	1-554-937-11	SWITCH, KEY BOARD ( $\Delta$ OPEN/CLOSE)	
S802	1-554-937-11	SWITCH, KEY BOARD (LEVEL FILE)	
S803	1-554-937-11	SWITCH, KEY BOARD (DISPLAY MODE)	
S804	1-570-157-51	SWITCH, SLIDE (TIMER)	
		< CERAMIC >	
X801	1-577-359-21	VIBRATOR, CERAMIC (4.19MHz)	
*****			
	* 1-637-413-11	HP BOARD	
		*****	
		< CAPACITOR >	
C461	1-162-290-31	CERAMIC 470PF 10% 50V	
C561	1-162-290-31	CERAMIC 470PF 10% 50V	
		< JACK >	
J451	1-568-519-31	JACK, LARGE TYPE (PHONES)	
*****			
	* 1-632-975-11	L. MOTOR BOARD	
		*****	
		< CAPACITOR >	
C001	1-136-157-00	FILM 0.022uF 5% 50V	

Ref. No.	Part No.	Description	Remark
	* 1-637-418-11	LINE OUT BOARD	
		*****	
		< DIODE >	
D491	8-719-107-94	DIODE 1SS202-1	
		< JACK >	
J401	1-568-101-11	JACK, PIN 4P (LINE OUT FIXED/VARIABLE)	
		< RESISTOR >	
R491	1-247-700-11	CARBON 100 5% 1/4W	
R591	1-247-700-11	CARBON 100 5% 1/4W	
		< RELAY >	
RY401	1-515-727-11	RELAY	
*****			
	* 1-637-412-11	M. VR BOARD	
		*****	
		< VARIABLE RESISTOR >	
RV461	1-241-321-11	RES, VAR, CARBON 10KX3 (LINE OUT/PHONE LEVEL)	
*****			
	* 1-637-417-11	OPT BOARD	
		*****	
		< CAPACITOR >	
C280	1-126-059-11	ELECT 10uF 20% 50V	
		< IC >	
IC204	8-749-921-12	IC GP1F32T (DIGITAL OUT OPTICAL)	

**POWER**

**SERVO**

Ref.No.	Part No.	Description	Remark
* A-4617-748-A POWER BOARD, COMPLETE (AEP, UK)			
*****			
* A-4617-943-A POWER BOARD, COMPLETE (Canadian)			
*****			
< BUS BAR >			
BUS901	* 1-569-135-11	BAR, BUS 4P	
< CAPACITOR >			
C901	1-136-177-00	FILM 1uF	5% 50V
C902	1-130-483-00	MYLAR 0.01uF	5% 50V
C903	1-124-523-11	ELECT 4700uF	20% 16V (Canadian)
C903	1-126-016-11	ELECT 4700uF	20% 16V (AEP, UK)
C904	1-124-523-11	ELECT 4700uF	20% 16V (Canadian)
C904	1-126-016-11	ELECT 4700uF	20% 16V (AEP, UK)
C905	1-136-165-00	FILM 0.1uF	5% 50V
C906	1-130-483-00	MYLAR 0.01uF	5% 50V
C907	1-130-483-00	MYLAR 0.01uF	5% 50V
C908	1-136-177-00	FILM 1uF	5% 50V
C909	1-130-483-00	MYLAR 0.01uF	5% 50V
C910	1-126-982-11	ELECT 5600uF	20% 35V
C911	1-126-982-11	ELECT 5600uF	20% 35V
C912	1-126-233-11	ELECT 22uF	20% 50V
C913	1-124-572-11	ELECT 100uF	20% 63V
C914	1-124-572-11	ELECT 100uF	20% 63V
C915	1-124-910-11	ELECT 47uF	20% 50V
C916	1-130-495-00	MYLAR 0.1uF	5% 50V
C917	1-130-483-00	MYLAR 0.01uF	5% 50V
C918	1-130-483-00	MYLAR 0.01uF	5% 50V
< CONNECTOR >			
CN901	* 1-535-123-00	TERMINAL (WITH BASE) 10P	
< DIODE >			
D901	8-719-937-49	DIODE RDF02M	
D902	8-719-200-89	DIODE 310F2-FA	
D903	8-719-200-89	DIODE 310F2-FA	
D904	8-719-200-89	DIODE 310F2-FA	
D905	8-719-200-89	DIODE 310F2-FA	
D911	8-719-200-82	DIODE 11ES2	
D914	8-719-913-62	DIODE HZ36-2L	
D915	8-719-933-48	DIODE HZS783L	
D922	8-719-107-94	DIODE 1SS202-1	
D923	8-719-107-94	DIODE 1SS202-1	
< COIL >			
L914	1-410-521-11	INDUCTOR 100uH	

Ref.No.	Part No.	Description	Remark
< TRANSISTOR >			
Q911	8-729-140-96	TRANSISTOR 2SD774-34	
< RESISTOR >			
R901	△ 1-212-871-11	FUSIBLE 39	5% 1/4W F
R902	△ 1-212-877-11	FUSIBLE 68	5% 1/4W F
R911	1-249-425-11	CARBON 4.7K	5% 1/4W
R912	1-249-429-11	CARBON 10K	5% 1/4W
R913	1-249-433-11	CARBON 22K	5% 1/4W
< THERMISTOR >			
TH901	△ 1-808-065-11	THERMISTOR, POSITIVE	
TH902	△ 1-808-065-11	THERMISTOR, POSITIVE	
TH903	△ 1-806-882-11	THERMISTOR (POSITIVE) 2.2	
*****			
* A-4617-601-A SERVO BOARD, COMPLETE			
*****			
7-682-147-15 SCREW, TR			
* 4-363-146-00 HEAT SINK, V. OUT			
* 4-922-525-01 HEAT SINK			
< CAPACITOR >			
C101	1-130-480-00	MYLAR 0.0056uF	5% 50V
C102	1-136-159-00	FILM 0.033uF	5% 50V
C103	1-136-165-00	FILM 0.1uF	5% 50V
C104	1-136-165-00	FILM 0.1uF	5% 50V
C105	1-161-375-00	CERAMIC 0.0022uF	20% 50V
C106	1-106-351-00	MYLAR 2200PF	5% 200V
C107	1-136-153-00	FILM 0.01uF	5% 50V
C108	1-136-153-00	FILM 0.01uF	5% 50V
C109	1-136-165-00	FILM 0.1uF	5% 50V
C110	1-136-161-00	FILM 0.047uF	5% 50V
C111	1-126-059-11	ELECT 10uF	20% 50V
C112	1-136-165-00	FILM 0.1uF	5% 50V
C113	1-126-162-11	ELECT 3.3uF	20% 50V
C114	1-126-049-11	ELECT 22uF	20% 25V
C115	1-136-153-00	FILM 0.01uF	5% 50V
C116	1-136-159-00	FILM 0.033uF	5% 50V
C118	1-124-442-00	ELECT 330uF	20% 6.3V
C119	1-124-442-00	ELECT 330uF	20% 6.3V
C121	1-136-153-00	FILM 0.01uF	5% 50V
C122	1-126-300-11	ELECT 0.47uF	20% 50V
C123	1-130-472-00	MYLAR 0.0012uF	5% 50V
C124	1-106-359-00	MYLAR 4700PF	5% 200V
C125	1-164-159-11	CERAMIC 0.1uF	50V
C127	1-164-159-11	CERAMIC 0.1uF	50V

**Note:**  
The components identified by mark △ or dotted line with mark △ are critical for safety. Replace only with part number specified.

**Note:**  
Les composants identifiés par une marque △ sont critiques pour la sécurité. Ne les remplacer que par une pièce portant le numéro spécifié.





Ref. No.	Part No.	Description	Remark	Ref. No.	Part No.	Description	Remark
C129	1-136-161-00	FILM	0.047uF 5% 50V	C929	1-124-122-11	ELECT 100uF 20% 50V	
C130	1-136-155-00	FILM	0.015uF 5% 50V	C990	1-125-622-11	DOUBLE LAYERS 0.1F 5.5V	
C131	1-164-159-11	CERAMIC	0.1uF 50V			< CONNECTOR >	
C132	1-130-477-00	MYLAR	0.0033uF 5% 50V	CN101	* 1-505-503-11	PIN, CONNECTOR 9P	
C133	1-164-159-11	CERAMIC	0.1uF 50V	CN102	* 1-564-338-00	PIN, CONNECTOR 4P	
C134	1-162-294-31	CERAMIC	0.001uF 10% 50V	CN103	* 1-564-340-00	PIN, CONNECTOR 6P	
C135	1-162-294-31	CERAMIC	0.001uF 10% 50V	CN104	* 1-564-339-00	PIN, CONNECTOR 5P	
C136	1-164-159-11	CERAMIC	0.1uF 50V	CN201	* 1-564-705-11	PIN, CONNECTOR (SMALL TYPE) 3P	
C137	1-124-478-11	ELECT	100uF 20% 25V	CN202	* 1-564-710-11	PIN, CONNECTOR (SMALL TYPE) 8P	
C138	1-124-478-11	ELECT	100uF 20% 25V	CN301	* 1-564-342-11	PIN, CONNECTOR 8P	
C139	1-124-478-11	ELECT	100uF 20% 25V	CN302	* 1-564-340-00	PIN, CONNECTOR 6P	
C140	1-124-478-11	ELECT	100uF 20% 25V	CN303	* 1-564-708-11	PIN, CONNECTOR (SMALL TYPE) 6P	
C141	1-124-442-00	ELECT	330uF 20% 6.3V	CN906	* 1-564-507-11	PLUG, CONNECTOR 4P	
C142	1-124-442-00	ELECT	330uF 20% 6.3V			< DIODE >	
C143	1-164-159-11	CERAMIC	0.1uF 50V	CN907	* 1-564-341-11	PIN, CONNECTOR 7P	
C144	1-164-159-11	CERAMIC	0.1uF 50V	CN908	* 1-564-506-11	PLUG, CONNECTOR 3P	
C145	1-124-478-11	ELECT	100uF 20% 25V			< IC >	
C146	1-124-478-11	ELECT	100uF 20% 25V	D906	8-719-107-94	DIODE 1SS202-1	
C150	1-164-159-11	CERAMIC	0.1uF 50V	D907	8-719-107-94	DIODE 1SS202-1	
C153	1-164-159-11	CERAMIC	0.1uF 50V			< IC >	
C154	1-124-442-00	ELECT	330uF 20% 6.3V	IC101	8-752-050-82	IC CXA1372Q	
C155	1-161-494-00	CERAMIC	0.022uF 25V	IC102	8-759-823-11	IC LA6523	
C156	1-161-494-00	CERAMIC	0.022uF 25V	IC103	8-759-823-11	IC LA6523	
C157	1-164-159-11	CERAMIC	0.1uF 50V	IC104	8-759-823-11	IC LA6523	
C170	1-161-494-00	CERAMIC	0.022uF 25V	IC201	8-752-337-26	IC CXD2500AQ	
C171	1-161-494-00	CERAMIC	0.022uF 25V			< IC >	
C173	1-161-494-00	CERAMIC	0.022uF 25V	IC301	8-759-635-51	IC M37460MB-376FP	
C174	1-161-494-00	CERAMIC	0.022uF 25V	IC302	8-759-822-78	IC LC3564PML-101S	
C201	1-106-347-00	MYLAR	1500PF 5% 200V	IC303	8-759-962-08	IC BA6208	
C202	1-136-161-00	FILM	0.047uF 5% 50V	IC901	8-759-231-53	IC TA7805S	
C203	1-136-155-00	FILM	0.015uF 5% 50V	IC902	8-759-604-47	IC M5F7905L	
C205	1-124-442-00	ELECT	330uF 20% 6.3V			< IC >	
C206	1-164-159-11	CERAMIC	0.1uF 50V	IC903	8-759-917-18	IC SN74HCU04AN	
C301	1-124-442-00	ELECT	330uF 20% 6.3V			< TRANSISTOR >	
C302	1-164-159-11	CERAMIC	0.1uF 50V			< TRANSISTOR >	
C303	1-136-165-00	FILM	0.1uF 5% 50V	Q101	8-729-900-89	TRANSISTOR DTC144ES	
C304	1-164-159-11	CERAMIC	0.1uF 50V	Q301	8-729-900-80	TRANSISTOR DTC114ES	
C305	1-124-768-11	ELECT	4.7uF 20% 50V			< RESISTOR >	
C310	1-164-159-11	CERAMIC	0.1uF 50V			< RESISTOR >	
C331	1-164-159-11	CERAMIC	0.1uF 50V	R101	1-249-429-11	CARBON 10K 5% 1/4W	
C919	1-126-012-11	ELECT	470uF 20% 16V	R102	1-247-887-00	CARBON 220K 5% 1/4W	
C920	1-126-012-11	ELECT	470uF 20% 16V	R103	1-249-429-11	CARBON 10K 5% 1/4W	
C921	1-124-556-11	ELECT	2200uF 20% 16V	R104	1-247-882-11	CARBON 130K 5% 1/4W	
C922	1-126-012-11	ELECT	470uF 20% 16V	R105	1-249-440-11	CARBON 82K 5% 1/4W	
C923	1-126-161-11	ELECT	2.2uF 20% 50V			< RESISTOR >	
C924	1-126-161-11	ELECT	2.2uF 20% 50V	R106	1-249-440-11	CARBON 82K 5% 1/4W	
C925	1-136-165-00	FILM	0.1uF 5% 50V	R107	1-249-431-11	CARBON 15K 5% 1/4W	
C927	1-126-012-11	ELECT	470uF 20% 16V	R108	1-249-429-11	CARBON 10K 5% 1/4W	
				R109	1-247-896-11	CARBON 510K 5% 1/4W	

**SERVO SWITCH**

Ref. No.	Part No.	Description	Remark
R110	1-247-886-11	CARBON	200K 5% 1/4W
R112	1-249-429-11	CARBON	10K 5% 1/4W
R113	1-249-441-11	CARBON	100K 5% 1/4W
R114	1-247-854-11	CARBON	9. 1K 5% 1/4W
R115	1-247-854-11	CARBON	9. 1K 5% 1/4W
R116	1-249-393-11	CARBON	10 5% 1/4W
R118	1-249-393-11	CARBON	10 5% 1/4W
R120	1-247-899-11	CARBON	680K 5% 1/4W
R121	1-249-441-11	CARBON	100K 5% 1/4W
R123	1-247-883-00	CARBON	150K 5% 1/4W
R124	1-249-438-11	CARBON	56K 5% 1/4W
R125	1-247-876-11	CARBON	75K 5% 1/4W
R126	1-249-433-11	CARBON	22K 5% 1/4W
R127	1-249-393-11	CARBON	10 5% 1/4W
R128	1-249-441-11	CARBON	100K 5% 1/4W
R129	1-249-441-11	CARBON	100K 5% 1/4W
R130	1-249-441-11	CARBON	100K 5% 1/4W
R131	1-249-441-11	CARBON	100K 5% 1/4W
R132	1-249-393-11	CARBON	10 5% 1/4W
R140	1-249-429-11	CARBON	10K 5% 1/4W
R141	1-249-429-11	CARBON	10K 5% 1/4W
R142	1-249-429-11	CARBON	10K 5% 1/4W
R143	1-249-393-11	CARBON	10 5% 1/4W
R144	1-249-429-11	CARBON	10K 5% 1/4W
R145	1-249-429-11	CARBON	10K 5% 1/4W
R146	1-249-429-11	CARBON	10K 5% 1/4W
R147	1-249-393-11	CARBON	10 5% 1/4W
R148	1-249-429-11	CARBON	10K 5% 1/4W
R149	1-249-393-11	CARBON	10 5% 1/4W
R150	1-249-417-11	CARBON	1K 5% 1/4W
R152	1-249-393-11	CARBON	10 5% 1/4W
R153	1-249-430-11	CARBON	12K 5% 1/4W
R154	1-249-429-11	CARBON	10K 5% 1/4W
R155	1-249-429-11	CARBON	10K 5% 1/4W
R156	1-249-393-11	CARBON	10 5% 1/4W
R170	△ 1-212-954-11	FUSIBLE	6. 8 5% 1/2W F
R201	1-249-423-11	CARBON	3. 3K 5% 1/4W
R202	1-249-423-11	CARBON	3. 3K 5% 1/4W
R203	1-249-429-11	CARBON	10K 5% 1/4W
R204	1-249-429-11	CARBON	10K 5% 1/4W
R205	1-249-429-11	CARBON	10K 5% 1/4W
R206	1-249-435-11	CARBON	33K 5% 1/4W
R209	1-249-413-11	CARBON	470 5% 1/4W
R210	1-249-413-11	CARBON	470 5% 1/4W
R211	1-249-413-11	CARBON	470 5% 1/4W
R230	1-249-417-11	CARBON	1K 5% 1/4W
R231	1-249-413-11	CARBON	470 5% 1/4W
R301	1-247-903-00	CARBON	1M 5% 1/4W
R302	1-249-411-11	CARBON	330 5% 1/4W

Ref. No.	Part No.	Description	Remark
R303	1-249-429-11	CARBON	10K 5% 1/4W
R304	1-249-429-11	CARBON	10K 5% 1/4W
R305	1-249-429-11	CARBON	10K 5% 1/4W
R306	1-249-429-11	CARBON	10K 5% 1/4W
R308	1-249-429-11	CARBON	10K 5% 1/4W
R309	1-249-429-11	CARBON	10K 5% 1/4W
R310	1-249-429-11	CARBON	10K 5% 1/4W
R311	1-249-429-11	CARBON	10K 5% 1/4W
R312	1-249-429-11	CARBON	10K 5% 1/4W
R313	1-249-417-11	CARBON	1K 5% 1/4W
R314	1-249-429-11	CARBON	10K 5% 1/4W
R315	1-249-429-11	CARBON	10K 5% 1/4W
R316	1-249-417-11	CARBON	1K 5% 1/4W
R317	1-249-429-11	CARBON	10K 5% 1/4W
R318	1-249-411-11	CARBON	330 5% 1/4W
R319	1-249-429-11	CARBON	10K 5% 1/4W
R320	1-249-429-11	CARBON	10K 5% 1/4W
R321	1-249-429-11	CARBON	10K 5% 1/4W
R322	1-249-429-11	CARBON	10K 5% 1/4W
R324	1-249-429-11	CARBON	10K 5% 1/4W
R903	1-249-426-11	CARBON	5. 6K 5% 1/4W
R905	1-247-887-00	CARBON	220K 5% 1/4W
R906	1-249-437-11	CARBON	47K 5% 1/4W
R907	1-247-891-00	CARBON	330K 5% 1/4W
< VARIABLE RESISTOR >			
RV201	1-228-994-00	RES. ADJ. METAL 10K	
RV202	1-228-994-00	RES. ADJ. METAL 10K	
< CRYSTAL >			
X301	1-577-377-11	VIBRATOR, CERAMIC 10MHz	
*****			
* 1-632-974-11 SWITCH BOARD			
*****			
< RESISTOR >			
R001	△ 1-215-880-00	METAL OXIDE	10 5% 2W F
R002	△ 1-215-880-00	METAL OXIDE	10 5% 2W F
< SWITCH >			
S001	1-571-736-11	SWITCH, LEAF (IN SW)	
S002	1-571-736-11	SWITCH, LEAF (OUT SW)	

**Note:**  
 The components identified by mark  or dotted line with mark  are critical for safety. Replace only with part number specified.

**Note:**  
 Les composants identifiés par une marque  sont critiques pour la sécurité. Ne les remplacer que par une pièce portant le numéro spécifié.

**TRANSLATION**

Ref.No.	Part No.	Description	Remark
	* 1-632-973-11	TRANSLATION BOARD *****	
		< CAPACITOR >	
C051	1-136-157-00	FILM 0.022uF 5% 50V	
C052	1-164-159-11	CERAMIC 0.1uF 50V	
C053	1-164-159-11	CERAMIC 0.1uF 50V	
		< CONNECTOR >	
CN051	1-568-799-11	SOCKET, CONNECTOR 16P	

\*\*\*\*\*

Ref.No.	Part No.	Description	Remark
		MISCELLANEOUS *****	
102	△ 1-557-577-11	CORD, POWER (Canadian)	
123	△ 1-555-795-00	CORD, POWER (AEP)	
124	△ 1-556-035-00	CORD, POWER (UK)	
204	△ 8-848-209-11	DEVICE, OPTICAL XSS-271A	
F991	△ 1-532-066-00	FUSE, TIME-LAG (T400mA) (AEP, UK)	
F991	△ 1-532-741-11	FUSE, GLASS TUBE (1.25A/125V) (Canadian)	
M001	A-4604-347-A	MOTOR (L) ASSY (LOADING)	
M002	X-4927-605-3	BASE ASSY, MECHANICAL (SPINDLE MOTOR)	
S991	△ 1-570-156-11	SWITCH, PUSH (AC POWER) (1 KEY) (POWER)	
T991	△ 1-450-039-21	TRANSFORMER, POWER (Canadian)	
T991	△ 1-450-523-11	TRANSFORMER, POWER (AEP, UK)	

\*\*\*\*\*

ACCESSORY & PACKING MATERIALS  
\*\*\*\*\*

- 1-465-593-11 COMMANDER, REMOTE (RM-D991)
- 1-558-271-11 CORD, CONNECTION
- 3-707-584-01 COVER, BATTERY
- \* 3-750-090-01 INSTRUCTION (Canadian)
- \* 3-795-629-11 INSTRUCTION (AEP)
- 3-752-484-11 MANUAL, INSTRUCTION  
(ENGLISH, FRENCH, SPANISH, PORTUGUESE)
- 3-752-484-41 MANUAL, INSTRUCTION  
(GERMAN, DUTCH, SWEDISH, ITALIAN) (AEP)
- \* 4-942-314-01 CUSHION (UPPER)
- \* 4-942-315-01 CUSHION (LOWER)
- \* 4-945-271-01 INDIVIDUAL CARTON

\*\*\*\*\*

**HARDWARE LIST**

- # 1 7-621-996-24 BOLT 2.6X4, HEXAGON SOCKET
- # 2 7-682-548-09 SCREW (3X8)
- # 3 7-682-561-09 SCREW +B 4X8
- # 4 7-685-134-19 SCREW +BTP 2.6X8 TYPE2 N-S
- # 5 7-682-547-09 SCREW +B 3X6
- # 6 7-682-549-09 SCREW +BVTT 3X10 (S)
- # 7 7-682-547-04 SCREW +BVTT 3X6 (S)
- # 8 7-682-560-04 SCREW +BVTT 4X6 (S)
- # 9 7-682-147-15 SCREW, TR
- # 10 7-685-647-79 SCREW +P 3X10 TYPE2 SLIT
- # 11 7-621-770-67 SCREW +BVTT 2.6X6 (S)
- # 12 7-624-105-04 STOP RING 2.3, TYPE -E
- # 13 7-682-544-04 SCREW +P 3X3
- # 14 7-685-646-79 SCREW, TAPPING
- # 15 7-685-132-19 + PTPWH (2.6X5)
- # 16 7-621-775-10 SCREW +BVTT 2.6X4 (S)

<p><b>Note:</b> The components identified by mark △ or dotted line with mark △ are critical for safety. Replace only with part number specified.</p>	<p><b>Note:</b> Les composants identifiés par une marque △ sont critiques pour la sécurité. Ne les remplacer que par une pièce portant le numéro spécifié.</p>
----------------------------------------------------------------------------------------------------------------------------------------------------------	--------------------------------------------------------------------------------------------------------------------------------------------------------------------