

CDP-S37/S207

SERVICE MANUAL

Canadian Model
AEP Model
UK Model
E Model
CDP-S37



US Model
Canadian Model
AEP Model
UK Model
CDP-S207

SPECIFICATIONS

Compact disc player

	CDP-S207	CDP-S37
Frequency response	5 Hz - 20 kHz (± 0.5 dB)	
Signal to noise ratio	More than 95 dB	
Dynamic range	More than 90 dB	
Harmonic distortion	Less than 0.05% (at 1 kHz)	
Channel separation	More than 90 dB	

Outputs

	CDP-S207	CDP-S37
LINE OUT (FIXED) (phono jacks)	Output level 2 V (at 50 kilohms) Load impedance over 10 kilohms	
HEADPHONES (stereo phone jack)	—	Output level max. 11 mW
	—	Load impedance 32 ohms

General

	CDP-S207	CDP-S37
Power requirements	AEP model: (CDP-S207/CDP-S37) 220V AC, 50/60Hz UK model: (CDP-S207) 240V AC, 50/60Hz US model: (CDP-S207) 120V AC, 60Hz Canadian model: (CDP-S207/CDP-S37) 120V AC, 60Hz E model: (CDP-S37) 110 ~ 120 or 220 ~ 240V AC adjustable, 50/60Hz	
Power consumption	10 W	
Dimensions (approx., including projections)	225 x 65 x 230 mm (w/h/d) (8 7/8 x 4 3/4 x 9 1/8 inches)	
Weight (approx.)	2.0 kg (4 lb 7 oz)	

Model Name Using Similar Mechanism	New
CD Transport Mechanism Type	KSS-211A
Optical Pick-Up Block Type	BU-5F

Supplied accessories

	CDP-S207	CDP-S37
Audio cord	1 (2 phono plugs - 2 phono plugs)	
Connecting cord	1	

Design and specifications subject to change without notice.

SAFETY-RELATED COMPONENT WARNING!!

COMPONENTS IDENTIFIED BY MARK Δ OR DOTTED LINE WITH MARK Δ ON THE SCHEMATIC DIAGRAMS AND IN THE PARTS LIST ARE CRITICAL TO SAFE OPERATION. REPLACE THESE COMPONENTS WITH SONY PARTS WHOSE PART NUMBERS APPEAR AS SHOWN IN THIS MANUAL OR IN SUPPLEMENTS PUBLISHED BY SONY.

ATTENTION AU COMPOSANT AYANT RAPPORT À LA SÉCURITÉ!

LES COMPOSANTS IDENTIFIÉS PAR UNE MARQUE Δ SUR LES DIAGRAMMES SCHÉMATIQUES ET LA LISTE DES PIÈCES SONT CRITIQUES POUR LA SÉCURITÉ DE FONCTIONNEMENT. NE REMPLACER CES COMPOSANTS QUE PAR DES PIÈCES SONY DONT LES NUMÉROS SONT DONNÉS DANS CE MANUEL OU DANS LES SUPPLÉMENTS PUBLIÉS PAR SONY.

COMPACT DISC PLAYER
SONY®



TABLE OF CONTENTS

<u>Section</u>	<u>Title</u>	<u>Page</u>	<u>Section</u>	<u>Title</u>	<u>Page</u>
SECTION1 GENERAL			3-5.	Circuit Description	15
1-1.	Location of Controls	3	3-6.	IC Block Diagram	17
SECTION2 ELECTRICAL ADJUSTMENTS			SECTION4 EXPLODED VIEWS		
4			4-1.	Cabinet Section	19
SECTION3 DIAGRAMS			4-2.	CDM13 Section	20
3-1.	Semiconductor Lead Layouts	6	4-3.	BU-5F Section	21
3-2.	Waveforms	7	SECTION5 ELECTRICAL PARTS LIST		
3-3.	Printed Wiring Board	8	22		
3-4.	Schematic Diagram	11			

SAFETY CHECK-OUT

After correcting the original service problem, perform the following safety check before releasing the set to the customer:

Check the antenna terminals, metal trim, "metallized" knobs, screws, and all other exposed metal parts for AC leakage. Check leakage as described below.

LEAKAGE TEST

The AC leakage from any exposed metal part to earth ground and from all exposed metal parts to any exposed metal part having a return to chassis, must not exceed 0.5 mA (500 microamperes). Leakage current can be measured by any one of three methods.

1. A commercial leakage tester, such as the Simpson 229 or RCA WT-540A. Follow the manufacturers' instructions to use these instruments.
2. A battery-operated AC milliammeter. The Data Precision 245 digital multimeter is suitable for this job.
3. Measuring the voltage drop across a resistor by means of a VOM or battery-operated AC voltmeter. The "limit" indication is 0.75 V, so analog meters must have an accurate low-voltage scale. The Simpson 250 and Sanwa SH-63Trd are examples of a passive VOM that is suitable. Nearly all battery operated digital multimeters that have a 2V AC range are suitable. (See Fig. A)

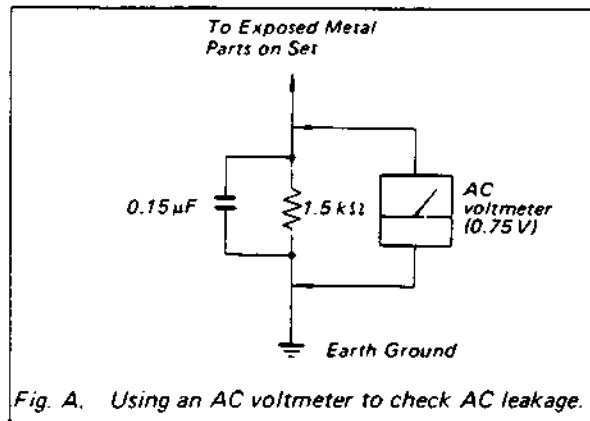

Fig. A. Using an AC voltmeter to check AC leakage.

SERVICING NOTE

NOTES ON HANDLING THE OPTICAL PICK-UP BLOCK OR BASE UNIT

The laser diode in the optical pick-up block may suffer electrostatic breakdown because of the potential difference generated by the charged electrostatic load, etc. on clothing and the human body. During repair, pay attention to electrostatic breakdown and also use the procedure in the printed matter which is included in the repair parts. The flexible board is easily damaged and should be handled with care.

CAUTION

Use of controls or adjustments or performance of procedures other than those specified herein may result in hazardous radiation exposure.

NOTES ON LASER DIODE EMISSION CHECK

The laser beam on this model is concentrated so as to be focused on the disc reflective surface by the objective lens in the optical pick-up block. Therefore, when checking the laser diode emission, observe from more than 30 cm away from the objective lens.

MODEL IDENTIFICATION
(Specification Label)

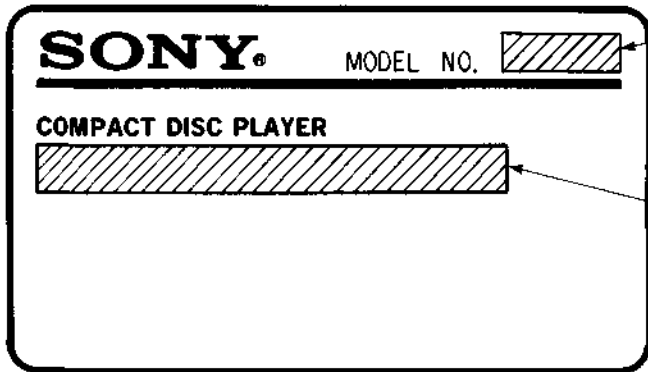

CDP-S37
CDP-S207

US model: AC 120V 60Hz 10W
 Canadian model: AC 120V 60Hz 10W
 AEP model: AC 220V~50/60Hz
 UK model: AC 240V~50/60Hz
 E model: AC 110-120/220-240V~50/60Hz 10W

SECTION 1
GENERAL

1-1. LOCATION OF CONTROLS

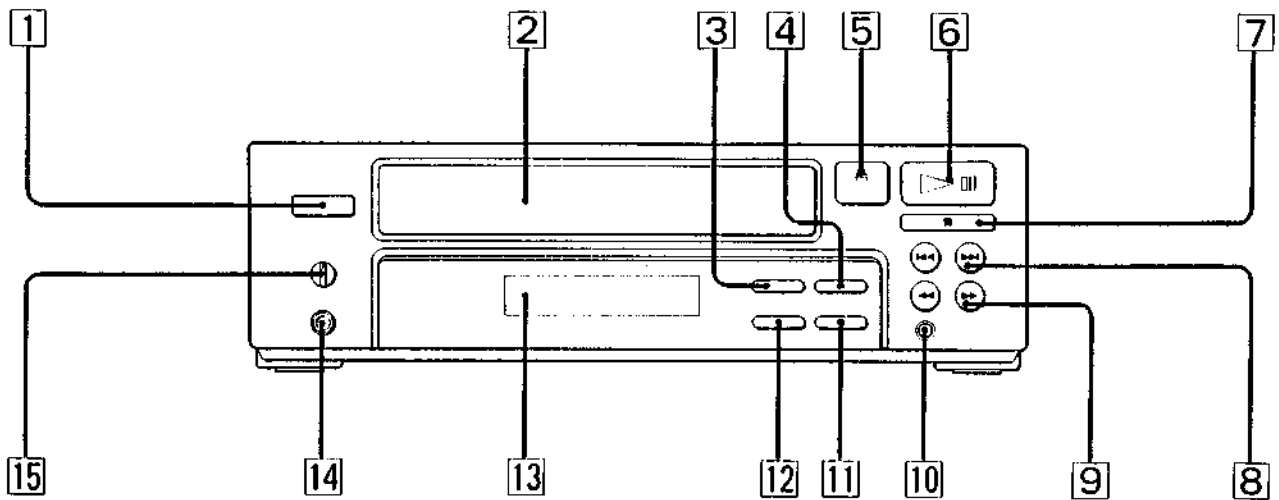

- 1 POWER switch
- 2 Disc compartment
- 3 PROGRAM button
- 4 SHUFFLE button
- 5 ▲ (open/close) button
- 6 ▶ (play/pause) button
- 7 ■ (stop) button
- 8 ◀▶ (AMS) button
- 9 ◀▶ (manual search) buttons
- 10 REPEAT button
- 11 CONTINUE button
- 12 TIME button
- 13 Display window
- 14 HEADPHONES jack (only for S37)
- 15 PHONE LEVEL (headphone Level) control (only for S37)

SECTION 2 ELECTRICAL ADJUSTMENTS

1. Perform adjustments in the order given.
2. Use YEDS-18 (Part No: 3-702-101-01) disc unless otherwise indicated.
3. Use the oscilloscope with more than 10 MΩ impedance.

RF PLL Frequency Adjustment/Lock Frequency Check

Procedure:

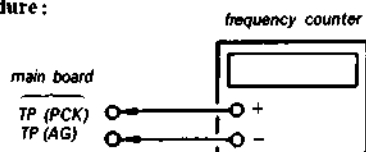

1. Connect test point TP (ASY) to ground with lead wire.
2. Turn POWER switch on.
3. Connect the frequency counter to test point TP (PCK) and TP (AG).
4. Adjust RV4 so that the reading on the frequency counter is $4.3218\text{MHz} \pm 30\text{kHz}$ (RF PLL frequency adjustment).
5. Remove lead wire connecting TP (ASY) to ground.
6. Put disc (YEDS-18) in and press ▷ button.
7. Confirm that the reading on frequency counter is 4.3218MHz (Lock frequency check).

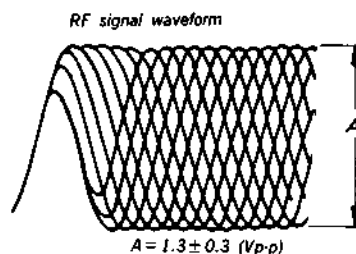

Adjustment Location : main board

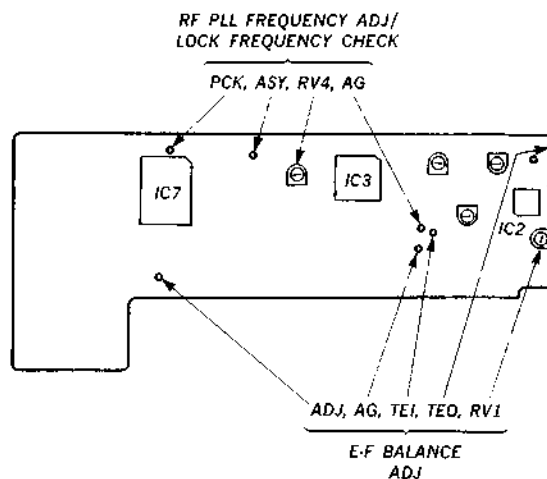

E-F Balance Adjustment

This adjustment should be made when replacing TOP (T-type Optical Pick-up).

Procedure:

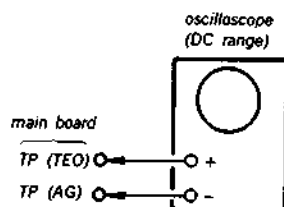

1. Connect test point TP (ADJ) and test point TP (TEI) to ground with lead wire.
2. Connect oscilloscope to test point TP (TEO) and TP (AG).
3. Turn POWER switch on.
4. Put disc (YEDS-18) in and press ▷ button.
5. Adjust RV1 so that the traverse waveform is symmetrical above and below.
6. After adjustment, remove the lead wire connected in step 5.

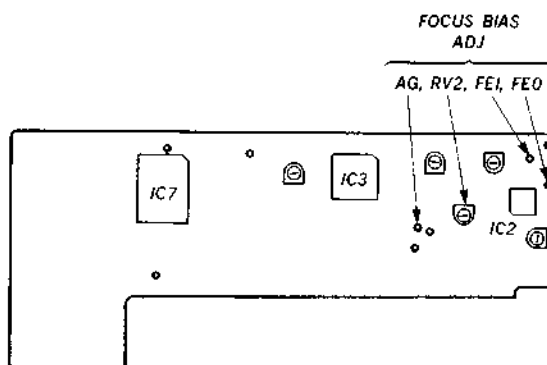
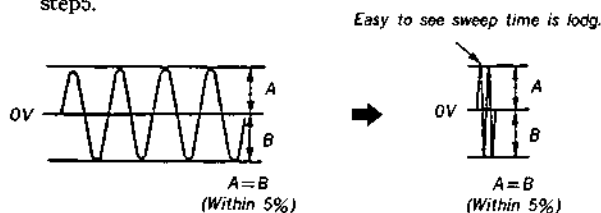

Focus Bias Adjustment

This adjustment should be made when replacing TOP (T-type Optical Pick-up).

Procedure:

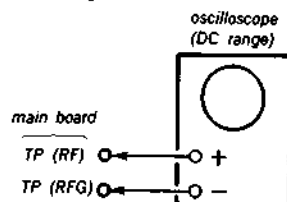

SECTION 3 DIAGRAM

REFERENCE

Focus/Tracking Gain Adjustments

A frequency response analyzer is necessary in order to perform this adjustment exactly.

However, this gain has a margin, so even if it is slightly off, there is no problem. Therefore, do not perform this adjustment.

Focus/tracking gain determines the pick-up follow up (vertical and horizontal) relative to mechanical noise and shock when the 2-axis device operate.

However, as these reciprocate, the adjustment is at the point where both are satisfied.

- When gain is raised, the noise when the 2-axis device operates increases.
- When gain is lowered, mechanical shock and skipping occurs more easily.
- When gain adjustment is off, the symptoms below appear.

Symptoms	Gain	Focus	Tracking
• The time until music starts becomes longer for $\blacksquare \rightarrow \triangleright$ or automatic selection. (\llcorner , \triangleright buttons pressed.) (Normally takes about 1 seconds.)		low	low or high
• Music does not start and disc continues to rotate for $\blacksquare \rightarrow \triangleright$ or automatic selection. (\llcorner , \triangleright buttons pressed.)		—	low
• Disc table opens shortly after $\blacksquare \rightarrow \triangleright$.		low or high	—
• Sound is interrupted during PLAY or time counter display stops progressing.		—	low
• More noise during 2-axis device operation.		high	high

The following is a simple adjustment method.

—Primary Adjustment—

Note: Since exact adjustment cannot be performed, remember the positions of the controls before performing the adjustment. If the position after the primary adjustment are only a little different, return the controls to the original position.

Procedure:

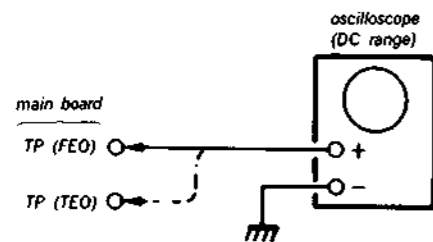

1. Keep the set horizontal.
(If the set is not horizontal, this adjustment cannot be performed due to the gravity against the 2-axis device.)
2. Insert disc (YEDS-18: Fifth Selection) and press \triangleright button.
3. Connect oscilloscope to main board TP (FEO).
4. Adjust RV3 so that the waveform is as shown in the figure below. (focus gain adjustment)
5. Connect oscilloscope to main board TP (TEO).
6. Adjust RV5 so that the waveform is as shown in the figure below. (tracking gain adjustment)

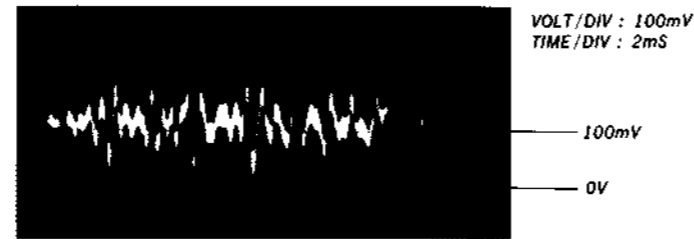

• Incorrect Examples (DC level changes more than on adjusted waveform)

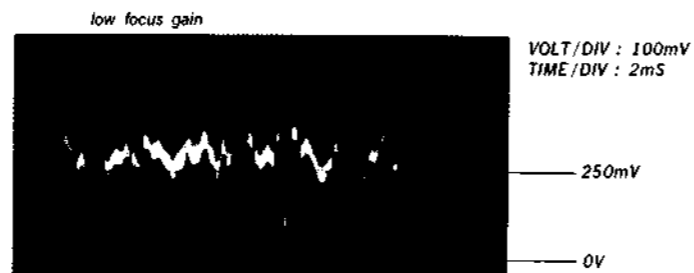

• Incorrect Examples (fundamental wave appears)

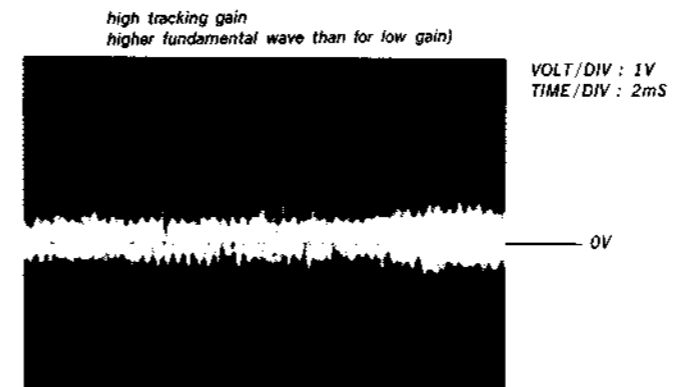

Adjustment Location: main board

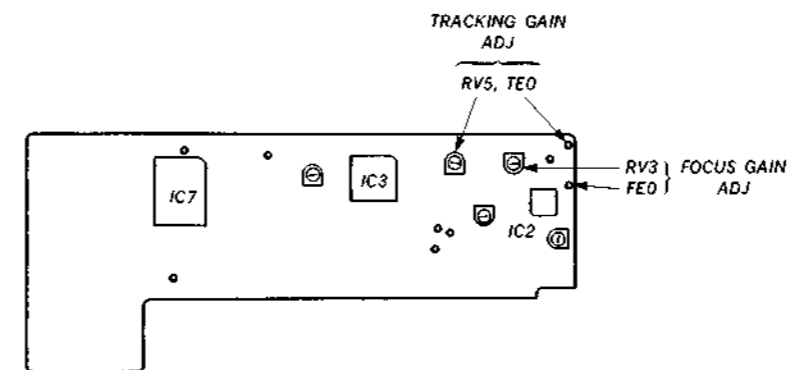

3-1. SEMICONDUCTOR LEAD LAYOUTS

2SK381-C



RD6.8FS-B1



10E2

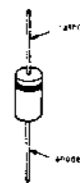

SECTION 3 DIAGRAM

3-1. SEMICONDUCTOR LEAD LAYOUTS

2SK381-C



RD6.8FS-B1

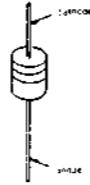

10E2

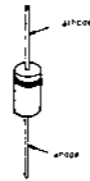

• Incorrect Examples (fundamental wave appears)

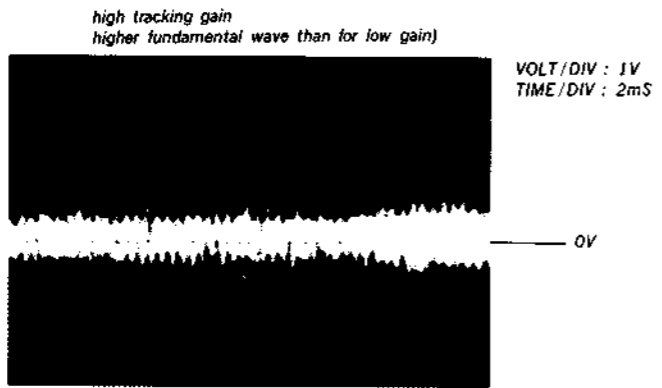
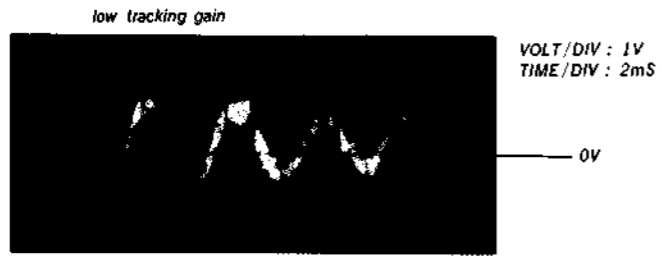

Adjustment Location : main board

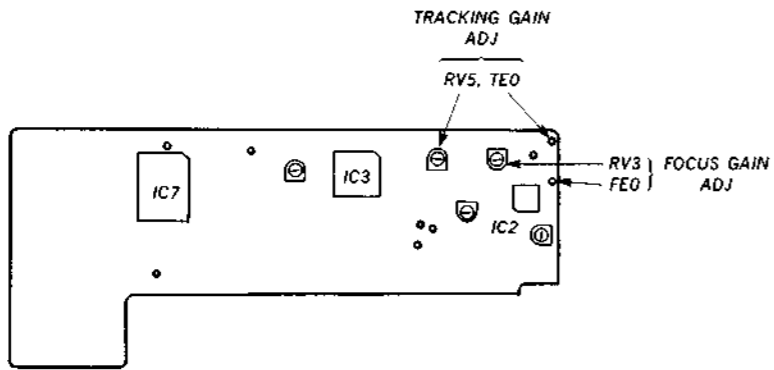

3-2. WAVEFORMS

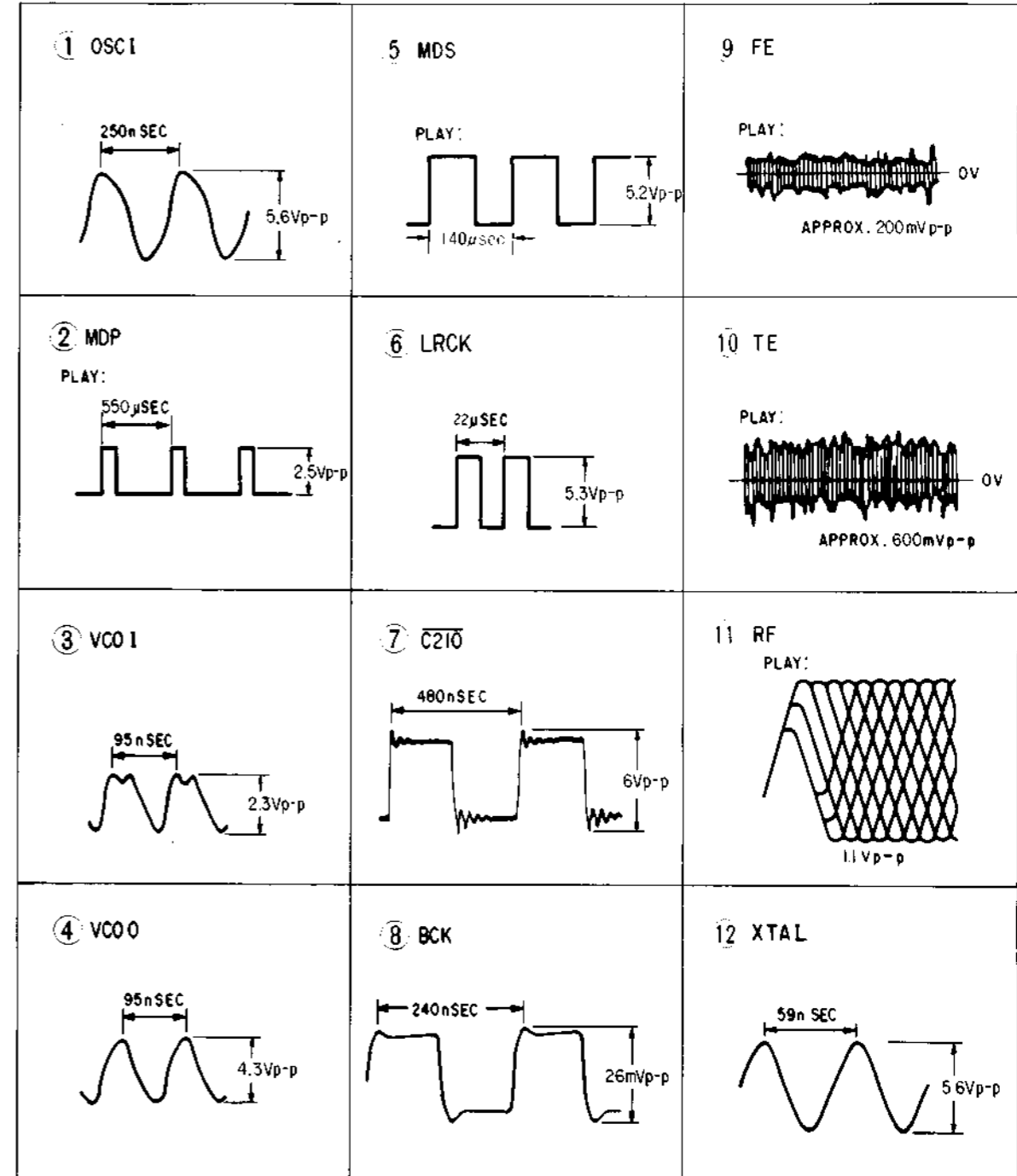

• Semiconductor Location

Ref. No.	Location
D1	A-10
D3	G-5
D4	G-5
D5	G-5
D6	A-9
D7	B-9
D8	A-9
D9A	A-8
D9B	B-9
D10	B-10
IC1	D-10
IC2	B-1
IC3	A-4
IC4	C-3
IC5	B-4
IC6	H-4
IC7	B-6
IC8	B-6
IC9	B-7
IC10	C-7
IC11	C-7
IC12	C-10
Q1	C-10
Q2	B-2
Q3	B-5
Q4	A-5
Q5	G-1
Q6	B-6
Q10	A-7
Q11	A-8

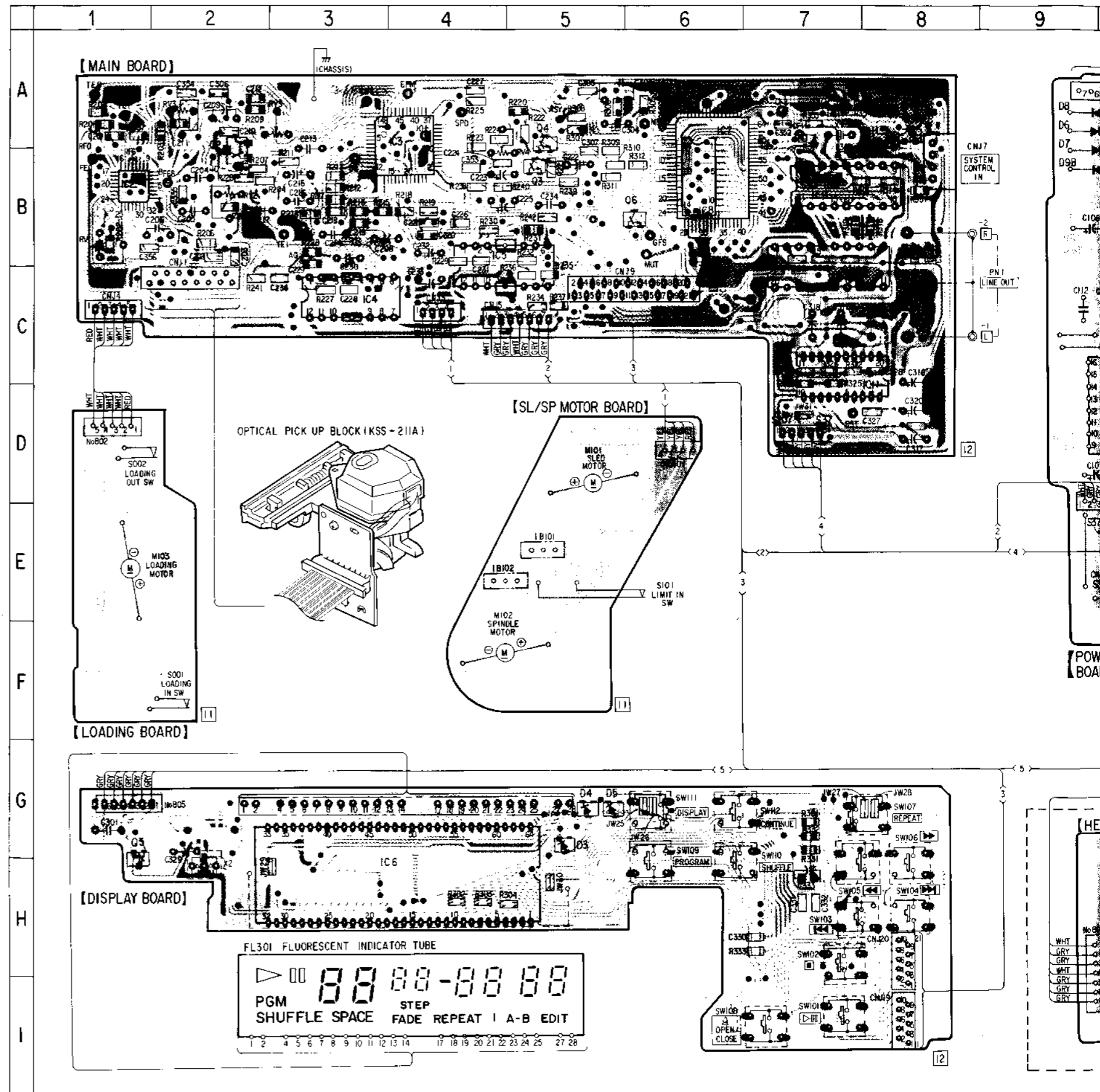

- — : parts extracted from the component side.
- : parts mounted on the conductor side.
- : Through hole.
- (with dot) : Pattern on the side which is seen.
- (with cross) : Pattern of the rear side.

1	2	3	4	5	6	7	8	9	10	11	12	13	14	15
---	---	---	---	---	---	---	---	---	----	----	----	----	----	----

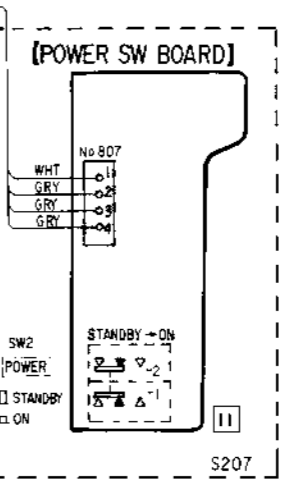
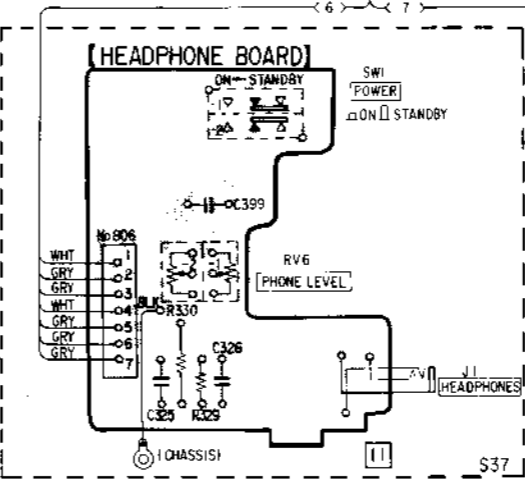
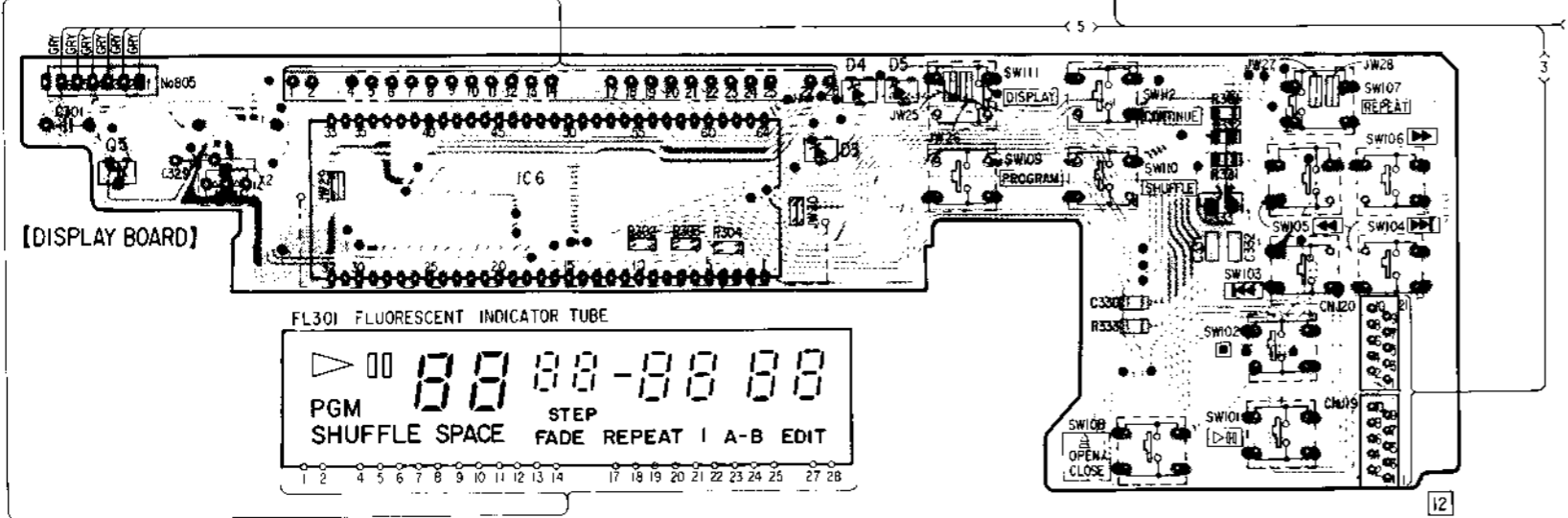
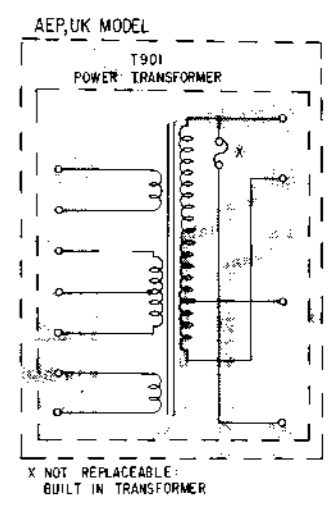
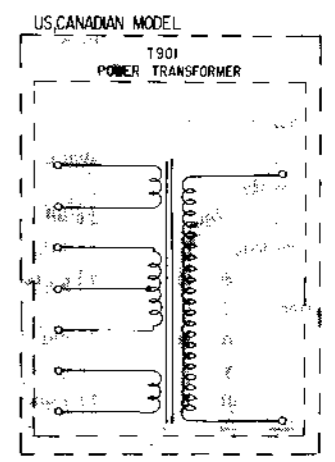
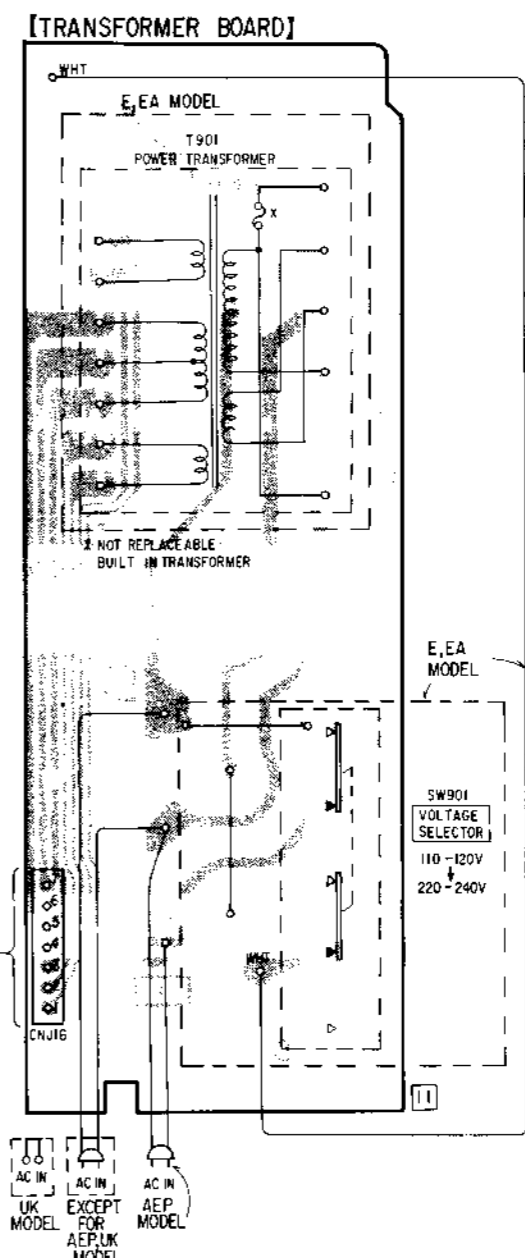
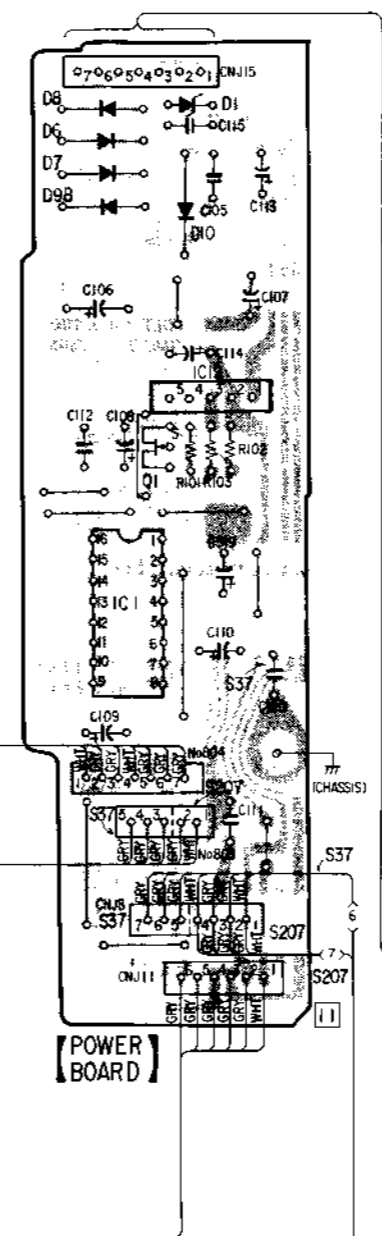
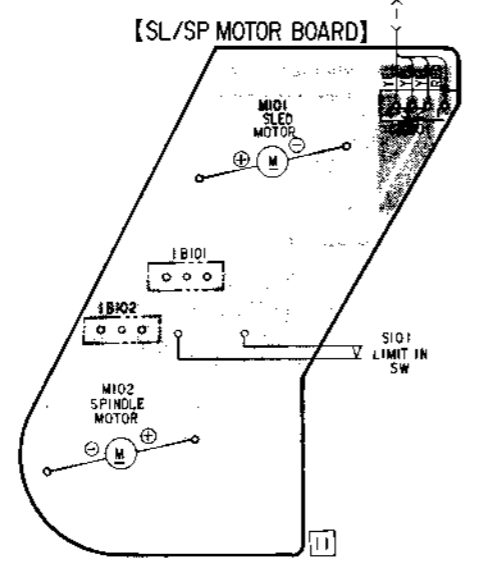
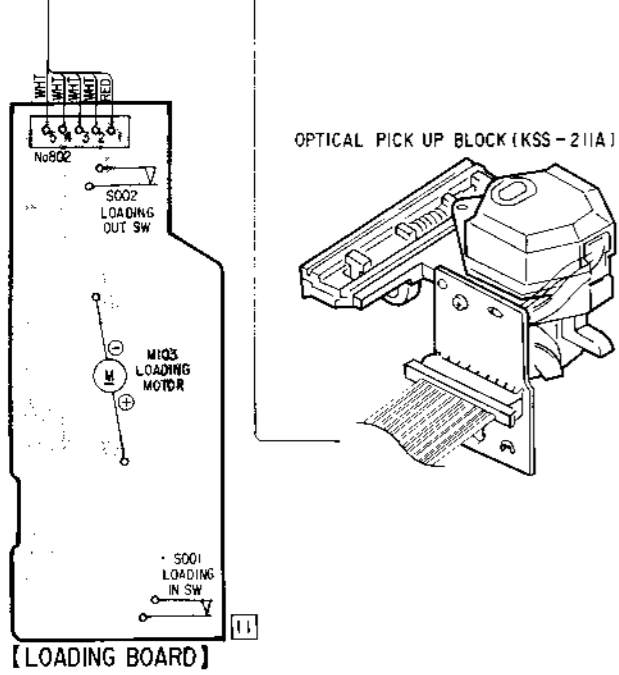
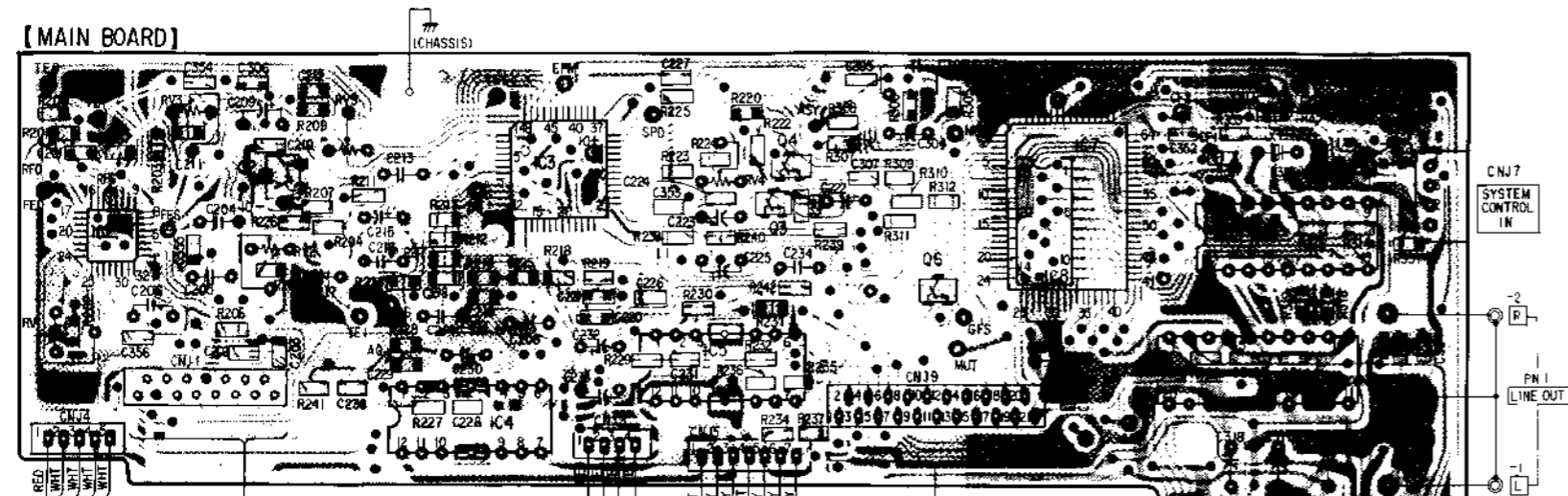

[DISPLAY BOARD]

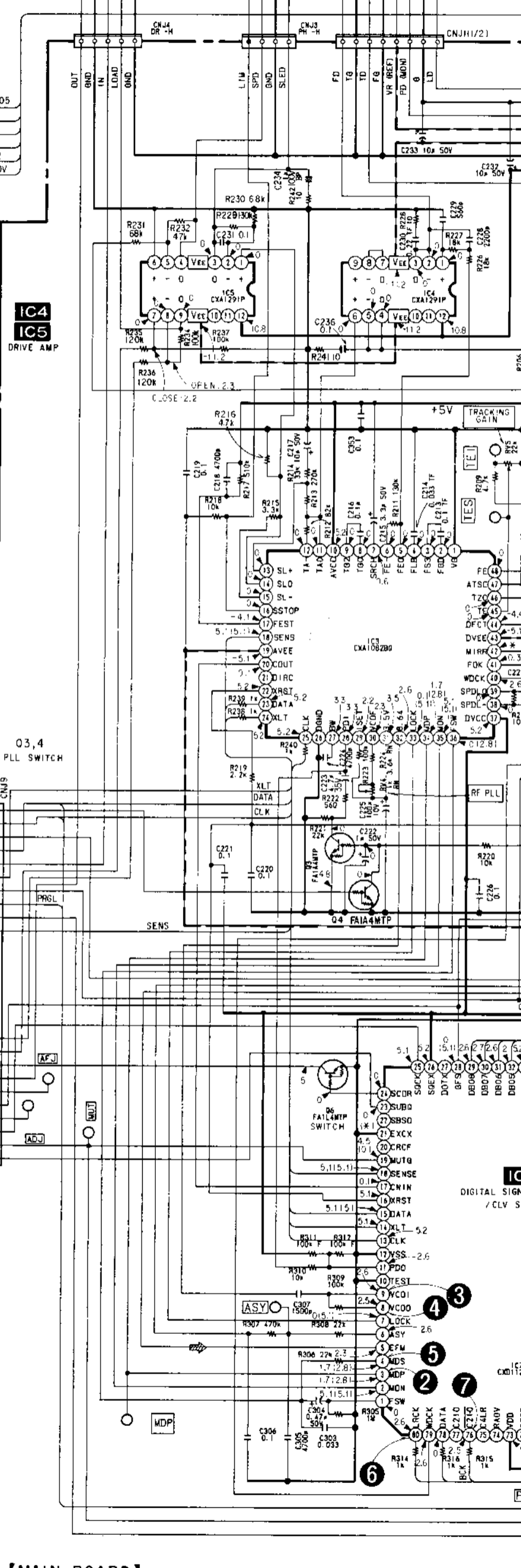
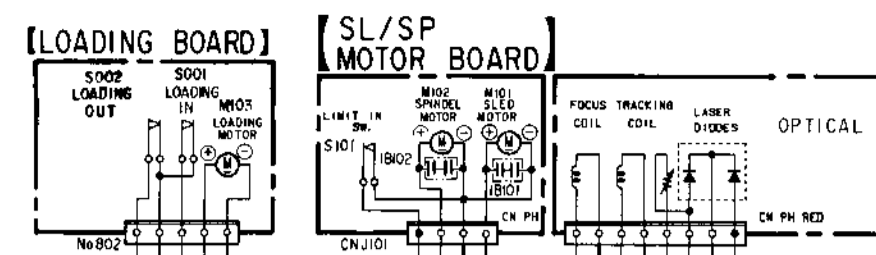
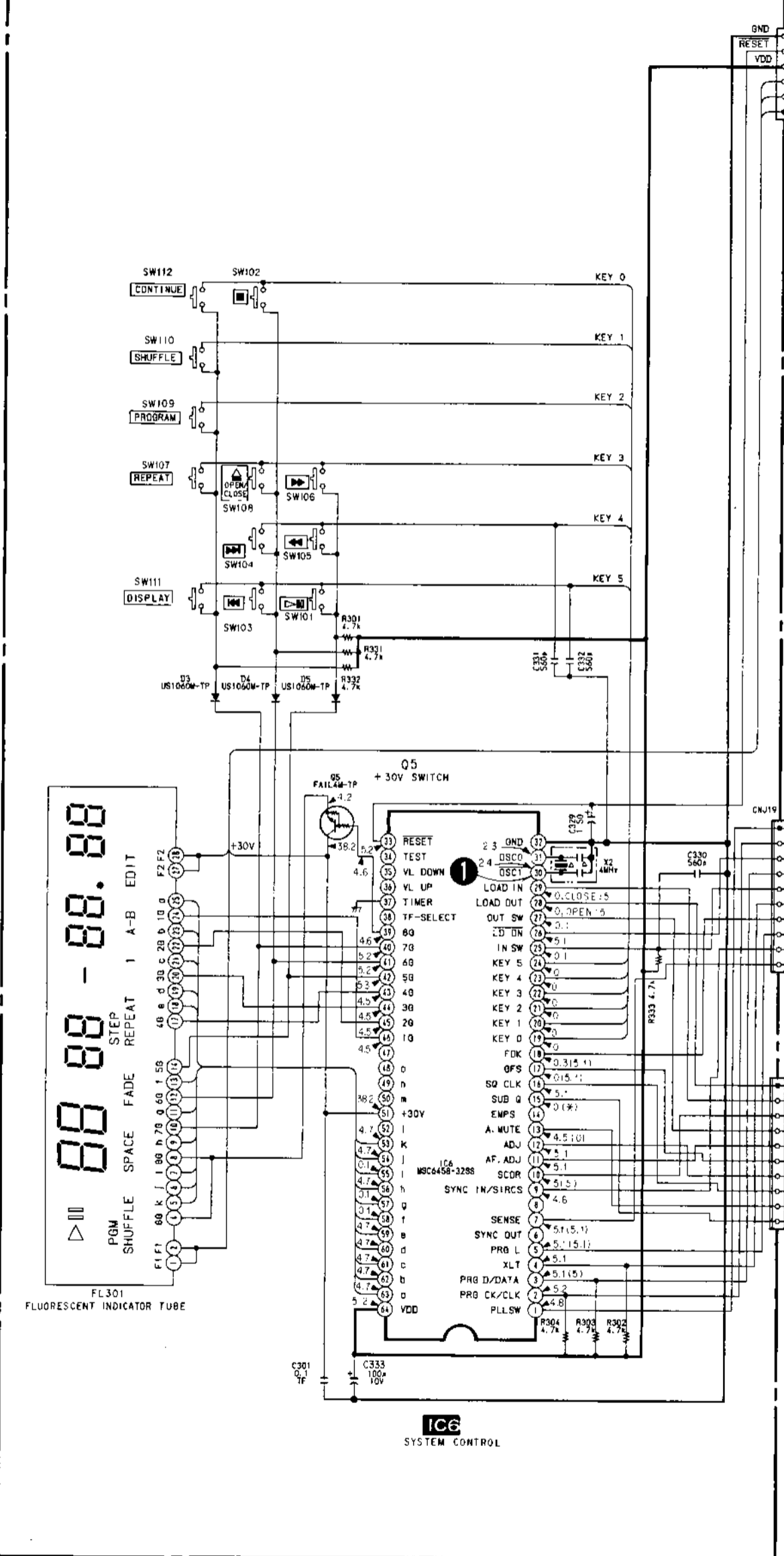

A
B
C
D
E
F
G
H
I
J
K
L
M
N
O
P

[TRANSFORMER BOARD]

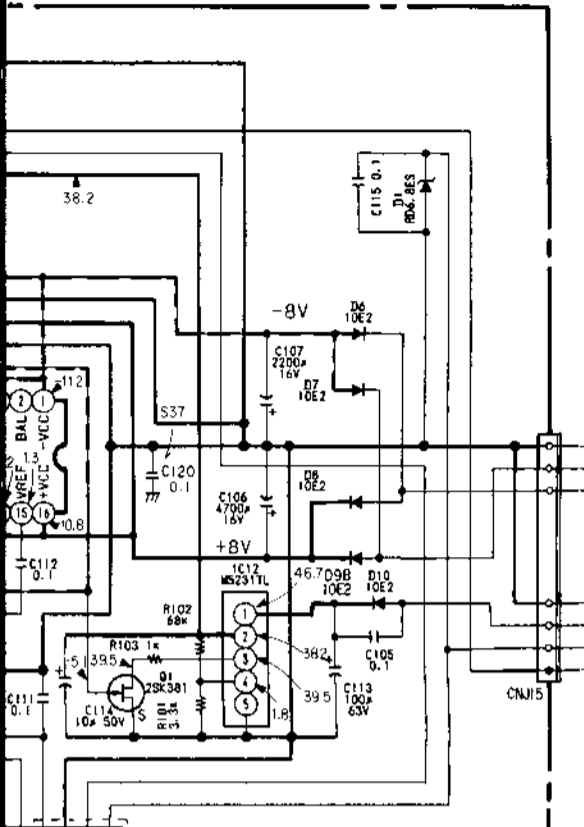
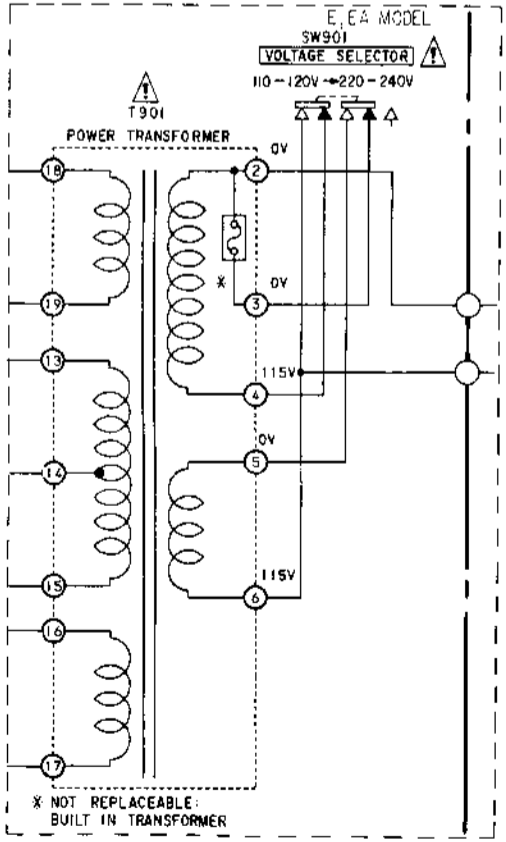
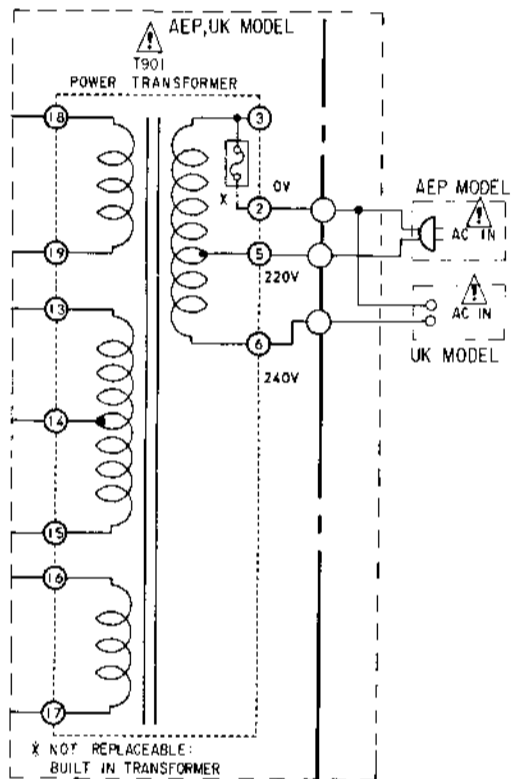
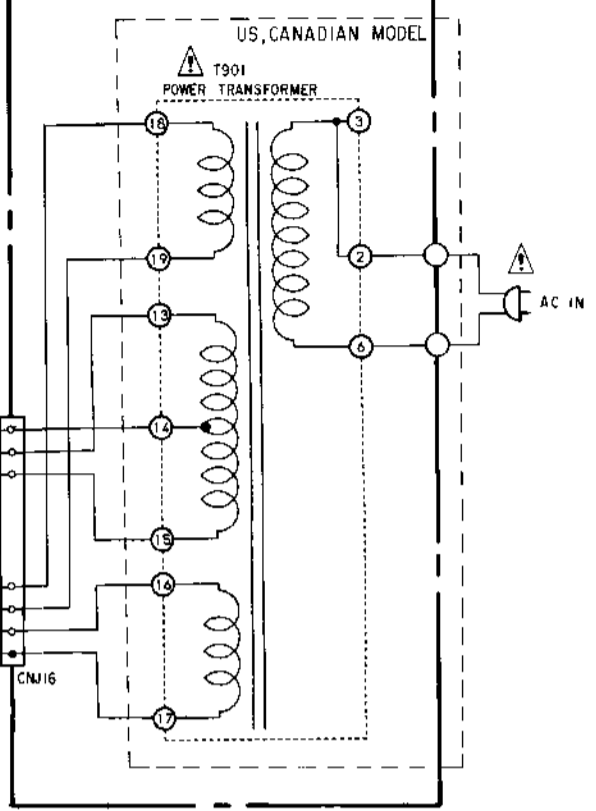

[HEADPHONE BOARD]

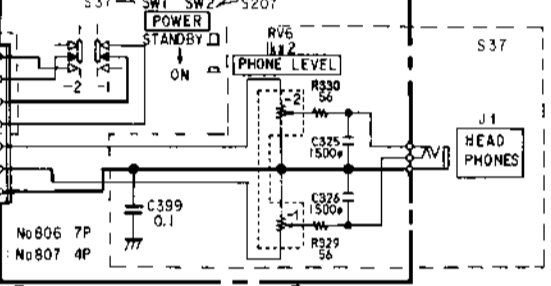

[POWER SW BOARD]

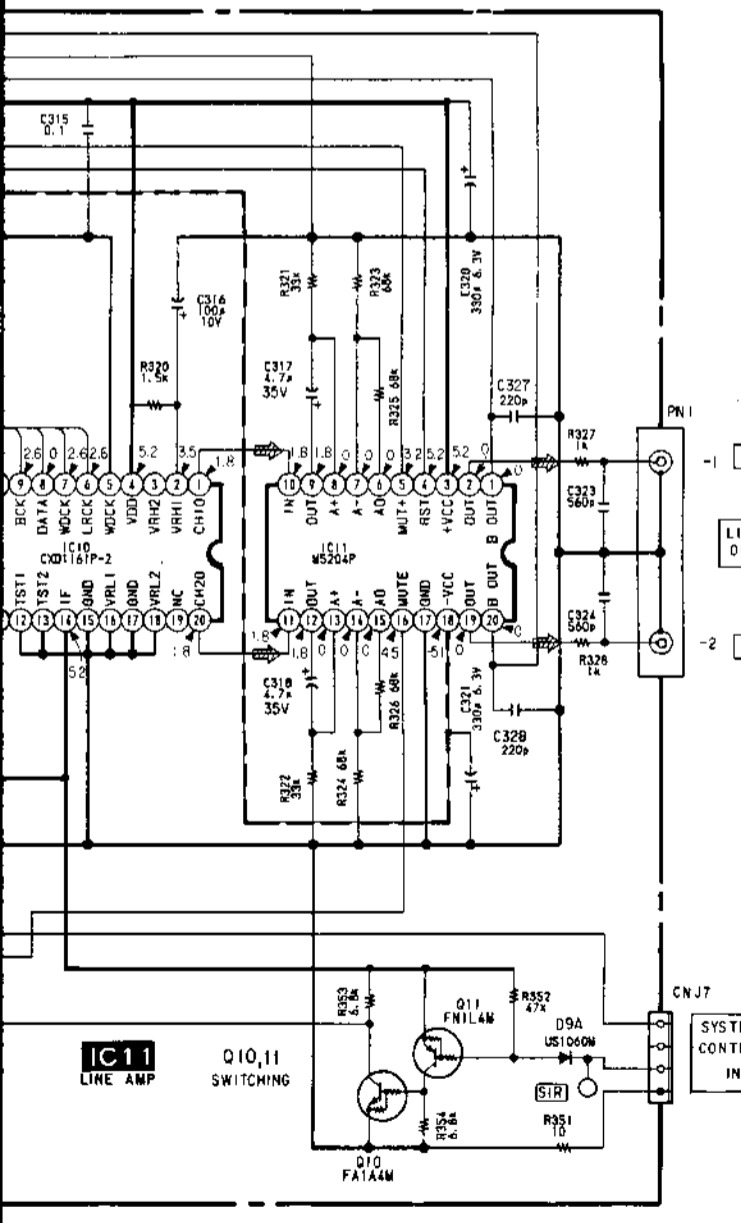
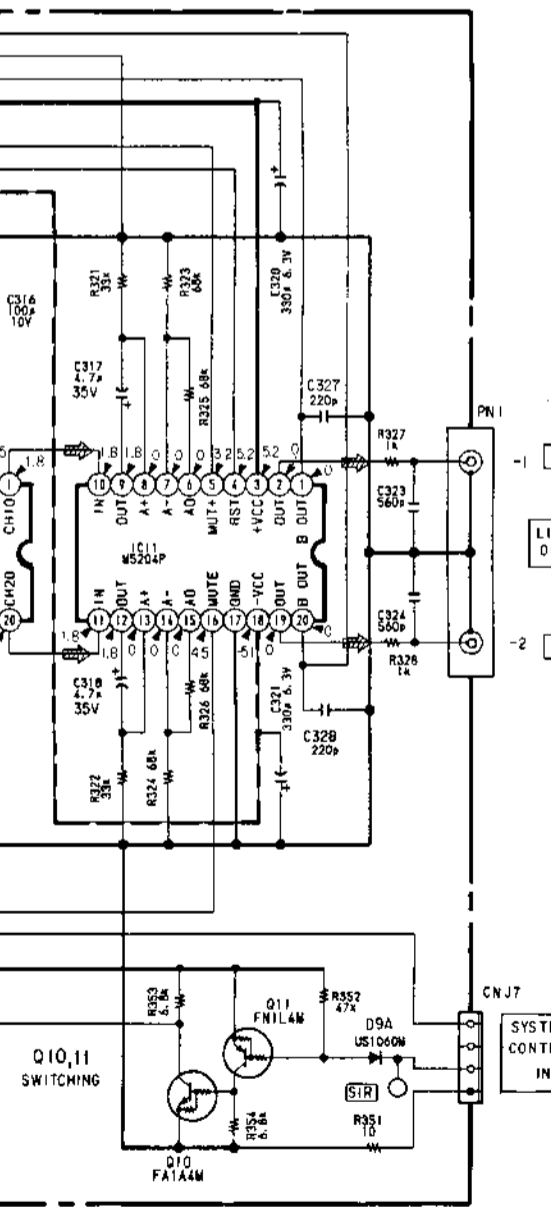

- All capacitors are in μF unless otherwise noted. pF : μF 50WV or less are not indicated except for electrolytics and tantalums.
- All resistors are in Ω and $\frac{1}{2}\text{W}$ or less unless otherwise specified.
- \triangle : internal component.
- — : B+ Line
- - - - : B- Line
- \square : adjustment for repair.
- AC voltage readings in the bias oscillator with a VTVM.
- Voltage and waveforms are dc with respect to ground under no-signal conditions.
- no mark : STOP
- () : PLAY
- Voltages are taken with a VOM (Input Impedance $10\text{M}\Omega$). Voltage variations may be noted due to normal production tolerances.
- Waveforms are taken with an oscilloscope. Voltage variations may be noted due to normal production tolerances.
- Circled numbers refer to waveforms.
- Signal path.
- \diamond : CD

Note:
The components identified by mark \triangle or dotted line with mark \triangle are critical for safety. Replace only with part number specified.

Note:
Les composants identifiés par une marque \triangle sont critiques pour la sécurité. Ne les remplacer que par une pièce portant le numéro spécifié.

3-5. CIRCUIT DESCRIPTION

IC6 (MSC6458) SYSTEM CONTROL MICROCOMPUTER

Table 1 Pin Functions IC6

Description of IC6 (MSC6458)

IC101 has the following functions:

- . Digital signal output to operation key
- . Sub Q signal loading and processing
- . Fluorescent display (FLD) control
- . Servo circuit control

Pin Function

Pin no.	Pin name	I/O	Description
1	PLL SW	O	"L" in play mode and "H" in search mode.
2	CLK	O	Command transfer of clock to SSP (IC3) and DSP (IC7).
3	DATA	O	Command transfer of data to SSP (IC3) and DSP (IC7).
4	XLK	O	Command transfer of latch to SSP (IC3) and DSP (IC7).
5	PRGL	O	Command transfer of latch to DFIL (IC9).
6	SYNC OUT	O	No connector (NC).
7	SENSE	I	SSP (IC2) and DSP (IC3) sense information.
8	SYNC ON	I	Sync REC ("L" in REC mode).
9	SIRCS	I	Remote control signal input.
10	SCOR	I	Q code read timing.
11	AF ADJ	I	No connection (NC)
12	ADJ	I	"L" in test mode.
13	AMUTE	O	ALL muting. Output to DSP (IC3) MUTG.
14	EMPS	O	No connection (NC)
15	SUBQ	I	Subcode data.
16	SQCLK	O	Subcode data read clock.
17	GFS	I	"H" when CLV is locked.
18	FOK	I	"H" when focus is on.
19	KEY0	I	Key matrix input. "H" active.
20	KEY1	I	Key matrix input. "H" active.
21	KEY2	I	Key matrix input. "H" active.
22	KEY3	I	Key matrix input. "H" active.
23	KEY4	I	Key matrix input. "H" active.
24	KEY5	I	Key matrix input. "H" active.
25	IN SW	I	Loading IN SW.
26	LDON	O	Laser on / off.
27	OUTSW	I/O	Loading OUT SW.
28	LODOUT	O	Loading motor control.
29	LODIN	O	Loading motor control.
30	OSC1	I	Oscillator input terminal (4 MHz).
31	OSC0	I	Oscillator input terminal (4 MHz).

Pin No.	Pin name	I/O	Description
32	GND	—	GND terminal.
33	RESET	I	Reset input terminal. Input when power is turned on.
34	TEST	—	No connection (NC).
35	VL DOWN	—	No connection (NC).
36	VL UP	O	Volume up.
37	TIMER	O	No connection (NC).
38	LED	O	Volume indicator.
39	8G	O	FLD timing output.
40	7G	O	FLD timing output.
41	6G	O	FLD timing output.
42	5G	O	FLD timing output.
43	4G	O	FLD timing output.
44	3G	O	FLD timing output.
45	2G	O	FLD timing output.
46	1G	O	FLD timing output.
47	NC	—	No connection (NC).
48	o	O	FLD segment output.
49	n	O	FLD segment output.
50	m	O	FLD segment output.
51	+ 30V	—	+ 30V
52	l	O	FLD segment output.
53	k	O	FLD segment output.
54	j	O	FLD segment output.
55	i	O	FLD segment output.
56	h	O	FLD segment output.
57	g	O	FLD segment output.
58	f	O	FLD segment output.
59	e	O	FLD segment output.
60	d	O	FLD segment output.
61	c	O	FLD segment output.
62	b	O	FLD segment output.
63	a	O	FLD segment output.
64	VDD	—	positive(+) power supply (5V)

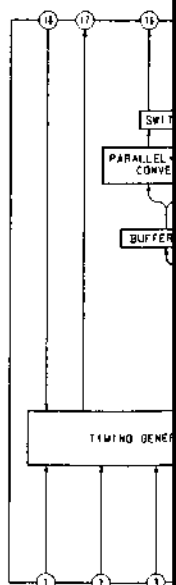
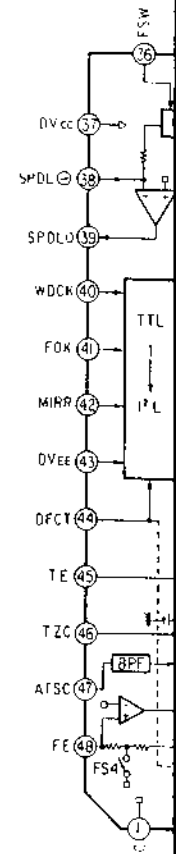

3-6. IC BLOCK DIAGRAM

• IC3 CXA-1082BQ

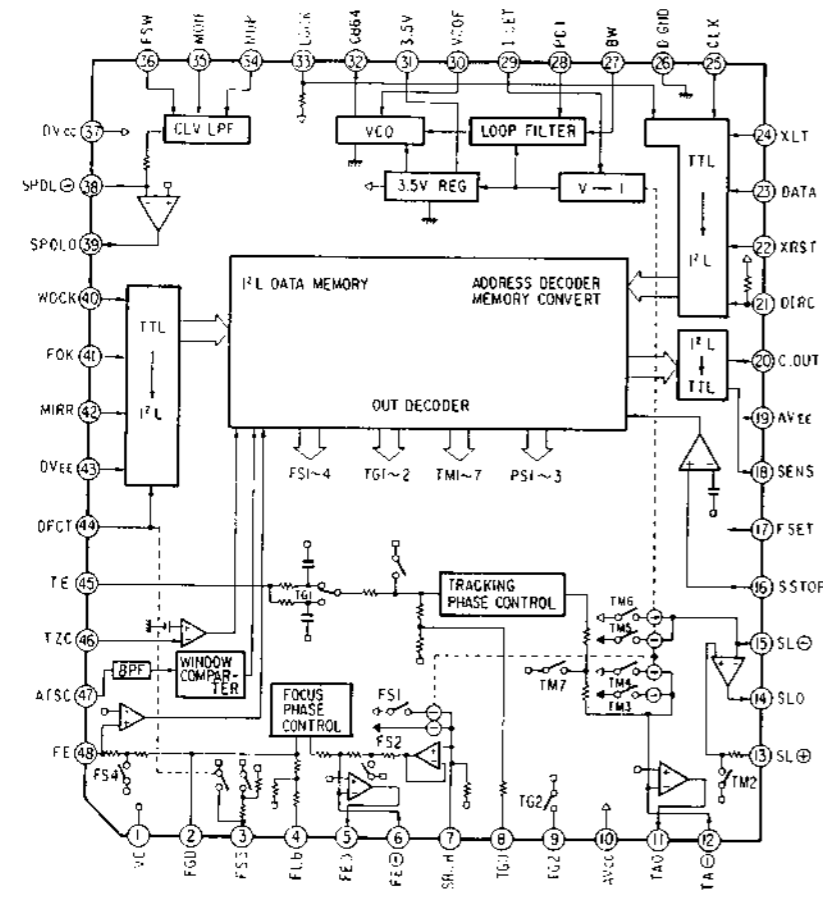

• IC8 LC9600PM-144

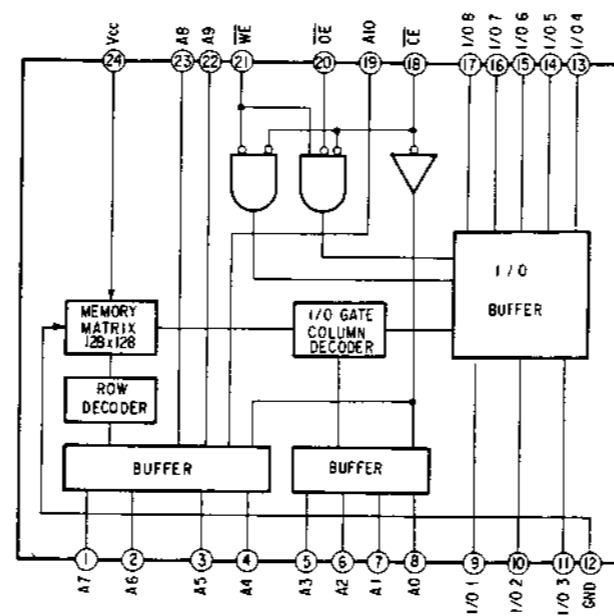

• IC11 M5204P

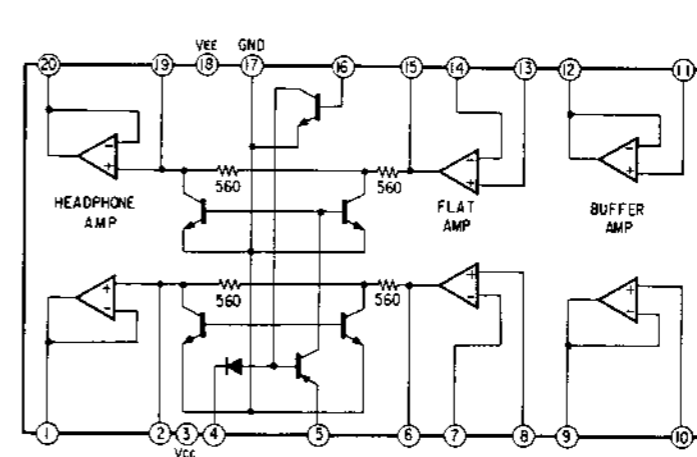

• IC12 M5231TL

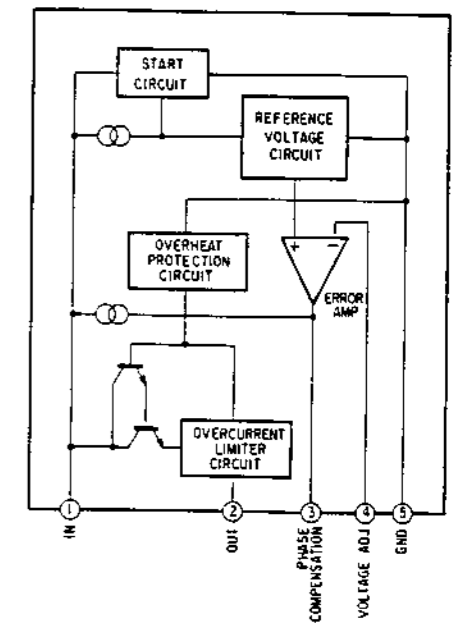

• IC1 M5294P

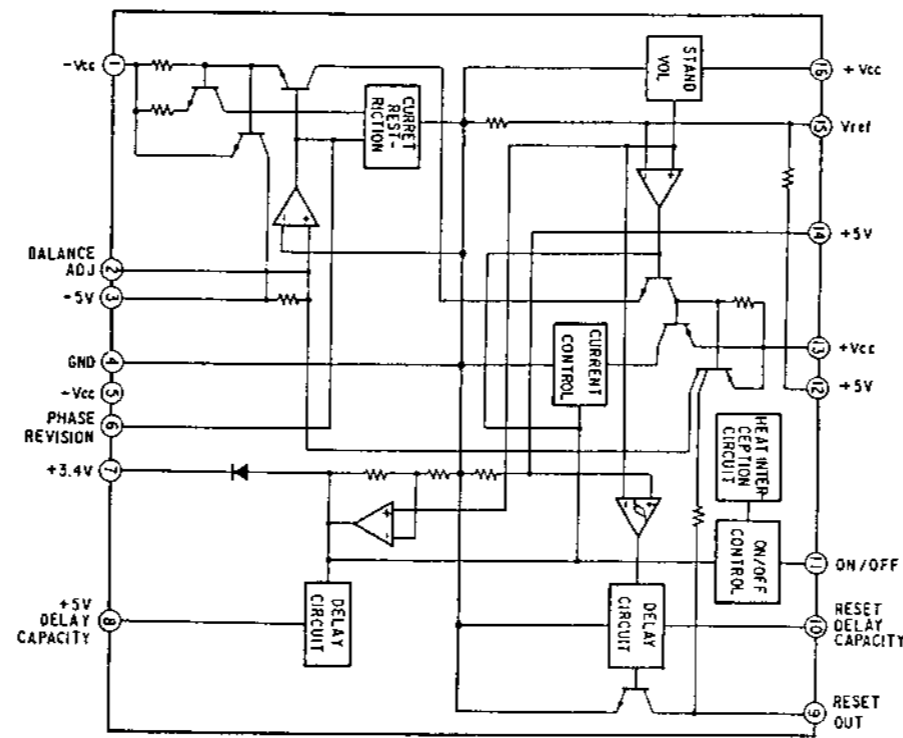

• IC4, 5 CXA1291P

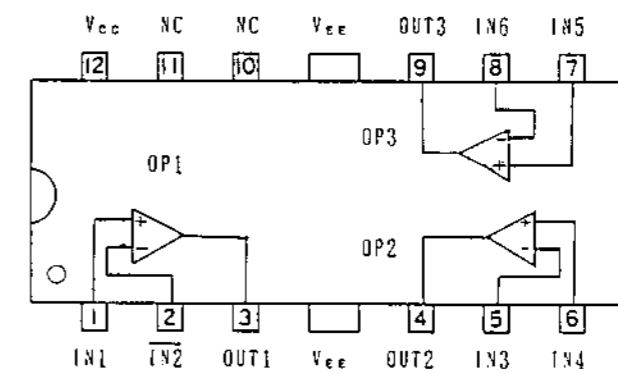

• IC9 CXD2550P

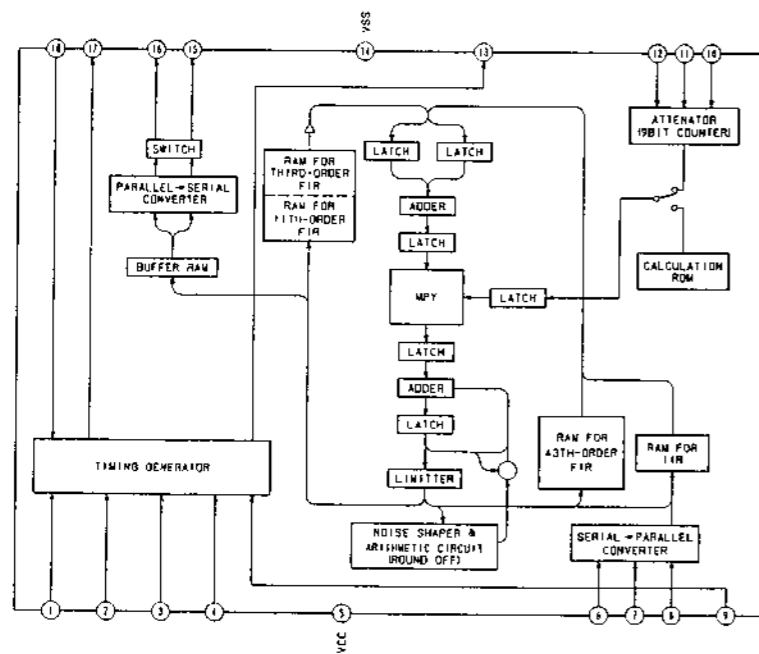

• IC10 CXD1161P-2

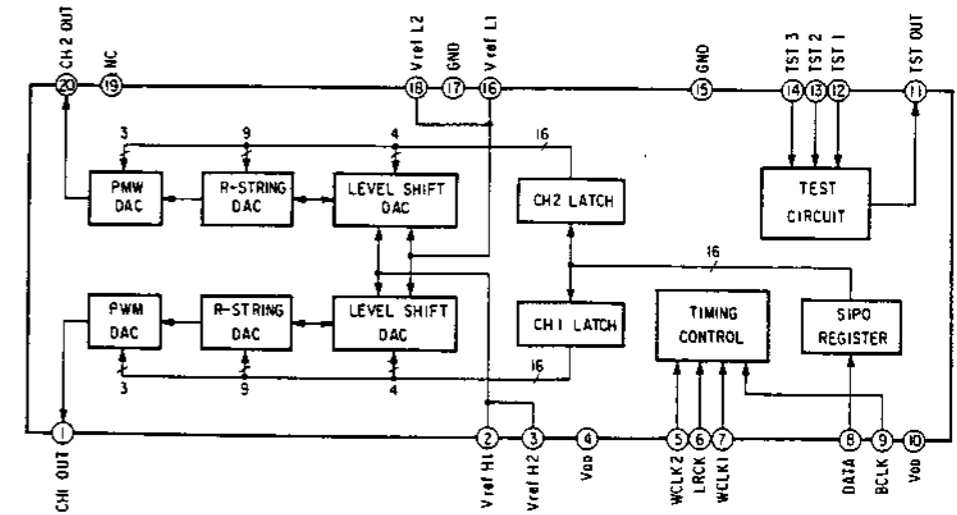

SECTION 4 EXPLODED VIEWS

NOTE:

- The mechanical parts with no reference number in the exploded views are not supplied.
- The construction parts of an assembled part are indicated with a collation number in the remark column.
- Items marked "*" are not stocked since they are seldom required for routine service. Some delay should be anticipated when ordering these items.

- Due to standardization, parts with part number suffix -XX and -X may be different from the parts specified in the components used on the set.
- Color Indication of Appearance Parts Example:
(RED) ... KNOB, BALANCE (WHITE)
↑ Cabinet's Color ↑ Parts' Color

The components identified by mark or dotted line with mark are critical for safety. Replace only with part number specified.

Les composants identifiés par une marque sont critiques pour la sécurité. Ne les remplacer que par une pièce portant le numéro spécifié.

4-1. CABINET SECTION

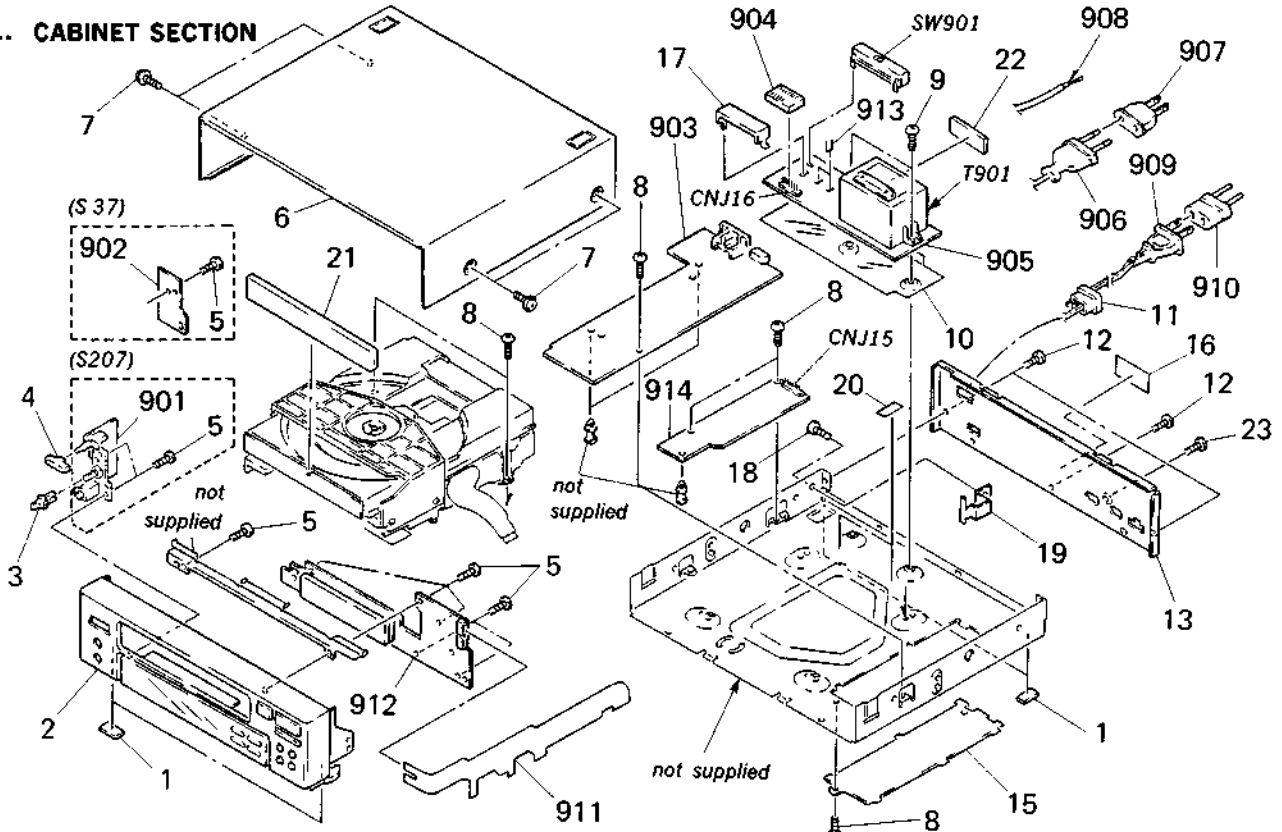

Ref.No	Part No.	Description	Remarks
1	4-930-336-01	FOOT (FELT)	
2	X-4929-701-1	(S37) ... PANEL ASSY, FRONT	
	X-4929-702-1	(S207) ... PANEL ASSY, FRONT	
3	4-929-707-11	(S37) ... KNOB (H.P)	
4	4-929-713-01	(S207) ... BUTTON (POWER)	
	4-929-713-11	(S37) ... BUTTON (POWER)	
5	7-685-134-19	SCREW +BTP 2.6X8 TYPE2 N-S	
6	4-930-347-01	(S207) ... CASE	
	4-930-347-11	(S37) ... CASE	
7	3-704-366-01	SCREW (CASE) (M3X8)	
8	7-682-547-04	SCREW +BVTT 3X6 (S)	
9	7-682-547-04	SCREW (+BVTT M3S)	
10	*4-929-711-01	COVER (A), POWER	
11	*3-703-244-00	(S37 : AEP/UK/EA,S207 : AEP/UK) ... BUSHING (2104), CORD	
	*3-703-571-11	(S37 : CND/E,S207 : US,CND) ... BUSHING (S)(4516), CORD	
12	7-685-872-09	SCREW +BVTT 3X8 (S)	
13	*4-929-702-01	(S207 : AEP) ... PANEL, BACK	
	*4-929-702-11	(US) ... PANEL, BACK	
	*4-929-702-21	(S207 : CND) ... PANEL, BACK	
	*4-929-702-31	(S207 : UK) ... PANEL, BACK	
	*4-929-702-41	(E/EA) ... PANEL, BACK	
	*4-929-702-51	(S37 : CND) ... PANEL, BACK	
	*4-929-702-61	(S37 : AEP) ... PANEL, BACK	
	*4-929-702-71	(S37 : UK) ... PANEL, BACK	
15	*4-929-708-01	PLATE, BOTTOM	
16	*4-885-838-00	LABEL, CLASS 1	
17	*4-929-710-01	COVER (B), POWER	
18	7-621-775-10	SCREW +B 2.6X4	
19	*4-929-712-01	(S37 : AEP/UK/E/EA,S207 : AEP/UK) ... COVER (C), POWER	

Ref.No	Part No.	Description	Remarks
20	3-831-441-XX	CUSHION (B), CABINET	
21	4-929-715-01	PANEL, LOADING	
22	*4-929-735-01	(S37 : CND/AEP/E/EA S207 : US/CND/AEP) ... CUSHION	
23	7-685-646-79	SCREW +BVTP 3X8 TYPE2 N-S	
901	*1-630-621-11	(S37) ... PC BOARD, HEADPHONE	
902	*1-630-617-11	(S207) ... PC BOARD, POWER SW	
903	*A-4617-080-A	(S37) ... MOUNTED PCB, MAIN	
	*A-4617-088-A	(S207) ... MOUNTED PCB, MAIN	
904	1-568-479-11	SOCKET, CONNECTOR (PC BOARD)7P	
905	*1-630-618-11	PC BOARD, TRANSFORMER	
906	Δ.1-555-750-00	(S37 : AEP/EA, S207 : AEP) ... CORD, POWER	
907	Δ.1-506-401-00	(EA) ... ADAPTOR, CONVERSION	
908	Δ.1-556-035-00	(S37 : UK, S207 : UK) ... CORD, POWER	
909	Δ.1-551-188-XX	(E) ... CORD, POWER	
	Δ.1-558-941-11	(S37 : CND, S207 : US/CND) ... CORD, POWER	
910	Δ.1-526-565-00	(E) ... AC PLUG ADAPTOR	
911	1-535-778-11	JUMPER, FILM (WITH TERMINAL)	
912	*1-630-616-11	PC BOARD, DISPLAY	
913	*1-535-771-11	TERMINAL	
914	*1-630-619-11	PC BOARD, POWER	
CNJ15	*1-568-480-11	PIN, CONNECTOR (PC BOARD) 7P	
CNJ16	*1-568-480-11	PIN, CONNECTOR (PC BOARD) 7P	
SW901	Δ.1-571-772-11	(E/EA) ... SWITCH, VOLTAGE SELECTION (VOLTAGE SELECTOR)	
T901	Δ.1-449-663-11	(E/EA) ... TRANSFORMER, POWER	
	Δ.1-449-664-11	(S37 : CND,S207 : US/CND) ... TRANSFORMER, POWER	
	Δ.1-449-665-11	(S37 : AEP/UK,S207 : AEP/UK) ... TRANSFORMER, POWER	

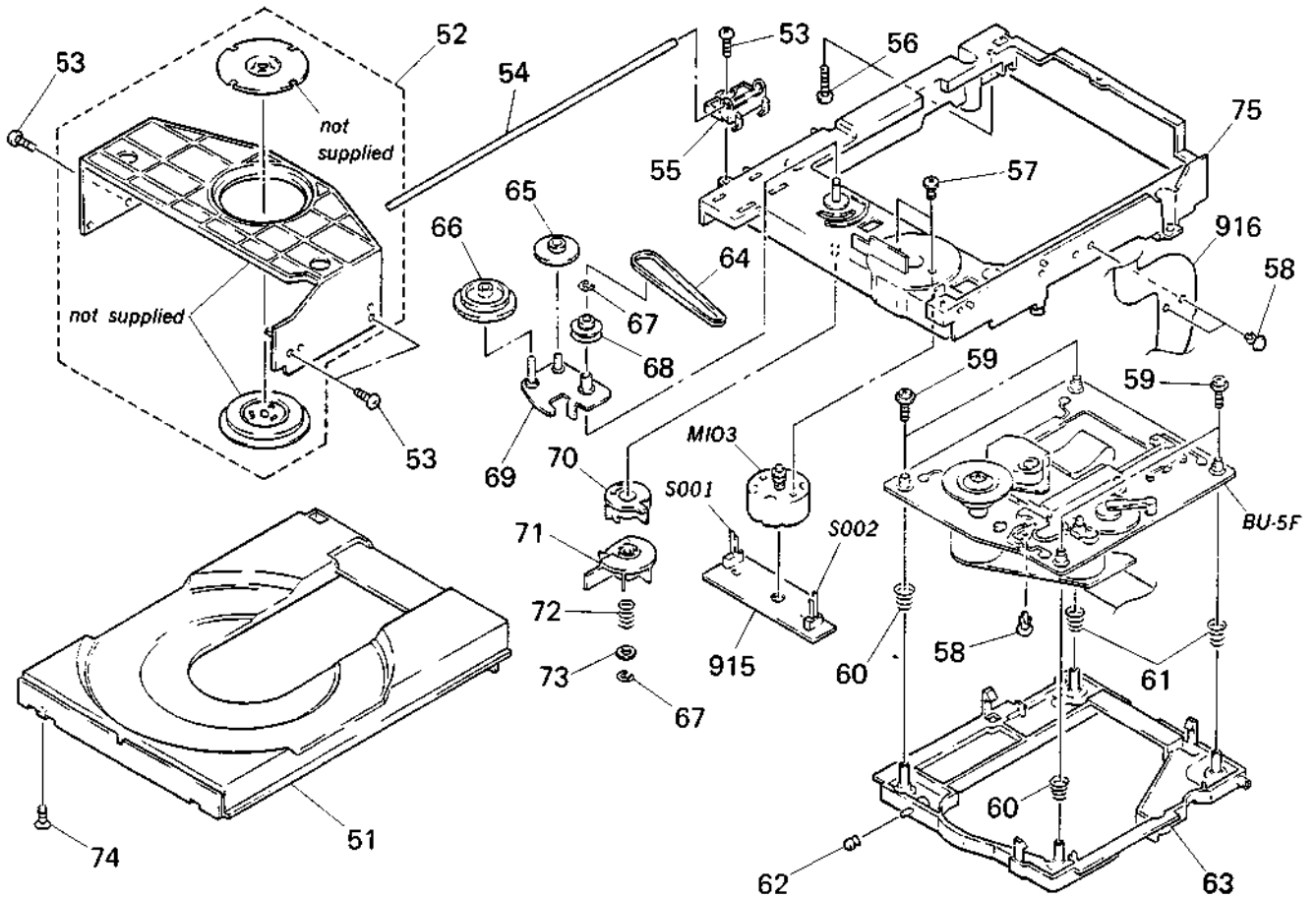

4-2. CDM13 SECTION

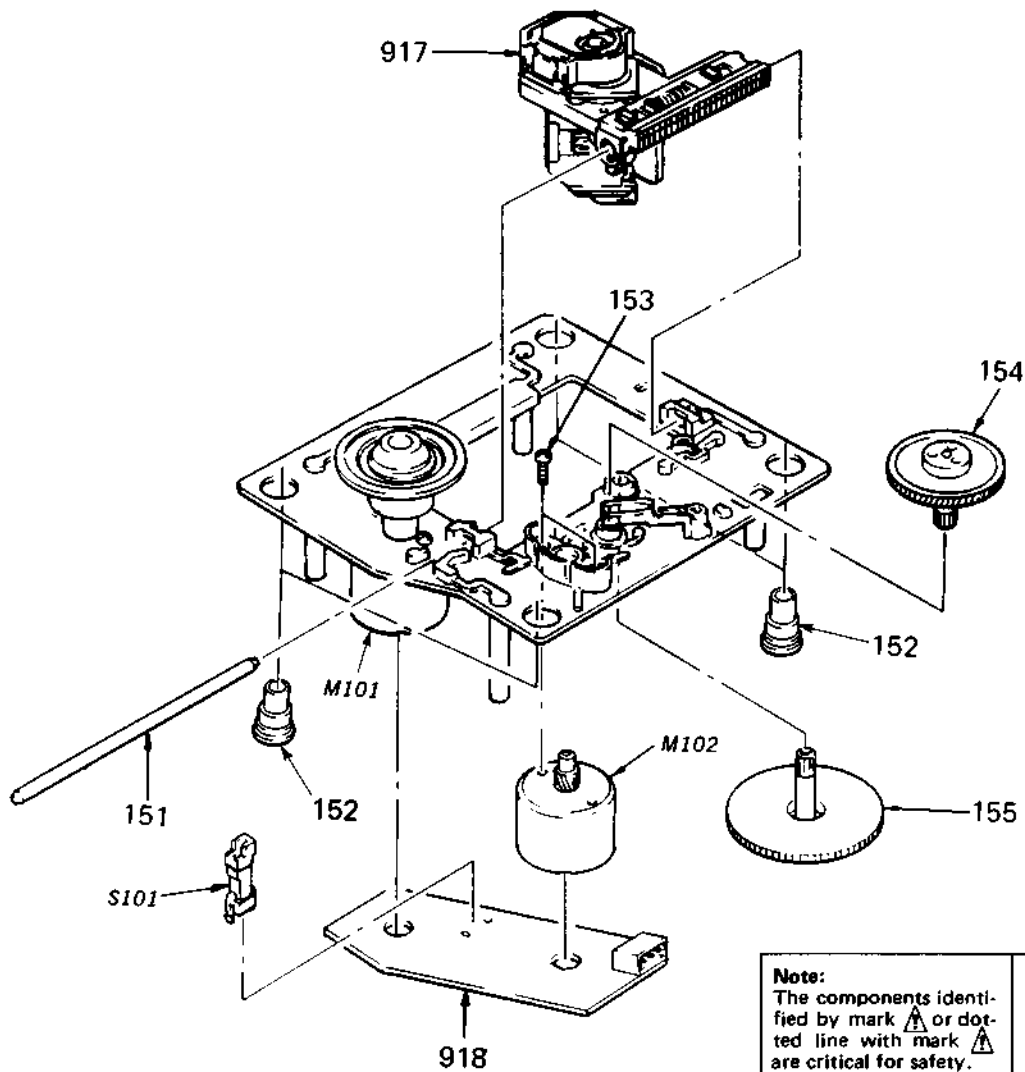

Ref.No	Part No.	Description	Remarks	Ref.No	Part No.	Description	Remarks
51	4-929-732-01	TABLE, DISK		66	4-927-620-01	GEAR (P)	
52	A-4604-219-A	HOLDER (MG) ASSY		67	7-624-105-04	STOP RING 2.3, TYPE -E	
53	7-685-646-79	SCREW +BVTP 3X8 TYPE2 N-S		68	4-929-724-01	PULLEY (B)	
54	4-929-721-01	SHAFT		69	X-4929-703-1	ARM ASSY, SWING	
55	4-929-723-01	GUIDE (T)		70	4-929-727-01	CAM (A)	
56	4-928-635-11	SCREW, +BV (2.6X16) TAPPING		71	4-929-729-01	CAM (B)	
57	7-621-775-10	SCREW +B 2.6X4		72	3-659-338-00	SPRING, COMPRESSION	
58	3-531-576-01	RIVET		73	4-927-654-01	WASHER (LIMITER)	
59	7-685-134-19	SCREW (+ PTPWH) (2.6X8)		74	7-685-234-19	SCREW +KTP 2.6X8 TYPE2NON-SLIT	
60	4-917-572-01	SPRING (B)		75	X-4929-704-1	CHASSIS (MD) ASSY	
61	4-917-541-01	SPRING (B)		915	*1-630-621-11	PC BOARD, LOADING	
62	4-927-631-01	ROLLER (L)		916	1-535-777-11	JUMPER, FILM (WITH TERMINAL)	
63	*4-929-730-01	HOLDER (BU-5)		M103	A-4608-362-A	MOTOR (L) ASSY (LOADING)	
64	4-927-649-01	BELT		S001	1-571-924-11	SWITCH, LEAF (LOADING IN SW)	
65	4-927-628-01	GEAR (C)		S002	1-571-924-11	SWITCH, LEAF (LOADING OUT SW)	

4-3. BU-5F SECTION



<p>Note: The components identified by mark  or dotted line with mark  are critical for safety. Replace only with part number specified.</p>	<p>Note: Les composants identifiés par une marque  sont critiques pour la sécurité. Ne les remplacer que par une pièce portant le numéro spécifié.</p>
--	--

Ref.No	Part No.	Description	Remarks	Ref.No	Part No.	Description	Remarks
151	4-917-565-01	SHAFT, SLED		917	 8-848-062-01	DEVICE, OPTICAL KSS-211A	
152	4-917-562-01	INSULATOR		918	*1-630-622-11	PC BOARD, SL/SP MOTOR	
153	7-621-255-15	SCREW +P 2X3		M101	X-4917-523-1	MOTOR, ASSY (SPINDLE)	
154	4-917-567-01	GEAR (M)		M102	X-4917-504-1	MOTOR, ASSY (SLED)	
155	4-917-564-01	GEAR (P), FLATNESS		S101	1-571-274-11	SWITCH, LEAF (LIMIT IN SW)	

SECTION 5 ELECTRICAL PARTS LIST

NOTE:

- Due to standardization, replacements in the parts list may be different from the parts specified in the diagrams or the components used on the set.
- Items marked "★" are not stocked since they are seldom required for routine service. Some delay should be anticipated when ordering these items.
- If there are two or more same circuits in a set such as a stereophonic machine, only typical circuit parts may be indicated and capacitors and resistors in other same circuits may be omitted.

CAPACITORS:

MF: μ F, PF: μ μ F.

RESISTORS

- All resistors are in ohms.
- F: nonflammable

COILS

- MMH: mH, UH: μ H

SEMICONDUCTORS

In each case, U: μ , for example:

UA...: μ A..., UPA...: μ PA...,
UPC...: μ PC, UPD...: μ PD...

The components identified by mark Δ or dotted line with mark Δ are critical for safety. Replace only with part number specified.

Les composants identifiés par une marque Δ sont critiques pour la sécurité. Ne les remplacer que par une pièce portant le numéro spécifié.

Ref.No	Part No.	Description	Ref.No	Part No.	Description			
901	* 1-630-621-11	(S37)...PC BOARD, HEADPHONE	C223	1-126-094-11	ELECT	4.7MF	20%	35V
902	* 1-630-617-11	(S207)...PC BOARD, POWER SW	C224	1-163-017-00	CERAMIC CHIP	0.0047MF	10%	50V
903	* A-4617-080-A	(S37)...MOUNTED PCB, MAIN	C225	1-124-443-00	ELECT	100MF	20%	10V
	* A-4617-088-A	(S207)...MOUNTED PCB, MAIN	C226	1-163-038-00	CERAMIC CHIP	0.1MF		25V
904	1-568-479-11	SOCKET, CONNECTOR (PC BOARD)?P	C227	1-163-117-00	CERAMIC CHIP	100PF	5%	50V
905	* 1-630-618-11	PC BOARD, TRANSFORMER	C228	1-164-161-11	CERAMIC CHIP	0.0022MF	10%	50V
906	Δ 1-555-750-00	(S37 : AEP/EA, S207 : AEP)...CORD, POWER	C229	1-163-135-00	CERAMIC CHIP	560PF	5%	50V
907	Δ 1-506-401-00	(EA)...ADAPTOR, CONVERSION	C230	1-136-169-00	FILM	0.22MF	5%	50V
908	Δ 1-556-035-00	(S37 : UK, S207 : UK)...CORD, POWER	C231	1-163-038-00	CERAMIC CHIP	0.1MF		25V
909	Δ 1-551-188-XX	(E)...CORD, POWER	C232	1-123-875-11	ELECT	10MF	20%	50V
	Δ 1-558-941-11	(S37 : CND, S207 : US/CND)...CORD, POWER	C233	1-123-875-11	ELECT	10MF	20%	50V
910	Δ 1-526-565-00	(E)...AC PLUG ADAPTOR	C234	1-124-611-00	ELECT	1MF	20%	100V
911	1-535-778-11	JUMPER, FILM (WITH TERMINAL)	C236	1-163-038-00	CERAMIC CHIP	0.1MF		25V
912	* 1-630-616-11	PC BOARD, DISPLAY	C301	1-136-165-00	FILM	0.1MF	5%	50V
913	* 1-535-771-11	TERMINAL	C302	1-124-443-00	ELECT	100MF	20%	10V
914	* 1-630-619-11	PC BOARD, POWER	C303	1-136-159-00	FILM	0.033MF	5%	50V
915	* 1-630-621-11	PC BOARD, LOADING	C304	1-124-902-00	ELECT	0.47MF	20%	50V
916	1-535-777-11	JUMPER, FILM (WITH TERMINAL)	C305	1-163-017-00	CERAMIC CHIP	0.0047MF	10%	50V
917	Δ 8-848-062-01	DEVICE, OPTICAL KSS-211A	C306	1-163-038-00	CERAMIC CHIP	0.1MF		25V
918	* 1-630-622-11	PC BOARD, SL/SP MOTOR	C307	1-163-145-00	CERAMIC CHIP	0.0015MF	5%	50V
CAPACITOR								
C105	1-164-159-11	CERAMIC	0.1MF		50V			
C106	1-124-898-11	ELECT	4700MF	20%	16V			
C107	1-124-556-11	ELECT	2200MF	20%	16V			
C108	1-124-443-00	ELECT	100MF	20%	10V			
C109	1-124-443-00	ELECT	100MF	20%	10V			
C110	1-124-927-11	ELECT	4.7MF	20%	50V			
C111	1-162-179-11	CERAMIC	0.1MF		50V			
C112	1-162-179-11	CERAMIC	0.1MF		50V			
C113	1-124-572-11	ELECT	100MF	20%	63V			
C114	1-123-875-11	ELECT	10MF	20%	50V			
C115	1-164-159-11	CERAMIC	0.1MF		50V			
C120	1-136-153-00	(S37)...FILM	0.01MF	5%	50V			
C201	1-164-161-11	CERAMIC CHIP	0.0022MF	10%	50V			
C202	1-163-093-00	CERAMIC CHIP	10PF	5%	50V			
C203	1-163-093-00	CERAMIC CHIP	10PF	5%	50V			
C204	1-136-153-00	FILM	0.01MF	5%	50V			
C205	1-136-153-00	FILM	0.01MF	5%	50V			
C206	1-136-159-00	FILM	0.033MF	5%	50V			
C208	1-124-443-00	ELECT	100MF	20%	10V			
C209	1-124-443-00	ELECT	100MF	20%	10V			
C210	1-164-161-11	CERAMIC CHIP	0.0022MF	10%	50V			
C211	1-163-017-00	CERAMIC CHIP	0.0047MF	10%	50V			
C212	1-164-161-11	CERAMIC CHIP	0.0022MF	10%	50V			
C213	1-136-165-00	FILM	0.1MF	5%	50V			
C214	1-136-159-00	FILM	0.033MF	5%	50V			
C215	1-123-382-00	ELECT	3.3MF	20%	50V			
C216	1-136-165-00	FILM	0.1MF	5%	50V			
C217	1-123-875-11	ELECT	30MF	20%	50V			
C218	1-163-017-00	CERAMIC CHIP	0.0047MF	10%	50V			
C219	1-163-038-00	CERAMIC CHIP	0.1MF		25V			
C220	1-163-038-00	CERAMIC CHIP	0.1MF		25V			
C221	1-163-038-00	CERAMIC CHIP	0.1MF		25V			
C222	1-124-438-00	ELECT	1MF	20%	50V			
C308	1-163-038-00	CERAMIC CHIP	0.1MF		25V			
C311	1-124-443-00	ELECT	100MF	20%	10V			
C312	1-163-097-00	CERAMIC CHIP	15PF	5%	50V			
C313	1-163-097-00	CERAMIC CHIP	15PF	5%	50V			
C314	1-163-038-00	CERAMIC CHIP	0.1MF		25V			
C315	1-163-038-00	CERAMIC CHIP	0.1MF		25V			
C316	1-124-443-00	ELECT	100MF	20%	10V			
C317	1-126-094-11	ELECT	4.7MF	20%	35V			
C318	1-126-094-11	ELECT	4.7MF	20%	35V			
C319	1-124-443-00	ELECT	100MF	20%	10V			
C320	1-124-442-00	ELECT	330MF	20%	6.3V			
C321	1-124-442-00	ELECT	330MF	20%	6.3V			
C323	1-163-135-00	CERAMIC CHIP	560PF	5%	50V			
C324	1-163-135-00	CERAMIC CHIP	560PF	5%	50V			
C325	1-161-374-11	(S37)...CERAMIC	0.0015MF	20%	16V			
C326	1-161-374-11	(S37)...CERAMIC	0.0015MF	20%	16V			
C327	1-163-125-00	CERAMIC CHIP	220PF	5%	50V			
C328	1-163-125-00	CERAMIC CHIP	220PF	5%	50V			
C329	1-124-438-00	ELECT	1MF	20%	50V			
C330	1-163-135-00	CERAMIC CHIP	560PF	5%	50V			
C331	1-163-135-00	CERAMIC CHIP	560PF	5%	50V			
C332	1-163-135-00	CERAMIC CHIP	560PF	5%	50V			
C333	1-124-584-00	ELECT	100MF	20%	10V			
C352	1-163-038-00	CERAMIC CHIP	0.1MF		25V			
C353	1-163-038-00	CERAMIC CHIP	0.1MF		25V			
C354	1-163-038-00	CERAMIC CHIP	0.1MF		25V			
C355	1-163-038-00	CERAMIC CHIP	0.1MF		25V			
C356	1-163-038-00	CERAMIC CHIP	0.1MF		25V			
C357	1-163-038-00	CERAMIC CHIP	0.1MF		25V			
C399	1-136-165-00	(S37)...FILM	0.1MF	5%	50V			
CNJ2	* 1-564-336-00	(S207)...PIN, CONNECTOR 2P						
	* 1-564-339-11	(S37)...PIN, CONNECTOR 5P						
CNJ3	* 1-564-338-00	PIN, CONNECTOR 4P						
CNJ4	* 1-564-339-00	PIN, CONNECTOR 5P						
CNJ5	* 1-564-341-11	PIN, CONNECTOR 7P						

Ref.No	Part No.	Description
CNJ7	1-564-980-11	PIN, CONNECTOR 4P (SYSTEM CONTROL IN)
CNJ8	*1-564-338-00	(S207)... PIN, CONNECTOR 4P
	*1-564-341-11	(S37)... PIN, CONNECTOR 7P
CNJ9	*1-568-506-11	SOCKET, CONNECTOR 21P
CNJ11	*1-564-340-00	PIN, CONNECTOR 6P
CNJ15	*1-568-480-11	PIN, CONNECTOR (PC BOARD) 7P
CNJ16	*1-568-480-11	PIN, CONNECTOR (PC BOARD) 7P
CNJ19	*1-568-505-11	HOUSING, CONNECTOR 10P
CNJ20	*1-568-505-11	HOUSING, CONNECTOR 10P
D1	8-719-109-96	DIODE RD6.8ES-B1
D3	8-719-100-03	DIODE 1S2835
D4	8-719-100-03	DIODE 1S2835
D5	8-719-100-03	DIODE 1S2835
D6	8-719-200-02	DIODE 10E2
D7	8-719-200-02	DIODE 10E2
D8	8-719-200-02	DIODE 10E2
D9A	8-719-100-03	DIODE 1S2835
D9B	8-719-200-02	DIODE 10E2
D10	8-719-200-02	DIODE 10E2
FL301	1-519-499-11	INDICATOR TUBE, FLUORESCENT
HS1	*4-922-525-01	HEAT SINK
IB101	1-233-171-11	COMPOSITION CIRCUIT BLOCK
IB102	1-233-171-11	COMPOSITION CIRCUIT BLOCK
IC1	8-759-631-40	IC M5294P
IC2	8-752-033-14	IC CXA1081Q
IC3	8-752-032-29	IC CXA1082BQ
IC4	8-752-035-28	IC CXA1291P
IC5	8-752-035-28	IC CXA1291P
IC6	8-759-978-34	IC MSC6458-32SS
IC7	8-752-328-62	IC CXD1125Q
IC8	8-752-323-64	IC CXK5816M-12L
IC9	8-752-328-72	IC CXD2550P
IC10	8-759-805-36	IC CXD1161P-3
IC11	8-759-631-39	IC M5204P
IC12	8-759-605-43	IC M5231TL
J1	1-507-967-51	(S37)... JACK (HEADPHONES)
JW25	1-216-295-00	METAL GLAZE 0 5% 1/10W
JW26	1-216-295-00	METAL GLAZE 0 5% 1/10W
JW27	1-216-295-00	METAL GLAZE 0 5% 1/10W
JW28	1-216-295-00	METAL GLAZE 0 5% 1/10W
JW29	1-216-295-00	METAL GLAZE 0 5% 1/10W
JW30	1-216-295-00	METAL GLAZE 0 5% 1/10W
JW31	1-216-295-00	METAL GLAZE 0 5% 1/10W
M101	X-4917-523-1	MOTOR, ASSY (SPINDLE)
M102	X-4917-504-1	MOTOR, ASSY (SLED)
M103	A-4608-362-A	MOTOR (L) ASSY (LOADING)
PN1	1-566-921-11	JACK, PIN 2P (LINE OUT)
Q1	8-729-600-94	TRANSISTOR 2SK381-C
Q2	8-729-101-07	TRANSISTOR 2SB798-DL
Q3	8-729-113-13	TRANSISTOR FA1A4M-L33
Q4	8-729-112-97	TRANSISTOR FA1L4M-L31
Q5	8-729-112-97	TRANSISTOR FA1L4M-L31
Q6	8-729-112-97	TRANSISTOR FA1L4M-L31
Q10	8-729-113-13	TRANSISTOR FA1A4M-L33
Q11	8-729-113-66	TRANSISTOR FN1L4M-M31
RESISTOR		
R101	1-249-423-11	CARBON 3.3K 5% 1/4W
R102	1-249-439-11	CARBON 68K 5% 1/4W
R103	1-249-417-11	CARBON 1K 5% 1/4W
R201	1-216-082-00	METAL GLAZE 24K 5% 1/10W



Ref.No	Part No.	Description			
R202	1-216-071-00	METAL GLAZE	8.2K	5%	1/10W
R203	1-216-049-00	METAL GLAZE	1K	5%	1/10W
R204	1-216-077-00	METAL GLAZE	15K	5%	1/10W
R205	1-216-077-00	METAL GLAZE	15K	5%	1/10W
R206	1-216-025-00	METAL GLAZE	100	5%	1/10W
R207	1-216-009-00	METAL GLAZE	22	5%	1/10W
R208	1-216-065-00	METAL GLAZE	4.7K	5%	1/10W
R209	1-216-065-00	METAL GLAZE	4.7K	5%	1/10W
R211	1-216-100-00	METAL GLAZE	130K	5%	1/10W
R212	1-216-095-00	METAL GLAZE	82K	5%	1/10W
R213	1-216-107-00	METAL GLAZE	270K	5%	1/10W
R214	1-216-085-00	METAL GLAZE	33K	5%	1/10W
R215	1-216-061-00	METAL GLAZE	3.3K	5%	1/10W
R216	1-216-065-00	METAL GLAZE	4.7K	5%	1/10W
R217	1-216-114-00	METAL GLAZE	510K	5%	1/10W
R218	1-216-073-00	METAL GLAZE	10K	5%	1/10W
R219	1-216-057-00	METAL GLAZE	2.2K	5%	1/10W
R220	1-216-073-00	METAL GLAZE	10K	5%	1/10W
R221	1-216-081-00	METAL GLAZE	22K	5%	1/10W
R222	1-216-043-00	METAL GLAZE	560	5%	1/10W
R223	1-216-097-00	METAL GLAZE	100K	5%	1/10W
R224	1-218-154-11	METAL GLAZE	3.6K	1%	1/10W
R225	1-216-097-00	METAL GLAZE	100K	5%	1/10W
R226	1-216-079-00	METAL GLAZE	18K	5%	1/10W
R227	1-216-079-00	METAL GLAZE	18K	5%	1/10W
R228	1-216-001-00	METAL GLAZE	10	5%	1/10W
R229	1-216-100-00	METAL GLAZE	130K	5%	1/10W
R230	1-216-069-00	METAL GLAZE	6.8K	5%	1/10W
R231	1-216-093-00	METAL GLAZE	68K	5%	1/10W
R232	1-216-089-00	METAL GLAZE	47K	5%	1/10W
R234	1-216-097-00	METAL GLAZE	100K	1%	1/10W
R235	1-218-163-11	METAL GLAZE	120K	1%	1/10W
R236	1-218-163-11	METAL GLAZE	120K	1%	1/10W
R237	1-216-097-00	METAL GLAZE	100K	1%	1/10W
R238	1-216-049-00	METAL GLAZE	1K	5%	1/10W
R239	1-216-049-00	METAL GLAZE	1K	5%	1/10W
R240	1-216-049-00	METAL GLAZE	1K	5%	1/10W
R241	1-216-001-00	METAL GLAZE	10	5%	1/10W
R242	1-216-001-00	METAL GLAZE	10	5%	1/10W
R301	1-216-065-00	METAL GLAZE	4.7K	5%	1/10W
R302	1-216-065-00	METAL GLAZE	4.7K	5%	1/10W
R303	1-216-065-00	METAL GLAZE	4.7K	5%	1/10W
R304	1-216-065-00	METAL GLAZE	4.7K	5%	1/10W
R305	1-216-121-00	METAL GLAZE	1M	5%	1/10W
R306	1-216-081-00	METAL GLAZE	22K	5%	1/10W
R307	1-216-113-00	METAL GLAZE	470K	5%	1/10W
R308	1-216-081-00	METAL GLAZE	22K	5%	1/10W
R309	1-216-097-00	METAL GLAZE	100K	5%	1/10W
R310	1-216-073-00	METAL GLAZE	10K	5%	1/10W
R311	1-216-097-00	METAL GLAZE	100K	1%	1/10W
R312	1-216-097-00	METAL GLAZE	100K	1%	1/10W
R314	1-216-049-00	METAL GLAZE	1K	5%	1/10W
R315	1-216-049-00	METAL GLAZE	1K	5%	1/10W
R316	1-216-049-00	METAL GLAZE	1K	5%	1/10W
R317	1-216-037-00	METAL GLAZE	330	5%	1/10W
R318	1-216-049-00	METAL GLAZE	1K	5%	1/10W
R319	1-216-049-00	METAL GLAZE	1K	5%	1/10W
R320	1-216-053-00	METAL GLAZE	1.5K	5%	1/10W
R321	1-216-085-00	METAL GLAZE	33K	5%	1/10W
R322	1-216-085-00	METAL GLAZE	33K	5%	1/10W
R323	1-216-093-00	METAL GLAZE	68K	5%	1/10W
R324	1-216-093-00	METAL GLAZE	68K	5%	1/10W
R325	1-216-093-00	METAL GLAZE	68K	5%	1/10W
R326	1-216-093-00	METAL GLAZE	68K	5%	1/10W
R327	1-216-049-00	METAL GLAZE	1K	5%	1/10W

Ref.No	Part No.	Description
R328	1-216-049-00	METAL GLAZE 1K 5% 1/10W
R329	1-249-402-11	(S37)....CARBON 56 5% 1/4W
R330	1-249-402-11	(S37)....CARBON 56 5% 1/4W
R331	1-216-065-00	METAL GLAZE 4.7K 5% 1/10W
R332	1-216-065-00	METAL GLAZE 4.7K 5% 1/10W
R333	1-216-065-00	METAL GLAZE 4.7K 5% 1/10W
R351	1-216-001-00	METAL GLAZE 10 5% 1/10W
R352	1-216-089-00	METAL GLAZE 47K 5% 1/10W
R353	1-216-069-00	METAL GLAZE 6.8K 5% 1/10W
R354	1-216-069-00	METAL GLAZE 6.8K 5% 1/10W
RV1	1-228-995-00	RES. ADJ. CARBON 22K
RV2	1-228-993-00	RES. ADJ. CARBON 4.7K
RV3	1-228-995-00	RES. ADJ. CARBON 22K
RV4	1-228-990-00	RES. ADJ. METAL GLAZE 1K
RV5	1-228-995-00	RES. ADJ. CARBON 22K
RV6	1-238-302-11	(S37)....RES. VAR. CARBON 1K/1K (PHONE LEVEL)
S001	1-571-924-11	SWITCH, LEAF (LOADING IN SW)
S002	1-571-924-11	SWITCH, LEAF (LOADING OUT SW)
S101	1-571-274-11	SWITCH, LEAF (LIMIT IN SW)
SW1	1-552-928-21	(S37)....SWITCH, PUSH (1 KEY) (POWER)
SW2	1-571-305-11	(S207)....SWITCH, PUSH (1 KEY) (POWER)
SW101	1-554-596-22	SWITCH, KEY BOARD (D)
SW102	1-554-303-21	SWITCH, KEY BOARD (■)
SW103	1-554-596-22	SWITCH, KEY BOARD (◀▶)
SW104	1-554-303-21	SWITCH, KEY BOARD (▶▶)
SW105	1-554-596-22	SWITCH, KEY BOARD (◀◀)
SW106	1-554-303-21	SWITCH, KEY BOARD (▶▶)
SW107	1-554-596-22	SWITCH, KEY BOARD (REPEAT)
SW108	1-554-596-22	SWITCH, KEY BOARD (OPEN/CLOSE)
SW109	1-554-596-22	SWITCH, KEY BOARD (PROGRAM)
SW110	1-554-596-22	SWITCH, KEY BOARD (SHUFFLE)
SW111	1-554-596-22	SWITCH, KEY BOARD (DISPLAY)
SW112	1-554-303-21	SWITCH, KEY BOARD (CONTINUE)
SW901A	1-571-772-11	(E/EA)....SWITCH, VOLTAGE SELECTION (VOLTAGE SELECTOR)
T901	△1-449-663-11	(E/EA)....TRANSFORMER, POWER
	△1-449-664-11	(S37 : CND,S207 : US/CND)....TRANSFORMER, POWER
	△1-449-665-11	(S37 : AEP/UK,S207 : AEP/UK)....TRANSFORMER, POWER
X1	1-567-908-21	VIBRATOR, CRYSTAL (16MHz)
X2	1-577-082-11	VIBRATOR, CERAMIC (4MHz)

Part No. Description

ACCESSORY & PACKING MATERIAL

1-558-233-11	CORD (WITH CONNECTOR) (SIRCS)4P
1-559-533-11	CORD, CONNECTION
3-750-220-11	(S37 : CND/AEP/E/EA, S207 : CND/AEP)....MANUAL, INSTRUCTION
3-750-220-41	(S37 : AEP, S207 : AEP/UK)....MANUAL, INSTRUCTION
*3-795-629-11	(S37 : AEP, S207 : AEP/UK)....INSTRUCTION
4-920-941-01	SHEET (B), PROTECTION
*4-929-703-01	CUSHION (LEFT)
*4-929-704-01	CUSHION (RIGHT)
*4-929-705-01	(S207)....INDIVIDUAL CARTON
*4-929-705-11	(S37)....INDIVIDUAL CARTON
*3-750-220-21	(S37 : UK, S207 : US/UK)....MANUAL, INSTRUCTION

Note:
The components identified by mark  or dotted line with mark  are critical for safety. Replace only with part number specified.

Note:
Les composants identifiés par une marque  sont critiques pour la sécurité. Ne les remplacer que par une pièce portant le numéro spécifié.